

1 Launching of the *Telstar* Satellite

By H. N. UPTHEGROVE, J. B. D'ALBORA, JR.,
A. R. KOLDING, and B. A. McLEOD

(Manuscript received March 20, 1963)

10893

The launching of the Telstar satellite from Cape Canaveral is described, with emphasis on the pre-launch testing and test facilities. AUTHOR

I. INTRODUCTION

The Telstar satellite was launched on July 10, 1962, from Cape Canaveral by a Delta launch vehicle. The pre-launch and launch operations were carried out jointly by the National Aeronautics and Space Administration (NASA) and Bell Telephone Laboratories. NASA had responsibility for procurement, checkout, and launch of the Delta vehicle and for mating of the Telstar spacecraft with the launch vehicle. Bell Telephone Laboratories was responsible for delivery, checkout and monitoring of the spacecraft, and observed and participated in the launch vehicle preparation and spacecraft-to-vehicle mating operation. Bell Telephone Laboratories provided radio command guidance for the Telstar launch, as for all Delta launches.

At Cape Canaveral the principal test locations for the Telstar launch operations are:

(1) Launch Complex 17, consisting of two launch pads, 17A and 17B, and supporting facilities; the Telstar satellite was launched from 17B.

(2) Guided Missile Control Facility No. 3, the Laboratories-operated command guidance ground station; Telstar launch operations facilities were located here.

(3) Spin Test Building, operated by Douglas Aircraft Company for NASA; here, the Telstar spacecraft was mated to the Delta third-stage motor and the combination was spin-balanced prior to installation on the launch vehicle.

II. LAUNCH PREPARATIONS AND FACILITIES

2.1 Summary

Following the final tests and inspections at the Hillside, N. J., Bell Telephone Laboratories, the spacecraft used in the launch operations

*In its Telstar¹⁴⁴⁹ 1, Vol. 2 Jun. 1963
81449-1473 refs (See N64-10882 02-00)
AS*

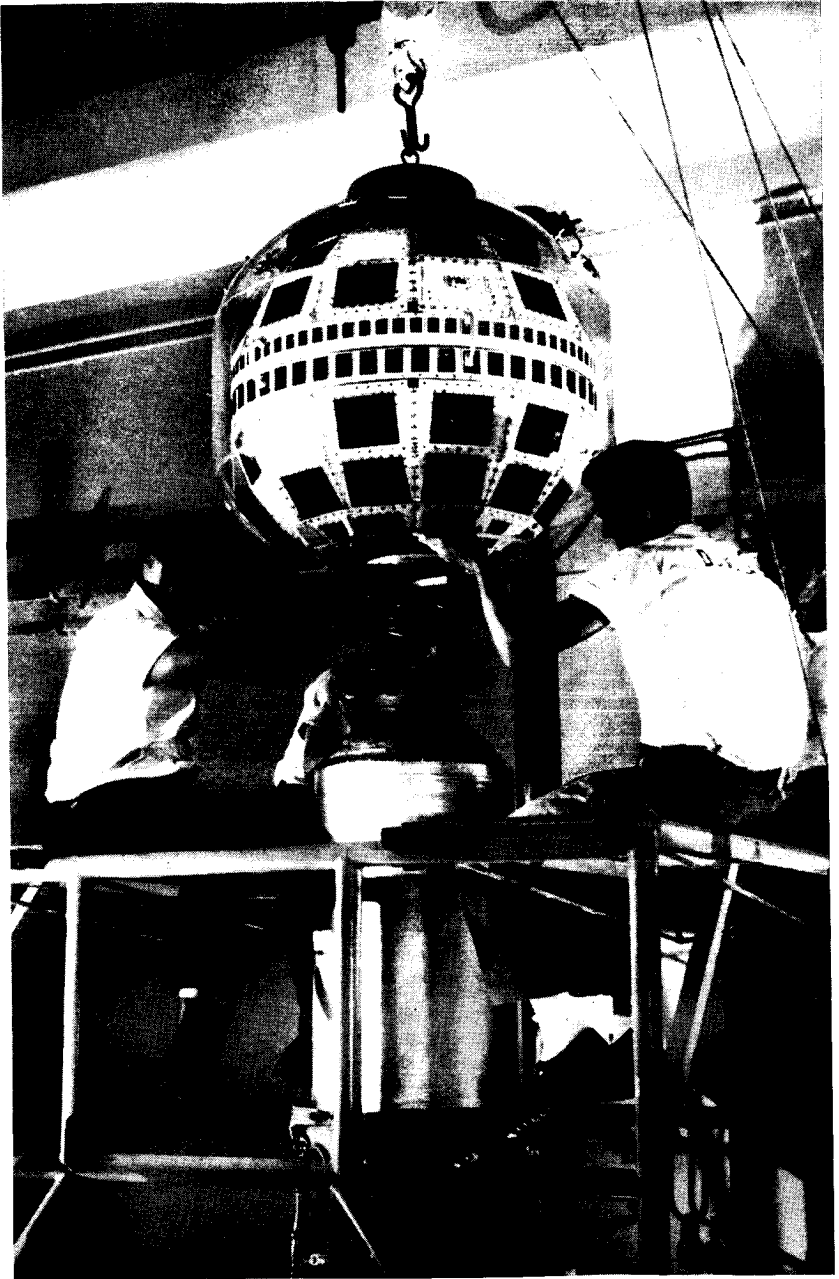

Fig. 1 — Mating the spacecraft to the Delta third stage.

were shipped by special truck to Cape Canaveral for the subsequent series of pre-launch tests and the mechanical operations involved in mating the satellite to the Delta launch vehicle.

The electrical testing required the establishment of new facilities at Cape Canaveral in three locations. The base location at the Laboratories' missile guidance area provides test equipment and spacecraft storage facilities in three air-conditioned 40-foot vans. In addition, there are an autotracking VHF antenna system for command and telemetry and several microwave antennas used for tests when the spacecraft is at either of the other two locations.

A second test location is in the spin test building. In this building, the spacecraft is mated to the third stage of the rocket as shown on Fig. 1, and the combination is dynamically balanced at spin rates it will have in flight. The special installation for the Telstar project consists primarily of three antennas mounted on a tower outside the building and coupled to the satellite to permit remote testing from the base location.

The third test location is the launch stand, where test equipment was installed in an existing test room on the seventh level. This was used together with the test equipment at the base location for tests of the satellite.

Before the flight models were available, the prototype model of the spacecraft was sent to Cape Canaveral and used to check out all of the testing and handling procedures at the three locations. It was also used in the radio-frequency compatibility test which is required by the missile range. Two spacecraft were provided to serve as the flight model and the back-up model. These were designated Fly 2 and Fly 3; Fly 2 was to be launched unless trouble developed requiring the substitution of Fly 3.

The first operation with the Fly 2 spacecraft after arrival at the Cape was the comprehensive arrival check to verify that all of its systems were intact after the trip from Hillside. Subsequent to this, the spacecraft was given a daily routine check during the period of time it remained in the satellite van prior to delivery to the spin building. The back-up spacecraft, Fly 3, was tested in the same way and then remained in the spacecraft van receiving daily checks until it was shipped back to Hillside after the launch.

On F - 9 day (9 days before launch), Fly 2 was moved from the spacecraft van to the spin building for mating to the live third stage.* This operation consists of coupling the spacecraft to the third stage. The combination of spacecraft and third stage was tested for eccentricity before the dynamic spin balancing operation. A remote electrical performance

* Discussed later in this paper. The live stage contained approximately 500 pounds of solid propellant.

test was then made from the vans at the base location to make sure that the spacecraft had not been damaged.

Following this test, the spacecraft and third-stage assembly was moved to the spin test fixture. In the balancing operation, the assembly was rotated at its flight rate and the imbalance measured with accelerometers. Following the balancing operation, another remote check was made to verify that no damage was done during the spin operation.

The mated third stage and spacecraft were then transported to the launch stand in a special carrying canister on F - 4 day. After attachment to the second stage of the rocket, the spacecraft and the live third stage were encased in a clear plastic enclosure which was continuously supplied with dust-free, dry, cool air.

Prior to roll-back of the gantry, the spacecraft was tested daily using test consoles on the seventh level of the gantry. After the gantry was rolled back the testing was done by direct radio coupling from the Telstar spacecraft antennas to the base location antennas. In the final minutes of the terminal count immediately preceding the launch, the spacecraft microwave repeater was again tested. Telemetry monitoring was continued through lift-off and until the satellite disappeared below the horizon.

2.2 Transportation to Cape Canaveral

A one-ton truck equipped for the special requirements of spacecraft transportation was procured. The body is insulated and contains a heater (independent of the cab heater) and a cooling device which uses solid carbon dioxide. The spacecraft carrying case contained a shock mounting to which the spacecraft was clamped. Additional shock suspension of the carrying case within the truck was found to be undesirable.

Road tests with a dummy spacecraft load verified that the truck and carrying case would provide safe transportation for the actual spacecraft.

The carrying case was filled with dry nitrogen before it left the Hillside Laboratories, and a small positive pressure was provided by a low-pressure feed of nitrogen from tanks in the truck.

2.3 Satellite Test Facilities at Base Location

The base location at the Bell Laboratories guidance area, GMCF-3, is far removed from the industrial area and vehicle traffic. Because of the unobstructed radio paths from this location to the spin building and to launch area 17, antennas could be mounted on low supporting structures. The arrangement of the vans and antennas at the base location is shown in Fig. 2.

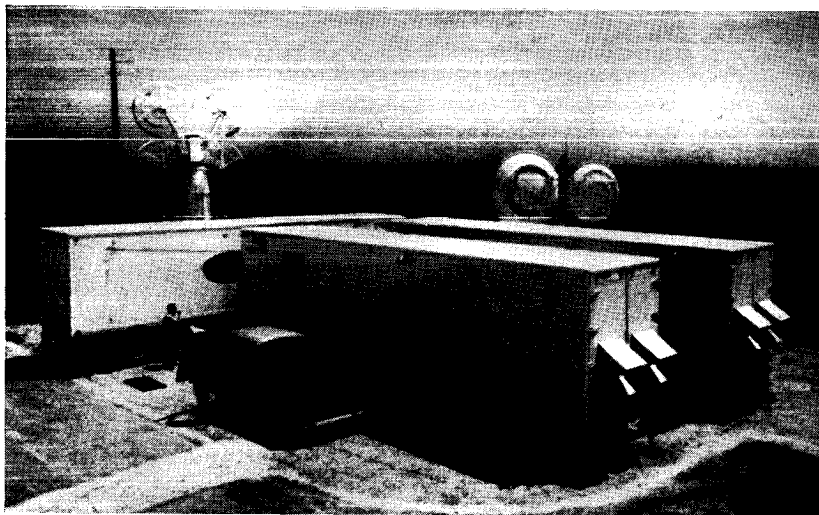

Fig. 2 — Launch operations — base location.

2.3.1 *Description of Vans*

The vans were designed for the particular requirements of the Telstar base location. The three vans are designated "spacecraft van," "telemetry van" and "command tracker van," where the names are those of the principal function of the van. Each van is 40 feet long and 8 feet wide and has about 7 feet of head room. All features required for long-distance road travel were provided to permit relocating the base.

The air-conditioning system provides air filtering and limits the maximum relative humidity. The spacecraft van has additional dust filtering which removes particles larger than 2 microns. The ac power is taken from the power supply of the missile guidance system. For launch operations and other critical operations, the power circuit is switched to two large diesel-driven generators.

The interior arrangements of the three vans are illustrated in Fig. 3. The spacecraft van is divided into three compartments. The central area contains mounting pedestals for two spacecraft. The end compartment is an unpacking area where the spacecraft in its carrying case is unloaded from the truck. In this area, the three-piece carrying case is removed and the spacecraft lifted off the base with a traveling electric hoist which carries the spacecraft to the mounting pedestal. After the arrival tests on each spacecraft, the daily routine tests were conducted remotely through cables to the telemetry van.

The limitation of traffic by the provision of a separate van for the

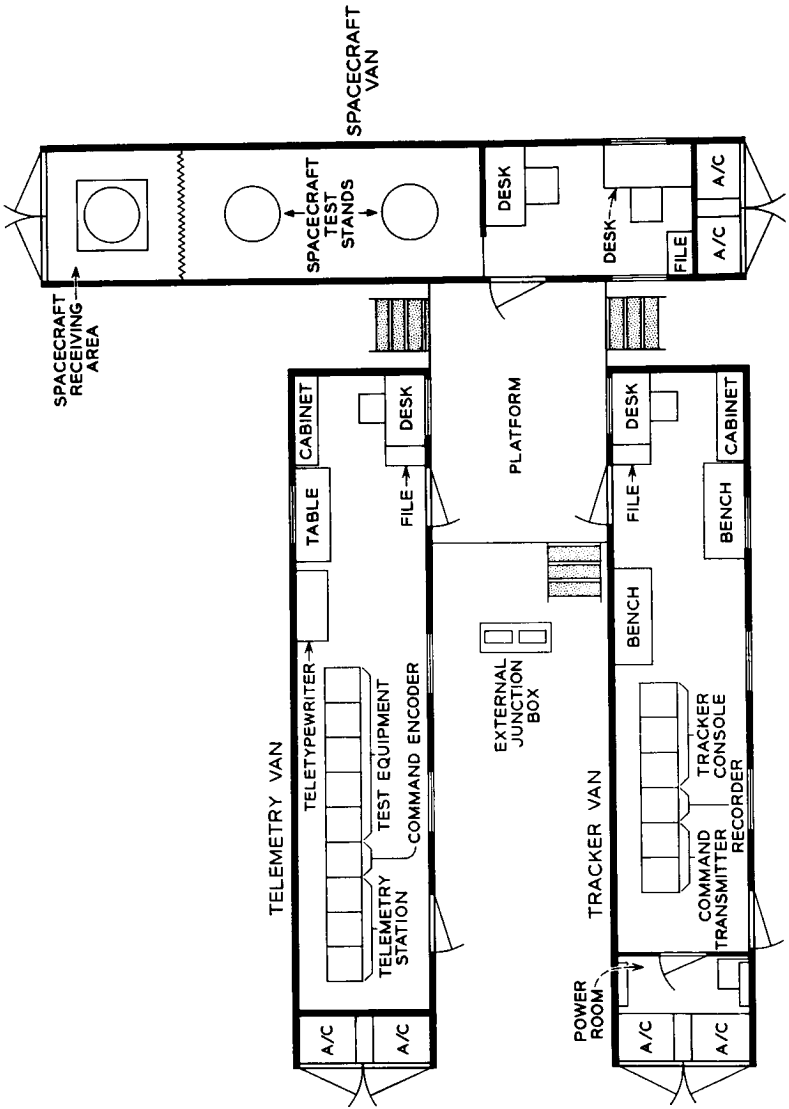

Fig. 3 — Van layout — base location.

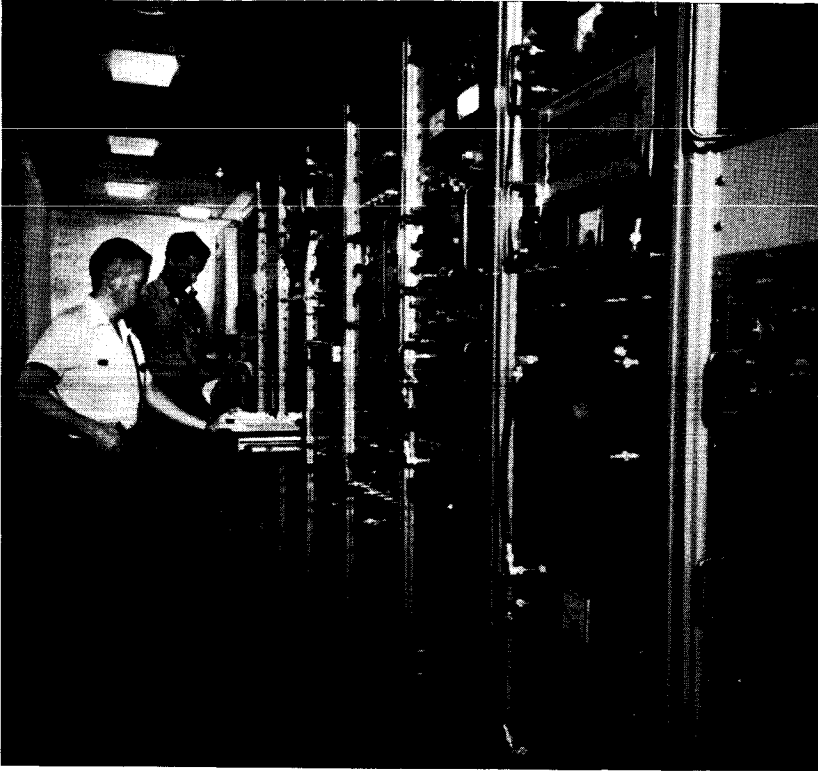

Fig. 4 — Interior view of telemetry van.

spacecraft minimizes exposure to contamination, humidity, and fluctuations in temperature.

The telemetry van provides the principal working area for pre-launch testing, countdown tests at launch, and telemetry and command activities in post-launch orbits.

This van contains a lineup of 9 cabinets, as shown in Fig. 4. Three of these house the telemetry receiver and decommutating circuits. The next cabinet contains the command encoder, whose output modulates either a low-power 123-mc* command transmitter for pre-launch testing or the 200-watt transmitter in the command tracker van. The remaining five cabinets contain a variety of test equipment. This van also contains an arrangement of teletypewriter instruments, primarily for the transmis-

* This value, as well as all other frequencies given in this paper, is approximate, but is within 1 per cent of actual.

sion of telemetry information from the Cape to Andover, Murray Hill, and Hillside. The telemetry decommutating system provides a punched tape for sending the data to other locations.

Provisions were made to use the identical telemetry reduction systems at the Cape and at the Hillside Laboratories as back-ups for each other. This allowed tests on two spacecraft to be conducted at the same time at the Hillside Laboratories during periods when the Cape telemetry was not in use. It also provided a back-up during critical operations against failure of the Cape telemetry system. The means for doing this required only the addition of a two-way audio-frequency data channel between the two locations to carry the 3-kc telemetry subcarrier and its sidebands. The teletypewriter circuit returned the output to the distant station in either case. Since the 136-mc receiver of the telemetry system was not included in the back-up, the 136-mc receiver of the command tracking antenna system was arranged to be used as a spare.

A full-period telephone line from the telemetry van to the Andover earth station was used to coordinate activities during launch and in subsequent tracking operations.

Telephone communication among all locations involved in launch and pre-launch operations was provided at Cape Canaveral by the Missile Operations Phone System (MOPS).

The command tracker van contains the equipment used for all tracking operations, sending of commands, and receiving telemetry. The 200-watt command transmitter and the control console for the command tracking antenna system are the principal items.

2.3.2 *Antennas*

Antennas at the base location were needed for remote testing by radio coupling to the spacecraft at the spin building, for terminal countdown tests on the launch stand and for the monitoring of telemetry during the ascent trajectory and subsequent orbits.

The same type quad-helix autotracking antenna designed for use at the Andover earth station was provided for command and telemetry. This antenna system provides autotracking of the 136-mc beacon to a precision of about $\pm 1^\circ$ in both azimuth and elevation. The 136-mc signal received by the antenna is amplified and sent to the telemetry receiver for detection and decommutation.

The 123-mc command signal from either the 200-watt or the 2-mw transmitter may be multiplexed to the antenna.

A boresight antenna for periodic alignment of the command tracker is located 100 feet away on a 50-foot wood pole. A low-level 136-mc signal

is sent from the command tracker van to this antenna over a coaxial cable.

Two parabolic dish antennas were installed at the base location for remote testing of the spacecraft at the spin building and on the gantry. The 6390-mc transmitting antenna is 8 feet in diameter, and the 4170-mc receiving antenna is 10 feet in diameter. Both antennas were attached to a rigid framework mounted on a 25-foot telephone pole embedded in concrete and well braced with guy wires. The framework is manually steerable to permit aiming at either of the two remote locations. A low-power optical telescope is used to aim the antenna.

2.4 Test Facilities at the Spin Building

At the spin building, two 4-foot diameter parabolic antennas were mounted facing the base location on a 40-foot steel tower. Waveguide runs connect these antennas to one port of each of the spacecraft's antennas. The same tower also supports a VHF corner reflector antenna for telemetry and command use. The only other test equipment at the spin building is a rectifier for supplying power to the spacecraft during electrical tests.

2.5 Spacecraft Facilities on the Launch Stand

Upon completion of spin balancing, the spacecraft-third-stage combination was enclosed in a carrying canister for transportation to the launch stand. The carrying canister was lifted up to the top level of the service tower and lowered to mate with the Delta second stage. After removal of the canister, the spacecraft and the third stage of the rocket were each enclosed in plastic shrouds continuously supplied with dry, cool air. The working area on this level was also enclosed in an air-conditioned tent.

Because of the presence of the live third stage, it was decided to put the test equipment consoles in an existing room on a lower level and connect to the spacecraft through waveguide and coaxial cable runs. Thus, the testing prior to removal of the gantry was done in a manner similar to the testing at the base location.

III. SPACECRAFT TESTING

3.1 Summary

Two types of tests were made on the spacecraft. The first was a comprehensive test which was made three times — after the spacecraft was

received from Hillside, again after mating to the third stage and balancing, and again after the spacecraft was moved into launch position. The second type of test was a daily routine which determined that all major systems continued to function properly.

The comprehensive test included: physical inspection; checks on the radiation package, microwave antennas, solar cells, and two-year timer; and the complete daily routine. The daily routine included VHF beacon measurements, telemetry encoder comparisons, and checks on the command receiver, command decoder, power plant, microwave repeater, transistor damage experiment, and temperature and pressure sensors.

The spacecraft was tested at the base of operations, at the spin building and at the gantry tower, using the test arrangements previously described. During the final hours of the terminal countdown, testing and monitoring continued via radio through the fairing to the antennas at the base location.

During the launch the command tracking antenna tracked the satellite to the horizon, so continuous communication was maintained until that time. Telemetry was closely watched during this period, so that in the event that any relays should change state due to shock, they could be corrected by sending the appropriate command.

3.2 *Specific Test Procedures*

In preparation for all tests in the vans the spacecraft circuits were coupled to the test equipment in the following manner:

- (1) The spacecraft helical antenna was disconnected near the canister and was replaced by a cable to the test equipment. This connection made possible precise measurements on the VHF systems without having to use the spacecraft antenna. It also permitted testing of the satellite without radiating power at the VHF beacon frequency or at the command frequency. The latter consideration is especially important at Cape Canaveral, where all radio-frequency radiation is carefully scrutinized and frequently prohibited for the sake of range safety.

- (2) A single port of each microwave antenna was connected through a special coupling device to the equipment in the telemetry van. The remainder of the ports were girded by RF absorbing bands which reduced radiation and provided a termination for the antennas.

- (3) A rectifier which supplied current required by the circuitry plus a small amount required for charging of the nickel-cadmium cells was connected through the battery jack.

The command and telemetry connections are shown in Fig. 5. A 20-db

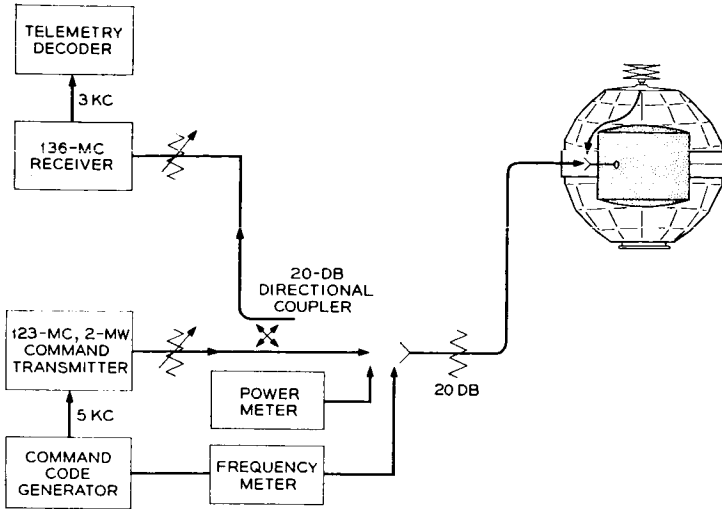

Fig. 5 — Command and telemetry test connections.

directional coupler was used to pick off the 136-mc signal for telemetry and to minimize the 123-mc command signal at the telemetry receiver input. The 20-db fixed pad was introduced to prevent the spacecraft from ever being subjected to the full power of the small command transmitter. It also attenuated the 136-mc signal down to the range of the power meter. The variable attenuators were used to set independently the desired power levels for both the 123-mc command and 136-mc beacon.

The microwave test connections are shown in Fig. 6. The 6-gc path contains only a variable attenuator. The 4-gc path has switching and filtering so that the composite 4-gc signal could be viewed on the spectrum analyzer and the 4170 and 4080-mc signals could be measured separately.

Figs. 7 and 8 show connections used to communicate with the spacecraft after it has left the van area. The test procedures in these locations were nearly the same as the van tests.

A description of each part of the daily test routine is given below.

3.2.1 VHF Beacon

The power output and frequency of the unmodulated 136-mc beacon were measured.

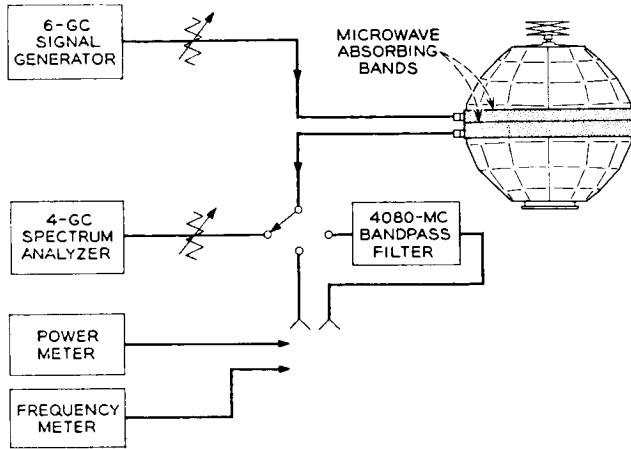

Fig. 6 — Microwave test connections.

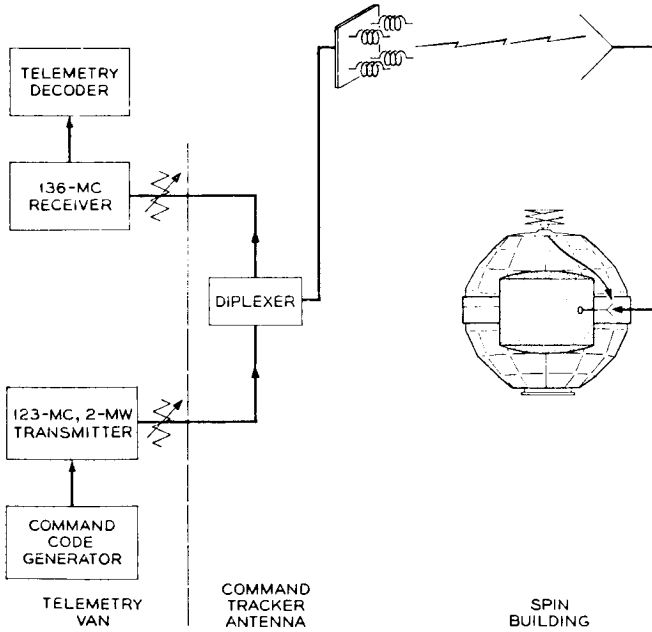

Fig. 7 — Command and telemetry connections for testing spacecraft in spin building.

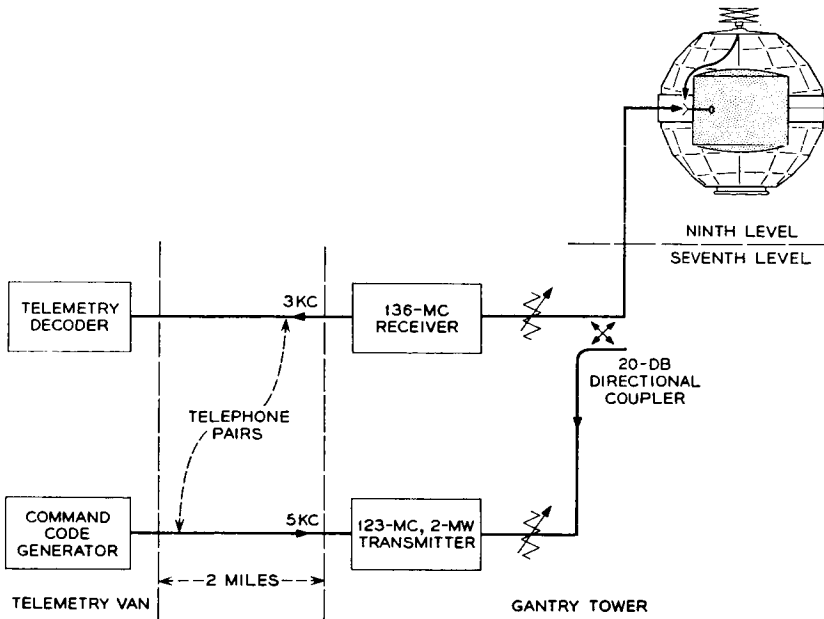

Fig. 8 — Command and telemetry connections from F - 5 day to F - 0 day.

3.2.2 Telemetry Encoder Comparisons

One complete frame of telemetry was taken from each of the two telemetry encoders and the readings compared.

3.2.3 Command Systems

The sensitivities of the two command receivers were checked with unmodulated signals. Following this, the commandability of each command receiver was verified.

3.2.4 Power Plant

The power plant test was an observation of 22 telemetered values of voltages, currents, and temperatures. Included were voltages and temperatures of the nickel-cadmium batteries and temperatures of key transistors in the regulators and dc-to-dc converters.

3.2.5 Temperatures and Pressures

Telemetry reads out 40 temperatures and 2 pressures. All values were checked and where possible were compared with external thermometers.

3.2.6 *Transistor Damage Experiment*

Six transistors with various degrees of shielding were placed in circuits which measured common-base short-circuit current gain. The values were checked via telemetry and compared with the known value of gain.

3.2.7 *Microwave Repeater*

The microwave repeater was checked using the following steps:

- (a) check all related telemetry channels,
- (b) with no signal input, measure 4-gc noise output,
- (c) with no signal input, measure 4080-mc beacon frequency and power,
- (d) with midrange signal input, measure beacon power,
- (e) with midrange signal input, measure signal output power,
- (f) view the spectrum of output signal for spurious sidebands, and
- (g) measure point-by-point frequency characteristic of repeater.

The following tests were made in addition to the daily routine for the comprehensive test:

3.2.8 *Microwave Antenna*

As a check of the 4-gc transmitting antenna, a power measurement was made at each of the 48 ports. This test was made in lieu of a pattern measurement, which could not be made with the existing facilities. As a check of the 6-gc receiving antenna, a low-level 6390-mc signal was sent separately to each of the 72 antenna ports while the 4170-mc signal was observed at a single 4-gc port. The level was chosen to be below the automatic gain control range of the repeater so that amplitude differences in 6390-mc signal reaching the repeater would cause differences in level of the 4170-mc output.

3.2.9 *Solar Cell Check*

The output of all 50 banks of solar cells in the power plant and all of the individual cells in the solar aspect circuit was read as each cell or bank of cells was illuminated with a low-intensity light source. For the solar power plant, short circuit current was read with a milliammeter, and the solar aspect circuits outputs were read by telemetry.

3.2.10 *Radiation Package Checks*

Each of the four radiation sensing circuits was tested by bypassing the actual sensing element and delivering pulses directly to the inputs of

the preamplifier circuits. The thresholds of all of the detectors were verified by changing the pulse amplitudes once per minute and observing the telemetered data.

3.2.11 *Two-year Timer Check*

This test involved temporary powering of the two-year timer, applying a start signal, and verifying that the timer had started. After verification, the timer was stopped by removing power.

3.3 *Testing of the Spacecraft at Remote Locations*

All testing of the spacecraft in the spin building was done remotely by radio from the base location. All of the tests described above were made, but some techniques had to be changed to accommodate the lower signal levels available over the radio link to the base location.

When the spacecraft was at the launch stand, daily tests continued. To reduce radiation at all working frequencies and to eliminate the variability of the path losses in the measurements, all of the spacecraft radio systems were terminated in test equipment on the seventh level of the gantry tower. From that point to the base location, telephone pairs were used to carry the 3-kc telemetry and the 5-kc command subcarriers. Microwave tests were made on the seventh level. All tests made on the gantry were under the direction of the test conductor in the telemetry van, so voice communication was maintained at all times.

IV. FROM F - 15 DAY TO F - 0 DAY

On F - 15 day (15 working days before launch) the prototype spacecraft was taken from the van to the spin building, where it was mated to a dummy third stage. This event was in preparation for the RF compatibility test on F - 11 day, but it also gave personnel of the Douglas Aircraft Company and of the Laboratories an opportunity to rehearse their procedures a few days in advance of the arrival of the flight model at the spin building.

On F - 12 day the prototype and dummy third stage were transferred to the launch stand and were attached to the second stage of the Delta vehicle. The RF compatibility test on F - 11 day showed that all the range radars, the guidance system, the destruct system, vehicle beacons, and the spacecraft systems were mutually compatible.

On F - 9 day the Fly 2 spacecraft was transferred to the spin building to be mated to the live third stage. Daily checks continued at the

spin building until F - 5 day, when the spacecraft was transferred to the launch stand.

From F - 5 to F - 1, daily checks continued on the spacecraft and the Delta vehicle.

The F - 0 countdown was started at 5:40 p.m., July 9, on the evening before the launch. The first check of the day, ending at 7:00 p.m., was a complete daily routine. After completion of the routine, telemetry was left on and the spacecraft battery was charged until 8:15 p.m. At approximately 10 p.m. preparation for fairing installation began. For this it was necessary to: (1) disconnect all test cables, (2) remove air-conditioning and shroud, (3) remove the plastic protective cover, (4) remove microwave absorption bands, (5) remove spacecraft access panel, (6) connect helix antenna, (7) verify two-year timer operation, (8) install access panel, (9) remove protective covers from radiation sensors and mirrors, and (10) inspect. After these preparations were made, the fairing was installed, leaving one access hole open for insertion of the umbilical plug, which was the final link between the spacecraft battery plant and the rectifier in the blockhouse.

By midnight the fairing was installed and all umbilical connections were made and checked. Once again, before the gantry tower was rolled away, the spacecraft was turned on for the purpose of making a test with commands going through the fairing to the helical antenna, as they would during the early part of the ascent trajectory. This task was completed successfully by 30 minutes after midnight, and the spacecraft was turned off again as a period of "no radiation — no switching" began.

At 1:10 a.m. checks of the van equipment were started as the gantry tower removal began. The command tracker was aligned with the bore-sight; the command transmitter was measured for proper VSWR, modulation percentage, and power output. Another command routine was made and completed at 2:10 a.m. For the next 50 minutes, batteries were charged and telemetry was watched very closely.

At the end of the 50 minutes, the time was 3 a.m. or T - 35 minutes. The terminal count began. Between T - 35 and T - 10 a brief command routine test was performed, and the microwave repeater was given a last test. At T - 10 all commandable circuits were in launch condition: i.e., all were turned off except for the 136-mc beacon and the telemetry modulating the beacon.

Lift-off occurred at 3:35 a.m. (0835 GMT) on schedule. The command tracking antenna autotracked the VHF beacon from lift-off to horizon. Small variations appeared in the signal level due to ground reflections and attenuation, but otherwise the track was routine. Until the satellite dropped below the radio horizon, telemetry was watched very closely

with particular emphasis on relay states, battery temperature and voltage, solar plant current, AGC level from command receivers and the low-level calibration channel.

To ensure that good command capability was maintained during the launch, the telemetered AGC levels of the spacecraft command receivers were watched, and at a predetermined level, the 123-mc carrier power was increased 20 db to the full 200 watts.

Other telemetry channels bore interesting information on several aspects of the ascent. Fig. 9 shows skin temperatures on two different facets of the satellite. One of the two was illuminated by the sun continually for approximately 10 minutes—from the time the spacecraft emerged from the earth's shadow until the spin rockets were fired, causing the satellite to spin and thereby putting the facet into the shadow of the satellite part of the time. The other facet shown was in complete darkness until spin-up, when it began to receive some solar radiation.

Fig. 10 shows on one trace the amount of current supplied to the satellite either by the blockhouse rectifier or by the solar plant. Between 0840 GMT and 0849 GMT the current showed a steady decrease because that part of the solar plant which was delivering the current was being warmed (see Fig. 9) and was becoming less efficient. After spin-up some of the cooler portions came into sunlight and the average current increased.

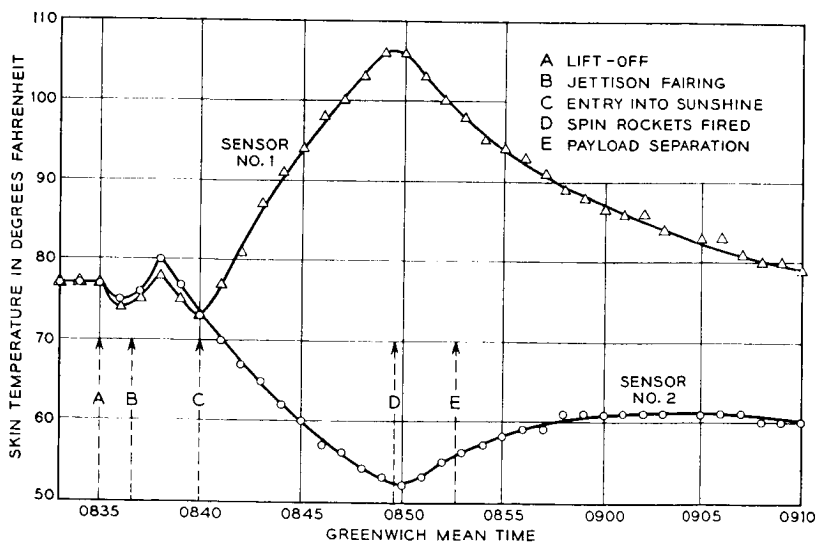

Fig. 9 — Skin temperature variation after lift-off

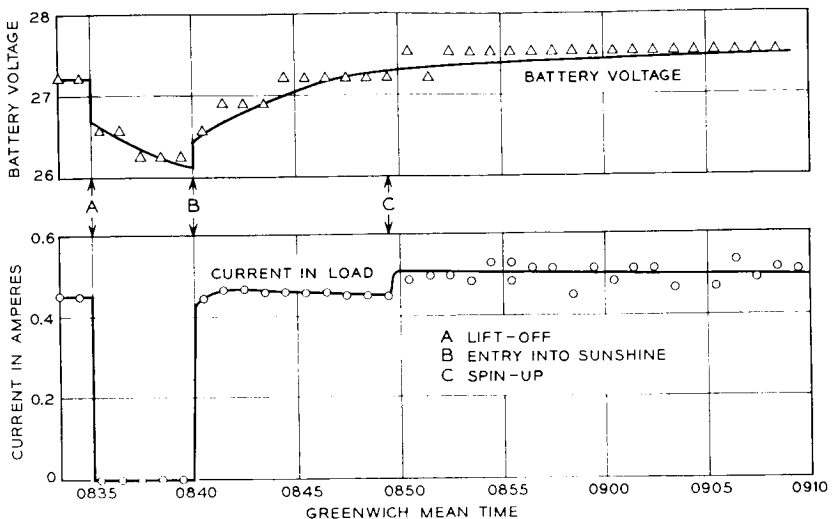

Fig. 10 — Ni-Cd battery voltage and current delivered to canister during launch.

The voltage of the battery plant is shown in the other trace of Fig. 10. The abrupt drop in the battery voltage at lift-off is attributable to the fact that when the rectifier in the blockhouse was disconnected, the current in the battery changed from a 0.3-ampere charge to a 0.2-ampere discharge. The battery continued to discharge until the satellite emerged into the sunlight, at which time the voltage began to increase.

The spacecraft went below the Cape Canaveral radio horizon at 0848 GMT (0348 EST), so all information shown beyond this time was taken from magnetic tape recordings made by the NASA Minitrack stations. Coverage by Cape Canaveral and by these stations was as follows:

- Cape Canaveral from lift-off to 0848 GMT
- Antigua from 0839 to 0853 GMT
- Ascension from 0845 to 0902 GMT
- Johannesburg from 0904 to 0917 GMT.

V. LAUNCH VEHICLE AND ORBIT

5.1 Description of the Delta Launch Vehicle

Fig. 11 is a cutaway view of the Delta vehicle as used for the Telstar launch. It is a three-stage rocket, with ground-guided, liquid-fueled first

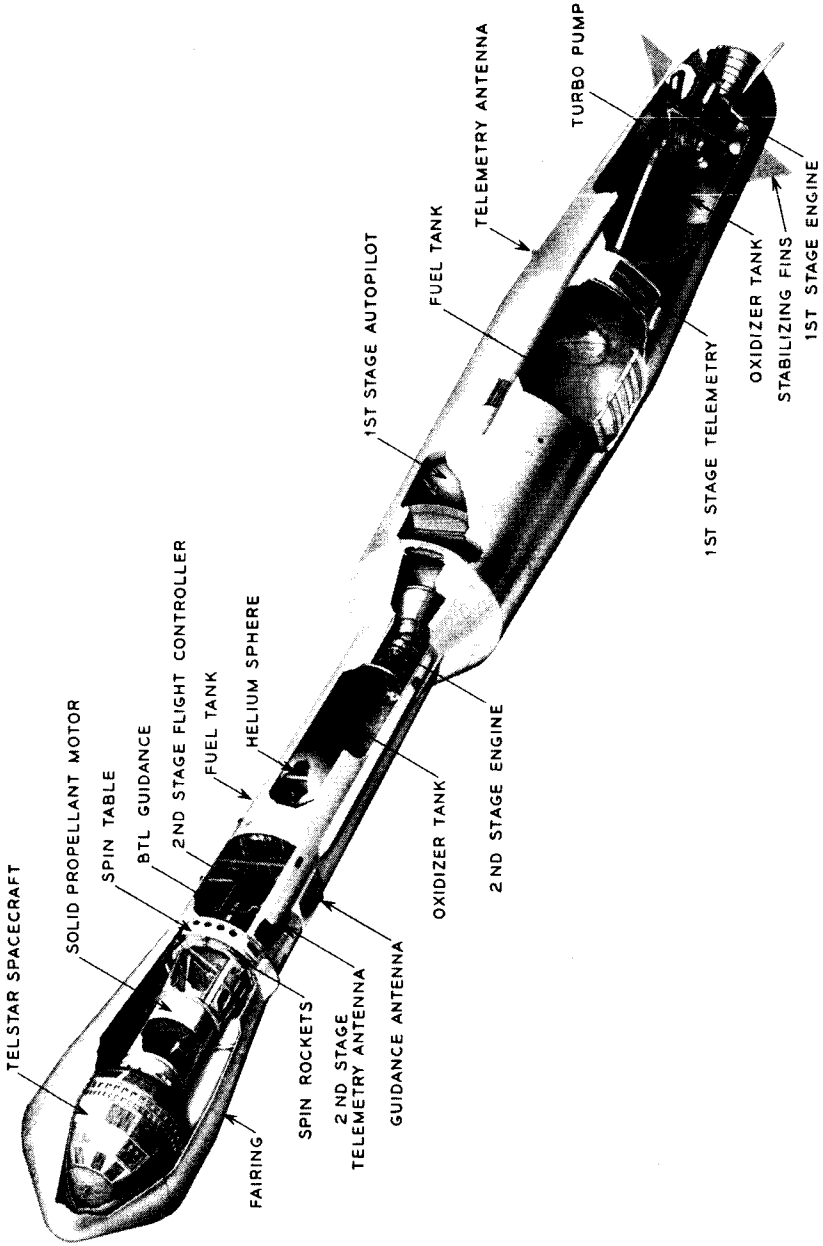

Fig. 11 — Delta vehicle-Telstar spacecraft.

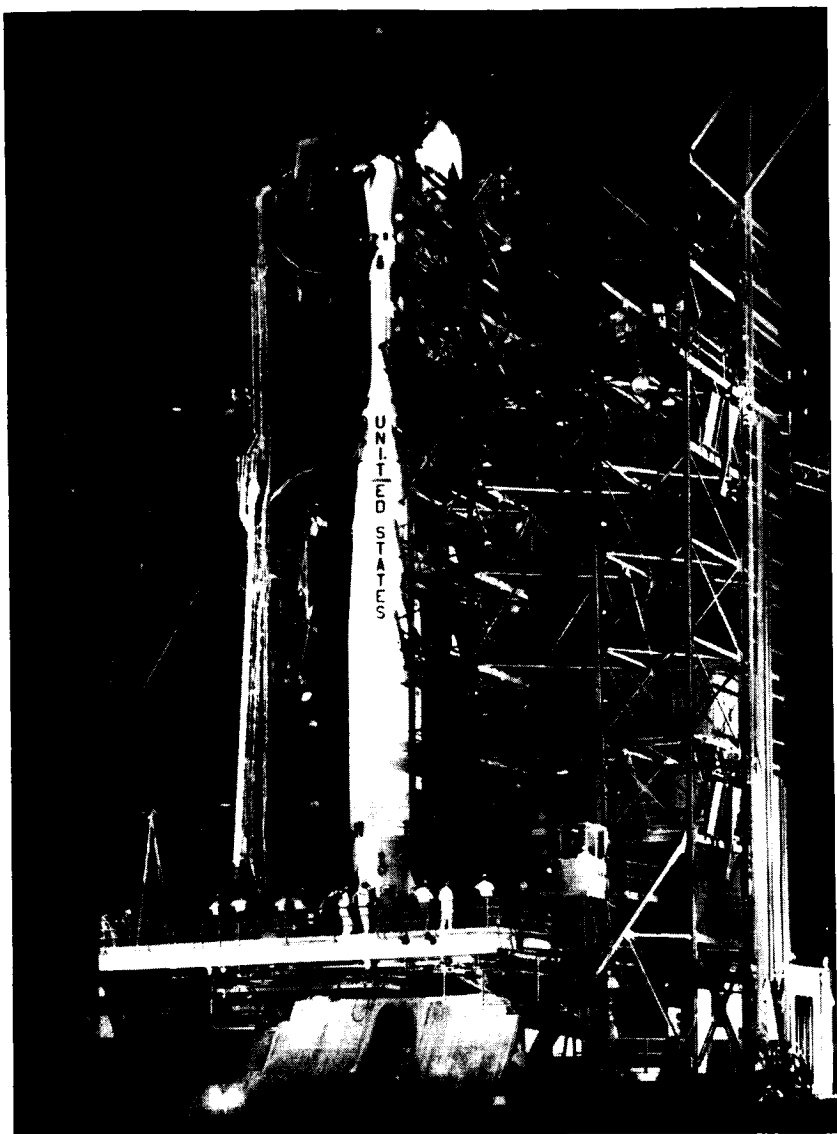

Fig. 12 — Delta vehicle and Telstar spacecraft in gantry.

and second stages, and a spin-stabilized, solid propellant third stage. A bulbous fiber glass fairing surrounds the third stage and the Telstar spacecraft mounted on it in the launch configuration. Fig. 12 shows Delta No. 11 in the service tower about three hours before launch. It is approximately 90 feet high and weighs about 57 tons, fueled and ready for launch.

The first stage is an operational-type Thor missile modified for the Delta use. Its engine uses RP-1 (kerosene) fuel with liquid oxygen (lox) as the oxidizer. Vehicle performance is based on use of at least 99 per cent of the propellants. A flight controller employing three integrating gyros, three rate gyros, and a programmer is used to provide open-loop control until the ground guidance system takes control at about 90 seconds after lift-off. Control is achieved by a combination of the gimballed main engine nozzle and two small vernier engines.

The second stage is a propulsion system which uses unsymmetrical dimethyl hydrazine fuel (UDMH) and inhibited white-fuming nitric acid as the oxidizer. A gaseous nitrogen retro system is used on the second stage to provide reverse thrust to get the required separation distance between the second and third stages at third-stage ignition.

Second-stage in-flight steering control is achieved by hydraulic gimbaling of the second stage engine thrust chamber. Roll control is accomplished by discharging helium gas through four roll jets, two of which react in a clockwise direction, and two of which react in a counter-clockwise direction. Both pitch and yaw control systems respond to commands from the Laboratories guidance system.

During the coast period, starting at second-stage burnout and ending at second/third-stage separation, the vehicle was turned to its proper spatial orientation by means of a second-stage coast phase control system. The gyros used to control the second stage during the powered portion of flight supply the attitude reference used to control the gas jet system during the coast phase. An on-off type of gas jet operation was used. To provide range safety destruct capability, the Delta vehicle carries radio receivers in the first and second stages. The flight termination system in each stage consists of the receiver and decoder, antenna system, safety and arming mechanism, detonating cord strand to rupture propellant tanks, and a power supply independent of vehicle power. Prior to first/second-stage separation, either system would destruct both stages. A large-diameter (approximately 22 inches) ball bearing mounted at the forward end of the second stage supports the spin table, which in turn supports the third-stage motor and spacecraft. Prior to third-stage ignition, the third stage and spacecraft were spin stabilized at approximately

180 rpm by small rocket motors attached to the spin table. The third-stage propulsion system had a solid propellant motor.

The separation of the third stage was delayed approximately 2 minutes after nominal fuel depletion to allow time for afterburning and outgassing of the third-stage motor and thus prevent contamination of the satellite. The third-stage motor was tumbled by an asymmetrical weight after separation to prevent impact with the satellite.

A bulbous fairing was provided to decrease aerodynamic drag and to protect the spacecraft and third-stage motor from aerodynamic heating during flight through the atmosphere. This fairing was jettisoned at an altitude of 85 nautical miles, where protection from aerodynamic heating was no longer required.

5.2 Spacecraft/Launch Vehicle Integration

The Delta vehicle for the Telstar project placed limits and requirements on the spacecraft to ensure compatibility. The dimensions of the standard bulbous fairing fixed the maximum diameter of a spherical spacecraft at slightly over 35 inches. A standard Delta payload attach fitting was incorporated as an integral part of the spacecraft structure, to mate with the corresponding fitting on the Delta. The compatibility of the spacecraft design was confirmed at a fit-check mating at Douglas Aircraft Company, Santa Monica, California, in December, 1961, when a full-scale, accurate mockup of the spacecraft was assembled with the appropriate launch vehicle components. The Fly 2 spacecraft weight, when delivered to Cape Canaveral, was 170.325 pounds. General environmental capabilities for temperature, humidity, shock, vibration, acceleration and thermal vacuum were established by qualification and acceptance tests at the Laboratories. Possible contamination from fairing outgassing due to aerodynamic heating was investigated and found to be of no concern.

5.3 Orbit Determination and Guidance

The desired Telstar satellite orbit resulted from a sequence of activities taking more than a year and involving several organizations. In 1960 and 1961, the Laboratories made parametric studies to relate Telstar transmission requirements to Delta capabilities in terms of achievable orbits and spacecraft weight and size. When the weight had been set at approximately 170 pounds, more detailed studies were made to precisely define the desired orbit. This study indicated that the Delta vehicle could place 170 pounds in an orbit of the following characteristics:

Apogee: 3000 nautical miles
Perigee: 500 nautical miles
Inclination of orbit to the earth's equator: 45°
Spin-axis azimuth at injection: $\geq 155^\circ$

A Delta trajectory to achieve this orbit was generated and its feasibility confirmed. This trajectory became part of the detailed test objectives (DTO) for Delta No. 11. The necessary guidance equations to represent the desired trajectory were developed. After translation into a punched guidance tape, these results were checked by simulation testing in the command guidance system at Cape Canaveral.

Because of range safety considerations, when a Delta vehicle is launched from Cape Canaveral the launch azimuth may not exceed 108° . This establishes a path which crosses the equator at an angle of about 33° . The orbital inclination will have this value if all three stages are fixed in the initial flight plane, as they would be for maximum energy use. The desired higher inclination of 45° was attained by yawing the second and third stages to the south of the initially established ascent trajectory plane when the vehicle had arrived at a point where the range was clear to the south. Since the energy imparted to a spacecraft is reduced by such yawing, the final apogee or perigee or both will be reduced.

In developing the ascent trajectory it is necessary to ensure that the command guidance system at the launch site maintains contact with the vehicle during first and second-stage burning. The vehicle must stay well above the launch site horizon, and certain limitations are imposed on the orientation of the axis of the vehicle so that its antenna pattern will properly receive guidance signals from the launch site. Several calculations are required for the determination of the optimum ascent trajectory.

After the second-stage engine cutoff (SECO), the vehicle is allowed to coast upward, losing speed, until finally it reaches the apogee of the ascent trajectory established by the first and second stages. At this point the third stage is ignited. The third-stage axis is maintained in the local horizontal plane at the time of firing, in order that no more energy be wasted than necessary, and so that the final perigee position will coincide with the ascent trajectory apogee. For the final Telstar satellite orbit, perigee was about 5° latitude north of the equator and apogee about 5° south.

Within this framework, various possible orbits were calculated. First, a particular spacecraft weight and perigee height were selected and a series of ascent trajectories was calculated with the object of finding ones

whose ascent trajectory apogees were equal to the specified final perigee height. One was chosen which had the maximum velocity at ascent trajectory apogee and still met the requirements that command guidance contact be maintained during the burning of first and second stages and that a certain amount of yawing to the south be accomplished during second-stage burning in order to increase inclination. When such an optimum ascent trajectory had been determined, possible final orbits were calculated, assuming the third stage to be yawed southward by increasing amounts, resulting in increasing inclinations and decreasing apogee heights. The result was a family of orbits where apogee height is a function of inclination. Iteration of this process produced a family of feasible orbits from which one was selected for the Telstar satellite.

The Telstar launch vehicle was guided by the command guidance system designed by the Laboratories. The command guidance system consists of a precision tracking ground radar, a digital computer and a missile-borne system in the second stage of the rocket, consisting of a radio receiver, decoder and transmitter. The ground guidance facility, GMCF-3, which is located about two miles from the launch pad, houses the radar and the computer. In the command guidance system the launch vehicle position is continuously determined by the precise ground-based automatic tracking radar. The computer accepts the position data and derives appropriate vehicle velocities. The missile position and velocity data are compared with precalculated values, representing the desired trajectory, which have been stored in the computer prior to flight. Coded steering commands, based on deviations between the actual and desired values, are transmitted to the missile on the radar beam.

An engine cutoff command is sent to the vehicle when the ground-based computer is satisfied that appropriate terminal conditions have been met. The high degree of accuracy of the command guidance system results primarily from the combination of reliable communications to the vehicle, precise radar tracking, and a unique computation process involving radio inertial guidance principles for determination of velocity.

TABLE I — *Telstar* ORBIT PARAMETERS

	Orbit Computed Preflight	Orbit Predicted From Burn-Out Parameters	Actual Orbit (NASA Minitrack)
Apogee (nm)	3000	2990	3043.2
Perigee (nm)	503	513.14	511.9
Period (min)	156.48	156.55	157.6
Inclination to equator (deg)	44.97	44.99	44.78

5.4 *Actual Orbit Achieved*

The Delta No. 11 second-stage burnout parameters obtained from the guidance computer at the conclusion of the second-stage guidance were used to predict the final orbit. The predicted orbit parameters obtained are shown on Table I, with the preflight computed orbit and the actual orbit obtained by tracking shown for comparison. Differences among the three are small.

VI. CONCLUSION

The testing methods and facilities developed by the Laboratories for the pre-launch and launch operations at Cape Canaveral were used successfully on the first Telstar launch, and only minor changes will be made for the second Telstar launch.

The excellent cooperation between all of the people of the Laboratories involved in the launch and the members of the National Aeronautics and Space Administration and its supporting agencies at Cape Canaveral contributed immeasurably to the successful launch.