

Final Report
for
Investigation and Study of a Multi-Aperture
Antenna System
(1 January 1964 - 1 April 1964)
Contract No. NAS 5-3472

Prepared by
Electronic Communications, Inc.
Research Division
1830 York Road
Timonium, Maryland

for
Goddard Space Flight Center
Greenbelt, Maryland

N65 24991

FACILITY FORM 602

(ACCESSION NUMBER)	(THRU)
<u>212</u>	<u>1</u>
(PAGES)	(CODE)
<u>CD 63082</u>	<u>07</u>
(NASA CR OR TMX OR AD NUMBER)	(CATEGORY)

GPO PRICE \$ _____
OTS PRICE(S) \$ _____
Hard copy (HC) 6.00
Microfiche (MF) 1.25

ABSTRACT

24991

This investigation was concerned with a multiple aperture adaptive antenna system for application to receiving telemetered data from remote space vehicles or satellites. The primary criterion for determining the feasibility of such a system has been economic considerations; but of necessity many physical constraints imposed on both a single antenna and a multiple aperture system have been evaluated. These include such factors as acquisition and combining of signals, look angle, shadowing, propagation influences, system spatial bandwidth, collimation, interference, doppler effects, reliability, and noise. Specific conclusions have been made for a system operating at a frequency of 2 Gc, but the system model adopted allows quick evaluation at other frequencies. At a frequency of 2 Gc, the crossover point between a single antenna or a multiple aperture configuration occurs for an 85 foot reflector. However this transition region is not critical. For lunar range communications a single antenna appears to be the most economical, whereas at interplanetary ranges aperture equivalents of around 400 feet are required and achieved by arraying eight 142 foot antennas.

Author

CONTRIBUTIONS

The following members of the ECI Staff are responsible for the work performed in this final report:

R. E. Feltman

H J. Peters

W. C. Core*

J. W. Sherman†

D. J. Lewinski

M. I. Skolnik

W. A. Visher

* Consultant - Johns Hopkins University

† Project Engineer

TABLE OF CONTENTS

		<u>Page</u>
1.	INTRODUCTION	1
2.	SUMMARY AND CONCLUSIONS	6
3.	COMMUNICATION SYSTEM MODEL	9
4.	THE NUMBER OF SUBAPERTURES	11
	4.1 <u>The Model</u>	11
	4.2 <u>Minimum Cost As a Function of Equivalent Aperture Size</u>	13
	4.3 <u>Optimum Number of Antennas as a Function of the Period of Operation</u>	19
	4.4 <u>Optimum Number of Antennas as a Function of the Frequency</u>	22
	4.5 <u>Maintenance and Operating Cost</u>	22
	4.6 <u>The Optimum Antenna Size</u>	22
5.	SITING	27
	5.1 <u>The Look Angle</u>	27
	5.2 <u>Shadowing</u>	33
	5.3 <u>Propagation Influences</u>	35
	5.4 <u>System Spatial Bandwidth</u>	47
	5.5 <u>Collimation</u>	48
	5.6 <u>Operation in the Presence of Interference</u>	53
	5.7 <u>Doppler Effects</u>	59
	5.8 <u>Noise Temperature</u>	60
	5.9 <u>The Spacing Configuration</u>	60
6.	COMBINING	67
7.	SYSTEM CONSIDERATIONS	76
	7.1 <u>Acquisition and Registration of Antenna Beams</u>	76
	7.2 <u>Bandwidth Considerations</u>	77
	7.3 <u>Operation at Higher Frequencies</u>	81
	7.4 <u>Antenna Temperature</u>	82
	7.5 <u>Transmission to Spacecraft</u>	84

TABLE OF CONTENTS (Continued)

	<u>Page</u>
APPENDIX V - Communication System Models	45
V.1 Summary of Spacecraft Communications Systems	45
V.2 Lunar-Range Communications	45
V.3 Communications Interplanetary-Range	50
APPENDIX VI - Application of the Fibonacci Search Procedure as a Combining Method	62
APPENDIX VII - Combining Methods for Interplanetary Range Communications	65
APPENDIX VIII - Noise Analysis of a Multiple Aperture System	78

TABLE OF CONTENTS (Continued)

	<u>Page</u>
8. SYSTEM DESIGN	87
8.1 <u>Introduction</u>	87
8.2 <u>The Lunar Range Receive System</u>	87
8.3 <u>The Interplanetary Receive System</u>	91
8.4 <u>Antenna Orientation of the Interplanetary Multiple Aperture System</u>	97
9. COMPARISON WITH CONVENTIONAL ANTENNAS	103
9.1 <u>Review of Previous Work</u>	103
9.2 <u>The Cost of Antennas</u>	108
9.3 <u>Characteristics Attractive for Space Communications</u>	112
 APPENDIX I - Brief Review of Previous Work in Multi-Aperture Combining	 1
I.1 <u>Diversity Combining in Scatter Communications</u>	1
I.2 <u>Predetection, or Coherent, Combining</u>	3
I.3 <u>Multi-Aperture Antennas</u>	6
APPENDIX II - Pointing Accuracies of Antennas	11
APPENDIX III - Statement of Requirements	14
APPENDIX IV - Analysis of Phase Measurement and its Application to the Coherent and Incoherent Combining of Signals in Multi-Aperture Arrays	16
I. On the Measurement of Phase of an Arbitrary Bandpass Signal	16
II. On the Measurement of the Phase of a Signal in a White Noise Environment	21
III. On the Coherent Combining of Identical Narrow Band RF Signals in Independent Noise Environments	25
IV. On the Coherent Combining of Modulated Signals	33
V. On the Incoherent Combining of Modulated Signals	39
VI. Comparison of a Communication System Employing M Antennas of Aperture A With One Employing a Single Antenna of Aperture MA	41

LIST OF ILLUSTRATIONS

<u>Figure</u>	<u>Title</u>	<u>Page</u>
4.1	Relative Cost of an 85' Equivalent Aperture Maximum Usable Frequency of 6 Gc Main- tained over 10 Years	14
4.2	Relative Cost of a 120' Equivalent Aperture Maximum Usable Frequency of 6 Gc Main- tained over 10 Years	15
4.3	Relative Cost of a 150' Equivalent Aperture Maximum Usable Frequency of 6 Gc Main- tained over 10 Years	16
4.4	Relative Cost of a 210' Equivalent Aperture Maximum Usable Frequency of 6 Gc Main- tained over 10 Years	17
4.5	Relative Cost of a 250' Equivalent Aperture Maximum Usable Frequency of 6 Gc Main- tained over 10 Years	18
4.6	Element Optimization as a Function of Electronics and Antenna Cost for Several Periods of Operation	20
4.7	Value of C_y as a Function of the Number of Years of Operation	21
4.8	Cost of operating and Maintaining a 250' 6 Gc Aperture for a 10 Year Period	23
5.1	Declination Angle of Several Planets for the Year 1964	29
5.2	Look Angle Geometry as a Function of the Site Positions	30
5.3	The Required Scan Angle in the East-West Direction as a Function of the Number of Antenna Sites	31
5.4	Mutual Aperture Blocking Geometry	34
5.5	Element Separation in Aperture Diameters vs Elevation Angle for No Self-Shadowing	36
5.6	Geometry for Point Receivers of a Distant Signal	38
5.7	Estimated Gain Loss as a Function of Zenith Angle at a Frequency of 2 Gc Due to Atmospheric Phase Perturbations	41

LIST OF ILLUSTRATIONS (Continued)

<u>Figure</u>	<u>Title</u>	<u>Page</u>
5.8	Bandwidth Limitations Imposed by the Ionosphere	42
5.9	Limits of Atmospheric Refraction Errors for a Standard Atmosphere	44
5.10	Maximum Difference Due to Relative Humidity in Refractive Errors	45
5.11	Maximum Aperture Size as a Function of the Look Angle	46
5.12	Bandwidth Limitations vs Zenith Angle for Several Aperture Sizes	49
5.13	Upper Bound on the Frequency as a Function of Aperture Size for Several Pointing Errors	50
5.14	Steering Requirements for a 250' Equivalent Antenna Pointed Between the Half-db Points	52
5.15	Superposition of Aperture Distributions	56
5.16	Example of a Linear Array Far Field Pattern with Reduced Sidelobes Near the Main Beam Positive θ Direction	57
5.17	Number of Sidelobes from a Linear Array Directed Toward the Sun or Moon	58
5.18	Reported Antenna Temperatures (After Giddis)	61
5.19	Approximate Signal-to-Noise Ratio vs Angle of Sun from Axis of Antenna Beam for a 250' Antenna	62
5.20	Grating Lobe Reaction Due to the Element Factor in a Linear Array	65
6.1	Adaptive, or Semi-Coherent, Combining	68
6.2	Incoherent (Baseband) Combining	69
6.3	Phase Lock Loop Combining on Pilot Signal	70
6.4	Adaptive Combining	72
6.5	Phase-Stripper (Incoherent) Combining	73
6.6	Pilot-Signal Controlled Combining	74

LIST OF ILLUSTRATIONS (Continued)

<u>Figure</u>	<u>Title</u>	<u>Page</u>
7.1	Descriptive Representation of Radiation Pattern of a Multi-Aperture Antenna System. Size and Shape of Lobes Will Depend on Spacing Configuration of Antennas	80
8.1	Antenna Diameter vs Information Bandwidth for a Lunar Range (3.8×10^8 Meters) Spacecraft	89
8.2	Antenna Cost as a Function of Frequency	90
8.3	Probability of Acquisition as a Function of the Relative Acquisition Time	94
8.4	Relative Acquisition Time for 90% Probability of Acquiring	96
8.5	Maximum Scan Angle as a Function of the No. of Grating Lobes in the Main Beam of the Element Factor	99
8.6	Possible Multiple Aperture Configurations	101
9.1	Gain as a Function of Frequency for Several Dish Sizes	107
9.2	Gain as a Function of Frequency for Two Dish Sizes	110
I-1	FTL Predetection Equal-Gain Combiner. This Can Be Used with Any Type of Modulation. (After Adams and Mindes ⁴)	4
I-2	a) Predetection Diversity Combiner Using Phase-Locked Loops b) Same As (a) But with a Primary Loop to Track Changes Common to Both Inputs. (After Laughlin ⁶)	5
I.3	Coherent Combining Method of Bello and Nelin ⁵ (Predetection Portion of Only One Receiver is Shown)	7
II.1	Maximum Dynamic Pointing Accuracy as a Function of Aperture Size	11a
IV.1-5	Various Forms of Combining Circuitry	19-28
IV.6	Coherent Output vs Phase Error	31
IV.7	Signal-to-Noise Ratio vs RMS Phase Error	36
IV.8	Coherent Output vs Phase Error	37

LIST OF ILLUSTRATIONS (Continued)

<u>Figure</u>	<u>Title</u>	<u>Page</u>
V. 1	Probability of Error vs Signal to Noise Ratio for Coherent and Noncoherent (Envelope) Detection for One Antenna	49
V. 2	Required Effective Aperture vs Average System Operating Temperature - T_{op}	51
V. 3	Bandwidth as a Function of Range and Antenna Dia.	55
V. 4	SNR vs Range for 100' Aperture Antenna	56
V. 5	SNR vs Range for 200' Aperture Antenna	57
V. 6	SNR vs Range for 400' Aperture Antenna	58
V. 7	SNR vs Range for 600' Aperture Antenna	59
VII. 1	Binary Phase Modulated Signal Detection with Frequency Doubling	67
VII. 2	Detection System for Phase Modulated Signals	67
VII. 3	Detection System Employing Digital Computer	69
VII. 4	Detection System by Systematic Adjustment of Phase	69
VII. 5	Two-Channel Receiver	71
VII. 6	Phase Lock Loop Receiver	71
VII. 7	Band-Pass Equivalent of Figure VII.5	75
VII. 8	Band-Pass Equivalent of Figure VII.6	75

1. INTRODUCTION

The ability to detect weak signals from distant space craft is directly related to the area of the ground antenna receiving aperture. Large collecting areas are necessary for wideband or for long range communications in order to achieve acceptable signal-to-noise ratios. Parabolic reflector antennas 85 feet in diameter, capable of hemispherical coverage, are more or less standard "catalog" items available from several manufacturers. The same is almost true of 120 foot apertures. Parabolic reflectors 210 feet in diameter are also available and can operate over a large part of the microwave region. Above approximately 300 feet diameter, hemispherical-coverage parabolic reflector antennas become increasingly more costly and economically prohibitive.

Larger antennas can be built by maintaining the reflector fixed and scanning the beam by moving the feed. The 1000 foot diameter spherical reflector antenna at Arecibo, P.R. (illuminated area of 600 feet diam.) is an example of such an antenna.¹ Its scan is limited to $\pm 20^\circ$. The inability to obtain anything near hemispherical coverage with large, scanning-feed antennas limits their usefulness in space communications.

Not only is it economically difficult to build large, moveable apertures, but other factors such as propagation media inhomogenities and beam pointing accuracy further restrict the ability to achieve large physical apertures.

Array antennas of many thousands of elements offer little practical advantage for large ground-to-space communication antennas in the sizes and at the frequencies desired. Their cost is as much, if not considerably more, than the large parabolic aperture. Furthermore, they are generally difficult to operate over more than a single frequency band. Large collecting apertures can also be obtained with a large number of flat plates each of modest size and feed from a source located on a high tower.² The beam is steered by positioning the individual flat plates. This approach has not been thoroughly tested and would probably have poorer sidelobes and a higher noise temperature than conventional

antennas. Furthermore such an antenna does not have hemispherical coverage. It might have specialized application, however in long range interplanetary communications.

The approach to large apertures presented in this report is to utilize a relatively small number (four to nine being typical) of more or less conventional, hemispherical coverage, parabolic reflector antennas properly combined and acting in unison to produce the effect of a single, large antenna. The multi-aperture antenna system is an economical and technically feasible method for realizing the type of performance needed to communicate satisfactorily at the long ranges required for spacecraft applications.

The major reason for considering the multi-aperture antenna system initially is the reduced cost as compared with the single antenna of equivalent area. However, there are other benefits which are inherent in this approach. These may be listed as follows:

Flexibility of Operation - The antennas may be operated as a coordinated group for highest performance or they may be divided into subgroups for separate simultaneous missions.

Reliability - The loss of one or two units does not cause catastrophic failure of the system.

Reduced Construction Time - Limited mass production can be applied and each antenna is a proven design that is within technological capability.

Improved Antenna Performance - Faster tracking and slewing rates are possible and it is easier to achieve a system at higher frequencies than with a single aperture.

Freedom From Atmospheric Inhomogeneity - The atmosphere is essentially uniform across each individual antenna aperture.

Beam Pointing - Potential exists for fine-grain electrical beam pointing as well as coarser mechanical pointing.

Diversity Reception - At low angles of elevation, when fading due to the propagation medium is important, the multi-aperture system

could be operated similar to the diversity systems of scatter communications.

Interference Reduction - Availability of many units permits some reduction of interference by proper combining.

Growth - Units may be readily added in the future.

The purpose of the study reported here is to evaluate the utility of the multi-aperture antenna concept and to suggest areas of application. The primary application is for receiving telemetry signals from spacecraft at lunar distances (3.8×10^5 km) and at interplanetary distances (2.6×10^8 km), but the system can be modified for transmission from the Earth to the spacecraft, if desired. The results of this study provide guidelines for determining the best system configuration including the optimum number of subapertures, their size, and spacing for a specified equivalent aperture size. The various methods of combining the outputs of the several antennas are examined and the advantages and limitations relative to conventional systems are established. The requirements describing the scope of this research as specified in the contract Statement of Work is reproduced in Appendix III.

The concept of the multi-aperture antenna system is an outgrowth of diversity reception commonly employed in communications and of the adaptive antenna. Appendix I gives a brief historical review of the origins of this type of system.

Following the summary in Section 2 is a section giving the assumptions made concerning the type of communications systems that might be carried by lunar and interplanetary range spacecraft. It is necessary to define a model of the spacecraft system so as to properly specify the ground antenna system, especially the combining method. The important system characteristics are the type of modulation employed and whether or not a pilot, or carrier, signal is available.

The analysis of the number of subapertures and the optimum dish size is presented in Section 4. The criterion is based primarily on economic considerations. Section 5 discusses the various factors that

enter into the spacing configuration. Methods of combining the outputs of the several antennas are described in Section 6.

Section 7 considers a number of problem areas relating to the system configuration. Two design examples are given in Section 8: one for lunar range, the other for interplanetary range. The final section compares the multi-aperture antenna systems to conventional antennas.

In addition to this final report, two quarterly reports^{3,4} have been issued which provide further detail.

SECTION I - REFERENCES

1. T. Maguire, "Arecibo, New Era in Radio Astronomy," Electronics, Vol. 36, No. 51, pp. 29-32, December 20, 1963.
2. A.C. Schell, "Optimization of Antenna Systems," AFCRL Report 62-736; September 1962.
3. J.W. Sherman, D.J. Lewinski and M.I. Skolnik, "First Quarterly Report for Investigation and Study of a Multi-Aperture Antenna System," (1 July 1963 - 1 October 1963) Contract No. NAS 5-3472, ECI Research Division, Timonium, Maryland.
4. J.W. Sherman and M.I. Skolnik, "Second Quarterly Report for Investigation and Study of a Multi-Aperture Antenna System" (1 October 1963 - 1 January 1964), Contract No. NAS 5-3472 ECI Research Division, Timonium, Maryland.
5. W.K. Victor, R. Titsworth, and E. Reichtin, "Telecommunication Aspects of a Manned Mars Mission," JPL Tech. Rept. No. 32-501, August 20, 1963.

2. SUMMARY AND CONCLUSIONS

The multi-aperture antenna concept is a feasible and economical method of achieving large receiving apertures when it is not practical to construct a single reflector antenna. The outputs of the antennas constituting the multi-aperture system can be efficiently combined by utilizing some adaptive scheme such as a phase lock loop for each antenna. This report details the major system factors that must be considered in assessing the feasibility and evaluating the utility of this antenna concept as well as providing design guides for system specification.

The optimum number and size of the individual antennas of the multi-aperture system are determined using the criterion of minimum system cost. Since antenna costs vary almost as the cube of the diameter it is cheaper to obtain a number of smaller antennas than one large antenna of the same total area if the cost of electronics per antenna is negligible. When the electronics cost is not negligible there is some optimum number for maximum economy. It is shown that the multi-aperture antenna becomes economically rewarding when the electronics cost for a single antenna is about one-tenth (or less) the antenna cost. The conditions under which the cross-over point is reached between the multiple aperture and single antenna depends primarily upon the frequency of operation. As it is more expensive to make antennas of a given size to operate at a higher frequency the use of the multiple aperture approach becomes more desirable as the frequency increases, assuming a fixed electronics cost. At 2 Gc, with minimum electronics cost of the order of \$100,000, the transition point is in the vicinity of an 80 to 85 foot aperture. Different electronic costs can change this conclusion. Furthermore, the cross-over between the two is not a sharp one.

It was found that there is little need for a multi-aperture antenna system to satisfy the specified space communications requirements for a lunar-range system at frequencies at least as high as 2 Gc. A single reflector antenna should be able to perform satisfactorily. If, on the

other hand, the operating frequency was 10 Gc and the electronic costs were again assumed to be \$100,000, the model developed in this study indicates that a multi-aperture antenna is preferred. Three subapertures (each having an approximate diameter of 50 feet) represent the minimum cost configuration, although the saving is relatively small - on the order of 25%.

The conclusions for an interplanetary range communication system are different than for the lunar range system. Multi-aperture antennas are decidedly advantageous in this application because of the need for collecting apertures larger than can be economically achieved with a single dish. For the model of the spacecraft parameters adopted it appears that aperture equivalent of at least 400 feet are required if the information bandwidth is of the order of 100 cps. At a frequency of 2 Gc such an antenna is most economically represented by eight 142 apertures. In converting the results presented here to practice it should be realized that antenna designs are available at certain preferred sizes. The "optimum" is not sharp and there would be little lost if the appropriate number of the nearest standard size antennas were used instead of the precise antenna diameter specified by the analysis.

While the state-of-the-art does probably allow construction of 400 foot apertures at a frequency of 2 Gc, an equivalent aperture can be achieved for less than half the cost (excluding fixed cost) if the multiple aperture approach is used. Furthermore, during acquisition detection capability equivalent to almost 25% of the worth of the 400 foot antenna may be lost due to pointing errors. Thus it appears desirable to use the multiple aperture antenna for receiving telemetry data from interplanetary sources.

There are other physical constraints beside pointing errors which limit antennas in physical size, and have been recognized for some time as limiting factors. It appears that thermal tolerances will limit the antenna gain of a single dish to around 64 db unless the antenna is operated in a radome or the multiple aperture system is adopted.

Trade-offs must then be made between increased noise temperature (for the radome) or combining losses.

Considerable study was given to the problem of efficiently combining the outputs of the various antennas. It is suggested that whenever possible a narrow band pilot signal be provided to aid in the combining process.

Other problems, including acquisition of signals, bandwidth, interference, reliability, and siting have been investigated and found to present no restriction.

The chief conclusion of this study is that the multi-aperture antenna has an important area of application when the maximum communication capability is desired and that there are no known fundamental limitations which might prevent the successful implementation of an operational system.

3. COMMUNICATION SYSTEM MODEL

In order to analyze the multi-aperture antenna as the ground terminal of a space communications system, some idea must be had of the nature of the spacecraft terminal. The contract Statement of Requirements listed in Appendix III, differentiates two types of communication systems, one for lunar ranges (3.8×10^5 km) and the other for interplanetary ranges (2.6×10^8 km). The considerable difference in range manifests itself primarily in the available information bandwidth that can be transmitted. The greater the bandwidth, the greater the transmitter power. With present technology, TV bandwidths are practical at lunar distances but information bandwidths are limited to a few cycles, or tens of cycles, at interplanetary distances. As related to the problem of optimum combining of the outputs from the several antennas the major difference in spacecraft systems is whether a suitable pilot or carrier signal is available. With a pilot, the combining can be accomplished adaptively to give the effect of efficient coherent addition. Without a pilot, incoherent addition may be more suitable.

The present state of technology in spacecraft communications is advancing rapidly. It is difficult to accurately specify a communication system that is typical. Nevertheless, some assumptions have been made for purposes of this study. These are summarized in Table 3.1.

Appendix V summarizes the characteristics of several spacecraft communication systems. Also given in this appendix are calculations of the performance of the assumed lunar and interplanetary range systems.

Although the interplanetary system is of relatively modest bandwidth and low data rate, there are indications that TV transmissions over these ranges are desired and being planned. Such a system would require considerably larger power and larger antenna apertures than assumed in Table 3.1. The availability of a pilot can be assumed in this case and the combining methods would be more like those for the lunar range system discussed in this report.

TABLE 3.1

Assumptions Concerning Spacecraft Communications

	<u>Lunar</u>	<u>Interplanetary</u>
Transmitter power	15 w	100 w
Antenna gain	6 db	17 db
Losses and design margin	5 db	6 db
Range	3.8×10^5 km	2.6×10^8 km
Telemetry mode	PCM/FM	PSK
Bandwidth	$\sim 10^6$ cps	~ 10 cps
Pilot	Yes	No

4. THE NUMBER OF SUBAPERTURES

4.1 The Model

In the second quarterly report¹ the cost of a single antenna was established to be approximately

$$\text{Cost} = 0.92 \sqrt{f} D^{2.94},$$

where f is the maximum usable frequency of the antenna expressed in gigacycles and D the diameter of the dish in feet. This cost expression includes the reflector, feed support structure, mount, and driving motors.

For antennas being used in multiple aperture systems the cost for a single antenna will vary as

$$\text{Cost} \propto 0.92 \sqrt{f} \frac{D^{2.94}}{n}.$$

But $D_n = D/\sqrt{n}$, where D is the diameter of a single dish of equivalent area. In other words, for a system requiring a ground antenna of diameter D , the same system can be composed of n antennas, each having a diameter D/\sqrt{n} . Thus, it is possible to specify the ground antenna cost as

$$\text{Cost} \propto 0.92 n \sqrt{f} (D/\sqrt{n})^{2.94}$$

However, this expression does not reflect the savings in development cost when more than one of the same quantity are built. Furthermore certain economies in mass production could result if the number of antennas is large. Based on information gathered during the course of this study, it seems reasonable to assume that the cost of the second antenna and succeeding antennas is 70% of the cost of the first antenna. A mathematical representation of such a model is

$$C_A = \text{Antenna Cost} = .92\sqrt{f} [1 + .7(n-1)] (D/\sqrt{n})^{2.94} \quad (4.1)$$

Electronic equipment will fall into three classes with respect to cost. First, certain electronic equipment will be common to both the single or the multiple antenna system and hence enter as a fixed cost. All fixed cost quantities are ignored in this discussion of

multiple aperture antenna systems. Second, some equipment will vary depending on the number of antennas and cause the electronics cost to increase as the number of antennas increases. Third, some electronic costs will not only vary with the number of antennas, but will vary according to the frequency.

Toward the goal of establishing a mathematical model of electronics cost in the receiving system several manufacturers of such equipment indicate that approximately 10% savings may be expected for each octave increase in the number of identical components. An approximate model is that the cost of electronics varies as $n^{0.9}$. Such a model says that 10 components can be purchased for the price of 8 singly and 100 components cost the same as 63 bought separately.

The cost of electronics may be written as

$$C_E = \text{Cost of Electronics} = an^{0.9} + \text{fixed cost}, \quad (4.2)$$

where a is a constant depending on the cost of electronics for a single antenna. If the electronics cost for a single antenna is \$200,000 then the model assumes that if 4 antennas are used (125 foot aperture size) the electronics cost is still \$200,000 for each antenna if purchased separately, but with a slight economy if purchased as a group of four (i.e., total electronics cost is \$697,000).

A third cost to be considered in designing a receiving system is the cost of operation and maintenance of the antenna, be it a conventional aperture or multiple aperture. This cost has been expressed in terms of a fraction of the initial cost for each year of anticipated operation.² Thus this expense might be expressed as

$$C_o = \text{Operation and Maintenance Cost} = (\beta C_A + \gamma C_E) y \quad (4.3)$$

where, the cost has been assumed to depend on a fractional part of the antenna cost (β) and the electronics cost (γ), over a specified period of operation y .

This model of operating cost can make the multiple aperture system cost more or less to maintain than a single dish. The quantities β and γ can be used as parameters to the problem to explore their effect on the number of subapertures. Since very few multiple apertures presently exist, it is difficult to obtain information on operating and maintenance cost.

The total cost of the multiple aperture system, aside from fixed cost common to both single or multiple antennas, may be written as the sum of Equations 4.1, 4.2, and 4.3. The possibility exists that there are other costs which have not been included but do vary with the number of antennas. For example foundation cost can vary with the number of antennas, but it is believed that such variations are small compared to the other included costs in this model. The decision to calculate each aperture equivalent rather than differentiate the expression to find a minimum was made during the previous quarter. The primary reason for this approach is to indicate the sensitivity of the cost to the number of elements.

4.2 Minimum Cost As a Function of Equivalent Aperture Size

It is difficult to estimate the parameters β and γ which govern maintenance and operating cost. For values reported in the literature of $\beta = 0.02$ and $\gamma = 0.10^2$, a family of curves may be developed in which all quantities are kept constant except the aperture size. Figures 4.1 through 4.5 indicate the cost of a multiple aperture system maintained for ten years of operation. Fixed costs are not included in these figures, and calculations have been made by summing Equations 4.1, 4.2, and 4.3. Each curve is labeled according to the electronic cost c .

It is observed that the ratio of the electronics cost to antenna cost greatly influences the optimum number of elements. The smaller this ratio the larger the optimum number of antennas to be used in the system. Furthermore, the optimum number of antennas is small.

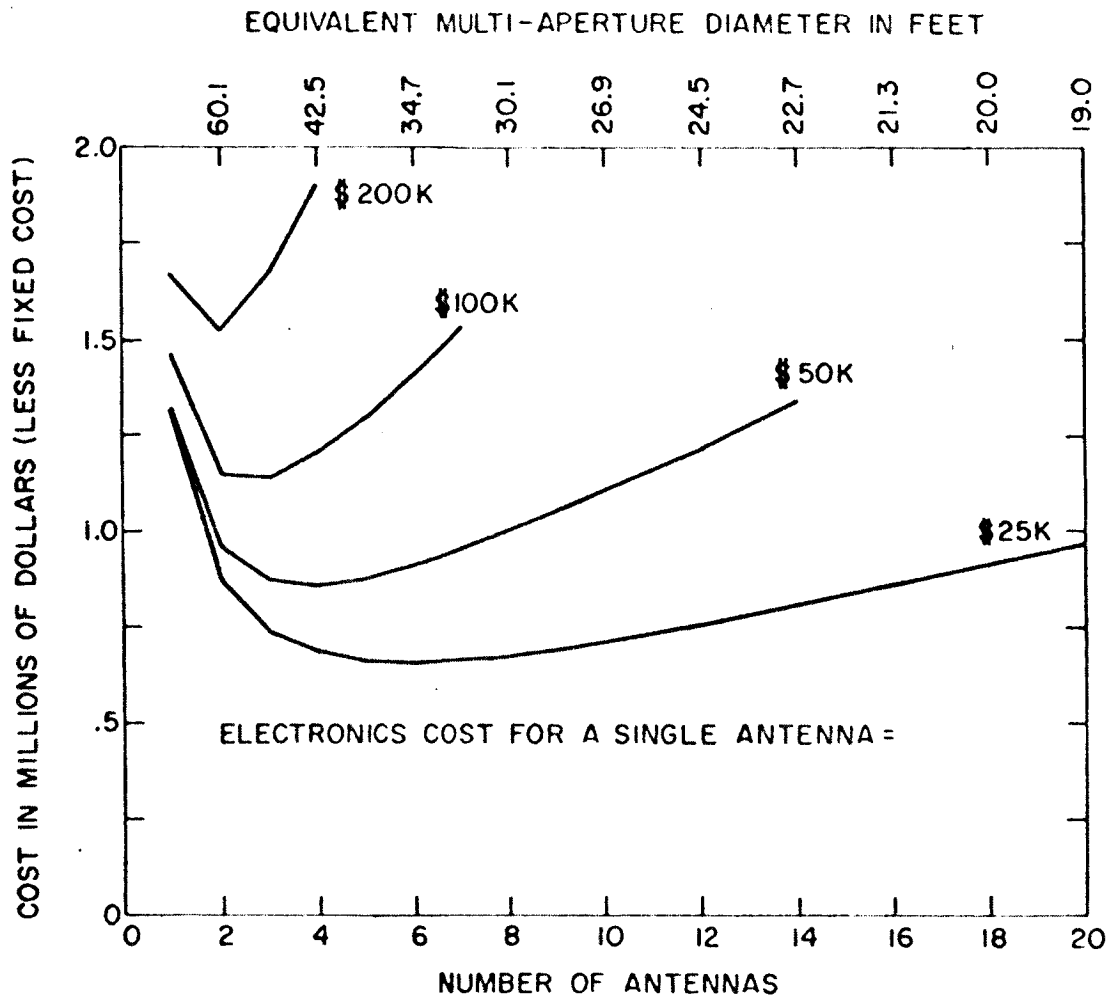

FIG. 4.1 - RELATIVE COST OF A 85' EQUIVALENT APERTURE
 MAXIMUM USABLE FREQUENCY OF 6 Gc MAINTAINED
 OVER 10 YEARS.

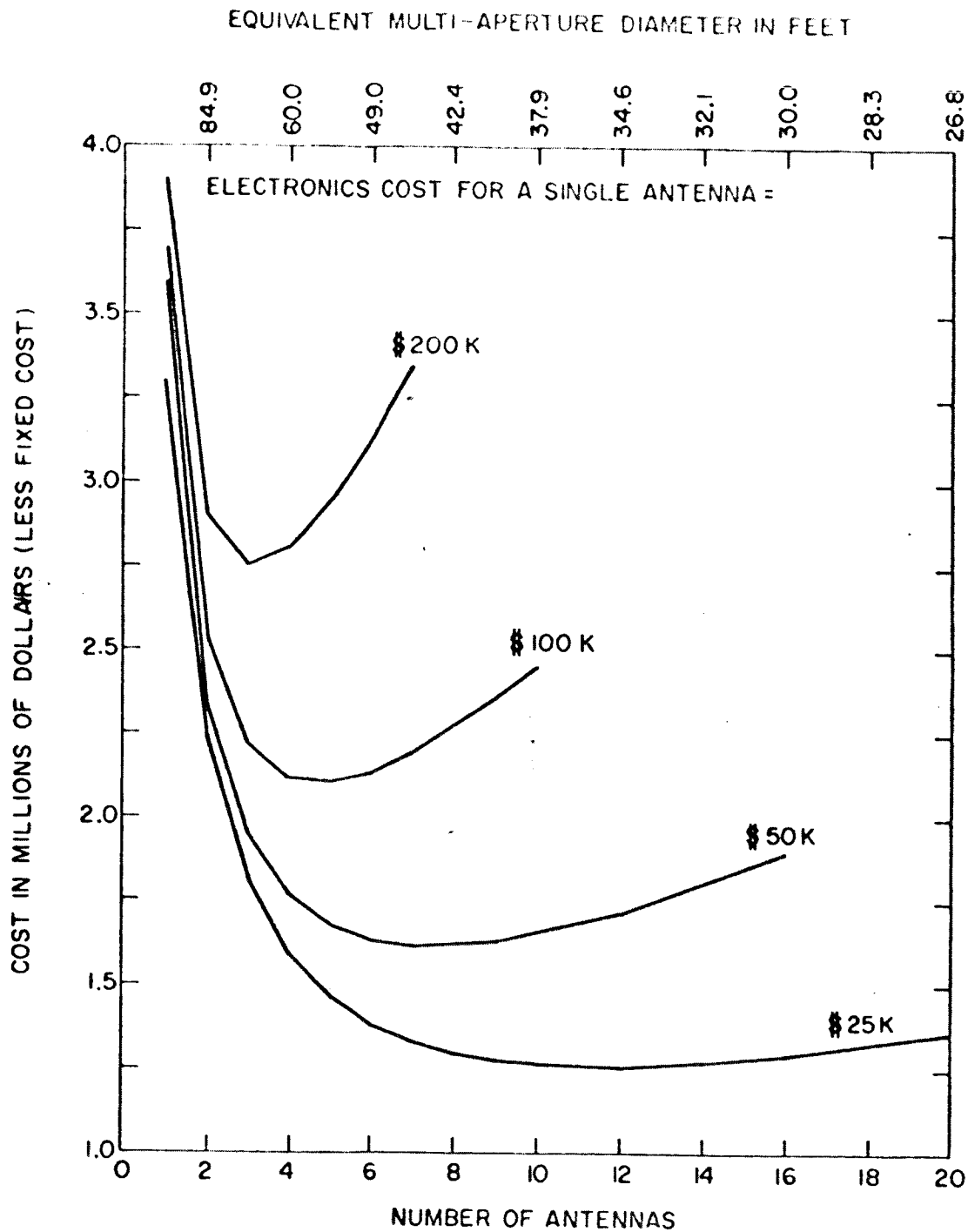

FIG 4.2 - RELATIVE COST OF A 120' EQUIVALENT APERTURE
 MAXIMUM USABLE FREQUENCY OF 6 Gc MAINTAINED
 OVER 10 YEARS.

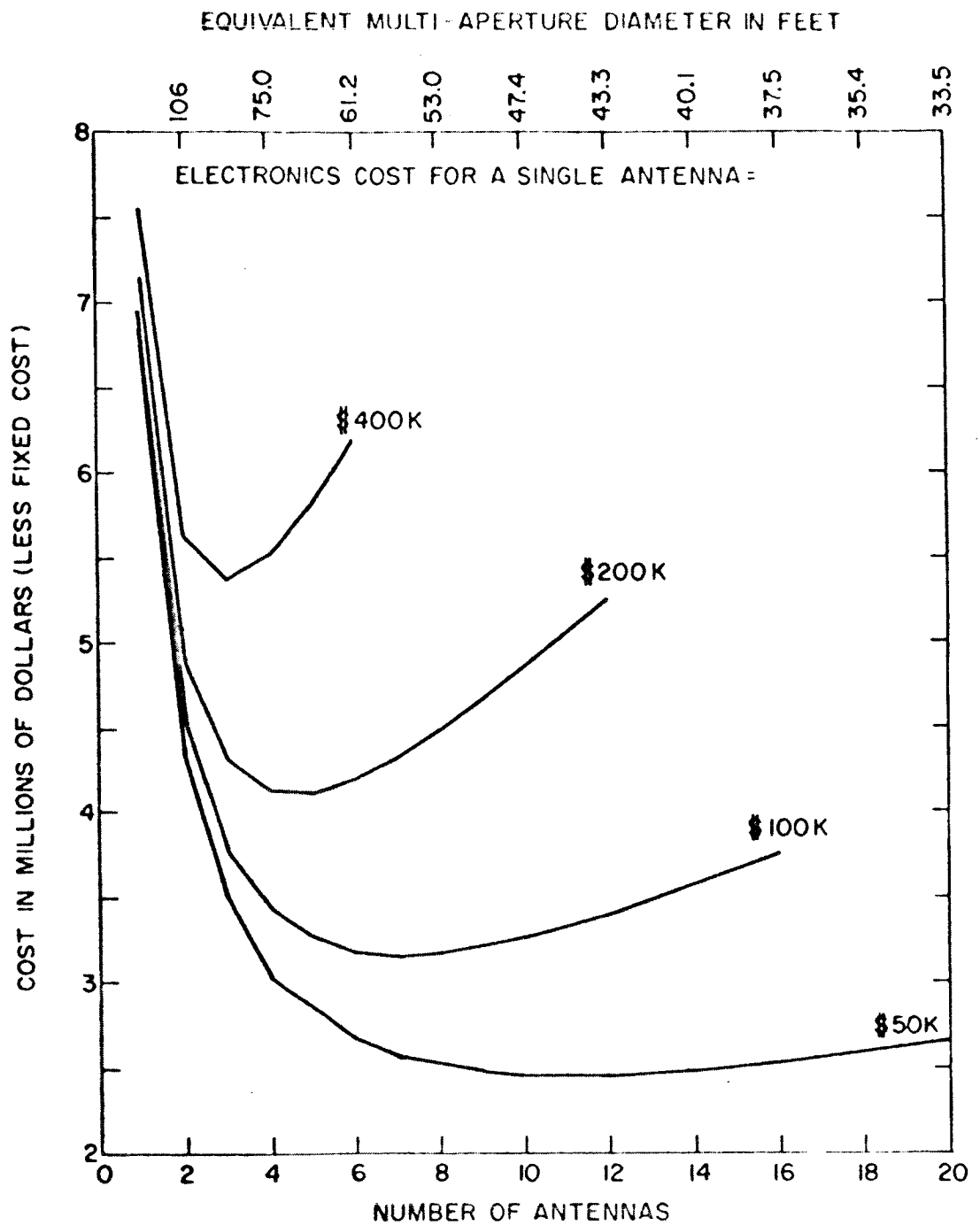

FIG. 4.3 - RELATIVE COST OF A 150' EQUIVALENT APERTURE
 MAXIMUM USABLE FREQUENCY OF 6 Gc MAINTAINED
 OVER 10 YEARS.

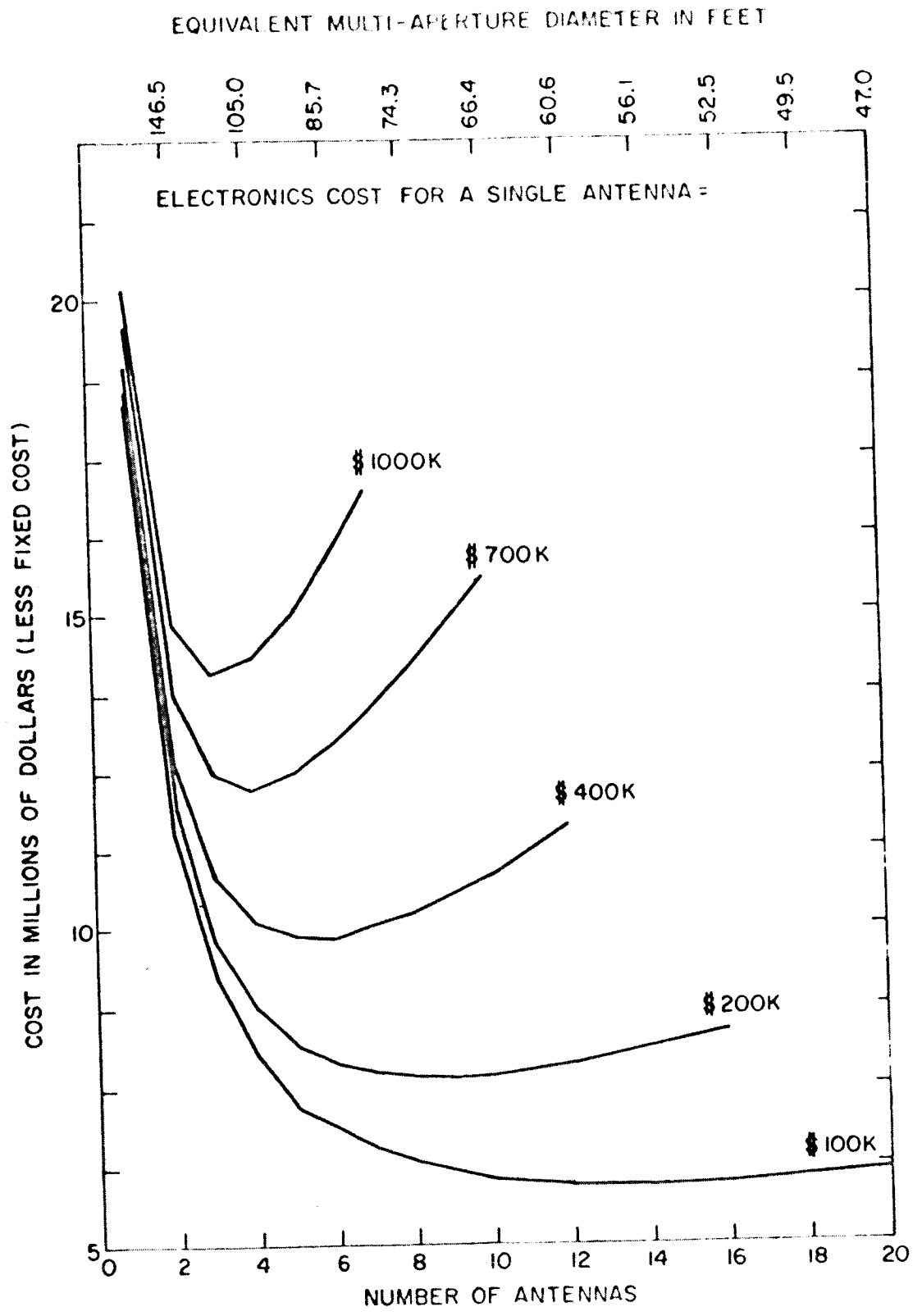

FIG.4.4 -RELATIVE COST OF A 210' EQUIVALENT APERTURE
 MAXIMUM USABLE FREQUENCY OF 6 Gc MAINTAINED
 OVER 10 YEARS

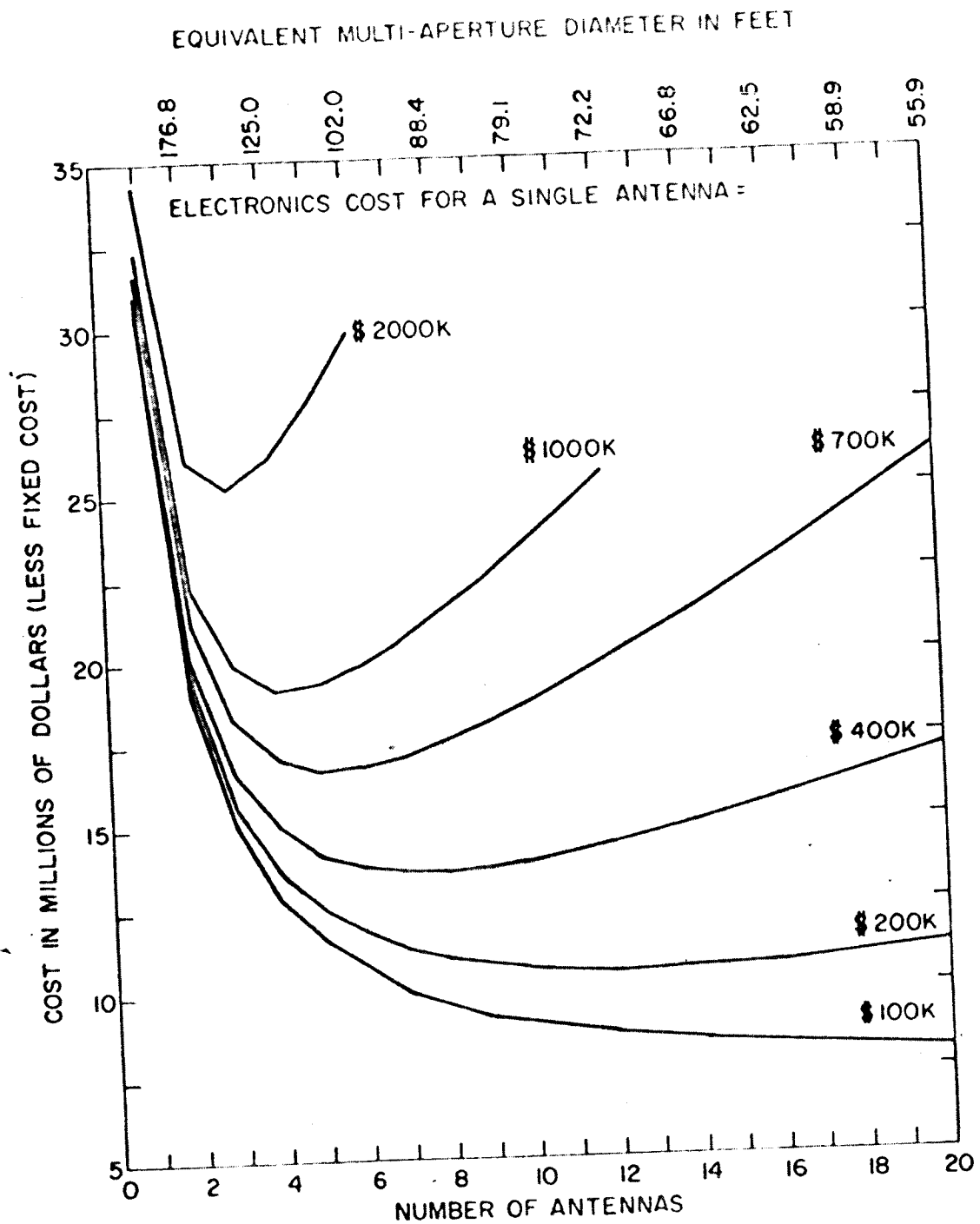

FIG. 4.5 - RELATIVE COST OF A 250' EQUIVALENT APERTURE
 MAXIMUM USABLE FREQUENCY OF 6 Gc MAINTAINED
 OVER 10 YEARS

A better way to indicate the information contained in these curves is to plot the ratio of electronics cost to antenna cost as a function of the optimum number of elements. The curve label 10 years in Figure 4.6 indicates the optimum number of antennas to be used once the electronics and antenna cost are established for a single aperture having the required size to give a needed signal-to-noise ratio. This curve is independent of the frequency of operation since the antenna cost increases as the frequency increases and thus alters the electronics to antenna cost ratio.

4.3 Optimum Number of Antennas as a Function of the Period of Operation

Two additional curves are shown in Figure 4.6 for 0 and 20 years of operation. The general conclusion that can be drawn from this result is that once the initial antenna and electronics cost are established for a single aperture the optimum number of elements decreases as the length of expected operation increases. For example, if the ratio of C_E to C_A is 0.01, then the optimum number of antennas is 14, 11, and 9 for 0, 10, and 20 years of operation.

The optimum number of subapertures to be used may be represented by

$$n_{\text{opt}} = \left(\frac{C_y}{C_E/C_A} \right)^{0.6353}, \quad (4.4)$$

where C_y is a constant depending on the number of years of expected operation. Values of C_y between 0 and 20 years can be expressed as

$$C_y = 0.656 - 4.45 \times 10^{-2} y + 2.4 \times 10^{-3} y^2 - 5.37 \times 10^{-5} y^3, \quad (4.5)$$

where y represents the number of years of operation. Equation 4.5 has been plotted in Figure 4.7.

It is evident that the optimum number of elements is not large for aperture equivalents up to 250 feet (less than a dozen for typical electronics cost). Equation 4.4 indicates that the optimum

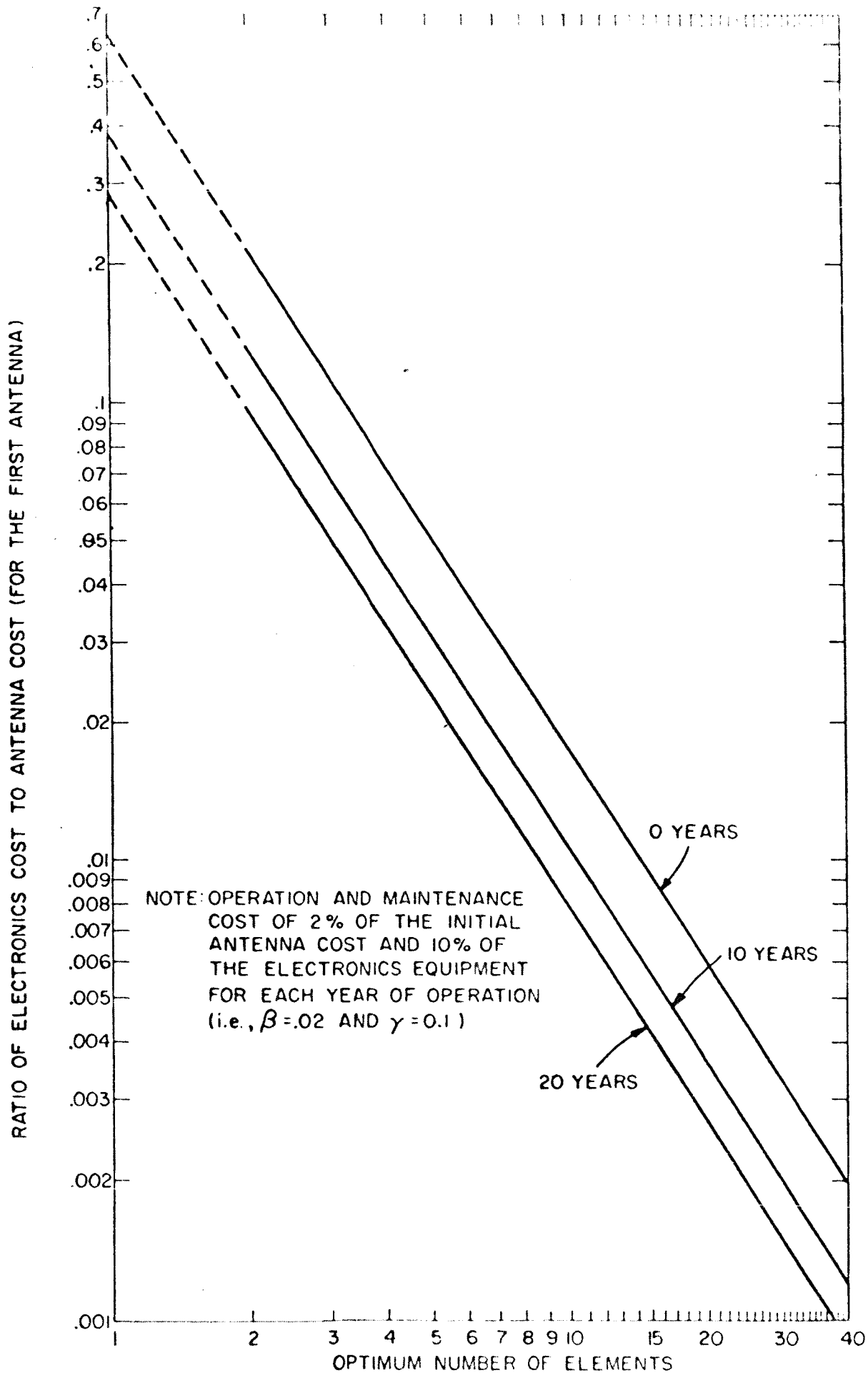

FIG. 4.6 -ELEMENT OPTIMIZATION AS A FUNCTION OF ELECTRONICS AND ANTENNA COST FOR SEVERAL PERIODS OF OPERATION

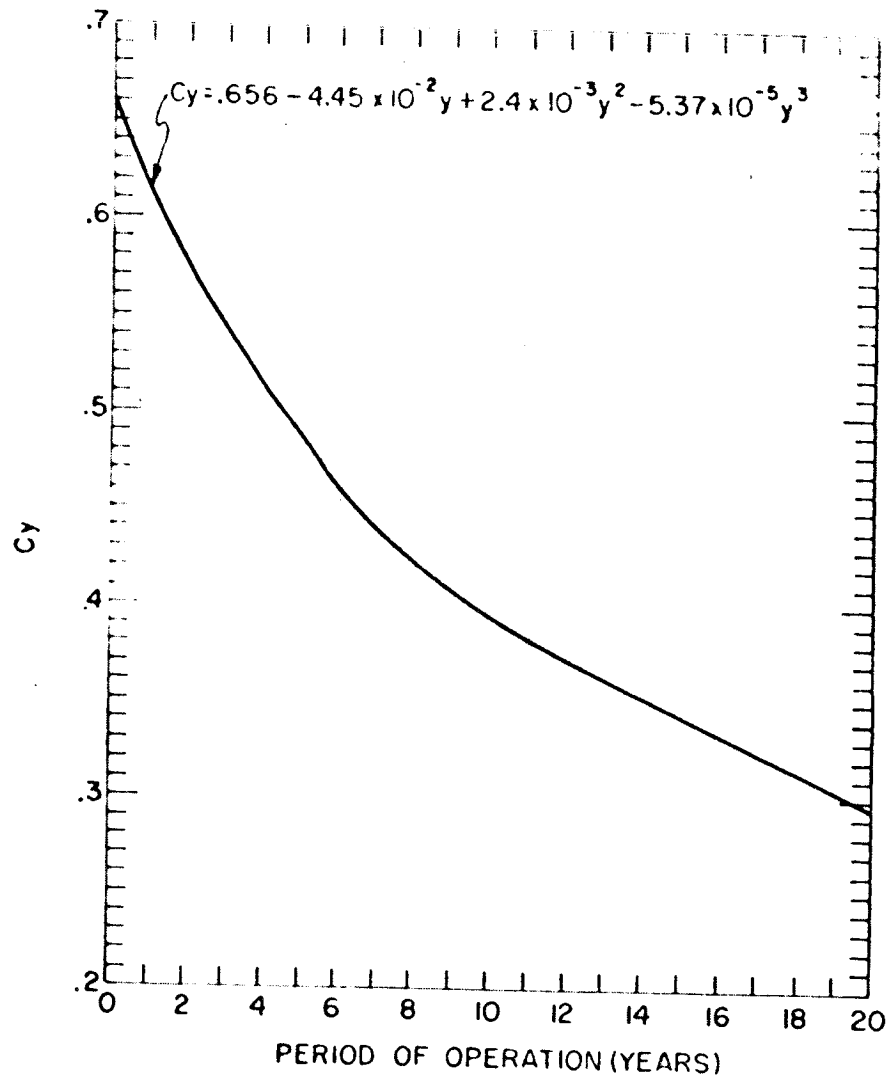

FIG. 4.7 - VALUE OF Cy AS A FUNCTION OF THE NUMBER OF YEARS OF OPERATION.

number of elements will increase if the aperture size becomes quite large. But even when $C_E/C_A = 0.0021$ corresponding to a 600 foot dish operating at 2 Gc for 10 years the optimum number of elements is 32 for an electronics cost of \$400,000.

4.4 Optimum Number of Antennas as a Function of the Frequency

The curves expressed in Figure 4.6 are most convenient since they are independent frequency as previously explained. However, the data contained in this curve should not be used indiscriminately. For example, aperture equivalents significantly less than 85 feet should not be used with this model, and frequencies which are greater than the maximum usable frequency established by thermal tolerances for a given aperture should not be used. (See Section 9.)

4.5 Maintenance and Operating Cost

The model adopted for the multiple aperture system cost involved a maintenance and operating factor which depended on both the antenna cost and the electronics cost. All figures sketched have been prepared on the basis of 2% antenna cost and 10% electronics cost ($\beta = 0.02$, $\gamma = 0.10$) for each year of expected operation. The sole basis for this choice is the work of Schrader who suggested these particular values.^{2, 3} Figure 4.8 establishes the cost of maintaining a 250 foot aperture equivalent for a ten year period for several values of electronics cost. Thus, the maintenance and operating costs vary, and actually have a minimum. Note that the minimum is different from the total system minimum cost (See Figure 4.5)

4.6 The Optimum Antenna Size

It is possible to express the optimum antenna size to be used in multiple aperture system rather than the optimum number of apertures. Table 4.1 summarizes the results of this section in terms of the optimum size apertures to be used as a function of electronics cost and length of operation. This Table is considered approximate because the number of subapertures is always an integer, and hence

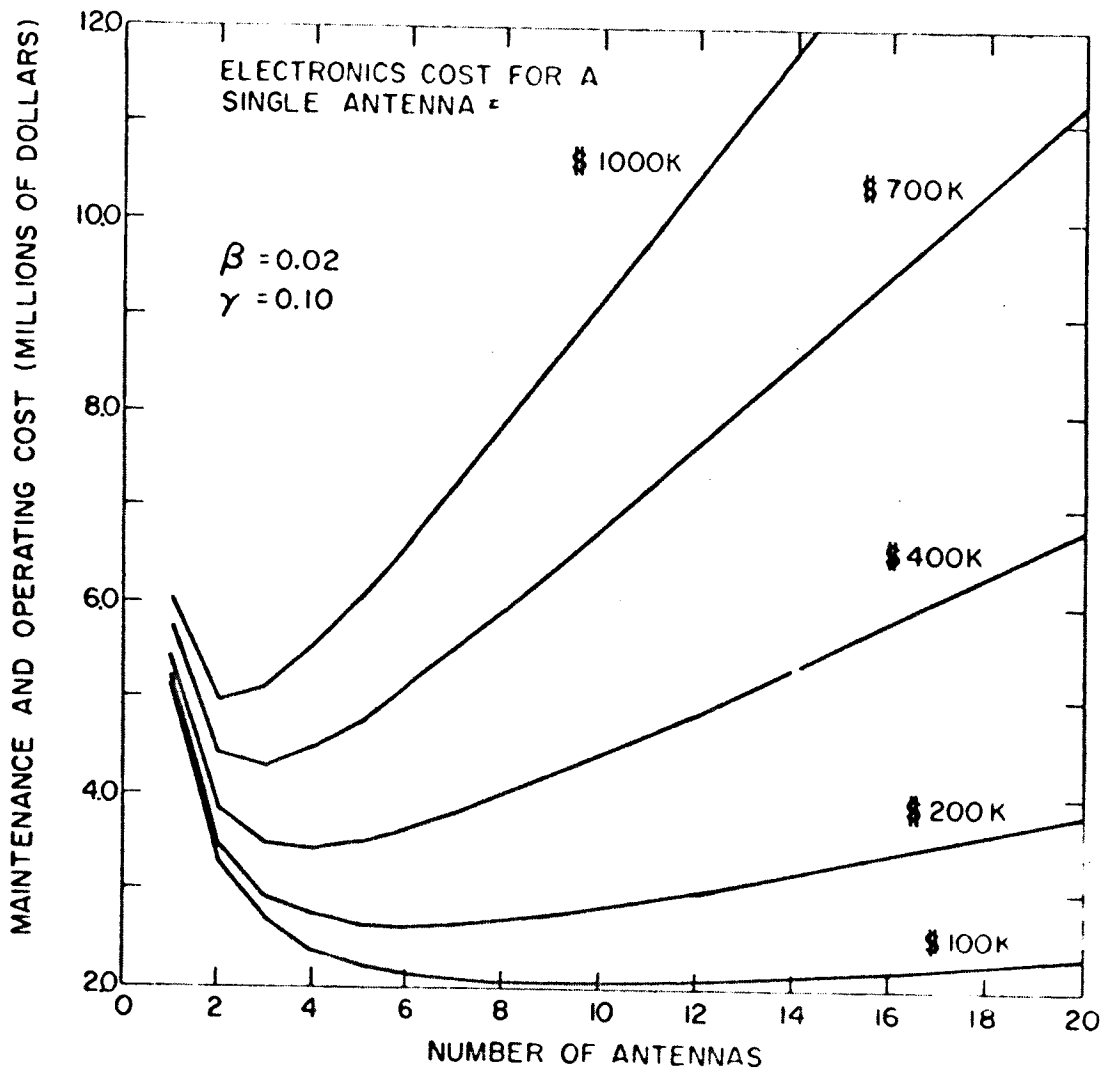

FIG. 4.8 - COST OF OPERATING AND MAINTAINING A 250' 6Gc APERTURE FOR A 10 YEAR PERIOD

MAXIMUM USABLE FREQUENCY (Gc)	LENGTH OF OPERATION (YEARS)	ANTENNA DIAMETER IN FEET AS A FUNCTION OF ELECTRONICS COST (IN THOUSANDS OF DOLLARS)					
		100	200	400	700	1000	2000
2	0	60	73	94	111	126	160
	10	70	85	108	131	147	188
	20	75	94	120	145	162	205
6	0	48	62	77	88	108	128
	10	56	72	90	103	121	151
	20	63	79	98	116	132	160
10	0	45	56	67	85	95	119
	10	52	66	81	92	111	140
	20	58	72	88	109	122	154

TABLE 4.1 - APPROXIMATE ANTENNA DIAMETERS FOR A MULTIPLE APERTURE SYSTEM

for fixed electronics cost, there can be some variation in the optimum aperture size. Several general observations may be made from this table. First, the subaperture size increases with an increasing length of operation as well as with increasing electronics cost. Second, the subaperture size decreases with increasing frequency of operation. These facts are evident from Figure 4.6 and Equation 4.4, but Table 4.1 establishes the relative subaperture sizes found in this section.

SECTION 4 - REFERENCES

1. J.W. Sherman and M.I. Skolnik, "Investigation and Study of a Multi-Aperture Antenna System," Second Quarterly Report, Contract No. NAS 5-3472, p 55; January 1, 1964.
2. J.H. Schrader, "Receiving System Design for the Arraying of Independently Steerable Antennas," IRE Trans., SET-8, pp. 148-153; June, 1962.
3. Oral Communication with Mr. J.H. Schrader, NASA, Langley Research Center, Langley Air Force Base, Virginia.

5. SITING

There are a large number of factors which influence the spacing configuration and the separation between elements in a multiple aperture antenna system, and include such quantities as the required look angle, shadowing, propagation effects in the atmosphere, transit time effects across the array, collimation, solar and lunar interference, and doppler frequency differences across the array. The topic of siting as defined here is limited solely to the decision of element placement and not the requirements of real estate on which to locate the multiple aperture system. Any real estate chosen for a single antenna will be adequate for the array antenna system, since normally the isolation of the antenna from man-made noise at the frequencies being considered may be accomplished by an environment removed from such noise sources.

Not all of the above factors are independent, and some depended on other parameters. For example the look angle depends not only on the propagation effects of the atmosphere, but on the noise temperature of the antennas. This noise temperature in turn depends on the frequency of operation. Nevertheless, the intent of this section is to establish the relative effects of each of these above factors on antenna siting.

5.1 The Look Angle

The look angle is defined as the angular coverage required of the aperture receive system. If no constraints had to be applied to the problem, the minimum number of complete systems to provide continuous coverage would be two, each having hemispherical coverage and located at opposite points on the earth. However, terrain conditions, isolation from noise, and multipath problems usually limit the coverage of an antenna to something less than a true hemisphere. It would appear then that at least three complete receive systems would be required. A beneficial constraint is obtained when the receiving aperture is

limited to a system of communications between the earth and moon, or the earth and other remaining planets. In Figure 5.1 the angle that several of the planets make with plane of the equator as a function of time during the year 1964 is sketched. It is observed that all planets lie well within $\pm 30^\circ$ at the equator. Similarly, the moon remains within $\pm 25^\circ$ in this period of time (these data have been obtained from reference 1). Thus, the coverage of space is achieved by steering $\pm 30^\circ$ in the north-south direction for antennas located near the equator and used for either lunar or interplanetary communications.

It is necessary to briefly discuss the nature of the overall communications system, because antenna siting requirements are highly dependent on the type of system used. For example, if continuous contact with the lunar or interplanetary vehicle is not necessary then a single antenna is sufficient. However, if the requirement is for continuous communications, then three antenna receive systems are believed necessary as previously mentioned. The geometry of the look angle is shown in Figure 5.2 where the elevation angle ϕ is used instead of the look angle (the angle measured from the zenith).

Figure 5.3 indicates the relationship between the look angle in the east-west direction at the equator as a function of the actual number of antenna sites when the space vehicle is at infinity. Using a finite range changes this curve only slightly at lunar ranges, and to a lesser extent for interplanetary ranges. If three sites are used around the earth separated by 120° in longitude, then communications from any two sites exist at a point six earth radii away from the center of the earth if the look angle is 70° (20° for ϕ in Figure 5.2).

It has been necessary to explore the features of the look angle in the light of certain constraints. These constraints are beneficial in that the required look angle is reduced to $\pm 30^\circ$ in the north-south direction with the reduction in the east-west direction depending on the number of receiving systems. The effect that these two factors

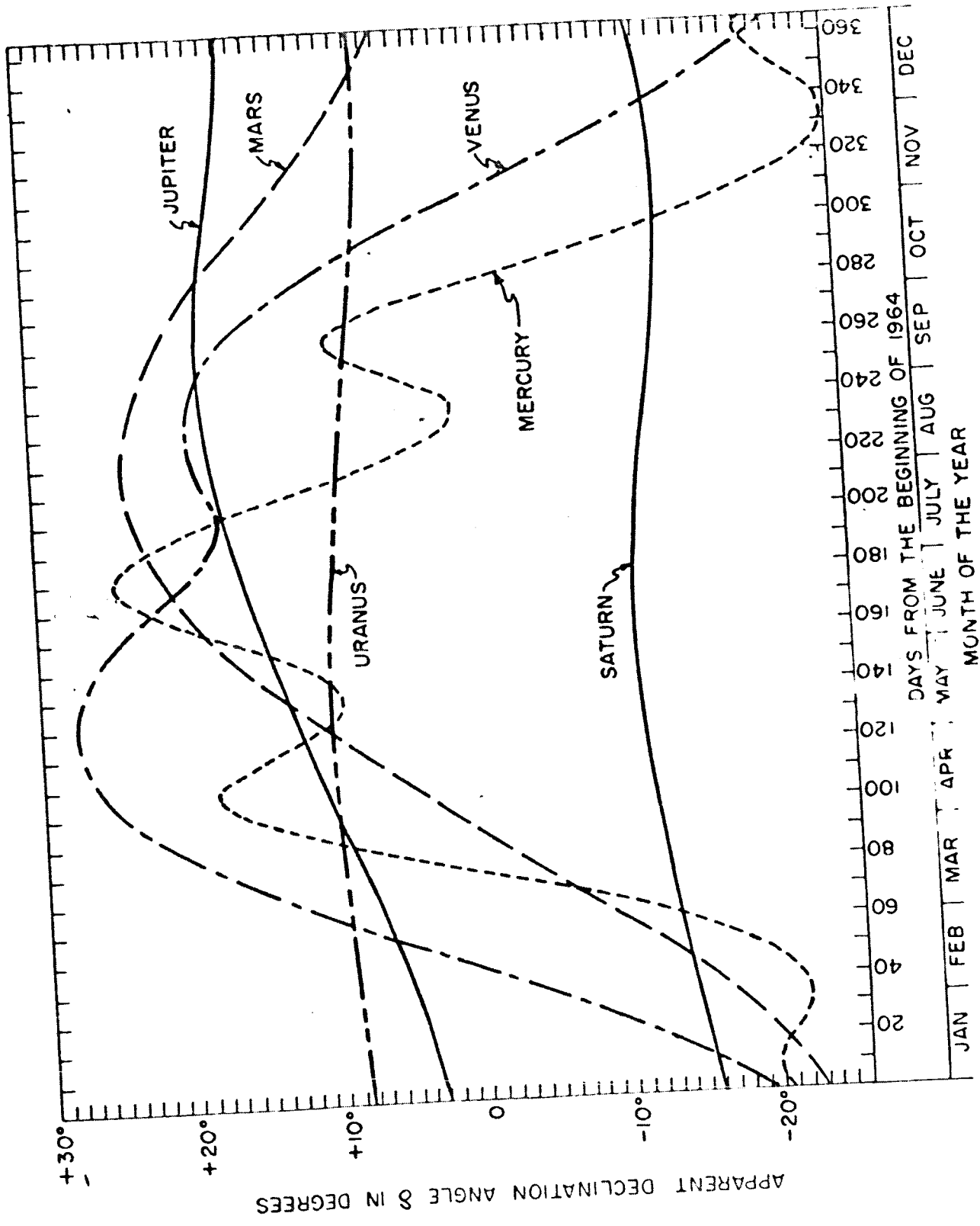

FIG. 5.1 - DECLINATION ANGLE OF SEVERAL PLANETS FOR THE YEAR 1964

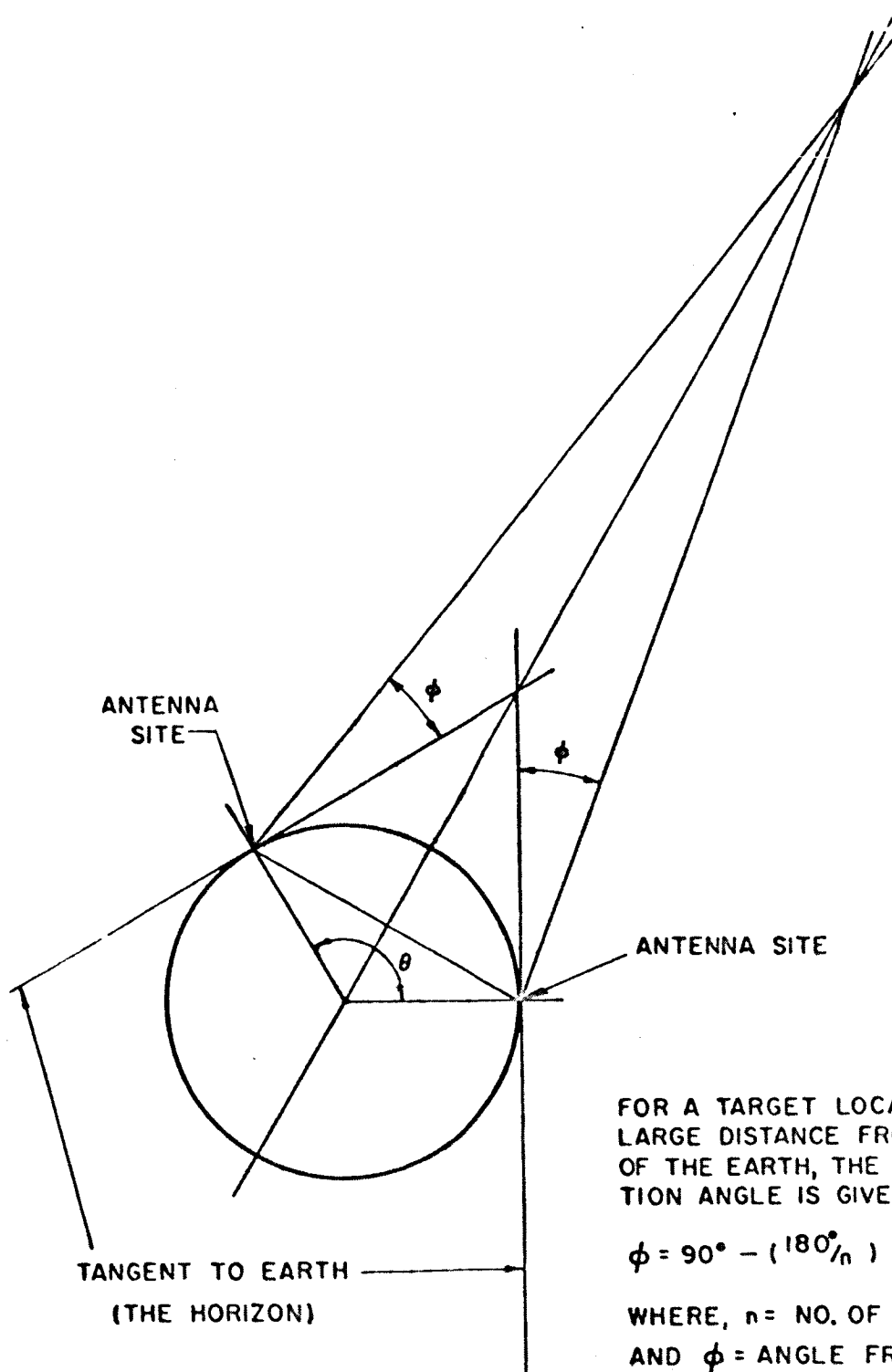

FIG.5.2 - LOOK ANGLE GEOMETRY AS A FUNCTION OF THE SITE POSITIONS

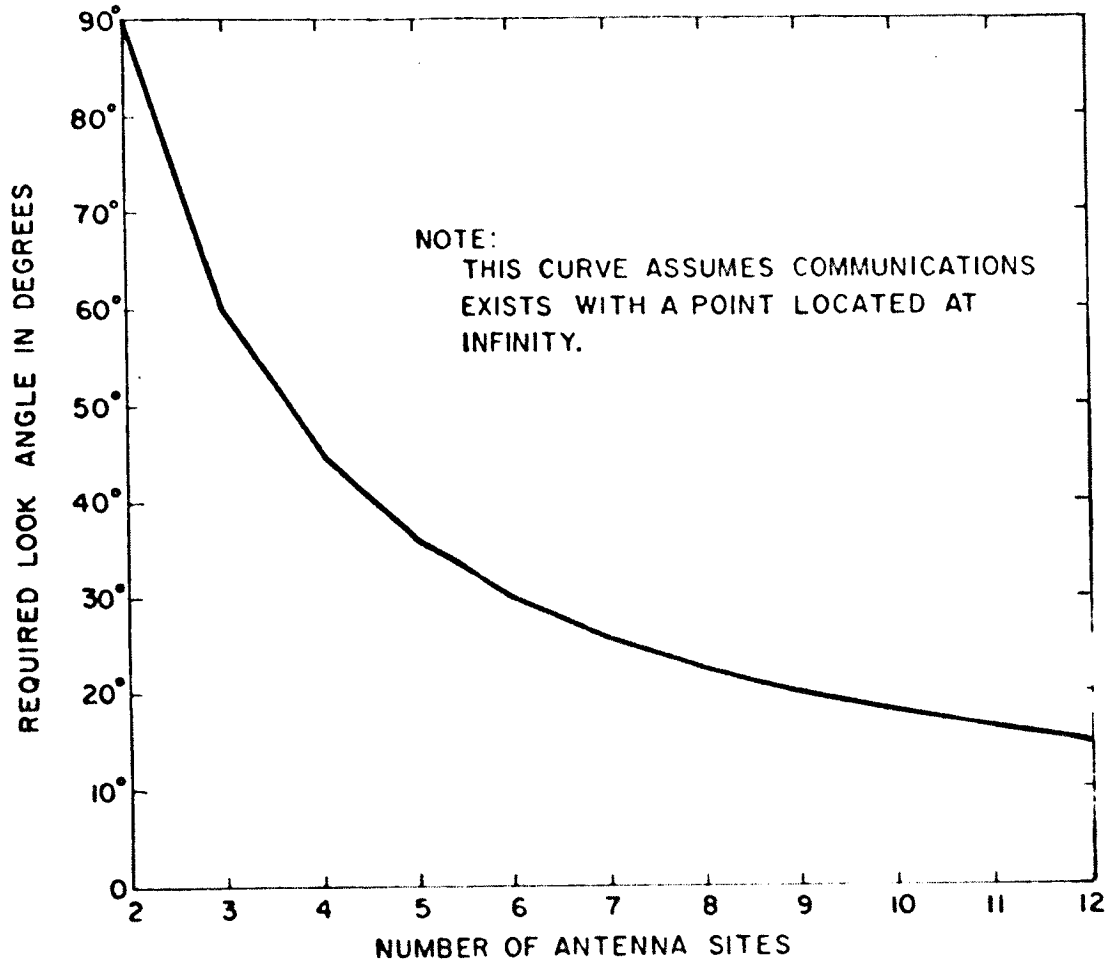

FIG. 5.3 - THE REQUIRED SCAN ANGLE IN THE EAST - WEST DIRECTION AS A FUNCTION OF THE NUMBER OF ANTENNA SITES

play in the actual element placement will be more evident in Sections 5.2 and 8.3.

Thus far only the constraints beneficial to limiting the look angle have been considered. To define an optimum look angle requires knowledge of the signal-to-noise ratio of the system for a given error rate.² For this reason it is recommended that the term "optimum" not be associated with the look angle because systems of this type are more readily evaluated in terms of signal-to-noise ratios and error rates. There is no look angle which is optimum, only maximum angles to which the receive system should perform. Also, depending on the nature of the system there could be two "optimum" look angles – one for acquisition and another in which the system could operate provided the system was "locked-up".

The look angle physically falls into two areas – those for which the designer has some control and those which are uncontrollable. In the latter category are two principal considerations, the atmosphere and the noise temperature of the earth. For the atmosphere the following areas must receive attention:

- a) noise
- b) refraction
- c) fading
- d) attenuation.

All of these must be evaluated as a function of zenith angle. Refraction effects have already been determined³ and summarized in Section 5.3 and on the basis of existing experimental evidence, this effect is not severe. Attenuation variation is also known to be less severe than phase perturbations so that only the increased attenuation due to increased path length within the atmosphere need be considered. Fading is of different origin than attenuation and phase (refraction) perturbation. Fading is here defined to be interference caused by multiple paths through the atmosphere, and this phenomenon is discussed more fully

in Section 5.3. The noise characteristics of single and multiple antennas are compared in Section 5.8. The origin and frequency characteristics of noise generated within the atmosphere are well known, as well as the effective noise temperature of the earth. Schrader⁴ considers this problem independent of the antenna radiation pattern and further analysis of the antenna pattern affects have been made in Sections 5.8 and 7.4 of this report on the received noise.

Those factors which affect the look angle over which the designer has some control are:

- a) Mechanical (Mount and Feed)
- b) Terrain
- c) Spacing (limitations due to shadowing, bandwidth and discrimination).

While the designer may not have absolute control over each of these factors, he can design to minimize their effect. For example, the mount and feed can be built to accommodate the required look angle. Feed considerations are mentioned because certain types of low-noise front-ends suffer coolant spillage if steered to far from the zenith. Terrain can be controlled to the extent that the antenna location would not be in a deep valley which would hinder communications but at the same time a shallow valley terrain might be most desirable to reduce man-made sources of noise.

It is obvious that the look angle cannot be considered independent of all other factors. All limitations affecting design are evaluated in the following sections.

5.2 Shadowing

The minimum spacing between antennas of a multi-aperture receive system is determined by their mutual aperture blocking, which depends on the minimum elevation angle at which space vehicles are to be observed. Note that the elevation angle is the complementary angle to the look angle. Figure 5.4 depicts the situation. The minimum

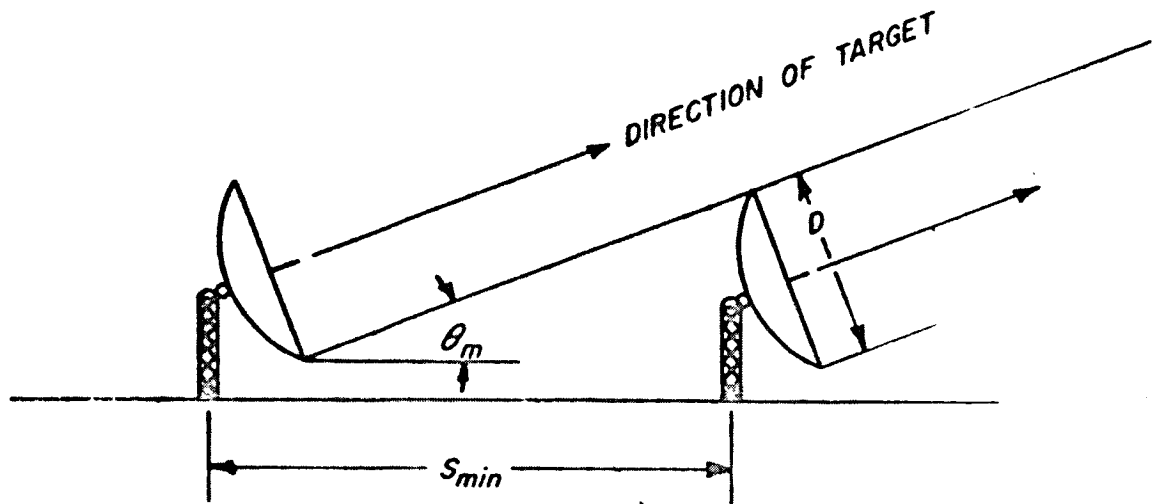

FIG. 5-4-MUTUAL APERTURE BLOCKING GEOMETRY

spacing S_{\min} is given in terms of the minimum elevation angle by

$$S_{\min} = D/\sin \theta_{\min} = D \csc \theta_{\min} \quad (5.1)$$

and is sketched in Figure 5.5. Thus, if θ_{\min} is 15° for 60-foot apertures the minimum spacing is 230 feet, and if θ_{\min} is 60° this spacing is reduced to 70 feet.

If the antennas are placed on a rectangular grid of spacing S_{\min} , the aperture blocking of Figure 5.4 occurs only when the target direction is parallel to the grid. However, for the particular system under study Equation 5.1 and Figure 5.5 do not pose any real limitations. This is due to the following considerations. First, the gain of the antenna system will depend on the number and size of the antennas and is essentially independent of their orientation. Second, the orientation of the elements will primarily influence the shape of the main beam, and could be advantageous in designing a beam to readily acquire the receive signal when the transmitter comes into "view". It is mandatory to make other decisions about the multi-aperture system before any conclusions can be reached about antenna element orientation. Other limitations such as the methods of combining signals as discussed in Section 6 influence the manner in which the elements may be located. For example, if phase-lock loops are used, then it is required that the elements be located close together to take advantage of the strong correlation existing between close elements as discussed in Section 5.3 so that the lock-up time will not be prolonged.

It is believed that shadowing will impose no strong limitations on the multi-receive system, and since the total number of sub-apertures is not large (at least from the viewpoint of economy as discussed in Section 4), the elements can be placed in such a manner that shadowing will not occur at any of the required look angles.

5.3 Propagation Influences

A detailed discussion of propagation effects has been previously performed and only the conclusions from this work are given

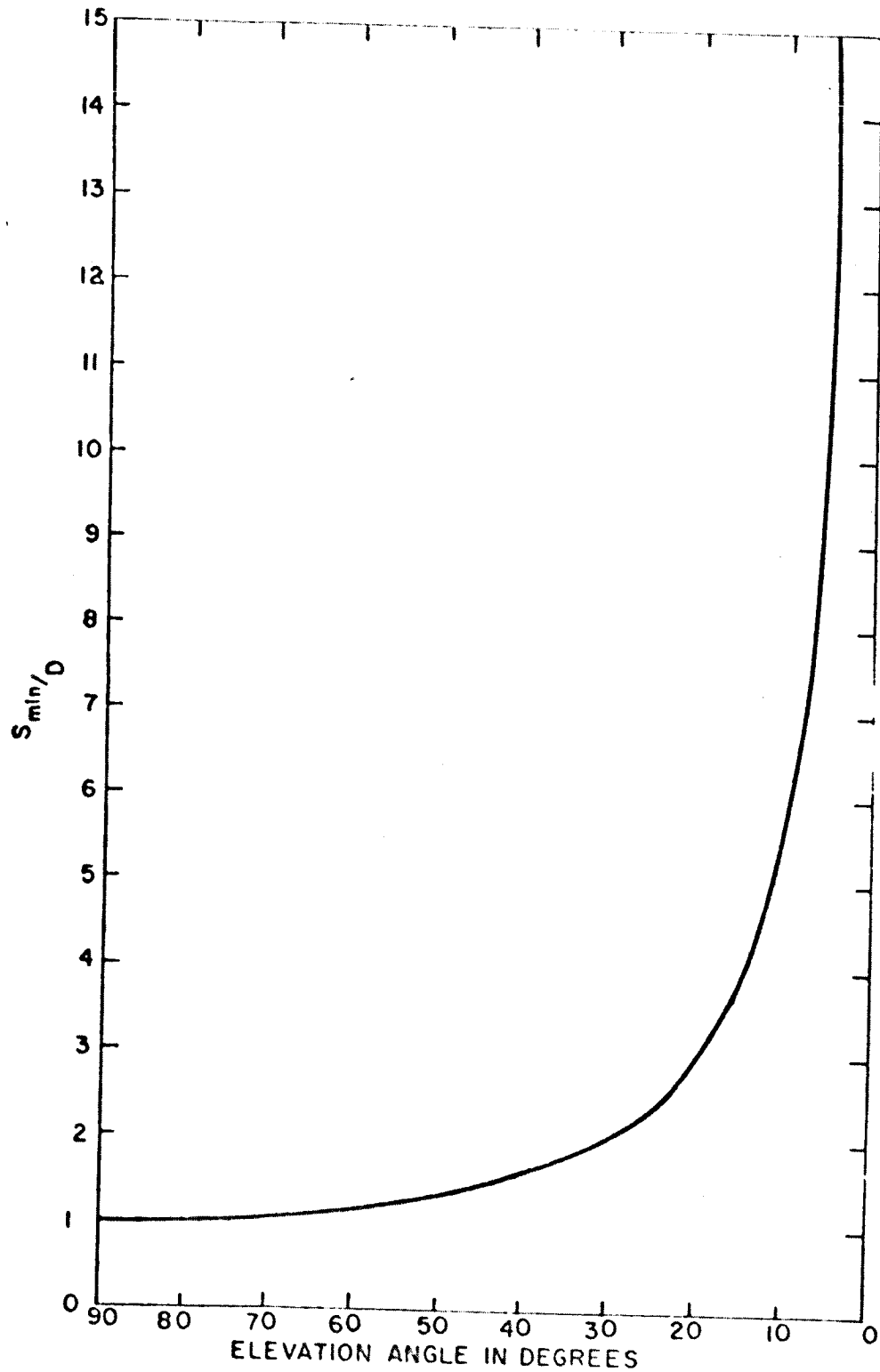

FIG.5-5 - ELEMENT SEPARATION IN APERTURE DIAMETERS vs ELEVATION ANGLE FOR NO SELF-SHADOWING

here.³ The sketch in Figure 5.6 establishes the geometry of two receivers looking at a signal originating at a very large distance. With such a model, it has been shown that

- a) the present theory of dielectric "blob" fluctuations in the troposphere is able to predict within experimental error the phase fluctuations encountered in a quiet atmosphere.
- b) the rms phase fluctuations vary linearly with the frequency in the troposphere,
- c) angle of arrival scintillations are less than the phase fluctuations,
- d) the model used for the troposphere to account for phase fluctuation can be modified to explain certain gross effects in the ionosphere,
- e) the rms phase fluctuations due to variations in the electron density in the ionosphere vary inversely with the frequency,
- f) the rms phase fluctuations also vary with the square of the critical frequency in the ionosphere,
- g) the phase scintillation cannot be predicted for the ionosphere with the confidence that it can for the troposphere due to lack of knowledge of parameters for this region,
- h) the loss in gain due to atmospheric perturbations is less than one tenth of a decibel for rms phase fluctuations less than 0.15 radians,
- i) strong correlation exists for antenna separations of up to one-half the blob size dimension,
- j) bandwidth limitations due to dispersion in the ionosphere exist,
- k) and more meteorological data is required to accurately predict the phase fluctuations and correlation between antennas.

Of primary importance is the effect that this model has on a receiving system. Several features will be demonstrated. First

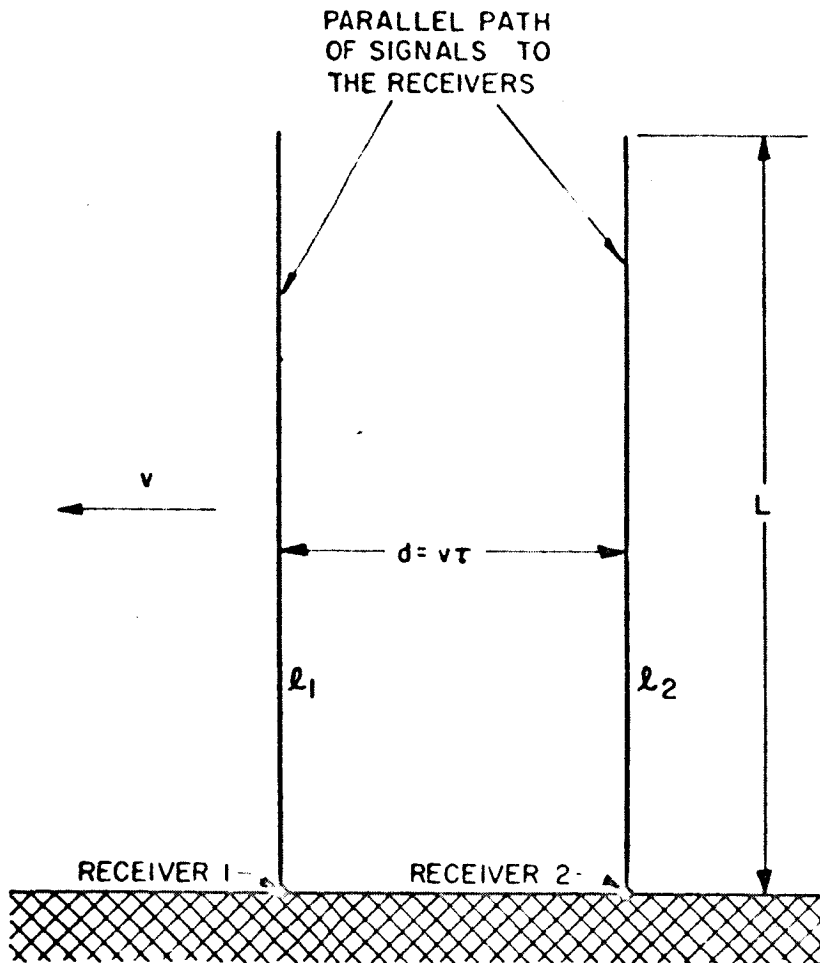

FIG. 5.6 - GEOMETRY FOR POINT RECEIVERS OF A DISTANT SIGNAL.

the troposphere has been shown to cause a mean square phase shift due to random phase delays given by

$$\overline{a_t^2} \cong \frac{8\pi^2 l_t L_t \overline{\Delta N^2} \cdot 10^{-12}}{\lambda^2} \quad (5.2)$$

where

l_t is a measure of the scale of turbulence in troposphere,

L_t is the path length of the signal in the troposphere,

ΔN is variation in the refractivity ($N = [n-1] \times 10^6$),

λ is the wavelength of the received signal.

Second, the ionosphere also creates a mean square phase shift given by

$$a_i^2 = 2\pi^2 l_i L_i \cdot \frac{\lambda^2}{\lambda_c^4} \left(\frac{\Delta N_\epsilon}{N_\epsilon} \right)^2 \quad (5.3)$$

where

l_i is a measure of the scale of turbulence in the ionosphere,

L_i is the path length of the signal in the ionosphere,

$\frac{\lambda_c}{\lambda_c}$ is the mean square value of the electron density $(\Delta N_\epsilon / N_\epsilon)^2$ from the mean and

λ is again the wavelength of the received signal.

Since the phase fluctuations in the two regions are independent the total mean square phase shift is given by

$$\overline{a^2} = \overline{a_i^2} + \overline{a_t^2} \quad (5.4)$$

The loss in gain due to such phase fluctuations is⁵

$$G = G_o e^{-\overline{a^2}} \quad (5.5)$$

If a model for the troposphere and ionosphere is assumed such that at the zenith $L_t \cong 10$ miles and $L_i \cong 40$ miles with L_i extending from 60 to 100 miles above the earth (radius of the earth equal to 3963 miles),

then it is possible to determine the gain loss due to fluctuations in the atmosphere. At a frequency of 2 Gc ($\lambda = 0.5$ foot), with $t_1 = 200$ feet, $t_2 = 16,400$ feet, $\lambda_c = 30$ meters (10 Mc, an extreme value⁶), $\frac{(\Delta N/N_c)^2}{\Delta N^2} = 3 \times 10^{-4}$ (Colin)⁷ and $\Delta N^2 = .25$, the gain loss as a function of zenith angle is illustrated in Figure 5.7. While this curve best depicts circumstances for a clear sky, non-turbulent atmosphere, it is believed that atmospheric conditions will not limit the multiple aperture approach under more severe forms of climate.

There are other considerations to be evaluated in considering propagation influences. The scintillation in the angle of arrival establishes the upper bound on the maximum antenna size, and in particular affects the single aperture more than the multiple aperture approach. This is because the larger antennas (in terms of wavelength) have the narrower beamwidth, and hence are more affected by a scintillation in the angle of arrival. Assuming that the troposphere is primarily responsible for scintillation in angle of arrival (at 2Gc ionospheric scintillation is an order of magnitude less than tropospheric) and assuming that the rms phase scintillation must lie within the 3db points of the main beam of the aperture, it is possible to establish an upper bound on the aperture size as a function of the zenith angle. However, this upper bound is large, and even for antennas looking near the horizon the maximum useful aperture size is approximately 6000 wavelengths. Observe that this value is increased from our previously reported 2500 wavelengths.³

The atmosphere also imposes other constraints on the ground antenna system, be it a multiple aperture or otherwise. Two limitations are imposed because the dielectric constant of the atmosphere is different from free space or a vacuum. First, dispersion in the ionosphere limits the bandwidth of the received signal. Figure 5.8 establishes the relationship between bandwidth and operating frequency. This phenomenon will only affect the lunar range communication

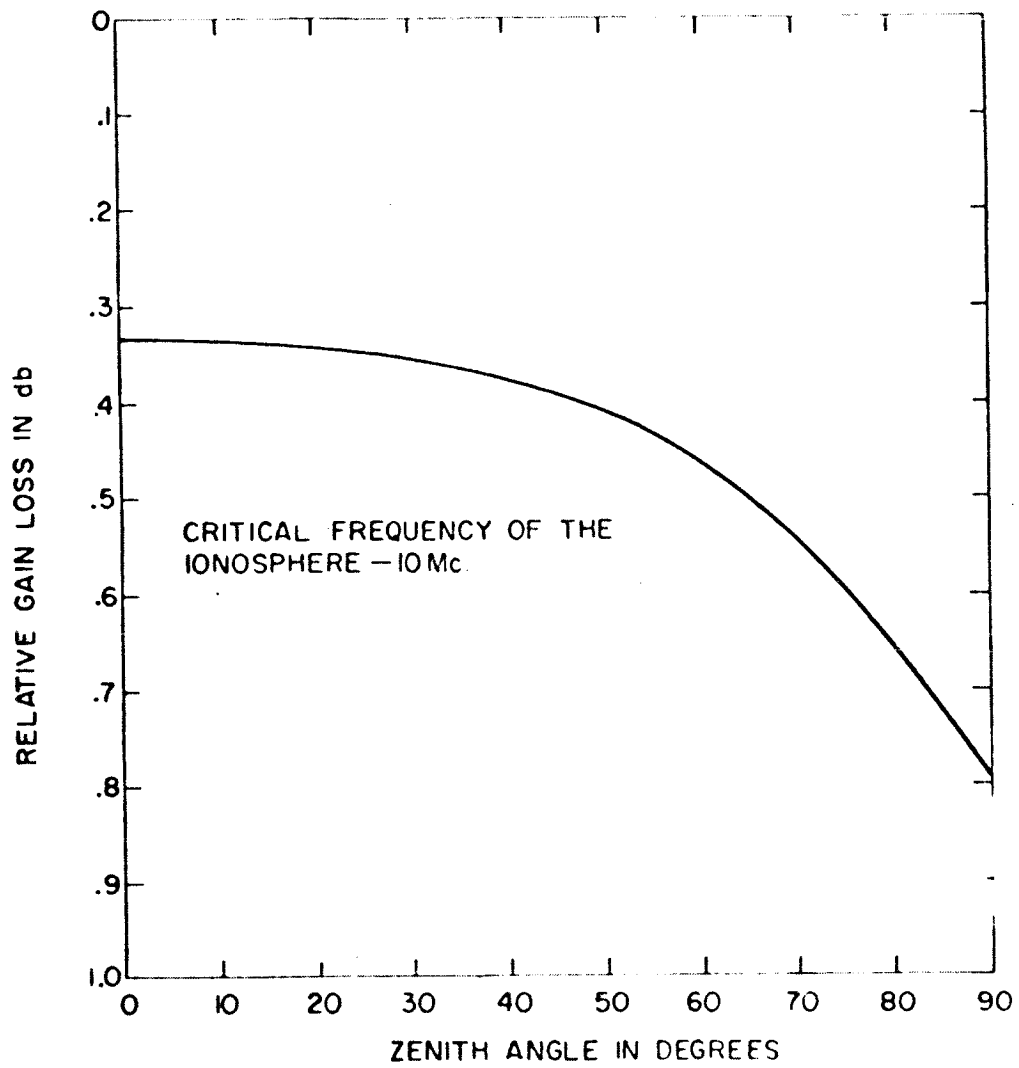

FIG. 5.7 - ESTIMATED GAIN LOSS AS A FUNCTION OF ZENITH ANGLE AT A FREQUENCY OF 2 Gc DUE TO ATMOSPHERIC PHASE PERTURBATIONS.

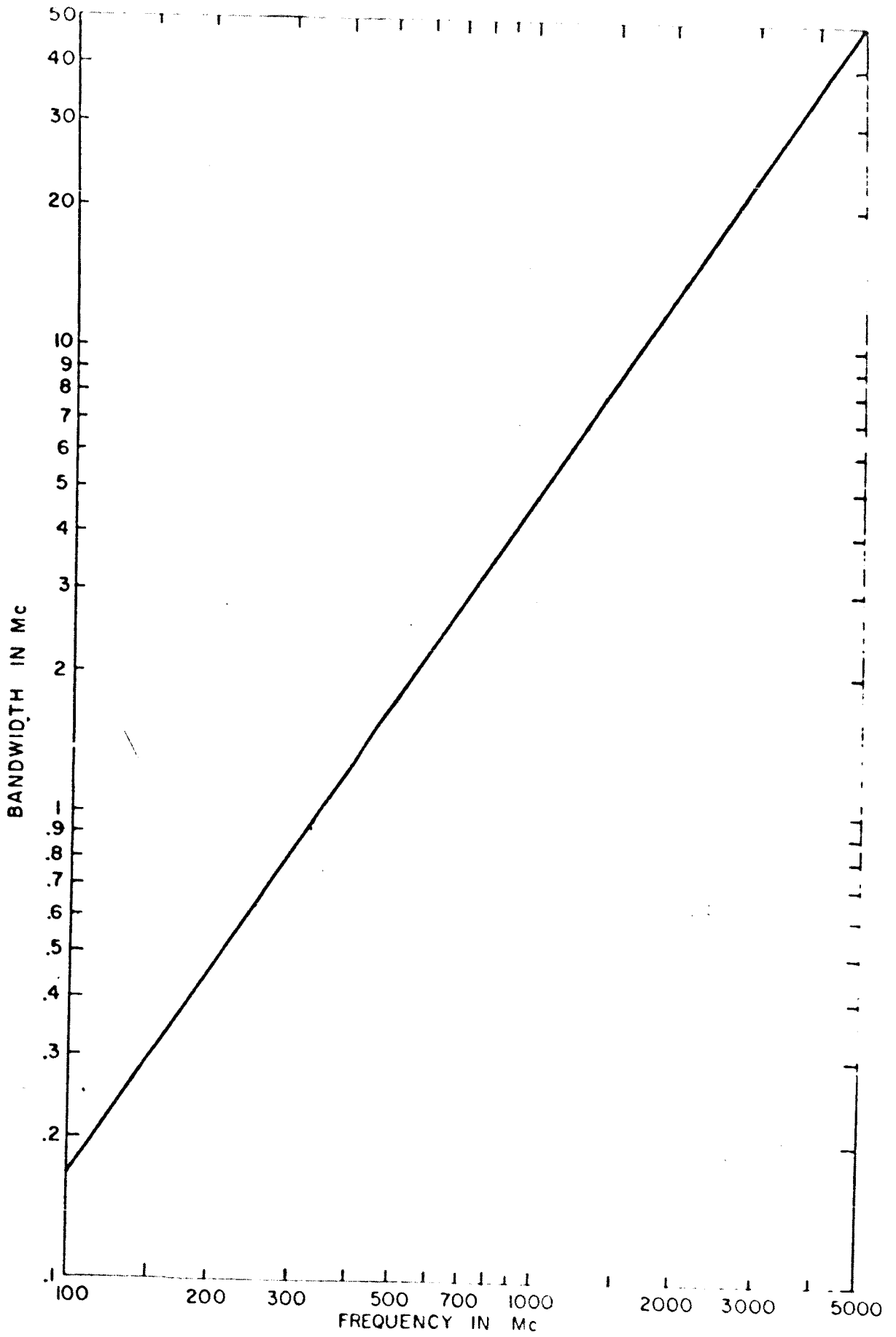

FIG 5-8-BANDWIDTH LIMITATIONS IMPOSED BY THE SYSTEM

system since the deep-space communications link is anticipated to be a relatively narrowband telemetry system. Second, the received signal arrives at the antenna from an apparent position different from the true position because of atmospheric refraction. If atmospheric conditions and the true position of the space probe are known the apparent position of the vehicle can be calculated. This does not include random effects which generate angle scintillation, but involves static atmospheric conditions. The extreme conditions for refraction angle error as a function of apparent angle of elevation can be sketched for 0% and 100% relative humidity as indicated in Figure 5.9 for the standard atmosphere.

This refraction phenomenon establishes the first real lower bound on the look angle of a practical antenna site. Curves such as Figure 5.9 can be readily calculated on a computer if sufficient information is available with regard to the atmosphere. However, unless meteorological soundings are taken quite frequently, this will not be the case. Of course such soundings are only necessary just prior to acquisition of the space vehicle, but will involve the tabulation of a large amount of experimental information in a relatively short time. Figure 5.10 indicates the difference in the refraction angle error between 0% and 100% relative humidity as a function of the apparent angle of elevation.

The primary effect of this phenomenon is to make the acquisition difficult. If it is required that the space vehicle be located in angle between the 3db points of the antenna, then the refraction error limits the look angle. To illustrate the influence of the atmosphere with regard to refraction consider Figure 5.11. Shown here is the maximum aperture size in wavelengths as a function of the look angle (zenith angle). It is obvious that if the antenna is corrected for either 0% or 100% relative humidity in the standard atmosphere, a much larger aperture may be used (this curve applies equally well to

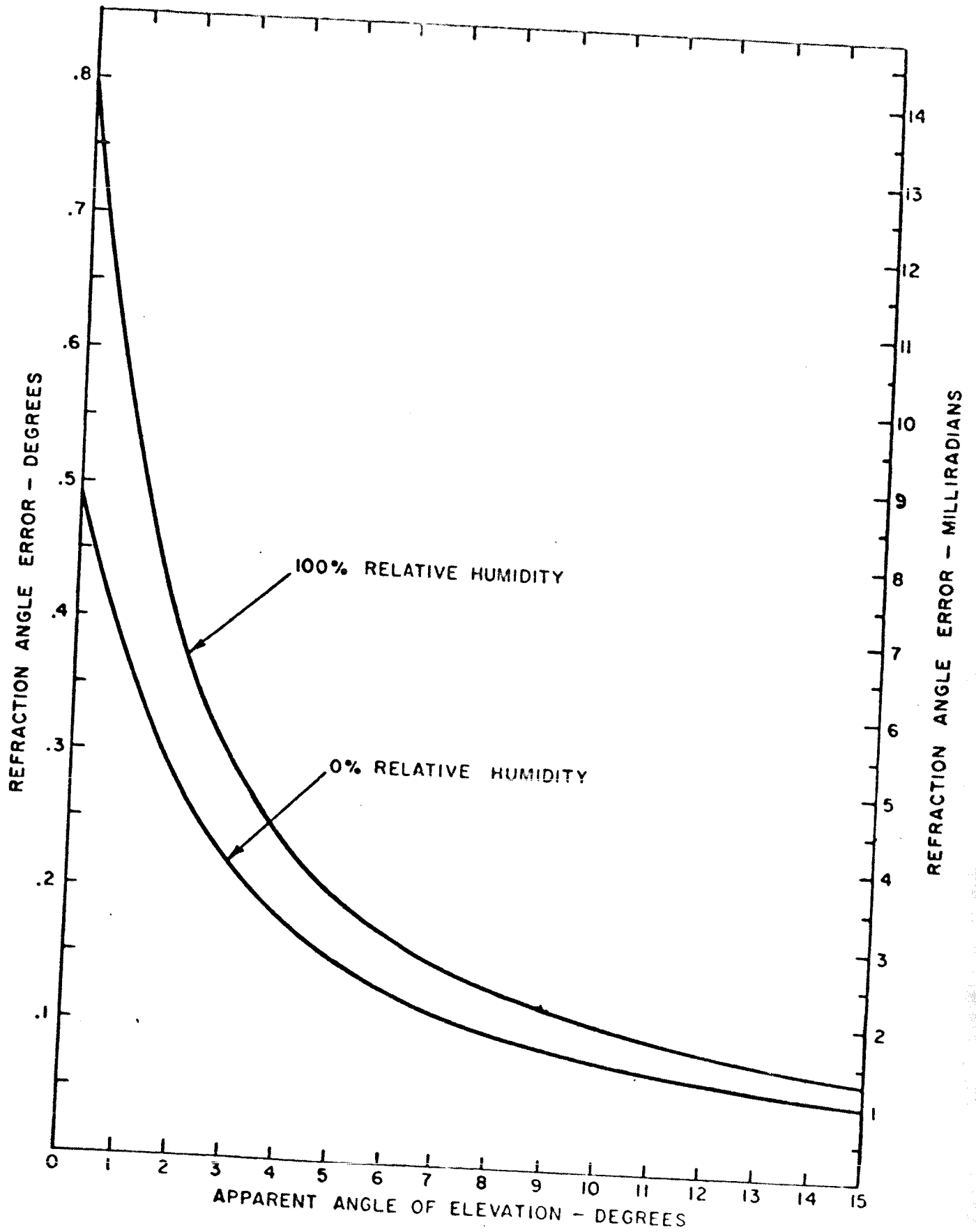

FIG. 5.9- LIMITS OF ATMOSPHERIC REFRACTION ERRORS FOR A STANDARD ATMOSPHERE

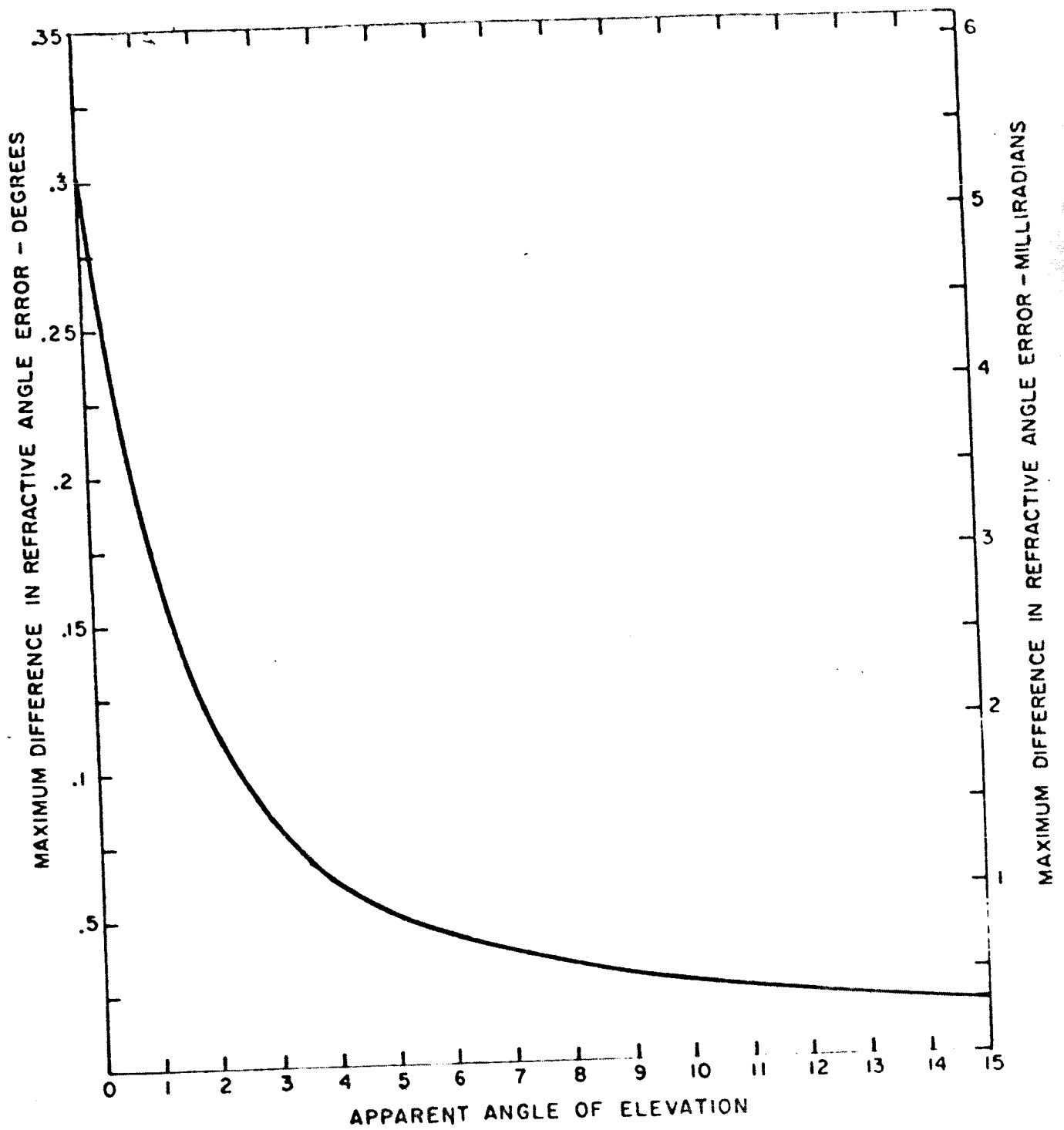

FIG. 5.10 - MAXIMUM DIFFERENCE DUE TO RELATIVE HUMIDITY
IN REFRACTIVE ERRORS

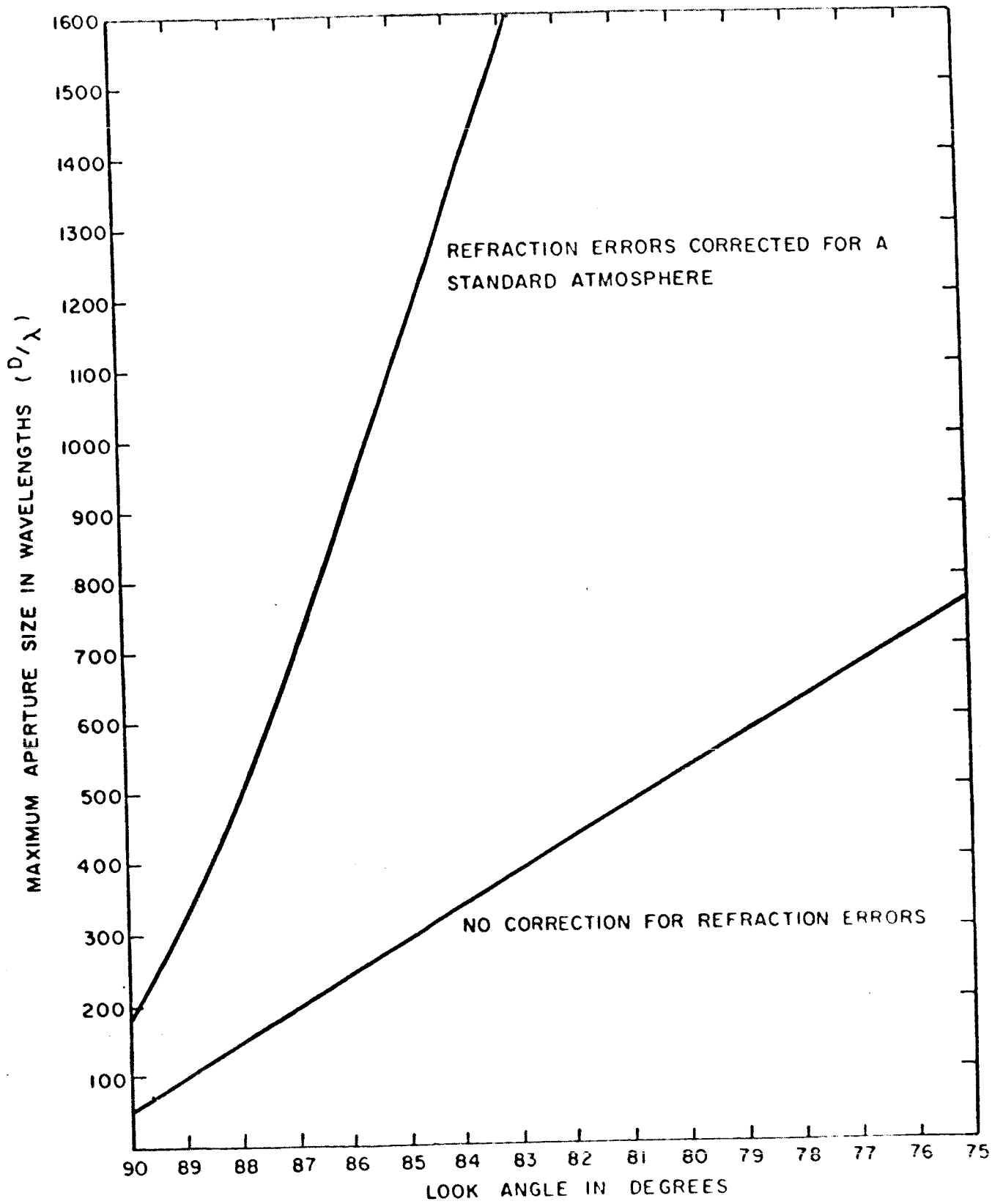

FIG. 5.11 - MAXIMUM APERTURE SIZE AS A FUNCTION OF THE LOOK ANGLE

either relative humidity level). An uncorrected antenna which is pointed in the true direction of the target is far more limited in size when scanned near the horizon, than one which is corrected according to the standard atmosphere. Regardless of atmospheric conditions or corrections, it appears that the multiple aperture system has an advantage over a single parabolic aperture when operated near the horizon (the effect of noise near the horizon is discussed in Sections 5.8 and 7.4).

The actual maximum look angle depends on the mode of operation in acquiring the probe signal. For example, if the multiple aperture is operated as an interferometer, then the baseline separation of the most distant antennas essentially determines the D/λ ratio. Hence, at 2 Gc and 500 feet between the furthest separated apertures the system could be steered $\pm 85^\circ$ if corrected for refraction and on the order of $\pm 70^\circ$ if uncorrected. However, operating with phase-lock loops, only the acquisition time is affected by the scan angle. If multiple-beam acquisition is used, then the 3 db beamwidth of the individual aperture probably governs the look angle. For a 250 foot equivalent aperture composed of 12 antennas (72.2 feet in diameter), this allows a look angle of $\pm 90^\circ$ if corrected, and $\pm 88^\circ$ if uncorrected.

To conclude the evaluation of propagation influences on a multiple aperture receive system it appears that atmospheric refraction will be the most limiting factor. However, as discussed in Section 5.1, it may not be necessary to have a look angle so large that refraction errors limit the system.

5.4 System Spatial Bandwidth

An electromagnetic signal travels at a relatively large velocity in free space, but it is nevertheless finite. Hence, if an aperture has a maximum linear dimension d , the signal will require a finite time to travel across the aperture. This time is dependent on the angle of arrival of the signal to the antenna and is independent

of the type aperture (i.e., continuous or discrete). If the signal arrives at an angle θ with respect to the normal to aperture, thus corresponding to the zenith angle, the transit time across the array is given by

$$\Delta t = (d/c) |\sin \theta| \quad (5.6)$$

where c is the velocity of the electromagnetic signal. The reciprocal of this expression is the effective bandwidth of the antenna unless compensation is made for this phenomenon. Techniques for compensating are suggested in Section 7.2, but if no corrections are made, then Figure 5.12 establishes the bandwidth of the aperture as a function of the scan angle of the array for several values of d .

5.5 Collimation

The task of pointing and calibrating the antenna or antennas in some specified direction is called collimation. The direction specified may be wither the true direction or the apparent direction of signal arrival. For purposes of discussing collimation, the atmosphere may be ignored completely. The position of a space vehicle will of necessity be known relatively accurately. A problem then of major concern is pointing the antenna in the proper direction (boresighting). The larger the antenna the more difficult this task becomes since first the beamwidth is inversely proportional to the aperture diameter in wavelengths, and second, the greater the physical size of the antenna the more difficult steering becomes. If it is required that the antenna be pointed to within the 3 db points of the main beam, then the anticipated state-of-the-art steering techniques (discussed in Appendix II) establish an upper bound on the aperture diameter as a function of maximum frequency of operation. It is to be emphasized that the pointing accuracies involved here have not yet been achieved, but are in the development stage of the 120 foot Haystack and the 210 foot JPL-NASA antennas. Failure to meet the specifications will require modification of the upper bound. Figure 5.13 establishes the upper bound on the frequency as a function of the aperture if the antenna is steered between the 3 db,

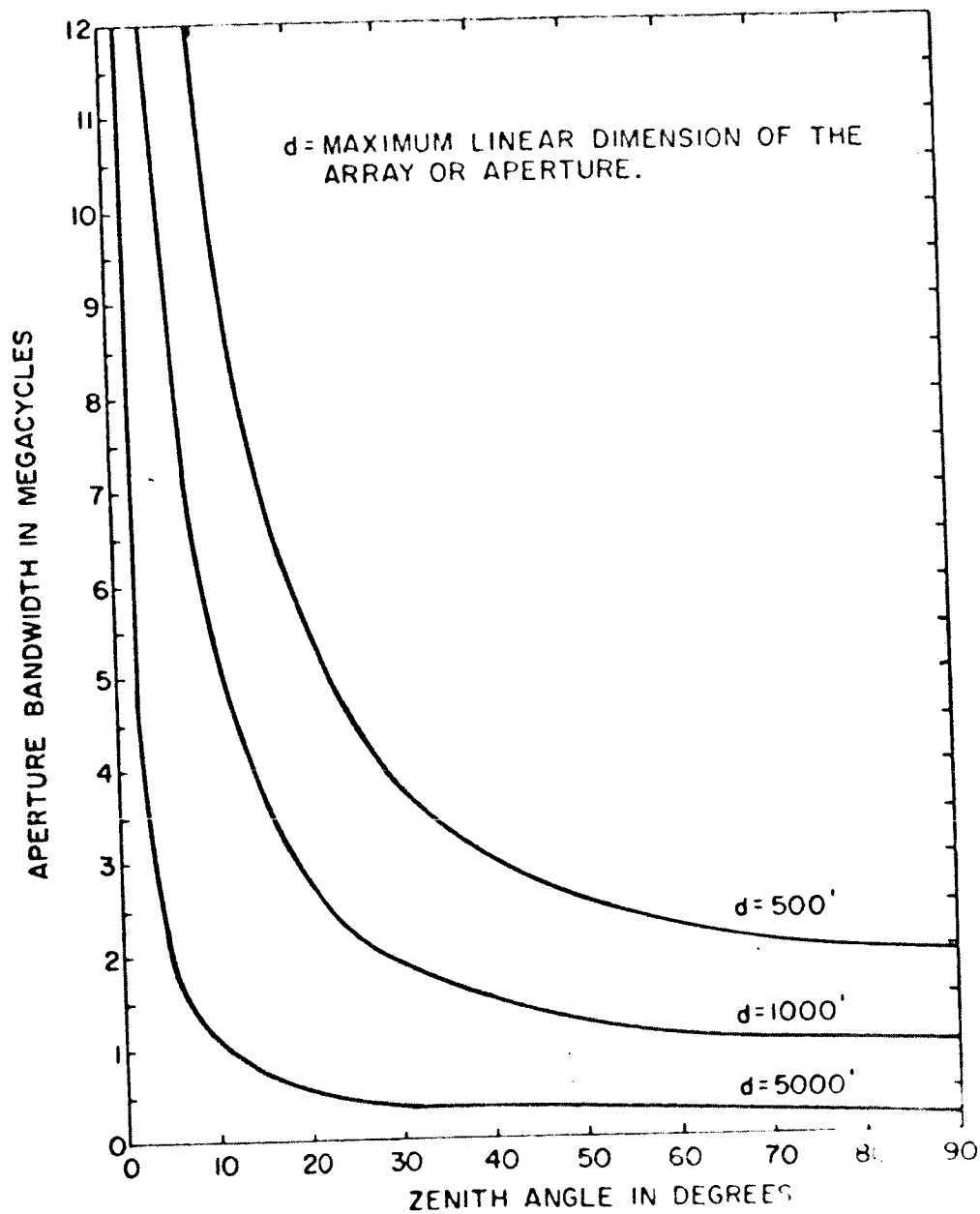

FIG. 5.12 - BANDWIDTH LIMITATIONS vs ZENITH ANGLE FOR SEVERAL APERTURE SIZES.

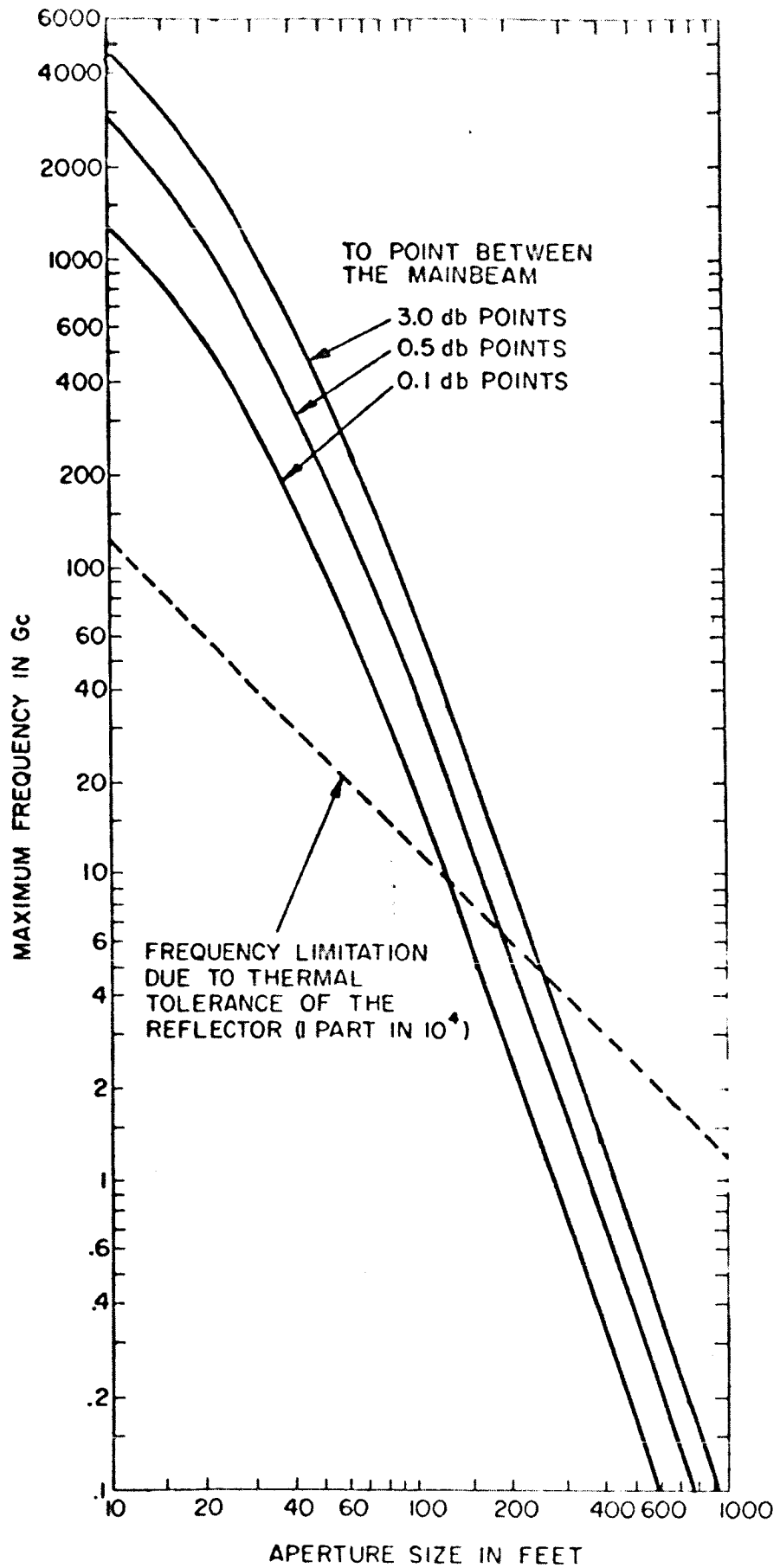

FIG.5.13 - UPPER BOUND ON THE FREQUENCY AS A FUNCTION OF APERTURE SIZE FOR SEVERAL

.5 db, and 0.1 db beamwidth. Also included is the frequency limitation due to thermal tolerances in design. For apertures less than 100 feet in diameter the thermal error limits more than the anticipated pointing accuracy of the aperture. In the region from 100 to 250 feet the two types of error are comparable, and above 250 feet point errors appear to limit the aperture size rather than thermal errors.

For a deep space system requiring a large aperture antenna, it becomes more and more important to use the multiple aperture approach since it appears first to be more economical and second, it is capable of overcoming mechanical limitations. A 250 foot aperture would require a dynamic point accuracy of ± 0.6 milliradians if the aperture was to point to within the 1/2 db points of the main beam at 2 Gc. This may seem to be a severe requirement to place on the antenna, but the antenna must be pointed quite accurately during acquisition of a deep-space vehicle. Recall that there is a relatively narrow bandwidth (of the order of 100 cps), and the aperture must search over both the frequency domain and space. Thus, the system should act to minimize both forms of search.

The effect of errors in siting a multiple aperture is less than for a single parabola. It is important, however, to establish the tolerance for a multiple antenna system. Consider the 250 foot antenna in which it is required that the pointing accuracy be .6 milliradians (within the 1/2 points). At a frequency of 2 Gc the pointing requirements of the multiple antenna system is shown in Figure 5.14 as a function of the number of elements for a maximum of 1/2 db of loss. It is obvious that not only are the steering requirements reduced as more antennas are used, but the antennas become easier to point because their physical diameter is also being reduced.

The only effect that the siting of these multiple apertures could have on collimation is the minimum displacement between the multiple aperture and the calibrating source. If the usual far field

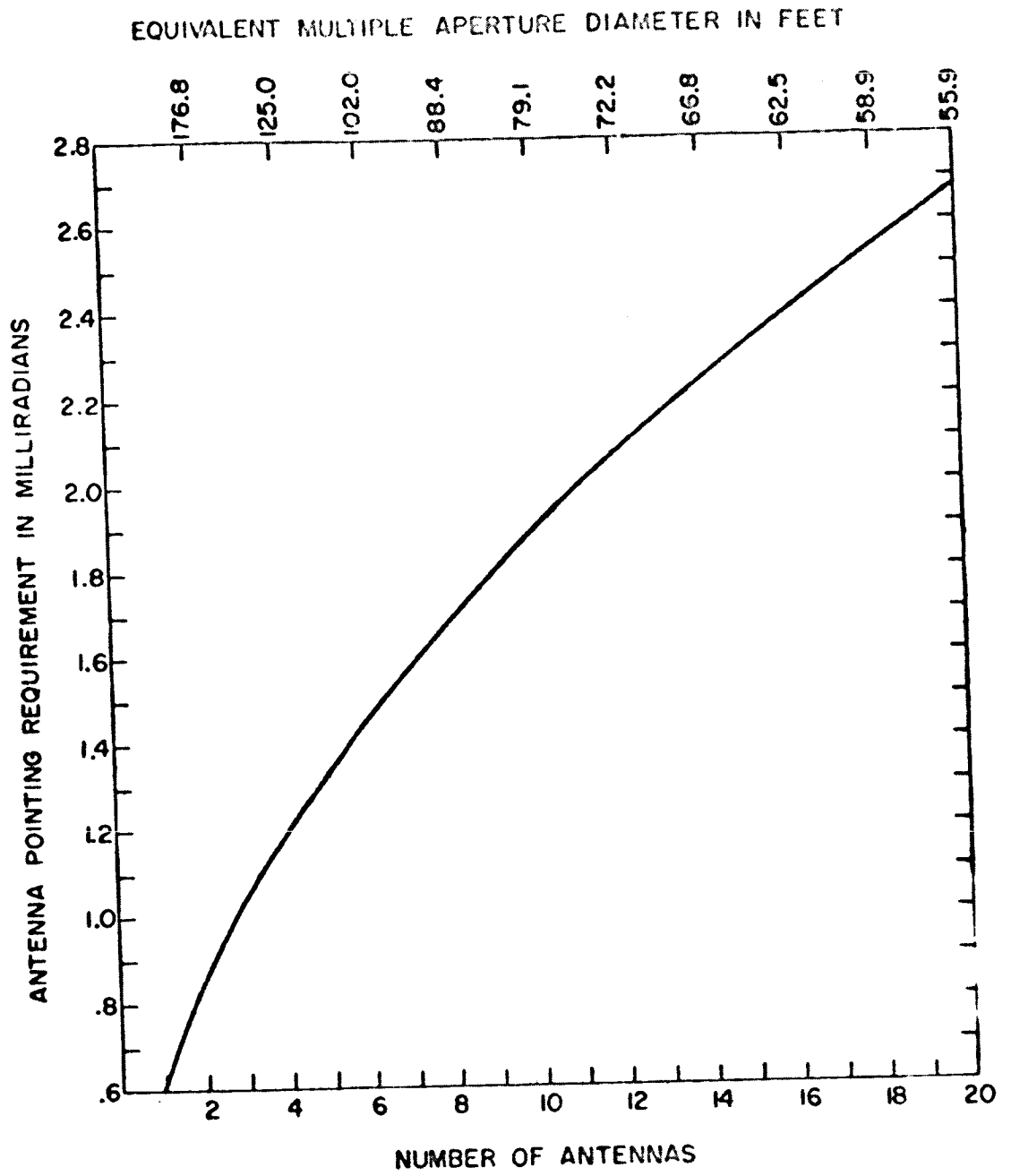

FIG. 5.14 - STEERING REQUIREMENTS FOR A 250' EQUIVALENT ANTENNA POINTED BETWEEN THE HALF-db POINTS.

criterion of $2D_a^2/\lambda$ is used to establish this range, the resulting error may be shown to be an order of magnitude less than the pointing error capabilities of the individual elements. For a maximum linear aperture dimension $D_a = 1000$ ft, this range is approximately 760 miles at 2 Gc. In reality it is only necessary to calibrate the subapertures in terms of the individual antennas and a known source. Thus, if bore-sighting is performed for each antenna, independent of the other antennas, collimation of the multiple aperture system is automatically achieved.

5.6 Operation in the Presence of Interference

The nature of a lunar mission or an interplanetary mission is such that there is a good likelihood that an interfering source will appear close in angle to the spacecraft and degrade the quality of communications by introducing added noise. The terminal phase of a lunar mission will result in the moon and the spacecraft being in close proximity. The effective noise temperature of the moon generally will be higher than that of the "cold" sky and may reduce the system sensitivity, especially if low noise maser front-ends are employed. Because the interplanetary spacecraft will lie approximately in the plane of the solar system, there is a possibility that the sun will eclipse the spacecraft or vice versa. The likelihood of an eclipse is small but a more usual situation would be to find the sun in the near vicinity of the spacecraft. The sun is a strong source of interfering noise and could severely degrade the receiving system sensitivity (See Section 5.8). In addition to the moon and the sun, there is always the possibility of some other nearby transmissions introducing interference.

There exist a number of circuit techniques for reducing or eliminating interference by discriminating in the time or the frequency domain. Any good communications system should be provided with those such safeguards that offer benefit. This study is not concerned with time or frequency domain interference reduction techniques.

Instead it will deal mainly with means for reducing interference by design of the composite radiation pattern of a multi-aperture antenna system. The availability of several individual antennas offers additional freedom which might be of use in enhancing the ratio of wanted-to-unwanted signal. As a design goal it is desired to achieve an attenuation of at least 20 to 30 for an unwanted signal by proper adjustment of the antenna outputs. It is conceivable that attenuations of 40 to 50 db might be possible in some situations. A properly engineered space communications system will probably include as many means as are practical and prove worthwhile for reducing the deleterious effects of interference.

The designer has available the outputs of the n individual antennas which may be combined for maximum signal-to-noise ratio, or if the interference is large compared to noise, the ratio of signal-to-interference may be maximized. In so doing, the desired signal may not be as large as it would be in the absence of interference alone, but the interference would be reduced more. Since the interference is localized in space proper adjustment of the phases and amplitudes at each antenna might offer the means for improvement.

To illustrate how the phases and amplitudes are adjusted, consider a linear array whose first sidelobe is looking at a source of interference. To minimize the interfering source using the method of Woodward,⁹ it is possible to describe two distributions

$$f_1(x) = 1. \quad (5.6)$$

$$f_2(x) = 0.2172 e^{ja_x/L}, \quad (5.7)$$

such that the actual distribution across the aperture is the vector sum

$$f(x) = f_1(x) + f_2(x). \quad (5.8)$$

The distribution imposed physically across the aperture is

$$\text{Real } f(x) = \sqrt{1.0472 + 0.4344 \cos a_x/L} \cos \phi \quad (5.9)$$

where

$$\phi = \tan^{-1} \frac{0.2172 \sin \alpha_x / L}{1 + 0.2172 \cos \alpha_x / L}$$

$$x = \sin \theta,$$

L = array length.

The distributions being combined are shown in Figure 5.15, both in regard to amplitude and phase. The right-hand column represents the resultant distribution. The resultant far field pattern of this aperture distribution as well as that of the uniformly illuminated aperture are shown in Figure 5.16. Several observations are to be made. First, the gain of the antenna system and hence the signal from the probe received via the main beam is reduced as can be seen by the difference in the relative voltage of the two patterns (this effect was mentioned previously). Second, the first sidelobe in the direction of positive θ is considerably reduced. It actually has a zero where there was a maxima (13.3 db) originally. Third, the radiation pattern is not significantly altered in the remaining portion of space. It may be necessary to modify several sidelobes instead of minimizing just one.

Both the sun and the moon subtend an angle of arc of about 0.5 degree. A single null in a narrow beam radiation pattern might not be sufficient to completely blank out interference from such sources and more complicated cancellation must be attempted. Figure 5.17 shows the number of sidelobes in an angle of arc of 0.5 degree near the main beam. While it may not be necessary to suppress this many sidelobes, it will probably be necessary to reduce several of them simultaneously. The technique discussed here is readily extended to any particular requirement that might arise. Even though the technique is extendable, it may not be possible to fully implement the required aperture distributions necessary to reduce the specified sidelobes. This is because the number of subapertures in the antenna are limited and hence complete control over amplitude and phase will not be

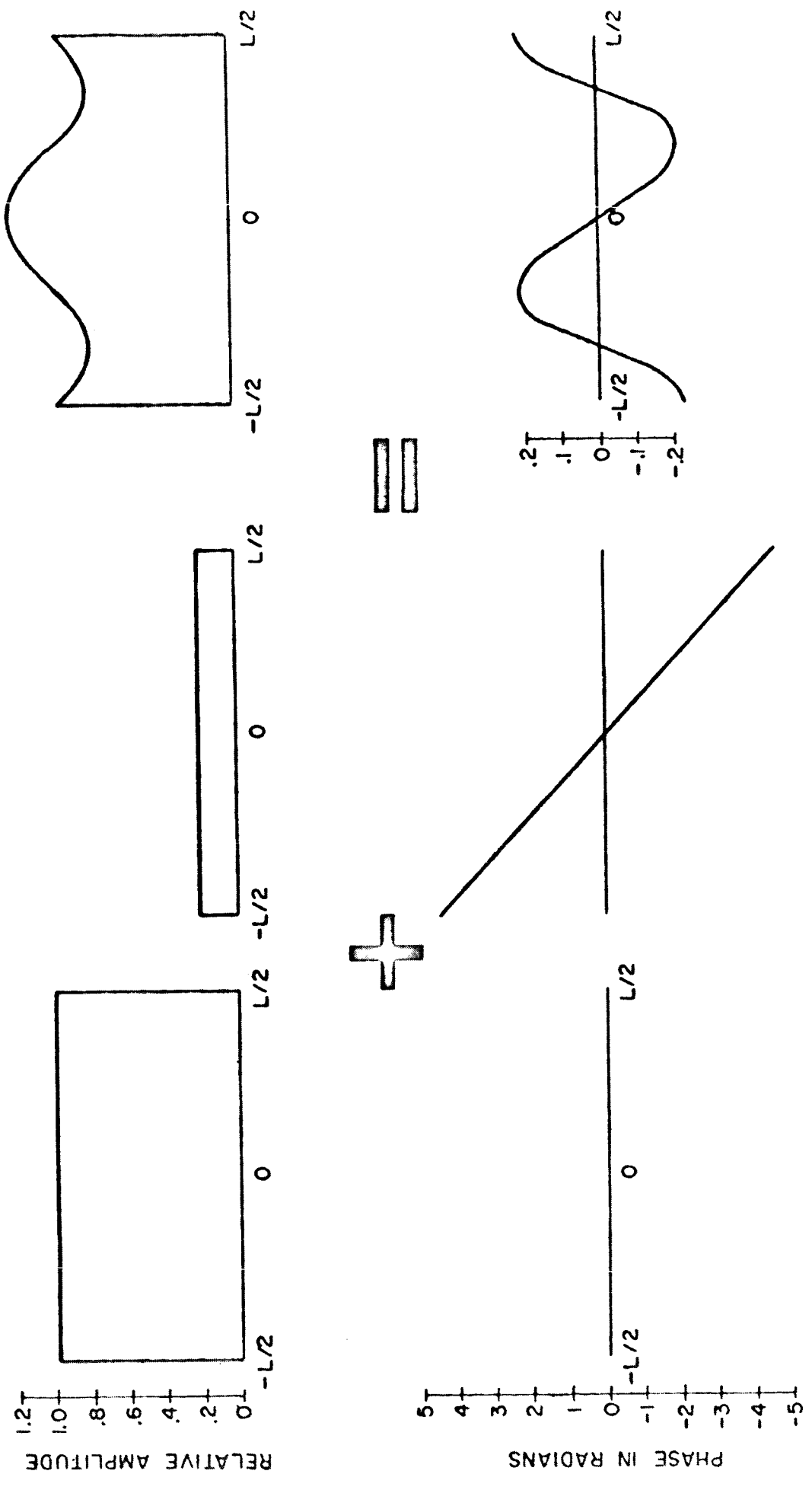

FIG. 5.15 -- SUPERPOSITION OF APERTURE DISTRIBUTIONS

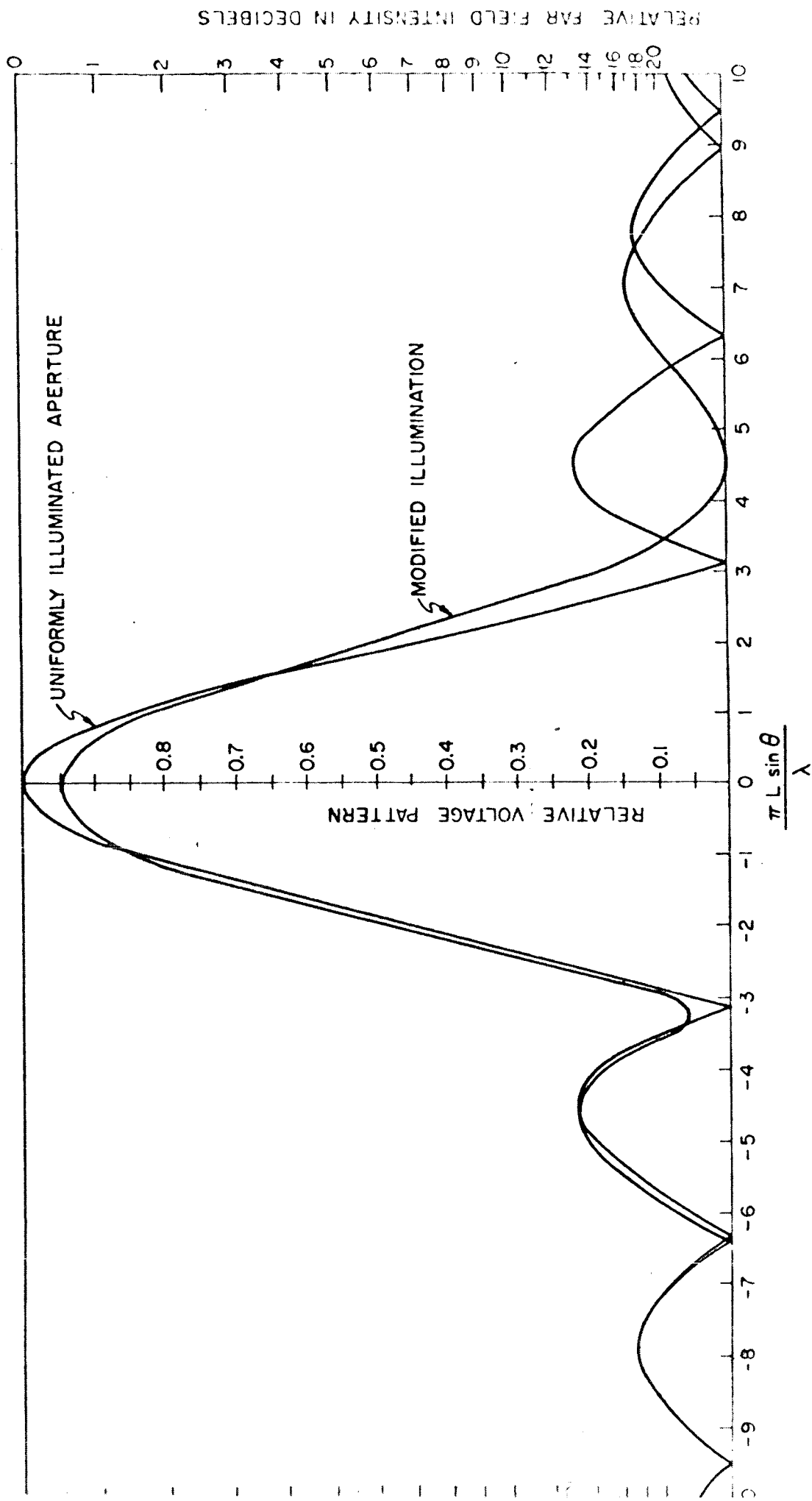

FIG. 5.16 - EXAMPLE OF A LINEAR ARRAY FAR FIELD PATTERN WITH REDUCED SIDELOBES NEAR THE MAIN BEAM POSITIVE θ DIRECTION.

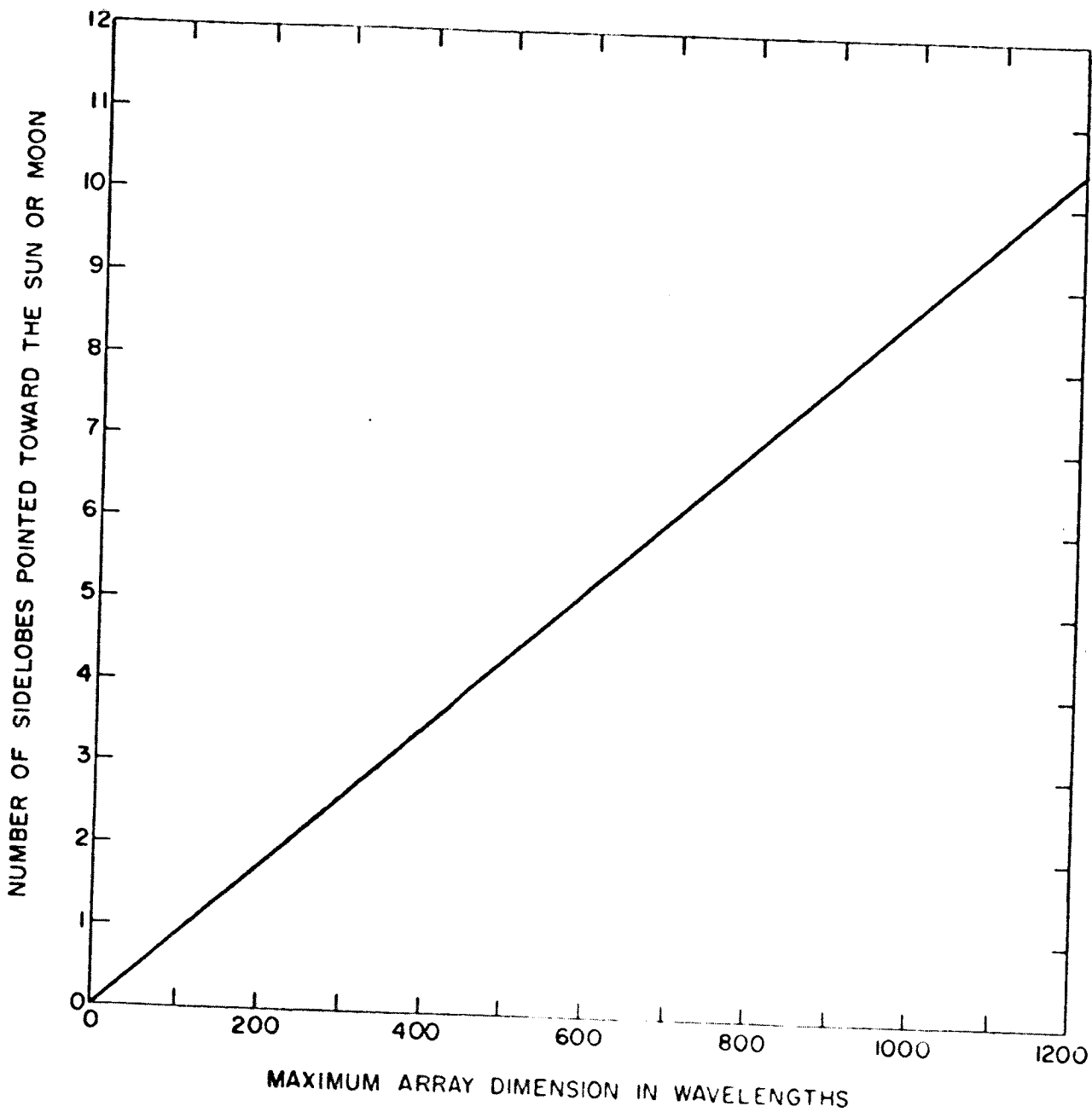

FIG.5.17 - NUMBER OF SIDELOBES FROM A LINEAR ARRAY DIRECTED TOWARD THE SUN OR MOON.

possible. Further discussion of sidelobe reduction techniques is in Section 8, and the effect of the sun on the signal-to-noise ratio is discussed in Section 5.8.

5.7 Doppler Effects

The Doppler shift of RF signals received from a space vehicle may be divided into two general categories each of which may be subdivided. First, there is a Doppler shift across the entire receiving aperture and second there can be a difference in the Doppler shift at various points in the aperture.

Doppler shifts across the entire aperture depend primarily on the radial component of velocity of the space vehicle with respect to the earth. A probe with a velocity of 25,000 mph with respect to the earth will have a Doppler shift of around 0.75 Mc at 2 Gc. The rotation of the earth will contribute a maximum shift of .03 Mc at this frequency.

More important to the multiple aperture system is the difference in Doppler shift between widely separated elements. At 2 Gc this difference would be maximum of 1×10^{-4} cps for a one mile separation between antennas and a probe at a range greater than 10 earth radii. Thus, doppler differences between elements are believed to be an ignorable factor.

This result is in contrast to Doppler differences for orbiting satellites. At 2 Gc and antennas separated by one mile, the doppler difference is approximately 50 cps at 1000 statute miles and 500 cps at 100 statute miles. A similar type of calculation shows that for satellite altitudes of 570 statute miles, and Doppler differences of 1 cps can be expected for points separated by 60 feet. The large displacement between the source and receiver in either the lunar or interplanetary system is a beneficial factor in reducing Doppler differences between antennas composing the multiple aperture system. This appears to be the only benefit of such large transmit-receive distances.

5.8 Noise Temperature

Appendix VIII discusses in detail the effects of noise temperature on an antenna system. Particular emphasis is given here to experimental results achieved by existing antennas. Figure 5.18 represents a summary of measured results as given by Gidd's for a number of antennas.¹⁰ The data of the Goldstone 85 ft (2388 Mc) Philco WDL 65 ft (2250 Mc) and NRL 84 ft (2930 Mc) are particularly useful since these antennas have been measured at frequencies important to the multiple aperture system. Antenna temperatures typically are below 50°K for elevation angles greater than 5° , and between 20° to 40°K for all other elevation angles. It would appear that 20°K is probably the minimum achievable temperature in practice.

The strongest noise source to contend with is the sun. Techniques for discriminating against such noise sources using a multiple aperture have been discussed in Section 5.6. The result of the increase in temperature of the system, and hence the decrease in signal-to-noise ratio may be expressed as a function of the angle of the sun with respect to the axis of the antenna beam. For a 250 foot antenna Figure 5.19 shows the relative change in the signal-to-noise ratio due to the sun at approximately 2 Gc. Maximum deviations of 38 to 40 db can be expected for a 250 foot antenna. If the equivalent size antenna is constructed from multiple apertures it will have an even greater deviation in the signal-to-noise ratio. Furthermore, as the angle from the axis of the main beam increases the signal-to-noise ratio will not be a monotonic increasing function, but will be perturbed by the grating lobes of the array factor if the antennas are equally spaced. The effect of these grating lobes will be further explored in the following section.

5.9 The Spacing Configuration

The total number of antennas in a multiple aperture system will probably not be large (32 or less for equivalent apertures up to 600

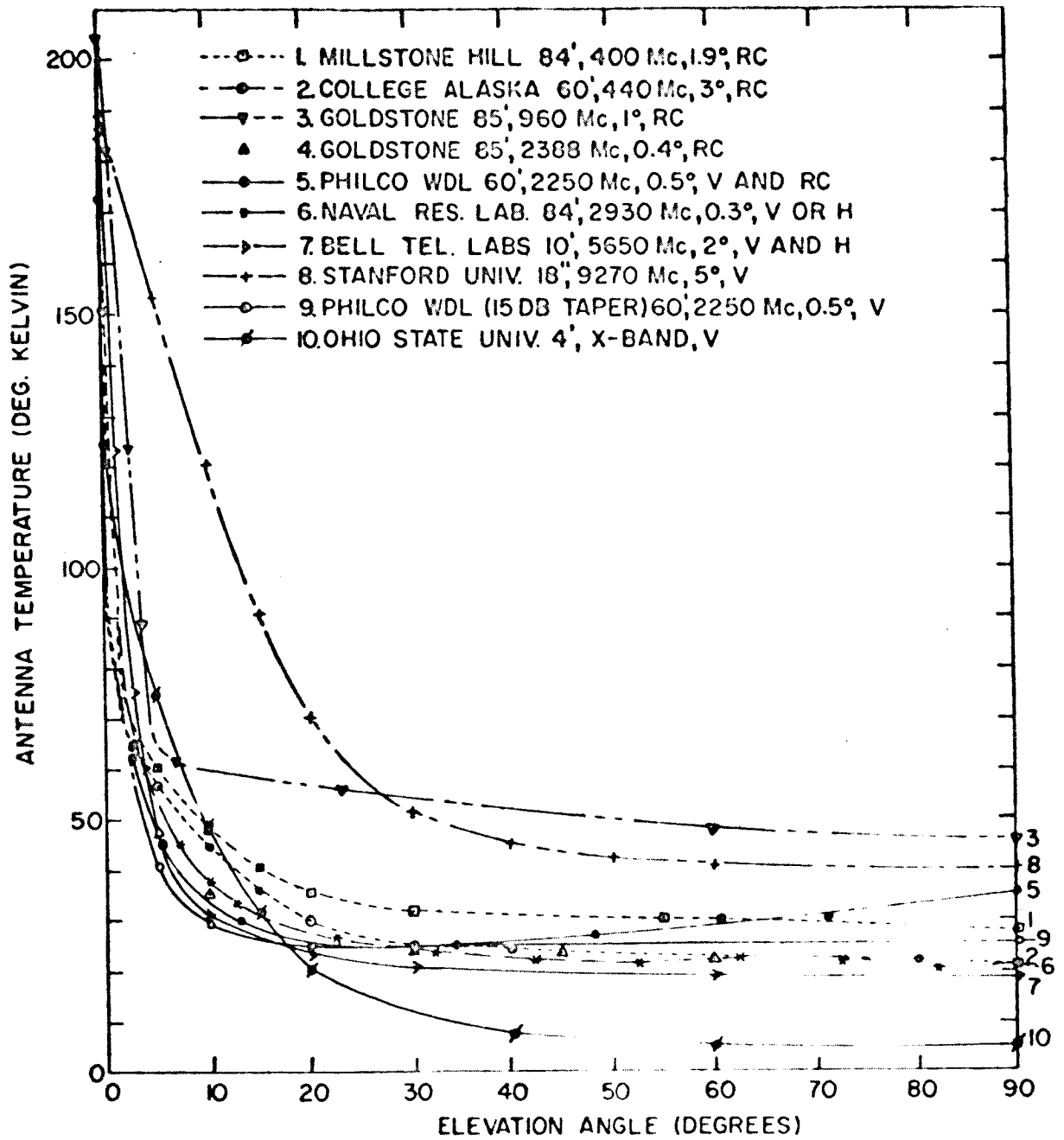

FIG. 5.18 - REPORTED ANTENNA TEMPERATURES (AFTER GIDDIS)

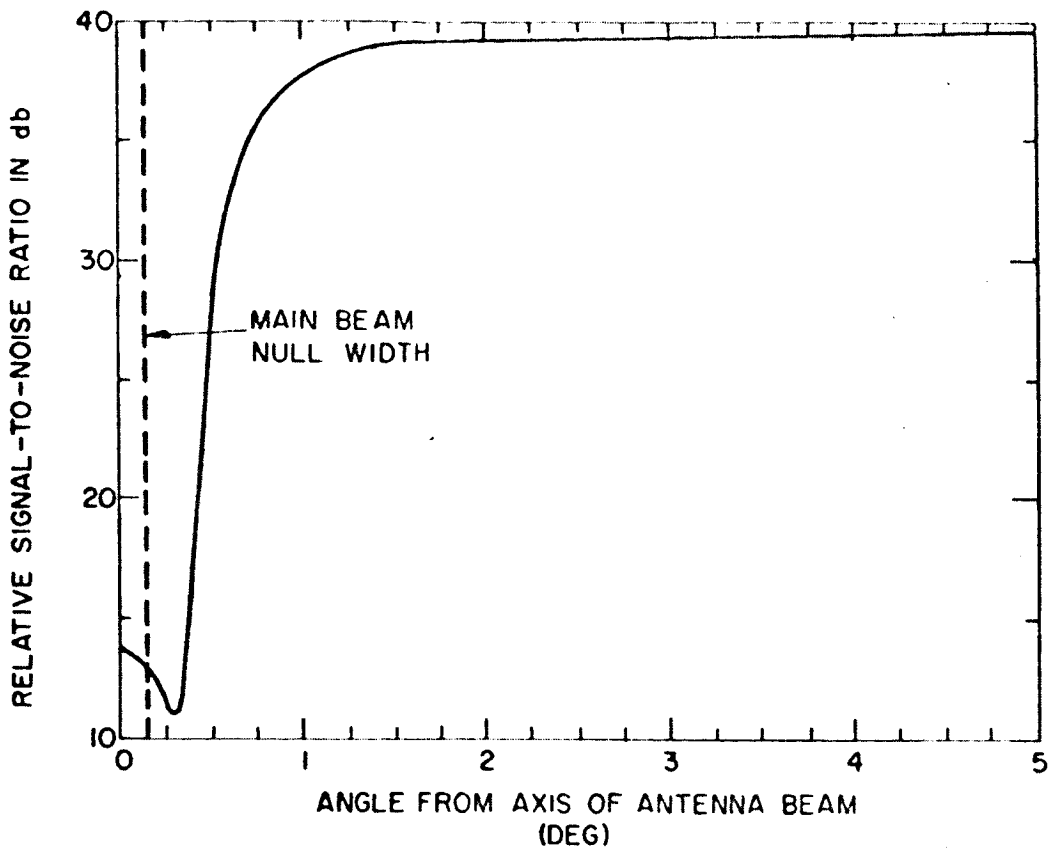

FIG. 5.19 - APPROXIMATE SIGNAL-TO-NOISE RATIO vs ANGLE OF SUN FROM AXIS OF ANTENNA BEAM FOR A 250' ANTENNA.

feet). The limitations imposed on antenna siting by each of the previously considered quantities may be summarized as follows:

Spatial Bandwidth	No limitation for bandwidths of up to 2 Mc. in uncompensated arrays having a maximum dimension of 1000 wavelengths (Figure 5.12).
Collimation	No limitations except those imposed by the atmosphere.
Atmosphere	Depends on the maximum dimension of the array, but primarily affects the acquisition time (excludes the atmospheric noise temperature).
Noise Temperature	Very frequency dependent but limits the scan angle to approximately $\pm 85^\circ$ at 2 Gc.
Interference	Widely separated antennas will generate grating lobes in the vicinity of the main beam which can cause strong interference. Hence, the spacing between elements should be a minimum.
Shadowing	The maximum scan angle is established in Figure 5.5, and is approximately $\pm 85^\circ$ for antennas separated by more than ten antenna diameters.
Required Look Angle	Depends on the number and location of ground antenna systems and the expected paths of the space vehicle. For three ground receive systems, continuous communication is possible with $\pm 60^\circ$ scan angle.

To evaluate the effect of grating lobes in an equally spaced configuration the antenna spacing may be expressed as a function of the subaperture diameter. The grating lobe in turn is suppressed by the element factor in the array, so that it is possible to show the relative

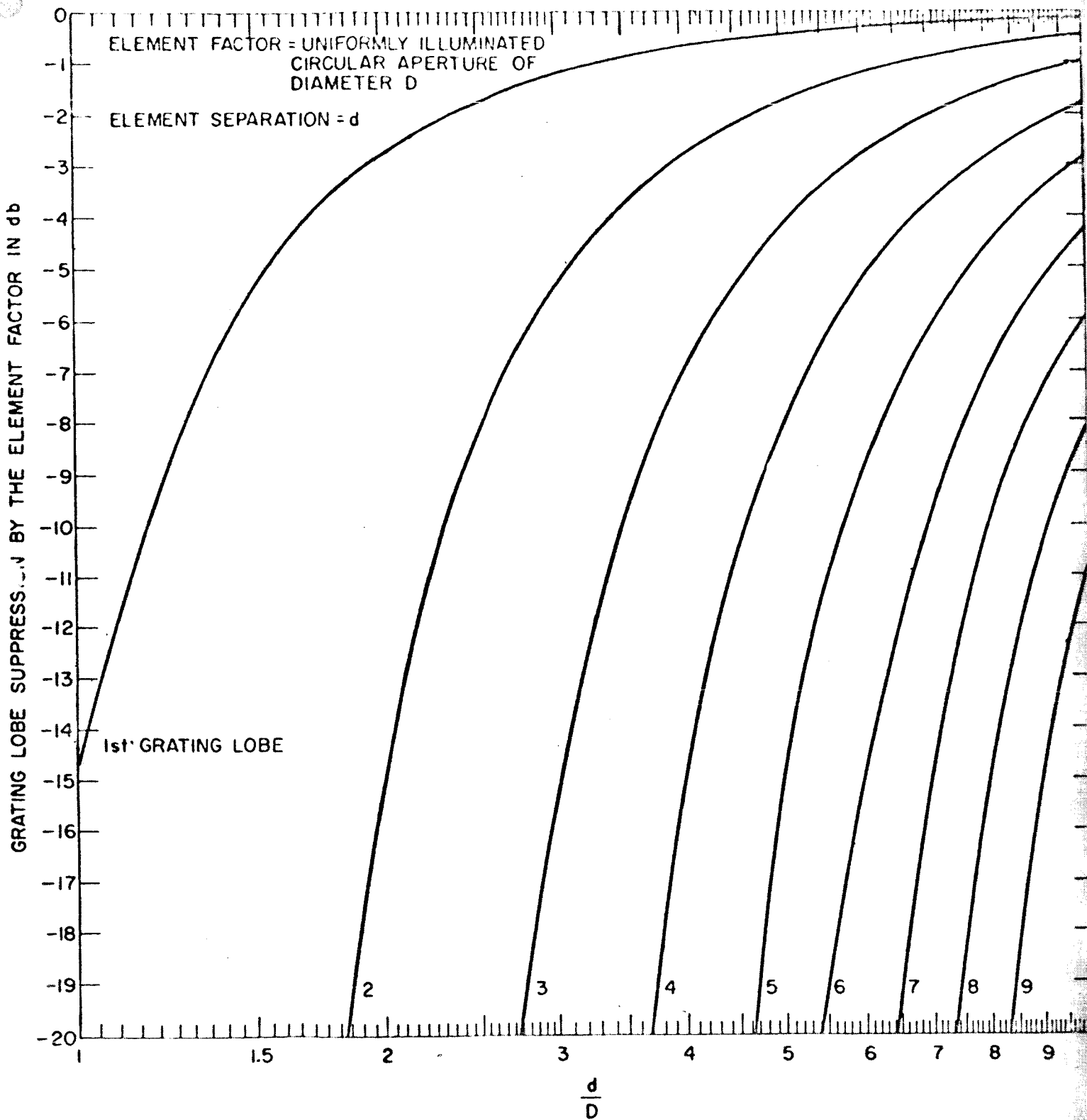

FIG. 5.20 - GRATING LOBE REDUCTION DUE TO THE ELEMENT FACTOR IN A
 LINEAR ARRAY.

SECTION 5-REFERENCES

1. The American Ephemeris and Nautical Almanac 1964 United States Government Printing Office; Washington, 1962.
2. J.W. Sherman, and M.I. Skolnik, "Investigation and Study of a Multi-Aperture Antenna System," Second Quarterly Report, Contract No. NAS 5-3472, p. 41; January 1, 1964.
3. J.W. Sherman, D.J. Lewinski, and M.I. Skolnik, "Investigation and study of a Multi-Aperture Antenna System," First Quarterly Report, Contract No. NAS 5-3472, pp. 19-44; October, 1963.
4. J.H. Schrader, "Receiving System Design for the Arraying of Independently Steerable Antennas," IRE Trans. SET-8, pp. 148-153; June, 1962.
5. J. Ruze, "The Effect of Aperture Errors on the Antenna Radiation Pattern," Supplemento al Nvovo Cimento, Vol. 9, No. 3, pp. 364-380; 1952. Also reprinted in the Proceedings of Symposium on Communication Theory and Antenna; AFCRC Technical Report 57-105, ASTIA Document No. AD 117067; January 1957.
6. R.B. Dyce, "Effects of the Ionosphere on Radio Waves at Frequencies Above 50 Mc," in Upper Atmosphere Clutter Research, Final Report, Part XIII. Effects of the Atmosphere on Radar Resolution and Accuracy. Edited by A.M. Peterson; Stanford Research Institute Project 2225, Contract AF 30(602)-1762; April 1960.
7. L. Colin, "The Effects of Atmospherically Induced Phase Scintillations," in Upper Atmosphere Clutter Research, Final Report, Part XIII; Effects of the Atmosphere on Radar Resolution and Accuracy. Edited by A.M. Peterson; Stanford Research Institute Project 2225, Contract AF 30(602)-1762; April 1960.
8. G.H. Millman, "Atmospheric and Extraterrestrial Effects on Radio Wave Propagation," General Electric Missile Detection Systems Section, Report R60EMH36; June, 1960.
9. P.M. Woodward, "A Method of Calculating the Field Over A Plane Aperture Required to Produce a Given Polar Diagram," Jour. IEEE, Part III-A, Vol. 93, pp. 1544-1558.
10. A.R. Giddis, "Influence of Natural Noise Upon Antenna System Performance," IEEE Trans. AS-1, pp. 287-300; August, 1963.

6. COMBINING

The success of a multi-aperture antenna system depends on the efficiency with which the outputs of the antennas can be combined. If the signals are of identical phase at each antenna, the full effect of the total energy content can be extracted by simply adding the signals at some central location which is connected to the antennas with equal lengths of transmission lines. It is quite unlikely, however, that the phases will be the same at each antenna, or even that they bear some definite relationship to one another. Therefore, it is assumed that the phase of the signals are more or less at random. The main purpose of the combining network is to add the several signals in such a manner that the maximum signal-to-noise energy ratio is obtained.

When the phases of the signals are unknown, the signal processor must either: 1) measure the phase of each signal and apply the phase correction necessary to add the signals coherently Figure 6.1, or 2) destroy the phase information before performing the addition Figure 6.2. The procedure involving the phase measurement and correction is called an adaptive, or semi-coherent, combiner, and the method which destroys the phase before addition is called incoherent combining.

Since the accuracy to which the phase of each signal can be measured is a function of the signal-to-noise ratio, the efficiency of adaptive, or semi-coherent, combining is inversely related to the number of signals to be combined. This limitation can be overcome to a large extent by taking advantage of the fact that a phase measurement requires little information and, hence, little bandwidth. Thus a portion of the transmitted signal energy can be diverted as a CW pilot to provide a means for performing the phase determination. The phase measurement of the pilot signal can be carried out with a narrow bandwidth receiver, of which the phase lock loop Figure 6.3 is an example. The phase lock loop offers some flexibility in the acquisition of the pilot so that the frequency need not be known beforehand to a high degree of

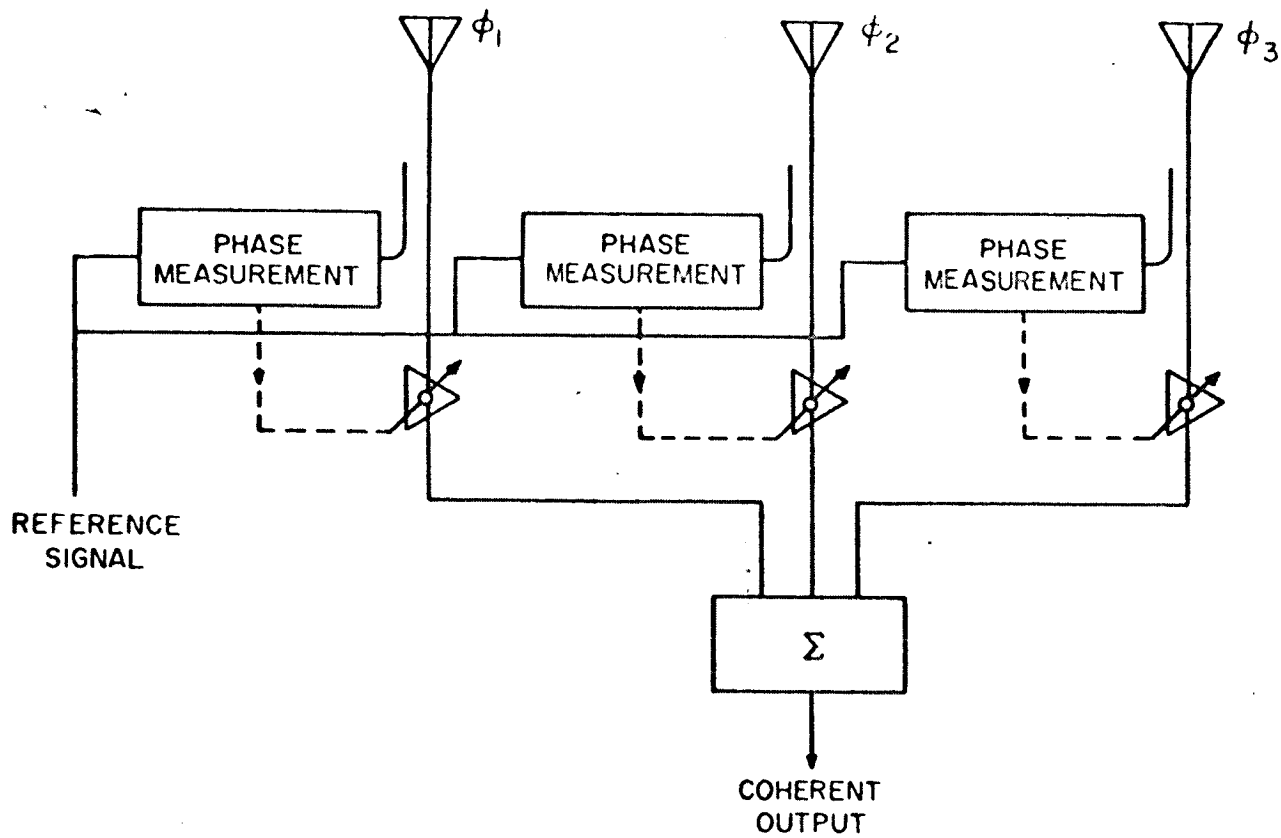

FIG. 6.1 - ADAPTIVE, OR SEMI-COHERENT, COMBINING

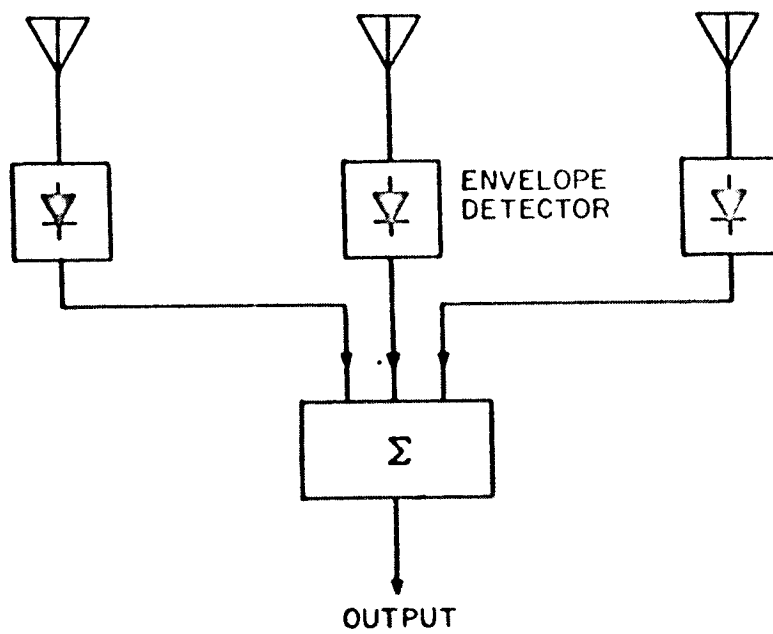

FIG. 6.2 - INCOHERENT (BASEBAND) COMBINING

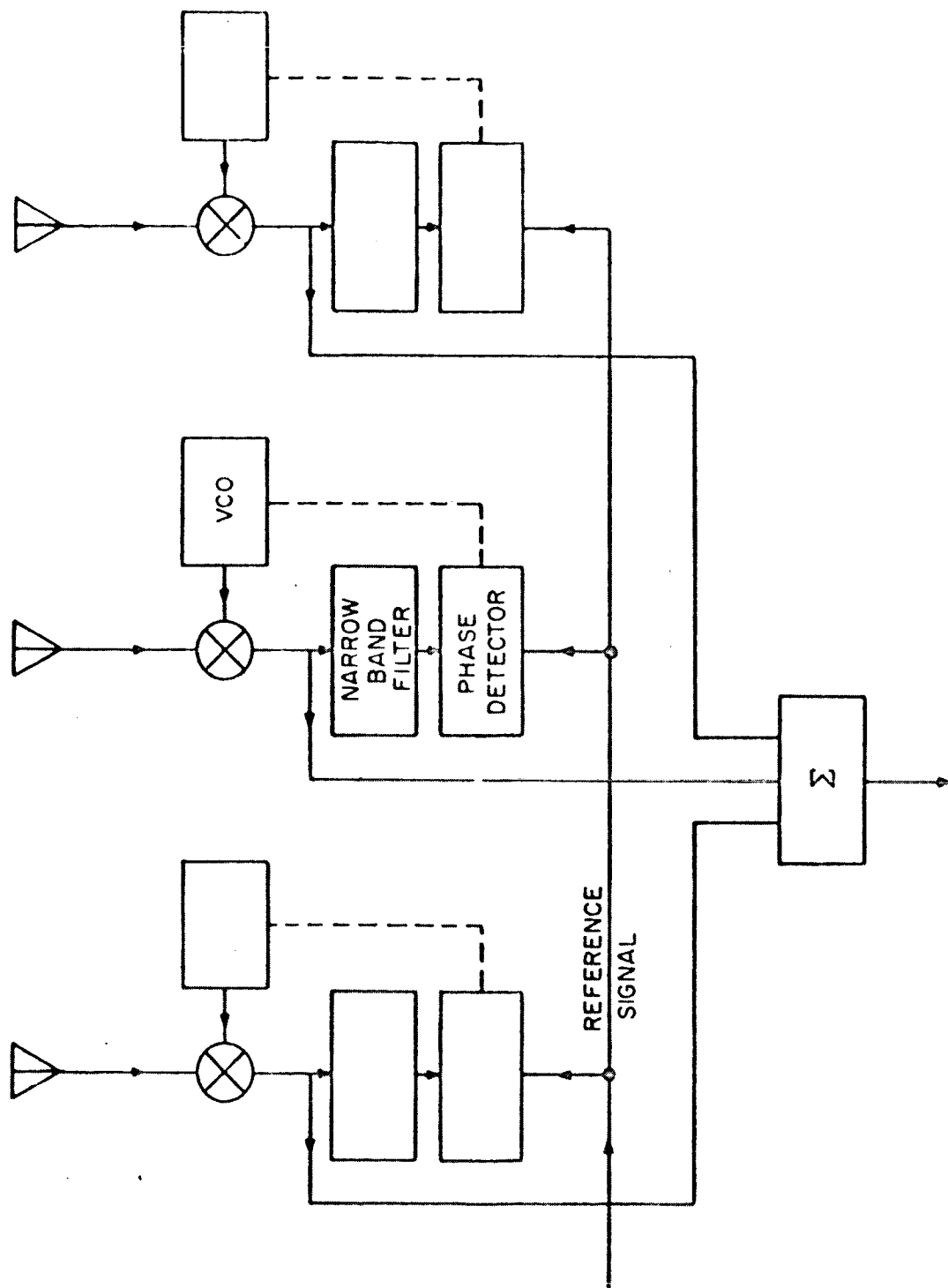

FIG. 6.3- PHASE-LOCK LOOP COMBINING ON PILOT SIGNAL

accuracy.

The several possible methods of combining and the problems of acquiring signals were described in the two quarterly progress reports.^{3,4} Examples of adaptive combining include the phase lock loop and the feedback phase shifter, both of which were described in the Second Quarterly Progress Report, (Figure 6.4). Techniques which strip the phase before combining include the envelope detector (Figure 6.2), phase-stripper combining (Figure 6.5), pilot-signal controlled combining (Figure 6.6), and redundant data systems. These are all described in Quarterly Progress Report No. 1.³ Incoherent systems are less efficient than coherent combining, and well designed adaptive systems. Furthermore, any lack of a priori knowledge of the precise frequency in those incoherent systems which extract a pilot signal, requires a wide predetection bandwidth and results in lower signal-to-noise ratio.

Another adaptive method for combining the outputs of n channels coherently is based on the Fibonacci search procedure. In this, one tries various possible values of the phase at each antenna in a trial-and-error search to determine the optimum combination. The search procedure using Fibonacci numbers offers a means for efficiently determining the proper values. This search technique is briefly discussed in Appendix VI.

An analysis of the loss associated with various types of signal combining was presented in the Second Quarterly Progress Report.⁴ In Appendix IV of the present report, a more general analysis is given of the measurement of phase, and its application to the combination of signals in a multi-aperture antenna system. The combining loss is obtained for both coherent and incoherent combining and conditions are given under which the general combining techniques are preferred.

Most of the analysis of combining has assumed the presence of a pilot. Whenever possible, it would seem preferable to design a communication system with a pilot to aid in combining efficiently. When the communication system is stretched to its limit, as in present

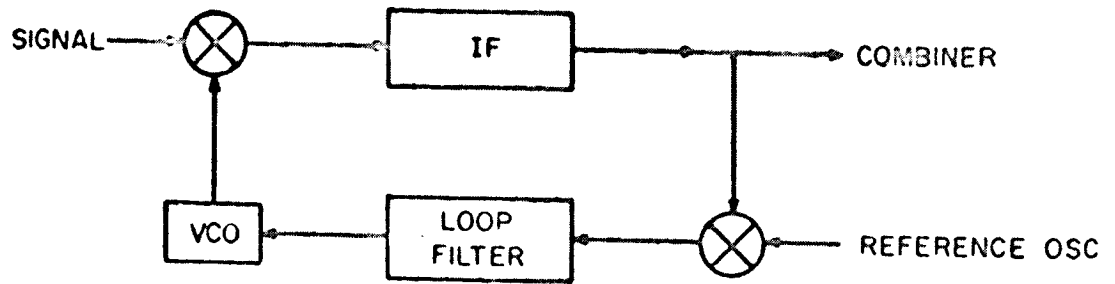

(a) - PHASE LOCK LOOP

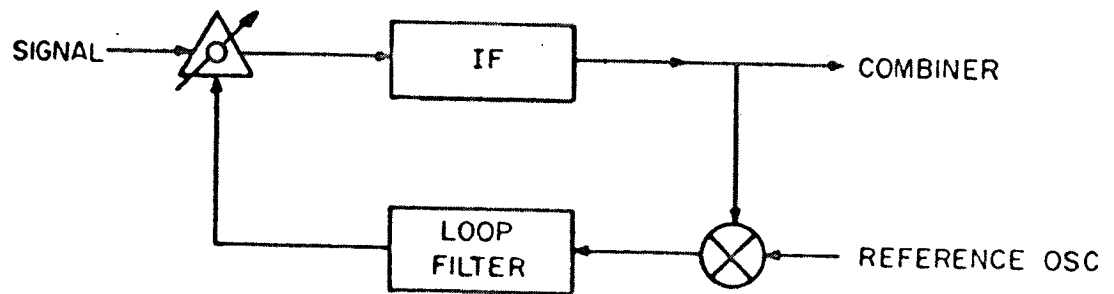

(b) - FEED BACK PHASE SHIFTER LOOP

FIG. 6.4 - ADAPTIVE COMBINING

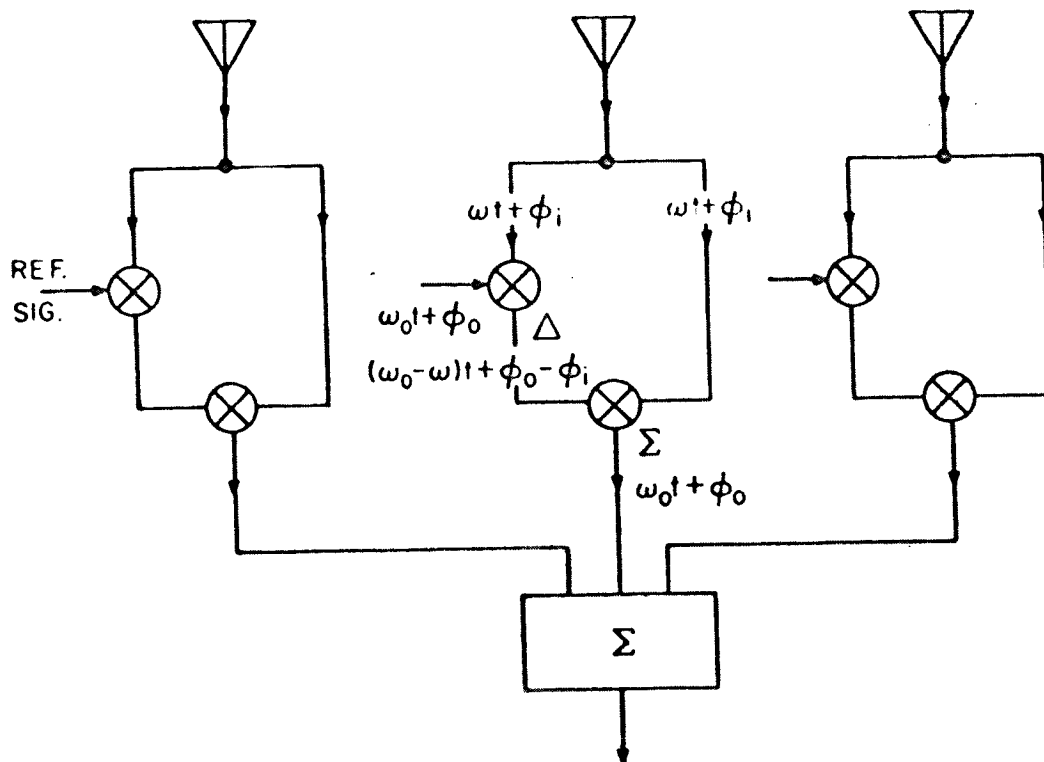

FIG. 6.5 - PHASE - STRIPPER (INCOHERENT) COMBINING

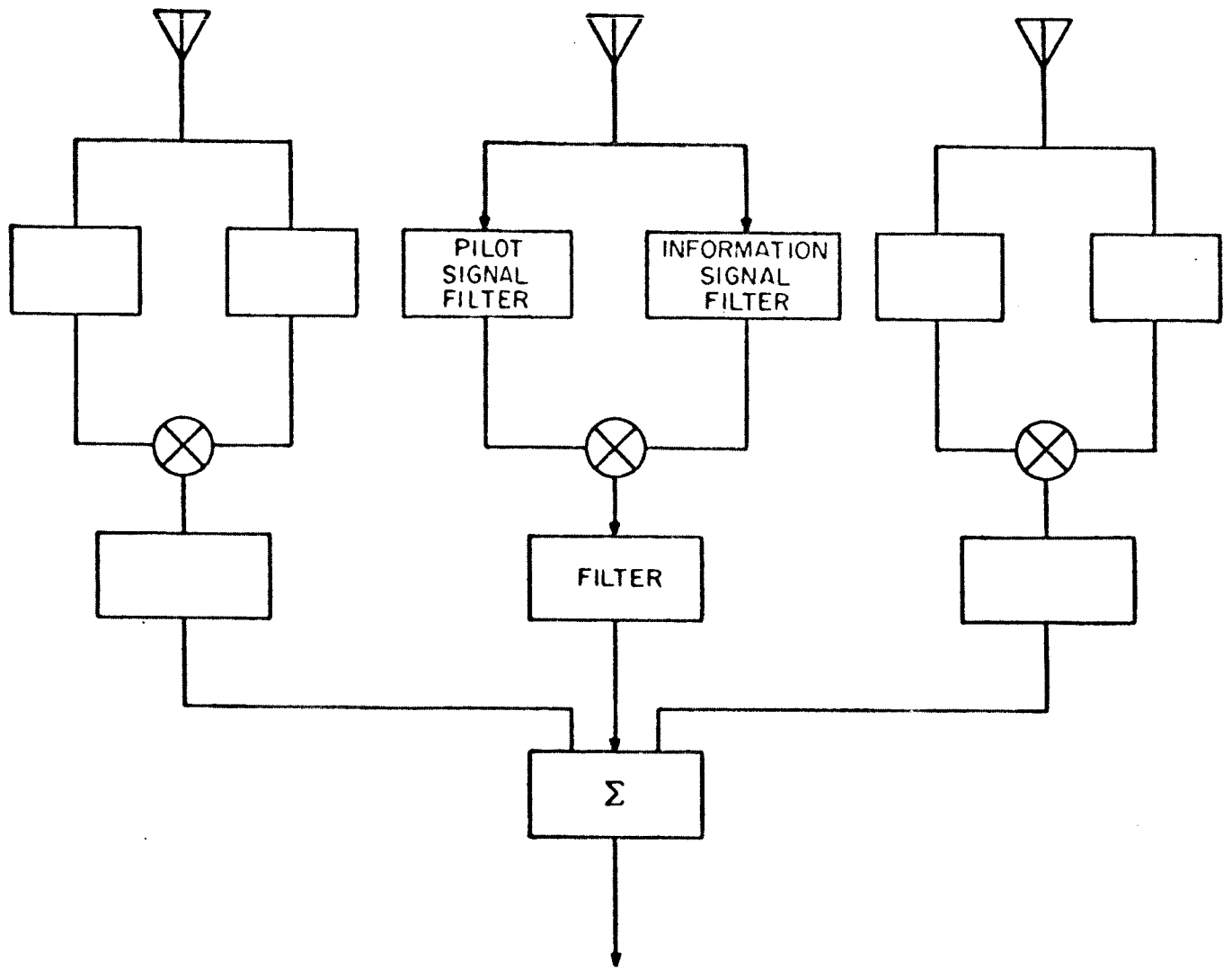

FIG.6.6-PILOT-SIGNAL CONTROLLED COMBINING

interplanetary range systems where adequate signal-to-noise ratio is a problem and information bandwidths are low, it may be necessary to operate without the conventional pilot. Appendix VII describes some possible alternative methods of operation in such instances.

Although the practical effectiveness of a multi-aperture system depends in a large part on how well the signals from the several antennas can be combined, no fundamental limitation to system effectiveness is expected from this source. It would be worthwhile, however, to determine for some specified mission the optimum combining technique and demonstrate its feasibility with a realistic laboratory breadboard. Such an experiment should demonstrate, 1) combining as a function of the signal-to-noise ratio, 2) operation with simulated doppler shifts, 3) effects of signal modulation, and 4) phase variations caused by antenna tracking.

7. SYSTEM CONSIDERATIONS

In this section several miscellaneous topics concerned with the multi-aperture antenna that do not fit other sections of the report will be discussed.

7.1 Acquisition and Registration of Antenna Beams

The difficulty or ease of acquiring a target signal from a particular direction depends in large part on the range and nature of the spacecraft. If the spacecraft is a low altitude satellite its angular motion is relatively high and acquisition is relatively difficult. This is the type of situation usually experienced by the Ohio State University multi-aperture antenna. At the longer ranges (lunar and interplanetary missions) the angular rates are small and determined more by the earth rotation than by spacecraft motion. This fact, plus the likelihood that the relative trajectory will be known quite well, makes the acquisition of a distant spacecraft signal less of a problem than from a close satellite. Pointing of the individual antennas should be more akin to that of pointing a telescope rather than the usual ground based antenna for satellite communications. Thus, it is concluded that in the application of most interest for a multi-aperture antenna system — interplanetary range communications — acquisition will probably be less of a problem than with shorter range systems.

A brief discussion of acquisition time and probability of acquisition is given in Section 8.3, where estimates of the signal-to-noise ratio has been made on the basis of the assumed interplanetary communication system.

When it is necessary to acquire at shorter than interplanetary or lunar ranges, the individual antenna beams can be programmed to form the following patterns:

- 1) A fan beam formed by using all elements
- 2) Each antenna element scan a portion of the search area
- 3) A cluster of beams formed to cover the search area.

The factors that will determine which of the above techniques is utilized are the following:

- 1) Knowledge of the vehicle trajectory
- 2) Available transmitter power and antenna gain aboard the vehicle.

If adequate information is available to predict the path of the vehicle, the formation of a fan beam with the multi-aperture elements seem appropriate for the search function. This technique should provide sufficient gain to receive the vehicle's signal.

Lack of information as to the vehicle trajectory but with sufficient transmitter power and/or antenna gain aboard the vehicle, the utilization at the individual elements to search separate areas offers the maximum possibility of detecting the target. If the vehicle's signal strength is not adequate for detection by individual antenna elements, then the use of a cluster of beams seems appropriate.

In summary, it is believed that acquisition of signals and registration of beams in space will not be a serious problem in those applications for which the multi-aperture antenna system seems best suited.

7.2 Bandwidth Considerations

The bandwidth requirements of a space communications system concern both the information bandwidth and the frequency range over which the equipment is to operate. These two considerations may be treated separately since one has little effect on the other in the present application. The multi-aperture antenna system must not only be able to handle the information bandwidths normally encountered in space communications, but must be able to operate, with but minor modification, at a number of different communication bands.

7.2.1 Frequency Range of Operation

Telemetry and space communication bands extend from VHF to X band. Experimental frequencies have been allocated

as high as K-band (30-35 Gc). Because of the large investment incurred with any ground based terminal of a space communications system, it is necessary to be able to operate a single equipment over as many bands as possible. Since the adaptive circuitry of a multi-antenna system is at an IF frequency, it imposes no limitation to the frequency of operation. With additional IF Channels, combining circuitry, and LO's it is possible to operate simultaneously at several frequencies. If the antenna and the feeds are designed for wide bandwidth, the multi-aperture system can be operated over the band by simply changing the local oscillator and the RF low-noise amplifier if one is used. Thus, the limitations to the frequency range of operation are no different than with a single conventional reflector antenna. The reflector of a multi-aperture system can be readily made broadband. This is not necessarily true for a large single-dish antenna system since mechanical tolerances and beam pointing accuracy eventually limit the maximum usable frequency. The multi-aperture system using antennas of relatively modest size need not have the same frequency limitations as a single dish antenna.

Any limitation to the frequency range of operation of a given antenna system will probably be due to the feed. Broadband feeds for parabolic reflectors have been demonstrated which cover a 10 to 1 frequency range. There is no reason to expect why antenna feeds with this capability cannot be used in a multi-aperture system. It is also possible to interchange feeds to cover a wider frequency range.

The antennas for the multi-aperture system should be designed for the highest frequency of operation that might be contemplated. This will increase the initial cost of the system, but will be considerably cheaper than replacing the system at a later date with one which operates at the higher frequencies.

An array antenna generally has a bandwidth limitation because of the appearance of grating lobes when the frequency is increased

sufficiently. Although the multi-aperture antenna is a form of array, the role that grating lobes play is different. Grating lobes are present because of the wide spacing, Figure 7.1, and if there were no noise sources could be completely ignored. As the source is tracked, the entire pattern moves as a group, which can move across strong noise sources such as the sun. Tracking in the vicinity of the sun will be difficult for either a single dish or multiple aperture system (Section 8.4), and requires the elements to be located as close as possible, which in turn reduces the steering capability due to shadowing.

7.2.2 RF Bandwidth

The bandwidth of the RF components must be sufficiently broad to accommodate the expected width of the communication band. This should present no problem. Different communication bands may be handled by parallel equipments.

7.2.3 Spatial Bandwidth

An antenna aperture, be it continuous or discrete, has a finite rise time for signals arriving from some angle other than broadside because the signal appears at one end of the aperture before the other. The time difference between the arrival of the signal at the ends of an aperture of extent d if the source direction is at an angle θ to the aperture normal is

$$T_r = (d/c) |\sin \theta| \quad (7.1)$$

For example, if the antennas extended over a distance $d = 1$ km and if the angle of arrival were 45° , the response time as given by Equation 7.1 would be $2.36 \mu\text{sec}$. A non-zero antenna response time means a finite bandwidth and will affect the system bandwidth just as if the circuit bandwidth were limited. In the above example, the bandwidth due to the finite response time is approximately 400 kc.

The limitation imposed by a finite response time can be overcome by one of two methods. The information band can be

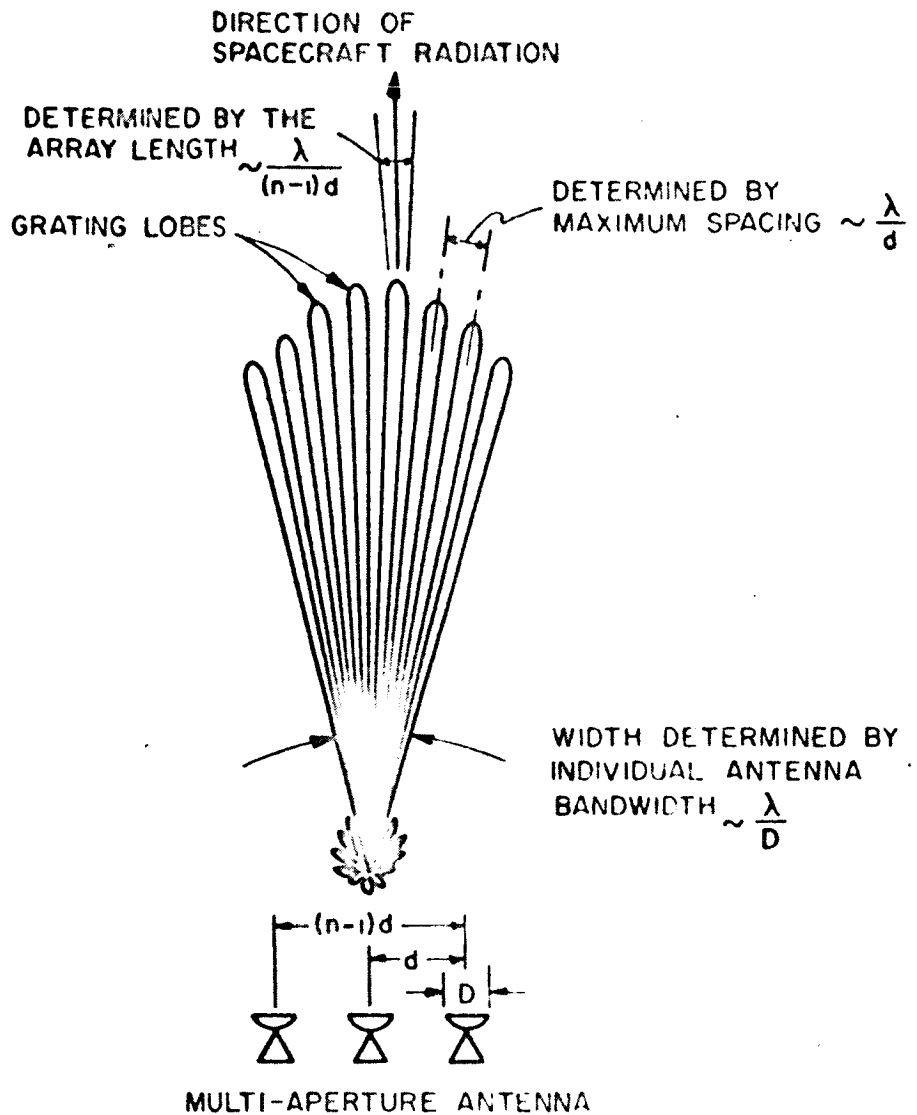

FIG. 7.1 - DESCRIPTIVE REPRESENTATION OF RADIATION PATTERN OF A MULTI-APERTURE ANTENNA SYSTEM. SIZE AND SHAPE OF LOBES WILL DEPEND ON SPACING CONFIGURATION OF ANTENNAS.

subdivided into a number of sub-bands each of which is narrow enough so as not to be affected by the finite response time. Each sub-band would have its own pilot signal and a separate phase lock loop would be required to phase each sub-band independently. This has been described by Bello¹ for scatter communications.

The other method for overcoming any limitations caused by antenna rise time is to include compensating time delays between the subapertures. Depending on the delay required, these could be lengths of RF or IF transmission line or acoustic delay lines. Of the two methods the introduction of delay lines seems preferable to use of multiple pilot signals. It seems, therefore, that the non-zero response time of the antenna aperture will present no fundamental limit to the system bandwidth, if proper means of compensation are introduced.

7.3 Operation at Higher Frequencies

The Statement of Requirements as listed in Appendix III state that the frequency range of interest be from 0.1 to 4 Gc. Primary emphasis has been centered at 2 Gc. There is interest, however, in frequencies as high as 35 Gc.

The basic concept of a multi-aperture system is not dependent on the frequency. However, the economics of antennas are such that the higher the frequency the more desirable the multi-aperture antenna. At millimeter wavelengths it is probably the only practical method for achieving large effective receiving aperture.

The major constraint on the upper frequency of a high gain parabolic reflector is the surface tolerance that can be maintained with present fabrication techniques. A twenty-eight foot parabolic reflector has been built and tested which will operate efficiently at 35 Gc. The measured power gain was 67.4 db compared to the calculated value of 68 db. The reflector had an overall surface error of 0.008". From published information, there is only one reflector which has a larger effective diameter in wavelengths, and that is a 72 foot parabolic reflector at the Lebedev Physical Institute in Moscow, USSR.

This antenna has been tested and operated at a wavelength of 8.5 mm and has a gain in excess of 70 db. At the present time, antenna surface tolerances can be maintained for efficient operation at a frequency of 35 Gc.

Readily available parametric amplifier specifications list models at 35 Gc but these units have a noise figure of 10 db and a gain of 12 db. Amplifiers operating at X-band have noise figures of 3.2 and a gain of 15 db. The state of the art has not progressed sufficiently to make 35 Gc units comparable to X-band ones. At the present time, the upper frequency limit on parametric amplifiers is X-band.

The principle contributor to ground-receiver noise is from external sources, or galactic noise and atmospheric noise. Galactic noise is important at frequencies below 400 Mc and is negligible for frequencies above 1 Gc. Atmospheric noise is essentially negligible below approximately 8 Gc, but absorption due to oxygen and water vapor causes this noise to increase rapidly for frequencies above 10 Gc.

Although much effort is devoted to the frequency region below 4 Gc future development may lead to use of the frequency region above 10 Gc. The reason for this is the difficulty in achieving large bandwidths without radio interference due to the crowded spectrum in the lower frequency region. The multi-aperture antenna concept is compatible with this trend.

7.4 Antenna Temperature

The antenna noise temperature due to a noise source of power P_N in a bandwidth B is defined as²

$$T_a = \frac{P_N}{kB} \quad (7.2)$$

where k is Boltzmann's constant ($1.38 \times 10^{-23} \frac{\text{joule}}{\text{K}}$). The total noise due to a number of sources is the sum of the corresponding antenna temperature multiplied by the bandwidth and Boltzmann's constant. The major sources of noise to be considered are cosmic

noise, solar system noise, sidelobe noise (noise radiated by the ground and intercepted by the antenna sidelobes), noise due to atmospheric absorption, resistive losses in RF plumbing and receiver noise.

The maximum cosmic noise background at 2 gigacycles is approximately 40°K according to reference 2. Solar system noise (noise from the sun and planets in the solar system) is not important unless the antenna is pointed very close to or directly at the body. For an antenna with a beamwidth of less than 0.5° the noise temperature of the sun is on the order of 2×10^5 degrees Kelvin. The noise temperature of Jupiter at 2 Gc is approximately 1000°K ; at 10 Gc the noise temperature of Venus, Mars, and Saturn are 600°K , 210°K and 105°K respectively. The moon has a noise temperature of 250°K at 1.4 Gc.²

Sidelobe noise caused by blackbody radiation from the ground cannot be totally eliminated. The limit on this type of noise appears to be around 20°K to 30°K for a parabolic antenna when the antenna is pointed away from the earth.³ (Also see Figure 5.18).

The noise due to ionospheric absorption is very small at 2 Gc; its maximum value is less than a fraction of a degree for an antenna with a noise temperature of 50°K and an ambient temperature of 300°K . Noise due to tropospheric absorption is much greater than that due to ionospheric absorption. Water vapor and oxygen are the chief absorbers of the electromagnetic energy. Atmospheric absorption noise data may be found in the work of Hogg and Mumford.³ At 2 Gc the noise temperature at 0° elevation is approximately 100°K , while at 5° and 90° elevation the noise temperatures are approximately 30°K and 2°K respectively.

The plumbing losses include the losses in the antenna transmission line and duplexer. The output temperature (T_o) may be calculated from the input temperature (T_{in}), the ambient temperature (T_{amb}) and the power loss L from the expression

$$T_o = \frac{L-1}{L} T_{amb} + \frac{1}{L} T_{in} \quad (7.3)$$

If a low noise RF amplifier a maser or parametric amplifier is used, then the receiver noise may be kept exceedingly low (50 to 60°K) as compared to crystal mixer receiver (2000°K).

Using the data discussed above, the equivalent temperatures caused by the various noise sources may be postulated as:

cosmic noise	40°K
atmospheric absorption	30°K
sidelobe noise	30°K
plumbing loss	40°K
receiver noise	<u>60°K</u>
Total	200°K

The noise temperatures for the Jodrell Bank antenna during the tracking of Pioneer V at 378 Mc were

cosmic noise	45°K
atmospheric absorption	10°K
sidelobe noise	30°K
plumbing loss	45°K
receiver noise	<u>120°K</u>
Total	250°K

Schrader⁵ has shown for a multi-aperture antenna system where the amplitude of the signals from the individual apertures are weighted by their respective signal to noise ratios that the effective system noise temperature is less than the average of the individual noise temperatures. In obtaining his results Schrader assumed that the noise between antennas was uncorrelated. Appendix VIII describes in detail the noise temperature of a multiple aperture configuration.

7.5 Transmission to Spacecraft

The multi-aperture antenna system is discussed in this report as a receiving system only. There is no reason, however,

why the adaptive receiving system cannot be readily converted to efficiently transmit signals from the ground to the spacecraft. The basic phase information contained in the combining portion of each antenna can be extracted and applied to the transmitting portion of the system. Several different approaches exist for applying the information in the received signal to retransmitting a signal which is coherent on reception back at the spacecraft. One such approach, recently described in the literature⁶ is based on the self-phasing principle.

SECTION 7 - REFERENCES

1. P. Bello and B. D. Nelin, "Predetection Diversity Combining with Selectively Fading Channels," 1962 IEEE International Convention Record.
2. R. D. Stephenson, "External Noise," Space Communications, A. V. Balakrishnan, Editor, McGraw-Hill, pp. 85-103; 1963.
3. R. C. Hansen, "Low Noise Antennas," Microwave Journal, pp. 19-24; June 1959.
4. D. C. Hogg and W. W. Mumford "The Effective Noise Temperature of the Sky," Microwave Journal, pp. 80-84; March 1960.
5. J. H. Schrader, "Receiver System Design for the Arraying of Independently Steerable Antennas," IRE Trans. on Space Electronics and Telemetry, Vol. SET-8, No. 2, pp. 148-153; June 1962.
6. M. I. Skolnik and D. D. King, "Self-Phasing Array Antennas," IEEE Trans., Vol. AP-12, pp. 142-149; March 1964.

8. SYSTEM DESIGN

8.1 Introduction

This section is devoted to a summary of a state-of-the-art operating receive system. Since two distinct models are being evaluated in this study, it is convenient to discuss each as a separate communication system. In either the lunar or interplanetary system it has been necessary to make certain assumptions about the actual spacecraft and the communications system. For example the lunar system has assumed a spacecraft transmitter of 15 watts and antenna gain of 6 db, so that any combination of gain and transmitter power totalling 17.8 db could be substituted. Section 3 has summarized the system model.

This investigation has been limited solely to the ground receive system as outlined in the statement of requirements in Appendix III. The optimum number of subapertures has been found in terms of equivalent aperture size and electronics cost as a function of the expected length of operation (Section 4). A truly optimum system would include the characteristics and relative cost of the spacecraft in terms of the number of anticipated missions over the expected length of operation.

8.2 The Lunar Range Receive System

The second quarterly report developed in detail the communications system (transmit) for a lunar range spacecraft which has been reviewed in Section 3 and typical systems summarized in Appendix V. Two parameters are necessary in calculating the required ground antenna size -- (1) the bandwidth of the signal to be received and (2) the equivalent noise temperature of the receiving system. Figure 5.18 indicates the reported antenna temperatures of a number of operating antennas, and Section 7 summarizes the receive system equivalent temperature for an antenna scanned $\pm 85^\circ$ (to within 5° of the horizon). Appendix VIII discusses the multiple aperture antenna temperature in terms of a single receive system, and indicates that if the combining

is perfect the two noise temperatures are identical. A conservative estimate for the equivalent noise temperature of the receive system is 200°K (a noise figure of 2.28 db). Figure 8.1 establishes the required aperture size as a function of bandwidth with temperature as a parameter. Included on the abscissa are the bandwidths and power consumed by several current aerospace TV systems. Excluding the Advanced Syncom System, there is no planned spacecraft with a bandwidth exceeding the TV system of Apollo (400 Kc.).

According to our model an antenna 16.5 meters (54 feet) in diameter is able to receive this signal with a probability of error of 10^{-6} . If the power is reduced from 15 watts to the 6.5 watts of power for Apollo, then the aperture size must be increased to 25 meters (80 feet). To evaluate a multiple aperture system having these two diameters, it is assumed in evaluating relative cost that the system will be maintained for a 20-year duration. Figure 4.6 of this report indicates that regardless of the operating frequency, the electronics cost must be no more than one-tenth the antenna cost if a multiple aperture configuration is to be economical. The aperture cost as a function of frequency is sketched in Figure 8.2 for 54 and 80 foot diameter antennas and is based on the model outlined in Section 9. If a minimal cost system is designed, the antenna surfaces do not have to meet thermal tolerances (1 part in 10^4) but instead approximately 1 part in 4×10^3 . Figure 5.1 in the first quarterly report⁴ illustrates the surface tolerance necessary. The minimum cost system then would have an 80 foot antenna with a maximum usable frequency of 3.75 Gc or 5.5 Gc for the 54 dish. It is emphasized that these frequencies are minimal, and the actual antenna would probably be built to operate at a much higher frequency.

According to the assumed model the 80 foot antenna will cost around \$770,000 and the 54 foot dish \$280,000 meaning that the electronics cost should be no more than \$77,000 or 28,000, respectively. Electronics cost for single antennas have been quoted between \$200,000

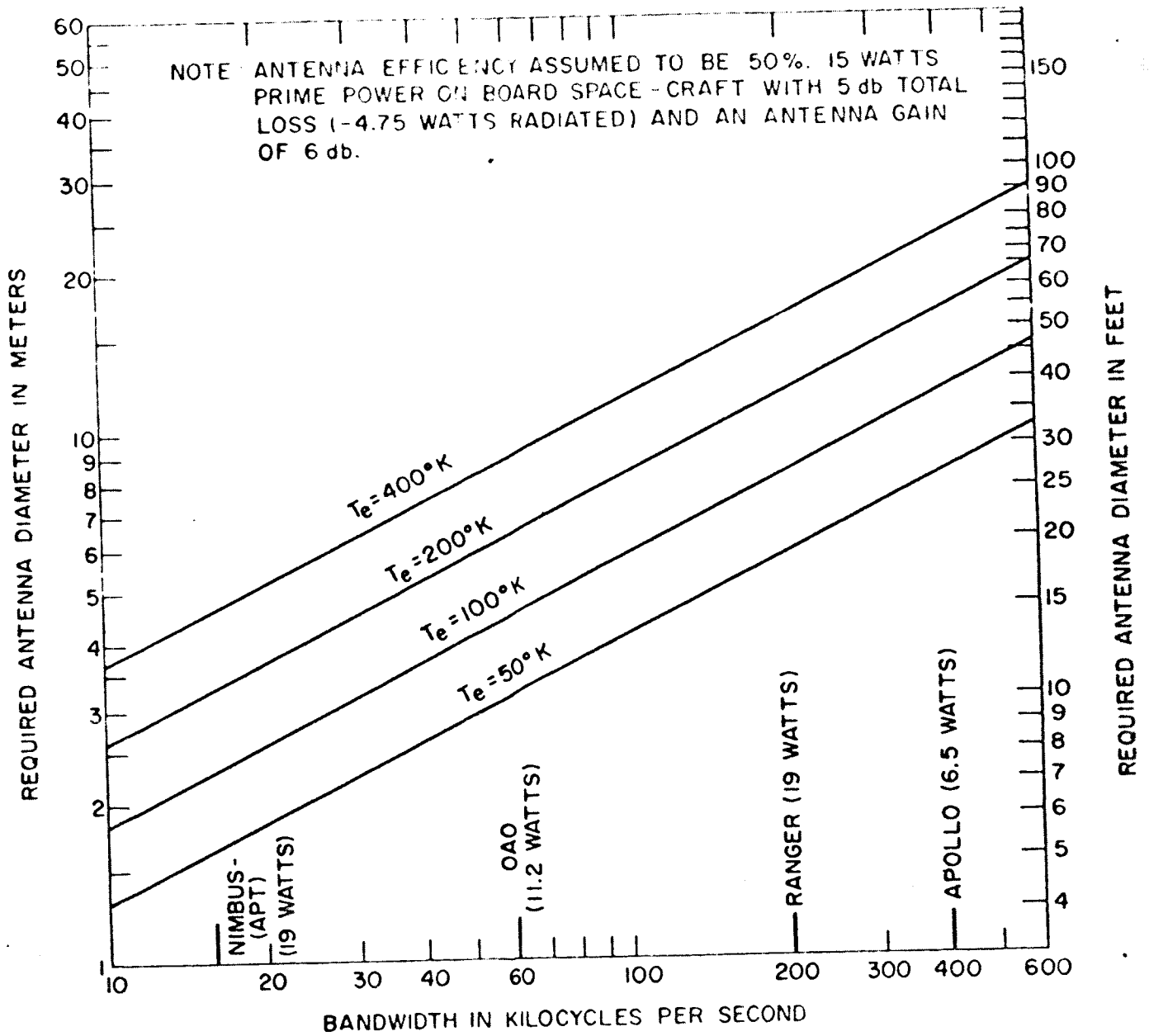

FIG. 8.1 - ANTENNA DIAMETER vs INFORMATION BANDWIDTH FOR A LUNAR RANGE (3.8×10^8 METERS) SPACECRAFT.

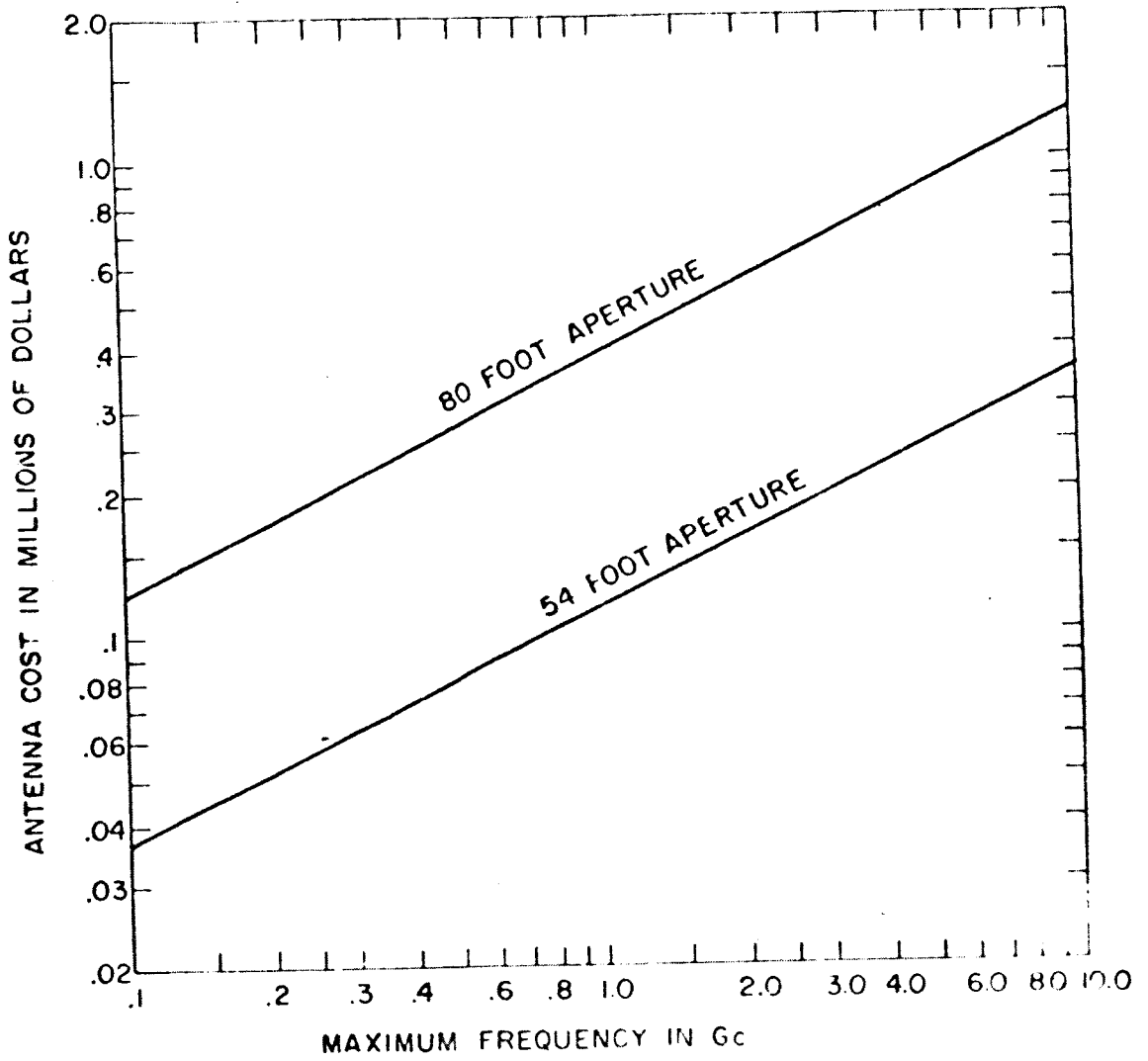

FIG. 8.2 - ANTENNA COST AS A FUNCTION OF FREQUENCY

to \$700,000.^{5, 6, 7} For a system designed to operate with minimal requirements even the lower figure of \$200,000 might be too large but in the light of an operational system expected to perform for 20 years, this figure is not out-of-line (true, a cheaper system can be devised, but operating and maintenance cost will be increased).

Since it appears that the cost of the electronics portion will be more than one-tenth the antenna cost for a lunar range system it is recommended that a multiple aperture antenna not be used for communications if the assumptions made heretofore apply. This recommendation is made primarily on the basis of economic considerations, but is also substantiated by practical, operational systems which already have demonstrated their ability to communicate at lunar ranges using a single aperture.

8.3 The Interplanetary Receive System

The lunar range model has only been reviewed in this final report, but the interplanetary model is developed more completely in Appendix V and outlined briefly in Section 3. Again the signal-to-noise ratio is assumed to be 15 db which gives a bit error probability of around 1×10^{-6} (See Figure V.1). The range requirement of the interplanetary system is 2.6×10^8 kilometers (1.62×10^8 miles) and corresponds to the maximum Earth-Venus range. Briefly, the important parameters are given in Table 8.2

TABLE 8.2 - Model Parameters of an Interplanetary System

P_t	= Spacecraft Transmitter	= 100 W
G_t	= Spacecraft Antenna Gain	= 20 db
ρ	= Ground Antenna Efficiency	= 50%
l	= Spacecraft System Design Margin	= 6 db
S/N (Bit Error Probability 10^{-6})		= 15 db
F	= Receiver Noise Figure	= 1 db

With this model it is possible to express the required aperture size in terms of the bandwidth as shown in Figure V.3. The most obvious

feature of the deep space receive system is the narrow bandwidth available for communication. For most any practical aperture size the bandwidth will be less than a thousand cycles per second and from the economic viewpoint will be probably no more than a hundred cycles per second. Using a bandwidth of 100 cps, it is necessary to have a 400 foot equivalent aperture (Figure V.6).

Let us evaluate the possibilities of using a single antenna having a 400 foot diameter. The critical parameters of large antennas have been shown to be the pointing error (Appendix II) and surface error tolerance (Section 9). Considering the surface tolerance first, thermal error in the reflector surface will give maximum gain at 2 Gc with a maximum usable frequency of 2.9 Gc (Figure 9.1).

Hence, error in the reflector surface does not make the 400 foot single aperture system unrealizable. The pointing error evaluated in Appendix II indicates that such an antenna could at best be pointed to within ± 1 milliradian. At 2 Gc the 3 db beamwidth of the 400 foot antenna is 1.25 milliradians, so that the antenna could be pointed to within the 1.8 db points of the main beam.

Before evaluating the effect of the pointing error involved, consider the cost of a 400 foot single antenna. Using Equation 9.2, the cost of this antenna is 46 million dollars. Since the antenna can only be pointed to within the 1.8 db points, it is possible for the antenna to be reduced to the equivalent of a 360 foot aperture, which cost 34 million dollars. The difference in these two apertures is 12 million dollars and represents the loss due to pointing error. This in itself is enough to suggest using a multiple aperture system. However, the pointing loss is now transferred to combining loss during acquisition. Before examining combining loss in the multiple aperture system, it is important to establish the approximate number of antennas involved.

Section 4 investigated the relative cost of a multiple aperture antenna in terms of frequency, aperture size and cost, electronics cost, and anticipated length of operation. Equation 4.4 indicates the optimum

number of antennas as a function of electronics and antenna cost.

In order to reduce as much as possible the required aperture size, the electronics for a deep space communications system will probably cost more than the lunar system. For example, the parametric amplifier would of necessity be replaced by a cooled maser front end. Thus, for a deep space communications receiver, the electronics cost will probably approach the \$700,000 figure mentioned in the lunar range discussion. For this value the optimum number of antennas is eight, representing an aperture size of 142 feet. The cost of the eight antennas is according to Equation 4.1, 19.3 million dollars, less than half the original single antenna cost. This cost figure is based on the same maximum usable frequency of the single dish (2.9 Gc).

The signal-to-noise ratio has been assumed in this model to be 15 db, which means that each of the eight antennas has a received signal-to-noise ratio of approximately 6 db. The major effect of this reduction in the signal-to-noise ratio in the subapertures is an increase in the acquisition time of the system, but this in part depends on the type of combining and the nature of the spacecraft (i. e., see Section 7.1). If it is assumed that each subaperture is made to acquire the signal independent of the other subapertures, then some estimates can be made with regard to acquisition time and/or probability. These estimates are based on the signal-to-noise ratio out of the IF. Frazier and Page⁸ have performed an analog study of phase lock loop with regard to frequency acquisition. Their results can be modified to give an estimate of the time required to acquire a signal. Since acquisition is a statistical process depending on random phase and/or frequency it is necessary to express the results in terms of the probability of acquiring. Figure 8.3 gives an estimate of the relative time to acquire for several different signal-to-noise ratios. Note however, that this is the signal-to-noise out of the IF and depends on the equivalent bandwidths of both the IF and the loop in a phase lock loop detector (Figure 6.4).

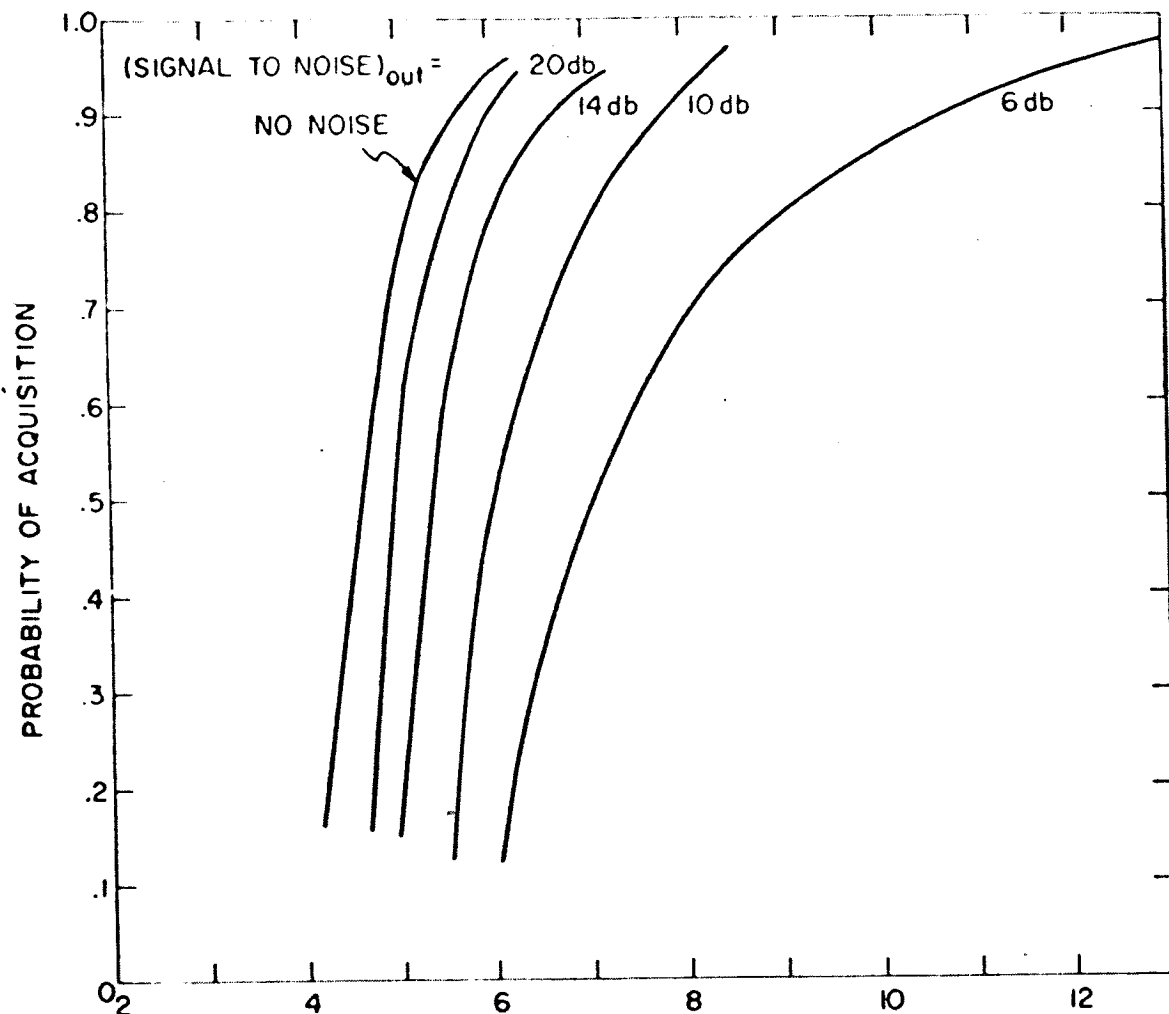

$\frac{\beta_n^2}{R}$ = RECIPROCAL OF NORMALIZED SWEEP RATE
 (A MEASURE OF RELATIVE ACQUISITION TIME)

NOTE:

$$\left(\frac{S}{N}\right)_{OUT} = \left(\frac{S}{N}\right)_{IF} \frac{\beta_{IF}}{\beta_n}$$

WHERE β_{IF} = EQUIVALENT IF NOISE BANDWIDTH

β_n = EQUIVALENT LOOP NOISE BANDWIDTH

R = VCO SWEEP RATE (CYCLES / SEC²)

THIS IS A LINEAR SYSTEM (NO LIMITING) WHICH IS CRITICALLY DAMPED.

FIG. 8.3 - PROBABILITY OF ACQUISITION AS A FUNCTION OF THE RELATIVE ACQUISITION TIME.

The empirical data of Figure 8.3 may be modified so that the relative acquisition time is known in terms of the signal-to-noise ratio. Figure 8.4 is such a sketch for 90% probability of acquiring the signal. Several features of this curve should be observed. First, for large S/N the minimum acquisition time is around 5.6 cycles. At 15 db (S/N ratio) this time is increased only fractionally to 6.35 cycles. Thus, a 15 db signal-to-noise ratio out of the IF suffers very little in terms of acquisition time. Second, it appears that this ratio should not be less than 5 or 6 db, or else the acquisition time will become prohibitively long (a long acquisition time is undesirable since propagation perturbations of the atmosphere become unstable over extended lengths of time as discussed in Section 5). At a S/N ratio of 6 db the relative acquisition time of the eight 142 foot antennas will be approximately 72% longer than the single 400 foot aperture. However, this is in the combining circuitry and does not include the actual search time involved for the antennas.

It is very difficult to estimate the total search time for either the single dish or the multiple aperture system, even when search times over frequency are excluded. An intelligent guess could be ventured on the following basis. Assume that

1. the scan rates do not limit either the single or multiple aperture approaches;
2. the antennas operating in the multiple aperture system detect independently of one another; and
3. the atmosphere is ignored and perfect phase correction is made between each antenna in the multiple aperture system creating a single beam.

Under the conditions the multiple aperture system would form a single beam in space whose width depends on the maximum dimensions of the multiple aperture, and typically this beam will be narrower than that of the single dish. However, since the effective area of both apertures is the same the gain of the two systems are equal. But because the beam of the multiple aperture is smaller it must be scanned over a larger area (in terms of beamwidths) and hence will require a longer search

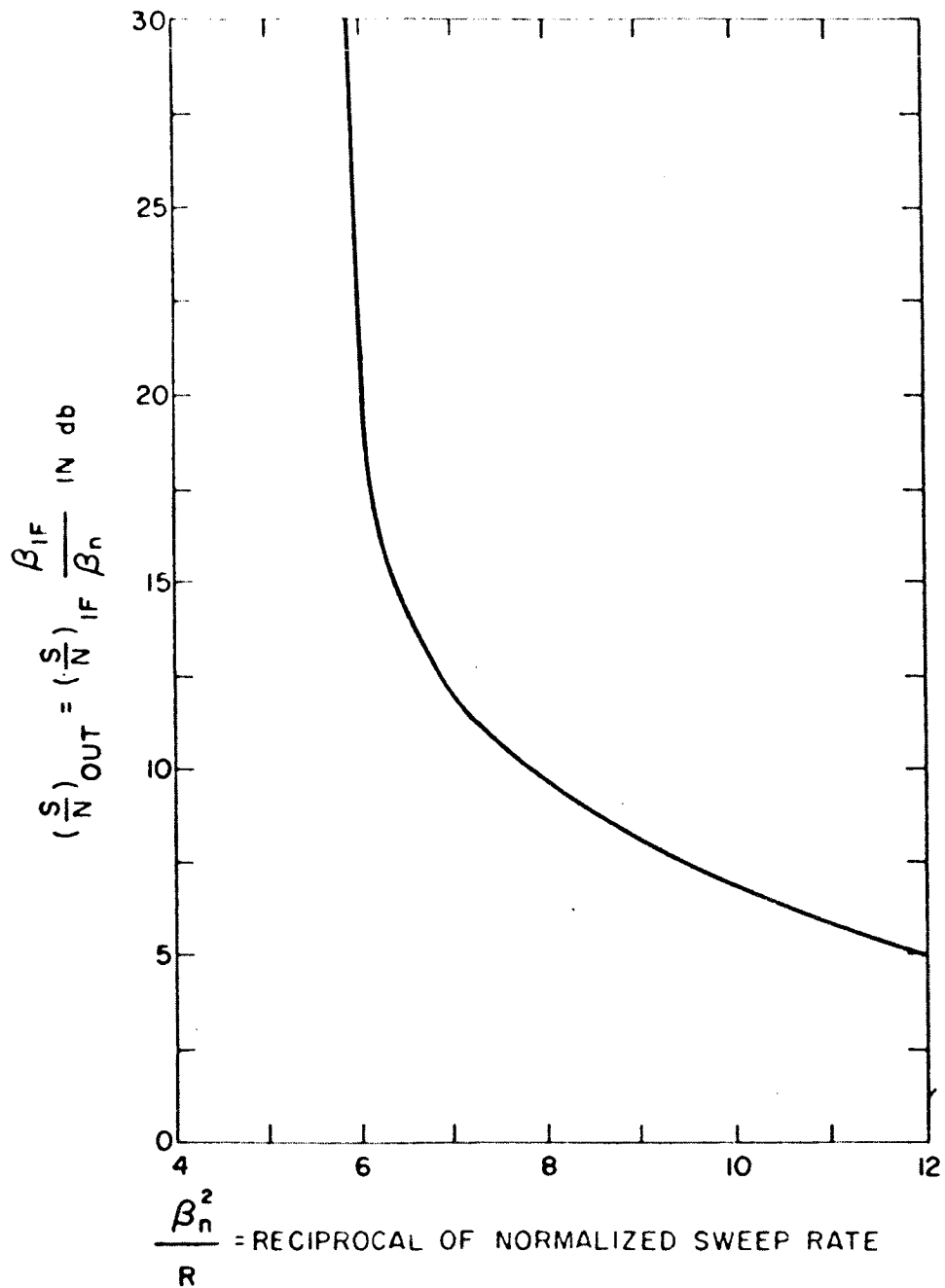

(A MEASURE OF RELATIVE ACQUISITION TIME)

FIG. 8.4 - RELATIVE ACQUISITION TIME FOR 90% PROBABILITY OF ACQUIRING.

time. (It should be noted here that the relative energy peak of both the main beams is the same, and if a discrepancy appears in the energy it is because of energy loss in the grating lobes of the multiple aperture antenna. See Section 5). If the multiple aperture is scanned faster than the single dish then the received energy per unit angle of space is even less than the 6 db, resulting in a lower signal-to-noise ratio. This in turn means that the signal-to-noise ratio is further reduced and the acquisition time increased. Thus, the multiple aperture system should be scanned at the same rate (or less) as the single antenna, and under this condition the relative increase in the acquisition time is the previously mentioned 72% for eight antennas equivalent to a 400 foot aperture.

On the basis of this intuitive argument it appears that acquisition of the space vehicle will generally be longer using the multiple aperture approach.

8.4 Antenna Orientation of the Interplanetary Multiple Aperture System

Before discussing the orientation of the antennas in the multiple aperture system, it is important to emphasize some of the physical constraints and limitations placed on a single antenna. Consider the 400 foot aperture antenna which is required by the model developed in this study. In Figure 5.20 the degradation of the signal-to-noise ratio due to scanning across the sun is shown for a 250 foot antenna. The same phenomena will occur for a 400 foot antenna except 1) the abscissa will be compressed by 60% and 2) the signal-to-noise level will have a minima which is less than the minima occurring in this figure. Since this curve has a 40 db signal-to-noise ratio in the absence of the sun, and since our model was developed to have a 15 db signal-to-noise ratio when at maximum range (2.6×10^8 kilometers), the antenna will not remain in communication with the spacecraft in the vicinity of the sun. Any sidelobes -15 db or higher in the radiation pattern looking at the sun will cause the signal-to-noise ratio to be one or less. Ideally, the peak sidelobes should be -30 db below the main beam, but in reality

will probably be around -20 to -25 db adjacent the main beam.

The performance of the multiple aperture system of eight 142 foot antennas can now be established relative to the single 400 foot dish. While it was shown in Section 5 that the sidelobes of the array factor can be controlled in the multiple aperture approach, it was also shown that grating lobes are created if these antennas are equally spaced. Figure 8.5 indicates the approximate number of grating lobes in the main beam of the element factor as a function of the scan angle for an equally spaced array (linear or planar). This sketch is somewhat unconventional and is intended to illustrate that grating lobes necessarily accompany the scan angle. Recall that noise in the atmosphere will limit the scan angle to approximately $\pm 85^\circ$ so that more than 10 grating lobes will be present in the main beam of the element factor. If reduced to $\pm 80^\circ$ only 6 grating lobes are present and the minimum spacing between elements is 5.75 diameters of the subaperture (Figure 5.4).

To relate the above information to the multiple aperture system recall that scanning of the antennas in latitude is only $\pm 30^\circ$ for any communication needs in the foreseeable future. This means that the antennas may be placed closer together in the north-south direction than in the east-west if necessary. For eight antennas several possibilities exist for orientation, each having advantages and disadvantages. Basically, they fall into three categories; 1) a circle, 2) a rectangular configuration, or 3) arranged as a linear array. A cross can also be considered.

Assuming $\pm 80^\circ$ for longitude steering the diameter of a circle of antennas is almost 6 diameters or 850 feet for 142 foot apertures. Such a configuration allows $\pm 80^\circ$ coverage in several directions for elements spaced 45° apart, has a reasonably symmetric main beam, and will not have grating lobes as such. However, it will have relatively high sidelobes due to the array factor. Such sidelobes will be on the order of -8db adjacent the main beam, and very little can be done to suppress them as in the linear case.

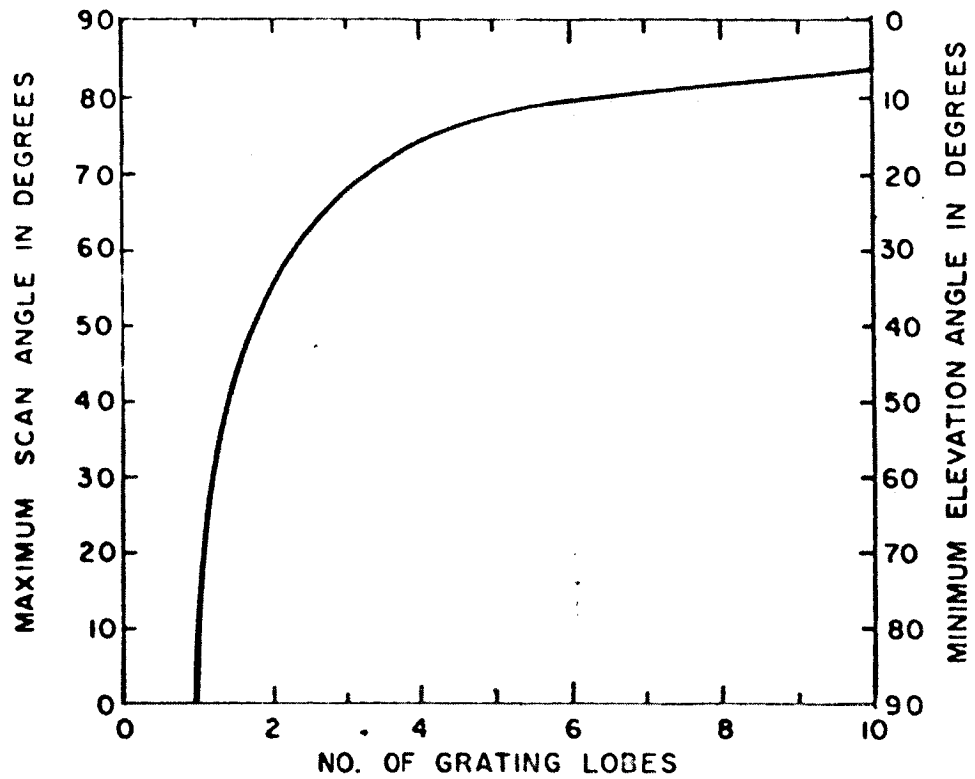
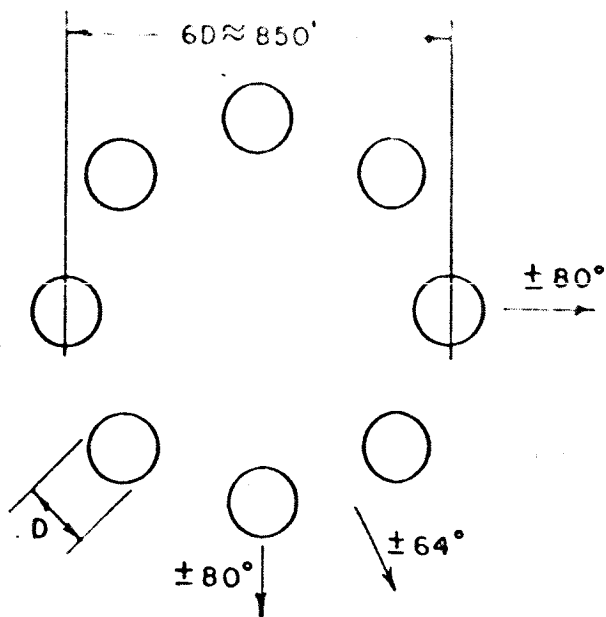

FIG. 8.5 - MAXIMUM SCAN ANGLE AS A FUNCTION OF THE NO. OF GRATING LOBES IN THE MAIN BEAM OF THE ELEMENT FACTOR

The rectangular array allows the orientation to take advantage of the reduced coverage required in latitude, and will have sidelobes on the order of -13db. The sidelobes can be controlled via amplitude and phase, but if equal spacing is used grating lobes develop.

The linear array if located orthogonal to the rotational motion of the earth (i. e., in the north-south) can be given complete coverage (± 90 if desired) in longitude, and by placing the elements two diameters apart will still have $\pm 30^\circ$ coverage in latitude. Such a configuration will have minimum interference via grating lobes. However, for this orientation no control exists over sidelobes orthogonal to the linear array and the beamwidth in this plane will be determined by the individual subapertures (142 feet a 2 Gc gives a 3 db beamwidth of approximately 3.5 milliradians).

The three basic configurations are shown in Figure 8.6 a, b, and c which meet the coverage of $\pm 80^\circ$ in the east-west direction. Also included are the directions and angles of minimum coverage for that particular orientation. It is not appropriate to determine at this time the best configuration for these eight elements, because orientation will depend heavily on interference rejection requirements of the system. The multiple aperture equivalent will in general be more susceptible to interference than a single antenna.



SYMMETRICAL MAIN BEAM NO GRATING LOBES

HIGH SIDELOBES DIFFICULT TO CONTROL

a) POSSIBLE CIRCULAR ARRANGEMENT

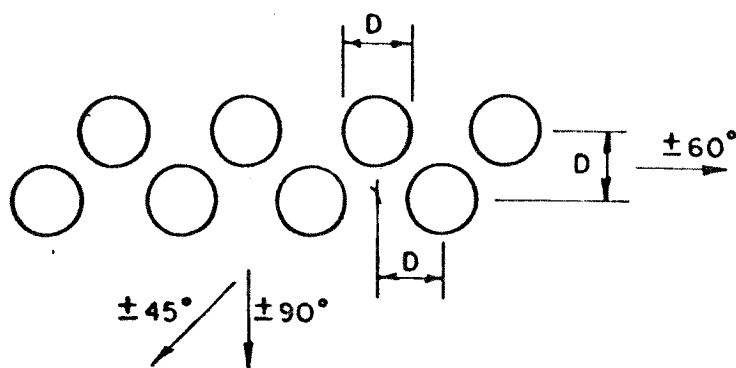

CONTROL OVER SIDELOBES

LOWER SIDELOBES THAN IN 'a'

GRATING LOBES PRESENT

b) POSSIBLE PLANAR ARRANGEMENT

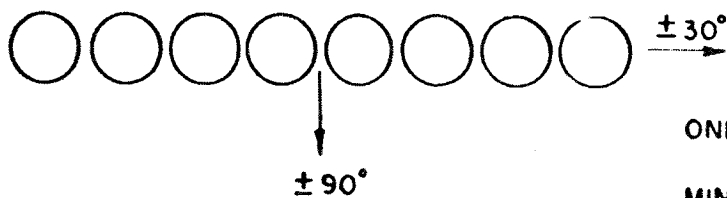

ONE GRATING LOBE

MINIMUM SHADOWING

CONTROL OVER SIDELOBES

RELATIVELY BROAD MAIN BEAM
ORTHOGONAL TO ARRAY

NO CONTROL OVER PATTERN
ORTHOGONAL TO ARRAY

c) LINEAR ARRAY

FIG. 8.6 - POSSIBLE MULTIPLE APERTURE CONFIGURATIONS

SECTION 8 - REFERENCES

1. J. W. Sherman, and M. I. Skolnik, "Investigation and Study of a Multi-Aperture Antenna System," Second Quarterly Report, Contract No. NAS 5-3472, pp. 51-54; January 1, 1964.
2. Ibid; pp. 78-80.
3. F. Leary, "Television From Space," Space/Aeronautics, pp. 70-79; March, 1964
4. J. W. Sherman, D. J. Lewinski, and M. I. Skolnik, "Investigation and Study of a Multi-Aperture Antenna System," First Quarterly Report, Contract No. NAS 5-3472, p. 47; October 1, 1963.
5. J. H. Schrader, "Receiving System Design for the Arraying of Independently Steerable Antennas," IRE Trans., Set-8, pp. 148-153; June, 1962.
6. L. E. Williams, "Automatic Tracking Antennas," Electronic Industries, pp 92-97; October, 1963.
7. W. K. Victor, "Ground Equipment for Satellite Communications," Jet Propulsion Laboratory Technical Report No. 32-137, pp. 37-38; August 1, 1961.
8. J. P. Frazier and J. Page, "Phase Lock Loop Frequency Acquisition Study," General Electric Defense Systems Dept., Syracuse, New York, TISR61DSD25, Contract AF 04(647)483, p. 3.2; September 1, 1961.

9. COMPARISON WITH CONVENTIONAL ANTENNAS

9.1 Review of Previous Work

9.1.1 Cost Factor

It would be advantageous to briefly summarize the assumptions and conclusions obtained in other studies so as to present the several viewpoints of these sources. As will be developed later we have reached somewhat different conclusions with regard to the antenna cost factor.

In Schrader's article,¹ the following assumptions were made in arriving at a relative cost estimate:

- 1) The cost of a fully steerable large parabolic antenna will vary as a function of the diameter approximately as $5 (\text{DIA})^{2.7}$
- 2) The estimated cost of equipment required at each antenna (feed assembly, RF amplifier, detection, digital tracking system components, etc.) will be on the order of \$700,000 at each antenna.
- 3) The operation and maintenance costs are 2% of the initial cost per year for the antennas and 10% of the initial cost per year of the electronic equipment.

With the above assumptions, an estimate of the cost of the initial installation and operation over a ten year period per square foot effective area may be made with the result that the optimum antenna size for purposes of economy is approximately 150 feet in diameter.

L.E. Willimas in his article² made the following assumptions:

- 1) The cost of the antenna system can be expressed as Total Cost = $5 (\text{DIA})^{2.7} + \text{FIXED COSTS}$.
- 2) Variable costs include the structure and the drive system.
- 3) Fixed costs include such items as the receiver, servo systems, and control console.

- 4) The minimum cost per unit area for a specified fixed cost can be determined from the following expression:

$$1.75 (\text{DIA})^{2.7} = \text{FIXED COSTS}$$

In Williams' example, the assigned fixed costs were \$200,000 per antenna resulting in a reflector diameter of about 80 feet as being near "optimum." When an aperture approaching the area of a 160 foot diameter reflector is required, it is more economical to utilize four 80 foot antennas. The aperture corresponding to 225 feet in diameter can be most economically provided by eight 80 foot diameter antennas. In this case the total cost is only 68% of that of the single antenna.

Studies^{3, 4} at the Jet Propulsion Lab. of the California Institute of Technology on antenna cost indicate these costs to vary as

$$\text{Antenna Cost} = 5 \times (\text{diameter})^{2.7}$$

Note that all three sources quoted above assume the same variation of cost with diameter.

The economics of a large single antenna versus an array of several smaller antennas was evaluated and may be summarized as follows: The overall cost picture depends upon the initial cost of the antenna; the initial cost of all the electronics servomechanisms, and instrumentation; and the total operating cost of the installation for a given period of time.

The following assumptions were made by JPL in arriving at the final cost estimate:

- 1) The initial cost of an antenna varies approximately as the 2.7 power of the diameter and linearly with the number of antennas.
- 2) The electronics, servomechanism, and instrumentation costs vary only slightly with antenna diameter but are linear functions of the number of antennas.

- 3) Operation costs are slightly higher with larger diameters, increase linearly with the number of antennas for a small number of antennas, but vary less than linearly for large numbers of antennas.

A single antenna was preferred at diameters of less than about 250 feet in the JPL analysis.

Summarizing the available information on optimum multi-apertures presents quite a problem since the basic assumptions made by each of the referenced articles were different. It is interesting to note that the optimum size of a single antenna varied from 80 feet to 250 feet. It is further believed that none of the existing models are as yet realistic. An analysis of the costs of large antennas has been made by ECI and presented in Section 9.2. A model is developed for the cost of a multiple aperture system and optimum results presented in Section 4.

9.1.2 Critical Parameters of Large Parabolic Antennas

In the two previous Quarterly Reports of this study a detailed discussion of the critical parameters of large parabolic antennas was made and are only reviewed in this report,^{5,6} with the exception of the antenna pointing accuracies (Appendix II).

Briefly, the three primary considerations for large apertures are the effects of the atmosphere, mechanical errors in the reflector surface, and beam pointing accuracies. Table 9.1 shows the relative limitation of each form of limitation.

The results in this table have been modified slightly from that previously reported with regard to the pointing accuracy. This change has been necessitated due to further study which is outlined in Appendix II.

The multi-aperture approach acts to compensate or overcome any of the above limitations on a large single aperture. It was indicated in Appendix II that the multi-aperture approach overcomes

TABLE 9.1 - Aperture Limitations

Limitation	Maximum Aperture Size in Feet			
	0.1 Gc	1 Gc	4 Gc	10 Gc
Angle of Arrival Fluctuations Due to the Atmosphere	25,000	2,500	625	250
Gain Limitations Due to Errors in the Reflector Surface (Thermal Tolerance)	10,000	1,000	250	100
Pointing to Within				
1) the 3 db beamwidth	915	425	268	198
2) the 0.5 db beamwidth	770	357	225	166
3) the 0.1 db beamwidth	593	275	174	128

the most serious limitation of pointing accuracy but similarly it can compensate for the others. A 400 ft dish equivalent may not be obtained as a single antenna at 2 Gc. Figure 9.1 indicates the limit imposed by thermal tolerances as a function of frequency. The antenna requirements can be met however if four 200 ft apertures are used.

9.1.3 Disadvantages of Multi-Aperture Antenna Systems

The primary disadvantage of the multi-aperture configuration is in the transmission of signals. Although theoretically possible, the desirability of transmitting energy in terms of cost and reliability is poor. For a phase coherent system, a single power source with a distribution network to supply each antenna with the proper amplitude and phase could be quite expensive especially if the elements are located over a wide area.

Another disadvantage is the grating lobe phenomena created by relatively large element spacings in the array. The multiple aperture system is capable of reducing sidelobes adjacent the main beam by proper adjustment of amplitude and phase between the elements, but little can be done about the grating lobes if equal spacing is maintained between the individual antennas. Both control of sidelobes and the grating lobe problem have been discussed in Section 5.

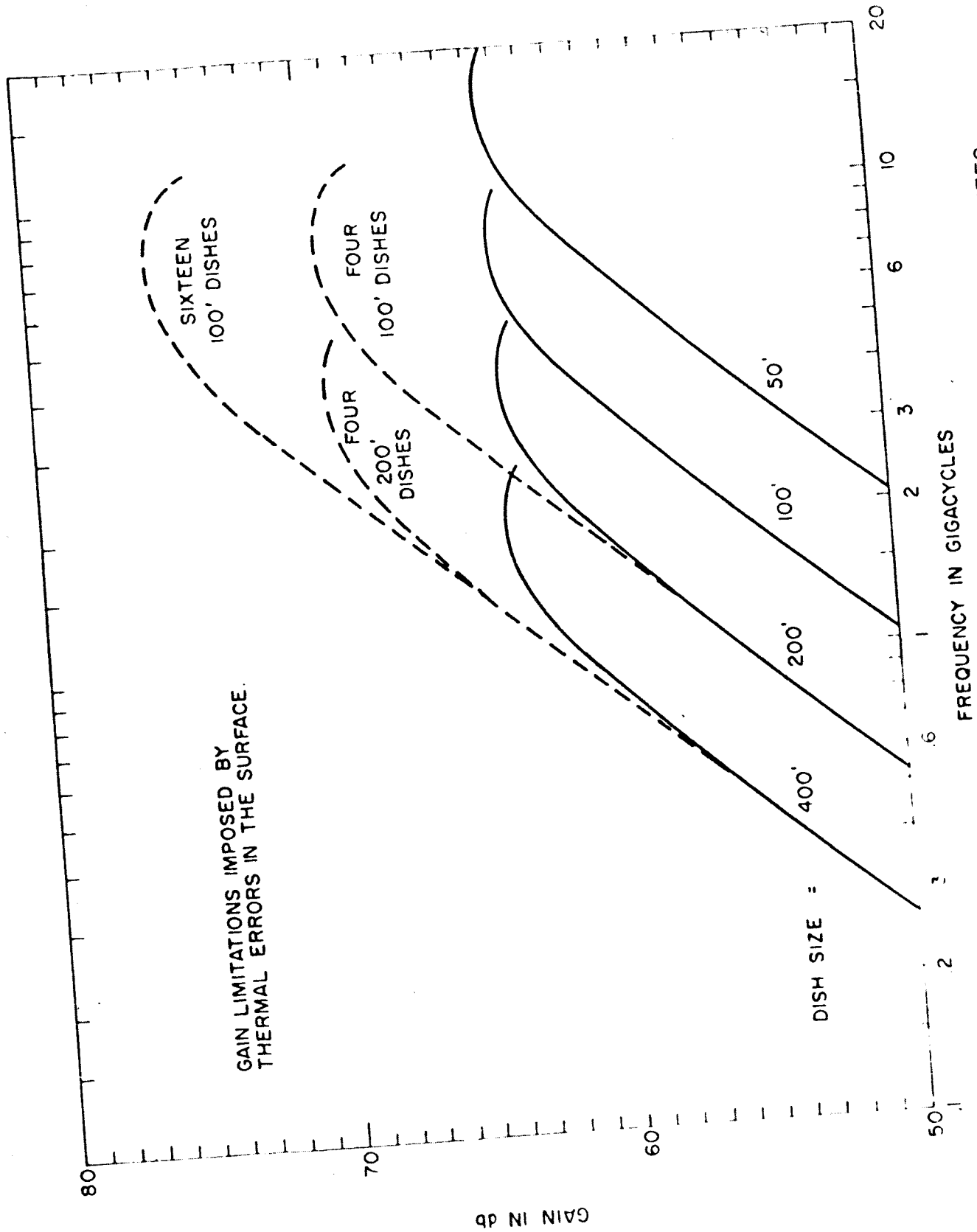

GAIN LIMITATIONS IMPOSED BY THERMAL ERRORS IN THE SURFACE.

FIG. 9.1 - GAIN AS A FUNCTION OF FREQUENCY FOR SEVERAL DISH SIZES.

9.1.4 Summary

The use of many small antennas instead of one large equivalent antenna has the advantage of more flexible and easier beam steering, enhanced reliability, capability of receiving simultaneously from more than one vehicle, and is less expensive to implement.

The critical parameters of large antennas, such as surface tolerances, required pointing accuracy, etc., place a limitation on the maximum diameter that can be efficiently utilized.

9.2 The Cost of Antennas

If the fixed cost of developing and implementing a large antenna site is ignored the most expensive single item is the antenna, which is defined to include the reflector and supporting structures, feed, mount, and servo-driving motors. Excluding foundation cost which will vary considerably depending on climate, geographical location, and soil-bearing pressure at the site, the cost of a steerable parabolic antenna has been indicated by several authors to be

$$\text{Cost} = 5 (\text{Diameter})^{2.7} \quad (9.1)$$

However, it is believed that this is not a realistic equation since it ignores completely the requirements made on the reflector tolerance. This tolerance is usually specified to be a fractional part of a wavelength. The shorter the wavelength the smaller the mechanical tolerance of the reflector becomes, so that it is more expensive to build a 100 foot diameter antenna at 10 Gc than at 1 Gc. Equation 9.1 does not bear out any such increase in cost. Furthermore, not only does the requirement on the reflector tolerance increase with frequency, but the support structures must maintain closer tolerances while steering, the mount must support additional weight, and improvement in the pointing accuracy places more stringent requirements on the driving motors. Thus, it is reasonable to expect the cost of a given size antenna to be frequency dependent. Other costs which are a function of antenna size are those of transportation and climate

conditions. Transportation costs are important as related to the weight of the antenna. Climate dictates the ruggedness of the structure.

Considering only a frequency and diameter dependency in the cost of a steerable antenna, the following model for cost has been determined from the available information on antenna prices.

$$\text{Cost} = 0.92 \sqrt{f} D^{2.94} \quad (9.2)$$

In this expression f is the maximum usable frequency of the dish expressed in gigacycles, and D the diameter expressed in feet. The choice of expressing the dish size in feet rather than meters was done primarily because large antennas are typically identified this way. The maximum usable frequency is a more convenient parameter than a tolerance figure for the reflector surface and requires further definition.

Figure 9.2 is a sketch similar to Figure 9.1 for two other antenna sizes. All antennas in these figures are designed to thermal tolerances (1 part in 10^4) and thus all have the same maximum gain. The 120 foot dish corresponds to the Lincoln Lab Haystack antenna and is said to have a maximum usable frequency of 10 Gc, although it will be specifically used in the frequency band from 7.125 to 8.5 Gc.⁷ The proposed JPL 210 foot antenna will have a maximum usable frequency of 6 Gc. It is seen that this maximum frequency is such as to give a gain decrease of 2 db below the maximum gain and is 9 db below the gain of a perfect antenna of the same physical size operating at the same frequency. The gain falls swiftly when the frequency is increased beyond the maximum usable frequency.

Difficulties exist often in determining what the actual costs are for the antenna. Table 9.2 compares the predicted value of Equation 9.2 with the known or most recently estimated cost. It is believed that the expression of Equation 9.2 is an adequate representation of antenna cost. This may be compared to the often quoted expression of Equation 9.1 which is listed for comparison in Table 9.3.

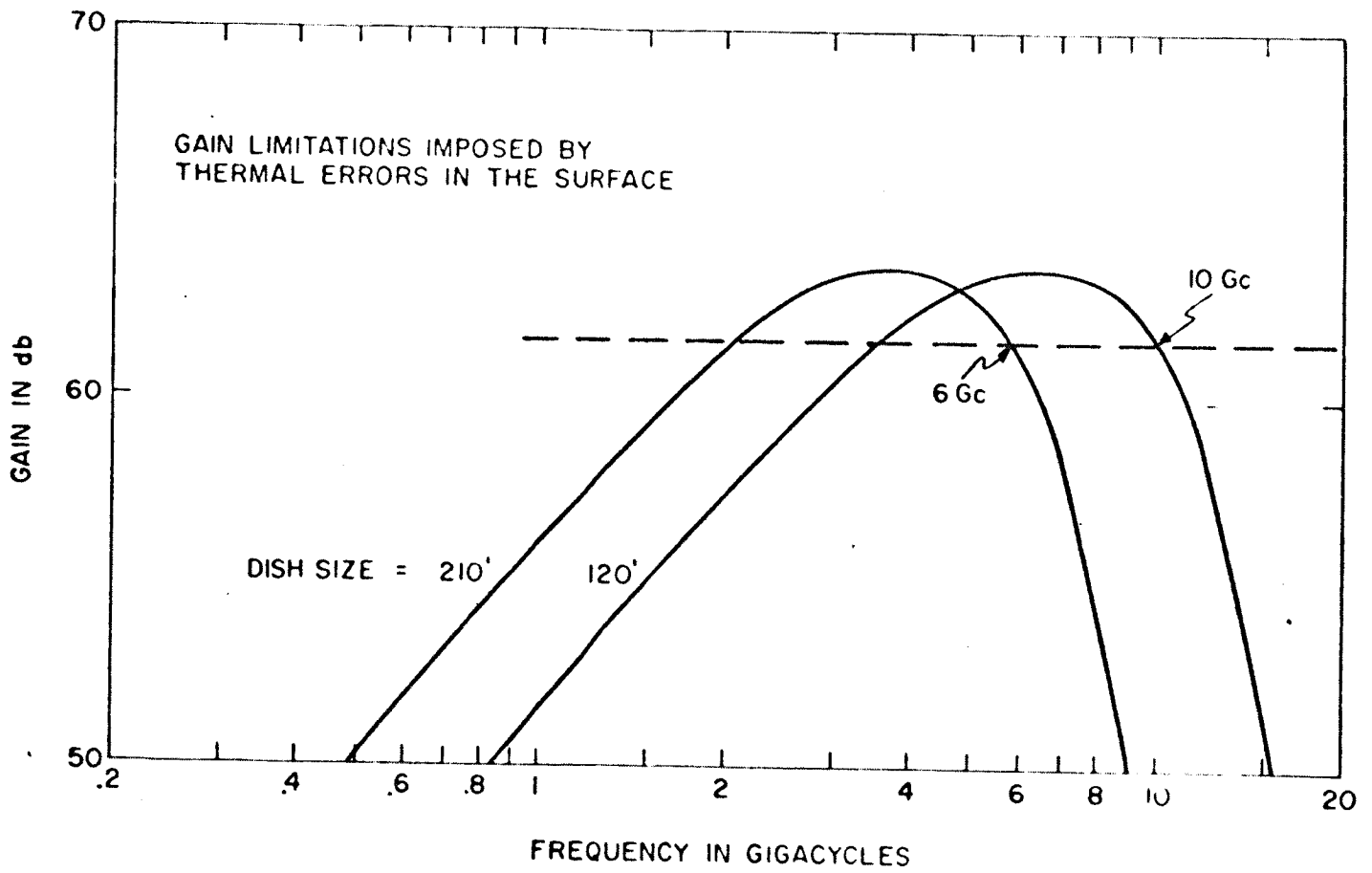

FIG. 9.2-GAIN AS A FUNCTION OF FREQUENCY FOR TWO DISH SIZES.

TABLE 9.2 - Predicted and Actual Antenna Cost

Max. Usable Frequency	Diameter in Feet	Predicted Cost	Actual Cost or Estimated Cost
3 Gc	60	\$.268 x 10 ⁶	\$.275 x 10 ⁶
	85	.747 x 10 ⁶	.75 x 10 ⁶
	600	234 x 10 ⁶	240 x 10 ⁶
6 Gc	210	\$ 15.1 x 10 ⁶	\$ 12-15 x 10 ⁶
10 Gc	25	\$.375 x 10 ⁵	\$.45 x 10 ⁵
	85	1.36 x 10 ⁶	1.56 x 10 ⁶
	120	3.77 x 10 ⁶	4-5 x 10 ⁶

TABLE 9.3 - Prediction of Antenna Cost, Equation 9.1

Diameter in Feet	Predicted Cost
25	\$.3 x 10 ⁵
60	3.15 x 10 ⁵
85	1.25 x 10 ⁶
120	2.08 x 10 ⁶
210	9.3 x 10 ⁶
600	158. x 10 ⁶

9.3 Characteristics Attractive for Space Communication

This section summarizes the special and unique characteristics that make a multi-aperture adaptive antenna system attractive for space communications as compared with a receiving system consisting of but a single large antenna. Although this section is mainly concerned with Item 4 in the contract Statement of Requirements (Appendix III) it is also related to the comparison of characteristics of Item 3 as discussed in the previous section of this report.

Cost One of the major reasons for considering the multi-aperture antenna system is that it appears to be more economical than the equivalent single-dish antenna. This results from the fact that the cost of single antennas varies almost as the cube of the diameter. The relative costs of single and multi-aperture systems are discussed in Sections 9.2 and 4, respectively. The multi-aperture system is shown to be of advantage economically especially if the size of the equivalent single antenna is large. The multi-aperture technique is probably the only economical method for achieving a large effective antenna aperture capable of hemispherical coverage once the practical limiting size of a single mechanical reflector has been reached. Although the benefits of reduced cost for a given range capability is probably the primary reason for originally considering the multi-aperture antenna there are other important benefits to be derived from its use as described below.

Flexibility of Operation The availability of n separate antennas of a multi-aperture system permit it to be used for up to n simultaneous, separate missions. Each antenna operating individually may be used in situations where the maximum sensitivity is not required or the antennas may be combined in groups of from 2 to n collectively operate as adaptive systems with enhanced receiving aperture.

Reliability This is achieved via the redundancy of the multi-aperture system. The failure of one unit will cause but little

overall degradation. Its effect is to reduce the data rate and/or increase the error rate. The presence of many identical antenna and receiving systems offers the possibility of recognizing a failure in any one unit by comparison with other operating units. Any weaknesses found in one unit can be corrected in the other units before they can cause failure. Catastrophic failure of the multi-aperture antenna system is far less likely than with a single antenna. The system may be said to "die-gracefully." Since each antenna is of more manageable size, the down time required to perform any necessary mechanical repairs should be less than with one large antenna. Routine maintenance can be more easily performed on the multi-aperture system since it is necessary to shut-down only one antenna at a time rather than the entire system.

Reduced Construction Time It seems reasonable to expect that the multiple, identical antennas could be manufactured in less time than a single antenna of equivalent aperture. Tooling, jigs, and handling equipment can be of smaller size and can be used over again for each antenna. The problem of lifting materials to high heights is progressively harder above levels of 150'-200'. Furthermore, the engineering of the individual antennas of the sizes needed for the multi-aperture systems has already been performed for many antenna types and a number of companies can supply these antennas almost as if they were a catalog item. This certainly applies to the 85 ft diameter antennas available from several antenna manufacturing sources. A single antenna considerably larger than those commonly used in present space applications might require significant development time and cost.

Improved Antenna Performance The more modest sizes of the individual antennas of a multi-aperture system mean that faster tracking and slewing rates can be achieved compared to a single dish antenna. The ability to move an antenna at high speed usually must be sacrificed as its size is increased in order to keep the power requirements of the drive motors to a reasonable value. Multi-aperture antenna systems

do not suffer this limitation. It should also be possible to design and build multi-aperture systems at higher frequencies than the single-antenna systems. Thermal elongations generally cause a limitation to the precision with which mechanical structures can be manufactured and maintained. A commonly quoted limit on the tolerance due to thermal effects is 1 part in 10^4 . If the dimensions must be held to at least one tenth of a wavelength, the maximum antenna size would be about 1000 wavelengths, which is about the size of the MIT Haystack Hill antenna. Multi-aperture antenna systems can be designed to overcome this limitation by using individual antennas of size less than the bounds set by thermal elongation and by using the ground as the base of reference rather than some structural bridgework suspended in "midair." This concept has proven quite successful in the design of radio astronomy antennas.

Freedom from Atmospheric Inhomogeneity The usual antenna is of small enough physical extent that the atmosphere into which it looks is relatively homogeneous. With very large antennas, however, the atmosphere might not be a uniform propagation medium and phase perturbations across the wavefront can result. This limit to conventional antennas is eliminated with the adaptive processing of the multi-aperture system.

Beam Pointing The individual dishes of the multi-aperture system, being of smaller size than the equivalent single-dish antenna, are easier to point in angle. This results from the fact that each antenna is a lighter mechanical structure as well as the fact that the individual beams are broader. The problem of precise pointing is transferred to the adaptive electronic combining circuitry. It was shown in Section 4 that beam pointing is probably one of the most severe limitations on large antennas.

Diversity Reception The primary objective of the multi-aperture system considered in this study is that of achieving a large

effective collecting aperture by utilizing in combination several, or many, antennas of relatively modest size. The availability of multiple apertures, however, also offers the possibility of diversity reception under severe fading conditions. Diversity reception has been widely used in short wave and tropospheric scatter communications to achieve reliable transmission of messages in spite of the vagrantness of the propagation medium. In communications with spacecraft, diversity reception could be of importance in reducing the minimum elevation angle at which communications can be accomplished. At angles near the horizon, fading due to multipath is more likely to occur. Its effects can be mitigated because of the diversity reception capability of the multi-aperture system.

Transmission Although the major portion of this study has been concerned with the reception of signals from spacecraft, simple modification of the adaptive circuitry plus the addition of power amplifiers permits transmission of signals from the ground to the spacecraft.

Growth The unit construction of the multi-aperture system permits almost unlimited growth as the requirements for space communication increase.

Upper Limit on Single Aperture Size Independent of cost there is a natural upper bound established on the antenna size and is best summarized by Figure 5.13 in Section 5. At 2 Gc it appears impractical to build an antenna larger than 400 feet.

SECTION 9 - REFERENCES

1. J. H. Schrader. "Receiving System Design for the Arraying of Independently Steerable Antennas," IRE Trans, SET-8, pp. 148-153; June 1962.
2. L. E. Williams, "Automatic Tracking Antenna System," Electronic Industries, pp. 92-97; October 1963.
3. W. K. Victor, Ground Equipment for Satellite Communication. JPL Tech. Report No. 32-137; August 1, 1961.
4. E. Techtin, B. Rule, R. Stevens. Large Ground Antennas. JPL Tech. Report No. 32-213; March 20, 1962.
5. J. W. Sherman, D. J. Lewinski, and M. I. Skolnik, "Investigation and Study of a Multi-Aperture Antenna System " First Quarterly Report. Contract No. NAS 5-3472, pp. 45-53; October 1, 1963.
6. J. W. Sherman, and M. I. Skolnik, "Investigation and Study of a Multi-Aperture Antenna System," Second Quarterly Report, Contract No. NAS 5-3472, pp. 105-107; January 1, 1964.
7. Electronic Science Preview, pp. 32-39; September 1963.

APPENDIX I

Brief Review of Previous Work in Multi-Aperture Combining

There has been considerable work in the past concerning the combining of the outputs of more than one antenna aperture for shortwave and scatter communications as well as for space communications. This section briefly describes some of the past work in this subject, as available in the published literature and contract reports. Most of the previous publications appearing in the literature have been concerned with methods for combining the outputs of the several antennas rather than with the engineering aspects of tracking, reliability, economics, acquisition, and so forth.

I Diversity Combining in Scatter Communications

The multi-aperture antenna concept is related to and stems from the concept of diversity combining employed with success in scatter communications¹ and, before that, for shortwave communications². Scatter communications are generally characterized by signal fading resulting from multipath propagation. Signals arriving via multiple paths give rise to interference effects, both constructive and destructive. By using more than one receiving system in which the fading is uncorrelated, the fluctuations in received signal strength can be smoothed. Reception systems for scatter communications have been based on diversity in space, polarization, frequency, angle, and time. Space diversity has probably seen the widest application and is the closest to the multi-aperture antenna systems considered here.

Space diversity is employed in scatter communications primarily to combat the deleterious effects of signal fading. Any increase in effective aperture because of more than one antenna is of secondary importance only. The multi-aperture antenna for space communications, on the other hand, is of interest primarily because of the increased aperture as compared with a single unit antenna and because it is more economical to implement than a single large

antenna of equivalent size. Fading due to multipath is not as important in space communications as it is in scatter communications with antennas beamed at or near the horizon. Because of the difference in application, space-diversity scatter communications generally employ only a few antennas, two or three being a typical number; while a multi-aperture system might employ at least four or six as a minimum.

The majority of the implemented operating space-diversity scatter communication systems seem to employ post detection combining in which the phase of the RF carrier need not be known. This has apparently proven satisfactory in many cases since one is not necessarily looking for enhanced signal-to-noise, but to prevent the signal from fading to an unusable level. Brennan¹ discusses the several methods of operating a diversity system including: (1) selection diversity in which the channel with the maximum signal is determined and then switched so as to receive only on that channel; (2) equal-gain combining in which all channels are summed with equal weighting; and (3) maximal-ratio combining in which the signals from each channel are weighted in amplitude according to their signal-to-noise ratios. Only the last two are of interest in the combining of the multi-aperture antenna system. The maximal-ratio combining is analogous in principle to the matched filter since it yields the maximum output signal-to-noise ratio. Equal-gain combining is less efficient, but in many cases the difference is slight.³ It is easier to implement.

Predetection combining techniques for scatter communications have been described in the literature⁴⁻⁶ although the extent of their application in actual systems is not known but is probably not as great as post detection combining. In the case of FM systems with a large deviation ratio or other bandwidth-exchange systems, predetection combining can lead to substantial improvement over post detection. This is a result of the threshold effect. A SNR at the detector input that is more than a few db above threshold yields a large output SNR

while an input ratio that is more than a few db below threshold yields a very small output ratio.

During deep fades or in the absence of a signal, the noise output from an FM receiver rises sharply to a level comparable to full signal output. This will have a serious effect on equal-gain post-detection combining. If post-detection combining is used, it must be maximal-ratio. Equal-gain combining can be used predetection, however. Since a large majority of telemetry utilizes frequency modulation, it is important to consider predetection combining so that full advantage can be obtained of the combining efficiency. An additional advantage claimed for predetection combining in FM systems is that FM multipath distortion is reduced. This is, of course, a factor more important in scatter communications than in space communications since multipath is more likely to occur in the former.

In spite of the differences in the application and the motivation for their use, the techniques developed for predetection, or coherent, diversity combining are similar to the combining methods which would be used in the multi-aperture antenna.

1.2 Predetection or Coherent, Combining

A number of predetection combining methods have been described. Figure I.1 is a block diagram of an IF combining system taken from the paper by Adams and Mendes⁴ and has been known as the FTL predetection equal-gain combiner. A phase detector compares the signals in the two channels and generates a corrective dc voltage which adjusts the phase of one of the local oscillators to bring about coincidence of the phases in the two channels. In essence, it acts like a phase lock loop with one of the two channels taking the part of the reference signal.

The combining method of Figure I.2a contains a separate phase lock loop in each channel which converts the signal phase to that of a common reference. This requires some prior knowledge of

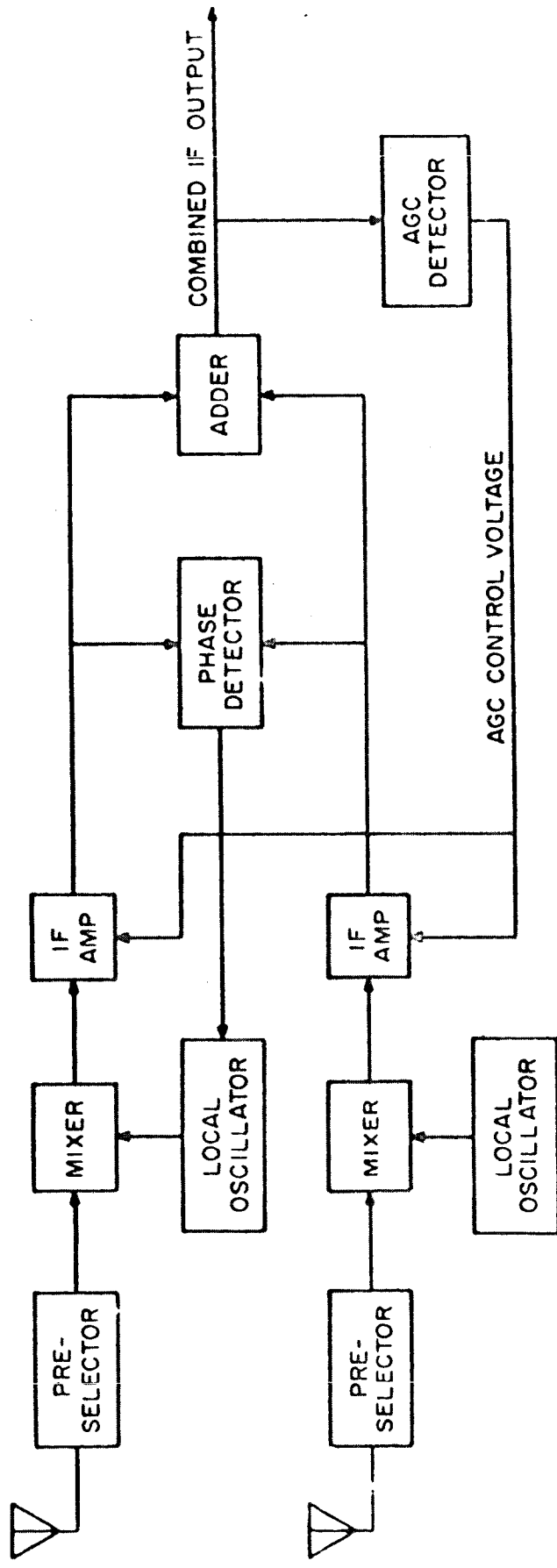
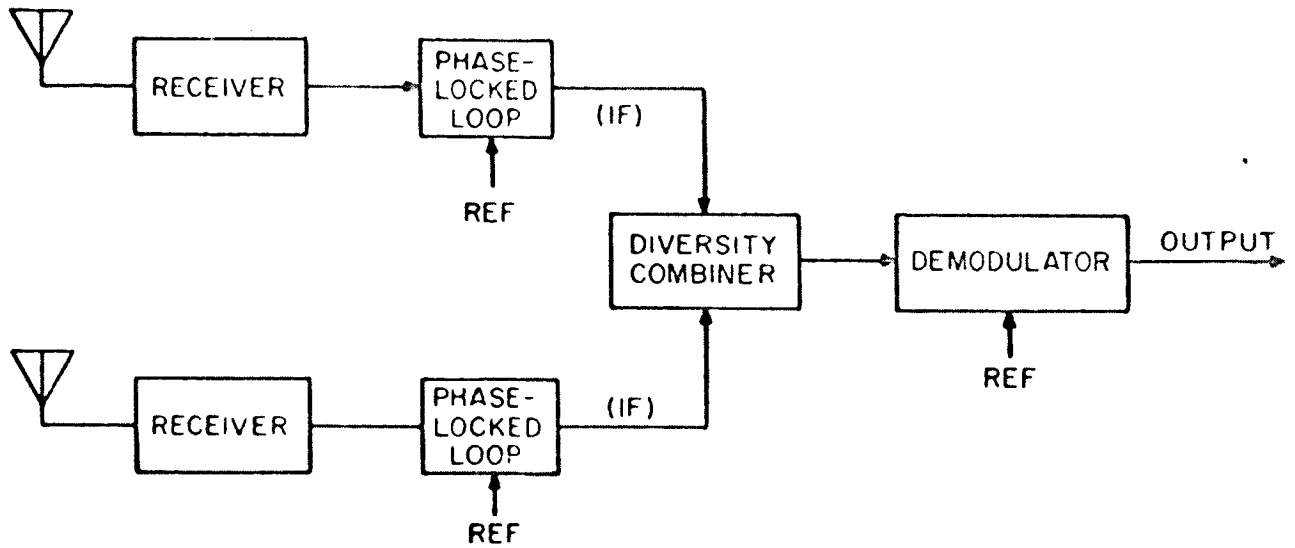
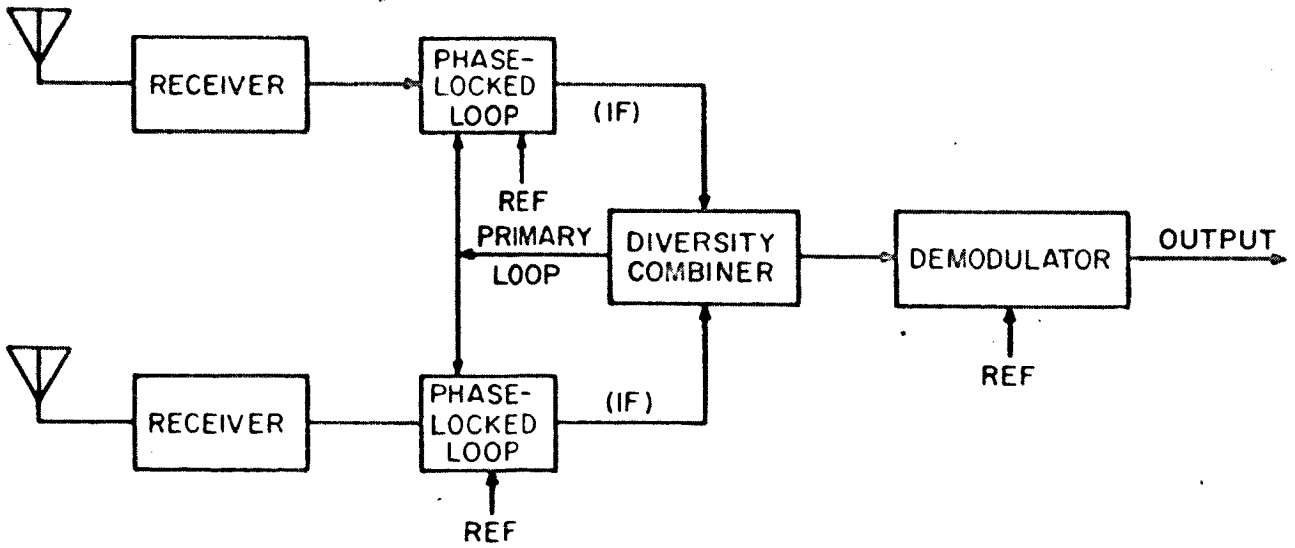

FIG. I.1 -FTL PREDETECTION EQUAL-GAIN COMBINER. THIS CAN BE USED WITH ANY TYPE OF MODULATION. (AFTER ADAMS AND MINDES⁴)



(a)



(b)

FIG. I.2 - a) PREDETECTION DIVERSITY COMBINER USING PHASE-LOCKED LOOPS.
 b) SAME AS (a) BUT WITH A PRIMARY LOOP TO TRACK CHANGES COMMON TO BOTH INPUTS. (AFTER LAUGHLIN⁶)

the frequency of the received signal. A disadvantage of this embodiment is that if one of the channels lost its signal the phase lock in that channel would be broken and according to Laughlin⁶ the loop will generally not relock because of the narrow bandwidths and wide tracking ranges and is thus lost from service. This can be avoided as in Figure 1.2b by providing a primary phase locked loop to track changes common to both inputs and two secondary loops which compensate for differential changes in the input to assure phase coherence for combining.

Bello and Nelin⁵ describe a "coherent" combining method in which a pilot tone is transmitted along with the information signal. The pilot is filtered in the receiver and used as the local oscillator reference in a heterodyne operation in which the difference frequency is extracted, as in Figure 1.3. The effectiveness of this technique depends on the signal-to-noise ratio in the pilot tone channel.

1.3 Multi-Aperture Antennas

Ohio State University Antenna Laboratory was probably the first to demonstrate for space applications the feasibility of the multi-aperture antenna concept.⁷ Their system consisted of four parabolic reflectors each 30 ft in diameter operating at a frequency of about 2 Gc. The total area was equivalent to that of a single 60 ft diameter aperture. The four antennas were located at the corners of a square having a side length of 60 feet. Each channel contained a separate phase lock loop for providing coherent combining. The common reference signal which is necessary for achieving phase coherence was provided by 1) the sum of all four antenna signals, 2) one of the antenna outputs, or 3) a separate locally generated reference oscillator, provided the frequency is known a priori. Ohio State demonstrated that such a system can be made to successfully acquire and track satellite targets.

Lehan and Hughes⁸ obtained a patent on the phase lock loop method of combining the outputs of an electronically scanning antenna

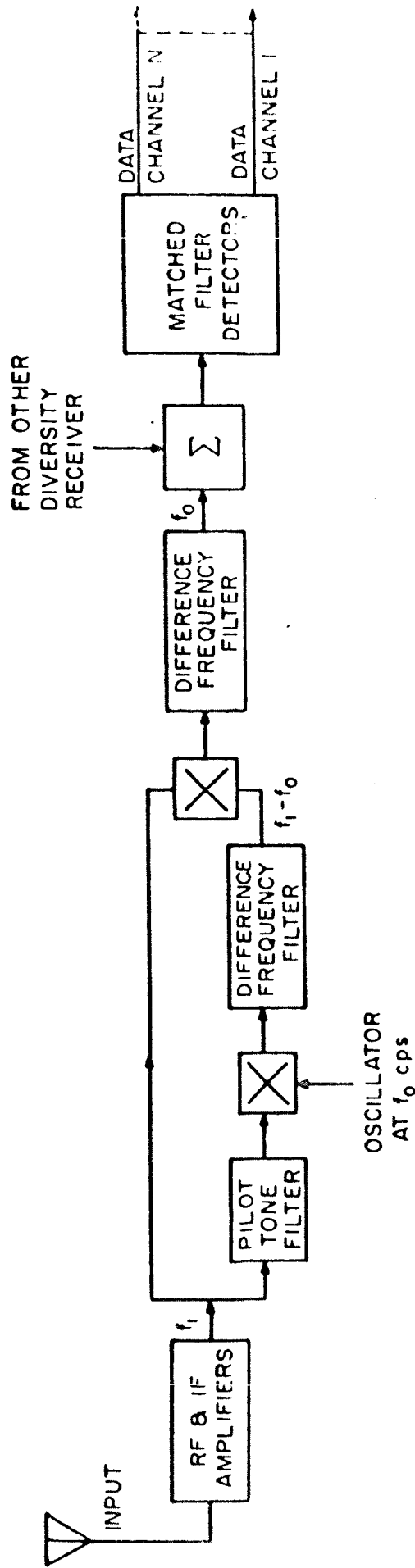

FIG. I. 3 - COHERENT COMBINING METHOD OF BELLO AND NELIN⁵ (PREDETECTION PORTION OF ONLY ONE RECEIVER IS SHOWN.)

system. This is described more completely by Gangi.⁹ The phase lock loop antenna system is adaptive in that it changes its bandwidth in response to the signal level. For large signals the bandwidth of the phase-lock system increases, thus allowing shorter acquisition times. Gangi reports on tests with a simulated system using audio frequencies. He also states that the system can, in theory, be designed to automatically acquire signals of any level in the shortest possible time.

Breese et al¹⁰ described a similar configuration of phase-locked loop antenna system but primarily for deep-space communication applications. The possibility of bandwidth limitation was pointed out if the spacing between elements was too large.

Other studies of the multi-aperture antenna are those of Schrader¹¹ and Williams.¹² Both of these papers have been referred to and discussed in other parts of this report.

Almost all of the references reported in this section have been concerned with space communications. The multi-aperture concept is well known in radio astronomy and manifests itself as large interferometer arrays. Drake¹³ has discussed the economy involved in the multi-aperture approach for radio astronomy.

REFERENCES - APPENDIX I

1. D.G. Brennan, "Linear Diversity Combining Techniques," Proc. IRE, Vol. 47, pp. 1075-1102, June, 1959.
A comprehensive treatment of diversity combining with extensive references to previous work and an annotated bibliography.
2. H.H. Beverage and H.O. Peterson, "Diversity Receiving System of RCA Communications, Inc., for Radiotelegraphy," Proc. IRE Vol. 19, pp. 531-562; April, 1931.
One of the first papers describing diversity including frequency, polarization, and space diversity. Equal gain combining at IF.
3. F.J. Altman and S. Sichak, "A Simplified Diversity Communication System for Beyond-the-Horizon Links," IRE Trans., Vol. CS-4, pp. 50-55; March, 1956.
Several comparative results are given on selection, equal-gain, and maximal-ratio systems in the presence of Rayleigh fading.
4. R.T. Adams and B.M. Mindes, "Evaluation of IF and Baseband Diversity Combining Receiver," IRE Trans., Vol. CS-6, pp. 8-13, June, 1958.
Theoretical and experimental comparison claims that IF combiner demonstrates significant advantages over the baseband combiner in distortion level, FM quieting, complexity, and reliability. Notes a reduction in FM multipath distortion by predetection equal-gain combining.
5. P. Bello and B.D. Nelin, "Predetection Diversity Combining with Selectively Fading Channels," IRE Trans. Vol. CS-10, pp. 32-42, March, 1962. Correction in Vol. CS-10, p. 466; December, 1962.
A pilot tone is transmitted with frequency division multiplexed channel signals to provide a phase reference for coherent combining. Pilot signal acts as the reference to remove phase from signal by heterodyning.
6. C.R. Laughlin, "The Diversity-Locked Loop - A Coherent Combiner," IEEE Trans., Vol. SET-9, pp. 84-92; September, 1963.
Describes use of the phase-locked loop to convert each received signal of a diversity system to an essentially constant frequency and phase for coherent combination prior to demodulation. Introduces the concept of the primary and the secondary phase lock loop.

REFERENCES - APPENDIX 1 (Continued)

7. J.W. Eberle, "High Gain Antenna Array Facilities at the Ohio State University." O.S.U. Report 1072-3, Contract AF 30(602)-2166; 22 September 1961.
Description of an antenna array consisting of four 30 ft diameter parabolic reflectors with phase lock loop combining.
8. F.W. Lehan and W.R. Hughes. "Electronically Scanning Antenna Employing Plural Phase-Locked Loops to Produce Optimum Directivity." U.S. Patent 3,036,210; May 22, 1962 Filed November 2, 1959.
Patent describing the use of phase detectors at each element of an antenna array to determine the phase error and a phase shifter or a voltage controlled oscillator to apply the phase correction at each element to achieve coherent combining.
9. A.F. Gangi, "The Active Adaptive Antenna Array System," IEEE Trans., Vol. AP-11, pp. 405-414; July, 1963.
Further details of the Space-General Corp. phase lock loop technique described in the patent of Lehan and Hughes. Considers the acquisition of a signal, phase lock loop theory, bandwidth, and discusses the results of an experimental demonstration.
10. M.E. Breese, R.P. Colbert, W.L. Rubin, and P.J. Sferrazza, "Phase-Locked Loops for Electronically Scanned Antenna Arrays." IRE Trans., Vol. SET-7, pp. 95-100, December, 1961.
Sperry Corporation "ATHESA" System for achieving high antenna gain for deep-space communication systems using phase lock loops with multiple antenna apertures.
11. J.H. Schrader, "Receiving System Design for the Arraying of Independently Steerable Antennas," IRE Trans., Vol. SET-8, pp. 148-153; June, 1962.
Concerned with the multi-aperture antenna for deep-space communications. Primary and secondary phase lock loops for combining. Discusses cost and optimum aperture size.
12. L.E. Williams, "Automatic Tracking Antenna Systems,"
Discussion of multi-aperture antenna for space communications.
13. F.D. Drake, "Optimum Size of Radio Astronomy Antennas." Proc. IEEE, Vol. 52, pp. 108-109; January, 1964.
Multi-aperture antennas in Radio Astronomy. The March 1964 issue of the IEEE Transactions on Antennas and Propagation is a special issue on active and adaptive antennas and contains a number of papers concerned with the subject of this report.

APPENDIX II - Pointing Accuracies of Antennas

It has been shown in the two previous quarterly reports^{1,2} that the major limitation to a large antenna is the ability to accurately point its beam in a specified direction. At low frequencies, where the width of the main beam is relatively large, this poses no limitation. However, as the frequency increases, the beam width decreases. It is therefore mandatory that the dynamic pointing accuracy of the antenna system be small enough to minimize losses due to incorrect pointing. This appendix revises the previous pointing accuracies reported^{1,2} in terms of anticipated results from two large antennas now under construction. The dynamic pointing accuracies specified for the 120 foot Haystack antenna, and the 210 foot JPL dish will represent definite improvements in the state-of-the-art. The Haystack antenna specification calls for a dynamic pointing accuracy of ± 0.005 degrees,³ and the JPL dish calls for ± 0.017 degrees.⁴ Figure II.1 shows these two antennas pointing accuracies along with several high quality operational antennas. The relationship between these two antennas can be represented mathematically by

$$\text{Dynamic Pointing Error} \propto (\text{Diameter})^{1.92}. \quad (\text{II. 1})$$

However, the information available does not justify a model expressed to such an accurate power, so that it will be assumed that

$$\text{Dynamic Pointing Error} \propto (\text{Diameter})^2. \quad (\text{II. 2})$$

This expression implies that as the diameter of the antenna approaches zero so does the pointing error. The greatest accuracy thus far accomplished for dynamic pointing of mounts is a laser telescope mount developed for NASA (± 2 seconds of arc). This suggests that with the present state-of-the-art there is a lower bound on the pointing error and in the model developed it is assumed to be independent of the aperture size for small apertures. Using the above value of ± 2 seconds of arc ($\pm 5.6 \times 10^{-4}$ degrees) as this lower limit the following mathematical model may be assumed

$$\text{Dynamic Pointing Error} = 6.5 \times 10^{-9} D^2 + 9.7 \times 10^{-6}, \quad (\text{II. 3})$$

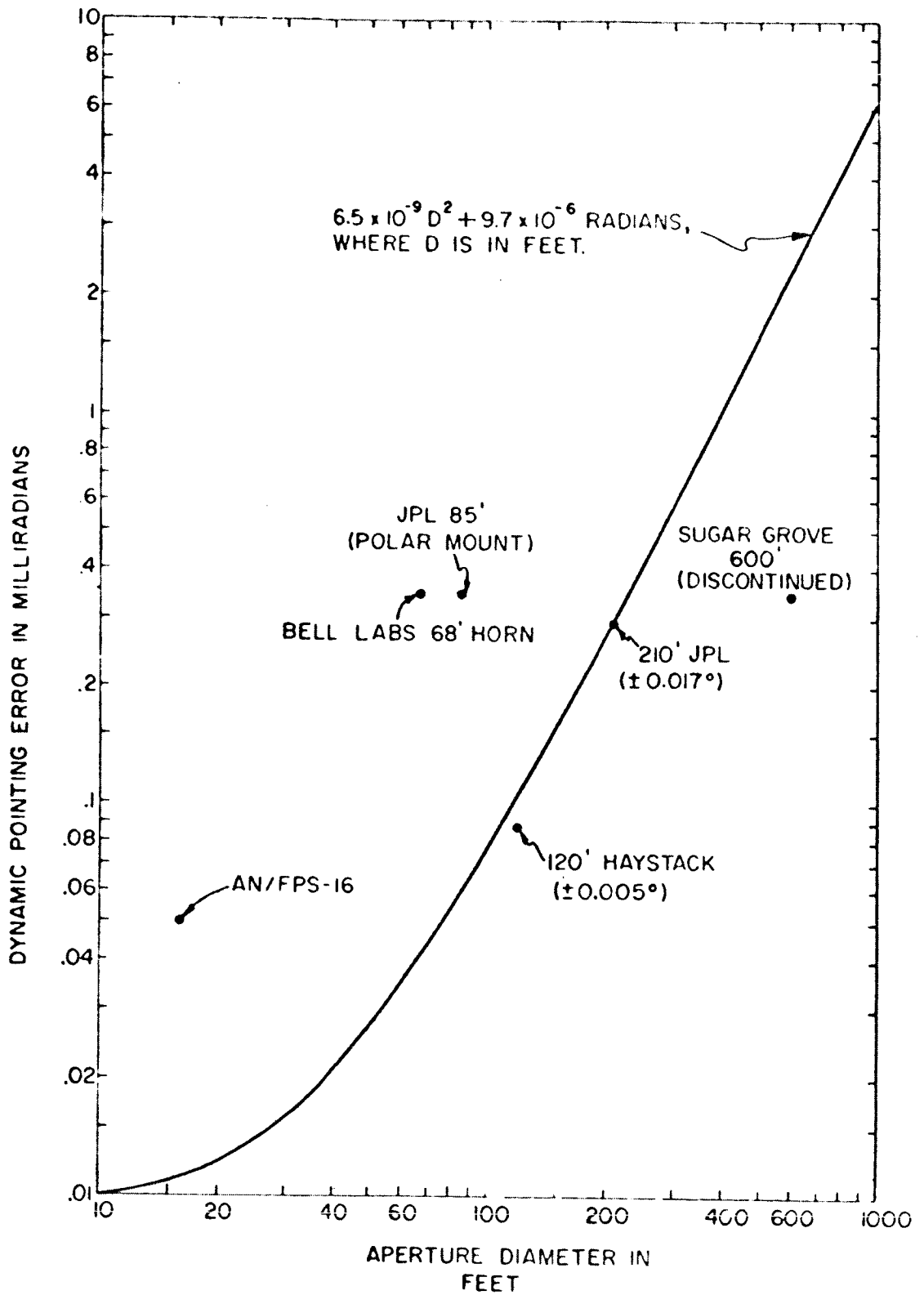

FIG. II.1 - MAXIMUM DYNAMIC POINTING ACCURACY AS A FUNCTION OF APERTURE SIZE.

where the dynamic pointing error is in radians and D is in feet. This equation is sketched in Figure II.1, and is the most optimistic model that can be made on the basis of anticipated pointing accuracies.

The importance of accurate pointing is greatest during the acquisition period of communications. The greater the pointing error, the less the signal-to-noise ratio during acquisition. The multiple aperture system enjoys two advantages in regard to pointing. First, the individual subapertures do not have to be pointed as accurately as the larger single dish. Second, because the subaperture is smaller, it can be pointed with greater ease and economy, without demanding improvement in the state-of-the-art.

The most effective way to judge the importance of pointing is to evaluate its dollars and cents cost. Consider a 250 foot antenna. If pointed to within the 3 db beamwidth (0.12 at 2 Gc) of the aperture, the antenna must be pointed to within $\pm 0.06^\circ$. Since it is possible to lose 3 db of signal with this pointing accuracy, the net result is an equivalent antenna which has half the area of the 250 foot dish (177 feet). But according to the model used in this study (i. e., Section 4) the difference in cost between a 177 foot and 250 foot aperture designed to have a maximum usable frequency of 6 Gc is of the order of 17 million dollars (The 250 foot antenna will cost around 25 million and the 177 foot dish will cost around 8 million dollars). Thus, it is possible to lose a large fraction of antenna cost (68% for this example) if the antenna is not pointed accurately. Because of this critical loss due to pointing, the aperture should point to within the 0.1 db points of the main beam ($\pm 0.016^\circ$, which is probably not within the state-of-the-art for this size antenna).

APPENDIX II - References

1. J. W. Sherman, and M. I. Skolnik, "Investigation and Study of A Multi-Aperture Antenna System," Second Quarterly Report, Contract No. NAS 5-3472, pp. 105-107; January 1, 1964.
2. J. W. Sherman, D. J. Lewinski, and M. I. Skolnik, "Investigation and Study of A Multi-Aperture Antenna System," First Quarterly Report, Contract No. NAS 5-3472, pp. 45-53; October 1, 1963.
3. L. E. Williams, "Automatic Tracking Systems," Electronic Industries, pp. 92-97; October, 1963.
4. E. Rechin, B. Rule, and R. Stevens, "Large Ground Antennas," Jet Propulsion Laboratory, Technical Report No. 32-213, p. 38, March 20, 1962.
5. Electronic Science Preview, p. 8; December 15, 1963.

APPENDIX III

Statement of Requirements

The scope of this research contract covers the investigation of a multi-aperture adaptive antenna system in order to establish its utility in receiving telemetered data from remote space vehicles or satellites. The technical objectives of this investigation must include, but are not necessarily limited to all of the following:

1. A study of the problems associated with acquisition of r-f signals and the adaptation of an optimum signal processing antenna system to this signal acquisition:
 - (a) In the frequency band from 0.1 to 4 Gc at lunar ranges (3.8×10^5 kilometers)
 - (b) In narrow band operation around 2 Gc at interplanetary ranges (2.6×10^8 kilometers)
2. A specific study of the problems of phase coherence, collimation and self shadowing of a multi-aperture adaptive antenna system
3. A comparison of the characteristics of a multi-aperture adaptive antenna system with conventional antenna systems (i. e. fed parabolas or phased arrays) used in acquiring telemetered r-f signals from satellites
4. A determination of the special and unique characteristics that make a multi-aperture adaptive antenna system attractive for space communication
5. An evaluation of the reliability of a multi-aperture adaptive antenna system by comparison to conventional antenna systems.
6. Establishment of the optimum look angle that can be achieved with a multi-aperture adaptive antenna system.
7. A study of the utility of an adaptive antenna system in successfully acquiring and discriminating a desired telemetry

signal in the presence of a nearby interfering source such as the sun or a nearby undesired transmitter.

8. A determination of the tracking potential of an adaptive antenna system.
9. The resolution of all of the above studies to determine a best configuration, number and arrangement of a multi-aperture adaptive antenna system, to recommend the most suitable subaperture type, and to establish the optimum bandwidth of the antenna system.

APPENDIX IV

Analysis of Phase Measurement and its Application to
the Coherent and Incoherent Combining of
Signals in Multi-Aperture Arrays*

* Prepared by Prof. Willis C. Gore, Dept. of Electrical
Engineering, Johns Hopkins University.

I. ON THE MEASUREMENT OF PHASE OF AN ARBITRARY BAND-PASS SIGNAL

While the phase (or argument) of a (constant amplitude) sinusoidal signal is a well defined concept, it should be realized that it is not easily extended for the case of an arbitrary signal. The difficulty is seen when one attempts to write:

$$e(t) = v(t) \cos \phi(t) \quad (1)$$

for an arbitrary signal $e(t)$. It is recognized that with the two functions, $v(t)$ and $\phi(t)$, to be specified, one could be assigned arbitrarily and the other determined by solving Equation 1 for the other. One way of assigning values to $v(t)$ and $\phi(t)$ which yields unambiguous results, and therefore is almost universally used, is to take the spectrum (Fourier transform) of $e(t)$ [Fourier transform will be denoted with a capital letter], $E(f)$, and divide it into its symmetrical and antisymmetrical parts with respect to an arbitrarily selected frequency f_0 . [A sufficient, but not necessary, condition for this method to be applied is the signal $e(t)$ must have a bandwidth less than one octave, and f_0 must be greater than $\frac{1}{2}$ the highest frequency of any of the components of $e(t)$.] The symmetrical part is defined as:

$$SE(f) = SE(f_0 + \Delta f) = \frac{1}{2} \{E(f_0 + \Delta f) + E^*(f_0 - \Delta f)\} \quad (2)$$

for $f > 0$

where the star (*) denotes the complex conjugate. The antisymmetrical part is defined as:

$$AE(f) = AE(f_0 + \Delta f) = \frac{1}{2} \{E(f_0 + \Delta f) - E^*(f_0 - \Delta f)\} \quad (3)$$

for $f > 0$

So that both $SE(f)$ and $AE(f)$ represent real signals, they are defined for $f < 0$ by:

$$SE(f) = SE^*(-f)$$

$$AE(f) = AE^*(-f)$$

It is obvious from (2) and (3) that:

$$SE(f_0 + \Delta f) + AE(f_0 + \Delta f) = E(f_0 + \Delta f)$$

or $SE(f) + AE(f) = E(t)$

or $se(t) + ae(t) = e(t)$ (4)

Further it is noted that if a real signal $p(t)$ [so that $P(f) = P^*(-f)$] is amplitude modulated on a cosinusoidal carrier of frequency f_0 , or:

$$e_1(t) = p(t) \cos 2\pi f_0 t \quad (5)$$

that:

$$\begin{aligned} E_1(f) &= \frac{1}{2} P(f - f_0) + \frac{1}{2} P(f + f_0) \\ &= \frac{1}{2} P(f - f_0) \quad f > 0 \\ &= \frac{1}{2} P(f + f_0) \quad f < 0 \end{aligned}$$

if f_0 is greater than the highest frequency component of $p(t)$. In addition:

$$\begin{aligned} SE_1(f) = SE_1(f_0 + \Delta f) &= \frac{1}{2} \{E_1(f_0 + \Delta f) + E_1^*(f_0 - \Delta f)\} \\ &= \frac{1}{4} \{P(\Delta f) + P^*(-\Delta f)\} \\ &= \frac{1}{2} P(\Delta f) \quad f > 0 \end{aligned} \quad (6)$$

and $AE_1(f) = 0$

Hence amplitude modulation of a cosinusoidal carrier produces a symmetrical spectrum, or a symmetrical spectrum can be considered to be a cosinusoidal carrier amplitude modulated by a signal which is twice the symmetrical spectrum translated a distance f_0 (Equation 5).

Similarly, if a real signal $q(t)$ [$Q(f) = Q^*(-f)$] amplitude modulates a sinusoidal carrier of frequency f_0 , or:

$$e_2(t) = q(t) \sin 2\pi f_0 t \quad (7)$$

that:

$$\begin{aligned} E_2(f) &= \frac{1}{2j} Q(f - f_0) - \frac{1}{2j} Q(f + f_0) \\ &= \frac{1}{2j} Q(f - f_0) \quad f > 0 \\ &= -\frac{1}{2j} Q(f + f_0) \quad f < 0 \end{aligned}$$

with the previously mentioned restrictions. In addition:

$$\begin{aligned} SE_2(f) = SE_2(f_0 + \Delta f) &= \frac{1}{2} \{E_2(f_0 + \Delta f) + E_2^*(f_0 - \Delta f)\} \\ &= \frac{1}{4j} \{Q(\Delta f) - Q^*(-\Delta f)\} \\ &= 0 \end{aligned}$$

and

$$\begin{aligned}
 AE_2(f) &= AE_2(f_0 + \Delta f) - \frac{1}{2} \{E_2(f_0 + \Delta f) - E_2^*(f_0 - \Delta f)\} \\
 &= \frac{1}{4j} \{Q(\Delta f) + Q^*(-\Delta f)\} \\
 &= \frac{1}{2j} Q(\Delta f) \quad f > 0
 \end{aligned} \tag{8}$$

Thus amplitude modulation of a sinusoidal carrier produces an antisymmetrical spectrum, or an antisymmetrical spectrum can be considered to be a sinusoidal carrier amplitude modulated by a signal which is twice the antisymmetrical spectrum translated a distance f_0 (Eq. (8)).

If we now identify $se(t)$ with $e_1(t)$ and $ae(t)$ [Equation 4] with $e_2(t)$, we have:

$$e(t) = p(t) \cos 2\pi f_0 t + q(t) \sin 2\pi f_0 t \tag{9}$$

which with some trigonometric substitutions is:

$$e(t) = \sqrt{p^2(t) + q^2(t)} \cos(2\pi f_0 t - \arctan \frac{q(t)}{p(t)}) \tag{10a}$$

$$= v(t) \cos \phi(t) \tag{10b}$$

where:

$$v(t) = \sqrt{p^2(t) + q^2(t)} \tag{11a}$$

$$\phi(t) = 2\pi f_0 t - \arctan \frac{q(t)}{p(t)} \tag{11b}$$

While the two terms of Equation 9 can be separated by an analysis of the spectrum of $e(t)$ in accordance with Equation 2 and 3, in practice it is done with product demodulators and low pass filters, as shown in Figure 1. The combination of multiplication and filtering (averaging or integrating) is the operation of correlation; and as is well known $\sin 2\pi f_1 t$ and $\cos 2\pi f_2 t$ are orthogonal or uncorrelated for all f_1 and f_2 . Thus the outputs of the two correlators are $q(t)$ and $p(t)$.

We now proceed to demonstrate the uniqueness of the representation (10a) and (10b). Since f_0 is an arbitrarily selected frequency there is no reason to believe that $v(t)$ and $\phi(t)$ are independent of f_0 . To demonstrate this we pick a new f_0 given by:

$$f'_0 = f_0 + \Delta f_0$$

and rewrite Equation 9 as:

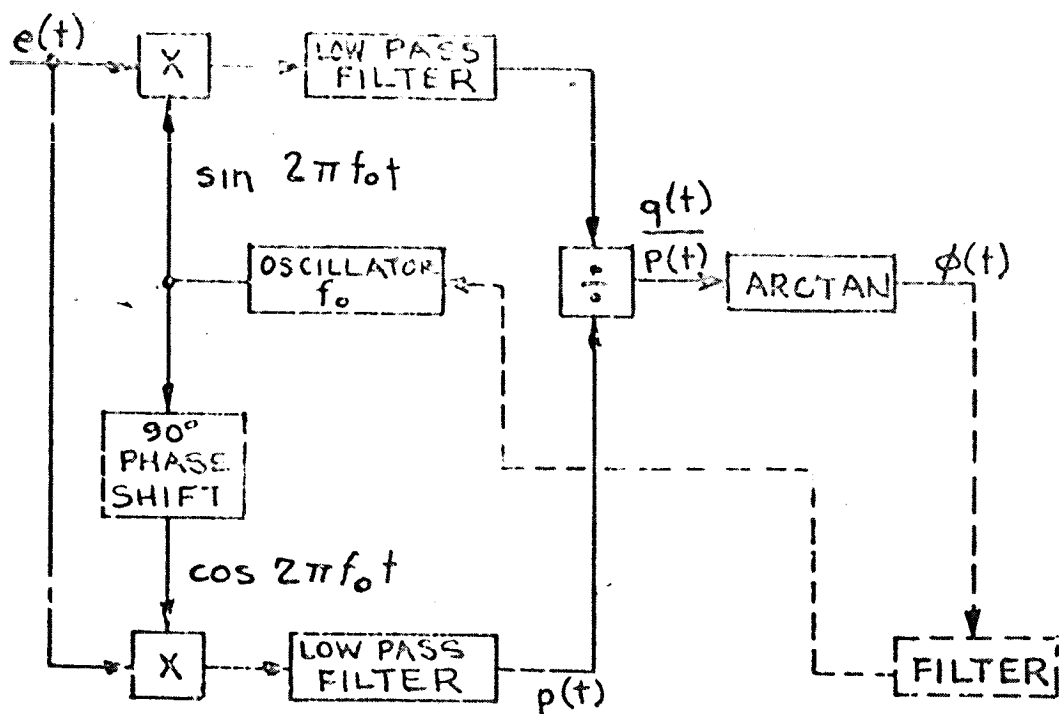

FIGURE 1
(DOTTED LINES SHOW ADAPTIVE CIRCUIT OF PART II)

$$\begin{aligned}
 e(t) &= p(t) \cos 2\pi(f'_0 - \Delta f_0)t + q(t) \sin 2\pi(f'_0 - \Delta f_0)t \\
 &= [p(t) \cos 2\pi\Delta f_0 t - q(t) \sin 2\pi\Delta f_0 t] \cos 2\pi f'_0 t \\
 &\quad + [p(t) \sin 2\pi\Delta f_0 t + q(t) \cos 2\pi\Delta f_0 t] \sin 2\pi f'_0 t \\
 &= p'(t) \cos 2\pi f'_0 t + q'(t) \sin 2\pi f'_0 t
 \end{aligned}$$

where: $p'(t) = p(t) \cos \theta - q(t) \sin \theta$

$q'(t) = p(t) \sin \theta + q(t) \cos \theta$

$\theta = 2\pi\Delta f_0 t$

Hence from Equations 11a and 11b, we have:

$$v'(t) = \sqrt{[p(t) \cos \theta - q(t) \sin \theta]^2 + [p(t) \sin \theta + q(t) \cos \theta]^2}$$

$$\begin{aligned}
 v'(t) &= \sqrt{[\cos^2 \theta + \sin^2 \theta] p^2(t) + [\cos^2 \theta + \sin^2 \theta] q^2(t) + 2p(t)q(t) \cos \theta \sin \theta - 2p(t)q(t) \cos \theta \sin \theta} \\
 &= \sqrt{p^2(t) + q^2(t)} = v(t)
 \end{aligned}$$

and:

$$\begin{aligned}
\phi'(t) &= 2\pi f'_0 t - \arctan \frac{p(t) \sin \theta + q(t) \cos \theta}{p(t) \cos \theta - q(t) \sin \theta} \\
&= 2\pi f'_0 t - \arctan \frac{\frac{\sin \theta}{\cos \theta} + \frac{q(t)}{p(t)}}{1 - \frac{q(t) \sin \theta}{p(t) \cos \theta}} \\
&= 2\pi f'_0 t - \theta - \arctan \frac{q(t)}{p(t)}
\end{aligned}$$

Since,

$$\tan (A + B) = \frac{\tan A + \tan B}{1 - \tan A \tan B}$$

$$\begin{aligned}
\phi'(t) &= 2\pi f'_0(t) - \theta - \arctan \frac{q(t)}{p(t)} \\
&= 2\pi f'_0 t - 2\pi \Delta f_0 t - \arctan \frac{q(t)}{p(t)} \\
&= 2\pi f_0 t - \arctan \frac{q(t)}{p(t)} = \phi(t) .
\end{aligned}$$

It is because of the uniqueness of the quantity $\phi(t)$ that it is actually possible to meaningfully speak of the "phase of a signal." While the above way is not the only way in which the "phase of a signal" can be defined (another way is make use of the signal and its Hilbert transform) they are equivalent. Furthermore (in the author's opinion) these other methods do not have the physical significance of the one presented.

The results of this part are two. First, a definition of "phase of a signal" and a circuit (Figure 1) for measuring it. Second, that all phase measurements are measurements of phase with respect to a reference. This follows from Equation 11b which states that the measurement $[\arctan q(t)/p(t)]$ is the difference $2\pi f_0 t - \phi(t)$; or it is the phase of the signal $\phi(t)$ with respect to a reference phase ($2\pi f_0 t$).

II. ON THE MEASUREMENT OF THE PHASE OF A SIGNAL IN A WHITE NOISE ENVIRONMENT

If the signal:

$$e(t) = p(t) \cos 2\pi f_0 t + q(t) \sin 2\pi f_0 t$$

is combined with the noisy signal:

$$n(t) = n_1(t) \cos 2\pi f_0 t + n_2(t) \sin 2\pi f_0 t \quad (12)$$

so that: $e_T(t) = e(t) + n(t)$; and if there exists no prior knowledge about either $e(t)$ or $n(t)$ to enable $e_T(t)$ to be separated, there will be an error made in the measurement of the phase due to the effects of the noise. The best that can be done (lacking any other information) is to measure the phase of $e_T(t)$ and call that the "phase of the signal."

Since:

$$\phi_T(t) = 2\pi f_0 t - \arctan \frac{q(t) + n_2(t)}{p(t) + n_1(t)}$$

while the actual phase is given by:

$$\phi(t) = 2\pi f_0 t - \arctan \frac{q(t)}{p(t)},$$

there is a phase error of:

$$\phi_\epsilon(t) = \phi_T(t) - \phi(t) = -\arctan \frac{q(t) + n_2(t)}{p(t) + n_1(t)} + \arctan \frac{q(t)}{p(t)}$$

$$= \arctan \left\{ \frac{\frac{q(t)}{p(t)} - \frac{q(t) + n_2(t)}{p(t) + n_1(t)}}{1 + \frac{q(t)}{p(t)} \frac{q(t) + n_2(t)}{p(t) + n_1(t)}} \right\}$$

$$= \arctan \frac{q(t)n_1(t) - p(t)n_2(t)}{\sqrt{2} \sqrt{(t) + p(t)n_1(t) + q(t)n_2(t)}}$$

Further if the signal is a constant amplitude signal of amplitude E , ($v(t) = E$), we have:

$$\phi_{\epsilon}(t) = \arctan \frac{\frac{q(t)}{E} \frac{n_1(t)}{E} - \frac{p(t)}{E} \frac{n_2(t)}{E}}{1 + \frac{p(t)}{E} \frac{n_1(t)}{E} + \frac{q(t)}{E} \frac{n_2(t)}{E}} \quad (13)$$

Hence as the signal to noise ratio increases ($n_1(t)/E$ and $n_2(t)/E$ decreases) $\phi_{\epsilon}(t)$ decreases; in the limit being inversely proportional to E . One way to decrease the noise (increase the signal to noise ratio) when the noise is white is to decrease the bandwidth of the noise. Since the multiplication operation in Figure 1 is a linear operation, the effective bandwidth of $e_T(t)$ (before the multiplier) is related only to the bandwidth after the multiplier (the bandwidth of the low pass filter). Thus to reduce the error in the phase measurement, the bandwidth of the low pass filter should be made as small as possible. However, the bandpass characteristics of the multiplier are a bandwidth of twice the low pass filter centered at the frequency of the constant frequency input f_0 . The error in the phase measurement will therefore continue to decrease as the bandwidth of the low pass filter decreases only if (as has been assumed) the signal $e(t)$ remains in the pass band of the multiplier. We can therefore conclude that the smallest phase error will be made when the low pass filter has a bandwidth equal to $\frac{1}{2}$ that of the signal and f_0 is the "center frequency" of the signal. ✓

In view of the preceding, we can state the following conclusions.

(1) If the center frequency is known, the error in the measurement of the phase of a constant frequency signal (bandwidth zero) can be made as small as desired by decreasing the bandwidth of the low pass filters following the multipliers to zero.

(2) If the center frequency is known, the error in the measurement of the phase of a signal whose frequency varies (bandwidth B) is a minimum (and non-zero) when the low pass filters following the multiplier are of bandwidth $B/2$. The actual error is given by Equation 13.

(3) If the center frequency is unknown, the error in the measurement of the phase of a signal can be no less than given by (1) and (2) above.

and in general is greater than these limits. One way to approach the limits of (1) and (2) above is to use an adaptive or feedback technique. In this case the difference of two phase measurements divided by the time interval between the measurements (average value of $\frac{d\phi}{dt} = \frac{1}{T} \int_t^{t+T} \frac{d\phi}{dt} dt = \frac{\phi(t+T) - \phi(t)}{T}$ = average instantaneous frequency) is used to control the frequency of the oscillator. It is noted that Figure 1 is equivalent to Figure 2. Further if $q(t)/v(t)$ is sufficiently small, $\arcsin q(t)/v(t) \approx q(t)/v(t)$, and Figure 3 then becomes equivalent to Figure 2. In practice the division is accomplished by an AGC circuit and Figure 3 is recognized as the familiar phase lock loop with AGC.

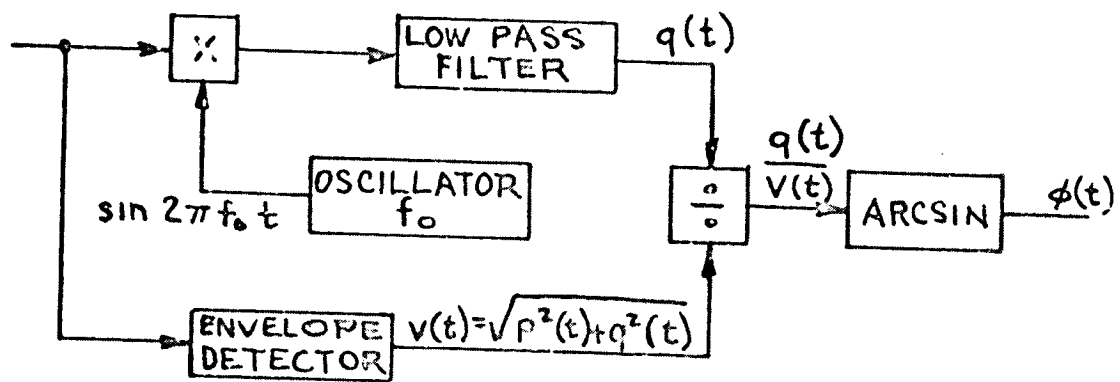

FIGURE 2

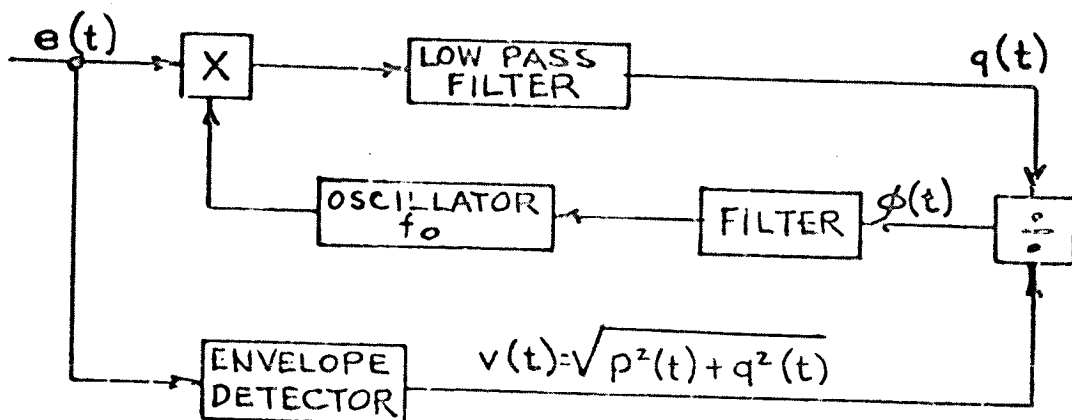

FIGURE 3

This circuit performs remarkably well, if the signal to noise ratio is large, giving limiting values of performance identical with (1) and (2) provided only sufficient time is available for the circuit to establish the center frequency by adaption.

If the signal to noise ratio is not large the performance of the circuit of Figure 3 deteriorates because the measurement of phase is nonlinear and ambiguous. It is nonlinear because the arc sin operation has been removed (see Figure 2) and ambiguous because $\sin(\frac{\pi}{2} + \theta) = \sin(\frac{\pi}{2} - \theta)$. (The ambiguity can be resolved by measuring both the sine and cosine of the angle as in Figure 1.) The nonlinearity causes the phase measurement rms value not to be a linear function of the noise rms value. The ambiguity causes an erratic performance when the angle measured is interpreted wrong. (We call this "loss of lock" and the performance of the circuit of Figure 3 is not at the limits described in (1) and (2) until lock is again restored.) There is every reason to believe that given sufficient time for the circuit to adapt (establish phase lock), the circuit of Figure 1 will have the same limiting performance as (1) and (2) even when the center frequency is unknown. This follows from the fact that the equivalent circuit of Figure 1 for the phase $\phi(t)$ is linear in ϕ .

III. ON THE COHERENT COMBINING OF IDENTICAL NARROW BAND RF SIGNALS IN INDEPENDENT NOISE ENVIRONMENTS

A. The Combining of Two Such Signals

We will take as our definition of narrowband rf signals those signals which can be made coherent (within practical limits) by a proper adjustment of the $\phi(t)$ phase of the signal within the meaning of these terms as developed in Parts I and II. If the two signals are:

$$e_{T_1}(t) = v_1(t) \cos \phi_1(t)$$

$$e_{T_2}(t) = v_2(t) \cos \phi_2(t)$$

We can combine them by using phase measuring circuits (Figure 1) and phase shifters as shown in Figure 4. (In practice these operations would be performed by using an oscillator at a different frequency than the input using band pass rather than low pass filters and a heterodyne operation to replace the phase shifting operation, but the effect is the same.) Our first conclusion which is obvious from an inspection of the output of Figure 4 is that those components of the signal within the pass band of the phase measuring circuit are combined incoherently. This follows from the fact that the amplitude of the output is the sum of the amplitudes of the input.

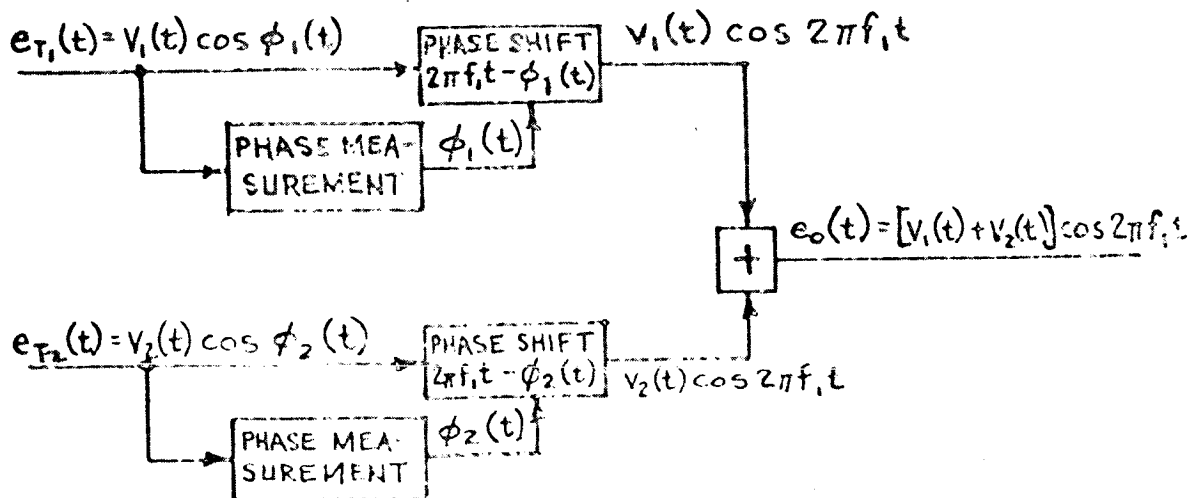

FIGURE 4

If, however, the signals of interest contain components outside the pass band of the phase measuring circuit which have a phase related to those components within the pass band of the phase measuring circuit; these may be combined coherently. Thus, if:

$$s_i(t) = m_a(t) \cos [\phi_{oi}(t) + m_p(t)] + v_{ni} \cos [\phi_{oi}(t) + \phi_{ni}(t)] + v_i(t) \cos [\phi_{oi}(t) + \phi_{\epsilon_1}(t)] \quad (14)$$

where $m_a(t)$ and $m_p(t)$ represent amplitude and phase modulation of the "signal" components outside the pass band of the phase measuring circuit, $v_{ni} \cos \phi_{oi}(t)$ represent the noise with components outside the pass band, and $v_i(t) \cos [\phi_{oi}(t) + \phi_{\epsilon_1}(t)]$ represents the "signal" and noise components inside the pass band of the phase measuring circuit where $\phi_{\epsilon_1}(t)$ represent the measured phase error of the signal due to the noise. Since the signal $s_i(t)$ is shifted in phase an amount $2\pi f_1 t - [\phi_{oi}(t) + \phi_{\epsilon_1}(t)]$, the signal out of the phase shifter is given by:

$$s_{oi}(t) = m_a(t) \cos [2\pi f_1 t + m_p(t) - \phi_{\epsilon_1}(t)] + v_{ni}(t) \cos [2\pi f_1 t + \phi_{ni}(t) - \phi_{\epsilon_1}(t)] + v_i(t) \cos 2\pi f_1 t \quad (15)$$

If two such signals as given by Equation 15 are added ($i = 1$ and 2) and use made of:

$$\cos A + \cos B = 2 \cos \frac{1}{2} (A-B) \cos \frac{1}{2} (A+B) \quad (16)$$

we obtain

$$\begin{aligned} s_o(t) &= s_{o1}(t) + s_{o2}(t) \\ &= 2m_a(t) \cos \left[\frac{\phi_{\epsilon_1}(t) - \phi_{\epsilon_2}(t)}{2} \right] \cos \left[2\pi f_1 t + m_p(t) + \frac{\phi_{\epsilon_1}(t) + \phi_{\epsilon_2}(t)}{2} \right] \\ &\quad + v_{n1}(t) \cos [2\pi f_1 t - \phi_{\epsilon_1}(t)] + v_{n2}(t) \cos [2\pi f_1 t - \phi_{\epsilon_2}(t)] \\ &\quad + [v_1(t) + v_2(t)] \cos 2\pi f_1 t \end{aligned} \quad (17)$$

Thus if the two noises are independent, they add incoherently while the two signals added coherently if $\cos [\phi_{\epsilon_1}(t) - \phi_{\epsilon_2}(t)/2] \approx 1$ or if $\frac{1}{2} [\phi_{\epsilon_1}(t) - \phi_{\epsilon_2}(t)]$ is small. As an example if the ϕ 's are independent,

gaussian, mean zero, and variance σ_x^2 , and σ is small, the loss due to the fact that the addition is not completely coherent is given by:

$$L = \overline{\cos^2 \frac{1}{2} [\phi_{\epsilon_1}(t) \pm \phi_{\epsilon_2}(t)]} = \frac{1}{2} + \frac{1}{2} \overline{\cos [\phi_{\epsilon_1}(t) \pm \phi_{\epsilon_2}(t)]} \quad (18)$$

but

$$\overline{\cos x} = e^{-\sigma_x^2/2} \quad (19)$$

where σ_x^2 is the variance of x if x is gaussian. Since both $\phi_{\epsilon_1}(t)$ and $\phi_{\epsilon_2}(t)$ are gaussian with equal variances and are independent, their sum is gaussian with variance $\sigma_x^2 = \sigma^2$. Thus:

$$L = \frac{1}{2} + \frac{1}{2} e^{-\sigma^2/2} \quad (20)$$

If L is to be 1 db ($L = 0.795$) σ must be 0.723 radians or 41.4° . It can be shown from Equation 13 that if $n_1(t)$ and $n_2(t)$ are gaussian, $\phi_{\epsilon_j}(t)$ is small and $p(t)$ and $q(t)$ are constant, then $\phi_{\epsilon_1}(t)$ is gaussian. The calculation of the moments of $\phi_{\epsilon_1}(t)$ to evaluate Equation 18 when $\phi_{\epsilon_1}(t)$ is not small is tedious and to this author's knowledge only the second moment has been calculated for the general case, and that only for constant $p(t)$ and $q(t)$.

In conclusion it can be stated that two signals can be combined coherently provided, (1) there is available a signal of similar phase as the signals to be combined from which a measurement of phase can be obtained, and (2) the ratio of the signal power in this test signal to the noise power in the bandwidth of the test signal is large enough to make the phase measurement error sufficiently small (41.4° for 1 db combining loss). While a loss of 1 db from coherent addition doesn't seem like much of a loss, it is to be remembered that the maximum increase with completely coherent addition is only 3 db. (Equation 18 shows that $L_{\min} = \frac{1}{2}$ which occurs when $\overline{\cos x} = 0$ or when σ_x^2 becomes sufficiently large. Thus the maximum loss is 3 db.

Since we are attempting to delay one of the two signals and add them coherently, it might be thought that an entirely different approach to the problem would be to correlate one signal with the other.

delay one until the correlation was a maximum, and then add or combine the two signals. Figure 5 shows such an implementation where the correlation is performed by the multiplier and low pass filter. The

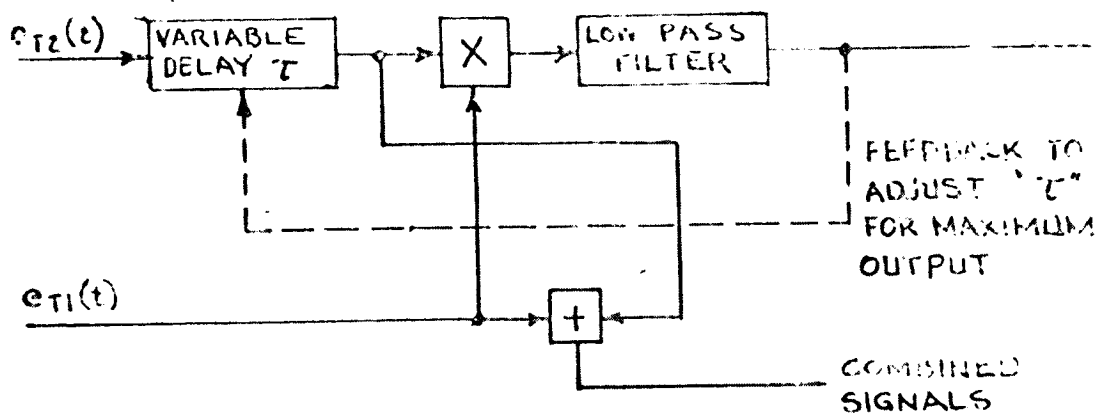

FIGURE 5

important thing to be observed from Figure 5 is that the effective bandwidth before the multiplier (the bandwidth of noise associated with e_{T2} which determines the accuracy with the time delay τ for maximum output is obtained) is the bandwidth of the signal e_{T1} plus twice the bandwidth of the low pass filter. (This is a generalization of the statement made previously that for a sinusoidal input (bandwidth zero) to a multiplier the bandwidth ahead of the multiplier is twice the bandwidth of the low pass filter.) Therefore it becomes necessary to prefilter the signal $e_{T1}(t)$ to as small a bandwidth as possible. In the absence of any prior information as to the exact center frequency of the signal, the only practical way this can be accomplished is with a circuit similar to Figure 1 with the feedback (or for small errors that of Figure 3). It can now be seen that if the two signal components have identical phase variation, differing only by a constant, the bandwidth of the low pass filter can approach zero. Since the effective bandwidths then become equal, the performance of Figures 4 and 5 will be the same. If the two signal components do not have the same phase variations, then the low pass filter must have a bandwidth sufficiently large to pass the frequency

components of the difference of the two phases. This results in a larger effective bandwidth for the signal $e_{T_2}(t)$ more noise in the output, greater phase (or time) error, and Figure 5 is poorer in performance than Figure 4.

B. The Combining of More Than Two Signals

In this case:

$$s_o(t) = \sum_{i=1}^M s_{oi}(t)$$

where $s_{oi}(t)$ is given by Equation 15. Again, as in Equation 17 the noise adds incoherently, because the individual parts are independent. Further, the envelopes of the test signals, $v_i(t) \cos 2\pi f_1 t$, add. The only remaining components are the signal components:

$$s = \sum_{i=1}^M m_a(t) \cos [2\pi f_1 t + m_p(t) - \phi_{\epsilon_i}(t)]$$

$$s = m_a(t) \left\{ \cos [2\pi f_1 t + m_p(t)] \sum_{i=1}^M \cos \phi_{\epsilon_i}(t) + \sin [2\pi f_1 t + m_p(t)] \sum_{i=1}^M \sin \phi_{\epsilon_i}(t) \right\}$$

$$= m_a(t) \sqrt{\left(\sum_{i=1}^M \cos \phi_{\epsilon_i}(t) \right)^2 + \left(\sum_{i=1}^M \sin \phi_{\epsilon_i}(t) \right)^2} \cos [2\pi f_1 t + m_p(t) - \phi(t)] \quad (21)$$

$$\text{where } \phi(t) = \tan^{-1} \frac{\sum_{i=1}^M \sin \phi_{\epsilon_i}(t)}{\sum_{i=1}^M \cos \phi_{\epsilon_i}(t)} \quad (22)$$

If we define loss due to imperfect coherent addition as the average of the square of the ratio of the amplitude of s (equation 21) with $\phi_{\epsilon_i}(t)$ to the value of s with $\phi_{\epsilon_i}(t) = 0$ (perfect coherent addition),

Thus:

$$L = \frac{\sqrt{\left(\sum_{i=1}^M \cos \phi_{\epsilon_i}(t)\right)^2 + \left(\sum_{i=1}^M \sin \phi_{\epsilon_i}(t)\right)^2}}{M}$$

$$L = \frac{\sum_{i=1}^M [\cos^2 \phi_{\epsilon_i}(t) + \sin^2 \phi_{\epsilon_i}(t)] + \sum_{i=1}^M \sum_{j=1, (i \neq j)}^M [\cos \phi_{\epsilon_i}(t) \cos \phi_{\epsilon_j}(t) + \sin \phi_{\epsilon_i}(t) \sin \phi_{\epsilon_j}(t)]}{M^2}$$

Since $\overline{\sin \phi_{\epsilon_i}(t) \sin \phi_{\epsilon_j}(t)} = \overline{\sin \phi_{\epsilon_i}(t)} \overline{\sin \phi_{\epsilon_j}(t)} = 0$, $i \neq j$ because $\phi_{\epsilon_i}(t)$ and $\phi_{\epsilon_j}(t)$ are (assumed) independent and gaussian with mean zero and $\sin x = -\sin(-x)$. Further, $\overline{\cos \phi_{\epsilon_i}(t) \cos \phi_{\epsilon_j}(t)} = \overline{\cos \phi_{\epsilon_i}(t)} \overline{\cos \phi_{\epsilon_j}(t)} = [\overline{\cos \phi_{\epsilon_i}(t)}]^2$, $i \neq j$, because all of the ϕ 's are assumed to have identical distributions. From Equation 19:

$$\overline{\cos x} = e^{-\sigma^2/2} \quad (19)$$

we have
$$[\overline{\cos \phi_{\epsilon_i}(t)}]^2 = e^{-\sigma^2} \quad (23)$$

Since there are $M(M-1)$ cross-product terms, we have:

$$L = \frac{M + M(M-1) e^{-\sigma^2}}{M^2} = \frac{1}{M} + \frac{M-1}{M} e^{-\sigma^2} \quad (24)$$

Figure 6 is a plot of L as a function of σ (in degrees) for various M . Table 1 shows the values of σ for 1 db loss for several values of M .

M	σ (radians)	σ (degrees)
2	0.723	41.4°
10	0.514	29.5°
∞	0.480	27.5°

The results of Figure 6 and Table 1 are quite striking. They show that the power loss due to incoherent addition is quite small even for relatively large rms phase errors (σ). As a matter of fact, all of the values in Table 1 are already larger in size than values which would

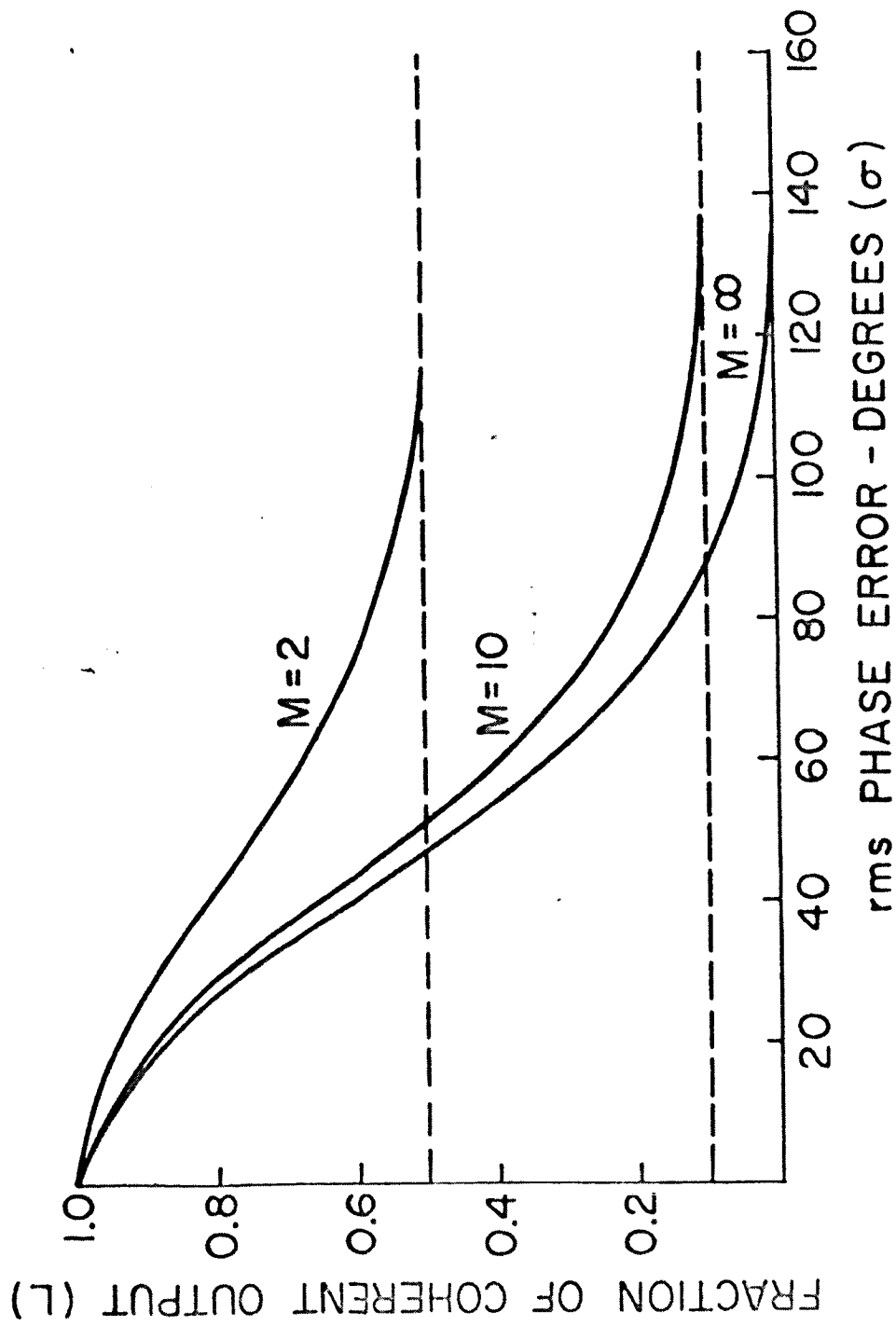

FIG. 6

assure the small angle approximations usually made to prove that the phase error has a gaussian distribution for gaussian noise:

IV. ON THE COHERENT COMBINING OF MODULATED SIGNALS

A. Amplitude Modulation

As demonstrated in Part III-A, in order to coherently combine two signals it is necessary to have their phases related to a test signal, on which a measurement of phase is made; otherwise incoherent addition occurs. Thus in practice it is necessary to send along a component of the unmodulated carrier for this purpose, and the requirements for coherent combining become similar to those for coherent, or synchronous, detection. In normal applications this adds no undue penalty since the bandwidth of the information is usually very much greater than the bandwidth of the unmodulated carrier. Under these conditions the power required in the unmodulated carrier is much smaller than that required for the modulated signal. If this is not the case, it should be determined whether better performance could not be obtained by transmitting the additional power in the modulated signal.

If an amplitude modulated wave is transmitted with an unmodulated carrier, several received waves may be (approximately) coherently combined as shown in Part III-B. The amplitude of this combination would be given by the amplitude of Equation 21, which would be the output of an envelope detector. Thus:

$$A = m_a(t) \sqrt{\left(\sum_{i=1}^M \cos \phi_{\epsilon i}(t)\right)^2 + \left(\sum_{i=1}^M \sin \phi_{\epsilon i}(t)\right)^2} \quad (25)$$

where $m_a(t)$ is the desired information signal. It now can be recognized that even though the loss due to lack of complete coherence (L in Figure and Table I) is small, there is a corrupting of the signal $m_a(t)$ by the factor represented by the radical in Equation 25. If, as we have assumed so far, $\phi_{\epsilon i}(t)$ is small, its bandwidth is one-half of the bandwidth of the unmodulated carrier. Thus while this is a low frequency the effect of the radical of Equation 25 cannot be separated by filtering, since it represents multiplicative noise and not additive noise. The effect of this

multiplicative noise will depend upon the nature of $m_a(t)$, being small for digital information, modest for voice information, and in all probability significant for high precision analog information. A better idea of the effect of this noise would be obtained if we evaluated its average value and its standard deviation. The average squared value has already been calculated, but the calculation of the average value appears to be quite formidable.

It should be noticed that part of our problem and part of this unwanted multiplicative noise could be eliminated if, instead of coherently combining the signals, we coherently detected them and then combined them. This would give for a result:

$$A' = m_a(t) \sum_{i=1}^M \cos \phi_{\epsilon_i}(t) \quad (26)$$

$$= F m_a(t)$$

where:

$$F = \sum_{i=1}^M \cos \phi_{\epsilon_i}(t)$$

Hence:

$$\bar{F} = \sum_{i=1}^M \overline{\cos \phi_{\epsilon_i}(t)} = M \epsilon^{-\sigma^2/2}$$

Further:

$$\bar{F}^2 = \left\{ \sum_{i=1}^M \overline{\cos^2 \phi_{\epsilon_i}(t)} + \sum_{i=1}^M \sum_{\substack{j=1 \\ i \neq j}}^M \overline{\cos \phi_{\epsilon_i}(t) \cos \phi_{\epsilon_j}(t)} \right\}$$

But:

$$\overline{\cos^2 \phi_{\epsilon_i}(t)} = \frac{1}{2} + \frac{1}{2} \epsilon^{-2\sigma^2}$$

and:

$$\overline{\cos \phi_{\epsilon_i}(t) \cos \phi_{\epsilon_j}(t)} = \overline{\cos \phi_{\epsilon_i}(t)} \overline{\cos \phi_{\epsilon_j}(t)} = \epsilon^{-\sigma^2}, \quad i \neq j$$

Thus:

$$\bar{F}^2 = \frac{M}{2} (1 + \epsilon^{-2\sigma^2}) + M(M-1) \epsilon^{-\sigma^2} \quad (27)$$

Also,

$$\begin{aligned} \sigma_F^2 &= \overline{F^2} - \overline{F}^2 = \frac{M}{2} (1 - 2\epsilon^{-\sigma^2} + \epsilon^{-2\sigma^2}) \\ &= \frac{M}{2} (1 - \epsilon^{-\sigma^2})^2 \end{aligned}$$

In conclusion:

$$\begin{aligned} \frac{\sigma_F}{\overline{F}} &= \frac{\sqrt{\frac{M}{2}} (1 - \epsilon^{-\sigma^2})}{M \epsilon^{-\sigma^2} / 2} \\ &= \frac{1}{\sqrt{2M}} (\epsilon^{+\sigma^2/2} - \epsilon^{-\sigma^2/2}) \end{aligned} \quad (28)$$

$$= \sqrt{\frac{2}{M}} \sinh\left(\frac{\sigma^2}{2}\right) \quad (28a)$$

The quantity σ_F/\overline{F} is like a noise-to-signal ratio for the factor F. It is noticed that this quantity is decreased by decreasing the rms phase error, σ , or by increasing the number of signals being combined, M. Figure 7 is a plot of σ_F/\overline{F} as a function of σ for various M, while Table 2 is a tabulation of the required values of σ for a -30 db noise-to-signal ratio.

TABLE 2

M	σ (radians)	σ (degrees)
2	0.252	14.4
10	0.377	21.6
100	0.677	38.4
∞	∞	∞

Figure 8 is a plot of the loss due to incoherent addition which, from Equation 27 is given by:

$$L' = \frac{\overline{F^2}}{M} = \frac{1}{2M} (1 + \epsilon^{-2\sigma^2}) + \frac{M-1}{M} \epsilon^{-\sigma^2} \quad (29)$$

Table 3 is a tabulation of the rms phase error required for 1 db loss of coherence.

RMS NOISE-TO-SIGNAL RATIO (σ_F/\bar{F}) FOR COHERENT DETECTION

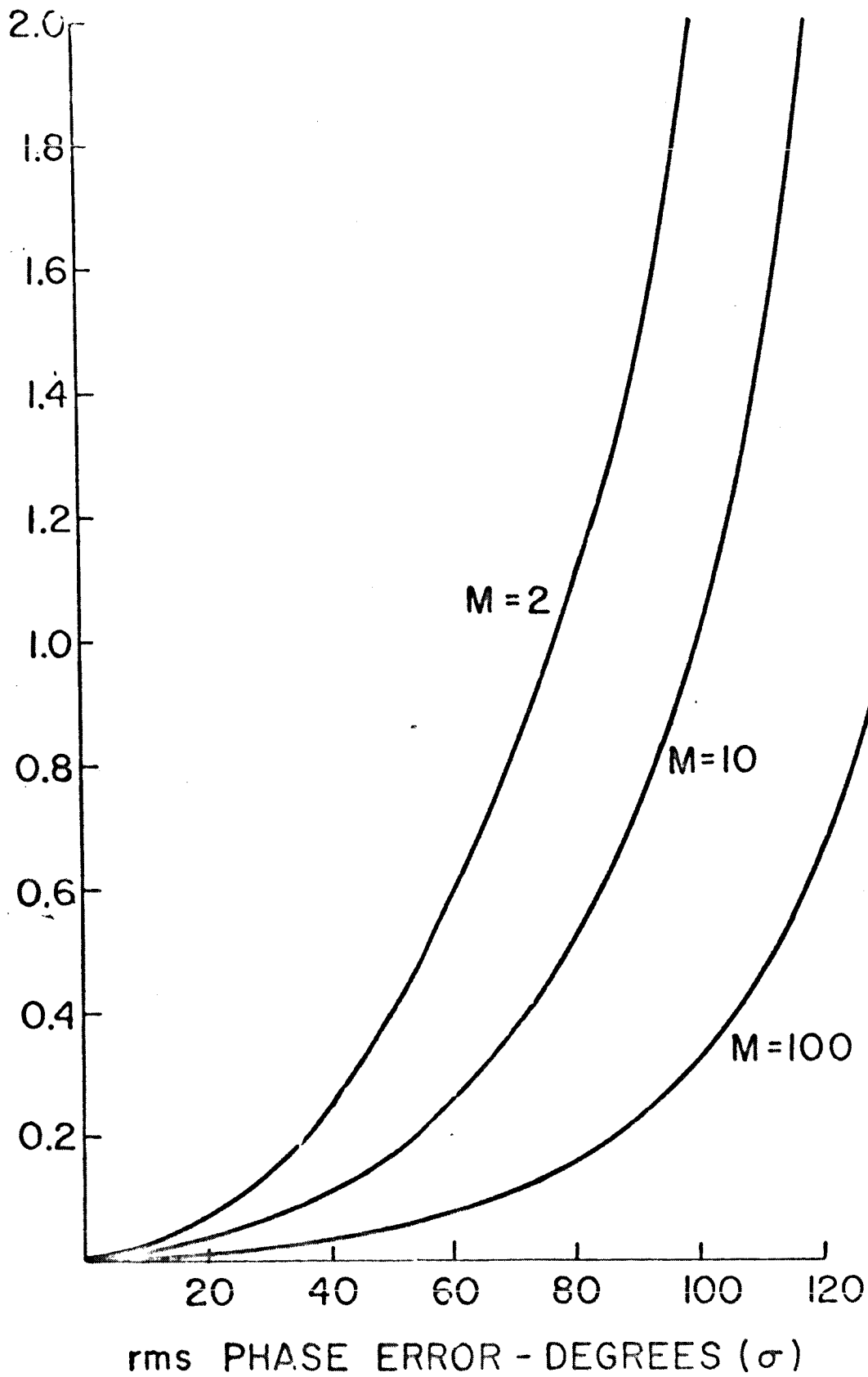

FRACTION OF COHERENT DETECTION OUTPUT (L')

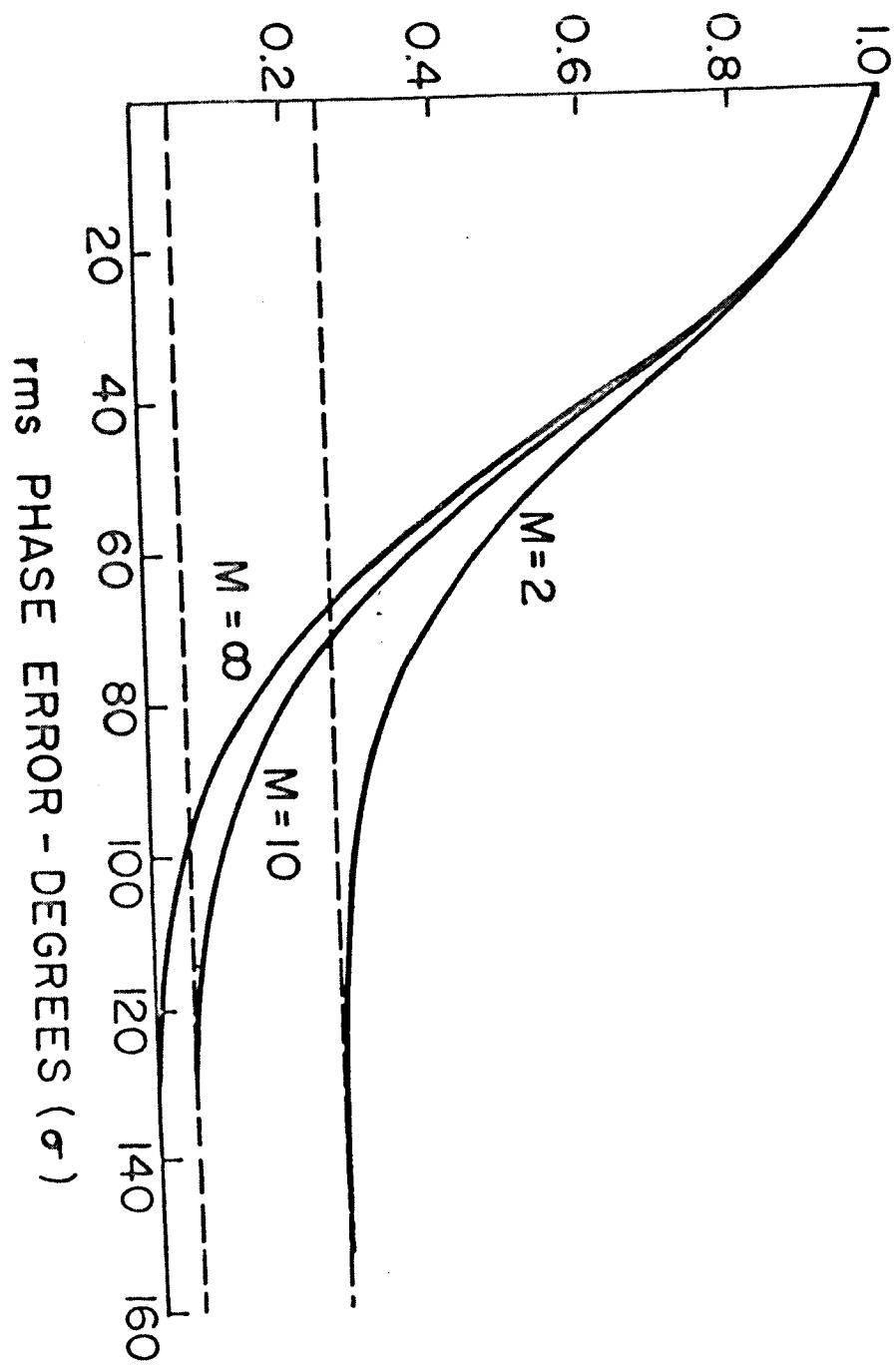

FIG. 8

TABLE 3

M	σ (radians)	σ (degrees)
2	0.525	30.1
10	0.483	27.7
100	0.480	27.5
∞	0.480	27.5

A comparison of Tables 2 and 3 shows that for small M the minimum acceptable rms phase error is set by the allowable multiplicative noise (Table 2), while for large values of M is set by the value of coherent loss which can be tolerated and still overcome the additive noise (Table 3).

B. Angle Modulation

Again for angle modulation, as for amplitude modulation, an unmodulated carrier must be transmitted to accomplish coherent addition. In this case the angle detector operates on the argument of Equation 21, which with the help of Equation 22 gives:

$$A = 2\pi f_1 t - \tan^{-1} \frac{\sum_{i=1}^M \sin \phi_{\epsilon_i}(t)}{\sum_{i=1}^M \cos \phi_{\epsilon_i}(t)} + m_p(t) \quad (30)$$

It is noticed that the noise introduced as a result of imperfect coherent addition (which is in addition to the noise produced by the noise present in the channel, which is not represented in Equation 30) for angle modulation is additive. Thus if the frequency components of the signal $m_p(t)$

and the noise $\tan^{-1} \left\{ \frac{\sum_{i=1}^M \sin \phi_{\epsilon_i}(t)}{\sum_{i=1}^M \cos \phi_{\epsilon_i}(t)} \right\}$

do not overlap, the noise can be removed by filtering. In some situations this may be a decided advantage of angle modulation over amplitude modulation.

V. ON THE INCOHERENT COMBINING OF MODULATED SIGNALS

As is well known, there are only two linear modulation systems. These are those systems using no modulation and those using amplitude modulation with a coherent (synchronous) detector supplied with a duplicate of the carrier used for modulation (correct phase and frequency). Since the practical systems under consideration in this paper do not fit this description, they are nonlinear. The nonlinearities of these systems complicates their analysis, but as can be demonstrated with simple modulations, and as can be observed in practice; the nonlinear systems behave as if they were linear for large input signal-to-noise ratios. They are linear in the sense that the output signal-to-noise ratio is a linear function of the input signal-to-noise ratios in this region. For small input signal-to-noise ratios the output signal-to-noise ratio decreases more rapidly than the decrease in the input signal-to-noise ratio. The point (or region) of transition from these two operating characteristics is referred to as the system threshold. It is to be observed that if the system is operating above threshold, a combination (sum) of M independent detected outputs (defined as incoherent addition) has the same signal-to-noise ratio as a coherent combination of the M independent noise modulated waves followed by detection. The performance of the incoherent combination will be poorer than the coherent combination only if the system is not above threshold for each of the M different signals.

Since any communication system requires a certain minimum output signal-to-noise ratio for acceptable performance, and since the maximum gain to be realized by coherent addition of M signals is $10 \log M$ in db, if the minimum acceptable output signal-to-noise ratio $((S/N)_{\min})$ is greater than the threshold signal-to-noise ratio $((S/N)_T)$ by at least $10 \log M$, the incoherent system will perform as well as the coherent one. This condition is:

$$10 \log M \leq (S/N)_{\min} - (S/N)_T \quad (31)$$

Since all (to the author's knowledge) communication systems require

operation above the threshold for acceptable performance, there is a minimum value of M below which coherent addition is not necessary.

This value is given by:

$$M_{\min} = 10^{\left[\frac{(S/N)_{\min} - (S/N)_T}{10} \right]} \quad (32)$$

VI. COMPARISON OF A COMMUNICATION SYSTEM EMPLOYING M ANTENNAS OF APERTURE A WITH ONE EMPLOYING A SINGLE ANTENNA OF APERTURE MA

It should be realized with the wide variation of communication systems (i.e., kinds of modulation) and information signals to be communicated that a simple conclusion regarding the comparison of a multiantenna system with a single antenna system with equal total aperture may not be possible, and indeed it isn't. Furthermore, since differences may appear only when signal levels are small where analytic techniques are inadequate for the nonlinearities encountered, it may be impossible to settle the issue except by experimentation. If it is assumed that the contributions to the output of the elemental areas of the single aperture antenna are coherent (which is certainly violated to some extent as the aperture is made larger), then the two systems will be exactly comparable if coherent addition can be accomplished for the multiantenna system. This task cannot be effected exactly in the presence of noise unless prior knowledge of the phase of the rf is available. In addition, if the M different antennas are spaced far enough apart coherent addition may be impossible due to a lack of a constant phase difference since the signals may propagate through different parts of space. It would therefore appear as if the multiantenna system will always be poorer in performance than the single antenna system. This, however, does not answer the practical question as to what the actual difference is, since the difference may be small enough to make their performances comparable. The following conclusions represent the general statements that can be made and which are established by the results of the preceding parts.

A. If the communication system operates above threshold there is a minimum value of M (Equation 32) below which incoherent addition (detection followed by addition) gives substantially identical system performance and above which incoherent addition results in the single antenna system being superior.

B. Above this minimum value of M the performances of the systems can be made comparable (other conditions being proper) only by transmitting a sample of the unmodulated carrier upon which a measurement of phase may be made to coherently add the contributions of the several antennas. This follows from the fact (Part III-A) that the components within the pass band of the phase measuring circuit are added incoherently and the conclusion A above means that the phase measurement could not be made on any of the information components (components produced by the modulation or sidebands).

C. Since our ability to effect coherent addition is dependent upon our ability to measure the phase of the reference carrier (Figures 6 and 8), and this in turn is dependent upon the signal carrier and noise amplitudes in the pass band of the measuring device (Equation 13):

1) The phase measuring circuit should have as small a bandwidth as possible, and this minimum value is determined by the received carrier bandwidth. (Which may be greater than the transmitted carrier bandwidth due to the effects of the propagation medium.)

2) If the carrier bandwidth is comparable to the information bandwidth, the carrier amplitude necessary to effect coherent addition may represent a significant part of the total power transmitted. The multiantenna system is then poorer in performance by an amount at least as great as the fraction of the total power in the information components (e.g., 20% in the carrier and 80% in the sidebands, 1 db loss of performance; 50% in the carrier and 50% in the sidebands, 3 db loss of performance; etc).

D. If the carrier frequency is not known to an accuracy comparable to the bandwidth of the received carrier, an adaptive frequency measuring circuit (phase lock loop) should be employed to effect a decrease in the allowable pass band of the phase measuring device (Part II).

E. The technique for combining contributions from the various antennas are basically two, phase measurement (comparison with a noiseless reference) and correlation (comparison with a noisy reference).

In the former case if an adaptive system is used (phase lock loop) the bandwidth of the phase measurement can be restricted to that of the received carrier and no better performance can be obtained. If the signals received at the several antennas are identical in shape (the propagation medium has no effect or an identical effect upon each received signal), one signal can be used as a reference in a correlator. It is necessary to filter this signal to the minimum bandwidth (that of the carrier) by using an adaptive frequency tracking filter) before it is used to be correlated with each of the other signals. The bandwidth of the correlation filter must be much smaller than the pass band of the signal (and it can be if the signals are identical) before this method is comparable to that employing phase measurement.

F. In an AM system, in addition to the regular additive noise whose effects (signal-to-noise ratio) are determined by the fraction of coherent output (Figure 6) realized by the attempts at coherent addition, there is introduced a multiplicative noise (Equation 25) as a consequence of the errors, $\phi_{\epsilon_i}(t)$, in measuring the phase of the carriers. Because it is multiplicative it cannot be removed by filtering.

G. If the AM signals are coherently detected and then added the multiplicative noise is decreased and can be evaluated for simple cases (gaussian phase error) is shown in Figure 7.

H. In an angle modulated system (FM or PM), in addition to the effects of the regular additive noise, the phase error introduces an additional additive noise (Equation 30). For small phase errors, $\phi_{\epsilon_i}(t)$, this noise is the same bandwidth as the carrier and can be removed by filtering if the lowest frequency in the signal is sufficiently greater than the highest frequency in $\phi_{\epsilon_i}(t)$.

I. Since in an AM system the effects of the additive noise, as measured by the fraction of coherent output in Figures 6 and 8, increases as M increases for fixed σ , while the effects of the multiplicative noise decreases as M increases (Figure 7); there is an optimum value of M for each system.

J. Since in an FM system both the regular noise and the additional noise (Conclusion II) increases with increasing M, the optimum value of M is as small as possible (1).

APPENDIX V

Communication System Models

In Section 3 of the main body of the report, the parameters assumed for a lunar range and an interplanetary range spacecraft communication system were summarized. In this appendix a rationalization is given for these assumptions by presenting the characteristics of existing spacecraft systems. Also presented are the calculations of performance of the model systems. The assumed parameters cannot be considered "typical" since it is difficult to define or to find a typical spacecraft. Instead they should be considered as an example whose purpose is to serve as a model for system calculations of the multi-aperture antenna.

V.1. Summary of Spacecraft Communications Systems

Table V.1 is a summary of various spacecraft communication systems as digested from the published literature. For more details one may refer to the papers listed at the end of this appendix. This table seems to indicate that the frequency range is from 1 Gc to 10 Gc, the transmitter power from 10 to 40 watts, and the antenna gain from 0 to 20 db. It is from an evaluation of data such as summarized in this table that the model system characteristics listed in Section 3 were derived.

V.2 Lunar-Range Communications

Any analysis of the multi-aperture antenna approach to lunar communications requires a knowledge of the spacecraft system parameters. With the parameters of the lunar communication system model as given in Table 3.1 as well as with some additional data, system calculations of performance will be made.

The effective antenna aperture diameter for the ground system can be shown to be given by the following equation *

* B.C. Martin, "The Mariner Planetary Communication System Design," JPL Rept. No. TR 32-85, May 15, 1961.

#	SPACECRAFT	TRANSPONDER MODES	P ₀ WATTS	RECEIVER FREQ. f ₁ -MC	RECEIVER FREQ. f ₂ -MC	TRANSMIT FREQ. f ₁ -MC	TRANSMIT FREQ. f ₂ -MC	RECEIVING ANTENNA	TRANSMITTING ANTENNA	POWER SOURCE	BIT RATE CR B/W
1	MARINER	FM / PM	3 25	960	2295	890	2113	+3db TURNSTILE	-6db OMNI 18.6db PARABOLIC	Ni-Cd BATTERY SOLAR CELLS	12.8 107 BT/S
2	SYNCOM	WIDEBAND FM	2 1.25	7360	—	136	1820	+2db SKIRTED DIPOLE	+6db SKIRTED DIPOLE ARRAY	Ni-Cd BATTERY PN SOLAR CELLS	4KC 4MC
3	ADVANCED SYNCOM	WIDEBAND FM	4 —	6000- 6300	—	3940- 4200	—	+8db COLLINEAR ARRAY	+18db PHASED ARRAY	Ni-Cd BATTERY NP SOLAR CELLS	25MC —
4	TELSTAR	Hi INDEX FM, TV	2 .02	6390	—	4170	—	ISOTROPIC LINEAR HELICAL	0 db	Ni-Cd BATTERY SOLAR CELLS	—
5	SURVEYOR	PCM, FM, FM/FM, FM/PM	10 .1	2000 4000	—	2000 4000	—	2-+2db OMNI DIRECTIONAL C. POL.	PLANAR ARRAY	Ag-Zn BATTERY SOLAR CELLS	550 B/S 4.4K B/S
6	APOLLO	PCM/FM AM, TV	10 20	2000	225 B 400	2000 2250	225 400	—	10 FT. PARABOLIC DISH	—	51.2 B/S 1.6 B/S
7	RANGER 3-5	PM	.05 —	890	—	960	—	+6db TURNSTILE	+6.5 db TURNSTILE	—	—
8	PIONEER IX	FM/PM	.275 —	—	—	960	—	—	+2.5db CONICAL	MERCURY CELLS	—
9	RELAY	PSK/PM	10 —	1725	—	4170	4080	COAXIAL	MONOPOLES COAXIAL	Ni-Cd PN SOLAR CELLS	—
10	GEMINI	PCM, FM	3 5	296/15	400 450	296	15 S BC BAND	16 F WHIP	—	—	51.2 KBS
11	PIONEER III & IV	PM	180 MW	—	—	960	—	—	2.5db SPIKE	—	10 BS

TABLE X-1 - TYPICAL SPACECRAFT SYSTEMS

$$D_e = \log^{-1} \left[\frac{R_b + \frac{ST_d}{N/B} + \frac{N}{B} + L_s + L_m + 20 \log R - P_d - G_t + 12}{20} \right] \quad (V. 1)$$

where

D_e = effective antenna aperture in meters

R_b = data bit rate -db (cps)

S = received signal power -dbm

T_d = telemetry data bit duration -db (sec)

N/B = system noise power spectral density dbm/cps

L_s = system design margin -db

L_m = miscellaneous spacecraft systems power losses -db

R = range (meters)

P_d = transmitter power allocated to data subcarrier -dbm

G_t = transmitter antenna gain above isotropic. -db

$$G_R = \frac{S_i T_d}{N/B} \times R_b \times \frac{N}{B} \times \frac{P_L L_m L_p}{P_d G_t}$$

$$(G_R)_{db} = \frac{S_i T_d}{N/B} + R_b + \frac{N}{B} + P_L + (L_m + L_p) - P_d - G_t \quad (V. 3)$$

now

$$G_R = \frac{4\pi}{\lambda^2} \cdot A_e = \frac{\pi^2 D_e^2}{\lambda^2}$$

$$P_L = \frac{(4\pi R)^2}{\lambda^2} = \frac{16\pi^2 R^2}{\lambda^2}$$

$$G_R = 20 \log \pi + 20 \log D_e - 20 \log \lambda$$

$$P_L = 10 \log 16 + 20 \log \pi + 20 \log R - 20 \log \lambda$$

Substituting the above in V. 3 and solving for D_e , the effective aperture diameter, gives the expression in Equation V. 1.

This may be derived as follows:

The received power is given by the usual equation

$$S_i = P_R = \frac{G_R P_d G_t}{L_m L_p P_L} \quad (V.2)$$

where

- G_R = Receiving antenna gain
- P_d = Effective transmitted power
- G_t = Transmitting antenna gain
- L_m = Misc. spacecraft losses.
- L_p = Design margin

$$P_L = \frac{(4\pi R)^2}{\lambda^2} = \text{monopath loss.}$$

We desire the expression to contain the ratio of received energy/bit per noise power/unit bandwidth = $\frac{S_i T_d}{N/B}$ where $T_d = \frac{1}{R_b}$ (R_b = bit rate). Solving Equation V.2 for G_R and multiplying the numerator and denominator by N/B .

$$G_R = \frac{S_i T_d R_b}{N/B} \cdot N/B \cdot \frac{P_L L_m L_p}{P_d G_t}$$

$\frac{S_i T_d}{N/B}$ in Equation V.1 is the required SNR and is a function of the bit probability error given in Figure V.1. For a coherent PSK system it can be shown that the required SNR is 3 db less than for the coherent FSK given in the figure. N/B is a function of the average operating noise temperature of the receiving system and is given by

$$\frac{N}{B} = k (\bar{T}_{i_1} + \bar{T}_e) \quad (V.4)$$

where

- k = Boltzman's constant
- \bar{T}_{i_1} = average noise temperature of the equivalent input to the receiver
- \bar{T}_e = average effective noise temperature of the receiver and is given by

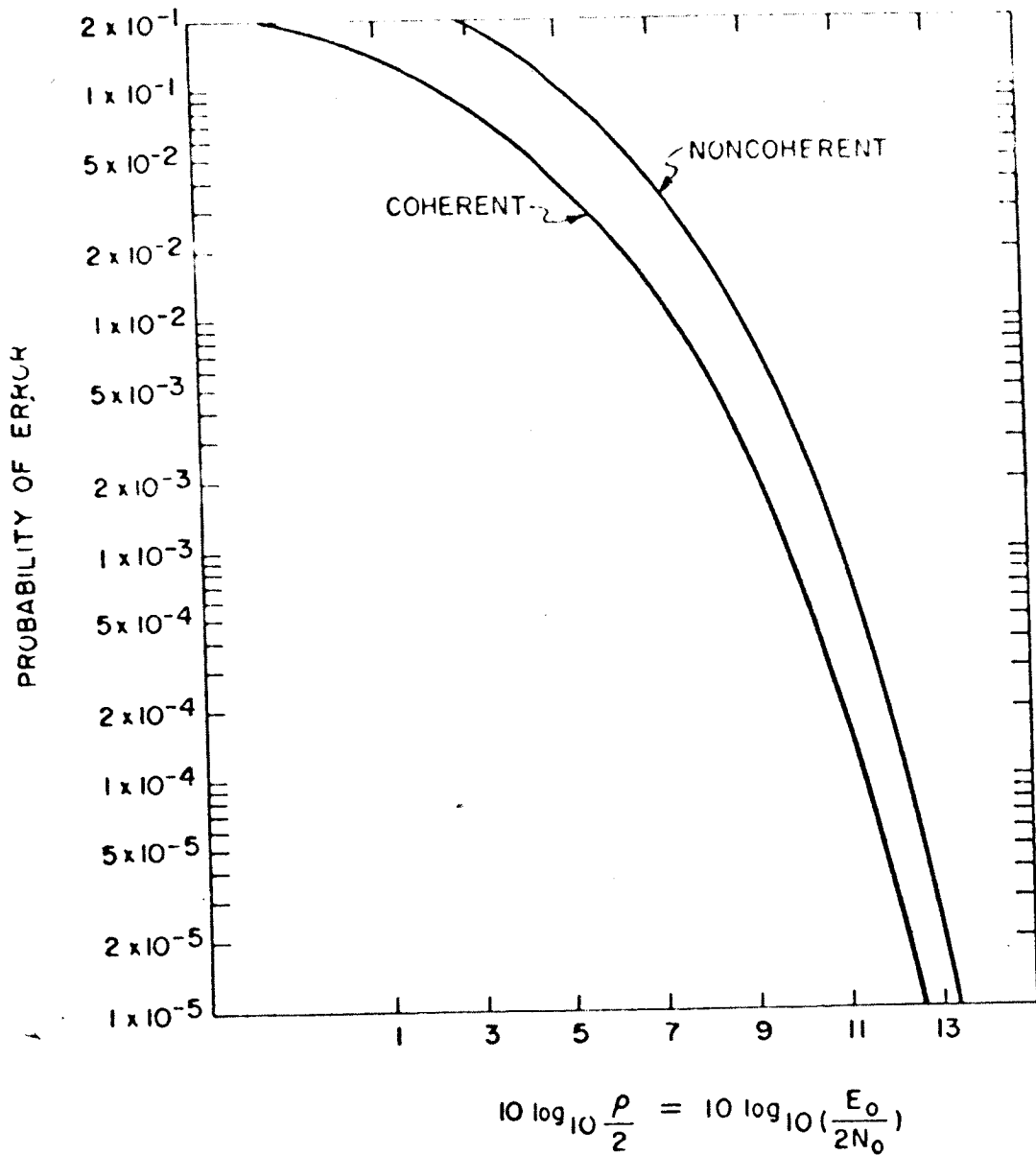

FIG V.1 - PROBABILITY OF ERROR vs SIGNAL TO NOISE RATIO FOR COHERENT AND NONCOHERENT (ENVELOPE) DETECTION FOR ONE ANTENNA.

$$\bar{T}_e = \frac{T_1 - Y T_2}{Y - 1} \quad T_1 > T_2 \quad (V.5)$$

where Y is the ratio of total noise power at some temperature T_1 to the total noise power at some lower temperature T_2 .

Using Figure V.1, Table 3.1 and Equation V.1 the total system performance can be described. Figure V.2 is a graphical description of the required effective antenna aperture vs average system operating temperature $\bar{T}_{op} = \bar{T}_{i2} + \bar{T}_e$ for various bit rates. Unless exceptionally large data rates are required effective receiver noise temperatures from 150-200°K could be tolerated and consequently parametric amplifier front ends would be suitable for lunar communication ranges.

For lunar communications the defined region of operating temperatures would be in the region of from 200 to 400°K. Bandwidths of from 20 to 60 kc can thus be obtained for an effective aperture of 10 meters. Apertures of 60 to 90 meters could handle a megabit rate.

V.3 Communications Interplanetary-Range

In this section an attempt is made to establish a suitable model for the interplanetary range communications system. Of fundamental importance to any communications system is the concept of effective energy; this is usually defined as the energy necessary to transmit the required information over the range required for the space mission. One is therefore limited by the allowable communications payload aboard the spacecraft since this in turn limits the total available energy. How effectively this energy is used determines the energy per bit of information available as effective radiated power.

This basic limitation allies itself to two problems namely: The generation, transmission, and reception of energy, and second the determination of the most effective method of modulating this energy to transmit the required information. For interplanetary ranges

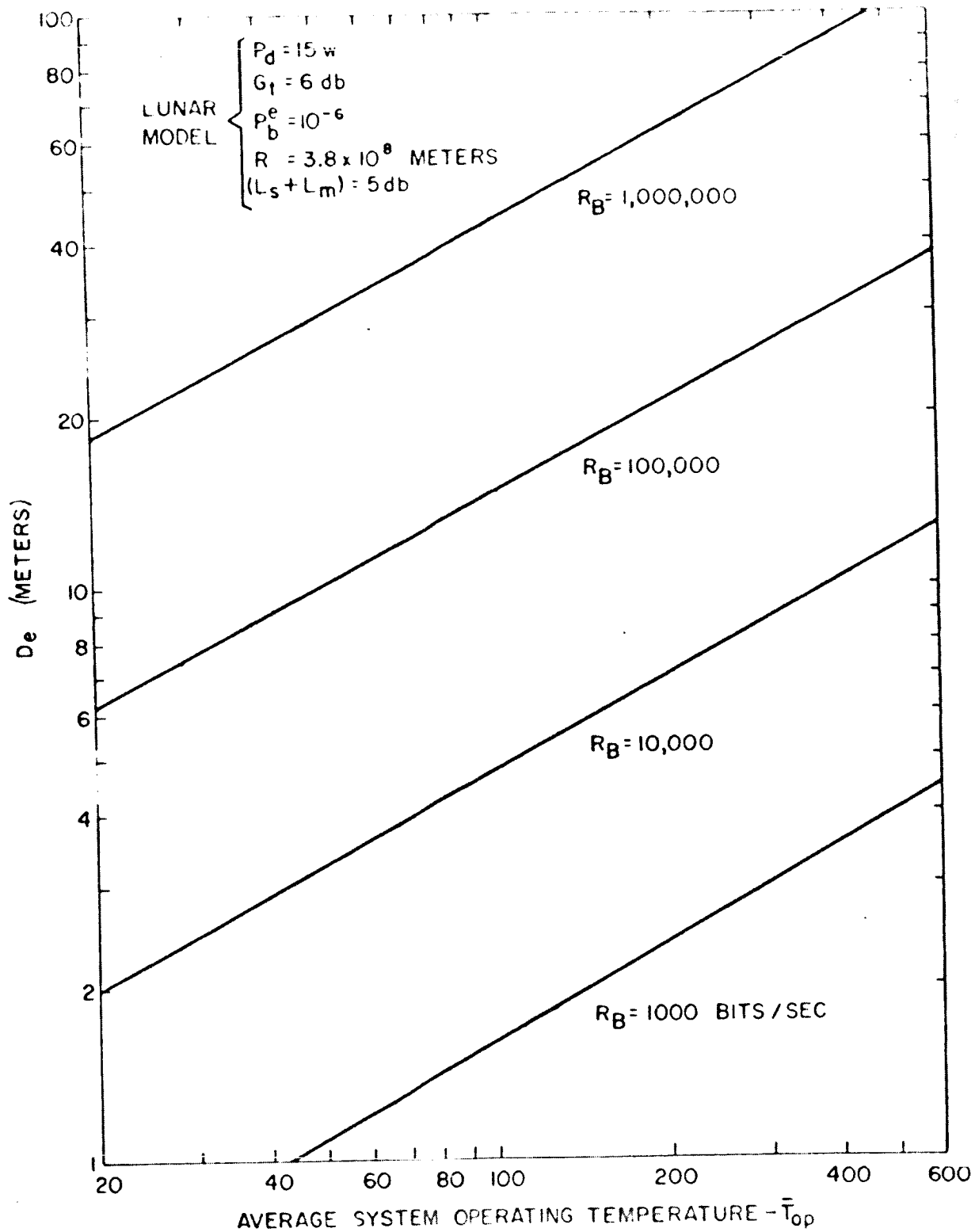

FIG. V.2 - REQUIRED EFFECTIVE APERTURE vs AVERAGE SYSTEM OPERATING TEMPERATURE - \bar{T}_{op} .

the information to be transmitted would necessarily presuppose a high degree of sophistication in both the modulation techniques and the data processing required within the satellite or probe.

Once the maximum available energy aboard the spacecraft has been determined, the effective power radiated from the probe may be maximized by 1) increasing the transmitter efficiency, 2) by increasing the antenna gain. It seems that major improvements in transmitter efficiency are unlikely. It is therefore realistic to assume maximum efficiencies of the order of 60% for transmitters operating at several Gc. The second method, that of increasing antenna gain aboard the spacecraft, is limited -- particularly in the case of an unmanned probe -- to the degree of attitude control available. One could impose boundary conditions on the above based upon the present state of the art and still arrive at innumerable possibilities for an interplanetary system by changing original assumptions concerning the ground receiving system. It becomes necessary, therefore, to consider the system collectively, accounting for all possible variations of system parameters. This method has been adopted in the following analysis and no single parameter will necessarily be maximized to achieve the desired results.

To investigate the effect of increasing ground antenna size, one may employ the following expression for power received as a function of power transmitted:

$$P_R = kTBF [S/N] = \frac{(P_T G_T) A_R \rho}{4\pi R^2 l} \quad (V.6)$$

where

- P_R = Received power
- kT = $1.3 \times 10^{-23} \times 290 \cong 4 \times 10^{-21}$
- B = Bandwidth, cps
- F = Receiver noise figure
- S/N = Required signal to noise ratio
- P_T = Vehicle transmitter power

G_T = Vehicle antenna gain

$A_R = \pi D^2/4$ = Antenna collection area (D diameter), sq ft

l = 6 db system design margin

$\rho \cong 0.5$ = antenna efficiency

R = Range in miles $\times 5.28 \times 10^3$ ft/mile

Solving Equation V.6 for D the antenna diameter

$$D = 4r \left[\frac{l K T B F (S/N)}{P_T G_T \rho} \right]^{1/2} \quad (V.7)$$

The required antenna diameter varies directly with the range while it is only moderately sensitive to other parameter variations.

Equation V.7 suggests innumerable possibilities of achieving the same result. Rather than assume fixed values for all parameters which would lead to a family of D vs R curves, the more important parameter will be treated as variables; namely, Bandwidth B, and Signal to noise ratio S/N.

Signal to noise ratio is inherently related to acquisition and the reliable recovery of the required information. In addition since there is a lower bound to S/N, the bandwidth assumes a role of equal importance.

One can examine Equation V.7 for the effects on bandwidth as a function of range for various antenna sizes. Solving for B as a function of R:

$$B = \frac{D^2}{16 R^2} \left[\frac{P_T G_T \rho}{l K T F S/N} \right] \quad (V.8)$$

Let us choose

$P_T = 100$ watts

$G_T = 100$

$\rho = 50\%$

$l = 6$ db = 4

$$KT \approx 4 \times 10^{-21}$$

$$S/N = 15 \text{ db} = 31.5$$

$$F = 1 \text{ db} = 1.26$$

Figure V. 3 then shows the effects of the ground antenna receiving aperture and spacecraft range on bandwidth. The minimum and maximum earth-venus distances are superimposed on the figure for comparison.

A similar investigation may be made in order to observe the effects of range on signal-to-noise ratio for various antenna apertures. When this is done the results are given by Figure V. 4 - V. 7.

Figure V. 4 shows that for a required minimum signal-to-noise ratio of 15 db, the available bandwidth is limited to less than 10 cps at Earth-Venus maximum distance for a 100 ft aperture system, while Figure V. 7 shows a bandwidth ≈ 500 cps for a 600 ft system, assuming the same required signal-to noise ratio. Both, of course, depend upon the model assumed.

From Equation V. 8 it is apparent that the effect of varying any of the parameters (except D and R) with respect to B or S/N is a linear process so that to estimate the effect of increasing the transmitter power ten fold for example would increase the values given in the figure by a factor of ten, etc. In this way one may extrapolate using the figures and determine available bandwidth or signal to noise ratio for any other combination of parameters directly.

There is much to be gained through using the most effective means of modulation to transmit the required information. Hartley and Shannon have both shown that the maximum amount of information which can be transmitted through a channel of given bandwidth and signal to noise ratio is given by

$$H = B_m \log_2 \left(1 + \frac{S}{N} \right) \quad (V. 9)$$

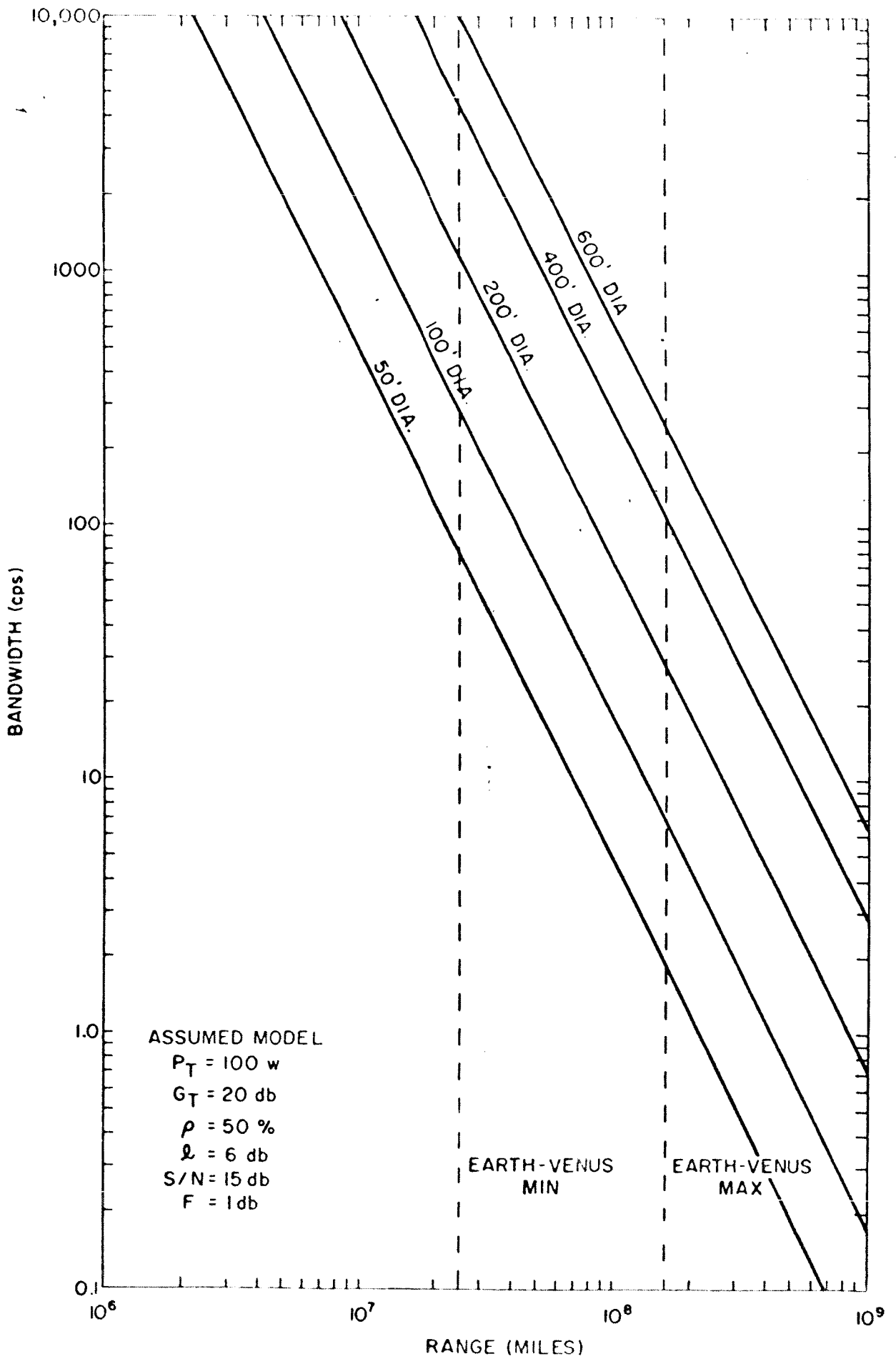
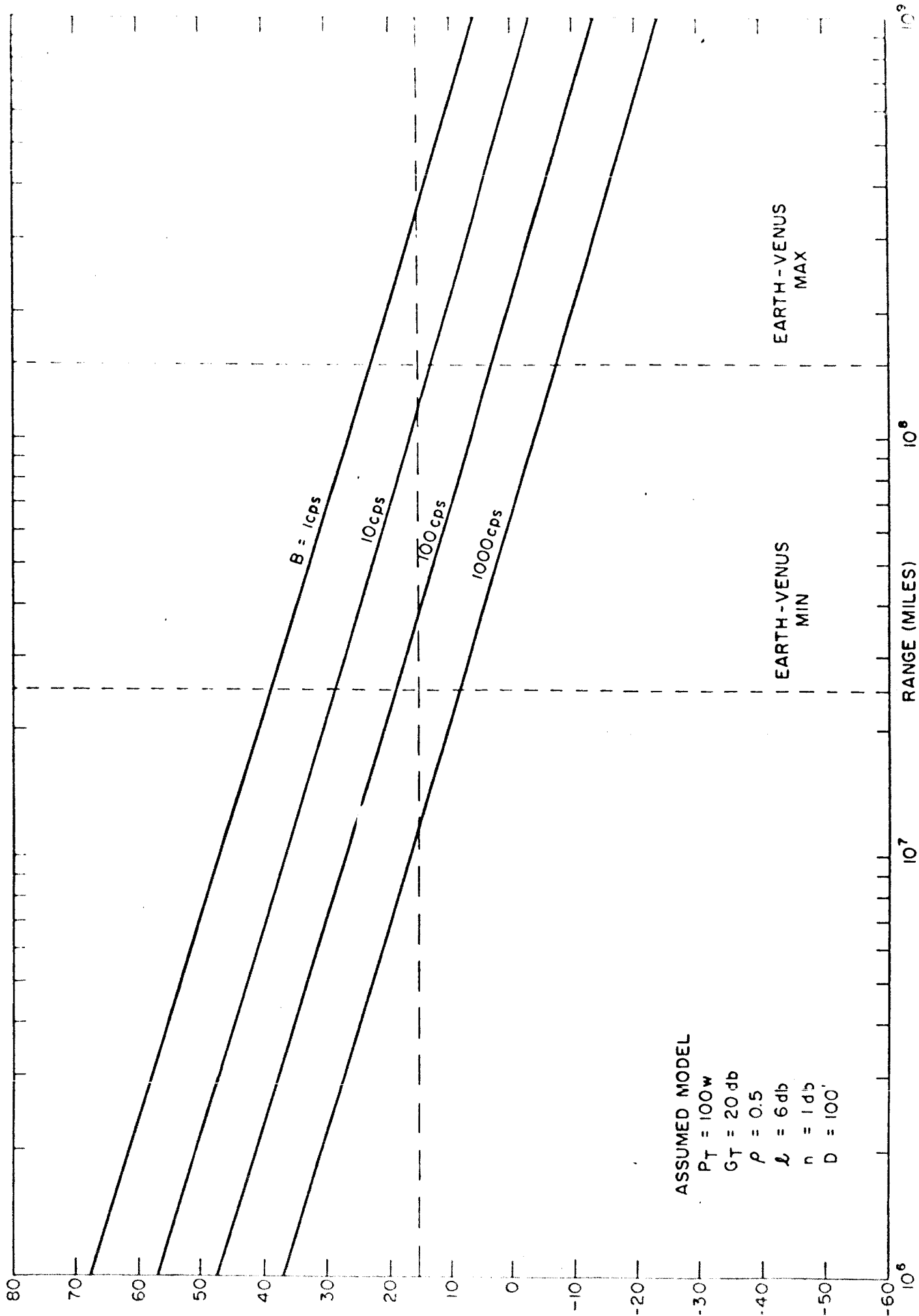
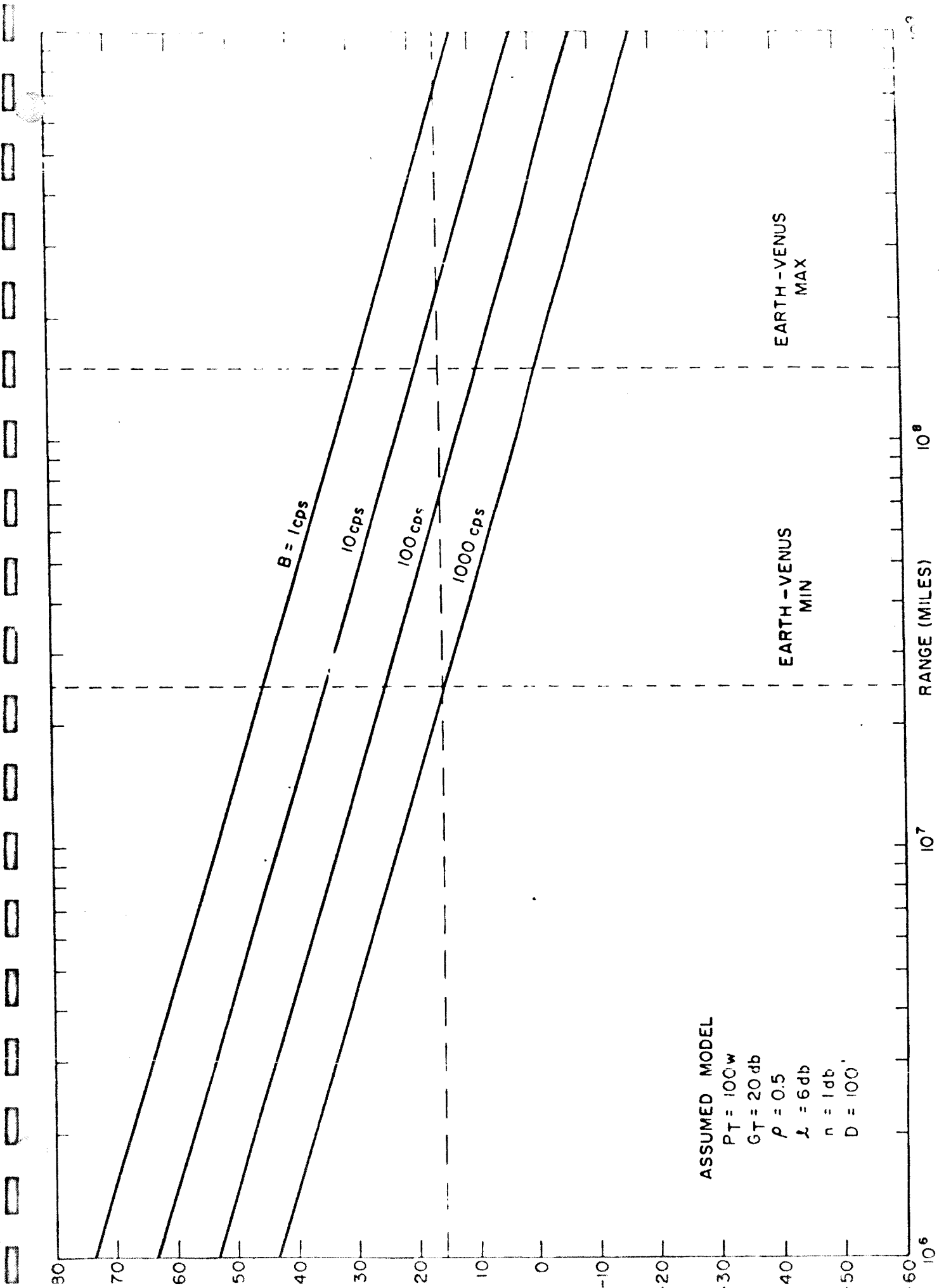

FIG. 3 - BANDWIDTH AS A FUNCTION OF RANGE AND ANTENNA DIA



ASSUMED MODEL
 $P_T = 100 \text{ w}$
 $G_T = 20 \text{ db}$
 $\rho = 0.5$
 $L = 6 \text{ db}$
 $n = 1 \text{ db}$
 $D = 100'$

FIG. V.4 - SNR vs RANGE FOR 100' APERTURE ANTENNA



ASSUMED MODEL
 $P_T = 100 \text{ w}$
 $G_T = 20 \text{ db}$
 $\rho = 0.5$
 $\lambda = 6 \text{ db}$
 $n = 1 \text{ db}$
 $D = 100'$

FIG. 5.5 - SNR vs RANGE FOR 200' APERTURE ANTENNA

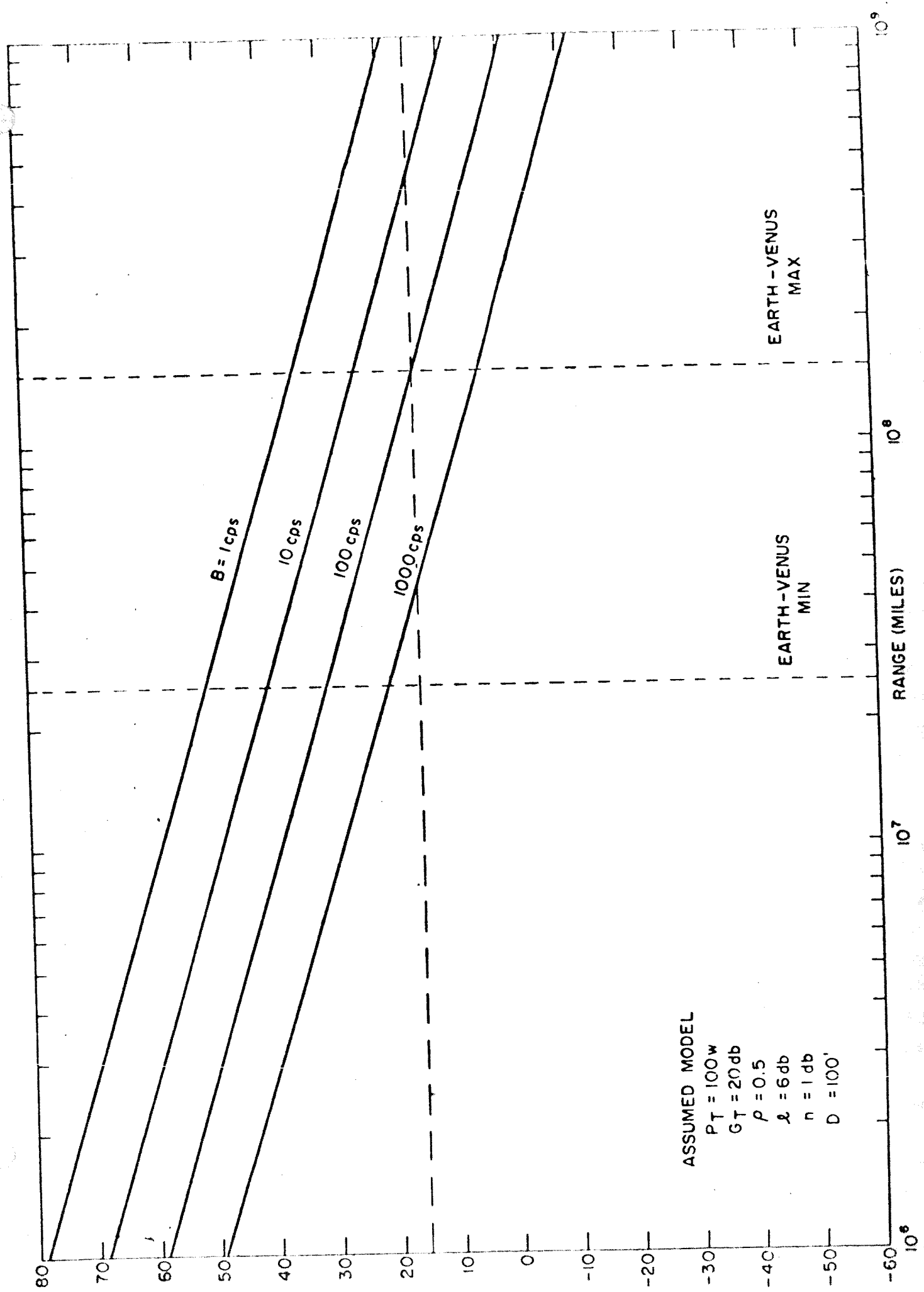
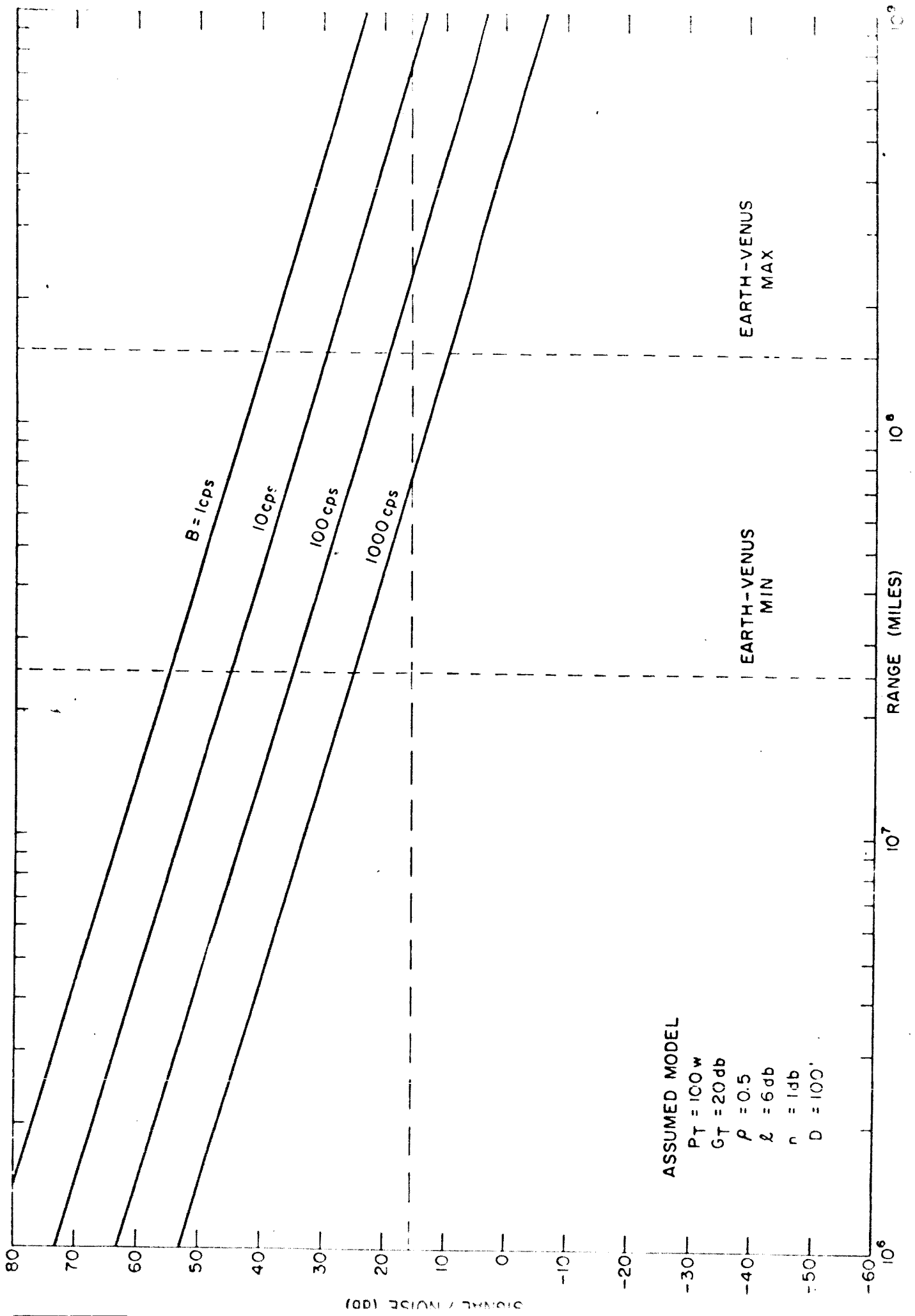

FIG. 6 - SNR vs RANGE FOR 400' APERTURE ANTENNA



ASSUMED MODEL

- $P_T = 100 \text{ w}$
- $G_T = 20 \text{ db}$
- $\rho = 0.5$
- $\ell = 6 \text{ db}$
- $n = 1 \text{ db}$
- $D = 100'$

FIG. I.7 - SNR vs RANGE FOR 600' APERTURE ANTENNA

where

- H = the information rate in bits per second
- B_m = the bandwidth of the message channel
- S = the signal and
- N = the noise in the bandwidth B_m .

Thus for

$$\begin{aligned} B_m &= 10 \text{ cps} \\ S/N &= 15 \text{ db } (B_T = B_m) \\ H_{\text{MAX}} &= 10 \times \log_2 (1 + 31.5) \\ &= 50 \text{ bits/sec} \end{aligned}$$

More often than not, the transmission channel bandwidth and the message channel bandwidth are not equal and $\frac{S}{N} = \left(\frac{S'}{N'}\right) \frac{B_m}{B_T}$ where $\frac{S'}{N'}$ is the transmission channel signal to noise ratio B_m = message bandwidth and B_T = transmission channel bandwidth. Thus high signal to noise ratios in the transmission channel as well as narrow transmission bandwidth, are essential in maximizing the available bit rate for the transmission of information.

REFERENCES FOR TABLE V.1

1. Philip J. Klass, "Apollo Communications Details Disclosed," Aviation Week and Space Technology; October 21, 1963.
2. D.R. Halcomb, "A Communication System for Apollo," Electronic Industries; October 1963.
3. I. Stambler, "Surveyor, Our First Lunar Lab," Space/Aeronautics, July 1963.
4. W.E. Giberson, "Surveyor Project Status," ARS, Lunar Missions Meeting; July 1962.
5. H.M Reynolds, L.S. Stokes, "Surveyor Spacecraft Data Handling," IEEE, Intl. Conv., 1962.
6. J.S. Green, "Surveyor Spacecraft Command and Data Handling GSE," ARS, Paper 2692-62; 1962.
7. S.J. Citron et al, "A Self-Contained Terminal Guidance Technique for Lunar Landing," ARS, Paper 2685-62; 1962.
8. B.D. Martin, "The Mariner Planetary Communications System Design," JPL Report No. TR #32-85; May 15, 1961.
9. S. Perlman, W. Russel, "Concerning Optimum Frequency For Space Vehicle Communication," IRE Transactions on Military Electronics, Vol. 4, April-July 1960.
10. "Space Programs Summary No. 37-22, Vol. III, Jet Propulsion Laboratory; July 31, 1963.
11. Paul E. Norsell, "Syncom," Astronautics and Aerospace Eng.; September 1963.
12. "A Syncom Satellite Program," Summer Meeting AIAA, No. 63-264, Los Angeles; June 17-20, 1963.
13. E. Rehtin, B. Rule, R. Stevens, "Large Ground Antennas," JPL Technical Report #32-213; March 20, 1962.

APPENDIX VI
Application of the Fibonacci Search Procedure
as a Combining Method*

* Prepared by M. E. Thomas

The problem we have is one of maximizing the output of some black boxes in this case the network combining the signals of the N antennas. This output is a function of N Variables (phase shifts) under our control. However, the function is a summation of N terms each of which is a function of only 1 of the N controllable variables. Therefore there is no interaction between any other controllable variables on the i^{th} one and we may consider this as N one-dimensional maximization problems in which the functionality is unknown – except that it is unimodal in each one dimensional problem over some period of time. *

If we simply define the phase of the first term (or reference antenna) as zero we can do our maximization relative to this term. Now consider the second term (or signal from the second antenna) – holding all others constant. Then the phase which maximizes the output will maximize that second term because we have as follows

$$E(\omega t, \phi_1, \phi_2, \dots, \phi_n, \alpha_1, \alpha_2, \dots, \alpha_n) = \sum_{n=1}^N \cos(\omega t + \phi_n + \alpha_n)$$

or considering only the second term'

$$E(\omega t, \phi_2, \alpha_2) = \cos(\omega t + \phi_2 + \alpha_2) + K$$

where K is now a constant with respect to change in α_2 (the alphas are our phase shifters). This is just a one dimensional search problem in α_2 . At any instant of time the function might look like what is shown below

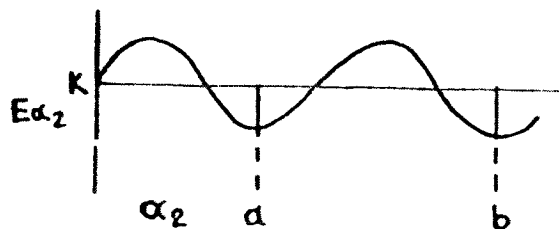

* R. E. Bellman, and S. E. Dreyfus, Applied Dynamic Programming, Princeton University Press, Princeton, N.J., 1962, Chapter IV.

If we consider just the range from a to b the function is unimodal. This region could be searched optimally by a Fibonacci Search procedure to find a_2^0 . Then fixing this we could proceed in the same manner with c_3, c_4, \dots, c_n . Since this would be accomplished on a computer we would define the number of points to be searched as one of the Fibonacci numbers. The Fibonacci numbers are generated by adding the two previous Fibonacci numbers. F_0 and F_1 may be defined as 1. Then $F_2 = 1 + 1 = 2$, $F_3 = 2 + 1 = 3$, $F_4 = 3 + 2 = 5$, $F_5 = 5 + 3 = 8$, $F_6 = 8 + 5 = 13$, $F_7 = 13 + 8 = 21$, $F_8 = 21 + 13 = 34$, $F_9 = 34 + 21 = 55$, etc. Suppose we had a function as shown below to search (defined on discrete points)

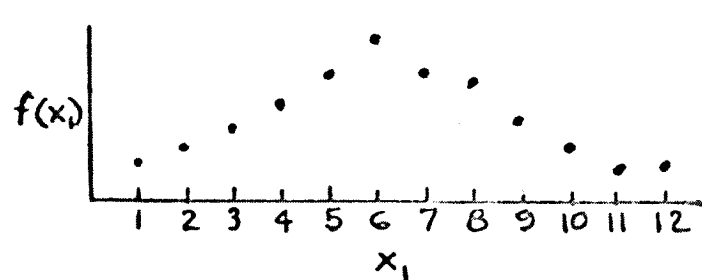

Since it is defined on a Fibonacci number of points we would proceed as follows: $F_7 = 13$. So we would place one point at $F_6 = 8$ at the other at $F_5 = 5$. Since $f(5) > f(8)$ and the function is unimodal we can eliminate point where $x = 8$ and all points to the right of it. Place next experiment symmetrically in the range, i.e., at $x = 2$. Notice that after each experiment the number of remaining points is a Fibonacci number. After the first two our region looks like this

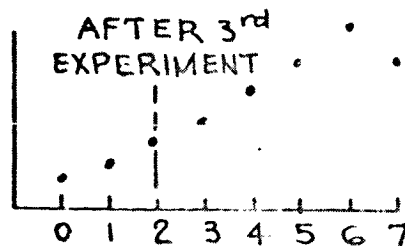

After placing the next one at 2 we can eliminate $x = 2$ and $x = 0, x = 1$, since $F(2) < f(5)$ and $f(x)$ is unimodal. We now have 5 points to search

optimally $x = 3, 4, 5, 6,$ and 7 . We have a point at $x = 5$ which is F_4 . So we place our next experiment at F_3 and F_2 . But we have one at F_3 so we place one at $F_2 = 2^{\text{nd}}$ point in remaining interval, i.e., $x=4$. Then we can eliminate $x=3$, and $x=4$ and have only $x=5, 6, 7$, to search. We place one at $x=6$. If $f(6) < f(5)$ we are through; if not, we must also look at $f(7)$. Therefore, at most we have searched 14 points in 6 experiments. Notice that if we have F_{n+1} number of points we can search them optimally in n observations. Example: Suppose we had 56 points. $55 + 1 = 56$ but $55 = F_9$ so we can search 55 points in 9 experiments and do it optimally.

This procedure has been programmed and can be done fairly easily.

If this search procedure were considered further, the effect of noise should be taken into account.

level of the grating lobes with respect to the main beam. For a linear array composed of uniformly illuminated circular apertures of diameter D with a spacing d between each element the suppression may be sketched as in Figure 5.20.* It is obvious that the grating lobe is reduced only slightly if the multiple aperture is to have any significant look angle. For example a scan of $\pm 60^\circ$ required $d/D=2$ (from Figure 5.5) so that two grating lobes exist, one -2.8 db below the main beam and the other -15 db.

Thus far the multiple aperture has been considered to be a linear array, but because of grating lobes created by the relatively large element spacing (to allow scanning), and because the pattern needs to be controlled in more than one dimension, the multiple aperture antenna could be in a planar array configuration. A configuration of the multiple aperture is suggested in Section 8, and the advantages and disadvantages of the multiple aperture system are summarized.

* Note that a partially suppressed grating lobe exists even when $d/D=1$. This is because the beamwidth of a circular aperture used as the element factor is slightly larger than for a rectangular aperture whose side is of length D . Any mutual coupling effects have been ignored.

APPENDIX VII

Combining Methods for Interplanetary Range Communications

Most of the analysis of combining methods thus far discussed in this report have been concerned with efficiently combining the outputs of several information channels which contain a narrowband pilot signal. A portion of the available transmitter energy must be made available for the pilot, thus lowering the total energy available for the information content. As long as the total energy is sufficient for maintaining wideband communications the amount taken by the carrier is generally negligible. However, as the range of communications is increased the available bandwidth (information rate) must be decreased in order to maintain the transmitted energy per bit to a reasonable value. As the bandwidth is shrunk a point is reached where the energy in the pilot is no longer an insignificant part of the total. One method of operating under such circumstances is to continue the use of the pilot signal for combining even though it is less efficient. This appendix discusses several other possible procedures for operating with narrow band information channels. Probably the best technical solution, but not necessarily the most economical, is to increase the spacecraft power and antenna gain so that a pilot can be utilized.

The combining technique that would be used for the lunar distance where the modulation bandwidths were several orders of magnitude wider than the equivalent noise bandwidth of the telemetry transmitter signal would not limit the number of antennas which could be combined. However, since the modulation bandwidths are much narrower and are more nearly equal to the equivalent noise bandwidth of the telemetry transmitter in the interplanetary range different combining techniques must be considered. These techniques must be compatible with the optimum modulation method and in general should not be the limiting factor in the number of antennas which can be combined. Binary

symmetric phase modulation using pulse codes seems to give good performance. All of the transmitted power should be used for the modulation. With these assumptions, the best technique -- the phase lock loop -- cannot be used for combining the antenna outputs. The phase lock loop is not stable under the conditions of rapid phase modulation of the signal. Normally this is overcome by transmitting a continuous, unmodulated carrier or pilot on which the phase lock loop operates. This pilot energy is subtracted from the total available transmitted signal energy and is therefore, a less efficient system.

There are at least four combining techniques which can operate with a phase modulated signal and which might be applied to the interplanetary case. In general any prior information about the frequency of the signal will shorten the search time. Also, the interplanetary telemetry transmitter must transmit a "clean" signal and have good short term frequency stability. Knowledge of the transmitted frequency, and the doppler frequency should be known to within several modulation bandwidths. If this be so, the main acquisition problem is the relative phase between the signals of the several antennas.

The first system is shown in Figure VII.1. The binary phase modulated signal is filtered, then doubled in frequency by a times-two multiplier. The output of the multiplier has the same phase regardless of the state of the phase modulation. The phase modulation of $\pm 90^\circ$ becomes a modulation of $\pm 180^\circ$ at twice frequency therefore, there will be no modulation component at twice frequency to confuse a phase-lock loop. The phase-lock loop is completed by using a reference oscillator signal, a loop filter, voltage controlled oscillator and frequency divider. The loop will perform as described before. A signal may be extracted from the loop which contains the modulation. In the loop shown this would be at one-half the reference frequency. This signal may be summed with all the corresponding signals from each receiving aperture. The modulation is recovered from the sum signal. The

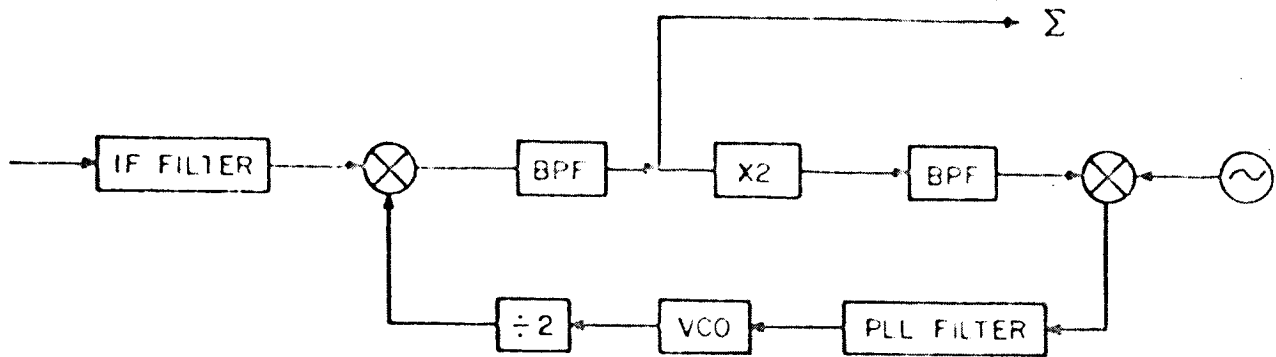

FIG. VII.1. - BINARY PHASE MODULATED SIGNAL DETECTION WITH FREQUENCY DOUBLING.

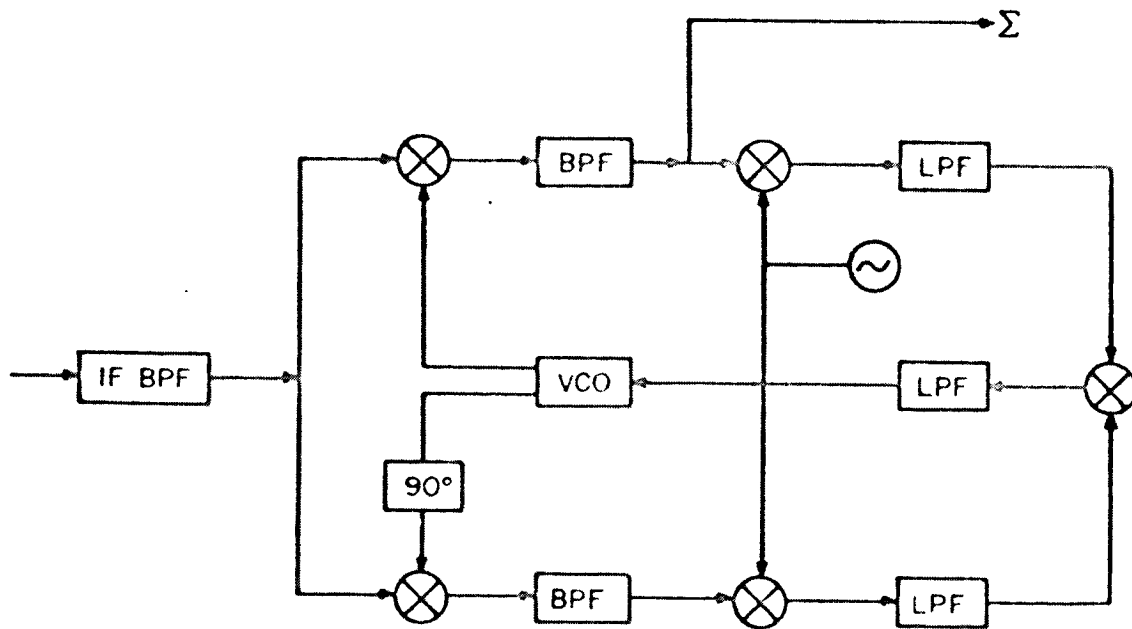

FIG. VII.2 - DETECTION SYSTEM FOR PHASE MODULATED SIGNALS

performance of this system is related to the signal-to-noise ratio at the multiplier. The minimum bandwidth of the phase lock loop is related to the noise bandwidths of the signals and the orbital parameters.

The second system is shown in Figure VII.2. An additional reference oscillator and bandpass filter are included so as to yield a signal with the appropriate frequency and phase for adding to the signals from other channels. The equation of the loop is the same as the first system. The signal is processed by heterodyning it against a voltage controlled oscillator with two outputs in quadrature with one another. After an additional mixing operation the resulting difference frequency is filtered out. The passband of these low pass filters must be sufficient to pass the modulation components. One further multiplication and filtering gives the control signal for the voltage controlled oscillator. This dual channel loop will lock the oscillator to the phase of the incoming signal. As before, there is a signal which may be used to add to the signals from the other channels to yield the sum signal.

The performance of this system is related to the signal-to-noise ratio at the final multiplication. The bandwidths are more easily controlled to match those of the signal on this circuit than they are in the first system. Also this circuit does not destroy the phase of the modulation, so there is no phase ambiguity. Slight variations in the circuit allow it to become an automatic frequency control circuit during initial acquisition. Still other modifications convert it into an amplitude detector.

The third system is shown in Figure VII.3 and, as far as is known is an original development. It is based on the phase lock loop but the usual loop filter is replaced by a computer. Each loop in the system would provide inputs to the computer, and it would control the phase shifters and various reference oscillators. The usual phase lock loop does not estimate the frequency or phase error from the error signals. However, a computer could analyze the average zero crossing rate for all of the channels and arrive at a good estimate

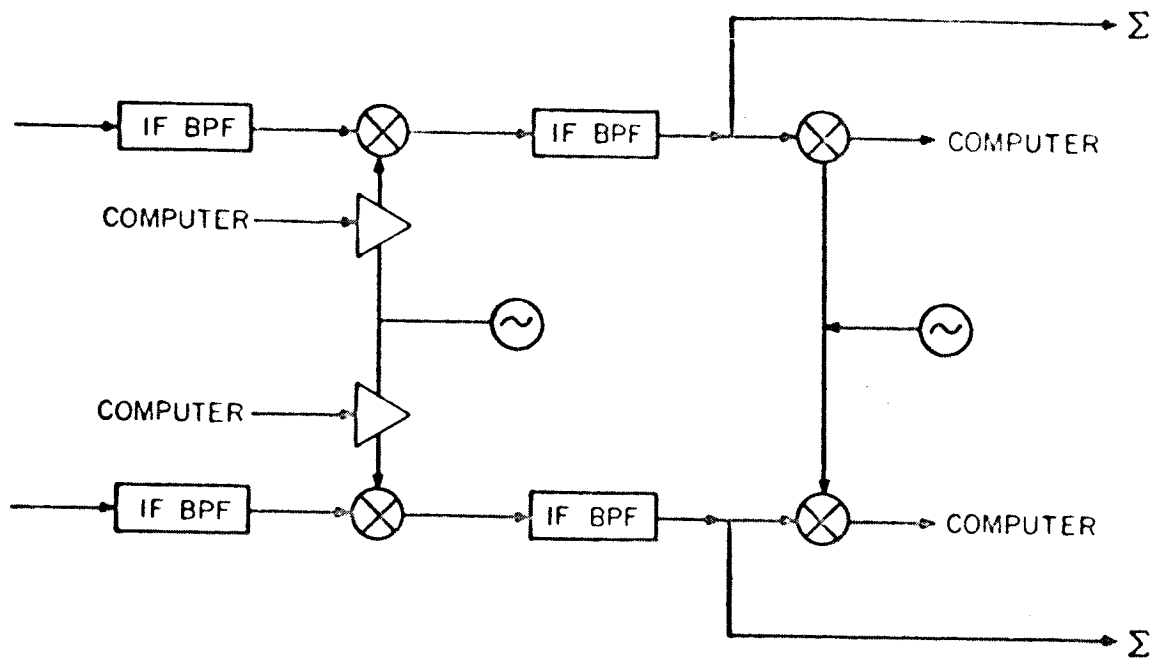

FIG. VII.3 - DETECTION SYSTEM EMPLOYING DIGITAL COMPUTER

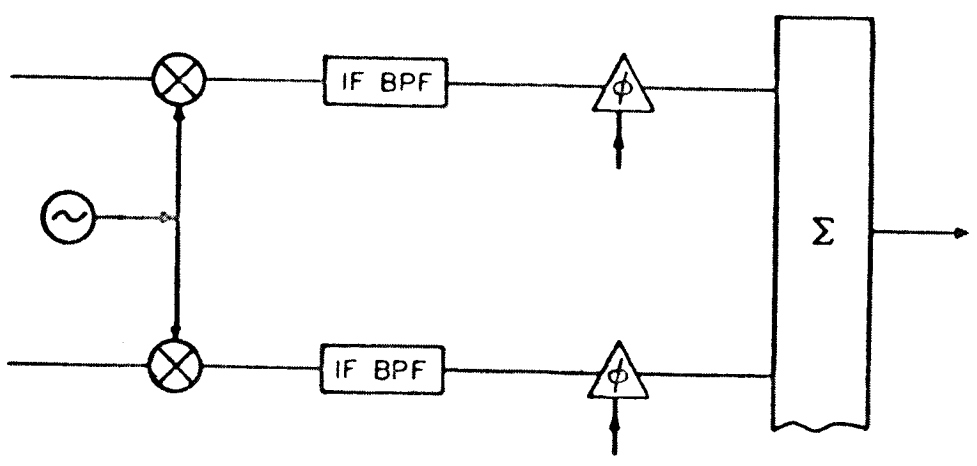

FIG. VII.4 - DETECTION SYSTEM BY SYSTEMATIC ADJUSTMENT OF PHASE.

of the frequency of the frequency error. The computer could not determine the direction of the frequency error but it would only have to make two trials (one for each of the two possible directions) to find the correct frequency. Then the phase lock-up could proceed under computer direction. The advantage of this approach is that the computer can analyze and compare the signal statistics in a more complete manner for all of the channels. The other schemes must operate by themselves since it is difficult to interconnect the various feedback loops. The computer could also recover the most probable modulation.

The fourth system is shown in Figure VII.4. In several respects this is the simplest system. The signals are added, imperfectly, most probably, at the start. Then in a systematic way such as discussed in Appendix VI each channel phase is varied and compared with the resulting amplitude variations of the output. Each channel's phase is set in turn to give the maximum output. Since it is an interacting process, after the first adjustment, a second setting is made. The limit on the accuracy of this phasing process is the signal-to-noise ratio. However, since in any real system the signals must add to a +15 db S/N, the problem reduces to that of seeing a small perturbation of amplitude as the phase is changed. A small variation in output may be due to a change in receiver gain, so periodic modulation of the phase and recovery of resulting modulation in a synchronous detector will reduce the effects of receiver gain changes.

In the remainder of this Appendix is presented a brief analysis of some common coherent demodulation systems which use the information signal as the reference or synchronizing signal. Van Trees* has shown that the receivers shown in Figure VII.5 and VII.6 are identical as far as the information part of the signal input to the low pass filters is concerned. Using analyses similar to Van Trees the above statement will be shown to be true.

* H. L. Van Trees "Optimum Power Division in Coherent Communication Systems," MIT Lincoln Laboratory Technical Report No. 301
19 February 1963.

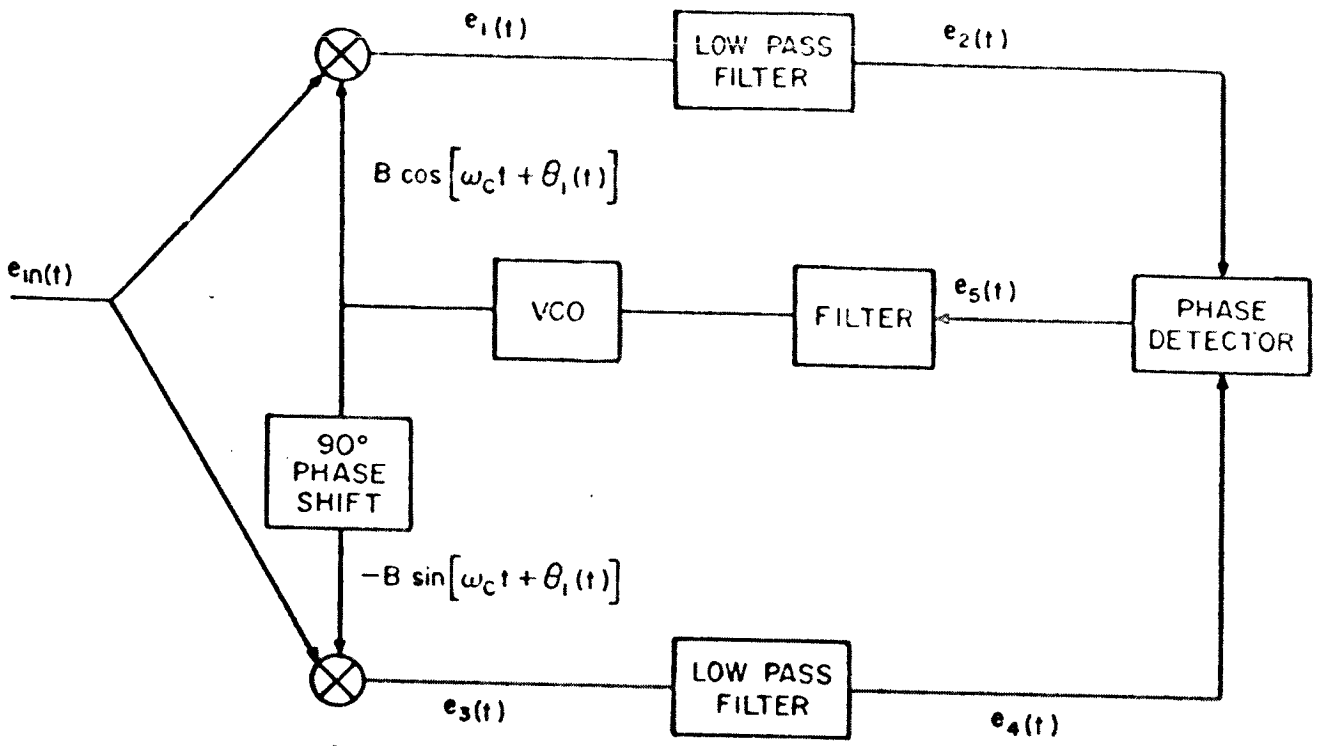

FIG. VII.5 - TWO-CHANNEL RECEIVER

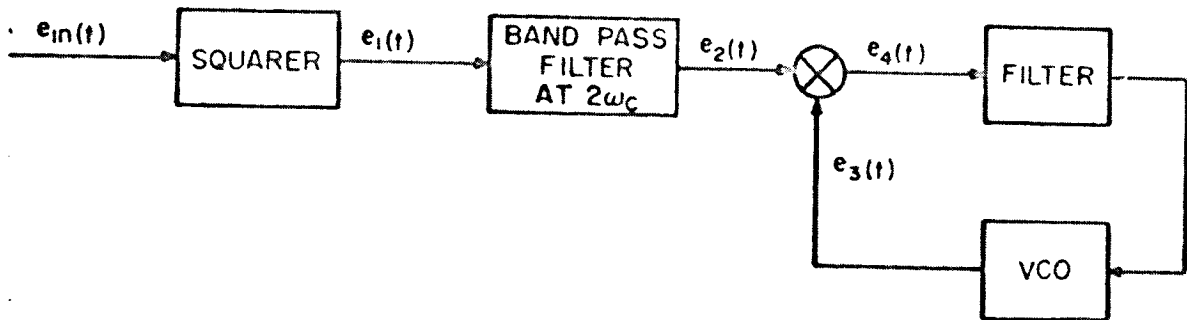

FIG. VII.6 - PHASE LOCK LOOP RECEIVER

Assuming that the information is used to biphase modulate a carrier, the signal at the receiver may be written as

$$e_{in}(t) = A(t) \sin [\omega_c t + \theta_{in}(t)] \quad (VII-1)$$

where $A(t)$ is the information consisting of a random sequence of pulses of amplitude $\pm A$, each pulse having a duration of T seconds. The random phase modulation $\theta_{in}(t)$ is caused by the time varying channel through which the signal propagates.

Consider the receiver shown in Figure VII.5. The signal given by Equation VII-1 is multiplied in the upper channel by the output of the oscillator which is given by

$$e_{LO_1}(t) = B \cos [\omega_c t + \theta(t)] \quad (VII-2)$$

$$\begin{aligned} e_1(t) &= A(t) B \sin [\omega_c t + \theta_{in}(t)] \cos [\omega_c t + \theta(t)] \\ &= \frac{A(t)B}{2} \left\{ \sin [2\omega_c t + \theta_{in}(t) + \theta(t)] + \sin [\theta_{in}(t) - \theta(t)] \right\} \end{aligned} \quad (VII-3)$$

Assuming that the low pass filter in the upper channel is ideal so that it passes the low frequency term without distortion and completely attenuates the high frequency term, the filter output is

$$e_2(t) = \frac{A(t)B}{2} \sin [\theta_{in}(t) - \theta(t)] \quad (VII-4)$$

In the lower channel the output of the local oscillator is advanced in phase by 90° , so the VCO input into the multiplier is

$$e_{LO_2}(t) = -B \sin [\omega_c t + \theta(t)] \quad (VII-5)$$

The mixer output

$$\begin{aligned} e_3(t) &= -A(t) B \sin [\omega_c t + \theta_{in}(t)] \sin [\omega_c t + \theta(t)] \\ &= \frac{-A(t)B}{2} \left\{ \cos [\theta_{in}(t) - \theta(t)] - \cos [2\omega_c t + \theta_{in}(t) + \theta(t)] \right\} \end{aligned} \quad (VII-6)$$

is filtered by the low pass filter (assumed ideal) to produce

$$e_4(t) = \frac{-A(t)B}{2} \cos [\theta_{in}(t) - \theta(t)] \quad (\text{VII-7})$$

The signals from the two low pass filters are fed to the phase detector where they are multiplied. The phase detector output

$$\begin{aligned} e_5(t) &= \frac{-A^2(t)B^2}{4} \sin [\theta_{in}(t) - \theta(t)] \cos [\theta_{in}(t) - \theta(t)] \\ &= \frac{-A^2(t)B^2}{8} \sin [2\theta_{in}(t) - 2\theta(t)] \end{aligned} \quad (\text{VII-8})$$

is sent to a filter which operates on it and feeds it to the voltage controlled oscillator.

Assuming the same input signal, Equation VII-1, for the receiver shown in Figure VII-6, the output of the squarer

$$\begin{aligned} e_1(t) &= A^2(t) \sin^2 [\omega_c t + \theta_{in}(t)] \\ &= \frac{A^2(t)}{2} \left\{ 1 - \cos [2\omega_c t + 2\theta_{in}(t)] \right\} \end{aligned} \quad (\text{VII-9})$$

is filtered by a flat bandpass filter with a center frequency of $2\omega_c$. The signal component input to the multiplier.

$$e_2(t) = \frac{-A^2(t)}{2} \cos [2\omega_c t + 2\theta_{in}(t)] \quad (\text{VII-10})$$

is multiplied in the mixer by the VCO output

$$e_3(t) = \frac{-B}{2} \sin [2\omega_c t + 2\theta(t)] \quad (\text{VII-11})$$

The mixer output is

$$\begin{aligned} e_4(t) &= \frac{+A^2(t)B}{4} \cos [2\omega_c t + 2\theta_{in}(t)] \sin [2\omega_c t + 2\theta(t)] \\ &= \frac{+A^2(t)B}{8} \left\{ \sin [4\omega_c t + 2\theta_{in}(t)] + \sin [2\theta(t) - 2\theta_{in}(t)] \right\} \end{aligned} \quad (\text{VII-12})$$

which has a low frequency output given by

$$\begin{aligned}
e_{4LF}(t) &= \frac{A^2(t)B}{8} \sin [2\theta(t) - 2\theta_{in}(t)] \\
&= \frac{-A^2(t)B}{8} \sin [2\theta_{in}(t) - 2\theta(t)] \quad (VII-13)
\end{aligned}$$

The low pass filter for $e_4(t)$ is included in the loop filter shown in Figure VII-6. Thus it is seen that the signal input to the loop filters of Figure VII-5 and VII-6 are identical.

In order to be used with the multi-aperture antenna system, the receivers shown in Figures VII-5 and VII-6 must be modified as shown in Figure VII-7. Each antenna of the system would have a receiver, but now the signal from the VCO in Figure VII-5 would be set to operate at a radian frequency of $(\omega_c - \omega_{IF})$ so that its output signal would be

$$e_{LO_1}(t) = B \cos [\omega_c - \omega_{IF} t + \theta(t)] \quad (VII-14)$$

The voltages $e_1(t)$ and $e_3(t)$ then become

$$e_1(t) = \frac{A(t)B}{2} \left\{ \sin [(2\omega_c - \omega_{IF})t + \theta_{in}(t) + \theta(t)] + \sin [\omega_{IF}t + \theta_{in}(t) - \theta(t)] \right\} \quad (VII-15)$$

$$e_3(t) = \frac{-A(t)B}{2} \left\{ \cos [\omega_{IF}t + \theta_{in}(t) - \theta(t)] - \cos [(2\omega_c - \omega_{IF})t + \theta_{in}(t) + \theta(t)] \right\} \quad (VII-16)$$

If the low pass filters in the upper and lower channels of Figure VII.5 are replaced by bandpass filters centered at ω_{IF} , then

$$e_2(t) = \frac{A(t)B}{2} \sin [\omega_{IF}t + \theta_{in}(t) - \theta(t)] \quad (VII-17)$$

and

$$e_4(t) = \frac{-A(t)B}{2} \cos [\omega_{IF}t + \theta_{in}(t) - \theta(t)] \quad (VII-18)$$

The phase detector output would be

$$e_5(t) = \frac{-A^2(t)B^2}{8} \sin [2\omega_{IF}t + 2\theta_{in}(t) - 2\theta(t)] \quad (VII-19)$$

If the phase detector output is multiplied by the signal from a local oscillator which has a frequency $2\omega_{IF}$, then

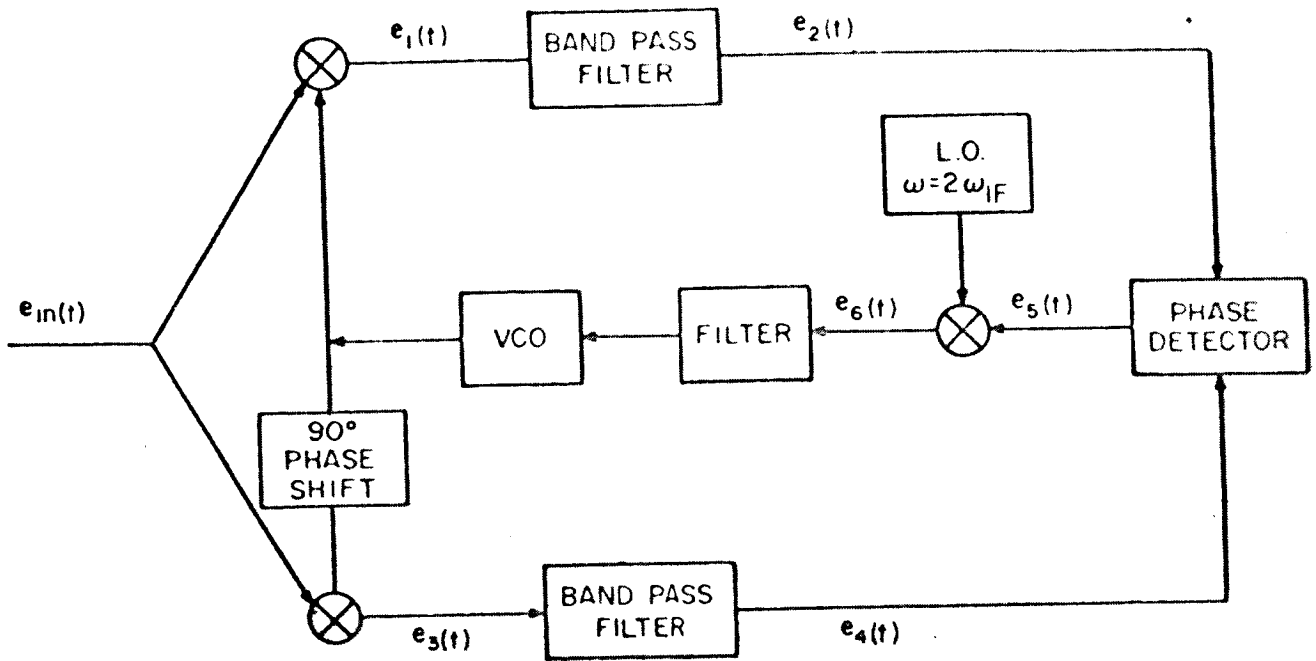

FIG. VII.7 - BAND-PASS EQUIVALENT OF FIG. VII.5

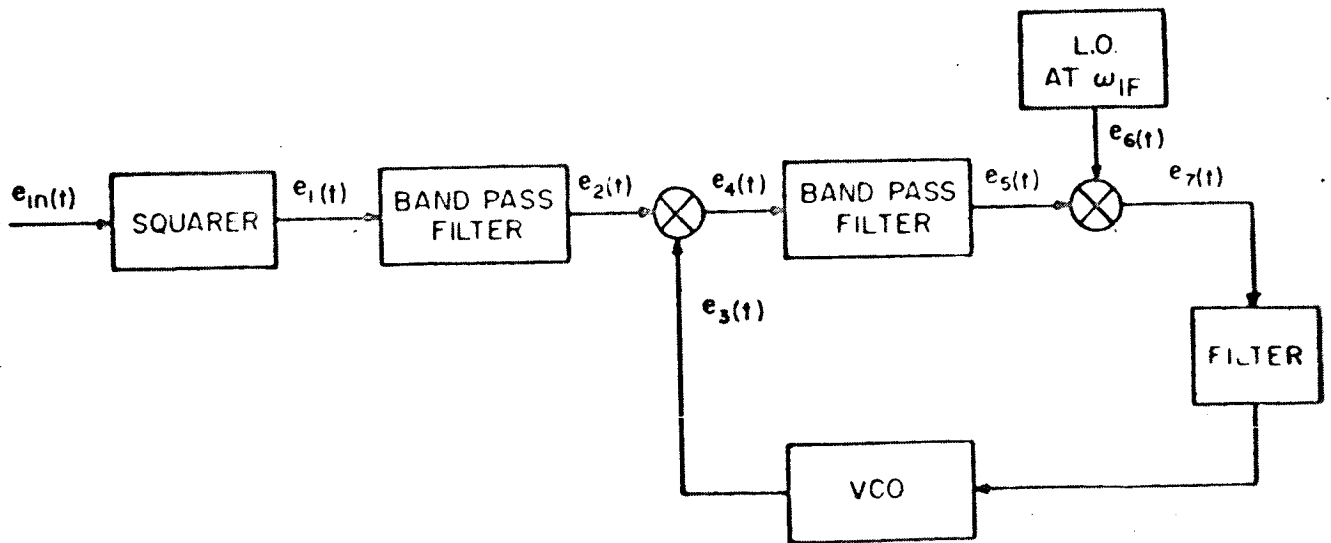

FIG. VII.8 - BAND-PASS EQUIVALENT OF FIG. VII.6

$$e_6(t) = \frac{-A^2(t)B^2}{16} \left\{ \sin [4\omega_{IF}t + 2\theta_{in}(t) - 2\theta(t)] + \sin [2\theta_{in}(t) - 2\theta(t)] \right\} \quad (\text{VII-20})$$

It is seen from Equation VII-20 that $e_6(t)$ has a low frequency term of

$$e_{6LF}(t) = \frac{-A^2(t)B^2}{16} \sin [2\theta_{in}(t) - 2\theta(t)] \quad (\text{VII-21})$$

which is needed to control the VCO.

The IF equivalent of the receiver shown in Figure VII-6 is given in Figure VII-8. The respective voltages are

$$e_1(t) = \frac{A^2(t)}{2} \left\{ 1 - \cos [2\omega_c t + 2\theta_{in}(t)] \right\} \quad (\text{VII-22})$$

$$e_2(t) = \frac{-A^2(t)}{2} \cos [2\omega_c t + 2\theta_{in}(t)] \quad (\text{VII-23})$$

$$e_3(t) = \frac{-B}{2} \sin [2\omega_c t - \omega_{IF}t + 2\theta(t)] \quad (\text{VII-24})$$

$$e_4(t) = \frac{A^2(t)B}{8} \left\{ \sin [4\omega_c t - \omega_{IF}t + 2\theta_{in}(t) + 2\theta(t)] - \sin [\omega_{IF}t - 2\theta(t) + 2\theta_{in}(t)] \right\} \quad (\text{VII-25})$$

$$e_5(t) = \frac{-A^2(t)B}{8} \sin [\omega_{IF}t - 2\theta(t) + 2\theta_{in}(t)] \quad (\text{VII-26})$$

$$e_6(t) = \cos \omega_{IF}t \quad (\text{VII-27})$$

$$e_7(t) = \frac{-A^2(t)B}{16} \left\{ \sin [2\omega_{IF}t - 2\theta(t) + 2\theta_{in}(t)] + \sin [2\theta_{in}(t) - 2\theta(t)] \right\} \quad (\text{VII-28})$$

An examination of Equations VII-21 and VII-27 show that the receivers of Figures VII-7 and VII-8 are mathematically equivalent as far as the low frequency signal component of the input to the loop filter is concerned. Essentially the function of the two channels in Figures VII-5 and VII-7 and the squaring device of Figures VII-6 and VII-8 is to reconstruct a constant frequency signal (pilot signal) from the biphase modulated input signal to use as a coherent reference.

The multi-aperture antenna system would take the IF signal from each antenna Equation VII-17 or VII-18 for the Figure VII-7 configuration and Equation VII-26 for the Figure VII-8 configuration and add it to the IF signals from the other antennas to arrive at the total information signal. Since the receivers at the individual antennas are independent, the phase errors at each antenna would be independent and the system operation would depend on the ability of each phase lock receiver to follow the random phase modulation at each antenna.

APPENDIX VIII - Noise Analysis Of A Multiple Aperture System

Following Schrader's derivation,¹ assume that the amplitudes of the signals from each antenna are weighted such that they are proportional to their signal-to-noise ratios (as in maximal ratio combining). Then

$$E_{Sm} = \sqrt{P_{Sm}} = k \frac{P_{Sm}}{P_{Nm}} \quad (\text{VIII. 1})$$

where E_{Sm} , P_{Sm} and P_{Nm} are the rms signal amplitude, signal power and noise power respectively at the m^{th} antenna. Therefore, the rms noise amplitude at the m^{th} antenna is

$$E_{Nm} = \sqrt{P_{Nm}} = k \sqrt{\frac{P_{Sm}}{P_{Nm}}} \quad (\text{VIII. 2})$$

If it is assumed that the signal combining is ideal (the signals are added perfectly in phase), the rms value of the sum signal from M antennas is

$$E_{SMo} = k \sum_{m=1}^M \frac{P_{Sm}}{P_{Nm}} \quad (\text{VIII. 3})$$

and the total signal power is

$$P_{SMo} = (E_{SMo})^2 = \left(k \sum_{m=1}^M \frac{P_{Sm}}{P_{Nm}} \right)^2 \quad (\text{VIII. 4})$$

Further assuming that the noise between antenna elements is incoherent,

$$E_{NMo} = \sqrt{k^2 \sum_{m=1}^M \frac{P_{Sm}}{P_{Nm}}} \quad (\text{VIII. 5})$$

and

1. J.H. Schrader, "Receiver System Design for the Arraying of Independently Steerable Antennas," IRE Trans. on Space Electronics and Telemetry, Vol. SET-8, No. 2, pp. 148-153; June, 1962.

$$P_{NMo} = k^2 \sum_{m=1}^M \frac{P_{Sm}}{P_{Nm}} \quad (\text{VIII. 6})$$

$$\frac{P_{SMo}}{P_{NMo}} = \sum_{m=1}^M \frac{P_{Sm}}{P_{Nm}} \quad (\text{VIII. 7})$$

The signal power at each antenna may also be written as

$$P_{Sm} = W_m A_m \quad (\text{VIII. 8})$$

where W_m is the power density (watts per square meter) at the m^{th} antenna element and A_m is the effective receiving area of the m^{th} antenna. The noise power at the m^{th} antenna is

$$P_{Nm} = KT_m B_m \quad (\text{VIII. 9})$$

where K is Boltzmann's constant (1.38×10^{-23} joule per degree Kelvin), T_m is the effective noise temperature of the m^{th} antenna and B_m is the effective noise bandwidth of the m^{th} channel. Therefore the signal to noise power ratio in the m^{th} channel is

$$\frac{P_{Sm}}{P_{Nm}} = \frac{W_m A_m}{KT_m B_m} \quad (\text{VIII. 10})$$

Using the expression in Equation VIII-10 and Equation VIII-7, it is seen that

$$\frac{P_{SMo}}{P_{NMo}} = \sum_{m=1}^M \frac{P_{Sm}}{P_{Nm}} = \sum_{m=1}^M \frac{W_m A_m}{KT_m B_m} \quad (\text{VIII. 11})$$

If the received power density is the same and if the effective area and bandwidths of the channels are identical, then Equation VIII-11 becomes.

$$\frac{P_{SMo}}{P_{NMo}} = \frac{WA}{KB} \sum_{m=1}^M \frac{1}{T_m} \quad (\text{VIII. 12})$$

The overall equivalent noise temperature of the system is

$$T_e = \frac{P_{NMo}}{KBG} \quad (\text{VIII. 13})$$

Since the gain of the receiver is equal to the signal power out divided by the signal power in,

$$G = \frac{S_o}{S_{in}} = \frac{P_{SMo}}{MWA} \quad (\text{VIII. 14})$$

If Equations VIII. 12 and VIII. 14 are substituted into Equation VIII. 13, the effective noise temperature becomes

$$T_e = \frac{M}{\sum_{m=1}^M \frac{1}{T_m}} \quad (\text{VIII. 15})$$

Since the average of the individual channel temperatures is

$$T_{av} = \frac{\sum_{m=1}^M T_m}{M} \quad (\text{VIII. 16})$$

Equation VIII. 15 may be written as

$$T_e = \frac{T_{av} M^2}{\sum_{m=1}^M T_m \sum_{m=1}^M \frac{1}{T_m}} \quad (\text{VIII. 17})$$

Now

$$\sum_{m=1}^M T_m \sum_{m=1}^M \frac{1}{T_m} \geq M^2 \quad (\text{VIII. 18})$$

so that

$$T_e \leq T_{av} \quad (\text{VIII. 19})$$

Equation VIII. 19 shows that the effective noise temperature of the system is less than or equal to the average effective noise temperatures of the individual channels.

A similar type of analysis may be performed for the case where the signal power and also the noise power are assumed equal at each antenna element and the output of each antenna is weighted equally. In this case if the signals are added coherently, then the total signal power out for M antennas is

$$P_{SM_o} = M^2 P_{Sm} \quad (\text{VIII. 20})$$

where P_{Sm} is the signal power out for one antenna. Using Schrader's definition of signal power in

$$P_{SM_{in}} = M W_m A_m \quad (\text{VIII. 21})$$

where W_m and A_m are as defined previously, the gain may be written as

$$G = \frac{P_{SM_o}}{P_{SM_{in}}} = \frac{M^2 P_{Sm}}{M W A} = \frac{M P_{Sm}}{W A} \quad (\text{VIII. 22})$$

for antennas with equal area when the power density is the same at each antenna element.

The equivalent noise temperature is

$$T_e = \frac{P_{NM_o}}{K B G} \quad (\text{VIII. 23})$$

where P_{NM_o} is the total noise power output for the system of M antennas.

Assuming that the noise from the individual antennas is incoherent, then

$$P_{NM_o} = M P_{Nm} \quad (\text{VIII. 24})$$

where P_{Nm} is the noise power in the m^{th} channel, which may also be written as

$$P_{Nm} = K T_m B \quad (\text{VIII. 25})$$

Substituting the relationships of Equations VIII. 22, VIII. 24, and VIII. 25 into Equation VIII. 23 gives the following

$$T_e = \frac{W A T_m}{P_{Sm}} = T_m \quad (\text{VIII. 26})$$

The two results derived in this section indicate that when the amplitude of the signals in the individual channels is made proportional to the channel signal to noise ratios, that the equivalent noise temperature of the system is less than or equal to the average of the temperature of the individual antennas. If the signals from the individual antennas are equally weighted before combining and if the signals as well as noise are equal in the various channels, then the equivalent noise temperature of the system is equal to the noise temperature of a single channel since each channel noise temperature is the same.