

FACILITY FORM 808

N65-28848

(ACCESSION NUMBER)

(THRU)

130

1

(PAGES)

14

(NASA CR OR TMX OR AD NUMBER)

(CATEGORY)

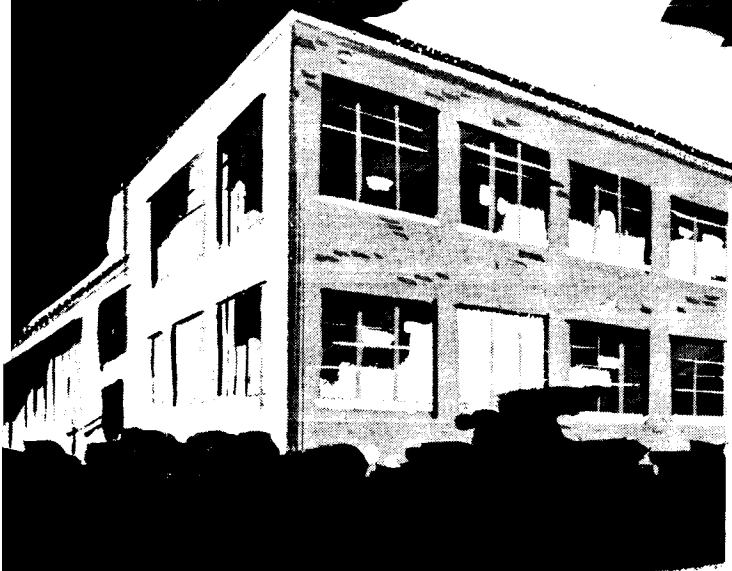

GPO PRICE \$ _____

CFSTI PRICE(S) \$ 2

Hard copy (HC) 4.00

Microfiche (MF) 1.00

ff 653 July 65

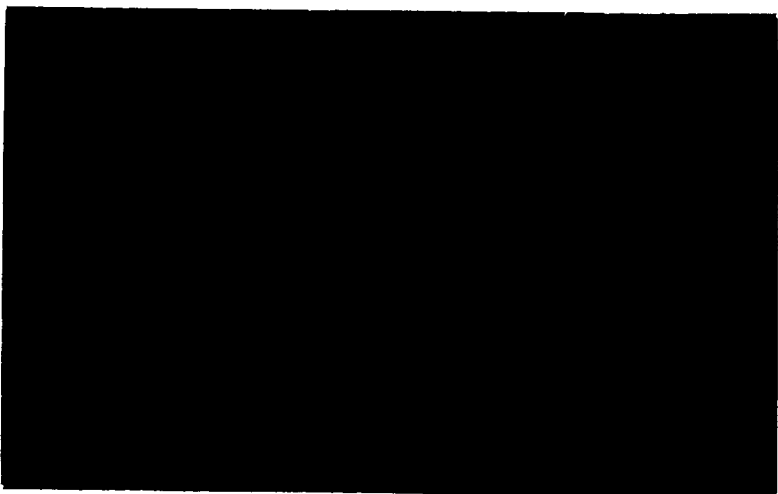



GOERZ OPTICAL COMPANY, INC.

FINAL REPORT

CONTRACT NUMBER NAS 9-3583

P-426A



GOERZ OPTICAL COMPANY

ENGINEERING STUDY PROGRAM
TO DETERMINE THE OPTIMUM DESIGN
FOR A HAND HELD CAMERA
TO BE USED ON THE LUNAR SURFACE

FINAL REPORT

P-426A

JUNE 4, 1965

CONTRACT NUMBER NAS 9-3583



GOERZ OPTICAL COMPANY, INC.

TABLE OF CONTENTS

	Page
I Introduction	1
A. Purpose and Scope	1
B. Study Program	3
C. Results of Study	5
II Optical Design	6
A. Requirements	6
A.1 Color Photography of Small Objects	7
A.2 Stereo Color Photographs of Near Objects	17
A.3 Photographs of the Lunar Surface in the UV and IR	21
A.4 Photographs of Celestial Objects	22
A.5 Summary of Design Requirements	23
B. Materials	25
C. Optical Design	28
III Format and Field Angle	43
IV Focus Considerations - Range Finder Requirements	64
A. Depth of Field	64
B. Range Finder Design	67
V View Finder	72
VI Shutter	77
A. Requirements	77
B. Choice of Basic Shutter Type	82
C. Development of Design	83



GOERZ OPTICAL COMPANY, INC.

	Page
VII Exposure Control	90
A. Requirements	98
B. Types of Light Sources	100
B.1 Pulsed Incandescent Sources	101
B.2 Gas Discharge Flash Sources	103
C. Automatic Exposure Control	106
VIII Time Recording	110
A. Electronic Methods of Generating Time	111
A.1 Synchronous Direct Couples Transistor Logic	112
A.2 Master Slave Binary Logic	115
A.3 Bi-Quinary Shift Register	115
B. Electronic Display	117
C. Electro-Mechanical Time Generation	119
IX Temperature Control	120
X Filters	131
XI Materials	135
A. Requirements	135
B. Environmental Conditions	135
C. Structural Materials	136
D. Bearing Materials	138
E. Elastomer	144
F. Surface Treatments	145
XII Distance and Attitude Recording	147



GOERZ OPTICAL COMPANY, INC.

	Page
XIII Camera Design	153
A. Camera Body	154
B. Seals and Pressurization of the Camera	161
C. Film Advance Mechanism and Frame Counters	164
C.1 Type I Camera Film Advance Mechanism	164
C.2 Type III Camera	169
C.3 Type IV Camera	169
D. Film Selecting Mechanism	169
D.1 Type I Camera	170
D.2 Type III Camera	170
D.3 Type IV Camera	175
E. Filter and Corrector Lens Selecting Mechanism	175
E.1 Type I Camera Filter Selecting Mechanism	175
E.2 Type III Camera	179
E.3 Infrared Filter Selector, Type IV Camera	179
F. Elapsed Time Recording	179
G. Loading the Camera with Film	180
G.1 Type I Camera; Film Change	180
G.2 Type III Camera; Film Change	182
G.3 Type IV Camera; Film Change	182
H. Automatic Exposure Control	185
I. Shutter Mechanism and Film Pressure Plates	186
J. Focussing Control and Range Finder	189



GOERZ OPTICAL COMPANY, INC.

	Page
K. Close Focus Attachment	190
L. Telescope	194
M. Detail Design Type I Camera	198
XIV Specifications	204
Appendix I	209
Appendix II	211
Appendix III	216
Appendix IV	221



GOERZ OPTICAL COMPANY, INC.

LIST OF TABLES

	Page	
Table I	Optical Properties of Materials	26
Table II	Back Focal Length vs. Wave Length	32
Table III	Back Focal Length vs. Wave Length	33
Table IV	Lens Characteristics	34
Table V	Recording Area Per Unit Weight as a Function of Frame Size	48
Table VI	Recording Area Per Unit Volume as a Function of Frame Size	49
Table VII	Recording Area Per Unit Volume as a Function of Frame Size with Constant Resolution	52
Table VIII	Monochromatic 3d Order Aberrations	54
Table IX	Focal Range	66
Table X	Range Finder Accuracy	69
Table XI	Shutter Accelerations	85
Table XII	Luminosity of Lunar Surface and F Stops as a Function of Target Brightness	94
Table XIII	Crystal Parameters	111
Table XIV	Equilibrium Temperatures	124
Table XV	Camera Cooling Rates	129
Table XVI	Properties of Structural Materials	140
Table XVII	Outgassing Characteristics of Plastics and Graphite	141
Table XVIII	Outgassing Characteristics of Dry Powders	142
Table XIX	Outgassing Characteristics of Dry Powders	142
Table XX	Outgassing Characteristics of Composites	143
Table XXI	Outgassing Characteristics of Plastic and Graphite	143



GOERZ OPTICAL COMPANY, INC.

LIST OF ILLUSTRATIONS

Figure		Page
1	Stereo Dissecting Microscope	12
2	High Resolution - Low Distortion Stereo Microscope Attachment	13
3	Close-up Attachment	16
4	Afocal Attachment	20
5	Graph of Indices vs. Relative Dispersion	27
6	Air Spaced Triplet	29
7	UV - IR Lens - Type I	36
8	UV - IR Lens - Type II - Long Back Focus	37
9	Visual - IR Lens - Type III	39
10	Recording Area Efficiency as a Function of Frame Size	50
11	Recording Area Efficiency as a Function of Frame Size with Constant Resolution	53
12	Range Finder	71
13	View Finder	74
14	Contrast Rendition as a Function of Shutter Type	78
15	Linear Shutter Model	84
16	Single Circular Shutter	87
17	Separate Disk Shutters	88
18	Optimum Shutter	89
19	Lunar Illumination and Viewing Model	92
20	Gas Discharge Schematic	105
21	Auto Exposure Control	109



GOERZ OPTICAL COMPANY, INC.

Figure		Page
22	Block Diagram Electronic Time Recording	113
23	Synchronous Direct Coupled Transistor Logic	114
24	Master Slave Binary Logic	116
25	Electroluminescent Display Logic	118
26	Equilibrium Temperature	125
27	Equilibrium Temperature	126
28	Camera Cooling Rates	130
29	Filter Characteristics	133
30	Filter Characteristics	133
31	Filter Characteristics	134
32	Filter Characteristics	134
33	Distance Measurement	149
34	Outline Drawing, Type I Camera	157
35	Outline Drawing, Type III Camera	158
36	Outline Drawing, Type IV Camera	159
37	Seals for Linear Motion	162
38	Seals for Angular Motion	163
39	Film Advance Mechanism, Type I Camera	165
40	Film Advance Mechanism, Type III Camera	171
41	Film Selecting Mechanism, Type I Camera	172
42	Film Selecting Mechanism, Type I Camera	173
43	UV Filter and Corrector Lens Mechanisms	177
44	IR Filter Selector, Type I Camera	178



GOERZ OPTICAL COMPANY, INC.

Figure		Page
45	Film Cassettes, Type I Camera	183
46	Film Cassettes, Type I Camera	184
47	Shutter Mechanism	187
48	Field Flattener - Pressure Plate	191
49	Focussing Mechanism	193
50	Close Focus Device	195
51	Telescope	196
52	Type I Camera - Back Cover Removal	205
53	Type I Camera - Longitudinal Section	206
54	Type I Camera - Cross Section	207



GOERZ OPTICAL COMPANY, INC.

I INTRODUCTION

A. PURPOSE AND SCOPE

The purpose of this study was to determine the optimum design for a hand held stereo camera considering the types of data to be taken, the environmental conditions, the limited dexterity of the space suited astronaut and the allowable space and weight. The scope of the study was limited by time and funding to a preliminary investigation of the best compromise between a wide array of conflicting capability requirements, a harsh environment, a somewhat limited photographer and a severe limitation on space and weight.

The Apollo mission, being exploratory, requires the collection of as wide a range of different types of data as practicable, both to provide immediate answers to a large number of questions about the nature of the surface of the moon and to provide order of magnitude data which will be useful in the design of specialized equipment for future missions. The types of pictures to be taken include color photographs of objects as small as 0.1 mm in linear dimension, stereo color photographs of physical relief conditions of the surface, color photographs of objects at distances up to one mile, photographs of surface features as far into the UV and IR portions of the spectrum as possible, and photographs of the earth and celestial objects in the ultraviolet, visible in color, and in the infrared. Object sizes range continuously from a few

microns up to celestial objects. Object distances range from a few centimeters to hundreds of millions of miles. Spectral range varies by a factor of five compared to a factor of less than two for the human eye.

The environmental conditions cover a similar range from that of the launch pad where contamination and corrosion must be guarded against, to the high vacuum of space where the super cleanliness of exposed metal surfaces creates the problem of welding on contact. The special environmental conditions which must be considered are the launch pad environment with salt spray, dirt and wide temperature variation, the transport environment and high vacuum, wide temperature variation and the radiation of the Van Allen Belts and the lunar surface environment of high vacuum, dense shadows and surface dust.

The limitations of the astronaut arise from the restrictions of motion and tactual sense and the requirement for large eye relief imposed by the space suit and the variety and number of tasks which he must perform in a limited time in a strange environment.

Design objectives of seven pounds and 1/4 cubic foot were set for the weight and size of the hand held camera. The study was conducted with the knowledge that each gram and each cubic centimeter used by the camera will reduce the balance allowable for other scientific experiments. Data points per pound and per cubic inch were constantly used as criteria although not always



GOERZ OPTICAL COMPANY, INC.

expressed as such.

To define the design which will produce the best sampling of the various types of data within the fixed environmental constraints and to show the trade-off between quality and reliability of data in terms of volume and weight is the purpose of the study.

The scope of the study was limited to preliminary investigations which determined feasibility of certain design approaches, determined the area in which detailed solutions would be found, and which showed the nature of the trade-off involved in restricting the range of collection of one type of data to increase the range of a different type. Detailed lens designs were made to prove the feasibility of covering the wide spectral range with a single lens and camera layout drawings were made to show the comparative costs of different film versatility approaches.

B. STUDY PROGRAM

The progress of the study can be described in three more or less distinct phases. The first phase was bounded in time by the receipt of the contract and the meeting of NASA, EG&G, and Goerz personnel late in November, 1964. The second phase extended from this meeting until the meeting following the presentation of the Mid-Term Report at NASA-MSO in February, 1965. The third phase extended from this meeting through completion of the contract.

During the first phase, the program was directed along the lines of the technical proposal toward the design of the simplest, most compact camera that would meet the requirements of the statement of work. Materials were selected and the optical design of a compact single lens that would cover the wide spectral range with high resolution was carried almost to completion. Investigations were made on types of auxiliary lighting, exposure requirements, suitability of structural materials and thermal problems.

As a result of the November meeting, the optical design emphasis was shifted to lenses of long back focal length to allow color or exposure separation so that four, rather than two, images would be recorded during each exposure. Camera components were investigated during this period. Where alternate forms were available, a selection was made or comparison data prepared to show relative advantages. Shutters, range finders, view finders and controls were defined separately. By the end of this phase, a preliminary packaging had been accomplished for both a Type I camera following initial guide lines, and a Type II camera using the long back focal length lens and beam splitters and folding mirrors.

The third period concentrated on packaging problems and refinement of component concepts. As a result of the Houston meeting in February, 1965, a third type of camera and additional film versatility were included in the study goals. The new camera type is to cover the restricted spectral range of 4000 to 9000A°



GOERZ OPTICAL COMPANY, INC.

and to extend the angular field to 45° across the diagonal of the format. Increased versatility of film selection would be provided by having a double film transport and an optical switch which would allow the selection of film to be exposed by a simple control. By the end of this phase, layouts showed methods of packaging and performing the required and desired functions for three basically different types of cameras.

C. RESULTS OF STUDY

The study shows that each of the three types of cameras provide a high degree of versatility and utility to the Apollo Program and provides design data, layout drawings and specifications to guide the detailed design and fabrication of the camera type or types selected.

II OPTICAL DESIGN

The optical design group investigated three basically different types of photographic objectives. The first design, which was carried through to the point of final optimization, meets all of the requirements of Exhibit "A" of the statement of work. The second design was similar to the first design, but included an afocal forward section to give the large back focal length required for a color or exposure separation camera. This design was also carried to the point of final optimization. The third design was restricted to the visual and near infrared, but covered a much wider field. The investigation of the third type was restricted to a preliminary choice of design form. Detail design of this type was prevented by time and funding limitations.

A. REQUIREMENTS

The basic photographic requirements of the camera lens are given in the statement of work and continue to be the basis of the specification of the Type I camera. These specifications were interpreted and made more specific in detail by discussions with NASA personnel at Inwood in late November and following the Mid-Term Report at Houston in February. The latter meeting generated a requirement for an alternate Type III camera with a wider field of view and narrower spectral range capability. The types of data to be taken which lead to the specifications of the lens are:



GOERZ OPTICAL COMPANY, INC.

1. Color photographs of objects which are as small as 0.1 mm in linear dimension with sufficient resolution and image size to permit positive identification of the object's shape.
2. Stereo color photographs to permit recording of the physical relief conditions of the surface near the LEM.
3. Color photographs which permit recognition of surface features, i.e., rocks, small craters, etc., six feet in linear dimension at a distance of one mile.
4. Photographs of the lunar surface near the LEM as far into the UV and IR portions of the spectrum as possible. (The film used in the camera is expected to have a spectral sensitivity ranging from 2,000Å to 10,000Å.)
5. Photographs of various celestial bodies, including the earth in the UV, visible (color) and IR portions of the spectrum with an angular resolution of one second of arc.

A.1 COLOR PHOTOGRAPHY OF SMALL OBJECTS

To positively identify the shape of objects as small as 0.1 mm in linear dimension will require an object space resolution of approximately 50 lines per millimeter. This means that the product of the contrast modulation of the object, the spatial frequency response of the lens, and the transfer function of film at the required image space frequency must combine to give a detectable modulation or contrast on the processed film. If the object space is reimaged at one to one by the

camera, the required image space frequency will be 50 lines per millimeter. With a three inch focal length camera lens, unity magnification could be achieved by moving the lens three inches forward from its infinity position. This solution was rejected from consideration because of the complication to the camera focussing mechanism, and because of the loss of resolution to be expected when a high resolution lens corrected to work at one infinite conjugate is used with equal conjugates.

In amateur photography, a portrait or close focus lens is frequently used to reduce the minimum focal distance. The lenses are simple positive lenses which add power to the normal lens and thereby reduce the back focal distance to within the range covered by the focussing mechanism. With inexpensive lenses, the use of such attachments does allow an increase in object space resolution by virtue of the higher magnification. Reduced image space resolution is inherent in the use of such attachments.

This problem has received the attention of physicists for over one hundred years. Maxwell showed that if a lens could be corrected to give perfect imagery for two pairs of conjugate planes, that the lens would give perfect imagery for all conjugate planes. Helmholtz showed that a necessary condition for providing perfect imagery at any object distance is given by



GOERZ OPTICAL COMPANY, INC.

$$nh \tan U = n' h' \tan U'$$

where n is the index of refraction of the object space, h is the height of the object point measured from the optical axis, and U is the convergence angle of the rim ray. The primed quantities are the image space index of refraction, image height and rim ray convergence angle. Abbe showed that a necessary condition for perfect imagery was given by $nh \sin U = n' h' \sin U'$. These relationships, known as the Helmholtz equation and the Abbe sine condition, are completely general and independent of the detailed design of the optical system. The two conditions can only be met simultaneously for rays so close to the optical axis that the sine and tangent are equal. Photographic lenses are usually corrected for use at infinity and give essentially constant resolution for object distances from infinity down to around fifty times the focal length. Lenses used in commercial photography are designed to work at finite conjugates. The Goerz Dagor is designed to give optimum performance at object distances equal to forty focal lengths. A slight sacrifice in infinity resolution is allowed in order to improve definition at shorter object distances. Process lenses are corrected individually to meet the customer's requirement of 1:1, 1:3, 1:5, 1:10 or 1:20 magnification. Enlarging lenses are normally corrected to give highest definition when used to give a magnification of 4:1.

highest definition will be achieved for extremely small objects by the use of a supplementary lens which reimages these objects at infinity or by the use of a separate lens corrected for unity magnification. Camera sealing and focussing problems are minimized by the use of a supplemental lens. To give unity magnification the supplemental lens must be of the same focal length as the camera lens. To give a magnification of one-seventh, the supplemental lens must have a focal length seven times as great as the camera lens. An object positioned at the focal point of the supplemental lens will then be imaged by it at infinity and reimaged on the film plane by the camera lens when it is focussed at infinity. This arrangement has the added advantage that the centering and spacing of the supplemental lens with respect to the camera lens is not critical.

The supplemental lenses should have the same degree of correction at the camera lens. The contrast transfer of the combination will be equal to the product of the contrast transfer function of the individual components. In the limit with high contrast objects and a perfect detector, the resolution would be equal to that of a single component. For lower contrast objects and a photographic emulsion as the detector, the resolution will be degraded by a factor of approximately two. To assure the recording of 50 lines per millimeter at unity



GOERZ OPTICAL COMPANY, INC.

magnification, the combination of camera lens and auxiliary lens should have a resolution of 100 lines per millimeter when measured by microscopic examination of the aerial image of a high contrast target.

Although the statement of work does not require stereo recording of extremely small objects, methods of stereo recording have been investigated. The stereo dissecting microscope uses objectives whose axes are inclined with respect to each other and parallel eyepiece axes, as shown in Figure 1. The extremely low numerical apertures and resolution allow the eye to accommodate for the out-of-focus condition caused by the tilted objective field. Such a system would give the required photographic resolution only along a narrow line at the center of the frame. A much more complex optical method of producing stereo pairs of small objects is shown in Figure 2. The objectives produce unity magnification images of the object plane on a plane parallel to the final film plane. The field lenses are used to reimage the aperture stops of the objectives at the entrance pupils of the camera lenses. The collimating lenses reimage the images formed by the objectives at infinity. The normal camera lenses finally produce images at the camera focal plane. The collimating lenses would be of the Petzval form, rather than the Cooke triplet shown, with their entrance pupils located at the entrance pupil of the camera lens. These lenses would be required to work at larger field angles and numerical

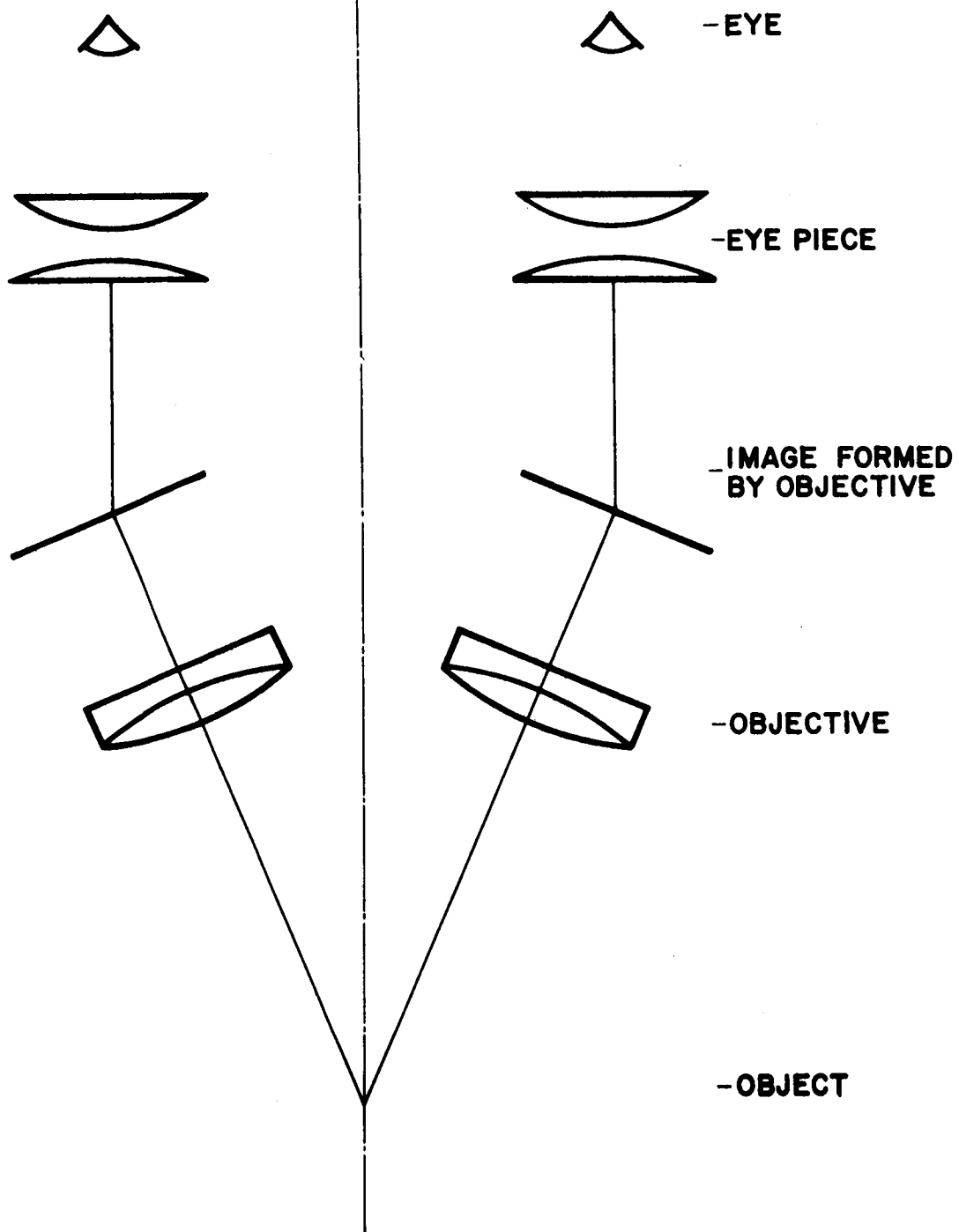

STEREO DISSECTING MICROSCOPE : FIGURE I.

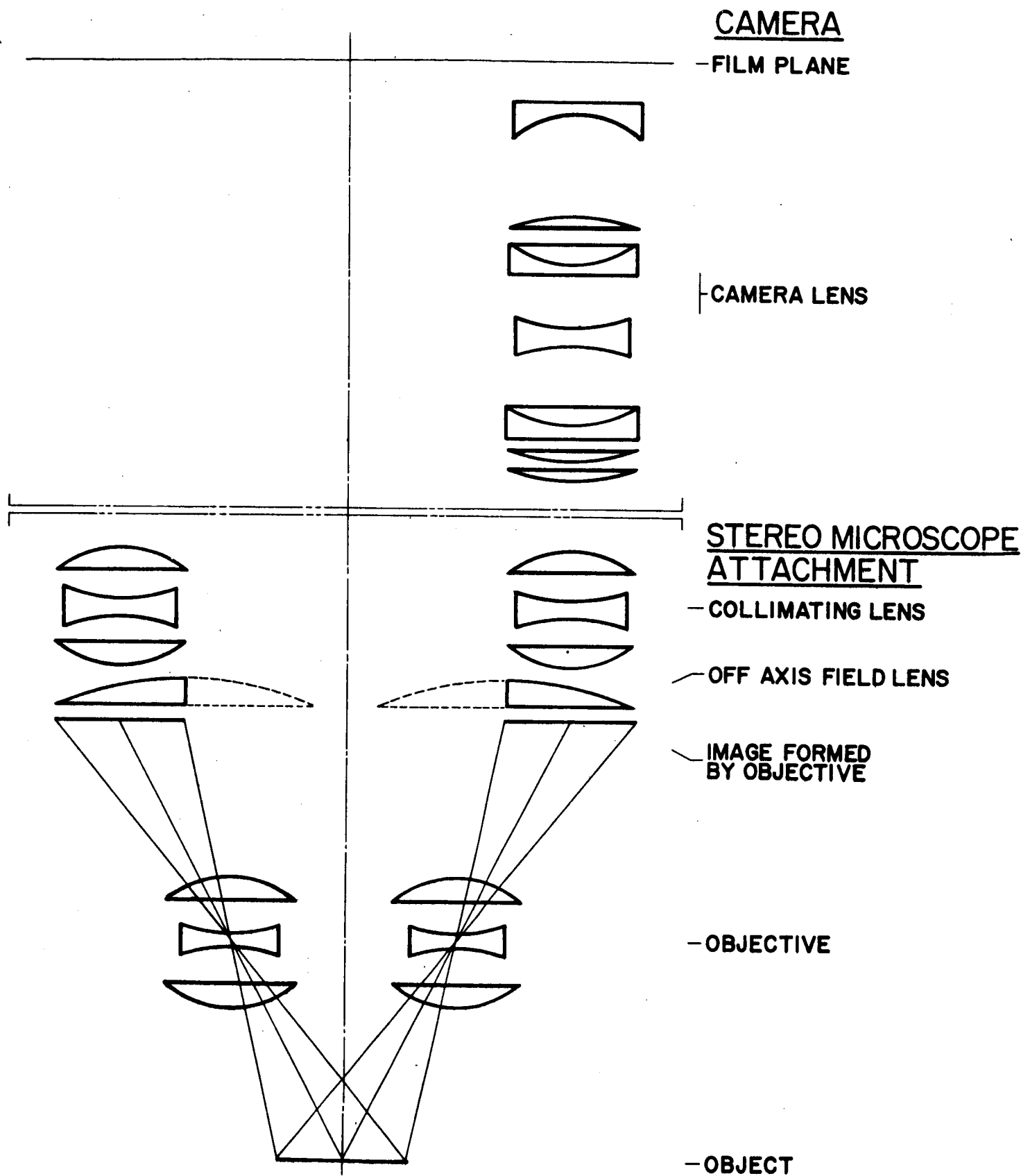

**HIGH RESOLUTION - LOW DISTORTION
STEREO MICROSCOPE ATTACHMENT**

FIGURE 2.

apertures than the camera lenses, but since performance is only required in the visible, adequate transfer response could be obtained.

To obtain single close up photographs auxiliary lenses could be mounted permanently in the camera with a mechanism to bring them into position when required, in a separate turret which would be attached to the camera when needed or in a completely separate fixture which would locate the auxiliary lens with respect to the object and the camera with respect to the auxiliary lens.

Making the lenses an integral part of the camera would permanently increase the bulk and weight of the camera. A separate turret which could be mounted on the camera, either in the LEM or on the surface of the moon, would allow the astronaut to carry and position the added weight only when use of the auxiliary lenses was anticipated. The disadvantage of this method is higher vulnerability of the attachment and the requirement for additional manipulation of loose pieces. The relative advantages of these two methods must be determined by mission requirements. If the camera is to be used only on the surface of the moon and not in the space craft, and if a variety of pictures are to be taken each time the astronaut leaves the LEM, the integral turret will be best. If the



GOERZ OPTICAL COMPANY, INC.

camera is to be used in the space craft and generally for objects from ten feet to infinity, the detachable turret or separate fixture will be superior. The detachable turret would require mechanism for indexing the lenses. To assure high reliability of the mechanism should be sealed and partially pressurized. Pressurization would in turn require entrance and exit windows. If pictures were to be taken in rapid sequence the additional weight and bulk of the turret might be justifiable, but assuming that the camera will be used to take a wide variety of pictures and that the close-up photographs will tend to be taken in groups. The simple separate fixture will be more advantageous in that the weight will be approximately one fourth that of the turret and the basic reliability will be higher in that no accurate mechanism will be required.

The separate fixture is shown in Figure 3. This fixture consists of three legs and a lens board. The lens board is positioned on the legs so that when the camera is mounted on one side of the lens board, one of the lenses is lined up with the 1 x lens and the short legs give the correct object distance.

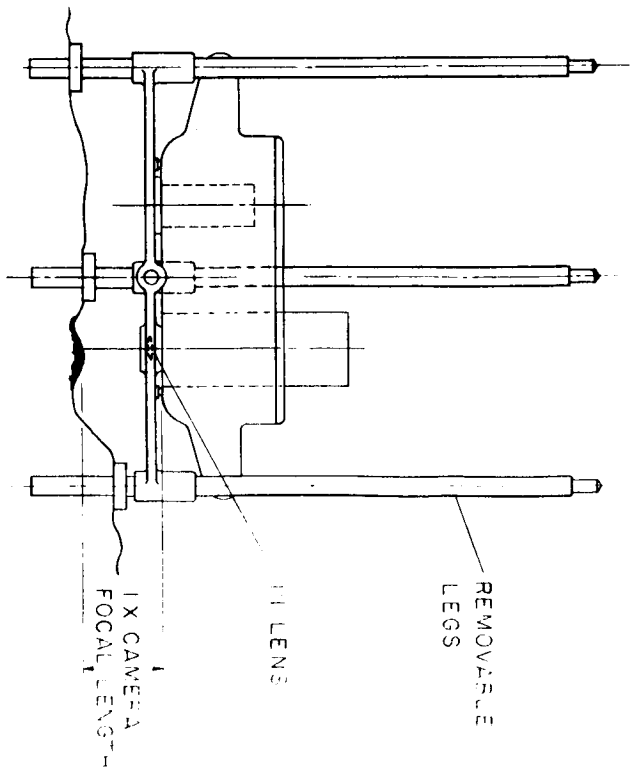
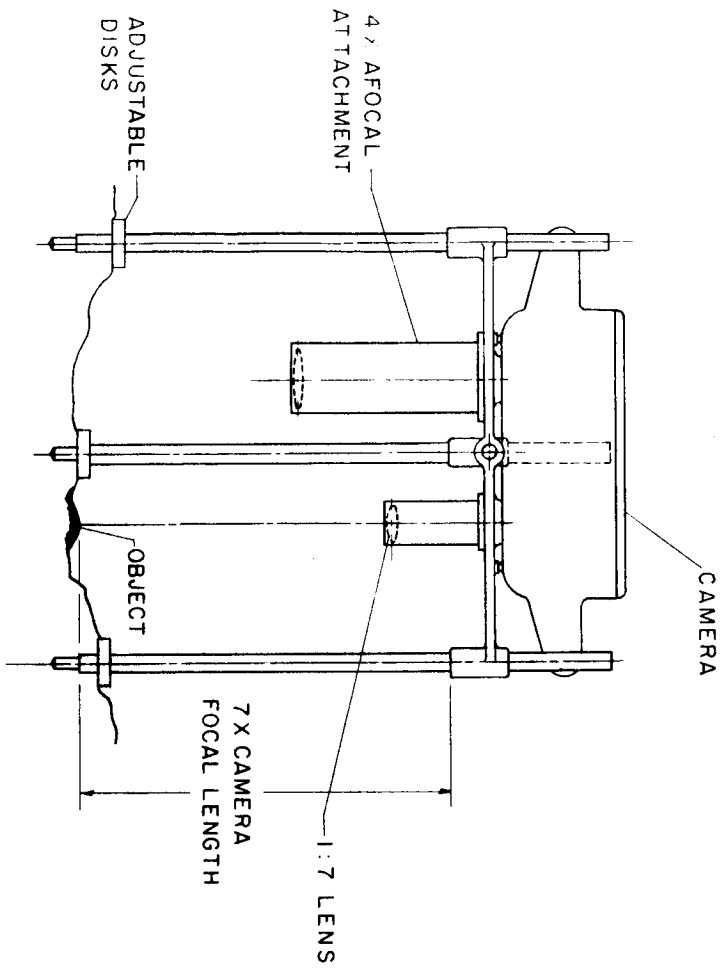

CLOSE-UP ATTACHMENT

FIGURE 3



GOERZ OPTICAL COMPANY, INC.

For $1/7$ x magnification, the camera is mounted on the opposite side of the lens board where it is positioned in front of the $1/7$ x lens and the longer legs give the correct object distance for this reduction. With this fixture, lenses with larger aperture and wider field correction would be supplied. Stops allowing a 0.2 inch shift of the camera between exposures would allow stereo pictures of small objects to be recorded. This fixture would require less weight and would give a near object stereo capability at the expense of greater bulk and less convenience compared to either the integral or separate turret.

A.2. STEREO COLOR PHOTOGRAPHS OF NEAR OBJECTS

Stereo color of objects near the LEM requires a double camera capable of being focussed to some "near" distance. This near distance can be determined if it is assumed that the camera should be capable of recording detail in range of sizes above those covered by the close focus attachment. Shape of objects up to one inch square are covered by the close focus attachment.

If the minimum focal distance is set at ten feet, the magnification will be approximately $1/40$. With an image space resolution of 50 lines per mm, the object space resolution will be slightly better than one millimeter. The depth of field for diffraction limited performance will be approximately four inches, but one millimeter object space resolution will be achieved over a

range of one foot so that the camera may be hand held for distances of ten feet and greater. At this distance, the object field will be forty inches square. The parallax between the view finder and the camera lenses is approximately two inches so that parallax correction will not be necessary. The requested focussing range for the Type I camera is three feet to infinity. At three feet, the required lens travel for refocussing is approximately 0.3 inches. The object field is approximately one foot square for each half of the camera and the depth of field for 50 lines per millimeter resolution is approximately 1.5 inches. To maintain this distance between measurement and exposure, a fixed camera support will be required. The parallax error is significant, but modification of the view finder for parallax correction is not considered desirable. The horizontal parallax will result in the object centered in the view finder being centered in the area of stereo overlap of the two half cameras. The vertical parallax will result in approximately one inch error in vertical centering of the object field. This could be corrected by a cam action connecting the view finder folding mirror to the focussing mechanism, but the increase in weight and complexity is not considered to be justified.

With an object distance of 6,000 feet, and a camera lens of three inch focal length, the magnification will be 1/24,000.



GOERZ OPTICAL COMPANY, INC.

An object six feet in linear dimension will have an image 0.003 inches or 0.076 mm long. If the sensitized material is only capable of recording spatial frequencies of 50 lines per mm, slightly less than four resolution elements will be available for recognition. If the lens film resolution approaches 200 lines per millimeter, 15 resolution elements will be available, so that surface features could easily be recognized as such at this distance. If the film to be used has a resolution capability of less than 50 lines per millimeter and recognition of objects of this size and distance is required, a longer focal lens will be required.

In order to maintain sealing of the camera, it is desirable that a longer focal length be provided by means of an attachment. This attachment would be in the form shown in Figure 4. This type of element is known as an afocal attachment in that the object and image are both at infinity. It acts as a telescope in that the cone of light from a given object point is compressed by a factor of four while the angles between principle rays are increased by a factor of four. The entrance pupil of the camera lens is magnified by a factor of four so that the f/ratio of the optical system remains unchanged. The angular field of view is likewise reduced by a factor of four.

The combination of camera lens and afocal attachment should be designed to give an image space resolution of 100 lines per

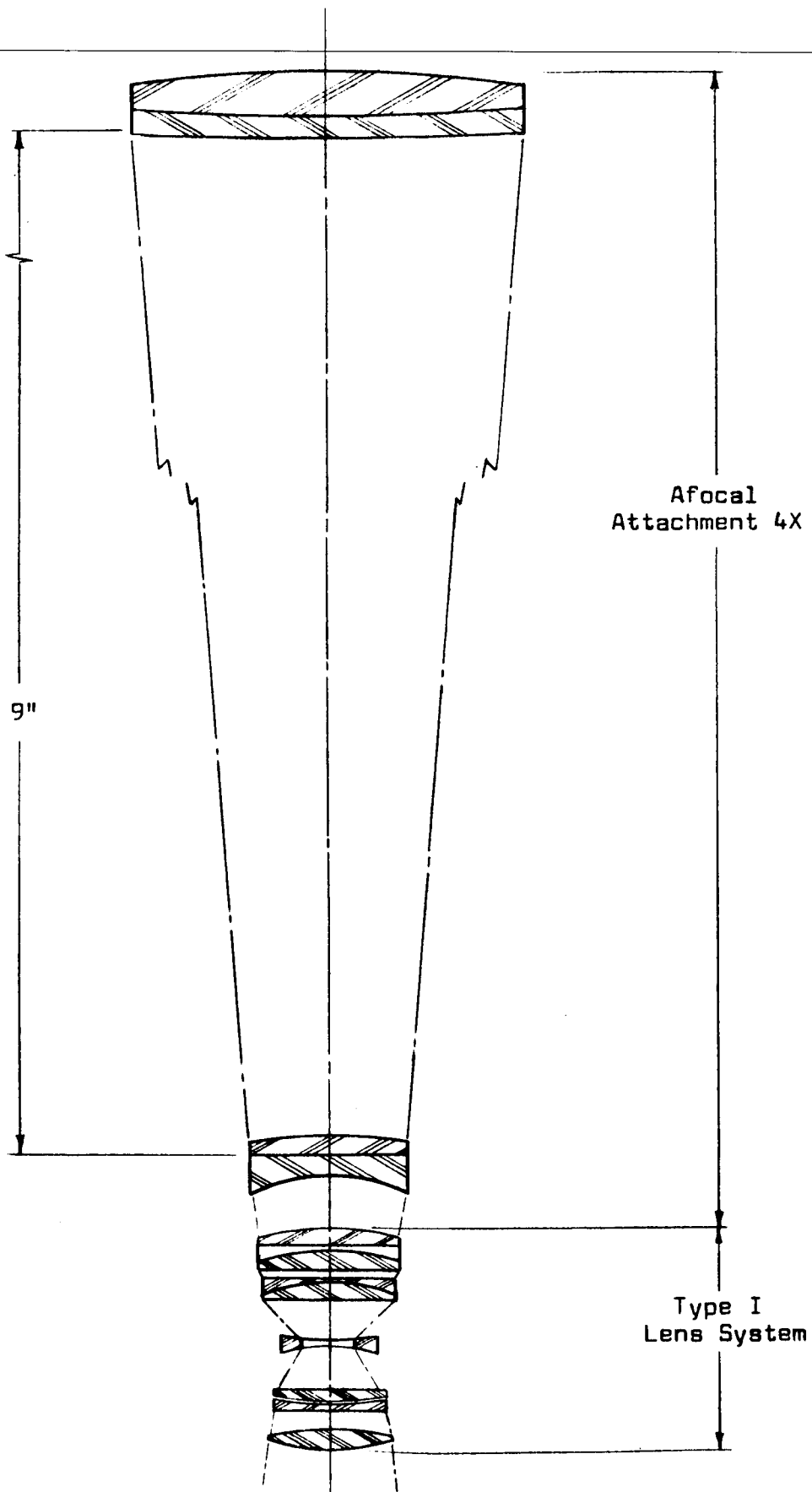

AFOCAL ATTACHMENT

FIGURE 4



GOERZ OPTICAL COMPANY, INC.

millimeter. With the Type I lens, 30 resolution elements would then be available in a six foot line and 20 resolution elements in the Type III or Type IV camera. An object 6 feet by 2 feet would have an image containing 300 elements with the Type I camera and 133 elements with the Type III and IV.

This attachment is incorporated in the close focus attachment and is located in front of the camera lens which is not used when making 1:7 reductions. This arrangement allows taking pictures through any one of three auxiliary lenses with only two sets of camera locating points on the fixture. One frame of film will be wasted each time an auxiliary lens is used because only one of the two camera lenses will be focussed in the object. The weight of film wasted will be considerably less than the weight additional complication to the mechanism necessary to allow single frame advance of the film and independent action of the shutters.

A.3. PHOTOGRAPHS OF THE LUNAR SURFACE IN THE UV AND IR

The statement of work states that the expected spectral sensitivity will range from 2,000A° to 10,000A°. A systematic search for suitable optical materials by Goerz Optical disclosed that, while the infrared limit presented no insurmountable problem, at the lower limit of the ultraviolet the loss of transparency and the rapid change of index of refraction made the design of a wide field, large aperture, high resolution

lens impossible. In a meeting with NASA and EG&G personnel, it was learned that the opacity of gelatin below 2,400A° made the production of an emulsion sensitive below this limit impractical and that the upper wave length range would probably be limited to around 9,000A°. Lens design was therefore restricted to coverage of the spectral range from 2,400A° to 10,000A°.

A.4 PHOTOGRAPHS OF CELESTIAL OBJECTS

The requirement to provide an angular resolution of one second of arc is an order of magnitude different from the above requirements. The least angular resolution in radians of a diffraction limited system is equal to the wave length divided by the diameter of the aperture, 1 second of arc =

$$\frac{1}{206,625} \frac{\text{radians}}{\text{second}} = \frac{\lambda}{d}$$

$$d = 206,625\lambda = \frac{206,625 \times 10,000\text{A}^\circ}{1 \text{ second}} \times \frac{10^{-10} \text{ meter}}{\text{A}^\circ} \times \frac{40 \text{ in.}}{\text{meter}} = 8.25 \text{ in./sec.}$$

A reasonable aperture for a system which resolves one second of arc in the near infrared is nine inches diameter. If this requirement were changed to read one second of arc in the middle of the visible, and two seconds of arc at 10,000A°, the aperture could be reduced to 4.5 inches diameter. Even this diameter is hopelessly large for a hand held stereo camera; a telescope attachment is required. To record this resolution on film would require an effective focal length of one meter at 200 lines per millimeter, 2 meters at 100 lines per millimeter and 4 meters at 50 lines per millimeter.



GOERZ OPTICAL COMPANY, INC.

In discussions following the Mid-Term, it was decided to provide a telescope attachment for the Type I camera and a separate telescope for the Type II camera. These telescopes are to be of six inch aperture and 60 inch focal length.

A.5 SUMMARY OF DESIGN REQUIREMENTS

The mission requirements, as discussed above, may be met with a stereo camera consisting of two identical cameras built in one case. The cameras must have matched lenses with three inch focal length and a one inch square format. An attachment to allow unity magnification is required to give shape recognition of 0.1 mm objects, and a telescope attachment is required to give one second of arc resolution of astronomical objects. The information collection efficiency of the camera system will be proportional to the square of the resolution of detail on the film.

The accuracy of stereo measurements is limited by the separation of the front principle points of the camera lenses. The greater the separation, the greater the distance at which a given accuracy of measurement can be achieved. Early in the program stereo separation, not being specified, had been sacrificed to obtain the most compact layout possible. As work progressed, it became apparent that, with proper packaging, the stereo separation of the Type I camera could be increased from 3 to 5 inches without significantly increasing the size of the camera.

During the discussions following the Mid-Term Report, the desirability of 6 inch stereo separation and of a larger field of view led to the request that a Type III camera be investigated which would have this stereo separation and a full field angular coverage of 45° to the corners of the format. Due to the problems associated with wide field coverage in the ultraviolet, the Type III camera was restricted to visual and infrared coverage.

The resolution of the lenses should be as high as practicable so as to take full advantage of the highest resolution emulsions available at the time of the Apollo missions. At the onset of the program, it was assumed that back focal length of the lens was not a critical factor. The possibility of use of either color or exposure separation techniques made the availability of a lens meeting the above requirements, but with an abnormally long back focus desirable.

Three separate lens requirements were thus generated during the course of the study. The Type I wide spectral coverage lens with three inch focal length and 26° coverage, the Type II lens with a long back focal length in addition to the requirements of the Type I lens and the Type III lens of 52 mm focal length and 45° coverage in the visual and infrared.



GOERZ OPTICAL COMPANY, INC.

B. MATERIALS

The first selection of materials was based on transparency over the required spectral range. A second selection was based on availability of materials suitable for the manufacture of high quality lenses. Finally, a rational set of indices and partial dispersions was computed and a final selection made on the basis of optical properties.

The American Institute of Physics Handbook lists twelve materials with reasonable transparency over the range of $2,000\text{\AA}$ to $10,000\text{\AA}$. These materials are:

- Fused Silica
- Calcium Fluoride
- Sodium Fluoride
- Lithium Fluoride
- Magnesium Fluoride
- Barium Fluoride
- Sodium Chloride
- Potassium Bromide
- Cesium Iodide
- ADP
- KRS-6
- Sapphire

ADP, KRS-6, Magnesium Fluoride and Cesium Iodide were rejected because of nonavailability of suitable quality material, without investigation of their optical properties. Potassium

Bromide was rejected because of its high solubility in water.

The indices of refraction are given at different wave lengths for different materials. In order to make a systematic selection of materials based on optical properties, the index of refraction of each of the remaining materials was calculated by the three constant formula $n = N + C/\lambda - 1$, for five widely separated wave lengths. Having calculated the indices, relative dispersion values were calculated for upper and lower portions of the spectral range. The results of these calculations are tabulated in Table I and plotted as Figure 5.

Material	Visual Centered		Ultraviolet	
	4046.6 n	10140.4 v	2445.3 n	4046.6 v
Fused Silica	1.45638	23.522	1.49032	11.878
Sodium Chloride	1.54065	15.626	1.61314	6.272
Sodium Fluoride	1.32438	31.011	1.34414	14.197
Calcium Fluoride	1.43250	34.163	1.45570	16.234
Lithium Fluoride	1.39080	34.012	1.40967	18.672
Barium Fluoride	1.4728	29.74	1.50338	17.180
Sapphire	1.76494	25.245	1.81838	13.242

TABLE I

In designing a color corrected lens with a given power, the use of materials with widely separated relative dispersions will result in flatter curves with lower values of higher order

K&E
 10 X 10 TO THE CENTIMETER 46 1517
 13 X 25 CM. • ALBANY, N.Y.
 KEUFFEL & ESSER CO.

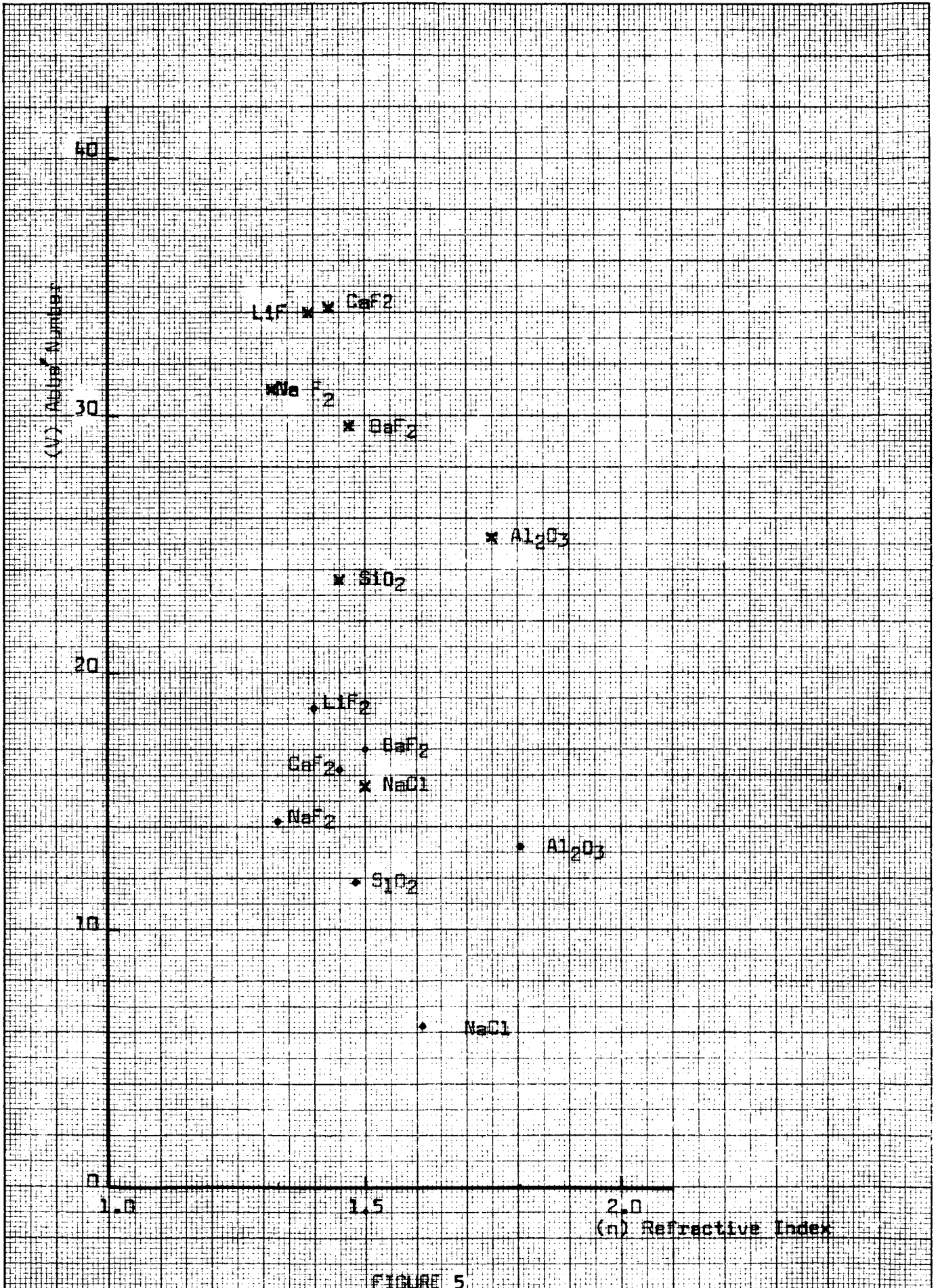

FIGURE 5

aberrations. Figure 5 shows that the widest possible separation would employ NaCl as the flint and CaF as the crown for the visual centered range, and NaCl and LiF for the UV centered range. NaCl is desirable because of its high solubility in water which would make it difficult to work and test. Fused quartz is the logical first choice for a flint material because of its availability and excellent mechanical properties. Calcium Fluoride was chosen as the first choice for the crown material in that it falls near the upper limit of the V values and is more readily available in optical quality than Lithium Fluoride.

Although sapphire has excellent mechanical properties, its V value falls in the center of the range of materials and is thus less suitable for achromatic lenses than Fused Silica. The choice of Fused Silica and Calcium Fluoride was confirmed by designing a lens with this combination and then checking for possible improvement by optimizing this lens with Lithium Fluoride and Barium Fluoride substituted for Calcium Fluoride and with Sodium Chloride replacing the Fused Silica and the Fused Silica substituted for the Calcium Fluoride. The original combination gave slightly better overall performance.

C. OPTICAL DESIGN

The starting point of the design is the well-known air-spaced triplet shown in Figure 6. In the systematic design of a lens,

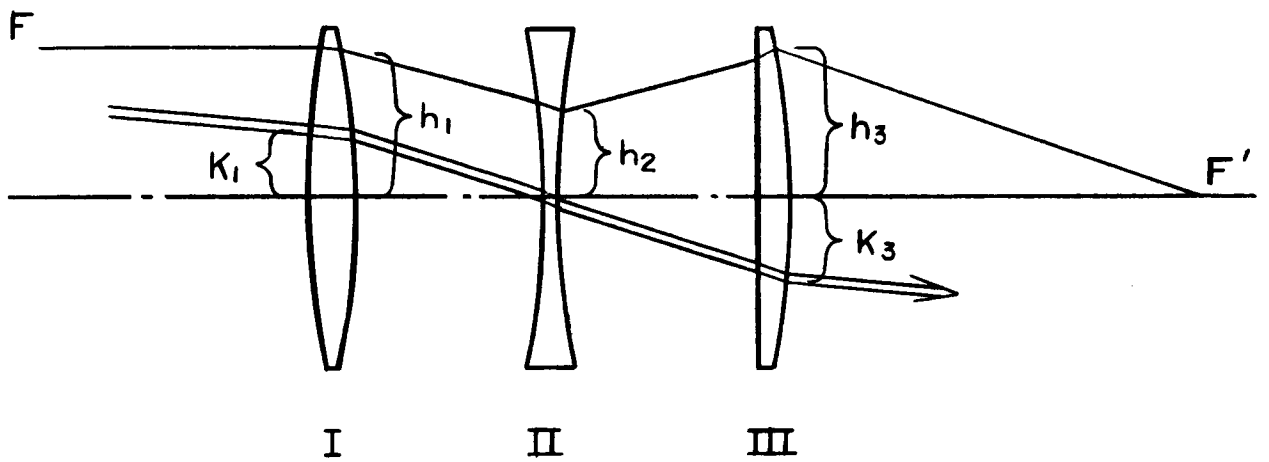

AIR SPACED TRIPLET

FIGURE 6

the chromatic aberrations are corrected first because their values are determined by the power and spacing of the individual lens elements while the field aberrations and spherical aberration are controlled by the shape of the lens elements and the stop position.

Assuming the lenses to be negligible thickness, the chromatic aberrations will be corrected when the following equations are satisfied.

$$(1) \sum h_i^2 \frac{\phi_i}{v_i} = 0$$

$$(2) \sum h_i k_i \frac{\phi_i}{v_i} = 0$$

where h_i is the ordinate of the marginal ray and k_i is the ordinate of the principle ray, ϕ_i is the power of the lens element and v_i is the relative dispersion or Abbe number of the material of which the lens is made, defined by the following equation:

$$v = \frac{n_c - 1}{n_2 - n_1}$$

where n_c is the index of refraction at the center of the spectral range and n_2 and n_1 are the indices at the ends of the spectral range. Equation (1) governs the longitudinal chromatic aberration and equation (2) the lateral chromatic aberration. The wide difference in v values for the upper and lower portions of the spectral range show that a lens corrected for one portion



GOERZ OPTICAL COMPANY, INC.

of the spectral range will be far from correct in the other portion. To solve this problem, interchangeable corrector lenses are added near the first and third elements. By making the corrector lenses near zero power, the axial spacing and centering becomes less critical than would be the case if elements of substantial power were used.

The thin lens design to test achromatism for this form over the extended visual range is described as follows:

<u>Element</u>	<u>Radii</u>	<u>Material</u>
I	$r_1 = 0.29611$	Calcium Fluoride
	$r_2 = \infty$	
	$r_3 = \infty$	F-13
1st Corrector	$r_4 = +1.95969$	sk-16
	$r_5 = \infty$	
Air Space =	0.16870	
II	$r_6 = 0.37105$	Fused Silica
	$r_7 = +0.37105$	
Air Space =	0.1804	

	$r_8 = \infty$	sk-16
2nd Corrector	$r_9 = 1.99340$	F-13
	$r_{10} = \infty$	
III	$r_{11} = \infty$	Calcium Fluoride
	$r_{12} = -0.261594$	

The back focal length of this lens was calculated as a function of wave length and found to be practically constant as shown in Table II.

BACK FOCAL LENGTH vs. WAVE LENGTH

Wave Length	Back Focal Length
4046.6	0.853645
6563.0	0.853643
10140.0	0.853645

TABLE II

The corrector lenses for the UV portion of the spectral range were calculated to be:

	$r_3 = \infty$	Calcium Fluoride
1st Corrector	$r_4 = -0.39339$	Fused Silica
	$r_5 = -5.57138$	
	$r_8 = +5.10960$	Fused Silica
2nd Corrector	$r_9 = -0.36078$	Calcium Fluoride
	$r_{10} = \infty$	



GOERZ OPTICAL COMPANY, INC.

Computing the back focal length as a function of wave length gave values which were not quite as good as those in the visual, but which were still quite acceptable. Computed values are shown in Table III. The difference in back focal length between the visual and UV will be corrected later by adjusting powers or thicknesses of correctors.

BACK FOCAL LENGTH vs. WAVE LENGTH

Wave Length	Back Focal Length
2445.3	0.816609
2915.6	0.816654
4046.6	0.816609

TABLE III

Thicknesses were then assigned to the lens elements and an attempt made to reduce and balance aberrations by third order theory. It was found to be difficult to correct the field aberration over the complete spectral range when different materials were used for the visual and UV correctors. New correctors were designed for the visual using fused quartz and calcium fluoride. Sphero-chromatism now proved to be a problem, that is, the correction for spherical aberration was sensitive to wave length. Spherical aberration could be corrected at any one wave length, but became progressively more pronounced at wave lengths distant from the one corrected. At this point, the same basic lens was tried with each of the following pairs of materials:

Fused Silica - Lithium Fluoride

Fused Silica - Barium Fluoride

Sodium Chloride - Fused Silica

In each case, the results were inferior to the original combination. The first positive element was then split into two lenses and a field flattening element was added. Redistribution of powers in the original combination were then made and exact residuals computed by ray tracing. By careful optimization of this lens form the following predicted performance was obtained:

LENS CHARACTERISTICS

	Visual	UV
Axial Resolution	250 lines/mm	200 lines/mm) Monochromatically
Off Axis Resolution	175 lines/mm	175 lines/mm)
Axial Resolution	180 lines/mm	180 lines/mm) Full Spectral Range
Off Axis Resolution	160 lines/mm	160 lines/mm
Effective Focal Length	75 mm	75 mm
Focal Ratio	f/5.6	f/5.6
Half Field Angle	12°	12°
Spectral Range	4040A°-10,000A°	2400A°-4040A°

TABLE IV

These values are based on 100% contrast transfer by the lens. Considering manufacturing tolerances, stray light and other degrading influences, these values should be achieved with relatively low contrast targets with 30 to 40 per cent modulation. A reduction in the UV range of 2400A° to 3600A° would lead to some improvement of performance in the UV. The final



GOERZ OPTICAL COMPANY, INC.

optimization of the lens should await receipt of actual materials with known refractive indices. The above calculations were based on catalog values of refraction index. Optical materials always vary slightly from piece to piece in optical properties. This lens is shown schematically in Figure 7.

The November 30, 1964 liaison meeting pointed up the desirability of a color separation process so that emulsions of very wide latitude could be used. Three color separation techniques have always employed relatively slow lenses in order to allow the use of beam splitters of moderate size. It was decided to try a two color separation system with Goerz designing a new lens system with a larger back focal length, and EG&G experimenting with color separation filters. Such a lens was derived from the lens described above by the addition of an afocal system consisting of a negative doublet and a positive singlet, as shown in Figure 8, and by the adjustment of parameters of the original lens.

This Type II lens was carried to the point of final optimization for the actual index and dispersion values and was found to give essentially the same performance as the Type I lens. For the values used, axial resolution was slightly inferior and off axis resolution slightly higher. When used to image scenes of high brilliance range the Type I lens would

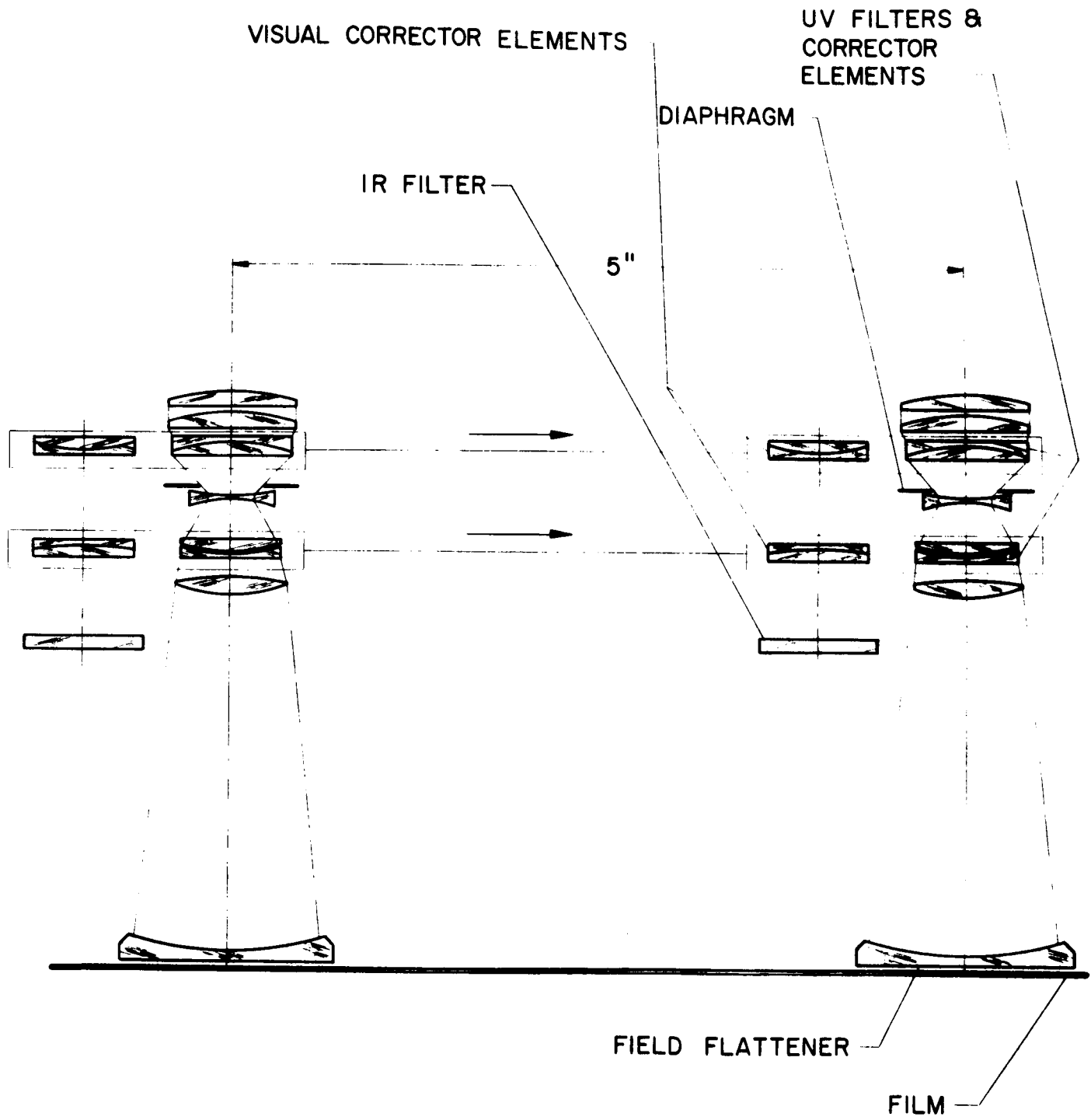

OPTICAL SCHEMATIC
UV-IR LENS TYPE I

FIG. 7

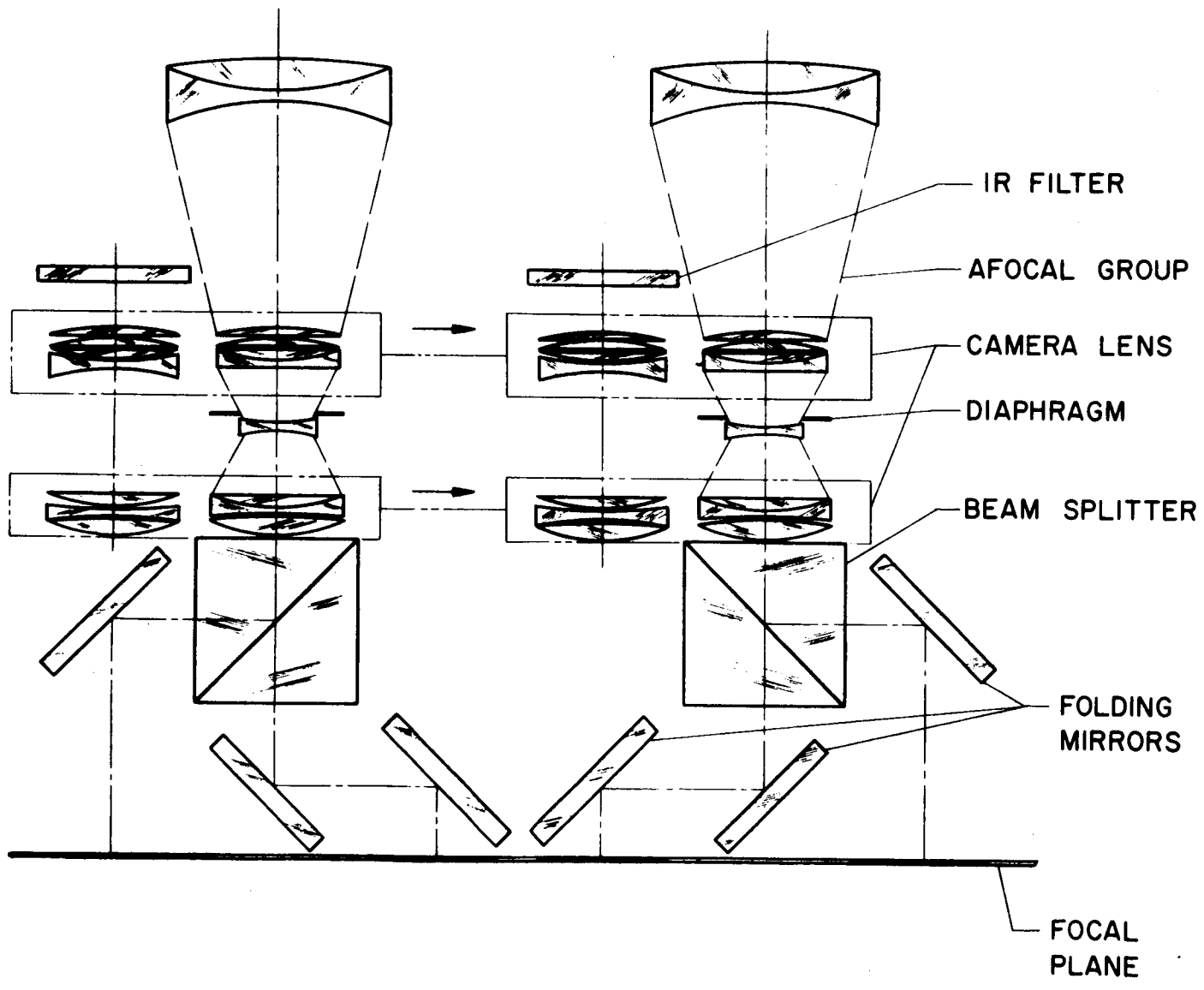

OPTICAL SCHEMATIC
TYPE II LENS

FIG. 8

give superior contrast rendition due to the lower number of air glass surfaces.

Lack of time prevented a detailed optical design of a lens for the Type III camera. However, the requirements of this lens fall in between those of the two broad classes of lenses which have received the most attention of optical designers for the last hundred years. Design work on lenses for hand held cameras, both still and cine, has been concentrated on lenses of higher speed while maintaining the axial resolution somewhat higher than that of available emulsions with less consideration of off axis resolution. This effort has led to a number of designs which give on the order of 200 lines per millimeter on axis over a narrow spectral range centered on the blue green, with speeds of approximately $f/2$. The design work for process lenses, mapping lenses, and lenses used in commercial photography has been directed toward the highest possible area weighted average resolution. Typical of this class of lenses are the Goerz Aerotar which is a 6 element $f/6.8$ lens with resolution of over one hundred lines per millimeter 20° off axis, and the Goerz Aerogar, an eight element lens, which at $f/4.5$ resolves 50 lines per millimeter 30° off axis. A preliminary investigation which included review of design patents and published performance data, and ray tracing of more promising forms indicates that the design form shown in Figure 9 can be developed to better

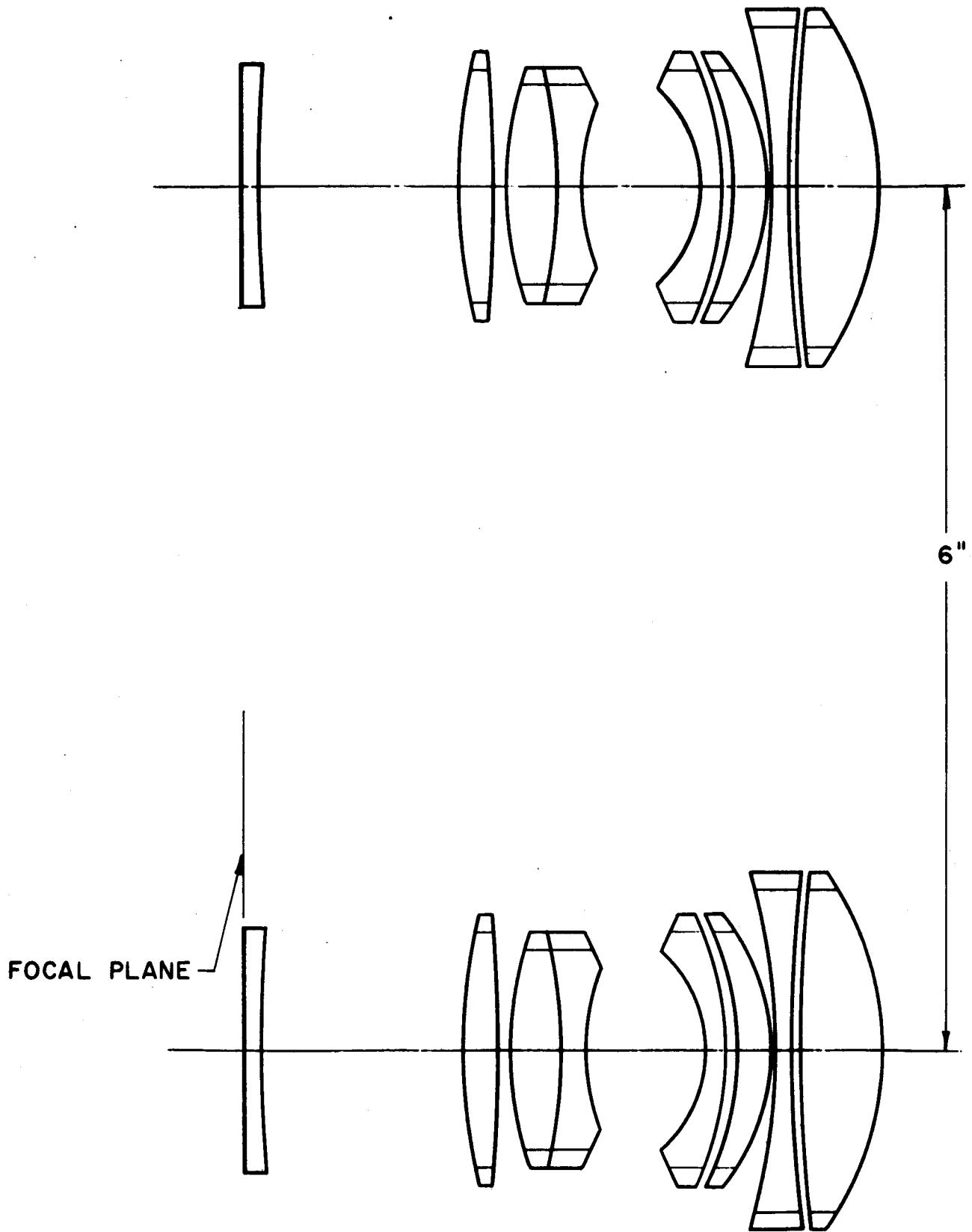

LENS FOR CAMERA TYPE III

FIGURE 9

than 100 lines per millimeter resolution on axis and 50 lines per millimeter 22.5° off axis over the visual and near infra-red range.

Detailed design of the copy lens attachments were not performed. For the 1:1 turret mounted lens the design would be identical to that of the camera lens. In the case of the Type I camera, the corrector doublets would be omitted with only slight change in the remaining elements and a small reduction in spacing if only visual photography were required. If wide spectral coverage is required the lens design would be identical to that of the camera lens. The attachment used for 7x reduction would again be of the same general design form but scaled by a factor of seven. The lens diameters would remain constant but radii would increase. Thickness of elements and air spacing would be adjusted to provide a more compact lens. Design specifications for the auxiliary lenses are given in terms of their performance in combination with the camera lens in appendices II, III and IV.

The design of the afocal attachment used to increase the effective focal length of the camera lens must be matched to the camera lens and to the film to be used. The size of the attachment will be determined by the magnification, speed and resolution. The auto exposure system provided for the normal camera lens will perform satisfactorily if the afocal attachment



GOERZ OPTICAL COMPANY, INC.

is designed so that the iris diaphragm continues to be the aperture stop of the system. This requires the front elements of the attachment to be larger than the front element of the camera lens by a factor approximately equal to the magnification of the attachment. Since apparent brightness tends to fall off with distance on the surface of the moon, a reduction in speed caused by this attachment would be undesirable. The required magnification and resolution will be determined by the resolution of the emulsion. As explained above if a resolution of 200 lines per millimeter were possible no magnification would be required with the Type I camera and a magnification of less than two would be adequate for the Type III lens. If the emulsion were capable of recording 100 lines per millimeter a magnification of two would be desirable for the Type I lens and a magnification of three with the Type III. Each reduction of film resolution requires a corresponding increase in magnification but establishes a lower requirement of resolution from the attachment. An afocal attachment with a power of four will be discussed and is shown in Figure 4.

The afocal attachment performs basically as a telescope, that is the angles in the object space are increased by a factor of four and the entrance pupil of the attachment is four times as great as the exit pupil. The allowable aberrations in the image are approximately four times as great as for the Type I camera lens.

A telescope consists of two basic elements, an objective and an eyepiece. The objective collects the light and produces a reduced real image at a finite distance in which the angles between principle rays and the optical axis are equal in the image and object spaces. The eyepiece portion forms a new image at infinity but with the principle ray angles increased by the power of the telescope. The power of the telescope is determined by the ratio of the focal length of the objective to the focal length of the eyepiece.

There are two basic types of telescope that differ in the sign of the power of eyepiece portion. If a positive lens is used, an inverted image is formed and the telescope is termed an astronomical or Keplerian telescope. If a negative lens is used the telescope is called a Galilean. The choice of the latter form for the afocal attachment is based on two fundamental considerations. The separation of the two telescope components is equal to the sum of their focal lengths. Thus the Galilean form will be shorter by twice the focal length of the second component. The Petzval curvature is proportional to the sum of the powers of the individual components. Thus the petzval contribution of the astronomical telescope is proportional to plus five times the eyepiece power and on the Galilean to minus three times the eyepiece power. Since the camera lens field must be separately flattened the afocal attachment must have a flat field. The Petzval curvature of the afocal



GOERZ OPTICAL COMPANY, INC.

attachment must be compensated by astigmatism. Therefore for any choice of component powers the Galilean form will give better imagery with shorter overall length.

To give a magnification of four the component separation is equal to three times the focal length of the negative component. Thus a very short attachment would result from a choice of a very short focal length negative component. But as shown above, this results in a high Petzval curvature and thus poor image quality. Experience has shown that reasonable image quality is obtained from afocal attachments when the power of the negative component is made equal to the power of basic camera lens. For the Type I camera this results in a system consisting of three inch focal length negative component and a twelve inch focal length positive component separated by nine inches. These components are shown schematically in Figure 4 as doublets. In an actual design based on specifications tailored to a specific emulsion some reduction in weight and moment may be possible by an increase in power coupled with the introduction of additional elements.

III FORMAT AND FIELD ANGLE

In selecting the format and field of view of the lunar camera, consideration was given to maximizing the amount of total useful information which may be recorded with a given weight and volume of camera and camera equipment. The amount of information recorded per exposure on a square format will be the product

of the number of information elements per unit area and the area of the film format or to the squares of the product of linear resolution and the length of the side of the square. Thus, for a given linear resolution, the information content per frame will increase as the area of the format. To a first approximation, holding the angular field of view constant, the volume and weight of the camera will increase as the cube of the frame length. This reasoning leads to the ridiculous solution that the optimum camera size is zero. A second approximation breaks down the camera into elements and assigns scaling factors to each type of elements.

The lens and lens mounts would scale as the cube of the frame length if the linear resolution were scaled also. Holding the resolution constant would require a more complicated lens. A scaling exponent of four is applied to the lens and lens mounting.

The area to be shuttered increases as the square of the frame length. But, if the shutter speed is held constant, the acceleration of the shuttering elements must increase as the square. The driving force for the shutter therefore increases as the fourth power of the frame length. A scaling exponent of three for both weight and volume appears reasonable if one compares the Leica shutters with that of the Speed Graphic.

The exposure meter, auxiliary lighting, time recording device, handles and some controls will be independent of format in both size and weight.



GOERZ OPTICAL COMPANY, INC.

The view finder if of the reflex type and the range finder, if required, will scale approximately as the cube in both size and weight.

If the case were only a light baffle and structural element, it would scale with an exponent in excess of three if resonant frequencies were maintained. However, the case weight is largely determined by shielding requirements and thus increases more nearly as the area or the second power of the frame length.

Assuming constant film base thickness, the weight of the film will scale as the square. The requirement to hold a larger film flat in the focal plane requires the weight and volume of the cassette and transport to increase as slightly more than the square.

The weight and volume may be expressed algebraically as:

$$w = A + Bd + cd^2 + Dd^3 + Ed^4$$

$$v = F + Gd + Hd^2 + Jd^3 + Kd^4$$

A = weight of exposure meter, auxiliary lighting, time recording device, handles, some controls.

$$B = 0$$

c = weight of case and film and cassette

D = weight of shutter, view finder and range finder

E = weight of lens and lens mounting

F = volume of exposure meter, auxiliary lighting, time recording device, handles some controls

$$G = 0$$

H = film and cassette volume

J = volume of shutter, view finder and case

K = volume of lenses and lens mounts

A qualitative picture of the trade-off of information content per unit volume and weight versus format size was obtained by estimating values for a three inch focal length and one inch square format. A first estimate of these values is:

Weight lbs	Volume in ³
A = 2.0	F = 200
C = 1.75	H = 40
D = 1.75	J = 180
E = 1.5	K = 10

These values have been used in the above power series to determine values of recording area per unit weight and per unit volume. These values are tabulated in Tables V and VI and are plotted as Figure 10.

Examination of Tables V and VI shows that although lens volume is not a critical factor, the lens weight increased from approximately 20% of the total weight for a one inch square format to 50% for a two inch square format. The reason for this may not be obvious. If a given lens has a certain blur circle of radius r at a given focal length f , then a doubling of each dimension of the lens will produce a lens of focal length $2f$ and a blur circle of radius $2r$. The recording area will



GOERZ OPTICAL COMPANY, INC.

increase from a square format of area S^2 to $4S^2$. Thus, a direct scaling of the lens to twice the focal length will increase the weight and volume by a factor of eight, but the number of resolved information elements will remain constant. Thus, if any gain is to be made in the amount of information to be recorded, the angular resolution of the lens must be improved as the focal length of the lens is increased. Although there is no theorem that relates resolution to lens complexity, it was assumed for this analysis that if the angular resolution were to be doubled, and hence the information resolution increased by a factor of four, that the lens would have to be doubled in complexity or number of elements.

RECORDING AREA PER UNIT WEIGHT AS A FUNCTION OF FRAME SIZE

S	S ²	S ³	S ⁴	A	CS ²	DS ³	ES ⁴	W	S ² /W
0.1	0.01	0.001	0.0001	2	0.018	0.002	0.00015	2.02	0.005
0.2	0.04	0.008	0.0016	2	0.070	0.014	0.0024	2.09	0.019
0.3	0.09	0.027	0.0081	2	0.158	0.047	0.012	2.22	0.040
0.4	0.16	0.064	0.026	2	0.280	0.112	0.039	2.43	0.066
0.5	0.25	0.125	0.063	2	0.437	0.218	0.095	2.75	0.091
0.6	0.36	0.216	0.130	2	0.630	0.378	0.195	3.20	0.112
0.7	0.49	0.343	0.240	2	0.856	0.600	0.320	3.78	0.129
0.8	0.64	0.512	0.410	2	1.12	0.895	0.615	4.64	0.138
0.9	0.81	0.729	0.656	2	1.42	1.27	0.985	5.68	0.143
1.0	1.0	1.0	1.0	2	1.75	1.75	1.5	7.0	0.143
1.1	1.21	1.331	1.46	2	2.12	2.33	2.19	8.64	0.140
1.2	1.44	1.728	2.07	2	2.52	3.02	3.11	10.65	0.135
1.3	1.69	2.197	2.85	2	2.96	3.84	4.27	13.07	0.130
1.4	1.96	2.744	3.84	2	3.42	4.80	5.76	15.98	0.123
1.5	2.25	3.375	5.06	2	3.94	5.90	7.58	19.42	0.116
1.6	2.56	4.096	6.55	2	4.47	7.16	9.82	23.45	0.109
1.7	2.89	4.913	8.35	2	5.05	8.60	12.5	28.15	0.103
1.8	3.24	5.832	10.5	2	5.66	10.2	15.3	33.16	0.978
1.9	3.61	6.859	13.0	2	6.32	12.0	19.5	39.82	0.906
2.0	4.00	8.00	16.0	2	7.00	14.0	24.0	47.0	0.852

TABLE V



GOERZ OPTICAL COMPANY, INC.

RECORDING AREA PER UNIT VOLUME AS A FUNCTION OF FRAME SIZE

S	F	HS ²	JS ³	KS ⁴	V	S ² /V
0.1	200	0.40	0.180	0.001	201	0.005
0.2	200	1.60	1.44	0.016	203	0.020
0.3	200	3.60	4.86	0.081	209	0.043
0.4	200	6.40	11.5	0.260	218	0.073
0.5	200	10.0	22.5	0.630	233	0.107
0.6	200	14.4	38.9	1.30	255	0.141
0.7	200	19.6	61.7	2.40	284	0.173
0.8	200	25.6	92.0	4.10	322	0.199
0.9	200	32.4	131.0	6.56	370	0.219
1.0	200	40.0	180.0	10.0	430	0.233
1.1	200	48.4	240.0	14.6	503	0.240
1.2	200	57.6	311.0	20.7	589	0.245
1.3	200	67.6	395.0	28.5	691	0.244
1.4	200	78.5	495.0	38.4	812	0.242
1.5	200	90.0	607.0	50.6	948	0.237
1.6	200	102.0	737.0	65.5	1105	0.232
1.7	200	116.0	885.0	83.5	1285	0.225
1.8	200	130.0	1050.0	105.0	1485	0.218
1.9	200	144.0	1235.0	130.0	1709	0.212
2.0	200	160.0	1440.0	160.0	1960	0.204

TABLE VI

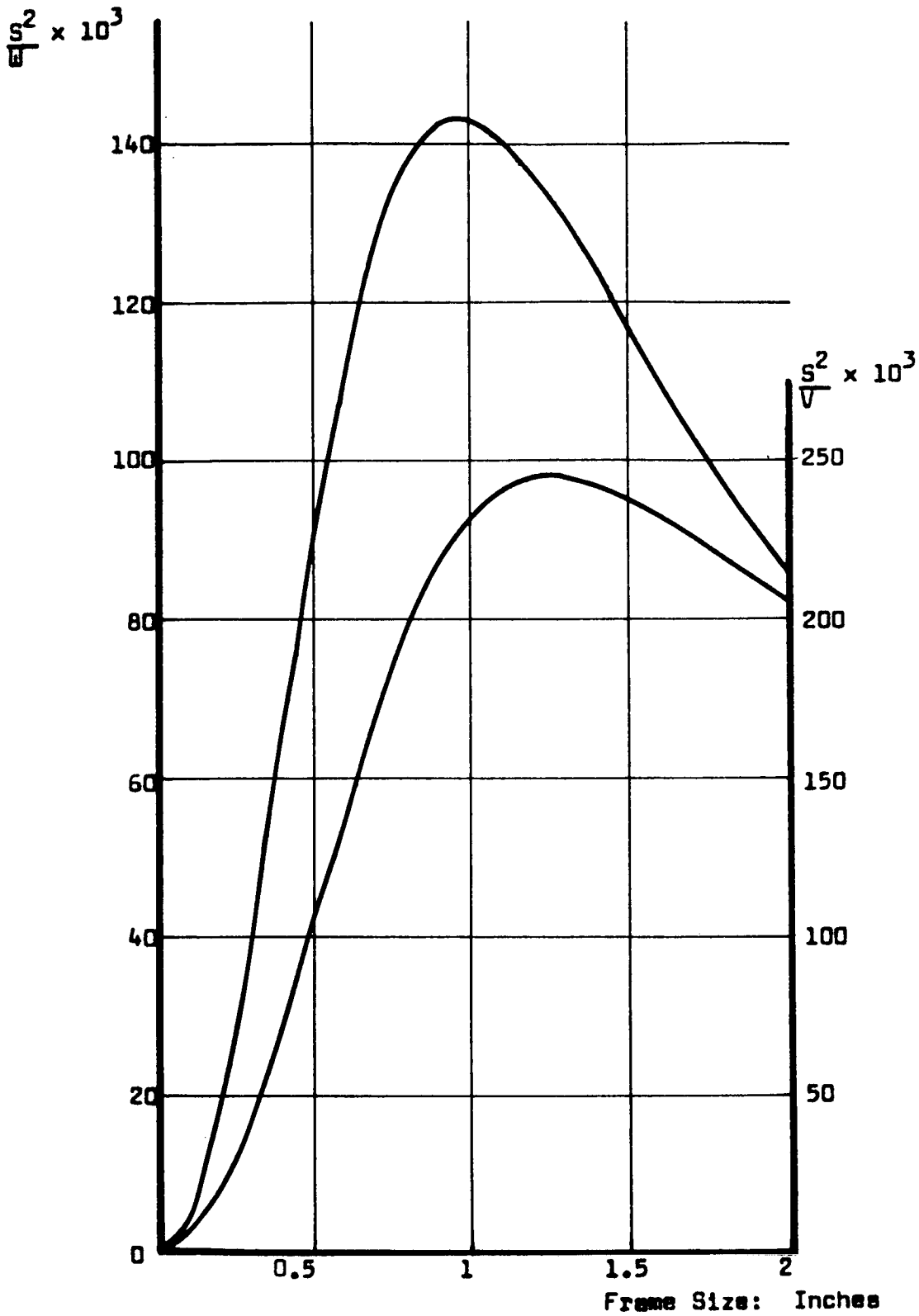

RECORDING AREA EFFICIENCY
AS A FUNCTION OF FRAME SIZE

FIGURE 10



GOERZ OPTICAL COMPANY, INC.

Since the amount of information recorded is proportional to the square of the linear resolution, it is important that the highest possible system resolution is achieved. The lenses designed for the Type I camera achieve the diffraction limit on axis and 90% of the diffraction limit at 10 mm off axis. Expressed in linear terms, the resolutions are 200 lines per mm on axis and 180 lines per mm off axis. Fine grain black and white emulsions are capable of utilizing this resolution. If low resolution emulsions are to be used, a gain in number of resolution elements per frame may be achieved by a direct scaling of this lens to a longer focal length. The data of Table V is recalculated with a scaling exponent of three for the lens and presented as Table VII and Figure 11. The tabulation shows that an increase in recording area by a factor of four will require an increase in weight by a factor of five. The 35 pound weight for a lunar stereo camera appears reasonable when it is compared with 14 pounds for the 70 mm single lens combat camera designed to work over a limited spectral range.

The field of **view** problem is independent of the format problem. With a given frame size, the field of view is determined by the focal length of the objective. In the design of a photographic objective, field of view, speed, resolution and practicability of construction are contradictory requirements. The reason for this may be seen by looking at the effect of aperture and image

RECORDING AREA PER UNIT WEIGHT AS A FUNCTION OF FRAME SIZE
WITH CONSTANT RESOLUTION

S	A	CS^2	$(D+E)S^3$	w	S^2/w
0.1	2	0.018	0.003	2.02	0.005
0.2	2	0.070	0.026	2.10	0.019
0.3	2	0.158	0.088	2.25	0.040
0.4	2	0.280	0.208	2.49	0.064
0.5	2	0.437	0.406	2.84	0.088
0.6	2	0.630	0.702	3.33	0.108
0.7	2	0.856	1.11	3.97	0.123
0.8	2	1.12	1.66	4.78	0.134
0.9	2	1.42	2.36	5.78	0.140
1.0	2	1.75	3.25	7.0	0.143
1.1	2	2.12	4.33	8.45	0.143
1.2	2	2.52	5.61	10.13	0.142
1.3	2	2.96	7.14	12.1	0.140
1.4	2	3.42	8.92	14.3	0.137
1.5	2	3.94	11.0	16.9	0.133
1.6	2	4.47	13.3	19.8	0.129
1.7	2	5.05	16.0	23.0	0.126
1.8	2	5.66	18.9	26.6	0.122
1.9	2	6.32	22.3	30.6	0.118
2.0	2	7.00	26.0	35.0	0.114

TABLE VII

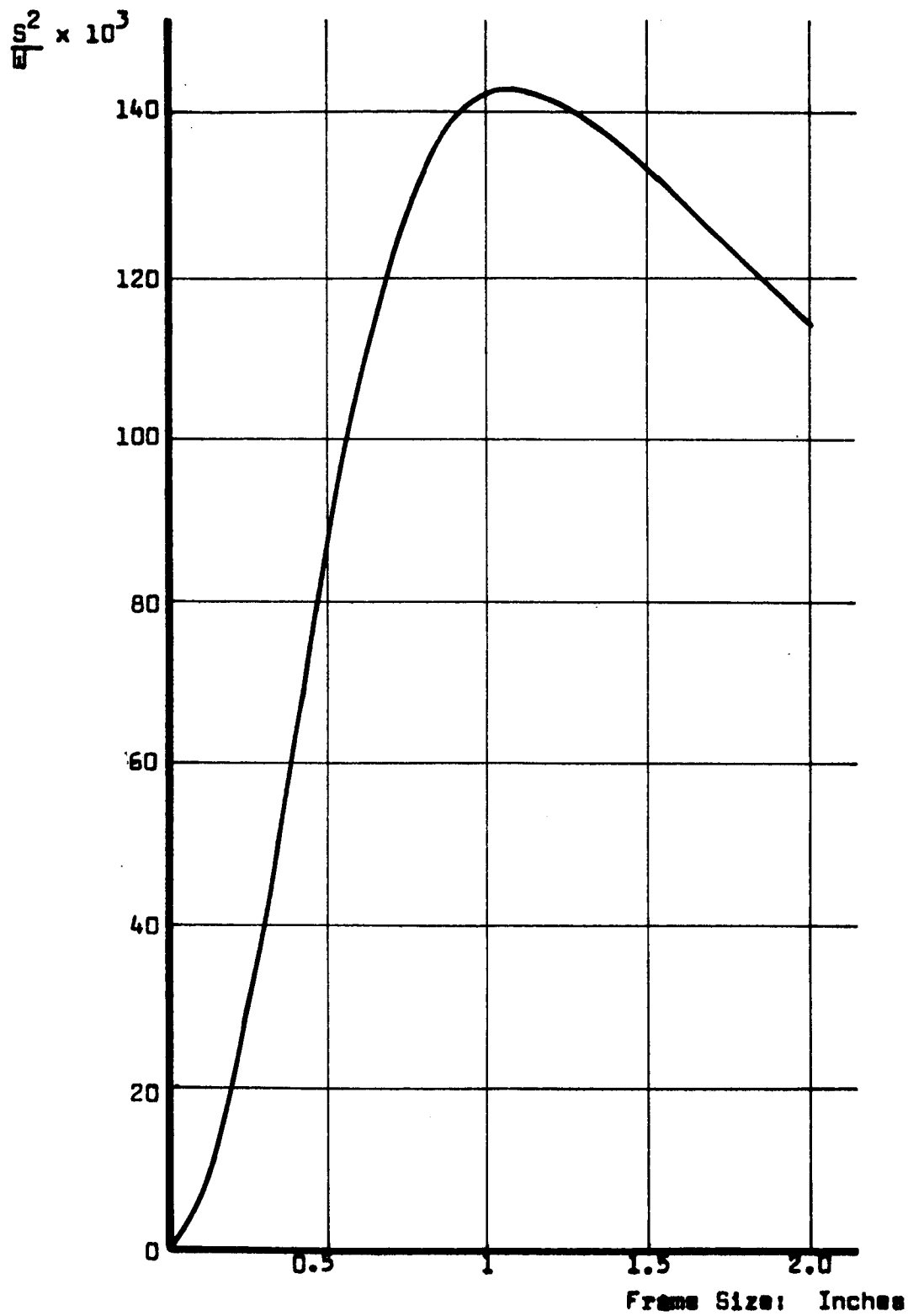

RECORDING AREA EFFICIENCY AS A FUNCTION
OF FRAME SIZE WITH CONSTANT RESOLUTION

FIGURE 11

height on the 3rd order monochromatic aberration as shown in Table VIII.

MONOCHROMATIC 3rd ORDER ABERRATIONS

Aberration	Variation w/Aperture	Variation w/Image Height
Spherical Aberration	As the Square	Independent
Coma	As the Square	Linear
Astigmatic Difference of Focus	Independent	As the Square
Astigmatic Focal Line Length	Linear	As the Square
Petzval Curvature	Independent	As the Square
Distortion	Independent	As the Square

TABLE VIII

It would appear from this table that if a given lens design were required to cover a field twice as large, that the resolution would be reduced by a factor of four or that to cover the increased field of view with the same resolution, that the complexity of the design would have to be increased by a factor of four. Within limits this prediction is substantiated by experience. The Leitz Elmar, which is manufactured as an f/3.5 lens at 50 mm focal length, is of the Tessar form, that is three individual elements with the last element an achromatic doublet. This lens becomes diffraction limited when stopped down two stops to f/6.3. To produce a lens of 28 mm focal length, the front two elements were separately achromatized increasing the number of pieces of glass from four to six and the relative aperture was reduced from f/3.5 to f/6.3.



GOERZ OPTICAL COMPANY, INC.

The Type I and Type II lenses which Goerz has designed for the lunar camera cover an angular field of approximately 25° . Goerz commercial lenses cover a half angle of 25° to 60° . The "standard" camera lens covers a field angle of 48 to 50 degrees. The difference is that standard lenses are transparent only above 4000\AA , and are corrected only for a narrow region in the visible portion of the spectrum. In the design of such lenses, the designer may choose from over 200 types of optical glass. In the design of ultra-violet lenses, the designer is restricted to a half dozen materials, some of which such as rock salt are extremely water soluble, others such as crystal quartz are highly bi-refrangent, that is the index of refraction is different for different planes of polarization and varies with the angle between the ray and the optical axis of the crystal. Thus a plane unpolarized wave front in passing through a sample lens made from a bi-refrangent material would come to a focus at two different locations. With the small number of usable materials, it is probably impossible to design a wide spectral range camera objective that will cover a 50° field angle and give high resolution.

The all mirror telescopes cover the spectral range, but only over narrow field angles. A Schmidt system might be designed to cover the wide field and spectral range, but only with a curved focal surface in an inaccessible location. The various two mirror combinations with corrector plates are capable of covering no wider field angle than the lenses designed for the lunar camera.

Optical design is still more of an art than a science. It is impossible to write meaningful trade-off equations which show explicitly the trade-off of field angle versus resolution or other variables as a continuous function. The design procedure is to choose a design form, add achromatizing elements to control the chromatic aberrations and chromatic variation of the 3rd order aberrations, bend the individual elements to balance the 3rd order aberrations over a selected field angle and spectral range, and then to ray trace and determine the performance of the lens. If the performance is extremely good over the selected field angle, the possibility exists of finding a solution with a slightly larger field angle with only moderately reduced performance.

The amount of increase in field can only be determined by an iterative process of tracing rays over the desired field, making small changes in the lens parameters and tracing through the lens again.

The basic problem is that the actual performance of a lens can only be determined exactly through the use of a set of equations involving transcendental functions for each ray and each surface. Hamilton, Luneberg and others have tried to approach the problem more directly by treating the performance of a wave front. These methods have never been sufficiently general to allow them to become useful tools to the optical designer. Rays, which are really wave front normals at a particular point on the wave front, are selected for different parts of the entrance pupil for a representative sample of points in



GOERZ OPTICAL COMPANY, INC.

the object field. These rays are traced through the lens trigonometrically by determining position and direction of incidence at the first surface, calculating the change in direction caused by refraction at this surface, calculating of the position of incidence at the next surface and repeating the process until the ray emerges from the last surface. The difference in points of incidence on the focal surface for rays from the same object point determines how well the point will be imaged.

Sets of rays may be treated analytically when simplifying assumptions are made. The basic law of geometrical optics is $n \sin i = n' \sin i'$. Where n and n' are the indices of refraction on two sides of a surface or boundary between two optical media and i and i' are the angles between the ray and the surface normal on the two sides of the surface. The sine function may be expanded in a series as $\sin i = i \frac{-i^3}{3!} + \frac{i^5}{5!} \frac{-i^7}{7!} + \dots$. If $\sin i$ is set equal to i and all

higher terms are ignored, equations can be derived that are valid for extremely small angles of incidence. This is called paraxial theory and is used for rough layout of optical systems. If the first two terms are used, a new set of approximate equations can be derived. This set of equations is known as third order theory and is the basis for the well known Seidel aberrations, spherical aberrations, coma, astigmatism, Petzval curvature and distortion. Although equations have been written for aberrations which include the fifth order term of the sine expansion, these are so complex

and offer so little improvement over third order theory that they are seldom of use to the practical designer.

Experience has shown that when the speed of the lens and field of view combine to make the angles of incidence so large that fifth order aberrations are important, all higher orders become important. Since any practical lens has only a limited number of parameters, it is impossible to correct the higher order aberrations in closed form. The working designer therefore makes a rough correction using third order theory, makes a trigonometrical ray trace and then compares the actual aberrations with the third order aberrations. The difference is due to the higher order aberrations. A small change of a single lens parameter followed by a ray trace will show the sensitivity of each aberration to this parameter. Repeating the process for each parameter allows the designer to prepare a matrix tabulation of aberrations and parameters, which will be valid over a small range of change of parameters. From this tabulation the designer can estimate how much each aberration will change when he simultaneously changes all parameters by given amounts. The coefficients in the table are based on small increments and would be valid if the functions were linear over the projected change. Since the functions involve transcendentals and higher order terms, they can only serve as a guide to a change which must be ray traced and then used as a basis for a new set of coefficients.

In the problem of increasing the field of view of a given design form, the designer frequently finds that he is able to achieve good



GOERZ OPTICAL COMPANY, INC.

resolution at the edge of the field and at the center of the field but that a wide zone which may cover half the area of the format becomes progressively worse as he makes changes which improve resolution at the edge of the field. At this point the designer can only retreat to the form which gives the best overall coverage, or make a drastic change such as splitting an existing element into two pieces of glass, changing one of the surfaces into an aspheric, or by going to a completely different design approach. Any of the drastic changes requires a return to basic third order theory and the systematic design of a new lens.

Splitting elements in optical design is analogous to adding stages in an electronic amplifier. To a first approximation the change is almost always immediately and obviously beneficial. Since the power required of each half of the lens is reduced, the spherical aberration is drastically reduced. The effect on other aberrations may not be as beneficial. Although almost always the net geometric performance will be improved, the derived form may not be better than some completely different form with $n+1$ elements and the weight and cost of the lens will have increased.

Descartes showed that a simple lens could be corrected for spherical aberration for any one set of conjugate distances by making one of the surfaces in the form of an ellipsoid. Newton showed that a concave mirror could be corrected for spherical aberration for an object at infinity by making the mirror a paraboloid. Cassegrain and Gregory showed that compound telescopes with two mirrors could be

corrected by the use of hyperboloids and ellipsoids. None of these early workers were able to verify their analysis by experiment because they lacked a method of testing the surfaces to determine their actual shape.

In 1859 Foucault invented or discovered the knife-edge test, which allows opticians to test surfaces which have the shape of a conic section rotated about its axis. Since that time it has been possible to work large mirror surfaces of aspheric or nonspherical shape provided that the required surface does not depart radically from a sphere. Other tests have been devised which allow testing, with varying degrees of accuracy, of surfaces of revolution with completely arbitrary shape.

Computer programs are available for tracing rays through surfaces described by power series with up to ten coefficients. Designs have been completed of optical systems with four or more arbitrary (non-conic) aspheric surfaces. These designs promise to give orders of magnitude higher performance than any lens now on the market. The problem at present is in the optical workshop.

When two pieces of material are rubbed over each other in a large number of orientations and with a suitable abrasive between them, spherical mating surfaces will result. By controlling pressures and speeds, the radius of curvature may be varied at will. This process is almost automatic because spherical surfaces are the only surfaces which will fit in all orientations and the action of the abrasive is to remove material in any area where the surface is



GOERZ OPTICAL COMPANY, INC.

too high to fit. The need for skilled opticians to finish spherical surfaces only arises with the additional requirements of holding a specific radius of curvature and that the finished surface be free of digs and scratches.

Methods of generating and polishing aspheric surfaces are chosen to fit the degree of asphericity and the size of the elements. If the departure from the closest sphere is on the order of tens of millionths of inches, the blank is usually generated and polished as a sphere and then aspherized by the use of sub-diameter tools. This technique really amounts to producing a number of spherical zones of different radii of curvature and blending them together. Where the departure is on the order of thousandths or tens of thousandths of an inch, the surface is generated by a profile milling operation and polished by some form of flexible lap.

These techniques tend to become more difficult to apply as the size of the element decreases. In a large element the total departure from sphericity may be great but the rate of change of radius of curvature from zone to zone is small. In small lenses, the power of the individual lenses tends to be high because of the short focal length. A useful amount of asphericity requires substantial change of radius of curvature over zones less than 0.1 inches wide. Although such surfaces can be made, they cannot be made in a predictable length of time or at a predictable cost. It is significant that although the advantages of aspherics have been known for many years, no known photographic lens of under three inch aperture, which employs aspherics, is commercially available.

Recognizing both the advantages and costs of aspheric elements at the beginning of this program, it was decided that an attempt would be made to avoid the use of aspherics completely but that if at any point in the design effort the introduction of a single aspheric would allow a significant improvement in performance, weight, volume or number of air glass surfaces, the trade-off would be explored in detail. In the design of the Types I and II lenses, diffraction limited performance was achieved without the use of aspherics and the number of elements could not be reduced by the use of aspherics.

The Type III lens represents a complete departure from the approach used for Type I and Type II. If the wider field angle were required over the wide spectral range, the Type III lens might be a starting point with substitution of quartz and fluorides for optical glasses, followed by splitting of elements to reduce curvatures as required by the lower indices of refraction and smaller differences of indices. The basic triplet became a nine element lens by this process, the Type III lens could well become a twenty-two element lens by the same process. Scattered light in the ultraviolet and stray light caused by the many air glass surfaces would make the contrast rendition of such a lens near zero for all useful spatial frequencies. Simplification by the use of aspherics would be required.

Stereo measurements require a measurable displacement of the two images of a given object. With a given stereo base, object distance and resolution, the displacement of images will be directly



GOERZ OPTICAL COMPANY, INC.

proportional to the focal length of the lenses. A decrease in focal length by a factor of two would decrease the distance at which stereo data could be obtained by a factor of eight.

From the above considerations, it appears that optimum information recording over the specified spectral range will be obtained with high resolution sensitized material with a format approximately one inch square and with a field angle approximately 25°.

The Type III represents a compromise in favor of general coverage at the expense of stereo accuracy. Stereometric measurement of distances is based on measurement of the difference in position of images of an object on the stereo negatives. Assuming that the two cameras are identical and have parallel optical axes, if an object is on the optical axis of one camera it will be away from the optical axis of the second camera by a distance equal to the separation of the two optical axes. The image will be formed on the optical axis in the first camera and at a point representing the angle subtended by the stereo base divided by the object distance in the second camera. For small angles, the linear displacement of the image is proportional to the product of the angle and the focal length of the camera lens. Thus for distant objects the displacement of the images in the stereo pair will be proportional to the product of the stereo base and the focal length. Taking the Type I camera as a reference the sensitivity and accuracy of the Type III camera will be $\frac{6}{5} \times \frac{50}{75} = 0.80$. Thus for a

given precision of measurement of image position, the limiting range of the Type III camera will be 80% of that of the Type I camera.

IV FOCUS CONSIDERATIONS - RANGE FINDER REQUIREMENTS

The depth of field has been calculated for a diffraction limited f/5.6, 3 inch focal length objective for a range of focal settings from 3 feet to infinity. As expected, the range of distances over which diffraction limited resolution will be achieved were found to be extremely shallow. At all ranges up to 800 feet, it will be necessary to provide the astronaut with a method of measuring the distance to the object of interest. The sensitivity of a unit power range finder with a stereo base of 6 inches has been tabulated and found to be well within the calculated depth of field. The use of a telescopic range finder would allow a reduction in stereo base, but would either reduce the field of view or increase the weight of the range finder. If less than diffraction limited performance is acceptable, the depth of field may be scaled, approximately as the diameter of the circle of confusion. The view finder, as described in Section V, may be used to obtain sufficiently sharp focus to record 15 lines per millimeter on the film, and by the addition of a magnifier a resolution level of 50 lines per millimeter may be reached.

A. DEPTH OF FIELD

The focal range, the range from the nearest to the farthest position which causes path differences not exceeding the



GOERZ OPTICAL COMPANY, INC.

Rayleigh Limit, is given by Conrady¹ as: Focal Range = 1 wave length / $(N' \sin^2 U_m')$. In which N' is the refractive index of the medium in which the image is formed, and U_m' is the angle under which the extreme marginal ray arrives at the focus. For an $f/5.6$ system $\tan U_m' = \frac{1}{2 \times 5.6} = .0901$ $\sin U_m' = .0898$.

$\sin^2 U_m' = 8.06 \times 10^{-3}$. $\lambda = 20 \times 10^{-6}$ inches, in the middle of the visible range. The focal range is thus equal to 2.48×10^{-3} inches.

The thin lens equation may be used directly for calculating the image distance for each object distance and then calculating new object distances for image distances plus and minus 0.001 inches from the central image distance. The remaining 0.0005 inches of tolerance is reserved for film flatness and focus mechanism tolerance. The depth of field calculated in this manner is given in Table IX.

¹Applied Optics and Optical Design, A.E. Conrady, page 136.

FOCAL RANGE

Focus Feet	Setting Inches	Image Distance	Near Object Distance		Far Object Distance		Range Feet
			Feet	Inches	Feet	Inches	
3	36	3.2727	2.99	35.88	3.01	36.12	0.02
4	48	3.200	3.98	47.78	4.02	48.23	0.04
5	60	3.1580	4.96	59.60	5.03	60.32	0.07
6	72	3.1305	5.95	71.44	6.04	72.50	0.09
8	96	3.0967	7.92	95.12	8.09	97.04	0.17
10	120	3.0769	9.88	118.5	10.3	123.1	0.38
20	240	3.0380	19.5	233.8	20.5	246.2	1.04
30	360	3.0251	29.0	347.8	31.4	376.4	2.37
40	480	3.0188	38.1	457.5	42.4	508.7	4.27
50	600	3.0150	47.1	565.6	53.8	646.0	6.70
60	720	3.0125	55.8	669.8	65.5	785.6	9.64
70	840	3.0108	63.8	765.9	76.7	920.8	12.9
80	960	3.0094	72.3	868.1	89.5	1074.0	17.2
90	1080	3.0084	80.0	960.6	101.6	1220.0	21.6
100	1200	3.0075	88.5	1062.0	116.0	1387.0	27.1
200	2400	3.0037	160.0	1916.0	278.0	3333.0	118.0
400	4800	3.0018	268.0	3215.0	936.0	11236.0	668.0
800	9600	3.0009	395.0	4739.0	∞	∞	∞

TABLE IX



GOERZ OPTICAL COMPANY, INC.

Similar reasoning may be applied to the Type III lens. A detailed calculation was considered unnecessary in that the relationship between linear and lateral magnification can be applied to show that for equal object space resolution equal tolerances in focussing will apply. With the shorter focal length the focal tolerance will increase more rapidly with distances, but this is a direct consequence of the loss in object space resolution.

B. RANGE FINDER DESIGN

Distances are measured by three basic methods: (1) direct comparison of the unknown distance to a standard, tapes, chains, micrometers; (2) Time of flight measurements, Radar, Geodimeter, Tellurometer; and (3) Triangulation, stadia or telemeter, range finder. The first method being the most basic is usually the most accurate, but is only convenient for relatively short distances. The second method is ruled out by the complexity and weight of the required equipment. Of the many methods of triangulation possible, only the stereo range finder is considered practical for use with the lunar camera. Stereo range finders are of two types: split field and superimposed field. The split field has been tentatively chosen for the lunar camera because it has higher brilliance and requires approximately one-half the weight and space. The basic configuration for either type is illustrated

by:

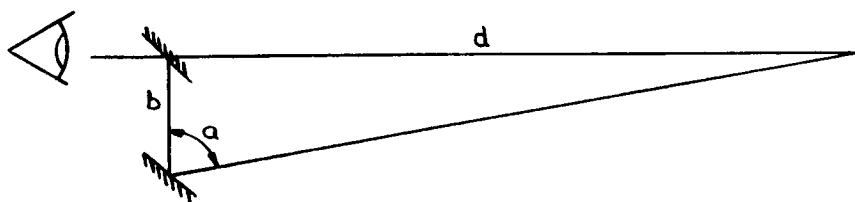

$$d = b \tan a$$

Where d is the object distance, b the stereo base and a the angle between the two lines of sight.

The sensitivity of the range finder is proportional to the stereo base b , and the sensitivity to the eye to small changes in the angle a . To minimize space and weight, b should be minimized. To make the instrument easy to use, the required sensitivity to changes in angle a should be well within human capabilities. The normal human eye is capable of resolving one minute of arc. Two half lines can be made coincident to within about one tenth of this amount or about 6 seconds of arc. Assuming a coincidence setting accuracy of ± 1 arc minute and a stereo base of 6 inches, the range finder error was calculated and tabulated with the focal range from Table IX in Table X.

This tabulation shows that at all ranges the unit power range-finder with 6 inch stereo base will allow settings which are within one-half of the depth of field of the photographic objective. At ranges of less than 10 feet it is probable that



GOERZ OPTICAL COMPANY, INC.

the astronaut will have moved the camera more than the focal range between focussing and making the exposure. Table IX shows that nearly three-fourths of the required change of lens to focal plane distance occurs in the object distance range of 3 to 10 feet. Considerable simplification in the camera design would result if the focussing range were restricted to the range of 10 feet to infinity.

Range Finder Accuracy

Actual D Inches	Range Finder Setting		Focal Range	
	Near Inches	Far Inches	Near Inches	Far Inches
36	35.94	36.07	35.88	36.12
48	47.88	48.12	47.78	48.23
60	59.82	60.18	59.60	60.32
72	71.74	72.25	71.44	72.50
96	95.55	96.47	95.12	97.04
Feet	Feet	Feet	Feet	Feet
10	9.94	10.06	9.88	10.26
20	19.77	20.24	19.48	20.52
30	29.47	30.54	28.97	31.36
40	39.08	40.98	38.12	42.39
50	48.55	51.52	47.13	53.83
60	57.99	62.28	55.82	65.46
70	67.25	73.08	68.83	76.73
80	76.39	84.01	72.34	89.51
90	85.51	95.18	80.01	101.6
100	94.55	106.5	88.46	115.6
200	179.0	227.4	159.6	277.8
400	325.6	550.9	268.0	936.3
800	540.6	1508.0	394.9	

TABLE X

In designing the range finder, consideration was given to the possibility of combining the range finder with the view finder and to making the range finder more compact by making use of telescopes.

If 2 x telescopes were incorporated in the range finder design, a 30 second displacement would appear as one minute of arc and adequate range finder accuracy could be achieved with a 3 inch stereo base.

Small refracting telescopes are of two forms: the Galilean, which uses a positive objective and a negative eyepiece to give an erect image, and the Keplerian which uses two positive lenses and gives an inverted image. The latter form is widely used in combination with erector lenses or prism erector assemblies. This telescope form is capable of giving good resolution over wide angular fields, but the weight and space required for the erecting system and the complexity of eyepiece required to give the necessary eye relief outweigh any advantage over the non-telescopic system. The Galilean telescope can only be corrected for narrow fields of view. The exit pupil lies between the eyepiece and the objective, so that for any accessible eye position the cones of light reaching the eye from off axis points are severely vignetted.

A unit power range finder with four inch eye relief and 5° field of view is shown in Figure 12. This is the basic system discussed

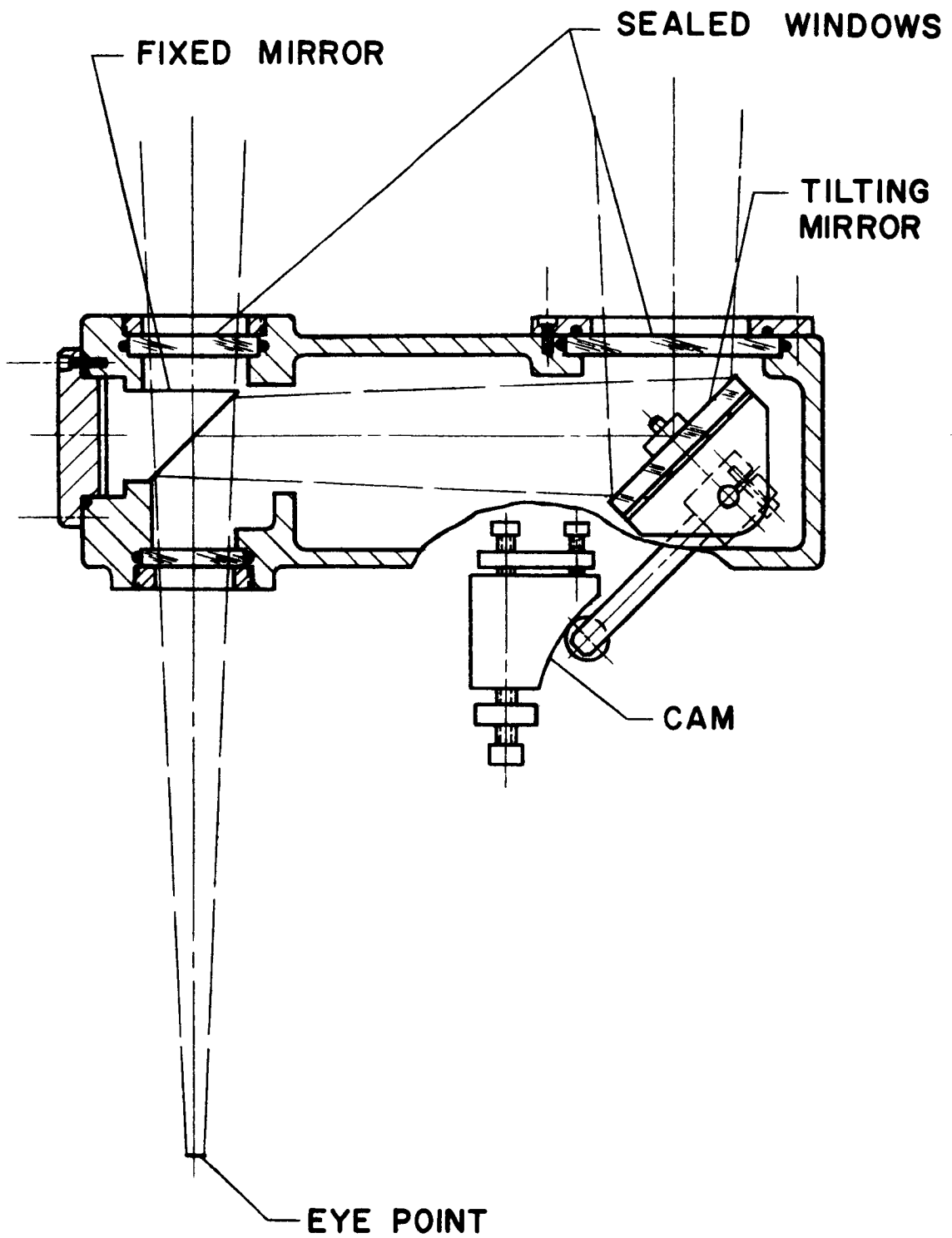

RANGEFINDER
FIG. 12

above and consists only of a fixed mirror and a rotating mirror. In order to seal the system, three windows are required. This system has been layed out to give an unvignetted 5° field coverage when the eye is positioned in a 0.250 inch square. Since this system is without power, focussing is not a problem and axial positioning of the eye is not critical.

V VIEW FINDER

Most modern hand held cameras are equipped with telescopic view finders of fractional magnification. Press cameras are usually equipped with a supplementary "sports finder" consisting of a small aperture and wire frame which subtends the same angle at the aperture as the film format at the nodal point of the lens. The third type of camera view finder in common use is the reflex finder which may use the picture taking lens as in the Hasselblad and Exacta or a separate lens as in the Rollieflex and Rolliecord. All three methods were examined for applicability to the Lunar Camera. The first two methods were found to be impractical because of the requirement for at least 3-1/2 inches eye relief and the desirability of increasing this distance to 18 to 20 inches. The single lens reflex was considered to be less desirable than the type using a separate lens for three reasons: (1) a separate lens with fixed mirror was considered to be more reliable than the swinging mirror and possible automatic iris control required in the single lens reflex, (2) a larger view finder format than film format was considered desirable due to



GOERZ OPTICAL COMPANY, INC.

the limited dexterity of the astronaut and difficulty in holding the camera near the face plate, (3) the separate lens design allows more freedom in arrangement of components in designing for minimum camera volume. This basic view finder was shown in Section 6 of the December monthly report. Since that time, the design has been refined, as shown in Figure 13, by an increase in format scale, a change of lens and the replacement of the ground glass with a Fresnel lens. Replacement of the 4 inch lens with a 3 inch lens allows the lens to be mounted on the same lens board as the camera lenses, so that view finder focus will be directly related to camera focus. To increase the effective focal length to 6 inches in order to show the camera field of view at double scale, a negative lens at a fixed distance from the screen, is mounted directly behind the 3 inch efl lens.

With the original layout, using the 4 inch lens, the field covered by the camera would occupy a central square of 1.33 x 1.33 inches and would be defined by dark lines on the ground glass. The 0.333 strip around this square would image the object space around the field of view of the camera. In going to a 6 inch effective focal length system, the field of view of the camera will fill the entire 2 x 2 inch screen.

Replacement of the ground glass screen with a Fresnel lens of 3.25 inch focal length will reimage the exit pupil of the lens

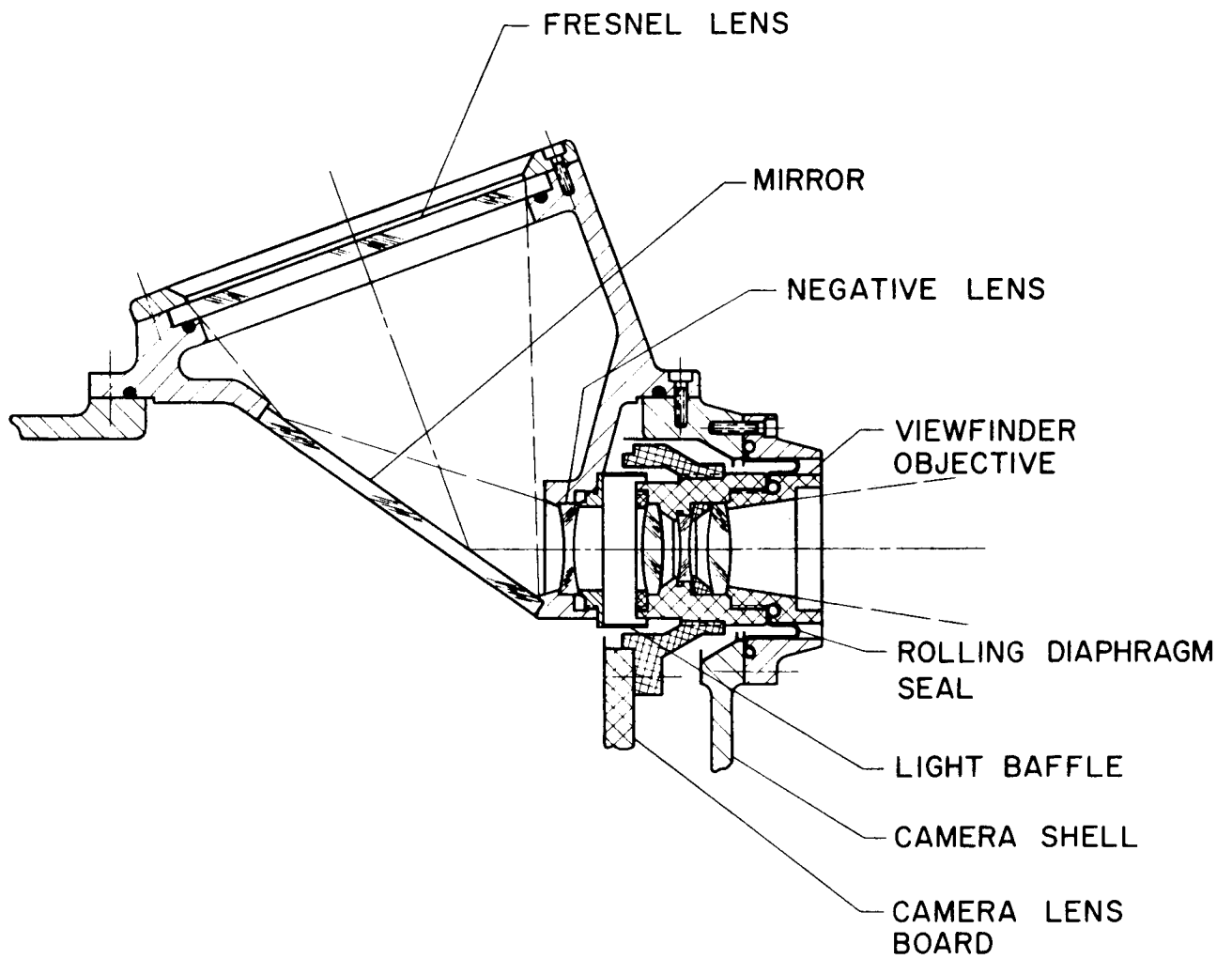

VIEWFINDER

FIG. 13



GOERZ OPTICAL COMPANY, INC.

at a distance of 18 inches from the Fresnel lens with a magnification of about $5\frac{1}{2}$, so that a brightly illuminated screen will be visible over an exit pupil approximately $2\frac{1}{2}$ inches in diameter. If, during training, this exit pupil is found to be too small, it may be increased by substituting a Fresnel lens of slightly longer focal length. The action of the fixed and moveable lens elements in producing a focussed image on the screen deserves a careful explanation. The screen is conjugate to a plane fixed with respect to the negative lens and the camera body. This plane has the same relationship to the viewfinder objective as the film plane has to the camera lenses. Any object in focus at the film plane will be in focus on this plane and will be reimaged by the negative lens on the viewfinder screen with a lateral magnification of two. Since the longitudinal magnification is equal to the square of the lateral magnification, an image that is 0.001 inches out of focus at the film plane will be 0.004 inches out of focus at the viewfinder screen. This appears to give a means of increasing the sensitivity of focus, but the magnification by a factor of two causes the focal ratio to be increased by a factor of two and the depth of focus is inversely proportional to the square of the focal ratio, so that the sensitivity of focus is the same at the viewfinder screen as at the film plane. A gain in scale is achieved. If the focus of an object plane is sufficiently close that 25 lines per millimeter detail is resolved

at the viewfinder screen, 50 lines per millimeter will be resolved at the film plane. The average eye will resolve one minute of arc. At a distance of eighteen inches, one minute subtends 0.0054 inches or 0.137 mm. Thus, visual focus will allow a resolution 7.3 lines/mm at the viewfinder screen or 14.6 lines/mm at the film plane. If the viewing distance is decreased to ten inches, the resolution will be increased by a factor of 1.8, giving a resolution of 26 lines per millimeter at the film plane. Thus, the viewfinder is capable of providing a coarse indication of focus. If a three power magnifier were provided for the center of field, film resolution could be increased to 50 lines per millimeter. This is normal practice on twin lens reflex cameras, but requires the photographer to accurately locate his eye with respect to the magnifier. If high resolution emulsions are to be used, the range finder will be required and the viewfinder should be left as shown. If low resolution films are used, the range finder should be eliminated and the viewfinder provided with a magnifier.

The viewfinder for the Type III camera would be similar to that of the Type I. The objective lens would be replaced with a lens with the same field coverage and focal length as the Type III camera. In order to maintain the viewing screen size at 2 inches square, the amplification by the negative lens will be reduced from a factor of 2 to a factor of 1.67.



GOERZ OPTICAL COMPANY, INC.

VI SHUTTER

A. REQUIREMENTS

The shutter must allow light to pass through the optical system to the film during the data recording period and prevent light from reaching the film plane at all other times. The requirements of the optimum shutter may be divided into three categories: optical, photographic and mechanical.

The optical requirement is that light from the full aperture of the lens be allowed to reach each image point for the highest practicable percentage of the exposure period. In a well corrected optical system, the resolution is directly proportional to the aperture. A shutter that allows light to pass through a progressively larger circle centered on the aperture stop will decrease the contrast rendition of the higher spatial frequencies as shown qualitatively by the comparison of curve b with curve a in Figure 14. A shutter that operates by decreasing a central obscuration will slightly extend the ultimate spatial resolution, but will reduce the contrast rendition at lower frequencies, as shown by curve c. A shutter that operates by passing a slit across the aperture will give good resolution in the direction parallel to the slit and poor resolution in the direction parallel to slit travel, as shown in curves d_{\perp} and d_{\parallel} .

A focal plane shutter will give the performance shown in curve a.

A conventional between the lens shutter will perform as shown by

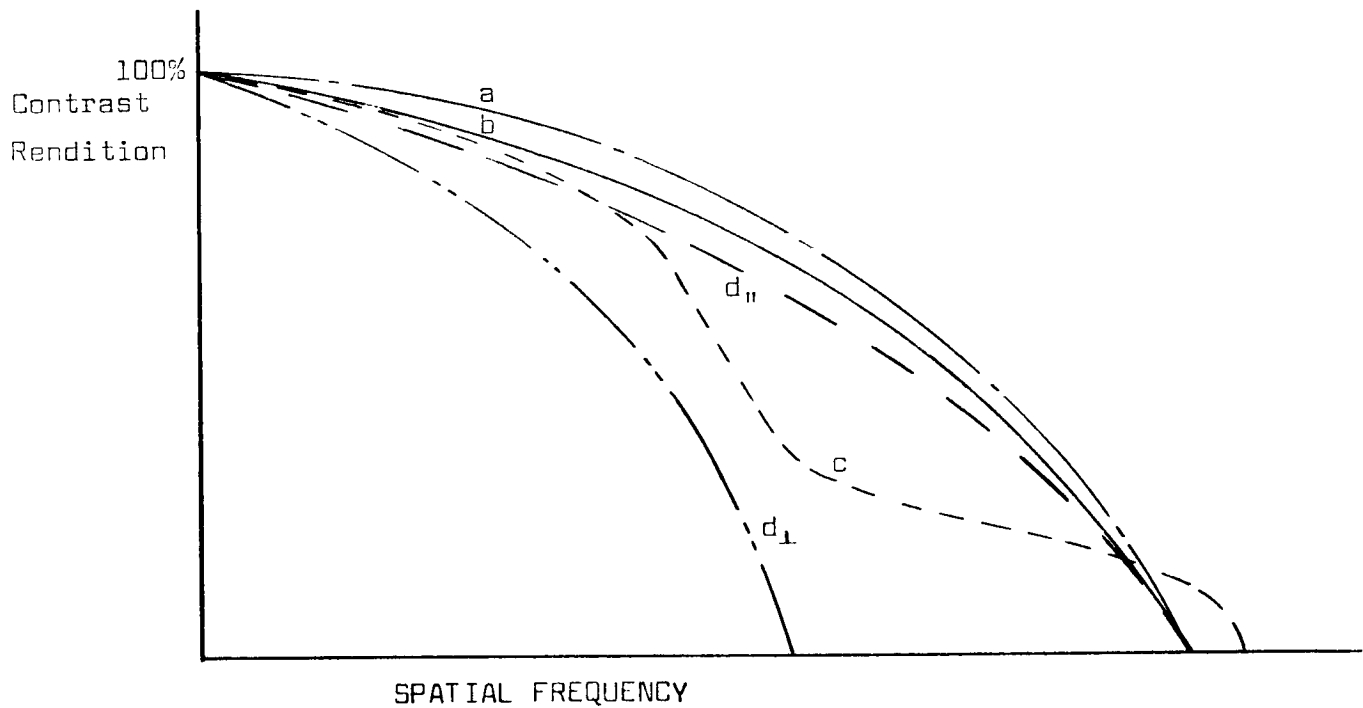

CONTRAST RENDITION AS A FUNCTION OF SHUTTER TYPE

- a. Contrast transfer of an unobstructed lens.
- b. Contrast transfer with aperture stop opened for a longer time at center than at the outer edge.
- c. Contrast transfer with aperture stop unobstructed at the edge for a longer time than at the center.
- $d_{||}$ Contrast transfer in direction parallel to slit.
- d_{\perp} Contrast transfer in direction perpendicular to slit.

FIGURE 14



GOERZ OPTICAL COMPANY, INC.

curve b. The departure of curve b from curve a will depend on the shutter efficiency or ratio of time that the aperture stop is completely unobstructed to the time of partial obscuration. For most emulsions and normal exposure times, curve b will be indistinguishable from curve a when the shutter efficiency is over 65%.

Photographically, the shutter must be open for the amount of time required to admit the amount of light required to produce the required density of the film and the exposure time must be sufficiently short to prevent image motion on the film due to motion of the object or camera. Exposure control range is determined by brightness range of scenes to be photographed. Required sensitivity of control is determined by the latitude of the emulsion. In amateur and professional photography, with natural illumination, exposure control is accomplished by a combination of lens aperture size and shutter speed. In technical photography where the highest possible resolution is required, neutral density filters are frequently used to avoid the loss of resolution caused by stopping down the lens. When the scene to be photographed contains objects at widely differing distances from the camera, the lens is stopped down to increase the average resolution. There are no dominant photographic reasons to choose between exposure control by length of exposure or by adjusting the amount of light flux per unit time passing through the shutter.

With regard to image motion, it appears to be safe to extrapolate from standard commercial practice. For effective exposure times less than 1/30 second, the Leica focal plane shutter transverses the film format in 1/30 second. With focal lengths up to five inches effective exposure time of 0.01 seconds or less are considered adequate for hand held cameras. The motion during the effective shutter opening will cause blurring of the image. Motion during the total exposure period causes distortion of the image. Since the mission of this camera is to record lunar surface features, assumed to be static, the motions to be considered are those introduced by the astronaut. Assuming a 3 inch focal length lens, a resolution of 200 lines per millimeter, and an exposure time of 0.01 seconds, the permissible angular velocity of the camera is:

$$\theta = \frac{d}{f} = \frac{.005\text{mm}}{3 \times 25.4\text{mm}} = 606 \times 10^{-6} \text{ radians} = 2 \text{ minutes of arc}$$

$$\omega = \frac{\theta}{t} = \frac{2}{.01} = 200 \text{ minutes of arc/second of time}$$

This appears to be a reasonable stability requirement to place on the astronaut. If lower resolution requirements are placed on the camera, slower shutter speed could prove to be useful.

The mechanical requirements of the shutter derive from the optical and photographic requirements, the environment, the available space and the dexterity of the astronaut. The optical requirements indicate that the shutter should be located at the focal plane or at the aperture stop and that, if placed at the aperture



GOERZ OPTICAL COMPANY, INC.

stop, the shutter should open symmetrically from the center and have an efficiency of better than 65%.

The photographic requirements set a minimum shutter speed for hand held use and show the desirability of providing a range of shorter exposure times. If artificial illumination is used, the shutter must allow exposure of the complete format during the period in which the flux is relatively constant. For maximum efficiency of artificial illumination the aperture and field should be unobstructed during the complete light pulse.

The environmental requirements are that the shutter operate after being exposed to the shock and vibration associated with transportation from the factory to the moon, that the shutter materials not change physical properties sufficiently to degrade performance when exposed to the thermal and radiation environment and that the shutter either operate in a hard vacuum or be sealed in a benevolent atmosphere. A factor to be considered in choosing between the focal plane shutter and the between the lens shutter is that the latter will not be damaged if the camera is pointed at the sun while the focal plane shutter will be subjected to an in focus image of the sun which would rapidly damage the shutter.

In optimizing the shutter for astronaut use, the best shutter will be the one which requires the simplest motions to energize, adjust for exposure time, and release. The motions required to energize

the shutter may be expected to be functionally related to the amount of energy required. The nature of this functional relationship will be related to the nature of the mechanism employed, but since the size of the camera is restricted and the amount of force that the astronaut can apply is limited, it can be assumed that if the energy requirement is modest, it may be supplied by a simple motion and that beyond this threshold either more motions or more complicated motions will be required. If the energy requirement is sufficiently small, energizing the shutter may be combined with advancing the film, thus reducing the number of operations required. Thus, from the astronaut's viewpoint, the optimum shutter will require the least energy.

B. CHOICE OF BASIC SHUTTER TYPE

Early in the program a comparison of shutter types indicated that a focal plane shutter should be used for the hand held camera. It was believed that a single shutter could be used to expose both halves of the stereo pair whereas separate between-the-lens shutters would be required. The inherent high efficiency of the focal plane shutter would lead to lower velocities and accelerations and the focal plane shutter elements would be less subject to damage by shock and vibration than the blades and gears used in the Compur type shutter.

As the program developed, the difficulty in providing artificial lighting for the focal plane shutter which controlled the illumination for two cameras became apparent and the poss-



GOERZ OPTICAL COMPANY, INC.

ible change to a separation camera using two lenses to expose four formats required a reexamination of the choice of shutter type. For efficient use of artificial lighting, it was necessary that at one time in the shutter cycle all of the focal surfaces be exposed simultaneously. This required either that the slit width be as wide as the total length of all of the focal surfaces, over four inches for the simple camera and over five inches for the separation camera, or that the shutter curtain be arranged to travel perpendicular to the direction of film travel. In the first case the curtain velocity would have to be 400 to 500 inches per second, and in the second case the curtain would have to be either 4 or 5 inches wide and have a velocity of at least 100 inches per second. In either case, the amount of energy required to accelerate the curtain would be extremely high. By comparison the area to be shuttered by a between-the-lens shutter would be approximately 0.2 square inches per lens. It was therefore decided to attempt the design of a between-the-lens shutter which could be driven by a single actuator and which would avoid the large number of small pieces and areas of high stress found in the currently available high speed between-the-lens shutters.

G. DEVELOPMENT OF THE DESIGN

The investigation started by analysis of the simplest configuration which appeared to be capable of giving the required performance. As shown in Figure 15, the starting configuration consisted of two flat blades with two rectangular apertures each. By accelerating each blade by the same amount, but in

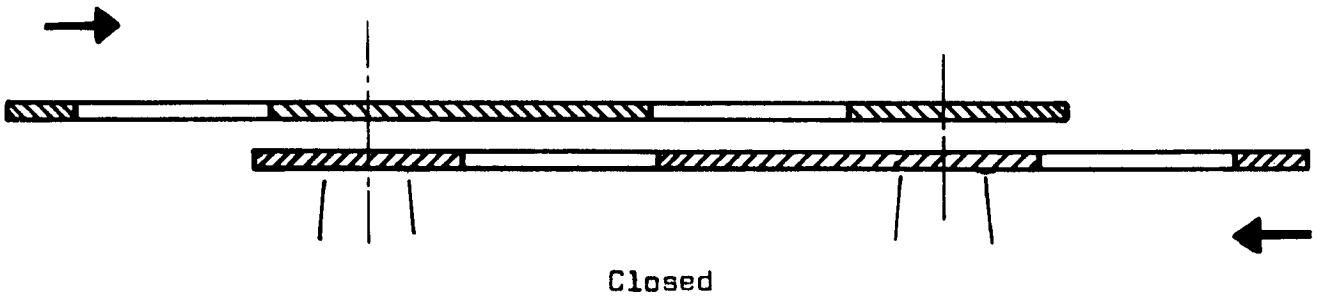
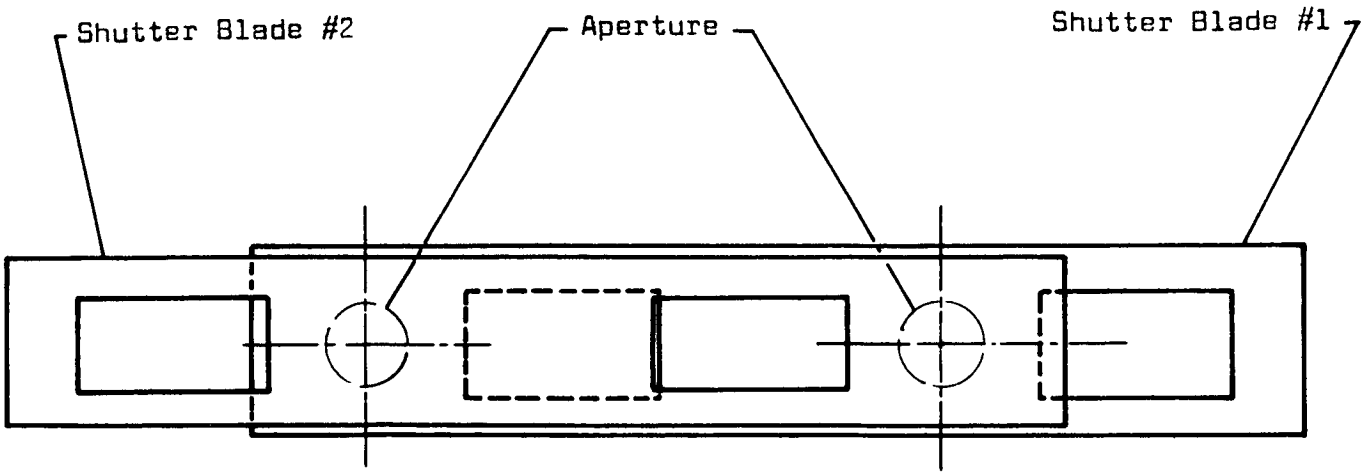

LINEAR SHUTTER MODEL

FIGURE 15



GOERZ OPTICAL COMPANY, INC.

the opposite direction, pairs of apertures would meet at the center of each lens aperture and open from the center toward the edge. A continuation of this motion would bring the opposite edges of the blade apertures together at the center of the lens aperture to close the shutter. The distance from the center of the lens to the edge of the blade aperture was allowed for acceleration of the blades. The complete shuttering action was assumed to take place at constant velocity. An over-travel equal to the pre-travel was allowed to bring the blades to rest. The percent shutter opening as a function of shutter displacement was plotted to determine shutter efficiency. The accelerations required for 0.01 and 0.005 second exposures were calculated for different shutter efficiencies and are tabulated as Table XI.

Shutter Efficiency	Effective Exposure Time	Acceleration
%	Seconds	g's
50	0.01	1.6
70	0.01	4.8
80	0.01	
50	0.005	
70	0.005	17
80	0.005	67

TABLE XI

The accelerations required to achieve the required speeds at 70% efficiency are reasonable, but for this type of shutter to work, accurate guiding and synchronization are required. The next step

in the evolution of the design is to move the guiding, driving and synchronizing functions to a center where the linear velocities and displacements are small so that energy lost in Coulomb and viscous friction will be small. The first step was to bend the shutter shown in Figure 16 into a circle whose center was midway between the lenses and whose pitch diameter was equal to the lens spacing. For disk shutters the inertia is proportional to the fourth power of the disk radius while the required velocity for a given exposure time and efficiency is proportional to the first power. An immediate decrease in driving energy can be achieved by providing separate shutter blades for each lens and moving the centers of rotation as near to the lens aperture as possible. Such a shutter is shown schematically in Figure 17. Each shutter consists of two disks each driven by a pinion which is in turn driven by a rack. Stress levels for the rack and pinion teeth and driving forces were calculated and found to be reasonable. However, in examining methods of absorbing the kinetic energy of the shutter after the exposure, it was found that by a further design evolution the actuator inertia could be used to reverse the direction of travel of the blades during the shutter open portion of the shutter cycle and, at the expense of higher accelerations, the blades and shutter driving mechanism could be made significantly lighter. This design is shown in Figure 18. This design form is considered to be close to the optimum design.

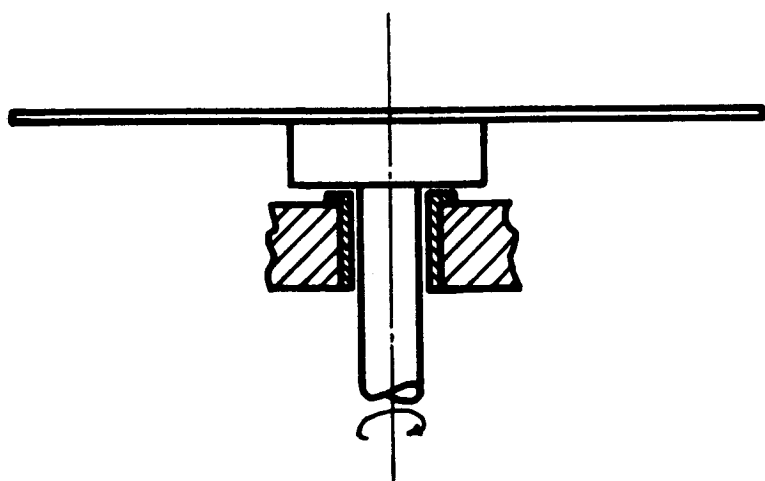
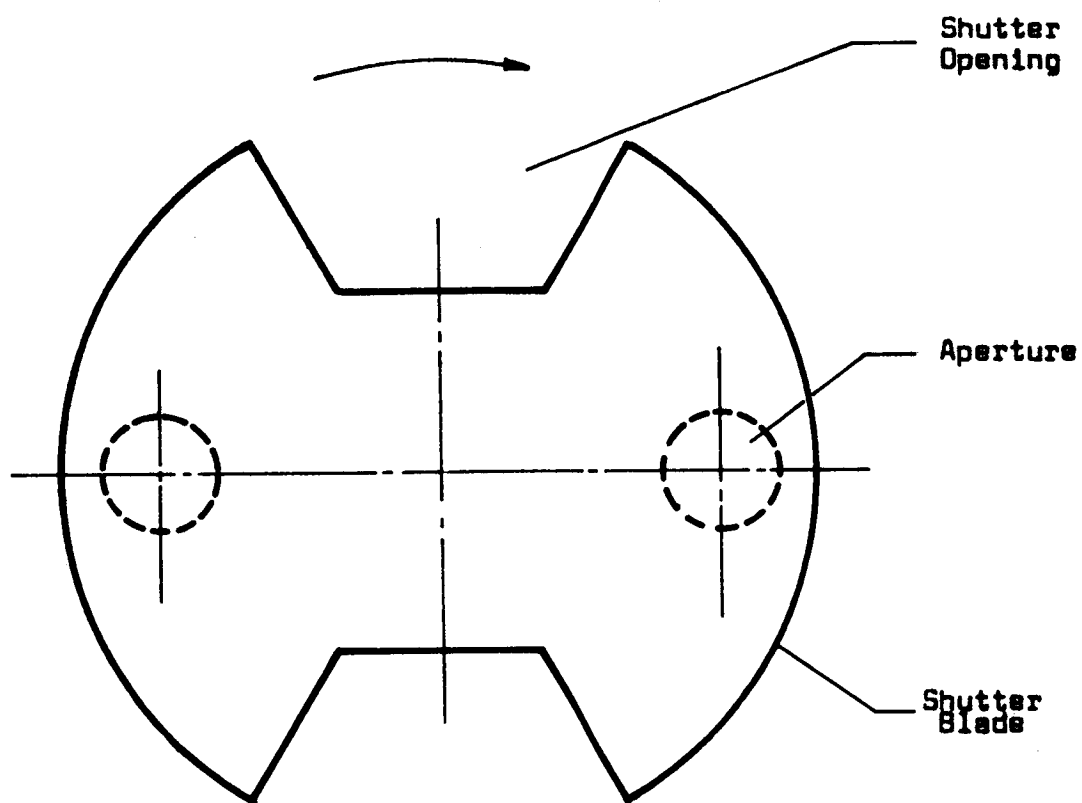

SINGLE CIRCULAR SHUTTER

FIGURE 16

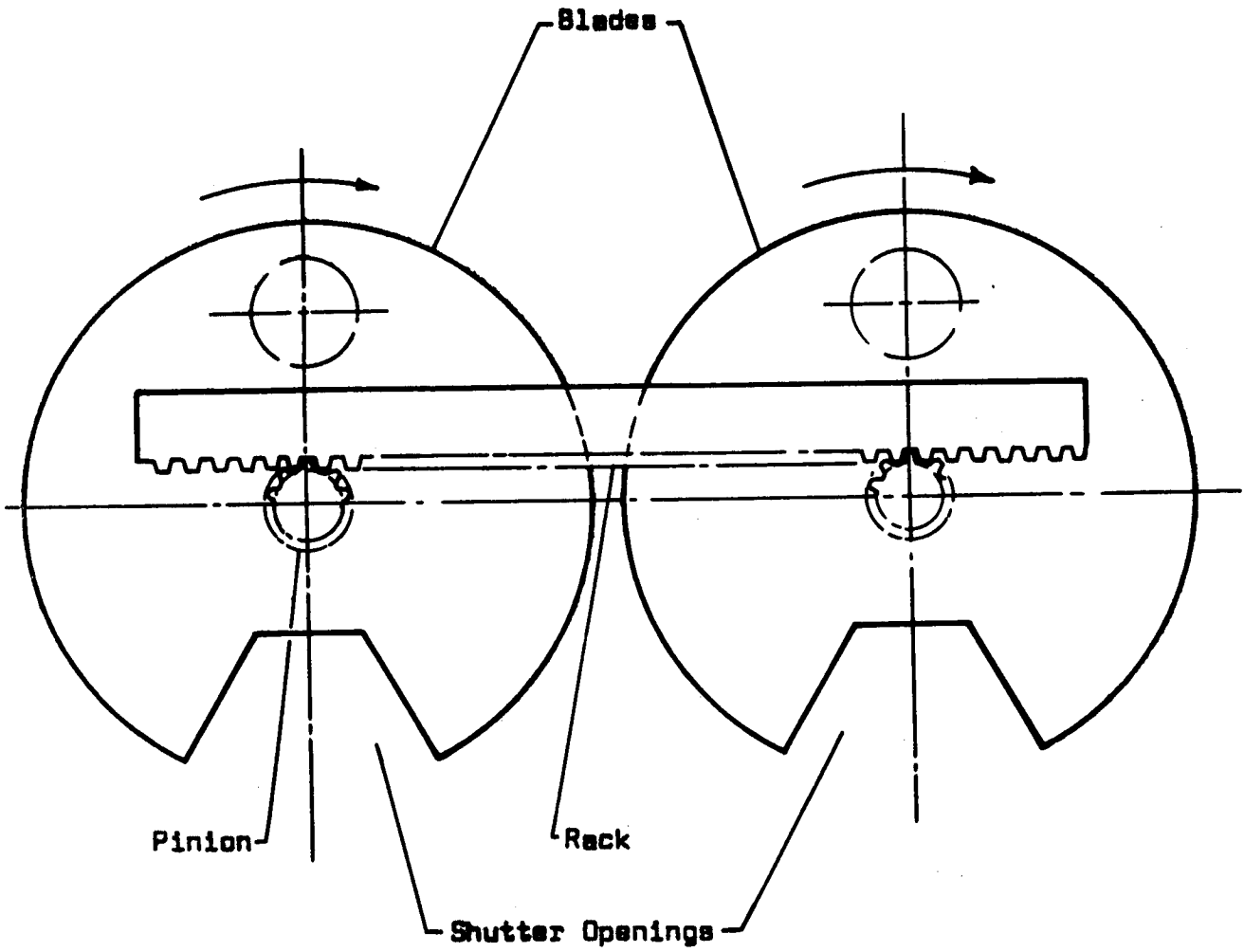

SEPARATE CIRCULAR SHUTTER

FIGURE 17

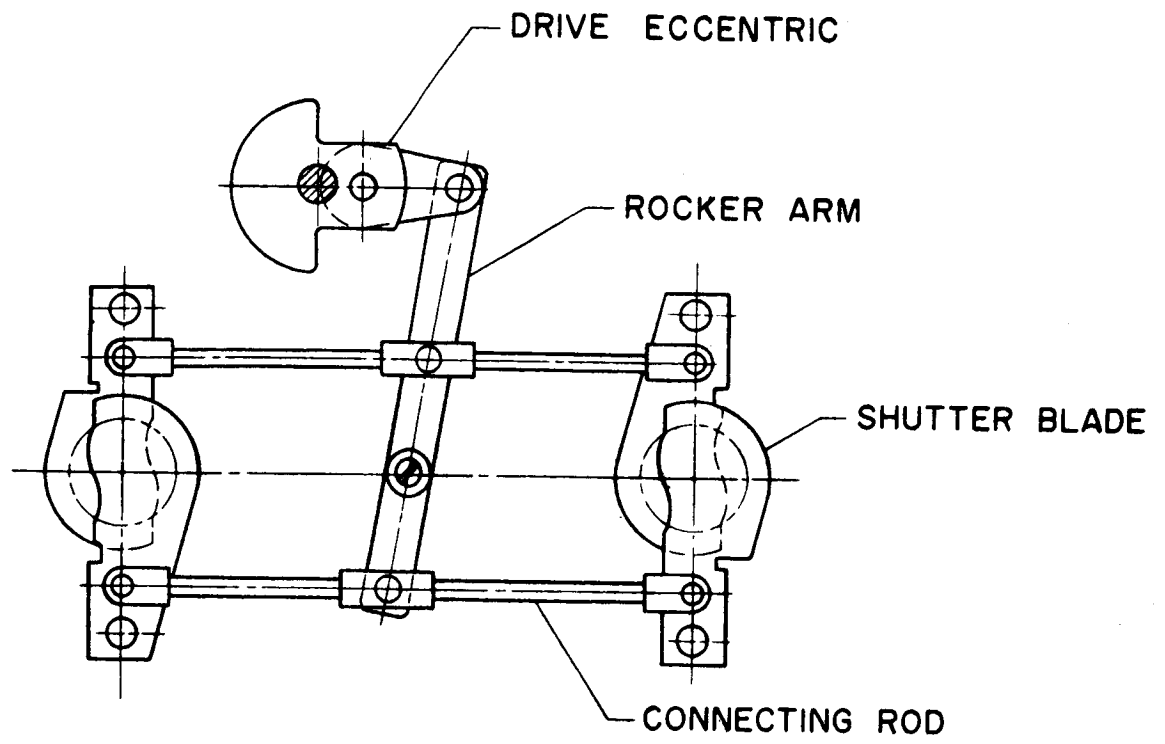

CLOSED

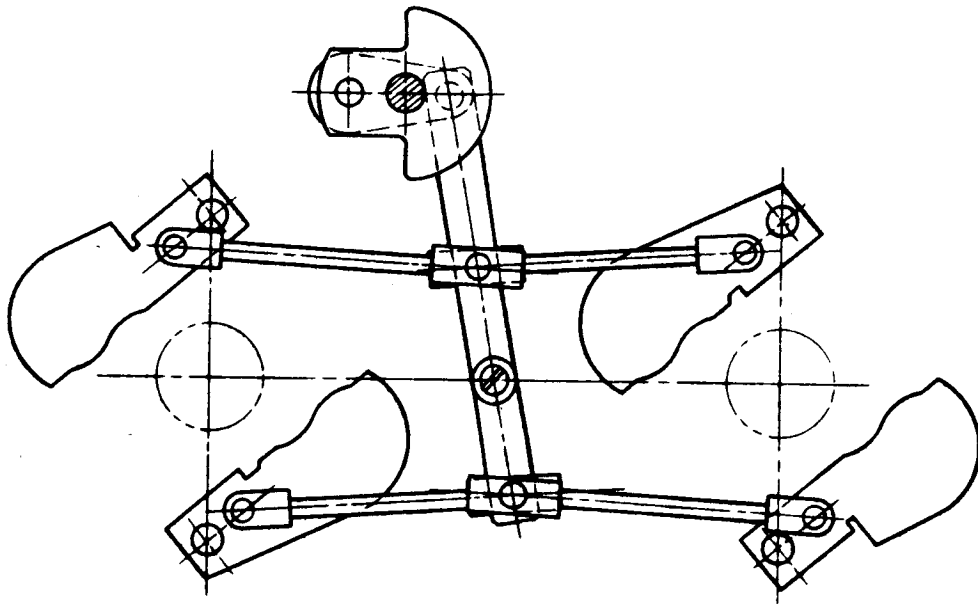

OPEN

OPTIMUM
SHUTTER

FIG. 18

VII EXPOSURE CONTROL

The photographic process is based on a change in opacity of a sensitized material by radiant energy. This change may be immediate but more frequently is a latent change which requires further processing, chemical or physical, to become real and permanent. To record information, it is necessary to match the amount of radiant energy to the sensitivity of the sensitized material. This matching process is exposure control. To develop an exposure control process for the hand held camera assumptions must be made on the sensitivity range of the emulsion to be used, data on the photometric properties of the lunar surface must be examined, weighted and converted into terms of incident flux at the entrance pupil of the camera and then a method of measuring and controlling this flux defined.

Exposure is defined as the total luminous energy sensitizing the film, and is given by:

$$E = I_t$$

where I = amount of light per unit area striking the film

t = time interval during which the film is subjected to I .

The relationship between the exposure and the density of the emulsion activated can be obtained by examining a $D \log E$ curve for the film used. The desired exposure is that which will cause the densities of the negative or print to be proportional



GOERZ OPTICAL COMPANY, INC.

to the corresponding brightness levels of the target photographed. In order for this condition to be fulfilled, the range of target brightness levels must be so related to the characteristics of the film, through proper exposure, that it corresponds to the linear portion of the $D \log E$ curve (i. e. toe to shoulder). The difference between the values of exposure at the toe and shoulder of the curve define the latitude of the film in use and in turn sets the acceptable scene brightness range.

To determine the levels of target brightness existing on the lunar surface, a model, Figure 19, was prepared to define the corresponding photometric function \varnothing based on the individual geometry of the illumination and viewing angles. The Jet Propulsion Laboratories¹ empirical formulation of the photometric function was used to compute the surface brightness for two extremes of lunar albedo values using the relationship²:

$$B_i = \frac{E_s}{\pi} \rho_i \varnothing$$

where E_s = solar constant of illumination

\varnothing = photometric function = $\varnothing(\alpha, \theta)$

$$\rho_i = \begin{cases} 0.05 & \text{Dark plains (maria)} \\ 0.16 & \text{Bright rays} \end{cases}$$

The results are shown in Table XII and are stated in terms of both luminosity and radiometric units. Using these values of

¹JPL Report No. 32-384

²ibid

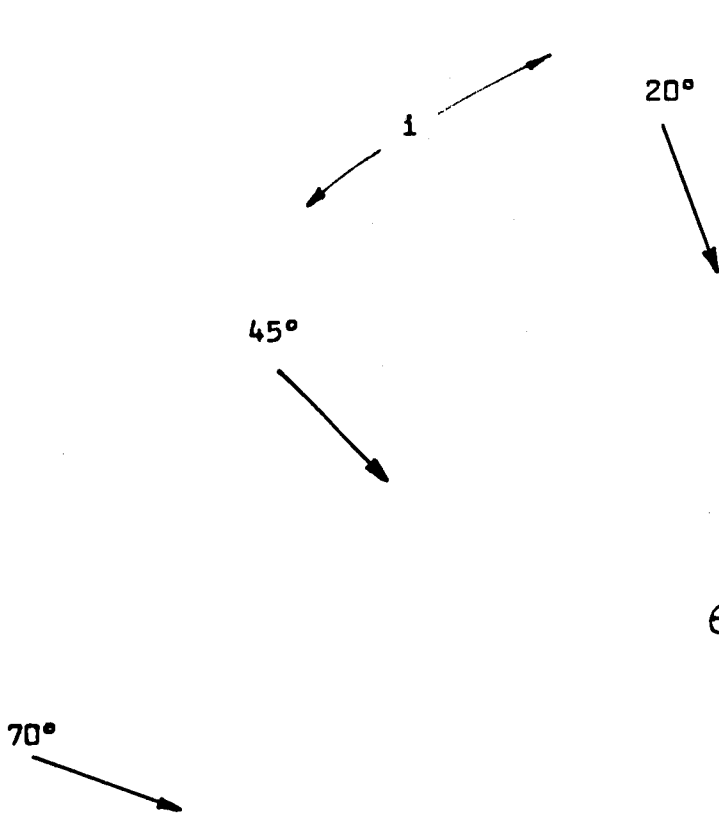

i = Incident solar illumination angles

ϵ = Viewing angles in 15° increments from the elementary area

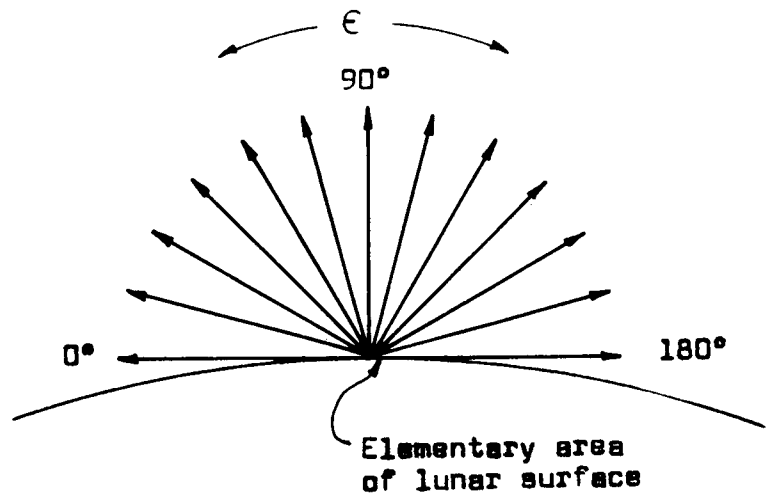

LUNAR ILLUMINATION AND VIEWING MODEL
FOR DETERMINATION OF THE PHOTOMETRIC

FUNCTION Φ

FIGURE 19



GOERZ OPTICAL COMPANY, INC.

target brightness levels, the proper exposure can be determined. As stated previously the exposure is the product of the light per unit area incident on the film and the time of exposure. Thus, to obtain the desired exposure one can vary either quantity or both. The camera design has incorporated a fixed exposure time of 1/100 second, thus allowing only a variation in I. The amount of light per unit area falling on the film is a function of the target brightness, transmittance of the optical system, and the aperture or stop. Since the target brightness for a given scene is fixed, only the transmittance and f - stop can be varied. The transmittance may be varied by the use of neutral density filters. The apertures may be varied by means of an iris diaphragm.

The film to be used in the camera being as yet unknown, commercially available films were used as a rough guide to determine exposure levels required and f - stops were calculated based on this data in conjunction with the brightness levels of the lunar surface previously calculated. One type, the Kodak Super-XX Aerographic Film was used as an ASA 100 guide, while for an ASA 1000 type, Kodak Royal-X Pan Recording Film was used. The amount of energy or exposure required for a given density above fog is determined from the mean spectral sensitivity of the film at that density. Sensitivity is defined as being the reciprocal of the exposure in ergs/cm^2 at a given wavelength.

$$S = \frac{1}{E} \text{ (at known } \lambda \text{)}$$

i SOLAR INCIDENCE ANGLE	ε VIEWING ANGLE	α PHASE ANGLE	θ PROJECTED E IN ED PLANE	φ PHOTO- METRIC FUNCTION	TARGET BRIGHTNESS				ASA 100 FILM	
					B _p	B _{p1}	B _{p2}	B _{p2}	f _{p1}	f _{p2}
					cd/cm ²	w/cm ² × 10 ⁹	cd/cm ²	w/cm ² × 10 ⁴		
0	0	90	-90	0.20	0.042	4.30	0.137	13.76	11.7	21.0
0	15	75	-75	0.25	0.053	5.38	0.171	17.20	13.1	23.4
0	30	60	-60	0.33	0.069	7.10	0.225	22.70	15.1	27.0
0	45	45	-45	0.41	0.086	8.82	0.280	28.21	16.7	30.2
0	60	30	-30	0.50	0.105	10.75	0.342	34.40	18.6	33.3
0	75	15	-15	0.67	0.141	14.41	0.458	46.10	21.5	38.5
0	90	0	0	1.00	0.213	21.50	0.683	68.80	26.2	47.0
0	105	15	-15	0.67	0.141	14.41	0.458	46.10	21.5	38.5
0	120	30	-30	0.50	0.105	10.75	0.342	34.40	18.6	33.3
0	135	45	-45	0.41	0.086	8.82	0.280	28.21	16.7	30.2
0	150	60	-60	0.33	0.069	7.10	0.225	22.70	15.1	27.0
0	165	75	-75	0.25	0.053	5.38	0.171	17.20	13.1	23.5
0	180	90	-90	0.20	0.042	4.30	0.137	13.76	11.7	21.0
20	0	70	-90	0.30	0.064	6.45	0.205	20.64	14.4	25.8
20	15	55	-75	0.38	0.080	8.17	0.259	26.14	16.2	29.0
20	30	40	-60	0.47	0.099	10.11	0.321	32.34	17.9	32.2
20	45	25	-45	0.60	0.126	12.90	0.410	41.28	20.4	36.4
20	60	10	-30	0.75	0.158	16.13	0.512	51.60	22.8	40.6
20	75	5	+15	0.80	0.168	17.20	0.546	55.04	23.6	42.0
20	90	20	0	0.55	0.116	11.83	0.376	37.84	19.5	34.7
20	105	35	-15	0.42	0.088	9.03	0.287	28.90	17.0	30.4
20	120	50	-30	0.35	0.074	7.53	0.239	24.08	15.5	27.9

1 of 3

LUMINOSITY OF THE LUNAR SURFACE AND
f-STOPS AS A FUNCTION OF TARGET BRIGHTNESS

TABLE XII

L SOLAR INCIDENCE ANGLE	ε VIEWING ANGLE	α PHASE ANGLE	θ PROJECTED ε IN EQ PLANE	φ PHOTO METRIC FUNCTION	TARGET BRIGHTNESS				ASA 100 FILM	
					B _{p1} cd/cm ²	B _{p1} μk/m ² × 10 ⁴	B _{p2} cd/cm ²	B _{p2} μk/m ² × 10 ⁴	f _{p1}	f _{p2}
0	0	0	0							
20	135	65	-45	0.30	0.064	6.45	0.205	20.64	14.4	25.8
20	150	80	-60	0.22	0.046	4.73	0.150	15.14	12.3	22.0
20	165	95	-75	0.18	0.038	3.87	0.123	12.38	10.9	20.0
20	180	110	-90	0.15	0.032	3.23	0.102	10.32	10.2	18.2
45	0	45	-90	0.55	0.116	11.83	0.376	37.84	19.5	34.7
45	15	30	-75	0.58	0.122	12.47	0.396	39.90	20.2	35.7
45	30	15	-60	0.73	0.153	15.70	0.499	50.22	22.2	40.8
45	45	0	-45	1.00	0.213	21.50	0.683	68.80	26.2	47.0
45	60	15	+30	0.52	0.109	11.18	0.355	35.78	19.0	33.9
45	75	30	+15	0.45	0.095	9.68	0.307	30.96	17.6	32.1
45	90	45	0	0.35	0.074	7.53	0.239	24.08	15.5	27.9
45	105	60	-15	0.25	0.053	5.38	0.171	17.20	13.1	23.4
45	120	75	-30	0.20	0.042	4.30	0.137	13.76	11.7	21.0
45	135	90	-45	0.17	0.036	3.66	0.116	11.70	10.8	19.4
45	150	105	-60	0.12	0.025	2.58	0.082	8.26	9.1	16.3
45	165	120	-75	0.10	0.021	2.15	0.068	6.88	8.4	14.9
45	180	135	-90	0.07	0.015	1.51	0.048	5.50	7.0	13.3
70	0	20	-90	0.70	0.147	15.05	0.478	48.16	22.0	39.2
70	15	5	-75	0.95	0.200	20.43	0.649	65.36	25.7	45.7
70	30	10	+60	0.40	0.084	8.60	0.273	27.52	16.7	29.8
70	45	25	+45	0.25	0.053	5.38	0.171	17.20	13.1	23.4

2 of 3

LUMINOSITY OF THE LUNAR SURFACE AND
f-STOPS AS A FUNCTION OF TARGET BRIGHTNESS

TABLE XII

i SOLAR INCIDENCE ANGLE	ε VIEWING ANGLE	α PHASE ANGLE	γ PROJECTED ε IN EQ PLANE	φ PHOTO- METRIC FUNCTION	TARGET BRIGHTNESS				ASA 100 FILM	
					B _p	B _{p1}	B _{p2}	B _{p2}	f _{p1}	f _{p2}
					cd/cm ²	μ/cm ² × 10 ⁴	cd/cm ²	μ/cm ² × 10 ⁴		
70	60	40	+30	0.20	0.042	4.30	0.137	13.76	11.7	21.0
70	75	55	+15	0.175	0.037	3.76	0.120	12.04	11.0	19.7
70	90	70	0	0.15	0.035	3.23	0.103	10.32	10.2	18.2
70	105	85	-15	0.10	0.021	2.15	0.068	6.88	8.4	14.9
70	120	100	-30	0.04	0.008	0.86	0.027	2.75	5.3	9.4
70	135	115	-45	0.05	0.011	1.08	0.034	3.44	5.9	10.7
70	150	130	-60	0.03	0.006	0.65	0.021	2.06	4.6	8.3
70	165	145	-75	0.02	0.004	0.43	0.014	1.38	3.7	6.8
70	180	160	-90	0.015	0.003	0.32	0.010	1.03	3.2	5.7

3 of 3

LUMINOSITY OF THE LUNAR SURFACE AND
f-STOPS AS A FUNCTION OF TARGET BRIGHTNESS

TABLE XII



GOERZ OPTICAL COMPANY, INC.

By taking the average sensitivity over the spectral range, the average exposure level for a given density is set, which in turn defines what f - stop is required to allow the necessary amount of target brightness (light) to sensitize the film to a constant film density. The f - stop is expressed in terms of the target brightness, film sensitivity, and shutter time by

$$f/\text{No.} = \left(\frac{1}{4} B \times 10^7 \times t \times T_o \times \frac{1}{E} \right)^{1/2}$$

where B = target brightness in w/cm^2

$$\frac{1}{E} = S = \text{film sensitivity in } (\text{ergs/cm}^2)^{-1} =$$

$$6.3 (\text{ergs/cm}^2)^{-1} \text{ for ASA 100}$$

$$26.2 (\text{ergs/cm}^2)^{-1} \text{ for ASA 1000}$$

t = exposure time in seconds

10^7 = conversion factor

T_o = optical transmission factor = 0.65

The values of f/stop for different target brightness levels calculated are shown in Table XII for the ASA 100 film. As a check the exposure ($\log E$) was computed with the known f/No. values in terms of luminosity units of target brightness. The f/No. values range from f/4.5 to f/47.

Since the ASA 1000 film is approximately 4 times as sensitive, a neutral density filter will be required to cut down the light level even further. This is required because a smaller aperture would reduce the diffraction limited resolution below an acceptable value. In the Type III camera a neutral density coating can be

applied to the field flatteners in front of the ASA 1000 film. A transmission factor of 0.228 would allow the ASA 1000 film to operate over the same range of f/Nos. as the ASA 100 film.

A. REQUIREMENTS

Auxiliary lighting may be required either to supplement the natural lighting or to reduce the scene brilliance range to that of the latitude of the film. With moderately fast films and lenses, natural light will be adequate for all exposures on the sunlit side of the moon with the exception of extreme close-ups where the astronaut or camera may cast a shadow on the area to be photographed.

On the dark side of the moon, if a large number, such as 300, exposures are to be made the weight will be minimized if a camera support is provided and earth shine is used as the illuminant. Regardless of the number of exposures, a higher reliability will result from the use of a camera support and long exposure times. If a camera is to be designed for use only on the dark side of the moon, the ultraviolet requirement should be eliminated and a much faster lens provided. Trade-off data for the design of a compromise camera or the design of separate cameras for earth shine and sunshine has been deferred because discussions with NASA personnel have shown that the probability of landing on the dark side of the moon during the first few missions is practically zero.



GOERZ OPTICAL COMPANY, INC.

The serious problem in lunar photography is the extreme scene brilliance range. If the surface of the moon is covered by a layer of loosely compacted dust with inter-connected voids, the cavities will act as nearly perfect light traps and the micro structure will appear as black bodies with the temperature of the surface of the moon. The scene brilliance range will be infinite in the visible spectral range and no reasonable amount of auxiliary light will reduce it. These cavities are expected to be small compared to the object space resolution of the camera except for extreme close-ups. In the typical scene, containing areas directly illuminated by the sun and shadow areas filled in by light scattered from the lunar surface, the scene brilliance range is expected to be approximately 10^4 . If the film has a latitude of 10^8 , no auxiliary lighting nor exposure control will be required. If the film latitude is 10^4 , exposure control will allow photography without auxiliary lighting. If the latitude is 10^2 , a typical value for black and white film, the scene brilliance range can be covered by making two exposures with a reduction in lens transmission by a factor of 100 between the shadow photograph and the highlight photograph. Single prints could be made by laboratory contrast compression. The more conventional solution is to supply sufficient fill-in lighting to bring the shadow brightness up to within 1% of the highlight brightness. In order to achieve this level of illumination, it is necessary that the artificial light source be such that at the shadow the product of its brightness and the angle sub-

tended in steradians is equal to 1% of the product of the brightness of the sun and the angle subtended by the sun at the highlight. Unless the spectral sensitivity of the film is constant a normalizing factor will be required to relate the spectral sensitivity of the film to sunlight to that of the film to the artificial light. This reasoning leads to the immediate consequence that the amount of artificial light required will vary directly as the square of the distance of the source assumed to be at the camera, from the shadow. A second result is that photography on the dark side of the moon would be much easier in this respect in that the required fill-in light would be scaled to the brightness of earth rather than the sun. If the latitude of the film is that of commercial color film, approximately 50, twice as much fill-in light will be required or with a given light source the range of fill-in would be reduced to 70%.

For the extreme close-ups, where a camera support will be required, only small amounts of light will be required. The choice of type of light source should be based on the weight and volume consideration.

B. TYPES OF LIGHT SOURCES

Rather than set an arbitrary latitude, distance, and number of exposures and then calculate light source requirements, light sources of different types that could be packaged within approximate size and weight limitations were examined to



GOERZ OPTICAL COMPANY, INC.

determine the maximum illumination level as a function of distance and the number of exposures possible without recharging the batteries. With this information, it is possible to relate the distance range to the latitude of the film. The basic types of light sources to be considered are chemical flash, continuous incandescent, pulsed incandescent and gas discharge flash. The chemical flash was not investigated. A preliminary examination showed that the power penalty for continuous incandescent would rapidly pay for shutter complications that would allow the use of a pulsed source. The pulsed incandescent and gas discharge flash were investigated in more detail.

B.1 PULSED INCANDESCENT SOURCES

The characteristics of possible incandescent sources were derived from typical values of space rated batteries and current practice in the manufacture of spotlight reflector and lens combinations and low voltage airport lamps. Conservative assumptions were made on beaming efficiency and only slight overrating of continuous values for lamp filaments was assumed for pulse operation. Optimizing the battery configuration could probably achieve a weight saving of 25% to 30%. Optimizing the lamp could possibly increase the range by a like amount.

The lamp was assumed to have four filaments, each having dimensions of 3mm x 10mm x .25mm. The volume of the combined

filaments would then be 0.03 cm^3 . The density of tungsten is 19.3 grams per cubic centimeter. The specific heat of tungsten is 0.04 calories per gram per degree centigrade. An operating temperature of 3200°K will require a temperature rise of 2900°C . Thus, the energy required to heat the filaments is 70 calories or approximately 300 joules.

The area of the combined filaments is 2.6 cm^2 . If it is assumed that half of the filaments are at 3200°K , the balance of the heat going into supports, and that half of the emitted light reaches the target the effective area will be 1.3 cm^2 and the effective brightness 1055 candles per cm^2 . The illumination of the target will be equal to the effective brightness of the filament times the ratio of the source area to the target area.

$$I_T = B_s A_s / A_t$$

With 230 candles per square foot highlight illumination and a film latitude of 100, the required target illumination is 2.3 candles per square foot. Substitution of these values in the equation for target illumination and solving for target area gives an area of $11.1 \times 10^5 \text{ cm}^2$. If the illuminated area is assumed to be a circle, the radius will be 19.6 feet. Assuming a half angle of 14° for the beam, the target distance is 78.5 feet.

The radiant power for tungsten at 3200°K is 203 watts per square centimeter or 264 watts for the chosen filaments. If



GOERZ OPTICAL COMPANY, INC.

a pulse length of 0.2 seconds is assumed, the radiant energy per pulse will be 53 watts seconds. Adding the heating energy gives a lamp energy requirement of 353 watt seconds. Assuming a 50% efficiency in switching and transmitting power to the lamp gives a total energy per pulse requirement of 700 watt seconds. A 28 volt battery rated at 35 ampere minutes is available which weighs 16.2 oz. and requires a volume of 14.4 in³. The energy storage of this battery is 6.26×10^4 watt seconds. Thus, it could provide energy for approximately 90 light pulses before requiring recharging.

The total weight of this system could be kept under two pounds, and the volume under 70 cubic inches.

B.2 GAS DISCHARGE FLASH SOURCES

A one watt-second Xenon gas discharge source was examined in conjunction with the aplanatic reflector. It is assumed that the reflector and light source would be mounted with the camera rather than away from it. This would provide maximum shadow fill-in light, since positioning the source at a distance from the camera produces a different illumination viewing condition thereby increasing or forming new shadows.

For lightly loaded flash tubes filled with Xenon, 5% of the stored energy is converted into visible light. Thus, for a flash duration of 25 μ -seconds, a reflector efficiency of 60%, and 75% reflectivity, 900 watts of luminous energy is available

from a 1 watt-sec. source. The beam dispersion angle of the reflector is approximately 30° for the Type I camera, when the target to be illuminated is at 20 feet, the target area is

$$A = (2 \times 20 \tan 15^\circ)^2 = 116 \text{ ft}^2 = 930 \times 116 = 10^5 \text{ cm}^2.$$

The amount of illumination on the target is therefore 9×10^{-3} W/cm². From the relationship

$$B = \frac{E_{\text{source}}}{\pi} \int \phi$$

the target brightness for an albedo factor of 0.05 is about 0.14 mw/cm². The photometric function ϕ is unity since the illumination and viewing are in the same line. Thus for a highlight brightness of 6.88 mw/cm², the one watt-second source provides about 2% of that quantity for shadow fill-in light. The particular flash tube under consideration is a U shaped tube one inch high, providing a continuous spectral output from 3000Å° to 8000Å°, at a color temperature of 65000°K.

The power for the tube is stored by means of a capacitor. For an anode voltage of 600v DC the capacitor value is found by the relationship

$$W = 1/2 CV^2$$

to be approximately 6μfd. This capacitor will weigh about 1 ounce and require a volume of 1 1/4 cubic inches. The supply voltage of 600V DC will be produced by a 6V battery and a transistorized inverter. The complete electronics for powering the flash tube is shown in Figure 20. The AC voltage obtained from the inverter is increased by transformer T1 by a factor of

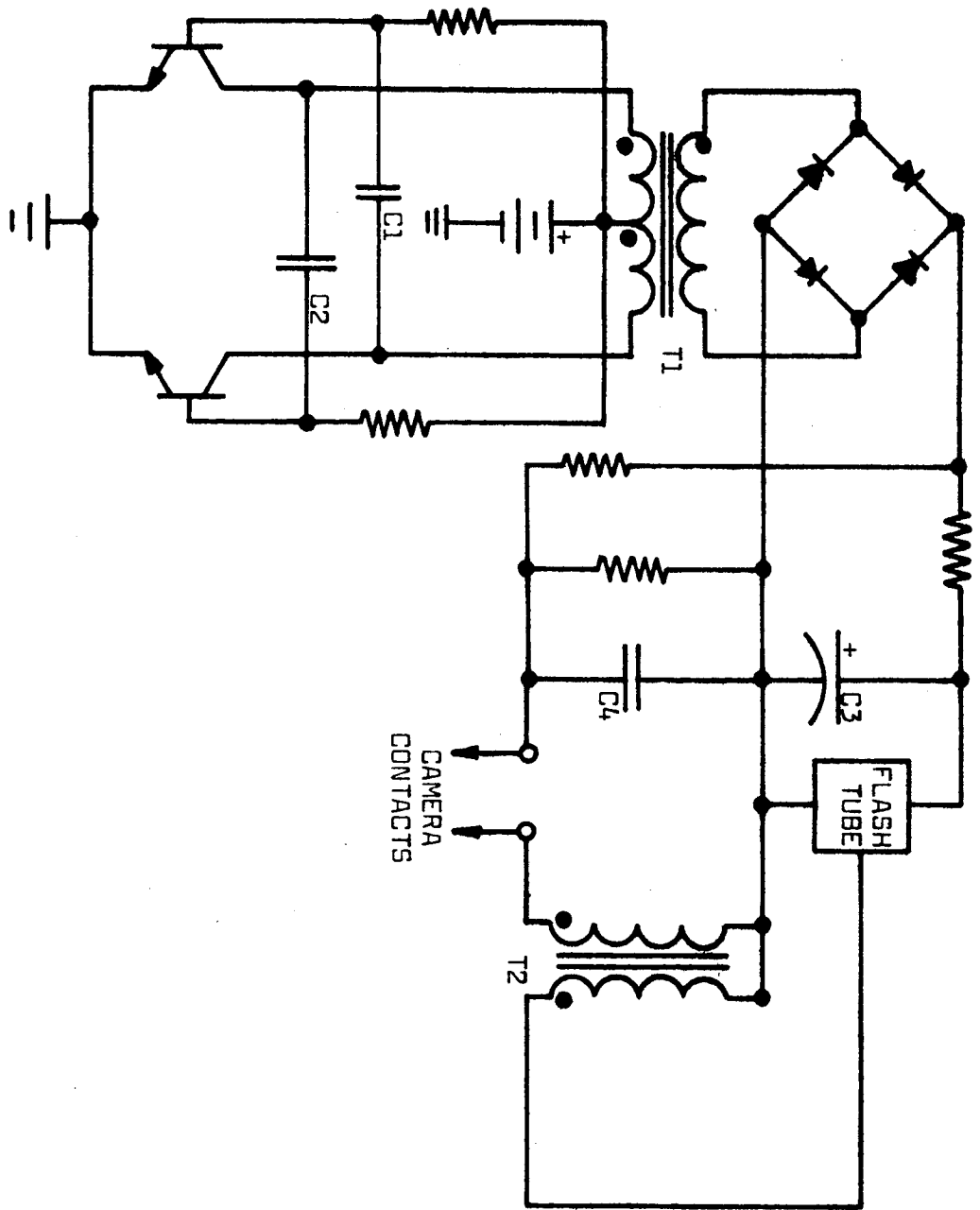

GAS DISCHARGE SCHEMATIC

FIGURE 20

50 to the required 600V level and rectified by a full wave bridge. The filtering action is accomplished by the energy storage capacitor. The selected tube requires a 4 KV trigger pulse. This is produced by discharging capacitor C_4 through the trigger transformer.

The circuit as shown in Figure 20 including the 6V battery takes up 7in³ and weighs about 6.5 oz. As mentioned previously the battery supply would power both the exposure control system and the auxiliary lighting for 1000 photographs when operated under worst case conditions, which is more than the anticipated number of 300 photographs. The lamp and reflector will be mounted between the lenses. The other components will be positioned as internal space permits.

The illumination required with the close focus attachment is provided by the same lamp and reflector. The additional requirements are a diffuser and an attenuator. These requirements can be met by a single piece of opal glass with proper surface treatment. In the case of the Type I camera a single unit is required. The camera Types III and IV will require two levels of attenuation, one for the 1:7 magnification and one for 1:1 magnification.

C. AUTOMATIC EXPOSURE CONTROL

Photographic exposure control methods are adopted to requirements of subject matter and results. Good quality outdoor pictures may be obtained by reading the directions supplied



GOERZ OPTICAL COMPANY, INC.

with the film and judging whether the day is bright or hazy. Amateur cine-cameras and some miniature still cameras introduced in the last few years incorporate a simple photometer and exposure controlling device. In these cameras the photometer measures average brightness over a large angular field and sets the exposure to place the average brightness near the center of the linear position of the $D \log E$ curve of the film. No adjustment is provided to adopt the control system to films of different latitudes. The serious photographer, striving for the highest quality, measures the brightness of shadows, highlights and area of greatest interest and compares the scene brightness range to the latitude of the film and the range of densities available in the final picture material either print paper or positive transparency and adopts the photographic process accordingly. The dynamic range of the photographic process can be controlled over a wide range by selection of exposure times and type of developer and amount of development of the latent image.

The control process recommended for the lunar camera is a compromise between the last two methods. The control mechanism consists of a narrow angle photometer and an iris diaphragm setting mechanism. The photometer measures the brightness over a 5° angle. Two modes of operation are provided. In the first mode a meter indication of brightness is displayed in the viewfinder. In the second mode the diaphragm setting mechanism adjusts the diaphragm to give proper exposure of the 5° area

centered in the viewfinder. Should the brightness of this object be out of the range of diaphragm adjustment, the meter will indicate the amount of error signal at the servo proportional to the latitude of the selected film. If the meter reading is at the center of the scale the operator will know that the object of interest will be exposed so as to fall at the center of the $D \log E$ curve of the film used. If the meter is pegged at either extreme the operator will know that a satisfactory exposure is impossible with natural light from that location. Too much illumination is only likely to occur because of a specular reflection and a small change in angle will reduce this value into the useable range. If the natural illumination is insufficient the operator will know that he must be within the range of the auxiliary flash lamp to obtain satisfactory illumination. The switch will be spring loaded so that when exposure control is not required the circuit will be de-energized.

The control mechanism is shown in Figure 21. Light from the 5° field is collected by an $f/3.0$ lens and imaged on a field stop.

The iris diaphragm of the photometer lens is mechanically coupled to the diaphragms of the two camera lenses so that the amount of light falling on the photocell is proportional to the amount of light reaching the film planes. The voltage across the photocell load resistor is compared with a reference voltage to derive an error signal which is amplified and used

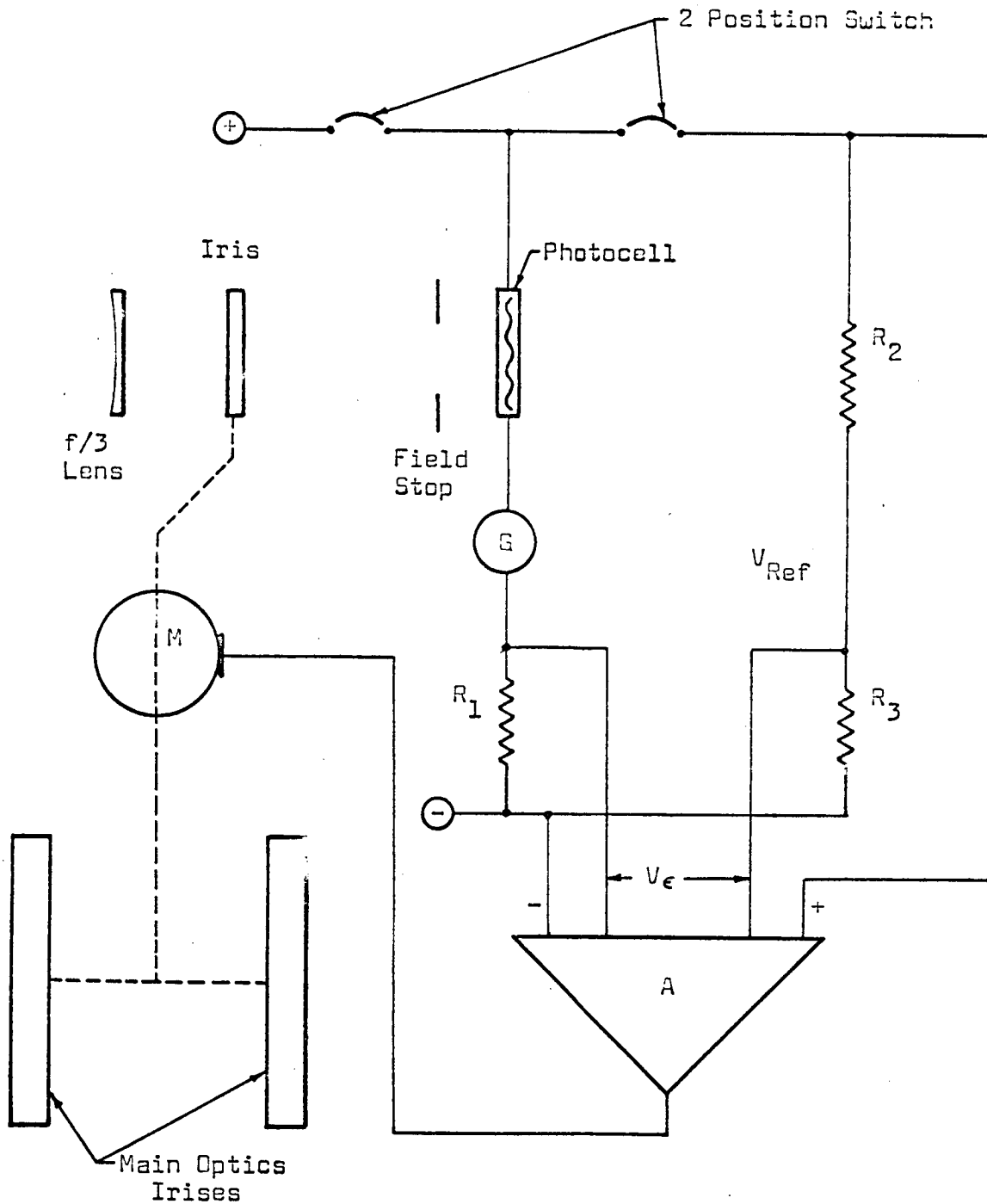

M = Inland DC Torque Motor special version of Model No. T-0709
 Dimensions: 1-1/8" diameter x 3/8" long, weight 1.1 oz.

A = Special designed amplifier and sensing circuits
 Dimensions: Volume 1 In³, Weight 1 oz.

Photocell = Clairex Cds Cell, No. CL605, Dimensions: 0.25 dia. x 0.50 long.

Supply = Main battery 6 V. DC housed with flash unit
 4 cells, each 1.5 V. Nominal with 35 amp - minutes capacity
 Eagle Picher Silver Zinc "A" Cells, Type No. 485
 Cell Dimensions: Volume 0.8 In³, Weight 0.9 oz.

AUTOMATIC EXPOSURE CONTROL

FIGURE NO. 21

to drive the torque motor which repositions the iris diaphragms to produce a null.

A cadmium sulphide photoresistive cell is recommended as the sensing device because it has a higher quantum efficiency than photovoltaic cells and being photoresistive, the voltage change across the load resistor will follow the reference voltage as the supply voltage changes.

A DC torque motor is preferable to small high speed DC motors because the required torque can be developed by a single stage of reduction gearing. The motor selected is 3/8 inch in diameter, 1 1/8 inches long, weighs 1.1 ounce and develops a one inch torque at 1.2 watts. This power is developed when 2 volts is applied.

The amplifier and voltage dividers can be packaged in one cubic inch and will weigh one ounce. A battery rated at six volts and 35 ampere minutes, which weighs 3.6 ounces and requires 3.2 cubic inches will power the exposure control system for over 1000 operations.

VIII TIME RECORDING

A method of recording the time of each photographic exposure is required. Accuracy of timing was not originally specified. In the discussions following the midterm report it was agreed that 1 second resolution and ± 1 second per day accuracy, by calibration after landing on the moon was readily attainable



GOERZ OPTICAL COMPANY, INC.

and sufficient for the requirements. Three methods of generating and recording time of exposure have been investigated: all electronic, electromechanical with electroluminescent display and electromechanical with optical projection of dials.

A. ELECTRONIC METHODS OF GENERATING TIME

All of the electronic methods of generating time which were investigated use a crystal as the basic timing element. The differences in the three methods lie in the means of counting down from the crystal frequency to the least significant increment to be recorded, and in counting and storing these time increments. In each system, the least significant time increment is one second. The investigation started with the assumption that a one megacycle crystal would be used because of its small size and low driving power requirements. As the investigation progressed and a minimum size and power requirements became known, it became apparent that the increased size, weight, and power of a crystal with a frequency of around 100 KC would be more than saved by the reduction in required logic elements. The comparison of crystal parameters is shown in Table XIII.

CRYSTAL PARAMETERS

	One Megacycle	One Hundred Kilocycle
Size	0.4 cu. in.	0.6 cu. in.
Weight	2 oz.	3 oz.
Stability	60 ppm @ 55 to 125°C	60 ppm
Input Power	3 volts - 100 milliwatts	3 volts - 100 milliwatts

TABLE XIII

The oscillator would not be an integrated unit due to the size of the crystal, but rather a hybrid where the crystal is external to an integrated amplifier. A block diagram of the electronic methods of elapsed time recording is shown in Figure 22.

The three electronic means of counting described below are based on micrologic elements built by CBS Laboratories, which to date seem to be the most promising in terms of power requirements.

A.1 SYNCHRONOUS DIRECT COUPLED TRANSISTOR LOGIC

This method employs decade countdown. Since a 100 KC source is desirable as a clock source, five decades would be required to countdown to 1 pps and seven decades would be used for counting the elapsed time. The counter capability would be 10^7 seconds which is about the length of the mission. A typical decade is shown in Figure 23. The entire count circuitry would consume 27.6 mW of power or 2.3 mW per decade, using available state of the art micrologic blocks. The only limitation of this method is that the master clock pulses from the oscillator have to be shaped to the proper mark to space ratio so that no logic is carried out at any time other than at the initiation of a clock pulse. This requires additional circuitry at the output of the oscillator to achieve the desired input to the count circuitry. All the micrologic blocks are 0.012 oz. and 0.011 in³. The dimensions of a decade would be 0.144 oz. and 0.132 in³.

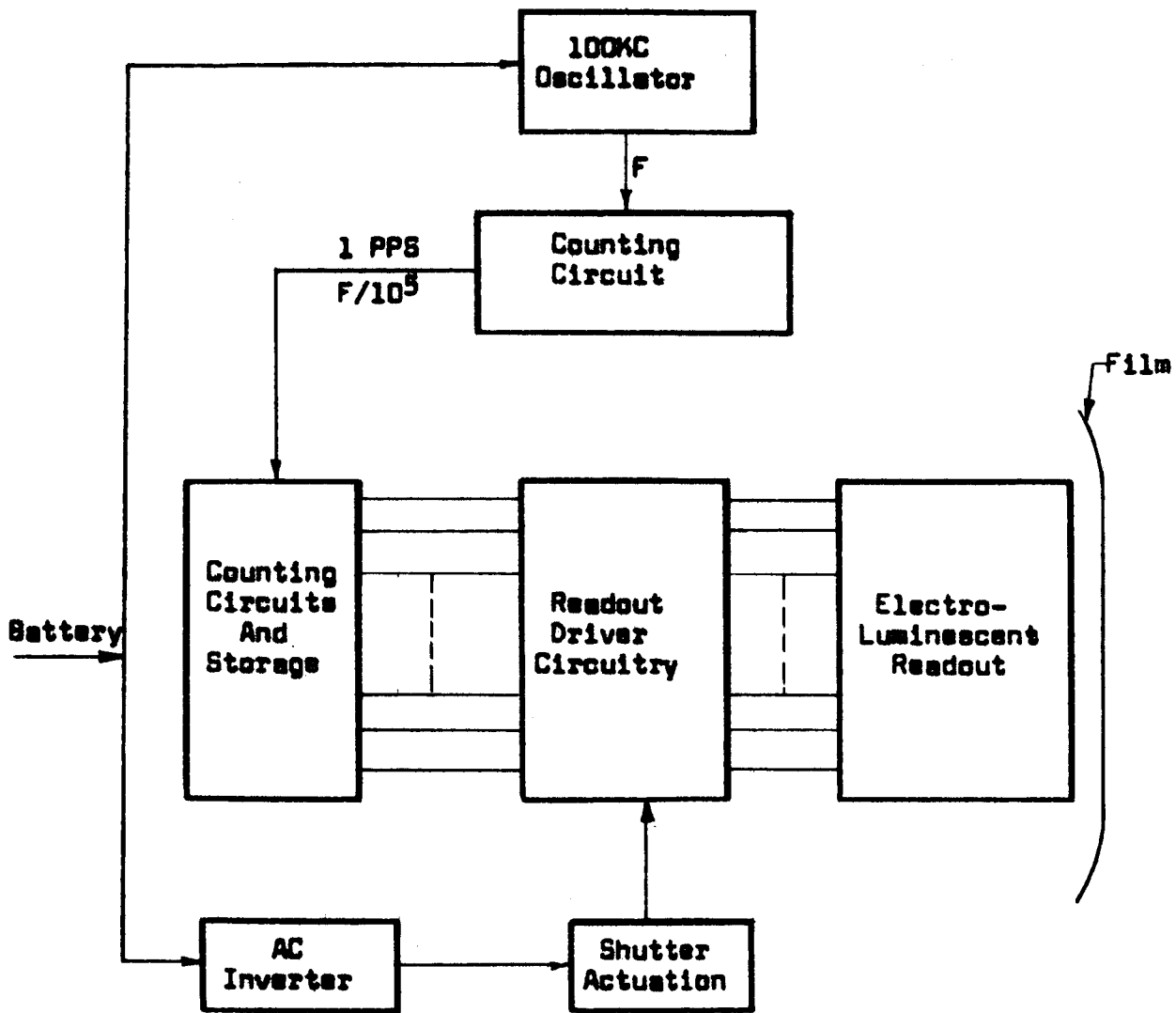

BLOCK DIAGRAM
ELECTRONIC TIME RECORDING

FIGURE 22

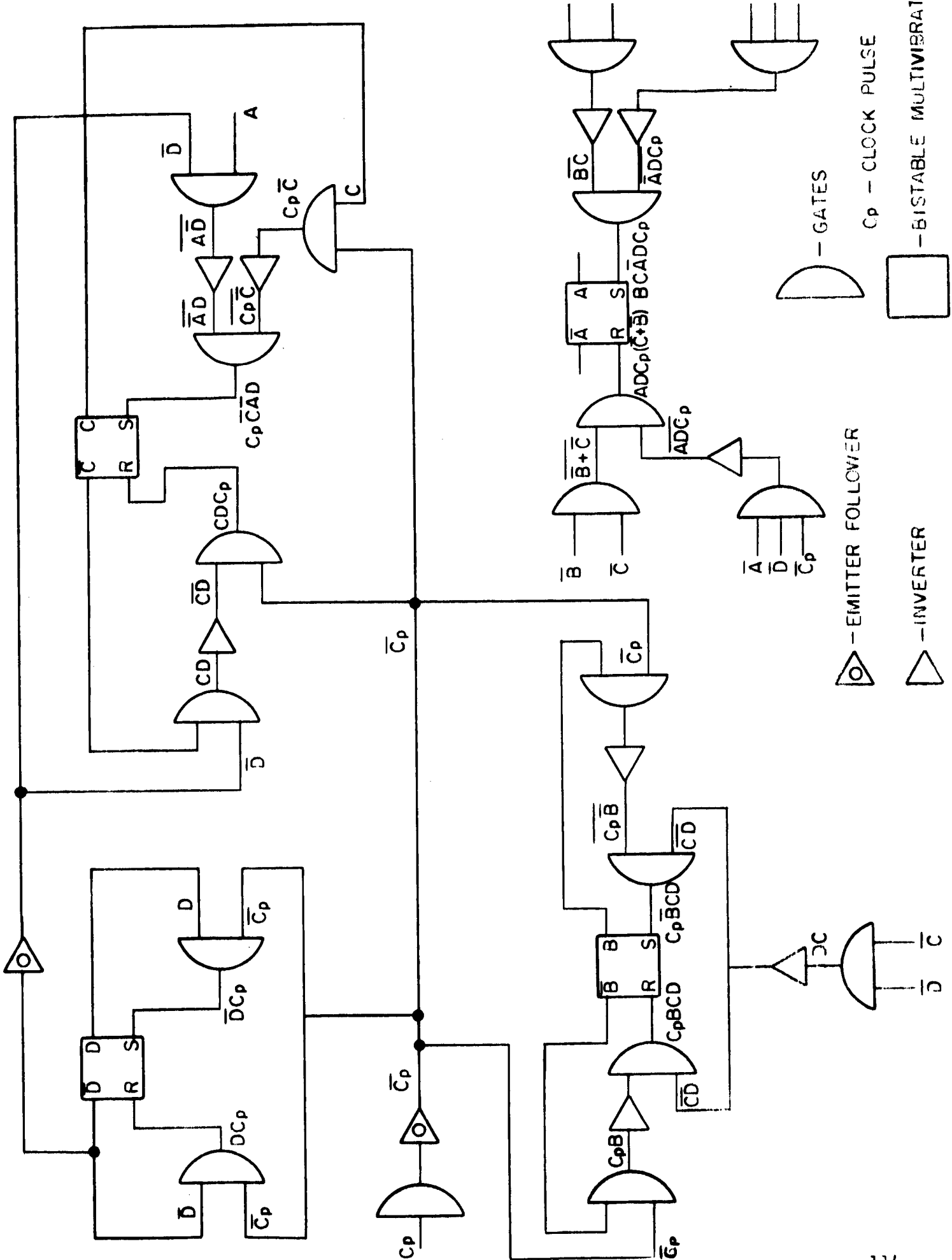

SYNCHRONOUS DIRECT COUPLED TRANSISTOR LOGIC
 FIGURE 23



GOERZ OPTICAL COMPANY, INC.

Since a total of 12 decades are required, the size and weight for the counter and oscillator would be 3.0 in^3 and 5.5 oz.

A.2 MASTER-SLAVE BINARY LOGIC

If the clock source were a binary multiple, a straight binary counting scheme could be used. Using a 128 KC crystal (to remain in the 100 KC range) a total of 17 master-slave binary stages will count down to 1 pps and 20 stages will count and store elapsed time. The master-slave binary configuration is shown in Figure 24. Each stage requires two bistable multi-vibrators and one inverter. The power consumption per binary stage is $420 \mu\text{W}$ or 15.5 mW for the whole counter. A total of 74 multi-vibrator modules and 13 inverter modules (each containing three inverters) are needed. When combined with the oscillator, the dimensions of the circuit are 4 oz and 1.6 in^3 . This scheme would not require any additional shaping or compensating networks.

A.3 BI-QUINARY SHIFT REGISTER

A shift register composed of the master slave binaries is also a possible means of performing the countdown, but for the count-up a straight binary configuration is still needed. Each shift register stage would contain five master-slave units, the output of the register fed back on itself. Since each shift register only drops the input clock frequency by 1/10, a total of five shift register stages would be needed to produce the 1 pps for countdown purposes. After each register stage, a

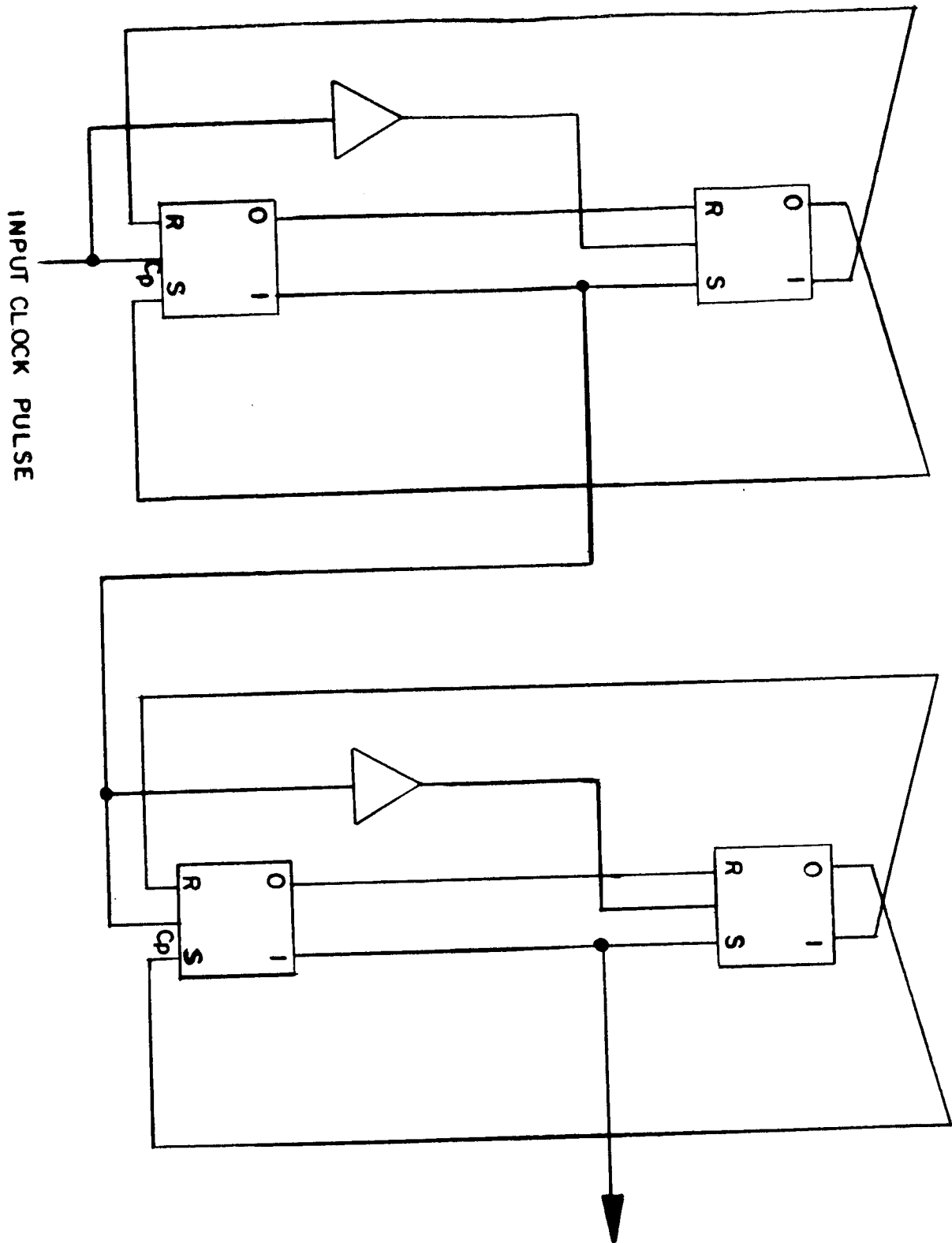

MASTER-SLAVE BINARY LOGIC

FIGURE 24



GOERZ OPTICAL COMPANY, INC.

gate is needed to act as a clock for the next stage. Thus, a total of 25 master-slave units and 5 gates are required for the countdown alone. This portion of the circuit alone consumes nearly as much power and space as the straight binary and consequently this approach was set aside.

B. ELECTRONIC DISPLAY

The electronic timing method requires a display to expose the film and gating circuits to activate the display at the time of exposure. For the display, an electroluminescent panel consisting of bit and bar matrix, made by Sylvania, was considered. When all bits and bars are energized, the total power consumption is 5 mW. The dimensions of the panel display area is 0.625 in. by 0.06 in. which would allow placing the panel on the focal plane for photographing it. It requires 250 V at 400 CPS to activate the phosphor. The light output is 10 foot lamberts. This voltage could be derived from an inverter as described for the gas discharge tube supply for artificial illumination. The gating or actuation of the electroluminescent panel could be achieved by seriesing each bit with a silicon controlled rectifier, and gating the SCR's (which can be matrixed on a semiconductor chip), by the existing signals from the counter stages at the initiation of the camera shutter. A simpler method would be to use the shutter action to activate a switch to supply or remove power from the 250 V source to the anodes of the SCR's. Figure 25 demonstrates this principle. The estimated power during each exposure is approximately 200 mW

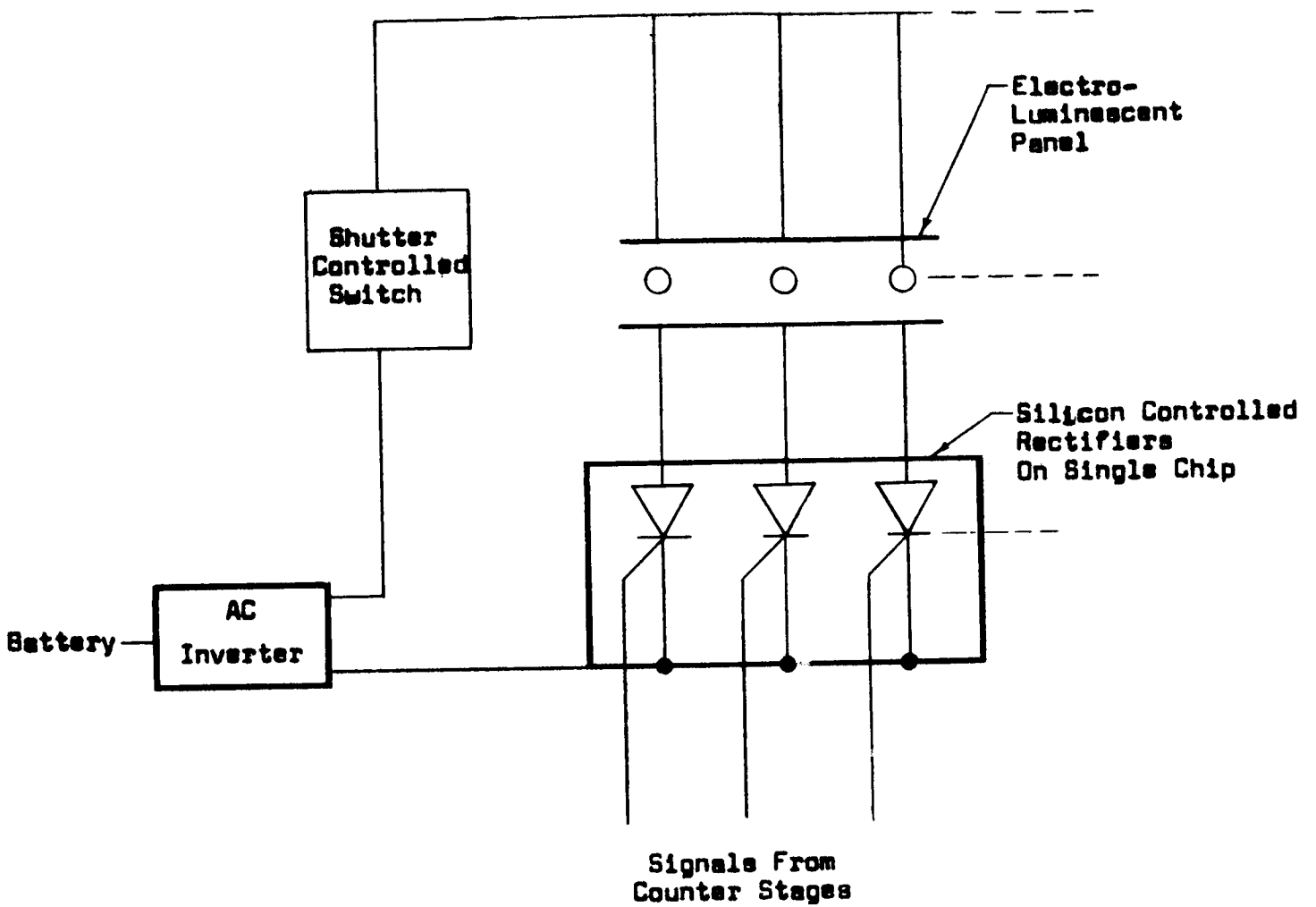

ELECTROLUMINESCENT DISPLAY LOGIC

FIGURE 25



GOERZ OPTICAL COMPANY, INC.

due to the holding current of the SCR's.

C. ELECTRO-MECHANICAL TIME GENERATION

The possibility of using an Accutron movement made by the Bulova Watch Company was also investigated. An attractive feature of the Accutron is that it is self-powered and needs no external source. There are two ways of using the Accutron for time recording. The method of timing in both cases would be by the Accutron movement, but the display would differ. A straightforward calendar watch could be used with a lens to project its reduced image onto the film. During each camera exposure the face would be illuminated by a small light source. The watch is contained in a 1-5/16" square, one inch thick and weighs 1.5 ounces. The light, optics and watch could then be housed in a self-contained unit. The Accutron can be supplied with printed circuit commutator modules for days, hours and minutes which provides a digital output for driving a gating module and electroluminescent panel as described above. The dimensions of this type of timing unit are 1-5/16" square by 2-1/2"; the weight is 2.5 ounces. Although this system requires no optics for recording the data on the film, a power supply is required to produce 250 V and the gating mechanism.

Considering weight, power and simplicity, the Accutron timer with optical projection of the dial onto the film appears to be superior to both the all electronic methods and to the hybrid system of Accutron timer and electroluminescent display.

IX TEMPERATURE CONTROL

The internal temperature of the camera must be maintained within the range of 0 - 25°C. Higher temperatures will cause fogging of the film, particularly emulsions sensitive to the near infrared. The lower temperature limit is determined by loss of sensitivity of the emulsion and possibly embrittlement of the film base. A preliminary analysis shows that this temperature may be maintained by providing proper surface treatment of the outside shell. This treatment must be optimized for the predicted landing point. To allow for occasional shading of the camera by the astronaut or terrain features, it will be necessary to provide a layer of thermal insulation between the outer shell and the camera proper.

In order for the camera to come to an equilibrium temperature, the total radiant heat input must equal the heat lost through radiation, q_t .

$$q_t = q_s + q_e + q_r + q_i$$

q_s = heat input from direct solar radiation

q_e = heat input from radiation from the lunar surface

q_r = heat input from solar radiation reflected from the surface of the moon

q_i = internal heat dissipation - this term is so small compared to other terms that it may be ignored

The heat inputs may be calculated from the following relationships:



GOERZ OPTICAL COMPANY, INC.

$$q_s = K \sum_s \alpha_s (A_p)_s$$

$$q_e = E_m \sigma (T_{ss} \cos \delta)^2 \sum_i \epsilon_i A_i F_i$$

$$q_r = K_p \cos \delta \sum_s \alpha_s A_s F_s$$

where the quantities required for the calculation are defined as follows:

K = solar radiation constant = 2 cal/min/cm²

α_s = Absorptivity of surface for solar radiation

$(A_p)_s$ = Projected area exposed to sun

E_m = Emittance of lunar surface = 0.93

σ = Stefan-Boltzmann Constant = 8.12 x 10⁻¹¹ cal/min/cm²/°K⁴

T_{ss} = Lunar surface temperature at the subsolar point = 389°K

δ = Solar illumination angle

$A_i = A_s$ = Surface area exposed to lunar surface

F_i = Configuration factor = 1/2 (1 + Cos θ)

θ = Angle between surface under consideration and lunar surface

ϵ_i = Total emittance of the control coating

ρ = Mean lunar a/bedo = 0.073

T = Temperature in °K

The Type I camera dimensions are 5" x 8" x 12". This corresponds to front and back areas of 387 cm², two side areas of 258 cm², and top and bottom areas of 619 cm². During normal camera operation, the back of the camera will be exposed to the astronaut's space suit. Since the thermal characteristics of the suit are unknown, the thermal evaluation was based on the back of the camera being

exposed to the lunar surface. The camera was treated only as a box with no consideration given to extrusions, lenses, levers, knobs, etc. In order for the camera to operate both in direct sunlight and in shade, the major contribution to the heat input should be from the lunar surface, so that a large differential in total heat input is not caused by a change from sunlight to shade. This requires that the top of the camera, and possibly one or two other areas, have fairly small $\frac{\alpha_s}{\epsilon}$ ratios, while those camera surfaces usually exposed to the lunar surface must have comparable larger ratios.

Two control coatings were considered for the Type I camera:

	α_s	ϵ
Polished nickel on steel	.15	.15
White paint on steel	.10	.85

For the sunlight situation, the top and front of the camera were considered to be exposed to incident solar radiation and coated with the white paint, the remaining sides being the polished nickel. The data in Table XIV shows the total heat input based on this configuration for various values of δ . In this table, the equilibrium temperatures the camera reaches, due to these total heat inputs, is also shown. The total heat input to the camera must equal the total heat radiated from the camera in order that an equilibrium temperature be reached. This is expressed



GOERZ OPTICAL COMPANY, INC.

by:

$$q_t = \sigma T^4 \sum_i \epsilon_i A_i$$

and

$$T = \left[\frac{q_t}{\sigma \sum_i \epsilon_i A_i} \right]^{1/4} \quad \text{In } ^\circ\text{K}$$

Figure 25 shows the relationship between the camera position on the moon as given by the solar illumination angle δ , and the temperature reached both in sunlight and shade at this position. This gives an optimum lunar surface interval of operation as set by the limits $0^\circ\text{C} - 25^\circ\text{C}$ for both sunlight and shade. If the top and bottom were not coated with the white paint and the remaining sides with polished nickel, a new optimum lunar surface interval is set. This configuration allows the camera to be safely operated in sunlight and shade near the terminator. The results are shown in Table XIV and Figures 26 and 27. Thus, knowing the approximate landing and operating area on the moon, the proper configuration of coatings may be used to insure that the temperature will be maintained within the specified limits.

An investigation was also carried out to see what length of time the camera could be kept in a situation where the equilibrium temperature would be a value outside the $0^\circ\text{C} - 25^\circ\text{C}$ range. That is, for example, if the camera were at a steady state temperature at either 0°C or 25°C and it was exposed to a condition where the temperature would tend to stabilize at some value outside the opposite limit. Three cases were considered. In each, the camera

γ	α_{TOP}	α_{FRONT}	α_{BOTM}	α_{BACK}	α_{SIDE}	ϵ_{TOP}	ϵ_{FRONT}	ϵ_{BOTM}	ϵ_{BACK}	ϵ_{SIDE}	ϵ_{SIDE}	g_s	g_2	g_2	g_T	$\sigma \sum \epsilon_i A_i$	T_{SUN}	T_{SHADE}
$^{\circ}$												CAL/MIN	CAL/MIN	CAL/MIN	CAL/MIN	$\times 10^{-8}$	$^{\circ}C$	$^{\circ}C$
20	.10	.10	.15	.15	.15	.85	.85	.15	.15	.15	.15	143	540	26	709	8.76	26	7
30	"	"	"	"	"	"	"	"	"	"	"	145	491	24	660	"	22	1
40	"	"	"	"	"	"	"	"	"	"	"	144	435	22	601	"	15	-7
50	"	"	"	"	"	"	"	"	"	"	"	140	367	18	525	"	5.5	-18
60	"	"	"	"	"	"	"	"	"	"	"	130	287	14	431	"	-8	-38
40	.10	.15	.10	.15	.15	.85	.15	.85	.15	.15	.15	168	820	20	1008	9.80	45	30
50	"	"	"	"	"	"	"	"	"	"	"	168	687	18	873	"	34	17
60	"	"	"	"	"	"	"	"	"	"	"	164	540	14	718	"	20	1
70	"	"	"	"	"	"	"	"	"	"	"	152	368	10	530	"	0	-25

EQUILIBRIUM TEMPERATURES

TABLE XIV

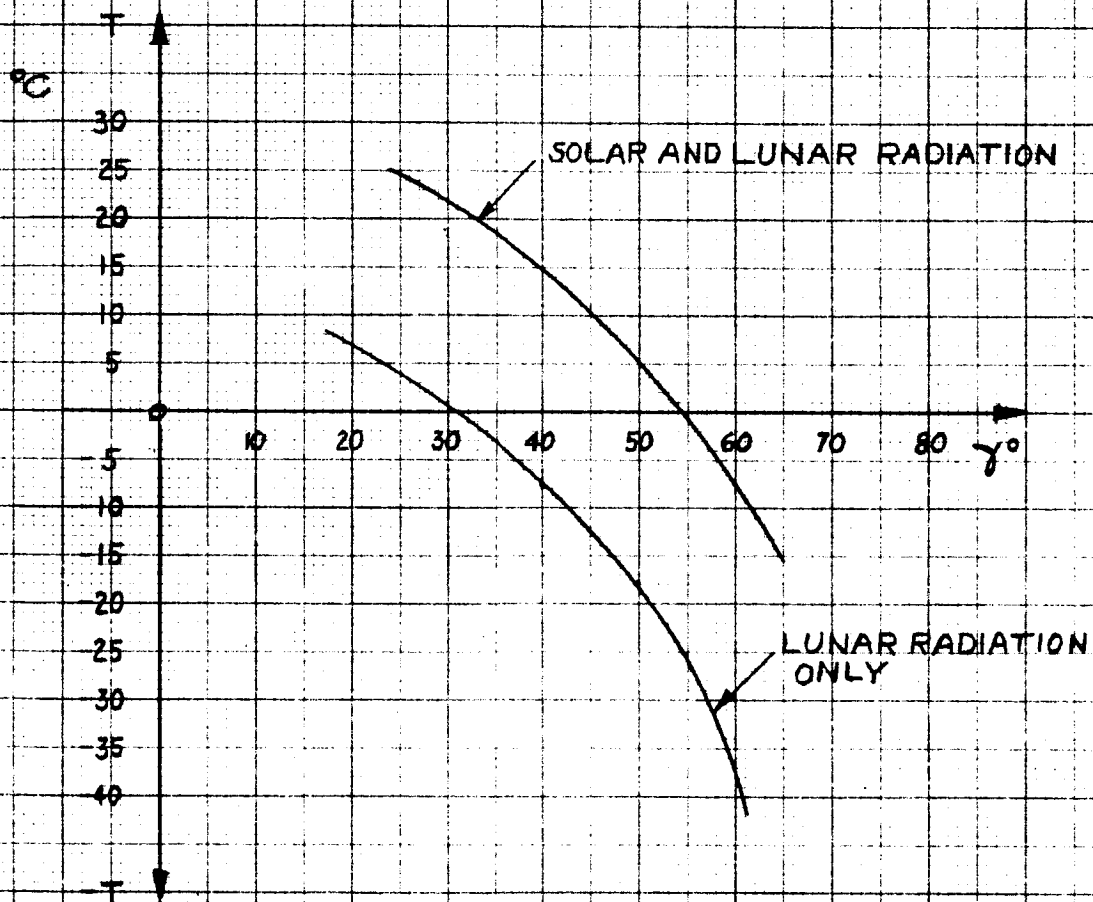

EQUILIBRIUM TEMPERATURE

FIGURE 26

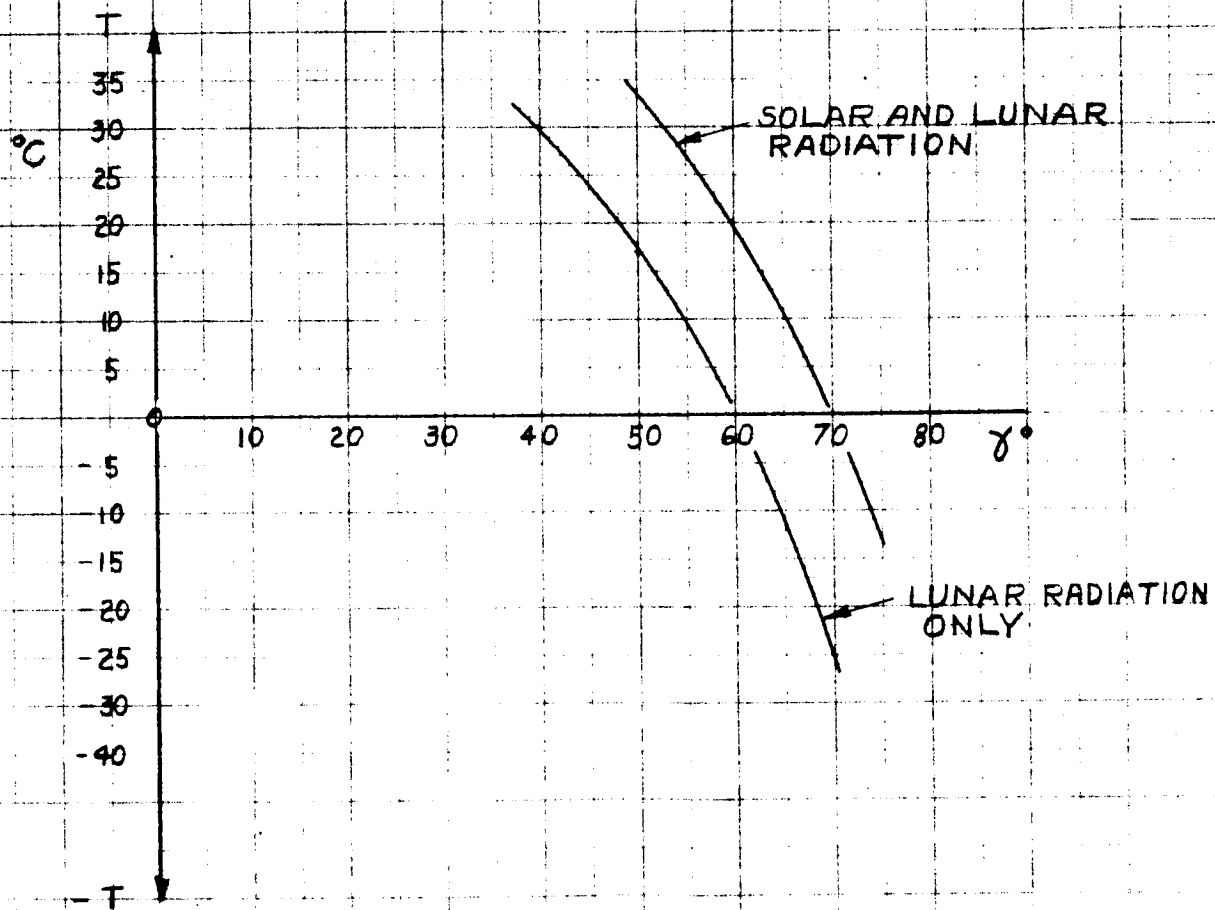

EQUILIBRIUM TEMPERATURE

FIGURE 27



GOERZ OPTICAL COMPANY, INC.

was taken to be at 25°C and the time that the camera would reach 0°C while tending to cool to -10°C, -25°C and -50°C respectively, was computed. The approach was to use simple heat transfer calculations over small temperature drops in going from 25°C to 0°C.

The amount of heat lost over each temperature drop is:

$$dq = mC_v (T_2 - T_1)$$

where m = camera mass = 7 lbs. = 3182 gms.

C_v = mean specific heat of camera = 0.1 cal/gm/°C

T_2 = internal camera temperature at each step

T_1 = temperature the camera reaches after losing dq units of heat

Between the outer shell of the camera and the inner structure, a polyurethane foam, made by Pittsburgh Plate Glass, will act as an insulator to increase the time of heating or cooling. Using the heat transfer relationship for a thin wall at different surface temperatures, the cooling time was determined for the three cases stated earlier. This formulation is:

$$\frac{dq}{dt} = kA \frac{(T_o - T_2)}{dx}$$

where

dq = heat lost over each drop (given previously)

dt = time in which dq is lost

k = thermal conductivity of insulating material
= 38×10^{-6} cal/sec/cm²/°C cm

T_o = temperature to which camera tries to cool to

T_2 = internal camera temperature at each step

dx = thickness of insulating material = $\frac{1}{4}$ in = 0.64 cm

A = total area of camera = 2528 cm²

$$\text{Thus } dt = \frac{-mCv \, dx}{kA} \frac{(T_2 - T_1)}{(T_o - T_2)}$$

The results are shown in Table XV and plotted in Figure 28.

The same results apply to the camera being initially at 0°C and heating to 35°C, 50°C or 75°C.

The results could be made more exact by solving the second order differential heat transfer equation in three dimensions with appropriate boundary conditions. However, the results obtained would not differ too greatly from those shown in Figure 28. The results have shown that materials are available to allow operation in the desired temperature range over most of the lunar surface.



GOERZ OPTICAL COMPANY, INC.

T_0 °C	T_2 °C	T_1 °C	dT_1 $T_2 - T_1$ °C	dT_2 $T_0 - T_2$ °C	t sec.
-25	25	25	0	-50	0
	25	24	1	-50	45.4
	24	22	2	-49	93
	22	20	2	-47	97.5
	20	15	5	-45	251.7
	15	10	5	-40	283.5
	10	5	5	-35	324.3
	5	0	5	-30	378.8
-50	25	25	0	-25	0
	25	24	1	-75	29.5
	24	22	2	-74	61.2
	22	20	2	-72	63.5
	20	15	5	-70	161.9
	15	10	5	-65	174.6
	10	5	5	-60	188.9
	5	0	5	-55	206.4
-10	25	24	1	-35	65.8
	24	22	2	-34	133.8
	22	20	2	-32	142.9
	20	15	5	-30	378.8
	15	10	5	-25	453.6
	10	5	5	-20	567
	5	0	5	-15	755.2

CAMERA COOLING RATES

TABLE XV

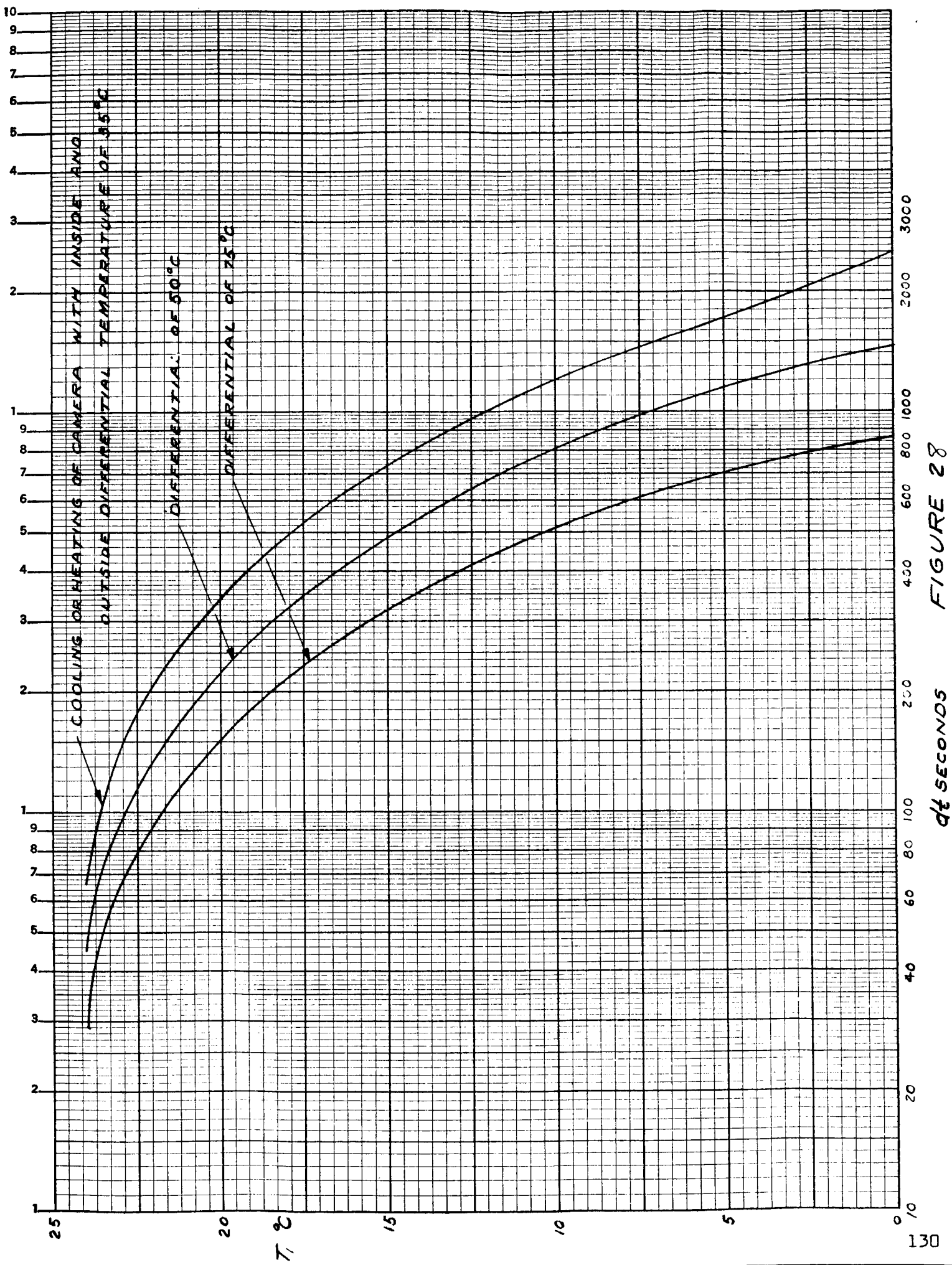

FIGURE 28

dt SECONDS



GOERZ OPTICAL COMPANY, INC.

X FILTERS

The spectral sensitivity of the lunar camera will be a function of the product of the spectral sensitivity of the emulsion and the transmittance of the camera optical system. The light used will be primarily sunlight with some shadow fill-in from the gas discharge source and small amounts due to fluorescence and black body radiation from the moon. Due to the low surface temperature, the amount of radiation from the moon will be extremely small in the photographic region.

With any given emulsion, the spectral sensitivity of the camera may be modified by changing the spectral transmittance of the optical system by including appropriate filters. In order to specify filters, it is necessary to know the desired spectral sensitivity of the combination and the spectral sensitivity of the emulsion. Neither of these have been specified in detail at this point. The desired sensitivity has been broadly specified to include three modes of operation covering the ultraviolet, visible and infrared. The visible portion of the spectrum is generally considered to cover the range of 4000 to 7500 Angstrom units. The photographic range is limited to 2400 Angstrom units on the ultraviolet side by the absorption of gelatin, and to a limit of between 9000 and 10,000 Angstroms on the red end by available sensitizers.

Filters are readily available to make the transmittance high over any one of these three regions and essentially zero over the other two. For example, the Corning 7-54, ultraviolet transmitting, visible absorbing filter with transmittance, shown in Figure 29, has a high transmittance over the ultraviolet range, essentially zero transmittance over the visible to 6800A° and a secondary transmittance peak at 7200A°. The transmittance in the violet can be attenuated by a thin film coating. The Bausch and Lomb coating 90-43, shown in Figure 30, in combination with this filter would have a transmittance at all points above 4000A° or less than 12%. Bausch and Lomb filter 90-21, shown in Figure 31, has high transmittance over the visual range and high reflectance outside of this range. Quoting from their description "Used in the beam from a tungsten source this coating will filter out by reflection 60% of the heat radiation with little more loss in the visible than from a glass plate inserted in the beam. The coating has negligible color".¹ The system may be peaked for the infrared by use of Bausch and Lomb coating 90-8, shown in Figure 32.

The camera designs provide for filters which may be changed with manual controls. Detailed specifications of filters to be used should be based on mission requirements and emulsion sensitivity.

¹Page 19, Bausch and Lomb Multi-Films, 44-306-0664, B & L.

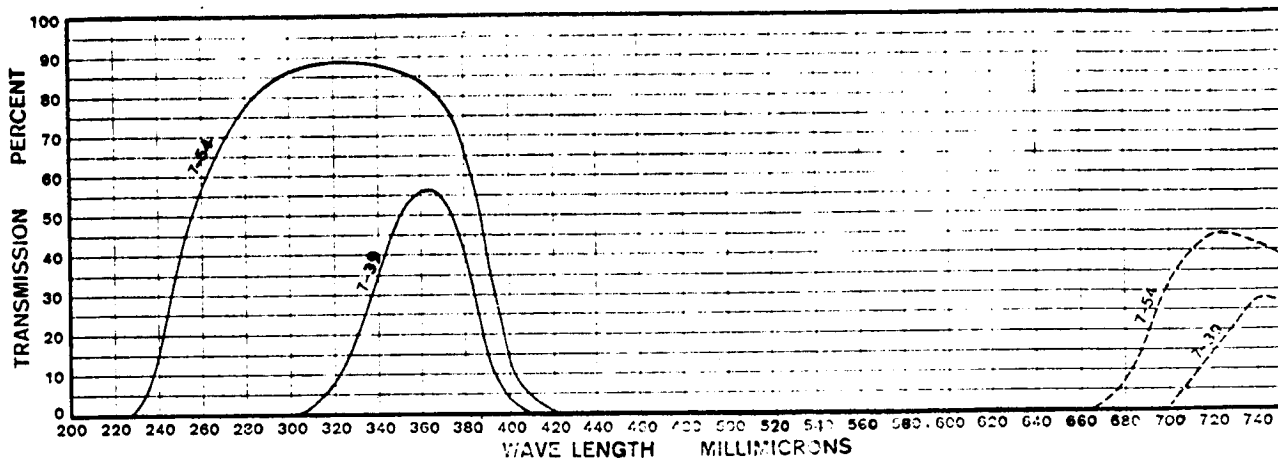

FIGURE NO. 29

90-43

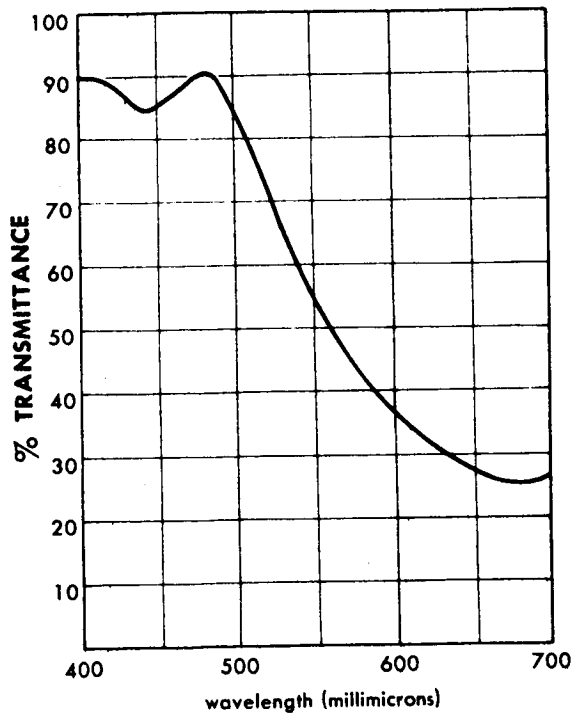

FIGURE NO. 30

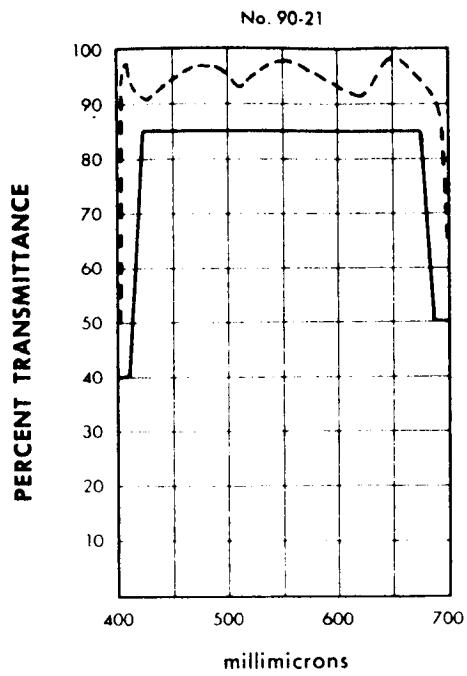

FIGURE NO. 31

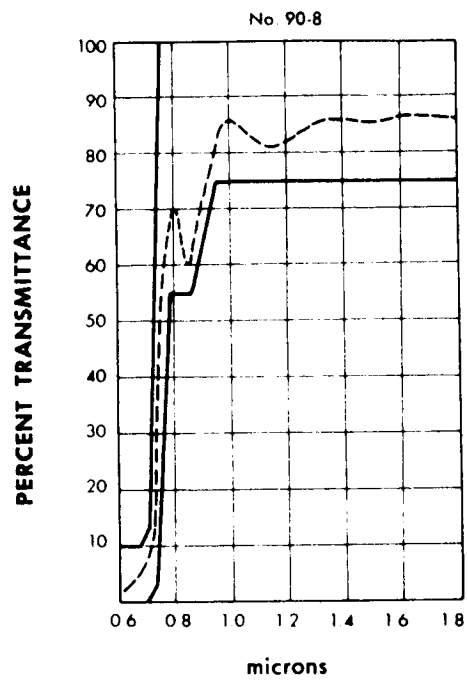

FIGURE NO. 32



GOERZ OPTICAL COMPANY, INC.

XI MATERIALS

A. REQUIREMENTS

Reliable performance of the camera in the space environment requires that the materials maintain acceptable characteristics for the required mission duration. Materials have been divided into four categories according to their function as follows:

- (1) Structural materials, where the ratio of weight to strength or stability is a major factor.
- (2) Bearing materials where friction, wear, tolerable contact pressure, matching or compatibility with other materials and the lubrication requirements are important.
- (3) Elastomer materials which must maintain pliability in the space environment.
- (4) Surface coatings, which must maintain reflective, emissive and abrasion resistance characteristics in the space environment.

B. ENVIRONMENTAL CONDITIONS

The space vacuum provides a condition where cold welding, adhesion or bond forming of materials in contact takes place much more frequently than on the surface of the earth. These effects are not limited to metals only. The problem is acute where materials in contact are in relative motion as in bearings and guides. For moving contact points, lubricants must be

employed capable of enduring the harsh environment, or "self lubricating" materials used to assure satisfactory performance. The outer surfaces of the camera shell are used to maintain thermal balance. The exposure to solar radiation for the camera is randomly variable since the camera must be maintained within certain temperature limits both when in shade of the operator or moonscape and when in the sunlight without any pattern or regularity of cycles of heat radiation exposure. In addition to the radiation exposure, the outer shell and the surfaces are subject to extensive handling.

C. STRUCTURAL MATERIALS

An important factor in the evaluation of structural materials is the specific rigidity and specific strength. Specific rigidity is the ratio of the modulus of elasticity to the specific weight:

$$R = \frac{E}{\gamma} .$$

Similarly, the specific strength is the ratio of the tolerable stress level to the specific weight $S = \frac{\sigma}{\gamma}$. When materials are subject to high deformation rates (as is the case under vibration) and are particularly sensitive to stress concentrations at sharp notches, the operating temperature range must also be considered. The impact test (Izod or Charpy v notch) performed on notched specimens indicates the likelihood of ductile or brittle failure.



GOERZ OPTICAL COMPANY, INC.

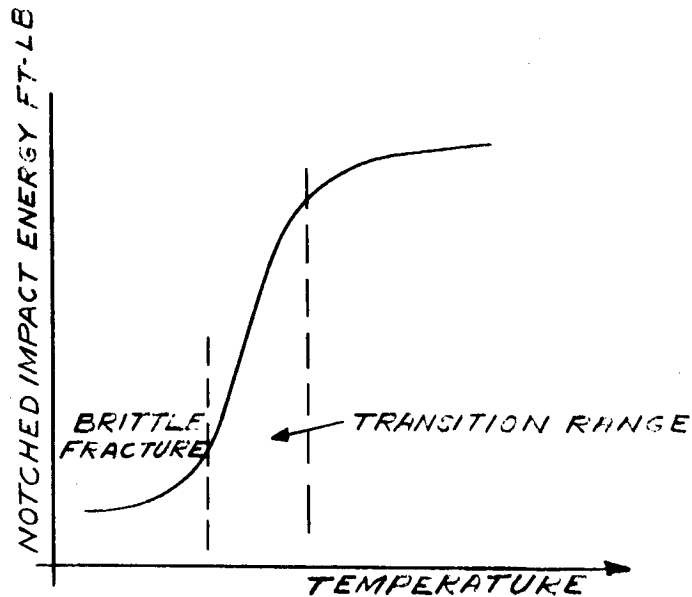

When materials exhibit transition from ductile to brittle behavior, low temperature application must be limited to the ductile region. Metals exhibiting brittle characteristics at room temperature, by having low values of percent elongation as well as low impact strength, can be expected to be brittle at low temperatures also. Magnesium alloys, some high strength aluminum alloys in the heat treated condition, and heat treated copper beryllium alloys all exhibit this behavior. Heat treatment and surface condition may alter the low temperature performance considerably. Mechanical design can also influence the tendency for brittle failure at low temperatures, and for this reason, it is essential that sharp notches be eliminated and that corners at changes of section be adequately filleted. An additional consideration in selecting camera materials is the possibility that the camera may be stored for days in high vacuum. The camera case should not be a strong

source of substances which may be deleterious to other equipment. Particularly, cadmium plating is to be avoided, as cadmium evaporates at low temperatures and pressures and may condense as a thin film on neighboring components. Similarly, all rapidly subliming or high vapor pressure metals and alloys must be avoided, e.g., magnesium and many of its alloys.

Titanium, beryllium, aluminum, gold and stainless steel, among other metals, have vapor pressures of less than 10^{-9} mm Hg. below 600°F and are useful for the camera application.

Table XVI lists recommended materials, together with their characteristic data for the structural parts of the camera. Their application in the camera design will be governed by evaluation of specific requirements.

D. BEARING MATERIALS

Although the literature contains many accounts of experiments performed to determine the suitability of various bearing materials and the behavior of real bearings with various loads and speeds in simulated space environments, sufficient data is not available to allow the straight forward design of high reliability mechanisms. By an elaborate design, many of the known problem areas associated with high vacuum bearings could be avoided. Such a design would require more weight, space and energy input than a design that used conventional techniques and was optimized for those parameters. The cost, in these



GOERZ OPTICAL COMPANY, INC.

terms, of sealing the camera for a low differential pressure has been examined and found to be no greater than that of providing adequate sealing for a high reliability precision instrument subject to dust or salt spray. The decision was made to avoid the bearing problem by choosing a sealed camera design. This design will avoid the use of materials which would be damaged by a short exposure to a high vacuum or an oxygen rich atmosphere so that film cassettes may be changed either in the pressurized LEM or on the surface of the moon, or the camera could be operated for shorter periods in the high vacuum in case of a pressure loss. Tables XVII through XXI lists tested dry lubricants for space environment.¹ Several bearing materials were studied in a vacuum of 10^{-6} Hg mm to determine the amount and composition of gases involved at various temperatures. Test temperature ranged from 160°F up to the point of thermal degradation for the plastic material and from 760°F to 1160°F for powders and composites. The test temperatures were much higher than the tolerable temperature range for the camera. Since lubricant evaporation is accelerated as the temperature increases, a material acceptable, based on the best result, will perform well in the camera.

¹Outgassing characteristics of dry lubricant materials in vacuum by P. H. Bowen and W. H. Hickam Research Laboratories, Washington Electric Corporation, Pittsburgh, Pennsylvania.

PROPERTIES OF STRUCTURAL MATERIALS
RECOMMENDED FOR THE USE ON THE LUNAR CAMERA

	Dimension	Beryllium	Stainless Steel 304	Titanium	Aluminum	Gold
Modulus of Elasticity, E	10^6 PSI	44	28	16	10.2	11.6
Yield Strength	10^3 PSI	50	75	110	37	30
Endurance Unit	10^3 PSI	30	34	95	20	4.6
Elongation	%		60	18	14	4
Specific Rigidity, R	10^8 in	6.57	0.965	0.993	1.05	0.166
Specific Strength, S	10^5 in	4.5	1.17	5.95	2.06	0.06
Specific Density	lb/cu in	0.067	.29	.161	.097	0.698
Coefficient of Linear Thermal Expansion	/°F	6.4	9.9	5.7	13.2	7.9
Thermal Conductivity	BTU/Hr/ sq ft °F/ ft	84.4	9.4	4.85	79.2	171
Specific Heat	BTU/lb/ °F	.46	0.12	0.131	0.22	0.031

TABLE XVI

TABLE XVII

—Outgassing Characteristics of Plastics and Graphite
In 20 Min, Before Bake-Out

Material	Wt of Sample (gm)	Temp (F)	Gases Evolved (mol per cent)								CO and or N ₂	SiF ₄	Unden- tified ¹	Miscel- laneous	Gases Evolved (cu cm/gm)	
			H ₂ O	CO	CO ₂	SO ₂	N ₂	O ₂	CO and or N ₂	SiF ₄						
1. Nylon	0.6421	160	97.19	2.81	0.0175	
		360	97.21	1.82	0.97	1.0723	
		460	96.99	1.96	1.05	0.4513	
2. Nylon with 20% C Filler	0.8023	160	87.33	9.49	3.18	0.0289	
		360	98.30	1.13	0.57	1.5216	
		560	93.96	5.54	0.50	0.9098	
		760	84.17	2.00	13.82 ²	41.3285	
3. PTFE (Polytetrafluoroethylene)	0.9010	160	12.07	62.51	25.42	0.0067	
		360	14.10	64.64	21.26	0.0164	
		560	6.28	1.78	72.88	19.06	0.0172	
		760	64.37	14.14	0.0052	
		960	1.36	12.19	4.85	81.60	0.0672
1060	0.87	0.40	98.73	2.0262		
4. PTFE with Mica Filler	0.8613	160	99.99	0.0056	
		360	96.76	0.96	1.49	0.79 ³	0.0615	
		460	92.27	2.03	4.18	1.52 ²	0.0262	
		560	81.06	3.84	10.52	4.58 ²	0.0199	
		560 ²	80.32	4.32	10.03	5.33 ²	0.0199	
		760	42.76	10.16	29.39	1.00	16.69 ²	0.0178
		860	20.91	9.73	27.40	10.00	31.96 ²	0.0388
		960	7.28	6.98	13.94	23.45	48.35 ²	0.1172
		1060	0.93	4.78	5.34	60.02	28.93 ²	2.1769
5. PTFE with Ceramic Filler	0.9573	160	99.99	0.0796	
		260	98.12	0.42	0.82	0.84	0.4005	
		360	91.33	0.97	4.20	3.50	0.1942	
		460	84.18	2.13	8.18	5.51	0.0767	
		560	59.88	4.02	15.40	20.09	0.41	0.20	0.2061
		560 ²	37.61	5.29	17.61	38.76	0.73	0.0419
		660	27.53	5.54	28.19	41.81	1.20	0.73	0.1664
		760	38.32	9.01	25.17	25.18	1.65	0.67	0.3974
6. PTFE with Glass-Fiber and MoS ₂ Filler	0.9501	160	98.92	0.48	0.21	0.39	0.1165	
		360	97.03	0.62	1.17	1.18	0.1094	
		560	97.44	0.82	1.06	0.94	0.2459	
		760	89.46	5.68	1.69	2.67	0.50	0.9117
		860	27.62	55.57	7.19	9.52	0.10	2.3885
7. PTFE with Glass-Cloth Filler	0.9385	160	99.99	0.0006	
		360	99.99	0.0010	
		560	99.99	0.0010	
		760	89.00	11.00	0.0030	
		860	38.14	19.72	37.88	1.48	0.53	2.25	0.0470
		960	11.82	15.96	33.13	2.12	1.78	35.19	0.0787
1060	2.96	4.26	2.38	90.40	16.6489		
8. PCTFE (Polychlorotrifluoroethylene)	1.0553	160	70.84	29.16	0.0008	
		360	4.82	67.68	26.13	1.33 ¹	0.0181	
		560	9.59	58.20	12.34	10.45	8.45	0.97 ¹	0.0211	
		760	21.10	24.20	54.70	0.0102	
860	99.99	3.6158		
9. Carbon-Graphite (Hard) with PTFE Impregnate	0.8767	160	35.09	52.94	11.97	0.0030	
		360	25.72	57.93	18.35	0.0020	
		560	36.25	1.54	39.97	22.24	0.0128	
		760	40.15	59.65	0.20	0.0250
		960	7.24	3.53	89.23	0.4673
10. Polypropylene	0.7231	160	81.72	18.15	50.13	0.0051	
		360	45.21	54.79	0.1220
		460	18.25	81.75	0.0632
11. Carbon-Graphite with Salt Impregnate	0.8767	160	99.99	0.0380	
		360	99.79	0.06	0.4192	
		560	99.25	0.31	0.07	1.4992	
		760	99.40	0.24	1.0871	
		960	98.77	0.45	0.2210	
		1160	92.55	2.53	0.10 ²	0.09 ²	0.2250
		1160 ²	82.85	15.97	0.37 ²	1.63 ²	0.0081
		1260	33.48	32.32 ²	0.0025

¹ Unidentified hydrocarbon compounds.² Heated for additional 90 min at 560 F.³ Heated for additional 20 min at 560 F.⁴ Heated for additional 20 min at 1160 F.⁵ NH₃, ⁶ C₂H₂, ⁷ Argon, ⁸ Believed to be H₂, ⁹ Hydrogen.

TABLE XVIII

—Outgassing Characteristics of Dry Powders
Before Bake-Out

Material	Wt of Sample (gm)	Temp (F)	Gases Evolved (mol per cent)							Gases Evolved (cu cm/gm)	
			H ₂ O	CO	CO ₂	SO ₂	N ₂	H ₂	CO and/or N ₂ Unidentified ¹		Misc.
12. Molybdenum Disulfide, MoS ₂	0.1918	160	99.99	0.0556	
		360	98.12	0.73	1.15	0.1338	
		560	87.52	1.72	2.34	8.42	0.4410	
		760	7.75	3.22	7.94	81.08	1.1317	
13. Graphitic Carbon, C	0.1114	160	99.99	0.0065	
		360	71.03	3.32	3.84	0.0927	
		560	60.84	5.54	21.93	2.45	0.2830	
		760	54.43	10.86	25.39	2.85	0.88	0.5925	
		960	60.05	15.01	19.47	4.44	3.4279	
14. Lead Chromate, PbCrO ₄	0.2863	160	82.46	2.48	15.06	0.0414	
		360	92.42	3.13	0.39	2.60	0.1586	
		560	53.32	2.31	22.47	0.71	10.70	0.1028	
		760	49.68	2.12	13.89	0.34	2.86	3.54 ²	
		960	19.98	2.56	2.01	0.06	1.05 ⁴	
15. Lead Sulfide, PbS	0.6497	160	97.41	0.84	1.75	0.0410	
		360	86.44	0.15	10.13	0.50 ³	2.78 ⁵	
		560	18.04	50.75	17.55 ³	13.66 ⁶	
16. Antimony Trisulfide, Sb ₂ S ₃	0.3616	160	58.57	2.13	5.12	25.56	2.03	6.59 ²	
		360	83.46	0.70	6.54	1.60	6.26	1.44 ²	
		560	45.83	4.43	36.52	7.03	4.94	0.28	0.94 ²
		760	34.49	6.14	43.02	6.78	8.70	0.87 ¹
		960	3.44	2.71	60.06	30.60	2.64	0.55 ¹
17. Silver Iodide, AgI	0.3530	160	
		360	51.08	25.31	23.61	
		560	12.05	35.23	14.42	
		760	7.27	31.79	15.46	
		960	7.16	34.93	19.93	
		1160	31.69	31.19	
18. Gallium Telluride, GaTe	0.1265	392	99.85	0.15	
		572	96.29	0.18	0.42	0.14	2.84	
		752	66.45	0.90	2.94	1.10	28.18	
		932	25.38	3.77	12.17	1.06	56.34	
		1112	2.28	3.24	6.18	0.65	86.36	
19. Tungsten Diselenide, WSe ₂	0.3123	160	49.62	50.38	
		360	56.16	19.39	12.66	11.79	
		560	41.66	25.31	21.84	11.19	
		760	39.37	39.87	12.33	1.47	6.96	
		960	22.00	6.35	3.20	63.46	0.50	
20. Tungsten Diselenide, WSe ₂ (purified)	0.9611	392	44.97	33.07	21.96	
		572	38.11	24.11	37.78	
		752	65.94	16.17	17.89	
		932	30.97	23.91	23.05	23.07	
		1112	29.99	44.58	17.07	7.42	0.94	

¹ Hydrocarbon compounds.² Hydrogen chloride, ³ Oxygen, ⁴ Acetic acid.⁵ Hydrocarbon and sulfur compounds.⁶ Oxygen, ⁷ Methane, ⁸ Nitric oxide.

TABLE XIX

—Outgassing Characteristics of Dry Powders
After 24-Hr Bake-Out

Material	Wt of Sample (gm)	Temp (F)	Gases Evolved (mol per cent)					Gases Evolved (cu cm/gm)
			H ₂ O	CO	CO ₂	SO ₂	H ₂	
12. Molybdenum Disulfide, MoS ₂	0.1918	760	< 0.0005
		960	23.27	60.11	16.63	0.0078
		1160	24.74	66.83	8.44	0.1691
13. Graphitic Carbon, C	0.1346	760	30.76	66.24	0.0034
		960	18.96	18.96	33.42	28.66	0.0241
		1160	21.43	75.06	3.53	0.1499
16. Antimony Trisulfide, Sb ₂ S ₃	0.6945	760	2.47	3.34	93.69	0.0121
		960	18.53	51.48	0.0003
		1160	7.81	74.03	18.16	0.0110
18. Gallium Telluride, GaTe	0.4256	760	< 0.0005
		960	26.29	46.43	27.28
		1160	5.39	59.22	5.39
20. Tungsten Diselenide, WSe ₂	0.7198	760	< 0.0004
		960	73.66	26.34	0.0016
		1160	60.90	39.10	0.0082
21. Molybdenum Diselenide, MoSe ₂	0.5112	760	10.44	83.16	6.40	0.0031
		960	27.36	64.46	2.78	5.40
		1160	28.20	65.61	2.60	3.59

TABLE XX

—Outgassing Characteristics of Composites
After 24-Hr Bake-Out at 760 F

Materials	Wt of Sample (gm)	Temp (F)	Gases Evolved (mol per cent)						Hydrocarbons	Gases Evolved (cu cm/gm)
			H ₂	CO	CO ₂	CH	H ₂ O			
22. 84 Fe, 16 C	4.7620	760	89.97	5.03	5.00	0.0014	
		960	97.18	1.42	1.40	0.0088	
		1160	51.07	10.20	11.26	27.47	0.0249	
23. 50 Fe, 50 C Heat Treated	2.6442	760	89.31	10.69	0.0008	
		960	94.58	4.11	1.31	0.0040	
		1160	57.51	30.24	4.28	7.97	0.0477	
24. 40 Fe, 60 C Heat Treated	1.8572	760	46.25	53.75	0.0006	
		960	56.78	11.78	31.28	0.0016	
		1160	11.98	40.40	41.62	0.0284	
25. 40 Ni, 60 C Carburized	2.2451	760	99.99	<0.0001	
		960	86.02	13.98	0.0003	
		1160	91.16	4.03	4.81	0.0021	
26. 30 Ni, 70 C Carburized	1.4621	760	63.09	36.91	0.0005	
		960	87.34	12.66	0.0027	
		1160	71.25	22.97	4.07	1.71	0.0145	
27. 20 Ni, 80 C	2.1350	760	26.33	61.81	11.86	0.0015	
		960	17.75	14.11	56.12	1.50	10.52	0.0115	
		1160	15.40	54.97	29.42	0.21	0.2990	
28. ¹ 55 Bronze, 27 PTFE, 18 MoS ₂	2.0381	360	<0.0004	
		560	3.47	12.87	67.22	6.33	9.99 ²	0.0137	
		760	3.14	10.87	69.54	3.68	12.83 ²	0.0237	
		960	3.40	11.86	56.48	6.10	49.15 ²	0.1218	
29. ¹ 70 Ag, 20 PTFE, 10 WSe ₂	3.6932	360	<0.0001	
		560	<0.0001	
		760	51.88	23.63	21.53	0.0004	
		960	1.94	8.36	2.65	3.13	49.39	0.2309	

¹Materials 28 and 29 were composites with a metal matrix. Composite 28 was a porous sintered bronze with PTFE and MoS₂ impregnated after sintering. Composite 29 was a premixed material and cold welded under temperature and pressure.

²Includes 6.20 mol per cent SO₂.
²Includes 13.34 mol per cent SiF₄.

TABLE XXI —Outgassing Characteristics of Plastics and Graphite
After 24-Hr Bake-Out

Material	Wt of Sample (gm)	Temp (F)	Gases Evolved (mol per cent)							Uniden- tified	Gases Evolved (cu cm/gm)	
			H ₂ O	CO	CO ₂	SO ₂	CO and/ or N ₂	SiF ₄	NH ₃			
2. Nylon with 30% C Filler	0.6968	160	88.19	11.81	0.0019	
		360	81.13	18.87	0.0020	
		560	56.90	13.10	0.0026	
		660	99.99	0.0021	
		760	99.99	0.0024	
860	38.29	41.29	2.85	17.57 ¹	0.6800		
3. PTFE	0.9344	160	99.99	0.0012	
		360	99.99	0.0016	
		560	99.99	0.0017	
		760	99.99	0.0009	
		960	3.33	3.96	11.89	80.82 ²	0.0608	
6. PTFE with Fiber-Glass and MoS ₂ Filler	0.9063	160	99.99	0.0006	
		360	99.99	0.0007	
		560	91.99	8.01	0.0039	
		760	45.75	36.86	6.06	10.13	1.20	0.2106	
7. PTFE with Glass-Cloth Filler	1.1691	160	99.99	0.0010	
		360	99.99	0.0016	
		560	99.99	0.0013	
		760	68.59	14.30	17.11	0.0024	
		960	0.63	7.51	15.92	1.29	2.67	71.98 ²	0.1621
8. PCTFE	1.2254	160	99.99	0.0008	
		360	No gases detected
		560	70.36	29.64	0.0017	
		760	99.99	0.0235	
9. Carbon-Graphite (Hard) with PTFE Impregnate	0.8428	160	99.99	0.0006	
		360	99.99	0.0011	
		650	99.99	0.0028	
		760	68.60	31.40	0.0044	
		960	9.00	6.15	84.85	0.1866	

¹ Hydrogen compounds. ² Carbon-fluorine compounds.

The listed outgassing data for all materials were recorded on a volume basis and are given as mol percent of the total gases evolved. All materials were screened for lubricating and outgassing properties. Those passing these tests were made into retainers and used to lubricate ball bearings rotating at 1800 RPM and a radial load of 75 pounds and an axial load of 5 pounds in a vacuum at pressures from 10^{-6} to 10^{-8} torr. Although this bearing test is much more severe than the actual bearing load experienced in the camera, the test results serve as a guide for the selection of the proper bearing material and lubricant. The selection of the optimum bearing material must not only be based on its mechanical behavior, but also from the standpoint of chemical reaction of the evolved gases with the film. In a later phase of camera design, tests must be made to determine the effects of lubricant vapors on the film.

E. ELASTOMERS

The high molecular weight polymers, without plasticizers, maintain a high percentage of their strength, hardness and elongation during exposure to high vacuum for 48 hours, (the hardness may increase). Low molecular weight species may contribute to weight loss in some plastics, especially if not properly polymerized. Better type elastomers for vacuum application are polyethylene, polypropylene, tetrafluorethylene, silicone resins, and polyethylene terephthalate. (Ethylene related and silicones.)



GOERZ OPTICAL COMPANY, INC.

For radiation resistance, particularly for long exposure, material properties are substantially preserved up to 10^9 ergs per gram of carbon for polyethylene, polystyrene, polyvinyl chloride and polyvinyl formal. Although tetrafluorethylene is not considered radiation resistant (such as for nuclear reactor core components) it would resist radiation adequately for the camera, where the radiation exposure is many orders of magnitude smaller than in a high performance reactor core.

F. SURFACE TREATMENTS

Surface treatment of the camera shell must be used to control the camera temperature and prevent damage by salt spray. Since the camera may be expected to receive fairly rough treatment in use due to the limited dexterity of the astronaut, the surfaces should be able to withstand a moderate amount of abrasion without serious change of reflectance and emissivity.

The literature shows that paints which have excellent properties on earth may not be appropriate for space applications. The high dosage of ultraviolet radiation may destroy chemical bonds in organic materials and the high vacuum may cause the formation of bubbles and the evaporation or sublimation of binders and other paint constituents so that even if the optical properties are preserved, the surface may become brittle and subject to gross damage by slight abrasion.

Fortunately, the preliminary thermal investigation indicates that the required optical properties may be achieved by finishing 304 stainless steel to the proper degree of polish. This surface will be both highly resistant to the abrasion and to corrosion by salt spray. A more refined thermal analysis after the shape of the external camera case is frozen will allow specification of the required degree of polish. Should this analysis indicate that stainless steel cannot be used for all of the external surfaces, selection will be made from inorganic coatings such as metal oxides, porcelain enamels, glasses, and paints with ultraviolet absorbers and low solvent contents.



GOERZ OPTICAL COMPANY, INC.

XII DISTANCE AND ATTITUDE RECORDING

It would be desirable to know the exact location and orientation of the camera at the time of each exposure. It would also be desirable to know the exact location of each object photographed. If the first objective could be accomplished, the second would only require a range measuring system. A complete solution for these objectives would require an inertial guidance system which at present would require more space and weight than allowable for the complete camera system. A preliminary investigation has been made to determine what elements could be included in the camera to provide partial information with reasonable space and weight requirements.

Range measurements may be made by stereo and stadia reduction. Stereo measurements are limited by the allowable stereo base and the focal length of the lenses employed. Stadia reduction is limited by the focal length of the lenses and by the availability and accuracy of suitable stadia targets.

Measurements on glass plates are made with an accuracy of one to three microns. Measurements on film can be made to something better than ten microns. If a resseau is provided on the field flattening elements, an accuracy of two microns should be attainable on film for distinct, sharp edged targets.

The stadia and stereo reductions are identical mathematically.

The length of the stadia rod or distance between stadia reference marks replaces the stereo base or lens axis separation. This distance is denoted by d .

For the general case where the stadia rod will not be centered on the optical axis the distance d will be broken into two parts d_1 and d_2 as shown in Figure 33. d_1 will subtend an angle A_1 at the first nodal point, P_1 , of the camera lens and d_2 an angle A_2 .

$$\frac{d_1}{r} = \tan A_1$$

$$\frac{d_2}{r} = \tan A_2$$

The images formed on the film will subtend equal angles at the second nodal point, P_2 , of the lens.

$$\frac{S_1}{f} = \tan A_1$$

$$\frac{S_2}{f} = \tan A_2$$

$$\frac{d_1}{r} = \frac{S_1}{f}$$

$$\frac{d_2}{r} = \frac{S_2}{f}$$

$$\frac{d_1 + d_2}{r} = \frac{S_1 + S_2}{f}$$

$$r = f \frac{d_1 + d_2}{S_1 + S_2} = f \frac{d}{s} \quad (1)$$

This relationship assumes that the stadia rod is parallel to the film plane. If this condition does not exist an error



GOERZ OPTICAL COMPANY, INC.

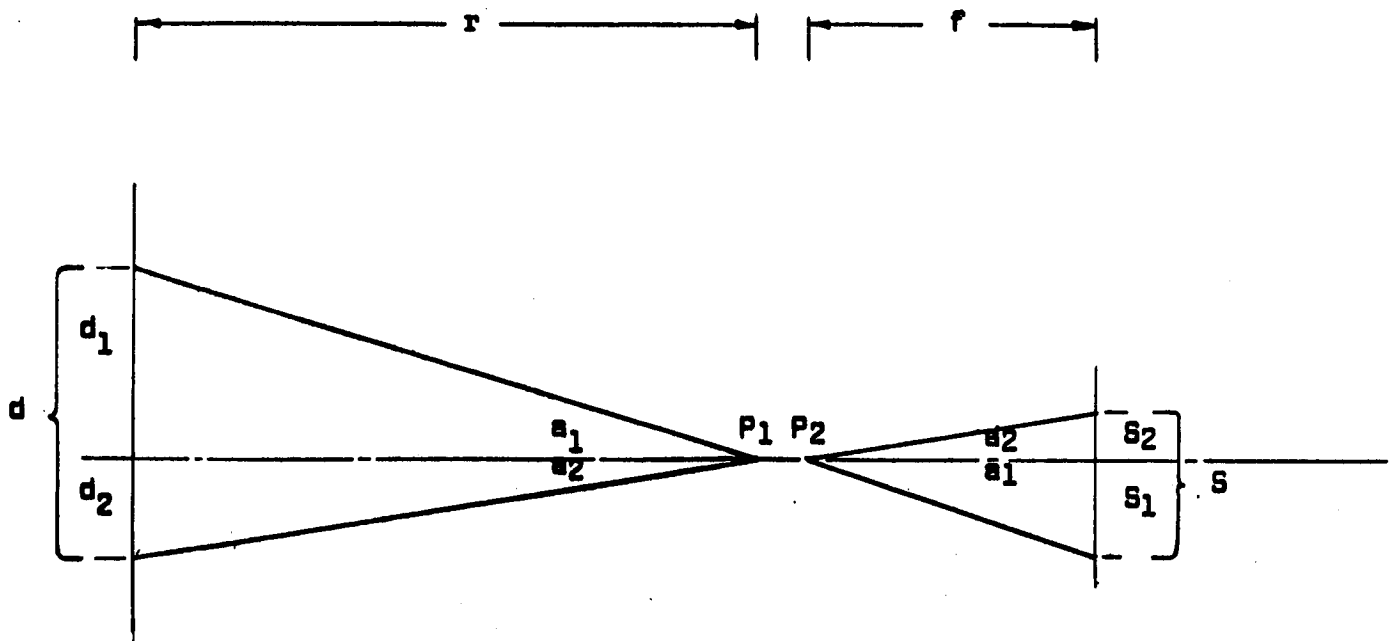

DISTANCE MEASUREMENT

FIGURE 33

proportional to the cosine of the angle of inclination will be introduced, but this error is less than 1% up to an angle of 8°.

As the camera is refocussed for finite distance objects the value of f will increase from the nominal value. This effect will introduce an error in r equal to $d/S \times \Delta f$. This error may be reduced by an iterative process. The range may be calculated using the nominal focal length.

Using this value for the range a new value for f may be calculated using the thin lens equation $1' = r f / (r - f)$. Inserting this value for f in equation (1) allows a more precise value of the range to be determined. Since this error is less than 2.5% at ten feet and becomes smaller as the range increases the convergence is quite rapid and few iterations are required to reduce this source of error to zero.

As a numerical example of this process assume a 2 inch focal length lens, a 100 inch stadid rod, and a measured image length of 1.000 inches. From (1)

$$r_1 = \frac{2 \times 100}{1.000} = 200.00$$

$$1'_1 = \frac{200 \times 2}{200 - 2} = 2.0202$$

$$r_2 = 2.0202 \times 100 = 202.02$$

$$1'_2 = \frac{202.02 \times 2}{202.02 - 2} = \frac{404.04}{200.02} = 2.019998 = 2.02000$$



GOERZ OPTICAL COMPANY, INC.

$$r_3 = 202.000$$

$$l'_3 = \frac{202.00 \times 2}{202.00 - 2} = \frac{404.00}{200.00} = 2.0200$$

$$r_4 = 202.000$$

The convergence will always be rapid because the change in focal distance is small compared to the focal length for all distances of more than a few feet.

Differentiating (1) with respect to s gives

$$dr = -fd \frac{ds}{s^2}$$

this shows that the error introduced by inaccurate measurement of the length of the image is inversely proportional to the square of the image length. To minimize this error the image of the stadia rod must be made as large as practicable. The final report study of Selenodetic Measurements for Early Apollo Mission by Geomatics, Inc. gives an excellent discussion of accurate light weight stadia devices which may be made a part of the LEM. In addition a square invar tube marked off in approximately one inch increments could be carried by the astronaut and used as a size reference and stadia rod for pictures taken at distances up to fifty feet. The astronaut could place the stadia rod in the center of the area to be photographed and then photograph the sample area and the LEM in sequence, thus providing distances from the camera to the object and from the camera to the LEM.

The azimuth of pointing of the camera would give the only additional information required to determine a rough location of the camera and sample field.

If the moon had a significant magnetic field, azimuth information could be recorded to an accuracy of one degree by photographing a small magnetic compass. Two methods of obtaining azimuth information are possible using gyroscopes. The simplest but least accurate would be to use a simple gimbal mounted gyro the direction of which could be determined by photographing circumpolar star fields periodically during the mission. The constant drift rate could be determined and corrections made to the data by using the time recorded on each frame. The random drifts and the perturbations introduced by random accelerations of the camera could not be compensated for in a simple manner. The second possibility would be a miniaturized gyro compass. This approach would have the advantages that power would only be required when a measurement was to be recorded and that errors would not be introduced by moving the camera from place to place. Both of these approaches are probably capable of giving orientation within a degree with a volume of a few cubic inches and with a weight of on the order of one half pound, but considerable development work would be required.



GOERZ OPTICAL COMPANY, INC.

A simpler method of determining orientation would be to use some form of sun compass. For missions near the sub solar point this device could take the form of a pinhole camera with the pinhole at the top of the camera and an optical system to transfer the sun image to the film. At large angles to the sub solar point several devices would be required to prevent severe restrictions to direction of camera pointing. At distances up to 30° from the sub solar point this type of device would require one frame of film to give azimuth direction through a 360° range and elevation angles up to 30° . Space could probably be found within the existing space envelopes on all three cameras. The added weight would be a few ounces. Restrictions would be imposed on the astronaut in methods of holding the camera in pointing at different directions with respect to the sun. The largest cost would be the additional film required for data recording.

Consideration was given to photographing spirit levels to give altitude of the camera with respect to the local vertical. The required range sensitivity product made this method bulky and complicated in addition to the failure to provide the azimuth data which is considered to be more important.

XIII CAMERA DESIGN

Design layouts have been completed for the Types I, III and

IV cameras. Many of the design requirements are common to all those types of cameras and are discussed in general terms. Where significant variations in design exist between camera types, a detailed explanation follows the general functional discussion.

A. CAMERA BODY

Beside being the main structural part defining and maintaining the relationship of the many sub-assemblies incorporated in the design, the camera body acts as a pressure shell providing the airtight enclosure for a controlled atmosphere inside the camera. The shape and surface texture of the camera housing are the controllable parameters for the passive temperature control. Since it is the largest individual part of the entire camera, the housing becomes a major factor in the weight calculation.

The material selected for the camera body must possess:

- a) High specific rigidity
- b) High specific strength
- c) High thermal conductivity to minimize temperature differences within the housing, thereby minimizing thermal stresses and deflections.
- d) Good formability and machinability.



GOERZ OPTICAL COMPANY, INC.

Judging by the properties of recommended structural materials listed in Table XVI, beryllium satisfies the requirements best followed by aluminum.

To withstand a pressure differential of 2 psi, the beryllium shell must have a thickness of 0.04 inches. Properly placed ribs and reinforcements are required to keep the deflection within tolerable limits.

The weight ratio of the aluminum versus the beryllium shell of equal rigidity is given by:

$$w = \frac{\text{weight Al}}{\text{weight Be}} = \frac{\delta_{Al}}{\delta_{Be}} \sqrt[3]{\frac{E_{Be}}{E_{Al}}}$$

$$w = \frac{0.097}{0.067} \frac{44}{10.6} = 2.33$$

where δ = specific weight

E = modulus of elasticity

A shell of equal rigidity made of aluminum would weigh 2.33 times more than one made of beryllium. Since the weight of different camera shell designs amounts to:

	Be	Al
Type I	1.5 lbs.	3.5 lbs.
Type III	1.9 lbs.	4.32 lbs.
Type IV	1.25 lbs.	2.9 lbs.

the use of beryllium is recommended. The weight penalty connected with the use of aluminum justifies the increased cost.

The outside of the camera body is insulated with a 1/4 inch thick polyurethane plastic foam. The thermal insulation is protected against damage in handling by a thin vacuum formed stainless steel skin. Stainless steel withstands abrasive forces, is corrosion resistant and can be oxidized or painted to provide the optimum surface characteristics for best thermal control.

For all three camera types, the design concept remains the same. Each housing consists of two parts, the main shell which contains the optics and the majority of the mechanism, and the cover which provides access to the film. For Types III and IV, the cover is an integral part of the film cassette. A pressure tight seal is provided on the interface of the cover and housing. The cover is fastened to the housing by means of a wing bolt, which enables the space suited astronaut to open the camera without the need of additional tools.

The outline drawings, Figures 34, 35, and 36 illustrate the shape and size of each camera type. The total weight of each camera housing with the cover, seal, reinforcements, thermal insulation and stainless steel skin amounts to:

Type I	2.04 lbs.
Type III	2.57 lbs.
Type IV	1.7 lbs.

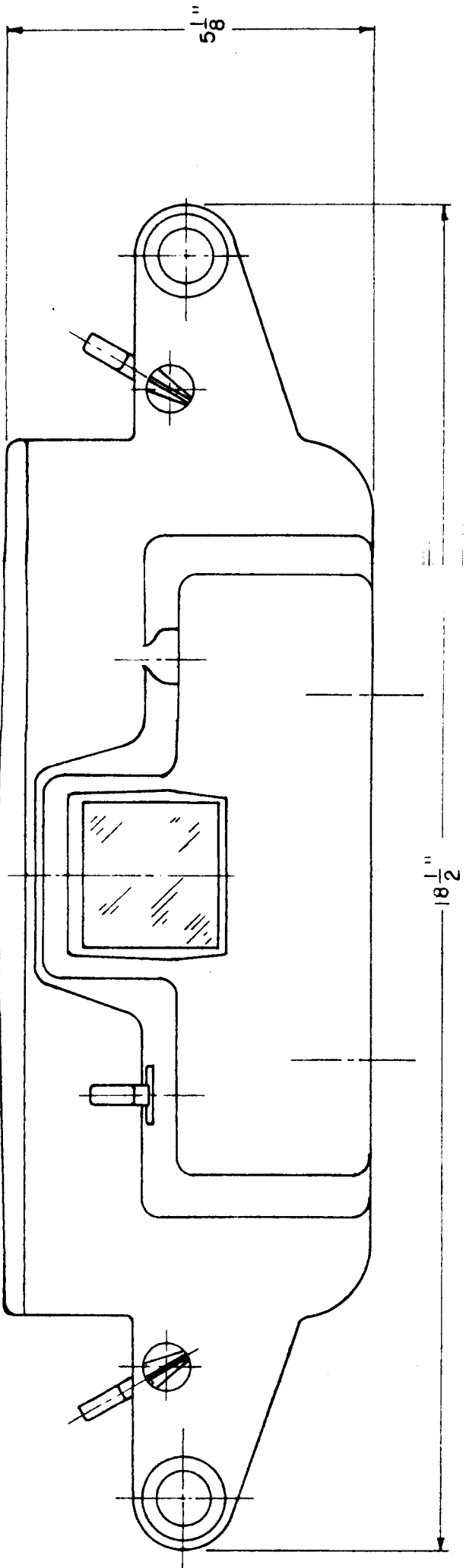

B →

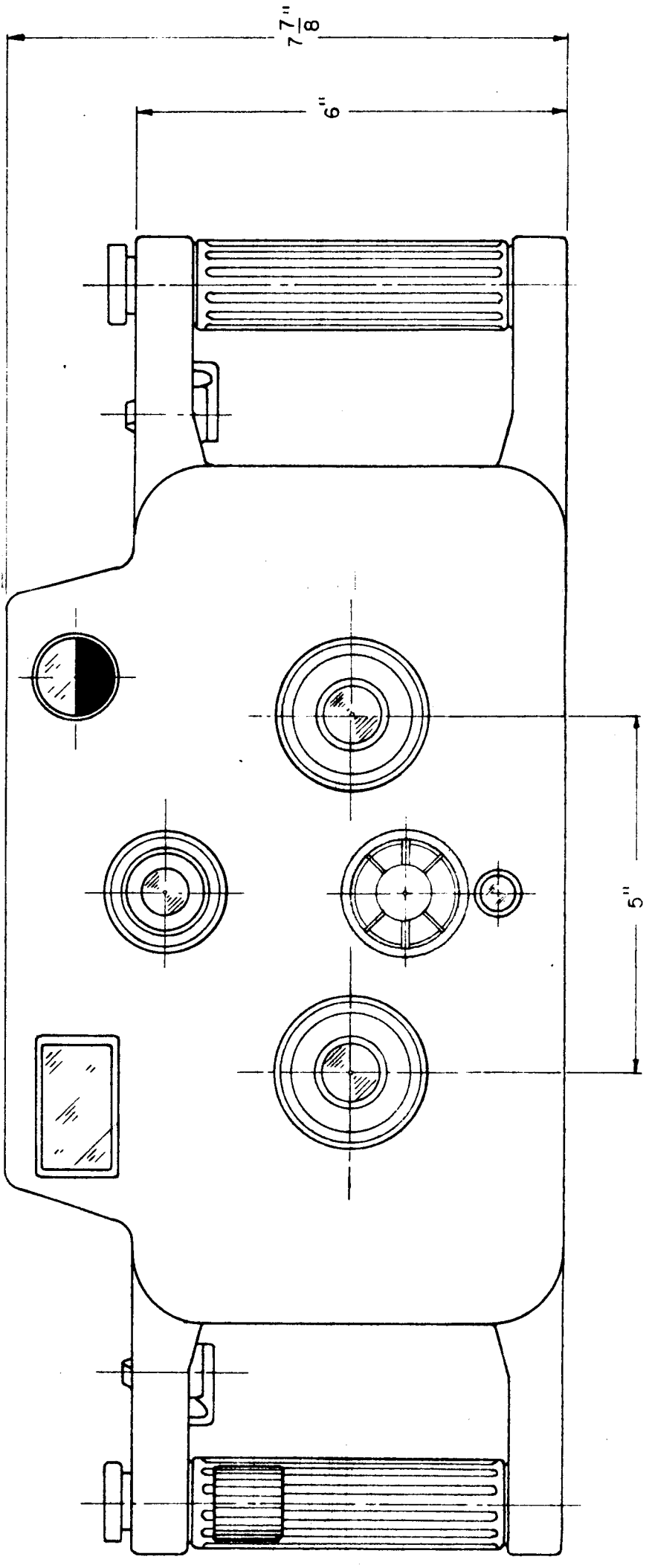

← A

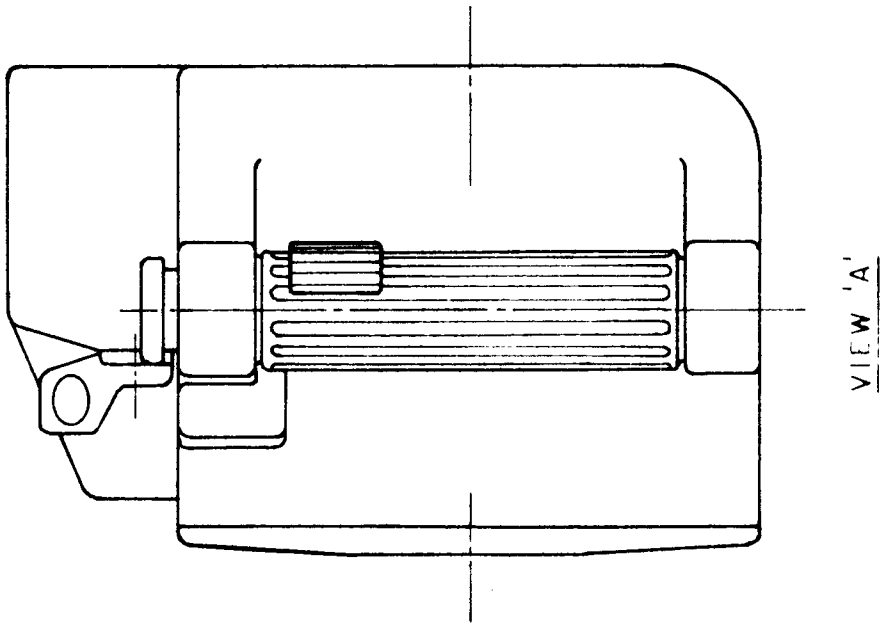

LUNAR CAMERA TYPE I
FIGURE 34

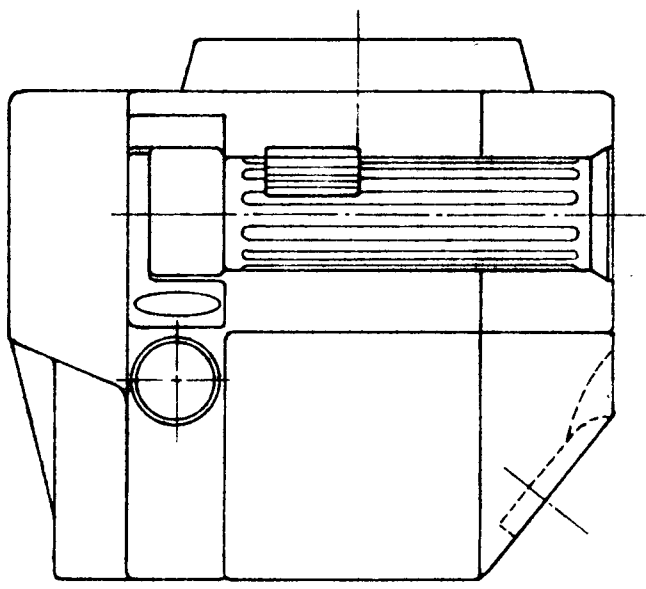
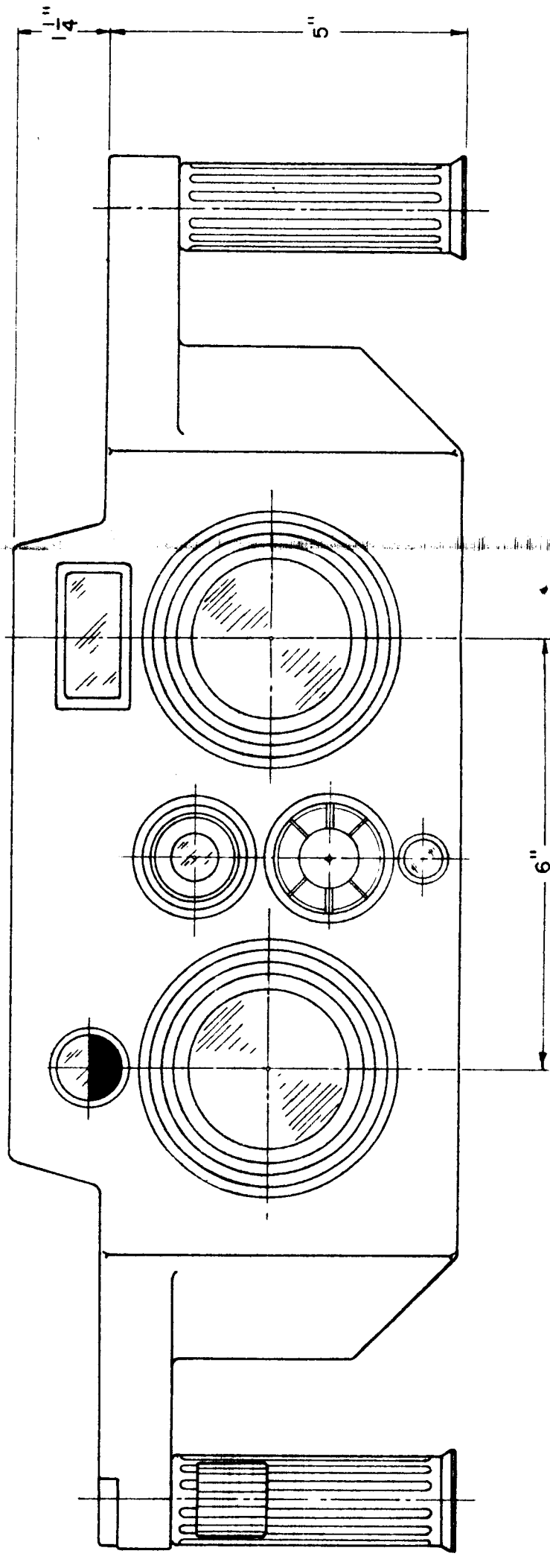
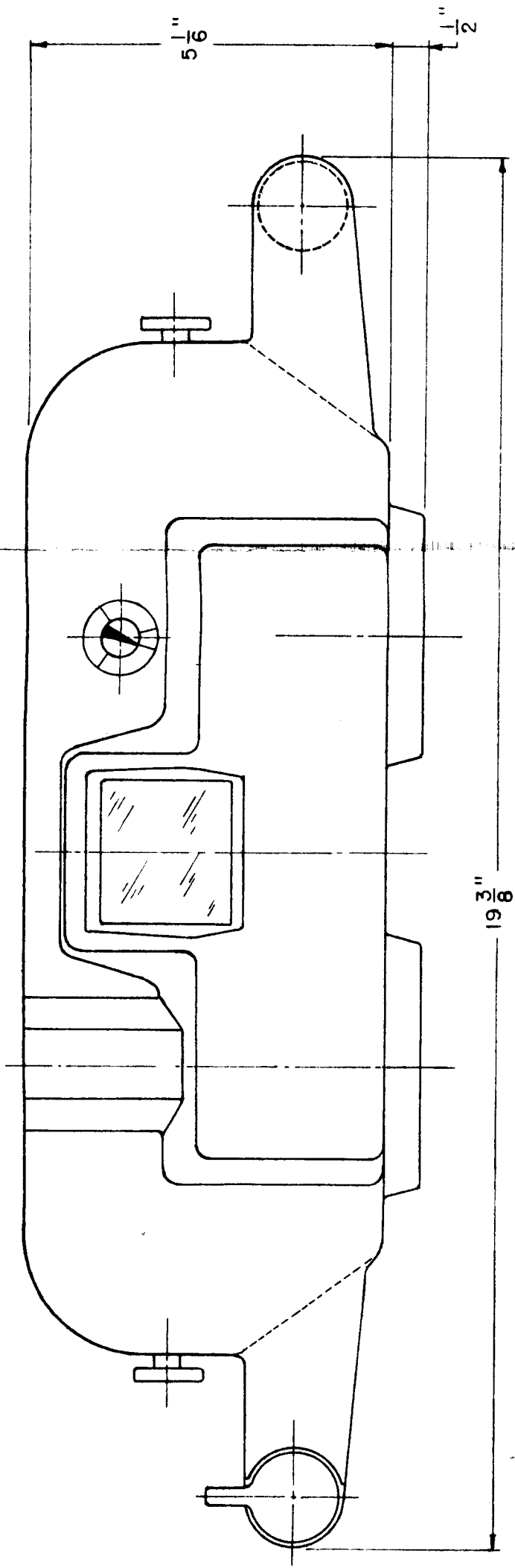

VIEW 'A'

'A' →

LUNAR CAMERA TYPE IV
FIGURE 36



GOERZ OPTICAL COMPANY, INC.

8. SEALS AND PRESSURIZATION OF THE CAMERA

For reasons discussed in other sections of this report, the mechanical design is based on a completely sealed and partially pressurized camera. Although sliding seals are used in a wide range of applications, it is apparent that more positive sealing and lower friction will result from the use of seals which flex as membranes. A number of such seals have been selected for use in the camera controls. Typical seals are shown in Figures 37 and 38. Space rated membrane materials are readily available.

The camera is pressurized from a special pressure capsule located in the camera housing. The capacity of a 2 inch diameter sphere containing nitrogen at 2000 psia pressure allows the camera to be repressurized approximately 10 times to 2 psia.

The pressurization is accomplished manually by the astronaut by actuating the pressure relief knob on the camera body. A pressure gauge indicates the pressure in the camera interior. A differential pressure relief valve set to 2 psi differential pressure between inside and outside protects the camera body from dangerous over-pressures. This way the camera is exposed to a defined pressure differential and automatically equalizes differential pressures larger than 2 psi. The protective atmosphere will not only prolong the life of the camera parts on the moon, but will also prevent dust and the corrosive atmosphere of the launch site from entering the camera.

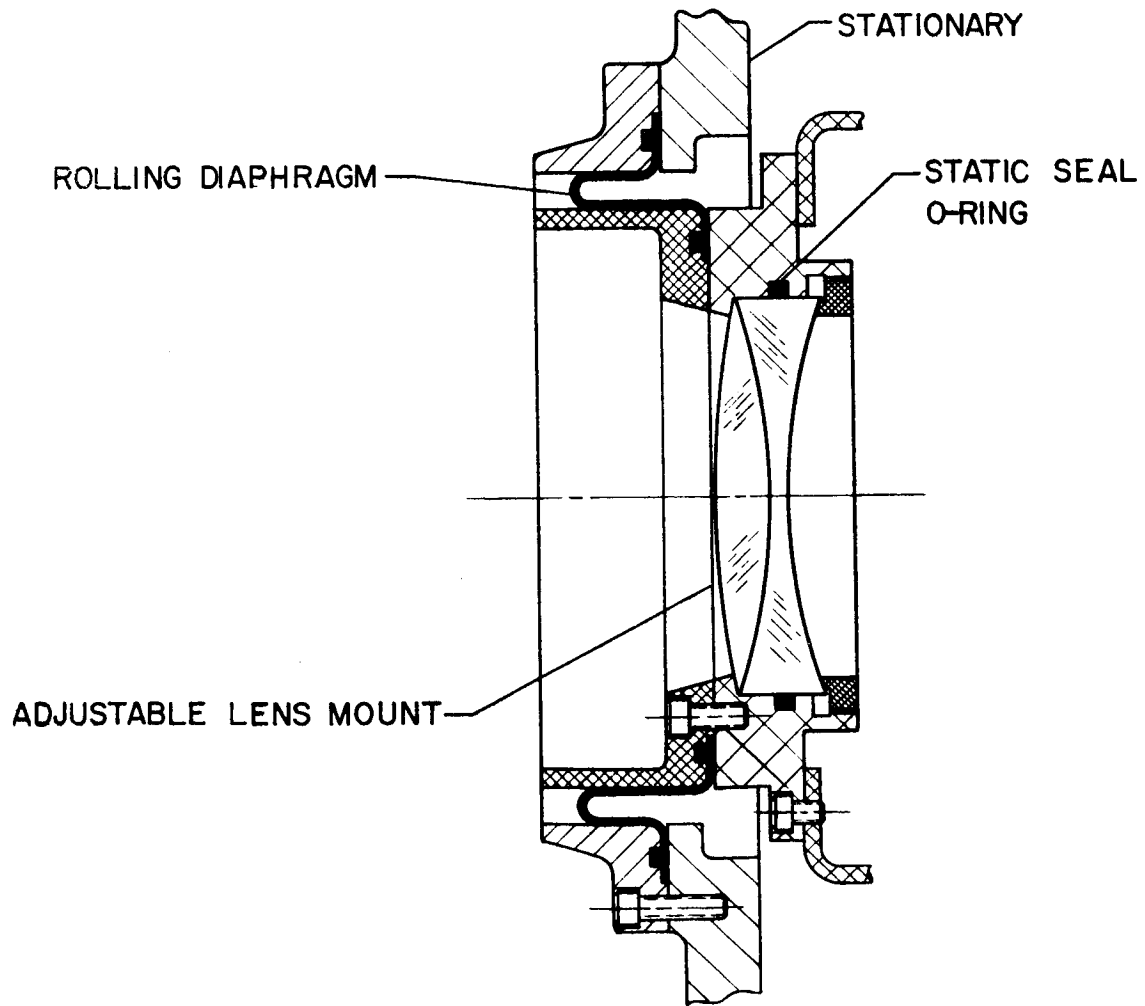
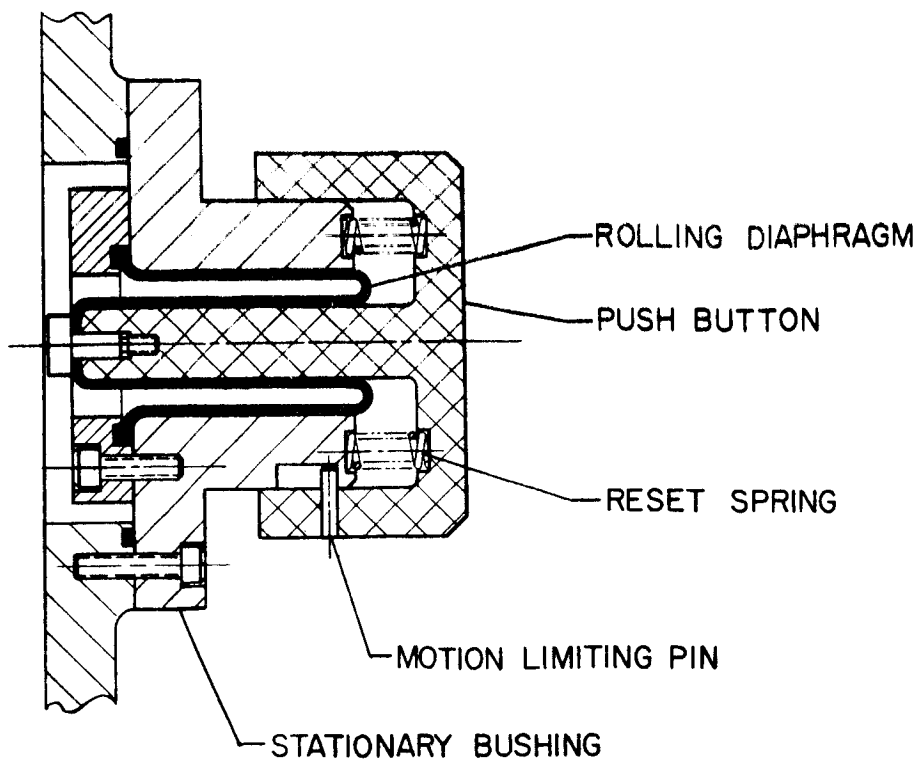

SEALS FOR LINEAR MOTIONS

FIG. 37

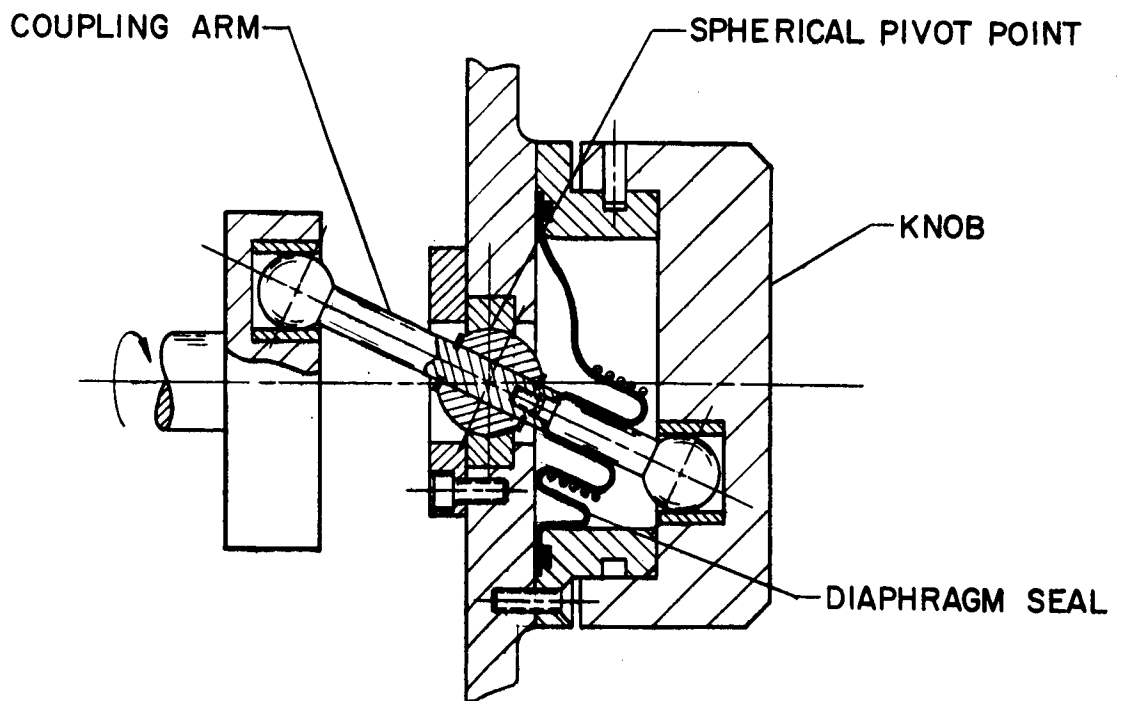
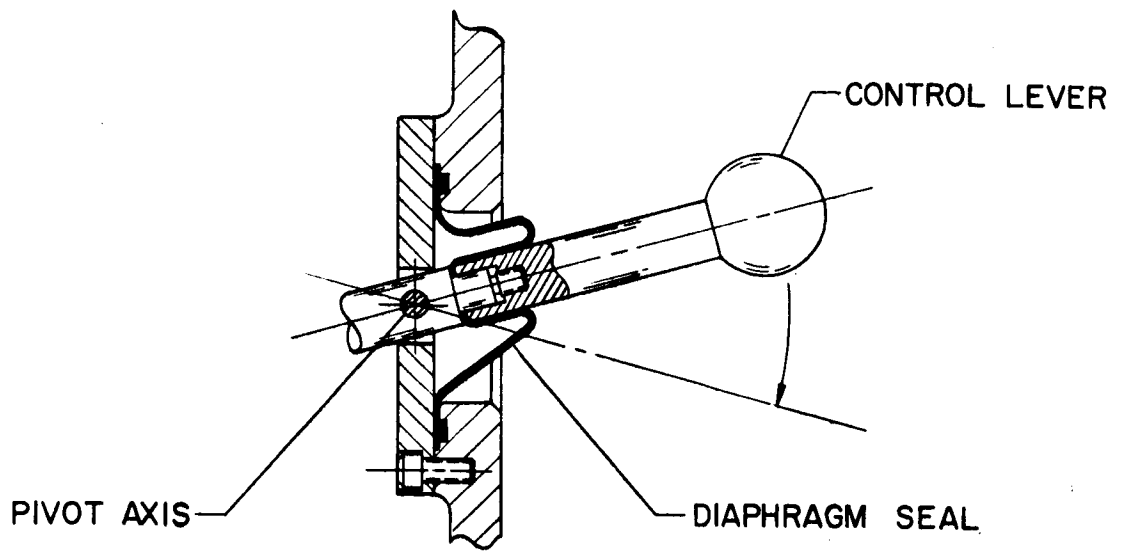

SEALS FOR ANGULAR MOTION

FIG. 38

C. FILM ADVANCE MECHANISM AND FRAME COUNTERS

GENERAL

The film advance mechanism is actuated by rotating the left-hand side handle through an angle of approximately 45° in counter-clockwise direction. In order to reach the best compromise between versatility and simplicity of operation, the following functions are combined with the film advance operation:

- a) Advancing of only one frame between exposures.
- b) Shutter release interlock preventing double exposure.
- c) Advancing the frame counter.
- d) Winding the shutter spring.

In order to avoid undue forces and stresses on the components of the film advance mechanism, a torque limiting clutch is provided in the handle. However, a distinct difference in torque will be apparent to the astronaut as soon as the film advance is completed.

C.1 TYPE I CAMERA FILM ADVANCE MECHANISM

Figure 39 shows the functions and interactions of the components of the Type I camera film advance mechanism. Before the film can be advanced, the shutter must be released. This pulls the rocker arm out of its interlocking position. The rocker arm is held in the new position by a snap spring. Rotating the Film



GOERZ OPTICAL COMPANY, INC.

Advance Handle causes the film to be advanced from the supply spool onto the take-up spool. Simultaneously the metering sprocket is rotated by the perforation of the film. The metering sprocket in turn drives through gears with a ratio of 1:1, a trip-pin disk and a cam disk. After a few degrees of rotation, the trip-pin pushes the rocker arm back into a "ready to interlock" position. Again, the rocker arm is held in this position by the same snap spring. The rocker arm cannot interlock into the ratchet because the notch in the cam disk that would allow this has moved away. One full revolution of the metering sprocket brings the notch back into the position where the rocker arm can snap in and interlock into the ratchet. No further film advance is now possible until the shutter is released again.

A film selector dictates which of the two films in the camera is to be advanced. This is accomplished by application of a friction brake to the one output shaft of the differential gear that is connected with the take-up spool of the film not to be advanced. Each film has a metering sprocket equipped with a one direction override clutch. The two metering sprockets have a common output shaft which actuates the interlocking mechanism. One metering sprocket remains in a fixed position while the other one is moved by the designated film.

Each metering sprocket is coupled to an individual frame

counter. The two counters are visible on the backside of the camera. They provide the astronaut with a visual display of the amount of film exposed on each take-up spool. The hand of each counter describes an arc of 330 degrees between the first and the last frame. This arc is divided into three equal segments, each one representing one hundred frames. The first segment is colored in green and marked "100", the second in amber and marked "200", the third in red and marked "300".

After the last frame has been exposed, neither film advance nor shutter release can be actuated. To continue operation, the camera must be switched to the other film that may still have remaining unexposed film or the camera must be returned to the LEM where it may be reloaded.

A small push-button, located inside the camera cover at the backside of each frame counter, resets the counter back to the zero position. This must be manually performed when a roll of fresh, unexposed film is inserted.

Each time when film is advanced, the coil spring of the shutter mechanism is automatically wound up, thus preparing the camera for the next exposure.



GOERZ OPTICAL COMPANY, INC.

C.2 TYPE III CAMERA

Figure 40 shows the configuration of the film advance mechanism of the Type III camera. Since the two take-up spools are located on a common shaft, the differential gear is unnecessary. Also, no brake is needed because there is no torque on the disengaged film spool.

The metering sprockets for the interlock mechanism are not used to drive the frame counters. Each frame counter has its own metering sprocket.

All other functions are similar to those of the Type I camera.

C.3 TYPE IV CAMERA

The film advance mechanism in the Type IV camera is similar to the one in the Type III with the exception that only one film is used. This eliminates all parts associated with the film selector.

D. FILM SELECTING MECHANISM

A manual control is incorporated to perform all necessary changes to switch the system from one film to another in those cameras where two films are specified. Affected are the following sub-systems:

- a) Film winding mechanism and frame counting
- b) Timing unit
- c) The optical system

D.1 TYPE I CAMERA

Figures 41 and 42 show the three functions of the film selecting mechanism. The movement of the snap lever is transmitted through gear and belt drive, torsion spring and bevel gear, to the prism shaft which is rotated through an angle of 90 degrees, thus reflecting the images of the stereo optics to either the upper or the lower film, whichever is selected. Adjustable end-stops for optical alignment are provided and a switch automatically controls a thin, solenoid-operated mask in the timing unit to open the appropriate light path for transmitting the timer data on film. Finally, the same movement of the snap lever is also transmitted to a brake system which applies friction to the appropriate output shaft of the differential gear, thus causing the film winding motion to advance only the film which has been exposed. After an exposure has taken place, the film selector can only be switched from one film to the other when the exposed film is properly advanced. At the same time, the appropriate frame counter is updated.

D.2 TYPE III CAMERA

In this camera, the film selecting mechanism moves the entire film cassette with both films vertically up or down, thus moving the selected film into the optical axis. Neither the timing unit nor the optical system are affected by the film selecting mechanism.

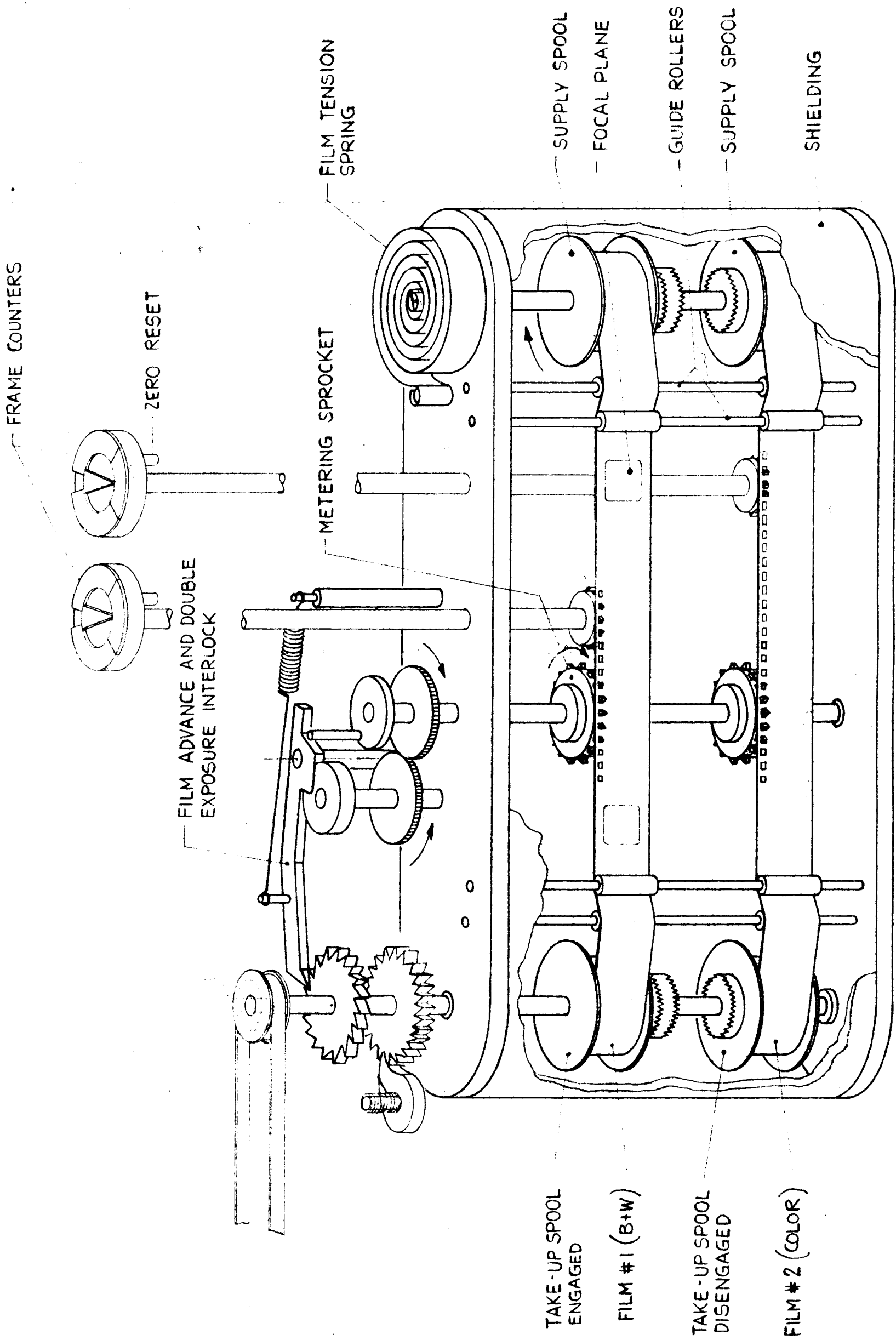

FILM ADVANCE MECHANISM, TYPE III CAMERA

FIG. 40

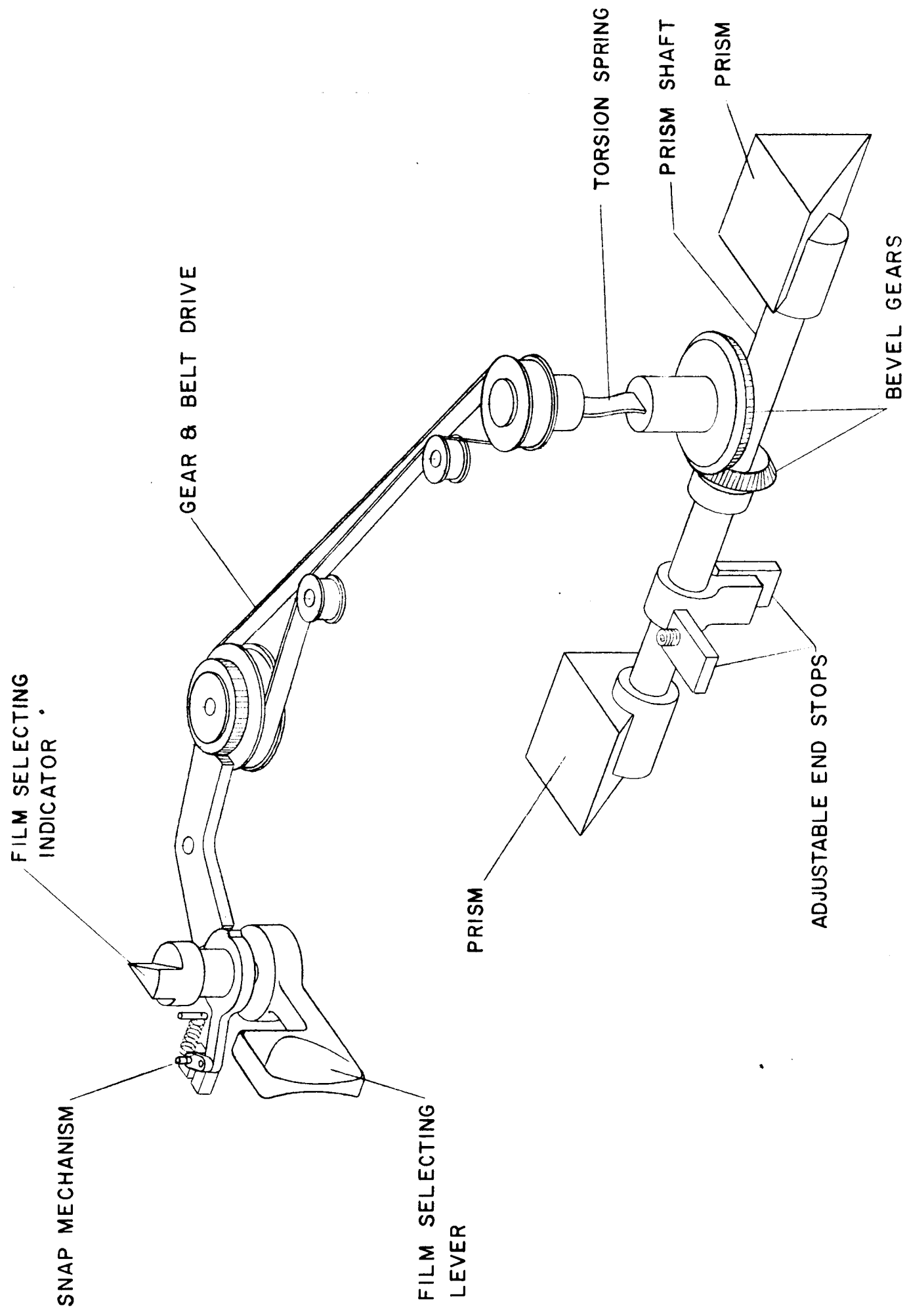

FILM SELECTING MECHANISM TYPE I CAMERA

FIGURE 41

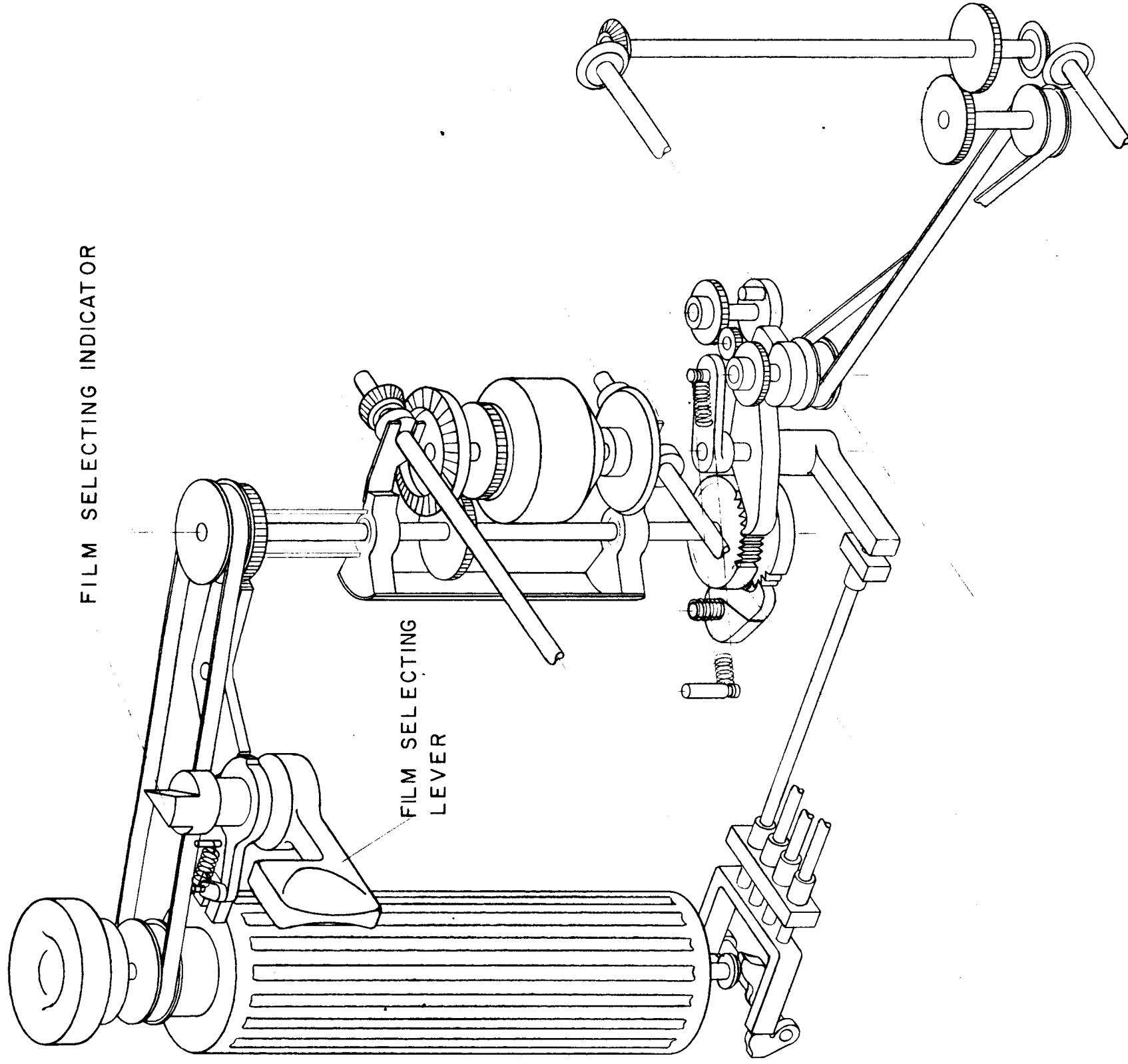

FILM SELECTING INDICATOR

FILM SELECTING
LEVER

UPPER FRICTION BRAKE

UPPER FILM WINDING SHAFT

DIFFERENTIAL GEAR ASSY.

LOWER FILM WINDING SHAFT

LOWER FRICTION BRAKE

FILM SELECTING MECHANISM TYPE I CAMERA

FIGURE 42



GOERZ OPTICAL COMPANY, INC.

D.3 TYPE IV CAMERA

No film selecting mechanism is required in this camera.

E. FILTER AND CORRECTOR LENS SELECTING MECHANISM

The Type I camera lens has pairs of correcting lens which are exchanged to shift the correction from the visual to the ultraviolet. A short wave length pass filter is incorporated in one doublet assembly to block the visual and infrared light when the camera is in the ultraviolet mode. All cameras have filters which may be inserted to block the ultraviolet and visual when infrared photography is desired.

E.1 TYPE I CAMERA FILTER SELECTING MECHANISM

Engaging and disengaging of the UV filters is accomplished manually from a snap action lever located near the right-hand side handle.

Figure 43 shows the mechanical components and their functions. The snap action of the lever which moves through an angle of approximately 30 degrees is transmitted through a gear and belt drive to a spring loaded flip-flop disk which in turn moves two sets of slides (which contain the doublets) into the desired position. These slides are under a constant spring tension from a leaf spring to insure positive positioning. Each slide is individually adjustable with respect to the optical axes and location is provided by guiding grooves and

spring plungers (not shown in figure).

The filter position indicator is located directly above the snap lever on the top side of the right-hand handle support arm. The two positions are clearly identified with "IN" and "OUT".

Infrared filters are required only for one of the two films, and are located near the two upper field flattener lenses. The upper film compartment is much heavier shielded than the lower and is primarily used for scientific rather than documentary films. Engagement and disengagement of the infrared filters is accomplished manually from a snap action lever located at the upper back side of the camera. It is actuated by thumb and/or index finger of the right hand. This is the only control that requires a hand to be removed from the handle.

Figure 44 shows the mechanical components and their functions. The snap action of the lever which moves through an angle of approximately 30 degrees is transmitted through a linkage to the filter holders which are hinged on a connecting rod. Spring tension ensures positive positioning in the engaged position. The position indicator is part of the actuation lever. The two positions are clearly identified with "IN" and "OUT".

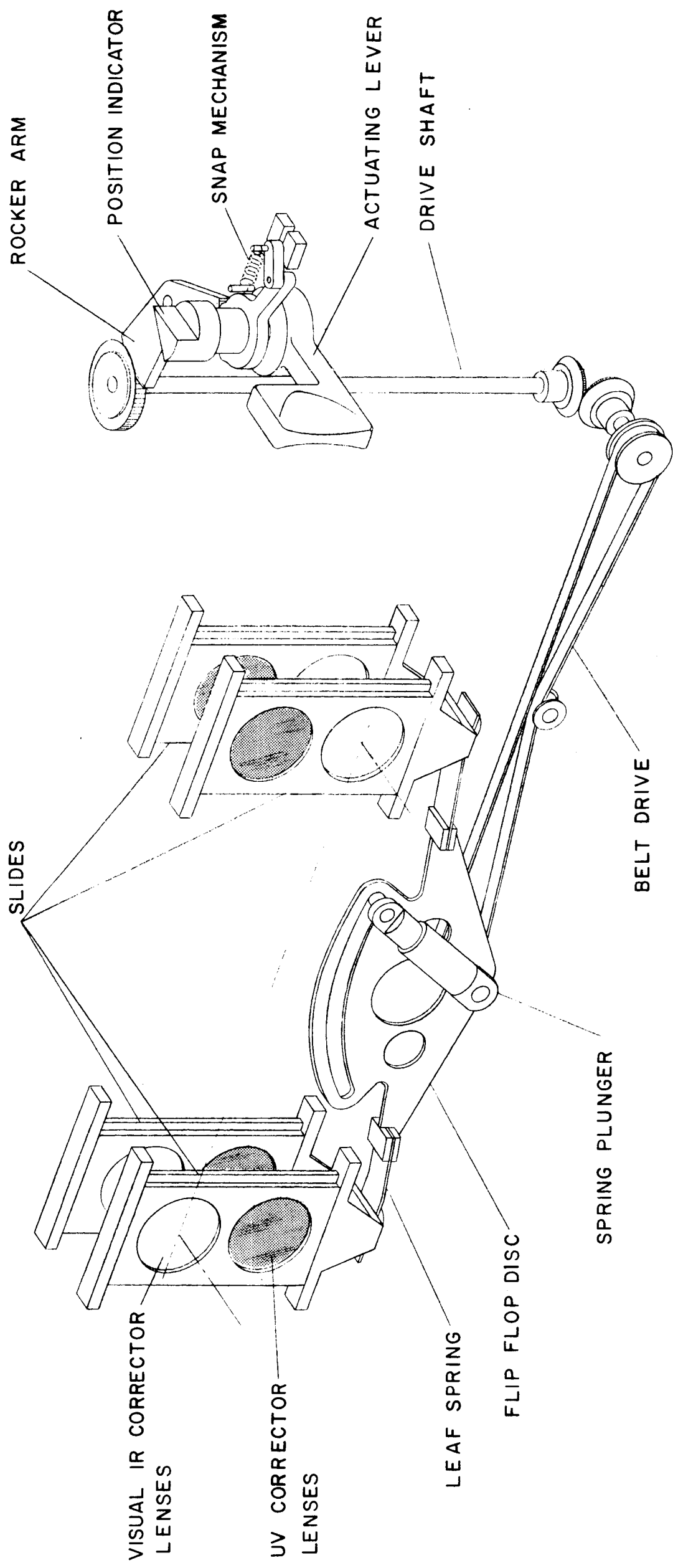

UV - FILTER & CONNECTING LENS MECHANISM

FIGURE 43

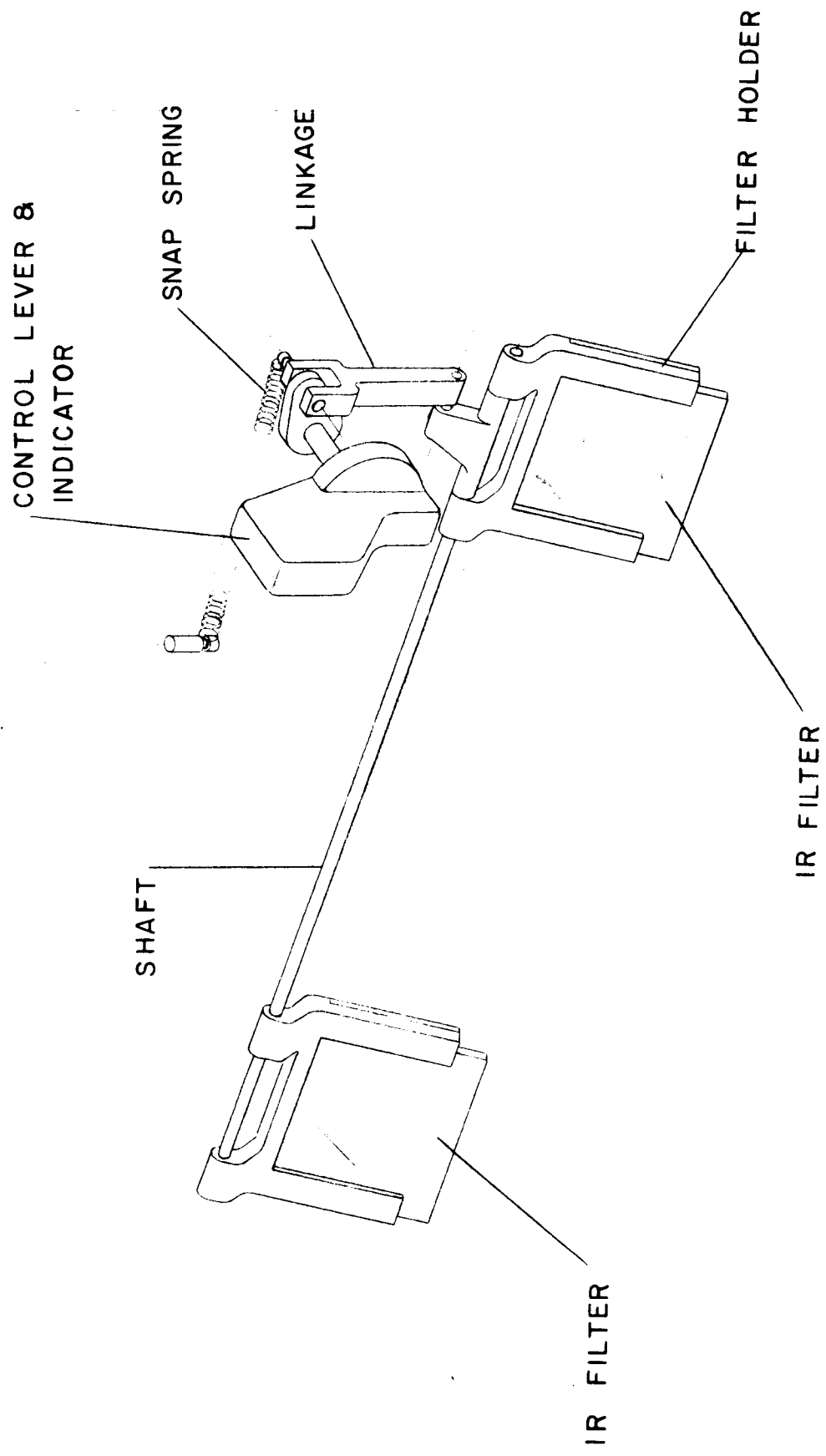

IR FILTER SELECTOR TYPE I CAMERA



GOERZ OPTICAL COMPANY, INC.

E.2 TYPE III CAMERA

The infrared filters are located in the main light paths and can therefore be used for both films in the camera.

Mechanism and control are similar to those described in Type I camera.

E.3 INFRARED FILTER SELECTOR, TYPE IV CAMERA

The infrared filters are located between the lenses and the film. Since this camera contains only one film, the filters may be used whenever desired. Mechanism and control are similar to those described in Type I camera.

F. ELAPSED TIME RECORDING

A light-tight housing contains the Accutron calendar clock Model TE-14-10, a light source with reflector, two lenses and a solenoid actuated masking disk. Two coherent fiber optics bundles, located directly behind the lenses, transmit the image of the clock to film #1 and #2 respectively. The mask, which is made of very thin foil has two small holes 90° apart, allowing the image to reach the film selected for exposure. The miniature solenoid is actuated by the film selecting mechanism by means of a microswitch.

The image size on the film must be at least 3mm in diameter to get sufficient resolution.

The location of the image on the film is shown in the following sketch:

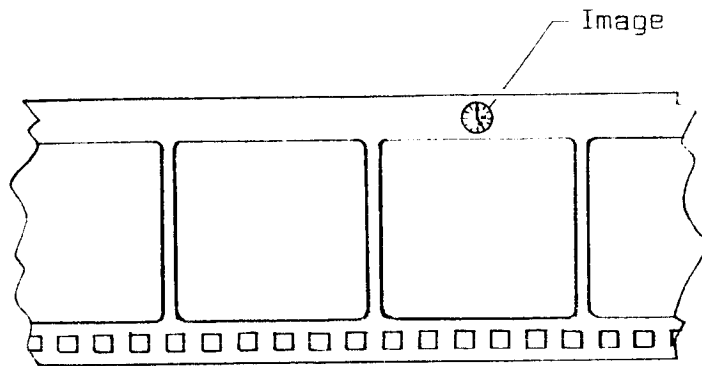

The lamp which illuminates the clock dial is triggered by the shutter movement by means of switch contacts. The pulse occurs when the shutter is fully open.

G. LOADING THE CAMERA WITH FILM

It is anticipated that before launch the camera will be loaded with fresh, unexposed film. This provides the astronaut with a capability of exposing 300 stereo pairs with a single film camera or 600 stereo pairs with a two-film camera. However, should a mission ever require more pictures to be taken, the film may be changed in the space environment. This may be accomplished either in the pressurized LEM or on the Lunar surface.

G.1 TYPE I CAMERA; FILM CHANGE

Spare film is contained in sealed, insulated plastic cans of oval shape. Each can contains two cassettes, one is equipped



GOERZ OPTICAL COMPANY, INC.

with an empty take-up spool, the other one is equipped with a supply spool fully loaded with unexposed film (See Figure 45). The beginning of the film is already securely threaded at the take-up spool.

This camera must be loaded inside the pressurized Lunar Excursion Module. To load the camera, the following steps are necessary:

- a) Remove the camera back-cover.
- b) Lift the rings on top of each cassette and carefully remove supply and take-up cassette simultaneously from the camera.
- c) Cut through the remaining piece of film that connects the two cassettes.
- d) Dispose of the empty supply cassette.
- e) Place the take-up cassette inside the insulated, shielded and pressurized container provided for exposed film material.
- f) Take one plastic container with unexposed film and rip it open.
- g) Remove the two cassettes and slowly pull them apart until the distance between centers is approximately 9 inches (Figure 46).
- h) Carefully insert the two cassettes into the camera at the same time.
- i) Make sure that the metering sprocket is engaged with the perforation in the film.

- j) Advance two full frames while the camera is still open and make sure the film is moving properly.
- k) Set the frame counter to zero.
- l) Place cover on camera and secure safely.
- m) Pressurize the camera to 2 psi.

The camera is now loaded and ready for operation.

G.2 TYPE III CAMERA; FILM CHANGE

Spare film is contained in a sealed, pressurized camera back, that is never opened. It is a unit consisting of two take-up and two supply spools, properly shielded and insulated. Film can be exchanged in space environment by simply opening two latches on the sides, which will detach the camera back with the exposed film inside. The new camera back with fresh film can now be attached by using the same two latches. The camera is now ready to be operated again.

The advantages of this system are simplicity, no threading, and compatibility with the space environment.

The disadvantage is excessive weight to be carried to and from the moon.

G.3 TYPE IV CAMERA; FILM CHANGE

Spare film is contained in sealed plastic cans which are opened shortly before use. Each can contains an unsealed

LIFT-UP RING

COVER

TAKE-UP SPOOL

EXPOSED FILM

TAKE-UP CASSETTE
BODY

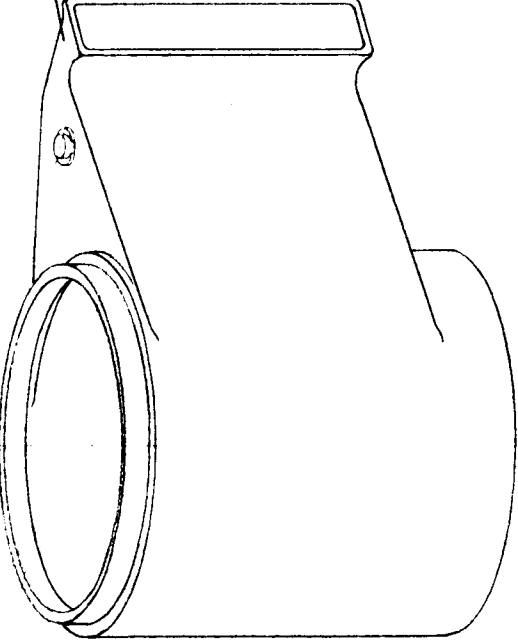
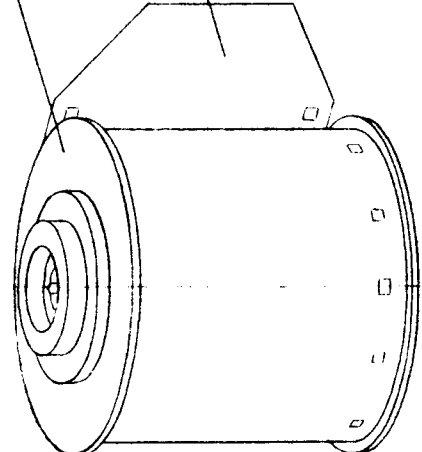
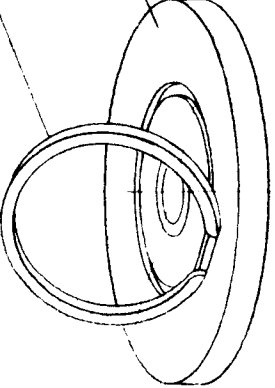

LIFT-UP RING

COVER

EMPTY SUPPLY SPOOL

SUPPLY CASSETTE BODY

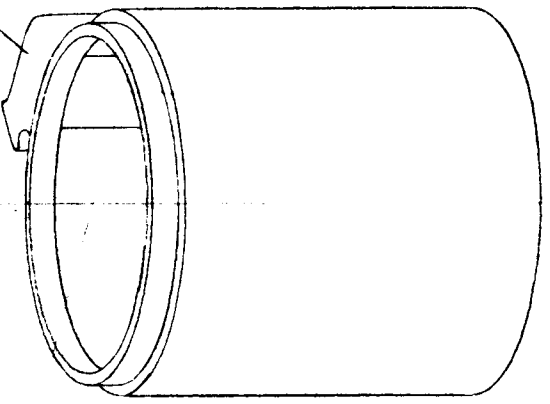
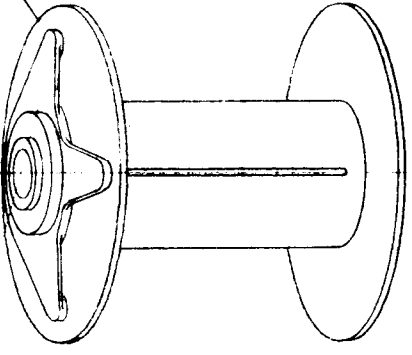
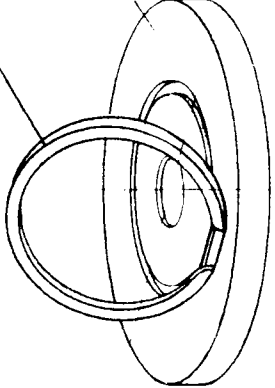

CASSETTES & FILM SPOOLS
FOR TYPE I CAMERA

FIGURE 45

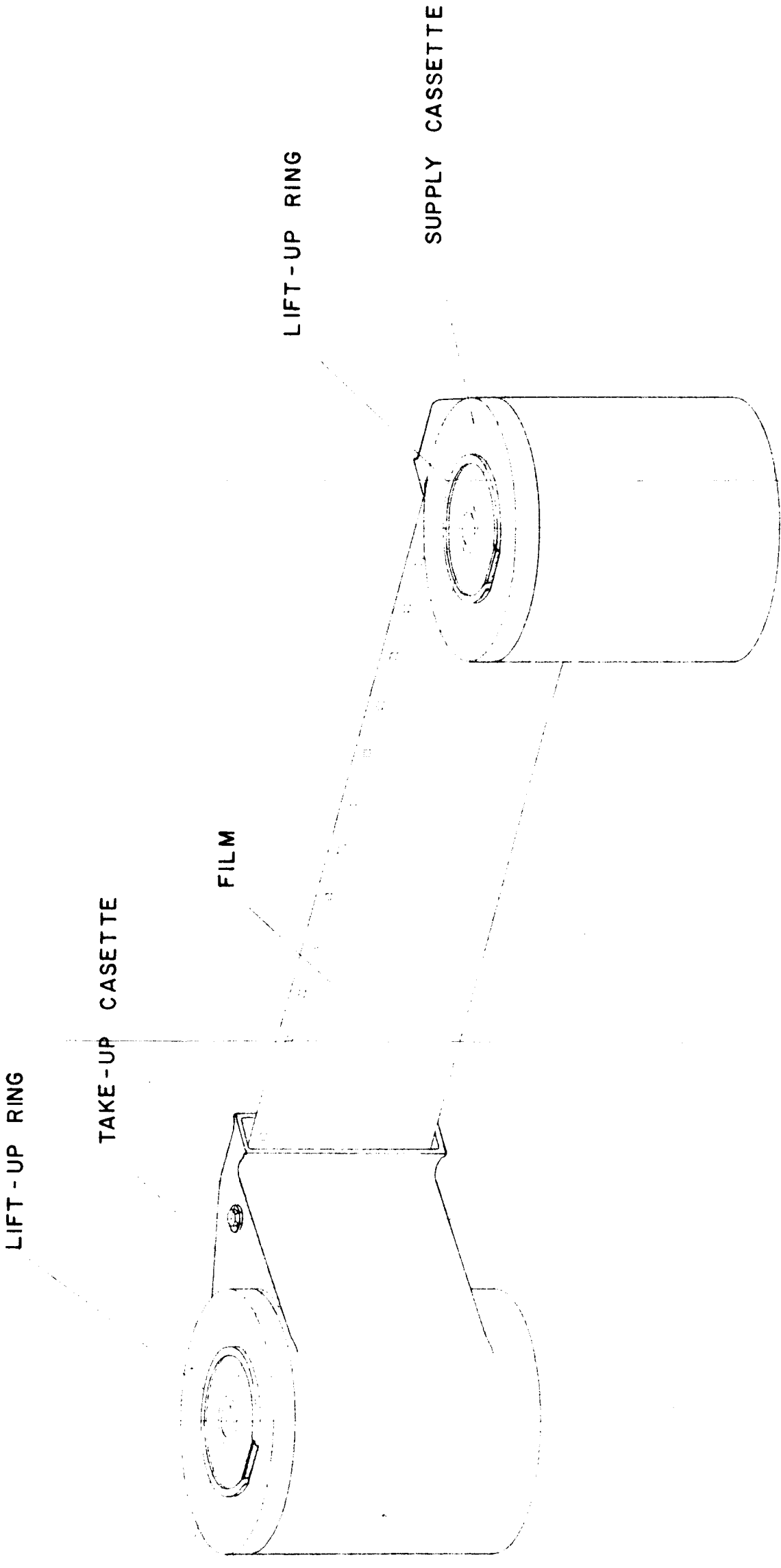

FILM CASSETTE FOR TYPE I CAMERA

FIGURE 46



GOERZ OPTICAL COMPANY, INC.

cassette which is equipped with one take-up and one supply spool. The film material is exposed to the space environment for a short time while the cassette is inserted into the camera. Immediately after the camera cover is securely locked the camera has to be repressurized. This is accomplished by a small pushbutton on the exterior which will open a valve and release gas from a capsule inside the camera until a pressure of 2 psi is reached.

H. AUTOMATIC EXPOSURE CONTROL

Physically, the automatic exposure control consists of four separately located units:

- a) The sensing unit
- b) The electronic unit - amplifier
- c) The iris motor drive
- d) The light level indicator

The sensing unit consists of a small optical re-imaging system, an aperture stop, a CdS cell and a feedback iris. The front lens is located on the vertical centerline of the camera front near the bottom, with optical axis collimated to the camera lenses. The electronics package encloses the sensing and reference circuits and the amplifier. This package is located near the sensing unit near the bottom of the camera. The iris motor drive is mounted in the center of the lens board. The movement of the torque motor shaft is transmitted

to the camera lens iris diaphragms by means of gears and belt drives. The ratio is approximately 4:1 thus allowing the torque motor to rotate one full revolution for the total range of the iris diaphragm control.

The light level indicator is a galvanometer located near the Fresnel lens of the viewfinder such that the moving hand can be seen in the viewfinder field as shown below:

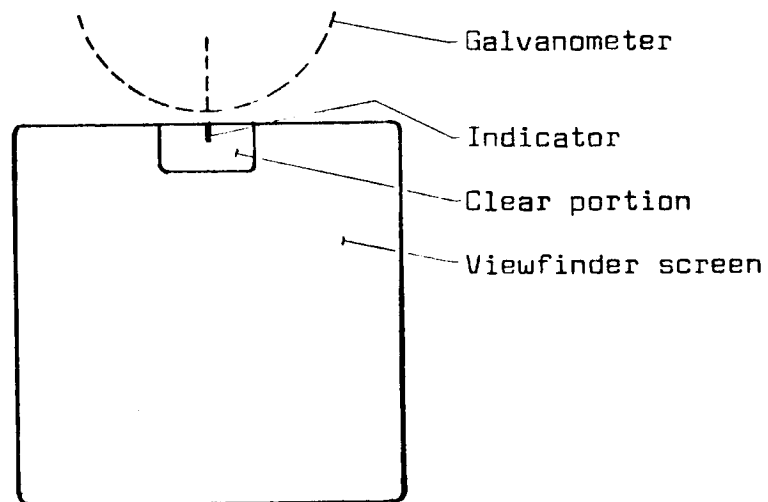

I. SHUTTER MECHANISM AND FILM PRESSURE PLATES

All three camera designs incorporate the same basic shutter mechanisms and film pressure plates. Figure 47 illustrates the design concept of the shutter with actuator and release mechanism. Simultaneously with the film advance motion of the camera handle, the shutter is wound. The slip clutch in the winding train limits the torque applied on the drive

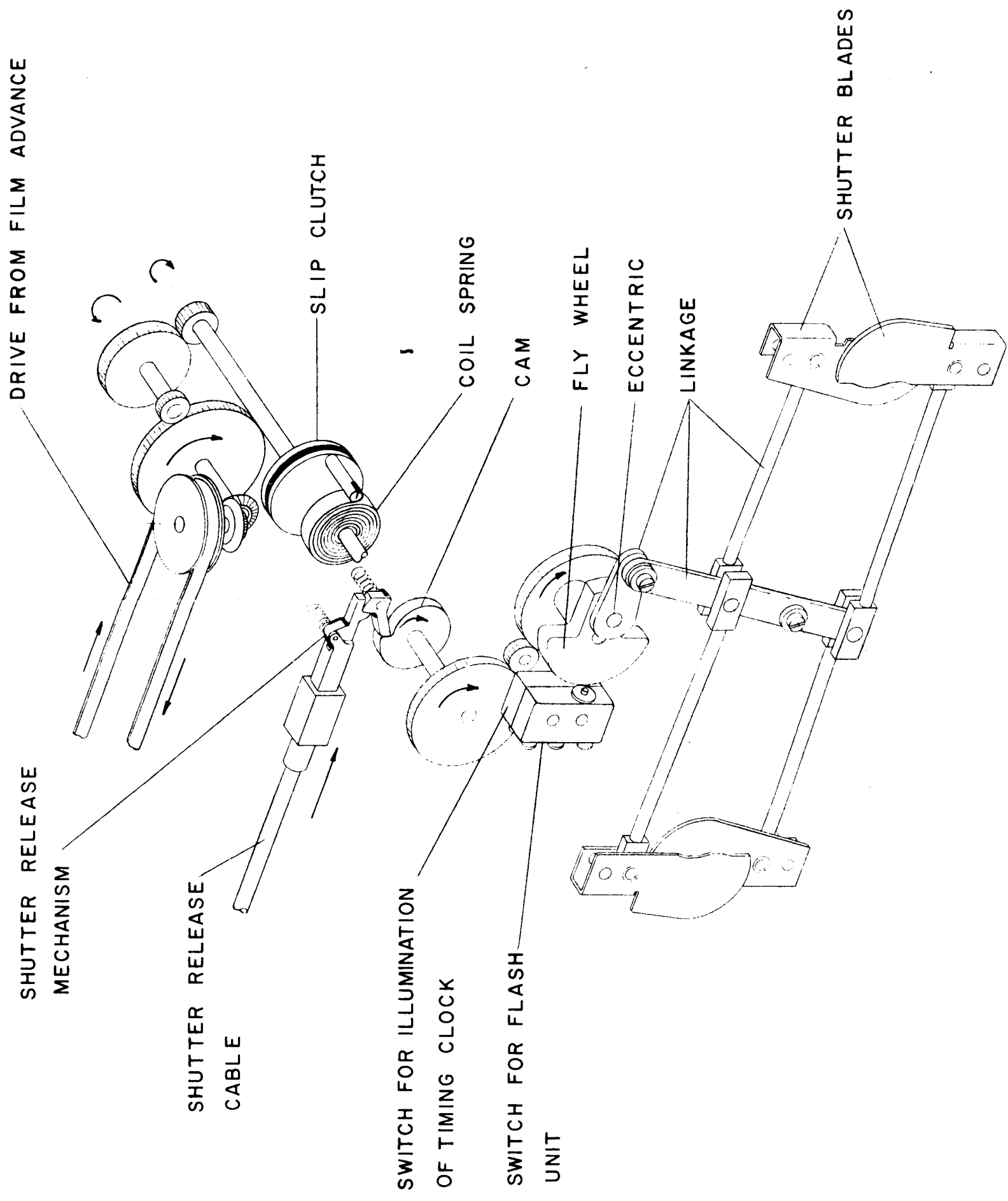

SHUTTER MECHANISM

FIGURE 47



GOERZ OPTICAL COMPANY, INC.

spring and thereby defines the spring tension. Changing the slip torque on the clutch will result in a change of the spring tension. Should the film require a larger latitude adjustment than provided with the diaphragm control, an adjustable slip clutch will allow different tensions on the drive spring, which causes a change of the exposure time. With the completion of the film advance motion the shutter drive mechanism is cocked. Depressing the shutter release button releases, through the shutter release cable, the catch on the cam which counteracts the spring tension. With the cam free to rotate the drive spring accelerates the eccentric mechanism. After 50° of eccentric rotation the shutter blades start to open up, the unrestricted aperture, since they are connected to the eccentric by a linkage system. After an additional 46° rotation of the eccentric the optical path is completely open and remains open for the following 168° rotation. Closing the shutter occurs during the next 46° , leaving the remaining 50° of the full rotation to decelerate the mechanism. With the full rotation completed the shutter is locked by means of the catch acting on the cam. Rewinding the film will ready the shutter for the next exposure. Besides actuating the shutter blades the eccentric also closes the switch contacts for the illumination of the elapsed time recording watch and flash unit contact. The shutter efficiency for the full



GOERZ OPTICAL COMPANY, INC.

aperture based on the nominal exposure time of .01 second is slightly better than 70%. Stopping down the aperture will considerably improve the efficiency.

The shutter release button also actuates, by means of a cable, the film pressure plate. To minimize friction, and possible damage to the emulsion, the film passes through the camera guided only by the rollers. At the time of exposure the film must be located with respect to the lens within ± 0.005 inches. This can only be accomplished when the film is loaded against a fixed plane. The film side of the field flattener, Figure 37, is factory adjusted to conform with the focal plane. The film pressure plate actuated at the time of the exposure presses the film against the field flattener. With the release of the shutter release button the film pressure plate retracts and frees the film for the following advancing motion.

J. FOCUSING CONTROL AND RANGE FINDER

Focussing is accomplished in all three designs by positioning the entire lens assembly with reference to the film plane defined by the back surface of the field flattener, Figure 48. In order to obtain diffraction limited performance the lens assembly must be positioned within 0.0025 inch of the theoretical value. Tests performed with the Rolliflex camera, taking into account the handicaps of the space suited astronaut shows a repeatability of

the lens mounting board within 0.010 inch on a well defined target and 0.20 inches on a repeating pattern target. The viewfinder for this test was equipped with a 75mm focal length lens and the in-focus position was judged by observing the target on the ground glass with and without the aid of a magnifier lens. The test results rule out the use of the ground glass viewfinder as an accurate focussing indicator. All three designs of the lunar camera are equipped with a range finder of a six inch stereo base. Alignment and simultaneous focussing of both, camera lens and viewfinder, is achieved by mounting all three lenses on one common lens board, as shown in Figure 49. Releasing the handle on the right side of the camera by depressing the focussing release knob permits the operator to position the lens board; thus the adjustment mechanism. Coupled to the lens board is the range finder which gives the operator the indication of the on-focus position. The resolution obtained with this system is described in Section IV-8.

K. CLOSE FOCUS ATTACHMENT

1:1 and 1:7 magnifications are obtained by focussing the camera lens at infinity and attaching the camera to the close focus attachment which consists of two lenses and two sets of legs as shown in Figure 50. The 1:1 magnification requires a copy lens of focal length equal to that of the camera lens. A seven to one reduction is obtained by making the focal length of the

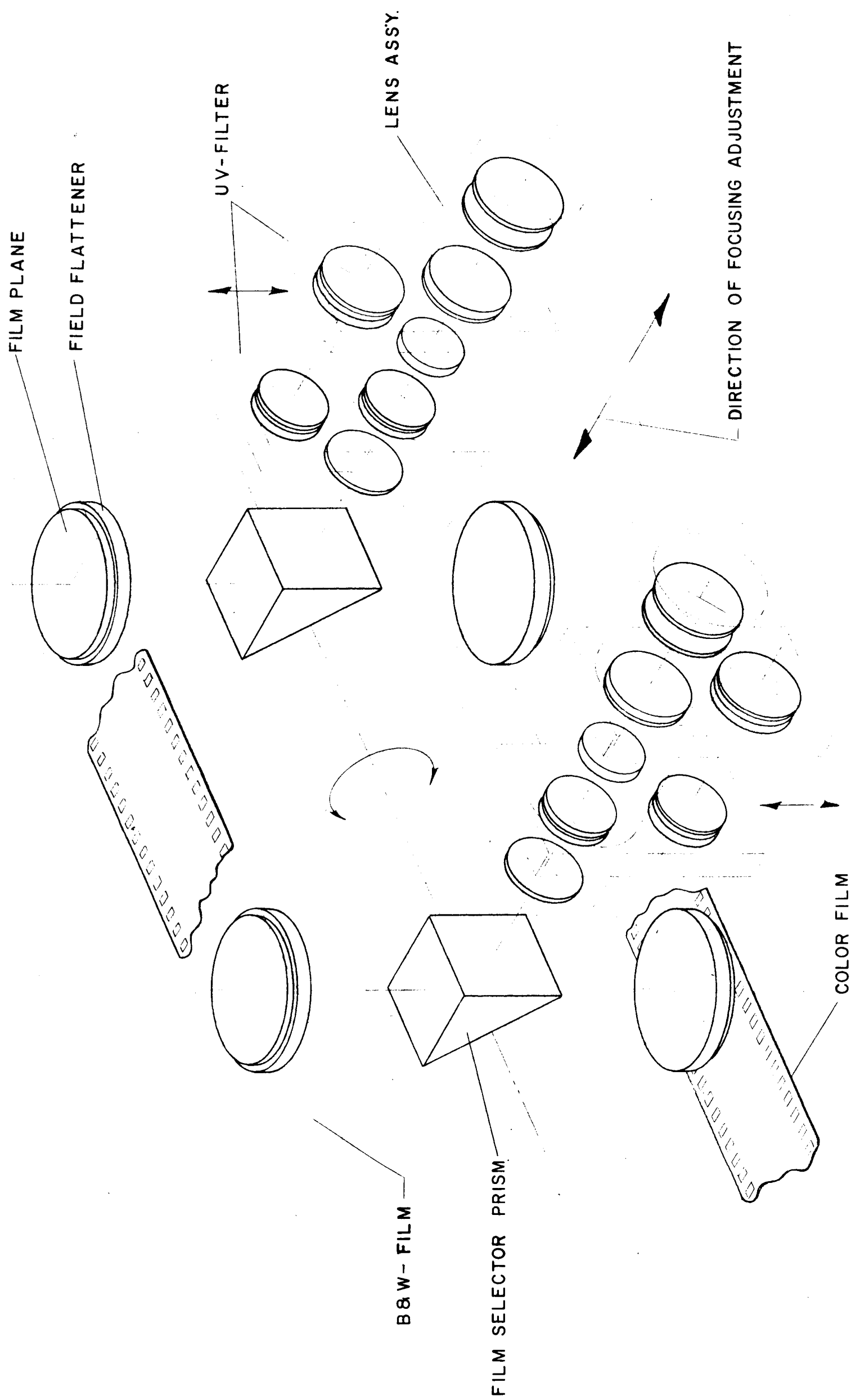

CAMERA OPTICS TYPE I CAMERA

FIGURE 48

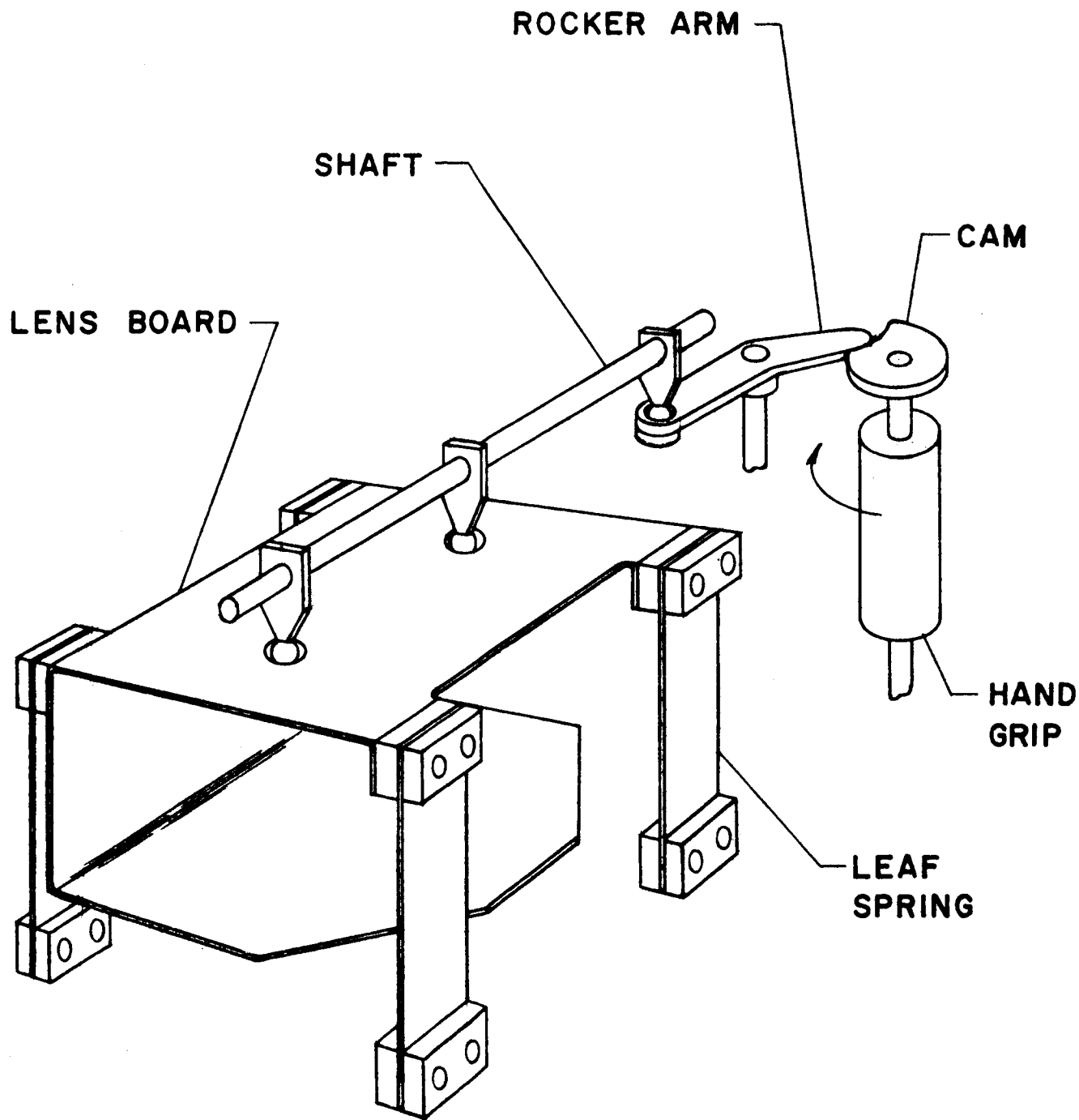

FOCUSING MECHANISM

FIG. 49

copy lens seven times the focal length of the camera lens. In each case the object to be photographed must be located at the focal plane of the copy lens. The fixture shown provides a mounting surface for the camera on either side of the lens mounting board and legs of the proper length to position the copy lens at the correct distance from the object. The detail design of the fixture would position the camera over the proper lens so that operation error would be impossible. Stereo pairs would be obtained by a shift in position of the camera in the attachment by a predetermined amount between sequential exposures.

L. TELESCOPE

The essential telescope elements are the primary mirror, Newtonian Mirror, film transport and shutter, viewfinder, supporting structure and panhead. These elements are shown pictorially in Figure 51.

The primary mirror is a 60 inch focal length paraboloidal mirror on a light weight beryllium substrate. The mirror blank is 6 inches in diameter and one inch thick. The back of the blank is cored out to reduce the weight to approximately 25 percent of that of a solid blank, approximately 0.6 pounds. The mirror will be supported by a beryllium ring of channel section, connected to the mirror by three leaf spring elements. The Newtonian mirror is an elliptical flat, also of beryllium, supported by four spider vanes from the main structural ring.

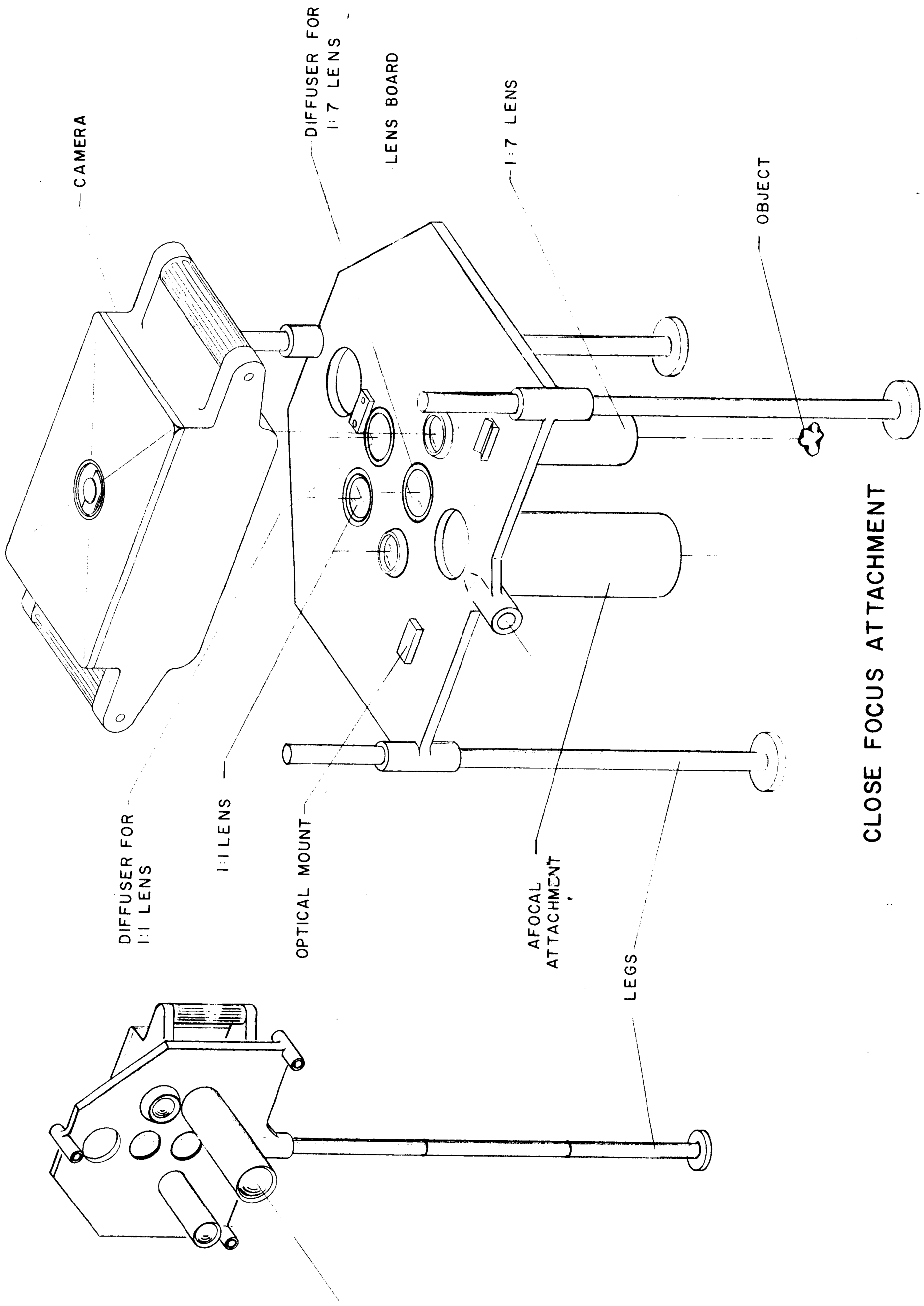

CLOSE FOCUS ATTACHMENT

FIGURE 50

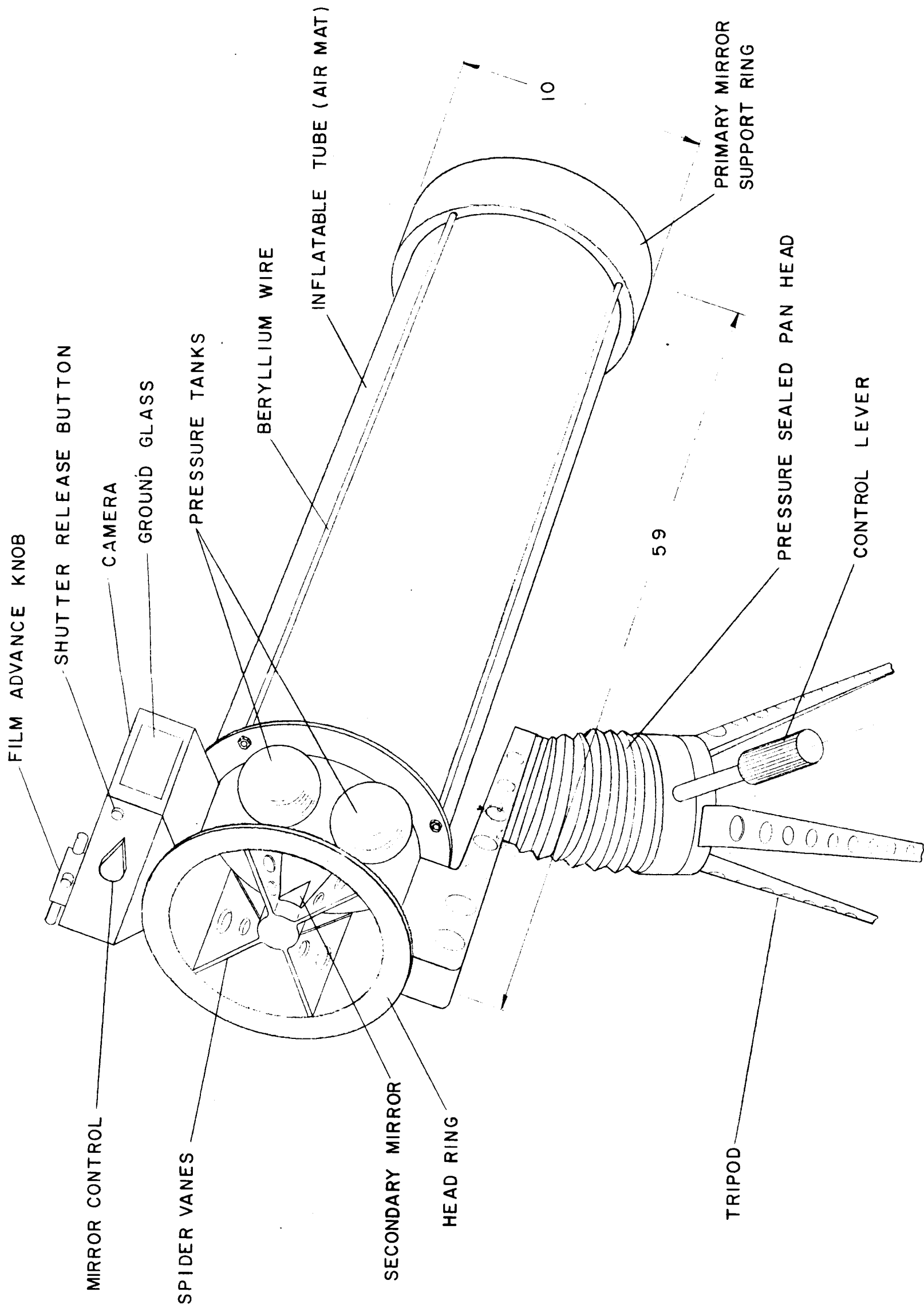

TELESCOPE

FIGURE 51



GOERZ OPTICAL COMPANY, INC.

In the case of the Type I camera, the telescope is to be used with the camera. A lens of focal length equal to that of the camera is mounted with its front focal plane coincident with the focal plane of the telescope. This lens serves two functions. It may be used as an eyepiece for pointing the telescope before attaching the camera and acts as a collimating lens to reimage the telescope image at infinity so that it may be photographed by the camera when it is focussed for infinity.

The telescope is a completely separate instrument when used with the Type III or Type IV camera. In this case a film transport of similar design to that of the camera is mounted and a reflex mirror with an eyepiece is used for pointing and focusing. In this case a window located just ahead of the reflex mirror is used to seal the mechanism and the film chamber.

The collapsible tube will be made from Goodyear Airmat. This material is essentially two layers of cloth woven so that 180 threads per square inch are transposed from one layer to the other. After weaving, the cloth is sealed by impregnation with a suitable elastomer. The finished tube may be folded, like a camera bellows, into a length of six inches. In use the space between the two layers of cloth is pressurized by gas bottles, located in the main structural ring, and becomes a rigid tube. This material is space rated and has been used

in lens cones of larger sizes than required for this application.

The accurate spacing of the secondary mirror relative to the primary mirror is obtained by three stainless wires which are stretched axially from the headring to the primary mirror support ring. The wires are fastened on the periphery of the both rings and spaced 120° apart.

The pan head consists of a ball joint protected by an enveloping bellows. The unbalanced moment about the ball will be approximately 4 foot-pounds on earth but will be insignificant on the surface of the moon.

M. DETAIL DESIGN TYPE I CAMERA

The integration of all the components discussed above into a single comprehensive camera design is illustrated for the Type I camera in Figures 52, 53 and 54. The details called out by number in these drawings may be identified by the following numerical listings:

CAMERA HOUSING

1. Reflective Coating
2. Thermal Insulation
3. Sheet metal structure
4. Radiation shield for film spools



GOERZ OPTICAL COMPANY, INC.

BACK COVER

6. Reflective Coating
7. Thermal Insulation
8. Sheet metal structure
9. Static seal
10. Locking mechanism
11. Frame counter
12. Zero reset

STEREO OPTIC

16. Lens
17. Rolling diaphragm seal
18. Main lens board
19. Field flattener lens
20. Lens board

UV FILTERS

21. Filter control lever
22. Filter control indicator
23. Rotary seal
24. Filter control drive
25. Filter slide
26. Leaf spring
27. Flip-flop disk
28. Spring plunger
29. UV correcting lens and filter
30. Visual IR corrector lens

IR FILTERS

31. Filter control lever and indicator
32. Filter
33. Filter drive mechanism
34. Filter holder

FOCUSSING MECHANISM

36. Focussing control handle
37. Focussing release
38. Rotary seal
39. Focussing control drive
40. Flexible coupling

AUTOMATIC EXPOSURE CONTROL

41. Exposure setting button
42. Rolling diaphragm
43. Static seal
44. Exposure control switch
45. Lens system
46. Iris feedback control
47. CdS Cell
48. Iris diaphragm motor drive
49. Main Iris Diaphragm
50. Light level indicator
51. Exposure control amplifier
52. Battery



GOERZ OPTICAL COMPANY, INC.

RANGE FINDER

- 56. Adjustable flat mirror
- 57. Front window right
- 58. Front window left
- 59. Fixed flat mirror
- 60. Viewing aperture

VIEW FINDER

- 61. Lens system
- 62. Rolling diaphragm
- 63. Flat reflecting mirror
- 64. Fresnel lens
- 65. Sunshade

FILM SELECTOR

- 66. Film Selector lever
- 67. Film selector indicator
- 68. Rotary seal
- 69. Film selector drive
- 70. Film selecting prism
- 71. Prism holder
- 72. Prism tilt drive
- 73. Prism shaft and gear
- 74. Torsion spring
- 75. Prism position stop

FILM ADVANCE MECHANISM

- 80. Film #1 (Black and White)
- 81. Film #2 (Color)
- 82. Film cassette for take-up spool
- 83. Film cassette for supply spool
- 84. Take-up spool
- 85. Supply spool
- 86. Lift-up ring
- 87. Guide roller
- 88. Film winding shaft
- 89. Film advance handle
- 90. Override safety clutch
- 91. Rotary seal
- 92. Drive shaft
- 93. Belt drive
- 94. Drive mechanism
- 95. Differential gear assembly
- 96. Film advance interlocking assembly
- 97. Actuator for interlock release
- 98. Metering sprocket
- 99. Metering drive



GOERZ OPTICAL COMPANY, INC.

SHUTTER MECHANISM

101. Shutter release button
102. Rolling diaphragm
103. Shutter winding mechanism
104. Shutter release and double exposure interlock
105. Shutter release transmission
106. Shutter release mechanism
107. Shutter and linkage
108. Switches for flashlight and timing illumination
109. Film pressure plates

ELAPSED TIME RECORDING UNIT

111. Accutron calendar clock
112. Light source and reflector
113. Rotating mask
114. Fiber optics bundles
115. Solenoid

FLASH UNIT

116. Reflectors
117. Flash tube
118. Electronics
119. Battery

PRESSURIZATION SYSTEM

- 121. Gas reservoir
- 122. Pressure gage
- 123. Pressure control unit

XIV SPECIFICATION

Detailed specifications for Types I, III and IV are listed in Appendices II, III, and IV. Specifications for the Type II camera were not detailed because preliminary layouts showed that the required additional space and weight were not justified by an adequate increased performance potential. A general specification applicable to all three types of cameras are covered in Appendix I.

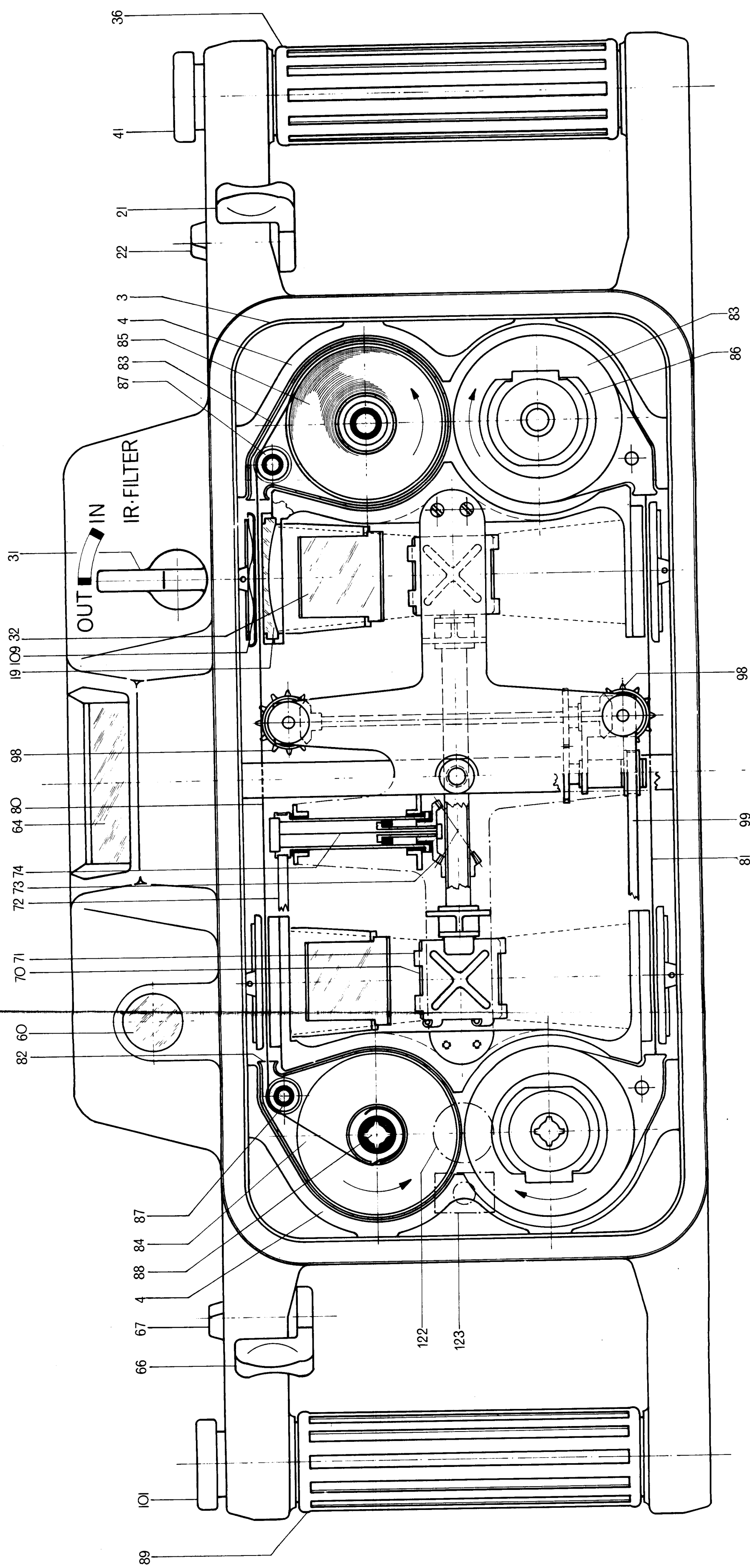

FIG. 52

1 2 INCHES

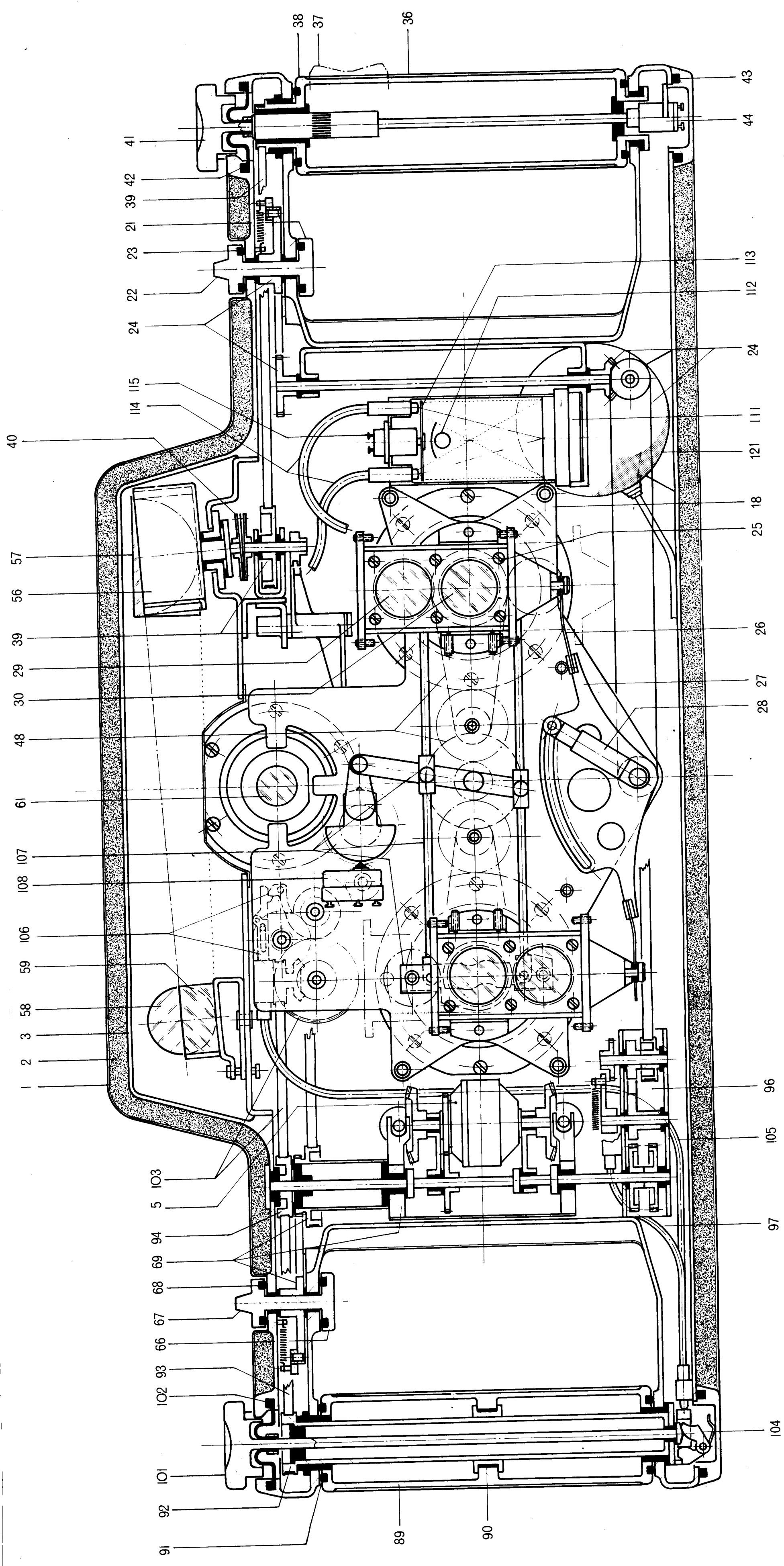

FIG. 5B

0 1 2 INCHES

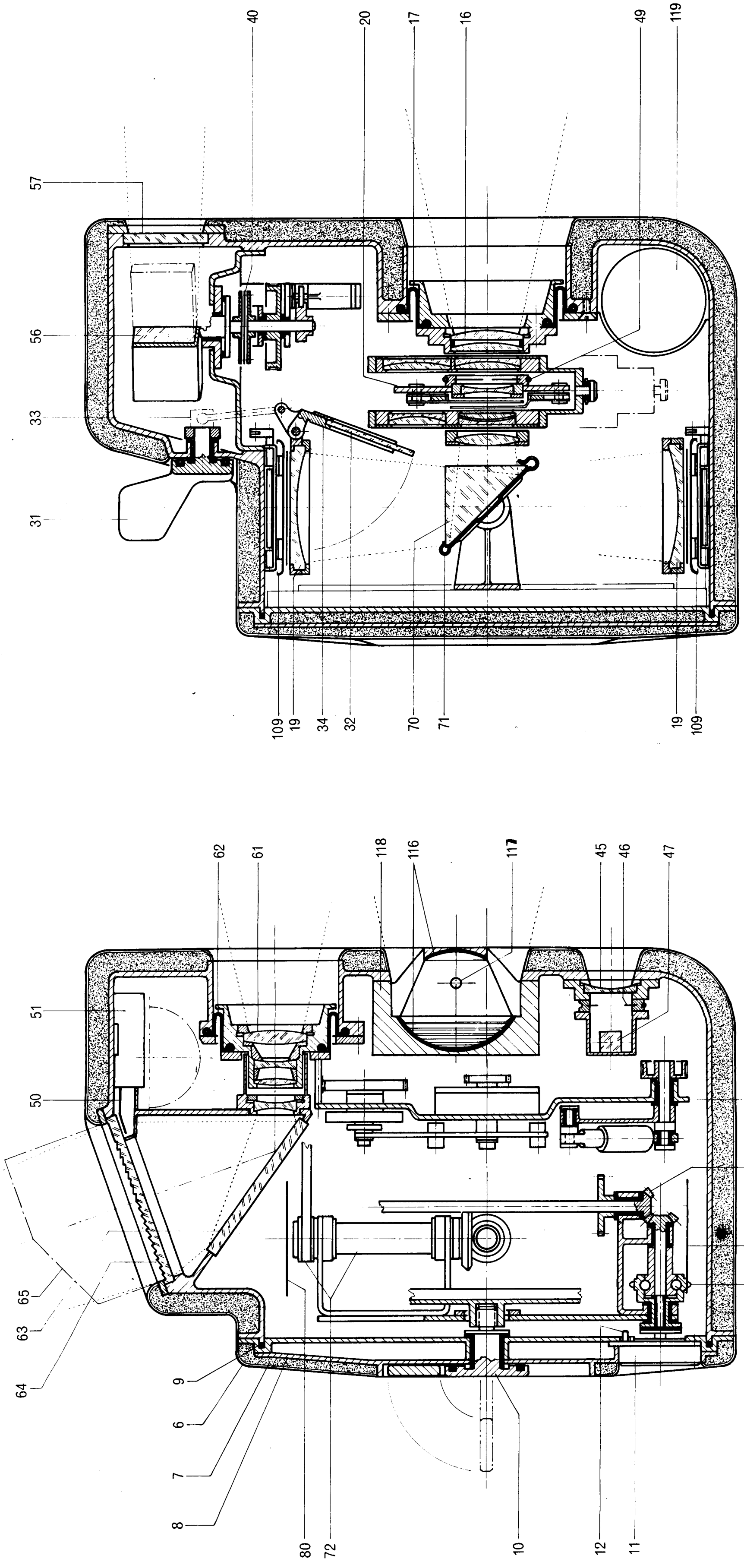

FIG. 54





GOERZ OPTICAL COMPANY, INC.

APPENDIX I

GENERAL SPECIFICATIONS FOR THE LUNAR SURFACE HAND HELD CAMERA

I INTRODUCTION

The Lunar Surface Hand Held Camera is to be used on the Apollo Mission to collect a wide variety of scientific data. Reliability under the diverse environmental conditions and compatibility with the space suited astronaut are the basic requirements of the camera.

II ENVIRONMENT

The basic environmental specification will be "Environment Specifications for Apollo Scientific Equipment", as included as Appendix I to Contract NAS 9-3583. In order to meet these requirements, it will be necessary for the camera to be pressurized to at least one millimeter of mercury to prevent outgassing of the emulsion and to prevent cold welding of internal mechanism. Adequate shielding must be provided to the film, before and after exposure, to prevent radiation fogging. The outer surface of the camera must have the proper emissivity and reflectivity properties to maintain the temperature within the range of 0°C to 25°C. Sufficient insulation must be provided to prevent rapid cooling of the camera when temporarily shaded from direct solar radiation. Controls must be provided which are compatible with the limited dexterity of the astronaut.

III OPTICAL PERFORMANCE

Lens performance will be measured according to applicable sections of MIL-STD-150 and National Bureau of Standard Circular 533 - "Method for Determining Resolving Power of Photographic Lenses".



GOERZ OPTICAL COMPANY, INC.

APPENDIX II

PERFORMANCE SPECIFICATIONS TYPE I CAMERA

I GENERAL DESCRIPTION

This stereo camera covers the entire photographic spectral range with high resolution in three ranges. A color film is used to cover the range of 2400A° to 7000A°. A black and white film is used to cover the range 4000A° to 9000A°. Both films are loaded into the camera simultaneously and advanced by separate film transports. Selection of film is by means of a rotating mirror or prism. Corrector lenses may be used to correct the performance of the lenses for the different spectral ranges. These lenses should be of zero or minimum power to minimize location problems and must be located inside of the camera in the pressurized zone. Filters are to be provided to isolate the three spectral ranges.

II OPTICAL REQUIREMENTS

Focal Length: 75mm

Aperture Ratio: f/5.6

Format: 1 x 1 inch

Focussing Range: 3 feet to infinity

Stereo Base: 5 inch minimum

Resolution	Axial	12½° Off Axis
3000A°	200 lines/mm	180 lines/mm
6000A°	200 lines/mm	180 lines/mm
8000A°	200 lines/mm	180 lines/mm

Transmission: 65% minimum

Relative Illumination: 75% at 12½° off axis.

III VIEWFINDER

Reflex type with separate lens. Lens must be coupled to camera lenses to give indication of focus. Format 2 x 2 inch to match 1 x 1 inch film format. Fresnel lens to be used at screen to provide exit pupil at approximately 18 inches from screen.

IV RANGE FINDER

A coupled, unit power, split field range finder with stereo base of 6 inches and an angular field of 5° is to be provided. Coupling mechanism must be repeatable to ± 0.0001 inches.

V MICROSCOPE ATTACHMENT

An attachment is to be provided which will allow high resolution photography at unit magnification. This attachment should employ an auxiliary lens of the same type as the camera lens, and provide a mechanical means of locating the camera at the proper distance from the object. This attachment must be capable of being installed and removed from the camera on the lunar surface by the astronaut. Stereo base shall be 0.2 inches, stereo pairs may be exposed sequentially.



GOERZ OPTICAL COMPANY, INC.

Optical performance when combined with camera lens:

Resolution: 100 lines/millimeter AWAR

Spectral Range: 4000A° to 7000A°

Transmission: 50%

Relative Illumination: Illumination at corners to be at least
75% of on axis illumination.

Focal Length: 75mm \pm 1mm

VI TELESCOPE ATTACHMENT

A telescope attachment of six inches aperture and sixty inches focal length shall be provided. This attachment must weigh less than six pounds and be capable of being stored in less than one cubic foot. Conversion from stored to operating configuration must be capable of being performed on the lunar surface. Methods of accurately pointing the telescope and mounting to the tripod are to be provided.

VII TRIPOD

A lightweight camera support is to be provided to locate and orient the camera when used at close distances where depth of focus is a problem and when used with the telescope attachment where accurate pointing is required. Weight of tripod is to be less than two pounds.

VIII ELAPSED TIME RECORDER

An Accutron watch or equivalent, with necessary projection lens

and illumination, is to be incorporated in the camera to provide a time record of each exposure. Required resolution is one second. Accuracy is to be ± 1 second per day when calibrated after landing on the moon.

IX AUXILIARY ILLUMINATION

A gas discharge flash lamp is to be provided for shadow fill-in and illumination of detailed objects in shaded areas. The beam angle is to be matched to the acceptance angles of the photographic objectives. Power supply is to be sufficient for at least 300 exposures. Illumination of targets 20 feet from the camera shall be equivalent to 2% of illumination from the sun.

X SHUTTER

The shutter shall be of the between-the-lens type with a minimum number of elements. Shutter speeds shall be 1/100 second and bulb. Shutter efficiency shall be at least 70%.

XI FILM TRANSPORT

Film transport mechanism shall transport 300 stereo pairs from each of two sealed, shielded supply cassettes into similar take-up cassettes. The mechanism shall be designed to prevent double exposures and shall not waste film by advancing unexposed film except for a maximum of 5 frames at beginning of roll. The transport mechanism shall locate film within 0.0005 inches of focal plane. No rubbing action on the emulsion during the film advance is permitted. The transport mechanism will not bend film so that emulsion side becomes convex at any time.



GOERZ OPTICAL COMPANY, INC.

XII SIZE AND WEIGHT

The camera with auxiliary light source, but exclusive of microscope attachment, telescope attachment, cassette radiation shielding, and tripod, shall weigh no more than 7 pounds and require no more than 1/4 cubic foot space.

APPENDIX III

PERFORMANCE SPECIFICATIONS TYPE III CAMERA

I GENERAL DESCRIPTION

This stereo camera covers the spectral range from 4000A° to 9000A° with high resolution in two ranges. A color film is used to cover the range of 4000A° to 7000A°. A black and white film is used to cover the range 4000A° to 9000A°. Both films are loaded into the camera simultaneously and advanced by separate film transports. Selection of film is by sliding film transports vertically in film plane. Filters are to be provided to isolate the visual and infrared spectral ranges.

II OPTICAL REQUIREMENTS

Focal Length: 52mm

Aperture Ratio: f/4.5

Format: 1.2 x 1.2 inches

Focussing Range: 10 feet to infinity

Stereo Base: 6 inch minimum



GOERZ OPTICAL COMPANY, INC.

Resolution	Axial	20° Off Axis
6000A°	100 lines/mm	100 lines/mm
8000A°	50 lines/mm	50 lines/mm

Transmission: 65% minimum

Relative Illumination: 75% at 20° off axis.

III VIEWFINDER

Reflex type with separate lens. Lens must be coupled to camera lenses to give indication of focus. Format 2 x 2 inch to match 1.2 x 1.2 inch film format. Fresnel lens to be used at screen to provide exit pupil at approximately 18 inches from screen.

IV RANGE FINDER

A coupled, unit power, split field range finder with stereo base of 6 inches and an angular field of 5° is to be provided. Coupling mechanism must be repeatable to ± 0.0001 inches.

V MICROSCOPE ATTACHMENT

An attachment is to be provided which will allow high resolution photography at 1:1 and 1:7 magnifications. This attachment should employ auxiliary lenses of the same type as the camera lens, and provide a mechanical means of locating the camera at the proper distances from the object. This attachment must be capable of being installed and removed from the camera on the lunar surface by the astronaut. Stereo base shall be 0.2 inches, stereo pairs may be exposed sequentially.

The auxiliary lenses shall be of 50mm ± 1 mm and 350mm ± 3 mm focal length. When combined with the camera lens, the combination shall give the following performance:

Resolution: 100 lines per millimeter AWAR

Spectral Range: 4000A° to 7000A°

Transmission: 50%

Relative Illumination: Illumination at the corners of the field when measured over a 2 millimeter square shall be at least 60% of on axis illumination.

VI TELESCOPE

A telescope of six inches aperture and sixty inches focal length shall be provided. This instrument must weigh less than ten pounds and be capable of being stored in less than one cubic foot. Conversion from stored to operating configuration must be capable of being performed on the lunar surface.

The telescope will be provided with a film transport of similar design to that of the camera and be capable of accepting the same film cassettes. Provisions shall be made for reflex focussing and pointing. A pan head shall be provided suitable for pointing of the telescope when clamped to the LEM, the Lunar Walker or other available support.

VII ELAPSED TIME RECORDER

An Accutron watch or equivalent, with necessary projection lens and illumination, is to be incorporated in the camera to provide



GOERZ OPTICAL COMPANY, INC.

a time record of each exposure. Required resolution is one second. Accuracy is to be ± 1 second per day when calibrated after landing on the moon.

VIII AUXILIARY ILLUMINATION

A gas discharge flash lamp is to be provided for shadow fill-in and illumination of detailed objects in shaded areas. The beam angle is to be matched to the acceptance angles of the photographic objectives. Power supply is to be sufficient for at least 300 exposures. Illumination of targets 20 feet from the camera shall be equivalent to 2% of illumination from the sun.

IX SHUTTER

The shutter shall be of the between-the-lens type with a minimum number of elements. Shutter speeds shall be 1/100 second and bulb. Shutter efficiency shall be at least 70%.

X FILM TRANSPORT

Film transport mechanism shall transport 300 stereo pairs from each of two sealed, shielded supply cassettes into similar take-up cassettes. The mechanism shall be designed to prevent double exposures and shall not waste film by advancing unexposed film except for a maximum of 5 frames at beginning of roll. The transport mechanism shall locate film within 0.0005 inches of focal plane. No rubbing action on the emulsion during the film advance is permitted. The transport mechanism will not bend film so that

emulsion side becomes convex at any time.

XI SIZE AND WEIGHT

The camera with auxiliary light source, but exclusive of microscope attachment, telescope and cassette shielding, shall weigh no more than 9.6 pounds and require no more than 1/3 cubic foot space.



GOERZ OPTICAL COMPANY, INC.

APPENDIX IV

PERFORMANCE SPECIFICATIONS TYPE IV CAMERA

I GENERAL DESCRIPTION

This stereo camera covers the spectral range from 4000A° to 10,000A° with high resolution in two ranges. A color film is used to cover the range of 4000A° to 7000A°. A black and white film is used to cover the range of 4000A° to 9000A°. The films will be loaded into the camera as required. Interchangeability of cassettes on the surface of the moon with minimum waste of film is required. Filters are to be provided to isolate the two spectral ranges.

II OPTICAL REQUIREMENTS

Focal Length: 52mm

Aperture Ratio: f/4.5

Format: 1.2 x 1.2 inches

Focussing Range: 3 feet to infinity

Stereo Base: 6 inch minimum

Resolution	Axial	20° Off Axis
6000A°	100 lines/mm	100 lines/mm
8000A°	50 lines/mm	50 lines/mm

Transmission: 65% minimum

Relative Illumination: 75% at 20° off axis.

III VIEWFINDER

Reflex type with separate lens. Lens must be coupled to camera lenses to give indication of focus. Format 2 x 2 inch to match 1.2 x 1.2 inch film format. Fresnel lens to be used at screen to provide exit pupil at approximately 18 inches from screen.

IV RANGE FINDER

A coupled, unit power, split field range finder with stereo base of 6 inches and an angular field of 5° is to be provided. Coupling mechanism must be repeatable to ± 0.0001 inches.

V MICROSCOPE ATTACHMENT

An attachment is to be provided which will allow high resolution photography at 1:1 and 1:7 magnifications. This attachment should employ an auxiliary lenses of the same type as the camera lens, and provide a mechanical means of locating the camera at the proper distance from the object. This attachment must be capable of being installed and removed from the camera on the lunar surface by the astronaut. Stereo base shall be 0.2 inches, stereo pairs may be exposed sequentially.

The auxiliary lenses shall be of 50mm ± 1 mm and 350mm ± 3 mm focal length. When combined with the camera lens, the combination shall give the following performance:



GOERZ OPTICAL COMPANY, INC.

Resolution: 100 lines per millimeter AWAR

Spectral Range: 4000A° to 7000A°

Transmission: 50%

Relative Illumination: Illumination at the corners of the field when measured over a 2 millimeter square shall be at least 60% of on axis illumination.

VI TELESCOPE

A telescope of six inches aperture and sixty inches focal length shall be provided. This instrument must weigh less than ten pounds and be capable of being stored in less than one cubic foot. Conversion from stored to operating configuration must be capable of being performed on the lunar surface.

The telescope will be provided with a film transport of similar design to that of the camera and be capable of accepting the same film cassettes. Provisions shall be made for reflex focussing and pointing. A pan head shall be provided suitable for pointing the telescope when clamped to the LEM, the Lunar Walker or other suitable support.

VII ELAPSED TIME RECORDER

An Accutron watch or equivalent, with necessary projection lens and illumination, is to be incorporated in the camera to provide a time record of each exposure. Required resolution is one second. Accuracy is to be ± 1 second per day when calibrated after landing on the moon.

VIII AUXILIARY ILLUMINATION

A gas discharge flash lamp is to be provided for shadow fill-in and illumination of detailed objects in shaded areas. The beam angle is to be matched to the acceptance angles of the photographic objectives. Power supply is to be sufficient for at least 300 exposures. Illumination of targets 20 feet from the camera shall be equivalent to 2% of illumination from the sun.

IX SHUTTER

The shutter shall be of the between-the-lens type with a minimum number of elements. Shutter speeds shall be 1/100 second and bulb. Shutter efficiency shall be at least 70%.

X FILM TRANSPORT

Film transport mechanism shall transport the film from a sealed, shielded supply cassette into a similar take-up cassette. The mechanism shall be designed to prevent double exposures and shall not waste film by advancing unexposed film except for a maximum of 5 frames at beginning of roll. The transport mechanism shall locate film within 0.0005 inches of focal plane. No rubbing action on the emulsion during the film advance is permitted. The transport mechanism will not bend film so that emulsion side becomes convex at any time. Cassettes must be readily interchangeable on the surface of the moon.



GOERZ OPTICAL COMPANY, INC.

XI SIZE AND WEIGHT

The camera with auxiliary light source, but exclusive of microscope attachment, telescope and cassette shielding, shall weigh no more than 7 pounds and require no more than 1/4 cubic foot space.