

NASA TECHNICAL NOTE

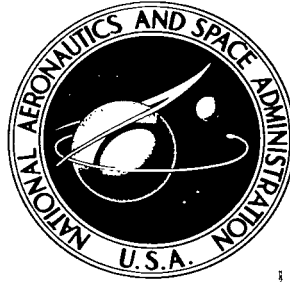

NASA TN D-2948

NASA TN D-2948

61  
LOAN COPY: RETURN  
AFWL (WLIL-2)  
KIRTLAND AFB, N



# ANALYTICAL DETERMINATION OF TRANSFER FUNCTIONS FOR RC COMMUTATED NETWORKS

*by S. N. Carroll*

*George C. Marshall Space Flight Center  
Huntsville, Ala.*

TECH LIBRARY KAFB, NM



0154739

NASA IN D-2070

ANALYTICAL DETERMINATION OF TRANSFER FUNCTIONS FOR  
RC COMMUTATED NETWORKS

By S. N. Carroll

George C. Marshall Space Flight Center  
Huntsville, Ala.

NATIONAL AERONAUTICS AND SPACE ADMINISTRATION

---

For sale by the Clearinghouse for Federal Scientific and Technical Information  
Springfield, Virginia 22151 - Price \$2.00



TABLE OF CONTENTS

	Page
SUMMARY . . . . .	1
SECTION I. INTRODUCTION. . . . .	1
SECTION II. GENERAL EXPRESSION FOR COMMUTATED NETWORK. . . . .	2
SECTION III. CLOSED FORM FOR $F(k, s)$ . . . . .	9
SECTION IV. RECURRENCE EQUATION. . . . .	12
SECTION V. TRANSFER FUNCTION FOR COUPLED CASE. . . . .	15
SECTION VI. TRANSFER FUNCTION FOR UNCOUPLED CASE. . . . .	17
SECTION VII. AMPLITUDE SPECTRA OF SIDEBAND FREQUENCIES. . . . .	18
SECTION VIII. EXPERIMENTAL AND THEORETICAL RESULTS . . . . .	21
SECTION IX. CONCLUSIONS. . . . .	23
REFERENCES. . . . .	24

## LIST OF ILLUSTRATIONS

Figure	Title	Page
1.	Coupled Configuration of Commutated Network . . . . .	3
2.	Uncoupled Configuration of Commutated Network . . . . .	3
3.	Equivalent Circuit for Coupled Commutated Network . . . . .	3
4A.	Equivalent Circuit for Uncoupled Commutated Network . . . . .	4
4B.	Equivalent Circuit for Uncoupled Commutated Network . . . . .	4
5.	N-Path Filter . . . . .	6
6.	N-Path Filter with Feedback . . . . .	6
7.	Commutating Function . . . . .	10
8.	Notch Filter . . . . .	21
9A.	ATN Frequency Response, Amplitude — Theoretical . . . . .	22
9B.	ATN Frequency Response, Phase — Theoretical . . . . .	22
10.	ATN Frequency Response, Amplitude — Theoretical and Experimental . . . . .	23

## DEFINITION OF SYMBOLS

Symbol	Definition
A	maximum value of input signal
a	break frequency, radians/second
C	capacitance, farads
D	special function
dc	direct current
F*	transfer function of commutated network
G	linear filter transfer function
h, H	filter network (time, frequency domain)
i	integer
j	$\sqrt{-1}$
K	potentiometer setting
K'	feedback gain
$k_0$	dc gain
k	integer
M	transfer function of notch filter
m	integer
N	number of paths (equal to number of commutated capacitors)
n	integer
$P_m$	Fourier coefficients of $p_i(t)$
$p_i(t)$	commutating functions
$Q_n$	Fourier coefficients of $q_i(t)$

## DEFINITION OF SYMBOLS (Concluded)

Symbol	Definition
$q_i(t)$	commutating functions
R	resistance, ohms
r	integer
s, s'	complex variables, radians/second
$T_0$	period of commutating functions, seconds
t	time, seconds
$w_i, W_i$	output of $p_i(t)$ (time, frequency domain)
x, X	input signal (time, frequency domain)
y, Y	output signal (time, frequency domain)
$z_i, Z_i$	output of network, h (time, frequency domain)
$\alpha_0$	reciprocal of equivalent time constant, 1/seconds
$\beta$	normalized frequency
$\gamma$	phasing parameter
$\lambda$	phase shift, radians
$\omega_0$	angular frequency of commutating functions, radians/second
$\omega$	angular frequency, radians/second
$\tau$	time constant, seconds

# ANALYTICAL DETERMINATION OF TRANSFER FUNCTIONS FOR RC COMMUTATED NETWORKS

## SUMMARY

A method of analysis for obtaining the transfer functions for RC commutated networks is presented in this report. The method is illustrated by analyzing two configurations of a commutated network which were studied during the development of an adaptive tracking notch filter at Marshall Space Flight Center. The analysis is performed by generating a recurrence equation and the summation of two infinite series. The total frequency spectra for the commutated network output can be calculated using the input spectrum, the transfer function of the commutated network, and the transfer function of a linear filter. The results show the comparison between the frequency response using the theoretical transfer function and an actual RC commutated network.

## SECTION I. INTRODUCTION

Before the N-path filter analysis technique [1] was presented in the literature, analysis of RC commutated networks was either restricted to simple circuits consisting of only a few commutated elements or contained mathematical approximations which invalidated the results except over specific intervals [2]. This paper develops a method of analysis to obtain exact frequency spectra for most RC commutated networks. This has been achieved, with the aid of the N-path filter development, by adding a feedback loop to the original N-path filter, introducing a phasing parameter, and developing a technique for generating a recurrence equation.

In many respects, a commutated RC network behaves in a linear manner. However, a very important nonlinearity is the generation of sideband frequencies that result from commutating the capacitors. This phenomenon is quite similar to that encountered in sampled-data systems. For a single input frequency (signal frequency), the output will contain a signal (or primary) frequency component and an infinite number of sideband components. The term "frequency response" is used herein to denote the network characteristics at the signal frequency. This report presents the derivation of the transfer function for two different configurations of commutated networks and also an expression for calculating the frequency spectra of the sideband components. The term "transfer function" as used in this report is defined in Section V.



In Section II, the equivalence between the commutated network and the N-path filter is presented. A general expression is then derived for an N-capacitor configuration. It is shown that the sideband frequencies depend on the number of capacitors and the phasing between the commutating functions. An expression is derived in Section III for the open loop characteristics of the equivalent N-path filter configuration.

The derivation of the recurrence equation is presented in Section IV. The expression presented in Section V gives the complete frequency domain characteristics of the four-capacitor coupled configuration. Section VI shows how the transfer function for the uncoupled configuration can be obtained from the results in Section V. How the sideband spectra can be calculated using the transfer function and the input spectrum is discussed in Section VII. Some experimental results obtained from an actual RC commutated network and how it compares with theoretical results are shown in the last section.

The formulation of the general expression in Section II was taken from Reference 1. It is included here so that this analysis will have continuity and provide background information to show how the phasing between commutating functions affects the sideband frequencies.

## SECTION II. GENERAL EXPRESSION FOR COMMUTATED NETWORK

The two RC commutated networks, shown in Figures 1 and 2, were studied during the development of an adaptive tracking notch filter [3]. Reference 3 presents the derivation of the integral equations describing the input/output relationship for the two commutated networks. Equivalent circuits for these configurations are shown in Figures 3, 4A, and 4B. The terms "coupled" and "uncoupled" have been adopted to define these two configurations, as suggested by their equivalent circuits. The equivalence between the two networks for the uncoupled case, shown in Figures 4A and 4B, can be ascertained by considering the feedback gain for each path in Figure 4A. The feedback gain between integrator output and integrator input is  $p_1^2(t) k_0$ . Because  $p_1(t)$  is a unity square wave, the term  $p_1^2(t)$  is unity for all values of time; thus each feedback path can be represented by a resistor R across each of the integrators as shown in Figure 4B.

From Reference 3, the integral equations describing the circuits in Figures 1 and 2 are:

$$-y(t) = \frac{1}{\tau} \sum_{i=1}^4 p_i(t) \int_0^t p_i(t) [x(t) + K'y(t)] dt \quad (\text{coupled}) \quad (1)$$

where  $\tau = R_1 c$ ,  $K' = \frac{KR_1}{R}$ , K is potentiometer setting,

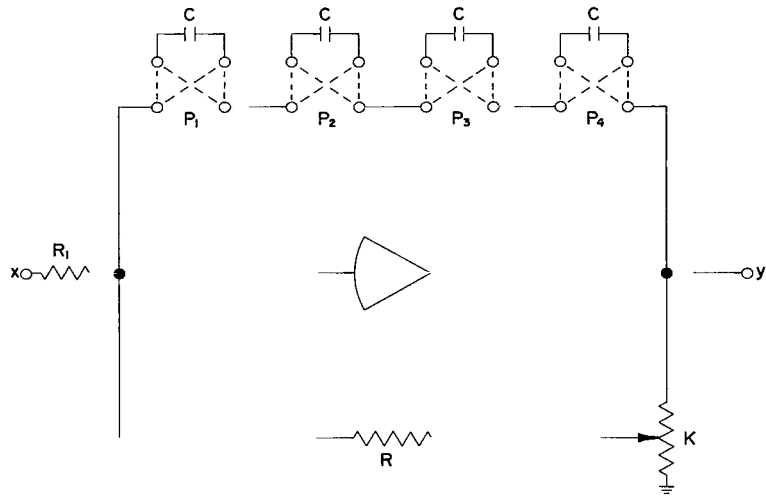

FIGURE 1. COUPLED CONFIGURATION OF COMMUTATED NETWORK.

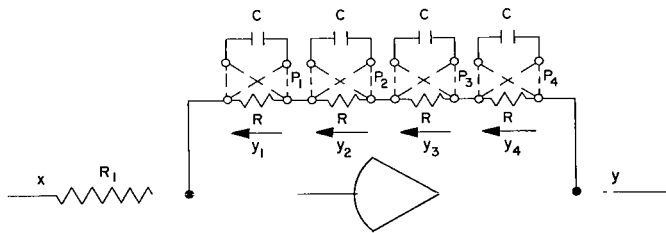

FIGURE 2. UNCOUPLED CONFIGURATION OF COMMUTATED NETWORK.

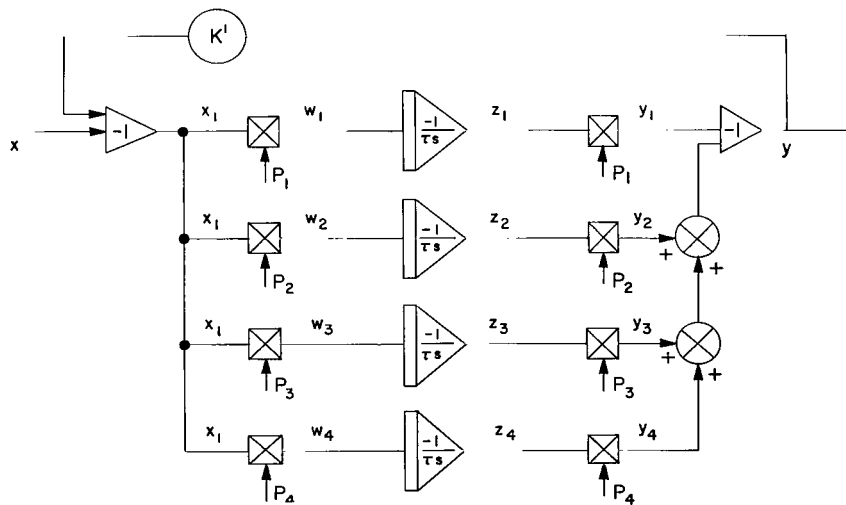

FIGURE 3. EQUIVALENT CIRCUIT FOR COUPLED COMMUTATED NETWORK.

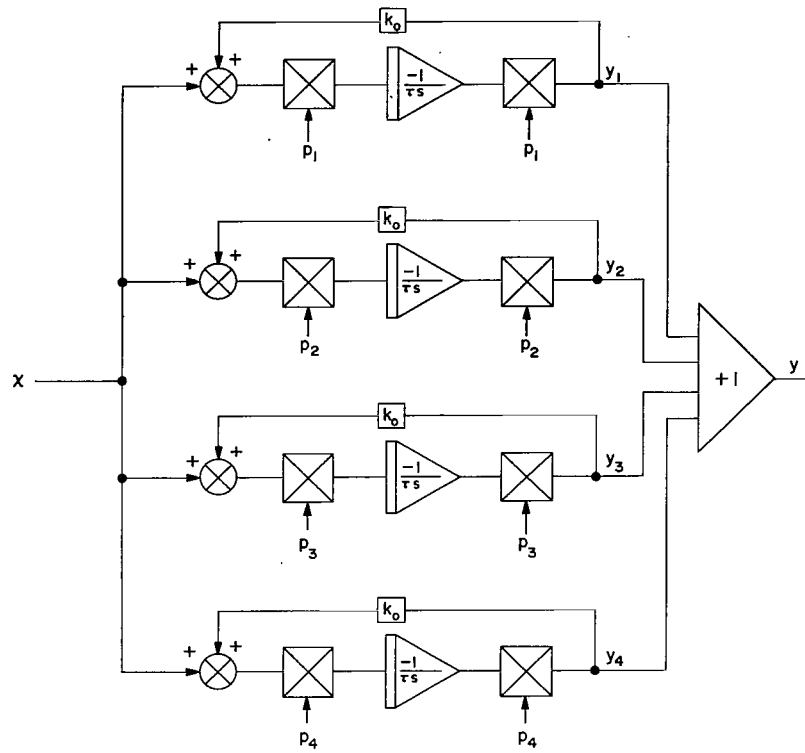

FIGURE 4A. EQUIVALENT CIRCUIT FOR UNCOUPLED COMMUTATED NETWORK.

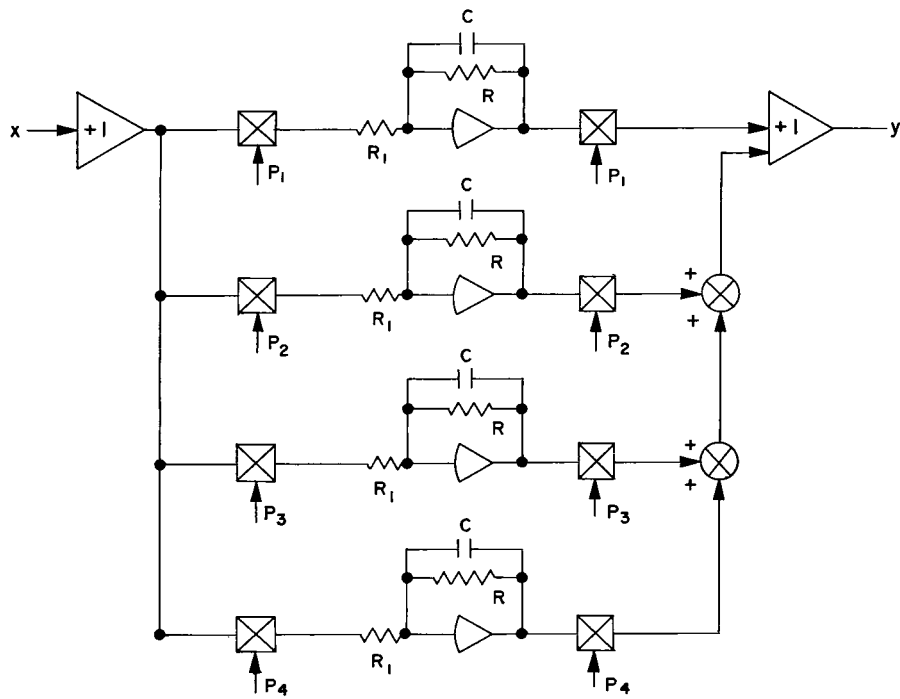

FIGURE 4B. EQUIVALENT CIRCUIT FOR UNCOUPLED COMMUTATED NETWORK.

$$-y(t) = \frac{1}{\tau} \sum_{i=1}^4 p_i(t) \int_0^t p_i(t) [x(t) + k_0 y_i(t)] dt \quad (\text{uncoupled}) \quad (2)$$

$$\text{where } \tau = R_1 C \text{ and } k_0 = \frac{R_1}{R}, y(t) = \sum_{i=1}^4 y_i(t)$$

It is easy to verify that equations 1 and 2 also describe the equivalent networks in Figures 3 and 4A. Figure 5 illustrates an N-path filter for which a general expression is derived in Reference 1. The  $p_i(q_i)$  functions in Figure 5 are equal in amplitude, but shifted in phase relative to one another. The h networks are identical and time-invariant. Although  $p_i$  is identically equal to  $q_i$ , the input and output commutating functions are represented by different symbols for mathematical convenience.

It is obvious that if a general expression exists for the N-path filter of Figure 5, the solution for the uncoupled case (Fig. 4B) can be obtained by specifying N,  $p_i$ , and h. An examination of Figures 3 and 4B also suggests that the uncoupled configuration can be treated as a special case of the coupled configuration by making  $K' = 0$  and modifying the network h. The approach taken in this report is therefore to derive the coupled case transfer function and then, by making a change in variables, obtain the uncoupled case transfer function. The N-path filter that will be analyzed is shown in Figure 6 and is equivalent to an N-capacitor coupled case. After deriving the general expression, N will be set equal to four to correspond to the original commutated network.

The commutating functions  $p_1(t)$  and  $q_1(t)$  can be expressed by a Fourier series as:

$$p_1(t) = \sum_{m=-\infty}^{\infty} P_m e^{jm\omega_0 t} \quad (3)$$

$$q_1(t) = \sum_{n=-\infty}^{\infty} Q_n e^{jn\omega_0 t}. \quad (4)$$

Since  $p_i(q_i)$  ( $i = 2, 3, \dots, N$ ) is equal in magnitude to  $p_1(t)$  and is shifted in phase relative to  $p_1(t)$  by a fixed amount, the  $i^{\text{th}}$  commutating function can be expressed in terms of  $p_1(t)$  by

$$p_i(t) = p_1 [t - (i - 1) \lambda] = \sum_{m=-\infty}^{\infty} e^{-jm\omega_0 \lambda (i-1)} P_m e^{jm\omega_0 t} \quad (5)$$

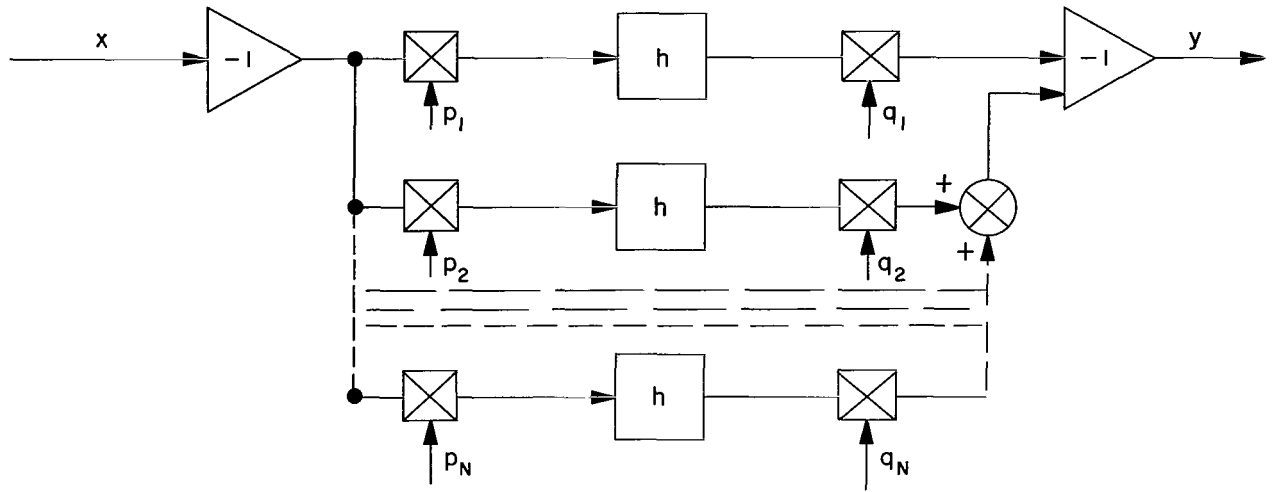

FIGURE 5. N-PATH FILTER.

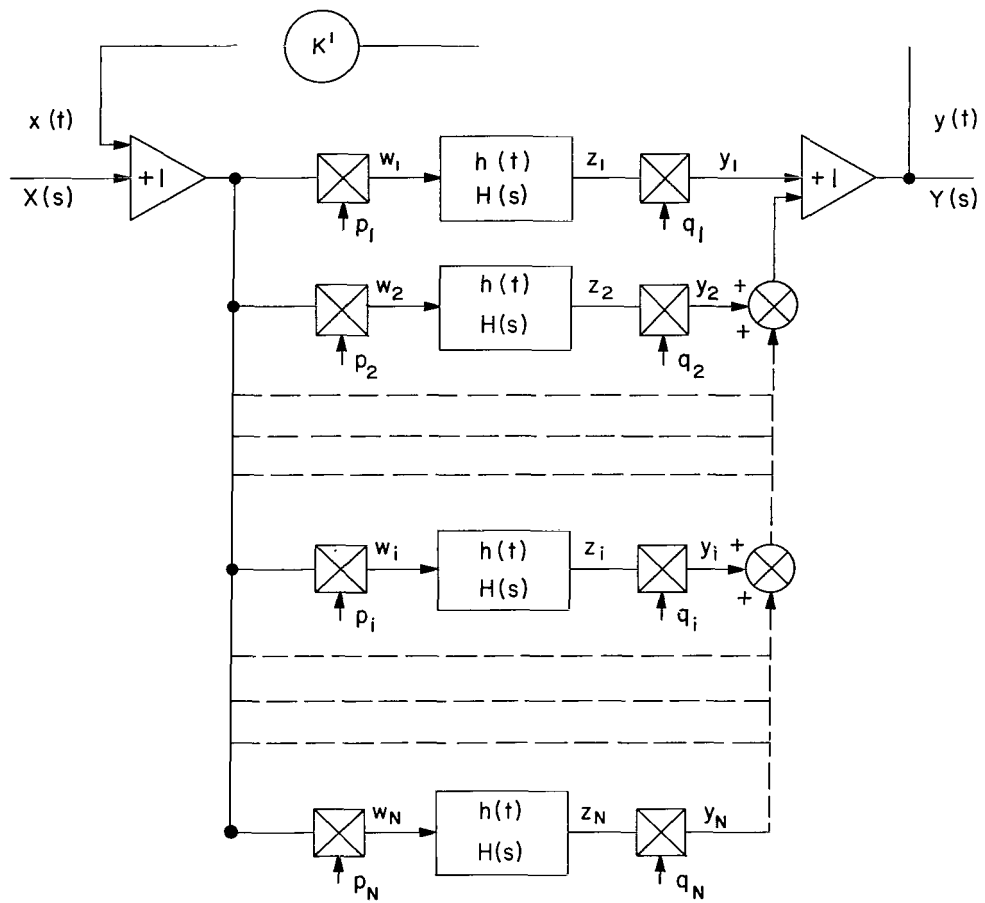

FIGURE 6. N-PATH FILTER WITH FEEDBACK.

$$q_i(t) = q_1 [t - (i-1)\lambda] = \sum_{n=-\infty}^{\infty} e^{-jn\omega_0\lambda(i-1)} Q_n e^{jn\omega_0 t} \quad (6)$$

where  $\lambda = \frac{T_0}{\gamma N}$

$T_0$  is the period of the commutating function

$N$  is the number of parallel feed forward paths (also equal to the number of commutated capacitors)

$\gamma$  is the phasing parameter (equal to 1 or 2).

Describing the  $i^{\text{th}}$  path of Figure 6, the following equations are written in Laplace transform notation where use has been made of the complex translation theorem.

$$W_i(s) = \sum_{m=-\infty}^{\infty} e^{-jm\omega_0(i-1)\lambda} P_m [X(s - jm\omega_0) + K'Y(s - jm\omega_0)] \quad (7)$$

$$Z_i(s) = W_i(s) H(s) \quad (8)$$

$$Y_i(s) = \sum_{n=-\infty}^{\infty} e^{-jn\omega_0(i-1)\lambda} Q_n Z_i(s - jn\omega_0) \quad (9)$$

Substituting equations 7 and 8 into equation 9 and then summing over  $i$ , the output is expressed by:

$$Y(s) = \sum_{i=1}^N Y_i(s) = \sum_{i,n,m} e^{-j\lambda\omega_0(m+n)(i-1)} P_m Q_n H(s - jn\omega_0) X[s - j\omega_0(n+m)] \quad (10)$$

$$+ K' \sum_{i,n,m} e^{-j\lambda\omega_0(n+m)(i-1)} P_m Q_n H(s - jn\omega_0) Y[s - j\omega_0(n+m)] .$$

Since  $i$  appears only in the exponent of  $e$  in equation 10, the summation over  $i$  is recognized as a geometric series. Let

$$B \triangleq \sum_{i=1}^N e^{-j\lambda\omega_0(i-1)(n+m)}. \quad (11)$$

From the definition of  $\lambda$ , it is seen that  $\lambda\omega_0 = \frac{2\pi}{\gamma N}$ . Substituting for  $\lambda\omega_0$  into equation 11 gives

$$B = \sum_{i=1}^N e^{-j2\pi(i-1)\left(\frac{n+m}{\gamma N}\right)}. \quad (12)$$

If  $n$  and  $m$  are such that  $\frac{n+m}{\gamma N}$  is an integer, i. e.,

$$\frac{n+m}{\gamma N} = k \text{ where } k = 0, \pm 1, \pm 2, \dots, \quad (13)$$

then each term in the geometric series is unity, giving the result that  $B = N$ .

If the condition expressed by equation 13 is not satisfied, then upon using the closed form expression for a geometric series, equation 12 becomes

$$B = \frac{1 - e^{-j2\pi\left(\frac{n+m}{\gamma}\right)}}{1 - e^{-j2\pi\frac{(n+m)}{\gamma N}}} \quad (14)$$

where  $\frac{n+m}{\gamma N} \neq k$ .

In Reference 1 no mention was made of the phasing parameter  $\gamma$ ; thus it was assumed to be unity by their definition of  $\lambda$ . For this reason, it is necessary to deviate from the outline given in Reference 1 and now specify that  $p$  and  $q$  are square waves.

This ensures that  $\frac{n+m}{\gamma}$  in equation 14 will always be an integer since  $P_m$  and  $Q_n$  are zero unless  $m$  and  $n$  are odd ( $m+n$  will be even). With this specification, it is seen that the numerator in equation 14 is always zero and the denominator is always nonzero. Thus

$$B = N \text{ if } n + m = k\gamma N \text{ where } k = 0, \pm 1, \pm 2, \dots \text{ and} \quad (15)$$

$$B = 0 \text{ if } n + m \neq k\gamma N.$$

Substituting the constraints given by equation 15 into equation 10 and then writing equation 10 as two equations gives

$$Y(s) = \sum_{k=-\infty}^{\infty} F(k, s) [X(s - jk\gamma N\omega_0) + K'Y(s - jk\gamma N\omega_0)] \quad (16A)$$

$$F(k, s) = N \sum_{n=-\infty}^{\infty} P_{k\gamma N-n} Q_n H(s - jn\omega_0) \quad (16B)$$

where  $k$  ranges over all integers and  $n$  ranges over only the odd integers. Hereafter the range of  $k$  and  $n$  in the summation symbol will be dropped where no ambiguity occurs.

Equations 16A and 16B describe an  $N$ -capacitor commutated network, for

$$H(s) = \frac{1}{\tau s}, \text{ with a phase shift of } \frac{2\pi}{\gamma N} \text{ radians between adjacent commutating functions.}$$

Letting  $s = j\omega$  it is seen from equation 16A that the term  $\gamma N$  (for a given  $\omega_0$ ) determines the location of the sideband frequencies relative to the input signal frequency. A more detailed discussion on the phasing parameter is contained in Reference 4. For this report,  $N$  will hereafter assume the value four and  $\gamma$  will be two. It should be noted, however, that making  $\gamma = 2$  instead of  $\gamma = 1$  has the same effect on the sideband frequencies as doubling the number of commutated capacitors.

### SECTION III. CLOSED FORM EXPRESSION FOR $F(k, s)$

From equation 16A it is seen that the output  $Y(s)$  is represented as a sum of weighted functions of both the input and output. The term  $F(k, s)$  is the weighting function and describes the open-loop characteristics of the  $N$ -path filter. To determine the effects of the weighting function, it must first be expressed in a usable form.

For  $N = 4$  and  $\gamma = 2$ ,  $F(k, s)$  is defined as

$$F(k, s) = 4 \sum_{n=-\infty}^{+\infty} P_{\frac{1}{2}k-n} Q_n H(s - jn\omega_0).$$



This can be written as

$$F(k, s) = 4 \sum_{n=1}^{\infty} [P_{8k-n} Q_n H(s - jn\omega_0) + P_{8k+n} Q_{-n} H(s + jn\omega_0)] \quad (17)$$

where  $n$  is now all positive odd integers.

For the square wave commutating functions,  $p_1(t)$  (Fig. 7), the Fourier coefficients are given by

$$P_n = Q_n = \frac{-2j}{\pi n} .$$

It follows that  $P_n = -P_{-n}$ ; also

$$\frac{P_{8k+n}}{P_{8k-n}} = \frac{8k - n}{8k + n} .$$

Using these relations, equation 17 becomes

$$F(k, s) = 4 \sum_n \frac{Q_n P_{8k-n}}{8k + n} [(8k + n) H(s - jn\omega_0) - (8k - n) H(s + jn\omega_0)] . \quad (18)$$

The Laplace transform for the network  $h$  is

$$H(s) = \frac{-1}{\tau s} , \text{ where } \tau = R_1 C .$$

$$\text{Hence } H(s - jn\omega_0) = \frac{-1}{\tau(s - jn\omega_0)} \quad (19)$$

$$H(s + jn\omega_0) = \frac{-1}{\tau(s + jn\omega_0)} . \quad (20)$$

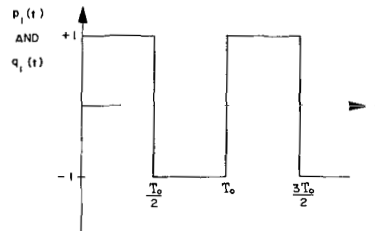

FIGURE 7. COMMUTATING FUNCTION.

Substitution of equations 19 and 20 into equation 18 gives

$$F(k, s) = \frac{-4}{\tau} \sum_n \frac{Q_n P_{8k-n}}{8k+n} \left[ \frac{8k+n}{s - jn\omega_0} - \frac{8k-n}{s + jn\omega_0} \right] \quad (21)$$

After substituting for  $Q_n$  and  $P_{8k-n}$  and putting the terms in brackets over a common denominator, the expression for  $F(k, s)$  becomes

$$F(k, s) = \frac{32}{\tau\pi^2} (s + j8k\omega_0) \sum_n \frac{1}{(64k^2 - n^2)(s^2 + n^2\omega_0^2)} \quad (22)$$

The terms to be summed are now written as two terms by partial fraction expansion.

$$F(k, s) = \frac{32}{\tau\pi^2} \frac{1}{(s - j8k\omega_0)} \sum_{n=1}^{\infty} \left[ \frac{-1}{n^2 - 64k^2} + \frac{\omega_0^2}{s^2 + n^2\omega_0^2} \right] \quad (23)$$

The following relation was taken from Reference 5.

$$\sum_{k=1}^{\infty} \frac{1}{(2k-1)^2 - \frac{4\theta^2}{\pi^2}} = \frac{\pi^2}{8} \frac{\tan \theta}{\theta} \quad (24)$$

Using equation 24, the closed form expression for  $F(k, s)$  becomes

$$F(k, s) = \frac{-4}{\tau(s - j8k\omega_0)} \left( \frac{\tan 4\pi k}{4\pi k} - \frac{\tan \beta}{\beta} \right) \quad (25)$$

$$\text{where } \beta = \frac{j\pi s}{2\omega_0} \quad .$$

It is seen that for  $k = 0$

$$F(0, s) = \frac{-4}{\tau s} \left( 1 - \frac{\tan \beta}{\beta} \right) \quad (26)$$

and for  $k \neq 0$

$$F(k, s) = \frac{4 \tan \beta}{\tau \beta (s - j8k\omega_0)} \quad (27)$$

#### SECTION IV. DERIVATION OF RECURRENCE EQUATION

Using equations 25 and 16, the general expression for the commutated network can be written as:

$$Y(s) = -\alpha_0 \sum_k \frac{1}{(s - j8k\omega_0)} \left( \frac{\tan 4\pi k}{4\pi k} - \frac{\tan \beta}{\beta} \right) [ X(s - j8k\omega_0) + K' Y(s - j8k\omega_0) ] \quad (28)$$

where  $\alpha_0 = \frac{4}{\tau}$  and  $\beta = j \frac{\pi s}{2\omega_0}$ .

In making an attempt to solve equation 28 for  $Y(s)$  in terms of the input, it becomes apparent that another equation is needed that eliminates  $Y(s - j8k\omega_0)$  from the right hand side of the equation. It should be noted that the extra equation is not required whenever the equivalent N-path filter has zero feedback gain, i. e.,  $K' \equiv 0$ . This would be analogous to the uncoupled case where the output  $Y(s)$  is expressed in terms of the input as a sum of weighted functions. It would appear reasonable to expect that the final expression for  $Y(s)$  describing the coupled configuration would be of the same general form as in the uncoupled configuration, i. e., the sum of weighted functions of the input. If the two expressions are to be similar in form, then by equation 28 a relationship that expresses  $Y(s - j8k\omega_0)$  in terms of  $Y(s)$  and  $X(s - j8k\omega_0)$  should be found. This type of relationship can be derived for the coupled configuration and it is referred to as the recurrence equation.

The required form of the recurrence equation suggests that a change of variables be made in equation 28 by substituting  $(s - jm8\omega_0)$  for  $s$ .

$$Y(s - j8m\omega_0) = -\alpha_0 \sum_k \frac{\frac{\tan 4\pi k}{4\pi k} - \frac{\tan \beta}{\beta + 4\pi m}}{s - j8\omega_0(k + m)} X[s - j8\omega_0(k + m)]$$

$$-\alpha_0 K' \sum_k \frac{\frac{\tan 4\pi k}{4\pi k} - \frac{\tan \beta}{\beta + 4\pi m}}{s - j8\omega_0(k + m)} Y[(s - j8\omega_0(k + m))] \quad (29)$$

The admissible values of  $m$  in equation 29 are specified to be all integers except zero.

To facilitate the derivation of the recurrence equation, it is convenient to express equation 28 as three terms, the first two terms corresponding to  $k = 0$  and  $k = m$  and the third term being written as a summation.

$$\begin{aligned}
Y(s) &= \frac{-\alpha_0}{s} \left( 1 - \frac{\tan \beta}{\beta} \right) [X(s) + K'Y(s)] \\
&+ \frac{\alpha_0 \tan \beta}{\beta(s - j8m\omega_0)} [X(s - j8m\omega_0) + K'Y(s - j8m\omega_0)] \\
&+ \frac{\alpha_0 \tan \beta}{\beta} \sum_{\substack{k=-\infty \\ k \neq 0 \\ k \neq m}}^{\infty} \frac{[X(s - j8k\omega_0) + K'Y(s - j8k\omega_0)]}{s - j8k\omega_0} \quad (30)
\end{aligned}$$

In a similar manner, except for  $k=-m$  instead of  $k=m$ , equation 29 is written as

$$\begin{aligned}
Y(s - j8m\omega_0) &= \frac{\alpha_0 \tan \beta}{s(\beta + 4\pi m)} [X(s) + K'Y(s)] \\
&- \alpha_0 \left( 1 - \frac{\tan \beta}{\beta + 4\pi m} \right) \left[ \frac{X(s - j8m\omega_0) + K'Y(s - j8m\omega_0)}{s - j8m\omega_0} \right] \\
&+ \frac{\alpha_0 \tan \beta}{\beta + 4\pi m} \sum_{\substack{k=-\infty \\ k \neq 0 \\ k \neq -m}}^{\infty} \left[ \frac{X(s - j8\omega_0(k + m)) + K'Y(s - j8\omega_0(k + m))}{s - j8\omega_0(k + m)} \right]. \quad (31)
\end{aligned}$$

In the last term of equation 31, substitute  $r = k + m$ . Because the integer values 0 and  $-m$  were deleted from the summation over  $k$ , the values  $m$  and 0 will be deleted from the summation over  $r$ . The substitution from  $k$  to  $r$  places in evidence that, except for a difference in coefficients, the summation term in equation 31 is identical to the summation term in equation 30. To make the coefficients in the two summations correspond, multiply equation 31 by  $(\beta + 4\pi m)$  and equation 30 by  $\beta$ . Equation 31 now becomes

$$\begin{aligned}
(\beta + 4\pi m) Y(s - j8m\omega_0) &= \frac{\alpha_0 \tan \beta}{s} [X(s) + K'Y(s)] \\
- \alpha_0 (\beta + 4\pi m - \tan \beta) &\left[ \frac{X(s - j8m\omega_0) + K'Y(s - j8m\omega_0)}{s - j8m\omega_0} \right] \\
+ \alpha_0 \tan \beta \sum_{\substack{r=-\infty \\ r \neq 0 \\ r \neq m}}^{\infty} &\left[ \frac{X(s - j8r\omega_0) + K'Y(s - j8r\omega_0)}{s - j8r\omega_0} \right] . \tag{32}
\end{aligned}$$

Rewriting equation 30 by multiplying through by  $\beta$  gives

$$\begin{aligned}
\beta Y(s) &= -\alpha_0(\beta - \tan \beta) \left[ \frac{X(s) + K'Y(s)}{s} \right] \\
+ \alpha_0 \tan \beta &\left[ \frac{X(s - j8m\omega_0) + K'Y(s - j8m\omega_0)}{s - j8m\omega_0} \right] \\
+ \alpha_0 \tan \beta \sum_{\substack{k=-\infty \\ k \neq 0 \\ k \neq m}}^{\infty} &\left[ \frac{X(s - j8k\omega_0) + K'Y(s - j8k\omega_0)}{s - j8k\omega_0} \right] . \tag{33}
\end{aligned}$$

Subtracting equation 33 from equation 32 gives

$$\begin{aligned}
(\beta + 4\pi m) Y(s - j8m\omega_0) - \beta Y(s) &= \frac{\alpha_0 \beta}{s} [X(s) + K'Y(s)] \\
- \alpha_0(\beta + 4\pi m) &\frac{[X(s - j8m\omega_0) + K'Y(s - j8m\omega_0)]}{s - j8m\omega_0} . \tag{34}
\end{aligned}$$

Simplifying equation 34 to solve for  $Y(s - j8m\omega_0)$  gives

$$Y(s - j8m\omega_0) = \frac{(s + K'\alpha_0) Y(s) + \alpha_0 X(s) - \alpha_0 X(s - j8m\omega_0)}{s - j8m\omega_0 + K'\alpha_0} . \tag{35}$$

Equation 35 is the recurrence equation and has the properties that permit the general expression to be solved explicitly for  $Y(s)$ . It should be emphasized that deriving the recurrence equation provides a method of analysis for handling a much larger class of RC commutated networks than just the two considered in this paper. The most important fact regarding the recurrence equation is that the analysis can be made for any number of commutated RC elements. Previously, most of the analysis assumed  $N$  to be very large so that the sideband components would be very high in frequency and hence of negligible magnitudes. Under these conditions, an approximate transfer function could be obtained from equation 16 by retaining only the terms corresponding to  $k = 0$ .

## SECTION V. TRANSFER FUNCTION FOR COUPLED CASE

With the closed form expression for the open loop characteristics of the  $N$ -path filter  $[F(k, s)]$  and the recurrence equation just derived, it is now possible to solve the general expression for the output of the commutated network in terms of the input.

By substituting equations 26, 27, and 35, into equation 16, the expression for  $Y(s)$  becomes

$$Y(s) = F(0, s) X(s) + K'F(0, s) Y(s) +$$

$$\left[ \alpha_0 K' (s + K' \alpha_0) \frac{\tan \beta}{\beta} Y(s) + \alpha_0^2 K' \frac{\tan \beta}{\beta} X(s) \right] \sum_{k=\pm 1}^{\pm \infty} \frac{1}{(s - j8k\omega_0 + K' \alpha_0) (s - j8k\omega_0)} \quad (36)$$

$$+ \alpha_0 \frac{\tan \beta}{\beta} \sum_{k=\pm 1}^{\pm \infty} \frac{X(s - j8k\omega_0)}{(s - j8k\omega_0 + K' \alpha_0)} .$$

To obtain a closed form expression, it is necessary to compute the series

$$D \triangleq \sum_{k=\pm 1}^{\pm \infty} \frac{1}{(s - j8k\omega_0 + K' \alpha_0) (s - j8k\omega_0)} . \quad (37)$$

Using partial fraction expansion and defining  $s' = s + K' \alpha_0$ , equation 37 can be written as

$$D = \frac{1}{K'\alpha_0} \left[ 2s \sum_{k=1}^{\infty} \frac{1}{s^2 + 64k^2\omega_0^2} - 2s' \sum_{k=1}^{\infty} \frac{1}{(s')^2 + 64k^2\omega_0^2} \right]. \quad (38)$$

From Reference 5,

$$\sum_{k=1}^{\infty} \frac{1}{k^2 + \frac{\theta^2}{\pi^2}} = \frac{\pi^2(\theta \coth \theta - 1)}{2\theta^2}. \quad (39)$$

Making use of equation 39, equation 38 becomes

$$D = \frac{1}{s(s + K'\alpha_0)} \left[ \frac{\pi s(s + K'\alpha_0)}{8\omega_0 K'\alpha_0} \left( \coth \frac{\pi s}{8\omega_0} - \coth \frac{\pi(s + K'\alpha_0)}{8\omega_0} \right) - 1 \right]. \quad (40)$$

After substituting for  $F(0, s)$  from equation 26 and representing equation 40 by  $D$ , equation 36 can now be written as

$$Y(s) = \frac{-\frac{\alpha_0}{s} \left( 1 - \frac{\tan \beta}{\beta} \right) + K'\alpha_0^2 D \frac{\tan \beta}{\beta}}{1 + \frac{K'\alpha_0}{s} \left( 1 - \frac{\tan \beta}{\beta} \right) - K'\alpha_0(s + K'\alpha_0) D \frac{\tan \beta}{\beta}} X(s) \quad (41A)$$

$$+ \frac{\alpha_0 \frac{\tan \beta}{\beta}}{1 + \frac{K'\alpha_0}{s} \left( 1 - \frac{\tan \beta}{\beta} \right) - K'\alpha_0(s + K'\alpha_0) D \frac{\tan \beta}{\beta}} \sum_{k=\pm 1}^{\pm\infty} \frac{X(s - j8k\omega_0)}{s - j8k\omega_0 + K'\alpha_0}.$$

Equation 41A completely characterizes the four capacitor commutated network. The output  $Y(s)$  contains the input transform  $X(s)$  and, in addition, an infinite number of shifted input transforms given by the infinite series. The coefficient of  $X(s)$  in equation 41A is referred to as the transfer function of the commutated network. The remaining terms in equation 41A describe the sideband spectra when  $j\omega$  is substituted for  $s$ . It is convenient to represent equation 41A as

$$Y(s) = Y_0(s) + Y_h(s) = F^*(s) X(s) + Y_h(s) \quad (41B)$$

so that the transfer function will be defined as

$$\frac{Y_0(s)}{X(s)} = F^*(s) = \frac{-\frac{\alpha_0}{s} \left(1 - \frac{\tan \beta}{\beta}\right) + K' \alpha_0^2 D \frac{\tan \beta}{\beta}}{1 + \frac{K' \alpha_0}{s} \left(1 - \frac{\tan \beta}{\beta}\right) - K' \alpha_0 (s + K' \alpha_0) D \frac{\tan \beta}{\beta}} \quad (42)$$

where  $\alpha_0 = \frac{4}{\tau}$ ,  $\beta = \frac{\pi}{2} \frac{js}{\omega_0}$ , and D is given by equation 40.

Two undetermined parameters in equation 42 are the RC time constant  $\tau$  and the feedback gain  $K'$ . Equation 42 represents a bandpass filter centered about  $\omega_0$ . The bandwidth is primarily determined by  $\tau$  and the gain at  $\omega_0$  is determined by  $K'$ . To make the gain unity at  $\omega_0$ , Reference 4 shows that  $K'$  must be set equal to

$$K' = \sum_k \frac{1}{1 + k^2} \quad (43)$$

where the index  $k$  in equation 43 corresponds to the order of harmonics that are present on the output of the commutated network. The sideband frequencies become harmonics of  $\omega_0$  when the input frequency is equal to  $\omega_0$ . For the four-capacitor case being considered, the harmonics present are the 7th, 9th, 15th, 17th, . . . . Using equation 43,  $K'$  should be set equal to

$$K' = \frac{1}{1 + \frac{1}{7^2} + \frac{1}{9^2} + \dots} \cong 0.95. \quad (44)$$

## SECTION VI. TRANSFER FUNCTION FOR UNCOUPLED CASE

For the uncoupled case,  $K' = 0$ ; therefore, the equation corresponding to equation 36 is

$$Y(s) = F_1(0, s) X(s) + \frac{\alpha_0 \tan \beta}{\beta} \sum_{k \pm 1}^{\pm \infty} \frac{X(s - j8k\omega_0)}{s - j8k\omega_0}. \quad (45)$$



$F_1(0,s)$  is similar to  $F(0,s)$ , the difference being a result of a different network  $h$  for the uncoupled case as compared to the coupled case. The transfer function  $H(s)$  for the uncoupled case can be written as

$$H(s) = \frac{-k_0}{\tau(s+a)}$$

where  $a = \tau^{-1}$  and  $k_0$  is the dc gain. To obtain  $F_1(0,s)$  from  $F(0,s)$ , it is sufficient to make the following substitutions in equation 26;  $\tau$  is replaced by  $\tau/k_0$  and  $s$  is replaced by  $s+a$ . Then

$$F_1(0,s) = \frac{-4k_0}{\tau(s+a)} \left( 1 - \frac{\frac{\tan \pi j(s+a)}{2\omega_0}}{\frac{\pi j}{2} \frac{(s+a)}{\omega_0}} \right) \quad (47)$$

$$F_1(0,s) = \frac{-4k_0}{\tau(s+a)} \left[ 1 - \frac{\tanh \frac{\pi}{2} \frac{(s+a)}{\omega_0}}{\frac{\pi}{2} \left( \frac{s+a}{\omega_0} \right)} \right]. \quad (48)$$

Equation 48 is the transfer function of the four capacitor uncoupled configuration. A more complete description of the characteristics for the uncoupled case is given in Reference 6.

## SECTION VII. AMPLITUDE SPECTRA FOR SIDEBAND FREQUENCIES

Since a commutated network will produce sideband frequencies in addition to the signal frequency, it is advantageous to know their magnitudes. This is particularly important whenever a feedback control loop is involved because the sideband frequencies that are fed back will produce a component of the signal frequency in the output of the network.

The spectra for the sideband frequencies for the coupled case are obtained from the second term of equation 41A and are given by

$$Y_h(s) = \frac{\alpha_0 \frac{\tan \beta}{\beta}}{1 + \frac{K'\alpha_0}{s} \left( 1 - \frac{\tan \beta}{\beta} \right) - K'\alpha_0 (s + K'\alpha_0) D \frac{\tan \beta}{\beta}} \sum_{k=\pm 1}^{\pm \infty} \frac{X(s - j8k\omega_0)}{s - j8k\omega_0 + K'\alpha_0}. \quad (49)$$

Representing  $F^*(s)$  as the transfer function (eq. 42), it can be shown that equation 49 can be written as

$$Y_h(s) = \sum_k [G(s) F^*(s) + \alpha_0] \frac{X(s - j8k\omega_0)}{G(s - j8k\omega_0)} \triangleq \sum_k Y_k(s) \quad (50)$$

where

$$G(s) = (s + K'\alpha_0).$$

By the definition given in equation 50, the term  $Y_k(s)$  is

$$Y_k(s) = [G(s) F^*(s) + \alpha_0] \frac{X(s - j8k\omega_0)}{G(s - j8k\omega_0)}.$$

The components  $y_k(t)$  can be expressed as the product of a carrier signal and a modulating function with the aid of the complex translation theorem. The advantage of writing  $y_k(t)$  in this manner is that for a sinusoidal input the steady state oscillation is readily determined. The amplitude and phase of the oscillation can be computed by evaluating the frequency response of known functions.

Let

$$x(t) = Ae^{j\omega t}$$

then

$$X(s) = \frac{A}{s - j\omega}.$$

The shifting theorem states that

$$\mathcal{L}^{-1} F(s) = e^{bt} \mathcal{L}^{-1} F(s + b). \quad (51)$$

Using equation 51, the components  $y_k(t)$  are

$$y_k(t) = \mathcal{L}^{-1} Y_k(s) = e^{j(\omega + 8k\omega_0)t} \mathcal{L}^{-1} \left\{ \frac{[G(s + j\omega + j8k\omega_0) F^*(s + j\omega + j8k\omega_0) + \alpha_0] A}{G(s + j\omega)} \right\}. \quad (52)$$

To compute the steady state oscillation of  $y_k(t)$ , it is only necessary to evaluate the residues for those poles that lie on the imaginary axis, since the remaining poles give rise to transient terms that decay to zero with time. The poles of  $[G(s + j\omega + j8k\omega_0) F^*(s + j\omega + j8k\omega_0) + \alpha_0]$  are the same as the poles of  $F^*(s)$  but are shifted in frequency (equations 42, 49, and 50). Because  $F^*(s)$  exhibits a stable frequency response, it is concluded that the only residue to be calculated is that of the pole at the origin. Representing the steady state oscillation of  $y_k(t)$  by  $y_{sk}(t)$ ,

$$y_{sk}(t) = A e^{j(\omega+8k\omega_0)t} \frac{[G(j\omega + j8k\omega_0) F^*(j\omega + j8k\omega_0) + \alpha_0]}{G(j\omega)} \quad (53)$$

Because  $y_{sh}(t) = \sum_k y_{sk}(t)$ , then

$$y_{sh}(t) = A \sum_{k \pm 1}^{\pm \infty} e^{j(\omega+8k\omega_0)t} \frac{[G(j\omega + j8k\omega_0) F^*(j\omega + j8k\omega_0) + \alpha_0]}{G(j\omega)} \quad (54)$$

The above representation of the sideband components is for an input  $x(t) = A e^{j\omega t}$ . If the input is not sinusoidal, but is specified by its Fourier transform  $X(j\omega)$ , then the following equation should be used.

$$\mathcal{L}^{-1} [Y_k(s)] = e^{j8k\omega_0 t} \mathcal{L}^{-1} \left\{ \frac{[G(s + j8k\omega_0) F^*(s + j8k\omega_0) + \alpha_0] X(s)}{G(s)} \right\}.$$

Multiplying by  $e^{-j8k\omega_0 t}$  gives

$$e^{-j8k\omega_0 t} \mathcal{L}^{-1} Y_k(s) = \mathcal{L}^{-1} [Y_k(s + j8k\omega_0)] = \mathcal{L}^{-1} \left\{ \frac{[G(s + j8k\omega_0) F^*(s + j8k\omega_0) + \alpha_0] X(s)}{G(s)} \right\}.$$

Dropping the inverse transform and letting  $s = j\omega$ , the spectra of the sideband components can be computed using the input spectrum, the transfer function evaluated at frequency  $\omega + 8k\omega_0$ , and the transfer function of a linear filter  $G$  evaluated at two different frequencies. Thus, it is evident that the maximum amplitude of the sideband component  $y_k(t)$ , occurring at frequency  $\omega + 8k\omega_0$ , is given by the absolute value of

$$Y_k(j\omega + j8k\omega_0) = \frac{[\alpha_0 + G(j\omega + j8k\omega_0) F^*(j\omega + j8k\omega_0)]}{G(j\omega)} X(j\omega). \quad (55)$$

The complete frequency spectrum for each sideband frequency can be computed from equation 55 by letting  $k$  assume different values. It can also be shown, using equation 55, that when  $\omega$  is equal to  $\omega_0$ , the 7th, 9th, 15th, ... harmonics are approximately equal to  $-1/7, \pm 1/9, -1/15, \dots$ .

## SECTION VIII. EXPERIMENTAL AND THEORETICAL RESULTS

In the adaptive tracking notch filter, the commutated network is employed as shown in Figure 8. As stated previously, the commutated network has a bandpass filter characteristic; thus when used as in Figure 8 with an additional feed forward path, the resulting circuit will be a notch filter. To compare theoretical results with those obtained experimentally, it was necessary to form the function

$$M(s) = 1 + F^*(s). \quad (56)$$

Figures 9A and 9B show the amplitude and phase of equation 56 for three values of  $\tau$ . In each case,  $K'$  was equal to 0.95 as given by equation 43. Figure 10 shows a comparison of the amplitude response between the experimental results and the theoretical results for  $\tau = 1.0$  second and  $K' = 0.95$ .

The frequency response using the uncoupled commutated network is approximately equal to the coupled commutated network for large  $\tau$  (greater than 1.0 second). For smaller values of  $\tau$ , the two cases do not give the same results because the quadrature component in the output signal is much larger for the uncoupled case than it is in the coupled case. Reference 4 discusses the effects a quadrature component has on the notch filter frequency response. Reference 6 contains a more detailed analysis on the uncoupled case than is presented in this report. In addition, it considers several parameter variations that are not mentioned in this analysis.

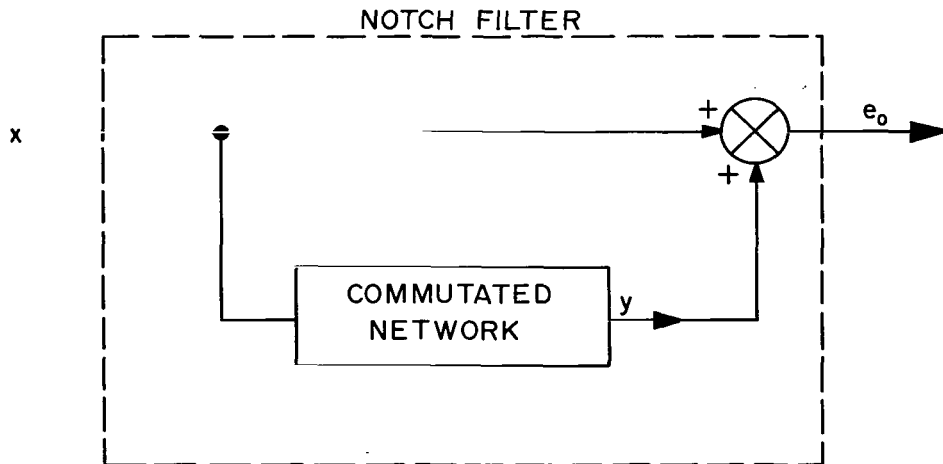

FIGURE 8. NOTCH FILTER.

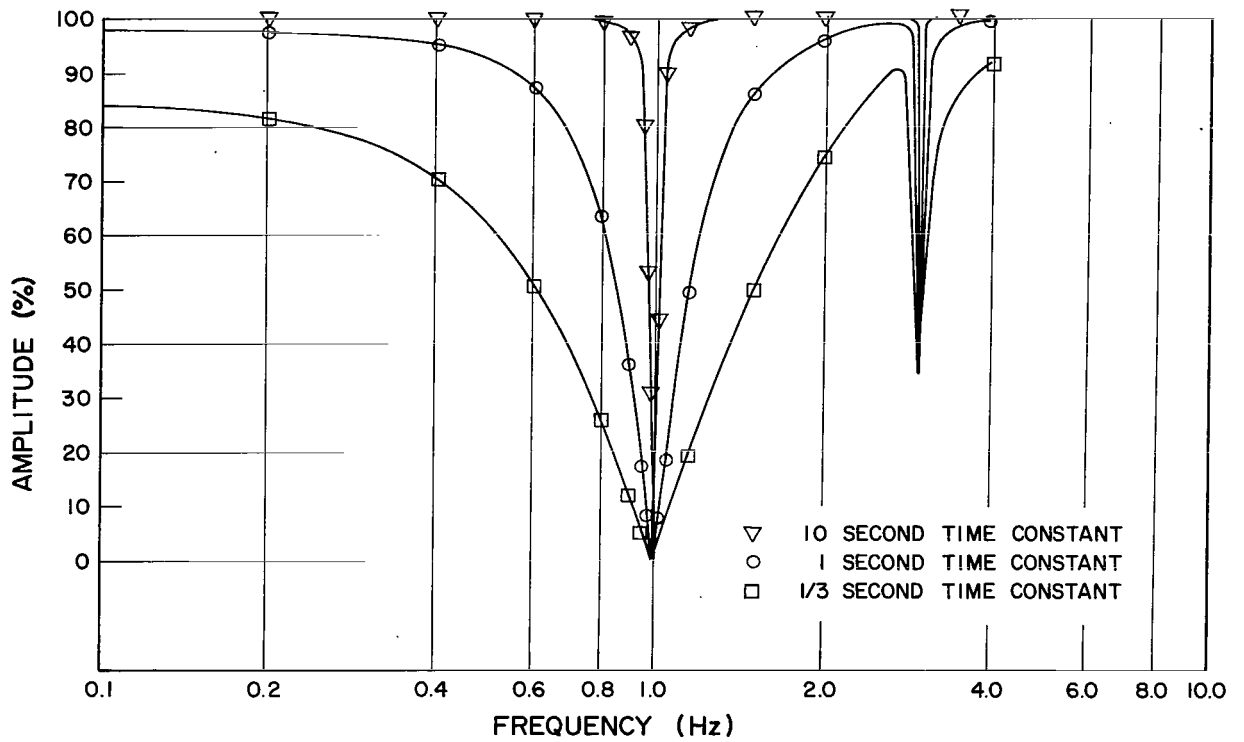

FIGURE 9A. ATN FREQUENCY RESPONSE, AMPLITUDE — THEORETICAL.

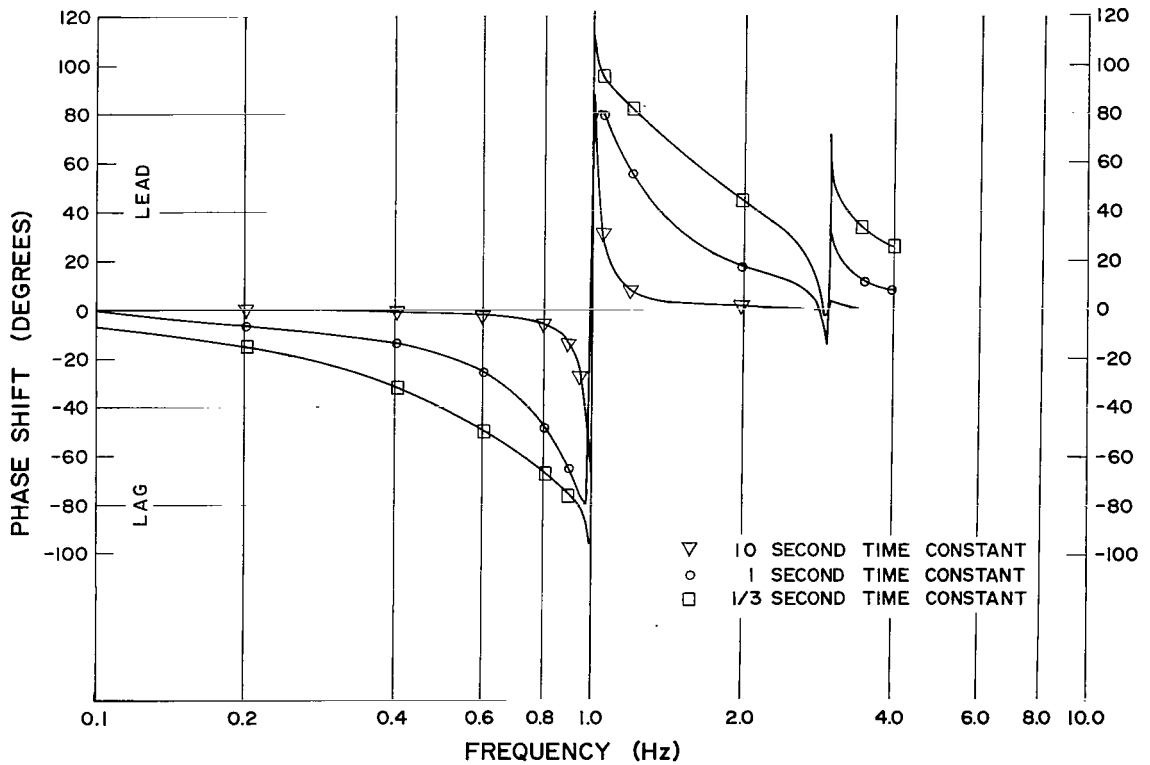

FIGURE 9B. ATN FREQUENCY RESPONSE, PHASE — THEORETICAL.

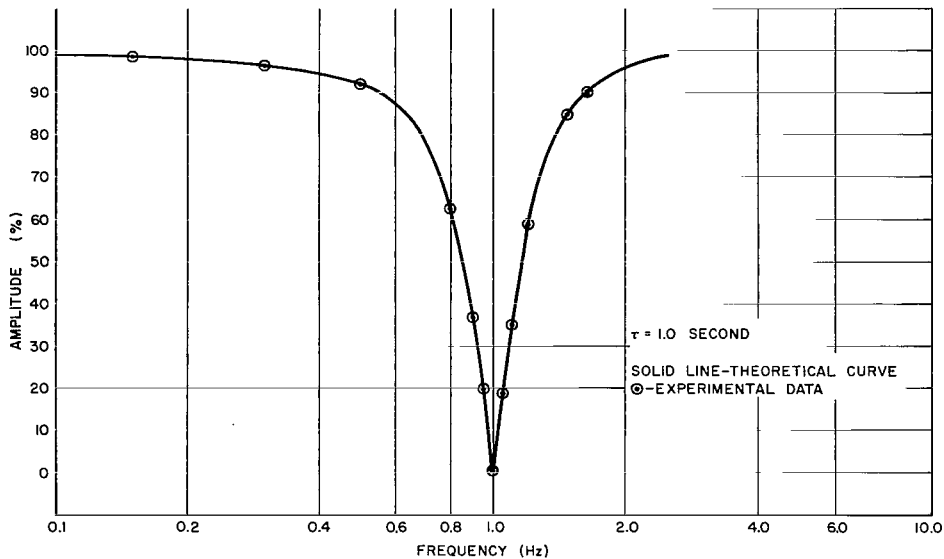

FIGURE 10. ATN FREQUENCY RESPONSE, AMPLITUDE  
 — THEORETICAL AND EXPERIMENTAL

### SECTION IX. CONCLUSIONS

This report summarizes a method for analyzing a linear network containing RC commutated elements. Application of this method yields two equations that completely characterize the total output signal. Although the method was illustrated by analyzing a specific network, the techniques used in developing this analysis can be applied to other types of RC commutated networks. It was shown that the order of the generated harmonics is dependent on the number of capacitors and the phasing between the commutating functions. For certain types of commutated networks [2], the phasing parameter is constrained to be unity because of the type of commutating functions employed. In general, if the commutating function contains both even and odd harmonics, the phasing parameter is forced to be unity; if the commutating function contains either all odd harmonics or all even harmonics, then either value of the phasing parameter can be selected. For the notch filter application, the value two was used to eliminate as many low frequency components as possible.

The commutated network exhibits certain useful properties that cannot be easily

obtained from conventional filters. The first property is the realization of a very narrow bandpass or notch filter for low frequency operation that does not depend on magnetic components. Furthermore, because the center frequency is controlled by electronic circuitry (e. g. , a phase-locked loop), the filter has the capability of continuous tracking or can be programed to sweep over a rather broad frequency range. The second property is the periodic filtering characteristics over certain frequency bands. As the number N is increased, the frequency response of the filter approaches that of the ideal comb filter. A third property is that the gain and bandwidth of the commutated network can be controlled independently by the feedback gain  $K'$  and the RC time constant, respectively.

#### REFERENCES

1. Franks, L. E. , and I. W. Sandberg, "An Alternative Approach to the Realization of Network Transfer Function: The N-Path Filter." The Bell System Technical Journal, September 1960.
2. Smith, B. D. , "Analysis of Commutated Networks," I. R. E. Trans. , PGAE-10, p. 21.
3. Borelli, Michael T. , and Hans H. Hosenthien, "An Adaptive Tracking-Notch Filter for Suppression of Structural Bending Signals of Large Space Vehicles." Astrionics Research and Development Report No. 1, NASA TM X-53000, October 1, 1963.
4. Borelli, Michael T. , Stanley N. Carroll, and Hans H. Hosenthien, "Recent Developments in Adaptive Tracking Notch Filter Techniques." Astrionics Research and Development Report No. 3, NASA TM X-53217, March 1, 1965.
5. Jolley, L. B. W. , Summation of Series. Dover Publication.
6. Asner, B. A. , "Analysis of Notch Networks Containing Synchronously Commutated Capacitors or RC Combinations." NASA TN D-2625, February 1965.

2/22/85

*"The aeronautical and space activities of the United States shall be conducted so as to contribute . . . to the expansion of human knowledge of phenomena in the atmosphere and space. The Administration shall provide for the widest practicable and appropriate dissemination of information concerning its activities and the results thereof."*

—NATIONAL AERONAUTICS AND SPACE ACT OF 1958

## NASA SCIENTIFIC AND TECHNICAL PUBLICATIONS

**TECHNICAL REPORTS:** Scientific and technical information considered important, complete, and a lasting contribution to existing knowledge.

**TECHNICAL NOTES:** Information less broad in scope but nevertheless of importance as a contribution to existing knowledge.

**TECHNICAL MEMORANDUMS:** Information receiving limited distribution because of preliminary data, security classification, or other reasons.

**CONTRACTOR REPORTS:** Technical information generated in connection with a NASA contract or grant and released under NASA auspices.

**TECHNICAL TRANSLATIONS:** Information published in a foreign language considered to merit NASA distribution in English.

**TECHNICAL REPRINTS:** Information derived from NASA activities and initially published in the form of journal articles.

**SPECIAL PUBLICATIONS:** Information derived from or of value to NASA activities but not necessarily reporting the results of individual NASA-programmed scientific efforts. Publications include conference proceedings, monographs, data compilations, handbooks, sourcebooks, and special bibliographies.

*Details on the availability of these publications may be obtained from:*

SCIENTIFIC AND TECHNICAL INFORMATION DIVISION  
NATIONAL AERONAUTICS AND SPACE ADMINISTRATION  
Washington, D.C. 20546