

# Conceptual Study of a Micrometeoroid Deep Space Satellite

## FINAL REPORT

Vol. 1  
Summary  
Development Plan  
Pricing

N 65-35793

FACILITY FORM 602

(ACCESSION NUMBER)	(THRU)
158	1
(PAGES)	(CODE)
	31
(NASA CR OR TMX OR AD NUMBER)	(CATEGORY)

GPO PRICE \$ \_\_\_\_\_  
CSFTI PRICE(S) \$ \_\_\_\_\_

Hard copy (HC) 5.00

Microfiche (MF) 1.25

ff 653 July 65

# ***Conceptual Study of a Micrometeoroid Deep Space Satellite***

**FINAL REPORT**

**Vol. I**

**Summary**

**Development Plan**

**Pricing**

Edward C. Weissmann  
Study Director

**January 1965**

**ER 13700-I**

Submitted to the NASA Langley Research Center  
in compliance with Contract No. NAS 1-4162.

***MARTIN***  
BALTIMORE DIVISION  
BALTIMORE, MARYLAND 21203

ABSTRACT

A conceptual study of a satellite to investigate the meteoroid environment in the region of space between the earth and the moon has been made. The study was based on an Atlas-Agena launch vehicle.

CONTENTS

	Page
Abstract . . . . .	v
I. System Summary . . . . .	I-1
A. Mission Objectives and Constraints . . . . .	I-1
B. System Studies . . . . .	I-7
C. System Definition . . . . .	I-38
II. Development Plan. . . . .	II-1
A. Development Plan. . . . .	II-1
B. Test Plan . . . . .	II-7
C. Aerospace Ground Equipment . . . . .	II-29
III. Projected Funding Plan . . . . .	III-1

**BLANK PAGE**

ABSTRACT

The System Summary chapter of this report is a synthesis of the technical chapters of Volumes II, III, III-A and IV which contain the results of the investigations conducted by the Martin Company in compliance with the Statement of Work of Contract NAS I-4162.

The mission objectives and sensor constraints were studied to determine the possibility of attaining the required objectives. The results of these studies, shown in detail in Volume II, Chapter I, indicated that all of the objectives of the MDSS mission can be satisfied using a number of available state-of-the-art sensors on a single spacecraft.

Orbital mechanics studies were concerned with launch vehicle and orbit selection. It was found early in the program that the Saturn 1B two-stage launch vehicle could not achieve orbits satisfying the mission objectives. The various studies leading to the selection of the Atlas (SLV-3)/Agena D launch vehicle are shown in Volume III, Chapter I, and in the Appendixes, Volume III-A. Orbit stability and launch window considerations, as well as orbit tracking problems, are also discussed in these chapters.

Volume IV of this report contains the reliability analyses which were conducted as part of the MDSS conceptual studies. Reliability analyses have been conducted throughout the entire study program, to assist first in the choice of launch vehicle, spacecraft configuration and orientation, later in the choice of the major items of equipment (i. e., in defining the baseline configuration), and finally in the incremental increases in probability of mission success of the MDSS. It was exceedingly difficult to separate the reliability analyses from the associated spacecraft and subsystem definition studies. Throughout all the technical chapters of Volumes II and III we have therefore indicated--as much as possible--the cross references between the various technical problems and the reliability analyses conducted and shown in Volume IV.

The recommended MDSS configuration is summarized in Section C (System Definition) of the System Summary chapter and is shown in detail in Volumes II and III of this report. Volume II contains the definition of the sensor complement (Chapter I) and of the Telecommunication System (Chapter II) which processes and telemeters the data obtained by the sensors. Volume III contains the definition of the Electrical Power Supply and Distribution system (Chapter II), the Attitude Sensing and Determination system (Chapter V), the Vehicle Design and Structure (Chapter III), and the Thermal Control system (Chapter IV). Also, as mentioned above, Volume III also contains the orbital mechanics studies conducted during this program (Chapter I).

The formats of all the technical chapters in this report have been kept as similar as possible. All chapters contain an Introduction, giving the background, requirements and constraints of the work, a Technical Discussion of the studies performed and the Conclusions and Recommendations resulting from the studies. Wherever required, appendixes were introduced to show either detailed supporting studies or reviews of the concepts which were formulated and considered at various times during the study program.

## I. SYSTEM SUMMARY

### A. MISSION OBJECTIVES AND CONSTRAINTS

The mission objectives and constraints for the Conceptual Study of a Micrometeoroid Deep Space Satellite are defined by the following excerpts from the Statement of Work, dated 25 June 1964.

#### 1. Introduction

In view of the NASA approved program for near-earth measurements of the meteoroid hazard (i. e. , S-55 series of satellites and Saturn-launched meteoroid experiments as well as the proposed meteoroid measurements in the vicinity of the moon on the Lunar-Crbiter and Surveyor lander), it is felt that the NASA Meteoroid Technology Program should now be directed toward obtaining meteoroid data in the region of space between the earth and the moon.

The variation of meteoroid impact and penetration fluxes as a function of distance from the earth, as well as the determination of mass and velocity distributions in the same environment are of particular interest in this region. These data measurements will provide information on the important physical parameters of meteoroids as well as penetration data in space.

#### 2. Guidelines for Selection of Objectives

Experimental objectives to be considered, in order of relative importance, are as follows:

- (1) Penetration rate variation with distance from the earth.
- (2) Impact rate variation with distance from the earth.
- (3) Mass distribution in the same environment.
- (4) Velocity distribution in the same environment.

The selection of objectives shall be based upon consideration of the following:

- (1) Probability of obtaining statistically significant results.
- (2) Time required to achieve the objectives.
- (3) Area required to achieve the objectives.

- (4) Reliability of the systems required to achieve the objectives.

Statistically significant penetration data are such that the penetration rate or rates obtained from these data have a 95% confidence interval no greater than  $(0.50\bar{\psi}, 1.50\bar{\psi})$ , where  $\bar{\psi}$  is the best present estimate of the mean penetration rate.

Statistically significant impact data are such that the mean impact rates obtained from these data have a 95% confidence interval no greater than  $(0.5\bar{\psi}, 1.5\bar{\psi})$ , where  $\bar{\psi}$  is the best present estimate of the mean impact rate.

Statistically significant velocity data are such that the mean velocity obtained from these data have a 95% confidence interval no greater than  $(0.75\bar{v}, 1.25\bar{v})$ , where  $\bar{v}$  is the best present estimate of mean velocity.

### 3. Guidelines for Selection of Sensors

Some meteoroid sensors which may be considered are as follows:

- (1) Pressurized cell penetration detectors.
- (2) Capacitor circuit penetration detectors.
- (3) Printed circuit penetration detectors.
- (4) Light sensitive penetration detectors.
- (5) Impact transducer momentum detectors.
- (6) Photomultipliers.
- (7) Pendulums.
- (8) Others and combinations.

Selection of sensors shall be based upon consideration of the following:

- (1) Reliability.
- (2) State of the art.
- (3) Simplicity.
- (4) Environmental effects.

#### 4. Guidelines for Selection of Spacecraft Orbit

The orbit shall be a highly eccentric, earth-centered orbit. Orbit perigee height shall be compatible with lifetime and injection error requirements. Orbit apogee height shall be selected such that data may be reliably extrapolated to the lunar distance, and that lunar perturbations do not adversely affect the orbit.

The apogee and the perigee altitudes shall remain reasonably constant for the required experimental lifetime.

The orbit shall be established using state-of-the-art techniques. Orbital selection shall consider the results of studies of nominal flight plan errors on the orbit characteristics.

#### 5. Guidelines for Selection of Booster Vehicle

The booster vehicles which shall be considered are the Saturn 1B, the Atlas plus X-259 and the Atlas-Agena combinations. Booster vehicle evaluation shall consider the requirements of paras 2 and 4 of this section.

#### 6. Guidelines for Selection of Telecommunications System Concept

The study shall determine the requirements and the preliminary design for the telecommunications system, using the following guidelines:

- (1) Determine requirements and concepts for tracking the spacecraft to accomplish the mission, as follows:
  - (a) Include the feasibility of tracking the spacecraft utilizing a radio beacon in the spacecraft emitting an unmodulated (OAO) signal and the interferometer tracking system of the NASA Space Tracking and DATA Acquisition Network (STADAN).
  - (b) Include the feasibility of tracking the spacecraft utilizing the NASA Range and Range Rate tracking system with an active transponder in the spacecraft.
  - (c) Include the feasibility of tracking the spacecraft utilizing radar, optical, or other techniques.
- (2) Determine the requirements, concepts, and techniques for processing and telemetering the data as shown below:

- (a) Determine quantity and characteristics of data to be telemetered. (This shall include housekeeping data as well as experimental data.)
  - (b) Include the feasibility of utilizing a noncoherent telemetry system in the 136 to 137 mcps space telemetry band and STADAN. The study shall be limited to flight-proven digital telemetry systems such as PCM.
  - (c) Include the feasibility, requirements, advantages, and disadvantages utilizing a coherent telemetry system and STADAN.
  - (d) Include other spacecraft systems and ground stations as required.
- (3) Determine requirements, concepts, and techniques for interrogating and commanding the spacecraft from the earth.
- (a) Determine the feasibility of interrogating and commanding the spacecraft utilizing the NASA address-execute tone command standard of STADAN.
  - (b) Determine requirements and methods of interrogating and commanding the spacecraft utilizing more sophisticated techniques as required.
- (4) Include the power supply requirements for the entire spacecraft and all systems and subsystems.
- (a) Include the feasibility of an N/P silicon solar cell, NiCd secondary battery power supply system.
  - (b) Include the requirements for, and the feasibility of, other power supply systems.
- (5) Include the reliability analysis of the telecommunications system, including power supply, to accomplish the mission. Tradeoffs between the unsophisticated and sophisticated systems shall be considered. Although schematics are not required, a reasonably accurate parts count is required.
- (a) The reliability design goal for the telecommunication system shall be 0.90 or greater.
  - (b) Consider the use of the most reliable, commercially available parts (i. e., MINUTEMAN). Failure rates

based on test data shall be used. Where these data are not readily available, failure rates from MIL-HDBK-217 shall be used. The confidence level for parts failure rates shall be 0.50 or higher.

- (6) The telecommunications concepts studied shall be compatible with the STADAN system.

## 7. Guidelines for Selection of Spacecraft Concept

The final integrated spacecraft concepts shall be fully compatible with, at least, the following requirements:

- (1) Objectives.
- (2) Maximum overall spacecraft reliability.
- (3) Telecommunications.
- (4) Motions, orientation and attitude control.
- (5) Deployment techniques, if applicable.
- (6) Thermal control.
- (7) Booster vehicle and flight plan.

## 8. Environmental Factors

Selection of objectives, sensors, flight plan, orbit, and telecommunications and spacecraft concepts shall take into account at least the following environmental factors:

- (1) Ascent environmental factors
  - (a) Static and dynamic loads.
  - (b) Temperature.
  - (c) Payload-booster vehicle separation.
  - (d) Payload deployment effects, if applicable.
- (2) Orbital environmental factors
  - (a) Motion dynamics in orbit.
  - (b) Temperatures.

- (c) Meteoritic (penetration and erosion).
- (d) High energy particle radiation.
- (e) Solar effects.
- (f) Lunar effects.
- (g) Vacuum effects.

9. Reliability Criteria

Maximum reliability shall be accomplished by minimum complexity, maximum use of state-of-the-art hardware, and redundancy where needed.

## B. SYSTEM STUDIES

### 1. Mission Objectives

#### a. Mission objectives and sensor constraints

Martin was requested to consider attaining four objectives for the Conceptual Study of a Micrometeoroid Deep Space Satellite, namely:

- (1) Penetration rate variation with distance from the Earth.
- (2) Impact rate variation.
- (3) Mass distribution in the same environment.
- (4) Velocity distribution in the same environment.

The first objective was to be assigned the highest priority; the other three are shown in the approximate order of priority. Previous to the MDSS, no executed or planned program had all these objectives jointly.

During our earlier studies, we had concluded that these objectives could all be attained using one spacecraft. In doing so, we assumed that the chief region of interest in the primary objective was to obtain data on penetration of engineering (structural) thicknesses of material. It was presumed that ideally, the achievement of the objectives would result if the measurements of penetration, velocity, impact and mass were made at the same time and from the same sample, i.e., using one instrument. With such data, an enormous improvement would be made--in one step--in resolving both the uncertainties in the environmental model and in the interaction or penetration model. We were aware of the fact that a sensor with such capabilities does not exist. Our earlier studies also indicated that sensors which could achieve all the objectives independently over a range of meteoroid masses capable of penetrating engineering (structural) thicknesses of material were also not in existence. Sensors were found which could satisfy all of the objectives, some independently, but only on the basis of taking their samples from different mass regions of the micro-meteoroid population.

The purpose of the present effort in this area was to survey and evaluate in greater detail, the availability and state-of-the-art of sensors required to achieve and select the objectives while considering their order of importance and requirements for implementation (mission time, measurement system size and reliability), and also

to select the best combination of sensors. The sensor selection was to be based on the state-of-the-art, simplicity, reliability considerations and environmental effects. Therefore, sensor and objective selections are not independent.

b. Satisfaction of mission objectives

All of the objectives of the MDSS mission can be satisfied using-- on a single spacecraft--a number of available "state-of-the-art" sensors that have similar or overlapping "sampling windows." However, that sampling window over which all of the objectives can be satisfied with state-of-the-art sensors occurs at particle sizes and masses which do not represent a hazard to space flight in terms of penetrating capability.

Even with the window, no one sensor can work toward all the objectives, nor can the sampling of a single particle contribute to the satisfaction of all the objectives. The basic problem is the availability of sensors capable of determining the particle velocity and also the penetration and impact properties over the width of the window. The existing sensor most suitable must be considered at best only a threshold penetration detector although it can measure velocity and impact. Velocity is an incident property of the particle. The other two require that the particle's incident properties be drastically altered if not completely lost.

Within the current state-of-the-art, it is possible to satisfy all the objectives, some of them individually and some of them in combinations, during the sampling of each particle. If it is desired that all the objectives be satisfied within a common range of meteoroid parameters, that range could be very narrow and centered about  $10^{-10}$  gm or about 0.1 mil. Obtaining penetration data at 0.1 mil is of little engineering value, and operating impact transducers or velocity sensors at  $10^{-10}$  gm sacrifices at least 2 decades of sensitivity.

One solution would be to consider satisfying only the primary objective--penetration rate versus distance from the earth. In effect, this solution was followed in sizing the spacecraft to obtain maximum penetration area and in the design of the primary data handling and telemetry system. However, rather than neglect the remaining three objectives because of the different sampling windows of existing sensors, it was decided to include sensors to satisfy all the objectives. This solution seemed reasonable because the associated sensors would be relatively easy to accommodate on the spacecraft. Each of the remaining objectives has intrinsic value. The velocity distribution of meteoroids smaller by two orders of magnitude than those meteoroids which penetrate the penetration sensors is a clue to the velocity distribution of the penetrating particles. The same can be also said for impact and mass data.

The proposed payload contains velocity and impact detectors with sensitivities to  $10^{-13}$  gm and penetration detectors sized to give the required statistical sample corresponding to masses as high as  $5 \times 10^{-7}$  gm. An overlap can be provided by a 1/4-mil penetration gauge which would respond to particles of  $6.6 \times 10^{-10}$ , or well within the response of the sensors chosen to measure velocity and impact.

The proposed payload complement is summarized in Section C. 2 of this volume.

## 2. Launch Vehicle and Orbit Selection

The most desirable cislunar orbit for the intended mission of the MDSS is one which has a long lifetime, up to one year, and yet has an apogee altitude approaching lunar distances. Unlike most other satellite mission, such an orbit must come under the strong influence of the moon. Over the satellite lifetime, the high ellipticity of the orbit makes it vulnerable to long term soli-lunar perturbations of large magnitude.

The purpose of the orbital mechanics studies was to demonstrate the practicality of achieving orbits satisfying the mission objectives and to match the spacecraft to one of three launch vehicle combinations: the Atlas/X-259, the Atlas-Agena, and the Saturn C-1B. These requirements have been satisfied.

The baseline orbit used throughout the study was one with a perigee altitude of 200 naut mi and an apogee altitude of 150,000 naut mi inclined 31 to 33 deg to the equatorial plane. The evaluation of orbit stability, launch vehicle performance and injection accuracy, and orbit lifetime criteria have substantiated this selection within the study guidelines. Since the mean lunar distance is 207,750 naut mi, the desirability of having orbits with even higher apogee altitudes is apparent. Although such orbits are feasible, they should be considered as special purpose missions which require considerably more detailed planning.

### a. Launch vehicle selection

The launch vehicles considered in this study were the Atlas (SLV-3)-X-259, the Atlas (SLV-3)-Agena D and the Saturn C-1B.

Preliminary configuration studies indicated that the spacecraft on top of either the Atlas-X-259 or Atlas-Agena would be size limited by the shroud rather than weight limited by launch vehicle performance capability. Since an X-259 configured spacecraft or Agena configured spacecraft could be propelled to near escape speed by selecting the optimum ascent technique and injection altitude, orbit selection was not directly included in the selection of the launch vehicle.

Two basic ascent techniques were investigated: the direct ascent assumes continuous burning from liftoff to final injection, interrupted only by the staging sequences; the indirect ascent assumes a burn-coast-burn type of ascent. A distinction was made between the Atlas-X-259 and Atlas-Agena. The Agena, having a restart capability, can be used in part during the initial burning period. After shutdown, the Agena plus spacecraft can coast to the final injection altitude where the remaining Agena propellant is consumed to achieve the desired injection velocity. The ascent profile used assumes first burnout at 90 naut mi, followed by a Hohmann transfer type coast to the desired final injection altitude.

The X-259 solid rocket motor does not have a restart or shutdown capability. With this launch vehicle, the coasting period must start at Atlas burnout with the X-259 ignition taking place after the coasting period. This arrangement does not allow the efficient Hohmann transfer type coast and results in considerably shorter coast times and downrange distances. The performance numbers obtained assume the use of the Project Fire attitude control system between Atlas burnout and X-259 ignition.

The payload capability of the Atlas/X-259 and Atlas-Agena launch vehicles is summarized in Fig. I-1 for both the direct and indirect ascent techniques. The curves represent nominal performance but the correction for  $3\sigma$  performance is noted on the figure. The design spacecraft weight (for the Agena shroud) is 696 lb. With the Atlas-Agena nominal payload capability of 1015 lb (855 lb  $3\sigma$ ) for the direct ascent and 1258 lb (1098 lb  $3\sigma$ ) for the indirect ascent, considerable weight growth is allowable. The selection between the direct or indirect type ascents had to be made on another set of criteria such as operational simplicity, orbit stability, launch window, and effect of ascent guidance accuracy.

Operational simplicity certainly suggests the direct as opposed to indirect ascent technique. By using the direct approach, restart capability in the Agena is not required, nor is the attitude control system required over the 45-min coast period. The time from liftoff to injection is much shorter, thus improving the probability of successful injection. Relaxation toward the indirect technique can be made should the spacecraft have an unusually large weight growth.

The smaller X-259 configured spacecraft would have less probability of satisfactorily achieving all of the mission objectives. The normal impulse uncertainty of any solid rocket motor coupled with the large velocity increment obtained by the X-259 for this mission (over 11,000 fps) indicated large burnout velocity errors, thus lowering the nominal orbit apogee. In addition, use of the direct ascent technique with Atlas/X-259 requires a low injection altitude (below 150 naut mi) which is undesirable. Use of indirect ascent results in range angles which are most adverse relative to orbit stability. On these bases, the emphasis was placed on the Atlas-Agena configured spacecraft.

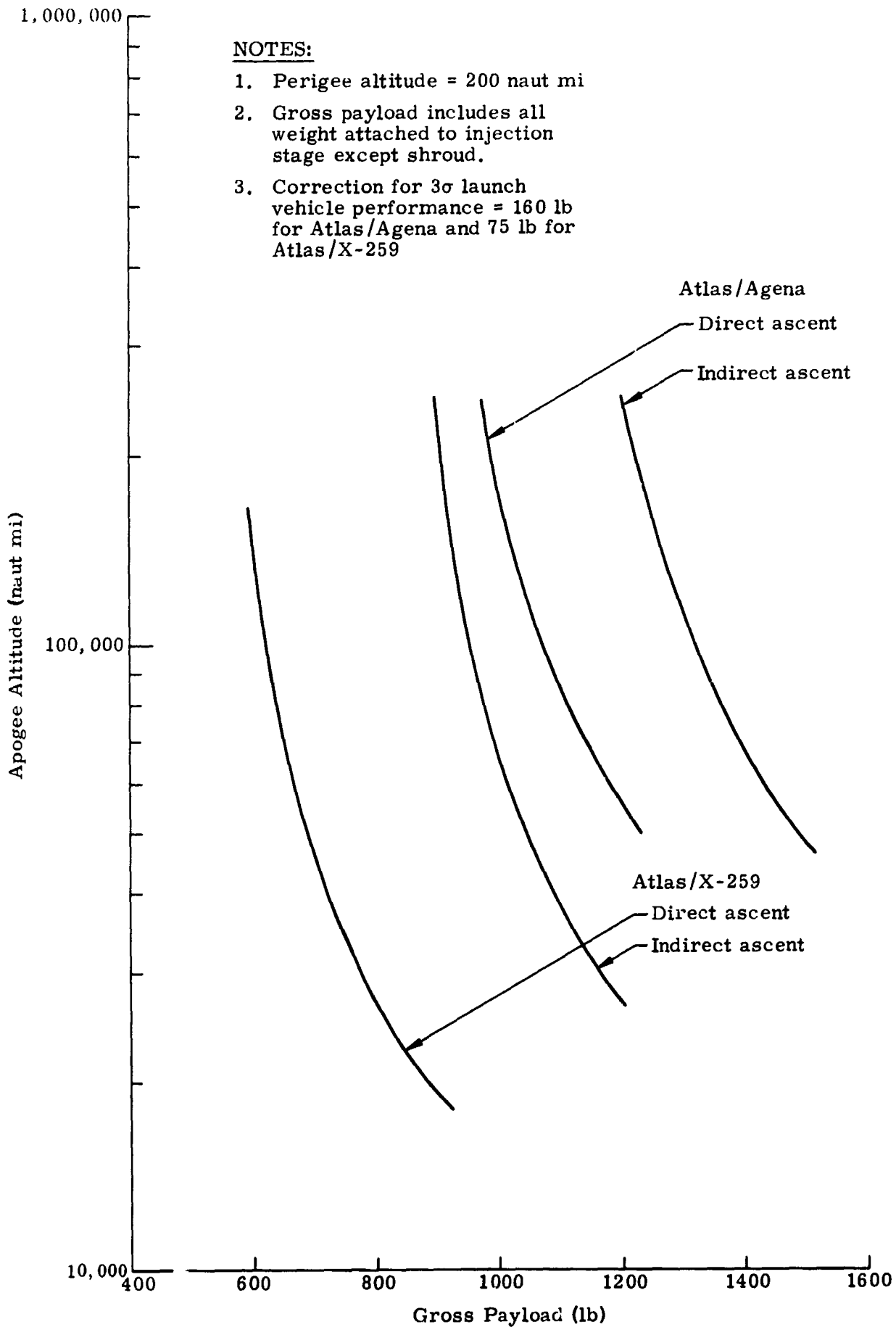

Fig. I-1. Nominal Launch Vehicle Payload Capability

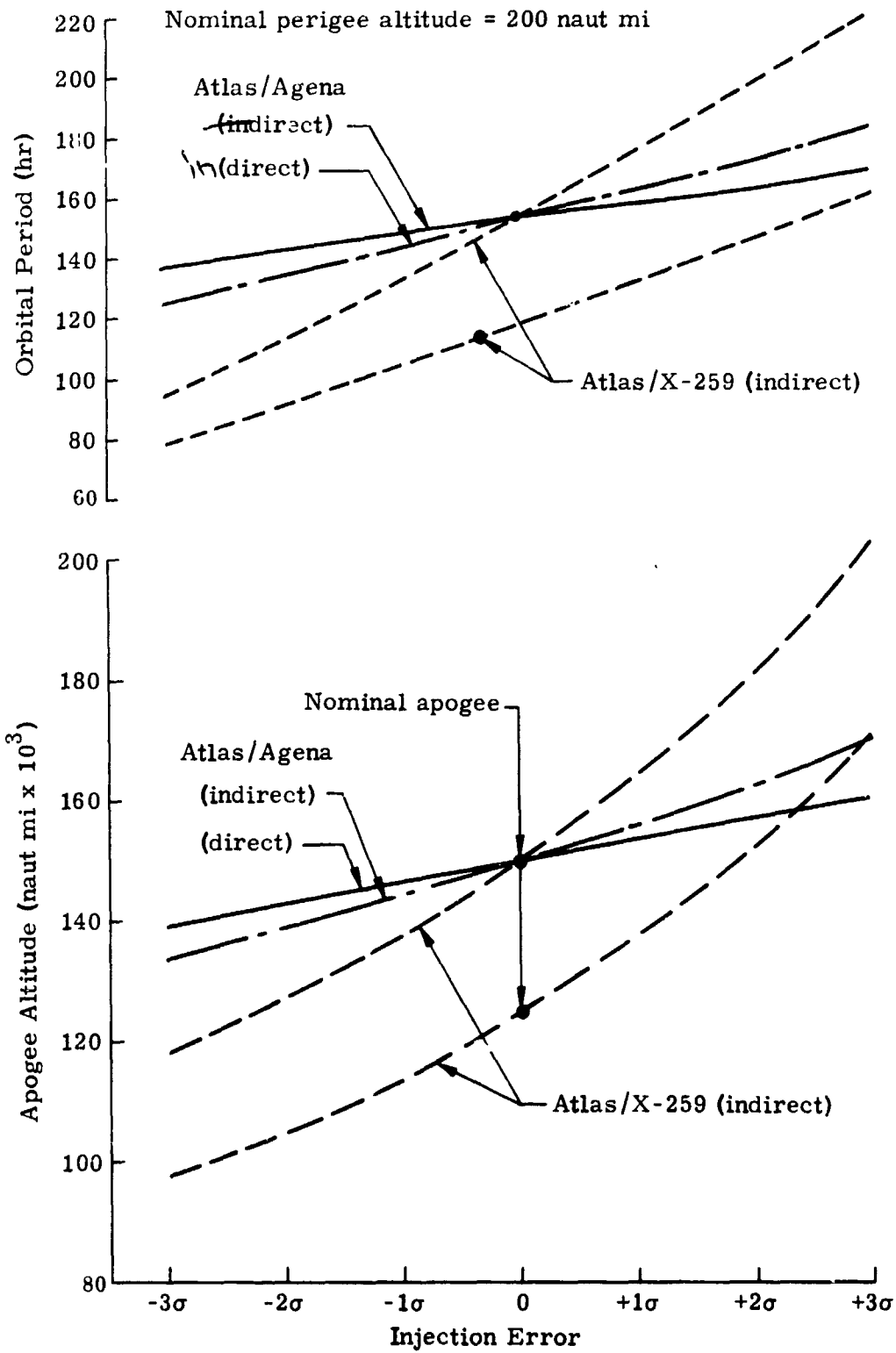

Fig. I-2. Effect of Injection Errors on Orbital Parameters

The Saturn C-1B data is not included in Fig. I-1. The use of a two-stage vehicle to reach injection velocities of over 35,000 fps is quite inefficient. The performance capability of the two-stage launch vehicle demonstrated the impracticality of the Saturn C-1B without an additional upper stage for this mission.

The desire to obtain maximum performance from the launch vehicle usually leads to specifying as low an injection altitude as is possible. The injection altitude selected for this mission (on the basis of orbit stability) is 200 naut mi, although it could be reduced to 175 naut mi or lower if necessary. Studies were conducted to determine the payload variation for the Atlas-X-259 and Atlas-Agena as a function of injection altitude. The payload is fairly insensitive to injection altitude for the indirect ascent technique, but highly sensitive for the direct ascent technique. Therefore, the use of the direct ascent technique requires the injection altitude to be as low as is practical. If any significant improvement in the overall mission could be gained by going to higher injection altitudes, the indirect ascent technique would be required.

The effect of ascent guidance accuracy was investigated. The nominal orbit will have injection velocities less than 500 fps below escape speed. Thus, 500 fps is the difference between achieving an orbit with an apogee of 150,000 naut mi and infinity. This illustrates the sensitivity of the orbit to injection velocity accuracy. The effect of ascent guidance accuracy on the nominal apogee radius is shown in Fig. I-2 for both the Atlas-X-259 and Atlas-Agena launch vehicles. It should be mentioned, however, that the X-259  $3\sigma$  total impulse uncertainty was assumed to be 1%. Although this is rather nominal for solid rocket motors, it could be worse for the standard motor or it could be made better by obtaining specially loaded motors. Needless to say, the performance of the X-259 motor is the primary difference between the Atlas-X-259 and Atlas-Agena data.

#### b. Orbit selection

The principal factors considered in the orbit selection were experiment requirements, orbit stability and aerodynamic effects on the orbit lifetime. Secondary considerations included spacecraft subsystem constraints such as eclipse time effects on electrical power generation and thermal control.

The MDSS mission requires a highly elliptical orbit with perigee near earth and apogee as close to lunar distance as is practical. The orbit orientation, relative to the earth-moon-sun system, might be

fixed to gather data near the earth-moon system libration points or to try to investigate the hypothesized "lens effect." Finally, the investigations will be carried out with orbits close to the ecliptic or moon's orbital plane.

Most of these experiment requirements can be easily met with the proposed configuration. The limiting factor is the orbit stability. The nominal mission requires an orbit lifetime of six months to one year. Over this long period of time, both the sun and moon will have significant effects on the orbit. The possible variations in perigee altitude over a year can be separated into a periodic and secular variations due to the sun and moon. Maximum changes which can be expected for an orbit with a 200 naut mi perigee and variable apogee have been determined. The potential perturbations, particularly the combined solar and lunar secular perturbations, are considerably greater than any practical injection altitude.

The dependence on injection time on any given launch date is quite apparent. This leads to the concept of the launch window map which displays the allowable launch times for each possible launch date. An example for the above orbit is shown in Fig. I-3 which gives the allowable injection times for launches between July 1964 and July 1965. The orbit stability criterion for this map is that the perigee height does not drop below 125 naut mi at any time for one year. Thus, ample launch opportunity exists for the conditions assumed for this orbit.

The ragged nature of the map is due to the lunar periodic perturbations. The data also shows a window calculated with the lunar secular terms included, but lunar periodic terms neglected. The regular nature of this map allows more straightforward analysis of the effect of various injection conditions such as injection altitude, injection point position and apogee altitude.

The most important parameter in establishing a stable orbit is to have the correct argument of perigee. This is obtained by controlling the ascent range angle (central angle measured at the center of the earth between the radius vectors pointing at the launch point and injection point).

The direct ascent for the Atlas-Agena results in the injection point being 23.6 deg downrange from the launch point. The indirect ascent results in the injection approximately 180 to 200 deg downrange from the launch point. Both are quite acceptable, with the direct ascent showing a slight advantage.

The Atlas-X-259 indirect ascent results in an injection point 86 deg downrange from the launch point. This, in fact, would be totally unacceptable from an orbit stability viewpoint since no effective launch window is available. This could be rectified by shaping the

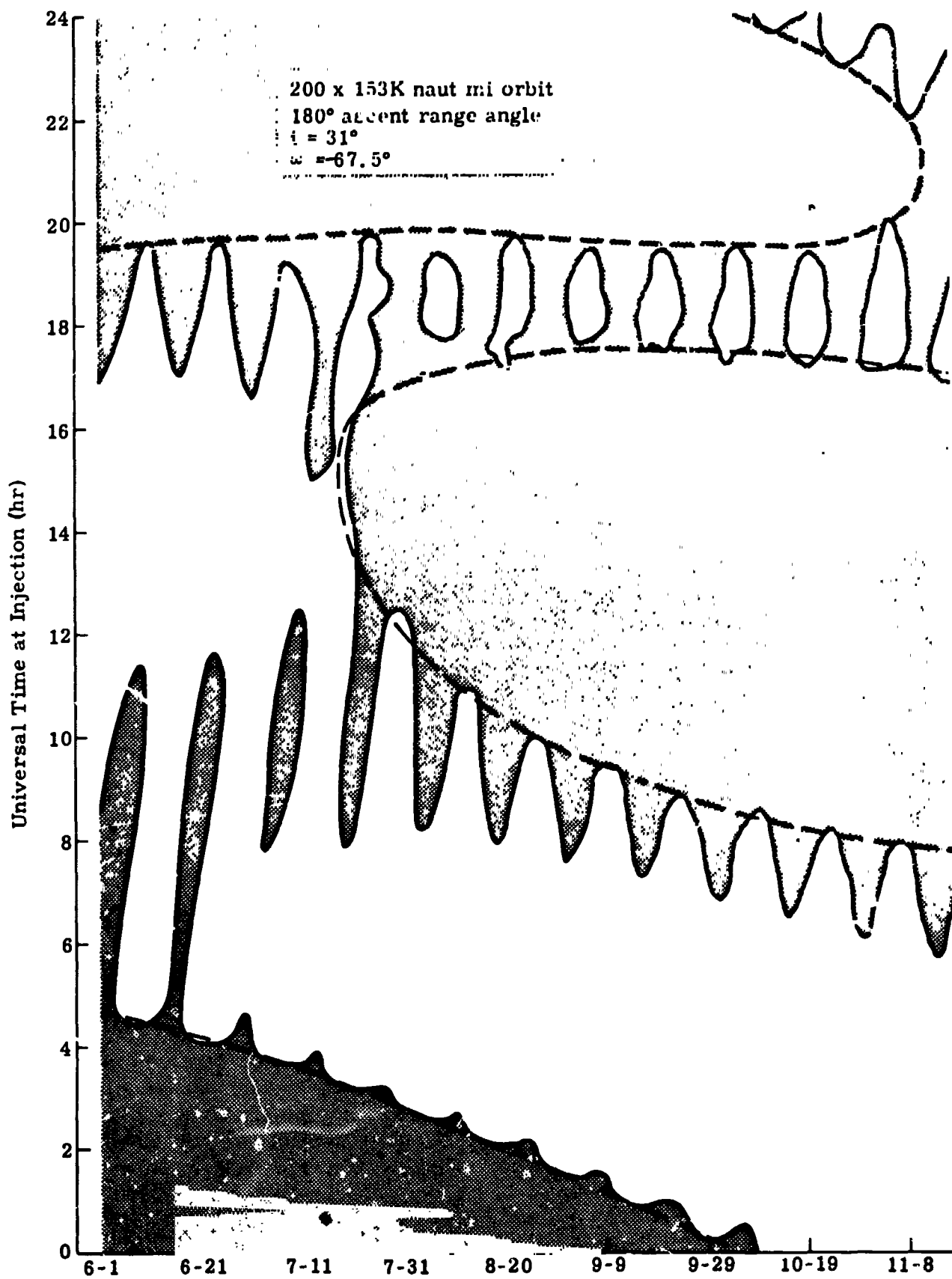

L

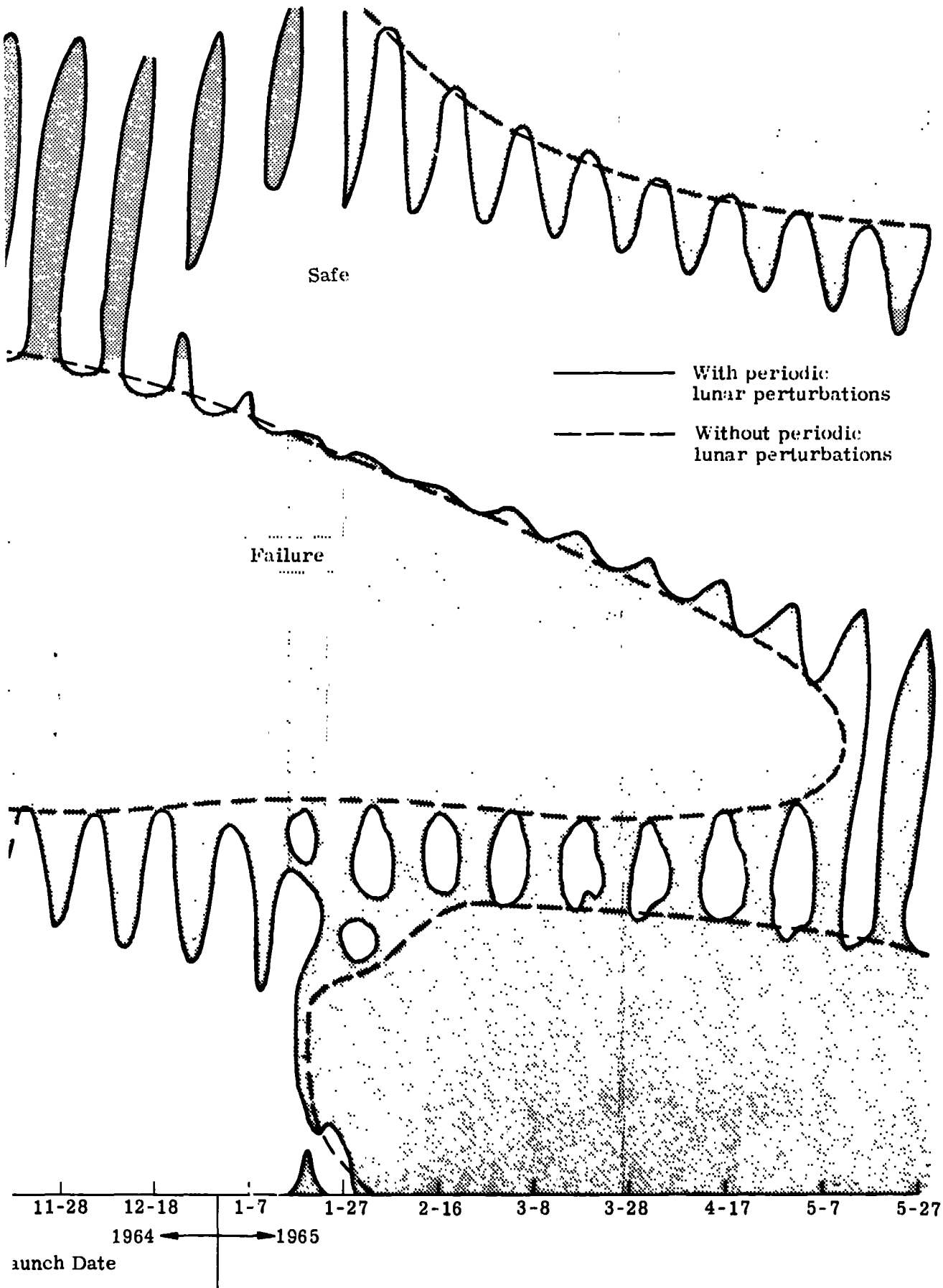

Fig. I-3. Launch Window

ascent trajectory at the expense of payload penalty and operational simplicity. The Atlas-X-259 direct ascent does not suffer from the adverse downrange position of the injection point (quite the contrary, in fact), but is incapable of achieving injection altitudes much higher than 150 naut mi, thus compromising its effectiveness to some degree. The higher injection altitude does require greater pitch rates during the sustainer burning period, however.

The studies conducted showed the large advantage of short range or very long range ascents. Ascent range angles around 80 deg to 120 deg give effectively no launch window when considering all other factors. The launch window is also relatively insensitive to apogee radius.

The effect of orbit perigee, apogee, and orbit inclination on the daily launch time tolerance was investigated. Apogee radius effects were found to be relatively small when compared to the changes realized by perigee and inclination variations.

Studies were conducted to select the minimum perigee altitude from an orbit stability viewpoint. The lunar periodic perturbation decreases the effective launch time tolerance more for low initial perigee altitudes than for higher ones. If the initial perigee altitude were increased from 200 to 580 naut mi, the resultant reduction in effective daily launch time tolerance would be lowered from 26% to approximately 12% (or about 1.5 hr). The gain in launch window does not seem to be worth the payload decrease, and 200 naut mi appears to be a good compromise.

The data previously discussed for orbit stability and launch windows included the long term periodic and secular perturbations of the sun and moon, plus the secular perturbations caused by earth oblateness. To this must be added the short term (or single orbit) perturbation which the moon can supply. This can occur any time the moon is at its closest point to the orbit when the spacecraft reaches apogee (or roughly every 28 days). This effect starts to become felt anytime the apogee gets over 130,000 naut mi and reaches serious proportions for apogee radii over 170,000 naut mi. At 170,000 naut mi, for example, the perigee altitude can be changed as much as 3000 naut mi up or 2000 naut mi down in a single orbit with an increase in apogee altitude of up to 7000 naut mi. A change of this magnitude is predictable for the first orbit, but, because of orbital period uncertainties, could not be accurately predicted for later orbits. Thus, the available launch window would have to be reduced to ensure at least a long period increase of over 2000 naut mi by the end of the first lunar month, plus the possible failure at the end of six months when the solar periodic perturbation tends to return the perigee to its near injection altitude level. On this basis, the practical upper limit on apogee altitude should be in the

**BLANK PAGE**

160,000 to 165,000 naut mi region, somewhat lower than the 170,000 naut mi example above, to reduce the possible single orbit perturbations, particularly if the close spacecraft to moon encounter occurs when the moon is near its orbital perigee.

It is apparent that the nominal apogee radius should be approximately 150,000 naut mi for the Atlas-Agena launched spacecraft and 125,000 naut mi for the Atlas-X-259 launched spacecraft. The potentially wide range of apogee altitudes which might result from the X-259 injection accuracy, coupled with the low nominal apogee radius (and potentially lower minus  $3\sigma$  apogee), were some of the factors which indicated that an MDSS with this launch vehicle would have a lower probability of mission success.

Although the above analysis suggests an upper limit on the nominal apogee radius, this is not to say higher apogee missions cannot be flown as special purpose missions after the initial data is satisfactorily obtained. It is possible to obtain limited launch windows for orbits with apogee radii as great as 190,000 naut mi by either selecting orbital periods and orientations which avoid close spacecraft to moon encounters or purposely using the moon to get very large perigee altitude increases (10,000 to 15,000 naut mi) on the first orbit, coupled with large secular soli-lunar perturbations. Such missions require separate mission planning in considerable detail, however, and were not within the scope of this task.

The final consideration in the orbital parameters selection is the effect of the atmosphere on the orbit. The main effect of atmospheric drag is a potential rapid decrease in apogee altitude (neglecting the thermal control problems). The apogee decay rate was determined for a ballistic coefficient,  $B = \frac{(C_D A)}{2m}$ , of one and for a 200 x 150,000 naut mi orbit, to be 1.63 naut mi per orbit. The actual spacecraft ballistic coefficient will lie between 10 and 15 (13.8 for the nominal design) resulting in a maximum decay rate of less than 25 naut mi per orbit. Over a one year period, this would amount to less than 1500 naut mi, a negligible drop. Even this drop in apogee will not be experienced due to the large increases in perigee altitudes that will be experienced.

#### c. Orbit tracking and communications coverage

The highly elliptical orbits required for this mission have the characteristic of having the spacecraft angular velocity greater than the earth's rotational speed near perigee and less than the earth's rotational speed near apogee. The break-even point occurs

when the spacecraft is about 20,000 naut mi from earth. In this altitude range, the spacecraft appears to be moving directly away or toward a ground fixed observer. At higher altitudes, the spacecraft appears to be slowly regressing (westerly motion). Near perigee, the spacecraft has a high relative speed to the ground in the easterly direction.

The selection of launch vehicle and ascent technique plays an important part in establishing the ground track of the orbit and the spacecraft position, relative to available tracking/communication stations. The short range (direct) ascents result in the injection point (and perigee) at northern latitudes as high as the latitude of Cape Kennedy. The spacecraft at apogee will have a ground track at the corresponding southern latitude. The opposite situation occurs for the Atlas-Agena launched spacecraft using the indirect ascent (Hohmann transfer). Here the injection point is in the southern latitudes, apogee in the northern latitudes. The Atlas-X-259 indirect ascent lies between these two extremes with both the apogee and perigee located in the vicinity of the equator.

The ground tracks show the high relative speed when the spacecraft is near perigee. In effect, tracking or communications when the spacecraft is less than 5,000 naut mi from earth will be uncertain and, if possible, will only be possible for several minutes, at best. On the other hand, when the spacecraft is in the region 10,000 to 30,000 naut mi from earth, a single station will generally be able to communicate with the spacecraft for over three hours and have little change in tracking azimuth and elevation. Above 75,000 naut mi, any station which can see the spacecraft will be able to communicate for several hours with the spacecraft slowly drifting westerly from horizon to horizon.

When the spacecraft is in the 10,000 to 30,000 naut mi region, the ground trace changes direction from east to west (or vice versa). This occurs near zero latitude. Thus, with the Atlas-Agena indirect ascent, stations in the equatorial and northern latitudes will have the most tracking and communications coverage. The inverse is true for the direct type ascents (any launch vehicle). In all cases, as long as the orbital inclination is not much greater than 30 deg, excellent tracking and communications coverage will be available.

The allowable tracking coverage is more than adequate to establish a good orbit ephemeris within the first half of the orbit. The  $1\sigma$  position uncertainty will be well under a mile using range and range rate data and less than ten miles for azimuth and elevation data only. For the R&R data, it was assumed that no tracking data could be taken when the spacecraft was over 100,000 naut mi from earth. The azimuth and elevation data is most effective near perigee and the R&R data is always effective.

### 3. Reliability Studies

The studies conducted considered the reliability of various conceptual designs of a Micrometeoroid Deep Space Satellite. Herein, reliability is concerned not only with the probability of survival of equipment in the cislunar operating environment, but with the basic tradeoffs between equipment reliability, modes of operation and levels of micrometeoroid data acquisition capability--in short, with mission success probability.

The analysis conducted treats in some detail, the reliability of vehicle systems and components. Although not generally accomplished in a conceptual design study, this has been performed in order to arrive at a completely integrated vehicle system.

It became apparent early in the study that very little was known about the micrometeoroid population in cislunar space. The Micrometeoroid Deep Space Satellite was, above all, a probe which must primarily define micrometeoroid penetration rates and their variation with earth altitude in cislunar space. Since capacitance panels were, therefore, the primary sensor as well as the volume critical equipment on board the vehicle, their characteristics became the chief design concept constraint; all operating modes must optimize the collection of statistically significant penetration data, and no other sensor or combination of sensors should substantially decrease the probability of successfully acquiring micrometeoroid penetration data. With these requirements established, the large number of possible concepts was quickly reduced to a manageable number of potentially successful configurations which was then progressively reduced through finer and finer evaluation stages.

#### a. Evaluation guidelines and philosophy

Reliability, or, more properly, mission success probability studies, had a number of specific objective and philosophies which are explained in the following paragraphs.

Definition of success. Classical reliability concepts might have defined success as the probability that the vehicle would perform in the manner intended within the specified environment for at least one year. Obviously, such a definition ultimately results in a number of opinions of success, depending entirely upon observer bias. It is unrealistic to anticipate that every bit of data capability designed into the vehicle must be returned in order to have success; loss of one or more capabilities does not spell mission disaster.

Several levels of mission success have therefore been defined, for example, the probability that penetration data from the capacitance panels will be acquired for 6 and 12 month periods or the probability that both penetration data and specific levels of other sensor data will be acquired.

These definitions anticipate the requirement for a numerical measure of success which can be used throughout the life of the project in which each derived success probability has associated with it a specific data acquisition capability. This measure or index shows quickly what a given data capability will cost--success-wise--and whether it is worth the cost.

Evaluation uniformity. Throughout the study, a uniform base for evaluation and comparison has been used. For example, parts counts in the various equipments are uniform and equitable, stress levels and derating factors have been defined for various operating modes and one group of basic failure rates has been used throughout the analyses. By this adherence to a common standard, fair evaluation of the various operating modes and equipments have been made without the use of weighting factors. Although it may be justly said that the quantitative values of success probability derived and those that will be achieved by the vehicle will never be the same, these values are, however, true levels of success. They are estimates of the relative success probabilities of various concepts (as nearly unbiased as possible). Additionally, these estimates establish reliability goals, aid in system integration, point out major critical problem areas and possible solutions, and indicate what a given capability will cost in terms of operational success.

#### b. Summary

The major results of the study of the Micrometeoroid Deep Space Satellite using a number of configurations, modes of operation, and on-board equipment are defined below:

Choice of launch vehicle, panel configuration and vehicle orientation. The effects of major operational parameters or probability of mission success have been determined.

Three capacitance panel configurations were considered along with a limited number of satellite supporting functions when used with the Atlas-X-259 and the Atlas-Agena launch vehicles. The Saturn C-1B vehicle was eliminated early in the study program as not being suitable for the cislunar micrometeoroid mission. Spheroidal and polyhedron-shaped capacitance panels were not deemed practical at this point although their continuously uniform intercept area is an ideal penetration measuring shape.

A micrometeoroid directionality and orientation required to maintain maximum sensor area in a preferred direction was assumed. The effects of complexity, orientation, panel configuration, and launch vehicles on relative levels of failure have been noted. The major concept chosen as best is of course the Atlas-Agena launch vehicle using the Z-capacitance panel configuration and an apogee altitude of 135,000 to 165,000 naut mi.

Choice of major items of equipment. Figure I-4 shows the baseline configuration in a reliability reference diagram. The salient features of this configuration have been determined by means of a number of tradeoffs during the study and are enumerated as follows:

- (1) Two separate telemetry systems are provided, Pri I and Pri II.
- (2) Penetration data from segmented capacitance panels (Panel A, 0.001 in. and Panel B, 0.002 in. thick) are transmitted on both Pri I and Pri II.
- (3) Pri I transmits only penetration data.
- (4) Pri II transmits penetration data except on command when secondary data is transmitted. Fail-safe condition of Pri II either maintains the penetration data transmission or returns to penetration data transmission from secondary data transmission in event of command switching failure.
- (5) Pri I and Pri II both have their own power supplies. Pri I power has no storage batteries, power being supplied by solar cell arrays. Pri I power is lost during the short duration dark periods, but overall reliability is improved by circuit simplification and parts reduction. Pri II power has sufficient storage battery capacity to furnish power to the secondary data system and to Pri I penetration counters during dark periods.
- (6) Unique Hall effect coupling devices are provided to assure complete isolation of penetration data processing systems of Pri I and Pri II from the common capacitance sensors Panel A and Panel B, thus assuring true data processing redundancy.
- (7) All penetration data is accumulated in counters, not in core storage devices. Penetration data counters are solid state flip-flop counters rather than nondestructive readout magnetic core counters. The reduction of parts plus added simplicity provide higher equipment reliability.

- (8) A unique method of determining capacitance panel operative area is incorporated. Great circuit simplification has been achieved and many parts eliminated with a resultant gain in equipment reliability.
- (9) Panel area segmentation reduces the effect of shorted capacitance panels. Segmentation coupled with determination of operative area permits accurate determination of penetration per unit of effective area.
- (10) Secondary data from velocity and Mariner gauges, IR flash detectors, altitude sensors and diagnostic instrumentation are processed by separate and parallel signal conditioning and data formatting channels. The loss of any one channel will not cause the loss of all data.
- (11) Three separate data storages are provided in the secondary data system. The loss of any one storage will not cause the loss of all data. The probability of obtaining data is further enhanced by counters and readout techniques which allow partial recovery of data in event of storage failure.
- (12) Redundant transmitters are provided in Pri II telemetry channel.
- (13) Duplicate command receivers are provided.
- (14) One master oscillator only is provided in the Pri II channel to eliminate possible phasing difficulties with the consequent loss of vital data.
- (15) Mariner gauge data are arranged such that the loss of data from any one of the gauges will still permit successful data acquisition.

Incremental increases in probability of mission success of the baseline configuration. Table I-1 and Fig. I-5 show the possible improvements in the baseline configuration with modes of operation, definition of mission success, and redundancy.

For the various data transmission modes (A through E) primary penetration data only can be acquired with an overall probability of mission success in excess of 90% for the 12 month mission. Continuous transmission (A) and transmission on command four times per zone have the highest probability of success and are substantially equal (97.1%) whereas automatic on/off transmission 10 min/hr has the lowest (94.5%) probability of success for the 12 month mission.

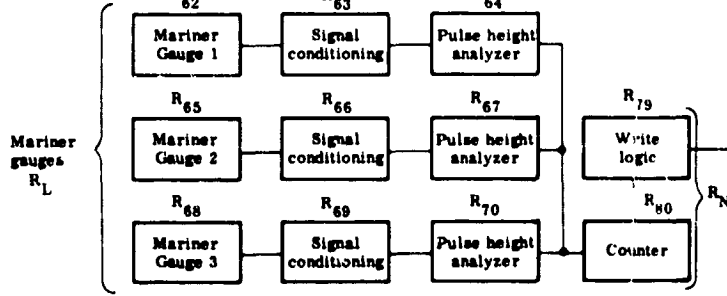
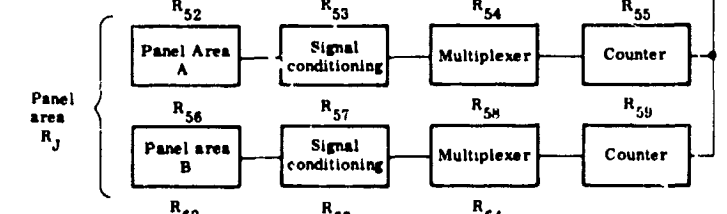
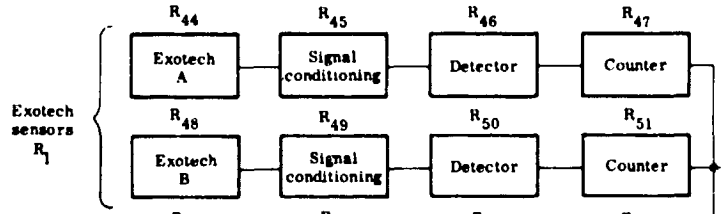
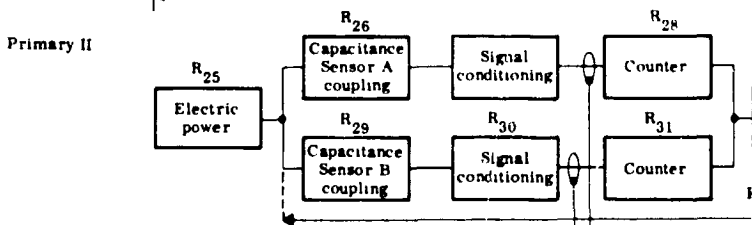
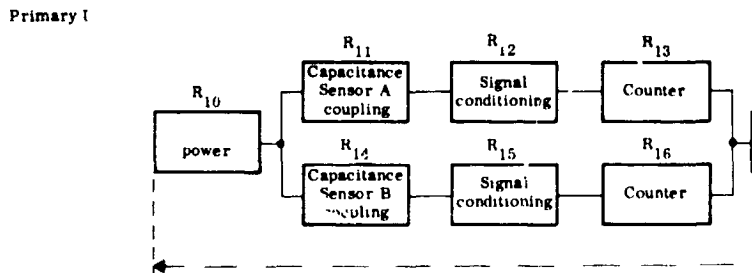
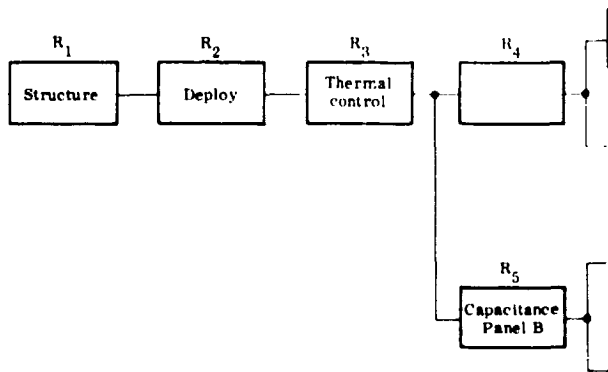
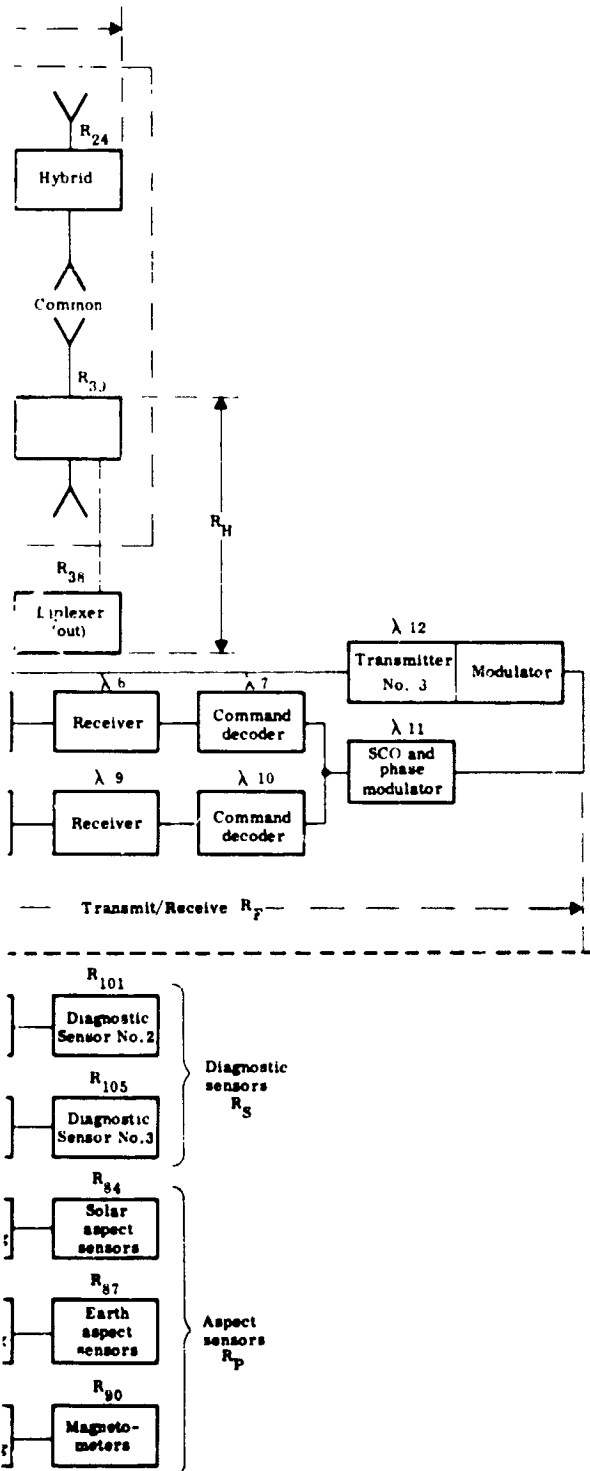

TABLE I-1  
Mission Success Probability Tradeoff Summary

Definition of Mission Success	Success Probability Model (see master reliability reference diagram, Fig. 1 and mathematical success probability models, Table 23)	Mission Time Transmit Time (hr)	Continuo Transmis:	
			6 mo	
			4320	
Return only penetration data from 001- and 0.002-mil capacitance models, R and R	$P_A$		0.991674	0
Return only penetration data from 001- and 0.002-mil capacitance models, R and R	$P_B$		--	
Return only penetration data from 001- and 0.002-mil capacitance models, R and R	$P_C$		--	
Return only penetration data from 001- and 0.002-mil capacitance models, R and R	$P_D$		--	
Return only penetration data from 001- and 0.002-mil capacitance models, R and R	$P_E$		--	
Return all data, penetration and secondary data	$P_F$		0.147557	0
Return all data, penetration and secondary data	$P_G$		0.372131	0

2 #



4. Master Reliability Reference Diagram

W Y

Designation	Modification to Baseline Configuration Required for Change in Operating Modes or for Success Probability Improvement	
A	Baseline configuration--high quality parts, continuous transmission Pri I/Pri II channels	Re 0. pa
B	Baseline configuration--high quality parts, command on/off transmission four times/zone on Pri I/Pri II channels--add command control switch (R <sub>4</sub> )	Re 0. pa
C	Baseline configuration--high quality parts, automatic on/off transmission 10 min/hr on Pri I/Pri II channels--add programmer (R <sub>2</sub> ), power switch (R <sub>3</sub> )	Re 0. pa
D	Baseline configuration--high quality parts, transmission once per day on Pri I/Pri II channels--add storage (R <sub>1</sub> ), command control switch (R <sub>4</sub> ), read logic (R <sub>5</sub> )	Re 0. pa
E	Baseline configuration--high quality parts, transmission once per orbit--add R <sub>1</sub> , R <sub>4</sub> , R <sub>5</sub> as in D above	Re 0. pa
F	Baseline configuration--high quality parts, transmit as in A, B, C, D, E above	Re se
G	Change baseline configuration--high quality parts, transmit as in A, B, C, D, E above. Changes: modified panel area multiplexer (R <sub>54</sub> , R <sub>58</sub> ), two out of three mariner gauges required (ground interpretation), either or both hourly or full write logic (R <sub>93</sub> , R <sub>44</sub> ), redundant master clock (R <sub>117</sub> ), either or both critical or full diagnostic (R <sub>R</sub> , R <sub>S</sub> )	Re se

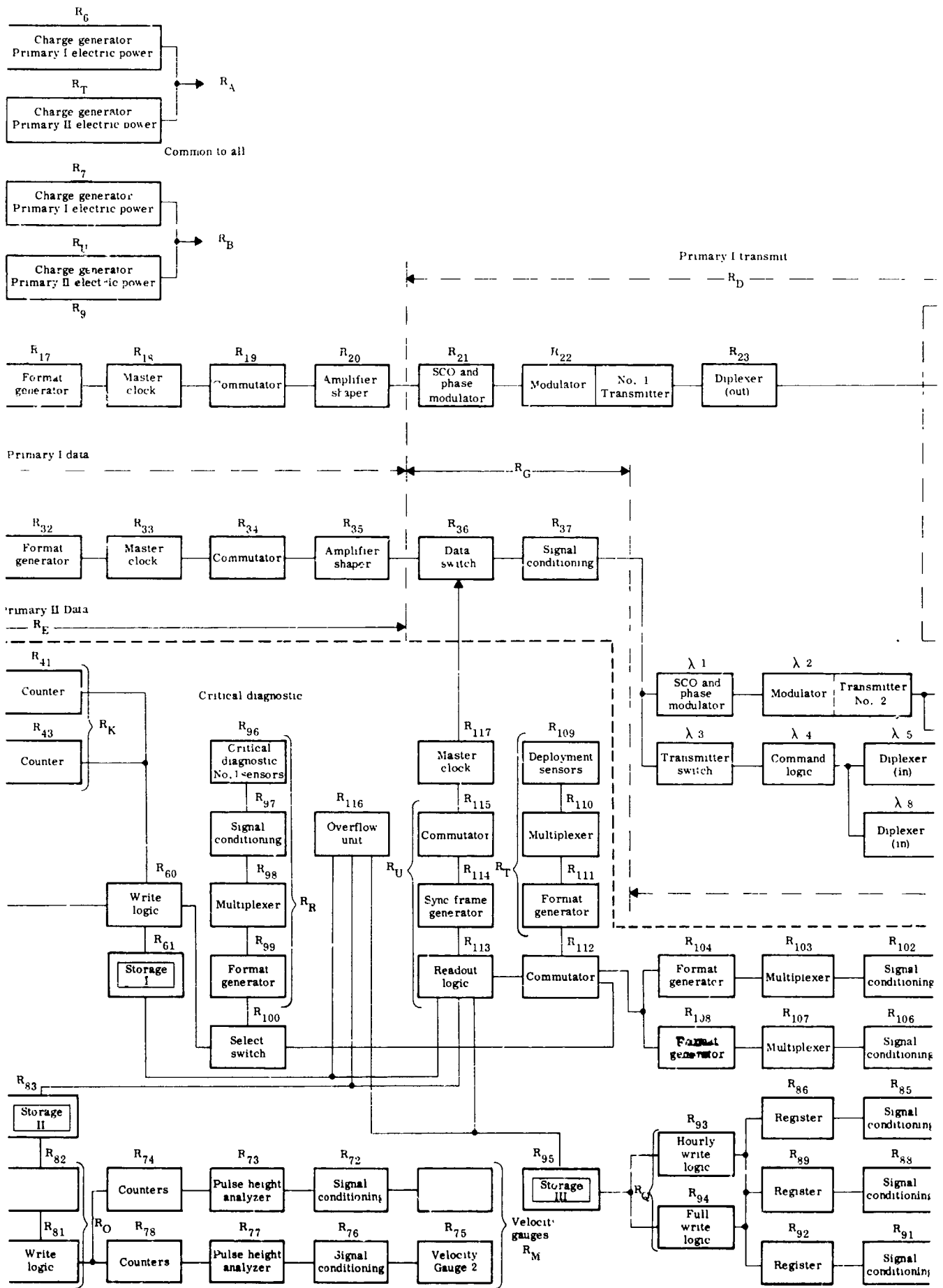

Fig. 1

Operating Mode								
Mission	Command On/Off 4 Times/Zone		Automatic On/Off 10 min/hr		Transmit Once per Day		Transmit Once per Orbit	
	6 mo 300	12 mo 600	6 mo 720	12 mo 1440	6 mo 180	12 mo 360	6 mo 60	12 mo 120
.971409	--	--	--	--	--	--	--	--
--	0.991599	0.971239	--	--	--	--	--	--
--	--	--	0.983718	0.944570	--	--	--	--
--	--	--	--	--	0.989743	0.964807	--	--
--	--	--	--	--	--	--	0.989844	0.965164
.021545	0.146529	0.021287	0.140208	0.019402	0.144850	0.020799	0.145109	0.020839
.123555	0.369413	0.121933	0.353600	0.111264	0.365605	0.119275	0.365954	0.119504

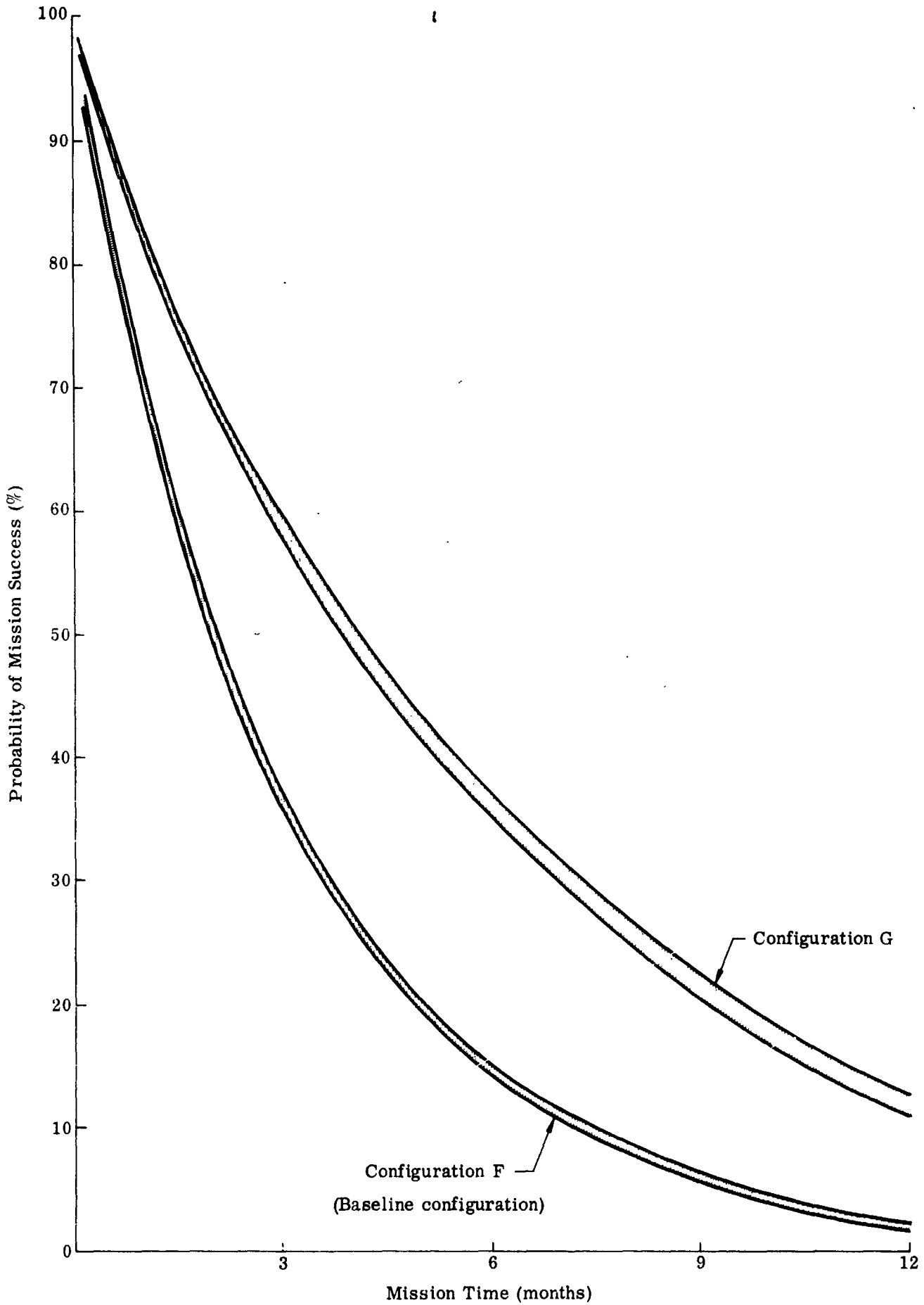

Fig. I-5. Probability of Mission Success For Various Configurations-- Operating Modes 1 to 5

As expected, the probability that all data will be received (both penetration and secondary data) using the baseline configuration is very low (2%). These values are overall values of mission success probability from launch vehicle separation through deployment and for 12 months operation.

Figure I-5 shows the plotted values of Table I-1; the bands of success probability show the spread of probability of success to be expected as transmitting modes are varied.

c. Technical approach

Since many conceivable combinations of equipments and modes of operation could be assembled into a Micrometeoroid Deep Space Satellite, the choice of one or two of the best combinations posed several problems. First, it was impossible to fully evaluate all combinations, and failing this, to have reasonable assurance that a better combination had not been overlooked. Secondly, it was imperative that the best combination of equipments and modes of operation be chosen. The study has therefore evaluated various concepts.

Major considerations which affect prime data acquisition or gross operating modes. Such parameters as shape and arrangement of capacitance panels, spinning and tumbling vehicles, the choice of Atlas-X-259, Atlas-Agena, or Saturn C-1B are compared and several combinations chosen for further analysis. A significant reduction in combinations of vehicles and basic design configurations was quickly and effectively made.

The effect of various onboard systems concepts on mission success probability. A preliminary analysis of a group of basic systems design concepts was made, and the effects of data acquisition capability on success probability were evaluated. The results of this evaluation defined the requirements for a baseline configuration.

Modes of operation and levels of success probability of the baseline configuration. With a baseline configuration established, various combinations of vehicle operating modes, data acquisition capability, redundancy and basic electronic circuitry were evaluated. These tradeoff studies demonstrated mission success probability variation with specific changes and aided in the definition of guidelines and restraints which would point the way to successful development of the Micrometeoroid Deep Space Satellite.

d. Mission probability of success evaluation

Mission success analysis was based on the evaluation of the micrometeoroid data acquisition capability of a number of mission essential elements and the reliability of satellite items of equipment used in a number of operating modes. This was accomplished by means of the sequence of analyses listed below.

(1) Choice of launch vehicle, panel configuration, and vehicle orientation

Micrometeoroid penetration data sampling

Capacitance panel segmentation

Launch vehicle effects on mission success

(2) Equipment operating stresses and parts failure rates

Functional analysis matrix

Equipment operating phases, times and stress levels

Definition of parts failure rates

(3) Preliminary vehicle reliability estimates and system definition

Preliminary vehicle configurations for primary data T/M

Reliability estimating

(4) Definition and evaluation of the baseline configuration

Baseline configuration

Reliability estimating

Evaluation of configurations

(1) Choice of launch vehicle, panel configuration, and vehicle orientation

(a) Micrometeoroid penetration data sampling

In sampling the penetration rates of the micrometeoroid population in cislunar space, capacitance panels must fulfill several basic requirements:

- (1) The sample must be representative of the micrometeoroid population.
- (2) Every micrometeoroid in the population must have an equal chance of penetrating the sensors.
- (3) Every combination of micrometeoroids must have an equal chance of being selected into the sample.

As an example, a sphere or a polyhedron presents the same area to micrometeoroids regardless of orientation. It can sample a meteoroid shower from one direction as well as particles from any other direction or from a random direction at the same time and still fulfill the basic sampling requirements at any instant in time.

A flat plate sensor projected area varies from 0 to a maximum equal to its one sided sensor area when viewed through  $4\pi$  steradians.

Over a long period of time it can sample omnidirectional micrometeoroids and partially meet the sampling requirements as well as the sphere whether it tumbles or remains stable. The probability of its meeting the sampling requirements for sporadic particles or showers does not, however, meet the basic requirements because of its projected area variation. If, of course, it is desired to sample in only one direction or in one place, the flat plate can be oriented to present a maximum target area in the required direction equal to its one sided sensor area or 50% if sensors are on both sides of the structure. Since the sphere or polyhedron offers an intercept area of only 25% of its total area, the gain in efficient use of sensor area can be appreciated. If, however, the flat plate orientation cannot be maintained, its mean intercept area is the same as the sphere, 25% of its total sensor area.

Since it was not practical to use a sphere or polyhedron to meet the sampling requirements in an unknown environment and since the flat plate did not meet basic sampling requirements, a number of other sensor configurations including X- and Z-configurations were made and evaluated. The Z-configuration, consisting of 4 equal paddles of Z cross section, came closest to meeting the basic sampling

requirements. Here, as in the cases of the X-configuration, mutual occulting of the plates reduced the mean intercept area to about 18.5%, although the min/max variation ranged from approximately 16% to 20.5% of the total sensor area. In addition to its sampling characteristics, the Z-configuration offered substantial gain in reliability since its number of hinge points and its deployment angular rotation requirements were less than for either the flat plate or the X-configurations for a vehicle which must be "folded" within the confines of an Agena aerodynamic fairing.

(b) Capacitance panel segmentation

In this study, the determination of micrometeoroid flux variation with altitude required the division of the earth-moon space into a number of altitude sampling zones. Five distinct altitude zones were defined such that in each zone the measured mean number of penetrations in each gauge was 16. Variations in penetration modes dictated that considerable flexibility must be anticipated in the zone definition which could only be completely established with analysis of actual data.

For purposes of this analysis, it had been assumed that the Poisson distributions define the spatial distribution of micrometeoroid penetrations on the sensor panels.

Tables of the point probability of the exact expected number of penetrations, along with density function and distribution function curves, have been made for each of the five zones.

The primary failure mode of the capacitance panels is permanent shorting which will render the panel useless for acquisition of penetration data. This shorting can be caused either by permanent mechanical contact caused by structural failure or by the micrometeoroid penetration mechanism itself. If the sensor area consists of an effectively single element, any one short circuit will destroy the prime sensor. If, however, each sensor is divided into a number of individual segments, the probability of loss of a substantial sensor area decreases as the number of isolated segments is increased.

The total target areas for each of the five altitude zone configurations were divided into a number of equal area segments; 10, 100, 1000 (and 10,000 for the five zone case only). The spatial distribution of a given number of penetrations in the segmented panels is shown in Fig. I-6. It will be noted that in the 5-zone case the probability of any one panel receiving more than one hit if there are 1000 segments is approximately 0.3%. If all penetrations shorted the panels, the probability of the loss of data from shorts caused by micrometeoroid penetrations is substantially zero.

If segmentation alone would eliminate the possibility of loss of data due to shorting of capacitance panels, any practical number of panel divisions could be made depending upon levels of probability desired. But each panel segment must be effectively isolated to permit electrical charging and penetration sensing. This coupling has a finite failure probability, and there is a tradeoff between segmentation and coupling reliability. For the conditions of this study, approximately 300 segments for each of the 0.001- and 0.002-in. capacitance sensors is optimum. At this level of segmentation, the probability of measuring penetrations if 75% of all penetrations will not cause shorting is only 92%. If area sensing is achieved, the probability of measuring penetrations for a given unit area is increased to substantially 100% with a short increase in mission time necessary to acquire the required 80 penetrations.

Only 120 segments of 0.001-in. panels and 144 segments of 0.002-in. panels were incorporated into the present design. This segmentation was made using sensing/charging couplings of conventional design. With improved coupling reliability achieved during the study, improved success probability has been achieved and the number of panel segments thereby will necessarily increase. This is a simple fabrication modification easily achieved.

(c) Launch vehicle effects on mission success

Assuming that the Atlas-X-259 and the Atlas-Agena have essentially the same launch reliability, several performance characteristics significantly affect probability of mission success.

First, of course, is payload capability. The wide margin of payload capability of Atlas-Agena over Atlas-X-259 permits a more flexible choice of operational equipments and certainly permits gains in probability of mission success incident to duplication of equipments for redundancy. Atlas-Agena is therefore a first choice. Secondly, Atlas-X-259 must spin up as well as be despun--one additional reliability problem, particularly in view of the large penetration panels required. Third, the probability of achieving a desired perigee/apogee limit for Atlas-Agena is superior to that for Atlas-X-259. Therefore, the Atlas-Agena is superior to Atlas-X-259 for the Micrometeoroid Deep Space Satellite.

If the directionality of the micrometeoroid population were known or if it were desired to sample a given area or direction, the most efficient utilization of sensor area would, of course, be the flat plate oriented in the desired direction, followed in order by the X- and the Z-configurations. Additionally, if the population directionality were unknown, the tumbling flat plate is the preferred configuration followed by the tumbling X and then by the tumbling or nontumbling Z. In both

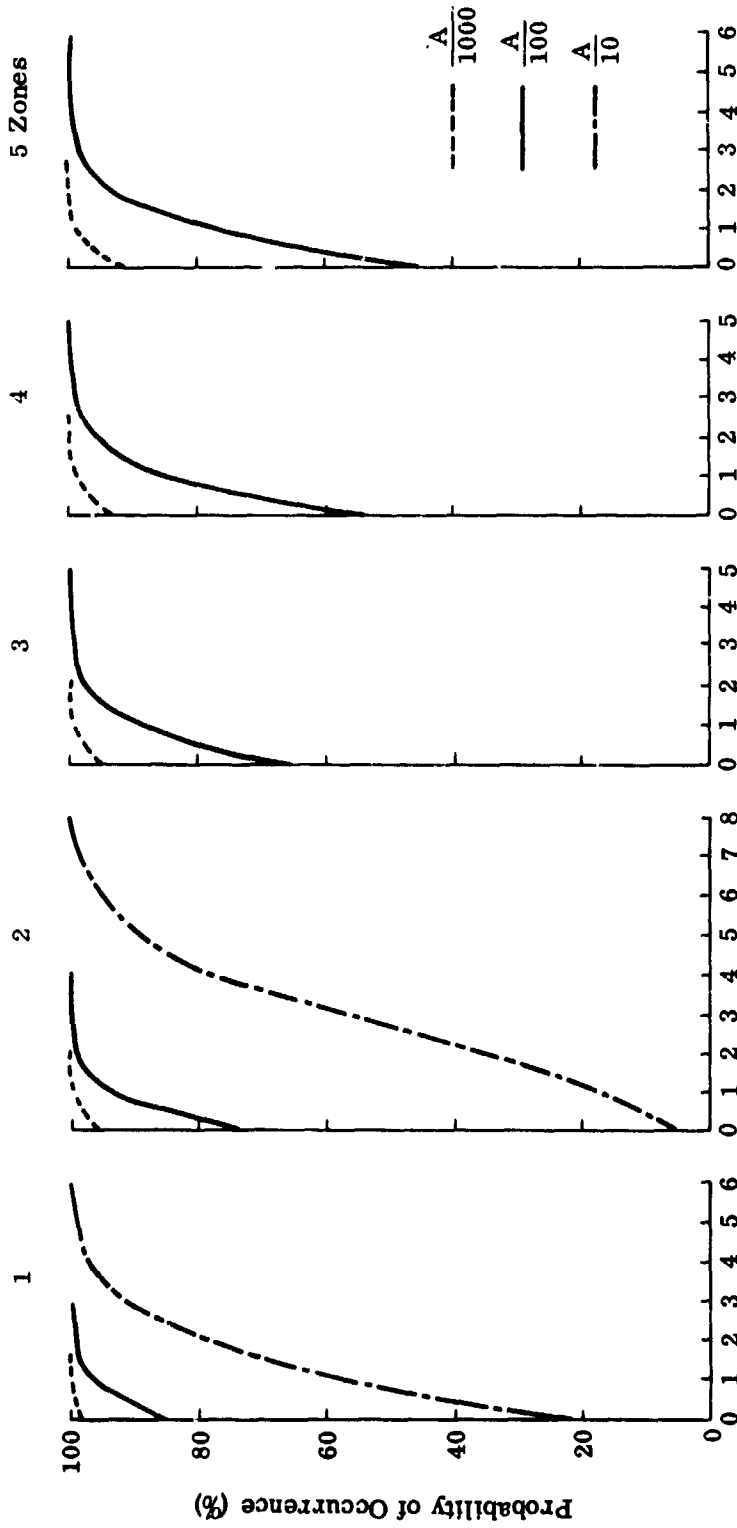

Fig. I-6. Expected Penetrations in Individual Cell Divisions

cases, the flat plate and the X shaped sensors have an orientation requirement necessary to assure a substantially uniform sampling area over a long period of time. Only the Z-configuration requires no specific orientation. Of course, the maximum Z projected area in any given direction is less than either the flat plate or the X, but it has no null spot in its intercept pattern.

Based upon penetration sampling criteria and failure levels shown, the Atlas-Agena launch vehicle using the Z-capacitance panel configuration (tumbling or spinning), and an apogee altitude of 135,000 to 165,000 naut mi is superior to the other combinations shown from a success probability standpoint and was, therefore, chosen as the prime concept for further evaluation. An additional advantage of the Atlas-Agena (not shown) is the payload capability for the direct injection mission; the resultant vehicle weight is sufficiently within payload capability at this point to assure adequate growth potential plus a margin sufficient to permit flexible mission planning and operation.

(2) Equipment operating stresses and parts failure rates

(a) Functional analysis matrix

During the complete satellite mission, a number of basic functions must be performed by the launch vehicle as well as the satellite in order to achieve mission success. These functions, along with appropriate orbital times, have been tabulated in a matrix which was used as an orderly systems integrating tool in the development of an integrated design concept and various modes of operation. Through its use, equipment operating times, phases and environmental stress levels could be estimated.

(b) Equipment operating phases, times, and stress levels

In evaluating equipment reliability, it was necessary to establish a uniform basis of equipment failure rates under various environmental conditions.

During the launch phase, the vehicle will experience a wide range of mechanical, thermal, and electrical stresses with the majority of equipments in a nonoperating state. Once in orbit, the fundamental stresses will be electrical and thermal. These stress levels have a significant effect on the reliability of equipment during both launch and orbit.

The relative environmental stress levels to which various equipments will be subjected during launch have been applied to basic tabulated failure rates to yield the estimated failure rate under the given phase stress level.

During orbit, thermal and electrical stress levels will be encountered depending upon the operating status of equipment and the sunlight/shade period exposure of the vehicle. A uniform electrical stress level of power loading = 0.4 was used for all orbital operations.  
power rating

The temperature conditions for transmitters and all other equipment during sunlight and dark periods, tumbling or spin oriented, and with active and passive thermal control have been considered. It was assumed that wide fluctuations in equipment temperature would adversely affect reliability. The factor listed for the various operating conditions has been used with MIL-HDBK-217 in the establishment of a group of uniform parts failure rates for use in these analyses.

(c) Definition of parts failure rates

Using MIL-HDBK-217 and the stress levels defined, failure rates for tumbling and spinning vehicles as well as vehicles with active and passive thermal control have been defined.

(3) Preliminary vehicle reliability estimates and system definition

(a) Preliminary vehicle configuration for primary data telemetry

Prior to the definition of a complete baseline vehicle configuration, the effects of various equipment changes on a minimum system were determined. In order to simplify the preliminary analysis, secondary data were not considered.

(b) Reliability estimating

Parts counts of each component required were made and reliability estimates established using the basic failure rates defined above. A summary of systems and vehicle reliabilities is shown in Fig. I-7 for spinning and tumbling vehicles with active and passive thermal control and transmitting penetration data continuously. Little difference can be noted between spinning/tumbling and active/passive thermal control conditions. This is chiefly because equipments are operating continuously and failures caused by temperature extremes have been minimized.

(c) Summary of evaluations

The preliminary reliability estimates made aided in defining the baseline configuration as follows:

- (1) Primary data should be transmitted on each of two separate telemetry channels, each having its own power supply.

- (2) Counters in lieu of core storages should be utilized for penetration data accumulation.
  - (3) Area multiplexers, although required, significantly degraded reliability and should be simplified if possible. (A simplified scheme for determining effective areas has been developed.)
  - (4) Housekeeping data acquisition must be effectively isolated first from primary data and later from secondary data, due to its complexity.
  - (5) Range and range rate capability should be applied to only one of the two primary data channels since it was not necessary for the complete mission.
  - (6) If possible, any secondary data should be completely isolated from the primary data system, preferably on a separate data channel.
  - (7) Command/control should be reduced to a minimum wherever possible.
- (4) Definition and evaluation of the baseline configuration
- (a) Baseline configuration

The essential elements of the baseline configuration are shown in Fig. I-4, "Master Reliability Reference Diagram." The salient features previously summarized as required to maximize reliability and thereby mission success probability have been incorporated. An attempt was made to supply a third telemetry channel, but since this channel proved impractical, redundant transmitters in the Pri II channel were provided as shown. In this transmit/receive loop, range and range rate capability were also incorporated.

(b) Reliability estimating

Reliability estimating followed the procedure used above. Component parts counts and component failure rates were estimated using the basic failure rates defined for reliability estimating.

Configuration	Name of Subsystem	Spin				Tumble			
		Active Thermal Control		Passive Thermal Control		Active Thermal Control		Passive Thermal Control	
		6 mo	12 mo	6 mo	12 mo	6 mo	12 mo	6 mo	12 mo
A <sub>0</sub>	Structure	.9999	.9998	.9999	.9998	.9999	.9998	.9999	.9998
	Electrical power and deploy	.9933	.9866	.9933	.9866	.9933	.9866	.9933	.9866
	Transmitter, phase modulator, SCO	.9839	.9682	.9839	.9681	.9839	.9681	.9823	.9648
	Signal conditioner and accumulator counter	.9860	.9724	.9860	.9724	.9860	.9724	.9860	.9724
	Charge generator	.9894	.9790	.9894	.9790	.9894	.9790	.9894	.9790
	Word orientation	.9402	.8840	.9402	.8840	.9402	.8840	.9402	.8840
	Pattern logic	.9625	.9264	.9625	.9264	.9625	.9264	.9625	.9264
	Sequencer and inhibit gate	.9986	.9972	.9986	.9972	.9986	.9972	.9986	.9972
	A <sub>0</sub> reliability (%)	86.15	74.25	86.15	74.24	86.15	74.24	86.00	73.99
	A <sub>1</sub>	Structure	.9999	.9998	.9999	.9998	.9999	.9998	.9999
Electrical power and deploy		Redundant $6 \text{ months } (R = 0.8628) R^2 + 2 RQ = 0.7444 + 2 \times 0.1872 \times 0.8628 = 0.9812 \text{ (6 months)}$ $12 \text{ months } (R = 0.7447) R^2 + 2 RQ = 0.5546 + 2 \times 0.2553 \times 0.7447 = 0.9348 \text{ (12 months)}$							
Transmitter and SCO									
Signal conditioner and accumulator counter									
Charge generator									
Word orientation									
Pattern logic									
Sequencer and inhibit gate									
Diplexer									
A <sub>1</sub> reliability (%)									
A <sub>2</sub> (area data required)	Configuration A <sub>0</sub> reliability (%)								
	Area multiplexer (%)	90.85	83.53	90.85	83.53	90.85	83.53	90.85	83.53
	A <sub>2</sub> reliability (%)	78.27	62.02	78.27	62.01	78.27	62.01	73.13	61.80
A <sub>2</sub> (area data not required)									
B <sub>0</sub>									

If area multiplexer data is not required for success and if the multiplexer is positively isolated from the penetration data system.

	R & R not required for success	86.15	73.03	86.15	73.02	85.43	73.02	85.29	72.77
B <sub>1</sub>	A <sub>0</sub> reliability (%)	86.15	73.03	86.15	73.02	85.43	73.02	85.29	72.77
	Add area channel to B <sub>0</sub> :								
	B <sub>0</sub> reliability (%)	83.94	70.49	83.94	70.48	83.94	70.48	83.80	70.24
	Area multiplexer	90.85	83.53	90.85	83.53	90.85	83.53	90.85	83.53
	Area multiplexer required for success								
	B <sub>1</sub> reliability (%)	76.25	58.88	76.25	58.87	76.25	58.87	76.13	58.67
B <sub>2</sub>	Area multiplexer not required for success								
	B <sub>0</sub> reliability (%)	83.94	70.49	83.94	70.48	83.94	70.48	83.80	70.24
	Add R + R̄ to A <sub>1</sub> :								
	A <sub>1</sub> reliability	.9730	.9192	.9730	.9192	.9730	.9192	.9730	.9192
	Diplexer	.9931	.9863	.9931	.9863	.9931	.9863	.9931	.9863
	R & R̄ switch	.9986	.9972	.9986	.9972	.9986	.9972	.9986	.9972
C <sub>0</sub>	R & R̄ receiver	.9825	.9652	.9825	.9652	.9825	.9652	.9825	.9652
	R + R̄ switch gate	.9986	.9972	.9986	.9972	.9986	.9972	.9986	.9972
	A <sub>0</sub> reliability	.8615	.7303	.8615	.7302	.8543	.7302	.8329	.7277
	Command logic, receiver, and decoder	.9784	.9572	.9784	.9572	.9784	.9572	.9784	.9572
	Signal conditioning channel (H/K)	90.85	83.53	90.85	83.53	90.85	83.53	90.85	83.53
	H/K deployment data processing	.9085	.8353	.9085	.8353	.9085	.8353	.9085	.8353
C <sub>1</sub> area added	Diplexer	.9931	.9863	.9931	.9863	.9931	.9863	.9931	.9863
	C <sub>0</sub> reliability (%)	74.61	55.43	74.61	55.42	73.99	55.42	72.14	55.23
	Add to C <sub>0</sub> :								
D <sub>0</sub> and D <sub>1</sub>	Area multiplexer reliability (%)	90.85	83.53	90.85	83.53	90.85	83.53	90.85	83.53
	C <sub>1</sub> reliability (%)	67.78	46.30	67.78	46.29	67.22	46.29	65.54	46.14
	Add to C <sub>1</sub> :								

E <sub>0</sub> and E <sub>1</sub>	Redundant SCO channels	.8661	.7504	.8661	.7503	.8661	.7503	.8647	.7480
	A <sub>0</sub> reliability	.9825	.9652	.9825	.9652	.9825	.9652	.9825	.9652
	R & R receiver	.9986	.9972	.9986	.9972	.9986	.9972	.9986	.9972
	R & R switch gate	.9784	.9572	.9784	.9572	.9784	.9572	.9784	.9572
	Command logic, receiver, and decoder	.9085	.8353	.9085	.8353	.9085	.8353	.9085	.8353
	H/K deployment channel	.9931	.9863	.9931	.9863	.9931	.9863	.9931	.9863
	Diplexer	.9085	.8353	.9085	.8353	.9085	.8353	.9085	.8353
	Area multiplexer	75.01	56.96	75.01	56.95	75.01	56.95	74.89	56.77
	D <sub>0</sub> (without area) reliability (%)	68.15	47.58	68.15	47.57	68.15	47.57	68.04	47.42
	D <sub>1</sub> (with area) reliability (%)								
	Add to A <sub>2</sub> :	.9691	.9392	.9691	.9392	.9691	.9392	.9691	.9392
	Read-write and parity generator	.9831	.9665	.9831	.9665	.9831	.9665	.9831	.9665
	7000-bit storage and timer switch	.7827	.6201	.7827	.6201	.7827	.6201	.7313	.6180
	A <sub>2</sub> reliability								
E <sub>2</sub> and E <sub>3</sub>	E <sub>0</sub> and E <sub>1</sub> reliability (%)	74.57	56.30	74.57	56.29	74.57	56.29	69.67	56.10
	Add R + R̄ to E <sub>0</sub> or E <sub>1</sub> :	.7457	.5630	.7457	.5629	.7457	.5629	.6967	.5610
	E <sub>0</sub> or E <sub>1</sub> reliability	.9831	.9863	.9831	.9863	.9831	.9863	.9831	.9863
	Diplexer	.9986	.9972	.9986	.9972	.9986	.9972	.9986	.9972
	R & R switch gate	.9825	.9652	.9825	.9652	.9825	.9652	.9825	.9652
	R & R receiver	72.66	53.44	72.66	53.44	72.66	53.44	67.88	53.26
E <sub>2</sub> or E <sub>3</sub> reliability (%)									
E <sub>4</sub> and E <sub>5</sub>	Add to E <sub>2</sub> and E <sub>3</sub> :	.9085	.8353	.9085	.8353	.9085	.8353	.9085	.8353
	E <sub>2</sub> or E <sub>3</sub> reliability								
	Signal conditioning H/K channel	66.00	44.64	66.00	44.63	66.00	44.63	61.67	44.48
H/K data processing									
E <sub>4</sub> or E <sub>5</sub> reliability (%)									

Fig. I-7. Reliability Summary

(c) Reliability summaries

These data transmission modes required equipments not listed on the Master Reliability Reference Diagram (Fig. I-4).

(5) Evaluation of base line and modified configurations

Table I-1 summarizes mission success probabilities for the various modifications to the baseline configuration. (A) through (G) tabulates the various modifications to the baseline configuration necessary in order to modify operating modes to meet specific operational requirements or for incremental improvements in mission success probability. Associated with each designation is a definition of mission success probability based on micrometeoroid data acquisition capability along with a designated mission success probability model.

(A) through (E) gives probabilities of mission success for the five data transmission modes and does not include secondary data. Continuous transmission and command on/off transmission, 4 times per zone are substantially equal and have the highest probability of success for a 12 month mission (97.1%), followed in order by transmit once per orbit, transmit once per day, and last by automatic on/off transmission 10 min/hr (94.5%).

When the definition of mission success includes the acquisition of secondary data (F), the 12 month probability of success decreases to values of 2.1% to 1.9% for the various modes of transmission, continuous transmission and command on/off transmission 4 times per zone still remaining highest. By modifying equipments and redefining data acquisition requirements (G), a substantial gain is achieved to approximately 12.4% to 11.7% for the 12 month mission. Figure I-5 shows plots of F and G success probabilities. As will be, these probabilities are shown as zones which show the variation of success over the five operating modes.

## C. SYSTEM DEFINITION

### 1. Vehicle Description

#### a. Recommended configuration

During this study, many configurations and structural arrangements were investigated which were applicable to one or more of the boosters considered. The configuration recommended as being most efficient for the cislunar mission is shown deployed in Figs. I-8 and I-9. The launch vehicle is the Atlas (SLV-3)/Agena D.

A distinctive characteristic of the design is the arrangement of the capacitance sensor panels in four arms of Z-cross section, thereby providing three dimensional space coverage. Solar cell panels are also incorporated in the arms so that electrical power generation is independent of the vehicle attitude. These features are obtained while retaining simplicity of arm and panel deployment. Each arm and panel is independent of all other arms and panels and only 90° of travel is required for full deployment of each arm and panel. The arms are mounted from the sides of the square frame, which also supports the systems module.

The spacecraft in orbit weighs 696 lb, which is well within the capability of Atlas (SLV-3)/Agena D for direct injection into cislunar orbit. It has a span of 290 in. and a basic height of 76 in. (exclusive of antennas and sensors). When packaged, it is contained within the payload envelope for the Agena long fairing. The only deployable item other than the capacitance sensor panels is one segment of the turnstile antenna which is mounted-spring loaded, partially deployed against the heat shield and deploys fully as the heat shield is separated. The turnstile antenna, mounted on top of the equipment module, and the cone disc antenna on the bottom of the equipment module provide omnidirectional coverage required by the random tumbling of the spacecraft in orbit.

The sensors on board the vehicle include: 39 sq ft (net area) of 0.001-in. aluminum target capacitance sensor panel, 503 sq ft (net area) of 0.002-in. aluminum target capacitance sensor panel, two velocity gages, three Mariner gages and 72 Exotech sensors (two in each capacitance sensor bay).

The spacecraft contains no attitude control equipment. Spacecraft attitude is determined on the ground from telemetered data collected by five sun sensors, five earth sensors and two magnetometers.

**BLANK PAGE**

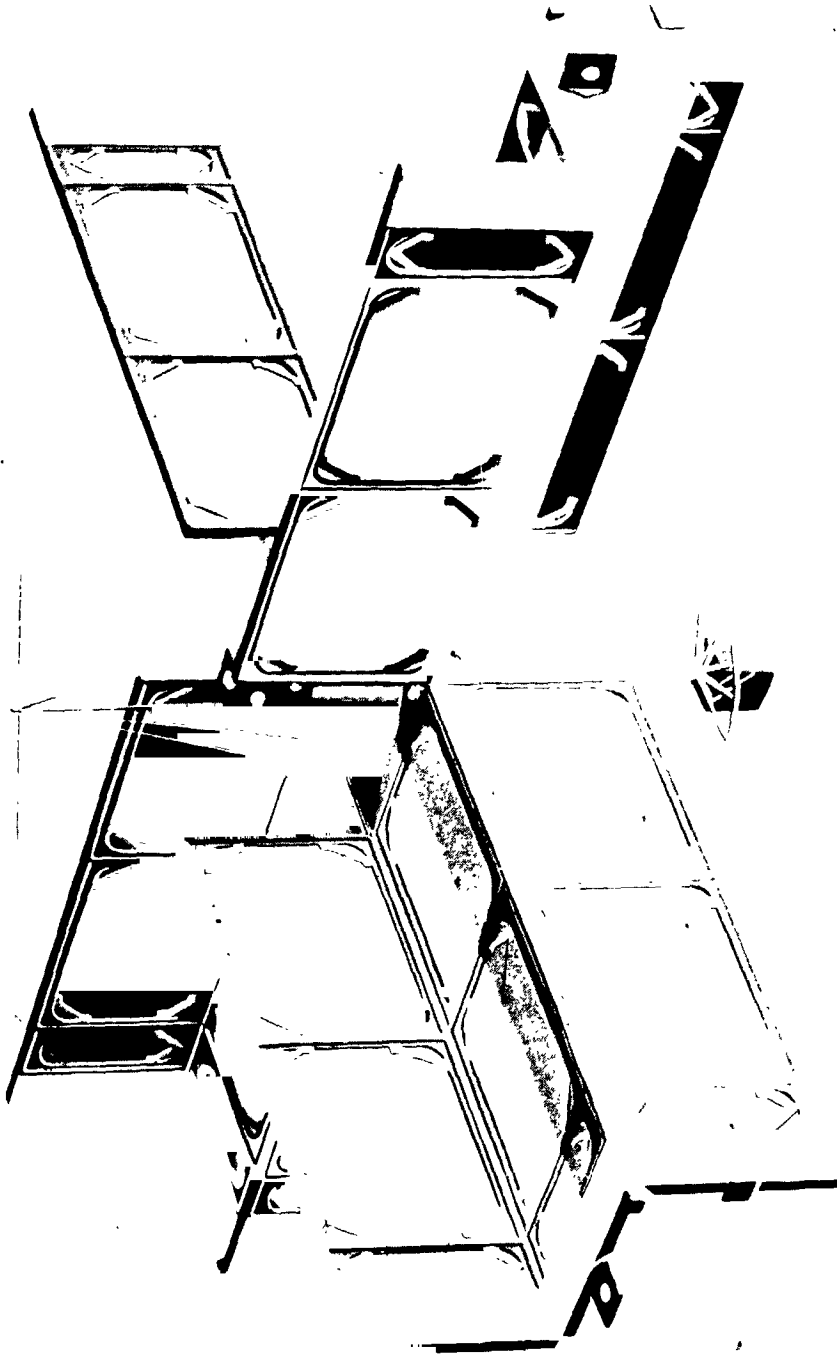
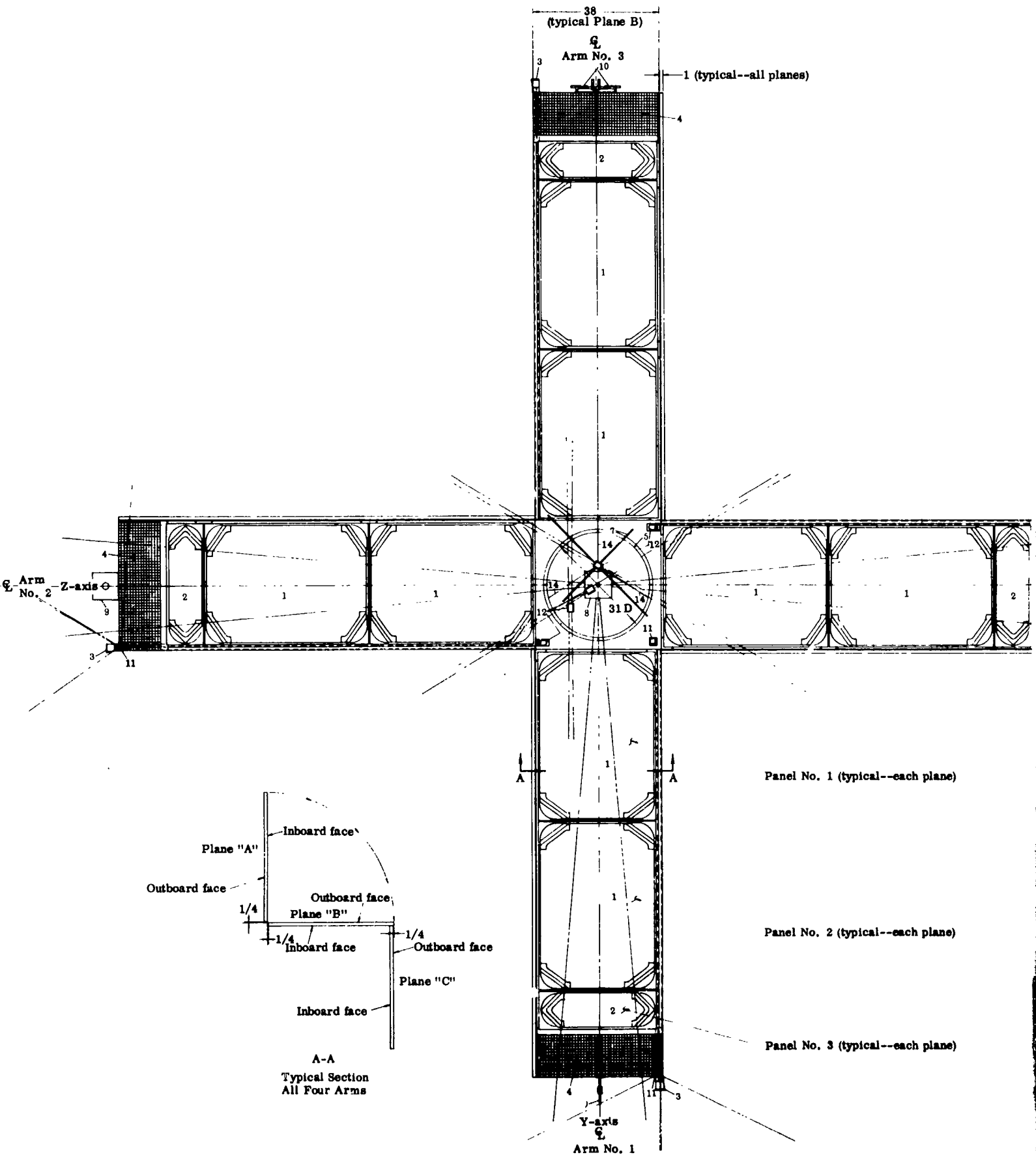

Fig. I-8. Micrometeoroid Deep Space Satellite



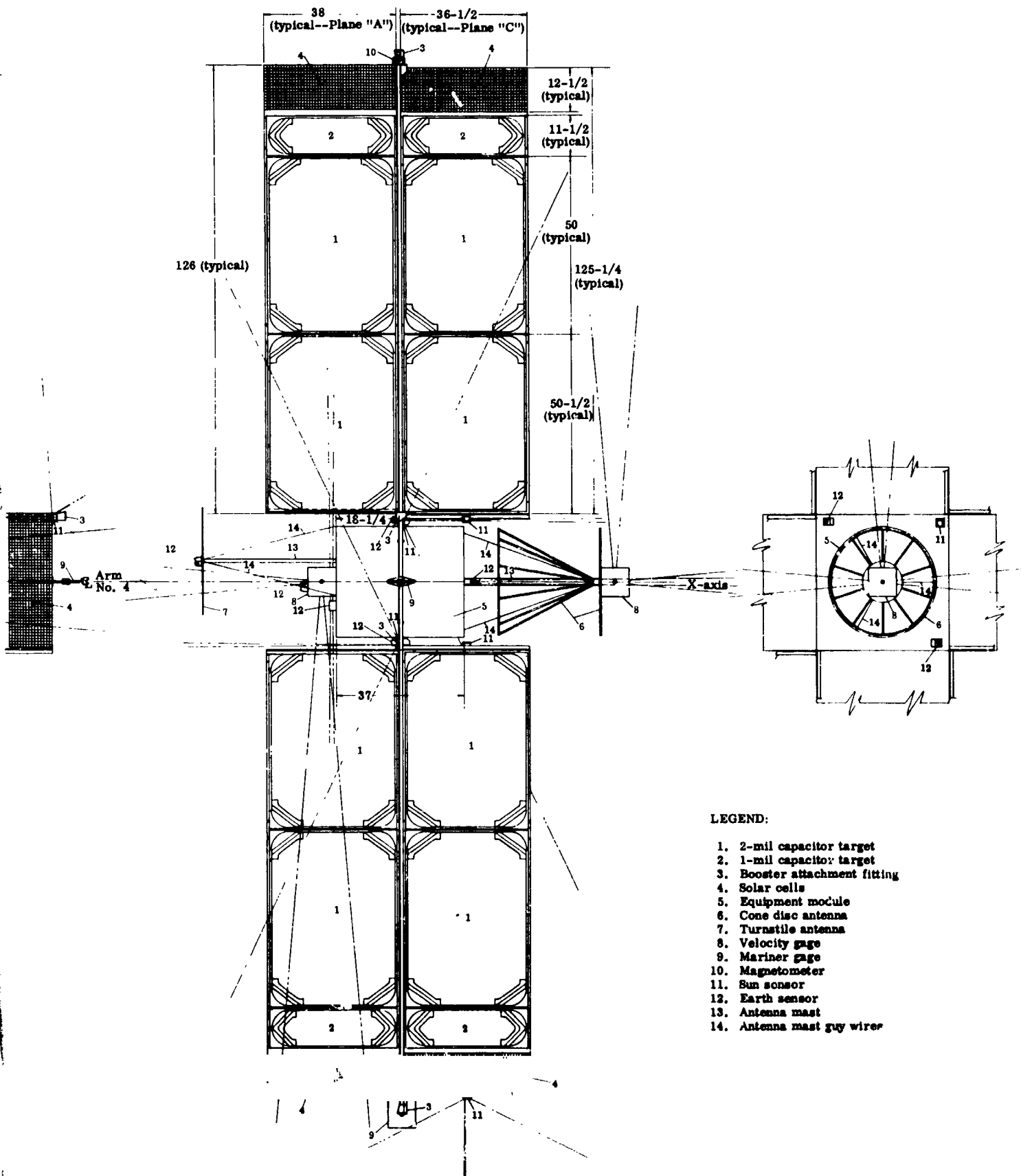

Fig. I-9. M100 General Arrangement

**BLANK PAGE**

## b. Weight summary

The following is a weight summary (recommended configuration) of the Atlas (SLV-3)/Agena D spacecraft equipment.

<u>Equipment</u>	<u>Weight (lb)</u>	
Structure, center	85.0	
Cylinder		75.0
Arm support		10.0
Power supply	122.1	
Solar cells		44.4
Battery, NiCd (2)		32.0
Battery, thermal (2)		0.9
Voltage regulator		1.3
Convectors (2 sets)		3.3
Charger limiter		0.2
Wiring, miscellaneous circuitry		40.0
Instrumentation of secondary sensors	170.4	
Signal conditioning units (4)		18.0
Exotech sensors and preamplifiers (72)		7.2
Exotech electronics (2)		4.0
Mariner gage and preamplifiers (3)		1.5
Mariner electronics (3)		12.0
Velocity gage (2)		8.0
Velocity gage electronics (4)		16.0
Time of flight converters (2)		3.0
Flux gate magnetometer (6 heads, 4 electronics)		15.0
Diagnostic system No. 1		4.0
Diagnostic system No. 2		3.0
Diagnostic system No. 3		2.0
Diagnostic system sensors (40)		4.0
Killer timer (2)		1.0
Deployment timer (2)		1.0
Capacitance panel test (2)		1.0
Panel charge generator (4)		1.0
Capacitor data unit (2)		0.5
Exotech data unit		0.6
Mariner data unit (2)		1.2
Diagnostic data unit		1.2
Master clock and divider unit (2)		0.2
Deployment data unit		0.1
Memory overflow unit		0.1
Memory unit A (2)		0.4
Memory unit B (2)		3.6
Memory unit C		3.5
Solar aspect electronics (2)		7.0

<u>Equipment</u>	<u>Weight (lb)</u>
Solar aspect sensors (5)	1.3
Earth sensor unit (2)	1.0
Aspect data unit (2)	2.0
Installation and circuitry	46.0
Communications	41.8
Hybrid and diplexer assembly	2.8
Beacon and data transmitter	1.5
VHF transponder (2)	5.4
Command decoder (2)	5.0
Command logic	3.0
Subcarrier oscillator and Mod Nos. 1 and 2	0.6
Input data selector and signal conditioner (2)	0.6
Coaxial switch	0.2
VHF antenna (2)	6.0
Installation and circuitry	16.7
Separation	15.0
Environmental control	10.0
Capacitor sensors	251.3
Supporting structure	140.8
Light shields	10.0
Hinges and mechanism	24.6
Panel stops	4.0
Bonded sensors (0.002)	67.0
Bonded sensors (0.001)	4.9
Total spacecraft weight	695.6
Agena adapter	22.4
Spacecraft straps	5.0
Total Agena payload	723.0

### c. Configuration development studies

The various stages by which the design described in Section I-C-1-a was developed are briefly summarized in the following paragraphs.

Configuration development. Configurations were developed for the Atlas-Agena and Atlas-X259 boosters that were compatible with the Atlas long fairing heat shield. Saturn 1B configurations were contained in a truncated cone payload envelope 336-in. high, with a 156-in. diameter at the top and a 260-in. diameter at the bottom.

During the proposal effort, the configuration shown in the technical proposal for the MDSS Conceptual Study (ER 13470, May 1964) was

developed. It was compatible with both the Atlas-Agena and Atlas-X259 boosters. It featured four sets of panels, each set containing three panels. Each set was rotated 90° in deployment and each set contained two movable panels which were then deployed 180°. The resultant configuration was essentially a flat plate. The panels were mounted from the bulkhead that supported the systems module and were non-load carrying. The corners of the movable panels were trimmed to provide necessary clearance. The X259 configuration, which had the systems module at the top, required a long adapter and required that the sets of panels be deployed 90° prior to separation. In the early phases of the study, the effort was directed toward obtaining maximum capacitor sensor area. Since the present configuration filled all available space between the heat shield and the X259, effort was then concentrated on the Atlas-Agena configuration where additional volume was available under the fairing. When the Z-configuration was conceived, the maximum (gross) sensor area available on the X259 was found to increase from 592 to 680 sq ft; but since performance trade-off studies showed that the Atlas-X259 booster was not as good as that of the Atlas-Agena, no further work was done on this configuration.

In developing the Atlas-Agena configuration, an additional panel was first added to each set on the proposal configuration and folded 180° into the now empty center of the folded configuration. This increased the available area from 592 to 702 sq ft; when the similar panel was added to the Z, the area increased to 790 sq ft. The Z-configuration, conceived first by rotating the movable panels only 90° instead of 180°, was intended basically to provide a 3-dimensional sensor surface. When investigated, it had many additional advantages. First, it eliminated the need for the clearance trim cut on the movable panels and thereby increased the available area. It also reduced the deployment requirements of the movable panels from 180° to 90°. It permitted two of the panels in each set to be built integral, thereby eliminating 4 hinge lines and mechanisms and making it possible to design the panels to support the spacecraft. This in turn permitted the systems module to be mounted on top which greatly simplified the antenna installation, vastly improved the serviceability of the systems module, and permitted an additional increase in available sensor area. The total available (gross) sensor area increased from 664 to 752 sq ft when the adapter was shortened so that the systems module became tangent to the separation plane. When the systems module was located on top and the adapter made as short as practical, the area increased to 790 sq ft. Further area increases were realized by adding additional Z-panels to each of the sets and stowing them in the volume formerly filled by the X259 motor. This concept was dropped because of the added complexity of deployment.

The spacecraft design described in Section I-C-1-a requires that the structural framework of the sensor arms and movable planes be secured

during launch so that they are structurally integral. Several methods were investigated.

Using the motion of the panels as an aid, tapered pins first without and then with pin pullers were tried but were rejected. It was felt that the tapered pins would tend to bind due to temperature change, and that they required too many pin pullers to be sufficiently reliable.

Tapered blocks were laid out so that the effect of temperature change in the longitudinal direction of the panels could be minimized. These were incorporated with a center truss structure to support the satellite, since the blocks could not carry the load in the longitudinal direction. However, the center truss complicated deployment of the satellite since clearance between the arms and the truss became critical even if the satellite arms were extended before separation.

The development of the 90° conical shear buttons solved the problem of the shear transfer of load between panels but still left the problem of holding the panels together to make the shear transfer effective. Mechanical methods of accomplishing this were explored without obtaining completely satisfactory solutions to date. The most promising system devised uses nylon straps and cutters. Other methods investigated involved shear pins and explosive separation.

Sensor panel design development. One of the design requirements for the spacecraft was that it provide as much sensor area as possible. To achieve this, the lightest method of supporting the sensor panels was sought. An idea advanced in the Lunar Orbiter Study was applied here. This was to spring mount the sensors and baffles in a tubular space frame. The baffles were sized from a meteoroid penetration study. A dynamic analysis revealed that the sensor suspension would not be critical but that the spring baffle panels would require additional study due to their mass. At this time, the idea of segmenting the sensors was developed. Statistical analyses showed that only a small percentage of the sensors would be shorted and this could be tolerated; thus, it became possible to save additional weight through removal of the baffles. The removal of the baffles also facilitated the installation of the Exotech sensor to serve as a backup to the capacitor. This required light shielding of the panel which is accomplished by using an opaque mylar light block. The capacitor consists of an aluminum target, mylar dielectric, and vapor deposited copper since this type is readily available. New capacitors using other dielectrics and capacitance plates can readily be adapted as they are developed.

An alternate capacitor sensor mounting was devised to supplement the spring-mounted panel if it posed any problems in development. The capacitors are bonded to an auxiliary frame which in turn is mounted in the spacecraft planes.

Pressurized sensors were also considered in a Z-configuration. This is a modification of the pressure sensors used in the Explorer series. Both sides of the 2-in. diameter sensor tubes are exposed and 600 sq ft of arm is thereby obtained. Another feasible method of providing a pressurized sensor is by using a sealed honeycomb panel whose faces are the target.

Consideration was also given to multilayer capacitor sensors and to bumper type sensors. These designs were not pursued at this time since they involved development programs for evaluation and calibration.

## 2. System Definition

### a. Sensor complement

#### (1) Sensor survey

A survey of sensors used to measure meteoroid incident and interaction parameters was made. The degree of detail that could be obtained varied. Sensors which could satisfy all the objectives were available and could be integrated within a spacecraft compatible with the capabilities of the launch vehicles.

Sizing of sensors for the primary objective was predicated upon the thickest gage that could be used and still meet the guidelines for the number of sample points. The environmental model used for sensor sizing was conservative relative to other existing models, but was based upon the actual penetration frequency of Explorer XVI sensors. Sensors to achieve the secondary objectives over the same portion of the meteoroid population as the penetration sensors were not available. Available sensors had "sampling windows" equivalent to much smaller particles necessitating extrapolation over a number of decades of mass in order to correlate the data.

On the other hand, such sensors were found to be relatively easy to accommodate physically. The largest requirement they imposed upon a spacecraft sized by penetration sensors was in data handling due to the increased sampling potential which extended over a number of decades of particle mass. A secondary requirement was for environmental measurements such as temperature and attitude needed for interpretation of their outputs.

Final sensor complement recommendation was for two thicknesses of capacitance penetration sensors. The mounting technique evolved for the capacitance sensors allowed the selection of a backup penetration flash detector which is installed in the volume defined by two capacitance sensor panels and their frames.

Meteoroid sensors used on OGO and Mariner 1964 were also selected for measuring velocity, impact and (derived) mass. Throughout this report, these two sensors are identified as the velocity gage and the Mariner gage, respectively.

Integration and data handling concepts were evolved to separate the primary sensor lines and allow for changes in the sensor outputs. This concept gives both flexibility to accommodate new sensors under development and minimizes the possible effects of individual sensor failure, so as to increase the reliability of achieving the primary objective.

## (2) Definition of sensor complement

The suggested sensor complement is summarized in Table I-2.

Penetration measurements will be made using tension-mounted capacitance gages consisting of 1-mil aluminum (5052-H19) target plates and 2-mil target plates. The initial calculations performed to determine the areas of capacitance sensors required were based on the mission objective of obtaining 80 penetrations in one year. During the early phases of this study, it was decided to design the spacecraft with sufficient sensor area to obtain the desired number of penetrations in 6 mo instead of 1 yr. Therefore, sensor area requirements became 50 sq ft for the 1-mil aluminum thickness and 530 sq ft for 2 mils. However, design restrictions in the present configuration (i.e., total gross panel area available, less structure, panel mounting doublers, air gaps, etc.) limit the net sensor areas to 39 sq ft and 503 sq ft, respectively, as shown in Chapter III, Volume III of this report. Therefore, using the same particle environment, it will require approximately 7.7 mo to obtain 80 penetrations in the 1-mil panel.

Several factors must be considered, however.

- (1) The present configuration has an oversized structural area for the solar cell arrays. It is possible to reduce this area and thus add area to the 1-mil panels without further changes to the vehicle structure.
- (2) While the capacitance sensor areas were sized for a 6-mo mission life, all other onboard sensors, as well as flight plans, have been defined for a 1-yr lifetime.
- (3) The capacitance sensor areas were based on a conservative estimate of the penetration equivalence of the Mylar dielectric.

Mylar with vacuum deposited copper will be used to complete the capacitor. A secondary penetration measurement will be made using infrared flash detectors mounted within the free volume defined by the capacitor sensors and the mounting frame. Extraneous light will be excluded by a flexible (conductive fabric) strip fastened to both the frame and the capacitor by a velcro fastener.

Instrument	Origin and Remarks	Size	Weight
Capacitance gages	LRC/Schjeldahl. 50 sq ft of 1-mil aluminum target plate gages plus 530 sq ft of 2-mil aluminum target plate. Sensor panels will form Z-configuration in each of four directions giving 12 wings. Each wing will be divided into 3 sensor bays. The 2 larger bays will have 2-mil panels on either side; the smaller bay will have 1-mil panels on either side. Penetrated sensor will be identified only as to one of six directions. IR sensor will identify bay so that penetrated sensor will be known to one of 3 or one of 5 segments.	1 mil, 10 x 35-1/2 2 mil, 49-1/2 x 35-1/2	0.59 psf 0.62 psf
Microphone capacitance gage plus thin film	GSFC/Mariner. Capacitor response will be pulse height analyzed for kinetic energy analog.	8 in. x 8 in.	0.5 lb each
Velocity tube	GSFC/OGO. Time of flight from 2-mc clock stopped by capacitor output. Capacitor output is also pulse height analyzed for energy response. Attitude needed but not necessarily measured at time of hit.	8-in. cube	4 lb
Light flash detector	Exotech, Inc. 2 sensors in each of the 36 bays. Each pair will be used in coincidence.	1 x 1 x 1/2 in. each	.05 lb each

\*8.3 E -8 ≡ 8.3 x 10<sup>-8</sup>

\*\*n = 6

\*\*\*per tube

\*\*\*\*Alternate for level A and/or B

## BLE I-2

## sor Complement

Output Name	Response	Output Per Sensor (mass equivalent gm)*	Number of Hits per Zone per Orbit	Number of Sensors
Thickness 1, String 1	(mv) 1/3	8.3 x E-8	0.53	24 panels of 1-mil target plate, each subdivided electrically into 5 segments. 48 panels of 2-mil target plate, each subdivided electrically into 3 segments.
Thickness 1, String n**	(mv) 1/3	8.3 x E-8	0.53	
Thickness 2, String 1	(mv) 1/3	4.8 x E-7	0.53	
Thickness 2, String n**	(mv) 1/3	4.8 x E-7	0.53	
Mike, Level 1	Momentum	10 x E-10	81.4	3 sensors = 6 surfaces; hit numbers are per sensor
Mike, Level 2	Momentum	5 x E-10	9.4	
Mike, Level 3	Momentum	10 x E-9	3.7	
Mike, Level 4	Momentum	5 x E-9	0.43	
Cap, Level A	(mv) x	10 x E-12	39,040	
Cap, Level B	(mv) x	10 x E-11	1,783	
Cap, Level 1	(mv) x	10 x E-10	81.4	
Cap, Level 2	(mv) x	5 x E-10	9.4	
Cap, Level 3	(mv) x	10 x E-9	3.7	
Cap, Level 4	(mv) x	5 x E-9	0.43	
Cap, Level 5***	(mv) x	(10 x E-8)	(0.2)	
Velocity analog	Time of flight	≥ E-13	33.2	2 sensors = 8 tubes; hit numbers are per tube
Cap, Level 1	(mv) x	10 x E-13	33.2	
Cap, Level 2	(mv) x	10 x E-12	1.5	
Cap, Level 3	(mv) x	5 x E-12	0.173	
Cap, Level 4	(mv) x	10 x E-11	0.07	
Mike, Level 1	Momentum	10 x E-12	1.5	
Mike, Level 2	Momentum	5 x E-12	0.173	
Mike, Level 3	Momentum	10 x E-11	0.07	
IR Level 1 (1-mil)	Penetration Threshold only	>8.3 x E-8	0.53	72
IR Level 2 (2-mil)		>4.8 x E-7	0.53	

Velocity and impact as well as penetration kinetic energy will be measured by two GSFC Velocity Sensors as used on the OGO satellite. Since the velocity section sensitivity exceeds the impact transducer sensitivity, velocity will be measured even though no coincident impact response occurs. (This is planned for the POGO version of the sensor.) Two velocity sensors will be used to obtain the desired sample.

Impact measurements will be extended to approximately  $10^{-8}$  gm using three orthogonally mounted gages of the type developed by GSFC for Mariner 1964. These gages will be mounted on the ends of three spacecraft "wings." Output of the capacitance sensor will be analyzed for a kinetic energy response.

### (3) Alternate state-of-the-art sensors

Any one of the different capacitor sensors under development can be mounted within the spacecraft "wing" frames. This would include the double (coincidence) sensor as developed at Lewis Research Center or the thin film dielectric and metallizing. Multilayer capacitance gages could be mounted in the same manner. The most promising version under development would be the thin film sensor because of the relatively small thickness added to the target plate.

The gold grid type of penetration gage or the pressurized cylinder gage could also be mounted within the same frames. For the latter, a large weight penalty would exist due to the relatively large weight fraction of non-target material.

Since all of these penetration sensors are threshold sensors only, substitution would not affect the data handling system. Power differences should be of negligible effect. The last two sensors store the penetration record (by virtue of their destruction) so that they would not have to be monitored continuously.

Physical mounting of a ceramic beam sensor should present no problems. A housing may be required if mounted external to the systems module. However, internal mounting would probably be more desirable. The spacecraft background noise may be greater than in the Pioneer satellite (because of thermal flexing of the large sensor panels) and may be a factor limiting the sensitivity that could be attained.

### (4) Sensors requiring considerable development

The modified version of the velocity tube, if available, can be physically substituted easily for the existing instrument. Because of the increased geometric factor, a much larger sample will be obtained

**BLANK PAGE**

and the sample can be extended to masses of  $10^{-9}$  to  $10^{-8}$  gm. The major new factor will however not be the total number of data samples per se out the sorting and storage of the 16 x 16 possible arrival directions in the velocity measurement. The increased resolution will also make it desirable to use an improved attitude sensing system. Considering that velocity resolution is less important than extending the sample to lower masses, it would appear desirable that a simpler version of this sensor also be built with a smaller matrix but with the same geometric factor. This would simplify the data handling with no loss of the sampling potential.

The basic improvement in the infrared flash sensor would be a reliable calibration of the flash intensity versus particle mass, velocity, penetration or related parameter and would not necessitate any modification over the present version insofar as the physical requirements of size and mounting. The outputs would be handled differently in that the signal from each sensor would be pulse-height analyzed, as opposed to just using the signal in coincidence from a set of two sensors as an event indicator.

Use of the ballistic pendulum and velocity sensor (which may be developed by NASA/MSC) should not present any mounting problems with respect to size and shape, but may be more sensitive to tolerable noise transmitted from the thermal flexing of the large sensor panels. The data rates and the output form should be easily accommodated.

## 5. Telecommunication system

### (1) Introduction

The basic requirement of this micrometeoroid deep space satellite (MDSS) conceptual study is to select techniques for measuring micrometeoroid impacts, associated data handling equipment to register the penetration and/or impact information and communication equipment to transmit these data to the ground. In addition, techniques were considered for measuring, recording and transmitting other information at the event time of micrometeoroid impact, to obtain a complete "hit history". Simple, as well as sophisticated, methods were investigated to obtain significant micrometeoroid data during the satellite mission lifetime.

A large number of tradeoff investigations were conducted. These tradeoffs considered reliability versus: technique simplicity, number of parts required, method of operation, ancillary equipment, storage requirements, power requirements, weight and volume constraints, communication considerations and many other factors. Tradeoff studies also considered the present and anticipated state of the art of equipment.

#### (a) Requirements and constraints.

To evaluate data requirements for the sensors, a priority of possible different scientific and engineering measurements was established. These requirements were modified during the study, by considering:

- (1) Simplicity of operation and the related reliability for each component and subsystem.
- (2) Feasibility of the recommended technique, as constrained by availability of space-proven hardware.
- (3) Limitations imposed by other spacecraft systems.
- (4) Convenient formatting of the various measurement data outputs, to reduce onboard storage requirements, power demand during transmission periods and switching operations.
- (5) Elimination of insignificant data by onboard data management and, therefore, reduction of ground station monitor time.
- (6) Minimum storage requirements, to keep memory units as small as possible to achieve higher reliability.
- (7) Adaptability of the data handling system to the outputs of the different sensors to allow flexibility in processing methods.

- (8) Sensor measurement and data processing capability during stored data readout and transmission.
- (9) Standard length of data frames (number of words), as well as length of data words (number of bits).
- (10) Elimination of power on/off switching wherever possible.
- (11) Minimum number of commands, to avoid system complexity.
- (12) Redundancy for measurements which represent primary objectives.

A general requirement was that, at no time throughout the mission should measurement of any significant micrometeoroid data be jeopardized by either the occurrence of a momentary switching or command function or any other event in the data processing system. At the beginning of this study, emphasis was placed on developing a data processing system which could automatically control any data flow condition which might come up in the course of the mission due to the coincidence of a number of measurement events.

(b) Summary. A design concept for MDSS instrumentation and on-board data processing has been established. A number of measurement systems pertinent to particle impact, energy and velocity detection have been investigated. Principal attention has been given to systems for detection of meteoroid penetration. Secondary parameters, for which sensors and associated data processing techniques were investigated include determination of particle influx rate, density, velocity and directionality. Sensing and data processing methods for determining satellite orientation at impacts were examined to correlate spacecraft attitude information and particle influx direction.

Each of the measurement systems was evaluated from the point of view of long-term reliability, sensing technique accuracy and compatibility with the requirements of other spacecraft systems. Effects of the individual sensor data outputs on storage and telemetry requirements were considered. Reliability in the design concept was emphasized, specifically for the micrometeoroid penetration measurement system, which was considered most important.

A design concept for the MDSS communication, command and tracking subsystems has been established. A number of communication techniques, associated with existing ground station networks, have been investigated. Each of these techniques was evaluated from the standpoint of compatibility with the primary and secondary measurement requirements, power requirements and especially long-term reliability requirements.

Numerous tradeoff studies were conducted.

Preliminary considerations for hardware selection and packaging techniques for components are also discussed in this report.

## (2) Conclusions and recommendations

### a. General

Design goals for the MDSS were achieved using the concept of two separate and mutually independent measurement systems (Fig. I-10). The telecommunication system consists of primary and secondary data processing subsystems, and a communication subsystem (telemetry, tracking and command).

#### (1) Data processing subsystems

The recommended data processing subsystems are a direct result of extensive reliability studies and failure mode analyses which were conducted to obtain maximum probability of primary data recovery.

**Maximum reliability is achieved throughout the system by development of a basic data module; thus, unit isolation is easily provided and data recovery is not jeopardized. Furthermore, areas of primary importance are further protected by redundancy in either circuit or element.**

**Handling of primary data is accomplished by two identical data units. The flexibility of this basic data unit is evidenced by the fact that an extended version is utilized throughout the secondary subsystem, with only input and control variations for the different sensors. One primary data unit provides continuous data formats of total capacitance sensor penetrations to a transmitter which operates continuously. The other primary data unit is redundant and provides identical data formats to another transmitter through an electronic data switch.**

**The secondary data system is composed of data units for each of the sensor groups and three core memories for data storage until data readout and transmission is commanded. Each memory is associated with two particular data units, greatly enhancing the probability of data recovery by reducing the logic required for utilization of a single large memory unit. Also, failure of one memory unit will not prevent recovery of data from the other memories. Data not entered into memory, such as deployment data, housekeeping information and memory**

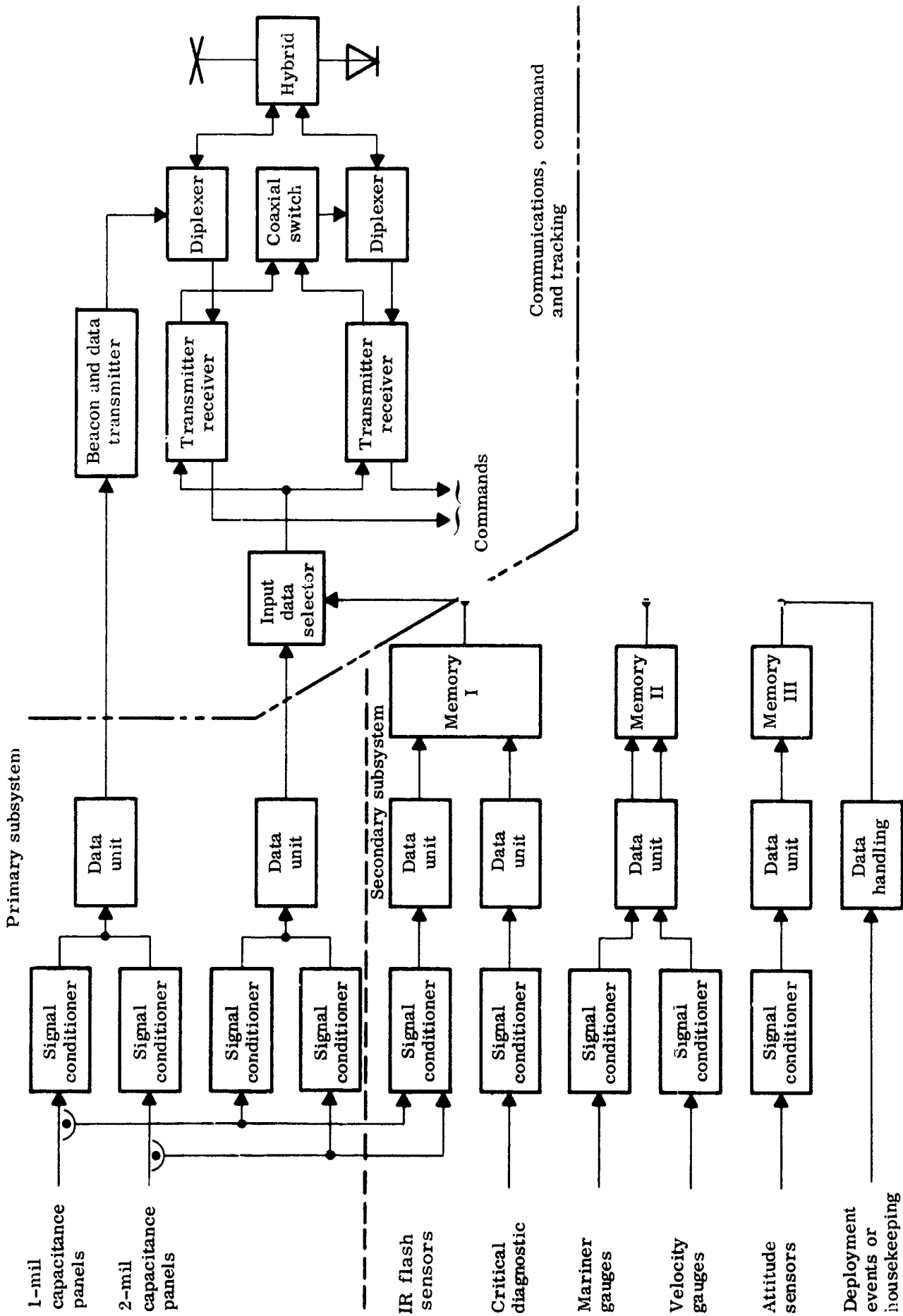

Fig. I-10. Telecommunications System Simplified Block Diagram

overflow are presented on the secondary data bus in real time for transmission. Real time data units are basically identical to the units entering data into memory, and require no interface to connect to a common data bus with the memory outputs.

Secondary data readout is commanded from the ground. Each memory is read out as a result of a unique command, which is decoded and enters the Read Data unit in the secondary data system. The function of this unit is to generate sync frames, command the prescribed memory unit to read out twice, and sequence any real-time data prescribed by the received command. The probability of transmission error occurrence is drastically reduced by two readouts per command, in conjunction with parity.

#### (2) Data processing techniques

Parity bit. There is no parity bit associated with the primary or redundant primary data processing subsystems. Since the primary data is continuously transmitted, there is little need for a parity bit. A transmission error can be detected and, hence, corrected simply by noting the correlation between successive data frames.

However, a parity bit has been included in each data word transmitted by the secondary subsystem, due to the latter subsystem's complexity and the fact that data are stored. Inclusion of the parity bit together with the repeated transmission of all information contained in the secondary subsystem, will greatly augment the error detection and correction of the transmitted data.

Frame sync and format identification. Since the data processing philosophy dictates a fixed format, it is necessary to identify each format in the secondary subsystem. To decode the information, it is necessary to distinguish between any one of 15 different formats. This is accomplished by assigning the first four bits of the data word for frame identification.

The deployment format also does not contain identification. This is not required, since transmission of other formats cannot take place until the transmission of the deployment format has been terminated.

Memory overflow data unit. To fully satisfy MDSS system requirements, some means of registering micrometeoroid impacts in excess of anticipated values must be provided. The recommended technique employs a memory overflow data unit which consists of a memory overflow counter for each sensor group. In the event that the particle density encountered is greater than the predicted maximum for which the memory units have been designed, the excess will be recorded on the respective counters in the memory overflow data unit. Simplicity of the recommended technique, and the additional flexibility which it presents to the system are in line with established design philosophies.

Data switch. Secondary data is transmitted upon receipt of a command, which causes the second transmission channel transmitter to be connected to the secondary data bus. It is recommended that the switching be achieved by means of a data switch. This switch normally connects the primary data bus to the transmitter but, upon receipt of a read-out command, the switch is toggled to the respective secondary data bus. Failure mode protection is accomplished by quad redundant techniques and also by a time function reset to the normal operating mode.

Clock synchronization. Since the second transmission channel is common to both redundant primary data and secondary data, it is necessary that sync be established between the two data lines to prevent loss of bit sync at the ground station. Data sync can be accomplished by using a common oscillator or by syncing one master oscillator to another. Reliability analyses have indicated that the former technique is more reliable.

Critical diagnostic data. Only spacecraft measurements of prime importance will be stored, to comply with design philosophy and maintain system simplicity; thus, a smaller memory unit may be used. The critical diagnostic format contains only measurement data mandatory for accurate data retrieval. Moreover, the critical diagnostic format is entered into storage only once per day, further reducing the size of the memory unit required and increasing system simplicity.

Attitude data. Attitude sensing and determination studies have resulted in a requirement for gathering a large quantity of attitude data near perigee, and considerably fewer data during the remainder of the orbit. The recommended system collects data at two different rates: in the "full attitude" mode of operation, data is collected every 2 min

during 5 hr in the vicinity of the perigee, and in the "hourly attitude mode" for the remainder of the orbit, data is collected once every hour. This dual mode of operation simplifies the secondary data processing subsystem, allowing the use of a much smaller memory unit which can be time-shared by the two modes. Also, individual data processing units can be employed for each attitude data mode, adding to system flexibility.

Primary-secondary subsystem isolation. To guarantee the highest probability of mission success, and in keeping with the design philosophy, it is required to isolate the primary, redundant primary and secondary data processing subsystems from one another. Of techniques investigated to date, Hall detector devices have been selected to attain the desired isolation. Since these devices are based on magnetic detection, no physical contact need be made with the primary signal source. Hence, a failure in one of these devices will in no way affect the operation of the primary data processing.

The Hall devices are space-proven items, of high packaging density, with high resistivity to radiation and wide temperature tolerance. However, it is recommended that further investigations be conducted to determine the practical application of the device for the intended use on the MDSS.

Memory units. Serial sequential single aperture ferrite core memories have been selected for the purpose of recording data. This type of memory device represents the most reliable storage method available, consistent with the present state of the art.

Velocity gauge and Mariner gauge data processing. The data processing for the velocity gauges includes identification of the individual sensor tube, thus defining the direction of the particle vector in respect to the spacecraft. However, the present data system only identifies the Mariner gauge which has been impacted. It is recommended that further consideration be given to the particle direction data derived from this sensor. The capability exists to identify the side of the sensor which has experienced an impact. Since the storage requirements have been established on the basis of scaled-down total impacts for one orbit, storage capacity need not be altered.

### (3) Communications

It has been concluded that the STADAN network should be used to support the MDSS program, rather than other NASA controlled networks. Use of an integrated VHF tracking, command and telemetry system is preferred to use of other STADAN frequencies. The recommended MDSS system uses the 136- to 137-mc band for telemetry and 148 mc for command. Use of both bands is required in the range and range rate mode

of operation, the higher frequency being required for the up-link and the lower frequency for the coherent down-link.

The recommended communication subsystem is based on an extended study of many configurations for which reliability considerations were heavily weighted. A dual-channel communication subsystem is used. Data from the primary data processing subsystem are continuously transmitted over one channel at a fairly low bit rate. Redundant primary or secondary subsystem data is being simultaneously transmitted over the second channel.

An omnidirectional antenna is required for a tumbling spacecraft, but design of a suitable system which will completely satisfy all link requirements appears extremely difficult. The recommended communication system is based on a very low rate of tumble for the spacecraft. Should further studies show tumble rates to be a problem, range and range rate system performance estimates and other possible effects would have to be reviewed.

b. Primary subsystem concept

The objective for the primary measurement subsystem is to obtain micrometeoroid penetration data with a reliability better than 90% for a period of one year. Therefore, the conceptual design of the subsystem has been simplified to a level of functional efficiency where this goal is ensured.

The primary subsystem is automatically energized during the deployment mode as soon as solar energy activates the solar cell arrays on the spacecraft "wings". No power switching is used once the primary subsystem is energized. This "no-switching" design philosophy also resolved the problem whether or not to provide command capability for the primary subsystem. The telecommunication system will continue to transmit cumulative micrometeoroid penetration data until a killer timer silences the spacecraft.

A major design requirement was that there should be no physical interface between the primary, redundant primary and secondary data processing subsystems. Several techniques were considered to determine the best way to transfer penetration signals from the capacitance sensors into the secondary subsystem, without any wiring connections. Of the three techniques investigated to date, it is recommended that magnetically coupled transducers (Hall detectors) be used.

The primary measurement subsystem uses the simplest means to acquire and telemeter micrometeoroid penetration data detected by the capacitance sensors. The operational mode consists of monitoring the output (penetration signals) of the capacitance sensors and keeping a count of penetrations for each of the two detector gages. Since the data accumulation occurs at a slow rate, and the data are strictly numerical values, PCM telemetry is most suitable.

The primary data processing subsystem programs, conditions, samples and encodes capacitance sensor penetration data. No other measurements or housekeeping data are taken by the primary subsystem. The recommended conceptual design satisfies the following design criteria:

- (1) Reliability of operation is paramount; no single failure will jeopardize the operational capability of other units in the system.
- (2) Simplicity of operation defines component size, volume and complexity.
- (3) The primary data processing subsystem is independent from other measurement subsystems. Thus, changes in the other systems (such as addition, deletion or replacement of sensors, data processing, etc.) will not affect the probability of successfully obtaining the required primary data.
- (4) Measurement data is in such a format that it can be correlated with the outputs of other sensors in the secondary system.
- (5) No bit parity is employed in the data encoding process to keep equipment modules to a minimum. Since the primary data is transmitted continuously, transmission errors can be detected, and corrected simply by noting the correlation between successive data frames.

The primary subsystem consists of two identical, continuous operating measurement networks for capacitance sensor panel penetration data. Four counters, two in each network, register cumulative penetrations on the 120, one-mil and the 144, two-mil capacitance sensors. Each counter has a capacity in excess of 30 times the anticipated number of micrometeoroid penetrations. Data collected by the first measurement network is telemetered continuously while that collected by the second network is interrupted only by a command to telemeter secondary data.

Each data unit is self-sufficient, no single failure will jeopardize the operational capability of other units in the system. The recommended system represents the most reliable configuration to accomplish the primary mission. The entire unit will be constructed with space-proven high reliability integrated circuits. The detailed block diagram of this

system is shown in Fig. I-11. The data format consists of four 7-bit words. The first two words are sync data and the last two are a binary number representing the total number of penetrations recorded in each capacitor gauge. The telemetry format of the primary system is shown in Table I-3. Time of event (penetration) is not included in the primary data format. During the mission lifetime, only 80 penetrations are expected; less than 3 per orbit. It was concluded that ground station monitoring of the continuous primary data transmission can define the time of event with sufficient accuracy. The primary data is continuously presented to the transmitters and is altered only as a result of another penetration. The redundant primary channel shares the second transmitter channel with the secondary data processing system such that when secondary data is being transmitted (on command), the primary data bus has been disconnected from the transmitter by the data switch. To enhance the probability of mission success, system design is such that a failure of the data switch will leave the redundant primary line "normally closed".

The effective capacitor sensor area in each gauge (i.e., the respective numbers of operating sensor panels) is not measured by the primary subsystem. This data is obtained by the secondary subsystem, and is used in combination with the penetration counts--to accurately determine micrometeoroid flux variation with orbit altitude.

To gather data during a shadow period, the recommended subsystem requires continuous power, and is therefore powered from an isolated bus. This technique has been selected as a result of reliability trade-offs versus accumulative NDRO magnetic counters.

c. Secondary data processing subsystem concept

(1) Measurements

Micrometeoroid measurements are taken by the secondary subsystem in two different modes. In one, penetration and/or impact data, as well as supplementary measurements (i.e., event time, particle velocity, direction, energy level, etc.) are monitored and edited into a hit history data frame by hit demand. These hit-demand frames are then entered into memory and read out on command. In the other, counts of cumulative hit registers for each sensor (and in each sensitivity level) along with housekeeping measurements are read out--in real time--by command.

Data collected by the different sensor groups are parallel to, and an extension of penetration data measured by the capacitance sensors in the primary subsystem. Hence, data from both subsystems can be easily correlated. This is especially true for penetration data. Measurements by the IR flash detectors (Exotech Sensors) serve as backup

for capacitance sensor data and, in addition, will give information on penetration location. Measurement ranges of the Mariner and Velocity gauges are more sensitive (i. e., can detect smaller particle impacts) than the capacitor sensors.

Spacecraft attitude data is recorded in two modes. In one, a "full attitude format" is measured continuously for a 5 hr period around perigee, and stored in memory. In the other, hourly frames of solar and earth aspect data are taken throughout the remainder of the orbital period and stored in memory. Hourly attitude frames are not measured during the full attitude mode.

Deployment measurements, which indicate execution of satellite (sensor panel) deployment functions are taken only during the deployment phase of the mission.

Critical diagnostic measurements are taken once daily and stored in memory. Efforts were made to limit the number of these measurements. These data are intended for status information of sensor group functioning, power supply system performance and critical calibration levels.

The full housekeeping measurement mode comprises miscellaneous measurements of check voltage points, environmental measurements, the critical diagnostic measurements (outlined above), and totalizer count data for all micrometeoroid detectors at all sensitivity levels. Command verification is not available at present. However, this is considered a valuable feature, and, therefore, it is recommended that further studies be conducted to determine the desirability of command verification and techniques to accomplish it.

Figure I-12 illustrates the flow of data signals from micrometeoroid sensors and all above-mentioned measurements. It can be seen that primary and secondary data flow lines are entirely separated and independent. Real-time data, playback of stored data, satellite attitude information, and range and range rate measurements are indicated. Redundancy of measurement information in the different telemetry data frames is shown by parallel data flow lines.

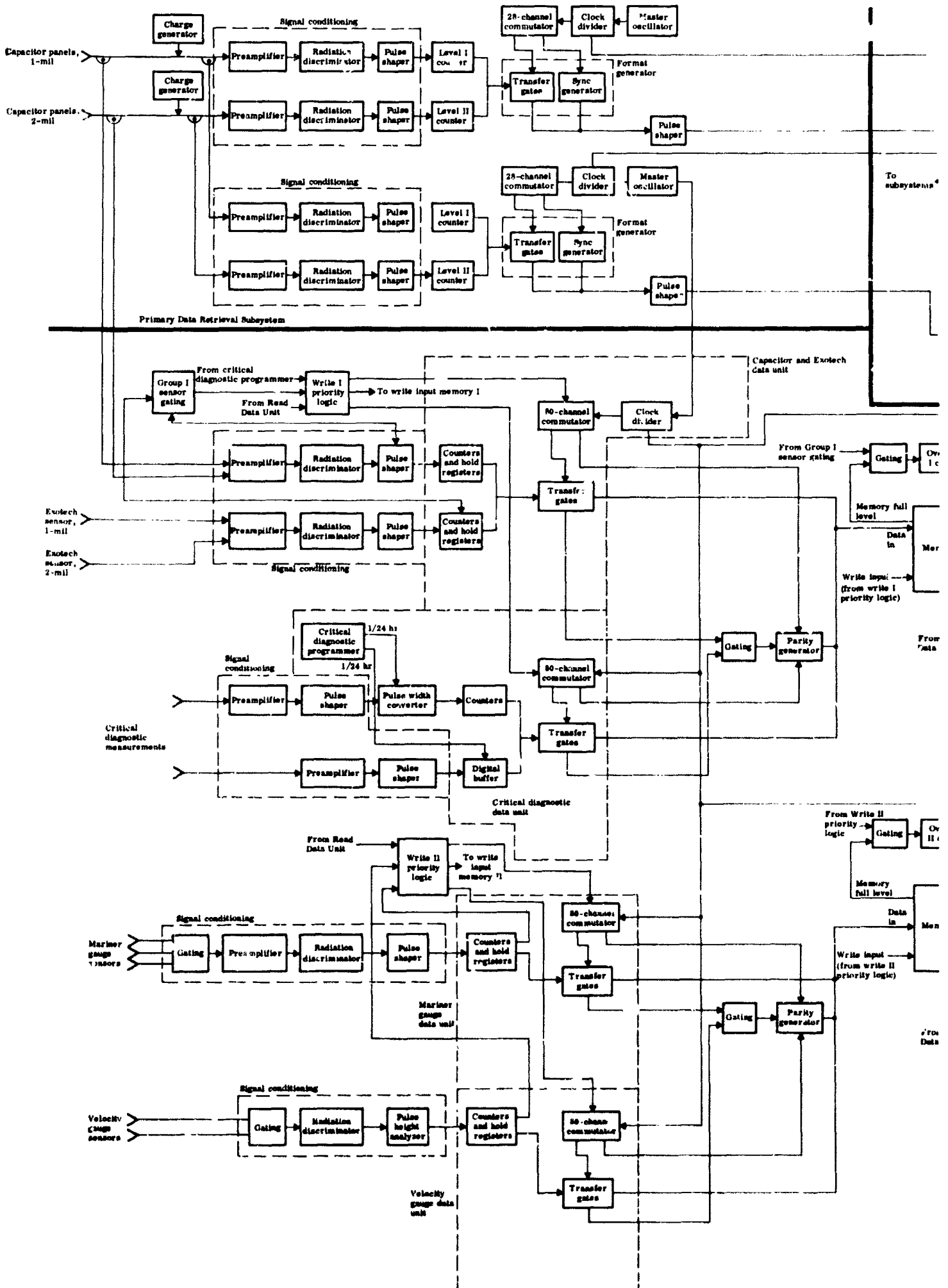

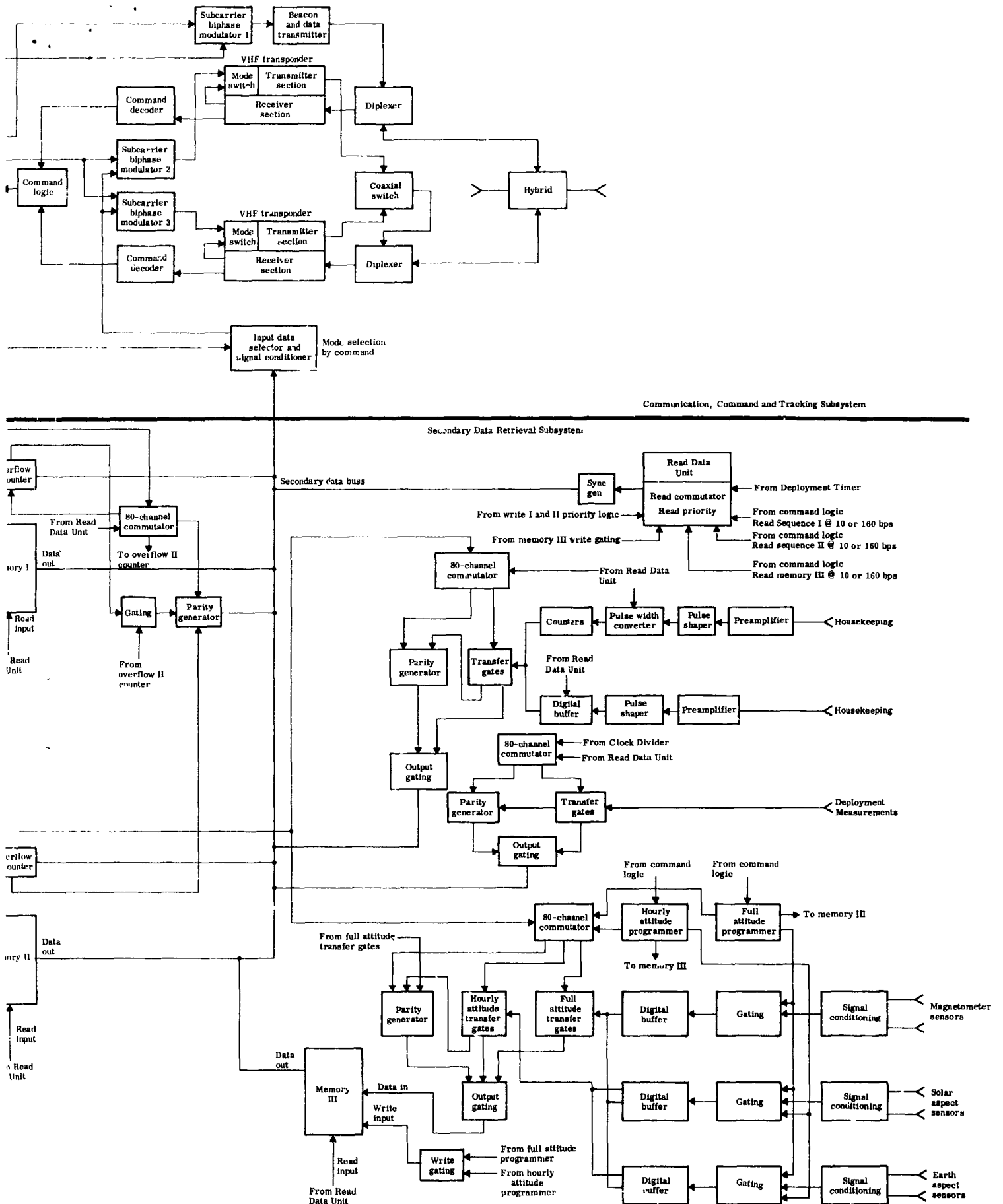

Fig. I-11. Recommended Telecommunications System

**BLANK PAGE**

**TAB**  
**System**

**A) SECONDARY SY**

**I. Capacitor Panel and IR-Flash Sensor Hit History F**

W <sub>1</sub>	W <sub>2</sub>	W <sub>3</sub>	W <sub>4</sub>	W <sub>5</sub>	W <sub>6</sub>
Frame ident (4 bits) Cap. hit direc- tion (3 bits)	S/C time (7 bits)	S/C time (4 bits) Days in (3 bits) orbit	1-mil capacitance (7 bits) panel area	2-mil capacitance (7 bits) panel area	Bay number Thickness ident

**II. Mariner Gauge Hit History Frame (10 word**

W <sub>1</sub>	W <sub>2</sub>	W <sub>3</sub>	W <sub>4</sub>	W <sub>5</sub>	W <sub>6</sub>
Frame ident (4 bits) Spacecraft time (3 bits)	S/C time (7 bits)	S/C time (1 bit) Days in (3 bits) orbit Cap.level B (3 bits) accum hits	Capacitor Level B (5 bits) accumulative hits Mike Level I (2 bits)	Mike Level I (2 bits) Mike Level II (2 bits) Mike Level III (2 bits) Mike Level IV (1 bit)	Mike Level IV Cap. Level I Cap. Level II

**III. Velocity Gauge Hit History Frame (10 words**

W <sub>1</sub>	W <sub>2</sub>	W <sub>3</sub>	W <sub>4</sub>	W <sub>5</sub>
Frame ident (4 bits) Spare (3 bits)	S/C time (7 bits)	S/C time (4 bits) Day in (3 bits) orbit	Microphone level and/or (7 bits) capacitor level ident (1 bit for each of 4 cap. levels and for each of 3 mike levels)	Capacitor and/or microphone (2 bits) initiation Velocity (5 bits)

**IV. Full Attitude Frame (10 words) (**

W <sub>1</sub>	W <sub>2</sub>	W <sub>3</sub>	W <sub>4</sub>	W <sub>5</sub>	W <sub>6</sub>
Frame ident (4 bits) S/C time (3 bits)	S/C time (2 bits) Solar aspect sensor (3 bits) ident Spare (2 bits)	Solar aspect angle 1 (7 bits)	Solar aspect angle 2 (7 bits)	Magnetometer X-axis (7 bits) magnetic field intensity vector	Magnetome magnetic fie

**V. Hourly Attitude Frame (10 words)**

W <sub>1</sub>	W <sub>2</sub>	W <sub>3</sub>	W <sub>4</sub>	W <sub>5</sub>
Frame ident (4 bits) Earth sensor ident (3 bits)	Time (7 bits)	Time (1 bit) Solar sensor ident (3 bits) Spare (3 bits)	Solar angle 1 (7 bits)	Solar angle 2 (7 bits)

**VI. Memory Over**

W <sub>1</sub> & W <sub>6</sub>	W <sub>2</sub> & W <sub>7</sub>	W <sub>3</sub> & W <sub>8</sub>
Frame ident (4 bits) Spare (3 bits)	Overflow counter (7 bits) capacitor panels	Overflow counter IR-flash senso

# LE I-3

## Formats

### ITEM FORMATS

name (10 words) (Entered into Storage on Hit-Demand)

	W <sub>7</sub>	W <sub>8</sub>	W <sub>9</sub>	W <sub>10</sub>
(6 bits) (1 bit)	1-mil capacitance (7 bits) accumulative hit count	2-mil capacitance (7 bits) accumulative hit count	1-mil Bay IR-flash (7 bits) sensor accumulative hit count	2-mil Bay IR-flash (7 bits) sensor accumulative hit count

) (Entered into Storage on Scaled Hit-Demand)

	W <sub>7</sub>	W <sub>8</sub>	W <sub>9</sub>	W <sub>10</sub>
(1 bit) (4 bits) (2 bits)	Capacitor Level (4 bits) III, IV Instrument 1 Level (3 bits) A hit count	Instrument 1 Level (7 bits) A hit count	Instrument 1 Level A (2 bits) hit count Instrument 2 Level (5 bits) A hit count	Instrument 2 Level A (7 bits) hit count

) (Entered into Storage on Scaled Hit-Demand)

	W <sub>6</sub>	W <sub>7</sub>	W <sub>8</sub>	W <sub>9</sub>	W <sub>10</sub>
Velocity (7 bits)	Total accumulative (7 bits) capacitor hits	Total accumulative (4 bits) capacitor hits Tube ident (3 bits)	Tube ident (1 bit) Total accumulative (6 bits) capacitor hits, Instrument 2	Total accumulative (5 bits) capacitor hits, Instrument 2 Spare (2 bits)	

Entered into Storage on Command)\*

	W <sub>6</sub>	W <sub>7</sub>	W <sub>8</sub>	W <sub>9</sub>	W <sub>10</sub>
Y-axis (7 bits) and intensity vector	Magnetometer Z-axis (7 bits) magnetic field intensity vector	Earth Sensor 1 sighting (4 bits) time Earth Sensor 2 sighting (3 bits) time	Earth Sensor 2 sighting (1 bit) time Earth Sensor 3 sighting (4 bits) time Earth Sensor 4 sighting (2 bits) time	Earth Sensor 4 sighting time (2 bits) Earth Sensor 5 sighting time (4 bits) High or low range flux gate magnetometer identification (1 bit)	

Entered into Storage on Command)\*\*

	W <sub>6</sub>	W <sub>7</sub>	W <sub>8</sub>	W <sub>9</sub>	W <sub>10</sub>
Earth sensor ident (3 bits) Spare (4 bits)	Time (7 bits)	Time (1 bit) Solar sensor ident (3 bits) Spare (3 bits)	Solar angle 1 (7 bits)	Solar angle 2 (7 bits)	

flow Frame\*\*\*

	W <sub>4</sub> & W <sub>9</sub>	W <sub>5</sub> & W <sub>10</sub>
(7 bits) Spare	Overflow counter (7 bits) Mariner gauges	Overflow counter (7 bits) velocity gauges

**TABLE I-3**

VII. Critical Diagnostic Data Frame

W <sub>1</sub>		W <sub>2</sub>		W <sub>3</sub>		W <sub>4</sub>		W <sub>5</sub>		M	II	
Frame ident (4 bits)	Capacitor panel (3 bits)	Capacitance panel diagnostic (2 bits)	(charge generator outputs)	Battery current (6 bits)	magnitude	Charge or discharge (1 bit)	Battery temperature (5 bits)	Velocity gauge system check (2 bits)	Electronic compartment temperature (5 bits)	Master clock temperature (2 bits)		
diagnostic (charge generator outputs)	Main bus voltage (5 bits)											

VIII. Deployment Verification Data Frame (Real

W <sub>1,4&amp;7</sub>		W <sub>2,5&amp;8</sub>	
Z wing A 1st fold stowed (1 bit)	Z wing A 1st fold erected (1 bit)	B 2nd fold erected (1 bit)	C 1st fold stowed (1 bit)
Z wing A 2nd fold stowed (1 bit)	Z wing A 2nd fold erected (1 bit)	C 1st fold erected (1 bit)	C 2nd fold stowed (1 bit)
B 1st fold stowed (1 bit)	B 1st fold erected (1 bit)	C 2nd fold erected (1 bit)	D 1st fold stowed (1 bit)
B 2nd fold stowed (1 bit)		D 1st fold erected (1 bit)	

IX. Full Housekeeping Form

W <sub>1</sub> (7 bits)	W <sub>2</sub> (7 bits)	W <sub>3</sub> (7 bits)	W <sub>4</sub> (7 bits)	W <sub>5</sub> (7 bits)	W <sub>6</sub>
-------------------------	-------------------------	-------------------------	-------------------------	-------------------------	----------------

Words 1 to 10	Critical diagnostic frame repeated
Words 11 to 14	4 voltage precision measurements
Words 15 to 18	4 temperature measurements
Words 19 to 20	Spacecraft time and days in orbit
Words 21 to 26	10-1/2 voltage measurements (4 bits each)
Word 27	1-1/2 voltage measurements plus 1 spare bit
Words 28 to 42	24 temperature measurements
Words 43 to 44	IR flash sensor amplifier voltage measurement
Word 45	IR flash sensor amplifier voltage measurement--2 bits; 1 temperature
Word 46	Bias voltage calibration
Words 47 to 51	5 voltage calibration measurements (7 bits each)
Words X to Y:	Cumulative hits capacitance panels: 1-mil panels
	Cumulative hits capacitance panels: 2-mil panels
	Cumulative hits IR flash sensors: 1-mil bays
	Cumulative hits IR flash sensors: 2-mil bays
	Effective capacitance panel area: 1-mil panels
	Effective capacitance panel area: 2-mil panels
	Cumulative hits 3 Mariner gauges Capacitance Level A

B) PRIMARY

Capacitance Panel Penetration Count Frame

W <sub>A</sub> + W <sub>D</sub>		W <sub>E</sub>
Frame synch (14 bits)	Penetration (7 bits)	Panel

\* Frame is repeated every 2 minutes for 5 hours near perigee.  
 \*\* Data repeated to formulate a format as close to 16 words as possible.  
 \*\*\* Format transmitted in readout of Sequences I and II.

(continued)

(Entered into Storage Once per Day)

W <sub>6</sub>	W <sub>7</sub>	W <sub>8</sub>	W <sub>9</sub>	W <sub>10</sub>
Master clock temperature (3 bits) Flash sensor system (4 bits) check	Attitude logic check (5 bits) Mariner gauge system (2 bits) check	Mariner gauge system (1 bit) check Magnetometer system (3 bits) bias Solar aspect logic (3 bits) Temperature 1	Solar aspect logic (2 bits) Temperature 1 Solar aspect logic (5 bits) Temperature 2	Solar aspect logic (5 bits) Temperature 3 Spare (2 bits)

Time Data Transmitted During Deployment Phase)

W <sub>3, 6&amp;9</sub>	W <sub>10</sub>
D 2nd fold stowed (1 bit) D 2nd fold erected (1 bit) Antennas deployed (2 bits) Timer start (1 bit) Spare (2 bits)	Spare (7 bits)

Realtime Data on Command)

(7 bits)	W <sub>7</sub> (7 bits)	W <sub>8</sub> (7 bits)	W <sub>9</sub> (7 bits)	W <sub>10</sub> (7 bits)	8 frames 10 words each

- Words Y to Z:
- Cumulative hits 3 Mariner gauges Capacitance Level B
  - Cumulative hits 3 Mariner gauges Capacitance Level 1
  - Cumulative hits 3 Mariner gauges Capacitance Level 2
  - Cumulative hits 3 Mariner gauges Capacitance Level 3
  - Cumulative hits 3 Mariner gauges Capacitance Level 4
  - Cumulative hits 3 Mariner gauges Microphone Level 1
  - Cumulative hits 3 Mariner gauges Microphone Level 2
  - Cumulative hits 3 Mariner gauges Microphone Level 3
  - Cumulative hits 3 Mariner gauges Microphone Level 4
  - Cumulative hits No. 1 Mariner gauge Capacitance Level A
  - Cumulative hits No. 2 Mariner gauge Capacitance Level A
  - Cumulative hits velocity gauges Tube No. 1
  - Cumulative hits velocity gauges Tube No. 2
  - Cumulative hits velocity gauges Tube No. 3
  - Cumulative hits velocity gauges Tube No. 4
  - Cumulative hits velocity gauges Tube No. 5
  - Cumulative hits velocity gauges Tube No. 6
  - Cumulative hits velocity gauges Tube No. 7
  - Cumulative hits velocity gauges Tube No. 8
  - Command verifications

Measurement--3 bits;  
2 spare bits

SYSTEM FORMAT

(Words) (Realtime Data Continuous Transmission)

W <sub>1</sub>	W <sub>2</sub>
Count: 1-mil	Penetration count: 2-mil (7 bits) panels

Primary System: Capacitance Panel Hit Counts

120 1-mil panels

144 2-mil panels

Secondary System:

12 Exotech sensors 1-mil bays

24 Exotech sensors 2-mil bays

Mariner Gauge 1 front and retro 2 capacitors, 6 levels  
 Mariner Gauge 2 front and retro 2 capacitors, 6 levels  
 Mariner Gauge 3 front and retro 2 capacitors, 6 levels  
 Mariner Gauge 1 1 microphone 4 levels  
 Mariner Gauge 2 1 microphone  
 Mariner Gauge 3 1 microphone

Velocity Gauge 1 (4 tubes) 4 capacitance levels, 3 microphone levels  
 Velocity Gauge 2 (4 tubes) 4 capacitance levels, 3 microphone levels

Critical housekeeping transducers  
 Calibration and diagnostic sensors

5 solar aspect sensors, each with 2 aspect angles

5 earth sensors

Flux gate Magnetometer 3 coils for 3-axes

Full attitude: time  
 Solar aspect Sensor No. X  
 Aspect Angle No. 1  
 Aspect Angle No. 2  
 Magnetometer X-axis  
 Magnetometer Y-axis  
 Magnetometer Z-axis  
 Earth Sensor No. X<sub>1</sub>  
 Earth Sensor No. X<sub>2</sub>  
 Earth Sensor No. X<sub>3</sub>  
 Hourly attitude: time  
 Solar aspect Sensor No. X  
 Aspect Angle Nos. 1 and 2  
 Earth Sensor No. X<sub>1</sub>  
 Earth Sensor No. X<sub>2</sub>  
 Aspect Angle No. 1 and 2

Storage C

Deployment verification sensors

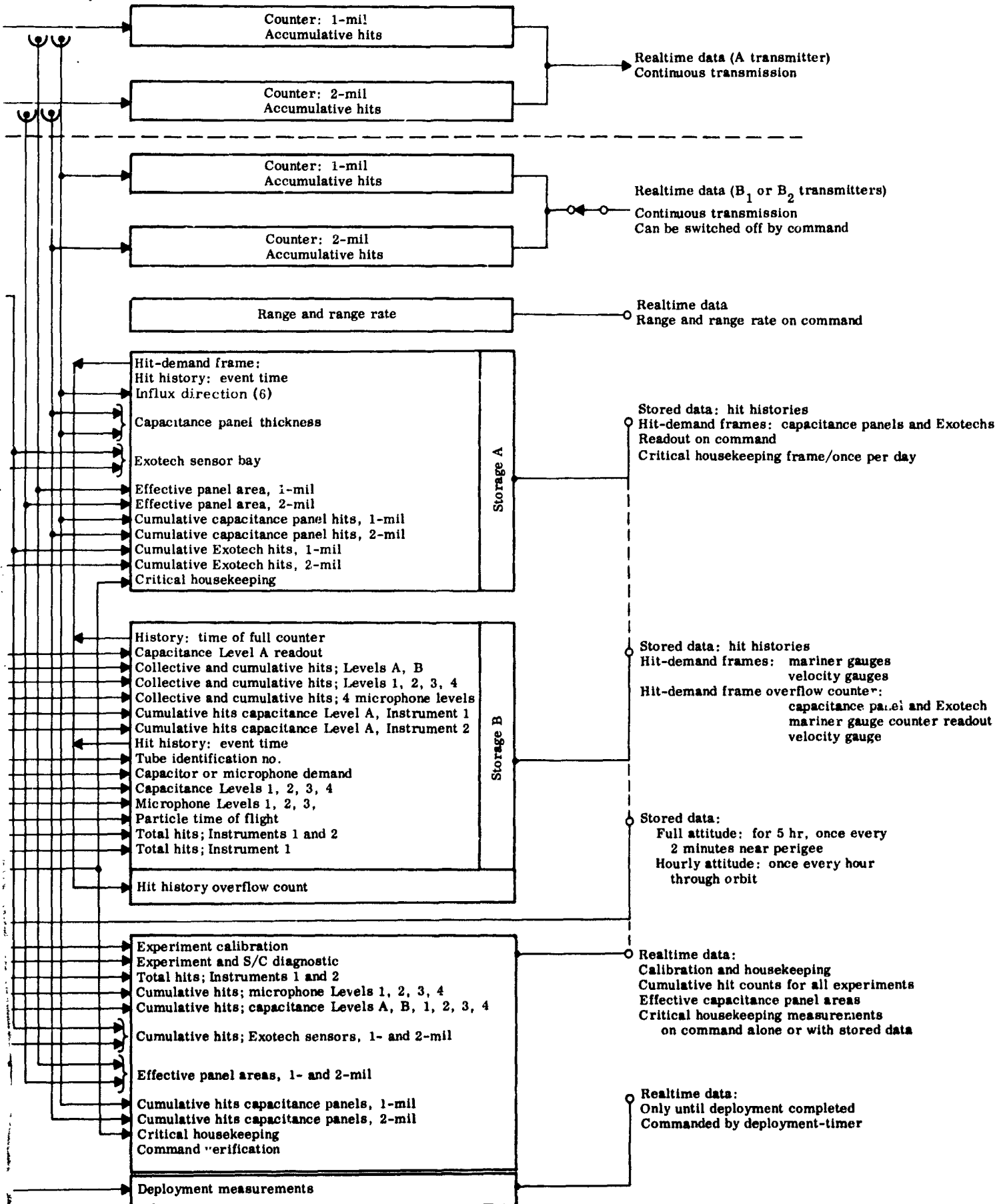
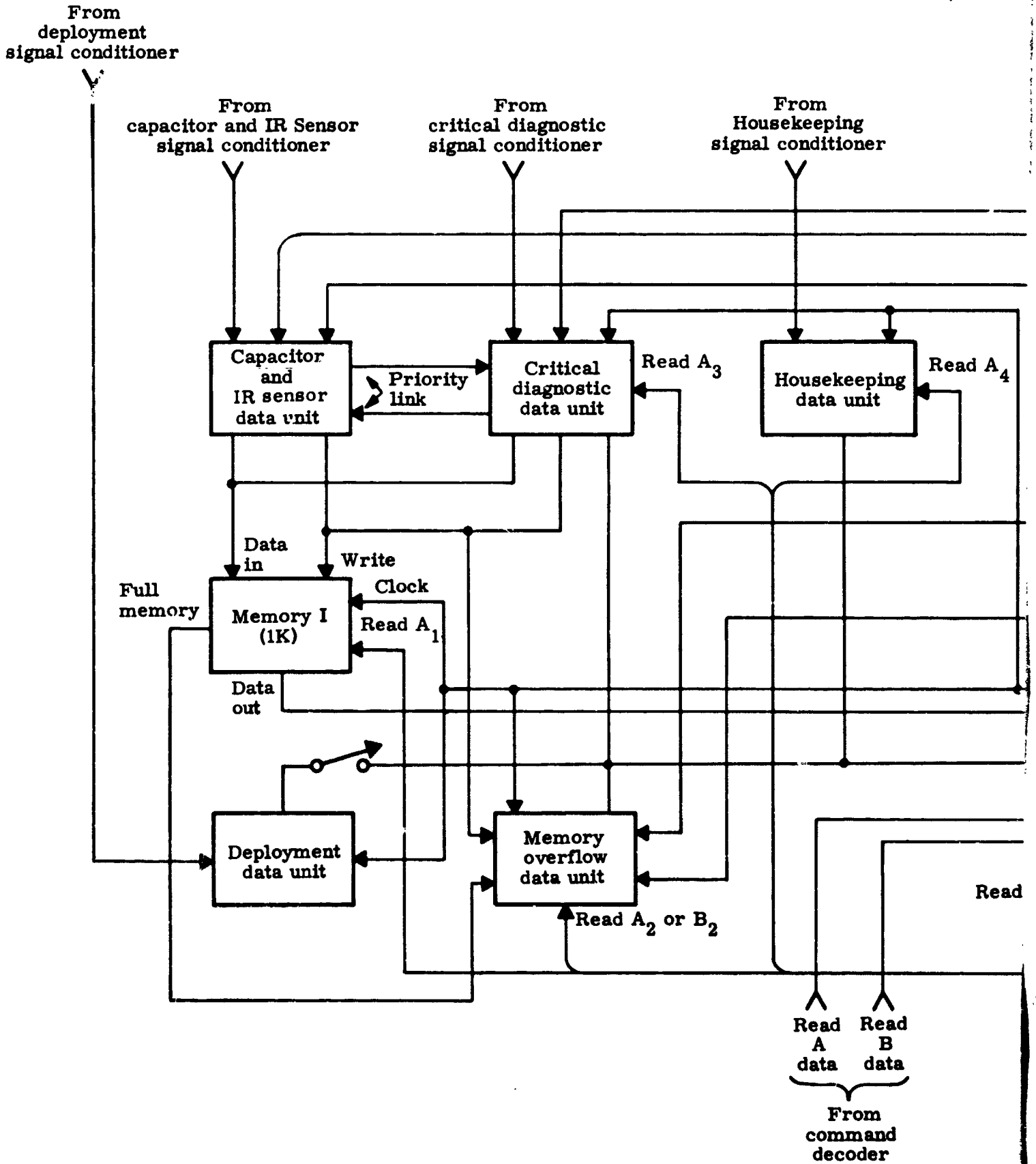

Fig. I-12. System Data Flow



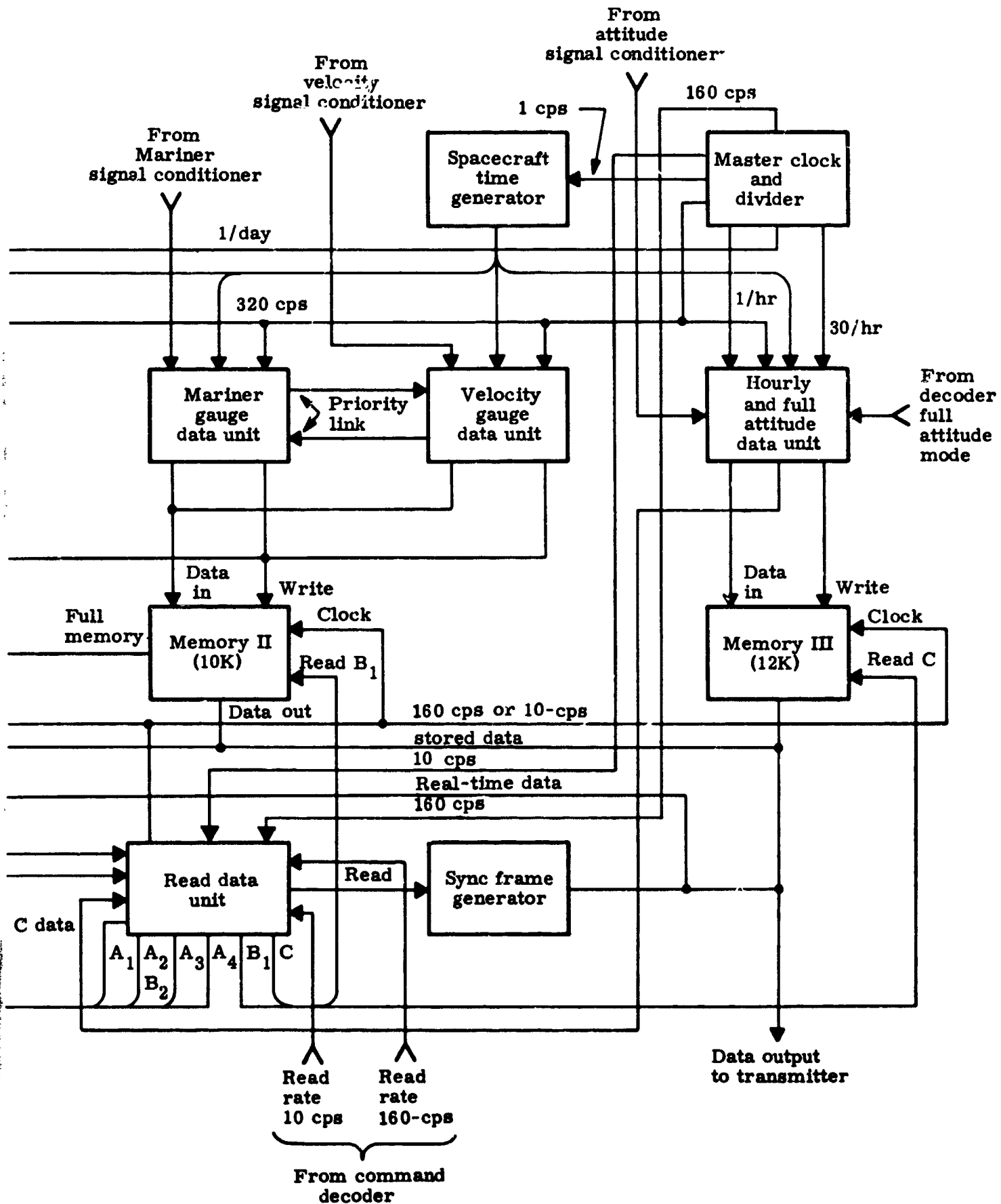

Fig. I-13. Secondary Data Handling Subsystem

**BLANK PAGE**

## (2) Data gathering

The secondary subsystem recommended as a result of this study program is shown in Fig. I-13. Each sensor group has an assigned data unit which collects the incoming data and processes it into a fixed format. All data units are basically the same in that each contains an 80-bit commutator, 80-bit transfer gates, and storage in the form of counters or hold registers for 80 bits of data. Differences occur in the storage type and organization; i. e., the number of bits in counters and hold registers, the read gates to enter data into hold registers and basic initiate and control logic.

The three memory concept is a direct result of reliability tradeoff studies. For a single memory, the logic required to sequence data and establish entry priority in the case of attempted simultaneous data entries deteriorates system reliability in that the logic is complex and contains failure modes which could abort the entire secondary data system. The three-memory concept, however, restricts each memory to only two data units, thus simplifying data entry priority logic and increasing reliability by preventing failure modes which jeopardize the remaining data units and their associated memories.

Sufficient storage is provided for a complete orbit so that command functions are not critical in time. Transmission time is simply a function of the data group commanded; each memory is read out only as a result of a unique command.

Where scientific sensor sensitivity results in an excessive amount of data, data is entered into memory on a scaled basis which still records more than the amount statistically required. Therefore, no actual data is lost and, from the hit event time which initiates data entries, the full hit environment may be reconstructed.

Reliability studies have shown significant gains can be achieved by utilizing integrated circuits plus increased packing density. Although the system shown is not based on a particular integrated logic circuit group, it is readily adaptable. Power requirements and package sizes given are representative of integrated devices.

## (3) Hit history concept

The concept for hit history data frames was developed to obtain additional measurements which will give supplementary information in connection with the micrometeoroid penetration or impact, namely:

- (a) Time of event
- (b) Sensor identification

- (c) Level of impact sensitivity of specific detector
- (d) Spacecraft attitude at time of event
- (e) Micrometeoroid velocity
- (f) Cumulative impacts received by the sensor or group of sensors in a certain sensitivity load.

Since complete hit history data require a certain number of data words, data frames are edited for each measurement. Hit history frames with equal word length were established to facilitate data processing and storage. Thus, data information in a typical hit history frame developed into an arrangement as shown in Table I-3.

Hit history frames are initiated on demand when an impact occurs. These frames might then be composed of the following data words.

- (a) Frame sync code
- (b) Event time
- (c) Frame identification
- (d) Sensor identification
- (e) Sensitivity level
- (f) Orientation or location of sensor
- (g) Cumulative number of previous hits in one or more sensitivity levels of this particular sensor

A uniform data frame length of 10 words (80 bits) has been established. As a result of tradeoff studies, attitude data was not included in these hit demand frames; spacecraft attitude and, therefore, particle directionality will be reconstructed on the ground from stored and transmitted attitude data.

#### (4) Data formatting

Secondary data is gathered into formats consisting of ten 8-bit words. Scientific data formats are tagged by the first four bits for identification, followed by 14 bits which represent the time of hit or data entry and the day in orbit of occurrence. The remaining bits in the formats contain the scientific data collected and sensor identification. House-keeping and attitude data are collected in the same basic format but are uniquely identified by varying the sync format. Sync data consists

of two 8-bit words which are generated prior to transmission of each 80-bit format. Generation of sync at this time has a two-fold advantage: sync is not stored in memory, thus storage capacity is considerably reduced; only one sync generator is required for the secondary data system.

The eighth bit of each data word is an odd-parity bit which increases the reliability of the data transmission. Also each data group is transmitted twice to ensure the reliability of the data transmission to the highest degree practical.

(5) Data processing

All secondary measurement signals are processed by the secondary data handling subsystem into binary formats. The techniques employed are the result of tradeoff studies which considered reliability, performance characteristics, operational simplicity, life expectancy, system flexibility and economy.

Data collected are divided into two groups: scientific data and housekeeping data. Scientific data are stored in memory, and housekeeping data is collected in real time. Secondary data readout is by ground command only.

Stored data. Data to be stored in memory is subdivided into three memories to enhance reliability and system simplicity and flexibility. Each secondary sensor group is associated with a specific memory which has a capacity calculated to contain data collected by those sensors in one full orbit.

Memory I stores data collected by the capacitor and IR flash data unit and the critical diagnostic data unit, each of which performs independently. Capacitor and IR flash data are placed in the same format on impact occurrence. Critical diagnostic data is collected by internal program once per day.

Memory II stores data collected by the Mariner and the velocity gauge data units, each of which performs independently. Since both sensors have a high sensitivity, data is scaled down to a level which permits particle environment reconstruction and also is commensurate with high reliability storage unit capacities. Data entry into memory is on a scaled impact occurrence basis.

Memory III stores only spacecraft attitude data collected by either the full attitude data unit or the hourly attitude data unit. Data requirements are such that these units do not operate simultaneously. Full attitude data is collected only on command during a 5-hr period at perigee. Data is collected every 2 min and entered into memory

during this 5-hr period. Hourly attitude is collected once per hour for the remainder of the orbit. Storage requirements are reduced to a minimum by reading out the memory at the points where the full attitude mode is commanded on and off.

Real time data. Real time data is collected by the deployment data unit, housekeeping data unit, and the memory overflow data unit. Deployment data is collected only during the deployment period and is programmed by the deployment timer. The other two data units collect data for transmission only as the result of a received command.

d. Communication, Command and Tracking

(1) Telemetry

Two continuous RF telemetry channels in the VHF 136- to 137-mc band are recommended for use in transmitting telemetry data to the STADAN stations.

VHF is preferable to S-band. The preferred modulation for each channel is PCM NRZ biphase modulation of a clock derived sub-carrier which, in turn, phase modulates the VHF transmitter. Continuous transmission of "primary PCM data" at a bit rate of 10 bps is provided by a 6-watt VHF "data" transmitter. The second RF channel is provided by the transmitter section of a 6-watt (RF) VHF range and range rate transponder when the transponder is in a data transmission mode (as opposed to a ranging mode).

The transmission on the second channel of real time or stored data and the desired channel bit rate are selectable by command (Table I-4). It should be noted that the transponder serves as a completely redundant transmitter channel for primary hit count data (a reliability requirement). A duplicate VHF transponder is provided to serve as a redundant active command and ranging receiver and as a standby (power off) transmitter for the second channel).

Both the data transmitter and the active transponder transmit continuously; however, as an option to reduce VHF band crowding, the transmitter portion of the active transponder could be commanded off when not being used.

A bit rate of 10 bps has been chosen to provide ground station data acquisition capability from apogee. For stored data readout, a rate of 160 bps has been chosen to provide readout to ranges of 30,000 naut mi on both inbound, (toward perigee), and outbound portions of each orbit. Stored data readout at 10 bps may also be accomplished

TABLE I-4  
Command List

<u>Number</u>	<u>Name</u>	<u>Priority</u> (Mandatory Desirable)	<u>Function</u>
1	Read rate 160 bps	(M)	Sets PCM transmission rate of secondary data to 160 bps
2	Read rate 10 bps	(M)	Sets PCM transmission rate of secondary data to 10 bps
3	Sequence I	(M)	Playback Memory I contents two times, followed by housekeeping data two times, followed by overflow counter contents two times
4	Sequence II	(M)	Playback Memory II contents two times, followed by memory overflow contents two times
5	5-hr attitude on Read "C" data	(M)	Playback Memory III contents two times, after which begin 5-hr attitude mode of writing into memory
6	5-hr attitude off Read "C" data	(M)	Playback Memory III contents two times, after which turn off 5-hr attitude mode of writing into memory
7	Switch to trans- mitter No. 2	(M)	Turns off transmitter section of active transponder, switch coaxial switch to space trans- mitter (transponder), applies power to "spare" transmitter
8	Switch to trans- mitter No. 3	(M)	Reverse switching of Command 7
9	Turn off trans- ponder (trans- mitter section only)	(D)	Turn off power to active trans- ponder (transmitter section)

TABLE I-4 (continued)

<u>Number</u>	<u>Name</u>	<u>Priority</u> (Mandatory Desirable)	<u>Function</u>
10 & 11	Sensor group off	(D)	Two commands to provide turn off capability for either of two sensor group config- urations
12 & 13	Sensor groups off	(D)	Reverse of Commands 10 and 11
14, 15, 16	Spare	(D)	For growth capability or added redundancy switching

for ranges beyond 30,000 naut mi. A third and higher bit rate in the order of 1600 bps could be added for data transmission very near perigee if further study shows a significant advantage could be gained thereby (fewer errors, etc.).

Use of odd parity bits (one per word) is recommended for stored data transmission modes to reduce word error rate and limit repeat of data transmissions to one repeat.

(2) Command

The tone digital system as described by Goddard Space Flight Center "Aerospace Data Systems Standards" is recommended for this spacecraft. Eight commands are considered mandatory for operation of the spacecraft in the recommended configuration. Eight additional commands are considered desirable from the standpoint of improving operational capabilities or for added redundancy.

Only real time commands are required. No updating of stored command sequences is contemplated. A list of recommended commands is given in Table II-2.

The receiver portions of GSFC-designed VHF range and range rate transponders will serve as both command receivers and range and range rate receivers after suitable modifications to the present design are effected. A redundant receiver and decoder is required to meet the reliability objective.

A reliable VHF command range of 100,000 naut mi is anticipated based on use of 5-kw transmitters and 22-db disc on rod antennas at the major STADAN ground stations. Commanding of spacecraft functions beyond a range of 140,000 naut mi will at times be marginal; however, commanding beyond a range of 100,000 naut mi, though desirable, is not mandatory.

The range and range rate (RRR) mode of operation is commanded from RRR tracking stations using phase modulated tones on the RRR uplink. The decoding for this mode of operation is internal to the VHF transponder.

### (3) Tracking and acquisition

The STADAN VHF range and range rate (RRR) system is preferable to the S-band system for this application and is recommended for use in tracking the spacecraft following injection into orbit. Minitrack interferometer cosine angles for satellite altitudes below 1000 naut mi (during perigee passes) may be used to supplement the RRR data.

Reliable VHF RRR tracking to ranges of 100,000 naut mi can be accomplished based on use of an omnidirectional spacecraft antenna. This range is more than adequate to obtain the required data for ephemeris determination. RRR tracking to ranges of 180,000 naut mi may be accomplished at times depending upon spacecraft orientation and other variable factors.

The active VHF RRR transponder is modulated with PCM telemetry data when it is not used for ranging and also serves as command receiver. Hence, use of the RRR system creates no weight, volume or power problem onboard the spacecraft.

All spacecraft transmitters are phase modulated and provide sufficient unmodulated residual carrier power for beacon acquisition to apogee and Minitrack interferometer tracking on most perigee passes.

### (4) Antenna

An omnidirectional spacecraft antenna system is recommended because of the impossibility of continuously pointing a higher gain antenna toward earth in a tumbling vehicle.

None of the other spacecraft systems require attitude stabilization. In order to use a directional antenna, 3-axis stabilization would be required. In addition to the antenna pointing problem, there would also be the reliability problems of keeping an attitude control system operating for 6 to 12 months.

The antenna system design presents a real problem because of the size (in wavelengths) and shape of the spacecraft.

Of four systems briefly considered, the system consisting of a turnstile on one side of the spacecraft and an unsymmetrical disc-cone on the other was chosen to be representative of what might be achieved in antenna performance. It is designed to work with the STADAN polarization diversity system (linear) for spacecraft-to-ground telemetry transmission; however, for RRR, where polarization diversity is not employed, it is marginal even at relatively low tumbling rates.

It is recommended that further antenna studies be conducted to provide a better solution to the antenna problem.

(e.) Ground net facilities

Use of the Space Tracking and Data Acquisition Network (STADAN) is recommended for data acquisition tracking and command of the spacecraft following injection into orbit. The STADAN stations recommended for use in orbital support of this program and their functions are shown in Table II-3. These selections are based on a 180° downrange injection from Cape Kennedy and are intended to be representative of support requirements.

**TABLE I-5**  
**STADAN Station Selections and Function**

Station	Function					
	Data Acquisition		Tracking		Command	
	85-ft Dish	SATAN	RRR	Other	RRR	Other
Ulaska	X		X		X	X
Quito		X		X		X
Santiago		X	X		X	X
Woomera		X		X		X
Johannesburg (Hartebeesthoek)		X		X		X
Madagascar			X		X	
Carnarvon			X		X	
Rosman	X		X	X	X	X

Stations shown provide more than adequate support for the program.

Data acquisition. Recording by ground stations (one or more) of the spacecraft telemetered primary hit count data at least five times per data zone is recommended.

Stored data playback is normally expected to be required twice per orbit. This is to be accomplished at spacecraft altitudes below 30,000 naut mi at 160 bps. Use of polarization diversity is recommended for reception of transmissions. Available station coverage time below 30,000 naut mi is expected to exceed 6 hr, with continuously available coverage periods as high as 3.5 hr.

The ground data acquisition facilities are compatible with the recommended spacecraft modulation system except for the requirement to add two biphasic subcarrier demodulators. These are minor additions to the network facilities.

Use of 85-ft dish antennas at Rosman or Ulaska is recommended for ranges beyond 100,000 naut mi for 10-bps data rates and between 20,000 and 50,000 naut mi for 160-bps rates.

Command. Use of the 5-kw high power command system with 22 db disc on rod antennas is required at all data acquisition stations for commanding the various data modes. The spacecraft command system and ground systems are compatible.

Tracking. The number and location of range and range rate tracking stations as presently shown provide adequate tracking coverage to support the mission. Use of only the VHF portion of the RRR system is required.

c. Power supply and distribution system

Concept development and the subsequent design of a solar array/battery power system has followed the requirements defined in the Statement of Work for the MDSS with Atlas-Agena launch vehicle.

The selected orbit, with a nominal apogee of less than 160,000 naut mi, results in the vehicle being in sunlight approximately 99-3/4% of the time, regardless of time of injection. Approximately 62% of the launch windows that permit a one-year orbital lifetime will result in orbits having a maximum of four hours of earth shade. The capacity of the battery has been selected so as to be able to furnish the full requirements of the system for four hours at a depth of discharge not exceeding 60 to 70%. Thus, the power requirements during the shorter boost phase (ascent) period during launch and cislunar orbit injection are met with adequate reserve capability.

The power supply and distribution system has been designed to be compatible with the telecommunication system. Solar array capacity has been determined so that two data transmitters may be operated continuously, thus providing high reliability and the greatest possible operational flexibility.

Power is furnished to each of the two continuously operating data transmitters from separate power systems. One of the systems is supported by a battery and the other, excluding a battery, operates only when in sunlight.

The solar arrays have been located on the deployed vehicle so that sufficient power is available, independent of vehicle attitude.

#### (1) Power requirements

The continuous loads of the primary system (for daytime transmission of penetration counts) and the secondary system (continuous transmission of penetration counts or transmission of stored data on command) require 26.20 and 37.42 watts respectively. Reserve, losses and battery charging when added to the continuous requirements result in a 28 v d-c requirement of 31.20 and 47.55 watts respectively from a solar array. If radioisotope-thermoelectric generators are used, the requirements become 37.61 and 54.48 watts, respectively. These requirements are based on the use of 28 v d-c transmitters.

The requirements are slightly higher if a 50 v d-c input transmitter is used. Since the transmitters consume 75% of the system power required, minimum voltage conversion and maximum reliability will be realized if the power system voltage is selected to match the input voltage requirements of the transmitters. Intermittent loads for both systems and shade period requirements of the solar cell system have been included in the respective battery charging requirements. Subsequent to the completion of the design of the finalized power systems, a more efficient 28 v d-c transmitter has been located. Its use would reduce the vehicle power requirements to about 3/4 of the aforesaid values.

#### (2) Conclusions and recommendations

The application of four space-proven SNAP-9A radioisotope (Pu-238) thermoelectric units to this mission has been compared with the use of an N/P silicon solar cell system. For this mission, with the satellite being almost continuously in sunlight, the solar cell system would be approximately 42 lb lighter than the isotope system even including a 34.5-lb battery. Since both systems would be of comparable reliability and since the isotope system does not offer any outstanding features for this particular mission, the lighter weight, nonradiative solar cell system has been selected.

Although all results shown in this study are based on the use of a nickel-cadmium battery, the use of a silver-cadmium battery should not be disregarded. Although more operational and laboratory test experience is available on the nickel-cadmium battery, the silver-cadmium cell offers a weight advantage and its low rate charge and discharge characteristics are most appropriate to this mission.

Two solar cell systems have been selected--one applicable to transmitters requiring a 28 v d-c input and the second for transmitters requiring 50 v d-c. The basic bus voltage of each system is the same as the transmitter voltage input.

Table I-6 is a summary of the characteristics of these alternative systems. Each has a separate primary and secondary power system containing identical continuous loads, reserve (installed growth), and line losses from the bus to the equipment. The primary systems contain a simple voltage regulator consisting of zener diodes. The secondary systems contain a high efficiency (95%) pulse width modulation type voltage regulator of redundant solid state devices, capable of maintaining the bus voltage within 1% of the desired setting. Multiple voltages required in the secondary system are obtained from redundant converters powered from the  $\pm 1\%$  bus. In the 28 v d-c system, the high voltage requirement (50 v) of the capacitor sensors are furnished by voltage boosters. The battery is charged at a constant current by a charge limiter at a 300-hr rate, thus returning the energy taken by the bus during shade periods and by intermittent loads that exceed the capacity of the array.

A power system growth capability of 42% has been provided by two means: (1) installation of a small excess capacity, and (2) provision on the structural areas reserved for solar cell arrays for the addition of more series strings of cells to either the primary or secondary section of each array area. Contrary to present trends, the smaller solar cells (1 x 2 cm) are recommended in order to preclude excessive loss of power in the event one string becomes inoperative.

Standard capacity nickel-cadmium cells have been selected, 12 and 3 amp hr respectively, for the two secondary systems. A 4-hour discharge will use only 59% or 70% of the battery capacity, respectively.

Power system reliability and vehicle reliability are enhanced by the provision of two independent power supplies. The primary system has a simple and reliable method for voltage regulation and for furnishing the low voltage needs. All its loads are directly connected and a battery has been excluded. The secondary system contains redundant voltage regulation and conversion and equipments are fused when redundant. Fortunately, the weights entailed by these facets that create

a highly reliable power supply have been permitted by the payload capability of the Atlas (SLV-3)-Agena D launch vehicle and by the efficient design in other vehicle systems.

For purposes of standardization and for a more flexible design, it is recommended that a transmitter requiring an input voltage of 28 v d-c be used.

It is further recommended that the development and test of hermetically sealed silver-cadmium cells, applicable to this mission, be actively encouraged.

#### d. Vehicle design and structure

The Vehicle Design Study was devoted to determining feasible configurations for a Micrometeoroid Deep Space Satellite for a cislunar mission. The boosters considered were the Atlas-Agena, Atlas-X-259, and Saturn 1B. Performance evaluations eliminated the Atlas-X-259 and Saturn 1B, although concepts compatible with them were developed in the early phases of the study. The recommended configuration is described in Section C1a and shown in Fig. I-8. It is known as the Z-configuration; its weight in orbit is 696 lb and it can be launched by direct injection into cislunar orbit by an Atlas-Agena.

##### (1) Configuration design features

Atlas Agena Launch Vehicle

Agena long fairing heat shield and separation system

Satellite

Weight	696 lb in orbit
Experiment sensors	
Capacitor sensor (net) area	39 sq ft 0.001 in. aluminum target 503 sq ft 0.002 in. aluminum target
Velocity gages	2
Mariner gages	3
Infrared flash detectors (Exotech sensors)	72 (2 as backup in each capacitor sensor bay)
Attitude sensors	

**TABLE I-6**  
**Final Power Supply Comparison Summary**

Item	Notes	Transmitter and System Voltage			
		28-v/d-c		50-v/d-c	
		Primary	Secondary	Primary	Secondary
Continuous loads*		26.20	37.42	26.20	37.42
Reserve	-10%	2.54	3.98	2.54	3.98
Losses--lines to equipment	-3-1/2%	1.01	1.46	1.01	1.46
--voltage regulator	Primary 1 ma/zener Secondary eff = 95%	0.84	1.83	0.93	1.83
--converters	25% of load	0.46	1.25	1.01	3.02
--boosters	22/50 x 25% of load	0.15	0.15	--	--
Battery charging	37 ma/22 ma total	--	1.30	--	1.36
Charge limiter loss	$\eta = 89.5\%/86\%$	--	0.16	--	0.22
<b>System watts required from array</b>		<b>31.20</b>	<b>47.55</b>	<b>31.69</b>	<b>49.29</b>
<b>Vehicle watts required from array</b>		<b>78.75</b>		<b>80.98</b>	
<b>Array</b>					
Installed capacity, watts		31.2	54.0	31.9	53.5
Installed growth (including reserve), watts		2.54	10.43	2.75	8.2
Available unused array area, watts		18.8		18.8	
Minimum average number of illuminated strings		20	28	12	16
Number of 1 x 2 cm cells/string		81	100	138	173
Minimum array voltage		30	37	51	4
<b>Battery</b>					
Typical discharge, w-hr			50		50
Maximum discharge, w-hr			214		223
a-hr			7.1		4.2
Total installed battery capacity, w-hr			360		318
a-hr			12		2 x 3
Constant charge rate, ma			37		2 x 11
hr			325		273
Weight, lb			34.5		41

\*Intermittent loads included in battery charging.

Magnetometers	2
Sun sensors	5
Earth sensors	5
Solar cell area	70 sq ft
Antennas	2 omnidirectional (1 turnstile, 1 unsymmetrical disc cone). No deployment except for automatic spring deployment of 1 segment of the turnstile.
Systems module	Removable from support bulkhead. Removable covers on top and bottom. Three shelves, two of which are removable. Center and upper shelf accessible on launch pad.
Spacecraft-booster separation system	V-band clamp explosively separated at 2 places and retained on adapter.
Adapter	Machined I-ring
Z-configuration	4 Z-arms present effectively equal meteoroid intercept area regardless of viewing angle.  Omnidirectional exposure of solar cells.  Four movable arms deployed independently 90° by torsion springs governed by planetary gear reduced DC motors.  Four movable planes, one per arm, deploy independently 90° using similar system to that of arms.  Ratchet locks control position of movable arms and planes throughout travel.

Deployment of arms and planes begins automatically with the guillotining of two nylon retaining straps.

Spacecraft packaged in heat shield has volume available for future growth in sensor area.

Spring mounted segmented capacitor sensor panels minimize structural weight, eliminate possible radiation shorts through elimination of sensor backup, facilitate Exotech sensor installation, and are less sensitive to temperature change.

No attitude stabilization system is required.

## (2) Structural arrangement

The structural framework of the vehicle consists of the four Z-arms which extend radially, one from each side of the square bulkhead in which the systems module is mounted. In the launch configuration, these arms fold together to form a hollow rectangular box shape (approximately 44-in. square and 131-in. high) with the bulkhead which supports the module and from which the arms are deployed at the forward or upper end.

Each corner of this box is the intersection of the two fixed perpendicular planes in each arm and forms the vertical load carrying column. The lower end of the column terminates in the fitting that attaches the spacecraft to the adapter. Two methods of attachment and separation, V-band clamp and tension bolts with shrouded explosive nuts, have been considered.

The four Z-arms are essentially the same. They have 1-in. sq aluminum tubing edge and cross members secured at the corners and intersections by aluminum plate gussets fastened by blind rivets. The two fixed perpendicular planes share a reinforced edge marker at their intersection and the folding plane of each arm which is the outboard plane at launch is attached to the free edge of one of the perpendicular panels by piano hinge segments. For the launch environment, the folded arms are interconnected by conical shear buttons located at the plane

edge and cross members, and are held in place to form a rigid box assembly by two nylon straps at the intermediate cross members.

The four arms are connected by piano hinge segments to the central support bulkhead which is square and consists of 1-in. thick aluminum honeycomb construction with aluminum edge members.

The arms and folding panels are deployed by means of torsion springs and electric motors and are held in position by ratchet-type locks.

The equipment module is mounted centrally in the support bulkhead and is attached to it by a flange on the center shelf.

### (3) Spacecraft arm and plane deployment

The folded vehicle configuration has four arms restrained by nylon straps. When the nylon retaining straps are cut, the movable arms and planes of the spacecraft are free to deploy independently. Since the deploying mechanisms are the same, the rate of each arm and plane deployment should be similar, but it is not necessary that they be synchronized or sequenced.

The basic mode of deployment is similar for both the arm and its movable plane. The operating mechanism for each consists of torsion springs and a planetary gear reduced dc motor fitted with a disc clutch. In normal operation, the torsion springs provide the energy for deployment and the motor with the clutch slipping serves as a speed governor. If increased torque is required due to a malfunction, the motor will supply it up to the slipping torque of the clutch. In the case of a malfunction in which the motor does not receive electrical power, the springs will drive the motor in reverse through the gearing and the motor will still serve as a speed governor. The clutch is provided so that if the gearing becomes inoperative, the springs will slip the clutch as they deploy the panels. In the earlier phases of the study, deployment without the use of a clutch was considered. Additional effort would be required prior to the selection of a deployment system for the operational vehicle. The work to date shows that the systems indicated are feasible although some testing is necessary for determining the proper spring and clutch characteristics.

Both the arms and movable planes are provided with a one-direction latch, i. e., a ratchet, which is self-energizing against the folding motion and prevents any reversal during deployment. It keeps the arms and planes under control at all times so that they will be in a locked position even if some malfunction should prevent complete deployment. Dashpot deceleration means are not considered necessary.

Since deployment occurs shortly after launch, lubrication problems occasioned by space environment are not serious. Distilled F-50 silicone oil may be used for lubrication of the motor reduction gear train. Hinge bearings can be bushed with reinforced Teflon bushings to reduce friction and to avoid the possibility of vacuum welding of material in the hinges.

#### (4) System installation

Capacitor panel installation. The capacitor sensors shown (Fig. I-14) consist of a 5052-H19 aluminum face, laminated mylar film dielectric, and vapor deposited copper. A total of 39 sq ft of 0.001-in. aluminum target is provided in 24 panels--2 panels back-to-back in each of the 12 planes. Each of these 24 panels has the copper divided into five segments so that 120 separate targets are available. A total of 503 sq ft of 0.002-in. aluminum target is provided in 48 panels--2 pair of back-to-back panels in each of the 12 planes. Each of these 48 panels has 3 segments so that there are 144 of these targets. Other segmentation schemes have also been considered.

The sensor panels are installed in the structural plane frames by means of tension springs attached to the frame gussets at each corner.

An opaque mylar light block 0.001 in. thick covers the gap between the sensor panels and the structural frame and is secured by Velcro closure strips bonded to the frame and light block for quick installation or removal.

This method of installation facilitates the use of the Exotech sensor as a backup, as well as requiring a minimum amount of support structure. It also eliminates the need for foam backup of the sensor. A detailed investigation has been made to determine the feasibility of tooling and installing such thin panels.

Solar cell installation. The solar cells are mounted on both sides of a substrate structure. This structure is brazed aluminum honeycomb, 1 in. thick, 13 in. wide and extends the full width of each of the 12 planes. Seventy sq ft of solar cell area is provided (Fig. I-9).

Systems module. This unit houses the electrical and electronic equipment of the satellite and provides the thermal environment and structural mounting for its components. It has a 31-in. diameter and is 37 in. high.

The housing structure consists of three circular shelves and a two-piece cylindrical outer cover, all constructed of bonded aluminum honeycomb sandwich material.

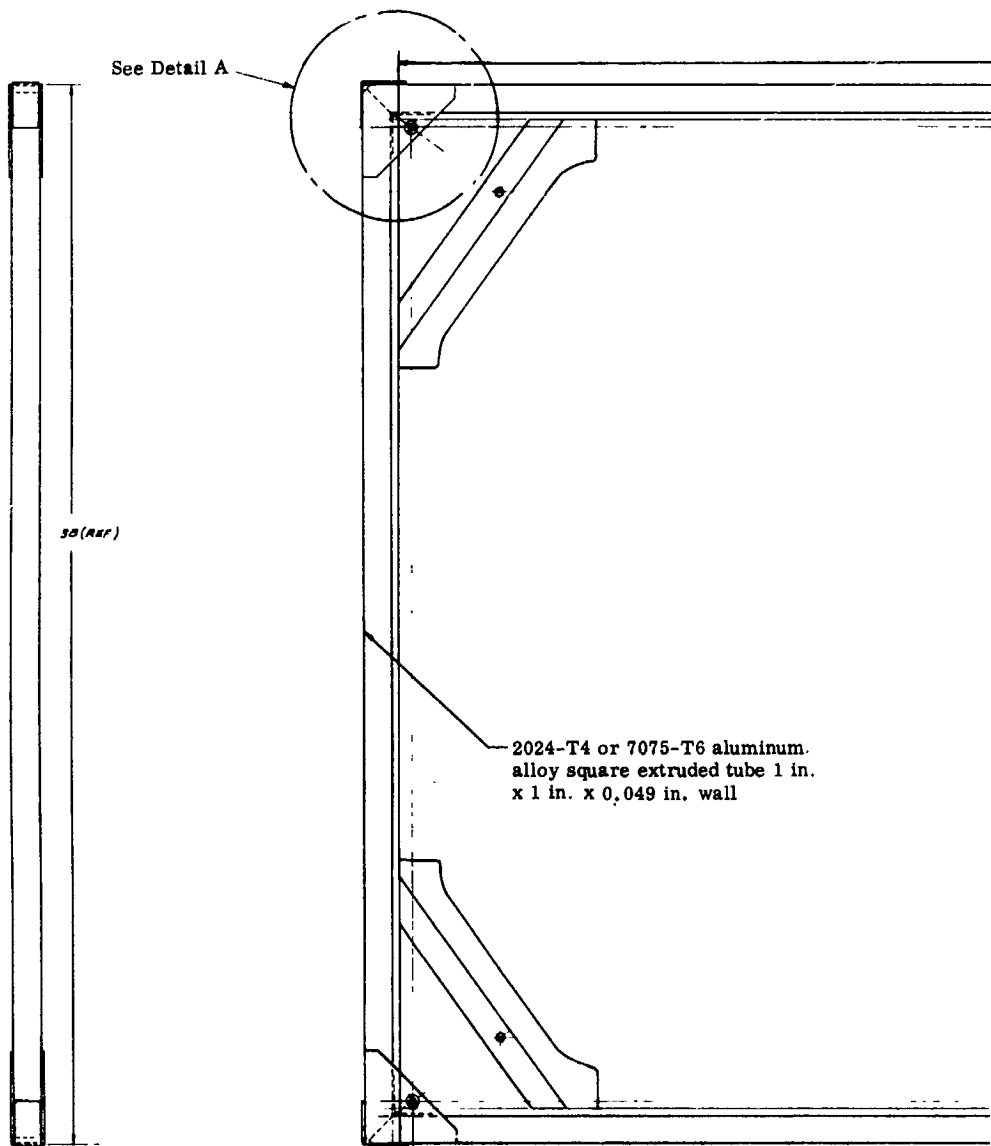

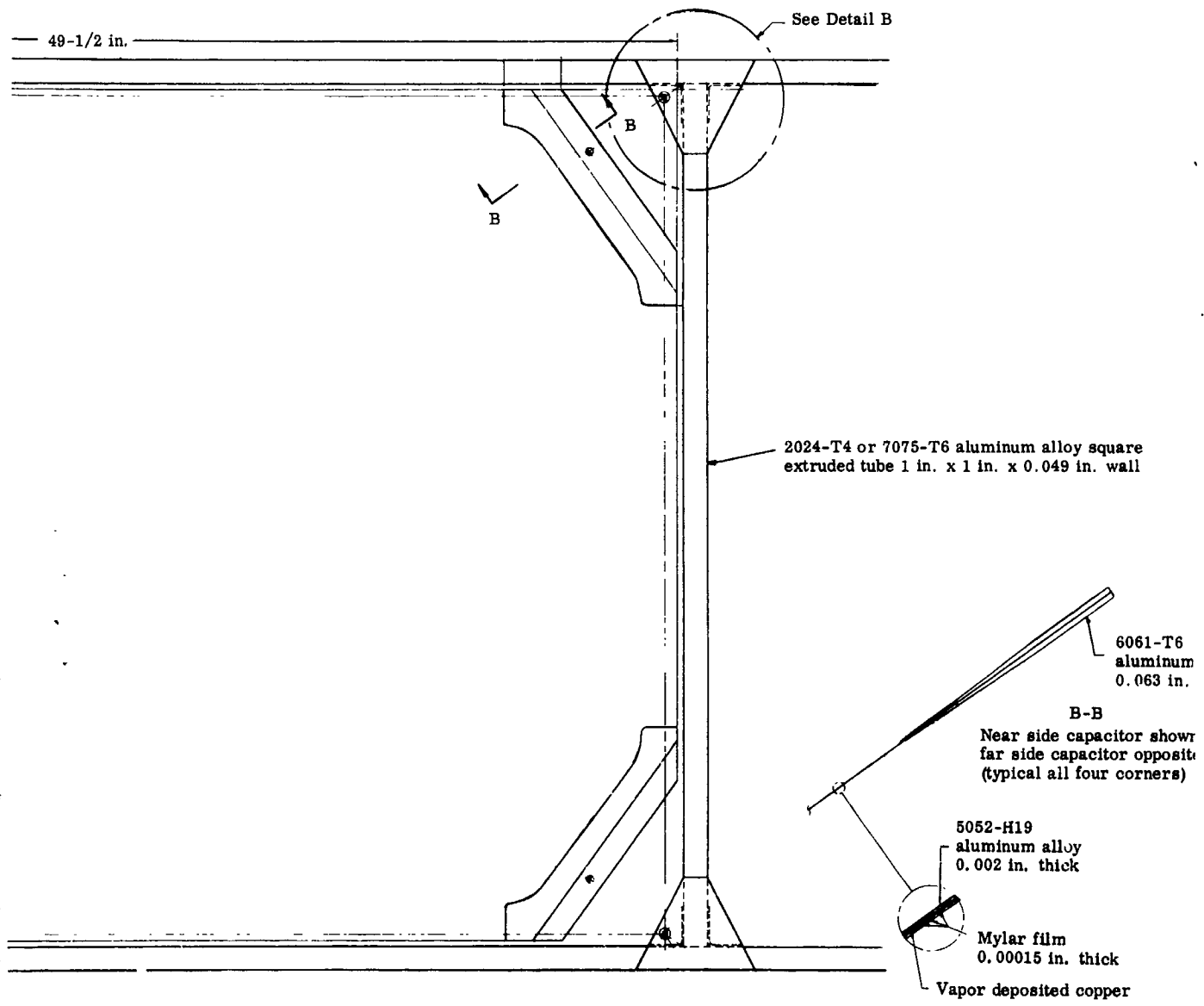

alloy }  
 thick } Bonded  
 to mylar  
 face

1  
 3

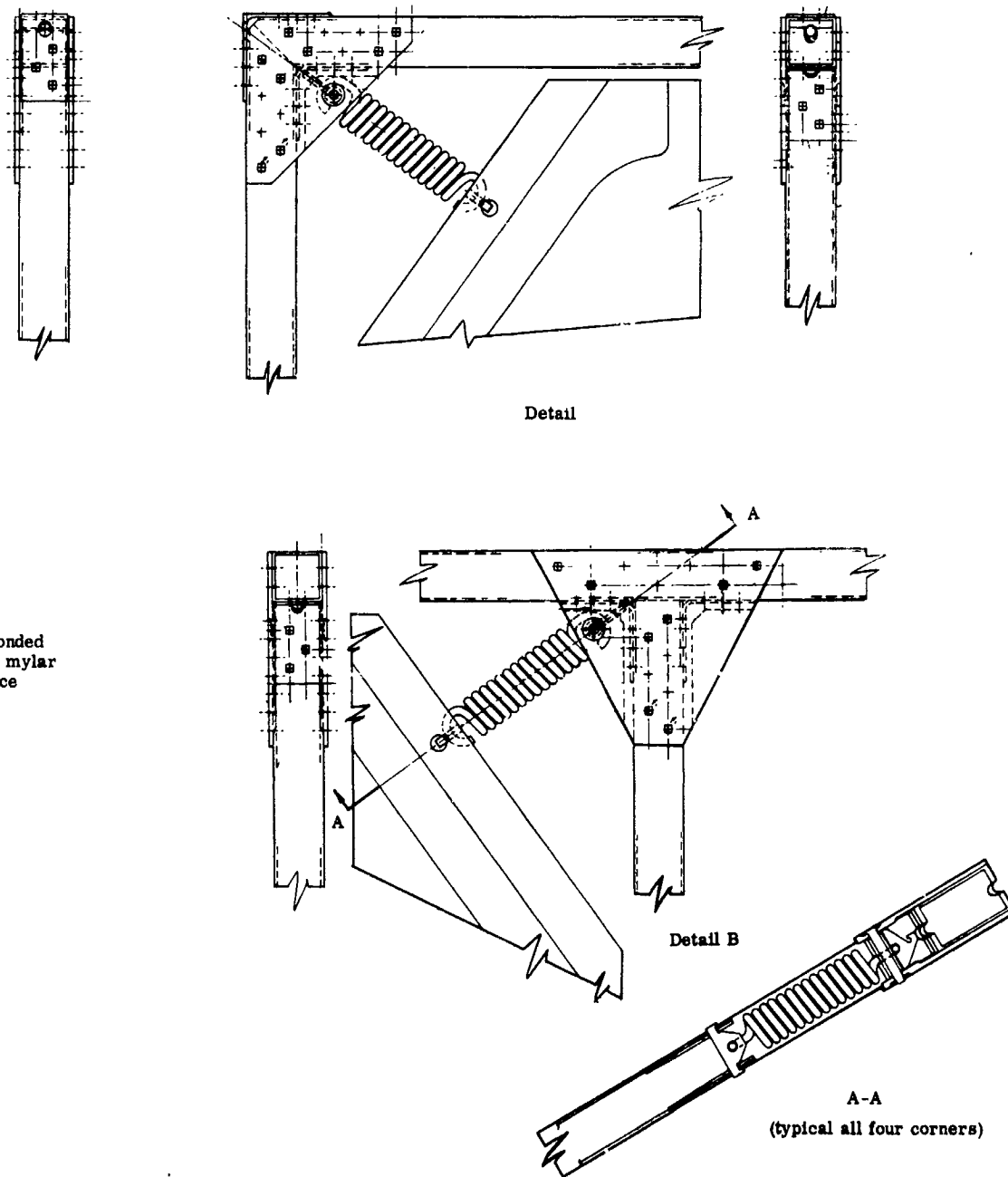

Fig. I-14. Capacitor Sensor Panels--Structural Details Only

The thermal radiators for the transmitters are aluminum plates built into the side wall of the covers but thermally isolated from the surrounding honeycomb. Each one replaces the honeycomb of the side wall for 10 in. of its height and 14-1/2 in. of its periphery.

In the schematic diagram on Fig. I-15, certain groupings of components are shown by dotted lines. These groupings comprise sub-assemblies that may be assembled and checked out independently. It will be noted that this grouping has been maintained in installation on the module shelves, simplifying the assembly and checkout operation and minimizing the interconnection wiring requirements.

Antenna installation. The spacecraft has two antennas which are mounted on the end covers of the equipment module.

One of these antennas is a turnstile type. It is mounted on top of a 1-in. diameter mast that extends 38 in. above the module upper cover and is braced with three guy wires. This mast is off center on the cover to keep the antenna out of the field of view of the velocity gage.

The other antenna is an unsymmetrical cone disc type mounted from the opposite end of the equipment module cover. It is also mounted on a 38-in. mast (of 2 in. diameter), braced by three guy wires and centered on the lower module cover.

Attitude sensing equipment installation. The configuration and installation of the sensors for this satellite are shown in Fig. I-9.

Two magnetometers have been installed on the outboard edge of one of the vehicle arms, such as to minimize vehicle magnetic effects.

Three sun sensors are mounted on the outboard ends of three adjacent arms of the satellite and two sun sensors are mounted on the center square bulkhead, allowing a free and unobstructed field of view.

One earth sensor is mounted on top of the equipment module upper cover. Another one is mounted atop the velocity gage. A third sensor is located on top of the turnstile antenna, and two others on the center square bulkhead.

Experiment sensors installation. Two velocity gages are installed in the satellite. One of the instruments is centered on the systems module upper cover. The other is mounted on the outer surface of the disc on the disc-cone antenna. (It is realized that mounting this instrument on the antenna may lead to RF problems. Further analysis would be required to definitely ascertain the feasibility of mounting the velocity gage in such a manner.)

Three Mariner gages are installed--one each off the outboard edges of three of the spacecraft arms. The instruments are installed so that their faces will be mutually perpendicular.

Exotech sensor (IR flash detector). The IR flash detector sensor is housed in a 1.0 x 1.0 x 0.5 in. container, along with its preamplifier. The sensor element is located in one of the 1.0 x 0.5 in. faces of this container. The sensor element has a 140° conical field of view.

Two sensors are required within each capacitor detector panel bay. These units are mounted between the capacitors on the narrow end of each panel frame, near the corners, so that their viewing axis is approximately along the panel diagonal. The sensor elements face each other across the bay. This provides maximum coverage of the panel.

#### (5) Conclusions and recommendations

The design and analysis efforts expended have shown the feasibility of the proposed design. The weight and volume of the satellite are within the payload capability of the Atlas-Agena for direct injection into cislunar orbit. The structure can be manufactured from available materials using existing tooling and methods.

The structural arrangement is suitable for the accelerations and vibrations of launch, the separation and deployment loads, and the environment of space. Temperature effects in space should be minimized by the satellite's tubular framework structure and the spring suspension of its capacitor sensors.

As a result of the study, the following items are selected as the more important ones requiring further analysis and/or development testing.

Spring suspended segmented capacitor. This recommended design has many desirable features and is applicable to the present capacitor as well as others under development. Additional analysis and development testing is needed to obtain design data. Tests would be conducted on the effect of spring load, panel thickness, and size on the ability of the panel to withstand launch vehicle noise and vibration in conjunction with decrease in air density during launch.

Backup capacitor designs. Other designs for mounting panels should be evaluated in the event that unforeseen difficulties arise in the development of the spring panel. One of these, presented in the Vehicle Design Chapter of this report (Volume III), has the sensor bonded to an auxiliary frame which is in turn mounted on the satellite arms structure. Development testing is also required similar to above.

Mounting and deployment of satellite. The method of supporting the systems module, which requires that the satellite arms be load-carrying and structurally integral during launch, should be checked by test

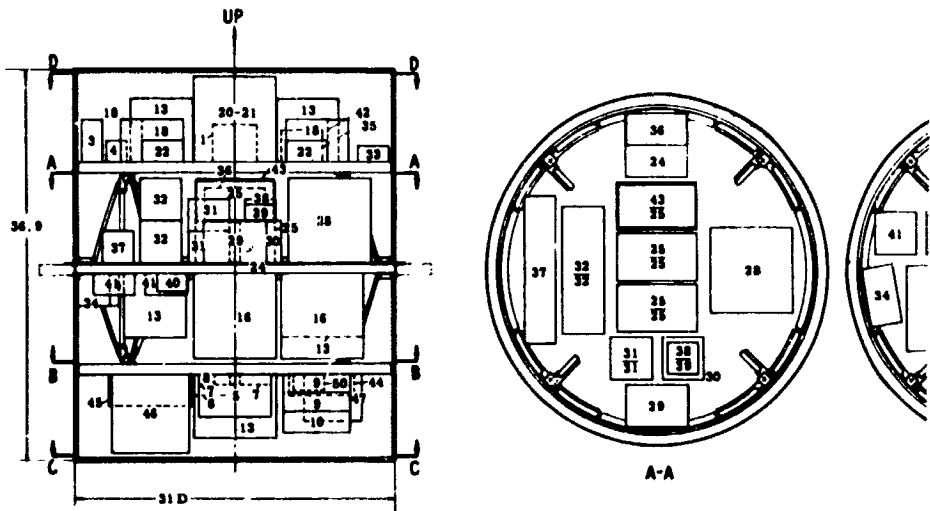
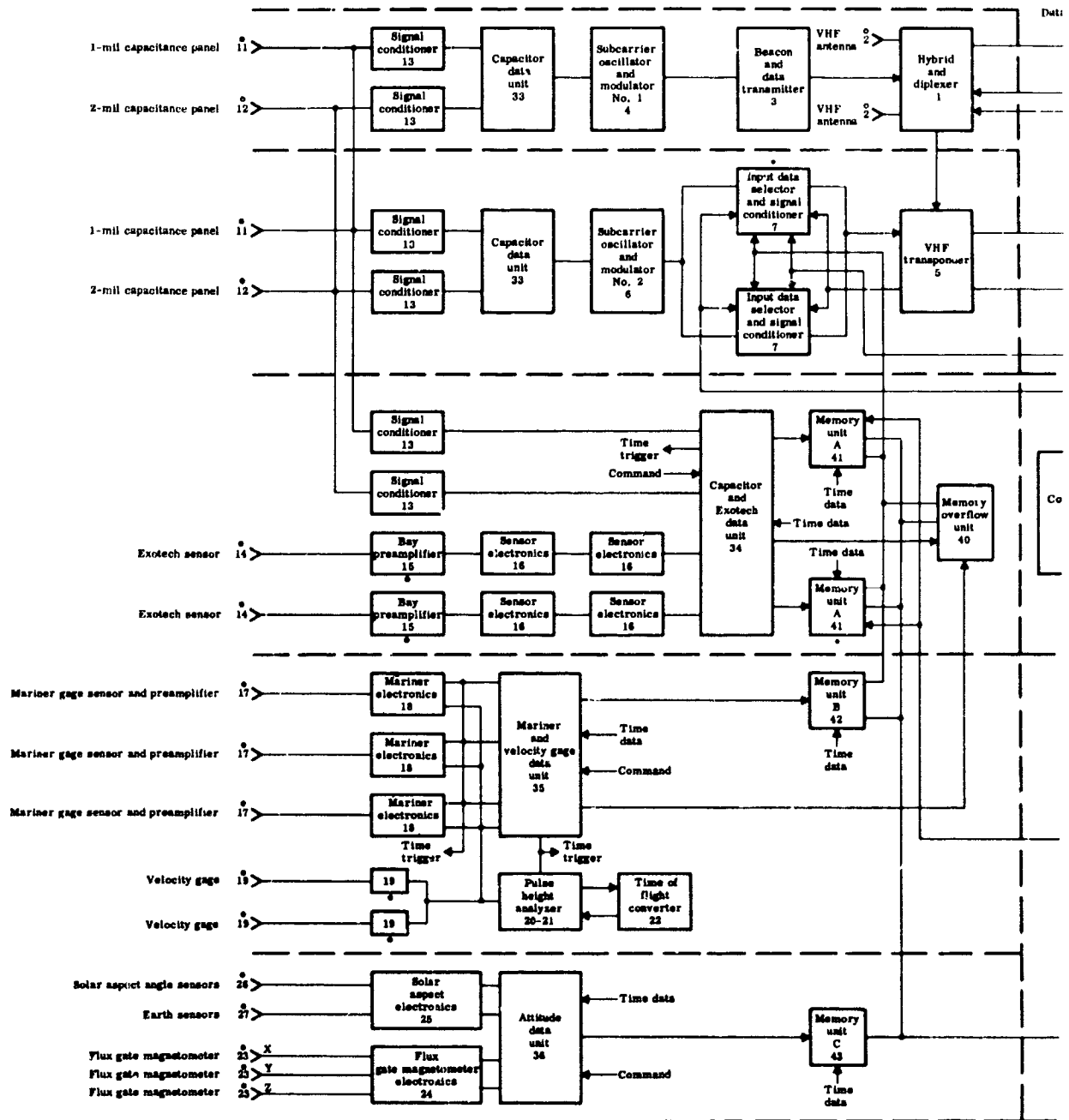

and Communication System

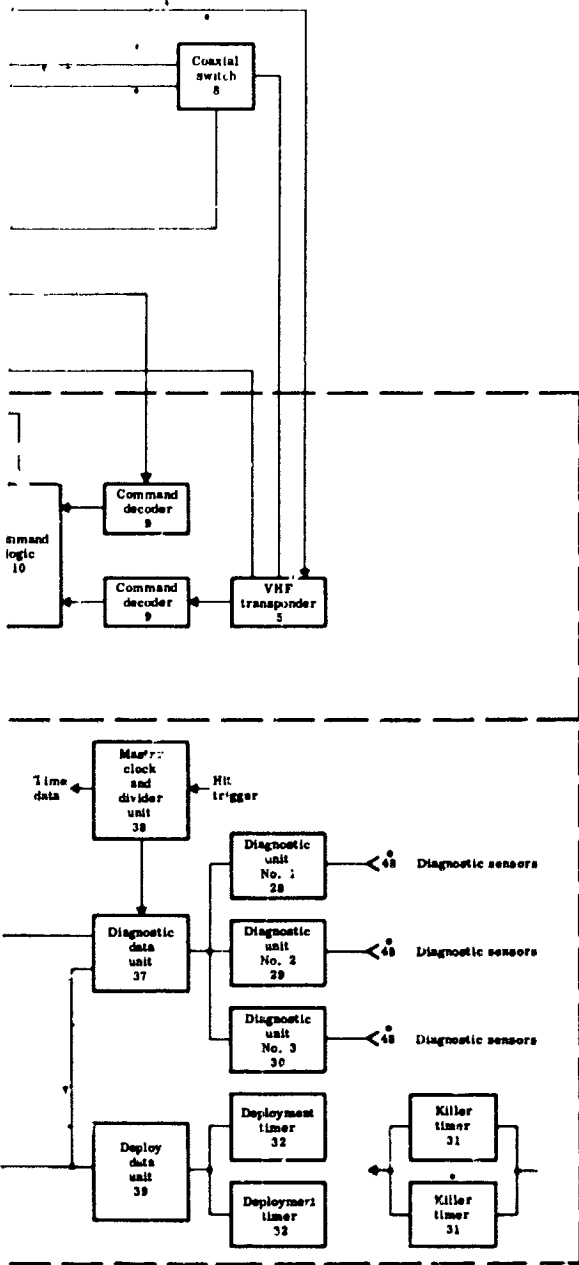

Electrical Power System

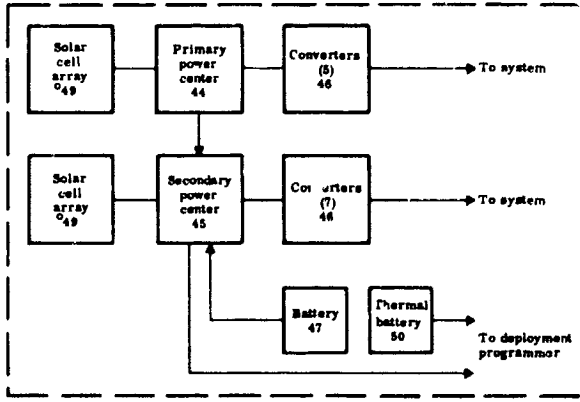

LEGEND: □ Located outside systems module  
 • Duplicated for redundancy

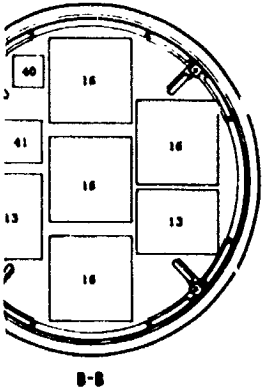

B-B

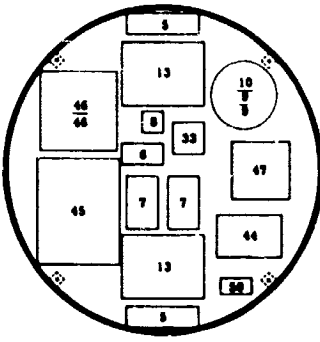

C-C

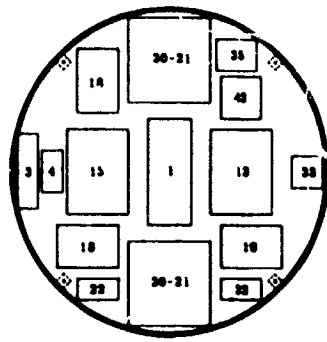

D-D

Fig. I-15. Systems Module Arrangement

2<sup>nd</sup>

to demonstrate structural stiffness and initiation of deployment. The release of the arms for deployment now accomplished by guillotining nylon straps should be tested. Although considerable effort during the conceptual study did not result in the design of a completely satisfactory mechanical release in lieu of the nylon straps, additional effort could be spent investigating this item.

#### e. Thermal Control System

The principal design goal for the thermal control system was to devise a simple passive system which did not depend on devices such as shutters and thermal switches. This goal was established based primarily on reliability considerations. The passive design was achieved with the maximum equipment temperature variation being from 88° to 19° F, well within the allowable operating limit of 0° to 120° F. The 19° F temperature accrues after four hours in the earth shadow. The temperature range of the capacitance sensors is from 140° to -380° F with the -380° F occurring after four hours in the earth shadow. This temperature range is not within the allowable range of -300° to +220° F.

The major mission influences on the thermal design are the earth shadow period of four hours and the intermittent shadowing on the systems module by the capacitance sensors. To limit the temperature decay of the equipment during the shadow period, the heat storage of the capacity of the equipment is used. In case of the primary and secondary redundant transmitter, 2.5 lb of mass are attached to each transmitter to limit the temperature decay. The thermal influence of the capacitance sensor arrays is mitigated by the influence of gravity and solar pressure which causes angular rates about the vehicle X and Y axes; thus, thermally the design is based on the vehicle rotating about these axes.

A basic thermal control system tradeoff was conducted between a completely passive system and a semipassive one using thermal control shutters. This tradeoff showed that the passive system, while more reliable, resulted in a five-pound increase in the systems module weight.

The analytical techniques used in the design analysis were both steady state and transient thermal analysis. Due to the thermal complexity of the vehicle, digital computers were employed for the solution of the steady state and transient equation. In both analyses, an exact solution was employed to account for the infrared and solar radiation exchange between the sensor arrays and the systems module.

**BLANK PAGE**

## (1) Recommended system

The module consists of three 1/2-in. aluminum honeycomb equipment shelves with the upper and lower shelves supported from the center shelf. The exterior cover is constructed in two halves and is made of 1/4-in. aluminum honeycomb. Each half of the cover attaches to the center shelf. The module is attached to the center vehicle truss at four points designed to reduce the heat transfer from the module. The primary and secondary transmitters are attached to the lateral surface of the exterior cover. This method is used to conduct the transmitters' thermal energy to the outer surface and then dissipate it by thermal radiation. To limit the temperature decay of the primary and redundant secondary transmitters when in the earth's shadow mass is added. The mass consists of a 2.5 pound water-glycol aluminum container attached to the transmitters. To assure high thermal conductivity between the surfaces, Dow Corning 340 heat sink compound is applied to the interfaces.

The interior surfaces of the module are painted with a black lacquer ( $\epsilon = 0.88$ ) to ensure an even temperature distribution across the module and to thermally couple the equipment to the exterior cover. The exterior lateral surface is coated with a pattern of aluminum paint ( $\alpha/\epsilon = \frac{0.5}{0.5}$ ) and gold plate ( $\alpha/\epsilon = \frac{0.4}{0.1}$ ) to achieve the desired  $\alpha/\epsilon$  ratio of  $0.43/0.221 = 1.96$ . The exterior top and bottom surface is coated with a pattern of aluminum paint ( $\alpha/\epsilon = \frac{0.25}{0.25}$ ) and gold plate  $\alpha/\epsilon = \frac{0.4}{0.1}$  with the resulting  $\alpha/\epsilon$  ratio of  $\frac{0.2}{0.08}$ . The exterior surfaces in contact with the transmitters are coated with a white lacquer ( $\alpha/\epsilon = \frac{0.33}{0.90}$ ).

The study concluded has resulted in a simple passive thermal control system. Although a slight weight penalty is incurred, a higher level of reliability (over a semiactive control system) was realized.

#### f. Attitude Sensing and Determination

The attitude determination requirements for the MDSS are imposed by two secondary mission objectives: (1) determine general directionality of the meteoroid which impacts the penetration gauges, and (2) determine the velocity of the micrometeoroid population in the cis-lunar space. The latter requirement is the last (in order of priority) of the mission objectives defined in the Statement of Work.

For the general directionality of particles, general orientation requirements have been estimated to be  $25^\circ$  to  $30^\circ$ . However, the requirements imposed by the velocity sensor are very stringent.

The velocity measurements are sensitive to sensor orientation with respect to the vehicle orbital velocity vector and the time of measurement. It is imperative to know the component of vehicle velocity in the direction of the sensor tube. An examination of the GSFC velocity tube inherent accuracy, both due to acceptance angle and oscillator limitations, has been conducted for a typical MDSS orbit. It was found that the timer was the limiting factor on velocity accuracy. The equivalent velocity error of the timer has been converted into an equivalent attitude accuracy.

The attitude accuracy required varies between  $0^\circ$  and  $36^\circ$ , depending on orbital conditions and the angle between the vehicle velocity vector and the sensor axis. From this we have determined attitude accuracies required to give 10% accuracy on meteoroid velocity measurements.

#### (1) Possible solutions

Attitude determination at the time of micrometeoroid impact requires knowledge of two distinct space vectors. For a spinning vehicle, the angular momentum vector is intrinsically defined and hence, measurement of the sun vector satisfies the necessary requirements. However, for a randomly tumbling vehicle, the knowledge of another vector such as the line of sight to earth or moon is required. The practical solution of this task is further complicated due to a large orbit eccentricity which produces a large variation in the earth subtense angle. With a controlled vehicle either space fixed or employing a controlled tumble, narrow field of view sensors are feasible and attitude is known within a very good accuracy at all times, but, of course, the system is more complex and is a weight penalty.

#### (2) Constraints

During the course of the study, ground rules were established which influenced the attitude determination system design. Since the requirement for attitude sensing is imposed by experiments, which are of secondary importance in terms of mission objectives, the following constraints were placed on the system design:

- (1) Spinning vehicle should not be used unless required by subsystems other than attitude sensing.
- (2) Passive techniques are preferred; no moving parts instrumentation should be used if feasible at the risk of performance degradation.
- (3) Active control system should not be used.

- (4) Redundancy should not be used to gain confidence in systems capability to obtain attitude data. The weight increase from this redundancy would be better utilized in other systems of the spacecraft (e. g. , in increased sensor area).
- (5) Completely independent attitude loops shall be used in the data handling and communication systems, including the memory storage unit.

With the above constraints and after evaluating the advantages and disadvantages of a spinning versus tumbling vehicle on the performance of other subsystems such as thermal and electrical power, the uncontrolled tumbling approach was selected.

### (3) Design philosophy

The design selection generated a difficult attitude sensing requirement. It was decided early in the program to use the sun as one of the basic reference sources and further to use one of the solar aspect sensing systems which had been demonstrated in space. Two problems were investigated: (1) what is the dynamic motion of the vehicle in orbit, and (2) what reference other than the sun would be used and how would this reference be sensed.

To answer the first of these questions, an IBM 7094 computer program development was initiated which in its final form would include the effects of the known sources of disturbing torques, the characteristics of the selected vehicle configuration and the characteristics of the orbit. Motion dynamics are studied first by examining the effects of each disturbing torque and later by including all disturbance sources. Such a program is complex and uses a great deal of computer running time, therefore, restrictions had to be placed on the total number of runs made to investigate vehicle motion. Illustrative runs were made to understand the causes of the vehicle motion and to develop typical vehicle motion time histories over the early part of the mission.

A review of the available literature was conducted and sensor manufacturers were contacted and the sensor problem discussed. The Earth was selected as the second basic attitude reference source and attempts were made to sense its source of radiation, both in the optical and infrared regions. After extensive review of the requirements, it was concluded that to achieve a  $4\pi$  steradian coverage was beyond the state of the art in earth sensors. Several approaches were suggested to meet the coverage requirement which consisted of modifications to present sensors and a developmental program. In most of the approaches, moving parts were involved and some basic technical questions would have to be answered through tests in the development program.

The magnetic field of the Earth has been measured at the surface in selected areas on many occasions. Recent measurements by Vanguard, Explorer X and IMP satellites have been compared to the various analytic models of the Earth's field successfully at least out to seven to ten earth radii. After considerable study and review of these comparisons, it was concluded that the Earth's magnetic field could be used as a source of measurement from which vehicle attitude could then be determined. Because of the limited regions over which satellite measurements had successfully compared with calculated values, some other technique would be required for the remainder of the orbit.

Since obtaining  $4\pi$  steradian coverage at any point in the orbit using earth sensors involved development programs and the probable use of moving parts, consideration was given to the use of a predictive technique. The approach would make rapid attitude measurements over portions of the orbit, determine the torques causing this motion and then use a computer program to determine the attitude time history in portions of the orbit in which sensor data is not available.

Using particular care in determining the moments of inertia, magnetic moments, center of gravity and center of pressure locations prior to flight, it is felt that the rotational behavior of satellites can be predicted. Using the onboard measurements made in certain regions of the orbit, the torques acting on the vehicle can be determined. These torques can then be integrated over the mission to predict the attitude time history. The accuracy of this approach depends on obtaining data spread over the orbit such that the torques primarily responsible for vehicle motion can be determined.

#### (4) System description

A functional block diagram of the attitude sensing subsystem is shown in Fig. I-16. Five digital solar aspect sensors are required for a  $4\pi$  steradian coverage. Each has a field of view of  $\pm 64^\circ$  in two mutually perpendicular axes. The five sensors are located on the vehicle with two sensors viewing perpendicular to a plane containing the other three, and in opposite directions. Five earth sensor units are used--each unit incorporates two narrow field-of-view IR (thermopile) sensors. Two three-axes (flux gate) magnetometers complete the attitude sensing system, one high-level and one low-level instrument. The magnetometers have been installed on the outboard edges of the capacitor sensor panels as far as possible from any ferromagnetic material on the vehicle.

All of the components selected have either already successfully flown on satellite programs or are planned for programs whose flight date precedes the MDSS. The Shonsted Type RAM-5C magnetometers

Full Attitude Mode

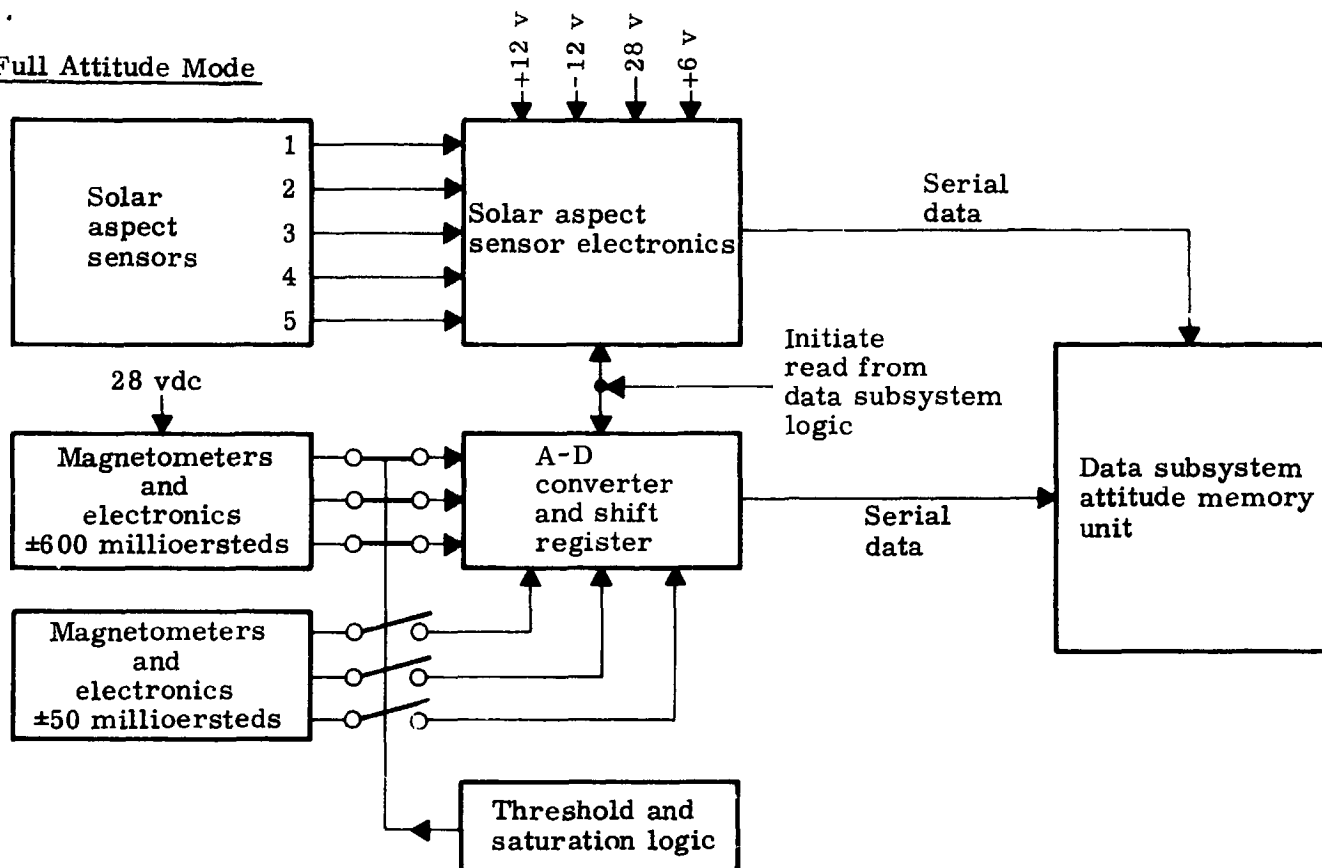

Hourly Attitude Mode

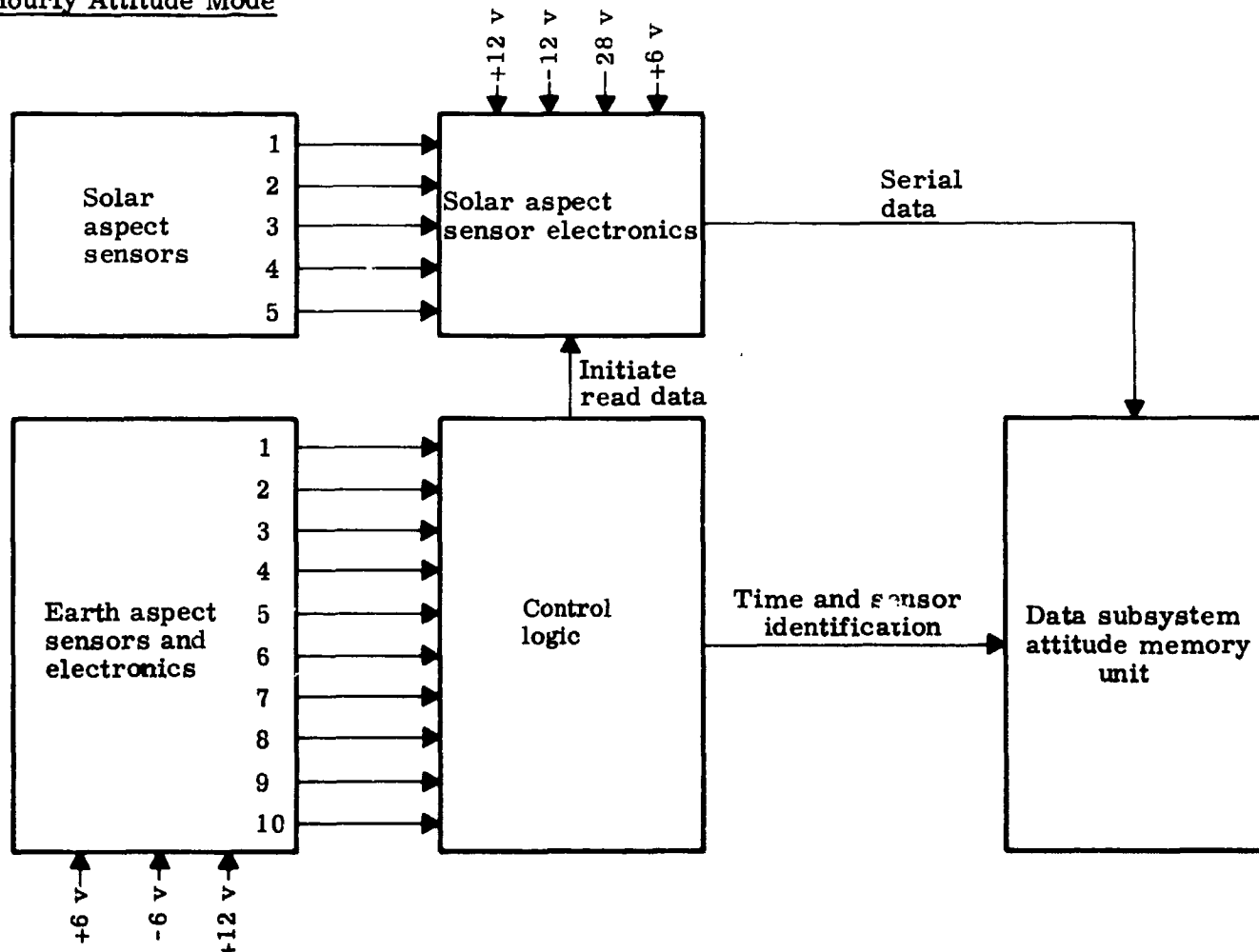

Fig. I-16. Attitude Control Functional Block Diagram

in a single axis configuration and a saturation level of  $\pm 30$  gamma were flown successfully on Explorer X. The Adcole Solar Aspect sensors similar to the proposed units have been qualified for the Tiros weather satellite. The Barnes IR Earth sensors are similar to units which are planned for the Pegasus Program, the Apollo Command Capsule antenna positioning system and a small counter-measure missile made by Raytheon.

The recommended system can uniquely determine attitude of the spacecraft near perigee and out to approximately seven earth radii by use of the magnetometers and solar aspect sensors. Due to the lack of correlation of the experimentally measured earth's magnetic field and that based on prediction beyond seven earth radii, use of the magnetometer data will be restricted to this region. Three axis magnetometer readings alone do not uniquely determine attitude in all cases. The solar aspect sensors are used both to provide the additional required reference directions for the ambiguous magnetometer cases and to provide a reference direction for use in other periods of the orbit with earth sensor data.

Because the mission requirements impose a highly elliptical orbit and thus, a wide range of variation of the earth's subtended angle, using the earth as a source of reference becomes very difficult. Using fixed narrow beam sensor a very large number of these are required when the earth subtends a small angle to obtain  $4\pi$  steradian coverage. The approach has been to use a minimum number, for the sake of simplicity and therefore, to obtain data using the vehicle dynamics to provide the scanning mechanism. From motion studies completed to date, it appears reasonably conservative to be able to see Earth at least once per hour in the region of the orbit in which the magnetometer cannot be used. Attitude and attitude rates as a function of orbit time will be determined, using the magnetometer solar aspect data obtained near perigee, the orbit tracking data and ground based computer programs. The prediction technique will then be used to determine attitude at any later time in the orbit.

Several prediction techniques can be applied. The first, which has been employed on the Explorer series motion studies, determines the torques acting on the vehicle which would produce the motion as given by the sensed data. From this torque is subtracted the gravitational torque and the residual torque is matched against the other possible sources such as magnetic, aerodynamic and solar pressures. Assuming various values for the most significant torques, the time variation of the torque is matched against that determined from the observed data. This process is continued until calculated torques agree with the observed. Motion is then predicted using these torques and checking against observed motion for the remainder of the mission time. This approach assumes rather good knowledge of the vehicle

inertias. A second approach is to determine vehicle attitude using the computer program which simulates attitude motion with the best estimate of inertias, center of pressure and center of gravity locations, initial conditions, aerodynamic drag and solar pressure constants. Results from this simulation would be compared with the observed data over a selected time interval and modifications made to each of the variables until the motion is matched. Using these selected values for pertinent variables, the motion would be continuously checked against the observed data.

Either of these techniques can be employed and probably a combination will be used with perhaps some statistical approach added to the second technique. This would increase the probability of obtaining the best combination of values for the variables to reproduce the observed motion. As with any prediction technique, the more frequent and accurate the observed data, the more confident one can be in the prediction of motion during periods when observed data is not available.

The recommended system was selected on the basis that a large amount of data would be obtained during periods of high torques, near perigee. This data would continue to be collected until the primary torque acting on the system would be solar pressure. The earth sensors were added in order to collect some data during the long mission time in which solar pressure only is acting on the vehicle. The predicted motion resulting from the magnetometer readings near their altitude limitation will be compared with the earth-solar aspect data.

#### (5) System operation

The recommended attitude sensing system has two modes of operation: full attitude and hourly attitude modes. The full attitude mode is used in the region of the orbit in which the magnetometers are effective, while the hourly attitude mode is based on obtaining data from the earth sensors. In both modes, data from the solar aspect sensor is obtained. Sampling frequency in both modes has been determined after considering the anticipated body motion, data storage requirements, sensor capability, attitude accuracy requirements, and the relative importance of attitude orientation data in the overall mission objectives. Attitude data is processed by the secondary data handling and communication system.

Full attitude mode. The full attitude mode is activated on command from the communication system. In this mode, solar aspect and magnetometer outputs are sampled every two minutes and stored in the attitude memory unit. Based on a saturation and threshold logic switching circuit, either the low level or the high level units are recorded. Each time the magnetometer readings are recorded, the

five solar aspect sensors are scanned until a unit is located with aspect data stored in the shift register. This unit is then identified and read into memory serially. Based on error analysis, the total time of data gathering in the full mode will be four to five hours. A total of 150 readings will be made during this time which consists of 10 words of 8 bits for full attitude information including sensor identification, sensor reading, and time of reading. Total storage required is 12,000 bits.

Hourly attitude mode. The hourly attitude mode is used to obtain data points throughout the remainder of the orbit once per hour. The solar aspect sensors and earth sensors are used in this mode. Since only five narrow beam ( $\pm 2^\circ$ ) earth sensors are used in the recommended system, the earth will not necessarily be within the field of view of a sensor for long periods of time. Dynamic analysis of vehicle motion suggests that there is a high probability that the earth will be viewed by at least one sensor during a period of one hour. The earth sensor electronics will generate a pulse when the earth sweeps through its field of view. This pulse activates a signal to store both time and sensor identification and to initiate a read out of the solar aspect data. The solar aspect electronics scan the five solar aspect sensors selecting and identifying the sensor which is illuminated. The solar aspect sensor electronics stores the sun angles in a 17-bit storage register until a read out command is received from the data handling system. This shift register, along with earth sensor identification and time, is read serially into the attitude memory unit once per hour. Circuits in the earth sensor electronics prevent a false reading to occur due to presence of moon or sun in the field of view. Memory requirements for this mode are based on 139 readings of ten 8-bit words or 11,120 bits. Transmission of this data is commanded prior to command of the full attitude mode.

#### (6) Error analysis

An attempt has been made to evaluate quantitatively the accuracy to which the attitude of the vehicle can be determined in each of the two operational modes (full attitude and hourly attitude). From this measured data and the vehicle dynamics program along with previous prediction results, one can qualitatively predict the accuracy of attitude at any time in the mission. Particular emphasis has been placed on the general considerations of using magnetometers and the effects of uncertainty in the earth's field, magnetometer instrument errors, and the effects of vehicle residual magnetic characteristics. Primary sources of error only are considered at this time. Other sources such as mechanical alignment of sensors, telemetry and data reduction errors, etc., are left for later analysis.

## (7) Summary

Solar aspect sensing in both the full and hourly attitude modes can be expected to be obtained to an accuracy of  $\pm 10^\circ$  with the exception, of course, of when the sun is occulted.

In the full attitude mode using the magnetometers, the analysis indicates that the RMS error in altitude can be held to below  $10^\circ$  at the time the measurements are made.

In the hourly attitude mode using the thermopile earth sensors, one can expect errors of one-half the subtended angle of the earth at the time of measurement. In general, this error will be less than  $10^\circ$ .

Based on previous experience and predicting vehicle rotational motions, during portions of the orbit where measurements are not available, it is expected that attitude can be obtained at any time to an accuracy of approximately  $10^\circ$ .

**IIA. DEVELOPMENT PLAN**

**Donald E. Wrede**

## II. DEVELOPMENT PLAN

### A. DEVELOPMENT PLAN

The Micrometeoroid Deep Space Satellite program development plan is shown in Figs. II-1 and II-2 (presented in a folder in the rear of this volume). The modified PERT diagram (Fig. II-2) shows the critical phasing and constraints of the program, while the Program Plan (Fig. II-1) shows the program overall phasing with considerably more detail than the PERT presentation.

Our recommended program covers a two-year period from go-ahead to launch, which includes a backup spacecraft being available at AMR to support the flight article.

The first phase of the program spans a 36-week period, and involves the development of design criteria procurement specifications as well as preliminary and detail design of the spacecraft and associated AGE. This period also encompasses the major part of the effort that is specifically directed toward the design and development of the components that comprise the various subsystems. The complete development cycle from parts selection and breadboarding through the bench testing of individual components is included, as well as the bench testing or subsystem integration testing of a complete set of components comprising a total subsystem. Also included in this phase is about 60% of the span time allocated to the qualification of individual components.

It is anticipated that this first phase will require a number of models and mockups in addition to the conventional breadboards and bench test installations. The first of these is the structural test model which will be full scale, with dummy components to be used initially for the static and dynamic test of the structure and component supports. At the completion of this series of tests, the model will be fitted with the sensor panels for a series of separation tests to dynamically prove the spacecraft, launch vehicle and shroud design, and separation hardware.

Sensor panels used in this separation test will have been previously designed, fabricated and subjected to a series of rigorous environmental tests that paralleled testing of the structure.

Two additional devices are required to support the design and development effort; one of which is a thermal model, built and tested as early as possible in the program to authenticate the theoretical thermal evaluation of the spacecraft. An antenna test mockup and preliminary pattern tests are required to support both structure and antenna and communications systems design, with final impedance and pattern tests to be performed later on a completely functional system.

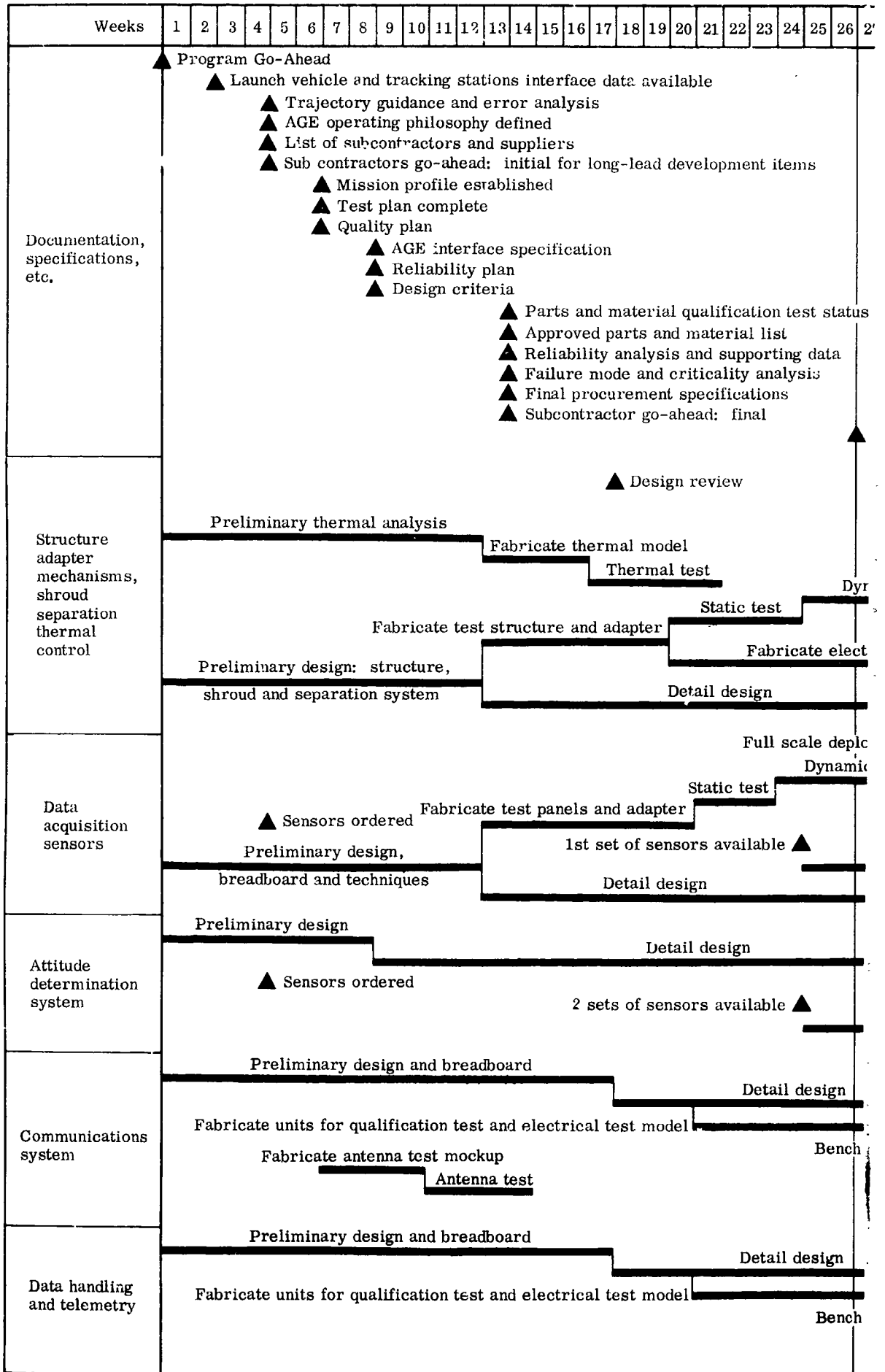

list

Manual outlines

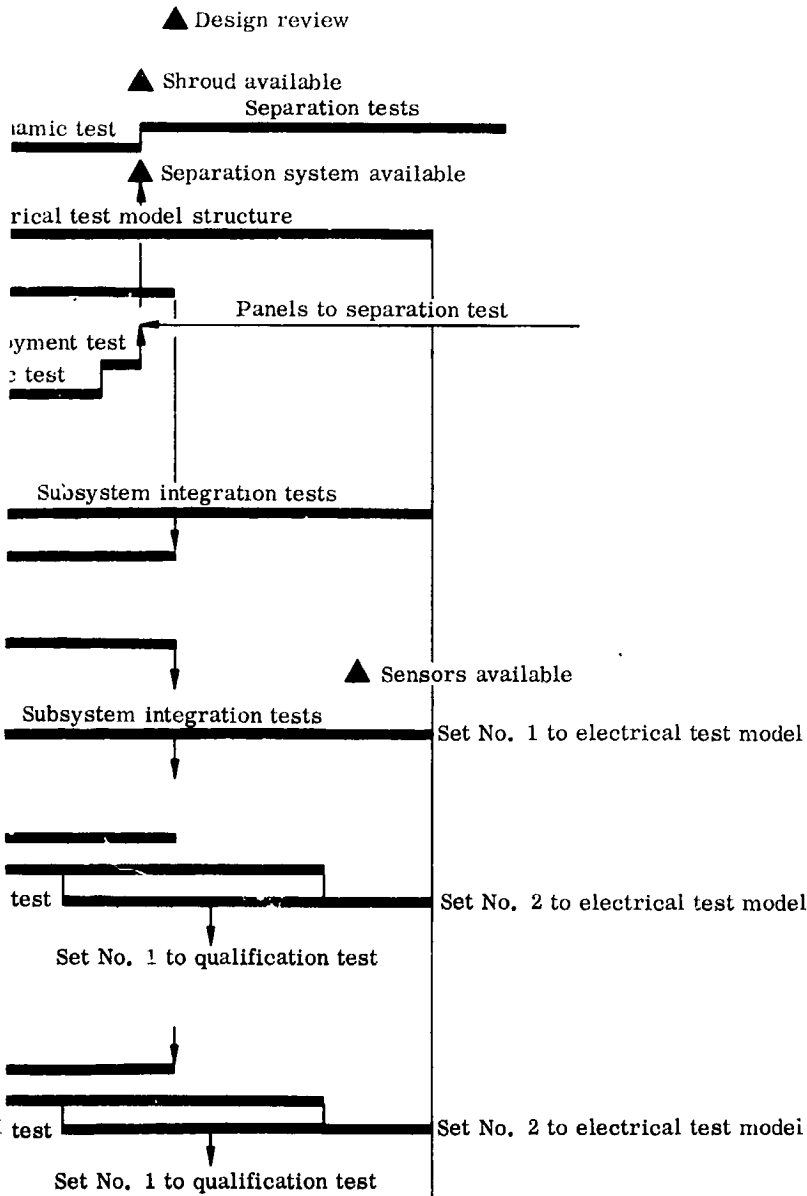

64	65	66	67	68	69	70	71	72	73	74	75	76	77	78	79	80	81	82	83	84	85	86	87	88	89	90	91	92	93	94	95	96	97	98	99	100	101	102	103	104
----	----	----	----	----	----	----	----	----	----	----	----	----	----	----	----	----	----	----	----	----	----	----	----	----	----	----	----	----	----	----	----	----	----	----	----	-----	-----	-----	-----	-----

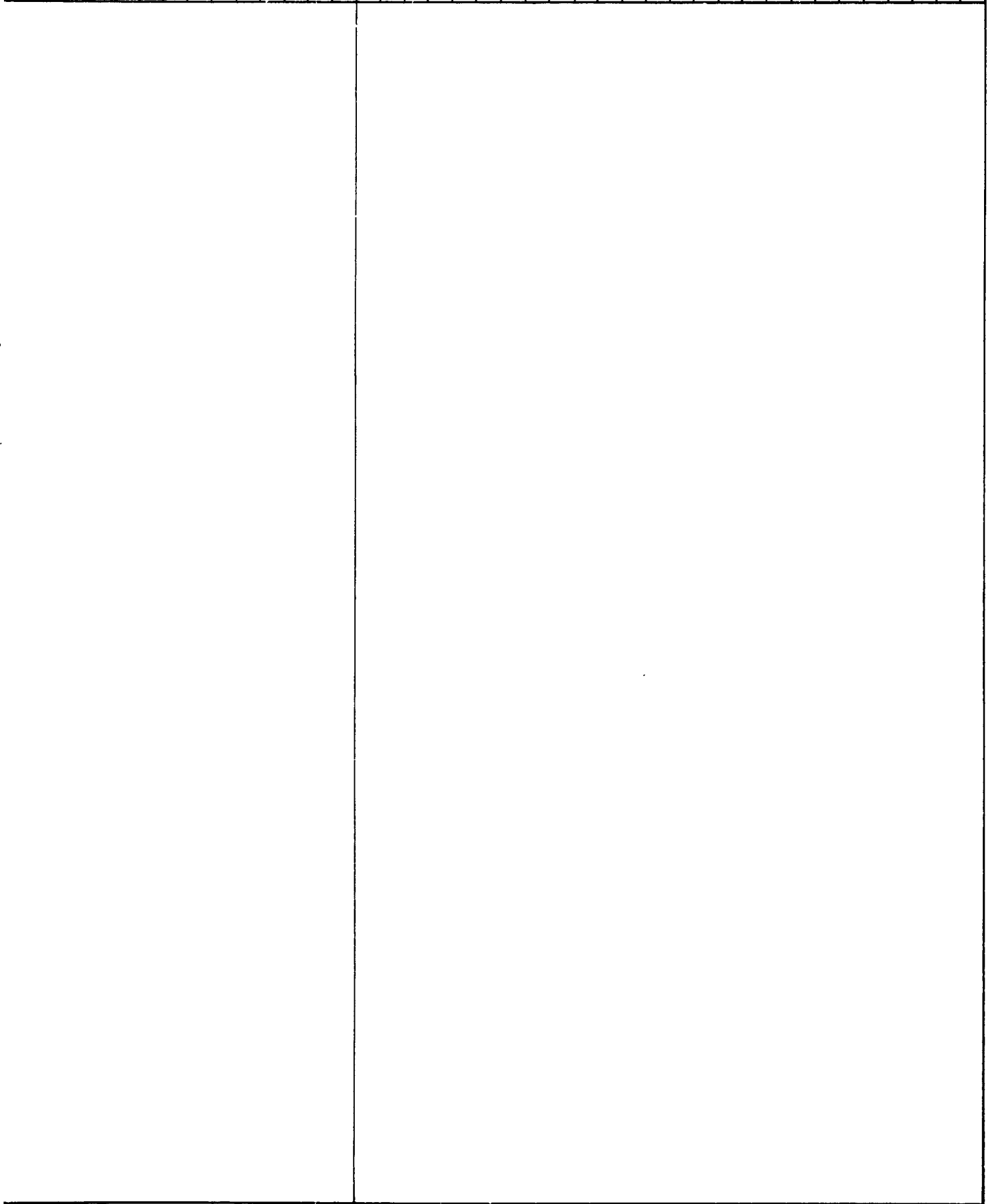

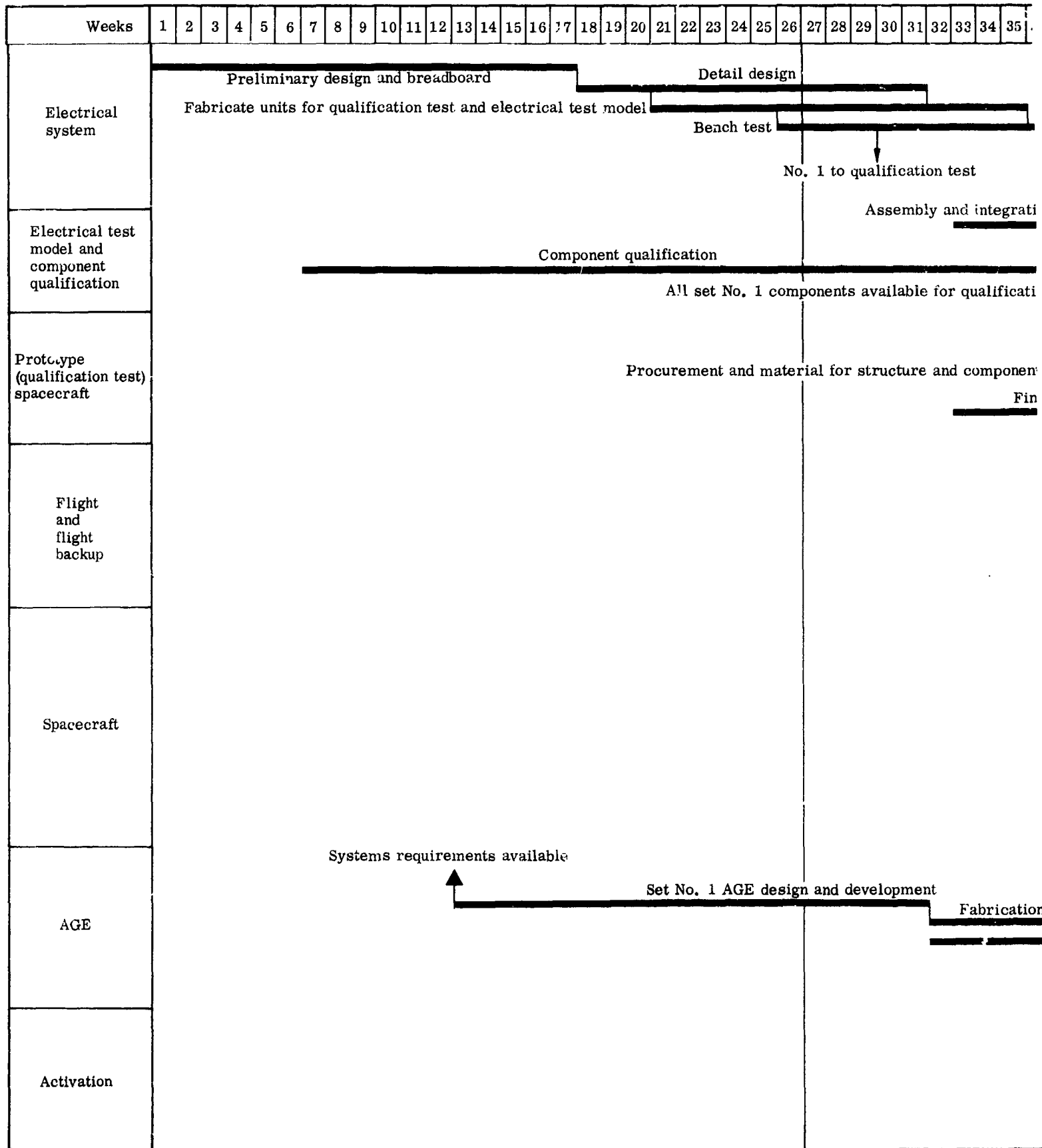

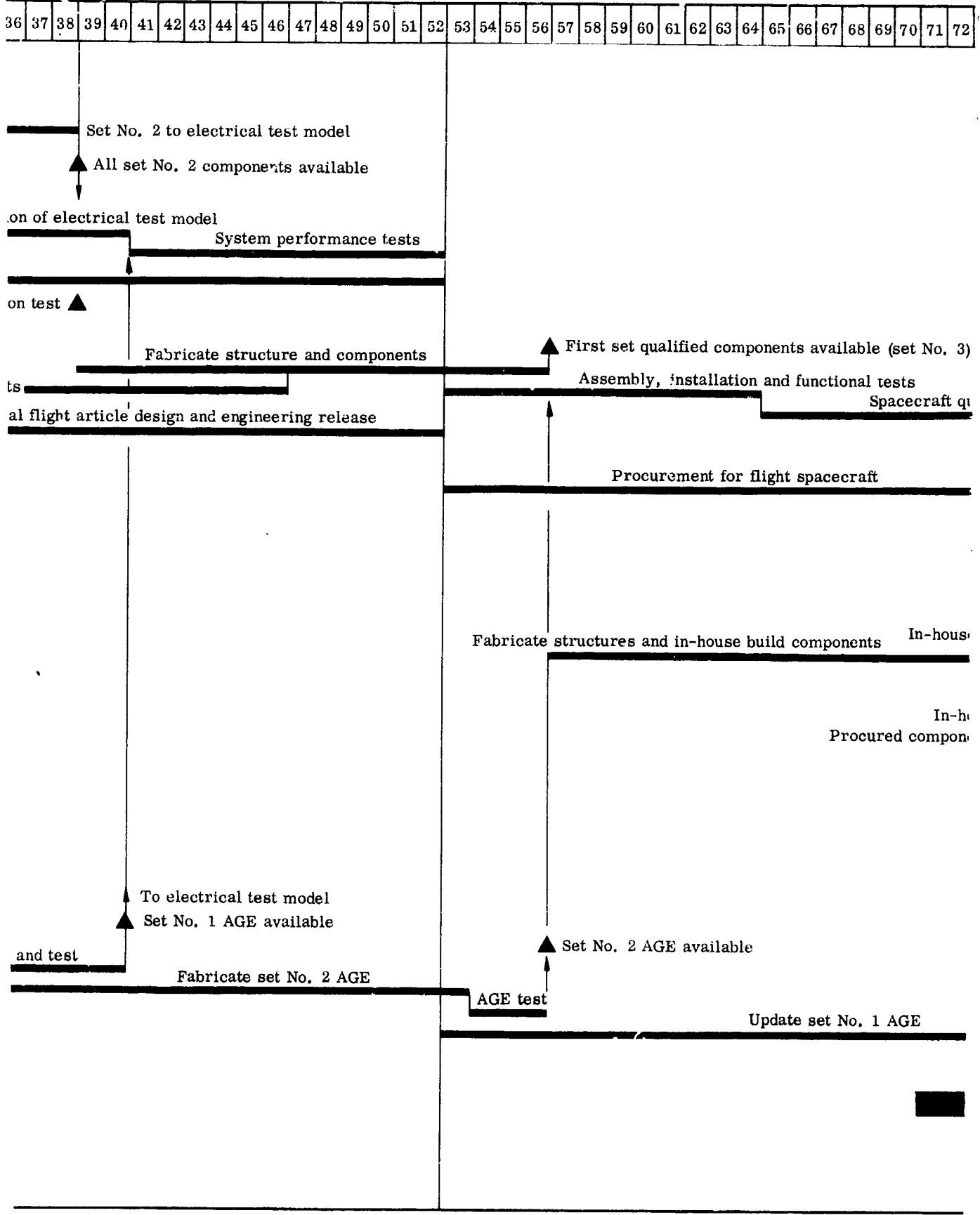

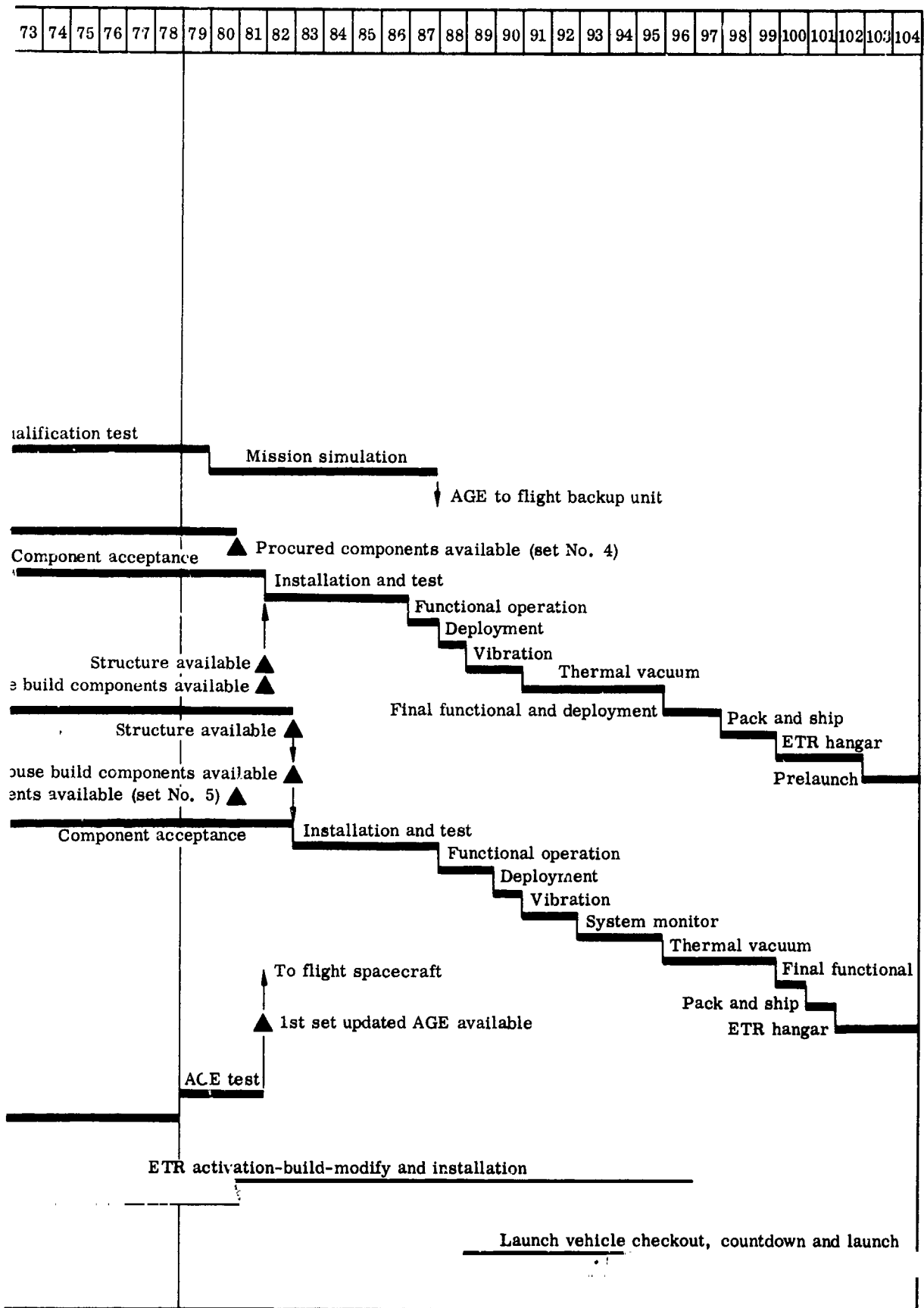

Fig. II-1. (continued)

Tests for the verification of the design of the complete electronics and electrical systems, together with initiation of the effort for building the prototype spacecraft comprise the greatest percentage of the effort in the second phase. During this phase, which covers a span of 20 weeks, the assembly of the electrical test model is accomplished and system performance testing is initiated for the first time on a completely integrated spacecraft. This spacecraft will resemble as closely as possible, the flight article configuration less the "Z" configured sensor panels.

The first set of AGE will complete the build and test cycle in time to support systems performance tests. Component qualification tests will also be completed during this period and paralleled, in part, by the final flight article design and engineering release with completion constrained by completion of system functional testing on the electrical test model and completion of component qualification tests.

The initial effort on the prototype spacecraft also begins during this Phase II period. Procurement and material become available shortly before the start of the build and test cycle of the components for the prototype, and all procured components are delivered as qualified items ready for installation. Build and test of the second set of AGE is completed concurrently with the last of the components for support of functional and subsequent tests of the prototype spacecraft.

The third phase covers 24 weeks, the period of the complete spacecraft functional and qualification test program. During this span, the major part of the procurement, and fabrication and test of components for the two-flight configuration spacecraft, is completed. The major factor constraining completion of both of these is the successful completion of the complete system qualification test. Because of this, the system qualification test looms as one of the most critical elements of the program.

The fourth phase, 24 weeks in duration, consists of assembly and test of the flight spacecraft and the flight backup spacecraft, and pre-launch and launch of the former. The mission simulation test on the prototype spacecraft is conducted during the first eight weeks of the period and, unless two thermal vacuum chambers are available, must be completed prior to the start of the thermal vacuum acceptance test of the flight spacecraft.

Any significant acceleration of first launch can be obtained only by further compromising the constraints of sequential, end-to-end tests and redesign cycles.

## 1. Advanced Programming Techniques

Experience with PERT on such programs as the Gemini Launch Vehicle, ASCEP, Sprint, Pershing, and Titan III has proved that this tool is effective in providing Customer and Contractor management with timely, action-oriented schedule and cost information. Information gained from PERT is used to answer:

- (1) Is the project on schedule and, if not, what is the amount of variance?
- (2) Is redistribution of resources required to ensure completion of the program on time?
- (3) Are cost overruns or underruns predicted?

It is mandatory, of course, in performing a correct analysis and determining answers to these questions, that the PERT plan be maintained on a current basis to reflect latest project status. We have also found that generation of both schedule and cost estimates from a single source ensures compatibility of both time and cost.

Implementation of PERT occurs in two cycles--planning and control. Elements most effective in the planning cycle are:

- (1) A well-defined contractual statement of work where all contract tasks are clearly delineated.
- (2) A work breakdown structure prepared to at least the fourth level.
- (3) Detailed fragnets prepared for each item at the fourth level.
- (4) Cost activities determined for most effective control, and account numbers assigned to each fragnet.
- (5) Cost estimates prepared for each cost activity.
- (6) Individual fragnets integrated into an overall program network and processed through the computer.

It has been shown that early control is best effected by concentrating on those fourth level items which begin at or near contract award. As these fragnets are approved, they are used at once, either individually or in small integrated groups, without waiting until a fully integrated system is available. Internal budget and schedule information is released to operating departments, and performance measurements are begun.

Two methods of integrating subcontractor events into the program networks are usable. In one, the subcontractor is required to submit complete networks and update biweekly. (This method is used on the Gemini Launch Vehicle and on Titan III.) In the other, a condensing computer routine is employed, which requires the subcontractors, through computer processing, to calculate the activity times between selected major events and interfaces on their respective networks. Decks of cards reflecting these activity times are then forwarded to the integration contractor for inclusion in his computer run. This technique enables the integration contractor to control all associates and subcontractors with a network of approximately 400 to 500 events instead of several thousand.

## B. TEST PLAN

A high degree of system reliability is a prime requirement for an effective deep space probe such as a micrometeoroid satellite. Therefore, the limited number of flight spacecraft and associated system reliability as stated in the contractual statement of work, make reliability by design rather than by test mandatory. Consequently, assurance of success must be enhanced by every possible step in the development of the spacecraft. A comprehensive test program, including component, subsystem and spacecraft test, efficiently carried out, is one of the most effective means of assessing the spacecraft reliability. This assessment depends exclusively on laboratory tests and the practical simulation of the expected environments. It requires that sufficient effort must be applied in determining test levels, test duration, operational parameters and the sequence of events. The nominal one-year mission life, with corresponding exposure to solar radiation, stresses the importance of the "accelerated life" testing concept to demonstrate the long term survivability of the various systems prior to first flight.

Goals of this phase of the study program were to:

- (1) Select a practical means of assessing reliability within the limits of the number of test vehicles and launch date.
- (2) Define possible constraints which testing may place on the basic design concept during tradeoff studies.
- (3) Provide essential data for the development program and its corresponding total cost.

### 1. Summary

To determine a test plan which meets the basic design, performance and reliability requirements for a micrometeoroid deep space satellite, a comprehensive study of the problems encountered has been made and possible solutions have been examined. This investigation has shown that it is feasible to proceed with the micrometeoroid deep space satellite and that no new technological breakthroughs or facility developments are necessary to meet test objectives.

The basic test program has been designed and tailored to ensure, as practical, that only reliable and high quality components are accepted for use on the spacecraft. Each component and subsystem will not only be subjected to formal qualification tests, but will also undergo operational and environmental acceptance tests. Integration of these components into the spacecraft assembly will be accomplished through a systematic step-by-step process using associated AGE.

During ground level checkout, all spacecraft systems will be functionally operated in their proper sequence as frequently as practical. Each complete subsystem (earth sensors, capacitance panels, etc.) will be stimulated and its performance monitored and evaluated through the spacecraft telecommunication system. The RF output will be hardlined to ground station receivers. Mechanical aspects (e.g., deployment technique) will be evaluated at frequent intervals throughout this checkout period.

A "burn-in" period, on both the component and spacecraft levels will be accomplished. Each component will be operated for a specified period of time, depending on its criticality to mission requirements.

It can be concluded that a test program containing the above features will:

- (1) Enhance reliability of the finished product.
- (2) Provide necessary assurance that the configuration will be compatible with the expected environments during powered and orbital flight.
- (3) Provide maximum data, commensurate with the proposed schedule.

## 2. Technical Discussion

The study effort has resulted in a test program specifically designed and tailored to meet the objectives of a micrometeoroid deep space satellite program. The program must intelligently utilize a combination of simulated environmental and electrical systems test to acquire necessary information concerning suitability of the spacecraft for flight (Table II-1).

### a. Test objectives and approach

#### (1) Test objectives

The overall test program provides seven basic test categories:

- (1) Development and Accelerated Life.
- (2) Component Acceptance and Qualification.
- (3) System Integration and Operation.
- (4) System Qualification.
- (5) Mission Simulation.

TABLE II-1  
Spacecraft Test Sequence

<u>Qualification</u>	<u>Flight Acceptance</u>
Electrical acceptance (functional)	Electrical acceptance (functional)
Mechanical acceptance (deployment)	Mechanical acceptance (deployment)
Weight	Weight
Center of gravity	Center of gravity
Moment of inertia	Moment of inertia
Radio Frequency Interference	
System check (functional)	System check (functional)
Magnetic	
System check (functional)	
Acceleration	
System check (functional)	
Vibration (150% expected flight levels)	Vibration (expected flight levels)
System check (functional)	System check (functional)
Thermal-vacuum (system check functional deployment)	Thermal-vacuum (system check functional deployment)
System check (functional)	System check (functional)
Mechanical acceptance	Mechanical acceptance
Electrical acceptance	Electrical acceptance

- (6) Flight Acceptance.
- (7) Launch Site Integration and Checkout.

Objectives of the micrometeoroid deep space satellite program which must be satisfied throughout the test program are:

- (1) Verify that new or unproven components meet performance requirements and show a satisfactory life expectancy.
- (2) Discover and acquire necessary data early in the program to eliminate potential weak links in design and manufacturing techniques.
- (3) Demonstrate interface mating compatibility of the system design.
- (4) Demonstrate the capability of the prototype spacecraft to properly perform the intended mission under the expected environmental and operational conditions after undergoing prelaunch testing.
- (5) Demonstrate the capability of each spacecraft to perform its mission.

(2) Test approach

The test approach selected to meet the above objectives is one in which each element of the spacecraft is evaluated by test during each stage of the development. Thus, each step in the spacecraft development can proceed with the best assurance that all design considerations were taken into account. This approach also gives the best possible assurance that no major design deficiencies or manufacturing defects show up in major tests involving the complete spacecraft. Such tests are costly and time consuming, and usually come at a critical point in the program schedule. In essence, the step from final spacecraft ground test to flight would be no larger than the step from system test to spacecraft test.

During the design and analytical phase, particular attention must be given to the problem of determining and specifying the various failure modes. The test program (both functional and environmental) must be designed to reveal the different failure modes using:

- (1) Effectively simulated environments, either singularly or combined.

- (2) Test articles which are representative replicas of the actual flight hardware.
- (3) Electrical and/or mechanical functional sequence of each test item faithfully reproduced.

The above guidelines must be implemented within the following constraints:

- (1) One nonflyable prototype spacecraft will be available for final systems qualification and mission simulation test.
- (2) The test program will be implemented by utilizing the combined facilities of Government and industry which are already developed and available.
- (3) Design areas for which least confidence is available will be given first priority to minimize expensive and time consuming redesign later in the program.

Because no space vehicle is under development in which both environmental levels and mission life requirements meet or exceed those of the micrometeoroid deep space satellite, most of the off-the-shelf hardware will either be re-evaluated or requalified as necessary. Other approaches which should be employed to ensure that requirements of the MDSS can be satisfied are:

Structural and thermal test assembly. As early as practical in the development of the spacecraft, a complete structural assembly with dummy components should be tested to determine such locally induced environments as temperature and vibration. This test can be used to provide early information for component design specifications as well as a means of determining optimum component placement and system harness configuration.

Electrical test model. Another effective technique used to evaluate electrical performance of the vehicle is to conduct interaction and compatibility tests utilizing a spacecraft structure and early prototype components. This provides a means for measuring the subtle interaction effects not readily amenable to analytical prediction.

The electromechanical compatibility of the spacecraft booster configuration should be demonstrated at this time. An Agena interface mockup containing all necessary electrical and mechanical interfaces would be required for this test.

Spacecraft test. Use of one prototype spacecraft for environmental testing is consistent with approaches taken on previously successful scientific satellites and probes. The prototype will be thoroughly tested and evaluated to assess its flight readiness. At the conclusion of the test program, the prototype should be retested until two additional cycles have been completed or a failure occurs. Each flight vehicle will be subjected to flight acceptance test. These tests (vibration and thermal vacuum) will be conducted at levels consistent with those expected in flight. AGE should be used as the monitoring and diagnostic system throughout this phase of the program.

Part and component life testing. In considering an approach to life testing, several basic failures were investigated: those due to long term degradation effects, and those due to fatigue or wear-out. Unless definite failure trends concerning the effects of long-term operation or the exposure to various environments can be determined, accelerated life test becomes impractical. Where these failure patterns can be readily established, a test that artificially induces the required physical property changes becomes more realistic.

Sensor Panels. The unique configuration of the sensor panels (large plate capacitor) presents the possibility that conditions of outer space may produce false indications of a micrometeoroid hit. When conditions are such that a charge-discharge cycle occurs, false hit information would be transmitted. A typical example would be the discharge of charges accumulated in the dielectric material while in the Van Allen radiation belt. To assess the influence of this space condition on the sensor panels, samples of the various configurations should be subjected to the appropriate fluxes of charged particles, the extreme environment of solar radiation, and the hard vacuum of outer space early in the development phase of the test program.

- b. Testing related to unique micrometeoroid satellite characteristics and requirements

To a large degree, the type of test, test procedures and simulated environmental levels are similar to those used for such programs as Nimbus, IMP and the OGO series, the main difference being in the facilities required to test. This is due to the increased size of the spacecraft and does not require a state-of-the-art breakthrough in testing technology. However, it is restrictive in how and where tests can be performed. This is particularly true in the areas of vibration, acceleration and thermal vacuum testing. Outlined below are some of the restrictive conditions that should be considered.

### (1) Acceleration

The requirement to expose the complete spacecraft with panels in the stowed condition to a steady-state longitudinal acceleration can be satisfied by using a large radius centrifuge. Because of the overall size of the spacecraft and to restrict the g gradient over the vehicle length, a centrifuge with a radius arm of at least 50 feet should be used. Even then, a gradient of approximately 3g will exist. For a 30-foot radius centrifuge, a gradient of approximately 6g will occur, resulting in considerable overttest at the extreme end (Ref. center of rotation of centrifuge) while the near end is undertested.

It appears logical to eliminate this test completely, based on the fact that, during the development phase, a complete spacecraft structure, equipped with dummy components, will be subjected to a static load test. If it is required to test component tiedown techniques, this can be accomplished using an equipment module only, and need for a large radius centrifuge (above a 20-foot radius) would be eliminated.

### (2) Vibration

The size of the proposed design places a definite limitation on the type of facility capable of meeting the objectives of the test program. Any object that has a cg well above the line of force input presents a problem with crosstalk in the other directions. Consequently, only certain facilities can be used in conducting the vibration test on this size specimen. A large shaker system (30,000 force pounds) with a hydrostatic slippery table (such as the TEAM table) should adequately meet the requirements. This technique best meets the objective of simulating the expected flight levels while assessing the system overall performance and tends to control the crosstalk in the off axes directions.

### (3) Thermal vacuum

Several approaches have been considered for conducting the thermal vacuum test, each of which is restrictive either in facility size and cost or technical data obtained.

Complete spacecraft test. A large thermal vacuum chamber (approximate 30-foot diameter) equipped with solar simulation would offer the most complete method of conducting the test. This size chamber would allow deployment of the sensor panels and provide a means of rotating and gimbaling the spacecraft, if required, to change orientation with respect to the solar simulator. This approach, in addition to limiting the test to only the large vacuum facilities, is also restricted by the diameter of the collimated beam of the solar simulator.

Instrument section and model. After conducting a thermal analysis of the entire spacecraft, a small scaled thermal model could be used to determine adequacy of the analytical techniques and the radiated thermal characteristics of the spacecraft (sensor panels). From this information, the center section, without sensor panels, could be installed in a small chamber and subjected to solar simulation test with heaters used to artificially produce the radiated or conducted heat load effect caused by the sensor panels. This approach, utilizing carbon arc lamps for IR simulation and/or shutters positioned between the solar simulator and the test article, will not be as complete a test as the previous one, but will provide most of the required data.

(4) Combined testing

The proposed capacitance panel configuration, with four tension springs holding the sensor panels, has large flat thin sheet panels which could be influenced by air mass effects during vibration. To properly assess the effects of this phenomenon, the combined environments of vibration and pressure should be simulated simultaneously. This type of test will indicate the effect of the air mass (or lack of same) on panel vibration characteristics. The damping effect of air can only be assessed by test. The test, although highly desirable, has not been suggested in the proposed test plan because of the unique facility requirement. The facilities exist at only a limited number of test agencies.

c. Integrated Test Plan

To effectively demonstrate space worthiness of the spacecraft without extracting operational life from its components, the following integrated test program has been developed. The step-by-step process of integrating subsystems and AGE equipment is the essence of the plan. The test may be accomplished in the following manner.

(1) Development and accelerated life

Development test. A series of development tests should be conducted to evaluate the performance characteristics of working model hardware. Some of the more significant development tests could include:

- (1) A vibration survey and structural impedance test on typical spacecraft structure equipped with simulated dummy components. The test will be repeated as part of the formal qualification test program conducted on a fully operative spacecraft system.

- (2) Samples of the most promising sensor panel configuration exposed to vibration, acoustic and thermal vacuum test to screen and evaluate the design concept.
- (3) Radiation and hypervelocity impact tests on samples of the most promising sensor panels including as much of the wiring as practical. These samples should be subjected to the appropriate fluxes of charged particles and simulated micrometeoroid impacts. The ability to simulate the radiation effects in which the Van Allen Belt electrons and protons, and other radiations of interest occur is within the present state of the art. Accelerators to produce high velocity charged particles to simulate micrometeoroid bombardment are available.
- (4) The deployment system operated and recycled many times in a simulated test stand to verify performance characteristics (deployment speed, unlatching and latching, etc.).
- (5) Antenna pattern and gain tests utilizing full scale antennas, mounted on a structural mockup of the spacecraft.
- (6) All newly developed or modified airborne components thoroughly evaluated in such critical environments as vibration, acoustics and thermal vacuum as soon as practical during their development phase.
- (7) A scaled thermal model of the entire spacecraft used to verify thermal analysis and establish a suitable means for conducting the thermal vacuum simulated mission test (i. e., scaled model versus entire deployed spacecraft).

Accelerated life test. Wherever a failure mode or pattern can be established concerning the influence of expected environments and equipment operating time on systems performance, accelerated life tests should be performed. These patterns may be established by observing the switching resistance, switching transient shape, circuit stability, performance under heat cycling, and/or initial material property changes throughout the early development of the components. Present studies show that accelerating test time by compressing transient events appears feasible for components and subsystems where long passive periods occur between transients. A command logic system that operates for short periods can be monitored to determine the environmental exposure time versus failure correlation, as well as the cyclic rate versus wearout time, by

observing the various response characteristics (resistance change, switching response, etc.). From this information, an accelerated life test could be designed by compressing the time between operation, and/or increasing the environmental test time or levels.

(2) Component qualification and acceptance

For this study, components are defined as complete assemblies or packages (black box level) which perform a discrete mission function and are considered separate units with regard to the various flight environments (e.g., thermal-vacuum, vibration, acoustics).

Component qualification test. Wherever it can be shown that an existing component has been previously qualified to environmental levels which meet or exceed the test specification for the micro-meteoroid deep space satellite, retest will not be required. Newly developed components will be exposed to environmental levels in excess of those expected in flight. Vibration levels will be approximately 1.5 times the expected flight level, and temperature over-stress will be dependent on the individual component's thermal characteristic. The environmental test (Fig. II-3) should be conducted while simultaneously checking the functional characteristics of the component. Table II-2 presents environmental levels associated with:

- (1) Vibration
- (2) Shock
- (3) Acceleration
- (4) Thermal vacuum with hot and cold soak
- (5) Electrical interference
- (6) Humidity
- (7) Temperature (high and low).

This does not preclude the possibility that other type tests will be performed.

Each component will be subjected to a "burn in" period prior to start of the environmental test, which will be part of the formal qualification test program.

TABLE II-17  
Environmental Test Requirements for Components

<u>Levels and Duration</u>		
<u>Test</u>	<u>Qualification</u>	<u>Flight Acceptance</u>
High temperature	+160° F for 10 hr	No requirement
Low temperature	-20° F for 10 hr	No requirement
Humidity	Temperature at ambient level with RH of 95% for 24 hr	No requirement
Acceleration	13.8 g (thrust axis) for 6 min 2.5 g (lateral axis) for 6 min	No requirement
Shock	30 g sawtooth, 3 axis 8-ms duration, 4 shocks per axis	No requirement
Vibration		
Sinusoidal	5 to 22 cps at 0.4-in. double amplitude 22 to 400 cps at 10 g 400 to 2000 cps at 15 g 15 min per axis	5 to 22 cps at 0.2-in. double amplitude 22 to 400 cps at 5.0 g 400 to 2000 cps at 7.5 g 10 min per axis
Random	20 to 400 cps at 0.06 g <sup>2</sup> /cps 400 to 2000 cps at 0.14 g <sup>2</sup> /cps 5 min per axis	20 to 400 cps at 0.035 g <sup>2</sup> /cps 400 to 2000 cps at 0.07 g <sup>2</sup> /cps 3.5 min per axis
Thermal-vacuum	Pressure equivalent of 10 <sup>-6</sup> torr with a low temperature soak at 0° F for 72 hr followed by a high temperature soak at 140° F for 72 hr	Pressure equivalent of 10 <sup>-6</sup> torr with a low temperature soak at 15° F for 36 hr followed by a high temperature soak at 120° F for 36 hr

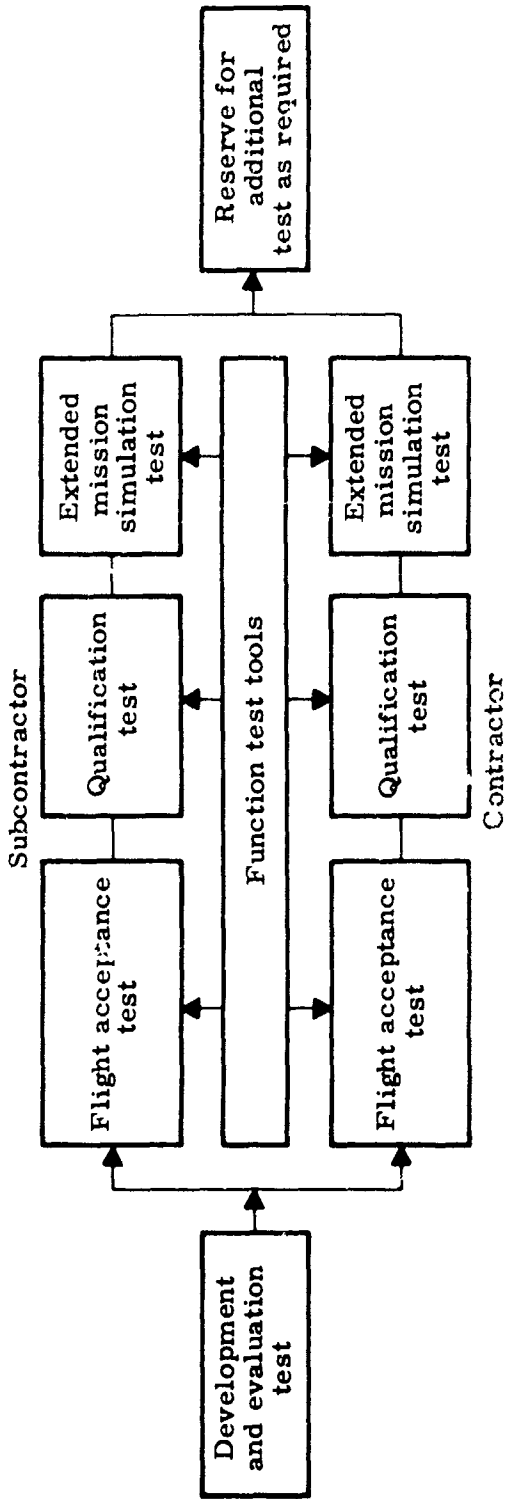

Fig. II-3. Flow Diagram Component Test Program.

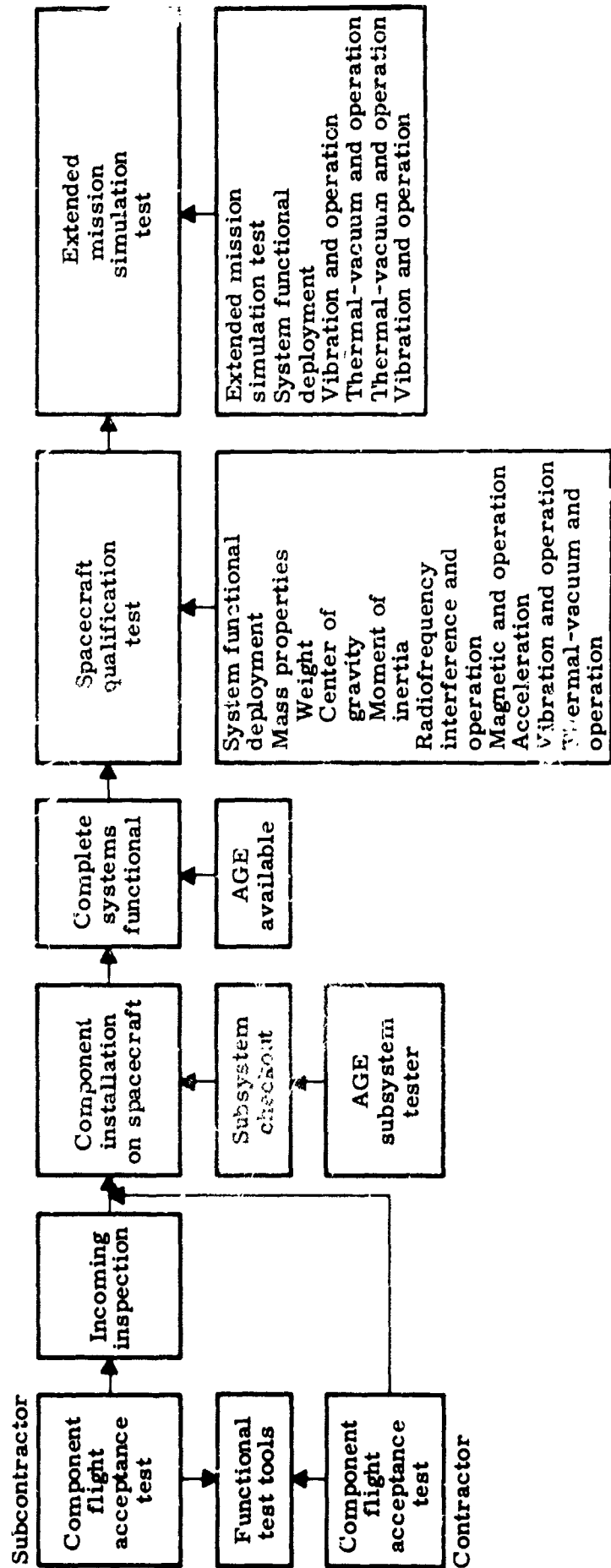

Fig. II-4. Flow Diagram Prototype Spacecraft Qualification Test Program.

To obtain a higher engineering confidence level, each component should be exposed to additional environmental tests at the conclusion of the qualification test program. These tests will consist of two consecutive environmental cycles simulating the launch phase (vibration), followed by those conditions experienced in orbit (thermal vacuum and solar simulation). As previously indicated for the qualification test, input functions (such as voltage) will be varied within the allowed extremes and its output functions monitored.

Component acceptance and structural compatibility test. Each delivered component or subassembly should be exposed to environmental levels (vibration and thermal vacuum) which simulate 100% the expected flight levels. The specimen will be functionally operated and its performance checked for all modes encountered during the mission (i. e., signal conditioning unit will condition signals properly for storage or transmission under vacuum conditions). Tests and checks to ensure proper interface conformance (input output) and subsystem compatibility will be performed as part of the acceptance test program.

An electrical test model should be used to accomplish integration of spacecraft components and eliminate interference problems (both mechanical and electrical) as each component is accepted. The spacecraft systems functional test procedure will be re-evaluated and modified as required. The test model can also be equipped with the required antennas to perform necessary pattern and gain tests. This early "integration testing" will provide necessary technical data and will assist in development of a well trained test crew prior to the start of the formal qualification test program.

### (3) System integration and operation

Spacecraft components, upon completion of the acceptance test (Fig. II-4), will be assembled onto the spacecraft structure and connected to the wire harness. A systematic installation, integration and functional check of each subsystem will proceed until the spacecraft is completed.

The complete spacecraft will be functionally operated (under room ambient conditions with associated AGE) and its performance characteristics determined. At this point, an intrasystem parameter variation test will be performed, in which the influence of one system parameter on another system will be assessed.

The test sequence and follow-on usage of the complete spacecraft is shown in Fig. II-5. Note that follow-on usage for this functional spacecraft will be the qualification test of the spacecraft as a system and to obtain additional test data for use in reliability studies.

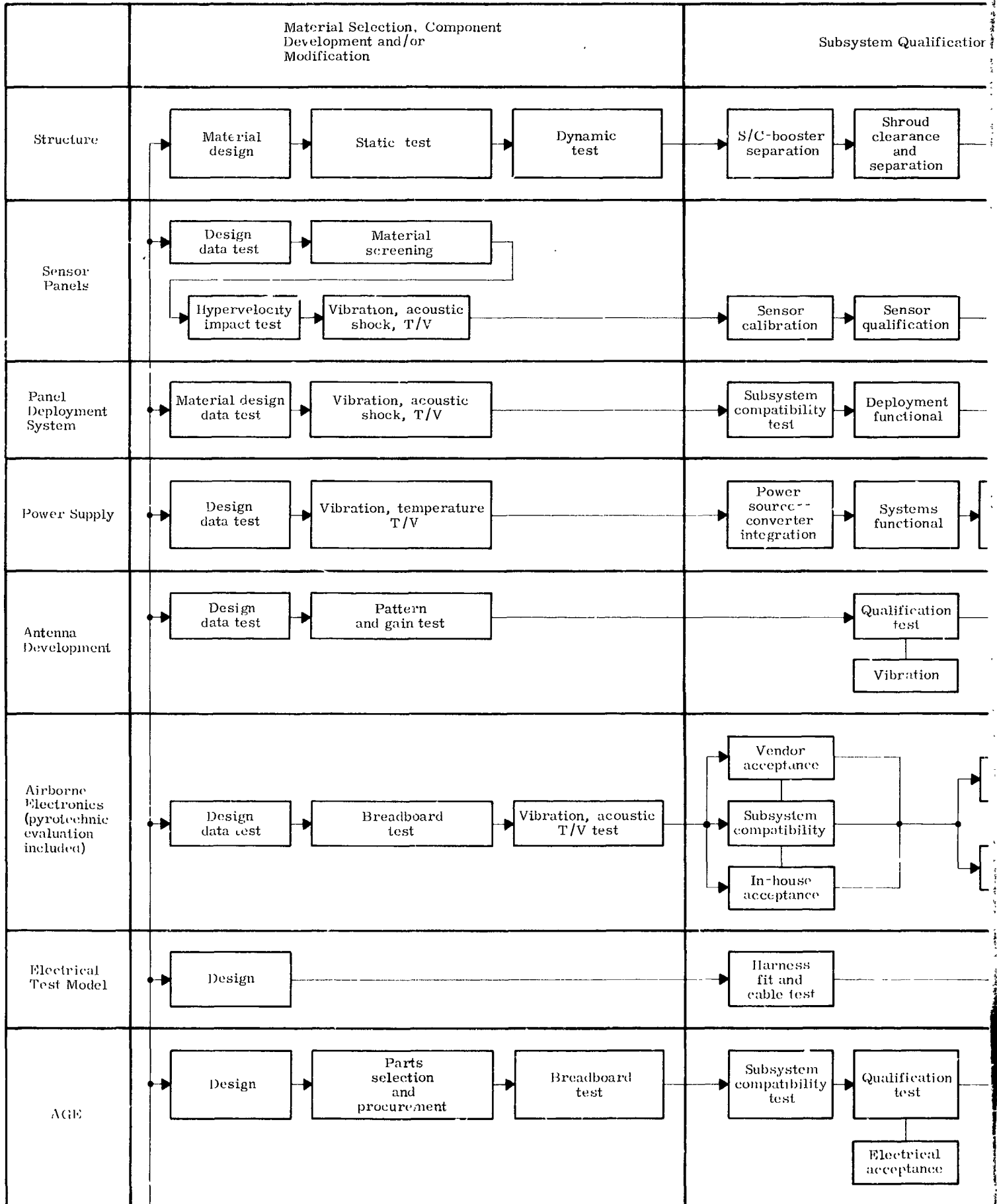

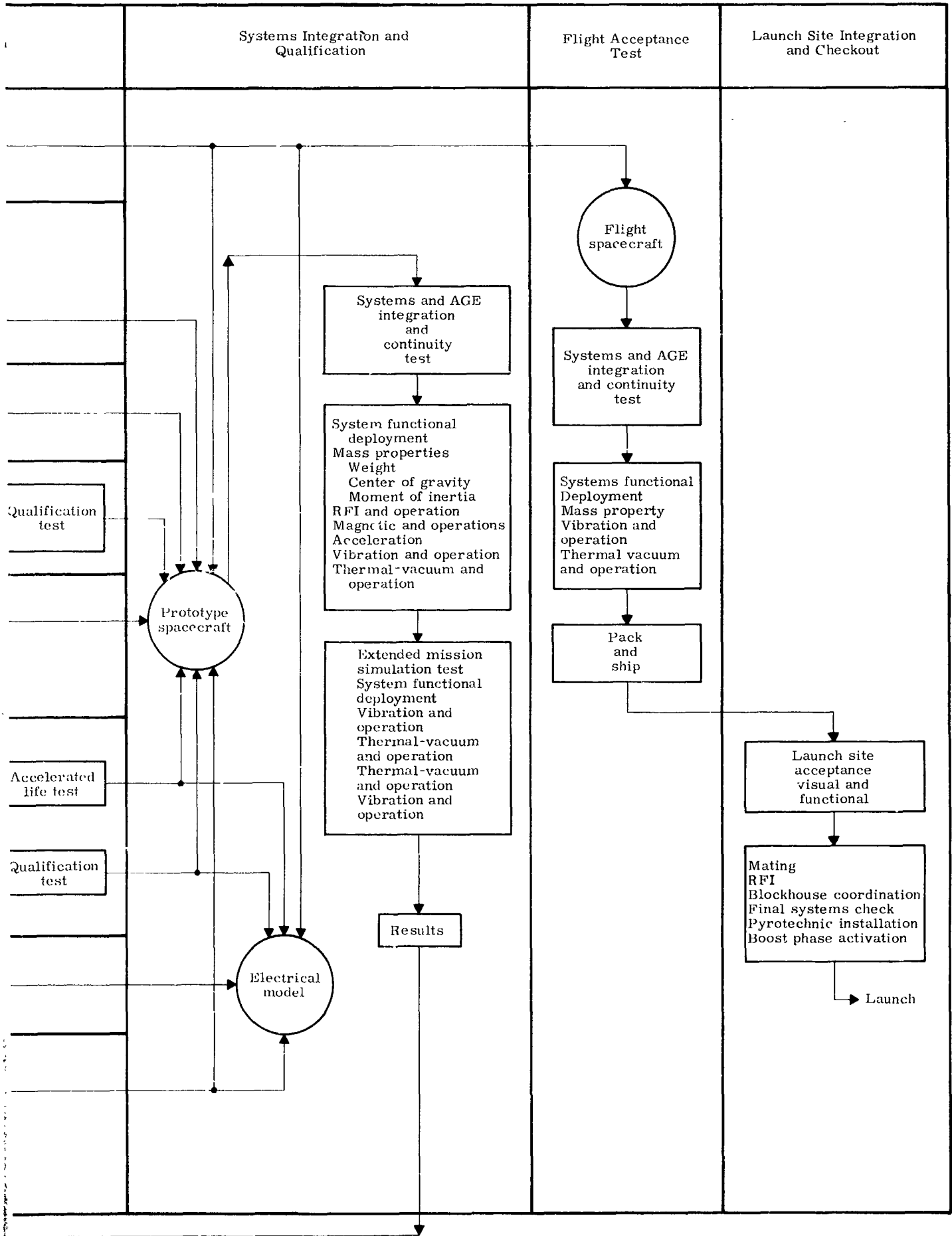

Fig. II-5. Test Plan Flow Chart

**BLANK PAGE**

(4) System qualification test (prototype)

The complete spacecraft, with all systems operative, will be mated with its AGE for use in a formal qualification test program. Several tests under room ambient environment precede the over-stress environmental tests (Table II-3):

Systems functional test--electrical functional. This test, under room ambient condition, will ensure that all systems operate in accordance with the specifications and will serve as a calibration point which provides a means of assessing any deviation in performance throughout the remainder of the program. A systems level "burn in" should be performed at this time.

Deployment--mechanical functional. A mobile system of counterbalances should be used to effect deployment of the panels in a simulated zero-g environment. The counterbalance system should be capable of operating in both ambient and hard vacuum environments.

Electrical/electronic interference test. Information from previous successful programs have shown the major RFI concern to be possible electrical interference between the booster, spacecraft and launch facility. Consequently, the only test proposed is of a limited nature, showing that range safety requirements can be met. These tests should be conducted while the spacecraft is in the stowed (folded) condition. The various operational modes will be simulated to determine the ability of the spacecraft design to meet the range safety requirements.

Mass properties test. The spacecraft will be weighed and its center of gravity determined. The moment of inertia will be measured by positioning the spacecraft on a pendulum apparatus and rotating it about each of the spacecraft axes.

Acceleration. The complete spacecraft assembly should be rigidly attached to the arm of a large radius centrifuge and subjected to longitudinal acceleration levels 1.25 times those expected in flight. However, as mentioned earlier, this test may not be required.

Vibration tests (simulating launch environments). The complete spacecraft assembly will be rigidly attached to an electromagnetic shaker and instrumented with accelerometers. A low level resonant search to determine the dynamic response of the system will be conducted in each of the three principal orthogonal axes. This portion of the test should be repeated at several input levels to determine the linearity of response. The spacecraft assembly should then be exposed to both random and sinewave tests at levels representative of 1.5 times those expected in flight.

TABLE II-3  
Test Requirements for Spacecraft

<u>Test</u>	<u>Levels and Duration</u>	
	<u>Qualification</u>	<u>Flight Acceptance</u>
Weight	To be determined	To be determined
Center of gravity	To be determined	To be determined
Moment of inertia	To be determined	To be determined
RF 1	Radiated interference	No requirement
Magnetic	Spacecraft level less than 10 gamma	No requirement
Acceleration	11 g thrust axis 6 min 2 g lateral axis 6 min	No requirement
Vibration	5 to 14 cps at 0.4-in. double amplitude	5 to 14 cps at 0.3-in. double amplitude
Sinusoidal	14 to 400 cps at 5.0 g 400 to 2000 cps at 7.5 g 15 min per axis	14 to 400 cps at 3.5 g 400 to 2000 cps at 5.0 g 10 min per axis
Random	20 to 400 cps at 0.05 $g^2/cps$ 400 to 2000 cps at 0.12 $g^2/cps$ 5 min per axis	20 to 400 cps at $0.035 g^2/cps$ 400 to 2000 cps at $0.07 g^2/cps$ 3.5 min per axis
Thermal vacuum	Pressure equivalent of $10^{-6}$ torr with a thermal profile as per Fig. II-6	Pressure equivalent of $10^{-6}$ torr with a thermal profile as per Fig. II-7

Magnetic. In the present configuration, flux-gate magnetometers are used for attitude sensing. The magnetic test cannot be standardized and should be specified in each case on the basis of spacecraft characteristics. However, sufficient measurements shall be made to determine the permanent, induced and stray magnetic effects of the spacecraft.

Thermal vacuum test. The test will be conducted in a vacuum chamber with pumping capacity capable of maintaining a specified vacuum level. A liquid nitrogen shroud should be provided for cryopumping and space heat sink simulation. A means of adjusting the angle of incidence to the solar source will be incorporated within the chamber.

Solar emitted heat will be programmed to simulate a typical flight sequence (Figs. II-6 and II-7). After deployment of the sensor panels, a hot and cold orbit cycle will be simulated. Subsystem performance parameters will be monitored through the telemetry system via an antenna coupler and coaxial cable. The criteria for qualification success are that the data meet specification and match the calibration points taken prior to start of test.

(5) Mission simulation tests

After successful completion of the qualification test, the spacecraft should be exposed to two complete cycles of the anticipated launch and space environments to demonstrate a mission life of one year. Tests will be conducted utilizing test levels equal to those expected in flight. Successful demonstration of this capability, combined with the qualification tests, will determine overall mission capabilities of the spacecraft design. This series of tests will also serve as a means of showing the degree of resistance the proposed design has to fatigue or wear-out and the actual launch itself. The complete AGE system should be used throughout these tests. There will be two, successive, real-time mission cycles of:

- (1) Complete systems functional.
- (2) Deployment (simulated zero g).
- (3) Vibration (100% expected flight levels).
- (4) Thermal vacuum (solar emitted flux will be programmed to match real time cycles).
- (5) Repeat complete systems functional.
- (6) Repeat deployment.

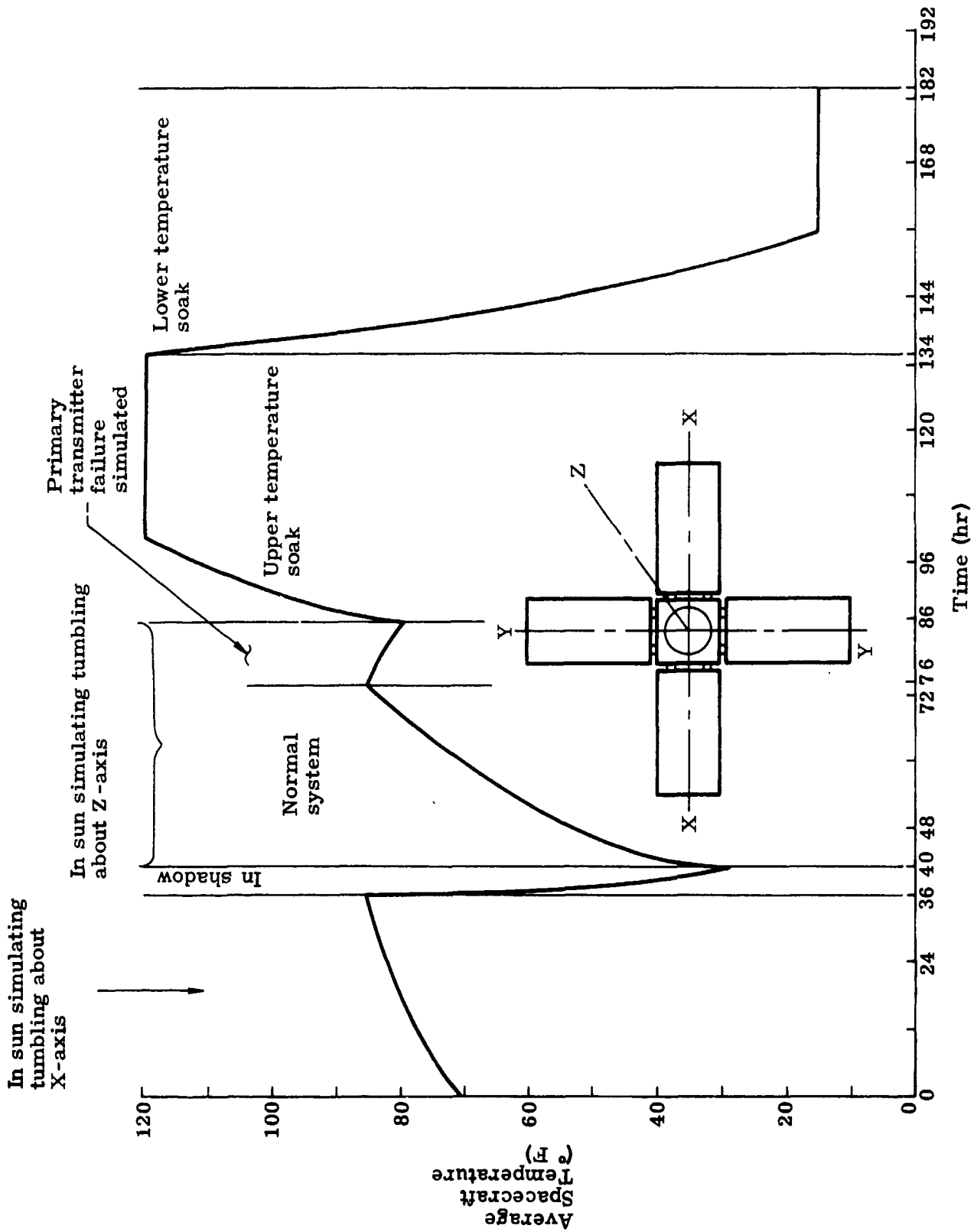

Fig. II-6. Thermal Profile for Spacecraft Qualification Test

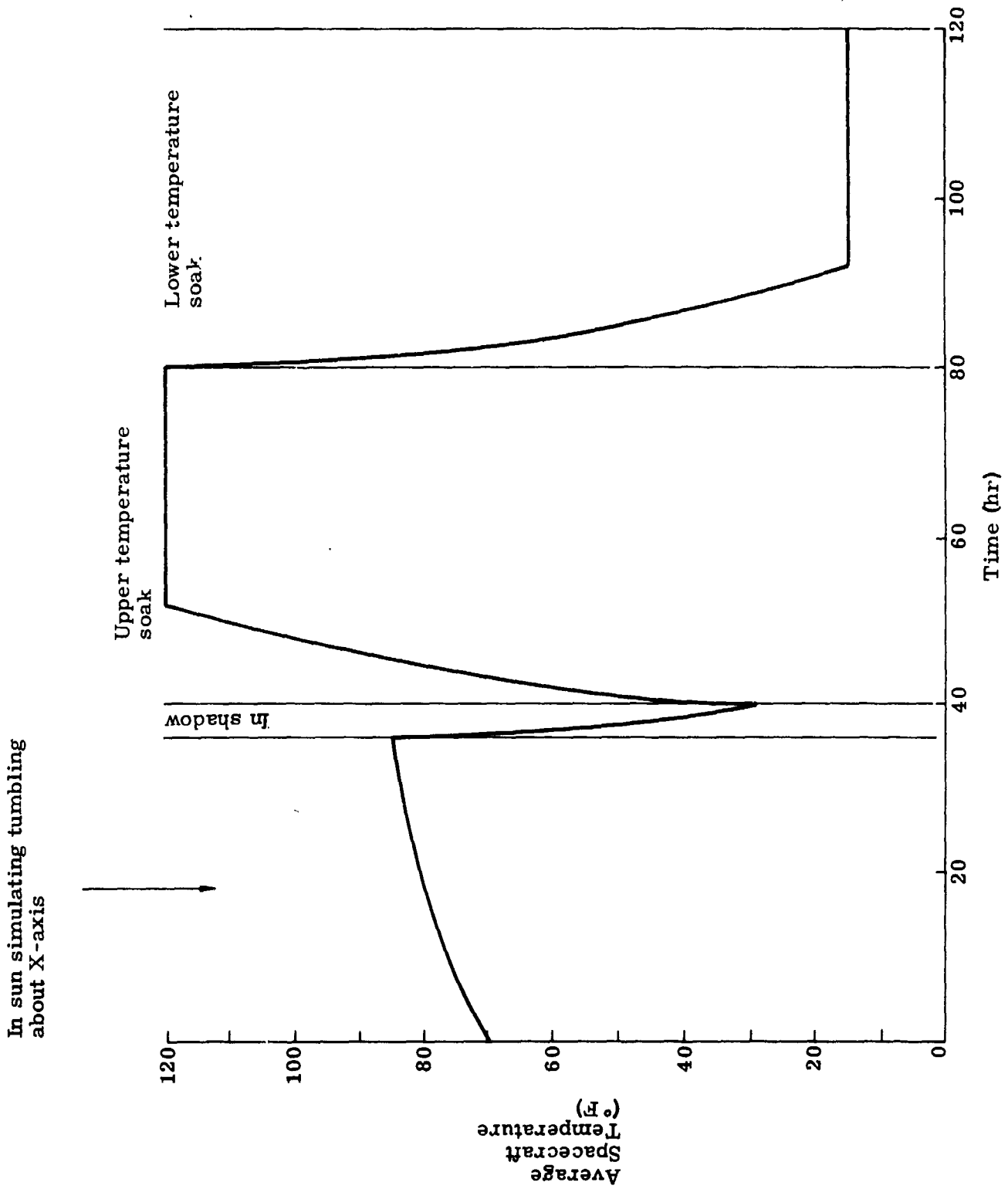

Fig. II-7. Thermal Profile for Spacecraft Flight Acceptance Test

(6) Spacecraft flight acceptance test

Each flight spacecraft should be subjected to the tests (Fig. II-8 for particular environments) outlined in Section 4 to demonstrate the inherent strength of each flight spacecraft. Levels used throughout this phase of the program will be equal to 100% of those expected in flight. A complete systems operational test, including deployment, should be conducted in the thermal vacuum environment.

(7) Launch site integration and checkout

After receiving inspection is performed to ensure no damage due to shipment, a system functional checkout using the appropriate AGE will be conducted. This should not include performing a systems deployment operation in a simulated zero-g environment, although a circuit continuity check of the pyrotechnic system used for deployment should be conducted at this time. After all preliminary checks are complete, the spacecraft should be mated to the Agena vehicle for electro-interference and compatibility checks. The shroud will be installed and the launch countdown should proceed with the spacecraft monitored using the associated AGE equipment.

d. Conclusions

Components and materials selected for use on the spacecraft program should be those that reflect a history of reliable usage in previous successful programs. The program should be initiated and accomplished using the theme "Reliability by design rather than test." Extensive testing on the component and subsystem level as well as use of an electrical test model permits timely modification where required.

The environmental test program has been designed to provide the most comprehensive evaluation of the overall spacecraft design within the limits of the program schedule. The qualification test program performed on prototype components and finally on a prototype spacecraft enhances the reliability of the finished product. The acceptance test serves to uncover any latent design or manufacturing defects which may develop during assembly of the components into a completed spacecraft.

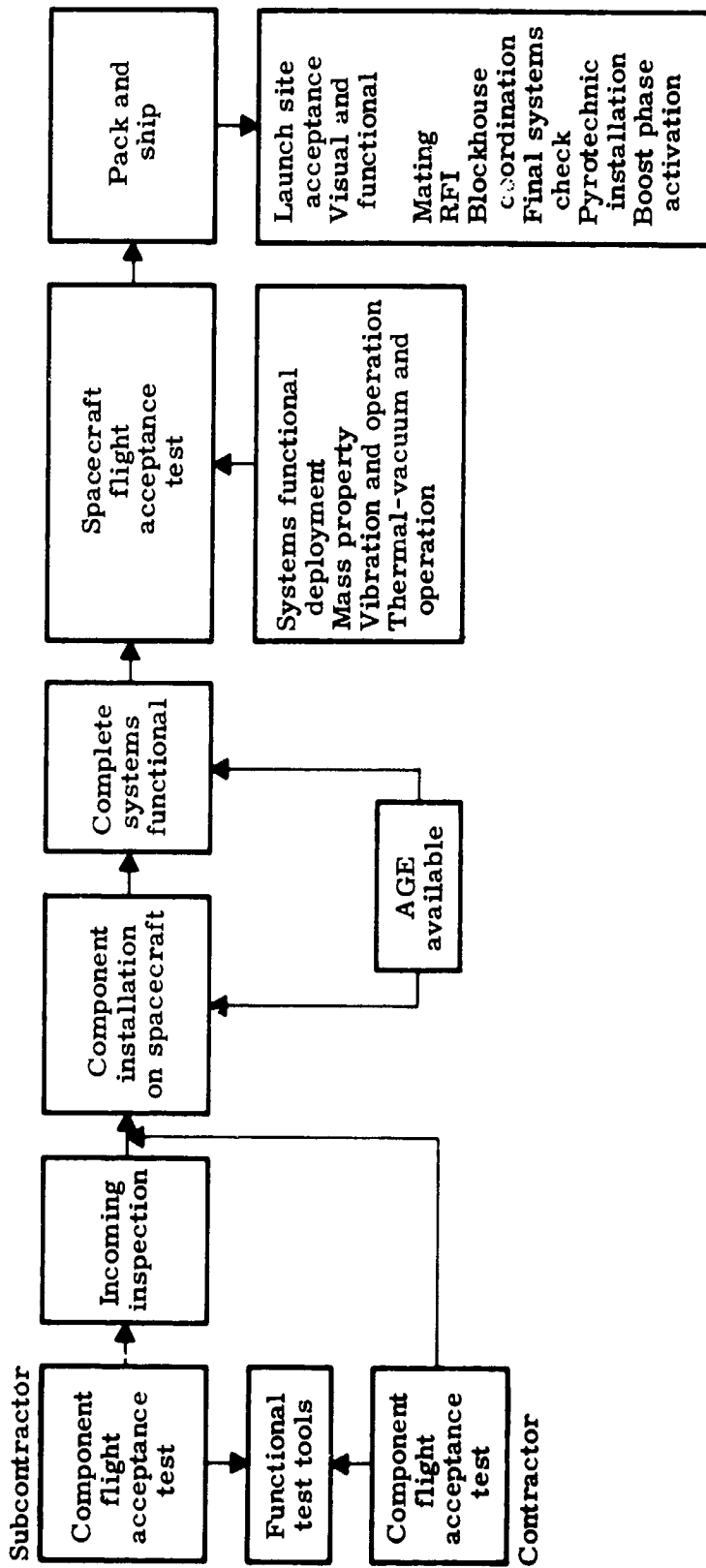

Fig. II-8. Flow Diagram Spacecraft Flight Acceptance Test Program

**IIC. AEROSPACE GROUND EQUIPMENT**

**John Colarusso**

## C. AEROSPACE GROUND EQUIPMENT

### 1. Requirements of AGE Checkout Equipment

Complete, accurate and rapid checkout of the spacecraft at the subsystem and system level, both in-plant and at the launch site is the primary requirement of the ground checkout equipment. The equipment must provide for complete checkout of all spacecraft functions and operational modes with capabilities for command, reception and display of all responses. Provisions should be made for manual or tape entry of commands, and for analog and digital output display. In general, requirements which should be met by the checkout equipment are:

- (1) Provide command control of the spacecraft to exercise it through all operational modes.
- (2) Provide for reception decommutation and display of all signal data including quick-look diagnostic and scientific measurements.
- (3) Provide monitoring for specific parameters such as power output and spectrum of the spacecraft transmitters.
- (4) Provide an external power source simulating spacecraft power, and monitoring and control of the external power.
- (5) Provide for electrical simulation of micrometeoroid impacts.
- (6) Provide means for calibration and isolation of troubles within the spacecraft.
- (7) Provide a means for checkout and calibration of the AGE itself.
- (8) Provide flexibility to accommodate changes in the spacecraft or testing routine, including conversion to automatic test equipment.
- (9) Provide mobility and rack-mounting capability to permit movement between different test areas.

### 2. AGE Checkout System Summary

AGE checkout equipment will be used in all phases of spacecraft testing, from subsystem tests as each component is integrated into the electrical test model, to final system acceptance tests. Tests

will be conducted in accordance with test procedures evolved early in the program. A typical test layout which can be used either in an environmental chamber or in the test area under ambient conditions is shown in Fig. II-9.

All mission functions must be demonstrated in their proper operational sequence using the AGE for command, control and monitoring of spacecraft responses. Commands will be generated from the encoder and transmitted either by hardline or RF radiation. During initial systems integration, and whenever the command receiver-decoder is not an integral part of the spacecraft, a hardline switching command system will be used which will consist of appropriate switching connected via the hardline to the spacecraft decoder output.

Spacecraft transmitter outputs will be routed to the ground station receivers through directional couplers and appropriate attenuation. This method assures a signal level at the receiver comparable to that normally expected during the mission, and allows continuous monitoring of the transmitter power output and spectrum. This is especially valuable, since it will result in a reasonable history of spacecraft performance.

Telemetry receiver outputs will be fed to a magnetic tape recorder, the primary storage device of all received data. This results in a permanent record of all data for later playback and comparison of test results. For checkout purposes, recording at the post-detection output will be adequate. The received signal spectrums will be displayed on a telemetry display unit affording visual indication of the receiver input signal.

After demodulation, the PCM wave train is fed to the PCM decommutation system in which bit synchronization and signal conditioning are accomplished. A master clock signal is developed from incoming data with the frequency equal to the incoming bit rate and phase coherent with the serial bit transitions. The signal, which contains noise and is hardly ideal for processing, is reconditioned for efficient handling by the rest of the system. This regenerated output is correlated in the frame sync recognizer to establish a reference for data decommutation. Correlation is accomplished by comparing the incoming data to a fixed sync data format. Upon frame sync acquisition, a serial-to-parallel conversion is performed. Subframe sync is obtained in a similar manner. The decommutator processes selected portions of the data for digital display and for further processing by digital-to-analog converters.

The outputs of the digital-to-analog converters will drive strip chart recorders and oscillographs, both for quick look display and for subsystem data analysis. Computer data processing is not anticipated at this time, but may be at a later date with the addition of a format converter feeding a digital tape recorder.

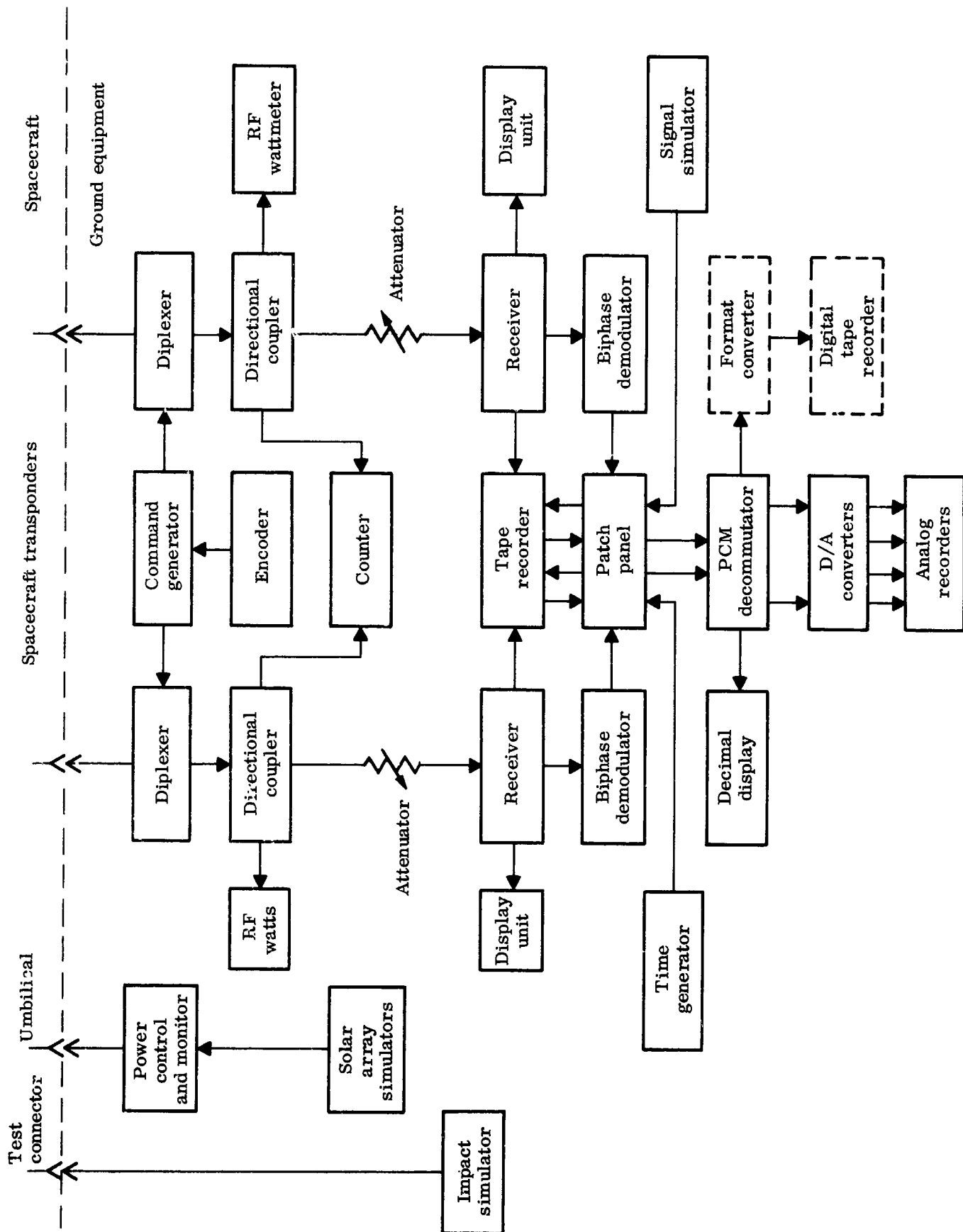

Fig. II-9. Typical Test Layout

### 3. Checkout Equipment

The major portion of the AGE, the checkout equipment, will be mounted in standard racks and housed within an air-conditioned van. The instrumented van will allow the same equipment configuration to be used no matter where the test site may be. As the spacecraft is moved between areas within the plant, or moved to any test facility outside the plant (as for the thermal/vacuum tests) the van will also be moved to the test location. Thus, same equipment and cabling will always be used, resulting in more coherent testing and a minimum of doubts due to test equipment changes. The mobility afforded by the van will be especially valuable at the launch site where the van can be positioned at the assembly area, other facilities and finally located strategically at or near the pad for optimum performance during launch operations.

#### a. Test stands

The test stands are illustrated in Fig. II-10. Components are mounted in standard 19-inch racks, removable for use in bench operation when desired. Racks are shock mounted and conditioned by airflow through base ducts. Overhead troughs will contain all cables and interconnections between racks. Racks can be classified according to their functional usage as:

- (1) Command control rack
- (2) Power control and monitor rack
- (3) Signal handling rack
- (4) PCM decommutation rack
- (5) Recording racks.

A brief description of the major components of each of these racks follows:

#### (1) Command control rack

Command encoder. The tone digital command format required by the spacecraft is generated by the command encoder. The format will consist of 8-bit PCM/AM digital address and execute commands which will modulate a command transmitter. Command codes can be automatically entered using a five-level punched paper tape and a tape reader. Manual entry of address and command codes is also provided. Each code is set up with four switches: two for address and two for command.

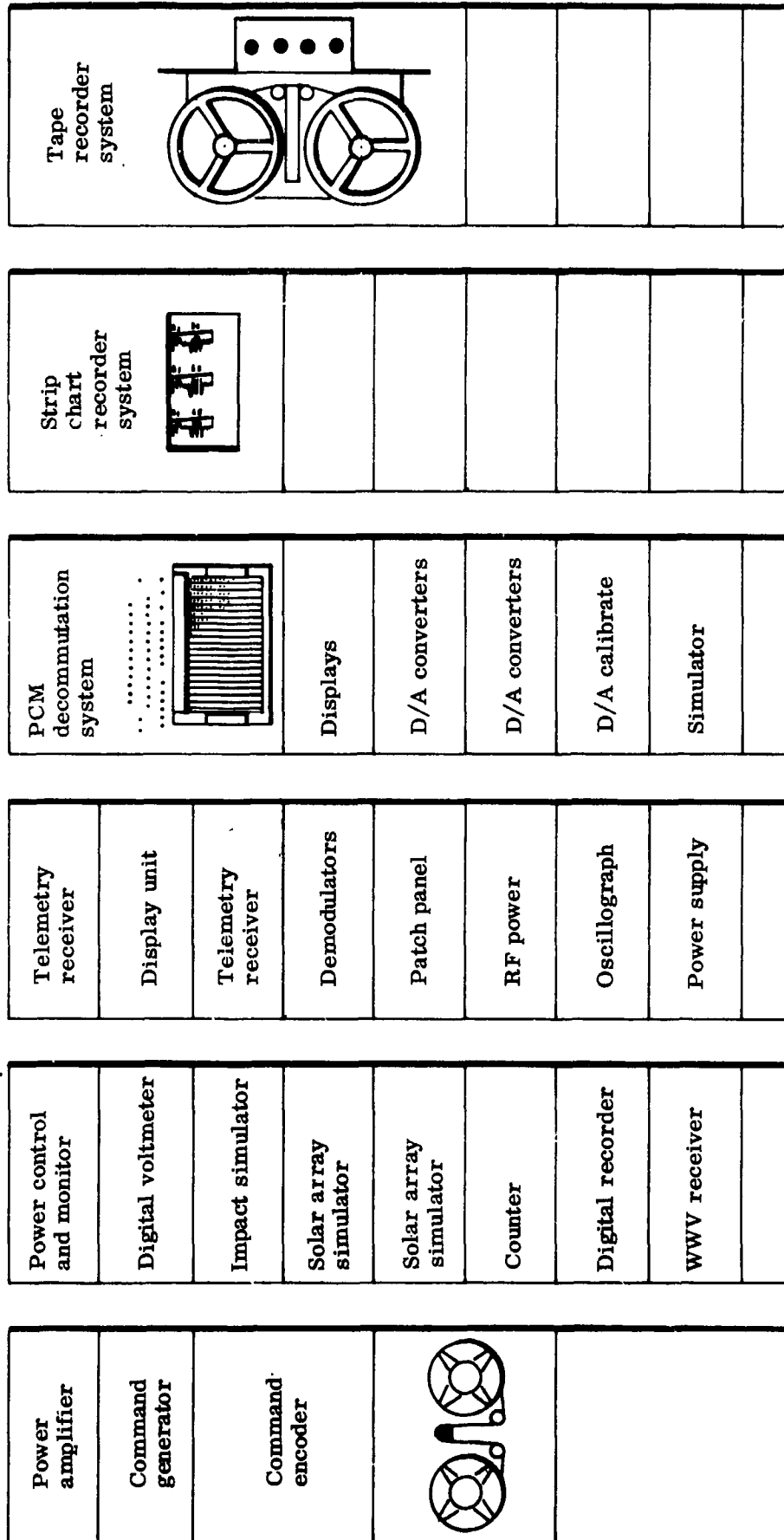

Fig. II-10. Test Stands

The tape reader allows for more rapid checkout, generating up to 70 valid and 180 invalid codes for extensive decoder analysis. The command encoder can be directly coupled to the spacecraft decoder, bypassing the RF link whenever advantageous. This may be desirable whenever the spacecraft receiver is either nonoperative, or not available for integration onto the spacecraft. It will also serve to isolate command problems or faults between the receiver and the decoder. A block diagram of the encoder is shown in Fig. II-11.

Command transmitter. The command generator and power amplifier are the RF portion of the command system. The command generator is a general purpose signal generator which will deliver sufficient energy for hardline coupling to the spacecraft. A Hewlett Packard 608 or similar unit would have the required characteristics. If, during any test phase, greater power is required (as may be the case at the launch site where the van may be positioned at a distance from the launch pad), the signal generator output will be amplified to about five watts by a power amplifier, such as a Boonton Radio Co. model 230-A. This amplified output can be fed hardline or, when desired, feed an eleven element Yagi antenna mounted on the van and positioned by an antenna rotator.

## (2) Power control and monitor rack

Power control and monitor panel. Accessibility to the power input lines of the spacecraft subsystems is provided through the turn-on test connector. Wiring between the test connector and the various components is a permanent part of the system harness, and the test connector is an integral part of the spacecraft. During all ambient testing, and whenever permissible in a test chamber, a test cable will run between the test connector and the power control and monitor panel. This panel will terminate the individual power input lines through panel-mounted ammeters, switches and fuses. Whenever this arrangement is not permissible, the turn-on shorting plug will be inserted at the connector.

The power control and monitor panel will permit continued monitoring of one important parameter of the component involved (the input power characteristics) allow individual on-off switching for certain types of fault isolation (and location of noise sources), and permit a general status decision. Each input current line monitored will automatically afford a voltage monitoring point. These points will be made available through a switch to a panel-mounted voltmeter for monitoring.

External power from the solar array simulators will be routed through the power control and monitor panel to the spacecraft umbilical connector allowing complete control of power at this panel. Any hardline commands, such as "start deployment timer," will originate at this panel and feed through the umbilical.

Impact simulator. Checkout of the complete spacecraft system requires stimulation of the various sensors. The simulation of micrometeoroid impacts or penetrations varies with the type sensor involved.

Since the capacitance panels when mounted to the spacecraft cannot easily be penetrated by any physical means that realistically simulates the mass and velocity of micrometeoroids, it is logical to simulate the capacitive discharge by momentarily shorting across the panel at the panel connector. During developmental testing on the electrical test model and whenever feasible on the prototype and flight models, an in-line test connector with shorting switch can be used to produce the momentary short. This is a simple method of inducing an input to the rest of the spacecraft system. The disadvantage to this method of checkout is the time needed to check all panels. A faster method would involve an electronic switching device to rapidly short each panel. This, however, would entail a cumbersome cabling harness and connectors for test purposes only. The disadvantage of this method is obvious and argues for the manual method which results in a simpler, more reliable system harness.

Shorting of a panel for a prolonged period will in effect simulate a shorted or inoperative panel and can be used as a check on the effective panel area as indicated in the corresponding telemetry word format. Prolonged shorts across the panel will also check capacitor panel charge supply capabilities.

Whenever the capacitance panels are not on the spacecraft or when testing the electronics module alone, a simulated signal will be supplied. This signal will be generated by an external RC charging network simulating the panel capacitance, charge limiting resistance and supply. The pulsed discharge will be fed directly to the signal conditioners to simulate a penetration. The resulting data handling and transmission of the "hit" will be observed on the appropriate readout device at the ground checkout station. External noise simulating radiation discharge will be introduced to check the signal conditioner's discrimination action.

The Exotech sensors, mounted within the capacitance panel frames, are IR sensitive devices, and can be stimulated by any source containing sufficient IR energy. These sensors will be excited by flashing a photoflash-type lamp through the appropriate "peep hole." The

telemetry format will be monitored for proper indication of sensor bay number and cumulative hit count. Discrimination against low frequency inputs will also be checked. As explained before, with no panel assembly available, a simulated hit will be generated and fed to the appropriate signal conditioner input.

The Mariner and velocity gauges will be checked out in accordance with procedures already developed for these GFE items, and use supplied GFE test equipment.

The aspect sensors and magnetometers will be stimulated by accurately positioned light and magnetic sources. The spacecraft will then be rotated through calibrated angles and the format word output monitored for correspondence to the known angles. Should it be determined more feasible, the stimuli could be rotated about the fixed spacecraft.

Solar array simulators. Since solar arrays and batteries will not be used for powering the spacecraft during the greater part of testing, power must be supplied from an external source. Ground checkout equipment will include two external power supplies having characteristics similar to those of the spacecraft arrays and batteries.

The DC power supply will be a 0-to 80-volt, 0-to 5-amp supply similar to the Sorensen DCR 80-5. This supply, in series with an appropriate resistor to simulate the output impedance of the solar arrays will be fed through the power control and monitor panel and to the umbilical. Whenever cycling is required, to simulate sunlight/shadow periods, a recycle timer will be used to program output voltage. The regulated supply will have controls with which the output voltage can be varied between expected upper and lower limits. This will be used in determining variations in system parameters with voltage supply variations.

General usage test equipment. The rest of the rack will contain general purpose test equipment for use in all phases of testing. Components, with suggested model numbers, are:

- (1) Digital voltmeter - - Hewlett Packard 405CR
- (2) Electronic counter - - Hewlett Packard 5243L
- (3) Digital recorder - - Hewlett Packard 561
- (4) WWV Receiver - - Beckman 905

## (3) Signal handling rack

Telemetry receivers. Two 136- to 137-mc receivers with a phase-locked loop around the entire receiver will provide phase demodulation of the received signal. A Defense Electronics TMR-6 could be used. With this receiver, the first local oscillator is voltage controlled, providing doppler tracking over a  $\pm 10$ kc range. The phase detector compares the instantaneous phase of the translated received signal with a crystal-controlled reference oscillator and frequency-locks the first local oscillator. The loop bandwidth is adjustable from 50 to 500 cps.

Telemetry display unit. The telemetry display unit provides a spectrum display of either receiver's input signals. A unit similar to Defense Electronics TDU-3 would provide this display.

Biphase demodulators. Similar to Defense Electronics Model TSD-1.

Patch panel. The patch panel will contain terminations for receivers, recorders, D/A converters, WWV receiver, PCM decommutation system and command transmitter, providing flexibility in selecting and inter-connecting various equipments.

Test equipment. Test equipment which the rack will contain in addition to the above are:

- (1) RF power equipment, including attenuators, couplers and wattmeters.
  - (2) Oscillograph: A high frequency recording oscillograph similar to the Consolidated Electrodynamics Type 5-124.
  - (3) Power Supply: A general purpose DC regulated supply similar to the Sorensen DCR 80-5.
- (4) PCM decommutation rack.

The PCM decommutation System is the heart of the checkout equipment, receiving the serial bit train from the demodulators and delivering for display any word in the format. A system that could be used would be the Telemetrics 620 (Figs. II-9 and II-12). Following is a brief description of the units involved:

Bit synchronizer. This unit accepts the serial PCM data train and provides a regenerated PCM serial data train and clock pulses which are synchronous in frequency and phase with the input PCM signal. Signal regeneration includes adjusting to the level of the input signal, correcting for polarity, filtering the noise, compensating for baseline shift, and producing a clean squared signal for the rest of the system.

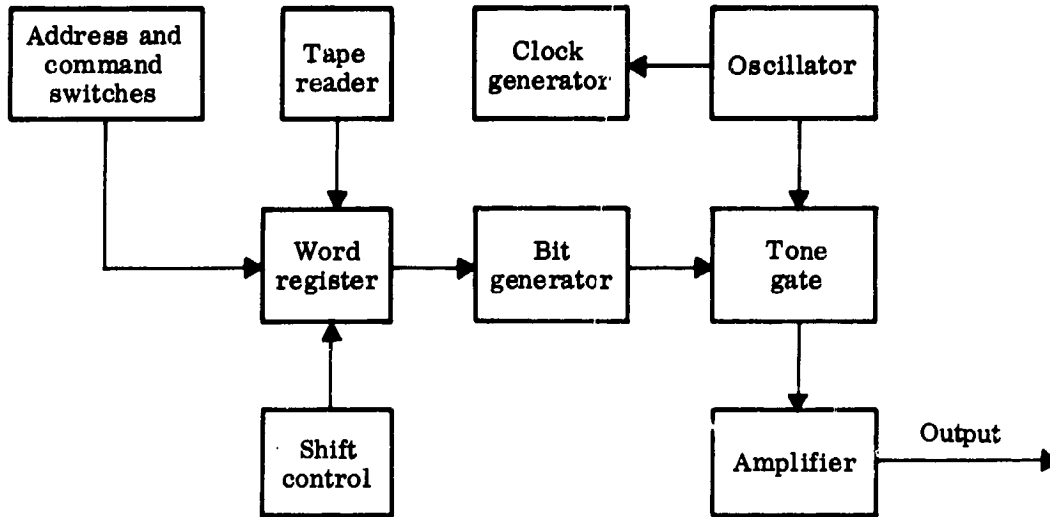

Fig. II-11. Encoder Block Diagram

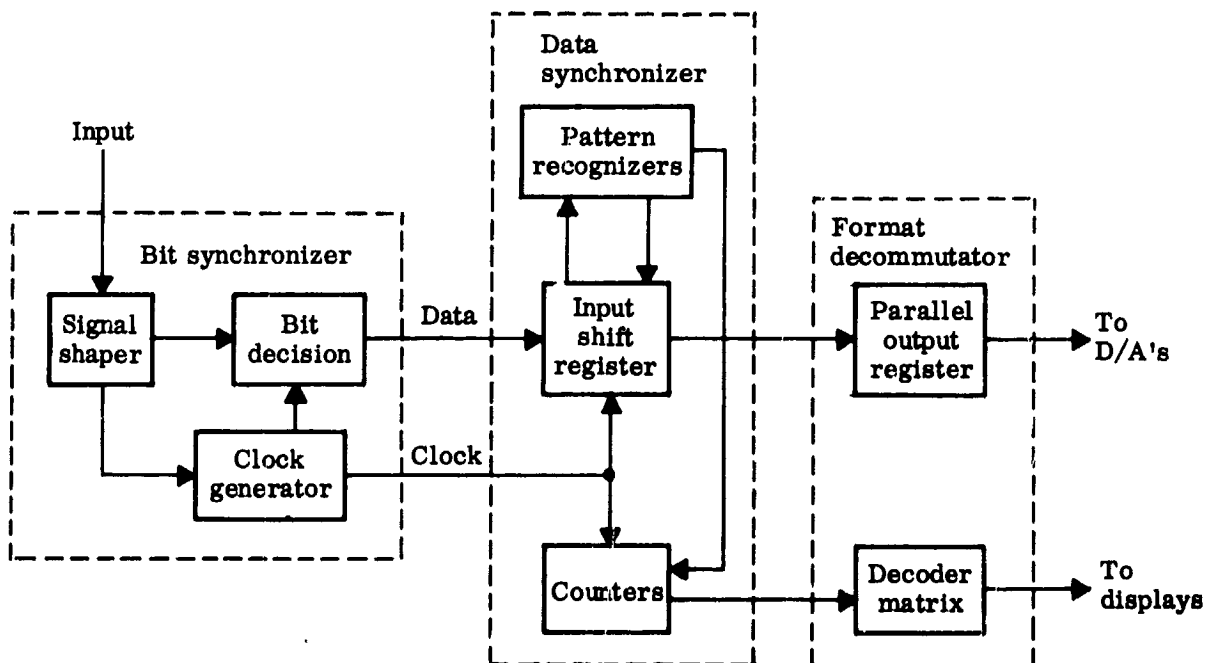

Fig. II-12. PCM Decommulation System

Data synchronizer. The regenerated PCM data train, along with the clock pulses, are fed to the data synchronizer which establishes frame and subframe synchronization and provides data words in parallel form and word, frame and subframe counts for identification purposes. A patchboard on the front of the unit provides for handling the particular telemetry format involved. Preprogrammed patchboards permit a change in format to be handled quickly. Functions that can be programmed at the patchboard include word length, frame length, subframe lengths and sync patterns.

Format decommutator. This unit provides parallel output data and makes available a sync pulse for each word time in the format. Inputs from the data synchronizer in parallel form include data and binary count pulses for frame and subframe. A converter within the format decommutator provides word time pulses for each word in the format. These pulses are available at the patchboard on the unit.

Digital-to-analog converters. The word time pulses are used to gate the data words into the digital-to-analog converters, whose analog output will be available at the main patchpanel for coupling to selected recorders. Two assemblies of 10 converters each will provide 20 analog outputs.

Decimal display. Any data word in the format may be selected at the format decommutator patchboard for direct decimal viewing. The decimal display is of the projection type, decoding the binary word into units, tens and hundreds.

D/A Calibrator. This unit supplies operating power to the 20 digital-to-analog converter. In addition, calibrated levels are supplied to the converters for adjustment and checkout. During operation any selected converter input can be displayed on the digital display lamps on the unit.

Signal simulator. The simulator provides an input signal to the PCM decommutation system simulating the spacecraft format, or any format desired, to evaluate, checkout and calibrate the decommutation system. The simulator serves as a valuable tool in isolating problems between the spacecraft and the checkout equipment.

#### (5) Recording racks

Recording racks are composed of a magnetic tape recorder and an eight-channel strip chart recorder. The prime recording medium is the magnetic-recorder, recording at the post detection output of the receivers. This will result in a permanent record of all test data for playback and analysis when desired. A seven-track recorder such as a MINCOM C-107 should be used. Receiver outputs will be recorded on two tracks; time from a WWV receiver on a third track; and voice commentary on a fourth track. All seven record-reproduce channels will terminate at the patchpanel.

The strip chart recorders, of which the Sanborn 850 is representative, provide analog recording and quick-look capabilities necessary during all test phases. All recorder inputs will be selected at the patchpanel. These recorders will be especially useful in monitoring critical diagnostic data.

b. Handling and shipping equipment

Throughout the program, from initial assembly of the spacecraft to transportation and handling at the launch site, various support items will be needed. These items have been included for cost purposes and are:

- (1) Shipping and handling frames for each pair of capacitance panels--described in Volume III, Chapter III.
- (2) Capacitance panel installation tool for mounting the capacitance panel within the frame--described in Volume III, Chapter III.
- (3) Handling sling for lifting and handling the assembled spacecraft.
- (4) System test mount--a wheeled dolly with gimbaled mount for the spacecraft, permitting working access to the spacecraft.
- (5) Protective covers--polyethelene bags which cover the overall structure to protect the spacecraft from foreign matter when stored.
- (6) Shipping containers-- shock-isolated reinforced container to house the assembled spacecraft during transportation to any distant test facility and to the launch site.

## PROJECTED FUNDING PLAN

The Prime Contractors total cost for the Micrometeoroid Program is \$15,654,299.

The following requirements have not been included in the above price.

Atlas-Agena Boosters  
 Booster Launch Support  
 Agena Payload Shroud  
 Interface Master Gauge  
 NASA Redesigned  
   Beacon and Data Transmitter  
   V.H.F. Transponder  
 NASA Modified  
   Mariner Gauge  
   Mariner Electronics  
   Velocity Gauge

The costs by element for each system/function is shown on page III-2.

Quarterly funding requirements on a liability basis is shown on page III-9.

An additional spacecraft, including launch support with a span of three months between launches, would add \$1,420,000 to the previously stated total cost.

Basis for Estimated Cost

Labor costs were estimated for each of the elements based on a description of the requirements as defined by the technical personnel. Correlation of the estimates with historical costs of previous programs, both internal and external to the contractor, was accomplished. The resultant hours were costed utilizing Martin-Baltimore projected labor rates and overhead burdens.

The material costs were generated, from a "Bill of Material" established by the technical team, using vendor data files, vendor catalogs and budgetary quotations for major items.

Other Direct Costs consists of travel, computer usage, consultant charges, printing costs and test facility rental.

Spares have been allocated on the basis of Manufacturing costs for one unit; Structural items- 5%, Systems items- 20% and A.G.E.- 10%.

	<u>Engr.</u> <u>Hours</u>	<u>Rate</u>	<u>Engineering</u> <u>Labor</u> <u>Dollars</u>
Spacecraft			
Program Mgm't., Document. & Reports	83,592	6.94	580,128
Structure, Mechanisms & Thermal Control	52,974	5.85	309,898
Data Acquisition (Sensors)	11,664	5.85	68,234
Attitude Determination System	19,926	5.85	116,567
Communications	32,562	5.85	190,488
Data Handling & Instrumentation	48,114	5.85	281,467
Electrical Power & Distribution	18,954	5.85	110,881
System Mockups & Models	7,776	5.85	45,490
Systems Integration- S/C, S/C & Vehicle	36,450	5.85	213,233
Reliability and Quality Assurance	26,244	5.85	153,527
Test Program	94,284	5.30	499,705
AGE			
Electrical and Electronics	30,618	5.85	179,115
Mechanical	7,776	5.85	45,490
Launch Operations	18,468	5.85	108,038
Spares			
TOTAL	489,402		2,902,261

\* Average Rate per hour.

BREAKDOWN BY ELEMENT

Engineering Overhead <u>100%</u>	Tlg. Hours	Tlg. Labor Dollars <u>4.06 *</u>	Tlg. Overhead <u>125%</u>	Mfg. Hours	Mfg. Labor Dollars <u>3.28 *</u>	Mfg. Overhead <u>125%</u>	Quality Hours	Qua Lab Dol <u>4.0</u>
580,128				6,124	20,087	25,109		
309,898	16,200	65,772	82,215	20,376	66,833	83,541		
68,234	1,944	7,893	9,866	3,735	12,251	15,314		
116,567	810	3,289	4,111	1,440	4,723	5,904		
190,488	2,268	9,208	11,510	4,725	15,498	19,373		
281,467	10,530	42,752	53,440	25,392	83,286	104,108		
110,881	1,134	4,604	5,755	1,845	6,052	7,565		
45,490				19,760	64,813	81,016		
213,233	1,620	6,577	8,221	1,296	4,251	5,314		
153,527							50,767	203
499,705				37,717	123,712	154,640		
179,115	972	3,946	4,933	2,232	7,321	9,151		
45,490	1,296	5,262	6,578	4,334	14,216	17,770		
108,038								
				3,472	11,388	14,235		
1,902,261	36,774	149,303	186,629	132,448	434,431	543,040	50,767	203,

2

ity r ars *	Quality Overhead 125%	Material and Procurement	Other Direct Costs	Subtotal Dollars	G & A 18%	Total Cost	Incentive Fee 10%	Total CPIF
			62,694	1,268,146	228,266	1,496,412	149,641	1,646,053
		46,671	48,435	1,013,263	182,387	1,195,650	119,565	1,315,215
		612,434	9,836	804,062	144,731	948,793	94,879	1,043,672
		269,396	36,705	557,262	100,307	657,569	65,756	723,325
		144,393	24,422	605,380	108,968	714,348	71,434	785,782
		471,864	36,086	1,354,470	243,805	1,598,275	159,827	1,758,102
		585,193	14,216	845,147	152,126	997,273	99,727	1,097,000
		344,381	5,832	587,022	105,664	692,686	69,268	761,954
		1,100	50,186	502,115	90,381	592,496	59,249	651,745
068	253,835		19,683	783,640	141,055	924,695	92,469	1,017,164
		495,348	535,710	2,308,820	415,588	2,724,408	272,440	2,996,848
		437,340	22,964	843,885	151,899	995,784	99,578	1,095,362
		13,785	5,832	154,423	27,796	182,219	18,221	200,440
			13,851	229,927	41,387	271,314	27,131	298,445
		177,145		202,768	36,498	239,266	23,926	263,192
068	253,835	3,599,050	886,452	12,060,330	2,170,858	14,231,188	1,423,111	15,654,299

3

## MATERIAL AND PROCUREMENT BREAKDOWN

	<u>Quantity</u>	<u>Total Cost</u>
<u>Structure, Mechanisms and Thermal Control</u>		
Aluminum sheet, plate and bar stock		\$ 14,163
Aluminum tubing, channel and extrusions		2,613
Aluminum honeycomb		2,571
Steel plate and bar stock		2,856
Explosive devices, separation bolts, cord cutters		6,099
Special springs and associated equipment		3,228
Adhesives, primes and curing agents		543
Thermal coatings, paint and lacquers		420
Tool material and standards		9,843
Globe motors and gear boxes	24	<u>4,335</u>
Total Structure, Mechanisms and Thermal Control		\$ 46,671
<u>Data Acquisition (Sensors)</u>		
Capacitor Panel		
.001" thickness	72	
.002" thickness	144	\$ 216,000
Tooling charges		75,750
G. T. Schjeldahl Co.		
Hall Pack Detector & Flux Concentrator	198	4,831
F. W. Bell, Inc.		
Seventy-two channel sensor system	3	270,000
Exotech Inc.		
Thermistors	72	3,744
Temperature sensors	18	1,350
Subminiature Dual Voltage Regulator	12	5,760
Subminiature Differential Low Level Amplifier	24	10,200
Microswitch	54	1,080
Precision resistors	240	12,000
Electronic components		9,192
Transistors, diodes, capacitors, etc.		
Tool material, raw material and standards		<u>2,527</u>
Total Data Acquisition (Sensors)		\$ 612,434
<u>Attitude Determination</u>		
Infrared Attitude Sensing System	3	\$ 203,000
Barnes Engineering		
Solar Aspect Sensor System	3	57,060
Adcole Corp.		
Fluxgate Magnetometer Coil Unit	18	9,135
Raw material and standards		<u>201</u>
Total Attitude Determination		\$ 269,396

	<u>Quantity</u>	<u>Total Cost</u>
<u>Communications</u>		
Hybrid and Diplexer Assembly Rantec Corp.	3	\$ 24,780
Command Decoder Consolidated Systems Corp.	6	106,800
Electronic Components Transistors, diodes, capacitors, etc.		7,671
Tool material, raw material and standards		<u>5,142</u>
Total Communications		\$ 144,393
<u>Data Handling and Instrumentation</u>		
Memory Unit Electronic Memories, Inc.	9	\$ 221,250
Analog to Digital Converter International Data Systems	3	19,500
Killer Timer Raymond Engineering	6	7,200
Deployment Timer Raymond Engineering	6	7,200
Fairchild Semiconductor Diode-Transistor Micrologic Units		
F.F. DTnL 931 series	3,828	95,700
Dual Gate DTnL 930 series	2,232	44,640
Electronic Components Transistors, diodes, resistors, capacitors, etc.		56,670
Tool material, raw material and standards		<u>19,704</u>
Total Data Handling and Instrumentation		\$ 471,864
<u>Electrical Power and Distribution</u>		
Solar cell panels (cells and installation) Hoffman Electronics Corp.	36	\$ 480,924
Nickel Cadmium Batteries Non-recurring Engineering Gulton Industries, Inc.	6	72,200 2,200
D.C. Converters ITT Industrial Products Division	6	14,145
Voltage Regulator Non-recurring engineering	3	2,700 10,000
Thermal Batteries Catalyst Research Inc.	6	750
Electronic Components Diodes, resistors, transistors, etc.		864
Raw material and standards		<u>1,410</u>
Total Electrical Power and Distribution		\$ 585,193

	<u>Quantity</u>	<u>Total Cost</u>
<u>System Mock-ups and Models</u>		
Electrical Mock-up - Complete unit except exclusions noted		
Structure, Mechanisms and Thermal Control Complete structure, excluding capacitor and solar panels		\$ 9,659
Data Acquisition (Sensors) Excludes capacitor sensors and seventy two channel sensor system		14,524
Attitude Determination Complete system		89,732
Communications Complete system		47,085
Data Handling and Instrumentation Complete Systems		152,836
Electrical Power and Distribution Excludes solar cells		29,879
Thermal Model - One sixth scale model of structure with thermal coatings		<u>666</u>
Total System Mock-ups and Models		\$ 344,381
<u>System Integration- S/C, S/C and Vehicle</u>		
Plant Arrangement Material		\$ 1,100
<u>Test Program</u>		
Capacitor test panels		\$ 29,250
Solar cell test panel		13,359
Aluminum sheet, plate and bar stock		4,668
Aluminum tubing, channel and extrusions		1,042
Aluminum jig plate		1,959
Steel plate and bar stock		5,458
Steel pipe, channel and angle iron		5,206
Lumber and plywood		2,534
Eyebolts, sleeves, eyelets and steel cable		338
Explosive devices, separation bolts and cutters		806
Miscellaneous hardware, helicoils, screws, clamps, etc.		1,859
Thermal coatings, paints and lacquers		110
Electrical equipment, components, shielded cable and wire		4,567

<u>Test Program (Continued)</u>	<u>Quantity</u>	<u>Total Cost</u>
Battery test cells		\$ 10,648
Load cells		1,500
Motors, gears, gear tracks and bearings		1,537
Universal transfer dollies		5,900
Oscillograph paper, Sandborn chart paper and magnetic tape		2,824
Liquid Nitrogen fuel for chamber test		18,748
 Qualification Test Components		
Data Acquisition (sensors)		55,078
Attitude Determination		6,090
Communications		32,896
Data handling and Instrumentation		242,372
Electrical Power		<u>46,599</u>
 Total Test Program		 \$ 495,348

AGE (Electrical and Electronics)

Telemetry Receiver with phase demodular and tunnel head, TMR-6, PMD-A6, TMH-A6A Defense Electronics	4	12,600
Telemetry Display TDV-3 Defense Electronics	2	1,590
Tape recorder C-107 Minn. Mining	2	28,926
PCM Decommutation system-620 Telemetry, Inc.	2	110,000
Digital to analog converter-6210 Telemetry, Inc.	4	18,000
DAC Calibrator-6206 Telemetry, Inc.	2	9,000
Signal Simulator -503 Telemetry, Inc.	2	26,000
Decimal display Telemetry, Inc.	4	36,000
Sub-carrier discriminator Model GD-600, Vector	4	5,960
Strip chart recorder Sanborn 850	2	10,600
Recorder preamps Sanborn 850-1000	16	4,000
Oscillographic recorder CEC-5-124	2	4,780
Galvanometers CEC 7-300	36	5,760

	<u>Quantity</u>	<u>Total Cost</u>
<u>AGE (Electrical and Electronics) - (Continued)</u>		
Encoder Consolidated Systems Corp.	2	\$ 18,400
VHF Signal Generator 608D Hewlett Packard	2	2,520
Wide Range Oscillator 200CD Hewlett Packard	2	390
WWV Receiver 905 Becman Instruments	2	1,150
Counter 5243L Hewlett Packard	2	5,900
Frequency Converter 5253B Hewlett Packard	2	1,000
Time Interval unit 5262A Hewlett Packard	2	600
Digital Voltmeter 405CR Hewlett Packard	2	1,920
Digital Recorder 561 Hewlett Packard	2	2,270
Power Supply DCR 80-5 Sorenson	6	1,950
Recycle timer- CMXP Industrial Timer Corp.	4	500
Oscilloscope RM 35 Tektronix	2	4,000
Directional Coupler 305 NARDA	4	1,600
Attenuator 355D Hewlett Packard	4	500
Thru-line Wattmeter 43-10D Bird Electronics	4	500
Dummy loads 80-A Bird Electronics	4	120
R.F. Patch Panel JS-96B/JB Trompeter Electronics, Inc.	2	930
Patch Cord PCM-18-50 Trompeter Electronics, Inc.	100	54,600
Rack Frame FR 27A EMCOR	6	582
Side Panel SP 27A EMCOR	12	300
Rear Door DO 70B EMCOR	6	258
Top Panel PN 21 LV EMCOR	6	42
Console Dolly CD HR-S1-2421 EMCOR	6	300

	<u>Quantity</u>	<u>Total Cost</u>
<u>AGE (Electrical and Electronics) - (Continued)</u>		
Trailer	2	\$ 56,540
Dorsey Trailer Co.		
Power Amplifier 230A	2	2,400
Boonton Radio Co.		
Antenna and Rotator	2	202
D.C. Voltmeter, OH meter, ammeter	2	710
Electronic Components		3,050
Tool material, raw material and standards		<u>890</u>
 Total AGE (Electrical and Electronics)		 \$ 437,340
 <u>AGE (Mechanical)</u>		
Aluminum (bar, sheets, tubing)		\$ 1,692
Steel (bar, plate, extrusions)		1,705
Plastic phenolic		1,248
Covers (polyethylene, canvas)		1,570
Lumber and padding		562
Tool Material and miscellaneous hardware		1,471
Dollies	3	<u>5,537</u>
 Total AGE (Mechanical)		 \$ 13,785
 <u>Spares</u>		 <u>\$ 177,145</u>
 GRAND TOTAL		 \$ 3,599,050

QUARTERLY FUNDING

(Dollars in Thousands)

	1st Qtr.	2nd Qtr.	3rd Qtr.	4th Qtr.	5th Qtr.	6th Qtr.	7th Qtr.	8th Qtr.	Total
<b>Spacecraft</b>									
Program Mgm't., Document. & Reports	197	213	213	215	213	213	197	185	1,646
Structure, Mechanisms & Thermal Control	117	224	275	288	185	144	58	24	1,315
Data Acquisition (Sensors)	38	141	38	211	210	284	103	16	1,044
Attitude Determination System	54	92	69	138	123	161	69	17	723
Communications	67	132	112	136	118	133	64	24	786
Data Handling & Instrumentation	106	270	231	367	309	325	126	24	1,758
Electrical Power & Distribution	42	94	66	222	234	307	116	16	1,097
System Mockups & Models	44	291	386	18	8	8	7	-	762
Systems Integration- S/C, S/C & Vehicle	91	105	108	90	71	70	59	58	652
Reliability & Quality Assurance	88	159	171	163	142	131	93	70	1,017
Test Program	211	580	840	506	361	204	192	103	2,997
<b>AGE</b>									
Electrical & Electronics	23	65	360	352	105	88	62	40	1,095
Mechanical	8	19	69	53	34	17	-	-	200
Launch Operations	16	16	16	16	23	39	47	126	299
Spares	-	-	-	29	44	126	64	-	263
<b>TOTAL</b>	1,102	2,401	2,954	2,804	2,183	2,250	1,257	703	15,654
<b>CUMULATIVE</b>	1,102	3,503	6,457	9,261	11,444	13,694	14,951	15,654	

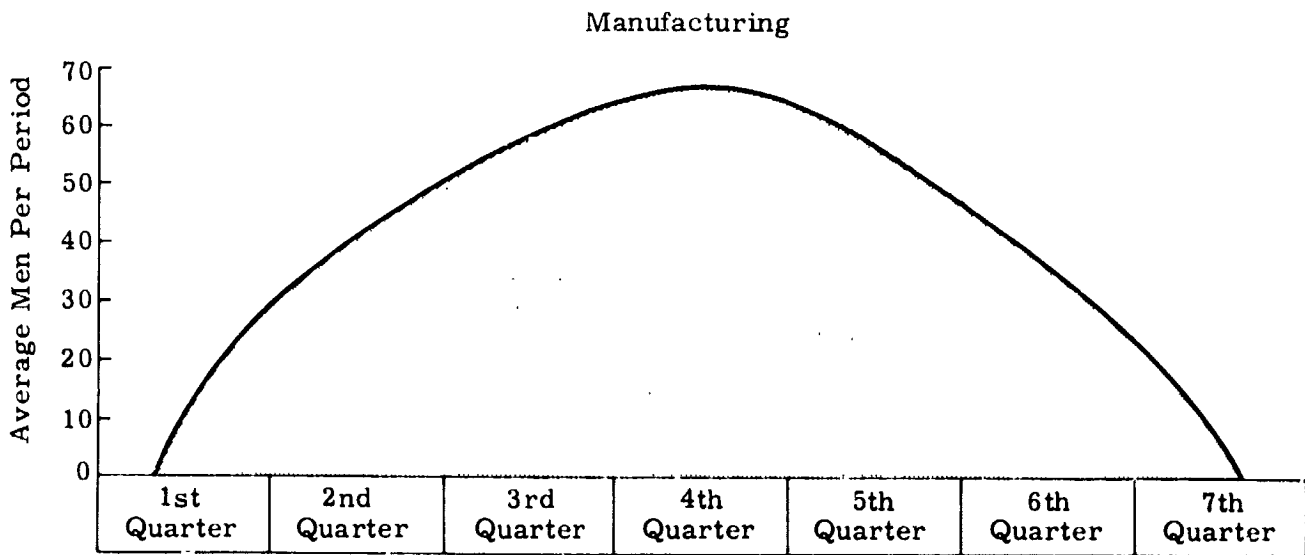
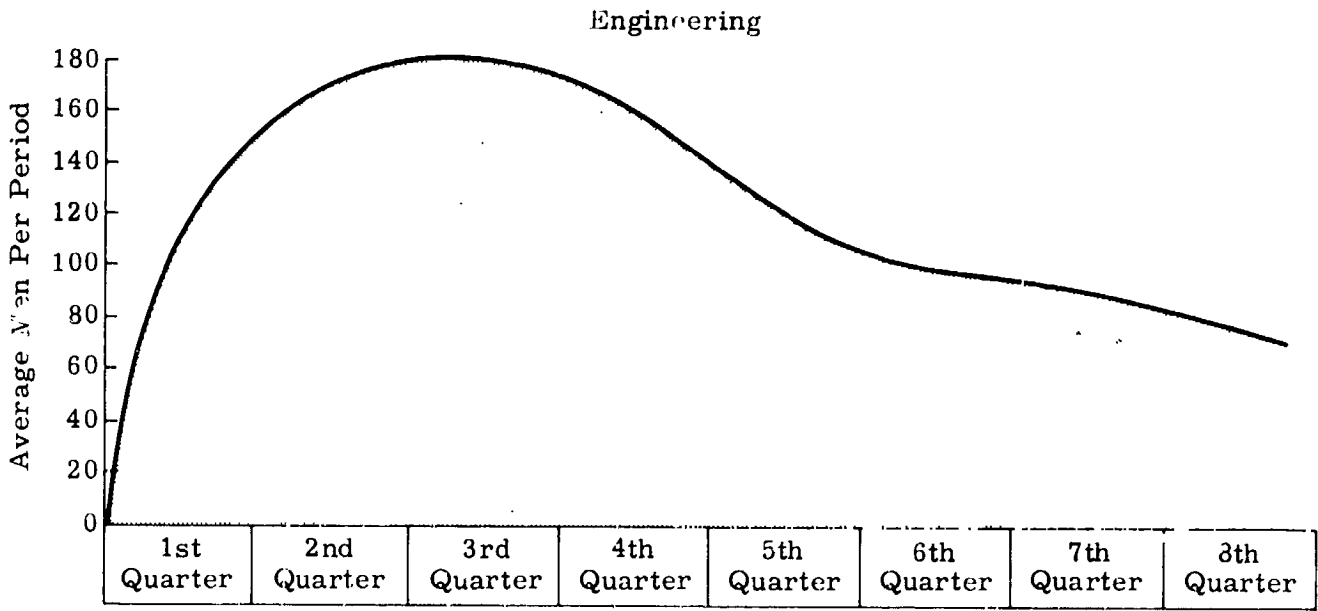

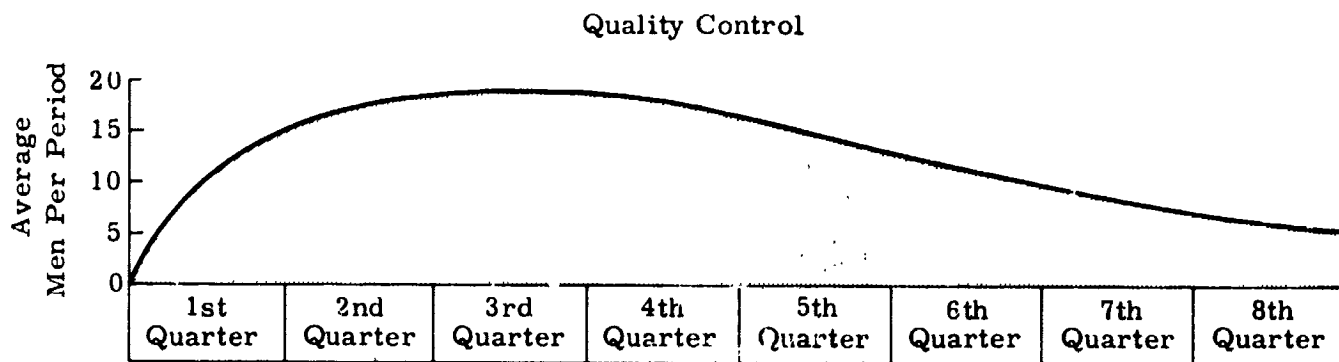
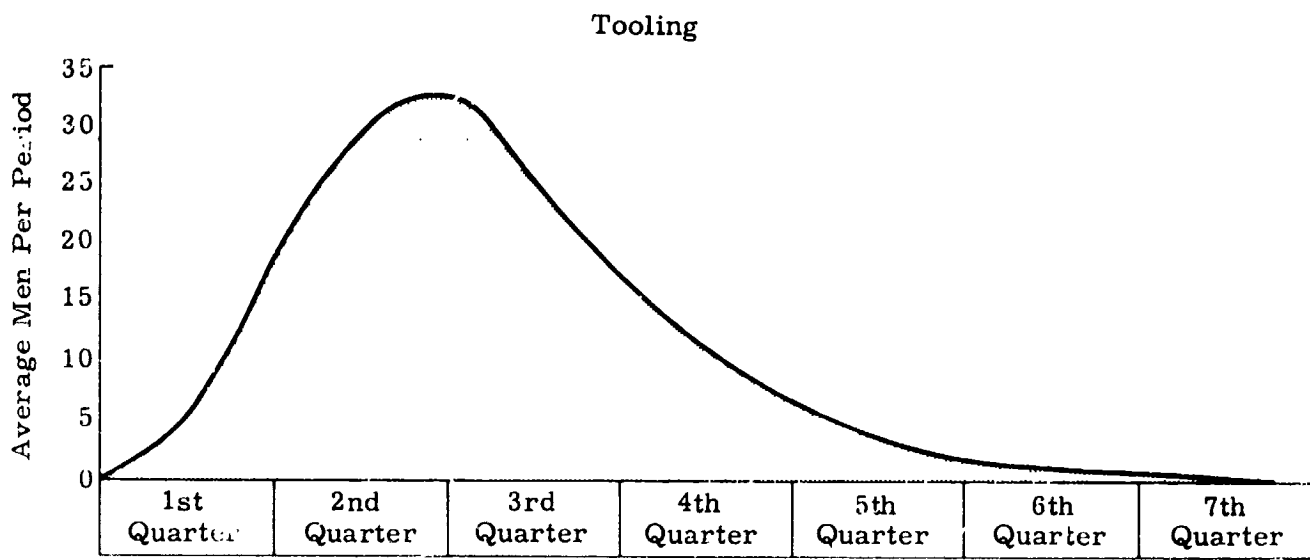

Fig. III-1. Anticipated Manpower

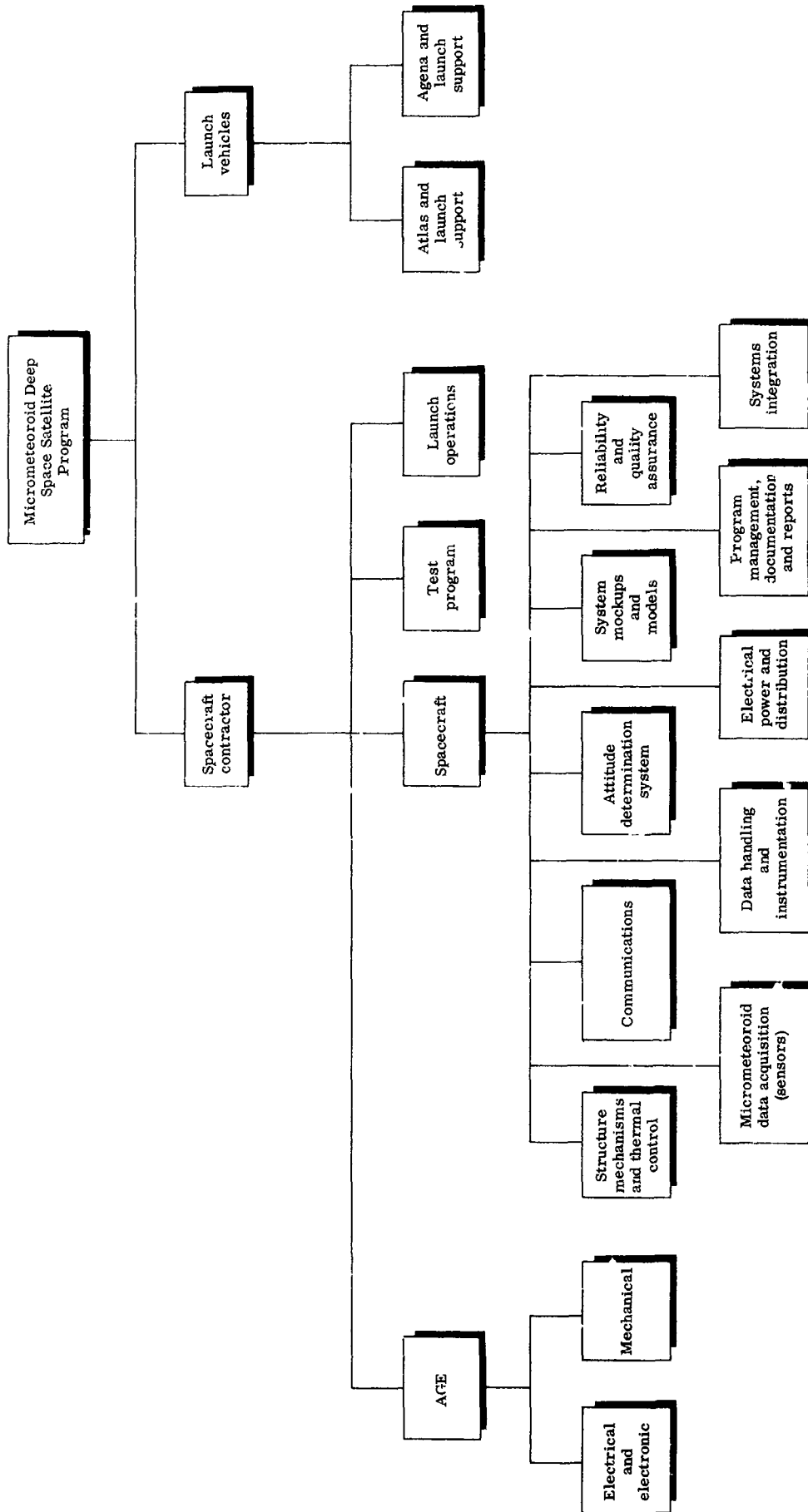

Fig. III-2. Work Breakdown Structures

10P. OF DIAGRAM

WEEKS AFTER GO-AHEAD	1	2	3
----------------------	---	---	---

Program go ahead

S  
Prelim thermal analysis

STRUCTURE, MECHANISMS,  
ADAPTER, SHROUD AND  
THERMAL CONTROL

S  
Prelim des-  
struct, adapt,  
mechanisms,  
shroud, sepat



S  
Prelim des  
data acquis  
system &  
sensors

DATA ACQUISITION SYSTEM  
(SENSORS)



S  
Prelim des  
attitude  
determin  
system

ATTITUDE DETERMINATION

4	5	6	7	8	9	10	11	12	13	14
---	---	---	---	---	---	----	----	----	----	----

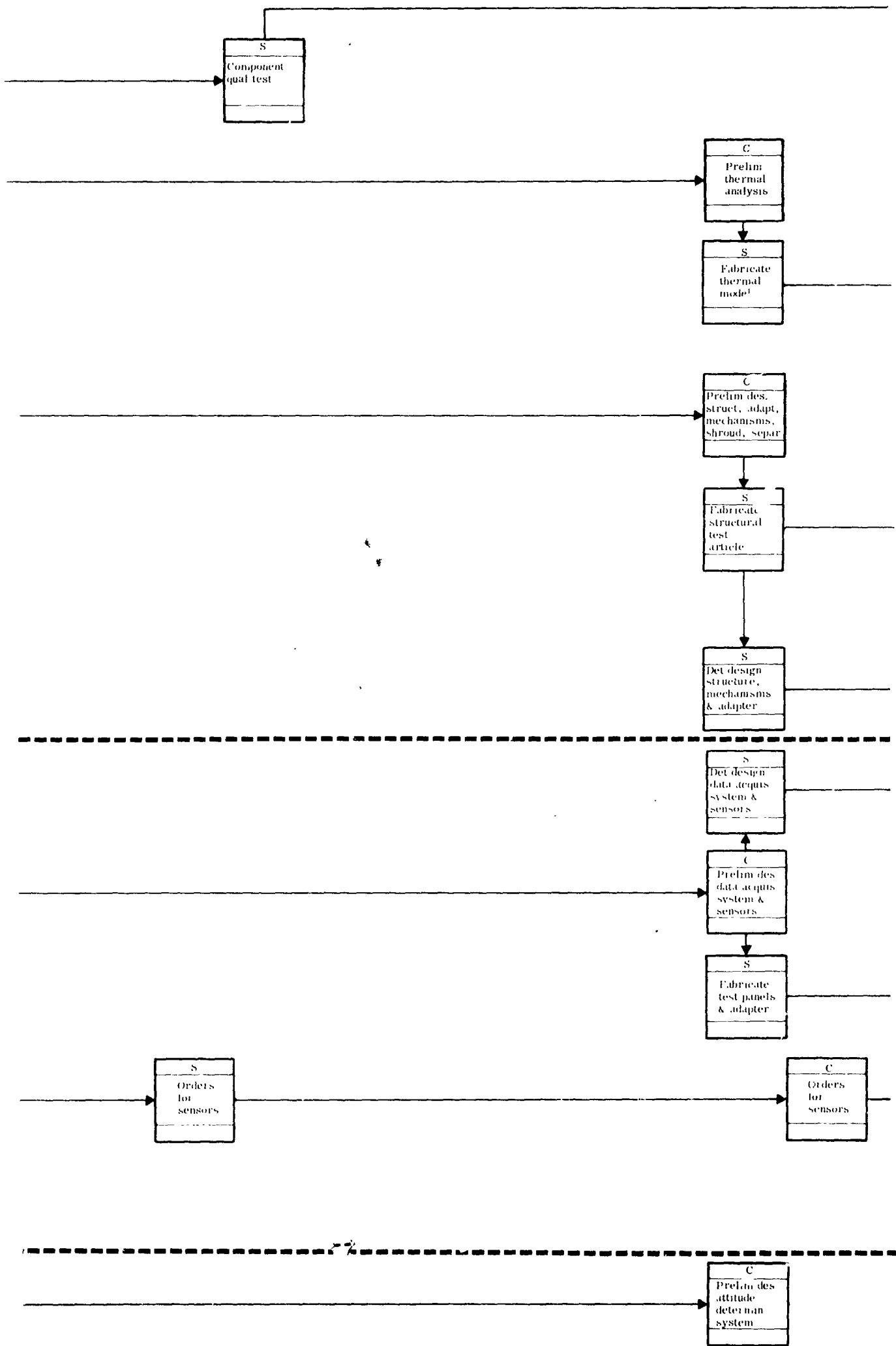

3 #

15	16	17	18	19	20	21	22	23	24	25
----	----	----	----	----	----	----	----	----	----	----

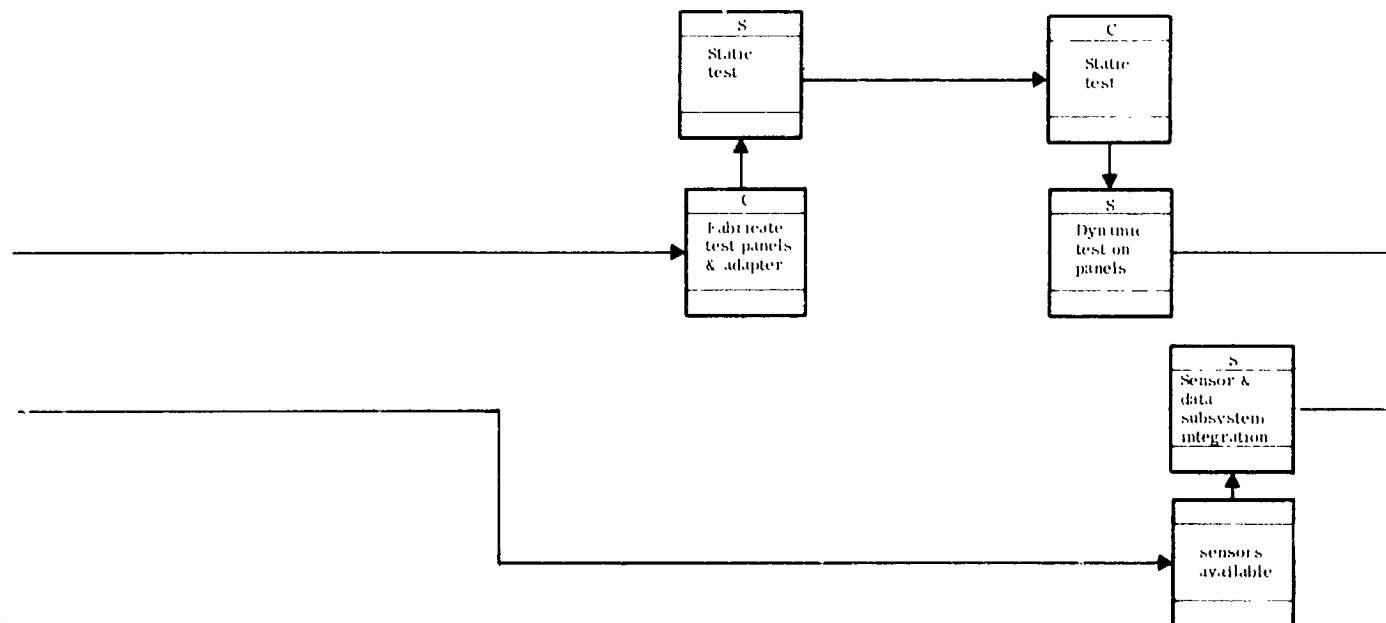
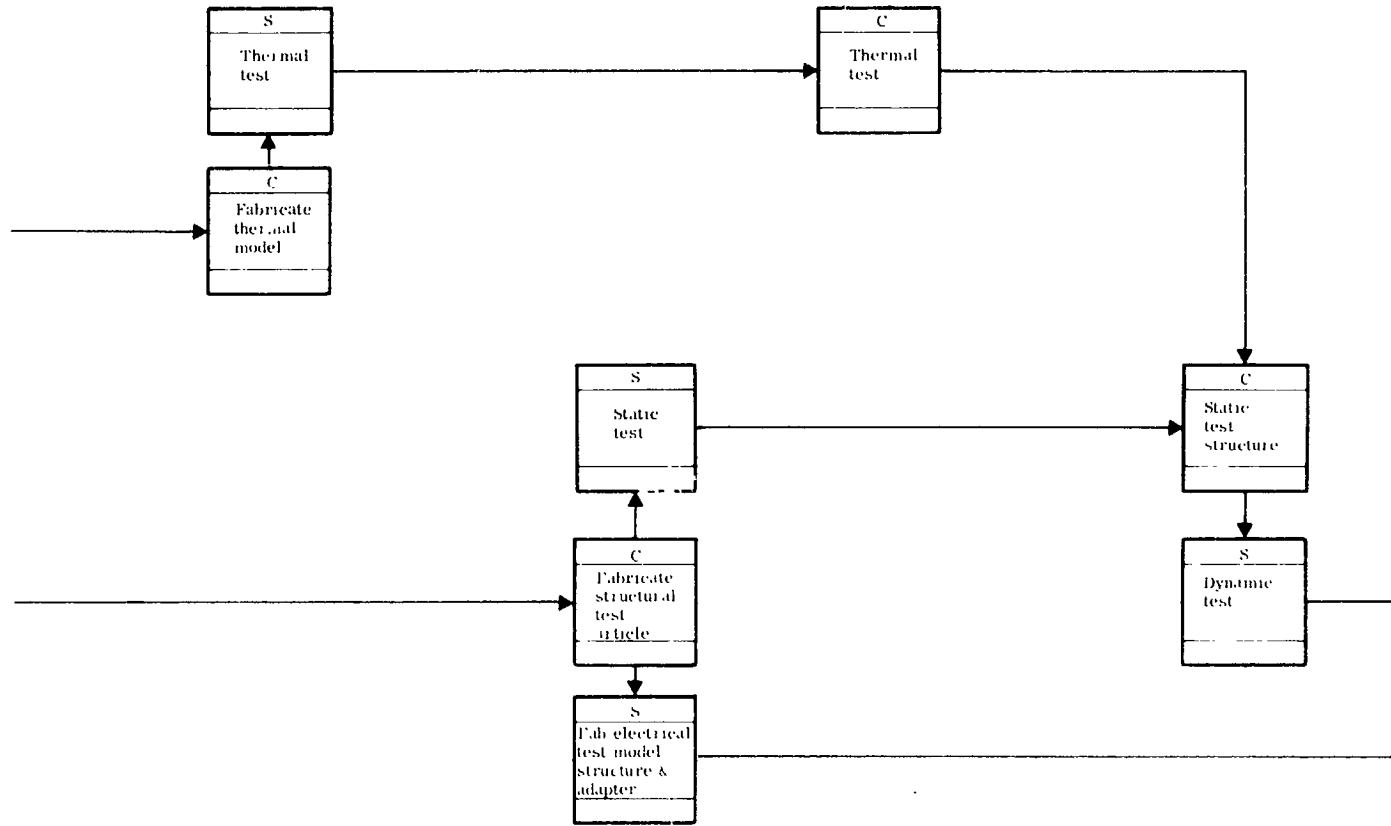

26	27	28	29	30	31	32	33	34	35	36
----	----	----	----	----	----	----	----	----	----	----

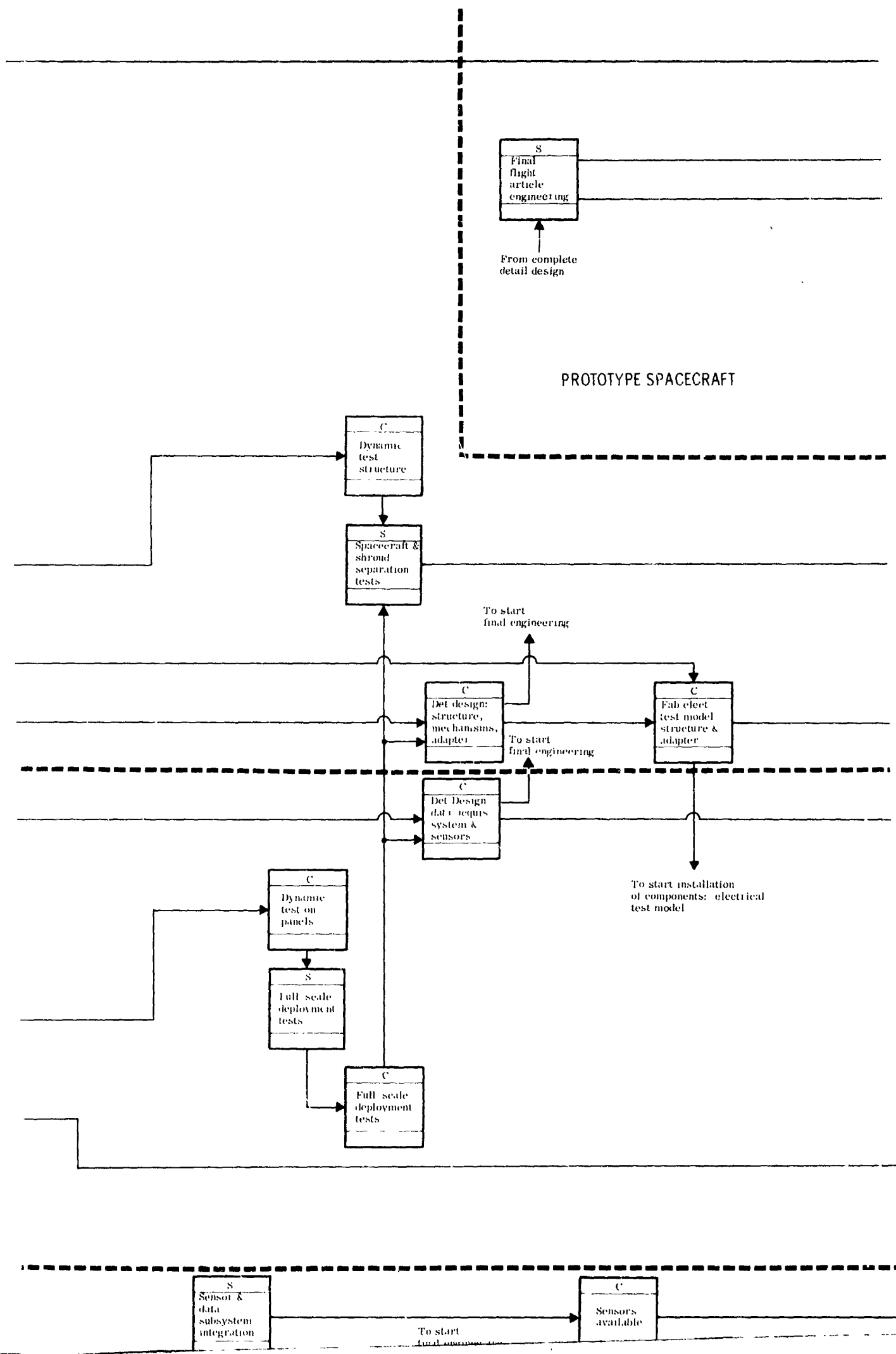

37	38	39	40	41	42	43	44	45	46	47	48
----	----	----	----	----	----	----	----	----	----	----	----

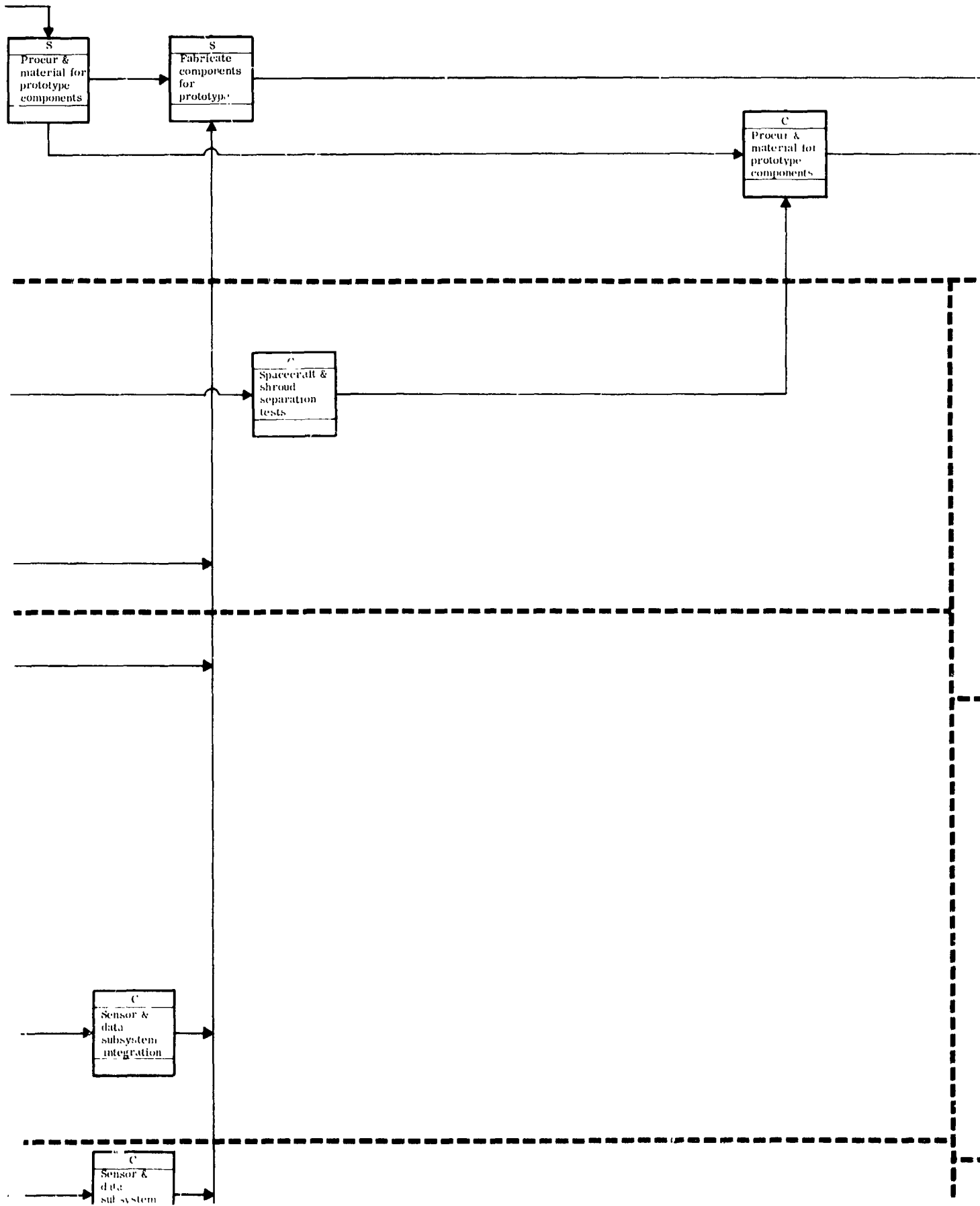

617

49	50	51	52	53	54	55	56	57	58	59	60
----	----	----	----	----	----	----	----	----	----	----	----

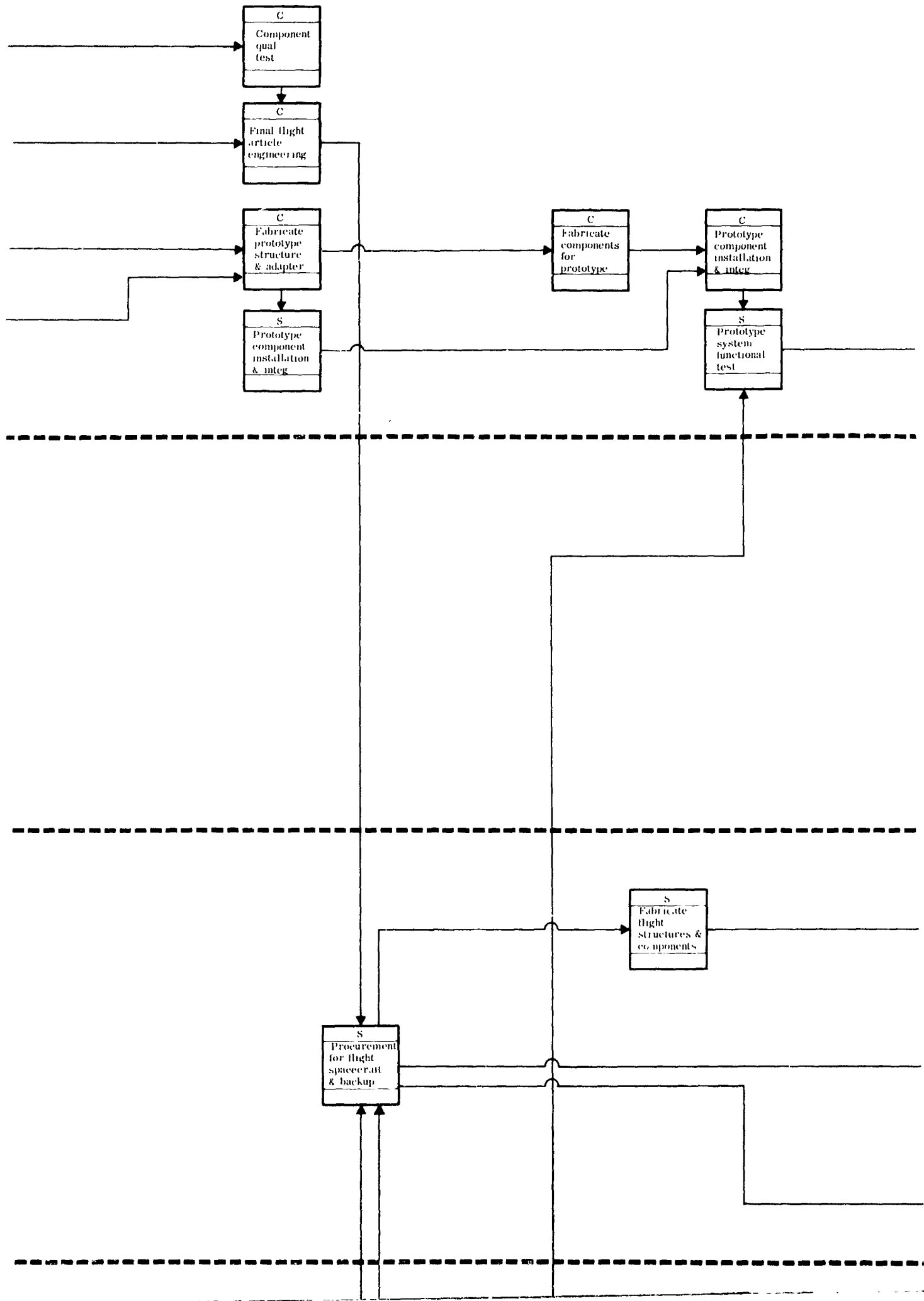

7#

61	62	63	64	65	66	67	68	69	70	71	72
----	----	----	----	----	----	----	----	----	----	----	----

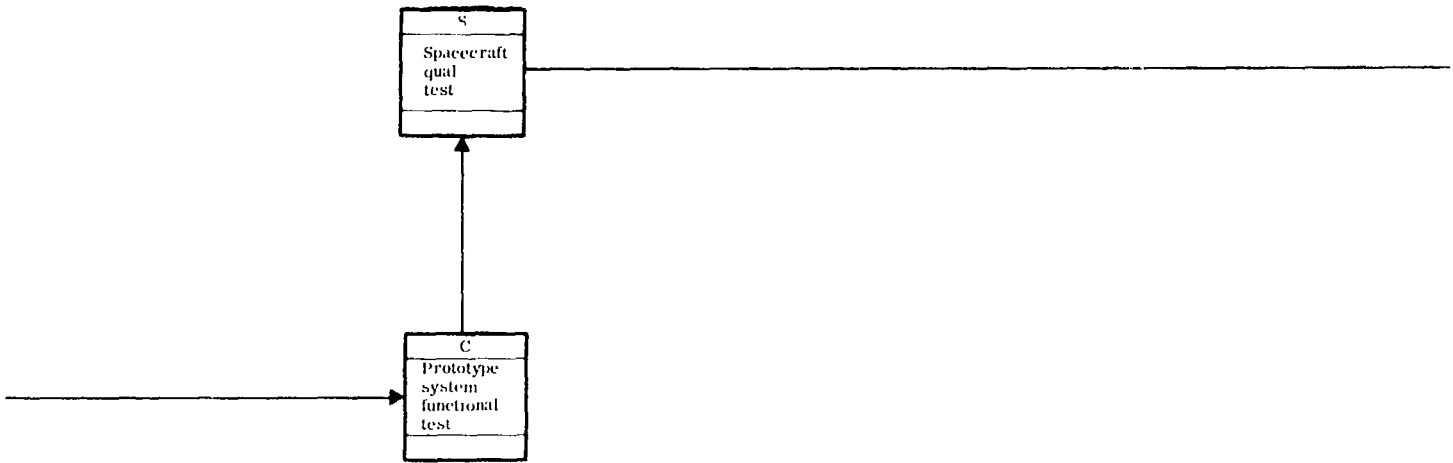

FLIGHT SPACECRAFT AND BACKUP

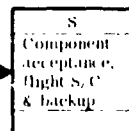
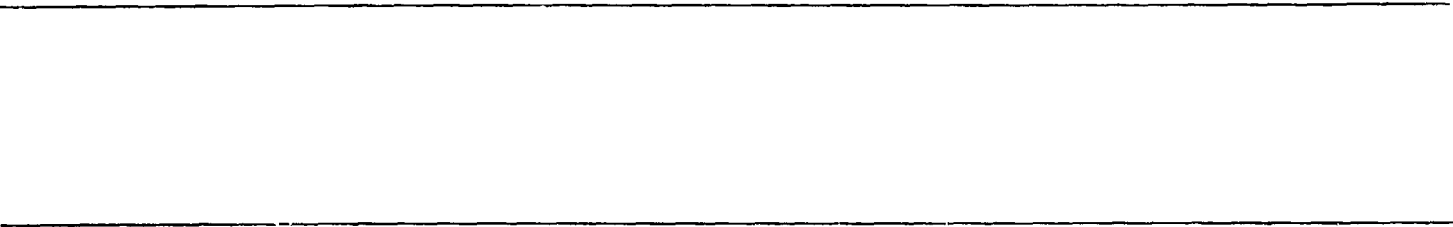

8A

73	74	75	76	77	78	79	80	81	82	83	84
----	----	----	----	----	----	----	----	----	----	----	----

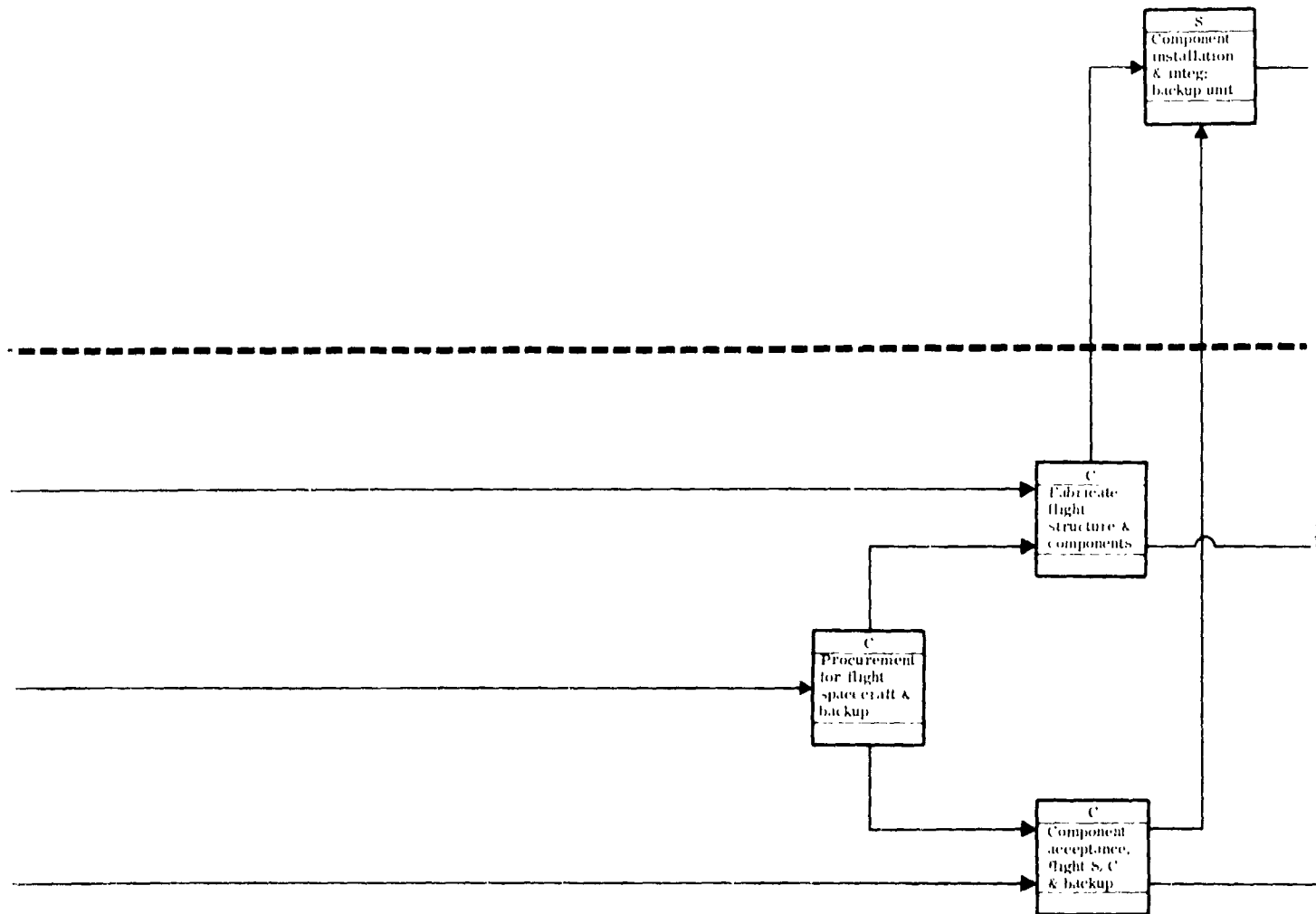
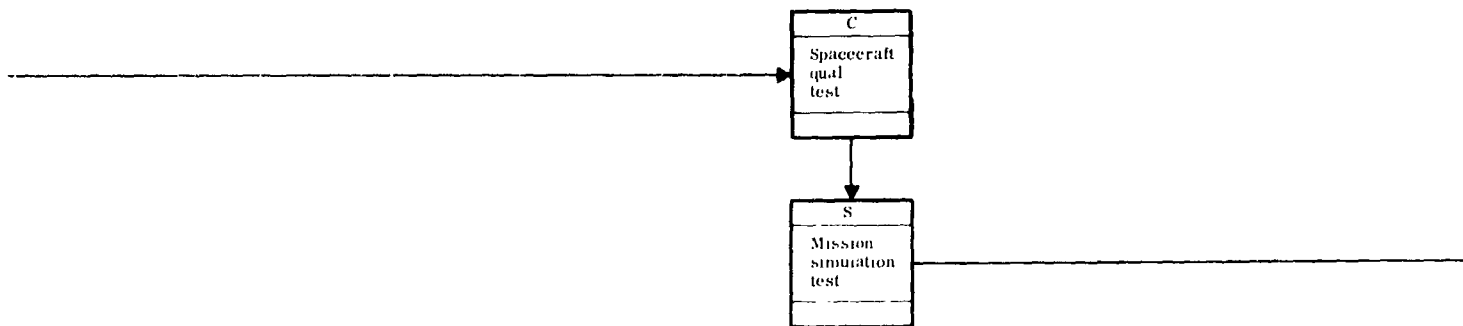

9 #

85	86	87	88	89	90	91	92	93	94	95	96
----	----	----	----	----	----	----	----	----	----	----	----

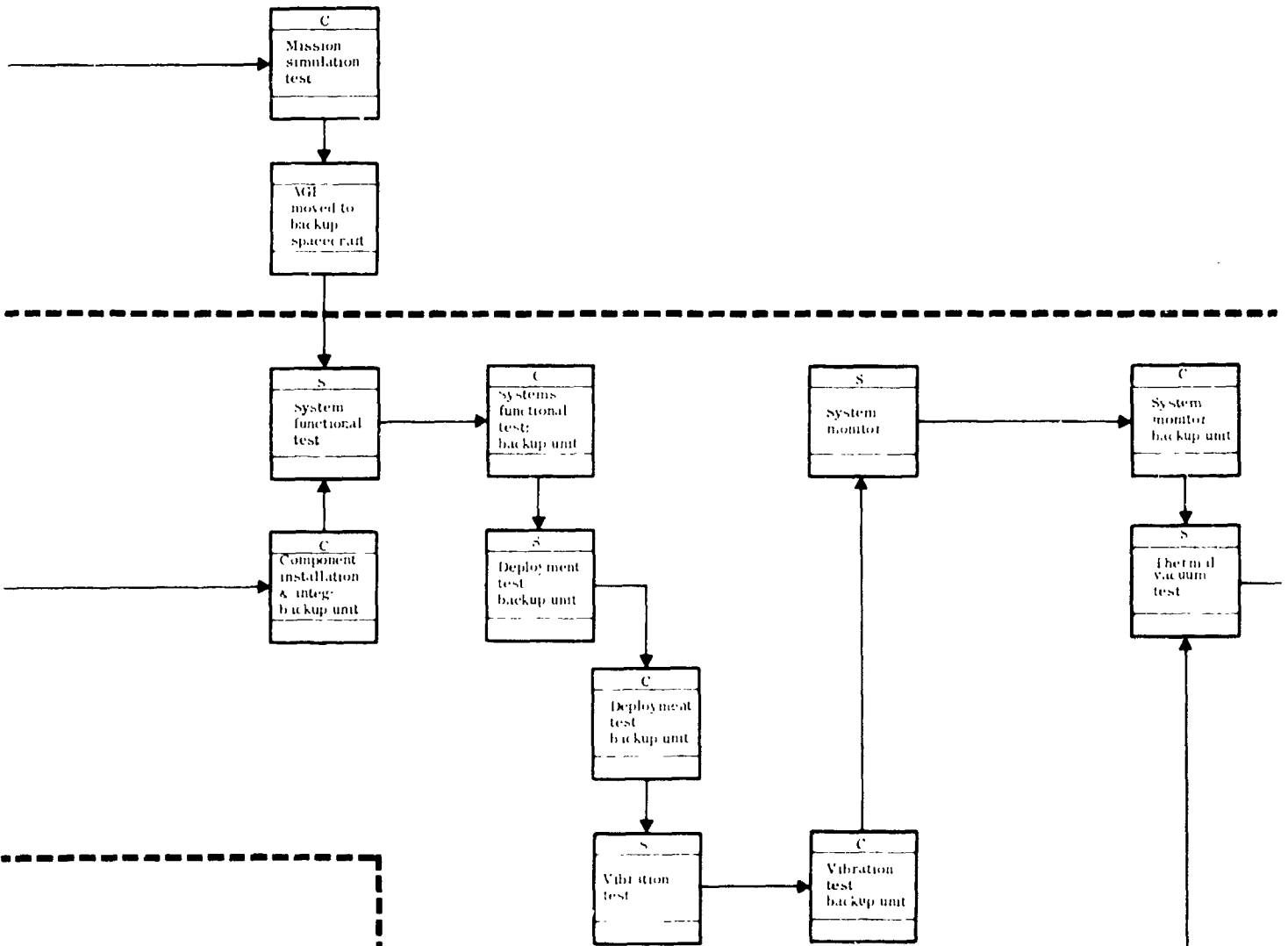

FLIGHT BACKUP SPACECRAFT

97	98	99	100	101	102	103	104
----	----	----	-----	-----	-----	-----	-----

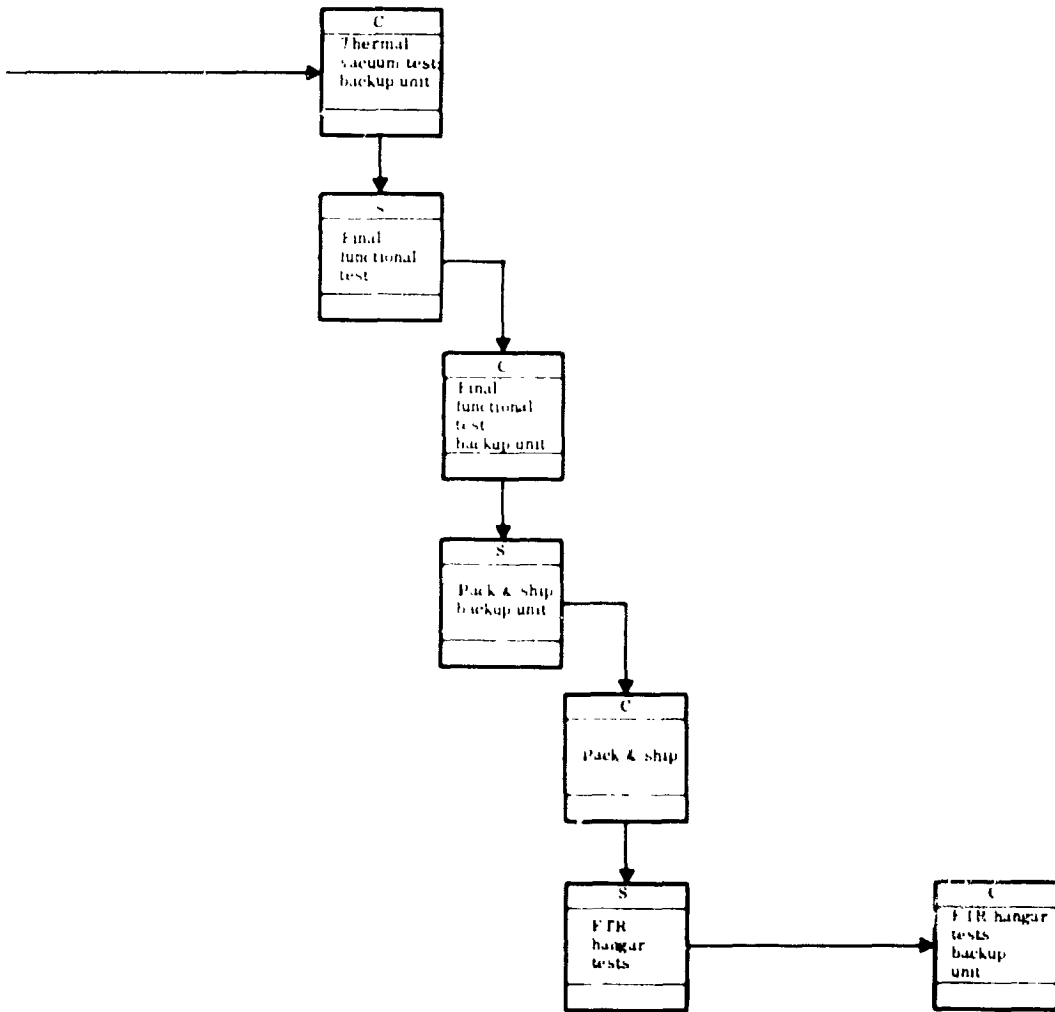

Bottom  
of DIHERAM #1

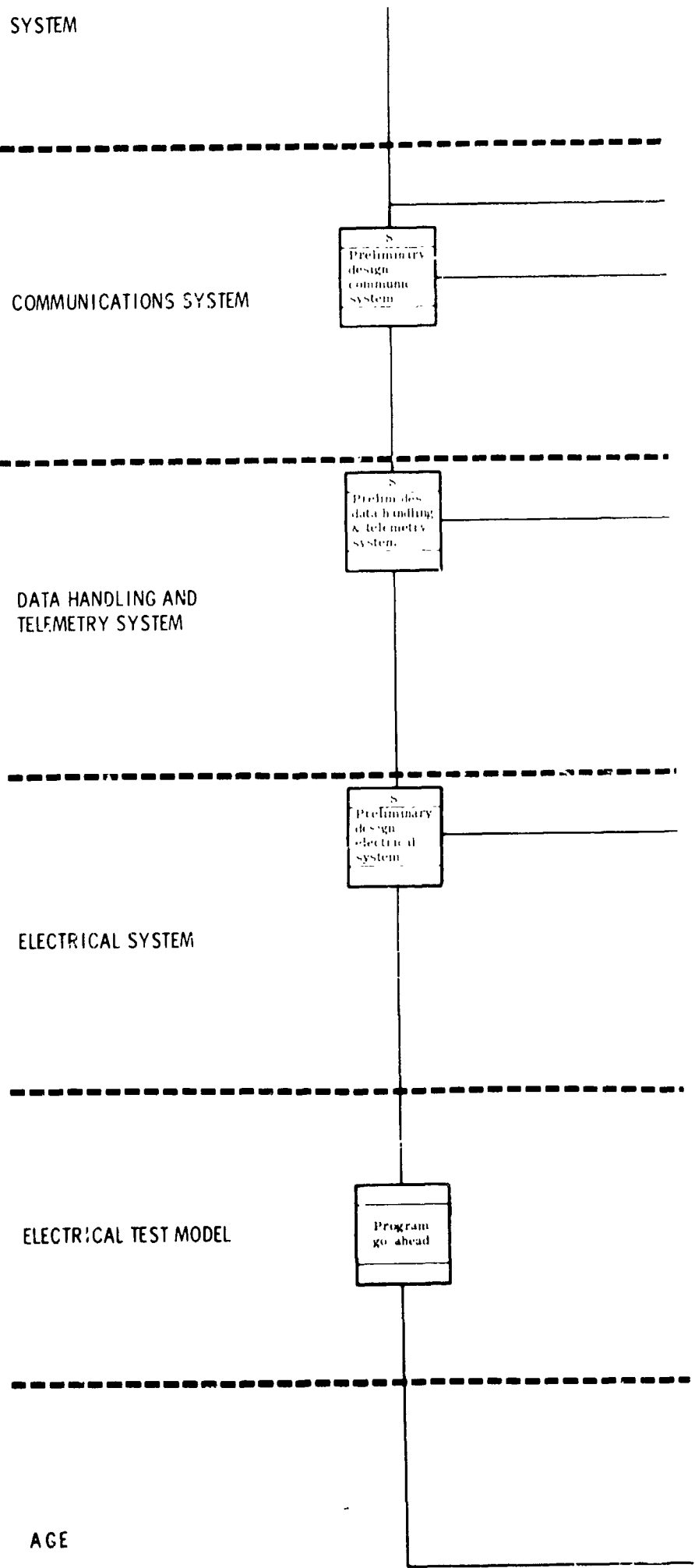

12#

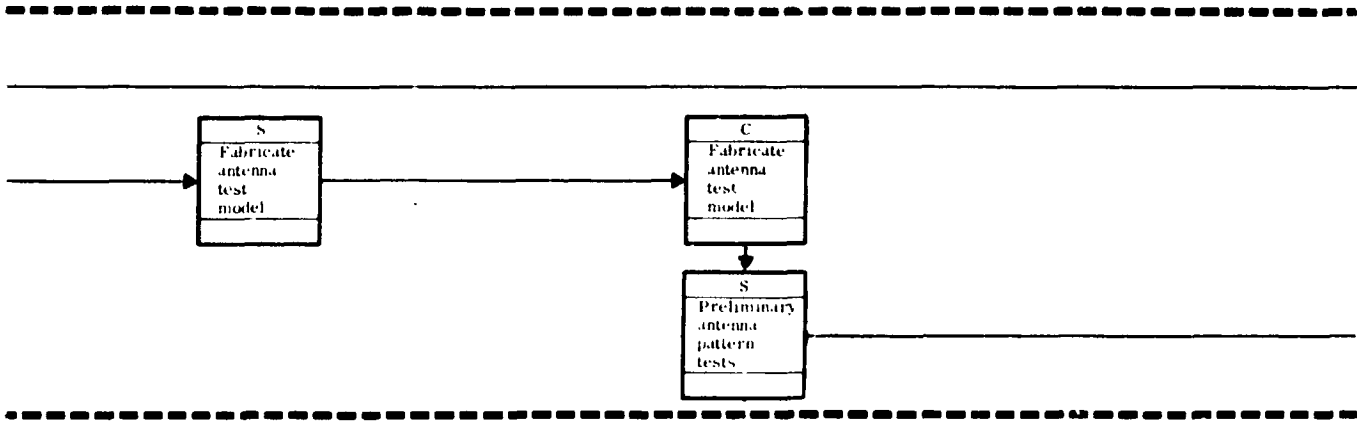
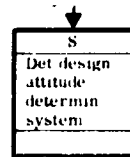

From start of preliminary system design

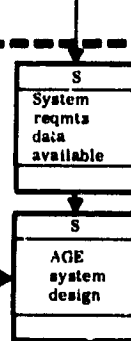

13A

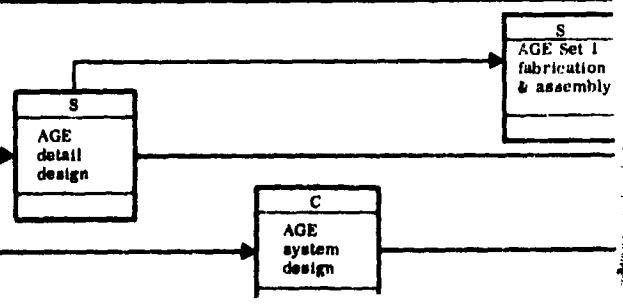
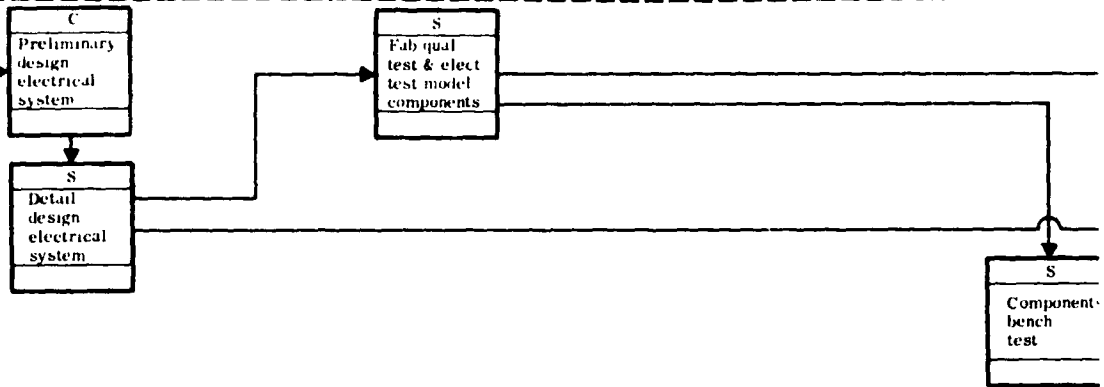
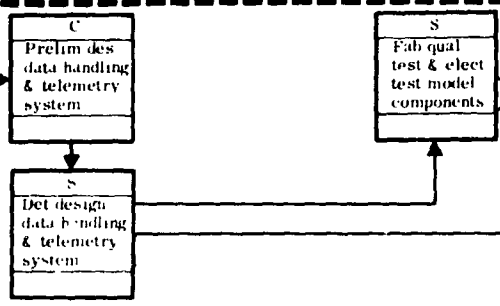
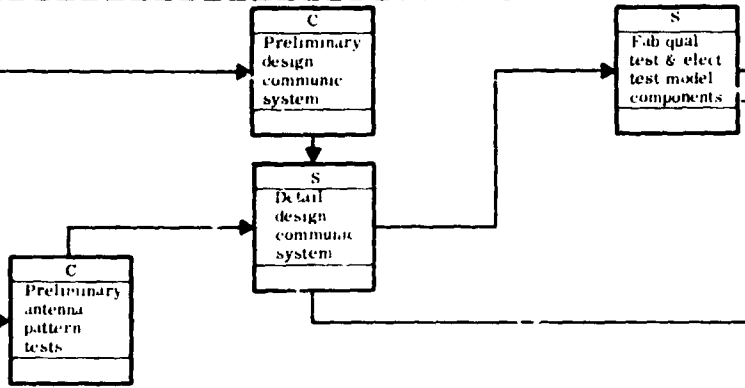
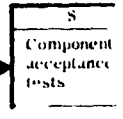

14#

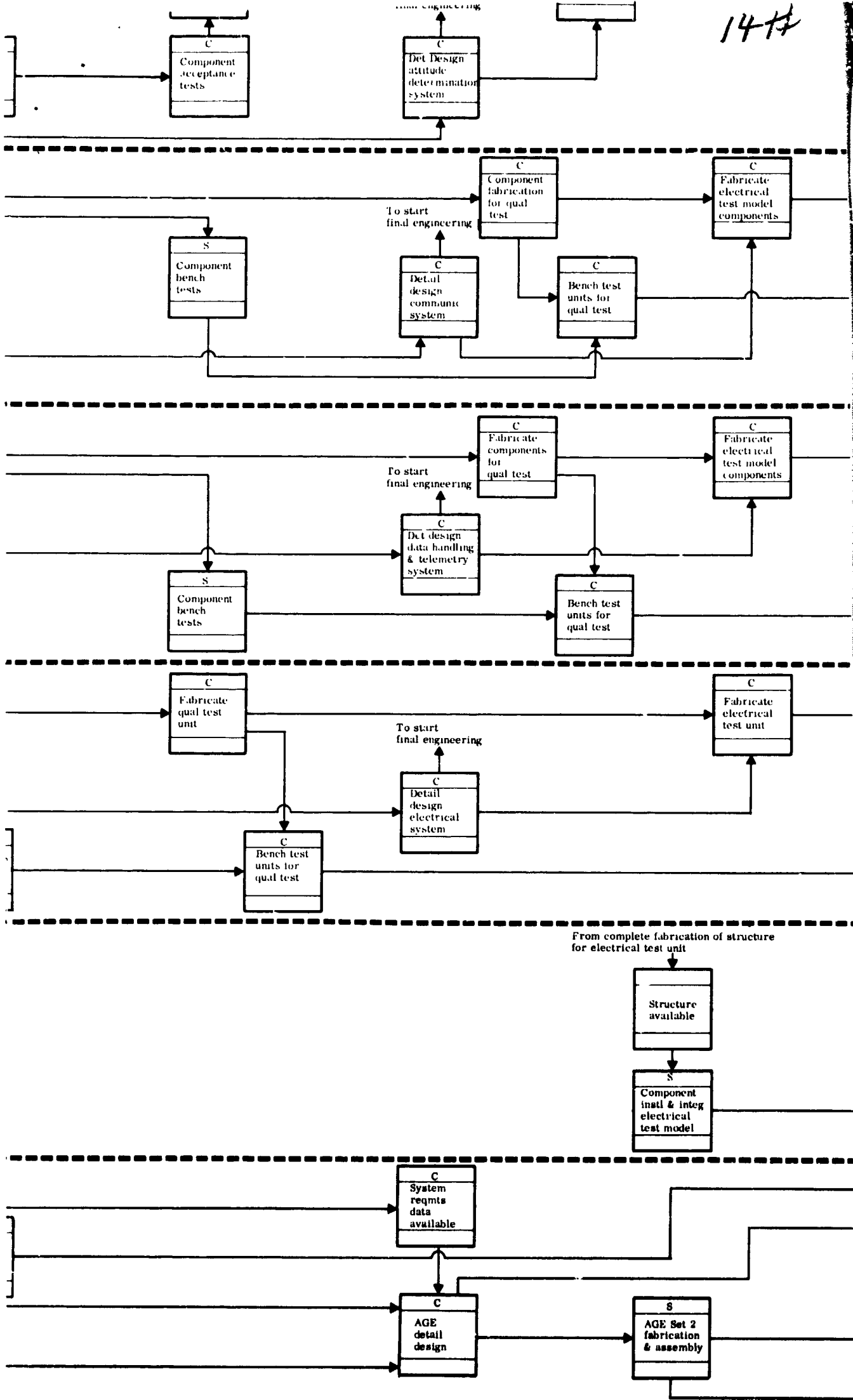

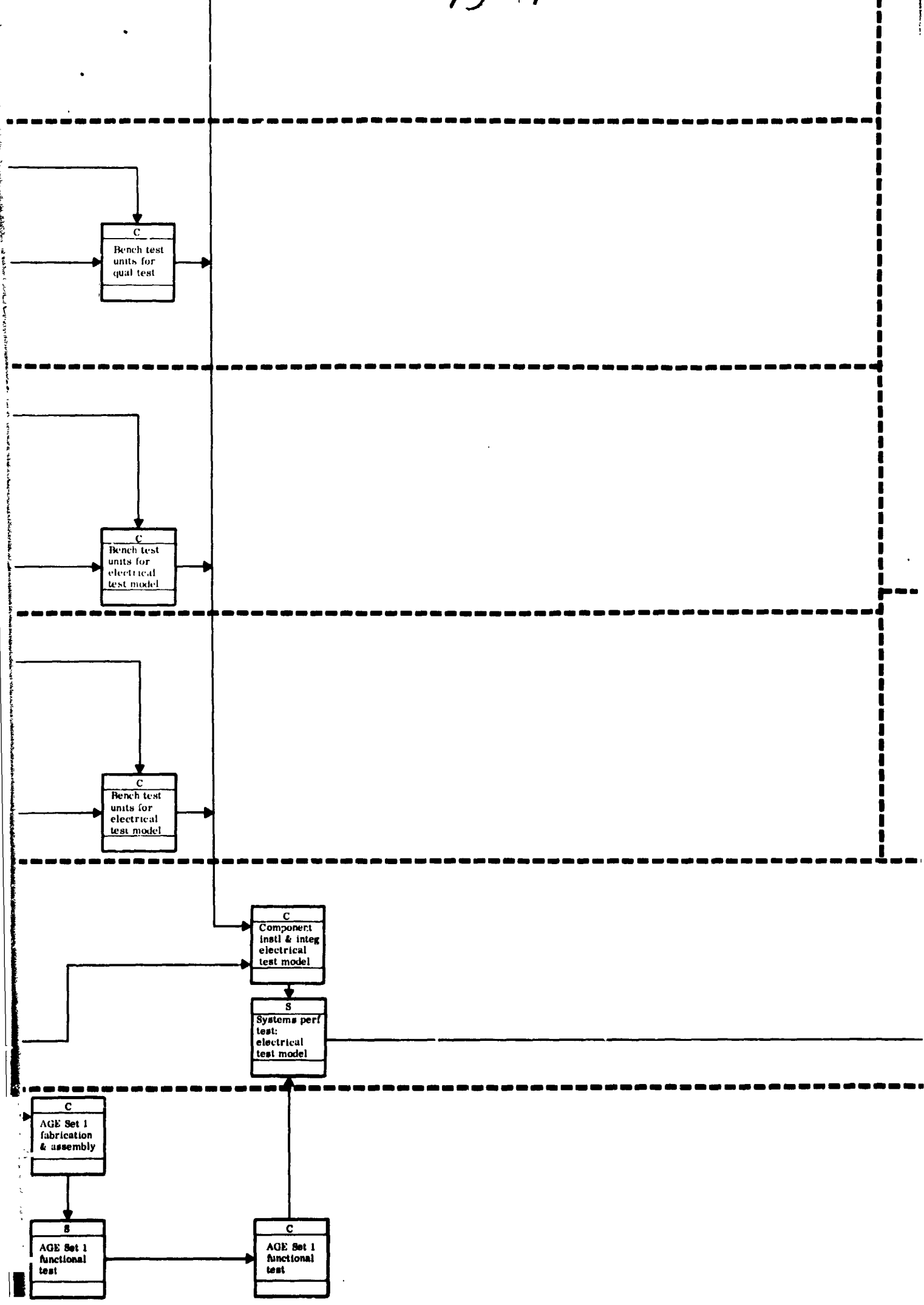

16A

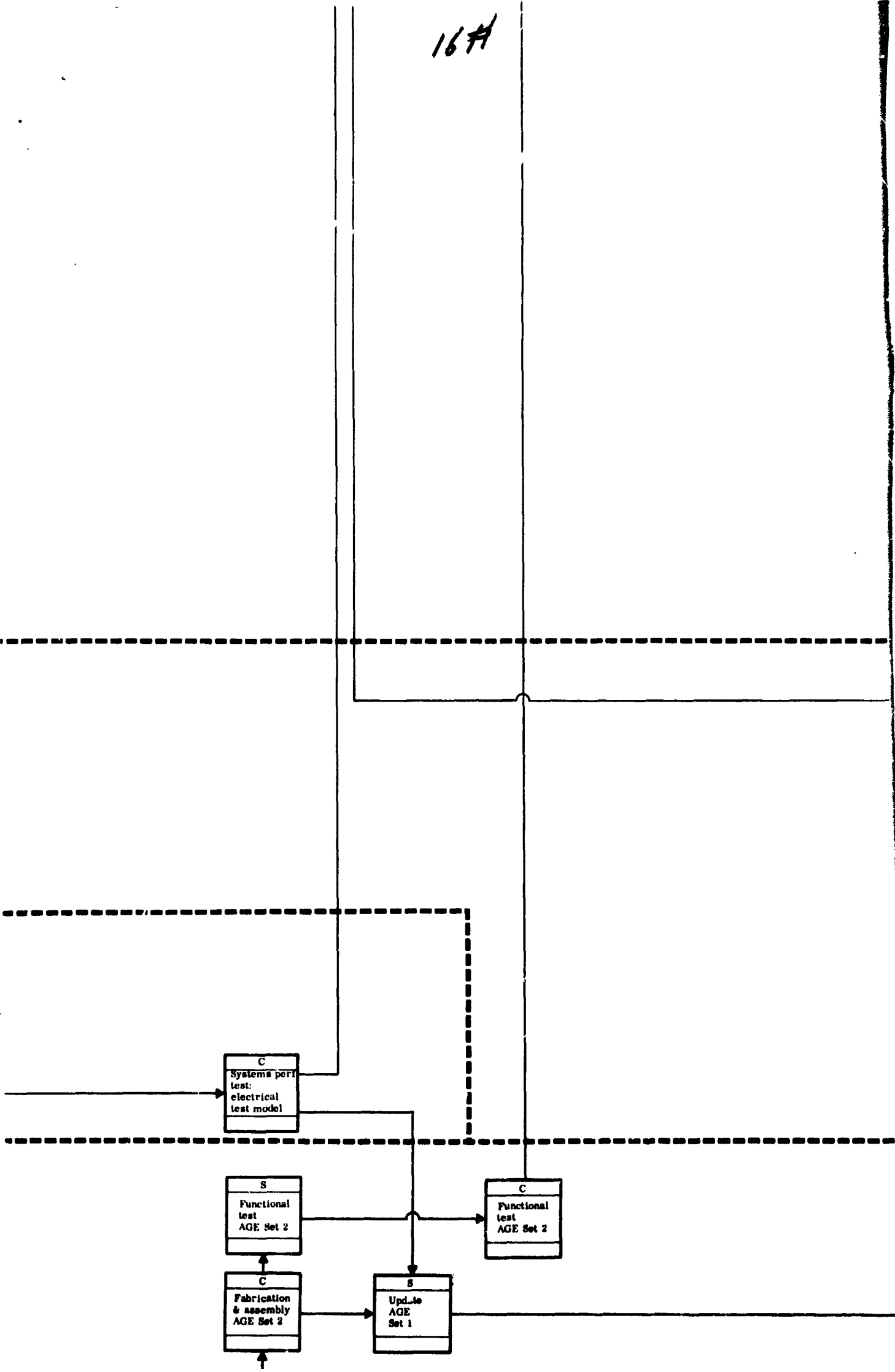

17 #

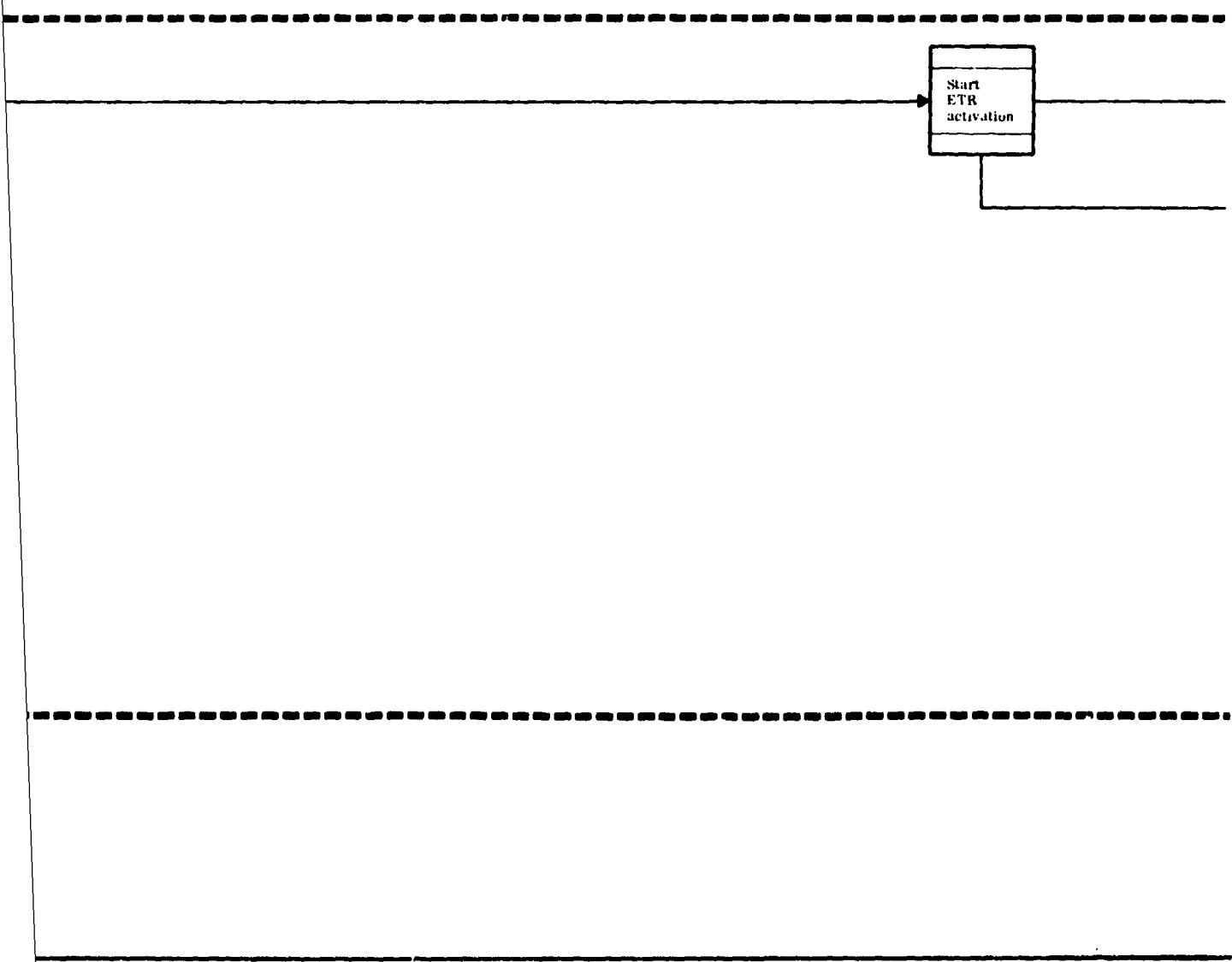

18#



FLIGHT SPACECRAFT

ETR ACTIVAT  
LAUNCH VEHICLE

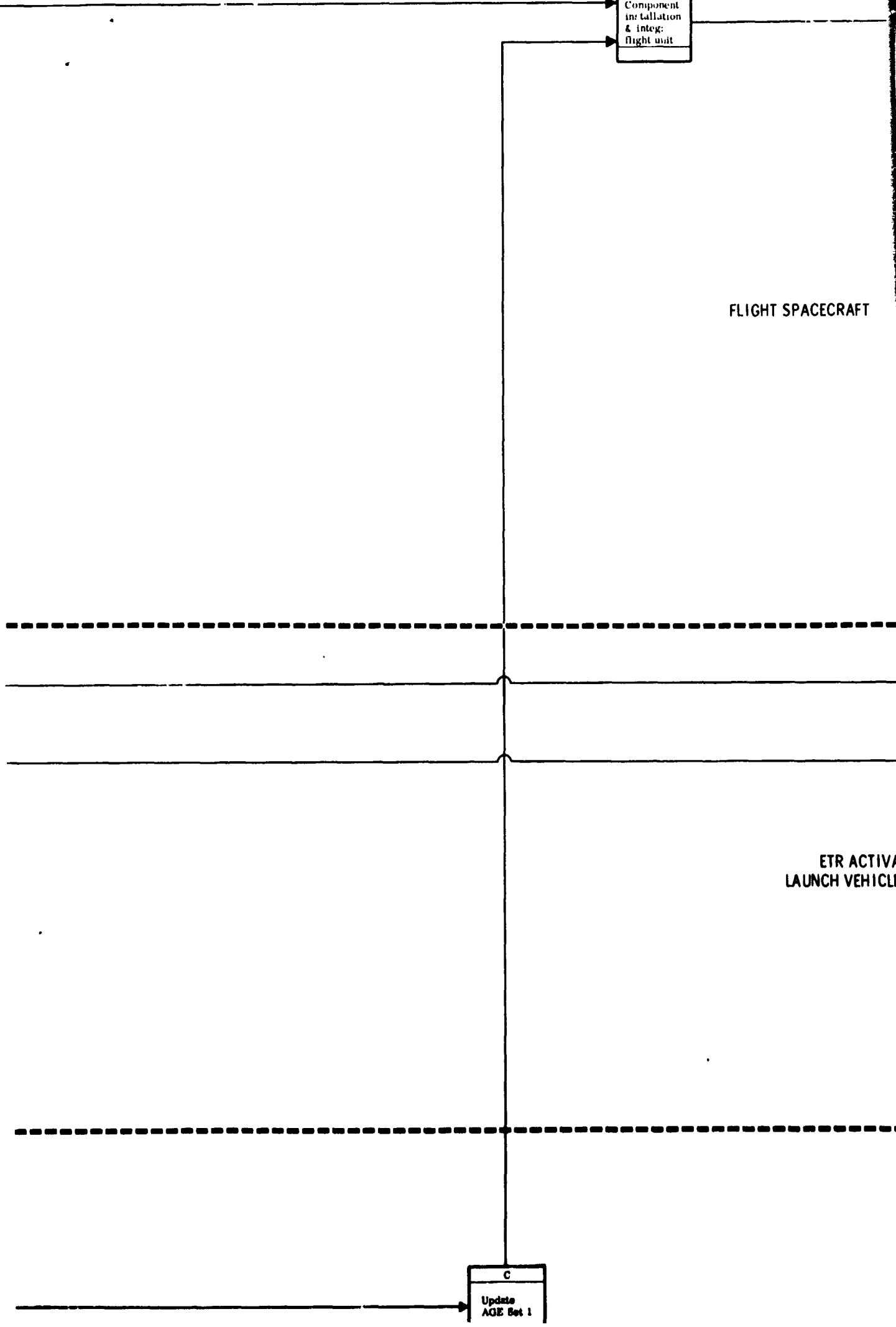
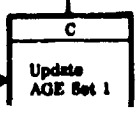

19 #1

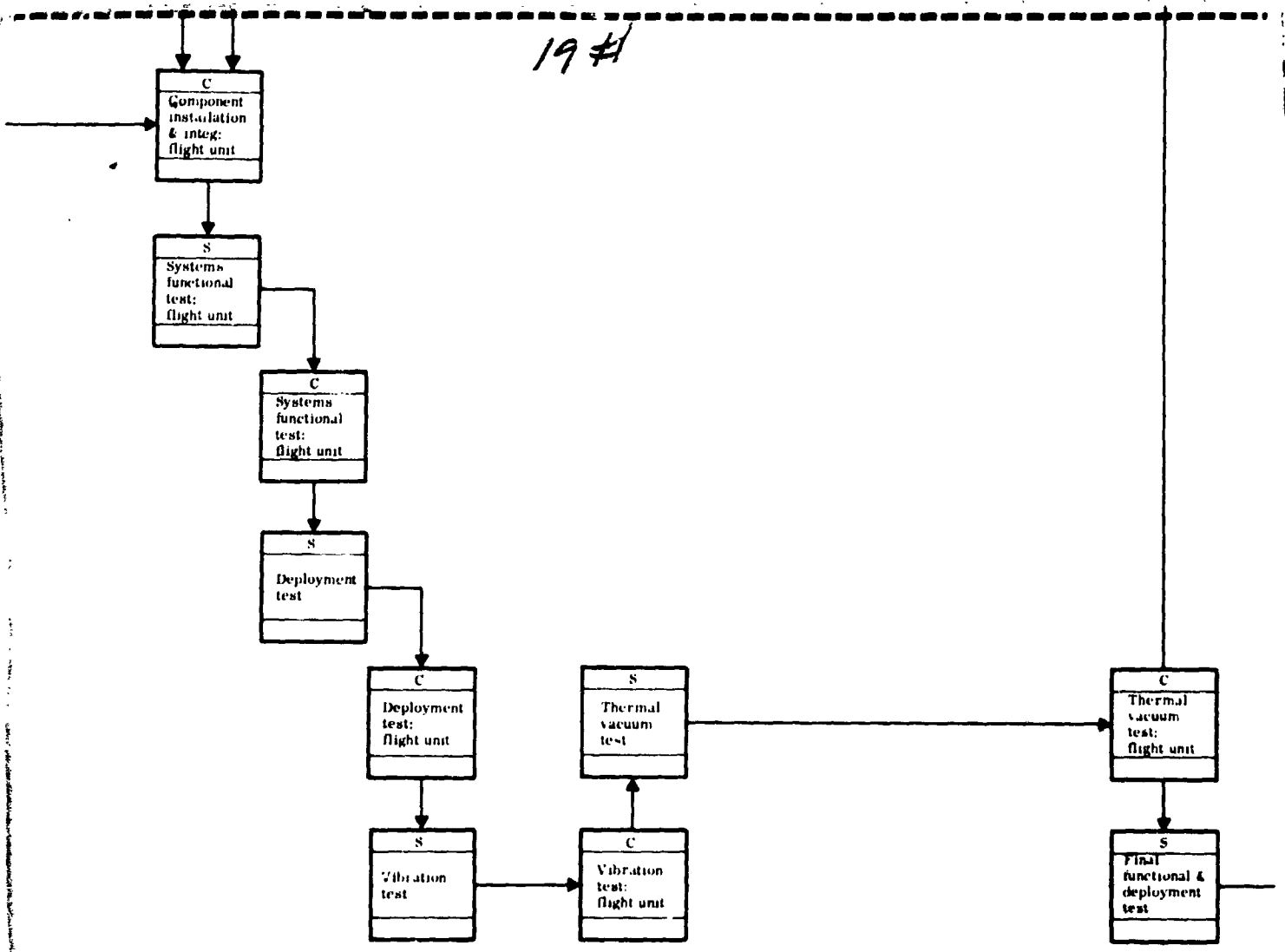

ION AND PREPARATION

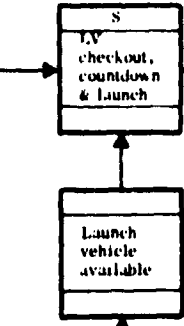

Launch vehicle fabrication and assembly complete

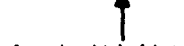

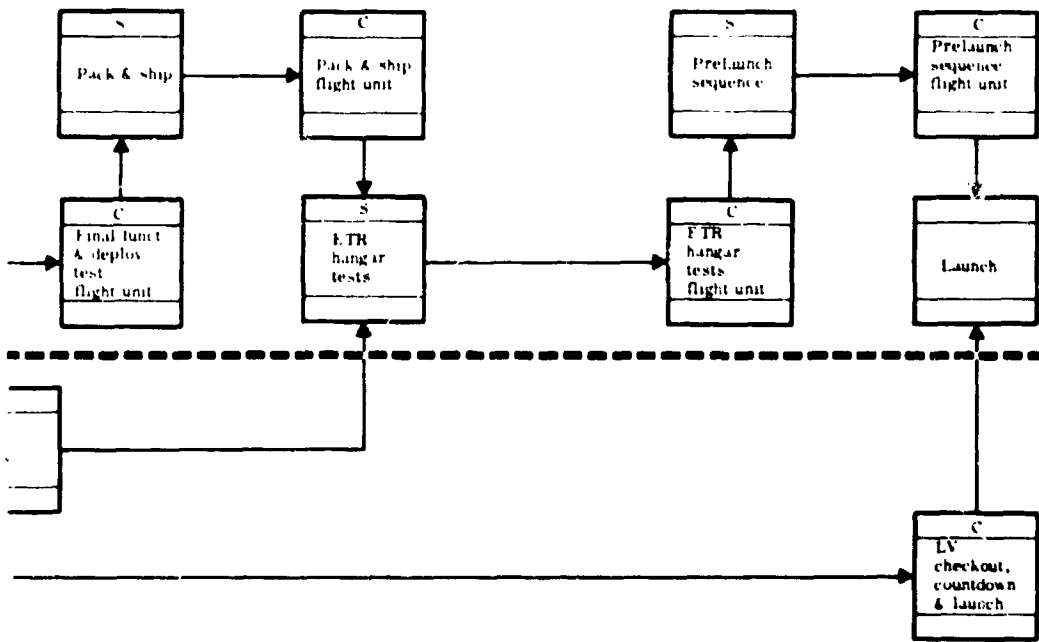

**Fig. II-2. MDSS PERT Network**