

FINAL REPORT

LASER COMMUNICATION TRANSMITTER

Contract NAS 9-4473

Prepared for

MANNED SPACECRAFT CENTER
NATIONAL AERONAUTICS AND SPACE ADMINISTRATION
HOUSTON, TEXAS 77058

Prepared by

APPLIED RESEARCH
DEFENSE ELECTRONIC PRODUCTS
RADIO CORPORATION OF AMERICA
CAMDEN, NEW JERSEY 08102

November 1965

TABLE OF CONTENTS

<u>Section</u>	<u>Page</u>
I INTRODUCTION.....	1
A. Design Goals.....	1
B. Performance Characteristics.....	1
C. Operation of Transmitter.....	2
D. Equipment Delivered.....	4
II LASER TRANSMITTER.....	5
A. Characteristics of RCA Room-Temperature Laser Diode	5
B. Circuits.....	9
C. Optics	12
1. Sighting Telescope.....	12
2. Laser Array Optics.....	15
3. Alignment Procedure	16
III OPTICAL AND ELECTRICAL MEASUREMENTS	20
A. Sighting Telescope.....	20
B. Laser Array	21
C. Battery Life	23
D. Oscillator Stability	23
IV LASER TEST SET	26
V EQUIPMENT MAINTENANCE.....	28
A. Introduction.....	28
B. Disassembly	28
C. Battery Pack	28
D. Cleaning Optical Elements.....	29
Appendix	
A Optimum Duty Factor of an Injection Laser Transmitter	32
B Laser Transmitter Schematics, Connection Diagram, Circuit Boards and Parts List	35
C Battery Charger Schematic, Circuit Boards and Parts List	43

SECTION 1

INTRODUCTION

20941

The objective of this program was to design and fabricate three injection laser transmitters to be used as part of the GT-7 Gemini experiments. One transmitter will be used by an astronaut to establish an experimental laser communication link with a ground receiving station at White Sands Missile Range. The remaining units will be used for qualification tests and as back-up units.

Overton

A. DESIGN GOALS

The minimum design goals cited in NASA's purchase request were:

Peak output power	8 watts
Maximum weight	10 pounds
Battery life	10 minutes
Modes of operation	100 pps 7 kHz \pm 1 kHz tone

B. PERFORMANCE CHARACTERISTICS

The best transmitter delivered by RCA (see Fig. 1) (NASA designation EE45000-3) has the following performance characteristics.

Peak output power	25 watts
Beamwidth	3 mrad
Wavelength	9060 Å
Spectral width	40 Å
Pulse duration	70 ns
Average pulse repetition rate:	
Voice	8000 pps
Tone	100 pps

Information bandwidth	3 kHz
Modulation method	PFM
Pulse frequency deviation	±500 Hz
Weight (including battery power supply)	5.2 lb
Size	3 x 5 x 8 inches
Telescope power	6X
Telescope field of view	6 degrees
Battery life: Voice	40 minutes
Tone	150 minutes

Clearly, the transmitter developed under this program exceeded all the original design goals.

C. OPERATION OF TRANSMITTER

To operate the transmitter, the astronaut first removes it from its stowage space and unfolds the two hand grips. He then places the safety goggles, stowed in one of the hand grips, in front of his eyes.

Looking through the sighting scope, the astronaut will search for the ground beacon. When the ground beacon is sighted, he will center it in the crosshair reticle. He will then push the toggle switch in the "on" position, resight and transmit at 100 pps. For voice communication he will depress the push button switch mounted on the right and speak into the microphone.

To cease operation and stow the transmitter, the above procedure is reversed. The combined set-up and stowage time should be well under one minute.

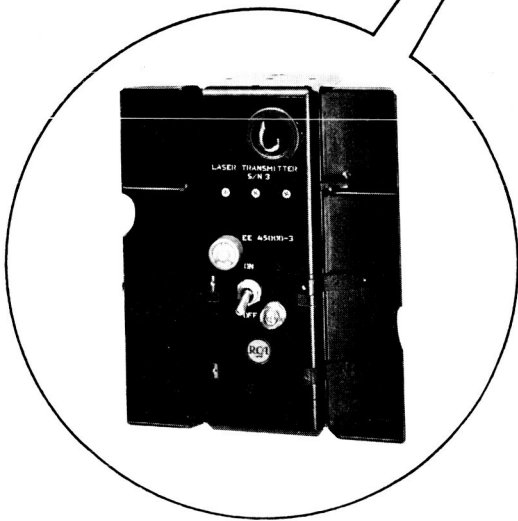
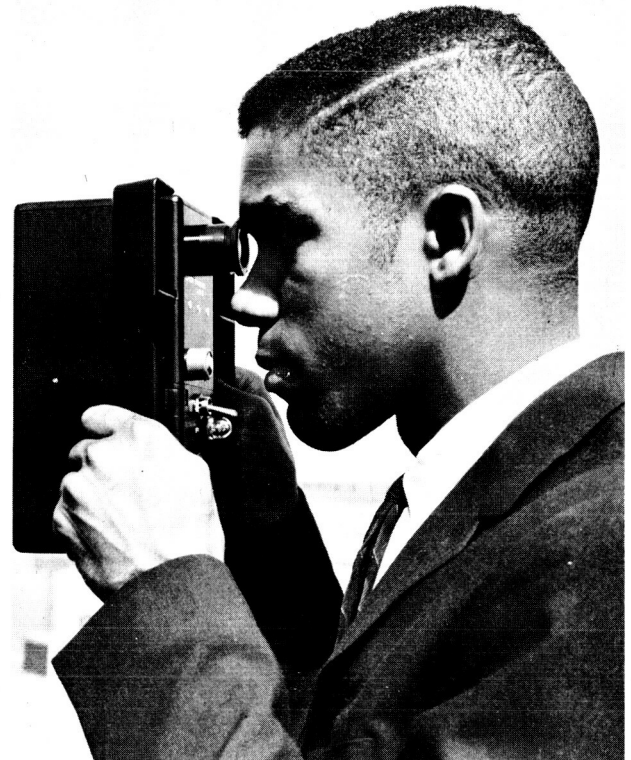
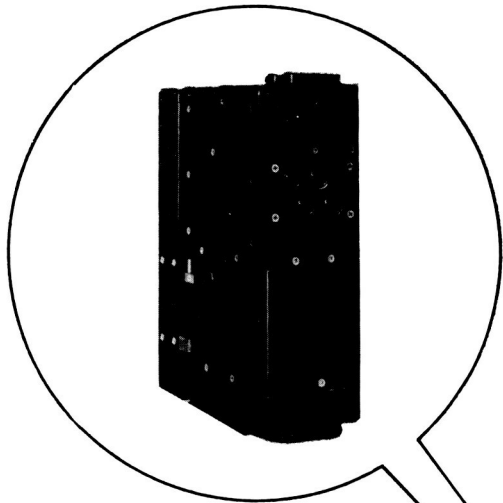

Fig 1. GT-7 Gemini laser communication transmitter.

D. EQUIPMENT DELIVERED

In response to several requests by NASA, during the program, the following equipment was delivered.

1. One (1) laser transmitter EE45000-1
2. Two (2) laser transmitters EE45000-3
3. One (1) battery charger EE45004
4. One (1) laser test set EE45005
5. One (1) battery pack EE45003
6. Three (3) shipping containers EE45008

SECTION II

LASER TRANSMITTER

A. CHARACTERISTICS OF RCA ROOM-TEMPERATURE LASER DIODE

The heart of the transmitter is an array of room-temperature gallium arsenide (GaAs) laser diodes.

Before the room-temperature laser diode was developed, the major deterrent to the use of laser diodes was the need to operate these devices at low temperature. Now, with the development of a new fabrication technique by the RCA Laboratories, laser operation has been achieved with a GaAs diode operating at room temperature at a threshold drive current of only 10 amperes. The low threshold permits simple, reliable drive circuits to be used, while elimination of refrigeration reduces power input, size and weight considerably.

Figs. 2, 3, 4 and 5 show the performance of the RCA laser diode tested during room-temperature operation. Fig. 2 is a photograph of a dual-beam

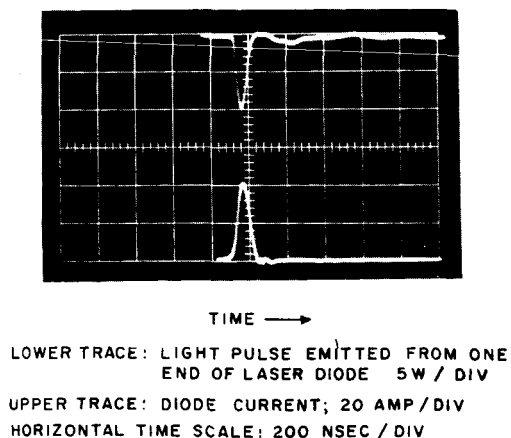

Fig. 2. Light output power and current input to GaAs laser diode.

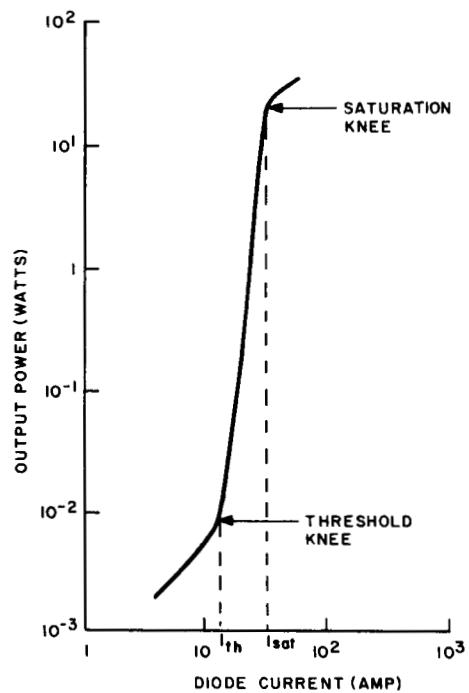

Fig. 3. Light output power vs diode current.

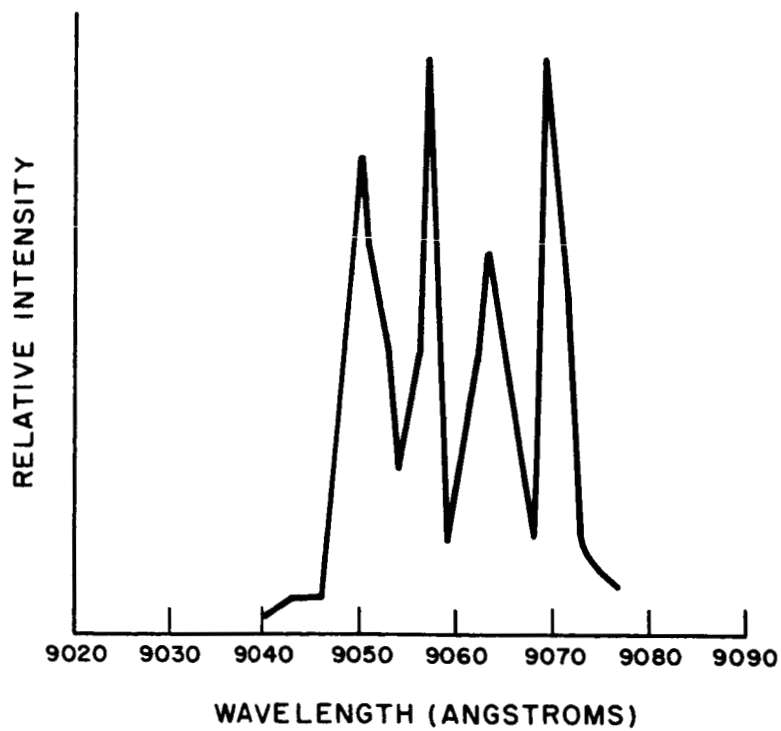

Fig. 4. Spectrum of room-temperature GaAs laser diode.

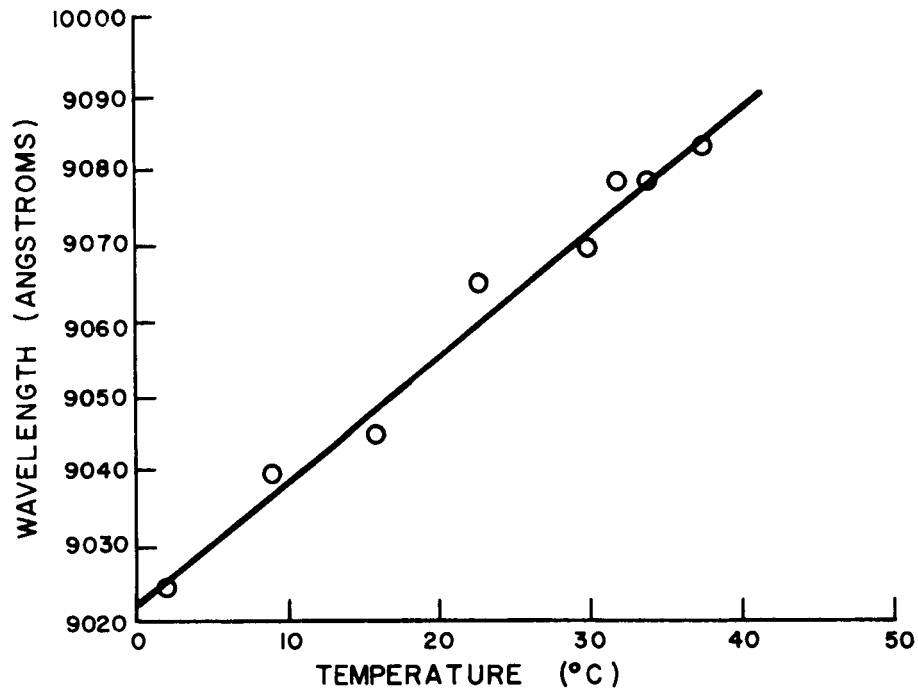

Fig. 5. GaAs laser wavelength vs temperature.

oscilloscope trace showing current input to the laser diode and the light output from it. The light pulse emitted from one end of the laser diode is represented in the lower trace and the diode current input is represented in the upper trace. Note that a peak output power of 10 W is achieved at a peak drive current of 40 A. This represents the performance of a typical diode; however, some diodes emit as much as 18 W with the same drive current.

Fig. 3 is a plot of output power radiated from one end of the diode as a function of diode current. The region around the lower knee of the curve, where the slope suddenly changes, represents the laser threshold of the diode. Typically the threshold current, I_{th} , is 10 amperes. For currents above I_{th} , the laser output increases steadily until heating effects cause the output to taper off.

Fig. 4 shows the measured spectrum of the light radiated from the diode. This measurement was made with a monochromator. The spectrum consists of four longitudinal modes spaced approximately 6 \AA apart, in agreement with the mode spacing calculated from the length of the Fabry-Perot cavity formed by the diode. At room temperature, laser emission occurs at about 9060 \AA , with a temperature-dependent shift of about 2 \AA per degree Celsius as shown in Fig. 5.

To obtain the best possible performance from an injection laser, it is necessary to optimize both the drive current and the duty factor of the laser diode. The optimum drive current can be determined by referring to the plot of power output vs drive current given in Fig. 3 where three regions of diode operation are clearly evident: (1) the nonlasing region below threshold current, (2) the lasing region between the threshold knee (defined as I_{th}) and the saturation knee (defined as I_{sat}) and (3) the lasing region beyond the saturation knee.

Clearly, the optimum operating point lies in the region above the lasing threshold. The exact location of this point is determined by the mathematical analysis in Appendix A. It is shown that when the diode drive current is less than I_{sat} (and greater than I_{th}) laser output power increases as the eighth power of drive current, whereas above I_{sat} laser output power increases in direct proportion to the drive current. In either region diode power dissipation increases as the square of the drive current. Therefore, maximum efficiency is achieved at the highest value of drive current in the region between I_{th} and I_{sat} , i. e. , at I_{sat} . At this value of drive current, duty factor is limited by the maximum average power dissipation $P_{d_{max}}$ tolerated by the diode; with this limit, optimum duty factor q_{opt} is shown in Appendix A (see Eq. A-8) to be

$$q_{opt} = \frac{\bar{P}_{d_{max}}}{\left(I_{sat}\right)^2 r} \quad (1)$$

where I_{sat} is the saturation current and r is the resistance of the diode.

Typical parameters for RCA laser diodes are $P_{\text{d}_{\text{max}}} = 0.2 \text{ W}$, $I_{\text{sat}} = 40 \text{ A}$ and $r = 0.2 \Omega$; therefore, the optimum duty factor is $q_{\text{opt}} = 0.06$ per cent. Since the duty factor is equal to

$$q = f \tau \quad (2)$$

where

τ = pulse duration

f = pulse repetition rate (Hz)

and since operational requirements call for a PRF (pulse repetition frequency) of 8000 Hz, the optimum pulse duration is approximately $\tau = 70 \text{ ns}$. Thus we conclude that the injection laser should be driven by 40-A, 70-ns pulses at a PRF of 8000 Hz.

B. CIRCUITS

The laser drive circuit shown in Fig. 6 will satisfy the above drive requirements. High current and fast rise time are achieved by charging a 10,000-pF capacitor to the supply voltage and then discharging it through the laser diode. An SCR, operated at high voltage, serves as the discharge switch. Every time a trigger pulse is applied to the gate of the SCR the capacitor is discharged and a short pulse of coherent light is emitted from the laser.

When the capacitor is being discharged, the current flowing through the diode combination CR biases charging transistor Q to cutoff, decoupling the power supply from the SCR. This type of decoupling enables the capacitor to be charged rapidly, allowing the transmitter to operate at high repetition rates; yet it ensures turn-off of the SCR switch.

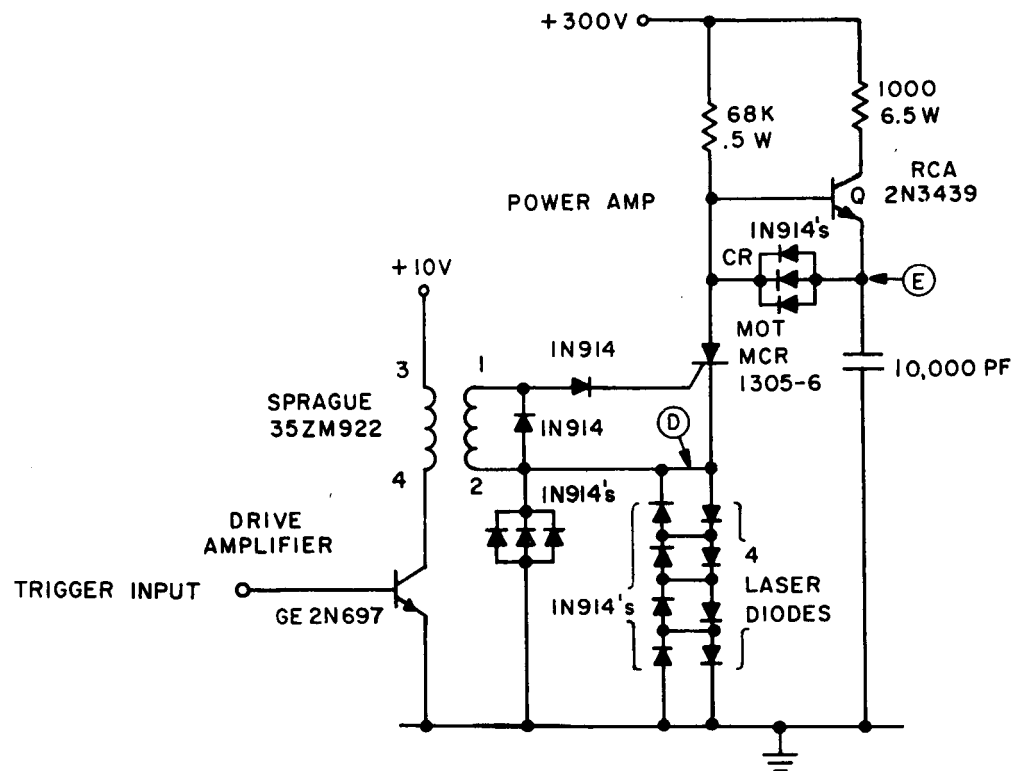

Fig. 6. Laser drive circuit.

To satisfy the requirement of providing a 100-pps tone and voice communication, the circuit shown in Fig. 7 was designed. 100-pps and 8000-pps signals are generated by unijunction oscillators. Voice signals are transmitted by pulse frequency modulating the 8000-pps unijunction oscillator. This is accomplished by varying the charging rate of the $0.022\text{-}\mu\text{F}$ capacitor in the unijunction oscillator (see Fig. 7) in accordance with the voice input signal.

The power supply (Fig. 8) consists of eight Sonotone S-102 cells connected in series to provide 10 volts, and a DC-to-DC converter and voltage regulator circuit to provide 300 volts regulated.

The power indicator circuit (Fig. 9) employs a peak detector (connected across the four laser diodes), an FET isolation amplifier and a 2N3439 transistor

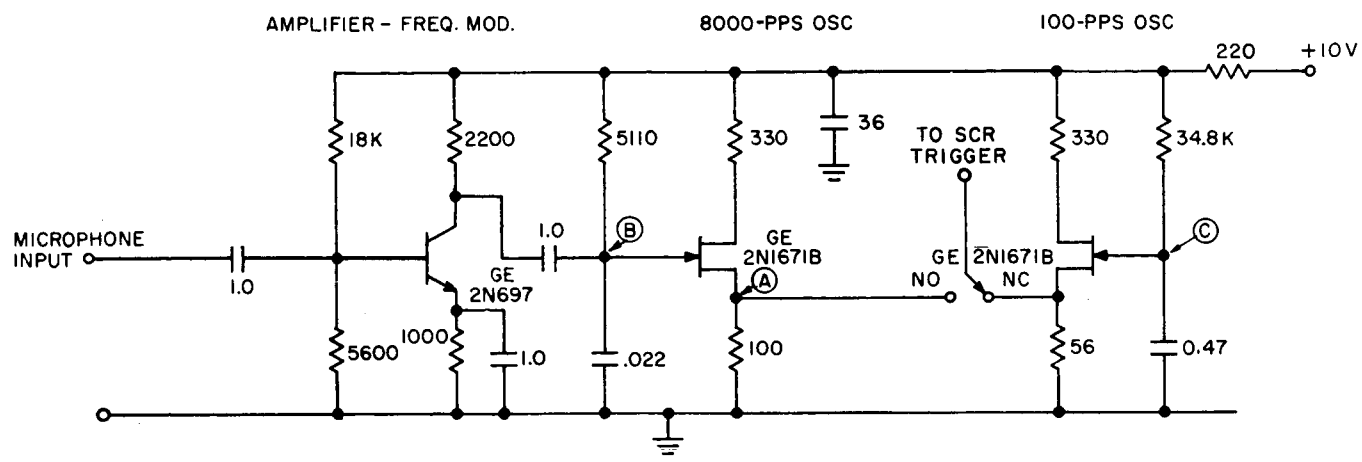

Fig. 7. 100-pps oscillator and PFM circuit.

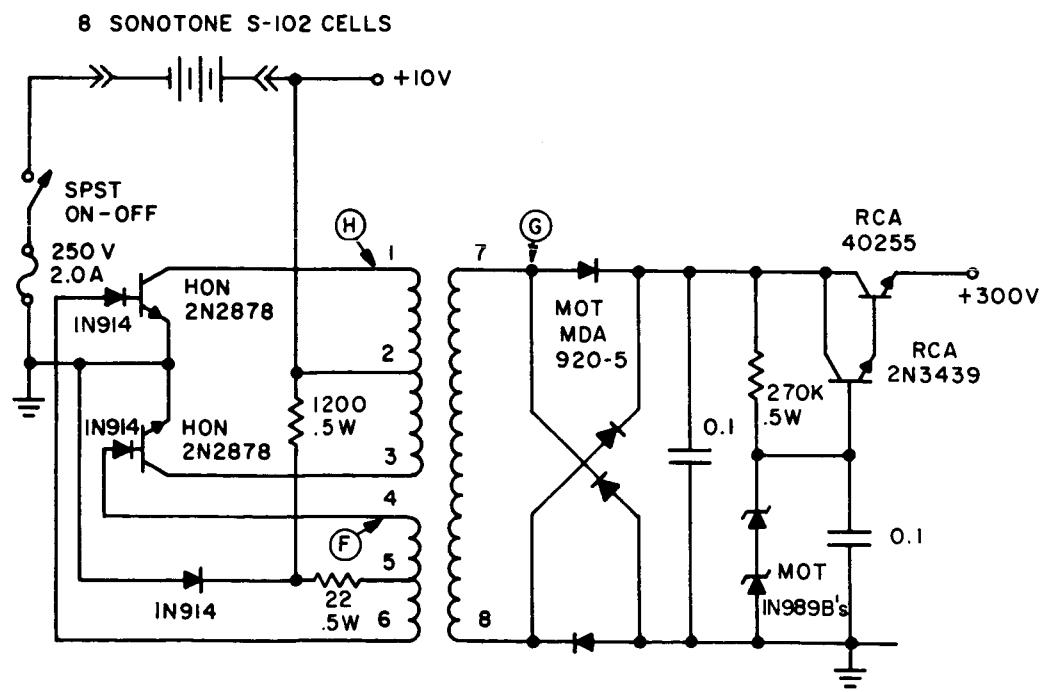

Fig. 8. Power supply.

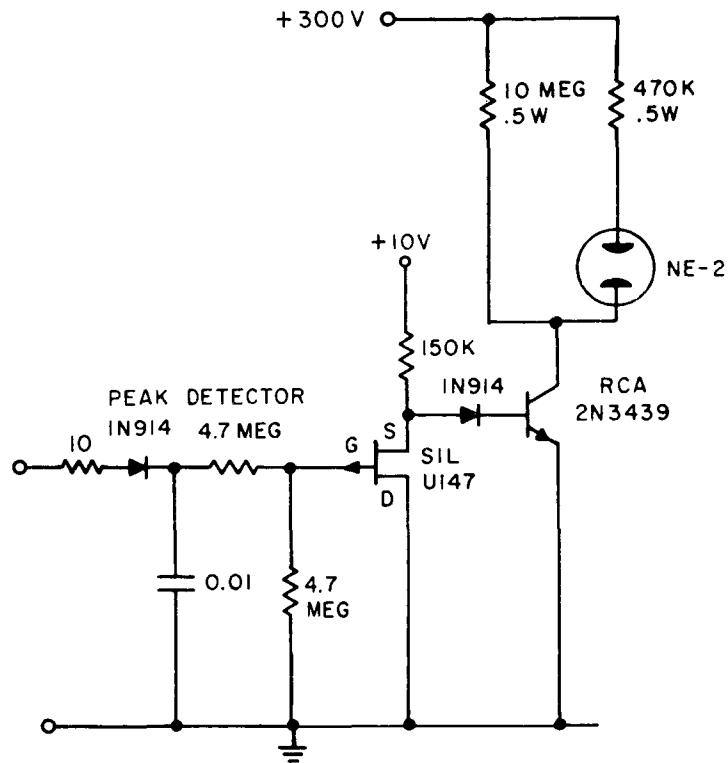

Fig. 9. Power indicator circuit.

amplifier to turn on a neon lamp when sufficient laser drive current is passing through the laser diodes.

C. OPTICS

The sighting telescope and the laser array contain optical elements. The sighting telescope consists of an objective lens, an eyepiece, a reticle, a Porro prism assembly and an interference filter. A 16-mm focal length microscope objective is used with each of the four laser diodes in the array.

1. Sighting Telescope

The sighting telescope is essentially one-half of a 6 x 30 binocular. Its components are shown in Fig. 10.

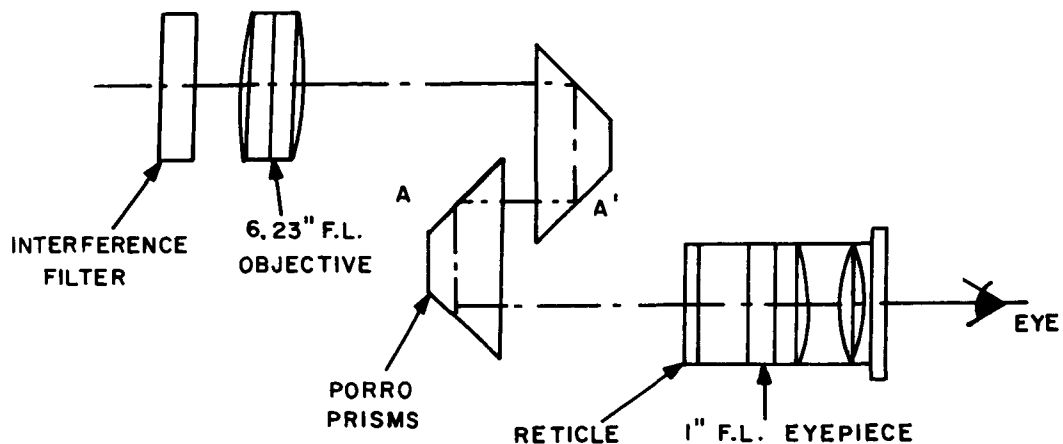

Fig. 10. Sighting telescope components.

The interference filter provides maximum transmission for the ground beacon argon laser and discriminates against background radiation. The Baird-Atomic B-4 interference filter has a peak transmission wavelength of 5000 angstroms, with a bandwidth of 400 angstroms. The special glass substrate is flat to within five circular fringes per inch.

The 6.23-inch focal length doublet objective lens forms an image of the beacon at the eyepiece reticle. The Porro prism assembly folds the optical path and provides an erect image at the reticle. In the telescope the second Porro prism and the eyepiece are rotated 90 degrees about the AA' axis. A special alignment procedure was used to ensure that the prisms were properly oriented and affixed to the prism shelf. A vertical line formed by a plumb line was viewed with a telescope. The telescope was rotated so that its vertical crosshair was parallel to the image of the plumb line. The prism shelf was then placed in the

optical path so that the plumb line was viewed through the Porro prisms. If the angle between the prisms is not 90 degrees, the image of the plumb line will not be parallel to the previously determined setting. One of the prisms is rotated with respect to the other until parallelism is obtained. The prism holding bands are tightened and epoxy applied at several points along the prism-shelf interface. The alignment is rechecked after the epoxy has cured.

The reticle has the pattern shown in Fig. 11. The numerals on the reticle pattern have no significance other than to identify the various circles. With the 6.23-inch focal length objective lens each side of the square in the pattern subtends 0.0264 radian. The diameters of the circles shown in Fig. 11 correspond to the receiver beamwidths shown as follows:

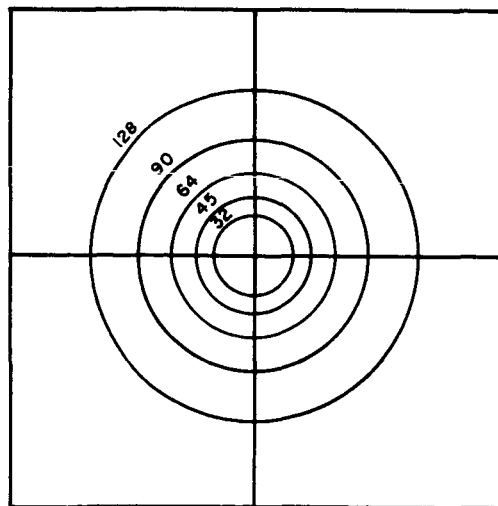

G5

Fig. 11. Reticle pattern.

<u>Circle</u>	<u>Beamwidth (in radians)</u>
128	0.01732
90	0.0122
64	0.00866
45	0.00610
32	0.00433

The eye relief provided by the 1-inch focal length eyepiece is 1.029 inches.

2. Laser Array Optics

The array of four laser diodes (each with its own collimating objective) is aligned to provide a composite beam pattern whose cross section is essentially square. A single diode gives a beam pattern with a 10:1 aspect ratio. As explained under "Alignment Procedure" below, each diode is slightly displaced from the optical axis of its objective so that, when viewed from the far field, the four diodes appear as a single source of larger area than a single diode. The collimating lens for each laser diode is an F/2 microscope objective having a focal length of 16 mm.

The sighting telescope and the laser optics must be boresighted; that is, the directions of the sighting axis and beam axis must be parallel in order that the radiated beam be incident upon the ground receiver when the beacon image is centered in the telescope reticle. Rather than rely on extremely tight mechanical tolerances in the fabrication of the optical components, a precise alignment technique was used. The boresighting axis is defined and determined by the optical axis of the sighting telescope objective, and the location of the eyepiece recticle crosshair intersection with respect to the optical axis.

3. Alignment Procedure

The optics module of the laser transmitter is mounted in a jig which maintains the unit in a fixed position. The various components required for alignment are shown in Fig. 12. The initial alignment is made on the sighting telescope and is accomplished in the following order:

- (a) With the plane parallel reference plate in place, the illuminator in the autocollimator is turned on. The illuminated reticle in the autocollimator provides a source at infinity for focusing the sighting telescope.
- (b) The autocollimator is elevated and moved laterally so that the beam of light falls upon the sighting telescope objective.
- (c) The reticle in the sighting telescope is observed and the eyepiece is focused so that the image of the autocollimator reticle is sharply defined. The orientation of the eyepiece housing relative to the optics module case is noted, and the eyepiece is removed and its reticle rotated so that, when the eyepiece is reinserted and focused, the reticle horizontal crosshair will be parallel to the top edge of the module case.
- (d) The angular position of the autocollimator is adjusted so that the image of the autocollimator is exactly coincident with the crosshair in the sighting telescope. Precise focus of the sighting telescope is obtained by rotating the eyepiece in its threaded mount until there is no parallax between the image and the crosshairs. The locking screw on the eyepiece is tightened. The telescope is now in focus and the boresight axis is determined by the intersection of the telescope reticle lines and the telescope objective optical axis.
- (e) A diffuser such as a piece of translucent paper is then placed over the sighting telescope eyepiece and is illuminated by a lamp. This provides illumination for the telescope reticle. Then the boresight axis is translated down to the laser array optics. This is accomplished with the autocollimator and the plane parallel plate.
- (f) The autocollimator illuminator is turned off and the image of the sighting telescope reticle is viewed in the autocollimator. If necessary the angular position of the autocollimator is adjusted so that its crosshair is coincident with the image of the sighting telescope reticle. The axis of the autocollimator is thus made parallel to the boresight axis.

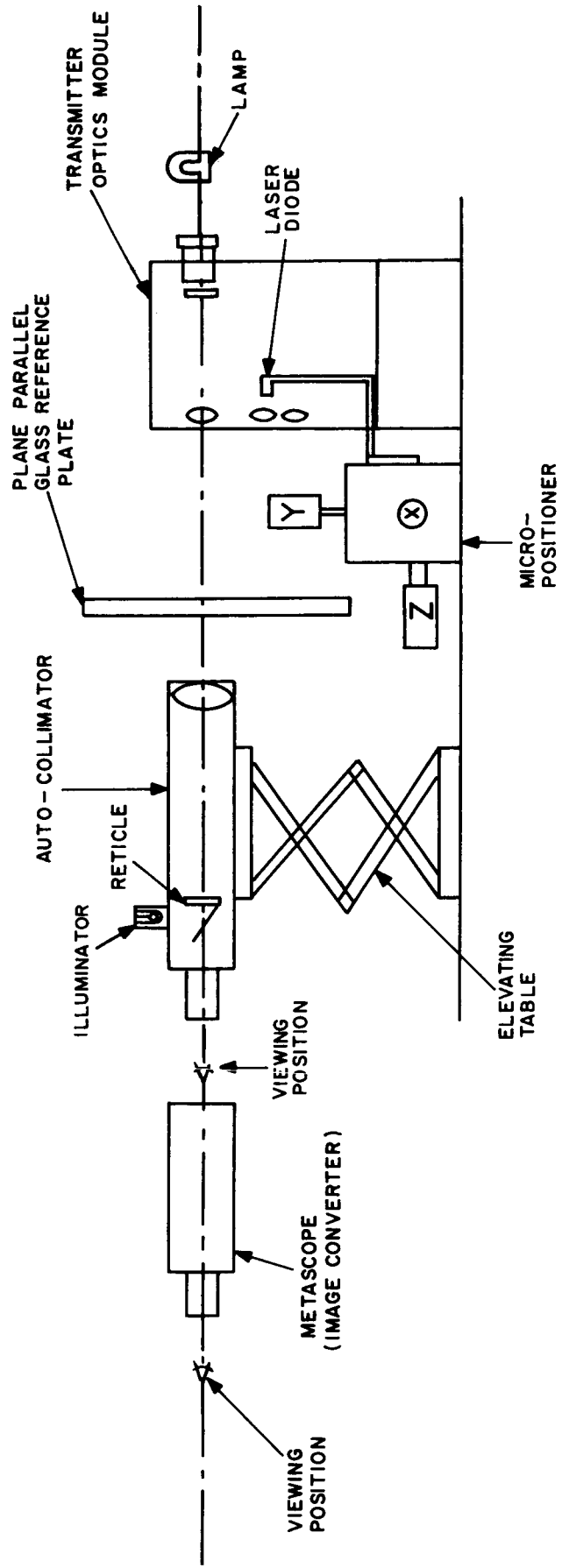

Fig. 12. Alignment components.

- (g) The autocollimator illumination is turned on and an opaque mask is placed between the reference plate and optics module to prevent reflections from the interference filter in the sighting telescope. The angular position of the plane parallel glass reference plate is adjusted so that the reflected image of the autocollimator reticle is returned upon itself when viewed in the autocollimator eyepiece. With a precision autocollimator such as the Hilger-Watts Microptic it is possible to align the reference plate to within a fraction of a second of arc normal to the boresight axis. With the reference plate locked in position, the autocollimator may be translated vertically and horizontally to accept radiation from the laser array optics. When in position to receive the radiation from laser optics, the angular position of the autocollimator is checked by observing the reflected image from the reference plate. The autocollimator is rotated so that the returned image reflected from the reference plate is coincident with the reticle.
- (h) The alignment jig has two micropositioners so that the two upper laser diodes may be located and epoxied with respect to their objectives. After curing, the micropositioners are released. The diameter of the autocollimator is sufficient to receive radiation simultaneously from any two adjacent objective lenses in the diode array. The two upper diodes are mounted first.
- (i) The metascope (image converter tube and optics) is used to observe the radiation from the diodes. When the metascope is focused for an infinite distant object, the reticle in the autocollimator is in focus. The two laser diodes connected in series are driven by a pulser, while one of the laser objectives is obscured so that the other may be aligned. The micropositioner is adjusted in X and Y directions so that the illumination appears in the metascope. The laser diode is thus positioned relative to its 16-mm collimating objective. The diode is focused by moving the Z slide of the micropositioner. When the diode is in focus, a sharply defined image of the emitting area of the diode is obtained. When the X and Y positioners are set properly, the diode may be referenced with respect to the autocollimator reticle and therefore to the boresight axis. To form the beam pattern array, each diode is displaced vertically from the boresight axis as viewed in the metascope. The X positioner is adjusted so that the long dimension (the horizontal) of the diode image is equally displaced about the vertical crosshair. The Y positioner is set so that the image of one of the upper diodes is displaced above the horizontal crosshair. It was determined by beam pattern measurements that the diodes should be separated from one another 0.0005

inch vertically. To accomplish this separation one diode was moved up 0.00025 inch in its holder and the other diode was moved up 0.00075 inch in its holder. Both diodes are aligned and may be viewed simultaneously in the metascope. In order to provide better uniformity in the fill-in areas of the beam, the diodes are defocused approximately 0.001 inch by the Z positioner. The diodes are defocused by moving them toward their objective lenses.

- (j) The two lower diodes are aligned in a similar manner. The auto-collimator is positioned to receive radiation from these two diodes and is referenced against the plane parallel plate to maintain the boresight axis. The lower diodes are displaced 0.00025 and 0.00075 inch below the horizontal crosshair reference position. The diodes are defocused in the same manner as described above. The diodes are epoxied into position and the micropositioner is removed after curing.

SECTION III

OPTICAL AND ELECTRICAL MEASUREMENTS

A. SIGHTING TELESCOPE

The sighting telescope was subjected to magnification and field-of-view tests. Determined by direct measurement of the focal length of the objective lens and the eyepiece lens, magnification is given by

$$M = \frac{\text{objective focal length}}{\text{eyepiece focal length}}$$

A nodal slide lens bench with a collimator source was used for the focal length measurement. The objective focal length measured 6.231 inches with a variation of 0.023 inch maximum for the lot of lenses obtained for the transmitters. The focal length of the eyepieces measured 1.002 inches. The magnification for the sighting telescope is

$$M = \frac{6.2}{1.00} = 6.2X$$

The field of view of the assembled telescope was determined as follows: the transmitter was mounted on a rotary table. A distant vertical object was viewed. The table was rotated so that the object appeared at the extreme left edge of the circular field as seen in the eyepiece. The angular setting of the table was recorded. The table was then rotated until the object moved to the right edge of the field. The difference between the angular settings is the coverage of the circular field. A field of 6.5 degrees was measured.

B. LASER ARRAY

The measurements on the laser array consist of the determination of the total emitted power and the angular subtense and distribution of the power in the beam in the far field.

Because of the physical separation between the optical axes of the four laser diode objectives, it is necessary that the far field measurements be made at a considerable distance from the transmitter. The distance is much greater than would be the case for one of the 16mm objectives alone. A practical method of measuring the beam characteristics was used. A 25-inch focal length doublet objective having a diameter of 5 inches was used to simultaneously focus the radiation from the four laser objectives. At the infinity focal plane of the 25-inch lens an image is formed in which the angular position and distribution of the beam is the same that would exist at many miles from the transmitter. The locations of the four individual sections of the beam are governed by angular displacement of the diodes from the boresight axis and is not dependent upon the physical separation between the four laser objectives.

An infrared phototube with a small aperture (0.002 inch) is used to explore the image formed by the 25-inch lens. A plot of intensity versus location in the focal plane is obtained. A three-dimensional picture of a typical beam pattern is shown in Fig. 13. The X-axis represents the horizontal position of the beam sensor; the Y-axis represents the vertical position of the beam sensor; and the Z-axis represents the intensity of the beam. The angular subtense between two locations is given by $\omega = \tan^{-1} d/25$ where d is the distance between the locations in inches.

The total emitted power is measured by using the laser test set (EE45005) discussed in Section IV. For measurement of power, the test set should be spaced no greater than one-half inch from the transmitter. Care should be taken that the entrance window is positioned so that none of the apertures of the trans-

mitter is obscured by the edges of the entrance window. The face of the entrance window should be parallel to the laser transmitter case wall containing the laser array optics. Since a 0.156-inch diameter aperture is located at the center of the phototube photocathode, no variations in sensitivity across the photocathode will be encountered. If the test set is tilted with respect to the transmitter, the image formed at the photocathode will not fall within the 0.156-inch aperture. The test set should be rotated through a small horizontal angle and a small vertical angle while observing the output signal on an oscilloscope (a Tektronix 545 oscilloscope with type L plug-in or equivalent). The maximum output signal will indicate proper orientation. In a similar manner a maximum signal obtained when the test set is given a small horizontal or vertical movement without changing angular orientation will ensure that the entrance window is correctly positioned with respect to the four elements of the array. Upon completion of the above procedure, the power can be calculated by observing the peak voltage on the oscilloscope. The calibration is 2 millivolts per watt incident upon the entrance window.

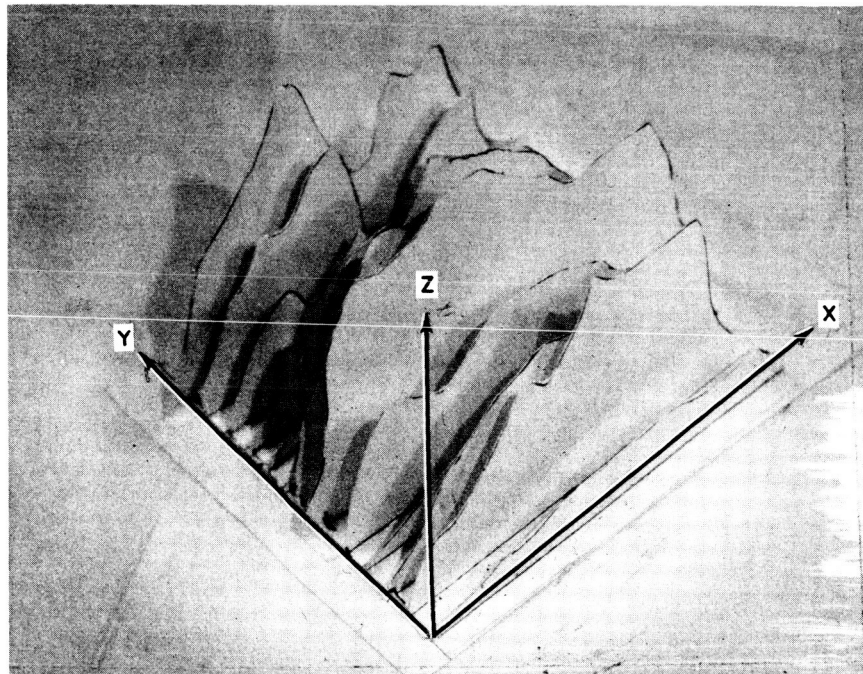

Fig. 13. Three-dimensional beam pattern.

The wavelength of the transmitter was measured by imaging the output upon the entry slits of a Bausch and Lomb monochromator. The output of the monochromator was detected by an RCA 7102 multiplier phototube; thus, the plot of intensity versus wavelength shown in Fig. 14 was obtained.

C. BATTERY LIFE

After charging to full capacity, the battery pack (EE45003) was discharged under a constant load which was equivalent to the 100-pps mode. The results of these tests are shown in Fig. 15. These results show that the transmitter will operate for more than two hours in the 100-pps mode. Calculations show that the unit will operate approximately 40 minutes in the voice mode.

D. OSCILLATOR STABILITY

The 100-pps oscillator was tested for stability as a function of operating time and supply voltage. The results are shown in Fig. 16. These results show a change in frequency of 0.3 per cent after operating for an hour at a constant supply voltage. A change of 2.8 per cent was noted when the supply voltage varied from 10 volts to 8 volts.

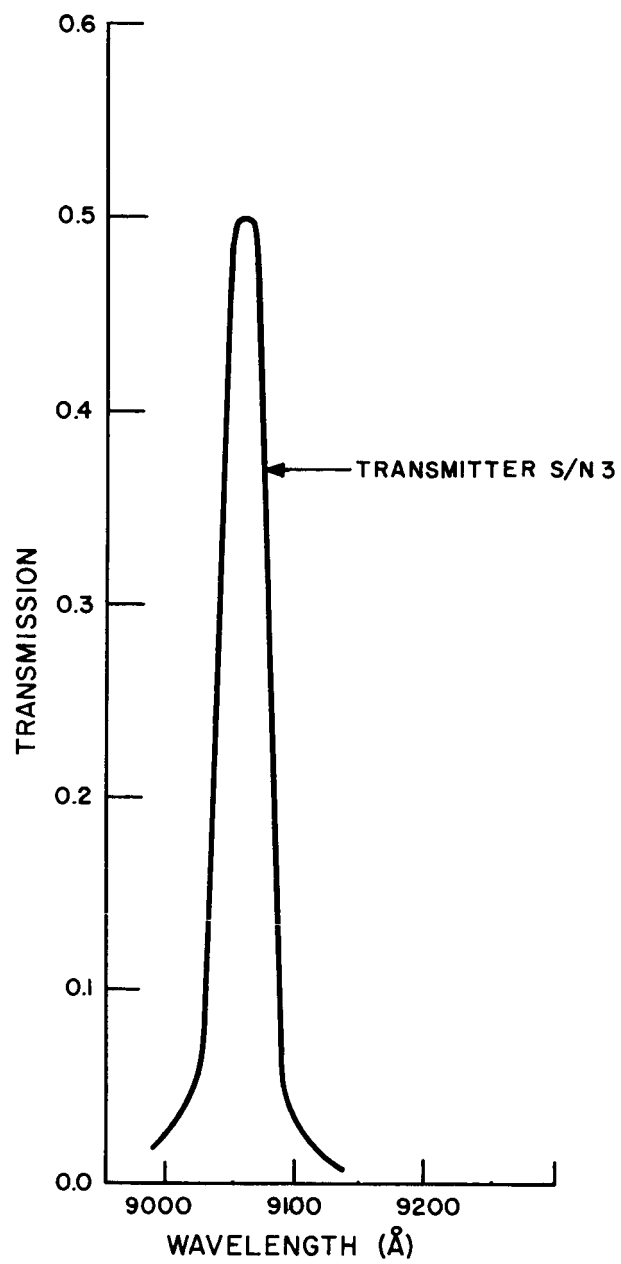

Fig. 14. Wavelength vs intensity.

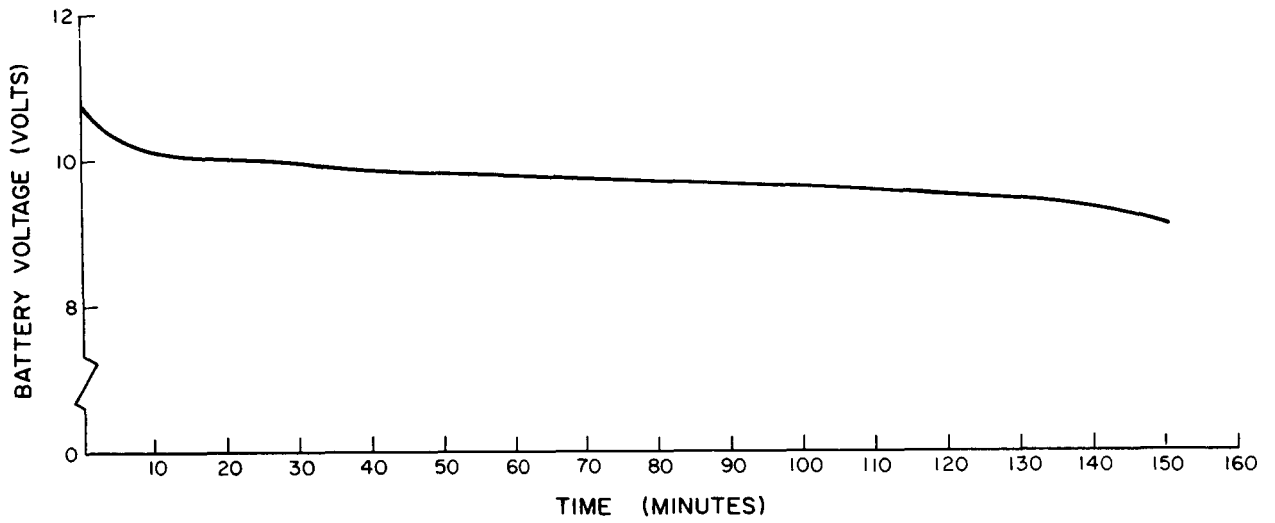

Fig. 15. Battery voltage vs time for 100-pps operation.

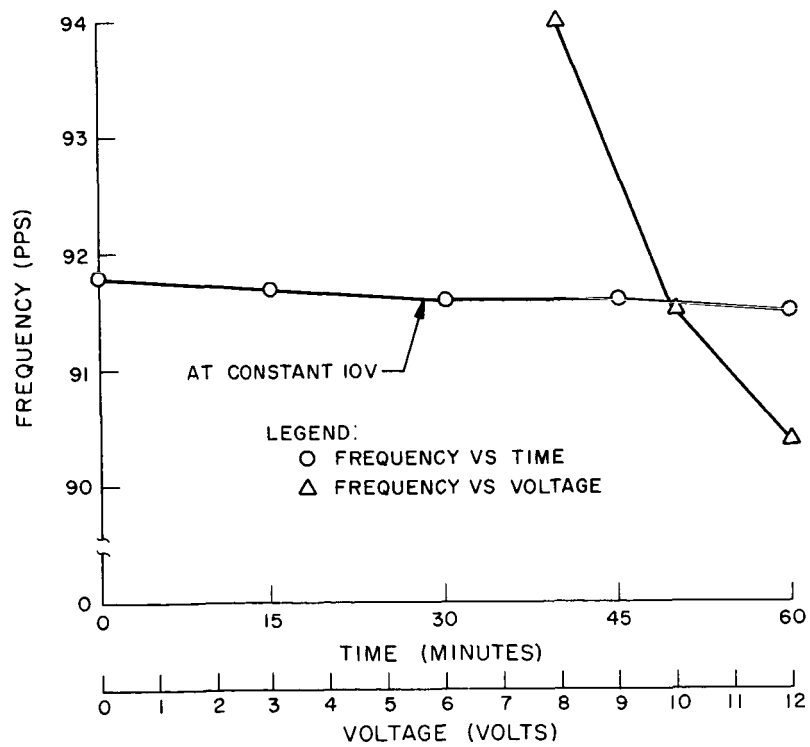

Fig. 16. Oscillator stability.

SECTION IV

LASER TEST SET

The test set (EE45005) consists of a housing containing an entrance window, a group of attenuating filters, a 2.81-inch focal length lens, an RCA 7102 multiplier phototube, a socket with voltage divider for the phototube, a 100-ohm load resistor, and an end plate containing BNC connectors for phototube voltage input and the output signal. A schematic and a mechanical layout are shown in Fig. 17.

The phototube was calibrated against Applied Research's primary standard phototube. The primary standard was calibrated at the RCA Tube Division in Lancaster, Pa. by measuring the absolute spectral sensitivity of the photocathode versus wavelength and the gain of the multiplier section at a specific multiplier voltage.

The attenuating filters consist of two ND3 and one ND2 Wratten filters.

The total density of 8 is for visible radiation and is somewhat less dense for the 9000 Å radiation. The attenuating filters limit the output current, thereby preventing saturation. The filters also ensure that the output will be linear over the range expected with the laser transmitter whether only one or all four of the array elements are measured.

The following precautions should be noted in using the test set.

1. The multiplier phototube power supply should be set at - 650 volts (positive ground).
2. The test set is not suitable for measuring the output of a laser diode that does not have a collimating lens.

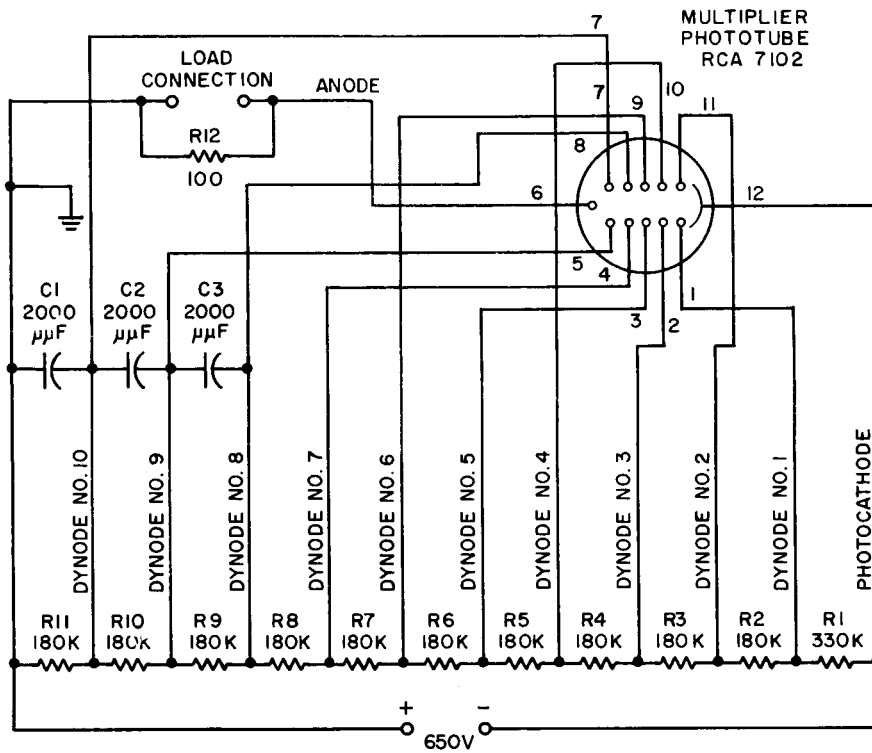

SCHMATIC

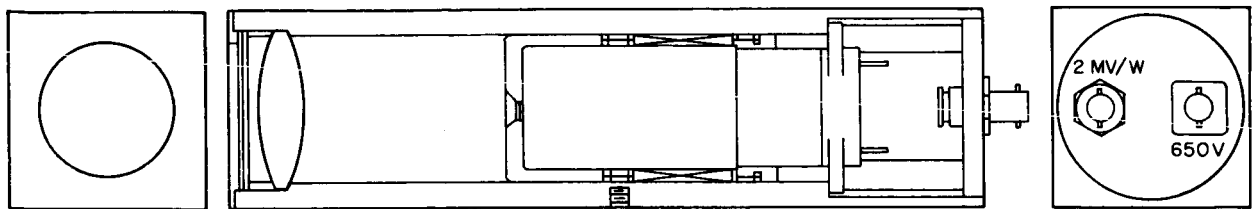

Fig. 17. Laser test set.

SECTION V

EQUIPMENT MAINTENANCE

A. INTRODUCTION

The laser transmitter is made up of three modules: optics module (EE45006) Fig. 18, electronics module (EE45007) Fig. 19, and battery pack (EE45003) Fig. 20. A complete schematic, wiring diagram and circuit boards are given in Appendix B.

Before any work is done on the transmitter, a clean clear working area should be prepared to avoid accidental damage to the optics and other components.

B. DISASSEMBLY

To disassemble the modules, the chassis retaining screws should be removed. A modest pull will disengage the modules. The connectors should then be disengaged.

C. BATTERY PACK

The battery charger (EE45004) consists of a power supply, a current regulator and a voltage regulator. The output voltage and current are adjustable. The schematic, circuit boards and parts list are given in Appendix C.

The batteries should be charged at a constant current of 80 mA for 14 hours, using battery charger EE45004. For maximum life, the batteries should not be discharged below 8 volts, nor should they be overcharged. Care should be observed not to short-circuit the battery pack.

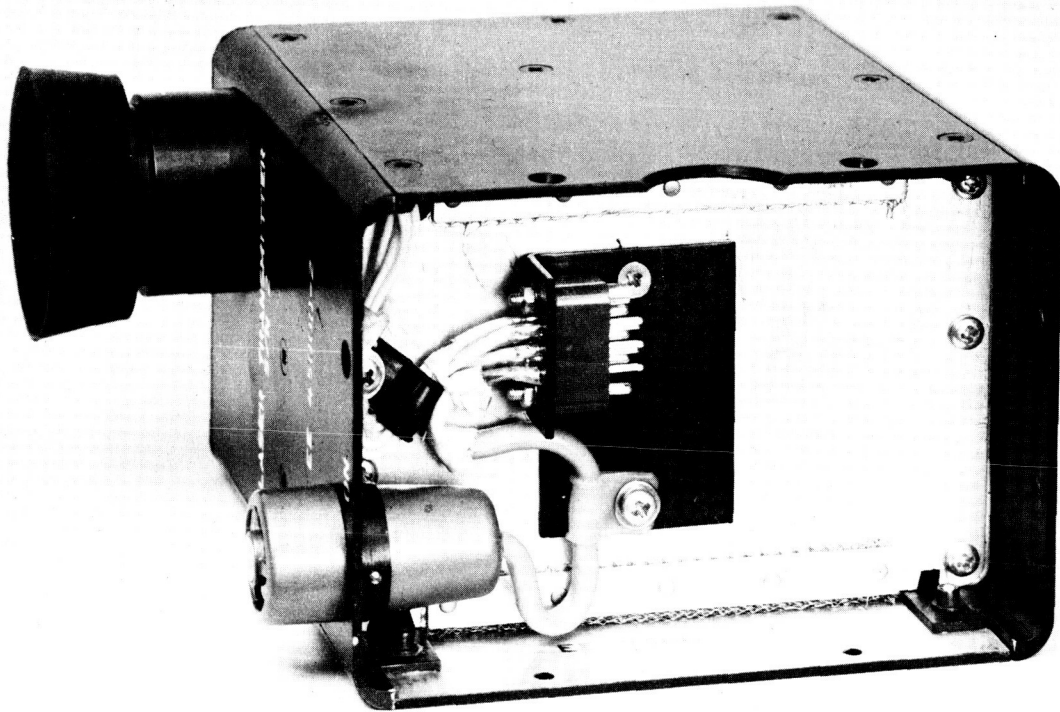
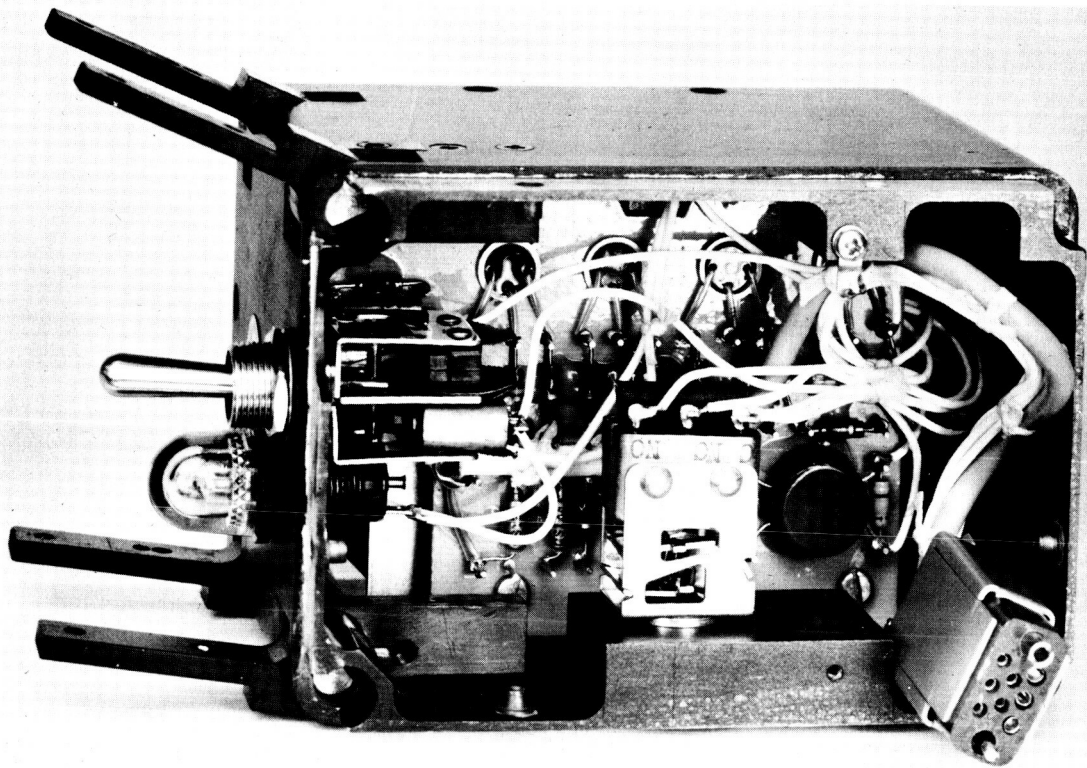

Fig. 18. Optics Module.

D. CLEANING OPTICAL ELEMENTS

For maximum light transmission and sighting efficiency, the exposed optical elements should be kept clean. They should be cleaned with pure acetone and lens tissue. Care should be taken to avoid scratching the elements.



(a) Top view

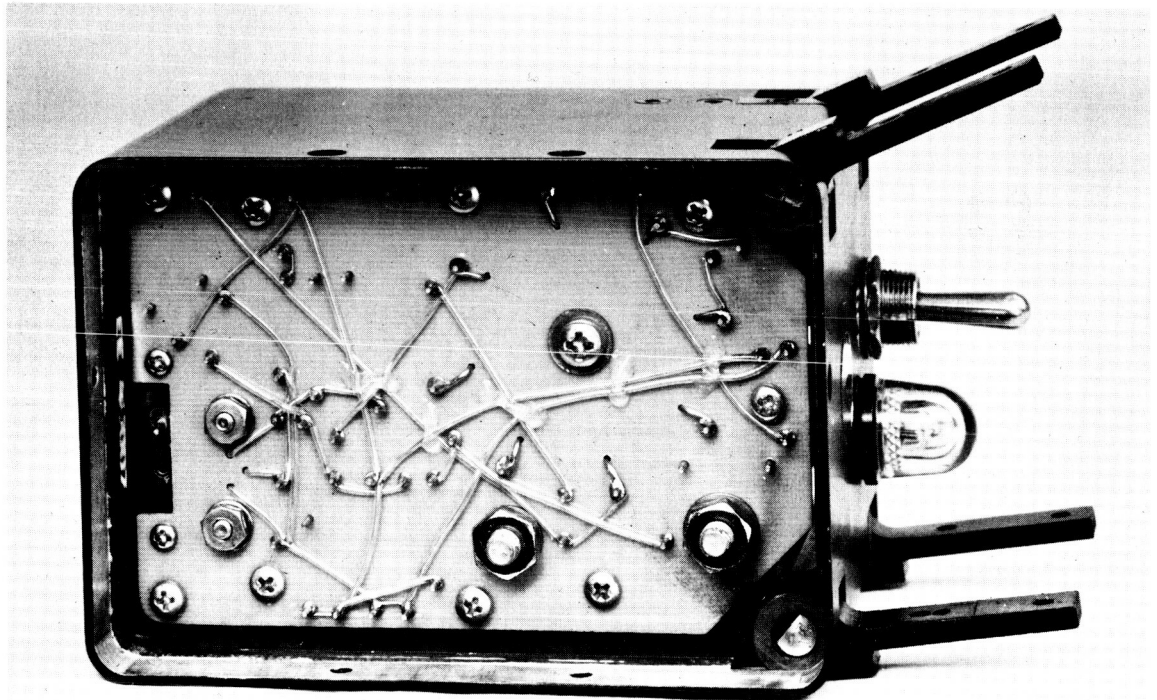

(b) Bottom view.

Fig. 19. Electronics module.

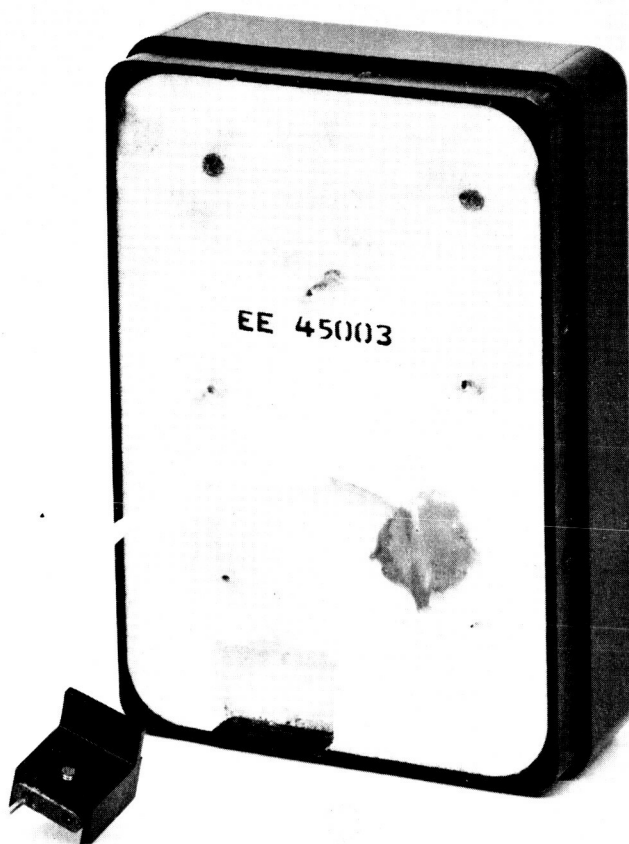

Fig. 20. Battery pack.

APPENDIX A

OPTIMUM DUTY FACTOR OF AN INJECTION LASER TRANSMITTER

The average power output from a pulsed laser diode is

$$\bar{P}_t = q \hat{P}_t \quad (\text{A-1})$$

where q is the duty factor of the laser and \hat{P}_t is the peak output power. To express average output power in terms of diode drive current, consider the curve of measured peak output power vs drive current for a GaAs diode plotted in Fig. A-1. In the region of this curve between the threshold and saturation knees, the relationship between peak output power \hat{P}_t and peak drive current I is approximately

$$\hat{P}_t \approx 1 \times 10^{-11} (I)^8 ; I < I_{\text{sat}} \quad (\text{A-2})$$

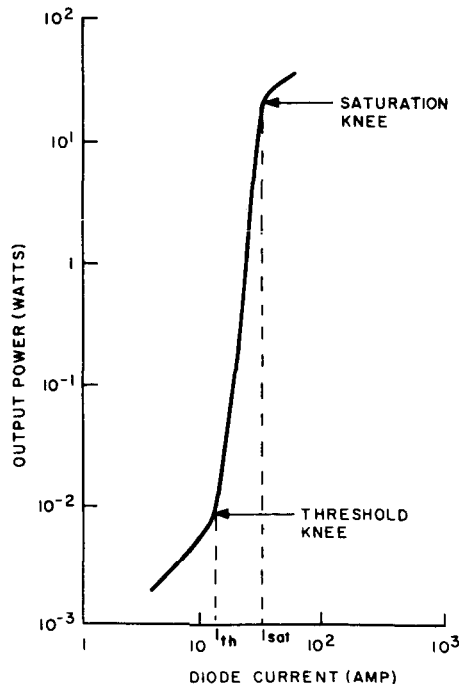

Fig. A-1. Power output vs drive current for a GaAs laser diode.

Above the saturation knee the output power is given by

$$\hat{P}_t = \eta_i E_g \hat{I} ; \hat{I} > I_{sat} \quad (A-3)$$

where η_i is the diode quantum efficiency and E_g is its gap voltage.

Because high drive current is needed for room-temperature laser operation, a good approximation for average power dissipation \bar{P}_d is

$$\bar{P}_d = q (\hat{I})^2 r \quad (A-4)$$

where r is the resistance of the laser diode. From this expression it follows that the maximum allowable duty factor is

$$q_{max} = \frac{\bar{P}_{d\ max}}{(\hat{I})^2 r} \quad (A-5)$$

Combining Eqs. A-1, A-2, A-3, and A-5, we find that the average power available \bar{P}_a (i. e. , the average power output obtained when the diode is operating at maximum average power dissipation) is

$$\bar{P}_a \approx \frac{1 \times 10^{-11}}{r} P_{d\ max} (\hat{I})^6 ; \hat{I} < I_{sat} \quad (A-6)$$

and

$$\bar{P}_a \approx \frac{\eta_i E_g}{r} \bar{P}_{d\ max} (\hat{I})^{-1} ; \hat{I} > I_{sat}$$

Eqs. A-6 and A-7 show that, when the drive current is below I_{sat} , output power increases as $(\hat{I})^6$ and, when the drive current is above I_{sat} , output power increases as \hat{I}^{-1} . In both of these regions, Eq. A-4 shows that power dissipation increases as \hat{I}^2 . Thus, it is evident that the ratio of power output to power dissipated is maximum at the boundary between the two regions, i. e. , at $I = I_{sat}$.

Hence, we conclude that average output power is maximized by driving the diode at the saturation level with a duty factor equal to

$$q_{\text{opt}} = \frac{\bar{P}_{\text{d max}}}{(I_{\text{sat}})^2 r} \quad (\text{A-8})$$

APPENDIX B
LASER TRANSMITTER SCHEMATICS,
CONNECTION DIAGRAM,
CIRCUIT BOARDS AND
PARTS LIST

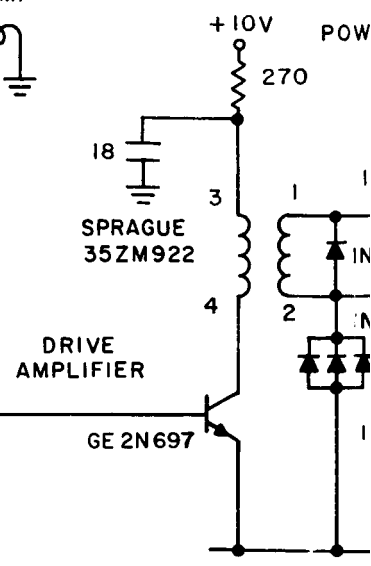
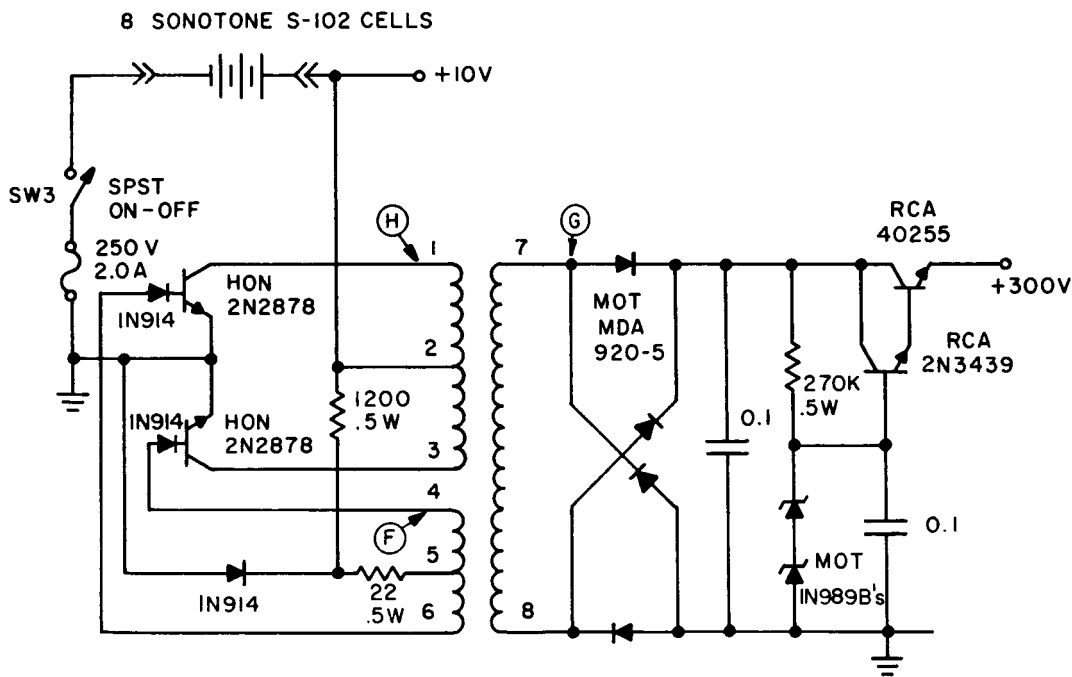
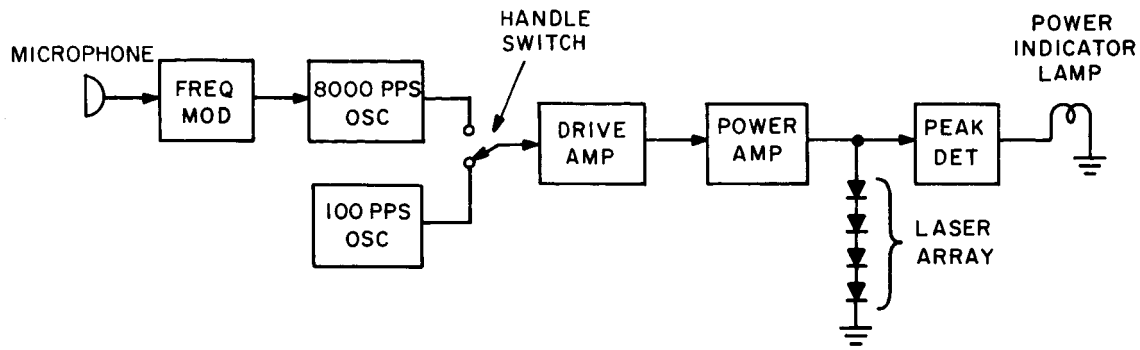

NOTE:
ALL RESISTORS ARE
UNLESS OTHERWISE
ALL CAPACITOR VALUES
ARE IN MICROFARADS

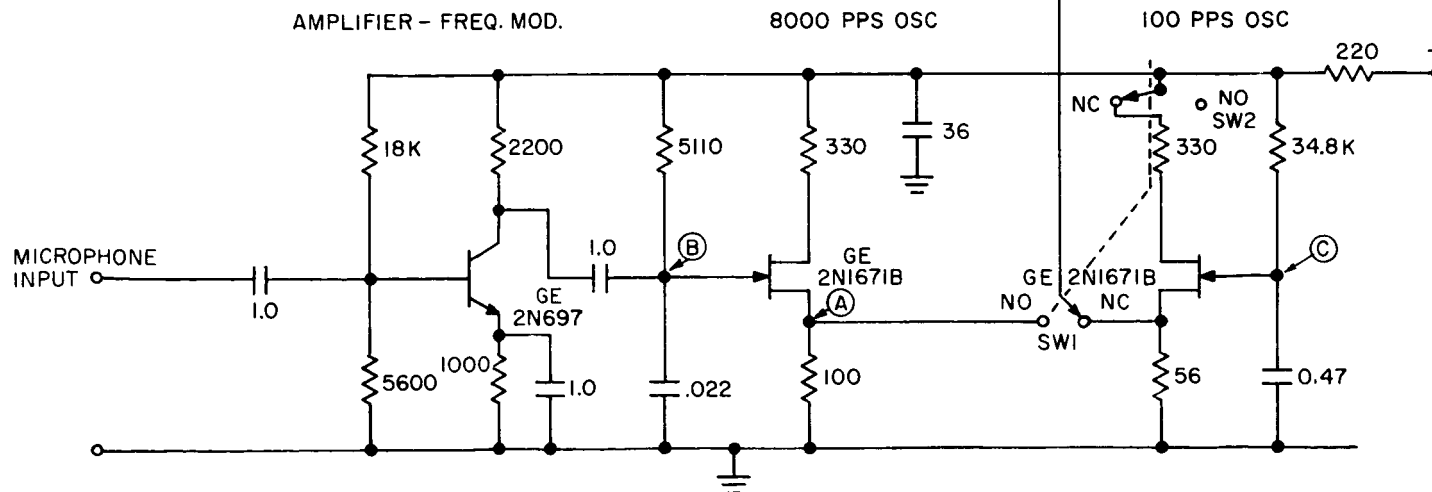

1

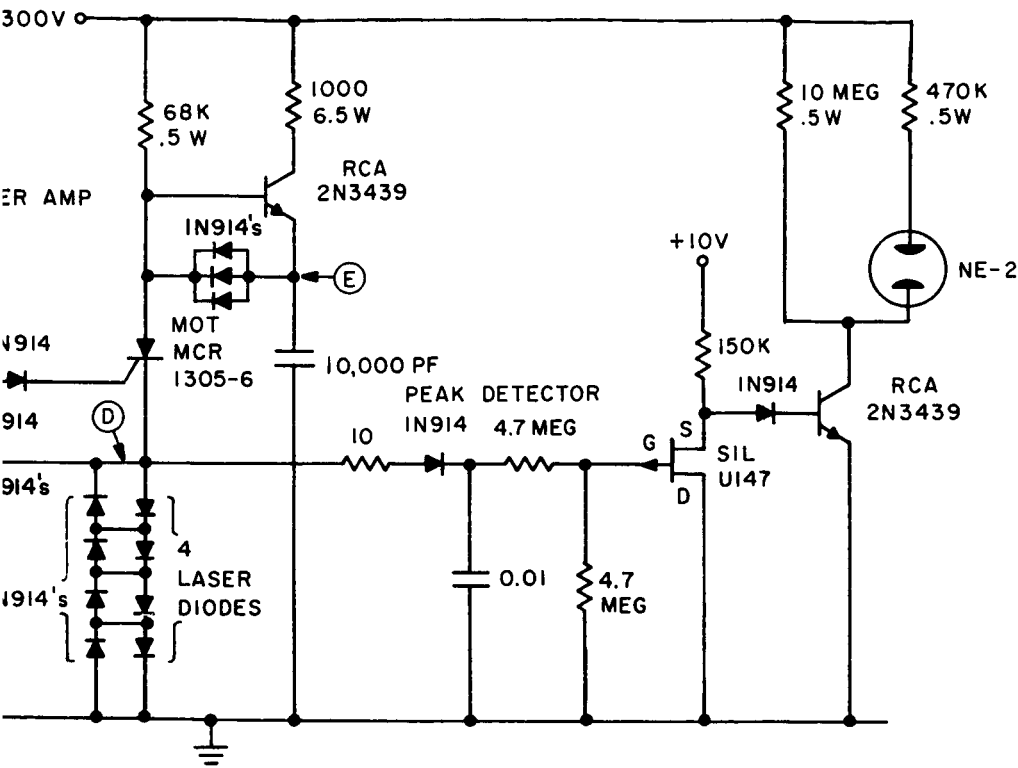

0.25 WATT
NOTED.
VALUES
OS.

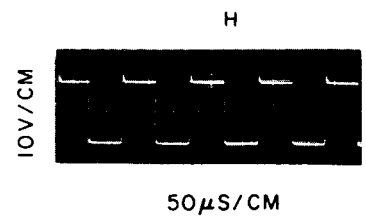
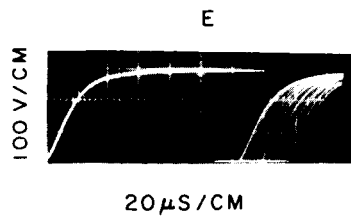
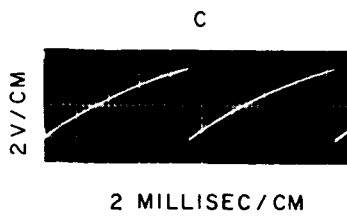
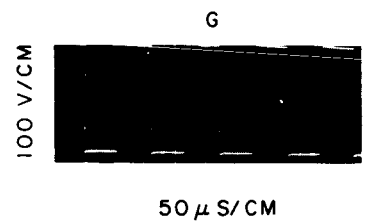
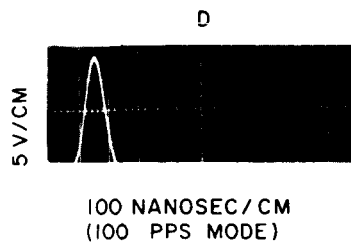
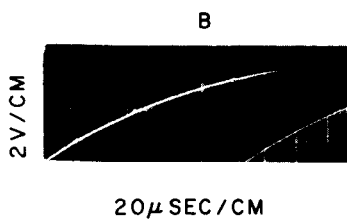
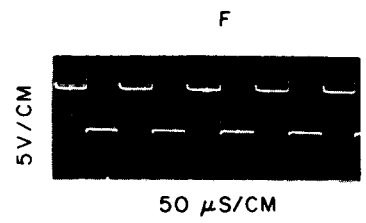
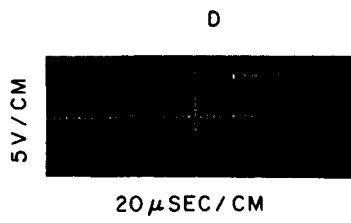
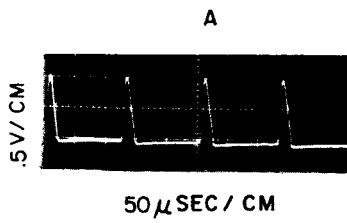

2

Fig. B-1. GT-7 laser transmitter schematic.

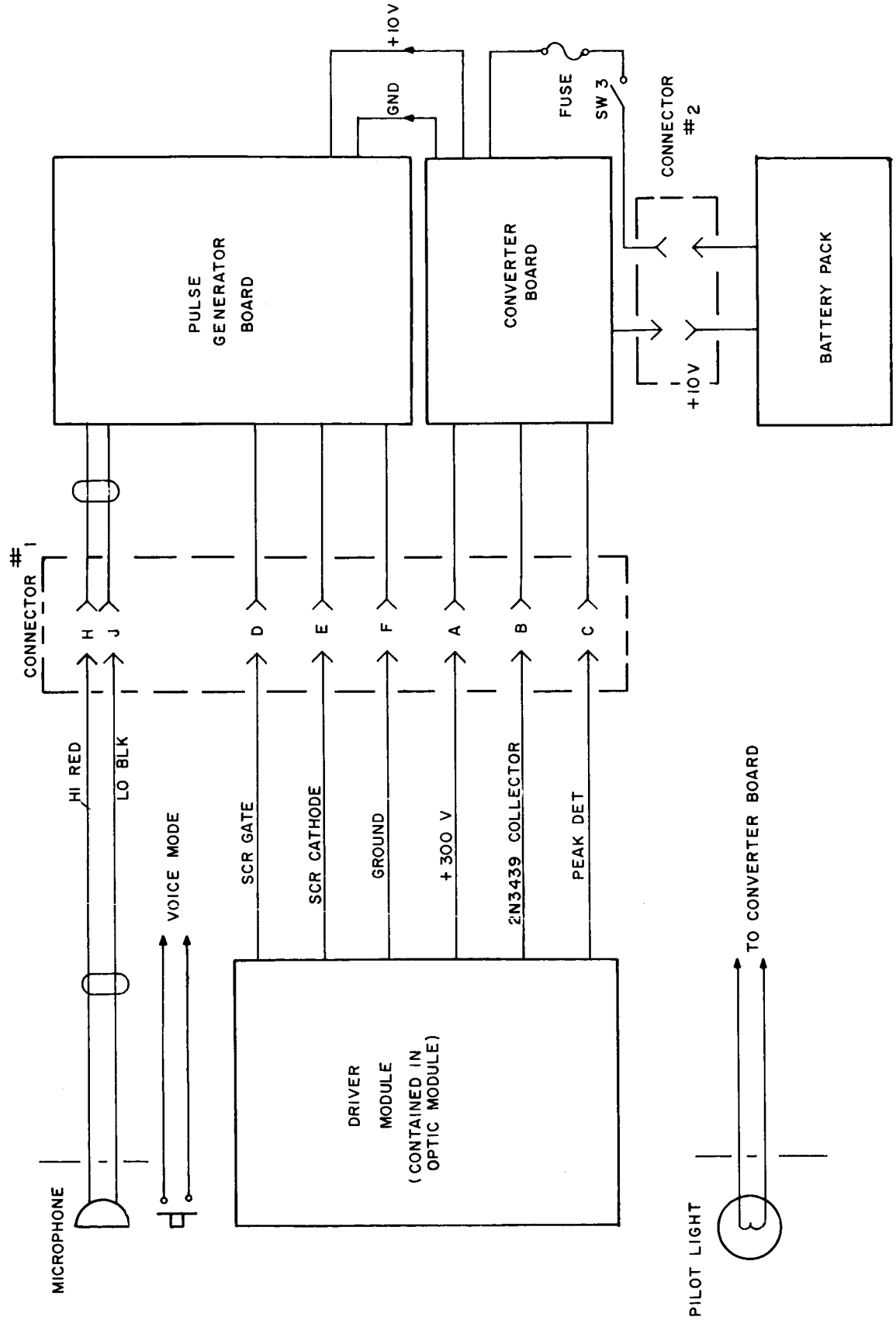
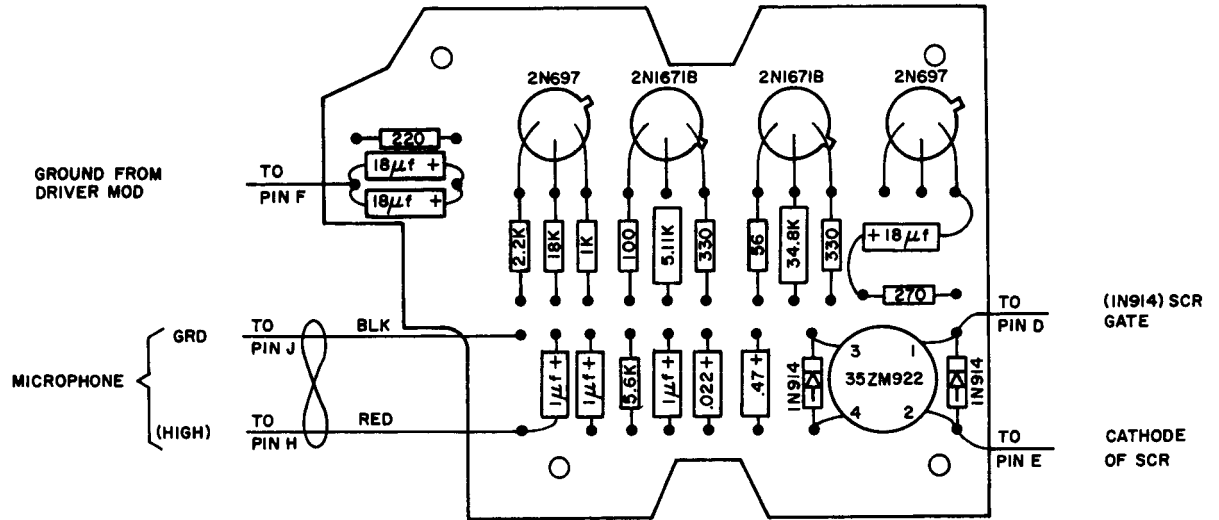
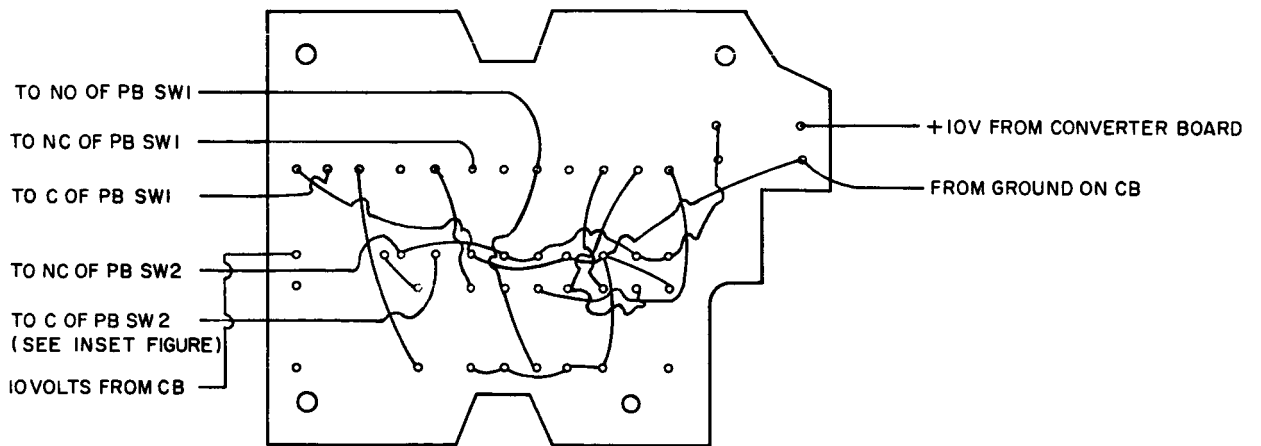
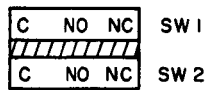

Fig. B-2. GT-7 laser transmitter module connections.



- NOTES :
1. PUT SLEEVING ON ALL TRANSISTOR LEADS .
 2. MAKE EXTERNAL LEADS 12 INCHES LONG .

Fig. B-3. GT-7 laser transmitter pulse generator board (top view).



- NOTE:
1. MAKE EXTERNAL LEADS 12 INCHES LONG.

Fig. B-4. GT-7 laser transmitter pulse generator board (bottom view).

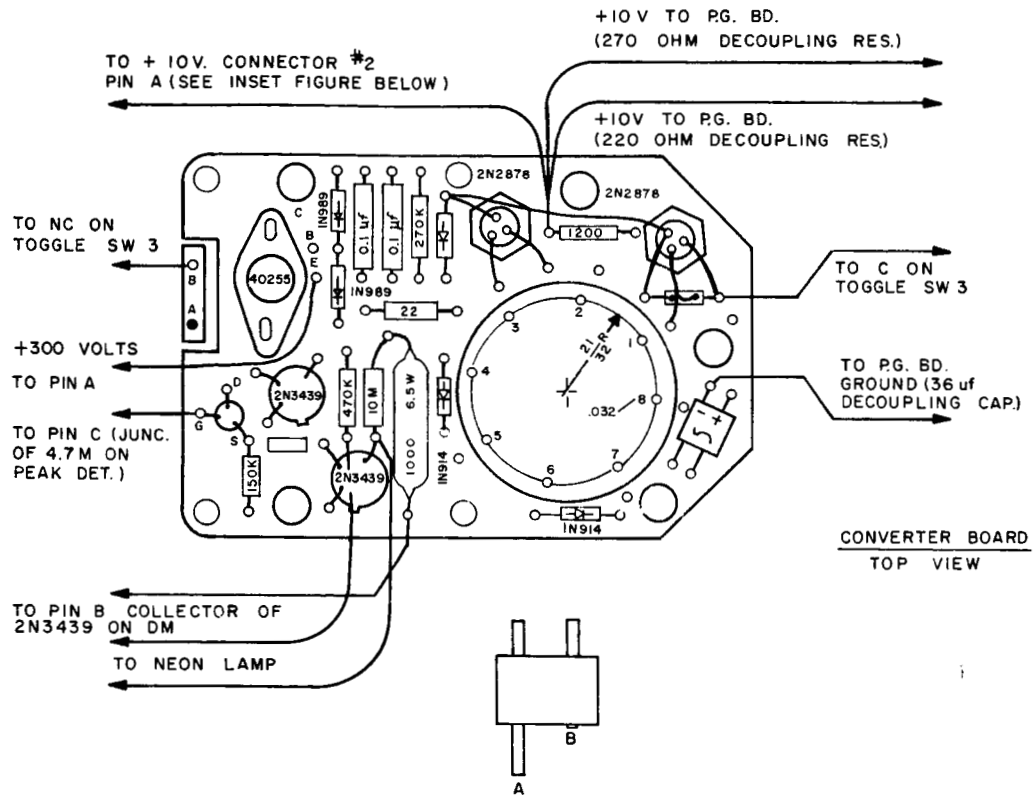

Fig. B-5. Converter board (top view).

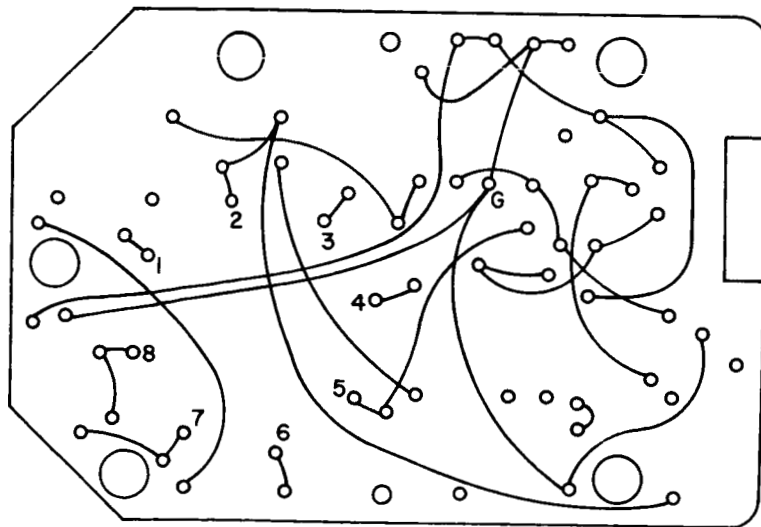

Fig. B-6. Converter board (bottom view).

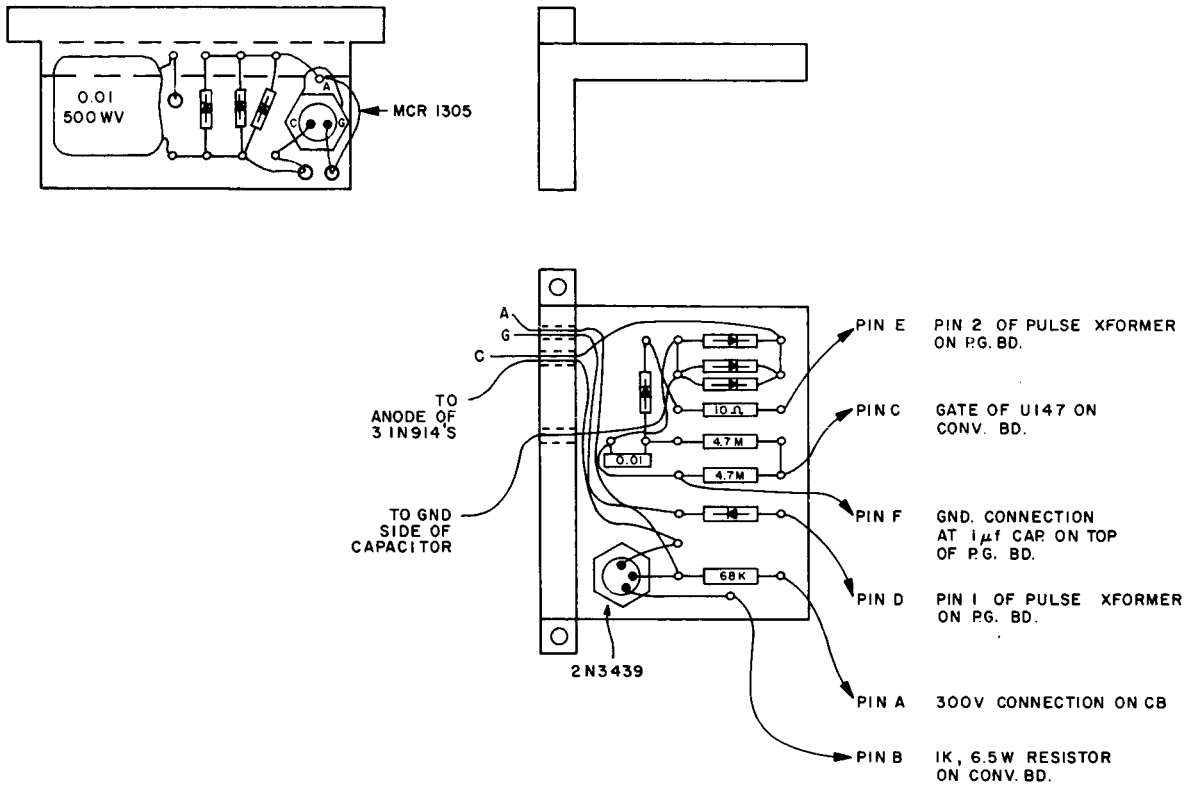
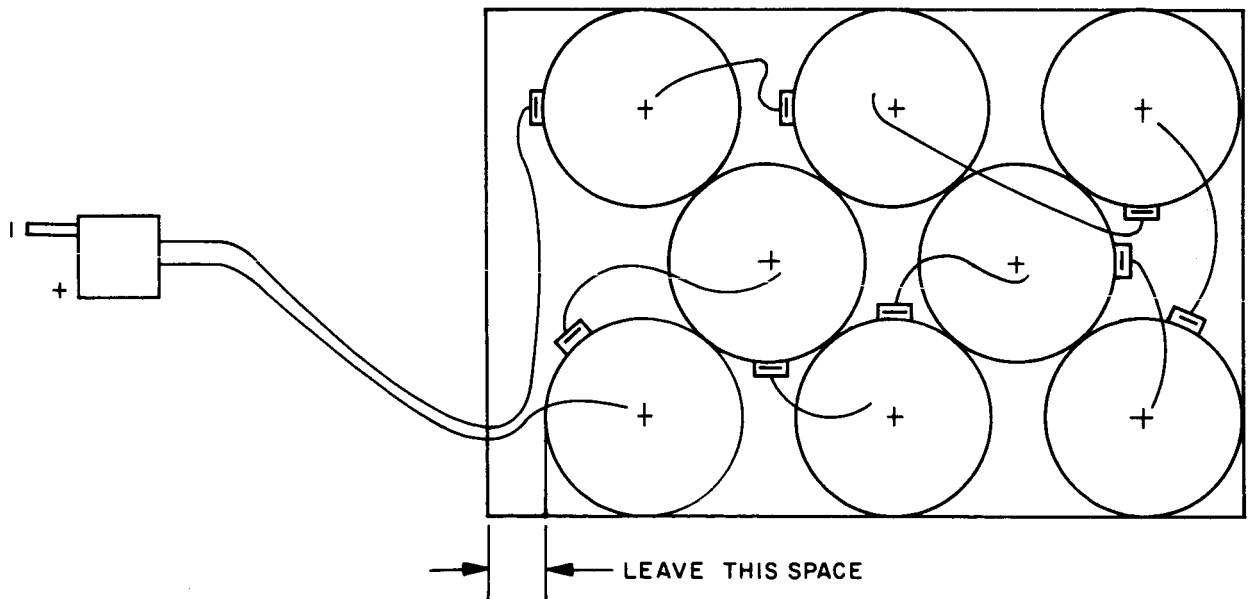

Fig. B-7. Laser drive module layout.



- NOTES:
1. MAKE EXTERNAL LEADS 6 INCHES LONG.
 2. BE CAREFUL NOT TO SHORT BATTERIES.
 3. CHECK EACH SOLDER CONNECTION.
 4. TAPE INSIDE EDGES OF CHASSIS.

Fig. B-8. GT-7 laser transmitter battery pack layout.

ELECTRICAL PARTS

<u>No. Req'd</u>	<u>Component</u>	<u>Type</u>	<u>Rating</u>	<u>Manufacturer</u>
1	Transistor	U147		Siliconix
1	Transistor	40255		RCA
2	Transistor	2N697		GE
1	Transistor	2N1132		Motorola
2	Transistor	2N2646		GE
2	Transistor	2N2878		Honeywell
3	Transistor	2N3439		RCA
1	Silicon Control Rectifier	MCR1305-6		Motorola
13	Diode	1N914		
2	Diode	1N989B		Motorola
1	Rectifier Assy.	MDA 920-5		Motorola
1	Heat sink	1101A		Thermalloy
1	Transformer	35ZM922		Sprague
1	Transformer	XT12262A		RCA
8	Battery	S102	1.25 V	Sonotone
1	Fuse	275002	2 A, 250 V	Littelfuse
1	Switch	701 PB1		Microswitch
1	Switch	223 AT1		Microswitch
1	Switch	1HM1 with J566 Actuator		Microswitch
4	Capacitor	CK06CW103K	0.01, 200 V	Erie
1	Capacitor		0.01, 500 V	
1	Capacitor	150D233X0035	0.022, 35 V	Sprague
1	Capacitor	8133-000XSR104K	0.1, 100 V	Erie
1	Capacitor	150D474X0035	0.47, 35 V	Sprague
2	Capacitor	150D105 X0035	1.0, 35 V	Sprague
2	Capacitor	41C92A10	0.1, 500 V	Sprague
1	Resistor		10 ohms, .25 W	Allen-Bradley
1	Resistor	RC20GF100K	10 ohms, .50 W	Allen-Bradley
2	Resistor	RC20GF220K	22 ohms, .50 W	Allen-Bradley
2	Resistor	RC07GF560K	56 ohms, .25 W	Allen-Bradley
2	Resistor	RC07GF271K	270 ohms, .25 W	Allen-Bradley
1	Resistor	RC07GF102K	1.0 Kilohm, .25 W	Allen-Bradley
1	Resistor	RC07GF122K	1.2 Kilohms, .25 W	Allen-Bradley
1	Resistor	RC20GF122K	1.2 Kilohms, .50 W	Allen-Bradley
1	Resistor	RC07GF562K	5.6 Kilohms, .25 W	Allen-Bradley
1	Resistor	RC07GF682K	6.8 Kilohms, .25 W	Allen-Bradley
3	Resistor	RC07GF103K	10 Kilohms, .25 W	Allen-Bradley
1	Resistor	RC07GF223K	22 Kilohms, .25 W	Allen-Bradley
1	Resistor	RC07GF473K	47 Kilohms, .25 W	Allen-Bradley
1	Resistor	RC20GF683K	68 Kilohms, .50 W	Allen-Bradley
1	Resistor	RC20GF154K	150 Kilohms, .50 W	Allen-Bradley
1	Resistor	RC20GF274K	270 Kilohms, .50 W	Allen-Bradley
1	Resistor	RC20GF474K	470 Kilohms, .50 W	Allen-Bradley
1	Resistor	RC20GF475K	4.7 Megohms, .50 W	Allen-Bradley
1	Resistor	RC20GF106K	10 Megohms, .50 W	Allen-Bradley
1	Resistor		1 Kilohm, 6.5 W	Allen-Bradley
1	Neon Lamp	NE2D		GE
1	Indicator Light	181-8536-937		Dialight

OPTICAL PARTS

1. Sighting telescope objective, corrected binocular doublet lens, antireflection coated, 1.450 inch diameter, 6.230 inch focal length, 6.000 inch back focal distance.
2. Porro prism assembly, consisting of two 45° -90° -45° prisms from a 6 x 30 military binocular.
3. Orthoscopic eyepiece, focal length 1.000 inch, eye relief 1.030 inch.
4. Eyepiece reticle, Edmund Scientific No. 30,270
5. "O" ring for eyepiece reticle
6. "O" ring for sighting telescope (used between bezel and filter).
7. Interference filter, Baird-Atomic Inc. Type B-4, peak wavelength 5000 Å, 1/2 bandwidth 400 Å, visual blocking, special glass substrate approx. 5 circular fringes per inch, filter diameter 1.45 inches + 0.000 inch - 0.020 inch, filter thickness 0.250 inch.
8. Four laser array collimating objectives, 16 mm focal length, 10X, NA 0.3.

APPENDIX C
BATTERY CHARGER SCHEMATIC,
CIRCUIT BOARDS AND PARTS LIST

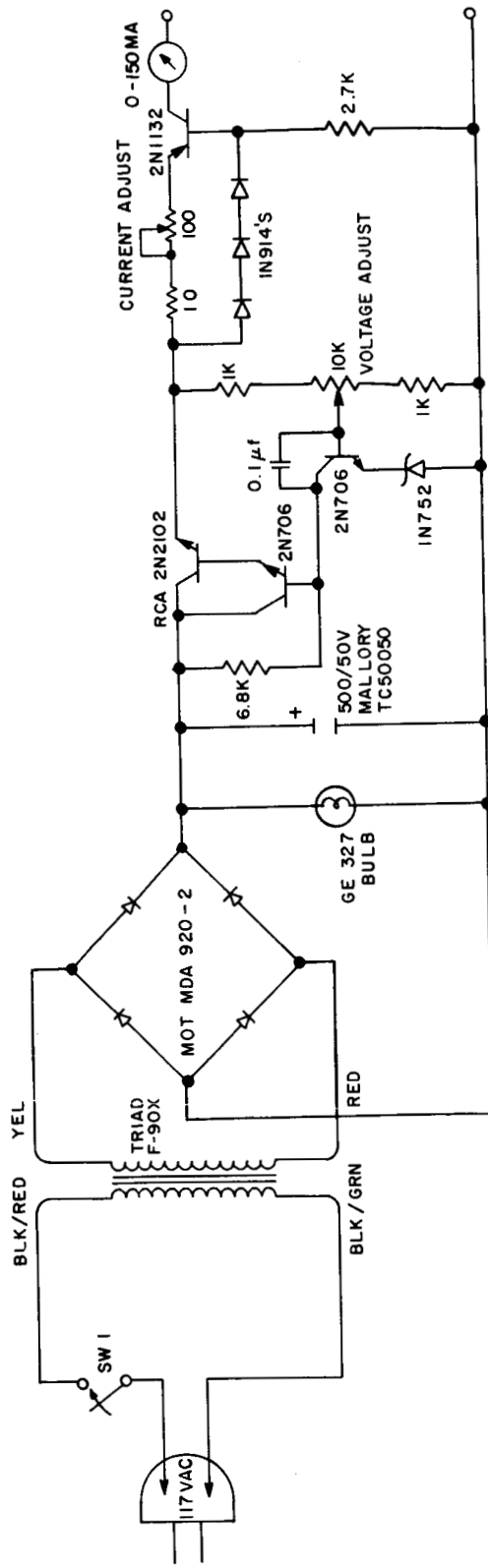

Fig. C-1. GT-7 laser transmitter battery charger schematic.

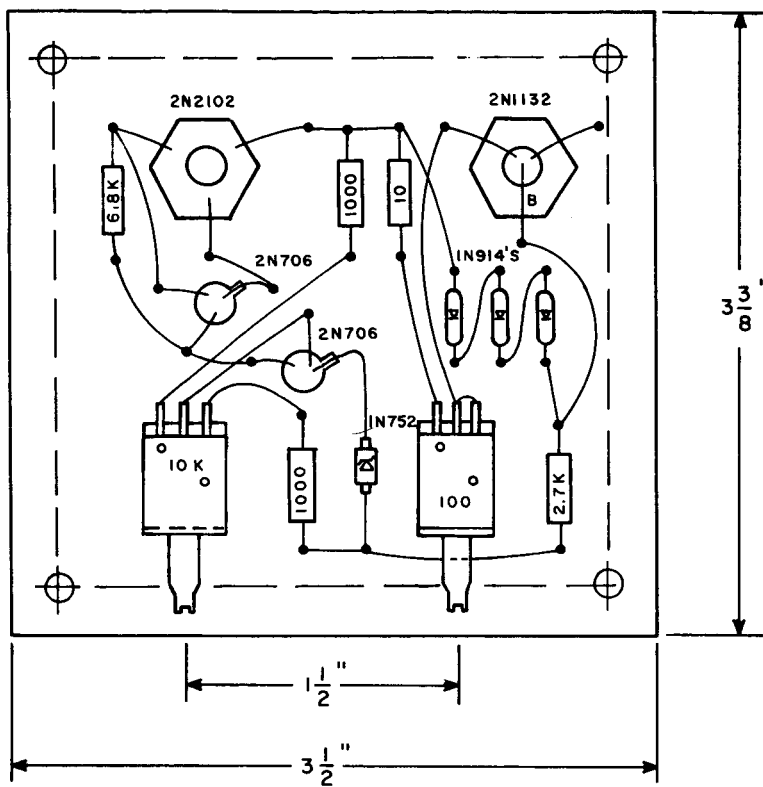

Fig. C-2. Battery charger regulator layout.

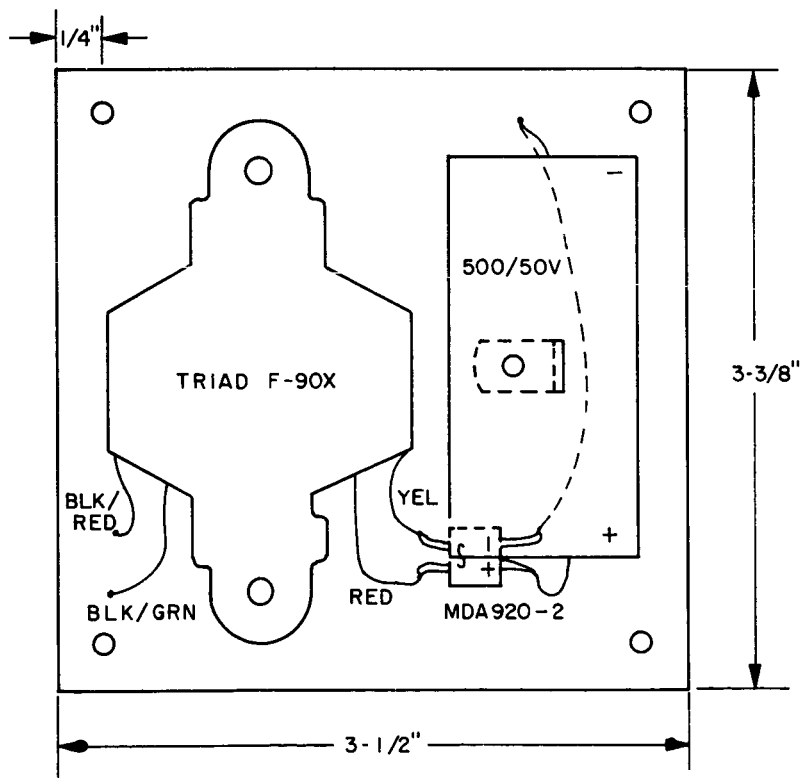

Fig. C-3. Battery charger power supply layout.

PARTS LIST (BATTERY CHARGER)

<u>Qty.</u>	<u>Part</u>		<u>Description</u>
1	Resistor	R5	10 ohms 0.5 watt
2	Resistor	R2, R4	1 kilohm 0.5 watt
1	Resistor	R7	2.7 kilohms 0.5 watt
1	Resistor	R1	6.8 kilohms 0.5 watt
1	Potentiometer	R6	100 ohms 0.3 watt
1	Potentiometer	R3	10 kilohms 0.3 watt
1	Capacitor	C1	500 μ F, 50 V Mallory TC50050
1	Capacitor	C2	0.1 μ F, 125 V
1	Transformer	T1	Triad F-90X
1	Switch	S1	
1	Fuse	F1	1/4 ampere
1	Fuseholder	F1	
1	Plug (AC)		
1	Rectifier (Bridge)	B1	MOT MDA 920-2
3	Diode	D2, D3, D4	1N914
1	Diode (Zener)	D1	1N752
2	Transistor		2N706
1	Transistor		2N2102
1	Transistor		2N1132
1	Milliammeter		Simpson model 1212
1	Lampholder & bulb		RCA 481372-8, GE 327
1	AC cord		
2	Heat sinks		Thermalloy 1101A