

~~CONFIDENTIAL~~
~~CONFIDENTIAL~~
~~CONFIDENTIAL~~

GROUND TRACKING OF THE APOLLO

A network of ground, sea and airborne stations strategically located around the world, constituting the Manned Space Flight Network, will keep "track" of the Apollo during the first flight to the moon.

by

Friedrich O. Vonbun

Goddard Space Flight Center, Greenbelt, Maryland

GPO PRICE \$ _____

CFSTI PRICE(S) \$ _____

Hard copy (HC) 2.00

Microfiche (MF) .50

N 653 July 65

N66-22219
SIGN NUMBER
43
(PAGES)
PMX-56661
(NASA CR OR TNX OR AD NUMBER)

(THRU) _____
(CODE) _____
07
(CATEGORY)

FACILITY FOR

INTRODUCTION

Immediately after liftoff of the 300 ton Saturn vehicle a vast global complex of tracking and communications stations will play a vital part in our lunar landing mission. This network of ground stations, ships and aircraft, the so called "Manned Space Flight Network" (MSFN), will constitute the only link between the earth and the three men occupying the Apollo Command Module.

The purpose of this network is to keep "track" of the spacecraft during its entire lunar mission except for those portions of the flight where the spacecraft is occulted by the moon (approximately for one hour during each two hour lunar parking orbit). The word "track" here really means more than just tracking in the usual sense; it means the establishment of a rather cumbersome "link" between the spacecraft and the Main Control Center at the Manned Spacecraft Center in Houston, Texas. This link consists of the many information, tracking, voice, telemetry and data channels necessary to keep up with the events of the flight.

In addition to providing communications between the Control Center and the spacecraft, the network has to fulfill another extremely vital function, namely that of space navigation. The decision to use the MSFN as a primary system for navigation was made some time ago. This was

based upon many analyses which showed that the position and velocity (trajectory) can be determined more accurately in a very short time (in the order of minutes) by using ground based tracking information, such as range, range rate and two angles (azimuth and elevation or equivalent) than by using on board tracking information. However, this statement should not be misconstrued as downgrading the on board tracking and navigation system. Both systems are needed and thus will be used to capacity when appropriate to fulfill the navigation and guidance requirements of the mission.

The advantage of the ground system for more accurate trajectory determination lies in the station geometry (strategically located worldwide), as well as in the quantities measured, which form an inherently stronger solution from a mathematical point of view. The on board system, measuring angles only between selected points on earth, planets or stars, lacks two important quantities for trajectory determination, namely range and range rate. In summary, a space trajectory can be determined with more accuracy by using range, range rate and two angles than by using angles alone.

The on board system is on the other hand much less complicated than the vast ground complex called the MSFN.

Therefore, the question of which system is "better" for space guidance and navigation, raised many times during discussions, cannot be answered unequivocally.

In order to follow the normal and logical sequence in describing the MSFN, we will start with a brief description of the tracking and communications system of the Saturn V and the Apollo. The major purpose of the MSFN is to support the vehicle during the mission. A detailed description of the network, with all of the land, sea and airborne stations, is presented. Finally, the major tracking and communications function of the network will be given for each of the major phases of the lunar landing mission. Completeness is not planned here since a thorough description of the MSFN with all of the stations, equipment and functions to be fulfilled would increase this paper to a formidable number of pages. The graphs presented show spacecraft velocity errors, which are in most cases more important than position errors. This was done in order to keep the number of graphs at a minimum. Work in this area will of course continue, and it is hoped that a better picture of the tracking and communications problems involved will be obtained as time progresses. Nevertheless, a rough overall picture of the Apollo network and the tracking and communications functions will be presented.

LAUNCH VEHICLE AND SPACECRAFT SYSTEMS
FOR TRACKING AND COMMUNICATIONS

Even though the Saturn V with the Apollo spacecraft is capable of "flying" independently, numerous types of tracking and telemetry systems are carried on board to track, check and test all vital systems during the flight. The Unified S-Band System (USBS)* (reference 1 and 2), carried on board the Instrument Unit (IU), the Command and Service Module (CSM) and the Lunar Excursion Module (LEM), will be used as the primary communications, telemetry and guidance system during the major phases of the lunar landing mission. The purpose, to be more specific, of these on board electronic systems is to enable the Launch Control Center at the Cape and the Mission Control Center in Houston via MSFN and the NASA Ground Communications System (NASCOM) to:

1. Track the vehicle.
2. Command abort for crew safety as well as for protection of life and property.
3. Record engineering data.

*USBS stands for Unified S-Band System. This system, as indicated by the name, combines tracking, telemetry, voice and TV transmission and reception - thus simplifying the spacecraft electronics.

4. Record biological data.
5. Record scientific data.
6. Operate displays for flight control in real time.
7. Communicate by voice with the astronauts.
8. Transmit guidance and navigation data.
9. Receive television signals from the spacecraft and the lunar surface.

Table I presents all of the tracking and telemetry systems used with the Apollo and Saturn V for each of the different stages depicted in Fig. 1. As a tracking system for the Saturn V, either the Azusa or the Mistram system will be used, but not simultaneously.

THE MANNED SPACE FLIGHT NETWORK (MSFN)

The MSFN (references 3, 4, and 6) is a complex of ground, sea and airborne stations strategically located around the world in order to support the Apollo during all of the flight phases. It represents the counterpart of the systems carried on board the spacecraft as shown in Table I.

All of the worldwide network stations that will be used for the lunar landing mission are shown in Table II. (In reference 4, only the stations and systems that are important to the space navigation tasks are listed; that is, the primary Apollo sites.) The stations are listed in sequence by

longitude starting with the launch site, Cape Kennedy ($\sim 80^\circ$ W.). This has a certain advantage if one wants to follow the stations that will "see" the spacecraft as it circles the earth going eastward from the Cape. Some of the stations are important only because of the launch phase. These are the ODOP receiver stations at the Cape, Merritt Island, Titusville, Playalinda, Grand Bahama, Walker Cay, Little Carter Cay and the transmitter stations at the Cape and Little Carter Cay. The ODOP system is a continuous wave electronic tracking system that utilizes integrated Doppler to obtain range sums and range differences. The ODOP stations are not listed in Table II, since only the S-IC stage carries an ODOP transponder. This means this system is in operation only a very short time compared to the other systems. For instance, the impact of the first stage takes place 650 km down range along the trajectory (see Fig. 2) approximately 12 minutes after liftoff. The burning time for the S-IC is about 150 seconds (see reference 6). The same is true for the Mistram stations at Valkaria and Eleuthera, as well as for the Glotrack stations at the Cape, (C-band radars) and the range rate stations at Cherry Point, Antigua and Grand Turk (see reference 7, p III-71).

The major stations of the network (asterisk in Table II) are:

Cape Kennedy, Grand Bahama Islands, Grand Turk Island, Bermuda, Antigua, Atlantic Ship ($\sim 49^\circ$ W., 28° N., insertion) Canary Islands, Madrid, Ascension, Indian Ocean Ship ($\sim 38^\circ$ E., 18° S., post injection)

Carnarvon, Guam, Pacific Ocean Ship ($\sim 174^{\circ}$ E., 8° N., post injection), Canberra, Hawaii, Goldstone, Guaymas, Corpus Christi, entry ships (two, Hawaii and Samoa area) and finally eight modified C-135 jet aircraft.

Only the areas that are directly connected with the MSFN and thus with the Goddard Space Flight Center are considered and discussed in this paper. Neither the launch nor the recovery phase (opening of drogue parachute) as such are treated in detail. The prelaunch and launch phase will be handled by the Launch Control Center at Cape Kennedy. Obviously, the Cape tracking and communications stations will be used for checkout of all systems before, during and shortly after liftoff. Accurate liftoff tracking will provide data for post-flight analyses.

The recovery phase starting with the opening of the drogue parachute ($\sim 25,000$ feet) will be handled by the Air Rescue Service which will use 63 propeller driven HC-130H recovery aircraft. Skin divers will, after locating the landed Command Module, parachute from the aircraft in order to assist in the final recovery.

THE NASA COMMUNICATIONS NETWORK (NASCOM)

In order to make the Apollo Network function, that is "connect" all the stations scattered around the world into a "network of stations," another network was established

(see references 4 and 8). This system is shown in Fig. 3 (reference 4, Fig. 5-1) and is a logical extension of the original Mercury communications network. The major stations of the network as well as the voice, telemetry and data links are indicated in this figure. The following list of letters with the technical meanings are used in Fig. 3 (references 4 and 8).

TTY	-	Teletype 60 words/min or 45.5 bits/sec
V	-	Voice 300 to 3000 cps
V/D	-	Voice or data, 300 to 3000 cps
HSD	-	High speed data, 2400 bits/sec
TV	-	Television channel, 500 kc/sec bandwidth, (Goldstone via commercial TV; Madrid and Canberra possibly via NASCOM)

Full duplex, 4-wire voice circuits will be used from all of the remote sites of the MSFN to the Manned Space Flight Control Center (MSCC) in order to communicate with the spacecraft.

Full duplex teletype transmission and reception facilities will be used at all sites for tracking and telemetry data, updata and message traffic.

Wide band (40.2 k bits/sec) and video circuits will be used between the Cape and MSCC for reception of prelaunch and launch telemetry data for support of the SIV-B/IU orbital operations.

As can be seen, this somewhat "separate" network plays a vital part since the MSFN can obviously not operate and support a mission without NASCOM.

In the following, since this paper is mainly concerned with the MSFN and its role, it is assumed that NASCOM is operating and all necessary information is received at the MSCC at the proper time in the correct format.

MAJOR TRACKING FUNCTIONS OF THE MSFN DURING THE APOLLO LUNAR MISSION

The main purpose of the MSFN is to provide tracking, communications, telemetry and voice capability in real time between the spacecraft and the MSCC in Houston, Texas.

Both, the telemetry data and voice capability have been mentioned, including the stations and capabilities (see Table II Tracking from the Cape and the down range stations (in case of a firing with $\alpha > 90^\circ$) using ODOP, Azusa or Mistram, and the FPS-16 radars will yield spacecraft position and velocity to an accuracy effected by these high precision missile tracking systems in the order of a few cm/s to 50 cm/s in velocity, as can be seen from the Range Instrumentation Survey (reference 7).

Leaving this launch and liftoff phase as a special case, we shall now concentrate more on the MSFN, its use and its capability for tracking the spacecraft. From here on,

"tracking" shall mean the determination of the spacecraft position and velocity, (or the six osculating elements of the orbits) or even better, the estimation of the errors based upon the data taken by the MSFN.

Based on present information, the errors shown are believed to be realistic. The graphs are self explanatory, and all pertinent information is presented with the curves to make a comparison with other calculations and methods possible. Random errors, bias errors, and errors in the location of the tracking stations are most important and thus cannot be neglected in an analysis of this kind. The errors assumed are on the pessimistic side to make sure that unpleasant surprises do not occur in the future (reference 4, Table 5-1).

Tracking the Insertion and Earth Parking Orbit Phase

One of the first tracking tasks of the MSFN will be the verification of the orbital capability (Go, No-Go) achieved by the spacecraft shortly after the cutoff of the SIV-B stage.

As can be seen from Fig. 2, only the insertion ship will be able to "track" the spacecraft after insertion (burn out) into the earth parking orbit (shown in Fig. 4). Present plans call for a daily maximum variation of the launch azimuth α of approximately 26° , or a launch window of $2\frac{1}{2}$ hrs. per day.

If, during this time the launch can not be accomplished for some reason, no further attempts will be made and the launch will be delayed until the following day. Three consecutive days are required for a "lunar launch attempt" by definition. Fig. 2 shows that a launch azimuth variation from 73° to 100° can be covered by the ship stationed as indicated. For one variation of α , one ship position is assumed. If the launch is delayed by one day, the ship is moved slightly as shown in Fig. 2. A ship's velocity of 10 knots can be assumed during a 24 hr period covering 240 nautical miles or 4° which is adequate in this case.

Fig. 5 shows the velocity errors one has to cope with when this ship is used with an FPS-16 radar type tracking system. For all error plots, position and velocity errors means the square root of the sum of the square of the components. This gives a maximum error and at the same time reduces the number of necessary graphs. These and all the other errors were calculated based upon the error equations given in references 9, 10, 11 and 12. Please note conditions as printed on Fig. 5 and all other curves. As can be seen for instance, a "perfect" ship's navigation system (no errors in ships' location, curve B) would have, after 90 seconds of tracking, no influence on the spacecraft velocity error as compared to one with a total error of error of 450 meters. The position errors follow a similar trend but are not shown since they are secondary in importance (3.5 km for 1 min, 1 km for $1\frac{1}{2}$ min of

tracking, all errors included as per curve C of Fig. 5). Similar results were obtained in a previous study (reference 13).

Another very important parameter for the so-called "Go, No-Go" decision is the error in perigee height, since it is directly related to the spacecraft orbital lifetime. Fig. 6 depicts this error, again as a function of ship's tracking time. Assuming a 200 km earth parking orbit, a perigee height error of 0.4 to 0.5 km as shown in this graph will certainly not alter the assumed orbital life time; and thus a "Go, No-Go" decision check can be made using the ship's navigation and tracking data indicated on Fig. 6. Please note the available tracking times for $\epsilon = 5^\circ$ above the horizon on the left corner of Fig. 2 for the cases considered. During the parking orbital phase this tracking is improved and depicted in Fig. 7. This graph shows the spacecraft velocity errors for the portion of the first earth parking orbit. The steps shown indicate the projection of the velocity error to the next tracking station, which in turn improves the situation (a similar curve applies for position). For this graph, a free flight was assumed. The influence of the venting of the SIV-B on position and velocity is given in reference 14 and is not included in Fig. 7.

Tracking at Injection, Post Injection and Lunar Transfer

No matter where injection occurs, the Apollo must be covered since this is a mission requirement. This is possible only when the aircraft can fly fast enough to cover the injection from the three earth parking orbits, which depends on the declination of the moon at that time. The required coverage includes those systems functions listed at the end of Table II. An example for a very unfavorable coverage situation is shown (hatched portions) in Fig. 4 (a lunar declination of -15°). Coverage is needed one minute before ignition of the SIV-B in the earth parking orbit during the burn and three minutes after engine cutoff in the lunar transfer trajectory. This covers approximately 5500 km (3000 nautical miles) along the parking orbit chosen for transfer. Please note that this is an example only. The trajectory chosen (reference 6) is that of September 17, 1969 and is used in this paper. For that particular case, the injection burn starts over the eastern Pacific and ends over the western part of the United States. Therefore, as shown in Fig. 4, the injection coverage for all three parking orbits is simpler, since the orbits are closer together than for injection near the equatorial region as shown on the previous example. Yet, coverage must be provided and enough aircraft must be on hand to cover the most unfavorable

The second parking orbit is chosen for injection since the probability for doing so is 70%. The probability for injection during the first orbit is 10% and during the third orbit it is 30%. The reason for this is that time is needed to make a complete systems check in earth orbit before starting the transfer maneuver.

It is further required that, seven minutes after engine cutoff in the lunar transfer orbit, tracking and communications can be accomplished independently from the particular injection point along the three earth parking orbits. Fig. 8 shows the outlines of all possible injection points for orbits 1 through 3 having a launch azimuth between 72° and 108° covering a range of lunar declinations from $+28\frac{1}{2}^\circ$ to $-28\frac{1}{2}^\circ$. The coverage circles (approximate circles only near equatorial regions) are those with a height $h = 1100$ km and a minimum tracking elevation angle of $\epsilon = 5^\circ$ (radius of this circle is 26° on the earth surface). This requirement is almost fulfilled with the network and the Indian and Pacific Ocean Ships as shown on Fig. 4. Communications via VHF and HF can be obtained for $\epsilon = 0^\circ$ or even negative. In this case, the total injection area in Fig. 8 is covered by the network.

The first portion of the lunar transfer (from second parking orbit) is shown in Fig. 9, together with time and height points along the trajectory. Using these points and the visibility contours in Fig. 10, one can deduce when and where the large dish facilities located at Goldstone, Madrid and Canberra can "see"

the spacecraft above an elevation angle of 5° . It is assumed here that "radio" visibility is identical with "optical" visibility. This of course is not always true. For certain spacecraft positions (attitudes), the on board antenna pattern precludes "radio" visibility (holes, side lobes). This is particularly true during the earth parking orbit when omni-directional antennas are used. Madrid will be able to contact the spacecraft first at ~ 15 min at a height of ~ 3700 km. The earth coordinates of the 15 min (3715 km) point of the lunar transfer trajectory shown in Fig. 9 are approximately 20° N. and 45° W. From Fig. 10 it may be determined that this point lies within the 4000 km visibility region of Madrid and therefore is in that station's field of view and will stay there for a few hours. As can be seen from Fig. 10, the three large dishes cover almost the total range of declinations of $\pm 28\frac{1}{2}^{\circ}$. The notches which occur on both sides of the visibility contours are due to the antenna keyhole, a mechanical obstruction of the X-Y mounted antennas.

Fig. 11 shows the errors in total spacecraft velocity for the referenced transfer trajectory using Bermuda, Ascension and Madrid tracking data (see references 15, 16 and 17). Again, in order to be "realistic" and sure during this analysis phase before installation and testing of hardware fairly

large noise and bias errors, particularly in range rate, have been assumed for a sampling rate of six measurements per minute. It is interesting to note that despite pessimistic assumptions about the tracking systems, random and bias errors, the spacecraft position and velocity can be determined fairly accurately during the first 30 minutes of the transfer flight. These figures improve during the flight toward the moon as far as velocity is concerned. Position errors go through a minimum and increase slightly with time to a few km. on arrival at the moon.

Lunar Orbits, Landing and Takeoff

During the flight towards the moon, three midcourse maneuvers are planned to correct the spacecraft trajectory to bring it within the specified lunar orbit of 150 ± 8 km height (reference 4). The initial lunar orbital phase starts with the shut down of the service module engine at 150 km circular lunar orbit. The geometry of the lunar tracking phases is shown in Fig. 12. During the lunar stay time, the CM will make one or two orbits before the LEM descent begins. During that time, the ground network will again be called upon to help in the checkout and lunar orbit determination phase. Fig. 13 gives an example of how accurately the spacecraft velocity can be determined using the scheme shown in Fig. 12

(see also reference 16). One prime station and two (or more) slave stations will be used for the determination of the lunar orbit.

The prime station employing a large dish will send a CW signal to the spacecraft transponder. The signal (actual frequency translated) is returned and mixed with the similarly translated version of the transmitted signal to extract the Doppler shift, which is, to the first order proportional to the range rate. The transmitted signal from the transponder will also be received by each of the two (or more) slave stations, to be mixed with its local rubidium oscillators (off by say 4×10^{10}) to extract a kind of pseudo Doppler corresponding to a pseudo, but calculable, range rate. All three of these values are then used for the trajectory determination. From Fig. 13 it is evident that the spacecraft velocity can be determined to within 5 cm/s to 50 cm/s.

The cyclic behavior of these errors is expected since they have to increase near the center of the moon, where the range rate is a very small component of the velocity; whereas near the lunar periphery the range rate increases and is almost equal to the spacecraft velocity. Since range rate can be measured very accurately, the errors in spacecraft velocity should be small. Throughout the lunar operations, (occultations excluded of course) both the CM and the LEM will be within the beamwidth of one of the large antennas, making simultaneous communications from both spacecraft possible. These dual capabilities are indicated in Table II.

Similar considerations apply to the LEM descent and ascent phases. For example, see Fig. 14, which shows the LEM position and velocity errors during the LEM ascent phase, using three-station range rate tracking only. Again, all data assumed necessary are shown in Fig. 14. The starting conditions are blown up position and velocity injection errors of the LEM guidance system.

Please note the difference in the assumed errors of 3 cm/s and 6 cm/s of the master and slave stations, respectively. Rubidium clocks are planned for all of our stations, with a short time stability of 4×10^{-10} (over 1 to 2 seconds). Again, this figure is larger than that given in the specifications of the manufacturer for safety reasons as mentioned previously. Assuming a frequency of 2 Gc/s, a shift of 4×10^{-10} corresponds to 0.8 cps or 6 cm/s for a two way Doppler mode. This means that even if the slave station is off frequency as much as 4×10^{-10} this analysis is still valid.

It should also be pointed out that it is not a must to utilize a three station solution. A one station solution using a large dish with the specified errors in range, range rate and two angles (X-Y mount) shown on the graphs, may be used in a similar manner. The position and velocity errors in this case are to be increased by a factor of ten when compared to the three station solution mentioned.

Earth Return Flight

This portion of the mission is similar to the lunar transfer phase as far as the ground network functions in general are concerned. Again, three midcourse maneuvers are planned, the ground network being the primary system for navigation before and after those maneuvers. Figure 15 shows the position and velocity errors, as a function of tracking time, for the first portion of the lunar return trajectory. The starting covariance matrix is that of the blown up burn out condition. The reason for this procedure is to assure that the values shown have not been influenced unduly by the starting condition thus making them optimistic.

To make conditions extremely bad for the ground system, assume for example that contact was lost with the spacecraft when it left the moon. Only 8 hours before entry into the earth atmosphere, contact and thus tracking was restored. Assuming that one ground station and one ship can track the spacecraft at one sample per minute, the entry velocity error is approximately 1 to 1.5 m/s and the position error is approximately 1 to 2 km. These figures include range rate and angular measurements taken once every 60 seconds using random and bias errors: ($\sigma_r = 3$ cm/s, $\sigma_\alpha = \sigma_\epsilon = 3 \cdot 10^{-4}$ rad., $\Delta\dot{r} = 2$ cm/s, $\Delta\alpha = \Delta\epsilon = 16 \cdot 10^{-4}$ rad., see also reference 4) Stations Canberra, Carnarvon and Guam can track this particular return. This is by far good enough for a proper atmospheric

entry. Even if "last" minute midcourse maneuvers are made it will not influence this situation very much (see reference 18, Fig. 14, 17 and 18 respectively). Please note that the use of a re-entry interferometer as indicated in this reference is no longer planned at this time, as was outlined in reference 18. Radar type acquisition methods are now being studied in some detail. In reference 19 the detection probabilities, best radar scan and optimum ship locations are investigated and outlined for numerous Apollo entry trajectories.

Atmospheric Entry

For this referenced mission (reference 4), an Hawaiian entry was planned. The spacecraft, nearing the earth, flies over the Pacific Ocean, the southern part of New Guinea, the southern part of Java, east of Ceylon, crosses over Burma, China, and southern part of Japan and enters the earth atmosphere near Midway Island and finally lands in the area of Hawaii. The end portion of the atmospheric entry is shown in Fig. 16 (reference 18, Fig. 1, 2 and 3). Also, during the last phase, the ground network will play a large role. Ships and aircraft will be deployed to track and communicate with the spacecraft during those portions where no radio blackout exists (see reference 18, Fig. 1 and 5, and reference 20 for more detail).

Using a tracking time of 90 sec with the entry ship's instrumentation yields a spacecraft position error of 1400 meters (at point C). Propagating this error (over a ballistic path point #2 to #3 in Fig. 16) to the second entry point #3 yields an error of 10,000 meters. This includes a ship's position error of 1 km in latitude and longitude. Under the assumed conditions, the crew can therefore compare and check the on board equipment and make corrections, if necessary, during this last critical phase of the flight.

REFERENCES

1. Jet Propulsion Laboratory, Research Summary Reports
No. 36-1 p 39, 36-2 p 26, 36-3 p 42, 36-4 p 64,
36-5 p 46, 36-6 p 60, 36-7 p 62, 36-8 p 52, 36-9 p 51,
36-10 p 26, 36-11 p 31, 36-12 p 66, 36-13 p 42,
36-14 p 51, 37-20 p 1, 37-21 p 5, 37-22 p 7,
37-23 p 8
2. Painter, T. H., Hondros, G., "Unified S-Band
Telecommunications Technique for Apollo," Vol. 1-
Functional Description, NASA TN D-2208, Mar. 1965
3. GSFC - Manned Flight Operations Branch, "Apollo Network,"
ANWG-Note, Aug. 28, 1964
4. MSC - GSFC, Apollo Navigation Working Group, Technical
Report No. 65-AN-1.0, "Apollo Missions and Navigations
Systems Characteristics," Feb. 5, 1965
5. Manned Flight Support Office, "A Review of Manned Space
Flight Network Implementation Schedules," GSFC Report
X-512-65-186, Apr. 21, 1965
6. Grumman Aircraft Eng. Corp., "Design Reference Mission,"
Apollo Mission Planning Task Force, Vol. I Contract
NAS9-1100, Report No. LED-540-12, Oct. 30, 1964
7. Vincent, B. G., "Range Instrumentation Survey, General
Electric, Nov. 1963

8. Dummons, P. M., "NASCOM Network Support of Orbital and Translunar Apollo Missions," GSFC - Apollo Evaluation Working Group Note, Aug. 3, 1964
9. Vonbun, F. O., Kahn, W. D., "Tracking Systems, Their Mathematical Models and Their Errors, Part I - Theory," NASA TND-1471, Oct. 1962
10. Kahn, W. D., Vonbun, F. O., "Tracking Systems, Their Mathematical Models and Their Errors, Part II - Least Square Treatment," to be published as a NASA TR
11. Schmidt, S., "Interplanetary Error Propagation Program." Philco WDL Division Contract No. NAS 5-3342, Report No. WDL-TR-2184 and 2185, Nov. 15, 1963
12. Cooley, J. L., "Tracking Systems Their Mathematical Models and Their Errors," Part III - Program Description, GSFC Report No. X-513-64-145, May 20, 1964 (Gives description of program used for Part II, reference 10 of this paper)
13. Marlow, A., "Error Analysis for Apollo Earth Parking Orbits Using Range Rate and Angle Measurements," GSFC Report No. X-513-65-42, Jan. 1965
14. Cooley, J. L., "The Influence of Venting on the Apollo Earth Parking Orbits," GSFC Rept. No. X-513-64-359, Nov. 24, 1964
15. Vonbun, F. O., "Parking Orbits and Tracking for Lunar Transfers," GSFC Rept. No. X-520-62-83, July 1962

16. Bissett-Berman Corporation, "Capabilities of MSFN for Apollo Guidance and Navigation," Final Report, Contract NAS W-688, C 60-18, Mar. 2, 1964
17. Vonbun, F. O., Kahn, W. D, "Tracking of a Lunar Transfer Orbit," GSFC Rept. No. X-513-64-353, Nov. 1964
18. Vonbun, F. O., "Re-Entry Tracking for Apollo," NASA TND-2880, Jun. 1965
19. Moore, J. R., "Apollo Entry - Radar Acquisition Study," GSFC Report X-513-65-225, May 25, 1965
20. Lehnert, R., Rosenbaum, B. "Plasma Effects on Apollo Re-Entry Communications, NASA TN D-2732, Mar. 1965

TABLE I

APOLLO-SATURN V

TRACKING AND TELEMETRY SYSTEMS

STAGE	SYSTEMS FUNCTION AND CHARACTERISTIC	
S-IC	ODOP	Tracking Transponder - Range Rate only Frequencies = 890 Mc (receiver), 960 Mc (Transmitter)
	UHF	Command (Abort Command Transmit, Range Safety) Frequency = 450 Mc (receiver) Sensitivity = -90 dbm (min.)
	VHF	Telemetry, Frequency 6 225-260 Mc, Modulation: PAM/FM/FM, SS/FM, PCM/FM
S-II	MISTRAM or AZUSA	Tracking
	MISTRAM	Transponder, Frequency = 8,148 Gc/s (receiver), 8,216 Gc/s (transmitter) Power = 0.2 to 0.5 W per channel
	AZUSA	Transponder Frequency = 5,060 Mc (receiver), 5,000 Mc (transmitter), Power = 2.5 W
	Command	See S-IC
	VHF	Telemetry, See S-IC
S-IVB	Command	See S-IC
	VHF	Telemetry, See S-IC
IU	MISTRAM or AZUSA	Tracking transponder, See S-II
	C-band Radar Trans- ponder	Frequency = 5,690 Gc/s (receiver), 5,765 Gc/s (transmitter) Power = 500 W (min, Peak), Single pulse, Bdw = 10 Mc/s Pulse Width = 1/4 or 3/4 sec.
	ODOP	Tracking transponder, See S-IC,
	USBS	Tracking (range and range rate), Frequency = 2,1018 Gc/s (receiver), 2,2825 Gc/s (transmitter) (+ 15 Mc)
	VHF	Telemetry, See S-IC
LEM	USBS	Tracking (range, range rate) Voice, voice-biomedical Telemetry, U-data, Television, Frequency 2,1064 Gc/s (receiver), 2,2725 Gc/s (transmitter), Normal mode: 51,200 bits/sec, Minimum mode: 1,600 bits/sec, (IU will be separated when LEM is transferred), Extra vehicular telemetry, Link for transmission of suit telemetry and voice from back-pack of astronaut during lunar surface operation. Frequency 296.8 Mc, Power 0.1 W, Link from LEM to CSM: Data rate 1,600 bits/sec.
	USBS	See LEM
CSM	VHF	Telemetry, Voice, Frequency: 225 to 260 Mc/s
	HF	Voice during earth orbital missions, Recovery operation, Frequency: 10 Mc/s, Power 5 W (AM) and 20 W (SSB)

TABLE II
MANNED SPACE FLIGHT NETWORK FOR THE APOLLO LUNAR LANDING MISSIONS

STATION	TRACKING	COMMUNICATIONS	STATUS	OPERATIONAL DATE	STATION	TRACKING	COMMUNICATIONS	STATUS	OPERATIONAL DATE			
Cape Kennedy* (Merritt Island)	FPS-16 AZUSA MISTRAM ¹ ODOP USBS dual 30'	UHF - Up-data VHF - Voice, TM HF - Voice ² Digital Command PCM - data separation	Operational	Now	Pretoria	MPS-26		Considered	Now			
			Operational	Now				Tananarive		VHF - Voice, TM - receive HF - Voice ⁴	Operational	Now
			Operational	Now								
			Operational	Now				Indian Ocean Ship*	same as Atlantic Ship	Planned	Nov. 66	
Operational	Now											
Patrick AFB	FPQ-6		Operational	Now	Carnarvon*	FPQ-6 USBS dual 30'	USB UHF - Up-data VHF - Voice, TM HF - Voice Digital Command PCM - data separation	Operational Planned Operational ⁴ Operational Operational	Now Dec. 66 Now Now Now Now			
Wallop Island	FPS-16		Operational	Now								
Curry Point	GLOTRACK		Operational	Now								
Grand Bahama*	FPS-16 USBS	USB UHF - Up-data VHF - Voice, TM HF - Voice PCM - data separation	Operational	Now	Guam	USBS dual 30'	USB VHF - Voice, TM HF - Voice Digital Command PCM - data separation	Planned Planned Planned Planned	Jan. 67 Aug. 66 Aug. 66 Aug. 66			
			Operational	Now								
Grand Turk	FPQ-18 GLOTRACK ³	UHF - Up-data VHF - Voice, TM HF - Voice ²	Operational	Now	Pacific Ocean Ship*	Same as Atlantic Ship		Planned	Jan. 67			
			Operational	Now								
Bermuda*	FPS-16 FPQ-6 GLOTRACK ³ USBS 30'	USB UHF - Up-data VHF - Voice, TM HF - Voice ² PCM - data separation	Operational	Now	Canberra*	USBS dual 85' DSIF dual 85'	USB USB Digital Command PCM - data separation	Planned Planned Standby Planned	Jul. 67 Jul. 67 Jul. 67 Jul. 67			
			Operational	Now								
Antigua*	FPQ-6 GLOTRACK ³ USBS 30'	USB UHF - Up-data VHF - Voice, TM HF - Voice ² PCM - data separation	Operational	Now	Hawaii*	FPS-16 USBS dual 30'	USB UHF - Up-data VHF - Voice, TM HF - Voice ² Digital Command PCM - data separation	Operational Planned Operational ⁴ Operational Operational	Now Feb. 67 Now Now Now Now			
			Operational	Now								
Atlantic Ship*	FPQ-6 USB dual 30'	USB UHF - Up-data VHF - Voice, TM HF - Voice ² Digital Command PCM - data separation	Planned	Aug. 66	Goldstone*	USBS dual 85' DSIF dual 85'	USB USB Digital Command PCM - data separation	Planned Planned Standby Planned	May 67 May 67 May 67			
			Planned	Aug. 66								
Canary Islands*	MPS-26 USBS 30'	UHF - Up-data VHF - Voice, TM HF - Voice Digital Command PCM - data separation	Existing	May 65	Point Arguello	FPS-16	VHF - Voice, TM HF - Voice ²	Operational Operational	Now Now			
			Planned	Sep. 67								
Ascension Island*	FPS-16 TDQ-18 USBS dual 30'	USB VHF - Voice, TM HF - Voice ² Digital Command PCM - data separation	Operational	Now	Guaymas*	USBS 30'	VHF - Voice, TM Digital Command PCM - data separation	Planned Operational ⁴ Operational	Apr. 67 Now Now Now			
			Operational	Now								
Madrid*	USBS dual 85' DSIF dual 85'	USB USB Digital Command PCM - data separation	Planned	Oct. 67	White Sands	FPS-16		Operational	Now			
			Planned	Oct. 67								
Arecibo*	VHF - Voice, TM - receive HF - Voice ²		Operational	Now	Corpus Christi*	USBS dual 30'	USB UHF - Up-data VHF - Voice, TM HF - Voice ² PCM - data separation	Planned Operational ⁴ Operational Operational	Mar. 66 Now Now Now			
			Operational	Now								
Arecibo*			Operational	Now	Eglin AFB	FPS-16		Operational	Now			
			Operational	Now								
Arecibo*			Operational	Now	Entry Ships (two)* #1, #2	FPS-16 USB 12'	USB VHF - Voice, TM HF - Voice ² PCM data separation	Planned Planned Planned Planned	#1 Feb. 67 #2 Apr. 67 Apr. 67 Apr. 67 Apr. 67			
			Operational	Now								
Arecibo*			Operational	Now	CSQ, RKV Ships		VHF - Voice, TM HF - Voice	Planned Planned	Jul. 65 Jul. 65			
			Operational	Now								
Arecibo*			Operational	Now	Injection Aircraft* (8 Modified C-135)		USB - Voice, TM VHF - Voice, TM HF - Voice Playback via VHF	Planned Planned Planned	Jan. 68 Jan. 68 Jan. 68			
			Operational	Now								

*Mistram or Azusa, not both will be flown)

¹ Mistram or Azusa, not both will be flown)

² For Gemini, not all lines for Apollo, all will be operational together with the USBS

³ Major MAFN ground stations

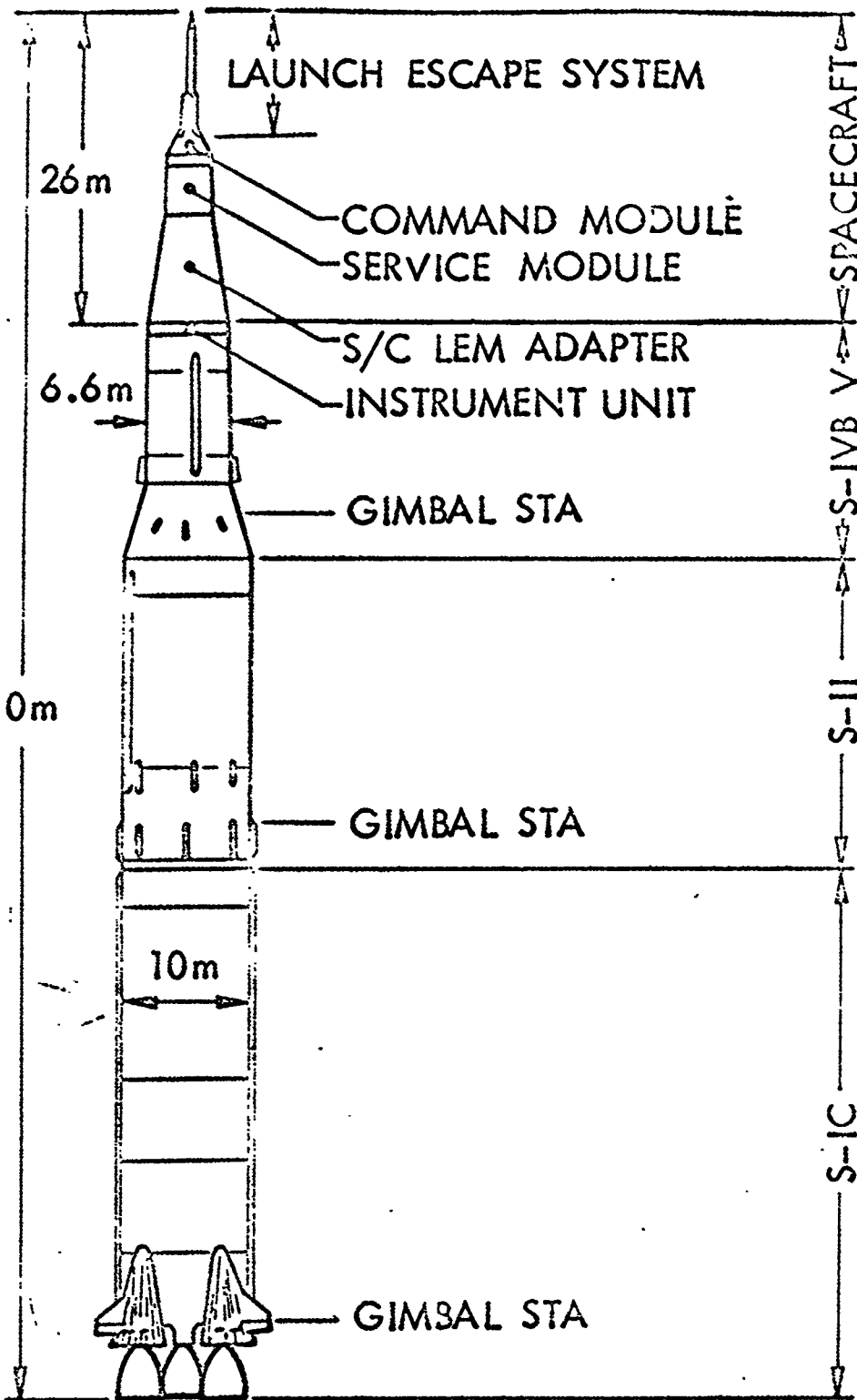

SATURN V LAUNCH VEHICLE

INSERTION TRACKING FOR APOLLO

$\alpha = 73^\circ$ to 100° & $\alpha = 80^\circ$ to 105°
 $h = 200$ km (110 nmi)

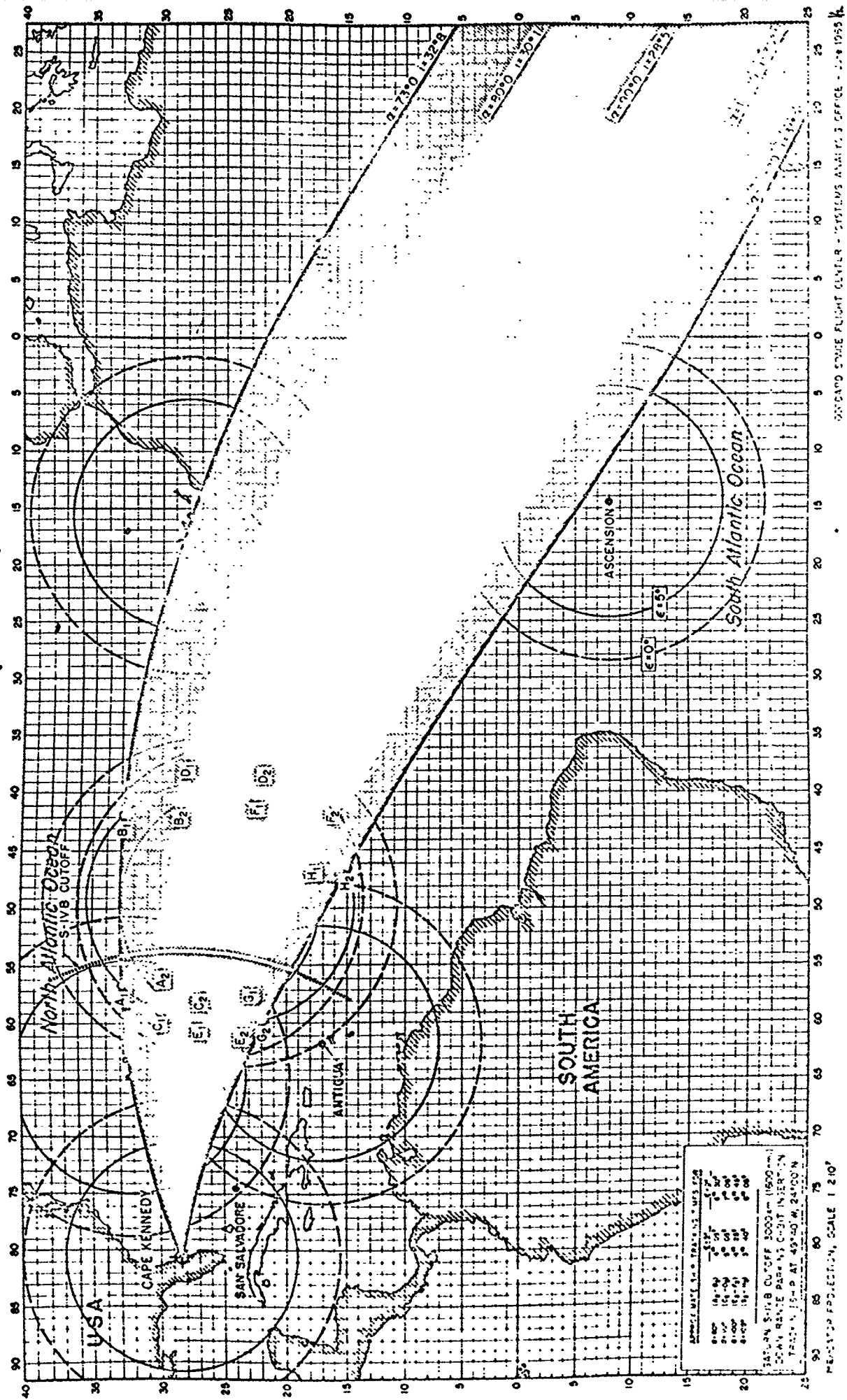

APOLLO TRACKING DATA

TIME	LONGITUDE	LATITUDE	ALTITUDE
01:00	100.0	30.0	200
02:00	100.0	30.0	200
03:00	100.0	30.0	200
04:00	100.0	30.0	200
05:00	100.0	30.0	200
06:00	100.0	30.0	200
07:00	100.0	30.0	200
08:00	100.0	30.0	200
09:00	100.0	30.0	200
10:00	100.0	30.0	200
11:00	100.0	30.0	200
12:00	100.0	30.0	200
13:00	100.0	30.0	200
14:00	100.0	30.0	200
15:00	100.0	30.0	200
16:00	100.0	30.0	200
17:00	100.0	30.0	200
18:00	100.0	30.0	200
19:00	100.0	30.0	200
20:00	100.0	30.0	200
21:00	100.0	30.0	200
22:00	100.0	30.0	200
23:00	100.0	30.0	200
24:00	100.0	30.0	200

SATURN S-IVB CUTOFF 10000m (100000)
 SOUVENIR PARACHUTE INSERTION
 TRACKING AT 49:40 W, 24:00 N

PROJECTION, SCALE 1:210⁷

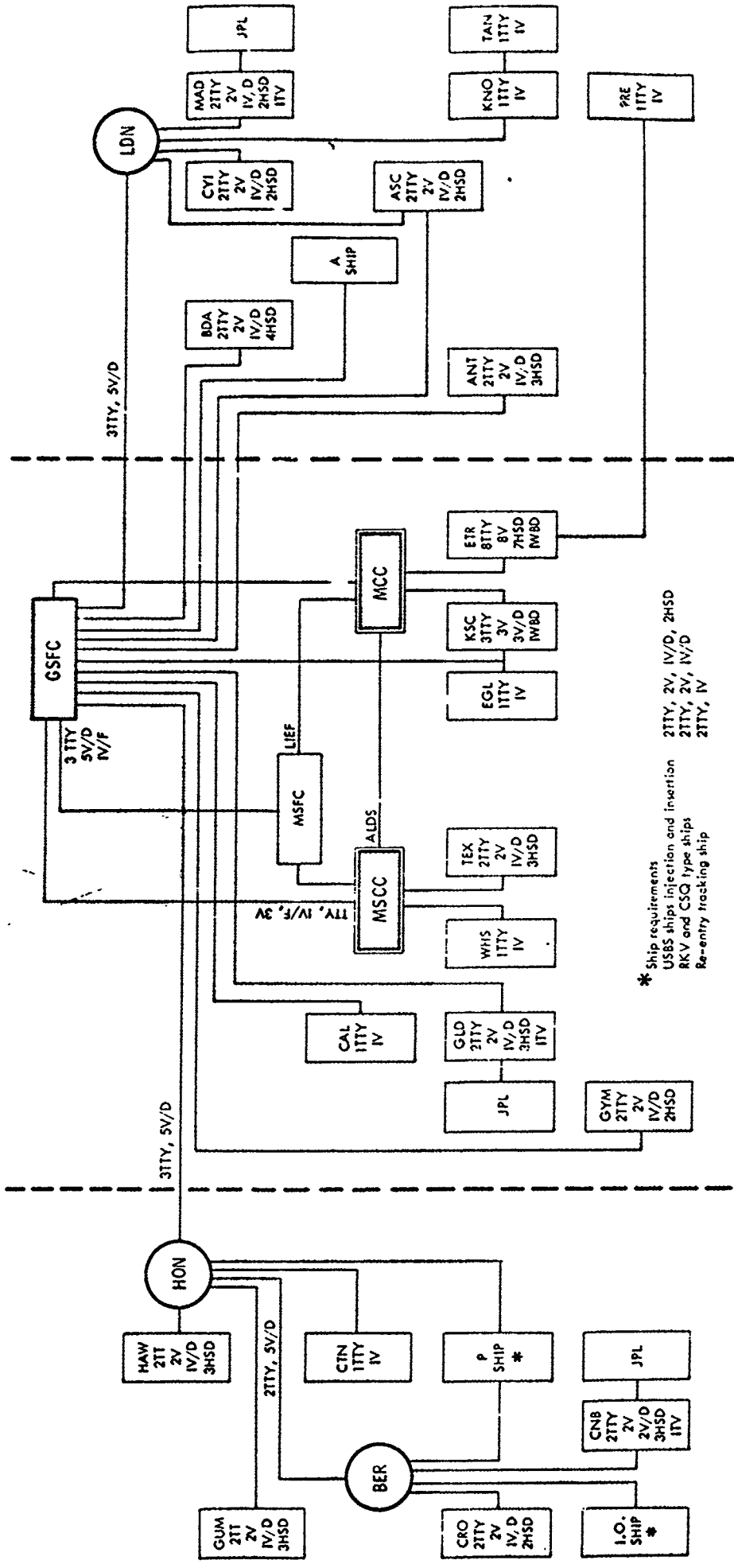

Apollo/Saturn-V Ground Communications Network

APOLLO PARKING ORBITS 1 through 3 for $\alpha=73^\circ$ and $a=100^\circ$ (Station Coverage)

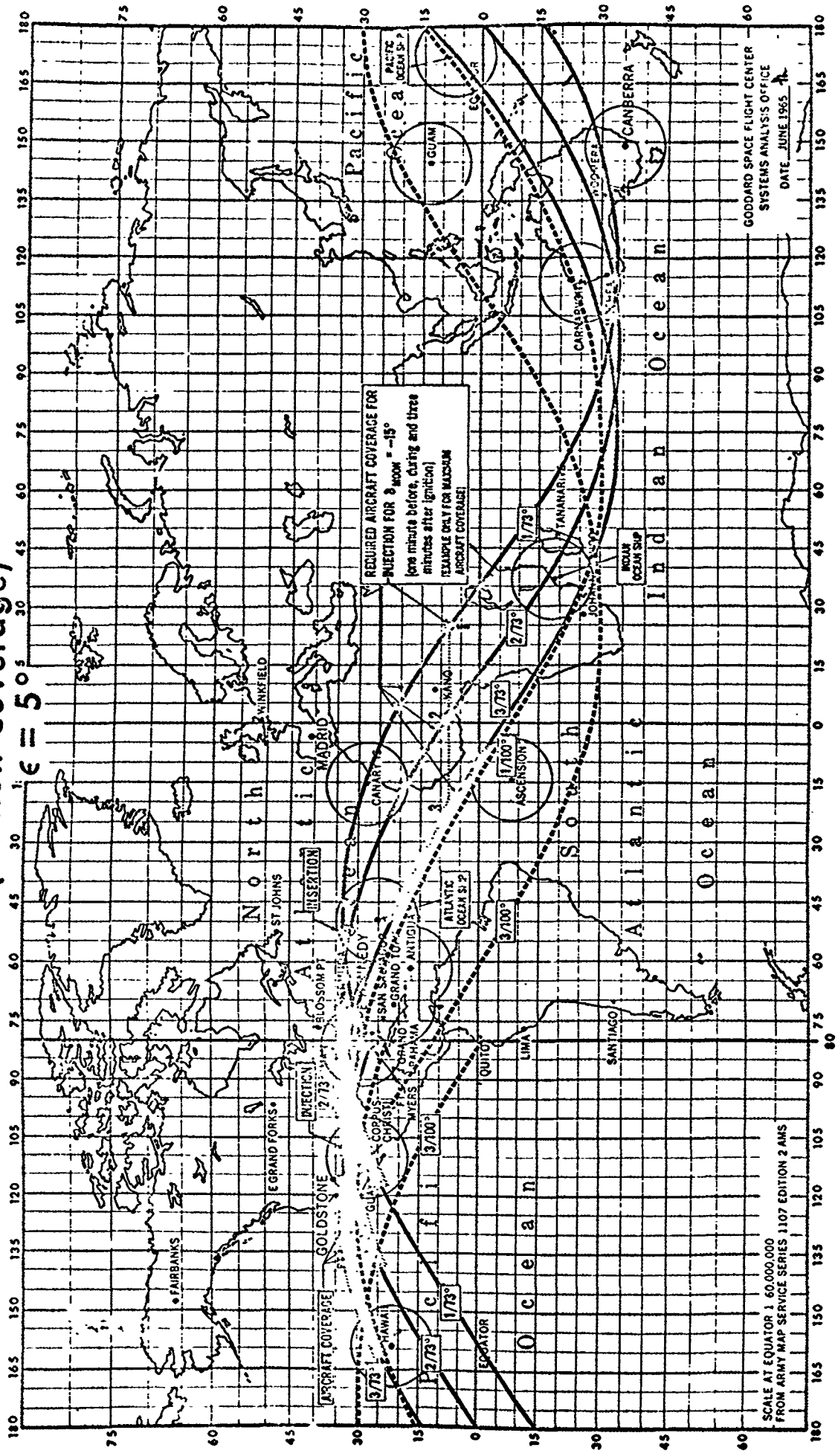

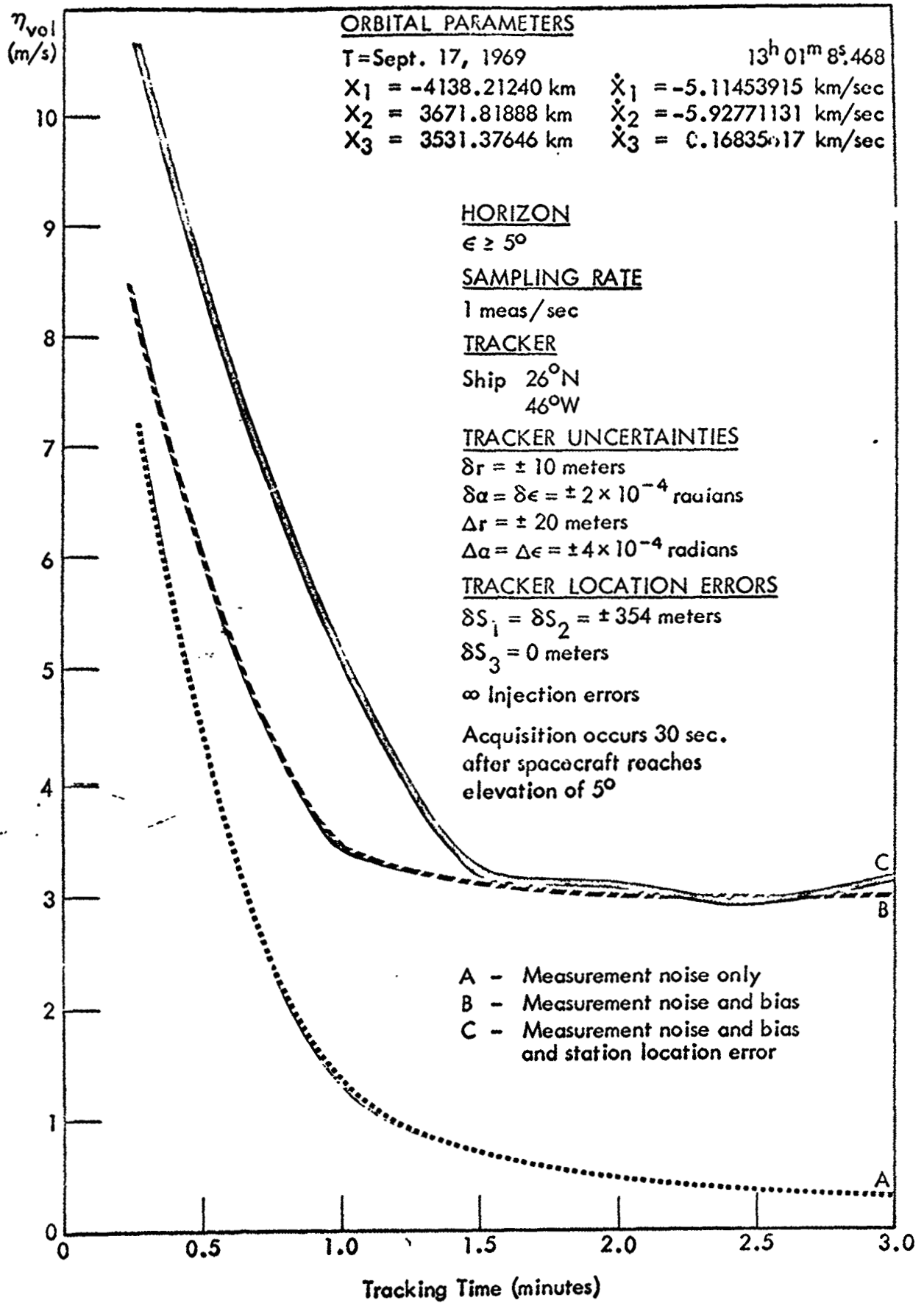

GODDARD SPACE FLIGHT CENTER
 SYSTEMS ANALYSIS OFFICE
 June 1965

VELOCITY ERRORS AT INSERTION USING THE ATLANTIC SHIP

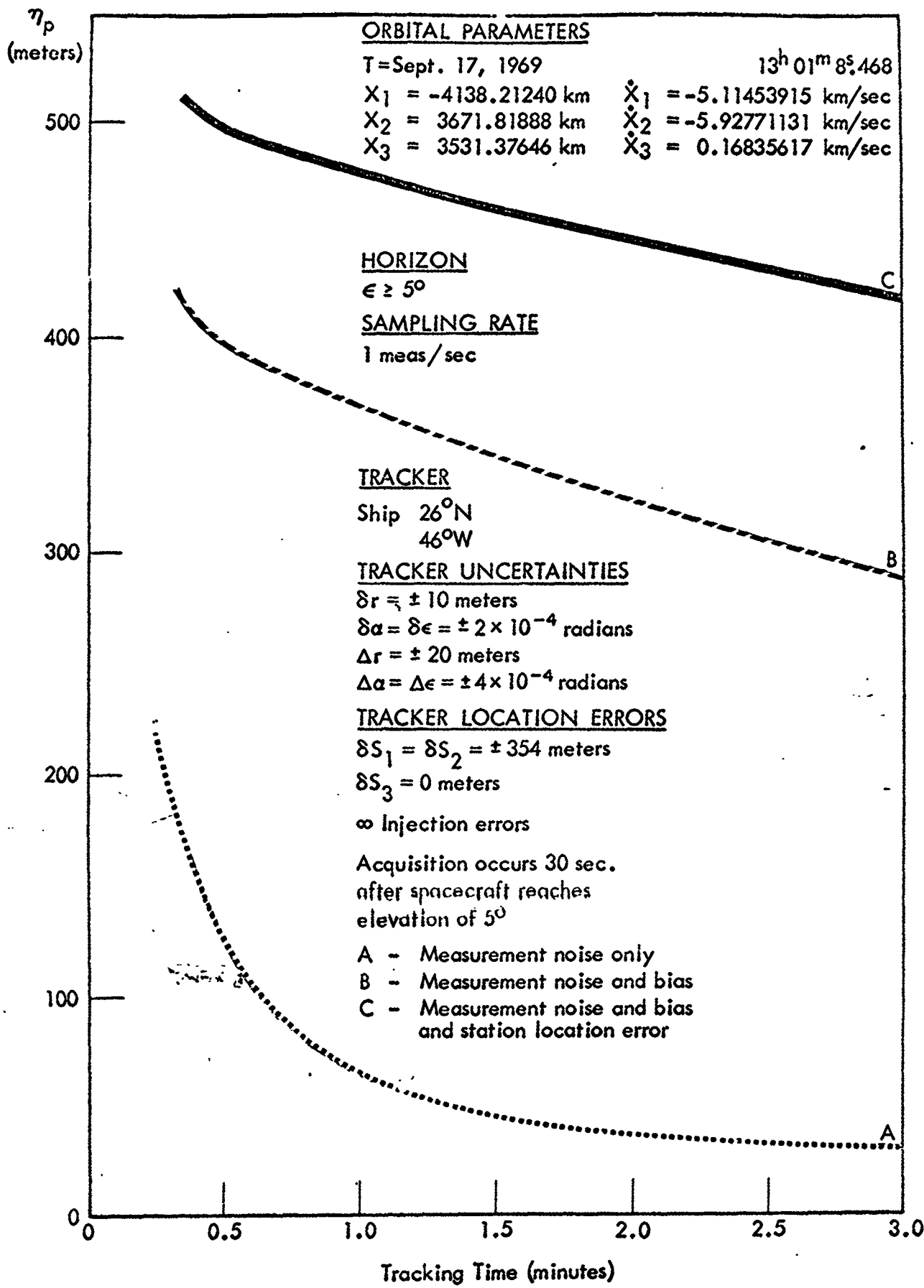

GODDARD SPACE FLIGHT CENTER
 SYSTEMS ANALYSIS OFFICE
 June 1965

PERIGEE ERRORS AT INSERTION USING THE ATLANTIC SHIP

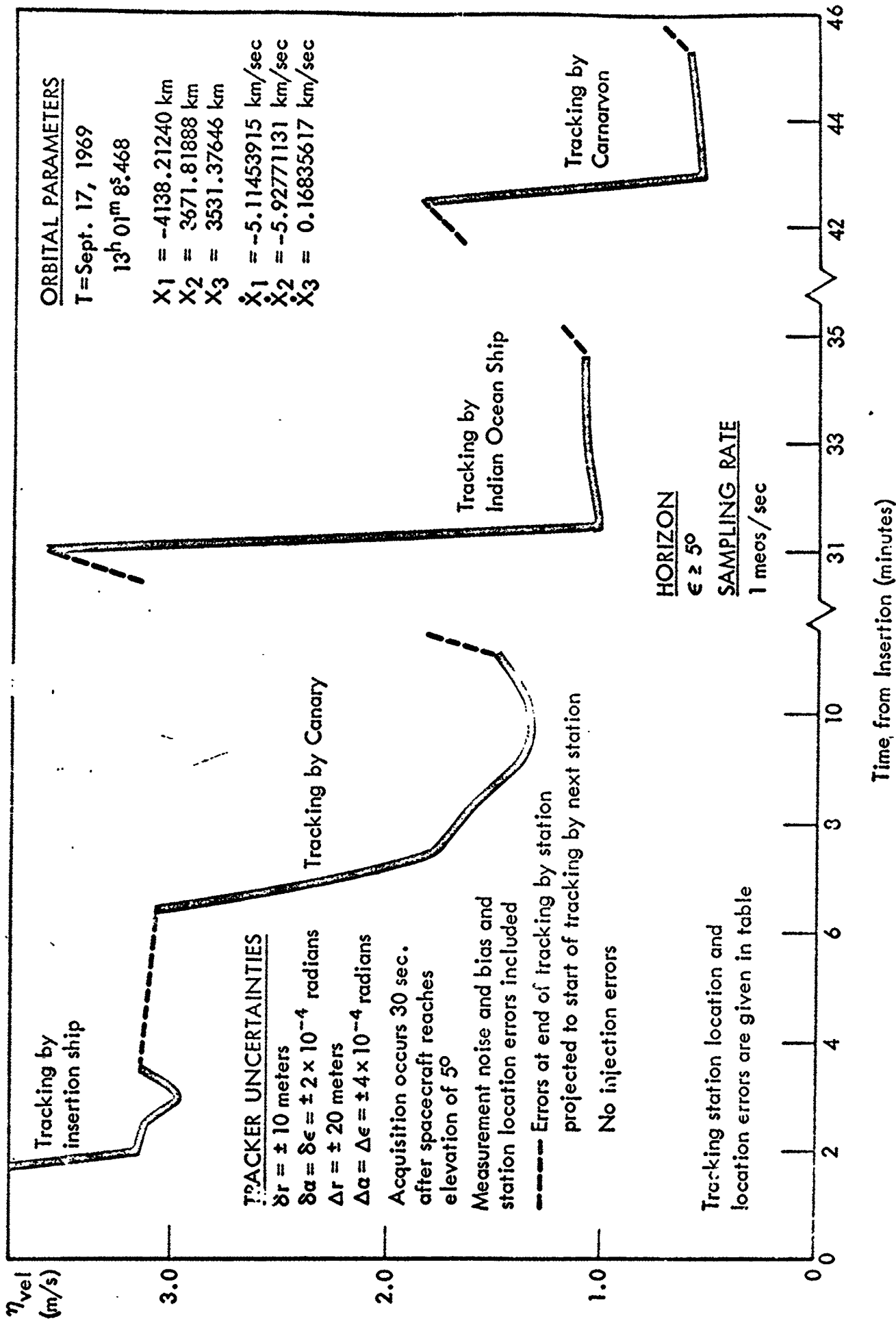

ORBITAL PARAMETERS
 T = Sept. 17, 1969
 13^h 01^m 8^s.468

X₁ = -4138.21240 km
 X₂ = 3671.81888 km
 X₃ = 3531.37646 km
 Ẋ₁ = -5.11453915 km/sec
 Ẋ₂ = -5.92771131 km/sec
 Ẋ₃ = 0.16835617 km/sec

PACKER UNCERTAINTIES
 $\delta r = \pm 10$ meters
 $\delta \alpha = \pm 2 \times 10^{-4}$ radians
 $\Delta r = \pm 20$ meters
 $\Delta \alpha = \pm 4 \times 10^{-4}$ radians

Acquisition occurs 30 sec. after spacecraft reaches elevation of 5°

Measurement noise and bias and station location errors included

----- Errors at end of tracking by station projected to start of tracking by next station
 No injection errors

Tracking station location and location errors are given in table

HORIZON
 $\epsilon \geq 5^\circ$
SAMPLING RATE
 1 mecs/sec

Time, from Insertion (minutes)

GODDARD SPACE FLIGHT CENTER
 SYSTEMS ANALYSIS OFFICE
 June 1965

**P031 INJECTION COVERAGE OF THE M.S.F.N.
(7 min. after injection, h=1100 km)**

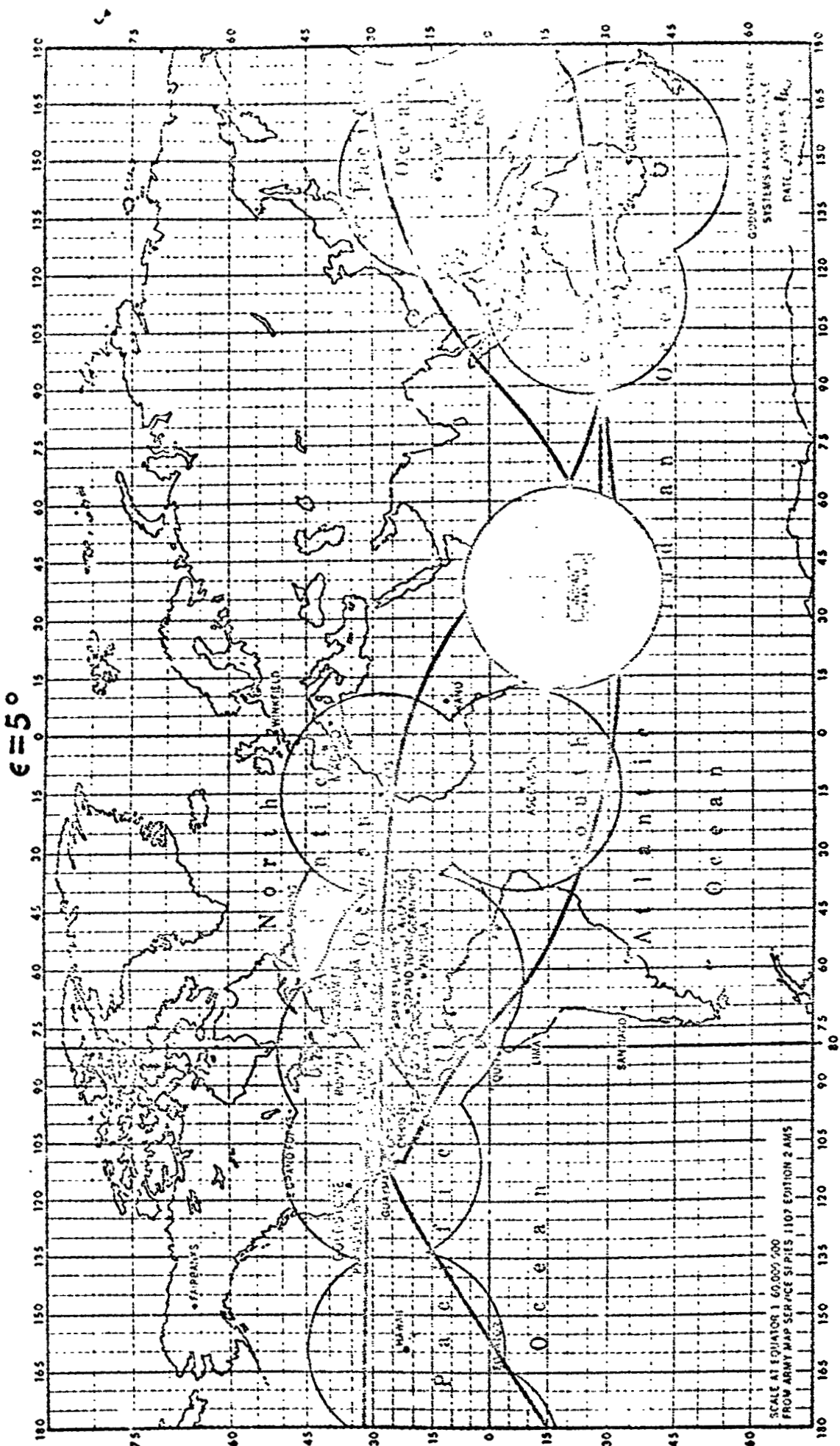

LUNAR TRANSFER FROM THE SECOND PARKING ORBIT, $\alpha = 73^\circ$

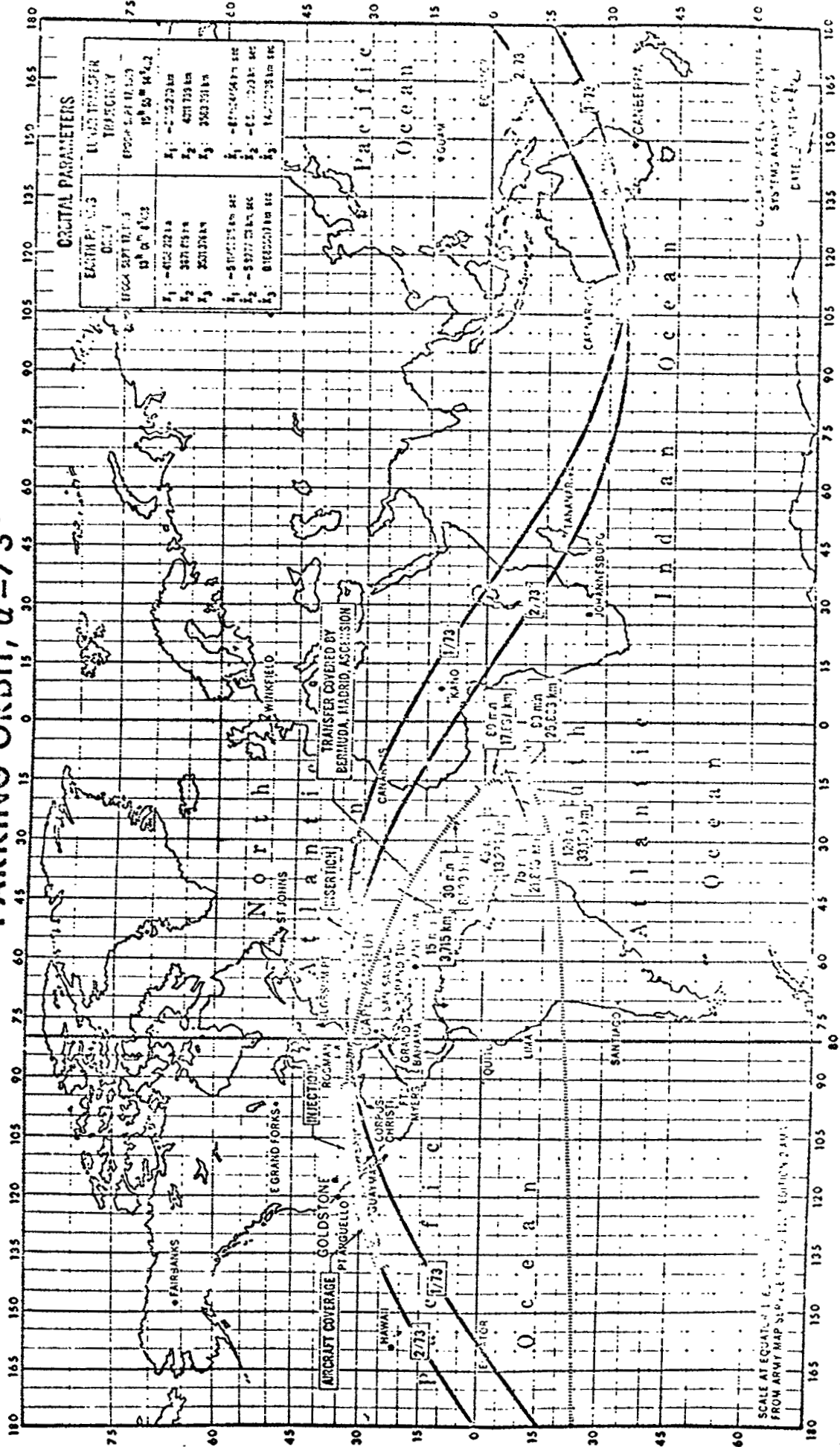

VISIBILITY CONTOURS FOR THE APOLLO 85' ANTENNAS ($\epsilon = 5^\circ$)

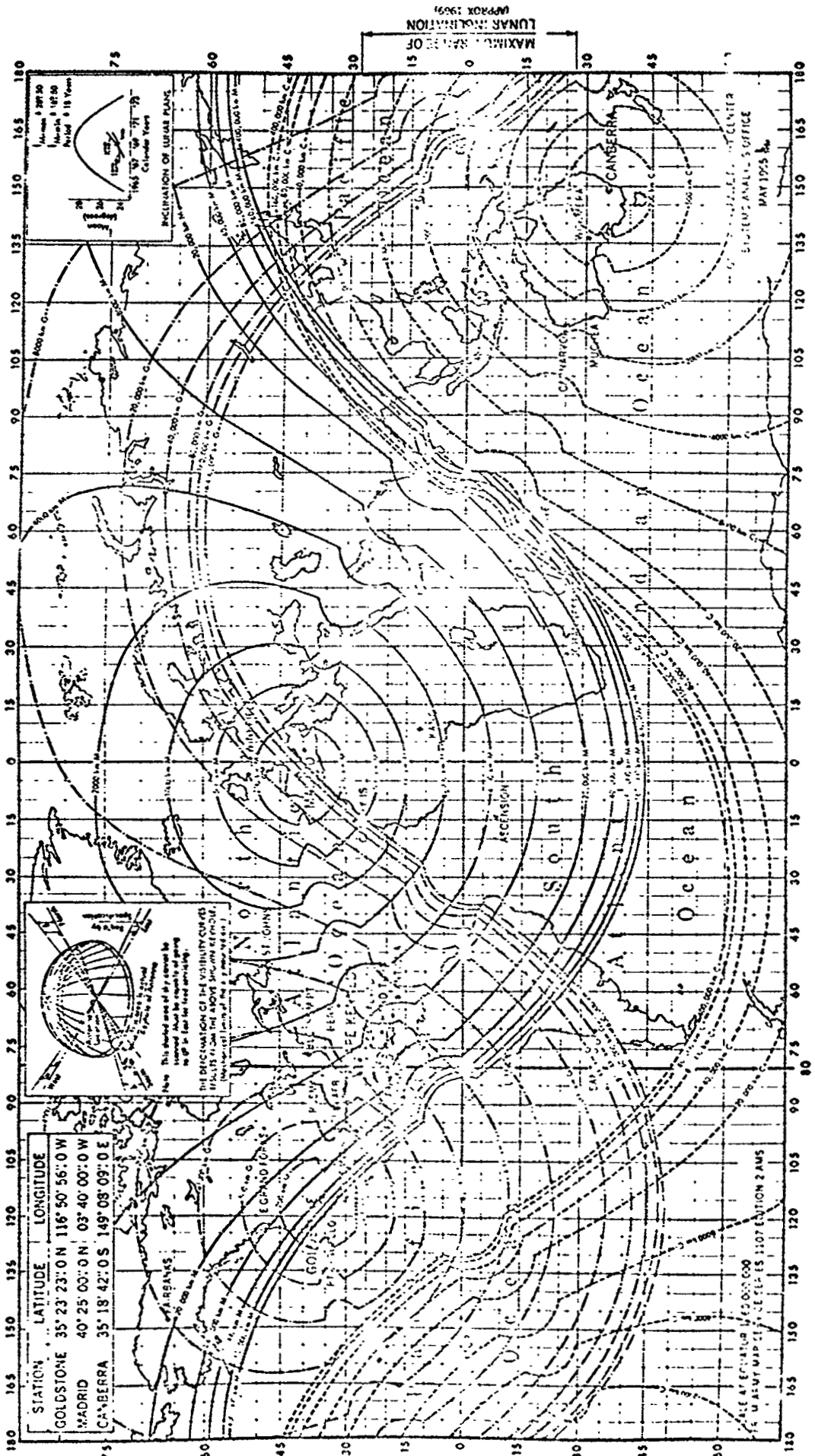

η_{vel}
(m/s)

ORBITAL PARAMETERS

T=Sept. 17, 1969

15^h 55^m 14^s.452

$X_1 = -3665.269860$ km $\dot{X}_1 = -8.51524454$ km/sec
 $X_2 = 4311.738986$ km $\dot{X}_2 = -6.56681023$ km/sec
 $X_3 = 3563.090604$ km $\dot{X}_3 = 1.49850836$ km/sec

HORIZON

$\epsilon \geq 5^\circ$

SAMPLING RATE

6 meas/minute

TRACKER UNCERTAINTIES

$\delta r = \pm 20$ meters
 $\delta \dot{r} = \pm 0.1$ m/s
 $\delta \alpha = \delta \epsilon = \pm 8 \times 10^{-4}$ radians
 $\Delta r = \pm 40$ meters
 $\Delta \dot{r} = \pm 0.07$ m/s
 $\Delta \alpha = \Delta \epsilon = \pm 1.6 \times 10^{-3}$ radians

TRACKING STATIONS

	Latitude	Longitude
Bermuda	32°3478 N	64°6538 W
Ascension	7°9730 S	14°4017 W
Madrid	40°4167 N	3°6667 W

STATION LOCATION ERRORS (meters)

	δS_1	δS_2	δS_3
Bermuda	39	41	39
Ascension	43	103	105
Madrid	39	31	37

- A - Measurement noise only
- B - Measurement noise and bias
- C - Measurement noise and bias and station location error

0.001

0

0.5

1.0

1.5

2.0

2.5

3.0

Tracking Time (hours)

GODDARD SPACE FLIGHT CENTER
SYSTEMS ANALYSIS OFFICE
June 1965

VELOCITY ERRORS FOR APOLLO LUNAR TRANSFER TRAJECTORY

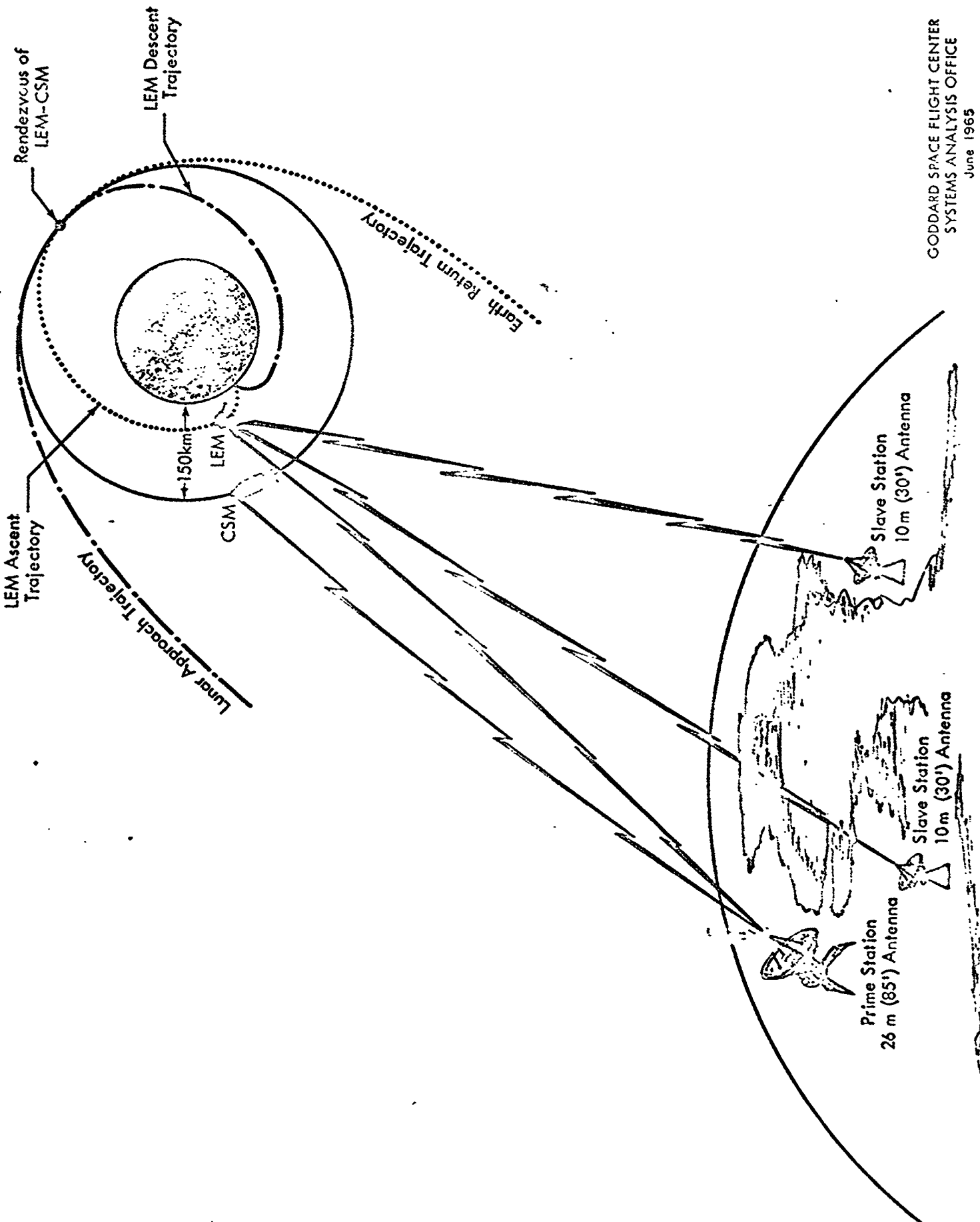

GODDARD SPACE FLIGHT CENTER
 SYSTEMS ANALYSIS OFFICE
 June 1965

TRACKING AND COMMUNICATIONS AT THE MOON

η_{vel}
(m/sec)

ORBITAL PARAMETERS

Eq uator of date coordinates - Moon centered

T = Sept. 20, 1969

5^h 10^m 12^s.176

X₁ = 306.76408 km $\dot{X}_1 = -1.5875100$ km/sec

X₂ = -1702.6861 km $\dot{X}_2 = -0.24903475$ km/sec

X₃ = -770.17548 km $\dot{X}_3 = -0.081752615$ km/sec

TRACKER LOCATIONS

Tracker Name	Latitude	Longitude	Ht (m)
Canberra	-35° 18' 41".50	149° 08' 09".00	50
Carnarvon	-24° 53' 50".48	113° 42' 57".84	64
Guam	13° 35' 00".00	144° 55' 30".00	20
Hawaii	22° 09' 30".96	-159° 40' 03".43	1142

HORIZON

$\epsilon \geq 5^\circ$

SAMPLING RATE

1 meas/min,

INJECTION ERRORS

$\eta_{pos} = \pm 173.2$ km, ± 5.2 km

$\eta_{vel} = \pm 1732.1$ m/s, ± 10.4 m/sec

TRACKER LOCATION UNCERTAINTIES

Name	Lat.	Long.	Ht (m)
Canberra	1.9"	2.2"	66.0
Carnarvon	1.9"	2.2"	66.0
Guam	6.4"	6.6"	32.0
Hawaii	1.4"	1.6"	43.0

TRACKER UNCERTAINTIES

$\delta \dot{r}$	$\delta \alpha = \delta \epsilon$
± 3 cm/sec	± 0.8 m rad
± 6 cm/sec	± 0.8 m rad
± 6 cm/sec	± 0.8 m rad
± 6 cm/sec	± 0.8 m rad

Tracking Occulted Tracking Occulted LEM Descent

0.01

0

1

2

3

4

5

6

Time from Lunar Orbit Insertion (hours)

GODDARD SPACE FLIGHT CENTER
SYSTEMS ANALYSIS OFFICE
June 1965

VELOCITY ERRORS OF THE CSM DURING LUNAR ORBITS

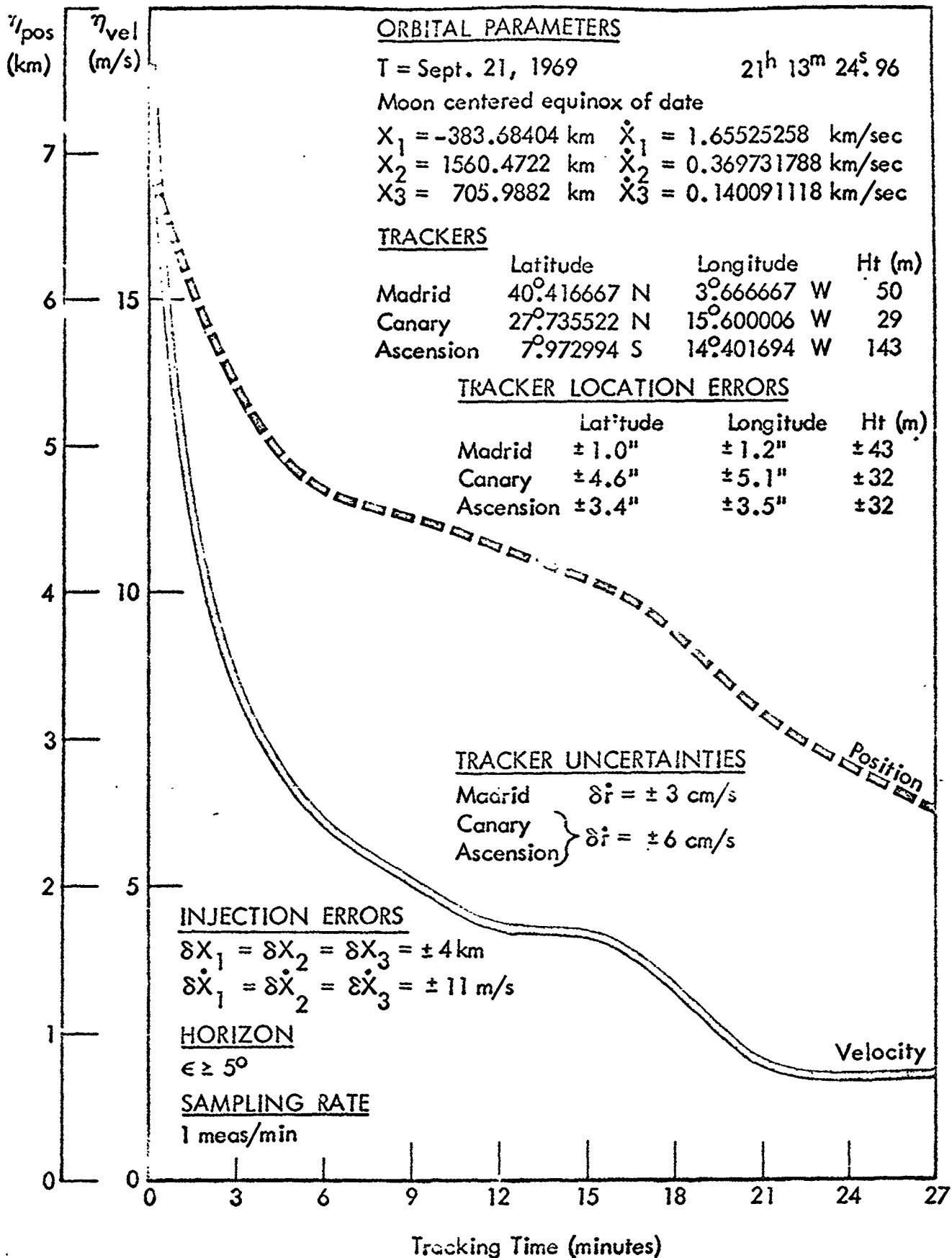

GODDARD SPACE FLIGHT CENTER
 SYSTEMS ANALYSIS OFFICE
 June 1965

ERRORS IN POSITION AND VELOCITY OF LEM DURING
 LUNAR ASCENT USING EARTH TRACKING DATA

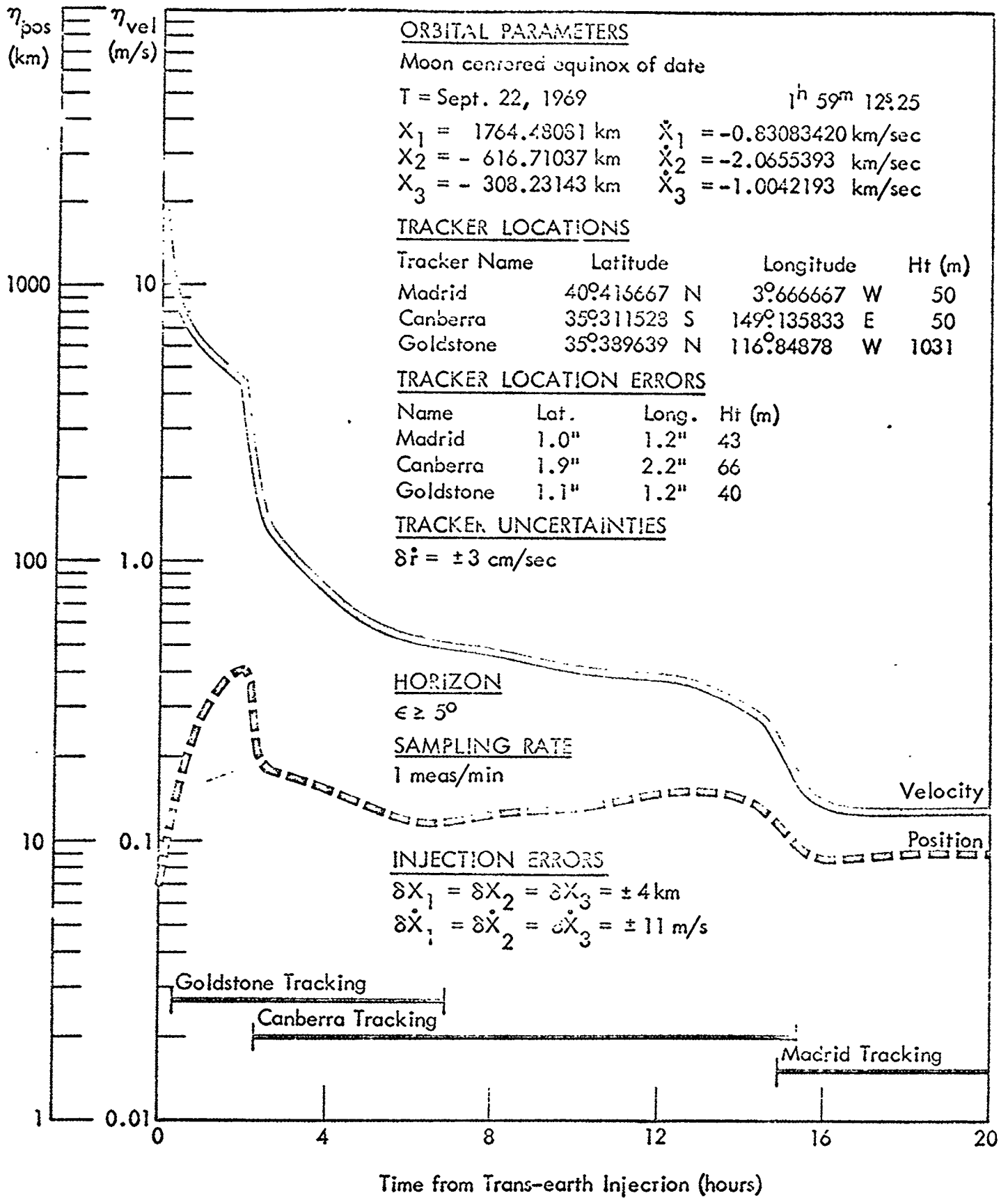

GODDARD SPACE FLIGHT CENTER
 SYSTEMS ANALYSIS OFFICE
 June 1965

POSITION AND VELOCITY ERRORS FOR THE APOLLO RETURN TRAJECTORY