

NASA TECHNICAL
MEMORANDUM

NASA TM X-53274

July 30, 1965

NASA TM X-53274

N66 29413

FACILITY FORM 908

(ACCESSION NUMBER)	(THRU)
22	1
(PAGES)	(CODE)
TMX-53274	11
(NASA CR OR TMX OR AD NUMBER)	(CATEGORY)

TECHNIQUES OF IMPLEMENTING LAUNCH
AUTOMATION PROGRAMS
(SATURN IB SPACE VEHICLE SYSTEM)

by WILLIAM G. BODIE
Astrionics Laboratory

GPO PRICE \$ _____

CFSTI PRICE(S) \$ _____

NASA

Hard copy (HC) \$1.00

Microfiche (MF) .50

*George C. Marshall
Space Flight Center,
Huntsville, Alabama*

ff 853 July 65

TECHNICAL MEMORANDUM X-53274

TECHNIQUES OF IMPLEMENTING
LAUNCH AUTOMATION PROGRAMS
(SATURN IB SPACE VEHICLE SYSTEM)

By

William G. Bodie

George C. Marshall Space Flight Center
Huntsville, Alabama
July 30, 1965

ABSTRACT

29413

This paper identifies the methods and equipment through which automation is becoming a major factor in testing and launching Saturn IB space vehicles. The merits of a digital guidance computer and its impact in extending automated checkout are stressed; also a logical basis is established for computer and manual test control. Hardware and software elements of the automated system are described, and details pertaining to reliability are emphasized. A concluding appraisal suggests that automation will play an expanding role in future test and launch operations.

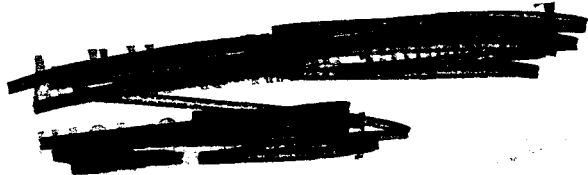

NASA-GEORGE C. MARSHALL SPACE FLIGHT CENTER

NASA-GEORGE C. MARSHALL SPACE FLIGHT CENTER

TECHNICAL MEMORANDUM X-53274

TECHNIQUES OF IMPLEMENTING
LAUNCH AUTOMATION PROGRAMS
(SATURN IB SPACE VEHICLE SYSTEM)

By

William G. Bodie

ELECTRICAL SYSTEMS INTEGRATION DIVISION
ASTRONICS LABORATORY
RESEARCH AND DEVELOPMENT OPERATIONS

TABLE OF CONTENTS

	Page
SUMMARY	1
INTRODUCTION.	1
EVOLUTION OF AUTOMATION IN THE SATURN VEHICLE SYSTEM	1
THE GROUND SYSTEM.	4
THE FLIGHT SYSTEM	7
AUTOMATED SYSTEM SOFTWARE.	12
BENEFITS, DISADVANTAGES, AND PROJECTIONS	14
REFERENCES	16

LIST OF ILLUSTRATIONS

Figure	Title	Page
1.	Saturn I/IB Systems Development Breadboard Facility	3
2.	Saturn IB Launch System Signal Flow Diagram	4
3.	ESE-Computer-Vehicle Functional Interface Diagram.	6
4.	Typical Stage Digital Data Acquisition System	9
5.	Remote Automatic Calibration System	10
6.	Switch Selector Command System	11
7.	ATOLL Test Program Development.	13

This report was prepared for presentation at the 4th Annual Reliability and Maintainability Conference, Los Angeles, California, July 30, 1965. Conference sponsors are the American Society of Mechanical Engineers, American Institute of Aeronautics and Astronautics, and Society of Automotive Engineers.

TECHNICAL MEMORANDUM X-53274

TECHNIQUES OF IMPLEMENTING LAUNCH AUTOMATION PROGRAMS (SATURN IB SPACE VEHICLE SYSTEM)

SUMMARY

This paper identifies the methods and equipment through which automation is becoming a major factor in testing and launching Saturn IB space vehicles. The merits of a digital guidance computer and its impact in extending automated checkout are stressed; also a logical basis is established for computer and manual test control. Hardware and software elements of the automated system are described, and details pertaining to reliability are emphasized. A concluding appraisal suggests that automation will play an expanding role in future test and launch operations.

INTRODUCTION

Automation contributes to vehicle reliability from manufacturing through prelaunch checkout. Because of the speed of the digital computer, more time is available for testing, fault analysis, investigation, and corrective action. As launch densities increase, conservation of vehicle checkout time will become more urgent. The computer checkout system will significantly reduce the burden imposed upon the launch crews by multivehicle missions. It is the aim of this paper, therefore, to present a broad picture of automation and the means for obtaining reliability assurance in launch operations of the Saturn IB space vehicle system.

EVOLUTION OF AUTOMATION IN THE SATURN VEHICLE SYSTEM

Automation is not new to space vehicles or the associated checkout and launch equipment. Space vehicles have been launched for many years with automated firing-command-through-liftoff sequences, time-based inflight event programming, and computer calculated velocity and position parameters to achieve planned trajectories. While this degree of automation has existed at least since

the days of the Redstone and Jupiter systems, important new concepts of automation are evolving in the Saturn space vehicle programs.

The Saturn inertial guidance system is designed around a gyroscopically stabilized platform with accelerometers and a digital computer. Primary functions of the computer are: calculating velocity and position of the vehicle, using this data for computing the trajectory, and generating steering signals for the vehicle control system. The computer must also issue a cutoff signal to the propulsion system when mission velocity is achieved. An adaptive guidance technique is used so that mission success is possible with loss of one or more engines; that is, the computer optimizes flight trajectory for propellant conservation. Analog computers are sufficiently accurate for many purposes, but do not provide the versatility required for guidance and master control of space vehicles or the degree of accuracy possible with a digital computer.

Versatility requirements and accuracy enhancement therefore led to the use of a digital computer with the capability of performing a multitude of functions in addition to its guidance role. These include orbital checkout, response to flight path correction signals from the ground, inflight sequencing of events that formerly had been performed by an electromechanical program device, and automated prelaunch checkout of the guidance and control system. Digital computers are inherently more flexible and accurate than analog computers. This flexibility results from a data storage or memory capacity which allows a pre-stored program to operate upon data from external sources. Thus, functions are changed by program changes instead of by rewiring patchboards or making other hardware changes. This storage capability also results in fewer arithmetic units required to perform a given computation. Also, since integration can be performed by a series of additions and multiplications, integrator arithmetic units are not required [1]. Accuracy in electronic analog computers is limited by component tolerances to approximately 0.01 percent, whereas digital computer accuracies are independent of component tolerances and depend upon word length or number of bits used to define a parameter [2].

The inclusion of a digital computer on the Saturn vehicle necessitated installation of a ground based digital computer for checkout of the guidance and control system. With all the capabilities of the ground based computer available for test and checkout purposes, the concept evolved to extend computer operations beyond the guidance and control system areas. Additional functions that have evolved are discrete and analog signal recording and display, measurement circuitry calibration, event programming for test and limited launch sequences, fuel temperature averaging calculations, and signal transmission between the launch control center (LCC) and automatic ground station (AGCS) computers.

Incorporation of launch-critical interlocking circuitry does not appear to be feasible at present as this would greatly complicate an already complex programming effort, make late changes to the system difficult, and degrade launch reliability. Considerable concern exists regarding the utilization of the computer as a launch sequence command element. Obviously, failures in the computer or auxiliaries could occur that would cause varying degrees of trouble, depending largely on time of occurrence. Electrical support equipment (ESE) hardware safing circuits have been provided to restore the vehicle to a safe condition in the event of a computer or auxiliary system failure.

To implement automation, it has been necessary to establish experimental and development facilities at the Marshall Space Flight Center for developing hardware, proving all launch site computer programs, and training personnel. Three computer facilities have been constructed to simulate the flight vehicle computer ESE system for the Saturn I, IB, and V programs. These facilities, while costly, are essential to a successful automation program. The Saturn I/IB facility is shown in Figure 1.

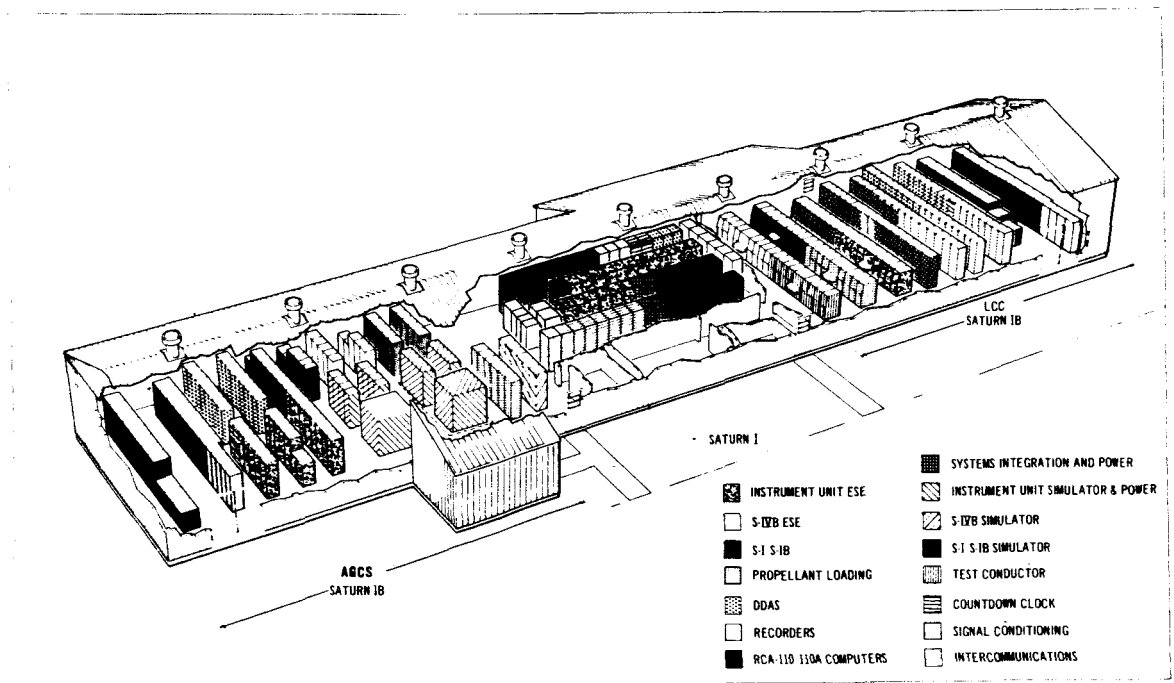

FIGURE 1. SATURN I/IB SYSTEMS DEVELOPMENT BREADBOARD FACILITY

The Saturn IB launch system is selected for specific description because its hardware and software are substantially defined and illustrate automation concepts for Saturn V. Major elements of the automated system are shown in Figure 2.

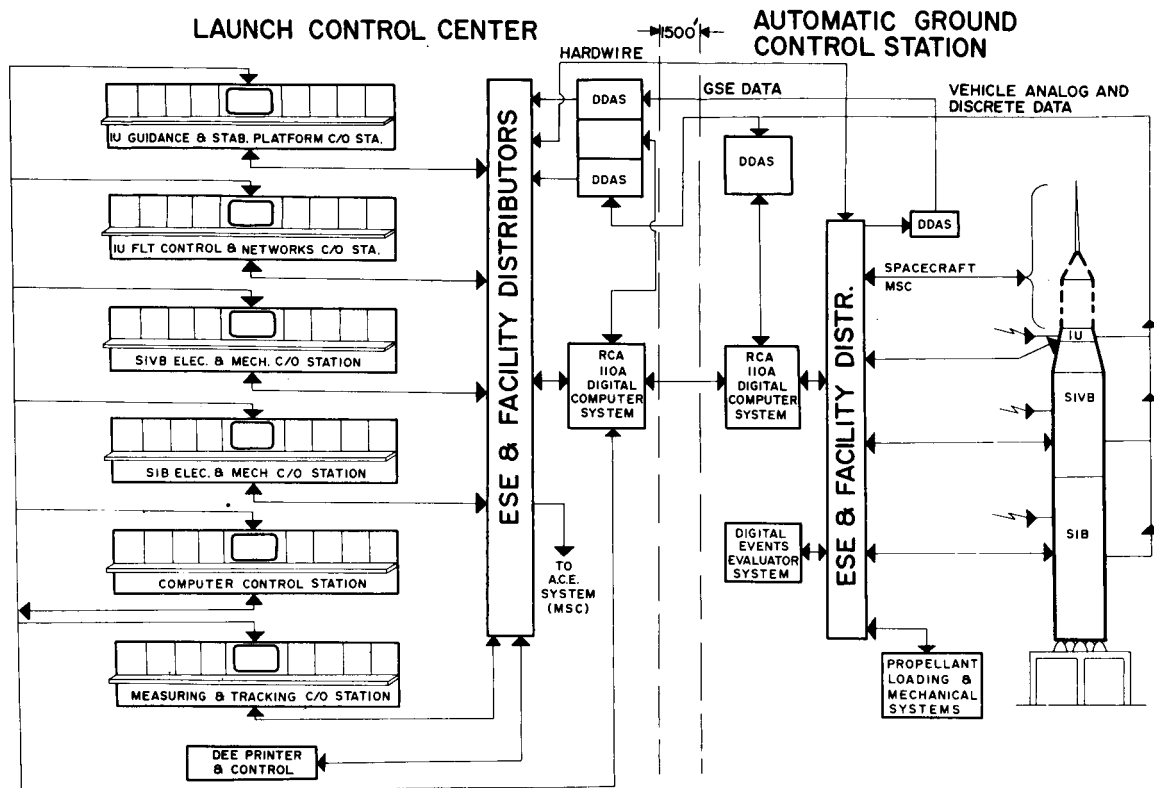

FIGURE 2. SATURN IB LAUNCH SYSTEM SIGNAL FLOW DIAGRAM

THE GROUND SYSTEM

The RCA 110A general purpose digital computer (system computer) was selected primarily to perform prelaunch checkout on the vehicle digital guidance system. It possesses a magnetic core memory of 32,768 words. It is not the fastest computer available but it has been designed for the job. The computer can recognize and respond to eight priority levels or channels stimulated by automatic sensors or manually operated switches [3]. As an example, the computer might be performing a hydraulic pump power-up sequence when a loss

of control voltage occurs. The computer would be advised of this condition by a signal from the ESE and, through its priority interrupt feature, would shift its program to initiate power off command to the hydraulic pumps. Thus personnel and vehicle can be protected against uncontrolled engine movements. Another feature of prime importance is the data link section that ties the LCC and the AGCS computers together via coaxial cable. This link will be as long as six miles for the Saturn V launch complex. Signal transmission rate is approximately 133,000 bits per second. An automatic parity bit error detection system is part of the link. In the event that a bit is lost, the sending computer will repeat the message. Thus message transmission and receipt are safeguarded. Two computers are used for similarity of checkout and launch procedures with the Saturn V program. The LCC computer commands the AGCS computer to perform test programs and issue signals initiated from the ESE stations. However, each computer may communicate with the other; i. e. , signal flow is bidirectional. Test programs are generally stored in the AGCS computer; the LCC computer provides the interface link with launch operations personnel.

The digital events evaluator (DEE) is a system for scanning all significant discrete events from the ESE or vehicle and provides a real time printout of changes on any of its 2160 input lines. An order-of-events program will be available to show deviations from planned sequencing of any event in the vehicle test or launch operations. The system delivers its output primarily by line printer, but also has paper tape or magnetic tape recording capability. The function of monitoring significant discrete commands and indications during test and launch has, until recently, been performed by strip chart recorders with approximately five milliseconds resolution. The DEE will provide typed copy with a time resolution of approximately two milliseconds. The main advantage over the old system is the reduction of time and effort required to examine and interpret the data.

The ESE performs several vital roles in automation although it is primarily associated with manual techniques. First in importance, the ESE provides the means through which the computer operates and keeps launch-experienced personnel in command during test and launch operations (Fig. 3). It also provides flexibility of testing and the means for troubleshooting system problems that cannot feasibly be done with an automated system. The ESE provides signal distribution and conditioning of all discrete commands into and out of the system computer; provides signal isolation and filtering for certain analog functions; reduces computer programming burden by incorporating function generation and network logic; and, through hardwire connections, provides backup to the data link for those circuits essential to safing the vehicle. Two notable items of automated ESE are the launch and ignition sequencers. The launch sequencer

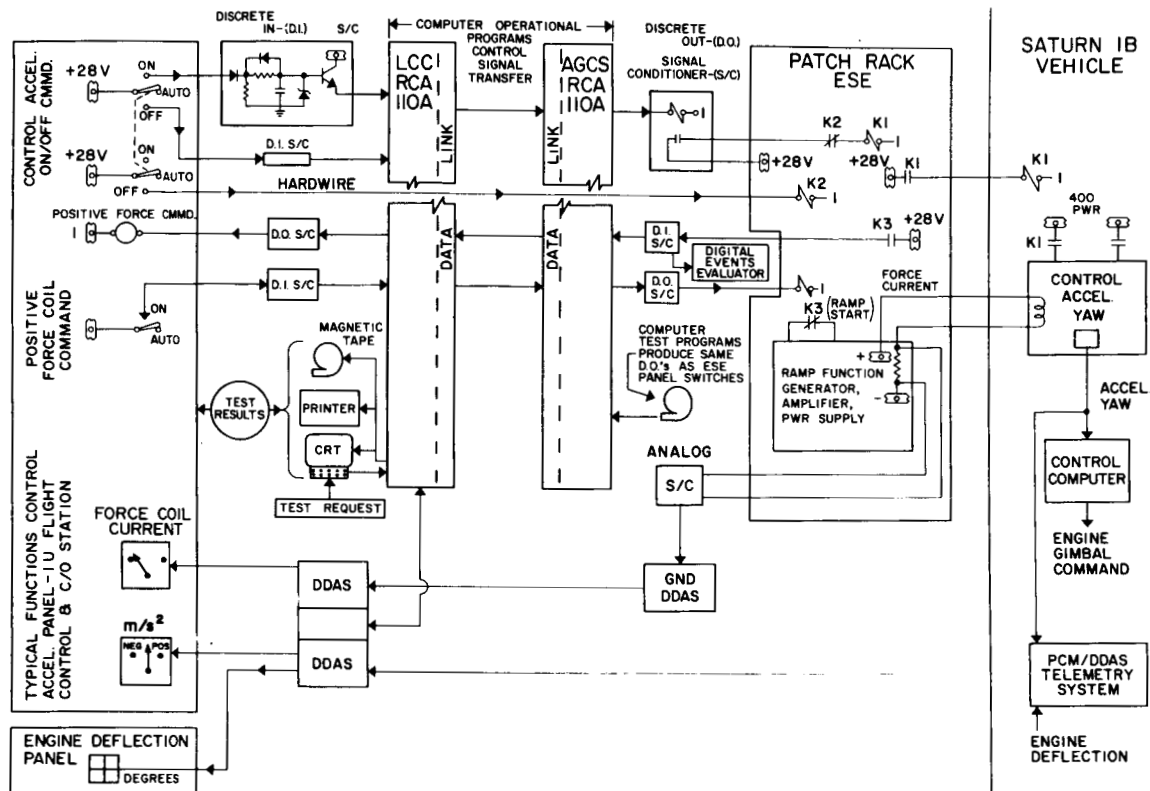

FIGURE 3. ESE-COMPUTER-VEHICLE FUNCTIONAL INTERFACE DIAGRAM

is energized at firing command and performs switching to initiate numerous launch critical functions such as stopping LOX bubbling, power transfer, LOX and fuel lines ejection, and vehicle release. The device is driven from the count clock and automates launch operations for approximately 163 seconds before liftoff. It also commands the ignition sequencer to begin a program of starting the eight engines. This hardware is designed to provide approximately 100 milliseconds interval between starting pairs of diametrically opposed engines. The system computer could perform all these functions quite handily; because of its component count, however, it is not considered as reliable as this ESE. Unless all engines satisfy a minimum thrust requirement within three seconds after ignition command, cutoff will be given. While cutoff has not marred a single Saturn launch, the requirement that all engines produce adequate thrust before vehicle release significantly enhances the probability of mission success. The scope of this paper precludes definition of all ESE in the Saturn IB program.

Functional categories of ESE most closely associated with automation are shown on the system diagram of Figure 2. Figure 3 illustrates the relationship of the ESE and computer and shows some detail of the system elements.

Propellant loading and unloading operations are automated to a high degree. For safety and reliability, however, complete manual control is available through the LCC stations. Automation is accomplished through a propellant tanking computer system (PTCS) for each propellant of both propulsion stages. It is a hybrid computer system in that analog and digital data are processed. The PTCS receives analog signals generated by vehicle tank level indicators. These signals are used by the PTCS to control bulk loading rates, time for activating cryogenic replenish control, and initiation of slow fill sequence for the RP-1 tank. The RP-1 tank is filled approximately two percent over mission requirements, and final level is adjusted by initiating level-adjust sequence in the launch countdown. The level adjust is accomplished through a drain valve controlled by the PTCS. All cryogenic propellants are maintained at 100 percent mission requirements by the replenishing valves or, in the case of the LH₂, a combination of slow bulk filling and replenishing valve action. The system checkout computer provides monitoring and display for this system and performs calculations based on RP-1 temperature to correct liftoff mass [4].

THE FLIGHT SYSTEM

The launch vehicle digital computer (LVDC) was required primarily for trajectory optimization for propellant conservation, high accuracy, and master control over vehicle functions during prelaunch checkout, launch, and orbital operations. The computer has two magnetic core memories which may be used in parallel or series. The parallel arrangement may be used with a selection network to provide higher reliability, or the memories may be used serially to provide more storage capacity. Triple modular redundancy is utilized in the logic portion of the computer so that one spurious output or the failure of a single component will not affect the output signal. This is accomplished through majority voting (two out of three inputs) establishing a true output signal. The computer may be commanded through the data adapter from the ground based digital command system to interrupt its program and perform priority instructions, or it may receive priority information from a flight sensor that can cause program alteration. When the instructions have been performed, it will resume the interrupted program. A few of the operations that the computer may perform are: computer self-test, mission simulation, telemetry check, stabilized platform performance monitoring, steering command generation, event sequencing,

and S-IVB engine restart at the proper time for spacecraft injection into a lunar trajectory. The launch vehicle data adapter (LVDA) provides signal conditioning for all signals from the computer to the controlled equipment, provides temporary data storage, performs error monitoring and detection, and controls the inputs to the LVDC. It utilizes triple modular redundant circuits in several vital subsystems to achieve high reliability. In short, it functions as the interface unit between the LVDC and all systems associated with it [5].

The digital data acquisition system (DDAS) output of the PCM/FM telemetry system is transmitted over coaxial cable and is a most important prelaunch information link between vehicle and ground. It eliminates the need for hundreds of umbilical hardlines that would otherwise be required for measurement calibration and noncritical vehicle status indicator functions. It is a major element of the automated system and offers the possibility of further reduction in hardwire links to the ESE. Three telemetry systems for transmitting information are available on each stage of the Saturn vehicle, but the PCM/FM system (from which the coaxial output is obtained) is the only one that interfaces with the system computer and is the most generally used. Each stage can transmit digital information into the ground computer through a ground DDAS receiving station. The ground station stores the data received in magnetic cores and makes the data available to the ground computer upon request [3, 6]. After liftoff the same information is transmitted by an RF PCM/FM transmitter. All significant vehicle analog data other than vibration and acoustic measurements are converted to digital values and transmitted to earth through the system. On the Instrument Unit, approximately 288 out of 315 transmitted signals are included on the DDAS. Thus the DDAS is the primary information system for automated and manual checkout. Many of the measurements applied to the PCM/FM system are also applied to the FM/FM system to give higher reliability through redundancy. Perhaps the most significant capability of the PCM/FM ground-computer system is that inflight data can be received and displayed on a real time basis. Real time display is achieved through the six cathode ray tubes and ESE control stations located in the LCC. Launch operations personnel will therefore have the capability of detecting anomalies as soon as they occur (Fig. 4).

Automation will be most useful in checkout of the vehicle measuring systems as there are well over 1300 measurements planned for the Saturn IB. Some of the transducers used are: force balance accelerometers for structural bending; bourdon tube potentiometers for pressure; thermistors, thermocouples, and resistance thermometers for temperatures; piezoelectric accelerometers for vibration; capacitance probes for liquid levels; potentiometers for position; and flowmeters for flow rates [7]. Each measurement signal conditioning

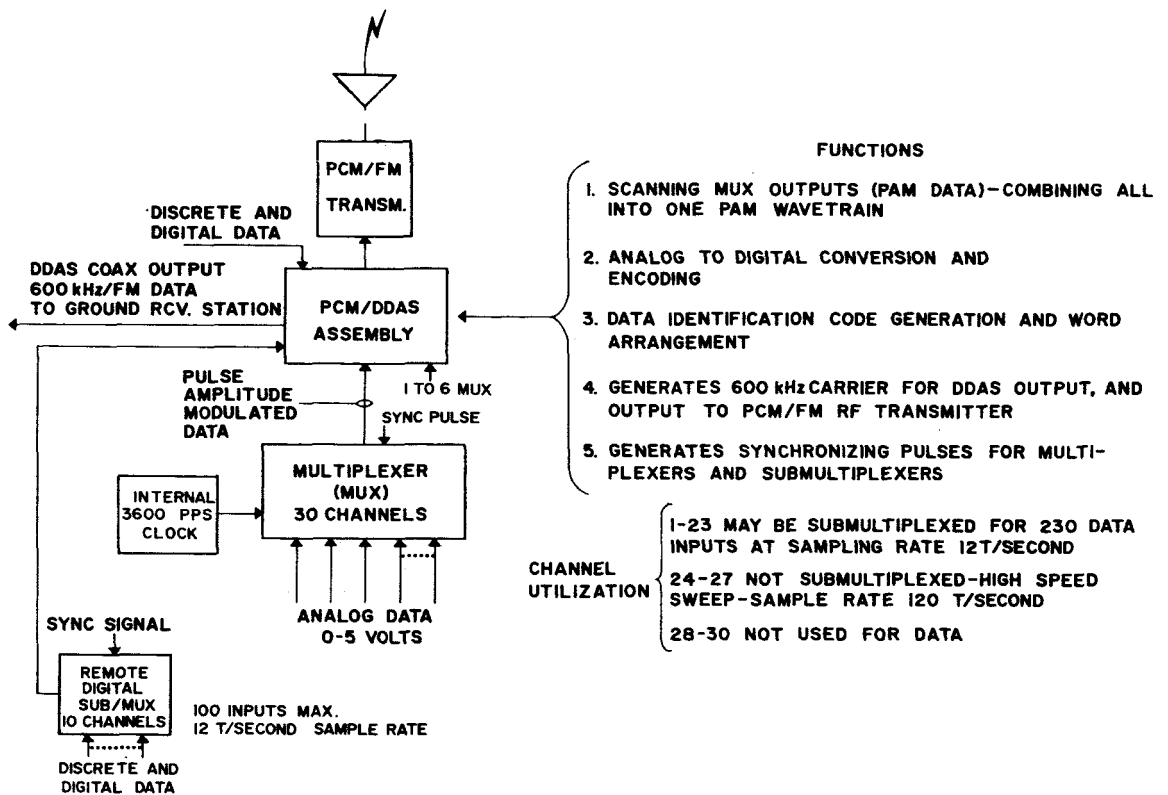

FIGURE 4. TYPICAL STAGE DIGITAL DATA ACQUISITION SYSTEM

circuit must be verified near launch time to assure the validity of flight data. This check is performed through the remote automation calibration system (RACS) (Fig. 5). It consists of a ground control station connected by hardwire through each stage umbilical to a measuring selector control package on the stage. The measuring selector is connected to the measuring rack, which is connected to the transducers. As many as 27 of these with 20 measurements per unit may be accommodated by one selector control package. Any measurement circuit may be selected from the ground control station in high or low range. Circuitry and switching provisions are included in the measuring racks to simulate the transducers' outputs at the high and low points of their calibration curves. These simulated transducer outputs are fed into an amplifier and converted to a signal level (usually 0 to 5 volts) compatible with the DDAS system. The entire operation can be performed by the ground system computer. The computer can also compare the measured values with prestored data and display the results including out-of-tolerance values at control stations in the LCC.

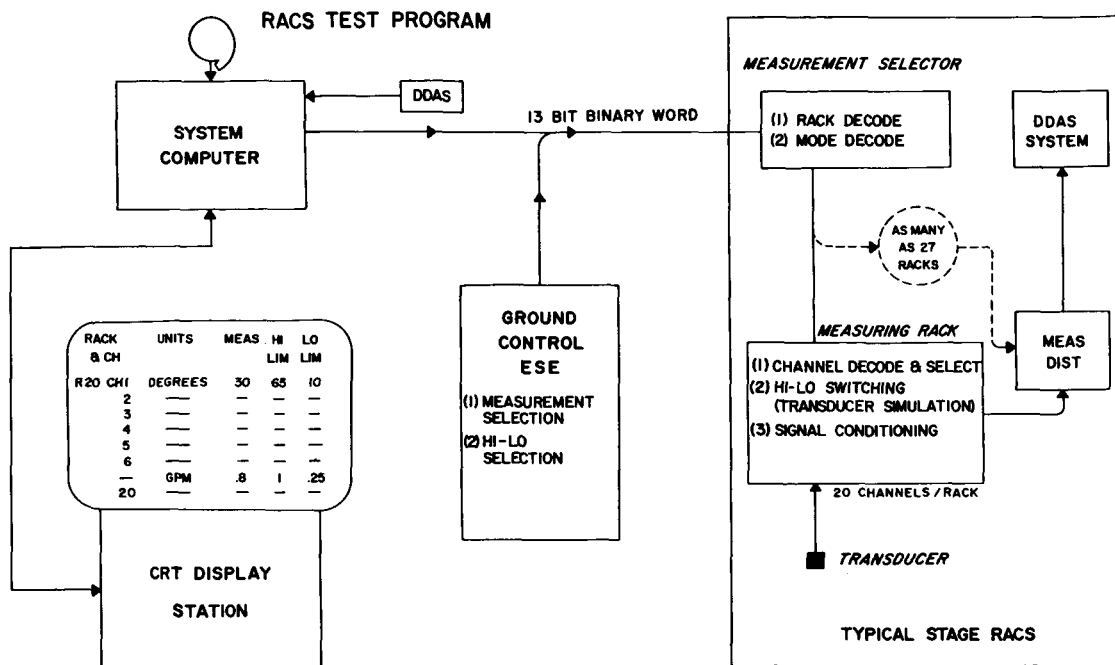

FIGURE 5. REMOTE AUTOMATIC CALIBRATION SYSTEM

Thus the RACS system is highly compatible with computer controlled checkout and provides for testing approximately 60 percent of the measurement circuits in a matter of minutes. Many of the measurements do not require signal conditioning and hence are not a part of the RACS. These are available to the system computer via DDAS, however, and therefore may be displayed and recorded in various subsystem tests and the launch sequence.

The switch selector provides the means for master control of each stage from the LVDC (Fig. 6). From liftoff to orbital injection, approximately 88 commands from the LVDC are decoded and channeled to operating components by the switch selector. Some typical command functions are: firing stage separation initiators, firing retrorockets, starting S-IVB engine, jettisoning the launch escape tower, and engine cutoff. The switch selector's binary decoding capability reduces substantially the connectors and wiring required throughout the vehicle. Each switch selector has a capacity of 112 individual output commands; these are selected by an eight bit binary word from the LVDC. Before any output gate is opened, the LVDC examines a verification word from the input register and determines whether the correct word was set into the input register.

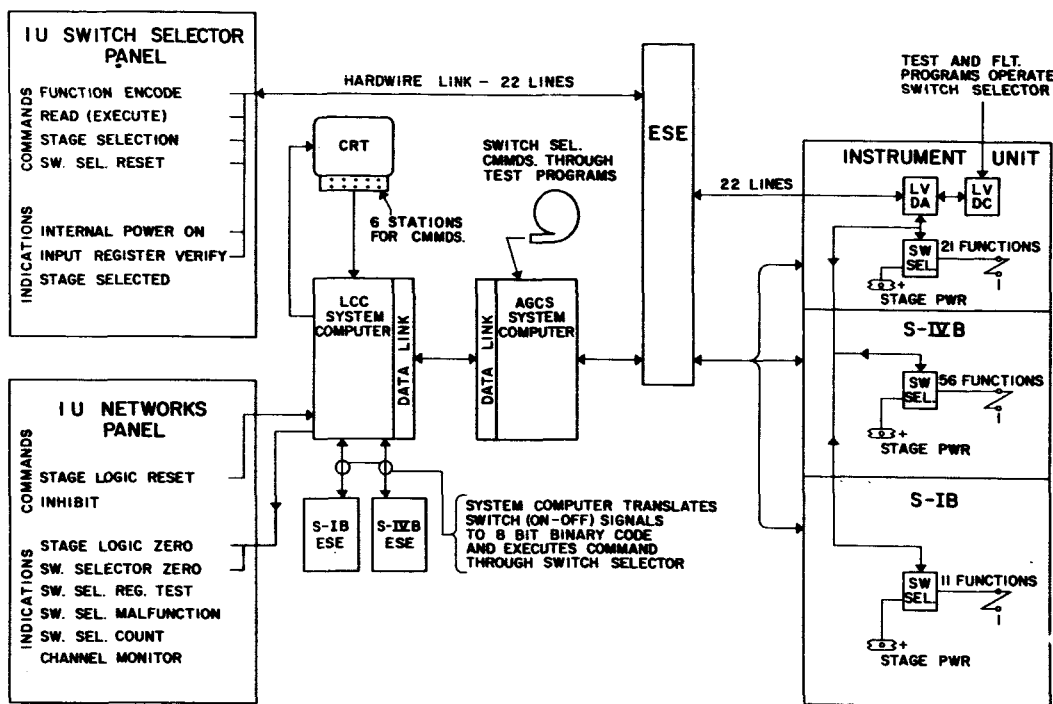

FIGURE 6. SWITCH SELECTOR COMMAND SYSTEM

If not, the LVDC will issue a reset command to restore the input register to its initial condition. The LVDC will then issue the binary complement of the original word and gate the same channel the original word would have gated under normal circumstances. This word verification check and the ability of the switch selector to issue the same command from the word complement greatly enhance event programming reliability. Redundancy is used in the design of the switch selector and its hardware link to the LVDA. Commands to the input register and register verification lines are through separate connectors; dual relays are used for stage select, reset, and output gating commands. One set of command hardwires will be provided for control of vehicle function during checkout and launch. Thus, through the Instrument Unit stage umbilical, a maximum of 112 events can be controlled on each stage from the ESE and ground system computer with only 22 hardwires. One hardware control panel will exist in the LCC and several other command stations will have access to the control lines through the system computer.

AUTOMATED SYSTEM SOFTWARE [6, 8]

Approximately 80 computer test programs are planned for the early launches of the Saturn IB space vehicle. In addition to these, some 40 operational programs will be required to guide the computer through all the operations necessary to perform the test programs. Operational programs control or manage the overall operation of the computer; tasks such as a priority interrupt, causing data to be read in from magnetic tape to memory; computer self-test; and data link control are examples (Fig. 3). Operational programs do not change and may be thought of as an integral part of the computer. Test programs are designed to perform precise functions on specific hardware; as the hardware changes, so must the test program change (Fig. 3). Computer test programs for the first launch are associated primarily with the LVDC/LVDA, stabilized platform, flight control system, switch selector, propellant loading, measuring system, and emergency detection system (EDS). Examples of test programs in each system, respectively, are: simulated flight, LVDC switch selector test, and LVDC/LVDA discrete output test; accelerometer monitor and azimuth laying; S-IB A_0 gain test and S-IB overall steering test; system computer switch selector channel test; propellant loading and monitoring; DDAS/RACS calibration; and engine out abort test [9].

Although many computer language systems exist, no single system was suitable for the numerous government and contractor-owned computer test facilities involved in qualifying all stages of the Saturn vehicle. It is axiomatic that the reliability attained in the Saturn program has been the result of a rigorous checkout program executed by personnel experienced in manual checkout techniques. It is to utilize this store of experience and to exercise comprehensive test program control that a common problem-oriented language is being developed. The language must be understandable in terms of manual checkout techniques, computer translatable into the system computer/machine language, and comprehensive to implement the multitude of instructions necessary to perform the tests. This system for test engineer/computer communication has been assigned the acronym ATOLL for acceptance, test, or launch language. Mnemonic symbols are used that generally are logical derivations of the functions to be performed. Most operator functions are defined by four characters such as BEGN for BEGIN, EXEC for EXECUTE, DISI for DISCRETE IN, ALGE for ALGEBRAIC COMPUTATION, etc. ATOLL is not as yet sufficiently developed to implement many launch checkout programs; thus another more detailed language system, symbolic language assembler program (SLAP), will be used for most programs for the first Saturn IB launch. The goal is ATOLL, however, and more tests will employ it as development progresses. The general procedure for preparing ATOLL test programs is shown in Figure 7.

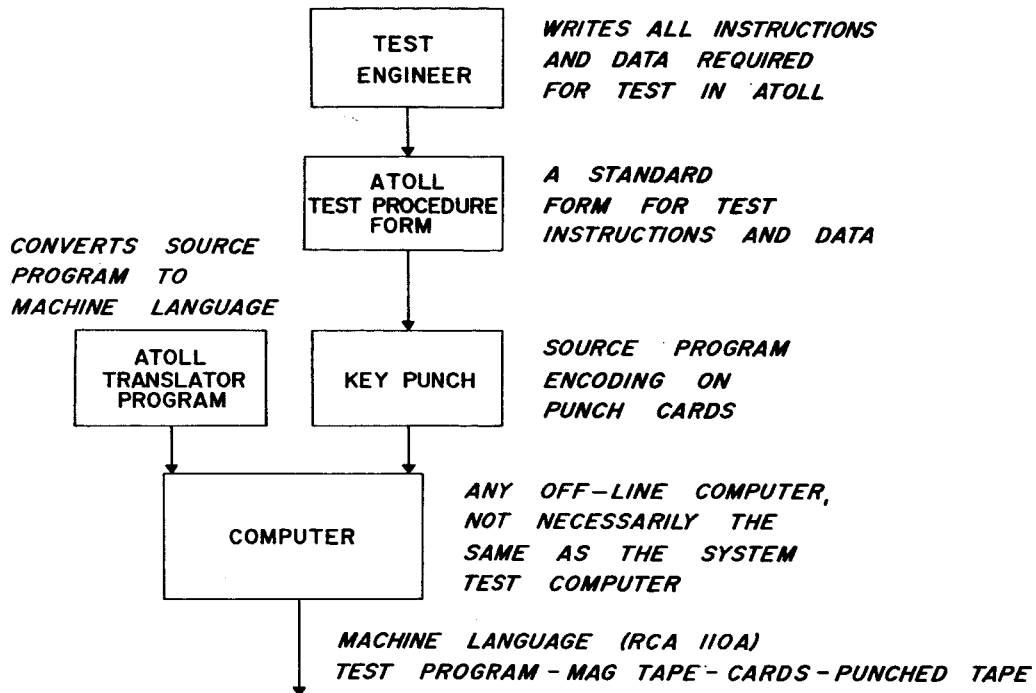

FIGURE 7. ATOLL PROGRAM DEVELOPMENT

A disturbing aspect of computer controlled operation is that software is just as vital to system performance as hardware (Fig. 3). An undiscovered programing error could have the same effect as a malfunctioning relay or other component. Therefore, it is necessary that all programs be thoroughly tested and "debugged." Computer programing evolves through four distinct phases; analysis, design, coding, and checkout. Analysis requires detailed specification writing of all test parameters and functions; design entails translation of the specifications into step by step statements of the problem; coding consists of writing these test instructions and data in a source language (ATOLL, SLAP, etc.) that will precisely control and command the computer to perform all operations; and checkout is, as the name implies, a "debugging" process. Documentation characteristic of the respective phases consists of detailed test specifications, program flow charts, source program printout and cards, and finally the magnetic tape and card deck machine language program. To generate the first Saturn IB test and launch programs and supporting documentation, it is estimated that an effort of approximately 21 man years will be required.

BENEFITS, DISADVANTAGES, AND PROJECTIONS

The tremendous speed of the digital computer has revolutionized repetitive industrial processes but has not advanced space vehicle launch schedules. The time required for individual tests has been reduced but more testing is being done [6]. More testing inevitably produces more reliable flight vehicles. Thus, automated techniques are providing the basis for higher reliability. Day-to-day tests in factory checkout provide data for determining component parameter variation. Libraries of test records may be stored on magnetic tape or typed copy in a fraction of the space required for strip chart records. Automated techniques facilitate solutions to problems because of the immediate availability of test results on typewritten copy [6]. Through rapid distribution of test data, all organizational elements concerned may simultaneously focus upon problem areas. Errors in interpretation and transposition are completely eliminated. Analysis of the data is much easier than extracting data from strip chart records. The data are also more accurate. Repeatability and accuracy are positive factors for computer controlled tests. The "canned" tests are all the same, and any deviation in results between tests would incriminate the tested system rather than lead to speculation regarding what, when, and how human operators had introduced a stimulus and observed a result. Automated test programs will provide significant time savings in redundant circuit verification as redundancy is extensively used for reliability enhancement in the flight control computer, the EDS rate gyros, and the LVDC. Real time display of flight performance parameters should prove to be of substantial value in analyzing various flight system failures and correcting spatial attitudes during orbital maneuvers.

Obviously automation is not the solution to all test and checkout problems. Some definite disadvantages must be recognized. Training of personnel to effectively use automated techniques is a substantial and continuing task. New organizations or contracts must be established to provide programing and documentation services. Flexibility of testing is somewhat restricted because the cost-to-benefits ratio for nonrepetitive testing is too high. The high speed capability of the computer makes it susceptible to system noise, necessitating the use of signal conditioners for low level analog hardwire data. Finally, the automated system is new and therefore must be treated with considerable reserve as a major launch command element.

All the capabilities of the ground system computer are not presently being used in the launch sequence. This is consistent with the basic concept of reliability. Only time and operating experience can provide the basis for establishing full confidence in the system computer as a major launch command element. Thus the Saturn launch system is designed to use the computer and ESE to provide maximum flexibility and safety in launch operations. As the computer system proves its reliability, and system hardware and software engineers get a better understanding of what should be automated, greater use will be made of the computer. As with any new concept, change evolves gradually and the first steps are the longest. Some possibilities for future computer operations are: utilization of the function generation capabilities of the computer to apply ramp function stimuli to the guidance and control system components; elimination of many analog recorders used for currents, voltages, and transducer measurements; absorption of some ESE event logic chains; pressure switch calibration; and RACS flight verification of measurement transducers.

REFERENCES

1. Leondes, C. T. , Computer Control Systems Technology, McGraw-Hill Book Co. , Inc. , N. Y. , London, Toronto, 1961, Ch. 1.
2. Karplus, W. J. , The Nature of Analog Computations (Notes U. C. L. A. Short Course, 1964, Introduction to Modern Engineering Application of Computer Control System Technology).
3. MSFC Automation Plan, Technical Staff MSFC Automation Board, June 1, 1964.
4. Saturn IB Electrical Ground Support Equipment for Launch Complex 34, Launch Support Equipment Engineering Division, KSC, December 21, 1964.
5. Instrument Unit Model Specification Saturn IB/V Launch Vehicle, MSFC, R-ASTR/R-P&VE.
6. Software for IU-201 at MSFC, SA-201 at KSC, SA-501 at KSC, MSFC Research and Development Operations, December 1, 1964.
7. Saturn I, Block II Instrumentation System Description, MSFC Communication and Instrumentation Division/Chrysler Corporation, Space Division, Huntsville Operations, August 15, 1964.
8. Launch and Checkout Computer Program Configuration and Control Plan, Revision B, MSFC Automation Sub-Board No. 4, October 26, 1964.
9. Specifications for the Test Programs for the Saturn IB/V Launch Computer Complex, IBM Huntsville Facility Space Guidance Center, April 20, 1965.

TECHNIQUES OF IMPLEMENTING
LAUNCH AUTOMATION PROGRAMS
(SATURN IB SPACE VEHICLE SYSTEM)

By William G. Bodie

The information in this report has been reviewed for security classification. Review of any information concerning Department of Defense or Atomic Energy Commission programs has been made by the MSFC Security Classification Officer. This report, in its entirety, has been determined to be unclassified.

This document has also been reviewed and approved for technical accuracy.



R. ADEN
Chief, Electrical Support Equipment Branch



H. FICHTNER
Chief, Electrical Systems Integration Division



W. HAEUSSERMANN
Director, Astrionics Laboratory

DISTRIBUTION

DIR Dr. von Braun	K-FA Mr. Dodd
I-DIR Gen. O'Connor/Mr. Hueter	K-P Mr. Claybourne
I-I/IB-DIR Col. James (3)	K-VG Mr. Rigell (2)
I-I/IB-E Mr. Vruels	K-VG2 Mr. Greenfield
I-I/IB-P Mr. Fikes	K-VG45 Mr. Terry
I-I/IB-U Mr. Simmons	K-DT Mr. Brewster
I-I/IB-F Mr. Cooper	LVO-E Mr. Williams
I-V-G Mr. S. E. Smith	R-DIR Dr. McCall
I-MICH-MGR Dr. Constan Mr. Stamy Mr. Rougon	R-AERO Dr. Geissler/Mr. O. C. Jean Dr. Speer
I-SE-CH Dr. Mrazek	R-ME-DIR Mr. Kuers
K-DIR Dr. Debus	R-P&VE-DIR Mr. Cline
K-D Mr. Poppel	R-P&VE-AA Mr. Galzerano
K-E Mr. Sandler	R-P&VE-P Mr. Paul Mr. Voss

DISTRIBUTION (Cont'd)

R-P&VE-V

Mr. Palaoro
Mr. Glover
Mr. McCullough
Mr. Faulkner
Mr. Thrower
Mr. Kistler
Mr. Schulze
Mr. Prasthofer

R-QUAL-DIR

Mr. Grau

R-QUAL-A

Mr. Henritze

R-QUAL-P

Mr. Brooks

R-QUAL-TS

Mr. Klauss

R-QUAL-OE

Mr. Lockridge
Mr. Boddie

R-REL-DIR

Mr. Schulze

R-RP-DIR

Dr. Stuhlinger

R-TEST-M

Dr. Sieber

R-TEST-T

Mr. Driscoll

R-ASTR-DIR

Dr. Haeussermann/Ref. File
Mr. Richard
Miss Flowers

R-ASTR-A

Mr. Digesu/Mr. Thornton

R-ASTR-E

Mr. Fichtner
Mr. Youngblood
Mr. Bennett

R-ASTR-EA

Mr. Smith
Mr. Paschal
Mr. Fuller
Mr. Felch

R-ASTR-ES

Mr. Aden
Mr. Baggs
Mr. Burdine
Mr. White
Mr. Milner
Mr. Glass
Mr. Woodruff
Mr. Cole
Mr. Haley
Mr. Barr
Mr. Robinson
Mr. Goodhue
Mr. Gallaher
Mr. Bodie (15)

R-ASTR-F

Mr. Hosenthien/Mr. Blackstone

R-ASTR-G

Mr. Mandel
Mr. Wood

R-ASTR-I

Mr. Hoberg

DISTRIBUTION (Concluded)

R-ASTR-M
Mr. Boehm

I-SC
Mr. Reinartz

R-ASTR-N
Mr. Moore
Mr. Wojtalik

I-SC-B
Mr. Chambers

R-ASTR-NG
Mr. F. A. Winkler

R-ASTR-ND
Mr. Turner

R-ASTR-TJ
Mr. Brandner (2)

R-ASTR-U
Mr. Weber
Mr. Payne
Mr. Cagle

MS-IPL (8)

MS-IP

MS-H

I-RM-M

CC-P

Scientific and Technical Information
Facility (25)
Attn: NASA Representative (S-AK/RKT)
P. O. Box 5700
Bethesda, Maryland