

NATIONAL AERONAUTICS AND SPACE ADMINISTRATION

Technical Report No. 32-948

***Computation of Stresses in Triangular
Finite Elements***

Senol Utku

M. E. Alper

M. E. Alper, Manager
Applied Mechanics Section

JET PROPULSION LABORATORY
CALIFORNIA INSTITUTE OF TECHNOLOGY
PASADENA, CALIFORNIA

June 15, 1966

Copyright © 1966
Jet Propulsion Laboratory
California Institute of Technology

Prepared Under Contract No. NAS 7-100
National Aeronautics & Space Administration

CONTENTS

I. Introduction 1

II. Stress Computation by Nodal Forces 2

**III. Stress Computation From a Best-Fit Deflection Field
in the Triangular Element 3**

**IV. Stress Computation by Best-Fit Curvature Change
and Strain Tensors at Nodes 4**

V. Numerical Results 7

VI. Conclusions 11

References 11

**Appendix A. Stress Computation in Triangular Elements
Assuming Linear Deflection Fields 12**

**Appendix B. Computation of Moments and Shears in Triangular
Elements by a Cubic Transverse Displacement
Field Yielding Minimum Strain Energy 15**

**Appendix C. Computation of Moments and Shears in Triangular
Elements by a Cubic Transverse Displacement
Field of Bounded Trace in Curvature Tensor 21**

**Appendix D. Computation of Shears and Moments by Best-Fit
Curvature Change Tensors at Nodes 24**

**Appendix E. Computation of Membrane Forces by
Best-Fit Strain Tensors at Nodes 28**

TABLES

1. Deflection of clamped plate by series method	7
2. Deflection of clamped plate by finite-element method	7
3. Bending moments and transverse shears of clamped-plate problem by series method	8

FIGURES

1. Definition of clamped square-plate problem and triangulation	6
2. Comparison of series and the finite-element solutions of w and $\theta_y = -\partial w/\partial x$ along x -axis	8
3. Comparison of series and the least-squares solutions of M_x moments of clamped plate along x -axis	9
4. Comparison of series and the least-squares solutions of M_y moments of clamped plate along x -axis	9
5. Comparison of different M_x moments of clamped plate along $y = 4/3$ -in. line (centroids of first row of triangles, Fig. 1)	9
6. Comparison of different M_y moments of clamped plate along $y = 4/3$ -in. line (centroids of first row of triangles, Fig. 1)	9
7. Comparison of different M_{xy} moments of clamped plate along $y = 4/3$ -in. line (centroids of first row of triangles, Fig. 1)	10
8. Comparison of different Q_x shears of clamped plate along $y = 4/3$ -in. line (centroids of first row of triangles, Fig. 1)	10
9. Comparison of different Q_y shears of clamped plate along $y = 4/3$ -in. line (centroids of first row of triangles, Fig. 1)	10

ABSTRACT

The work described in this Report is concerned with the calculation of stresses in linear thin shells of aeolotropic material using the deflections obtained by the finite-element method. When displacements and rotations of a thin shell or plate middle surface are known at sufficiently many nodal points, approximations for the stress resultants and couples may be computed by (1) distributing the nodal forces and moments of a triangular element along nodal lines, (2) obtaining a best-fit deflection field in the triangle from the available nodal deflections and using this field in the computation of strains and curvature changes, (3) obtaining best-fit displacement distributions along nodal lines from available nodal deflections and computing the components of best-fit strain and curvature-change tensors at nodes by least-squares from these distributions, and, finally, (4) combining the methods described in (2) and (3). Methods (1) and (2) enable one to keep the modular character of the finite element scheme. Methods (3) and (4) are semimodular, since they require information at all the neighboring nodes in order to compute the stresses at a node. These methods are formulated and discussed, and it is shown that the curvatures of the middle surface may be taken into account in all four instances.

I. INTRODUCTION

The finite-element method is being used successfully in conjunction with the displacement approach in the deflection analysis of plate and shell structures. The displacement approach is so called because the computations start with a continuous and piecewise differentiable trial deflection field which accepts as undefined parameters the displacements and rotations at sufficiently many middle surface points (nodes) to permit approximations to be made for the stress resultants and couples. In this approach, the total potential energy of the system is established in terms of the trial deflection field by writing the volume and surface integrals as the sum of those of

the subdomains defined by the lines joining neighboring nodes.

If the integrand of the energy expressions for a subdomain contains only the deflections of those nodes which are used to define the subdomain, the subdomain is considered a finite element, and the approach is called the finite-element method. In this approach, the minimization equations of the whole system can be obtained from the minimization equations of each element by the standard assembly technique of the direct-stiffness method, in which the procedure is modular in elements. If the curva-

ture of the middle surface is neglected in the triangular elements, such elements are called flat triangular elements. Since the method is basically a stationary functional method, the level of confidence in the mean values of the results thus obtained is usually high, although the local values cannot generally be treated with the same confidence.

In cases of gradually varying actual deflections in triangular subdomains established by the nodes, the results obtained by the finite-element method are in very good agreement with the analytical results, even on a local basis (Refs. 1 and 2). In such cases, one may expect to obtain acceptable approximations for the stress resultants and couples which are related only to the first derivatives of computed deflections. The degree of accuracy of the latter is, of course, dependent on, and somewhat inferior to, the degree of accuracy in the computed deflections.

Therefore, one should proceed to compute the stresses only after being certain that the computed deflection field is of sufficient accuracy. In this work, it is assumed that the displacements and rotations are sufficiently accurate and that, in any given triangular subdomain, the second derivatives of the actual deflection components either do not change sign, or if they do, their magnitudes remain very small. These assumptions enable one to compute stress resultants and couples in a triangle by merely using the nodal deflections of the triangle. In this way, the modular character of the finite-element method is preserved during the stress calculation phase. For increased accuracy, one may compute stresses in the finite element by considering the deflections of a node as well as those of neighboring nodes. This scheme is not modular to the element, but it is modular in node sets. In this Report only those stress calculation schemes which are modular either in triangular elements or in node sets are considered.

II. STRESS COMPUTATION BY NODAL FORCES

Nodal forces of a triangular element are the derivatives of the strain energy associated with the element, with respect to corresponding nodal deflections. These derivatives are linear in deflections, and the coefficient matrix is called the element stiffness matrix if the strain energy of the element is expressed in terms of its own nodal deflections. Elemental stresses may be computed from elemental nodal forces because the elemental stiffness matrices are already available in the computer memory as an intermediate step of deflection computation; therefore, a method taking advantage of this readily available information would be economical. The elemental forces are obtained by a multiplication from the elemental stiffness matrix and the associated nodal deflections and can be looked upon as the approximate interelemental forces of the element lumped at the nodes. The way in which they are lumped is a function of the distribution of the trial deflection field in the element. In order to determine the distribution of the forces along the sides of the element, reference must be made to the trial deflection field. If this field is linear in spatial variables, the stress field in

the element is invariably constant. This makes possible a uniform distribution of the elemental nodal forces along the sides of the element. Assuming a linear distribution for middle surface tangential displacements in a flat triangular element yields a constant membrane force state (Ref. 3). Assumption of a linear distribution for rotations of normals to the middle surface results in a constant bending-moment state (Ref. 4). However, the latter also implies a zero transverse shear-force state, which is not acceptable. For a constant transverse shear-force state in the element, a quadratic distribution of rotations is necessary. Any trial deflection field which is not linear in spatial variables, however, will complicate the rules for distributing the elemental nodal forces along the sides. In the stress computation by nodal forces, one generally obtains two sets of stresses for a nodal line, one from each of the two neighboring triangles. The sets will be identical if, and only if, the trial deflection field is the true one. In dealing with approximate deflection fields, one should be prepared to find discontinuities in the computed stresses across the nodal lines.

III. STRESS COMPUTATION FROM A BEST-FIT DEFLECTION FIELD IN THE TRIANGULAR ELEMENT

The computed nodal displacements and rotations can be used to obtain a best-fit deflection field in the triangle, from which the strains of the middle surface and the change of curvatures can be obtained. These, in turn, may be used in the stress-strain relationships to obtain the membrane forces and bending moments. Since the best-fit deflection fields are not necessarily the true fields, there will be discontinuities in stress resultants and couples along the nodal lines. However, a single valued stress field may be defined by taking into account only the centroidal values of the elemental stress fields. Having computed the moment field in the triangle, the transverse shears can be computed from the moments.

The available information on the nodal deflections of a triangular element allows one to make unique linear distributions of tangential displacements and rotations. From the linear distributions, constant membrane force and bending moment fields may be obtained, as shown in Appendix A. The single-valued stress field of the whole structure is obtained by associating these constant values with the centroid of each element. The computation of the bending moments and the membrane forces at a centroid requires only the nodal deflections of the associated triangle. However, unless the centroidal moments of three neighboring triangles are used, this scheme gives zero transverse shears.

In order to obtain at least a constant transverse shear field, one needs a parabolic distribution for rotations or, equivalently, a cubic distribution for the transverse displacements in the triangular element. The available information on deflections at the nodes of a triangular element makes possible a cubic distribution of the transverse displacements with one free parameter. (One transverse displacement and two rotation components at each of the three nodes provide nine pieces of scalar information, whereas the most general cubic distribution in two dimensions contains ten constants.) This free parameter should be evaluated rationally in order to obtain a good approximation for the true stress state. Some of the possible methods of evaluating the free parameter are discussed below:

1. A prescribed value (including zero) may be assigned to one of the ten constants of cubic variation. This idea is not justified, since it would cause unrealistic distortions in the computed stress field. This method,

of course, includes the case in which any two of the ten constants are taken to be equal (Ref. 5).

2. One may try to compute the free parameter by using any pertinent known information about the true stress or deflection state in the triangle. However, this procedure is not compatible with the concept of automatic computation.
3. The free parameter may be determined so that the discontinuity in one of the bending moments or transverse shears at a point on a nodal line will be as small as possible. However, application of this concept requires the use of nodal deflections of the whole structure, even if only the stresses of a single triangle are needed. Therefore, the method cannot be justified, because the cost of the additional computational labor far exceeds the value of the expected increase in accuracy.
4. The free parameter may be evaluated by minimizing the total potential energy of the element with prescribed transverse displacements and rotations along the nodal lines. (The nodal deflections define a cubic variation of transverse displacements and a linear variation of their normal derivatives along a nodal line.) This effectively means that the element strain energy for an element loaded at the nodes only is being minimized. (The total potential energy is the sum of the strain energy and the loss of potential energy of those boundary forces whose displacements are not prescribed.) It is necessary that the trial deflection function with one free parameter satisfy the essential boundary condition, i.e., the prescribed deflections along the sides of the triangle. One finds that it is not possible to satisfy these essential boundary conditions with a cubic variation still retaining the free parameter. An attempt to evaluate the free parameter by satisfying the essential boundary conditions in the direction of sides—but not in the normal direction—is described in appendix B. The results were found unsatisfactory.
5. Retaining the modular character of the computations, the free parameter can be evaluated to give reasonably good transverse shear forces by using the average curvature changes implied by the nodal rotations. The second derivatives of the cubic give the local curvature changes as a linear function of the spatial variables and the free parameter. The

local curvature changes, when integrated over the triangle, yield the area of the triangle times the average curvature changes.

On the other hand, the average curvature changes in the triangle can also be obtained directly from the nodal rotations. By equating the changes, three scalar equations are obtained to evaluate the free parameter. The best value of the free parameter may be obtained from these equations by least-squares. However, the equation which relates the change of the average twist of the triangular element is not as reliable as the other two, since the average twist change of the triangle can be computed from the nodal rotations by using either the rotations in the xz -planes or the rotations in the yz -planes. (The z -axis is normal to the middle surface.) The arithmetic average of the results of these two alternatives is usually assumed as the average change in twist. However, the twist change may be a weighted average in place of an arithmetic average. Therefore, this equation may not be taken into account.

Although the least-squares technique may be applied to the remaining two equations to evaluate the free parameter, it is more reasonable and less troublesome to combine these equations before solving for the free parameter. For example, by equating the average gaussian curvature change of the

triangle obtained from the cubic to that obtained from the nodal rotations, one derives one equation for the free parameter. Since the resulting equation will be nonlinear in the free parameter (the square of the gaussian curvature being the determinant of the curvature tensor), this scheme is not attractive. Furthermore, the average gaussian curvature change obtained from the nodal rotations contains the same uncertainty (as described above) in the average twist change of the triangular element.

These difficulties can be eliminated easily by using the second curvature invariant (i.e., the trace of the curvature tensor*) in place of the first invariant (i.e., the gaussian curvature*). A desirable single equation from which the free parameter may be evaluated is established by equating the trace of the average curvature change tensor of the triangle obtained from the cubic to the one obtained from the nodal rotations. Since the trace of the curvature tensor is the sum of the diagonal elements, i.e., the normal curvatures along orthogonal directions, this equation is linear in the free parameter and independent of the average twist change of the element. This scheme is worked out in detail in Appendix C. The stresses obtained with the above method are quite satisfactory.

*See Ref. 6.

IV. STRESS COMPUTATION BY BEST-FIT CURVATURE CHANGE AND STRAIN TENSORS AT NODES

A more realistic moment and transverse shear computation may be achieved by considering the best-fit curvature tensor at a node. If the node does not correspond to an actual middle surface point of essential singularity (such as the vertex of a cone), a best-fit curvature change tensor can be obtained from all the normal curvature changes along at least three nodal lines meeting at this node, so that the three independent components of the curvature change tensor can be defined by means of the Dupin's indicatrix (Ref. 6). If more than three nodal lines meet at a node, the least-squares technique may be utilized to derive the best fit curvature change tensor.

If the node is at the intersection of two or more middle surfaces, a best-fit curvature change tensor is obtained at the node for each surface, taking into account only those nodal lines which are on the same surface.

Once the best-fit curvature change tensor at a node has been found, it is an easy matter to obtain the moments at this node by using the material matrix. If the node has more than one best-fit curvature change tensor (the case in which the node is on more than one middle surface), then more than one set of moments will be obtained.

In order to compute the normal curvature at a node along a nodal line, one first defines a best-fit transverse deflection curve along the nodal line using end deflections in the normal plane—a plane containing the nodal line and normals to the middle surface at its ends, assuming that the nodal line is a geodesic. Then one obtains the normal curvature change by evaluating the second arc-length derivative of the curve at the node. This procedure clearly indicates that, in order to determine the best-fit curvature change tensor at a node which is not essentially singular, one needs deflection information at this node and its immediate neighbors. Calling the node and its neighbors a "node set," one concludes that this method of stress calculation is modular in node sets.

With this scheme, the moments are computed at the nodes. Moments at other points may be obtained by interpolation. Transverse shear forces may be calculated at the centroids of triangular elements from the moment equilibrium equations, assuming linear variations of moments on the elements. Very good moments and trans-

verse shear forces are obtained with this method, which is formulated in Appendix D.

The same ideas may be used in obtaining the components of a best-fit strain tensor for the middle surface at a given node. Here, too, one needs at least three nodal lines of the same middle surface meeting at the node to define the three independent components of the strain tensor. From the end deflections of a nodal line, the tangential strain in the direction of the nodal line may be computed. Then, using the laws of strain transformation, together with at least three strains of this kind, the components of the strain tensor may be obtained. If the number of nodal lines meeting at a node of nonessential singularity is more than three, a best-fit strain tensor may be computed by the least-squares technique, and the membrane forces at this node may then be easily derived by using the material matrix. The membrane forces at other points may be obtained by linear interpolation. Obviously, the computation of membrane forces at nodes (as formulated in Appendix E) is also modular in node sets.

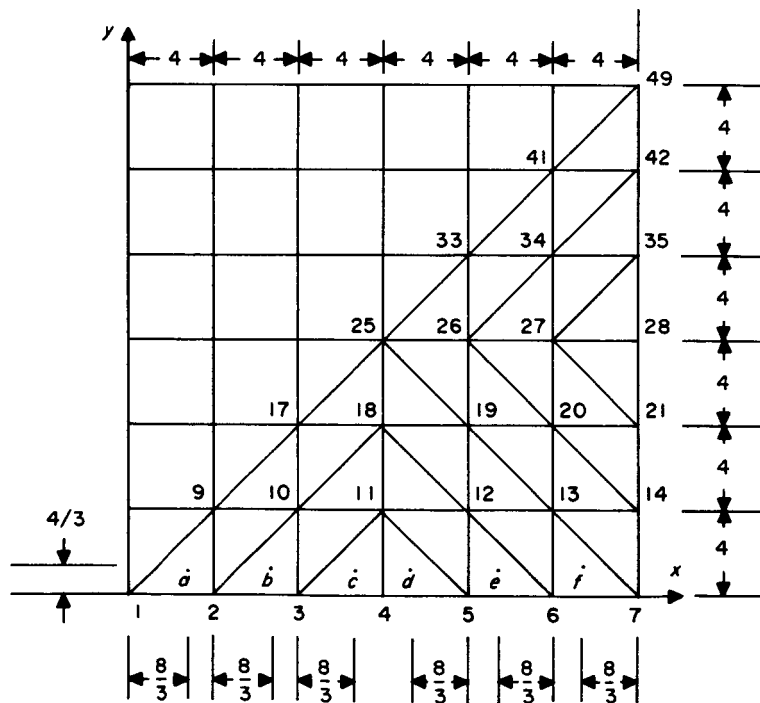
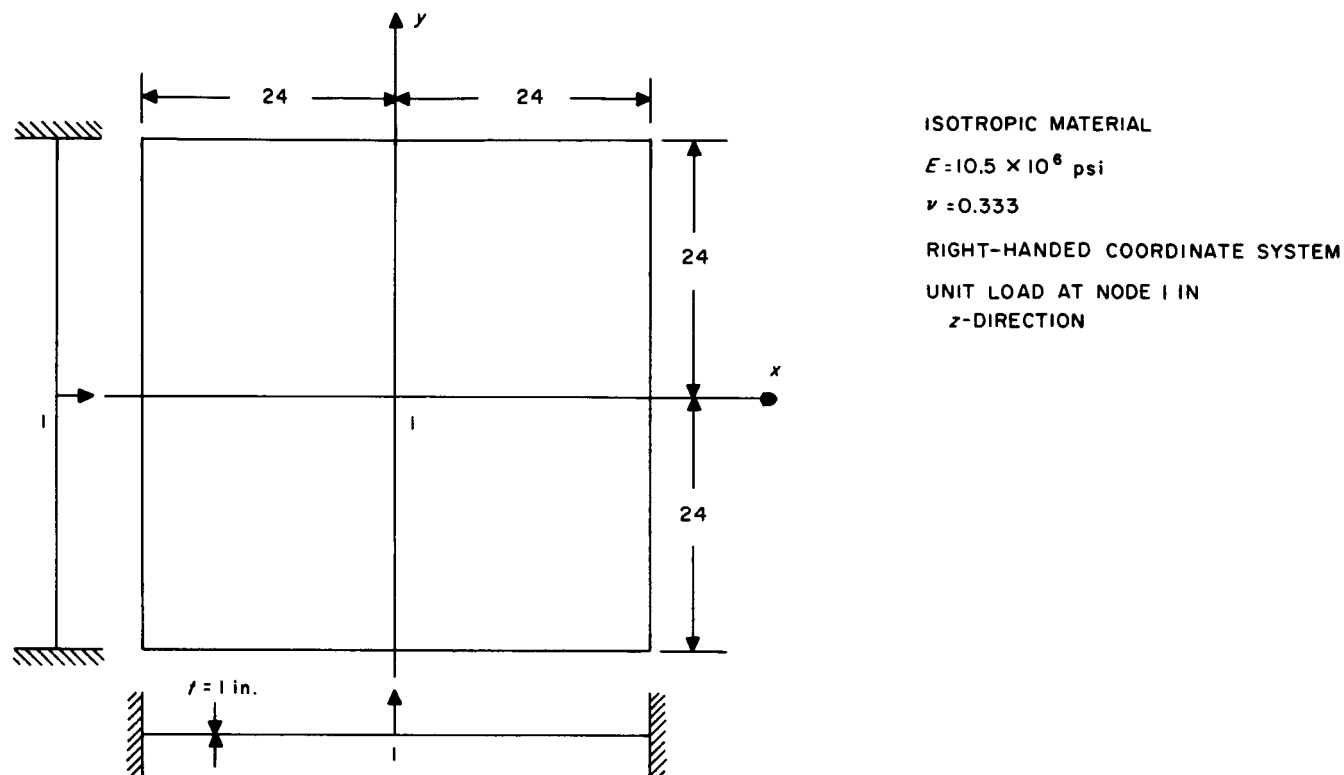

ALL DIMENSIONS IN INCHES

Fig. 1. Definition of clamped square-plate problem and triangulation

V. NUMERICAL RESULTS

The methods described above have been applied to a clamped square plate subjected to a central concentrated transverse load. Figure 1 shows the plate, the coordinate system, and the triangulation. Table 1* gives the series solution (Ref. 7) of the nodal deflections. Using the program described in Ref. 4, the finite-element solutions of nodal deflections were obtained and are presented in Table 2. The series solutions (Ref. 7) of bending moments

and transverse shears are given in Table 3.* Figure 2 compares the series and the finite-element solutions of w and θ_y along the x -axis.

Using the values presented in Table 2, the shears and moments are computed by the methods presented in this Report. The results are compared in Figs. 3-9.

*Obtained by Prof. H. E. Williams, Harvey Mudd College, Pomona, California.

Table 1. Deflections of clamped plate by series method

Nodal point	$10^5 w$	$10^6 \theta_z = \frac{\partial w}{\partial y} 10^6$	$10^6 \theta_y = -\frac{\partial w}{\partial x} 10^6$
1	1.3124	0.	
2	1.1617	0.	0.5978
3	0.8835	0.	0.7588
4	0.5777	0.	0.7516
5	0.2973	0.	0.6316
6	0.0866	0.	0.3986
7	0.	0.	0.0009
9	1.0551	-0.4831	0.4831
10	0.8153	-0.3246	0.6774
11	0.5366	-0.1986	0.6929
12	0.2766	-0.1003	0.5891
13	0.0804	-0.0297	0.3709
14	0.	0.	0.0002
17	0.6434	-0.5077	0.5077
18	0.4284	-0.3275	0.5463
19	0.2213	-0.1692	0.4725
20	0.0640	-0.0507	0.2965
21	0.	0.	0.0001
25	0.2869	-0.3652	0.3652
26	0.1475	-0.1918	0.3191
27	0.0418	-0.0575	0.1968
28	0.	0.	-0.0004
33	0.0742	-0.1668	0.1668
34	0.0199	-0.0492	0.0977
35	0.	0.	0.0006
41	0.0045	-0.0258	0.0258
42	0.	0.	-0.0004
49	0.	0.	0.

Table 2. Deflections of clamped plate by finite-element method

Nodal point	$10^5 w$	$10^6 \theta_z = \frac{\partial w}{\partial y} 10^6$	$10^6 \theta_y = -\frac{\partial w}{\partial x} 10^6$
1	1.2640	0.	0.
2	1.1370	0.	0.6027
3	0.8656	0.	0.7446
4	0.5636	0.	0.7587
5	0.2857	0.	0.6256
6	0.0804	0.	0.3945
7	0.	0.	0.
9	1.0370	-0.4888	0.4888
10	0.8007	-0.3233	0.6814
11	0.5248	-0.1933	0.6911
12	0.2676	-0.0915	0.5888
13	0.0750	-0.0269	0.3686
14	0.	0.	0.
17	0.6327	-0.5117	0.5117
18	0.4205	-0.3263	0.5444
19	0.2160	-0.1662	0.4738
20	0.0607	-0.0465	0.2985
21	0.	0.	0.
25	0.2814	-0.3671	0.3671
26	0.1436	-0.1955	0.3196
27	0.0398	-0.0600	0.1968
28	0.	0.	0.
33	0.0710	-0.1670	0.1670
34	0.0187	-0.0476	0.0941
35	0.	0.	0.
41	0.0046	-0.0242	0.0242
42	0.	0.	0.
49	0.	0.	0.

Table 3. Bending moments and transverse shears of clamped-plate problem by series method

Point	M_x	M_y	M_{xy}	Q_x	Q_y
1	0.39646	0.44951	0.	0.	0.
2	0.13041	0.18220	0.	-0.03983	0.
3	0.04516	0.09381	0.	-0.02021	0.
4	-0.00339	0.04212	0.	-0.01434	0.
5	-0.03382	0.01193	0.	-0.01255	0.
6	-0.06864	-0.01361	0.	-0.01329	0.
7	-0.12619	-0.04207	0.	-0.01677	0.
9	0.10639	0.10637	-0.02773	-0.01982	-0.01982
10	0.04351	0.07219	-0.02332	-0.01599	-0.00753
11	0.00209	0.03825	-0.01827	-0.01263	-0.00294
12	-0.03169	0.00885	-0.01400	-0.01139	-0.00039
13	-0.06774	-0.01675	-0.00334	-0.01204	0.00184
14	-0.11615	-0.03872	0.00012	-0.01470	0.00475
17	0.03440	0.03440	-0.03009	-0.00932	-0.00932
18	0.00150	0.01869	-0.02828	-0.00881	-0.00435
19	-0.02674	0.00131	-0.02322	-0.00841	-0.00054
20	-0.05560	-0.01538	-0.01496	-0.00883	0.00311
21	-0.09109	-0.03036	-0.00015	-0.01028	0.00747
25	-0.00197	-0.00197	-0.03002	-0.00460	-0.00460
26	-0.02101	-0.00735	-0.02606	-0.00456	-0.00056
27	-0.03935	-0.01330	-0.01705	-0.00456	0.00362
28	-0.05797	-0.01932	0.00007	-0.00476	0.00888
33	-0.01573	-0.01573	-0.02300	-0.00060	-0.00060
34	-0.02302	-0.01115	-0.01472	-0.00027	0.00315
35	-0.02357	-0.00786	0.00010	0.00173	0.00764
41	-0.00981	-0.00981	-0.00831	0.00245	0.00245
42	-0.00228	-0.00076	-0.00028	0.00467	0.00265
49	0.0	0.00	0.00021	-0.00057	-0.00057
a	0.15558	0.19045	-0.02151	-0.04775	-0.02336
b	0.06409	0.10945	-0.01085	-0.02312	-0.00448
c	0.01534	0.05929	-0.00736	-0.01541	-0.00155
d	-0.00970	0.03366	-0.00604	-0.01365	-0.00073
e	-0.04505	0.00148	-0.00440	-0.01240	0.00011
f	-0.08765	-0.02581	-0.00228	-0.01393	0.00095

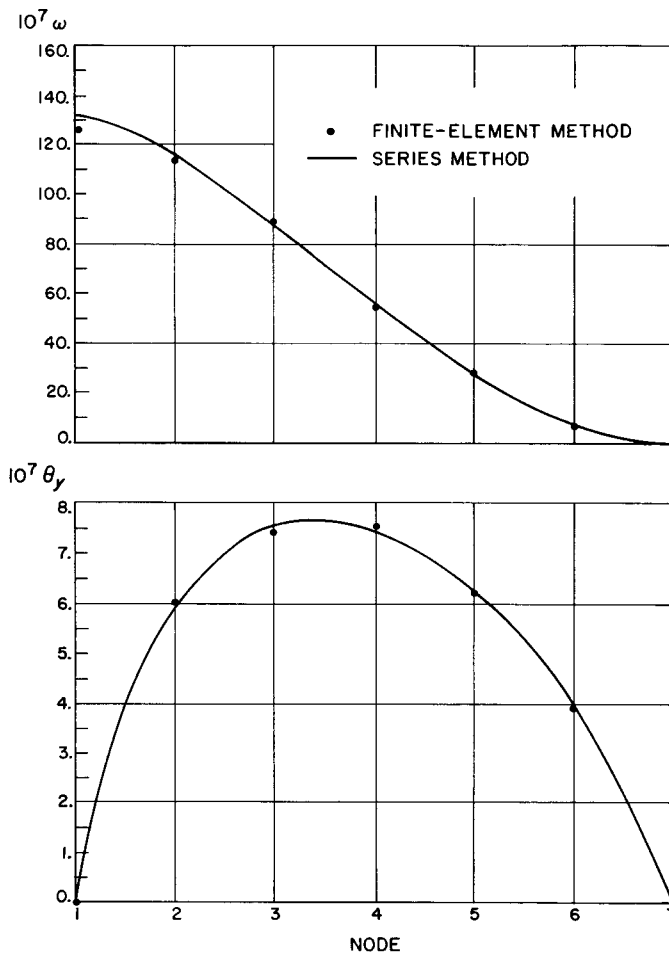

Fig. 2. Comparison of series and the finite-element solutions of w and $\theta_y = -\partial w/\partial x$ along x -axis

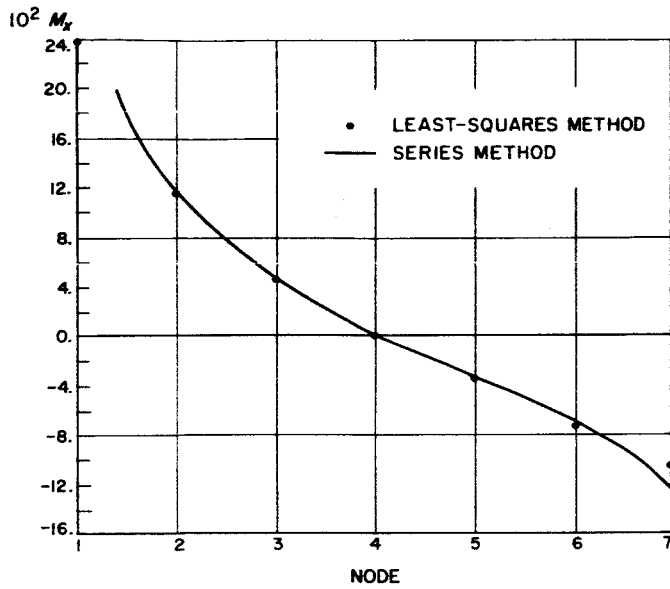

Fig. 3. Comparison of series and the least-squares solutions of M_x moments of clamped plate along x-axis

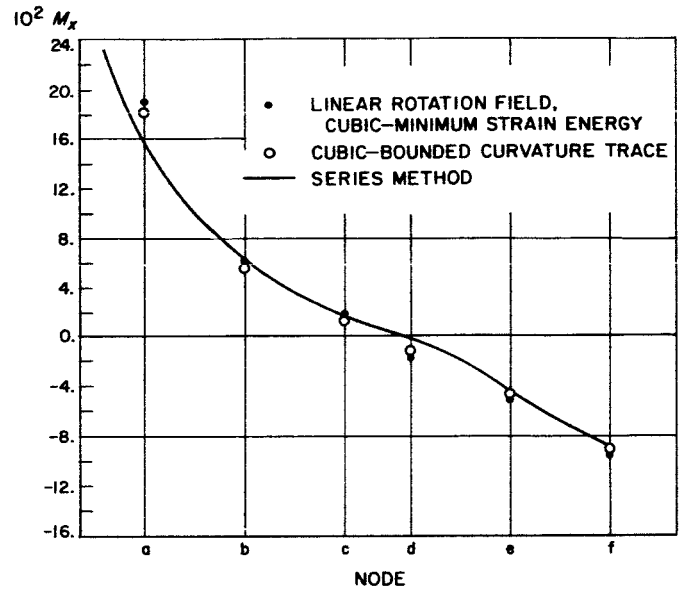

Fig. 5. Comparison of different M_x moments of clamped plate along $y = 4/3$ -in. line (centroids of first row of triangles, Fig. 1)

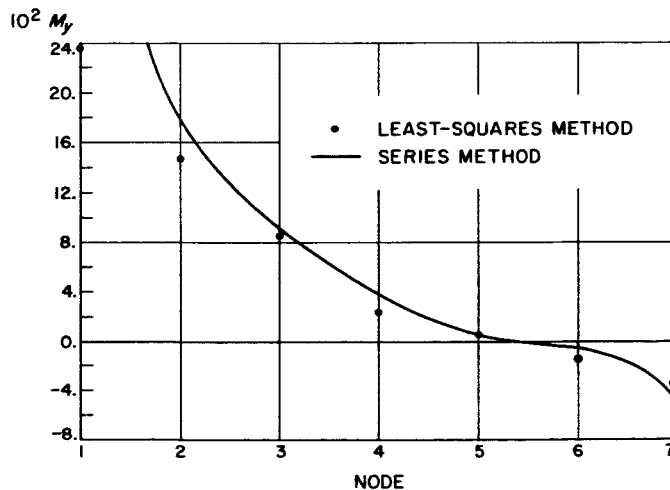

Fig. 4. Comparison of series and the least-squares solutions of M_y moments of clamped plate along x-axis

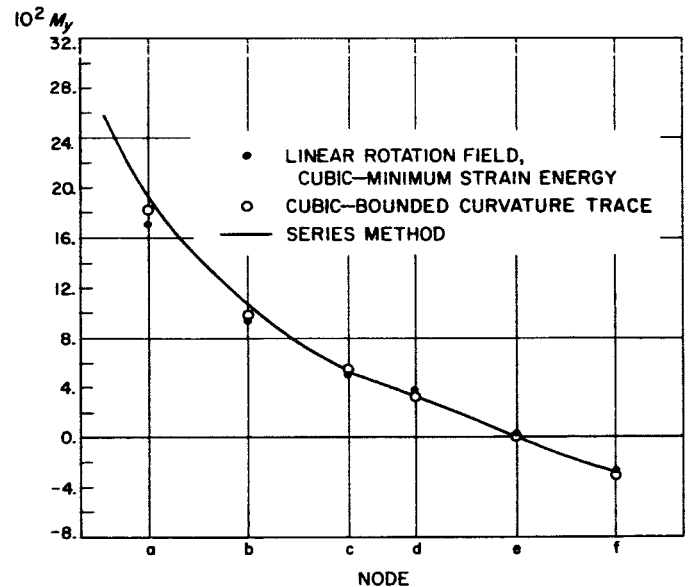

Fig. 6. Comparison of different M_y moments of clamped plate along $y = 4/3$ -in. line (centroids of first row of triangles, Fig. 1)

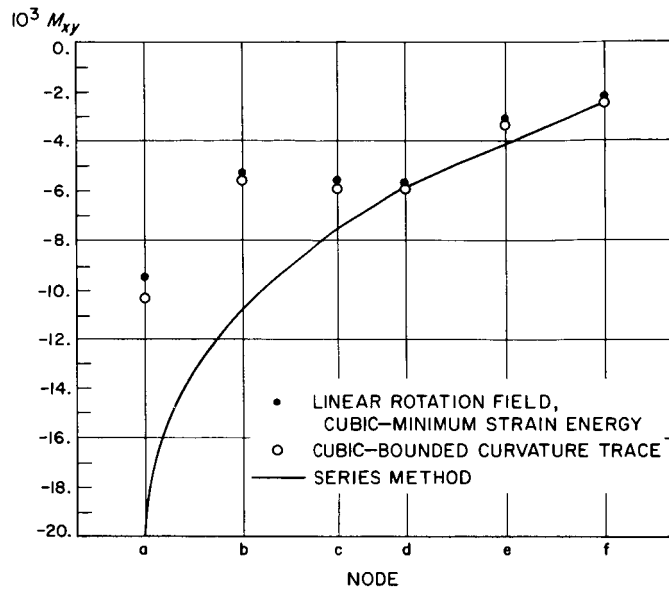

Fig. 7. Comparison of different M_{xy} moments of clamped plate along $y = 4/3$ -in. line (centroids of first row of triangles, Fig. 1)

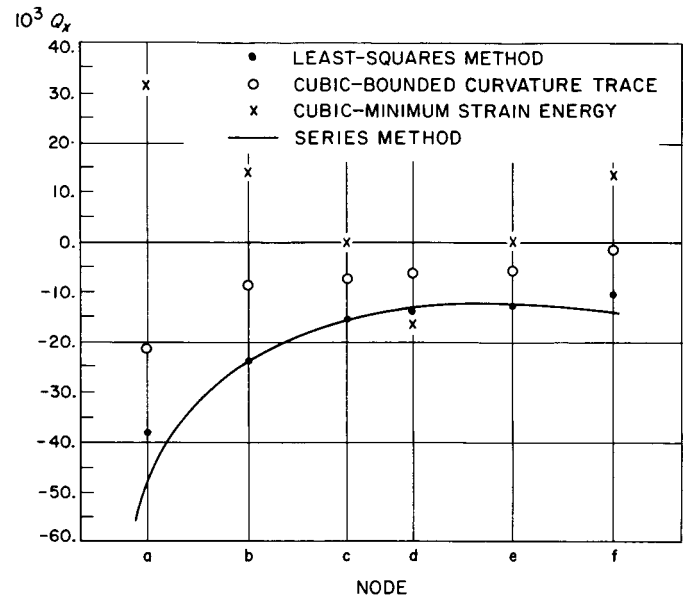

Fig. 8. Comparison of different Q_x shears of clamped plate along $y = 4/3$ -in. line (centroids of first row of triangles, Fig. 1)

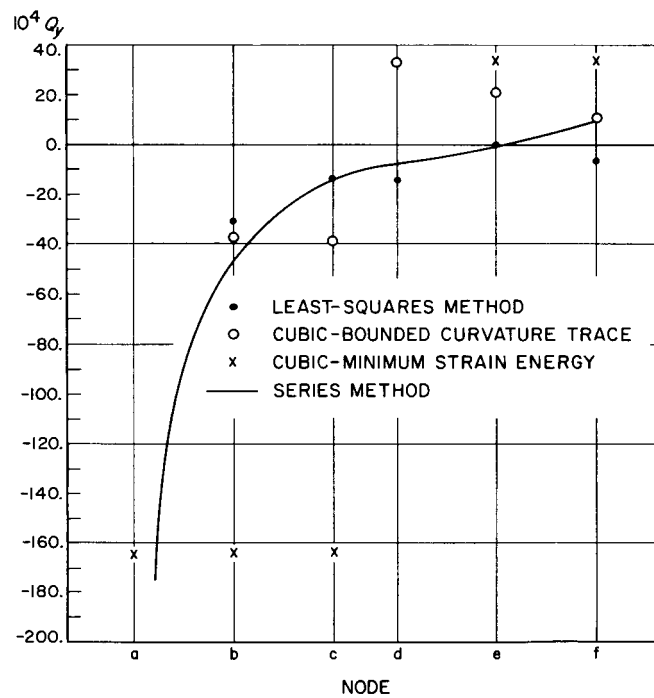

Fig. 9. Comparison of different Q_y shears of clamped plate along $y = 4/3$ -in. line (centroids of first row of triangles, Fig. 1)

VI. CONCLUSIONS

There are several modular stress computation methods for finite-element schemes using triangles in thin linear shells of aeolotropic material. Stress resultants and couples can be computed in modules of (1) elements or (2) node sets, provided that the nodal deflections are already computed with sufficient accuracy and the second derivatives of actual deflection components either do not change sign or, if they do, their magnitudes remain very small in the triangular subdomains. The stress computation methods which are modular in triangles are less accurate but easier to program than those which are modular in node sets. If one does not need to compute the transverse shear forces, probably the best method that is modular in triangular elements is the one which assumes a linear deflection field in the triangular element (Appendix A). If the transverse shear forces are also required, the method which assumes a cubic distribution of transverse displace-

ments (having the trace of the average curvature tensor as its own average) gives very good results (Appendix C). The methods based on the best-fit curvature change and strain tensors in the least-squares sense are superior to the methods which are modular in triangles (Appendixes D and E). However, since the former are modular in node sets, they are harder to program than those which are modular in triangular elements.

The methods described in Appendixes A and C use flat elements. However, curvatures of the actual middle surface are implicitly taken into account in the computation of tangential and transverse deflections of the flat element from the nodal deflections of the actual middle surface. The methods described in Appendixes D and E explicitly allow for the inclusion of curvatures of the actual middle surface in the computations.

REFERENCES

1. Greene, B. E., Strome, D. R., Weikel, R. C., *Application of Stiffness Method to the Analysis of Shell Structures*, ASME Paper No. 61-AV-58, January 1961.
2. Lang, T. E., *Description of Test Problems for the Structural Analysis and Matrix Interpretive Systems*, Jet Propulsion Laboratory, Pasadena, California (to be published).
3. de Veubeke, B. F., *Matrix Methods of Structural Analysis*, New York: Pergamon Press, 1964, pp. 169-170.
4. Melosh, R. J., Christiansen, N. H., *Structural Analysis and Matrix Interpretive System*, Interim Technical Report EMO 264, Philco Corporation, Western Development Laboratory, Palo Alto, California, February 1964.
5. McMahan, L. L., *Development and Application of the Direct Stiffness Method for Out of Plane Bending Using a Triangular Plate Element*, M. S. Thesis, University of Washington, May 1962.
6. Gol'denveizer, A. L., *Theory of Elastic Thin Shells* (English Translation), New York: Pergamon Press, 1961.
7. Stiles, W. B., "Bending of Clamped Plates," *ASME Journal of Applied Mechanics*, A-56, March 1957.

APPENDIX A

Stress Computation in Triangular Elements Assuming Linear Deflection Fields

Figure A-1 shows a triangular flat element of thickness t , referenced to the (xyz) -coordinate system. Nodes 1, 2, and 3 are in the (xy) -plane. Let u_i , v_i , and w_i be x -, y -, and z -components, respectively, of the displacement vector at node i , and θ_{x_i} and θ_{y_i} , the rotations about x - and y -axes, respectively, of the normal to the middle surface at the same node. Using nodal information, one can write

$$\begin{pmatrix} u \\ v \\ \theta_x \\ \theta_y \end{pmatrix} = \begin{bmatrix} u_1 & u_2 & u_3 \\ v_1 & v_2 & v_3 \\ \theta_{x_1} & \theta_{x_2} & \theta_{x_3} \\ \theta_{y_1} & \theta_{y_2} & \theta_{y_3} \end{bmatrix} \begin{bmatrix} x_1 & y_1 & 1 \\ x_2 & y_2 & 1 \\ x_3 & y_3 & 1 \end{bmatrix}^{-1T} \begin{pmatrix} x \\ y \\ z \end{pmatrix} \quad (\text{A-1})$$

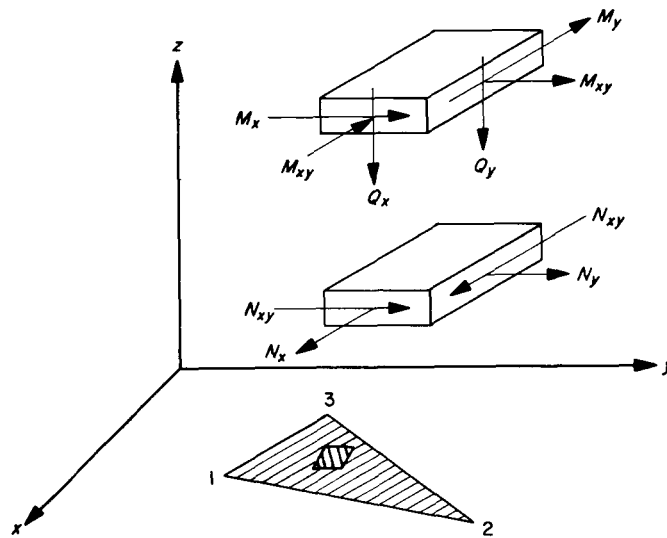

Fig. A-1

to define the linear deflection field in the triangle. (Note that the w -field is not included, since it will not be a linear field when rotation fields are linear. The w -field is not required for the computations below. However, it may be defined by integration from the first Kirchoff assumption, recalling that $\theta_x = \partial w / \partial y$ and $\theta_y = -\partial w / \partial x$.) The coordinates x_i and y_i are of the i th node. Taking the inverse and the transposition indicated in (A-1), one obtains

$$\begin{pmatrix} u \\ v \\ \theta_x \\ \theta_y \end{pmatrix} = \frac{1}{2A} \begin{bmatrix} u_1 & u_2 & u_3 \\ v_1 & v_2 & v_3 \\ \theta_{x_1} & \theta_{x_2} & \theta_{x_3} \\ \theta_{y_1} & \theta_{y_2} & \theta_{y_3} \end{bmatrix} \begin{bmatrix} y_{23} & x_{32} & x_2 y_3 - x_3 y_2 \\ y_{31} & x_{13} & x_3 y_1 - x_1 y_3 \\ y_{12} & x_{21} & x_1 y_2 - x_2 y_1 \end{bmatrix} \begin{pmatrix} x \\ y \\ z \end{pmatrix} \quad (\text{A-2})$$

where A is the area of the triangle ($2A = x_{21}y_{31} - x_{31}y_{21}$) and $x_{ij} = x_i - x_j$, $y_{ij} = y_i - y_j$.

According to the Kirchhoff assumption,

$$\begin{pmatrix} \epsilon_x \\ \epsilon_y \\ \epsilon_{xy} \end{pmatrix} = \begin{pmatrix} \epsilon_{x_0} \\ \epsilon_{y_0} \\ \epsilon_{xy_0} \end{pmatrix} - z \begin{pmatrix} K_x \\ K_y \\ 2K_{xy} \end{pmatrix} \quad (A-3)$$

where ϵ_{x_0} , ϵ_{y_0} and ϵ_{xy_0} are the middle surface strains and K_x , K_y , and K_{xy} are the changes in normal curvatures and surface twist. The variable z is the distance from the middle surface. For flat elements,

$$\begin{pmatrix} \epsilon_{x_0} \\ \epsilon_{y_0} \\ \epsilon_{xy_0} \end{pmatrix} = \begin{pmatrix} \frac{\partial u}{\partial x} \\ \frac{\partial v}{\partial y} \\ \frac{\partial u}{\partial y} + \frac{\partial v}{\partial x} \end{pmatrix} \quad (A-4)$$

and for flat and/or shallow shell elements,

$$\begin{pmatrix} K_x \\ K_y \\ 2K_{xy} \end{pmatrix} = \begin{pmatrix} -\frac{\partial \theta_y}{\partial x} \\ \frac{\partial \theta_x}{\partial y} \\ \frac{\partial \theta_x}{\partial x} - \frac{\partial \theta_y}{\partial y} \end{pmatrix} \quad (A-5)$$

These can be evaluated from the linear field (A-2) as

$$\begin{bmatrix} \epsilon_{x_0} & K_x \\ \epsilon_{y_0} & K_y \\ \epsilon_{xy_0} & 2K_{xy} \end{bmatrix} = \frac{1}{2A} \begin{bmatrix} y_{23} & y_{31} & y_{12} & 0 & 0 & 0 \\ 0 & 0 & 0 & x_{32} & x_{13} & x_{21} \\ x_{32} & x_{13} & x_{21} & y_{23} & y_{31} & y_{12} \end{bmatrix} \begin{bmatrix} u_1 & -\theta_{v_1} \\ u_2 & -\theta_{v_2} \\ u_3 & -\theta_{v_3} \\ v_1 & \theta_{x_1} \\ v_2 & \theta_{x_2} \\ v_3 & \theta_{x_3} \end{bmatrix} \quad (A-6)$$

Let the stress-strain relations be

$$\begin{pmatrix} \sigma_x \\ \sigma_y \\ \tau_{xy} \end{pmatrix} = \begin{bmatrix} d_{11} & d_{12} & d_{13} \\ & d_{22} & d_{23} \\ \text{sym} & & d_{33} \end{bmatrix} \begin{pmatrix} \epsilon_x \\ \epsilon_y \\ \epsilon_{xy} \end{pmatrix} \quad (A-7)$$

in the (xyz) -coordinate system. If the material axes are coincident with a (ξ, η, z) -system but not with the (x, y, z) -system, the material matrix in the (ξ, η, z) -system should be transformed into the (x, y, z) -system by

$$\begin{bmatrix} d_{11} & d_{12} & d_{13} \\ & d_{22} & d_{23} \\ \text{sym} & & d_{33} \end{bmatrix} = \begin{bmatrix} c^2 & s^2 & -cs \\ s^2 & c^2 & cs \\ 2cs & -2cs & c^2 - s^2 \end{bmatrix} \begin{bmatrix} \bar{d}_{11} & \bar{d}_{12} & \bar{d}_{13} \\ & \bar{d}_{22} & \bar{d}_{23} \\ \text{sym} & & \bar{d}_{33} \end{bmatrix} \begin{bmatrix} c^2 & s^2 & cs \\ s^2 & c^2 & -cs \\ -2cs & 2cs & c^2 - s^2 \end{bmatrix} \quad (\text{A-8})$$

where $c = \cos \alpha$, $s = \sin \alpha$, and the barred quantities refer to the (ξ, η, z) -system, and α is the angle between the x -axis and the ξ -axis, measured counterclockwise from the x -axis.

Substituting (A-6) into (A-3) and then (A-3) into (A-7), one obtains

$$\begin{Bmatrix} \sigma_x \\ \sigma_y \\ \tau_{xy} \end{Bmatrix} = \frac{1}{2A} \begin{bmatrix} d_{11} & d_{12} & d_{13} \\ & d_{22} & d_{23} \\ \text{sym} & & d_{33} \end{bmatrix} \begin{bmatrix} y_{23} & y_{31} & y_{12} & 0 & 0 & 0 \\ 0 & 0 & 0 & x_{32} & x_{13} & x_{21} \\ x_{32} & x_{13} & x_{21} & y_{23} & y_{31} & y_{12} \end{bmatrix} \begin{Bmatrix} u_1 + z\theta_{y_1} \\ u_2 + z\theta_{y_2} \\ u_3 + z\theta_{y_3} \\ v_1 - z\theta_{x_1} \\ v_2 - z\theta_{x_2} \\ v_3 - z\theta_{x_3} \end{Bmatrix} \quad (\text{A-9})$$

Stress resultants N_x , N_y , N_{xy} and stress couples M_x , M_y , M_{xy} may be obtained by integrating (A-9) across the thickness of the element with weights 1 and z , respectively. The result is

$$\begin{bmatrix} \frac{N_x}{t} & \frac{M_x}{t^3/12} \\ \frac{N_y}{t} & \frac{M_y}{t^3/12} \\ \frac{N_{xy}}{t} & \frac{M_{xy}}{t^3/12} \end{bmatrix} = \frac{1}{2A} \begin{bmatrix} d_{11} & d_{12} & d_{13} \\ & d_{22} & d_{23} \\ \text{sym} & & d_{33} \end{bmatrix} \begin{bmatrix} y_{23} & y_{31} & y_{12} & 0 & 0 & 0 \\ 0 & 0 & 0 & x_{32} & x_{13} & x_{21} \\ x_{32} & x_{13} & x_{21} & y_{23} & y_{31} & y_{12} \end{bmatrix} \begin{bmatrix} u_1 & \theta_{y_1} \\ u_2 & \theta_{y_2} \\ u_3 & \theta_{y_3} \\ v_1 & -\theta_{x_1} \\ v_2 & -\theta_{x_2} \\ v_3 & -\theta_{x_3} \end{bmatrix} \quad (\text{A-10})$$

Note that (A-10) gives a constant stress-resultant and couple field for the flat triangle. A single-valued stress field for the whole structure may be obtained by associating the stresses defined by (A-10) with the centroid of the element. The stress state at any other locations in the triangle should be obtained by linear interpolation from the stress values of the centroids surrounding this point.

The transverse shear forces Q_x and Q_y may be derived for the centroids of a set of new triangles established by the centroids of the original elements. Using the moment equilibrium equations

$$\begin{aligned} Q_x &= \frac{\partial M_x}{\partial x} + \frac{\partial M_{xy}}{\partial y} \\ Q_y &= \frac{\partial M_y}{\partial y} + \frac{\partial M_{xy}}{\partial x} \end{aligned} \quad (\text{A-11})$$

where the derivatives may be evaluated from the linear moment fields over the new triangles.

If the triangular element shown in Fig. A-1 is not flat, (A-10) may still be used to represent the stress state at the centroid, provided that (1) the triangular shell element is shallow in the (xyz) -system, and (2) the tangent plane of the shell middle surface corresponding to the centroid of the flat element is parallel to the (xy) -plane. In the shallow shell theory, the middle surface strains are*

$$\begin{pmatrix} \epsilon_{x_0} \\ \epsilon_{y_0} \\ \epsilon_{xy_0} \end{pmatrix} = \begin{pmatrix} \frac{\partial u}{\partial x} + \frac{\partial w}{\partial x} \frac{\partial z_0}{\partial x} \\ \frac{\partial v}{\partial y} + \frac{\partial w}{\partial y} \frac{\partial z_0}{\partial y} \\ \frac{\partial u}{\partial y} + \frac{\partial v}{\partial x} + \frac{\partial w}{\partial y} \frac{\partial z_0}{\partial x} + \frac{\partial w}{\partial x} \frac{\partial z_0}{\partial y} \end{pmatrix} \quad (\text{A-12})$$

and the curvature change are as given in (A-5). The additional straining of the middle surface vanishes at the centroid if the tangent plane at this point is parallel to the (xy) -plane; i.e., $\partial z_0/\partial x$ and $\partial z_0/\partial y$ are zero. In (A-12), $z_0 = z_0(x, y)$ defines the geometry of the middle surface.

*See, for example, Marguerre, K., *Proceedings of 5th International Congress of Applied Mechanics*, 1938, pp. 93-101.

APPENDIX B

Computation of Moments and Shears in Triangular Elements by a Cubic Transverse Displacement Field Yielding Minimum Strain Energy

Figure B-1 shows a triangular flat element of thickness t , referenced to the (xyz) -coordinate system. Nodes 1, 2, and 3 are in the (xy) -plane. To minimize algebraic manipulations, the origin of the (xyz) -system is placed at node 1. Let w_i be the transverse displacement in the z -direction and θ_{x_i} and θ_{y_i} the rotations about the x - and y -axes, respectively, of the middle surface at node i . A cubic transverse displacement can be defined as

$$w = a_1x^3 + a_2y^3 + a_3x^2y + a_4xy^2 + a_5x^2 + a_6y^2 + a_7xy + a_8x + a_9y + a_{10} \quad (\text{B-1})$$

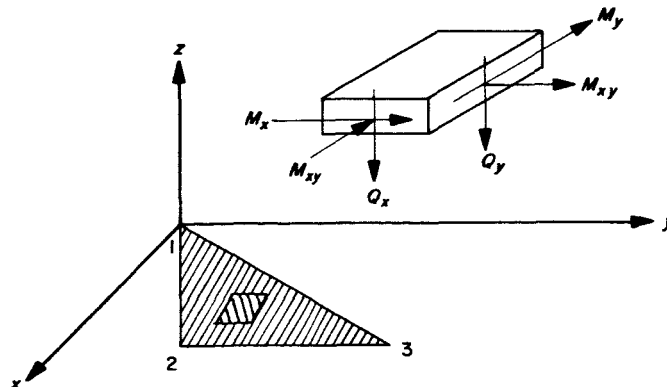

Fig. B-1

Nine of the ten constants ($a_j, j = 1, 2, \dots, 10$) may be evaluated by

$$\left. \begin{aligned} w(x_i, y_i) &= w_i \\ \left(\frac{\partial w}{\partial x}\right)_i &= -\theta_{y_i} \\ \left(\frac{\partial w}{\partial y}\right)_i &= \theta_{x_i} \end{aligned} \right\} \quad i = 1, 2, 3 \quad (B-2)$$

The remaining parameter will be evaluated by minimizing the strain energy of the element.

The special choice of the origin of the (xyz) -system enables one to write

$$\begin{aligned} a_8 &= -\theta_{y_1} \\ a_9 &= \theta_{x_1} \\ a_{10} &= w_1 \end{aligned} \quad (B-3)$$

by using (B-2) for $i = 1$. The remaining conditions of (B-2) yield

$$\begin{pmatrix} a_1 \\ a_2 \\ a_3 \\ a_4 \\ a_5 \\ a_6 \end{pmatrix} = \left[\begin{array}{c} \\ \\ \\ \\ \\ \\ \end{array} \right] X^{-1} \left[\begin{array}{c} w_2 - w_1 + \theta_{y_1}x_2 - \theta_{x_1}y_2 \\ w_3 - w_2 + \theta_{y_1}x_3 - \theta_{x_1}y_3 \\ \theta_{y_1} - \theta_{y_2} \\ \theta_{y_1} - \theta_{y_3} \\ \theta_{x_2} - \theta_{x_1} \\ \theta_{x_3} - \theta_{x_1} \end{array} \right] - a_7 \begin{pmatrix} \\ \\ \\ \\ \\ \\ \end{pmatrix} Y \quad (B-4)$$

where

$$\left[\begin{array}{c} \\ \\ \\ \\ \\ \\ \end{array} \right] X = \begin{bmatrix} x_2^3 & y_2^3 & x_2^2y_2 & x_2y_2^2 & x_2^2 & y_2^2 \\ x_3^3 & y_3^3 & x_3^2y_3 & x_3y_3^2 & x_3^2 & y_3^2 \\ 3x_2^2 & 0 & 2x_2y_2 & y_2^2 & 2x_2 & 0 \\ 3x_3^2 & 0 & 2x_3y_3 & y_3^2 & 2x_3 & 0 \\ 0 & 3y_2^2 & x_2^2 & 2x_2y_2 & 0 & 2y_2 \\ 0 & 3y_3^2 & x_3^2 & 2x_3y_3 & 0 & 2y_3 \end{bmatrix}, \quad \left\{ \begin{array}{c} \\ \\ \\ \\ \\ \\ \end{array} \right\} Y = \left\{ \begin{array}{c} x_2y_2 \\ x_3y_3 \\ y_2 \\ y_3 \\ x_2 \\ x_3 \end{array} \right\}$$

Let

$$\begin{Bmatrix} \sigma_x \\ \sigma_y \\ \tau_{xy} \end{Bmatrix} = \begin{bmatrix} d_{11} & d_{12} & d_{13} \\ & d_{22} & d_{23} \\ \text{sym} & & d_{33} \end{bmatrix} \begin{Bmatrix} \epsilon_x \\ \epsilon_y \\ \epsilon_{xy} \end{Bmatrix} \quad (\text{B-5})$$

be the stress-strain relations in the (xyz) -system. The bending strain energy of the element is

$$U = \frac{t^3}{24} \int_A \left[\frac{\partial^2 w}{\partial x^2} \quad \frac{\partial^2 w}{\partial y^2} \quad 2 \frac{\partial^2 w}{\partial x \partial y} \right] \begin{bmatrix} d_{11} & d_{12} & d_{13} \\ & d_{22} & d_{23} \\ \text{sym} & & d_{33} \end{bmatrix} \begin{Bmatrix} \frac{\partial^2 w}{\partial x^2} \\ \frac{\partial^2 w}{\partial y^2} \\ 2 \frac{\partial^2 w}{\partial x \partial y} \end{Bmatrix} dA \quad (\text{B-6})$$

where dA is the area element at the middle surface. Substituting the second derivatives from (B-1), one can write

$$U = \frac{t^3}{24} \int_A [a_1 \ a_2 \ a_3 \ a_4 \ a_5 \ a_6 \ a_7] \begin{bmatrix} 6x & 0 & 0 \\ 0 & 6y & 0 \\ 2y & 0 & 4x \\ 0 & 2x & 4y \\ 2 & 0 & 0 \\ 0 & 2 & 0 \\ 0 & 0 & 2 \end{bmatrix} \begin{bmatrix} d_{11} & d_{12} & d_{13} \\ & d_{22} & d_{23} \\ \text{sym} & & d_{33} \end{bmatrix} \begin{bmatrix} 6x & 0 & 2y & 0 & 2 & 0 & 0 \\ 0 & 6y & 0 & 2x & 0 & 2 & 0 \\ 0 & 0 & 4x & 4y & 0 & 0 & 2 \end{bmatrix} \begin{Bmatrix} a_1 \\ a_2 \\ a_3 \\ a_4 \\ a_5 \\ a_6 \\ a_7 \end{Bmatrix} dA$$

or, by taking the integral,

$$U = \frac{t^3}{24} [a_1 \ a_2 \ a_3 \ a_4 \ a_5 \ a_6 \ a_7] [T] \begin{Bmatrix} a_1 \\ a_2 \\ a_3 \\ a_4 \\ a_5 \\ a_6 \\ a_7 \end{Bmatrix} \quad (\text{B-7})$$

where

$$[T] = \begin{bmatrix}
 36I_y d_{11} & 36I_{xy} d_{12} & 12I_{xy} d_{11} + 24I_y d_{12} & 12I_y d_{12} + 24I_{xy} d_{13} & 12S_y d_{11} & 12S_y d_{12} & 12S_y d_{13} \\
 & 36I_x d_{22} & 12I_x d_{12} + 24I_{xy} d_{23} & 12I_{xy} d_{22} + 24I_x d_{23} & 12S_x d_{12} & 12S_x d_{22} & 12S_x d_{23} \\
 & & 4I_x d_{11} + 16I_y d_{33} + 16I_{xy} d_{13} & 8I_x d_{13} + I_{xy} (4d_{12} + 16d_{33}) + 8I_y d_{33} & 4S_x d_{11} + 8S_y d_{13} & 4S_x d_{12} + 8S_y d_{23} & 4S_x d_{13} + 8S_y d_{33} \\
 & & & 4I_x d_{22} + 16I_{xy} d_{23} + 16I_x d_{33} & 4S_y d_{12} + 8S_x d_{13} & 4S_y d_{22} + 8S_x d_{23} & 4S_y d_{23} + 8S_x d_{33} \\
 & & \text{sym} & & 4Ad_{11} & 4Ad_{12} & 4Ad_{13} \\
 & & & & & 4Ad_{22} & 4Ad_{23} \\
 & & & & & & 4Ad_{33}
 \end{bmatrix} \tag{B-8}$$

and

$$\begin{aligned}
 A &= \int_A dA & I_x &= \int_A y^2 dA \\
 S_x &= \int_A y dA & I_y &= \int_A x^2 dA \\
 S_y &= \int_A x dA & I_{xy} &= \int_A xy dA
 \end{aligned}$$

The constants a_j ($j = 1, 2, \dots, 6$) in Eq. (B-7) are functions of a_7 (Eq. B-4); hence, a_7 is the free parameter. Then, to minimize the strain energy, one writes

$$\frac{\partial U}{\partial a_7} + \frac{\partial U}{\partial a_j} \frac{\partial a_j}{\partial a_7} = 0 \tag{B-9}$$

where the repeated subscript j indicates summation over the range $j = 1, 2, \dots, 6$. The partial derivatives of U appearing in (B-9) may be obtained from (B-7), and $\partial a_j / \partial a_7$ can be calculated from (B-4).

The expressions are:

$$\frac{\partial U}{\partial a_7} = \frac{t^3}{12} [a_1 a_2 a_3 a_4 a_5 a_6 a_7] \left\{ \begin{matrix} \uparrow \\ t_7 \\ \downarrow \end{matrix} \right\} \tag{B-10}$$

$$\left[\frac{\partial U}{\partial a_j} \right] = \frac{t^3}{12} [a_1 a_2 a_3 a_4 a_5 a_6 a_7] [T^*] \tag{B-11}$$

$$\left\{ \frac{\partial a_j}{\partial a_7} \right\} = - [X] \{Y\} \tag{B-12}$$

where $\{t_7\}$ is the seventh column and $[T^*]$ is the first six columns of $[T]$, which is given by (B-8). Substituting (B-10), (B-11), and (B-12) into (B-9), one obtains

$$[a_1 a_2 a_3 a_4 a_5 a_6 a_7] \left\{ \begin{matrix} r_1 \\ r_2 \\ r_3 \\ r_4 \\ r_5 \\ r_6 \\ r_7 \end{matrix} \right\} = 0 \tag{B-13}$$

where

$$\left\{ \begin{matrix} r_1 \\ r_2 \\ r_3 \\ r_4 \\ r_5 \\ r_6 \\ r_7 \end{matrix} \right\} = \left\{ \begin{matrix} \uparrow \\ t_7 \\ \downarrow \end{matrix} \right\} - [T^*] [X] \{Y\} \tag{B-14}$$

Equation (B-13) is the condition which guarantees the minimization of the strain energy associated with (B-1) and (B-2). Constants a_j ($j = 1, 2, \dots, 7$) may be obtained by solving simultaneously (B-4) and (B-13). These equations may be combined to yield

$$\begin{pmatrix} a_1 \\ a_2 \\ a_3 \\ a_4 \\ a_5 \\ a_6 \\ a_7 \end{pmatrix} = \begin{bmatrix} & & & & & & \\ & & & & & & \\ & & & & & & \\ & & & & & & \\ & & & & & & \\ & & & & & & \\ r_1 & r_2 & r_3 & r_4 & r_5 & r_6 & r_7 \end{bmatrix}^{-1} \begin{pmatrix} w_2 - w_1 + \theta_{y_1}x_2 - \theta_{x_1}y_2 \\ w_5 - w_2 + \theta_{y_1}x_3 - \theta_{x_1}y_3 \\ \theta_{y_1} - \theta_{y_2} \\ \theta_{y_1} - \theta_{y_3} \\ \theta_{x_2} - \theta_{x_1} \\ \theta_{x_3} - \theta_{x_1} \\ 0 \end{pmatrix} \quad (\text{B-15})$$

Obtaining a_j ($j = 1, 2, \dots, 10$) from (B-3) and (B-15) and using these in (B-1), a unique cubic transverse displacement field is obtained.

The curvature changes associated with (B-1) are obtained by taking second x - and y -derivatives of (B-1):

$$\begin{pmatrix} K_x \\ K_y \\ 2K_{xy} \end{pmatrix} = \begin{bmatrix} 6a_1 & 2a_3 & 2a_5 \\ 2a_4 & 6a_2 & 2a_6 \\ 4a_3 & 4a_4 & 2a_7 \end{bmatrix} \begin{pmatrix} x \\ y \\ 1 \end{pmatrix} \quad (\text{B-16})$$

Using these curvature changes, the linear moment field of the element may be written as

$$\begin{pmatrix} M_x \\ M_y \\ M_{xy} \end{pmatrix} = -\frac{t^3}{12} \begin{bmatrix} d_{11} & d_{12} & d_{13} \\ & d_{22} & d_{23} \\ \text{sym} & & d_{33} \end{bmatrix} \begin{bmatrix} 6a_1 & 2a_3 & 2a_5 \\ 2a_4 & 6a_2 & 2a_6 \\ 4a_3 & 4a_4 & 2a_7 \end{bmatrix} \begin{pmatrix} x \\ y \\ 1 \end{pmatrix} \quad (\text{B-17})$$

The coordinates of the centroid of a triangle are

$$\begin{aligned} x_4 &= \frac{x_1 + x_2 + x_3}{3} \\ y_4 &= \frac{y_1 + y_2 + y_3}{3} \end{aligned} \quad (\text{B-18})$$

By evaluating (B-17) for (x_4, y_4) , the moments at the centroid are obtained.

The transverse shear forces may be derived from

$$\begin{aligned} Q_x &= \frac{\partial M_x}{\partial x} + \frac{\partial M_{xy}}{\partial y} \\ Q_y &= \frac{\partial M_y}{\partial y} + \frac{\partial M_{xy}}{\partial x} \end{aligned} \quad (\text{B-19})$$

Evaluating the derivatives in (B-19) from (B-17) yields

$$\begin{Bmatrix} Q_x \\ Q_y \end{Bmatrix} = -\frac{t^3}{12} \begin{bmatrix} 6d_{11} & 6d_{23} & 6d_{13} & 2(d_{12} + 2d_{33}) \\ 6d_{13} & 6d_{22} & 2(d_{12} + 2d_{33}) & 6d_{23} \end{bmatrix} \begin{Bmatrix} a_1 \\ a_2 \\ a_3 \\ a_4 \end{Bmatrix} \quad (\text{B-20})$$

which is a constant field. A single-valued moment and transverse shear field may be defined by taking the centroidal values of the moments and transverse shear forces defined by (B-17) and (B-20) and assuming linear variation between the centroids. The same field would be obtained if the triangular elements were not flat and one used the shallow shell theory.

APPENDIX C

Computation of Moments and Shears in Triangular Elements by a Cubic Transverse Displacement Field of Bounded Trace in Curvature Tensor

Figure C-1 shows a triangular flat element of thickness t , referenced to the (xyz) -coordinate system. Nodes 1, 2 and 3 are in the (xy) -plane. To minimize algebraic manipulations, the origin of the (xyz) -system is placed at node 1. Let w_i be the transverse displacement in the z -direction and θ_{x_i} and θ_{y_i} the rotations about x - and y -axes, respectively, of the middle surface at node i . A cubic transverse displacement field can be defined as

$$w = a_1x^3 + a_2y^3 + a_3x^2y + a_4xy^2 + a_5x^2 + a_6y^2 + a_7xy + a_8x + a_9y + a_{10} \quad (\text{C-1})$$

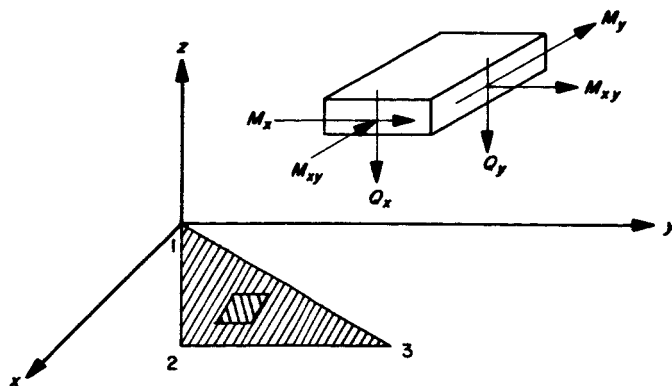

Fig. C-1

Nine of the ten constants ($a_j, j = 1, 2, \dots, 10$) may be evaluated by

$$\left. \begin{aligned} w(x_i, y_i) &= w_i \\ \left(\frac{\partial w}{\partial x} \right)_i &= -\theta_{x_i} \\ \left(\frac{\partial w}{\partial y} \right)_i &= \theta_{y_i} \end{aligned} \right\} i = 1, 2, 3 \quad (C-2)$$

and the remaining parameter may be evaluated by equating the trace of the average curvature change tensor of the triangle obtained from (C-1) to the one obtained from the nodal rotations. The special choice of the origin of the (xyz) -system enables one to write

$$\begin{aligned} a_8 &= -\theta_{y_1} \\ a_9 &= \theta_{x_1} \\ a_{10} &= w_1 \end{aligned} \quad (C-3)$$

by using (C-2) for $i = 1$. The remaining conditions of (C-2) yield

$$\begin{bmatrix} x_2^3 & y_2^3 & x_2^2 y_2 & x_2 y_2^2 & x_2^2 & y_2^2 & x_2 y_2 \\ x_3^3 & y_3^3 & x_3^2 y_3 & x_3 y_3^2 & x_3^2 & y_3^2 & x_3 y_3 \\ 3x_2^2 & 0 & 2x_2 y_2 & y_2^2 & 2x_2 & 0 & y_2 \\ 3x_3^2 & 0 & 2x_3 y_3 & y_3^2 & 2x_3 & 0 & y_3 \\ 0 & 3y_2^2 & x_2^2 & 2x_2 y_2 & 0 & 2y_2 & x_2 \\ 0 & 3y_3^2 & x_3^2 & 2x_3 y_3 & 0 & 2y_3 & x_3 \end{bmatrix} \begin{pmatrix} a_1 \\ a_2 \\ a_3 \\ a_4 \\ a_5 \\ a_6 \\ a_7 \end{pmatrix} = \begin{pmatrix} w_2 - w_1 + \theta_{y_1} x_2 - \theta_{x_1} y_2 \\ w_3 - w_1 + \theta_{y_1} x_3 - \theta_{x_1} y_3 \\ \theta_{y_1} - \theta_{y_2} \\ \theta_{y_1} - \theta_{y_3} \\ \theta_{x_2} - \theta_{x_1} \\ \theta_{x_3} - \theta_{x_1} \end{pmatrix} \quad (C-4)$$

The trace of the average curvature change tensor obtained from the linear rotation field is

$$H_1 = \frac{\partial \theta_x}{\partial y} - \frac{\partial \theta_y}{\partial x} = \frac{1}{2A} [y_{23} \ y_{31} \ y_{12} \ x_{32} \ x_{13} \ x_{21}] \begin{pmatrix} -\theta_{y_1} \\ -\theta_{y_2} \\ -\theta_{y_3} \\ \theta_{x_1} \\ \theta_{x_2} \\ \theta_{x_3} \end{pmatrix} \quad (C-5)$$

where A is the area of the triangle and $x_{ij} = x_i - x_j, y_{ij} = y_i - y_j$. The trace of the curvature change tensor at a point in the triangle computed from (C-1) is

$$\nabla^2 w = \frac{\partial^2 w}{\partial x^2} + \frac{\partial^2 w}{\partial y^2} = (6a_1 + 2a_4)x + (2a_3 + 6a_2)y + (2a_5 + 2a_6) \quad (C-6)$$

The average of $\nabla^2 w$ for the triangle is

$$H_2 = \frac{1}{A} \int_A \nabla^2 w \, dA = (6a_1 + 2a_4)x_4 + (2a_3 + 6a_2)y_4 + (2a_5 + 2a_6) \quad (C-7)$$

where x_4, y_4 are the coordinates of the centroid of the triangle and are defined as

$$\begin{aligned} x_4 &= \frac{x_1 + x_2 + x_3}{3} \\ y_4 &= \frac{y_1 + y_2 + y_3}{3} \end{aligned} \tag{C-8}$$

The condition that $H_1 = H_2$ yields

$$[6x_4 \ 6y_4 \ 2y_4 \ 2x_4 \ 2 \ 2 \ 0] \begin{pmatrix} a_1 \\ a_2 \\ a_3 \\ a_4 \\ a_5 \\ a_6 \\ a_7 \end{pmatrix} = H_1 \tag{C-9}$$

One can now solve for the a_j ($j = 1, 2, \dots, 7$) by combining (C-4) and (C-9):

$$\begin{pmatrix} a_1 \\ a_2 \\ a_3 \\ a_4 \\ a_5 \\ a_6 \\ a_7 \end{pmatrix} = \begin{bmatrix} x_2^3 & y_2^3 & x_2^2 y_2 & x_2 y_2^2 & x_2^2 & y_2^2 & x_2 y_2 \\ x_3^3 & y_3^3 & x_3^2 y_3 & x_3 y_3^2 & x_3^2 & y_3^2 & x_3 y_3 \\ 3x_2^2 & 0 & 2x_2 y_2 & y_2^2 & 2x_2 & 0 & y_2 \\ 3x_3^2 & 0 & 2x_3 y_3 & y_3^2 & 2x_3 & 0 & y_3 \\ 0 & 3y_2^2 & x_2^2 & 2x_2 y_2 & 0 & 2y_2 & x_2 \\ 0 & 3y_3^2 & x_3^2 & 2x_3 y_3 & 0 & 2y_3 & x_3 \\ 6y_4 & 6y_4 & 2y_4 & 2x_4 & 2 & 2 & 0 \end{bmatrix} \begin{pmatrix} w_2 - w_1 + \theta_{v_1} x_2 - \theta_{x_1} y_2 \\ w_3 - w_2 + \theta_{v_1} x_3 - \theta_{x_1} y_3 \\ \theta_{v_1} - \theta_{v_2} \\ \theta_{v_1} - \theta_{v_3} \\ \theta_{x_2} - \theta_{x_1} \\ \theta_{x_3} - \theta_{x_1} \\ H_1 \end{pmatrix} \tag{C-10}$$

Using these in (C-1), a unique cubic transverse displacement field is obtained.

The curvature changes associated with (C-1) are obtained by calculating second derivatives of w :

$$\begin{pmatrix} K_x \\ K_y \\ 2K_{xy} \end{pmatrix} = \begin{bmatrix} 6a_1 & 2a_3 & 2a_5 \\ 2a_4 & 6a_2 & 2a_6 \\ 4a_3 & 4a_4 & 2a_7 \end{bmatrix} \begin{pmatrix} x \\ y \\ 1 \end{pmatrix} \tag{C-11}$$

If the stress-strain relations in the (xyz) -system are

$$\begin{pmatrix} \sigma_x \\ \sigma_y \\ \tau_{xy} \end{pmatrix} = \begin{bmatrix} d_{11} & d_{12} & d_{13} \\ & d_{22} & d_{23} \\ \text{sym} & & d_{33} \end{bmatrix} \begin{pmatrix} \epsilon_x \\ \epsilon_y \\ \epsilon_{xy} \end{pmatrix} \tag{C-12}$$

the linear moment field of the element may be written as

$$\begin{pmatrix} M_x \\ M_y \\ M_{xy} \end{pmatrix} = -\frac{t^3}{12} \begin{bmatrix} d_{11} & d_{12} & d_{13} \\ & d_{22} & d_{23} \\ \text{sym} & & d_{33} \end{bmatrix} \begin{bmatrix} 6a_1 & 2a_3 & 2a_5 \\ 2a_4 & 6a_2 & 2a_6 \\ 4a_3 & 4a_4 & 2a_7 \end{bmatrix} \begin{pmatrix} x \\ y \\ 1 \end{pmatrix} \tag{C-13}$$

The transverse shear forces may be obtained from

$$\begin{aligned} Q_x &= \frac{\partial M_x}{\partial x} + \frac{\partial M_{xy}}{\partial y} \\ Q_y &= \frac{\partial M_y}{\partial y} + \frac{\partial M_{xy}}{\partial x} \end{aligned} \quad (C-14)$$

Evaluating the derivatives in (C-14) from (C-13) gives

$$\begin{Bmatrix} Q_x \\ Q_y \end{Bmatrix} = -\frac{t^3}{12} \begin{bmatrix} 6d_{11} & 6d_{23} & 6d_{13} & 2(d_{12} + 2d_{33}) \\ 6d_{13} & 6d_{22} & 2(d_{12} + 2d_{33}) & 6d_{33} \end{bmatrix} \begin{Bmatrix} a_1 \\ a_2 \\ a_3 \\ a_4 \end{Bmatrix} \quad (C-15)$$

which is a constant field. A single-valued moment and transverse shear field may be defined by taking the centroidal values of moments and transverse shear forces defined by (C-13) and (C-15) and assuming linear variation between the centroids. The same field would be obtained if the triangular elements were not flat but shallow shell elements.

APPENDIX D

Computation of Shears and Moments by Best-Fit Curvature Change Tensors at Nodes

Figure D-1 shows a node of nonessential singularity, its immediate n neighbors, and a typical nodal line $0i$. Nodes i ($i = 0, 1, \dots, n$) establish a node set. The i th normal plane ($i \neq 0$) is the plane which contains the nodal line $0i$ and the z -axis. The intersection of the i th normal plane with the tangent plane (xy) defines the ξ_i -axis, which is headed toward i . The (ξ_i, η_i, z) -system is a right-handed system. Let w_i ($i = 0, 1, \dots, n$) represent the transverse displacements, and θ_{N_i} and θ_{F_i} ($i = 1, 2, \dots, n$) rotations about the η_i -axis at nodes 0 and i , respectively. Because of the Kirchhoff assumption

$$\begin{aligned} \left(\frac{\partial w}{\partial s_i} \right)_0 &= -\theta_{N_i} \\ \left(\frac{\partial w}{\partial s_i} \right)_i &= -\theta_{F_i} \end{aligned} \quad (D-1)$$

where s_i is the arc length along $0i$. Noting that transverse displacements at nodes 0 and i are w_0 and w_i , one may approximate the actual transverse displacement distribution in the i th normal plane with

$$w = a_1 s_i^3 + a_2 s_i^2 + a_3 s_i + a_4 \quad (D-2)$$

Using (D-1) and w_0 and w_i , the end transverse displacements, the a_k ($k = 1, 2, \dots, 4$) can be defined as

$$\begin{Bmatrix} a_1 \\ a_2 \\ a_3 \\ a_4 \end{Bmatrix} = \begin{bmatrix} L_i^3 & L_i^2 & L_i & 1 \\ 3L_i^2 & 2L_i & 1 & 0 \\ 0 & 0 & 1 & 0 \\ 0 & 0 & 0 & 1 \end{bmatrix}^{-1} \begin{bmatrix} w_i \\ -\theta_{F_i} \\ -\theta_{N_i} \\ w_0 \end{bmatrix} \quad (D-3)$$

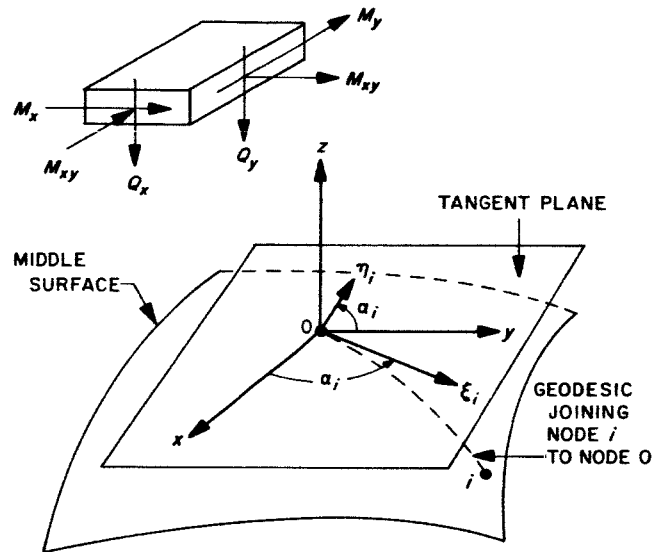

(a) REFERENCE COORDINATE SYSTEM AT NODE 0

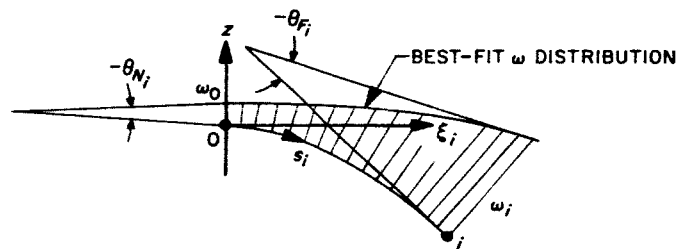

(b) NODAL LINE O_i AND BEST-FIT TRANSVERSE DISPLACEMENT CURVE

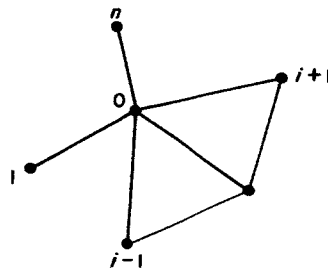

(c) NODE SET

Fig. D-1

where L_i is the arc length distance between nodes 0 and i . Using (D-2), one can obtain the change in the normal curvature of the middle surface at node i in the ξ_i -direction as

$$K_i = \left(\frac{\partial^2 w}{\partial \xi_i^2} \right)_0 = 2a_2 \tag{D-4}$$

or, using the value of a_2 obtained from (D-3),

$$K_i = 6 \frac{w_i - w_0}{L_i^2} + 2 \frac{2\theta_{N_i} + \theta_{F_i}}{L_i}, i = 1, 2, \dots, n \tag{D-5}$$

Designate K_x , K_y , and K_{xy} as the curvature changes in the x - and y -directions and the twist change, respectively, at node 0. The relation between K_i and K_x , K_y , and K_{xy} can be expressed by (see Fig. D-2)

$$[x \ y] \begin{bmatrix} K_x & K_{xy} \\ K_{xy} & K_y \end{bmatrix} \begin{Bmatrix} x \\ y \end{Bmatrix} = 1 \tag{D-6}$$

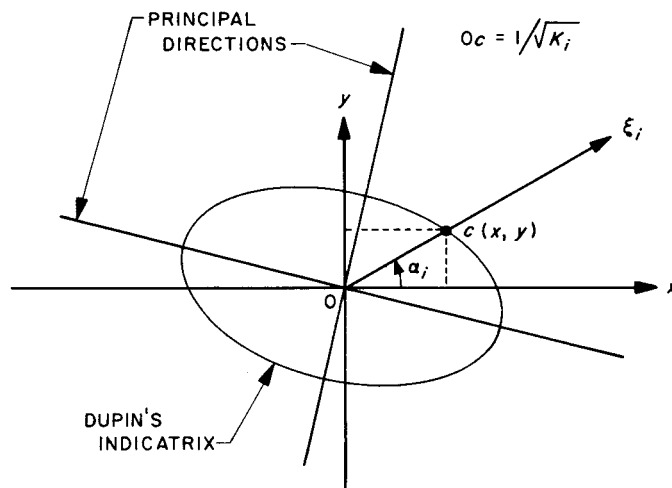

Fig. D-2

which defines an ellipse in the tangent plane (Dupin's indicatrix*). This ellipse has the following property: the length of radius $0C$ in any ξ_i -direction is equal to $1/\sqrt{K_i}$. Therefore, substituting $x = \cos \alpha_i/\sqrt{K_i}$ and $y = \sin \alpha_i/\sqrt{K_i}$ into (D-6), one can write

$$K_x \cos^2 \alpha_i + K_y \sin^2 \alpha_i + 2 K_{xy} \sin \alpha_i \cos \alpha_i = K_i \tag{D-7}$$

In the present problem, we have the knowledge of K_i and α_i ; however, K_x , K_y , and K_{xy} are not known. If one can write (D-7) for at least three independent ξ_i -directions, K_x , K_y , and K_{xy} can be computed uniquely. We have

$$\begin{bmatrix} C_1^2 & S_1^2 & 2C_1S_1 \\ C_2^2 & S_2^2 & 2C_2S_2 \\ \cdot & \cdot & \cdot \\ \cdot & \cdot & \cdot \\ \cdot & \cdot & \cdot \\ C_n^2 & S_n^2 & 2C_nS_n \end{bmatrix} \begin{Bmatrix} K_x \\ K_y \\ K_{xy} \end{Bmatrix} = \begin{bmatrix} K_1 \\ K_2 \\ \cdot \\ \cdot \\ \cdot \\ K_n \end{bmatrix} \tag{D-8}$$

*See, for example, A. L. Gol'denveizer, *Theory of Elastic Thin Shells*, English Translation, New York: Pergamon Press, 1961, pp. 14-15.

where $C_i = \cos \alpha_i$, $S_i = \sin \alpha_i$, and $n \geq 3$. Equation (D-8) may be solved by least-squares for K_x , K_y , and K_{xy} :

$$\begin{pmatrix} K_x \\ K_y \\ K_{xy} \end{pmatrix} = \begin{bmatrix} \sum_{i=1}^n C_i^4 & \sum_{i=1}^n C_i^2 S_i^2 & 2 \sum_{i=1}^n C_i^3 S_i \\ & \sum_{i=1}^n S_i^4 & 2 \sum_{i=1}^n C_i S_i^3 \\ \text{sym} & & 4 \sum_{i=1}^n C_i^2 S_i^2 \end{bmatrix}^{-1} \begin{pmatrix} \sum_{i=1}^n C_i^3 K_i \\ \sum_{i=1}^n S_i^3 K_i \\ 2 \sum_{i=1}^n C_i S_i K_i \end{pmatrix} \quad (\text{D-9})$$

So long as $n \geq 3$, (D-9) will always give best-fit components for the curvature change tensor at node 0.

If the stress-strain relations in the (xyz) -system are

$$\begin{pmatrix} \sigma_x \\ \sigma_y \\ \tau_{xy} \end{pmatrix} = \begin{bmatrix} d_{11} & d_{12} & d_{13} \\ & d_{22} & d_{23} \\ \text{sym} & & d_{33} \end{bmatrix} \begin{pmatrix} \epsilon_x \\ \epsilon_y \\ \epsilon_{xy} \end{pmatrix} \quad (\text{D-10})$$

the bending moments at node 0 can be expressed as

$$\begin{pmatrix} M_x \\ M_y \\ M_{xy} \end{pmatrix} = -\frac{t^3}{12} \begin{bmatrix} d_{11} & d_{12} & d_{13} \\ & d_{22} & d_{23} \\ \text{sym} & & d_{33} \end{bmatrix} \begin{pmatrix} K_x \\ K_y \\ 2K_{xy} \end{pmatrix} \quad (\text{D-11})$$

where t is the thickness. Having computed the moments at the nodes, one can compute transverse shears from

$$\begin{aligned} Q_x &= \frac{\partial M_x}{\partial x} + \frac{\partial M_{xy}}{\partial y} \\ Q_y &= \frac{\partial M_y}{\partial y} + \frac{\partial M_{xy}}{\partial x} \end{aligned} \quad (\text{D-12})$$

by assuming linear variation for moments on the triangular elements. Let the nodes of a triangular element be labeled 1, 2, and 3; then,

$$\begin{pmatrix} Q_x \\ Q_y \end{pmatrix} = \frac{1}{2A} \begin{bmatrix} M_{x_1} & M_{x_2} & M_{x_3} & M_{xy_1} & M_{xy_2} & M_{xy_3} \\ M_{xy_1} & M_{xy_2} & M_{xy_3} & M_{y_1} & M_{y_2} & M_{y_3} \end{bmatrix} \begin{pmatrix} y_{23} \\ y_{31} \\ y_{12} \\ x_{32} \\ x_{13} \\ x_{21} \end{pmatrix} \quad (\text{D-13})$$

where $x_{ij} = x_i - x_j$, $y_{ij} = y_i - y_j$ and numerical subscripts indicate the associated node number. The parameter A is the area of the triangle. These shears should be associated with the centroid of the triangle.

APPENDIX E

Computation of Membrane Forces by Best-Fit Strain Tensors at Nodes

Figure E-1 shows a node of nonessential singularity, its immediate n neighbors, and a typical nodal line $0i$. Nodes i ($i = 0, 1, 2, \dots, n$) establish a node set. The i th normal plane ($i \neq 0$) is the plane which contains the nodal line $0i$ and the z -axis. The intersection of the i th normal plane with the tangent plane (xy) defines the ξ_i -axis, which is headed toward i . The angle between the ξ_i -axis and the x -axis is α_i , which is measured from the x -axis in a counterclockwise direction. Let us assume that the following information is available:

X_i = curvature of nodal line at 0 ($i = 1, 2, \dots, n$)

w_0 = transverse displacement at node 0

u_{N_i} = tangential displacement at 0 in i th normal plane

u_{F_i} = tangential displacement at i in i th normal plane

Then, the middle surface strain at 0 in the ξ_i -direction may be expressed as

$$\epsilon_{0_i} = \frac{u_{F_i} - u_{N_i}}{L_i} + X_i w_0 \quad i = 1, 2, \dots, n \quad (\text{E-1})$$

where L_i is the distance between 0 and node i . (It is assumed that the z -axis heads away from the center of curvature.) Let ϵ_{x_0} , ϵ_{y_0} and ϵ_{xy_0} represent the components of the middle surface strain at node 0 in the (xyz) -system. The strain ϵ_{0_i} and ϵ_{x_0} , ϵ_{y_0} , ϵ_{xy_0} are related by

$$\epsilon_{x_0} \cos^2 \alpha_i + \epsilon_{y_0} \sin^2 \alpha_i + 2 \epsilon_{xy_0} \sin \alpha \cos \alpha = \epsilon_{0_i} \quad (\text{E-2})$$

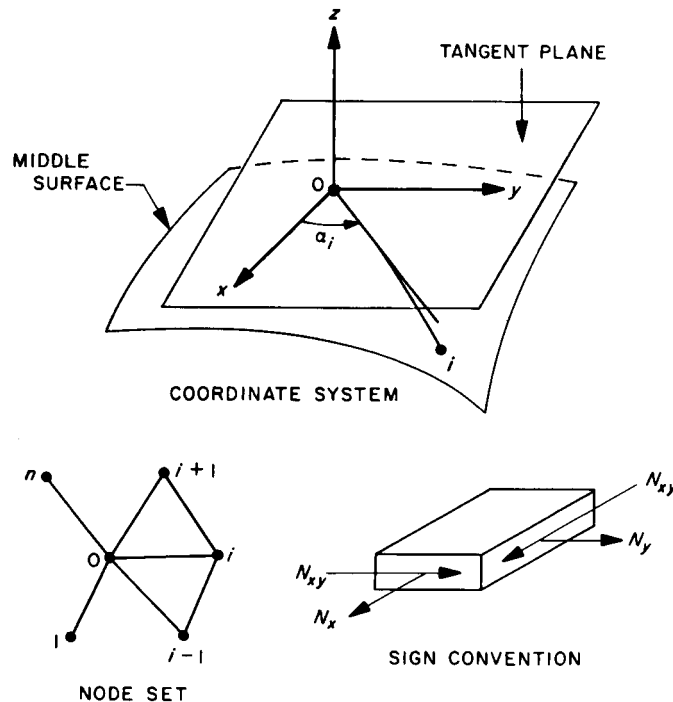

Fig. E-1

In the present problem, we have knowledge of ϵ_{0_i} and α_i ; however, ϵ_{x_0} , ϵ_{y_0} , and ϵ_{xy_0} are unknown. If one can write (E-2) for at least three independent directions, ϵ_{x_0} , ϵ_{y_0} , and ϵ_{xy_0} can be computed uniquely. We have

$$\begin{bmatrix} C_1^2 & S_1^2 & 2C_1S_1 \\ C_2^2 & S_2^2 & 2C_2S_2 \\ \vdots & \vdots & \vdots \\ C_n^2 & S_n^2 & 2C_nS_n \end{bmatrix} \begin{Bmatrix} \epsilon_{x_0} \\ \epsilon_{y_0} \\ \epsilon_{xy_0} \end{Bmatrix} = \begin{Bmatrix} \epsilon_{0_1} \\ \epsilon_{0_2} \\ \vdots \\ \epsilon_{0_n} \end{Bmatrix} \quad (\text{E-3})$$

where $C_i = \cos \alpha_i$, $S_i = \sin \alpha_i$, and $n \geq 3$. Equation (E-3) may be solved by least-squares for ϵ_{x_0} , ϵ_{y_0} and ϵ_{xy_0} :

$$\begin{Bmatrix} \epsilon_{x_0} \\ \epsilon_{y_0} \\ \epsilon_{xy_0} \end{Bmatrix} = \begin{bmatrix} \sum_{i=1}^n C_i^4 & \sum_{i=1}^n C_i^2 S_i^2 & 2 \sum_{i=1}^n C_i^3 S_i \\ & \sum_{i=1}^n S_i^4 & 2 \sum_{i=1}^n C_i S_i^3 \\ \text{sym} & & 4 \sum_{i=1}^n C_i^2 S_i^2 \end{bmatrix}^{-1} \begin{Bmatrix} \sum_{i=1}^n C_i^2 \epsilon_{0_i} \\ \sum_{i=1}^n S_i^2 \epsilon_{0_i} \\ 2 \sum_{i=1}^n C_i S_i \epsilon_{0_i} \end{Bmatrix} \quad (\text{E-4})$$

As long as $n \geq 3$, (E-4) will always give best-fit components of the middle surface strain tensor at node 0.

If the stress-strain relations in the (xyz) -system are

$$\begin{Bmatrix} \sigma_x \\ \sigma_y \\ \tau_{xy} \end{Bmatrix} = \begin{bmatrix} d_{11} & d_{12} & d_{13} \\ & d_{22} & d_{23} \\ \text{sym} & & d_{33} \end{bmatrix} \begin{Bmatrix} \epsilon_x \\ \epsilon_y \\ \epsilon_{xy} \end{Bmatrix} \quad (\text{E-5})$$

the membrane forces at node 0 can be expressed as

$$\begin{Bmatrix} N_x \\ N_y \\ N_{xy} \end{Bmatrix} = t \begin{bmatrix} d_{11} & d_{12} & d_{13} \\ & d_{22} & d_{23} \\ \text{sym} & & d_{33} \end{bmatrix} \begin{Bmatrix} \epsilon_{x_0} \\ \epsilon_{y_0} \\ \epsilon_{xy_0} \end{Bmatrix} \quad (\text{E-6})$$

where t is the thickness.