

NASA CONTRACTOR REPORT



NASA CR-617

NASA CR-617

GPO PRICE \$ _____

POST PRICE(S) \$ _____

Hard Copy (HC) 4.00

Microfiche (MF) 1.00

953 July 65

FACILITY FORM 602

N67 12278
(ACCESSION NUMBER)

137
(PAGES)

NASA CR-617
(NASA CR OR TMX OR AD NUMBER)

(THRU)

(CODE)

10
(CATEGORY)

ALGEBRAIC METHODS FOR DYNAMIC SYSTEMS

by G. J. Thaler, D. D. Siljak, and R. C. Dorf

Prepared by

UNIVERSITY OF SANTA CLARA

Santa Clara, Calif.

for Ames Research Center

ALGEBRAIC METHODS FOR DYNAMIC SYSTEMS

By G. J. Thaler, D. D. Siljak, and R. C. Dorf

Distribution of this report is provided in the interest of information exchange. Responsibility for the contents resides in the author or organization that prepared it.

Prepared under Contract No. NAS 2-2609 by
UNIVERSITY OF SANTA CLARA
Santa Clara, Calif.

for Ames Research Center

NATIONAL AERONAUTICS AND SPACE ADMINISTRATION

For sale by the Clearinghouse for Federal Scientific and Technical Information
Springfield, Virginia 22151 - Price \$3.00

ABSTRACT

12278

This report summarizes, in tutorial form, the mathematical theory of algebraic methods and the techniques developed from January, 1965, through December, 1965, for the application of algebraic methods to the analysis and design of dynamic systems.

Manipulation of the characteristic polynomial after use of Mitrovic's transformation of variable leads to simultaneous equations which permit mapping s-plane contours on a coefficient plane or parameter plane. Analysis and design may be accomplished with these graphs.

Another technique for synthesis involves analytic treatment of the simultaneous equations rather than graph plotting. Both techniques have the advantage of being two parameter methods, with capability of extension to three or more parameters under suitable circumstances.

Anton

CONTENTS

ABSTRACT		ii
CHAPTER		
I	HISTORICAL BACKGROUND	1
1.1	Introduction	1
1.2	Origins of the Problems	1
1.3	Early Russian Studies: Vishnegradsky	2
1.4	Modern Russian Methods: Neimark	2
1.5	An American Approach: Evan's Root Locus Method	3
1.6	Mitrovic's Method and Extensions	3
1.7	Some Miscellaneous Methods	4
1.8	Present Status	5
	REFERENCES	6
II	FUNDAMENTAL LINEAR THEORY	7
2.1	Introduction. Statement of the Problem	7
2.2	Mitrovic's Approach to the Root-Finding Problem	9
2.3	Derivation of Basic Relationship. The Coefficient Plane and the Parameter Plane.	10
2.4	Illustrations	15
2.5	Some Comments	22
	REFERENCES	25
III	THE COEFFICIENT PLANE	26
3.1	Introduction	26
3.2	Stability Analysis	26
3.3	Sketching Techniques	34
3.4	Root Evaluation	38
3.5	Universal Curves on the Coefficient Plane.	44
3.6	Elementary Analysis	48
3.7	Elementary Synthesis. Cascade Compensation	50
3.8	Feedback Compensation. Use of Derivative Signals	53
3.9	Three Parameter Studies	55
3.10	Analytic Techniques	59
3.11	Frequency Response Evaluation	69
	REFERENCES	76

CONTENTS

CHAPTER

IV	THE PARAMETER PLANE	77
	4.1 Introduction. Generalized Derivation of the Algebraic Relationships	77
	4.2 Stability Analysis	85
	4.3 Root Evaluation	96
	4.4 Elementary Analysis and Synthesis Techniques.	97
	4.5 Analytic Techniques	113
	REFERENCES	121
APPENDIX A	THE D-PARTITION METHOD	122
APPENDIX B	TABLE OF $U_k(\zeta)$ FUNCTIONS	133

Chapter I

HISTORICAL BACKGROUND

1.1 Introduction.

The purpose of this chapter is to establish the position of the algebraic theory at the time this research was undertaken. To do so the origins of the basic problems are indicated, and the amount of progress made in solving these problems. The capabilities of other methods are roughly assessed, and the advantages to be gained as a result of this research are indicated.

1.2 Origins of the Problems.

After several applications of feedback control systems, such as centrifugal governors for the regulation of windmills and water wheels, and Watt's flyball governor for the steam engine, Maxwell¹ was the first to postulate theoretically the problems of these systems in mathematical terms. Among these problems, the foremost one is stability of a control system which was treated by Maxwell using linear differential equations as the mathematical model of the control system. Maxwell interpreted the stability of control systems as conditions which should be satisfied by the coefficients of the corresponding characteristic equation so that all the roots have negative real parts. Numerous stability criteria have been developed following Maxwell's concept of stability to check the mentioned conditions being satisfied.

Stability criteria do not constitute a complete satisfactory theory for design of control systems. In a wide variety of control problems, the designer is interested not only in the stability of the system but also in the essential features of the system response. The problem of control systems is to choose system parameters and structures which will yield a satisfactory system behavior over time. To solve such control problems, it is necessary to know not only that all the roots of the characteristic equation have negative real parts, but also their numerical values. This results in an algebraic concept of control system

design in which the relations between the coefficients of the characteristic equation, which is an algebraic equation, and the root locations are essential.

1.3 Early Russian Studies: Vishnegradsky.

The idea of investigating the system response in the algebraic domain was first introduced by Vishnegradsky². The algebraic method of Vishnegradsky designates that the two middle coefficients of the third degree characteristic equation be considered variables. In the plane of the variable coefficients, a diagram is plotted which enables the determination of these coefficients with respect to both the stability and the nature of the steady-state and transient system responses. The diagram divides the plane of the variable coefficients into four parts which correspond to different locations of three characteristic equation roots. One of the parts corresponds to an oscillatory response (two dominant complex conjugate roots and the third real), and the two others to different types of periodic responses (one dominant real root and the other two complex conjugate roots, and all three roots real). The fourth part of the coefficient plane represents the unstable region for which at least one of the roots has a positive real part. Therefore the Vishnegradsky diagram permits the designer to choose the parameters of the system, which appear in the coefficients of the third degree characteristic equation, so that a root configuration is obtained with results in a desired system response. From the work of Vishnegradsky, however, it was not possible to see how the approach could be extended to higher degree characteristic equations.

1.4 Modern Russian Methods: Neimark.

An extension of Vishnegradsky's algebraic concept was presented by Neimark³ in his D-partition method for the stability analysis of control systems. By utilizing Neimark's procedure, the designer may assume two-system parameters, which appear linearly in coefficients of the n-th degree characteristic equation, to be variables. Then the mapping of the imaginary axis of the complex variable plane onto the plane of the variable parameters permits the designer to determine the number of the

left-half-plane roots of the characteristic equation in various areas of the parameter plane. If the mapping procedure is applied to a straight line parallel to the imaginary axis of the complex variable plane, the method may be extended to investigations of the degree of stability; however, the plotting of the corresponding diagram becomes a time-consuming task. Attempts to apply the D-partition method to the design of control systems in terms of the transient response generates real difficulties since in applying the method the designer is unable to obtain information about, or control over, the root locations of the characteristic equation.

1.5 An American Approach: Evan's Root Locus Method.

About the same time that Neimark proposed his D-partition method, Evans⁴ presented his root locus techniques for the synthesis of control systems in the algebraic domain. The root locus method readily provides information about all the roots of the characteristic equation and permits a simple numerical evaluation of these roots for different values of the gain constant. The procedure admits control over both the time-domain and the frequency-domain characteristics, and it is convenient to consider the influence of the system structure on these characteristics. However, the root locus method has two significant limitations: First, it is basically a one-parameter method; and second, it makes the synthesis of multiloop systems inconvenient. An important drawback of the root locus techniques is that there is no explicit analytical expression of the root locus, and accurate plotting of the locus requires a considerable amount of labor. In addition, if a system parameter other than gain is considered as variable, the added difficulty of plotting root loci may discourage the use of root locus techniques in any but simple problems.

1.6 Mitrovic's Method and Extensions.

The algebraic problem of control systems has been solved by Mitrovic⁵ for the n-th degree characteristic equation. The method proposed by Mitrovic designates the two last coefficients of the characteristic equation as variables. By plotting the characteristic curves in the plane

of the variable coefficients, the method enables the adjustments of these coefficients so that all the roots of the characteristic equation are set at some desired location. The curves are readily plotted since the explicit analytical expression is available. After the curves are plotted, the variable coefficients can be adjusted without any calculations. All analytical and graphical operations are performed in the real domain. Since the method places in evidence all roots of the characteristic equation, it can be used to design both transient and frequency responses. The limitations of the method arise due to the fact that only the last two coefficients can be considered variable. The method has been extended later by Elliot, Thaler, and Heseltine⁶ to several specific pairs of coefficients. Siljak⁷ generalized the method so that arbitrary pairs of coefficients of the characteristic equation can be considered variable. The generalized method achieves the same degree of simplicity as does the method in its primary form. However, the method still remains with a limitation that the adjustable parameters may appear in no more than two coefficients of the characteristic equation, which reduces the flexibility of the method.

A correlation between adjustable parameters and all the characteristic equation roots has been obtained in the Siljak⁸ parameter plane method. In the plane of two parameters, which can appear nonlinearly in any and all of the coefficients of the characteristic equation, certain diagrams are obtained. From the diagram, all roots are determined simultaneously in a straightforward manner. The method is particularly suitable for analysis and synthesis of multiloop control systems with more than one adjustable system parameters. Both steady-state and transient responses can be simultaneously considered in the parameter plane. By using the describing function technique, the parameter plane method is readily applied to the stability analysis of nonlinear control systems. The sensitivity, transient response, asymmetrical oscillations and other related problems of nonlinear control can be advantageously solved by the parameter plane method.

1.7 Some Miscellaneous Methods.

Besides the algebraic methods listed, which were conceptually based upon the work of Vishnegradsky, several specific techniques have been developed. By prescribing numerical values of two or more roots, the Popov-Sokolov method⁹ reduces the degree of the characteristic equation. The best case is considered to be that in which a pair of complex roots of the characteristic equation is closest to the imaginary axis. Then the system parameters remaining in the reduced equation are determined so that the system has a desired transient response. The method requires individual approach to each system structure, taking into account the physical realizability of the requirements placed on the transient response. This generates difficulties in the application of the method and makes it convenient only for specific systems. A similar philosophy is proposed in the Guillemin method¹⁰ for synthesis of control systems. In this method, the adjustable part of the system is essentially chosen to cancel out all the poles and zeros of the transfer function representing the fixed part of the system, and re-insert a satisfactory set of characteristic root locations. In Guillemin's method the concept of cancellation compensation and inherent problems of physical realizability of the system components make the method impractical in a majority of control system designs. Similar objections may be made to the method presented recently in ref. 11.

1.8 Present Status.

More complete analyses are available with the coefficient plane - parameter plane methods than with any of the other algebraic methods. These methods also provide satisfactory synthesis techniques when two or three adjustable parameters are available. There are limitations to the capabilities of these methods, of course, but avenues for extension and for new developments are clearly available. The purpose of this research is to explore some of these avenues.

REFERENCES

1. Maxwell, J. E.: On Governors. Proceedings of the Royal Society of London, vol. 16, 1868, pp. 270-283.
2. Vishnegradsky, J.: Sur la theorie generale des regulateurs. Compt. Rend., Acad. Sci., Paris, vol. 83, 1867, pp. 318-321.
3. Neimark, J. K.: On Determination of Parameter Values which Ensure Stability of Automatic Control Systems. Avtomatika i Telemekhanika, No. 3, Moscow, 1948 (in Russian).
4. Evans, W. R.: Graphical Analysis of Control Systems. AIEE Transactions, vol. 67, pt. II, 1959, pp. 547-551.
5. Mitrovic, D.: Graphical Analysis and Synthesis of Feedback Control Systems. I - Theory and Analysis; II - Synthesis; III - Sampled-data Feedback Control Systems, AIEE Transactions, vol. 77, pt. II, Jan, 1959, pp. 476-503.
6. Elliott, D. W.; Thaler, G. J.; and Heseltine, J. C. W.: Feedback Compensation Using Derivative Signals. IEEE Transactions, Pt. II, Nov., 1963.
7. Siljak, D. D.: Generalization of Mitrovic's Method. IEEE Transactions, vol. 83, pt. II, Sept., 1964, pp. 314-320.
8. Siljak, D. D.: Analysis and Synthesis of Feedback Control Systems in the Parameter Plane. I - Linear Continuous Systems; II - Sampled-data Systems; III - Nonlinear Systems, IEEE Transactions, Pt. II, vol. 83, Nov., 1964, pp.449-466.
9. Popov, E. P.: The Dynamics of Automatic Control Systems. Pergamon Press, Ltd., Addison-Wesley Pub. Co., Inc., USA, 1962.
10. Truxal, J. G.; Automatic Feedback Control Systems Synthesis. McGraw-Hill Book Co., Inc., New York, 1955.
11. Liu, S. H.; and Thaler, G. J.: An Analytical Method for Analysis and Design of Control Systems. IEEE Transactions, vol. AC-10, No. 1, Jan., 1965, pp. 49-59.

Chapter 2

FUNDAMENTAL LINEAR THEORY

2.1 Introduction. Statement of Problem.

Mathematical studies concerned with the dynamics of linear systems must eventually face the problem of evaluating the roots* of a polynomial. Frequently the mathematical description of the system is given by a single linear differential equation which may be transformed to provide a polynomial expression commonly called the "characteristic equation". The roots of this characteristic equation are usually needed for analysis and/or synthesis purposes. In other cases the mathematical description may be a set of simultaneous first order equations, so matrix representation is used and the characteristic equation may not be formulated explicitly. However the eigenvalues are required for further analysis or synthesis, and the eigenvalue problem is precisely that of finding the roots of the characteristic polynomial. Thus a rapid and reasonably accurate method is needed for factoring polynomials.

Many root findings methods are available, including digital computer programs. However, beyond the basic function of providing root values, few of these methods are of much help in analysis or synthesis. The reason for this is that engineering analysis and synthesis is concerned not only with root values, but with the relationships between these root values and the values of various parameters of the dynamical system. Ultimately the analyst is concerned not only with the dynamic performance of a given system, but also with the change in dynamic performance which may occur with unintentional parameter variations, or which may be made to occur with deliberate changes in parameter values. Since the basic root finding methods such as digital programs, synthetic division, etc., do not relate roots to parameters, analysis with such methods requires iteration, a laborious, time consuming, and usually

*The term "roots" is used rather than "zeros" to reserve the latter term for cases where a ratio of polynomials (transfer function) is treated.

unsatisfactory procedure.

Alternate methods that relate dynamic performance to parameters are very desirable. An obvious technique is simulation (analog or digital) which is very useful, but limited in its ability to predict performance for conditions not actually tested, and also limited when the desired result is an optimum (or near optimum) set of parameter values. Graphical frequency response methods are very useful, and avoid the root finding problem by depending on the correlations between frequency domain and time domain. They can be very useful, particularly when applied by persons having considerable experience, but are limited in the number and kind of parameter variations that can be considered intelligently. In general the frequency response methods may be considered a "one parameter" method, in that it is difficult to study the effect of variations in more than one parameter at a time. Perhaps the best method in general use is the "root locus" method, which provides curves showing not only the root locations on the s-plane, but the way in which all roots move as functions of one chosen parameter. If desired iteration may be used to obtain a family of root loci for which a second parameter is the family parameter. Thus the root locus method is basically a one parameter method that can be extended to studies of two parameters with considerable additional labor. All of these methods; simulation, frequency response, root locus are excellent for certain classes of problems, but are inadequate for more complex classes of problems. What is needed is a method or methods that is capable of considering problems which involve more than one variable parameter.

The algebraic methods to be developed here possess (to some degree) the capabilities that are needed. They are inherently two parameter methods which can be extended to treat three (or more) variable parameters for many types of problems. They provide the desired dynamic information in terms of root values, i.e., the methods basically find the roots of the characteristic polynomial and make available information about the values of each root as a function of the adjustable (or variable) parameters.

2.2 Mitrovic's Approach to the Root-Finding Problem.

From complex variable theory (Cauchy's Principle of Argument) it is well known that the conformal mapping of a closed contour on the s-plane through a mapping function produces a contour on the polar plane, and the encirclements of the origin of the polar plane by the mapped curve can be interpreted in terms of the singularities (zeros and/or poles) of the mapping function that are enclosed by the s-plane contour. This is the basis of the Nyquist criterion. This has also been the basis for other methods which have attempted to evaluate roots by various manipulations. This is also the basis for Mitrovic's approach to the problem.

The basic steps in applying the principle of argument to the root finding problem are:

- a) Choose a contour (or contours) on the s-plane.
- b) Choose a mapping function.
- c) Choose a transformation of variable such that the mapping function can be resolved to two (or more) equations such as

$$\sum \text{Reals} = 0; \quad \sum \text{Imaginary} = 0.$$

- d) Interpret these equations to determine stability, root values, etc.

For (a) Mitrovic chose radial (constant ζ) lines on the s-plane, closing with an infinite radius circular arc around the left half plane. For (b) he chose the characteristic equation as a mapping function. Other people had previously attacked this problem from exactly the same starting point, and the success of Mitrovic's approach is due to the fact that for (c) he chose the simple transformation of variable

$$s = \mp \zeta \omega \mp j\omega \sqrt{1 - \zeta^2}$$

The reason why this transformation works well is not at all apparent, but the results obtained are quite remarkable, as will be seen.

The details of equation derivations, manipulations, basic curve plotting, and evaluation of roots are given in the remainder of this

chapter. Techniques for applying the algebraic methods to analysis and design to linear systems are given in chapters 3 and 4.

2.3 Derivation of Basic Relationships. The Coefficient Plane and the Parameter Plane.

Let a characteristic polynomial be

$$F(s) = a_n s^n + a_{n-1} s^{n-1} + \dots + a_2 s^2 + a_1 s + a_0 = 0 \quad (2.1)$$

In summation notation this is

$$F(s) = \sum_{k=0}^n a_k s^k = 0 \quad (2.2)$$

This polynomial is to be used as a mapping function, and the s-plane contour to be mapped consists of any radial line from the origin and its conjugate, with closure being an infinite circular arc directed counter-clockwise from the upper radial line. Any point, s, on the radial lines may be designated by

$$\begin{aligned} s &= -\zeta\omega \mp j\omega\sqrt{1 - \zeta^2} \\ &= \omega \left(-\zeta \mp j\sqrt{1 - \zeta^2} \right) \end{aligned} \quad (2.3)$$

where ζ is the cosine of the angle between the radial line and the real axis

ω is the distance along the radial line from origin to the point being considered.

Substituting (2.3) in (2.2)

$$\begin{aligned} \sum_{k=0}^n a_k s^k &= \sum_{k=0}^n a_k \omega^k \left(-\zeta + j\sqrt{1 - \zeta^2} \right)^k \\ &= \sum_{k=0}^n a_k \omega^k \left[T_k(-\zeta) + j\sqrt{1 - \zeta^2} U_k(-\zeta) \right] = 0 \end{aligned} \quad (2.4)$$

where $T_k(-\zeta)$ is the real part of the expanded ζ -function and $\sqrt{1-\zeta^2} U_k(-\zeta)$ is the imaginary part of the expanded ζ -function.

Now

$$T_k(-\zeta) = (-1)^k T_k(\zeta)$$

$$U_k(-\zeta) = (-1)^{k+1} U_k(\zeta)$$

and by inspection

$$T_0(\zeta) = 1$$

$$T_1(\zeta) = \zeta$$

$$U_0(\zeta) = 0$$

$$U_1(\zeta) = 1$$

Further manipulation indicates that $T_k(\zeta)$ and $U_k(\zeta)$ are Chebishev functions, and may be computed from the recurrence relations

$$T_{k+1}(\zeta) - 2\zeta T_k(\zeta) + T_{k-1}(\zeta) = 0$$

$$U_{k+1}(\zeta) - 2\zeta U_k(\zeta) + U_{k-1}(\zeta) = 0$$
(2.5)

Requiring that reals and imaginaries become zero independently, (2.4) may be rewritten as two equations

$$\sum_{k=0}^n a_k \omega^k T_k(-\zeta) = 0$$

$$\sum_{k=0}^{\infty} a_k \omega^k U_k(-\zeta) = 0$$
(2.6)

To eliminate $T_k(-\zeta)$ from (2.6) and obtain equations in one Chebishev function only, it is noted that

$$T_k(\zeta) = \zeta U_k(\zeta) - U_{k-1}(\zeta)$$
(2.6a)

then(2.6) may be rewritten

$$\sum_{k=0}^n (-1)^k a_k \omega^k [z U_k(z)] - \sum_{k=0}^n (-1)^k a_k \omega^k U_{k-1}(z) = 0 \quad (2.7)$$

$$\sum_{k=0}^n (-1)^k a_k \omega^k U_k(z) = 0$$

but the first part of this equation is redundant so the conditions may be simplified to

$$\sum_{k=0}^n (-1)^k a_k \omega^k U_{k-1}(z) = 0 \quad (2.8)$$

$$\sum_{k=0}^n (-1)^k a_k \omega^k U_k(z) = 0$$

Equations (2.8) are two equations in one unknown if the coefficients of the characteristic polynomial have all been defined numerically; i.e., if the coefficients are known then all a_k are known, and if the mapping contour has been chosen then z is known, $U_k(z)$ and $U_{k-1}(z)$ are known numbers, and ω is then the variable parameter. In general it is intended to let ω vary from $-\infty$ to $+\infty$ in order to map the chosen contour, thus it is possible to choose two other quantities as unknown parameters and solve (2.8) simultaneously for these two parameters.

Initially Mitrovic chose the coefficients a_0 and a_1 as parameters, and developed techniques based only on these coefficients as variables. Later Elliott, Heseltine and Thaler used the coefficient pairs a_1 , and a_2 and a_2 and a_3 as variables for specific feedback compensation problems. Finally Siljak generalized the derivation showing that solution for any two coefficients can be obtained. In addition Siljak postulated that if any two parameters, α and β , appeared in any number of the coefficients, but always appeared linearly (i.e., $a_k = b_k \alpha + c_k \beta + d_k$) then (2.8) can also be solved for the parameters α and β . Derivations are as follows.

Choose any two coefficients a_p and a_q as variables, such that

$n \geq p > q \geq 0$, and for convenience indicate that these coefficients are variables by using upper case letters, $A_p A_q$. Then (2.8) may be rewritten

$$(-1)^p A_p \omega^p U_{p-1}(\zeta) + (-1)^q A_q \omega^q U_{q-1}(\zeta) = - \sum_{\substack{k=0 \\ k \neq p, q}}^n (-1)^k a_k \omega^k U_{k-1}(\zeta) \quad (2.9a)$$

$$(-1)^p A_p \omega^p U_p(\zeta) + (-1)^q A_q \omega^q U_q(\zeta) = + \sum_{\substack{k=0 \\ k \neq p, q}}^n (-1)^k a_k \omega^k U_k(\zeta) \quad (2.9b)$$

Solving simultaneously:

$$A_p = \sum_{\substack{k=0 \\ k \neq p, q}}^n (-1)^{k-p} \omega^{k-p} a_k \left[\frac{U_{q-1} U_k - U_q U_{k-1}}{U_q U_{p-1} - U_{q-1} U_p} \right] \quad (2.10)$$

$$A_q = \sum_{\substack{k=0 \\ k \neq p, q}}^n (-1)^{k-q} \omega^{k-p} a_k \left[\frac{U_{p-1} U_k - U_p U_{k-1}}{U_p U_{q-1} - U_{p-1} U_q} \right]$$

It can be shown that

$$U_q U_{p-1} - U_{q-1} U_p = U_{p-q}$$

Then

$$A_p = -1 \sum_{\substack{k=0 \\ k \neq p, q}}^n (-1)^{k-p} \omega^{k-p} a_k \left(\frac{U_{k-q}}{U_{p-q}} \right) \quad (2.10a)$$

$$A_q = \sum_{\substack{k=0 \\ k \neq p, q}}^n (-1)^{k-q} \omega^{k-q} a_k \left(\frac{U_{k-p}}{U_{p-q}} \right)$$

For those problems involving parameters which occur in several coefficients of the polynomial a general derivation is also available. Assume that the parameters of interest are α and β , and that they occur linearly in the coefficients, i.e.,

$$a_k = b_k \alpha + c_k \beta + dk \quad (2.11)$$

where b_k , c_k and d_k can be any number, including zero. Then the polynomials of (2.8) can be rewritten

$$\begin{aligned} \alpha \sum_{k=0}^n (-1)^k b_k \omega^k U_{k-1}(\zeta) + \beta \sum_{k=0}^n (-1)^k c_k \omega^k U_{k-1}(\zeta) + \\ + \sum_{n=0}^k (-1)^k d_k \omega^k U_{k-1}(\zeta) = 0 \end{aligned} \quad (2-12)$$

$$\begin{aligned} \alpha \sum_{k=0}^n (-1)^k b_k \omega^k U_k(\zeta) + \beta \sum_{k=0}^n (-1)^k c_k \omega^k U_k(\zeta) + \\ + \sum_{k=0}^n (-1)^k d_k \omega^k U_k(\zeta) = 0 \end{aligned}$$

Equations (2.12) may be shortened to

$$\alpha B_1(\zeta, \omega) + \beta C_1(\zeta, \omega) + D_1(\zeta, \omega) = 0 \quad (2.13)$$

$$\alpha B_2(\zeta, \omega) + \beta C_2(\zeta, \omega) + D_2(\zeta, \omega) = 0$$

where B , C , D are the summations indicated in (2.12). Solving (2.13) simultaneously,

$$\begin{aligned} \alpha &= \frac{C_1 D_2 - C_2 D_1}{B_1 C_2 - B_2 C_1} \\ \beta &= \frac{B_2 D_1 - D_2 B_1}{B_1 C_2 - B_2 C_1} \end{aligned} \quad (2.14)$$

Using (2.10) or (2.14) the mapping of the chosen s-plane contour is readily accomplished. When (2.10) is used A_p and A_q become the ordinate and abscissa of a rectangular coordinate plot which may be called the "coefficient Plane" since A_p and A_q are coefficients of the characteristic equation. In like manner if (2.14) is used α and β become the ordinate and abscissa, and the plot may be called the "Parameter Plane" since α and β are parameters which appear in the characteristic equation.

It is clear that the Parameter plane is the most general of these, and reduces to the coefficient plane when α and β appear in two coefficients only, with α in one coefficient and β in the other. If no more than two coefficients contain α and β , but either α or β appears in both coefficients, then either the coefficient plane or the Parameter plane may be used. Finally if the coefficient plane is used for coefficients A_0 and A_1 , then the coefficient plane is also the Mitrovic plane. Note that for any problem suitable for these methods the parameter plane can be used. As will be seen later, however, many interpretations are more easily made on the coefficient plane, so that it may often be preferred when working on a suitable problem.

2.4 Illustrations

Consider the polynomial

$$F(s) = 100,000 + 30,000s + 4960s^2 + 496s^3 + 30s^4 + s^5 = 0 \quad (2.15)$$

and assume that it is desired to map the imaginary axis ($\zeta = 0$) of the s-plane onto the $A_0 - A_1$ coefficient plane. The choice of the $A_0 - A_1$ plane is arbitrary here, since all coefficients are stated numerically. In most engineering applications the coefficients chosen are those which can be altered by adjustment of parts of the system (for which the polynomial is the characteristic equation). This may be done directly by substitution in (2.10) but for the purposes of this illustration the starting point shall be (2.4). For a fifth order equation (with ζ designated symbolically) (2.4) expands to:

$$\begin{aligned}
\sum_{k=0}^5 a_k s^k &= a_0 + a_1 \omega(-\zeta + j\sqrt{1-\zeta^2}) + a_2 \omega^2 [-1 + 2\zeta^2 + j\sqrt{1-\zeta^2}(-2\zeta)] \\
&+ a_3 \omega^3 [3\zeta - 4\zeta^3 + j\sqrt{1-\zeta^2}(-1 + 4\zeta^2)] \\
&+ a_4 \omega^4 [1 - 8\zeta^2 + 8\zeta^4 + j\sqrt{1-\zeta^2}(4\zeta - 8\zeta^3)] \\
&+ a_5 \omega^5 [-5\zeta + 20\zeta^3 - 16\zeta^5 + j\sqrt{1-\zeta^2}(1 - 12\zeta^2 + 16\zeta^4)]
\end{aligned} \tag{2.16}$$

From (2.16) the functions $T_k(-\zeta)$ and $U_k(-\zeta)$ are

$$\begin{array}{ll}
T_0(-\zeta) = 1 & U_0(-\zeta) = 0 \\
T_1(-\zeta) = -\zeta & U_1(-\zeta) = 1 \\
T_2(-\zeta) = -1 + 2\zeta^2 & U_2(-\zeta) = -2\zeta \\
T_3(-\zeta) = 3\zeta - 4\zeta^3 & U_3(-\zeta) = -1 + 4\zeta^2 \\
T_4(-\zeta) = 1 - 8\zeta^2 + 8\zeta^4 & U_4(-\zeta) = 4\zeta - 8\zeta^2 \\
T_5(-\zeta) = -5\zeta + 20\zeta^3 - 16\zeta^5 & U_5(-\zeta) = -1 - 12\zeta^2 + 16\zeta^4
\end{array}$$

and by inspection, if the sign of ζ is reversed

$$\begin{array}{ll}
T_0(\zeta) = 1 & U_0(\zeta) = 0 \\
T_1(\zeta) = \zeta & U_1(\zeta) = 1 \\
T_2(\zeta) = -1 + 2\zeta^2 & U_2(\zeta) = 2\zeta \\
T_3(\zeta) = -3\zeta + 4\zeta^3 & U_3(\zeta) = -1 + 4\zeta^2 \\
T_4(\zeta) = 1 - 8\zeta^2 + 8\zeta^4 & U_4(\zeta) = -4\zeta + 8\zeta^2 \\
T_5(\zeta) = 5\zeta - 20\zeta^3 + 16\zeta^5 & U_5(\zeta) = 1 - 12\zeta^2 + 16\zeta^4 \\
\vdots & \vdots \\
T_k(\zeta) = (-1)^k T(-\zeta) & U_k(\zeta) = (-1)^{k+1} U_k(-\zeta)
\end{array}$$

From the above (2.5) can be verified by inspection; for example

$$\begin{aligned}
T_5(\zeta) &= 2 \zeta T_4(\zeta) - T_3(\zeta) = 2 \zeta(1 - 8 \zeta^2 + 8 \zeta^4) - (-3 \zeta + 4 \zeta^3) \\
&= 2 \zeta - 16 \zeta^3 + 16 \zeta^5 + 3 \zeta - 4 \zeta^3 \\
&= 5 \zeta - 20 \zeta^3 + 16 \zeta^5
\end{aligned}$$

Equation (2.6a) can also be verified:

$$\begin{aligned}
T_5(\zeta) &= \zeta U_5(\zeta) - U_4(\zeta) = \zeta(1 - 12 \zeta^2 + 16 \zeta^4) - (-4 \zeta + 8 \zeta^3) \\
&= \zeta - 12 \zeta^3 + 16 \zeta^5 + 4 \zeta - 8 \zeta^3 \\
&= 5 \zeta - 20 \zeta^3 + 16 \zeta^5
\end{aligned}$$

It is thus seen that the $U_k(\zeta)$ functions are really quite simple functions of ζ . They are Chebishev functions as previously stated, and the recurrence relationships of (2.5) are easily implemented in a digital computer. A table of $U_k(\zeta)$ values for various $0 \leq \zeta \leq 1$ is given in an Appendix. Note that for simple problems to be worked longhand, such a table of values is needed; for more complex problems requiring the digital computer, the recurrence relationship is used.

For the specific polynomial of (2.15) the A_0 and A_1 equations are determined from (2.10a) noting that $p = 1$ and $q = 0$. Expanding the summation

$$\begin{aligned}
A_1 &= + \omega a_2 \left(\frac{U_2}{U_1} \right) - \omega^2 a_3 \left(\frac{U_3}{U_1} \right) + \omega^3 a_4 \left(\frac{U_4}{U_1} \right) - \omega^4 a_5 \left(\frac{U_5}{U_1} \right) \\
&= \frac{\omega}{U_1} \left(+ a_2 U_2 - \omega a_3 U_3 + \omega^2 a_4 U_4 - \omega^3 a_5 U_5 \right)
\end{aligned} \tag{2.17}$$

$$\begin{aligned}
A_0 &= \omega^2 a_2 \left(\frac{U_1}{U_1} \right) - \omega^3 a_3 \left(\frac{U_2}{U_1} \right) + \omega^4 a_4 \left(\frac{U_3}{U_1} \right) - \omega^5 a_5 \left(\frac{U_4}{U_1} \right) \\
&= \frac{\omega^2}{U_1} \left(a_2 U_1 - \omega a_3 U_2 + \omega^2 a_4 U_3 - \omega^3 a_5 U_4 \right)
\end{aligned}$$

Substituting numerical values for the $U(\zeta)$ functions, for $\zeta = 0$:

$$A_1 = \frac{\omega}{1} \left(+ \omega a_3 - \omega^3 a_5 \right) = + \omega^2 a_3 - \omega^4 a_5 \quad (2.18)$$

$$A_0 = \frac{\omega^2}{1} \left(a_2 - \omega^2 a_4 \right) = \omega^2 a_2 - \omega^4 a_4$$

Substituting the numerical values of a_2 , a_3 , a_4 , a_5 from (2.15)

$$A_1 = 496 \omega^2 - \omega^4 \quad (2.19)$$

$$A_0 = 4960 \omega^2 - 30 \omega^4$$

The map of the imaginary axis of the s-plane through the mapping function of (2.15) onto the $A_0 - A_1$ coefficient plane is obtained by substituting values of ω in (2.19). A portion of this contour is shown on fig. 2.1. The contour divides the plane into two areas, one of which must be the "enclosed" area in a mapping sense, and criteria must be developed to determine which area is the enclosed one. Derivation of these criteria is deferred to a later section. A point M(30,000; 100,000) has been added to the figure since these are the numerical values of A_1 and A_0 specified by (2.15). This is the critical point, (i.e., it corresponds to the origin of the polar plane for a conformal map) and is used with the $\zeta = 0$ curve to check stability, i.e., if the M-point were on the curve two imaginary roots are guaranteed, and the position of the M-point relative to the $\zeta = 0$ curve is interpretable in terms of the existence of roots with positive or negative real parts. For purposes of analysis, if curves for various values of ζ are drawn the M-point location permits numerical evaluation of all roots to an accuracy limited only by time and labor. For purposes of synthesis of a physical system, if the chosen coefficients (in this case A_0 and A_1) are physically adjustable the M-point can be moved as desired, and at any location of the M-point the relationship between root locations and coefficients is determined by the plot. This permits ready estimation of the limits of dynamic performance of a given system and enables adjustment to desired performance within those limits. These statements are developed rigorously in Chapter 3 of this treatment, which also contains many sophisticated

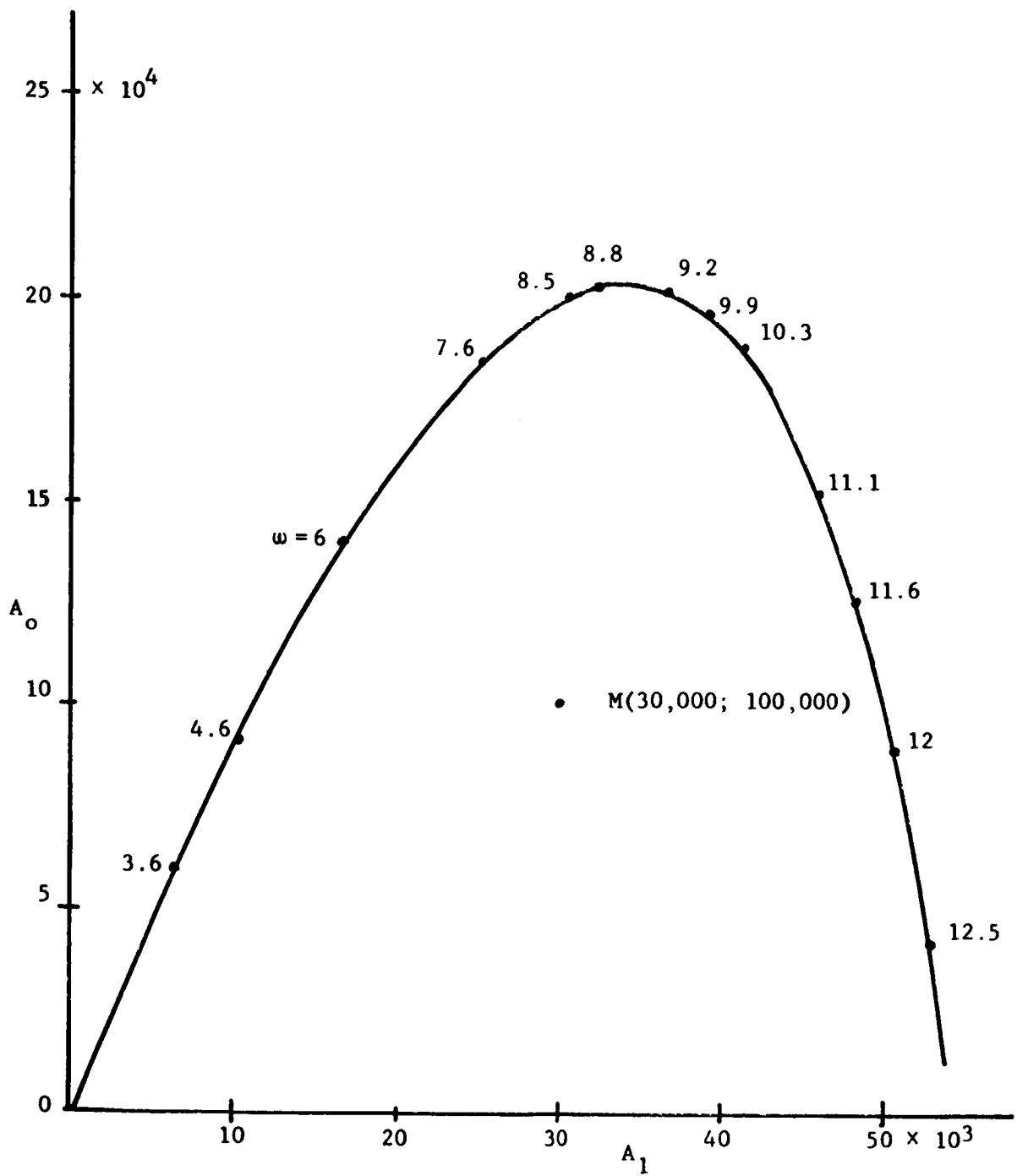

Fig. 2.1 Map of the Polynomial
 $F(s) = 10^5 + 3 \times 10^4 s + 4960s^2 + 496s^3 + 30s^4 + s^5$

techniques based on these fundamental concepts.

The polynomial of (2.15) can also be analyzed on the parameter plane if some simple and rather arbitrary assumptions are made. All that is necessary is to insert parameters α and β in several coefficients. For the purposes of this illustration the following is chosen:

$$F(s) = 100,000 + (30,000 + 50 \beta)s + (4960 + 6 \alpha + 11 \beta)s^2 + (496 + \alpha)s^3 + 30s^4 + s^5 = 0 \quad (2.20)$$

In practice the α and β would correspond to adjustable parameters in a physical system. It should also be noted that when $\alpha = \beta = 0$ equation (2.20) reduces to (2.15).

Equation (2.20) is used with (2.12) to obtain

$$\alpha [6 \omega^2 U_1 - \omega^3 U_2] + \beta [-50 \omega U_0 + 11 \omega^2 U_1] + [100,000 U_{-1} - 30,000 \omega U_0 + 4960 \omega^2 U_1 - 496 \omega^3 U_2 + 30 \omega^4 U_3 - \omega^5 U_4] = 0 \quad (2.21)$$

$$\alpha [6 \omega^2 U_2 - \omega^3 U_3] + \beta [-50 \omega U_1 + 11 \omega^2 U_2] + [100,000 U_0 - 30,000 \omega U_1 + 4960 \omega^2 U_2 - 496 \omega^3 U_3 + 30 \omega^4 U_4 - \omega^5 U_5]$$

From (2.21) the following functions are defined:

$$B_1 = 6 \omega^2 U_1 - \omega^3 U_2$$

$$C_1 = -50 \omega U_0 + 11 \omega^2 U_1$$

$$D_1 = 100,000 U_0 - 30,000 \omega U_0 + 4960 \omega^2 U_1 - 496 \omega^3 U_2 + 30 \omega^4 U_3 - \omega^5 U_4$$

$$B_2 = 6 \omega^2 U_2 - \omega^3 U_3$$

$$C_2 = -50 \omega U_1 + 11 \omega^2 U_2$$

$$D_2 = 100,000 U_0 - 30,000 \omega U_1 + 4960 \omega^2 U_2 - 496 \omega^3 U_3 + \\ + 30 \omega^4 U_4 - \omega^5 U_5$$

These functions may be substituted in (2.14) to obtain expressions for α and β . Evaluation then permits plotting a curve of α vs θ .
For $\zeta = 0$

$$B_1 = 6 \omega^2$$

$$C_1 = 11 \omega^2$$

$$D_1 = -100,000 + 4960 \omega^2 - 30 \omega^4$$

$$B_2 = + \omega^3$$

$$C_2 = -50 \omega$$

$$D_2 = -30,000 \omega + 496 \omega^3 - \omega^5$$

Then from (2.14)

$$\alpha = \frac{11 \omega^2 (-30,000 \omega + 496 \omega^3 - \omega^5) - (-50 \omega) (-100,000 + 4960 \omega^2 - 30 \omega^4)}{(6 \omega^2) (-50 \omega) - (\omega^3) (11 \omega^2)} \\ = \frac{-330,000 \omega^3 + 5456 \omega^5 - 11 \omega^7 - 5 \times 10^6 \omega + 248,000 \omega^3 - 1500 \omega^5}{-300 \omega^3 - 11 \omega^5} \\ = \frac{-5 \times 10^6 \omega - 82,000 \omega^3 + 3956 \omega^5 - 11 \omega^7}{-300 \omega^2 - 11 \omega^5} \quad (2.22a)$$

$$\beta = \frac{\omega^3 (-100,000 + 4960 \omega^2 - 30 \omega^4) - (6 \omega^2) (-30,000 \omega + 496 \omega^3 - \omega^5)}{-300 \omega^2 - 11 \omega^5} \\ = \frac{-100,000 \omega^3 + 4960 \omega^5 - 30 \omega^7 + 100,000 \omega^3 - 2976 \omega^5 + 6 \omega^7}{-300 \omega^2 - 11 \omega^5} \\ = \frac{80,000 \omega^3 + 1984 \omega^5 - 24 \omega^7}{-300 \omega^2 - 11 \omega^5} \quad (2.22b)$$

The parameter plane expressions of (2.22) are obviously much more

complex than the corresponding coefficient plane expressions of (2.18). This is a natural consequence of the fact that the $\alpha - \beta$ parameter problem is a much more complex relationship. When a problem can be approached using either coefficient plane or parameter plane, the curve plotting part of the problem is usually less labor on the coefficient plane. However, the majority of complex problems require use of the parameter plane, and use of a digital computer to prepare the curves is desirable.

The parameter plane plot for (2.22) is given on fig. 2.2. To analyze the polynomial of (2.20), the M-point must be placed at the origin of the parameter plane ($\alpha = \beta = 0$). Stability is analyzed from the location of the M-point relative to the $\zeta = 0$ curve. If more ζ curves are added all roots can be evaluated and the functional relationship between the roots and the α, β parameters is established.

It is apparent that the manipulations and calculations required for the parameter plane are more laborious than those required for the coefficient plane. However, the parameter plane permits analysis and synthesis situations which are too complex for the coefficient plane. Computation of the curves by computer seems the only practical procedure, and also seems justified because of the complex type of problem that can be handled.

2.5 Some Comments.

From the preceding developments, it is seen that the algebraic methods under discussion establish relationships between the roots of a polynomial and various variable parameters appearing in the coefficients of the polynomial. The methods are not concerned with the origin of the polynomials, and so may be used for the analysis and design of any physical system whose dynamics can be described (or approximated) by a linear polynomial. This treatment is primarily concerned with the dynamics of feedback control systems so the terminology and illustrations are chosen largely from this area. In like manner many of the specific techniques have been derived specifically for cases involving feedback loops and probably cannot be used for non-feedback types of problems. Other techniques are much more general as is pointed out where convenient.

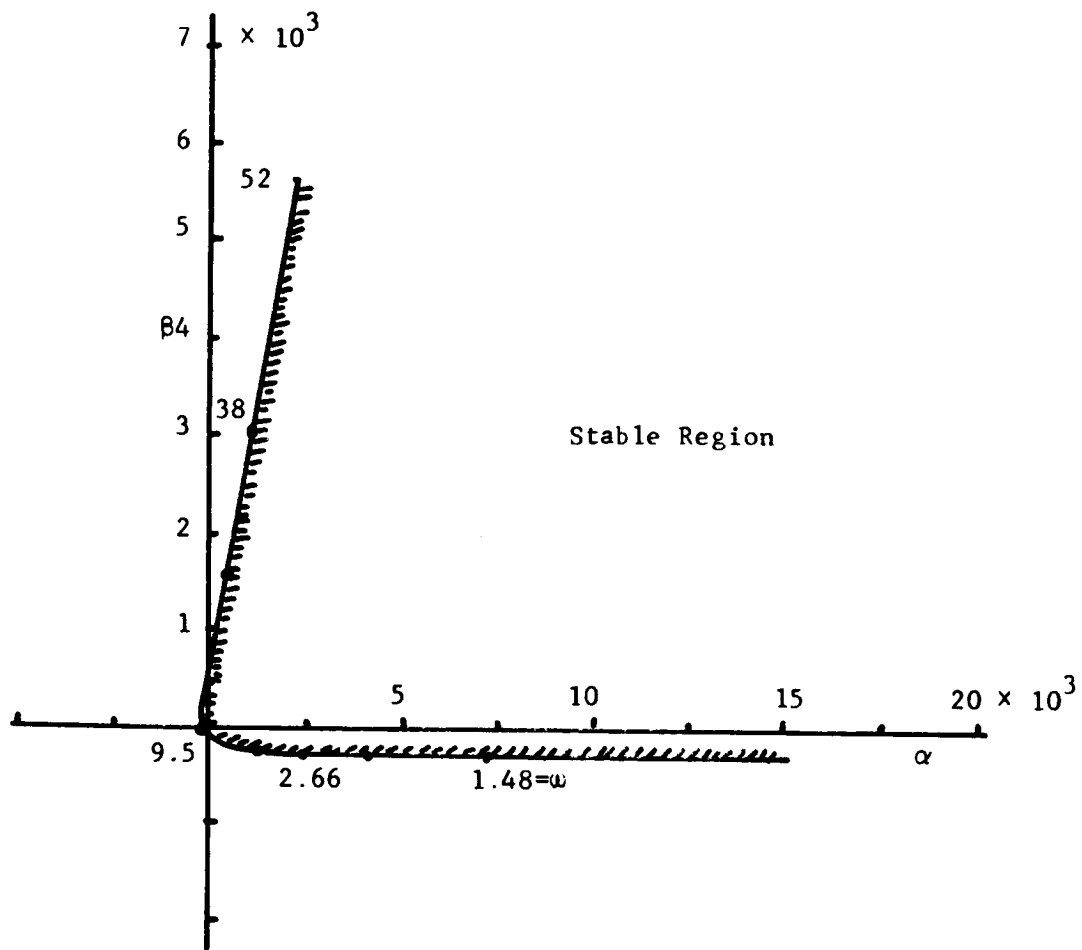

Fig. 2.2 Parameter Plane Plot
of Eqn. 1.22 for $\zeta = 0$

Although the coefficient plane is a special case of the parameter plane, it is much easier to use wherever it is applicable, and it is useful in a large number of practical cases. This is one reason why the coefficient plane is treated in detail in Chapter 3 and the parameter plane is developed in similar detail in Chapter 4. As will be seen, many problems which can be treated by either method (for example, stability analysis) require quite different techniques for the parameter plane as compared with the coefficient plane. These differences frequently require separate and lengthy derivations before satisfactory techniques are obtained.

The coefficient plane is treated first because it is readily applicable to a number of relatively familiar problems, is easily extended to treat substantially more difficult problems, and can be applied using slide rule or desk-calculator manipulations if these seems desirable. The techniques developed also serve as an introduction to the developments needed for the parameter plane, building a background of familiarity which it is hoped will be valuable. The parameter plane method is applicable to problems which are substantially more complex than those solvable on the coefficient plane, but considerably more labor is required to compute the curves. This makes use of a digital computer almost mandatory for all except the simplest problems (of course a computer is advantageous with coefficient plane problems also). If a computer is to be used many additional techniques become practical as is shown.

REFERENCES (Chapter 2)

1. Mitrovic, D: Graphical Analysis and Synthesis of Feedback Control Systems Parts I, II, III, AIEE Transactions, Pt. II, vol. 77, Jan. 1959.
2. Siljak, D. D: Generalization of Mitrovic's Method, IEEE Transactions on Applications and Industry, vol. 83, Sept. 1964.
3. Siljak, D. D.: Analysis and Synthesis of Feedback Control Systems in the Parameter Plane. Pt. I, II, III, IEEE Transactions on Applications and Industry, vol. 83, November. 1964.
4. Thaler, G. J.; Brown, B. G: Analysis and Design of Feedback Control Systems, Ch. 10, McGraw Hill Book Co., Inc., New York, N. Y., 1960.

Chapter 3

THE COEFFICIENT PLANE

3.1 Introduction.

Mitrovic's original work defines a plane on which the coordinates are the coefficients of the zero and first power terms in the characteristic equation. Later work by Siljak generalized the theory so that any two coefficients may be used. This chapter treats the theory and application of such coefficient planes. While the coefficient plane may be considered just a special case of the parameter plane (developed in Chapter 4) it originated before the parameter plane, its development has been refined to a greater extent, and various convenient techniques for its application have been discovered. These features, in addition to the fact that it is more convenient than the parameter plane for some problems, justify devoting a separate chapter to its development.

3.2 Stability Analysis

A linear system is stable if all roots of the characteristic equation have negative real parts. Thus, to determine stability on the coefficient plane, the $\zeta = 0$ contour must be used because it is a map of the imaginary axis of the s-plane (and closing infinite semicircle) through the characteristic equation as a mapping function. The singularities (zeros) of the mapping function are precisely the roots of the characteristic equation; the mapping contour closes around the left half of the s-plane; therefore all roots of the mapping function must be enclosed if the system under consideration is to be stable. On the coefficient plane the $\zeta = 0$ contour defines an enclosed area as ω is varied from zero through positive values then along the infinite semicircle and finally from $-\infty$ back to zero. To determine stability from the plot one must be able to recognize whether an "enclosed area" exists and precisely where it is. Then, for the system to have all roots in the left half at the s-plane the M-point must be in this enclosed area.

The procedure for deriving the necessary criteria is quite simple

and is the same procedure for any pair of coefficients. However, the derivation has to be performed for each set of coefficients used as coordinates. Here the derivation is performed only once, for the A_0 vs A_1 plane, but results for additional cases are tabulated.

Any polynomial $F(s)$ can be arranged in the form

$$F(s) = f(s) + a_i s^i + a_j s^j \quad (3.1)$$

where $F(s)$ is not zero except for those values of s which are roots of the polynomial. The same polynomial can be expressed with variable coefficients, i.e.,

$$F_1(s) = f(s) + A_i s^i + A_j s^j \quad (3.2)$$

and $F_1(s)$ is now zero for any value of s providing numerical values for A_i and A_j satisfy the relationships developed in Chapter 1. Subtracting (3.2) from (3.1)

$$F(s) - F_1(s) = (a_i - A_i) s^i + (a_j - A_j) s^j \quad (3.3)$$

but $F_1(s) \equiv 0$ for all s if A_i and A_j are properly chosen, so (3.3) reduces to

$$F(s) = (a_i - A_i) s^i + (a_j - A_j) s^j \quad (3.4)$$

For stability studies $\zeta = 0$ and $s = \omega / \frac{\pi}{2}$, which can be extended to any radial line in the left half plane by noting $s = \omega / \frac{\pi}{2} + \theta$ where $\zeta = \sin \theta$. Substituting in (3.4)

$$\begin{aligned} \overrightarrow{F(\omega)} &= (a_i - A_i) \omega^i / \underline{i \left[\frac{\pi}{2} + \theta \right]} + (a_j - A_j) \omega^j / \underline{j \left[\frac{\pi}{2} + \theta \right]} \\ &= (a_i - A_i) \omega^i \vec{e}_i + (a_j - A_j) \omega^j \vec{e}_j \end{aligned} \quad (3.5)$$

where \vec{e}_i and \vec{e}_j are unit vectors in the directions $\frac{i\pi}{2} + i\theta$ and $\frac{j\pi}{2} + j\theta$. Then (3.5) can be used to obtain the map of any radial s -plane contour through the characteristic equation onto a polar plane, and can

be used to correlate this map with the coefficient plane curve because (3.5) is expressed in terms of the coefficients A_i, A_j .

Consider the specific case of the Mitrovic plane, for which the coefficients are A_0 and A_1 , and consider the stability case for which $\theta = 0$. Then (3.5) becomes

$$\overrightarrow{F(\omega)} = (a_1 - A_1) \omega / \frac{\pi}{2} + (a_0 - A_0) / 0^0 \quad (3.5a)$$

Using (3.5a) the stability conditions are derived as follows:

- a) It is assumed that all roots of $F(s)$ are in the left half of the s -plane and the necessary graphical relationships are to be determined.
- b) The polar map of the s -plane contour is sketched using the assumption of (a).
- c) The coefficient plane curve is sketched using the polar map of (b) and (3.5a) to determine the conditions that must exist.
- d) The rules for stability determination are obtained from (c).

To sketch the polar map of the s -plane contour (with characteristic equation, $F(s)$, as mapping function) start at $\omega = 0$ and let ω increase to $+\infty$, noting that for $F(s)$ of N^{th} order the polar plot starts at $F(s) \equiv a_0 / 0^0$; the angle of $F(s)$ increases in a positive (counterclockwise) sense approaching $\phi = \frac{N\pi}{2}$ as $\omega \rightarrow +\infty$; the magnitude of $F(s)$ approaches infinity as $\omega \rightarrow \infty$. Then, as the mapping point traverses the infinite semicircle from $\omega = +\infty$ to $\omega = -\infty$, the angle of $F(s)$ increases by $N\pi$. Finally, as ω varies from $-\infty$ to zero, the angle of $F(s)$ increases by $N\pi/2$. Thus the total angle swept by the vector $F(s)$ is $2N\pi$, as shown on fig. 3.1a. The map of fig. 3.1a is sketched by inspection, since both the magnitude and phase of $F(s)$ vary monotonically with ω , and only the order of the equation, N , is needed as long as all zeros are in the left half of the s -plane.

The curve of fig. 3.1a may also be mapped onto the A_1 vs A_0 coefficient plane using (3.5a) but it is easier to plot the A_1 vs A_0 curve from the equations

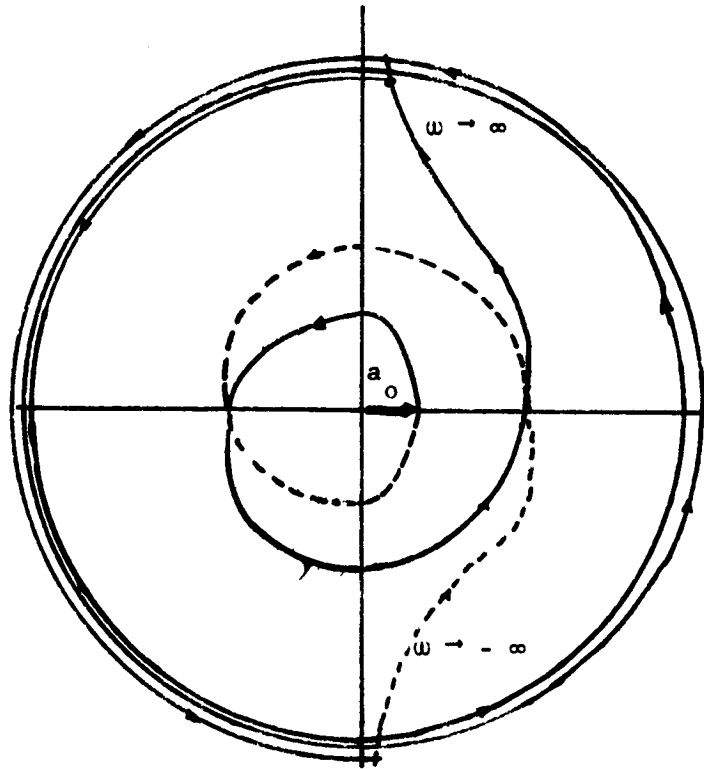

a) Polar Map of the $\zeta = 0$ contour (and closing circular arc) through $F(s)$ as a mapping function

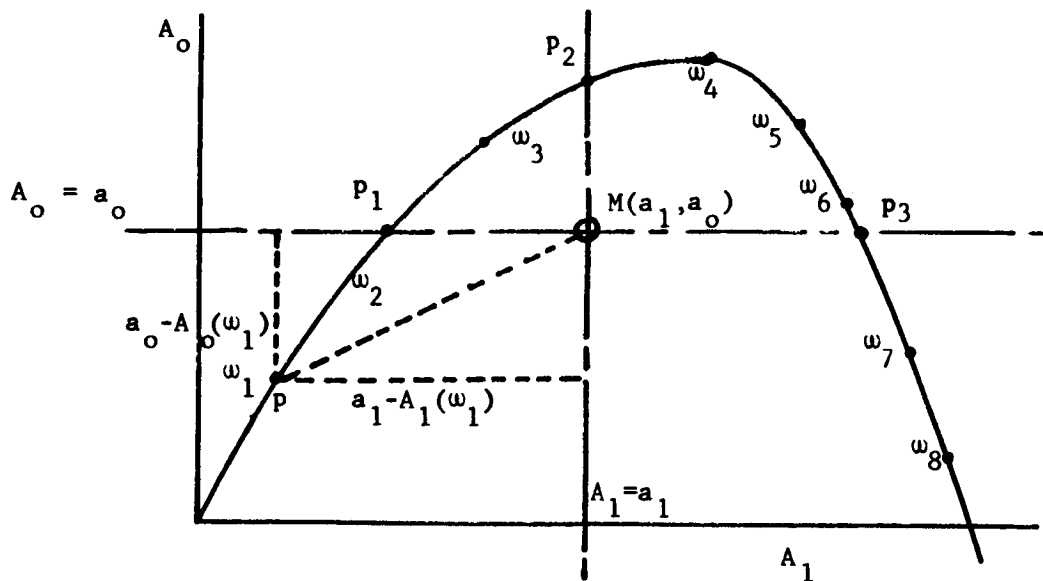

b) A_1 vs A_0 Coefficient Plane Curve

Fig. 3.1 Mapping Relationships for Stability Interpretation

$$A_1 = -1 \sum_{k=2}^n (-1)^{k-1} \omega^{k-1} a_k U_k \quad (3.6)$$

$$A_0 = \sum_{k=2}^n (-1)^k \omega^k a_k U_k$$

and interpret the results. Such an A_0 vs A_1 curve is sketched on fig. 3.1b. If a critical point, $M(a_1, a_0)$ is chosen, then (3.5a) may be related to this point by a simple graphical interpretation as shown on fig. 3.1b: at point $P(\omega_1)$, the vector PM has components $a_1 - A_1(\omega_1)$ and $a_0 - A_0(\omega_1)$ which are the coefficients of (3.5a) in magnitude and in sign. If desired the values of these coefficients could be measured on the A_1 vs A_0 plane (for any ω) and substituted into (3.5a) to evaluate $F(s)$ at that value of ω . However, only the angle of $F(s)$ is of interest in determining stability, and the angular orientation of the $F(s)$ vector can be interpreted from the A_1 vs A_0 curve.

Assume that the M-point on fig. 3.1b is located within the stable area. Note that at $P_0(\omega = 0)$ $A_0 = 0$, $A_1 = 0$, and substituting in (3.5a) $F(s) = a_0 / 0^0$; then at P_1 : $a_0 - A_0 = 0$, and $a_1 - A_1$ is positive so $F(s) = +\omega |a_1 - A_1| / \frac{\pi}{2}$; at P_2 : $a_1 - A_1 = 0$, $a_0 - A_0$ is negative and $F(s) = -|a_0 - A_0| / 0^0 = +|a_0 - A_0| / \pi$; at P_3 $a_0 - A_0 = 0$, but $a_1 - A_1$ is negative and $\angle F(s) = 3\pi/2$. Thus the angle of $F(s)$ is seen to increase monotonically as ω increases, which is a necessary condition for all roots of $F(s)$ to be in the left half plane. To assure stability the A_0 vs A_1 curve should (theoretically) be continued until the entire s-plane contour is mapped, and the number of encirclements of the M-point must then be equal to N , the order of $F(s)$, to guarantee all roots in the left half plane. In practice only $0 < \omega < +\infty$ is required, for which the encirclements of the M-point should be $N/4$.

Since the coefficient plane is a rectangular coordinate system, and any two coefficients may be used as ordinate and abscissa, ambiguity may

arise if the stability test is described in the terms of "clockwise" or "counter clockwise" encirclements of the M-point. It is better to define a rule in terms of the sequence in which the curve must intersect horizontal and vertical lines through the M-point. On fig. 3.1b the horizontal line is the $A_0 = a_0$ line, and the vertical line is the $A_1 = a_1$ line. For this case the stability rule may be phrased: as ω increases from zero to $+\infty$, the lines must be intersected in the sequence $A_0 \rightarrow A_1 \rightarrow A_0 \rightarrow A_1$, and the number of intersections required to guarantee stability is $N-1$ where N is the order of $F(s)$. For other combinations of coefficients the $\zeta = 0$ contour does not necessarily start at the origin for $\omega = 0$, and the enclosure rule must be derived for each case. The results can always be expressed in terms of a sequence in which the curve intersects the horizontal and vertical line through the M-point (as ω varies from zero to $+\infty$); and this sequence may be defined by simply specifying the line which must be cut first. The stability rules for the most common coefficient planes are summarized in Table I.

TABLE I

STABILITY CRITERIA ON THE COEFFICIENT PLANE.

RULE FOR SEQUENCE OF ENCIRCLING M-POINT WITH $\zeta = 0$ CURVE.

Coefficient Plane	Line to be Cut First	Least Number of Intersections
$A_0 - A_1$	$A_0 = a_0$	$N - 1$
* $A_0 - A_2$	$A_0 = a_0$	$N + 1$
$A_0 - A_3$	$A_0 = a_0$	$N - 1$
* $A_0 - A_4$	$A_0 = a_0$	$N + 1$
$A_1 - A_2$	$A_2 = a_2$	$N - 1$
* $A_1 - A_3$	$A_3 = a_3$	$N + 1$
$A_1 - A_4$	$A_4 = a_4$	$N - 1$
$A_2 - A_3$	$A_2 = a_2$	$N - 1$
* $A_2 - A_4$	$A_4 = a_4$	$N + 1$
$A_3 - A_4$	$A_4 = a_4$	$N - 1$

* For these cases the $\zeta = 0$ curve is not defined. To check the stability the curve must be plotted for ζ slightly greater than zero. The rule as stated here is for $\zeta = 0+$.

The principle of argument can be applied to the mapping of any closed contour in the s-plane. If a contour $\zeta < 0$ (with closing infinite semicircle) is mapped through the characteristic equation an "enclosed area" may (or may not) exist, but if it does exist, and if the M-point is inside this enclosed area, then all of the roots of equation have ζ greater than the value mapped.

Encirclement rules for $\zeta > 0$ can also be formulated just as the stability rules were derived and some results are given in Table II. Note that the rules stated in Table II apply for any $\zeta > 0$, and constitute a test for the existence of a set of coefficient values that will provide all roots with ζ greater than a desired value.

TABLE II
RULES FOR EXISTENCE OF AN "ENCLOSED"
AREA WHEN $\zeta > 0$.

Coefficient Plane	Line to be Cut First	Least Number of Intersection Points
$A_0 - A_1$	$A_0 = a_0$	N
$A_0 - A_3$	$A_0 = a_0$	N
$A_1 - A_2$	$A_1 = a_1$	N + 1
$A_2 - A_3$	$A_3 = a_3$	N + 1
$A_3 - A_4$	$A_3 = a_3$	N + 1
$A_1 - A_4$	$A_1 = a_1$	N + 1
$A_0 - A_2$	$A_0 = a_0$	N + 1
$A_0 - A_4$	$A_0 = a_0$	N + 1
$A_1 - A_3$	$A_3 = a_3$	N + 1
$A_2 - A_4$	$A_4 = a_4$	N + 1

Illustration:

Consider the third order polynomial

$$s^3 + s^2 + 0.6s + 0.2 = 0$$

Fig. 3.2 shows the $A_0 - A_1$ plot for $\zeta = 0.5$, with M-point located. From the rules in Tables I and II, it is seen that the $\zeta = 0$ curve

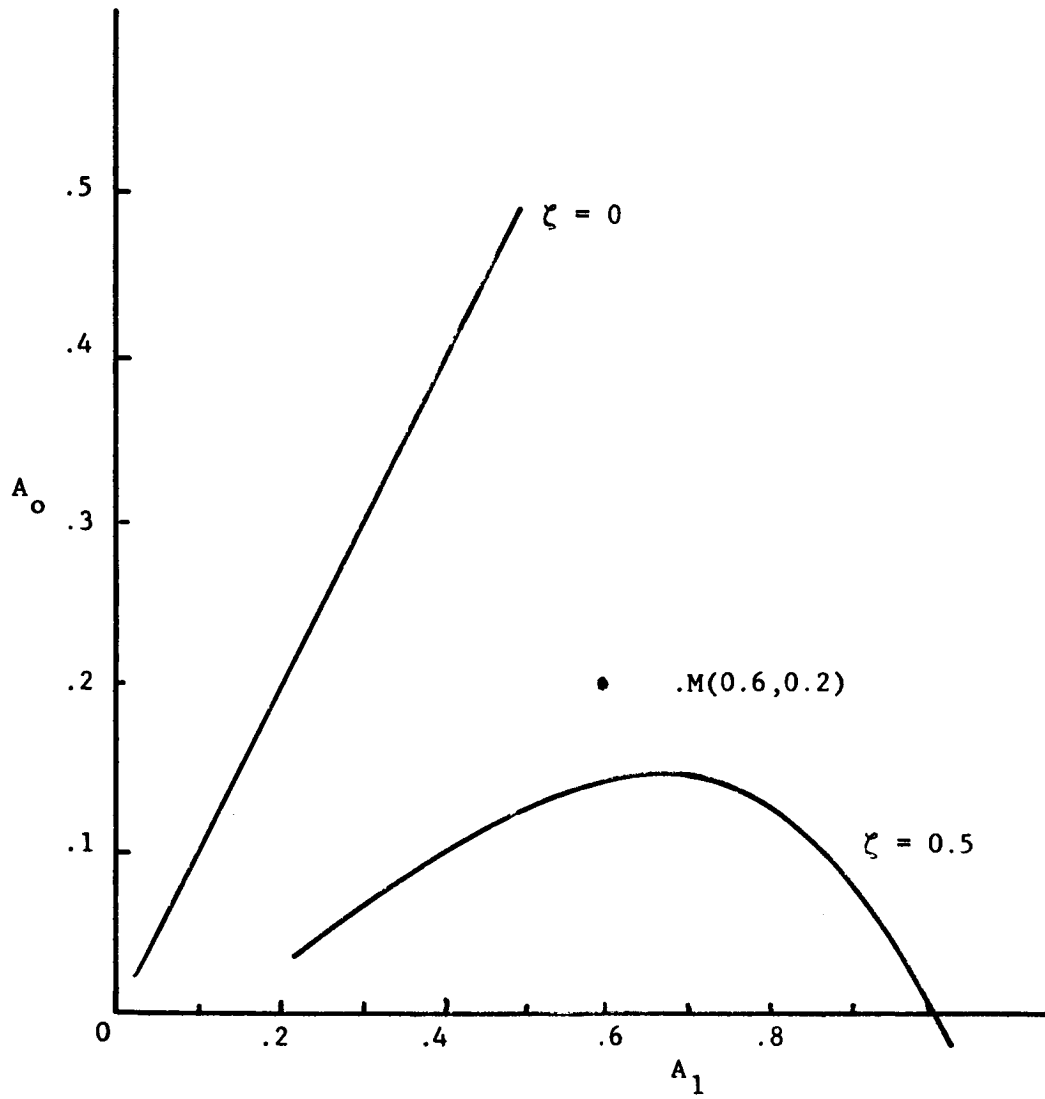

Fig. 3.2 Coefficient Plane for
 $s^3 + s^2 + 0.6s + 0.2 = 0$

encloses the M-point but the $\zeta = 0.5$ curve does not. Therefore this polynomial has all its roots in the left half of the s-plane, but some of these roots have $\zeta < 0.5$.

Consider the polynomial

$$s^5 + 7s^4 + 18s^3 + 40s^2 + 30s + 6 = 0$$

The $\zeta = 0$ contour on the $A_1 - A_2$ plane is shown on fig. 3.3, with M-point located. Application of the rule from Table II shows that the M-point is inside an "enclosed" area, so all roots of the polynomial are in the left half of the s-plane.

3.3 Sketching Techniques

The calculation and plotting of coefficient plane curves is a simple task because the equations are not complicated and only real numbers are needed. The time and labor required can be appreciable, however, and increases with the order of the characteristic equation. Any of these curves can be sketched using ordinary curve sketching techniques.

In particular the $\zeta = 0$ curves can be sketched quite easily for equations up to seventh order, thus providing a rapid stability check. For other values of ζ , and for higher order equations, the sketching techniques may be used but some labor is required. (When a family of curves is required use of a digital computer is desirable).

The procedures used in sketching are:

- a) Evaluate A_x and A_y at $\omega = 0$ and at $\omega = \infty$. This gives the location of the two "ends" of the curve.
- b) Evaluate $dA_x/d\omega = 0$ and $dA_y/d\omega = 0$ to find the values of ω at which maxima and minima occur. (Note that this procedure requires evaluation of the zeros of polynomials, and this is the main reason why the sketching techniques are practical only for low order polynomials).
- c) Substitute the values of ω found in (b) into the equations for A_x and A_y to find the coordinates of the maxima and minima.

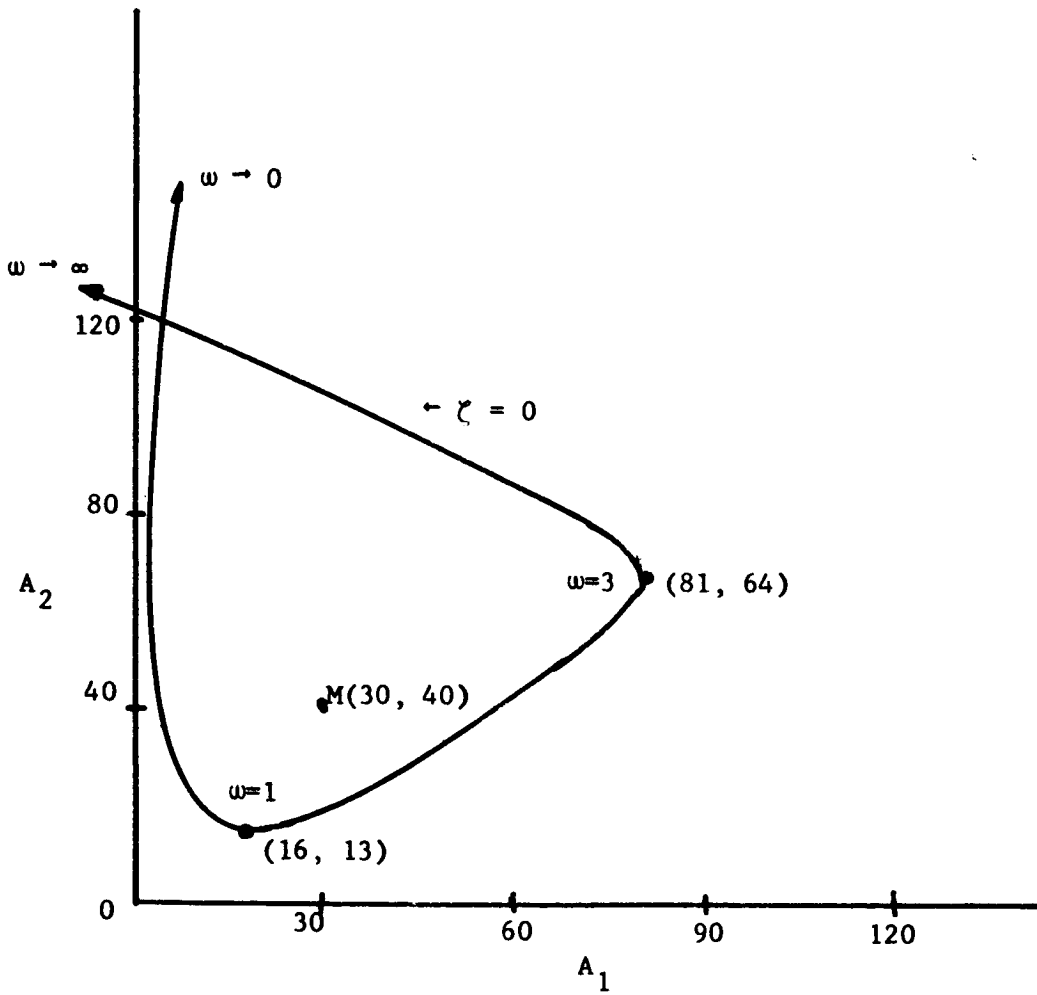

Fig. 3.3 Map of $s^5 + 7s^4 + 18s^3 + 40s^2 + 30s + 6 = 0$
on the A_1 vs A_2 Coefficient Plane

- d) Plot the points located in (c), and sketch the curve on the $A_x - A_y$ plane starting at $\omega = 0$ and progressing through the plotted points in order of increasing ω , noting that each plotted point is either a maximum or a minimum.
- e) If convenient find values of ω for which $A_x = 0$ and $A_y = 0$, with corresponding values A_y and A_x .

Illustration:

Consider the equation

$$s^4 + 3s^3 + 4s^2 + 5s + 2 = 0$$

If the $A_2 - A_3$ plane is to be used the equations for A_2 and A_3 with $\zeta = 0$ are

$$A_2 = \frac{2}{\omega^2} + \omega^2$$

$$A_3 = \frac{5}{\omega^2}$$

from which, at $\omega = 0$; $A_2 = A_3 = \infty$

at $\omega = \infty$; $A_2 = \infty$, $A_3 = 0$

Maximizing, A_3 , has no maximum, but A_2 has a maximum at

$$\omega = \left(\frac{a_0}{a_4} \right)^{\frac{1}{4}} = 4\sqrt{2} = 1.18$$

for which $A_2 = 2.92$

$$A_3 = 3.83$$

The sketch of the A_2 vs A_3 plane is shown on fig. 3.4.

As a convenience in the maximizing procedure it may be noted that the derivatives of the coefficient equations with respect to ω can be obtained from (2 10a) and are:

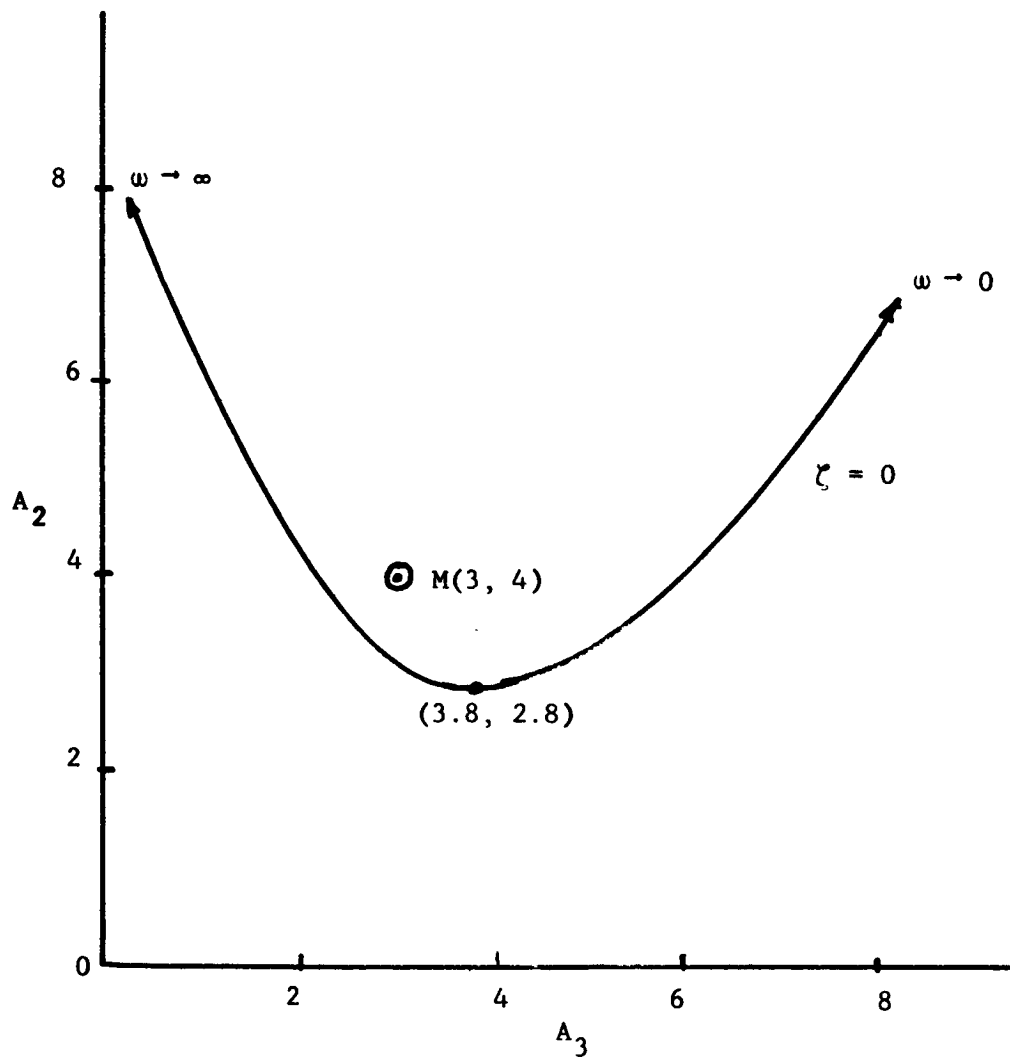

Fig. 3.4 Sketch of the $\zeta = 0$ curve on the A_2 vs A_3 plane for $s^4 + 3s^3 + 4s^2 + 5s + 2 = 0$

$$\frac{dA_p}{d\omega} = \sum_{\substack{k=0 \\ k \neq p, q}}^n (-1)^{k-p+1} (k-p) \omega^{k-p-1} a_k \frac{U_{k-q}}{U_{p-q}} \quad (3.7)$$

$$\frac{dA_q}{d\omega} = \sum_{\substack{k=0 \\ k \neq p, q}}^n (-1)^{k-q} (k-q) \omega^{k-q-1} a_k \frac{U_{k-p}}{U_{p-q}}$$

Also, the sketching of the $\zeta = 0$ curve for a stability check, or to estimate plotting scales is sufficiently useful to warrant tabulation of some of the formulae for maxima, minima, etc., these results are listed in Table III.

3.4 Root Evaluation

From the nature of the mapping process it is clear that when the contour on the coefficient plane passes through the critical point (M-point), the original mapping contour on the s-plane passes through a point which is a root of the characteristic equation. The value of ζ chosen for the mapping contour is then the ζ for the root. The value of ω (the mapping parameter for the contour) associated with the point on the contour which coincides with the M-point is the radial distance from the origin of the s-plane to the root. Thus a complex root is determined when the M-point lies on a constant $-\zeta$ curve in the coefficient plane. The value of this root (and its complex conjugate) in rectangular coordinates is

$$s = -\zeta\omega \pm j\omega\sqrt{1 - \zeta^2} \quad (3.8)$$

If there are several pairs of complex roots then the coefficient plane curves required to define these roots all pass through the M-point. For example, if the complex root pairs have different values of ζ , then the pertinent constant $-\zeta$ curves all intersect at the M-point; if the complex root pairs have the same ζ but different values of ω , then the constant $-\zeta$ curve must pass through the M-point twice. These characteristics are illustrated in fig. 3.5a, b, c. The procedure for

TABLE III
 DATA TO ASSIST SKETCHING THE $\zeta = 0$ CURVES
 N = ORDER OF THE CHARACTERISTIC EQUATION

$\omega \rightarrow$	N	$\omega = \infty$						ω_{\max} OR ω_{\min}			
		3	4	5	6	3	4	5	6		
A_0	0	+	-	-	+	0	0, $\sqrt{a_2/2a_4}$	0, $\sqrt{a_2/2a_4}$	0, $\left[\left\{ a_4 \pm \sqrt{a_4^2 - 3a_2 a_6} \right\} 3a_6 \right]^{\frac{1}{2}}$		
A_1	0	+	-	-	-	0	0	0, $\sqrt{a_3/2a_5}$	0, $\sqrt{a_3/2a_5}$		
A_1	0	+	+	-	-	0	0	0, $\sqrt{a_3/2a_5}$	0, $\sqrt{a_3/2a_5}$		
A_2	+	0	+	+	-	∞	$(a_0/a_4)^{\frac{1}{2}}$	$(a_0/a_4)^{\frac{1}{2}}$???		
A_2	+	0	+	+	-	+	$(a_0/a_4)^{\frac{1}{2}}$	$(a_0/a_4)^{\frac{1}{2}}$???		
A_3	+	0	0	+	+	+	+	$(a_1/a_5)^{\frac{1}{2}}$	$(a_1/a_5)^{\frac{1}{2}}$		
A_3	+		0	+	+		+	$(a_1/a_5)^{\frac{1}{2}}$	$(a_1/a_5)^{\frac{1}{2}}$		
A_4	-		0	0	+		$\sqrt{2a_0/a_2}, \infty$	$\sqrt{2a_0/a_2}, \infty$			

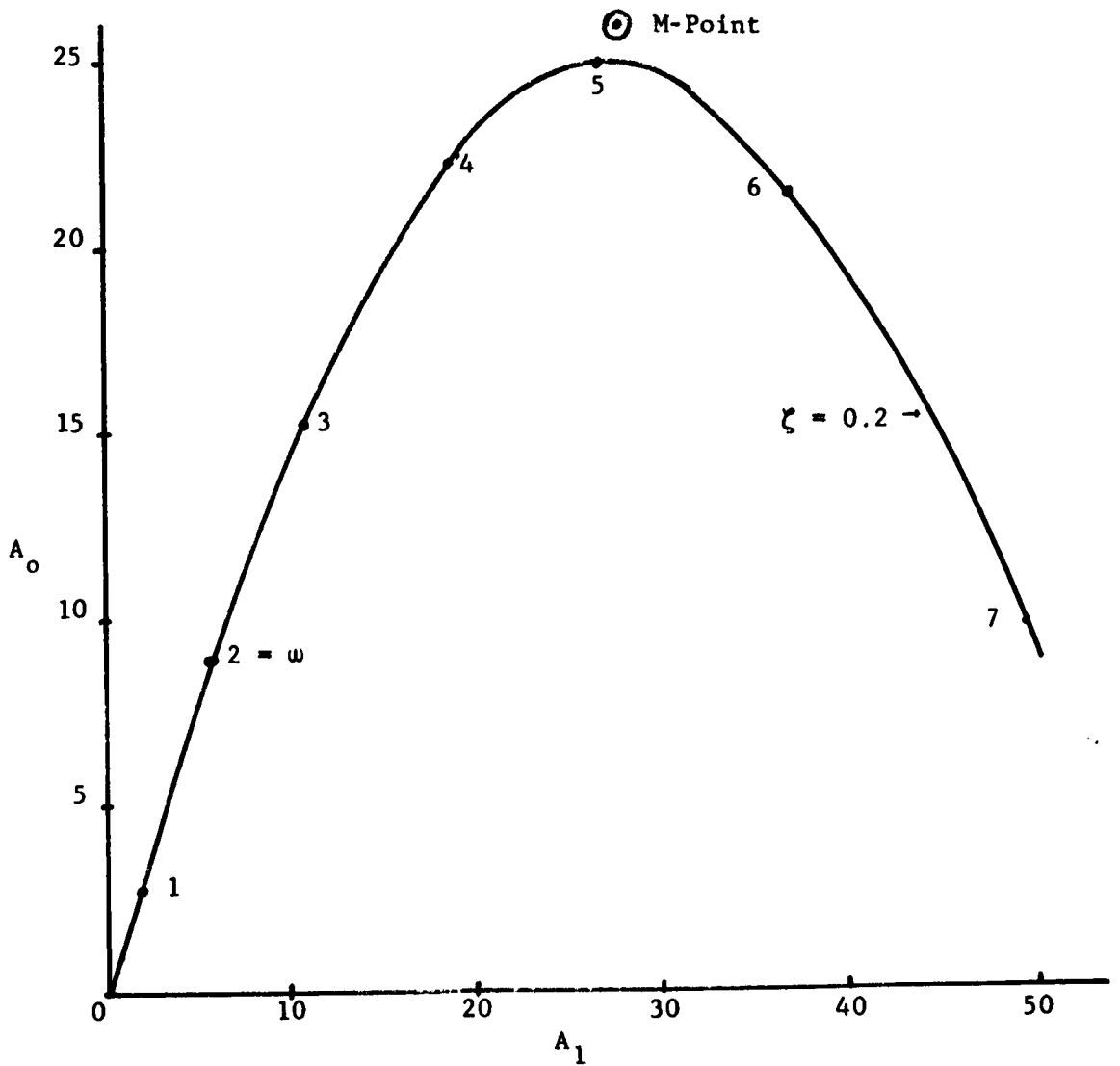

Fig. 3.5a Mitrovic Plot for $s^3 + 3s^2 + 28s + 26 = 0$
 Location of M-Point indicates that two roots are complex
 $\zeta = 0.2$ -; $\omega_n = 5$ + (Actual, $\omega_n = \sqrt{26}$; $\zeta = 1/\sqrt{26}$)

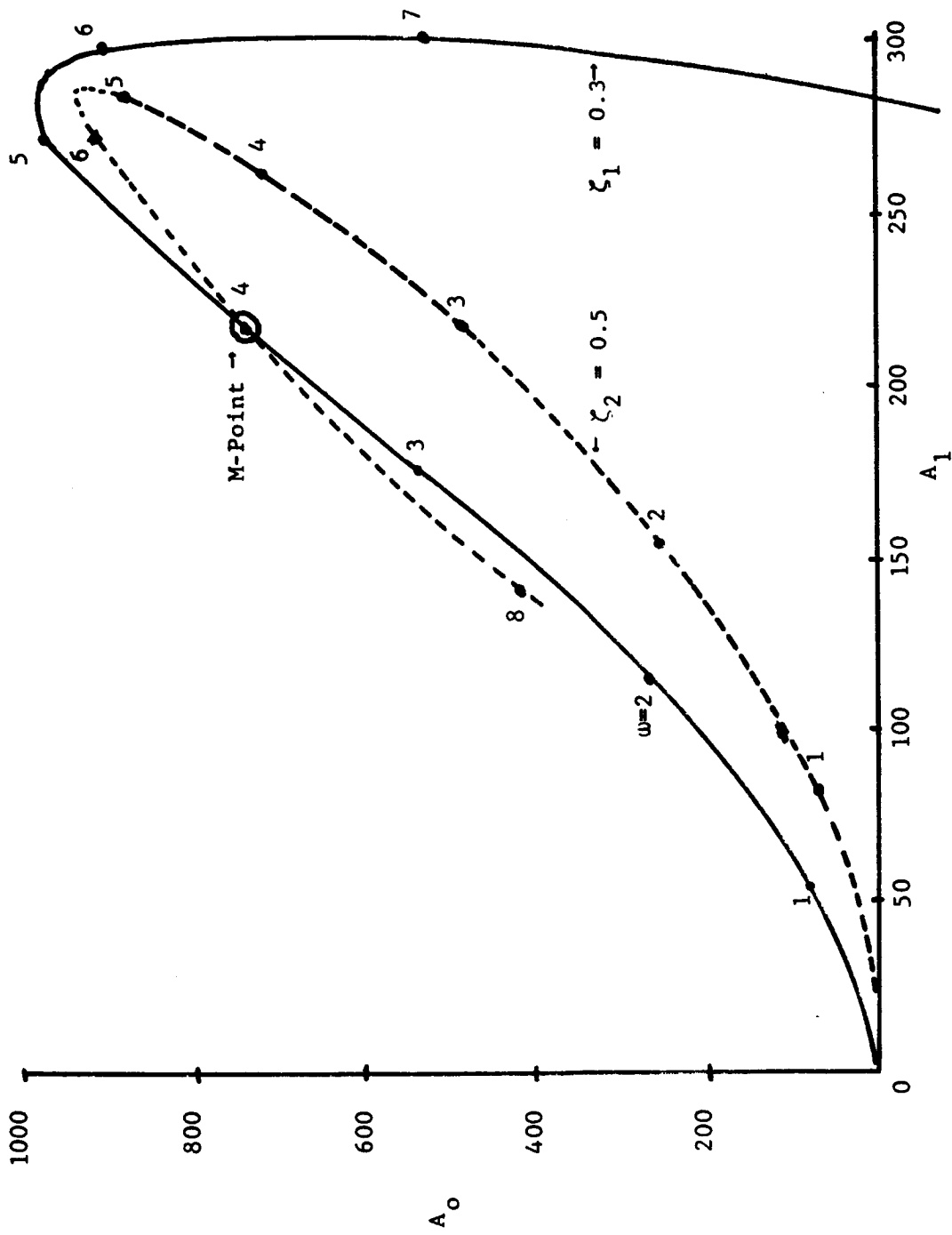

Fig. 3.5b Mitrovic Plot for $s^4 + 9.4s^3 + 81.8s^2 + 229.6s + 784 = 0$

Location of M-point shows two pairs of complex roots: $\zeta_1 = 0.3, \omega_1 = 4$
 $\zeta_2 = 0.5, \omega_1 = 7$

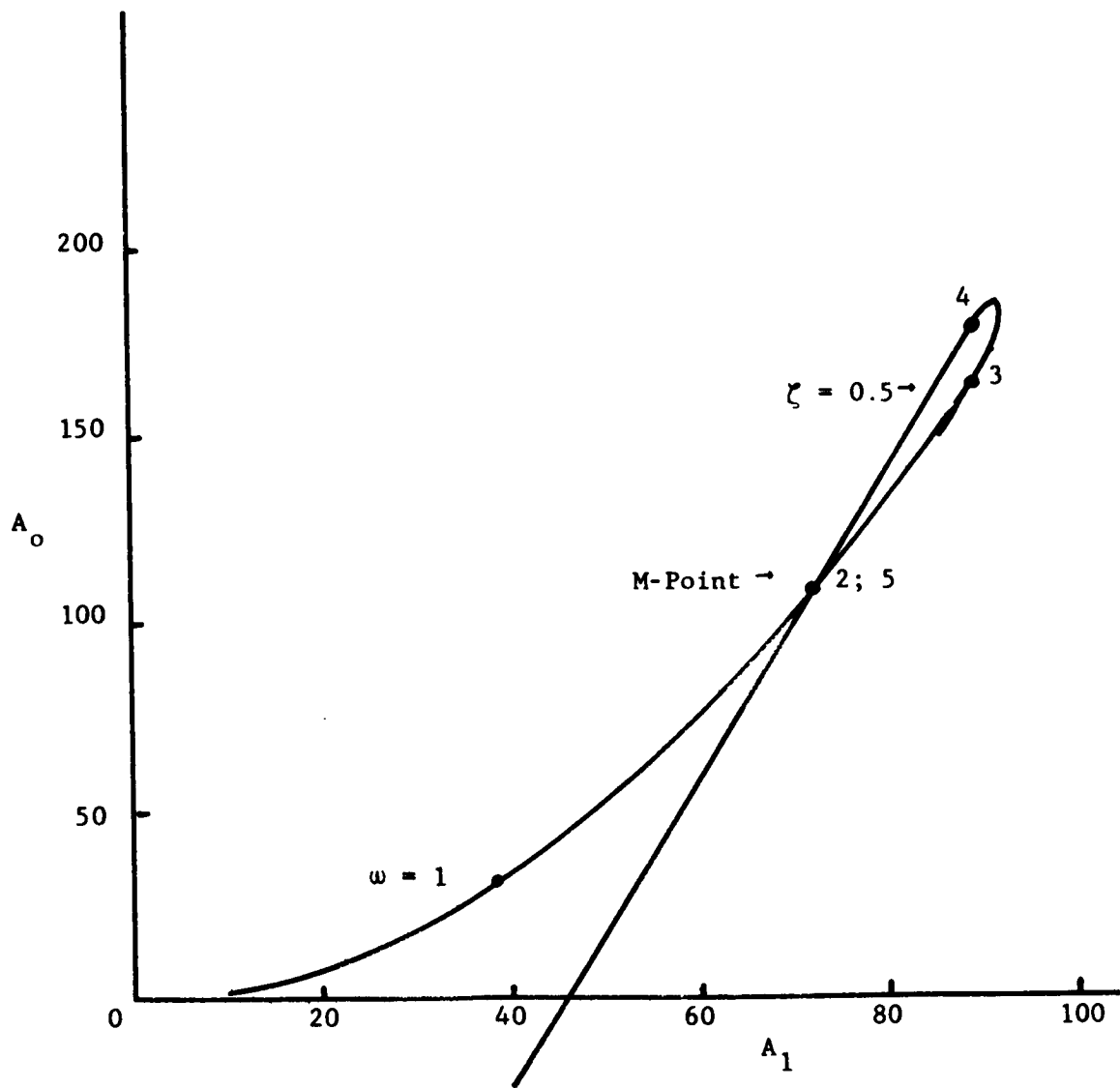

Fig. 3.5c Mitrovic Plot for $s^4 - 7s^3 + 39s^2 + 70s + 100 = 0$
 Location of M-point shows two pair of complex roots
 $\zeta_1 = 0.5, \omega_1 = 2; \zeta_2 = 0.5, \omega_2 = 5.$

evaluating complex roots is to select values of ζ , plot the constant $-\zeta$ curves, mark the M-point. If the M-point falls on one or more of the curves then ζ and ω for the roots are determined; usually the M-point lies between constant $-\zeta$ curves, then interpolation is used to find values for ζ and ω (constant ω curves can be computed if needed).

Note that the above procedures are just a graphical technique for the simultaneous solutions of (2.9), i.e., if the M-point is given, then values of A_p and A_q are known and the complex roots are defined by those values of ζ and ω which satisfy both of (2.9) simultaneously. Analytic solution of this problem is not easy, so the graphical procedure of Mitrovic is used. Note that the converse problem is very easily solved, i.e., given a desired ζ and ω for the complex roots it is very easy to solve (2.9) for A_p and A_q .

When real roots are to be evaluated it is easiest to return to the characteristic equation which is (2.2). This may be rewritten as

$$A_p s^p + A_q s^q + \sum_{\substack{k=0 \\ k \neq p, q}}^n a_k s^k = 0 \quad (3.9)$$

for $s = -\sigma$ (a real number) this is the equation of a straight line on the $A_p - A_q$ coefficient plane for chosen values of σ . If any of these lines passes through the M-point, then the coordinates of the M-point satisfy the equation and value of σ associated with that straight line defines a real root. Again interpolation is often convenient.

It can be shown that these straight lines are all tangent to the $\zeta = 1.0$ contour, that they are tangent to the $\zeta = 1.0$ contour at a point where the mapping parameter (ω) is numerically equal to the value of σ used to determine the straight line, and that the slope of the tangent itself is numerically equal to the negative of the value of σ . By considering limits, it is seen that location of the M-point on the $\zeta = 1.0$ curve defines a repeated real root. Thus two graphical procedures are available: a number of straight lines may be calculated for

chosen σ and interpolation used to evaluate real roots, or the $\zeta = 1.0$ curve can be computed, and straight lines drawn so as to pass through the M-point and be tangent to the $\zeta = 1.0$ curve. Each line so constructed defines a real root.

3.5 Universal Curves on the Coefficient Plane

Coefficient plane curves can be used to evaluate all roots of any order polynomial. For high order polynomials a number of constant ζ curves may be computed and drawn. Unless some preliminary estimate of the root values is available the set of ζ -values and the range of ω values used must be quite large. In the general case there is no way to avoid this, but for second and third order equations a simple transformation of variable permits calculation and plotting of a Universal set of curves which may be used for any problems, thus eliminating curve plotting. For a fourth order equation a single universal curve family is not convenient, but fourth order equations can be represented by a set of curve sheets obtained as sections of a three dimensional parameter space; these can be chosen such that a few such curve sheets include virtually all cases of engineering interest.

For the second order case the defining equation is

$$s^2 + A_1 s + A_0 = 0 \quad (3.10)$$

from which the Mitrovic equations are

$$A_0 = 2 \zeta \omega a_2 \quad (3.11)$$

$$A_0 = \omega^2 a_2$$

These equations are plotted to give a universal chart for a second order equation as presented in fig. 3.6. Note that any second order equation can be scaled within the limits of this coordinate system, for example, if the quadratic to be factored is

$$s^2 + 14 \times 10^8 s + 10^{18} = 0$$

let $s = 10^9 S$. Then the equation becomes

$$10^{18} S^2 + 1.4 \times 10^{18} S + 10^{18} = 0 = S^2 + 1.4S + 1$$

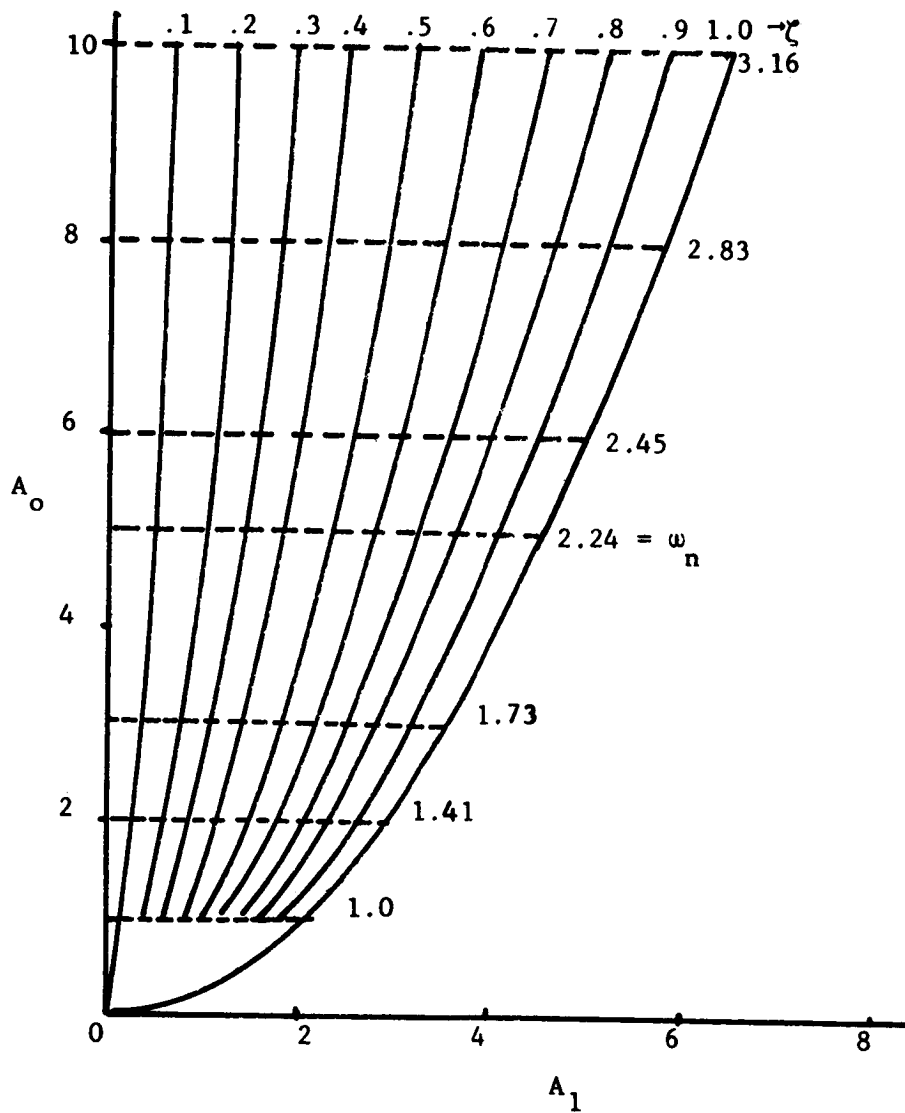

Fig. 3.6 Universal Second Order Curves
on the Mitrovic Plane

which is easily factored using the chart.

For third order systems the polynomial can always be put in the form

$$s^3 + a_2 s^2 + a_1 s + a_0 = 0 \quad (3.12)$$

This form is not suitable for universal Mitrovic curves because there are three coefficients that may change in value. Using a simple transformation of variable

$$s = Pa_2$$

This equation becomes

$$P^3 + P^2 + \frac{a_1}{a_2} P + \frac{a_0}{a_2} = 0 \quad (3.13)$$

which now has only two variable coefficients, so a set of A_0 vs A_{1*} curve can be computed and are then universal, i.e. they factor any cubic.

A set of third order universal curves is given in fig. 3.7. Use of a slightly different transformation

$$s = Pa_0$$

provides a third order equation of the form

$$P^3 + \frac{a_2}{a_0} P^2 + \frac{a_1}{a_0} P + 1 = 0 \quad (3.14)$$

Again only two coefficients are variable, so universal curves for a third order equation can be plotted on the A_2 vs A_1 plane.

For a fourth order polynomial the use of transformations to rearrange the coefficients (so that only two are variable) is possible but not particularly useful. The usual algebraic form for the quartic is

$$s^4 + a_3 s^3 + a_2 s^2 + a_1 s + a_0 = 0 \quad (3.15)$$

* The curves, as given, are plotted only for values of ζ in the left half of the s-plane, and therefore do not evaluate roots with positive real parts.

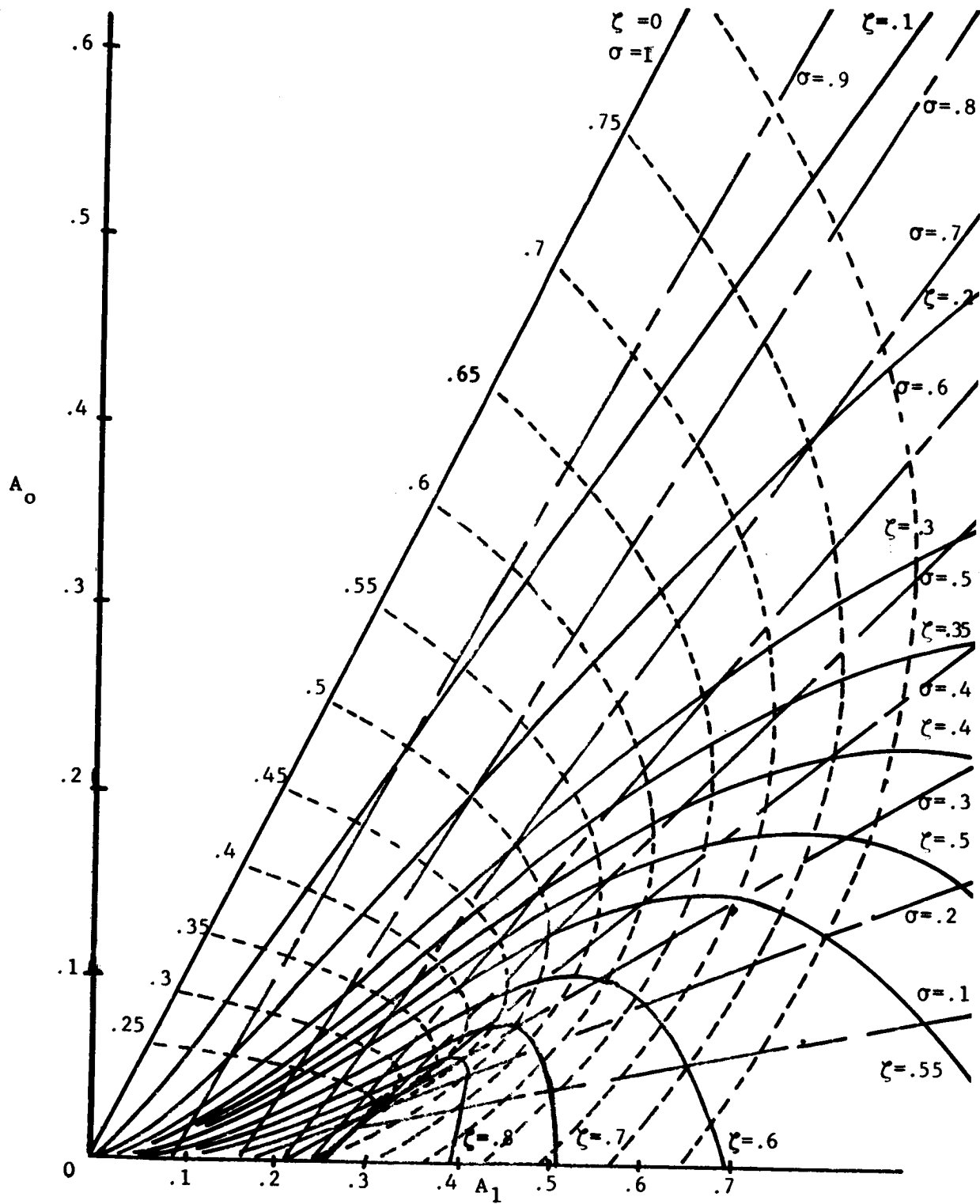

Fig. 3.7 Universal Curves for the Polynomial:

$$s^3 + s^2 + A_1s + A_0 = 0$$

then the transformation $s = Pa_3$ reduces this equation to

$$P^4 + P^3 + \frac{a_2}{a_3} P^2 + \frac{a_1}{a_3} P + \frac{a_0}{a_3} = 0 \quad (3.16)$$

In this equation three coefficients may be variables. Using the simplified form

$$P^4 + P^3 + A_2 P^2 + A_1 P + A_0 = 0$$

this equation defines a family of surfaces in the three dimensional coefficient space for A_0, A_1, A_2 . If A_2 is chosen then a family of curves can be drawn on the A_1 vs A_0 plane corresponding to a section taken perpendicular to the A_2 axis at the chosen value of A_2 . Re-petition of this provides a set of curve families which can be used in place of a three dimensional coefficient space though some interpolation is required.

It is not practical to calculate curve families to include all possible fourth order cases, but it has been shown that for $0 < A_2 < 1$ virtually all cases of roots in the left half plane are included, except perhaps the cases of two pairs of lightly damped complex roots. Thus a set of curves on the A_0 vs A_1 plane for values of A_2 less than unity can be of practical value.

3.6 Elementary Analysis

Many manipulations of an analysis type can be carried out with the information and techniques developed in the preceding pages. A number of these are listed here with brief explanations and will be used as needed in following sections.

a) Stability Analysis

After formulating the characteristic equation the $\zeta = 0$ curve may be sketched, or calculated, and the M-point located on the coefficient plane. This immediately indicates the stability condition. If either or both coefficients are completely adjustable, the M-point may be moved to any desired location on the plane and the required coefficient values read off. If the coefficients are variable within limits, these limits may

be marked on the coefficient plane; then by inspection it is determined whether any permissible values of the coefficients can stabilize the system.

b) Root values, transient performance, dominance

By plotting curves for many values of ζ , the location of the M-point in a stable region permits evaluation of all roots of the characteristic equation if desired. Accurate evaluation of transient performance then requires a separate computation such as use of the inverse Laplace Transformation. As is well known, however, the salient features of the transient response can usually be estimated from the root values, particularly if it is clear that specific roots are dominant. Since all real roots can be evaluated with reasonable accuracy using the M-point and the $\zeta = 1.0$ curve, and the location of the M-point on the curve family clearly defines the ζ and ω (radial distance from origin) of the complex root pair closest to the origin of the s-plane, a reasonably accurate estimate of dominance is available. For a feedback system the existence of zeros of the system transfer function should be checked, and the possible effect of such zeros on the residues at the roots.

c) Limits of available dynamic performance

For all cases in which the coefficients used as coordinates are adjustable, the limits of such adjustments define an area on the plane within which the M-point may be located at any desired point. Since all roots of the characteristic equation can be evaluated at any location of the M-point, the range of possible root combinations obtainable with the given adjustments is readily defined, usually by inspection.

d) Some limitations placed by specifications

In the analysis of systems using the coefficient plane, the permissible locations of the M-point may be restricted by performance specifications. Such specifications may forbid location of the M-point in a specified area, or may require location of the M-point on a specific line, etc. As long as

specifications can be interpreted in terms of the geometry of the coefficient plane, then the effects of these limitations on stability and transient performance can be analyzed. For example, a feedback control system may require that the forward gain available under static (standstill) conditions must exceed a certain number, and in addition there must be a pair of dominant complex roots with $\zeta \geq 0.5$. If analyzed on the A_0 vs A_1 plane these specifications simply require that the M-point be located at a value of A_0 greater than that defined by the minimum gain, and within the area enclosed by the $\zeta = 0.5$ curve. The analysis indicates, first, whether such an area exists, second, if the area does exist it indicates the range of root values available and from these the dominance conditions are evaluated. In like manner the specifications may define a required value of an error coefficient, a required value of ζ , or of ω , or of $\zeta\omega$, all of which are expressible as lines on the coefficient plane on which the M-point must be located if the specified limitations are to be satisfied.

e) Frequency response and available bandwidth

Since location of the M-point defines all root values, then root values may be used to write the system function in factored form, from which the frequency response is readily plotted using Bode Diagram techniques. If one wishes to avoid this labor and is satisfied with approximate evaluations, inspection of the root values establishes dominance, and if the dominant roots are a complex conjugate pair, then the resonant frequency, height of resonance peak, and bandwidth can be estimated using standard second order correlations. When adjustment of the coefficients is permissible, then the largest value of ω within the range of available adjustments provides an estimate of the maximum available bandwidth.

3.7 Elementary Syntheses. Cascade Compensation

Synthesis using the coefficient plane is the process of selecting values for the adjustable coefficients which guarantee acceptable roots

for the characteristic polynomial, and also satisfy all other specifications of the problem. This can require considerable trial and error if the problem is complex, and it should be recognized that in many cases an acceptable solution may not exist for the problem as initially stated. In broader sense, then, synthesis (of a control system) is the process of choosing a structure (the components selected and the method of interconnection) which can provide an acceptable solution, and adjusting the variable parameters in this structure to obtain the desired solution.

The selection of the structure and its adjustable parameters is an engineering task outside the scope of algebraic methods. In fact, the algebraic methods themselves are not particularly helpful in guiding the choice of structure, changes in structure or additions to a structure (compensators). This is not a serious handicap, since there exists an extensive background of theory and experience to aid in the choice of structure and compensators. Once the choice has been made, synthesis using the coefficient plane may be undertaken.

For simple systems procedures including choice of compensator (structural change) can be developed using the universal curves. For higher order systems similar procedures are applicable but the coefficient plane curves must be computed as needed. Consider a second order servo as indicated by the block diagram of fig. 3.8. Such systems have only one convenient adjustment, the gain. Typical specifications establish a minimum value for K_v to assure accuracy. Assume $K_v \geq 64$, then for the given system the roots are complex and very lightly damped, and no permissible value of K_v can provide a well damped system. A cascade compensator with transfer function

$$G_c = \alpha \frac{s + z}{s + p} \quad (3.17)$$

can be used. Then the forward transfer function of the compensated system becomes

$$GG_c = \frac{K_v \alpha (s + z)}{s(s + 1)(s + p)} \quad (3.18)$$

Two procedures are available in applying the coefficient plane:

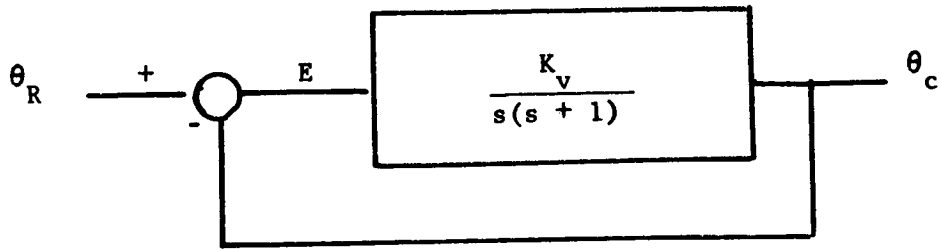

Fig. 3.8 A Second Order Servo

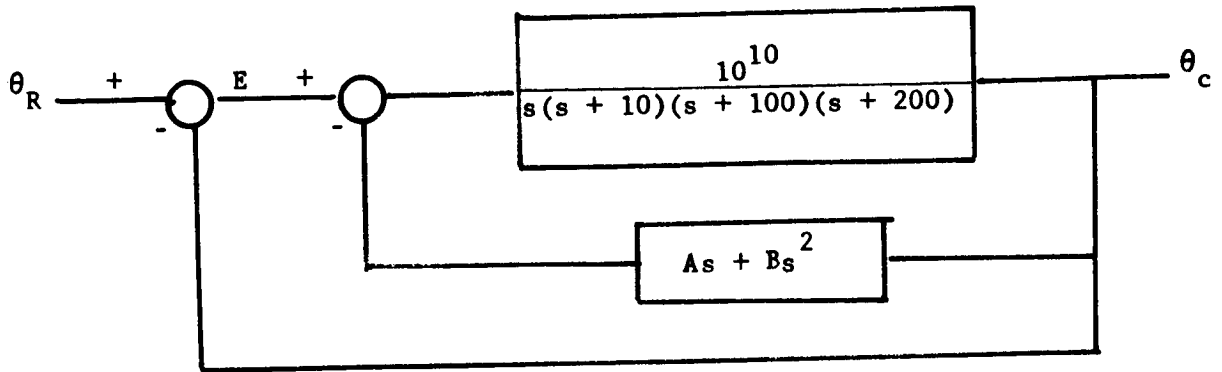

Fig. 3.9 A System with Derivative Feedback

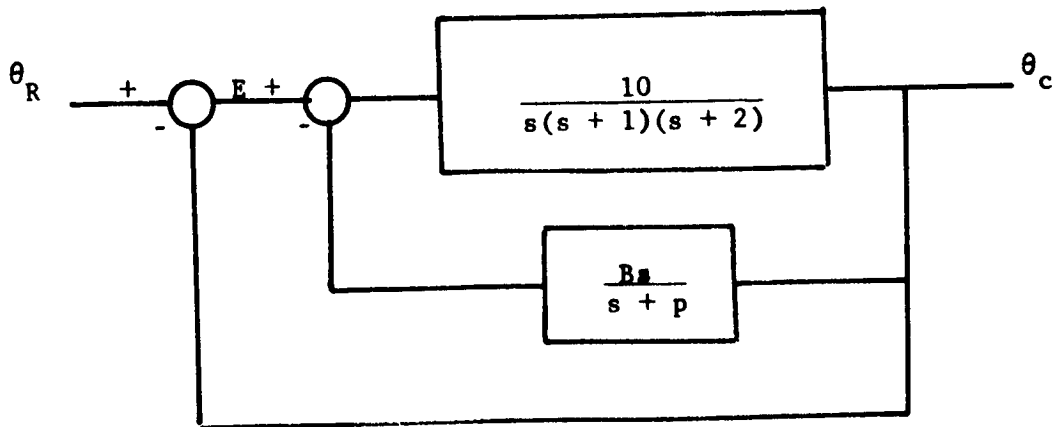

Fig. 3.10 Derivative Feedback Compensator with Pole in Transfer Function

a) Use cancellation compensation; let $z \equiv 1$, then

$$GG_c = \frac{K_v \alpha}{s(s + p)}$$

and the characteristic equation is

$$s^2 + ps + K_v \alpha = 0$$

two coefficients are adjustable, and the second order curves may be used.

b) A numerical value may be chosen for p . Then the characteristic equation becomes

$$s^3 + (1 + p)s^2 + (p + K_v \alpha)s + K_v \alpha z = 0$$

Again two coefficients are adjustable, and the third order universal curves may be used. Note that the selection of p is arbitrary, and for a specific choice of p a satisfactory solution may not exist so that trial and error repetition of the calculations is required.

If the uncompensated system is third order, then the same techniques apply. Cancellation compensation with one or two sections of compensator may be used thus confining graphical studies to the third order curves. If cancellation is not used then introduction of one section of compensator raises the order of the system to fourth order for which the prepared universal curves may be used, or introduction of two sections of compensator changes the system equation to fifth order, for which a coefficient plane curve family must be calculated. In the general case the change in structure due to addition of a compensator raises the order of the characteristic equation and requires use of a new coefficient plane for the changed system.

3.8 Feedback Compensation. Use of Derivative Signals

For many systems the most convenient structural change is the feeding back of some measured signals around part (or all) of the forward transmission path. Such feedback may be direct, or may process the signal through an intermediate component. In the general case the

order of the characteristic equation is changed, but several coefficients may become adjustable.

A most convenient form of feedback is the feedback of pure derivative signals. There are many sensors available which provide an accurate measurement of velocities and accelerations over a wide range of values, and the time-lags (poles) associated with such devices are negligible for some problems or can be measured and incorporated in the computations for other problems. A typical case of feedback compensation with derivative signals is shown in fig. 3.9, where the transfer functions are stated quantitatively for illustration purposes. The characteristic equation of the uncompensated system is

$$s^4 + 310s^3 + 23,000s^2 + 2 \times 10^5 s + 10^{10} = 0 \quad (3.19)$$

The compensated system has a characteristic equation

$$s^4 + 310s^3 + (23,000 + B)s^2 + (2 \times 10^5 + A)s + 10^{10} = 0 \quad (3.20)$$

and the coefficient plane for A_1 vs A_2 permits ready evaluation of suitable values for the feedback gains A and B .

For cases where the feedback compensator is not a pure derivative device the coefficient plane technique may be used if the adjustable parameters appear in no more than two coefficients. Consider the system of fig. 3.10. The uncompensated characteristic equation is

$$s^3 + 3s^2 + 2s + 10 = 0 \quad (3.21)$$

and the other compensated characteristic equation is

$$s^4 + (3 + p)s^3 + (2 + 3p)s^2 + (2p + 10B)s + 10 = 0 \quad (3.22)$$

The existence of the energy storage capability indicated by p has raised the order of the polynomial, and the value p appears in three coefficients. If the numerical value of p is known or can be estimated, then the only adjustable parameter is the gain B , and the problem of adjusting the value of B is readily handled on either the A_0 vs A_1 plane or the A_1 vs A_2 plane. In addition the problem

can be made a two parameter problem by using the A_0 vs A_1 plane and permitting the forward gain to be adjustable. However, if p is one of the adjustable parameters, then this problem in general, cannot be solved on the coefficient plane except by trial and error, or by using a three parameter space (discussed later). The best approach to such problems is the parameter plane.

For more complex feedback compensation schemes, the utility of the coefficient plane is determined by the number of variable coefficients in the characteristic equation. If adjustable parameters appear in no more than two coefficients, then the coefficient plane technique is directly applicable. If adjustable parameters appear in three coefficients, then the coefficient plane may still be used, but the concepts must be broadened to consider a three dimensional coefficient space.

3.9 Three Parameter Studies

Consider the case of a system with n^{th} order characteristic equation and three adjustable coefficients:

$$s^n + a_{n-1}s^{n-1} + \dots + A_x s^x + A_y s^y + A_z s^z + \dots + a_2 s^2 + a_1 s + a_0 = 0 \quad (3.23)$$

where the adjustable coefficients A_x, A_y, A_z can be any three coefficients and need not be consecutive. If a numerical value is chosen for A_x , then the A_y vs A_z coefficient plane curves are calculable. Assume that a single value of ζ ($\zeta = 0$ for example) is chosen and A_x is allowed to vary from $-\infty < A_x < +\infty$. Then the coefficient plane curves for A_y vs A_z define a three dimensional surface for $\zeta = 0$ in the A_x, A_y, A_z coefficient space. This is illustrated for a fourth order equation in fig. 3.11. The volume enclosed by this surface defines all values of A_x, A_y, A_z for which it is guaranteed that the value of ζ for all roots is greater than the value of ζ used to map the surface. While the illustration of fig. 3.11 is for a fourth order equation with $\zeta = 0$, the philosophy applies for any value of ζ and for any order equation.

Since three dimensional devices of the type indicated are not

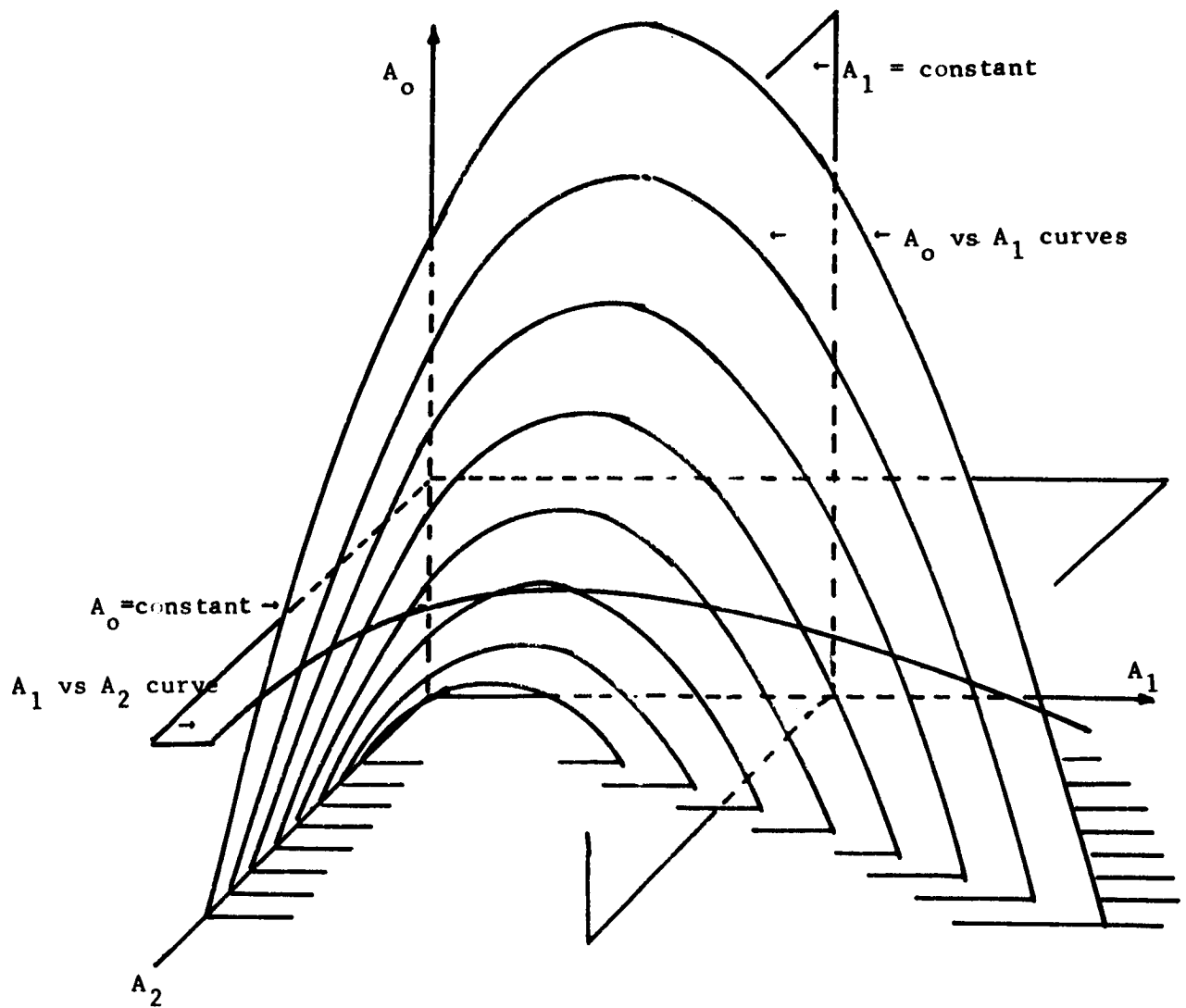

Fig. 3.11 The Three Dimensional $\zeta = 0$ Surface
for a Fourth Order Equation

convenient for engineering calculations, one practical alternative is to plot sets of A_y vs A_z curves for selected values of A_x , thus providing two dimensional representation with the ability to interpolate. Assuming that a family of curve sets is available for a given problem the procedure in using the curves would be a trial and error technique: select a curve sheet, select M-point location, read off all root values, evaluate suitability of this solution and progress to either another M-point on the chosen sheet or to another curve sheet. This process normally converges rapidly if an acceptable solution exists in the range of values for the third coefficient (parameter). This is frequently possible using a "constant ζ " plane. The "constant ζ " plane is simply a family of curves on the A_y vs A_z plane such that each curve is calculated for the same value of ζ but for different A_x . Thus the entire three dimensional surface for a given ζ is presented on a two dimensional plot. The advantage of this in a synthesis procedure may be seen from the following comments: specifications for a system are usually interpretable in terms of a desirable ζ for a pair of dominant roots; (this value of ζ would be chosen for the constant ζ plane) additional specifications usually indicate a desirable range for the value of ω for the root, and the physical nature of the system establishes upper and/or lower bounds for the coefficients A_x, A_y, A_z . Thus a desirable value for ζ is known, and a permissible area on the constant ζ plane is defined by the bounds on the coefficients. By inspection of the ζ plane it is determined whether roots with acceptable ω can be obtained by placing the M-point in the permissible area. If so, then the problem is solved providing the roots thus located are dominant. Dominance cannot be checked on the constant ζ plane. To evaluate all other roots (thus checking dominance) the A_y vs A_z plane curves are computed for that value of A_x determined by selection of a suitable M-point on the constant ζ plane.

Note that the computation of a single constant ζ plane permits evaluation of a single value of A_x (or a limited range for A_x) in which more detailed calculations presumably will be profitable, thus minimizing labor. While digital computer computation is desirable if

available, the constant ζ plane has certain mathematical characteristics which permit rapid long hand computation if necessary. These characteristics are shown from the following relationships.

On the A_y vs A_z plane, the Mitrovic curves for any order equation are defined by:

$$A_y = \sum_{\substack{k=0 \\ k \neq y, z}}^n (-1)^{k-y} \omega^{k-y} a_k \left(\frac{U_{k-z}}{U_{y-z}} \right) \quad (3.24)$$

$$A_z = \sum_{\substack{k=0 \\ k \neq y, z}}^n (-1)^{k-z} \omega^{k-z} a_k \left(\frac{U_{k-y}}{U_{y-z}} \right)$$

If ζ is restricted to a chosen value, ζ_1 and all of the coefficients are constants except some coefficient a_i , then (3.24) becomes

$$A_y = a_i (-1)^{i-y} \omega^{i-y} \left(\frac{U_{i-z}}{U_{y-z}} \right) + \sum_{\substack{k=0 \\ k \neq y, z, i}}^n (-1)^{k-y} \omega^{k-y} a_k \left(\frac{U_{k-z}}{U_{y-z}} \right) \quad (3.25)$$

$$A_z = a_i (-1)^{i-z} \omega^{i-z} \left(\frac{U_{i-y}}{U_{y-z}} \right) + \sum_{\substack{k=0 \\ k \neq y, z, i}}^n (-1)^{k-z} \omega^{k-z} a_k \left(\frac{U_{k-y}}{U_{y-z}} \right)$$

Then for any chosen value of ω , say $\omega = \omega_x$, the summation terms are simply constants and (3.25) may be rewritten

$$A_y(\omega_x) = a_i C_y + C_z \quad (3.26)$$

$$A_z(\omega_x) = a_i D_y + D_z$$

which are the parametric equations of a straight line on the A_y vs A_z plane. The slope and intercepts of this straight line are easily calculated if needed, but the important point is that on the constant ζ

plane the locus of any selected frequency is a straight line. Thus if two curves are calculated on the A_y vs A_z plane (for $\zeta = \zeta_1$ and two selected values of A_x) straight lines may be drawn through points of the same frequency and may be used to construct additional curves for other values of A_x . The same result may be obtained with one calculated curve and the calculated slope of the constant ω line. This is illustrated on fig. 3.12a, b.

3.10 Analytic Techniques

Equation (3.24) gives the generalized form of the Mitrovic equations. If it is desired that a system described by a linear equation have a root at a designated location in the s-plane, then the values of ζ and ω associated with this root may be substituted in the right hand side of (3.24) thus determining the numerical values which the coefficients A_y and A_z must obtain to provide a root at the desired location. For any physical system the coefficients A_y and A_z are set to the desired values by adjusting some physical parameters in the system. Thus there must exist a functional relationship between A_y , A_z and the system parameters which can be expressed by equations, thus providing a second set of equations for the values of A_y , A_z . For any specific problem both sets of equations must provide the same values for A_y and A_z ; then A_y and A_z can be eliminated between these equations, providing explicit relationships for the values of the physical parameters that must be adjusted. Thus, if it is required that a root be located at a specific value of s , the adjustment of A_y and A_z may be done analytically and no curves need be calculated; values of adjustable parameters used to set A_y and A_z are found as a part of this computation. Note that this calculation does not guarantee either stability of the system or dominance of the chosen root, and computation of the coefficient plane curves may well be the best way to check such features.

When the structure of a system is changed by insertion of a compensating device the order of the characteristic equation may be changed, and adjustable physical parameters may alter more than two coefficients.

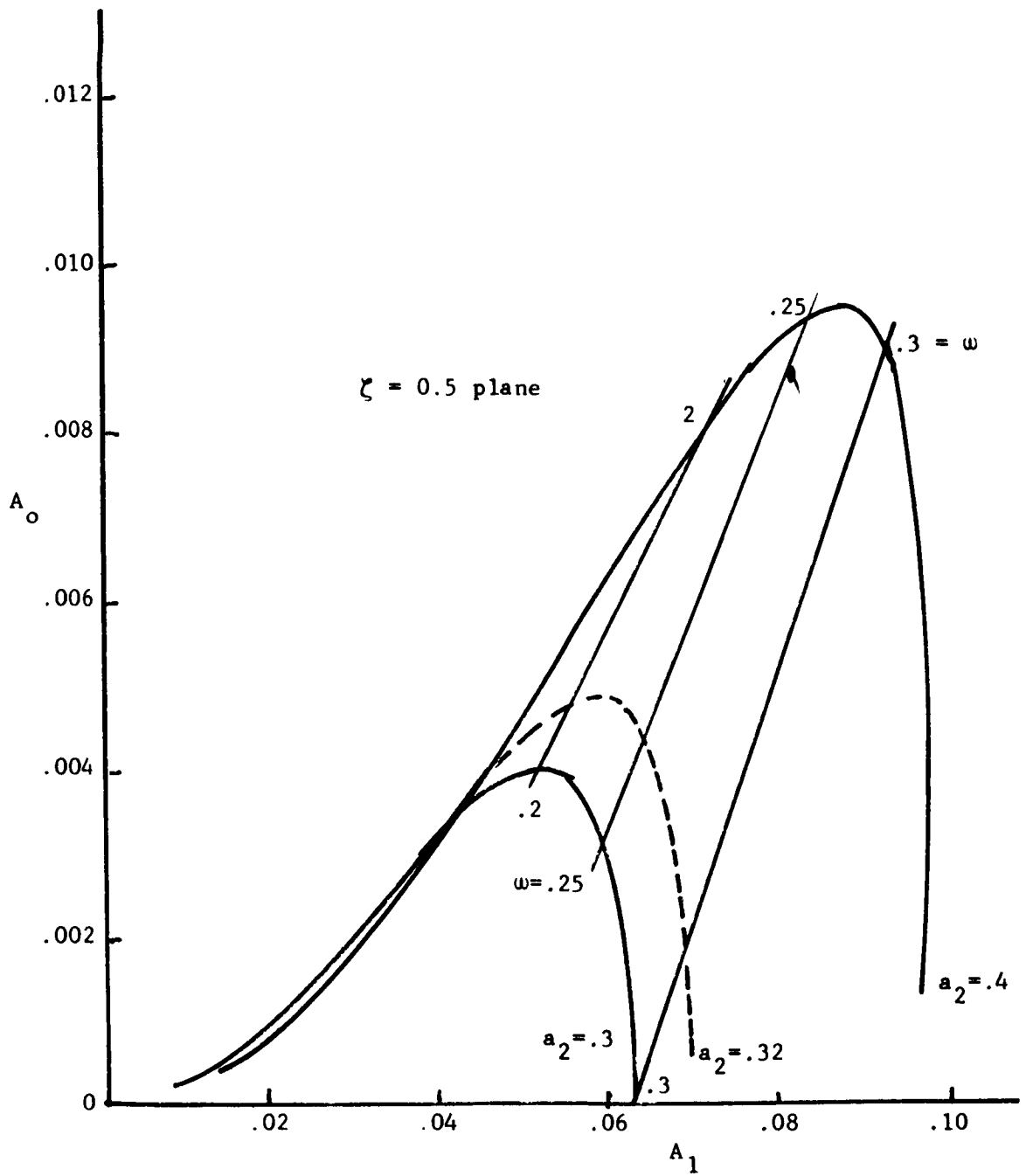

Fig. 3.12a Loci of Constant ω on the Constant ζ Plane

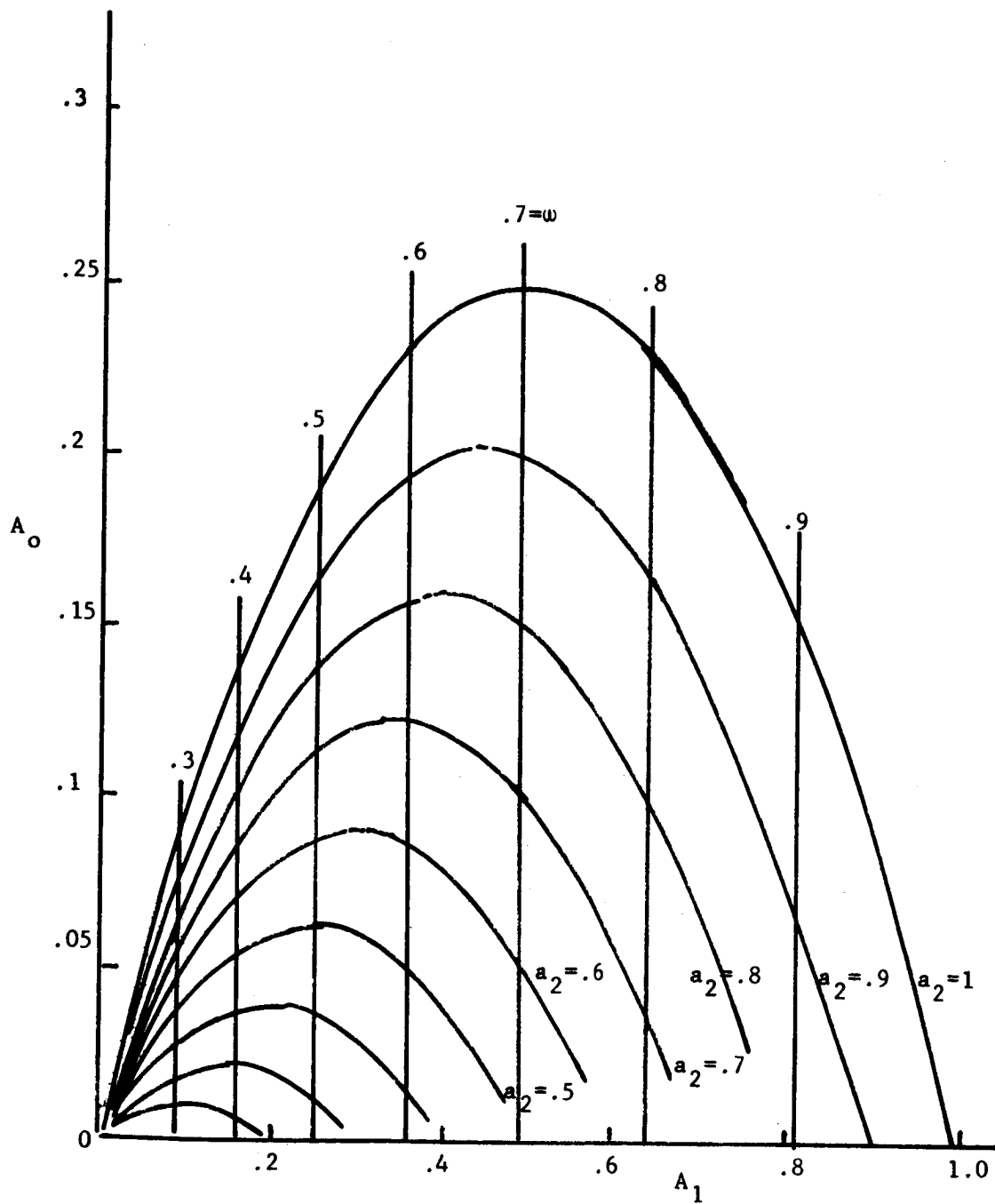

Fig. 3.12b Constant ω Loci on the $\zeta = 0$ plane

In many cases analytic techniques may still be used to assure that a root will exist at a designated location. The manipulations involved are best shown by illustrative example; consider the block diagrams of fig. 3.13. For these systems the characteristic equations are as follows:

- a) $D(s) + K = 0$
- b) $sD(s) + pD(s) + K_1s + K_1 = 0$
- c) $sD(s) + pD(s) + K(1 + K_t)s + K = 0$

For the uncompensated single loop system $D(s)$ is a polynomial in s , and the only adjustable parameter is K . An apparent choice for the coefficient plane is the use of A_0 vs A_1 coordinates. (3.24) may be used with the polynomial $D(s)$ to establish the specific Mitrovic equations for A_0 and A_1 , and from the characteristic equation itself it is seen that (for an assumed type 1 transfer function)

$$\begin{aligned} A_0 &= K \\ A_1 &= a_1 \end{aligned} \tag{3.27}$$

where a_1 is the numerical value of the coefficient of the s^1 term in $D(s)$. If a desired root location is selected and the ζ and ω values inserted in (3.24), numerical values are obtained for A_0 and A_1 . These are substituted in (3.27) and if the value of A_1 computed with (3.24) happens to be exactly a_1 , then K can be adjusted to the required value for A_0 . Usually adjustment to a specified root value is not possible with only one adjustable parameter.

For case (b), cascade compensation, the characteristic equation is the sum of two polynomials plus two additional terms:

$$sD(s) + pD(s) + Ks + Kz = 0$$

where $sD(s)$ and $pD(s)$ are the polynomials. Normal procedures (such as adding these polynomials term for term) are not profitable. Note that the equations are linear, therefore the Mitrovic equation for the sum $sD(s) + pD(s)$ is exactly the sum of the Mitrovic equations for $sD(s)$ and for $pD(s)$. Then, choosing the A_0 vs A_1 coefficient plane and

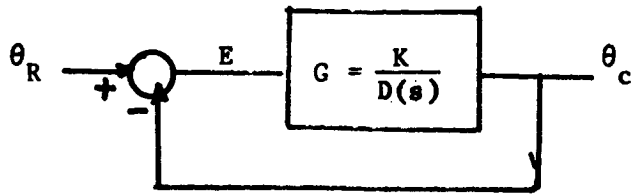

a) Single Loop, Uncompensated

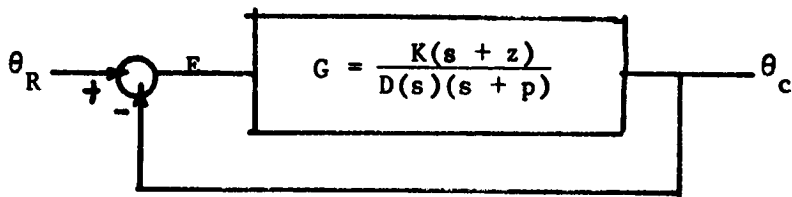

b) Single Loop, Cascade Compensated

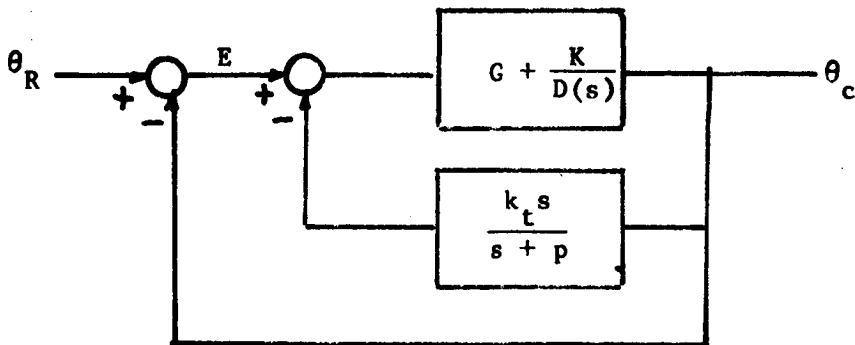

c) Feedback Compensated

Fig. 3.13 Typical Cases for Analytic Design

using (3.24)

$$A_0^c = A_0'(\zeta, \omega) + pA_0(\zeta, \omega) \quad (3.28)$$

$$A_1^c = A_1'(\zeta, \omega) + pA_1(\zeta, \omega)$$

where $A_0'(\zeta, \omega)$ and $A_1'(\zeta, \omega)$ are the Mitrovic equations for $sD(s)$.

$A_0(\zeta, \omega)$ and $A_1(\zeta, \omega)$ are Mitrovic equations for $D(s)$.

A_0^c and A_1^c are the Mitrovic equations for the compensated system.

From the characteristic equation

$$A_0^c = Kz \quad (3.29)$$

$$A_1^c = a_1p + K$$

where it is assumed that the transfer function is Type 1, and a_1 is the coefficient of the s^1 term in $D(s)$.

Selecting a desired root location (ζ_1, ω_1) and inserting in (3.28) gives

$$A_0^c = A_0'(\zeta_1, \omega_1) + pA_0(\zeta_1, \omega_1) \quad (3.30)$$

$$A_1^c = A_1'(\zeta_1, \omega_1) + pA_1(\zeta_1, \omega_1)$$

where the designated function of ζ_1 and ω_1 have been evaluated numerically and are real numbers. Then (3.30) may be written

$$A_0^c = X + pY \quad (3.31)$$

$$A_1^c = V + pW$$

Solving simultaneously with (3.29)

$$X + pY = Kz \quad (3.32)$$

$$V + pW = a_1p + K$$

which provides two simultaneous linear equation in three variable (K, p, z) thus assuring an infinite number of valid solutions. In the usual case of control system design another constraint is added, which

may be:

- a) for static accuracy $K \geq$ some selected number.
- b) for tracking accuracy (Type 1 system) $K_v \geq$ some number

For a system with zeros in the forward transfer function

$$K_v = \frac{a_0}{a_1} = \frac{kz}{a_1 p + K} \quad (3.33)$$

which provides a third equation thus reducing the number of possible solutions to one. (Note: engineering design practice permits tolerances on both K_v and the root-location, but this is difficult to include in the algebraic equations. In practice a number of solutions would be acceptable)

For case c (feedback compensation) the Mitrovic equations remain exactly the same as (3.28). From the coefficients of the characteristic equation however

$$A_0^c = K \quad (3.34)$$

$$A_1^c = K(1 + K_t)$$

Combining (3.34) with (3.31)

$$X + pY = K \quad (3.35)$$

$$V + pW = K(1 + K_t)$$

again providing two equations in three variables (p, K, K_t). Another constraint can be added as needed.

When the compensation problem requires several sections of filter for solution or more complex feedback compensators, then the number of adjustable parameters far exceeds the number of simultaneous relationships and it is difficult to find enough meaningful constraints to define a unique yet useful solution. Several special techniques are available, as will be shown. To define the problem more clearly, consider a unity feedback system with forward transfer function

$$G(s) = \frac{K}{D(s)} \quad (3.36)$$

If two sections of cascade compensation are needed the transfer function

becomes

$$G_c(s) = \frac{K_a(s+z_a)(s+z_b)}{D(s)(s+p_a)(s+p_b)} \quad (3.37)$$

from which the characteristic equation is

$$s^2 D(s) = (p_a + p_b)sD(s) + p_a p_b D(s) + K_a s^2 + K_a(z_a + z_b)s + K_a z_a z_b = 0 \quad (3.38)$$

Mitrovic's equations on the A_0 vs A_1 plane take the form

$$A_1^c = A_1''(\zeta, \omega) + (p_a + p_b)A_1'(\zeta, \omega) + p_a p_b A_1(\zeta, \omega) + K_a \omega U_2(\zeta) = 0 \quad (3.39)$$

$$A_0^c = A_0''(\zeta, \omega) + (p_a + p_b)A_0'(\zeta, \omega) + p_a p_b A_0(\zeta, \omega) + K_a \omega^2 = 0$$

and the coefficient relationships give

$$A_1^c = K_a(z_a + z_b) \quad (3.40)$$

$$A_0^c = K_a z_a z_b$$

Equations (3.39) and (3.40) combine to provide two simultaneous equations in parameters p_a , p_b , z_a and z_b . Some simplification is possible by choosing the pole to zero ratios and expressing the z 's in terms of p 's. However the equations always retain product terms of the form $p_a p_b$ which makes solution of the equations impractical.

Some techniques which are useful in solving the cascade compensation problem are as follows: (similar techniques can be developed for feedback compensation problems).

a) The single section design technique is applied twice.

One section is designed to accomplish part of the compensation; this requires selection of an intermediate root point (same value of ζ and ω) and an intermediate gain value. The result of this step is to provide numerical values for two parameters such as p_a and z_a . Then in (3.39) and (3.40) there remain only three unknown parameters, i.e., a second application of the single section design technique is easily accomplished.

b) Compensator sections are required to be identical.

With this restriction, for a two section compensator

$$G_c = \frac{K\alpha^2 (s + p/\alpha)^2}{D(s)(s + p)^2} \quad (3.41)$$

and the characteristic equation is

$$s^2 D(s) + 2psD(s) + p^2 D(s) + K\alpha^2 s^2 + 2K\alpha ps + Kp^2 = 0 \quad (3.42)$$

where $\alpha = p/z$.

The Mitrovic equations for $s = \zeta_1 + j\omega_1$ become:

$$A_1^c = A_1''(\zeta_1, \omega_1) + 2pA_1'(\zeta_1, \omega_1) + p^2 A_1^o(\zeta_1, \omega_1) + K\alpha^2 U_2(\zeta)\omega_1 \quad (3.43)$$

$$A_o^c = A_o''(\zeta_1, \omega_1) + 2pA_o'(\zeta_1, \omega_1) + p^2 A_o^o(\zeta_1, \omega_1) + K\alpha^2 \omega_1$$

and the coefficient relationships give

$$A_1^c = a_1 p^2 + 2K\alpha p \quad (3.44)$$

$$A_o^c = Kp^2$$

In (3.43) and (3.44) the unknown parameters are K , α , p , so that the introduction of one constraint (such as a value for the error coefficient) provides three simultaneous relationships. Since the algebraic equations represent conic sections, their solution involves finding the zeros of a quartic. In like manner the compensation can be accomplished with three identical sections, but the algebraic solution involves finding the zeros of a sixth order polynomial.

c) Find an equivalent multi-section compensator from an unacceptable single section design.

When a single section compensator is not capable of meeting specifications, application of the design procedure produces numerical values for z and p , but the values obtained represent an unrealizable (or perhaps just undesirable) filter. However, these numerical values can be used to assist in the

design of a two (or multi-) section compensator. When the objective of compensation is to locate a root at a designated point $s = s_1$, then the compensator used must introduce a specific gain and phase at $s = s_1$. Thus the transfer function of a single section compensator and that of a two section (or multi section) compensator must evaluate to the same magnitude and angle at $s = s_1$:

$$\left. \frac{\alpha_1 \alpha_2 (s + p_1/\alpha_1)(s + p_2/\alpha_2)}{(s + p_1)(s + p_2)} \right|_{s = s_1} \equiv \left. \frac{\alpha_o (s + p_o/\alpha_o)}{s + p_o} \right|_{s = s_1} \quad (3.45)$$

Expanding (3.45) and discarding a factor of s_1

$$s_1^2 (\alpha_o - \alpha_1 \alpha_2) + s_1 [(p_1 + p_2) \alpha_o + p_o (1 - \alpha_1 \alpha_2) - p_1 \alpha_2 - p_2 \alpha_1] + [p_1 p_2 \alpha_o + p_o (p_1 + p_2 - p_1 \alpha_2 - p_2 \alpha_1) - p_1 p_2] = 0 \quad (3.46)$$

Equation (3.46) is a second order polynomial in four parameters, $\alpha_1, \alpha_2, p_1, p_2$ (assuming α_o and p_o are known numerically from an application of the single section design technique). These can be reduced to two parameters by an arbitrary definition, i.e., choose numerical values for α_1 and α_2 , or alternately choose identical sections so $\alpha_1 = \alpha_2 = \alpha$ and $p_1 = p_2 = p$. The Mitrovic equations may be written for this second order polynomial to obtain two values for A_o and A_1 :

$$A_1 (\zeta_1 \omega_1) = (\alpha_o - \alpha_1 \alpha_2) 2 \zeta_1 \omega_1 \quad (3.47)$$

$$A_o (\zeta_1 \omega_1) = (\alpha_o - \alpha_1 \alpha_2) \omega_1^2$$

and the coefficient relationships define

$$A_o (\zeta_1, \omega_1) = p_1 p_2 \alpha_o + p_o (p_1 + p_2 - p_1 \alpha_2 - p_2 \alpha_1) - p_1 p_2 \quad (3.48)$$

$$A_1 (\zeta_1, \omega_1) = (p_1 + p_2) \alpha_o + p_o (1 - \alpha_1 \alpha_2) - p_1 \alpha_2 - p_2 \alpha_1$$

Thus, combining (3.47) and (3.48)

$$2(\alpha_0 - \alpha_1\alpha_2)\zeta_1\omega_1 = (p_1 + p_2)\alpha_0 + p_0(1 - \alpha_1\alpha_2) - p_1\alpha_2 - p_2\alpha_1 \quad (3.49)$$

$$\omega_1^2(\alpha_0 - \alpha_1\alpha_2) = \alpha_0 p_1 p_2 + p_0(p_1 + p_2 - p_1\alpha_2 - p_2\alpha_1) - p_1 p_2$$

and equations (3.49) may be solved simultaneously for the two chosen parameters.

CAUTION: The analytic methods just discussed merely guarantee to locate a root as specified. The procedures used to obtain these results have eliminated the ability to readily evaluate other roots, thus the resulting compensated system could be unstable, or some root other than the specified root may be dominant. Additional procedures which guarantee stability and dominance can be developed, but are not presented here.

3.11 Frequency Response Evaluation

In general the closed loop transfer function of a linear system may be expressed by

$$\frac{\theta_c}{\theta_R}(s) = \frac{N(s)}{F(s)} = \frac{N(s)}{s^n + a_{n-1}s^{n-1} + \dots + a_1s + a_0} \quad (3.50)$$

Which becomes the closed loop frequency transfer function if s is replaced by $j\omega$:

$$\frac{\theta_c}{\theta_R}(j\omega) = \frac{|N(j\omega)|/N(j\omega)}{|R_e F(j\omega) + jI_m F(j\omega)| \tan^{-1} \frac{I_m F(j\omega)}{R_e F(j\omega)}}$$

Rearranging the terms in the polynomial $F(j\omega)$:

$$F(j\omega) = a_0 + a_2(j\omega)^2 + a_4(j\omega)^4 + \dots + j\omega [a_1 + a_3(j\omega)^2 + a_5(j\omega)^5 \dots] \quad (3.53)$$

Inspection of (3.53) shows that these groups of terms are precisely Mitrovic polynomials, so that the characteristic polynomial $F(j\omega)$ can be expressed using Mitrovics equations in a number of forms such as

$$\begin{aligned}
F(j\omega) &= | a_0 - A_0 + j\omega(a_1 - A_1) | \tan^{-1} \frac{\omega(a_1 - A_1)}{a_0 - A_0} \\
&= | -\omega^2(a_2 - A_2) + j\omega(a_1 - A_1) | \tan^{-1} \frac{-\omega(a_1 - A_1)}{-\omega^2(a_2 - A_2)} \\
&= | -\omega^2(a_2 - A_2) - j\omega^3(a_3 - A_3) | \tan^{-1} \frac{-\omega^3(a_3 - A_3)}{-\omega^2(a_2 - A_2)}
\end{aligned} \tag{3.54}$$

Thus the closed loop frequency response can be studied on any coefficient plane by proper interpretation of the equations.

If the A_0 vs A_1 plane is used

$$\frac{\theta_c}{\theta_R}(j\omega) = \frac{| N(j\omega) | / \angle N(j\omega)}{| (a_0 - A_0) + j\omega(a_1 - A_1) | \tan^{-1} \frac{\omega(a_1 - A_1)}{a_0 - A_0}} \tag{3.55}$$

The denominator of (3.55) may be evaluated on the A_0 vs A_1 plane. As shown on fig. 3.14, $a_0 - A_0$ is the difference in ordinate between the M-point and the point on the $\zeta = 0$ curve, while $a_1 - A_1$ is the difference in abscissa between the M-point and the point on the $\zeta = 0$ curve. The procedure required is to evaluate $a_1 - A_1$ at selected ω , multiply by ω to get $\omega(a_1 - A_1)$, and lay off this distance horizontally from a vertical line through the M-point, using the same scale as for the A_1 axis. Repeating this procedure provides the $\omega(a_1 - A_1)$ curve as shown on fig. 3.14. The magnitude of the denominator of (3.55) at any frequency $\omega = \omega_1$, is simply the radius of a circle (with center at the M-point) which intersects the $\omega(a_1 - A_1)$ curve at $\omega = \omega_1$. The angle of the denominator may be measured from the plot with a protractor, and is the angle θ_1 on fig. 3.15. For systems with no zeros, this graphical computation is all that is needed to evaluate the frequency response. When there are zeros, then the magnitude and angle of the numerator, $N(j\omega)$ must be evaluated. For $N(j\omega)$ a first or second order polynomial the calculations are easy. For third or higher order, if in factored form, the Bode diagram is recommended; if not in factored form,

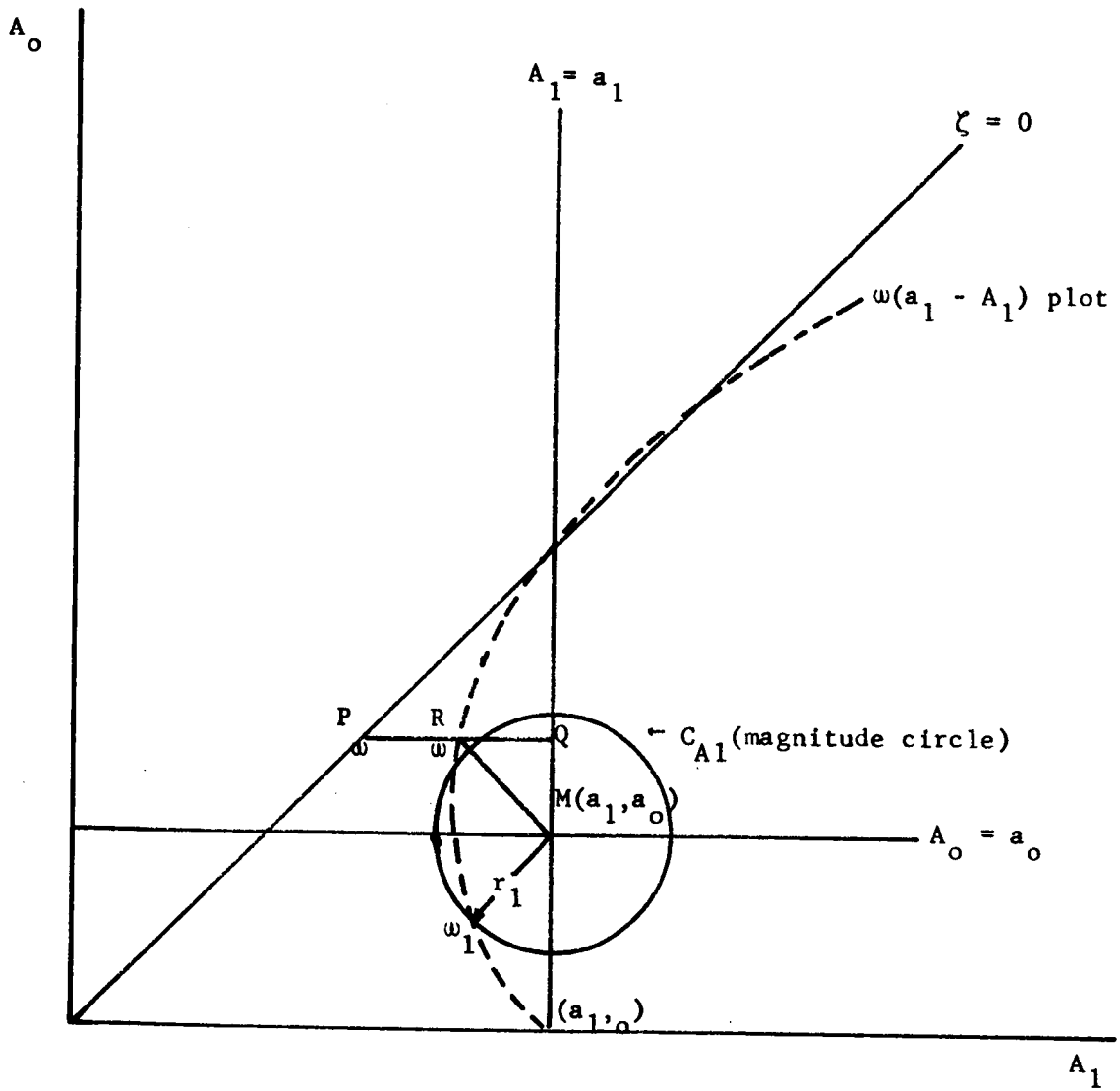

Fig. 3.14 Calculation of the $\omega(a_1 - A_1)$ curve

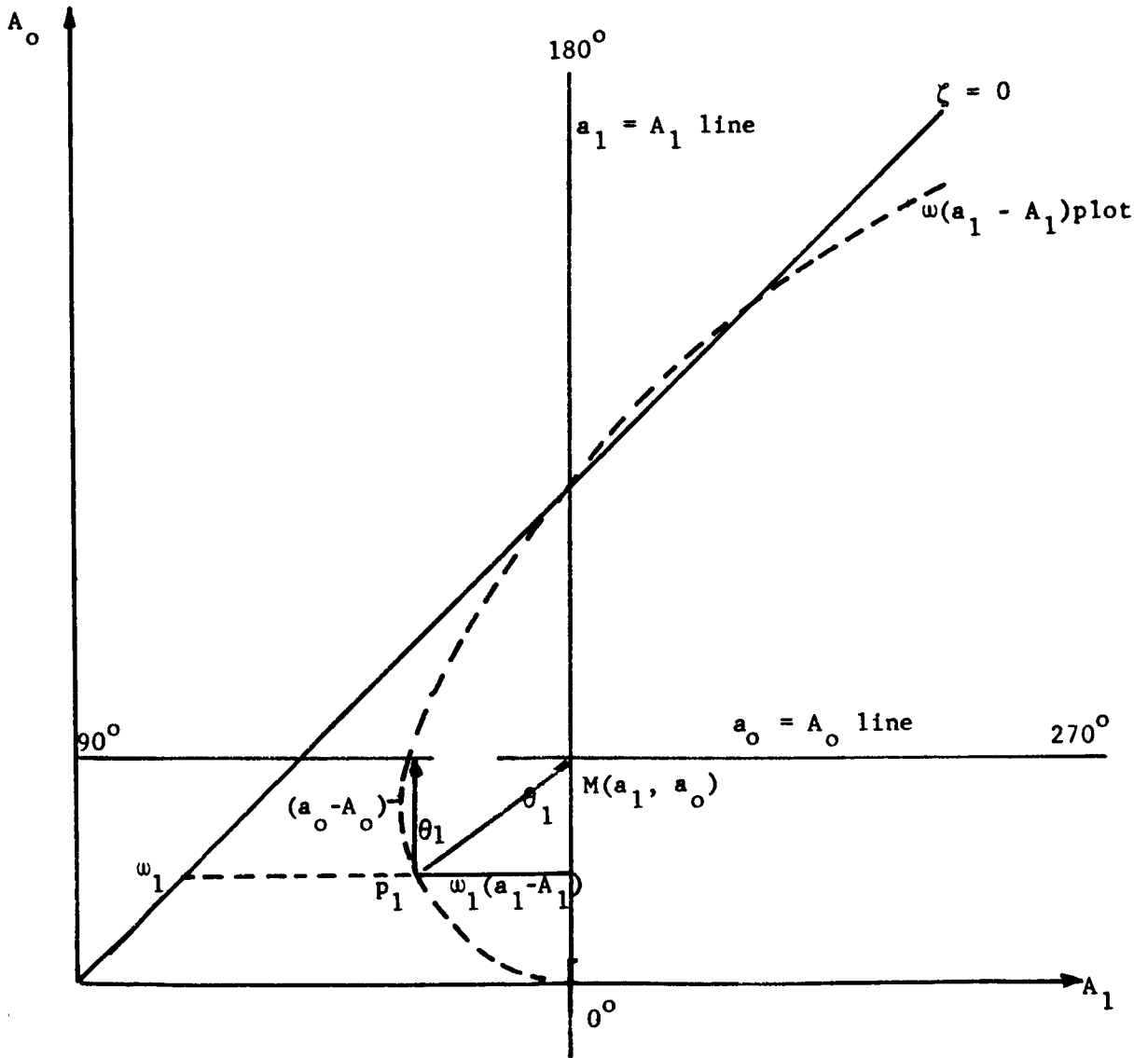

Fig. 3.15 Calculation of the Phase of the Frequency Response

another coefficient plane curve may be drawn for $N(j\omega)$ and used to evaluate its magnitude and phase variation with frequency.

The height of the resonance peak and the resonant frequency (for systems with no zeros) are determined by the circle of smallest radius for the $\omega(a_1 - A_1)$ curve of the denominator, i.e., the radius of this circle determines the height of the resonance peak and the ω at the point of tangency is the resonant frequency. When the closed loop transfer function has zeros the resonance peak does not necessarily occur at the frequency for which the denominator has minimum magnitude, but in many cases this gives a reasonable approximation. Thus, when the coefficient plane is used to design for desired root locations, the frequency response of this system may be checked quite readily for selected locations of the M-point.

Occasionally the frequency response of the open loop system is of interest. If the closed loop studies have been performed on the A_0 vs A_1 plane then the open loop frequency response can be computed from the closed loop coefficient plane. Note that the open loop transfer function is

$$G(s) = \frac{N_o(s)}{D_o(s)} \quad (3.56)$$

and is simply a ratio of two polynomials, as was (3.50) for the closed loop function. Thus all of the techniques used for the closed loop function are applicable. However, if $N_o(s)$ is either a constant or a first order polynomial, then the Mitrovic equations for $D_o(s)$ are the same as the Mitrovic equations for the closed loop characteristic equation, but the location of the M-point is different. The curve for $\omega(a_1 - A_1)$ is not changed but the circle construction is carried out from a different center. This permits calculation of the open loop frequency response from the closed loop A_0 vs A_1 plots.

From the viewpoint of analysis, if one wishes to know the bandwidth of a system it is readily obtained by inspection of the frequency response curve. Thus the procedures given in section 3.11 are adequate for analysis. From a synthesis viewpoint there are often separate (and

not necessarily compatible) specifications on dynamic response and on bandwidth. Then the designer must adjust parameter values to achieve acceptable root locations, hoping that the bandwidth achieved is within specifications.

It is readily shown that loci of constant bandwidth can be superimposed on the coefficient plane. Then the designer may locate an area on the coefficient plane within which the bandwidth specifications are satisfied. If the M-point may be located within this region, i.e., if a suitable root combination can be achieved by locating the M-point within this region, then an acceptable bandwidth is guaranteed. This is shown as follows: by definition the bandwidth of a system is that frequency for which

$$\left| \frac{\theta_c}{\theta_R}(j\omega) \right| = \frac{1}{\sqrt{2}} \quad (3.57)$$

Using the Mitrovic equation form and defining the bandwidth frequency to be $\omega = \omega_b$:

$$\frac{|N(j\omega_b)|}{\left| a_o - A_o(\omega_b) + j\omega_b [a_1 - A_1(\omega_b)] \right|} = \frac{1}{\sqrt{2}} \quad (3.58)$$

from which

$$\left| a_o - A_o(\omega_b) + j\omega_b [a_1 - A_1(\omega_b)] \right| = \sqrt{2} |N(j\omega_b)| \quad (3.59)$$

Specific interpretation of (3.59) depends on the nature of $N(j\omega)$. When the closed loop transfer function has no zeros, so $N(j\omega) = a_o$, then

(3.59) manipulates to

$$\left[a_o + A_o(\omega_b) \right]^2 - \omega_b^2 \left[a_1 - A_1(\omega_b) \right]^2 = A_o^2(\omega_b) \quad (3.60)$$

Choosing a numerical value for the bandwidth ω_b , $A_o(\omega_b)$ and $A_1(\omega_b)$ become a real numbers and (3.60) is then the equation of a hyperbola on the A_o vs A_1 plane for any order characteristic equation. When the desired bandwidth has been specified the hyperbola can be drawn on the A_o vs A_1 plane for the chosen ω_b ; then the designer can choose for the M-point any location on this constant bandwidth curve, and the

desired bandwidth is guaranteed.

When the numerator polynomial has one zero, $N(s) = b_1 s + a_0$, a similar manipulation can be made. Note that, for a normal feedback configuration, the coefficient a_1 of the characteristic equation is not independent of b_1 , but is usually related such that $a_1 = b_1 + d_1$, where d_1 is the coefficient of the first power of s in the denominator of the open loop transfer function. Using this definition the numerator polynomial becomes $N(s) = (a_1 - d_1)s + a_0$, and the bandwidth equation manipulates to:

$$\left[a_0 + A_0(\omega_b) \right]^2 + \omega_b^2 \left[a_1 + \left\{ A_1(\omega_b) - 2d_1 \right\} \right]^2 = F(\omega_b, d_1) \quad (3.61)$$

where

$$F(\omega_b, d_1) = Q \left[A_0^2(\omega_b) + \omega_b^2 \left\{ A_1(\omega_b) - d_1 \right\}^2 \right] \quad (3.62)$$

When $F(\omega_b, d_1) > 0$, (3.61) represents an ellipse, and for each value of d_1 a family of ellipses is defined by a set of values for ω_b .

For higher order numerator polynomials the same procedures apply, and the constant bandwidth curves can be computed as needed. Note also that the constant bandwidth relationships are not restricted to the A_0 vs A_1 plane but can be applied to any coefficient plane.

REFERENCES (Chapter 3)

1. Mitrovic, D: Graphical Analysis and Synthesis of Feedback Control Systems Parts I, II, III, AIEE Transactions, Pt. II, vol. 77, Jan. 1959.
2. Mitrovic, D: Automatic Plotting of Characteristic Curves and Analog Solution of Algebraic Equations. AIEE Transactions, Pt. I, vol. 80, Jan. 1962.
3. Siljak, D. D: Generalization of Mitrovic's Method, IEEE Transactions on Applications and Industry, vol. 83, Sept. 1964.
4. Elliott, D. W.; Thaler, G. J.; Heseltine, J.C.W.: Feedback Compensation using Derivative Signals, Pt. II, Mitrovic's Method. IEEE Transactions on Applications and Industry, vol. 82, Sept. 1963.
5. Thaler, G. J; Ohta, T.: Mitrovic's Method, Some Fundamental Techniques, USN Postgraduate School, Research Paper 39, Jan. 1964.
6. Choe, H. H.: Some Extensions of Mitrovic's Method in Analysis and Design of Feedback Control Systems. M. S. Thesis, USN Postgraduate School, 1964.
7. Hyon, C. H: A Direct Method of Designing Linear Feedback Control Systems by Applying Mitrovic's Method. M. S. Thesis, USN Postgraduate School, 1964.

Chapter 4

THE PARAMETER PLANE

4.1 Introduction, Generalized Derivation of the Algebraic Relationships

As indicated in Chapter 2, the adjustable, or variable, parameters in a system appear in the coefficients of the characteristic equation. For some problems these parameters appear in only two, or perhaps three, coefficients so that the generalized Mitrovic method (coefficient plane) may be used for analysis and synthesis. In some such problems the parameters may appear in all of the coefficients, so that an additional algebraic manipulation is required to interpret the coefficient values in terms of the specific parameters. This is inconvenient; a solution giving the parameter values directly is often desired. In addition, there are many problems for which the adjustable parameters appear in more than three coefficients, in which cases the coefficient plane is of little value. For this reason Siljak has developed the "parameter plane" method in which two parameters, α and β , may appear in any or all coefficients of the characteristic equation, and solutions may be obtained using the same basic transformation proposed by Mitrovic, with additional manipulations as required by the specific situation.

A derivation of the basic parameter plane equations has been given in Chapter 1. A more detailed derivation is given here in order to extend and generalize the parameter plane concept.

Consider the characteristic equation

$$F(s) = \sum_{k=0}^n a_k s^k = 0 \quad (4.1)$$

in which any coefficient may be a function of the two parameters α and β . Parameter plane* (α vs β plane) solutions may be obtained for algebraic forms as follows

* By definition α is the abscissa and β is the ordinate, and the rules for stability analysis are formulated on the basis of this definition.

$$\begin{aligned}
a_k &= b_k \alpha + c_k \beta + d_k \\
a_k &= b_k \alpha + c_k \beta + h_k \alpha \beta + d_k \\
a_k &= b_{k2} \alpha^2 + b_{k1} \alpha + h_k \alpha \beta + c_{k1} \beta + c_{k2} \beta^2 + d_k \\
a_k &= b_{kn} \alpha^n + b_{k(n-1)} \alpha^{n-1} + \dots h_{k(n-1)} \alpha^{n-1} \beta + \dots \\
&\quad c_{k(n-1)} \beta^{n-1} + c_{kn} \beta^n + d_k
\end{aligned} \tag{4.2}$$

In the following derivation each of these is treated separately for convenience.

If s is expressed by

$$\begin{aligned}
s &= -\zeta \omega = j\omega \sqrt{1-\zeta^2} = \omega(-\zeta + j\sqrt{1-\zeta^2}) \\
&= \omega(\cos \theta + j \sin \theta) = \omega e^{j\theta}
\end{aligned} \tag{4.3}$$

where $\theta = \cos^{-1} \zeta$, then s^k can be written

$$s^k = \omega^k e^{jk\theta} = \omega^k (\cos k\theta + j \sin k\theta) \tag{4.4}$$

from which the Chebyshev functions are obvious and are

$$T_k(\zeta) = \cos k\theta = \cos (k \cos^{-1} \zeta) \tag{4.5}$$

$$\bar{U}_k(\zeta) = \frac{\sin (k\theta)}{\sin \theta} = \frac{\sin (k \cos^{-1} \zeta)}{\sin (\cos^{-1} \zeta)} \tag{4.6}$$

Thus

$$\begin{aligned}
s^k &= \omega^k \left[T_k(-\zeta) + j \sqrt{1-\zeta^2} \bar{U}_k(-\zeta) \right] \\
&= \omega^k \left[(-1)^k T_k(\zeta) + \sqrt{1-\zeta^2} (-1)^{k+1} \bar{U}_k(\zeta) \right]
\end{aligned} \tag{4.7}$$

Inserting in (4.1) and requiring that reals and imaginaries go to zero independently provides the two equations

$$\begin{aligned}
\sum_{k=0}^n a_k \omega^k (-1)^k T_k(\zeta) &= 0 \\
\sum_{k=0}^n a_k \omega^k (-1)^{k+1} \bar{U}_k(\zeta) &= 0
\end{aligned} \tag{4.8}$$

but

$$T_k(\zeta) = \zeta \bar{U}_k(\zeta) - \bar{U}_{k-1}(\zeta) \quad (4.9)$$

and upon substitution in (4.8) the following equations are obtained:

$$\sum_{k=0}^n (-1)^k a_k \omega^k \bar{U}_{k-1}(\zeta) = 0 \quad (4.10)$$

$$\sum_{k=0}^n (-1)^k a_k \omega^k \bar{U}_k(\zeta) = 0$$

Thus the characteristic equation is expressed in terms of two simultaneous equations using the Chebyshev function. In these equations the coefficients are functions of α and β , so it is always possible to rearrange the equations as sums of parameter-times-polynomial terms, the specific format depending on the coefficient-parameter relationships as in (4.2).

CASE I $a_k = b_k \alpha + c_k \beta + d_k$

For this case (4.10) rearrange in the form

$$\alpha B_1(\zeta, \omega) + \beta C_1(\zeta, \omega) + D_1(\zeta, \omega) = 0 \quad (4.11)$$

$$\alpha B_2(\zeta, \omega) + \beta C_2(\zeta, \omega) + D_2(\zeta, \omega) = 0$$

where

$$\begin{aligned} B_1 &= \sum_{k=0}^n (-1)^k b_k \omega^k \bar{U}_{k-1}(\zeta) & B_2 &= \sum_{k=0}^n (-1)^k b_k \omega^k \bar{U}_k(\zeta) \\ C_1 &= \sum_{k=0}^n (-1)^k c_k \omega^k \bar{U}_{k-1}(\zeta) & C_2 &= \sum_{k=0}^n (-1)^k c_k \omega^k \bar{U}_k(\zeta) \\ D_1 &= \sum_{k=0}^n (-1)^k d_k \omega^k \bar{U}_{k-1}(\zeta) & D_2 &= \sum_{k=0}^n (-1)^k d_k \omega^k \bar{U}_k(\zeta) \end{aligned} \quad (4.12)$$

Using Cramer's rule solutions for α and β are

$$\alpha = \frac{C_1 D_2 - C_2 D_1}{B_1 C_2 - B_2 C_1} \quad \beta = \frac{B_2 D_1 - D_2 B_1}{B_1 C_2 - B_2 C_1} \quad (4.13)$$

Note: $\bar{U}_k(\zeta)$ may be calculated from the recurrence formula

$$\bar{U}_{k+1}(\zeta) - 2\zeta \bar{U}_k(\zeta) + \bar{U}_{k-1}(\zeta) = 0 \quad (4.14)$$

where $\bar{U}_0(\zeta) = 0$, $\bar{U}_1(\zeta) = 1$.

A given constant ζ contour is easily mapped onto the $\alpha - \beta$ plane, since all $\bar{U}_k(\zeta)$ values need be calculated but once, then (4.13) expresses α and β as functions of ω only.

$$\text{CASE II} \quad a_k = b_k \alpha + c_k \beta + h_k \alpha \beta + d_k$$

For this case (4.11) becomes

$$\begin{aligned} \alpha B_1(\zeta, \omega) + \beta C_1(\zeta, \omega) + \alpha \beta H_1(\zeta, \omega) + D_1(\zeta, \omega) &= 0 \\ \alpha B_2(\zeta, \omega) + \beta C_2(\zeta, \omega) + \alpha \beta H_2(\zeta, \omega) + D_2(\zeta, \omega) &= 0 \end{aligned} \quad (4.15)$$

where the definitions of (4.12) apply, and in addition

$$H_1 = \sum_{k=0}^n (-1)^k h_k \omega^k \bar{U}_{k-1}(\zeta) \quad (4.16)$$

$$H_2 = \sum_{k=0}^n (-1)^k h_k \omega^k \bar{U}_k(\zeta)$$

Equations (4.15) can be solved for α and β providing their Jacobian $J \neq 0$. Eliminating β from (4.15), the solutions for α are

$$\alpha_{1,2} = \frac{-e \pm \sqrt{e^2 - 4ac}}{2a} \quad (4.17)$$

and substitution of these values in the equation provides the corresponding values for β .

$$\beta_{1,2} = \frac{B_1 \alpha_{1,2} + D_1}{H_1 \alpha_{1,2} + C_1} = - \frac{B_2 \alpha_{1,2} + D_2}{H_2 \alpha_{1,2} + C_2} \quad (4.18)$$

which are the solutions for α and β if $a \neq 0$. Note that

$$\begin{aligned} a &= B_2 H_1 - B_1 H_2 & c &= C_1 D_2 - C_2 D_1 \\ b &= C_2 H_1 - C_1 H_2 & d &= B_1 D_2 - B_2 D_1 \\ e &= B_2 C_1 - B_1 C_2 + H_1 D_2 - H_2 D_1 \\ f &= C_2 B_1 - B_2 C_1 + H_1 D_2 - H_2 D_1 \\ J &= -\alpha a + b\beta + B_1 C_2 - B_2 C_1 \end{aligned}$$

If $a = 0$ but $b \neq 0$ the solution for α and β may be obtained by eliminating α from (4.15) obtaining

$$\beta_{1,2} = \frac{-f \pm \sqrt{f^2 - 4bd}}{2b} \quad (4.19)$$

and substitution of these values in the equations gives

$$\alpha_{1,2} = \frac{C_1 \beta_{1,2} + D_1}{H_1 \beta_{1,2} + B_1} \quad (4.10)$$

When both $a = 0$ and $b = 0$ Case II reduces to Case I and the solutions are given by (4.13).

$$\text{CASE III } a_k = b_{k2} \alpha^2 + b_{k1} \alpha + h_k \alpha \beta + c_{k1} \beta + c_{k1} \beta^2 + d_k$$

In this case the characteristic equation (4.11) becomes:

$$\alpha^2 B_{21} + \alpha B_{11} + \alpha \beta H_1 + \beta C_{11} + \beta^2 C_{21} + D_1 = 0 \quad (4.21)$$

$$\alpha^2 B_{22} + \alpha B_{12} + \alpha \beta H_2 + \beta C_{12} + \beta^2 C_{22} + D_2 = 0$$

These equations may be first considered as quadratics in α , and a more convenient notation is

$$\begin{aligned} \alpha^2 B_{21} + \alpha E_1 + I_1 &= 0 \\ \alpha^2 B_{22} + \alpha E_2 + I_2 &= 0 \end{aligned} \quad (4.22)$$

where

$$E_1 = B_{11} + \beta H_1$$

$$E_2 = B_{12} + \beta H_2$$

$$I_1 = \beta C_{11} + \beta^2 C_{21} + D_1$$

$$I_2 = \beta C_{12} + \beta^2 C_{22} + D_2$$

Two more equations are formed by multiplying (4.22) by α , thus

$$\alpha^3 B_{21} + \alpha^2 E_1 + \alpha I_1 = 0 \quad (4.23)$$

$$\alpha^3 B_{22} + \alpha^2 E_2 + \alpha I_2 = 0$$

Equations (4.22) and (4.23) can be written in the vector matrix form

$$\begin{bmatrix} 0 & B_{21} & E_1 & I_1 \\ 0 & B_{22} & E_2 & I_2 \\ B_{21} & E_1 & I_1 & 0 \\ B_{22} & E_2 & I_2 & 0 \end{bmatrix} \begin{bmatrix} \alpha^3 \\ \alpha^2 \\ \alpha \\ 1 \end{bmatrix} = 0 \quad (4.24)$$

from which it is necessary that

$$\begin{vmatrix} 0 & B_{21} & E_1 & I_1 \\ 0 & B_{22} & E_2 & I_2 \\ B_{21} & E_1 & I_1 & 0 \\ B_{22} & E_2 & I_2 & 0 \end{vmatrix} = 0 \quad (4.25)$$

The determinant of (4.25) may be expanded to obtain a fourth order polynomial in β , ζ , ω , from which four numerical values of β may be obtained for each ζ and ω (only real solutions for β are physically meaningful). Each such value of β is then inserted in (4.21) to obtain corresponding values for α .

CASE IV

$$a_k = b_{kn} \alpha^n + b_{k(n-1)} \alpha^{n-1} + \dots + h_{k(n-1)} \beta + \dots + c_{k(n-1)} \beta^{n-1} + c_{kn} \beta^n = d_k$$

Substituting in (4.11) and collecting to form a polynomial in α with coefficients that are functions of β :

$$\alpha^n B_{n1} + \alpha^{n-1} B_{(n-1)} + \dots + \alpha B_{11} + \alpha^0 B_{01} = 0$$

$$\alpha^n B_{n2} + \alpha^{n-2} B_{(n-1)2} + \dots + \alpha B_{12} + \alpha^0 B_{02} = 0$$
(4.26)

where the B's are functions of β, ζ, ω .

Additional equations are formulated by multiplying (4.26) by, $\alpha, \alpha^2, \alpha^3 \dots$ until the resulting matrix array is square:

$$\begin{bmatrix} 0 & 0 & \dots & B_{n1} & B_{(n-1)1} & \dots & B_{11} & B_{01} \\ & & & B_{n2} & B_{(n-1)2} & & B_{12} & B_{02} \\ & & B_{n1} & B_{(n-1)1} & & & B_{0i} & 0 \\ & & B_{n2} & B_{(n-1)2} & & & B_{02} & 0 \\ & & \cdot & \cdot & & & \cdot & \cdot \\ & & \cdot & \cdot & & & \cdot & \cdot \\ & & & & & & & \alpha \\ & & & & & & & 1 \end{bmatrix} = 0$$
(4.27)

Evaluating the determinant provides a polynomial in β , the real zeros of which are the desired values.

Calculation and plotting of the $\alpha - \beta$ curves is readily accomplished for Case I using either longhand or computer methods, though the labor involved in longhand computation is appreciable. For Case II a digital computer program is available (and necessary). Cases III and IV will require computer solution, but programs are not yet available. Note that in the equations for Case I, (4.13) and for Case II, (4.17, 4.18, 4.19, 4.20) α and β are functions of both ζ and ω . Thus families of constant ζ curves (ω is then a parameter) and constant ω curves (ζ is a parameter) are readily available. In addition to constant ζ and constant ω curves it is necessary (for reasons shown later) that points on the real axis be mapped, and in particular the origin must be mapped. To do this note that (4.1) may be rewritten as

$$F(s) = \sum_{k=0}^n a_k s^k = \sum_{k=0}^n (b_k \alpha + c_k \beta + d_k) s^k = 0 \quad (4.28)$$

and for $s = \sigma$ (a real number) this can be written

$$\alpha B_1(\sigma) + \beta C_1(\sigma) + D_1(\sigma) = 0 \quad (4.29)$$

where $B_1(\sigma)$, $C_1(\sigma)$ and $D_1(\sigma)$ are constants for any chosen value of σ . Thus (4.29) is the equation of a straight line on the $\alpha - \beta$ plane, and in particular the origin of the s -plane maps as a straight line. This is true, of course, only for Case I coefficients.

For Case II equations

$$F(s) = \sum_{k=0}^n (b_k \alpha + c_k \beta + h_k \alpha \beta + d_k) s^k = 0 \quad (4.30)$$

and for $s = \sigma$

$$\alpha \beta H_1(\sigma) + \beta C_1(\sigma) + \alpha B_1(\sigma) + D_1(\sigma) = 0 \quad (4.31)$$

which is the equation of a curve on the $\alpha - \beta$ plane. In like manner for Case III or Case IV equations a curve is obtained for any $s = \sigma$.

Occasionally it is convenient to have curves of constant real part of a complex root, i.e., maps of lines parallel to the imaginary axis of the s -plane. Equations of such curves may be derived starting with (4.7).

$$s^k = \omega^k \left[(-1)^k T_k(\zeta) + j \sqrt{1-\zeta^2} (-1)^k U_k(\zeta) \right] \quad (4.7)$$

and redefining such that

$$s^k = p_k + j \omega \sqrt{1-\zeta^2} Q_k \quad (4.32)$$

where

$$p_k = (-1)^k \omega^k T_k(\zeta)$$

$$Q_k = (-1)^k \omega^{k-1} U_k(\zeta)$$

$$P_{k+1} + 2 \zeta \omega P_k + \omega^2 P_{k-1} = 0$$

$$Q_{k+1} + 2 \zeta \omega Q_k + \omega^2 Q_{k-1} = 0$$

$$P_k = -\zeta \omega Q_k - \omega^2 Q_{k-1}$$

$$P_0 = 1; \quad p_1 = -\zeta \omega; \quad Q_0 = 0; \quad Q_1 = 1$$

Proceeding as was done for the constant ζ curves results in

$$\sum_{k=0}^n a_k Q_{k-1} = 0; \quad \sum_{k=0}^n a_k Q_k = 0 \quad (4.33)$$

From these equations (for Case I)

$$\alpha = \frac{C_1 D_2 - C_2 D_1}{B_1 C_2 - B_2 C_1} \quad \beta = \frac{B_2 D_1 - B_1 D_2}{B_1 C_2 - B_2 C_1} \quad (4.34)$$

where

$$\begin{aligned} B_1 &= \sum_{k=0}^n b_k Q_{k-1} & B_2 &= \sum_{k=0}^n b_k Q_k \\ C_1 &= \sum_{k=0}^n c_k Q_{k-1} & C_2 &= \sum_{k=0}^n c_k Q_k \\ D_1 &= \sum_{k=0}^n d_k Q_{k-1} & D_2 &= \sum_{k=0}^n d_k Q_k \end{aligned} \quad (4.35)$$

Similarly equations can be obtained for the other Cases if needed.

The equations thus derived permit calculation of the parameter plane curves for two parameters α and β appearing in the coefficients of a polynomial in almost any combination. For virtually all cases of even slight complexity, computer calculation of the $\alpha - \beta$ curves is required because of the amount of labor involved.

4.2 Stability Analysis

Since the purpose of a stability analysis is to determine whether the polynomial has any zeros in the right half of the s-plane, the

obvious procedure is to use (4.12) to map the imaginary axis of the s-plane onto the $\alpha - \beta$ plane. Thus the parameter ζ is set to zero in applying (4.13). After mapping has been accomplished for $-\infty < \omega < +\infty$, stability is determined by interpretation of the curve on the $\alpha - \beta$ plane. This is not always a simple task, and the following discussion points out the basic theory, the required techniques and certain special conditions which may be encountered. (Note, since (4.13) for $\zeta = 0$ are precisely Neimark's equations for the D-partition, the bulk of the discussion follows Neimark's development.)

Before undertaking the analysis of stability on the Parameter Plane, it should be noted that the coefficient plane (which is a special case of the Parameter Plane) is not subject to the difficulties encountered with the Parameter Plane. As previously shown, the M-point on the coefficient plane must be in the first quadrant, and stability can be interpreted from the way in which the curve encircles the M-point. Neither of these features is applicable to the more general case of the $\alpha - \beta$ plane.

Consider any polynomial for which some of the coefficients are functions of two parameters α and β . In theory both α and β may have unlimited variation, i.e., $-\infty < \alpha < +\infty$. For any specific pair of values (α_1, β_1) , all coefficients of the polynomial are defined numerically, and thus all zeros (roots) are also defined. For some polynomials no pair of α, β values can force all roots into the left half plane. For other polynomials only a small set of α, β values provides all roots in the left half plane, and for still other cases a large set of α, β values provides all left half roots. If α and (or) β are varied continuously over some range of values, then some (or all) coefficients of the polynomial vary continuously, and the root values also vary continuously, i.e., on the s-plane all roots move so that the set of points associated with each root forms a continuous curve. These curves may cross the axis of imaginaries on the s-plane, indicating that roots are moving from left half plane to right half plane, or vice versa. Since $\zeta = 0$ curve on the $\alpha = \beta$ plane is a map of the imaginary axis of the s-plane, an auxiliary curve on the $\alpha - \beta$ plane (showing the variation in α and β) must cross

the $\zeta = 0$ curve whenever the root curves on the s-plane cross the axis of imaginaries. Furthermore, these crossings indicate (with proper interpretation) whether one real root or two complex roots cross the axis, and in which direction. Note that the crossing of roots from one half of the plane to the other is the only feature which is obvious on the $\alpha - \beta$ plane. Other important features may be deduced as follows: if an area on the $\alpha - \beta$ plane is bounded by the $\zeta = 0$ curve, then for all points in this area the polynomial has the same number of roots in the left half plane, and points in any adjacent areas define a different number of roots in the left half plane. Thus by determining rules for interpreting the direction of crossing the curve in terms of the direction in which roots cross the s-plane imaginary axis, the number of left half plane roots associated with each stability area on the $\alpha - \beta$ plane can be found, providing that the number of left half plane roots can be evaluated for any one area.

The rule developed by Neimark to interpret the direction in which the roots cross the imaginary axis is quite simple: for polynomials in which α and β appear linearly in the coefficients (Case I), if the $\alpha - \beta$ curve* (for $\zeta = 0$) is traversed in the direction of increasing ω (from $\omega = -\infty$ to $\omega = +\infty$), the left hand edge of the curve is marked (shaded) for all values of ω for which the determinant (see (4.11).

$$A = \begin{vmatrix} B_1(\zeta_1\omega) & C_1(\zeta_1\omega) \\ B_2(\zeta_1\omega) & C_2(\zeta_1\omega) \end{vmatrix}$$

is positive (greater than zero), and the curve is marked (shaded) on the right hand edge for all values for ω for which the determinant is negative ($\Delta < 0$). When $\Delta \equiv 0$, this condition is called "singular" and in general it means that the two generating equations are not independent for the value of ω which gives $\Delta = 0$. For such values of ω a straight line is obtained from one of (4.11). Also, if the coefficient of the highest power term in this polynomial is a function of

* α is the abscissa variable and β the ordinate variable.

α and β , a straight line is obtained at $\omega = \infty$. For such straight lines the marking must be such that near the point of intersection with the curve, the shaded sides of straight line and curve are directed towards each other. If Δ becomes zero for $\omega \neq \infty$ or $\omega \neq 0$, but does not change sign, then the line defined at that value of ω should not be shaded.

For Cases II, III and IV, the shading rules are the same except that the criterion to be used is not the determinant, Δ , but the Jacobian $J \left(\frac{\alpha, \beta}{\omega, \zeta} \right)$. To prove this, construct a cartesian three dimensional vector space on the parameter plane such that there is a position vector:

$$\vec{r}(\alpha, \beta, z) = \alpha \hat{i} + \beta \hat{j} + z \hat{k} \quad (4.36)$$

and the position vector at every point on the parameter plane itself is

$$\vec{r}(\alpha, \beta) = \alpha \hat{i} + \beta \hat{j} \quad (4.37)$$

Since the parameter plane curves are plotted from parametric equations of the form

$$\alpha = \alpha(\zeta, \omega_n) \quad (4.38)$$

$$\beta = \beta(\zeta, \omega_n)$$

these equations permit writing the position vector as

$$\vec{r}(\zeta, \omega_n) = \alpha(\zeta, \omega_n) \hat{i} + \beta(\zeta, \omega_n) \hat{j} \quad (4.39)$$

and the $\alpha - \beta$ curve for a constant value of $\zeta = \zeta_0$ is traced by the vector

$$\vec{r}(\zeta_0, \omega_n) = \alpha(\zeta_0, \omega_n) \hat{i} + \beta(\zeta_0, \omega_n) \hat{j} \quad (4.40)$$

at a given point on this curve, i.e., for $\omega_n = \omega_0$, the motion of that point resulting from an incremental increase in ζ is

$$d\vec{r}(\zeta_0 + \Delta\zeta, \omega_0) = \frac{\partial \vec{r}(\zeta_0, \omega_0)}{\partial \zeta} d\zeta \quad (4.41)$$

The direction of the vector of (4.41) defines the direction of M-point motion. Since M-point moving in a direction to increase ζ causes roots to enter the area enclosed by the constant $-\zeta$, that side of the $\alpha - \beta$ curve toward which the vector $\frac{\partial \vec{r}(\zeta_0, \omega_0)}{\partial \zeta}$ points is the side to be

shaded. A graphical interpretation based on the above is adequate, but at times inconvenient. For a mathematical formulation note also that the tangent to the constant ζ_0 curve on the $\alpha - \beta$ plane at the point (ζ_0, ω_0) is given by $\frac{\partial \vec{\Gamma}(\zeta_0, \omega_0)}{\partial \omega_n}$ where this vector is in the direction of increasing ω_n . If the counter-clockwise rotation of the vector $\frac{\partial \vec{\Gamma}(\zeta_0, \omega_0)}{\partial \omega_n}$ into the vector $\frac{\partial \vec{\Gamma}(\zeta_0, \omega_0)}{\partial \zeta}$ is more than 180° , the latter vector points to the right of the constant ζ_0 curve and that side should be shaded; if the rotation is less than 180° the latter vector points to the left of the constant ζ_0 curve and the left side should be shaded. This criterion is exactly the definition of the cross product of two vectors lying in a cartesian plane:

$$\frac{\partial \vec{\Gamma}(\zeta_0, \omega_0)}{\partial \omega_n} \times \frac{\partial \vec{\Gamma}(\zeta_0, \omega_0)}{\partial \zeta} = A \hat{k} \quad (4.42)$$

If A is negative shade the right hand side of the $\alpha - \beta$ plane curve (when facing in the direction of increasing ω_n), if it is positive, shade the left hand side.

It is easily shown the A is the Jacobian:

$$\begin{aligned} \frac{\partial \vec{\Gamma}(\zeta_0, \omega_0)}{\partial \omega_n} &= \frac{\partial \alpha(\zeta_0, \omega_0)}{\partial \omega_n} \hat{i} + \frac{\partial \beta(\zeta_0, \omega_0)}{\partial \omega_n} \hat{j} \\ \frac{\partial \vec{\Gamma}(\zeta_0, \omega_0)}{\partial \zeta} &= \frac{\partial \alpha(\zeta_0, \omega_0)}{\partial \zeta} \hat{i} + \frac{\partial \beta(\zeta_0, \omega_0)}{\partial \zeta} \hat{j} \end{aligned} \quad (4.43)$$

$$\text{and } \frac{\partial \vec{\Gamma}(\zeta_0, \omega_0)}{\partial \omega_n} \times \frac{\partial \vec{\Gamma}(\zeta_0, \omega_0)}{\partial \zeta} = \begin{vmatrix} \frac{\partial \alpha(\zeta_0, \omega_0)}{\partial \omega_n} & \frac{\partial \beta(\zeta_0, \omega_0)}{\partial \omega_n} \\ \frac{\partial \alpha(\zeta_0, \omega_0)}{\partial \zeta} & \frac{\partial \beta(\zeta_0, \omega_0)}{\partial \zeta} \end{vmatrix} \hat{k} \quad (4.44)$$

where the determinant is well known to be the Jacobian.

While the equations for α and β in terms of ζ and ω_n are

always known in order to compute the $\alpha - \beta$ curves, they are not in convenient form for evaluation of the Jacobian of (4.44). However, Siljak has indicated that the Jacobian can be evaluated as follows; let:

$$R \triangleq \alpha B_1(\zeta, \omega) + \beta C_1(\zeta, \omega) + \alpha\beta H_1(\zeta, \omega) + D_1(\zeta, \omega) \quad (4.45)$$

$$I \triangleq \alpha B_2(\zeta, \omega) + \beta C_2(\zeta, \omega) + \alpha\beta H_2(\zeta, \omega) + D_2(\zeta, \omega)$$

Then

$$J \left(\begin{array}{c} \zeta, \omega \\ \alpha, \beta \end{array} \right) = \begin{vmatrix} \frac{\partial R}{\partial \alpha} & \frac{\partial R}{\partial \beta} \\ \frac{\partial I}{\partial \alpha} & \frac{\partial I}{\partial \beta} \end{vmatrix} \quad (4.46)$$

Some simple illustrations of the shading are as follows:

A. Let the characteristic equation be

$$F(s) = 0 = s^5 + 30s^4 + 496s^3 + 4960s^2 + (3 \times 10^4 + \alpha)s + 10^5 + \beta$$

Then, for $\zeta = 0$:

$$B_1 = 0$$

$$B_2 = -\omega$$

$$C_1 = -1$$

$$C_2 = 0$$

$$D_1 = -10^5 + 4960\omega^2 - 30\omega^4$$

$$D_2 = -3 \times 10^4\omega + 496\omega^3 - \omega^5$$

$$\alpha = \frac{C_1 D_2 - C_2 D_1}{\Delta} = -3 \times 10^4 + 496\omega^2 - \omega^4$$

$$\beta = \frac{B_2 D_1 - D_2 B_1}{\Delta} = -10^5 + 4960\omega^2 - 30\omega^4$$

$$\Delta = B_1 C_2 - B_2 C_1 = -\omega$$

Fig. 4.1 gives the $\alpha - \beta$ parameter plane plot. Since Δ is negative, the shading is on the right hand side.

B. Let the characteristic equation be:

$$F(s) = 0 = s^5 + 30s^4 + (496 + \alpha)s^3 + (4960 + 6\alpha + 4\beta)s^2 + (30,000 + 50\beta)s + 100,000$$

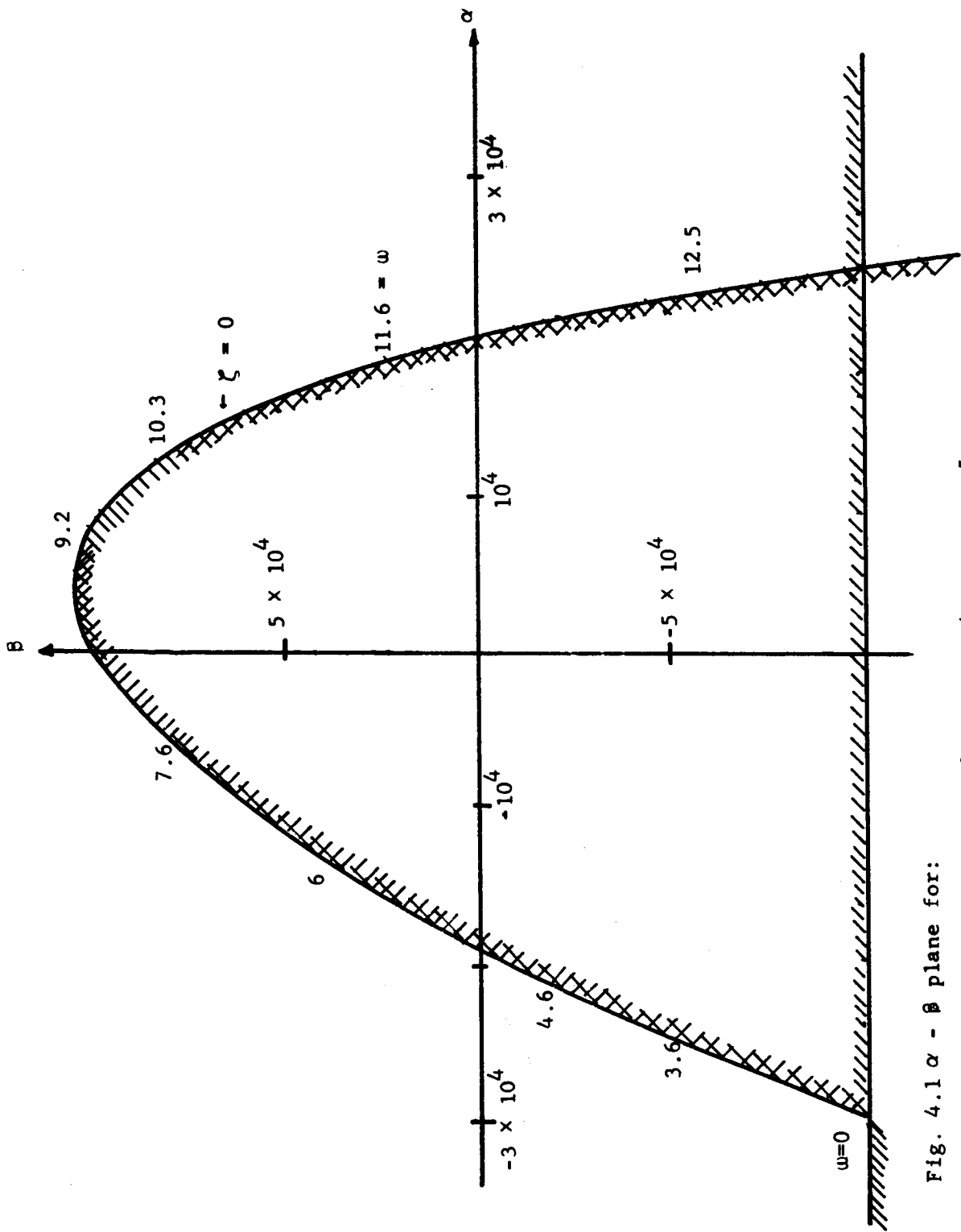

Fig. 4.1 $\alpha - \beta$ plane for:

$$F(s) = s^5 + 30s^4 + 496s^3 + 4960s^2 + (3 \times 10^4 + \alpha)s + 10^5 + \beta = 0$$

Then for $\zeta = 0$

$$\begin{aligned} B_1 &= 6\omega^2 & B_2 &= \omega^3 \\ C_1 &= 11\omega^2 & C_2 &= -50\omega \\ C_1 &= -100,000 + 4960\omega^2 - 30\omega^4 & D_2 &= -30,000\omega + 496\omega^3 - \omega^5 \end{aligned}$$

From which

$$\begin{aligned} \alpha &= \frac{-5 \times 10^6 \omega - 82,000\omega^3 + 3956\omega^5 - 11\omega^7}{-300\omega^2 - 11\omega^5} \\ \beta &= \frac{80,000\omega^3 + 1984\omega^5 - 27\omega^7}{-300\omega^2 - 11\omega^5} \\ \Delta &= B_1 C_2 - B_2 C_1 = -300\omega^3 - 11\omega^5 \end{aligned}$$

The parameter plane curve is shown on fig. 4.2.

C. Let the characteristic equation be

$$F(s) = 0 = \alpha\beta s^2 + (\alpha\beta + 1 - \beta)s + 1$$

Then, for $\zeta = 0$

$$\begin{aligned} B_1 &= 0 & B_2 &= 0 \\ C_1 &= 0 & C_2 &= \omega \\ H_1 &= \omega^2 & H_2 &= -\omega \\ D_1 &= -1 & D_2 &= -\omega \\ f &= -\omega - \omega^3 & b &= \omega^3 & d &= 0 \\ \beta &= \frac{1 + \omega^2}{\omega^2} & \alpha &= \frac{1}{1 + \omega^2} \\ J &= \alpha\beta + \omega^3\beta = \frac{1}{\omega^2} + \omega + \omega^3 \end{aligned}$$

The parameter plane plot, with shading, is shown on fig. 4.3.

The construction of the $\alpha - \beta$ curve for $\zeta = 0$ is just the first step in stability analysis. The second step is to determine whether any area in the $\alpha - \beta$ plane provides values of α and β for which all roots of the polynomial are in the left half of the s -plane. There is no direct way to do this in general. The normal procedure is to choose

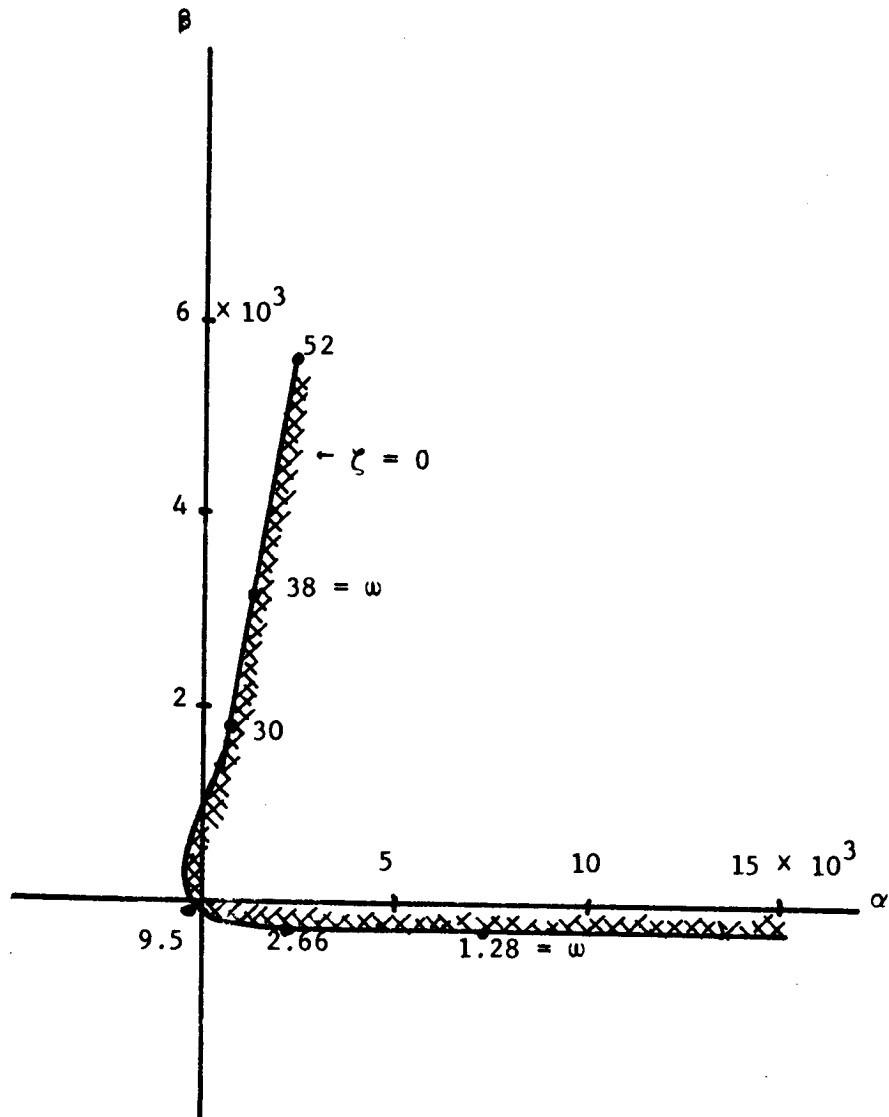

Fig. 4.2 Parameter Plane Plot for
 $F(s) = 0 = s^5 + (496 + \alpha)s^3 + (4960 + (4960 + 6\alpha + 11\beta)s^2$
 $+ (30,000 + 50\beta)s + 100,000$

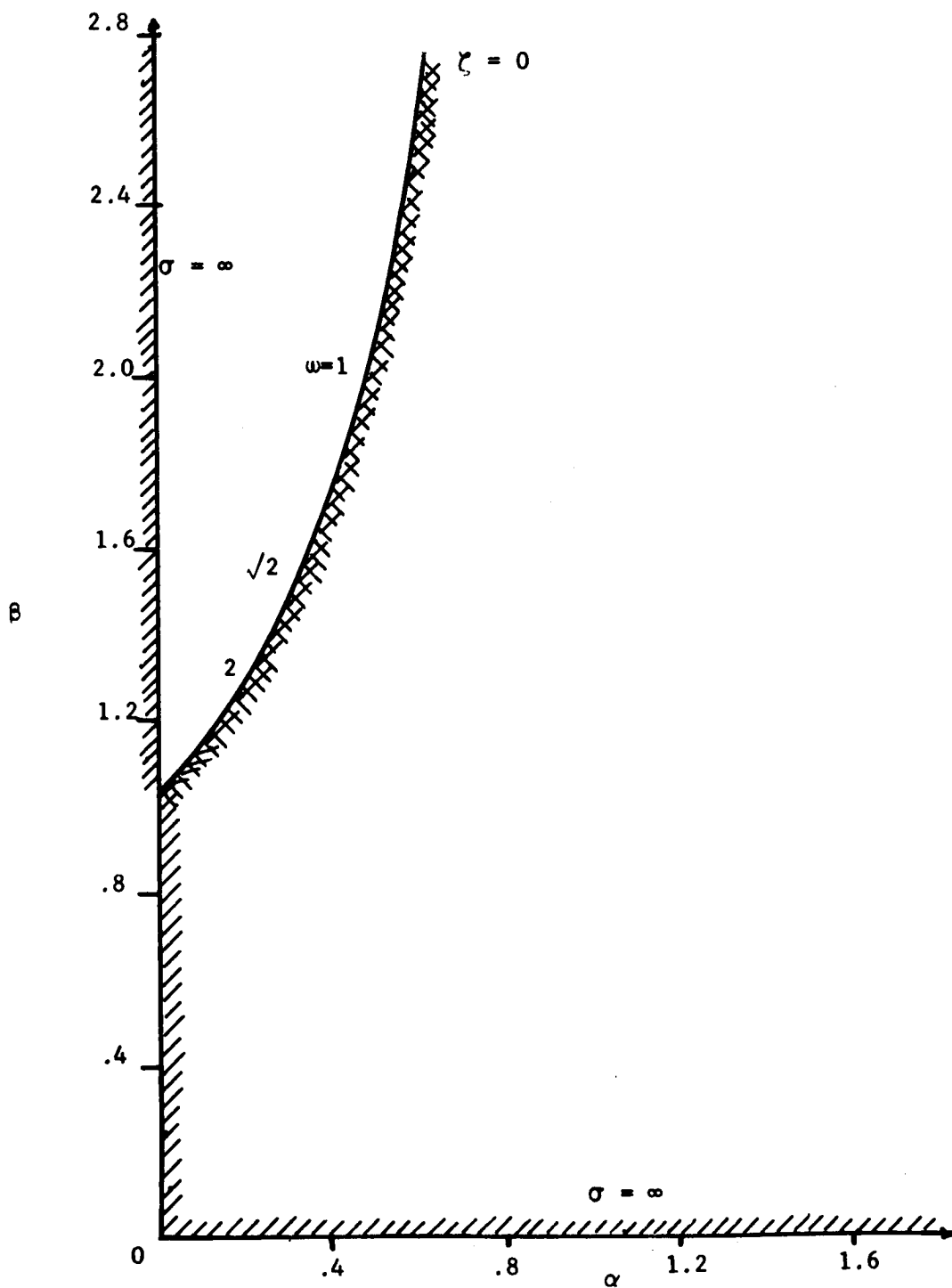

Fig. 4.3 Parameter Plane Plot for the Polynomial
 $F(s) = 0 = \alpha\beta s^2 + (\alpha\beta + 1 - \beta)s + 1$

a specific α, β pair, thus defining all coefficients of the polynomial numerically. The polynomial may then be factored, or the number of left half plane roots determined, and the shading on the curves utilized to define the number of left half plane roots associated with each area. A number of procedures are available, and are discussed in the following paragraphs.

When the parameter plane curves are computed with a digital computer a subroutine may be included which factors the polynomial for one pair of α, β values. Usually $\alpha = \beta = 0$ is a convenient choice since the origin of the coordinate system is usually included on any graphical display. The factors thus obtained specify the number of roots of the polynomial that are in the left half s-plane for $\alpha = \beta = 0$, thus providing an association with the area on the $\alpha - \beta$ plane which includes the origin. The number of left half s-plane roots obtained for $\alpha - \beta$ pairs in other areas may then be determined from the shading.

A second method of determining the number of left half s-plane roots associated with an area on the $\alpha - \beta$ plane is to choose a point in an area of interest, insert the numerical values of α and β in the polynomial, and apply the Routh criterion.

A third method is to apply the Mikhailov criterion; i.e., choose α and β , insert in the polynomial, then map the imaginary axis of the s-plane onto a polar plane through the polynomial used as a mapping function, and interpret the number of left half s-plane roots from the number of times the polar curve encircles the origin of the polar plane.

A fourth method is to evaluate all roots numerically from the parameter plane plot. This requires that $\alpha - \beta$ curves be obtained for a number of values of ζ , and that a number of constant σ curves be added. If a sufficient number of curves are available the M-point location defines all of the roots numerically.

A fifth method - and possibly the best method for engineering problems when digital computer factoring is not used, is to choose an $\alpha - \beta$ pair and then sketch the Mitrovic curve for $\zeta = 0$. Since choice of

α and β provides all numerical coefficients for the polynomial, one may choose any two coefficients as variables (their known numerical values then define the M-point) and the coefficient plane curves may be obtained. The Mitrovic A_0 vs A_1 plane is probably the easiest to use and only a sketch of the $\zeta = 0$ curve is needed. The location of the M-point on this sketch determines immediately whether all roots are in the left half s-plane or not. If all roots are not in the left half s-plane for a specific choice of α and β , it may be possible to use shading techniques on the Mitrovic plane to determine the exact number of left half plane roots. In engineering problems, however, the usefulness of the $\alpha - \beta$ plane lies in the possibility of selecting an $\alpha - \beta$ pair which guarantees an acceptable set of roots; a normal requirement being that all roots must be in the left half of the s-plane. Therefore the $\alpha - \beta$ plane is of interest only when it contains at least one area in which the values of $\alpha - \beta$ provide a stable system (all roots in the left half s-plane). The shading on the $\alpha - \beta$ plane curve for $\zeta = 0$ permits visual determination of the areas which correspond to the maximum number of left half s-plane roots. Such areas are completely bounded by lines that are shaded on the inner side, so that any adjacent area contains a smaller number of left half plane roots. By choosing a point in such an area, reading off α and β , and sketching the Mitrovic curve, it is immediately determined whether the selected area corresponds to all left half s-plane roots; furthermore, if the selected area does not satisfy this requirement then the system is inherently unstable, i.e., there are no values of α and β which will provide all left half s-plane roots.

4.3 Root Evaluation

Root evaluation on the parameter plane is accomplished as already explained for the Mitrovic plane. The procedure is:

- a) Plot constant ζ curves for an adequate range of values of ζ and ω .
- b) Plot constant σ curves for an adequate range of σ values.
- c) Select desired values of α and β and locate the M-point thus defined.

- d) At the M-point read the values of ζ and ω for all ζ curves passing through this point, interpolating if necessary. These are the complex roots.
- e) At the M-point read the values of σ for all σ curves passing through this point, interpolating if necessary. These are the real roots.

The number of roots evaluated in steps (d) and (e) should correspond exactly to the order of the polynomial. When it appears that the curves determine too few roots, either an inadequate number of curves has been plotted, or some of the constant ζ curves have not been evaluated for large enough values of ω .

4.4 Elementary Analysis and Synthesis Techniques

The parameter plane is a convenient and useful tool for the analysis and synthesis of dynamic systems. The elementary techniques for using this tool require that the system characteristic equation be obtained and parameter plane curves must be plotted based on this characteristic equation. Analysis then consists of determining the roots of this characteristic equation for specified values of the parameters α and β . Synthesis consists of choosing values of α and β which provide a set of roots such that dynamic performance specifications are satisfied. Most problems require additional studies which are partly analysis and partly synthesis, such as the expression of other specifications as auxiliary curves on the α and β plane. These techniques are best explained by illustrative examples, which follow:

Illustration No. 1

A feedback control system is stabilized with tachometer feedback as shown in fig. 4.4a.

- a) Construct the parameter plane curves; add curves of constant error coefficient K_v .
- b) Analyze the effect of various K and K_t combinations in terms of available K_v , dominance of the complex roots, and damping ratio obtainable.

The characteristic equation is

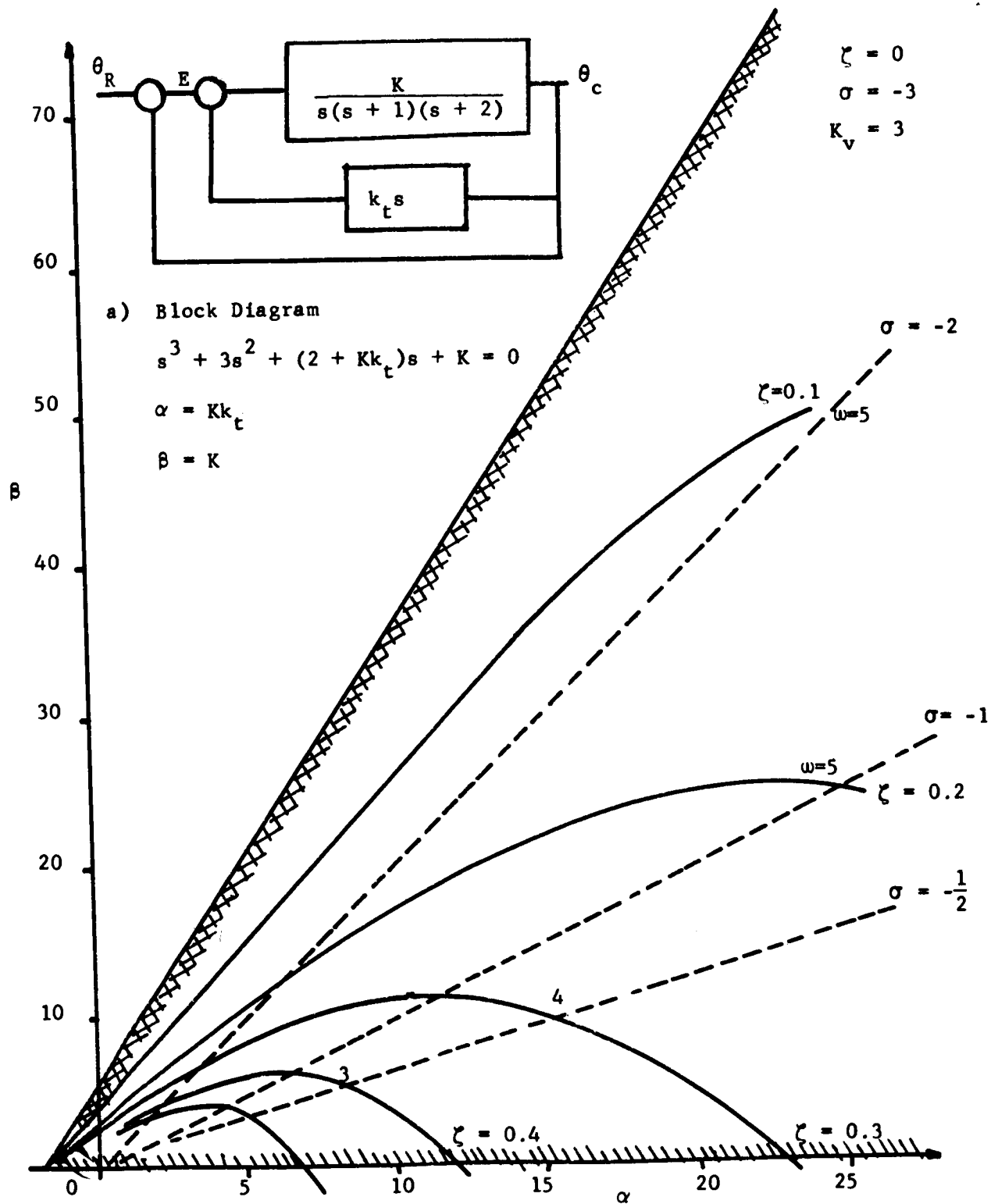

Fig. 4.4b Parameter Plane for $s^3 + 3s^2 + (2 + \alpha)s + \beta = 0$

$$s^3 + 3s^2 + (2 + KK_t)s + K = 0$$

Let $KK_t = \alpha$ and $K = \beta$, then the equation becomes

$$s^3 + 3s^2 + (2 + \alpha)s + \beta = 0$$

From which

$$B_1 = 0$$

$$C_1 = -1$$

$$D_1 = 3\omega^2 - \omega^3 U_2(\zeta)$$

$$B_2 = -\omega$$

$$C_2 = 0$$

$$D_2 = -2\omega + 3\omega^2 U_2(\zeta) - \omega^3 U_3(\zeta)$$

$$\Delta = -\omega$$

$$\alpha = -2 + 3\omega U_2(\zeta) - \omega^2 U_3(\zeta)$$

$$\beta = 3\omega^2 - \omega^3 U_2$$

The parameter plane plot is shown on fig. 4.4b.

To add curves of constant error coefficient note that

$$K_v \stackrel{\Delta}{=} \lim_{s \rightarrow 0} s(G(s)) = \frac{K}{2 + KK_t} = \frac{\beta}{2 + \alpha}$$

from which $\beta = \alpha K_v + 2K_v$. For constant K_v this is a straight line on the $\alpha - \beta$ plane with slope K_v and β intercept of $2K_v$. Fig. 4.5 shows some constant K_v lines on the $\alpha - \beta$ plane. It is seen that in this case the $K_v = 3$ line coincides with the $\zeta = 0$ line. Thus no values of the available adjustments can achieve a $K_v \geq 3$ without producing an unstable system. If good damping is desired ($\zeta \approx 0.5$) K_v must be less than 1.0, and ω must be less than 3.0, unless a real root is permitted to be dominant. For example, if the M-point is located near the origin, as at $\omega = 2$; $\zeta = 0.3$, then the real part of the complex roots is $-\zeta\omega = -.6$, while the real root appears to be a $\sigma = 1.9$, so the complex roots are dominant, K_v is about 1.2, but the system is poorly damped because $\zeta = 0.3$ and is slow because $\zeta\omega = .6$. If the M-point

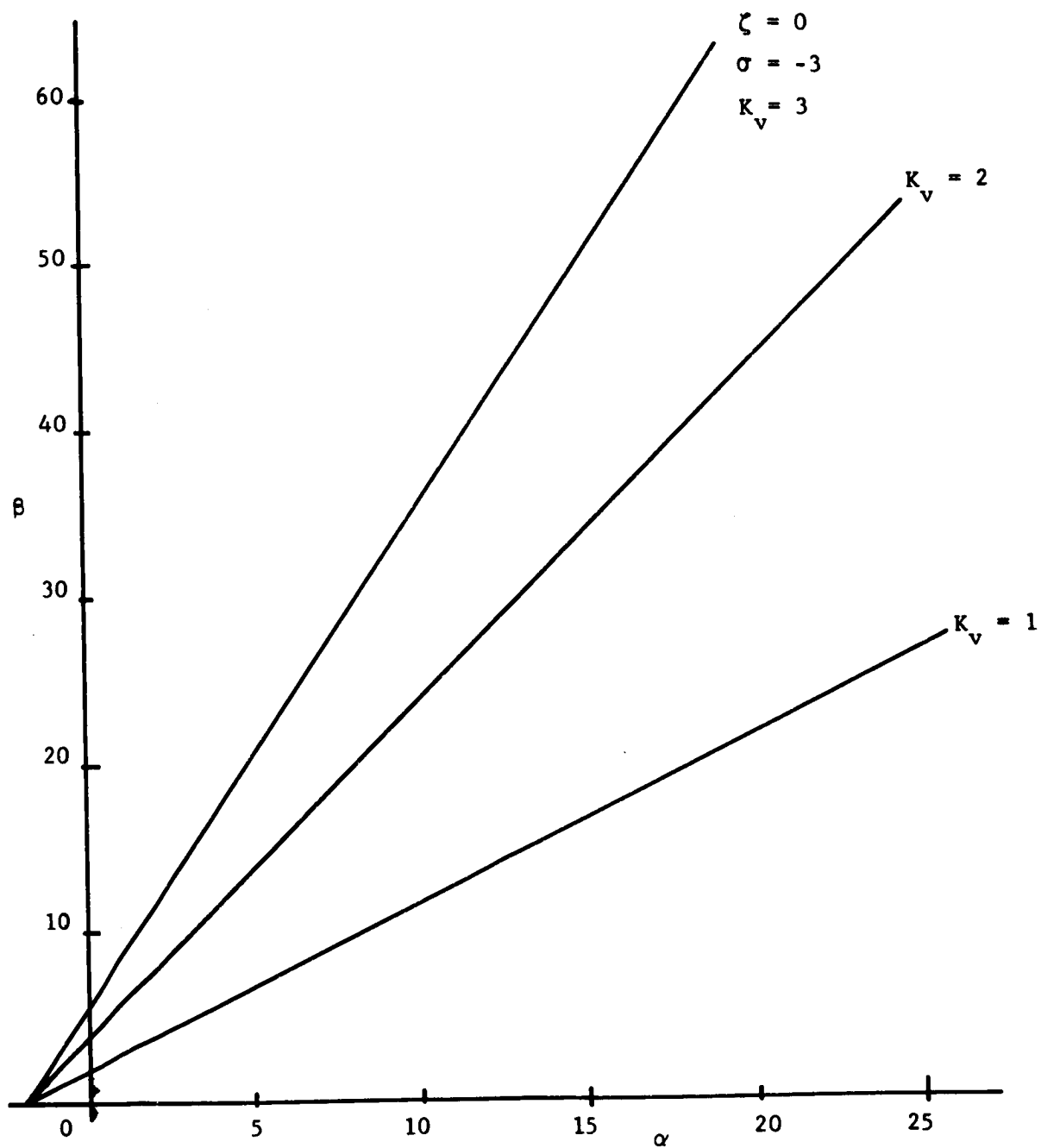

Fig. 4.5 Constant K_v Lines

is located at $\zeta = 0.3$; $\omega = 4$, then $-\zeta\omega = -1.2$ while the real root is at $\sigma = -0.5$, so the real root is dominant. The system is slow because the real root is small, and K_v is appreciably less than 1.0.

The values of K and K_t are easily determined since α and β are read from the plot at the M-point, and

$$\alpha \equiv K$$

$$\beta = 2 + Kk_t; \quad k_t = \frac{\beta - 2}{\alpha}$$

Many instrument servos use tachometer feedback for damping but are operated only as static positioning systems. For such systems the minimum permissible K is set by nonlinear threshold conditions, and there is usually a "speed of response" specification which may be related to the system bandwidth, or to the settling time. For the system under consideration assume that the minimum acceptable K is 10. This restriction could be represented on the parameter plane of fig. 4.4 by a vertical line at $\alpha = 10$ (not shown on fig. 4.4). The M-point must be chosen to the right of this line. By inspection one sees that for large α and small β the real root is dominant but the system is slow because the real root is small. Conversely, if α is large but β is also large (chosen so system remains stable) the complex roots are dominant but their real part is small so the system has a long settling time. It is usually easy to see whether any choice of $\alpha - \beta$ can meet specifications, and when this is not possible a change in the structure of the system is clearly indicated.

Illustration No. 2

An unstable servo is to be compensated using both velocity and acceleration feedback as shown in fig. 4.6a. The characteristic equation is

$$s^3 + (3 + 10k_a)s^2 + (2 + 10k_t)s + 10 = 0$$

Let $k_a \equiv \alpha$ and $k_t \equiv \beta$

$$B_1 = +10\omega^2$$

$$C_1 = 0$$

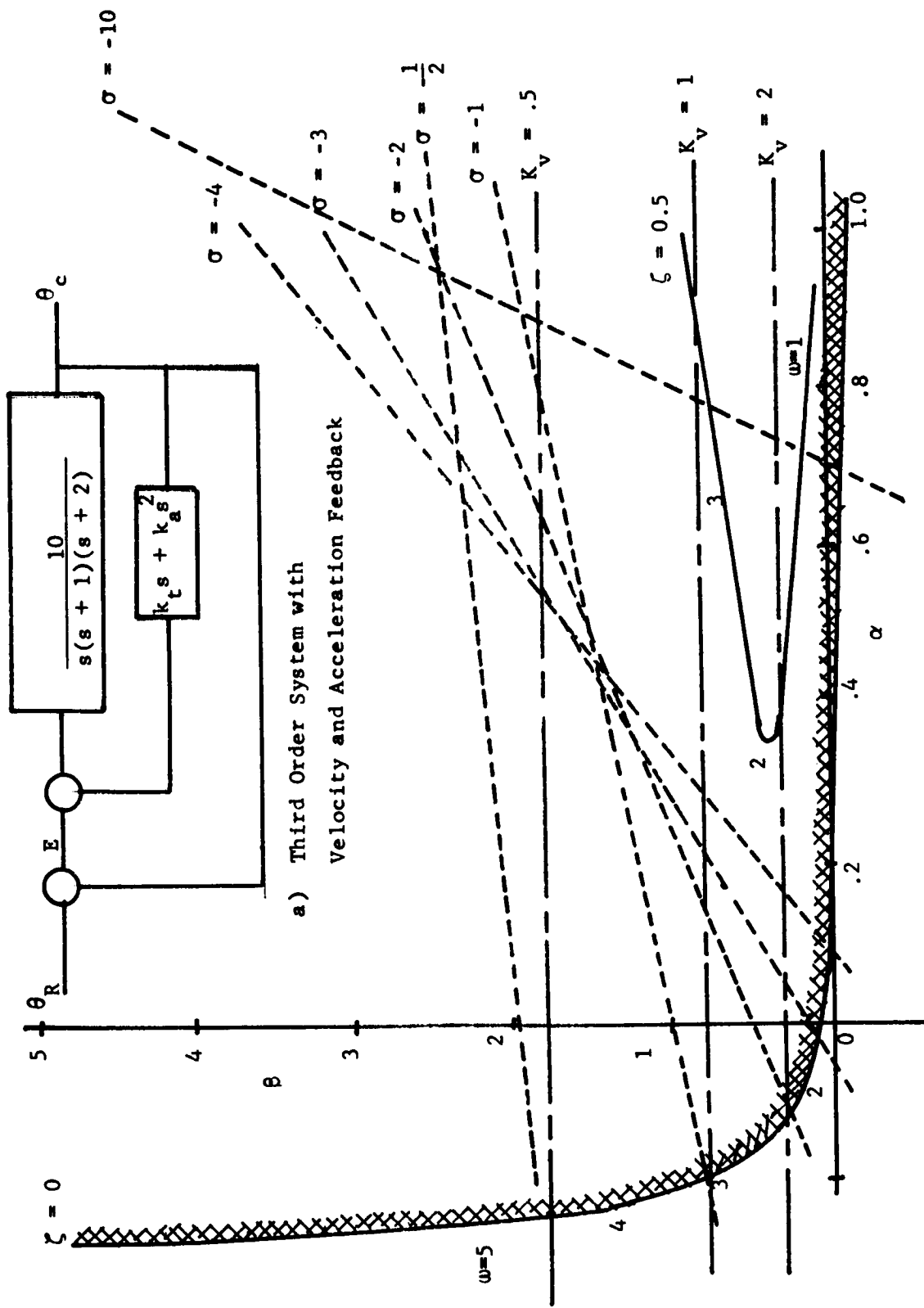

Fig. 4.6b Parameter Plane for $s^3 + (3 + 10\alpha)s^2 + (2 + 10\beta)s + 10 = 0$

$$D_1 = -10 + 3\omega^2 - \omega^3 U_2(\zeta)$$

$$B_2 = 0$$

$$C_2 = -10\omega$$

$$D_2 = -2\omega + 3\omega^2 U_2 - \omega^3 U_3$$

$$\Delta = B_1 C_2 - B_2 C_1 = -100\omega^3$$

$$\beta = \frac{B_2 D_1 - B_1 D_2}{\Delta} = -.2 + .3\omega U_2 - .1\omega^2 U_3$$

$$\alpha = \frac{C_1 D_2 - C_2 D_1}{\Delta} = +\frac{1}{\omega^2} - .3 + .1\omega U_2$$

The parameter plane curves for $\zeta = 0$ and $\zeta = 0.5$ are shown on fig. 4.6b with some real root lines. Note that the entire plot is for a static gain of $K = 10$, so static gain (or threshold gain) cannot be used as a constraint. However, if the velocity coefficient is of interest,

$$K_v = \frac{10}{2 + 10\beta}$$

from which

$$\beta = -.2 + \frac{1}{K_v}$$

Some constant K_v lines are shown on fig. 4.6b. It is seen that the system can be stabilized and almost any desired damping can be obtained. If a large K_v is desired β must be small; good damping is obtainable with large α , but only at the sacrifice of bandwidth.

Illustration No. 3

A single loop servo is to be stabilized with cascade compensation as shown in fig. 4.7a. In general the transfer function of the compensator must be chosen on the basis of previous analysis of the problem, and the parameter plane method is not necessarily helpful in making this choice. In normal design one or more sections of R-C filter would be used, with basic transfer function

$$G_c = \frac{s + z}{s + p}$$

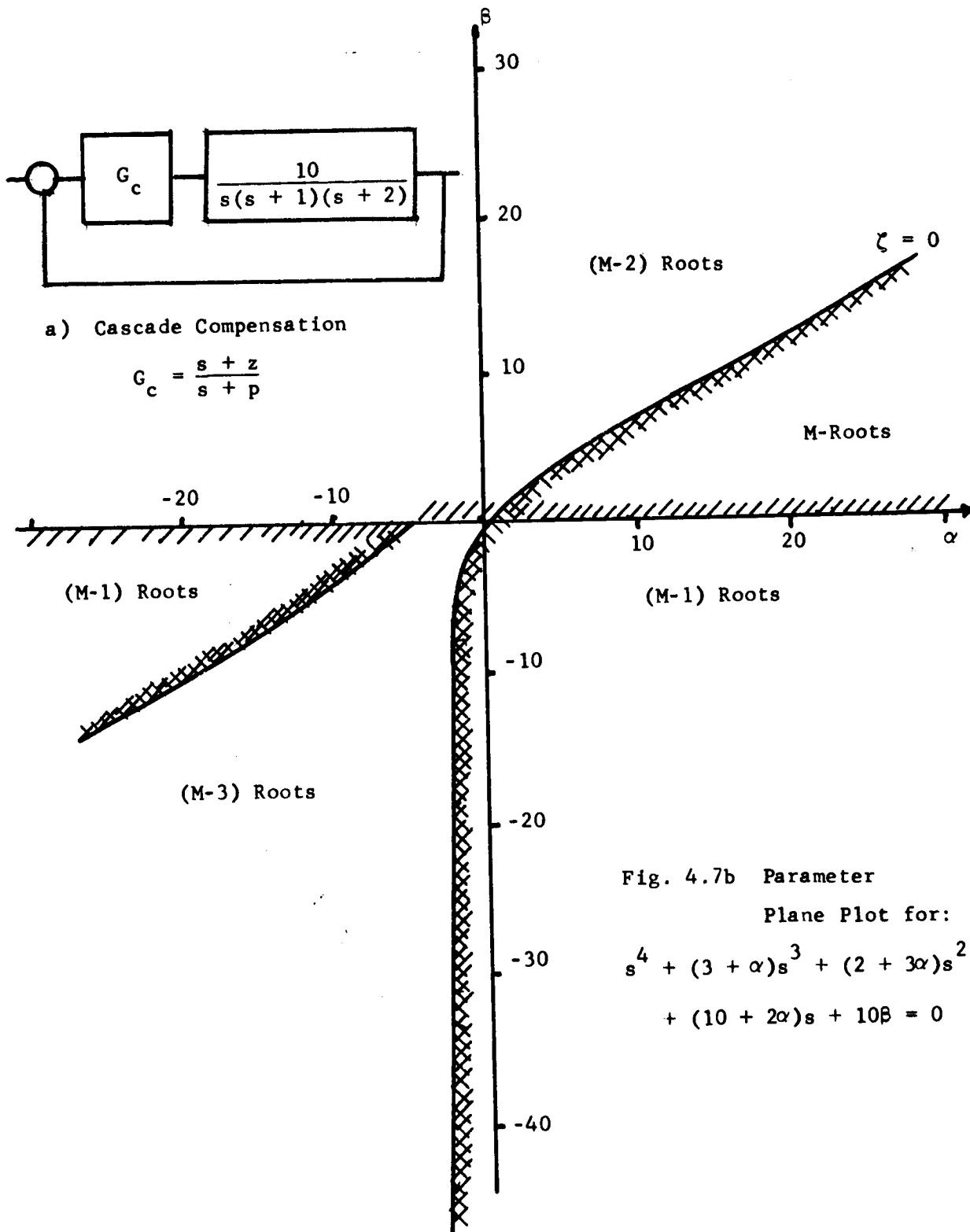

For the system of fig. 4.7a, if one filter section is used

$$G_c G = \left(\frac{s+z}{s+p} \right) \left(\frac{10}{s(s+1)(s+2)} \right)$$

and the characteristic equation becomes:

$$s^4 + (3+p)s^3 + (2+3p)s^2 + (2p+10)s + 10z = 0$$

let $p = \alpha$; $z = \beta$

$$B_1 = 3\omega^2 - \omega^3 U_2$$

$$C_1 = -10$$

$$D_1 = +2\omega^2 - 3\omega^3 U_2 + \omega^4 U_3$$

$$B_2 = -2\omega + 3\omega^2 U_2 - \omega^3 U_3$$

$$C_2 = 0$$

$$D_2 = -10\omega + 2\omega^2 U_2 - 3\omega^3 U_3 + \omega^4 U_4$$

$$\Delta = B_1 C_2 - B_2 C_1 = 0 + (-2\omega + 3\omega^2 U_2 - \omega^3 U_3)(+10)$$

$$\alpha = \frac{C_1 D_2 - C_2 D_1}{\Delta} = \frac{+10 - 2\omega U_2 + 3\omega^2 U_3 - \omega^3 U_4}{-2 + 3\omega U_2 - \omega^2 U_3}$$

$$\beta = \frac{B_2 D_1 - D_2 B_1}{\Delta} =$$

$$= \frac{\omega^2}{10} \left[\frac{26 + 8\omega U_2 + \omega^2(5U_3 - 7U_2^2) + \omega^3(3U_2 U_3 - 12U_4) + \omega^4(U_2 U_4 - U_3^3)}{-2 + 3\omega U_2 - \omega^2 U_3} \right]$$

for $\zeta = 0$

$$\alpha = \frac{10 - 3\omega^2}{-2 + \omega^2}$$

$$\beta = \frac{\omega^2}{10} \left(\frac{26 - 5\omega^2 - \omega^4}{-2 + \omega^2} \right)$$

The $\zeta = 0$ curve is plotted on fig. 4.7b to check stability and to choose a region of interest for additional calculations. From the hatching on

fig. 4.7b it is seen that the region corresponding to the values of α and β which will provide a maximum number of roots in the left half s-plane is in the first quadrant and is marked "M-roots". The actual number of the left half plane roots is not known, and should be checked before proceeding. Since the characteristic equation is of fourth order M should be 4, otherwise the proposed compensator cannot stabilize the system. For this particular problem several easy tests are available, however we shall illustrate the use of the Mitrovic plane for this purpose. First choose an M-point in the region to be tested, (i.e., $\alpha = 10$; $\beta = 5$), and substitute in the characteristic equation obtaining:

$$s^4 + 13s^3 + 32s^2 + 30s + 50 = 0$$

The Mitrovic equation (3.6) are

$$A_1 = -1(-32\omega U_2 + 13\omega^2 U_3 - \omega^3 U_4)$$

$$A_0 = 32\omega^2 U_1 - 13\omega^3 U_2 + \omega^4 U_3$$

and for $\zeta = 0$ these become

$$A_1 = + 13\omega^2$$

$$A_0 = 32\omega^2 - \omega^4$$

This is easily sketched, since A_1 is always positive, $A_0 = 0$ at $\omega = 0$ and $\omega = \sqrt{32} = 5.66$ for which $A_1 = 416$. Also A_0 has a maximum at $\frac{d}{d\omega} (32\omega^2 - \omega^4) = 0 = 64\omega - 4\omega^3$ for which $\omega = 4$, $A_1 = 208$, $A_0 = 256$. After additional points are calculated and the Mitrovic curve is sketched on fig. 4.7c, and the location of the M-point indicates that all roots are in the left half plane. Therefore on the parameter plane of fig. 4.7b the value of M is 4, and the "M-root" area represents values of α and β that will provide a stable system.

The $\alpha - \beta$ curves in the region of interest are shown on fig. 4.7d. Inspection of these results indicates that use of the compensator in the fashion indicated must produce a very slow responding system. To provide a faster response provision must be made to increase the forward gain

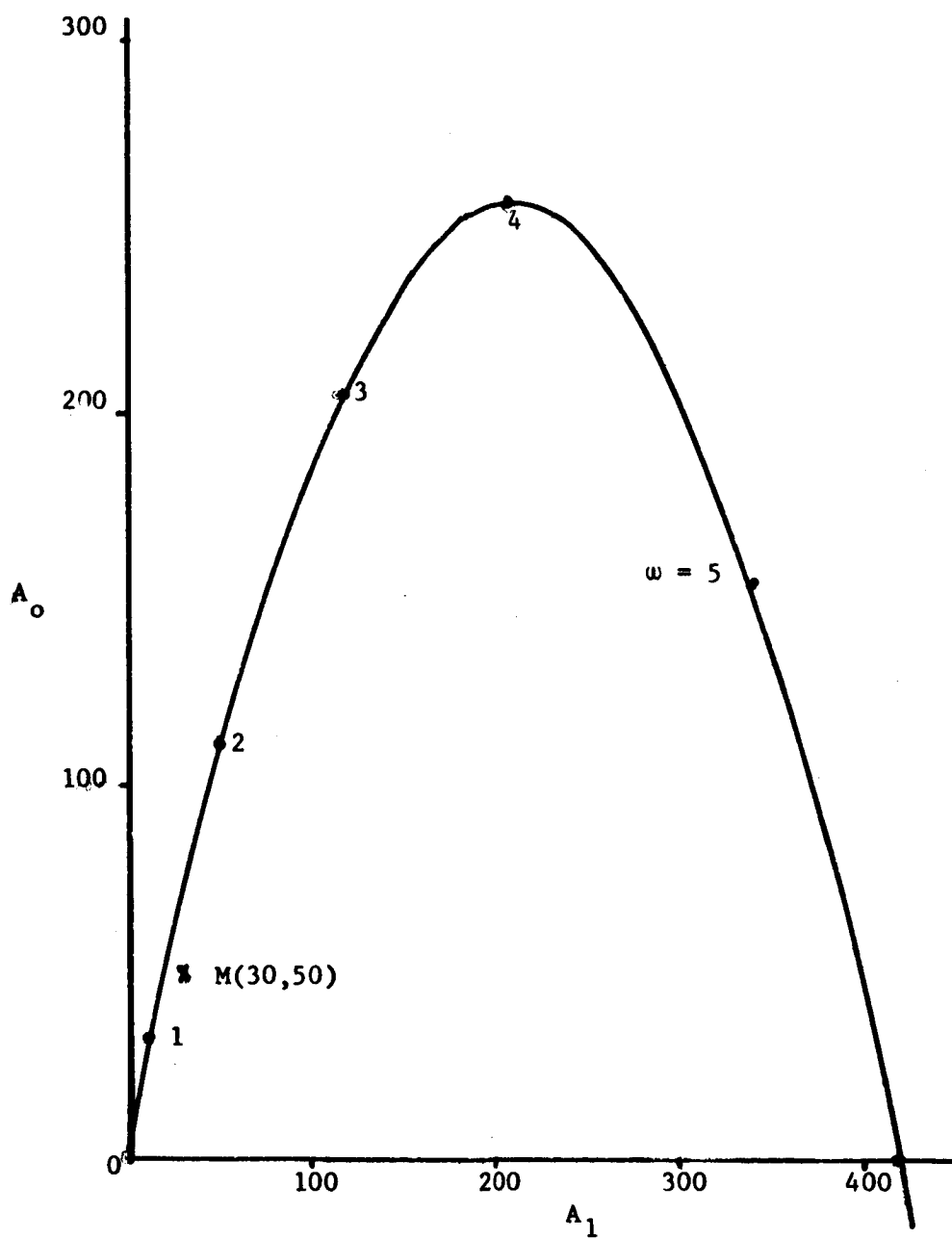

Fig. 4.7c Mitrovic Plot for

$$s^4 + 13s^3 + 32s^2 + 30s + 50 = 0$$

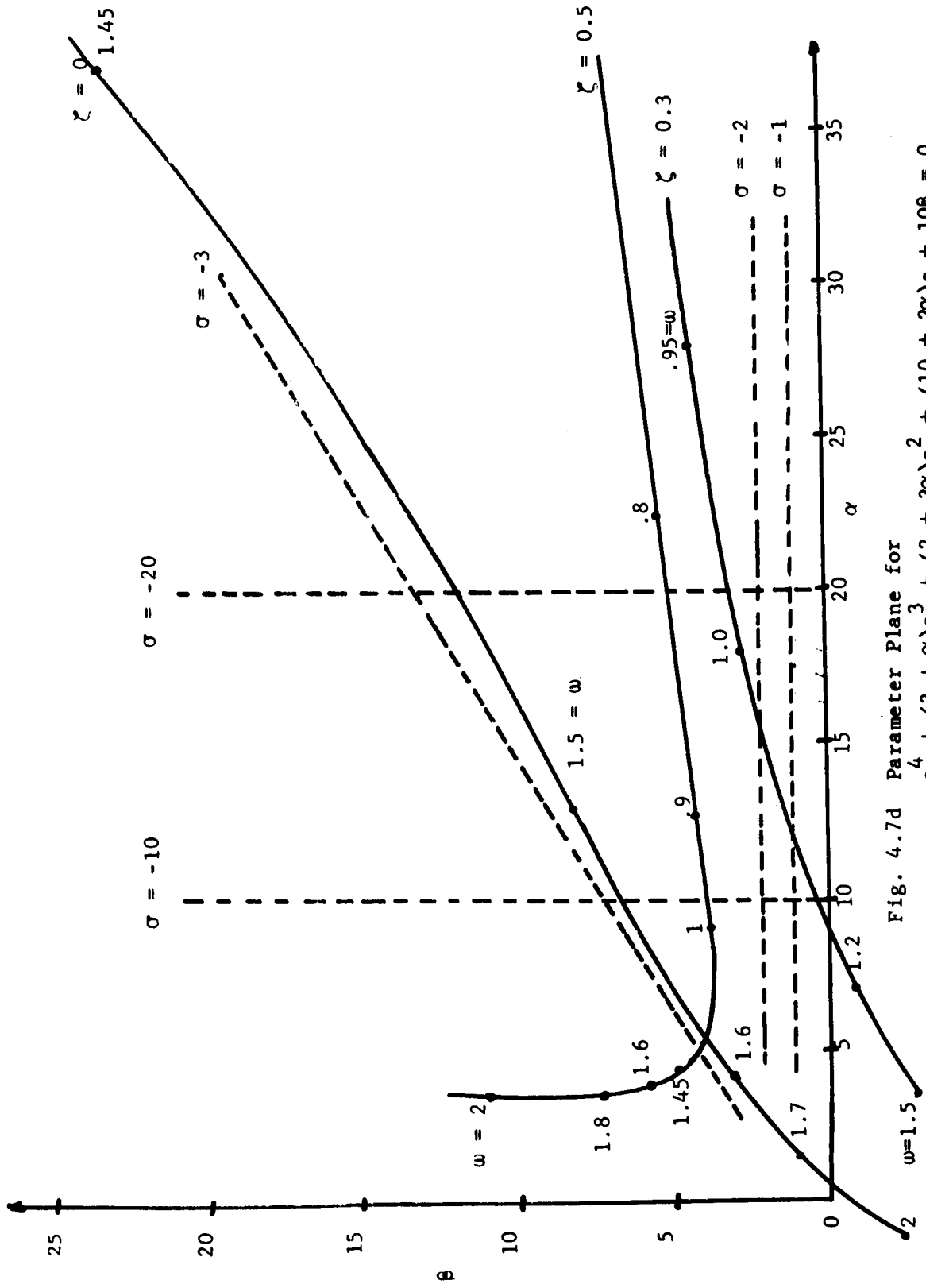

Fig. 4.7d Parameter Plane for $s^4 + (3 + \alpha)s^3 + (2 + 3\alpha)s^2 + (10 + 2\alpha)s + 10\beta = 0$

thus counter-balancing the attenuation of the filter. Since this provision was not made formulating the problem from fig. 4.7a (i.e., the gain was kept constant at $K = 10$), the parameter plane curves of fig. 4.7d do not provide a satisfactory solution.

Illustration No. 4

If the gain in fig. 4.7a is made adjustable, the characteristic equation of the cascade compensated system becomes

$$s^4 + (3 + p)s^3 + (2 + 3p)s^2 + (K + 2p)s + K_z = 0$$

in which there are three parameters, K , p , z . Three parameter problems can, in general, be solved by choosing a set of values for one parameter, and computing the $\alpha - \beta$ plane curves (often only one value of ζ is needed) for each value of the chosen parameter until an acceptable solution is obtained. Thus, if a set of values is chosen for K , the curves for fig. 4.7d would be one of the family of parameter planes. Other obvious alternatives are to choose a set of values for z , then $\alpha \triangleq p$ and $\beta \triangleq K$; or choose a set of values for p and use the Mitrovic plane ($A_1 = K + 2p$; $A_0 = K_z$). Such three parameter studies are effective, and the only objectionable feature is the time required for computation of the curves.

Another alternative is to add a restriction that defines the desired gain in mathematical terms. The usual restriction is that the error coefficient should not be reduced; i.e., the gain of the uncompensated system is set to obtain the desired error coefficient, and when a compensator is cascaded the effect of this compensator on the error coefficient is eliminated by altering the gain. For the system of fig. 4.7a, this is accomplished by requiring the compensator transfer function to be

$$G_c = \frac{p}{z} \frac{s + z}{s + p}$$

With this transfer function for the compensator, the characteristic equation of the system becomes

$$s^4 + (3 + p)s^3 + (2 + 3p)s^2 + \left(\frac{10p}{z} + 2p\right)s + \left(\frac{10p}{z}\right)z = 0$$

which rearranges to

$$s^4 + (3 + p)s^3 + (2 + 3p)s^2 + p\left(\frac{10}{z} + 2\right)s + 10p = 0$$

Defining $p = \alpha; \frac{10}{z} + 2 = \beta$, this becomes

$$s^4 + (3 + \alpha)s^3 + (2 + 3\alpha)s^2 + \alpha\beta s + 10\alpha = 0$$

which expresses the problem in terms of two parameters α and β with a product $\alpha\beta$ in one coefficient.

An alternate formulation is to define

$$\frac{z}{p} = \gamma$$

Substitution of this definition in the characteristic equation gives

$$s^4 + (3 + p)s^3 + (2 + 3p)s^2 + (\frac{10}{\gamma} + 2p)s + 10p = 0$$

Choosing $p = \alpha$ and $\frac{10}{\gamma} = \beta$, this becomes

$$s^4 + (3 + \alpha)s^3 + (2 + 3\alpha)s^2 + (\beta + 2\alpha)s + 10\alpha = 0$$

thus expressing the same problem with different definitions of the parameter α and β , but obtaining coefficients which are linear in α and β .

Still another formulation is to define $p = \alpha, (\frac{10p}{z} + 2p) = \beta$, then the characteristic equation becomes

$$s^4 + (3 + \alpha)s^3 + (2 + 3\alpha)s^2 + \beta s + 10\alpha = 0$$

Again the coefficients are linear in α and β .

The curves for the $\alpha\beta$ product case are readily computed. Using equations (4.12) and (4.16)

$$B_1 = -10 + 3\omega^2 - \omega^3 U_2$$

$$C_1 = 0$$

$$D_1 = 2\omega^2 - 3\omega^3 U_2 + \omega^4 U_3$$

$$H_1 = 0$$

$$B_2 = 3\omega^2 U_2 - \omega^3 U_3$$

$$C_2 = 0$$

$$D_2 = 2\omega^2 U_2 - 3\omega^3 U_3 + \omega^4 U_4$$

$$H_2 = (-1)_1 \omega U_1 = -\omega$$

from which

$$\alpha_{1,2} = \frac{-e \pm \sqrt{e^2 - 4ac}}{2a}$$

where

$$a = B_2H_1 - B_1H_2 = -10\omega + 3\omega^3 - \omega^4U_2$$

$$c = C_1D_2 - C_2D_1 = 0$$

$$e = B_2C_1 - B_1C_2 + H_1D_2 - H_2D_1 = +2\omega^3 - 3\omega^4U_2 + \omega^5U_3$$

$$\begin{aligned} \alpha_{1,2} &= 0, \quad \frac{-2e}{2a} = \frac{e}{a} = \frac{2\omega^3 - 3\omega^4U_2 + \omega^5U_3}{-10\omega + 3\omega^3 - \omega^4U_2} \\ &= \frac{-2\omega^2 + 3\omega^3U_2 - \omega^4U_3}{-10 + 3\omega^2 - \omega^3U_2} \end{aligned}$$

$$\beta_{1,2} = \frac{B_1\alpha_{1,2} + D_1}{H_1\alpha_{1,2} + C_1} = \frac{B_2\alpha_{1,2} + D_2}{H_2\alpha_{1,2} + C_2}$$

$$= \frac{-20U_2 + 30\omega U_3 - 10\omega^2U_4 + \omega^3(7U_2^2 - 7U_3) + \omega^4(3U_2U_3 + 3U_4) + \omega^5(-U_2U_4 + U_3^2)}{-2\omega + 3\omega^2U_2 - \omega^3U_3}$$

for

$$\zeta = 0$$

$$\alpha = \frac{-2\omega^2 + \omega^4}{-10 + 3\omega^2}$$

$$\beta = \frac{-30 + 7\omega^2 + \omega^4}{-2 + \omega^2}$$

The curves for the stability limit are given on fig. 4.8. Due to the definitions used this entire parameter plane gives values of α and β which keep K_v at the predetermined value. The areas indicated in the first quadrant guarantee all roots to be in the left half s-plane, and the compensator can be chosen as a lead device or a lag device as desired. It can be shown the $0 \leq \zeta \leq 1$ is obtainable in the lag area, but in the lead area $0 \leq \zeta < .5$

Illustration No. 5

Complex problems of compensation can often be reduced to a form

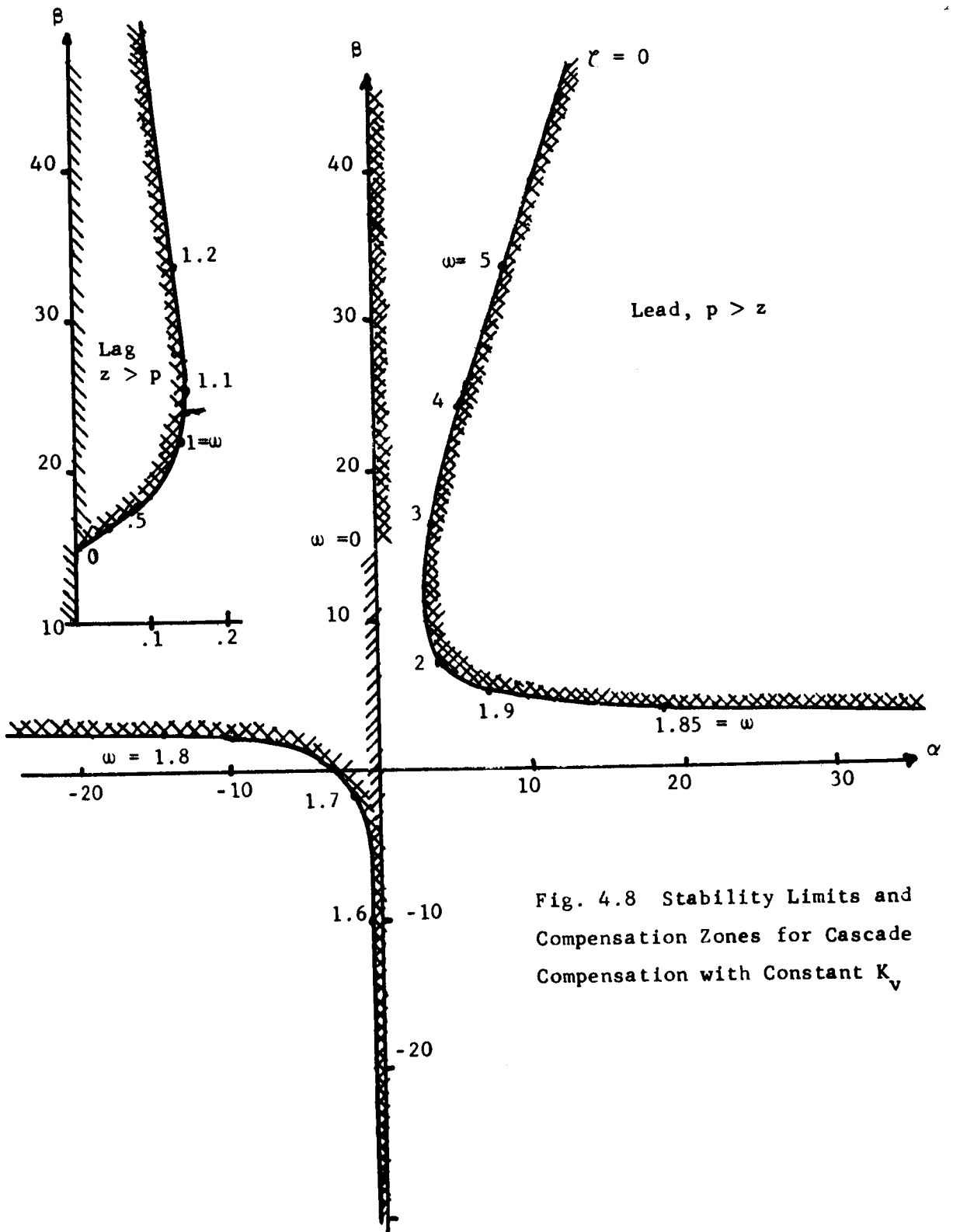

Fig. 4.8 Stability Limits and Compensation Zones for Cascade Compensation with Constant K_v

suitable for the parameter plane by use of the third parameter technique. Consider the block diagram of fig. 4.9 which shows a compensation scheme combining cascade and feedback compensators. In practice it is frequently true that neither a simple cascade filter nor a simple velocity feedback loop is adequate by itself, and it is desired to try both in combination. The usual design procedure is to design one of the compensators to some arbitrarily chosen "best" performance in the presence of the arbitrary initial design. Considerable iteration may be needed before a suitable combination is obtained, and in the process of designing interpolation or extrapolation of results is usually not an obvious step.

The characteristic equation for the system of fig. 4.9 is:

$$s^4 + (3 + p)s^3 + (2 + 3p + Kk_t)s^2 + (2p + Kk_t p + K \frac{p}{z})s + kp = 0$$

in which there are four variables, p , z , K , k_t . Since the parameter plane method allows only two variables, two of the four must be eliminated. One procedure which leads to satisfactory results is:

- a) Restrict the cascade compensator to be a lead filter, and define $\gamma = \frac{z}{p} = 0.1$, where the numerical value is based on common engineering practice.
- b) Choose K as a "third parameter", and select a sequence of numerical values for K .

The above procedure reduces the number of parameters to two; let $p \triangleq \alpha$ and $Kk_t = \beta$, and the characteristic equation becomes:

$$s^4 + (3 + \alpha)s^3 + (2 + 3\alpha + K\beta)s^2 + (2\alpha + K\alpha\beta + 10K)s + K\alpha = 0$$

A family of parameter plane curves is prepared for each value of K until a satisfactory solution is obtained. (Note that interpolation between K values is not difficult).

4.5 Analytic Techniques

Thus far in the development of the parameter plane method a family of curves has been obtained on the $\alpha - \beta$ plane; analysis and synthesis have proceeded by visual inspection of this curve family, resulting in the choice of an M-point which provided the values of α and β to be

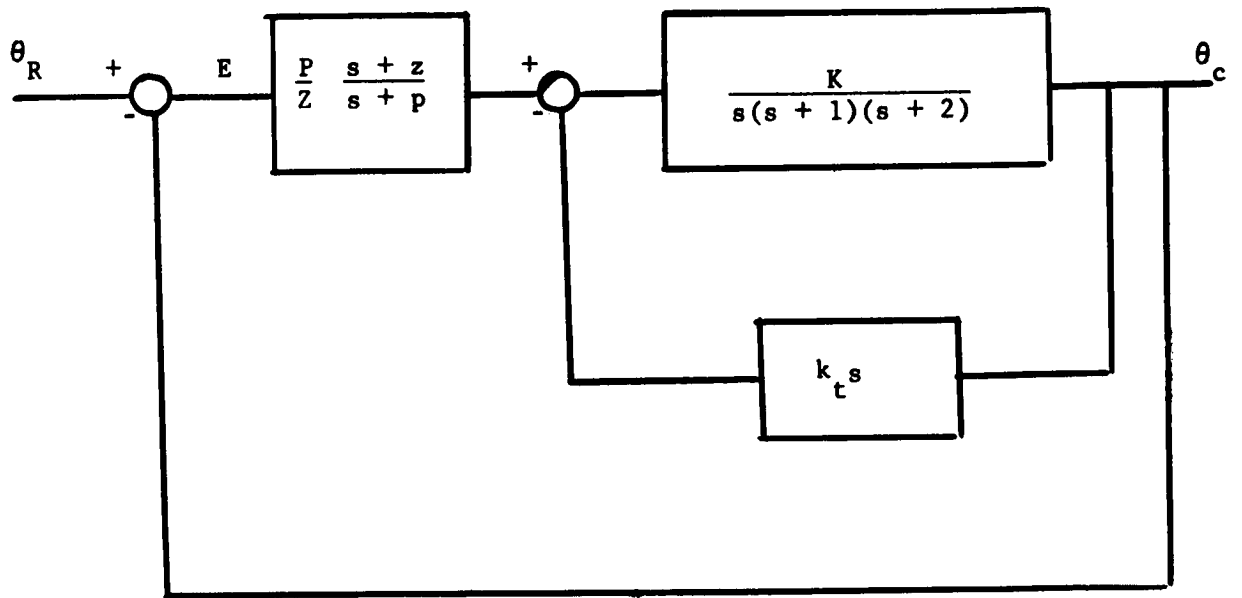

Fig. 4.9 Combined Cascade - Feedback Compensation

used. For many synthesis problems (and some analysis problems) the curve family is not required and purely analytic techniques can be used. The theory and methodology are developed in the following paragraphs.

Equation (4.12), for example, provide solutions for α and β as functions of ζ and ω , which may be written

$$\alpha = A(\zeta, \omega); \quad \beta = B(\zeta, \omega) \quad (4.47)$$

In normal usage these equations generate the curve family, and choice of the M-point selects values of α and β . Certain values of ζ and ω (the roots of the characteristic equation) provide these values of α and β if any of these root values is substituted in $A(\zeta, \omega)$ and $B(\zeta, \omega)$. Therefore, if a specific point of the s-plane

$$s = -\zeta_1 \omega_1 + j\omega \sqrt{1 - \zeta_1^2}$$

is chosen as a desired location for a root, the values ζ_1 and ω_1 may be substituted in (4.47) obtaining

$$\alpha_1 = A(\zeta_1, \omega_1); \quad \beta_1 = B(\zeta_1, \omega_1) \quad (4.48)$$

and the required values of α_1 and β_1 are thus determined without drawing any curves.

By this procedure roots at the selected location are guaranteed; but all other roots are also determined, though with locations unknown. Thus the choice of the root location may provide a system with desirable dynamics, but it may possibly provide an unstable system or one in which the chosen roots are not dominant, or a system with unsuitable steady state performance. With experience and familiarity with the problem, the engineer can frequently choose the desired root location so as to obtain an acceptable result; but verification of stability and dominance is usually necessary. The advantages of the technique are a tremendous reduction in computational labor and, as will be shown, the ability to introduce additional parameters into the study.

The formulation of the α , β equations (4.48) involves all of the coefficients of the characteristic equation. Steady state accuracy requirements, however, involve only a few of these coefficients and

constraints on the permissible values of α and β may be established from the steady state accuracy requirements. For feedback control systems steady state accuracy is usually determined by the coefficients a_0, a_1, a_2 ; but for other types of dynamic systems additional coefficients may be involved. Each problem requires special interpretation, but in general a second set of equations relating α and β are obtained from specifications other than a chosen dominant root location. To illustrate this a number of specific cases are recorded here. Consider first the servo of fig. 4.4a which is compensated by tachometer feedback. The characteristic equation is

$$s^3 + 3s^2 + (2 + Kk_t)s + K = 0$$

from which $Kk_t \stackrel{\Delta}{=} \alpha = -2 + 3\omega U_2(\zeta) - \omega^2 U_3(\zeta)$

$$K \stackrel{\Delta}{=} \beta = 3\omega^2 - \omega^3 U_2$$

The error coefficient for this system is

$$K_v = \frac{a_0}{a_1} = \frac{K}{2 + Kk_t} = \frac{\beta}{2 + \alpha}$$

from which

$$\alpha = \frac{\beta - 2K_v}{K_v}$$

From the first pair of equations choice of a pair of dominant complex roots at $s = -\zeta_1 \omega_1 + j\omega_1 \sqrt{1 - \zeta_1^2}$ defines both α and β numerically, and the second equation relating α and β to K_v can be used to evaluate the K_v that is obtained, but cannot be used as a constraint. Conversely, if a desired value of K_v is chosen the required relationship between α and β is established, but the root point cannot be chosen arbitrarily and there is no simple way to evaluate ζ and ω algebraically - recourse to the $\alpha - \beta$ plane is necessary. The reason for this is that the system has only two adjustable parameters (K and k_t) both of which are constrained when two roots (a complex pair) are specified. To provide the ability to satisfy an additional constraint (such as a K_v specification) a third adjustable parameter is necessary. If, in the system of fig. 4.4a, it is possible to make one of the poles

adjustable so that

$$G(s) = \frac{K}{s(s+1)(s+p)}$$

this pole provides the third parameter and both the root constraint and the K_v constraint may be imposed. The characteristic equation becomes

$$s^3 + (1+p)^2 + (p + Kk_t)s + K = 0$$

Let $Kk_t = \alpha$ and $K = \beta$

$$\alpha = -p + (1+p)\omega U_2(\zeta) - \omega^2 U_3(\zeta)$$

$$\beta = (1+p)\omega^2 - \omega^3 U_2$$

$$K_v = \frac{a_0}{a_1} = \frac{K}{p + Kk_t}; \quad \alpha = \frac{\beta - pK_v}{K_v}$$

Substitution of a selected root in the first pair of equations, and of a numerical value for K_v in the last equation provides simultaneous relationships for α and β in terms of p and these are readily solved for α , β and p .

An alternate way of introducing a third parameter into the problem is to insert acceleration feedback as in fig. 4.10a, for which the characteristic equation is

$$s^3 + (3 + k_a)s^2 + (2 + k_t)s + K = 0$$

Let $\alpha = k_a$; $\beta = k_t$, then

$$\alpha = \frac{K - 3\omega^2 + \omega^3 U_2}{\omega^2} \quad \beta = \frac{-KU_2 + 2\omega - \omega^3(U_2^2 - U_3)}{\omega}$$

and also $K_v = \frac{K}{2 + \alpha}$ from which

$$\alpha = \frac{K}{K_v} - 2$$

These equations can be solved for α and β when a pair of complex roots are specified and the error coefficient, K_v , is also specified.

A similar situation arises when a single section cascade compensator

is used so that

$$G_{eq} = G_c G = \frac{s+z}{s+p} \frac{K}{s(s+1)(s+2)}$$

where z , p and K are adjustable. The characteristic equation is

$$s^4 + (3+p)s^3 + (2+3p)s^2 + (K+2p)s + K_z = 0$$

Defining $p = \alpha$ and $z = \beta$

$$\alpha = \frac{K - 2\omega U_2 + 3\omega^2 U_3 - \omega^3 U_4}{-2 + 3\omega U_2 - \omega^2 U_3}$$

$$\beta = \frac{(K-4)\omega^2 + (6-K)\omega^3 U_2 + \omega^4(5U_3 - 7U_2^2) + \omega^5(3U_3 - 3U_4) + \omega^6(U_2 U_4 - U_3^2)}{K(-2 + 3\omega U_2 - \omega^2 U_3)}$$

The error coefficient relationship is

$$K_v = \frac{K\beta}{K + 2\alpha}$$

from which

$$\alpha = \frac{K\beta}{2K_v} - \frac{K}{2}$$

and these equations may be solved for K , α and β when a pair of complex roots are specified and K_v is chosen.

In like manner, if the compensator consists of two identical cascaded sections then

$$G_{eq} = \left(\frac{s+z}{s+p} \right)^2 \frac{K}{s(s+1)(s+2)}$$

and the characteristic equation becomes

$$s^5 + (2p+3)s^4 + (p^2+6p+2)s^3 + (3p^3+4p+K)s^2 + (2p^2+2Kz)s + Kz^2 = 0$$

Let $p = \alpha$ and $z = \beta$, then equation (4.21) and following apply. An

equation for the error coefficient is obtained as usual and is

$$K_v = \frac{Kz^2}{2p^2} = \frac{K\beta^2}{2\alpha^2}$$

from which $\alpha^2 = \frac{K\beta^2}{2K_v}$

Again solution for α , β and K can be obtained for specific ζ , ω and K_v .

Systems with more than three parameters may also be treated if an additional restraint is readily available. Consider the system of fig.4.9 which uses both cascade and feedback compensation, and for which the characteristic equation is:

$$s^4 + (3 + p)s^3 + (2 + 3p + Kk_t)s^2 + (2p + Kk_t + p + \frac{Kp}{z})s + Kp = 0$$

let $k_t = \alpha$ and $\frac{1}{z} = \beta$

then

$$\alpha = \frac{K_p(U_{-1}U_1 - U_o^2) + (2 + 3p)\omega^2(U_1^2 - U_oU_2) + (3 + p)\omega^3(U_oU_3 - U_1U_2) + \omega^4(U_1U_3 - U_oU_4)}{K\omega^2(U_oU_2 - U_1^2)}$$

$$\beta = \frac{K_p(U_o^2 - U_{-1}U_1) + K_p\omega(U_{-1}U_2 - U_oU_1) + \omega^2(2 + p)(U_oU_2 - U_1^2) + (3 + p)\omega^3(U_1U_2 - U_oU_3) + \omega^4(3 + p)(U_oU_4 - U_2^2) + \omega^5(U_2U_3 - U_1U_4)}{Kp\omega^2(U_oU_2 - U_1^2)}$$

and the error coefficient specification gives

$$K_v = \frac{K}{2K + Kk_t} = \frac{K}{2 + K\alpha}$$

from which $\alpha = \frac{1}{K_v} - \frac{2}{K}$

An additional constraint is needed to supply a fourth relationship. Since the choice of a pair of complex roots normally assumes that they will be dominant, a logical choice for another constraint is that of a location for one real root which is sufficiently large to be compatible with the dominance assumption.

Let

$$s = -\sigma_1$$

and substitute in the characteristic equation:

$$\begin{aligned} & + \sigma_1^4 + (3 + p)(-\sigma_1^3) + (2 + 3p + K\alpha)\sigma_1^2 \\ & + (2p + Kp\alpha + Kp\beta)(-\sigma_1) + Kp = 0 \end{aligned}$$

from which

$$\alpha(K\sigma_1^2 - Kp\sigma_1) - \beta Kp\sigma_1 + \sigma_1^4 - (3 + p)\sigma_1^3 + (2 + 3p)\sigma_1^2 - 2p\sigma_1 + Kp = 0$$

Choosing numerical values for the complex root location, for K_v and σ_1 then provides four equations that can be solved for α , β , p and K , though the solution is not necessarily easy because the equations are not linear.

REFERENCES (Chapter 4)

1. Siljak, D. D.: Analysis and Synthesis of Feedback Control Systems in the Parameter Plane. Pt. I, II, III, IEEE Transactions on Applications and Industry, vol. 83, Nov., 1964.
2. Siljak, D. D.: Generalization of the Parameter Plane Method. IEEE Transactions on Automatic Control, vol. AC-11, Jan., 1966.
3. Nutting, R. M.: Parameter Plane Techniques for Feedback Control Systems. MS Thesis, USN Postgraduate School, 1965.
4. Miller, A. R.: Parameter Plane Analysis of Sampled Data Systems. Ph.D Thesis, USN Postgraduate School, 1965.
5. Hollister, F. H.: Network Analysis and Design by Parameter Plane Techniques. Ph.D Thesis, USN Postgraduate School, 1965.
6. Hollister, F. H.; Thaler, G. J.: Loaded and Null Adjusted Symmetrical Parallel-Tee Network. Proc. of National Electronics Conference, 1965, vol. 21.
7. Hollister, F.H.; Thaler, G. H.: Parameter Plane Analysis and Design of the Symmetrical Parallel Tee Network. Proc. Allerton Conference on Circuits and Systems, 1965.

Appendix A

THE D-PARTITION METHOD

Consider any polynomial of the form

$$\sum_{i=0}^{i=n} a_i s^i = 0$$

and restrict the value of n to be some chosen finite integer $n = N$. Then a space of N -dimensions can be defined as a rectangular coordinate space in which each of the coefficients $a_0, a_1, a_2, \dots, a_{n-1}, a_N$ is a coordinate axis. Each point in this coefficient space defines a complete set of a -coefficients, and therefore a complete set of roots for the specific polynomial. In general, these roots may be located anywhere on the s -plane, but there must exist in the coefficient space a set of points for which all roots are in the left half of the s -plane. The boundary of this set of points is then the stability boundary, and it may be said that this boundary PARTITIONS the coefficient space into a stable region and an unstable region. Obviously, the above statements are valid for any value of the order n , and thus apply to any order polynomial.

The stability boundary, by the nature of its definition, is a boundary such that any point on this boundary guarantees that the polynomial in question has roots on the imaginary axis of the s -plane; either complex roots or a single real root at the origin. The converse is not true, however; i.e., if it is possible to find a point in coefficient space such that the polynomial has roots on the imaginary axis, this does not guarantee that the point is on the stability boundary, since other roots may be in the right half of the s -plane. The basic technique of the D-partition method is to find a curve such that each point on the curve guarantees roots on the imaginary axis of the s -plane. Then an additional check is required to determine whether any sections of this curve are on the stability boundary.

In concept, the curve determined could be a multidimensional space curve, or a hypersurface; in practice the curve must be two-dimensional to be useful and thus the D-partition calculations are normally restricted

to two parameters. These parameters may be one or two coefficients of the polynomial, or they may be other quantities such as gains, time constants, etc., that enter one or many coefficients. Examples of the types of parameters that are readily handled are

$$s^3 + a_2 s^2 + Xs + Y = 0$$

$$s^3 + (aX + b)s^2 + (cY + d)s + eX + f = 0$$

$$s^3 + (aX + bY + c)s^2 + (dX + eY + f)s + gX + hY + i = 0$$

where it is seen that the parameters X and Y appear linearly in the coefficients. As will be shown, such combinations are easily treated because an algebraic solution of the equations for these parameters is readily accomplished. It is also possible to apply D-partition methods to polynomials with more complex combinations of two parameters such as

$$s^3 + (aX + bY + cXY + d)s^2 + (eX + f)s + gY + hXY + i = 0$$

In fact, the coefficients can be the general quadratic form. However, the calculations involved are sufficiently complex that they require the use of a digital computer.

The D-partition method is applied by mapping the imaginary axis of the s-plane through the characteristic polynomial onto a parameter plane. This is done by making the substitution $s = j\omega$ in the polynomial, requiring that the real and imaginary part of the polynomial go to zero independently, and thus obtaining two independent equations for the parameters in terms of ω . Thus, as the frequency is varied from $-\infty < \omega < +\infty$, for each value of ω a pair of values are determined for the parameters; and if the parameters are adjusted to these values, it is guaranteed that the polynomial will have roots on the imaginary axis of the s-plane. The curve determined in this fashion is a Partition curve and it encloses an area on the X-Y (or parameter) plane. If the parameters are set to values corresponding to a point in the enclosed area, it is guaranteed that the polynomial has at least some roots in the left half of the s-plane. In particular, the roots associated with

the calculated Partition curve are in the left half plane, but it is not guaranteed that all roots are in the left half plane; that is, the Partition curve is not necessarily the stability boundary, as will be shown, and the additional checks are needed.

As simple illustrations, consider

$$s^3 + as^2 + Xs + Y = 0$$

let $s \equiv j\omega$

$$j\omega(-\omega^2 + X) + (Y - a\omega^2) = 0$$

from which

$$X = \omega^2, \quad Y = a\omega^2$$

are the parametric solutions and define the Partition curve as a straight line on the X vs Y plane. This obviously is the Mitrovic curve for $\zeta = 0$ and need not be pursued here.

Next consider

$$s^3 + (a + bp)s^2 + (c + pd)s + e + pf = 0$$

let $s \equiv j\omega$; or equivalently*, rearrange the polynomial so that

$$s^3 + as^2 + cs + e + p(bs^2 + ds + f) = 0$$

from which

$$p = -\frac{s^3 + as^2 + cs + e}{bs^2 + ds + f}$$

Now let $s \approx j\omega$

$$p = \frac{-j\omega^3 - a\omega^2 + j\omega + e}{-b\omega^2 + dj\omega + f}$$

It is convenient to define p to be complex; i.e., let $p = u + jv$, in order to obtain a curve on a two-dimensional $u-v$ plane. The right hand side is then resolved into real and imaginary parts and solutions for u and v obtained. The curve on the $u-v$ plane then encloses an area, but for practical physical systems a parameter such as p must be real

*This form corresponds to the Russian approach, but is not necessary. Direct substitution of $j\omega$ is adequate.

(and usually positive) so that only points on the u axis are meaningful.

For an equation such as

$$s^3 + (aX + bY + c)s^2 + (dX + eY + f)s + gX + hY + i = 0$$

one can substitute $s \equiv j\omega$ and solve for X and Y using Cramer's rule.

Note that the equation becomes

$$-j\omega^3 - \omega^2 (aX + bY + c) + j\omega(dX + eY + f) + gX + hY + i = 0$$

from which

$$-\omega^2 + (dX + eY + f) = 0, \quad -\omega^2(aX + bY + c) + gX + hY + i = 0$$

Rearranging,

$$dX + eY + f - \omega^2 = 0, \quad (g - a\omega^2)X + (h - b\omega^2)Y + i - c\omega^2 = 0$$

which is of the form

$$AX + BY + C = 0, \quad DX + EY + F = 0$$

and by Cramer's Rule,

$$X = \frac{CE - FB}{AE - DB}, \quad Y = \frac{FA - CD}{AE - DB}$$

Thus

$$X = \frac{(f - \omega^2)(h - b\omega^2) - (i - c\omega^2)e}{d(h - b\omega^2) - (g - a\omega^2)e}$$

$$Y = \frac{(i - c\omega^2)d - (f - \omega^2)(g - a\omega^2)}{d(h - b\omega^2) - (g - a\omega^2)e}$$

Illustrations No. 1

Consider the polynomial

$$s^2 + ps + 10 = 0$$

where p is the adjustable parameter and is defined to be complex;

$p = u + jv$. Letting $s \equiv j\omega$ and substituting

$$-\omega^2 + (u + jv)j\omega + 10 = 0$$

from which

$$+ u\omega = 0$$

$$-\omega^2 + 10 - v\omega = 0$$

No plot is required since $u = 0$, and the obvious interpretation is that

the equation can have imaginary roots only when $p = 0$.

Illustration No. 2

For the polynomial

$$2ps^2 + (2 + p)s + 2 = 0$$

note that

$$p(2s^2 + s) + 2s + 2 = 0$$

$$p = \frac{2(s + 1)}{2s^2 + s}$$

Let $p = u + jv$ and let $s = j\omega$

$$u + jv = \frac{2j\omega + 2}{-2\omega^2 + j\omega} - \frac{-\omega^2 - j(\omega + 2\omega^3)}{\omega^2 + 4\omega^4}$$

from which

$$u = \frac{-\omega^2}{\omega^2 + 4\omega^4}$$

$$v = \frac{-\omega - 2\omega^3}{\omega^2 + 4\omega^4}$$

A plot of these equations is shown on the $u-v$ plane of fig. A.1. The hatching on the curve follows the rule of Neimark; i.e., as one follows the curve in the direction of increasing ω , the hatching is on the left hand side. The $u-v$ plane is partitioned into two areas in this case, and the two roots can move from the left half s -plane to the right half if the values of $p(u,v)$ is altered so that the parameter point crosses the partition curve from the hatched side to the unhatched side. In this case, there are only two roots so the regions can be marked "stable" and "unstable". Also, this is a one-parameter case so that p must be a real number for physical realizability; then only points on the real axis of fig. A.1 have physical meaning.

Consider next the polynomial

$$s^5 + 7s^4 + 18s^3 + B_2s^2 + B_1s + 6$$

where two parameters are B_1 and B_2 . By manipulation, it follows that

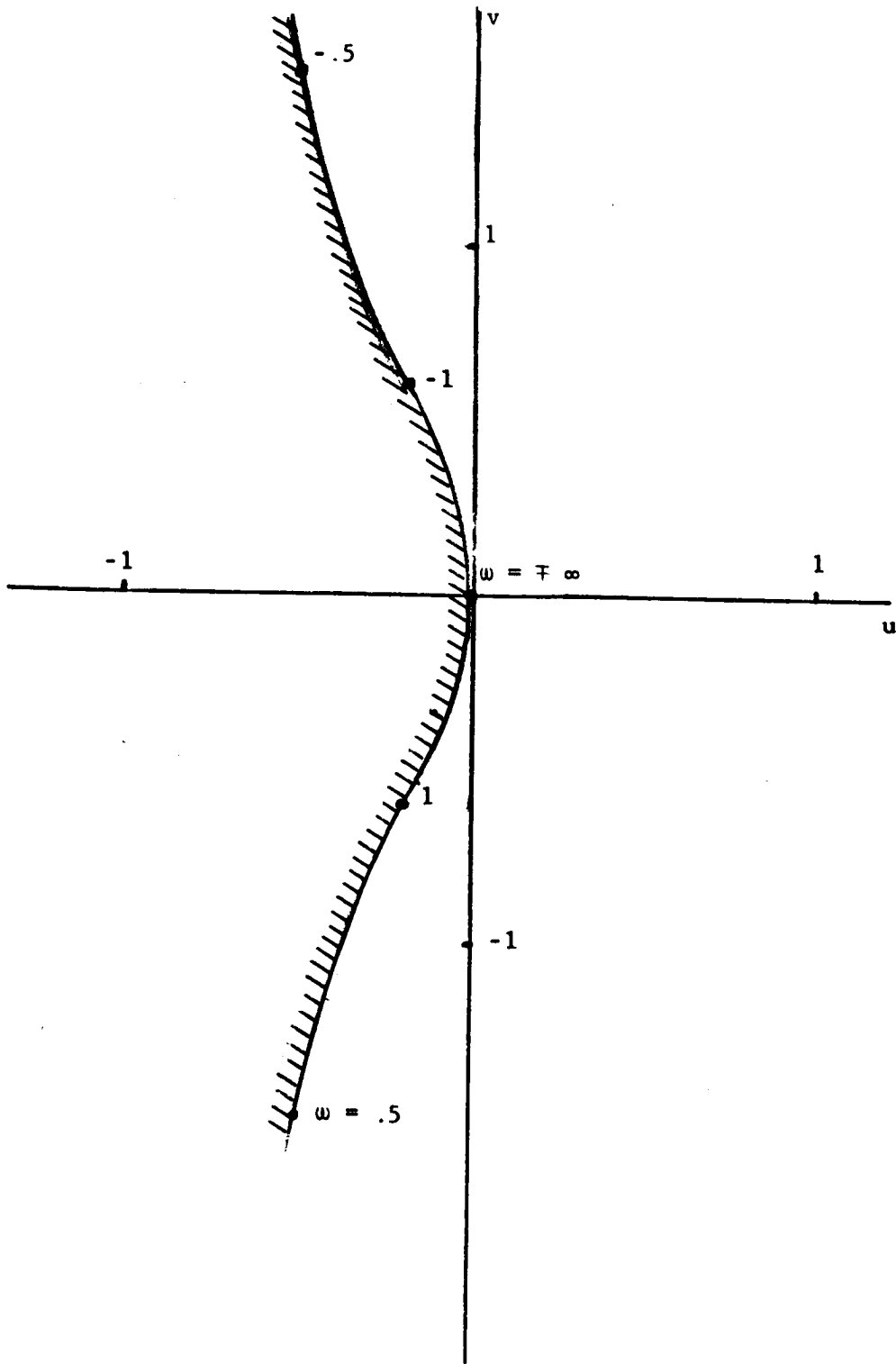

Fig. A.1 D - partition for $2ps^2 + (2 + p)s + 2 = 0$

$$B_1 = 18\omega^2 - \omega^4, \quad B_2 = \frac{6}{\omega^2} + 7\omega^2$$

The D-partition curve is shown on fig. A.2 with hatching included, and the number of roots in the left half s-plane indicated for each area. In general, the evaluation of the number of roots within one area must be determined by some other method (such as the Routh test); then evaluation for the remaining areas is done with Neimark's hatching rules.

The D-partition curves are precisely the same as the Parameter Plane curve for $\zeta = 0$. However, the derivation of the D-partition curves follow a purely algebraic manipulation and results in rather cumbersome expressions. In deriving the Parameter Plane relationships, Siljak recognized the possibility of using Chebishev functions, which greatly reduces the computational labor. It is suggested that application of the D-partition method would be greatly facilitated by introducing the Chevi-shev function. Other advantages of the Parameter Plane approach will be pointed out as the occasion arises.

Note: The Chebishev functions are introduced as follows:

$$\begin{aligned} s &\equiv -\zeta\omega + j\omega\sqrt{1 - \zeta^2} \\ &\equiv \omega(\cos \theta + j \sin \theta) \\ &\equiv \omega e^{j\theta} \end{aligned}$$

where ω is the radial distance from the origin of the s-plane to the designated point.

$$\zeta = \cos (\pi - \theta)$$

θ = angle of radial line from origin to point.

It follows that

$$\begin{aligned} s^k &= \omega^k e^{jk\theta} \\ &= \omega^k (\cos k\theta + j \sin k\theta) \end{aligned}$$

but the Chebishev functions are

$$\begin{aligned} T_k(\zeta) &= \cos (k \cos^{-1} \zeta) \\ U_k(\zeta) &= \frac{\sin(k \cos^{-1} \zeta)}{\sin(\cos^{-1} \zeta)} \end{aligned}$$

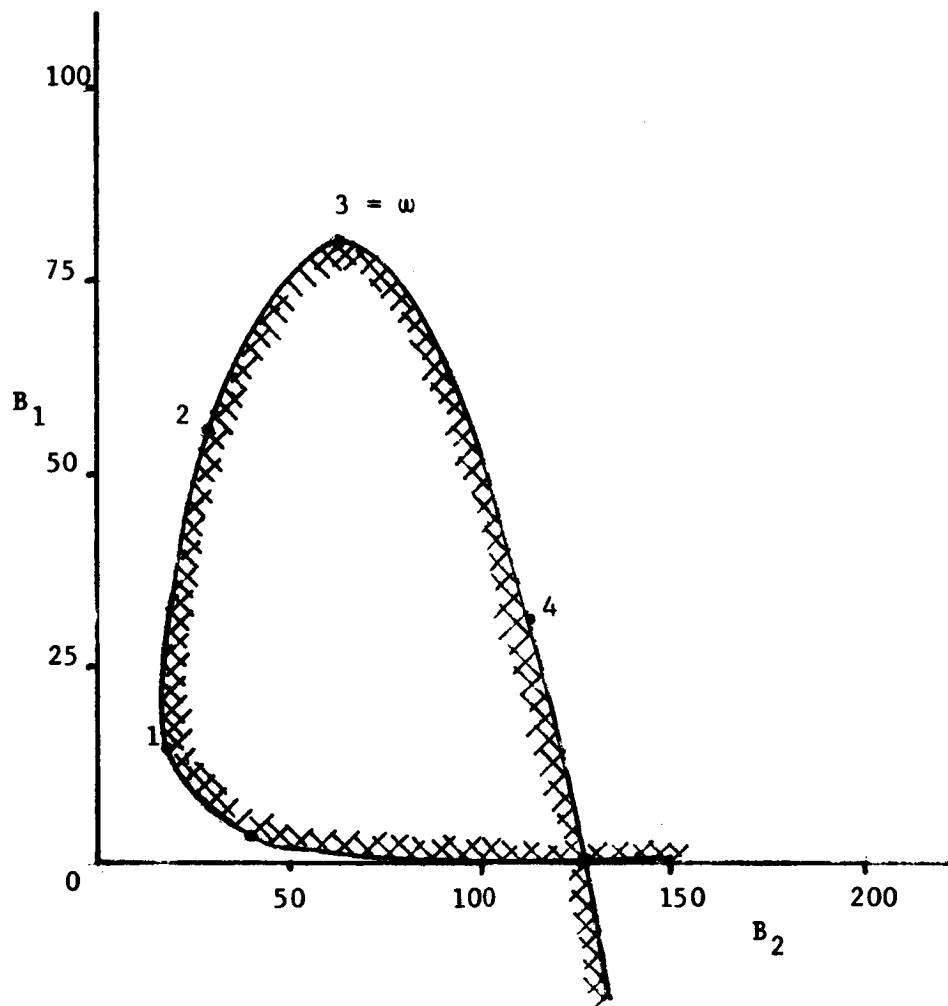

Fig. A.2 D-Partition for
 $s^5 + 7s^4 + 18s^3 + B_2s^2 + B_1s + 6 = 0$

from which

$$\begin{aligned} s^k &= \omega^k \left[T_k(-\zeta) + j \sqrt{1-\zeta^2} U_k(-\zeta) \right] \\ &= \omega^k \left[(-1)^k T_k(\zeta) + j(-1)^{k+1} \sqrt{1-\zeta^2} U_k(\zeta) \right] \end{aligned}$$

Inserting this result in a polynomial and requiring that the real part and the imaginary part go to zero independently, there results

$$\begin{aligned} \sum_{k=0}^n a_k \omega^k (-1)^k U_{k-1}(\zeta) &= 0 \\ \sum_{k=0}^n a_k \omega^k (-1)^k U_k(\zeta) &= 0 \end{aligned}$$

If the coefficients are linear functions of two parameters

$$a_k = b_k \alpha + c_k \beta + d_k$$

the polynomials become

$$\alpha B_1(\zeta, \omega) + \beta C_1(\zeta, \omega) + D_1(\zeta, \omega) = 0$$

$$\alpha B_2(\zeta, \omega) + \beta C_2(\zeta, \omega) + D_2(\zeta, \omega) = 0$$

where

$$B_1 = \sum_{k=0}^p (-1)^k b_k \omega^k U_{k-1}, \quad B_2 = \sum_{k=0}^p (-1)^k b_k \omega^k U_k$$

$$C_1 = \sum_{k=0}^q (-1)^k c_k \omega^k U_{k-1}, \quad C_2 = \sum_{k=0}^q (-1)^k c_k \omega^k U_k$$

$$D_1 = \sum_{k=0}^r (-1)^k d_k \omega^k U_{k-1}, \quad D_2 = \sum_{k=0}^r (-1)^k d_k \omega^k U_k$$

The solutions for α and β are of the form

$$\alpha = \frac{C_1 D_2 - C_2 D_1}{B_1 C_2 - B_2 C_1} \quad \beta = \frac{B_2 D_1 - B_1 D_2}{B_1 C_2 - B_2 C_1}$$

These results can be written by inspection once the Chebishev function relationships are seen, programming in a computer is simplified, and even longhand calculations are made less laborious. Note that the D-partition curve is obtained when the Chebishev functions are evaluated for $\zeta = 0$.

REFERENCES

1. Meerov, M. V.: Introduction to the Dynamics of Automatic Regulating of Electrical Machines. Butterworths, London, 1961.
2. Aizerman, M. A.: Theory of Automatic Control. Pergamon Press, Addison-Wesley Pub. Co., Reading, Mass., 1963.
3. Lanzkrom, R. W.; and Higgins, T. J.: D-Decomposition Analysis of Automatic Control Systems. AIEE Conf. Paper, about 1957.
4. Lehnigk, S. H.: On Stability Regions of Polynomials Having Parameter Dependent Coefficients. ABMZ-DG-TM-5-60.
5. George, J.H.: "Comments on "A New Stability Criterion of Linear Servomechanisms by a Graphical Method". ABMA-DG-TM-20-59.
6. Hosenthien, H.H.: Stability Limits of a Sixth-Order System. Definition of a Stable Area Based on the Hurwitz Criterion". ABMA-G & C-MEMO 137.
7. Blanton, J.E.: Stability Regions for an Accelerometer Controlled Missile. ABMA-DG-TM-50-59.
8. Numakura, T.; and Miura, T.: Servomechanisms by a Graphical Method. Trans. AIEE, Pt. II, March, 1957.

APPENDIX B
FUNCTIONS $U_k(\zeta)$

ζ	U_0	U_1	U_2	U_3	U_4	U_5	U_6	U_7	U_8	U_9
0.00	1	0.00	-1.000	0.0000	1.0000	0.0000	-1.00000	0.0000	1.0000	0.0000
0.05	1	0.05	-0.995	-1.1495	0.9800	0.3475	-0.94529	-0.4420	0.9010	0.5321
0.10	1	0.10	-0.980	-0.2960	0.9208	0.4801	-0.84276	-0.6451	0.6957	0.7842
0.15	1	0.15	-0.955	-0.4365	0.8240	0.6837	-0.61893	-0.8693	0.3581	0.9768
0.20	1	0.20	-0.920	-0.5680	0.6928	0.8451	-0.35475	-0.9870	-0.0400	0.9709
0.25	1	0.25	-0.875	-0.6875	0.5312	0.9531	-0.05468	-0.9804	-0.4355	0.7626
0.30	1	0.30	-0.820	-0.7920	0.3448	0.9988	0.25452	-0.8461	-0.7622	0.3888
0.35	1	0.35	-0.755	-0.785	0.1400	0.9765	0.54352	-0.5960	-0.9607	-0.0764
0.40	1	0.40	-0.680	-0.9440	-0.0752	0.8838	0.78227	-0.2580	-0.9886	-0.5329
0.45	1	0.45	-0.595	-0.9855	-0.2919	0.7227	0.94242	0.1254	-0.8295	-0.8720
0.50	1	0.50	-0.500	-1.0000	-0.5000	0.5000	1.00000	0.5000	-0.5000	-1.0000
0.55	1	0.55	-0.395	-0.9845	-0.6879	0.2277	0.93848	0.8045	-0.0534	-0.8633
0.60	1	0.60	-0.280	-0.9360	-0.8432	-0.0758	0.75219	0.9784	-0.4219	-0.4721
0.65	1	0.65	-0.155	-0.8515	-0.9519	-0.3860	0.45010	0.9711	0.8124	0.0849
0.70	1	0.70	-0.020	-0.7280	-0.9992	-0.6708	0.05996	0.7548	0.9968	0.6406
0.75	1	0.75	0.125	-0.5625	-0.9687	-0.8906	-0.36718	0.3398	0.8769	0.9755
0.80	1	0.80	0.280	-0.3520	-0.8432	-0.9971	-0.75219	0.2063	0.4219	0.8815
0.85	1	0.85	0.445	-0.0935	-0.6039	-0.9332	-0.98251	-0.7370	-0.2704	0.2772
0.90	1	0.90	0.620	0.2160	-0.2312	-0.6321	-0.90668	-0.9998	-0.8930	-0.6076
0.95	1	0.95	0.805	0.5795	0.2960	-0.0170	-0.32835	-0.6068	-0.8247	-0.9600
1.00	1	1.00	1.000	1.0000	1.0000	1.0000	1.00000	1.0000	1.0000	1.0000

"The aeronautical and space activities of the United States shall be conducted so as to contribute . . . to the expansion of human knowledge of phenomena in the atmosphere and space. The Administration shall provide for the widest practicable and appropriate dissemination of information concerning its activities and the results thereof."

—NATIONAL AERONAUTICS AND SPACE ACT OF 1958

NASA SCIENTIFIC AND TECHNICAL PUBLICATIONS

TECHNICAL REPORTS: Scientific and technical information considered important, complete, and a lasting contribution to existing knowledge.

TECHNICAL NOTES: Information less broad in scope but nevertheless of importance as a contribution to existing knowledge.

TECHNICAL MEMORANDUMS: Information receiving limited distribution because of preliminary data, security classification, or other reasons.

CONTRACTOR REPORTS: Technical information generated in connection with a NASA contract or grant and released under NASA auspices.

TECHNICAL TRANSLATIONS: Information published in a foreign language considered to merit NASA distribution in English.

SPECIAL PUBLICATIONS: Information derived from or of value to NASA activities. Publications include conference proceedings, monographs, data compilations, handbooks, sourcebooks, and special bibliographies.

TECHNOLOGY UTILIZATION PUBLICATIONS: Information on technology used by NASA that may be of particular interest in commercial and other nonaerospace applications. Publications include Tech Briefs; Technology Utilization Reports and Notes; and Technology Surveys.

Details on the availability of these publications may be obtained from:

SCIENTIFIC AND TECHNICAL INFORMATION DIVISION
NATIONAL AERONAUTICS AND SPACE ADMINISTRATION

Washington, D.C. 20546