

## **General Disclaimer**

### **One or more of the Following Statements may affect this Document**

- This document has been reproduced from the best copy furnished by the organizational source. It is being released in the interest of making available as much information as possible.
- This document may contain data, which exceeds the sheet parameters. It was furnished in this condition by the organizational source and is the best copy available.
- This document may contain tone-on-tone or color graphs, charts and/or pictures, which have been reproduced in black and white.
- This document is paginated as submitted by the original source.
- Portions of this document are not fully legible due to the historical nature of some of the material. However, it is the best reproduction available from the original submission.

NI

DRF  
W/

MONOGRAPH 14  
*FRBZ*

# KINEMATICS NOMENCLATURE FOR PHYSIOLOGICAL ACCELERATIONS

*With Special Reference to Vestibular Applications*

W. Carroll Hixson, Jorma I. Niven, and Manning J. Correia

N 67-53331	
(ACCESSION NUMBER)	(PAGES)
98	83568
(THRU)	(CATEGORY)
(CODE)	OS
(NASA CR OR TMX OR AD NUMBER)	

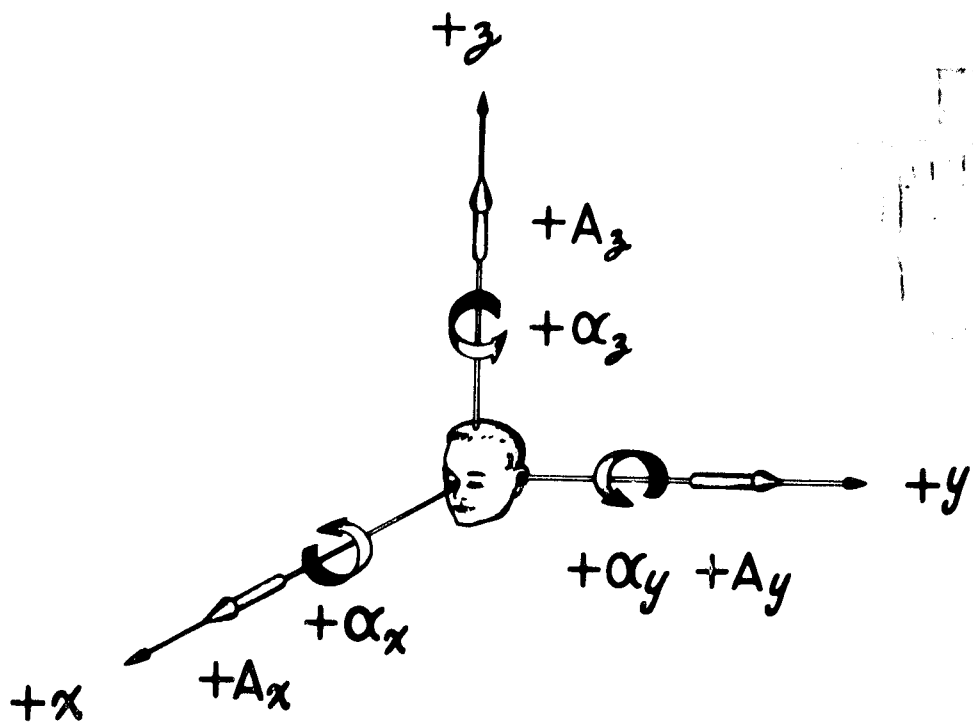

RECEIVED  
AUG 10 1967  
LIBRARY

NAVAL AEROSPACE MEDICAL INSTITUTE  
NATIONAL AERONAUTICS AND SPACE ADMINISTRATION



August 1966

Distribution of this document is unlimited.

Distribution of this document is unlimited.

KINEMATICS NOMENCLATURE FOR PHYSIOLOGICAL ACCELERATIONS\*

With Special Reference to Vestibular Applications

W. Carroll Hixson, Jorma I. Niven, and Manning J. Correia

Monograph 14

Approved by

Ashton Graybiel, M. D.  
Director of Research

Released by

Captain H. C. Hunley, MC USN  
Commanding Officer

8 August 1966

\*This research was sponsored in part by the Office of Advanced Research and Technology, National Aeronautics and Space Administration, NASA R-93.

NAVAL AEROSPACE MEDICAL INSTITUTE  
NAVAL AEROSPACE MEDICAL CENTER  
PENSACOLA, FLORIDA 32512

## ACKNOWLEDGMENTS

The authors wish to acknowledge their debt to Drs. Hermann J. Schaefer and Fred E. Guedry, Jr., for discussion and comment throughout the preparation of this monograph and most especially to Dr. Ashton Graybiel who has provided both the research climate and the impetus for the present endeavor.

We wish also to thank Geraldine E. Thomas for her patience and skill in the typing of the manuscript.

## TABLE OF CONTENTS

I. INTRODUCTION	1
II. BASIC ACCELERATION NOTATION	2
THE CARDINAL HEAD AXES AND PLANES	3
RESULTANT LINEAR ACCELERATION	3
General Notation	3
Magnitude/Direction Notation	9
Dimensional Units	10
RESULTANT ANGULAR ACCELERATION	10
General Notation	10
Magnitude/Direction Notation	11
Dimensional Units	12
III. DISCUSSION AND RATIONALE	12
SELECTION OF THE BASIC NOTATION	18
Morphological Reference Frame	18
Resultant Acceleration Symbols	19
RELATION TO THE $G$ AND $\dot{R}$ REACTION SYMBOLS	20
IV. RECOMMENDED APPLICATION FORMAT	21
ILLUSTRATIVE EXAMPLES	27
Earth-Vertical Rotation	27
Earth-Horizontal Rotation	32
Earth-Horizontal Translation	35
Translation Within a Rotating Environment	39
Rotation Within a Rotating Environment	50
Continuous Head Rotation at Constant Angular Velocity	56
Head Rotation Over a Finite Angle	61
Angular Acceleration Description of Angular Coriolis Stimuli	61
Angular Velocity Impulse Description of Angular Coriolis Stimuli	65
ANCILLARY CONSIDERATIONS	76
LIST OF REFERENCES	78
SYNOPSIS OF ACCELERATION NOTATION	79
APPENDIX	
NOMENCLATURE FOR SELECTED VESTIBULAR RESPONSES	A-1
STATIC AND DYNAMIC EYE MOTIONS	A-1
VISUAL TARGET ORIENTATION	A-4
THEORETICAL CUPULA-ENDOLYMPH MOTIONS	A-9
LIST OF REFERENCES	A-12

**BLANK PAGE**

## I. INTRODUCTION

A nomenclature system is needed to provide separate mathematical identifications for vestibular acceleration stimuli and related vestibular responses. The variety of acceleration environments encountered in the flight and simulation phases of manned space operations has broadened greatly the stimulus range over which the functional characteristics of the vestibular system must be evaluated. The accelerations may be static or dynamic, linear or angular; they may act singly, simultaneously, or jointly in cross-coupled Coriolis configurations. The evoked vestibular responses are correspondingly simple or complex. A review of the acceleration literature reveals many independent terminologies and notations; these, using different environmental or morphological references, limit optimal communication within and among the disciplines involved. Particularly significant is the absence of a formal man-referenced nomenclature to identify vestibular stimuli in kinematic terms, an interpretation fundamental to the study of motion and its biological effects.

A kinematics-based, man-referenced nomenclature directed specifically toward obtaining quantitative mathematical descriptions and notations for physiological acceleration stimuli and certain vestibular-related responses is proposed. Through kinematics, consistent definitions of all motion parameters, e.g., displacement and velocity as well as acceleration, result whether they pertain to a stimulus condition or to a movement of a biological organ or receptor. Selected morphological coordinates of man, rather than coordinates of some spatial environment which may change, are proposed as the primary reference standard for presentation of stimulus data.

The response nomenclature (Appendix) is similarly man-referenced and includes notation recommendations to describe the instantaneous angular displacement, velocity, and acceleration of the eyes so that static eye displacement and dynamic eye motion data can be mathematically identified and related to acceleration stimuli. Notation is provided to identify the spatial attitude of visual targets commonly used to measure the subjective perception of the direction of a static force field. Recommendations for the description of the theoretical motion parameters and related theoretical biophysical characteristics of the cupula-endolymph elements of the semicircular canals are also included.

The proposed nomenclature is also relevant to the general acceleration physiology area. It affords researchers in this field an alternative system for describing stimuli in terms of applied accelerations without the conflicts inherent in systems based on reacting forces and torques. The nomenclature does not cover all elements of the vestibular system; indeed, a comprehensive

system covering all possible stimulus-response configurations is not feasible. On the other hand, it does provide a set of acceleration standards which can find quantitative working application in both the vestibular and general physiological acceleration areas. The development of more inclusive standards must be the joint responsibility of all concerned with the biological effects of acceleration.

## II. BASIC ACCELERATION NOTATION

In this section, acceleration stimuli are defined by identifying separately the instantaneous resultant linear acceleration and the instantaneous resultant angular acceleration of the head and resolving each into its components acting along or about three mutually orthogonal cardinal head axes. By this procedure, stimuli arising from different devices or vehicles can be resolved into the same form for direct comparison of the acceleration environments. It is implicit throughout that the discussed accelerations are real in that their existence can be detected by inertial linear and inertial angular accelerometers and that they can produce actual displacements of internal biological mass elements relative to the skull. It is implicit also, that the directions of these stimuli, whether due to motion or gravitational action, are to be identified in the kinematical sense and thus linked to the applied forces of kinetics. Since the development of the nomenclature is keyed to these points, a few fundamentals of kinematics, its relationship to kinetics, and its representation of gravitational action will be recalled before presentation of the actual stimulus notation.

In kinematics, the motion parameters of a body, e.g., displacement, velocity, and acceleration are measured or calculated relative to some selected reference frame. The direction of a motion, and the direction of changes in motion, of the body are identified in exact correspondence with that which would be seen by an observer attached to the selected reference frame. Every change in the magnitude or direction of the velocity of the body relative to this frame is accompanied by an acceleration of the body relative to the same frame; the direction of the acceleration is symbolized by a vector drawn in the direction denoted by the observed velocity change. If the reference frame is of inertial origin, i.e., if it is held in static alignment with (or translates at constant velocity relative to) a point fixed in space, e.g., a fixed star, the observed acceleration is said to be real. For most practical purposes a reference frame fixed to the Earth's surface can be assumed to be of inertial origin if one accounts for gravitational action.

In many applications of kinematics, the direction of an acceleration relative to a body is not particularly significant. As a result, an identification of the resultant linear and angular acceleration of the body relative to directional references provided by the measurement frame is



usually an adequate problem solution. However, the direction of an acceleration relative to man is a critical determinant of the perceptual and physiological response to the stimulus. Accordingly, an anatomical reference frame must be established which will allow the directional characteristics of an acceleration environment to be man-referenced. Thus if the resultant acceleration of man is calculated initially relative to some directional reference of the environment, a definitive description of the stimulus will not result until the direction of the acceleration is further related to the selected anatomical reference frame.

Since man and his biological components possess the properties of mass, a kinematic description of his changes in motion is never really separated from a kinetic description of the force which must be applied to him to effect the change in motion. In general, the direction of a kinematics acceleration vector drawn to symbolize a change in motion of a body corresponds to the direction that a force vector is drawn to symbolize the direction that a force must be applied to the body to accomplish the change in motion. Though it would be possible to develop a nomenclature system based on the applied forces and torques of kinetics rather than the linear and angular accelerations of kinematics, the latter approach has distinct advantages in terms of numerical quantification of stimuli. The accelerations of kinematics are readily measured with inertial accelerometers and can be treated quantitatively without reference to the physical characteristics of man. An equivalent numeric identification of the forces and torques of kinetics cannot be presented without precise knowledge of the mass and rotational inertia characteristics of man. Although this knowledge is highly important, the development of a consistent nomenclature need not await its acquisition.

A point of major concern to the proper application of the proposed nomenclature is that when Earth's gravitational action on a body is described in terms of either an applied kinetic force or an equivalent kinematic acceleration, the related force or acceleration vector is drawn upward away from the Earth's surface. From the force viewpoint, a mass is held motionless on the Earth's surface when the surface applies an upward-directed force to the mass which is equal to the downward force exerted by the mass, i.e., weight, on the surface as a result of gravity. This concept and the equivalence of gravitational action to acceleration can be interpreted as follows: Consider a man standing at rest on the Earth's surface and assume, for the moment, that the Earth's gravitational field is nonexistent. Let a force be applied to the man, which results in his upward acceleration at increasing velocity away from the Earth's surface. This change in motion would be symbolized in kinematics by a linear acceleration vector drawn upward in alignment with an Earth-vertical axis; the applied force would be symbolized by a force vector drawn

in the same direction. During the period of acceleration, examine the direction of movement of an internal biological element, say, for example, the heart. As a result of the inertia of the heart, it will tend to maintain its original resting state of motion even though the torso is being accelerated upward. In other words, the heart is displaced downward relative to the torso, the actual displacement being a function of the torso acceleration, the mass of the heart, and the physical characteristics of its suspension system within the torso. Now consider the actual environment where the gravitational field is applied to man. For this case, the identical form of response condition arises when man stands motionless on the Earth's surface; the heart is displaced downward relative to the torso. In this context, kinematics equates gravitational action to an upward acceleration.

This relationship between gravitational action and inertial acceleration is formally stated by the "equivalence principle" which may be expressed as follows: The condition where a point mass,  $m$ , is moving at an acceleration,  $a$ , relative to an inertial reference frame is indistinguishable from the condition where the same mass is held motionless but exposed to a gravitational field,  $g$ , when  $a = g$ . That is,  $ma$  is indistinguishable from  $mg$ . From the biological viewpoint, the principle implies that man will not be able to sense the difference between the condition where he stands motionless on the Earth's surface in its gravitational field and the condition where he accelerates in free space (outside gravitational influence) at  $32.2 \text{ ft/sec}^2$ .

The relationship is readily observed on a practical basis when one makes a few selected measurements with an inertial linear accelerometer. Such an instrument is typified by transducers which obtain an electrical signal analog to the direction and magnitude of an acceleration acting along a given axis through the measurement of the displacement of a sensing mass relative to the transducer case. To illustrate, let the bidirectional sensing axis of such an instrument be aligned always with an axis perpendicular to the Earth's surface; assume that the transducer is oriented along this Earth-vertical axis so that when the case is accelerated upward away from the Earth's surface, a positive output signal is produced; and let the magnitude of the analog acceleration output signal be expressed as a multiple of  $g = 32.2 \text{ ft/sec}^2$ .

When the accelerometer is held motionless, its output will be  $+1.0g$  denoting the upward acceleration due to gravitational action. When the instrument is accelerated upward at  $32.2 \text{ ft/sec}^2$ , i.e., at a  $1.0g$  rate, away from the surface, a  $+2.0g$  output will result. If the instrument is allowed to free-fall, i.e., accelerate downward at  $32.2 \text{ ft/sec}^2$  relative to the Earth's surface, its output will be  $0.0g$  which denotes the weightless environment afforded by such a condition. The kinematics description of gravitational action is further emphasized by

noting that for a negative output signal to be produced (without altering the orientation of the accelerometer), the instrument must be accelerated downward at a rate greater than the acceleration of gravity. For example, the instrument would have to be accelerated downward relative to the Earth's surface at  $64.4 \text{ ft/sec}^2$  to produce an output of  $-1.0g$ .

## THE CARDINAL HEAD AXES AND PLANES

The cardinal axes of the head are defined as  $x$ ,  $y$ , and  $z$  and describe an erect, right-handed, rectangular Cartesian coordinate reference frame as illustrated in Figure 1. These axes and related cardinal planes of the head are anatomically established as follows: The horizontal plane of the head is defined by the highest point of both external auditory meati and the lowest point of the two eye sockets; the  $y$  axis is the line joining the highest point of both external auditory meati; the  $x$  axis lies in the horizontal head plane and intersects at right angles the midpoint of the  $y$  axis; the  $z$  axis is the line erected perpendicular to the horizontal head plane at the intersection of the  $x$  and  $y$  axes; the intersection of the mutually orthogonal  $x$ ,  $y$ , and  $z$  axes defines the origin of the reference frame.

To assign polarity sense to the cardinal head axes and to facilitate vector representation of accelerations acting along and about these axes,  $\bar{i}$ ,  $\bar{j}$ , and  $\bar{k}$  are defined as unit vectors directed along the  $x$ ,  $y$ , and  $z$  axes, respectively. The positive directions of  $x$ ,  $y$ , and  $z$ , as defined by  $+\bar{i}$ ,  $+\bar{j}$ , and  $+\bar{k}$ , respectively, are toward the front, toward the left, and toward the vertex of the head, respectively. The  $yz$ ,  $xz$ , and  $xy$  planes identify the frontal, midsagittal, and horizontal planes of the head, respectively. For angular motions the  $x$ ,  $y$ , and  $z$  axes correspond to the roll, pitch, and yaw axes, respectively, of the head.

## RESULTANT LINEAR ACCELERATION

### General Notation

The instantaneous resultant linear acceleration of the head is to be identified in the kinematical sense and symbolized by the vector  $\bar{A}$ ; the identification shall include the contribution of gravitational action as well as all accelerations which occur as a result of movement relative to a fixed reference frame considered to be of inertial origin. For vestibular applications  $\bar{A}$  can be described by its components acting along each of the three cardinal head axes. These components are identified as  $A_x$ ,  $A_y$ , and  $A_z$  and individually represent the projection of  $\bar{A}$  to the  $x$ ,  $y$ , and  $z$  head axes, respectively, as illustrated at the top left in Figure 2. When it is desired to express  $\bar{A}$  in vector equation form, the  $\bar{i}$ ,  $\bar{j}$ , and  $\bar{k}$  unit vectors may be utilized

# VESTIBULAR NOMENCLATURE CARDINAL HEAD AXES AND PLANES

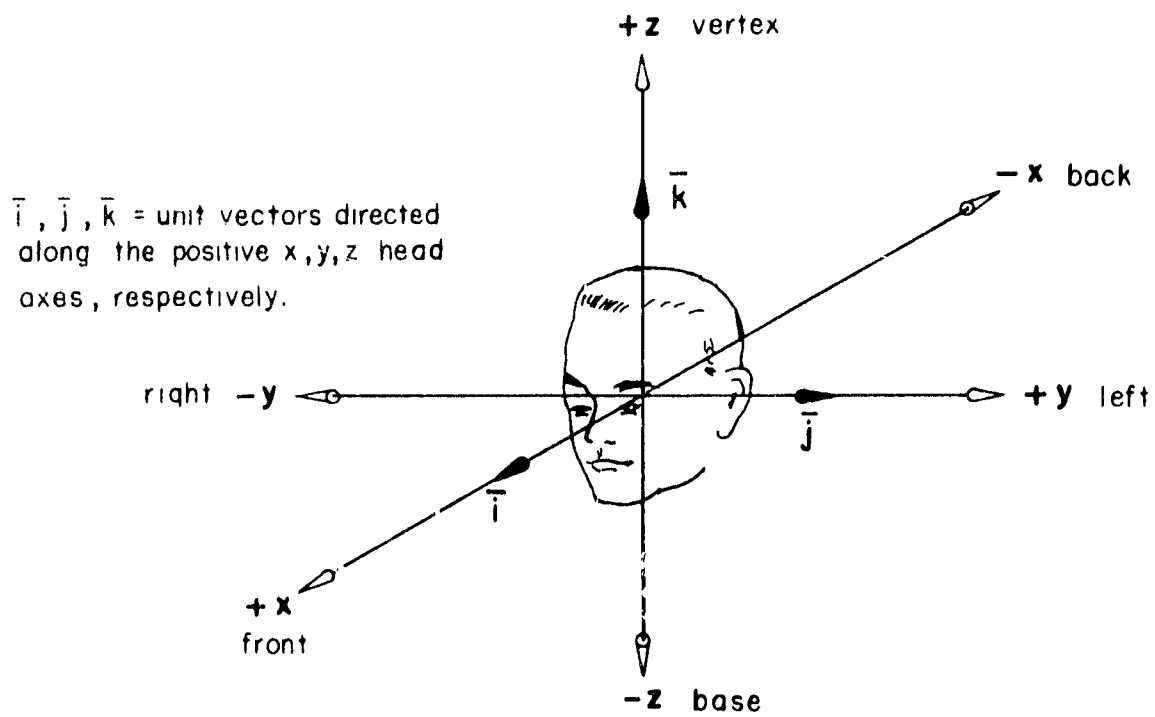

yz FRONTAL PLANE	xz MID-SAGITTAL PLANE	xy HORIZONTAL PLANE

Figure 1

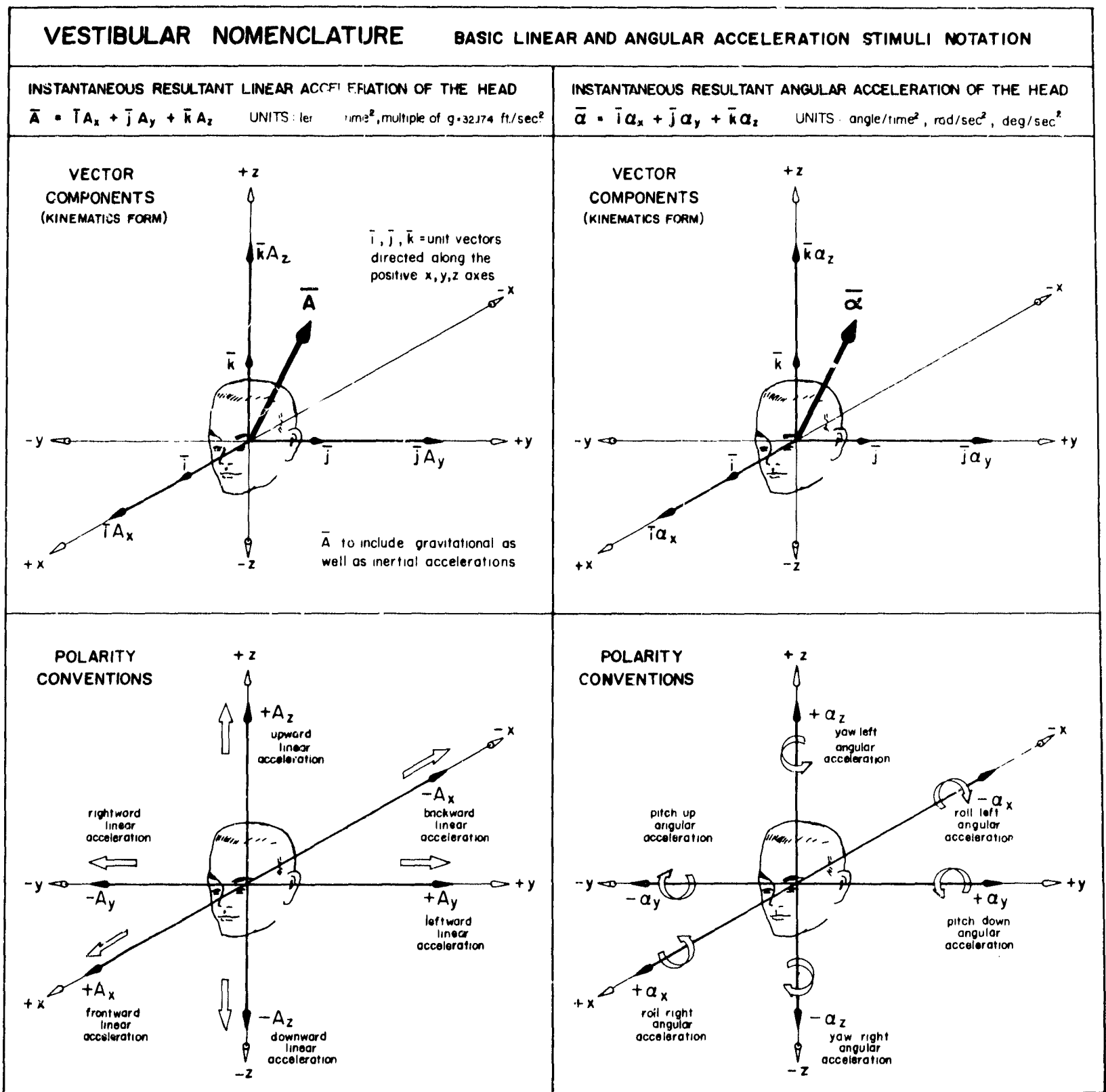

Figure 2

to establish directional references so that the resultant linear acceleration of the skull can be identified as

$$\bar{A} = \bar{i} A_x + \bar{j} A_y + \bar{k} A_z$$

where the absolute magnitude of  $\bar{A}$  is

$$|\bar{A}| = (A_x^2 + A_y^2 + A_z^2)^{\frac{1}{2}}$$

It is implicit that any of these accelerations may be time dependent so that  $\bar{A} \equiv \bar{A}(t)$ ,  $A_x \equiv A_x(t)$ ,  $A_y \equiv A_y(t)$ , and  $A_z \equiv A_z(t)$ .

When it is desired to describe  $\bar{A}$  by identifying the magnitude and direction of each of the  $A_x$ ,  $A_y$ , and  $A_z$  components without a unit vector prefix, the common convention of using a plus or minus sign to denote the direction of the component along the pertinent head axis can be followed. In all cases the polarity sign used to denote the direction of the component will derive from the polarity sense established for the cardinal head axes. For example, the symbol  $A_z$  describes the component of the resultant linear acceleration of the head directed along the  $z$  (head-foot) axis. When the component is directed along the  $+z$  axis to represent upward acceleration of the subject, positive values of  $A_z$  result; when directed along the  $-z$  axis to represent downward acceleration, negative values of  $A_z$  result. When it is desired to specify the direction of  $A_z$  in general terms, the notation  $+A_z$  or  $-A_z$  can be used to denote upward (headward) or downward (footward) directed acceleration. It follows that the directional characteristics of the components of  $\bar{A}$  are generally identified as

$+A_x =$  forward linear acceleration

$-A_x =$  backward linear acceleration

$+A_y =$  leftward linear acceleration

$-A_y =$  rightward linear acceleration

$+A_z =$  upward (headward) linear acceleration

$-A_z =$  downward (footward) linear acceleration

The vector representation of each of the above components is illustrated in the sketch at the bottom left in Figure 2.

### Magnitude/Direction Notation

Independent control of the magnitude and direction parameters of an acceleration stimulus acting solely within a single cardinal head plane represents a fundamental experimental approach to the study of the response characteristics of the vestibular system. This approach is exemplified by centrifuge studies concerned with the static response of the linear acceleration receptors and involving variations in steady-state centrifuge velocity and subject head tilt to obtain a change in magnitude and/or direction of the resultant of the accelerations due to gravitational and centripetal action. In such experimental situations analytical advantages can be gained if the magnitude and direction parameters of the acceleration acting in the given head plane can be separately identified.

This identification, in a form fully related to the previously defined  $A_x$ ,  $A_y$ , and  $A_z$  nomenclature, is afforded by conventional vector shorthand notation which allows an acceleration vector  $\bar{A}$  to be written as  $\bar{A} = |\bar{A}| \angle \phi$ . With this representation the absolute magnitude of the acceleration vector is identified as  $|\bar{A}|$ ; the morphological orientation of this vector relative to the anatomical reference frame of the subject is identified by the angle  $\phi$  (lower case Greek phi, sometimes  $\phi$ ). The nomenclature makes this notation definitive for each of the three cardinal head planes as follows. The projections of the resultant linear acceleration vector  $\bar{A}$  to the frontal  $yz$ , mid-sagittal  $xz$ , and horizontal  $xy$  head planes are identified as  $\bar{A}_{yz}$ ,  $\bar{A}_{xz}$ , and  $\bar{A}_{xy}$ , respectively, as illustrated in the three-dimensional sketch shown at the top in Figure 3. The orientation of these planar vectors in their related planes is identified by the angles  $\phi_x$ ,  $\phi_y$ , and  $\phi_z$  which measure the angular deviation of the planar vectors from a given head reference axis. Application of the vector shorthand notation results in a  $\bar{A}_{yz} = |\bar{A}_{yz}| \angle \phi_x$ ,  $\bar{A}_{xz} = |\bar{A}_{xz}| \angle \phi_y$ , and  $\bar{A}_{xy} = |\bar{A}_{xy}| \angle \phi_z$  magnitude/direction description of the planar components of  $\bar{A}$  acting in three cardinal head planes. A double subscript denoting the head plane of concern is used to distinguish between the planar vectors; each of the direction angles are distinguished by a single subscript which denotes the cardinal head axis about which the directional changes in the related planar vector occur.

A pictorial summary of the magnitude/direction notation for each of the cardinal head planes is shown in the two-dimensional sketches at the bottom in Figure 3. The mathematical relationships between this notation and the related  $A_x$ ,  $A_y$ , and  $A_z$  axial components of  $\bar{A}$  are summarized by the equations listed beneath the sketches. As shown in the sketch at the lower left, the  $+z$  head axis serves as reference for the  $\phi_x$  angular measure of the direction

of  $\bar{A}_{yz}$  in the frontal  $yz$  head plane; when  $\bar{A}_{yz}$  is directed upward along the  $z$  axis,  $\phi_x = 0^\circ$ . It can be inferred that whenever a change occurs in the morphological orientation of the  $\bar{A}_{yz}$  vector in this plane, the change is fully equivalent to rotation of the vector about the  $x$  head axis; hence the  $x$  subscript of  $\phi_x$ . On an intuitive basis, when a subject stands in a head erect posture in a normal gravitational field (i.e., with the  $+z$  head axis in alignment with the direction of  $\bar{A}$ ), changes in the direction of  $\bar{A}$  will occur in the frontal  $yz$  plane when the head is rolled toward the left or right shoulder, viz., when the head is rotated about its  $x$  head axis.

The notation follows correspondingly for the mid-sagittal  $xz$  plane as illustrated at the lower center in Figure 3. The head erect posture relative to  $\bar{A}_{xz}$  again serves as reference for measurement of the angle  $\phi_y$  where  $\phi_y = 0^\circ$  when  $\bar{A}_{xz}$  is directed upward along the  $+z$  head axis. The  $y$  subscript of  $\phi_y$  also follows since changes in the orientation of  $\bar{A}_{xz}$  in the mid-sagittal  $xz$  plane occur when the head is pitched forward or backward, i.e., rotated about the  $y$  head axis. For the horizontal  $xy$  head plane, illustrated at the lower right in Figure 3, the supine posture serves as reference for measurement of the direction of  $\bar{A}_{xy}$  where  $\phi_z = 0^\circ$  when  $\bar{A}_{xy}$  is directed along the  $+x$  head axis. For this orientation yaw-type head tilts about the  $z$  axis lead to changes in the orientation of  $\bar{A}_{xy}$  in the horizontal  $xy$  head plane.

The drafting conventions of Figure 3 for the display of the three cardinal head axes are also adopted in all subsequent discussions involving the magnitude/direction notation. The frontal  $yz$ , mid-sagittal  $xz$ , and horizontal  $xy$  head planes will always be drawn as seen by an observer viewing the subject from the direction of his  $+x$ ,  $+y$ , and  $+z$  head axes, respectively, i.e., as seen from the front, to the left, and above the subject. Further, the  $+z$  head axis will be drawn upright in alignment with the long (vertical) dimension of the page in the frontal  $yz$  and mid-sagittal  $xz$  views; the  $+x$  head axis will be placed in similar alignment for the horizontal  $xy$  view.

Using these conventions, each of the three planar vectors will be in its zero reference position ( $\phi = 0^\circ$ ) when drawn upright on the page. In accordance with standard trigonometric practice, the measurement of  $\phi$  as a positive or negative angle when the planar vector is displaced away from its zero reference position follows identically for each plane. That is,  $\phi$  is measured as a positive angle when the planar vector is angularly displaced in the direction produced by counterclockwise (CCW) rotation of the vector away from its zero reference



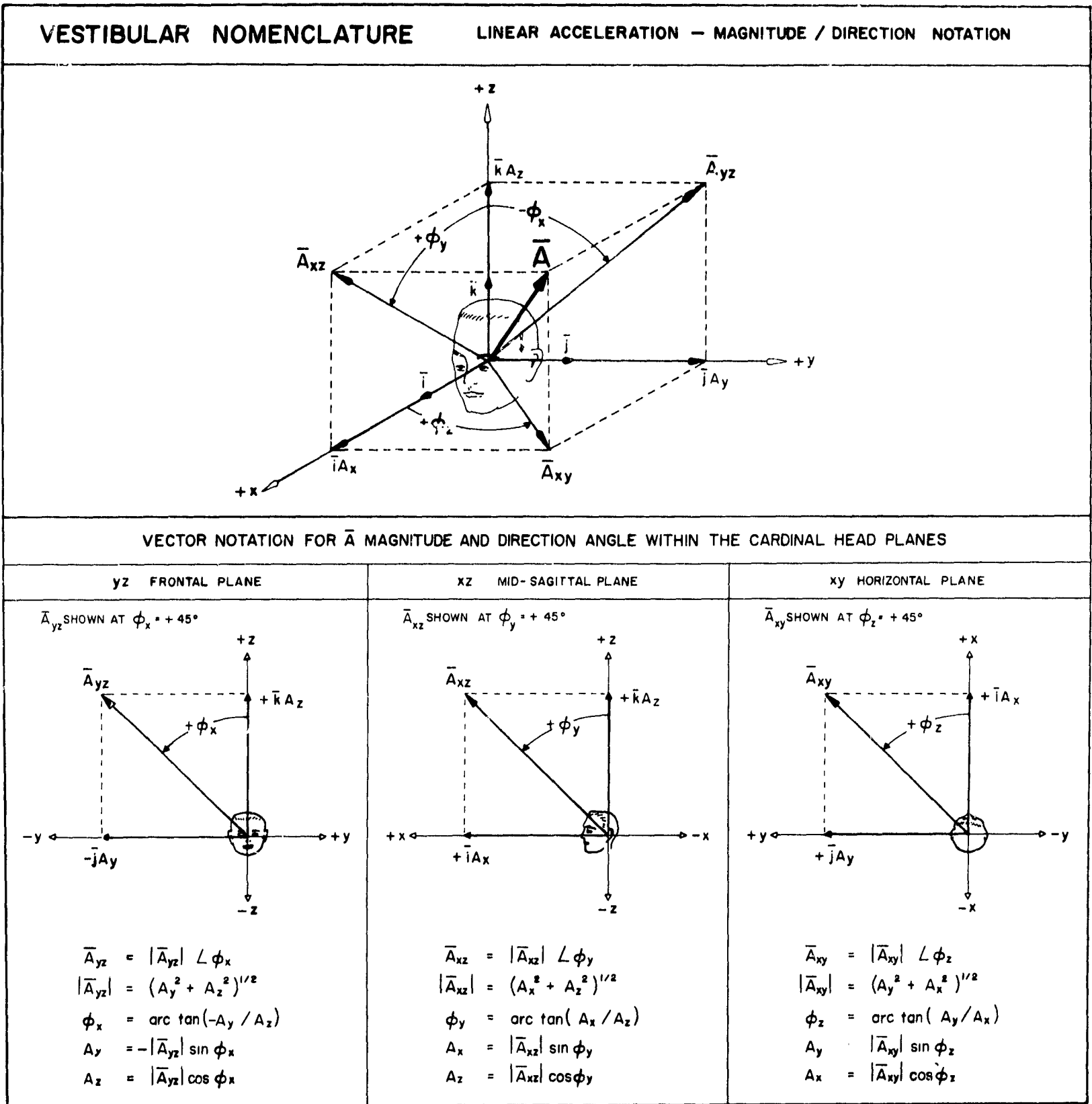

Figure 3

position as viewed in Figure 3. An angular displacement of the planar vector in the direction produced by clockwise (CW) rotation away from the zero reference position is measured as a negative  $\phi$  angle. Since  $\bar{A}_{yz}$ ,  $\bar{A}_{xz}$ , and  $\bar{A}_{xy}$  are all drawn in comparable CCW displacements in the three sketches at the bottom in Figure 3, the direction of these vectors in their related planes is described by equal and positive  $\phi$  angles; in this case  $\phi_x = \phi_y = \phi_z = +45^\circ$ . (It should be recognized that coterminal angles, e.g.,  $\phi = +45^\circ$  and  $\phi = -315^\circ$ , provide identical descriptions of the morphological orientation of the planar vector.)

A further clarification of these conventions can be gained by treating each sketch in Figure 3 independently and assuming that the related planar vector describes the acceleration due to gravitational action. Thus for the sketch at the left where  $\bar{A}_{yz}$  is shown at an orientation of  $\phi_x = +45^\circ$  in the frontal  $yz$  plane, this condition would arise if the head were rolled  $45^\circ$  away from the head erect posture in the direction of the left shoulder. For the center sketch, the  $\phi_y = +45^\circ$  orientation of  $\bar{A}_{xz}$  would result if the head were pitched back  $45^\circ$  away from the erect posture; for the right sketch, the  $\phi_z = +45^\circ$  orientation of  $\bar{A}_{xy}$  would result if the head were yawed  $45^\circ$  toward the right away from the supine posture. Note especially how, by the use of the described drafting conventions, the sketches emphasize that the polarity of  $\phi$  depends upon the direction of movement of the vector relative to man and not vice versa. The head axes serve as measurement references and remain fixed; it is the vector  $\bar{A}$  which deviates through the angle  $\phi$  in each case.

The magnitude/direction notation also is applicable in the description of dynamic linear acceleration stimuli involving time variations in the morphological orientation of a planar vector. This is typified by experiments involving constant velocity rotation of a subject about an Earth-horizontal axis where one of the cardinal head axes is aligned with the rotational axis. In this situation, a single cardinal head plane is continually reoriented relative to the Earth's gravitational field; hence the absolute magnitude, but not the direction of the stimulus, can be regarded as constant. For stimuli of this form, the positive polarity sense of rotation of the planar vector is established by the right-hand rule of rotation. When the thumb of the right hand is pointed in the direction of the positive head axis about which rotation of the planar acceleration vector occurs (the axis denoted by the  $\phi$  subscript) the positive sense of rotation of the vector is in the direction denoted by the curl of the fingers, i.e., the CCW direction for each of the three head planes as viewed in Figure 3.

As a practical shortcut, it should be observed that the same right-hand rule can be used to determine if  $\phi$  should be measured as a positive or negative angle under static stimulus conditions.

This can be illustrated for small head tilt angles by referring to the frontal view shown at the lower left in Figure 3. When the thumb is pointed along the  $+x$  head axis (out of the page), the curl of the fingers denotes the positive sense of rotation of  $\bar{A}_{yz}$  away from its  $\phi_x = 0^\circ$  position. Since  $\bar{A}_{yz}$  as drawn in this figure is in a position which would result from the CCW displacement indicated by the curl of the fingers,  $\phi_x$  is measured as a positive angle. If  $\bar{A}_{yz}$  were drawn in the  $+y, +z$  head quadrant, i.e., were rotated in the direction opposite to that indicated by the curl of the fingers,  $\phi_x$  would be measured as a negative angle.

### Dimensional Units

The basic dimensions of linear acceleration describing the magnitude of the resultant linear acceleration  $\bar{A}$ , its planar projections  $\bar{A}_{yz}$ ,  $\bar{A}_{xz}$ , and  $\bar{A}_{xy}$ , and its axial components  $A_x$ ,  $A_y$ , and  $A_z$  are length/time<sup>2</sup> without exception. These accelerations may be expressed directly in these dimensions, typically ft/sec<sup>2</sup> (cm/sec<sup>2</sup>), or as a multiple of the Earth's standard gravitational acceleration at sea level which is identified in scalar form as  $g \equiv g_0 = 32.174 \text{ ft/sec}^2$  (980.665 cm/sec<sup>2</sup>). For example, the level of an acceleration with a magnitude equal to three times the gravitational reference may be described as either 96.522 ft/sec<sup>2</sup> or as 3.0  $g$  since  $3.0 g = (3)(32.174 \text{ ft/sec}^2)$ .

## RESULTANT ANGULAR ACCELERATION

### General Notation

The instantaneous resultant angular acceleration of the head relative to a fixed reference frame considered to be of inertial origin shall be identified in the kinematical sense and symbolized by the vector  $\bar{\alpha}$  (lower case Greek alpha). For vestibular application,  $\bar{\alpha}$  can be described by its components acting about each of the three cardinal head axes. These components of  $\bar{\alpha}$  are identified as  $\alpha_x$ ,  $\alpha_y$ , and  $\alpha_z$ , and individually represent the projection of  $\bar{\alpha}$  to the  $x$ ,  $y$ , and  $z$  head axes, respectively, as illustrated at the upper right in Figure 2 (p. 7). When it is desired to express  $\bar{\alpha}$  in vector equation form, the  $\bar{i}$ ,  $\bar{j}$ , and  $\bar{k}$  unit vectors directed along the  $x$ ,  $y$ , and  $z$  head axes, respectively, may be utilized to establish directional references such that the resultant angular acceleration of the skull can be identified as

$$\bar{\alpha} = \bar{i} \alpha_x + \bar{j} \alpha_y + \bar{k} \alpha_z ,$$

where the absolute magnitude of  $\bar{\alpha}$  is

$$|\bar{\alpha}| = (\alpha_x^2 + \alpha_y^2 + \alpha_z^2)^{\frac{1}{2}}$$

It is implicit that any of these angular accelerations may be time dependent so that  $\bar{\alpha} = \bar{\alpha}(t)$ ,  $\alpha_x = \alpha_x(t)$ ,  $\alpha_y = \alpha_y(t)$ , and  $\alpha_z = \alpha_z(t)$ . When it is desired to describe  $\bar{\alpha}$  by listing separately the individual  $\alpha_x$ ,  $\alpha_y$ , and  $\alpha_z$  components without a unit vector prefix, the common convention of assigning a positive or negative sign to the component to denote its direction about the pertinent head axis can be followed. The polarity sense of the angular accelerations are identical to the polarity sense established by application of the right-hand rule of rotation to the cardinal head axes. (When the fingers of the right hand are curled about the rotational axis in the directional sense of the angular acceleration, the motion is described by an angular acceleration vector drawn in the direction denoted by the thumb.) Thus when the head is angularly accelerated about the  $z$  head axis in the CCW direction as viewed from above, the stimulus direction is described by an angular acceleration vector drawn upward along the  $+z$  head axis to denote a positive value of  $\alpha_z$ . Conversely, if the angular acceleration is in the CW direction, the vector will be drawn downward along the  $-z$  head axis to denote a negative value of  $\alpha_z$ . Letting the  $x$ ,  $y$ , and  $z$  axes represent the roll, pitch, and yaw axes of the head, the directional characteristics of the axial components of  $\bar{\alpha}$  are identified as

- $+\alpha_x =$  roll rightward angular acceleration
- $-\alpha_x =$  roll leftward angular acceleration
- $+\alpha_y =$  pitch downward angular acceleration
- $-\alpha_y =$  pitch upward angular acceleration
- $+\alpha_z =$  yaw leftward angular acceleration
- $-\alpha_z =$  yaw rightward angular acceleration

The vector representation of each of the above components is illustrated in the sketch at the bottom right in Figure 2.

#### Magnitude/Direction Notation

As with the linear acceleration stimulus, analytical advantages result when the magnitude and direction of the resultant angular acceleration of the head are separately identified in vector shorthand notation as  $\bar{\alpha} = |\bar{\alpha}| \angle \beta$ . With this representation the absolute magnitude of  $\bar{\alpha}$  acting in a given head plane is identified as  $|\bar{\alpha}|$  with an appropriate double subscript to denote the cardinal head plane of concern. The instantaneous morphological orientation or direction of  $\bar{\alpha}$  in the same cardinal head plane is identified as  $\beta$  (lower case Greek beta)

with an appropriate single subscript to denote the cardinal head axis about which the changes in orientation of the stimulus occur. The basic elements of the magnitude/direction notation for each of the three cardinal head planes are presented in Figure 4. In the three-dimensional sketch shown at the top, the projections of the resultant angular acceleration vector  $\bar{\alpha}$  to the frontal  $yz$ , sagittal  $xz$ , and horizontal  $xy$  planes are identified in vector form as  $\bar{\alpha}_{yz}$ ,  $\bar{\alpha}_{xz}$ , and  $\bar{\alpha}_{xy}$ , respectively; the angular orientation of these vector projections within the same three head planes are identified by the direction angles  $\beta_x$ ,  $\beta_y$ , and  $\beta_z$ , respectively.

As may be observed by comparing Figure 4 to Figure 3, the magnitude/direction notation for the angular vectors follows identically that shown for the linear vectors except for the symbols proper. Thus the component of  $\bar{\alpha}$  in the frontal  $yz$  plane is  $\bar{\alpha}_{yz} = |\bar{\alpha}_{yz}| \angle \beta_x$  where  $\beta_x = 0^\circ$  when  $\bar{\alpha}_{yz}$  is aligned with the  $+z$  head axis; the sagittal plane component is  $\bar{\alpha}_{xz} = |\bar{\alpha}_{xz}| \angle \beta_y$  where  $\beta_y = 0^\circ$  when  $\bar{\alpha}_{xz}$  is aligned with the  $+z$  head axis; and the horizontal  $xy$  plane component is  $\bar{\alpha}_{xy} = |\bar{\alpha}_{xy}| \angle \beta_z$  where  $\beta_z = 0^\circ$  when  $\bar{\alpha}_{xy}$  is aligned with the  $+x$  head axis.

### Dimensional Units

The basic units of angular acceleration which describe the magnitude of the resultant angular acceleration  $\bar{\alpha}$ , its planar components  $\bar{\alpha}_{yz}$ ,  $\bar{\alpha}_{xz}$ , and  $\bar{\alpha}_{xy}$ , or its axial components  $\alpha_x$ ,  $\alpha_y$ , and  $\alpha_z$  are angular measure/time<sup>2</sup>, generally expressed as rad/sec<sup>2</sup> or deg/sec<sup>2</sup>. Care should be taken to note that most equations used for calculation of acceleration stimuli produced by rotation require all angular measures to be expressed in radian form.

### III. DISCUSSION AND RATIONALE

Although a man-referenced kinematics nomenclature has not been presented formally in biological literature, it has been generally used in the vestibular area in the discussion of angular motion stimuli and associated responses. For example, a CCW angular acceleration of the skull from rest as viewed from a stationary position above is described as producing CW angular displacement, velocity, and acceleration of a nonrigidly coupled sensing element, such as the cupula-endolymph system of the semicircular canals, relative to the skull.

With linear motion stimuli of static form, however, the vestibular area has often shifted reference to a "reaction force" rather than an "applied force" or an "applied acceleration" concept of vestibular stimulation (classically, centrifugal force rather than centripetal acceleration) and has sometimes used the  $G_x$ ,  $G_y$ , and  $G_z$  reaction notation formalized for the physiological acceleration field to identify the stimuli. This shift of reference is a natural

VESTIBULAR NOMENCLATURE

ANGULAR ACCELERATION — MAGNITUDE / DIRECTION NOTATION

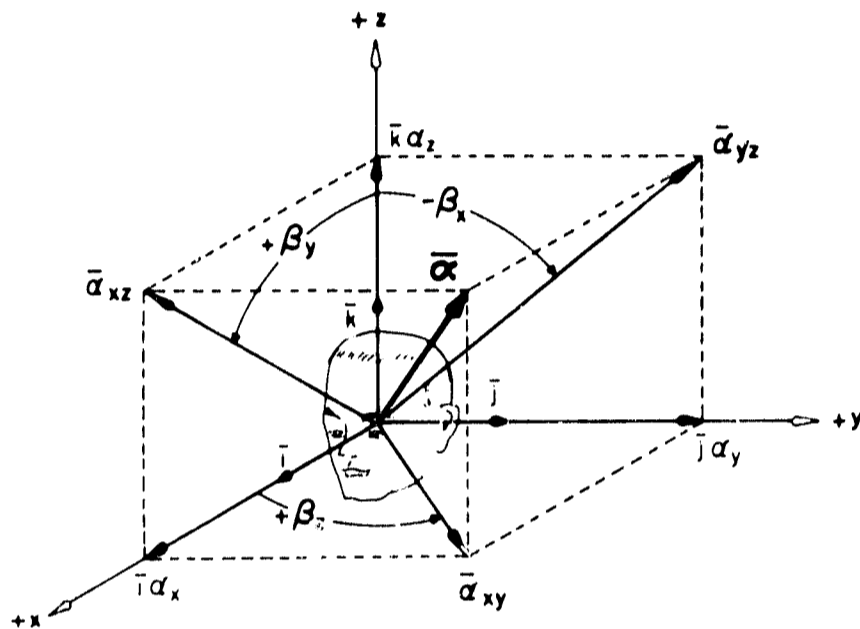

VECTOR NOTATION FOR  $\bar{\alpha}$  MAGNITUDE AND DIRECTION ANGLE WITHIN THE CARDINAL HEAD PLANES

yz FRONTAL PLANE	xz MID-SAGITTAL PLANE	xy HORIZONTAL PLANE
<p><math>\bar{\alpha}_{yz}</math> SHOWN AT <math>\beta_x = +45^\circ</math></p>	<p><math>\bar{\alpha}_{xz}</math> SHOWN AT <math>\beta_y = +45^\circ</math></p>	<p><math>\bar{\alpha}_{xy}</math> SHOWN AT <math>\beta_z = +45^\circ</math></p>
$\bar{\alpha}_{yz} =  \bar{\alpha}_{yz}  \angle \beta_x$ $ \bar{\alpha}_{yz}  = (\alpha_y^2 + \alpha_z^2)^{1/2}$ $\beta_x = \text{arc tan}(-\alpha_y / \alpha_z)$ $\alpha_y = - \bar{\alpha}_{yz}  \sin \beta_x$ $\alpha_z =  \bar{\alpha}_{yz}  \cos \beta_x$	$\bar{\alpha}_{xz} =  \bar{\alpha}_{xz}  \angle \beta_y$ $ \bar{\alpha}_{xz}  = (\alpha_x^2 + \alpha_z^2)^{1/2}$ $\beta_y = \text{arc tan}(\alpha_x / \alpha_z)$ $\alpha_x =  \bar{\alpha}_{xz}  \sin \beta_y$ $\alpha_z =  \bar{\alpha}_{xz}  \cos \beta_y$	$\bar{\alpha}_{xy} =  \bar{\alpha}_{xy}  \angle \beta_z$ $ \bar{\alpha}_{xy}  = (\alpha_y^2 + \alpha_x^2)^{1/2}$ $\beta_z = \text{arc tan}(\alpha_y / \alpha_x)$ $\alpha_y =  \bar{\alpha}_{xy}  \sin \beta_z$ $\alpha_x =  \bar{\alpha}_{xy}  \cos \beta_z$

Figure 4

outgrowth of early studies concerned with the static or steady-state response of a biological system, say the displacement of the heart or the form of an illusion, where the dynamics of the situation, i.e., the transition from one acceleration state to another, was not of primary concern. Although this viewpoint serves well in such applications, the reaction approach is not directly concerned with the instantaneous linear and angular accelerations of man from which the applied physiological forces and torques may be derived, but with the reacting forces or torques produced by the applied accelerations.

It might be argued that either concept, "action" in terms of applied accelerations or forces or "reaction" in terms of reacting forces, will describe the biological stimuli of concern equally well, if proper recognition is made of the polarity and dimensional unit differences between the two systems; i.e., an applied acceleration to the right leads to a leftward directed reaction force. However, in the vestibular area, attention must be given to how the motions of man are physiologically sensed and psychologically interpreted or perceived in various force environments; i.e., to the study of the transduction characteristics of the various mechanisms and systems involved in establishing a particular biological mode of response to motion.

A classical example is the response of the semicircular canals to angular motion stimuli where it may be desired to obtain quantified relationships between the instantaneous angular acceleration of the skull, the instantaneous angular displacement of the cupula-endolymph, and the instantaneous angular velocity of the eyes during the slow component of nystagmus. Another example would be the relation of the subjective perception of linear motion, say linear velocity, to change in magnitude of the linear acceleration, i.e., jerk, of the head. In essence, a stimulus notation is required which defines acceleration in the same context as displacement and velocity so that the motion as well as the applied force characteristics of vestibular stimuli can be described with a single, unified language.

When such motions are described kinematically, the same rules for determining the polarity sense or directional nature of the event apply throughout, whether it be a head acceleration, a biological sensor displacement, an eye velocity, or a visual target displacement, even though different reference frames or coordinates may be used for measurement of each event. In effect, the direction of the instantaneous linear or angular displacement, velocity, or acceleration of a mass relative to some reference frame is as actually viewed by an observer fixed to that frame. Most simply, if the linear velocity of the head is increasing in a given direction, the head is being accelerated in that direction; if a biological sensor is moving with increasing velocity toward the rear of the skull, it is being accelerated to the rear; if the eyes

are rotating to the right with increasing angular velocity, they are being angularly accelerated to the right.

Two additional advantages encourage the selection of the kinematical rendition of acceleration stimuli. The first involves the actual calculation of a particular acceleration stimulus generated by a known motion profile of a vehicle or research device. When one calculates the instantaneous spatial coordinates and orientation of the vehicle relative to a fixed reference frame, the directional nature or polarity of the accelerations arrived at in these calculations will be those of kinematics. The second point involves the actual measurement of acceleration. With the conventions of the instrumentation field, the analog output signals of accelerometers (whether of linear or angular form) indicate acceleration directions identical to those of kinematics. To summarize, the directions of kinematically expressed acceleration stimuli are defined as they would be visually observed, mathematically calculated, and physically measured.

## SELECTION OF THE BASIC NOTATION

### Morphological Reference Frame

The symbolic identification of the cardinal head axes as  $x$ ,  $y$ , and  $z$ , and the anatomical directions denoted by these symbols were chosen to correspond, in general, with the  $X$ ,  $Y$ , and  $Z$  symbols and the denoted anatomical directions of the existing  $G$  and  $R$  "reaction" terminology. However, lower case symbols are used to draw attention to the fact that differences exist between the two systems in terms of axis polarity. The  $\bar{i}$ ,  $\bar{j}$ ,  $\bar{k}$  unit vectors follow mathematical convention in being assigned to the  $x$ ,  $y$ , and  $z$  axes, respectively. With the mutually orthogonal orientation of the  $x$ ,  $y$ , and  $z$  axes and the polarity sense identified by the  $\bar{i}$ ,  $\bar{j}$ , and  $\bar{k}$  unit vectors, the morphological reference system is defined by a right-handed reference frame. It follows that conventional analytical procedures of vector algebra can be utilized in the calculation of vestibular stimuli presented by inertial motion of the head reference frame.

The particular anatomical reference selected for the  $x$ ,  $y$ , and  $z$  head axes is established by Polyak's (ref. 7) definition of the horizontal plane of the head. With this definition the  $z$  (vertex-base) head axis is for all practical purposes aligned with the Earth's gravitational field when a subject maintains an upright and head-erect posture with the horizontal  $xy$  head plane lying in an Earth-horizontal plane. Of practical advantage is the ease with which the cardinal axes can be located with respect to the exterior landmarks provided by the primary definitions.

It should be noted that this anatomical definition of the cardinal head axes is not meant to describe the primary sensing axes or planes of the linear and angular motion receptors of the



labyrinth. In contradistinction, it is intended that these axes provide a readily discernible anatomical reference to which experimentally derived stimulus-response parameters can be easily related and, more important in many situations, provide a reference of practical advantage to the actual measurement of such data. As an example, consider the problem of determining the angular acceleration stimulus presented to the horizontal semicircular canals. If the  $z$  head axis were treated as the primary axis of sensitivity of the canals, the component of the resultant angular acceleration of the head acting about this axis, i.e.,  $\alpha_z$ , would serve as an adequate description of the stimulus. However, since the horizontal canals are generally accepted as lying in a head plane tilted back in the range of  $10^\circ$  to  $40^\circ$  from the horizontal  $xy$  head plane herein defined, a head axis tilted back correspondingly in the midsagittal plane away from the  $z$  axis would better serve as the axis of sensitivity. Such a situation is readily treated with the nomenclature by merely calculating the component of the resultant acceleration acting along the anatomical axis of interest and using the  $x$ ,  $y$ , and  $z$  head axes as reference to define the orientation of the particular axis.

It should be mentioned that the common designation of the  $x$ ,  $y$ , and  $z$  head or body axes as the roll, pitch, and yaw axes, respectively, though of vehicular rather than biological origin, has certain advantages when applied to this nomenclature. For example, the directional nature of angular motions whether they be of the head, eye, or a visual target can be described in identical form as motions which occur about the roll, pitch, and yaw axes, e.g., a pitch-downward angular acceleration of the head, a pitch-upward motion of the eye, and a pitch-downward displacement of a visual target. If other descriptive references are used, their application is not always so compatible. For example, the expressions "somersault forward," "cart-wheel left," and "twist left" (ref. 6) quite adequately describe pitch forward, roll left, and yaw left angular motions of the whole body but are semantically awkward when applied to equivalent motions of the head, eyes, or a visual target.

### Resultant Acceleration Symbols

The primary factor involved in the selection of notation to describe the resultant accelerations of man was the need to use symbols which differed from the  $G$  and  $R$  identifications of existing reaction nomenclature in order to draw sharp attention to the fact that the nomenclature of this paper is directly concerned with applied biological accelerations and not with reaction forces or torques. The selection of  $A$  and  $\alpha$  to denote the resultant linear and angular accelerations, respectively, is an obvious choice because of their extensive usage in physics to denote the same parameters. The  $\alpha$  symbol has also found wide acceptance in the vestibular area

as a description of angular acceleration. An upper case A is used to prevent conflict with the lower case a used in the NASA aircraft acceleration nomenclature.

The  $|\bar{A}| \angle \phi$  and  $|\alpha| \angle \beta$  magnitude/direction notation follows conventional vector shorthand practices in which the symbol  $\phi$  has been selected because of its long usage in centrifuge studies to denote the direction of the resultant linear acceleration relative to an Earth-vertical reference axis. The direction of the resultant angular acceleration vector acting in a given head plane is identified by a different symbol  $\beta$  since, in many experimental situations,  $\bar{A}$  and  $\bar{\alpha}$  will not be identically oriented.

#### RELATION TO THE G AND R REACTION SYMBOLS

To establish the relationships which exist between the A and  $\alpha$  notation of the proposed kinematics nomenclature and the G and R notation (refs. 2, 4, 6) of the reaction nomenclature, a brief comparative outline of the two systems is presented. It should be noted that the notation of the kinematics system can find immediate application in the physiological acceleration stress/tolerance area as well as in the vestibular area by merely extending the  $x$ ,  $y$ , and  $z$  definitions of the cardinal head axes to the body. There cannot be a similar joint application of the reaction system since only reacting forces and torques are dealt with. In effect, the reaction system is related to the kinematic system only to the extent that it describes forces or torques which arise in response to, and are oppositely directed to, the applied linear and angular physiological accelerations of man. These points are well discussed by Dixon and Patterson (ref. 3) in their monograph on the determination of physiological stimuli in centrifuges and in flight.

With the "reaction" terminology, three mutually orthogonal cardinal axes of man, identified by upper case X, Y, and Z, comprise a right-handed rectangular Cartesian coordinate frame which is drawn inverted relative to the head erect posture. The general morphological direction identified by each of these axes is as follows: The X axis denotes the front-back or anteroposterior direction; the Y axis denotes the left-right or side-to-side direction, and the Z axis the cephalocaudal, up-down, or head-foot dimension. Directional polarity of these axes is such that the + X axis is directed toward the back of man, + Y toward the left, and + Z downward toward the feet.

The symbols G and R are used to indicate reaction force and reaction torque, respectively; their components acting along or about each of the X, Y, and Z axes are identified by the appropriate subscript. Accordingly, the components of reaction force are  $G_x$ ,  $G_y$ , and  $G_z$  while the reaction torque components are  $R_x$ ,  $R_y$ , and  $R_z$ , respectively. In general, R is

treated as only symbolic notation for angular reaction and the dot superscript does not necessarily denote mathematical shorthand for the first time-derivative of an angular-velocity-related quantity  $R$  acting about the same axis.

The magnitude and direction components of the reaction forces can then be described by linear force vectors drawn along the  $X$ ,  $Y$ , and  $Z$  axes in the appropriate directions, while the reaction torques can be described by angular torque vectors drawn along the same axes. Thus  $+G_x$ ,  $+G_y$ , and  $+G_z$  denote reaction forces directed along the  $+X$  (toward the back),  $+Y$  (toward the left), and  $+Z$  (toward the feet) axes, respectively. Similarly  $+R_x$ ,  $+R_y$ , and  $+R_z$  denote reaction torques which act about the  $X$ ,  $Y$ , and  $Z$  axes, respectively, in a CCW direction as viewed by an observer from the direction denoted by the  $+X$ ,  $+Y$ , and  $+Z$  axes. These "reaction" relationships are summarized pictorially at the right in Figure 5.

With the kinematics nomenclature of this paper, the cardinal axes of man are similarly identified as  $x$ ,  $y$ , and  $z$  and define a right-handed rectangular Cartesian coordinate frame, but one which is drawn erect relative to the head erect posture. Importantly, these  $x$ ,  $y$ , and  $z$  axes denote morphological directions which are identical, except for polarity, to the  $X$ ,  $Y$ , and  $Z$  axes of the reaction nomenclature. Directional polarities are such that  $+x$  is directed toward the front,  $+y$  toward the left, and  $+z$  upward toward the vertex of the head. The symbols  $\bar{A}$  and  $\bar{\alpha}$  are used to denote the resultant linear and the resultant angular acceleration, respectively; their components acting along or about each of the  $x$ ,  $y$ , and  $z$  axes are identified by the appropriate subscript. Accordingly,  $+A_x$ ,  $+A_y$ , and  $+A_z$  denote linear accelerations which are directed along the  $+x$  (toward the front),  $+y$  (toward the left), and  $+z$  (toward the vertex) axes. Similarly,  $+\alpha_x$ ,  $+\alpha_y$ , and  $+\alpha_z$  denote CCW angular acceleration about the  $x$ ,  $y$ , and  $z$  axes, respectively, as observed from the directions denoted by the positive sense of these axes. These elements of the kinematics nomenclature are depicted at the left in Figure 5.

These relationships between the two systems may be summarized as follows:

- $+A_x$  (frontward) linear acceleration leads to a  $+G_x$  (backward) reaction force;
- $+A_y$  (leftward) linear acceleration leads to a  $-G_y$  (rightward) reaction force;
- $+A_z$  (headward) linear acceleration leads to a  $+G_z$  (footward) reaction force;
- $+\alpha_x$  (roll right) angular acceleration leads to a  $+R_x$  (roll left) reaction torque;
- $+\alpha_y$  (pitch down) angular acceleration leads to a  $-R_y$  (pitch up) reaction torque;
- $+\alpha_z$  (yaw left) angular acceleration leads to a  $+R_z$  (yaw right) reaction torque.

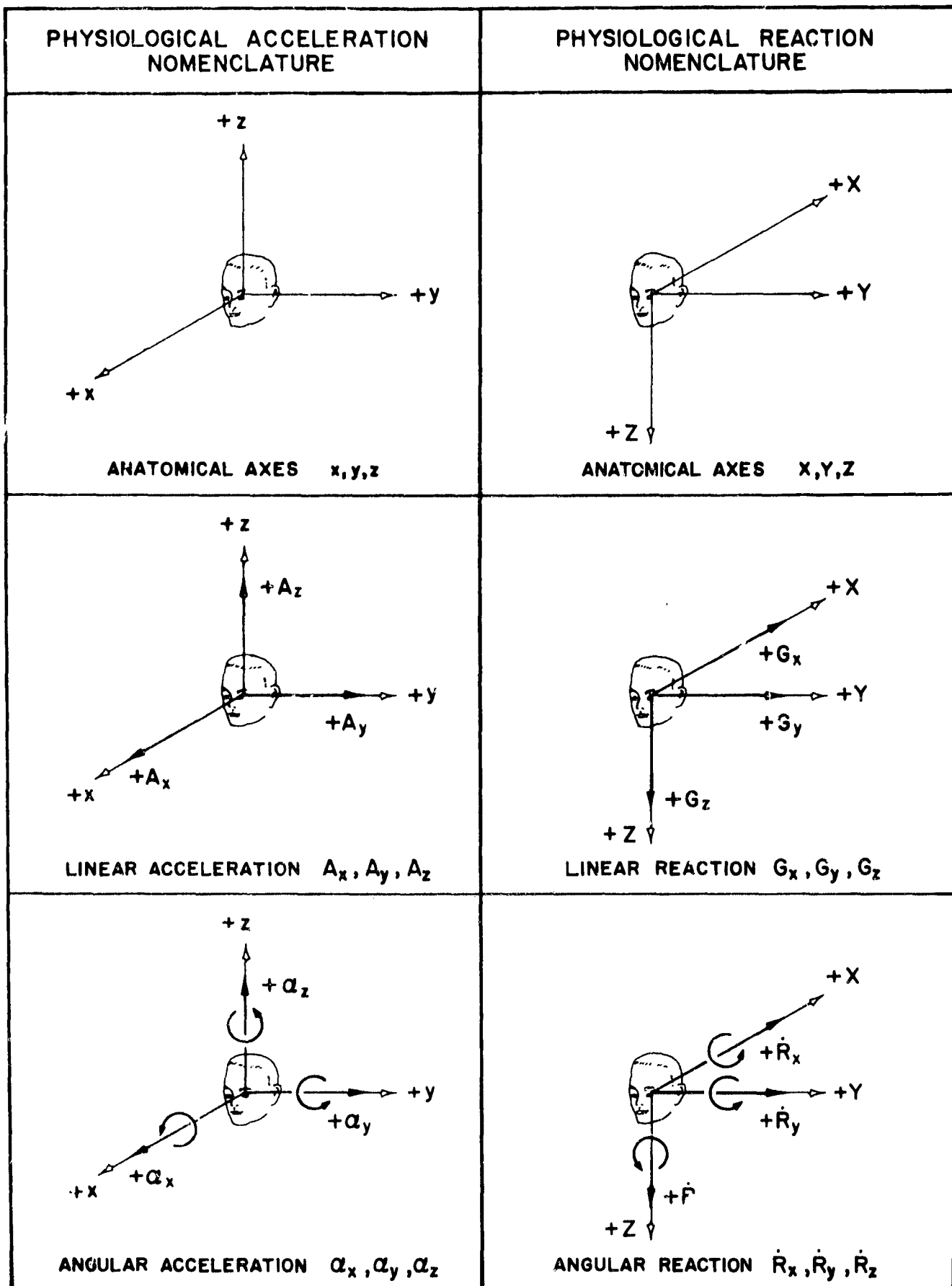

Figure 5

By making erect the orientation of the  $xyz$  frame, a one-to-one polarity correspondence between the "kinematics" and "reaction" notation can be achieved for two of the three axes. To illustrate, aircraft maneuvers classically described as exposing a pilot to "positive acceleration" or "negative acceleration" along the head-foot axis are equivalently described in both systems by accelerations  $A_z$  or reactions  $G_z$  of the same polarity. That is, a "positive acceleration" of the aircraft results in a headward acceleration directed along the  $+z$  head axis and is identified as  $+A_z$ ; this acceleration leads to a footward displacement of the heart along the  $+Z$  axis and is identified as a  $+G_z$  reaction. Equally important,  $A_z$  and  $G_z$  both are positive for man standing erect in the normal terrestrial environment.

The same polarity correspondence holds for accelerations along the  $x$  axis where  $+A_x$  accelerations lead to  $+G_x$  reactions. Since the majority of the acceleration stress/tolerance data that have been collected deals primarily with accelerations directed along the  $x$  and  $z$  head axes, little chance for semantic difficulties will arise in discussions of the directional nature of such stimuli since accelerations denoted of one polarity will lead to reactions of the same polarity; i.e.,  $+A_x$  and  $+A_z$  lead to  $+G_x$  and  $+G_z$ , respectively.

This polarity correspondence cannot be achieved for all three axes, however, since the positive  $y$  and  $Y$  axes are identically directed to the left of man. If either of these axes were reversed and directed toward the right to accomplish this ideal polarity correspondence, the related reference frame would become of left-handed form. Since the conventions of mathematical analyses of motion require the  $xyz$  kinematic frame to be right-handed, full correspondence could be achieved best by reversing the  $Y$  axis of the reaction frame, as did Dixon and Patterson (ref. 3), since this latter frame does not have such a mathematical requirement.

One further distinguishing feature between the two systems that is of major significance involves the dimensions or units selected to describe quantitatively the magnitude of a stimulus. With the reaction symbols the units are properly those of force or torque. An absolute, quantified description of the magnitude of the  $G_x$ ,  $G_y$ , and  $G_z$  symbols cannot be given unless the mass of the biological specimen is known; similarly, the rotational inertia of the specimen must be established before  $R_x$ ,  $R_y$ , and  $R_z$  can be quantitatively identified. Yet even when these data are known, confusion can result since the calculated values of the  $G$  and  $R$  stimuli will differ for two individuals exposed to the same force environment unless their bodies have identical mass and rotational inertia characteristics. A partial solution for the linear reaction force is afforded by the upper case  $\underline{G}$  symbol which can be treated as a gravitationally normalized force as well as the ratio between an actual acceleration and the gravitational acceleration  $g$ .

That is, it becomes possible to express the magnitude of the  $G_x$ ,  $G_y$ , and  $G_z$  symbols as a multiple of  $\underline{G}$ ; e.g.,  $G_x = 3.0 \underline{G}$ . However, one is now confronted with the problem that since  $\underline{G}$  is dimensionless,  $G_x$ ,  $G_y$ , and  $G_z$  also become dimensionless, an obvious conflict with the original force unit definition. Even this approach is not available for describing quantitatively the  $\dot{R}_x$ ,  $\dot{R}_y$ , and  $\dot{R}_z$  torques.

No such problems arise with the quantitative description of the magnitude of the kinematics-based symbols since, by definition, the units of  $A_x$ ,  $A_y$ , and  $A_z$  are those of linear acceleration while the units of  $\alpha_x$ ,  $\alpha_y$ , and  $\alpha_z$  are those of angular acceleration. Thus the linear acceleration components possess the units of length/time<sup>2</sup> and can be described directly in these dimensions or as a multiple of the lower case  $g$  symbol, e.g.,  $A_x = 3.0 g$ . Since  $g \equiv g_0$  is a physical constant, 32.174 ft/sec<sup>2</sup>, describing the standard gravitational acceleration, no questions can arise relative to the parameter, i.e., acceleration, being described or quantified. Because of its acceleration dimensions, the lower case  $g$  cannot be used to describe the magnitude of the  $G_x$ ,  $G_y$ , and  $G_z$  reactions. Conversely, it would be in error to describe the magnitude of the  $A_x$ ,  $A_y$ , and  $A_z$  symbols with the upper case  $\underline{G}$  symbol; i.e.,  $A_x \neq 3.0 \underline{G}$ , since  $\underline{G}$  is dimensionless, while  $A_x$  possesses length/sec<sup>2</sup> units. To emphasize, the units of the  $A$  and  $\alpha$  symbols are those of acceleration, at all times and for all conditions, without qualification.

#### IV. RECOMMENDED APPLICATION FORMAT

In the application of this nomenclature, each stimulus condition is to be described by separate identifications of the resultant linear acceleration  $\bar{A}$  and the resultant angular acceleration  $\bar{\alpha}$  of the head using the cardinal  $x$ ,  $y$ , and  $z$  axes as directional reference. The nomenclature in its most basic form has provided these identifications in the two vector equations

$$\begin{aligned}\bar{A} &= \bar{i} A_x + \bar{j} A_y + \bar{k} A_z \\ \bar{\alpha} &= \bar{i} \alpha_x + \bar{j} \alpha_y + \bar{k} \alpha_z\end{aligned}\tag{1}$$

It is not intended to recommend that physiological acceleration stimuli should be defined always in the vector form summarized by equation set (1). Although these equations offer advantages in simplicity of expression, a fully equivalent format can result if  $\bar{A}$  and  $\bar{\alpha}$  are

described by merely listing the magnitude and direction of each component acting along or about the three cardinal head (body) axes, as follows:

$$\begin{aligned}
 A_x &= \pm [ \quad ] \text{ ft/sec}^2 & \alpha_x &= \pm [ \quad ] \text{ rad/sec}^2 \\
 A_y &= \pm [ \quad ] \text{ ft/sec}^2 & \alpha_y &= \pm [ \quad ] \text{ rad/sec}^2 \\
 A_z &= \pm [ \quad ] \text{ ft/sec}^2 & \alpha_z &= \pm [ \quad ] \text{ rad/sec}^2
 \end{aligned}
 \tag{2}$$

where the magnitude of each acceleration component would be entered within the brackets while its direction along or about the axis would be denoted by attaching the proper polarity sign prefix. Since this form of identification describes the direction as well as scalar magnitude of each acceleration component, it lends itself directly to either vector interpretation or scalar numerical quantification of the stimuli.

When the vector shorthand, magnitude/direction notation is used,  $\bar{A}$  and  $\bar{\alpha}$  are described in terms of their magnitude and direction in each of the three cardinal head planes, i.e., the frontal  $yz$  plane, the sagittal  $xz$  plane, and the horizontal  $xy$  plane. Definition of the overall acceleration stimuli will derive from

$$\begin{aligned}
 \bar{A}_{yz} &= | \bar{A}_{yz} | \angle \phi_x & \bar{\alpha}_{yz} &= | \bar{\alpha}_{yz} | \angle \beta_x \\
 \bar{A}_{xz} &= | \bar{A}_{xz} | \angle \phi_y & \bar{\alpha}_{xz} &= | \bar{\alpha}_{xz} | \angle \beta_y \\
 \bar{A}_{xy} &= | \bar{A}_{xy} | \angle \phi_z & \bar{\alpha}_{xy} &= | \bar{\alpha}_{xy} | \angle \beta_z
 \end{aligned}
 \tag{3}$$

which are mathematically related to the acceleration components along or about the  $x$ ,  $y$ , and  $z$  axes as shown in the equations listed at the bottom in Figure 3 and Figure 4. In most vestibular applications this notation will be of advantage only when the stimulus is selected so as to act solely within one of the three cardinal head planes. For this condition  $\bar{A}$  or  $\bar{\alpha}$  will be defined by a single member of equation set (3).

Thus equation sets (1), (2), and (3) offer three alternative methods or formats to identify the resultant linear acceleration  $\bar{A}$  and the resultant angular acceleration  $\bar{\alpha}$  which comprise the basic vestibular stimuli. Of these formats, equation set (2) has particular application in describing the acceleration profile of a vehicle or a device whose motion characteristics are not fully known on an a priori basis. In such a measurement task, it is common instrumentation practice to use inertial linear and angular accelerometers as the primary transducers, each unit

being bidirectionally responsive to accelerations occurring along or about a single axis of sensitivity. Since the vehicle motion can occur with six degrees of freedom, a minimum of three linear and three angular accelerometers is required.

Usually, one linear and one angular accelerometer are assigned to each of three measurement axes made mutually orthogonal for simplicity of data reduction and for optimal utilization of the full-scale sensitivity rating of each transducer. In vehicular environments, e.g., aircraft, missiles, and naval vessels, the three mutually orthogonal axes of accelerometer sensitivity are typically aligned with the roll, pitch, and yaw motion axes of the vehicle proper. The magnitude-time display of the output from the six accelerometers then represents an analog display of the over-all linear and angular acceleration profile which is in a format completely compatible with the man-referenced format of equation set (2). A vestibular investigator may readily convert the data to the man-referenced form after noting the relative orientation between the vehicle and the biological station of interest. It would be even more advantageous for vestibular investigators concerned with the determination of  $\bar{A}$  and  $\bar{\alpha}$  at a particular station within a vehicle to request measurement personnel, whenever possible, to orient their accelerometers along and about axes which correspond in direction and polarity to the morphological axes of the man positioned at that station.

The individual components of  $\bar{A}$  and  $\bar{\alpha}$  as listed in equation set (2) can also be used to derive the magnitude and morphological direction of the over-all stimulus as well. That is, the absolute magnitudes of  $\bar{A}$  and  $\bar{\alpha}$  are described simply as

$$\begin{aligned} |\bar{A}| &= (A_x^2 + A_y^2 + A_z^2)^{\frac{1}{2}} \\ |\bar{\alpha}| &= (\alpha_x^2 + \alpha_y^2 + \alpha_z^2)^{\frac{1}{2}} \end{aligned} \quad (4)$$

respectively. The orientation of the  $\bar{A}$  and  $\bar{\alpha}$  vectors relative to the anatomical axes can be visualized, as well as quantified, by noting that the ratio of the magnitude of a single axial acceleration component to the absolute magnitude of the resultant acceleration vector is equal to the cosine of the angle between the vector and the head axis along which the axial component is directed. For example, the ratio  $A_x / |\bar{A}|$  is the cosine of the angle between  $\bar{A}$  and the  $x$  head axis; the ratio  $\alpha_z / |\bar{\alpha}|$  is the cosine of the angle between  $\bar{\alpha}$  and the  $z$  head axis. Even more important is the point that if a vestibular stimulus is described in terms of its  $A_x, A_y, A_z, \alpha_x, \alpha_y,$  and  $\alpha_z$  components within this rectangular Cartesian format, the data



can be readily transformed to cylindrical, polar, or other mathematical coordinate systems that may be more suited analytically to specific research applications.

### ILLUSTRATIVE EXAMPLES

The kinematics nomenclature system is illustrated in the following sections through its application to some typical stimulus configurations encountered in vestibular research. In general, the examples are directed toward the beginning vestibular worker to demonstrate the ease with which actual experimental stimuli and related responses may be incorporated in the proposed nomenclature system. For this reason, stimulus configurations involving minimal use of mathematics have been selected, and emphasis placed on the details of concept rather than rigor of notation. Though vector operations are held to a minimum in these simple examples, it should be obvious to the vestibular worker studying acceleration environments of a more complex nature that the most productive analytical results will be achieved through the full utilization of vector mathematics.

#### Earth-Vertical Rotation

The motion parameters of a simple fixed-radius centrifuge, e.g., the one illustrated in Figure 6, which rotates about an Earth-vertical axis  $V-V'$  are to be defined as follows: Let the instantaneous angular displacement, velocity, and acceleration of the device about  $V-V'$  be identified in dot notation as  $\theta_v$ ,  $\dot{\theta}_v$ , and  $\ddot{\theta}_v$  (lower case Greek theta). Measure  $\theta_v$  as the

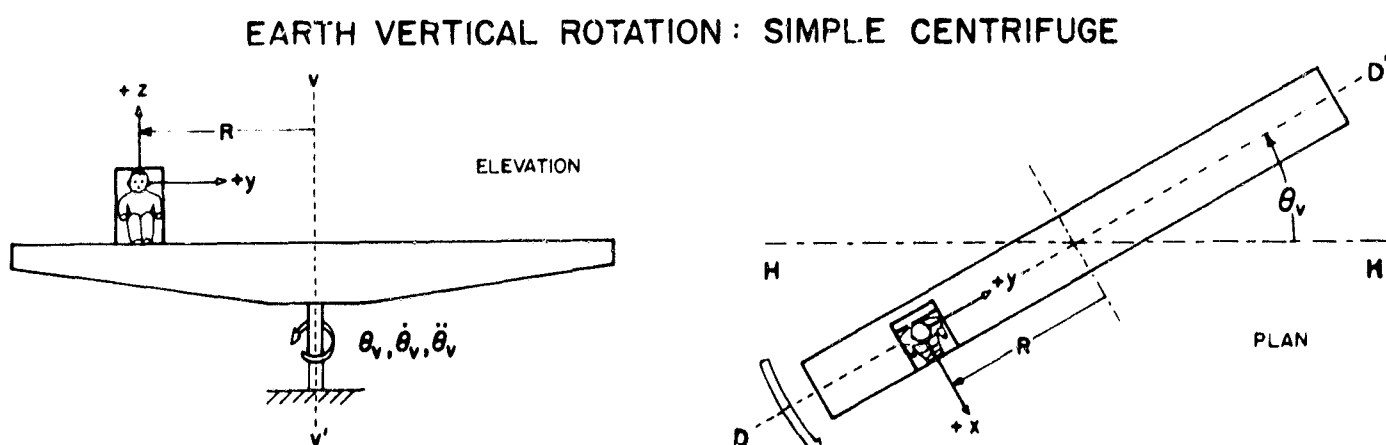

Figure 6

Elevation and plan views of a simple fixed-radius centrifuge which rotates about an Earth-vertical axis  $V-V'$  with an instantaneous angular displacement, velocity, and acceleration of  $\theta_v$ ,  $\dot{\theta}_v$ ,  $\ddot{\theta}_v$ , respectively, where  $\theta_v$  is measured as the angular deviation of axis  $D-D'$ , fixed to the radial arm of the centrifuge, from an arbitrarily selected nonrotating reference axis  $H-H'$  fixed in an Earth-horizontal plane. The subject is shown at radius  $R$ , seated in a head erect posture facing tangentially in the direction of the CCW rotation.

angular deviation of the radial arm, D-D', of the centrifuge from an arbitrarily selected reference axis, H-H', which is fixed in an Earth-horizontal plane. The subject is seated tangentially in a head erect posture on the centrifuge facing the direction of rotation. His  $z$  head axis is aligned with Earth vertical, his  $y$  axis (left side) is directed radially inboard, and his horizontal  $xy$  head plane lies in an Earth-horizontal plane. The subject's head (origin of the  $x, y, z$  reference frame) is assumed to be at a fixed radial distance  $R$  from the rotational axis of the device V-V'.

Initially, let the device be angularly accelerated from rest in a CCW direction as viewed from above in Figure 6. For this condition the linear acceleration stimulus is defined as the resultant of a centripetal acceleration vector of magnitude  $\dot{\theta}_v^2 R$  acting radially inboard along D-D' and directed leftward toward D' along the  $+y$  axis; a tangential acceleration vector of magnitude  $\dot{\theta}_v R$  acting at right angles to D-D' and directed forward along the  $+x$  axis; and a gravitational acceleration vector of magnitude  $g$  directed upward along the  $+z$  axis. The angular acceleration stimulus is described by an angular acceleration vector of magnitude  $\ddot{\theta}_v$  drawn upward along the  $+z$  head axis.

The resultant  $\bar{A}$  and  $\bar{\alpha}$  stimuli can be defined in terms of their individual components as

$$\begin{aligned} A_x &= +\dot{\theta}_v R & \alpha_x &= 0 \\ A_y &= +\dot{\theta}_v^2 R & \alpha_y &= 0 \\ A_z &= +g & \alpha_z &= +\ddot{\theta}_v \end{aligned} \quad (5)$$

The components of  $\bar{A}$  and  $\bar{\alpha}$  are shown pictorially in the three-dimensional sketches at the top left and top right, respectively, in Figure 7. For those wishing to define the stimuli in vector equation form, the resultant linear and resultant angular accelerations would be identified separately as

$$\begin{aligned} \bar{A} &= +i \dot{\theta}_v R + j \dot{\theta}_v^2 R + k g \\ \bar{\alpha} &= +k \ddot{\theta}_v \end{aligned} \quad (6)$$

Now let the centrifuge be decelerated to rest from this CCW rotation condition. During this interval, the angular acceleration,  $\ddot{\theta}_v$ , and consequently the tangential linear acceleration,  $\dot{\theta}_v R$ , will be in the direction opposite that during

acceleration from rest. That is, during deceleration the change in centrifuge angular velocity describes a CW angular acceleration as seen from above. For this case, the components of  $\bar{A}$  and  $\bar{\alpha}$  are described as

$$\begin{aligned} A_x &= -\ddot{\theta}_v R & \alpha_x &= 0 \\ A_y &= +\dot{\theta}_v^2 R & \alpha_y &= 0 \\ A_z &= +g & \alpha_z &= -\ddot{\theta}_v \end{aligned} \quad (7)$$

or in vector equation form as

$$\begin{aligned} \bar{A} &= -\bar{i} \ddot{\theta}_v R + \bar{j} \dot{\theta}_v^2 R + \bar{k} g \\ \bar{\alpha} &= -\bar{k} \ddot{\theta}_v \end{aligned} \quad (8)$$

These components are illustrated in the sketches at the bottom of Figure 7. It can be noted in this figure that the conventions of the nomenclature allow explicit specification of the directions of the acceleration components acting along or about the  $x$ ,  $y$ , and  $z$  axes by a simple + or - prefix. For example, the tangential acceleration directed along the  $x$  head axis is identified as  $A_x = +\dot{\theta}_v R$  during the CCW acceleration phase to describe the forward acceleration exposure of the subject and as  $A_x = -\dot{\theta}_v R$  during the deceleration phase to denote the backward acceleration. Similarly, during the CCW velocity buildup the yaw-leftward angular acceleration is identified as  $\alpha_z = +\ddot{\theta}_v$ ; during deceleration, the yaw-rightward angular acceleration as  $\alpha_z = -\ddot{\theta}_v$ .

If the device were to be angularly accelerated from rest in the opposite (CW) direction,  $A_x$  and  $\alpha_z$  would be negative quantities during velocity buildup while  $A_y$  would remain positive. However, if instead, the orientation of the subject relative to the device were reversed  $180^\circ$  so that he sat tangentially with his back in the direction of CCW acceleration from rest,  $A_y$  and  $A_x$  would both be negative quantities during velocity buildup signifying a rightward and backward linear acceleration condition. The  $\alpha_z$  angular acceleration component would remain positive during the same interval.

This centrifuge example can be used also to demonstrate application of the magnitude-direction vector notation. Consider that the device is being accelerated as before toward a given CCW angular velocity, and that once this steady state velocity is reached,  $\dot{\theta}_v$  becomes zero.

**PICTORIAL DISPLAY OF COMPONENTS OF THE  
RESULTANT LINEAR ACCELERATION** **RESULTANT ANGULAR ACCELERATION**

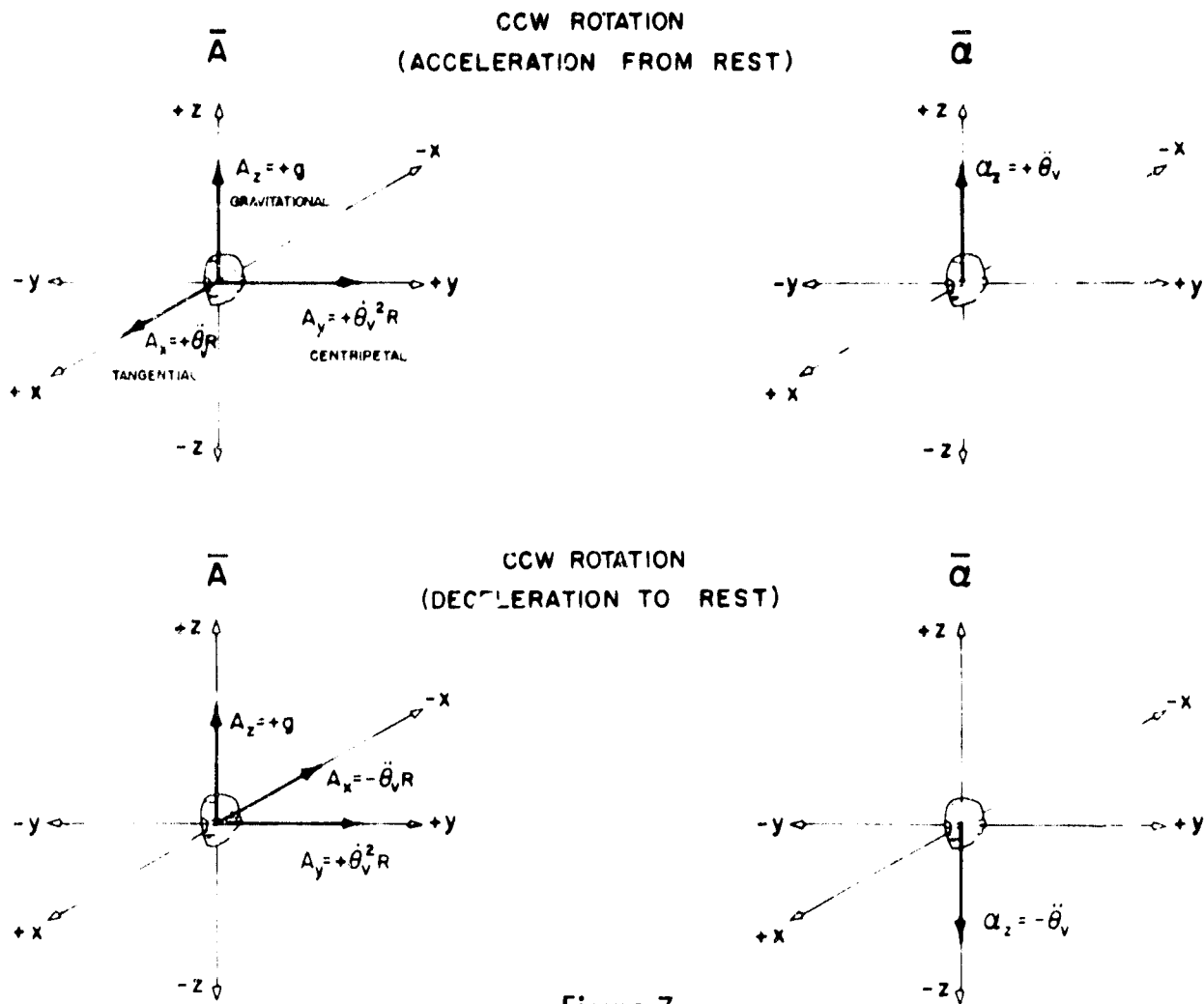

Figure 7

The three-dimensional sketches of the head shown at the top represent a pictorial display of the components of  $\bar{A}$  (left) and  $\bar{\alpha}$  (right) which act on a subject exposed to the centrifuge stimulus conditions described in Figure 6 where the device is assumed to be angularly accelerating from rest in the CCW direction. The tangential, centripetal, and gravitational components of the resultant linear acceleration  $\bar{A}$  are described by vectors drawn along the  $+x$ ,  $+y$ ,  $+z$  head axes to denote forward-, leftward-, and upward-directed linear accelerations of the head, respectively. The resultant angular acceleration is described by a vector drawn upward along the  $+z$  head axis to denote a yaw-leftward angular acceleration of the head. The components of  $\bar{A}$  and  $\bar{\alpha}$ , shown at the bottom, depict the stimulus conditions occurring during deceleration to rest.

Then  $\bar{A}$  and  $\bar{\alpha}$  are described in component form as

$$\begin{aligned}
 A_x &= 0 & \alpha_x &= 0 \\
 A_y &= +\dot{\theta}_v^2 R & \alpha_y &= 0 \\
 A_z &= +g & \alpha_z &= 0
 \end{aligned}
 \tag{9}$$

or in vector equation form as

$$\begin{aligned} \bar{A} &= +j \dot{\theta}_v^2 R + k g \\ \bar{\alpha} &= 0 \end{aligned} \tag{10}$$

This stimulus configuration is often used in vestibular studies to explore the effect of static linear accelerations acting in the frontal  $yz$  head plane on subjective perception of vertical or horizontal. By selecting different steady-state centrifuge velocities, stimuli of variable magnitude can be made to act in various directions within the frontal head plane. In effect, each change in steady-state velocity causes the resultant linear acceleration vector (the resultant of the centripetal and gravitational accelerations) to rotate about the  $x$  head axis. Since the stimulus is directed in the frontal  $yz$  plane,  $\bar{A}$  may be equivalently described as  $\bar{A}_{yz}$ . This in turn can be represented in vector shorthand notation as a vector of magnitude  $|\bar{A}_{yz}|$  and direction  $\angle \phi_x$  and written as  $\bar{A}_{yz} = |\bar{A}_{yz}| \angle \phi_x$ . As shown in the equation sets at the bottom left in Figure 3, the magnitude and direction parameters of  $\bar{A}_{yz}$  are calculated from  $|\bar{A}_{yz}| = (A_y^2 + A_z^2)^{\frac{1}{2}}$  and  $\phi_x = \text{arc tan} - A_y/A_z$ . These equations combined with the values of  $A_y$  and  $A_z$  shown in equation set (9) describe the stimulus as simply

$$\bar{A} = \bar{A}_{yz} = |\bar{A}_{yz}| \angle \phi_x \tag{11}$$

where

$$\begin{aligned} |\bar{A}_{yz}| &= [ (\dot{\theta}_v^2 R)^2 + g^2 ]^{\frac{1}{2}} \\ \phi_x &= \text{arc tan} - \dot{\theta}_v^2 R / g \end{aligned}$$

as illustrated in Figure 8.

As a numerical example consider that the centrifuge is rotating at a constant CCW angular velocity of 16 rpm (96 deg/sec, 1.6752 rad/sec) with the subject in the tangential orientation of Figure 6 at a radius of  $R = 19.85$  ft. For this condition, the centripetal acceleration is  $55.72 \text{ ft/sec}^2$  or  $1.732 g$ , leading to a resultant acceleration of  $2.0 g$  acting at an angle of  $60^\circ$  relative to the Earth-vertical axis. The magnitude/direction notation describes this stimulus as

$$\bar{A} = \bar{A}_{yz} = 2.0 g \angle - 60^\circ \tag{12}$$

which is valid for either CW or CCW rotation. If the subject's orientation relative to the centrifuge were reversed  $180^\circ$  so that his  $-y$  axis (right side) was directed radially inboard, the stimulus would be defined as

$$\bar{A} = \bar{A}_{yz} = 2.0g \angle +60^\circ \quad (13)$$

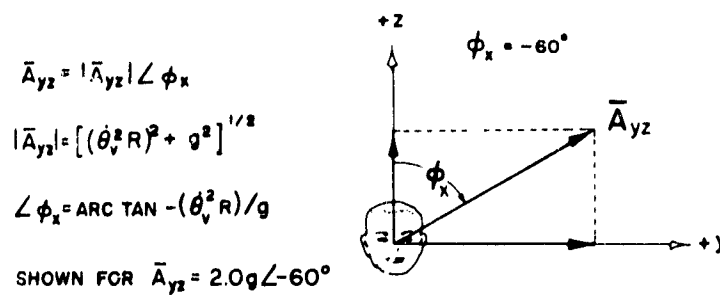

Figure 8

Magnitude/direction vector description of the resultant linear acceleration of the head for CCW rotation of the centrifuge at constant angular velocity with the subject in the tangential orientation noted in Figure 6. The resultant of the gravitational and centripetal accelerations is shown as a vector  $\bar{A}_{yz}$  whose orientation in the frontal  $yz$  head plane is denoted by the angle  $\phi_x$ . The  $x$  subscript of  $\phi_x$  denotes that changes in centrifuge velocity or subject radius will effect a change in direction of  $\bar{A}_{yz}$  equivalent to its rotation about the  $x$  head axis.

In equation (12),  $\phi_x$  is measured as a negative angle ( $\phi_x = -60^\circ$ ) since  $\bar{A}_{yz}$  has been rotated away from its alignment with the  $+z$  head axis ( $\phi_x = 0^\circ$ ) so that it lies in the  $+z, +y$  head quadrant. Since  $\bar{A}_{yz}$  in equation (13) lies in the  $+z, -y$  head quadrant,  $\phi_x$  is measured as a positive angle ( $\phi_x = +60^\circ$ ) for this stimulus orientation.

### Earth-Horizontal Rotation

Consider the stimulus produced by a device which rotates about an Earth-horizontal axis with the subject so positioned that the center of the head lies on the rotational axis of the device. Assume that the subject is oriented so that his  $z$  axis (head-foot dimension) is aligned with the Earth-horizontal rotational axis H-H' as illustrated in the drawing at the left in Figure 9. Let the instantaneous angular displacement, velocity, and acceleration of the device about H-H' be identified as  $\theta_h, \dot{\theta}_h, \ddot{\theta}_h$ , respectively. Measure  $\theta_h$  as the angular deviation of the  $+x$  head axis from the Earth-vertical reference axis V-V' as shown in the center sketch in Figure 9 where the head is depicted at an instant where  $\theta_h = +30^\circ$ . Assume, also at this

instant, that the angular velocity and angular acceleration of the subject are in the direction of the curved arrow drawn around the  $+z$  head axis in the left sketch.

EARTH HORIZONTAL ROTATION

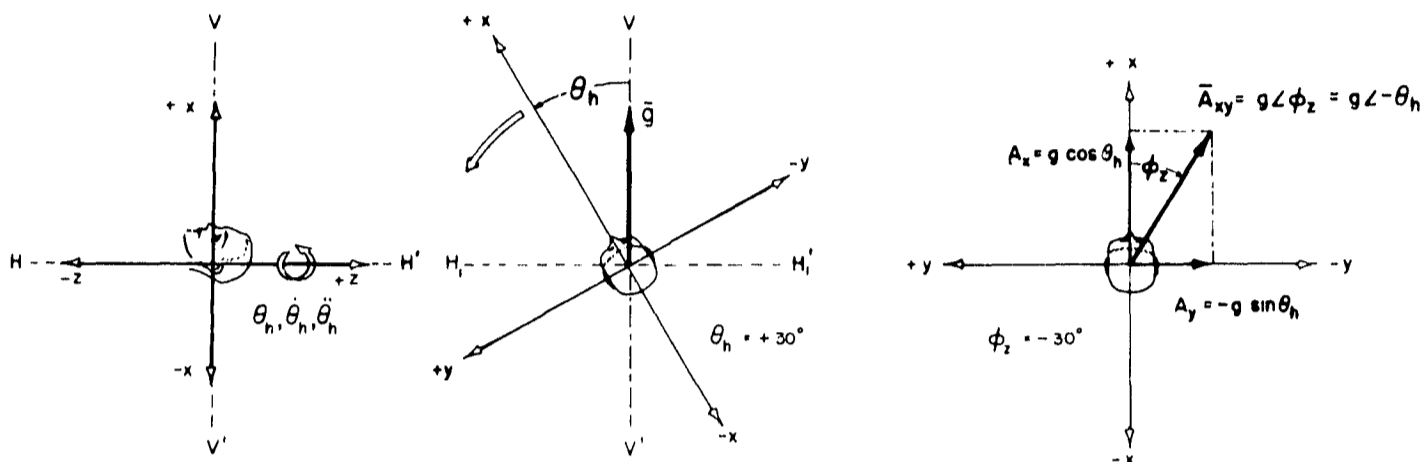

Figure 9

The sketches at the left and center identify the motion parameters of a device assumed to rotate a subject about an Earth-horizontal axis where the  $z$  head axis is aligned with the rotational axis. The magnitude/direction vector description of  $\bar{A}$  for these conditions is shown at the right where the acceleration due to gravitational action is treated as a vector which rotates about the  $z$  head axis through the horizontal  $xy$  head plane.

For these conditions the resultant angular acceleration stimulus derives directly from the angular motion parameters of the device and can be described by the single axial component  $\alpha_z = +\ddot{\theta}_h$ . However, the instantaneous linear acceleration stimulus, neglecting short-radius tangential and centripetal acceleration effects, depends only upon the instantaneous orientation of the head relative to the gravitational field. In effect, the horizontal  $xy$  head plane is being continually rotated through a linear acceleration vector of constant magnitude  $g$  which leads to an  $A_x = g \cos \theta_h$  and an  $A_y = -g \sin \theta_h$  description of the instantaneous linear acceleration acting along the  $x$  and  $y$  head axes, respectively. The components of  $\bar{A}$  and  $\bar{\alpha}$  are then listed as

$$\begin{aligned}
 A_x &= +g \cos \theta_h & \alpha_x &= 0 \\
 A_y &= -g \sin \theta_h & \alpha_y &= 0 \\
 A_z &= 0 & \alpha_z &= +\ddot{\theta}_h
 \end{aligned}
 \tag{14}$$

For rotation at constant angular velocity, where  $\theta_h = \dot{\theta}_h t$ , the  $A_x$  and  $A_y$  components describe sinusoidally varying linear acceleration stimuli each of peak magnitude  $1.0g$  and

cyclic oscillation frequency  $F = \dot{\theta}_h / 2\pi$  cps but  $90^\circ$  out of phase with each other. This interpretation of the stimulus allows a frequency response evaluation of stimulus-response interrelationships and is of particular interest in the analyses of the sinusoidally modulated horizontal eye nystagmus arising in response to constant angular velocity rotation of the head under the stimulus conditions defined in Figure 9.

The  $|\bar{A}| \angle \phi$  magnitude/direction notation is especially suited to this example as a result of its direct numerical rendition of the instantaneous magnitude and direction of a linear acceleration stimulus. Since the directional changes of the gravitational acceleration vector relative to the subject occur in the horizontal  $xy$  head plane, the linear acceleration stimulus can be described as simply

$$\bar{A} = \bar{A}_{xy} = |\bar{A}_{xy}| \angle \phi_z = \vartheta \angle -\theta_h \quad (15)$$

This notation is illustrated in the view of the horizontal  $xy$  head plane shown at the right in Figure 9 where the subject is visualized fixed in space and the  $\bar{A}_{xy}$  linear acceleration vector due to gravitational action is rotating CW about his  $z$  head axis. In this view the direction of  $\bar{A}_{xy}$  is drawn for the instant depicted in the center sketch in Figure 9 where the subject is shown angularly displaced  $30^\circ$  from vertical and  $\theta_h$  is measured as a positive angle. It is self-evident that  $\phi_z = -\theta_h$  since  $\phi_z$  measures the orientation of the gravitational vector relative to the man while  $\theta_h$  has been defined as the angle which measures the orientation of the man relative to the gravitational vector, and the same sign conventions were applied to the measurement of both angular displacements.

The  $\phi$  direction angles can also be used as aids in the correlation of response data evoked by Earth-horizontal rotation at constant angular velocity to the instantaneous attitude of the subject relative to the gravitational field. This arises since the angles provide a clear definition of the orientation of a linear acceleration vector relative to the anatomical head axes which is independent of the direction of rotation. Thus for Earth-horizontal rotation of the head about the  $x$ ,  $y$ , or  $z$  head axes, the instantaneous attitude of the acceleration vector due to gravity relative to the head is described by  $\phi_x$ ,  $\phi_y$ , or  $\phi_z$  direction angles, respectively. The orientations of a subject described by representative direction angles and their coterminal values are summarized in Table I.

When one of the three cardinal axes is aligned with an Earth-horizontal axis and a subject is rotated about that axis, the resulting nystagmus response exhibits both similarities and



Table I

Direction Angle  $\phi$  Description of the Instantaneous Orientation of a Subject Undergoing Rotation About an Earth-Horizontal Axis

Instantaneous Value of $\phi$	Earth-Horizontal Rotation of a Subject About His:		
	$x$ - axis	$y$ - axis	$z$ - axis
	Instantaneous Body Orientation	Instantaneous Body Orientation	Instantaneous Body Orientation
$\phi_{x, y, z} = 0^\circ$	Head erect	Head erect	Supine
$\phi_{x, y, z} = +90^\circ (-270^\circ)$	Right side up	Supine	Left side up
$\phi_{x, y, z} = +180^\circ (-180^\circ)$	Head inverted	Head inverted	Prone
$\phi_{x, y, z} = +270^\circ (-90^\circ)$	Left side up	Prone	Right side up

differences with respect to the classical response observed when the rotational stimulus is aligned with an Earth-vertical axis. The two stimulus situations may be equated insofar as their angular acceleration components are made identical, but, as it has been demonstrated above, rotation about an Earth-horizontal axis involves an additional variable linear acceleration component arising from a rotation of the subject's  $xy$ ,  $xz$ , or  $yz$  head plane through the linear acceleration vector due to gravitational action.

Angular acceleration about a horizontally aligned  $x$ ,  $y$ , or  $z$  axis will produce rotary, vertical, or horizontal nystagmus, respectively, with the direction of the slow component of the nystagmus opposite the direction of the stimulus acceleration, just as if the rotational axis of concern were oriented vertically. Compared to the nystagmus evoked by rotation of an erect subject about an Earth-vertical axis, however, that initiated by angular acceleration about a subject's  $z$  axis aligned with Earth-horizontal persists for a much longer period after constant velocity has been attained. Sustained horizontal nystagmus has been observed for periods of up to five minutes. Similar observations have been made for rotary and vertical nystagmus responses when the  $x$  and  $y$  head axes, respectively, are aligned with the Earth-horizontal axis of rotation.

#### Earth-Horizontal Translation

An elevation view of a device capable of producing rectilinear translation of a subject

along an Earth-horizontal axis is shown at the top of Figure 10. The movable element is a subject carrier which is coupled to a motive power system that can be programmed to produce

### EARTH HORIZONTAL TRANSLATION

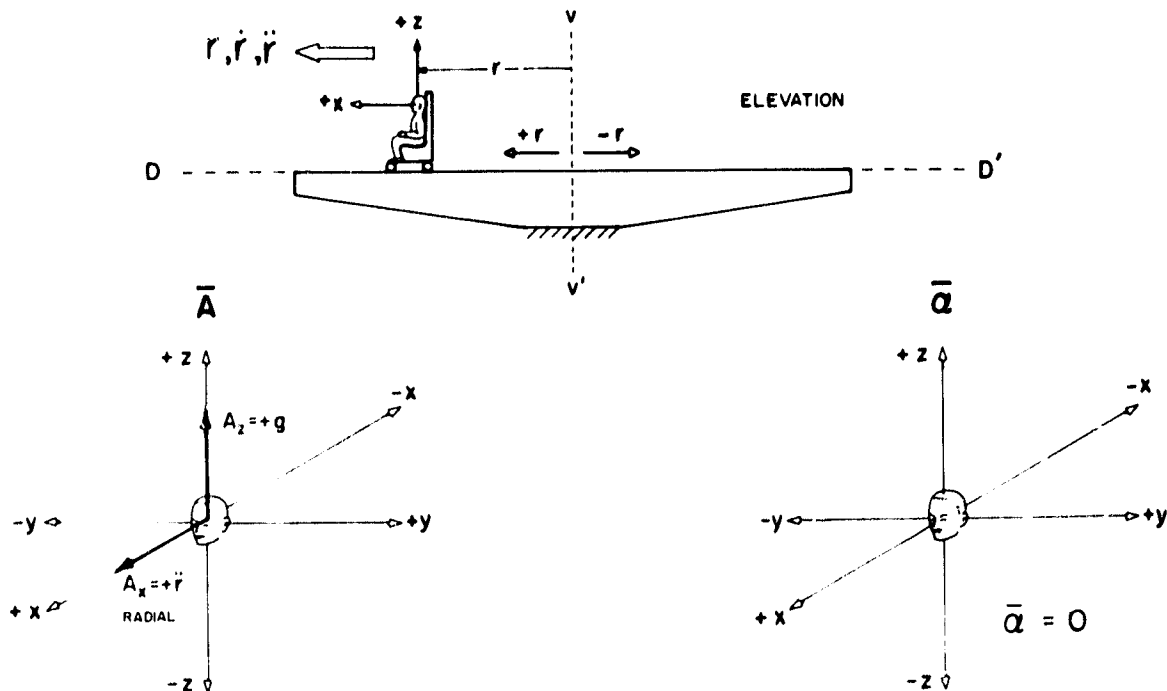

Figure 10

An elevation view of a device which produces time-varying linear displacements of a subject along a rectilinear Earth-horizontal path D-D' is shown at the top. The instantaneous linear displacement, velocity, and acceleration of the subject are identified as  $r$ ,  $\dot{r}$ , and  $\ddot{r}$  respectively. The components of  $\bar{A}$  and  $\bar{a}$  shown at the bottom are for a forward-directed  $\ddot{r}$  acceleration (to the left toward D) of the subject.

time-varying displacements of the carrier in either direction along an Earth-horizontal axis D-D'. The motion parameters of the device are arbitrarily defined as follows: Let the instantaneous linear displacement, velocity, and acceleration of the subject carrier along the rectilinear path D-D' be identified as  $r$ ,  $\dot{r}$ , and  $\ddot{r}$ . Measure the displacement  $r$  of the subject as the distance between the origin of the  $x$ ,  $y$ , and  $z$  head axes and a fixed Earth-vertical reference line V-V' at the center of the device. Let positive and negative values of  $r$  denote displacements of the subject carrier toward D and D', respectively, as viewed in Figure 10. Linear velocity and linear acceleration of the carrier toward D then result in positive values of  $\dot{r}$  and  $\ddot{r}$ , respectively.

Assume that the subject is seated in the carrier in a head erect posture with his  $z$  and  $x$  head axes always maintained in parallel alignment with the Earth-vertical reference axis V-V' and the Earth-horizontal axis of linear motion D-D', respectively. Let the subject's orientation be such that his  $+x$  head axis is directed toward D (facing to the left in Figure 10).

Initially, let the subject carrier be positioned at the center of the device where  $r = 0$ . The drive system is then programmed to produce a displacement of the carrier toward D with increasing linear velocity so that  $\dot{r}$ ,  $\ddot{r}$ , and  $r$  are all positive quantities. The resulting frontward linear acceleration of the subject is measured as  $A_x = +\ddot{r}$ . The components of  $\bar{A}$  and  $\bar{\alpha}$  are thus identified as simply

$$\begin{aligned} A_x &= +\ddot{r} & \alpha_x &= 0 \\ A_y &= 0 & \alpha_y &= 0 \\ A_z &= +g & \alpha_z &= 0 \end{aligned} \quad (16)$$

which are represented pictorially in the two sketches of the head shown at the bottom of Figure 10. In magnitude/direction notation,  $\bar{A}$  is identified as

$$\bar{A} = \bar{A}_{xz} = |\bar{A}_{xz}| \angle \phi_y$$

where

$$\begin{aligned} |\bar{A}_{xz}| &= [\ddot{r}^2 + g^2]^{1/2} \\ \phi_y &= \text{arc tan } \ddot{r}/g \end{aligned} \quad (17)$$

as illustrated in Figure 11.

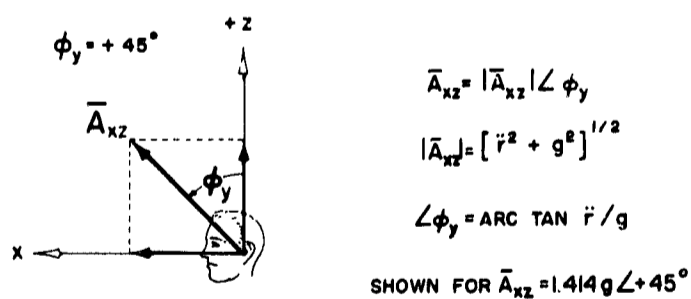

Figure 11

Magnitude/direction vector description of  $\bar{A}$  for the Earth-horizontal rectilinear translation device and subject orientation depicted in Figure 10. The resultant vector  $\bar{A}_{xz}$  is drawn for the case where  $\ddot{r} = +1.0g$ .

Consider now the case where a subject experiences simple harmonic translation to either side of the center of the device. Let the drive system be programmed so that the instantaneous linear displacement of the device from V-V' follows the profile defined by  $r = R \sin \omega t$  where R is the peak displacement in feet of the subject carrier to either side of the central axis;  $\omega$  is

the angular oscillation frequency in rad/sec and is related to the cyclic frequency  $F$  in cps by  $F = \omega / 2 \pi$ ; and  $t$  is the time in seconds. The motion parameters of the device can be summarized as

$$\begin{aligned} r &= R \sin \omega t & (\text{ft}) \\ \dot{r} &= \omega R \cos \omega t & (\text{ft/sec}) \\ \ddot{r} &= -\omega^2 R \sin \omega t & (\text{ft/sec}^2) \end{aligned} \quad (18)$$

Since  $A_x = -\omega^2 R \sin \omega t$ , the subject is exposed to a backward acceleration both while moving toward D in Figure 10 from  $r = 0$  to  $r = +R$  and while moving toward D' in returning from  $r = +R$  to  $r = 0$ . Conversely, he experiences a frontward acceleration both while moving toward D' from  $r = 0$  to  $r = -R$  and while moving toward D in returning from  $r = -R$  to  $r = 0$ . As with all simple harmonic motions of this form,  $r$  and  $\ddot{r}$  reach their maximum values at the outer limit of each cycle while the linear velocity  $\dot{r}$  is maximum as the subject passes through the center of the device. In addition,  $r$ ,  $\dot{r}$ , and  $\ddot{r}$  have identical sinusoidal waveforms but  $\dot{r}$  and  $\ddot{r}$  are displaced in phase relative to  $r$  by  $\omega t = \pi/2$  rad ( $90^\circ$ ) and  $\pi$  rad ( $180^\circ$ ), respectively.

For this condition, the components of  $\bar{A}$  and  $\bar{\alpha}$  are listed as

$$\begin{aligned} A_x &= -\omega^2 R \sin \omega t & \alpha_x &= 0 \\ A_y &= 0 & \alpha_y &= 0 \\ A_z &= +g & \alpha_z &= 0 \end{aligned} \quad (19)$$

or  $\bar{A}$  is described in magnitude/direction notation as

$$\bar{A} = \bar{A}_{xz} = |\bar{A}_{xz}| \angle \phi_y$$

where

$$\begin{aligned} |\bar{A}_{xz}| &= \left[ (-\omega^2 R \sin \omega t)^2 + g^2 \right]^{1/2} \\ \phi_y &= \text{arc tan } -\omega^2 R \sin \omega t / g \end{aligned} \quad (20)$$

The effect is to rotate the vector  $\bar{A}_{xz}$  back and forth about the  $y$  head axis. The vector will have an angular displacement  $\phi_y = 0$  whenever the subject is at the center of the device and a

maximum angular displacement of  $\phi_y = \arctan \omega^2 R/g$  from the  $z$  head axis whenever  $r = \pm R$ . Similarly, its magnitude will vary sinusoidally from a minimum of  $1.0g$  when aligned with the  $z$  axis to a maximum of  $\sqrt{(\omega^2 R)^2 + g^2}$  at its maximum displacements. Parenthetically, whereas Earth-horizontal linear motion devices produce a change in both the magnitude and direction of the resultant linear acceleration stimulus, Earth-vertical linear motion devices alter only the magnitude of the resultant since the  $r$  and  $g$  components are directionally aligned.

### Translation Within a Rotating Environment

In this section the nomenclature is applied to the description of acceleration stimuli which arise when time-varying rectilinear translation of a subject occurs in the plane of rotation of a device turning at constant angular velocity. A device capable of producing straight-line motion of a subject along a supporting structure which can be simultaneously rotated about an Earth-vertical axis V-V' is schematized in Figure 12. It is identical to the

TRANSLATION IN A ROTATING ENVIRONMENT

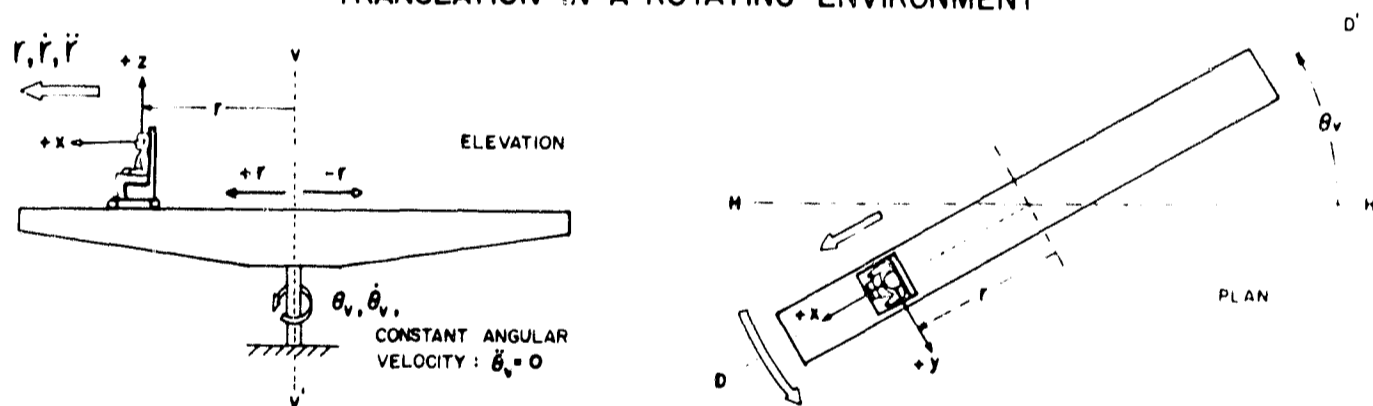

Figure 12

Elevation and plan sketches of a combined linear and angular motion device where the drive systems for each form of motion are independently controlled. Identification of  $r$ ,  $\dot{r}$ , and  $\ddot{r}$  and  $\theta_v$ ,  $\dot{\theta}_v$ ,  $\ddot{\theta}_v$  follows that shown for the devices depicted in Figures 6 and 10, respectively.

device depicted in Figure 10 with respect to its linear motion characteristics and to the device of Figure 6 with respect to its angular motion capability. For continuity of discussion, the instantaneous linear displacement, velocity, and acceleration of the subject carrier along axis D-D' in Figure 12 will be identified as  $r$ ,  $\dot{r}$ , and  $\ddot{r}$  in exact correspondence with the notation used in Figure 10; the instantaneous angular displacement, velocity, and acceleration of the radial arm D-D' about V-V' will be identified as  $\theta_v$ ,  $\dot{\theta}_v$ , and  $\ddot{\theta}_v$  in exact correspondence with the centrifuge described in Figure 6. The subject's orientation is that of Figure 10 with the  $x$  head axis aligned with the D-D' axis of linear motion with  $+x$  directed toward D.

The device's capabilities can be summarized as follows: The subject carrier is coupled to a linear motion drive system which can be programmed to produce  $r$ ,  $\dot{r}$ , and  $\ddot{r}$  linear motions of the subject carrier along axis D-D'. The supporting structure is coupled to a rotary motion drive system which can rotate the entire device about V-V' to produce  $\theta_v$ ,  $\dot{\theta}_v$ , and  $\ddot{\theta}_v$  angular motion parameters. Finally, the two drive systems are independent so that programmed linear movements of the subject do not affect the angular motion parameters and, conversely, the angular motions of the entire device will have no effect upon the programmed linear motions. With these conditions it can be recognized that  $r$ ,  $\dot{r}$ , and  $\ddot{r}$  are measured relative to a rotating reference frame, while  $\theta_v$ ,  $\dot{\theta}_v$ , and  $\ddot{\theta}_v$  are measured relative to a fixed reference frame attached to the Earth.

Initially, let the device be rotating CCW as viewed from above at constant angular velocity with the subject carrier positioned so that the center of the subject's head is on the rotational axis where  $r = 0$ . At some arbitrarily selected time  $t = 0$ , let the linear motion drive system be programmed to translate the subject radially outboard toward D with  $r$ ,  $\dot{r}$ , and  $\ddot{r}$  all measured as positive quantities, i.e., a frontward linear displacement, velocity, and acceleration of the subject. The combined linear and angular motions of the subject carrier result in a linear acceleration of the head along the  $x$  axis which is the algebraic sum of two components, one directed radially outboard toward D due to the programmed linear motion of the carrier and the other directed radially inboard toward the rotational center due to centripetal action so that  $A_x = +\ddot{r} - \dot{\theta}_v^2 r$ . Hence, the subject is exposed to a frontward acceleration of magnitude  $\ddot{r}$  that is opposed by a backward acceleration of magnitude  $\dot{\theta}_v^2 r$ . The subject is exposed also to a linear Coriolis acceleration of magnitude  $2 \dot{\theta}_v \dot{r}$  which acts in the plane of rotation at right angles to the D-D' axis of linear motion and is directed along the  $+y$  head axis leading to a leftward linear acceleration of the subject. In addition, gravitational action leads to an upward head acceleration of magnitude  $g$  directed along the  $+z$  head axis.

The components of  $\bar{A}$  and  $\bar{\alpha}$  are then described as

$$\begin{aligned}
 A_x &= +\ddot{r} - \dot{\theta}_v^2 r & \alpha_x &= 0 \\
 A_y &= +2 \dot{\theta}_v \dot{r} & \alpha_y &= 0 \\
 A_z &= +g & \alpha_z &= 0
 \end{aligned}
 \tag{21}$$

where  $\bar{\alpha}$  is obviously zero as a result of the assumed constant angular velocity condition. The components of equation set (21) are illustrated in Figure 13 where  $A_x$  is shown directed along

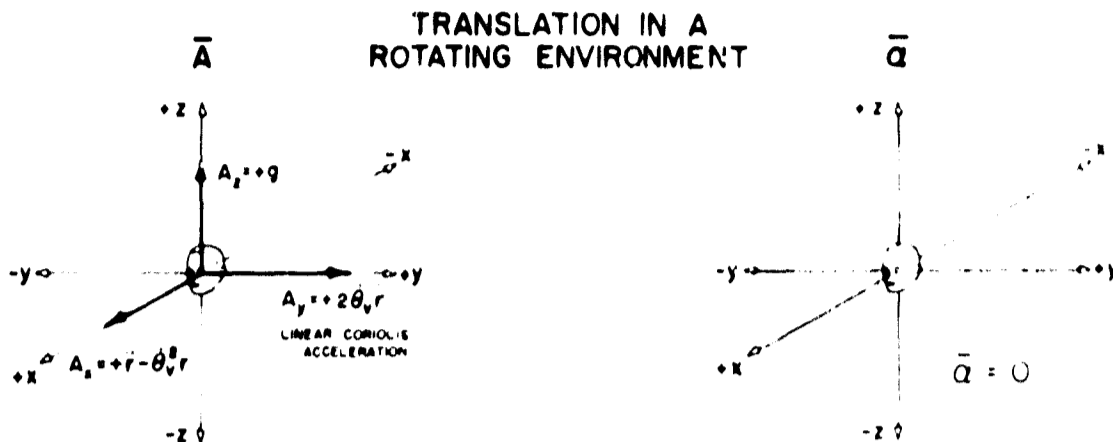

Figure 13

Components of  $\bar{A}$  and  $\bar{\alpha}$  for the stimulus conditions of Figure 12 where a subject is exposed to a forward linear velocity and acceleration along device axis D-D' while rotating CCW at constant angular velocity. Note that the linear Coriolis acceleration stimulus produces a leftward ( $+A_y$ ) linear acceleration of the head.

the  $+x$  head axis to denote that the motion parameters of the device are assumed to be such that  $r$  is greater than the centripetal acceleration  $\theta_v^2 r$  at the depicted instant.

From the vestibular viewpoint, a rather unique stimulus condition arises when the device is programmed to produce continuous, sinusoidal, linear oscillations of the subject carrier to either side of center while undergoing simultaneous rotation. For sinusoidal motion of the form described in equation set (18), and for constant angular velocity rotation, the linear and angular motion parameters of the device can be described as

$$\begin{array}{ll}
 r = R \sin \omega t & \text{(ft)} \\
 \dot{r} = \omega R \cos \omega t & \text{(ft/sec)} \\
 \ddot{r} = -\omega^2 R \sin \omega t & \text{(ft/sec}^2\text{)}
 \end{array}
 \qquad
 \begin{array}{ll}
 \theta_v = \dot{\theta}_v t & \text{(rad)} \\
 \dot{\theta}_v = \text{constant} & \text{(rad/sec)} \\
 \ddot{\theta}_v = 0 & \text{(rad/sec}^2\text{)}
 \end{array}
 \qquad
 (22)$$

By referring to equation sets (21) and (22) it can be seen that for these conditions, the nomenclature will identify the components of  $\bar{A}$  and  $\bar{\alpha}$  as

$$\begin{array}{ll}
 A_x = -(\omega^2 + \dot{\theta}_v^2) R \sin \omega t & \alpha_x = 0 \\
 A_y = +2 \dot{\theta}_v \omega R \cos \omega t & \alpha_y = 0 \\
 A_z = +g & \alpha_z = 0
 \end{array}
 \qquad
 (23)$$

Thus,  $A_x$  reaches a peak acceleration level of  $(\omega^2 + \dot{\theta}_v^2) R$  when the subject is maximally displaced from the rotational center. It describes a backward acceleration ( $-A_x$ ) for maximum

displacement toward D in Figure 12 where  $r = +R$ , and a frontward acceleration ( $+A_x$ ) for maximum displacement toward D' where  $r = -R$ . At the instant the subject passes through the center of the device where  $r = 0$ ,  $A_x$  is zero since the carrier's programmed linear acceleration as well as centripetal acceleration is zero. On the other hand,  $A_y$  reaches a maximum at the instant the chair passes through the center since the linear velocity  $\dot{r}$  of the chair reaches its maximum value of  $\omega R$  at  $r = 0$ , thus leading to maximal linear Coriolis acceleration. The linear Coriolis acceleration stimulus is a leftward acceleration ( $+A_y$ ) as the subject moves toward D from  $r = -R$  through  $r = 0$  to  $r = +R$ , and a rightward acceleration ( $-A_y$ ) as the subject moves toward D' from  $r = +R$  through  $r = 0$  to  $r = -R$ . Since  $\dot{r}$  is zero at the peak displacement of the subject, the linear Coriolis acceleration is zero when  $r = \pm R$ .

Now consider the specific operating condition in which the angular velocity  $\theta_v$  of the entire device and the angular oscillation frequency  $\omega$  of the sinusoidal linear displacements of the subject, both constants, are adjusted so as to equal each other. That is,  $\theta_v \equiv \omega = \text{constant}$ , where each is expressed in rad/sec units. The instantaneous angular displacement of the device relative to axis H-H' is then related to the instantaneous linear displacement of the subject from V-V' through  $\theta_v = \theta_v t = \omega t$ . Hence, from equation set (23), the components of  $\bar{A}$  and  $\bar{\alpha}$  become

$$\begin{aligned} A_x &= -2\omega^2 R \sin \omega t & \alpha_x &= 0 \\ A_y &= +2\omega^2 R \cos \omega t & \alpha_y &= 0 \\ A_z &= +g & \alpha_z &= 0 \end{aligned} \tag{24}$$

Equation (24) shows immediately that the peak magnitude of the linear Coriolis acceleration acting along the  $y$  head axis is identical to the peak magnitude of the acceleration acting along the  $x$  head axis. In addition, the sinusoidal magnitude-time profiles of  $A_x$  and  $A_y$  are identical except for a  $90^\circ$  ( $\pi/2$  rad) phase difference.

A more concise interpretation of  $A_x$  and  $A_y$  for these conditions is offered by the magnitude/direction notation which identifies the component of  $\bar{A}$  acting in the horizontal  $xy$  head plane as

$$\bar{A}_{xy} = |\bar{A}_{xy}| \angle \phi_z = 2\omega^2 R \angle \theta_v + 90^\circ$$

since

$$\begin{aligned} |\bar{A}_{xy}| &= (A_x^2 + A_y^2)^{\frac{1}{2}} \\ \phi_z &= \text{arc tan } A_y / A_x \end{aligned} \tag{25}$$



Thus the stimulus is equivalent to the continuous rotation of a linear acceleration vector of constant magnitude  $2\omega^2 R = 2\dot{\theta}_v^2 R$  through the horizontal head plane where the instantaneous direction of the vector is defined by the angle  $\phi_z = \theta_v + 90^\circ$ . The rate at which this vector rotates through the head, i.e.,  $\dot{\phi}_z$ , is simply  $\dot{\theta}_v = \omega$  rad/sec. The instantaneous orientation of  $\bar{A}_{xy}$  is illustrated in Figure 14 where the vector is drawn at the instants corresponding to  $\theta_v = \dot{\theta}_v t = \omega t = 0^\circ, 30^\circ, 60^\circ, 90^\circ, 120^\circ, \text{ and } 150^\circ$ . As indicated in this figure,  $\bar{A}_{xy}$

SINUSOIDAL TRANSLATION WITHIN A ROTATING ENVIRONMENT

$$\dot{\theta}_v = \omega \text{ rad/sec}$$

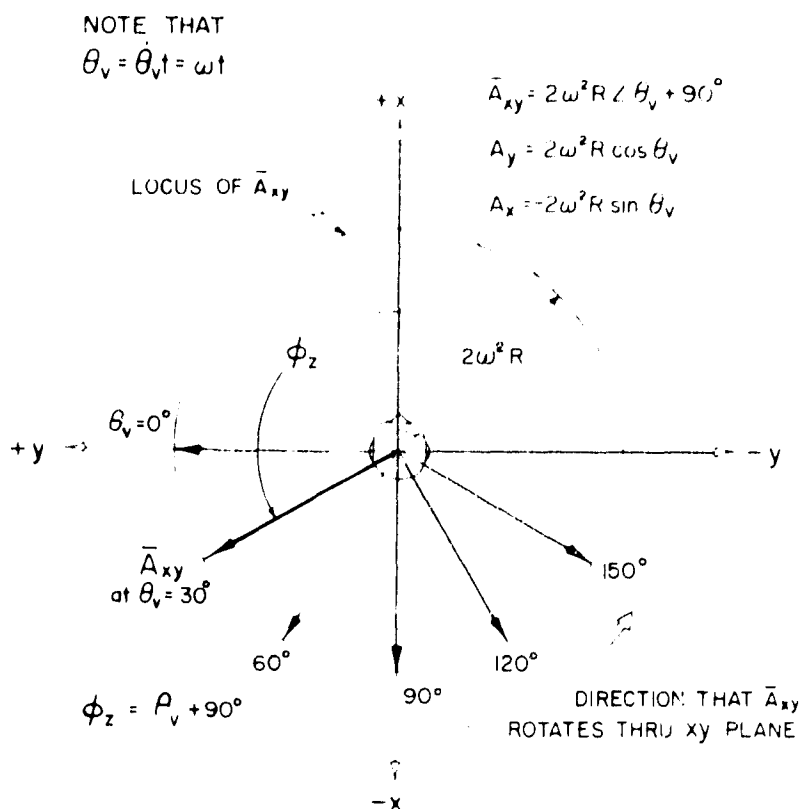

Figure 14

Magnitude/direction notation for the horizontal head plane component of  $\bar{A}$  for sinusoidal linear displacement  $r = R \sin \omega t$  of the subject along device axis D-D' (Figure 12) while rotating CCW at constant angular velocity  $\dot{\theta}_v$  where  $\omega \equiv \dot{\theta}_v$ . The subject is exposed to a linear acceleration vector of constant magnitude  $|\bar{A}_{xy}| = 2\omega^2 R$  which rotates continuously through the horizontal  $xy$  head plane. The position of the vector  $\bar{A}_{xy}$  is shown at various time increments marked by the listed values of  $\theta_v$ . See Figure 15 for specific device motion parameters.

rotates CCW through the horizontal head plane and describes a circular locus of radius  $2\omega^2 R$  ft/sec<sup>2</sup>. When  $A_z$  is taken into account, the resultant linear acceleration vector  $\bar{A}$  describes a circular conic section of height  $g$ . From the vestibular viewpoint, there results a stimulus condition in which the direction of a constant magnitude linear acceleration vector can be continually changed in a given head plane without being accompanied by angular acceleration.



conditions where the subject is being exposed to linear motion of simple harmonic form along D-D' while undergoing simultaneous constant velocity rotation. At an arbitrarily selected time  $t = 0$ , let the CCW rotating arm be aligned with the fixed, nonrotating reference line, H-H', where the D end of the arm is directed to the left toward H. The angular displacement of the radial arm at this instant is then measured as  $\theta_v = \dot{\theta}_v t = 0^\circ$ . At the same instant, let the subject carrier be at the center of the device and moving along D-D' toward D; i.e., the subject is at  $r = 0$  and moving with a maximal forward head velocity of  $\dot{r} = \omega R$  ft/sec.

With these initial conditions as reference, the angular deviation of the radial arm away from H-H' and the linear displacement of the subject along D-D' have been drawn for the instant when  $\theta_v = \dot{\theta}_v t = \omega t = +30^\circ$ . Since  $r = R \sin \omega t$ , the subject has moved a distance  $R/2$  away from the center of the device, and axis D-D' is deviated  $30^\circ$  away from H-H'. When the position of the subject is plotted for other instants, corresponding to  $\theta_v$  angles of  $0^\circ$ ,  $60^\circ$ ,  $90^\circ$ ,  $120^\circ$ , and  $150^\circ$ , it becomes apparent that the path of the subject, as seen by the fixed observer, is described by the dashed circular line drawn in Figure 15. If one notes the dimensions of this path, the time it takes the subject to complete one revolution around the path, and the instantaneous orientation of the subject's head axes relative to this path, the following observations can be made: The subject travels a circular path of radius  $R/2$  relative to the nonrotating orthogonal reference axes H-H' and  $H_1 - H_1'$  fixed to the Earth-horizontal plane and dividing the area into quadrants I, II, III, and IV. The center of the path is located on axis  $H_1 - H_1'$  a distance  $R/2$  ft below the actual center of the device. In the time that it takes the device to complete a half revolution, i.e.,  $\theta_v = 180^\circ$ , the subject has rotated  $360^\circ$  about the  $R/2$  origin. Thus relative to this origin, the subject is rotating CCW at  $2 \dot{\theta}_v$  rad/sec. However, as may be observed by noting the orientation of the  $x$  and  $y$  head axis relative to this origin, the subject is also rotating CW simultaneously on the path at  $\dot{\theta}_v$  rad/sec about his own  $z$  axis.

The fixed observer will never see the subject move above axis H-H', i.e., enter quadrants I and II of the device chamber, even though the subject moves a peak distance  $R$  in either direction along the radial arm. As far as the fixed observer is concerned, the same stimulus condition could be obtained if the combined linear and angular motion device under discussion were replaced by a pure angular motion device constructed in the form of a centrifuge with a counterrotating subject carrier or chair. Specifically, the replacement device would consist of a centrifuge positioned so that its rotational center lies on axis  $H_1 - H_1'$  a distance  $R/2$  below the center of the original device, and a counterrotating chair installed on the centrifuge a distance  $R/2$  away from the rotational center. The centrifuge would rotate CCW at a constant

angular velocity of  $2 \dot{\theta}_v$  rad/sec and the counterrotating chair turn CW at a constant velocity of  $\dot{\theta}_v$  rad/sec. In effect, the horizontal  $xy$  head plane is rotated at half the centrifuge velocity through a centripetal acceleration vector of magnitude  $(2 \dot{\theta}_v)^2 R/2 = 2 \dot{\theta}_v^2 R$ . The description of the stimulus produced by this pure angular motion device then follows identically that listed in equation sets (24) and (25) which were derived for the combined linear and angular motion device. This identification of the two stimuli as equivalent demonstrates another advantage of a unified nomenclature.

The specific operating condition outlined in Figure 15 can also be used to place practical emphasis on the point that any description of a resultant linear acceleration stimulus which contains a discrete component that may be identified as the "linear Coriolis acceleration" is based in part on motion parameter data measured relative to a rotating reference frame. In contradistinction, a description of such a stimulus which is based on motion parameter data measured relative to a fixed nonrotating reference frame will not contain a discrete "linear Coriolis acceleration" term. This point can be illustrated by noting that in the calculations of this section the linear velocity of the subject was measured along device axis D-D' which was assumed to be rotating at constant angular velocity. In effect,  $\dot{r}$  was measured relative to a rotating reference frame while  $\dot{\theta}_v$  was measured relative to a fixed reference frame. Accordingly, one component of the resultant linear acceleration, e.g.,  $A_y$  in equation set (24), could be identified specifically as the linear Coriolis acceleration component. If an alternative approach of measuring the instantaneous linear velocity of the subject relative to a fixed reference frame had been followed, an equivalent description of the stimulus would result without any reference to Coriolis acceleration. Specifically, if a fixed observer ignored the configuration of the device depicted in Figure 15 and viewed only the subject and the circular path he travelled in space, he could describe the stimulus in terms of a single acceleration directed normal to the path.

This distinction between a fixed and a rotating reference frame for the measurement of the motion parameters of a moving body can be interpreted in more general terms as follows. Think of an observer attached to some given reference frame and required to view the motions of a body moving along a selected path that is fixed to the reference frame, and let the observer be assigned the task of calculating the instantaneous linear acceleration of the body relative to that reference frame. He could begin by measuring the instantaneous position of the body relative to the frame and identifying the related data by a position or displacement vector  $\bar{r}$ . By taking the first and second time derivative of  $\bar{r}$ , the observer could calculate the instantaneous linear velocity  $\bar{v}$  and the instantaneous linear acceleration  $\bar{a}$ , respectively, of the body

relative to this frame. From the observer's viewpoint, the resultant linear acceleration  $\bar{a}$  would be described completely by two linear acceleration components: one directed tangentially along the path due to changes in the magnitude of  $\bar{v}$ , and one directed normal to the path due to changes in the direction of  $\bar{v}$ . That is, regardless of the complexity of the path, the observer could describe the resultant acceleration by calculating these two acceleration components. If it could be shown that the reference frame of concern were of inertial origin, then  $\bar{a}$  would equal the  $\bar{A}$  identification of the resultant linear acceleration provided by the nomenclature.

Now consider the identical situation with the exception that the just discussed reference frame is assumed to be rotating at constant angular velocity  $\bar{\omega}$  relative to a fixed reference frame considered to be of inertial origin. Let the body follow the same selected path within the rotating reference frame so that its motion parameters relative to the rotating reference frame remain as defined before with the addition of an  $r$  subscript to denote the fact that the frame is now rotating, i.e.,  $\bar{r}_r$ ,  $\bar{v}_r$ , and  $\bar{a}_r$ . Assume that the task of the observer, still attached to the original reference frame, is to calculate the acceleration of the body relative to the inertial reference frame. (As a result of the rotation of the path of the body, it is obvious that  $\bar{A} \neq \bar{a}_r$ .) Two approaches to the task will be discussed.

In the first approach, the observer could move to the fixed reference frame and follow the identical procedure used originally to determine  $\bar{a}$ ; i.e., measure the instantaneous position of the body relative to the fixed reference frame, identify the data in position vector form as  $\bar{R}$ , and calculate the instantaneous linear velocity and acceleration of the body relative to this frame as  $\bar{V}$  and  $\bar{A}$ . This description of  $\bar{A}$  would include only acceleration components due to changes in the magnitude and direction of  $\bar{V}$ . With this approach, the observer completely ignores the previously obtained  $\bar{r}_r$ ,  $\bar{v}_r$ , and  $\bar{a}_r$  description of the motion parameters of the body.

In the second approach, the observer can use the original measurement data and obtain an equivalent and numerically equal description of  $\bar{A}$  which does contain a component which it is convention to identify as the linear Coriolis acceleration. The observer first determines the motion of the body relative to the rotating reference frame ( $\bar{r}_r$ ,  $\bar{v}_r$ , and  $\bar{a}_r$ ). He then moves to the fixed reference frame and observes that the rotating reference frame proper has an angular velocity  $\bar{\omega}$ . From the basic kinematics equations associated with rotating frames of reference, the observer can then fully describe  $\bar{A}$  as

$$\bar{A} = \bar{a}_r + \left[ \bar{\omega} \times (\bar{\omega} \times \bar{r}_r) \right] + \left[ 2 \bar{\omega} \times \bar{v}_r \right] \quad (26)$$

which can be interpreted as follows. The resultant linear acceleration  $\bar{A}$  is equal to the sum of three acceleration components:  $\bar{a}_r$ , the acceleration of the body as seen by an observer attached to the rotating reference frame;  $\bar{\omega} \times (\bar{\omega} \times \bar{r}_r)$ , the acceleration of the body due to rotation of the position vector  $\bar{r}_r$ ; and  $2 \bar{\omega} \times \bar{v}_r$ , the acceleration of the body due to rotation of the linear velocity vector  $\bar{v}_r$ . The first bracketed term can be treated as the normal or centripetal acceleration, the second bracketed term as the linear Coriolis acceleration.

In essence, though both approaches lead to the same over-all value of  $\bar{A}$ , only the second approach, which utilizes data measured relative to a rotating frame of reference, leads to the specific identification of a Coriolis acceleration. The latter approach is of particular value when its application results in the simplification of the mathematics associated with the calculation of a given stimulus configuration. It is also of applied value to vestibular experimentation involving rotating environments since observations and measurements of subject motion are made within the environment.

Equation (26) can be applied to the description of the stimulus conditions discussed in this example if the previously defined linear and angular motion parameters are expressed in vector form. For example, the instantaneous linear displacement, velocity, and acceleration of the subject along axis D-D' as seen by an observer attached to the rotating device could be described as  $\bar{r}_r = \bar{r}$ ,  $\bar{v}_r = \dot{\bar{r}}$ , and  $\bar{a}_r = \ddot{\bar{r}}$ , respectively; the angular velocity of the rotating reference frame as seen by a fixed nonrotating observer could be described as  $\bar{\omega} = \dot{\bar{\theta}}_v$ . The resultant linear acceleration (neglecting gravitational action) could then be identified as

$$\bar{A} = \ddot{\bar{r}} + \left[ \dot{\bar{\theta}}_v \times (\dot{\bar{\theta}}_v \times \bar{r}) \right] + \left[ 2 \dot{\bar{\theta}}_v \times \dot{\bar{r}} \right] \quad (27)$$

where the linear Coriolis acceleration, i.e., the linear acceleration due to inertial rotation of a linear velocity vector, is the vector represented by the  $2 \dot{\bar{\theta}}_v \times \dot{\bar{r}}$  cross product.

The rules of vector cross-product multiplication which lead to the determination of the magnitude and direction of the linear Coriolis acceleration can be summarized in general terms as follows: The vector cross product of an angular velocity vector  $\bar{\omega}$  and any other vector, say  $\bar{S}$ , is a third vector, say  $\bar{T}$ , which may be written as

$$\bar{T} = \bar{\omega} \times \bar{S} \quad (28)$$

The absolute magnitude of  $\vec{T}$  is simply the product of the absolute magnitudes of  $\vec{\omega}$ ,  $\vec{S}$ , and the sine of the angle between the line along which  $\vec{\omega}$  is directed and the line along which  $\vec{S}$  is directed. This can be written as

$$|\vec{T}| = |\vec{\omega}| |\vec{S}| |\sin \angle \vec{\omega}, \vec{S}| \quad (29)$$

with the interpretation that the only component of  $\vec{S}$  which contributes to the vector cross product is that which lies in the plane of rotation of  $\vec{\omega}$ . The orientation or direction of  $\vec{T}$  is also readily established:  $\vec{T}$  acts along a line which is at right angles to both  $\vec{\omega}$  and  $\vec{S}$  and in the direction along this line that the sense of rotation depicted by  $\vec{\omega}$  tends to turn or rotate  $\vec{S}$ .

This is demonstrated by identifying the linear Coriolis acceleration as a vector  $\vec{A}_{co}$  which is equal to the last term in equation (27) so that

$$\vec{A}_{co} = 2 \vec{\theta}_v \times \vec{r} \quad (30)$$

For the first condition of this example (see equation set (21) and Figure 13) the linear velocity of the subject relative to the device can be represented by a linear velocity vector  $\vec{r}$  directed along the radial axis D-D'. With the chosen subject orientation,  $\vec{r}$  would be drawn along the +x head axis as shown in Figure 16 to denote the forward linear velocity of the subject at the instant of concern. The simultaneously occurring CCW rotation of the entire device would be represented by an angular velocity vector  $\vec{\theta}_v$  drawn upward along the +z head axis which is maintained in parallel alignment with the Earth-vertical rotational axis V-V' of the device. From equation (29), the absolute magnitude of the linear Coriolis acceleration is simply

$$|\vec{A}_{co}| = 2 |\vec{\theta}_v| |\vec{r}| \text{ ft/sec}^2 \quad (31)$$

where  $\vec{\theta}_v$  is in rad/sec and  $\vec{r}$  in ft/sec<sup>2</sup>. (With  $\vec{r}$  being perpendicular to  $\vec{\theta}_v$ ,  $|\sin \angle \vec{\theta}_v, \vec{r}|$  is unity.) Since  $\vec{A}_{co}$  must be directed along a line in the plane of rotation which is at right angles to  $\vec{r}$  (i.e., perpendicular to axis D-D' along which the linear motions of the subject occur), it acts along the y head axis. Since the  $\vec{\theta}_v$  vector tends to turn or rotate  $\vec{r}$  in the CCW direction, as viewed in Figure 16, away from its alignment with the +x head axis toward the left of the subject, the linear Coriolis acceleration is directed along the +y

head axis leading to a leftward acceleration of the subject. As a general statement applicable to all CCW rotating devices, the linear Coriolis acceleration will always be directed to the left of the direction of travel along any path in the plane of rotation. The converse is true for CW rotating devices.

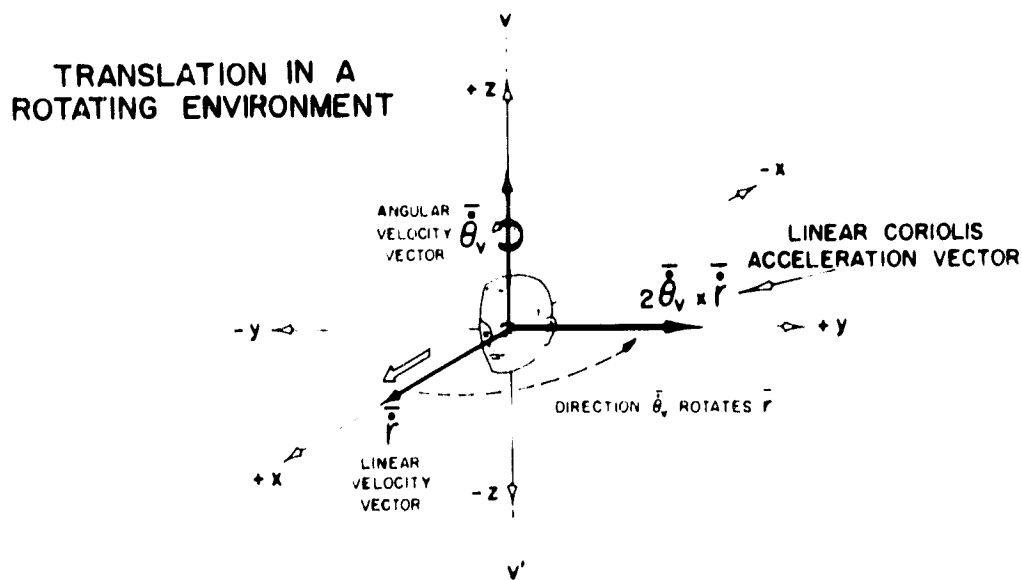

Figure 16

The sketch illustrates the method used to determine the direction of the linear Coriolis acceleration vector  $2\vec{\theta}_v \times \vec{r}$  where  $\vec{\theta}_v$  is an angular velocity vector describing the CCW rotation of the centrifuge as seen by a fixed observer and  $\vec{r}$  is a linear velocity vector describing the velocity of the subject as seen by an on-board centrifuge observer.

The same approach can be used to identify the magnitude and direction of the centripetal term of equation (26) to further establish the directional characteristics of  $\vec{A}$ ; a complete description would require the inclusion of gravitational action as well.

### Rotation Within a Rotating Environment

In this section the nomenclature is utilized to describe angular Coriolis acceleration stimuli which arise when rotary head motions are made within a rotating environment. Visualize a subject standing in a head erect posture aboard a centrifuge such as that described in Figure 6 where the center of the head is at the rotational center of the device. Let the  $z$  head axis be coincident with the Earth-vertical rotational axis  $V-V'$  so that the horizontal  $x y$  head plane lies in an Earth-horizontal plane. To allow the instantaneous orientation of the subject to be identified relative to some reference fixed to the centrifuge, it will be assumed that the  $y$  head axis is parallel with the radial arm  $D-D'$  of the centrifuge, where  $+y$  is directed toward  $D'$ .



Initially, assume the centrifuge is not rotating and the subject makes a head motion in the pitch downward direction where the motion is of pure rotational form without translation. That is, the head is rotated about the  $y$  axis with the condition that the  $y$  axis remains in the Earth-horizontal plane and never changes its alignment with the D-D' axis of the centrifuge. The motion characteristics of the head movement are described as follows: Let the instantaneous angular displacement, velocity, and acceleration of the head about the  $y$  axis be identified as  $\theta_y$ ,  $\dot{\theta}_y$ , and  $\ddot{\theta}_y$ , respectively. Measure  $\theta_y$  as the instantaneous angular displacement of the  $+z$  head axis from the Earth-vertical rotational axis V-V' of the centrifuge as shown in the sketch at the left in Figure 17. This sketch depicts the orientation of the head at the instant following initiation of the head motion at which  $\theta_y = +30^\circ$ , and  $\dot{\theta}_y$  and  $\ddot{\theta}_y$  are both assumed to be occurring in the pitch downward direction (i.e.,  $\dot{\theta}_y$  and  $\ddot{\theta}_y$  would be described by an angular velocity vector and an angular acceleration vector, respectively, drawn to the left of the subject along the  $+y$  head axis).

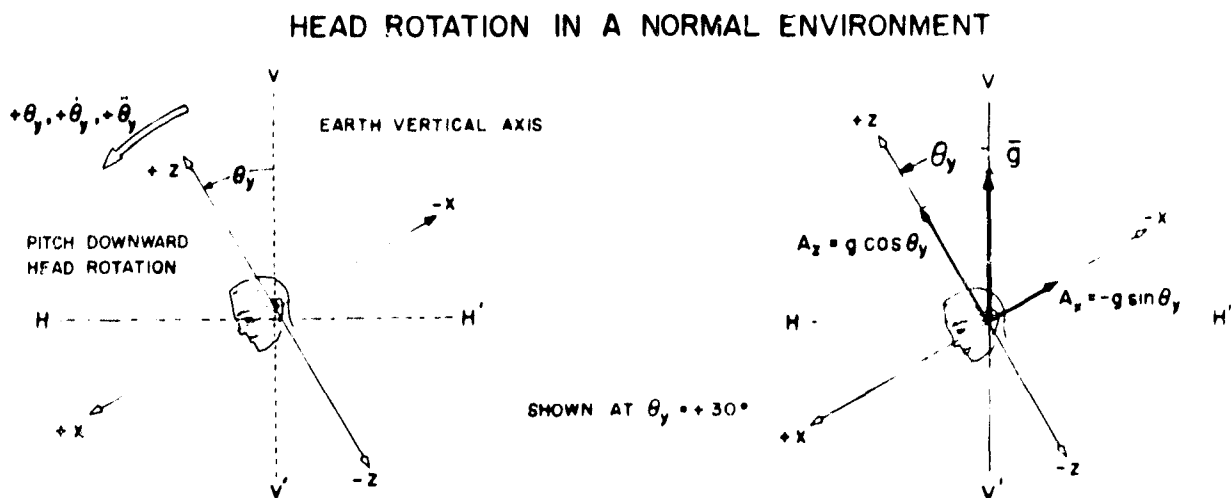

Figure 17

The angular motion parameters of a pitch downward rotary head movement made in the normal gravitational environment are shown as  $\theta_y$ ,  $\dot{\theta}_y$ , and  $\ddot{\theta}_y$  in the sketch at the left where rotation occurs about the  $y$  head axis. This condition is illustrated as rotation of the sagittal  $xz$  head plane through a linear acceleration vector  $\bar{g}$  in the sketch at the right where the  $A_x$  and  $A_z$  projections of  $\bar{g}$  are shown at the instant  $\theta_y = +30^\circ$ .

As a result of the head motion itself, the orientation of the  $x$  and  $z$  axes, i.e. the sagittal  $xz$  head plane, is continually changed relative to the Earth-vertical linear acceleration due to gravitational action (the vector  $\bar{g}$  in the sketch at the right in Figure 17). The instantaneous linear acceleration of the head along the  $x$  and  $z$  head axes is derived directly from the projection of  $\bar{g}$  to these axes. With the condition that the centrifuge is at rest, the components of  $\bar{A}$  and  $\bar{\alpha}$  can be listed as

$$\begin{aligned}
A_x &= -g \sin \theta_y & \alpha_x &= 0 \\
A_y &= 0 & \alpha_y &= + \ddot{\theta}_y \\
A_z &= g \cos \theta_y & \alpha_z &= 0
\end{aligned}
\tag{32}$$

In this case the angular acceleration stimulus derives solely from the head motion itself, i.e.,  $\alpha_y = + \ddot{\theta}_y$ . If the head motion occurred over a finite angular displacement, the time-integral of the initial pitch downward angular acceleration and the final pitch backward angular acceleration required to terminate the motion would be zero.

Now consider that the centrifuge is rotating CCW at constant angular velocity  $\dot{\theta}_v$  and that the subject is again standing in the head erect posture relative to the device. At  $t = 0$ , let the subject make a pitch downward head motion identical to that described in Figure 17. For this condition, a fixed, nonrotating observer sees a continuous change in the spatial orientation of the  $y$  axis about which the head pitches. The resultant angular acceleration of the head can thus be described in general terms by the expression

$$\bar{\alpha} = \bar{\alpha}_r + [ \bar{\omega} \times \bar{\omega}_r ]
\tag{33}$$

which is the angular acceleration equivalent of equation (26) used to discuss linear Coriolis acceleration stimuli. In equation (33),  $\bar{\alpha}$  represents the inertial angular acceleration of the head as seen by a fixed, nonrotating observer;  $\bar{\omega}_r$  and  $\bar{\alpha}_r$  the instantaneous angular velocity and angular acceleration of the head as seen by an on-board observer fixed to the rotating centrifuge; and  $\bar{\omega}$  the instantaneous angular velocity of the on-board observer's reference frame as seen by the fixed observer. Of concern to this section is the bracketed term of equation (33),  $\bar{\omega} \times \bar{\omega}_r$ , which is the angular Coriolis (cross-coupled) acceleration arising from inertial rotation of an angular velocity vector.

For the example of this section, the instantaneous angular velocity and acceleration of the head as seen by an on-board observer would be identified in vector form as  $\bar{\omega}_r = \dot{\theta}_y$  and  $\bar{\alpha}_r = \ddot{\theta}_y$ . The angular velocity of the on-board observer would be  $\bar{\omega} = \dot{\theta}_v$ . Equation (33) can then be written

$$\bar{\alpha} = \ddot{\theta}_y + [ \dot{\theta}_v \times \dot{\theta}_y ]
\tag{34}$$

The determination of the magnitude and the direction of the angular Coriolis acceleration vector follows the procedure previously described in conjunction with equations (28) and (29).

For discussion purposes, the angular Coriolis acceleration  $\bar{\theta}_v \times \bar{\theta}_y$  term of (34) will be symbolized as  $\bar{\alpha}_{co}$  so that

$$\bar{\alpha}_{co} = \bar{\theta}_v \times \bar{\theta}_y \quad (35)$$

The identification of these vectors is illustrated in the three-dimensional sketch of the head shown at the left in Figure 18. The head is drawn at an instant immediately following HEAD ROTATION WITHIN A ROTATING ENVIRONMENT

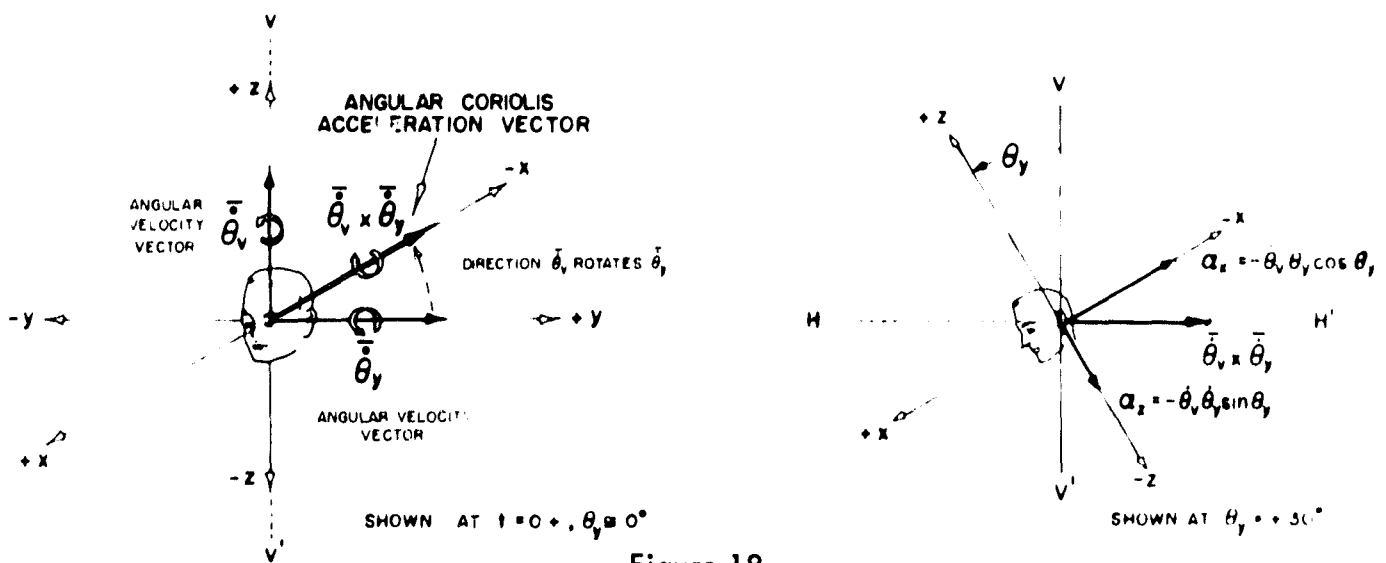

The sketch at the left illustrates the method used to determine the direction of the angular Coriolis acceleration vector  $\bar{\theta}_v \times \bar{\theta}_y$  where  $\bar{\theta}_v$  and  $\bar{\theta}_y$  are angular velocity vectors describing the CCW rotation of the centrifuge as seen by a fixed observer and the pitch downward head motion as seen by an on-board centrifuge observer, respectively. In the sketch at the right, the stimulus condition is represented by rotation of the sagittal  $xz$  head plane through the angular Coriolis acceleration vector which remains fixed in the Earth-horizontal plane of rotation of the centrifuge (note the similarity between this sketch and the one at the right in Figure 17).

initiation of the rotary head motion at which the head is assumed to be pitching downward about the  $y$  axis but at which insufficient time has elapsed to allow the  $z$  head axis to be significantly removed from its initial alignment with the Earth-vertical rotational axis  $V-V'$  of the centrifuge. The instantaneous angular velocity of the head about the  $y$  axis is thus depicted as a vector  $\bar{\theta}_y$  drawn along the  $+y$  head axis to denote a pitch downward head velocity. The instantaneous angular velocity of the centrifuge is described by a vector  $\bar{\theta}_v$  drawn upward along the centrifuge axis  $V-V'$ . Since, by definition, the  $y$  head axis always remains in parallel alignment with the radial axis  $D-D'$  of the centrifuge, the  $\bar{\theta}_y$  vector always remains in the Earth-horizontal plane of rotation of the device, i.e., at right angles to  $\bar{\theta}_v$ . The absolute

magnitude of the angular Coriolis acceleration vector is simply

$$|\bar{\alpha}_{c.o.}| = |\dot{\bar{\theta}}_v| |\dot{\bar{\theta}}_y| \quad \text{rad/sec}^2 \quad (36)$$

where both  $\dot{\bar{\theta}}_v$  and  $\dot{\bar{\theta}}_y$  are expressed in rad/sec units. As with the linear Coriolis acceleration stimulus, the only component of a rotary head motion which contributes to the angular Coriolis acceleration stimulus is that which is in the plane of rotation.

The direction of  $\bar{\alpha}_{c.o.}$  is also readily established. That is,  $\bar{\alpha}_{c.o.}$  will be directed along a line in the plane of rotation of the centrifuge which is at right angles to  $\dot{\bar{\theta}}_y$  and in the direction along this line that the sense of rotation signified by  $\dot{\bar{\theta}}_v$  tends to turn or rotate the head velocity vector  $\dot{\bar{\theta}}_y$ . As illustrated at the left in Figure 18,  $\dot{\bar{\theta}}_v$  tends to turn the  $\dot{\bar{\theta}}_y$  vector away from its alignment with the +y head axis and back toward the -x head axis. At the depicted instant  $\bar{\alpha}_{c.o.}$  is described by an angular acceleration vector which lies in the plane of rotation of the device on a line at right angles to D-D' and is directed along this line toward the rear of the subject.

Thus the angular Coriolis acceleration stimulus is described by a vector which maintains a fixed alignment with a reference system fixed to the centrifuge. However, by the very nature of the rotary head motion the sagittal xz head plane is being continually reoriented relative to this  $\bar{\alpha}_{c.o.}$  acceleration vector. This is illustrated in the sagittal plane view of the head shown at the right in Figure 18 where the head is depicted at the instant when  $\theta_y = +30^\circ$ . The projections of the  $\bar{\alpha}_{c.o.} = \dot{\bar{\theta}}_v \times \dot{\bar{\theta}}_y$  vector to the x and y head axes at this instant are also illustrated. For these conditions the components of  $\bar{A}$  and  $\bar{\alpha}$  are identified as

$$\begin{aligned} A_x &= -g \sin \theta_y & \alpha_x &= -\dot{\theta}_v \dot{\theta}_y \cos \theta_y \\ A_y &= 0 & \alpha_y &= +\ddot{\theta}_y \\ A_z &= g \cos \theta_y & \alpha_z &= -\dot{\theta}_v \dot{\theta}_y \sin \theta_y \end{aligned} \quad (37)$$

which are illustrated pictorially in Figure 19. The components of  $\bar{A}$  remain as described in equation set (32) for nonrotation where short-radius tangential and centripetal acceleration effects are not considered. The components of  $\bar{\alpha}$  include the  $\dot{\theta}_y$  contribution due to the head motion proper as well as the angular Coriolis acceleration contribution; the subject is exposed to a roll leftward ( $-\alpha_x$ ) and a yaw rightward ( $-\alpha_z$ ) angular acceleration as a result of the Coriolis effect.

### HEAD ROTATION WITHIN A ROTATING ENVIRONMENT

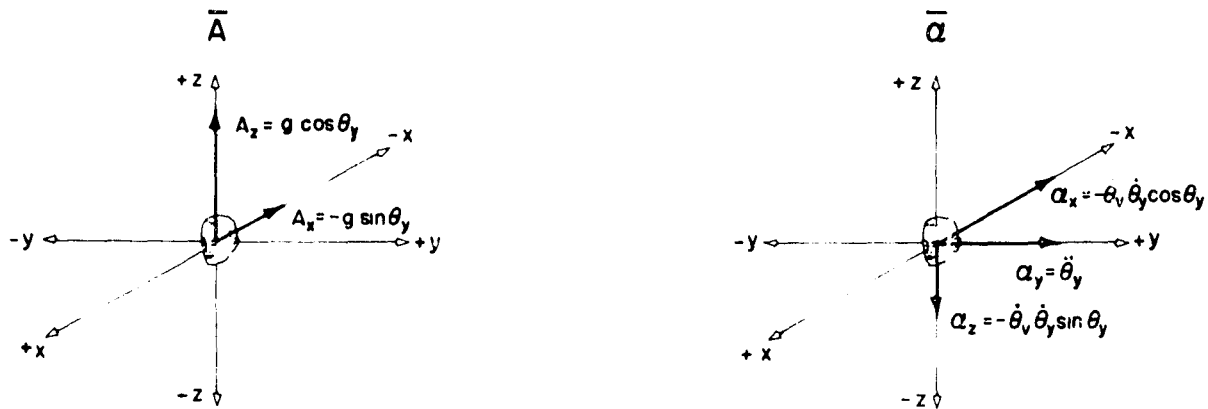

Figure 19

Components of  $\bar{A}$  and  $\bar{\alpha}$  at a given instant during a pitch downward head rotation made at the center of a centrifuge turning CCW about an Earth-vertical rotational axis. Note that the angular Coriolis acceleration leads to a roll leftward ( $-\alpha_x$ ) and a yaw rightward ( $-\alpha_z$ ) angular acceleration of the head.

The stimulus conditions of this example can be summarized by stating that the head simultaneously rotates through an Earth-vertical constant magnitude linear acceleration vector  $\bar{g}$  due to gravitational action and a variable magnitude angular acceleration vector  $\dot{\theta}_v \times \bar{\theta}_y$  which lies in an Earth-horizontal plane. This action is described in magnitude/direction notation as

$$\begin{aligned} \bar{A}_{xz} &= |\bar{A}_{xz}| \angle \phi_y = g \angle -\theta_y \\ \bar{\alpha}_{xz} &= |\alpha_{xz}| \angle \beta_y = \dot{\theta}_v \dot{\theta}_y \angle -(\theta_y + 90^\circ) \end{aligned} \quad (38)$$

which are independently depicted in the sagittal plane views in Figure 20. This particular example serves to demonstrate a stimulus condition in which the morphological direction of the resultant linear acceleration, as denoted by the angle  $\phi$ , differs from the morphological orientation of the resultant angular acceleration, as denoted by the angle  $\beta$ . It should be remembered that actual head movements include translatory as well as rotatory components of motion so that in the practical situation, both linear and angular Coriolis acceleration stimulation can result. Most important, a subject may be exposed to linear Coriolis accelerations which can be made to maintain a fixed morphological orientation relative to the subject, but such is not the case for angular Coriolis accelerations which continually change their orientation relative to the subject.

### HEAD ROTATION WITHIN A ROTATING ENVIRONMENT

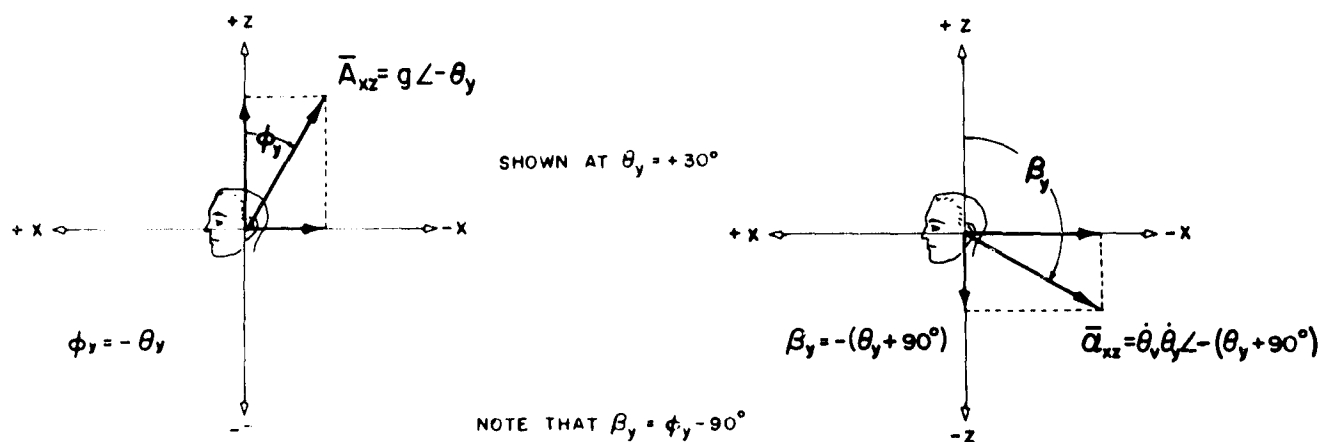

Figure 20

Magnitude/direction vector description of the sagittal  $xz$  head plane components of  $\bar{A}$  and  $\bar{\alpha}$  where  $\bar{A}_{xz}$  is shown as a linear acceleration vector of magnitude  $g$  and  $\bar{\alpha}_{xz}$  as an angular acceleration vector of magnitude  $\dot{\theta}_v \dot{\theta}_y$  due to angular Coriolis action. The position of these vectors corresponds to the instant depicted in Figure 17 where  $\theta_y = +30^\circ$ .

Continuous Head Rotation at Constant Angular Velocity. In this section the description of the angular Coriolis acceleration stimulus provided in equation set (37) will be applied to the case in which the head is made to rotate continuously at constant angular velocity within an environment which is also turning at constant angular velocity. This could be achieved in the experimental situation by placing the subject in a small single-axis rotator which turns about an Earth-horizontal axis and installing the rotator at the center of a centrifuge. It is assumed that the center of the head lies at the intersection of the rotational axes of the two devices and that the Earth-horizontal rotation occurs about the  $y$  head axis in the pitch downward direction. The angular motion parameters of the head movement are identified as  $\theta_y$ ,  $\dot{\theta}_y$ , and  $\ddot{\theta}_y$  in exact correspondence with the previously established definitions. As a time reference, let  $t = 0$  at the instant in which the head is in the erect posture relative to the Earth-vertical rotational axis of the CCW-turning centrifuge. With these conditions, it follows that equation set (37) can then be written as

$$\begin{aligned}
 A_x &= -g \sin \dot{\theta}_y t & \alpha_x &= -\dot{\theta}_v \dot{\theta}_y \cos \dot{\theta}_y t \\
 A_y &= 0 & \alpha_y &= 0 \\
 A_z &= g \cos \dot{\theta}_y t & \alpha_z &= -\dot{\theta}_v \dot{\theta}_y \sin \dot{\theta}_y t
 \end{aligned}
 \tag{39}$$

where  $\theta_y = \dot{\theta}_y t$ , and  $\ddot{\theta}_y = 0$  since  $\dot{\theta}_y = \text{constant}$ .

From equation set (39) it follows that  $\alpha_x$  and  $\alpha_z$ , as well as  $A_x$  and  $A_z$ , describe sinusoidal acceleration waveforms which have oscillation frequencies directly proportional to the rate at which the head is pitched about its  $y$  axis. In effect, each of these stimulus components has an angular oscillation frequency of  $\omega = \dot{\theta}_y$  rad/sec, a cyclic oscillation frequency of  $F = \dot{\theta}_y / 2\pi$  cps and a period of  $T = 1/F$  seconds. The  $\pi/2$  rad or  $90^\circ$  phase lag of  $\alpha_z$  behind  $\alpha_x$  becomes more obvious when the angular components of equation set (39) are rewritten, following trigonometric conversion, as

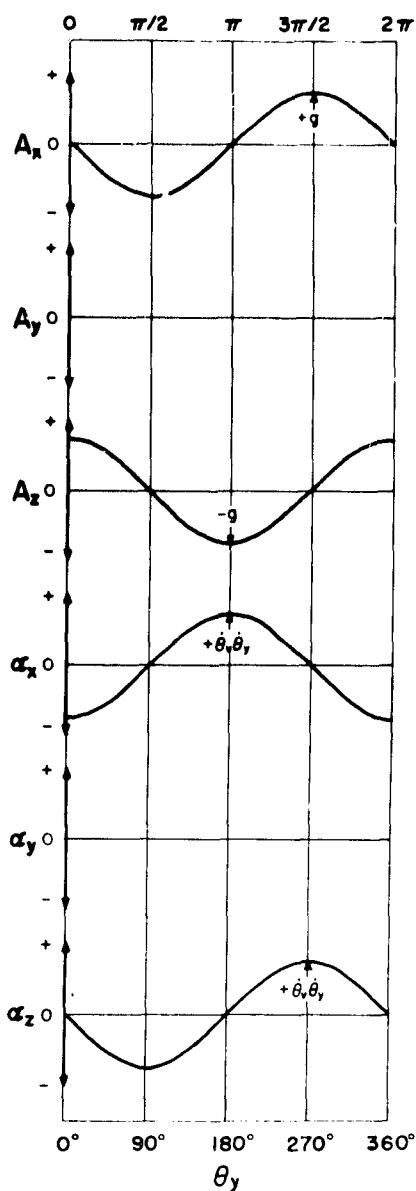

Figure 21

Plot of the  $A$  and  $\alpha$  components of equation set (39) as a function of  $\theta_y$

The ease with which high-level angular acceleration stimulation is accomplished under these conditions can be illustrated by calculating the peak magnitude of  $\alpha_x$  and  $\alpha_z$  for the specific case in which the angular velocity  $\dot{\theta}_y$  of the centrifuge is 10 rpm and the angular

$$\alpha_x = \dot{\theta}_v \dot{\theta}_y \sin(2\pi Ft - \pi/2)$$

$$\alpha_y = 0 \quad (40)$$

$$\alpha_z = \dot{\theta}_v \dot{\theta}_y \sin(2\pi Ft - \pi)$$

or equivalently, as

$$\alpha_x = \dot{\theta}_v \dot{\theta}_y \cos(2\pi Ft - \pi)$$

$$\alpha_y = 0 \quad (41)$$

$$\alpha_z = \dot{\theta}_v \dot{\theta}_y \cos(2\pi Ft - 3\pi/2)$$

Thus  $\alpha_x$  and  $\alpha_z$  describe sinusoidal angular acceleration stimuli with identical waveforms of peak magnitude  $\dot{\theta}_v \dot{\theta}_y$  rad/sec<sup>2</sup> with the condition that their peak values, as well as their directional transitions through zero acceleration, occur  $T/4$  seconds apart. These phase relationships are shown graphically in Figure 21 where the instantaneous magnitude of each component of  $\bar{A}$  and  $\bar{\alpha}$  is plotted as a function of the instantaneous pitch attitude  $\theta_y = \theta_y t$  of the head over a complete  $360^\circ$  rotation about the  $y$  axis.

velocity  $\dot{\theta}_y$  of the head is 15 rpm. Since  $1 \text{ rpm} = 6 \text{ deg/sec} = 0.1047 \text{ rad/sec}$ , the absolute amplitude of the Coriolis acceleration stimulus is  $\dot{\theta}_v \dot{\theta}_y = 1.64 \text{ rad/sec}^2$  ( $94.0 \text{ deg/sec}^2$ ). The cyclic frequency is  $F = 0.25 \text{ cps}$  and the period of a single cycle is  $T = 4.0 \text{ seconds}$ .

From equation set (39) it may be noted that if the centrifuge velocity  $\dot{\theta}_v$  is halved, the peak amplitude of the stimulus is halved but the frequency will remain constant at  $F = 0.25 \text{ cps}$ . If the head velocity  $\dot{\theta}_y$  is halved, not only is the amplitude of the stimulus similarly halved, but the frequency is also decreased to  $F = 0.125 \text{ cps}$ . In short, angular accelerations can be made to act about two preselected head axes and either frequency or amplitude can be held constant while the other is varied. That is to say, frequency is varied by altering  $\dot{\theta}_y$  and amplitude held constant by adjusting  $\dot{\theta}_v$  as required to maintain  $\dot{\theta}_v \dot{\theta}_y$  constant in equation (39). Conversely, amplitude is varied by altering  $\dot{\theta}_v$  while  $\dot{\theta}_y$ , and hence frequency, is held constant.

The instantaneous magnitude and direction of these angular Coriolis accelerations can be discussed with specific reference to the vestibular area by considering the form of nystagmus and the body sensation of turning predicted to arise by the angular components of equation set (39). This discussion will be based on the generally accepted assumption that the cardinal head axes, for most practical purposes, serve as the primary axes of sensitivity to angular acceleration. When the head is angularly accelerated about the  $x$  axis, a roll sensation of turning and rotary nystagmus result; when angularly accelerated about the  $y$  axis, a pitch sensation of turning and vertical nystagmus result; and when angularly accelerated about the  $z$  axis, a yaw turning sensation and horizontal nystagmus result. The direction of each of these responses relative to the direction of each of the  $\alpha_x$ ,  $\alpha_y$ , and  $\alpha_z$  stimulus components is tabulated below.

Table II

Nystagmus and Sensation of Turning Responses to Angular Acceleration Stimuli				
Stimulus Direction	Nystagmus Response	Direction of Slow Component	Turning Response	Direction of Turning
$+\alpha_x$	rotary	left	roll	right
$-\alpha_x$	rotary	right	roll	left
$+\alpha_y$	vertical	up	pitch	down
$-\alpha_y$	vertical	down	pitch	up
$+\alpha_z$	horizontal	right	yaw	left
$-\alpha_z$	horizontal	left	yaw	right



The direction of the sensation of turning is the same as that of the acceleration stimulus; the direction of the slow component of nystagmus is opposite that of the stimulus. In contrast to common clinical usage, the direction of the slow, rather than the fast, component is selected to denote the direction of the ocular response since the velocity of the slow component and its waveform are usually taken as a measure of the strength and form of nystagmus in the experimental situation.

By treating each of the angular components of equation set (39) as independently occurring stimuli, it can be seen that the following types of responses due to angular acceleration are predicted by the  $\alpha_x$ ,  $\alpha_y$ , and  $\alpha_z$  equations. Since  $\alpha_x$  is finite, the sensation of roll and rotary nystagmus would be present; since  $\alpha_y$  is zero, vertical nystagmus due to angular acceleration would not be predicted; and since  $\alpha_z$  is finite, the sensation of yaw and horizontal nystagmus would be produced. Since  $\alpha_x$  and  $\alpha_z$  are of sinusoidal form, it follows from current semicircular canal response theory that the waveform of the instantaneous magnitude of the slow component of the related nystagmic eye velocity will be predicted to be sinusoidal. This is illustrated graphically in Figure 22 where the waveforms of  $\alpha_x$  and  $\alpha_z$  and the hypothesized nystagmus response (neglecting the fast component) are drawn over a single  $360^\circ$  revolution

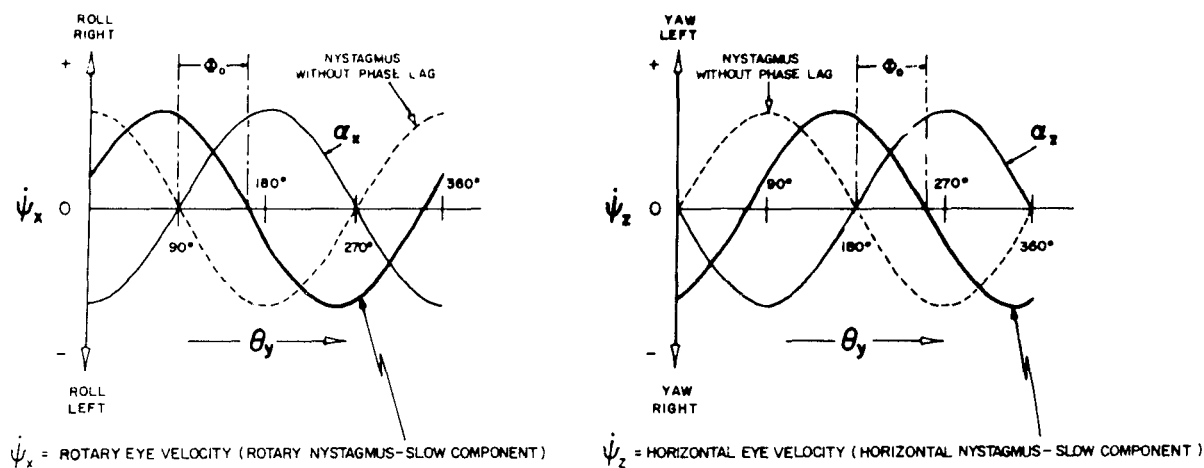

Figure 22

The instantaneous magnitude of the slow component of rotary nystagmus predicted by the  $\alpha_x$  term of equation set (39) is shown plotted, with and without phase lag, as a function of  $\theta_y$  at the left. Equivalent curves shown at the right describe the waveform of the horizontal nystagmus response predicted by the  $\alpha_z$  term.

of the head about the  $y$  axis. As indicated in the sketch at the right,  $\alpha_z$  describes a yaw rightward angular acceleration of the head over the  $0^\circ < \theta_y < 180^\circ$  half of the cycle and a yaw leftward acceleration over the remaining  $180^\circ < \theta_y < 360^\circ$  half. Theoretically it would be expected that if the oculovestibular system had extremely fast response characteristics compared

to the frequency of the  $\alpha_z$  stimulus, the sinusoidal waveform of the nystagmus would be  $180^\circ$  out of phase with  $\alpha_z$ , as indicated by the dashed line sinusoid in the figure. That is, the slow component of horizontal nystagmus would be to the left for  $0^\circ < \theta_y < 180^\circ$  and to the right for  $180^\circ < \theta_y < 360^\circ$ , would reach a maximum value at  $\theta_y = 90^\circ$  and  $\theta_y = 270^\circ$ , and would reverse direction as  $\alpha_z$  goes through its zero level at  $\theta_y = 0^\circ$  and  $\theta_y = 180^\circ$ .

However, since the time-constant of the oculovestibular system is known to be relatively long, say, 10-25 seconds, it would be predicted that the horizontal nystagmus would lag the  $\alpha_z$  stimulus by a measurable amount. This phase lag is typified by the heavily lined sinusoid shown in Figure 22. The nystagmus response is hypothesized to lag  $\alpha_z$  by an angle  $\Phi_0$  which is measured as the interval between the transition of  $\alpha_z$  through zero acceleration and the subsequent transition of the nystagmus through zero eye velocity. The transitions are marked by the vertical dashed lines arbitrarily drawn to represent a phase shift of about  $70^\circ$ .

The form of rotary nystagmus predicted by the  $\alpha_x$  stimulus equation is similarly represented at the left in Figure 22. In this case  $\alpha_x$  describes a roll rightward angular acceleration over the  $90^\circ < \theta_y < 270^\circ$  interval and a roll leftward stimulus over the remaining portion of the cycle. Thus  $\alpha_x$  is maximum at  $\theta_y = 0^\circ$  and  $\theta_y = 180^\circ$  and goes through zero level at  $\theta_y = 90^\circ$  and  $\theta_y = 270^\circ$ . The hypothesized rotary nystagmus response, with and without the effect of the finite time constant of the responsible oculovestibular system, is shown in heavy and dashed outline as before.

It should be borne in mind that the above discussion of rotary and horizontal nystagmus evoked by continuous head rotation in a constantly rotating environment is based on an independent occurrence of the  $\alpha_x$  and  $\alpha_z$  stimulus components. In actuality, the latter occur simultaneously, and so do the associated responses. Further, although no vertical nystagmus due to angular acceleration of the head about the  $y$  axis would be predicted since  $\alpha_y = \dot{\theta}_y = 0$ , it is known that rotation of the sagittal  $xz$  head plane through a linear acceleration vector (as discussed in the Earth-Horizontal Rotation section) does elicit vertical nystagmus. Since the stimulus condition of this example continually alters the orientation of the sagittal plane relative to the gravitational field, it would be expected that vertical nystagmus would, in fact, exist and modify the response predicted on the basis of the angular acceleration components alone. Although such comprehensive treatments of specific stimulus situations are beyond the purview of the present report, it is apparent that by a definitive description of stimulus acceleration parameters, by analysis and prediction of the basic form of pertinent response components in terms of current knowledge of sensor transduction characteristics, and, finally, by synthesis and evaluation

of the final predicted response in terms of the observed response, one can immediately direct attention to the problem of discovering what element, characteristic, or mode of response of the biological system does not fit the existing vestibular stimulus-response theory.

Head Rotation Over a Finite Angle. Of particular interest to the vestibular area are the stimuli which arise when a subject makes a rotary head motion over some finite angle to effect a change in the steady-state orientation of the head relative to the rotating environment. In the following section the stimuli are discussed in terms of the instantaneous magnitude and direction of the  $\alpha_x$ ,  $\alpha_y$ , and  $\alpha_z$  components of the resultant angular acceleration of the head. In a succeeding section an equivalent angular velocity impulse description of angular Coriolis stimulation is provided in the language of the proposed nomenclature which gives a quantitative description of the stimuli associated with relatively fast head motions and serves to demonstrate how the nomenclature can be readily modified to meet different requirements.

Angular acceleration description of angular Coriolis stimuli: The first head movement to be treated is the previously discussed pitch downward rotation which, as before, will be assumed to be of pure rotary form and to occur at the center of a CCW-rotating centrifuge. The identification of the head motion parameters remains as  $\theta_y$ ,  $\dot{\theta}_y$ , and  $\ddot{\theta}_y$ .

The motion will be assumed to be of smooth continuous form such as can be accomplished with a normal head movement and to be of  $\tau$  seconds' duration. The initial and final positions of the head are defined as follows: Before the movement is started the head will be considered to be at an angle  $\theta_y = \theta_{y1}$  relative to V-V', the Earth-vertical rotational axis of the centrifuge. At  $t = 0$  the head motion will be initiated in the pitch downward direction and terminated  $\tau$  seconds later. The final position of the head will be measured as the angle  $\theta_y = \theta_{y2}$ . The head will be considered to be held immobile both before and after the head movement so that  $\dot{\theta}_y$  and  $\ddot{\theta}_y$  will be zero except for the interval  $0 < t < \tau$ . The acceleration of the head during this interval is identified in exact accordance with equation set (37), rewritten with specific boundary conditions as

$$\begin{aligned}
 A_x &= -g \sin \theta_y & \alpha_x &= -\dot{\theta}_v \dot{\theta}_y \cos \theta_y \\
 A_y &= 0 & \alpha_y &= \ddot{\theta}_y \\
 A_z &= g \cos \theta_y & \alpha_z &= -\dot{\theta}_v \dot{\theta}_y \sin \theta_y
 \end{aligned} \tag{42}$$

where for  $t \leq 0$ ,  $\theta_y = \theta_{y1}$  and  $\dot{\theta}_y = \ddot{\theta}_y = 0$

and for  $t \geq \tau$ ,  $\theta_y = \theta_{y2}$  and  $\dot{\theta}_y = \ddot{\theta}_y = 0$

Before discussing this equation set some knowledge of the motion parameters of the head movement itself is required. First, it should be recognized that the angular velocity of the head is in the same direction ( $+\dot{\theta}_y$ ) throughout the movement since the motion occurs in the pitch downward direction. Second, although the head is initially accelerated downward ( $+\alpha_y$ ) to begin the movement, the head will necessarily be accelerated upward ( $-\alpha_y$ ) in order to terminate the movement at the final  $\theta_{y,f}$  position. Moreover, since the head is held immobile before and after movement and the  $y$  axis always lies in the plane of rotation of the centrifuge, it follows that the initial and final angular velocities of the head about the  $y$  axis are zero. Consequently, the net value of the  $\alpha_y = \dot{\theta}_y$  stimulus averaged over the  $\tau$  second period, i.e., the total change in angular velocity about the  $y$  head axis, is zero.

Actual measurements of the  $\dot{\theta}_y$  and  $\ddot{\theta}_y$  parameters involved in a typical pitch downward head movement over a finite angle, for example, from  $\theta_{y,i} = 0^\circ$  to  $\theta_{y,f} = 60^\circ$ , show that it can quite readily achieve a peak angular velocity of  $\dot{\theta}_y = 600$  deg/sec (100 rpm) and a peak angular acceleration of  $\ddot{\theta}_y = 5000$  deg/sec<sup>2</sup>. The peak head velocity occurs at about the midpoint of the angle over which the head is being tilted. If this peak value of  $\dot{\theta}_y$  is assumed to occur aboard a centrifuge rotating at  $\dot{\theta}_v = 10$  rpm = 1 rad/sec, it can be seen that the peak magnitude  $\dot{\theta}_v \dot{\theta}_y$  of the angular Coriolis acceleration vector can reach a level in the vicinity of 10 rad/sec<sup>2</sup> (600 deg/sec<sup>2</sup>). However, as signified by the  $\cos \theta_y$  and  $\sin \theta_y$  terms in equation set (42), the peak magnitudes of  $\alpha_x$  and  $\alpha_z$  are also functions of the instantaneous orientation of the head as well as the peak angular velocity it reaches during the movement.

Specifically, for identical movements made from different initial positions of the head, the peak angular Coriolis acceleration acting about a given head axis will be maximized when the peak angular velocity of the head occurs at the instant the head axis becomes parallel to the rotational plane of the centrifuge. Thus the peak magnitude of  $\alpha_x$  will be maximized when the peak value of  $\dot{\theta}_y$  occurs at an instant when  $|\cos \theta_y|$  is unity, i.e., as the head passes through either the erect ( $\theta_y = 0^\circ$ ) or the inverted ( $\theta_y = 180^\circ$ ) orientations relative to the Earth-vertical V-V' axis of the centrifuge. Similarly,  $\alpha_z$  will be maximized when the peak value of  $\dot{\theta}_y$  occurs at an instant when  $|\sin \theta_y|$  is unity, i.e., as the head passes through either the prone ( $\theta_y = 90^\circ$ ) or the supine ( $\theta_y = 270^\circ$ ) orientations. It follows then, that though equation (42) generally predicts that a pitch downward head movement produces roll ( $\alpha_x$ ) and yaw ( $\alpha_z$ ) angular acceleration stimulation, the relative strength and indeed the directions of the components are greatly modified by the initial and final orientations of the head.

This point can be illustrated by discussing three identical pitch downward head motions made over a  $30^\circ$  angle ( $\theta_{y f} - \theta_{y i} = +30^\circ$ ) from three different initial orientations of the head where the limits for each motion are as follows:

Orientation:	1	2	3	
Initial Position	$\theta_{y i} = 0^\circ$	$\theta_{y i} = -30^\circ$	$\theta_{y i} = -15^\circ$	(43)
Final Position	$\theta_{y f} = +30^\circ$	$\theta_{y f} = 0^\circ$	$\theta_{y f} = +15^\circ$	

For the movement made from Orientation 1,  $\alpha_x$ , as identified in equation set (42), will be negative throughout since  $\cos \theta_y$  is positive over the  $0^\circ \leq \theta_y \leq +30^\circ$  tilt range while  $\dot{\theta}_y$  and  $\ddot{\theta}_y$  are both positive quantities. Similarly,  $\alpha_z$  is negative throughout the head motion since  $\sin \theta_y$  is positive over the same tilt range. Thus, the net angular effect of the pitch downward head rotation about the  $y$  axis is to produce a roll leftward and yaw rightward angular acceleration about the  $x$  and  $z$  head axes, respectively. Unlike the  $\alpha_y = \ddot{\theta}_y$  stimulus whose time-integral or average over the  $\tau$ -second duration of the movement is zero,  $\alpha_x$  and  $\alpha_z$  describe angular accelerations which, when integrated over the period of the movement, describe finite changes in the angular velocity of the head about the  $x$  and  $z$  head axes, respectively.

Since  $\alpha_x$  and  $\alpha_z$  are both negative, it follows from Table II that, if treated independently,  $\alpha_x$  will lead to a roll leftward turning sensation of the body and rotary nystagmus with a roll rightward slow component of rotary eye velocity, and  $\alpha_z$  will lead to a yaw rightward turning sensation and horizontal nystagmus with a leftward directed slow component. Assuming that  $\theta_y$  reaches its peak magnitude at the  $\theta_y = +15^\circ$  midpoint of the movement,  $\alpha_x$  will tend to reach a maximum slightly before this orientation is reached since  $\cos \theta_y$  is a decreasing function. Similarly,  $\alpha_z$  would tend to reach its maximum at an instant following  $\theta_y = +15^\circ$  since  $\sin \theta_y$  is an increasing function. And finally, since  $\cos \theta_y$  is greater than  $\sin \theta_y$  in the  $0^\circ < \theta_y < +30^\circ$  range,  $\alpha_x$  will be greater than  $\alpha_z$  so that the roll stimulus would be predominant. The nystagmus and sensation responses due to  $\alpha_x$  and  $\alpha_z$  will exist after cessation of the head motion, i.e., for  $t > \tau$ , since the time-integral of each of these stimulus components is not zero and because the relevant biological mechanisms have a relatively long response time.

In Orientation 2 the head is initially tilted back  $30^\circ$  and then pitched forward to the erect posture. Since  $\cos \theta_y$  remains positive in this  $-30^\circ < \theta_y < 0^\circ$  tilt range while  $\sin \theta_y$  becomes negative, it follows that  $\alpha_x$  remains negative while  $\alpha_z$  becomes positive. Thus the pitch downward head motion will evoke a yaw leftward sensation of turning and horizontal nystagmus

with a slow component to the right which are in the direction opposite to that predicted for Orientation 1. The  $\alpha_x$  response predictions would remain as stated before. In addition,  $\alpha_x$  would remain the predominant stimulus.

In Orientation 3,  $\alpha_z$  will be positive over the  $-15^\circ < \theta_y < 0^\circ$  portion of the movement and negative over the  $0^\circ < \theta_y < +15^\circ$  portion since  $\sin \theta_y$  is negative and positive, respectively, over the same ranges. Thus, it would be predicted that the sensation of turning will be in the yaw leftward and yaw rightward directions during the initial and final halves, respectively, of the movement, and, correspondingly, that the  $\alpha_z$  stimulus would tend to produce horizontal nystagmus with slow components to the right and left, respectively, over the same intervals. Again  $\alpha_x$  remains negative and produces a roll leftward sensation and roll rightward rotary nystagmus during the entire interval. The net effect of  $\alpha_z$  would be zero since the head movement did not produce a net change in the angular velocity acting about the  $z$  axis so that  $\alpha_x$  is the only stimulus which produces an aftereffect.

The same interpretations can be applied to a roll head movement made in a rotating environment. Since this movement rotates the head about the  $x$  axis, the motion parameters could be identified as  $\theta_x$ ,  $\dot{\theta}_x$ , and  $\ddot{\theta}_x$  in correspondence with the definitions provided for the pitch downward movement. If  $\theta_x$  is measured as the angular deviation of the  $z$  head axis from  $V-V'$  and as a positive angle when the head is displaced toward the right shoulder, the components of  $\bar{A}$  and  $\bar{\alpha}$  equivalent to those presented in equation set (42) can be listed as

$$\begin{aligned}
 A_x &= 0 & \alpha_x &= \ddot{\theta}_x \\
 A_y &= g \sin \theta_y & \alpha_y &= \dot{\theta}_v \dot{\theta}_x \cos \theta_x \\
 A_z &= g \cos \theta_y & \alpha_z &= -\dot{\theta}_v \dot{\theta}_x \sin \theta_x
 \end{aligned} \tag{44}$$

where for  $t \leq 0$ ,  $\theta_x = \theta_{x1}$  and  $\dot{\theta}_x = \ddot{\theta}_x = 0$

and for  $t \geq \tau$ ,  $\theta_x = \theta_{x2}$  and  $\dot{\theta}_x = \ddot{\theta}_x = 0$

For this head movement the angular Coriolis acceleration vector  $\bar{\theta}_v \times \ddot{\theta}_x$  acts in the frontal  $yz$  plane resulting in  $\alpha_y$  and  $\alpha_z$  stimulations. Thus a roll head motion made in a rotating environment would be expected to produce vertical and horizontal nystagmus and the sensation of pitch and yaw. For  $30^\circ$  tilts about the  $x$  axis with initial and final head orientations equivalent to those described in equation set (43),  $\alpha_y$  would be the predominant stimulus.

The final case to be considered is yaw head rotations made from the erect posture. If the motion parameters are defined as  $\theta_z$ ,  $\dot{\theta}_z$ , and  $\ddot{\theta}_z$  where yaw left motions establish the positive sense of rotation, the components of  $\bar{A}$  and  $\alpha$  are defined as

$$\begin{aligned} A_x &= 0 & \alpha_x &= 0 \\ A_y &= 0 & \alpha_y &= 0 \\ A_z &= +g & \alpha_z &= \ddot{\theta}_z \end{aligned} \quad (45)$$

where for  $t \leq 0$ ,  $\theta_z = \theta_{z1}$  and  $\dot{\theta}_z = \dot{\theta}_z = 0$   
 and for  $t \geq \tau$ ,  $\theta_z = \theta_{z1}$  and  $\dot{\theta}_z = \dot{\theta}_z = 0$

Angular Coriolis stimulation would not result since the head rotation occurs about the  $z$  axis which is maintained parallel to the rotational axis of the centrifuge so that  $\bar{\theta}_y \times \bar{\theta}_z = 0$ .

Angular velocity impulse description of angular Coriolis stimuli: Unless measurement data are available to describe the magnitude-time profile of the actual parameters involved in a given head motion, equation sets (42) and (44) provide only a qualitative description of the intensity of an angular Coriolis acceleration stimulus. Moreover, when the rotary head motions are of complicated form, or when rotation occurs about a head axis other than the cardinal references, considerable effort may be required to obtain a set of stimulus equations comparable to those presented in equation set (42), (44), or (45).

When the motions are relatively fast, however, these limitations may be overcome if one resorts to the impulse-momentum approach of elementary physics to simplify the description of such stimuli, as has been done effectively by Bornschein and Schubert (ref. 1). This approach is based on the principle that a torque applied to a rigid body over a given interval of time produces a change in the angular momentum of the body, and that this change of momentum, identified as the "angular impulse," is a measure of the total influence or net effect of the applied torque in terms of changing the rotational state of the body. When one is concerned with motion per se, it is convention to describe the net effect of an angular acceleration  $\alpha$  of a body over a given interval of time  $\tau$  in terms of the accompanying change in angular velocity of the body  $\Delta \omega$ . This change in velocity is designated as the "angular velocity impulse" and may be written as

$$\int_0^\tau \alpha \, dt = \int_{\omega_1}^{\omega_2} d\omega = \omega_2 - \omega_1 = \Delta \omega = \text{angular velocity impulse} \quad (46)$$

where the  $i$  and  $f$  subscripts denote initial and final values of the angular velocity  $\omega$ , i.e.,  $\omega = \omega_i$  at  $t = 0$  and  $\omega = \omega_f$  at  $t = \tau$ .

The angular velocity impulse measure of an acceleration stimulus is valid for long- as well as short- duration stimuli, although, in colloquial usage, impulse implies acting for a short time. For example, if a body is accelerated from rest,  $\omega_i = 0$ , to some constant angular velocity, say  $\omega_f = 10$  rpm, the net effect of the stimulus will be measured as the 10-rpm change in angular velocity it produces; i.e.,  $\Delta \omega = 10$  rpm, whether it takes 1, 10, or 100 seconds. Thus the velocity impulse describes only the net effect of an acceleration profile and does not give any stimulus information during the period of its application. From the vestibular viewpoint, an impulse description is not of particular advantage when acceleration stimuli are of long duration since it is usually desired to observe the response variations during application of the stimulus as well as following its removal. If, however, the duration of the stimulus is relatively short compared to the response-time characteristics of the system under study, the stimulus can be treated as a step-function change in angular velocity. For vestibular studies concerned with the response of the semicircular canals the relatively long time-constants of the mechanisms usually allow such a step-function interpretation when a stimulus interval is less than 1 or 2 seconds.

Such an angular velocity impulse representation of a stimulus can be man-referenced in the context of the nomenclature by letting  $\omega_x$ ,  $\omega_y$ , and  $\omega_z$  describe the instantaneous angular velocity of the head about the  $x$ ,  $y$ , and  $z$  axes, respectively, with polarity conventions which follow in exact correspondence with those established for  $\alpha_x$ ,  $\alpha_y$ , and  $\alpha_z$  so that

- +  $\omega_x$  = roll rightward angular velocity
- $\omega_x$  = roll leftward angular velocity
- +  $\omega_y$  = pitch downward angular velocity
- $\omega_y$  = pitch upward angular velocity
- +  $\omega_z$  = yaw leftward angular velocity
- $\omega_z$  = yaw rightward angular velocity

Specification of initial and final head velocities before and after exposure to the stimulus may be accomplished by use of a second subscript,  $i$  and  $f$ , respectively.



With this notation, the angular velocity impulse can be made specific to each of the three axes as follows

$$\int_0^{\tau} \alpha_x dt = \int_{\omega_{x1}}^{\omega_{xf}} d\omega_x = \omega_{xf} - \omega_{x1} = \Delta \omega_x = \text{roll angular velocity impulse}$$

$$\int_0^{\tau} \alpha_y dt = \int_{\omega_{y1}}^{\omega_{yf}} d\omega_y = \omega_{yf} - \omega_{y1} = \Delta \omega_y = \text{pitch angular velocity impulse} \quad (47)$$

$$\int_0^{\tau} \alpha_z dt = \int_{\omega_{z1}}^{\omega_{zf}} d\omega_z = \omega_{zf} - \omega_{z1} = \Delta \omega_z = \text{yaw angular velocity impulse}$$

Consistent with the intent of the nomenclature, the + or - prefix for the angular velocity impulse corresponds to the direction of angular acceleration which the impulse produces. The directional identification of each of these impulses and the direction of the associated angular acceleration (shown in parentheses) are listed below.

- +  $\Delta \omega_x$  = roll rightward angular velocity impulse (+  $\alpha_x$ )
- $\Delta \omega_x$  = roll leftward angular velocity impulse (-  $\alpha_x$ )
- +  $\Delta \omega_y$  = pitch downward angular velocity impulse (+  $\alpha_y$ )
- $\Delta \omega_y$  = pitch upward angular velocity impulse (-  $\alpha_y$ )
- +  $\Delta \omega_z$  = yaw leftward angular velocity impulse (+  $\alpha_z$ )
- $\Delta \omega_z$  = yaw rightward angular velocity impulse (-  $\alpha_z$ )

With this notation it becomes possible to describe the angular acceleration stimulus produced by a pitch downward head motion made in a rotating environment in terms of the angular velocity impulse acting about each of the three cardinal head axes. By applying the equation set (47) integrations to the angular components of equation set (42), one obtains the following descriptions of the angular velocity impulse for these axes:

$$\Delta \omega_x = \int_0^{\tau} \alpha_x dt = -\dot{\theta}_v \int_{\theta_{y1}}^{\theta_{yf}} \cos \theta_y d\theta_y = -\dot{\theta}_v [\sin \theta_{yf} - \sin \theta_{y1}]$$

$$\Delta \omega_y = \int_0^{\tau} \alpha_y dt = \int_0^{\tau} \ddot{\theta}_y dt = 0 \quad (48)$$

$$\Delta \omega_z = \int_0^{\tau} \alpha_z dt = -\dot{\theta}_v \int_{\theta_{y1}}^{\theta_{yf}} \sin \theta_y d\theta_y = +\dot{\theta}_v [\cos \theta_{yf} - \cos \theta_{y1}]$$

it can be seen that the initial and final angular velocities of the head about the three axes, as defined in equation set (47), are

$$\begin{aligned} \omega_{x1} &= -\dot{\theta}_v \sin \theta_{y1} & \omega_{y1} &= 0 & \omega_{z1} &= \dot{\theta}_v \cos \theta_{y1} \\ \omega_{xf} &= -\dot{\theta}_v \sin \theta_{yf} & \omega_{yf} &= 0 & \omega_{zf} &= \dot{\theta}_v \cos \theta_{yf} \end{aligned} \quad (49)$$

The stimulus can be interpreted in terms of the initial and final angular velocity components of equation set (49) as follows: The pitch downward head motion produces an angular acceleration stimulus about the  $x$  head axis which is equivalent to a change in angular velocity about the  $x$  head axis from  $\omega_{x1}$  to  $\omega_{xf}$ . The stimulus acting about the  $z$  head axis is equivalent to a rapid change in angular velocity from  $\omega_{z1}$  to  $\omega_{zf}$ . Since  $\omega_{y1} = \omega_{yf}$ , no change occurs in the velocity of the head about the  $y$  axis and, therefore, the net  $\alpha_y$  stimulus effect is zero.

As a specific numerical example, consider that initially the head is tilted back  $30^\circ$  away from the centrifuge axis V-V' so that  $\theta_{y1} = -30^\circ$  and then is quickly rotated to a  $45^\circ$  pitch forward posture so that  $\theta_{yf} = +45^\circ$ , as illustrated in Figure 23. Assuming further that the centrifuge is rotating at 10 rpm CCW, the initial and final angular velocities of the head for each of the three cardinal axes, as calculated from equation set (49), are

$$\begin{aligned} \omega_{x1} &= +5.00 \text{ rpm} & \omega_{y1} &= 0 & \omega_{z1} &= +8.66 \text{ rpm} \\ \omega_{xf} &= -7.07 \text{ rpm} & \omega_{yf} &= 0 & \omega_{zf} &= +7.07 \text{ rpm} \end{aligned} \quad (50)$$

so that  $\Delta \omega_x = -12.07 \text{ rpm}$ ,  $\Delta \omega_y = 0$ , and  $\Delta \omega_z = -1.59 \text{ rpm}$ .

It is implicit in the  $\Delta \omega_x$  impulse description that the angular acceleration stimulus acting about the  $x$  axis due to the pitch downward head movement, when treated as an independent action, can be simulated by placing the subject in a simple rotator where the  $x$  head axis is aligned with the rotational axis of the device and exposing him to the following profile. Initially, the device would be rotating the subject in the roll rightward direction at a constant angular velocity of 5 rpm ( $\omega_{xi} = +5.00$  rpm). At some instant  $t = 0$  the rotator would quickly be decelerated in  $\tau$  seconds through 0 rpm to a roll leftward constant angular velocity in the opposite direction of 7.07 rpm ( $\omega_{xf} = -7.07$  rpm). The resulting roll leftward angular stimulus is described in impulse form as  $\Delta \omega_x = -12.07$  rpm, thus predicting that the pitch downward head motion will lead to a roll leftward sensation of turning and rotary nystagmus with a roll rightward slow component of eye velocity following termination of the movement.

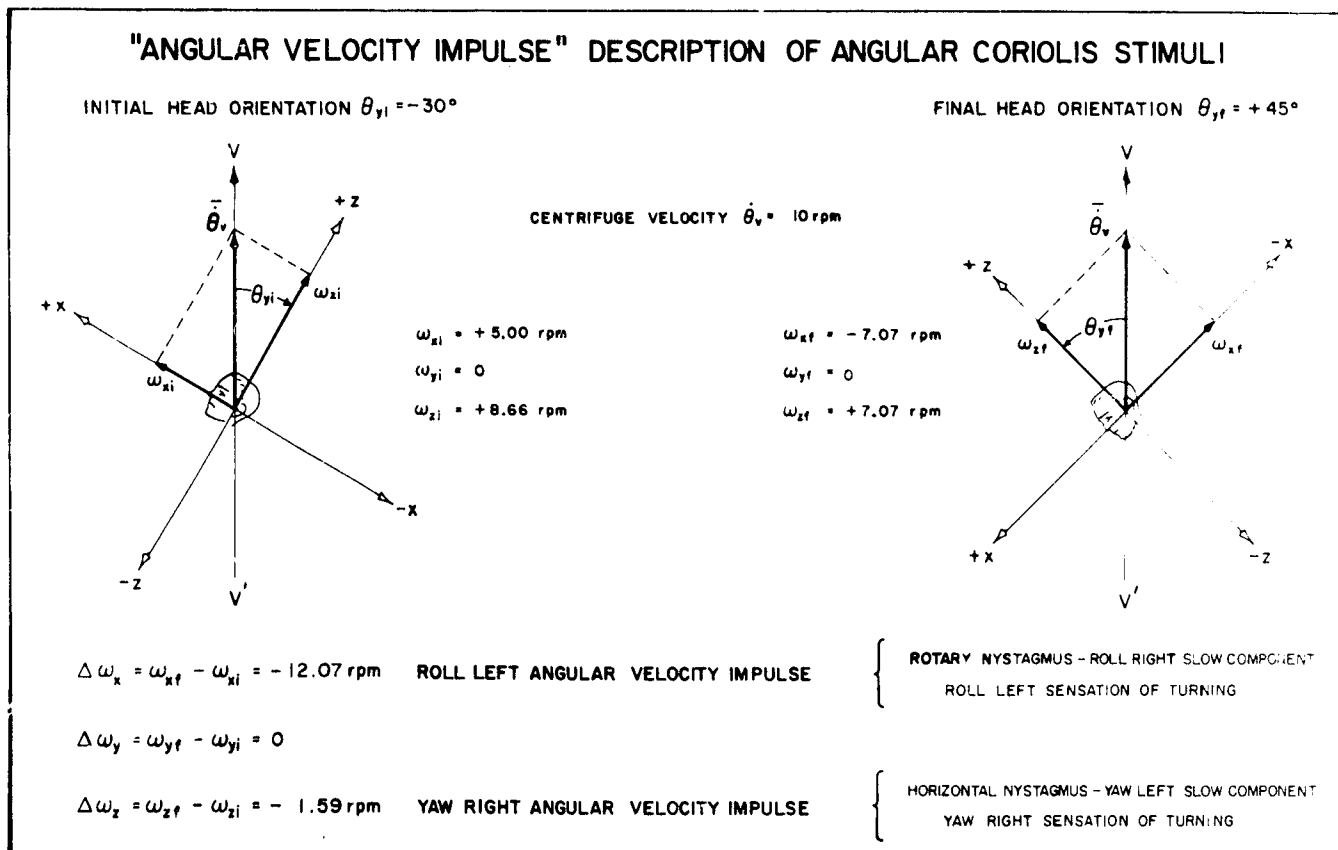

Figure 23

Graphical illustration of the angular velocity impulse description of the angular motion stimuli produced by a rotary head movement made from a  $30^\circ$  pitch backward inclination to a  $45^\circ$  pitch forward orientation in a CCW rotating environment. Also listed are the form of nystagmus and the body sensation of turning predicted by each impulse component.

The angular acceleration stimulus acting about the  $z$  head axis can be simulated in like manner by realigning the subject's  $z$  axis with the rotational axis and causing a rapid change in angular velocity from  $\omega_{zi} = +8.66$  rpm to  $\omega_{zf} = +7.07$  rpm. Hence,  $\Delta \omega_z = -1.59$  rpm and

thus describes a yaw rightward angular acceleration ( $-\alpha_z$ ) which predicts a yaw rightward sensation of turning, and horizontal nystagmus with a slow component to the left will result. Since  $\Delta \omega_x$  is almost eight times greater than  $\Delta \omega_z$ , it would be expected that rightward rotary nystagmus and the sensation of roll left turning would be the predominant responses in the stimulus situation shown in Figure 23.

At this point it should be noted that the initial and final angular velocities of the head listed in equation set (50) were stated to be calculated from equation set (49) which, in turn, was obtained from equation set (48). However, if one observes that each angular velocity component of concern is simply that component of the centrifuge velocity which acts about the given head axis, considerable mathematical simplification results. In fact, one obtains a quantified description of the magnitude and direction of each angular velocity component by merely projecting the centrifuge velocity vector to each of the cardinal head axes. This is graphically illustrated in Figure 23 where the magnitude and direction of the  $\omega_x$  and  $\omega_z$  components derive directly from the projection of the centrifuge velocity vector  $\vec{\theta}_v$  to the  $x$  and  $z$  head axes, respectively.

The simplicity of the method can be further demonstrated by calculating the angular velocity impulses associated with the three previously discussed  $30^\circ$  pitch downward head motions listed in equation set (43). In Figure 24, the head and the  $x$  and  $z$  axes are shown in heavy outline for each of the three initial head postures. The direction of the head movement is shown by the curved arrow, and the final position of the head at the end of the movement is marked by the dashed outline of the  $x$  and  $z$  head axes. For the head motion shown at the left  $\Delta \omega_x$  and  $\Delta \omega_z$  are both finite, thus predicting the existence of rotary and horizontal nystagmus and the sensations of roll and yaw. Since  $\Delta \omega_x$  is greater than  $\Delta \omega_z$ , the roll stimulus is predominant. The equivalent representations for the other two orientations are shown at the center and right of Figure 24 where the response due to the predominant stimulus is shown in upper case letters in the related table. Each of the three orientations produces a roll leftward angular acceleration stimulus about the  $x$  axis since  $\Delta \omega_x$  is negative. In addition,  $\Delta \omega_z$  is negative for Orientation 1, positive for Orientation 2, and zero for Orientation 3.

The equivalent angular velocity impulse description of the stimulus produced by a  $60^\circ$  roll rightward head movement is shown in Figure 25 for three different initial head orientations. The form and direction of the nystagmus and the body sensation responses predicted from each of

the angular velocity impulses are tabulated at the bottom in this figure where the response due to the predominant stimulus is shown in upper case letters.

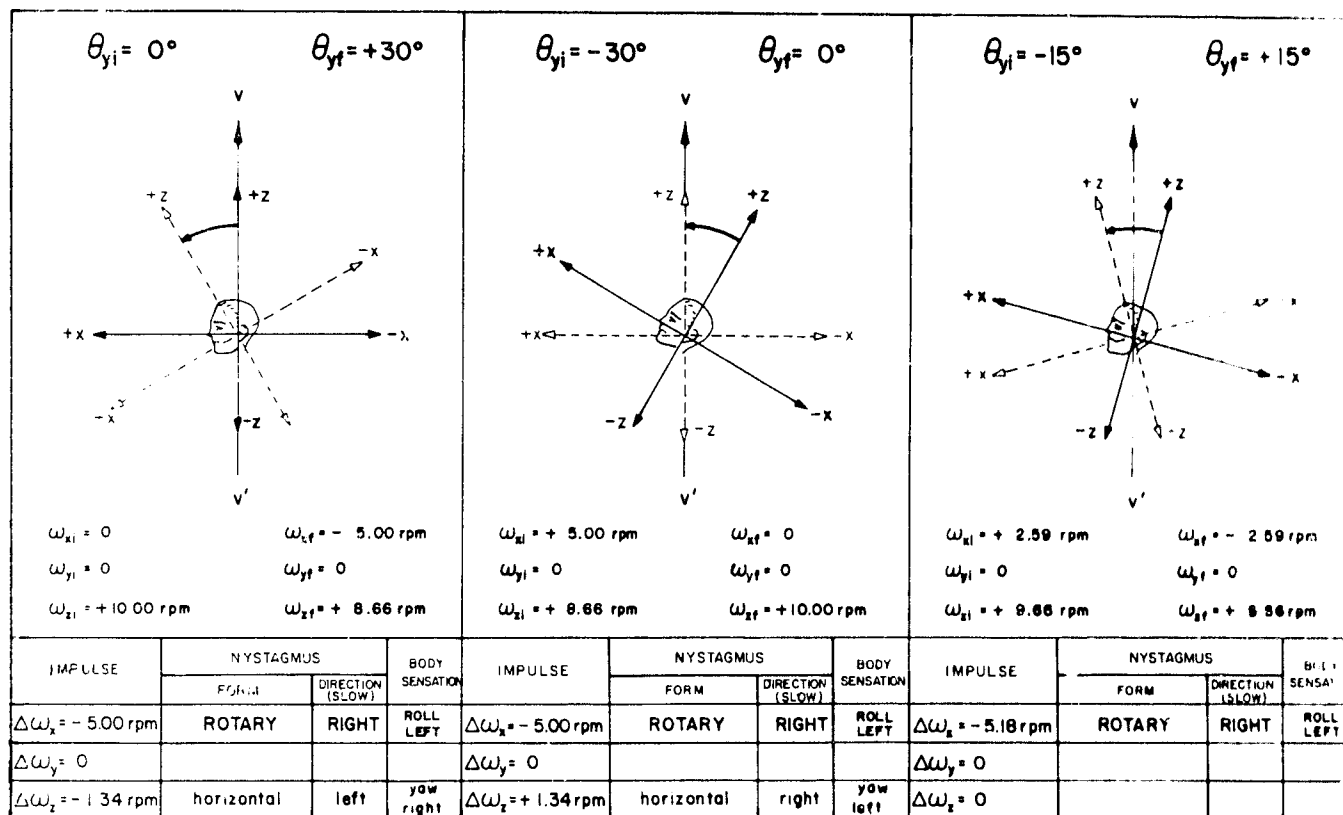

Figure 24

Angular velocity impulse components and predicted responses for three identical  $30^\circ$  pitch downward head movements made from three different initial head orientations in a centrifuge rotating about axis V-V' at 10 rpm in a CCW direction as viewed from above.

If yaw type head motions are made aboard the centrifuge in the erect posture, i.e., the head rotated about the  $z$  head axis which is aligned with the Earth-vertical rotational axis of the centrifuge, the angular velocity impulse will be zero since the movement does not change the angle between any head axis and the rotational axis of the centrifuge. This is in accordance with the stimulus description of equation set (45) in which the angular Coriolis acceleration  $\vec{\theta}_v \times \vec{\theta}_z$  was zero.

Angular Coriolis stimuli have been discussed for roll, pitch, and yaw head motions which were assumed to be of pure rotary form and made in the head erect posture with the subject at the center of the centrifuge. For these conditions the angular acceleration stimulus is independent of the direction that the subject faces. That is, the magnitude and direction of the stimuli produced by the pitch movements described in Figure 24 or the roll movements described in Figure 25 will be the same regardless of the direction in which the subject faces. Similarly, the yaw head movements will be the only type which do not result in an angular Coriolis stimulus. In effect, for the head erect posture the  $z$  head axis serves as a relief axis. However, as

discussed by Guedry (ref. 5), such will not be the case in a spacecraft undergoing rotation to establish a simulated gravitational acceleration field. For such an environment the head erect

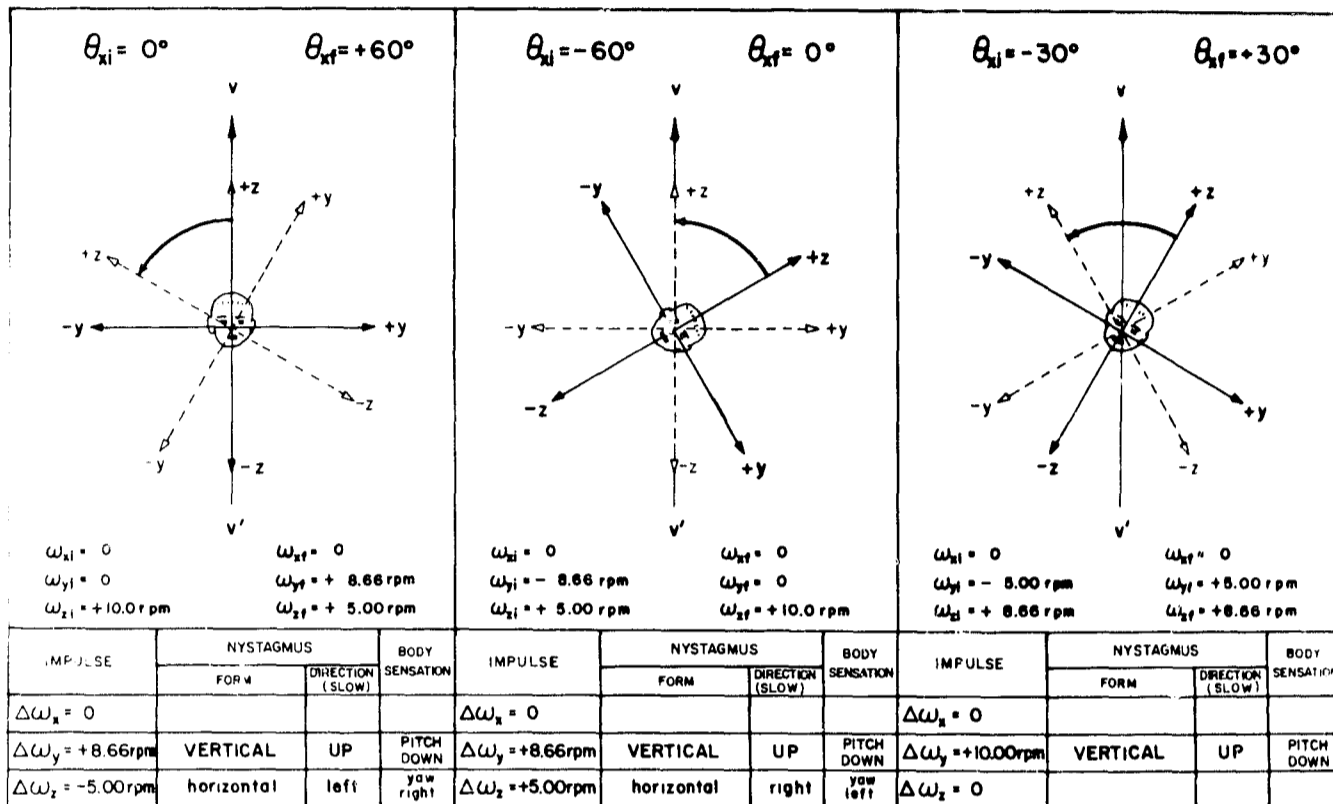
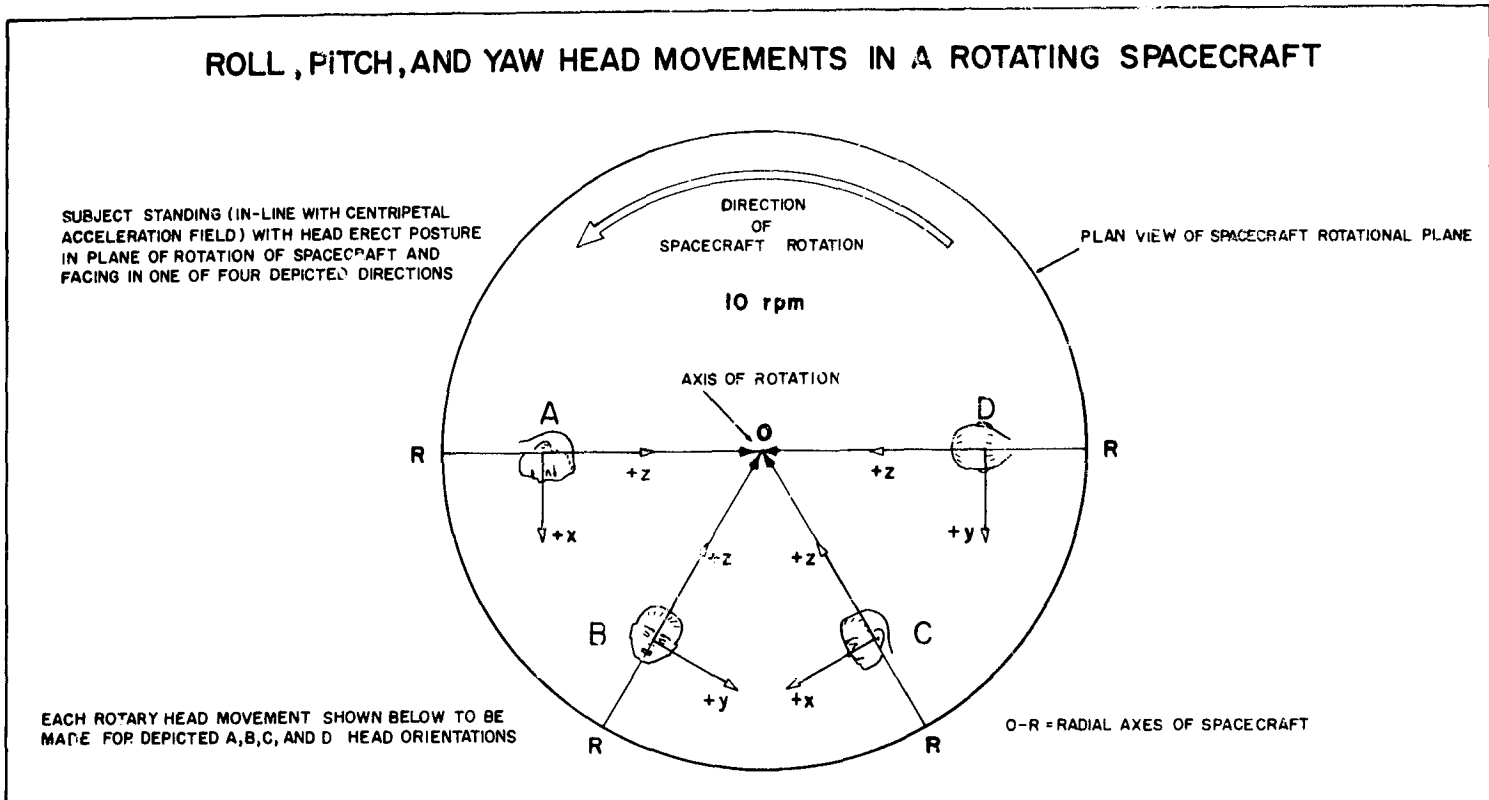

Figure 25

Angular velocity impulse components and predicted responses for three identical  $60^\circ$  roll rightward head movements made from three different initial head orientations in a centrifuge rotating about axis V-V' at 10 rpm in a CCW direction as viewed from above.

standing posture is established when the longitudinal z axis of the body is in parallel alignment with the force vertical established by the centripetal acceleration.

This point can be interpreted on a quantitative basis by considering some typical head motions made from different orientations within a rotating spacecraft. A plan view of such a vehicle is shown at the top in Figure 26. For discussion purposes it will be assumed that the vehicle is rotating at a constant angular velocity of 10 rpm in the denoted direction and that the subject is standing in the plane of rotation so that in the head erect posture, the z head axis will be aligned with a radial axis O-R of the vehicle. To be considered are the angular velocity impulse components which arise when roll, pitch, and yaw head movements are made over a finite angle from four different subject orientations denoted as A, B, C, and D. In Position A, the subject is assumed to be facing the direction of rotation so that his sagittal xz head plane is in the plane of rotation. In Position B, established by having the subject turn  $90^\circ$  toward his right from Position A, the frontal yz head plane is in the plane of rotation. Position C, established by a  $90^\circ$  right turn from Position B, is the same as Position A except the subject is facing



SPATIAL ORIENTATION OF HEAD	30° ROLL RIGHT			30° PITCH DOWN			30° YAW LEFT					
	IMPULSE	NYSTAGMUS		BODY SENSATION	IMPULSE	NYSTAGMUS		BODY SENSATION	IMPULSE	NYSTAGMUS		
		FORM	DIRECTION (SLOW)			FORM	DIRECTION (SLOW)			FORM	DIRECTION (SLOW)	
A	$\Delta\omega_x = 0$				$\Delta\omega_x = 0$				$\Delta\omega_x = -5.00\text{rpm}$	ROTARY	RIGHT	ROLL LEFT
	$\Delta\omega_y = +1.34\text{rpm}$	vertical	up	pitch down	$\Delta\omega_y = 0$				$\Delta\omega_y = +1.34\text{rpm}$	vertical	up	pitch down
	$\Delta\omega_z = +5.00\text{rpm}$	HORIZONTAL	RIGHT	YAW LEFT	$\Delta\omega_z = 0$				$\Delta\omega_z = 0$			
B	$\Delta\omega_x = 0$				$\Delta\omega_x = -1.34\text{rpm}$	rotary	right	roll left	$\Delta\omega_x = -1.34\text{rpm}$	rotary	right	roll left
	$\Delta\omega_y = 0$				$\Delta\omega_y = 0$				$\Delta\omega_y = -5.00\text{rpm}$	VERTICAL	DOWN	PITCH UP
	$\Delta\omega_z = 0$				$\Delta\omega_z = +5.00\text{rpm}$	HORIZONTAL	RIGHT	YAW LEFT	$\Delta\omega_z = 0$			
C	$\Delta\omega_x = 0$				$\Delta\omega_x = 0$				$\Delta\omega_x = +5.00\text{rpm}$	ROTARY	LEFT	ROLL RIGHT
	$\Delta\omega_y = -1.34\text{rpm}$	vertical	down	pitch up	$\Delta\omega_y = 0$				$\Delta\omega_y = -1.34\text{rpm}$	vertical	down	pitch up
	$\Delta\omega_z = -5.00\text{rpm}$	HORIZONTAL	LEFT	YAW RIGHT	$\Delta\omega_z = 0$				$\Delta\omega_z = 0$			
D	$\Delta\omega_x = 0$				$\Delta\omega_x = +1.34\text{rpm}$	rotary	left	roll right	$\Delta\omega_x = +1.34\text{rpm}$	rotary	left	roll right
	$\Delta\omega_y = 0$				$\Delta\omega_y = 0$				$\Delta\omega_y = +5.00\text{rpm}$	VERTICAL	UP	PITCH DOWN
	$\Delta\omega_z = 0$				$\Delta\omega_z = -5.00\text{rpm}$	HORIZONTAL	LEFT	YAW RIGHT	$\Delta\omega_z = 0$			

Figure 26

A plan view of the rotational plane of a CCW rotating spacecraft turning at a constant angular velocity of 10 rpm is shown at the top where the subject is assumed to be standing in the erect posture facing in one of four directions. The angular impulse components and predicted responses for three different rotary head motions performed while facing in each direction are shown in tabulated form.

away from the direction of rotation. Position D is the same as Position B except that the subject faces into the plane of rotation. The three specific head movements of concern, illustrated individually at the center in Figure 26, include a  $30^\circ$  roll of the head away from the erect posture toward the right shoulder, a  $30^\circ$  pitch downward movement of the head away from the erect posture, and a  $30^\circ$  yaw leftward rotation of the head.

The angular velocity impulse components produced by each of the three head movements for each of the four head positions are tabulated at the bottom of Figure 26 along with the associated responses predicted by the related angular impulse. As before, the response associated with the stimulus component of greatest magnitude is written in upper case letters. It may be observed that the roll type head movement produces no angular acceleration stimulus in Positions B and D where the  $x$  head axis is aligned with the rotational axis of the vehicle. However, in both Position A and Position C, angular stimulation about the  $y$  and  $z$  head axis occurs with the latter being of greater magnitude. It would be predicted then that the sensation of pitch and yaw would be experienced with the latter being predominant. Significantly, the direction of  $\Delta\omega_x$  and  $\Delta\omega_z$  reverses from Position A to Position C. However,  $\Delta\omega_z$  remains the stronger stimulus.

For the pitch type head movement, Positions A and C serve as relief orientations since there is no stimulation when the subject faces toward or away from the direction of rotation. In Positions B and D, roll and yaw angular stimulation results with  $\Delta\omega_z$  remaining the stronger stimulus. Again, the direction of the stimulus reverses when the subject changes from one position to its  $180^\circ$  opposite.

For the yaw head motion, however, roll and pitch angular stimulation results in all four body orientations. In effect, a relief orientation is not available for yaw motions made from the head erect posture. With the subject in Positions A and C, the roll stimulus is stronger, with the direction of both  $\Delta\omega_x$  and  $\Delta\omega_y$  reversing when changing from A to C. The directions of the stimuli also reverse when changing from Position B to D. For these two orientations, however, the predominant stimulus is that of pitch. But note that certain changes in orientation of the head for yaw motions alter the relative strength of the  $\Delta\omega_x$  and  $\Delta\omega_y$  stimulus impulses, as well as their direction.

From the practical viewpoint, the tabulated calculations of Figure 26 indicate that for the head erect posture, roll head movements can be performed with minimal stimulation if the subject faces at right angles to the plane of rotation. Similarly, pitch movements from the erect posture are best performed when the subject faces toward or away from the direction of rotation. For yaw



movements a preferred orientation is not available. Similar analysis of the strength of the stimulus components afforded by other postures, for example with the subject supine or on his side, for the same types of head movements can be derived with this impulse approach.

The procedures involved in the calculation of the magnitude and direction of the angular velocity impulse produced by a rotary head motion of finite extent made within a rotating environment can be summarized in more general terms as follows. Let the angular velocity vector  $\bar{\Omega}$  (upper case Greek omega) describe the constant angular velocity rotation of the environment where the vector is drawn along the axis of rotation in the direction of the thumb of the right hand when the fingers are curled in the direction of rotation of the environment. The projection of this vector to each of the cardinal head axes before and after the head movement describes the initial and final steady-state angular velocities of the head about these axes. The algebraic difference between the final and initial velocities describes the angular velocity impulse which acted about each of the head axes.

These procedures can be made specific to the applied situation, and described in equation form, by identifying a given head orientation in terms of the measured angular deviation of each of the three cardinal head axes from the rotational axis of the environment. For instance, the symbols  $\Theta_{x1}$ ,  $\Theta_{y1}$ , and  $\Theta_{z1}$  (upper case Greek theta) can be used to identify the orientation of the  $x$ ,  $y$ , and  $z$  head axes, respectively, before the rotary head movement is made;  $\Theta_{x2}$ ,  $\Theta_{y2}$ , and  $\Theta_{z2}$  the orientation of the axes following the movement. For measurement reference,  $\Theta_x$ ,  $\Theta_y$ , and  $\Theta_z$  could be defined as equal to  $0^\circ$  whenever the  $+x$ ,  $+y$ , or  $+z$  axes, respectively, are aligned with the rotational axis of the environment in the same direction as the angular velocity vector  $\bar{\Omega}$ . With this notation the angular velocity impulse for each of the three cardinal head axes can be written as

$$\begin{aligned}\Delta \omega_x &= |\bar{\Omega}| (\cos \Theta_{x2} - \cos \Theta_{x1}) \\ \Delta \omega_y &= |\bar{\Omega}| (\cos \Theta_{y2} - \cos \Theta_{y1}) \\ \Delta \omega_z &= |\bar{\Omega}| (\cos \Theta_{z2} - \cos \Theta_{z1})\end{aligned}\tag{51}$$

which is appropriate for any form of rotary head movement made over any finite angle.

Inspection of equation set (51) shows that a given impulse component will be maximized when the difference between the cosine terms is maximized; i.e., maximal angular stimulation about a given head axis will occur when the given head axis is initially aligned with the

rotational axis of the environment and the head then rotated  $180^\circ$  so that the same head axis is again aligned with the rotational axis, but in the opposite direction. A  $180^\circ$  head movement made under these conditions results in an angular impulse of  $2 |\bar{\Omega}|$  rad/sec. Thus, the strongest angular stimulus which can result from a finite rotary head movement made in a rotating environment is equivalent to a rapid acceleration from a constant angular velocity of  $|\bar{\omega}|$  in one direction to a constant angular velocity of  $|\bar{\Omega}|$  in the opposite direction. Equation set (51) indicates that the net acceleration stimulus will be zero if the initial and final postures of the head relative to the rotational axis of the environment are the same regardless of the complexity of the short-duration head motion. That is, if the head is always returned to its initial steady state posture, then minimal after-stimulation results.

#### ANCILLARY CONSIDERATIONS

Whenever a finite-dimensional mass, such as the head, is rotated, a linear acceleration difference, or gradient, will exist from point to point within the mass since the resultant linear acceleration acting on each element of the mass is dependent, in part, upon its instantaneous displacement from the axis of rotation. From the vestibular viewpoint, the existence of these gradients implies that "widely spaced" internal elements of the skull, say, the left and right labyrinths, are not identically stimulated, or on a more micro level, that an acceleration difference can exist even along the dimensions of a receptor located within the labyrinth.

In the discussion of the centrifuge depicted in Figure 6 the resultant linear acceleration of the head was calculated on the basis that the head could be treated as a single point mass located a radial distance  $R$  from the axis of rotation. However, it is obvious that internal elements of the skull located to the outboard side of  $R$  will be exposed to a resultant linear acceleration greater than that of those located on the inboard side as a result of radii differences. Thus, the definition of  $\bar{A}$  provided in those examples involving rotation must be interpreted in the strict sense only as the resultant linear acceleration of a mass positioned at the origin of the cardinal  $x$ ,  $y$ , and  $z$  head reference frame. If one is interested in the stimulus conditions at another point within the head, it becomes necessary to define the anatomical position of the point and the resultant linear acceleration of a mass at this point.

The significance of these acceleration gradients, more often discussed than investigated, is generally resolved by assuming that the differences in linear acceleration level within the skull, as compared to the absolute level of  $\bar{A}$  defined at the center of the head, are negligible in terms of affecting the primary vestibular response. It is not necessary, however, that the

proposed nomenclature be limited to the definition of stimulus conditions where this assumption may be valid. To illustrate, consider that it is desired to identify quantitatively the resultant linear acceleration of a receptor mechanism treated as a point mass, located within one of the labyrinths. The nomenclature could be adapted to this situation as follows. The  $x, y, z$  reference frame could be used as a reference for measuring the anatomical location of the mass, i.e., as  $x = x_1, y = y_1$  and  $z = z_1$ , where  $x = y = z = 0$  at the origin of the reference frame. An identical reference frame could next be erected at the receptor location where the three mutually orthogonal axes of the new frame would be in exact parallel alignment with the  $x, y,$  and  $z$  axes of the cardinal head frame. The resultant linear acceleration of the receptor could then be defined in terms of its components along the axis of the new frame, thus preserving the directional significance of the  $A_x, A_y,$  and  $A_z$  symbols. In effect,  $A_x, A_y,$  and  $A_z$  can be specified for any point mass within the skull by listing the anatomical coordinates of the mass for which the definition of  $\bar{A}$  is provided. Equivalently, acceleration gradient effects can also be recognized by presenting a description of the variation of  $A_x, A_y,$  and  $A_z$  as a continuous function of displacement along each of the three cardinal axes.

As a final point, attention is brought to the specific notation used in each of the examples to discuss the identification of  $\bar{A}$  and  $\alpha$ . Typically, symbols such as H-H' and V-V' were used to describe Earth-referenced axes; D-D' as a device axis;  $r, \dot{r}, \ddot{r}$  as device linear motion parameters; and  $\theta_y, \dot{\theta}_y,$  and  $\ddot{\theta}_y$  as head motion parameters measured relative to environmental references. It should be stated that these symbols were arbitrarily selected to establish only the characteristics of the motion under discussion so that specific identifications could be made of the associated physiological acceleration stimuli. Thus it is not necessary to treat these symbols as a formal part of the recommended nomenclature. A synopsis of the symbols pertinent to the proposed acceleration nomenclature follows.

## REFERENCES

1. Bornschein, H., and Schubert, G., Die Richtung des vestibulären Coriolis-Effektes. Z. Biol., 113: 145-160, 1962. (FAA translation).
2. Clark, C. C., Hardy, J. D., Crosbie, R. J., and Hessberg, R. R., Human acceleration studies terminology. National Research Council Publication 913. Washington, D. C.: National Academy of Sciences, 1961.
3. Dixon, F., and Patterson, J. L., Jr., Determination of accelerative forces acting on man in flight and in the human centrifuge. NSAM-515. Pensacola, Fla.: Naval School of Aviation Medicine, 1953.
4. Gell, C. F., Table of equivalents for acceleration terminology. Aerospace Med., 32: 1109-1111, 1961.
5. Guedry, F. E., Jr., Comparison of vestibular effects in several rotating environments. In: The Role of the Vestibular Organs in the Exploration of Space. NASA SP-77 Washington, D. C.: National Aeronautics and Space Administration, 1965. Pp 243-255.
6. Pesman, G. J., Acceleration terminology. Table of comparative equivalents. Presented to The Biodynamics Committee of the Aerospace Medical Panel, Advisory Group for Aerospace Research and Development, Munich, Germany, Sept. 1965.
7. Polyak, S. L., The Human Ear in Anatomical Transparencies. Elmsford, N. Y.: Sonotone Corp., 1946.

## SYNOPSIS OF ACCELERATION NOTATION

### Cardinal Head Axes and Planes of Man

- |   |  |
|---|--|
| <p><math>x</math> axis = Roll axis denoting the front-back direction where <math>+x</math> is toward the front of the head.</p> <p><math>y</math> axis = Pitch axis denoting the left-right direction where <math>+y</math> is toward the left of the head.</p> <p><math>z</math> axis = Yaw axis denoting the vertex-base (head-foot) direction where <math>+z</math> is directed toward the vertex of the head.</p> | <p><math>yz</math> plane = Frontal plane determined by the <math>y</math> and <math>z</math> axes.</p> <p><math>xz</math> plane = Sagittal plane determined by the <math>x</math> and <math>z</math> axes.</p> <p><math>xy</math> plane = Horizontal plane determined by the <math>x</math> and <math>y</math> axes.</p> |
|---|--|

$\bar{i}, \bar{j}, \bar{k}$  = Unit vectors directed along the  $x, y,$  and  $z$  axes, respectively.

The horizontal  $xy$  head plane of man is defined anatomically by the highest point of both external auditory meati and the lowest point of both eye sockets. The  $y$  axis is that line which joins the highest point of both external auditory meati; the  $x$  axis is that line in the horizontal plane which is perpendicular to the midpoint of the  $y$  axis; and the  $z$  axis is that line drawn perpendicular to the horizontal head plane at the midpoint of the  $y$  axis. The  $x, y,$  and  $z$  axes describe an erect, right-handed, rectangular Cartesian coordinate reference frame.

### Linear Acceleration - General Notation

$\bar{A}$  = Linear acceleration vector symbolizing instantaneous resultant linear acceleration of the head (upper case Roman A). Includes accelerations due to gravitational action as well as inertial motion, both defined kinematically.

$$\bar{A} \equiv \bar{A}(t) = \bar{i} A_x + \bar{j} A_y + \bar{k} A_z$$

$|\bar{A}|$  = Absolute magnitude of  $\bar{A}$

$$|\bar{A}| = (A_x^2 + A_y^2 + A_z^2)^{\frac{1}{2}}$$

$A_x$  = Axial component of  $\bar{A}$  directed along the  $x$  axis where  $+A_x$  and  $-A_x$  denote frontward and backward linear acceleration.

$$A_x \equiv A_x(t)$$

$A_y$  = Axial component of  $\bar{A}$  directed along the  $y$  axis where  $+A_y$  and  $-A_y$  denote leftward and rightward linear acceleration.

$$A_y \equiv A_y(t)$$

$A_z$  = Axial component of  $\bar{A}$  directed along the  $z$  axis where  $+A_z$  and  $-A_z$  denote upward (headward) and downward (footward) linear acceleration.

$$A_z \equiv A_z(t)$$

### Dimensions

Basic: length/time<sup>2</sup>  
 Typical: ft/sec<sup>2</sup>, cm/sec<sup>2</sup>, or multiple of  
 $g \equiv g_0 = 32.174 \text{ ft/sec}^2 (980.665 \text{ cm/sec}^2)$

### Angular Acceleration - General Notation

$\bar{\alpha}$  = Angular acceleration vector symbolizing the instantaneous resultant angular acceleration of the head (lower case Greek alpha).

$$\bar{\alpha} \equiv \bar{\alpha}(t) = \bar{i} \alpha_x + \bar{j} \alpha_y + \bar{k} \alpha_z$$

$|\bar{\alpha}|$  = Absolute magnitude of  $\bar{\alpha}$

$$|\bar{\alpha}| = (\alpha_x^2 + \alpha_y^2 + \alpha_z^2)^{\frac{1}{2}}$$

$\alpha_x$  = Axial component of  $\bar{\alpha}$  directed along the  $x$  axis where  $+\alpha_x$  and  $-\alpha_x$  denote roll rightward and roll leftward angular acceleration.

$$\alpha_x \equiv \alpha_x(t)$$

$\alpha_y$  = Axial component of  $\bar{\alpha}$  directed along the  $y$  axis where  $+\alpha_y$  and  $-\alpha_y$  denote pitch downward and pitch upward angular acceleration.

$$\alpha_y \equiv \alpha_y(t)$$

$\alpha_z$  = Axial component of  $\bar{\alpha}$  directed along the  $z$  axis where  $+\alpha_z$  and  $-\alpha_z$  denote yaw leftward and yaw rightward angular acceleration.

$$\alpha_z \equiv \alpha_z(t)$$

### Dimensions

Basic: angular measure/time<sup>2</sup>  
 Typical: rad/sec<sup>2</sup> or deg/sec<sup>2</sup>

## SYNOPSIS OF ACCELERATION NOTATION

### Linear Acceleration - Magnitude/Direction Notation

$$\begin{aligned} \bar{A}_{yz} &= \text{Planar component of } \bar{A} \text{ directed in the frontal } yz \text{ head plane.} \\ \bar{A}_{yz} &= \bar{j} A_y + \bar{k} A_z \end{aligned}$$

$$\begin{aligned} \bar{A}_{xz} &= \text{Planar component of } \bar{A} \text{ directed in the sagittal } xz \text{ head plane.} \\ \bar{A}_{xz} &= \bar{i} A_x + \bar{k} A_z \end{aligned}$$

$$\begin{aligned} \bar{A}_{xy} &= \text{Planar component of } \bar{A} \text{ directed in the horizontal } xy \text{ head plane.} \\ \bar{A}_{xy} &= \bar{i} A_x + \bar{j} A_y \end{aligned}$$

$$\begin{aligned} |\bar{A}_{yz}| \angle \phi_x &= \text{Magnitude/direction vector notation for } \bar{A}_{yz}. \\ |\bar{A}_{yz}| \angle \phi_x &\equiv \bar{A}_{yz} \end{aligned}$$

$$\begin{aligned} |\bar{A}_{xz}| \angle \phi_y &= \text{Magnitude/direction vector notation for } \bar{A}_{xz}. \\ |\bar{A}_{xz}| \angle \phi_y &\equiv \bar{A}_{xz} \end{aligned}$$

$$\begin{aligned} |\bar{A}_{xy}| \angle \phi_z &= \text{Magnitude/direction vector notation for } \bar{A}_{xy}. \\ |\bar{A}_{xy}| \angle \phi_z &\equiv \bar{A}_{xy} \end{aligned}$$

$$\begin{aligned} |\bar{A}_{yz}| &= \text{Absolute magnitude of } \bar{A}_{yz}. \\ |\bar{A}_{yz}| &= (A_y^2 + A_z^2)^{\frac{1}{2}} \end{aligned}$$

$$\begin{aligned} |\bar{A}_{xz}| &= \text{Absolute magnitude of } \bar{A}_{xz}. \\ |\bar{A}_{xz}| &= (A_x^2 + A_z^2)^{\frac{1}{2}} \end{aligned}$$

$$\begin{aligned} |\bar{A}_{xy}| &= \text{Absolute magnitude of } \bar{A}_{xy}. \\ |\bar{A}_{xy}| &= (A_x^2 + A_y^2)^{\frac{1}{2}} \end{aligned}$$

$$\begin{aligned} \phi_x &= \text{Direction angle denoting the orientation of } \bar{A}_{yz} \text{ in the frontal } yz \text{ head plane where} \\ &\phi_x = 0 \text{ when } \bar{A}_{yz} \text{ is directed upward along the } +z \text{ head axis. Angular displacement} \\ &\text{of } \bar{A}_{yz} \text{ away from this alignment toward the } -y \text{ (right) head axis denoted as positive } (+\phi_x). \\ \phi_x &\equiv \phi_x(t) = \arctan(-A_y/A_z) \end{aligned}$$

$$\begin{aligned} \phi_y &= \text{Direction angle denoting the orientation of } \bar{A}_{xz} \text{ in the sagittal } xz \text{ head plane where} \\ &\phi_y = 0 \text{ when } \bar{A}_{xz} \text{ is directed upward along the } +z \text{ head axis. Angular displacement of} \\ &\bar{A}_{xz} \text{ away from this alignment toward the } +x \text{ (front) head axis denoted as positive } (+\phi_y). \\ \phi_y &\equiv \phi_y(t) = \arctan(A_x/A_z) \end{aligned}$$

$$\begin{aligned} \phi_z &= \text{Direction angle denoting the orientation of } \bar{A}_{xy} \text{ in the horizontal } xy \text{ head plane where} \\ &\phi_z = 0 \text{ when } \bar{A}_{xy} \text{ is directed frontward along the } +x \text{ head axis. Angular displacement of} \\ &\bar{A}_{xy} \text{ away from this alignment toward the } +y \text{ (left) head axis denoted as positive } (+\phi_z). \\ \phi_z &\equiv \phi_z(t) = \arctan(A_y/A_x) \end{aligned}$$

## SYNOPSIS OF ACCELERATION NOTATION

### Angular Acceleration - Magnitude/Direction Notation

- $\bar{\alpha}_{yz}$  = Planar component of  $\bar{\alpha}$  directed in the frontal  $yz$  head plane.  

$$\bar{\alpha}_{yz} = \bar{j} \alpha_y + \bar{k} \alpha_z$$
- $\bar{\alpha}_{xz}$  = Planar component of  $\bar{\alpha}$  directed in the sagittal  $xz$  head plane.  

$$\bar{\alpha}_{xz} = \bar{i} \alpha_x + \bar{k} \alpha_z$$
- $\bar{\alpha}_{xy}$  = Planar component of  $\bar{\alpha}$  directed in the horizontal  $xy$  head plane.  

$$\bar{\alpha}_{xy} = \bar{i} \alpha_x + \bar{j} \alpha_y$$
- $|\bar{\alpha}_{yz}| \angle \beta_x$  = Magnitude/direction vector notation for  $\bar{\alpha}_{yz}$ .  

$$\bar{\alpha}_{yz} \equiv |\bar{\alpha}_{yz}| \angle \beta_x$$
- $|\bar{\alpha}_{xz}| \angle \beta_y$  = Magnitude/direction vector notation for  $\bar{\alpha}_{xz}$ .  

$$\bar{\alpha}_{xz} \equiv |\bar{\alpha}_{xz}| \angle \beta_y$$
- $|\bar{\alpha}_{xy}| \angle \beta_z$  = Magnitude/direction vector notation for  $\bar{\alpha}_{xy}$ .  

$$\bar{\alpha}_{xy} \equiv |\bar{\alpha}_{xy}| \angle \beta_z$$
- $|\bar{\alpha}_{yz}|$  = Absolute magnitude of  $\bar{\alpha}_{yz}$ .  

$$|\bar{\alpha}_{yz}| = (\alpha_y^2 + \alpha_z^2)^{\frac{1}{2}}$$
- $|\bar{\alpha}_{xz}|$  = Absolute magnitude of  $\bar{\alpha}_{xz}$ .  

$$|\bar{\alpha}_{xz}| = (\alpha_x^2 + \alpha_z^2)^{\frac{1}{2}}$$
- $|\bar{\alpha}_{xy}|$  = Absolute magnitude of  $\bar{\alpha}_{xy}$ .  

$$|\bar{\alpha}_{xy}| = (\alpha_x^2 + \alpha_y^2)^{\frac{1}{2}}$$
- $\beta_x$  = Direction angle denoting the orientation of  $\bar{\alpha}_{yz}$  in the frontal  $yz$  head plane where  $\beta_x = 0$  when  $\bar{\alpha}_{yz}$  is directed upward along the  $+z$  head axis. Angular displacement of  $\bar{\alpha}_{yz}$  away from this alignment toward the  $-y$  (right) head axis denoted as positive ( $+\beta_x$ ).  

$$\beta_x \equiv \beta_x(t) = \arctan(-\alpha_y/\alpha_z)$$
- $\beta_y$  = Direction angle denoting the orientation of  $\bar{\alpha}_{xz}$  in the sagittal  $xz$  head plane where  $\beta_y = 0$  when  $\bar{\alpha}_{xz}$  is directed upward along the  $+z$  head axis. Angular displacement of  $\bar{\alpha}_{xz}$  away from this alignment toward  $+x$  (front) head axis denoted as positive ( $+\beta_y$ ).  

$$\beta_y \equiv \beta_y(t) = \arctan(\alpha_x/\alpha_z)$$
- $\beta_z$  = Direction angle denoting the orientation of  $\bar{\alpha}_{xy}$  in the horizontal  $xy$  head plane where  $\beta_z = 0$  when  $\bar{\alpha}_{xy}$  is directed frontward along the  $+x$  head axis. Angular displacement of  $\bar{\alpha}_{xy}$  away from this alignment toward the  $+y$  (left) head axis denoted as positive ( $+\beta_z$ ).  

$$\beta_z \equiv \beta_z(t) = \arctan(\alpha_y/\alpha_x)$$

APPENDIX

NOMENCLATURE FOR SELECTED VESTIBULAR RESPONSE MEASURES



## APPENDIX

### NOMENCLATURE FOR SELECTED VESTIBULAR RESPONSE MEASURES

This appendix presents recommendations on nomenclature for the mathematical identification of experimental data collected to quantify response measures commonly used to study the static and dynamic characteristics of the vestibular system. Establishment of the cardinal head axes as a common measurement reference for all motion parameters provides a consistent means of relating eye, target, and cupula response measures to the evoking stimuli.

#### STATIC AND DYNAMIC EYE MOTIONS

The function of this section is to provide notation for the mathematical identification of the various static and dynamic oculovestibular responses which may be elicited by acceleration stimuli. The notation is intended specifically for vestibular investigations which require mathematical identification of measured eye motions of the three basic forms generally described as rotary, vertical, and horizontal, and is not directed toward the study of the biophysical characteristics of the eye proper or its suspension system. When treated independently, each form of eye motion is for all practical measurement purposes equivalent to rotation of the eye about an axis parallel to one of the cardinal head axes. In essence, rotary eye motion is equivalent to rotation of the eye about an axis parallel to the  $x$  (front-back) head axis so that the eye is observed to roll left or right in the frontal head plane. Vertical eye motion is equivalent to rotation of the eye about an axis parallel to the  $y$  (left-right) head axis so that the eye is observed to pitch up or down in a sagittal head plane. Horizontal eye motion is equivalent to rotation of the eye about an axis parallel to the  $z$  (vertex-base) head axis so that the eye is observed to yaw left or right in a horizontal head plane.

The symbol  $\psi$  (lower case Greek psi) has been chosen as the basic motion symbol for rotation of the eye about each of the axes. The instantaneous angular displacement, velocity, and acceleration of the eye measured relative to the skull are identified as  $\psi$ ,  $\dot{\psi}$ , and  $\ddot{\psi}$ , respectively, and an appropriate  $x$ ,  $y$ , or  $z$  subscript is assigned to each parameter to denote the form of eye motion. This notation can be summarized as follows:

$\psi_x$ ,  $\dot{\psi}_x$ ,  $\ddot{\psi}_x$  = Rotary (roll) eye motion: Instantaneous angular displacement, velocity, and acceleration of the eye about the  $x$  head axis. Roll rightward motions denoted as positive ( $+\psi_x$ ,  $+\dot{\psi}_x$ ,  $+\ddot{\psi}_x$ ).

$\psi_y, \dot{\psi}_y, \ddot{\psi}_y$  = Vertical (pitch) eye motion: Instantaneous angular displacement, velocity, and acceleration of the eye about the  $y$  head axis. Pitch downward motions denoted as positive ( $+\psi_y, +\dot{\psi}_y, +\ddot{\psi}_y$ ).

$\psi_z, \dot{\psi}_z, \ddot{\psi}_z$  = Horizontal (yaw) eye motion: Instantaneous angular displacement, velocity, and acceleration of the eye about the  $z$  head axis. Yaw leftward motions denoted as positive ( $+\psi_z, +\dot{\psi}_z, +\ddot{\psi}_z$ ).

The form of this nomenclature is summarized at the top of Figure A1. In this sketch an erect, right-handed, rectangular Cartesian coordinate frame with mutually orthogonal  $x_e, y_e,$  and  $z_e$  axes is assumed to be rigidly fixed to a single eye. For one particular quiescent orientation of the eye, the  $x_e, y_e,$  and  $z_e$  primary eye axes are assumed to be in parallel alignment with the  $x, y,$  and  $z$  cardinal head axes. Rotary eye motions are then defined by rotation of the eye about its  $x_e$  axis which changes the orientation of the  $y_e$  and  $z_e$  axes of the frontal plane of the eye relative to the  $y$  and  $z$  axes of the frontal plane of the head. The practical aspects of the measurement of the resultant  $\psi_x$  displacement are illustrated in the two drawings at the lower left of Figure A1 which represent frontal plane views of the eye as seen by an observer facing the subject. As shown in the upper drawing,  $\psi_x = 0^\circ$  when the eye is in the resting position where  $z_e$  is aligned with  $z$ ; at the bottom,  $\psi_x = +45^\circ$  for a  $45^\circ$  roll of the eye toward the right of the subject where  $\psi_x$  is measured as the angular deviation of  $z_e$  from  $z$ . A  $45^\circ$  roll of the eye toward the left of the subject would be identified as  $\psi_x = -45^\circ$ .

An equivalent  $\psi_y$  description of vertical eye displacement is provided in the drawings at the center in Figure A1 which represent sagittal views of the eye as seen from the left. The angular deviation of the  $x_e$  eye axis from the  $x$  head axis serves for measurement of  $\psi_y$ . A similar  $\psi_z$  description of horizontal eye displacement is presented at the lower right in Figure A1 where the eye is shown as viewed from above. Again, the angular displacement of the  $x_e$  eye axis from the  $x$  head axis serves for measurement of  $\psi_z$ .

Regardless of the form of the eye motion, the plus or minus sign prefix to be assigned to the measured values of  $\psi, \dot{\psi}, \ddot{\psi}$  to describe the direction of the parameter derives from application of the right-hand rule of rotation to the positive head/eye axes. That is, when the thumb of the right hand is pointed in the direction of the positive head/eye axis about which the angular motions are occurring, eye displacement, velocity, or acceleration in the direction signified by

# VESTIBULAR NOMENCLATURE

# EYE MOTION NOTATION

$\psi, \dot{\psi}, \ddot{\psi}$  = INSTANTANEOUS ANGULAR DISPLACEMENT, VELOCITY, AND ACCELERATION OF THE EYES

$\dot{\psi} \equiv \dot{\psi}(t)$   
units: degrees, radians

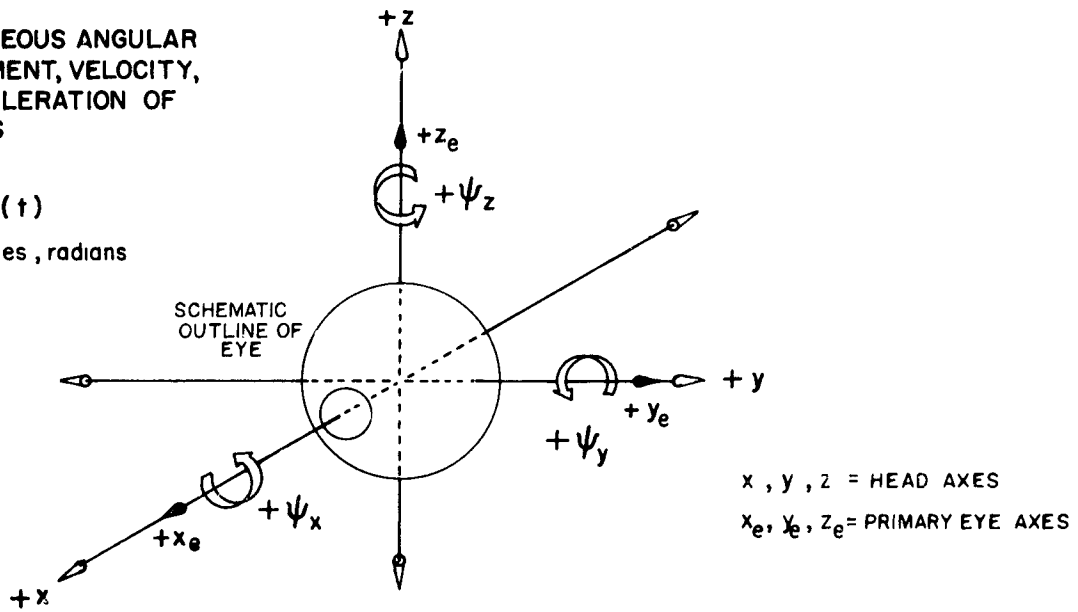

$x, y, z$  = HEAD AXES  
 $x_e, y_e, z_e$  = PRIMARY EYE AXES

$\psi_x, \dot{\psi}_x, \ddot{\psi}_x$ ROTARY (ROLL) EYE MOTIONS	$\psi_y, \dot{\psi}_y, \ddot{\psi}_y$ VERTICAL (PITCH) EYE MOTIONS	$\psi_z, \dot{\psi}_z, \ddot{\psi}_z$ HORIZONTAL (YAW) EYE MOTIONS
yz FRONTAL PLANE VIEW	xz MID-SAGITTAL PLANE VIEW	xy HORIZONTAL PLANE VIEW
<p><math>\psi_x = 0^\circ</math></p>	<p><math>\psi_y = 0^\circ</math></p>	<p><math>\psi_z = 0^\circ</math></p>
<p><math>\psi_x = +45^\circ</math></p> <p>EYE ROLL RIGHT</p>	<p><math>\psi_y = +45^\circ</math></p> <p>EYE PITCH DOWN</p>	<p><math>\psi_z = +45^\circ</math></p> <p>EYE YAW LEFT</p>

Figure A1

the curl of the fingers will be measured as positive values of  $\psi$ ,  $\dot{\psi}$ , and  $\ddot{\psi}$ , respectively. The resultant polarity conventions are such that positive values of  $\psi_x$ ,  $\psi_y$ , and  $\psi_z$  denote angular displacements of the eye in the roll right, pitch down, and yaw left directions, respectively, with negative values of  $\psi_x$ ,  $\psi_y$ , and  $\psi_z$  denoting displacements in the roll left, pitch up, and yaw right directions, respectively.

The identification of the primary eye axes as  $x_e$ ,  $y_e$ , and  $z_e$  is provided only to establish the polarity sense implied by the notation and can be disregarded in the actual application of the nomenclature. Consider a typical experimental situation in which it is expected that a particular stimulus will produce an oculovestibular response in the form of a static rotary eye displacement (ocular torsion or counterroll). Regardless of the technique used to record the angular eye motion the procedure will become one of obtaining a measure of the eye orientation under quiescent or control conditions and a measure of the eye orientation while exposed to the stimulus. For example, assume that a measurement technique showed that the eyes were oriented  $0.8^\circ$  to the left before applying the stimulus and  $6.0^\circ$  to the right after application of the stimulus. The notation would describe these data as  $\psi_x = -0.8^\circ$  and  $\psi_x = +6.0^\circ$ , respectively.

The same procedure can be used to identify quantitatively dynamic vertical and horizontal eye motions which may be of smooth continuous form or of discontinuous nystagmic form (motions marked by distinct fast and slow components of the eye velocity). In general, the directional nature of such nystagmus responses is identified in terms of the direction of the motion of the eye, i.e., eye velocity, rather than of the exact instantaneous displacement of the eye. It is common clinical practice to use the expressions "nystagmus left" or "nystagmus up" to describe horizontal and vertical nystagmus with fast components of eye velocity directed to the patient's left and upward, respectively. However, in many research applications the instantaneous magnitude and direction of the slow component of eye velocity and its time or phase relationship to the effecting stimulus are considered the distinguishing characteristics of the nystagmic response. For such applications it is obvious that an equation describing nystagmic eye velocity will derive its polarity sense from the direction of the slow component with  $+\dot{\psi}_x$ ,  $+\dot{\psi}_y$ , and  $+\dot{\psi}_z$  denoting that, at the instant of concern, the slow components of nystagmus are in the roll right, pitch down, and yaw left directions, respectively.

## VISUAL TARGET ORIENTATION

In studies concerned with static time-invariant linear acceleration stimuli, the subjective perception of the spatial orientation of a visual target relative to coordinates established by either the force field environment proper or by the anatomy of the participating subject has

served as a measure of vestibular function. Depending upon the experimental approach, the subject may be given direct control of the visual target motions so that he can manually align the target with an assigned reference frame or he may be only required to estimate the orientation of a fixed-attitude visual target relative to the reference. For static tilts of the frontal  $yz$  head plane in the terrestrial environment, a typical subjective judgment would involve the alignment of the long dimension of a rotary line target to either an Earth-vertical axis or an Earth-horizontal plane as defined by the direction of the gravitational acceleration vector and a plane at right angles to the vector, respectively. If this same tilt were performed aboard a centrifuge, the resultant vertical axis and resultant horizontal plane, as defined by the direction of the resultant of the gravitational and centripetal accelerations and a plane at right angles to the resultant, respectively, would generally serve as the force-based reference for the subjective judgments.

When the task involves the alignment of a target to egocentrically based coordinates, the anatomical axes and planes of the subject serve as reference. Such judgments might involve the alignment of the long dimension of a target to the longitudinal body axis, i.e., morphological vertical axis, and the elevation or depression, or the left or right displacement, of a target so that it would be in the visual dead ahead position.

In general, whether the judgments are keyed to extracorporeal or to morphological reference coordinates, it is possible to describe the related visual target adjustments in terms of three basic angular motions of the target. By man-referencing these target motions, each can be independently equated to rotation of the target about one of the three cardinal  $x$ ,  $y$ , and  $z$  head axes. As viewed by the subject, a target can be made to rotate (roll) about the  $x$  head axis so that it appears tilted CW or CCW; it can be made to rotate (pitch) about the  $y$  head axis so that it appears to be elevated or depressed; or it can be made to rotate (yaw) about the  $z$  head axis so that it appears displaced to the left or right. It is proposed that the orientation of a visual target be specified in terms of its angular displacements about the cardinal head axes, where the measured angles are to be identified by the symbol  $\tau$  (lower case Greek tau) with an appropriate  $x$ ,  $y$ , or  $z$  subscript to distinguish among the three forms of target motion. The angles  $\tau_x$ ,  $\tau_y$ , and  $\tau_z$  thus provide a quantified description of the just-described roll, pitch, and yaw target motions, respectively.

The three forms of target motion pertinent to this notation can be separately described as follows. The roll motion involves the rotation of a line target in a plane parallel to the frontal  $yz$  head plane where the rotational axis of the target lies on a projection of the  $x$  head axis

at eye level. The pitch motion involves the elevation or depression of a target which is constrained to move in a projection of the mid-sagittal  $xz$  head plane. The yaw motion involves the left or right displacement of a target which is constrained to move in a projection of the horizontal  $xy$  head plane at eye-level. For these three forms of target motion,  $\tau_x$ ,  $\tau_y$ , and  $\tau_z$  are separately identified and measured as

$\tau_x$  = Roll target rotation about the  $x$  head axis: Measured as the angular deviation (CW or CCW) of a line target from the mid-sagittal  $xz$  head plane where  $\tau_x = 0$  when the long dimension of the target is in this plane; roll right displacement (CW tilt) as viewed by subject denoted as positive angle ( $+\tau_x$ ).

$\tau_y$  = Pitch target rotation about the  $y$  head axis: Measured as the angular deviation of the target above or below the horizontal  $xy$  head plane at eye level where  $\tau_y = 0$  when the target lies in this plane; pitch downward displacement as viewed by subject denoted as positive angle ( $+\tau_y$ ).

$\tau_z$  = Yaw target rotation about the  $z$  head axis. Measured as the angular deviation of the target to the left or right of the mid-sagittal  $xz$  head plane where  $\tau_z = 0$  when the target lies in this plane; yaw leftward displacement as viewed by subject denoted as positive angle ( $+\tau_z$ ).

The form of the notation is described pictorially at the top of Figure A2 where it is schematically hypothesized that a subject is surrounded by a target sphere which can be made to rotate about him. The  $x_t$ ,  $y_t$ , and  $z_t$  axes define the coordinates of a right-handed, rectangular Cartesian coordinate frame which is fixed to the target sphere and whose origin (center of the sphere) is coincidental with the origin of the cardinal  $x$ ,  $y$ , and  $z$  head axes. Under quiescent conditions the corresponding axes of both frames are assumed to be in parallel alignment. As indicated in this drawing, a simple line target is assumed to be rigidly fixed to the interior of the sphere where the center of the target lies on the  $x_t$  axis and its long dimension is parallel to the  $z_t$  axis. The target is thus dead ahead of the subject along the  $x$  head axis at eye level and aligned with the  $z$  head axis so that its orientation is measured as  $\tau_x = \tau_y = \tau_z = 0^\circ$ .

**VESTIBULAR NOMENCLATURE**

**VISUAL TARGET ORIENTATION-HEAD REFERENCE**

$\tau$  • ANGULAR MEASURE OF TARGET ORIENTATION RELATIVE TO THE CARDINAL HEAD AXES

units: degrees, radians

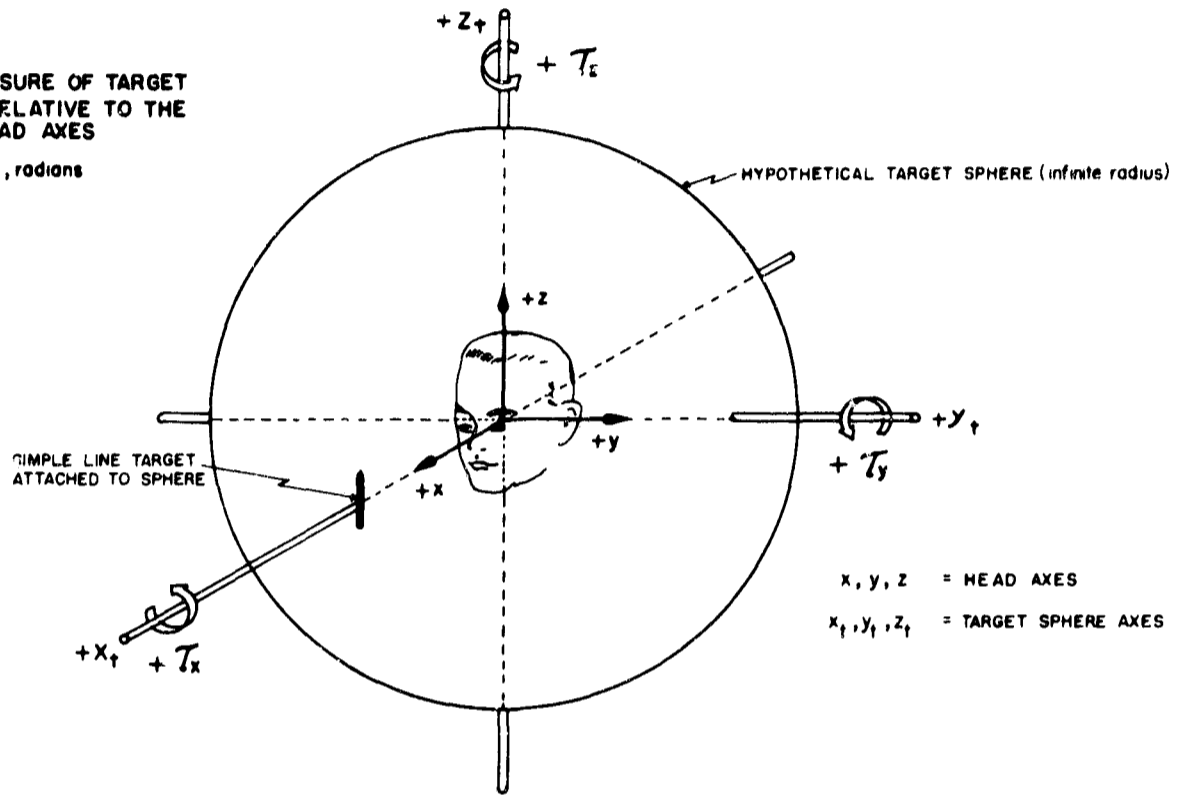

$x, y, z$  = HEAD AXES

$x_t, y_t, z_t$  = TARGET SPHERE AXES

$T_x$ CW-CCW (ROLL) TARGET MOTIONS	$T_y$ UP-DOWN (PITCH) TARGET MOTIONS	$T_z$ LEFT-RIGHT (YAW) TARGET MOTIONS
$yz$ FRONTAL PLANE VIEW	$xz$ MID-SAGITTAL PLANE VIEW	$xy$ HORIZONTAL PLANE VIEW
<p><math>T_x = 0^\circ</math></p> <p>A circular diagram showing the <math>yz</math> frontal plane view. The vertical axis is <math>+z_t</math> and the horizontal axis is <math>+y_t</math>. A head icon is centered at the origin. The angle <math>T_x = 0^\circ</math> is indicated.</p>	<p><math>T_y = 0^\circ</math></p> <p>A circular diagram showing the <math>xz</math> mid-sagittal plane view. The vertical axis is <math>+z_t</math> and the horizontal axis is <math>+x_t</math>. A head icon is centered at the origin. The angle <math>T_y = 0^\circ</math> is indicated.</p>	<p><math>T_z = 0^\circ</math></p> <p>A circular diagram showing the <math>xy</math> horizontal plane view. The vertical axis is <math>+x_t</math> and the horizontal axis is <math>+y_t</math>. A head icon is centered at the origin. The angle <math>T_z = 0^\circ</math> is indicated.</p>
<p><math>T_x = +45^\circ</math></p> <p>TARGET ROLL RIGHT</p> <p>A circular diagram showing the <math>yz</math> frontal plane view at <math>T_x = +45^\circ</math>. The axes <math>+z_t</math> and <math>+y_t</math> are rotated 45 degrees clockwise from their original positions. A head icon is centered at the origin. The angle <math>T_x = +45^\circ</math> is indicated.</p>	<p><math>T_y = +45^\circ</math></p> <p>TARGET PITCH DOWN</p> <p>A circular diagram showing the <math>xz</math> mid-sagittal plane view at <math>T_y = +45^\circ</math>. The axes <math>+z_t</math> and <math>+x_t</math> are rotated 45 degrees clockwise from their original positions. A head icon is centered at the origin. The angle <math>T_y = +45^\circ</math> is indicated.</p>	<p><math>T_z = +45^\circ</math></p> <p>TARGET YAW LEFT</p> <p>A circular diagram showing the <math>xy</math> horizontal plane view at <math>T_z = +45^\circ</math>. The axes <math>+x_t</math> and <math>+y_t</math> are rotated 45 degrees clockwise from their original positions. A head icon is centered at the origin. The angle <math>T_z = +45^\circ</math> is indicated.</p>

Figure A2

With the subject remaining fixed in space, rotation of the sphere about each of its  $x_t$ ,  $y_t$ , or  $z_t$  axes produces the roll, pitch, or yaw angular displacements of the target which are measured as  $\tau_x$ ,  $\tau_y$ , or  $\tau_z$ , respectively. The zero reference and the positive measurement sense for each of the three target angles are shown in the three sets of drawings at the bottom of Figure A2 which present frontal, sagittal, and horizontal views of the subject enclosed within the target sphere. In each set only one form of target motion is allowed; e.g., in the frontal view the target sphere is rotated only about its  $x_t$  axis so that  $\tau_y = \tau_z = 0^\circ$ . In each case target displacements are measured as positive angles when the displacement is in the direction of the curl of the fingers of the right hand when the thumb is directed along the positive  $x$ ,  $y$ , or  $z$  head/target axis about which the target rotates. As with the eye axis notation, the  $x_t$ ,  $y_t$ , and  $z_t$  target axes have been defined to establish only the measurement intent of the notation and may be disregarded in practice.

The notation has the most direct application in centrifuge studies in which the head is tilted about either the  $x$  or  $y$  axis relative to the resultant linear acceleration. In such studies the visual target device proper usually moves with the subject so that its axes remain in fixed alignment with the cardinal head axes. Hence, direct measures of the  $\tau_x$ ,  $\tau_y$ , and  $\tau_z$  target angles can be readily obtained in the experimental situation. For the roll type of motion  $\tau_x$  is usually derived directly by conventional angular displacement measurement techniques (potentiometer, synchro, shaft-encoder, etc.). However, vertical pitch and horizontal yaw motions are usually produced by devices which move a target along a rectilinear path with the position of the target being measured as its linear displacement from some reference point on the path. These linear displacements can be converted to the angular  $\tau_y$  and  $\tau_z$  measures through the simple trigonometric relationships existing between the linear target displacement and the distance between the target and the eyes.

The primary advantage of the  $\tau$  notation, other than its simplicity of form, derives from the fact that the description of the spatial orientation of extracorporeal targets, visual or otherwise, is man-referenced to the cardinal head axes. The same rules used to define the morphological direction of an acceleration stimulus, e.g., the linear acceleration direction angle  $\phi$  of the magnitude/direction notation, can be used to establish the morphological direction or orientation of a visual target. Further, when a response task involves judgments keyed to directional parameters of the stimulus, a numerical as well as polarity correspondence will result between the  $\tau$  response notation and the  $\phi$  stimulus notation.



To illustrate, consider the previously discussed centrifuge example (Figure 6) in which a subject was seated tangentially with his face in the direction of the CCW rotation. With the centrifuge at constant angular velocity the resultant linear acceleration stimulus is defined in magnitude/direction form as  $\bar{A} = \bar{A}_{yz} = |\bar{A}_{yz}| \angle \phi_x$ . Changes in the steady-state velocity level thus change the magnitude and direction of  $\bar{A}$  in the frontal  $yz$  head plane. Under these conditions a typical experimental task is to have a subject align a rotary target with his perception of the direction of resultant vertical, i.e., the direction of the resultant acceleration vector. With the recommended  $\tau$  notation the angular displacement of the target away from the  $z$  head axis is measured as  $\tau_x$ .

For the operating condition of this example described by equation (12), the acceleration stimulus is identified as  $\bar{A} = \bar{A}_{yz} = 2.0 g \angle -60^\circ$ . If the visual target were aligned initially with the  $z$  head axis, the subject would rotate the target CCW toward  $\bar{A}_{yz}$ , leading to negative values of  $\tau_x$ . If the subject exactly aligned the target with the objective value of resultant vertical, then the measured value of  $\tau_x$  would be  $-60^\circ$ . In effect, the objective value of  $\tau_x$  will always equal  $\phi_x$  for this form of judgment regardless of how the frontal plane stimulus is generated, e.g., whether accomplished by varying centrifuge velocity as in this example, or by varying head tilt on a centrifuge which has a free-swinging chair that moves to the resultant angle.

The same format obtains when a subject is required to estimate the height of the resultant horizon by raising or lowering a visual target when the stimulus is directed in the sagittal  $xz$  head plane. The target is objectively oriented at the horizon when its  $\tau_y$  angular displacement about the  $y$  head axis is equal to the  $\phi_y$  direction angle of the stimulus.

#### THEORETICAL CUPULA-ENDOLYMPH MOTIONS

It has been common analytical practice to treat each set of the three sets of semicircular canals as a single receptor mechanism whose cupula-endolymph elements are angularly displaced relative to the canal whenever the mechanism is angularly accelerated. The theoretical motion parameters of the cupula-endolymph system are then related to the angular motion parameters of the head to derive a functional relationship between acceleration input and cupula-endolymph output.

When such an approach is used, it is recommended that the motion parameters of the cupula-endolymph system be keyed to the symbol  $\xi$  (lower case Greek xi) used by van Egmond, Groen, and Jongkees (ref. A.1). With their notation the theoretical instantaneous angular

displacement, velocity, and acceleration of the cupula-endolymph system relative to the skull are identified as  $\xi$ ,  $\dot{\xi}$ , and  $\ddot{\xi}$ , respectively. When it is desired to become specific about the relative direction of these parameters, the  $x$ ,  $y$ , and  $z$  head axes in conjunction with the right-hand rule of rotation can serve as reference. For example, the primary axis of sensitivity of the horizontal semicircular canals to angular acceleration stimuli may be assumed in general alignment with the  $z$  head axis (although more probably tilted back  $20^\circ$  to  $30^\circ$  in the sagittal  $xz$  head plane). When the head is angularly accelerated from rest about the  $z$  axis in the CCW direction as viewed from above,  $\alpha_z$  is measured as a positive quantity ( $+\alpha_z$ ). This condition results in a CW displacement of the cupula-endolymph system of the horizontal canals measured relative to the skull so that  $\xi$ ,  $\dot{\xi}$ , and  $\ddot{\xi}$  would all be of negative polarity. When it is desired to identify separately the directional response of each member of a particular set of canals, it is obvious that the description of the theoretical cupula-endolymph motions can be further reduced to their ampullofugal or ampullopetal directions of flow.

It is also recommended that when these motion parameters are used in conjunction with Steinhausen's torsion pendulum concept of semicircular canal behavior to develop a linear, second-order, differential equation description of the system, the related equations of motion be defined as either

$$\ddot{\xi} + \frac{\Pi}{\Theta} \dot{\xi} + \frac{\Delta}{\Theta} \xi = \alpha(t) \quad (\text{A1})$$

according to the mechanics convention used by van Egmond, Groen, and Jongkees (ref. A.1) or as

$$\ddot{\xi} + 2 \zeta \omega_n \dot{\xi} + \omega_n^2 \xi = \alpha(t) \quad (\text{A2})$$

according to the servomechanism convention used by Hixson and Niven (ref. A.2). Equation (A1) presents a direct description of the theoretical physical characteristics of the cupula endolymph system defined simply as

$\Theta$  = equivalent rotational inertia

$\Pi$  = equivalent rotational viscous damping

$\Delta$  = equivalent rotational stiffness

$\alpha(t)$  = angular acceleration of the skull

Equation (A2) presents a fully equivalent description in terms of the system performance characteristics

$\zeta$  = equivalent damping ratio

$\omega_n$  = equivalent undamped characteristic angular frequency

The coefficients of the two equations are related as

$$\Pi / \Theta = 2 \zeta \omega_n$$

$$\Delta / \Theta = \omega_n^2$$

$$\Pi / \Delta = 2 \zeta / \omega_n$$

In certain cases it may be desirable to approach the biophysics of the two sets of vertically oriented semicircular canals in a similar manner. Although the axes of these canal sets are not in anatomical alignment with the  $x$  and  $y$  head axes, for all practical purposes it might be hypothesized that their axes of sensitivity, relative to the production of rotary and vertical nystagmus, are so aligned. The various response combinations of these four canals could then be interpreted by assuming that they could be replaced by two equivalent canals, one with a sensitive axis aligned with the  $x$  head axis and the other with a sensitive axis aligned with the  $y$  head axis. Again, the  $x$ ,  $y$ , and  $z$  cardinal head axes can be used as subscripts to distinguish among the  $\xi$ ,  $\xi$ ,  $\xi$  motion parameters of the three sets of canals.

## REFERENCES

- A.1. van Egmond, A. A. J., Groen, J. J., and Jongkees, L. B. W., The mechanics of the semicircular canal. J. Physiol., 110: 1-17, 1949.
- A.2. Hixson, W. C., and Niven, J. I., Application of the system transfer function concept to a mathematical description of the labyrinth: I. Steady-state nystagmus response to semicircular canal stimulation by angular acceleration. NSAM-458. NASA Order R-1. Pensacola, Fla.: Naval School of Aviation Medicine, 1961.