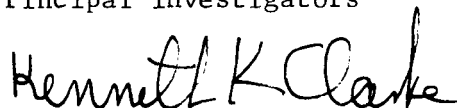

A SPACE COMMUNICATION STUDY
PROGRESS REPORT
SEPTEMBER 15, 1966 - MARCH 15, 1967
PREPARED FOR
NATIONAL AERONAUTICS AND SPACE ADMINISTRATION
ELECTRONIC RESEARCH CENTER
UNDER
NASA GRANT NGR-33-006-020

Principal Investigators

Kenneth K. Clarke, Professor

Raymond L. Pickholtz, Associate Professor

Donald L. Schilling, Associate Professor

DEPARTMENT OF ELECTRICAL ENGINEERING
POLYTECHNIC INSTITUTE OF BROOKLYN

Introduction

This Progress Report summarizes the work done from 15 September 1966 to 15 March 1967 in the area of Space Communications.

The problems considered during this period were:

- I. Optimal Reception of FM Signals Using the Maximum Likelihood Estimator
- II. Threshold Extension Devices
 - A. The Phase Locked Loop
 1. A Solution Using the Spike Approach
 2. A Solution of the Fokker Planck Equation
 - B. The Frequency Locked Loop
 - C. Multiple Threshold Spike Detection and Elimination Systems
- III. Detection of Signals in Noise Using Recursive Techniques
- IV. Channel Simulation Experiments
- V. Synchronization Techniques

The research performed in the above areas are summarized in the following reports. More comprehensive material will be presented in the final report and is available in the published literature (see "Published Papers").

I. Optimal Reception of FM Signals Using the Maximum Likelihood Estimator

The Maximum Likelihood Estimator (MLE) has been discussed since 1954. Although block diagram configurations have been derived for this device, no computer technique for solving the MLE equation under all conditions of modulation index and CNR was available. Thus, although the MLE was known to be optimum, its threshold extension capability was unknown.

In this study a solution for the MLE equation developed by Youla⁽¹⁾ and Lawton⁽²⁾ was obtained using an iteration technique. A similar, although more elementary, procedure developed by VanTrees⁽³⁾ for iterating this equation was tested, but failed to converge in many practical, as well as theoretical, cases of interest.

The new technique consists of generating a sequence of test solutions by varying a parameter, ϵ , in the following equation:

$$\text{Test Solution} = \text{Old Test Solution} + \epsilon \text{ Solution error due to the Old Test Solution}$$

The solution error is defined as the error produced when substituting the old test solution in the MLE equation. For each value of ϵ selected, the likelihood function of the associated test solution is evaluated; the test solution for which the likelihood function is a maximum replaces the old test solution. The integral of the absolute value of the solution error over all time (called the total solution error) is evaluated and the process is repeated. When the total solution error goes below some preset value, the process stops. The last test solution is then an approximate solution to the ML equation.

Figure 1 shows a plot of output SNR versus input CNR of the Maximum Likelihood Estimator. The spectrum of the modulation was assumed to have the form $\frac{1}{\omega^2 + \alpha^2}$. The solid curve represents the high CNR asymptote. It should be noted that the output SNR has the form

$$\text{SNR} = \left[\frac{8\beta^3 \text{CNR}}{\pi} \right]^{1/4}$$

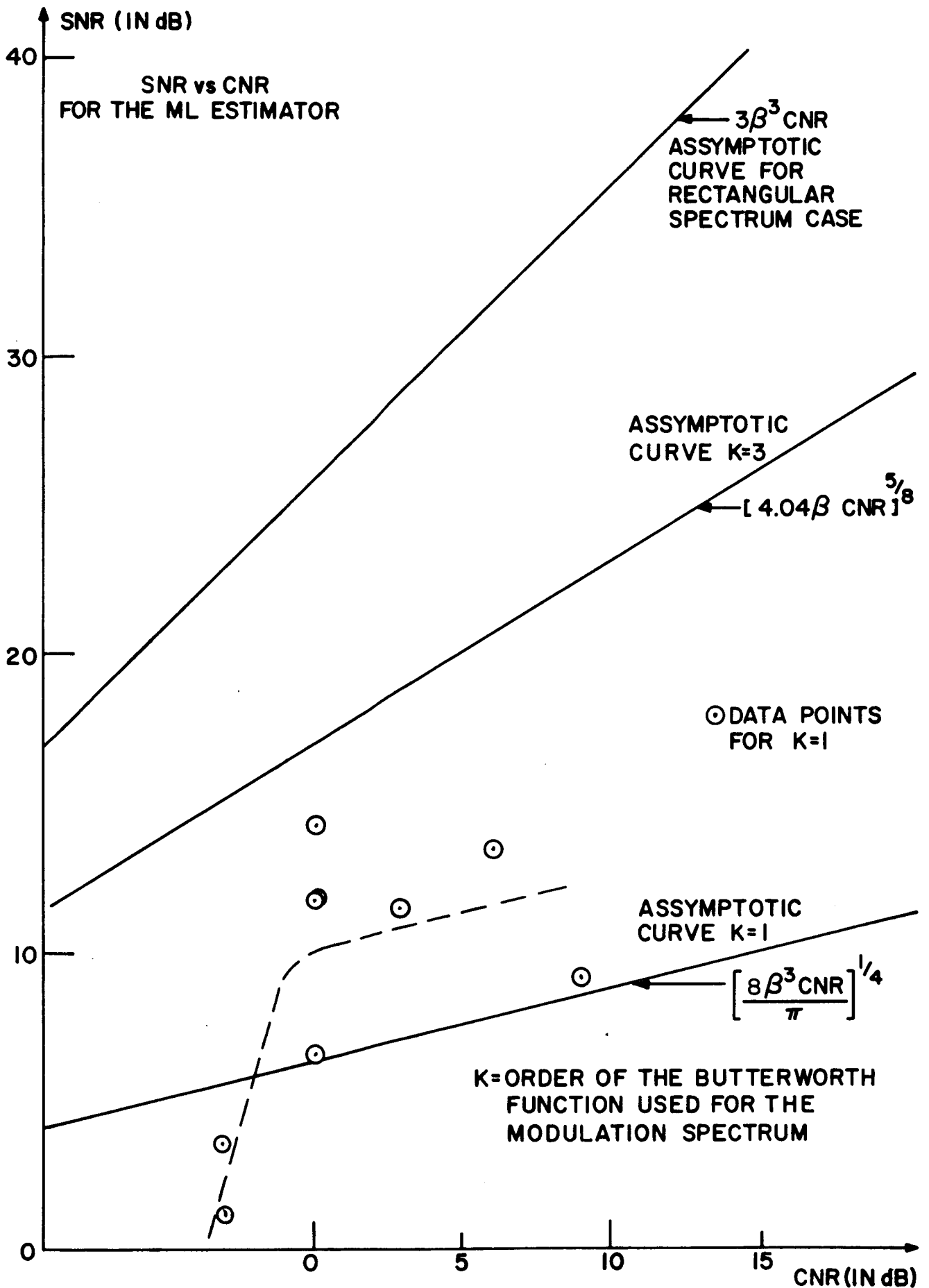

1.1 SNR vs CNR For the Maximum Likelihood Estimator

for this type spectrum. (If the spectrum were rectangular then $SNR = 3\beta^3 CNR$, which is the usually assumed FM equation).

It is seen from the computer solution shown that threshold occurs somewhere between -3db and 0db. A more precise determination of threshold will be given in the final report. It is also seen that the experimental points fall above the theoretical curve. It is felt that this is due to the short time noise samples employed to keep computing costs low. Different programming techniques are being investigated which, it is believed, will use a larger noise sample at a minimal increase in computer time and hence represent a more typical noise sample.

References

1. D. Youla The use of the method of maximum likelihood in estimating continuous-modulated intelligence which has been corrupted by noise
IRE Trans., Information Theory 3/54
2. J. Lawton Results of Investigations of analog and digital communication techniques
IEEE Convention Record, Part 6, 3/64
3. H. VanTrees The structure of efficient demodulators for multidimensional phase modulated signals
IEEE Trans., Communication Systems, 9/63

II. Threshold Extension Devices

A. The Phase Locked Loop

In the past several years many solutions to the phase locked loop have been presented. Most of these solutions have required approximations which severely limited their usefulness. A digital computer solution to the PLL was attempted at the Polytechnic Institute of Brooklyn. However, to insure accuracy, 100 spikes had to be counted at each CNR. This required the duration of each computer run to be excessive.

1. A Solution Using the Spike Approach

A method for solving the PLL equation which does not require lengthy running time or complex computer operations has been developed. The technique is based on Rice's spike analysis for the FM discriminator. In this procedure the locus of the input noise which results in a PLL spike is determined. Integrating over this locus results in the expected number of spikes occurring per second.

The results obtained are illustrated for the first order PLL with a loop bandwidth of unity:

$$\dot{\phi} + \sin \phi = \frac{x(t)}{A} \cos \phi + \frac{y(t)}{A} \sin \phi$$

The locus of positive and negative spike regions are shown in Fig. 1. Note that the area in the whole first quadrant represents the region of negative spikes for the discriminator, while the area above the PLL locus represents the PLL spike region. Thus, the technique illustrated by Fig. 1 can be used to compare different systems and to determine threshold.

An approximate expression for the spikes present in the PLL is

$$\frac{N_+}{B_{1F}} = \frac{N_+}{(\beta+1)f_m} \approx \text{erfc} \sqrt{5\text{CNR}}$$

This result was obtained by integrating over the area in Fig. 1. The results are shown in Fig. 2.

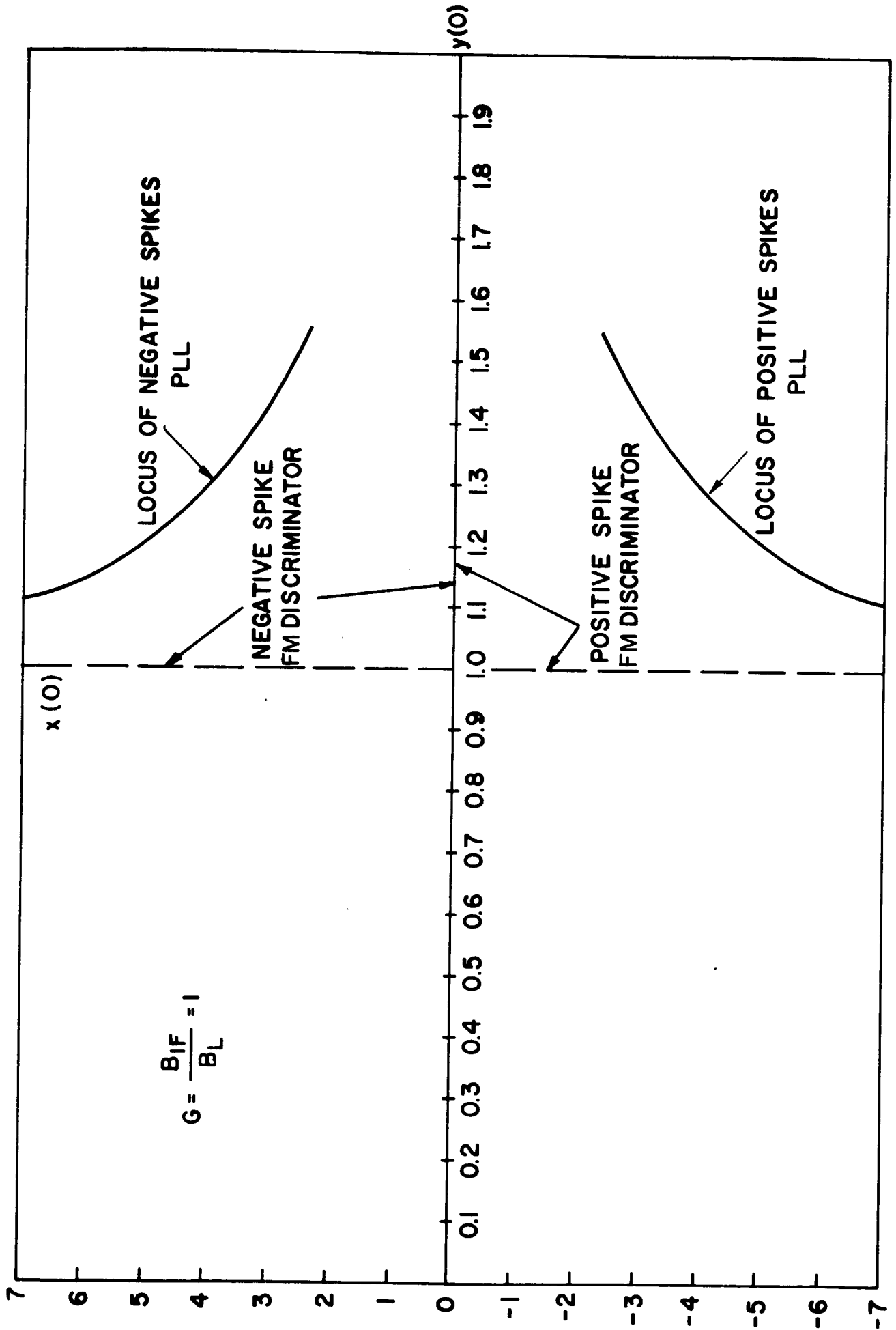

II.1 Locus of Spikes for the Unmodulated First Order Phase Locked Loop and FM Discriminator

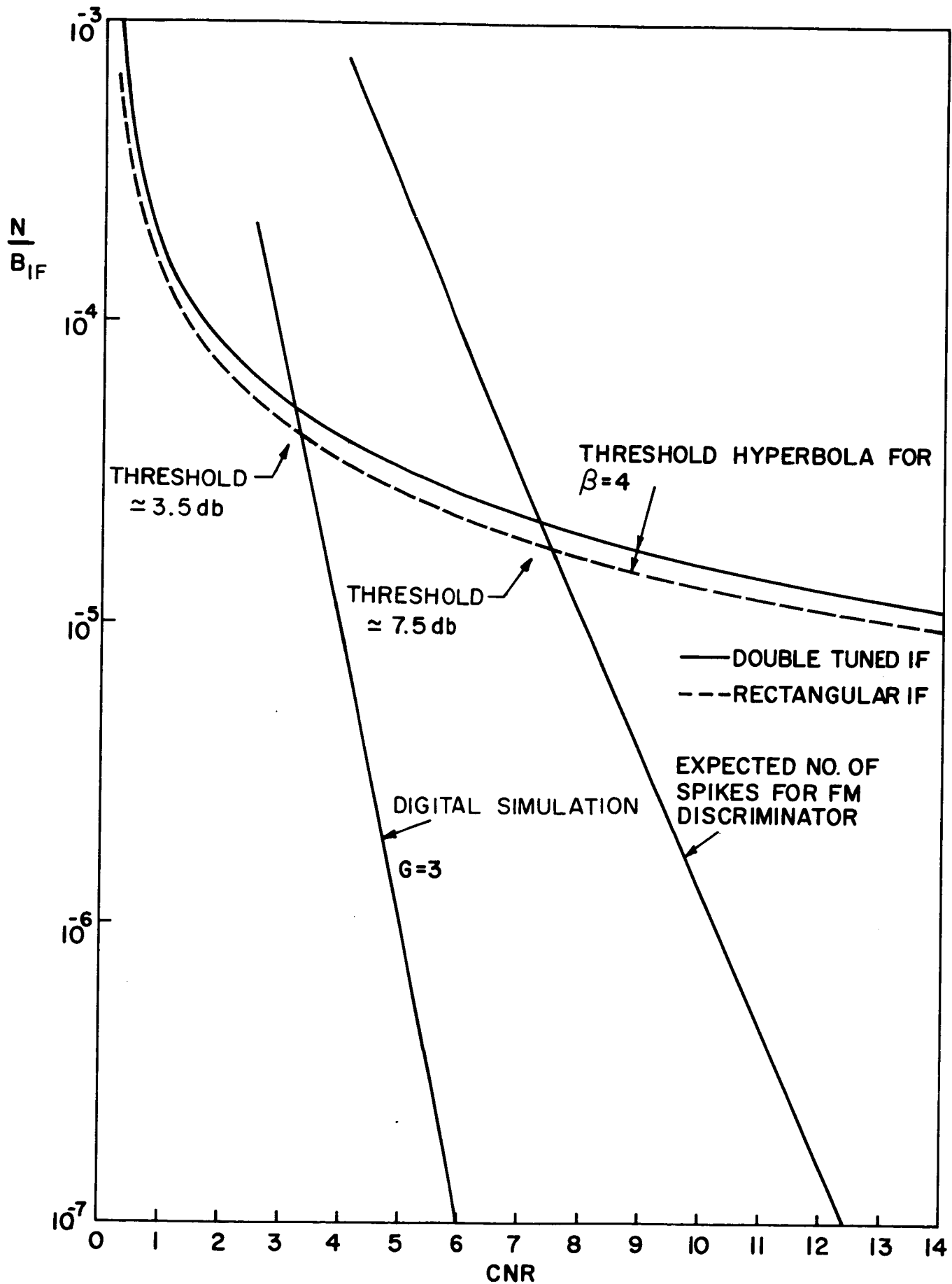

II.2 Normalized Spikes/second and Threshold for an Unmodulated First Order PLL and FM Discriminator

This work is being continued and will be expanded to consider the FMFB, higher order PLL systems, modulation and optimization of filter and phase detector. A more comprehensive discussion of these results will be presented in the final report.

2. Solutions of the Fokker-Planck Equation

Numerical solutions have been obtained for the probabilistic behavior of a phase locked loop in the presence of noise. The normalized Fokker-Planck equation is

$$\frac{\partial p}{\partial \tau} = \frac{\partial}{\partial \phi} \left[(\sin \phi - \gamma) p \right] + \frac{1}{\alpha} \frac{\partial^2 p}{\partial \phi^2}$$

where

$$B_L = \frac{AK}{4} = \text{loop bandwidth (sec}^{-1}\text{)}$$

$$\alpha = \frac{A^2}{N_o B_L} = \text{SNR in bandwidth of loop (dimensionless)}$$

$$\gamma = \frac{\omega - \omega_o}{4 B_L} = \text{fractional frequency ratio (rad)}$$

$$\tau = 4 B_L t = \text{dimensionless time}$$

$p(\phi, \tau)$ = conditional p.d.f. of phase transition in

Several computer results are shown in Figs. 3, 4, and 5.

PROBABILITY DENSITY FUNCTION OF PHASE ERROR

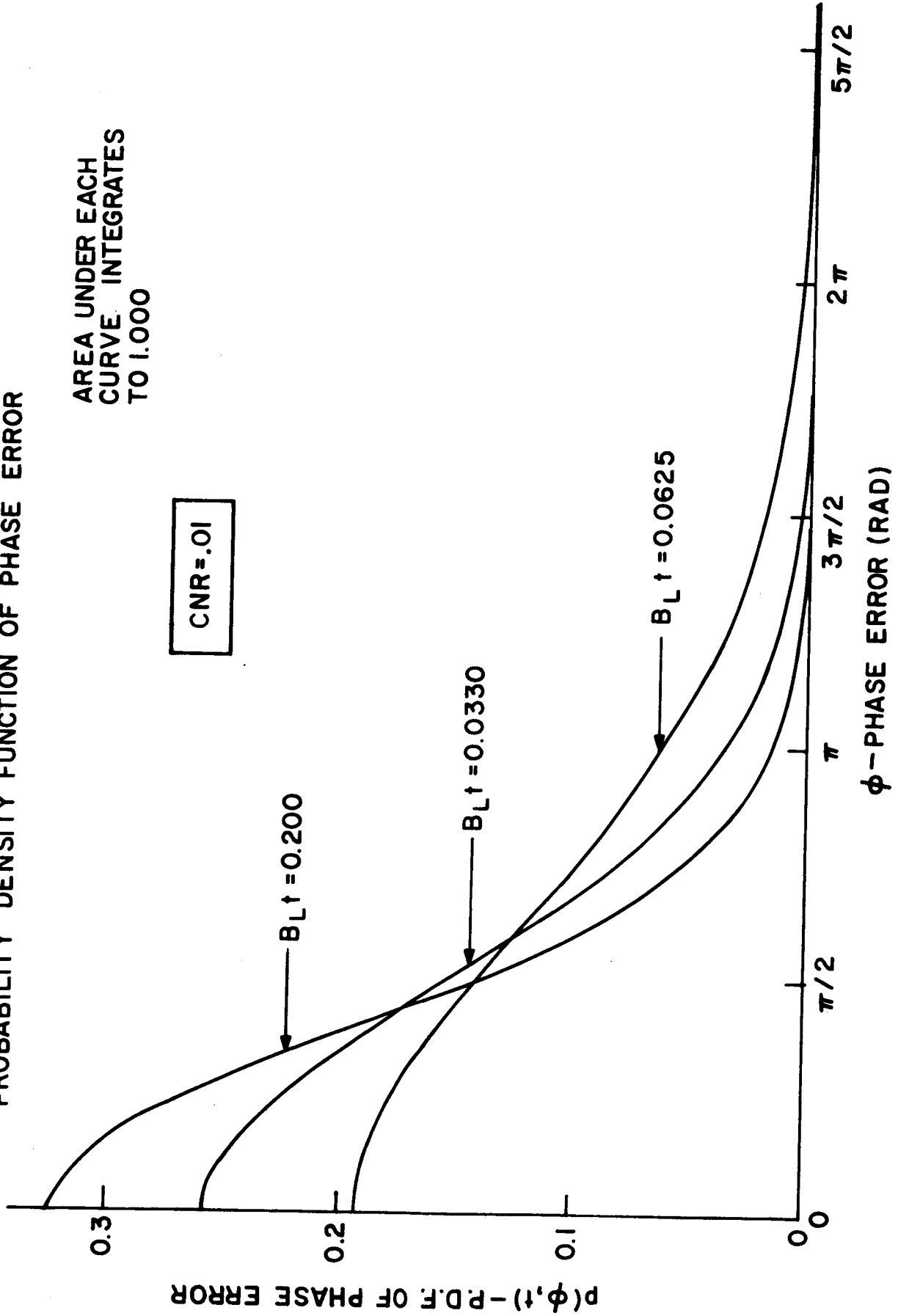

II.3 Probability Density Function of Phase Error CNR = 0.01

PROBABILITY DENSITY FUNCTION OF PHASE ERROR

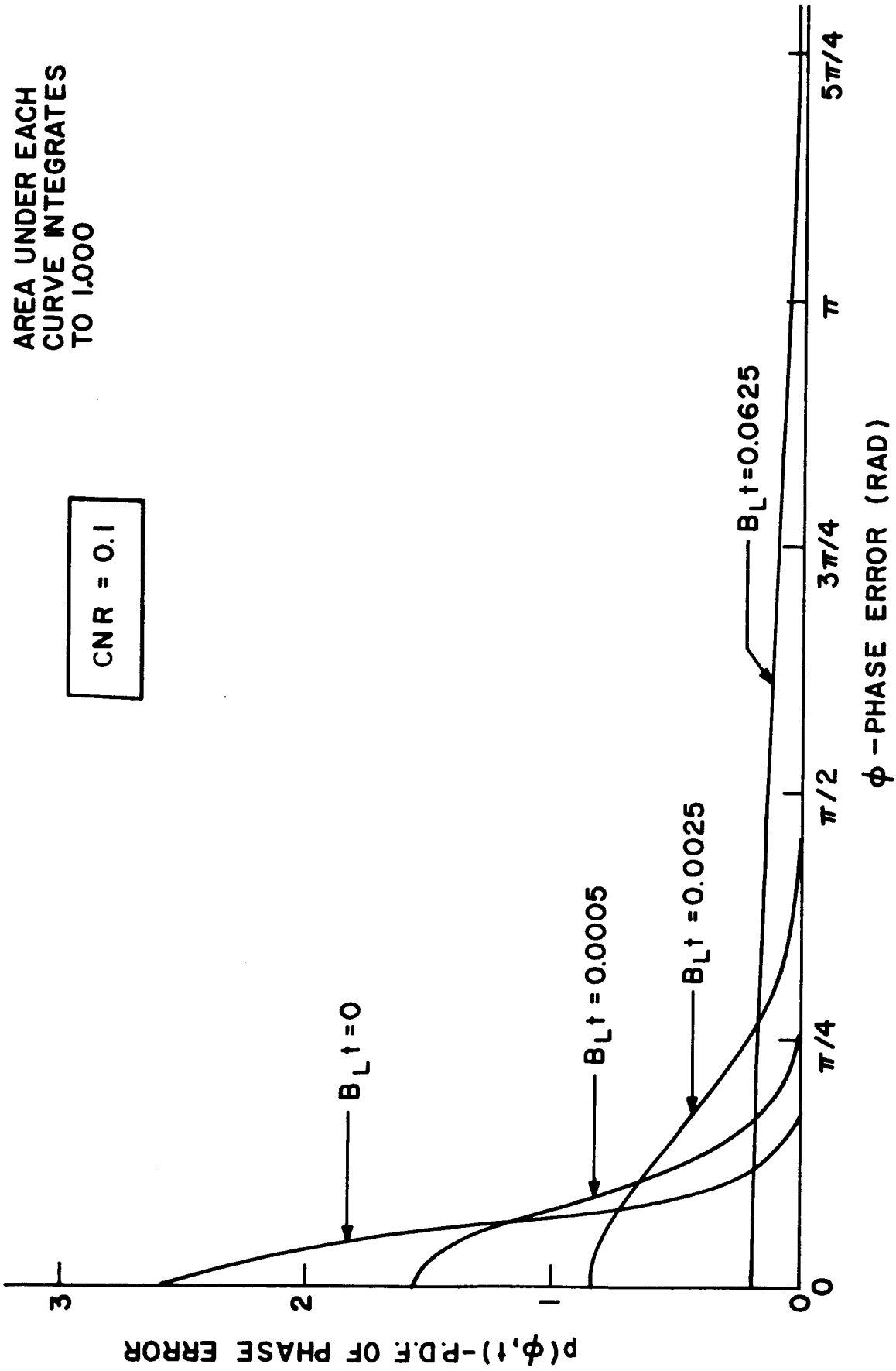

II.4 Probability Density Function of Phase Error CNR = 0.1

PROBABILITY DENSITY FUNCTION OF PHASE ERROR

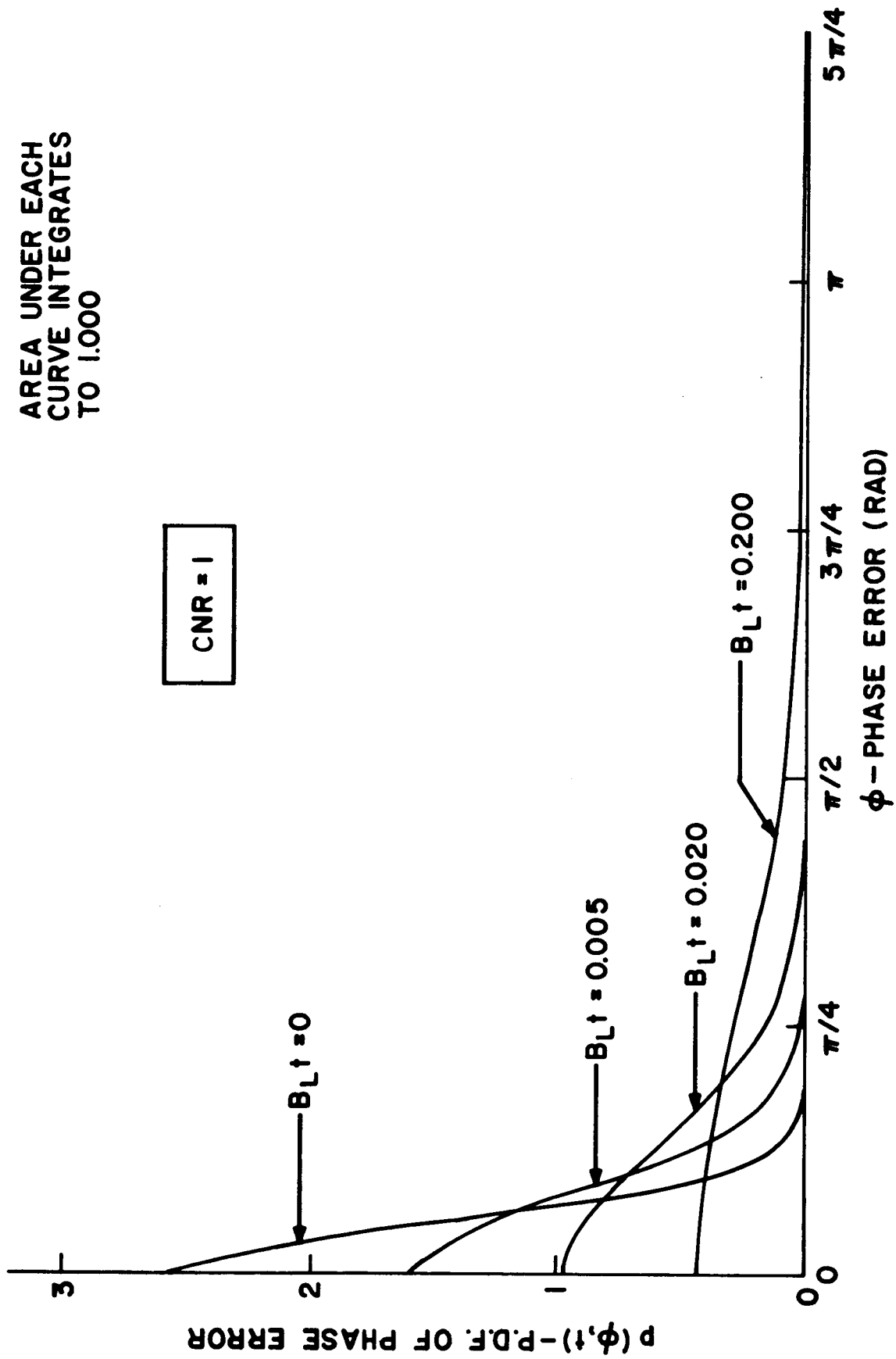

B. The Frequency Locked Loop⁽¹⁾

The Frequency Locked Loop is currently being used in the reception of both analog and digital FM signals that have been transmitted via the PIB water tank simulator.

It has been found experimentally that the normal effect of multipath (in the channel simulator) upon an FM wave is to produce "click-like" disturbances only when the net received signal is very low. Hence, multipath produced "clicks" and low envelope amplitudes tend to occur simultaneously. However, this is exactly the optimum situation as far as click removal or reduction, by a Frequency Locked Loop type of circuit. It is hoped that this circuit will prove useful in extending thresholds in systems operating via fading channels. Detailed work is proceeding in this area. Figure 6 shows a baseband loop with a built in wideband AM detector useable up to 10MHz. Figure 7 shows a "frozen multipath" click disturbance and simultaneous amplitude reduction occurrence. Figure 8 shows dynamic multipath FM clicks produced by transmitting $\beta = 12.5$, $f_m = 2$ KHz, $f_o = 3.9$ MHz, FM via the scatterer.

Reference:

1. K. K. Clarke and D. T. Hess, "The Frequency Locked Loop FM Demodulator" IEEE Transactions on Communication Technology, August 1967.

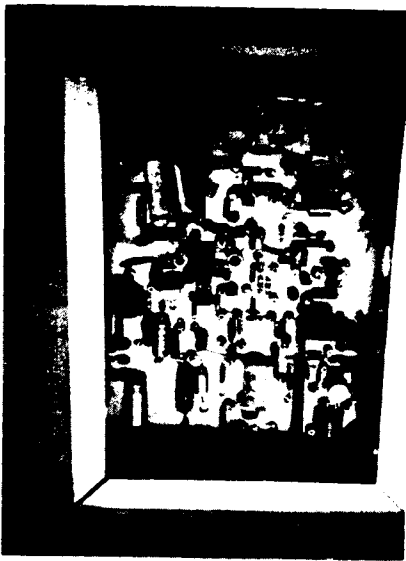

II.6 Baseband version of the frequency locked loop.

II.7 Demodulated sine wave and envelope amplitudes for FM via a "frozen" multipath situation. 2kHz modulation, $\beta=12.5$, 0.5v/cm vertical

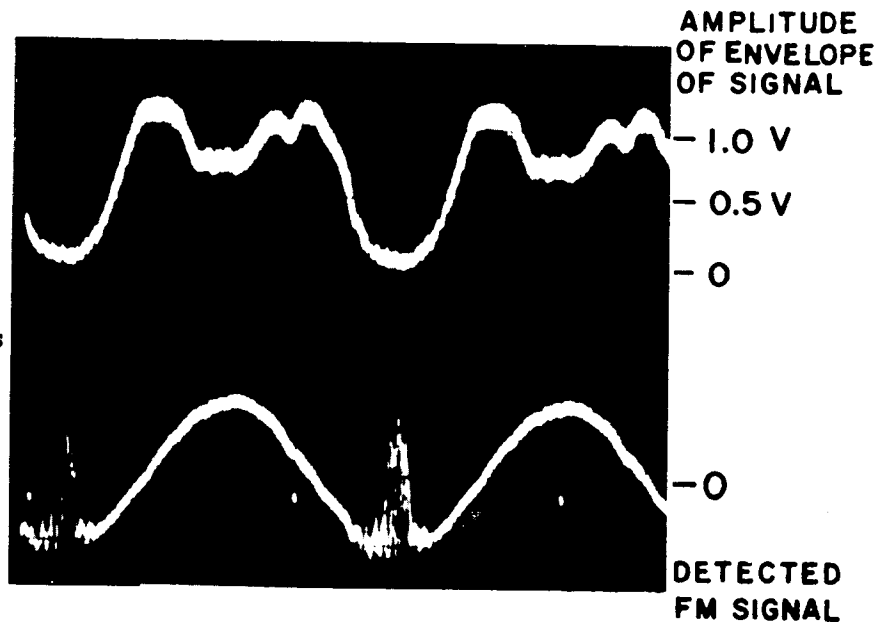

II.8 Demodulated sine wave [multiple exposure] for an FM signal via a fading channel. $\beta=12.5$, 2kHz modulating signal. 0.5 rpm rotation of the multipin scatterer.

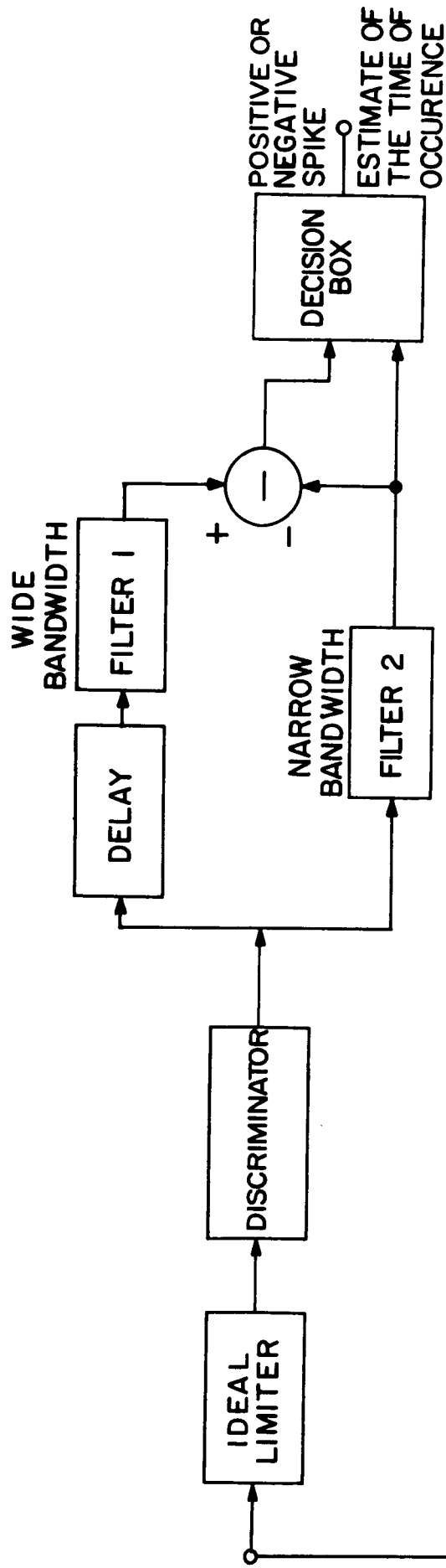

$$\text{INPUT} = A \cos(\omega_c t + \beta \omega_m \int_0^t \sin \omega_m \lambda d\lambda) + n(t)$$

II. 9 Spike Detector and Correcting Circuit

C. Multiple Threshold Spike Detection and Elimination System for Analog FM Signals

In this study Schilling's⁽¹⁾ work on spike detection in an FSK system has been extended to the case of spike detection in an analog FM system. Using a computer simulation of an FM discriminator, sinusoidal modulation ($\beta = 5$) and additive gaussian noise, spikes have been detected and eliminated using the properties of spikes described by Rice⁽²⁾.

The system employed is shown in Fig. 9. The Decision circuit decides whether or not a spike is present. It basis this decision on the observation of the phase of the signal and noise. The circuit determines when this phase exceeds an estimate of the signal by approximately π radians. When a spike is detected, a narrow pulse of area 2π and polarity opposite that of the spike is inserted to cancel the spike (by creating a doublet).

At this time we have been able to eliminate 24 of the 42 spikes present in the computer simulation. This represents a threshold improvement of approximately 2db.

This study is continuing and a non-computerized experimental model is being constructed.

References:

1. D. L. Schilling, E. Nelson, and E. Hoffman, "Error Rates for Digital Signals Demodulated by an FM Discriminator"
IEEE Transactions, ComTech, August 1967.
2. S. O. Rice, "Noise in FM Receivers"
Chapter 25 of Time Series Analysis, edited by Rosenblatt, Wiley, 1963.

III. Detection of Signals in Noise Using Recursive Techniques

The problem of detecting 1 of M known signals in non-white Gaussian noise has been completely reformulated and solved using state variable methods⁽¹⁾. A difference equation is derived for the optimal test statistic. The terms in the difference equation are given directly in terms of the description of the noise. These results being in recursive form, significantly reduces the computational effort for detecting signals from discrete samples. For example, the highest order matrix inversion necessary depends only on the number of poles in the filter from which the noise is generated and not on the number of samples that are used. Furthermore, the memory requirements are independent of the number of samples since the single, most recently calculated test statistic contains all the necessary information about all the previous data.

In the analog processing of signals, an explicit expression is derived without any need to solve integral equations. The signal-to-noise ratio is calculated explicitly for both stationary and non-stationary noise. Thus, it is now possible to calculate the probability of error directly for any noise and also to use the results to observe the effects of deviations from the assumed filter characteristics. Examples have been worked out and will be presented in the final report.

Reference:

1. R. L. Pickholtz and R. R. Boorstyn - "A Recursive Approach to Signal Detection"
Paper accepted for Information Theory Symposium, Athens, Greece, 1967.

IV. PIB Water Tank Channel Simulator

The basic advance that has been made with the channel simulator during this reporting period is a change in the reflecting medium. For most purposes it has been found to be advantageous to replace the "air bubble cloud" with a pattern of reflectors that is rotated at a particular speed.

Figure 1 shows the basic configuration. Two receiving antennas are shown in position for possible diversity reception. A scattering set is mounted on a keyed shaft driven by a multi-speed motor. Thus a given combination of scatterers may be driven at speeds of 20 rpm, 10 rpm, 5 rpm, etc., down to $(1/25.4)$ rpm. Since the pattern of the array determines the type and duration of the multipath while the speed determines the "fading rate" one has completely separated the fading rate and probability density specifications. Figures 2-4 indicate variation of fading rate with speed of rotation.

Figures 5-7 show several sets of scatterers and the motor and drive unit. They also indicate a representative envelope variation for the particular arrays.

Figure 8 indicates probability density measurements for a channel at two different speeds indicating the independence of speed and probability density.

Figure 9 shows pulse dispersion results for a 4.4 sec pulse transmitted via the array of Fig. 5. Figure 10c shows diversity reception of a single pulse transmitted to two antennas separated by more than 100λ .

In addition to the flexibility allowed by the independence of fading rate and the type of fading one has the further great advantage that the channel may be "frozen" in any particular multipath situation. For example, in FM studies one may "stop" the channel in a position such that "click" producing multipath is occurring so that the phenomena may be examined on essentially a "Static" basis instead of on the normal random occurrence basis.

Studies that are currently underway utilize the channel simulator to study the transmission of binary and analog FM signals, and of the transmission, reception and error examination of digital diversity systems for both AM and FSK. Other projects that are in the active planning stage are considered under "New Projects."

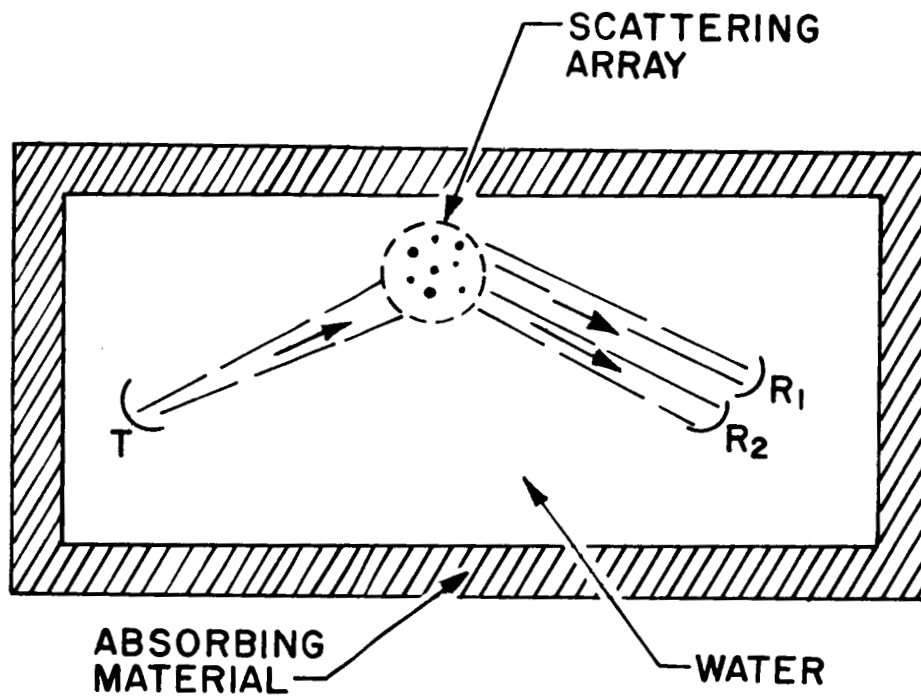

IV.1 Top view of water tank channel simulator

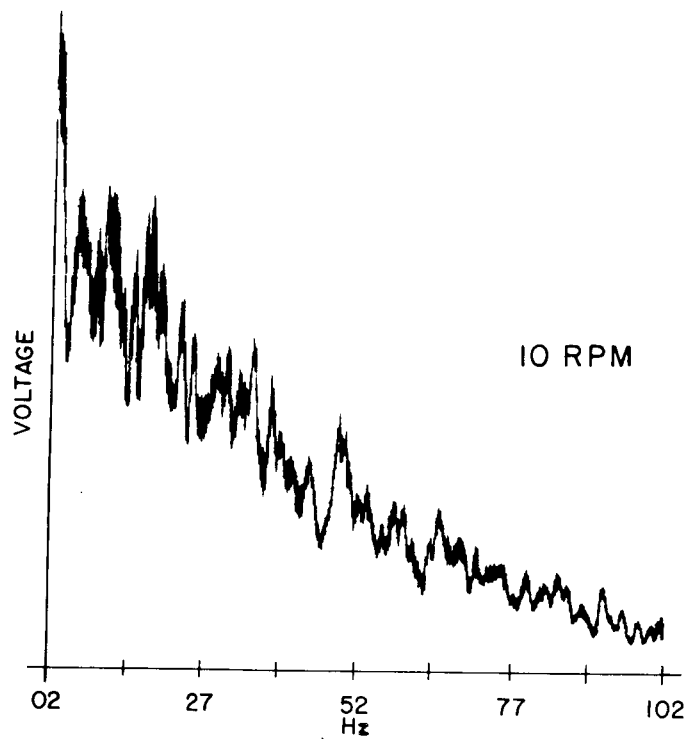

IV.2 Voltage Spectrum of the Envelope of 3.9 MHz carrier [2.5v pp] transmitted via scattering array of Fig. 5. Measured with Quantech 304 Wave Analyzer.

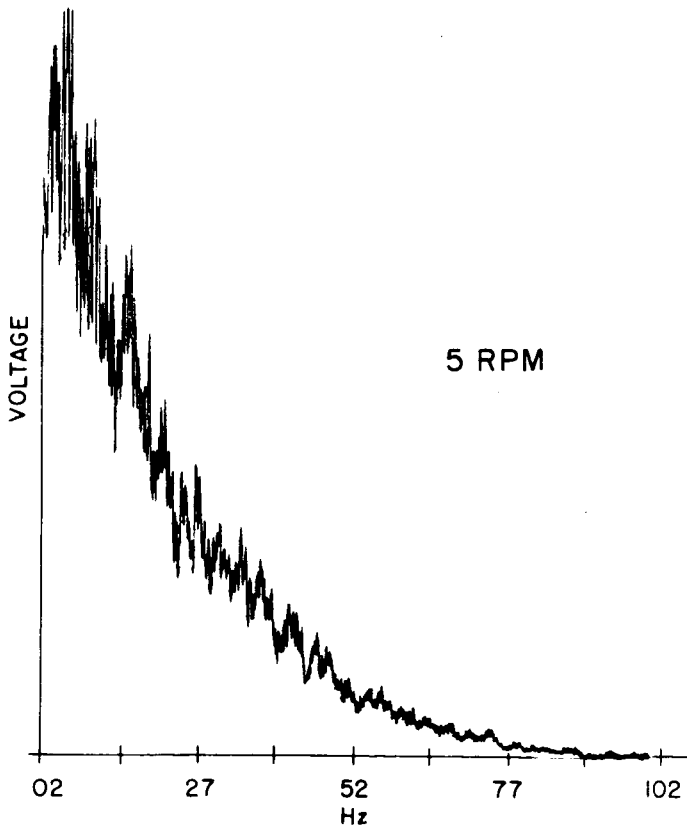

IV.3 Voltage Spectrum of the Envelope of 3.9 MHz carrier 2.5v pp transmitted via scattering array of Fig. 5. Measured with Quantech 304 Wave Analyzer.

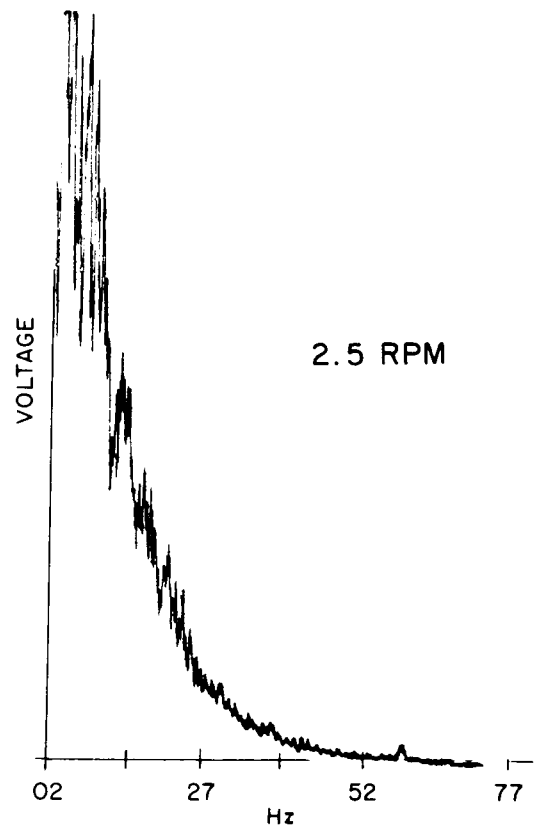

IV.4 Voltage Spectrum of the Envelope of 3.9 MHz carrier 2.5v pp transmitted via scattering array of Fig. 5. Measured with Quantech 304 Wave Analyzer.

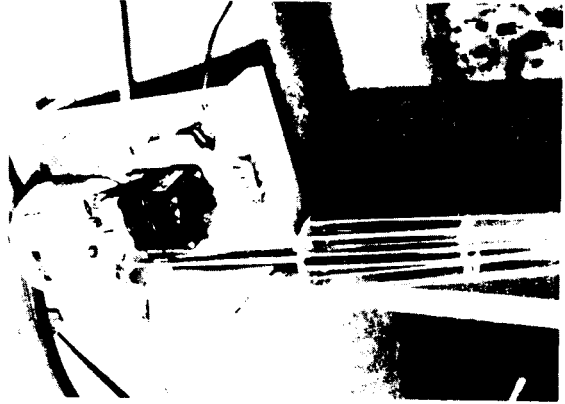
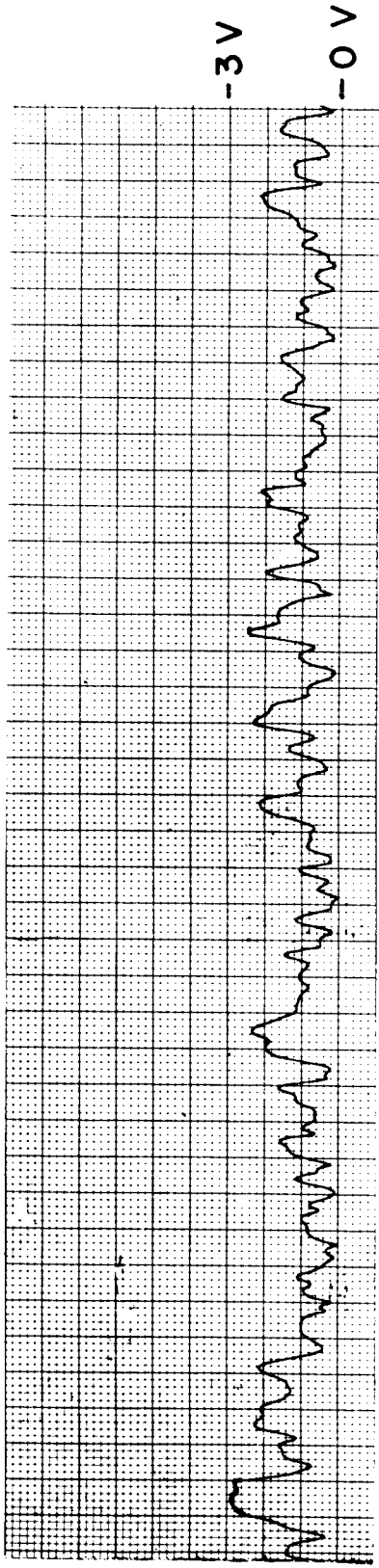

IV.5 Motor, multipin array and chart recordings of the envelopes of simultaneous diversity reception of two 3.9 MHz signals transmitted via this array rotation. 100mm/sec chart 5 RPM speed Rayleigh Fading.

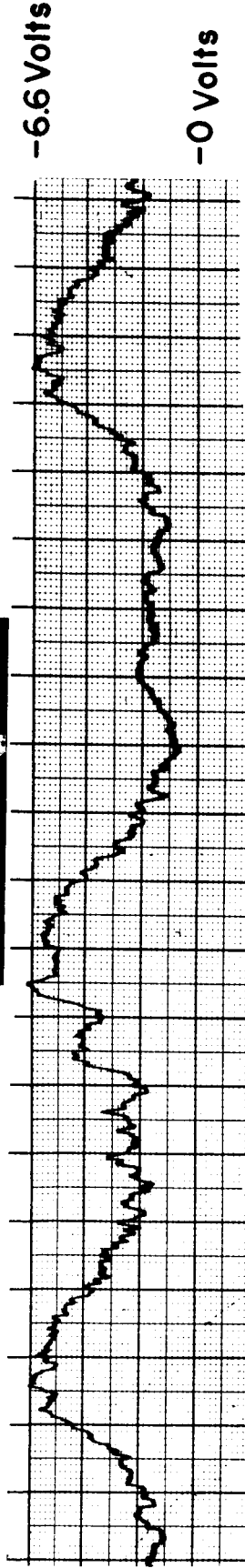
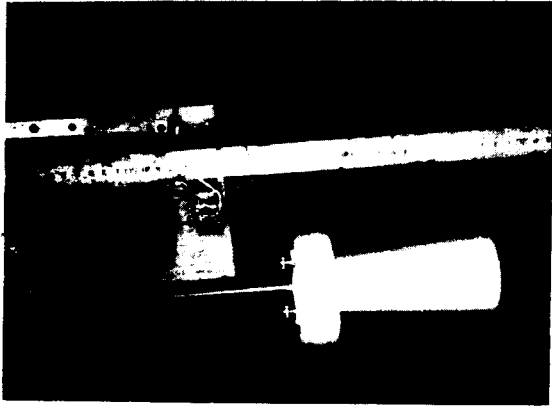
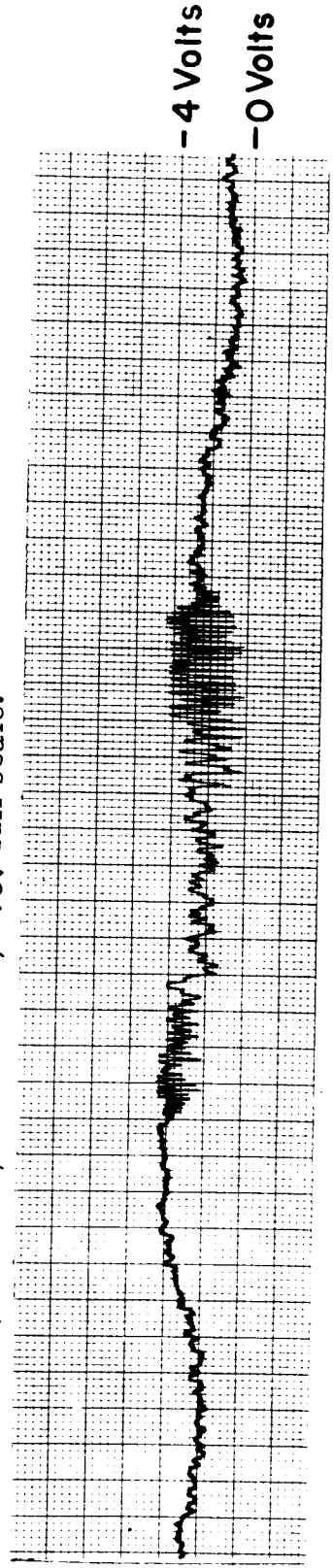
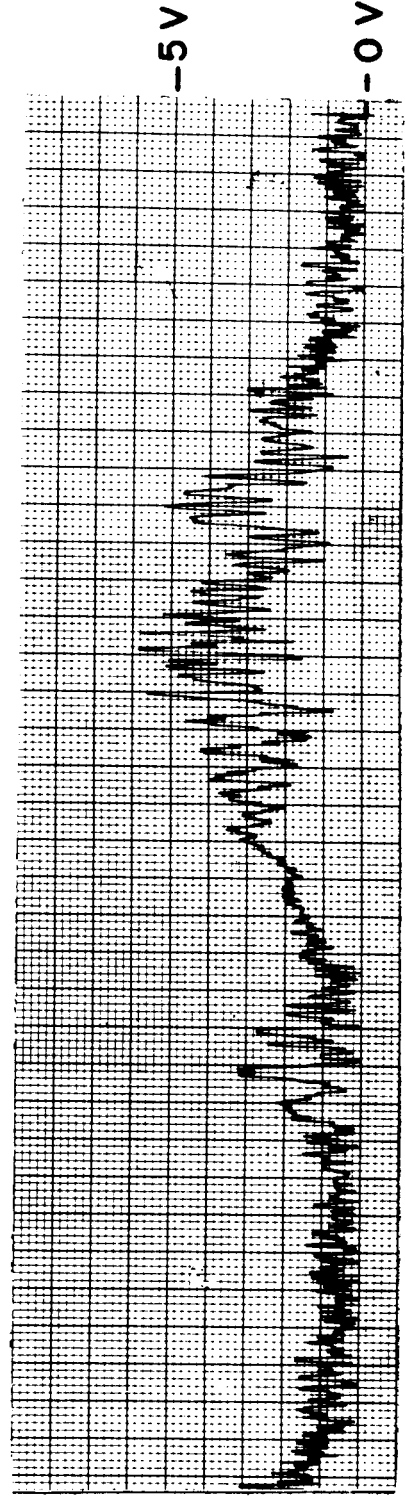
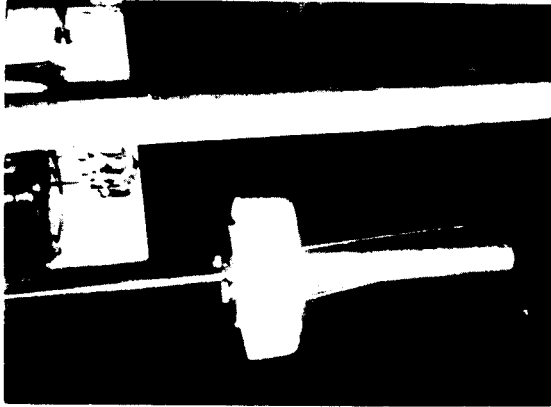

Fig. 6a "Slow" Fading Array and signal via this array.
5mm/sec. 2 RPM, 6.6v full scale.



IV.6 "Slow Fading with aeroplane across the path." Array of Fig.6a
with single additional scatterer.



IV.7 Combination of fast and slow fading. Array and diversity reception signals.

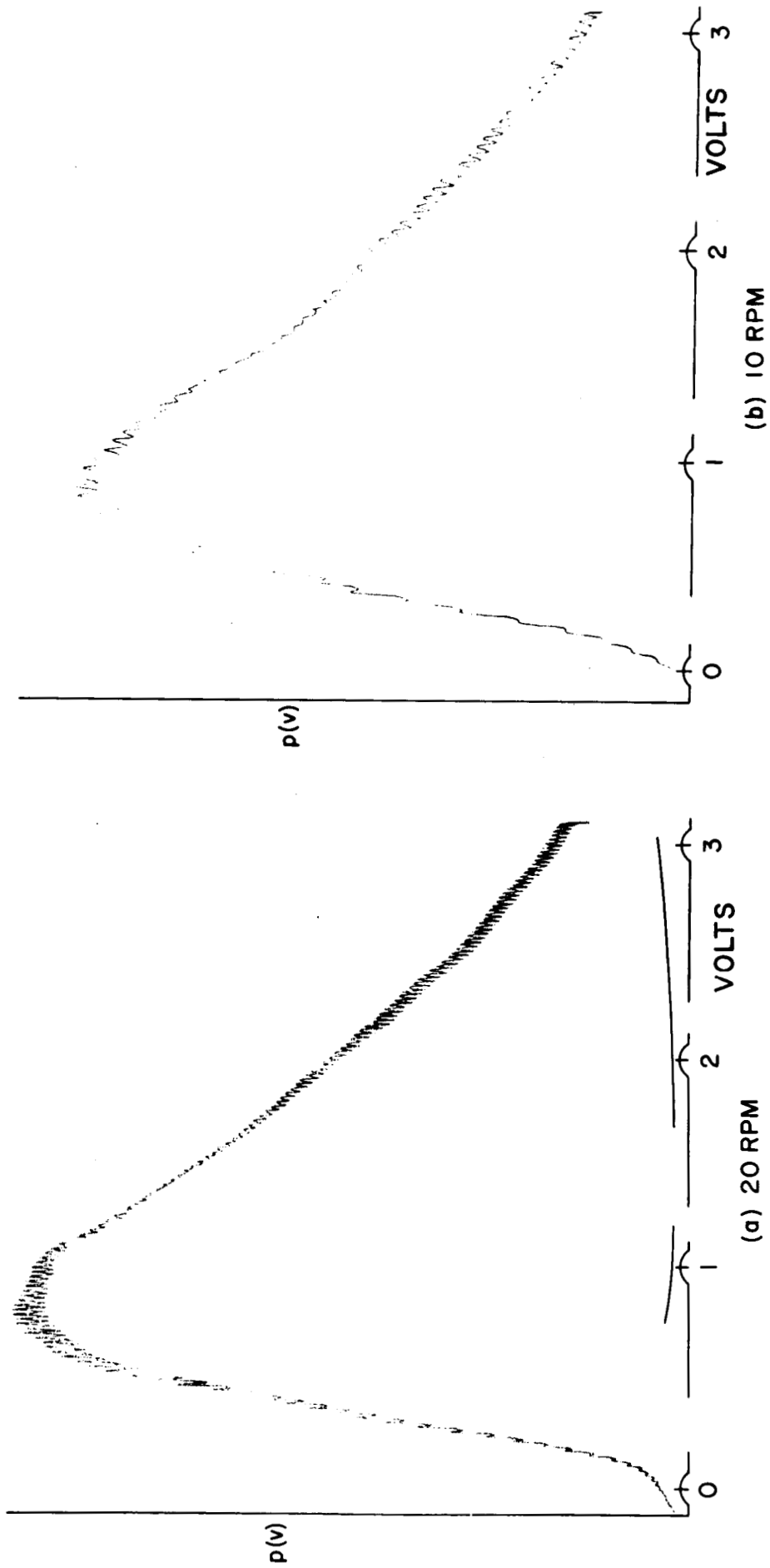

IV.8 Probability density vs voltage for the envelope of a 4 MHz carrier transmitted via the scattering arrangement of Figure 5.

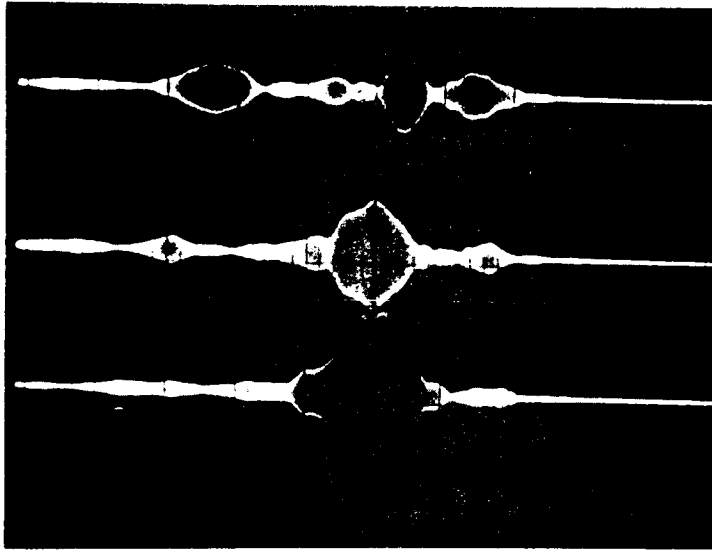

(a) Single channel

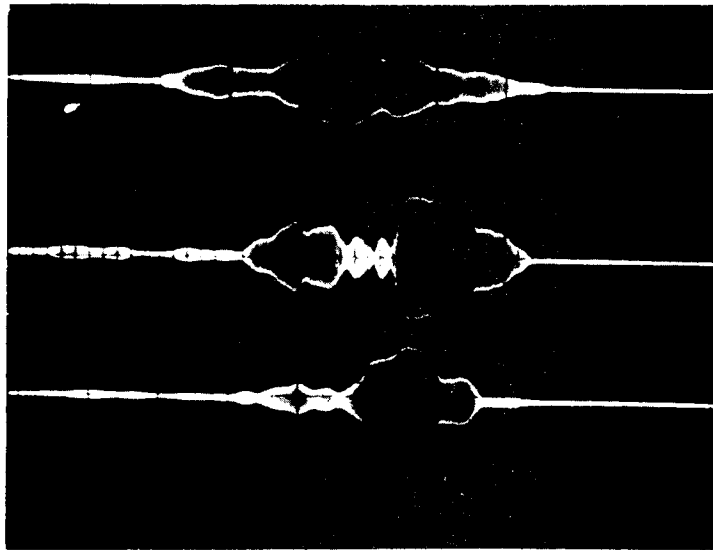

(b) Single channel

← TIME

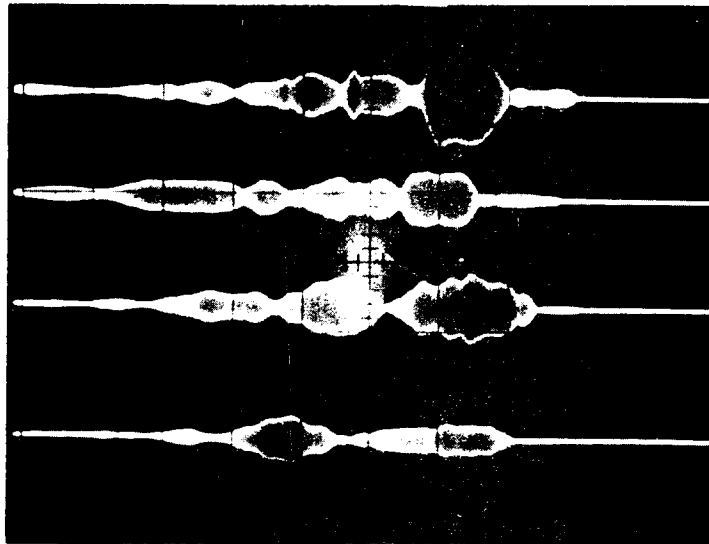

LEFT }
 RIGHT }
 LEFT }
 RIGHT }

(c) Diversity

IV.9 Pulse dispersion for 4 μ sec bursts of 4 MHz signal transmitted via the array of figure 5. 4 μ sec/cm horizontally. 0.5v/cm vertically.

V. Synchronization Problems⁽¹⁻⁹⁾

This section is more elaborate than the other sections as it includes a short report on PSK synchronization techniques.

Advantage of PSK

Binary phase-shift keyed (PSK) communication systems have received much attention because their "anticorrelated" signal waveforms yield a 3db power saving over comparable orthogonal systems. The optimum PSK demodulator (Fig.1) uses a reference signal with perfect phase coherence; such a reference is unavailable in practical systems due to oscillator phase jitter, doppler, random variation of channel propagation delay, etc. Often, however, substitution of a noisy or imperfect reference signal obtained by some phase estimation technique will yield a probability of error $P(E)$ very near that of the ideal system.

Practical Systems

We have shown that the detector of Fig.1 remains optimum (minimum $P(E)$) under the following very general conditions on the probability density of the phase error $\phi = \theta - \hat{\theta}$ (assumed to be constant during each band).

- 1) symmetry: $f(-\theta) = f(\theta)$
- 2) decreasing: $f(\theta_1) \leq f(\theta_2)$ for $|\theta_1| > |\theta_2|$

Therefore, the emphasis in the study of PSK systems is placed on securing "good" estimates of the phase θ and evaluating the performance of the PSK detector (Fig.1) using these estimates.

The PSK systems of interest fall into two categories: single channel, and transmitted reference. The single channel systems derive their phase estimate directly from the keyed PSK signal, while the transmitted reference systems estimate the phase from a reference signal transmitted separately from the keyed signal.

The following are popular single channel systems (Figs.2-5):

- 1) Differential PSK (D-PSK)
- 2) Decision Directed Measurement PSK (DDM-PSK)
- 3) Harmonic Tracking (Squaring) PSK (HY-PSK)
- 4) Costas Synchrolink PSK (CS-PSK)

The major advantage of these systems is that the entire transmitter power is used for both information transmission and synchronization. Their common disadvantage is mark-space ambiguity; i.e., the demodulator is sensitive only to phase differences and not to absolute phases. Consequently, the derived reference signal can be out of phase by π radians, which results in a reversal of the output data stream and a $P(E)$ near 1. In some cases this problem can be solved by differential data encoding, but if the phase reversal occurs at a significant rate with respect to the data rate the degradation in $P(E)$ becomes appreciable.

Two popular transmitted reference systems are (Figs.6,7):

- 1) Adjacent Tone PSK (AT-PSK)
- 2) Quadrature Reference PSK (QR-PSK)

These systems are theoretically equivalent, but QR-PSK is immune to many of the practical problems which beset AT-PSK. AT-PSK and QR-PSK do not suffer from mark-space ambiguity, but they do have the disadvantage that a certain fraction of the total transmitter power must be reserved for transmission of the reference signal only, reducing the power available for the information-bearing signal. Also, the optimum power split between the reference and keyed signals depends on the received signal-to-noise ratio (SNR) and other parameters which are generally unknown at the transmitter. The operational details of the systems mentioned above are described in the references.

Comparison of Previous Analyses

Two basically different approaches, which we shall call the ideal and the practical, have been used to analyze the PSK problem. In the ideal approach, one proposes some criterion of optimality for the angle estimate (e.g. maximum likelihood or least mean square error) and proceeds to derive the system configuration and obtain its performance. Although these ideal systems are often difficult or impossible to implement, their performance may be used to rate the performance of sub-optimum demodulators. In the practical approach one chooses a system configuration which is known to be realizable and have good performance (e.g., the phase locked loop (PLL)), analyzes its operation and optimizes the relevant parameters. Even in the practical approach, many

assumptions and idealizations are made. The phase is assumed to be approximately constant over q bauds, or the systems are linearized, or an approximate probability density is used for the phase error, and the cycle-slipping phenomenon of the PLL is ignored.

Figures 8 and 9 compare the results of various authors. $P(E)$ is plotted as a function of q for input SNR's of $E/N_o = 5\text{db}$ and 10db . Optimum power split is assumed for transmitted reference systems. $B_L T = \frac{1}{q}$ has been chosen (rather arbitrarily) as the basis of comparison of the ideal and practical systems ($B_L = \text{PLL noise bandwidth}$).

Because of the varied assumptions made by the authors in their calculations, the comparisons are not exact. They do indicate that the ideal systems are superior to their practical counterparts. Also, single channel systems are consistently superior to transmitted reference systems. The omission of the mark-space ambiguity problem, however, casts serious doubt on this last result.

A More Realistic and Reliable Analysis

Corresponding Ideal and Practical Systems: In order to provide a reliable estimate of the degradation experienced by a practical system, corresponding ideal and practical systems of various types are being studied with similar simplifying assumptions. The value of PLL's in these systems will be evaluated by considering the additional performance degradation occurring when simple bandpass filters (perhaps followed by limiters) are substituted.

Effect of Phase Variations: Optimum estimators for time-varying phase angles will be derived in order to find the best weighting coefficients for previous bauds and an equivalent q for these more realistic cases. A maximum likelihood estimator for phase in terms of two adjacent bauds with correlated but unequal phases has been derived and is shown in Fig.10. The performance of this and certain sub-optimum estimators which it suggests is being evaluated using Monte Carlo methods on a digital computer. The phase angle model is being modified so that the analysis can be extended to n bauds, and so that the optimum estimator can be synthesized as an open-loop system.

Reference Signal Reversal: Analyses to date have neglected the mark-space ambiguity problem in single channel PSK systems. The problem is important in space applications, where the received SNR's are small and the bit rates are very low. It is clear that for very low bit rates the phase cannot be considered constant even over one baud, and the behavior of the PLL with time is important. The quasi-linear and "click" characteristics of the PLL will be studied separately, and their effect on P(E) assessed.

System Comparison and Development: The various systems are being analyzed under similar assumptions, leading to a clearer comparison between systems. A preliminary investigation shows that HT-PSK and CS-PSK give equivalent results at high SNR; this investigation is being pursued further. VanTrees has examined a hybrid system employing both AT-PSK and HT-PSK, and has found that HT-PSK alone should be used to minimize P(E). He neglected the cycle-slipping of the PLL. It is expected that in many cases of interest for space communications the cycle-slipping problem cannot be ignored, and that when it is considered a different conclusion will be reached, and a hybrid system found to be optimum.

REFERENCES

1. H. D. Becker and J. G. Lawton, "Theoretical Comparison of Binary Data Transmission Systems," Cornell Aeronautical Laboratory Rept. CA-1172-S-1, May 1958.
2. J. J. Busgang and M. Leiter, "Phase Shift Keying with a Transmitted Reference," IEEE Trans. COM, Feb. 1966, pp. 14-22.
3. S. S. L. Chang and B. Harris, "An Optimum Self-Synchronized Communication System," Communication and Electronics, May 1962, pp. 1-7.
4. J. P. Costas, "Synchronous Communications" Proc. IRE, Dec. 1956, pp. 1713-1718.
5. W. C. Lindsey, "Phase-Shift-Keyed Signal Detection with Noisy Reference Signals," IEEE Trans. AES, July 1966, pp. 393-401.
6. J. G. Proakis, P. R. Drouilhet and R. Price, "Performance of Coherent Detection Systems Using Decision-Directed Channel Measurement," IEEE Trans. CS, March 1964, pp. 54-63.
7. J. J. Stiffler, "On the Allocation of Power in a Synchronous Binary FSK Communication System," Proc. Nat'l. Telemetry Conf., June 2-3, 1964, paper 5-1, 11 pp.
8. H. L. VanTrees, "Optimum Power Division in Coherent Communication Systems," IEEE Trans. SET, March 1964, pp. 1-9.
9. A. J. Viterbi, "Optimum Detection and Signal Selection for Partially Coherent Binary Communication," IEEE Trans. IT, April 1965, pp. 239-246.

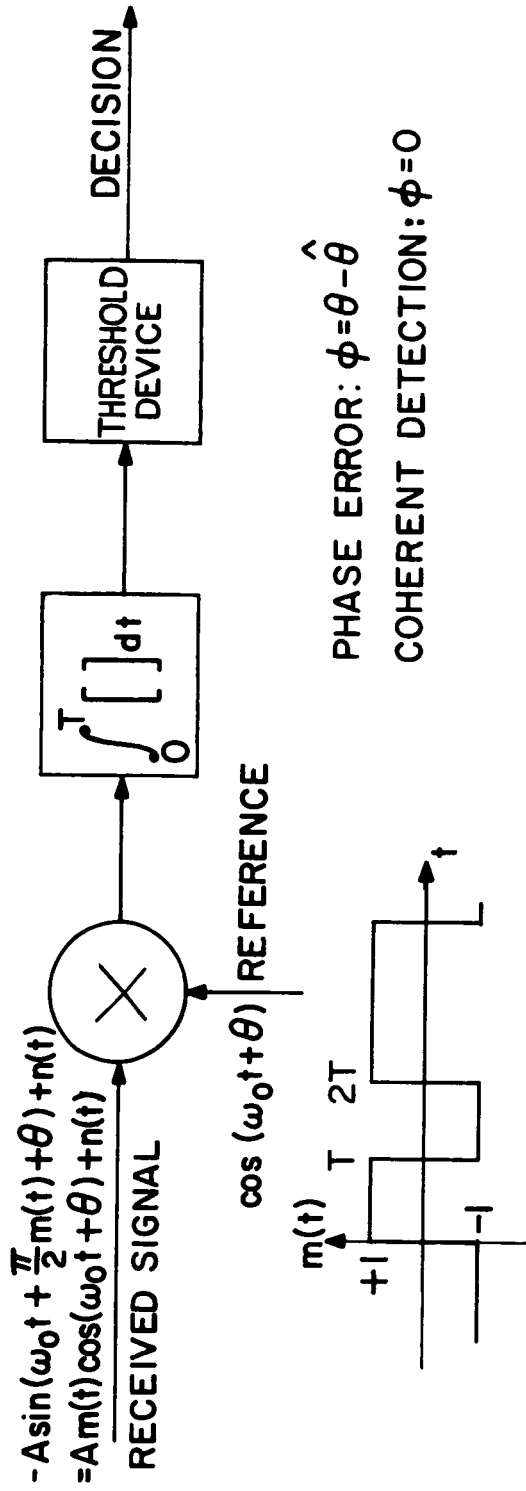
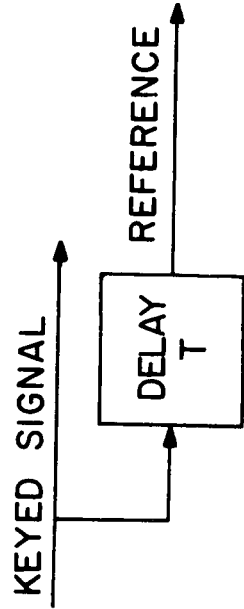
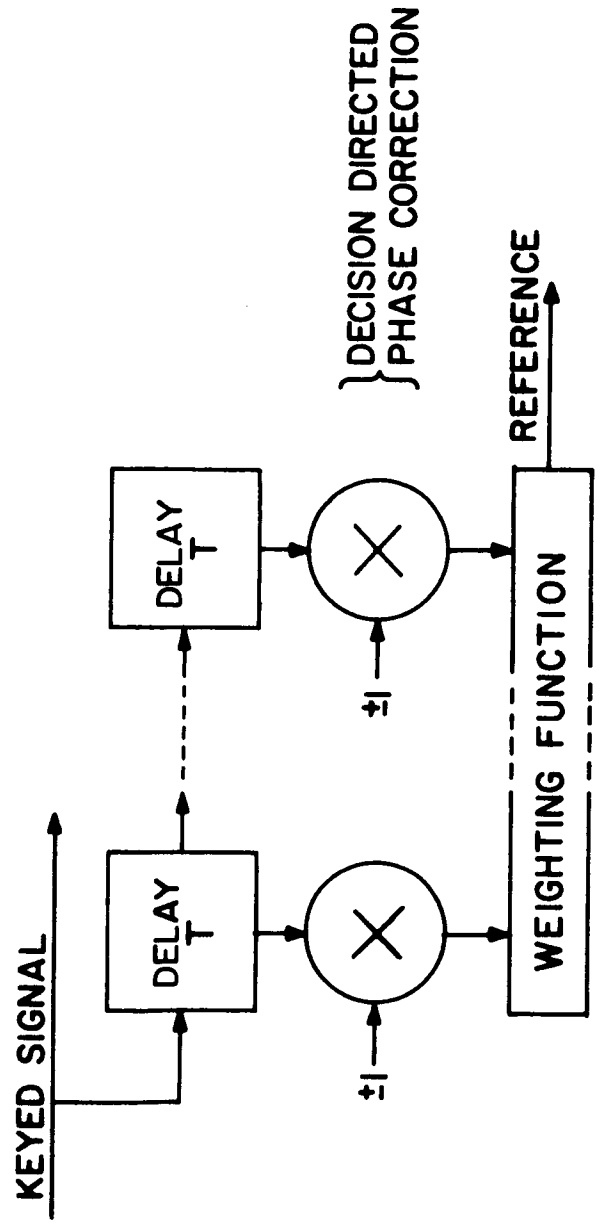

Fig. V.1 Optimum binary PSK demodulator



NOTE: DIFFERENTIAL DATA
ENCODING IS USED



V.3 Decision Directed Measurement PSK

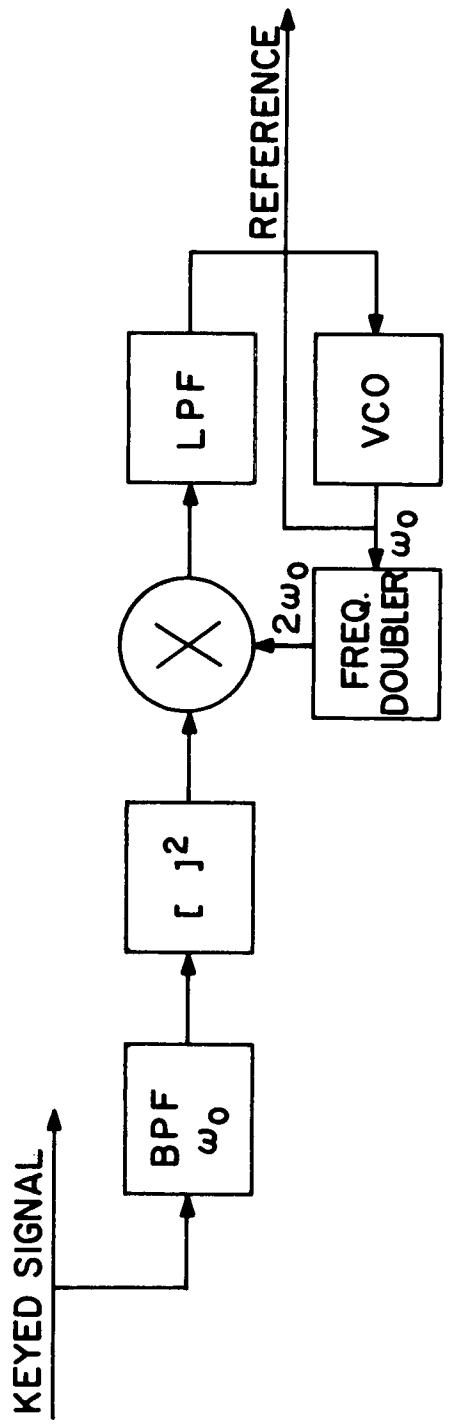
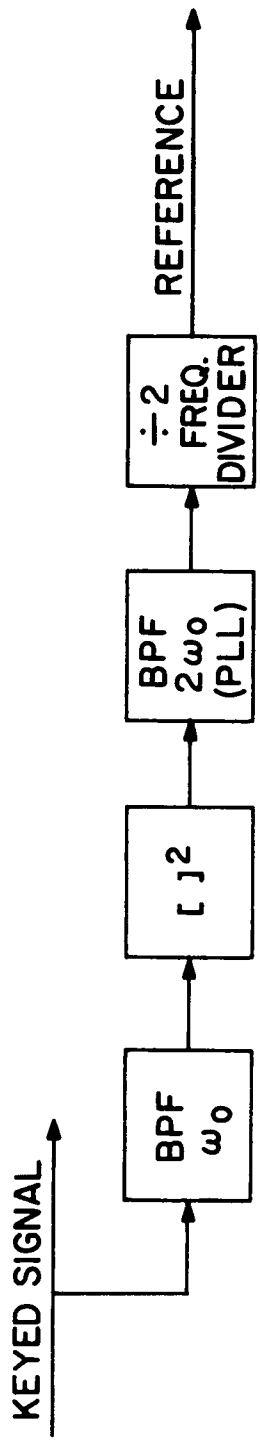

V.4 Two Harmonic Tracking PSK Systems

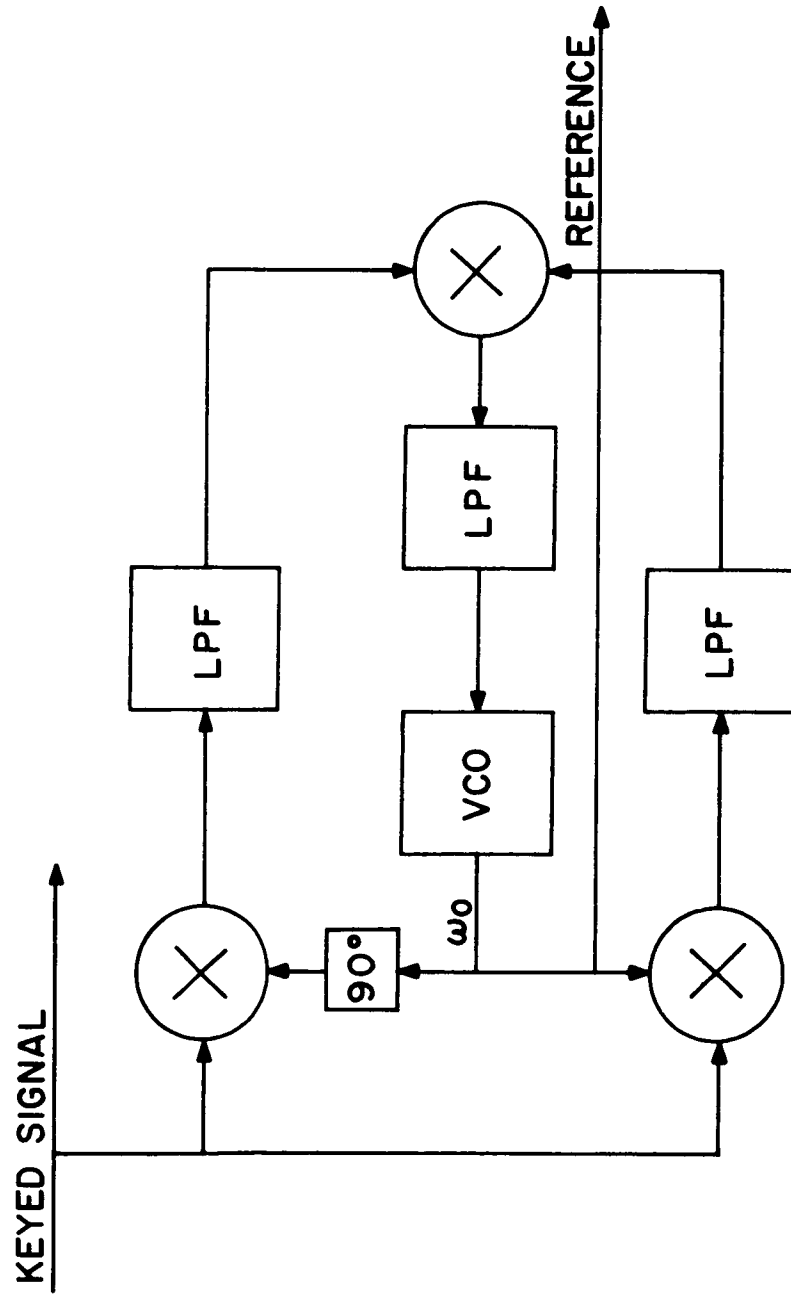

V.5 Costas Synchrolock PSK

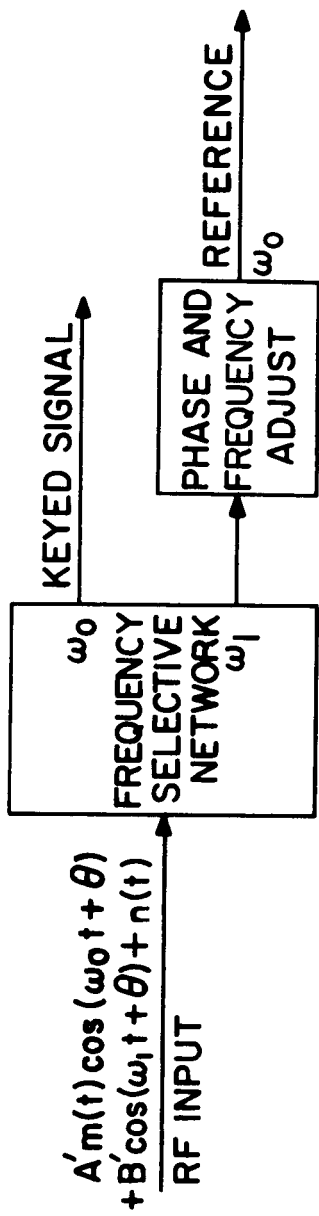

V.6 Adjacent Tone PSK

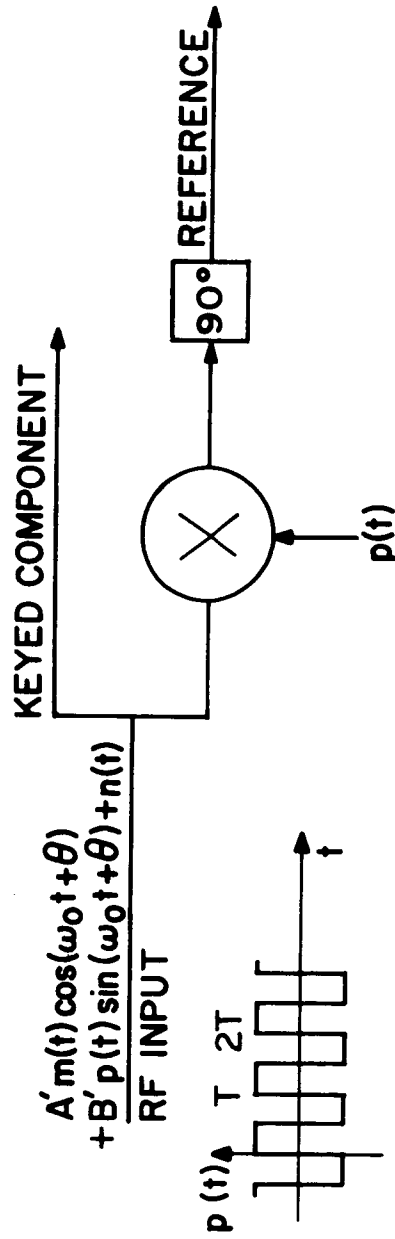

NOTE: CONTAMINATING COMPONENTS DUE TO QUADRATURE TERMS AVERAGE TO ZERO IN EVERY BAUD INTERVAL

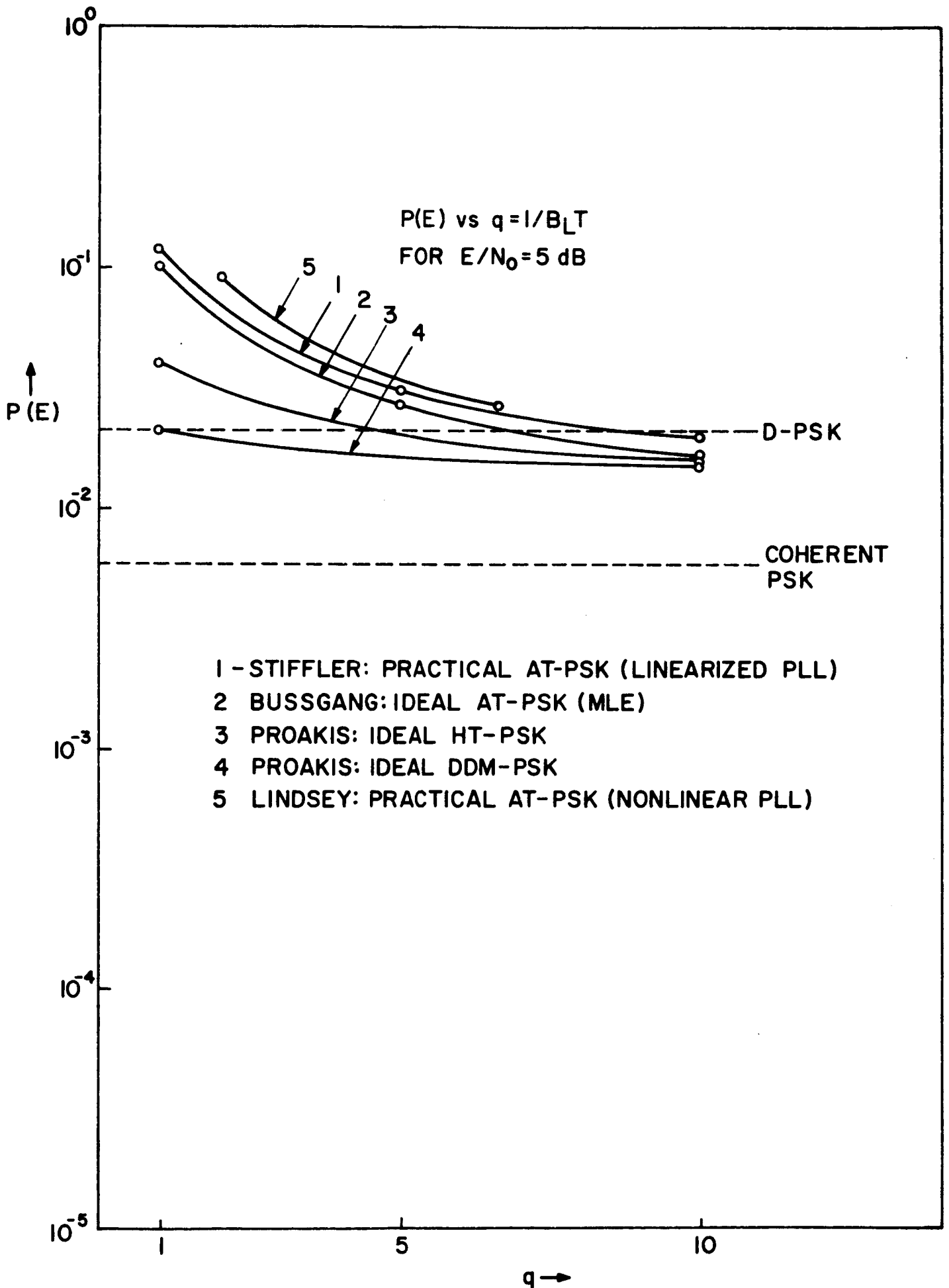

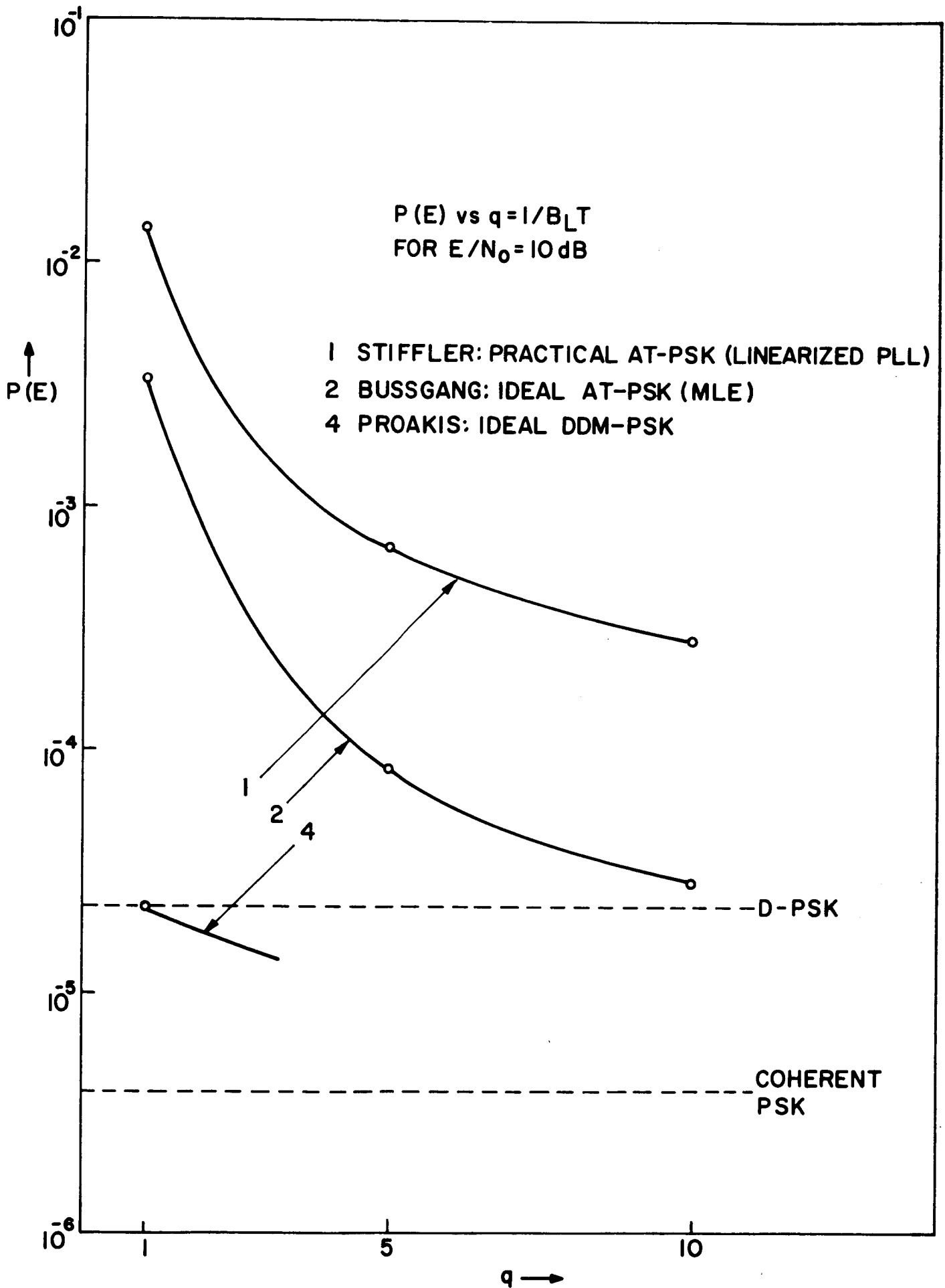

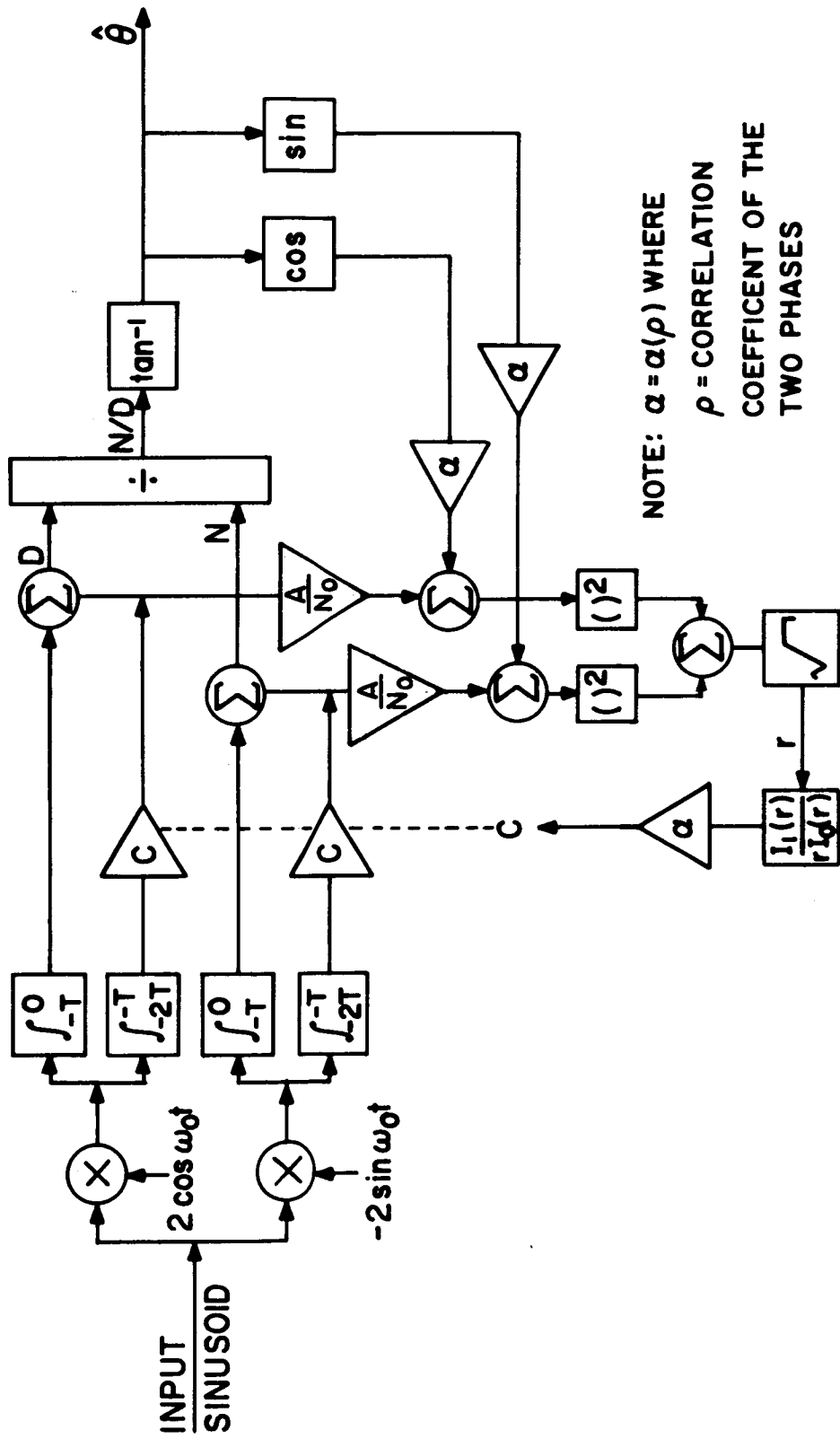

V.10 A Maximum Likelihood Phase Estimator using two Bauds

New Projects

1. Research will continue to determine the threshold extension capability of the Maximum Likelihood Estimator and the Least Mean Square (Bayes) Estimator. Realizable forms of these estimators will be constructed and tested to determine the threshold extension possible.

2. The threshold of the PLL will be determined for the first, second and higher order systems. The optimum filter and phase detector will be found. The characteristics of the FMFB will be determined. During the next year the phase locked loop problem will be completely solved.

Spike Detection and correction systems will be constructed and tested. These schemes are capable of extending the PLL threshold several db.

3. Synchronization techniques will include the effect of cycle slipping on the error rate of a transmitted PSK signal. In addition, the phase variation during a baud will be considered. This is a very important problem since in deep space communications the bit rate is extremely slow and phase jitter occurs within a bit.

4. The channel simulator will be used to test several receiving systems. Television transmitted using FM will be studied in detail.

(a) A 100 line flying spot scanner is being completed so that very shortly a 20 KHz video system will be available for transmission via the channel simulator. Initially this transmission will be via FM. The use of the frequency locked loop⁽¹⁾ as detector for such signals will be examined. It is believed that this circuit's "spike" reduction properties will prove valuable in extending the useful threshold for the transmission of video via fading channels.

(b) Arrangements are in progress to allow the transmission of Prof. Deutsch's 200 KHz random scan TV system⁽²⁾ via the channel simulator. Again the use of the FLL as a detector will be compared with other more conventional reception methods.

(c) The difference between the effects of a fading channel upon video transmitted via the conventional raster from (a) and the random scan raster of (b) will be investigated experimentally.

(d) A 4 MHz RF version of the frequency locked loop is being designed and constructed. When it is completed both RF and baseband versions will be run in parallel and an attempt made to determine the practical advantages of each. (Theoretically their performance should be identical).

(e) A baseband version of the frequency locked loop with binary rather than analog multiplication of the $\dot{a}(t)$ signal is under construction. It appears intuitively that this binary version may offer some gain in error reduction in certain ranges of input C/N ratios.

5. A study is in progress to determine the analog threshold effects in Pulse Code Modulation systems. The effects of binary or M-ary decision errors on the mean square error of the demodulated signals has been determined for the additive gaussian noise channel and is being investigated for an FM channel. An analog-digital converter is being constructed with integrated circuitry to accommodate 20KHz analog signals with 5 bit PCM. This encoder will be used to experimentally confirm the theoretical results. The possibilities of threshold extension for demodulation will be explored together with the potentialities of a feedback channel for improving the overall performance. Work in both areas are in progress.

6. The effects of random FM multipath on the distortion of signals is being studied. Experimental work is in progress.

(1) K. K. Clarke and D. T. Hess, "The Frequency Locked Loop FM Demodulator" IEEE Transactions on Communications Technology, August 1967 - An early version of this paper is included as section III B of the final report, 15 September 1965 - 15 September 1966 prepared for NASA, ERC, under NASA Grant NGR 33-006-020.

(2) Sid Deutsch, "Pseudo-Random Dot Scan Television Systems" - IEEE Transactions on Broadcasting, Vol. BC 11, July 1965, pp. 11-21.

Papers Published

Papers scheduled for publication during this grant period are listed below. Conference papers are not listed. A complete listing of all papers, including Theses and Dissertations will be published with the final report.

1. D. L. Schilling and M. Smirlock, "Intermodulation Distortion in a Phase Locked Loop Demodulator," IEEE Trans. on ComTech, April 1967.
2. D. L. Schilling, E. Nelson, K. K. Clarke, "The Response of an FM Discriminator to an Analog FM Signal in Randomly Fading Channels," IEEE Trans. on ComTech, April 1967.
3. D. L. Schilling, E. Hoffman, E. Nelson, "Error Rates for Digital Signals Demodulated by an FM Discriminator," IEEE Trans. on ComTech, August 1967.
4. K. K. Clarke and D. T. Hess, "The Frequency Locked Loop FM Demodulator," IEEE Trans. on ComTech, August 1967.

Graduate Student Support

The following number of students are being partially supported under this
NASA Grant:

Masters Students - 20

Doctoral " - 10