



FOR RELEASE: THURSDAY A.M.
November 2, 1967

RELEASE NO: 67-275

N67-40589

PROJECT: APOLLO 4
(To be launched no earlier than Nov. 7)

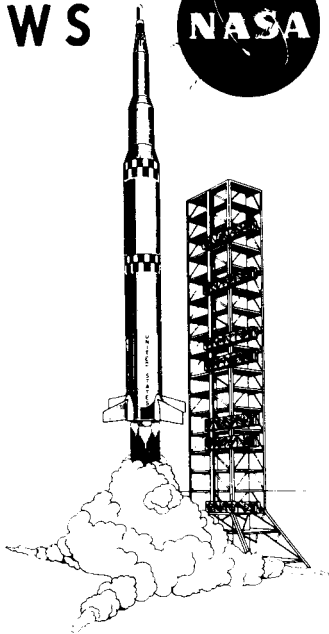

P
R
E
S
S

K
I
T

contents

84
pages *0*
Code

GENERAL RELEASE-----	1-5
SATURN V LAUNCH VEHICLE-----	6-11
VEHICLE ENVIRONMENTAL MEASURING PROGRAM-----	12-13
Measurements and Instrumentation-----	13
HISTORICAL BACKGROUND-----	14-17
Saturn Launches-----	15
APOLLO 4 SPACECRAFT-----	18-26
Command Module (CM)-----	18-19
Service Module (SM)-----	19-20
Spacecraft Lunar Module Adapter (SLA)-----	20
Lunar Module Test Article (LTA-10R)-----	20
Spacecraft Systems-----	20-26
APOLLO 4 LAUNCH OPERATIONS-----	27-29
APOLLO 4 COUNTDOWN-----	29-30
KSC LAUNCH COMPLEX 39-----	30-31
The Mobile Concept-----	31
THE VEHICLE ASSEMBLY BUILDING-----	32-33
THE LAUNCH CONTROL CENTER-----	33-34
MOBILE LAUNCHER-----	34-35
THE TRANSPORTER-----	35-36
THE MOBILE SERVICE STRUCTURE-----	37
WATER DELUGE SYSTEM-----	37
FLAME TRENCH AND DEFLECTOR-----	38
PAD AREAS-----	38-39
MISSION PROFILE-----	40-47
Flight Profile and Sequence of Events-----	40-44
Apollo 4 Normal Events Summary-----	45-47
APOLLO 4 RECOVERY-----	48-49
Atlantic Recovery Forces-----	48-49
MISSION CONTROL CENTER - HOUSTON (MCC-H)-----	50

THE MANNED SPACE FLIGHT NETWORK (MSFN)-----	50-56
Ground Systems for Space Guidance, Command and Control-----	50
New Developments-----	50
Why?-----	51
Sites and Status-----	51
Participating Stations-----	52
The Network Support Team-----	52
Testing the Network-----	52-53
Final Configuration-----	53
Computers That Switch-----	53
Realtime Is Now-----	53-54
Data on Call-----	54
More and More Data-----	54
The Tie That Binds - NASCOM-----	54
Satellite Communications-----	54
Reentry Communications Blackout Study-----	55
High Speed Reentry-----	55
Search for an Answer-----	55
The Scientists Take a Look-----	55
Focus on the Problem-----	56
APOLLO/SATURN PROGRAM MANAGEMENT-----	57
APOLLO/SATURN OFFICIALS-----	57-58
MAJOR APOLLO/SATURN CONTRACTORS-----	59-61
SATURN V LAUNCH VEHICLE CONTRACTORS-----	62-63
MANNED SPACE FLIGHT NETWORK CONTRACTORS-----	64
LAUNCH COMPLEX CONTRACTORS-----	65



FOR RELEASE: THURSDAY A.M.
November 2, 1967

RELEASE NO: 67-275

FIRST SATURN V FLIGHT TEST

The first flight test of the Apollo/Saturn V space vehicle is scheduled for launch from the National Aeronautics and Space Administration's John F. Kennedy Space Center, Fla., no earlier than Nov. 7. The mission is designated Apollo 4.

The Apollo/Saturn V is the most powerful space vehicle developed in the United States space program. It is 363 feet tall and its first-stage engines produce 7,500,000 pounds of thrust at liftoff. Weight fully fueled is 6,220,025 pounds. The Saturn V launch vehicle will place 278,699 pounds in a 101-nautical-mile (117-statute-mile) Earth orbit.

Objectives of the Earth-orbital unmanned mission are to obtain flight information on launch vehicle and spacecraft structural integrity and compatibility, flight loads, stage separation, subsystem operation, emergency detection subsystem operation and to evaluate the Apollo command module (CM) heat shield under conditions encountered on return from a Moon mission.

The Apollo 4 mission also will test flexible thermal seals to be used in the new outward-opening, quick-release hatch for the command module. On Apollo 4, the command module hatch window has been replaced with a test panel containing simulations of the seals and gaps between the hatch and the surrounding heat shield.

The Apollo 4 mission includes several significant milestones in the United States program to land men on the Moon and return them safely to Earth.

... It will mark the first launch from the Kennedy Space Center Launch Complex 39;

... The first flight of the integrated Apollo/Saturn space vehicle;

... First flight of the first (S-IC) and second (S-II) stages of the Saturn V launch vehicle;

... First engine restart in orbit of the upper (S-IVB) stage of the Saturn vehicle, and the first demonstration of Apollo spacecraft performance entering the Earth's atmosphere at speeds reached on return from a mission to the Moon.

The Apollo 4 flight plan calls for the Saturn V launch vehicle to place the Apollo spacecraft and the launch vehicle third (S-IVB) stage into a 101-nautical-mile (117-statute-mile) circular orbit inclined 32.73 degrees to the equator.

After completing two orbits, the third stage will ignite a second time to place the Apollo spacecraft into orbit with an apogee of 9,391 nautical miles (10,800 statute miles).

After separating from the third stage the spacecraft will raise its apogee to 9,890 nautical miles (11,400 statute miles) by firing its service propulsion system (SPS) engine. A second service propulsion system burn during descent from apogee will boost reentry velocity to 36,333 feet-per-second (25,000 statute miles-per-hour, 21,800 knots) for the spacecraft command module.

The command module, protected by its heat shield, will re-enter the atmosphere, return to Earth, and be recovered about 540 nautical miles (622 statute miles) northwest of Hawaii. Landing will be eight hours, 41 minutes after liftoff.

The spacecraft for the Apollo 4 mission consists of a Block I command and service module (CSM) and a lunar module (LM) boilerplate. The service module (SM) will be separated from the command module before reentry.

The lunar module boilerplate will remain attached to the third stage of the launch vehicle which will follow an orbit similar to that of the spacecraft and reenter the atmosphere over the Pacific Ocean.

The Saturn V launch vehicle consists of three stages and an instrument unit (IU).

The first stage (S-IC) is 138 feet tall, 33 feet in diameter and weighs 307,000 pounds empty. Its fuel and oxidizer tanks have a capacity of 4,400,000 pounds (214,200 gallons of RP-1 kerosene, and 346,400 gallons of liquid oxygen). Its five F-1 engines develop a combined 7,500,000 pounds of thrust at liftoff and burn 15 tons of fuel per second.

The second stage (S-II) is 81.5 feet tall, 33 feet in diameter and weighs 88,000 pounds empty. Fully loaded it weighs 1,033,000 pounds including 267,700 gallons of liquid hydrogen fuel and 87,400 gallons of liquid oxygen. Its five J-2 engines provide 1,000,000 pounds of thrust.

The third stage (S-IVB) is 58.4 feet tall, 21 feet eight inches in diameter and weighs 26,500 pounds empty. It carries 230,000 pounds of propellants -- 66,900 gallons of liquid hydrogen and 20,400 gallons of liquid oxygen. Its single J-2 engine develops 200,000 pounds of thrust in space.

The instrument unit is three feet high and 21 feet eight inches in diameter. It weighs 4,750 pounds and contains six major systems -- structural, thermal control, guidance and control, measuring and telemetry, radio frequency and electrical.

The Apollo 4 spacecraft includes the conical command module, 12 feet high and 12 feet 10 inches in diameter at the base. It weighs 12,000 pounds.

The service module is a cylinder 22 feet high, 12 feet 10 inches in diameter and weighs 55,000 pounds including fuel at launch. It contains the service propulsion system engine which develops 21,500 pounds of thrust.

The lunar module boilerplate, which weighs 29,500 pounds, is contained within the spacecraft lunar module adapter (SLA) which is 28 feet high, and tapers from 22 feet in diameter at the base to 12 feet 10 inches at the top. The spacecraft lunar module adapter weighs 3,900 pounds.

The spacecraft launch escape system atop the command module is 33 feet tall with a base diameter of four feet. It weighs 8,200 pounds including a boost protective cover which fits over the apex of the command module to protect it against aerodynamic heating during launch and from the rocket exhaust of the launch escape system motors. The launch escape system provides the capability to lift the command module from the remainder of the space vehicle in event of an emergency on the pad or shortly after launch. The launch escape system is jettisoned shortly after ignition of the second stage of the launch vehicle.

(BACKGROUND AND TECHNICAL INFORMATION FOLLOWS)

SATURN V LAUNCH VEHICLE

The Saturn V launch vehicle stands 281 feet tall. Total height of the Apollo 4 on the launch pad, with the Apollo spacecraft and launch escape system in place, is 363 feet and it weighs 6,220,025 pounds when fully fueled.

The three-stage launch vehicle is capable of placing 125 tons of payload into low Earth orbit or sending 48 tons to the Moon. The Saturn V is painted white with sections marked in black for more **efficient** optical tracking. Other painted markings include identification in red letters and the United States flag on the first stage.

First Stage

The first stage (S-IC) of the Saturn V is 138 feet tall and 33 feet in diameter, not including the fins and engine shrouds on the thrust structure. It was developed jointly by the National Aeronautics and Space Administration's Marshall Space Flight Center, Huntsville, Ala., and The Boeing Co.

Marshall assembled four S-IC stages: a structural test model, a static test version and the first two flight stages, one of which is the first stage of the Apollo 4.

Boeing, as prime contractor, built two ground test units. Boeing is responsible for assembly of the other 13 flight stages at Marshall's Michoud Assembly Facility, New Orleans.

The static test model and the first three flight versions were fired at the Marshall Space Flight Center Test Laboratory. All other S-IC stages are being test fired at Marshall's Mississippi Test Facility in Hancock County, Miss.

Dry weight of the first stage is about 307,000 pounds. Its two propellant tanks have a total capacity for 4.4 million pounds of fuel and oxidizer -- some 214,200 gallons of RP-1 (kerosene) and 346,400 gallons of liquid oxygen. The normal propellant flow rate to the five F-1 engines is 28,000 pounds per second. The five engines produce a combined thrust roughly equivalent to 180 million horsepower at maximum velocity.

The engines, during the normal 150 seconds of burn time, will propel the Apollo/Saturn V to an altitude of 33.5 nautical miles (38.5 statute miles) and carry it downrange 47.5 nautical miles (54.9 statute miles). The vehicle will be moving at 5,300 knots (6,100 statute miles per hour) at first stage engine cutoff.

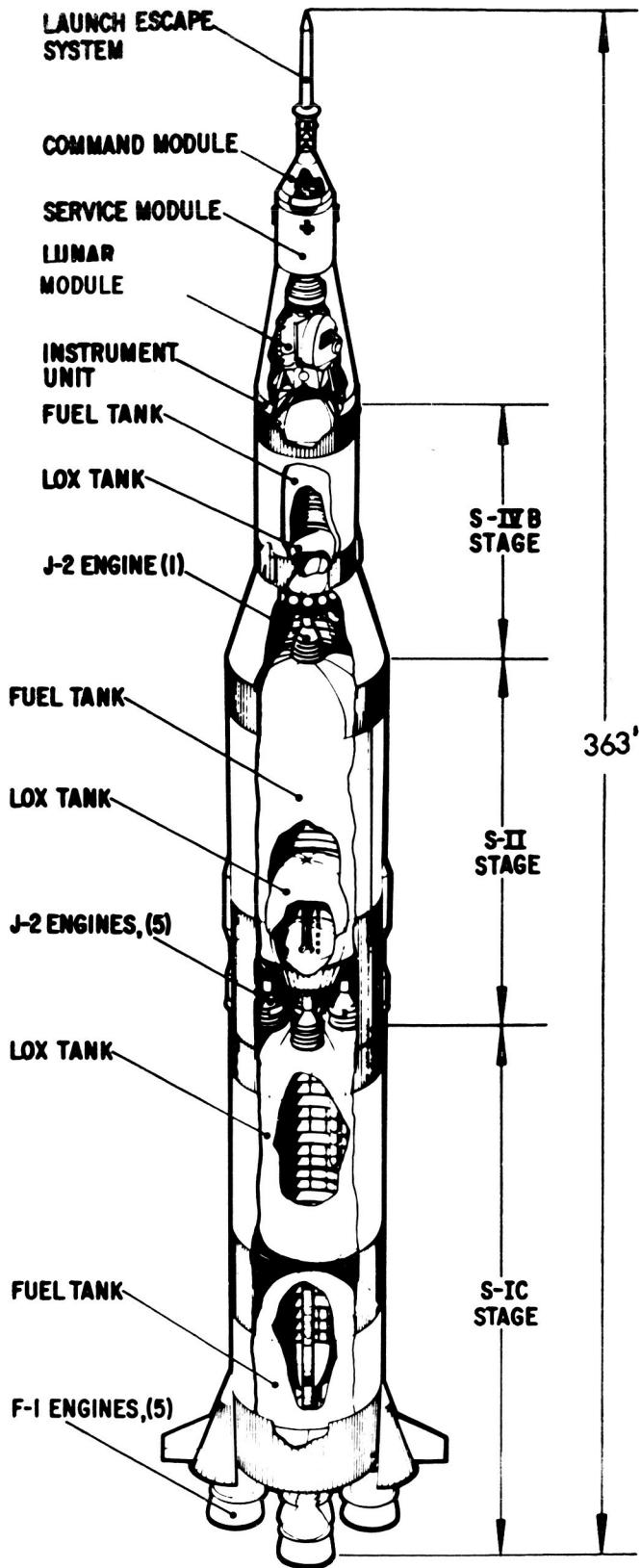

SATURN V

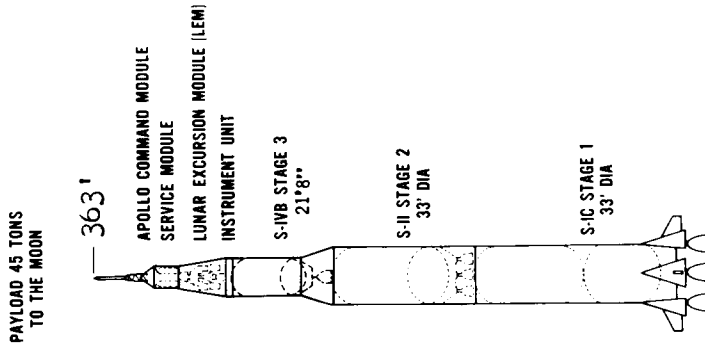
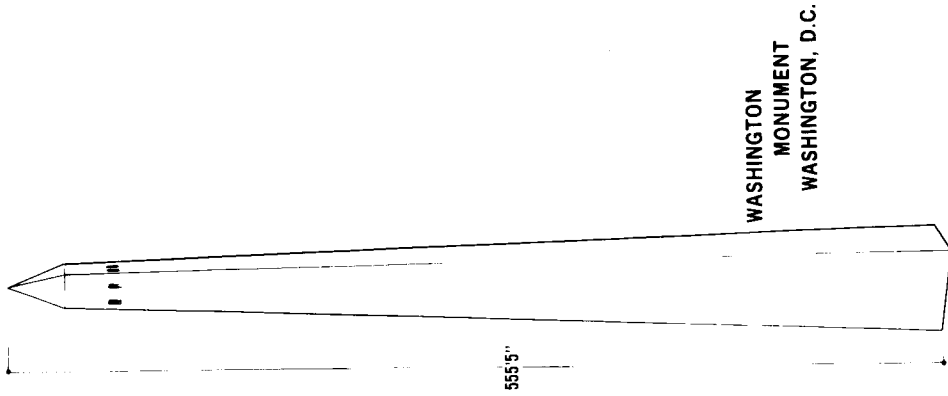

Saturn V
3 Stage

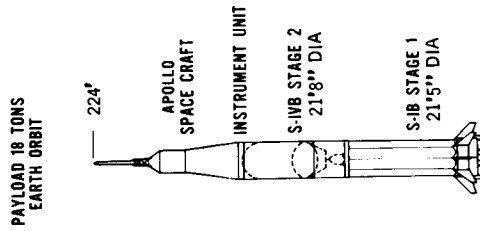

Upgraded Saturn I
2 Stage

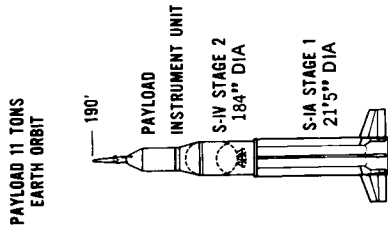

Saturn I
2 Stage

Saturn Comparison

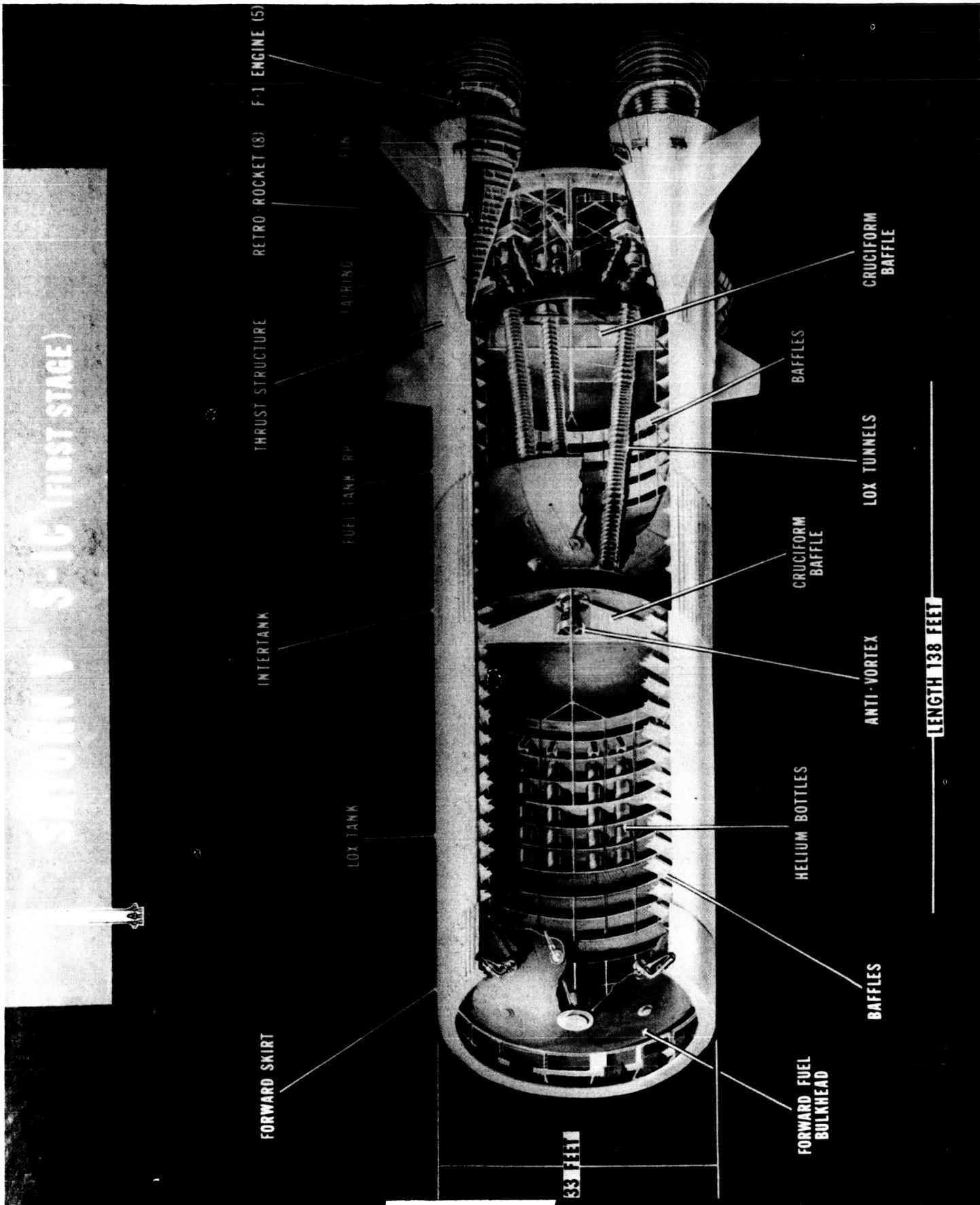

Four of the engines are mounted on a ring, each 90 degrees from its neighbor. These four can be gimballed to control the rocket's direction of flight.

The fifth engine is mounted rigidly in the center.

Second Stage

The second stage (S-II) is $81\frac{1}{2}$ feet tall and 33 feet in diameter. Its dry weight is about 88,000 pounds but when fully fueled it will weigh 1,033,000 pounds.

The stage, excluding propellants for the five J-2 engines, will weigh about 103,000 pounds when it separates from the S-IC. This extra weight covers the 10,650-pound S-IC/S-II interstage section, 2,720 pounds of ullage rocket propellants and other items still on board at the time of separation.

The stage's two propellant tanks will carry about 267,700 gallons of liquid hydrogen and 87,400 gallons of liquid oxygen. Its five J-2 engines develop a total thrust of 1,000,000 pounds.

The second stage carries the rocket to an altitude of 101 nautical miles (117 statute miles) and a distance of some 810 nautical miles (935 statute miles) downrange. The speed attained before S-II burnout is 13,300 knots (15,300 statute miles per hour). The J-2 engines will run 6.1 minutes.

The Space Division of North American Aviation, Inc., builds the second stage at Seal Beach, Calif. The cylindrical vehicle is made up of the forward skirt (to which the third stage connects), the liquid hydrogen tank, the liquid oxygen tank, the thrust structure (on which the engines are mounted) and an interstage section (to which the first stage connects). The two tanks are separated by an insulated common bulkhead.

North American conducted research and development static testing at the Santa Susana, Calif., test facility and at the NASA Mississippi Test Facility. The flight stage for the Apollo 4 was shipped via the Panama Canal for captive firings at Mississippi Test Facility, where all S-II flight stages are tested.

Third Stage

The third stage (S-IVB) was developed by the McDonnell Douglas Corp. at Huntington Beach, Calif. It is the larger and more powerful successor to the S-IV that served as the second stage of the Saturn I.

SATURN V

S-II STAGE

-7A-

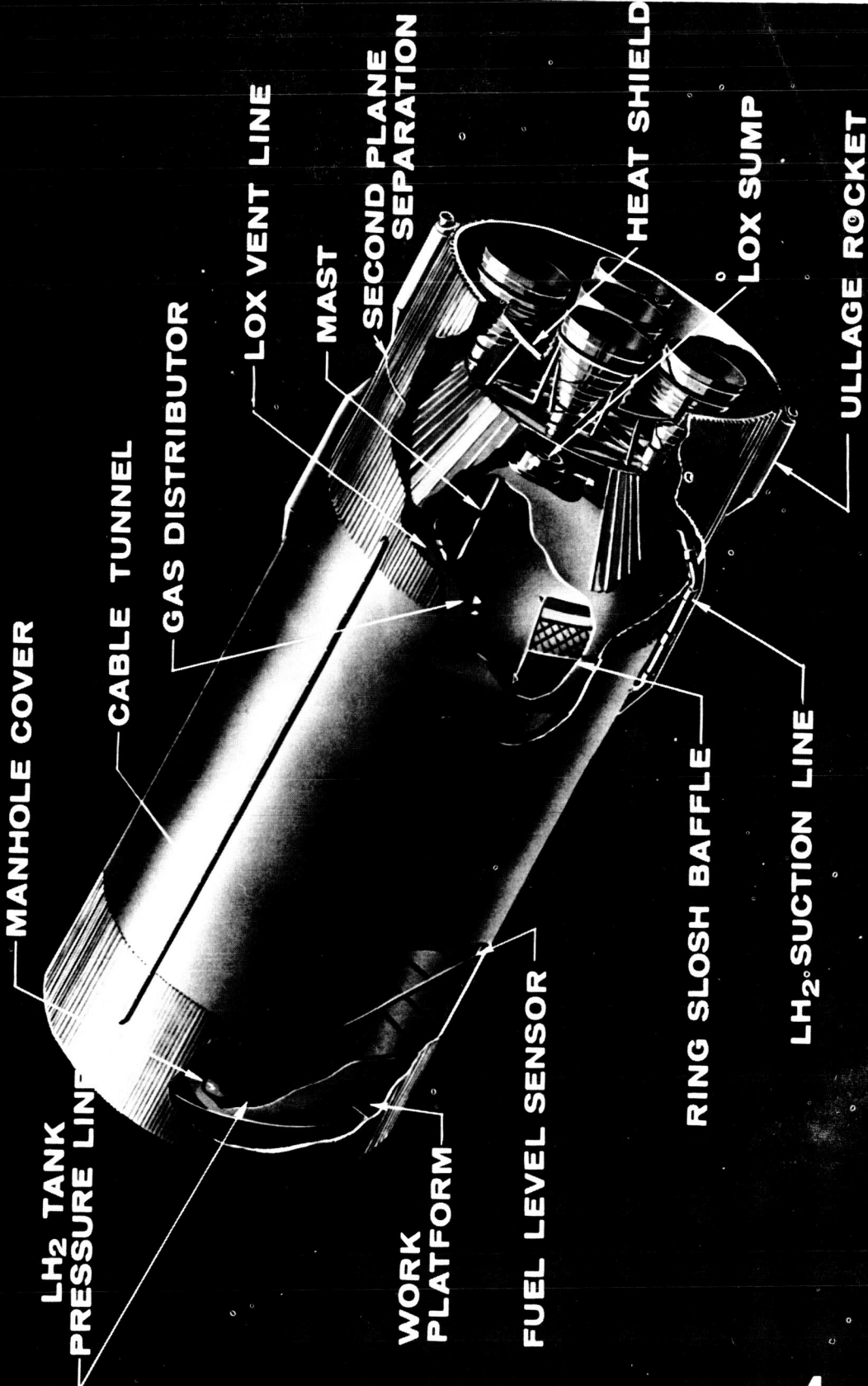

-more-

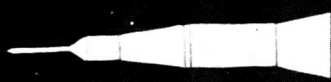

S-V

The stage is 58 feet, 5 inches long and 21 feet, 8 inches in diameter. Its dry weight is 26,500 pounds but at separation from the second stage its weight will be 29,170 pounds exclusive of the liquid hydrogen and liquid oxygen carried in the main tanks. This extra weight consists mainly of solid and liquid proeplants used in retro and ullage rockets and in the auxiliary propulsion system (APS).

An interstage section connects the second and third stages. This 7,627-pound interstage stays with the second stage at separation, exposing the single J-2 engine mounted on the thrust structure of the third stage. The after skirt, connected to the interstage at the separation plane, encloses the liquid oxygen tank which holds some 20,400 gallons of the oxidizer. Above this is the large fuel tank holding about 66,900 gallons of liquid hydrogen.

Total usable propellants carried in the two tanks is 230,000 pounds. The fuel and oxidizer tanks, as in the second stage, are separated by an insulated common bulkhead. Insulation is necessary in both upper stages at this point because liquid oxygen, at about 293 degrees below zero Fahrenheit, is much "hotter" than liquid hydrogen, which is some 423 degrees below zero.

The aft skirt also serves as a mount for two auxiliary propulsion system modules spaced 180 degrees apart. Each module contains three liquid-fueled 147-pound thrust engines, one each for roll, pitch and yaw, and a 72-pound-thrust, liquid-fueled ullage engine.

Four solid-propellant retrorockets of 37,500 pounds thrust each are mounted on the interstage to back the second stage away from the third stage upon separation. The third stage also carries two solid-fueled ullage motors of 3,400-pounds-thrust each. These motors help to move the third stage forward and away from the second stage upon separation and serve the additional purpose of settling the liquid propellants in the bottoms of the tanks in preparation for J-2 ignition. The first J-2 burn is for 136 seconds and the second burn is for almost six minutes.

The third stage is moved from its manufacturing site by barge or Super Guppy aircraft to Douglas' Sacramento Test Center for static test firings. After firing and checkout, the stage is flown to the NASA Kennedy Space Center.

Propulsion

The propulsion systems of the Saturn V launch vehicle vary greatly -- thrust ratings ranging from more than 1.5 million pounds down to 72 pounds, some engines using liquid propellants and others using solids. The Saturn V uses a total of 41 rocket engines in performing its function as the carrier for the Apollo spacecraft.

SATURN V

S-IVB STAGE

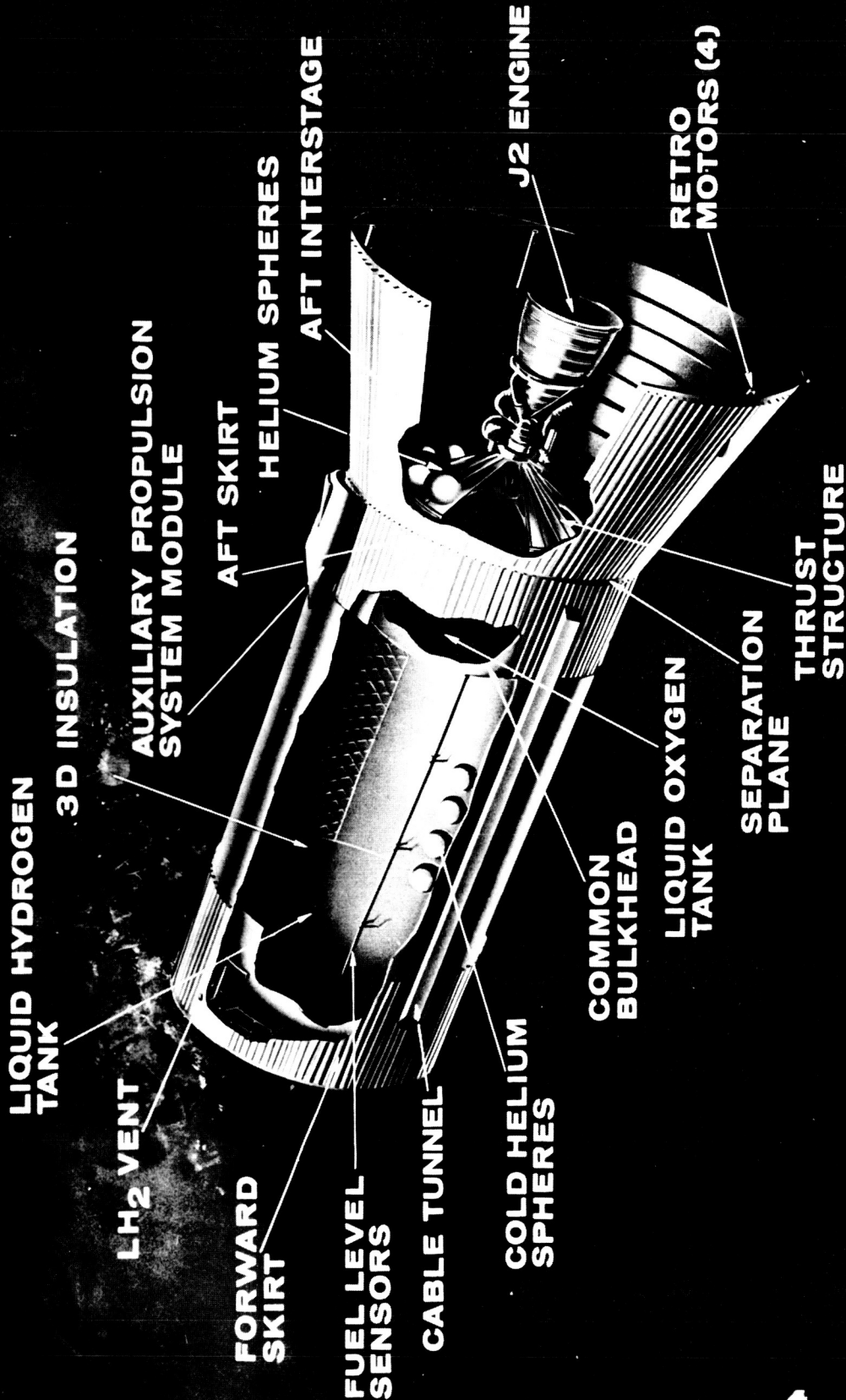

The five F-1 engines that provide the main power for the first stage burn RP-1 (kerosene) and liquid oxygen. Each engine in the first stage develops 1,514,000 pounds of thrust at lift-off, building up to 1.7 million pounds thrust before cutoff. The cluster of five F-1s gives the first stage a thrust range of from 7.57 million pounds at liftoff to 8.5 million pounds just before cutoff. Technology gained from development of the H-1 and other rocket engines using RP-1 and liquid oxygen was used in extending the state of the art to a point at which the F-1 could become a reality.

Each F-1 engine weighs almost 10 tons, is more than 18 feet high and has a nozzle-exit diameter of almost 14 feet. The F-1 engines undergo static testing for 650 seconds in being qualified for the 150-second run during the Saturn V first stage boost phase. This 800-second period is still far less than the 2,200 seconds for which the engine is "guaranteed." Each engine consumes almost three tons of propellants per second.

The first stage of the Saturn V also has eight other rocket motors. These are the solid-fuel retrorockets which will slow the stage and "back it away" from the second stage and avoid possible collision when the two stages separate. The retrorockets are mounted in pairs, two in each of the four engine shrouds. Each rocket produces a thrust of 87,900 pounds for .6 seconds.

The main propulsion for the second stage is a cluster of five J-2 engines burning liquid hydrogen and liquid oxygen. Each engine develops a mean thrust of 200,000 pounds (variable from 175,000 to 225,000 in phases of flight), giving the stage a total thrust of a million pounds.

Designed to operate in the vacuum of outer space, the 3,500-pound J-2 is a more efficient engine than the F-1 because it burns the high-energy fuel hydrogen.

The second stage also has eight solid-fuel rockets, each with a thrust of 21,000 pounds. These are the ullage rockets mounted on the interstage section. After these rockets fire to assure that liquid propellants are settled in the bottoms of the main tanks, and also to help attain a "clean" separation from the first stage, the rockets drop away with the interstage at second plane separation.

Fifteen rocket engines perform various functions on the third stage. A single J-2 engine provides the main propulsive force for the stage's flight. The stage also has two main ullage rockets, four retrorockets and eight smaller engines in the auxiliary propulsion system. (See "Third Stage" for descriptions.)

Instrument Unit

The Instrument Unit (IU) is a cylinder three feet high and 21 feet 8 inches in diameter, the same diameter as the third stage. The instrument unit for Apollo 4 weighs 4,750 pounds.

Components making up the "brain" of the Saturn V are mounted on cooling panels fastened to the inside surface of the instrument unit skin. The refrigerated "cold plates" are part of a thermal conditioning system that removes heat by circulation of fluid coolant through a heat exchanger that evaporates water from a separate supply into the vacuum of space.

The six major systems of the instrument unit are structural, thermal control, guidance and control, measuring and telemetry, radio frequency and electrical.

The instrument unit performs the following functions: navigation, guidance and control of the vehicle; measurement of vehicle performance and environment; data transmission between the vehicle and ground stations, in both directions; radio tracking of the vehicle; checkout and monitoring of vehicle functions; detection of emergency situations; generation and network distribution of electrical power for system operation; and preflight checkout and launch and flight operations.

A path-adaptive guidance scheme is used in the Saturn V's instrument unit. A programmed trajectory is used in the initial launch phase with guidance beginning only after the vehicle has left the atmosphere. This is to prevent the vehicle from performing maneuvers that might cause it to break apart while attempting to compensate for winds, jet streams and gusts encountered in the atmosphere.

If such air currents displace the vehicle from the optimum trajectory during its climb, the vehicle derives a new trajectory from its instantaneous state of position, velocity and direction. This calculation is made about once each second throughout the flight. The launch vehicle digital computer and launch vehicle data adapter perform the navigation and guidance computations.

The ST-124M inertial platform -- considered the heart of the navigation, guidance and control system -- provides space-fixed reference coordinates and measures acceleration along the three mutually perpendicular axes of the coordinate system.

International Business Machines Corp. is prime contractor for the instrument unit and is the supplier of the guidance signal processor and guidance computer. Major suppliers of instrument unit components are: Electronic Communications, Inc., control computer; Bendix Corp., ST-124M inertial platform; and IBM Federal Systems Division, launch vehicle digital computer and launch vehicle data adapter.

SATURN IB/V INSTRUMENT UNIT

MAJOR I.U. SYSTEMS

- GUIDANCE & CONTROL
- ELECTRICAL
- TELEMETRY & MEASURING
- RADIO FREQUENCY
- STRUCTURAL
- THERMAL CONTROL

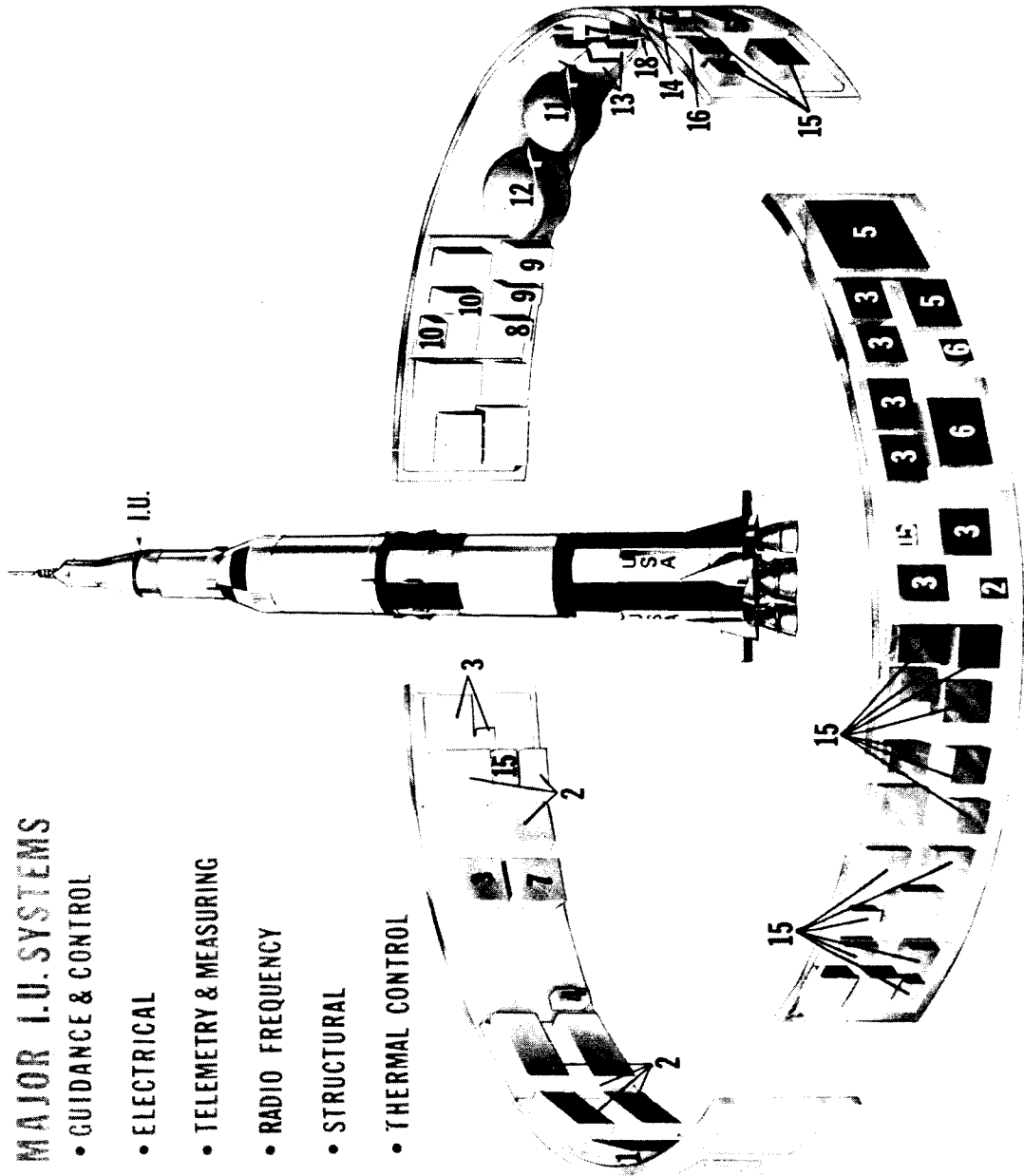

1. ENVIRONMENTAL CONTROL SYS.
2. ELECTRICAL POWER SYS.
3. MEASURING SYS.
4. CONTROL ACCELEROMETERS
5. CONTROL COMPUTER SYS.
6. EDS
7. RADAR ALTIMETER
8. C-BAND RADAR
9. AZUSA SYS.
10. MINITRACK SYS.
11. ST-124-M PLATFORM
12. PLATFORM AIR SUPPLY
13. PLATFORM ELECTRONICS
14. GUIDANCE COMMAND SYS.
15. TELEMETRY SYS.
16. SWITCH SELECTOR
17. GUIDANCE COMPUTER
18. DATA ADAPTER

Transportation

The Saturn V stages are too large for movement by conventional highway, rail or air facilities. Special barges move the first stages tested at Huntsville via the Tennessee, Ohio and Mississippi Rivers, the Gulf of Mexico and intercoastal waterways to the Kennedy Space Center, a distance of more than 2,200 miles.

Barges also move the first stages produced at the Michoud Assembly Facility to the Mississippi Test Facility and the launch site in Florida. Second stages produced on the West Coast are shipped via the Panama Canal to Mississippi Test Facility and Kennedy Space Center. The NASA barge, Poseidon, carries the first stage, and two modified open-deck vessels make shuttle runs between Michoud and Mississippi Test Facility. Propellants are carried to Mississippi Test Facility on specially-built cryogenic barges.

On the West Coast, the "Point Barrow" carries the second stage from Los Angeles to Kennedy Space Center. This vessel is operated by the Military Sea Transportation Service (MSTS) of the Navy. A modified aircraft known as the "Pregnant Guppy" is used for flying single F-1 engines and other items to various points. Aerospace Lines, Inc., builder of the Guppy, has also built a "Super Guppy" which is used as a carrier for the Saturn V third stage and other large items of hardware.

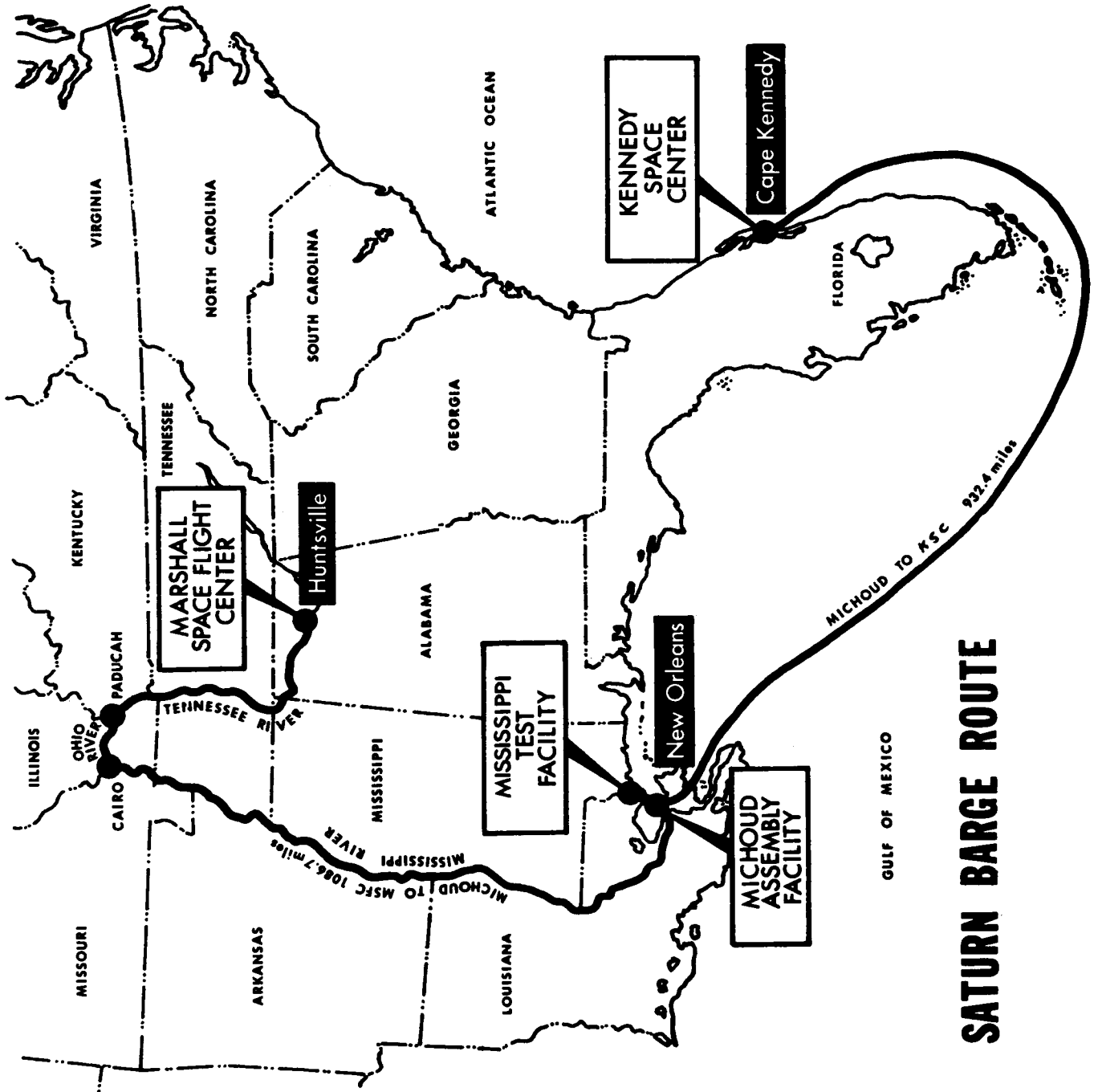

SATURN BARGE ROUTE

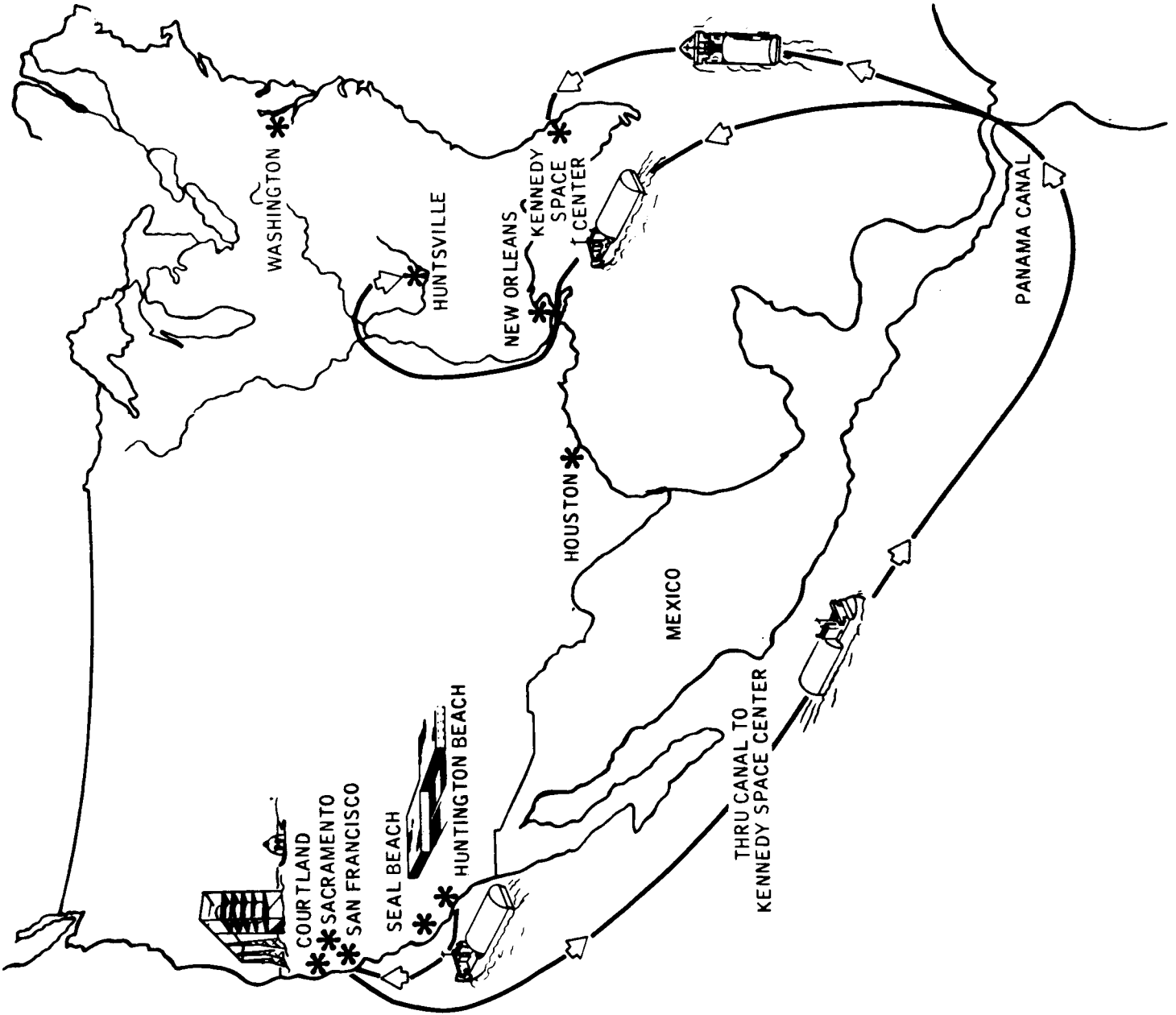

VEHICLE ENVIRONMENTAL MEASURING PROGRAM

The total number of measurements to be made on the Saturn V launch vehicle, not including those from the Apollo spacecraft, during the Apollo 4 flight is approximately 2,894. This includes 972 in the first stage, 976 in the second stage, 609 in the third stage and 337 in the instrument unit.

The Saturn V will carry 22 telemetry systems, two tracking systems and two motion picture cameras. The cameras are mounted on the second stage to record photographically the dual plane separations of the first stage and interstage from the second stage. The cameras will be ejected for descent by paraballoon and splashdown in the Atlantic Ocean about 470 miles from the launch site where they will be recovered by teams homing on each camera's radio beacon.

The 2,894 measurements scheduled are in sharp contrast to the average 1,365 measurements taken on Uprated Saturn I vehicles, 925 on Saturn I (from 510 on SA-1 to 1,378 on SA-7), 150 on the Jupiter and 75 on the Redstone.

Measurements and Instrumentation
(Approximate numbers)

Type	IU	S-IVB	S-II	S-IC	Totals
Acceleration	4	1	8	3	16
Acoustic	1	12	5	4	22
Temperature	57	244	326	252	879
Pressure	12	107	203	330	652
Vibration	28	34	60	80	202
Flow Rate	11	4	10	35	60
Position	21	8	36	1	66
G & C	54	0	0	0	54
RF & TM	26	0	0	0	26
Signals	70	75	228	143	516
Liquid Level	0	12	4	19	35
Electric Power	20	41	63	11	135
Misc.	0	37	4	15	56
Angular Velocity	33	0	3	3	39
Strain	0	32	16	71	119
RPM (Speed)	0	2	10	5	17
Totals	337	609	976	972	2,894

Telemetry Systems

PAM/FM/FM	1	3	3	3	10
SS/FM	1	1	2	2	6
PCM/FM	1	1	1	1	4
CCS	1	0	0	0	1
FM/FM	1	0	0	0	1
Totals	5	5	6	6	22

Tracking

Azusa & C-Band	1	0	0	0	1
ODOP	0	0	0	1	1

Cameras

Television	0	0	0	0	0
Film	0	0	2	0	2

HISTORICAL BACKGROUND

The national goal of a manned lunar landing before 1970, set by the late President Kennedy, created the need for a launch vehicle larger than the Saturn I. NASA announced in January 1962 that the Marshall center had been assigned the task of developing such a vehicle -- the Saturn V.

The first Saturn vehicle, a Saturn I using only a live first stage, had been launched Oct. 27, 1961. Nine more were launched successfully during the next four years. Technology gained in developing the Saturn I and the Up-rated Saturn I -- three of which were launched in 1966 on successful missions -- was essential to design of the Saturn V.

New tools, jigs and fixtures had to be designed and built and new manufacturing techniques developed before actual fabrication of the Saturn V could begin. The new rocket was to be so large that most of it would have to be built in sections and then assembled vertically. This, in turn, required the construction of taller buildings with overhead cranes and adjustable work platforms.

The size of the vehicle also required the construction of new, giant test facilities and the design and manufacture of special transporters. Barges large enough for the big rocket stages had to be acquired, modified and outfitted for hauling the first and second stages. A factory at New Orleans was reactivated and converted into an assembly plant for the first stages, and a big part of a swampy Mississippi county was acquired and converted into a test site for the first two stages. Other new manufacturing and testing facilities had to be provided for the second and third stages and the powerful new engines.

The Marshall center, as plans took shape, took its needs to industry, negotiating contracts with dozens of major aerospace firms and hundreds of smaller concerns. These firms, in turn, negotiated subcontracts with thousands of other suppliers.

Scientists and engineers in the several laboratories at the Marshall center also helped with the task. At dozens of locations materials were tested, new materials developed and proved, revolutionary welding methods developed, aerodynamic studies made, computers installed and programs set up to solve the myriad problems. Test monitoring and recording instruments were installed, checkout procedures developed, reliability standards established, electronics systems designed and built and guidance schemes developed.

The first Saturn V first stage, a static test model, was rolled out of its Marshall Space Flight Center hangar March 1, 1965, and test-fired for the first time on April 9, 1965.

Saturn Launches

Type Vehicle	Flight Designation	Payload	Date Launched
Saturn I (Block I)	SA-1	Dummy and nose cone.	10-27-61
Saturn I (Block I)	SA-2	Dummy and nose cone.	4-25-62
Saturn I (Block I)	SA-3	Dummy and nose cone.	11-16-62
Saturn I (Block I)	SA-4	Dummy and nose cone.	3-28-63
Saturn I (Block II)	SA-5	Live second stage, nose cone, boilerplate spacecraft.	1-29-64
Saturn I (Block II)	SA-6	Live second stage, nose cone, boilerplate spacecraft.	5-28-64
Saturn I (Block II)	SA-7	Live second stage, nose cone, boilerplate spacecraft.	9-18-64
Saturn I (Block II)	SA-9	Pegasus I Meteoroid Technology Satellite.	2-16-65
Saturn I (Block II)	SA-8	Pegasus II.	5-25-65
Saturn I (Block II)	SA-10	Pegasus III.	7-30-65
Upgraded Saturn I	AS-201	Apollo CSM	2-26-66
Upgraded Saturn I	AS-203	Nose cone, experiments	7-5-66
Upgraded Saturn I	AS-202	Apollo CSM	8-25-66

The first flight stage, the first stage of Apollo 4, was completed at the Marshall center Sept. 27, 1965, and test fired Feb. 17 and 25, 1966. The second stage for Apollo 4 was test fired at the Mississippi Test Facility on Dec. 1 and 30, 1966. The Apollo 4 third stage was static tested at Sacramento May 20 and 26, 1966.

Assembly of Apollo 4 in the Vehicle Assembly Building at KSC began Oct. 27, 1966. It was rolled out of the building on its mobile launcher Aug. 26, 1967, and taken to the launch site, Launch Complex 39.

The Apollo lunar landing mission is not the only use to which the Saturn V will be put. It will be the mainstay in the heavy vehicle area in United States space exploration for the next several years. It will be used in the Apollo Applications Program, the follow-on to the manned lunar landing.

Studies are in progress on methods of adapting the Saturn V to meet the needs of various programs, either by reducing or increasing its payload capability. Payloads not requiring the full power of a Saturn V but requiring more than that of the Uprated Saturn I could conceivably be carried to mission completion by a two-stage model, possibly with the number of engines reduced. Payloads greater than the Saturn V's present capability could be carried by increasing the vehicle's power in a number of ways. The main methods under consideration include increasing the performance of engines and adding strap-on solid rocket motors to augment booster thrust.

		Dates						
Stage	Completed	Test Fired	Post-Static Checkout	Shipped	Arrived At KSC	Assembled	Checkout Complete	
First S-IC-501	9-27-65 at MSFC	2-17-66, 2-25-66 at MSFC	Completed 8-10-66	8-26-66 (Layover at MAF.) 9-7-66	9-12-66	10-27-66	12-21-66	
Second S-II-501	Systems Check completed at Seal Beach 7-29-66. Shipped 7-31-66. Arr. MTF 8-13-66.	12-1-66 12-30-66 at MTF	None at MTF	1-16-67	1-21-67	"Spacer" used from 10-31-66 to 2-15-67. S-II-501 emplaced 2-25-67	1-21-67 through 1-25-67	
Third S-IVB-501	1-28-66 at Huntington Beach. Shipped to Sacramento 3-11-66	5-20-66, 5-26-66, Sacramento Test Facility	7-27-67	8-12-66 (Via Super Guppy)	8-14-66	11-1-66	8-14-66 through 11-1-66	
Instrument Unit S-IU-501	1-28-66 Structural Assembly; May 1966 Component Assembly; 6-4-66 Assembly Completed, IBM, Huntsville.	N/A	6-4-66 Checkoff Completed, Huntsville; 8-20-66 Checkout Completed	8-24-66 Via Super Guppy	8-24-66	11-1-66	8-24-66 through 11-1-66	

APOLLO 4 SPACECRAFT

Command Module (CM)

The command module is a cone 12 feet high with base diameter of 12 feet 10 inches, a habitable volume of 210 cubic feet and an approximate launch weight of 12,000 pounds.

Outer structure is stainless steel honeycomb bonded between steel alloy sheets with surface application of phenolic epoxy resin ablative material varying from $\frac{1}{2}$ to $2\frac{1}{2}$ inches thick for protection from reentry temperatures to 5,000 degrees Fahrenheit.

Inner structure is aluminum honeycomb between aluminum alloy with sandwich thickness from $\frac{1}{4}$ inch at forward access tunnel to $1\frac{1}{2}$ inches at base; fibrous insulation separates outer and inner structures.

The command module has an inner pressure structure and an outer structure (heat shield) separated by stringers for support and a microquartz fiber for thermal insulation. The outer housing limits heating of the pressure structure to less than 600 degrees F. The combined structures keep temperatures inside the spacecraft at comfortable levels during orbital flight and below 200 degrees F. during reentry.

The three-piece heat shield is constructed of brazed honeycomb stainless steel to which is bonded a phenolic epoxy resin ablative (heat dissipating) material. The ablative material burns away during reentry. Thickness of the ablative material varies from 0.7 to 2.7 inches based on the anticipated aerodynamic heat distribution over the command module. The three sections of the shield include forward heat shield, crew compartment heat shield, and the aft heat shield.

The Apollo 4 has a basic Block I (Earth-orbit type) heat shield but with the same thickness, thermal coating, protuberances and manufacturing technique used in the Block II (lunar mission) heat shield. A simulated Block II umbilical will be on command module in addition to the active Block I umbilical.

An Apollo mission programmer with special equipment needed for operation of the spacecraft subsystems in the absence of a crew will be installed.

The VHF and S-band omnidirectional antennas also will be modified to reflect the Block II configuration.

The command module hatch window has been replaced with an instrumented test panel containing simulations of the flexible thermal seals and gaps between the hatch and surrounding heat shield. Successful performance of the thermal seals during reentry heating will qualify the seals for use on manned command modules which will have the new quick-operating outward-opening hatches.

Design effort on the new hatch was begun in December 1966 and intensified as a result of the Apollo 204 fire of Jan. 27, 1967. First flight test of the complete new hatch is scheduled for the second Apollo/Saturn V mission.

A Maurer Model 220-G Earth and sky observer camera will be installed in the command module to take color photography as the spacecraft passes its apogee during the third orbit. The camera will photograph a 42-degree field of view and will take pictures once every 11 seconds beginning about an hour before the spacecraft reaches apogee until about an hour after apogee.

Service Module (SM)

The service module is 22 feet high and cylindrical in shape, including an extension to service propulsion system (SPS) engine, with a diameter of 12 feet 10 inches. Approximate launch weight is 55,000 pounds with an engine thrust of 21,500 pounds in vacuum.

Structure is aluminum honeycomb outer skin one inch thick formed by six panels bolted to solid aluminum structural uprights. The interior is divided into six wedge-shaped compartments of three different sizes around a center cylindrical section:

- (1) 50-degree segments house auxiliary equipment, are designated sectors 1 and 4;
- (2) 60-degree segments house fuel tanks for SPS, are designated sectors 3 and 6; and
- (3) 70-degree segments house oxidizer tanks for SPS, sectors 2 and 5.

A cylindrical center section houses two helium tanks to pressurize service propulsion system tanks, and the SPS engine.

Space radiators to dissipate heat from the electrical power system (EPS) and the environmental control system (ECS) are located externally on four of the six panels making up the service module skin; electrical power system radiators are on sectors 1 and 4, environmental control system radiators on 2 and 5. However, these radiators are not connected for the Apollo 4 mission.

Four reaction control system (RCS) packages each made up of four engines and one fuel tank, oxidizer tank, and pressurant tank with associated plumbing and electrical connections, are located equidistant around the circumference of the service module.

Spacecraft Lunar Module Adapter (SLA)

The Spacecraft Lunar Module Adapter is a tapered cylindrical shape 28 feet high and 22 feet in diameter at base, 12 feet 10 inches at top, of 1 3/4 inch thick aluminum honeycomb weighing 3,900 pounds. It houses the lunar module boilerplate LTA-10R.

Lunar Module Test Article (LTA-10R)

This lunar module test article is instrumented to measure vibration, acoustics, and structural integrity at 36 points in the spacecraft lunar module adapter. Data will be telemetered to the ground stations during the first 12 minutes of flight.

The test article will remain with the last stage of the launch vehicle. Lunar Test Article-10R uses a flight-type descent stage without landing gear. Its propellant tanks will be filled with water glycol and with freon to simulate fuel and oxidizer. The ascent stage is a ballasted aluminum structure containing no flight systems. Weight of the lunar module test article is 29,500 pounds.

Spacecraft Systems

Reaction Control System (RCS)

The reaction control system provides thrust for attitude maneuvers of the spacecraft in response to automatic control signals from the stabilization and control system (SCS) in conjunction with the guidance and navigation system (G&N) or to manual control signals from crew through hand controllers.

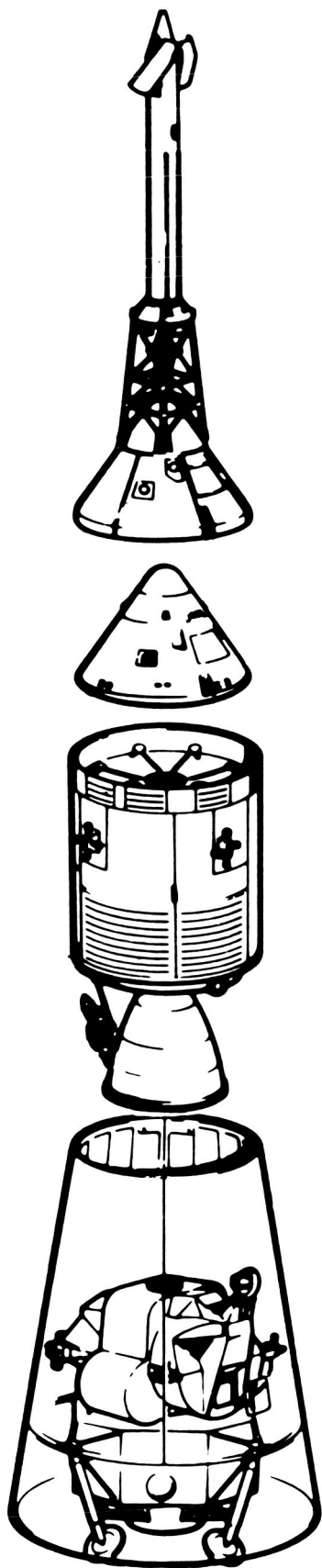

LAUNCH
ESCAPE SYSTEM

BOOST
PROTECTIVE COVER

COMMAND MODULE

SERVICE MODULE

ADAPTER

LUNAR MODULE

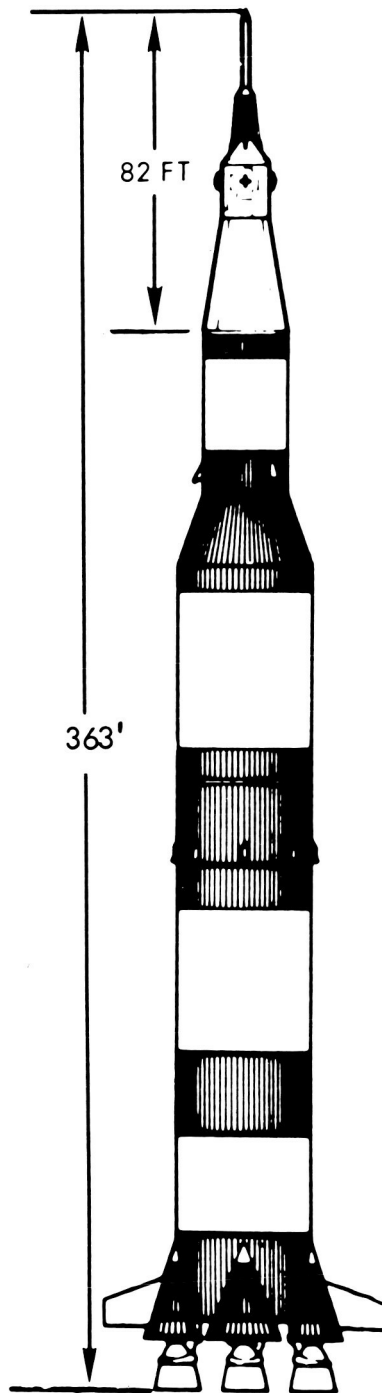

Service module reaction control system consists of four independent subsystems of four 100-pound-thrust engines each (16 engines total) packaged as modules and located in quadrants near the top of the service module. Propellant is hypergolic igniting spontaneously when fuel and oxidizer are mixed. It is made up of Aerozine 50 (half-and-half blend of hydrazine and unsymmetrical dimethylhydrazine) fuel and nitrogen tetroxide oxidizer. In each quad, two of the four engines give roll control, the other two either yaw or pitch control depending on the location of the quad.

Command Module

Reaction control system includes two independent subsystems of six 93-pound thrust engines each (12 engines total) operating in tandem. A single subsystem is able to provide adequate attitude control should one subsystem fail. Propellant is hypergolic with monomethyl-hydrazine fuel and nitrogen tetroxide oxidizer. The command module reaction control system is not activated until after the command module and the service module have separated before reentry.

Service Propulsion System (SPS)

The service propulsion system has to provide thrust for major velocity changes and in Earth orbital mission, for the de-orbit burn to achieve reentry. The engine is 3 feet 5 inches high with nine-foot, four-inch exhaust expansion skirt of columbion-titanium. It weighs approximately 810 pounds, produces 21,500 pounds of thrust in a vacuum, and is rated at 36 restarts with eight minutes 20 seconds of total burn time. Propellant is hypergolic Aerozine 50 fuel and nitrogen tetroxide oxidizer and is pressure fed from the service module storage tanks by helium gas. The service propulsion system engine is gimbal-mounted to keep the direction of thrust aligned through the spacecraft center of gravity.

Launch Escape System (LES)

The launch escape system includes a solid propellant launch escape motor and pitch control motor to pull spacecraft up and out from launch vehicle in the event of mission abort on the pad or during launch up to an altitude in excess of 270,000 feet. The launch escape system is 33 feet tall with a four-foot base diameter. It weighs approximately 8,200 pounds including a boost protective cover which fits over the apex of the command module for protection against boost heating and the rocket exhaust of the launch escape motors. The three solid propellant motors of the launch escape system are:

- (1) Launch escape motor with 147,000 pounds of thrust over three seconds' duration;
- (2) Pitch control motor with 2,850 pounds of thrust for 0.5 seconds and;
- (3) Tower jettison motor, 32,000-pounds-thrust for one second. Propellant in all three motors is polysulfide.

Stabilization and Control System (SCS)

The stabilization and control system controls spacecraft attitude, thrust vector of the service propulsion system engine, and may serve as backup inertial reference system. It operates automatically or manually. Components of the stabilization and control system appropriate to the Apollo 4 mission are:

(1) Body-mounted attitude gyros (BMAG): Three identical units mounted along spacecraft body axes. Attitude displacement creates signal to the reaction control system to restore desired attitude.

(2) Rate gyro assembly (RGA): Three gyros to show rate of change of spacecraft attitude.

(3) Attitude gyro accelerometer assembly (AGAA): The three BMAG units plus a pendulous accelerometer to display acceleration data for automatic termination of service propulsion system engine thrusting.

(4) Attitude set and gimbal position indicators which set desired angle changes and displays service propulsion system engine gimbal pitch and yaw position angle.

(5) Velocity change indicator displays remaining velocity change or Delta V.

(6) Electronic control assemblies to process and condition signals from SCS components.

Mission Control Programmer (MCP)

The Mission Control Programmer receives information from the updata link ground command, the Saturn instrument unit, ground support equipment, the guidance and navigation, Earth landing and environmental control systems.

ENGINE LOCATION

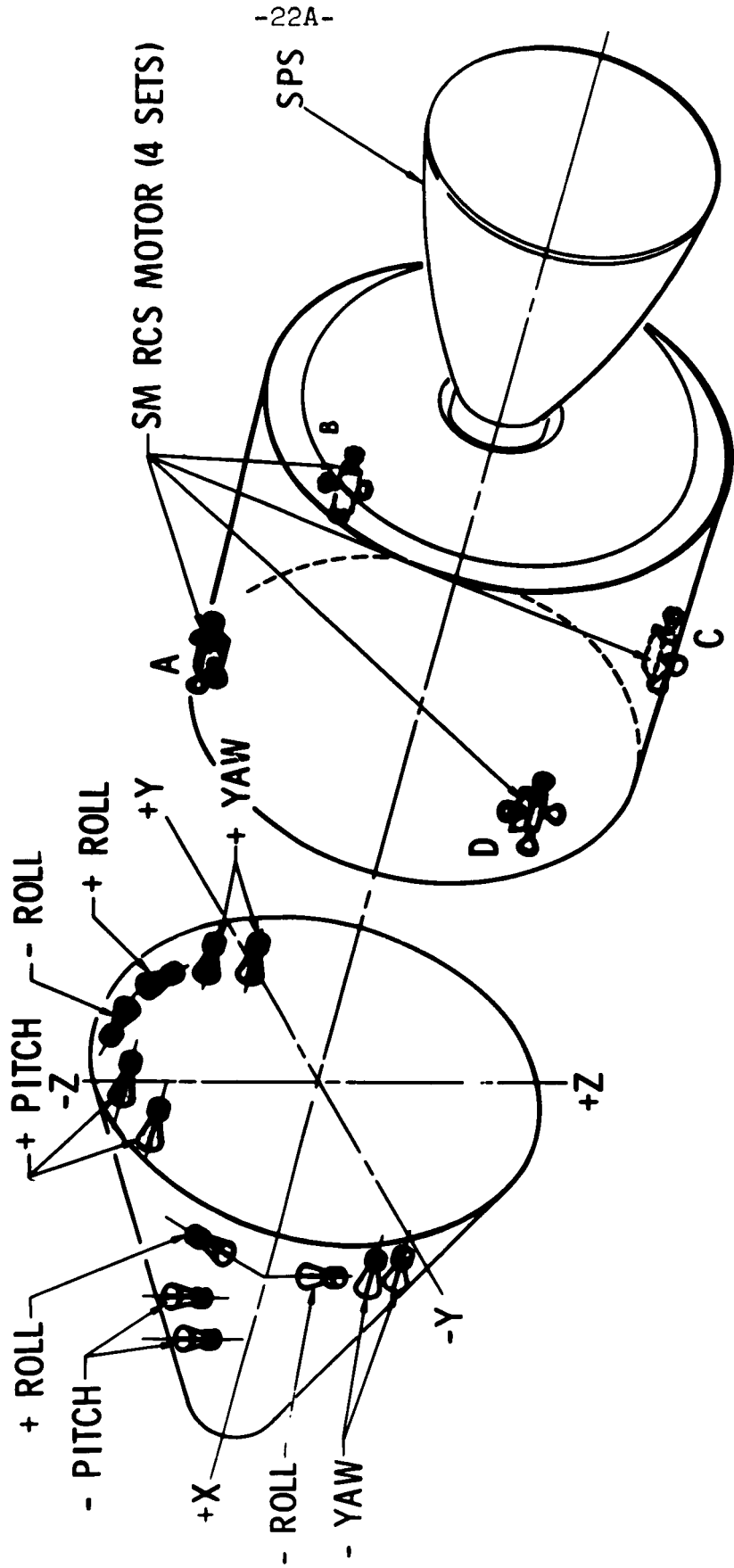

Guidance and Navigation (G&N)

The Guidance and Navigation System is a semi-automatic system interrelated with stabilization and control system, service propulsion system, reaction control system, electrical power system, environmental control system, telecommunications, and instrumentation systems. It performs basic functions of inertial guidance, attitude reference, and optical navigation. The system has two Apollo 4 related subsystems:

(1) Inertial guidance to measure changes in spacecraft attitude, help generate steering command, and measure changes in velocity. It is operated automatically by the guidance computer;

(2) Guidance computer and two display and keyboard panels (DSKY) to calculate steering signals and engine on-off signals, to position inertial measurement unit stable member, to position optical unit, to conduct limited G&N malfunction isolation, and to provide display panel information. The computer is digital with both an erasable and a fixed memory.

Earth orbital operations of the guidance and navigation system are in prelaunch, guidance monitor, orbital navigation, inflight inertial measuring unit alignment, attitude control and reentry phases.

Electrical Power System (EPS)

The electrical power system is made up of six main areas:

(1) Fuel cells to produce electricity through chemical reaction of hydrogen and oxygen pressure-fed into cells by nitrogen gas.

Each of the three power plants consists of 31 series-connected cells and each cell contains a hydrogen compartment, an oxygen compartment, a hydrogen electrode and an oxygen electrode. Each power plant is 44 inches high, 22 inches in diameter and weighs 245 pounds.

(2) Three zinc-silver oxide batteries located in the command module lower equipment bay to provide spacecraft power during reentry and after landing and to supplement fuel cell power during peak load periods, plus two independent and isolated zinc-silver oxide batteries to ignite explosive devices, plus two similar batteries in the service module to power service module jettison controllers after command module and service module separation.

(3) Cryogenic storage tanks and plumbing to hold and route hydrogen and oxygen for fuel cells and oxygen for environmental control system.

(4) Three solid-state inverters in the command module lower equipment bay convert fuel cell and battery direct current power to alternating current.

(5) The associated power distribution equipment.

(6) Three batteries for the Mission Control Programmer.

Environmental Control System (ECS)

The Environmental Control System consists of:

(1) The water system which holds about 17 quarts of potable water, some of it a by-product of the fuel cells, and about 28 quarts of waste water used in the evaporator which helps cool the glycol system.

(2) The glycol system to absorb and transport heat from the cabin, electronic equipment, and a portion of the potable water to the space radiators.

Telecommunications System

The Telecommunications System provides telemetry and tracking and ranging communications between the spacecraft and ground stations, and capability to synchronize timing references for other spacecraft systems and to correlate telemetry data. The Apollo 4 system falls into two main categories:

(1) Data, with transmission and tape recording capability for structure and system inflight instrumentation and timing data, and

(2) Tracking and ranging, using C-band and S-band tracking by ground stations to help determine accurately the angular position and range of the spacecraft from the station.

System equipment divides into three groups:

(1) Data, including signal-conditioning, data storage, and central timing equipment, up data digital decoder, pulse-code modulation telemeter, premodulation processor;

(2) RF electronics, including VHF/FM transmitter and VHF/AM transceiver, C-band transponder, unified S-band equipment, VHF recovery beacon, and HF transceiver;

(3) Antennas, which are VHF omnidirectional, S-band, VHF recovery HF recovery, C-band.

Operational instruments associated with the data equipment and data transmission include some 24 classes of transducers to measure system pressure, temperature, flow, attitude, angular position, rates, events quantity and frequency.

Earth Landing System (ELS)

The Earth Landing System safely lands the command module through automatic sequence of drogue and main parachute deployment system includes recovery equipment for deployment and activation after landing.

Parachute Subsystem:

- (1) drogue chutes (two), conical ribbon nylon with canopy diameter of 13.7 feet;
- (2) pilot chutes (three), ring-slot nylon 7.2 feet diameter;
- (3) main chutes (three) ringsail nylon 83.5 feet diameter weighing 127 pounds each including canopy, risers and deployment bag.

Recovery Equipment:

- (1) uprighting system consisting of three compressor-inflated bags, two of which are used to upright the spacecraft if it lands apex down (Stable II) in the water (third bag is backup);
- (2) fluorescein sea dye marker with 12-hour capacity;
- (3) flashing beacon on command module apex;
- (4) VHF recovery beacon transmitter, located in command module lower equipment bay and activated during descent to provide continuous line-of-sight signals;
- (5) swimmer's umbilical, part of the tether holding the sea dye marker cannister.

Launch Escape System (LES)

The Launch Escape System provides safe abort capabilities from prior to liftoff through first 173 seconds of flight through automatic initiation by the emergency detection system (EDS) which senses booster malfunction. The three launch escape system abort phases -- pad, low altitude, and high-altitude -- are indicated in the accompanying chart. In the normal mission, the launch escape system is jettisoned shortly after ignition of the launch vehicle second stage; an abort after that time is accomplished by the service propulsion system engine. Operation of the Earth landing system under abort conditions is essentially the same as in a normal reentry descent.

-more-

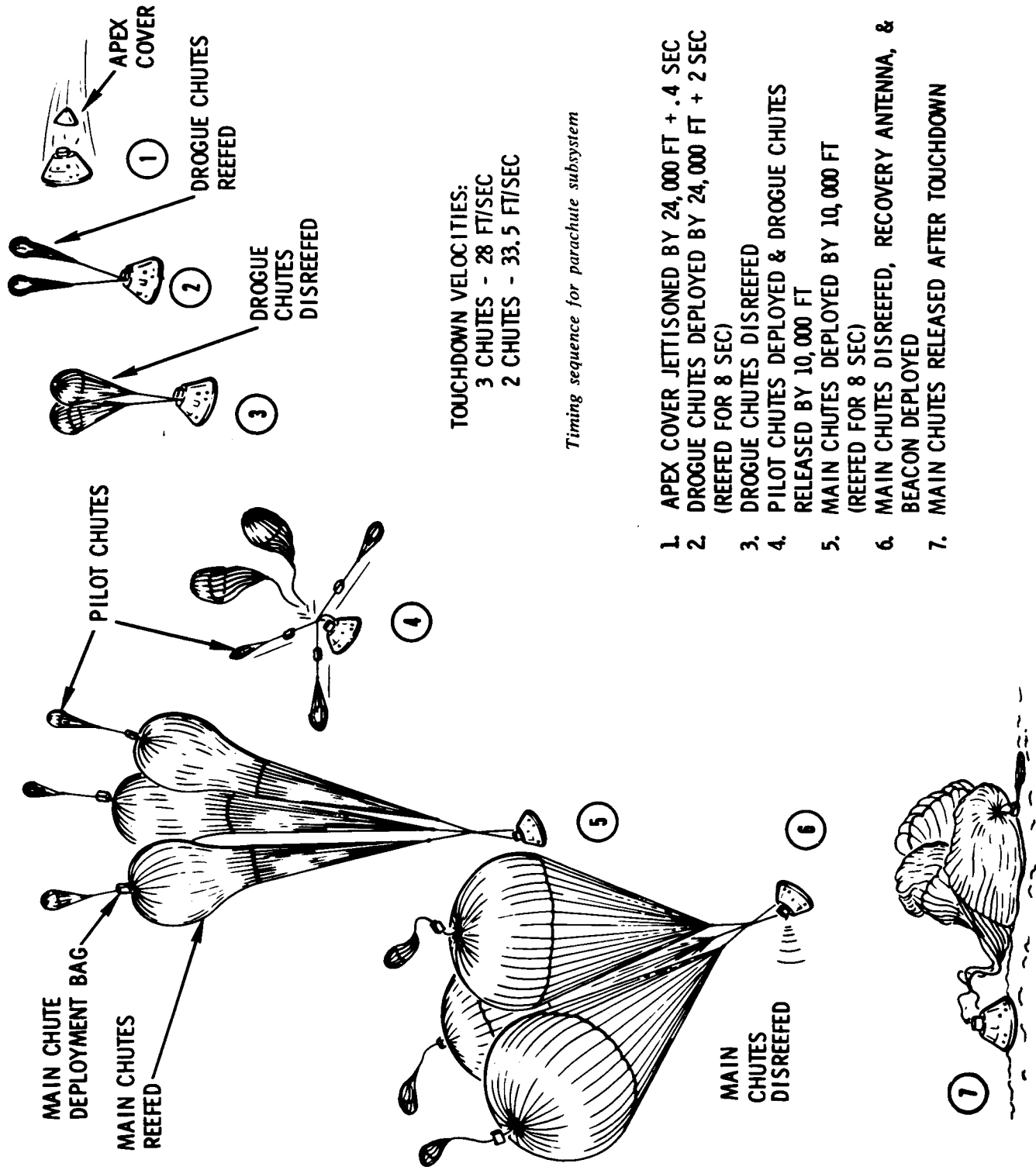

TOUCHDOWN VELOCITIES:

- 3 CHUTES - 28 FT/SEC
- 2 CHUTES - 33.5 FT/SEC

Timing sequence for parachute subsystem

1. APEX COVER JETTISONED BY 24,000 FT + .4 SEC
2. DROGUE CHUTES DEPLOYED BY 24,000 FT + 2 SEC (REEFED FOR 8 SEC)
3. DROGUE CHUTES DISREEFED
4. PILOT CHUTES DEPLOYED & DROGUE CHUTES RELEASED BY 10,000 FT
5. MAIN CHUTES DEPLOYED BY 10,000 FT (REEFED FOR 8 SEC)
6. MAIN CHUTES DISREEFED, RECOVERY ANTENNA, & BEACON DEPLOYED
7. MAIN CHUTES RELEASED AFTER TOUCHDOWN

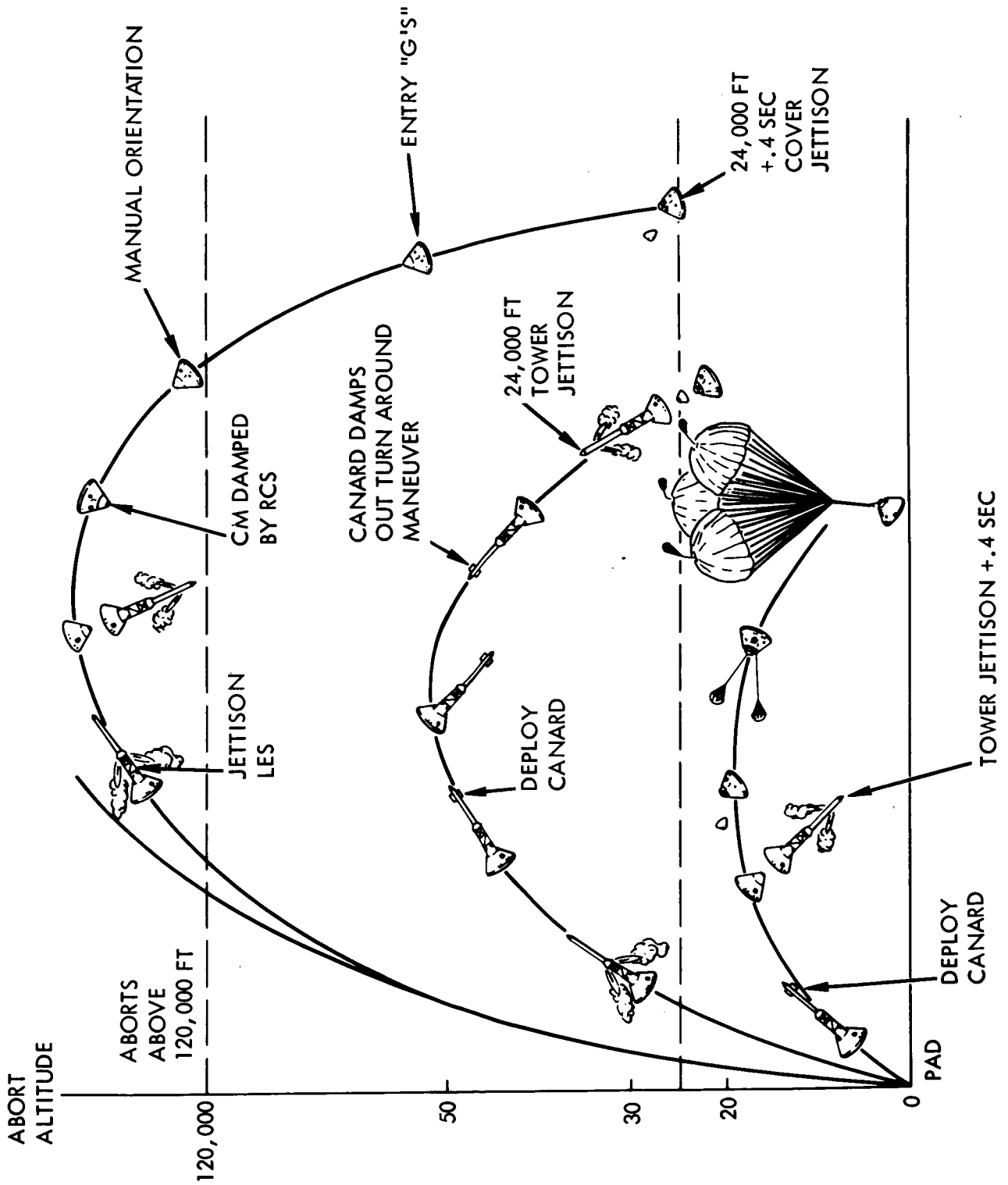

Sequence of pad, low-altitude, and high-altitude aborts

APOLLO 4 LAUNCH OPERATIONS

Apollo 4 mission launch operations are conducted by a team directed by NASA's John F. Kennedy Space Center. The final countdown will be run by a crew of more than 450 from Firing Room 1 in the Launch Control Center, Complex 39.

KSC launches manned and unmanned Apollo missions, using both the Uprated Saturn I and Saturn V launch vehicles. The KSC responsibilities include preflight test and checkout of the launch vehicle, spacecraft and support facilities, mate and integration of the overall space vehicle, countdown and launch.

All of these activities will come together for the first time at Complex 39 with the launch Apollo 4, the first Apollo/Saturn flight.

Two of the propulsion stages and the instrument unit of the Apollo 4 launch vehicle arrived at KSC during the last half of 1966: the first stage (SI-C) by barge from the Marshall Space Flight Center's Michoud Assembly Facility, New Orleans, in September; the third stage (S-IVB) from Sacramento by Super Guppy aircraft in August; and the instrument unit from Huntsville, also in August. The S-II second stage came in from Marshall's Mississippi Test Facility, Bay St. Louis, by barge in January 1967. Prior to S-II stage arrival, preliminary testing was begun on the other stages in the high bay of KSC's Vehicle Assembly Building (VAB) using a spacer in place of the S-II in the launch vehicle "stack."

The three stages and instrument unit were electrically mated in High Bay I of the VAB last February.

The Apollo 4 command and service modules arrived at KSC in December 1966. The spacecraft underwent preliminary checkout in the Manned Spacecraft Operations Building (MSOB) before it was mated to its adapter and moved to the VAB Jan. 12, 1967.

Following some preliminary tests, the Apollo 4 spacecraft was taken down in February and returned to the MSOB checkout area at KSC where the electrical wiring system was modified and reverified as a result of the Apollo 204 accident investigation.

The S-II stage was de-mated from the "stack" June 3 when some hairline cracks were discovered in the seams of a follow-on S-II stage undergoing checkout preparations at the contractor plant in Seal Beach, Calif. A series of X-ray and dye penetrant tests were conducted. No major discrepancies were found and the stage was re-erected June 20.

A series of launch vehicle combined systems tests followed before the spacecraft was brought to the VAB and electrically mated to the launch vehicle July 24. Combined tests of the overall space vehicle were now ready to begin.

Checks of the space vehicle emergency detection system and a series of simulated countdown and flight operations were made -- first with the umbilical connections intact (plugs in) and then with the umbilicals releasing at simulated liftoff (plugs out). Verification of the launch vehicle swing arm performance and a final simulated flight test were held before the launch vehicle retro and ullage rockets and the launch escape tower were installed.

Because of the tremendous complexity of the Apollo 4 space vehicle, Radio Corporation of America 110 A computers and digital data techniques are used throughout the automatic checkout from the time the launch vehicle is erected in the VAB through liftoff.

A similar but separate computer operation called ACE/SC (Acceptance Checkout Equipment/Spacecraft) is used to verify the flight readiness of the spacecraft systems.

Rollout of the Apollo 4 was Aug. 26 when the 363-foot space vehicle and its mobile launcher were transported 3.5 miles from the Vehicle Assembly Building to Pad A aboard the Transporter.

After the space vehicle and Mobile Launcher were mated to the pad, the computer data links that were disconnected for the rollout were again hooked up between Apollo 4 and the Launch Control Center.

The same Transporter used to carry the space vehicle to the pad moved the Mobile Service Structure (MSS) into position Aug. 28. The MSS permits 360-degree access to the launch vehicle and spacecraft during the final weeks of preparation.

Ground support equipment (GSE), such as communications circuitry, pneumatic and propellant lines, environmental controls and electrical power supply lines were connected, power was applied to the vehicle, and control and monitor links were verified.

Launch vehicle propellant loading tests and spacecraft systems verification checks were completed, leading up to the next major milestone -- the countdown demonstration test (CDDT).

The CDDT, which takes place about three weeks before launch, is a complete "dress rehearsal" of the actual countdown, including propellant loading. The test ends just before engine ignition.

Prior to entering the countdown phase, a final flight readiness test (FRT) is conducted to insure all elements of the mission are ready.

The FRT consists of a series of sequence tests in parallel with the actual countdown and in-flight operations. Tracking stations of the Eastern Test Range and the Mission Control Center, Manned Spacecraft Center, Houston, participate.

When the unfueled vehicle arrives at the pad, it weighs approximately 515,000 pounds. At liftoff the vehicle will weigh more than six million pounds.

APOLLO 4 COUNTDOWN

The clock for the Apollo 4 countdown will start at T-49 hours. Two built-in holds, totalling seven hours duration, are included in the count. Following are some of the highlights of the count.

- T-49 hrs. -- Power up launch vehicle. Start countdown.
- T-46 to T-39 hrs. -- Spacecraft helium servicing. Third stage auxiliary propulsion systems checks.
- T-38:30 hrs. -- Start spacecraft fuel cell activation.
- T-33:30 hrs. -- Load spacecraft fuel cell cryogenic (liquid oxygen and liquid hydrogen)
- T-21:30 hrs. -- Install space vehicle flight batteries.
- T-16:00 hrs. -- Range Safety checks.
- T-13:30 hrs. -- Launch vehicle power transfer test.
- T-11:30 hrs. -- Space vehicle emergency detection system test.
- T-11:00 hrs. -- Remove mobile service structure to park position.
- T-9:15 hrs. -- Install launch vehicle destruct packages.
- T-9:00 hrs. -- Spacecraft closeout -- 2.5 hour operation. Spacecraft switch list verification, final cabin inspection, environmental control system checks, hatch installation, and cabin leak checks.
- T-6:45 hrs. -- Retract Apollo spacecraft access arm.
- T-6:30 hrs. -- Start six-hour built-in hold.
- T-6:30 hrs. -- Resume count - Preparation for launch vehicle propellant loading.
- T-5:25 hrs. -- Start third stage (S-IVB) liquid oxygen loading.
- T-4:25 hrs. -- Start second stage (S-II) liquid oxygen loading.

- T-4:00 hrs. -- Start 90-minute built-in hold to complete S-II liquid oxygen load.
- T-4:00 hrs. -- Resume count. Start second stage (S-II) liquid oxygen load.
- T-3:30 hrs. -- Start first stage (S-IC) liquid oxygen load.
- T-2:30 hrs. -- Start second stage (S-II) liquid hydrogen load.
- T-1:34 hrs. -- Start third stage (S-IVB) liquid hydrogen load.
- T-60 mins. -- Start final launch vehicle radio frequency and telemetry checks.
- T-45 mins. -- Begin terminal countdown -- spacecraft final RF and communications checks.
- T-40 mins. -- Remove mobile launcher.
- T-27 mins. -- Power transfer test.
- T-15 mins. -- Spacecraft on internal power.
- T-10 mins. -- Arm launch escape system.
- T-8 mins. -- Space vehicle status check.
- T-3 mins.,
10 secs. -- Initiate firing command (automatic sequencer).
- T-50 secs. -- Launch vehicle power transfer to internal.
- T-8.9 secs. -- Ignition sequence starts.
- T-0 secs. -- Launch commit and liftoff.

NOTE: These times are approximate and subject to change prior to the launch date.

KSC LAUNCH COMPLEX 39

Until the Apollo 4 mission, NASA's launch operations have all been carried out at Cape Kennedy launch sites under the direction of the Kennedy Space Center.

When the late President Kennedy in 1961 announced the goal of landing astronauts on the Moon before the end of the decade, a suitable launch site had to be found to handle the 7.5 million pound thrust Saturn V vehicle required for the lunar flight. The 17,000-acre Cape Kennedy tract did not offer sufficient space for such a launch site.

A thorough study undertaken by NASA and the Department of Defense showed that the best location to launch the more powerful Moon rockets would be at an 88,000-acre site on Merritt Island, north and west of the Cape. The Center was relocated at what was designated the Kennedy Space Center in 1964.

With the development of the Saturn family of large thrust vehicles, and the resulting requirements for increased capabilities in all areas, the need for a new and improved launch concept was evident. These new requirements resulted in the mobile launch concept introduced at Complex 39.

The Mobile Concept

Since 1958, when the United States launched its first satellite, the fixed launch concept has been used exclusively in all NASA missions. This method calls for assembly, checkout and launch of a space vehicle at one site. In addition to tying up the launch pad, this method also can leave the flight equipment exposed to the vagaries of the weather for extended periods.

Using the mobile concept, the space vehicle is thoroughly checked in an enclosed building before it is moved to the launch pad for final preparations. This affords greater protection, a more systematic checkout process, and a high launch rate in the future, since the pad time will be minimal.

Apollo 4 is the first NASA mission using the mobile concept.

The major components of Complex 39 include: (1) the Vehicle Assembly Building (VAB) where the Apollo 4 space vehicle was assembled and prepared; (2) the Launch Control Center, electronic "brain" of the Complex; (3) the Mobile Launcher, upon which the Apollo 4 was erected for checkout and from which it will be launched; (4) the Mobile Service Structure, which provides external access to the Apollo/Saturn V space vehicle at the launch site; (5) the Transporter which carries the space vehicle, its Mobile Launcher, and the Mobile Service Structure to the launch pad; (6) the Crawlerway; and (7) the launch pad itself.

THE VEHICLE ASSEMBLY BUILDING

The Vehicle Assembly Building is the heart of Launch Complex 39. Covering eight acres, it is where the 363-foot-tall space vehicle is assembled and tested.

The VAB contains 129,482,000 cubic feet of space. It is 716 feet long, and 518 feet wide and it covers 343,500 square feet of floor space.

The foundation of the VAB rests on 4,225 steel pilings, each 16 inches in diameter, driven from 150 to 170 feet to bed-rock. If placed end to end, these piles would extend a distance of 123 miles. The skeletal structure of the building contains approximately 60,000 tons of structural steel. The exterior is covered by more than a million square feet of insulated aluminum siding.

The building is divided into a high bay area 525 feet high and a low bay area 210 feet high, with both areas serviced by a transfer aisle for movement of vehicle stages.

The low bay work area, approximately 442 feet wide and 274 feet long, contains eight stage preparation and checkout cells. These cells are equipped with systems to simulate stage interface and operation with other stages and the instrument unit of the Saturn V launch vehicle.

After the Apollo 4 launch vehicle upper stages arrived at the Kennedy Space Center, they were moved to the low bay of the VAB. Here, the second and third stages underwent acceptance and checkout testing prior to mating with the S-IC first stage atop Mobile Launcher #1 in the high bay area.

The high bay provides the facilities for assembly and checkout of both the launch vehicle and spacecraft. It contains four separate bays for vertical assembly and checkout. At present, two bays are equipped, a third bay is being outfitted and the fourth will be reserved for possible changes in vehicle configuration.

Work platforms -- some as high as three-story buildings -- in the high bays provide access by surrounding the launch vehicle at varying levels. Each high bay has five platforms. Each platform consists of two bi-parting sections that move in from opposite sides and mate, providing a 360-degree access to the section of the space vehicle being checked.

A 10,000-ton-capacity air conditioning system, sufficient to cool about 3,000 homes, helps to control the environment within the entire office, laboratory, and workshop complex located inside the the low bay area of the VAB. Air conditioning is also fed to individual platform levels located around the vehicle.

The Mobile Launcher also carries a chilled water system to assist in controlling the environment within the vehicle assembly area.

There are 141 lifting devices in the VAB, ranging from one-ton hoists to two 250-ton high-life bridge cranes.

The Mobile Launchers, carried by Transporter vehicles, move in and out of the VAB through four doors in the high bay area, one in each of the bays. Each door is shaped like an inverted T. They are 152 feet wide and 114 feet high at the base, narrowing to 76 feet in width. Total door height is 456 feet.

The lower section of each door is of the aircraft hangar type that slides horizontally on tracks. Above this are seven telescoping vertical lift panels stacked one above the other, each 50 feet high and driven by an individual motor. Each panel slides over the next to create an opening large enough to permit passage of the Mobile Launcher.

These doors are designed to withstand hurricane-force winds. Operating time for opening and closing is about 45 minutes.

THE LAUNCH CONTROL CENTER

Adjacent to the VAB is the Launch Control Center (LCC). This four-story structure is a radical departure from the dome-shaped blockhouses at other launch sites.

The electronic "brain" of Launch Complex 39, the LCC was used for checkout and test operations while Apollo 4 was being assembled inside the VAB. The LCC contains display, monitoring, and control equipment used for both checkout and launch operations.

The building has telemeter checkout stations on its second floor, and four firing rooms, one for each high bay of the VAB, on its third floor. Three firing rooms will contain identical sets of control and monitoring equipment, so that launch of a vehicle and checkout of others may take place simultaneously.

A high speed computer data link is provided between the LCC and the Mobile Launcher for checkout of the launch vehicle. This link can be connected to the Mobile Launcher at either the VAB or at the pad.

The three equipped firing rooms have some 450 consoles which contain controls and displays required for the checkout process. The digital data links connecting with the high bay areas of the VAB and the launch pads carry vast amounts of data required during checkout and launch.

There are 15 display systems in each LCC firing room, with each system capable of providing digital information instantaneously.

Sixty television cameras are positioned around the Apollo/Saturn V transmitting pictures on 10 modulated channels. The LCC also contains 112 operational intercommunication channels used by the crews in the checkout and launch countdown.

MOBILE LAUNCHER

The Mobile Launcher is a transportable launch platform and umbilical tower for the space vehicle.

The launch platform is a two-story steel structure, 25 feet high, 160 feet long, and 135 feet wide, which is positioned on six steel pedestals 22 feet high when in the VAB or at the launch pad. At the launch pad, in addition to the six steel pedestals, four extendable columns also are used to stiffen the Mobile Launcher against rebound loads, should engine cutoff occur.

The umbilical tower, extending 398 feet above the launch platform, is mounted on one end of the launch platform. A hammer-head crane at the top has a hook height of 376 feet above the deck with a traverse radius of 85 feet from the center of the tower.

The 12-million-pound mobile launcher stands 445 feet high when resting on its pedestals. The base, covering about half an acre, is a compartmented structure built of 25-foot steel girders.

The launch vehicle sits over a 45-foot-square opening which allows an outlet for engine exhausts into a flame trench containing a flame deflector. This opening is lined with replaceable steel blast shield, independent of the structure, and will be cooled by a water curtain initiated two seconds after liftoff.

The umbilical tower service arms and related plumbing, cabling and equipment. It incorporates 18 work and access platforms, two 600-foot-per-minute elevators, and systems for propellant and pneumatic distribution, communications, closed circuit television, electrical power, instrumentation and water.

There are nine hydraulically-operated service arms. These swing arms support lines for the vehicle umbilical systems and provide access for personnel to the stages.

On the Apollo 4 mission two of the service arms (including the Apollo spacecraft access arm) are retracted early in the count. A third is released at T-30 seconds, and a fourth at T-16.7 seconds. The remaining five arms are armed at T-0 and swing back at vehicle first motion.

The swing arms are equipped with a backup retraction system in case the primary mode fails.

The Apollo 4 vehicle is secured to the Mobile Launcher by four combination support and holddown arms mounted on the launcher deck. The holddown arms are a one-piece casting approximately six by nine feet at the base and 10 feet tall, weighing over 20 tons. Damper struts secure the vehicle near its top.

After the engines are ignited, the arms will hold Apollo 4 for about six seconds until the engines build up to 95 per cent thrust and other monitored systems indicate they are functioning properly. The arms release on receipt of a launch commit signal at the zero mark in the count.

Three tail service masts are connected to the base of the vehicle. They carry umbilical connections for environmental control of the S-IC boattail area, RP-1 fuel loading, and emergency draining of the first stage liquid oxygen supply.

THE TRANSPORTER

The six-million-pound Transporters, the largest tracked vehicles known, move Mobile Launchers into the VAB and Mobile Launchers with assembled Apollo space vehicles to the launch pad. They also are used to transfer the Mobile Service to and from the launch pads.

The first operational test of the Transporter came in May 1966, during the rollout of the Apollo/Saturn 500F facility model. The half-million-pound Saturn V model and 12-million-pound Mobile launcher were transported 3.5 miles to Launch Pad A. The 500F was used at the pad to verify launch facilities, develop and test checkout procedures, and train launch crews.

On June 8, 1966, when a hurricane threatened the KSC area, the Transporter moved the 500F back into the VAB until the storm threat passed.

The Transporter is 131 feet long and 114 feet wide. The vehicle moves on four double-tracked crawlers, each 10 feet high and 40 feet long. Each shoe on the crawler tracks seven feet six inches in length and weighs about a ton.

Sixteen traction motors powered by four 1,000-kilowatt generators, which in turn are driven by two 2,750-horsepower diesel engines, provide the motive power for Transporter. Two 750-kw generators, driven by two 1,065-horsepower diesel engines, power the jacking, steering, lighting, ventilating and electronic systems.

Maximum speed of the Transporter is about one-mile-per-hour loaded and about two-miles-per-hour unloaded. A trip from the pad with a Mobile Launcher, made at less than maximum speed, takes approximately seven hours.

The Transporter has a system designed to keep the top of the space vehicle vertical within plus-or-minus 10 minutes of arc -- about the dimensions of a basketball.

This system also provides leveling operations required to negotiate the five per cent ramp which leads to the launch pad, and keeps the load level when it is raised and lowered on pedestals both at the pad and within the VAB.

The overall height of the Transporter is 20 feet from ground level to the top deck on which the Mobile Launcher is mated for transportation. The deck is flat and about the size of a baseball diamond (90 by 90 feet).

Two operator control cabs, one at each end of the chassis located diagonally opposite each other, provide totally enclosed stations from which all operating and control functions are coordinated.

The Transporter moves on a roadway 131 feet wide, divided by a median strip. This is almost as broad as an eight-lane turnpike and is designed to accommodate a combined weight of about 18 million pounds.

The roadway is built in three layers with an average depth of seven feet. The roadway base layer is two-and-one-half feet of hydraulic fill compacted to 95 per cent density. The next layer consists of three feet of crushed rock packed to maximum density, followed by a layer of one foot of selected hydraulic fill. The bed is topped and sealed with an asphalt prime coat.

On top of the three layers is a cover of river rock, eight inches deep on the curves and six inches deep on the straightway. This layer reduces the friction during steering and helps distribute the load on the Transporter bearings.

THE MOBILE SERVICE STRUCTURE

A 402-foot-tall, 9.8-million-pound tower is used to service the Apollo launch vehicle and spacecraft at the pad. The 40-story steel-trussed tower, called a Mobile Service Structure, provides 360-degree platform access to both the Saturn vehicle and the Apollo spacecraft.

The service structure has five platforms -- two self-propelled and three fixed, but relocatable. Two high-rise elevators carry personnel and equipment between work platforms. The platforms have the capability of opening and closing around the 363-foot space vehicle.

After depositing the Mobile Launcher with its space vehicle on the pad, the Transporter returns to a parking area about 7,000 feet from the pad. There it picks up the Mobile Service Structure and moves it to the launch pad. At the pad, the high tower is lowered and secured to four mount mechanisms.

The top three work platforms are located in fixed positions which serve the lunar module, the service module, the command module and the launch escape system of the Apollo spacecraft.

The two lower platforms serve the Saturn V and can be moved vertically.

The Mobile Service Structure remains in position until about T-6 hours when it is removed from its mounts and returned to the parking area.

WATER DELUGE SYSTEM

A water deluge system will provide a million gallons of industrial water for cooling and fire prevention during launch of Apollo 4. Once the service arms are retracted at liftoff, a spray system will come on to cool these arms from the heat of the five Saturn F-1 engines during liftoff.

On the deck of the Mobile Launcher are 29 water nozzles. This deck deluge will start immediately after liftoff and will pour across the face of the launcher for 30 seconds at the rate of 50,000 gallons-per-minute. After 30 seconds, the flow will be reduced to 20,000 gallons-per-minute.

Positioned on both sides of the flame trench are a series of nozzles which will begin pouring water at 8,000 gallons-per-minute, 10 seconds before liftoff. This water will be directed over the flame deflector.

Other flush mounted nozzles, positioned around the pad, will wash away any fluid spill as a protection against fire hazards.

FLAME TRENCH AND DEFLECTOR

The flame trench is 58 feet wide and approximately six feet above mean sea level at the base. The height of the trench and deflector is approximately 42 feet.

The flame deflector weighs about 1.3 million pounds and is stored outside the flame trench on rails. When it is moved beneath the launcher, it is raised hydraulically into position. The deflector is covered with a four-and-one-half-inch thickness of refractory concrete consisting of a volcanic ash aggregate and a calcium aluminate binder. The heat and blast of the engines are expected to wear about three-quarters of an inch from this refractory surface during the Apollo 4 launch.

PAD AREAS

Both Pad A and Pad B of Launch Complex 39 are roughly octagonal in shape and cover about one fourth of a square mile of terrain.

The center of the pad is a hardstand constructed of heavily reinforced concrete. In addition to supporting the weight of the Mobile Launcher and the Saturn V vehicle, it also must support the 9.8-million-pound Mobile Service Structure and 5.5-million-pound Transporter, all at the same time.

Saturn V propellants -- liquid oxygen, liquid hydrogen, and RP-1 -- are stored near the pad perimeter.

Stainless steel, vacuum-jacketed pipes carry the liquid oxygen (LOX) and liquid hydrogen from the storage tanks to the pad, up the Mobile Launcher, and finally into the launch vehicle propellant tanks.

LOX is supplied from a 900,000-gallon storage tank. A centrifugal pump with a discharge pressure of 320 pounds-per-square-inch pumps LOX to the vehicle at flow rates as high as 10,000-gallons-per-minute.

Liquid hydrogen, used in the second and third stages, is stored in an 850,000-gallon tank, and is sent through 1,500 feet of 10-inch, vacuum-jacketed invar pipe. A vaporizing heat exchanger pressurizes the storage tank to 60 psi for a 10,000-gallons-per-minute flow rate.

The RP-1 fuel, a high grade of kerosene is stored in three tanks -- each with a capacity of 86,000 gallons. It is pumped at a rate of 2,000 gallons-per-minute at 175 psig.

The Complex 39 pneumatic system includes a converter-compressor facility, a pad high-pressure gas storage battery, a high-pressure storage battery in the VAB, low and high-pressure, cross-country supply lines, high-pressure hydrogen storage and conversion equipment, and pad distribution piping to pneumatic control panels. The various purging systems require 187,000 pounds of liquid nitrogen and 21,000 gallons of helium.

MISSION PROFILE

Launch

Launch of Apollo 4 will be from Pad A of Launch Complex 39 at the Kennedy Space Center. Earliest liftoff is 7 a.m. EST and the latest time is 12 noon EST on date of launch. Flight azimuth is 72 degrees from true north.

Flight Profile and Sequence of Events

Flight Profile

The first stage of the Saturn V will carry the vehicle and Apollo spacecraft to an altitude of 33.5 nautical (38.5 statute) miles and 47.5 nautical (54.9 statute) miles downrange, building up speed to 5,300 knots (6,100 miles-per-hour) during its 2½ minutes of powered flight. After separation from the second stage, the first stage will continue on a ballistic trajectory that will let it fall into the Atlantic Ocean some 340 nautical (391 statute) miles downrange from Cape Kennedy (latitude 30.2 degrees North and longitude 74.3 degrees West) about nine minutes after liftoff.

The second stage, with engines running 6.1 minutes, will propel the vehicle to an altitude of about 101 nautical (117 statute) miles some 810 nautical (935 statute) miles downrange, building velocity to 13,300 knots (15,300 statute) miles-per-hour (space fixed velocity). The spent second stage will impact the Atlantic Ocean about 20 minutes after liftoff some 2,260 nautical (2,600 statute) miles from KSC, approximately at latitude 31.8 degrees North and longitude 36.8 degrees West.

The third stage, in its 136-second initial burn period, will place itself and the Apollo spacecraft into a circular orbit 101 nautical (117 statute) miles above the Earth. Its inclination will be 32.73 degrees and its orbital period 88.2 minutes. Apollo 4 enters orbit at 55 degrees West longitude, 32.6 degrees North latitude at a velocity of 25,568 feet-per-second 17,500 statute miles-per-hour, or 15,200 knots.

During the two revolutions of Earth parking orbit, the Saturn V third stage will maintain an orbital pitch rate to keep the spacecraft and third stage in an attitude which would place a crew heads down, facing forward into the line of flight if the mission were manned. No major propulsion systems are used during the Earth parking phase, but low-level ullage and venting thrust from the Saturn V third stage will cause small changes in the orbit.

Second Third-Stage Burn

When the spacecraft passes over the western coast of the United States on the second revolution, the preignition sequence will begin for the second burn of the Saturn V third stage. Time from liftoff will be about three hours and six minutes, about six minutes before third-stage ignition.

The stage will maneuver at rates of one degree-per-second to reach a predetermined alignment for the burn. The burn is designed to achieve an Earth-intersecting coast ellipse with a 30.15-degree inclination, a 9,300 -nautical-mile apogee (10,710 statute-mile) an entry flight path angle of 9.15 degrees down from local horizontal, and an entry point at 20.8 degrees North latitude and 157 degrees East longitude.

The trajectory meets requirements for a four-hour spacecraft cold-soak and results in an entry load factor of about 17.7 g to insure a moderately high entry heat rate test in the event of a service propulsion system (SPS) failure.

The predetermined attitude for this burn is a pitch angle of -40.08 degrees and a yaw angle of 14.85 measured in the launch site inertial reference system.

Engine burn is based on nominal fuel depletion, and is estimated at 305 seconds. At engine cutoff, the spacecraft attitude is 57.7 degrees pitch and 17.04 degrees yaw.

Orbital Coast and Cold-Soak

After third-stage cutoff, the spacecraft is oriented relative to the Sun so that the thick side of the command module heat shield is in shadow. The cold-soak attitude is held until the start of the preignition sequencing for the first service propulsion system burn and through the coast phase following that burn.

Ten minutes after third-stage engine cutoff, a programmed separation signal is fed into the Apollo guidance computer (AGC) to initiate separation of the command and service modules from the Saturn V third stage. The Apollo Guidance Computer initiates a service module reaction control system burn to achieve a forward thrust. After 1.7 seconds of thrusting, the spacecraft and the launch vehicle third stage separate. Reaction control system thrusting continues for another 8.3 seconds to separate the vehicles at a rate of about two feet-per-second.

The third stage is expected to reenter over the Pacific about four and one-half hours after separation.

At thrust termination, the command and service module begins a 26-second reorientation maneuver from the cold-soak attitude to an attitude for service propulsion system ignition. A 64-second attitude-hold phase follows. Since there is no further thrusting during the attitude-hold phase, the mission requirement for a no-ullage start of the service propulsion system is met.

First Burn

Ignition attitude for the first service propulsion system burn is pitch up about 28 degrees from the inertial velocity vector, or 56 degrees from the local horizontal. The burn will last 16 seconds and will result in an apogee of 9,890 nautical miles (11,400 statute miles), a perigee of 43 nautical miles (-49.5 statute miles). Inclination will be 30.13 degrees. Reentry velocity and flight path angle, in the event the second service propulsion system ignition does not occur, will be 32,312 feet-per-second and 8.75 degrees down from the local horizontal with a resultant maximum load factor of 16 g.

Insertion into this new ellipse will occur about 12.15 degrees North latitude, 19.35 degrees West longitude at service propulsion system engine cutoff three hours and 29 minutes after liftoff.

Earth Intersecting Coast

After service propulsion system cutoff, the spacecraft initiates a programmed reorientation maneuver to reestablish the cold-soak attitude. This is a nominal 26-second maneuver. At this same time, the Apollo guidance computer begins calculation of the time of free fall to reentry (400,000 feet). The coast phase ends 25 minutes before reentry.

About two hours and 20 minutes after service propulsion system cutoff -- five hours and 49 minutes after liftoff -- the spacecraft reaches apogee and begins its descent. The coast phase will end about two hours 10 minutes after apogee. At this time Carnarvon, Australia, ground station will update the Apollo guidance computer with spacecraft position, velocity and time of free fall to reentry.

Some two minutes after this update is received the Apollo guidance computer schedules the second service propulsion system ignition for two minutes later. When time of free fall to reentry reaches 599.6 seconds, the command and service module reaction control system begins a 30-second ullage maneuver, which is followed immediately by service propulsion system ignition. Time from first service propulsion system cutoff is some four hours 46 minutes, from liftoff eight hours 15 minutes.

Second Service Propulsion System Burn

The second burn of the service propulsion system is designed to achieve a reentry velocity of 36,333 feet-per-second (25,000 statute miles-per-hour, 21,800 knots) and a flight path angle 7.13 degrees below the local horizontal. The burn will last about 269 seconds. Ignition attitude is about 25.5 degrees below the inertial velocity vector, or 48.5 down from the local horizontal, in pitch.

Reentry Sequence

At service propulsion system cutoff, about 240 seconds remain until reentry begins (400,000-feet-altitude). During this period the command module and service module separation and the command module reentry attitude orientation maneuvers will be performed. The maneuvers occur over the West Pacific within the Guam area of coverage.

When time of free fall to reentry equals 200 seconds, the spacecraft will reorient itself with the +X axis 60 degrees above the inertial velocity vector. The attitude is such that a crew would be heads up and facing forward. This attitude remains constant until time of free fall to reentry becomes 85 seconds. At that time, physical separation occurs with the four service module reaction control system forward-firing thrusters providing a rearward push to the service module. The thrusters fire until reaction control system propellant depletion.

Nominal splashdown for the service module (spin-stabilized, non-tumbling reentry) will be about eight hours and 41 minutes after liftoff -- 15 minutes 15 seconds after separation -- 28.8 North latitude and 178.2 East longitude.

Allowing about five seconds after separation for command module stabilization, the guidance and navigation system will reorient the spacecraft to the predetermined reentry attitude. This attitude is 154.8 degrees angle of attack with the relative velocity vector, with the lift vector up. A crew would be heads down, facing rearward.

Reentry, considered as beginning when the spacecraft reaches 400,000 feet altitude, will occur about eight hours and 23 minutes after liftoff at 22.3 degrees North latitude and 152.7 degrees East longitude with inertial velocity of 36,333 feet-per-second (25,000 statute miles-per-hour) and an inertial flight path angle of 7.13 degrees below the local horizontal. Applying a nominal command module lift-to-drag (L over D) ratio of 0.35 to the reentry profile, the splash point will be 30.05 degrees North latitude and 171.0 degrees West longitude, some 2,000 nautical miles (2,300 statute miles) downrange from reentry.

This reentry provides the criteria for certification of the command module heat shield. Those criteria are a maximum reentry heat rate of 568 British Thermal Units (BTU) per-square-foot-second, a total heat load of 35,740 BTU per-square-foot, and a maximum reentry load factor of 8.28 g. The maximum heat rate will be encountered about 59 seconds after a normal reentry, maximum load about 72 seconds after reentry.

Communications blackout will occur some 26 seconds after reentry and will last about 108 seconds. Blackout is referenced to C-band tracking. Drogue parachute deployment takes place 14 minutes and 24 seconds after reentry at an altitude of 23,500 feet, main parachute deployment 50 seconds later at 10,200 feet. Splashdown for a nominal mission will be eight hours 43 minutes after liftoff at 30.5 degrees North latitude and 71.0 degrees West longitude, or some 540 nautical miles (622 statute miles) northwest of the Kauai, Hawaii, tracking station.

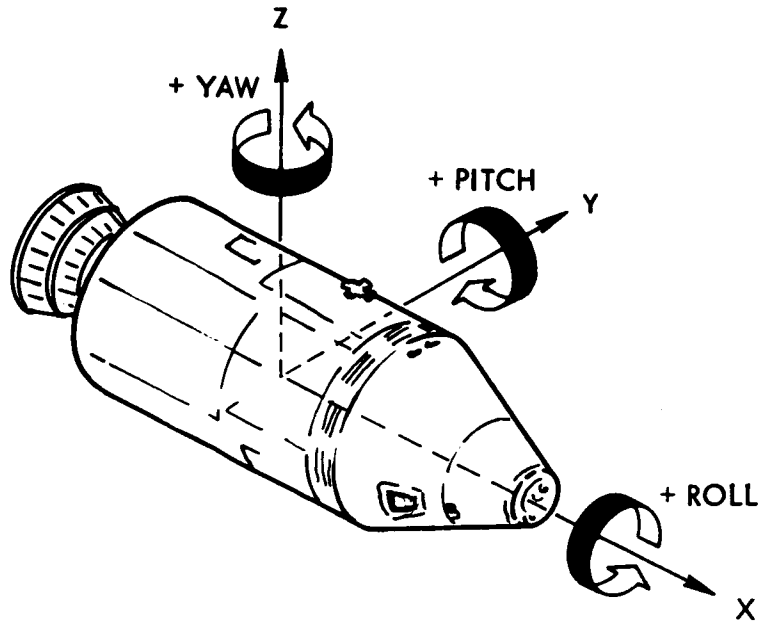

SPACECRAFT COORDINATE SYSTEM

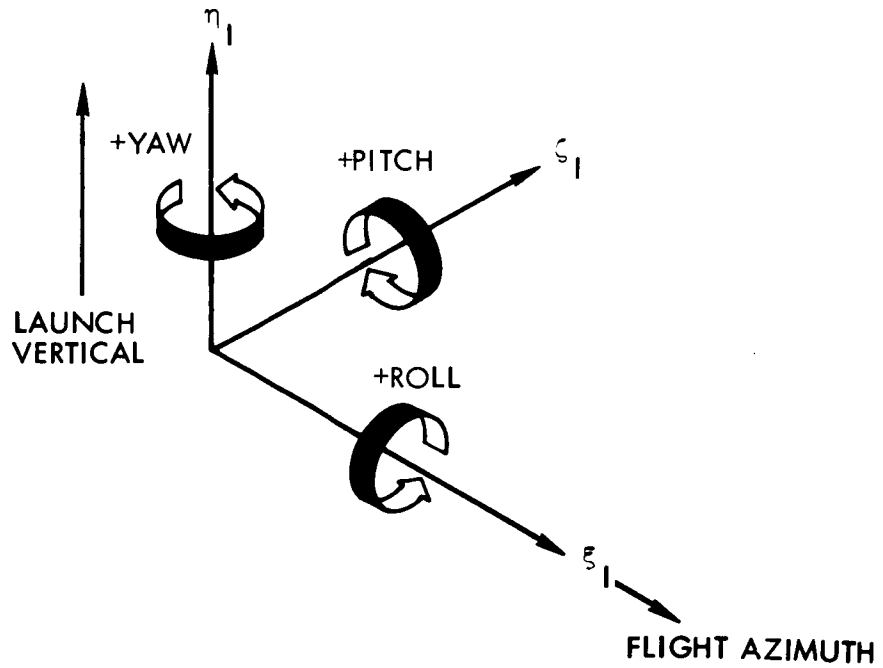

LAUNCH SITE INERTIAL ATTITUDE REFERENCE SYSTEM

Spacecraft and Reference Coordinate Systems

Apollo 4 Normal Events Summary

Event	Time From Lift-Off (Hr:Min:Sec)	Weight (Lbs.)	Altitude (Ft.)	Geodetic Latitude (Deg.)	Longitude (Deg.)	Inertial Velocity (Ft/Sec)
<u>Earth Parking Orbit</u>						
Start Earth Parking Orbit	00:11:10	274,830	628,129	32.6N	55.0W	25,568
Start Second Revolution	01:38:35	273,868	634,036	32.5N	80.5W	25,568
Start 3rd Stage Attitude Orientation and Preig- nition Sequence	03:05:07	272,889	645,208	32.3N	105.6W	25,560
<u>Second 3rd Stage Burn</u>						
Engine Ignition	03:11:33	272,235	645,921	31.8N	80.8W	25,560
Engine Cut-off	03:16:37	126,254	1,915,479	27.3N	56.9W	30,689
<u>Coast to First SPS Burn</u>						
Begin Reorientation to Cold- Soak Attitude	03:16:55	126,254	1,915,479	27.3N	56.9W	30,689
End of Reorientation to Cold- Soak Attitude	03:19:59	126,254	3,589,844	23.7N	44.1W	29,281
CSM/3rd Stage Separation	03:26:57	51,759	8,179,504	14.6N	23.7W	25,999
Begin Reorientation to First SPS Ignition Attitude	03:27:05	51,747	8,276,797	14.4N	23.4W	25,938
End of Reorientation to First SPS Ignition Attitude	03:27:31	51,735	8,581,507	13.9N	22.4W	25,745

-more-

Apollo 4 Normal Events Summary (Cont'd.)

Event	Time From Lift-Off (Hr:Min:Sec)	Weight (Lbs.)	Altitude (Ft.)	Geodetic Latitude (Deg.)	Longitude (Deg.)	Inertial Velocity (Ft/Sec)
<u>First SPS Burn</u>						
SPS Engine Ignition	03:28:18	51,735	9,338,869	12.6N	20.2W	25,276
SPS Engine Cut-off	03:28:34	50,114	9,626,106	12.2N	19.4W	25,385
<u>Earth Intersecting Coast</u>						
Begin Reorientation to Cold- Soak Attitude	03:28:59	50,070	9,636,329	12.1N	19.3W	25,385
End of Reorientation to Cold- Soak Attitude	03:29:26	50,058	9,952,012	11.6N	18.5W	25,198
Apogee	05:48:42	50,016	60,037,519	28.8S	37.6E	8,410
Begin Reorientation to Second SPS Ignition Attitude	08:01:09	49,977	14,977,108	12.4S	91.9E	22,522
End of Reorientation to Second SPS Ignition Attitude	08:01:41	49,967	14,591,678	11.9S	92.6E	22,711
RCS Thrusters On	08:14:08	49,965	5,590,702	3.4N	116.7E	28,018
<u>Second SPS Burn</u>						
Second SPS Engine Ignition	08:14:43	49,922	5,256,557	4.3N	118.05E	28,266
Second SPS Engine Cut-off	08:19:72	31,665	2,275,763	13.1N	133.0E	34,818

Apollo 4 Normal Events Summary (Cont'd.)

Event	Time From Lift-Off (Hr:Min:Sec)	Weight (Lbs.)	Altitude (Ft.)	Geodetic Latitude (Deg.)	Longitude (Deg.)	Inertial Velocity (Ft./Sec)
<u>Pre-Entry Sequence</u>						
Begin Reorientation to CM/SM Separation Attitude	08:19:45	31,620	1,852,430	14.7N	135.9E	35,152
End of Attitude Orientation Coast to CM/SM Separation	08:20:00	31,608	1,714,073	15.2N	137.0E	35,260
CM/SM Separation	08:21:40	11,250	886,027	19.1N	145.1E	35,925
Start CM Attitude Orientation for Entry	08:21:45	11,250	851,761	19.3N	145.5E	35,953
End of Attitude Orientation Coast to Entry	08:22:03	11,240	734,509	19.9N	147.1E	36,051
<u>Atmospheric Entry</u>						
400,000-Ft. Altitude	08:23:12	11,240	400,000	22.3N	152.7E	36,333
Enter Communications Blackout	08:23:31	11,240	293,856	23.2N	155.2E	36,416
Exit Communications Blackout	08:25:19	11,240	211,360	25.9N	171.0E	24,281
Drogue Parachute Deployment	08:37:29	10,543	23,500	30.05N	171.0E	1,395
Main Parachute Deployment	08:38:19	10,226	10,200	30.05N	171.0E	1,338
CM Splash	08:41:00	9,877	0	30.05N	171.0E	1,320

APOLLO 4 RECOVERY

The Apollo 4 mission landing area is in the mid-Pacific near Hawaii (Zone 4).

Sea and air recovery vehicles and crews are provided by the Department of Defense. Deployment of forces, and techniques of search and recovery, will follow those used during previous Apollo missions.

The normal recovery plan calls for landing during daylight hours. Recovery aids activated just before and after landing will, however, assist recovery crews in locating the spacecraft in darkness as well as daylight.

Abort Recovery

Mode 1 aborts using the launch escape system occur "off-the-pad" prior to or at liftoff, at "low altitude" (to 120,000 feet) and at "high altitude" (above 120,000 feet). After launch escape system jettison 173 seconds after liftoff, Mode 2 abort is accomplished by a full-lift reentry after a service module reaction control system separation maneuver.

Some 14 seconds after an off-the-pad -- or an extremely low altitude abort is initiated -- the launch escape system is jettisoned from the command module. At higher altitudes, it is jettisoned at 24,000 feet.

Sequencing of the Earth landing system (ELS) is the same as for landing after orbital flight.

Boundaries of the launch abort landing corridor, beyond the launch site landing area immediately surrounding the launch pad, are the most extreme launch azimuth ground tracks anticipated. Spotting of recovery forces within this corridor is based on the probability of a landing in or near each particular area.

Access time to abort landing points is greater for some areas in the abort corridor than for the planned landing zone for orbital flight. Aircraft access time of no more than four hours to any point in the abort corridor is probable, however.

Atlantic Recovery Forces

Stationed downrange in the Atlantic in the 300-400-mile range from Cape Kennedy will be recovery ships and planes to locate and recover two camera capsules and to serve as a spacecraft recovery team if there should be an aborted mission.

A secondary requirement will be the sighting and recovery, if possible, of the S-IC booster or any portion surviving reentry and impact.

MID-PACIFIC RECOVERY ZONE

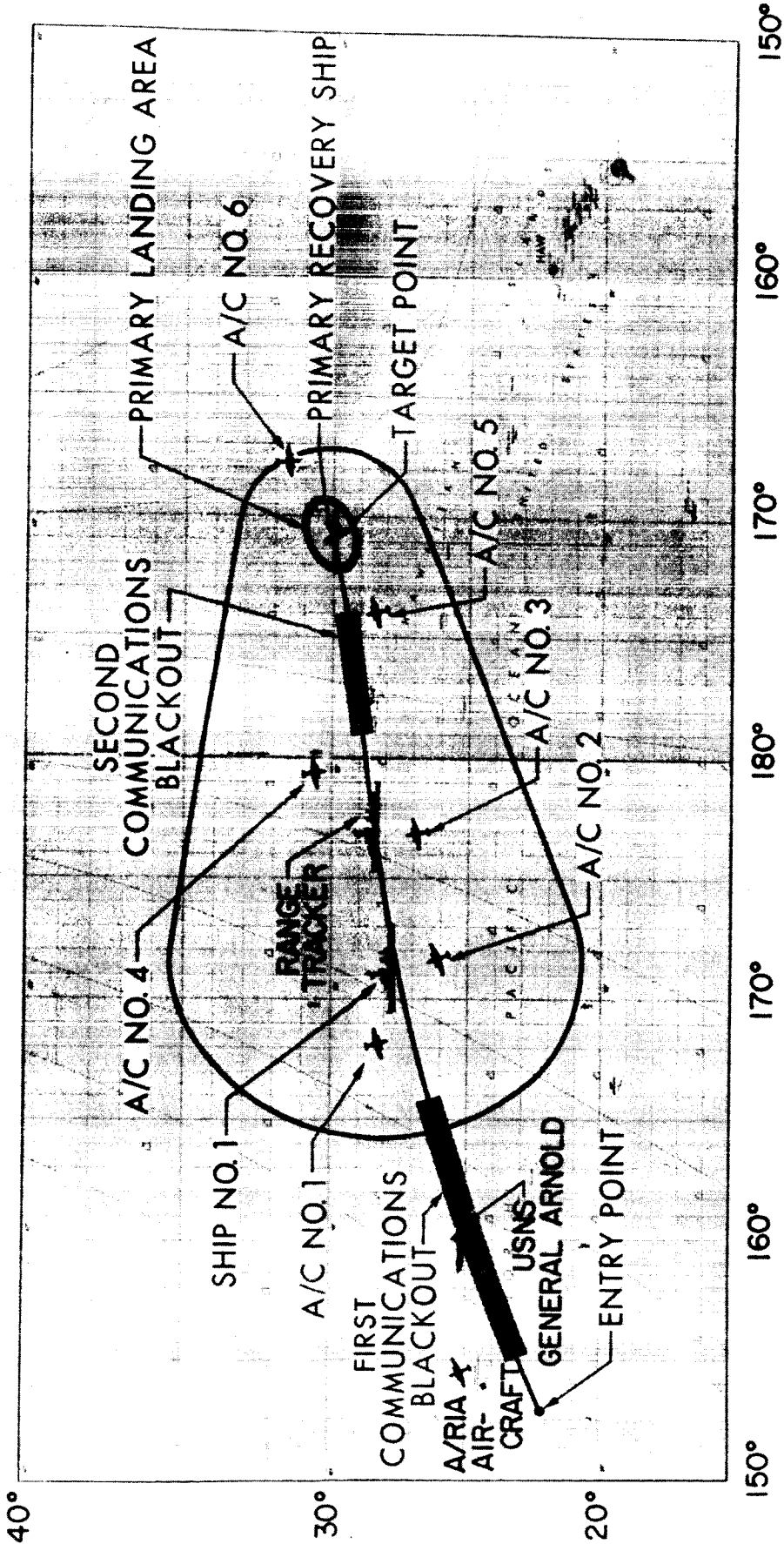

An LPD (landing platform dock) will be in the immediate area in which the cameras and booster are expected to impact. Helicopters launched from the ship's heliport will search for the camera capsules ejected some 38 seconds after first and second-stage first-plane separation. Impact point should be some 470 miles from the launch site.

These personnel and those in Air Force planes in the area will also attempt to sight the booster and photograph the impact. Should any portion of the booster survive the impact and float, the LPD will attempt a recovery. Two Marshall center representatives will be on the ship to identify components and decide if they may be safely recovered. The LPD's lower section may be flooded to allow large sections to be hauled aboard. Should the draft of any floating component be too great for the ship, alternate procedures call for towing it to the nearest land and beaching the component.

The booster reentry sighting-and-recovery exercise is being conducted to support an advanced missions study on recovering and refurbishing large space vehicles.

MISSION CONTROL CENTER - HOUSTON (MCC-H)

The Mission Control Center at the Manned Spacecraft Center in Houston will be the focal point for all Apollo flight control activities. In performing the control function, and determining the progress of the flight, the Mission Control Center - Houston will receive tracking and telemetry data from the Manned Space Flight Network. This data will be processed through the Mission Control Center - Houston Real-Time Computer Complex (RTCC-H) and used to drive displays for the flight controllers and engineers in the Mission Operations Control Room and Staff Support rooms. Real-time spacecraft television will be received at the Mission Control Center - Houston from the Cape Kennedy area.

A portion of the Mission Control Center - Houston flight control responsibility will be delegated to the flight control teams from Houston which will be manning three of the Manned Space Flight Network stations. These teams will have display and communications capabilities which will permit them to operate somewhat independently or "remote," in network terminology. During the time these stations are operating remote, telemetry data will be transmitted to the Mission Control Center - Houston in teletype form only. Spacecraft commands also may be initiated from the remote stations by the flight control team located there.

THE MANNED SPACE FLIGHT NETWORK (MSFN)

Ground Systems for Spacecraft Guidance, Command and Control

The Manned Space Flight Network is an around-the-world extension of the Mission Control Center's monitoring and command control capabilities. Apollo 4 will demonstrate the network's ability to provide the Flight Director complete navigational and mission event control through its global remote facilities.

Geographically, the Manned Space Flight Network for Apollo is similar to the configuration employed in both Projects Mercury and Gemini. As the magnitude and technology of Project Apollo increased, the worldwide ground systems' sophistication increased to fill Apollo's greater needs.

New Developments

Extensive alterations have been made to network equipment to accommodate the greater volumes of astronaut and spacecraft information to be exchanged with ground stations over longer periods of time. A higher degree of reliability has also been incorporated into the network by designing redundancy where necessary.

GROUND STATIONS FOR APOLLO-4 MISSION

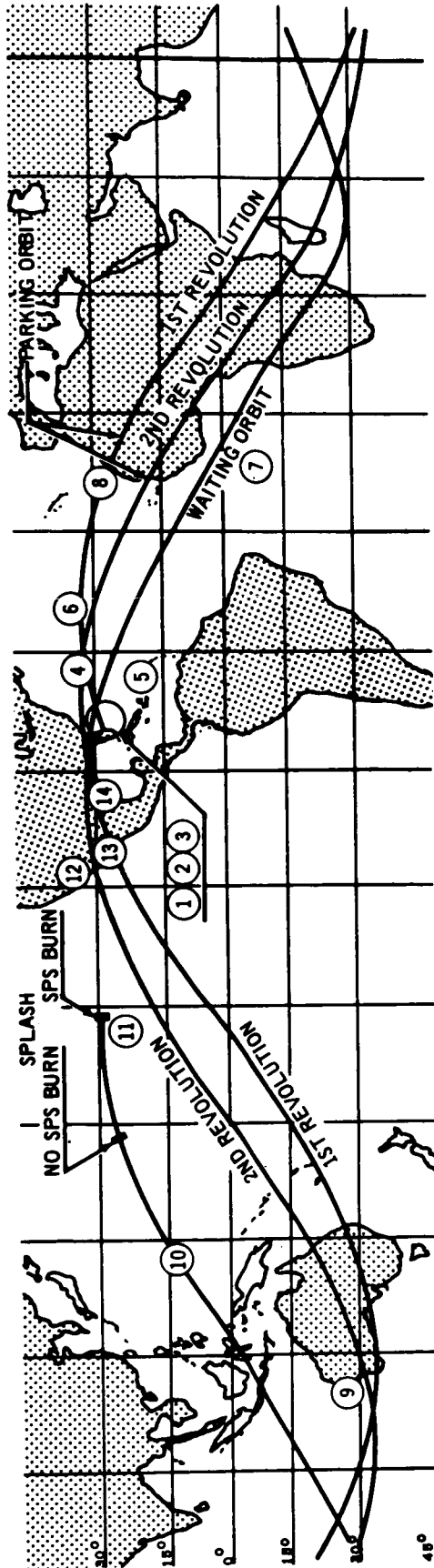

- | | | |
|-----------------|-------------------|--------------------|
| 1. KSC AREA | 6. INSERTION SHIP | 11. HAWAII |
| 2. GRAND BAHAMA | 7. ASCENSION | 12. GOLDSTONE |
| 3. GRAND TURK | 8. GRAND CANARY | 13. GUAYMAS |
| 4. BERMUDA | 9. CARNARVON | 14. CORPUS CHRISTI |
| 5. ANTIGUA | 10. GUAM | |

Why?

Apollo spacecraft weight, space limitations, mission duration and distance demanded a more compact tracking/communications system of greater power, flexibility and reliability. Out of these requirements, the Apollo Unified S-Band System (USB) was born. This system combines in a single transmission several mission functions previously requiring the separate systems.

These are:

- (a) Tracking and determining flight path and velocity
- (b) Commanding the spacecraft via coded radio signals
- (c) Receiving telemetry (coded radio)
- (d) Receiving telemetry on spacecraft integrity, systems condition, batteries, fuel state and performance

Some USB ground stations have the additional capability to provide tracking and communications data exchange for two spacecraft simultaneously as long as both are within the single-beam-width of the antenna system.

Sites and Status

The Unified S-Band sites are located and equipped for the type duties they perform. Ten land-based stations are equipped with 30-foot diameter antenna systems, three with 85-foot diameter dishes. The Grand Bahama Island station has a transportable van-mounted system with an erectable 30-foot antenna.

The USB systems are under engineering evaluation. Network experience to date has included highly successful tests with the Lunar Orbiter spacecraft in orbit around the Moon and on Apollo/Saturn 202. While prime support for the early Apollo flights will be through the proven Gemini systems, the new USB systems will again be tested during Apollo 4 in actual mission support by those portions of the USB systems not related to the astronauts.

As the new systems are pronounced fully operational and techniques perfected during successive Earth-orbital flights, a phase-over from the Gemini systems will be made to the USB systems.

Participating Stations

For Apollo 4, 12 NASA USB stations, two Department of Defense associated radar land stations, two range instrumentation ships, and four Apollo Instrumented Aircraft (ARIA) will provide the required tracking, data acquisition and communications services.

USB Sites:

30-Ft. Antenna Sites

Antigua (ANG).
Ascension Island (ACN).
Bermuda (BDA).
Canary Island (CYI).
Carnarvon (CRO), Australia.
Grand Bahama Island (GBM).
Guam (GWM).
Guaymas (GYM), Mexico.
Hawaii (HAW).
Merritt Island (MIL), Fla.
Texas (TEX), Corpus Christi.

85-Ft. Antenna Sites

Canberra (CNB)*, Australia.
Goldstone (GDS), Calif.
Madrid (MAD)*, Spain.

*Not required for Apollo 4.

Participating Ships:

USNS VANGUARD-Insertion/Injection-Atlantic.
USNS ROSE KNOT VICTOR - Powered Flight Ship.

The Network Support Team

Around-the-clock control of the Manned Space Flight Network is maintained by a 30-man team (per eight-hour shift) of network systems specialists housed in a new and highly instrumented operations room at the Goddard Space Flight Center, Greenbelt, Md. The operation's room was designed especially to monitor every aspect of the worldwide network. Formerly located at the Mission Control Center, Manned Spacecraft Center, Houston (MCC-H), the team will continue to report its status and findings to the mission flight director in the Houston Mission Operations Control Room (MOCR) but will retain its autonomy for checks, balances and corrections for continuity of coverage.

Testing the Network

Before Apollo 4 is flown, a total of 14 days of checking and testing will have been accomplished. Each network at each station has its own performance criteria that must be met before the Manned Space Flight Network may be pronounced ready to participate in the mission.

At Goddard these criteria are stored in a computer memory system. Each station reports, via the NASA Communications Network high-speed digital circuits, its own system-by-system checks. These reports are automatically compared with the stored normal values. Any variation from the desired values is detected by the computer and a "no-go" condition exists. If there is no variation from desired norms, a "go" is reported. The process is repeated until the test conductor states that the entire network is ready to participate. The ritual is repeated for each mission and is known as CADFISS, short for Computer and Data Flow Integrated Subsystems tests.

Final Configuration

When completed, the Apollo Manned Space Flight Network will consist of 11 30-foot Earth-orbit USB antenna sites; three 85-foot antenna sites with 85-foot antenna backup sites for deep space tracking/communications; five Apollo ships and eight Instrumented Aircraft (ARIA) with USB facilities. Three of the ships are equipped with 30-foot antennas (VANGUARD, REDSTONE, MERCURY) for insertion/injection coverage. Two ships are equipped with 12-foot antennas for reentry coverage (HUNTSVILLE, WATERTOWN). The aircraft are equipped with a seven-foot dish in the nose. In addition to the USB sites listed, other ground stations providing telemetry, C-Band (space position) radar and voice relay will be used as required. It will require a manning effort of some 2,000.

Computers That Switch

Computers are key components in this system. They are in effect, electronic traffic policemen. UNIVAC 642 computers at the USB stations sort the data received from Apollo and route it to on-station displays and, via telecommunications, to the Houston Mission Control Center. Tracking stations ashore and afloat are linked through dual UNIVAC 418 Realtime Systems that function as communications subswitchers with the control center at Goddard, which is equipped with much larger UNIVAC 494 Realtime Automatic Switching Systems.

Realtime Is Now

At fraction-of-a-second intervals, the digital data processing systems, with NASA's Manned Spacecraft Center at Houston as the focal point, "talk" in computer digital language to each other, or to the spacecraft, in realtime.

Commands are thus sent to the Apollo spacecraft quickly, even though the capsule may be thousands of miles from the control center. The command capability is needed for such matters as control of cabin pressure, orbital guidance, or "go/no go" decisions.

Before it is sent to the spacecraft, each command is automatically checked with pre-programmed information by the on-station computers to determine validity and thus guarantee that only the correct commands are sent to the spacecraft.

Data On Call

For the downward data from Apollo, sensors built into the spacecraft continually sample such spacecraft parameters as cabin temperature, capsule attitude, and heatshield information. These data are then transmitted to the ground. The on-site UNIVAC systems detect changes or variations for comparison with stored data; provide continual displays; and assemble, log, and store data for immediate "on-call" display. The computers process data for on-site flight controllers, or if controllers are not there, the data are put into form for transmission to Mission Control Center in Houston.

More and More Data

Each succeeding generation of the space program calls for vastly increased requirements. During Project Mercury, for example, the amount of network traffic handled through the Goddard center was the equivalent of a standard printed page every second. Apollo mission control traffic will approximately be that contained in novel each second, or an encyclopedia of material each minute.

The Tie That Binds - NASCOM

Tying all these sites together is the NASA Communications Network (NASCOM). Headquarters at Goddard, the hub of NASA communications, NASCOM's Automatic Communications Switching Center functions as the one central facility through which the Mission Control Center in Houston is instantly connected with the worldwide Manned Space Flight Network stations.

Through one million circuit miles, the network provides low, medium, and high-speed messages along with voice-grade connections. Circuits between centers are provided by common carriers and local telephone companies in many countries.

Satellite Communications

Circuits will be provided via two Intelsat synchronous communications satellites: one over mid-Pacific and a second over mid-Atlantic, providing alternate and backup communications across both oceans where only cable and radio have been available. The network pioneered use of satellites for space operational use by employment of NASA's Syncom III during the Gemini program.

Reentry Communications Blackout Study

For the first time NASA scientists and engineers will have an opportunity to gather information on the communications characteristics and reentry behavior of the Apollo spacecraft under actual lunar return conditions.

High Speed Reentry

At approximately eight hours and 23 minutes into the mission, the command module will enter the Earth's atmosphere after having been accelerated by the second service propulsion system burn to the same entry velocity (36,333 feet-per-second) expected during a lunar mission entry. This speed is roughly 14 times that of a military high-powered rifle bullet.

Two periods of communications blackout will be experienced during reentry. The first of these periods will be of approximately two and one-half minutes duration beginning at 350,000 feet, terminating at approximately 200,000 feet. After a four-minute coast and cool-off period, the second blackout phase of one and one-half minutes begins as the spacecraft starts its second descent.

Search for an Answer

Much is known about the problem of communications blackout during spacecraft reentry, but little has been discovered leading to a permanent solution. Weight and space limitations aboard the spacecraft preclude some of the obvious answers associated with known techniques.

Atmospheric electrons are so disturbed by the spacecraft's friction-generating speed that they form a superheated envelope surrounding the spacecraft. Ground station radio signals bounce off this envelope. During the phenomenon, mission directors, flight controllers, communicators, and tracking station personnel have no contact with the spacecraft.

The Scientists Take a Look

During this period, Goddard's Mission Trajectory and Analysis Division will observe and record all possible data regarding communications blackout phenomena. Observers will be stationed aboard aircraft and ships in the western Pacific Ocean along the 5,000-mile return path from Marcus Island to Hawaii.

Focus on the Problem

Assisting in the acquisition of data will be two Range Instrumentation Tracking Ships and two Apollo/Range Instrumentation Aircraft (ARIA) stationed in the western Pacific along the entry landing path (see map). The ships will provide radar coverage along the entry trajectory in which the Apollo 4 command module emerges from the communications blackout and during the final phase of the entry. ARIA aircraft will participate primarily for performance evaluation purposes. Two ARIA will operate in the Atlantic, as will the second Range Instrumentation Tracking Ship.

Atlantic aircraft (Nos. 1 and 2) will be airborne and collecting data during launch, the second orbit and the second third-stage (S-IVB) burn.

Pacific aircraft (Nos. 3 and 4) will be airborne and collecting data in the Hawaii area. No. 3 will track the orbiting third stage/spacecraft as it passes west of Hawaii during the second orbit. It will then proceed to Midway Island prior to covering the spacecraft entry taking a position about 60 miles south of the command module landing point. ARIA No. 4 will collect data only during entry at a point approximately 150 nautical miles north of the entry ground track. ARIA 5 will be uprange of communications blackout to attempt to track as far into blackout as possible and then attempt to re-establish track prior to or immediately after exit from blackout.

APOLLO/SATURN PROGRAM MANAGEMENT

Direction of the Apollo Program, the United States' effort to land men on the Moon and return them safely to Earth before 1970, is the responsibility of the Office of Manned Space Flight (OMSF), Headquarters, National Aeronautics and Space Administration, Washington, D.C.

The NASA Manned Spacecraft Center (MSC), Houston, Texas, is responsible for development of the Apollo spacecraft, flight crew training and mission control.

The NASA Marshall Space Flight Center (MSFC), Huntsville, Ala., is responsible for development of the Saturn launch vehicles.

The NASA John F. Kennedy Space Center (KSC), Kennedy Space Center, Fla., is responsible for Apollo/Saturn launch operations.

The NASA Goddard Space Flight Center (GSFC), Greenbelt, Md., manages the Manned Space Flight Network under the overall direction of the NASA Headquarters Office of Tracking and Data Acquisition (OTDA).

APOLLO/SATURN OFFICIALS

Dr. George E. Mueller	Associate Administrator for Manned Space Flight, NASA Headquarters
Maj. Gen. Samuel C. Phillips	Director, Apollo Program Office, OMSF, NASA Headquarters
Lee B. James	Deputy Director, Apollo Program Office, OMSF
William C. Schneider	Apollo Mission Director, OMSF NASA Headquarters
Maj. Gen. John D. Stevenson	Director, Mission Operations, OMSF, NASA Headquarters
Dr. Robert R. Gilruth	Director, Manned Spacecraft Center, Houston
George M. Low	Manager, Apollo Spacecraft Program Office, MSC

Donald K. Slayton	Director, Flight Crew Operations, MSC
Christopher C. Kraft, Jr.	Director, Flight Operations, MSC
Glynn S. Lunney	Apollo 4 Flight Director, Flight Operations, MSC
Dr. Wernher von Braun	Director, Marshall Space Flight Center, Huntsville, Ala.
Brig. Gen. Edmund F. O'Connor	Director, Industrial Operations, MSFC
Dr. Arthur Rudolph	Manager, Saturn V Program Officer, MSFC
Leland F. Belew	Manager, Engine Program Office, MSFC
Dr. Kurt H. Debus	Director, John F. Kennedy Space Center, Fla.
Rocco A. Petrone	Director, Launch Operations, KSC
Dr. Hans F. Gruene	Director, Launch Vehicle Operations, KSC
John J. Williams	Director, Spacecraft Operations, KSC
Paul C. Donnelly	Launch Operations Manager, KSC
Edmond C. Buckley	Associate Administrator, Tracking and Data Acquisition, NASA Headquarters, Washington
H. R. Brockett	Director of Operations, Communications and ADP Management Division, OTDA
Norman Pozinsky	Director, Network Support Implementation Division, OTDA
Dr. John F. Clark	Director, Goddard Space Flight Center, Greenbelt, Md.
Ozro M. Covington	Assistant Director for Manned Space Flight Tracking, GSFC
Dr. Friedrich O. Vonbon	Chief, Mission Trajectory and Analysis Division, GSFC
Walter I. Adams	CADFISS Operations Director, GSFC

MAJOR APOLLO/SATURN CONTRACTORS

Prime Contractor:

North American Aviation, Inc. Space and Information Systems
Division, Downey, Calif.

Contractor

Item

Bellcomm
Washington, D. C.

Apollo Systems Engineering

General Electric-Apollo Support
Department, Daytona Beach, Fla.

Apollo Checkout and
Reliability

Spacecraft Contractors

Grumman Aircraft Engineering Corp.,
Bethpage, Long Island, N. Y.

Lunar Module

North American Aviation, Inc.
Space Division, Downey, Calif.

Spacecraft Command and
Service modules

Massachusetts Institute of
Technology, Cambridge

Guidance & Navigation
(Technical Management)

General Motors Corp., AC
Electronics Division, Milwaukee

Guidance & Navigation
(Manufacturing)

General Electric Co., Apollo
Support Department,
Daytona Beach, Fla.

Acceptance checkout
Equipment

Avco Corp., Wilmington, Mass.

Heat shield ablative material

North American Aviation, Inc.,
Los Angeles Division,
Inglewood, Calif.

VHF antenna, boost cover,
LES tower, canards, radial
beams, forward heat shield

Aeronca Manufacturing Co.,
Middletown, Ohio

Stainless steel honeycomb
panels

Eagle Pitcher,
Joplin, Mo.

Batteries

ITT, Industrial Products Division,
San Fernando, Calif.

Battery charger

United Aircraft Corp., Pratt &
Whitney Aircraft Division,
East Hartford, Conn.

Fuel cell modules

Collins Radio Co.,
Cedar Rapids, Iowa

Communications and data
system

Radcom,
College Park, Md.

C-band antenna

General Time Corp.,
Aeronetics Division
Rolling Meadows, Ill.

Central timing system

The Havilland Aircraft
of Canada Ltd.,
Ontario

HF antennas

Motorola Inc.,
Government Electronics Division,
Scottsdale, Ariz.

Digital up-data link

Beckman Instruments Inc.,
Scientific and Process Instruments
Division, Fullerton, Calif.

Data acquisition equipment

Control Data Corp.,
Government Systems Division,
Minneapolis, Minn.

Digital test command system

Electro-Optical Systems Inc.,
Micro-Systems Division
Pasadena, Calif.

Transducers and instru-
mentation

General Precision Inc.,
Link Group,
Binghamton, N. Y.

Mission simulator trainer

Ford Motor Co.,
Philco-Ford Corp.,
Houston

Displays in Mission Control
Center

International Business Machines
Federal Systems Center,
Gaithersburg, Md.

Computers in Mission Control
Center

SATURN V LAUNCH VEHICLE CONTRACTORS

North American Aviation, Inc.
Rocketdyne Division,
Canoga Park, Calif.

J-2 Engines, F-1 Engines

The Boeing Co.,
New Orleans

First Stages (S-IC) of
Saturn V Flight Vehicles,
Saturn V Systems Engineering
and Integration
Ground Support Equipment

North American Aviation, Inc.
Space Division,
Seal Beach, Calif.

Development and Production
of Saturn V Second
Stage (S-II)

Douglas Aircraft Co.,
Huntington Beach, Calif.

Development and Production
of Saturn V Third Stage
(S-IVB)

International Business Machines
Huntsville, Ala.

Instrument Unit (Prime
Contractor)

Bendix Corp.,
Navigation and Control Division
Teterboro, N. J.

Guidance Components for
Instrument Unit (Including
ST-124M Stabilized Platform)

General Electric Co.,
Huntsville, Ala. and
Bay St. Louis, Miss.

Saturn V Support at Mississippi
Test Facility; Ground support
equipment

Radio Corp. of America,
Van Nuys, Calif.

Ground Support Equipment

Mason-Rust
New Orleans, La.

Saturn V Support at Michoud
Assembly Facility

Sanders Associates
Nashua, N. H.

Ground Support Equipment

Arrowhead Products Division
Federal-Mogul Corp.,
Los Alamitos, Calif.

Propellant Feed Ducting for
Saturn V First Stage

Allis Chalmers Manufacturing Co.,
Milwaukee

Open Cycle Fuel Cell Systems

Flexonics Division,
Calumet & Hecla, Inc.
Bartlett, Ill.

Propellant Feed Ducting for
Saturn V First Stage

AiResearch Manufacturing Co., The Garrett Corp., Phoenix, Ariz.	Prevalves for Saturn V First Stage
Electronic Communications, Inc. St. Petersburg, Fla.	Electronic Components and Systems
Dortech Inc. Dorr Oliver Co. Stamford, Conn.	Saturn V First Stage Transporters
Douglas Aircraft Co. Santa Monica, Calif.	Large Sandwich Segments for Forming Common Domes
Parker Aircraft Co. Los Angeles	10-inch Lox Vent and relief valves
Northrop Corp. Norwood, Mass.	Hermtically Sealed Gyro Packages
Brown Engineering Co. Huntsville, Ala.	Propulsion and Vehicle Engineering Laboratory Space Sciences Laboratory Support
Sperry-Rand Corp. New York, N. Y.	Astrionics Laboratory Support
Spaco, Inc. Huntsville, Ala.	Quality and Reliability Assurance Laboratory Support
Vitro Services, Fort Walton Beach, Fla.	Test Laboratory Support
Hayes International Corp. Huntsville, Ala.	Manufacturing Engineering Laboratory Support
Northrop Corp. Norwood, Mass.	Aero-Astrodynamic Laboratory Support
Computer Sciences Corp. El Segundo, Calif.	Computation Laboratory Support

MANNED SPACE FLIGHT NETWORK CONTRACTORS

Collins Radio Co. Dallas	Unified S-Band Systems
Collins Radio Co. Dallas	85' Antenna Systems Electronics
Blaw-Knox Co. Pittsburgh, Pa.	85' Antenna Structures
General Dynamics Electronics Division Rochester, N. Y.	Apollo Insertion/Injection Ships
General Dynamics Shipbuilding Corp. Quincy, Mass.	Tracking ships
Reeves Instrument Co. Garden City, N. Y.	Apollo Insertion/Injection Ships Antenna Structures
Ling-Tempo-Vought Corp. Dallas	Apollo Reentry Ships
Radio Corporation of America Moorestown, N. J.	Apollo Ships Radar (FPS-16) C-Band
Collins Radio Co. Dallas	Apollo Ships S-Band System
Dynatronics Corp. Orlando, Fla.	Pulse Code Modulation Telemetry Systems (Shipboard and land stations)
Univac Division Sperry Rand Corp. Minneapolis	Digital Data Processor System (Shipboard and land stations)
Raytheon Corp. Lexington, Mass.	Flight Controller and Apollo Systems Display Consoles
Westinghouse Electric Corp. Pittsburgh	Antenna Systems Switching Gear and Generators

LAUNCH COMPLEX CONTRACTORS

Morrison-Knudsen Co., Inc. Perini Corp. Paul Hardeman Construction Co., Inc. South Gate, Calif.	Vehicle Assembly Building (VAB) (outfitting and equip) Mobile Service Structure Launch Control Center portion of Crawlerway
Blount Brothers Corp. Montgomery, Ala.	VAB (foundation)
U.S. Steel, American Bridge Division Atlanta	VAB (steel erector)
Urbahn-Roberts-Seelye-Moran New York, N. Y.	VAB and LCC (design)
George A. Fuller Co. Los Angeles	Launch Pad B Portion of Crawlerway
Blount Brothers Corp. and M. M. Sundt Construction Co. Montgomery, Ala.	Launch Pad A Portion of Crawlerway
Pacific Crane and Rigging Paramount, Calif.	Ground Support Equipment for Mobile Launchers
Catalytic Construction Co. Philadelphia	Cryogenic Propellant System for Mobile Launcher
Ingalls Iron Works Birmingham, Ala.	Mobile Launcher (structural work)
Smith/Ernst (joint venture) Tampa, Fla., Washington, D. C.	Electrical Mechanical Portion of Mobile Launchers
Power Shovel, Inc. Marion, Ohio	Transporter
Hayes International Birmingham, Ala.	Swing Arm