

BONE DENSITY AND CALCIUM BALANCE STUDIES
ON PROJECT GEMINI

NASA Contract NSR 44-024-006

March 1967

Texas Institute for Rehabilitation and Research
Texas Medical Center
Houston, Texas

GPO PRICE \$ _____

CFSTI PRICE(S) \$ _____

Hard copy (HC) 3.00

Microfiche (MF) .65

Facility Form 602

N68-11380 (THRU)
113 (PAGES)
04 (CATEGORY)
0890218 (NASA CR OR TMX OR AD NUMBER)

BONE DENSITY AND CALCIUM BALANCE STUDIES
ON PROJECT GEMINI

by

Fred B. Vogt, M.D.

March 1967

From the Texas Institute for Rehabilitation and Research, Texas Medical Center, Houston, Texas. This research was performed under sponsorship of the National Aeronautics and Space Administration under Contract NSR 44-024-006. Computer services were provided at the Texas Medical Center, Regional Computer Facility, under sponsorship of NIH Grant FR-00254.

Dr. Vogt is affiliated with the Texas Institute for Rehabilitation and Research, and The University of Texas Graduate School of Biomedical Sciences in the Texas Medical Center, Houston, Texas.

TABLE OF CONTENTS

| | Page |
|---|------|
| I. Foreword | ii |
| II. Bone Density and Calcium Balance Studies On Project Gemini | 1 |
| A. Background | 1 |
| B. Statement of the Problem | 1 |
| C. Method | 2 |
| D. Figure 1 | 7 |
| E. Results | 11 |
| F. Table I | 12 |
| G. Table II | 13 |
| H. Table III | 14 |
| I. Table IV | 16 |
| J. Table V | 17 |
| K. Table VI | 18 |
| L. Table VII | 19 |
| M. Table VIII | 20 |
| N. Table IX | 21 |
| O. Table X | 22 |
| P. Table XI | 23 |
| Q. Table XII | 24 |
| R. Table XIII | 25 |
| S. Table XIV | 26 |
| T. Table XV | 27 |
| U. Table XVI | 28 |
| V. Table XVII | 29 |
| W. Discussion | 33 |
| X. Conclusions | 42 |
| Y. Recommendations | 44 |
| Z. References | 45 |
| III. Appendix | 47 |
| A. Bone Densitometer Assembly for Measurement of Roentgenographic Bone Density | A-1 |
| 1. Introduction | A-1 |
| 2. Instrumentation | A-1 |
| 3. Figure 1 | A-3 |
| 4. Figure 2 | A-4 |
| 5. Sequence of Operations in Making a Bone Mass Determination | A-6 |
| 6. Figure 3 | A-7 |
| 7. References | A-10 |

TABLE OF CONTENTS (cont.)

| | Page |
|---|------|
| B. Reproducibility of An X-Ray Bone Densitometry Technique | B-1 |
| 1. Introduction | B-1 |
| 2. Method | B-1 |
| 3. Results | B-2 |
| 4. Figure 1 | B-3 |
| 5. Table I | B-4 |
| 6. Table II | B-6 |
| 7. References | B-9 |
| C. Human Evaluation of a Chemical Urine Volume and Measurement System | C-1 |
| 1. Introduction | C-1 |
| 2. Method | C-1 |
| 3. Results | C-2 |
| 4. Discussion | C-2 |
| 5. Summary | C-4 |
| 6. References | C-4 |
| 7. Table I | C-5 |
| 8. Table II | C-5 |
| 9. Table IIIA | C-6 |
| 10. Table IIIB | C-6 |
| 11. Table IIIC | C-7 |
| 12. Table IIID | C-7 |
| 13. Table IVA | C-8 |
| 14. Table IVB | C-8 |
| D. Calcium Balance in Association With A 30 Day Bedrest Study | D-1 |
| 1. Introduction | D-1 |
| 2. Method | D-1 |
| 3. Results | D-1 |
| 4. Figure 1 | D-2 |
| 5. Figure 2 | D-3 |
| 6. Figure 3 | D-4 |
| 7. Figure 4 | D-5 |
| 8. Figure 5 | D-6 |
| 9. Figure 6 | D-7 |
| 10. Figure 7 | D-8 |
| 11. Figure 8 | D-9 |
| 12. Table I | D-11 |
| 13. Table II | D-12 |
| 14. Discussion | D-13 |

FOREWORD

This paper attempts to evaluate and relate bone density, calcium balance, and nitrogen balance studies that have been performed in association with Gemini space flights to observations made from ground-based studies. The lack of appropriate data in association with the flights made it impossible to achieve this objective to the extent desired by the author. No attempt has been made to present an extensive discussion of the techniques, implications of space flight, or the interpretation of data. The theme of the report has been limited to presentation of obvious limitations on these experiments so that false conclusions would not be reached from the data acquired. The presentation of the data, discussion, and interpretation of data are the responsibility of the author and do not represent the views of the National Aeronautics and Space Administration.

Portions of the data presented in the Appendix were collected by Dr. Pauline Beery Mack under NASA Grant NsG 440 at the Texas Woman's University, Denton Texas. The analysis of urine, diet, feces, and sweat relating to the calcium and nitrogen balance studies during flight Gemini VII were performed under the direction of Dr. Leo Lutwak under Contract NAS 9-5375 to the Clinical Nutrition Unit of the Graduate School of Nutrition, Cornell University, Ithaca, New York. Bone X-ray densitometry studies in association with flights Gemini IV, Gemini V, and Gemini VII were performed by Dr. Pauline Beery Mack of Texas Woman's University, Denton, Texas. Computer services for this report were provided at the Texas Medical Center, Regional Computer Facility, under sponsorship of NIH Grant FR 00254.

Contract NSR 44-024-006, a portion of which this report represents, was sponsored by the National Aeronautics and Space Administration. Technical direction from the National Aeronautics and Space Administration has come from Dr. Jefferson F. Lindsey, Dr. Robert L. Jones, and Dr. Lawrence F. Dietlein. Dr. Paul A. LaChance served as the Manned Spacecraft Center Investigator and was responsible for the coordination of Experiments M-6 and M-7, portions of which are reported in this document. The Principal Investigators for Project M-7 were Drs. G. Donald Whedon and William Newman.

The author wishes to acknowledge the assistance of Mr. Michael A. Craig, Mr. Robert E. Stein, Mr. Charles M. Friel, Dr. Rudolph J. Freund, Mrs. Annie Weems, Mrs. Arlene Brown, and Mrs. Joyce Erfurd in the preparation of this report.

BONE DENSITY AND CALCIUM BALANCE STUDIES ON PROJECT GEMINI

by

Fred B. Vogt, M.D.

BACKGROUND

Clinical studies on patients suffering from chronic disease processes, and research evaluations of normal healthy persons subjected to reduced physical activity and gravitational stress have demonstrated changes in the musculoskeletal system. Of special interest in such studies were the observations of changes in the nitrogen metabolism, calcium balance, and bone mineralization. Following the time of these earlier observations, additional experimental studies have been conducted on animals and humans by numerous investigators to document further the changes in the above measurements. Since many of the conditions related to these experimental studies also would be found in association with space flight, some investigators anticipated that changes in the musculoskeletal system in association with prolonged space flight could result in a detriment of the physical capability and performance of the astronauts. Experiment M-6 was initiated on flight Gemini IV, and continued on flights Gemini V and Gemini VII to evaluate the X-ray density of roentgenographs from selected anatomical sites of the astronauts before and after flight. A more comprehensive experimental protocol, including Experiments M-6 and M-7, was planned and executed on flight Gemini VII.

STATEMENT OF THE PROBLEM

The primary objectives of Experiments M-6 and M-7 were to obtain data on the effects of space flights of up to 14 days duration on two of the largest metabolically active tissue masses in the human body, namely the skeletal and muscular systems. Changes in the skeletal system can be reflected partially in terms of the balance of dietary intake and combined output of the mineral calcium. In addition a more direct and qualitative assessment can be made of the skeletal system by means of X-ray bone densitometry. An evaluation of the changes in the muscular system can be made indirectly by chemical measurements of excreta, or by direct testing of the strength or functional activity of the muscles.

An evaluation of X-ray bone density of the os calcis, the talus, and hand phalanges (4-2 and 5-2) was performed on roentgenographs taken of the hand and foot of the astronauts before and after flight. The evaluations of the roentgenographs were made in the laboratories of the Texas Woman's University Research Institute. Evaluation of changes in skeletal X-ray bone density, by necessity, could be performed only before and after flight since equipment has not been developed which could be

utilized on the spacecraft during flight. Some problems were presented in obtaining high quality roentgenographs. The requirement to use different X-ray machines and limited numbers of films was met by using highly standardized techniques for taking and processing roentgenographs. In addition, the methodology used by the operators of the densitometer scanning equipment was standardized. All personnel were under the direct supervision of Dr. Pauline Beery Mack. It was realized that the bones selected for densitometry studies may show changes not totally representative of changes in all parts of the skeleton. For technical reasons, bones of the extremities, namely of the hand and foot, were selected for study; the small amount of soft tissue overlying the bones, the anticipated rapidity of change in mineralization, and previous experience with taking and processing roentgenographs influenced the selection of these sites.

The performance of a calcium or nitrogen balance study in association with a space flight likewise presented numerous difficulties. In order to calculate an accurate balance, precise and standardized techniques must be used. The dietary intake of each of the astronauts must be known exactly, and it is preferable that a standardized and regulated diet be utilized. Sources of output of calcium include primarily the fecal calcium, urine calcium, and sweat calcium. The selection of the dietary level of calcium is important in obtaining an equilibration of the calcium in the bones. The period of time during which the astronauts were able to be put on controlled diets was somewhat limited because of many other requirements of their time. The collection of fecal and urine samples did not present as great a difficulty in the pre-flight control period as in the inflight period where total collection of the fecal material presented some difficulty. Urine collection inflight was achieved by an aliquot system using an isotope tracer; the accuracy of this system has not been determined during space flight. The utilization of fecal dye markers to separate different periods of study also has presented difficulties in calcium balance studies. An evaluation of sweat loss in this particular flight experiment was difficult since it was collected by a non-standard technique. The exact techniques used are described in the methodology section of this report.

The compilation of the data and an evaluation of its significance for more prolonged flights is complicated by the study on few astronauts, namely the two astronauts on flight Gemini VII, who were exposed to a multitude of factors that could affect the X-ray bone densitometry and the calcium and nitrogen balance. Included would be the factors described earlier, the normal day-to-day variation in these measurements, the inaccuracies of the techniques used, physical inactivity, weightlessness, dietary changes, psycho-physiological stress, sleep deprivation, and sweat losses. At best, only a general comparison of the flight measurements can be made to the more controlled observations made in bedrest studies. However, the data should serve to document the changes that occurred in association with the 14 day flight, Gemini VII, and should point to difficulties which must be overcome if more comprehensive and useful studies or experiments are to be performed on future and more prolonged space flights in order to assure the safety and well-being of the astronauts.

METHOD

The same basic methodology was used for taking the roentgenographs of the hand and foot of the astronauts participating in flights Gemini IV, Gemini V, and

Gemini VII. It was the standardized procedure followed in the Texas Woman's University's research laboratories. The X-ray machines were calibrated before each exposure using an r-meter manufactured by the Victoreen Instrument Company to provide a type of standardized exposure condition. An aluminum alloy wedge was radiographed simultaneously by placing it adjacent to the bone which was being evaluated. The aluminum alloy wedge thus provided a standardized calibration technique for each roentgenograph to provide accurate calibration to compensate for minor changes due to any variation in the conditions of taking or processing the roentgenograph. The conditions of exposure (ma., kv., time, distance) had been selected previously to minimize the effect of the protein component, and to maximize the mineral component in bone.

For the flight Gemini IV, roentgenographs were made of the lateral view of the left foot and of the postero-anterior view of the left hand of astronauts McDivitt and White at the following times: (a) 9 days before lift-off, taken at Cape Kennedy; (b) 3 days before lift-off, taken at Cape Kennedy; (c) on the morning of lift-off, taken at Cape Kennedy; (d) immediately after recovery, taken on the Carrier USS Wasp; (e) 16 days after return, taken at the Manned Spacecraft Center; and (f) 50 days after return, taken at the Manned Spacecraft Center. Members of the Texas Woman's University research team were stationed at Cape Kennedy, on the Carrier Wasp in the Atlantic, and in the Hawaiian Islands to assure that roentgenographs would be taken should descent occur in either ocean.

A similar procedure was followed for the conduct of Experiment M-6 on flight Gemini V. Radiographs were made pre-flight and post-flight of the lateral projection of the left foot and of the postero-anterior projection of the left hand of each of the astronauts pre-flight at 10 days, 4 days, and 2 days prior to lift-off, and on the morning of lift-off at Cape Kennedy. Roentgenographs also were made post-flight immediately after recovery of the spacecraft, again 24 hours after recovery on the aircraft carrier, USS Lake Champlain, and finally at the Manned Spacecraft Center 10 days and 58 days following termination of the flight.

The investigation conducted in association with the 14 day flight, Gemini VII, was directed primarily at determining the calcium and nitrogen balance. The X-ray bone densitometry technique essentially was the same as that followed on previous studies. Roentgenographs were made pre-flight and post-flight of the left foot in the lateral projection and of the left hand in the postero-anterior projection on each of the astronauts at the following times: (a) 10 days pre-flight at Cape Kennedy, (b) 3 days pre-flight at Cape Kennedy, (c) on the morning of launch at Cape Kennedy, (d) immediately after recovery on the carrier USS Wasp, (e) 24 hours after recovery on the Carrier Wasp, (f) 11 days after recovery at the Manned Spacecraft Center, and (g) 47 days following recovery at the Manned Spacecraft Center.

The film used in these studies was Kodak type AA Industrial X-Ray film. The history and the development of the scanning technique for measuring bone mass and X-rays have been reported by Mack et al.,⁷ by Mack, Brown, and Trapp,⁶ and Mack.⁸

For a given distance of 36 inches, 100 ma, and 0.5 sec, the kilovoltage of the X-ray machine was adjusted to give an exposure of 0.167 ± 0.002 roentgen using a Victoreen r-meter. The X-ray film holders were double-loaded so that one film could be developed immediately each time a roentgenograph was taken. The remaining film was kept for processing under controlled conditions in the laboratory at Texas Woman's University.

The scanning path on the film of the os calcis utilized the anterior and posterior landmarks on the central os calcis to provide the pathway known as the "conventional scan." A trace across this scanning path was made on the successive films of this longitudinal series using a scanning beam with a height 1.3 mm. Each time a film was taken, the hand or foot was positioned with extreme care to assure that the resulting roentgenographic image of the bone on each film could be superimposed exactly over that of preceding films. The initial film was marked with a pin prick at each end of the bone to thus define the limits of the tracing path for that and successive films.

A more detailed presentation of the technique for scanning and calculating the X-ray bone densitometry is given in the Appendix of this report. The equipment assembly used to evaluate sections of the bone from the exposed roentgenographs is a special purpose analog computer consisting of a series of sub-assemblies, all designed to operate as an integrated system. The basic units of the over-all system have been described by Mack, Vose, and Nelson,⁷ by Mack,⁸ and by Vogt, Mack, et al.¹⁰

The Experiment M-7, which involved primarily the measurement of calcium and nitrogen balance and related biomedical parameters under known dietary conditions pre-flight, inflight, and post-flight, was performed only in association with flight Gemini VII. The experimental protocol for this experiment is quite involved and is documented in more detail elsewhere.²³ The results of the analysis of data collected in association with this experiment are reported in a NASA Contract Report²² prepared under Contract NAS 9-5375 by Dr. Leo Lutwak of the Clinical Nutrition Unit, Graduate School of Nutrition, Cornell University, Ithaca, New York. The following description summarizes the methodology planned prior to the flight; deviations from this design will be described under the section entitled Results.

The experiment was divided into three phases for the acquisition of data: (a) a pre-flight phase of 10 days duration extending from F-13 to F-3; (b) the inflight phase which had an anticipated duration of 14 days of orbital flight; and (c) a post-flight phase planned for a duration of 3 or 4 days, beginning on the recovery carrier immediately post-flight.

A rigorously controlled dietary intake was planned for consumption by the astronauts. The calcium intake was determined to be optimal at approximately 800-1000 mg/day. The milk intake was set at 3 half pints per day, pre-flight and post-flight; other dairy products (such as ice cream, cheese, etc.) were omitted, as were seafoods. The pre-flight menu provided a low residue diet during the last 3 days prior

to the flight. The menus were formulated and prepared by a dietitic staff to provide approximately 100-110 g protein daily and approximately 95 g of fat, to thus approximate the inflight menu in nutrient composition. There was no restriction placed on smoking or chewing gum, but the accidental swallowing of such things as toothpaste, which are high in calcium content, was avoided.

The diets were formulated on the basis of calculations from food composition tables; however, all foods were analyzed chemically to determine the precise composition by preparing identical diets or meals to that served to the astronauts. Pre-weighed meals were served. With few exceptions (such as milk, cheese, ice cream, and shell fish), no limit was placed on the total quantity of food ingested. Any food remaining on the plate after a meal was weighed and consumption record corrections were made accordingly.

The inflight diet was composed of a Gemini menu of freeze-dried foods and otherwise dried or processed foods of known composition. Each serving was weighed before flight and any remaining food material weighed after flight to make corrections. Fluid intake was allowed ad libitum, but the quantity of fluid intake was recorded.

The Gemini flight food items had been prepared within the pre-determined weight tolerance, and each package had a serial number. A record was kept by the astronaut of food consumed during flight. The composition of each lot of food was determined so that the consumption of calories, protein, fat, carbohydrate, and selected nutrients could be calculated.

The collection of excretory specimens followed a carefully planned procedure. The pre-flight and post-flight urine and stool specimens were collected by providing separate facilities for urine and stool collection which were located at permanent locations at Cape Kennedy and on the primary recovery ships. Otherwise, appropriate containers were made available in a carrying case for use at other locations, for example, when the astronaut was on travel. The collection of fecal material inflight utilized the Gemini defecation devices to provide for the collection, preservation, and storage containers. Defecation gloves P/N 9557-3-109 were provided as follows: three-fourths glove per man per day, plus 20% contingency. A tab for identifying the name and mission time was attached.

The spacecraft engineering restraints did not allow for retention of all urine voided. Therefore, a urine transport system was provided as a means for measuring the total volume of each micturition by means of a tracer dilution technique.⁹ A detailed description of an evaluation of this system is presented in the Appendix of this report. Aliquots of urine were collected and labeled with the astronauts' initials, mission time of voiding, etc.; these were recorded on a sample bag P/N 9557-3-485. Six sample bags were provided per man per day, plus 20% contingency; in other words, a total of 200 bags were stowed on board.

An attempt was made to obtain information on the sweat excretion pre-flight, during flight, and after flight. In the pre-flight phase, for two 24 hour intervals

separated by at least 2 days, the astronauts wore constant wear garments (one during the day and one at night) for the collection of sweat. These garments were washed and rinsed in distilled water prior to drying. On the day of sweat collection, the astronaut was required to shower and after a regular rinse was rinsed again with distilled water, and finally dried with a towel which had been prepared with distilled water. Following this the astronaut then donned the constant wear garment, which was similar to a pair of long underwear that could be worn under a summer weight flight suit or similar clothing. Upon changing of underwear, (at 12 hour intervals, if desired, and definitely after a 24 hour period was completed) the astronaut turned the garment over to the responsible person who assured that the garment did not become soiled by contacting the floor, the sides of the shower, etc. The participants then, prior to showering, rinsed off with a moist towel prepared with distilled water; the towel then was placed in a collection basin and kept for analysis. A similar procedure was repeated during the post-flight period.

During flight the constant wear garments were prepared in a similar manner prior to donning and were removed post-flight in a similar manner. Because of fecal contamination during the flight, a portion of the crotch of the underwear was removed before an analysis was made of the chemical composition of the sweat collected. No attempt was made to collect sweat from areas such as the palm of the hands.

After recovery, the spacecraft engineer assured that all food containers eaten or uneaten, all urine sample bags, all identification devices, and waste containers were provided to the Manned Spacecraft Center coordinator of the experiment who was on the recovery ship, so that processing of these biological samples could be implemented without delay. Access to onboard log and voice tape information relevant to food, drinking, urine, feces, and emesis (if any) was obtained. The dietary intake and scheduling of meals is described in detail elsewhere. The techniques of biochemical analysis of the food, feces, underwear, and urine also is described elsewhere.

Since all urine volume could not be retained, a special system was devised for the collection and storage of aliquots of the urine using a tracing material to determine the total volume urinated. A block diagram of the chemical urine volume measuring system is shown in Figure 1. The unique feature of this system is the storage of the tracer material in a cylindrical container extending into the coiled urine exhaust line. It also provides a metering system to inject a given amount of tracer chemical into the urine. A mixing bag with the capacity of 800 ml, made of nylon reinforced neoprene, was attached permanently to the main body of the function selector valve. A separate sample bag was used and attached to the valve for each micturition.

The unit is provided with a function selector valve having four positions: blow down, sample, urinate, and by-pass. The sealing of the valve is accomplished by a teflon coated tapered plug which has additional "O" ring seals, top and bottom,

OPERATIONAL BLOCK DIAGRAM

Chemical Urine Volume Measuring System

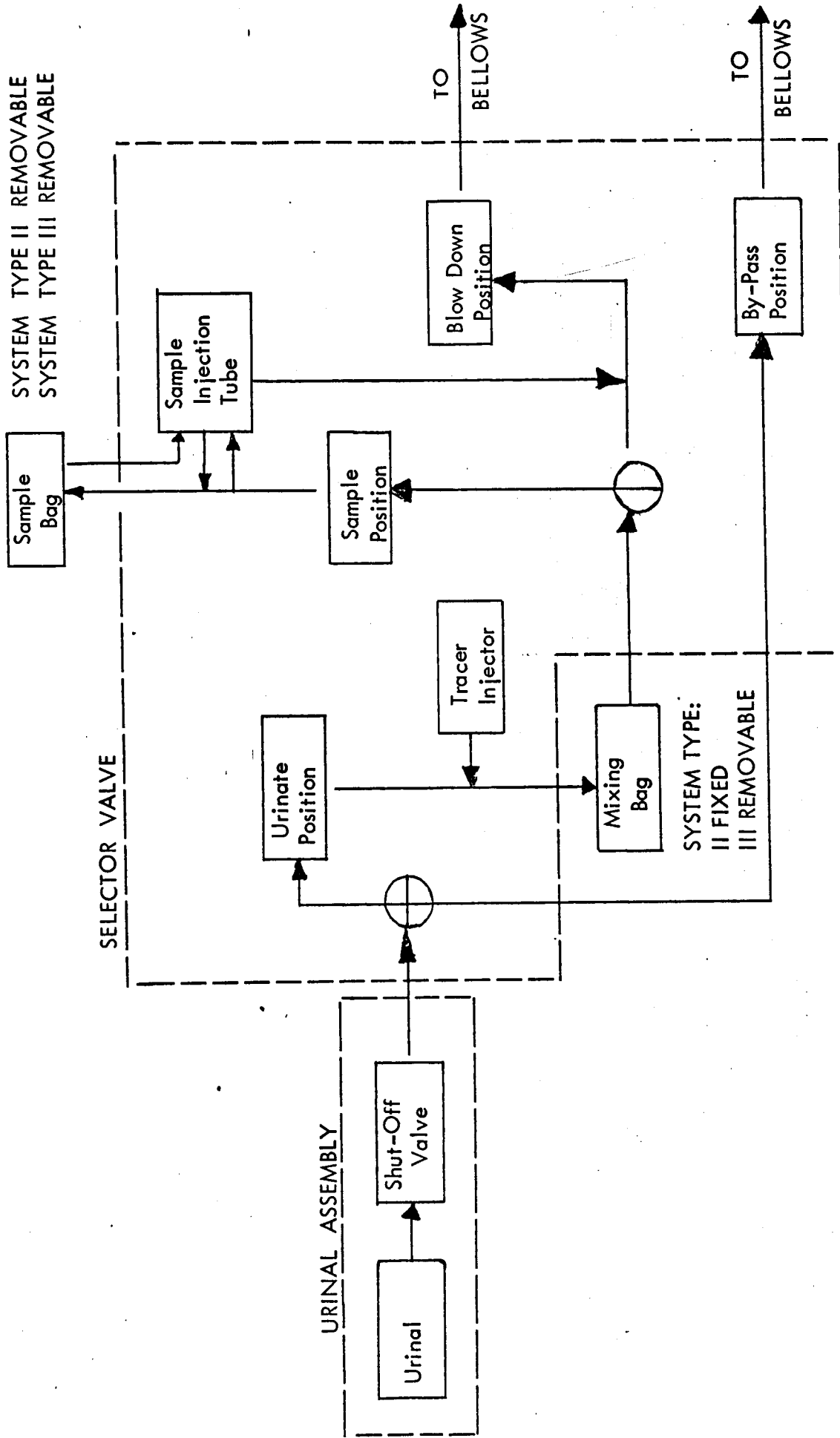

FIGURE 1

Type II and III - Two Bag Tracer Injector Systems

to insure no leakage into the space cabin. A cam actuated sample syringe was provided to complete the connection of the valve to the sample bag. A tracer chemical metering pump, built into the main body of the valve, is activated by the movement of the valve selector knob. This delivers a fixed volume of tracer chemical for the urine inlet passages before the start of urination. The rotation of the valve selector knob from the by-pass position to the urine position causes the knob cam surface to make contact with the tracer chemical metering pump piston. The cam surface then will force the piston down to expel the tracer chemical beyond the outlet check valve and into the urine inlet line. The stroke of the metering pump is controlled by a cross pin which limits the travel of the piston (and therefore the volume of the chemical) in both directions.

When the cam has completely passed over the pump piston, a built-in spring retracts the piston, drawing a fresh charge of tracer chemical into the metering cavities through the storage bladder check valve. The driving force for the movement of the tracer chemical from its reservoir, through the check valve and into the metering cavity, is obtained by a combination of the 5 psi cabin pressure and the 5 to 10 psi tracer chemical storage bladder pressure.

The tracer chemical is stored in a long cylindrical rubber balloon enclosed in an aluminum housing extending from the main body of the selector valve into the center of the coiled urine exhaust line. The balloon storage system is used to provide relatively uniform back pressure for a more reliable operation of the two check valves of the tracer chemical metering system.

The chemical urine volume measuring system is stored with the selector valve in the blow down position. After the crewman has attached the urinal to his penis, the selector valve is rotated counter-clockwise through 180° , beyond the by-pass position to the urine position. The selector knob then points directly at the crewman. The flow of urine from the pilot washes the tracer chemical from the urine inlet line, where it was deposited by the metering pump, into the mixing bag. The tracer chemical and the urine then must be mixed by thorough manipulation of the mixing bag.

The sample bag is attached to the fitting on the main body of the valve and the syringe cam knob rotated 90° . This action causes the syringe needle to move out of its housing and to pierce the silicon rubber seal on the sample bag. This action also uncovers an additional port in the syringe to complete a passage from the selector valve plug to the sample bag. When the selector valve is rotated 90° , it will line up with the passage in the selector valve plug and the sample syringe line. The crewman then squeezes the mixing bag and transfers approximately 100 cc's of the urine tracer chemical mixture into the sample bag. Then by rotating the sample syringe knob back 90° , the syringe is withdrawn from the sample bag and the inlet passage of the base of the syringe is closed. The selector valve plugs turn to the blow down position by a further 90° turn, where the excess urine is blown overboard, using the existing U.T.S. bellows and valving system.

The following information on the collection, storage, and preservation of samples in relation to M-7 is extracted from Appendix IV from the Manned Spacecraft Center project document report for Gemini Inflight Experiment M-7. The material was prepared by Miss Marilyn E. George for the collection of urine. Monitors will accompany the astronauts at all times and be responsible for providing containers, accepting specimens, processing them and maintaining accurate records. Specimens representative of 24 hour collections were collected for 10 days pre-flight. For the inflight samples, the tracer dilution technique described above was used to measure the volume of each micturition. Aliquots of each voiding were collected and mixed with the preservative; each was labeled with the subject's initial and mission time. The collection of the samples post-flight was accomplished by monitors as in the pre-flight period. Twenty-four urine samples were collected for 3 days post-flight starting the morning after landing. All urine samples were collected from the time of landing until after the time of the first micturition the following morning; all specimens were processed separately.

During the pre-flight and post-flight periods when the subjects were not accompanied by monitors, they were supplied with a collection case holding containers for individual urine samples. This case was insulated and had a compartment containing dry ice. When an astronaut was away from the usual collection area, he was instructed to void directly into the container, cap it tightly, and label it with his initials and time, and to place it in the dry ice compartment of the collection case. Upon return to the main collection area, the monitor removed the sample and placed it in a deep freeze. There were a total of twenty-six 24 hour specimens pre-flight and post-flight, 13 from each subject, 10 pre-flight, and 3 post-flight. The number of urine aliquots and urine samples collected on the days of launching and landing varied for the two subjects and are described in the results. Prescribed amounts of urine were set up for each of the primary parameters of interest.

For the pre-flight and post-flight 24 hour urine specimens, the urine specimens were pooled and kept in a refrigerator at 4°C. until the 24 hour specimen was completed. Then the total volume, pH, and specific gravity were measured; a routine urinalysis was done, consisting of qualitative tests for sugar, albumin, blood, and a microscopic examination of the urine sediment. For some of the tests, special preservative materials were provided. The urine aliquots collected inflight were stored at cabin temperature in polyethelene bags containing a preservative and a tracer material. As soon as possible after recovery, these samples were stored in a deep freeze. After these specimens were delivered to the laboratory, the total volume of each micturition was determined from the dilution of the tracer, and a 24 hour volume was calculated by a method to be described later.

The feces passed in the 10 day pre-flight period were collected and pooled in 3 day samples. Carmine dye was given to the subjects every 3 days to help separate the 3 day samples. All fecal specimens inflight were collected in a fecal glove device containing a preservative. The fecal collection post-flight was performed in a manner similar to that pre-flight. Carmine dye was given the first day after landing as an indicator of the start of a new collection period.

Approximately 4 g of fecal material were required for each pooled sample for the determination of calcium phosphorus, magnesium, and nitrogen. For the pre-flight and post-flight periods, these samples were collected in a plastic bag; the sample was weighed and inspected grossly for Carmine dye, and then was labeled and placed in the deep freeze. Individual specimens, comprising the 3 day samples, were kept and pooled together at the laboratory. The inflight stool specimens were weighed and frozen when obtained after landing of the spacecraft. After collection and proper labeling, the specimen was weighed and all identification recorded in the record book as well as on the bag label. It then was placed in a can in a deep freeze.

The fecal samples from the 3 day collection periods were stored and processed in a gallon can with a grooved lid. These cans were used to homogenize the samples. The feces were frozen and the bags were delivered to the lab; the samples were expelled from the bags directly into the can, and an equal weight of water and pure acid washed silica chips were added, and the entire can shaken. The homogenized samples then were stored in a can in the refrigerator, without the possibility of drying, and aliquots were taken as needed, to thus obviate the necessities for repeated transfer of fecal samples to blenders, storage containers, etc.

RESULTS

A summary of the results of the X-ray bone density measurements made on the astronauts^{1,2,3,4,5} in association with flights Gemini IV, Gemini V, and Gemini VII are shown in Table I. The data are expressed in percent change in bone mass, based on the X-ray absorbency of the aluminum alloy calibration wedge (described in the Appendix). Evaluations were made (a) for the conventional scan of the os calcis as described in the Appendix A of this report, (b) for multiple scans of the os calcis, (c) for multiple scans of the hand phalanx 5-2, and (d) for multiple scans of the hand phalanx 4-2. It should be noted that scans of hand phalanx 4-2 were not made for flight Gemini IV.

The data for the bone density of the phalanx represent the average of multiple scans made across the finger phalanx 5-2, or the finger phalanx 4-2, in terms of the wedge mass equivalency values. The scans were made across the postero-anterior view of the finger. The technique is described in Appendix A of this report and the instrumentation is documented^{6,7,8} elsewhere.

These data show appreciable losses in bone mass occurred at all sites measured in association with flights Gemini IV and Gemini V, with the greatest change observed in association with flight Gemini V. Smaller, and doubtfully statistically significant changes were observed in association with flight Gemini VII.

In addition to the difference in duration of three space flights, the amount of calcium intake by the astronauts was considerably different for these three flights. The comparison of the flight bone density data with bedrest data under conditions of similar dietary intakes of calcium are shown in Table II. The day-to-day change in bone density for the astronauts cannot be presented because roentgenographs could not be taken during flight. In Table III is shown the recovery pattern for bone density for astronauts who showed loss in X-ray bone density during flight.

As seen in Table II, astronauts on flight Gemini IV showed a greater loss in bone density than the bedrest subjects on a similar level of calcium intake for a similar 4 day period of time. One of the astronauts on flight Gemini V showed greater loss in bone density, for the specified calcium intake, than the four Texas Woman's University bedrest subjects consuming similar amounts of calcium for the same period of time. The other astronaut, the pilot of flight Gemini V, showed a comparable loss of bone density as the four subjects who participated in the bedrest study at Texas Woman's University. The data for the astronauts on flight Gemini VII show slightly smaller losses in bone density than the average loss of the four subjects in the Texas Woman's University bedrest of 14 days duration; the two groups were on comparable dietary intake of calcium. However, it is doubtful that there is a statistical significance in the difference in the data on the two groups of subjects. It is probable that there can be multiple factors responsible for changes in X-ray bone density; the effect of these various mechanisms on the bone density changes cannot be made from these data alone.

TABLE I

Bone Density Changes in Association
With Flights Gemini IV, Gemini V, and Gemini VII

| Anatomical Site | Change in bone mass (percent) | |
|------------------------------|-------------------------------|-------|
| | Command Pilot | Pilot |
| Conventional os calcis scan: | | |
| Gemini IV | -7.8 | -10.3 |
| Gemini V | -15.1 | -8.9 |
| Gemini VII | -2.9 | -2.8 |
| Multiple os calcis scans: | | |
| Gemini IV | -6.8 | -9.3 |
| Gemini V | -10.3 | -8.9 |
| Gemini VII | -2.5 | -2.5 |
| Hand phalanx 5-2 scans: | | |
| Gemini IV | -11.9 | -6.2 |
| Gemini V | -23.2 | -17.0 |
| Gemini VII | -6.8 | -7.8 |
| Hand phalanx 4-2 scans: | | |
| Gemini IV | --- | --- |
| Gemini V | -10.0 | -11.4 |
| Gemini VII | -6.6 | -3.8 |

TABLE II

Comparison of Astronaut and Bedrest Bone Density
Changes as Related to Dietary Intake

| Gemini IV | Calcium Intake (mg/day) | Change in Os Calcis Bone Density (%) |
|--------------------------|----------------------------|---|
| Command Pilot | 679 | -7.8 |
| Pilot | 739 | -10.3 |
| TWU Bed Rest | | |
| Subject 1 | 675 | -2.7 |
| Subject 2 | 659 | -4.3 |
| Subject 3 | 636 | -3.4 |
| Subject 4 | <u>636</u> | <u>-3.6</u> |
| Mean of Bedrest Subjects | <u>651</u> | <u>-3.5</u> |
| Gemini V | | |
| Command Pilot | 373 | -15.1 |
| Pilot | 333 | -8.9 |
| TWU Bed Rest | | |
| Subject 1 | 307 | -8.7 |
| Subject 2 | 292 | -5.1 |
| Subject 3 | 303 | -7.9 |
| Subject 4 | <u>308</u> | <u>-8.1</u> |
| Mean of Bedrest Subjects | <u>302</u> | <u>-7.4</u> |
| Gemini VII | | |
| Command Pilot | 945 | -2.9 |
| Pilot | 921 | -2.8 |
| TWU Bed Rest | | |
| Subject 1 | 931 | -3.5 |
| Subject 2 | 1,021 | -3.6 |
| Subject 3 | 1,034 | -5.8 |
| Subject 4 | 1,020 | -5.1 |
| Subject 5 | <u>930</u> | <u>-5.9</u> |
| Mean of Bedrest Subjects | <u>987</u> | <u>-4.8</u> |

An assessment of the significance of a change in the bone mass must be evaluated in terms of the reproducibility of the technique, the day-to-day change in the bone density of subjects undergoing a routine schedule, the dietary intake, the psycho-physiological stress, weightlessness, physical activity, and possibly a host of other factors. The results of a reproducibility study of the X-ray bone densitometry technique and an expression of the day-to-day variability in measurements expected in normal subjects undergoing a regular routine of activity are presented in the Appendix of this report.

The results presented in Table IV through Table XVII are extracted from a NASA Contractor Report prepared under Contract NAS 9-5375, furnished to the author by the National Aeronautics and Space Administration. This report concerned "The Chemical Analyses of the Diet, Urine, Feces and Sweat Parameters Relating to the Calcium and Nitrogen Balance Studies During Gemini-7 Flight (Experiment M-7)." The report was prepared by Dr. Leo Lutwak of the Clinical Nutrition Unit, Graduate School of Nutrition, Cornell University, Ithaca, New York, for the National Aeronautics and Space Administration, Manned Spacecraft Center, and was dated September, 1966. The data in this report are all that has been furnished to the author for evaluation of the calcium and nitrogen balance from the flight studies. It is hoped that extraction of data and the discussion of it do not result in conclusions that would be out of context with the presentation of the report in which the data were submitted to the National Aeronautics and Space Administration. As is pointed out carefully in Dr. Lutwak's report and other papers considered in the discussion of this report, there was thought to be problems with the urine collection system during the flight. Therefore, some of the data had been corrected, assuming a constant creatinine excretion over a 24 hour period, using the means of the data collected on the astronauts pre-flight and post-flight. These data have been selected for presentation in this report as they relate to an evaluation for determining a calcium balance.

In Table IV is shown a summary of the dietary composition of calcium and nitrogen for the two astronauts participating in the flight Gemini VII. The pre-flight and post-flight dietary intake was of a different composition from the inflight diet; the inflight diet consisted of specially prepared freeze-dehydrated and bite size foods. The reader is referred to the above-mentioned report by Dr. Lutwak for further details of the dietary intake, and for results of other chemical analyses of the diet, urine, feces and sweat parameters not presented in this report.

In Tables V and VIII are presented the pre-flight urine samples on the individual astronauts giving the time, volume per micturition, specific gravity and 24 hour urine volume. (Note that in Table VIII, on the date 11-24, a time 7200 is indicated; this probably should be 1200 and represented a typographical error in the original report.) The collection of data in the pre-flight period very closely approximated 24 hour collection periods for the resulting pooling to determine the 24 hour volume. In Tables VI and IX are presented the inflight urine data for the

TABLE IV

SUMMARY OF DIETARY COMPOSITION

| Day | Lovell | Borman | Lovell | Borman |
|------------|----------|----------|---------|---------|
| Preflight | Ca (gm.) | Ca (gm.) | N (gm.) | N (gm.) |
| T-12 | 1.2940 | 1.2873 | 21.981 | 25.481 |
| T-11 | 1.3780 | 1.3359 | 21.693 | 24.945 |
| T-10 | 1.2773 | 1.2558 | 25.019 | 28.094 |
| T-9 | 1.3260 | 1.3553 | 22.978 | 24.384 |
| T-8 | 1.3483 | 1.3483 | 23.510 | 27.452 |
| T-7 | 1.2534 | 1.2630 | 24.867 | 27.947 |
| T-6 | 1.3074 | 1.3354 | 22.048 | 22.314 |
| T-5 | 1.3554 | 1.3289 | 23.590 | 26.974 |
| T-4 | 1.2423 | 1.2840 | 24.732 | 28.248 |
| T-3 | 1.3029 | 1.3272 | 21.977 | 22.226 |
| Mean | 1.3085 | 1.3121 | 23.240 | 25.807 |
| s. d. | .0419 | .0343 | 1.237 | 2.185 |
| Inflight | | | | |
| 1 | .8705 | .8705 | 18.275 | 18.275 |
| 2 | 1.1561 | 1.1561 | 13.275 | 13.046 |
| 3 | .9702 | .9702 | 10.914 | 10.914 |
| 4 | .7142 | .7142 | 15.495 | 15.495 |
| 5 | 1.2734 | 1.2734 | 15.625 | 15.625 |
| 6 | 1.3189 | 1.3189 | 19.239 | 19.239 |
| 7 | 1.1651 | 1.1651 | 17.287 | 17.287 |
| 8 | .8817 | .8817 | 17.526 | 17.526 |
| 9 | .8279 | .8279 | 18.490 | 18.490 |
| 10 | 1.1039 | 1.1039 | 17.502 | 17.502 |
| 11 | .5555 | .5555 | 16.905 | 16.905 |
| 12 | .4700 | 1.4700 | 15.533 | 15.533 |
| 13 | 1.3267 | 1.3267 | 16.497 | 16.497 |
| 14 | .9551 | .9551 | 8.958 | 8.958 |
| Mean | 1.0421 | 1.0421 | 15.807 | 15.807 |
| s. d. | .2513 | .2513 | 2.847 | 2.847 |
| Postflight | | | | |
| 1 | 1.2537 | 1.2372 | 19.841 | 22.044 |
| 2 | 1.3477 | 1.3913 | 25.428 | 28.920 |
| 3 | 1.1250 | 1.1735 | 24.091 | 21.869 |
| 4 | 1.4126 | 1.4118 | 22.457 | 22.244 |
| Mean | 1.2835 | 1.3035 | 22.954 | 23.769 |
| s. d. | .1100 | .1009 | 2.083 | 2.977 |

TABLE V

PRE-FLIGHT URINE SAMPLES
Borman

| Date | Time | Vol. (ml.) | 24-Hr. Vol. (ml.) | S. G. |
|----------|------|---------------|----------------------|-------|
| 11-22-65 | 0920 | 99 | | 1.022 |
| 11-22-65 | 1230 | 750 | | 1.005 |
| 11-22-65 | 1600 | 785 | | 1.006 |
| 11-22-65 | 2030 | 480 | | 1.011 |
| 11-22-65 | 2320 | 462 | | 1.508 |
| 11-23-65 | 0700 | 515 | | 1.012 |
| | | | <hr/> 3091 | |
| 11-23-65 | 1125 | 575 | | 1.008 |
| 11-23-65 | 1400 | 812 | | 1.005 |
| 11-23-65 | 1645 | 668 | | 1.006 |
| 11-23-65 | 2200 | 572 | | 1.012 |
| 11-24-65 | 0450 | 665 | | 1.010 |
| 11-24-65 | 0640 | 122 | | 1.017 |
| | | | <hr/> 3414 | |
| 11-24-65 | 0945 | 225 | | 1.013 |
| 11-24-65 | 1315 | 356 | | 1.011 |
| 11-24-65 | 1615 | 880 | | 1.005 |
| 11-24-65 | 1730 | 325 | | 1.009 |
| 11-24-65 | 2315 | 805 | | 1.010 |
| 11-25-65 | 0330 | 235 | | 1.020 |
| 11-25-65 | 0650 | 187 | | 1.019 |
| | | | <hr/> 3013 | |
| 11-25-65 | 0930 | 260 | | 1.011 |
| 11-25-65 | 1145 | 279 | | 1.010 |
| 11-25-65 | 1500 | 478 | | 1.009 |
| 11-25-65 | 1600 | 612 | | 1.002 |
| 11-25-65 | 1715 | 450 | | 1.003 |
| 11-25-65 | 2110 | 515 | | 1.010 |
| 11-25-65 | 2300 | 420 | | 1.006 |
| 11-26-65 | 0610 | 480 | | 1.014 |
| | | | <hr/> 3494 | |
| 11-26-65 | 0940 | 342 | | 1.010 |
| 11-26-65 | 1200 | 400 | | 1.008 |
| 11-26-65 | 1400 | 405 | | 1.006 |
| 11-26-65 | 1500 | 655 | | 1.003 |
| 11-26-65 | 1615 | 340 | | 1.006 |
| 11-26-65 | 2000 | 300 | | 1.015 |
| 11-26-65 | 2300 | 510 | | 1.009 |
| 11-27-65 | 0630 | 485 | | 1.014 |
| | | | <hr/> 3437 | |

TABLE V (Cont.)

PRE-FLIGHT URINE SAMPLES
Borman

| Date | Time | Vol. (ml.) | 24-Hr. Vol. (ml.) | S. G. |
|----------|------|---------------|----------------------|--------|
| 11-27-65 | 0900 | 360 | | 1.010 |
| 11-27-65 | 1000 | 350 | | 1.005 |
| 11-27-65 | 1220 | 630 | | 1.006 |
| 11-27-65 | 1610 | 915 | | 1.007 |
| 11-27-65 | 1800 | 303 | | 1.010 |
| 11-27-65 | 2330 | 380 | | 1.0185 |
| 11-28-65 | 0600 | 325 | | 1.021 |
| | | | <u>3263</u> | |
| 11-28-65 | 0945 | 167 | | 1.0185 |
| 11-28-65 | 1030 | 370 | | 1.003 |
| 11-28-65 | 1200 | 373 | | 1.005 |
| 11-28-65 | 1610 | 590 | | 1.011 |
| 11-28-65 | 2020 | 410 | | 1.014 |
| 11-28-65 | 2345 | 650 | | 1.007 |
| 11-29-65 | 0630 | 332 | | 1.017 |
| | | | <u>2892</u> | |
| 11-29-65 | 1030 | 463 | | 1.0105 |
| 11-29-65 | 1205 | 257 | | 1.0085 |
| 11-29-65 | 1340 | 232 | | 1.009 |
| 11-29-65 | 1645 | 880 | | 1.006 |
| 11-29-65 | 2030 | 344 | | 1.014 |
| 11-29-65 | 2300 | 340 | | 1.0135 |
| 11-30-65 | 0630 | 440 | | 1.016 |
| | | | <u>2956</u> | |
| 11-30-65 | 1045 | 565 | | 1.010 |
| 11-30-65 | 1310 | 380 | | 1.008 |
| 11-30-65 | 1710 | 672 | | 1.009 |
| 11-30-65 | 2000 | 194 | | 1.017 |
| 11-30-65 | 2100 | 273 | | 1.006 |
| 11-30-65 | 2300 | 188 | | 1.014 |
| 12-01-65 | 0300 | 455 | | 1.011 |
| 12-01-65 | 0645 | 184 | | 1.021 |
| | | | <u>2911</u> | |
| 12-01-65 | 1200 | 655 | | 1.011 |
| 12-01-65 | 1400 | 288 | | 1.0095 |
| 12-01-65 | 1600 | 685 | | 1.005 |
| 12-01-65 | 1900 | 240 | | 1.015 |
| 12-01-65 | 2100 | 720 | | 1.0045 |
| 12-01-65 | 2230 | 257 | | 1.007 |
| 12-02-65 | 0620 | 390 | | 1.013 |
| | | | <u>3235</u> | |

TABLE VI

Inflight Urine Samples
Borman

| G.E.T. | Volume of Aliquot (ml) | Calculated Volume (ml) | S.G. | (ml) Volume taken for 24-hr. Pool | Pool No. | Calculated 24-hr. Volume(ml) |
|--------|---------------------------------|------------------------------|--------|--|-------------|------------------------------------|
| 04+54 | 40 | 363.5 | | 13.7 | | |
| 14+00 | 38 | 519.2 | | 19.5 | | |
| 21+33 | 50 | 318.7 | 1.0195 | 12.0 | I | 1201.4 |
| 32+24 | 35 | <u>258.0</u> | | 12.0 | | |
| 48+21 | 23 | 315.9 | 1.0295 | 14.7 | II | 573.9 |
| 56+25 | 40 | <u>233.8</u> | | 10.0 | | |
| 68+25 | 38 | 406.5 | 1.026 | 17.4 | III | 640.3 |
| 77+45 | 38 | <u>366.9</u> | | 16.3 | | |
| 89+06 | 45 | 225.7 | | 10.0 | | |
| 94+42 | 28 | 384.8 | 1.023 | 17.1 | IV | 977.4 |
| 99+24 | 42 | <u>398.3</u> | 1.0195 | | | |
| 102+14 | 35 | 311.3 | 1.0175 | | | |
| 112+10 | 48 | 478.5 | 1.019 | | | |
| 117+45 | 2 | 344.2 | --- | | | |
| 123+14 | 57 | 529.6 | 1.0148 | | V | 2406.1 |
| 128+07 | -- | --- | --- | | | |
| 136+00 | 55 | 404.4 | 1.026 | | | |
| 143.39 | 36 | 369.6 | 1.0293 | | VI | 774.0+ |
| 149+13 | 42 | 386.5 | | 15.0 | | |
| 159+46 | 55 | 542.5 | | 21.1 | | |
| 165+30 | 45 | 397.5 | | 15.4 | | |
| 170+00 | 42 | 413.9 | 1.0188 | 16.1 | VII | 1740.4 |
| 173+42 | 45 | <u>316.9</u> | | 17.2 | | |
| 185+00 | 50 | 304.9 | | 16.6 | | |
| 192+51 | 27 | 276.1 | 1.0183 | 15.0 | VIII | 897.9 |
| 195+12 | 42 | <u>375.4</u> | 1.0223 | | | |
| 207+40 | 40 | 368.1 | 1.029 | | | |
| 212+31 | 1 | 157.0 | --- | | | |
| 215+13 | 48 | 218.8 | 1.013 | | IX | 1276.3+ |
| 220+31 | 1 | <u>18.8</u> | --- | | | |
| 223+50 | 50 | 422.5 | 1.0125 | | | |
| 233+24 | 48 | 370.0 | 1.009 | | | |
| 231+ | 42 | 686.8 | 1.0128 | | | |
| 237+49 | 40 | 302.7 | 1.0245 | | | |
| 240+45 | 60 | 349.3 | 1.013 | | X | 2168.8 |
| 247+58 | 50 | <u>339.0</u> | | 17.1 | | |
| 257+00 | 50 | 296.9 | | 15.0 | | |
| 266+40 | 52 | 452.3 | 1.0248 | 22.9 | XI | 1088.2 |
| 267+11 | 50 | <u>577.6</u> | | 25.6 | | |

Table VI (cont.)

Inflight Urine Samples
Borman

| G. E. T. | Volume of Aliquot (ml) | Calculated Volume (ml) | S. G. | (ml) Volume taken for 24-hr. Pool | Pool No. | Calculated 24-hr. Volume(ml) |
|-------------|---------------------------------|------------------------------|--------|--|-------------|------------------------------------|
| 282+52 | 58 | 534.1 | | 23.7 | | |
| 286+32 | 42 | 391.6 | | 17.4 | | |
| 290+40 | 47 | 338.6 | 1.0168 | 15.0 | XII | 1841.9 |
| 297+48 | 36 | <u>229.0</u> | | 15.0 | | |
| 308+17 | 43 | 399.5 | | 26.2 | | |
| 311+30 | 65 | 353.8 | 1.023 | 23.2 | XIII | 982.3 |
| 315+25 | 42 | 328.6 | | 20.2 | | |
| 322+50 | 40 | 244.5 | | 15.0 | | |
| 326+32 | 50 | 428.7 | | 26.3 | | |
| Post-Flight | 556 | <u>556.</u> | 1.0138 | 34.1 | XIV | 1001.8 |

TABLE VII

POST-FLIGHT URINE SAMPLES
Borman

| Date | Time | Vol. (ml.) | 24-Hr.-Vol. (ml.) | S. G. |
|----------|------|---------------|----------------------|--------|
| 12-18-65 | 1210 | 505 | | 1.009 |
| 12-18-65 | 1800 | 345 | | 1.018 |
| 12-18-65 | 2130 | 368 | | 1.0125 |
| 12-19-65 | 0600 | 645 | | 1.014 |
| 12-19-65 | 0835 | 428 | | 1.0225 |
| 12-19-65 | 1200 | 430 | | 1.016 |
| | | | <u>2216</u> | |
| 12-19-65 | 1730 | 453 | | 1.018 |
| 12-19-65 | 2100 | 230 | | 1.019 |
| 12-19-65 | 2310 | 205 | | 1.0225 |
| 12-20-65 | 0600 | 303 | | 1.022 |
| 12-20-65 | 0800 | 213 | | 1.011 |
| 12-20-65 | 1000 | 342 | | 1.009 |
| 12-20-65 | 1200 | 352 | | 1.011 |
| | | | <u>2098</u> | |
| 12-20-65 | 1400 | 480 | | 1.006 |
| 12-20-65 | 1510 | 347 | | 1.006 |
| 12-20-65 | 1830 | 588 | | 1.009 |
| 12-20-65 | 2100 | 530 | | 1.0085 |
| 12-20-65 | 2230 | 435 | | 1.004 |
| 12-21-65 | 0500 | 270 | | 1.009 |
| 12-21-65 | 0730 | 308 | | 1.018 |
| 12-21-65 | 1120 | 605 | | 1.008 |
| | | | <u>3563</u> | |
| 12-21-65 | 1400 | 690 | | 1.0055 |
| 12-21-65 | 1500 | 495 | | 1.005 |
| 12-21-65 | 1710 | 625 | | 1.004 |
| 12-21-65 | 2000 | 230 | | 1.012 |
| 12-21-65 | 2230 | 655 | | 1.0045 |
| 12-22-65 | 0630 | 390 | | 1.0175 |
| 12-22-65 | 1000 | 182 | | 1.016 |
| 12-22-65 | 1200 | 540 | | 1.007 |
| | | | <u>3807</u> | |

TABLE VIII

PRE-FLIGHT URINE SAMPLES
Lovell

| Date | Time | Vol. (ml.) | 24-Hr. Vol. (ml.) | S. G. |
|----------|------|---------------|----------------------|--------|
| 11-22-65 | 1300 | 275 | | 1.023 |
| 11-22 | 1700 | 210 | | 1.022 |
| 11-22 | 2345 | 355 | | 1.023 |
| 11-23 | 0700 | 445 | | 1.0135 |
| | | | <u>1285</u> | |
| 11-23 | 1300 | 418 | | 1.017 |
| 11-23 | 1730 | 535 | | 1.012 |
| 11-23 | 2245 | 429 | | 1.016 |
| 11-24 | 0635 | 530 | | 1.013 |
| | | | <u>1912</u> | |
| 11-24 | 7200 | 292 | | 1.019 |
| 11-24 | 1730 | 417 | | 1.019 |
| 11-24 | 2315 | 279 | | 1.022 |
| 11-25 | 0700 | 342 | | 1.023 |
| | | | <u>1330</u> | |
| 11-25 | 0945 | 157 | | 1.022 |
| 11-25 | 1330 | 318 | | 1.011 |
| 11-25 | 1830 | 240 | | 1.027 |
| 11-25 | 2330 | 195 | | 1.025 |
| 11-26 | 0730 | 368 | | 1.024 |
| | | | <u>1278</u> | |
| 11-26 | 1200 | 270 | | 1.020 |
| 11-26 | 1400 | 223 | | 1.010 |
| 11-26 | 1630 | 495 | | 1.0075 |
| 11-26 | 2345 | 350 | | 1.024 |
| 11-27 | 0630 | 270 | | 1.026 |
| | | | <u>1608</u> | |
| 11-27 | 1015 | 540 | | 1.009 |
| 11-27 | 1200 | 265 | | 1.009 |
| 11-27 | 1520 | 480 | | 1.0105 |
| 11-27 | 1800 | 188 | | 1.019 |
| 11-27 | 2330 | 267 | | 1.023 |
| 11-28 | 0630 | 333 | | 1.023 |
| | | | <u>2073</u> | |
| 11-28 | 1000 | 120 | | 1.026 |
| 11-28 | 1300 | 130 | | 1.026 |
| 11-28 | 1600 | 248 | | 1.024 |
| 11-28 | 2030 | 152 | | 1.028 |
| 11-28 | 2345 | 160 | | 1.029 |
| 11-29 | 0715 | 385 | | 1.020 |
| | | | <u>1195</u> | |

TABLE VIII (Cont.)

PRE-FLIGHT URINE SAMPLES
Lovell

| Date | Time | Vol. (ml.) | 24-Hr. Vol. (ml.) | S. G. |
|----------|------|---------------|----------------------|--------|
| 11-29-65 | 1045 | 423 | | 1.009 |
| 11-29 | 1340 | 258 | | 1.0145 |
| 11-29 | 1700 | 568 | | 1.008 |
| 11-29 | 2030 | 247 | | 1.0175 |
| 11-29 | 2200 | 140 | | 1.021 |
| 11-30 | 0630 | 325 | | 1.023 |
| | | | <hr/> 1961 | |
| 11-30 | 1115 | 345 | | 1.018 |
| 11-30 | 1645 | 540 | | 1.013 |
| 11-30 | 2000 | 190 | | 1.020 |
| 11-30 | 2230 | 187 | | 1.0225 |
| 12-01 | 0645 | 475 | | 1.0175 |
| | | | <hr/> 1737 | |
| 12-01 | 1205 | 355 | | 1.020 |
| 12-01 | 1600 | 265 | | 1.021 |
| 12-01 | 2300 | 325 | | 1.026 |
| 12-02 | 0730 | 265 | | 1.026 |
| | | | <hr/> 1210 | |

TABLE IX

Inflight Urine Samples
Lovell

| G. E. T. | Volume of Aliquot (ml) | Calculated Volume (ml) | S. G. | (ml) Volume taken for 24-hr. Pool | Pool No. | Calculated 24-hr. Volume(ml) |
|----------|---------------------------------|------------------------------|--------|--|-------------|------------------------------------|
| 4+38 | 35 | 90.7 | 1.0328 | 5.0 | | |
| 11+50 | 68 | 420.8 | 1.0303 | 23.2 | | |
| 21+33 | 40 | 377.1 | --- | 20.8 | I | 888.6 |
| 32+25 | 22 | <u>198.3</u> | | 16.3 | | |
| 46+00 | 33 | 218.8 | | 18.0 | | |
| 48+20 | 15 | <u>121.8</u> | 1.0335 | 10.9 | II | 538.9 |
| 52+06 | -- | --- | --- | --- | | |
| 56+30 | -- | --- | --- | --- | | |
| 68+50 | -- | --- | --- | --- | III | --- |
| 77+46 | 12 | 101.8 | | 4.8 | | |
| 80+41 | 8 | 42.7 | | 2.0 | | |
| 89+00 | 50 | 187.5 | | 8.8 | | |
| 94+40 | 28 | 280.7 | 1.035 | 13.1 | IV | 612.7 |
| 102+13 | 35 | <u>277.7</u> | | 17.7 | | |
| 118+00 | 45 | 235.4 | | 15.0 | | |
| 121+08 | 43 | 320.2 | 1.0335 | 20.4 | V | 833.3 |
| 127+30 | 42 | <u>214.8</u> | | 15.0 | | |
| 140+10 | 55 | 346.7 | | 24.2 | | |
| 146+37 | 34 | 218.6 | 1.0273 | 15.3 | VI | 780.1 |
| 159+02 | 25 | <u>205.4</u> | | 15.0 | | |
| 165+51 | 45 | 279.2 | | 20.4 | | |
| 171+47 | 35 | 241.0 | 1.0323 | 17.6 | VII | 725.6 |
| 185+17 | 58 | <u>313.8</u> | | 16.6 | | |
| 192+50 | 42 | 320.1 | | 17.0 | | |
| 197+28 | 34 | 283.0 | 1.031 | 15.0 | VIII | 916.9 |
| 209+09 | 54 | <u>319.3</u> | | 24.8 | | |
| 215+25 | 46 | 287.9 | | 22.4 | | |
| 220+33 | 35 | 193.2 | 1.0313 | 15.0 | IX | 800.4 |
| 231+52 | 40 | <u>267.2</u> | | 12.0 | | |
| 237+35 | 21 | 278.1 | | 12.5 | | |
| 244+00 | 20 | 326.3 | 1.0313 | 14.7 | X | 871.6 |
| 254+21 | 30 | <u>205.3</u> | | 15.0 | | |
| 266+20 | 68 | 317.3 | | 23.2 | | |
| 272+10 | 46 | 318.0 | 1.028 | 23.2 | XI | 840.6 |
| 282+39 | 50 | <u>300.7</u> | | 20.5 | | |
| 286+00 | 48 | 328.1 | | 22.4 | | |
| 290+44 | 51 | <u>219.8</u> | 1.0255 | 15.0 | XII | 848.6 |

Table IX (cont.)

Inflight Urine Samples
Lovell

| G. E. T. | Volume of Aliquot (ml) | Calculated Volume (ml) | S. G. | (ml) Volume taken for 24-hr. Pool | Pool No. | Calculated 24-hr. Volume(ml) |
|-------------|---------------------------------|------------------------------|--------|--|-------------|------------------------------------|
| 302+19 | 45 | 158.7 | | 13.9 | | |
| 308+21 | 56 | 317.9 | | 27.8 | | |
| 313+50 | 23 | 137.4 | 1.026 | 12.0 | XIII | 614.0 |
| 317+35 | 48 | <u>188.8</u> | | 16.9 | | |
| 322+50 | 55 | 206.4 | | 18.4 | | |
| 326+44 | 43 | 168.0 | | 15.0 | | |
| Post-Flight | 484 | <u>484.0</u> | 1.0185 | 43.2 | XIV | 563.2 |
| | 44 | <u>176-186)</u> | 1.0303 | | | |
| | 33 | 206-218) | 1.0378 | | | |
| | 30 | 140-148) | 1.034 | | | |
| | 45 | 268-284) | 1.0323 | | | |

TABLE X

Post-Flight Urine Samples
Lovell

| Date | Time | Vol. (ml) | 24-Hr. Vol. (ml) | S. G. |
|----------|------|--------------|---------------------|--------|
| 12-18-65 | 1109 | 440 | | 1.010 |
| 12-18-65 | 1800 | 287 | | 1.019 |
| 12-18-65 | 2030 | 185 | | 1.026 |
| 12-19-65 | 1230 | 263 | | 1.024 |
| | | | <u>735</u> | |
| 12-19-65 | 1500 | 290 | | 1.022 |
| 12-19-65 | 2230 | 325 | | 1.0225 |
| 12-20-65 | 0600 | 485 | | 1.015 |
| 12-20-65 | 1215 | 305 | | 1.021 |
| | | | <u>1405</u> | |
| 12-20-65 | 1830 | 370 | | 1.023 |
| 12-20-65 | 2330 | 315 | | 1.026 |
| 12-21-65 | 0730 | 488 | | 1.016 |
| 12-21-65 | 0950 | 142 | | 1.019 |
| | | | <u>1315</u> | |
| 12-21-65 | 1930 | 388 | | 1.027 |
| 12-22-65 | 0630 | 853 | | 1.04 |
| 12-22-65 | 0750 | 210 | | 1.013 |
| 12-22-65 | 1200 | 165 | | 1.022 |
| | | | <u>1616</u> | |

TABLE XI

FECAL SAMPLES

Borman

| Date | Time | G.E.T. | Marker | Date Marker Admin. (1965) | Wet Wt. (gm.) | Dry Wt. (gm.) |
|--------------------|------|--------|--------|------------------------------------|---------------------|---------------------|
| <u>Preflight</u> | | | | | | |
| 11-23 | 1130 | | 13 | 11-22 | 98.6) | |
| 11-24 | 0650 | | 13 | | 90.6) | |
| 11-25 | 0935 | | ---- | | 63.4) | 130.2 |
| 11-26 | 0715 | | ---- | | 90.1) | |
| 11-27 | 0700 | | ---- | | 116.6) | |
| 11-28 | 0645 | | R | 11-27) | | |
| 11-28 | 2400 | | R |) | | |
| 11-29 | 2150 | | ---- |) | 493.5 | 126.9 |
| 11-30 | 2130 | | ---- |) | | |
| 12-01 | 1715 | | B(fr.) | 12-01) | | |
| <u>Inflight</u> | | | | | | |
| | | 50+13 | R | | 178.5 | 79.55 |
| | | 96+59 | ---- | | 113.0 | 45.91 |
| | | 140+25 | ---- | | 170.0 | 68.01 |
| | | 170+00 | ---- | | 75.0 | 32.92 |
| | | 193+17 | ---- | | 109.0 | 37.85 |
| | | 240+49 | ---- | | 104.5 | 44.87 |
| | | 287+25 | ---- | | 113.5 | 54.28 |
| | | 308+44 | ---- | | 122.0 | 56.10 |
| | | | | | TOTAL | 419.49 |
| <u>Post-Flight</u> | | | | | | |
| 12-18 | 0835 | | ---- | 12-18 | 73.6 | 21.40 |
| 12-19 | 2200 | | B | | 241.6) | |
| 12-20 | 1400 | | ---- | | 214.6) | 94.60 |
| 12-21 | 0800 | | ---- | 12-21 | 91.6) | |

TABLE XII

FECAL SAMPLES

Lovell

| Date | Time | G.E.T. | Marker | Date Marker Admin. (1965) | Wet Wt. (gm.) | Dry Wt. (gm.) |
|--------------------|------|--------|---------|------------------------------------|---------------------|---------------------|
| <u>Preflight</u> | | | | | | |
| 11-23 | 1300 | | ---- | | 41.6) | |
| 11-24 | 2100 | | B | 11-22 | 116.6) | |
| 11-25 | 0945 | | B | | 121.4) | 100.8 |
| 11-26 | 2130 | | B (tr.) | | 81.8) | |
| 11-27 | 1230 | | ---- | | 85.6) | |
| 11-28 | 1100 | | R | 11-27) | | |
| 11-29 | 2030 | | R(tr.) |) | | |
| 11-30 | 1710 | | ---- |) | 337.5 | 85.3 |
| 11-30 | 2245 | | ---- |) | | |
| 12-01 | 1615 | | ---- |) | | |
| 12-01 | 2100 | | B | 12-01) | | |
| <u>Inflight</u> | | | | | | |
| | | 138+26 | R | | 46.0 | 15.69 |
| | | 143+48 | R | | 70.3 | 39.92 |
| | | 187+00 | ---- | | 88.1 | 38.08 |
| | | 232+00 | ---- | | 44.5 | 21.54 |
| | | 257+00 | ---- | | 60.5 | 27.84 |
| | | 261+27 | ---- | | 96.5 | 41.80 |
| | | 285+46 | ---- | | 155.0 | 59.92 |
| | | | | | TOTAL | 244.79 |
| <u>Post-Flight</u> | | | | | | |
| 12-18 | 2030 | | ---- | 12-18 | 130.6 | 57.91 |
| 12-19 | 0600 | | B | | 79.6) | |
| 12-20 | 0800 | | B | | 294.6) | 135.53 |
| 12-21 | 1045 | | ---- | 12-22 | 187.6) | |

TABLE XIII

DAILY URINE EXCRETIONS

| Date (1965) | Borman | | | Lovell | | |
|--------------------|-------------|------------|---------------------|-------------|------------|---------------------|
| | Ca (mg.) | N (gm.) | Creatinine (gm.) | Ca (mg.) | N (gm.) | Creatinine (gm.) |
| <u>Preflight</u> | | | | | | |
| 11-22 | 201 | 21.54 | 2.278 | 160 | 16.83 | 1.769 |
| 11-23 | 220 | 21.69 | 2.278 | 171 | 18.39 | 1.849 |
| 11-24 | 199 | 24.23 | 2.190 | 169 | 17.96 | 2.055 |
| 11-25 | 207 | 22.84 | 2.436 | 140 | 20.99 | 2.247 |
| 11-26 | 261 | 27.70 | 2.277 | 195 | 21.22 | 2.130 |
| 11-27 | 216 | 26.82 | 2.300 | 167 | 24.56 | 2.183 |
| 11-28 | 245 | 20.98 | 2.417 | 141 | 22.51 | 2.457 |
| 11-29 | 198 | 19.35 | 2.362 | 155 | 19.00 | 2.202 |
| 11-30 | 173 | 23.45 | 2.253 | 140 | 21.01 | 2.198 |
| 12-01 | 226 | 19.73 | 2.089 | 150 | 21.17 | 2.405 |
| Mean | 215 | 22.83 | 2.285 | 159 | 20.36 | 2.150 |
| s. d. | 24 | 2.65 | .098 | 17 | 2.20 | .205 |
| <u>Post-Flight</u> | | | | | | |
| 1 | 288 | 30.86 | 3.046 | 150 | 15.07 | 2.196 |
| 2 | 284 | 27.38 | 2.283 | 180 | 22.55 | 2.382 |
| 3 | 284 | 21.79 | 2.637 | 172 | 21.76 | 2.195 |
| 4 | 288 | 21.36 | 2.739 | 187 | 20.30 | 2.479 |
| Mean | 286 | 25.34 | 2.679 | 172 | 19.92 | 2.313 |
| s. d. | 2 | 3.97 | .273 | 14 | 2.91 | .122 |

TABLE XIV

PRE-FLIGHT DAILY URINARY CREATININE EXCRETIONS

| Day | Borman (Gm.) | Lovell (Gm.) |
|-------|-----------------|-----------------|
| T-12 | 2.2782 | 1.7693 |
| T-11 | 2.2490 | 1.8499 |
| T-10 | 2.1899 | 2.0545 |
| T-9 | 2.4357 | 2.2465 |
| T-8 | 2.2773 | 2.1299 |
| T-7 | 2.2995 | 2.1831 |
| T-6 | 2.4166 | 2.4570 |
| T-5 | 2.3623 | 2.2022 |
| T-4 | 2.2525 | 2.1980 |
| T-3 | 2.0890 | 2.4046 |
| Mean | 2.2850 | 2.1495 |
| s. d. | .0980 | .2047 |

TABLE XV

INFLIGHT DAILY URINARY CREATININE EXCRETIONS

| Day | Borman* (Gm.) | Lovell+ (Gm.) |
|-------|------------------|------------------|
| 1 | 1.6760 | 1.1980 |
| 2 | 1.4721 | 1.4744 |
| 3 | 1.3216 | ----- |
| 4 | 1.5834 | 1.6672 |
| 5 | 1.4232 | 2.1074 |
| 6 | 1.4949 | 1.7365 |
| 7 | 2.1146 | 1.7632 |
| 8 | 1.4196 | 2.0850 |
| 9 | 1.4415 | 1.8489 |
| 10 | 1.7532 | 2.0317 |
| 11 | 1.9849 | 1.5812 |
| 12 | 2.0556 | 1.6242 |
| 13 | 1.6650 | 1.2397 |
| 14 | 1.2022 | 1.8944 |
| Mean | 1.6148 | 1.7545 |
| s. d. | 0.2677 | 0.2479 |

* Mean of pre- and post-flight: 2.3968

+ Mean of pre- and post-flight: 2.1963

TABLE XVI

Corrected Inflight Daily Urine Excretion

| Borman * | | | Lovell + | | |
|----------|------------|-----------|----------|------------|-----------|
| Day | Ca (mg) | N (gm) | Day | Ca (mg) | N (gm) |
| 1 | 215 | 16.26 | 1 | --- | --- |
| 2 | 215 | 13.27 | 2 | 122 | 14.26 |
| 3 | 214 | 15.45 | 3 | --- | --- |
| 4 | 195 | 16.51 | 4 | 143 | 15.70 |
| 5 | 249 | 22.42 | 5 | 149 | 16.50 |
| 6 | 215 | 17.22 | 6 | 175 | 16.09 |
| 7 | 260 | 19.72 | 7 | 160 | 16.78 |
| 8 | 264 | 19.85 | 8 | 185 | 18.07 |
| 9 | 296 | 19.62 | 9 | 160 | 17.78 |
| 10 | 273 | 19.82 | 10 | 158 | 17.58 |
| 11 | 242 | 18.79 | 11 | 154 | 19.74 |
| 12 | 268 | 18.47 | 12 | 192 | 15.50 |
| 13 | 252 | 17.25 | 13 | 180 | 14.14 |
| 14 | 178 | 15.97 | 14 | 160 | 12.75 |
| Mean | 238 | 17.90 | Mean | 162 | 16.24 |
| s.d. | 32 | 2.27 | s.d. | 19 | 1.86 |

*Corrected for mean of pre- and post-flight creatinine excretions. (2.397 gm/24-hr.)

+Corrected for mean of pre- and post-flight creatinine excretions. (2.196 gm/24-hr.)

TABLE XVII
Sweat Excretions

| | Date | Ca (mg) | Na (mEq) | K (mEq) | N (gm) |
|---------------|---------------|------------|-------------|------------|-----------|
| <u>Borman</u> | | | | | |
| Pre-flight | 11-23 | 23 | 27.8 | 9.5 | .20 |
| Pre-flight | 11-26 | 29 | 21.6 | 11.3 | .18 |
| Inflight | 12-4 to 12-18 | 14 | 2.3 | 1.1 | .03 |
| Post-flight | 12-20 | 43 | 7.9 | 9.4 | .23 |
| Post-flight | 12-21 | 42 | 16.1 | 12.5 | .28 |
| <u>Lovell</u> | | | | | |
| Pre-flight | 11-23 | 14 | 25.1 | 12.9 | .31 |
| Pre-flight | 11-26 | 31 | 25.2 | 15.9 | .40 |
| Inflight | 12-4 to 12-18 | 16 | 2.9 | 1.6 | .04 |
| Post-flight | 12-20 | 41 | 6.4 | 9.3 | .24 |
| Post-flight | 12-21 | 48 | 13.2 | 13.4 | .34 |

individual astronauts giving the time of voiding, the volume of the aliquot, the calculated volume (using the tracer technique), the specific gravity, volume taken for the 24 hour pool, and the resulting calculated 24 hour volume for the pool. It should be noted that the volumes under the heading "24-Hr. Volume" refer to the uncorrected values of the sums of the volumes of the individual micturitions that occurred over that period. There was no attempt to have the astronaut urinate at a specified time in order to give exact 24 hour samples. The resultant pools of data thus represent pools both greater and less than 24 hours. This is mentioned since data later were corrected by assuming a constant 24 hour excretion of creatinine. This correction apparently neglected the correction to a true 24 hour volume and neglected to consider possible variability in the error of the volume determination for each of the micturitions. The exact source of error in the volume determination technique used during flight or the constancy of this source of error has not been determined. (A ground-based evaluation⁹ of the system is presented in Appendix C.)

In Tables VII and X are presented the post-flight urine samples indicating the time, volume, specific gravity of each micturition, and the 24 hour volume for the first 4 days after flight. It should be noted that these data were collected for 24 hour periods running from 12:00 to 12:00. The first urine sample for both astronauts was included in the flight data even though it was obtained after they landed. It also should be noted in Table X that for Astronaut Lovell, the urine collecting period was 2-1/2 hours short of the 24 hour collection on 12-20-65; therefore, the collection period for 12-21-65 would be correspondingly longer. This should contribute to a variability in the measurements made post-flight on this astronaut on these two days. This is borne out later in Table XIII in which the 24 hour daily urine excretions of calcium, nitrogen and creatinine were expressed for this astronaut on these two days.

In Tables XI and XII are shown the data on fecal samples for the two astronauts pre-flight, inflight, and post-flight. Indicated are the time of collection, the appearance of a marker, the date the marker was administered, the wet weight of the fecal sample, and the dry weight of the sample.

In Table XIII are presented the daily urine excretions pre-flight and post-flight for the calcium, nitrogen, and creatinine for the two astronauts. These data have been separated from the inflight data because of the possibility of error in the urine aliquoting system which would possibly result in erroneous determinations of volume, and hence daily urine excretions of the different products. These data are presented in this table to provide a comparison of the pre-flight and post-flight data, since it is thought that these data were collected and recorded properly, and that accurate volume determinations were made on them. From these data there can be seen an appreciable increase for Astronaut Borman in the urinary calcium excretion post-flight compared to his pre-flight data. The excretion of creatinine post-flight also was somewhat higher for this astronaut. The value for the calcium excretion

on Astronaut Lovell post-flight was elevated above that of the mean for the calcium excretion pre-flight, but by a considerably smaller amount. This astronaut also showed 24 hour urine excretions pre-flight as large as post-flight values. Astronaut Lovell also showed a somewhat greater excretion of creatinine, though not significant. The standard deviation for the creatinine post-flight was smaller than pre-flight, even though there were fewer samples and one of the 4 post-flight samples was considerably less than a 24 hour specimen and another was greater than a 24 hour pool.

In Table XIV are presented the pre-flight daily urinary creatinine excretions for the two astronauts giving the daily values, the mean, and the standard deviation as presented by Dr. Lutwak in his report. In Table XV are presented the inflight daily urinary creatinine excretions for Astronauts Borman and Lovell, using the aii-quotes and volumes calculated from the dilution technique. At the bottom of this table are indicated the mean of the pre-flight and post-flight creatinine excretions for the two astronauts. It thus is evident that there was an appreciably lower excretion of urinary creatinine during the flight as compared to the pre-flight and post-flight excretions. It was assumed by Dr. Lutwak and associates that this most likely represented an error in the urine collecting system technique for determining volume of individual micturitions. Therefore, the mean daily urinary creatinine excretion was used to correct these data to new volumes which would be used in the calculation of all excretion products.

In Table XVI are presented the "corrected" inflight daily urine excretions of calcium and nitrogen for the two astronauts, calculated by assuming a constant creatinine excretion approximating that of the mean creatinine collected during the pre-flight and post-flight periods.

It is interesting to note that the "corrected" calcium excretion for Astronaut Borman for days 1 through 6 inflight were 215 mg, 215 mg, 214 mg, 195 mg, 249 mg, and 215 mg of calcium.

Considering that the original data pooled to represent a 24 hour volume for this astronaut on the first day are indeterminate, since it is not known whether he urinated at time zero G.E.T., that the collection period for the second day was approximately 27 hours, and that the collection period for the third day 20 hours, etc.; considering the possibility of a variability in the urine collecting technique for each micturition; and considering the expected day-to-day variability in calcium excretion, these values have remarkably small variability. Whatever the correction technique was to estimate the inflight calcium values, it is interesting to note that the results on four of the first 6 days of flight very closely approximated the mean value of 215 mg/day pre-flight for Astronaut Borman. There appears to be a pattern of increased urinary excretion of calcium in the following days of the flight if one accepts this as an appropriate technique for correcting the urine data. There was more variability in measurements on the other astronaut. Astronaut Borman also showed very little variability in his urinary calcium excretion for the 4 days post-flight.

In Table XVII are indicated the data for the sweat excretions using the technique described under the Method section. The values for calcium, sodium, potassium, and nitrogen are indicated. The inflight average excretion of calcium in the sweat was lower for both astronauts than their average values pre-flight and post-flight. It is interesting to note, however, that the pre-flight and post-flight values, obtained using this technique on the astronauts undergoing regular activity schedules, were obtained ranging only from 14 to 48 mg/day of calcium.

No further description or calculations have been made of these data since the extent of the error of the urine aliquot collecting system used during flight can not be determined. It was thought by the author that any other further manipulation of the data would likely lead to erroneous conclusions and was not justified.

DISCUSSION

An evaluation of the X-ray bone densitometry could be made only pre-flight and post-flight. Therefore, any changes which occurred during flight that were of a more dynamic nature would not be reflected on the longer flights. Results of bedrest studies by Vogt, et al.¹⁰ suggested that when additional stressional situations are superimposed upon a bedrest experiment, there is a possibility for an accentuated initial loss in bone density, followed by a return towards normal, and then a more progressive decline in the bone density. The measurement made for the flights of different durations would seem to support this earlier observation from bedrest studies. However, the subjects were different for each flight and other factors (such as dietary intake) were not controlled as in the bedrest studies.

Studies performed in association with other bedrest experiments^{10,11} have indicated a more linear relationship between the bone density changes and the duration of the periods of recumbency. This same time dependency can not be interpreted to occur in association with the flights, although there was a greater change in bone density in association with flight Gemini V than in association with the shorter flight Gemini IV.

The small number of subjects that participated in the flights, the variability in the observations, and the fact that measurements could be made only pre-flight and post-flight mean that the observations made to date cannot be extended to make predictions of changes on longer flights of the future. At best, the data collected to date document the changes that occurred in association with the three flights on which the experiments were performed. However, the data may give a clue as to other mechanisms that may be operative in causing changes in bone density, such as the decreased dietary intake on flight Gemini V.

An assessment of the significance of changes in X-ray density after flight compared to before flight also requires information on the reproducibility of the technique and the expected day-to-day variability in a subject's bone density under controlled experimental conditions. The results of such studies are given in Appendix B and Appendix D of this report.

X-ray density changes include the effect of changes in bone protein and the underlying and overlying tissue. Conditions of exposure (kv, ma, and time) have been selected to minimize the protein and fluid effects, and to maximize the effects of changes of the mineral element in the bones. Such optimization is possible because of the higher atomic number of calcium and phosphorous in comparison with other elements involved in bone and surrounding tissue.

It is interesting that the phalanx of the fifth digit, and the phalanx of the fourth digit (of which cross sections of segments were evaluated for bone mass) showed some decline in X-ray density in as short a time as 4 days. In bedrest studies conducted at Texas Woman's University,¹¹ no significant changes in bone X-ray absorption in phalanx 5-2 site have been found, except during more prolonged bedrest periods.

Changes in the X-ray density of peripheral bones do not necessarily represent changes of the more centralized bones; therefore, no assessment can be made of the potential hazard to the astronauts for changes in bone density of the magnitude found in association with the three flights on which measurements were made. However, in clinical studies and experiments on normal subjects, it has been found that loss in bone calcium was progressive with time. It thus would seem advisable to continue to perform X-ray bone density studies in association with the more prolonged space flights. It does not seem advisable to attempt to perform studies during the flights because of the extreme difficulty of developing instrumentation for such an experiment. If the methodology that could be used in flight did not have the precision as that presently used before and after flights, the interpretation of the data would become even more confusing.

A detailed description of the instrumentation technique and methodology used for the X-ray bone densitometry studies is presented in Appendix A of this report. The need for an exact and reproducible method in taking films, developing films, and in evaluating the films on the X-ray densitometer is the reason that personnel from the laboratory of Texas Woman's University participated directly in this experiment, including taking the roentgenographs of the recovery ship.

It seems desirable that further studies should be conducted to evaluate the effect of acute stressful situations on the change in bone density, perhaps including a study of the effect of hormonal injections in normal subjects. Further evaluation also should be made of the effect of exercise on the X-ray bone density.

No comparison can be made of bone density changes and the actual calcium losses from the body during flight Gemini VII, since the calcium balance studies were not performed adequately to make any interpretation of them.

The evaluation of nitrogen and calcium balance in association with the space flight presents many difficulties. For a calculation of an accurate calcium balance or nitrogen balance, it is required that the dietary intake and all output including urine, feces, and sweat be measured accurately. For the data represented as the results of the studies conducted in association with the Experiment M-7 on flight Gemini VII, the question of the validity of the urine data leads one to the conclusion that an estimation of the calcium and nitrogen balance is not justified. The reasons for this conclusion are based primarily on the difficulty in obtaining representative urine samples during the flight portion of the experiment. At most, comparisons can be made of pre-flight and post-flight urine measurements. Also, the amount of sweat calcium as compared to data presented in this literature is low on the astronauts during periods of normal activity pre-flight and post-flight.

The inflight urine aliquots were stored at cabin temperature in polyethelene bags containing preservative and a tracer material. As soon as possible after landing, the samples were stored in a deep-freeze. After the urine specimens were delivered to the laboratory, the total volume of each micturition sample was measured by determining the dilution of the tracer. The actual specimens or aliquots collected during

approximately 24 hour periods then were pooled. Apparently no correction was made to "convert" this volume to an "actual" 24 hour volume. In other words, no correction was applied to a 22 hour sample to make it a 24 hour sample by multiplying by 24 over 22. From the total calculated volume (using the tracer technique) using the total number of aliquots collected during an approximate 24 hour period, the volume taken from each sample was a representation of a "24 hour pool" as based on the percentage of the total volume as was determined by the calculated volume for each aliquot. For example, if the total "24 hour volume" was 1200 ml and one of the micturitions volumes was 300 ml, it represents 25% of the calculated total. Therefore, 25% of the final pool sample for analysis was taken from this aliquot. Theoretically, this technique is valid if the urine collecting system is accurate. However, in this experiment there is some question as to the reproducibility and accuracy of the method for determining urine volume. This would mean that each aliquot, if each had a different error for the volume determination, could be misrepresented by taking a portion to pool for a "24 hour volume."

The pooling of the urine samples by taking aliquots of urine passed within 24 hour periods, rather than collecting at a prescribed beginning time for each 24 hour period, results in a greater day-to-day variance in 24 hour volume and values for excretory products. Using such variable time periods for pooling data collected during the flight phase, especially if a urine sample is lost or if there is a sample-to-sample variability in the error of the collection system, would further compound the error for a true 24 hour volume. Correction of the urine volume using the average of the pre-flight and post-flight creatinine, assuming a constant 24 hour urine creatinine excretion, could be extremely misleading. It would seem to the author that it would be more appropriate to recognize the deficiencies in the technique and of the system used on flight Gemini VII and to take steps to correct the deficiencies if studies of this type are done in association with space flights in the future. Nothing can be gained from further manipulation of bad data. Analysis of each urine sample should be performed before pooling results; this would preserve the information on relative rates of excretion of different products even if there is error in the volume determination.

It would seem most appropriate to discuss the data in terms of problems apparent to an uninvolved observer in order that appropriate measures may be taken to assure collection of adequate data in future flights. The difficulties in performing calcium balance studies or nitrogen balance studies under the most ideal circumstances, as may be found on a metabolic ward, likewise are difficult. The further complications of doing such a study in association with a space flight obviously were expected to present difficulties, and the persons involved in these analyses and studies recognized these possibilities. Even though the data obtained are inadequate to perform a balance study, it would seem appropriate to consider the experiment successful if knowledge was gained from the experience of this past flight which would be helpful in planning for future flights.

A comparison of the data collected inflight with the data collected pre-flight and post-flight indicates a smaller daily urinary volume and urinary excretion of creatinine. The analyses of these data were performed by Dr. Leo Lutwak, under Contract

NAS 9-5375, at the Clinical Nutrition Unit of the Graduate School of Nutrition, Cornell University, Ithaca, New York. Dr. Lutwak recognized the possible problems with the urine collection system, as exemplified by the lowered urine volume and daily excretion of creatinine. For this reason all results presented were corrected to "24 hour urine samples" on the basis of the pre-flight and post-flight creatinine values. Since the daily poolings representative of their "24 hour value" also had some error, and because of the possibility of variability in the error for sample-to-sample, the error in the final results would be expected to be compounded. This does not seem to be the case, however, if one observes Table XVI in which it is noted that the corrected inflight calcium values for the first 6 days are 215 mg, 215 mg, 214 mg, 195 mg, 249 mg, and 215 mg daily. The cumulative effect of the previous errors and the small variation in the calcium in the urine using this correction technique makes one wonder whether there is some undefined aspect of this procedure lending insensitivity to the procedure, thus reducing the expected variability.

An evaluation⁹ has been made of the chemical urine volume measurement system (CUVMS) by Paul A. LaChance, Ph.D., of the Crew Systems Division of the National Aeronautics and Space Administration of the Manned Spacecraft Center, Houston, Texas, and Marilyn E. George, of the 6570th Aerospace Research Laboratory, Wright-Patterson AFB, Ohio. In an unpublished paper (see Appendix C) entitled "Human Evaluation of a Chemical Urine Volume and Measurement System," they utilized standardized metering of a solution of tritiated water and propylene glycol to evaluate human urine during two experiments. During one experiment the CUVMS was directly utilized by four subjects for 3 days and indirectly utilized (urine poured through) for an additional 3 days. In another experiment, three subjects utilized the CUVMS directly for a period of several days. The measured volumes of each voiding and the volumes obtained from aliquots and assayed by a tritium dilution technique correlated closely with the volumes measured by conventional calibrated laboratory glassware." They did note, however, that significant errors were introduced by improper handling and/or operation of the CUVMS, in particular if there was insufficient blending of the urine and tritium. They concluded that the CUVMS, in these ground-based studies, is capable of providing reproducible and accurate results. "Twenty-four urine volumes with less than a 5% error were obtained."

Such a urine aliquoting system was used because the Gemini spacecraft allows less free volume or free weight per man than the Mercury spacecraft, and the flight durations of up to 14 days were contemplated. Therefore, the storage of all urine voided during flight was considered to be an impracticable consideration.

The persons analyzing the samples of the M-7 experiment were of the opinion that there was some difficulty with the urine collection system; other persons who obtained urine for evaluation apparently had reservations concerning this conclusion. At a meeting sponsored by the Space Medicine Directorate of the Office of Manned Space Flight of the National Aeronautics and Space Administration, held at the Management Center, John F. Kennedy Space Center, Florida, August 23, 1966, and documented in "A Review of the Medical Results of Gemini 7 and Related Flights,"

the following observations were made. In a presentation of medical Experiment M-5, "Biochemical Analysis of Body Fluids in Manned Space Flight," by principal investigators Harry Lipscomb, M.D., Elliott Harris, Ph.D., and Lawrence Dietlein, Ph.D., the following question was asked (see page 77) "What effect would the accuracy of the volume determinations have on your confidence in the reliability of the data?" The answer was as follows, "If the urine collection devices were not working properly and the total volume collections were not correct, the data certainly would not be reliable. In such a case, one would expect erratic results. However, in this case, the values for sodium, potassium, and chloride are so remarkably similar for the two men that we believe the variations seen are valid observations." There thus is implied in this answer that the inflight urine collection system functioned properly. These authors did not indicate the source of the determination of urinary volume by the dilution technique. It is not clear whether the same volumes as used in the calculations in the report by Dr. Lutwak were used or whether independent determinations were made.

These authors noted, however, that the urinary sodium excretion decreased slightly during flight in both members of the crew. Immediately post-flight there was a retention of sodium. Then a short time later, there was a marked rise in urinary sodium levels, interpreted by them as excretion of retained sodium. However, in their figure 3 and figure 4, showing the 17-hydroxycorticosterone and cathcholamines, one graph shows data "not corrected" for creatinine and the other one "corrected" for creatinine. The meaning of the work "corrected" or "not corrected," and whether it applied to the sodium, potassium, and chloride data are unclear from this report.

It thus is impossible for an investigator to attempt to interpret results acquired from these flights without further documentation of the procedures followed. If data of this type is considered to belong to the entire medical community, so that each scientist may utilize his experience and knowledge to evaluate the data and arrive at his interpretation independently, it must be recommended that data from future flights be presented in as well documented form as possible. If this is not the case, then one must provide the data collectors with full responsibility to provide interpretation of the results.

Some more experienced investigators have thought the data adequate to make interpretations of results. A presentation was made by G. Donald Whedon, M.D., Director of the National Institute of Arthritis and Metabolic Diseases, National Institutes of Health, Bethesda, Maryland, as part of closed circuit television panel discussion entitled "Results of Long Duration Manned Space Flights in Gemini Spacecraft" on Thursday, April 21, 1966, at the Aerospace Medical Association Meeting in Las Vegas, Nevada. He said, "In order to obtain sensible urinary data from this first effort to obtain metabolic data in space, it is necessary to make the assumption that renal clearance did not significantly change and thus to correct the analyzed inflight urinary data on the basis of the difference between inflight and pre-flight urinary creatinine values." On this basis, Dr. Whedon stated, "There was a 25% increase in the urinary calcium in one astronaut and no significant change in the other." At the same time, Dr. Whedon stated that, "The fecal

calcium was modestly increased in the astronaut who showed no change in urinary calcium but fecal calcium was not increased in the one whose urinary calcium increased."

Later that year Dr. Whedon, at the American Physiological Society Fall meeting in Houston, September 2, 1966, made a presentation of Gemini VII Metabolic Studies in Symposium on "Man's Physiological Response to the Space Flight Environment" (based principally on group papers presented by Dr. Lutwak to Endocrine Society, June, 1966). In slides showing the metabolic balance data, he described "the negative shift of calcium balance in both astronauts was approximately 100 mg/day." He interpreted this of questionable significance, "because of the short period of the study."

The 24 hour values of calcium in the sweat determination on the astronauts contributed a relatively small amount of the total balance. Larger values for the sweat calcium have been reported by other authors. It generally is recognized that the sweat from the skin of the body may contain considerable calcium, with the exception of the insensible perspiration of the soles and palms of the hands. The amount of sweat calcium has been considered by some to be great enough to result in erroneous conclusions concerning dietary calcium requirements. In long term studies, the apparent retention of the calcium may be partly due to the loss of calcium which was not accounted for in the sweat. This is described and documented further in Appendix D of this report in which there was an apparent positive balance of calcium in the pre-bedrest phase of a study and probably was a reflection of that calcium excreted in the sweat.

Mitchell and Hamilton¹² found that in studies on men receiving an average daily calcium intake of 1.1 g, there was some suggestion that an increased excretion of calcium by the sweat glands is associated with a decreased excretion in the urine. Further, they noted that under comfortable environmental conditions, the loss of calcium from the skin averaged 6.2 mg/hr. or 14% of the total loss of body calcium. They noted that under profuse sweating, there was an average continuous loss of 20.2 mg/hr., compared with the loss of 6.2 mg under comfortable conditions. This former value accounted on the average for 29.9% of the total loss of body calcium, over twice that lost in the urine. On a 24 hour basis, under comfortable conditions, in which sweating is minimal, the subjects excreted 149 mg of calcium per 24 hours in the sweat.

In another study by Consolzaio et al.,¹³ the authors noted that (with room temperatures of 30.5°C, 30% relative humidity during waking hours and 33.1°C during the evening hours when men slept) an average of 184 mg/24 hr. of calcium was excreted by the 12 subjects. These authors had reported in an earlier study (Consolazio, et al., U.S. Army Med. Lab. Report 266, 1962) on eight normal men maintained for 4 periods at 70°F, the average sweat calcium loss was 144 mg/day when these subjects were maintained on a 0.44 g daily calcium diet. These authors noted that the skin calcium losses increase with increasing room temperature.

In contrast, Gittelman and Lutwak,¹⁴ in an abstract, reported "despite the recognized importance of measuring dermal losses of minerals in subjects under study by metabolic

balance techniques, the magnitude of this route of loss is difficult to assess by available methods. Direct measurement of dermal losses of mineral from the entire body (excluding head and neck, hands, and perineum) were made utilizing a special collection technique on four elderly females with osteoporosis and one elderly female with osteitis deformans in the course of metabolic balance studies under conditions of comfortable temperature and non-perspiring activity. Dermal excretions were collected for two 3 day periods for each subject. Mineral content of hand and forearms sweat produced by pilocarpine stimulation was also measured. Daily excretions (ave mg/day \pm 1 s.d. for 2 determinations, all subjects) were calcium 15.4 ± 10.8 mg. No correlation was noted between measured body dermal loss and body size, dietary intake, urinary excretion, mineral balance, or mineral content of stimulated sweat." These authors concluded that the magnitude of cutaneous loss of calcium is quantitatively insignificant and may be disregarded in an interpretation of metabolic balance studies, provided that they are conducted under conditions where sweating is avoided. These data were collected from elderly females with osteoporosis, and the methodology is not described well. An attempt to find further documentation of this abstract has been unsuccessful.

McKey, et al.¹⁵ also reported negligible calcium in the sweat under sedentary conditions in an air conditioned metabolic ward. This abstract read as follows: "Twenty-four-hour losses of minerals from the entire integument (excluding wrists and hands) of a woman fully-clothed in cotton garments and working in a laboratory at 72-78° were determined for 42 consecutive days in mid-winter. Collection garments, body, and scalp were washed separately and successively in alcohol, acetic acid and redistilled water until the washings were free of calcium. Each collection garment had its own control which had been washed the same number of times and in the same volume of solvents. Preliminary data indicate that the total dermal loss of calcium did not exceed 10 mg/day. Calcium in scalp and body washings averaged 3.0 ± 0.59 mg/day. In the garment washings, variation in calcium content occurred, not only in the collection garments but also in their controls. Studies are now in progress to determine the number and type of controls necessary, the minimum length of the collection period required, and the most efficient type of wash solvents."

These two abstracts of Gittelman et al., and McKey et al., both reporting low calcium losses from the skin, are sketchy and are difficult to accept in view of more definitive studies reported elsewhere. However, it would appear that the low losses of calcium reported in association with the space flight are more in line with these two abstract reports, and perhaps may be explained by the methodology or technique of performing the analysis and collection of sweat.

The data from studies conducted at Texas Woman's University, as indicated in Appendix D of this report, indicate that an appreciable amount of calcium loss is unaccounted for when only urine and fecal calcium losses are considered in relation to the dietary calcium intake. It is logical to assume that a fair proportion of this would be that lost in the sweat if the subjects were not in continued positive calcium balance. In these studies there was no reason to assume that the subjects were in continued positive calcium balance. Since the data found by this indirect technique correspond closely to

that reported as the 24 hour sweat calcium losses for other subjects, it would seem reasonable to assume this higher figure to be more nearly correct. The data reported in association with the flight probably represent the values characteristic of that technique of collecting and analyzing sweat; the appropriateness of using this value cannot be ascertained by the author of this paper.

The assumption that the creatinine excretion of an individual is constant from day-to-day is one that has come after many years of documented studies. A review of these studies indicates that in many cases it has been stressed that the creatinine excretion of an individual is relatively constant from day-to-day for a wide range of dietary intake, but that the day-to-day creatinine excretion shows considerable variability. At least, the variability probably is greater than that desired to introduce into this study as a possible complicating factor in evaluating calcium balance over a short-term study of the effect of space flight.

Jones¹⁶ points out several reasons for variability of creatinine excretion in some individuals. His experience indicated that the variability could arise without biological variation due to two possible sources of error: (a) failure to correct for the deviation of the picric acid-creatinine complex from Beers Law, and (b) occasional contamination of some urine samples by creatinine splitting organisms. It had been observed in their laboratory that creatinine splitting organisms could sometimes contaminate the bottle used for urine collection. These organisms produce a creatinase which is most active at alkaline pH. With contaminations associated with alkaline decomposition of urine, a rapid destruction of creatinine takes place to give an erroneously low result. This author recommended that the estimation of creatinine should be performed immediately upon completion of collection, or the urine should be kept in a refrigerator until the estimation is made.

Bleiler and associates¹⁷ reported a study in sequential 24 hour urinary creatinine determinations on 12 men. They noted that even though the 24 hour urine specimens were collected under controlled conditions, the creatinine values over 15 or more days for 12 subjects receiving weighed general diets were surprisingly variable. Analytical variation determined by a replicate analyses was 1% or less, and was considered unimportant as the cause of variability observed in these experiments. These authors thought also that the reagent specificity also had a negligible contribution to the variability since only a small proportion of non-creatinine chromogen appears in urine. They did note that creatinine excretion always decreased upon changing from meat containing diets to formulas. Even when the daily formulas contained as much as 140 g of protein, this decline continued generally throughout the formula period. Whether such a change could occur from changing from a normal diet to an inflight diet has not been determined to the best knowledge of the author.

Mills¹⁸ reported studies of the circadian rhythms of a subject in whom numerous measurements were made during and after 3 months of solitude underground. In these studies he noted that the creatinine excretion was always low during sleep. Addis et al.¹⁹ also noted that there was a drop in creatinine excretion during the period from 10:00 p.m. to 7:00 a.m., and a rise during the period from 7:00 a.m. until 12:00 noon, after a creatinine free breakfast, on all diets. The factors responsible for the nocturnal drop must be other than the dietary protein consumption.

One of the earlier reports on the constancy of the creatinine in the urine is reported by Folin¹⁹ in discussing the laws governing the chemical composition of urine, reported in 1905. He noted, "While the amount of kreatinin eliminated with the urine is for each individual practically a constant quantity, independent of the total amount of nitrogen and of the volume of urine eliminated, the amount may be different for different persons." He noted that the "extraordinary variation in the normal daily kreatinin elimination showed by Gregor's figures render them, however, decidedly doubtful, although I am inclined to believe that his main contention may be correct." Folin noted that "turning from the consideration from the percent in terms of the total nitrogen to that of the absolute quantity of kreatinin eliminated, we find the remarkable fact that the absolute quantity of kreatinin eliminated in the urine in a meat-free diet is a constant quantity different for different individuals but wholly independent of change in the total amount of nitrogen eliminated." He noted that "small variations do occur, but the constancy of the kreatinin as compared with all other nitrogenous constituents, is certainly remarkable, especially in view of the fact that the muscles and most of, if not all other organs, must at all times contain very considerable quantities of kreatinin." He also noted that the variations that do occur are independent of the volume of the urine and of the total nitrogen.

In a study by Albanese²⁰ on 30 normal subjects studied for 38-60 days under normal and experimental dietary conditions, individuals daily variations of 10-25% were observed in the total urine creatinine. These observations would seem to indicate that the irregularities in creatinine excretion are greater than heretofore presumed and that the variations in creatinine output are not necessarily indicative of inaccurate 24 hour collections. By the same token one could reason that inaccurate 24 hour collections could not be corrected by using an assumed constant value for creatinine output. In another extensive study reported by Wang²¹ the authors performed an extended study on 33 normal male and females on hospital diets. This author reported fluctuations of 10-25% of the individual creatinine output to be common occurrence.

It does not seem to the author that there is adequate justification presented in the literature to warrant consideration of the excretion of creatinine as a constant measurement day-to-day that would allow correction of urine volumes on this basis, especially for the purpose of using the results in a calcium balance study.

CONCLUSIONS

1. Appreciable change (loss) in X-ray bone density occurred during flights Gemini IV and Gemini V; less change was observed during flight Gemini VII.
2. The marked changes in bone density on the flight Gemini V most likely were associated with the decreased dietary intake of calcium in addition to other conditions in association with this flight.
3. X-ray bone densitometry appears to be a precise and reproducible technique for estimating the mineral change in the os calcis. (See Appendix A and B)
4. No better non-invasive technique is known which can be used on astronauts in association with space flights to assess mineral changes in a specific bone.
5. The relation is not known of the change in X-ray bone density of the os calcis and other large bone masses of the body during space flight.
6. The relation between the change in X-ray bone density and calcium balance during flight Gemini VII cannot be assessed.
7. The values presented for calcium excretion during flight probably are not valid because of errors inherent in the method for collection, pooling, and analysis; these errors are larger than would justify use of the data in calcium balance calculations.
8. A comparison of pre-flight urine calcium excretion to post-flight urine calcium excretion on flight Gemini VII suggests an increase in the urinary calcium excretion; but since calcium loss in the sweat and feces is needed for an estimation of the calcium balance, no further conclusions can be drawn.
9. The results for excretion of calcium in the sweat by the method used are low in comparison to data adequately documented in the literature.
10. An evaluation of relative excretion of different urine products is not possible since pooled samples were used; the aliquots for the pool may have variable rates of excretion for each of the substances and each of the samples pooled may have had a different error involved in determining the volume represented.
11. Data and available literature on the day-to-day variability, the error in the ground-based volume determination method, and pooling of data present variability too great to make corrections for urine volume measurements by using a factor that assumes constant excretion of creatinine.

12. The data obtained by sweat evaluations took much time of the astronauts and other personnel and does not appear to be justified on future flights unless a more simple and reliable method is established.

13. There probably are many factors associated with a space flight which could effect bone density, calcium balance, and nitrogen balance; they cannot be separated or defined from the studies conducted.

14. Ground-based studies are useful to define experimental procedures and the limits in methodology which later may be used for flight experiments.

RECOMMENDATIONS

1. Further experiments should be conducted to define the factors responsible for day-to-day variation in bone density, such as inactivity, diet, stress, etc., in order to assess the possible contribution of each during a space flight.

2. Further experimental methods should be devised to estimate accurately the bone mass of other than peripheral bones.

3. A comprehensive study should be performed to evaluate the limitations of the urine collection system using the isotope dilution method (or any other method); this study should include documentation of the reliability of the method in the zero gravity situation.

4. The analyses of inflight urine samples should be made on each of the samples collected; twenty-four hour urine volumes could be represented by the time span of the collection period multiplied by an appropriate factor to convert the data to 24-hour volumes.

5. It would be extremely desirable to have longer pre-flight control periods.

6. A study should be made of the effect of change in the dietary composition (i.e., changes from regular diets to flight diets) on the bone density, calcium excretion and creatinine excretion.

7. It would seem appropriate to omit the determination of sweat calcium on future flights because too much time of the astronaut is taken to perform an acceptable technique which would give small error.

8. The errors in present instrumentation technique to assess bone mass during flight are too great to justify inflight evaluation of bone density or bone mass.

9. There should be a continuation of the effort to perform experiments in association with space flights to document changes in bone density and calcium balance.

REFERENCES

1. Mack, P. B., G. P. Vose, F. B. Vogt, and P. A. LaChance: Contract Report on Experiment M-6: Bone Demineralization on Gemini IV. Nelda Childers Stark Laboratory for Human Nutrition Research. Texas Woman's University, 1965.
2. Mack, P. B., G. P. Vose, F. B. Vogt, and P. A. LaChance: Contract Report on Experiment M-6: Bone Demineralization on Gemini V. Nelda Childers Stark Laboratory for Human Nutrition Research. Texas Woman's University, 1966.
3. Mack, P. B., P. A. LaChance, G. P. Vose, and F. B. Vogt: Contract Report on Experiment M-6: Bone Demineralization on Gemini VII. Nelda Childers Stark Laboratory for Human Nutrition Research. Texas Woman's University, 1966.
4. Mack, P. B., P. A. LaChance, G. P. Vose, and F. B. Vogt: Medical Experiment M006 - Bone Demineralization: A Review of Medical Results of Gemini VII and Related Flights. Proceedings of a conference held at Kennedy Space Center, Florida. August 23, 1966. pp. 83-126.
5. Mack, P. B., G. P. Vose, F. B. Vogt, and P. A. LaChance: Experiment M-6, Bone Demineralization. Gemini Midprogram Conference, Houston, Texas. February 23-25, 1966. NASA SP-121.
6. Mack, P. B., W. N. Brown, Jr., and H. D. Trapp: The Quantitative Evaluation of Bone Density. Amer. J. Roentgen. 61:808, 1949.
7. Mack, P. B., G. P. Vose, and J. D. Nelson: New Development in Equipment for the Roentgenographic Measurement of Bone Density. Amer. J. Roentgen. 82:303, 1959.
8. Mack, P. B.: Radiographic Bone Densitometry. Conference on Progress In Development of Methods in Bone Densitometry. Washington, D.C., March, 1965. NASA SP-64.
9. LaChance, P. A. and M. E. George: Human Evaluation of a Chemical Urine Volume and Measurement System. Unpublished Report - Personal Communication.
10. Vogt, F. B., P. B. Mack, W. C. Beasley, W. A. Spencer, D. Cardus, and C. Vallbona: The Effect of Bedrest on Various Parameters of Physiological Function. Part XII. The Effect of Bedrest on Bone Mass and Calcium Balance. NASA CR-182. April, 1965.

11. Mack, P. B.: Unpublished NASA Grant and Contract Reports, NsG 440. From the Texas Woman's University, Denton, Texas.
12. Mitchell, H. H. and T. S. Hamilton: The Dermal Excretion Under Controlled Environmental Conditions of Nitrogen and Minerals in Human Subjects With Particular Reference to Calcium and Iron. *J. Biol. Chem.* 178:345, 1949.
13. Consolazio, C. F., L. O. Matoush, R. A. Nelson, G. J. Isaac, and J. E. Canham: Comparisons of Nitrogen, Calcium and Iodine Excretion in Arm and Total Body Sweat. *Amer. J. Clin. Nutr.* 18:443, 1966.
14. Gittelman, H. J. and L. Lutwak: Dermal Losses of Minerals in Elderly Women Under Non-Sweating Conditions. *Clinical Research* 11:42, 1963. (Abstract)
15. McKey, B. V., G. L. Borchers, D. Navarrete, C. C. Chen, M. J. Gowdy, and J. O. Holmes: Dermal Loss of Minerals in Sedentary Man. *Fed. Proc.* 22:551, 1963. (Abstract 2332)
16. Jones, F.: A Note On 24-Hour Urinary Creatinine Estimation As An Index of Accuracy in 24-Hour Urine Collection. *J. Med. Lab. Tech.* 21:156, 1964.
17. Bleiler, R. E. and H. P. Schedl: Creatinine Excretion: Variability and Relationships to Diet and Body Size. *J. Lab. and Clin. Med.* 59:945, 1962.
18. Mills, J. N.: Circadian Rhythms During and After Three Months In Solitude Underground. *J. Physiol.* 174:217, 1964.
19. Folin, Otto: Laws Governing the Chemical Composition of Urine. *Amer. J. Physiol.* 13:66, 1905.
20. Albanese, A. A. and D. M. Wangerin: The Creatine and Creatinine Excretion of Normal Adult Males. *Science* 100:58, 1944.
21. Wang, E.: Clinical and Experimental Investigation on the Creatine Metabolism. *Acta Med. Scan. Suppl.* 105-108, 1939-1940.
22. Lutwak, L.: The Chemical Analysis of the Diet, Urine, Feces, and Sweat Parameters Relating to the Calcium and Nitrogen Balance Studies During Gemini 7 Flight. Unpublished report prepared under Contract NAS 9-5375. September, 1966.
23. LaChance, P. A.: Definitive Documentation. Gemini In-Flight Experiment M-7; Calcium and Nitrogen Balance: Principal Investigators Dr. G. Donald Whedon, Dr. William Neuman. March 1, 1965.

APPENDIX

BONE DENSITOMETER ASSEMBLY FOR MEASUREMENT
OF ROENTGENOGRAPHIC BONE DENSITY

APPENDIX A

BONE DENSITOMETER ASSEMBLY FOR MEASUREMENT OF ROENTGENOGRAPHIC BONE DENSITY

INTRODUCTION

The optical density of a roentgenographic bone image can be related to the mass of mineral present in the bone, if conditions of exposure and developing of the film are standardized and kept constant. Marked departures from normal bone mineralization and changes in bone mineralization can be seen readily upon visual inspection of roentgenograms, but are not easily quantitated without more refined techniques. It generally is recognized that changes in bone mineralization of the order of 20-30% are necessary before visual inspection will detect changes in the roentgenogram. However, change of a few percentage values in the skeletal mineralization is of interest in a number of experimental and clinical situations; for example, the evaluation of drug therapy, and in disease processes such as osteoporosis, osteomalacia, nutritional deficiencies, etc. Accurate techniques are required for determination of meaningful serial measurements. A change in bone mass in association with bedrest¹ and space flight² also requires accurate and reproducible techniques.

In order to obtain quantitative measurements of the optical changes in a roentgenographic bone image, a controlled technique of X-ray exposure, film processing, and film analysis is required. In addition, a technique for calibrating roentgenographs is essential; an aluminum alloy wedge serves this purpose. Using such a technique, small changes in mineral content are reflected in changes in X-ray bone density and can be evaluated very accurately in serial roentgenographs of a given individual or astronaut. The selection of optimum exposure techniques helps distinguish some of the effects from soft tissue, organic bone matrix, and the inorganic bone material. Other problems inherent in a roentgenographic bone density technique, and means to overcome them, are described in other presentations. The purpose of this paper is to describe briefly the technique which uses a special computer for the evaluation of signals obtained from the output of an optical scanning system used to evaluate the light transmittance through a roentgenograph.

INSTRUMENTATION

The instrumentation in use at the Texas Woman's University at the time of analysis of the flight films is a modification of previous models started by Dr. Pauline Beery Mack.* The densitometer is a special purpose analog computer^{3,4}, consisting of an electromechanical servomechanism and an integrating unit. The major units of the instrumentation used in

*Dr. Mack since has added a digital computer to the system to provide automatic calibration and analysis of results.

evaluating the radiographs in these laboratories are shown in Figure 1. The equipment consists of five major subassemblies, all designed to operate together as an integrated system. The basic units of the overall assembly are the following:

- (a) A modifier Knorr-Albers scanning unit (unit at right of figure);
- (b) A Speedomax Model G transmitting recorder (unit in center of the figure);
- (c) A series of 20 potentiometers in the same panel as (b);
- (d) A Speedomax Model G recording potentiometer (unit at left of the figure);
- (e) An Instron integrator (mounted below d.)

Figure 2 shows a schematic diagram of the integrated microdensitometer system. A signal proportional to light transmittance through the film is produced by the scanning unit. This signal is received by the first recorder as an uncorrected, or uncalibrated, trace of a wedge or bone on the roentgenograph being scanned. An adjustable slidewire is mounted in this first recorder, which serves as a function generator, tapped at 21 points to give 20 sections of equal length. Twenty potentiometers are associated with the 20 sections of the slidewire to permit manual adjustment for purposes of modifying the output of the first recorder to give a calibration related to the wedge trace. After the function generator has been adjusted, the circuit setting is transferred to the receiving recorder, thus permitting a corrected or calibrated wedge scan as well as a corrected bone scan to be received and displayed on this second recorder. The output of the calibrated trace gives a readout count on the integrator.

Scanning Unit

The scanning unit consists of an optical system, a plate stage, a drive mechanism for the plate stage, and a DC amplifier. The optical system includes a special tungsten lamp powered from a highly stabilized power pack having a constancy of output of $\pm 0.1\%$ for AC line voltages between 100-125 volts at frequencies between 55 and 65 cycles. The beam from this lamp is focused on a photocell after passing through the X-ray film plate being scanned. The film is mounted on a plate stage that is supported by ball-bearing rollers on a carriage rod, all accurately machined to very close tolerance.

The drive mechanism for the plate stage has nine selectable speeds, varying from 0.1 mm/min. to 50 mm/min. Each plate travel speed is regulated closely by a synchronous motor drive. Adjustable limit switches govern the limit of travel in either direction, and the direction of plate travel is conveniently reversed by means of a switch.

A scale, mounted on the scanning unit and calibrated in millimeters, subdivided by a vernier, indicates plate travel and enables the operator to scan a number of precisely equal segments of the film trace. This scale also permits the operator to retrace exactly the same length of film on repeated scans and serves as the guide for integrating the equal trace segments. The plate travel is synchronized with recording chart travel

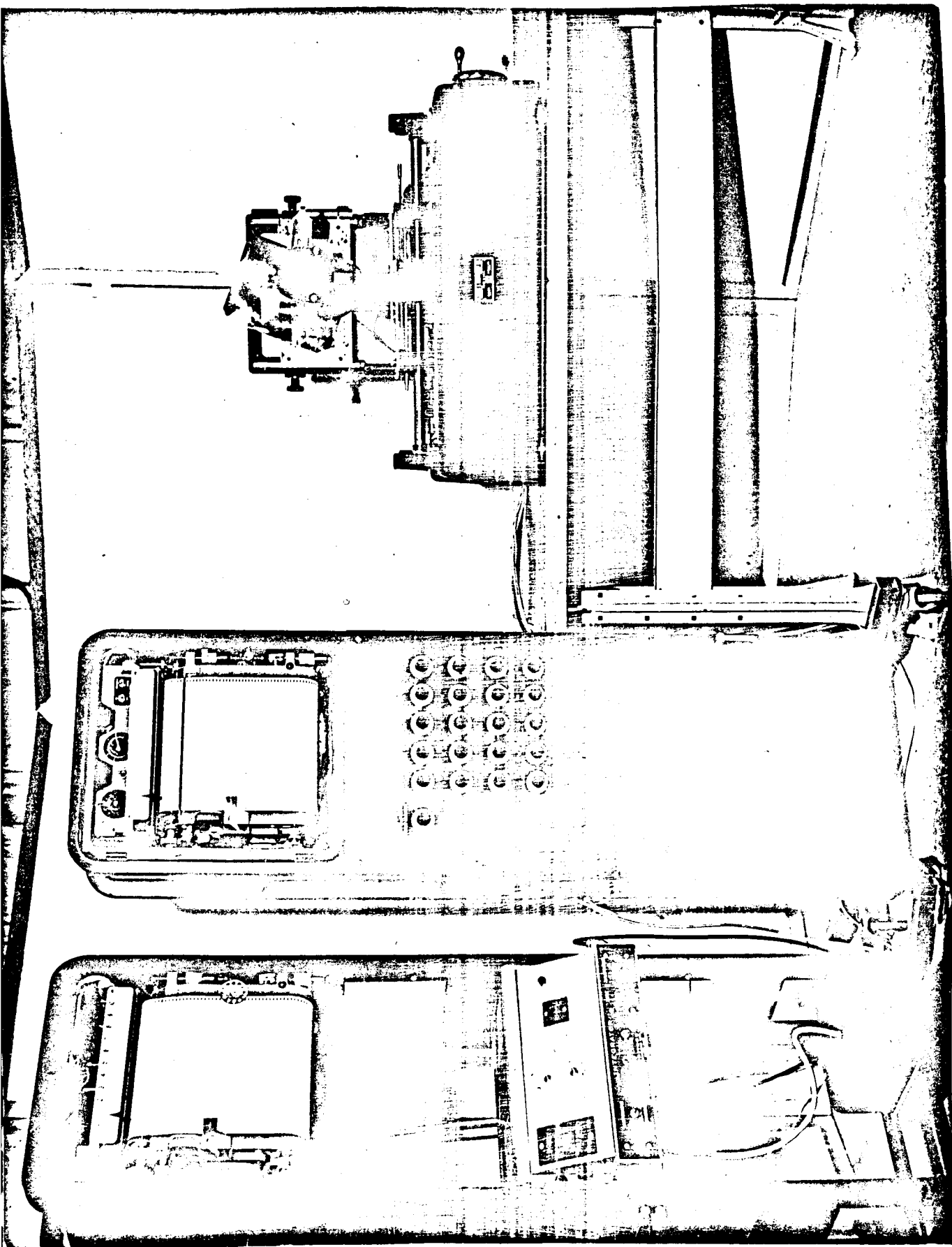
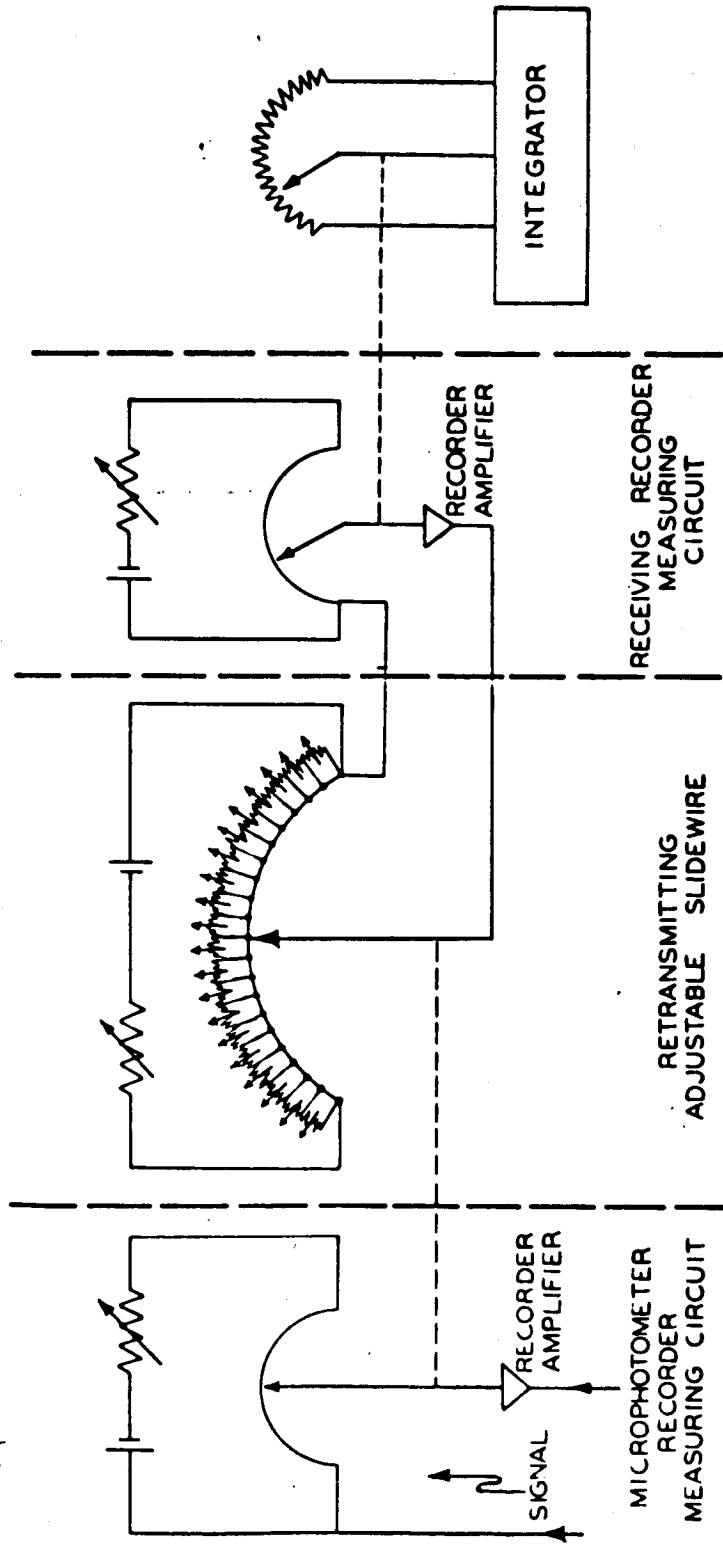

Figure 1. Texas Woman's University X-ray Bone Densitometer



**SCHEMATIC DRAWING OF THE MECHANICAL AND ELECTRICAL SYSTEM
OF THE INTEGRATING MICRODENSITOMETER**

Figure 2. Schematic Diagram

to insure that quantitative measurements of density can be produced and reproduced accurately. A precision DC amplifier multiplies the output from the photocell to a value measurable by the self-balancing potentiometer recorder.

First Recorder

The first recorder (center unit in Figure 1) consists of a Speedomax Type G, self-balancing function recorder, having an adjustable zero, adjustable span, and a full scale balancing speed of less than one second. This recorder indicates continuously the magnitude of the amplified photocell output and traces a graph on its chart in synchronism with the scanning unit plate travel.

A major feature of the complete assembly consists of a special DC retransmitting slidewire mounted in this Speedomax potentiometer recorder, with a moving contact on a slidewire driven in synchronism with the recording pen. This retransmitting slidewire is divided very precisely into 20 equal segments, each segment is shunted by an adjustable ten-turn potentiometer. An adjustable DC voltage is impressed across the total slidewire; and the output along portions of the slidewire is characterized by adjustments of the 20 potentiometer dials which provide a calibrated output from this slidewire referenced to the trace of the reference or calibration wedge which is physically a linear model.

The uncorrected wedge trace on the first recorder is scaled by the operator at 20 equal intervals, using a special transparent rule calibrated to provide a calibration factor on the 20 potentiometers. Since the scale of the first recorder is determined by the percentage of light transmitted through the film, and the calibrating retransmitting slidewire corrects the scale of the second recorder to standard wedge density, there is produced a straightline trace of the calibrating wedge on the second recorder in conformity with the wedge slope.

Second Recorder

The second recorder receives, displays, and records the signal from the special calibrating retransmitting slidewire which serves as a function transformer, providing a line graph of the reference wedge and a calibrated density trace of the bone sample. Its graphic output also is synchronized with the automatic scanning unit. A retransmitting potentiometer is driven from the output shaft of this second recorder and drives an Instron integrator located in the base of this second recorder unit.

Instron Integrator

The integrator provides a digital readout proportional to the area under the calibrated densitometer trace of the bone section which has been scanned on the second recorder. The integrator is equipped with two counter readouts. One is reset after

each segment is integrated, if a trace is segmented, while the second readout acts as a continuous or total counter on the readings taken from the first counts. A bell actuated by the limit switch on the plate travel mechanism signals the operator that the desired scan travel has been completed; the integrator counting is stopped automatically at this point.

SEQUENCE OF OPERATIONS IN MAKING A BONE MASS DETERMINATION

The fundamental step to obtain a satisfactory calibration for a trace of a bone section from an X-ray film is provided by the use of a calibration wedge exposed simultaneously as the bone. The image of a bone and the wedge are shown in Figure 3. The wedge is made of an aluminum alloy with X-ray absorption characteristics similar to that of bone. The roentgenographs are taken as described in the previous section of the report. The wedge composition is 93.4% aluminum, 0.6% manganese, 1.5% magnesium, and 4.5% copper. The material of which the wedge is made was carefully rolled to provide a homogenous alloy. All wedges in use at the Texas Women's University have utilized the same original aluminum alloy to assure reproducible standard wedges.

The wedge, which has a slope of 1:10, is traced from its beginning to a distance 13 cm along the base. This provides a linear calibration in units from 0 to 1.3 cm of aluminum alloy wedge equivalency. The range of film density for an os calcis in normal adult males corresponds to the film density along 50-80% of the wedge length.

The initial record obtained on the first recorder from scanning the wedge with the densitometer without correction provides the basis for calibrating the wedge curve for the film. Represented in this tracing is the percent light transmission through the film for displacement along the wedge from the beginning to 13 cm out on the wedge trace. The shape of this uncorrected curve is influenced by many factors including the film itself, the film exposure, and the film processing techniques.

It is desirable to integrate a tracing obtained across a line on a bone X-ray image to provide an expression of equivalent bone mass for a given film. Since the roentgenographic process distorts a linear graph which would represent the wedge accurately, the units of light transmission must be calibrated to equivalent wedge thickness before integration of the area under the tracing of a bone, if the results of the latter are to be meaningful. This calibration procedure is provided through an electro-mechanical servomechanism which uses the wedge trace to provide calibration factors over 20 segments of the wedge trace. The sequence of operations needed to achieve calibration of a density curve and to integrate the area under the curve of a bone on the same radiograph follows.

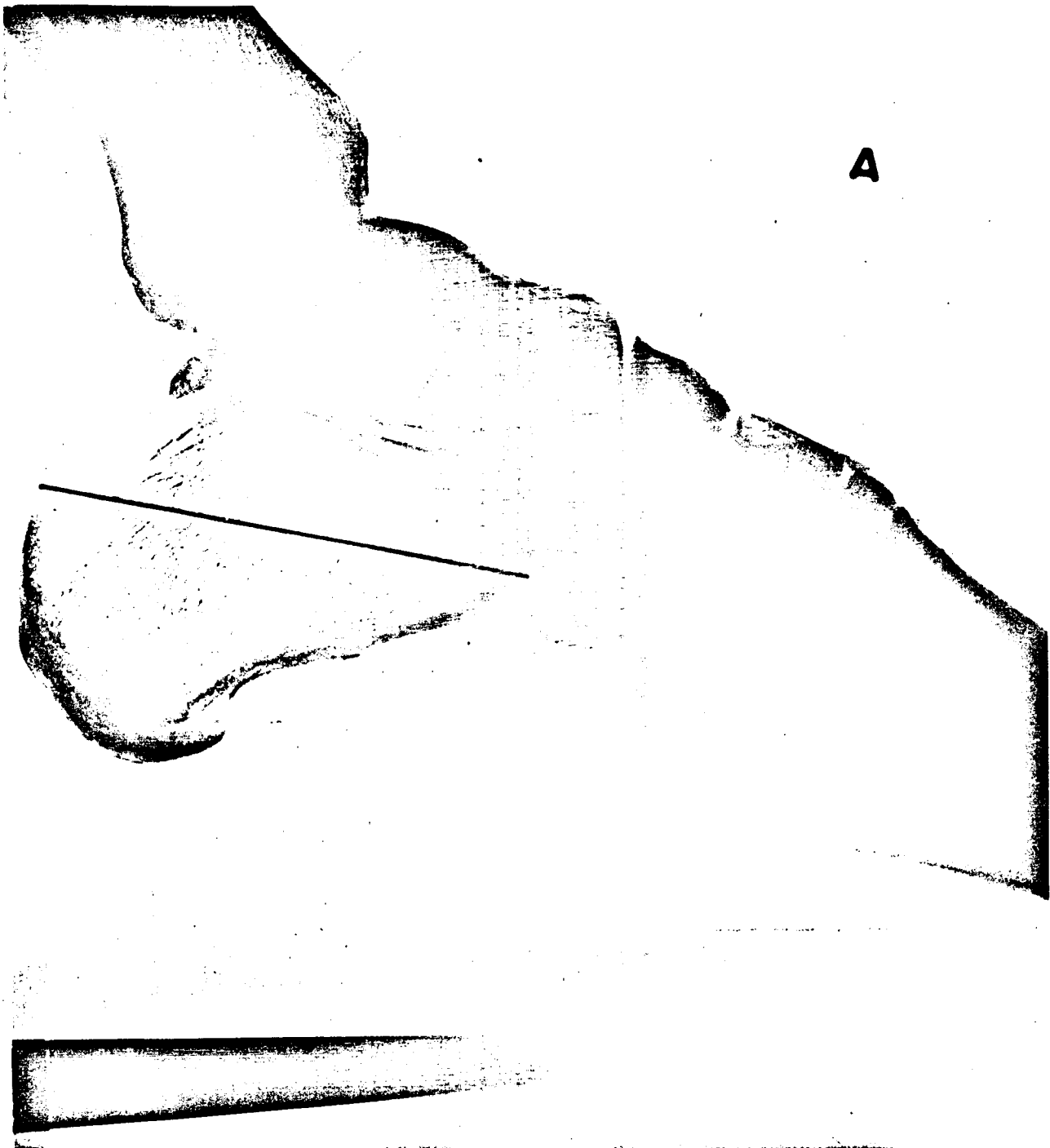

Figure 3. Conventional Scan on os calcis and calibrating wedge adjacent to foot

(a) The wedge roentgenographic image first is scanned for the purpose of providing the density calibration curve of that film on the recorder. Prior to the wedge scan, the first recorder is balanced to zero for the "no light transmission" condition obtained by inserting an opaque object between the light source and the photocell. Full scale output of the recorder is obtained for the light transmission 13 cm out on the wedge trace by adjusting the light source voltage and/or the amplifier gain. Once this adjustment is made, it remains the same throughout the rest of the procedure. In this manner, the extreme limits of the wedge are set the same for each procedure. The use of a site on the wedge other than 13 cm out the base would require corresponding changes in the multiplication factor for converting integrator units to equivalent wedge mass. The uncorrected curve for the wedge then is traced on the first recorder.

(b) Using the uncalibrated curve, the technologist measures the curve at 20 points along the chart and sets the 20 potentiometers in the panel to provide a calibration factor for each of the 20 divisions. The current through the slidewire and its shunted potentiometers then is set to give full scale deflection on the second recorder for the zero light transmission and for light transmission 13 cm out the wedge. The retransmitting slidewire is mechanically coupled to the first recorder tracing which is proportional to the electrical inputs. In this manner, a calibration factor is applied by each potentiometer according to the reading of the first recorder, so that the output can be used to drive the second recorder to display a calibrated output curve.

(c) When the potentiometers are set as required to obtain the resistance for calibrating the original wedge trace, a retrace of the wedge is made on the second recorder. If the potentiometers have been adjusted correctly, a straight line is obtained, confirming the correctness of the calibration procedure.

(d) After the second recording potentiometer has recorded the signal from the special transmitting slidewire and has received and displayed the corrected wedge trace, a calibrated density trace is made of a section of a bone on the same film as the calibration wedge image. This bone trace, also displayed on the second recorder panel, is synchronized with the automatic scanning system. Since the calibration procedure has corrected the scale of the second recorder to standard wedge density, the X-ray absorption of the bone section, as indicated by its densitometer trace, is related directly to the X-ray absorption of the standard wedge.

(e) A retransmitting potentiometer is driven mechanically from the output shaft of this second recorder which actuates the Instron integrator, providing a digital readout proportional to the area under the calibrated densitometer bone section trace.

The counts secured from the integrator may be used directly from one bone mass evaluation to another on a given individual. A conversion of integrator counts to other units such as equivalent wedge volume or equivalent wedge mass would involve the use of the same conversion factor for each set of counts, thus resulting in the same percentage

change from a roentgenograph of one subject made at one time to that made at subsequent times, provided the scanning speeds were the same. The counts usually are converted to equivalent wedge volume and to equivalent wedge mass since the density of the aluminum alloy wedge is known.

The aluminum alloy wedge has been used to calibrate calcium compounds which are components of, or are associated with, bone mineral. The calibrations have been made by placing chemically pure calcium compounds, or mixtures of compounds of known weight, in plastic encasements and exposing them on the same film as the standard wedge. The wedge image and the image of the chemical compound then can be traced in their entirety with parallel crosswise scans running the length of each image.

As a result of such a calibration, the bone mass data of living subjects is sometimes reported in terms of "calcium hydroxyapatite equivalency." The reporting of bone mass in such a term is not intended to denote that the bone under consideration contains this amount of calcium hydroxyapatite, but that the substances in the portion of the X-ray which was evaluated had an X-ray absorption value equivalent to the designated quantity of this calcium complex. The materials present in living bone and underlying and overlying tissue include bone mineral, protein, water, and fat. The respective contributions of the separate substances to the mass absorption coefficient of the entire bone tissue are dependent upon the X-ray exposure applied to the bone.

REFERENCES

1. Vogt, F. B., P. B. Mack, W. C. Beasley, W. A. Spencer, D. Cardus, and C. Vallbona: The Effect of Bedrest on Various Parameters of Physiological Function. Part XII. The Effect of Bedrest on Bone Mass and Calcium Balance NASA CR-182. April, 1965.
2. Mack, P. B., G. P. Vose, F. B. Vogt, and P. A. LaChance: Experiment M-6 Bone Demineralization. Gemini Midprogram Conference. February 23-25, 1966. NASA SP-121.
3. Mack, P. B., W. N. Brown, Jr., and H. D. Trapp; The Quantitative Evaluation of Bone Density. Amer. J. Roentgen. 61:808, 1949.
4. Mack, P. B., G. P. Vose, and J. D. Nelson: New Development in Equipment for the Roentgenographic Measurement of Bone Density. Amer. J. Roentgen. 82:303, 1959.

REPRODUCIBILITY OF AN X-RAY BONE
DENSITOMETRY TECHNIQUE

APPENDIX B

REPRODUCIBILITY OF AN X-RAY BONE DENSITOMETRY TECHNIQUE

INTRODUCTION

Changes in the calcium balance and bone mineral content of astronauts during prolonged space flights have been predicted on the basis of clinical and experimental observations made over the past several decades. One of the techniques for assessing the mineral content of bone is that of X-ray bone densitometry. Prior to the developments of standardized techniques and improved instrumentation for analysis of roentgenographs, a change of roentgenographic density in the order of 20-30% was required for distinction by the unaided human observer. The technique described herein^{1,2,3} has been applied to the study of selected bone roentgenographs in association with bedrest studies⁴ and space flight.^{5,6,7,8} An evaluation of the results of data collected from the bedrest and space flight experiments requires an understanding both of the sensitivity of the technique to changes in mineral mass and of the reproducibility of the X-ray bone densitometry technique. A description of the rationale for the technique of taking roentgenographs and a description of the instrumentation for evaluating them is presented elsewhere in detail. The use of standards for calibration of the roentgenograph and improved methods to distinguish roentgenographic density have increased the power to resolve change by at least a factor of ten.

It was the purpose of this study to evaluate the reproducibility of an X-ray bone densitometry technique used in evaluation of os calcis bone mass in terms of an equivalent aluminum alloy calibrating wedge. The evaluation was made of the entire methodology used, including positioning and X-raying the bone, developing the films, and evaluating the light transmittance of the resultant roentgenograph using a photo scanner and special purpose analog computer.

METHOD

The experiment was designed to evaluate all factors that enter into the results ultimately obtained--positioning, exposure, developing, and analysis of roentgenographs. Eight roentgenographs were made of one subject within a 20 minute period of time to assure that there were no significant changes in the bone mass being X-rayed. Between exposing each successive film, the subject was required to sit up, and then to step down from the X-ray table, to provide independent positioning for each roentgenograph. For each exposure, the subject was placed in a horizontal position with his body covered with lead shielding except for the foot being X-rayed.

The lateral aspect of the left foot was placed flat against the film with a small sand bag positioned under the toes to provide support, and to assure stabilization of the foot. An aluminum alloy wedge, which serves as a calibration standard for each film, then was placed adjacent to the heel of the foot, and the film was exposed. A standardized X-ray exposure, obtained by using a roentgen meter, was used for taking each roentgenograph; the approximate values used were 60 kv, 100 ma, 0.5 sec taken at a distance of 36 inches from the film. High quality Kodak Industrial X-ray film, type AA, was used in the study.

The eight films were developed for 5 minutes using a standardized developing solution maintained at a temperature of $68^{\circ}\text{F} \pm 1^{\circ}\text{F}$. Fixing and drying of the film were performed in the usual manner followed in the Research Institute at Texas Woman's University. An example of a resultant roentgenograph of the os calcis and the adjacent calibration wedge is shown in Figure 1.

Each of the eight films then was analyzed three times on the densitometer by evaluating each consecutive film in the series, and then repeating the analysis of the series at a later time until each film had been evaluated three times. For each analysis, the film was positioned in the densitometer and the calibration curve determined separately. An additional interrupted scan was performed which divided the conventional scan into 10 segments. This maneuver was performed to provide information on the accuracy of starting and stopping the densitometer scan mechanism, and to allow comparison of integrator counts for sections on the roentgenograph which have different light transmittance. There are thus 240 observed values (8 (films) X 3 (readings) X 10 (segments) = 240) which are used in the analysis of the reproducibility of the technique.

RESULTS

The results of the analysis performed on the roentgenographs are indicated in Table I. The data presented for a given film represent the integrator counts obtained from the output of the densitometer computer and thus have a calibrated relationship to the bone X-ray absorption in terms of equivalent aluminum wedge absorption. The magnitude of these numbers depends on the scanning speed, as well as other factors described elsewhere.³ Conversion to aluminum wedge equivalency requires multiplication by constants only, and thus is not performed here since it would not influence the objectives of the study.

The total counts represent the sum of the counts obtained for the 10 individual segments and thus is a measure of the integrated light transmittance for the conventional scan. The range of values of counts for different segments occurs because of differences in light transmittance in different parts of the roentgenograph, and is related to the anatomical structure or bone mass present at these segments.

A 2 A M
1 1

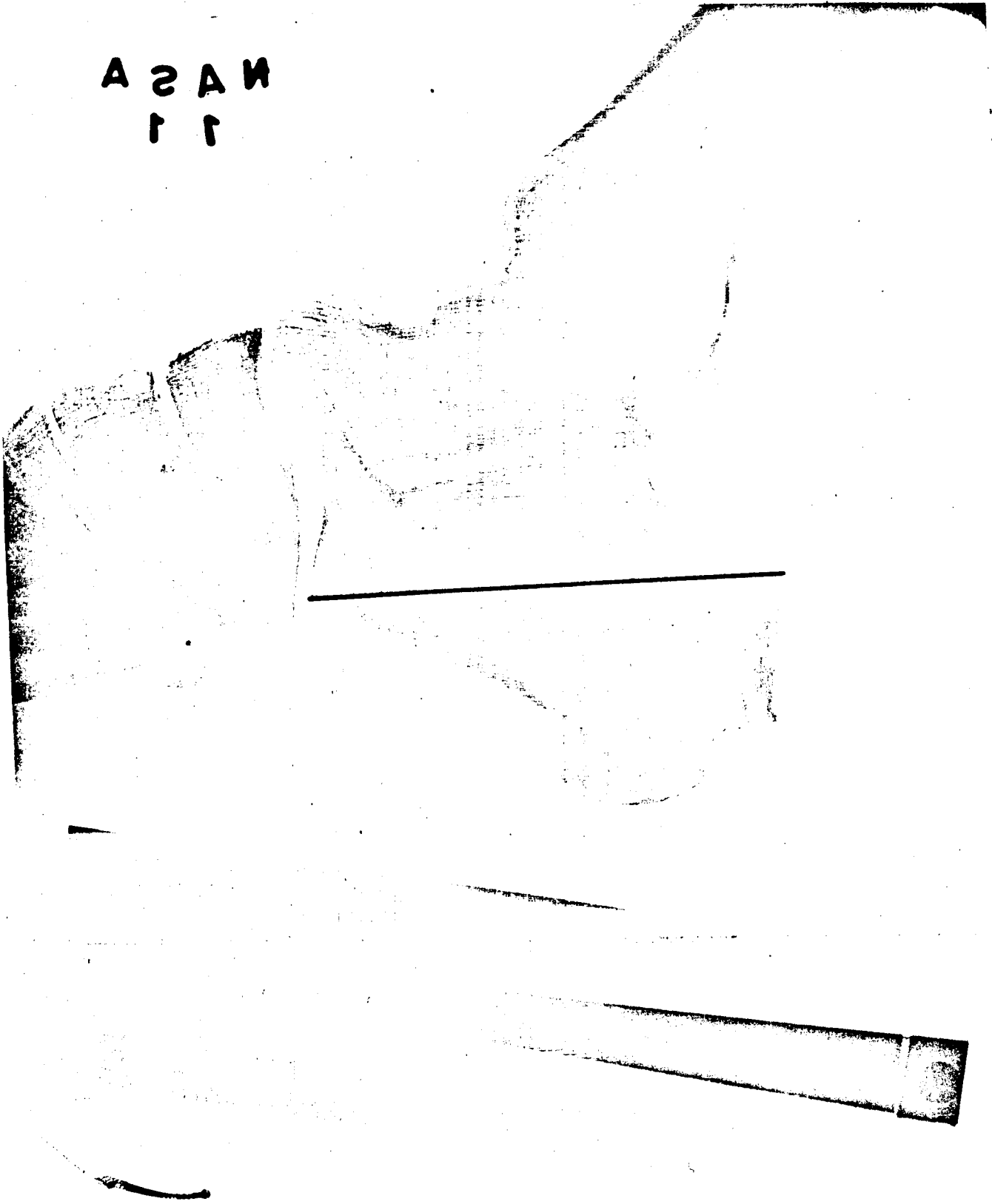

Figure 1: Roentgenograph showing conventional scan path across os calcis and calibration wedge adjacent to foot.

TABLE I

Integrator Counts for Densitometer Analysis of Eight Roentgenograph on the Same Subject

| Film 1 | | | | Film 5 | | | |
|------------|--------------|--------------|--------------|------------|--------------|--------------|--------------|
| Segment 1 | 496 | 498 | 506 | Segment 1 | 500 | 501 | 502 |
| Segment 2 | 791 | 796 | 782 | Segment 2 | 804 | 799 | 800 |
| Segment 3 | 1037 | 1041 | 1041 | Segment 3 | 1053 | 1058 | 1054 |
| Segment 4 | 1240 | 1237 | 1253 | Segment 4 | 1264 | 1269 | 1239 |
| Segment 5 | 1287 | 1281 | 1302 | Segment 5 | 1311 | 1314 | 1310 |
| Segment 6 | 1279 | 1275 | 1294 | Segment 6 | 1306 | 1304 | 1306 |
| Segment 7 | 1232 | 1239 | 1240 | Segment 7 | 1241 | 1245 | 1240 |
| Segment 8 | 1230 | 1226 | 1229 | Segment 8 | 1232 | 1238 | 1243 |
| Segment 9 | 1265 | 1264 | 1254 | Segment 9 | 1265 | 1278 | 1269 |
| Segment 10 | 1223 | 1231 | 1225 | Segment 10 | 1229 | 1236 | 1249 |
| Total | <u>11080</u> | <u>11088</u> | <u>11126</u> | Total | <u>11205</u> | <u>11242</u> | <u>11212</u> |
| Film 2 | | | | Film 6 | | | |
| Segment 1 | 506 | 502 | 497 | Segment 1 | 504 | 503 | 505 |
| Segment 2 | 787 | 784 | 787 | Segment 2 | 796 | 799 | 798 |
| Segment 3 | 1034 | 1039 | 1033 | Segment 3 | 1048 | 1051 | 1051 |
| Segment 4 | 1241 | 1236 | 1234 | Segment 4 | 1259 | 1253 | 1268 |
| Segment 5 | 1280 | 1294 | 1274 | Segment 5 | 1301 | 1290 | 1310 |
| Segment 6 | 1286 | 1301 | 1281 | Segment 6 | 1300 | 1286 | 1297 |
| Segment 7 | 1222 | 1229 | 1227 | Segment 7 | 1247 | 1245 | 1245 |
| Segment 8 | 1234 | 1239 | 1235 | Segment 8 | 1243 | 1240 | 1243 |
| Segment 9 | 1271 | 1269 | 1251 | Segment 9 | 1270 | 1266 | 1278 |
| Segment 10 | 1239 | 1240 | 1255 | Segment 10 | 1243 | 1241 | 1247 |
| Total | <u>11100</u> | <u>11133</u> | <u>11074</u> | Total | <u>11211</u> | <u>11174</u> | <u>11242</u> |
| Film 3 | | | | Film 7 | | | |
| Segment 1 | 501 | 498 | 497 | Segment 1 | 503 | 503 | 502 |
| Segment 2 | 783 | 781 | 800 | Segment 2 | 803 | 810 | 806 |
| Segment 3 | 1046 | 1053 | 1041 | Segment 3 | 1041 | 1046 | 1044 |
| Segment 4 | 1254 | 1247 | 1237 | Segment 4 | 1241 | 1244 | 1243 |
| Segment 5 | 1299 | 1283 | 1291 | Segment 5 | 1294 | 1310 | 1302 |
| Segment 6 | 1286 | 1277 | 1290 | Segment 6 | 1291 | 1300 | 1297 |
| Segment 7 | 1240 | 1242 | 1231 | Segment 7 | 1231 | 1236 | 1239 |
| Segment 8 | 1237 | 1234 | 1236 | Segment 8 | 1229 | 1233 | 1231 |
| Segment 9 | 1275 | 1265 | 1258 | Segment 9 | 1274 | 1265 | 1268 |
| Segment 10 | 1228 | 1236 | 1234 | Segment 10 | 1244 | 1241 | 1234 |
| Total | <u>11149</u> | <u>11116</u> | <u>11115</u> | Total | <u>11151</u> | <u>11188</u> | <u>11166</u> |
| Film 4 | | | | Film 8 | | | |
| Segment 1 | 507 | 502 | 502 | Segment 1 | 496 | 503 | 507 |
| Segment 2 | 800 | 801 | 804 | Segment 2 | 797 | 807 | 791 |
| Segment 3 | 1041 | 1041 | 1039 | Segment 3 | 1033 | 1029 | 1058 |
| Segment 4 | 1260 | 1262 | 1237 | Segment 4 | 1236 | 1240 | 1265 |
| Segment 5 | 1304 | 1291 | 1296 | Segment 5 | 1300 | 1304 | 1314 |
| Segment 6 | 1295 | 1287 | 1301 | Segment 6 | 1294 | 1311 | 1302 |
| Segment 7 | 1240 | 1243 | 1230 | Segment 7 | 1230 | 1232 | 1239 |
| Segment 8 | 1249 | 1240 | 1236 | Segment 8 | 1240 | 1238 | 1243 |
| Segment 9 | 1263 | 1260 | 1278 | Segment 9 | 1267 | 1275 | 1275 |
| Segment 10 | 1237 | 1228 | 1250 | Segment 10 | 1228 | 1239 | 1252 |
| Total | <u>11196</u> | <u>11155</u> | <u>11173</u> | Total | <u>11126</u> | <u>11178</u> | <u>11246</u> |

An analysis of variance was performed on these data; the following linear model ⁹ was assumed:

$$y_{ijk} = m + s_i + f_j + (sf)_{ij} + r_{k(j)} + (sr)_{ik(j)}$$

Where y_{ijk} is the observed density of the k-th segment of the j-th reading of the i-th film, and the parameters of the model:

- m is the overall mean
- s_i is the effect (fixed) of the i-th segment, $i = 1, 2, \dots, 10$
- f_j is the effect (random) of the j-th roentgenograph, $j = 1, 2, \dots, 8$; variance of f_j is σ^2_f
- $(sf)_{ij}$ is the interaction (random) effect of the i-th segment on the j-th roentgenograph, and reflects differences in positioning, exposure, and developing of different portions of the roentgenograph; variance of $(sf)_{ij}$ is σ^2_{sf}
- $r_{k(j)}$ is the effect (random) of the k-th reading (densitometer analysis) within the j-th roentgenograph, $k = 1, 2, 3$, independently numbered within each roentgenograph, and represents variation of factors involved in these readings; variance of $r_{k(j)}$ is $\sigma^2_{r(f)}$
- $(sr)_{ik(j)}$ is the interaction (random) of the readings by segments within the j-th roentgenograph. This expresses variation in readings of different parts of the roentgenograph due to densitometry instrumentation. The term is used as the sampling error; variance of $(sr)_{ik(j)}$ is $\sigma^2_{sr(f)}$

A fixed effect expresses the anatomical difference in the portions of the bone being evaluated; in this study there are expected differences in the bone mass in different sections of a particular bone as represented in the segment divisions of the conventional scan path. The random effects which are of primary interest in this analysis include variability among films and readings resulting from positioning, X-ray exposure, calibration, film developing and film analysis. Interactions between a fixed and random effect are defined to be random.

In Table II are shown the results of a standard analysis of variance according to the model given, using the 240 individual readings. The column $E(ms)$ defines the ms (mean squares) estimate in terms of the parameters of the assumed linear model. The F values in the table are the result of statistical significance tests of the various parameters of the model. These tests indicate definite evidence of film-to-film variability and reading-to-reading variability. There also is evidence of a segment by film interaction reflecting possible differences in positioning, etc. This analysis indicates a consistent film-to-film and reading-to-reading pattern reflecting overall reproducibility for different portions of the roentgenograph. There is obviously a very large segment-to-segment variability, as would be expected

TABLE II

Summary of Analysis of Variance

| Source | df | ms | E (ms) | F |
|-------------------|-----|-----------|---|---------|
| Segments | 9 | 1,690,389 | $\sigma^2_{sr(f)} + 3\sigma^2_{fs} = 24E^2/9$ | 25,020 |
| Films | 7 | 666.29 | $\sigma^2_{sr(f)} + 10\sigma^2_{r(f)} + 30\sigma^2_f$ | 6.532** |
| Segments x Films | 63 | 67.56 | $\sigma^2_{sr(f)} + 3\sigma^2_{fs}$ | 1.558* |
| Readings in Films | 16 | 102.00 | $\sigma^2_{sr(f)} + 10\sigma^2_{r(f)}$ | 2.353** |
| (S x R) in Films | 144 | 43.36 | $\sigma^2_{sr(f)}$ | — |

* $p < 0.05$ ** $p < 0.01$

because of the anatomical structural differences in the bone. The film-to-film variations are expected probably due to the small differences that result from repositioning the foot each time the film was taken. One still must consider the effect of small differences in the X-ray exposures and small differences in the developing which cannot be defined by this experimental approach.

The expected mean squares are equated to the actual mean squares to obtain estimates of the variance components of the linear model. These estimated components are as follows:

$$\sigma^2_f = 18.81 \quad (2)$$

$$\sigma^2_{sf} = 8.006 \quad (3)$$

$$\sigma^2_{r(f)} = 5.864 \quad (4)$$

$$\sigma^2_{sr(f)} = 43.36 \quad (5)$$

From the magnitude of these components, it can be seen that the readings-in-films and the film-by-segment interaction components, although statistically significant, are quite small. The variance component estimates can be used to obtain an estimate of the variance of a mean for a segment or for the total of all segments for the complete analysis performed here. The variance of the mean (of all segments) is estimated as follows:

$$\text{Variance of } \bar{y} = \frac{\sigma^2_f}{8} + \frac{\sigma^2_{r(f)}}{24} + \frac{\sigma^2_{sr(f)}}{240} = 2.351 + .244 + .181 = 2.776 \quad (6)$$

Since the estimated bone mass is 10 times the mean per segment, the variance will be 10^2 times the variance of the mean; hence the variance of an estimated total is 277.6 and the standard error is $\sqrt{277.6}$. This standard error is used to obtain the 99% confidence interval for the estimate of the total bone mass of the entire os calsis, as follows:

$$99\% \text{ C.I.} = 11,160.2 \pm (2.576)(16.66) = 11,160.2 \pm 42.9 \text{ or } m \pm 0.38\%m$$

The value, ± 2.576 , represents the 99% interval of the Normal Distribution.

The variance components can be used further to obtain estimates of the variance of the mean or total of different experimental replication designs, as follows:

$$\text{Variance of } \bar{y} = \frac{\sigma^2_f}{\text{No. of films}} + \frac{\sigma^2_{r(f)}}{\text{No. readings} \times \text{No. of films}} + \frac{\sigma^2_{sr(f)}}{\text{Total no. observations}} \quad (7)$$

The obvious consideration for the above type analysis would come in describing a statistically significant difference in bone mass between films for different conditions; for example, films taken pre-flight compared to films taken post-flight. The following analysis, based on the above linear model, can be applied to estimate the difference in X-ray bone mass values which would be required to state that the bone masses were significantly different at the 99% confidence level.

Consider the experiment of one film before and one film after a flight, each analyzed in triplicate on the densitometer. Using formula (7), we can derive the variance for the mass of an average segment as follows:

$$V(\bar{y}, \text{ one film}) = \frac{\sigma^2_f}{1} + \frac{\sigma^2_{r(f)}}{3} + \frac{\sigma^2_{sr(f)}}{30} = 22.072$$

As before, the variance of the estimate of total mass is 2207.2.

If the same experimental procedure was used for the films both before and after flight, the variance for the estimated difference in total mass is the sum of the two variances. Since we assume the same experimental conditions, this results in twice the variance given above in expression (8). Thus the variance of the difference between the two totals is 4414.4 and the corresponding standard error 66.44.

As before, in order to obtain a 99% confidence interval for the difference which does not include zero (no difference), an estimated difference of 2.576×66.44 is required. Thus, an estimated difference of 171.1 counts between the two films or a difference of approximately 1.66% would be evidence at the 99% statistical confidence level, that there is present a difference of the total mass as expressed by the X-ray bone density. If it is desired to obtain a more sensitive analysis, formula (7) can be used for any other number of films and readings both before and after a flight.

It should be emphasized that this analysis only gives an indication of differences in total bone mass--not in changes of pattern of the bone mass along the conventional scanning path. The same type of analysis would be used for such situations, but there would be additional means and uses of the segment by film interaction; the interaction would include not only the factors indicated above, but also differences in the pattern of bone mass due to flight conditions.

Other statistical techniques can be applied to data to define the reproducibility of the technique and the clinical confidence that can be attached to a given bone densitometry reading. Other studies have been conducted and various analyses performed, and will be reported to NASA when a formal manuscript is prepared.

REFERENCES

1. Mack, P. B., W. N. Brown, Jr., and H. D. Trapp: The Quantitative Evaluation of Bone Density. *Amer. J. Roentgen.* 61:808, 1949.
2. Mack, P. B., G. P. Vose, and J. D. Nelson: New Development in Equipment for the Roentgenographic Measurement of Bone Density. *Amer. J. Roentgen.* 82:303, 1959.
3. Mack, P. B.: Radiographic Bone Densitometry. Conference on Progress In Development of Methods In Bone Densitometry. Washington, D. C., March, 1965. NASA SP-64, 1965.
4. Vogt, F. B., P. B. Mack, W. C. Beasley, W. A. Spencer, D. Cardus, and C. Vallbona: The Effect of Bedrest on Various Parameters of Physiological Function. Part XII. The Effect of Bedrest on Bone Mass and Calcium Balance. NASA CR-182. April, 1965.
5. Mack, P. B., G. P. Vose, F. B. Vogt, and P. A. LaChance: Report on Experiment M-6: Bone Demineralization on Gemini IV. Nelda Childers Stark Laboratory for Human Nutrition Research. Texas Woman's University, 1965.
6. Mack, P. B., G. P. Vose, F. B. Vogt, and P. A. LaChance: Report on Experiment M-6: Bone Demineralization on Gemini V. Nelda Childers Stark Laboratory for Human Nutrition Research. Texas Woman's University, 1966.
7. Mack, P. B., G. P. Vose, F. B. Vogt, and P. A. LaChance: Experiment M-6: Bone Demineralization. Gemini Midprogram Conference. NASA SP-121, p. 407-415. February 23-25, 1966.
8. Mack, P. B., G. P. Vose, F. B. Vogt, and P. A. LaChance: Medical Experiment M 006, Bone Demineralization. Proceedings of Conference. A Review of Medical Results of Gemini 7 and Related Flights. Held at John F. Kennedy Space Center, August 23, 1966. p. 83-126.
9. Steel, R. G. D., and J. H. Torrie: Principles and Procedures of Statistics. McGraw-Hill, 1960. p. 115.

HUMAN EVALUATION OF A CHEMICAL URINE
VOLUME AND MEASUREMENT SYSTEM

APPENDIX C

HUMAN EVALUATION OF A CHEMICAL URINE VOLUME AND MEASUREMENT SYSTEM*

by Paul A. LaChance, Ph.D. **, and
Marilyn E. George, B.S.***

INTRODUCTION

The collection and interpretation of urinary biochemical specimens requires precise urine volume data.

The relatively short Mercury flight permitted the use of urine collection devices in which all urine voided during flight was collected and retained for post-flight analysis. Since the Gemini spacecraft allows less free volume per man than the Mercury spaceflight and since flight durations up to 14 days were contemplated, the stowage of all urine voided during flight was completely impractical. Spacecraft engineers attempted to design a method for dumping urine into the spacecraft Environment Control System's evaporator; however, a satisfactory liquid gas separator could not be engineered in sufficient time and so by means of an intermediate urine storage tank, the tank was periodically vented overboard. The urine collection and transport system, developed and actually utilized in the early Gemini missions, involved the manual suction of urine into a bellows. An inline trocar device permitted either the emptying of the insuit urine collection device, or if required, the collection of an aliquot of each micturition. The height of the bellows was suggested as a possible method of measuring total volume. Inhouse testing revealed that the method had accuracies of $\pm 20\%$ and the intermixing of crewmen aliquots could not be controlled. The requirement to provide precise inflight output data demanded the design of a system with greater accuracy. This presentation will discuss the functional verification of the Chemical Urine Volume Measurement System (CUVMS), its advantages and disadvantages.

METHOD

On two separate occasions and with different subjects two CUVMS were evaluated. These tests were both conducted at the 6570th Aerospace Medical Research Laboratories. During various times the CUVMS was either evaluated in the AMRL evaluator or in a metabolic ward with and without the wearing of an unventilated pressure garment. In both experiments, the outlet of the CUVMS was connected to a litter bottle which in turn was linked to a pump so that a 5.0

* Unpublished Report—personal communication from Dr. LaChance.

** Dr. LaChance is affiliated with the Manned Spacecraft Center, Houston, Texas.

*** Marilyn George is affiliated with the 6570 Aerospace Medical Research Laboratory, Wright Patterson Air Force Base, Ohio,

psi pressure differential would be obtained when the selector valve handle was placed in the DUMP position and the collection-mixing bag was being emptied. During each micturition, a sample bag was placed on the line and the remainder of the urine specimen collected in the liter bottle. The liter bottles and sample bags were labelled with subject number, date, and time of void. At various times during the experiments both distilled water and urine of known volumes were poured through the system to verify the accuracy of the CUVMS, and to provide indices of possible subject error in utilizing the system.

All sample bags and bottles were stored in the refrigerator and transported to the isotope laboratory every morning for processing and counting.

The sample bags were shaken to insure thorough mixing of the urine specimen and two ends of the bag cut open. The urine was poured into a calibrated graduated cylinder, the volume recorded, and an aliquot taken for isotope counting. The specimens collected in the bottles were also measured, the volumes recorded, and the total volume of each micturition (bottle plus bag) recorded.

A standard solution of tritiated water and propylene glycol was prepared by diluting tritiated water, specific activity 1 mc/ml, with a solution of 50% distilled water and 50% propylene glycol to a final specific activity of 14 μ c/ml. This standard was used in the tracer storage accumulators, as the spiking solution, and as the standard for tritium counting. Six vials containing 10 ml of Brays Solution were used for each urine sample counted. Five-tenths milliliter of urine was added with a calibrated pipette to each vial and 0.01 ml of the standard tritium solution was added to three of these vials as a spike. Three vials containing 10 ml of Brays Solution only were prepared for background counts and three vials containing 10 ml of Brays Solution plus 0.01 ml of the standard solution were prepared for standards daily. All samples were counted for 10 minutes in a Packard Tri Carb Liquid Scintillation Spectrometer. The three urine sample counts and the three spiked counts were each averaged and background counts subtracted.

$$\text{Quench Factor: } \frac{\text{standard cpm}}{\text{spike cpm-urine cpm}}$$

$$\text{Volume: } \frac{\text{Standard cpm/ml} \times \text{amount of tritium solution delivered by the metering pump (constant unique to each CUVMS)}}{\text{urine cpm/ml} \times \text{Quench Factor}}$$

RESULTS AND DISCUSSION

The results of the experiment, during which significant problems were encountered and subsequently remedied by engineering improvements, will be discussed first.

A CUVMS which had previously been a qualification test unit was utilized on and off over a 16 day period with three subjects sharing the device. On two separate occasions the sample trocar began "freezing up." When the probe was removed, cleaned and lubricated, the data obtained on urine volume by tritium dilution remained extremely poor. Over one 6 day period, 64% of the volumes varied more than $\pm 5\%$ from the measured volume. Again, after minor modification, a second 4 day period indicated that 45% of the sample volumes varied more than $\pm 5\%$ from the measured volumes. It was obvious that some difficulty in the delivery of tritium was being encountered. It was discovered that the sealant to the removable tracer storage accumulator was crumbling in microscopic amounts and the "grit" was lodging in the upstream check valve of the metering pump, causing delivery of unequal volumes of tritium solution. The valve was cleaned and a CUVMS with a tracer storage accumulator containing a new sealant was utilized. The results of this study are given in summary form in Table I. The results for one subject are given in Table II. Since the identical unit was being utilized by the three subjects, the larger error for subjects One and Two was traced to two other variables, the accidental depression of the metering pump button, resulting in double injections of tritium, and the case of insufficient tritium delivery, attributable to a too-rapid depression of the metering pump button, caused by a passing over the detent position due to a shallow detent. The subjects found the system more difficult to use while suited and wearing gloves. Twice during the experiment it was noted that the concept of utilizing a 1200 ml collection bag (tested by only one subject to study the feasibility of reducing the number of sample bags to be stored) was not large enough to contain urine from two consecutive micturitions. Engineering changes in the strength of the detent, and widening of a guard on the selector valve handle to prevent accidental depressions of the metering pump were incorporated into the flight hardware.

Results of another experiment involving four subjects were considerably better. The system was utilized six days providing worse-case use equivalent to 24 days by one man. Table III provides a summary of the data. Prior to the start of experimentation, five urine samples of 100, 200, 300, 400, and 500 ml were prepared and an exact amount of standard radioactivity added. The samples were counted periodically. In addition, 17 randomly selected urine samples were similarly prepared and stored under refrigeration for 30 days to determine the effects of time and storage on the method. The results are given in Table IV.

Important observations made during this experiment were the need for increasing the strength of the urine sample bag and the requirement for thorough mixing of urine in the collection-mixing bag, a minimum of 20 seconds, for accurate and reproducible results.

SUMMARY

A chemical urine volume measurement system utilizing standardized metering of a solution of tritiated water and propylene glycol was satisfactorily evaluated.

The technique is capable of providing reproducible and accurate results; however, the system is very sensitive and prone to significant errors with improper handling. Considerable motivation and meticulousness is required to obtain precise results. A simplified method requiring less manipulation and automatic recording of output data is required for use during extended missions.

REFERENCES

1. System for Measurement of Micturition Volume by Tracer Dilution Technique. Paul Petrack, Arde, Inc., William J. Huffstetler and Richard Serpas, Gemini Support Crew Provisions Office, NASA-Manned Spacecraft Center (EC-8), Houston, Texas. Presented at 37th Annual Scientific Meeting, Aerospace Medical Association, April 18-21, 1966, Las Vegas, Nevada.

TABLE I

| Subject | Number of Voids | Percentage Non Valid Samples | Accuracy of Valid Samples |
|---------|-----------------|------------------------------|---------------------------|
| No. 1 | 19 | 42 | +3.0% (+5.4 to -2.0) |
| No. 2 | 19 | 10 | +0.7% (+6.1 to -3.1) |
| No. 3 | 13 | None | +0.7% (+2.5 to -2.0) |

TABLE II

| Subject | Sample Number Date No. of Void | Measured Volume | Tritium Dilution Volume | Percentage Difference |
|---------|--------------------------------|-----------------|-------------------------|-----------------------|
| No. 3 | 18-1 | 253 | 253 | 0 |
| | 18-2 | 585 | 558 | -4.6 |
| | 18-3 | 271 | 276 | +1.8 |
| | 19-1 | 421 | 438 | +4.0 |
| | 19-2 | 439 | 444 | +1.1 |
| | 19-3 | 353 | 342 | -3.1 |
| | 19-4 | 410 | 403 | -1.7 |
| | 20-1 | 288 | 309 | +7.3 |
| | 20-2 | 486 | 483 | -0.6 |
| | 20-3 | 387 | 398 | +2.8 |
| | 21.1 | 346 | 352 | +1.7 |
| | 21.2 | 575 | 577 | +0.3 |
| | 21-3 | 215 | 217 | +0.9 |
| | | -- | -- | |
| | | | 5029 | 5050 |

TABLE III A
(Subject No. 37)

| Day No. | No. of Voids Per Day | 24 Hour Volume | | Percentage Difference |
|------------|----------------------------|----------------|---------|--------------------------|
| | | Measured | Tritium | |
| 1 | 4 | 1322 | 1368 | +3.5 |
| 2 | 5 | 1794 | 1798 | +0.2 |
| 3 | 4 | 1069 | 1046 | -2.2 |
| 4 | 4 | 1490 | 1465 | -1.7 |
| 5 | 4 | 1403 | 1338 | -4.6 |
| 6 | 6 | 2383 | 2468 | +3.6 |
| | | ---- | ---- | |
| | | 9461 | 9483 | +2.3 |

TABLE III B
(Subject No. 38)

| Day No. | No. of Voids Per Day | 24 Hour Volume | | Percentage Difference |
|------------|----------------------------|----------------|---------|--------------------------|
| | | Measured | Tritium | |
| 1 | 5 | 762 | 789 | +3.5 |
| 2 | 4 | 695 | 704 | +1.3 |
| 3 | 4 | 769 | 758 | -1.4 |
| 4 | 4 | 751 | 727 | -3.2 |
| 5 | 6 | 984 | 956 | -2.8 |
| 6 | 4 | 795 | 800 | +0.6 |
| | | --- | --- | |
| | | 4756 | 4734 | -4.6 |

TABLE III C
(Subject No. 39)

| Day No. | No. of Voids Per Day | 24 Hour Volume | | Percentage Difference |
|---------|----------------------|----------------|---------|-----------------------|
| | | Measured | Tritium | |
| 1 | 3 | 1164 | 1190 | +2.2 |
| 2 | 3 | 797 | 791 | -0.8 |
| 3 | 3 | 866 | 924 | +6.7 |
| 4 | 2 | 587 | 559 | -4.8 |
| 5 | 3 | 1050 | 1043 | -0.7 |
| 6 | 6 | 1410 | 1391 | -1.3 |
| | | --- | --- | |
| | | 5874 | 5898 | +4.0 |

TABLE III D
(Subject No. 40)

| Day No. | No. of Voids Per Day | 24 Hour Volume | | Percentage Difference |
|---------|----------------------|----------------|-------------|-----------------------|
| | | Measured | Tritium | |
| 1 | 3 | (667) | Malfunction | |
| 2 | 3 | 629 | 658 | +4.6 |
| 3 | 3 | (616) | Malfunction | |
| 4 | 4 | 516 | 494 | -4.3 |
| 5 | 3 | 615 | 615 | 0 |
| 6 | 4 | 703 | 709 | +0.9 |
| | | --- | --- | |
| | | 2463 | 2476 | +5.2 |

TABLE IV A
STANDARD URINE SAMPLE VOLUMES

| Measured ml | Determined ml | Percentage Difference |
|----------------|------------------|--------------------------|
| 100 | 100 | 0 |
| 200 | 205 | +2.5 |
| 300 | 294 | -2.0 |
| 400 | 416 | +4.0 |
| 500 | 513 | +2.6 |
| --- | --- | |
| 1500 | 1528 | +1.9 |

TABLE IV B
URINE SAMPLES (10 Days Storage)

| Day 1 | Day 10 | Percentage Difference |
|----------|-----------|--------------------------|
| 342 | 353 | +3.2 |
| 239 | 245 | +2.5 |
| 282 | 285 | +1.1 |
| 379 | 378 | -0.3 |
| 61 | 63 | +3.3 |
| 145 | 141 | -2.7 |
| 358 | 347 | -3.1 |
| 447 | 448 | +0.2 |
| 294 | 294 | 0 |
| 392 | 403 | +2.8 |
| 205 | 208 | +1.5 |
| 161 | 162 | +0.6 |
| 140 | 144 | +2.8 |
| 224 | 223 | -0.4 |
| 319 | 316 | +0.9 |
| 275 | 267 | -2.9 |
| 207 | 205 | -1.0 |

CALCIUM BALANCE IN ASSOCIATION WITH
A 30 DAY BEDREST STUDY

APPENDIX D

CALCIUM BALANCE IN ASSOCIATION WITH A 30 DAY BEDREST STUDY

INTRODUCTION

An evaluation of the calcium balance in five normal subjects undergoing normal activity, bedrest, and recovery from bedrest is presented in the following results obtained from a study conducted by Dr. Pauline Beery Mack at the Texas Woman's University, Denton, Texas. These data are presented to demonstrate (a) a technique for displaying calcium balance information, (b) to show the day-to-day variability in X-ray bone densitometry in a group of subjects, and (c) to demonstrate expected variability creatinine excretion in the urine in a group of subjects under controlled experimental conditions.

METHOD

Five subjects participated in this study initially; only four of the subjects completed the study. The subjects were on controlled dietary intake approximating 1 gm of calcium daily. In the pre-bedrest period, the subjects performed work and underwent a routine of normal activity except for the imposition of a carefully controlled dietary and sleep schedule in the experimental ward. During the 30 day bedrest period, the subjects were restricted to bed and were fed by dietitians.

RESULTS

Figures 1 through 8 show the cumulative calcium balance on the four subjects during a 120 day period of time, divided into four time periods: (1) pre-bedrest, (2) bedrest, (3) post-bedrest, and (4) post-post-bedrest. In Figure 1 is shown the cumulative balance on the four subjects during the pre-bedrest period. The top line of each diagram shows the cumulative dietary intake, the bottom line indicates the urinary calcium output, and the second line from bottom indicates the fecal excretion of calcium. Thus, the dashed areas represent the cumulative balance status of the individual for the period. For the four graphs indicated in Figure 1, all subjects are in positive balance during the 30 day pre-bedrest period. Since sweat excretion of calcium is not considered, this positive balance may, in fact, represent that calcium lost in the sweat rather than calcium retained by the body. Calculations of the average daily amount of calcium contributing to this portion of the balance data yields results as follows: for subject 1P, 280 mg/day; for subject 3Q, 279 mg/day; for subject 4T, 380 mg/day; and for subject 5S, 103 mg/day.

In Figure 2 are shown the cumulative balance studies starting at day zero of bedrest for the same four subjects. It should be noted that these graphs differ from

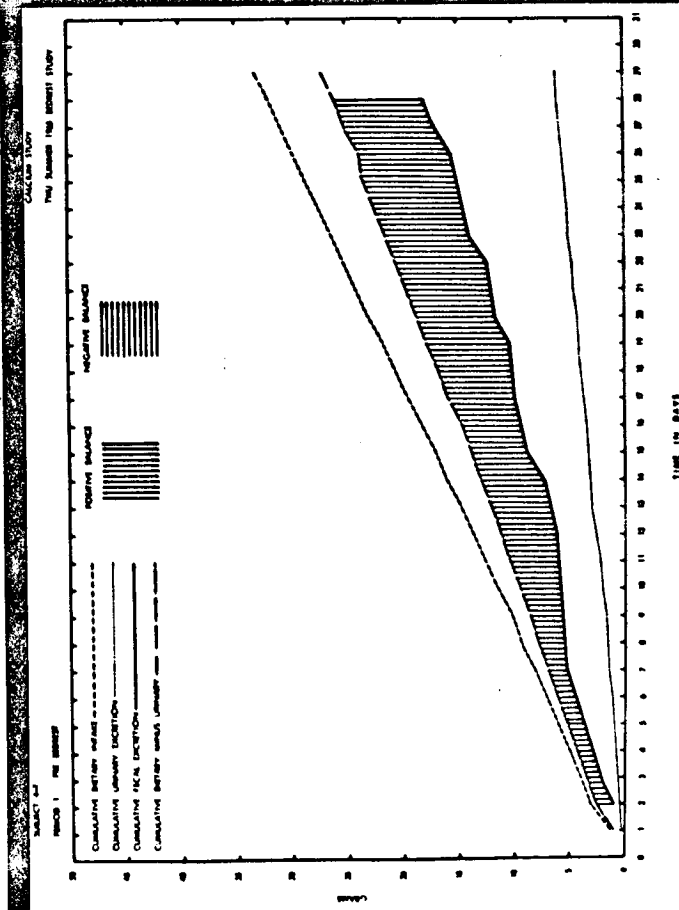
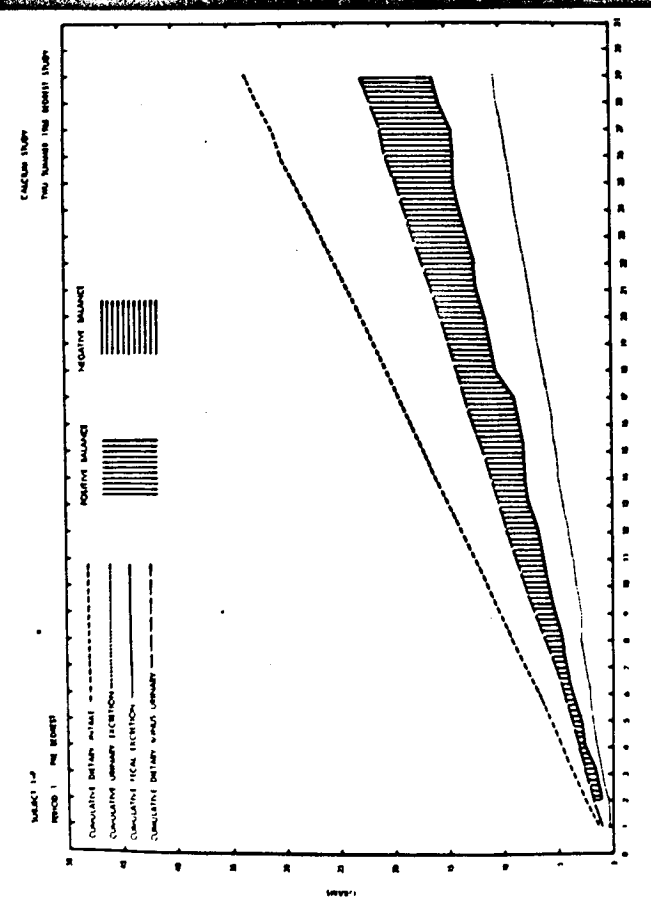
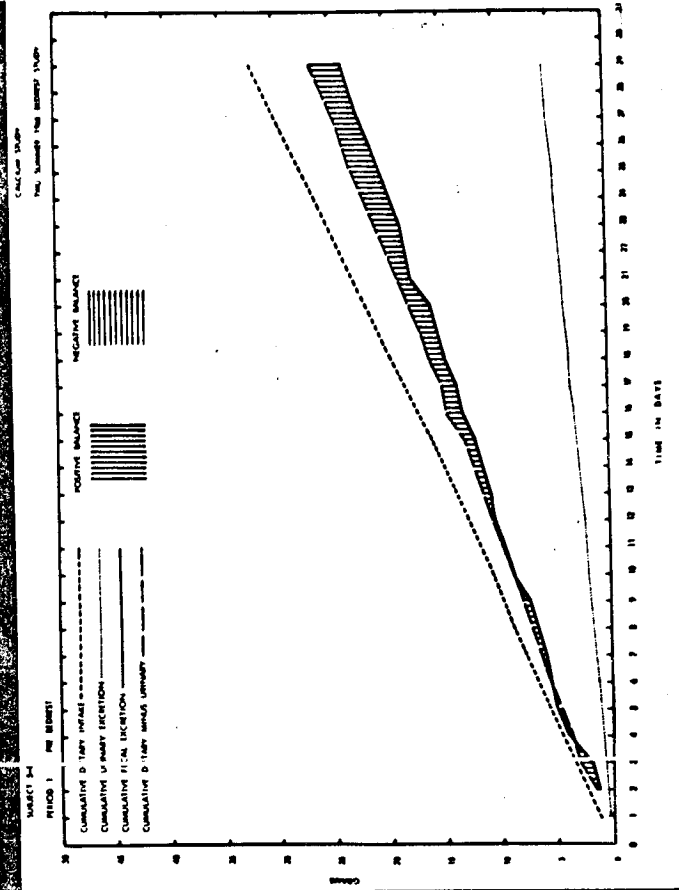
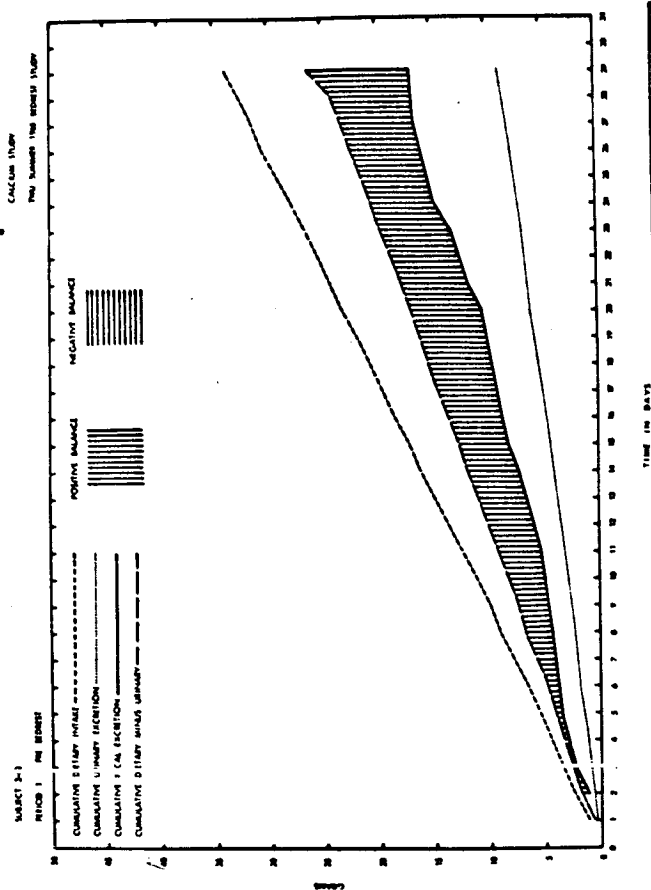

Figure 1. Cumulative Calcium Balance on Four Subjects During Pre-Bedrest

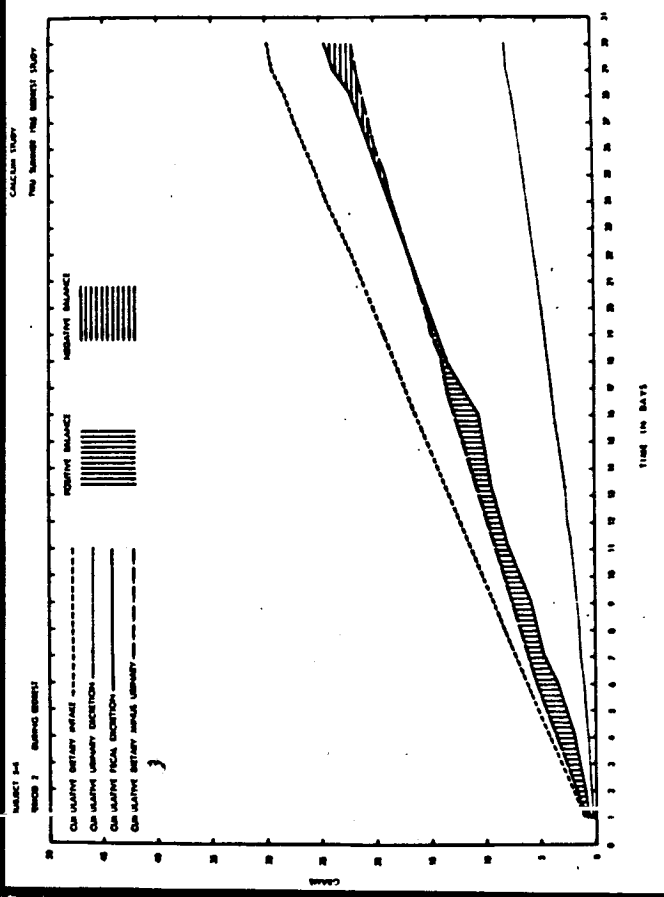
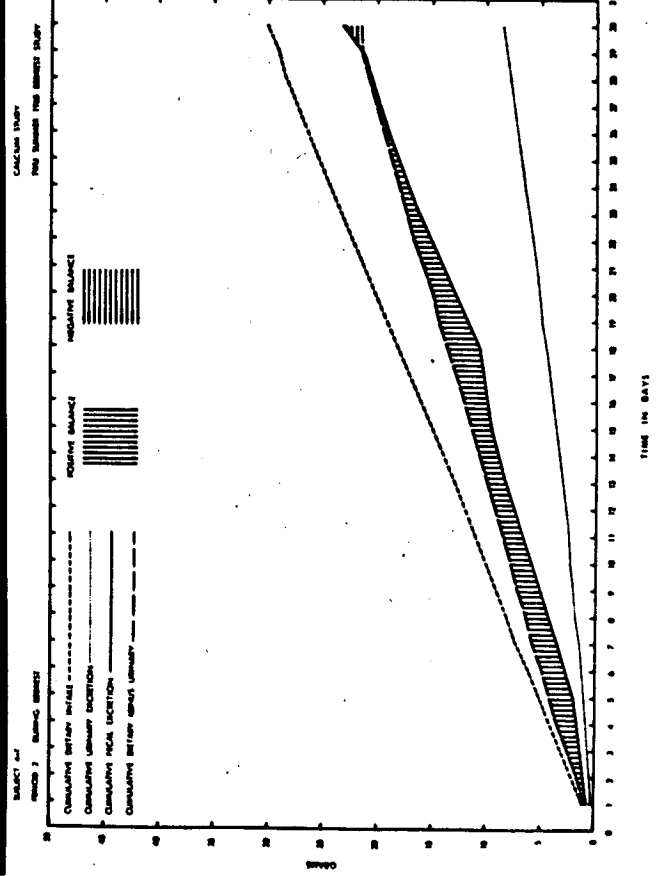
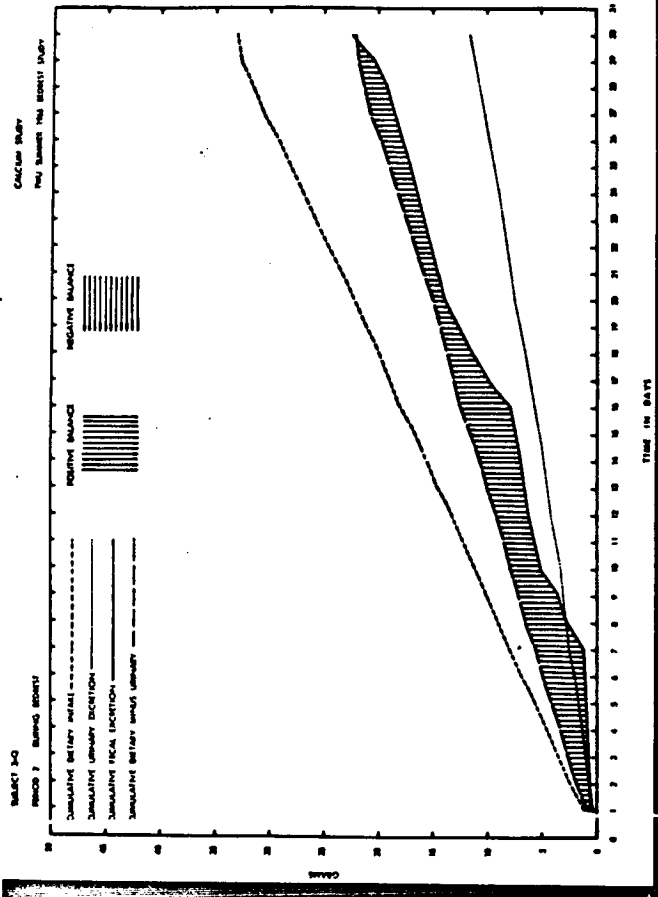
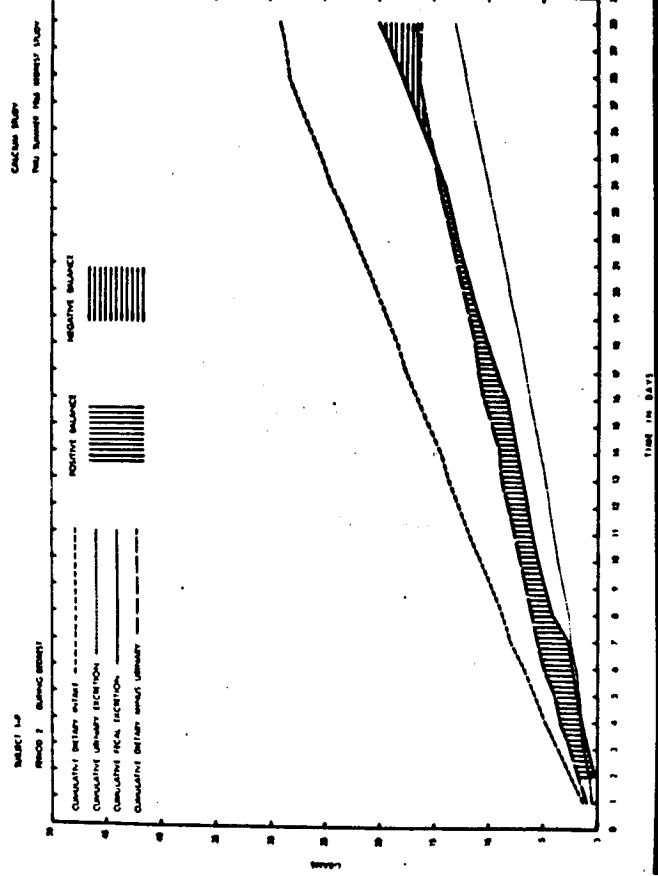

Figure 2. Cumulative Calcium Balance on Four Subjects During Bedrest

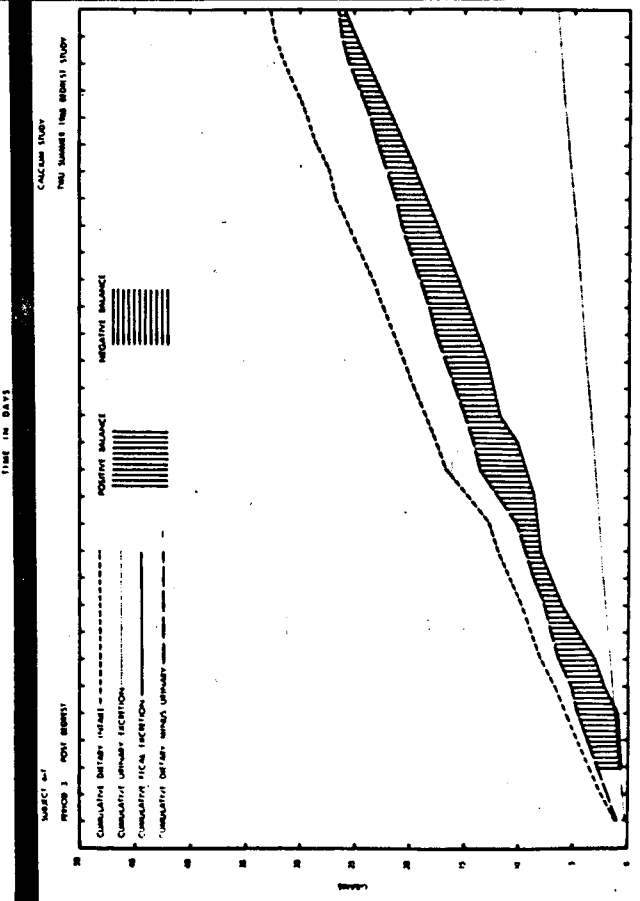
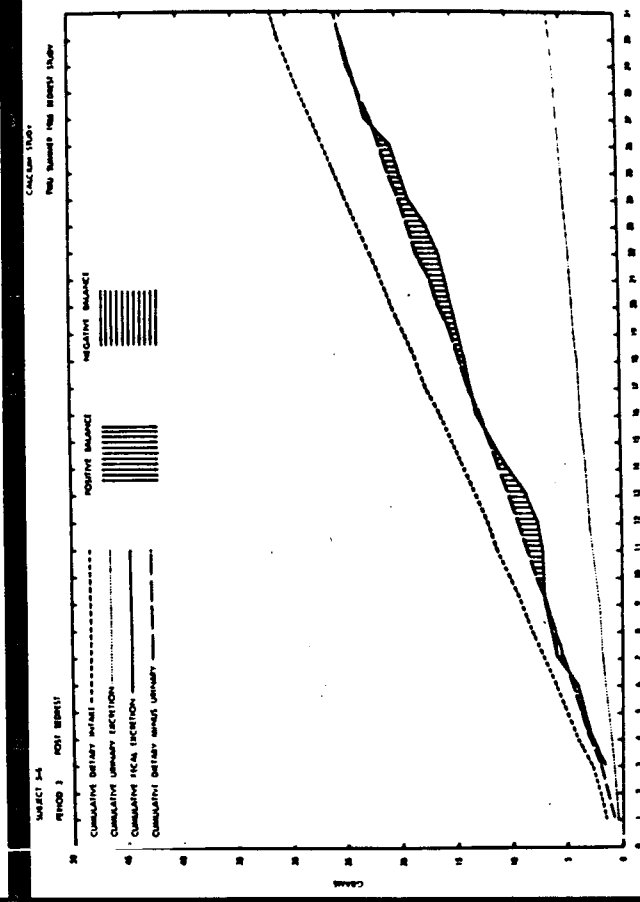
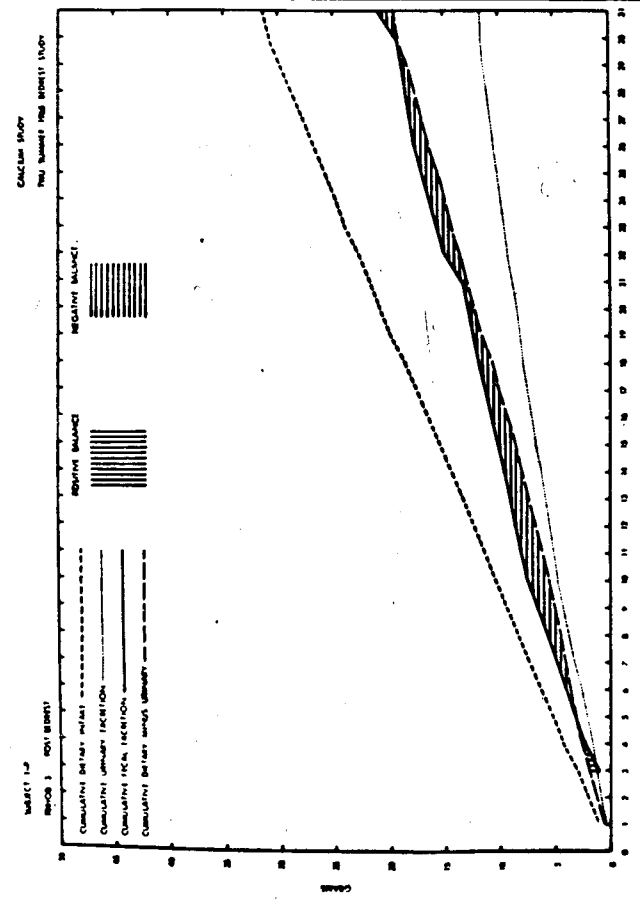
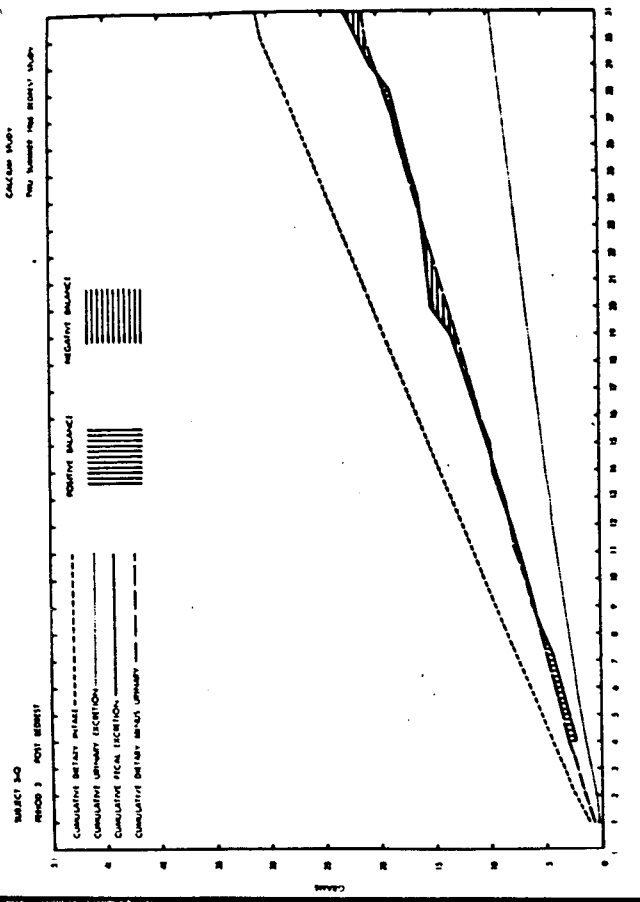

Figure 3. Cumulative Calcium Balance on Four Subjects During Post-Bedrest

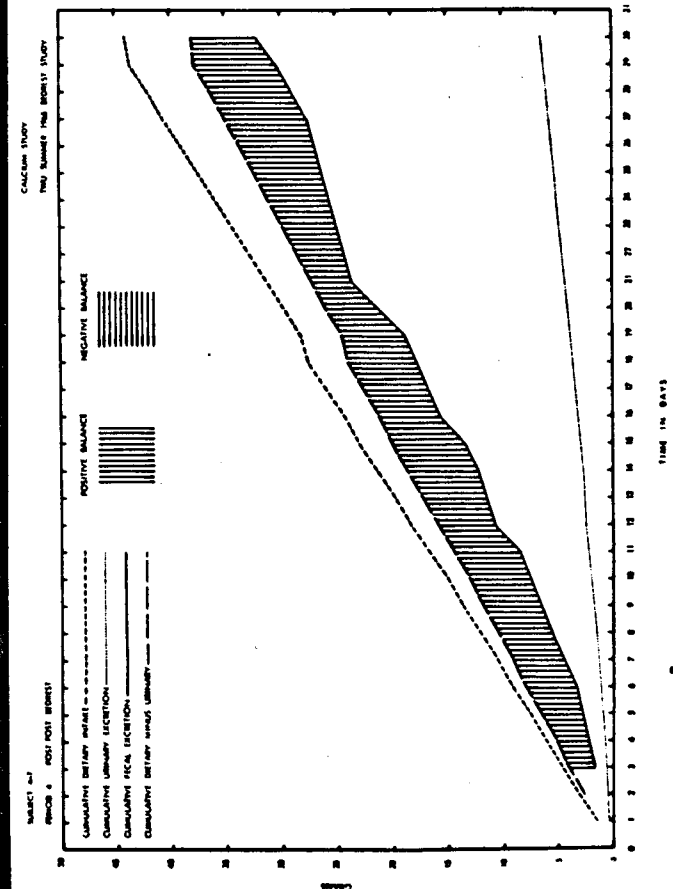
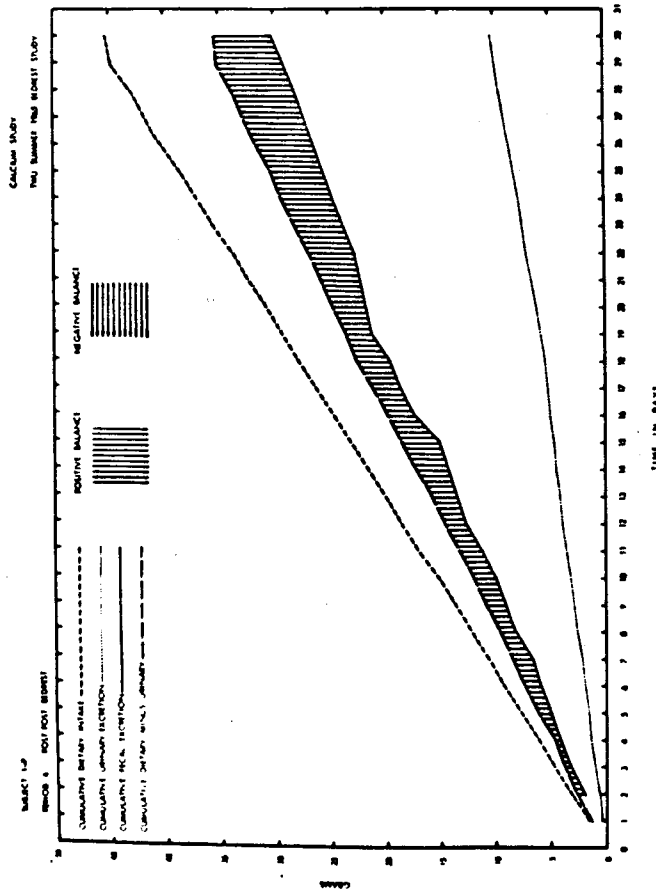
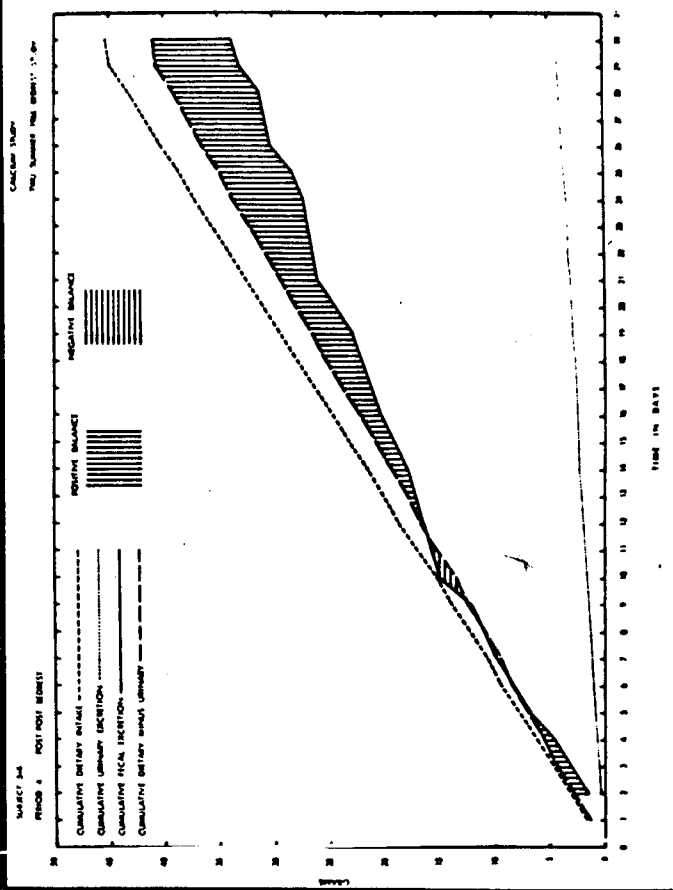
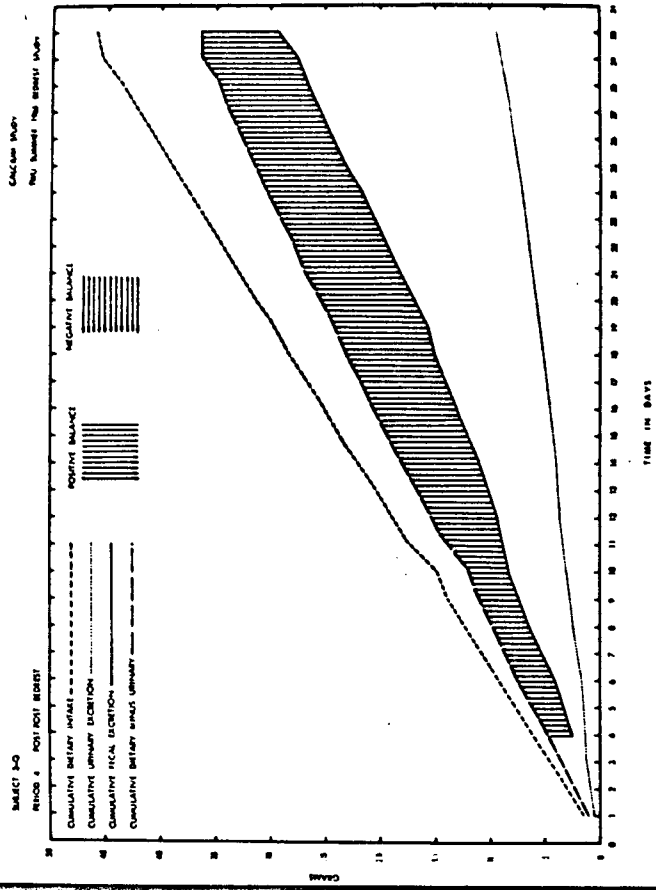

Figure 4. Cumulative Calcium Balance on Four Subjects During Post-Post-Bedrest (Recovery)

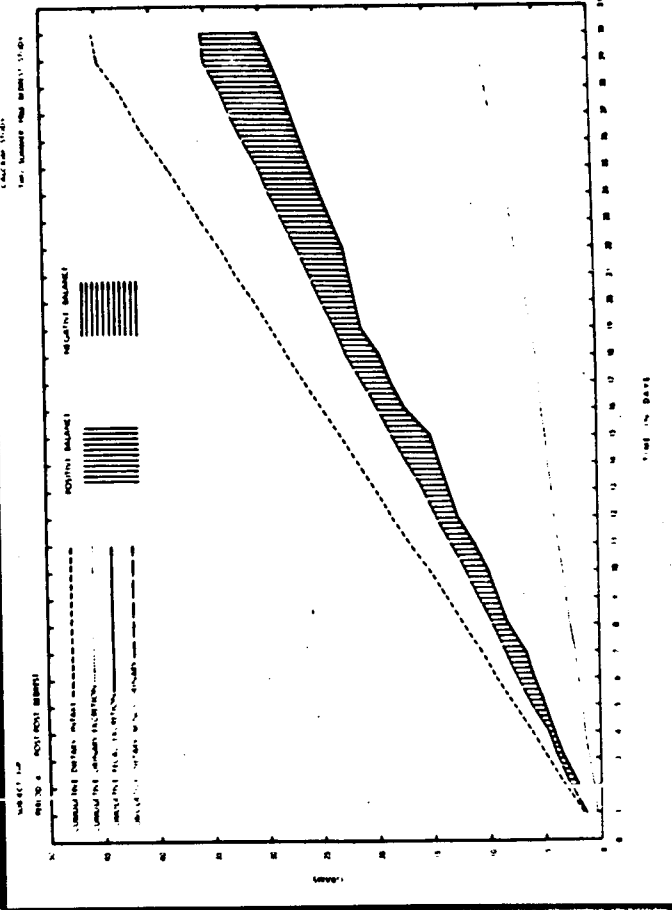
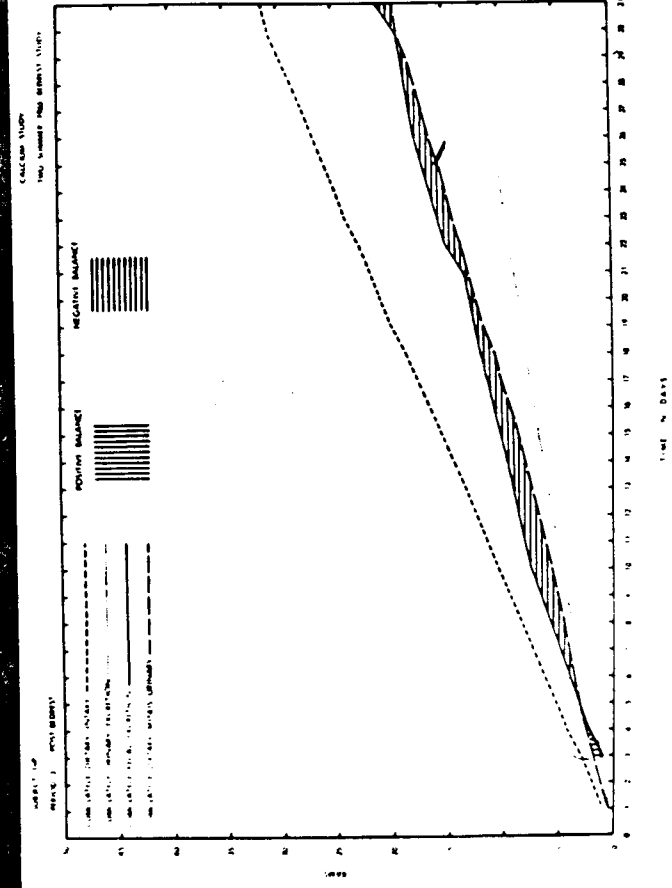
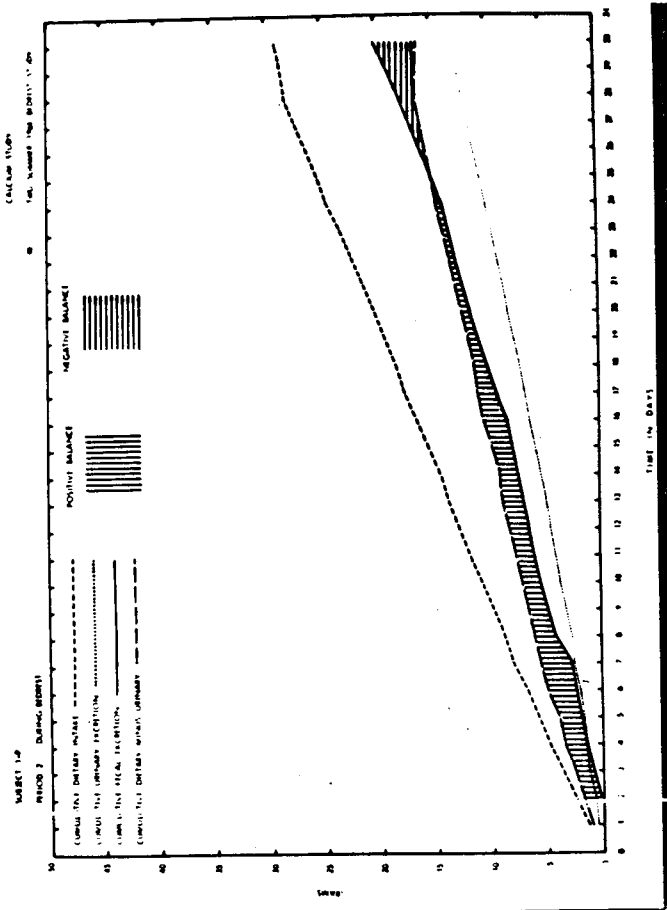
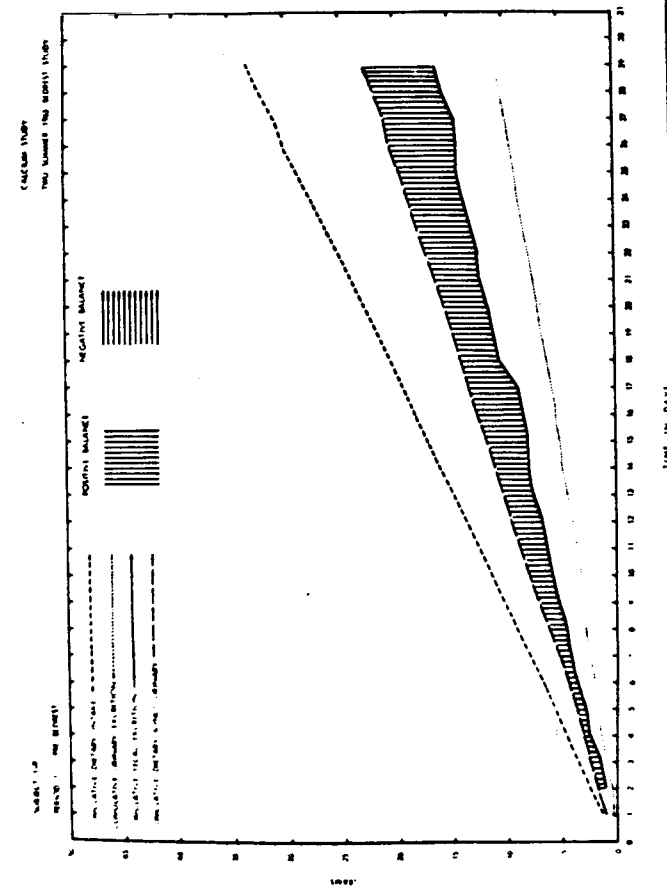

Figure 5. Cumulative Calcium Balance on Subject 1-P During Four Phases of Study

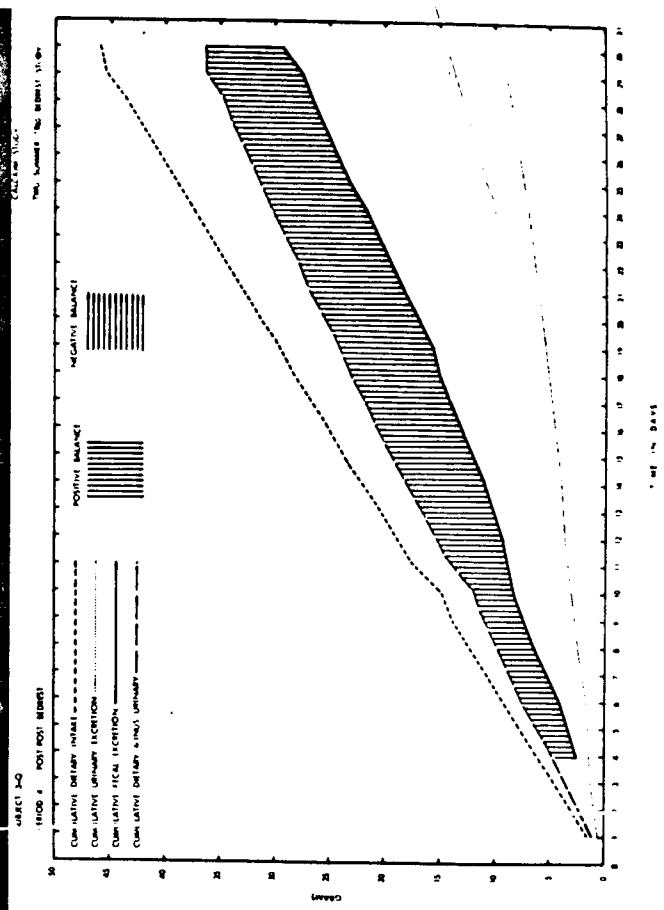
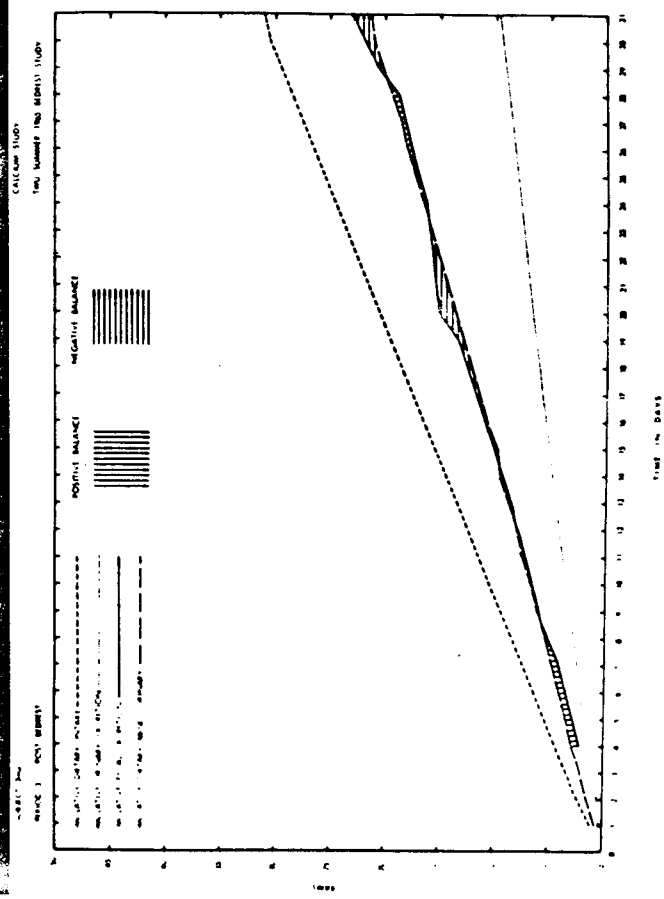
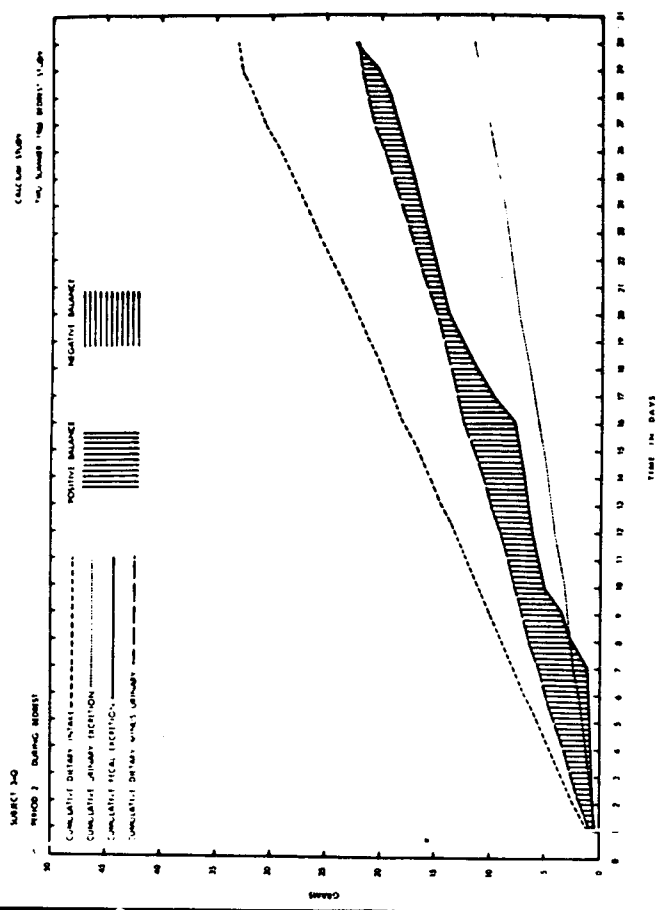
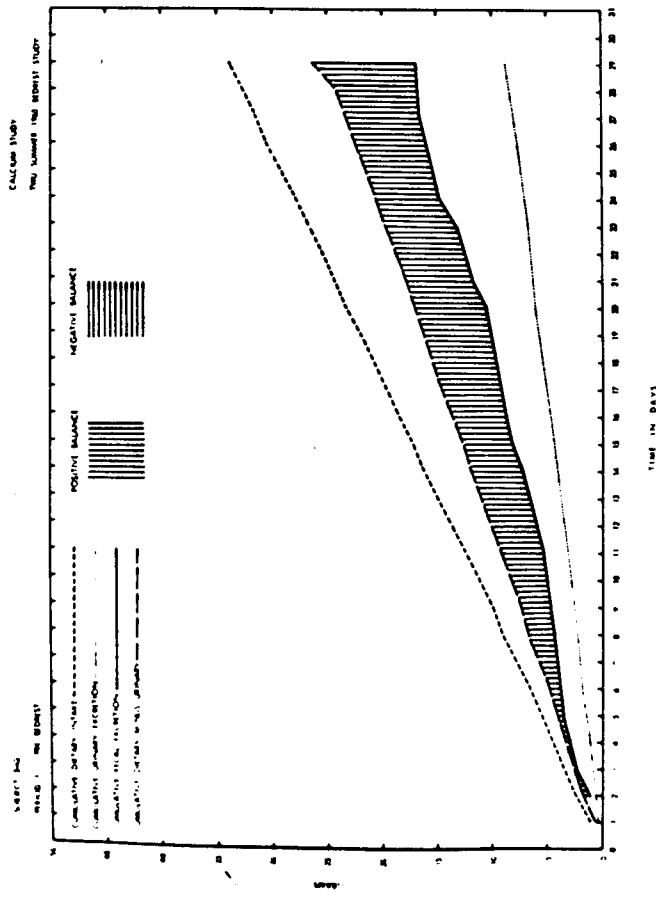

Figure 6. Cumulative Calcium Balance on Subject 3-Q During Four Phases of Study

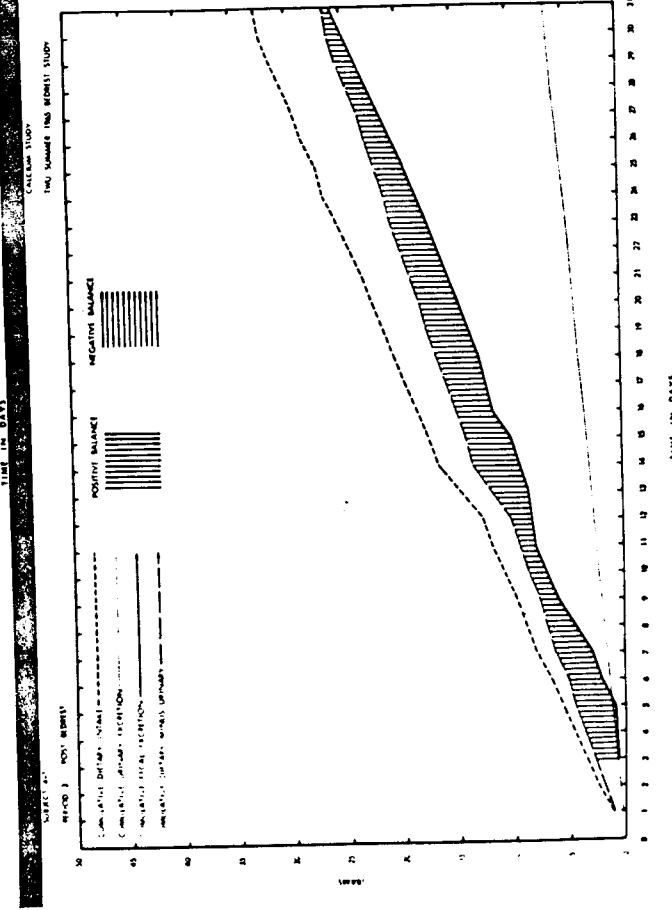
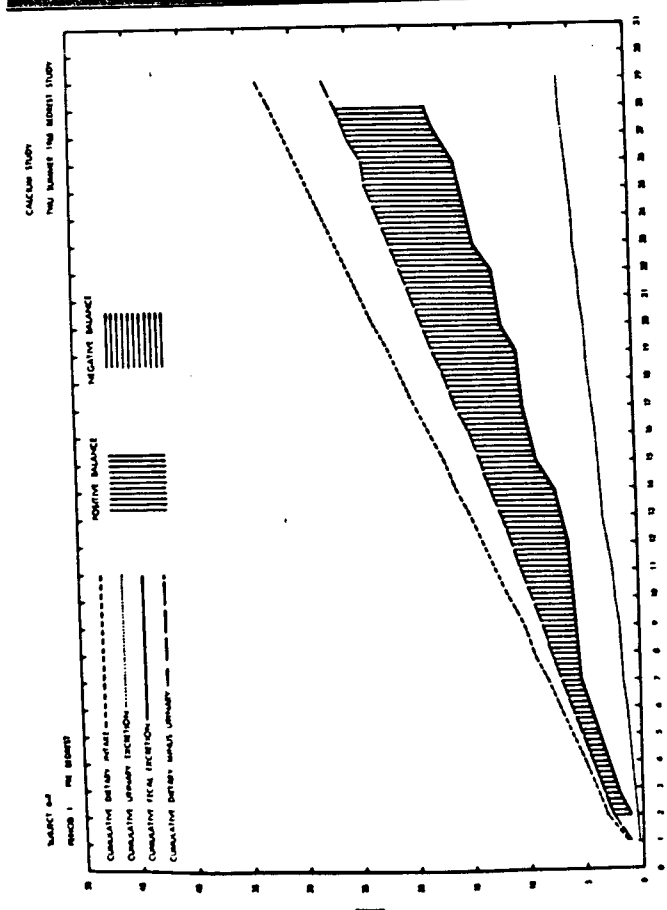
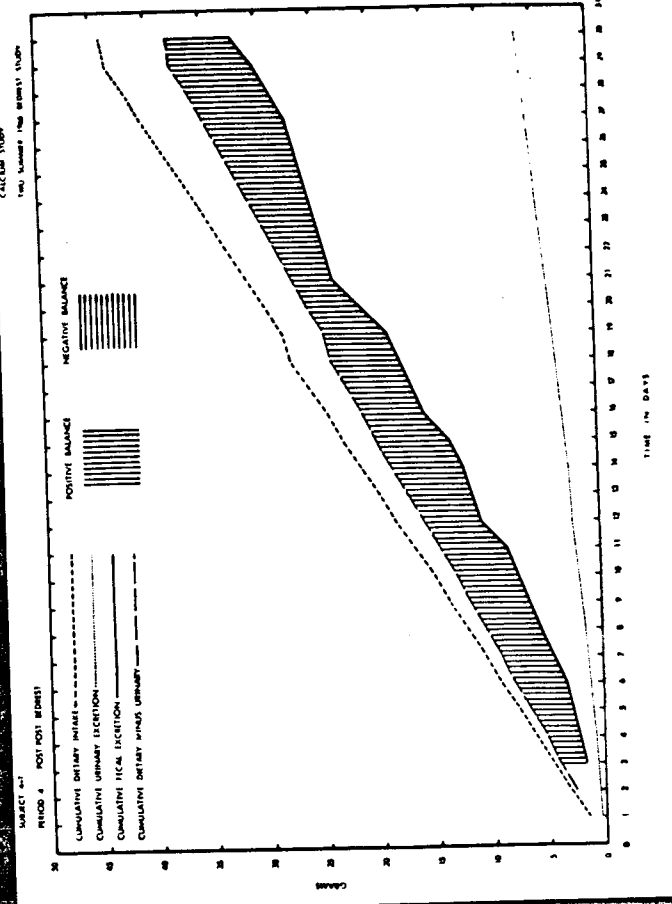
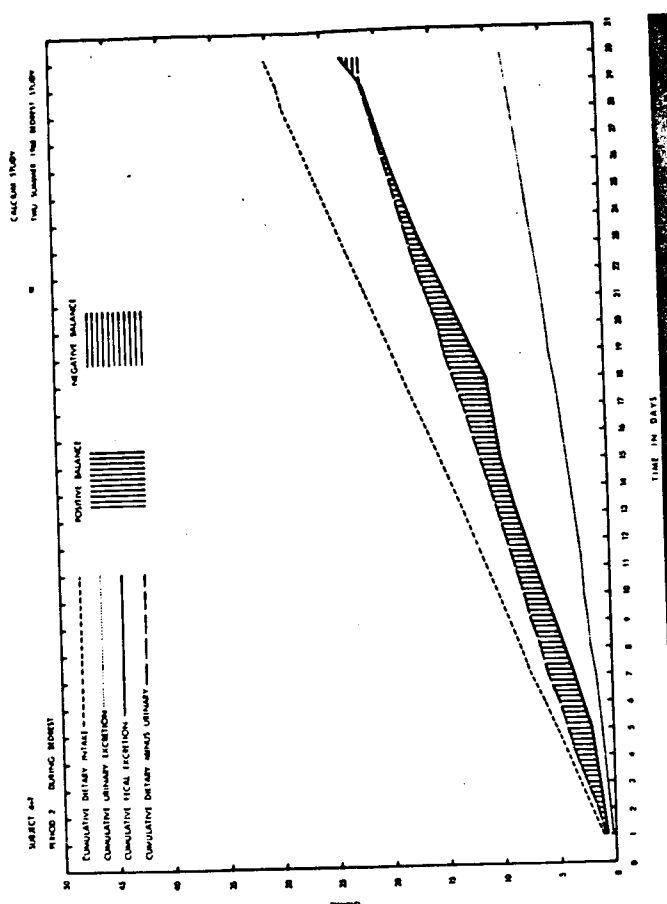

Figure 7. Cumulative Calcium Balance on Subject 4-T During Four Phases of Study

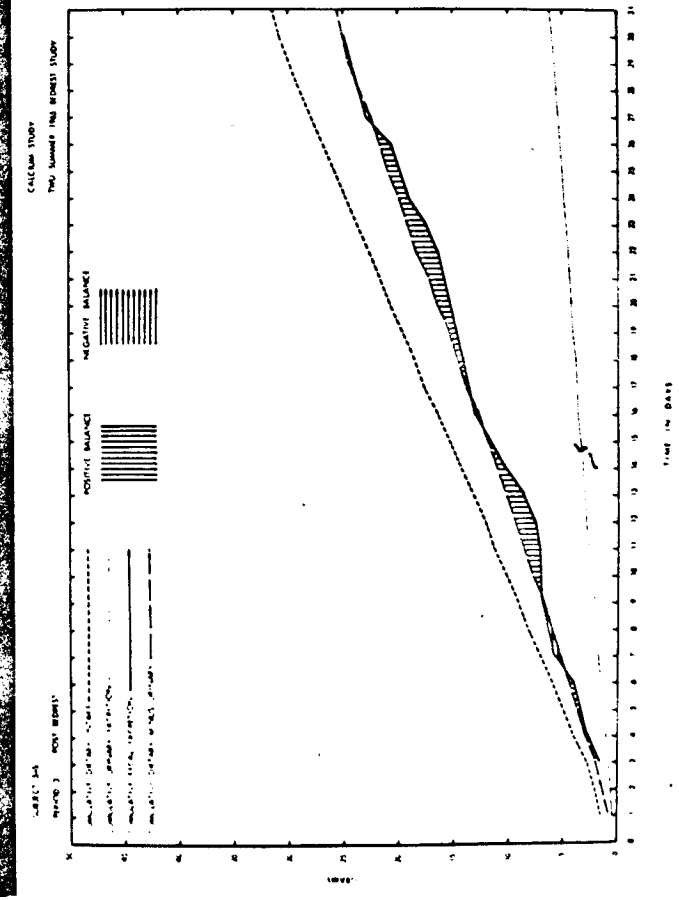
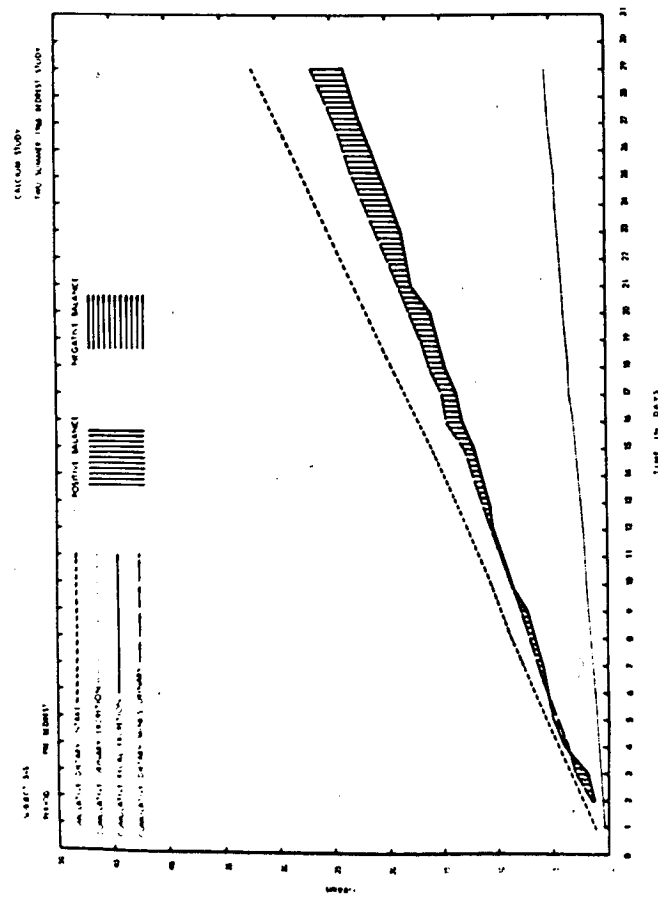
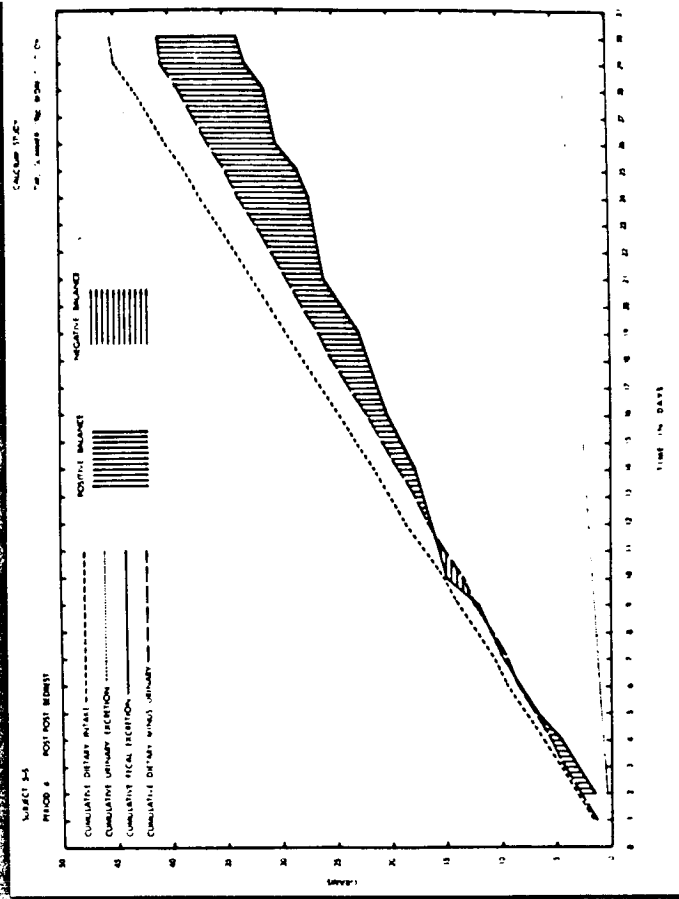
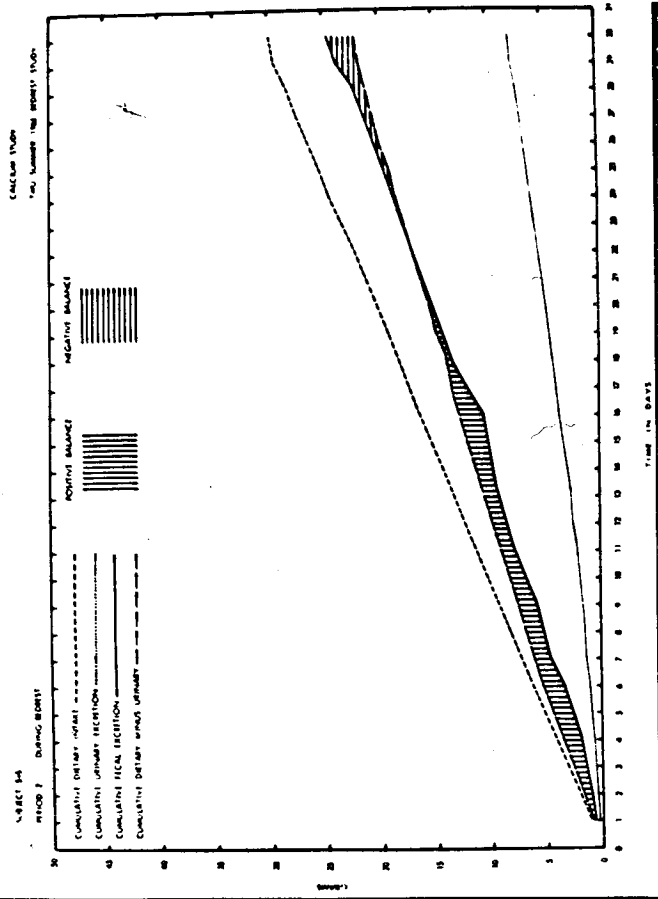

Figure 8. Cumulative Calcium Balance on Subject 5-5 During Four Phases of Study

the others in that the "positive balance" no longer continues as a cumulative effect. In fact, there is a change in the pattern so that the subjects ultimately are in negative balance. It would be expected that the subjects possibly would have less sweat calcium during this time because of decrease activity, and thus decreased sweat production, to possibly account for some of the differences observed. However, if one considers the first few days of bedrest as an indication of the trend of the balance study, it is apparent there initially is a tendency for a "positive calcium balance" similar to that pre-bedrest, indicating the probability of continued loss of calcium in the sweat. The fact that the curves then reverse their trend and indicate negative calcium balance are indicative of an establishment of a pattern of negative balance after a given period of time. Careful inspection of the slope of the cumulative urinary calcium outputs indicate a change in the rate of excretion after 6 to 8 days. The change in the pattern of fecal excretion is less clear.

In Figure 3 are shown the cumulative calcium balance on the four subjects beginning on the first day of recovery. During this time they were undergoing normal activity as in the pre-bedrest period. Again, it is noted that there is not the progressive continuation of a "positive calcium balance," indicating that the subjects remain in a state of negative calcium balance for a period extending after the period of recumbency. These data do not demonstrate clearly the time at which the subjects ultimately returned to balance. In Figure 4 are shown the cumulative calcium balance on these same four subjects in a "post-bedrest period" with the cumulative balances beginning at a time 30 days after bedrest. Data are obtained very similar to that obtained in the pre-bedrest period, indicating that the subjects have recovered by this time and show a pattern similar to that observed during the pre-bedrest phase. It is interesting to note that for subject 5S, a very small positive calcium balance was noted. If this represents the sweat loss of a person "in balance," then this subject lost less calcium in the sweat. It is interesting that an observation had been made of this subject. The subjects normal pattern of activity was one in which very little physical exercise was engaged and the subject did not spend much time out-of-doors. It thus would be expected that the sweat calcium would be lower in this subject if he sweated correspondingly less than the other subjects.

The Figures 5 through 8 show the data for each of the individual subjects for the 4 periods of study. Enlarged graphs for each of these time periods, for the individual subjects, are presented in the tables following at the end of this section.

In Table I are presented the daily urinary creatinine excretions during the pre-bedrest period for the four subjects. These data are presented to show the day-to-day variation that might be expected in controlled experimental conditions for which accurate 24 hour urines were collected and analyzed in triplicate. The data for these four subjects gave a mean of 1.885 gm/day with a 99% confidence limit of 1.820 to 1.951 gm/day, and a coefficient of variability of 14.7%.

TABLE I

Daily Urinary Creatinine Excretion
During the Pre-Bedrest Period
(grams per 24 hours)

| Day | Subject P | Subject Q | Subject T | Subject S |
|-----|--------------|--------------|--------------|--------------|
| 1 | 1.648 | 1.599 | 0.946 | 1.800 |
| 2 | 2.128 | 1.866 | 1.714 | 2.061 |
| 3 | 2.022 | 2.040 | 1.510 | 1.980 |
| 4 | 1.824 | 1.722 | 1.652 | 1.762 |
| 5 | 1.890 | 1.942 | 1.132 | 1.764 |
| 6 | 1.943 | 1.924 | 1.744 | 1.962 |
| 7 | 1.755 | 1.624 | 1.643 | 1.688 |
| 8 | 1.932 | 1.702 | 1.597 | 1.786 |
| 9 | 2.241 | 1.279 | 1.678 | 1.478 |
| 10 | 1.802 | 1.831 | 1.500 | 1.960 |
| 11 | 1.956 | 2.041 | 1.644 | 2.024 |
| 12 | 1.903 | 1.938 | 1.635 | 1.980 |
| 13 | 1.944 | 1.550 | 1.552 | 1.740 |
| 14 | 1.882 | 2.100 | 1.592 | 1.937 |
| 15 | 2.044 | 1.946 | 1.888 | 2.041 |
| 16 | 1.733 | 1.730 | 1.605 | 1.790 |
| 17 | 2.402 | 2.312 | 2.120 | 2.046 |
| 18 | 1.942 | 1.923 | 1.678 | 1.932 |
| 19 | 1.931 | 1.828 | 1.406 | 1.893 |
| 20 | 2.295 | 2.216 | 2.256 | 2.140 |
| 21 | 2.082 | 1.987 | 1.796 | 2.000 |
| 22 | 1.788 | 1.778 | 1.378 | 1.728 |
| 23 | 2.587 | 2.466 | 2.277 | 2.458 |
| 24 | 2.070 | 2.037 | 2.147 | 1.754 |
| 25 | 1.859 | 1.822 | 1.602 | 1.854 |
| 26 | 2.164 | 1.998 | 1.870 | 2.362 |
| 27 | 2.298 | 2.366 | 1.705 | 1.942 |
| 28 | 1.937 | 1.808 | 1.752 | 1.699 |
| 29 | 2.258 | 2.400 | 1.635 | 2.470 |

TABLE II

Pre-Bedrest Period Bone Density Data

| Day | Subject 1-P | Subject 3-Q | Subject 4-T | Subject 5-S |
|-----|----------------|----------------|----------------|----------------|
| 1 | 2.135 | | 2.178 | 1.817 |
| 2 | | 2.230 | | |
| 3 | 2.174 | | 2.165 | 1.934 |
| 4 | | 2.234 | | |
| 5 | 2.166 | 2.218 | 2.174 | |
| 6 | 2.196 | | 2.192 | 1.927 |
| 7 | | 2.226 | | |
| 8 | | | 2.202 | 1.916 |
| 9 | | 2.224 | | |
| 10 | 2.188 | | 2.236 | 1.918 |
| 11 | | | | |
| 12 | | 2.221 | | |
| 13 | 2.177 | | 2.255 | 1.922 |
| 14 | | | | |
| 15 | 2.173 | | 2.249 | 1.924 |
| 16 | | | | |
| 17 | | | | |
| 18 | 2.183 | 2.235 | 2.259 | 1.915 |
| 19 | | | | |
| 20 | 2.206 | | | 1.944 |
| 21 | 2.222 | 2.229 | | |
| 22 | | | | 1.966 |
| 23 | 2.230 | 2.227 | | |
| 24 | | | 2.265 | 1.919 |
| 25 | | | | |
| 26 | | | | |
| 27 | | | | |
| 28 | | | | |
| 29 | 2.225 | 2.222 | 2.253 | 1.918 |

The bone density data on the same group of subjects in the pre-bedrest period is presented in Table II, and gives an indication of the expected day-to-day variability of bone density of normal subjects undergoing routine activities on a controlled experimental diet. The mean value of bone density was 2.208 (aluminum wedge equivalency) and the 99% confidence limits for the data were 2.142 to 2.275, with a coefficient variability of 8.7%.

DISCUSSION

It is not the intent of this brief report to discuss the factors involved in the determination of bone density, calcium balance, and creatinine excretion. These data and results are presented (a) to give an indication of the expected day-to-day variability in bone density in normal subjects, (b) to express the day-to-day variability in urinary excretion of creatinine of an individual, and (c) to demonstrate a technique for the display of calcium balance data. A detailed discussion and analyses of results of this experiment have been presented in reports prepared by Dr. Mack under NASA Grant NsG 440.

CALCIUM STUDY
TWO SUMMER 1965 BEDREST STUDY

SUBJECT 1-P

PERIOD 1 PRE BEDREST

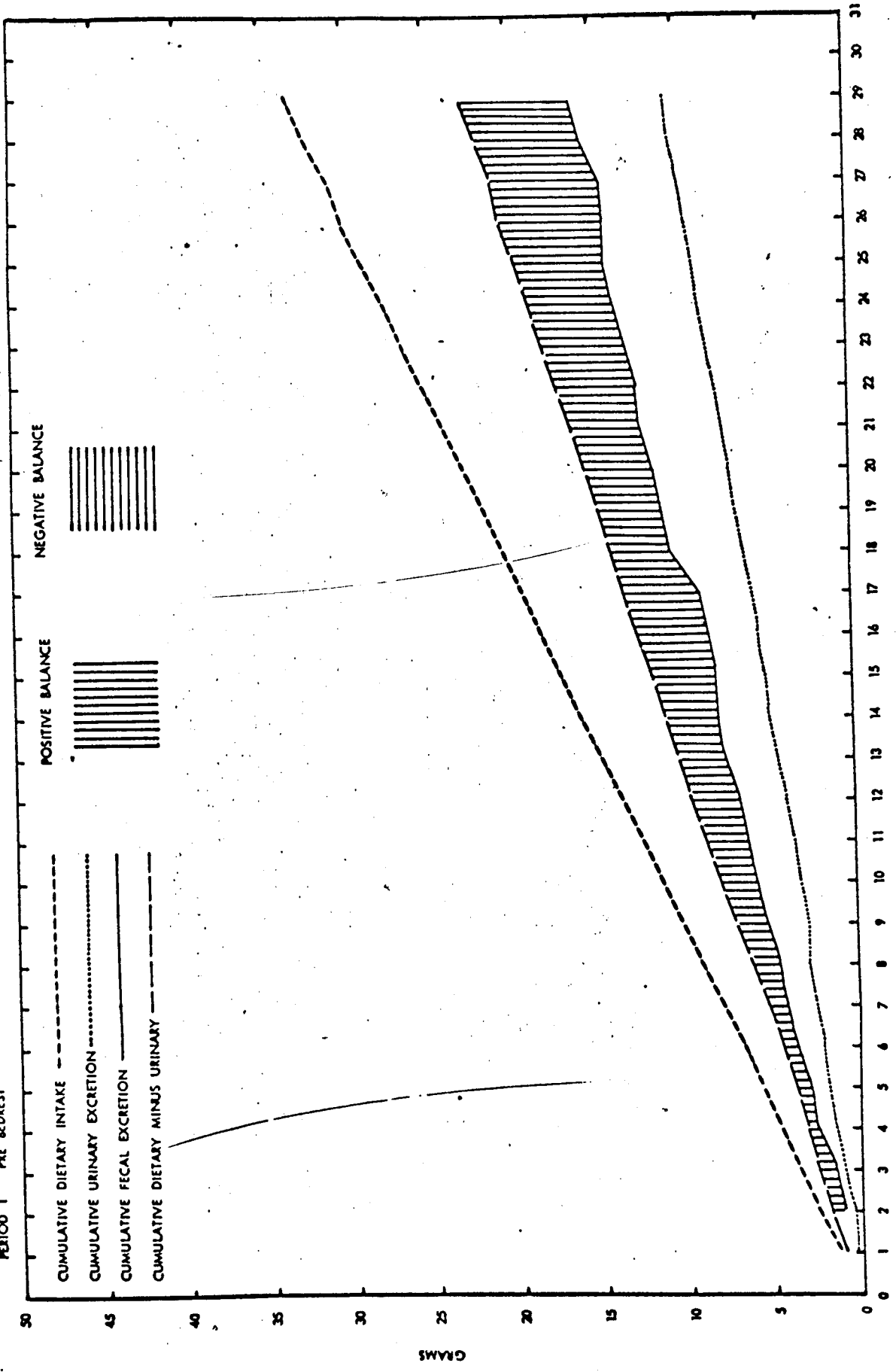

NEGATIVE BALANCE

POSITIVE BALANCE

CUMULATIVE DIETARY INTAKE
CUMULATIVE URINARY EXCRETION
CUMULATIVE FECAL EXCRETION
CUMULATIVE DIETARY MINUS URINARY

TIME IN DAYS

GRAMS

CALCIUM STUDY
 TWU SUMMER 1965 BEDREST STUDY

SUBJECT 1-4

PERIOD 2 DURING BEDREST

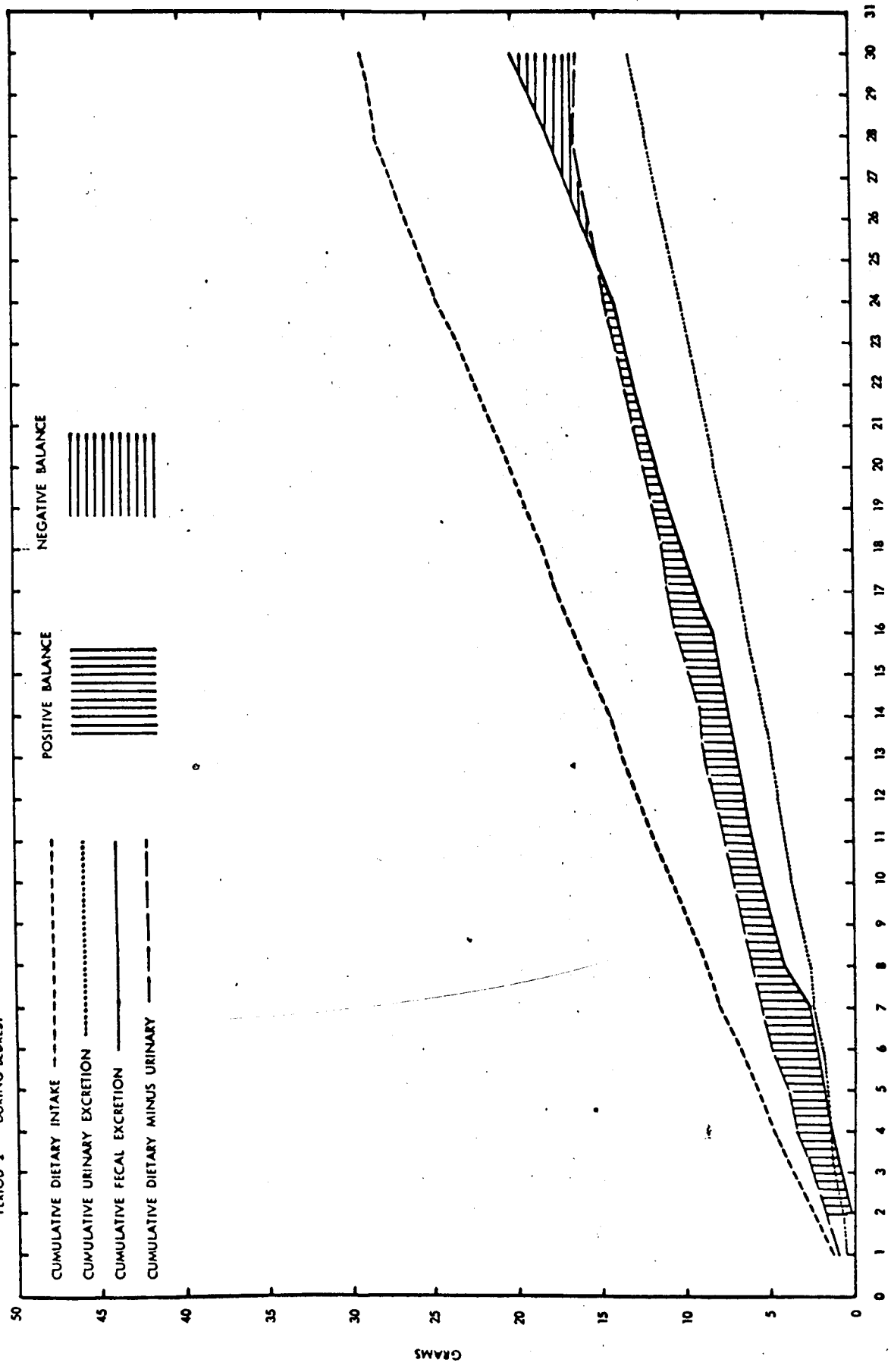

TIME IN DAYS

GRAMS

CALCIUM STUDY
 TWU SUMMER 1965 BEDREST STUDY

SUBJECT 1-P

PERIOD 3 POST BEDREST

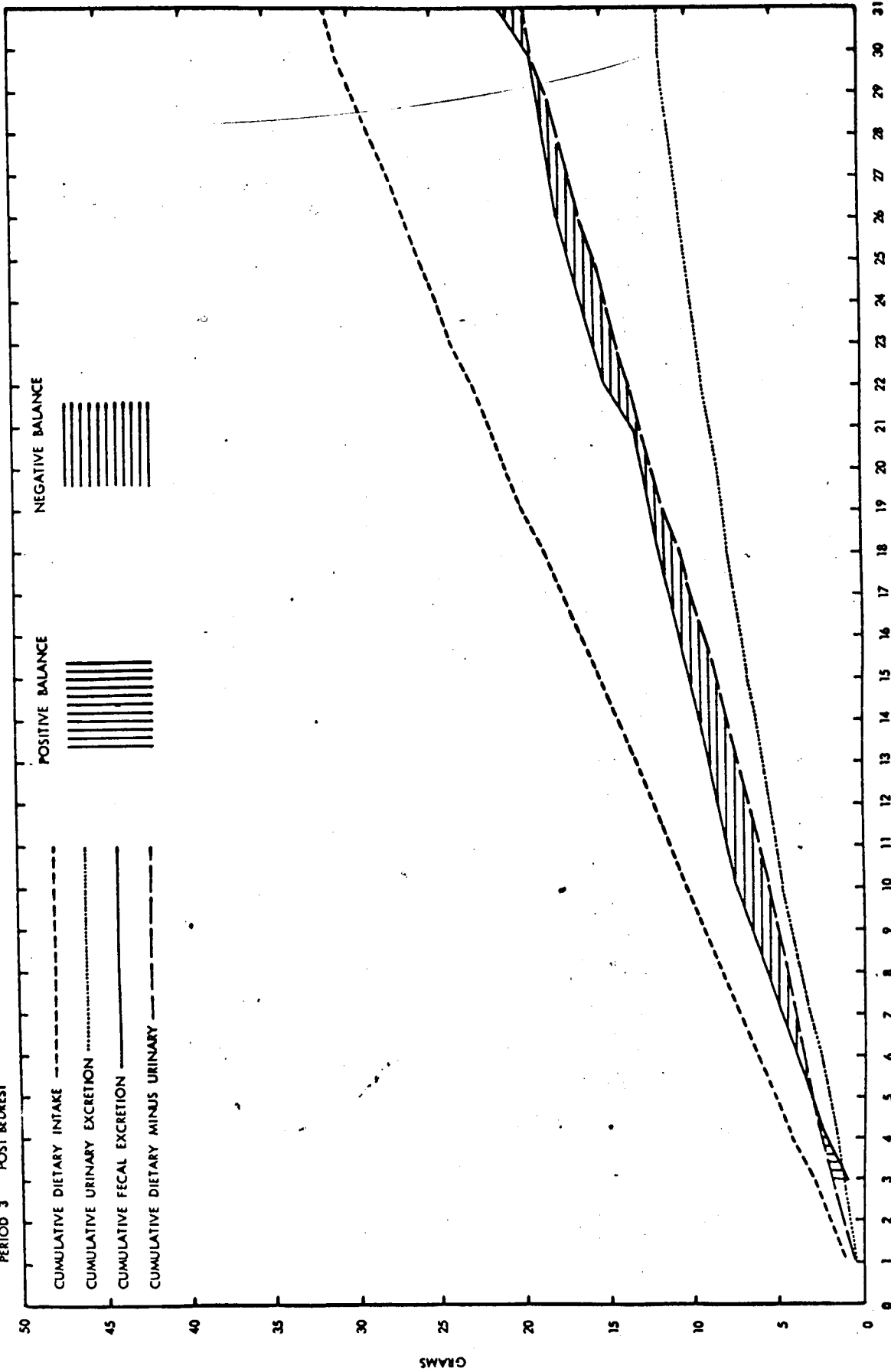

TIME IN DAYS

GRAMS

CALCIUM STUDY
 TWU SUMMER 1965 BEDREST STUDY

SUBJECT 1-P

PERIOD 4 POST POST BEDREST

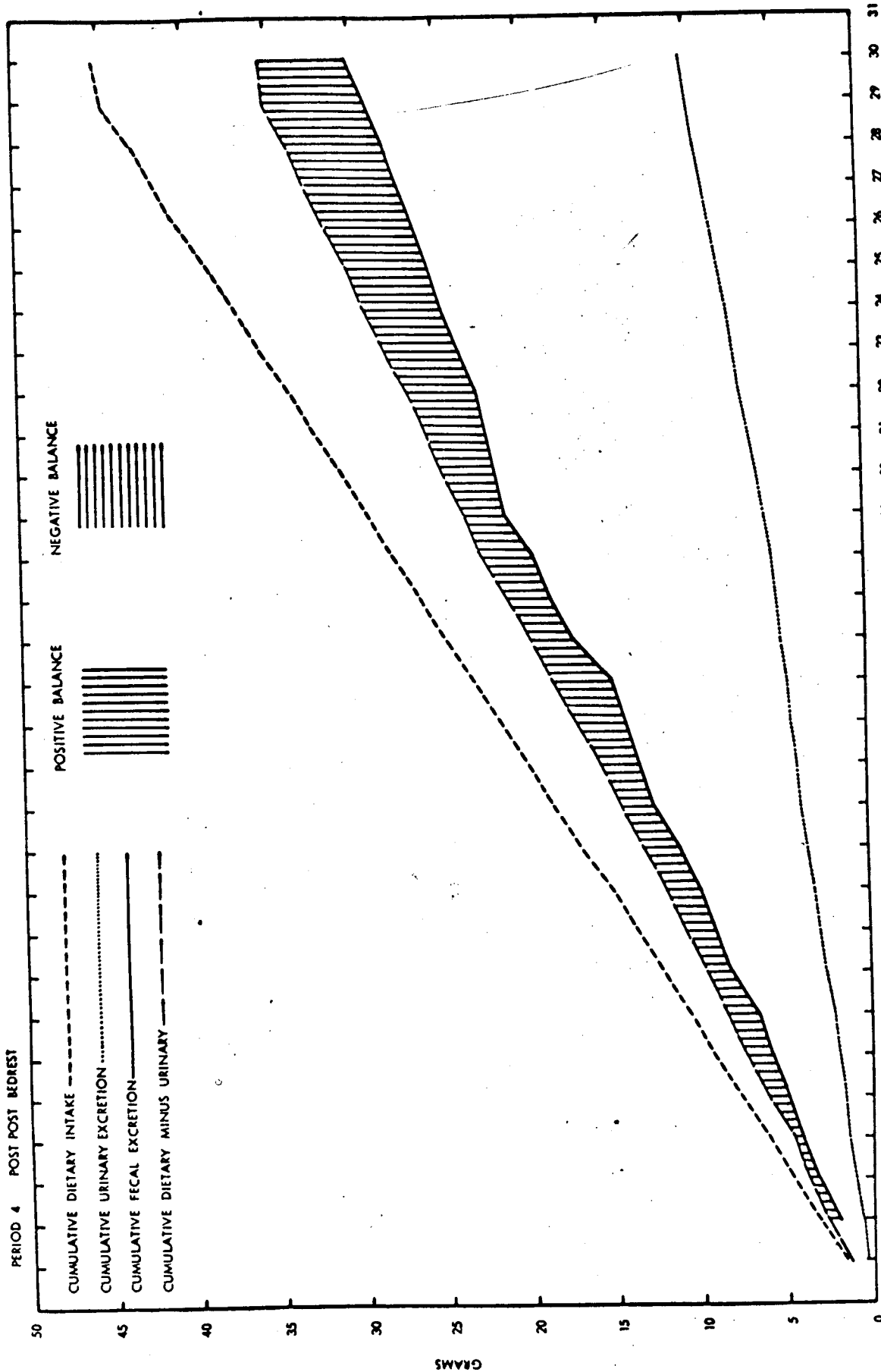

TIME IN DAYS

CALCIUM STUDY
 TWU SUMMER 1965 BEDREST STUDY

SUBJECT 2-R
 PERIOD 1 PRE BEDREST

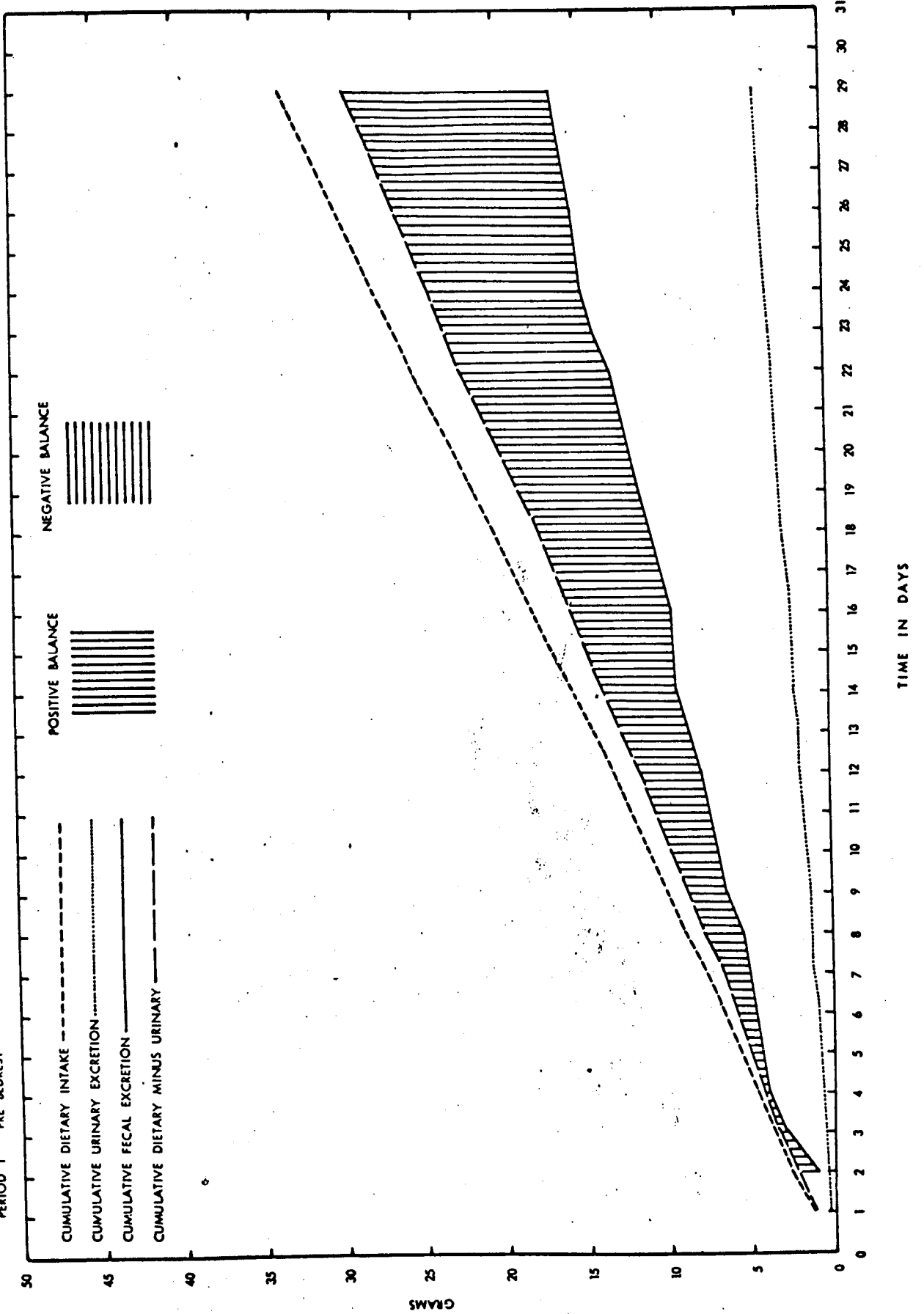

CALCIUM STUDY
 TWU SUMMER 1965 BEDREST STUDY

SUBJECT 2-R
 PERIOD 2 DURING BEDREST

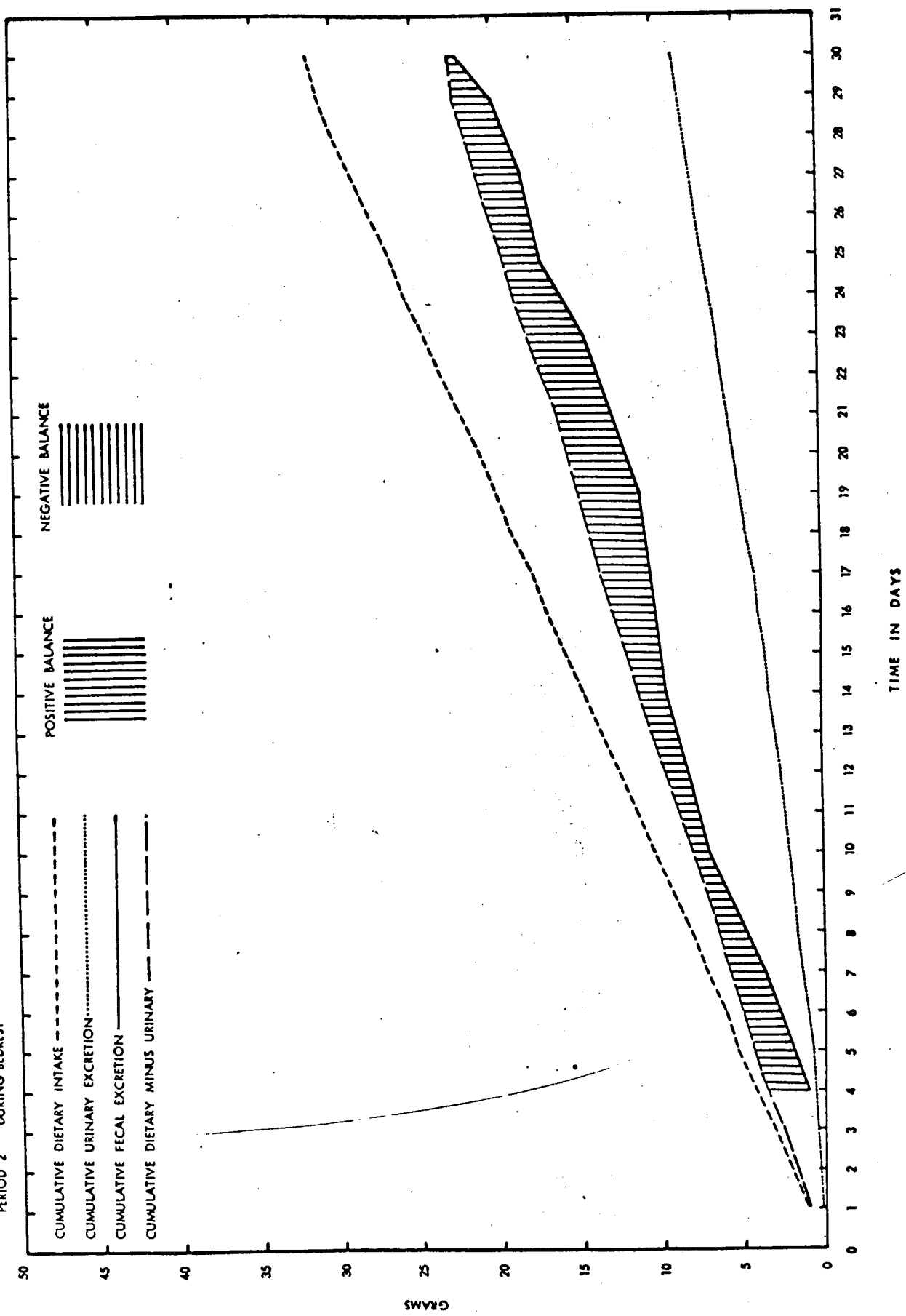

POSITIVE BALANCE
 NEGATIVE BALANCE

--- CUMULATIVE DIETARY INTAKE
 — CUMULATIVE URINARY EXCRETION
 CUMULATIVE FECAL EXCRETION
 - · - CUMULATIVE DIETARY MINUS URINARY

GRAMS

TIME IN DAYS

CALCIUM STUDY
TWU SUMMER 1965 BEDREST STUDY

SUBJECT 3-Q

PERIOD 1 PRE BEDREST

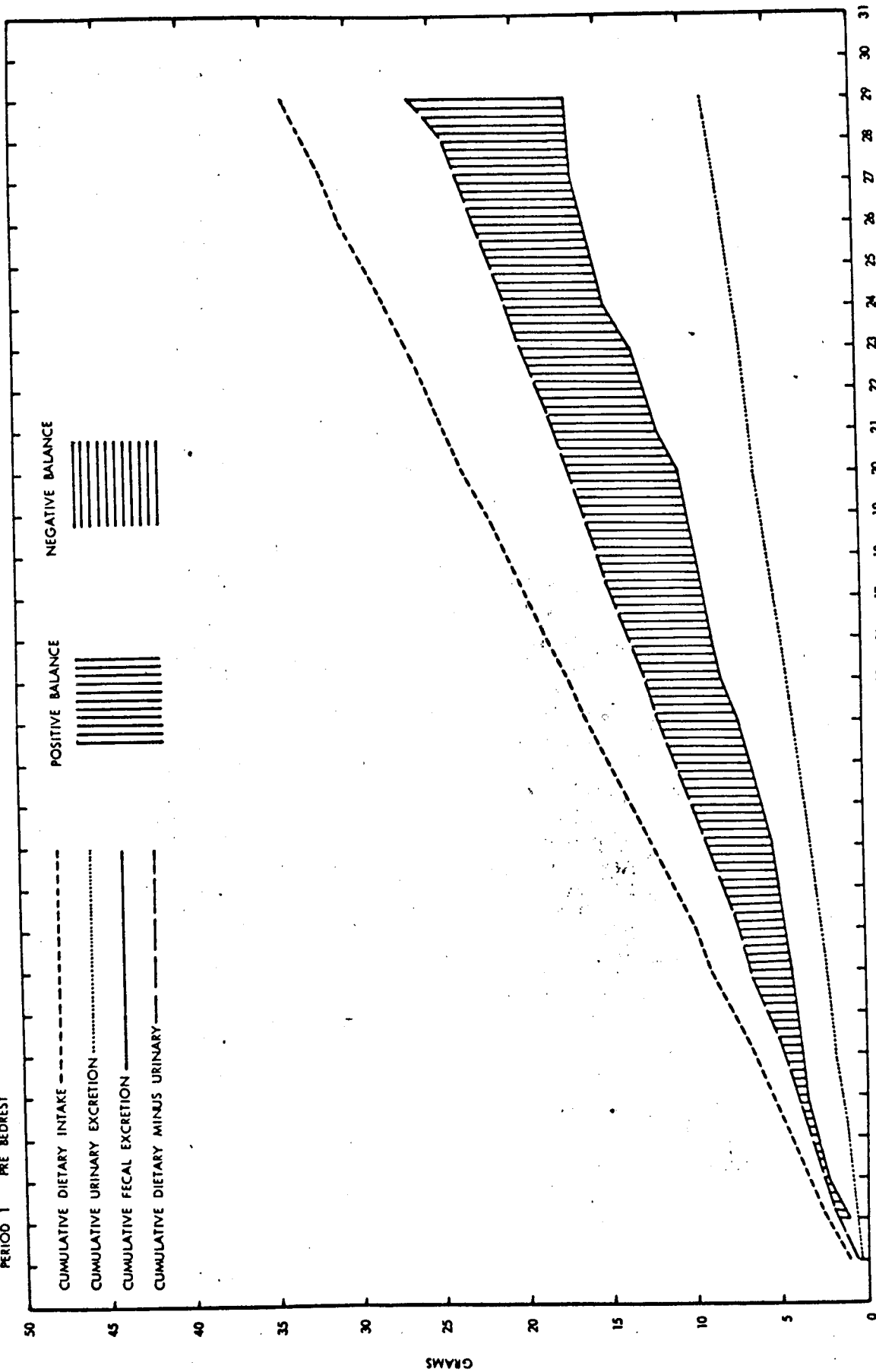

TIME IN DAYS

CALCIUM STUDY
 TWJ SUMMER 1965 BEDREST STUDY

SUBJECT 3-Q

PERIOD 2 DURING BEDREST

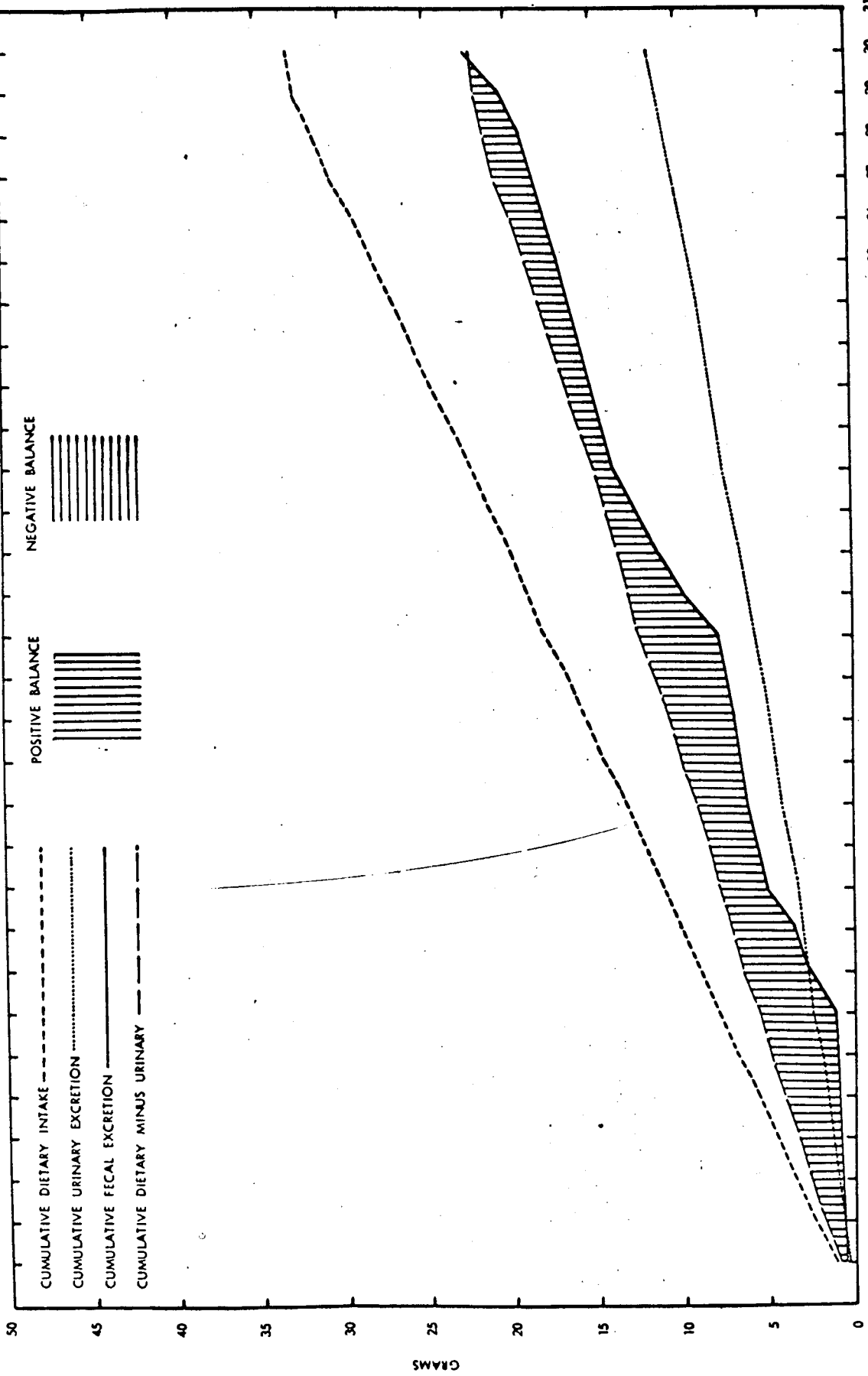

NEGATIVE BALANCE

POSITIVE BALANCE

- CUMULATIVE DIETARY INTAKE - - - - -
- CUMULATIVE URINARY EXCRETION ······
- CUMULATIVE FECAL EXCRETION —————
- CUMULATIVE DIETARY MINUS URINARY - · - · - ·

TIME IN DAYS

GRAMS

CALCIUM STUDY
 TWU SUMMER 1965 BEDREST STUDY

SUBJECT J-Q
 PERIOD 3 POST BEDREST

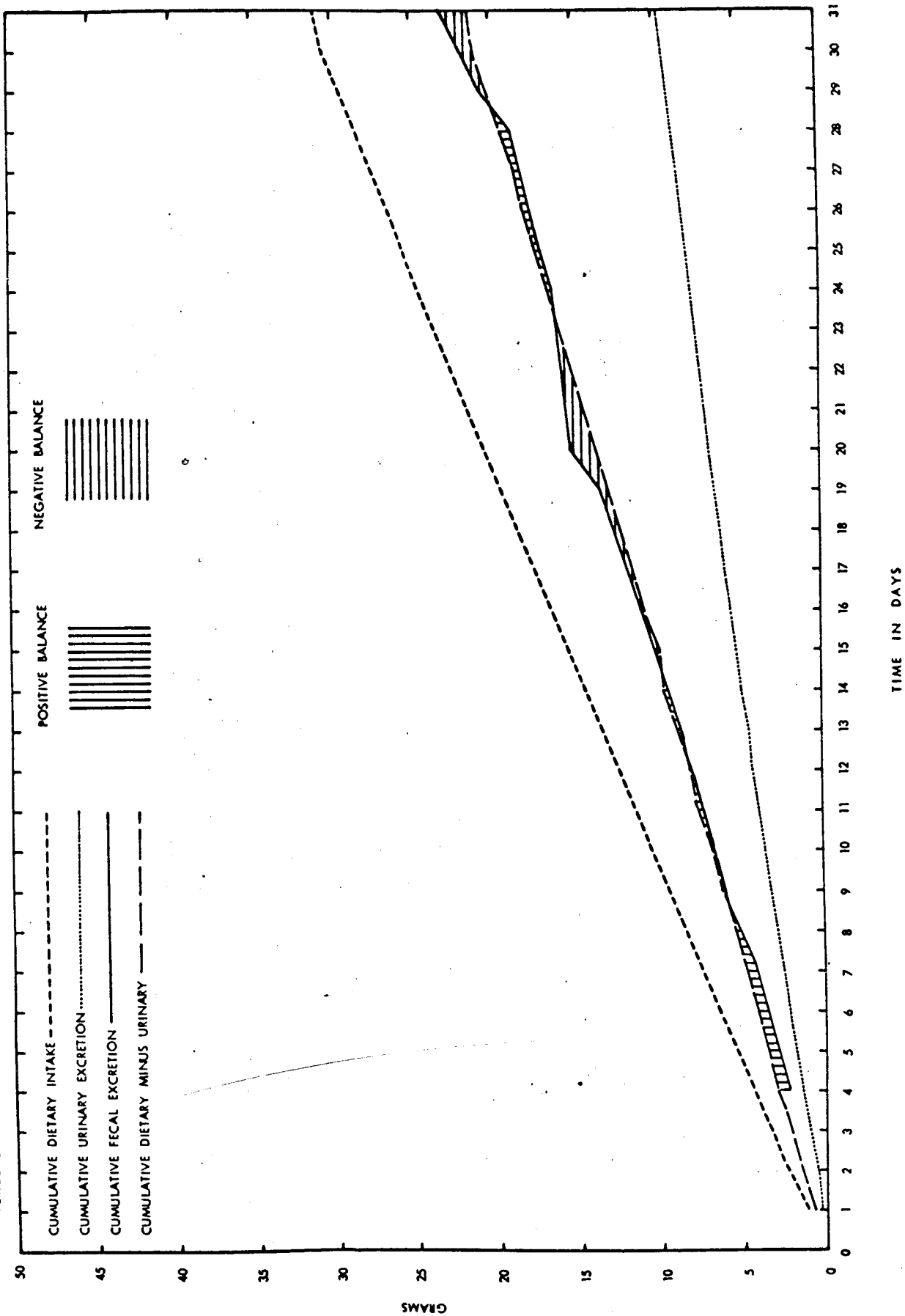

CALCIUM STUDY
 TWU SUMMER 1965 BEDREST STUDY

SUBJECT 3-Q

PERIOD 4 POST POST BEDREST

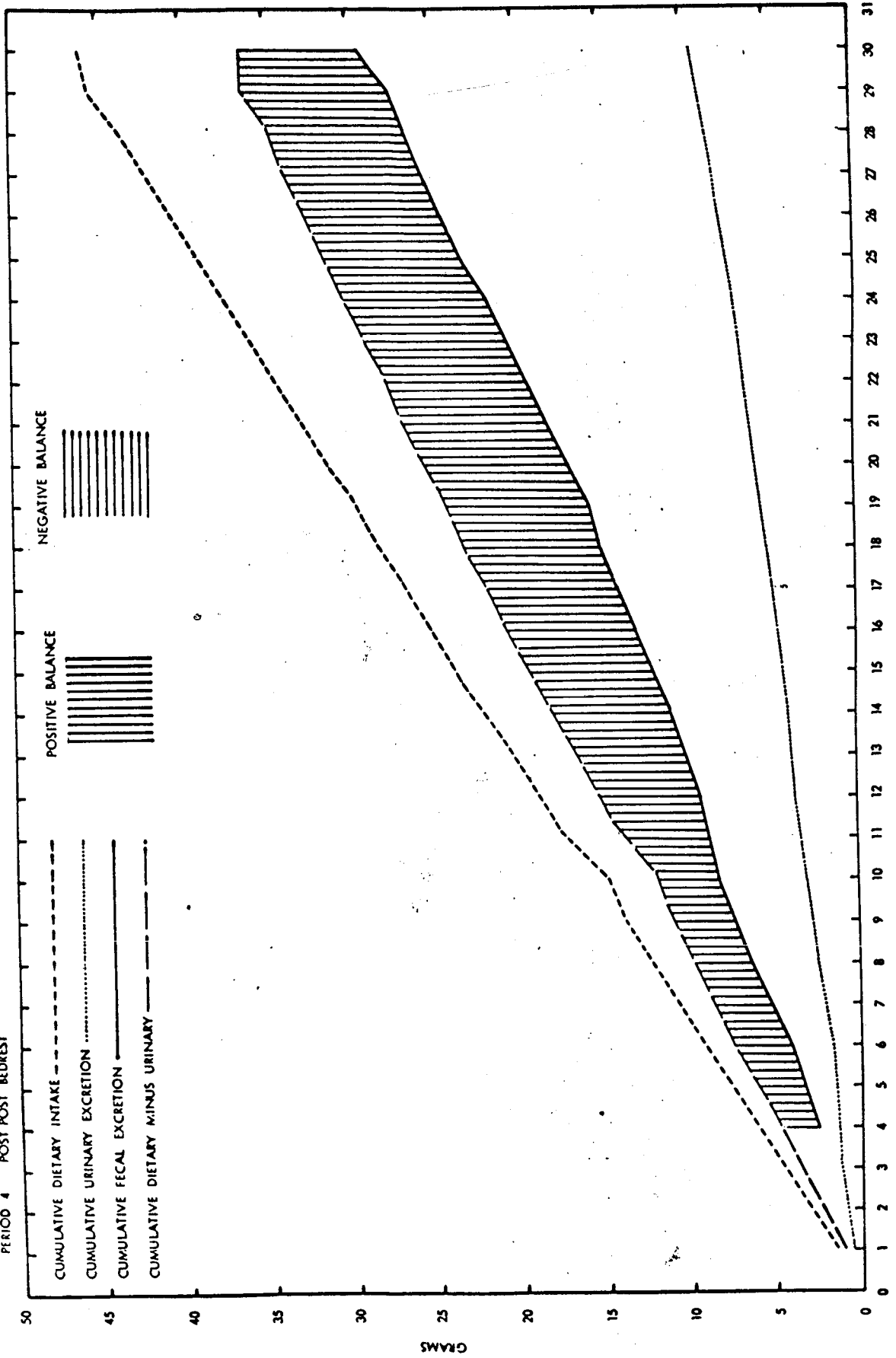

TIME IN DAYS

CALCIUM STUDY
 TWU SUMMER 1965 BEDREST STUDY

SUBJECT 4-T
 PERIOD 1 PRE BEDREST

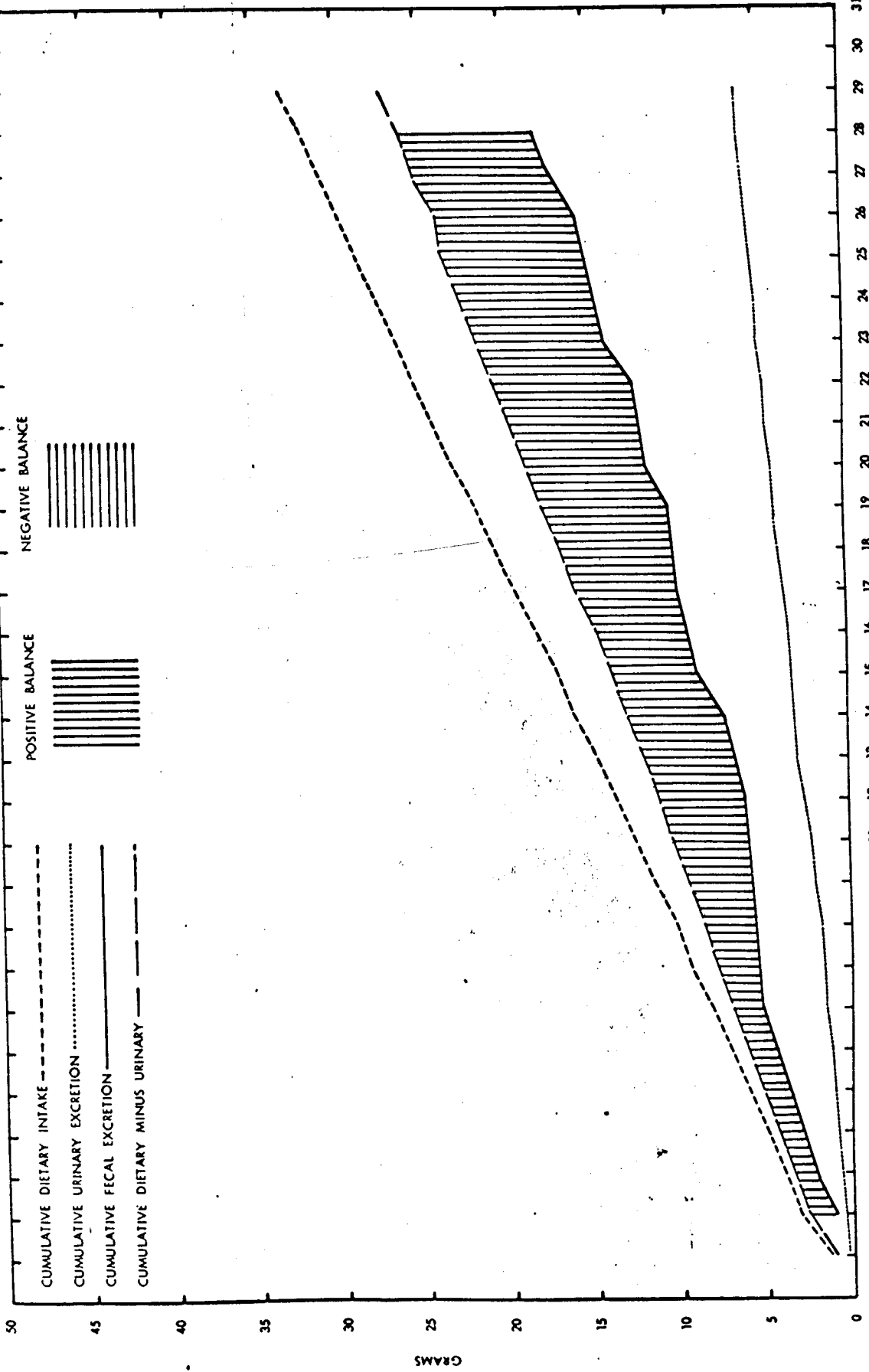

CALCIUM STUDY
 TWU SUMMER 1965 BEDREST STUDY

SUBJECT 4-1

PERIOD 2 DURING BEDREST

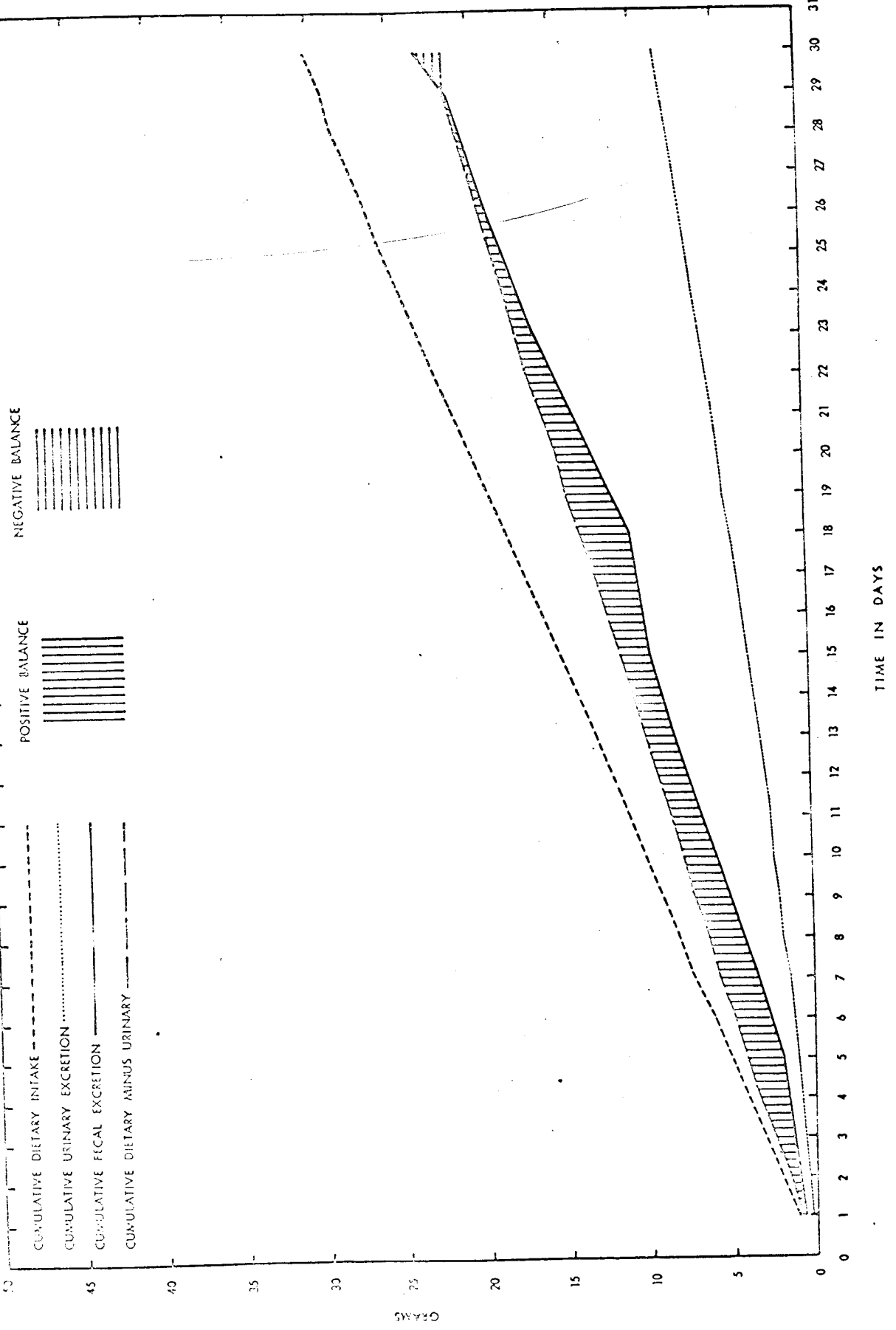

NEGATIVE BALANCE

POSITIVE BALANCE

CUMULATIVE DIETARY INTAKE
 CUMULATIVE URINARY EXCRETION
 CUMULATIVE FECAL EXCRETION
 CUMULATIVE DIETARY MINUS URINARY

GRAMS

TIME IN DAYS

CALCIUM STUDY
 TWO SUMMER 1955 BEDREST STUDY

SUBJECT 4-T
 PERIOD 3 POST BEDREST

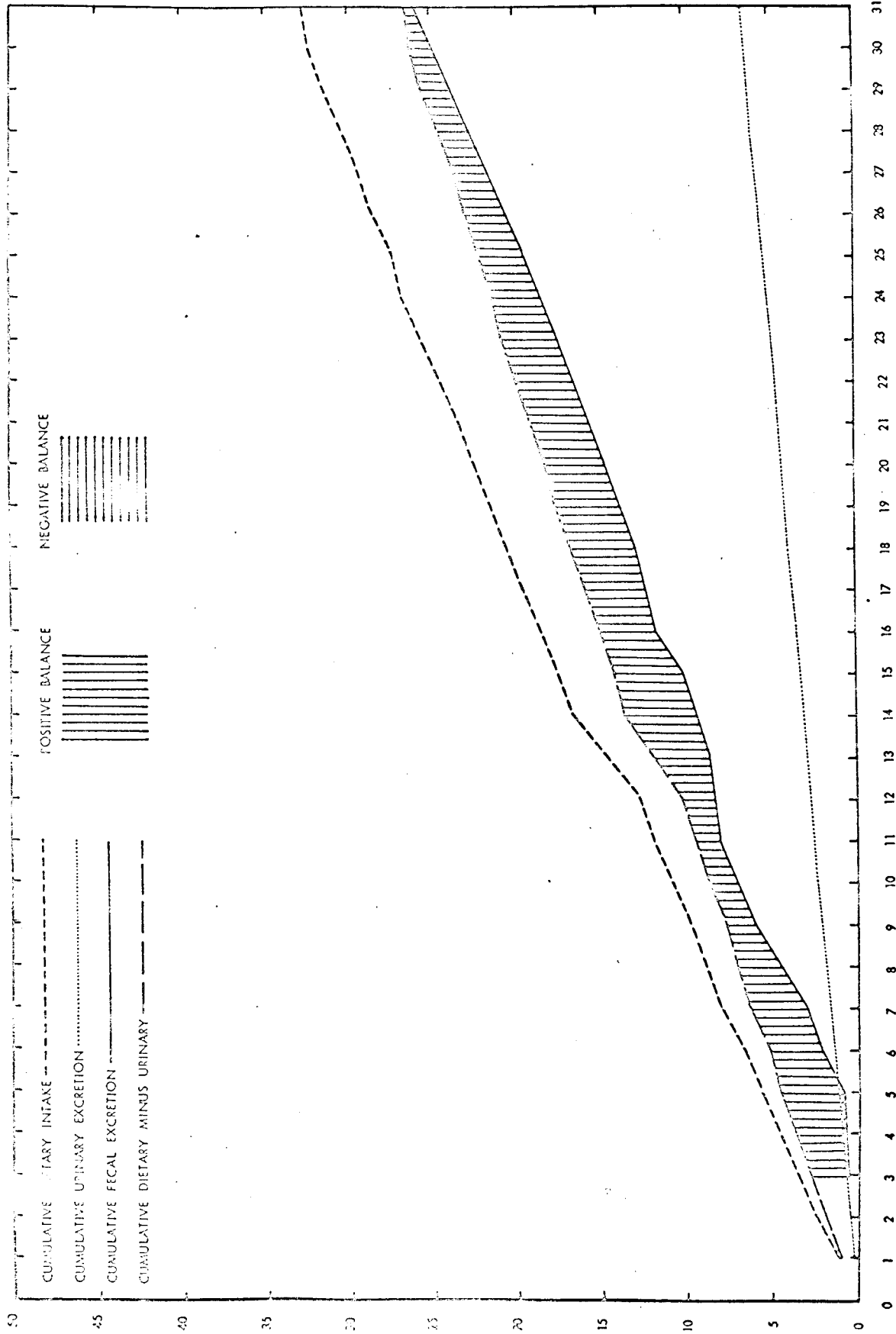

TIME IN DAYS

CALCIUM STUDY
 THU SUMMER 1985 BEDREST STUDY

SUBJECT 4-T

PERIOD 4 POST POST BEDREST

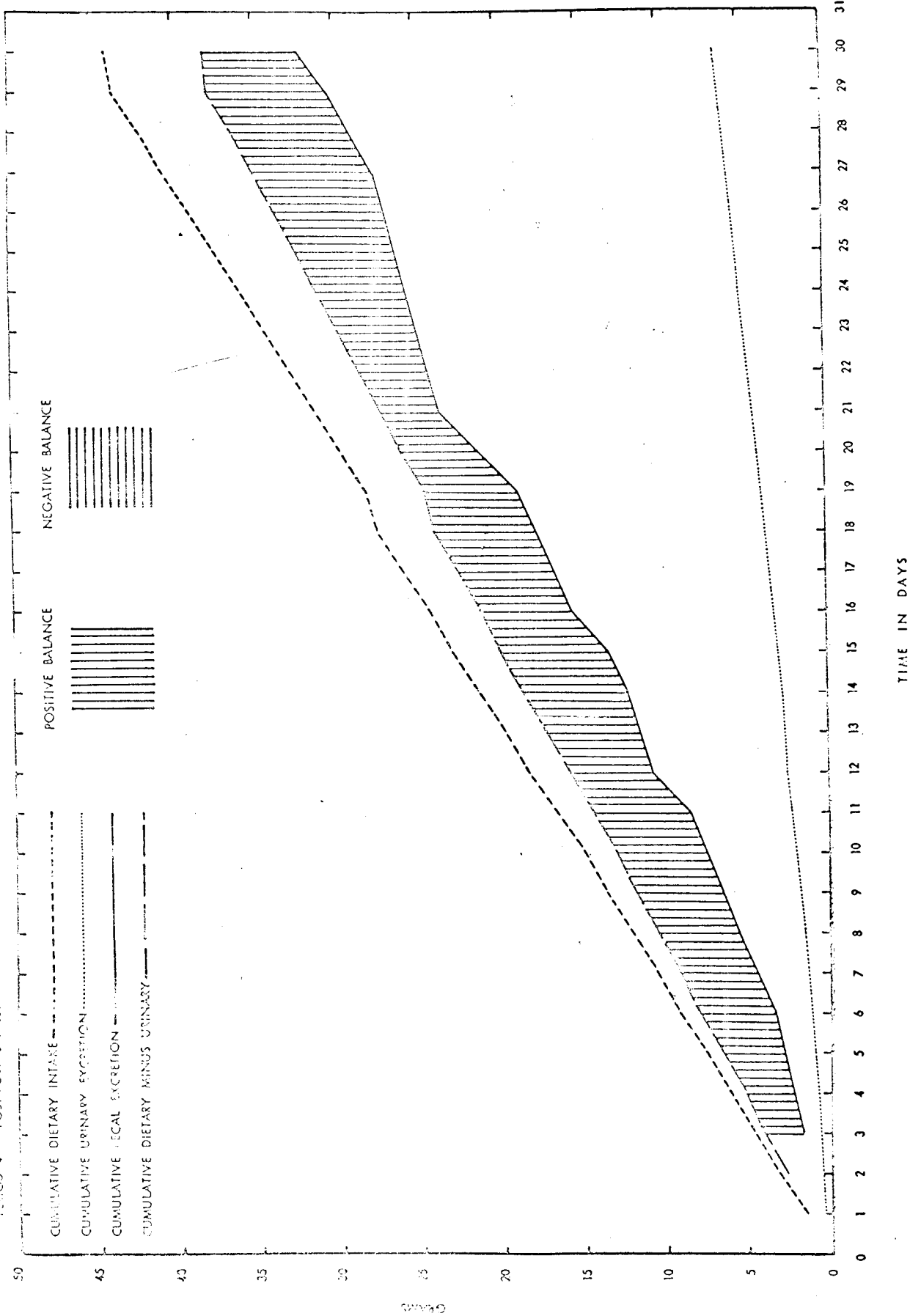

CALCIUM STUDY
 TNU SUMMER 1965 BEDREST STUDY

SUBJECT 5-5
 PERIOD 1 PRE-BEDREST

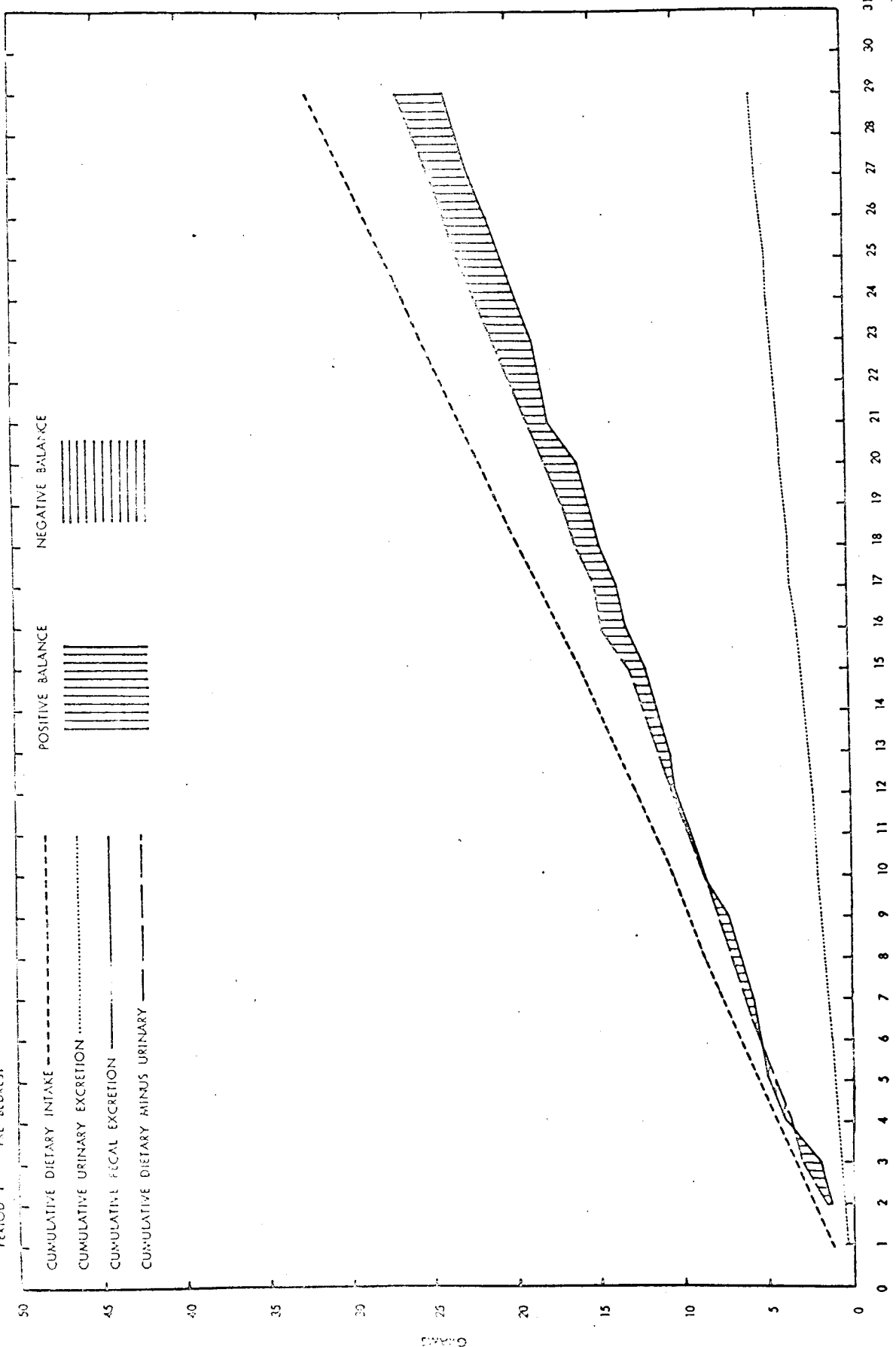

TIME IN DAYS

CALCIUM STUDY
 TWU SUMMER 1965 BEDREST STUDY

SUBJECT 5-5

PERIOD 2 DURING BEDREST

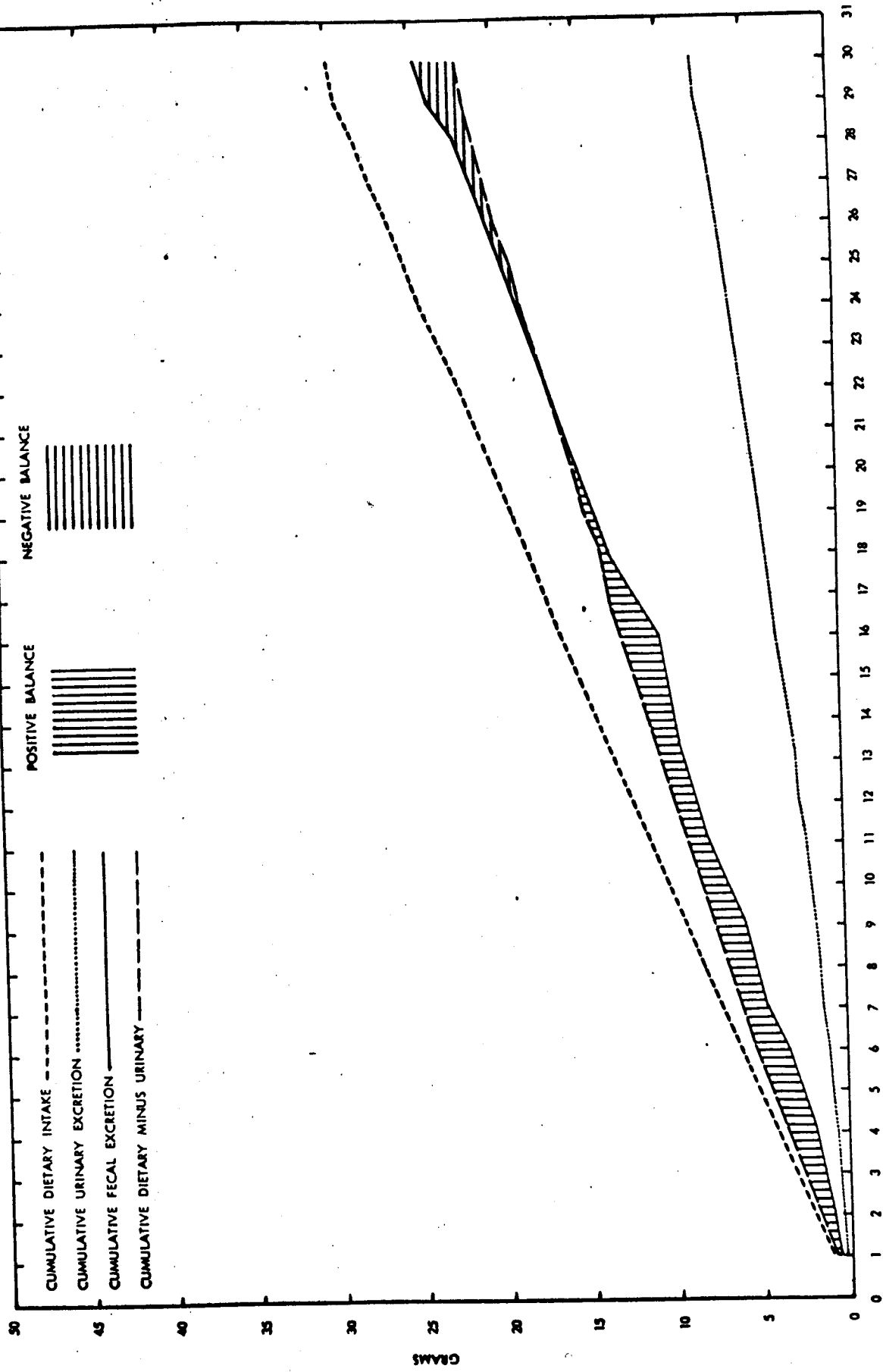

TIME IN DAYS

POSITIVE BALANCE

NEGATIVE BALANCE

CUMULATIVE DIETARY INTAKE - - - - -
 CUMULATIVE URINARY EXCRETION
 CUMULATIVE FECAL EXCRETION _____
 CUMULATIVE DIETARY MINUS URINARY - . - . -

CALCIUM STUDY
 TWU SUMMER 1965 BEDREST STUDY

SUBJECT 5-5

PERIOD 3 POST BEDREST

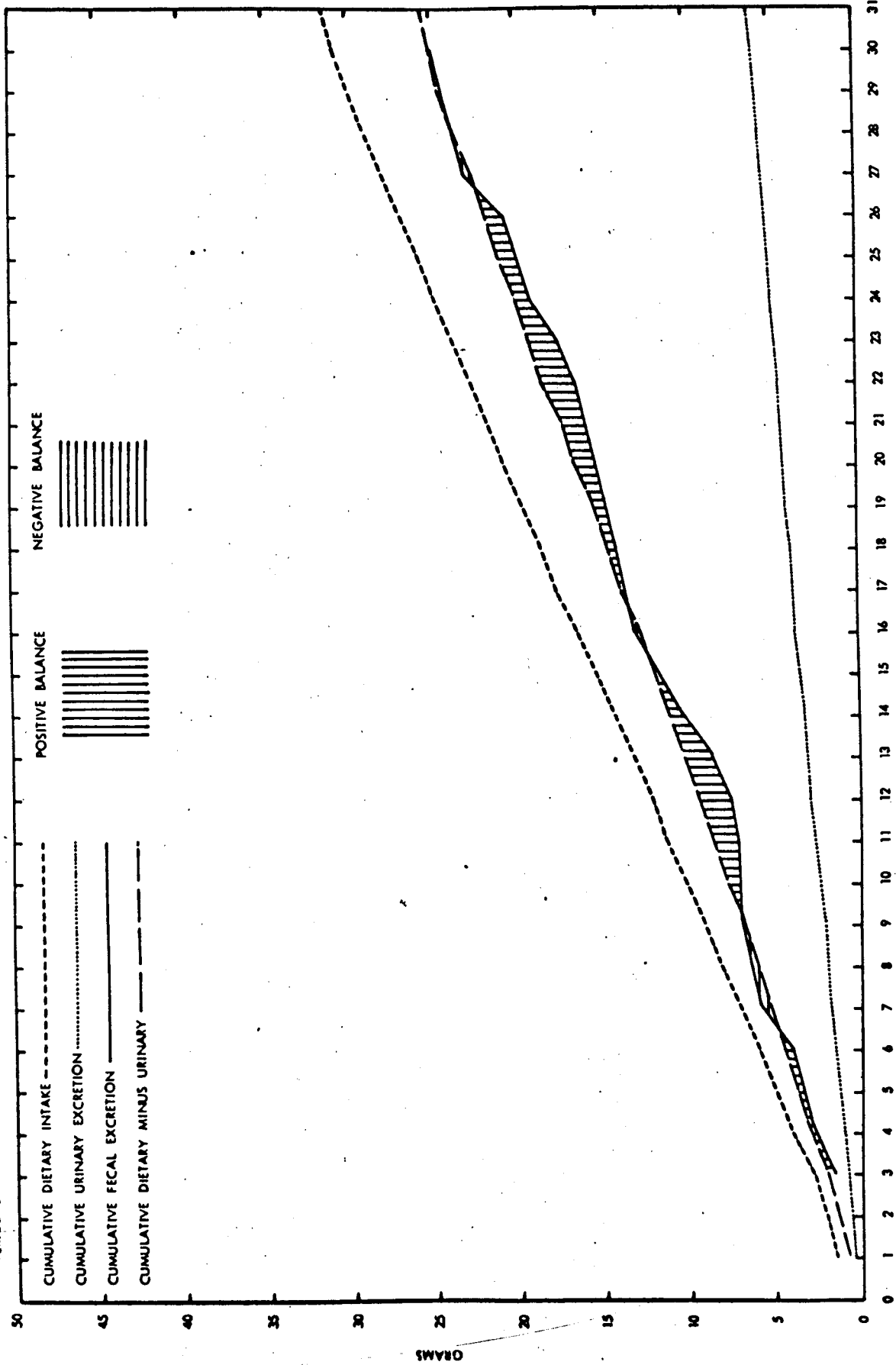

TIME IN DAYS

CALCIUM STUDY
TWO SUMMER 1965 BEDREST STUDY

SUBJECT 5-5

PERIOD 4 POST POST BEDREST

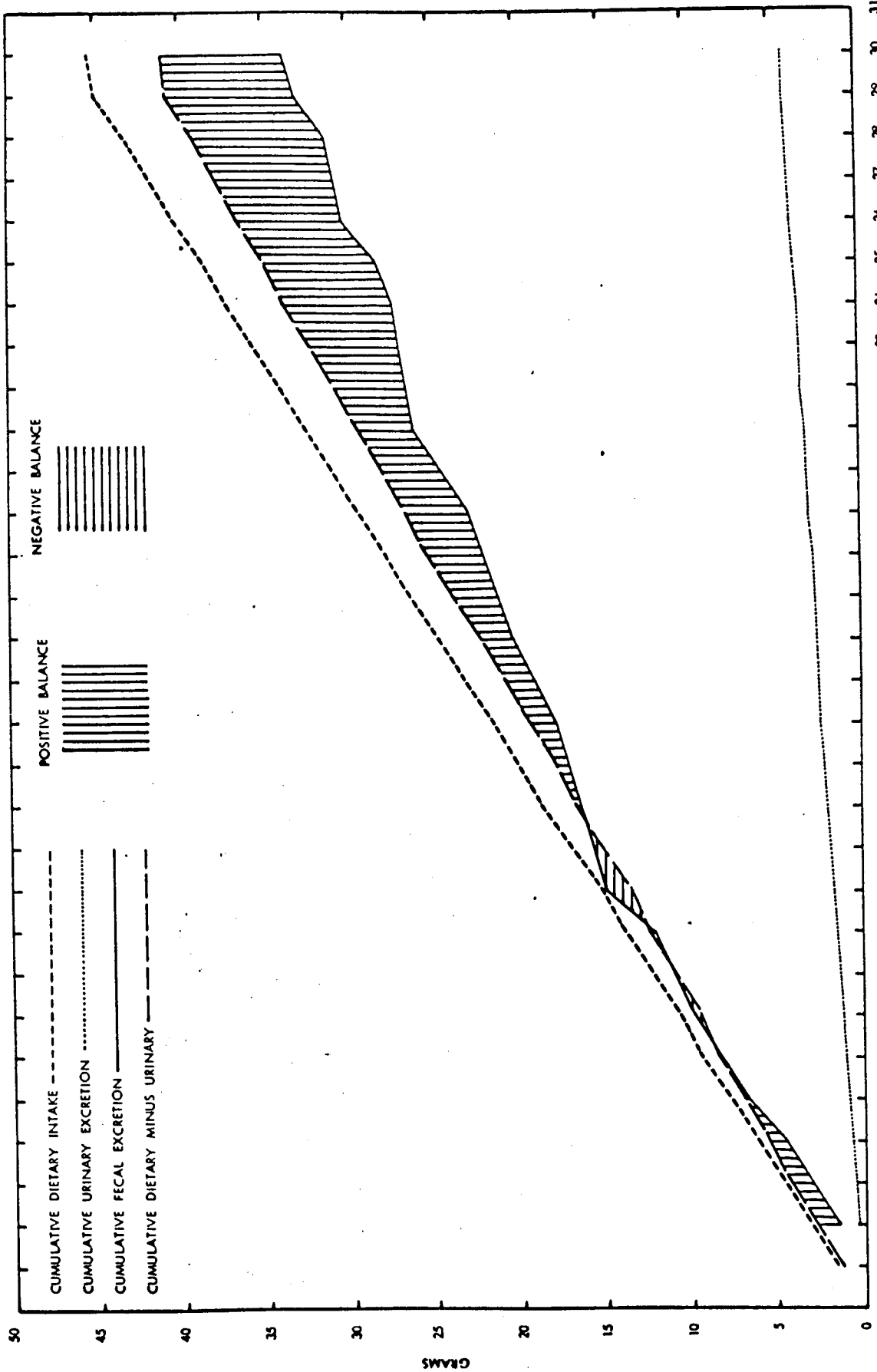

TIME IN DAYS