

SUPPLEMENTARY TO FINAL REPORT
CONTRACT NO. NAS8-20529

EXPERIMENTAL INVESTIGATION OF A
SABOT STRIPPING METHOD FOR A
0.5 INCH LIGHT GAS GUN

7457/R1 (SUPP. 1)

SUBMITTED TO

GEORGE C. MARSHALL SPACE FLIGHT CENTER,
NATIONAL AERONAUTICS AND SPACE ADMINISTRATION,
HUNTSVILLE, ALABAMA, U. S. A.

24 OCTOBER 1967

GPO PRICE	\$	_____
CFSTI PRICE(S)	\$	_____
Hard copy (HC)		<u>3.00</u>
Microfiche (MF)		_____

ff 853 July 65

N68-11656

N68-11656	(ACCESSION NUMBER)	(THRU)	
<u>4</u>	(PAGES)	<u>5</u>	(CODE)
<u>CR-90503</u>	(NASA CR OR TMX OR AD NUMBER)	<u>11</u>	(CATEGORY)

FF No. 602(A)

AVAILABLE TO NASA OFFICES AND NASA RESEARCH CENTERS ONLY

COMPUTING DEVICES
OF CANADA LIMITED
AN AFFILIATE OF THE BENDIX CORPORATION

SUPPLEMENTARY TO FINAL REPORT
CONTRACT NO. NAS8-20529

EXPERIMENTAL INVESTIGATION OF A
SABOT STRIPPING METHOD FOR A
0.5 INCH LIGHT GAS GUN

7457/R1 (SUPP. 1)

SUBMITTED TO

GEORGE C. MARSHALL SPACE FLIGHT CENTER,
NATIONAL AERONAUTICS AND SPACE ADMINISTRATION,
HUNTSVILLE, ALABAMA, U. S. A.

24 OCTOBER 1967

PREPARED BY

J. R. B. MURPHY
SPACE SCIENCES DIVISION

COMPUTING DEVICES
OF CANADA LIMITED
AN AFFILIATE OF THE BENDIX CORPORATION

CONTENTS

ABSTRACT	iii
INTRODUCTION	1
CHOICE OF THE DISCARD METHOD	2
THEORETICAL CONSIDERATIONS	4
EXPERIMENTS	7
Stripper Material	7
Pin Interference	8
Effect of Projectile Diameter	8
Effect of Projectile Density	9
Stripper Configuration	10
Stripper with Separation Device	12
CONCLUSIONS	14
REFERENCES	15

LIST OF ILLUSTRATIONS

Figure 1	X-ray Photograph for Firing 804.	20
Figure 2	Sabot Trap and Target for Firing 788.	21
Figure 3	Sabot Trap and Target for Firing 798.	22
Figure 4	Sabot Trap and Target for Firing 799.	23
Figure 5	Sabot Trap and Target for Firing 803.	24
Figure 6	Sabot Trap and Target for Firing 804.	25
Figure 7	Sabot Trap and Firing 812.	26
Figure 8	Sabot Trap and Target for Firing 818.	27
Figure 9	X-ray Photograph for Firing 812.	28
Figure 10	Sabot Trap and Target for Firing 819.	29
Figure 11	Sabot Trap and Target for Firing 820.	30
Figure 12	X-ray Photograph for Firing 824.	31
Figure 13	Sabot Trap and Target for Firing 830.	32
Figure 14	X-ray Photograph for Firing 830.	33
Figure 15	Sabot Trap and Target for Firing 854.	34
Figure 16	Sabot Trap and Target for Firing 857.	35
Figure 17	Sabot Trap and Target for Firing 859.	36

ABSTRACT

An experimental program to develop a sabot stripping method for a 0.5 inch light gas gun is described. Sabots carrying spherical projectiles of various densities and sizes were employed, at velocities in excess of 20,000 feet per second. Dispersion of the sabot fragments was required within a length of less than two feet.

It was found that a combination of a gasdynamic decelerator tube and a cruciform configuration of wedge shaped tungsten pins provided best results. The decelerator tube separated the sabot and projectile, and the pins interfered with the sabot to produce high energies and pressures which dissipate the sabot material.

1. INTRODUCTION

The micrometeoroid simulation facility delivered to the NASA Marshall Space Flight Center, described in References 1 and 2, provides the demonstrated capability of launching discrete cylindrical projectiles of various materials having diameters of 0.062 inch and 0.189 inch at velocities up to 30,000 feet per second. The constant area accelerator described in Reference 2 provides the potential for much higher velocities but has not yet been developed to the stage at which discrete projectiles, having useful length to diameter ratios, may be employed.

It was therefore decided to develop the capability of operating the 0.5 inch light gas gun, which was supplied as part of the above facility, with sabot spherical projectiles having a wide mass and density range. The major difficulty lay in developing a sabot discard method which would effectively discard the sabot in the very short dump tank of the facility.

This report describes an experimental program to develop an efficient sabot discard method. The program took place at ComDev and used the company's 0.5 inch light gas gun and range facilities.

2. CHOICE OF THE DISCARD METHOD

Previous experience at ComDev had included the investigation of most of the known methods for discarding the sabot. These methods included the following:

- (a) Petalling-type air-opening sabot
- (b) Gas separator tube with deflection ramp
- (c) Spinning segmented sabot
- (d) Sabot stripper.

The objective of each of these methods was to obtain dispersion of the sabot segments or fragments away from the projectile line of flight. The sabot fragments were stopped on a sabot-trap, which is a steel plate having a small hole to permit the passage of the projectile.

In the ComDev range facility, the sabot trap is 10 feet and the target 29 feet from the light gas gun muzzle. Due to space limitations the range tank of the MSFC facility is relatively small, so that the sabot trap may be only about 2 feet and the target 3.5 feet from the muzzle. Since methods (a), (b) and (c) above require relatively long distances over which to achieve adequate dispersion, method (d) was chosen as having most promise for use in the short range tank.

The sabot stripper method is simple in principle and is illustrated below:

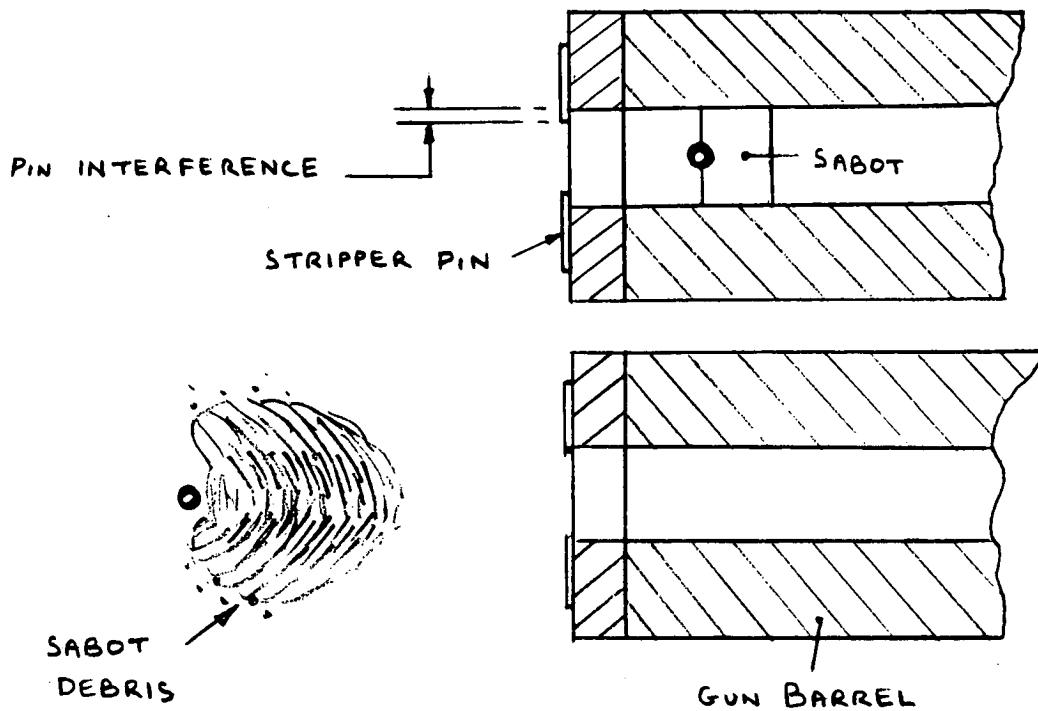

In a typical configuration the sabot interacts with four diametrically opposed metal pins. This causes shock waves to propagate into the sabot material, which gives rise to extremely high pressures and energies in the plastic sabot material. This results in the attainment of high radial momentum by the sabot material, as may be seen from an X-ray, taken at the muzzle of the gas gun, shown in Figure 1. This X-ray is for a 0.5 inch diameter sabot carrying a 0.25 inch aluminum sphere. The vertical lines in the picture are about 1.5 inches apart in the plane of the flight path. Experience indicated that, by suitable manipulation of the stripper configuration and material, adequate dispersion could be achieved in a length of about two feet.

3. THEORETICAL CONSIDERATIONS

As indicated in the sketch below, the interaction of the sabot with the four stripper pins causes very strong shock waves to be propagated in the sabot and pin material.

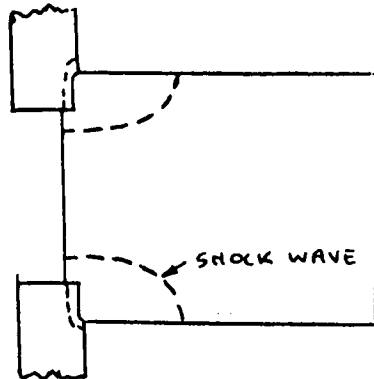

The shock waves will reflect in a complex three-dimensional process and high internal energies and pressures would ideally be produced throughout the sabot. Rarefaction waves originating at the free surfaces will produce expansion of the shocked sabot material. It is desirable to create the highest possible internal energies and pressures inside the sabot, in order to generate the maximum possible radial expansion of the sabot material.

The process is too complicated to analyze quantitatively in its entirety. However, it is qualitatively apparent that the strength of the shock waves will be governed by the stripper configuration and material. The interaction between pin and sabot is a hypervelocity impact process, and therefore some insight into the shock propagation in the pin and sabot may be gained by considering the equations governing shock strength in one-dimensional hypervelocity impact.

The dynamics of shock wave propagation produced by the impact

of a hypervelocity projectile is well known through the Rankine-Hugoniot equation. Conditions in dissimilar impacting materials may be determined through the requirements of equal pressure and velocity at the contact discontinuity.

A computer program was written to solve the Rankine-Hugoniot conditions for various metals impacting on Zelux polycarbonate sabot material. Experimentally-established empirical equations-of-state for the materials were employed; with Zelux assumed similar to Plexiglas. Solutions were obtained for the shock propagation velocities, particle velocities and pressures; for magnesium, aluminum, titanium, steel, copper, lead, gold and tungsten impacts. It was found that highest pressures in the Zelux would be generated by tungsten pins.

It was also found that the shock propagation speed in the tungsten was lower than for the other metals. The advantage of this is explained by reference to the sketch below:

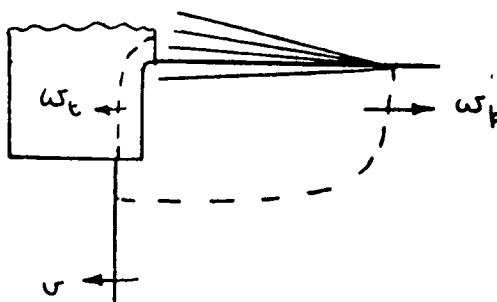
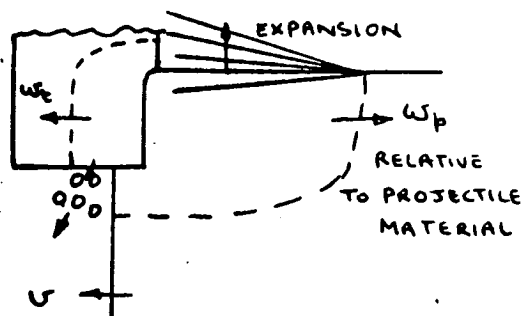
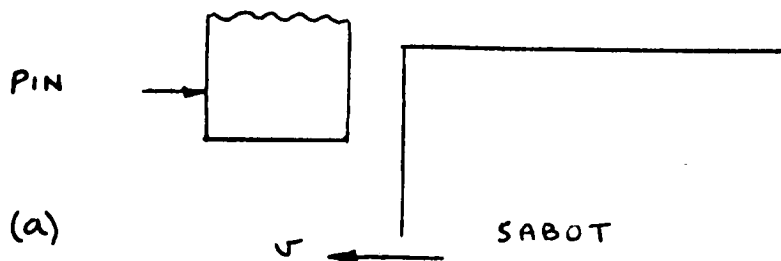

Initial conditions are shown in (a). In the case (b) the shock wave in the stripper pin moves faster than the sabot front face. This would lead to premature spalling of the pin material, as indicated by the particles in (b). In the case (c) the shock in the pin lags behind the sabot face, avoiding premature pin spalling. Higher pressures and energies would as a result be generated in the sabot.

It was found from the computations that shock velocities in tungsten would be lower than the sabot velocity for sabot speeds greater than about 16,000 feet per second.

Tungsten was adopted as stripper material early in the firing program.

4. EXPERIMENTS

The experimental program was performed on the ComDev 0.5 inch light gas gun and range facilities. The sabot trap plate was installed at a distance of about 20 inches from the gun muzzle. Thirty-five firings were made, and are summarized in Table 1.

In the following subsections the experimental trends are discussed under the following headings:

Stripper Material

Pin Interference

Effect of Projectile Diameter

Effect of Projectile Density

Stripper Configuration

Stripper with Separation Device

4.1 Stripper Material

Shock propagation theory discussed in Section 3 showed the apparent virtue of tungsten as a stripper material. Experimental firings confirmed the merit of tungsten as compared with steel. Initial firings (783, 786, 787 and 788) employed four 0.125 inch steel rods spaced at 90 degrees and interfering with the outer circumference of the sabot. Tungsten pins of the same configuration were used in subsequent firings up to Firing 821. A substantial improvement in sabot dispersion was noted, as indicated by photographs of the sabot traps and targets for Firings 788 and 803, in which almost identical conditions prevailed save for the stripper

material (Figures 2 and 5). The tungsten pins used in Firing 803 resulted in greater dispersion of the four significant craters on the sabot trap. The four craters, caused by sabot fragments, were consistently observed with the pin arrangement. The craters, together with the associated radiating lines of very small impacts, were oriented at 45 degrees to the pin axes.

4.2 Pin Interference

Firings 798, 799, 801, 802, 803 and 804 investigated the influence on dispersion of varying the interference of 0.125 inch tungsten pins. Interference was varied between 0.020 and 0.080 inch. Sabots carrying 0.25 inch aluminum spheres continued to be employed. In Figures 3, 4, and 5, it may be seen that increased dispersion resulted as interference was increased, and clean target impacts were achieved on all firings. The effect of reducing muzzle velocity to just over 20,000 feet per second was investigated in Firing 804 (Figure 6). It was found that a slight deterioration resulted as compared with Firing 803. Firings at higher velocity were not investigated because of a desire to minimize gun wear, however on the basis of past experience it may be expected that no deterioration in performance would result. An X-ray photograph of the sabot debris close to the stripper in Firing 804 is shown in Figure 1.

4.3 Effect of Projectile Diameter

As the diameter of the aluminum spherical projectile was reduced from 0.25 inch to 0.125 inch and then to 0.062 inch, it was observed that

the dispersion of the four important sabot fragments was reduced to an unacceptable degree. This is illustrated by photographs of the targets and sabot traps from Firings 803, 812, and 818, shown in Figures 5, 7, and 8. In firing 818, an inspection of the target photograph shows that four sabot fragments struck the target, having passed through the hole in the sabot trap.

A number of firings were made with 0.125 inch aluminum projectiles in which no hits were achieved on the target (Firings 812, 813, 815, 817). It was decided that the target was placed too far away from the muzzle to guarantee consistent hits by smaller projectiles. Targets had been mounted 29 feet from the muzzle so that impact flash could be monitored, and projectile velocity measured, with existing instrumentation to assist in firing diagnosis. Projectiles were known to be intact after stripping, as may be seen from the muzzle X-ray photograph for Firing 812 (Figure 9). For subsequent firings the targets were placed at an improvised location approximately 3.5 feet from the muzzle. Muzzle velocity was inferred from measurements of the light gas gun piston velocity, which is considered adequately accurate.

4.4 Effect of Projectile Density

Firings 812, 819, and 820 investigated the effect of firing 0.125 inch aluminum, titanium and copper spheres, respectively. There was a trend of decreasing sabot dispersion with projectile density, as shown by the sabot trap and target photographs (Figures 7,10, and11). In firing 820 the four small sabot fragments appeared to have impacted on the target.

In the above experiments, the most significant problem was the difficulty in achieving adequate dispersion of four small sabot fragments. Their dispersion was strongly influenced by the sphere size and material, and the pin material also appeared to have a strong influence; but varying the interference of the pins, while strongly influencing the size of the fragment craters, appeared to have little or no effect on the radial dispersion of the fragments. Configurational changes to the pins were therefore considered as a means of enhancing the shock strength in the sabot, thereby eliminating the fragments or increasing their dispersion.

The sketches below show three pin configurations which were employed experimentally.

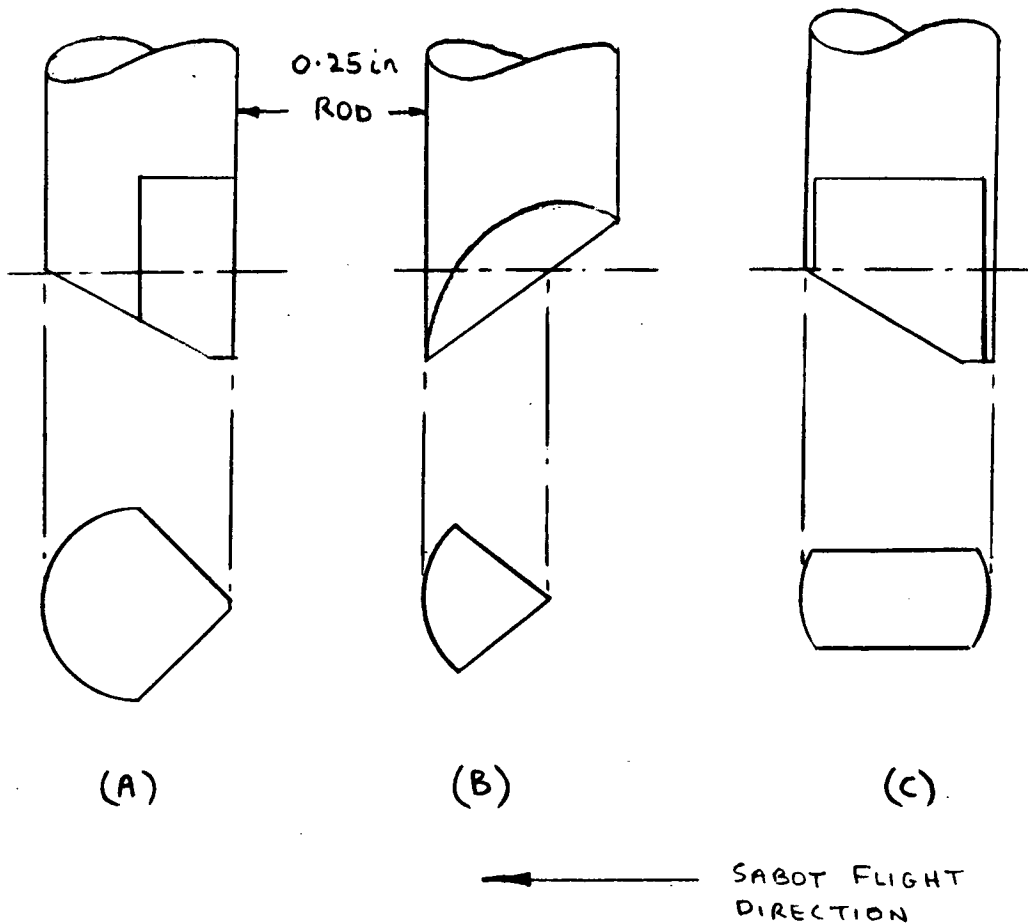

The wedge-shaped cross section of pin (A) ensured that a shock wave of nearly constant strength was driven into the sabot material. It also ensured that the sabot material driven by the pin was provided with a lateral component of particle velocity. The rear of the pin was sloped away from the line of flight to permit radial expansion of shocked material at the centre of the sabot. Pin (B) also had a wedge-shaped cross section, but was configured so that strong shock waves were driven towards the centre of the sabot. Pin (C) was in effect similar to the 0.125 inch diameter pin but with increased depth in the plane containing the projectile line of flight.

In addition to the pin configurations, two firings were made in which a continuous tungsten ring interfered with the circumference of the sabot.

Firings which employed pin (A) were 822, 823, 829 and 830; pin (B) was used in Firing 827; and pin (C) was used in Firing 828. Tungsten rings, 0.125 inch in thickness were employed in Firings 824 and 826. It was found that the tungsten ring eliminated the four sabot fragments, as expected, but had the disadvantage that the sabot debris was concentrated close to the projectile flight path, as shown by the muzzle x-ray photograph for Firing 824 (Figure 12). In addition the target crater size (not illustrated) was smaller than normal for the 0.125 inch copper sphere, which suggested that the latter had been damaged by the stripping action. Pin (B) had a similar effect in that the sabot fragments were eliminated but the projectile appeared to be damaged. Pin (C) was not successful in eliminating the sabot fragments.

Best results were obtained with pin (A) at an interference of 0.120 inch, in Firing 829 with a 0.125 inch copper sphere, and in Firing 830 with a 0.125 inch aluminum sphere. Although the sabot fragments were not eliminated, they were reduced in size and better dispersed. Figure 13 shows photographs of the sabot trap and target for Firing 830. The muzzle x-ray photograph indicated that the aluminum projectile was slightly deformed by the stripping action (Figure 14).

4.6 Stripper with Separation Device

From the above experiments, it appeared that pin configurations which provided satisfactory stripping were also liable to damage the projectile. It was therefore decided to separate the sabot and projectile prior to stripping. The separator device is illustrated in the following sketch.

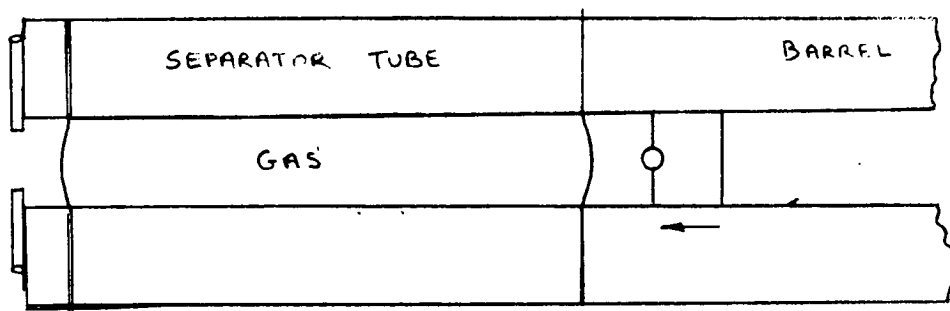

The sabot drives a shock wave ahead of it as it slows down. The projectile is free to move ahead of the sabot into the driven gas, since it experiences relatively little drag. Provided the shock wave remains ahead of the projectile, the latter will continue to move ahead of the sabot. Suitable gas loading conditions in the separator tube may readily be found from gasdynamic considerations.

Firings 852, 853 and 854 investigated the stripping action of the pins on a sabot carrying no projectile. It was found necessary to increase the interference of pin (A) to about 0.18 inch to achieve a clean target. Photographs of the target and sabot trap for this interference (Firing 854) are shown in Figure 15. The low velocity splash on the target was apparently caused by a piece of spalled piston.

Firings 855 and 856 studied the separation of a 0.125 inch copper sphere, using an 8.4 inch long separator tube loaded with air to pressures of 65 lb/in² (855) and 32 lb/in² (856). No stripper was used. Firing 856 produced an undamaged sabot which was considered desirable for efficient stripping.

The combination of separator tube and stripper was investigated in Firings 857, 858 and 859. A 0.125 inch copper sphere was employed in Firing 857 and a clean target and well dispersed sabot debris were achieved. (Figure 16). In Firing 858 a 0.062 inch copper projectile was damaged by striking the pin due to deviation from its flight path. Pin interference was increased slightly in 859 which resulted in a clean impact and well dispersed sabot debris (Figure 17).

5. CONCLUSIONS

The use of four wedge-shaped tungsten stripper pins was found to provide adequate dispersion of sabot debris in a dump tank length of about 20 inches. Separation of the sabot and projectile prior to stripping was found to be necessary for smaller diameter projectiles, to avoid possible damage to the projectile during the stripping process. The separation was effected by a gasdynamic separator tube 8.4 inches in length. The latter length was chosen so that existing hardware (accelerator compression tubes) at MSFC may be employed as separator tubes.

It was not possible to investigate experimentally the entire range of velocity, mass and density of interest. The experiments indicated that the stripper technique will be effective at all gas gun velocities above 20,000 feet per second, for projectiles having diameters between 0.25 inch and 0.062 inch (or less). No problem is foreseen in employing a wide density range, except that very low-density small-diameter projectiles may become dispersed from the line of flight and may not pass through the sabot trap hole. The mass and density ranges used in the experiments were as follows:

Mass range:	0.38 gm to 0.0058 gm.
Specific gravity:	2.7 to 9.0

REFERENCES

1. Cowan, P.L. Development of a Micrometeoroid Simulation Device, Volume I. Computing Devices Report 7456/R1, October 1967.
2. Murphy, J.R.B. Development of a Micrometeoroid Simulation Device, Volume II - The Constant Area Accelerator. Computing Devices Report 7456/R1, October 1967.

Firing Number	Date	Stripper Configuration	Interference inches	Muzzle Velocity ft/sec.	Projectile Mat.	Projectile Dia. inch	Target Condition	Projectile Condition (X-ray)	REMARKS		
824	21 Sep 67	Tungsten Ring	0.080	23,000	Cu.	0.125	Fair	Apparent Damage	Debris near flight path.		
826	21 Sep 67	"	0.080	24,000	Cu.	0.125	Spray only	Damaged	Projectile struck trap		
827	21 Sep 67	Pin (B)	0.120	24,000	Cu.	0.125	Poor	Apparent Damage			
828	22 Sep 67	Pin (C)	0.100	23,500	Cu.	0.125	Fair		Four sabot fragments on target		
829	22 Sep 67	Pin (A)	0.120	23,500	Cu.	0.125	Fair	Apparent Damage			
830	22 Sep 67	Pin (A)	0.120	24,000	Al.	0.125	Fairly Clean	Damaged			
852	12 Oct 67	Pin (A)	0.120	23,500	None		Sabot fragment				
853	12 Oct 67	Pin (A)	0.120	23,500	None		Sabot fragment				
854	13 Oct 67	Pin (A)	0.185	23,500	None		Clean		Excellent dispersion		
855	13 Oct 67	None	--	23,500	Cu.	0.125			Separator test		
856	16 Oct 67	None	--	23,500	Cu.	0.125			Separator test		
857	16 Oct 67	Pin (C)	0.175	23,500	Cu.	0.125	Clean	N.V.	Excellent dispersion		
858	17 Oct 67	Pin (C)	0.185	23,500	Cu.	0.062	Proj. fragments	N.V.	Sphere may have struck pin		
859	17 Oct 67	Pin (C)	0.165	23,500	Cu.	0.062	Clean	N.V.	Excellent dispersion		

Table 1

Table 1. Summary of Stripper Firings (Sheet 1 of 2)

Firing Number	Date	Stripper Configuration	Interference inches	Muzzle Velocity ft/sec	Projectile Mat.	Projectile Dia. inch	Target Condition	Projectile Condition (X-ray)	REMARKS		
783	24 Aug 67	0.125 inch Steel Pin	0.020	N.R.	A1	0.25	Poor	N.V.	Velocity low		
786	25 Aug 67	"	0.020	20,500	A1	0.25	Clean	N.V.	Dispersion poor		
787	28 Aug 67	"	0.070	26,000	A1	0.25	Clean	N.V.	Dispersion fair		
788	29 Aug 67	"	0.070	23,300	A1	0.25	Clean	N.V.	Dispersion fair		
798	5 Sep 67	0.125 inch Tung. pin	0.020	24,000	A1	0.25	Clean	Good	Dispersion poor		
799	6 Sep 67	"	0.040	24,000	A1	0.25	Clean	N.V.	Dispersion fair		
801	6 Sep 67	"	0.060	N.R.	A1	0.25	Clean	N.V.	Dispersion good		
802	6 Sep 67	"	0.080	13,200	A1	0.25	Fairly Clean	N.V.	Low velocity		
803	8 Sep 67	"	0.080	23,000	A1	0.25	Clean	N.V.	Dispersion very good		
804	8 Sep 67	"	0.080	20,600	A1	0.25	Clean	Good	Dispersion good.		
812	14 Sep 67	"	0.080	23,000	A1	0.125	No Hit	Good	Dispersion fair		
815	15 Sep 67	"	0.080	23,000	A1	0.125	No Hit	N.V.	Dispersion fair		
813	15 Sep 67	"	0.080	22,700	A1	0.125	No Hit	N.V.	Dispersion fair		
814	15 Sep 67	"	0.080	23,000	A1	0.25	Clean	Apparent Good	Dispersion good. Check round.		
817	18 Sep 67	"	0.100	23,000	A1	0.125	No Hit	N.V.	Dispersion good.		
818	18 Sep 67	"	0.100	24,000	A1	0.062	Unacceptable	N.V.	Four sabot fragments on target.		
819	19 Sep 67	"	0.100	25,000	Ti.	0.125	Very poor	Good	Sabot fragments on target.		
820	19 Sep 67	"	0.100	24,000	Cu.	0.125	Possibly unacceptable	N.V.	Sabot fragments on target.		
821	19 Sep 67	"	0.100	24,000	Cu.	0.125	Unacceptable	Poss. struck trap	Trap moved close to muzzle.		
822	20 Sep 67	Pin (A)	0.120	24,000	Cu.	0.125	Fair	N.V.	Small sabot fragments on target		
823	20 Sep 67	Pin (A)	0.120	23,500	Ti.	0.125	Unacceptable	Poss. Damaged			

Table 1

Table 1. Summary of Stripper Firings (Sheet 2 of 2)

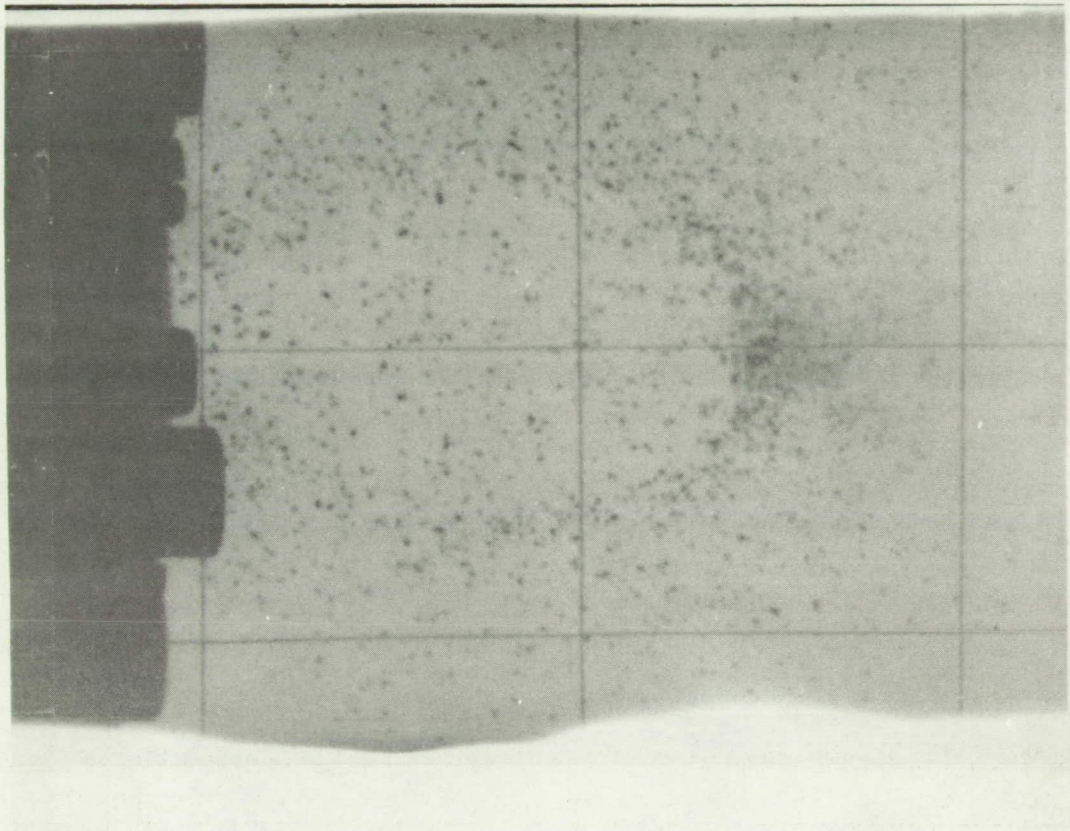

Figure 1
X-Ray Photograph for Firing 804

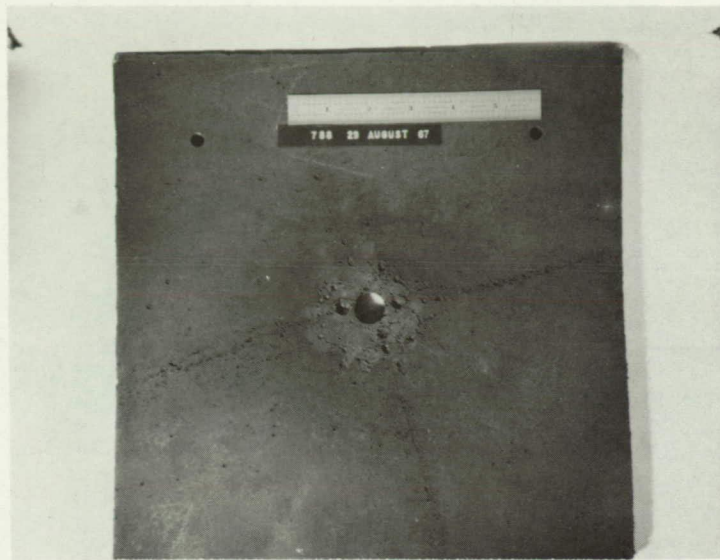

Figure 2
Sabot Trap and Target for Firing 788



Figure 3

Sabot Trap and Target for Firing 798

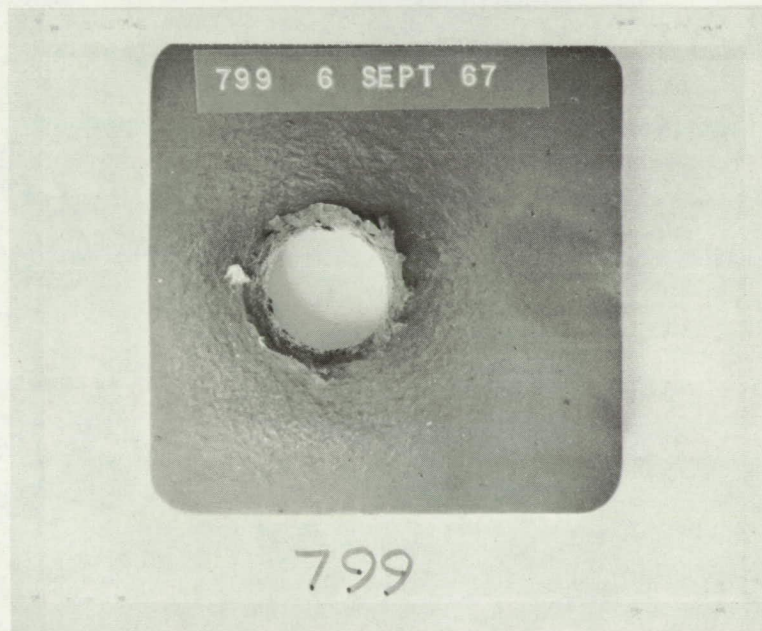
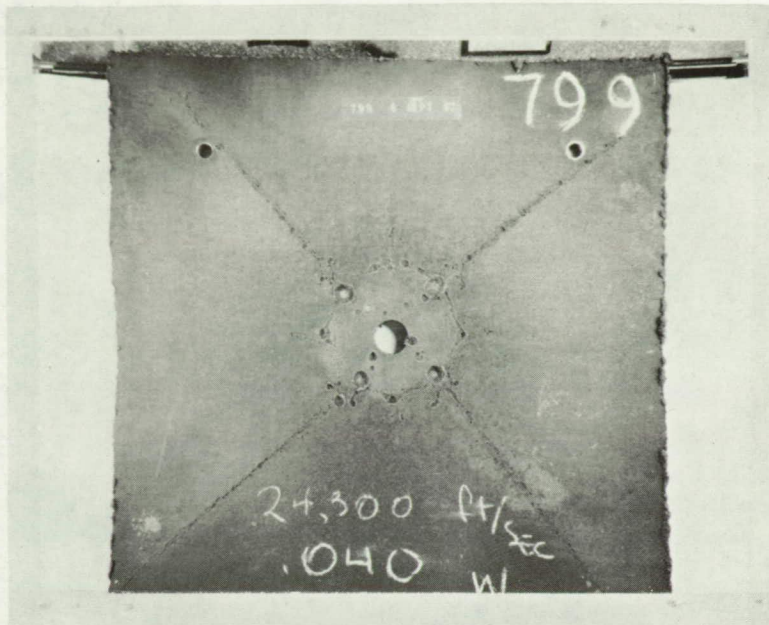

Figure 4

Sabot Trap and Target for Firing 799

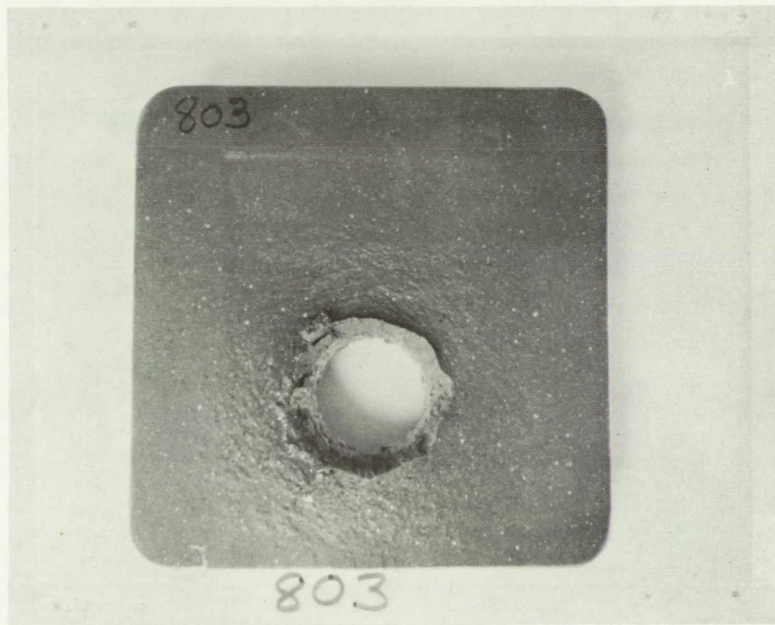
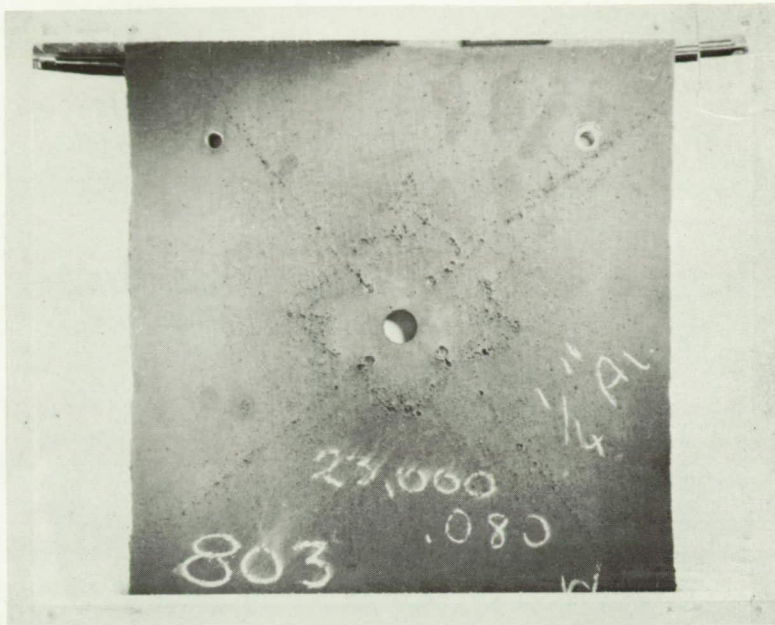

Figure 5

Sabot Trap and Target for Firing 803

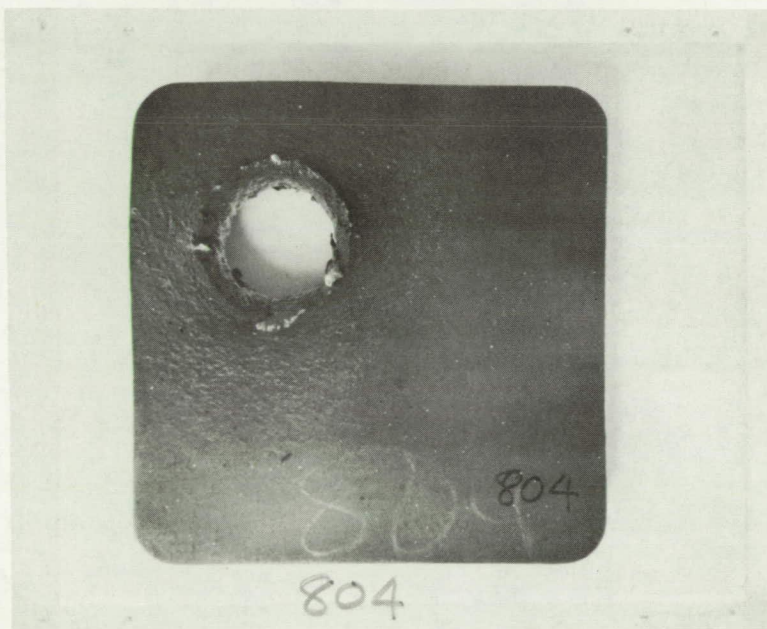
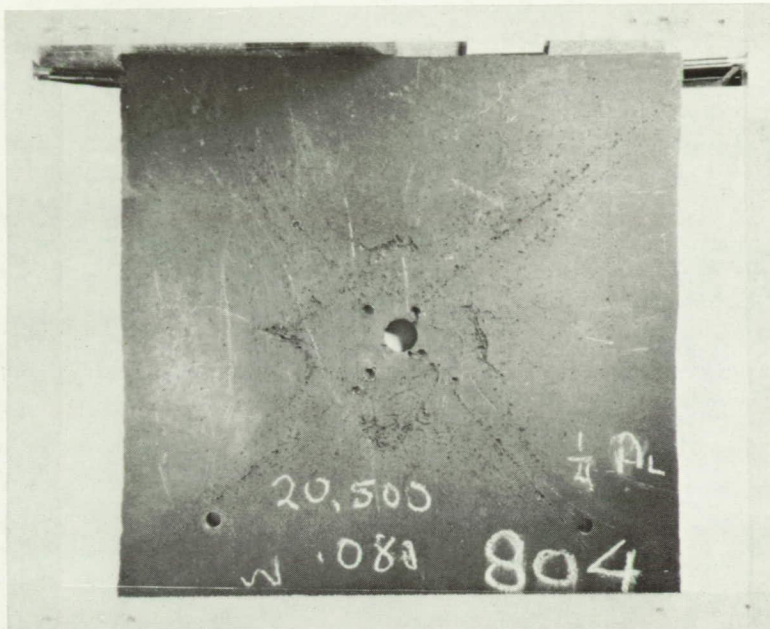
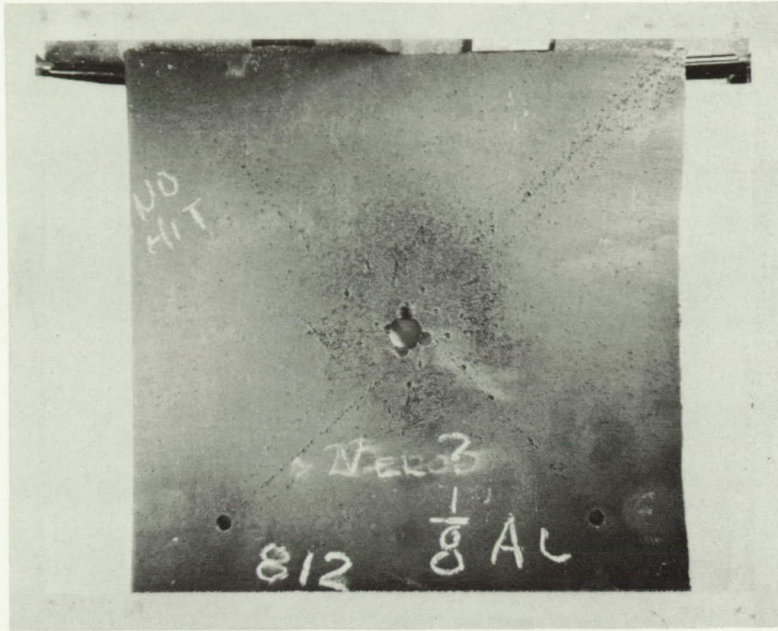

Figure 6

Sabot Trap and Target for Firing 804



No Hit on Target

Figure 7
Sabot Trap for Firing 812

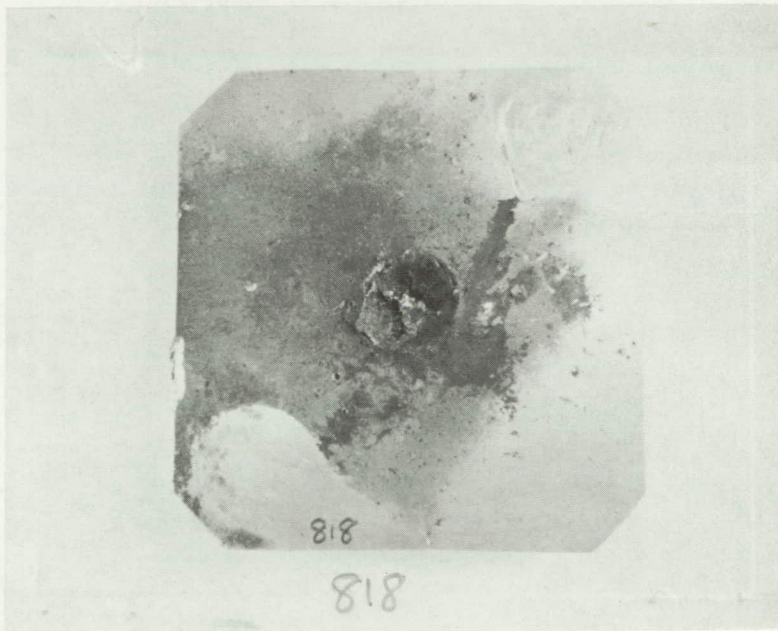

Figure 8

Sabot Trap and Target for Firing 818

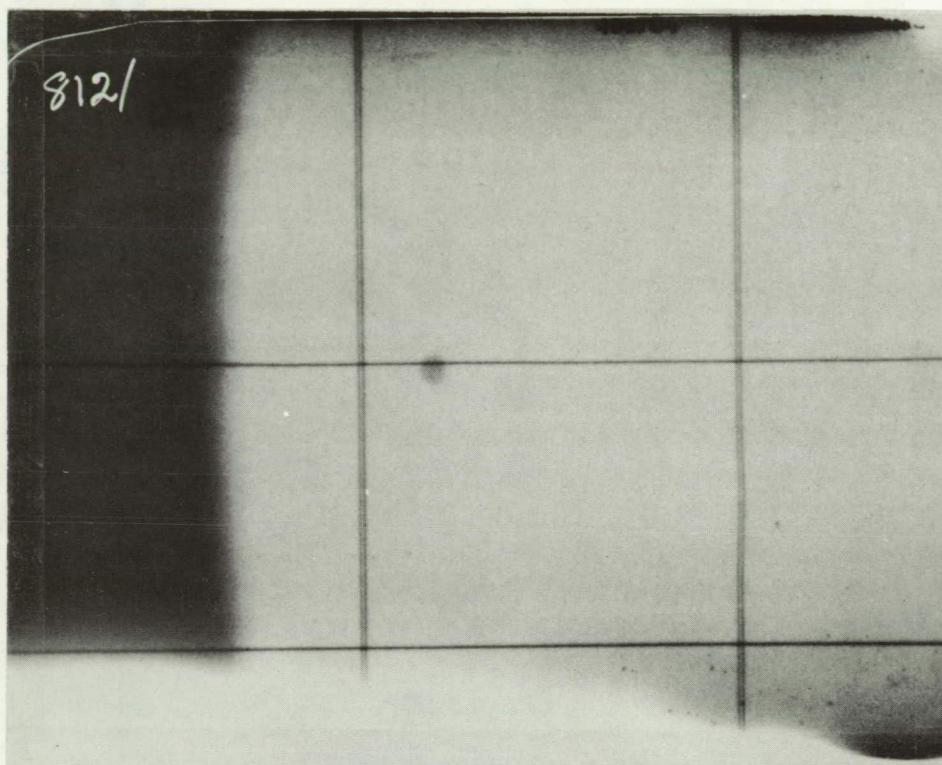

Figure 9

X-Ray Photograph for Firing 812

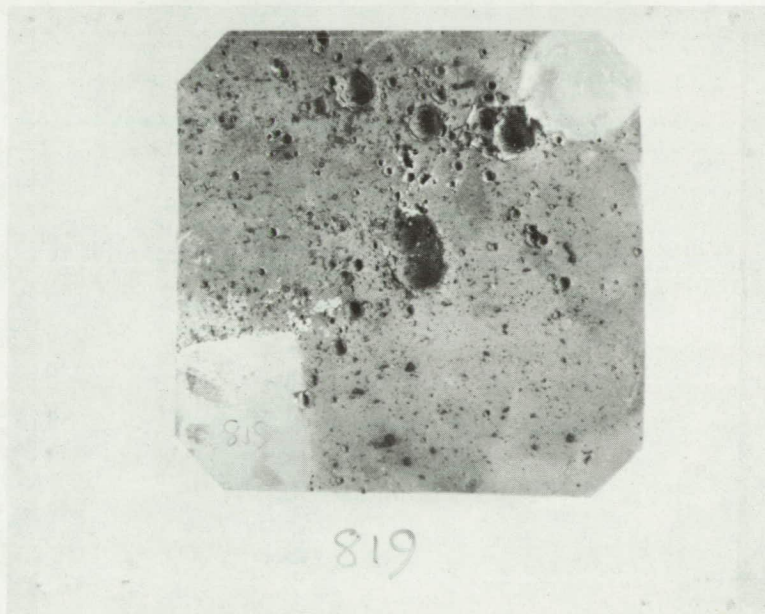
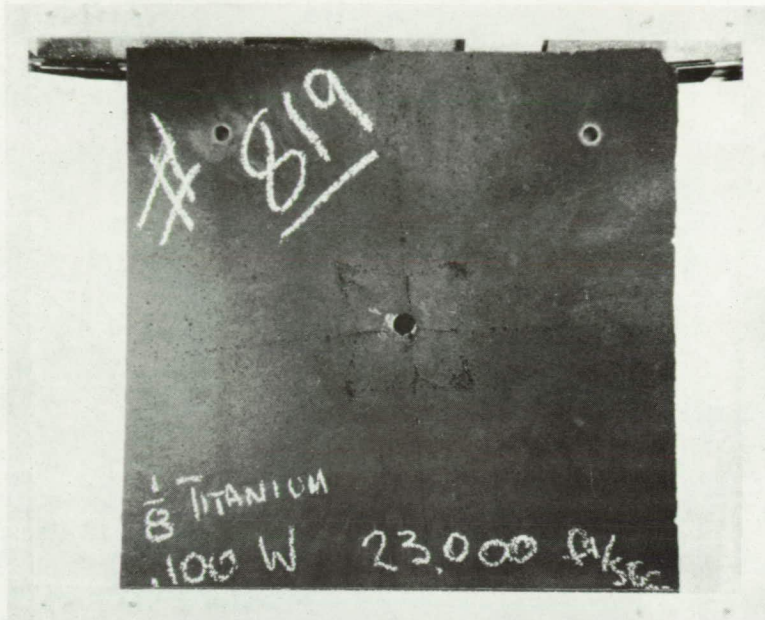

Figure 10

Sabot Trap and Target for Firing 819

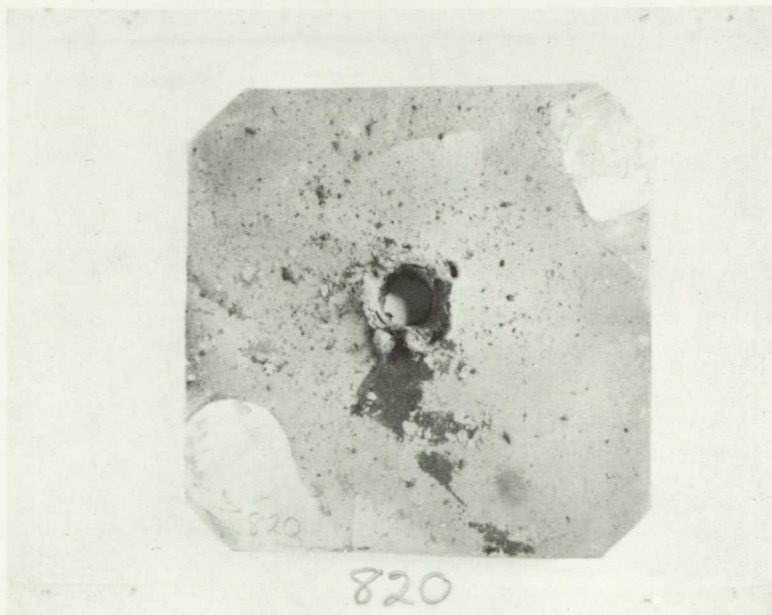
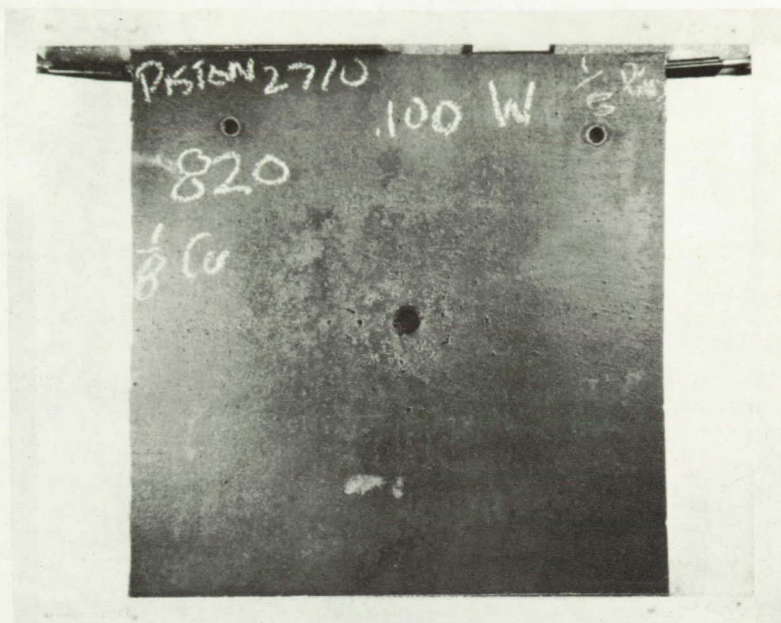

Figure 11

Sabot Trap and Target for Firing 820

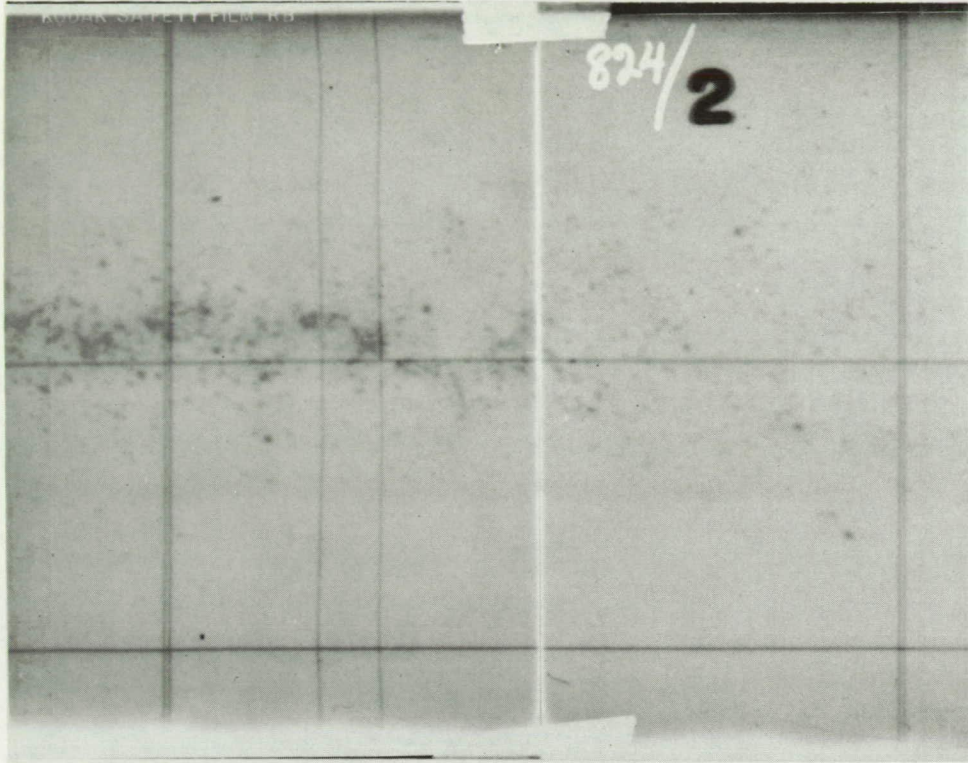

Figure 12
X-Ray Photograph for Firing 824

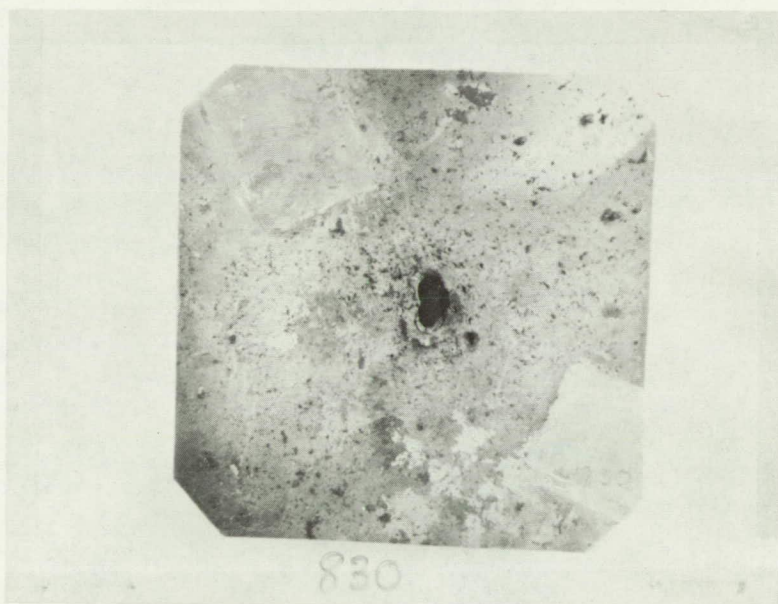

Figure 13

Sabot Trap and Target for Firing 830

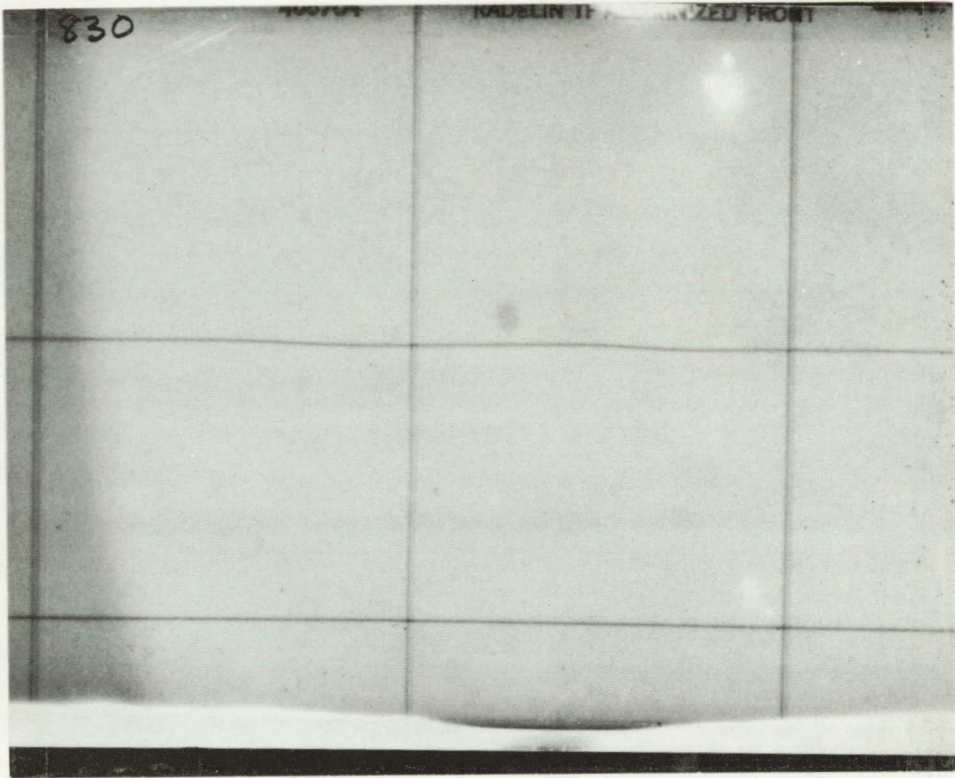

Figure 14

X-Ray Photograph for Firing 830

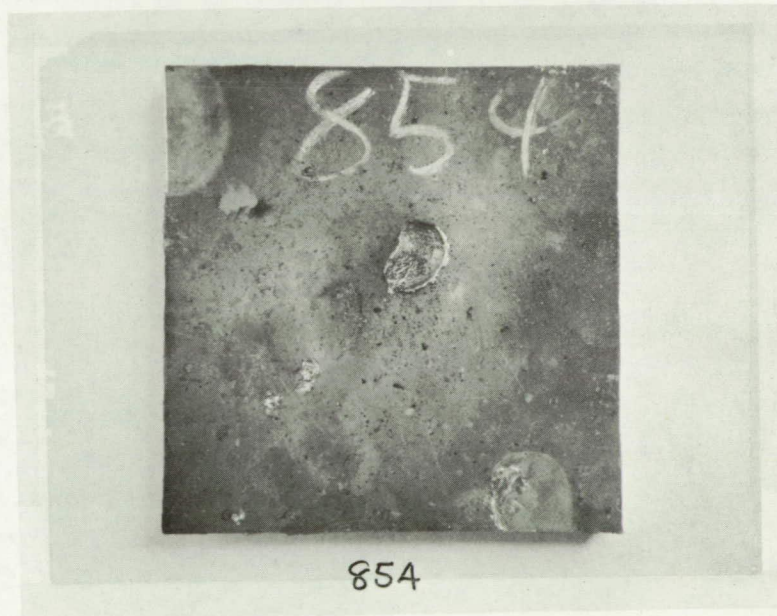
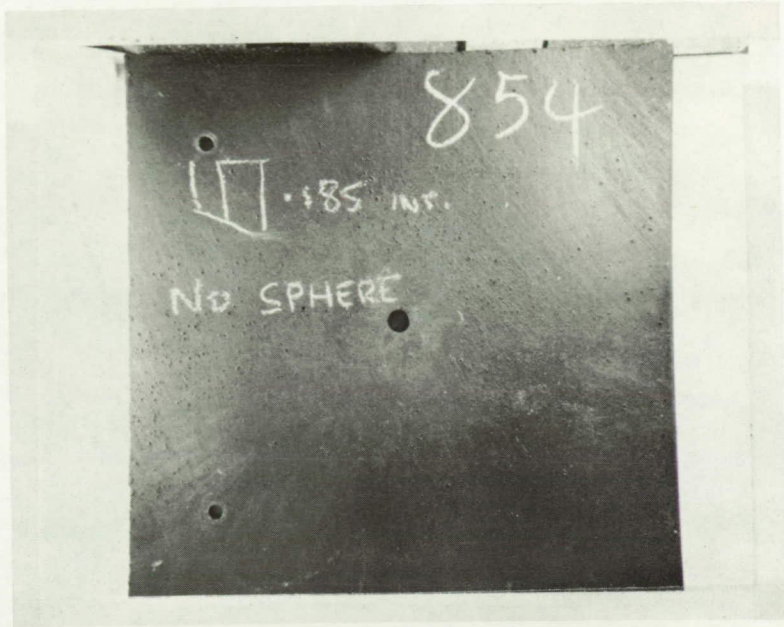

Figure 15

Sabot Trap and Target for Firing 854

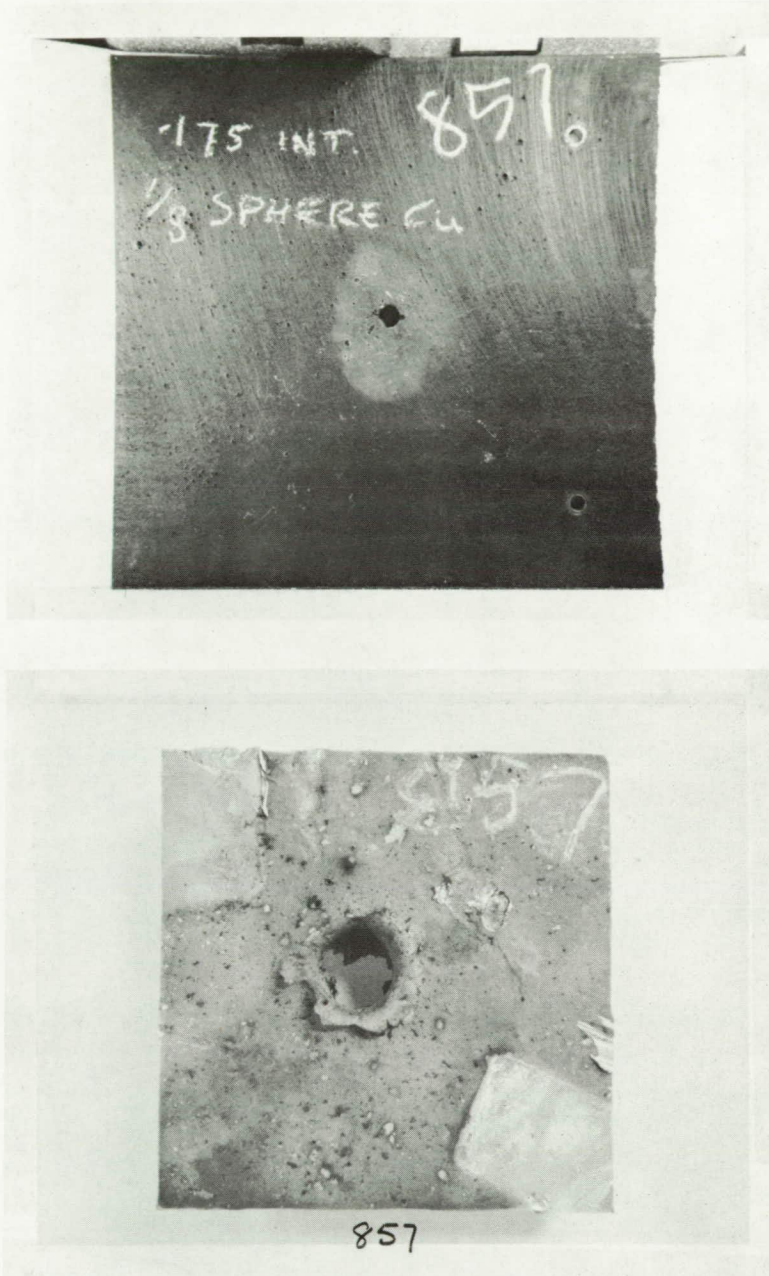

Figure 16

Sabot Trap and Target for Firing 857

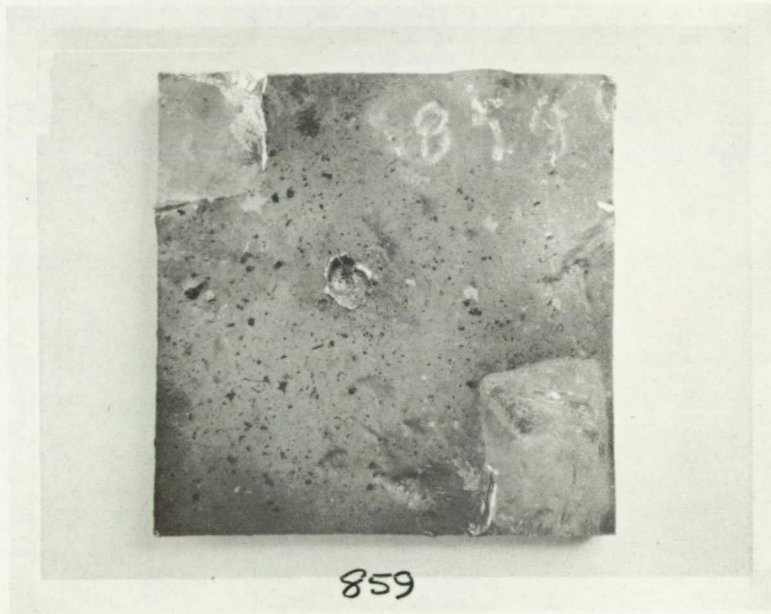
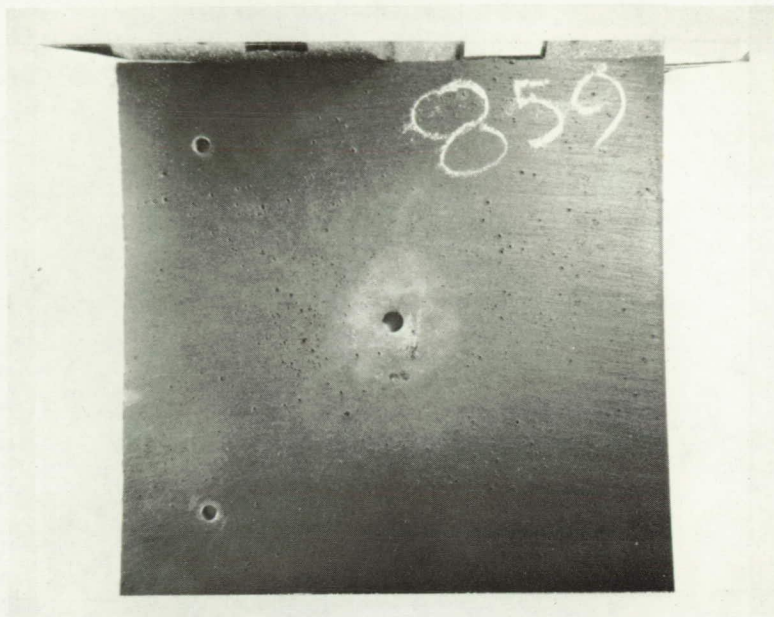

Figure 17

Sabot Trap and Target for Firing 859

© 1967 COMPUTING DEVICES OF CANADA LIMITED
OTTAWA CANADA

Printed and published in Canada by

Computing Devices
OF CANADA LIMITED