

168-13750

CASE FILE COPY

NASA TECHNICAL
MEMORANDUM

NASA TM X-58014
December 1967



POTENTIAL LUNAR LANDING AREAS

FOR EARLY APOLLO MISSIONS

By James H. Sasser and Andrew W. Patteson
Manned Spacecraft Center
Houston, Texas

NATIONAL AERONAUTICS AND SPACE ADMINISTRATION

ABSTRACT

One of the primary functions of the Lunar Orbiter Program was to provide high-resolution photographic coverage of potential Apollo landing sites. The photographs were screened by using Apollo lunar landing criteria to exclude rough areas and to select the smoothest sites for further study. On this basis, eight potential landing areas have been located and are undergoing detailed analysis.

POTENTIAL LUNAR LANDING AREAS FOR EARLY APOLLO MISSIONS

By James H. Sasser and Andrew W. Patteson
Manned Spacecraft Center

SUMMARY

The better potential lunar landing areas within the Apollo zone of interest were selected as Lunar Orbiter targets on the basis of telescopic photography and measurements. Photographs obtained from each Lunar Orbiter mission were considered in selecting target sites for subsequent missions.

All photographs obtained for Apollo-landing site analysis were screened by the techniques described in this paper, and those areas were located which best met the Apollo landing criteria.

The eight potential lunar landing areas presented in this report are the best known sites for the first Apollo lunar landing mission, when both lunar surface topography and Apollo operational constraints are considered. More detailed analysis will be required to describe these areas in terms of lunar-module interaction with the lunar surface.

INTRODUCTION

The process of selecting a lunar landing site is one of orderly elimination of areas under consideration. Some of the reasons for eliminating large areas of the moon are obvious. The far side of the moon, for example, can be eliminated from consideration because of the desire to maintain continuous communication with the crewmen on the lunar surface. The area under consideration has been narrowed to a rectangular area in the center of the visible side of the moon for reasons of an operational nature, such as the desire to maintain a free-return trajectory for early lunar missions, spacecraft performance, and the time available to track the descending or ascending lunar module (LM) from tracking stations located on earth. This area, the Apollo zone of interest, is bounded by the parallels of 5° north and south latitude and the meridians of 45° east and west longitude on the moon (fig. 1). These restrictions were determined without regard to the nature of the lunar surface.

The purpose of this paper is to present the current status of the lunar-landing-site selection program and to identify those areas still under consideration for the first Apollo lunar landing mission.

The work reported in this paper was performed by personnel and contractors of the Manned Spacecraft Center (MSC), who collaborated with personnel of the U. S. Geological Survey Branch of Astrogeology. The work was performed in the facilities of the NASA Langley Research Center Lunar Orbiter Project Office and in the MSC Mapping Sciences Laboratories.

Before Surveyor and Lunar Orbiter photography was available, studies of potential lunar landing areas were necessarily restricted to the use of Ranger imagery, telescopic photography, or visual telescopic observations. The results of these studies were considered in the selection of potential Surveyor landing areas or areas to be photographed on Lunar Orbiter missions. Since the primary objectives of the Surveyor Program and the Lunar Orbiter Program were to aid in selecting Apollo lunar landing sites, both programs have concentrated on obtaining a maximum amount of information about specific locations within the Apollo zone of interest which appeared (from earth) to be suitable Apollo landing areas. The entire set of potential Surveyor landing sites and Lunar Orbiter photographic targets within the Apollo zone of interest comprised a set of potential Apollo landing areas (usually referred to as set A) from which the elimination process could continue.

By mid-1966, the potential Surveyor landing areas and Lunar Orbiter photographic targets had been chosen, so set A of potential Apollo landing areas was identified. It was apparent that limitations of personnel, resources, and schedules would not allow comprehensive analysis of the entire set of approximately 40 areas. Plans were made to select, on the basis of a rapid analysis of Surveyor and Orbiter results, a subset (usually referred to as set B) of about 10 of the more suitable lunar landing areas for more extensive analysis. This paper identifies those potential lunar landing areas for the first Apollo lunar landing mission that comprise set B.

DISCUSSION

Lunar Orbiter Program

In August 1966, Lunar Orbiter I took the first pictures of the moon from lunar orbit. Although more than 200 medium-resolution (MR) pictures were transmitted to earth, the complete success of the mission, the first in the series, was marred by an unfortunate malfunction in the high-resolution (HR) camera. Lunar Orbiter II, launched in November 1966, obtained both MR and HR pictures of the lunar surface. Lunar Orbiter III was launched in February 1967, but again a malfunction occurred, so that final readout of the photography was not completed, and coverage of only the western portion of the moon was obtained. Lunar Orbiter V, launched in August 1967, was used to photograph special areas which had been photographed previously.

Each mission was part of a planned lunar-exploration program designed to photograph the most desirable portions of the lunar surface for potential Apollo landing areas. The areas shown in figure 2 are those areas in the Apollo zone of interest of which photographic coverage was obtained on the first three Lunar Orbiter missions.

Photographic Coverage

The types of photographic coverage obtained over the prime sites are wide-angle or MR vertical photography, narrow-angle or HR vertical photography, MR and HR convergent photography, and MR and HR oblique photography. Table I is a matrix showing the uses of each type of photography. Figure 3 shows eight potential sites which were selected through the screening process and also the type of coverage obtained over each site. Vertical and oblique photographs of these sites are shown later.

Screening

The present lack of detailed knowledge of lunar-surface engineering properties and the lack of experience in landing manned spacecraft on the moon makes it desirable, at least for the first few manned lunar landings, to select as landing sites those areas that are less demanding of the spacecraft and the crew. As knowledge of the lunar surface increases and experience is gained in spacecraft performance, the criteria for selecting landing sites will change. Screening is only the first step in a series of analyses needed to select lunar landing sites. Potential landing areas located through screening will be subjected to more detailed analysis at a later date. The steps in Lunar Orbiter screening are explained briefly in the following paragraphs.

Construction of templates. - Photographic support data were used to determine the photographic scale for constructing LM landing-ellipse templates (fig. 4) and radar-approach templates (fig. 5).

Delineation of gross reject areas. - Gross reject areas are rough areas which are obviously unsuitable for LM landings. Examples are areas with steep slopes, many craters, large craters, high escarpments, hills, and blocks. These areas were located and outlined on MR photographs. Figure 6 shows a typical site with only the location grid imposed. The same site is shown in figure 7 after the gross reject area has been outlined.

Scanning MR photographs for ellipse areas. - The MR photographs are scanned by use of an ellipse template at the scale of the photographs. The ellipse is moved over the photographs with the major axis oriented in an east-west direction. Areas with the least amount of reject area but large enough to contain an ellipse are delineated (fig. 8). Only those ellipses within the area of HR photographic coverage were considered for landing evaluation. Ellipses outside this area were used for mission-planning purposes.

Selection of better ellipse locations with favorable radar approaches. - The ellipses with the most favorable radar approach were noted. Radar templates at the scale of the photographs were placed on the ellipses so that the maximum and minimum approach angle for the entire year could be marked (fig. 9).

Selection and evaluation of best ellipses on MR photographs. - An evaluation was performed on the MR photographs so that the ellipses within a site could be compared and the best one transferred to an HR photograph for further evaluation. In the evaluation of the MR photographs, all craters identifiable in the ellipse were considered to

be hazards to the LM. These areas and all other reject areas were measured. Ellipse evaluation was performed by the following formula.

$$N = \frac{0.5X}{A} + \frac{0.4Y}{B} + \frac{0.1Z}{C}$$

where N = probability of the LM not encountering any feature identified as a hazard on the photograph

X = total area minus reject area in the 50-percent ellipse

Y = total area minus reject area in the 90- to 50-percent ellipse

Z = total area minus reject area in the 99.78- to 90-percent ellipse

A = total area in the 50-percent ellipse

B = total area in the 90- to 50-percent ellipse

C = total area in the 99.78- to 90-percent ellipse.

Evaluation of ellipses on HR photographs. - After the ellipses were evaluated on the MR photographs, the highest priority ellipse from each of the best sites was transferred to the HR photographs and was reevaluated for comparison between sites. Craters with diameters as small as 10 meters were counted, and the area of each crater was calculated. It was found that craters of this size could be identified readily on the photographs. The same formula and calculations previously employed with the MR data were used with the HR data, and an HR N number was obtained.

RESULTS

Screening of the prime photographs shown in figure 2 has resulted in the eight potential landing areas shown in figure 10. The results of the evaluation of these eight sites are shown as a landing-site matrix in table II.

Photographs of the eight prime sites are shown in figures 11 to 34. Each site is depicted on an MR photograph, on an HR photograph, and on an oblique photograph. The MR photograph has the prime ellipse marked with an arrow. The HR photograph shows only the prime ellipse. The oblique photograph shows a view of the ellipse from the east, from an altitude of about 46 km above the moon.

CONCLUSIONS

Consideration of the preferred lighting conditions during the lunar landing and the desire to afford multiple launch opportunities during any month make it very desirable to select three or four candidate lunar landing sites for each lunar landing mission. These candidate lunar landing sites for the first lunar landing mission will be selected after a detailed analysis of the operational suitability and also of the lunar-surface properties of the sites presented herein.

Additional sites will be chosen for later lunar landing missions. The sites identified here can be considered to be a "reservoir" from which sites can be selected. This reservoir will be replenished with other sites as operational considerations or mission objectives are changed.

Manned Spacecraft Center
National Aeronautics and Space Administration
Houston, Texas, December 12, 1967
914-50-10-06-72

TABLE I. - TYPES OF PHOTOGRAPHY DESIRED AND THE USE OF EACH TYPE

Type		Use						
		Screening	Regional slope	Intermediate regional slope	LM landing ability	Local control and landmarks	Large-scale maps for traverses	Astronaut training
Vertical	MR	X	X			X		
	HR	X			X		X	
Convergent	MR		X					
	HR			X				
Oblique	MR					X		X
	HR					X		X

TABLE II. - LANDING-SITE MATRIX

Site	Ellipse location		MR N	HR N
	Latitude	Longitude		
II P-2	2° 40' N	34° 00' E	0.944	0.904
II P-6	0° 45' N	23° 37' E	.947	.907
II P-8	0° 25' N	1° 20' W	.923	.822
II P-11	0° 25' N	19° 55' W	.955	.851
III P-9	3° 07' S	23° 25' W	.900	.791
III P-11	3° 30' S	36° 25' W	.908	.865
II P-13	1° 40' N	41° 40' W	.920	.836
III P-12	2° 09' S	44° 23' W	.838	.719

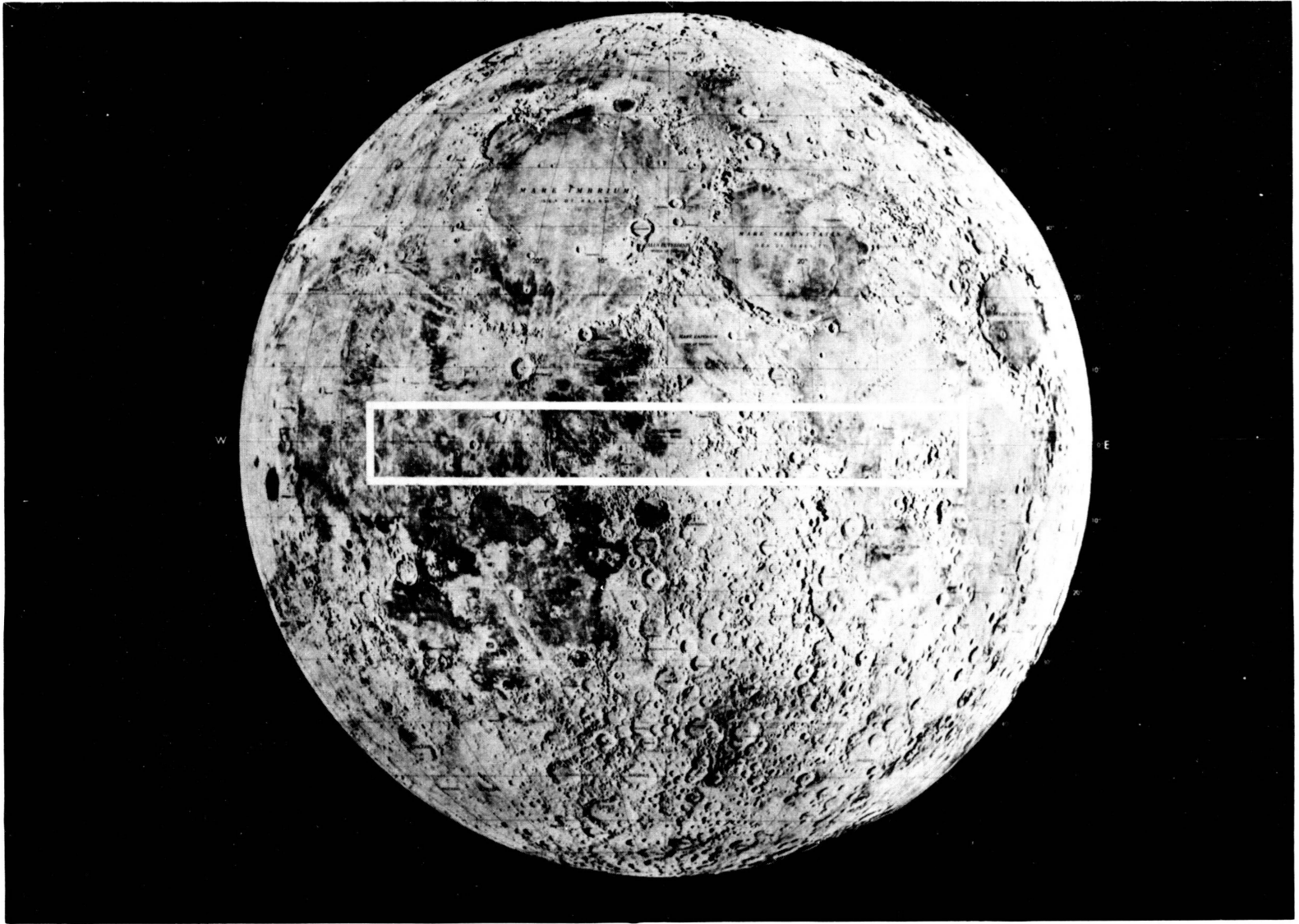
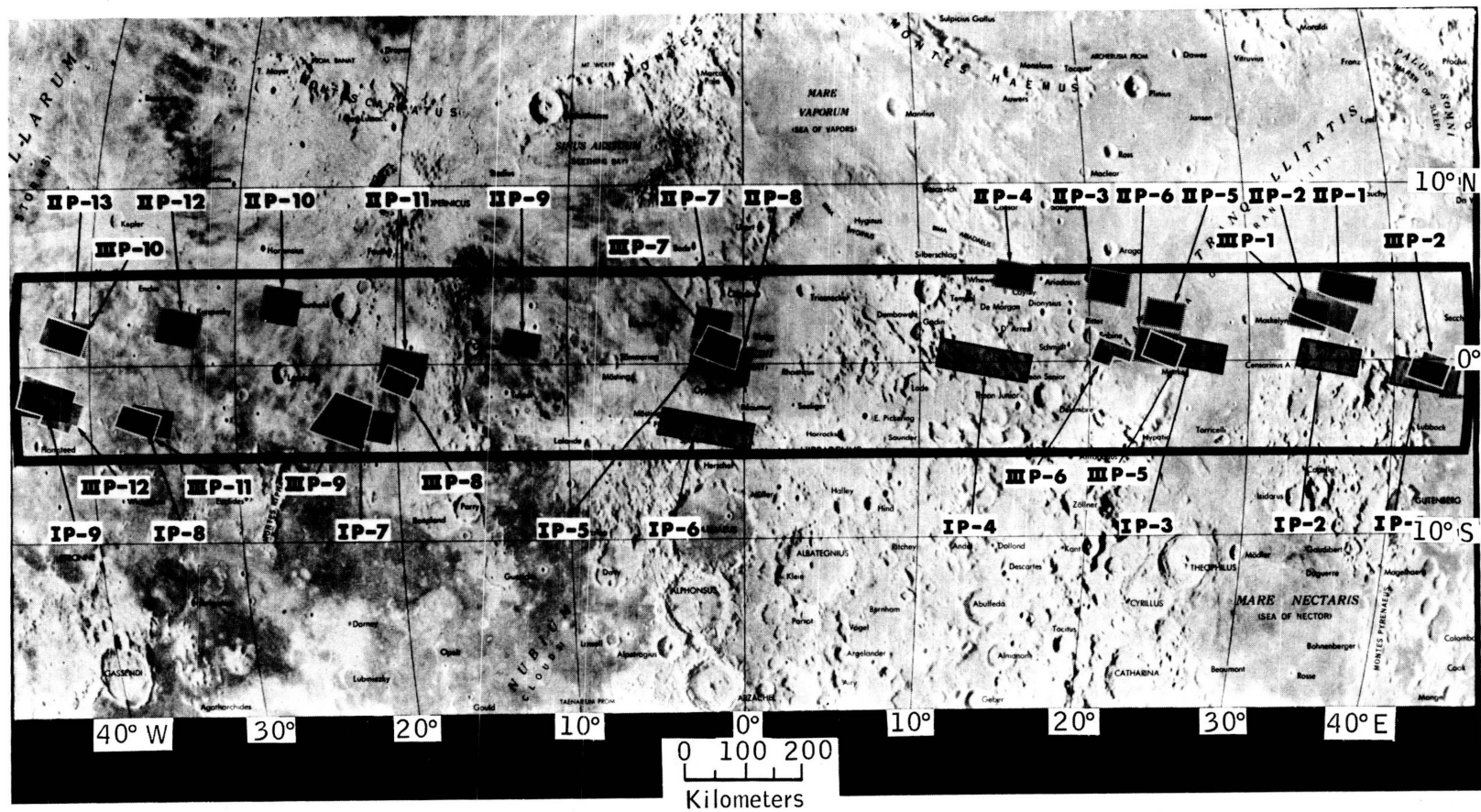

Figure 1. - Lunar mosaic showing Apollo landing area.



□ Actual Mission I
photographic coverage

■ Actual Mission II
photographic coverage

□ Actual Mission III
photographic coverage

Figure 2. - Lunar Orbiter Sites, Missions I, II, and III.

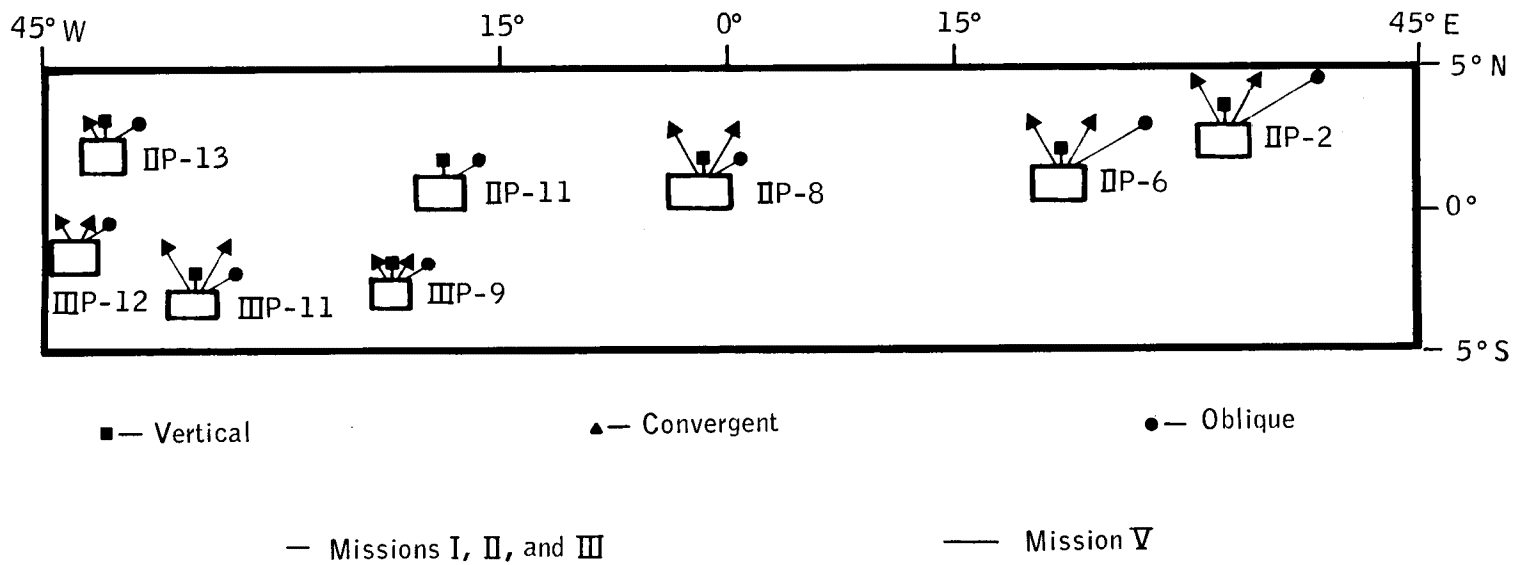
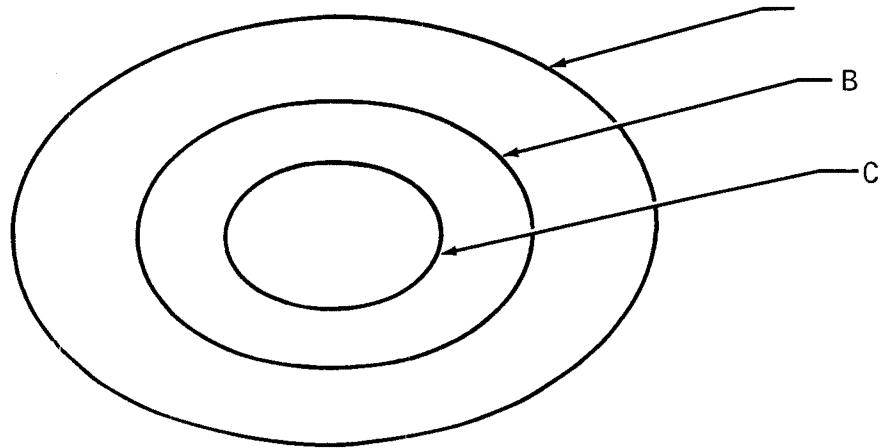

Figure 3. - Photographic coverage of prime sites.



Key

- A An ellipse with a landing probability of 99.78 percent dimension - 7.9 km by 5.3 km
- B An ellipse with a landing probability of 90 percent dimension - 4.88 km by 3.24 km
- C An ellipse with a landing probability of 50 percent dimension - 2.66 km by 1.78 km

Figure 4. - LM landing ellipse template.

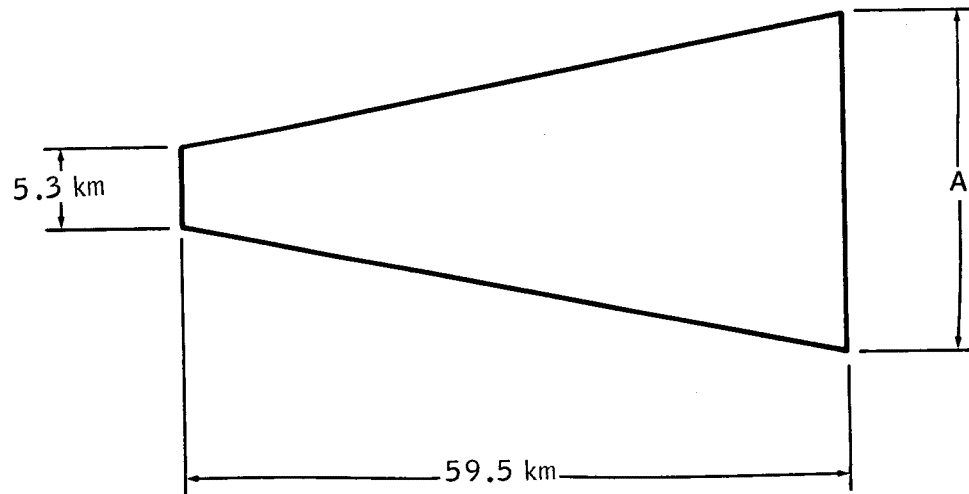

Key

- A The boundary outlining the radar coverage of approach trajectory for the entire year

Figure 5. - Radar approach template.

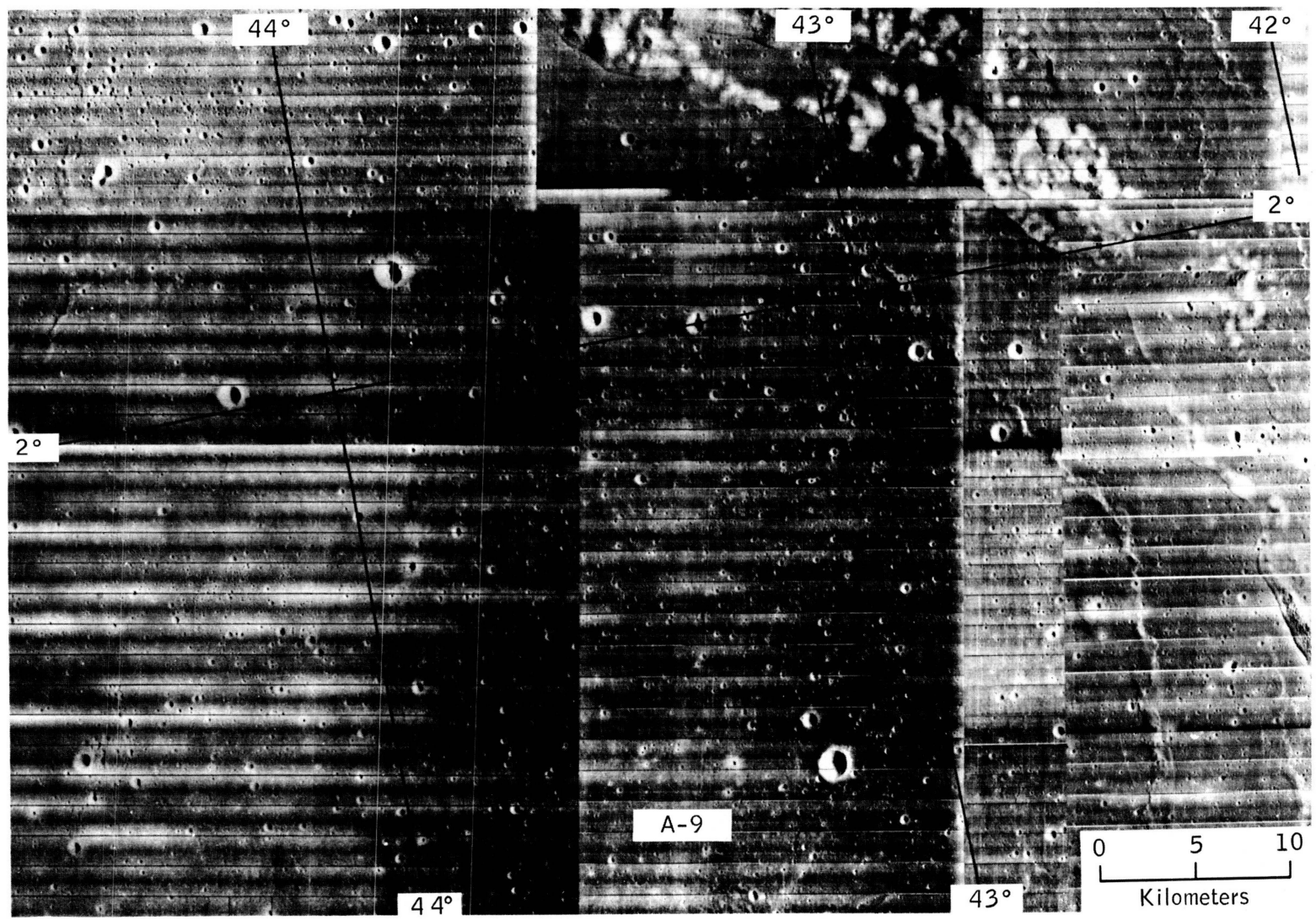

Figure 6. - Lunar Orbiter site mosaic.

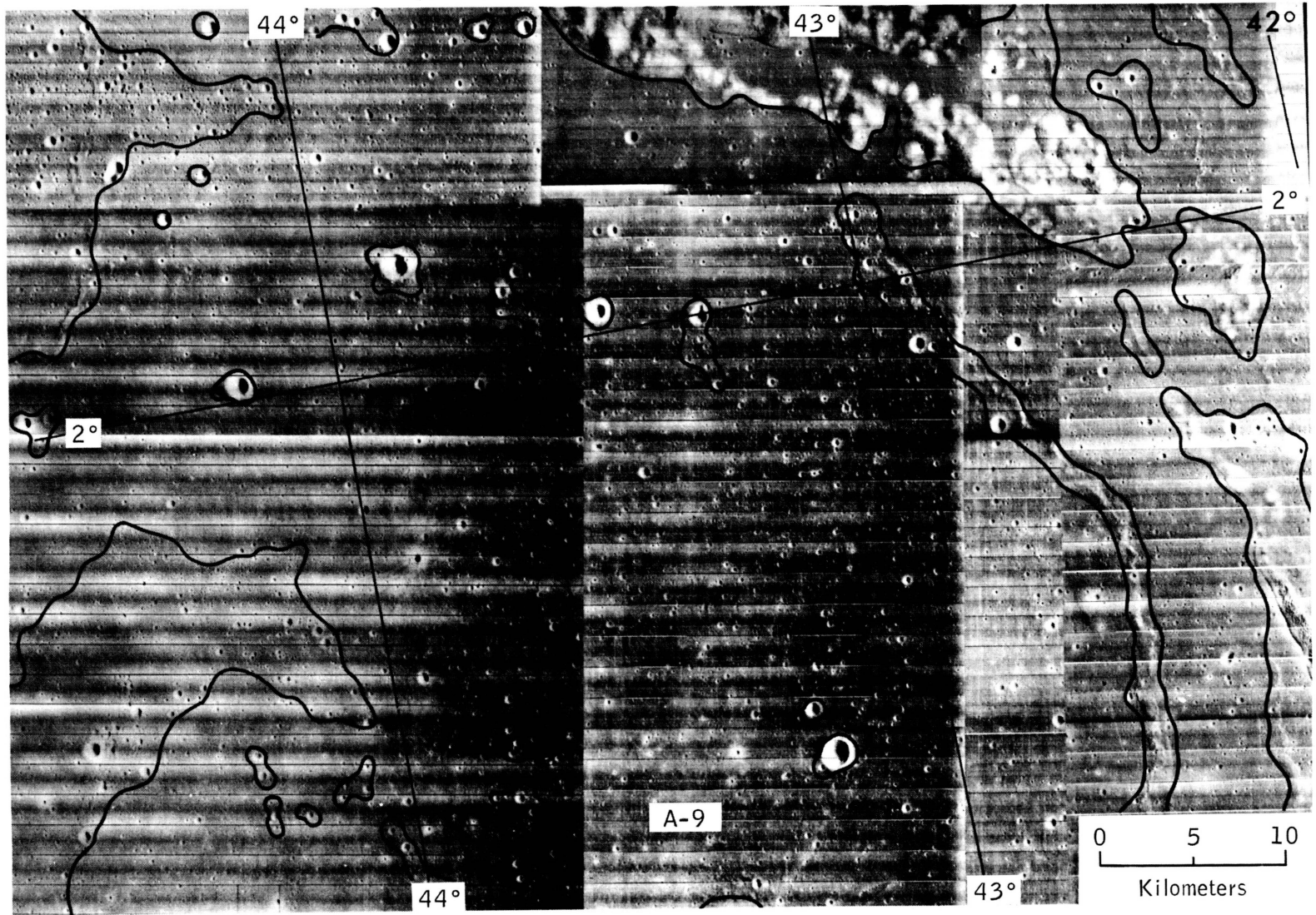

Figure 7. - Rejected areas.

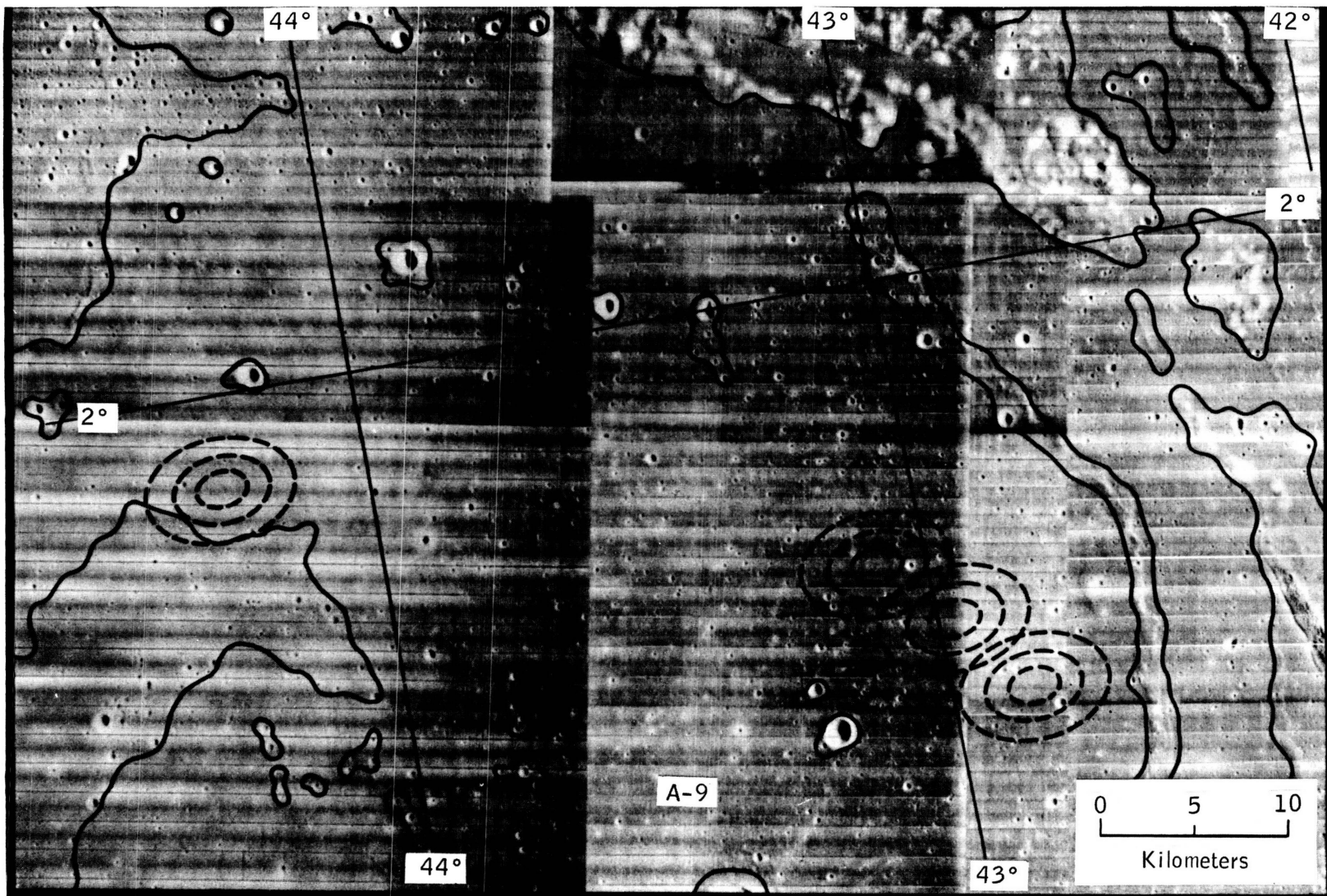

Figure 8. - Ellipses delineated.

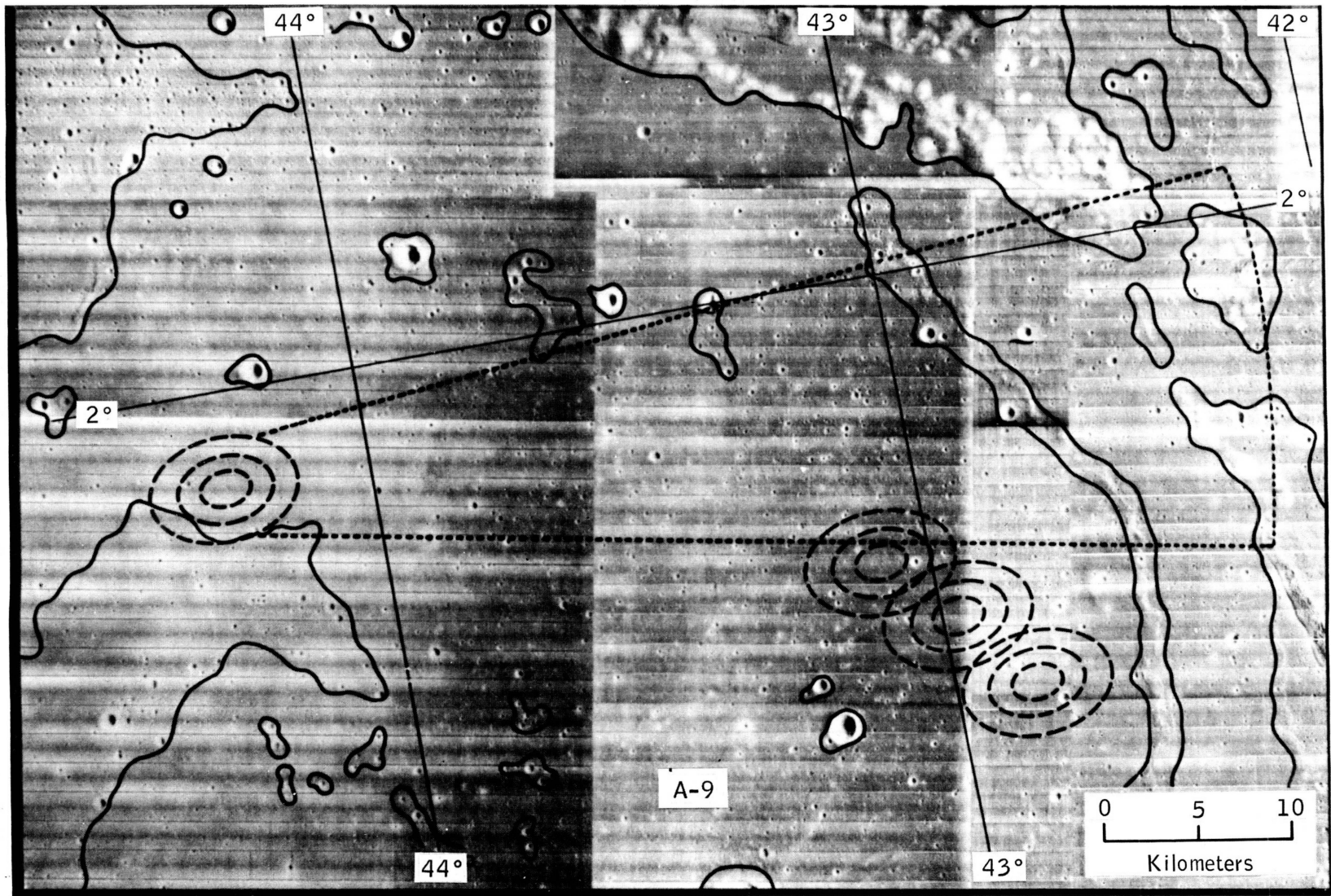

Figure 9. - Radar approach path.

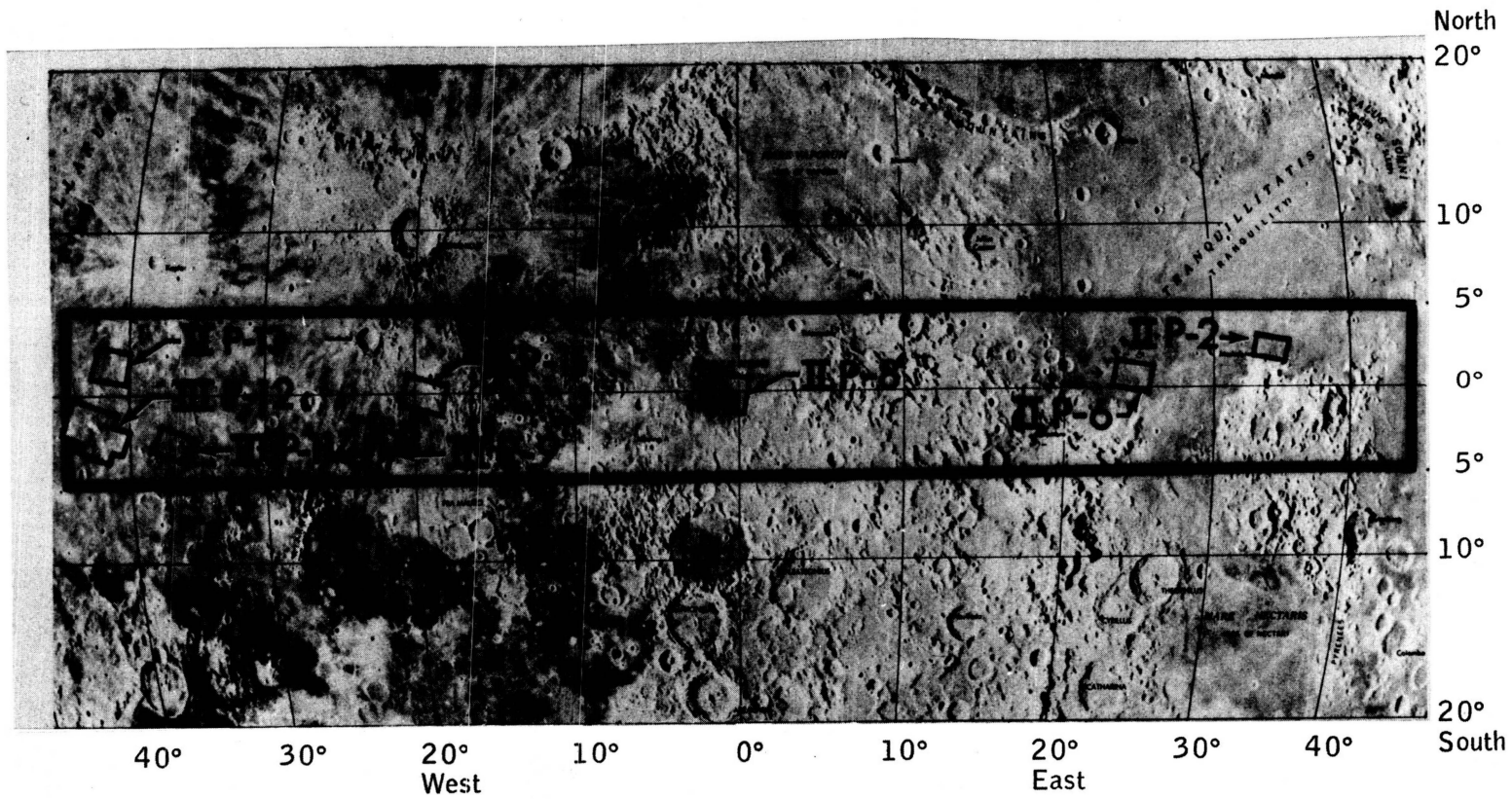
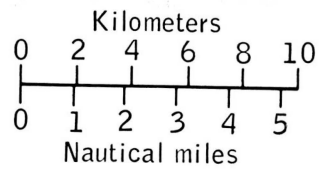
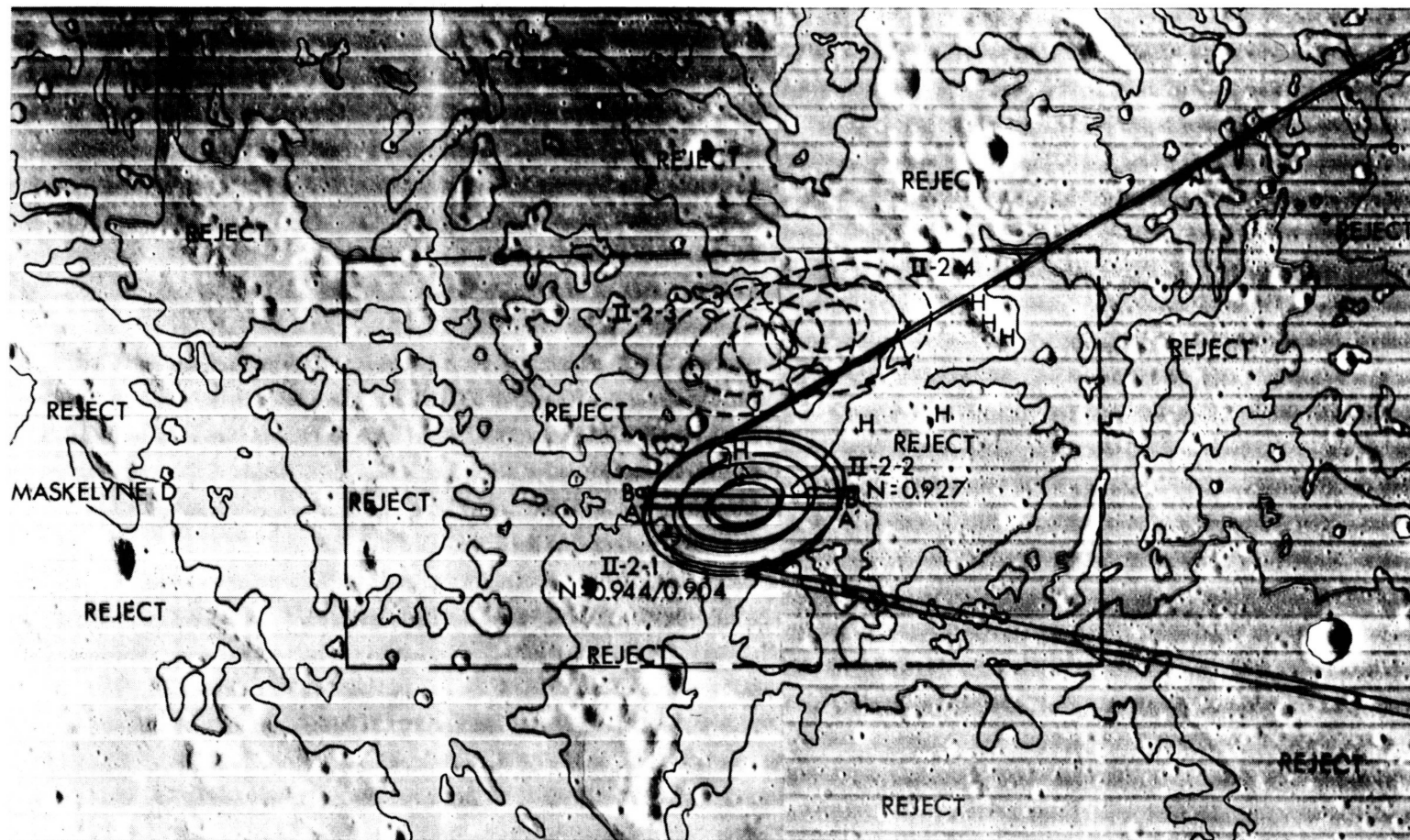

Figure 10. - Set B, Mission I Apollo zone of interest.



Average sun elevation = 23.3°

Figure 11. - Site II P-2, medium resolution.

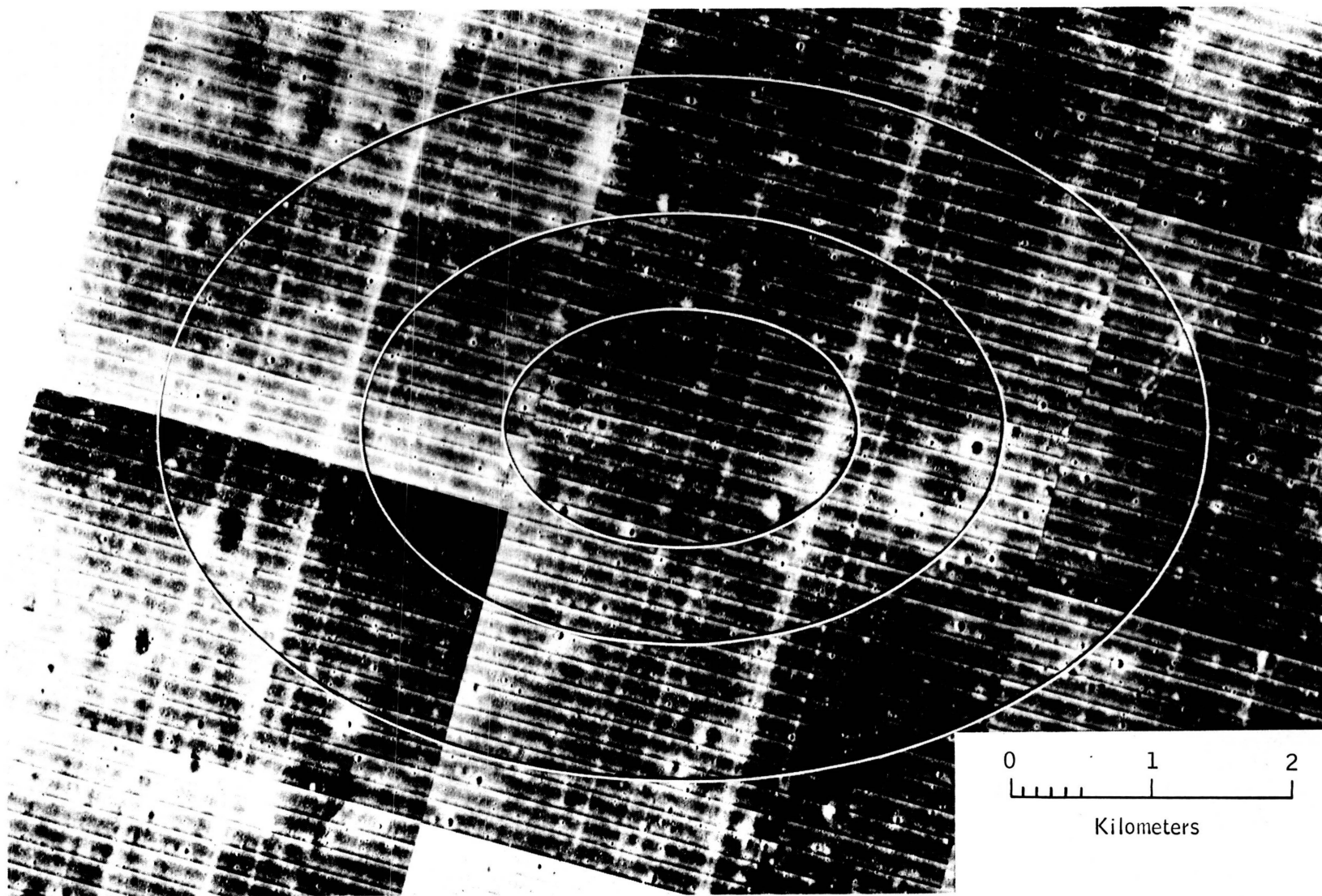

Figure 12. - Site II P-2, high resolution.

Keyed to Lunar Orbiter V,
frame MR 052.

Slant range spacecraft to
ellipse is 206 km.

Grid from uncontrolled
mosaic is approximate.

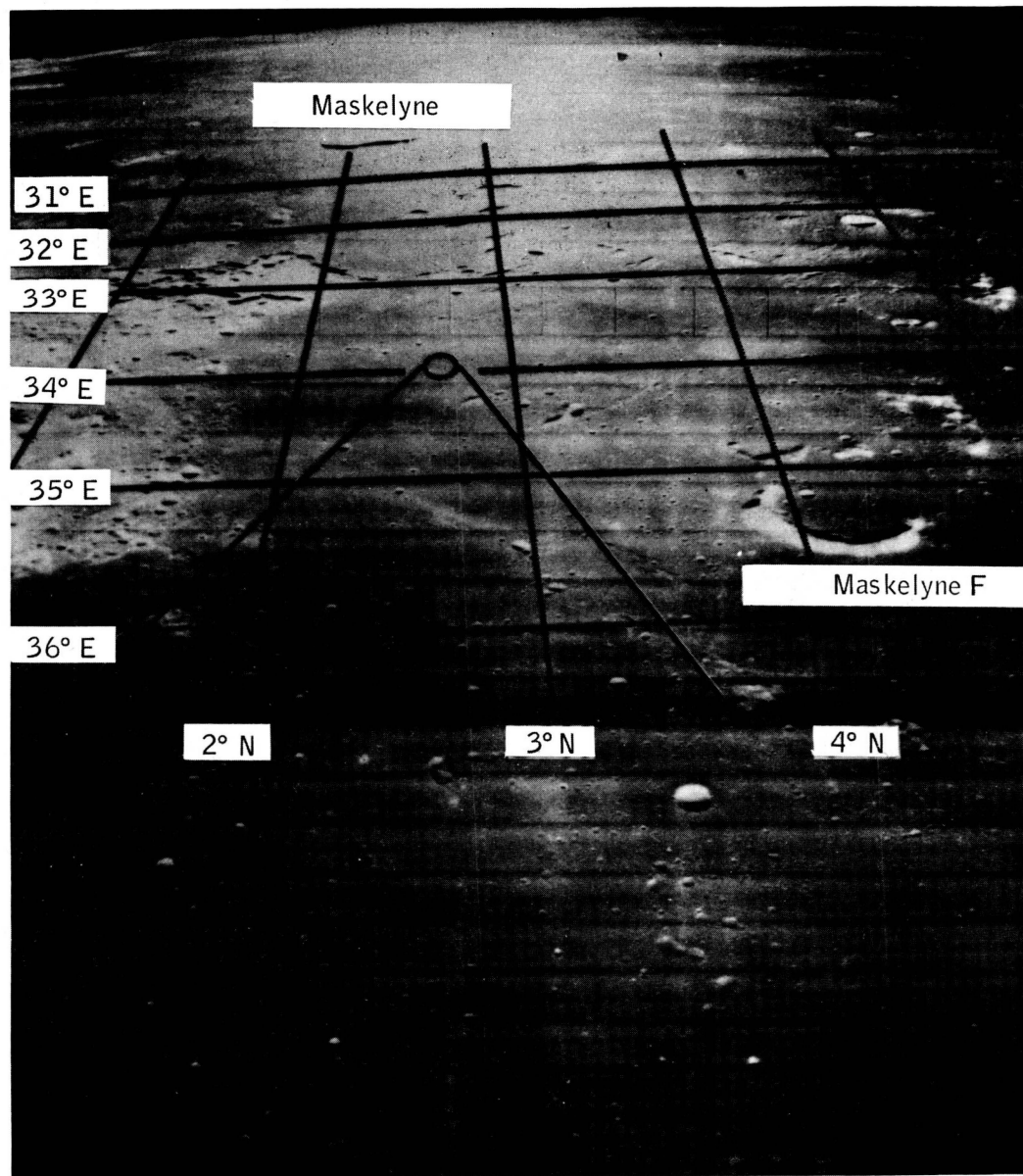
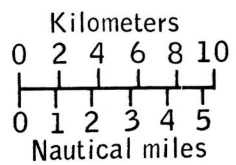
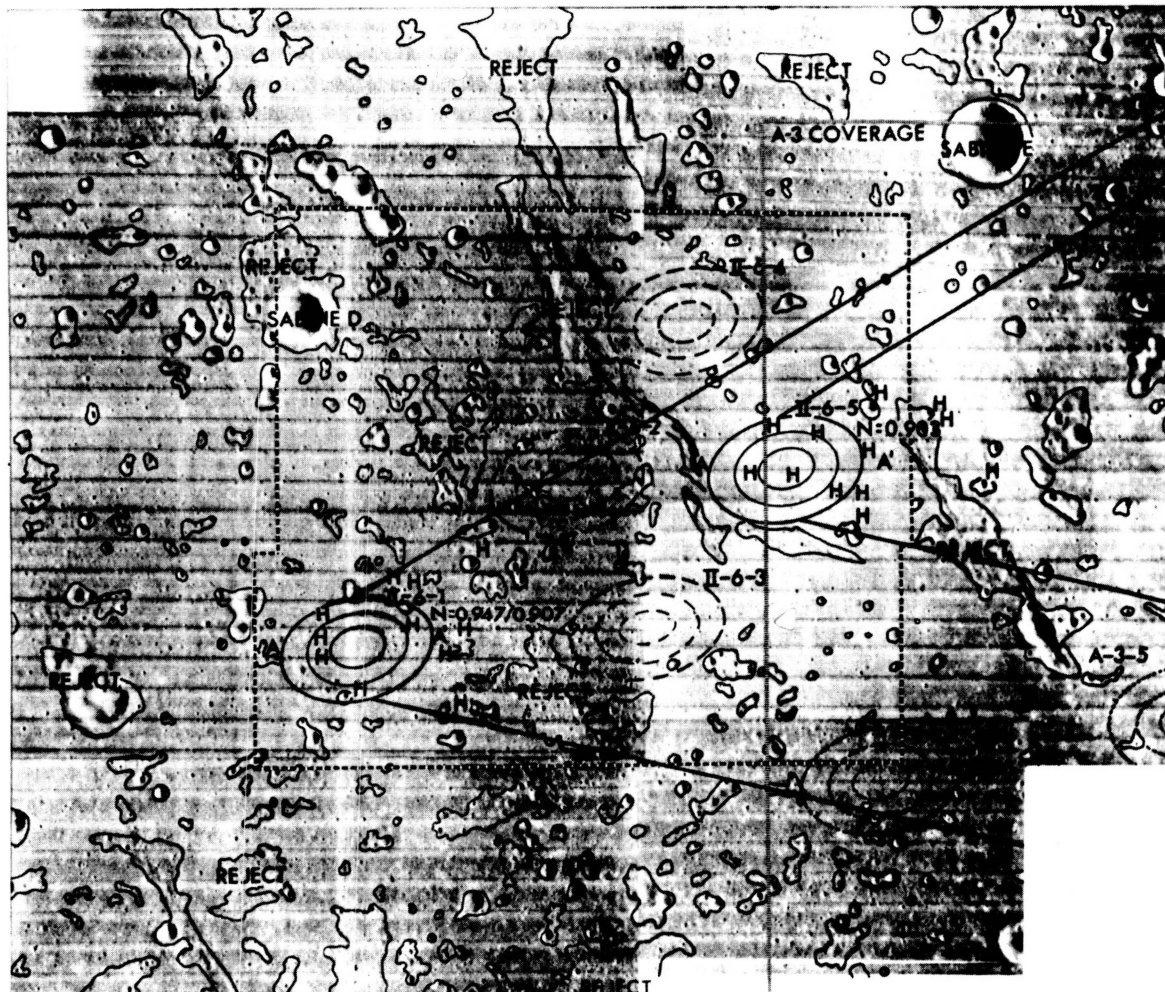

Figure 13. - Site II P-2, oblique.



Average sun elevation = 29.4°

Figure 14. - Site II P-6, medium resolution.

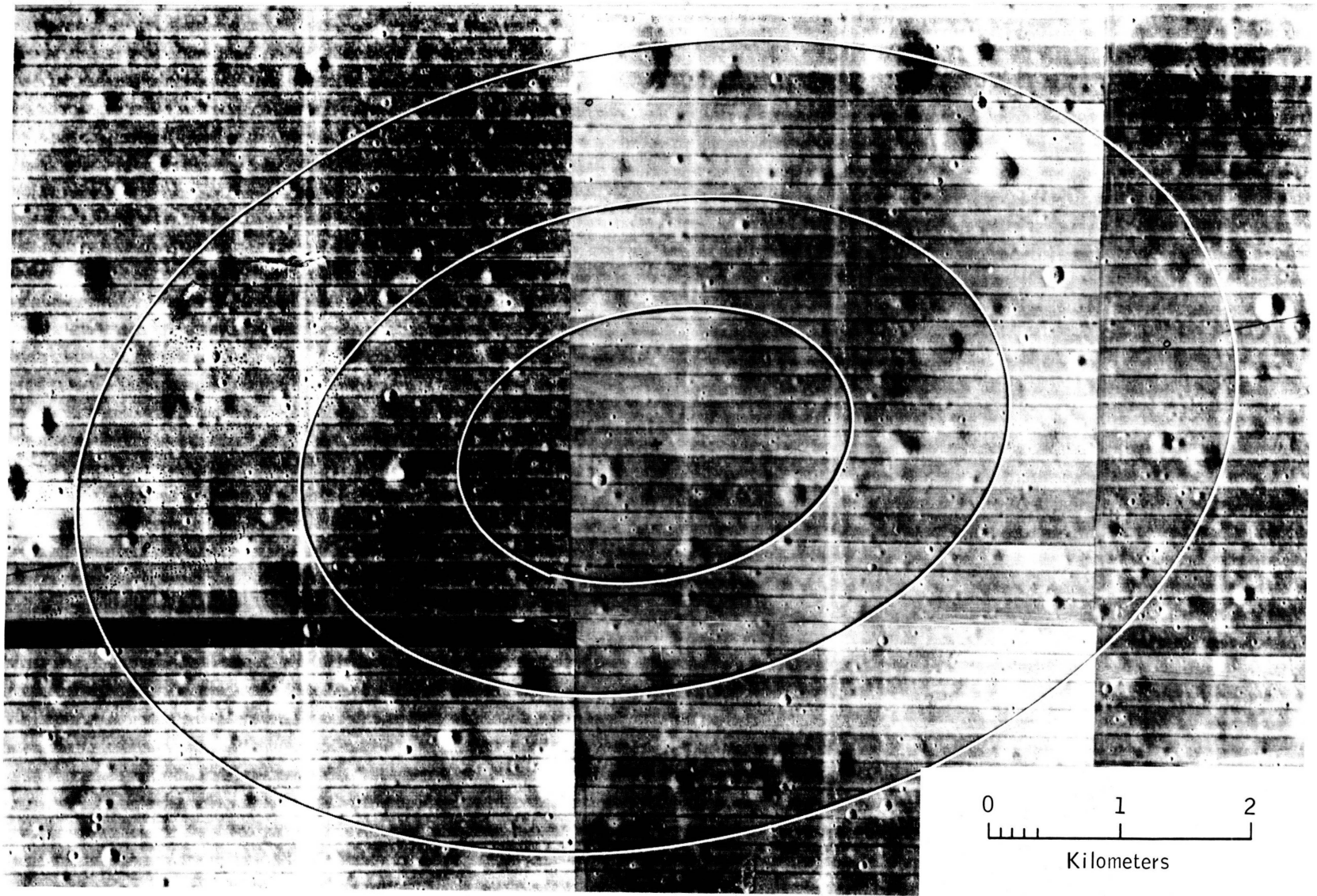

Figure 15. - Site II P-6, high resolution.

Keyed to Lunar Orbiter V,
frame MR 064.

Slant range spacecraft to
ellipse is 196 km.

Grid from uncontrolled mosaic
is approximate.

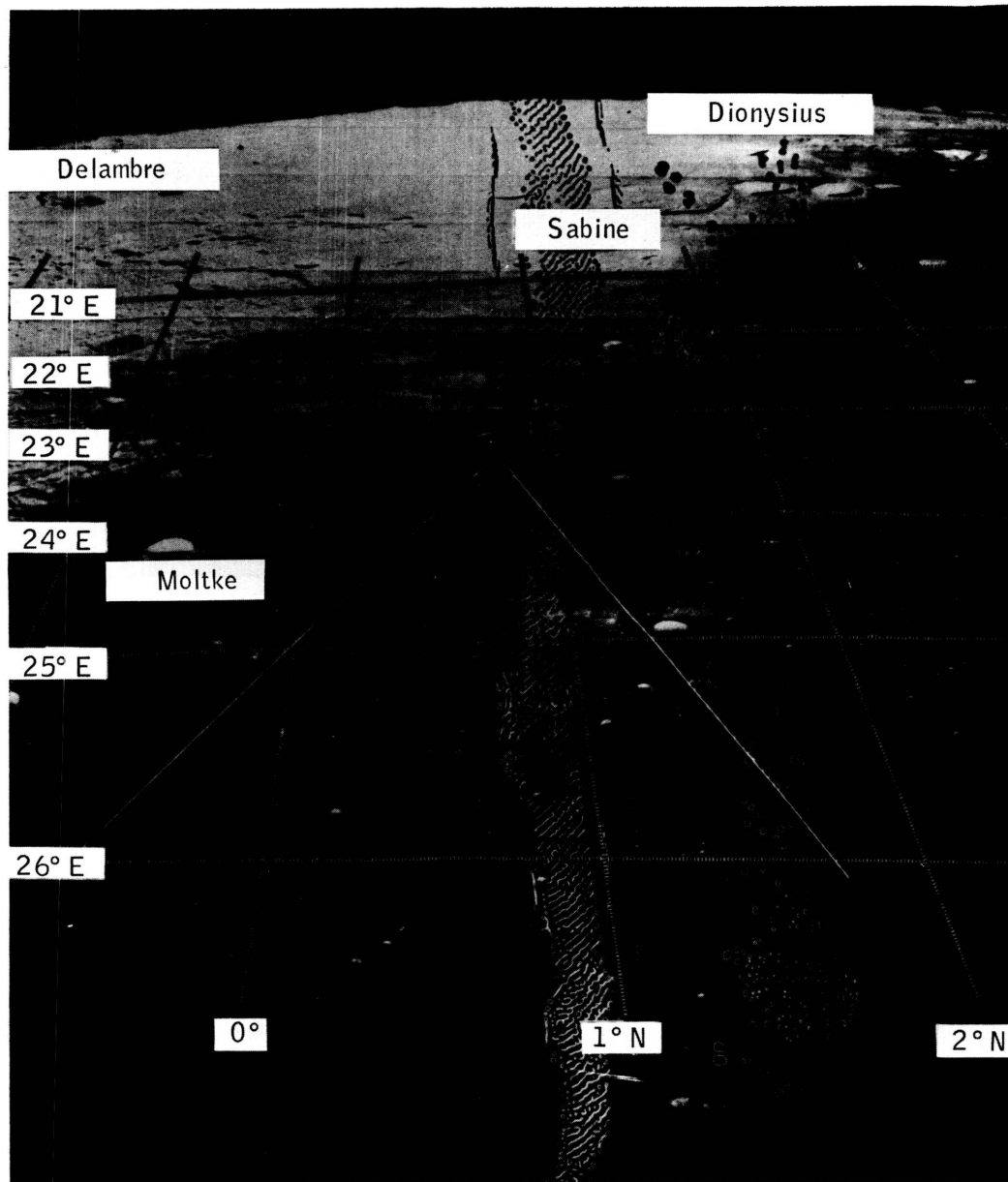
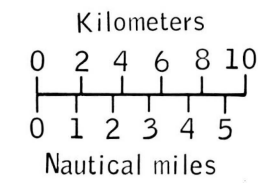

Figure 16. - Site II P-6, oblique.



Average sun
elevation = 29.8°



Figure 17. - Site II P-8, medium resolution.

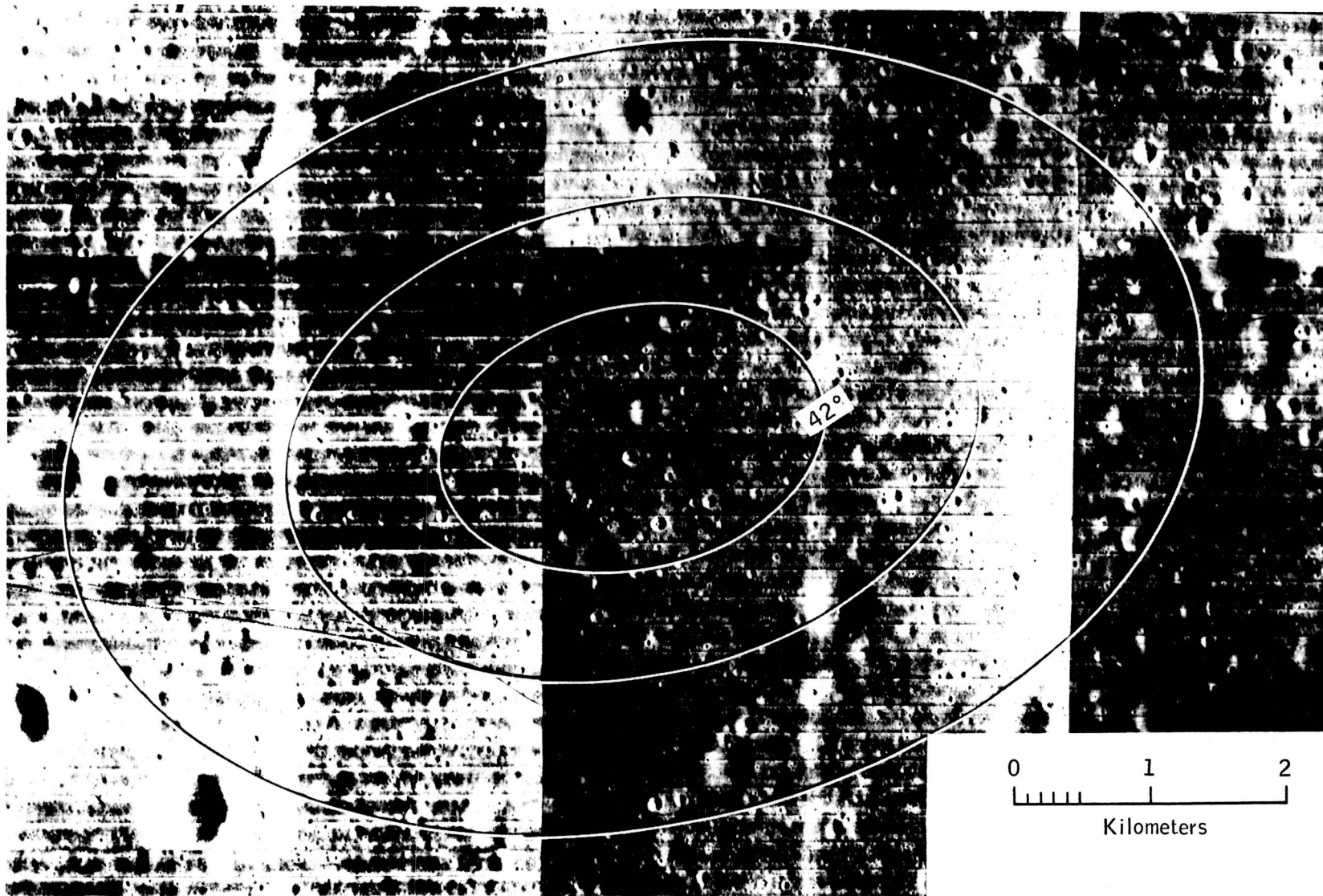

Figure 18. - Site II P-8, high resolution.

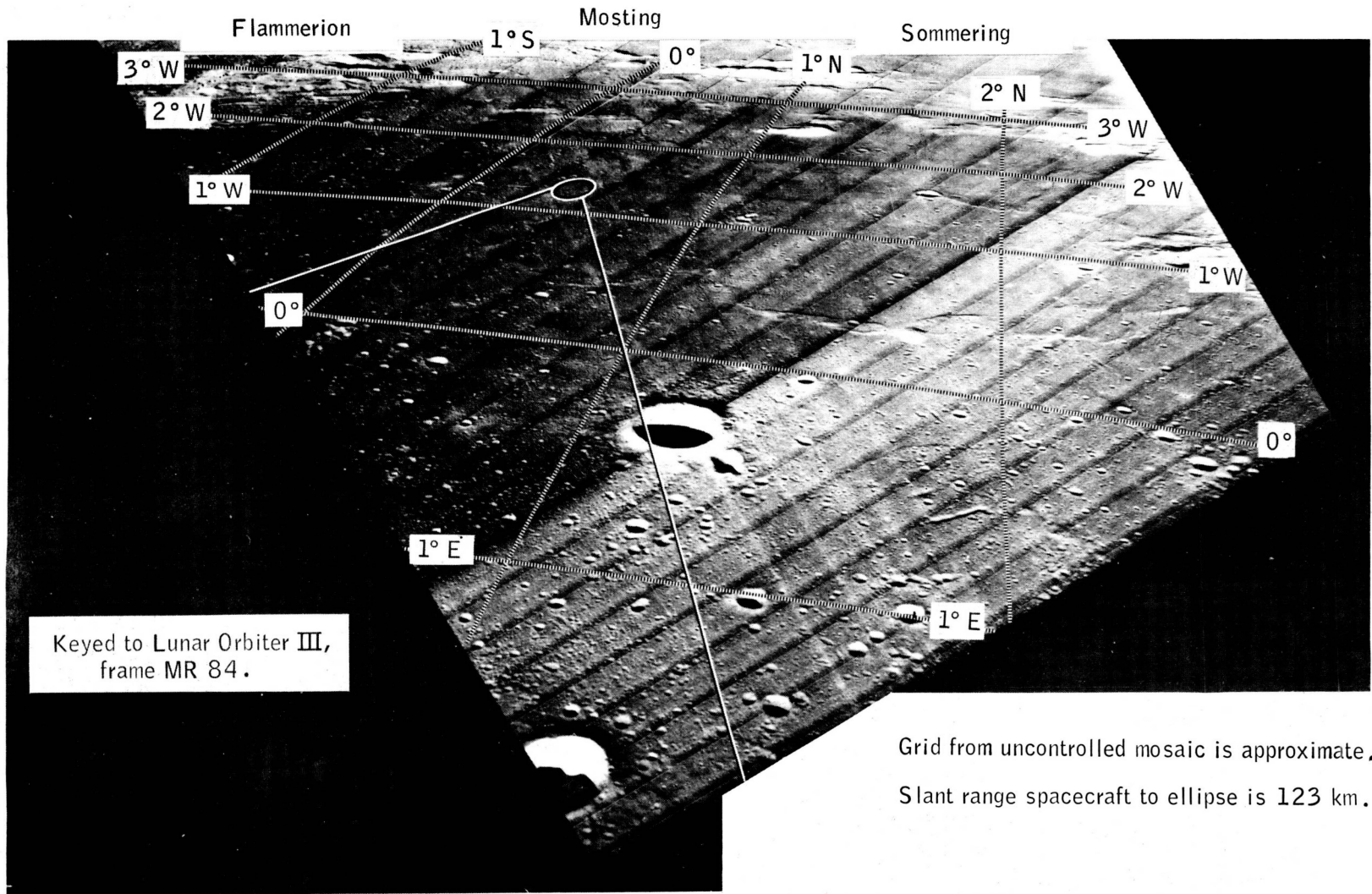
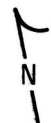
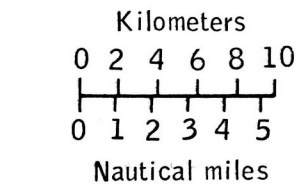
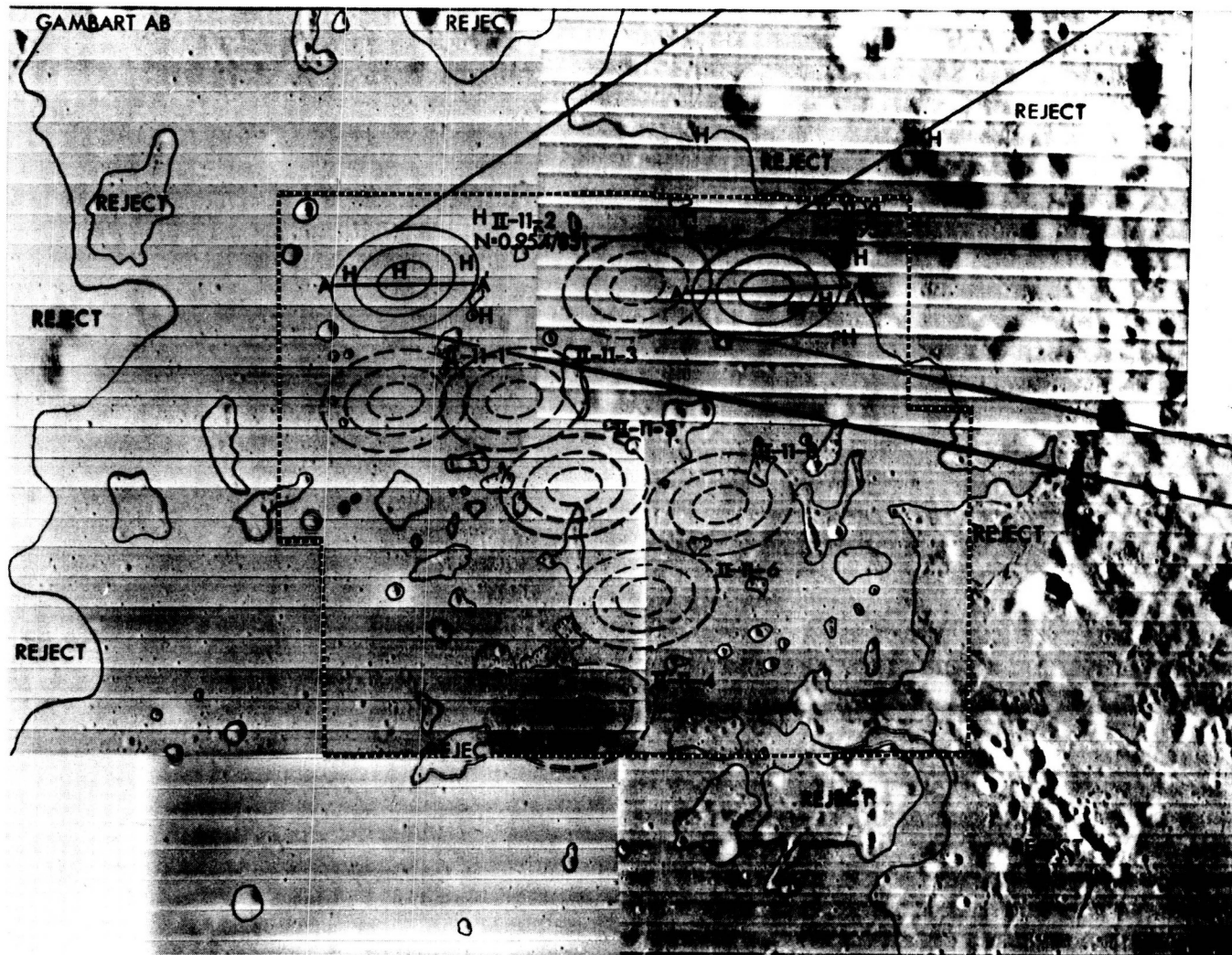

Figure 19. - Site II P-8, oblique.



Average sun elevation = 29.3°

Figure 20. - Site II P-11, medium resolution.

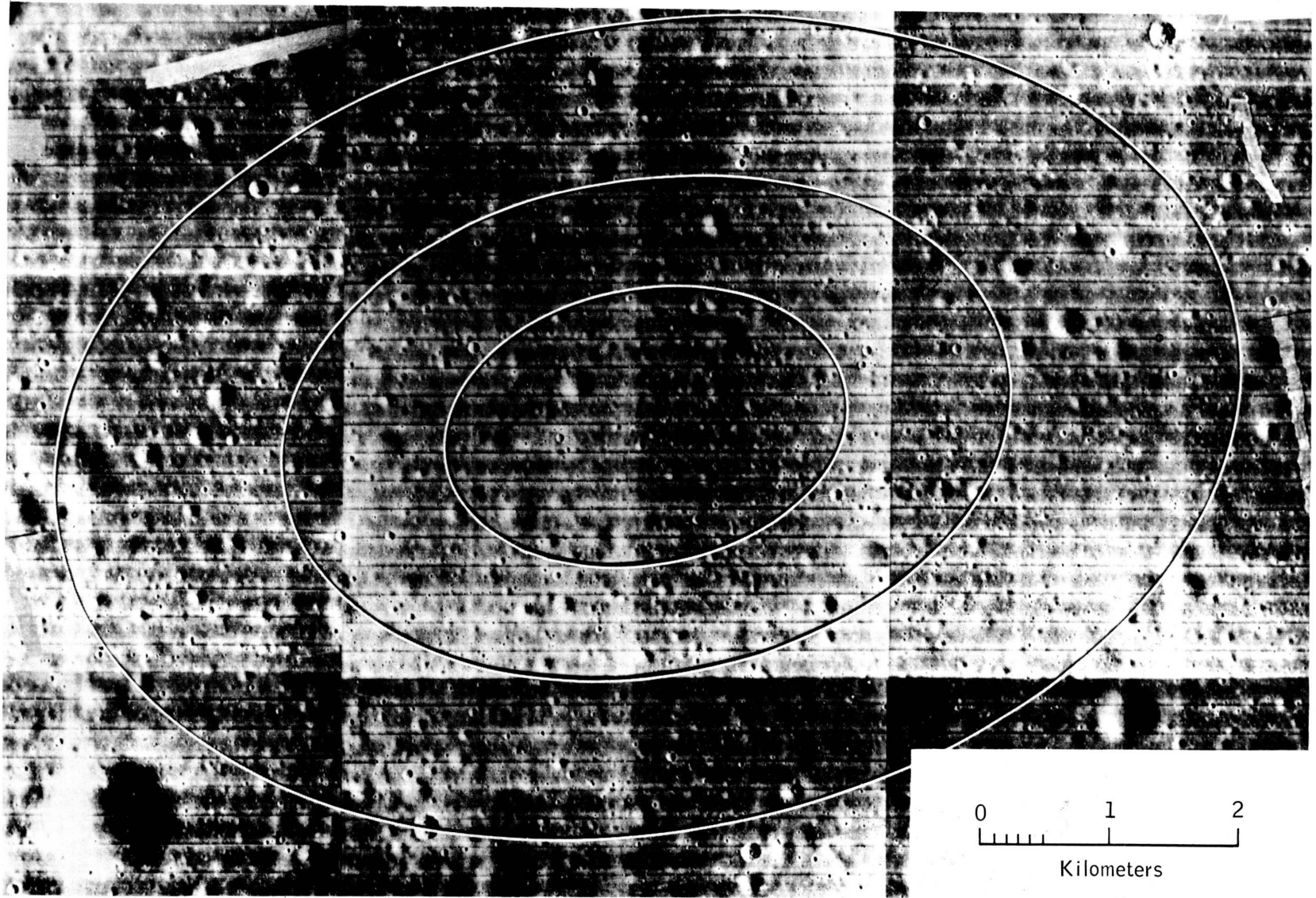

Figure 21. - Site II P-11, high resolution.

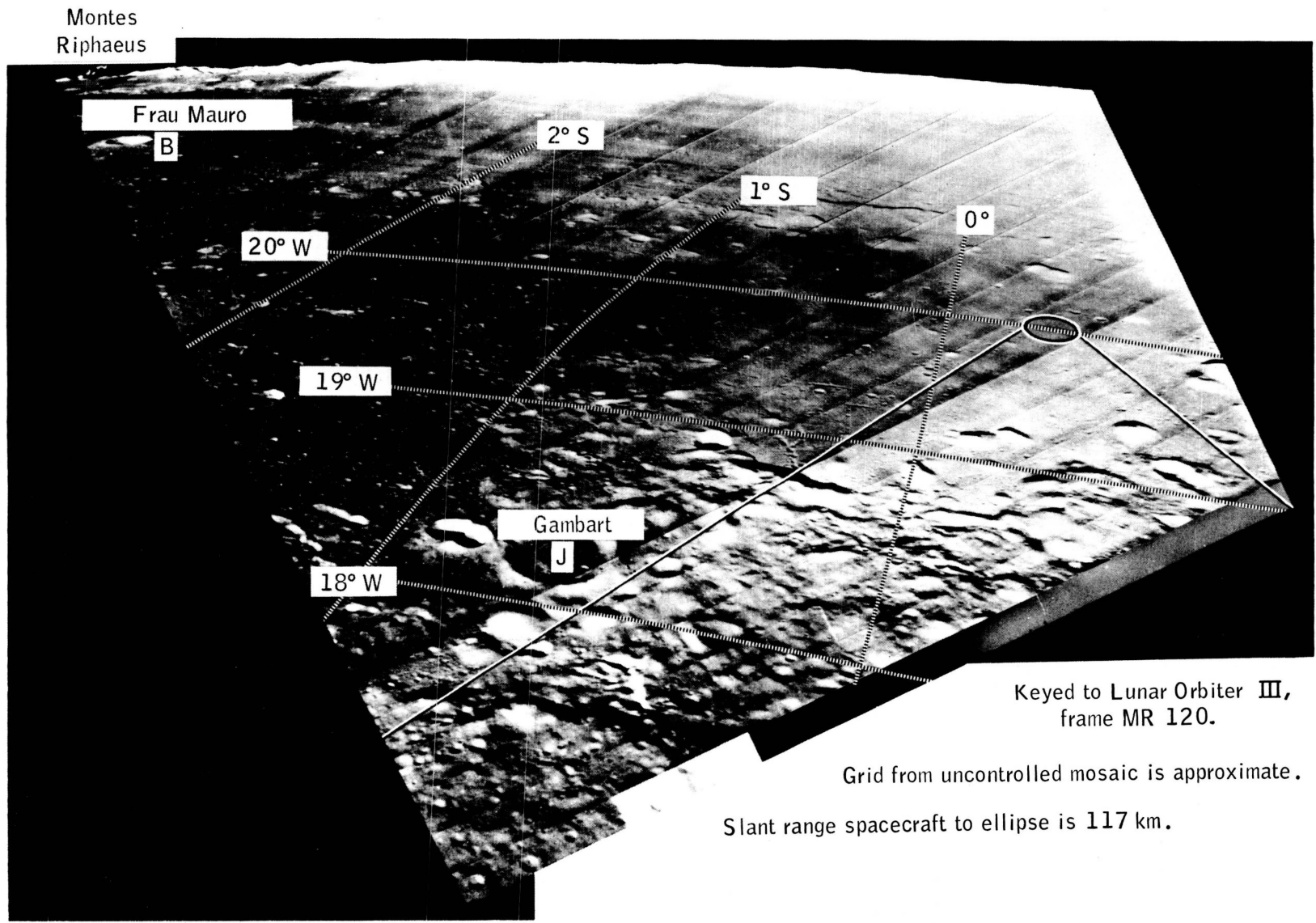

Figure 22. - Site II P-11, oblique.

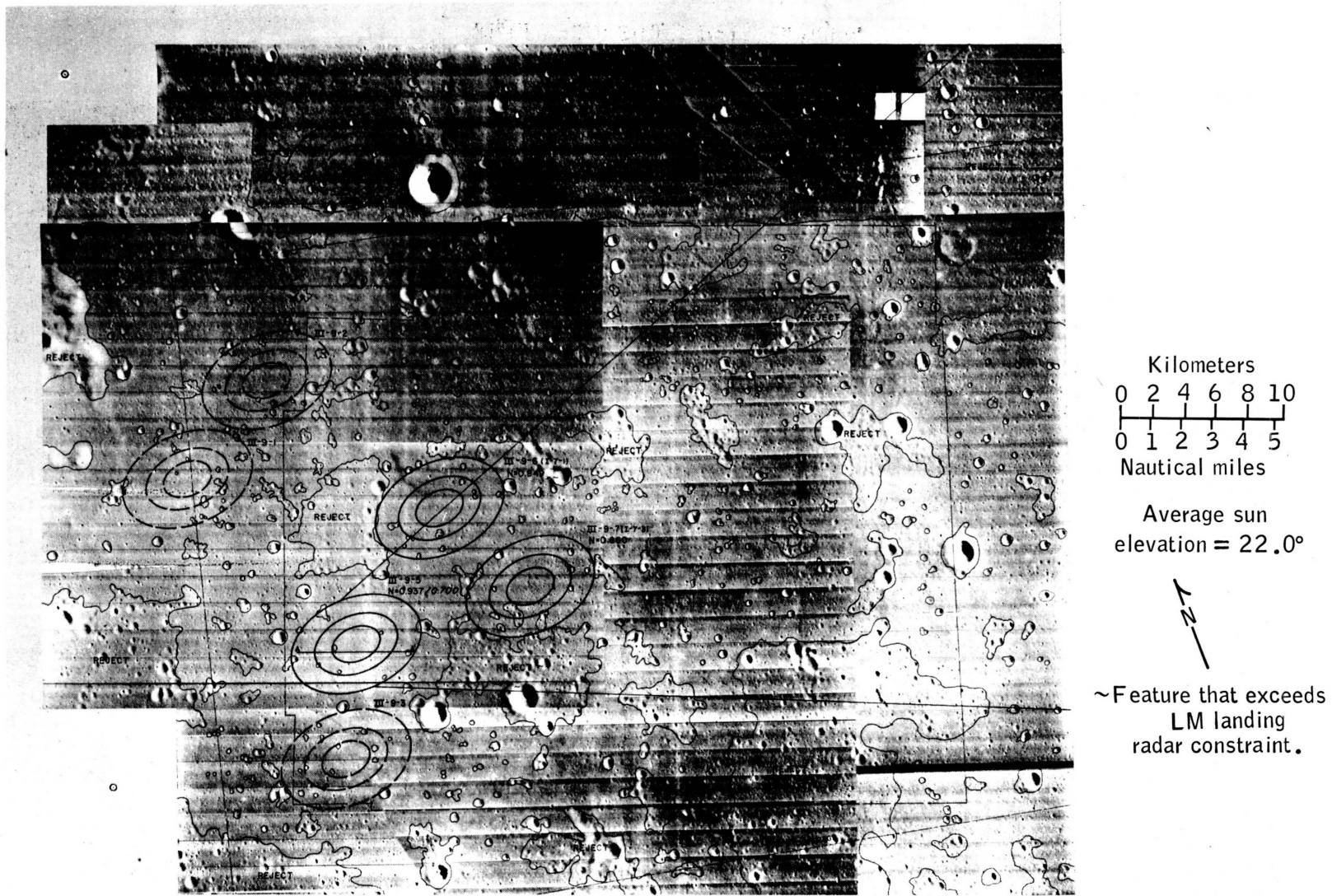

Figure 23. - Site III P-9, medium resolution.

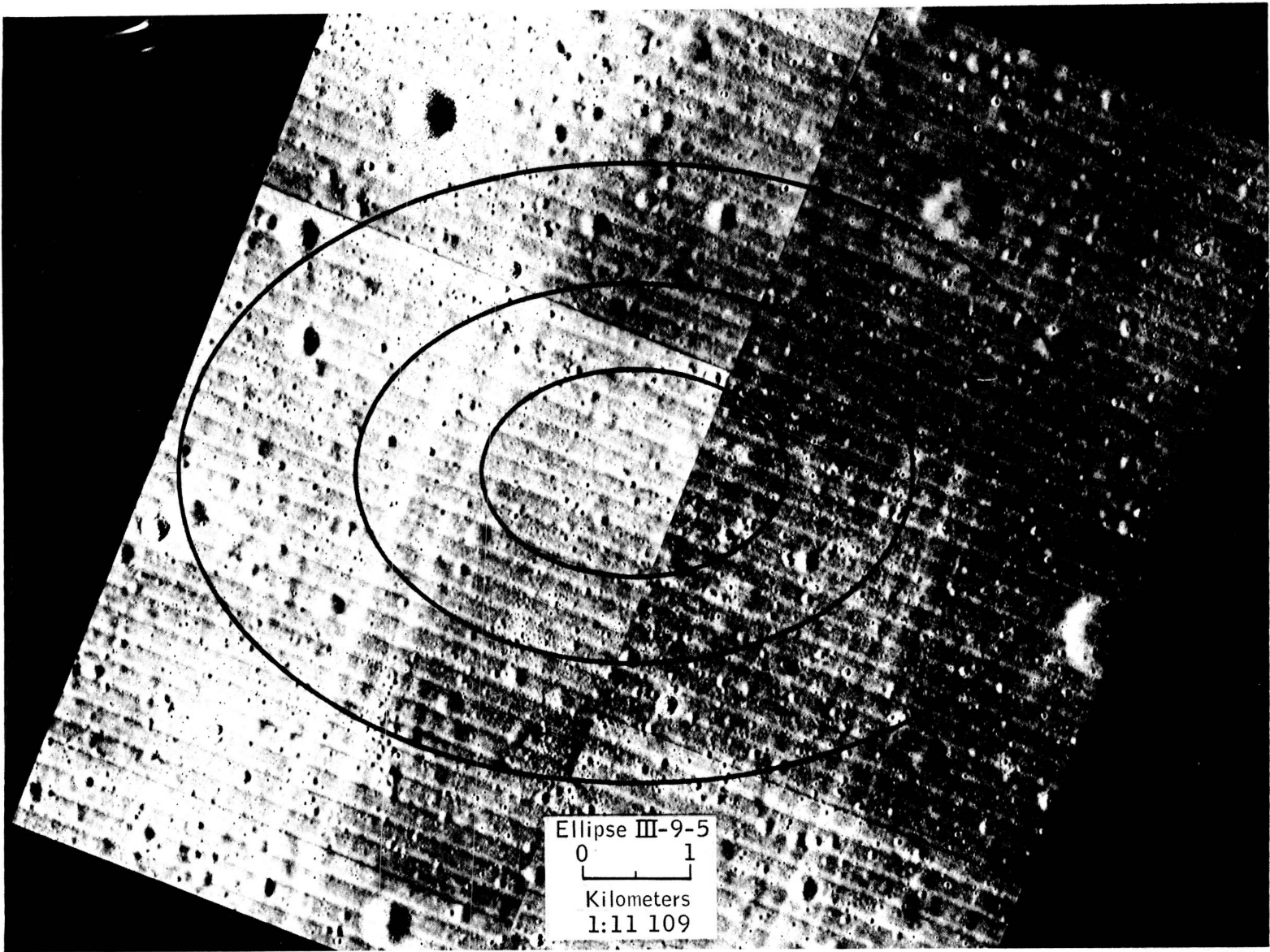

Figure 24. - Site III P-9, high resolution.

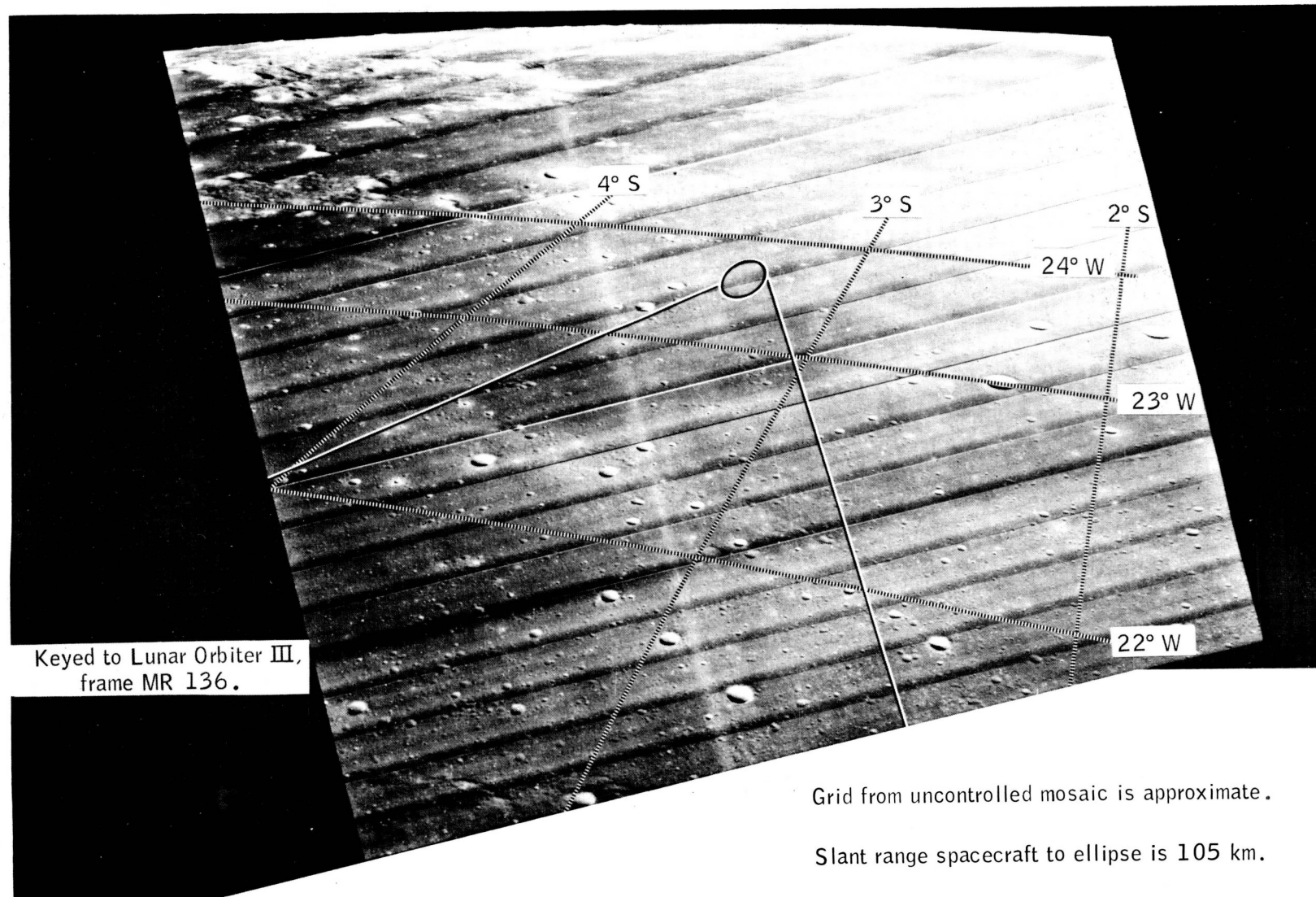
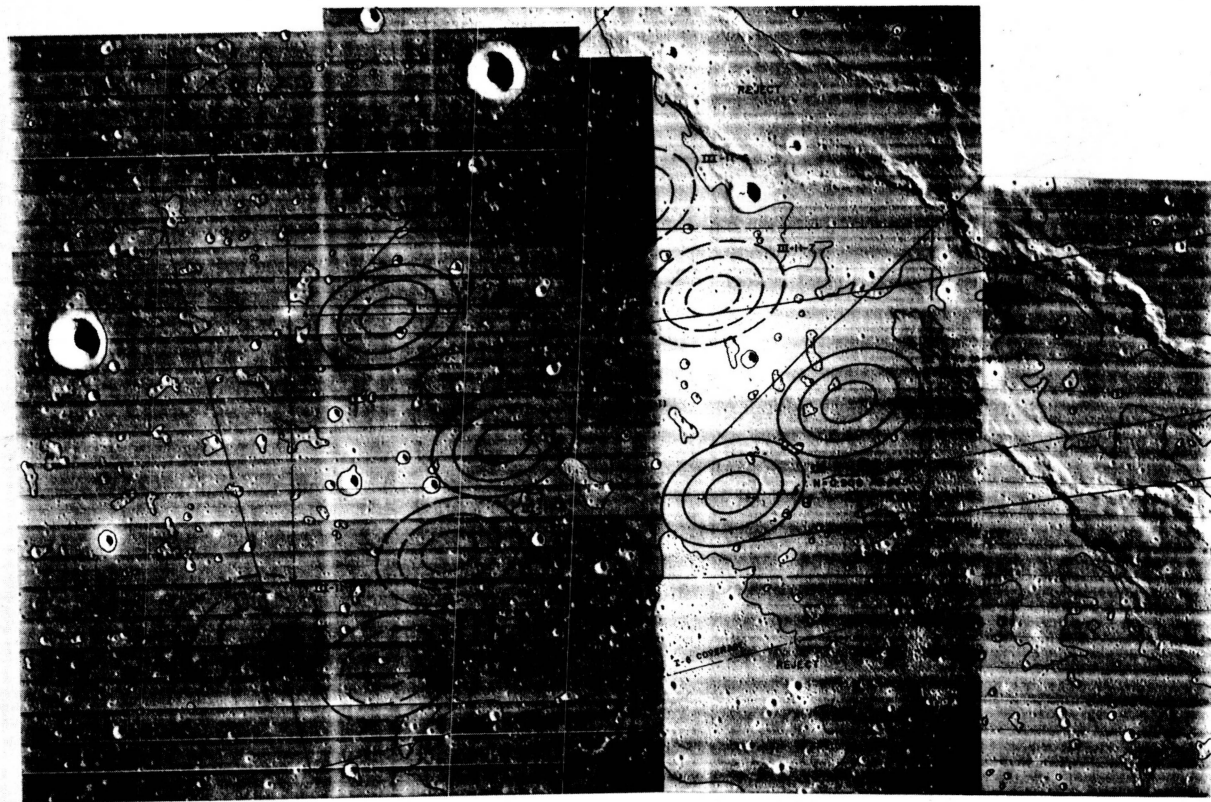

Figure 25. - Site III P-9, oblique.



Kilometers
0 2 4 6 8 10
0 1 2 3 4 5
Nautical miles

Average sun
elevation = 21.8°



~ Feature that exceeds LM
landing radar constraint

Figure 26. - Site III P-11, medium resolution.

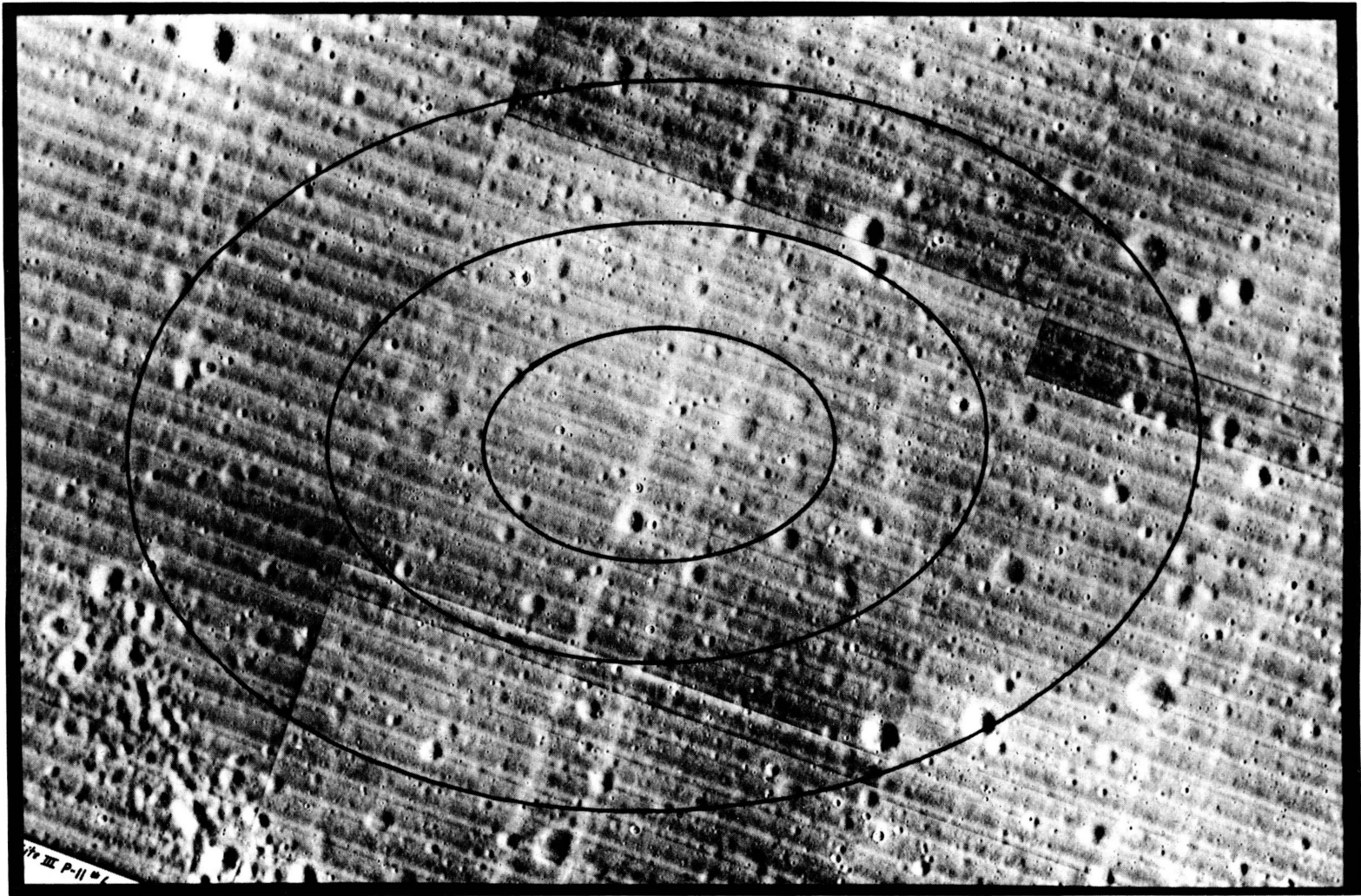

Ellipse III-11-8

0 1
Kilometers
1:11 800

Figure 27. - Site III P-11, high resolution.

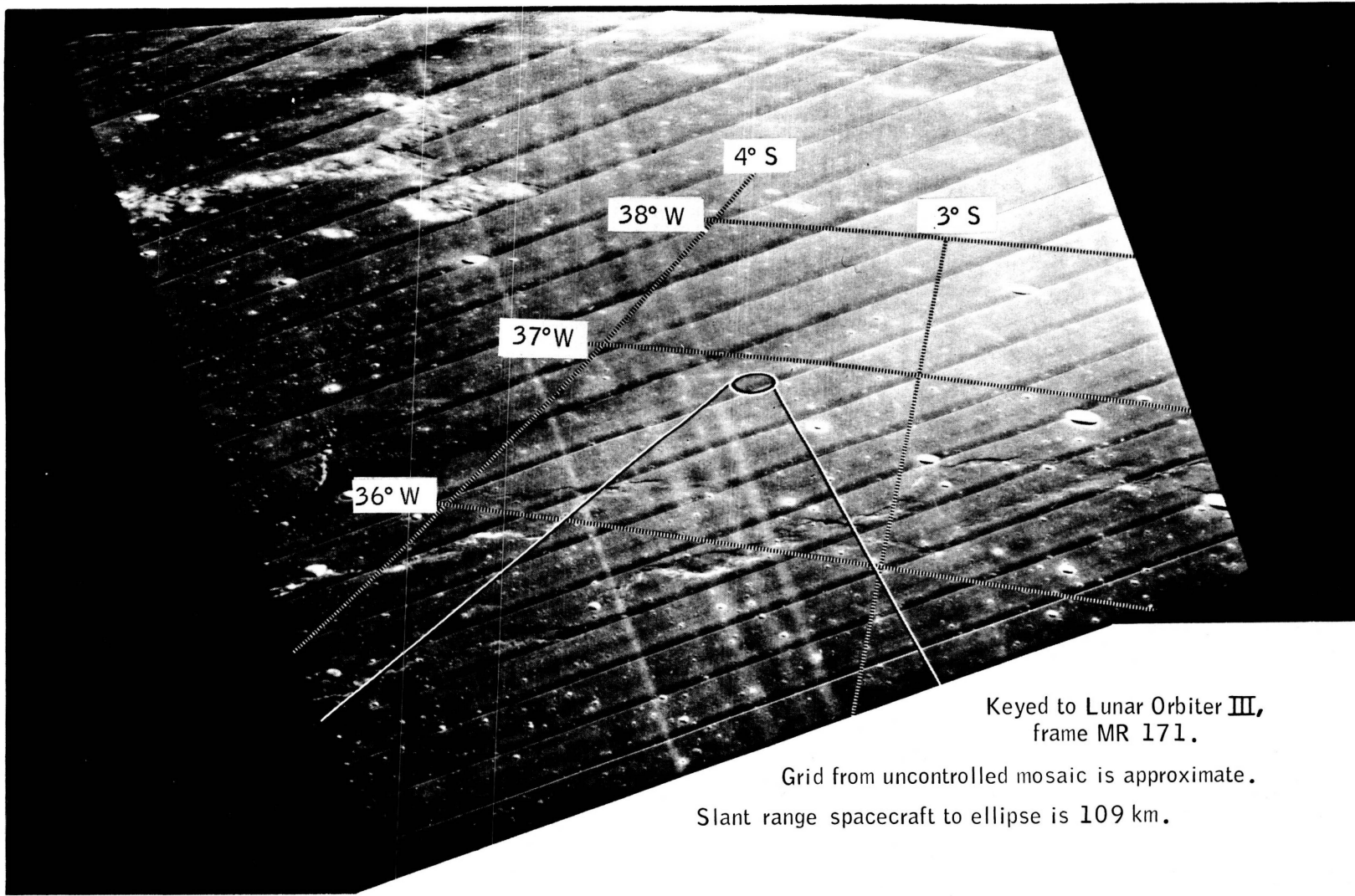

Keyed to Lunar Orbiter III,
frame MR 171.

Grid from uncontrolled mosaic is approximate.

Slant range spacecraft to ellipse is 109 km.

Figure 28. - Site III P-11, oblique.

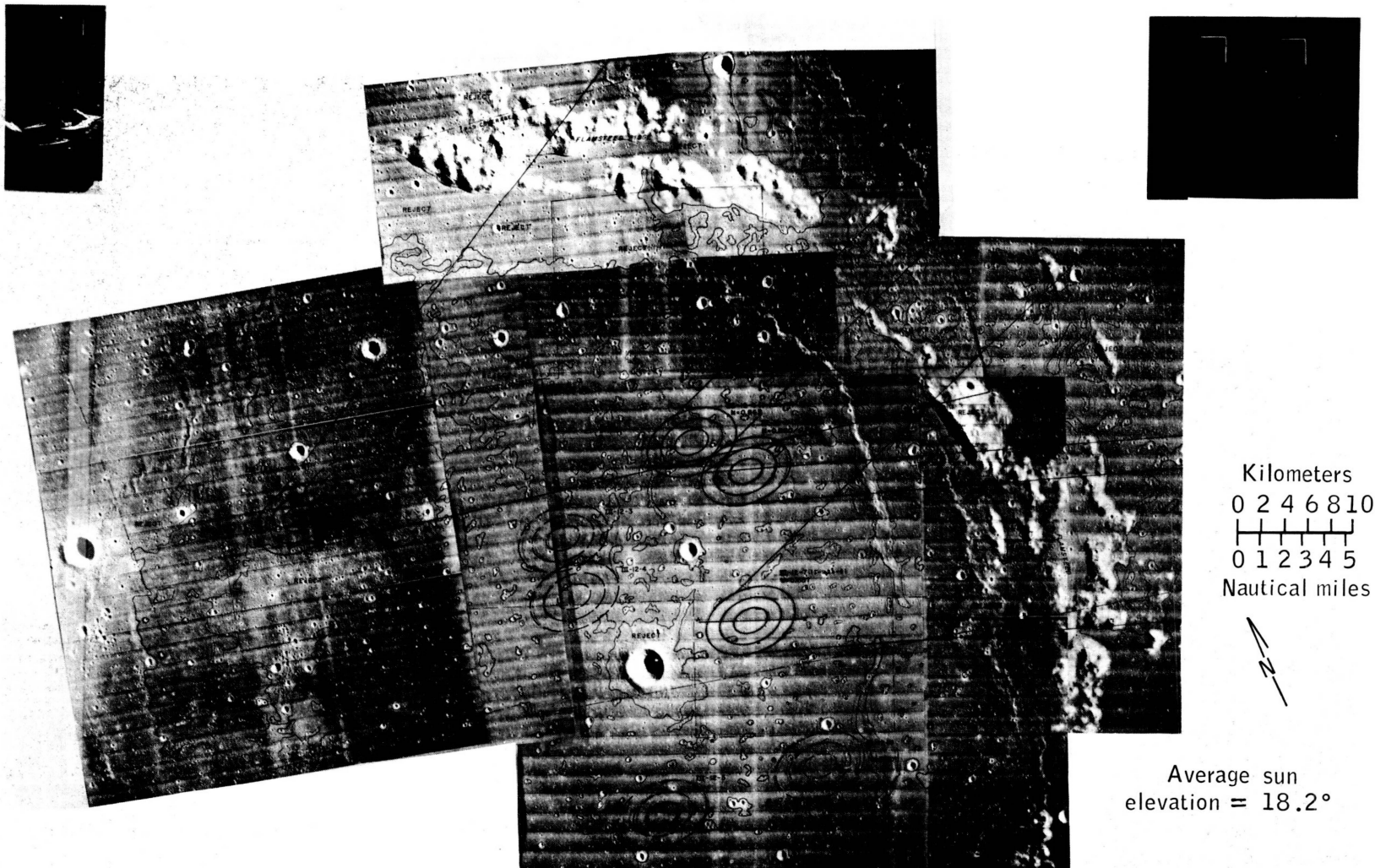

Average sun elevation = 18.2°

~ Feature that exceeds LM landing constraint.

Figure 29. - Site III P-12, medium resolution.

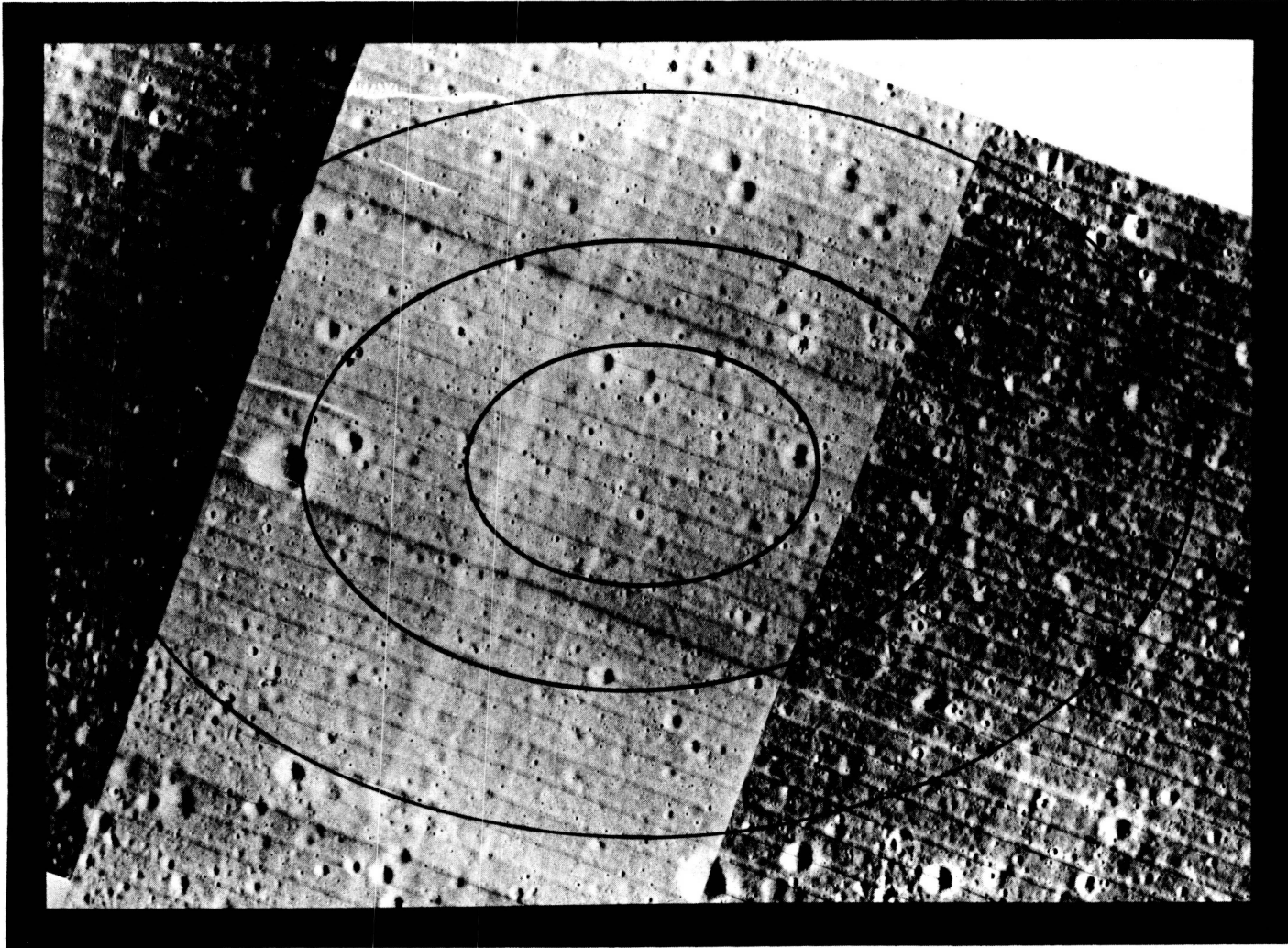

0 1

Kilometers

1:11 800

Ellipse III-12-1

Figure 30. - Site III P-12, high resolution.

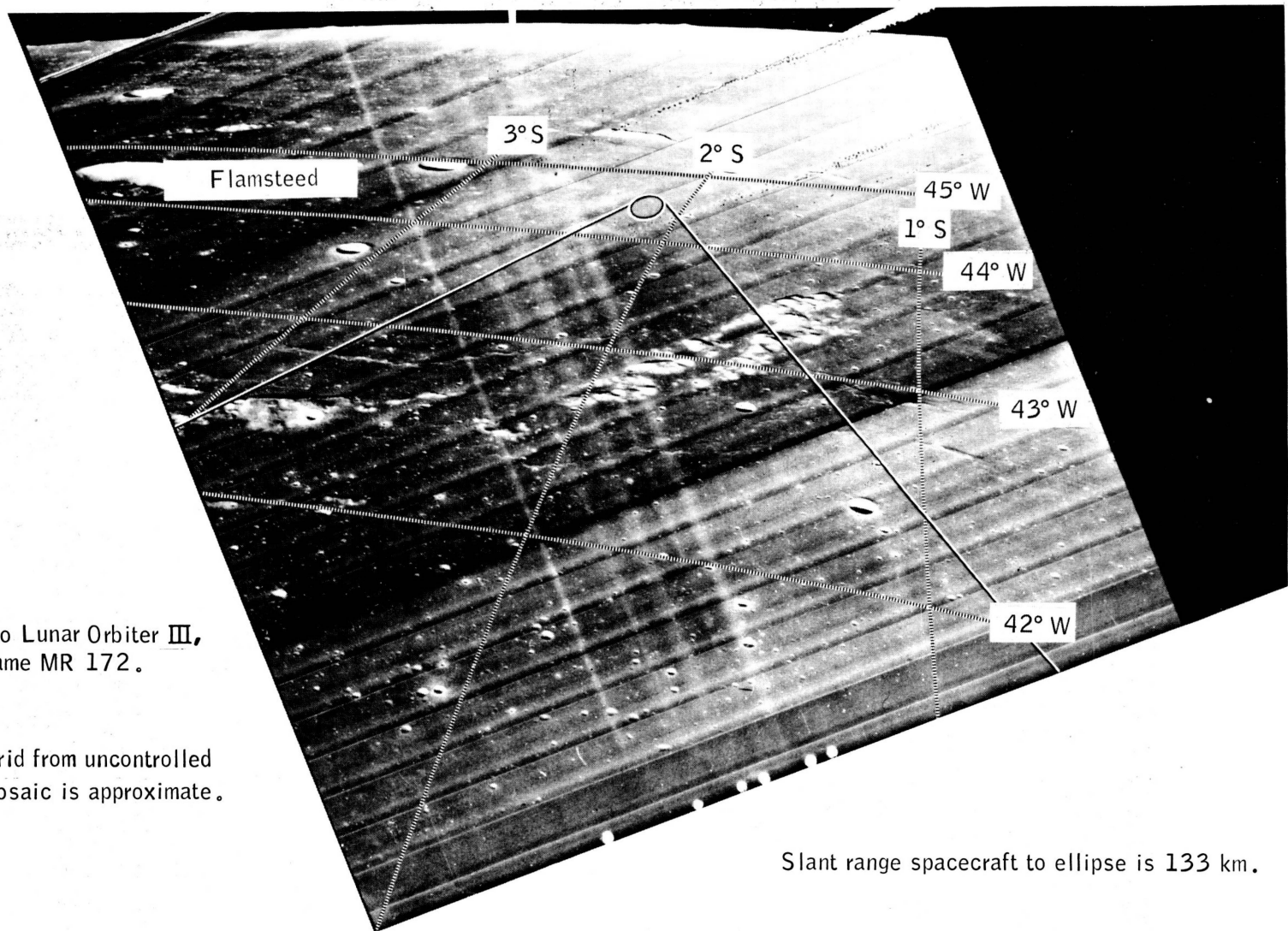

Keyed to Lunar Orbiter III,
frame MR 172.

Grid from uncontrolled
mosaic is approximate.

Slant range spacecraft to ellipse is 133 km.

Figure 31. - Site III P-12, oblique.

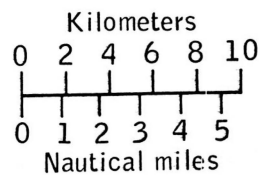
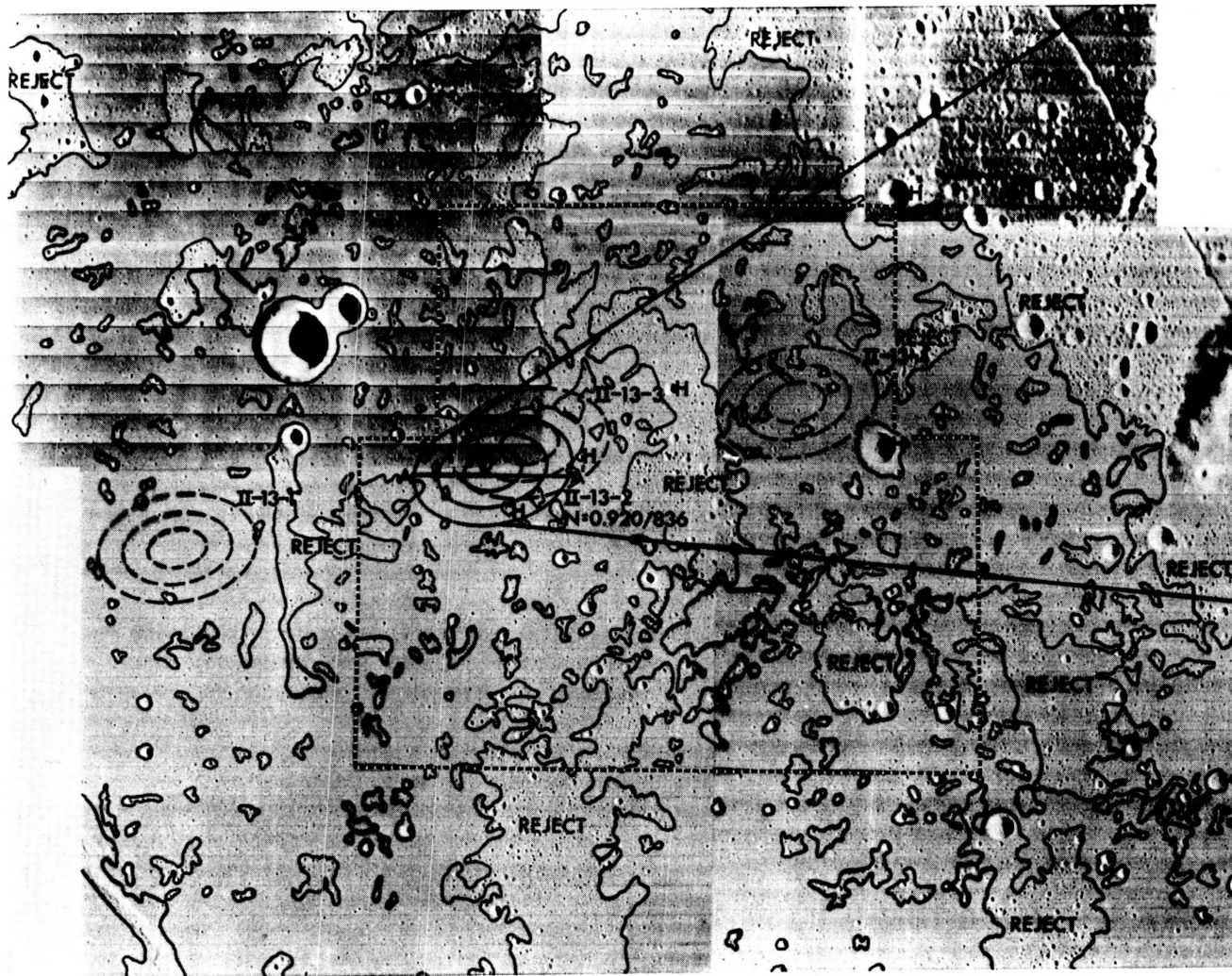

Average sun elevation = 19.2°

Figure 32. - Site II P-13, medium resolution.

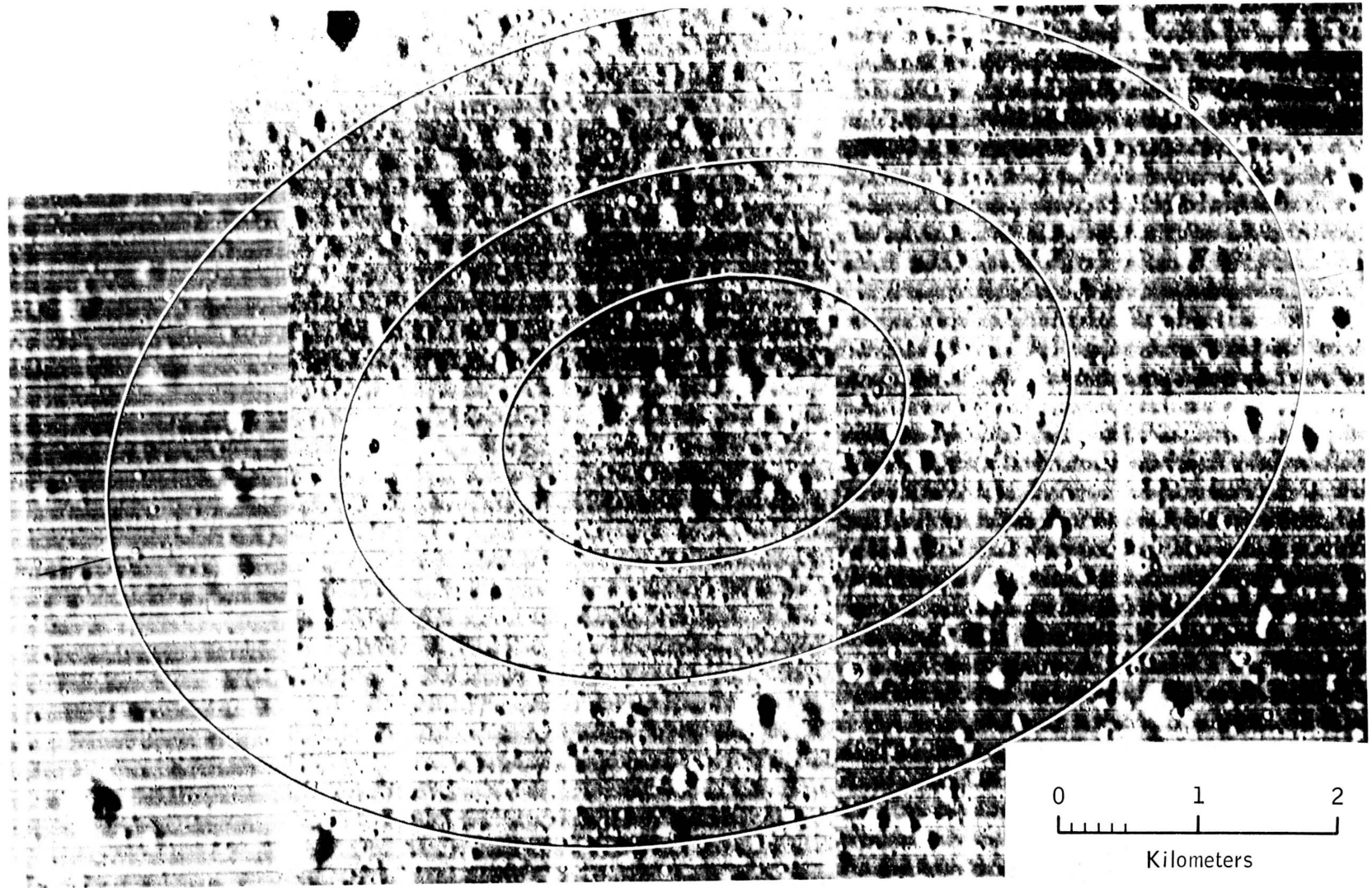
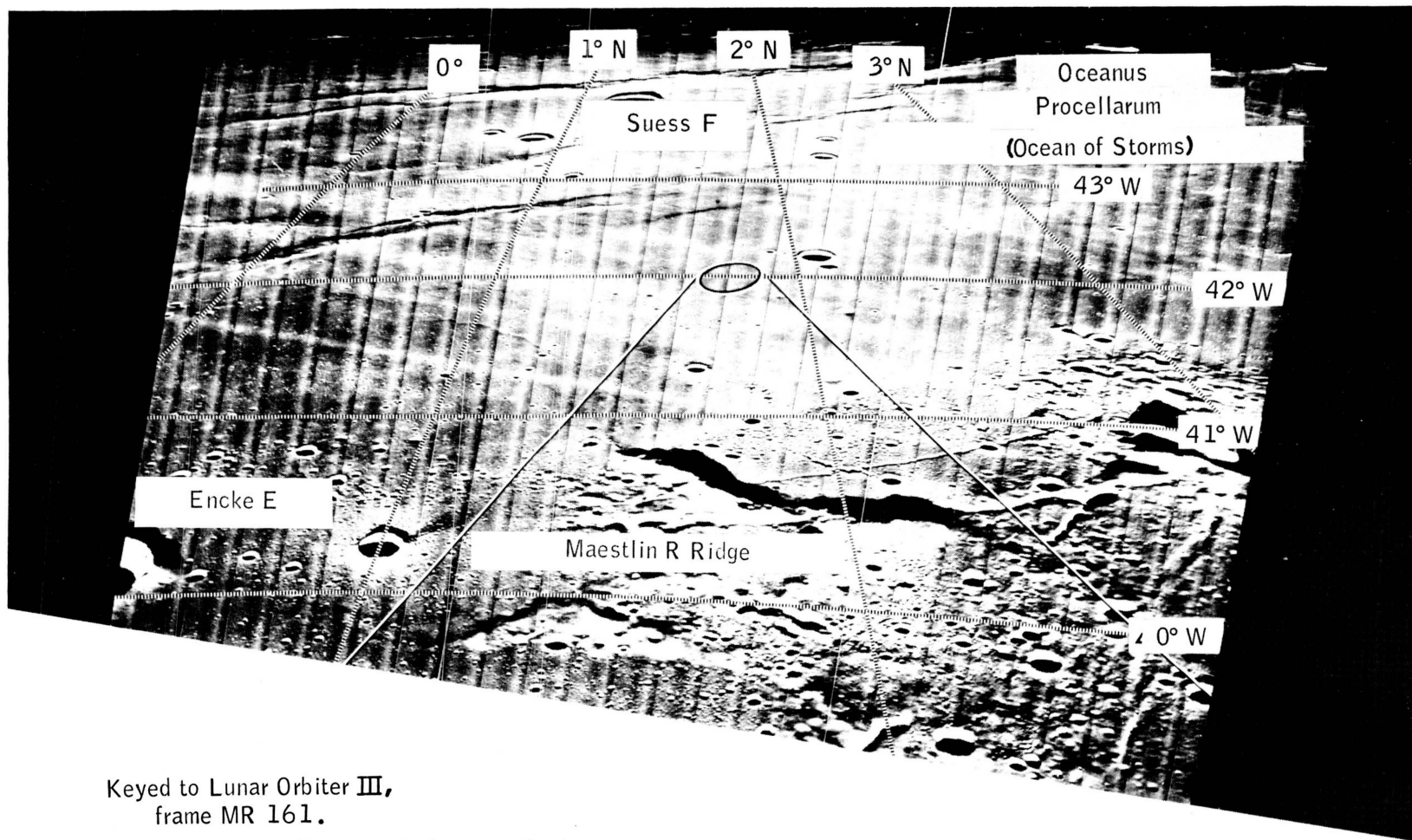

Figure 33. - Site II P-13, high resolution.



Keyed to Lunar Orbiter III,
frame MR 161.

Grid from uncontrolled mosaic is approximate.

Figure 34. - Site II P-13, oblique.