

NASA TECHNICAL NOTE

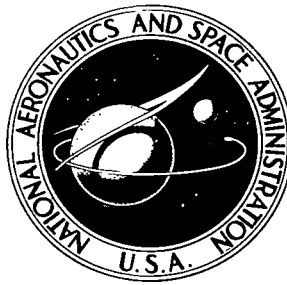

NASA TN D-4299

C.1

NASA TN D-4299

LOAN COPY; RE
AFWL (WL
KIRTLAND AFB

0131403



TECH LIBRARY KAFB, NM

NUCLEAR THERMIONIC SPACE POWER SYSTEM CONCEPT EMPLOYING HEAT PIPES

by Colin A. Heath and Edward Lantz

Lewis Research Center

Cleveland, Ohio



NUCLEAR THERMIONIC SPACE POWER SYSTEM
CONCEPT EMPLOYING HEAT PIPES

By Colin A. Heath and Edward Lantz

Lewis Research Center
Cleveland, Ohio

NATIONAL AERONAUTICS AND SPACE ADMINISTRATION

For sale by the Clearinghouse for Federal Scientific and Technical Information
Springfield, Virginia 22151 - CFSTI price \$3.00

NUCLEAR THERMIONIC SPACE POWER SYSTEM

CONCEPT EMPLOYING HEAT PIPES

by Colin A. Heath and Edward Lantz

Lewis Research Center

SUMMARY

A space power system employing out-of-pile thermionic diodes and using concentric heat pipes for both heating and cooling of these diodes has been examined. For an early application, the out-of-pile thermionic diode has some advantages over an in-pile system because it is removed from the reactor environment. Moreover, the heat pipe permits emitter temperatures that are not much less than the temperature of the fuel clad.

Laboratory data on the performance of heat pipes has been examined and the results used to estimate reasonable performance levels for thermionic diodes which were consequently incorporated into a small, fast-spectrum nuclear reactor concept. Performance levels and system weights including shield weights, have been estimated from first order calculations.

The overall system can have the advantage of the safety inherent in heat pipe redundancy and the improved performance available from components that are removed from the reactor environment.

INTRODUCTION

This paper presents a conceptual design of a space power system consisting of a reactor, heat pipe, and thermionic diode. The thermionic diodes are outside the reactor, and they are both heated and cooled by heat pipes. The design is intended to be as simple as possible and to indicate performance levels that might be available from future systems of this type. This concept could well be applied to a range of power levels, but the specific design considered herein represents the smallest reactor size possible within reactivity limitations. The values of system power that are available from this reactor

are established by the maximum fuel temperature, heat-transfer capabilities of the heat pipes, and the presently obtained efficiencies of thermionic diodes. The useful power output of such a reactivity limited system is approximately 400 kilowatts thermal power with a probable electrical output of more than 35 kilowatts. A larger system of this type could supply power for an electrical propulsion system for unmanned deep space probes, a direct broadcast satellite or other space applications.

The utilization of the heat pipe in the reactor - thermionic-diode system has several advantages. The heat pipe operates with only a few Kelvin degrees temperature change down its entire length, while conducting large quantities of heat so that it has a very high value of effective thermal conductivity. With this feature, it should be possible to obtain a diode emitter surface with a temperature close to the temperature of the fuel clad while still being placed outside the core.

Then, since the heat pipe is essentially an isothermal heat-transfer device, it may be possible to operate many thermionic diode emitters at the same temperature even though the power density generated throughout the reactor is not constant. This should alleviate the amount of power tailoring that needs to be done in the reactor.

Also, if the thermionic diodes are placed outside the reactor core, diode shorting caused by fuel swelling is eliminated. It then becomes possible to design diodes with smaller spacing between emitter and collector and reap higher values of power level and efficiency. Furthermore, the electrical insulation material can be removed from high radiation regions and thus reduce the damage by fast neutrons.

These advantages have previously been recognized at Los Alamos Scientific Laboratory (ref. 1) and Lawrence Radiation Laboratory. A design study of an out-of-pile heat pipe thermionic reactor has been performed (ref. 2). However, this previous study was devoted to power levels around 10 megawatts electric. At such power levels, the complexity of the heat removal system included thousands of heat pipes and a very complex heat pipe exchanger using liquid silver. This study deals with a more simple, lower power system. The proposed arrangement contains only four fuel regions, all of which could be constructed as thick disks. Experimental results from laboratory tests of both heat pipes and thermionic diodes have been used as performance levels that are obtainable on the basis of present experience.

HEAT PIPE AND THERMIONIC DIODE PERFORMANCE

A heat pipe (ref. 3) is illustrated schematically in figure 1, which shows a sealed pipe that has been out gassed to vacuum for several hours and then filled with a small quantity of liquid metal. The pipe contains some type of capillary geometry or wick material close to the inside wall. When heat is added to the evaporator end of the heat

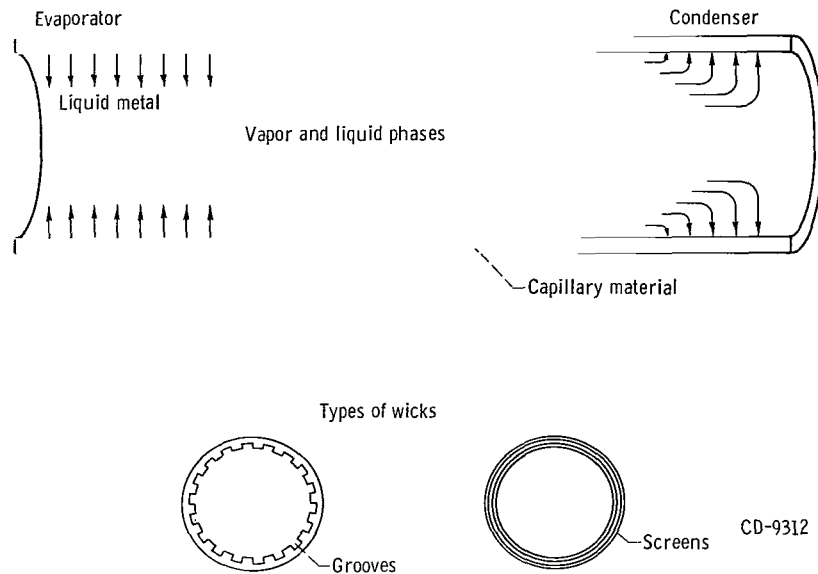

Figure 1. - Schematic of heat pipe operation.

pipe, it heats and vaporizes the liquid metal that is there and the local vapor pressure increases. Vapor then flows down the pipe under the pressure gradient to the cooled end where it condenses. The liquid metal then returns to the evaporator as a result of the capillary pumping in the wick material. The heat pipe operates with only a few Kelvin degrees temperature change down its entire length.

Calculations of Feldman and Whiting (ref. 3) indicate that a lithium heat pipe that is operated at 1770° K might be able to transfer up to 1600 thermal watts for each square centimeter of evaporator area. This indication is supported by the theoretical analyses of Cotter (ref. 4) and Anand (ref. 5), but both of these analyses assume that the only limiting condition is that the pressure rise due to capillary forces be strong enough to override pressure drops in the flowing liquid and vapor. Whether or not this is a valid assumption remains to be proven.

A series of heat pipe capability experiments have been performed at Los Alamos Scientific Laboratory and have been reported by Kemme (ref. 6). Tests were performed with a number of pipes, all of which were 30 centimeters long with a vapor passage diameter of 1.5 centimeters. Tests were run with sodium, potassium, and lithium with various configurations of capillary geometry. The results obtained for the upper limit of heat transfer with sodium and potassium working fluids were in fairly good agreement with theoretically predicted values.

Kemme also reported a test with lithium as a working fluid in a niobium - 1-weight-percent-zirconium heat pipe. The capillary geometry in this pipe was constructed as 88 channels cut into the inside wall of the pipe; each channel was 0.12 millimeter wide and 0.30 millimeter deep. At 1123° K this geometry had given heat-transfer limits of 14.6

and 53 watts per square centimeter with sodium and lithium, respectively. At 1423^o K, the lithium heat pipe was limited to 106 watts per square centimeter (total heat 4000 W). No limits could be determined above 1423^o K since the heat-transfer equipment could remove only 4000 watts.

These data represent the highest heat-transfer limits to date. However, Kemme increased the limiting heat flux with sodium at 1123^o K by a factor of three by changing the channels from 0.12 by 0.30 millimeter to 0.16 by 0.40 millimeter, respectively. Also, an addition of a screen inside the heat pipe increased the limiting heat flux of sodium by another factor of 2.5. If a similar increase of the lithium heat-transfer limit can be attained by these geometry changes, this limit may be as high as 800 watts per square centimeter at 1423^o K.

Considerable experimental work has been performed on the combination of thermionic diodes and heat pipes by Harbaugh (ref. 7). At the time of a recent termination of a contract, a TZM (Mo - 0.5-percent Ti - 0.08-percent Zr) heat pipe with a molybdenum capillary screen had operated with a lithium working fluid for about 3000 hours at 1623^o K and was still running correctly when reported. This heat pipe had three diodes mounted in series on the condenser end of the pipe. They were insulated from the pipe by a sheath of aluminum oxide (Al₂O₃). The output from this assembly averaged around 120 watts or 2 watts per square centimeter of diode throughout the operating life (ref. 7). This unit was operated for a short period of time at 1773^o K and delivered more than 4 watts per square centimeter. Thus, it appears that present technology does permit the building and operation of a heat pipe using lithium at 1773^o K. Reference 5 states that small amounts of impurities seriously effect the lifetime of the heat pipe. But a heat pipe that is correctly manufactured should be reliable and maintenance free; that is, since it will be permanently sealed, it should not have the reconditioning problems that are prevalent in the more conventional liquid-metal systems.

A prototype of a thermionic diode with its emitter heated by a heat pipe and its collector cooled by a heat pipe has been built and operated (ref. 8). A cylindrical converter (1.77 cm diam) was constructed with the tungsten emitter vapor-plated on the outside of a tantalum heat pipe. The emitter area was 17.5 square centimeters and the gap between the emitter and collector was 0.035 centimeter. The collector was molybdenum sintered to a niobium - 1-weight-percent zirconium heat pipe. The emitter heat pipe was constructed of tantalum and contained lead as a working fluid. The collector heat pipe of niobium - 1-weight-percent zirconium employed cesium as a working fluid. The emitter pipe was heated by radio frequencies, the collector pipe was cooled by radiation. The maximum power output of 5.2 watts per square centimeter was obtained at 0.4-volt output with an emitter temperature of 1773^o K and a collector temperature of 1000^o K.

Figure 2 shows a set of curves compiled by Williams, Ward, and Breitweiser of Lewis which represent an envelope of thermionic data obtained at different laboratories

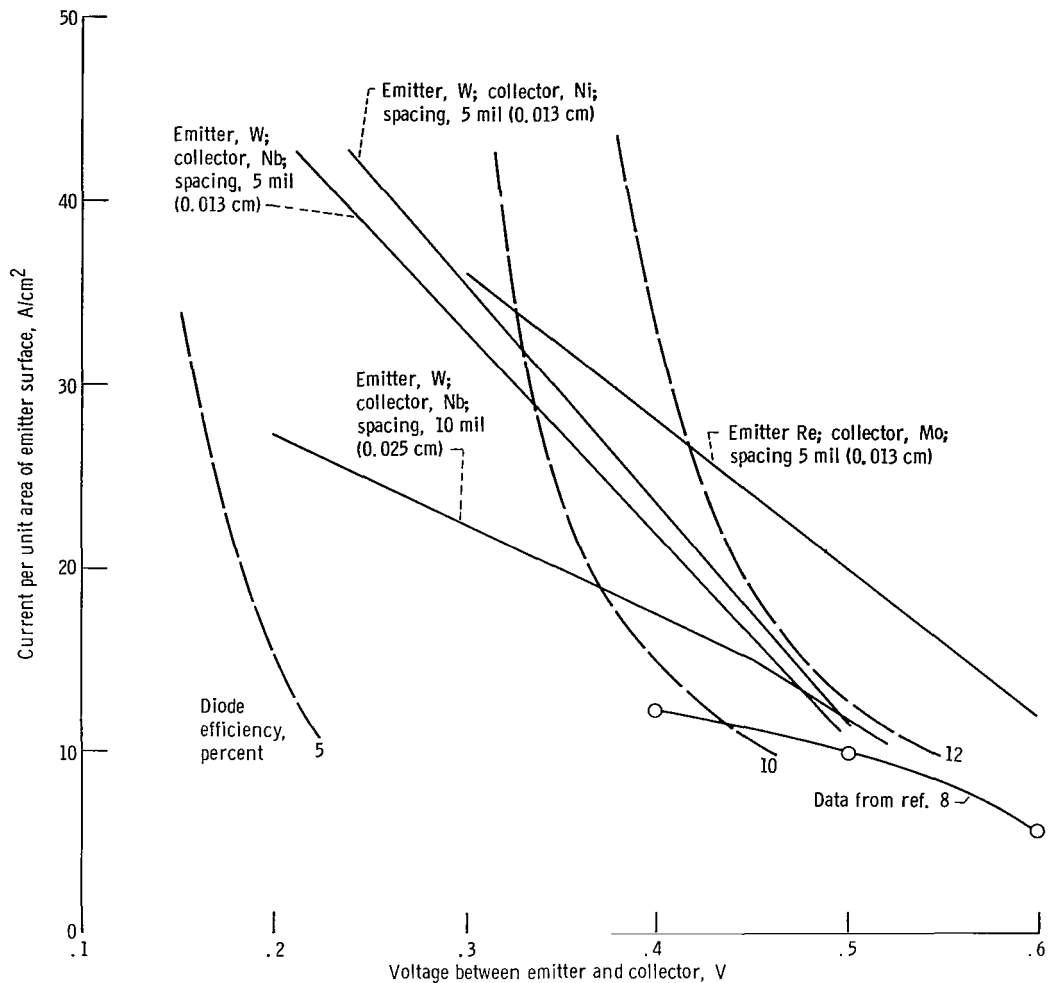

Figure 2. - Summary of experimental diode performances. Emitter temperature, 1770° K; collector temperature, 973° K.

(refs. 9, 10, and unpublished data obtained under NASA contract NAS3-8511). The data from the heat pipe - thermionic diode combination (ref. 8) has been added to the compilation. These data compare well with other experimental tests. The lower values of current at a given voltage probably result from the approximately 0.036-centimeter diode spacing compared with the 0.013- and 0.025-centimeter spacings shown in the figure.

INTEGRATION OF THERMIONIC DIODES AND HEAT PIPES WITH NUCLEAR POWER SOURCE

Based on the experimental data presented in the previous section, a concept has been developed using out-of-pile thermionic diodes and heat pipes for a power source for an

unmanned scientific space probe. This particular design does not necessarily represent a final configuration, but instead it is a first step toward a thermionic reactor system design.

From the heat pipe analyses and experiments previously described, it appears that a heat flux of 280 watts per square centimeter of evaporator surface should be readily obtainable in a lithium heat pipe operating at a temperature greater than 1773° K, so this value was used for the design of the evaporator. For the thermionic emitter, which will be designed for operation at 1773° K, a heat flux of 45.5 watts per square centimeter was selected as being representative of presently obtainable performance. The electrical output of the system will depend primarily on the efficiency of the operating diode. As was shown in figure 2, a diode efficiency of approximately 10 percent is a reasonable value that has been frequently obtained.

A plan view of the arrangement of heat pipes inside the reactor core is shown in figure 3. The proposed design employs heat-pipe evaporator sections shaped as sectors of a circle. The heat flux surfaces are those flat surfaces in the horizontal plane that bound the top and bottom of the sectors. That heat-pipe section that passes through the heavy metal reflector is a circular cylinder that is assumed to operate as an adiabatic section of the heat pipe.

Outside the heavy metal reflector, the high-temperature heat pipe is sheathed with an electrical insulating material on which are placed the emitters of thermionic diodes. Concentrically around the emitter surfaces is placed the collector heat pipe in a fashion similar to the design used by Busse, Caron, and Cappelletti (ref. 8). The cesium supply may be connected to the interdiode space (fig. 3) in a region where space is available.

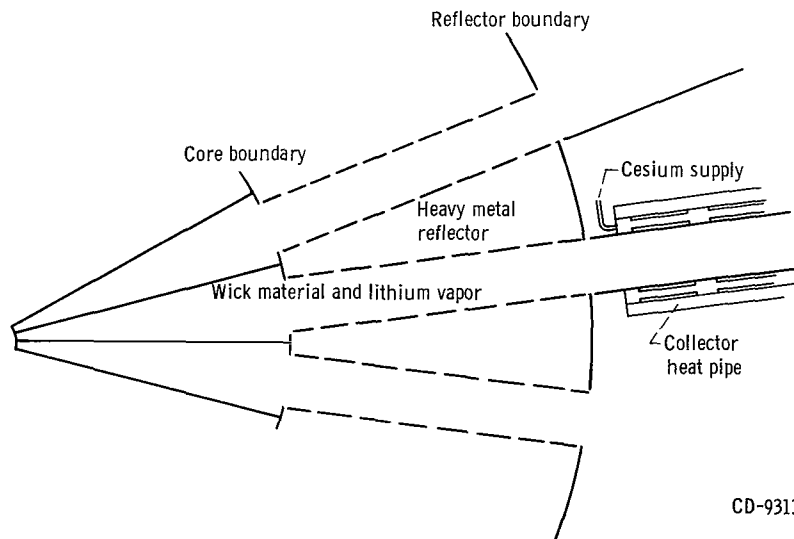

Figure 3. - Plan view through heat pipes in fast spectrum reactor.

A side view of the reactor concept is shown in figure 4. Calculations as described in appendix A show that a core of this size is required to achieve criticality with the 29-percent void fraction in the core due to the presence of the heat pipes.

The simplicity of this core concept is evident in that only four fuel elements with a simple disk geometry are needed. The thickness of these fuel elements has been established as 2.92 centimeter based on a heat pipe operating temperature of 1838°K and a centerline temperature that is lower than the melting point of the fuel. The melting point of uranium 233 nitride with a nitrogen overpressure of 2.5 atmospheres (25.3 N/cm^2) has been reported as 3120°K (ref. 11). The 2.5 atmospheres (25.3 N/cm^2) of nitrogen pressure is sufficient to prevent disassociation. The centerline temperature of the fuel element in this design will be 2828°K with a surface heat flux of 280 watts per square centimeter.

Although this centerline temperature seems rather high, recent experimental evidence indicates that high fuel temperatures permit better operation when the fuel is vented. At fuel temperatures below 1673°K , the fission product atoms are not suffi-

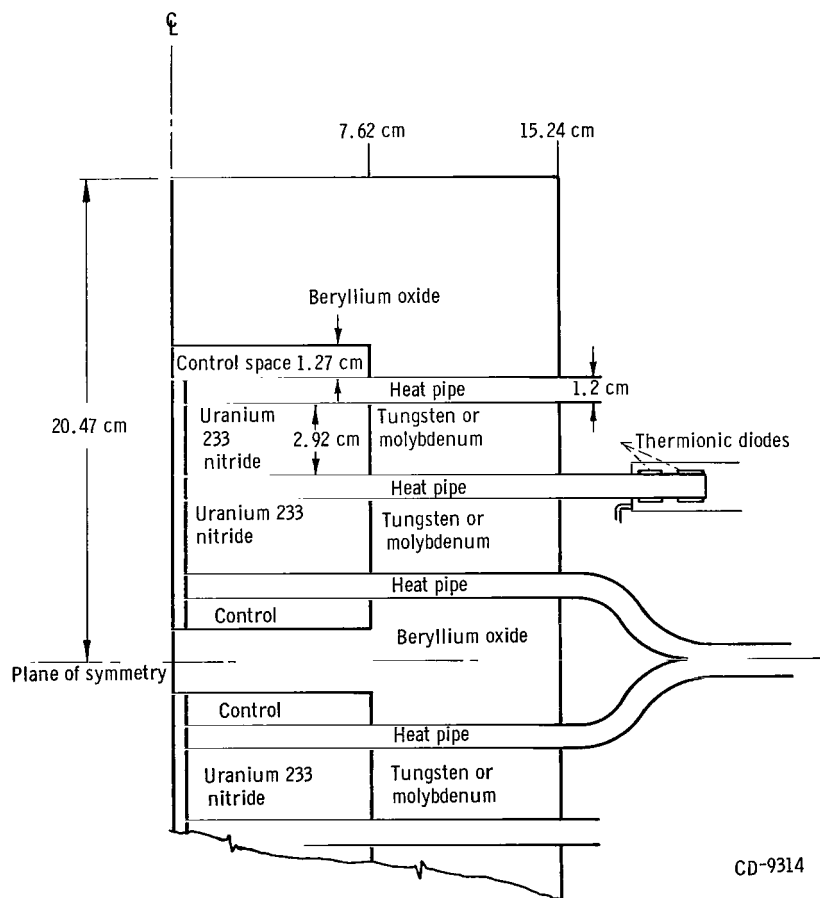

Figure 4. - Schematic of internal composition of fast reactor with spectrum softening control.

ciently mobile to conglomerate into bubble regions that cause fuel swelling (ref. 12). At temperatures around 2073°K the fuel swelling problem becomes very troublesome. However, at a temperature of 2473°K , fission product atoms migrate more easily and can be released. If the fuel matrix temperature is sufficiently high, fuels may be successfully vented without serious swelling and cracking problems. However, an alternative design using a tungsten-uranium nitride cermet for the fuel material is described in appendix B. This design has a fuel centerline temperature of 2278°K . The heat pipes in a system using this cermet fuel element will be redundant when one fuel sector is cooled by two heat pipes. Thus a complete failure of a single heat pipe should not lead to a catastrophic system failure. The ceramic fuel elements, however, with the high center temperatures will require careful design and probably the addition of more tungsten to ensure heat pipe redundancy.

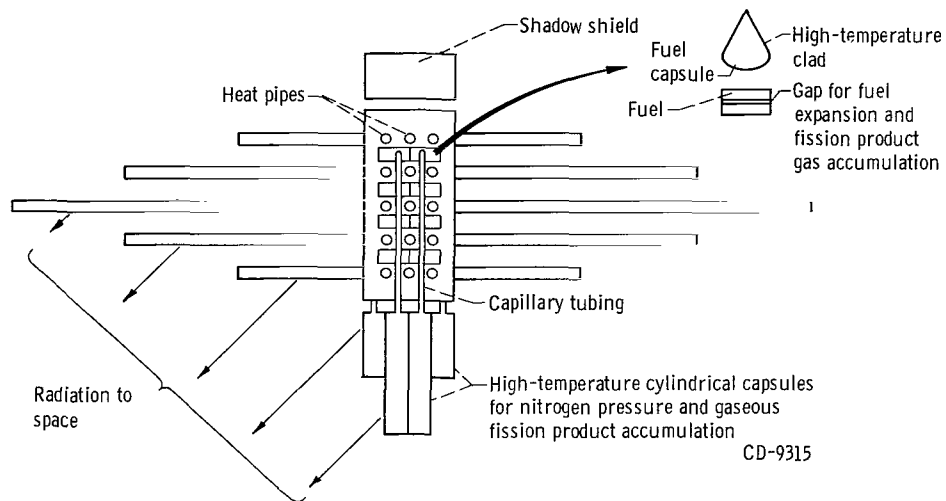

Figure 5. - Possible method for maintaining nitrogen overpressure on uranium nitride and for gaseous fission product pressure reduction within fuel capsule.

Since it is not feasible to vent uranium nitride to space, it is proposed to vent the fuel to a nitrogen gas system maintaining the overpressure on the fuel. The arrangement of this gas system is shown in figure 5. The fueled regions are connected to the overpressure gas region through small orifices or molecular sieves that will prevent uranium ^{233}U nitride movement out of the fuel disk. These uranium flow restrictors would be located in a high-temperature region of the core to possibly prevent plugging by recondensed fuel or fission product atoms.

CONTROL OF FAST REACTOR USING INTERNAL REFLECTION

Figure 4 also shows a schematic representation of the proposed control system. The traditional form of control for thermal reactors has been the use of a neutron absorbing

material in the form of a rod that could be inserted into the reactor core. However, in fast spectrum reactors, the neutron absorbing control rod concept does not work as well. The problem lies in the values of neutron absorption cross sections for neutrons of high energy. The absorption cross sections of the best absorbers of fast neutrons are smaller than the fuel absorption cross section, whereas in a thermal spectrum there are absorbers with cross sections that are many times greater than fuel absorption cross sections.

One approach to this problem has been to surround the fast reactor core with a neutron thermalizing reflector. Neutron absorbing materials are then placed in the reflector regions to obtain control of the neutron density. The concept illustrated in figure 4 places neutron thermalizing regions inside the core in heterogeneous slabs and places control material regions around them. This has the effect of producing two or more small, fast reactor zones that achieve criticality by coupling. Insertion of a material such as lithium 6 in the control regions shown obtains control by absorption of thermalized neutrons. For a reactor of the dimensions shown in figure 4, the effective multiplication factor dropped by 5.5 percent when nitrogen gas in the control spaces was replaced by lithium 6.

The neutron energy spectrum in this reactor core is shown in figure 6. The solid line histogram represents the flux spectrum in the reactor when only nitrogen is con-

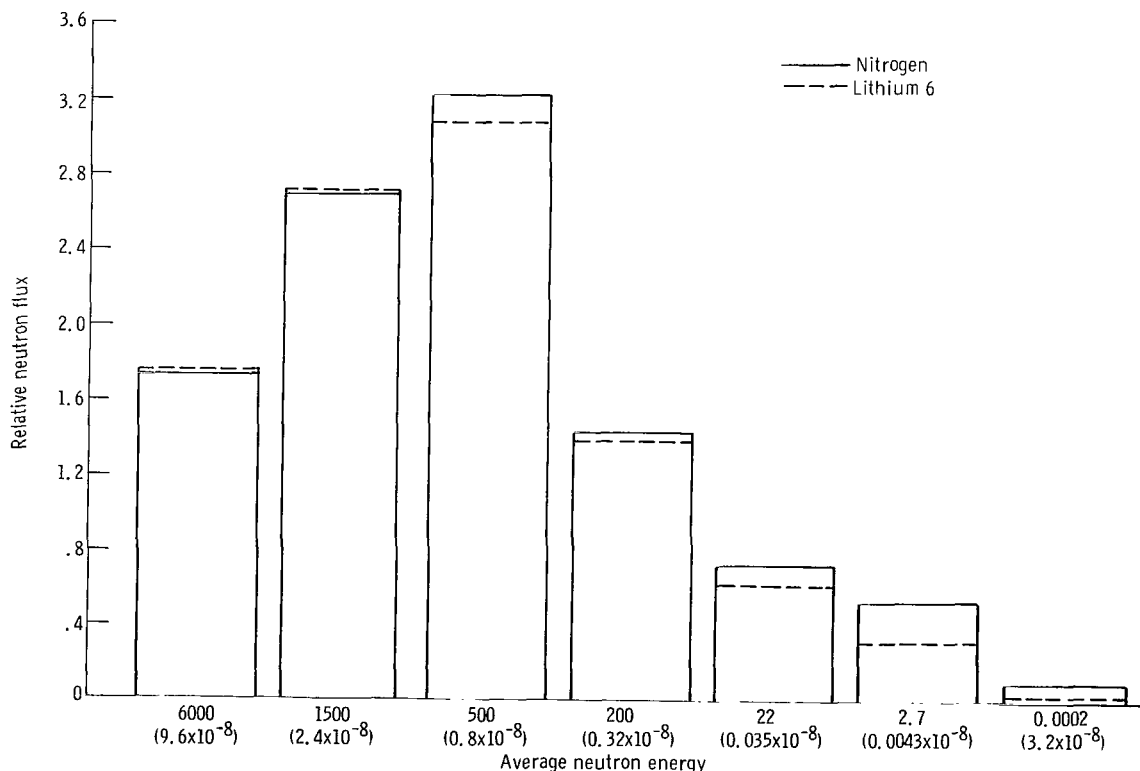

Figure 6. - Comparative spectra of neutrons causing fissions for nitrogen and lithium 6 in control chamber. (Neutron energy values are in keV (pJ).)

tained in the control space. The dashed line represents the spectrum calculated when lithium 6 has been inserted. The reactivity control is obtained by the removal of thermal neutrons produced in the internal reflectors. A description of the energy groups used and of the calculations of these spectra is given in appendix A.

A typical operating power distribution with this control system is presented in figures 7 and 8. Lithium 6 has been removed from the two end regions in the core to reach a clean critical condition, but lithium 6 is left in the central regions for later burnup compensation and other control requirements. These power profiles represent the fissions per unit volume within the core region. If the axial peak-to-average value shown in figure 8 causes excessive fuel temperature in larger, higher power density reactors of this type, the thickness of a particular fuel element at the maximum power generation point may be decreased since the fuel elements are of the slab type, that is, essentially one dimensional geometry.

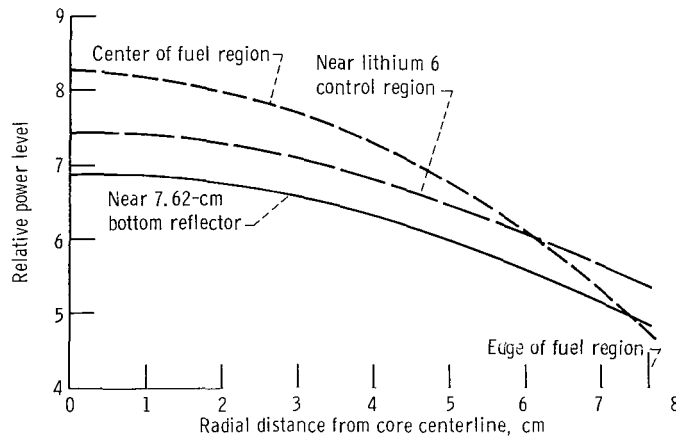

Figure 7. - Radial power profiles in uranium nitride reactor internally reflected and controlled.

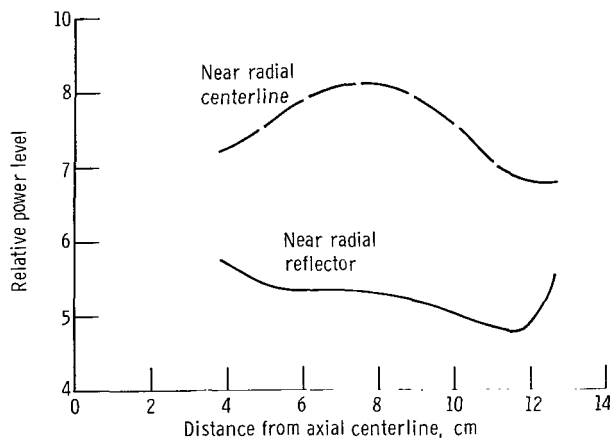

Figure 8. - Axial power profiles with control material in central region only.

A possible mechanism for transfer of control material into the control spaces is shown in figure 9. The nitrogen and lithium will be separated by some form of a piston which will be correctly oriented by guide tubes running inside slots in the internal reflector material. The lithium 6 can be introduced into the reactor by use of a positive displacement pump. It is also proposed that the lithium 6 fill a central hole through the center of the reactor. The expansion of lithium 6 from this central hole into the control chamber may be sufficient to provide a negative-temperature reactivity coefficient. This proposal would be valid only for those reactors with sufficiently long core sections. The lithium located adjacent to the fuel region in the reactor is exposed to a fast neutron spectrum in which it has a low value of absorption cross section. If the core temperature rises and causes the lithium to expand, some atoms of lithium 6 will be removed from the fast spectrum region into the more nearly thermal region.

Additional calculations have indicated that the moderating material, zirconium hydride, would be even more effective than beryllium oxide for controlling reactivity. It is theoretically possible to obtain a change in reactivity as high as 25 percent using the reactor geometry shown in figure 3. Excessively high values of power peaking are associated with this 25 percent change in reactivity so that this particular configuration is not proposed as a design concept. However, the magnitude of the effects obtained do indicate the versatility of this type of control scheme.

The use of beryllium oxide as the internal-reflector in the core introduces material that is susceptible to fast neutron damage. However, this application of beryllium oxide is not as demanding as its use as an electrical insulator. The dose of fast neutrons

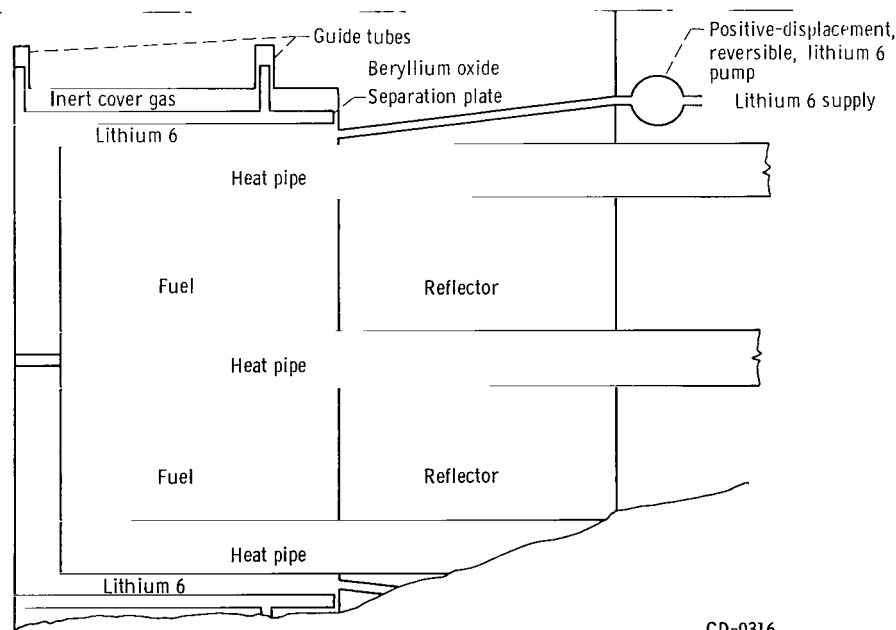
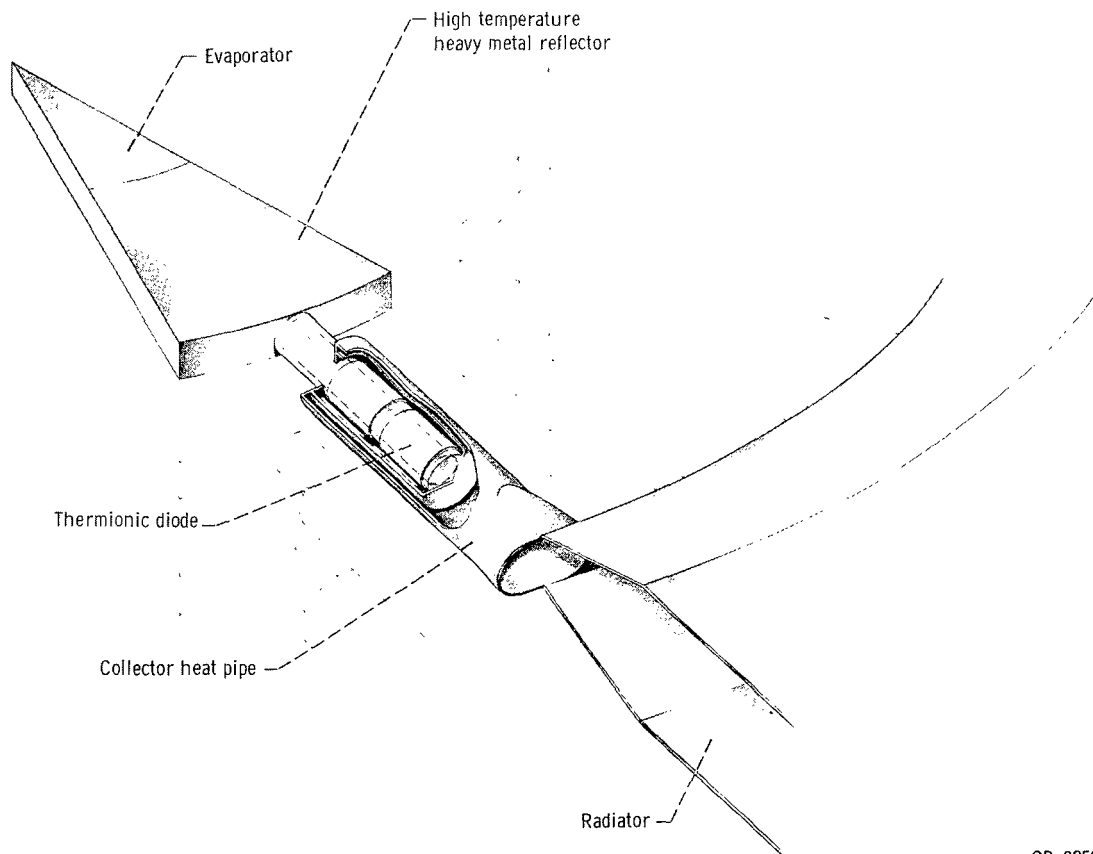

Figure 9. - Reactivity control system.

above 1 MeV (1.6×10^{-13} J) in the present core is about 1.6×10^{21} neutrons per square centimeter in 10 000 hours at its maximum in the moderating material. Present testing at Oak Ridge National Laboratory indicates that this dose produces minor fracturing in beryllium oxide. This condition would be tolerable in a canned material, but intolerable in an insulating sheath.

SUMMARY OF CONDITIONS AND CONFIGURATION

Figures 10 and 11 show overall pictures of what the heat-pipe - thermionic-diode power reactor might look like. The core and reflector in figure 10 have an outside diameter of 30.48 centimeters. The heat pipe emerging from the radial reflector has a diameter of 1.2 centimeter and is shown with an electrical insulating sheath around it. Preliminary calculations indicate that a sheath of beryllium oxide with a thickness of 0.058 centimeter could hold electrical leakage to 5 percent with a total series voltage across the diodes of 50 volts. The encircling collector heat pipe is also represented in figure 10 and is shown connected to a radiator section through a transition piece.



CD-9259

Figure 10. - Heat pipe - thermionic diode in reactor.

The radiator construction would be multiple heat pipes in a cellular arrangement similar to that proposed by Salmi (ref. 1). One possible radiator arrangement is presented in figure 11. The radiators are arranged as five circular disks having outside radii of 0.75, 1.23, and 1.41 meters. These dimensions result from a preliminary calculation using an effective surface emissivity of 0.90, a surface view factor of 0.85 for those surfaces not covered by an adjacent disk, and a sink temperature for deep space of 0° K. It was assumed that 412 kilowatts was radiated from these disks. It should be reemphasized, that this particular radiator configuration in no way represents the optimum design for a radiator. The intended purpose of the calculation is to provide an estimate of system size.

A summary of reactor, heat pipe, and thermionic diode operating conditions is presented in the following table:

Reactor:

Fuel	Uranium 233 nitride
Cooling	Molybdenum (TZM) or tungsten heat pipes
Cooling fluid	Lithium
Maximum fuel temperature, °K	2828
Fuel clad temperature, °K	1850
Heat flux at clad, W/cm ²	280

Thermionic diodes:

Temperature at emitter heat pipe condensing surface, °K	1836
Total number of diodes	384
Emitter area per diode, cm ²	23.6
Emitter diameter, cm	1.32
Emitter length, cm	5.7
Heat flux at diode, W/cm ²	45.5
Emitter electrical power density, W/cm ²	4.55
Collector surface temperature, °K	973
Electrical power per diode, W	107.4
Output voltage, V	0.5

System output:

Number of parallel circuits	4
Gross output, V	48
8-Percent lead drop, V	3.8
Net output potential, V	44.2
5-Percent power lost through leadage, kW	2.1
Total net output current, A	815
Net output power (unconditioned), kW	36

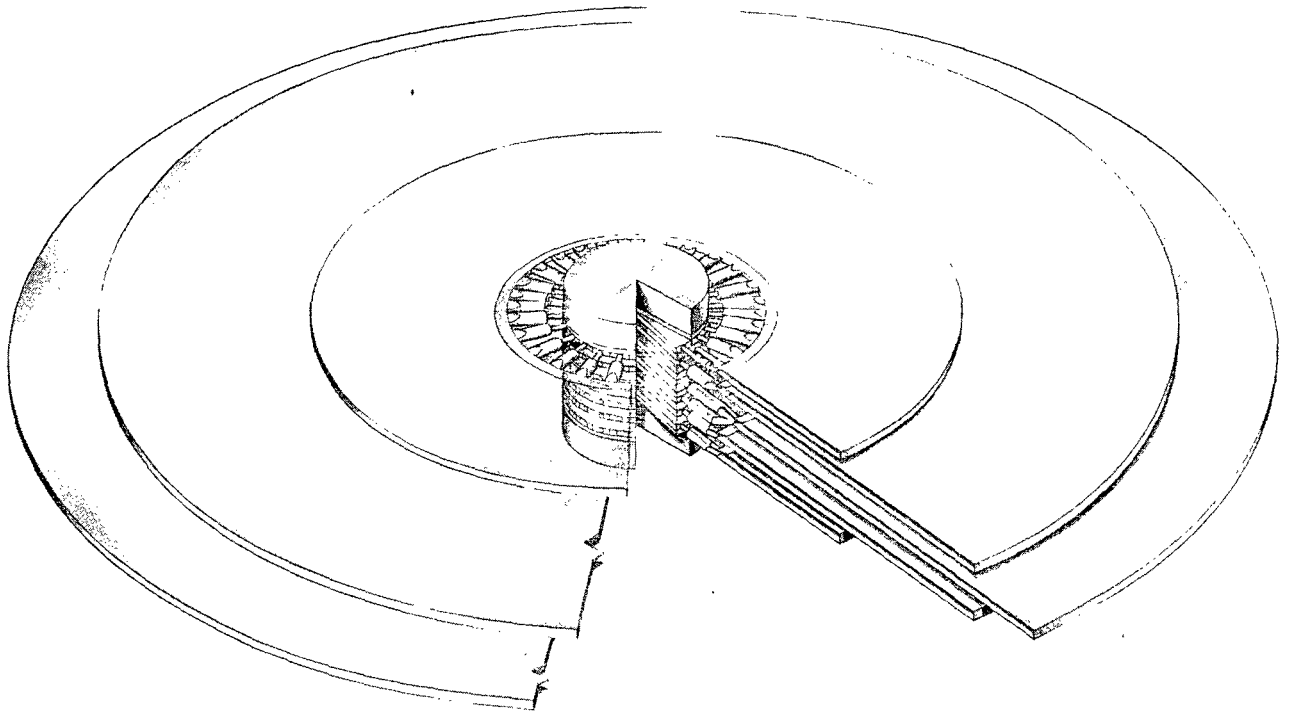

CD-9260

Figure 11. - Radial heat pipe - thermionic reactor system.

TABLE I. - MATERIAL WEIGHTS

Components	Volume, cm ³	Weight, kg
Reactor materials		
Uranium nitride	2 131	30.5
Lithium	927	.37
Tungsten	111	2.11
Beryllium	18 997	34.95
Molybdenum reflector	13 369	136.36
Total reactor materials	-----	204.31
Radiator ^a	-----	49.7
Diode	-----	<10
Total ^b		264

^a30 mil (0.076 cm) beryllium for surface of five disks.

^bExcluding shielding.

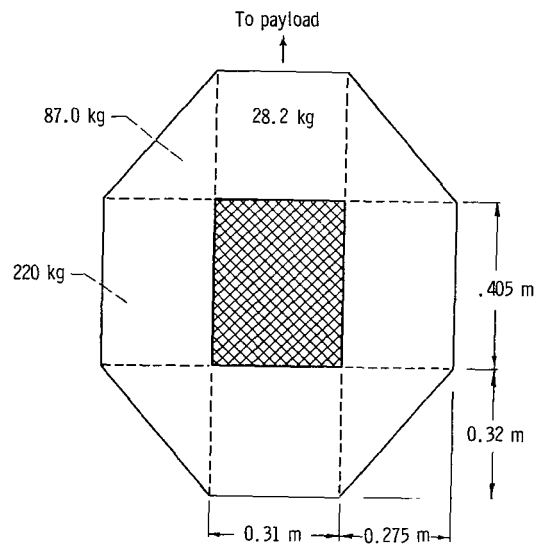

CD-9317

Figure 12. - Possible shield configuration for unmanned vehicle with uranium nitride heat pipe power supply. Shadow shield weight, 28.2 kilograms; wrap around shield weight, 335 kilograms; 4π shield weight, 450 kilograms; payload removed, 45.7 meters.

These conditions represented the smallest reactor to meet criticality requirements with the power output set by the 280 watts per square centimeter that may be transferred across the evaporator surfaces in the heat pipes. The electrical output available from the system is set by the obtainable efficiency of the thermionic diodes, which was assumed to be 10 percent, and the current and voltage losses through the network of diodes. For an assumed 8-percent drop in the leads and a 5-percent current loss, the unconditioned output power is 36 kilowatts electric.

A summary of reactor weights and materials is shown in table I. The total weight for reactor, diodes, and radiator is around 264 kilograms providing a specific weight of 7.3 kilograms per kilowatt electric excluding the required shielding.

In regard to the shielding of an unmanned probe, the payload would be placed on the vertical axis of the cylindrical reactor core. The control reservoir containing lithium 6 would be placed on that axial face of the core nearest the payload. For present day electronic components and devices, an integrated fast neutron dose (>1 MeV or 1.6×10^{-13} J) of 10^{13} neutrons per square centimeter (nvt) is considered acceptable and a gamma dose of 10^6 rads (10^6 cJ/kg) is considered tolerable (ref. 13). In view of these limitations, if it can be arranged so that the payload is removed from the reactor core by a distance of 45.7 meters, there will be no additional shielding required for tolerable gamma doses, but 235 kilograms per square centimeter of surface area of lithium hydride will be required as a fast neutron shield to attenuate the fast flux by a factor of 40. If it becomes necessary to operate with a 15.3 meter separation, approximately 50.8 centimeters of lithium hydride (366 kg/m^2) would be needed.

A summary of fast neutron shield weights is indicated in figure 12. A first-flight shadow shield for a 6.1 meter wide payload would weigh 28.2 kilograms. A calculation of secondary neutron and gamma scatter off the radiator is beyond the scope of this conceptual study. However, a maximum weight limit would be that connected with a radial shield providing the same attenuation as the straight shadow shield. This maximum limit would then be 335 kilograms. A full shield configuration (4π) would come to 450 kilograms.

With the wrap around shield included, the specific weight of the system would increase to 16.6 kilograms per kilowatt electrical, but this does not include the weight of the 45.7 meter deployment structure.

SUMMARY OF RESULTS

A conceptual design of an out-of-pile thermionic space power system using concentric heat pipes for both heating and cooling the thermionic diodes has been examined. This design presents several advantages. The thermionic diode is now removed from

high doses of fast neutron flux and from other problems of the reactor environment. The tolerance of electrical insulation materials to fast neutrons appears to lie around an integrated flux of 10^{21} neutrons per square centimeter, a level usually encountered within 10 000 hours in in-pile thermionic designs. Furthermore, since the diode emitter is no longer the clad material for the fuel element, small amounts of fuel swelling will no longer affect diode performance. The interdiode spacing can thus be made smaller to obtain higher power levels and efficiencies.

The thermionic diode performance has now been decoupled from reactor power profiles and radial flux shifts. By correct design and manufacture, all the heat pipes feeding the diode emitters should run at nearly the same temperature and minimum temperature gradients will exist along emitter lengths.

Although it is true that the temperature of the thermionic emitter is lower than the temperature of the fuel clad, thus reducing diode efficiency, the practically isothermal operation of the heat pipe (refs. 1 and 4) reduces this difference considerably. The primary temperature drop takes place within the necessary electrical insulation around the emitter heat pipe and through the emitter-insulator bond. The 63° K temperature drop from heat pipe to emitter indicated in table I is based on experimental values (ref. 7).

The only mechanical pumps required in this heat pipe concept are the drivers for the lithium in the control regions. These pumps will require power only during periods of reactivity adjustment. No other electrical power for mechanical pumps need be diverted from the system output. Furthermore, after the end of useful operating life, no additional mechanical energy will be needed to prevent core melt down, disintegration, and consequent contamination of space. The heat pipes will easily handle the afterheat produced in the core after shutdown.

The reliability of the heat-pipe system is a result of the redundancy in the system. As discussed by Salmi (ref. 1), the cellular structure of a heat pipe radiator eliminates the need for substantial micrometeorite armor. In a similar way, open circuiting of a thermionic diode or corrosion failure of a single heat pipe would not be fatal to the reactor, for a design where one fuel sector is cooled by two heat pipes. Increased load on neighboring heat pipes will perturb the system performance, but correct design should preclude total system failures due to a serious malfunction of nonadjacent heat pipes.

Lewis Research Center,
National Aeronautics and Space Administration,
Cleveland, Ohio, August 30, 1967,
128-27-05-20-22.

APPENDIX A

DETAILS OF NUCLEAR CALCULATIONS

Because of the small size of the reactor cores considered and the complexity of spectral changes throughout the core, it was necessary to perform nuclear calculations in two dimensions. The two-dimensional neutron transport program (TDSN) (ref. 14) was used for all neutron transport calculations. The core region was assumed to be composed of the homogeneous materials which it encompasses. The model used for the calculations is shown in figure 13.

Neutron cross sections over 18 energy groups were prepared using the programs GAM II and GATHER (refs. 15 and 16). Fast group cross sections for the fuel were generated from a spectrum obtained in a 60-volume-percent uranium 233 nitride - tungsten fuel composite with 5-volume-percent lithium 7 in the core region. Thermal cross

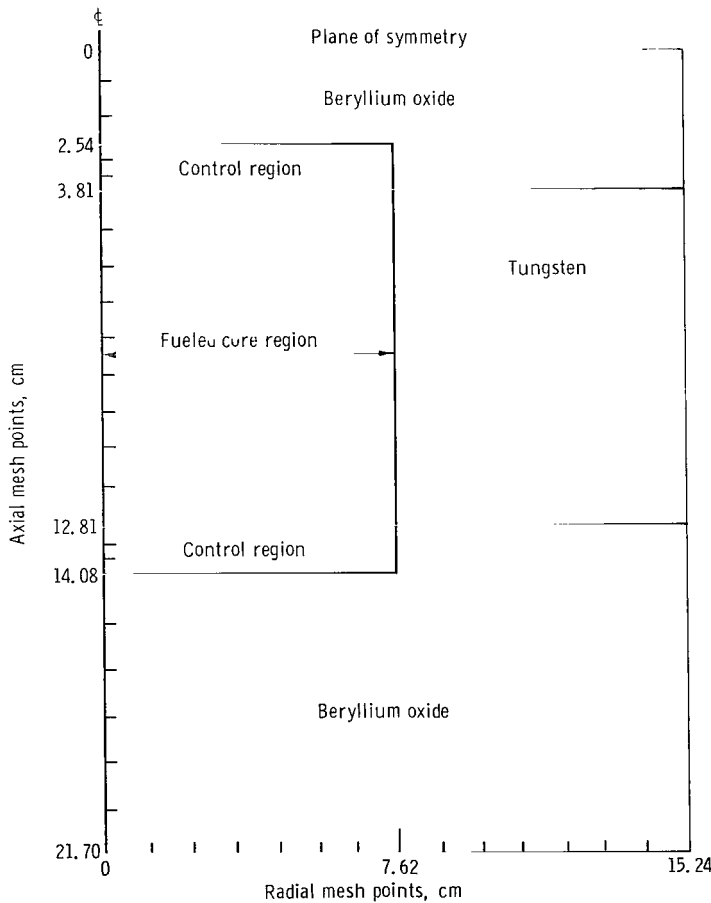

Figure 13. - Neutronic calculational model of reactor.

sections for the fuel region and for reflector materials came from a 95-volume-percent beryllium oxide - 5-volume-percent lithium 7 composite spectrum.

Eighteen energy group cross sections (see table II) were used in axial calculations throughout the reactor using the S_4 approximation for transport theory. The flux integrals obtained for each material in these calculations were used to reduce 18-group cross section sets to the 7-group structure also shown in table II.

Criticality calculations were then performed in two-dimensional cylindrical geometry using the S_4 transport theory approximation. Seven energy group cross sections were used with P_0 terms and the diagonal transport approximation.

This procedure has been checked on uranium 233 - tungsten critical experiments as described in reference 17. It agrees within 2 percent of the experimental values.

TABLE II. - ENERGY GROUP STRUCTURE IN
TRANSPORT CALCULATIONS IN
LETHARGY UNITS

Groups		Lethargy ^a
1-D calculation	2-D calculation	
1	1	-0.4
2	2	1.0
3	↓	1.5
4	↓	2.0
5	3	2.5
6	↓	3.0
7	↓	3.5
8	4	4.0
9	4	4.5
10	5	5.5
11	5	6.5
12	6	7.5
13	6	9.5
14	7	17.0
15		17.5
16		17.9
17		18.7
18	↓	19.9

^aZero lethargy at 1.6×10^{-13} J.

APPENDIX B

ALTERNATE REACTOR DESIGN RESULTING IN LOWER FUEL TEMPERATURE

The core geometry as presented is by no means the only one possible for the concept presented. A series of calculations using the method described in appendix B has been performed to evaluate a similar reactor system using 65-percent uranium 233 nitride - 35-percent tungsten as the fuel. A comparison of this cermet fuel reactor with the previously calculated reactor with the uranium 233 nitride fuel, which was previously calculated, is shown in table III. Because of this dilution of the fuel material, the core size must be enlarged to retain criticality. If the axial height, number of fuel elements, and fuel element thickness are held constant, the increased radius of the core would also provide a greater surface area for heat transfer. Thus, if the limit of heat-pipe capability is retained, the system may provide more total power.

A reactor core fueled with 65-percent uranium 233 nitride - 35-percent tungsten and reflected internally with beryllium oxide was sized to provide the same reactivity as the first model. The required core radius would increase from 7.6 centimeters to 12.5 centimeters so that total core and neutron reflector weight would increase from 204 to 374 kilograms. However, it is now possible to operate the reactor at 1094 kilowatts (thermal power) which would provide 95.6 electrical kilowatts with the same assumed efficiencies.

Keeping the volume of the control spaces constant in this modified design provided more change in the effective multiplication factor with addition of lithium 6 than would be necessary. The 1.27 centimeter thick spaces shown in figure 6 provided a 10-percent control swing when nitrogen gas was replaced by lithium 6. A more detailed study of this alternate fuel system would show that the size of the control spaces could be decreased.

A comparison of core sizes, weights, power levels, and temperature is presented in table III.

TABLE III. - COMPARISON OF REACTOR FUELED BY URANIUM
AND URANIUM NITRIDE - TUNGSTEN CERMET

Component	Uranium nitride	65-vol. % uranium nitride - 35-vol. % tungsten
Core radius, cm	7.62	12.5
Radial reflector, cm	7.62	7.62
Total reactor height, cm	43.4	43.4
Reactor weight, kg	204	375
Reactor power to diodes, kW _t	412	1094
Centerline fuel temperature, °K	2828	2278
Core weight per electrical output	5.8	3.9

REFERENCES

1. Salmi, E. W.: A Study of a Nuclear Thermionic Propulsion System. Paper No. 67-229, AIAA, Jan. 1967.
2. Barnett, Charles S.: An Out-of-Pile Heat Pipe Thermionic Space-Power Concept. Trans. Am. Nucl. Soc., vol. 9, no. 2, Nov. 1966, pp. 338-339.
3. Feldman, K. Thomas, Jr.; and Whiting, Glen H.: The Heat Pipe. Mech. Eng., vol. 89, no. 2, Feb. 1967, pp. 30-33.
4. Cotter, T. P.: Theory of Heat Pipes. Rep. No. LA-3246-MS, Los Alamos Scientific Lab., Feb. 23, 1965.
5. Anand, D. K.: On the Performance of a Heat Pipe. J. Spacecraft and Rockets, vol. 3, no. 5, May 1966, pp. 763-765.
6. Kemme, J. E.: Heat Pipe Capability Experiments. Rep. No. LA-3585-MS, Los Alamos Scientific Lab., Aug. 22, 1966.
7. Harbaugh, Willis E.; Gelhaus, Floyd E.; and Longsdorff, Richard W.: The Development of an Insulated Thermionic Converter-Heat Pipe Assembly. (AFAPL TR-67-45, DDC No. AD-813 424), Radio Corp. of America, Apr. 1967.
8. Busse, C. A.; Caron, R.; and Capelletti, C.: Prototypes of Heat Pipe Thermionic Converters for Space Reactors. Paper presented at the International Conference on Thermionic Electrical Power Generation, European Nuclear Energy Agency and Institution of Electrical Engineers, London, Sept. 20-25, 1965.
9. Kitrilakis, S.; Lieb, D.; Rufeh, F.; and van Someren, L.: Thermionic Research Program. Rep. No. TE-12-67 (NASA CR-80525), Thermo Electron Eng. Corp., Aug. 1966.
10. Wilson, V. C.; and Lawrence, J.: Operating Characteristics of Two Thermionic Converters Having Rhenium - Nickel and Tungsten - Nickel Electrodes. Advanced Energy Conversion, vol. 4, no. 4, Dec. 1964, pp. 195-221.
11. Bugl, J.; and Keller, D. L.: Uranium Mononitride - A New Reactor Fuel. Nucleonics, vol. 22, no. 9, Sept. 1964, pp. 66-70.
12. Zebroski, E. L.; Kittel, H.; and Moss, D.: Reviews of Status of Technology of Fast Reactor Fuels. Fast Reactors National Topical Meeting. Rep. No. ANS-101, American Nucl. Soc., Apr. 1967, pp. 2-66.
13. Hamman, Donald J.; Drennan, James E.; Veazie, Walter H.; Shober, Fred R.; and Leach, E. R.: Radiation-Effects State of the Art, 1965-1966. Rep. No. REIC-42, Battelle Memorial Inst., June 30, 1966. (Available from DDC as AD-802986).

14. Barber, Clayton E.: A Fortran IV Two-Dimensional Discrete Angular Segmentation Transport Program. NASA TN D-3573, 1966.
15. Joanou, G. D.; and Dudek, J. S.: GAM II. A B_3 Code for the Calculation of Fast-Neutron Spectra and Associated Multigroup Constants. Rep. No. GA-4265, General Dynamics Corp., Sept. 16, 1963.
16. Joanou, G. D.; Smith, C. V.; and Vieweg, H. A.: GATHER-II - An IBM-7090 Fortran-II Program for the Computation of Thermal-Neutron Spectra and Associated Multigroup Cross Sections. Rep. No. GA-4132, General Dynamics Corp., July 8, 1963.
17. Lahti, G. P.; Lantz, E.; and Miller, J. V.: Preliminary Considerations for a Fast-Spectrum, Liquid-Metal Cooled Nuclear Reactor Program for Space-Power Applications. Estimated publication, December 1967.

OFFICIAL BUSINESS

04U 001 47 51 3DS 68074 00903
AIR FORCE WEAPONS LABORATORY/AFWL/
KIRTLAND AIR FORCE BASE, NEW MEXICO 87117

ATT MISS MADELINE F. CANOVA, CHIEF TECHNIC
LIBRARY /WLIL/

POSTMASTER: If Undeliverable (Section 158
Postal Manual) Do Not Return

"The aeronautical and space activities of the United States shall be conducted so as to contribute . . . to the expansion of human knowledge of phenomena in the atmosphere and space. The Administration shall provide for the widest practicable and appropriate dissemination of information concerning its activities and the results thereof."

—NATIONAL AERONAUTICS AND SPACE ACT OF 1958

NASA SCIENTIFIC AND TECHNICAL PUBLICATIONS

TECHNICAL REPORTS: Scientific and technical information considered important, complete, and a lasting contribution to existing knowledge.

TECHNICAL NOTES: Information less broad in scope but nevertheless of importance as a contribution to existing knowledge.

TECHNICAL MEMORANDUMS: Information receiving limited distribution because of preliminary data, security classification, or other reasons.

CONTRACTOR REPORTS: Scientific and technical information generated under a NASA contract or grant and considered an important contribution to existing knowledge.

TECHNICAL TRANSLATIONS: Information published in a foreign language considered to merit NASA distribution in English.

SPECIAL PUBLICATIONS: Information derived from or of value to NASA activities. Publications include conference proceedings, monographs, data compilations, handbooks, sourcebooks, and special bibliographies.

TECHNOLOGY UTILIZATION PUBLICATIONS: Information on technology used by NASA that may be of particular interest in commercial and other non-aerospace applications. Publications include Tech Briefs, Technology Utilization Reports and Notes, and Technology Surveys.

Details on the availability of these publications may be obtained from:

SCIENTIFIC AND TECHNICAL INFORMATION DIVISION
NATIONAL AERONAUTICS AND SPACE ADMINISTRATION

Washington, D.C. 20546