

NASA CR 61207

EDDY CURRENT
Volume I - Basic Principles

Prepared under Contract NAS 8-20185

Convair Division
General Dynamics Corporation
San Diego, Calif.

for George C. Marshall Space Flight Center

NATIONAL AERONAUTICS AND SPACE ADMINISTRATION

FACILITY FORM 602	<u>N 68-28779</u>	(THRU)
	<u>296</u>	(CODE)
	<u>CR-61207</u>	<u>15</u> (CATEGORY)
	(ACCESSION NUMBER)	
	(PAGES)	
	(NASA CR OR TMX OR AD NUMBER)	

TABLE OF CONTENTS

	Page
Preface	ii
Acknowledgments	iv
Introduction	v
Instructions.	vi
 Chapter 1 - Basic Eddy Current Concepts.	 1-1
Eddy Currents	1-2
Conductivity and Resistance	1-8
Factors Affecting Eddy Current Indications.	1-12
Coils	1-21
Review.	1-24
 Chapter 2 - Eddy Current Generation and Distribution	 2-1
Magnetic Field Generation	2-1
Eddy Current Distribution	2-9
Review.	2-20
 Chapter 3 - Coil-Specimen Coupling Factors.	 3-1
Distance	3-1
Lift-Off Effect	3-2
Fill Factor	3-8
Review.	3-15
 Chapter 4 - Specimen's Magnetic and Electrical Effects	 4-1
Permeability	4-6
Flux Density	4-7
Magnetizing Force	4-19
Saturation.	4-41
Hysteresis	4-44
Review.	4-61
 Chapter 5 - Basic Electrical Concepts Related to Eddy Current Testing.	 5-1
Impedance Testing	5-5
Phase Analysis	5-30
Modulation Analysis	5-116
Review.	5-132
 Self Test	 T-1



PREFACE

Programmed Instruction Handbook - Eddy Current Testing (5330.12, Vols. I-II) is home study material for familiarization and orientation on Nondestructive Testing. This material was planned and prepared for use with formal Nondestructive Testing courses. Although these courses are not scheduled at this time the material will be a valuable aid for familiarization with the basics of Nondestructive Testing. When used as prerequisite material, it will help standardize the level of knowledge and reduce classroom lecture time to a minimum. The handbook has been prepared in a self-study format including self-examination questions.

It is intended that handbook 5330.9 be completed prior to reading other Programmed Instruction Handbooks of the Nondestructive Testing series. The material presented in these documents will provide much of the knowledge required to enable each person to perform his Nondestructive Testing job effectively. However, to master this knowledge considerable personal effort is required.

This Nondestructive Testing material is part of a large program to create an awareness of the high reliability requirements of the expanding space program. Highly complex hardware for operational research and development missions in the hazardous and, as yet, largely unknown environment of space makes it mandatory that quality and reliability be developed to levels heretofore unknown. The failure of a single article or component on a single mission may involve the loss of equipment valued at many millions of dollars, not to mention possible loss of lives, and the loss of valuable time in our space timetable.

A major share of the responsibility for assuring such high levels of reliability, lies with NASA, other Government agencies, and contractor Nondestructive Testing personnel. These are the people who conduct or monitor the tests that ultimately confirm or reject each piece of hardware before it is committed to its mission. There is no room for error -- no chance for reexamination. The decision must be right -- unquestionably -- the first time. This handbook is one step toward that goal.

General technical questions concerning this publication should be referred to the George C. Marshall Space Flight Center, Quality and Reliability Assurance Laboratory, Huntsville, Alabama 35812.

The recipient of this handbook is encouraged to submit recommendations for updating and comments for correction of errors in this initial compilation to George C. Marshall Space Flight Center, Quality and Reliability Assurance Laboratory (R-QUAL-OT), Huntsville, Alabama 35812.

ACKNOWLEDGMENTS

This handbook was prepared by the Convair Division of General Dynamics Corporation under NASA Contract NAS8-20185. Assistance in the form of process data, technical reviews, and technical advice was provided by a great many companies and individuals. The following list is an attempt to acknowledge this assistance and to express our gratitude for the high degree of interest exhibited by the firms, their representatives, and other individuals who, in many cases, gave considerable time and effort to the project.

Aerojet-General Corp.; Automation Industries, Inc., Sperry Products Division; AVCO Corporation; The Boeing Company; The Budd Co., Instruments Division; Douglas Aircraft Co., Inc.; Dr. Foerster Institute; General Electric Co.; Grumman Aircraft; Mr. John Hall; Mr. Richard Hochschild, Microwave Instruments Co.; Mr. H. L. Libby, Lockheed Aircraft Corp.; Magnaflux Corp.; Magnetic Analysis Corporation; The Martin Co. (Denver); McDonnell Aircraft Corp.; North American Aviation, Inc.; Pacific Northwest Laboratories, Batelle Memorial Institute; Rohr Corporation; Southwest Research Institute; St. Louis Testing Laboratories, Inc.

Our thanks is also extended to the many individuals who assisted in the testing of the materials to validate the teaching effectiveness. Their patience and comments contributed greatly to the successful completion of the handbook.

INTRODUCTION

This handbook presents the principles and applications of eddy currents in the area of nondestructive testing. As you will see, eddy currents are small circulating electrical currents that are induced in conductive materials when a coil with an alternating current is placed near the material. The fact that the material affects the flow of eddy currents provides the basis for a nondestructive testing system.

THE EDDY CURRENT TESTING PROGRAMMED INSTRUCTION series is two volumes which provide the background material you will need before you perform actual eddy current testing. Successful completion of these two volumes is dependent on prior completion of 5330.9 INTRODUCTION TO NONDESTRUCTIVE TESTING. So, if you haven't already done so, read 5330.9 before you start this eddy current testing volume. The contents of the two volumes covering eddy current testing are summarized as follows:

Volume I - BASIC PRINCIPLES

The purpose of this volume is to present the basic concepts of eddy currents, to explain how eddy currents are generated and distributed, to point out how the specimen's magnetic and electrical effects relate to eddy currents, and to provide the basic electrical concepts related to eddy current testing.

Volume II - EQUIPMENT, METHODS, AND APPLICATIONS

In this volume you become familiar with the equipment designed for eddy currents, the various methods which use eddy currents, and the applications where eddy currents can perform the task of nondestructive testing.

INSTRUCTIONS

The pages in this book should not be read consecutively as in a conventional book. You will be guided through the book as you read. For example, after reading page 3-12, you may find an instruction similar to one of the following at the bottom of the page -

- Turn to the next page
- Turn to page 3-15
- Return to page 3-10

On many pages you will be faced with a choice. For instance, you may find a statement or question at the bottom of the page together with two or more possible answers. Each answer will indicate a page number. You should choose the answer you think is correct and turn to the indicated page. That page will contain further instructions.

As you progress through the book, ignore the back of each page. **THEY ARE PRINTED UPSIDE DOWN.** You will be instructed when to turn the book around and read the upside-down printed pages.

As you will soon see, it's very simple - just follow instructions.

Turn to the next page.

Our study of eddy current testing begins with basic concepts. Let's start by first realizing that eddy current testing is another form of nondestructive testing. This means that we have a typical nondestructive testing system in which a testing medium is applied to a specimen and the specimen reacts with this medium. The resulting reaction is sensed and displayed for interpretation.

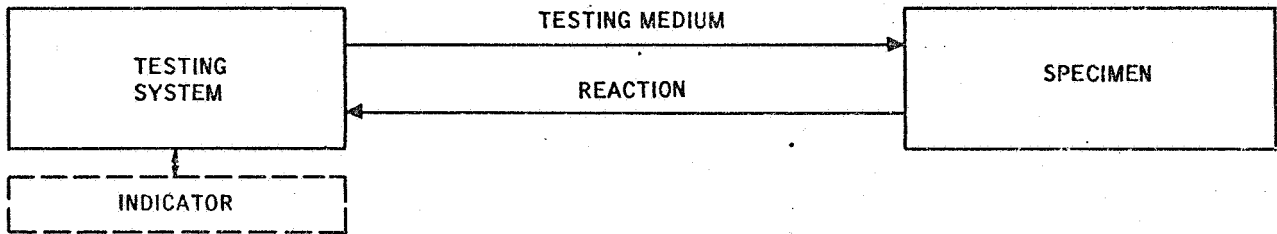

In the eddy current testing system, the nondestructive testing system consists of a generator, a test coil, and an indicator. The generator provides an alternating current to the test coil which develops a magnetic field. This field, in turn, induces eddy currents into the specimen. The indicator, of course, tells us how the specimen is affecting the eddy currents. But! more of this later.

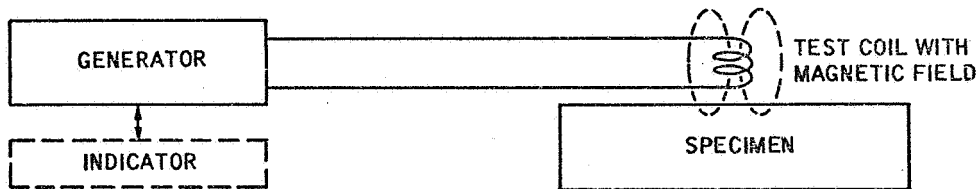

Turn to page 1-2.

Since our subject is eddy currents, let's start with a definition. An eddy current is defined as a circulating electrical current induced in an isolated conductor by an alternating magnetic field. One way to do this is to apply alternating current (ac) to a coil and place the coil above the surface of an isolated material which will conduct an electrical current. The magnetic field of the coil will induce an eddy current into the material.

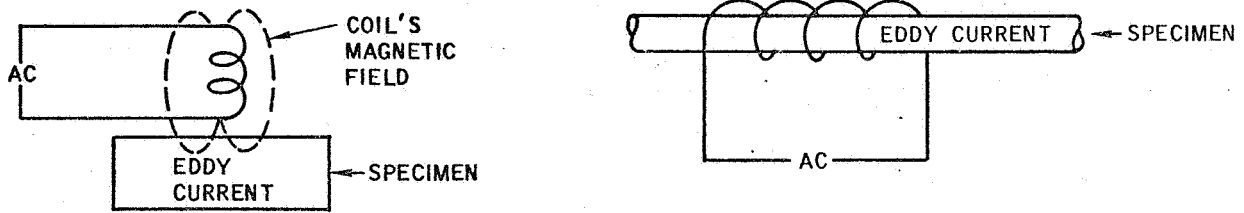

Or, if you wish, you can place the isolated material (a cylinder) inside the coil. Either way, you get eddy currents. Note that in both cases, the material is not connected to any external circuit.

Of course, you probably are wondering where the current flows. That's simple. The current just flows in small circles or paths within the isolated material.

If a conductor (metal bar or plate) with an external circuit (view A) is placed in the alternating magnetic field of a coil, a current will flow and can be detected by a meter. If the external circuit is removed (view B),

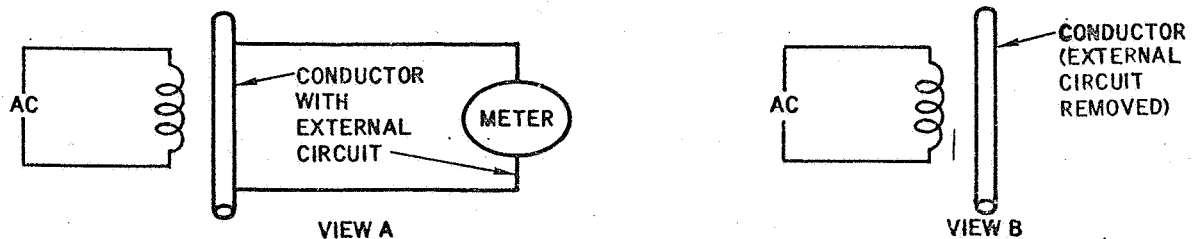

No alternating current (ac) will flow within the conductor Page 1-3

Alternating current (ac) will still flow within the conductor Page 1-4

Sorry you are wrong when you say that no alternating current (ac) will flow within the conductor when the external circuit across the conductor is removed. Actually, alternating current (ac) will still flow within the conductor.

Recall that an eddy current is defined as a circulating electrical current induced in an isolated conductor by an alternating magnetic field. The conductor does not need to be connected to an external circuit.

Turn to page 1-4.

Correct! If the external circuit is removed, alternating current (ac) will still flow within the conductor. After all, an eddy current is defined as a circulating electrical current induced in an isolated conductor by an alternating magnetic field.

It is interesting to see what actually happens when a test coil is placed above the surface of an isolated material.

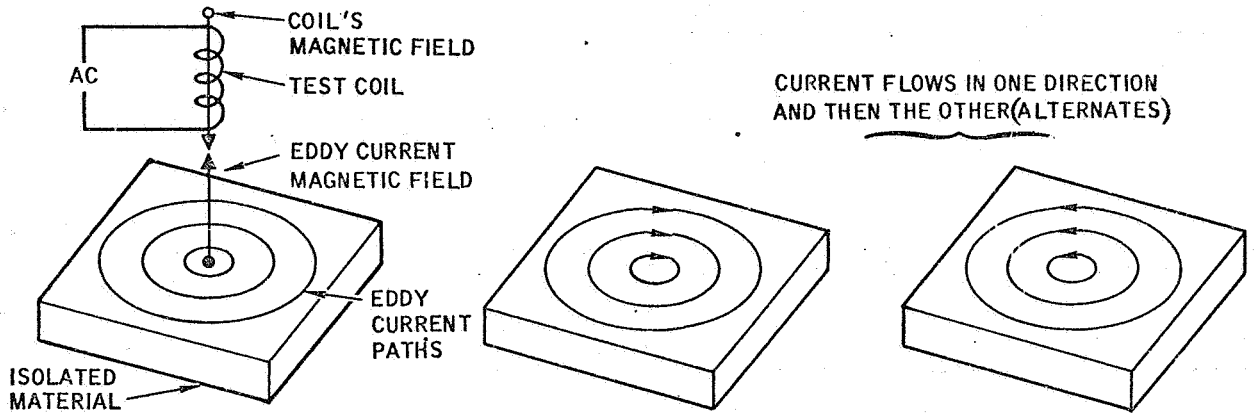

When a test coil is placed above the surface of an isolated conducting material, the coil's magnetic field induces current into the material. This current (eddy current) will flow in small circular paths and will alternate as the coil's magnetic field alternates. Recall that the coil is conducting an alternating current which reverses itself. This means the coil's magnetic field will reverse itself (alternates).

At this point, let's learn another fact about magnetic fields. A current flowing through a conductor will generate a magnetic field around the conductor. That's how we got the magnetic field for the coil. It is also true that the flow of eddy current will generate a magnetic field. Now we have two magnetic fields; one for the test coil and one for the eddy currents. And we learn something about the material because the two magnetic fields react. In fact, the eddy current field opposes the coil's magnetic field. The amount of opposition depends partly on what is happening to the eddy current within the material.

It is important to remember that the flow of eddy current within a material generates a magnetic field that:

- Opposes the coil's magnetic field Page 1-5
- Aids the coil's magnetic field Page 1-6

Fine! The eddy current's magnetic field opposes the coil's magnetic field. And this provides a basis for learning something about the material or specimen.

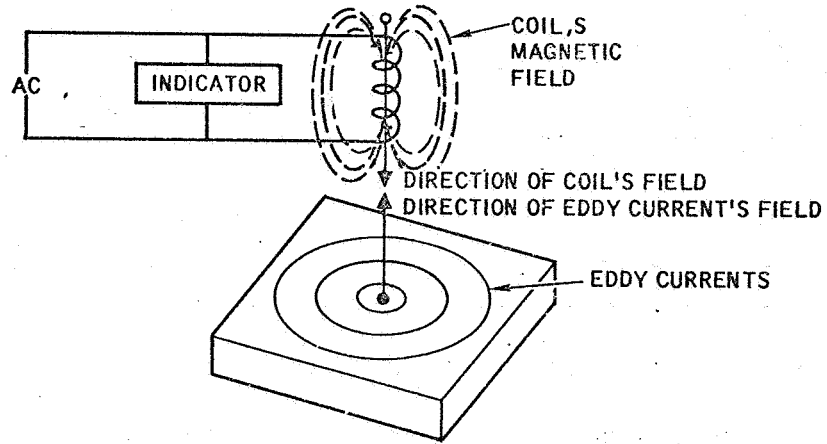

If an indicating device is connected across the test coil, a means will exist for learning something about a specimen. The indication will reflect the state of the test coil which is affected by the magnetic field around the coil. If the magnetic field around the test coil changes, the indication will change.

We have just learned that the flow of eddy currents will generate a magnetic field and this field opposes the coil's magnetic field. This means that if the flow of eddy current varies, the indication across the test coil will:

Remain unchanged Page 1-7

Change as the flow of eddy current changes Page 1-8

No, you are wrong. The magnetic field developed by the flow of eddy current opposes, not aids, the coil's magnetic field.

An alternating current (ac) applied to a test coil generates a magnetic field. This field has a specific strength and direction. The eddy current's field will oppose the coil's field and reduce the strength of the coil's field.

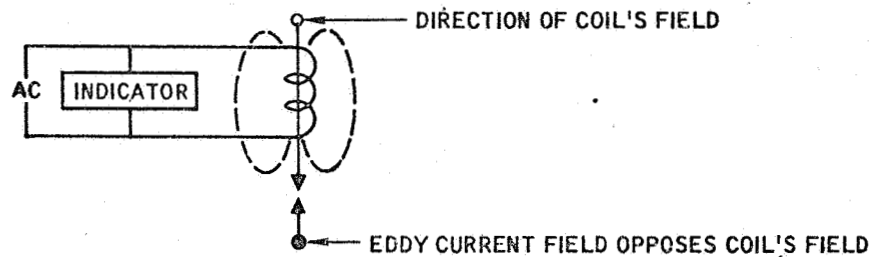

The fact that the coil's field will change as a result of the eddy currents provides a means of getting an indication about the material.

Turn to page 1-5.

No, you are not correct when you say that the indication across the test coil remains unchanged as the flow of eddy current within the specimen varies.

The indication across the test coil will change as the magnetic field around the test coil changes. This field is affected by the magnetic field generated by the flow of eddy current. Since the flow of eddy current changes, the eddy current magnetic field changes and this, in turn, changes the test coil's magnetic field. The result is a change in the indication across the coil.

Turn to page 1-8.

This is correct. If the flow of eddy current changes, the indication across the test coil changes.

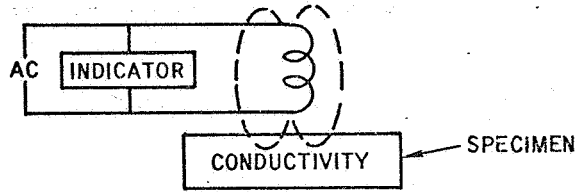

Of course, to induce eddy currents into a specimen, the specimen must be able to conduct an electrical current. This willingness to conduct an electrical current is called conductivity. Each material has a unique conductivity and this will vary if the specimen's properties vary. In general, if the conductivity is increased, the flow of current will increase.

Often times it is convenient to think in terms of resistance rather than in terms of conductivity. Resistance is just the opposite of conductivity. Conductivity is the willingness of the material to conduct current; resistance is the unwillingness to conduct current. Thus we can think of a material in two ways. It may have high conductivity (low resistance) or it may have low conductivity (high resistance).

Visualize that a test coil is placed above the surface of a specimen with a nonconductive (high resistance) coating. Eddy currents will:

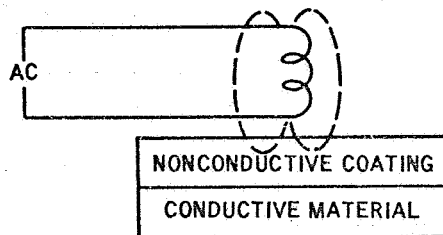

Not be induced into the coating Page 1-9

Be induced into the coating Page 1-10

Correct again. Eddy currents will not be induced into the nonconductive coating. To have eddy currents, the material must be conductive.

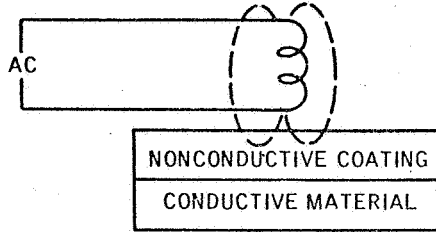

You have just learned that eddy currents are not induced into a nonconductive material. We used as an example a nonconductive coating on a conductive material.

Perhaps you are wondering if you can induce an eddy current in the conductive material below the surface. The answer is "Yes." For example, if a test coil is placed on the surface of a conductive specimen that is coated with paint (a nonconductive coating), the coil's magnetic field will extend through the paint and will induce eddy currents into the conductive material.

Later we will see that this coating's thickness can be measured by eddy current methods. For the moment, however, the important thing to keep in mind is that the test coil's magnetic field will:

Not pass through nonconductive materials Page 1-11

Pass through nonconductive materials Page 1-12

You said that eddy currents will be induced into the coating. This is not true. The coating is a nonconductive (high resistance) material and will not conduct eddy currents. Thus no eddy currents will be induced into the coating.

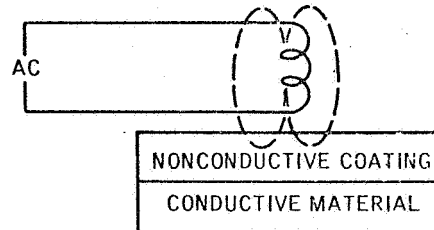

Keep in mind that eddy currents can be induced into a conductive material only. If the material is a high resistance, nonconductive material, no eddy currents will flow through the material.

Turn to page 1-9.

No! You have missed an important fact when you say that the test coil's magnetic field will not pass through nonconductive materials. Maybe you were thinking of eddy currents. The fact is that the magnetic field will pass through the nonconductive material.

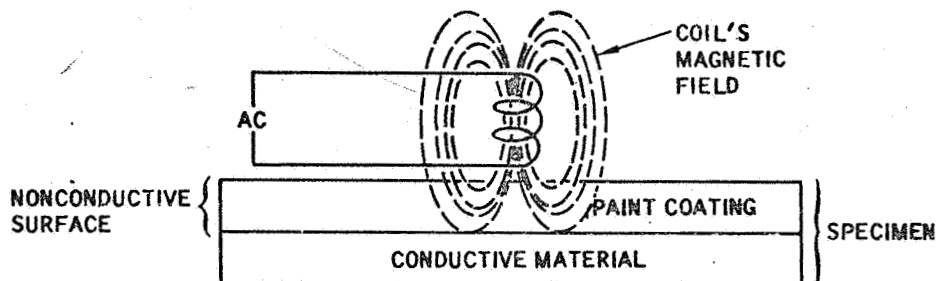

Visualize a test coil positioned on the surface of a specimen. The specimen's surface is coated with a nonconductive paint. The specimen's main body is a conductive material. As shown above, a magnetic field extends outwards from the coil and passes through the paint surface to the body of the specimen. Since the body of the specimen is a conductive material, eddy currents will be induced into the specimen. Thus you can say that a magnetic field will pass through a nonconductive material.

Turn to page 1-12.

Fine! You realize that a coil's magnetic field will pass through a nonconductive material and will induce eddy currents into a conductive material.

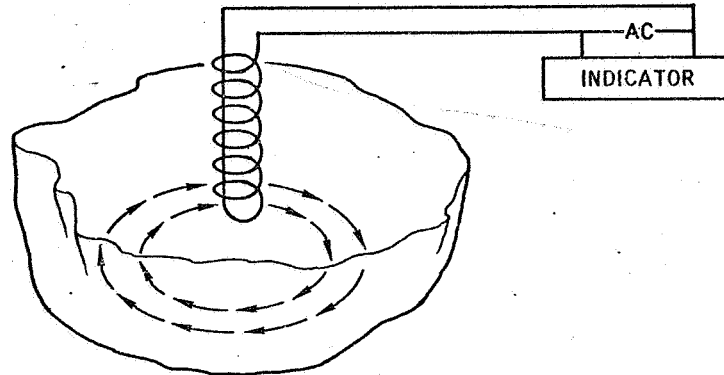

Eddy current testing is based on the fact that certain factors within a specimen will affect the flow of eddy currents. If one of these factors varies, the flow of eddy current varies. This, in turn, will change the indication across the test coil.

The material's chemical composition is a prime factor in determining the material's conductivity. Generally, this is a fixed value for a given specimen. As shown above, eddy currents will form a small circle of current paths with the amount of current being determined by the specimen's conductivity.

A flow of current generates a magnetic field which reacts against the coil's magnetic field. If the flow of current is constant, the effect on the test coil's magnetic field is constant. This, of course, means that the indication across the test coil will be constant.

If you were moving a test coil across a surface and the indication changed to a new value and remained constant at this new value do you feel that the specimen's chemical composition has changed?

- Yes Page 1-13
- No Page 1-14

Good, we agree. It is logical to assume that the specimen's chemical composition has changed.

Of course, there are other factors that can cause a change in indication. For example, a crack or inclusion may interrupt the flow of current.

EDDY CURRENT PATHS

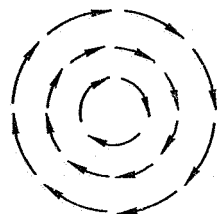

CRACK

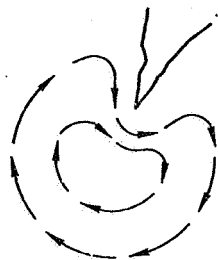

INCLUSION

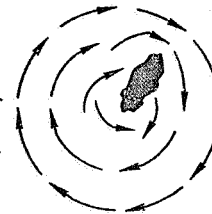

Eddy currents will follow specific paths within the material. These paths will be established by the test coil's field and by the nature of the specimen. And for a given pattern of paths, a specific eddy current field will be developed and will react against the test coil's magnetic field.

Consider now what happens if the pattern is broken or changed by a crack or inclusion. We get a different eddy current field, don't we. And that means the reaction on the test coil's magnetic field will change.

Thus we can say that eddy current testing can detect cracks and inclusions as well as changes in conductivity.

False Page 1-15

True Page 1-16

You said "No." The answer should be "Yes". Here's why.

As you recall, you were moving a test coil across the surface of a test specimen and had a steady indication until a certain point was reached. Then the indication changed to a new value and remained steady at the new value. Under these conditions, the specimen's chemical composition has changed. Of course, there could be other reasons for the change; but, a change in chemical composition is a logical reason.

Eddy current testing is based on the conductivity of the material which is primarily determined by the material's chemical composition. If this composition changes, the indication across the test coil will change.

Turn to page 1-13.

You selected the wrong answer. The statement that eddy current testing can detect cracks and inclusions as well as changes in conductivity is true.

The eddy current field developed by the flow of eddy currents will vary as the flow of eddy current varies. Cracks, inclusions, and changes in conductivity will cause this flow to vary.

Return to page 1-13, review the illustrations, and try the question again.

Certainly true. Eddy current testing can detect cracks and inclusions as well as changes in conductivity.

Another factor which can cause a variation in the output indication of an eddy current testing system is heat. This heat can come from the air surrounding the specimen or it can be generated within the specimen. Since the conductivity of a material varies slightly with temperature, the presence of heat is another factor to be considered. In general, for most metals, the conductivity of the material decreases as the temperature increases.

One source of heat within the specimen is the flow of eddy currents. Current flowing through a material generates heat. It is important to realize that this heat is dissipated by the specimen and, therefore, represents an energy loss. Think about this for a moment.

The test coil's magnetic field is a form of energy. Part of this energy is transferred to the specimen in the form of eddy currents. Since the flow of eddy currents generates heat and heat is a form of energy, this means that some of the coil's energy is lost through heat dissipation within the specimen.

Visualize that you place a test coil on a specimen's surface and observe an indication on an indicating device connected across the coil. If you left the test coil in the same place for several minutes do you think the indication might change?

No Page 1-17

Yes Page 1-18

You said "No." The answer is "Yes." We asked, "If you left the test coil in the same place for several minutes do you think the indication might change?"

The flow of eddy currents generates heat and the conductivity of a material will change as the temperature changes. Under certain conditions, a test coil left in one position for several minutes might generate sufficient heat through the eddy currents to cause a change in the indication across the test coil.

Turn to page 1-18.

The answer "Yes" is correct. Eddy currents generate heat and heat changes the conductivity of a material; therefore, the indication across the coil can be expected to change if a test coil is left in one place for several minutes.

So far you have learned that the conductivity of a material is determined by the chemical composition of the material and is affected by temperature. You have also seen that cracks and inclusions will affect the flow of eddy currents.

The conductivity of a material is also affected by the internal structure of the material which can be altered by cold working the material or by heat treatment. Since this structure is related to the material's strength and hardness, this means that conductivity measurements can indirectly provide information about the hardness and strength of the material.

The hardness of a material can be changed if the material is subjected to excessive heat. For example, fire damage to a tank can change the hardness of the metal skin of the tank. Eddy current testing can:

Be used to detect the change in the hardness of the tank's skin Page 1-19

Not be used to detect changes in hardness Page 1-20

Fine! You recognized that eddy current testing can be used to detect the change in hardness of a material. And, of course, this is possible because the hardness of the material is related to the material's conductivity. Since, in many metals, the material's strength is related to the material's hardness, this means that eddy current testing can also provide a relative indication about a change in the material's strength.

Test coils for eddy current testing can be divided into three classes as shown below. An encircling coil surrounds the material and the material is fed through the coil. In some cases, the coil is placed inside the material (hollow tube). In other instances, a surface (probe) coil is moved over the surface of the material. Note that in each of the three classes only a single (primary) coil is used.

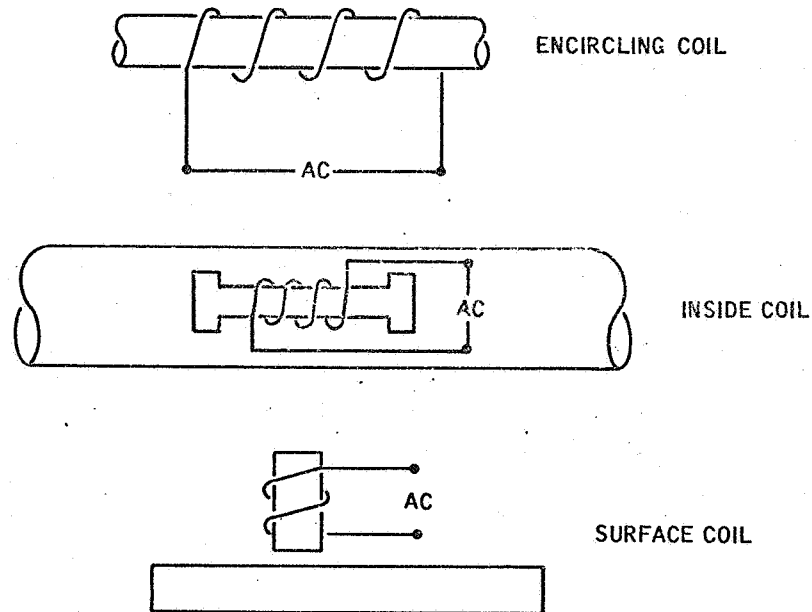

Turn to page 21.

No you are not correct when you say that eddy current testing cannot be used to detect changes in hardness. Detecting changes in hardness is one of the useful applications of eddy current testing.

For example, the skin of a tank is an alloy with a specific hardness. If the tank is subjected to fire, this hardness may change at certain areas on the tank's surface. Eddy current testing can detect this change in hardness. It can do this because the hardness of the material changes the electrical conductivity of the material.

Turn to page 1-19.

Up to now we have been working with a single coil. The same coil is used to induce eddy currents into the specimen and to detect changes within the specimen. Note as shown below that the alternating current (ac) is applied to the coil and that the indicating device is connected across the coil. This arrangement can be used for all three classes: encircling coils, inside coils, and surface coils.

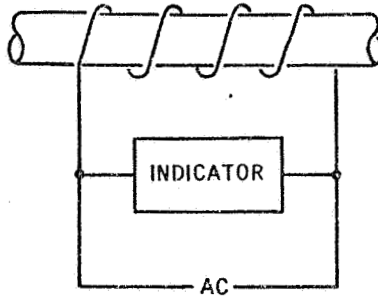

It is also possible to use two coils; one to establish the magnetic field and induce eddy currents into the specimen, and one to detect the changes in eddy current flow. Note that this secondary coil has the indicating device connected across the coil and is not connected to an ac source. Normally the secondary coil is located inside the primary coil and the two coils are referred to as a double coil.

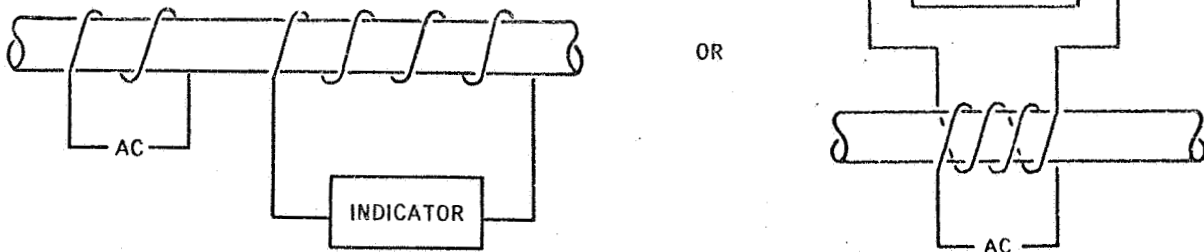

In the double coil arrangement, the primary coil induces eddy currents into the specimen. The eddy currents, in turn, generate a magnetic field that reacts against the primary coil and also induce current in the secondary coil. The indicating device indicates the changes in eddy current flow.

A double coil arrangement is two coils in which ac is applied to:

Both coils and the indicating device is connected across the secondary coil Page 1-22

One coil and an indication is obtained across a second coil Page 1-23

• ~~.....~~

No you are not right when you say that a double coil arrangement is two coils in which ac is applied to both coils and the indicating device is connected across the secondary coil. In a double coil arrangement ac is applied to one coil and an indication is obtained across a second coil.

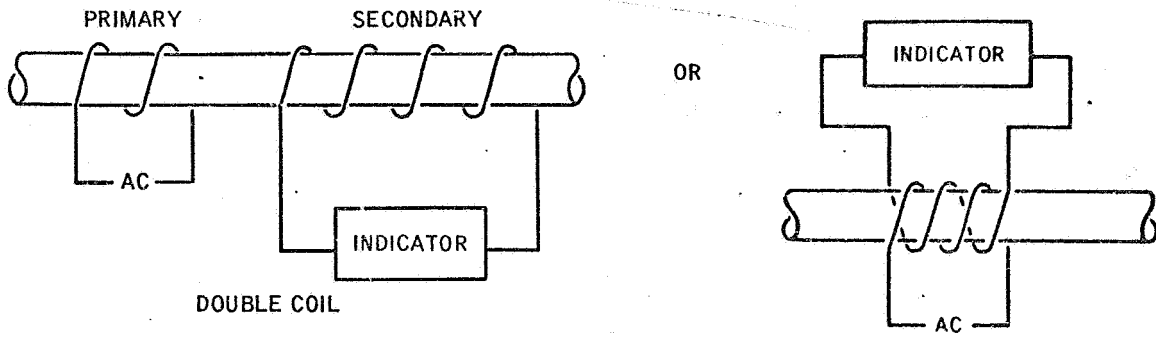

Turn to page 1-23.

Right again. A double coil arrangement is two coils in which ac is applied to one coil and an indication is obtained across a second coil.

As you can see below, test coils can be classed as single coils or double coils. Such coils can be used as encircling coils, inside coils, or surface coils.

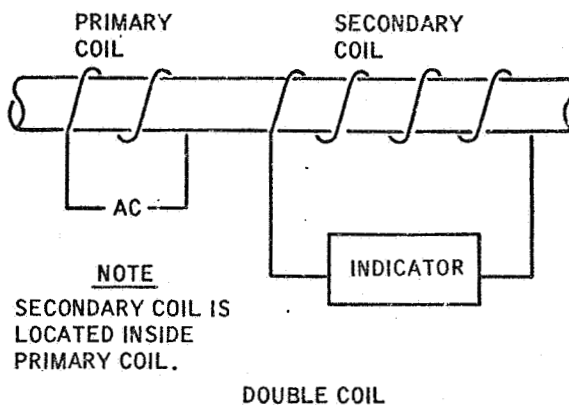
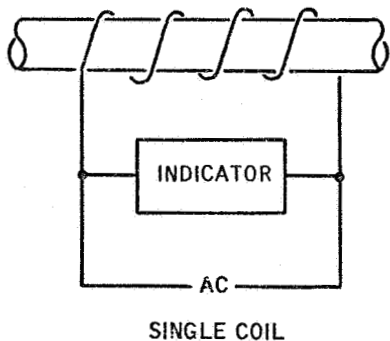

Turn to page 1-24.

From page 1-23

1. The next few pages are different from the ones which you have been reading. There are _____ arrows on this entire page. (Write in the correct number of arrows.) Do not read the frames below. FOLLOW THE ARROW and turn to the TOP of the next page. There you will find the correct word for the blank line above.
- 

4. eddy

5. An eddy current is defined as a circulating electrical current induced in an isolated conductor by an alternating magnetic field. Eddy current testing is based on the fact that the flow of eddy currents generates a m _____ f _____ that opposes the magnetic field developed by the test coil.
- 

8. conductivity

9. The conductivity of a specimen is affected by several factors within the specimen. One such factor is the specimen's chemical composition. If the chemical composition changes, we can expect the flow of eddy current to _____ .
- 

12. cracks, inclusions

13. Thus we can see that eddy current testing provides a basis for detecting cracks and inclusions as well as changes in the material's c _____ .
- 

This is the answer to the blank in Frame number 1.

1. four  Frame 2 is next

2. These sections will provide a review of the material you have covered to this point. There will be one or more blanks in each f_____.

Turn to the next page.
Follow the arrow. 

5. magnetic field

6. The flow of eddy currents generates a magnetic field which reacts against the test coil's magnetic field. This reaction will change if the flow of eddy currents c_____.

9. change



(a.) CONDUCTIVE MATERIAL



(b.) NONCONDUCTIVE MATERIAL

10. The adjacent illustration shows a test coil applying a magnetic field to a specimen. Two specimens are shown. No eddy currents will be induced in specimen_____.

13. conductivity

14. Test coils for eddy current testing are divided into three classes: encircling coil, inside coil, and surface coil. If I passed a steel rod through a coil, I would be using an_____coil.

2. frame

3. By following the arrows or instructions you will be directed to the section which follows in sequence. Each section presents information and requires the filling in of _____.

6. change

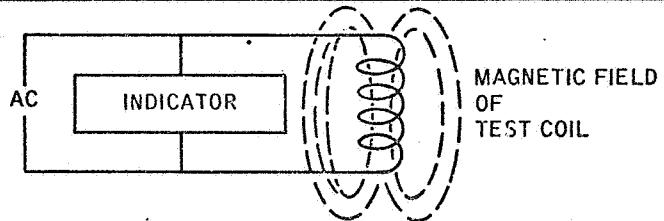

7. An indicating device connected to a test coil will be affected by the coil's magnetic field. This field, in turn, is affected by the eddy current's magnetic field. This means that if the flow of eddy current changes, the indication of the indicating device will _____.

10. (b.)

11. While it is true that eddy currents can only be induced in conductive materials, it is also true that eddy currents can be induced in a material that is coated with a nonconductive material. This is based on the fact that a test coil's magnetic field will pass through a _____ material.

14. encircling

15. Test coils are also classified as single coil or double coil. When alternating current (ac) is applied to a test coil and an indicating device is connected across the same coil, the coil is called a _____ coil.

3. blanks (or spaces
or words)

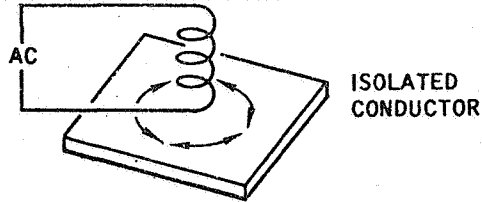

ISOLATED
CONDUCTOR

4. When alternating current (ac) is passed through a coil, an alternating magnetic field develops around the coil. This field will induce small electrical currents into an isolated conductor placed near the coil. Such currents in the conductor are called _____ currents.



Return to page 1-24, frame 5,
and continue with the review.

7. change

8. An electrical current will only flow in a material that has conductivity (conductivity means a willingness to conduct an electrical current). Since eddy currents are small circulating electrical currents, we can expect that eddy currents will only exist in materials that have _____.



Return to page 1-24, frame 9,
and continue with the review.

11. nonconductive

12. When eddy currents are induced into a material, small circular paths are formed. These eddy current paths can be changed by c _____ or i _____ in the material. Such discontinuities change the flow of current and cause a change in the indicating device connected across the test coil.



Return to page 1-24, frame 13,
and continue with the review.

15. single

16. And when ac is applied to one coil and an indicating device is connected across a second coil positioned inside the first coil, the whole coil is called a double coil.

This completes the review of
Chapter 1. Turn to page 2-1.





You should not have turned to this page. The instructions were to return to page 1-24, frame 5, and continue with the review.



You should not have turned to this page. The instructions were to return to page 1-24, frame 9, and continue with the review.



You should not have turned to this page. The instructions were to return to page 1-24, frame 13, and continue with the review.



Disregard this page. The instructions are to turn to page 2-1.

So far we have presented to you a general idea about eddy currents. Now let's look at the details of eddy current generation and distribution.



As you have seen, the test coil's magnetic field provides the basis for generating eddy currents. This field is established by passing an alternating current through the coil. And since the alternating current is periodically reversing its direction, the coil's magnetic field is periodically reversing its direction. Note the direction of the arrows in the above illustration. View A illustrates the direction of the magnetic field when the current is flowing in one direction through the coil. View B illustrates the magnetic field's direction when the alternating current reverses and flows in the opposite direction through the coil.

The alternating current (ac) applied to a test coil does not have a steady value. Instead, the value varies back and forth about a center value. This means that the amount of current flowing through the coil varies. Since the "intensity" of the coil's magnetic field depends upon the amount of current flowing through the coil, this means that the coil's magnetic field intensity will vary as the ac varies.

Turn to page 2-2.

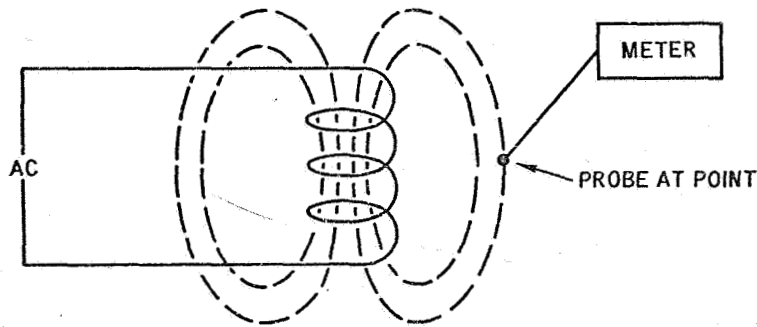

The magnetic field around a coil can be visualized as a pattern of lines. At each point on each line a definite magnetic force exists. This can be measured. Normally, one speaks of the force at a point in terms of an intensity. Thus, one says that the magnetic field has an intensity. This intensity varies within the magnetic field (from point to point).

Visualize that you have a probe which can be positioned at a point within the coil's magnetic field. A meter connected to the probe will indicate the intensity at the point. Since the alternating current applied to the test coil is varying, would you expect the meter indication to:

- Remain unchanged Page 2-3
- Change Page 2-4

You are wrong when you say that you would expect the meter indication to remain unchanged.

Since the intensity of the coil's magnetic field depends on how much electrical current is flowing through the coil, the intensity will vary as the current varies. This also applies for a specific point within the field. This is why the correct answer to the question is "change."

Turn to page 2-4.

Correct! You would expect the meter indication to change since the flow of current through the coil is changing.

While an alternating current is a fluctuating current, such a current has an average value. And since the coil's magnetic field intensity depends upon the alternating current, this means that the intensity at a point will have an average value. Indicating devices such as a meter can be designed to read just the average value. If we used such a meter, we could expect the meter to remain unchanged at a specific point in the coil's magnetic field. Throughout the rest of this handbook we will be referring to the average value when we use the term "intensity."

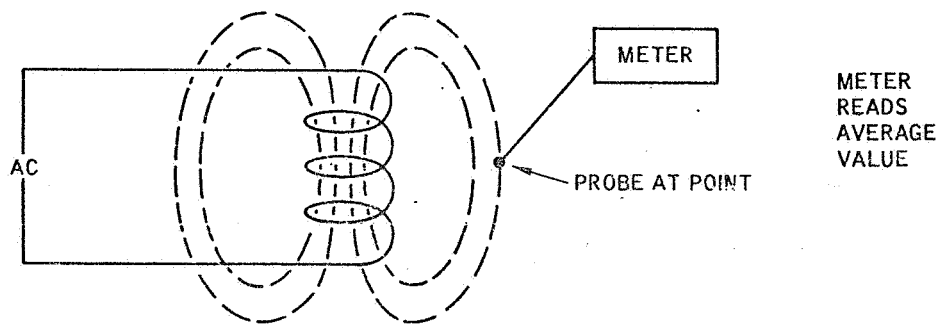

Turn to page 2-5.

Since the amount of eddy current induced into a specimen is related to the test coil's magnetic field intensity, it is important to understand how the magnetic intensity varies with distance.

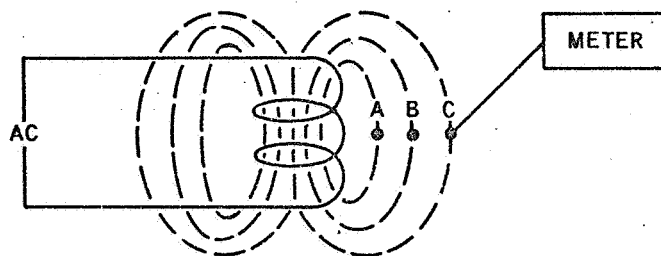

Visualize that you have a meter that measures average values of magnetic field intensity. Using this meter, you measure the coil's field intensity at three distances (A, B, and C) from the outer surface of the coil. From this you learn that the coil's field intensity decreases as you move further from the coil's surface. Thus the intensity at point C is less than at point B; and point B's intensity is less than point A's.

The lines of force in the coil's magnetic field form closed loops. Note that these lines extend out the ends of the coil, circle the coil, and return through the opposite end of the coil. Since all lines pass through the coil and appear at the ends of the coil, the ends of the coil represent areas of strong magnetic intensity.

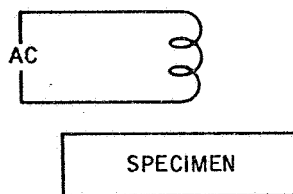

In the figure shown above, a test coil is located above the surface of a specimen. Since the amount of eddy current induced into a specimen increases as the field intensity increases, do you think the amount of eddy current induced into the specimen will increase if:

The coil is moved away from the specimen Page 2-6

The coil is moved closer to the specimen Page 2-7

No, you are not correct when you say that the amount of eddy current induced into the specimen will increase if the coil is moved away from the specimen. To increase the amount of eddy current induced into the specimen you must move the test coil closer to the specimen.

The amount of eddy current induced into the specimen depends upon the coil's field intensity. The greater the intensity, the larger the eddy current. Since the intensity decreases with distance, the intensity applied to the specimen can be increased by moving the coil closer to the specimen.

Turn to page 2-7.

Certainly true! Since the coil's intensity increases as you move closer to the coil, more eddy current will be induced into the specimen if you move the coil closer to the specimen. Doesn't this also mean that the amount of eddy current induced into the specimen will vary if the distance between the specimen and the coil is varied. Right! That's why it is important to hold the distance constant during eddy current testing.

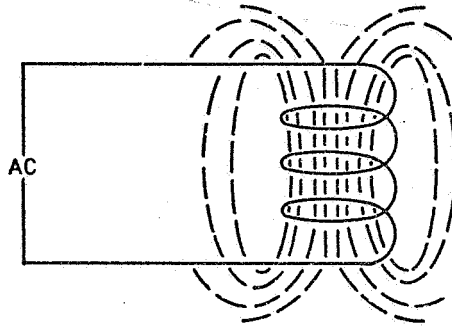

The above view illustrates the distribution of field intensity inside the test coil. In eddy current testing, this field is assumed to have a constant intensity across the coil's inside diameter. This assumption is based on the use of an alternating current, small coils, and certain factors related to the formulas that are used to design an eddy current testing system. For all practical purposes this assumption is valid.

It should be pointed out that in magnetic particle testing (direct current), the magnetic field intensity across the inside diameter of the coil is not constant.

For eddy current testing, we can summarize our facts about the coil's magnetic field intensity as follows:

Select the correct statement:

The coil's field intensity decreases with distance outside the coil and varies across the diameter inside the coil Page 2-8

The coil's field intensity decreases with distance outside the coil and is assumed to be constant across the diameter inside the coil Page 2-9

Sorry but you are wrong. We are talking about eddy current testing, not magnetic particle testing.

For eddy current testing, it is assumed that the magnetic field intensity across the inside diameter is constant. There are reasons for this; however, these reasons are beyond the scope of this manual. Just accept the fact, but keep in mind that this applies only to eddy current testing, not to magnetic particle testing.

Turn to page 2-9.

Again you're right when you say that the coil's field intensity decreases with distance outside the coil and is assumed to be constant across the diameter inside the coil. Now let's put this intensity to work.

Electrical currents are the flow of small negative particles called "electrons." Such electrons are influenced by magnetic fields. And if electrons are placed in an alternating magnetic field, the electrons will move. First in one direction, then in the opposite direction. That gives us an eddy current.

Of course to have eddy currents, we need a material that has a few extra electrons - ones that are free to move about. Since a conductor has such electrons we can use a conductor (or conductive material) to get eddy currents. This means that if we place a test coil near a conductor (e.g. copper) we can expect to move the electrons in the conductor back and forth.

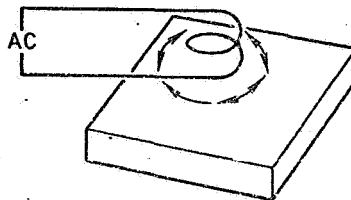

In the above illustration, we have a test coil positioned above the surface of a specimen. Note that the path of the eddy currents in the specimen forms a circle which is parallel to the surface. Also note that this path is parallel to the windings of the test coil.

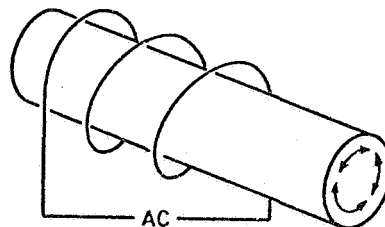

Now let's look at a rod inside a coil. The above illustration shows the eddy currents flowing in circular paths across the rod's cross section. Would you say that this represents the proper flow of eddy current within a rod?

Yes Page 2-10

No Page 2-11

Fine, you have the direction. When a rod is placed inside a coil, the flow of eddy current looks like this.

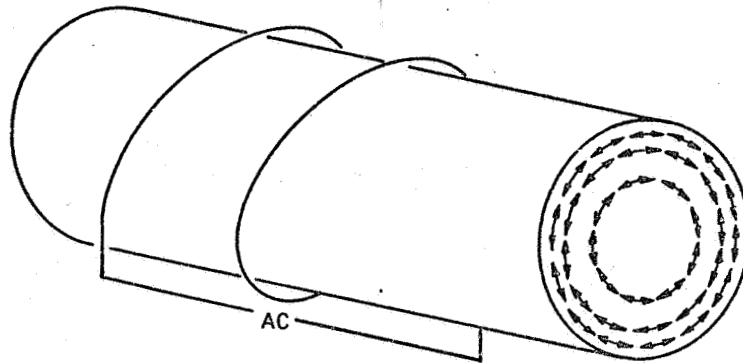

You might expect that the distribution of eddy current across the rod's cross section is constant and that all areas have the same amount of eddy current. This is not true. Note in the illustration above that the eddy currents are concentrated near the surface and that no eddy currents exist at the center of the rod.

A moment ago you learned that the coil's field intensity inside the coil is the same across the coil. And perhaps you recall that the amount of eddy current in the specimen is related to the field intensity. Why then is the eddy current greater near the surface?

The answer you know ... you just don't realize it. A flow of eddy current generates a magnetic field that opposes the coil's magnetic field. This, of course, means the coil's magnetic field intensity is decreased.

Near the surface, the coil's full intensity is applied to the rod and this generates large eddy currents. These currents, in turn, develop a field that opposes the coil's field intensity. The difference is then applied to deeper areas within the rod. Again eddy currents are developed and the resulting field opposes the coil's field. Ultimately the coil's field becomes so weak that no further eddy currents are induced into the rod.

Makes sense doesn't it?

We can summarize the distribution of eddy current of a rod within a coil by saying:

The eddy current is the same across the cross section of the rod Page 2-12

The eddy current is a maximum at or near the rod's surface and decreases in value as you move towards the center of the rod Page 2-13

Sorry, you are wrong. The illustration did represent the proper flow of eddy current within the rod. Let's look at it again.

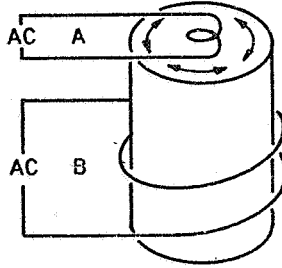

The above illustration shows two coils. Coil A is positioned at the end of a rod and will induce currents that are parallel to the coil and the cross section of the rod. Coil B is a coil wrapped around the rod. Again, the currents will be parallel to the coil. Both coils develop the same direction of eddy current flow.

Return to page 2-9, read the text, and try the question again.

You missed that one. You said that the eddy current is the same across the cross section of the rod. By this you mean that the amount of eddy current near the surface of the rod is the same as the amount of eddy current deep within the cross section of the rod. This is not true.

The eddy current is a maximum at or near the rod's surface and decreases in value towards the center of the rod. At the center of the rod, no eddy current exists.

This condition is caused by the fact that the flow of eddy currents develops a magnetic field that opposes the coil's magnetic field. This means the effect of the coil's magnetic field is weakened as the field penetrates the rod. As the coil's field is weakened, less eddy current flows. At the center, a small field exists; however, it is not strong enough to induce any appreciable eddy currents.

Turn to page 2-13.

What you say is correct. When a rod is placed inside a coil, the distribution of eddy current is at a maximum at the rod's surface, or near the surface, and decreases to essentially zero at the rod's center.

Eddy current testing is based on the fact that discontinuities affect the flow of eddy currents. If the eddy current path is interrupted or changed, the eddy current magnetic field will change and will affect the test coil's magnetic field. The stronger the eddy current, the more sensitive the system will be to the detection of discontinuities.

Since eddy currents are greater near the surface of a rod placed in a coil, eddy current sensitivity is greater near the surface.

A definite relationship exists between the frequency of the ac applied to the test coil and the distribution of eddy currents within the rod. As the frequency is increased, eddy current distribution concentrates near the surface and decreases deep within the rod. The reverse is also true. As the frequency is lowered, eddy current distribution extends deeper into the rod.

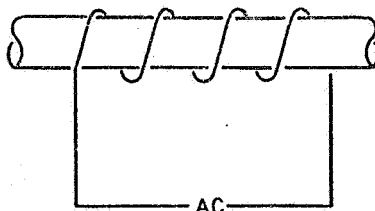

Visualize you are performing eddy current testing using an encircling coil. Your objective is to locate discontinuities near the surface of the rod. To maximize the sensitivity of the test system towards discontinuities would you:

Increase the frequency Page 2-14

Decrease the frequency Page 2-15

Right again. The distribution of eddy currents within a rod can be changed by changing the frequency. As the frequency is increased, the eddy current distribution within the rod will concentrate at the surface. Since the ability to detect discontinuities is increased as the eddy current is increased, the sensitivity of the system towards the detection of surface or near surface discontinuities is increased as the frequency is increased.

For a rod in a test coil, we have just learned that the depth of eddy current penetration varies with the frequency of the ac applied to the test coil. This is also true for a coil placed above the surface of a specimen.

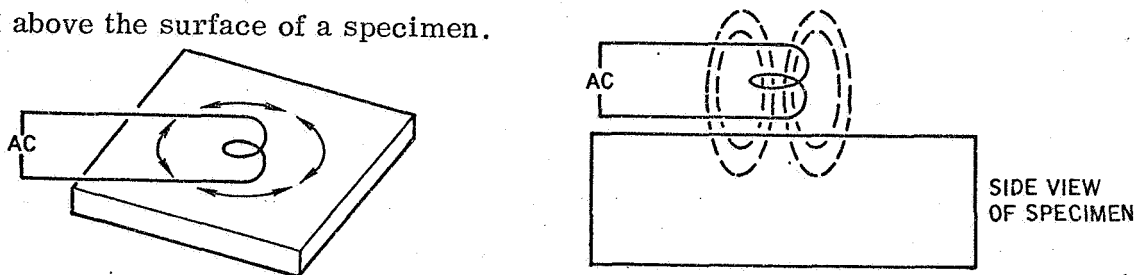

As shown above, a surface coil above or on a specimen's surface will induce currents into the specimen. The current paths will be small circles parallel to the surface. And since the surface coil's magnetic field penetrates the specimen, these current paths will also be formed below the specimen's surface. The depth of penetration will vary with the frequency of the ac applied to the coil. The depth of penetration increases as the frequency decreases.

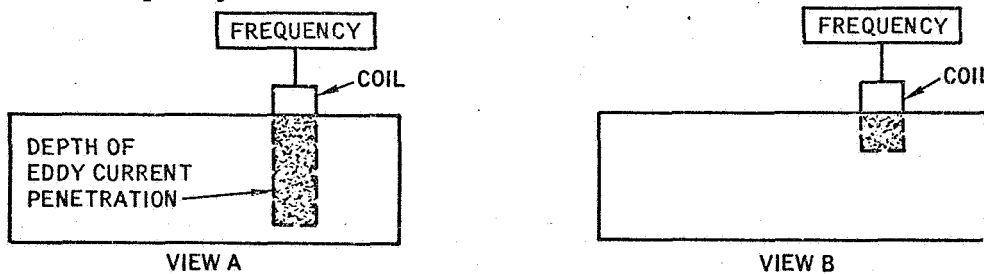

The above illustration shows two different test frequencies applied to the same material. Note that the depth of penetration varies. Would you say that the test frequency in view A is:

Higher than the test frequency in view B Page 2-16

Lower than the test frequency in view B Page 2-17

You have your direction reversed. To maximize the sensitivity at the surface of a rod in a test coil you would increase the frequency, not decrease the frequency.

In conventional eddy current testing a single frequency is used. For example: 100 cycles per second, (c.p.s.), 1000 c.p.s., 100,000 c.p.s. The distribution of eddy current within a rod in a test coil is related to this frequency. In general, the distribution is concentrated near the surface of the rod. This can be changed by changing the frequency. For example, if the frequency is increased (e.g., from 1000 c.p.s. to 5000 c.p.s.) the eddy currents will increase near the surface and decrease deep within the rod.

On the other hand, if deep penetration is needed, the frequency can be lowered. It's all a question of frequency.

Turn to page 2-14.

No, you are not correct when you say that the test frequency in view A is higher than the test frequency in view B.

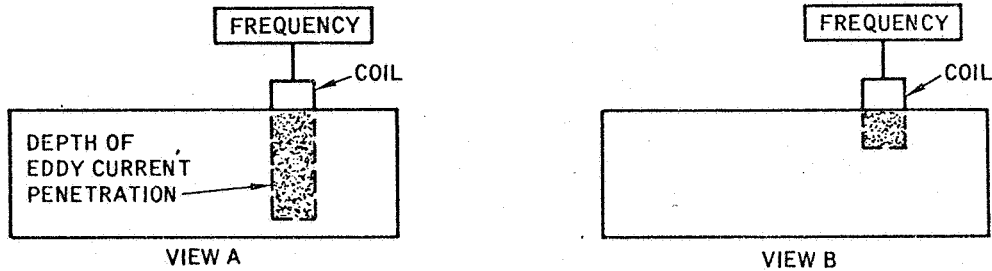

In both view A and B the material and the test coil are the same. The only difference is the test frequency. The depth of eddy current penetration varies with the frequency. View A shows a deep penetration into the specimen and this means that a low frequency was used. View B, on the other hand, shows a shallow penetration. This means that a high frequency was used.

Keep in mind that a high frequency causes the eddy currents to accumulate near the surface. A low frequency puts the eddy currents deep into the material. That's why the correct answer to the question is "Lower than the test frequency in view B."

Turn to page 2-17.

Good, we agree. The test frequency in view A is lower than the test frequency in view B. This is because the lower frequency provides greater eddy current penetration.

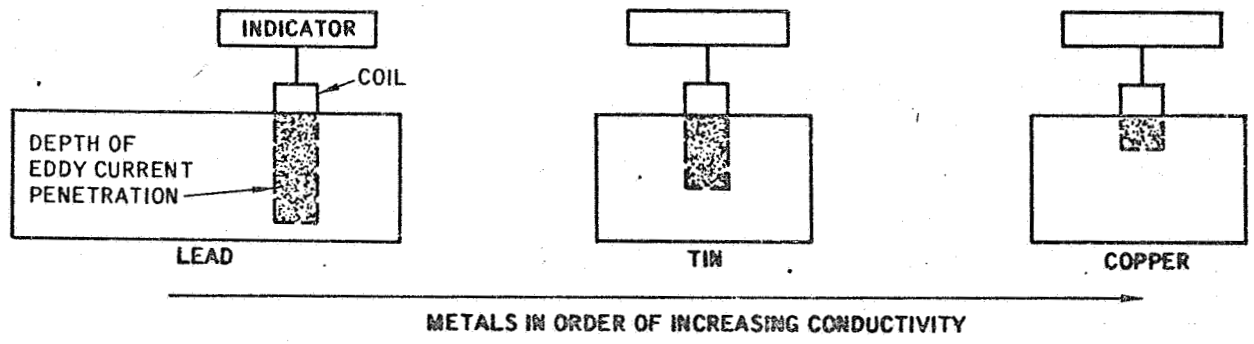

The above figure illustrates that the depth of eddy current penetration also varies with the specimen's conductivity. As the conductivity increases, the depth of eddy current decreases.

Copper is a better conductor than tin. If we place a surface coil on a copper specimen, eddy currents will penetrate the specimen to a certain depth. Now if we move the coil to a tin specimen, we find that the eddy currents will penetrate more deeply than in the copper specimen.

Visualize that you have two specimens: A and B. Specimen A is more conductive than specimen B. Using the same surface coil and test frequency, you apply the coil first to specimen A and then to specimen B. Are you:

Inspecting to the same depth in both specimens Page 2-18

Not inspecting to the same depth in both specimens Page 2-19

You said that you were inspecting to the same depth in both specimens. This is not true.

You just learned that the depth of penetration varies with the specimen's conductivity. As the conductivity increases, the depth of penetration decreases.

In our example specimen A is more conductive than specimen B. This means that the depth of penetration will not be the same and the depth will be less in specimen A than in specimen B. That's the reason why you are not inspecting to the same depth in both specimens.

Turn to page 2-19.

Fine! You recognized that you are not inspecting to the same depth when the conductivity of the two specimens is not the same.

Perhaps you are wondering why the depth of eddy current penetration decreases as the conductivity increases. Let's think it out.

When the conductivity increases, the flow of current increases. This, in turn, generates a larger eddy current magnetic field. As this field develops, it opposes the test coil's magnetic field and the result is a reduction in the intensity of the coil's field as applied to the specimen. And as the intensity decreases, the depth of penetration into the specimen decreases. Makes sense, doesn't it?

We can summarize our facts about eddy current penetration into a specimen by saying:

1. The depth of eddy current penetration decreases when -
 - a. the conductivity increases
 - b. or the frequency is increased
2. The depth of eddy current penetration increases when -
 - a. the conductivity decreases
 - b. or the frequency is decreased

Turn to page 2-20.

From page 2-19

1. When an alternating current (ac) is applied to a coil, the coil develops a magnetic field. This field has a magnetic force which varies from place to place around the coil. The value of this force at a specific place is called the magnetic field i _____.

5. constant

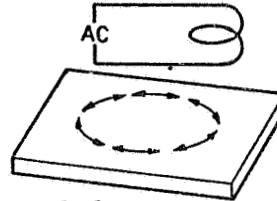

6. The windings of a surface coil placed above a specimen are parallel to the specimen's surface. The eddy currents induced into the specimen form a circular path as shown above. The circular path of eddy currents is p _____ to the windings of the test coil.

10. frequency

11. To increase the amount of eddy currents deep within the rod, the frequency can be in creased.

15. in

16. The depth of penetration is also affected by the conductivity of the specific material. As the conductivity increases, the depth of penetration de creases.

1. intensity

2. The coil's magnetic field intensity outside the coil varies with the distance from the coil's surface. As the distance from the coil's surface increases, the magnetic field intensity ___ creases.



6. parallel

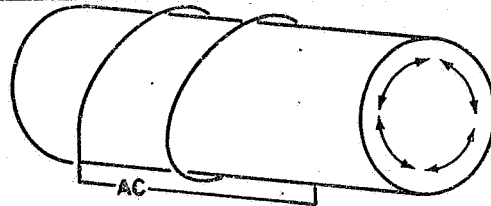

7. When a surface coil is placed above a specimen, the circular path of eddy currents induced into the specimen's surface is parallel to the coil's windings. This is also true when the coil encircles the specimen as shown above.



11. de

12. On the other hand, if we want a maximum amount of eddy current near the surface of the rod, we can ___ crease the frequency applied to the test coil.



16. de

17. We can summarize the facts by saying that the depth of eddy current penetration ___ creases when:
- the conductivity increases
 - or the frequency is increased



2. de

3. The fact that the coil's magnetic field intensity varies with distance is important because the amount of eddy current induced into a specimen depends upon the value of the field intensity. If a coil placed above a specimen is moved closer to the specimen, the amount of eddy current induced into the specimen will _____ crease.



7. (No response required)

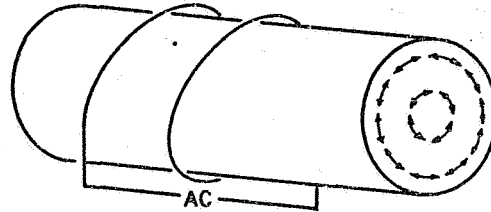

8. Eddy currents are not uniformly distributed through a specimen (e.g., a rod in a coil). The above figure shows a typical distribution within a rod. As you can see, the eddy currents are greater near the _____ of the rod.



12. in

13. Similar rules apply to a test coil placed above the surface of a specimen. The depth of eddy current penetration can be changed if the _____ applied to the test coil is changed.



17. de

18. And the depth of eddy current penetration _____ creases when:
- the conductivity decreases
 - or the frequency is decreased



3. in

4. And of course this increase in eddy current will change the eddy current m _____ f _____.

8. surface

9. It is also true that no eddy currents exist at the _____ of the rod.

13. frequency

14. If a specific frequency is applied to a test coil (surface coil), the depth of eddy current penetration will be some fixed value as determined by the specimen. If the frequency is increased, the depth of penetration will ___ crease.

18. in

19. This completes the review of Chapter 2. Turn to page 3-1.

H

4. magnetic field

5. Outside the test coil, the magnetic field intensity varies with the distance from the coil. Inside the coil, this is not true. Instead, the intensity across the inside diameter of the coil is assumed to be c.



Return to page 2-20, frame 6, and continue with the review.

9. center

10. The distribution of eddy current varies within a rod. The maximum current is at or near the rod's surface. The current decreases within the rod to a zero value at the rod's center. This distribution can be changed by changing the _____ of the ac applied to the test coil.



Return to page 2-20, frame 11, and continue with the review.

14. de

15. And if the frequency is decreased, the depth of penetration will _____ crease.



Return to page 2-20, frame 16, and continue with the review.

Disregard this page. The instructions were to turn to page 3-1

In eddy current testing, the distance between the coil and the specimen is a significant factor. If the distance varies, the output indication varies. This is true for two conditions:

1. when the coil is placed above the specimen (view A)
2. and when the specimen is placed inside the coil (view B)

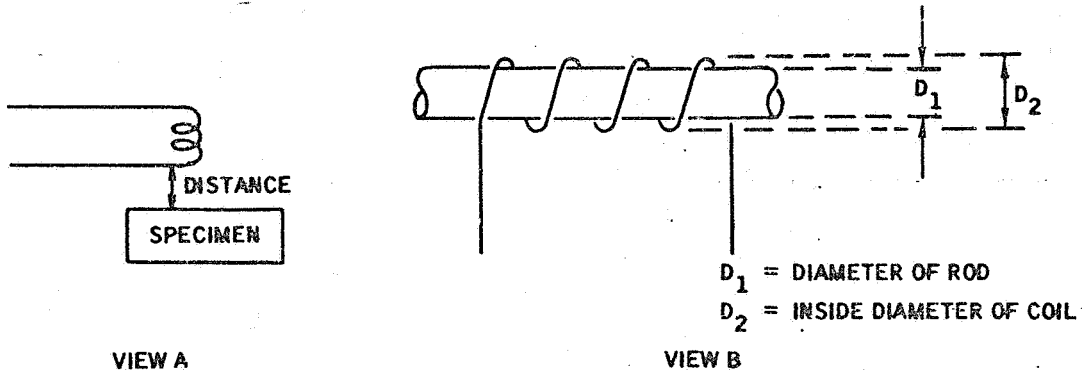

Since the specimen is coupled to the coil through the coil's magnetic field, the relationship between the specimen and the coil can be called a coupling factor.

Turn to page 3-2.

It's not necessary to remember the term "coupling factor;" however, there is a word you need to remember. It's called "lift-off" and appears on the panels of several brands of eddy current test equipment. Let's see what the term "lift-off" means.

The term "lift-off" is used when you are talking about the use of a surface coil on the surface of a specimen.

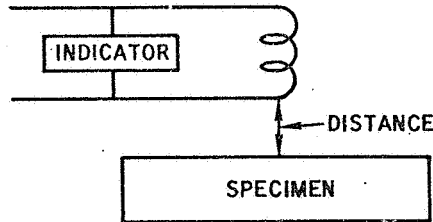

Visualize that you have a coil placed directly on the top surface of a specimen. Under these conditions, you get a specific output indication. Now visualize that you lift the coil slightly off the specimen's surface and observe a change in the output indication. And finally, visualize that you alternately raise and lower the coil above the surface and notice a change in indication. This change in the output indication as the distance between the coil and the top surface of the specimen is varied is called the "lift-off effect."

Lift-off is a term that is related;

Only to surface coils Page 3-3

Both to surface coils and to encircling coils Page 3-4

Certainly right. Lift-off is a term that is related only to surface coils; there's another term called "fill-factor" that applies to specimens enclosed in coils. We cover that later.

Visualize that you have a surface coil on a specimen. The specimen is coated with a nonconductive surface. Now recall that eddy currents are not induced into a nonconductive material; however, the coil's magnetic field will pass through a nonconductive material.

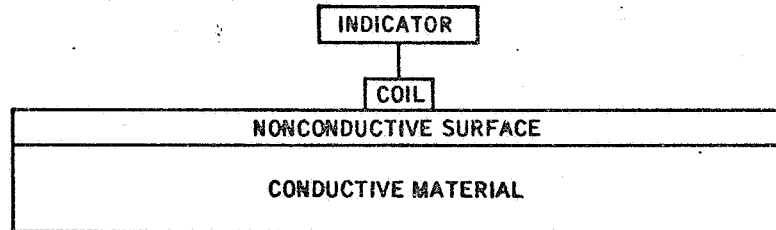

Under these conditions, if you were moving the coil across the specimen's surface and encountered variations in output caused by the thickness variations of the nonconductive coating, would you say that the variations in output were:

Based on the lift-off effect Page 3-5

Not related to the lift-off effect Page 3-6

Sorry, but you are wrong ... but we'll take the blame. The question was:

"Lift-off is a term that is related:

Only to surface coils.

Both to surface coils and to encircling coils"

You said "Both to surface coils and to encircling coils"

If you recall, we said that lift-off is used when you are talking about the use of a surface coil on the surface of a specimen. The term only applies to surface coils. There's another name for encircling coils. It's called "fill-factor" and we cover it later. For the moment, we are concerned only with surface coils and lift-off.

Turn to page 3-3.

Again you are correct. The variation in the nonconductive material is varying the distance between the coil and the conductive area of the specimen and this is causing a variation in the output indication. This is the lift-off effect.

In some test applications, the lift-off effect presents a problem. For example, if the specimen's surface is irregular or if the pressure between the coil and the surface is varied (by the operator), then the output indication will vary. This can be overcome by a special control in the eddy current test equipment (Often labelled LIFT-OFF). When this control is properly positioned, small variations in distance will not be reflected on the equipment's indicator.

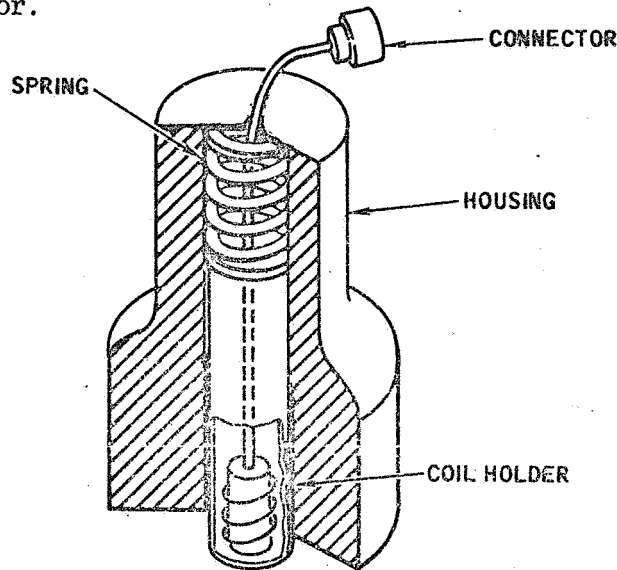

The above figure shows a surface coil mounted in a coil holder which is spring-loaded within a housing. Would you say that the purpose of the spring is to minimize lift-off effects during eddy current testing?

No Page 3-7

Yes Page 3-8

You selected the wrong answer. The variations in output were based on the lift-off effect. You said they were not related to the lift-off effect.

The lift-off effect is defined as the change in output indication as the distance between the coil and the specimen is varied. The nonconductive surface of the specimen separates the coil from the conductive area of the specimen and represents the distance between the coil and the specimen. If this distance varies (by variations in the thickness of the material), the output indication varies. And that's the lift-off effect.

Turn to page 3-5.

You said "No". The question, "Would you say that the purpose of the spring is to minimize lift-off effects during eddy current testing?" should have been answered "Yes".

Keep in mind that we are concerned about the distance between the coil and the specimen and this distance can be small. Even a difference in pressure might make a difference in distance. That's why a spring is used to hold the coil firmly against the surface. And that's why we say that the spring is related to the lift-off effect.

Turn to page 3-8.

Fine, you have the idea of lift-off. The purpose of the spring is to keep the coil positioned firmly against the specimen's surface. And this is needed to minimize the lift-off effect.

By now you should have a good idea of the term "lift-off." It's a term used when you are talking about surface coils and the change in the output indication when the distance between the coil and the specimen is changed. Now let's talk about an encircling coil.

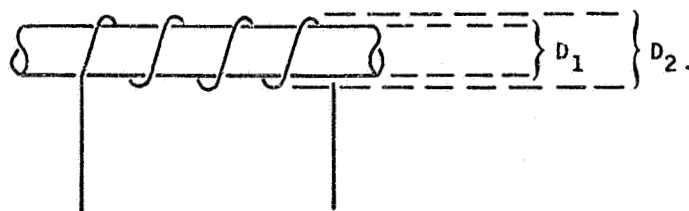

$$\text{FILL-FACTOR} = \frac{\frac{\pi D_1^2}{\text{AREA}}}{\frac{\pi D_2^2}{\text{AREA}}} = \left(\frac{D_1}{D_2}\right)^2$$

The term "fill-factor" is used when talking about the change in output indication as the distance between a rod and a coil is varied. Note that fill-factor is a ratio of two diameters. One diameter is the diameter of the rod within the coil. The other diameter is the inside diameter of the test coil. Also note that each diameter is squared and the fill-factor is the ratio of the squares. The maximum fill-factor is the number one; however, since room is needed to pass the rod freely through the coil, the actual fill-factor will be less than one.

It is not important that you remember the formula for fill-factor. It is important, however, to remember that the term "fill-factor" applies to:

Surface coils Page 3-9

Encircling coils Page 3-10

You have your coils mixed when you say that the term "fill-factor" applies to surface coils. Look at the following table.

LIFT-OFF	FILL-FACTOR
SURFACE COILS	ENCIRCLING COILS

Lift-off applies to surface coils

Fill-factor applies to encircling coils

Got it now? Good! Turn to page 3-10.

That's right. The term "fill-factor" applies to encircling coils and the term "lift-off" applies to surface coils.

When eddy current inspection is performed by the use of encircling coils, it is common practice to use guides to keep the rod properly positioned within the test coil.

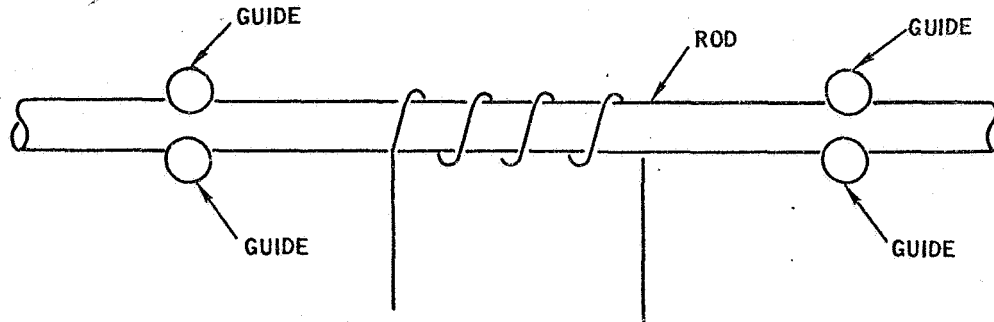

The purpose of the guides is to ensure that the lift-off is constant:

False Page 3-11

True Page 3-12

You didn't get fooled that time, did you? You're right when you say that the statement "the purpose of the guides is to ensure that the lift-off is constant" is false. The guides are related to the fill-factor, not the lift-off.

In eddy current testing, the significant fact is the variation in the output indication across the test coil. If the specimen's conductivity changes, the output indication will change. And based on the amount of variation, the inspector can learn something about the specimen.

You have just learned that varying the distance between the coil and the specimen also changes the output indication. This, of course, means that we now have two variables that can cause a change in the output indication; conductivity and distances.

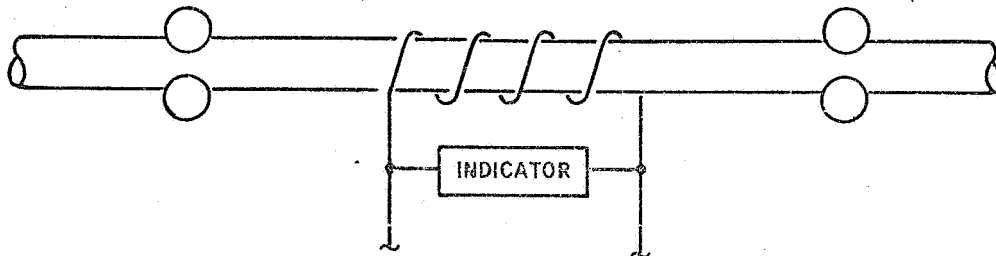

Visualize that you are performing eddy current testing, using an encircling coil and guides to keep the rod properly positioned within the coil. At a certain point in your test, a change in output indication occurs. Could you definitely say that the change was caused by a change in the specimen's conductivity?

No Page 3-13

Yes Page 3-14

No you are not correct when you say that the purpose of the guides is to ensure that the lift-off is constant. Lift-off applies to surface coils, not to encircling coils. The term "fill-factor" applies to encircling coils.

The purpose of the guides is to ensure that the fill-factor is constant, not the lift-off. That's why the statement in the test question is false. You need the word "fill-factor" in the statement to make the statement true.

Turn to page 3-11.

Good! You got the point when you recognized that you could not definitely say that the change was caused by a change in the specimen's conductivity.

So far, you have two variables: conductivity and dimensional changes. The dimensional changes are changes in the rod's diameter and these can be sensed. This means that the output will have two possible meanings. A change in output indication may be caused by a change in the rod's diameter. Or it may be caused by a change in the rod's conductivity. Or you can have both effects showing up in the output indication at the same time. Normally you assume that the fill-factor is constant and the conductivity is the variable that is affecting the output indication.

Turn to page 3-15.

You said "Yes." That means you feel that you can definitely say that the change was caused by a change in specimen's conductivity. I'm sorry but you are wrong. You can't be definite.

True, you have standardized the fill-factor by using guides to firmly position the rod in the coil; therefore, you feel that the only cause of variation can be the specimen's conductivity. Now I'll ask you a question. What if one section of the rod's diameter is larger and this section is inside the guides? That changes the fill-factor, doesn't it. Thus you can still get variations in fill-factor and these can't be distinguished from the conductivity variations.

This means that you have two variables: conductivity and dimensional changes in the specimen. And either one or both can cause a variation in the output indication.

Turn to page 3-13.

From page 3-13

1. The distance between the test coil and the specimen is a significant factor. If this distance varies, the output indication across the test coil will _____.

2. lift-off

3. Variation of the output indication as the distance between the coil and the specimen changes applies to both surface coils and encircling coils. The term "lift-off," however, applies only to _____ coils.

4. fill

5. The fill-factor is a variable that changes the output indication. The other variable that we have talked about so far in this book is the specimen's c _____.

7. output indication

8. Since a change in a specimen's dimension affects the fill-factor, we can say that both fill-factor and conductivity changes are reflected in the output indication. If it is necessary to separate the two variables, special electrical circuits are required. Normally, you assume the _____ is constant.

1. vary

2. When the distance between a surface coil and the specimen varies, the output indication varies. The phenomenon is called the _____ effect.

 Return to page 3-15, frame 3, and continue with the review

3. surface

4. How well the specimen (rod) fills the inside area of the test coil is an important factor. The factor is called the _____ factor and is the ratio of the square of the rod's diameter to the square of the coil's inside diameter.

 Return to page 3-15, frame 5, and continue with the review

5. conductivity

6. And we have learned that the specimen's conductivity or the specimen's dimensional changes can both effect the o _____ i _____ .

 Return to page 3-15, frame 7, and continue with the review

8. fill-factor

9. This completes the review of chapter 3. Turn to page 4-1.



So far you have learned that two factors affect the output indication in eddy current testing. One factor is the specimen's electrical conductivity; the other factor is the coupling between the test coil and the specimen. This coupling has been referred to as the lift-off effect for surface coils and as the fill-factor for the encircling coil. We have also seen that in a properly arranged encircling coil test system mechanical guides are used to ensure proper constant positioning of the rod within the coil. Under these circumstances, the only remaining variable would be the dimensional changes of the rod.

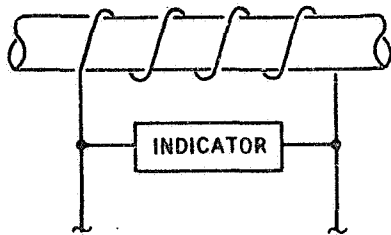

NONMAGNETIC MATERIALS	
ELECTRICAL VARIABLES	MAGNETIC VARIABLES
CONDUCTIVITY	DIMENSIONAL CHANGES

It is convenient to classify variables as either electrical or magnetic. Conductivity is an electrical variable; dimensional changes are magnetic variables. This is true because the specimen is coupled to the test coil through a magnetic field.

With these facts established, we can now start looking at the output indication in terms of variables. So far we have learned that the output indication is reflecting two variables: conductivity (electrical) and dimensional changes (magnetic).

Turn to page 4-2.

What we know about a specimen is obtained through a test coil and the characteristics of the test coil. In the next chapter we will learn that a coil has both electrical and magnetic characteristics. It is the effect of the specimen on these coil characteristics that provides the basis for separating the variables within the specimen.

The purpose of this present chapter is to learn something about the specimen's electrical and magnetic characteristics. In doing so, remember that these characteristics represent "effects" on the test coil.

Some specimens are not magnetic and only electrical effects of the specimen exist within the specimen. Under these conditions in the test system shown below would you say that the output indication has:

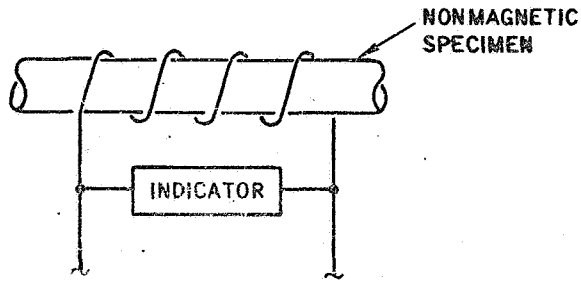

- Only electrical effects Page 4-3
- Both electrical effects and magnetic effects Page 4-4

No, you are not correct when you say that the output indication has only electrical effects. True, the specimen did not have any magnetic effects; however, there are still magnetic effects in the system.

The coupling between the specimen and the test coil is a magnetic effect and this can change as the dimension of the rod changes. Thus there are dimensional changes (magnetic effects) still in the system and these will affect the output indication. That's why the correct answer is "both electrical and magnetic effects."

Turn to page 4-4.

Fine! You recognized that the rod's dimensional changes (a magnetic effect) are still in the test system; therefore, the output indication will have both electrical and magnetic effects...even though the specimen does not have any magnetic effects.

Before we discuss specimens with magnetic characteristics (magnetic materials) let's be sure that you realize that a magnetic field can exist in a nonmagnetic material. We will assume for the moment that you know what a magnetic material is; however, we will define it later.

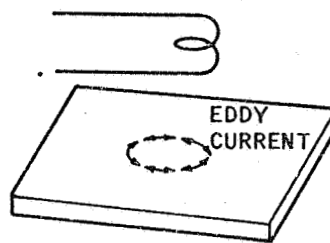
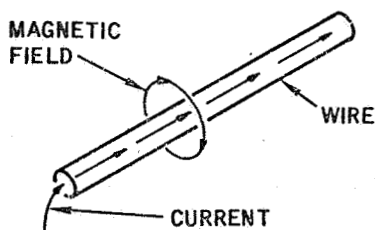

When an electrical current flows through a wire, a magnetic field develops around the wire. The wire can be a nonmagnetic material. In previous chapters, you have learned that a test coil will induce an electrical current (eddy current) into an isolated material. Again the material can be nonmagnetic. The material must, of course, be able to conduct a current. And you have also learned that a flow of current in such a specimen will develop a magnetic field that reacts against the test coil's magnetic field.

These facts mean that magnetic fields:

Exist only in magnetic materials Page 4-5

Exist in both nonmagnetic and magnetic materials Page 4-6

You are not correct. You said that magnetic fields exist only in magnetic materials.

This is not true. Magnetic fields can also exist in nonmagnetic materials.

Eddy currents can be induced into nonmagnetic materials and these currents generate a magnetic field that opposes the test coil's magnetic field.

Return to page 4-4, read the page, and try the question again.

Of course, you're right. Magnetic fields exist in nonmagnetic materials as well as in magnetic materials.

So far we have identified two variables that are reflected in the output indication. And we have said that conductivity is an electrical variable and dimensional changes are a magnetic variable. If the specimen is a nonmagnetic material, these are the only two variables appearing in the output indication. If, on the other hand, the specimen is a magnetic material, we get a third variable. It's called permeability and we use the symbol μ (pronounced MU) to denote this characteristic.

MAGNETIC MATERIALS	
ELECTRICAL VARIABLES	MAGNETIC VARIABLES
1. CONDUCTIVITY	2. DIMENSIONAL CHANGES
	3. PERMEABILITY (μ)

In the next few pages, we will define permeability and see why it presents a problem to us in eddy current testing. Keep in mind that eddy current testing is concerned with conductivity, not permeability; therefore, permeability is an undesirable variable to us. In later chapters, you will see that special equipment is required to separate the permeability variable from the conductivity variable.

Turn to page 4-7.

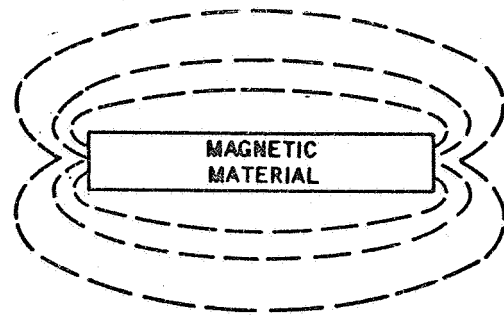
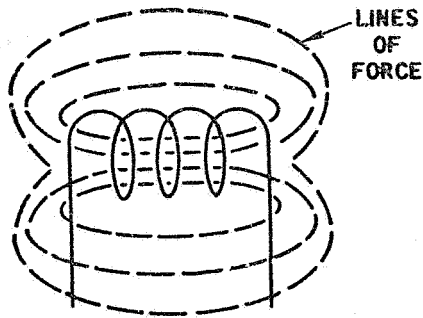

Before we get into this problem of permeability, let's be sure we have our magnetic terms defined. These terms are:

- | | |
|-------------------|----------------------|
| 1. lines of force | 3. flux density |
| 2. magnetic flux | 4. magnetizing force |

It can be shown that a coil or a magnetic material has a magnetic field which can be shown as a pattern of lines (dashed lines above). This field has a magnetizing force. In a previous chapter you learned that this force varied from point to point and we called this the field intensity. For our purposes, we will just refer to this intensity as the magnetizing force.

It is convenient to talk about all the lines of force or a group of them. The term "magnetic flux" is used for this purpose. Thus we can say the coil or the magnetic material has magnetic flux (or just flux, to keep the term short). Sometimes we need to talk about the number of lines of force in a given unit area (say one square inch). We use the term "flux density" to do this. Note that the lines of force spread out from the coil or the magnetic material; therefore, the flux density varies with the position within the magnetic field.

Below is shown lines of force passing through one square inch of cross section. View A has four lines of force; view B has six lines of force. Would you say that the flux density in view B is:

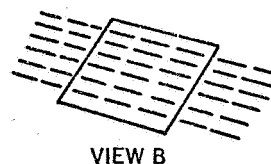
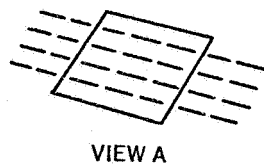

Less than the flux density in view A Page 4-8

More than the flux density in view A Page 4-9

You don't quite have the idea of flux density when you say that the flux density in view B is less than the flux density in view A.

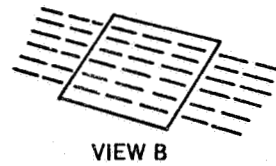
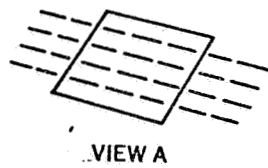

Flux density is defined as the number of lines of force passing through a unit area. For our purposes, we had an area of one square inch. In view A, four lines of force passed through this area. In view B, six lines of force passed through the same area. This means that view B has more lines of force than view A. It also means that view B shows a flux density that is more than that in view A. Remember! Flux density is the number of lines of force passing through a unit area.

Turn to page 4-9.

Good! You got the idea. Flux density is defined as the number of lines of force per unit area. Since view B has more lines of force than view A, view B has more flux density than view A.

The amount of flux is not the same in all areas outside a coil or a magnetic material. Notice how the lines of force spread out in the area outside the test coil. As you can see, the farther you get from the coil, the less the number of lines in a specific area.

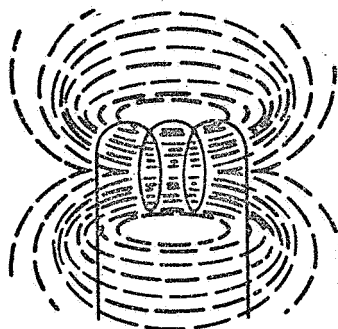

This means that the flux density outside the coil:

Decreases with distance from the coil Page 4-10

Increases with distance from the coil Page 4-11

Right again! The flux density outside the coil decreases with distance from the coil. And this makes sense because the number of lines of force in a given area decreases as you move further from the coil.

Inside the coil, the story is different. As you can see below, the lines of force are evenly distributed across the inside diameter of the coil. That makes the flux density constant across the coil.

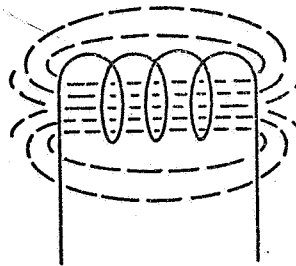

Flux density also applies to a magnetic material. Outside the material, you have lines of force, just like the coil. And again, the flux density decreases with distance.

You are probably familiar with a magnet or a magnetic material. But let's review a few basic ideas. As you know, it's something that attracts or repels something else. And you probably know that it has a north pole and a south pole. If you have two magnets and move the north pole of one close to the south pole of the other one, the two magnets attract each other. On the other hand, if you move the two north poles near each other, the two magnets repel each other.

A magnetic material can be visualized as a group of small magnets called domains. These magnets (or domains) can be randomly positioned as shown in view A or they can be aligned as shown in view B.

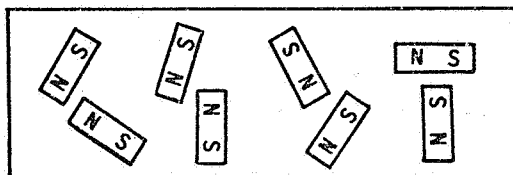

VIEW A

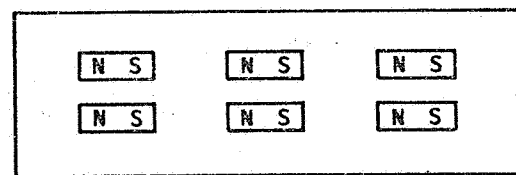

VIEW B

What's important to us is that the magnets can be positioned by an external magnetizing force.

Turn to page 4-12.

Not true. You have the concept reversed. You said that the flux density increases with distance from the coil. Actually the flux density decreases (not increases) with distance from the coil.

Keep in mind that the lines of force spread out in the area outside the coil. And, as you can see, the number of lines per unit area will decrease. Since flux density is the number of lines per unit area, this means that the flux density decreases with distance.

Turn to page 4-10.

One way to align the "small magnets" within a magnetic material is to place the material in a coil. As we have seen, an electrical current applied to a coil will establish a magnetic field around the coil. Up to now, we have been working with an alternating current (ac) which means that the magnetic field periodically reverses itself. Perhaps you are wondering what this really means.

When an electrical current is passed through a coil in one direction only, a magnetic field is established with one end of the coil being a north pole and the other end being a south pole. Thus the coil acts just like a magnet. If now the current is reversed, the poles will reverse. Of course, if the current is periodically reversed, the poles will also periodically reverse.

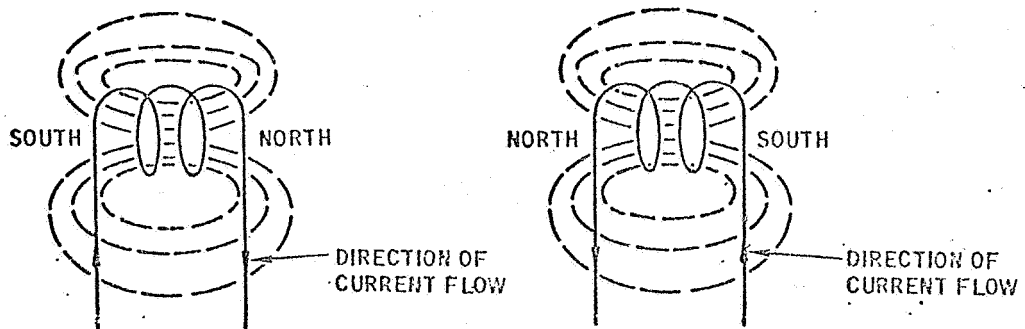

When a magnetic material is placed in a coil, the small magnets within the material will be aligned to correspond with the direction of the poles of the coil as shown below.

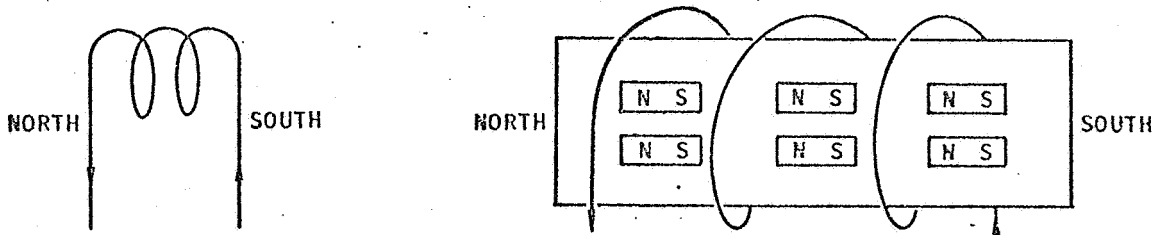

If the current in the coil is reversed, would you expect that the small magnets within the magnetic material would:

- Remain unchanged Page 4-13
- Reverse their direction Page 4-14

No, you are not right when you say that the small magnets remain unchanged. Instead, they will reverse their direction.

The small magnets within a magnetic material align themselves in the same direction as the direction of the magnetic field that is applied to the magnetic material. If the field reverses, then the magnets reverse.

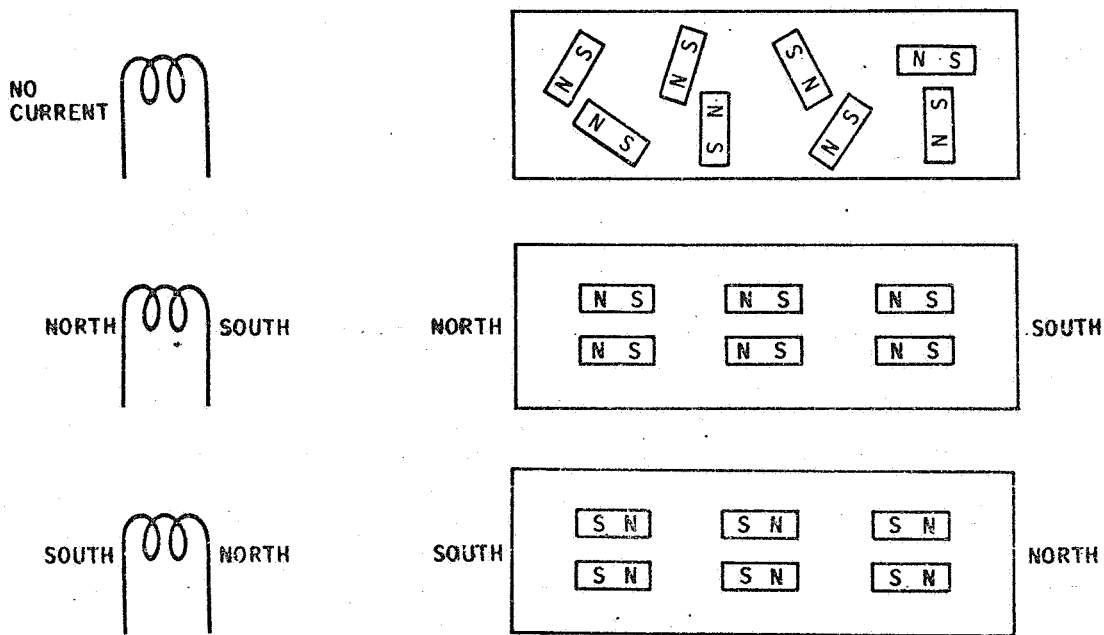

Turn to page 4-14.

Perfectly correct. Since the alignment of the small magnets within a magnetic material is influenced by the coil's field, you would expect that the magnets would reverse direction if the coil's field direction is reversed.

The terms lines of force, magnetic flux, and flux density also apply to a magnetic material. A magnet acts just like a coil's magnetic field. The magnet has lines of force, magnetic flux, and flux density. And this is true both inside and outside the material.

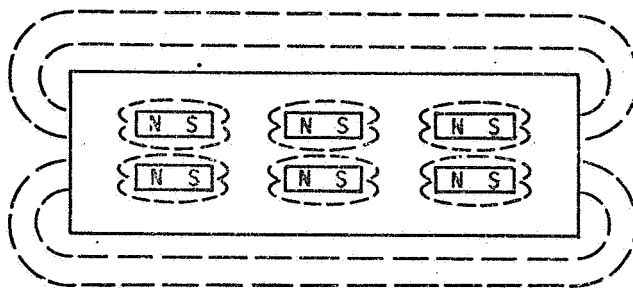
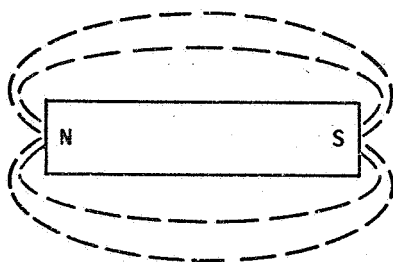

Inside the material, the material can be viewed as a group of small magnets with each magnet having lines of force, magnetic flux, and flux density. As applied to eddy current testing, we are particularly interested in the magnetic material's flux density.

Visualize that you place a specimen with magnetic properties inside a test coil. The test coil is connected to a source of alternating current. Would you say that the direction of the specimen's flux:

- Alternates (first in one direction, then in the other direction) Page 4-15
- Remains constant in one direction Page 4-16

Of course, you're correct. The specimen has flux and the direction of the flux will change as the direction of the test coil's field changes.

Now that you have a feel for magnetic materials, let's see where we are. If you recall, we started with a nonmagnetic specimen and placed it in a test coil. Under these conditions, the coil's field induced eddy currents into the rod (specimen) and the resulting flow was in the same direction as the windings of the coil. This flow generates a magnetic field that is perpendicular to the current flow. And of course this field will have lines of force and a flux density.

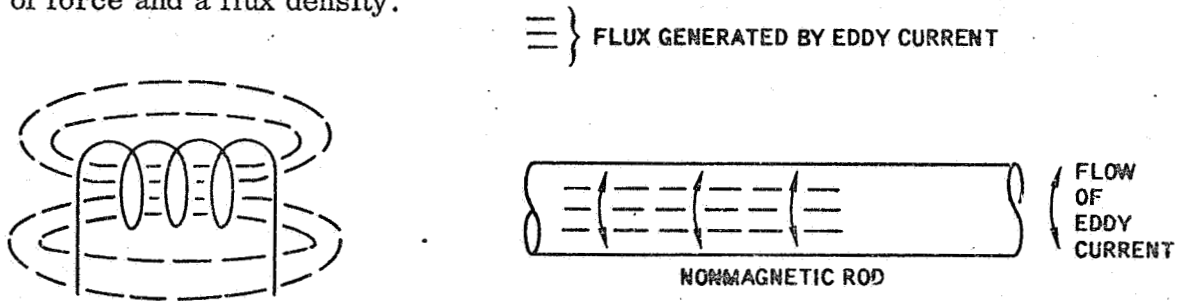

Consider now that we use a magnetic specimen instead of a nonmagnetic specimen. Again we have eddy currents and the eddy current's magnetic field. We also have the magnetic field of the magnetic material. Note that we now have two fields within the specimen. One is the eddy currents magnetic field; the other is the field developed by the magnetic material's domains. Isn't it also true that we have two flux densities? Certainly. One is caused by the eddy current; the other, by the specimen's magnetic properties.

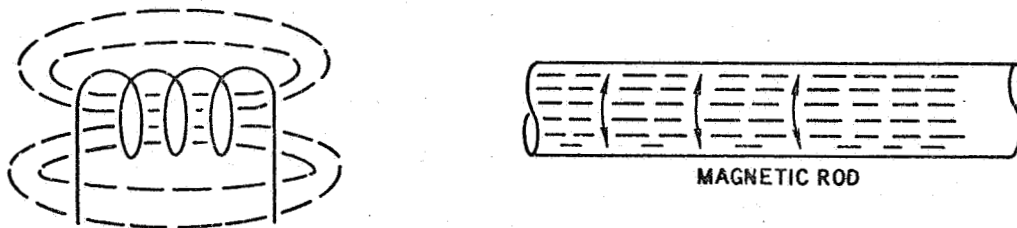

The output across a test coil changes as the coil's magnetic field changes. The coil's magnetic field changes as the flux density of the specimen changes. For a magnetic specimen, the output indication reflects:

- Only conductivity changes Page 4-17
- Both conductivity and magnetic property changes Page 4-18

What you say is not correct. You said that the specimen's magnetic flux will remain constant in one direction when the test coil's magnetic field periodically reverses.

The specimen's magnetic flux is generated by the small magnets within the specimen. These magnets, you have seen, reverse themselves as the test coil's field is reversed. This means that the direction of the specimen's flux alternates as the direction of the coil's field changes.

Turn to page 4-15.

Sorry, you missed a turn that time. Your answer "For a magnetic specimen, the output indication reflects only conductivity changes" is not correct. Both conductivity and magnetic property changes are reflected in the output indication.

The coil's magnetic field is affected by the specimen's flux changes. These changes come from two areas. The eddy currents develop one set of flux changes; the magnetic properties of the specimen develop another set of flux changes. The sum of the two sets of changes affects the coil's magnetic field. Of course, this is only true when the specimen is a magnetic material.

Turn to page 4-18.

Fine, you're on the right track. For a magnetic specimen, the output indication reflects two changes. One is the conductivity change; the other is the magnetic change. However, before we add the magnetic effects to the output indication, let's briefly review the eddy current sequence.

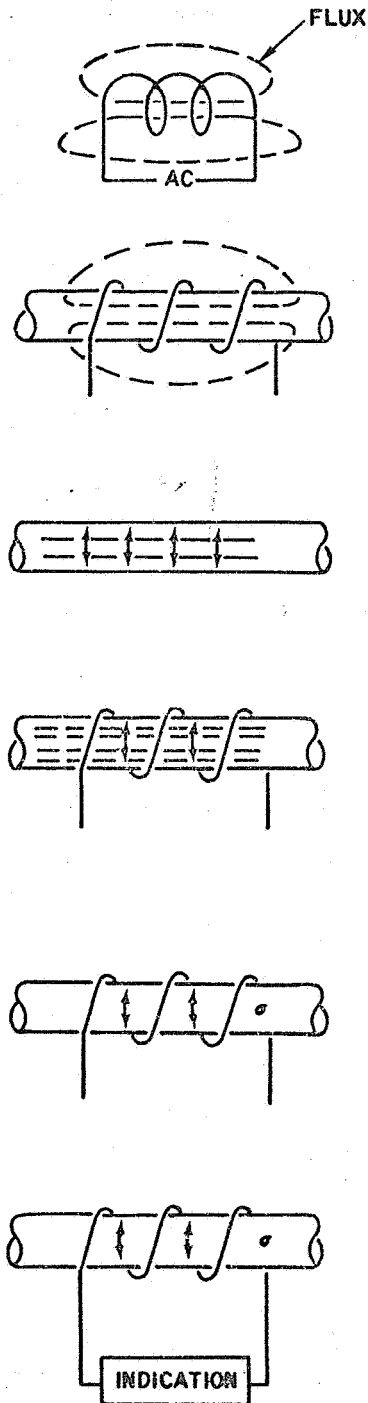

1. An alternating current (ac) applied to a coil will cause the coil to develop a magnetic field with a definite pattern of flux. Since the current is periodically reversed, the flux will periodically reverse.
2. If a nonmagnetic rod is placed in the coil, the coil's flux will enter the rod. Since the coil's flux is alternating, the flux within the rod will alternate.
3. An alternating flux within the rod will induce eddy currents which flow in a direction that is perpendicular to the flux.
4. A flow of current develops a magnetic field with a definite flux pattern. This is also true for eddy currents. The eddy current flux will oppose the flux established by the coil.
5. The flow of eddy current is influenced by the conductivity of the rod. If the conductivity (σ)* changes, the eddy current flow changes. Such changes also cause a change in the flux.
6. An output indication, connected across the coil, will sense changes in flux through the characteristics of the coil. It thus becomes possible to sense conductivity changes because of the interaction between the coil's flux and the eddy current's flux.

* (σ) Sigma

Turn to page 4-19.

Now that you have the eddy current sequence in mind, let's realize that the flux in the test coil varies because the alternating current (ac) applied to the coil varies.

The flux density of the coil is a magnetizing force and this force will magnetize a magnetic material placed inside the coil. This magnetizing force will vary with the amount of current applied through the coil.

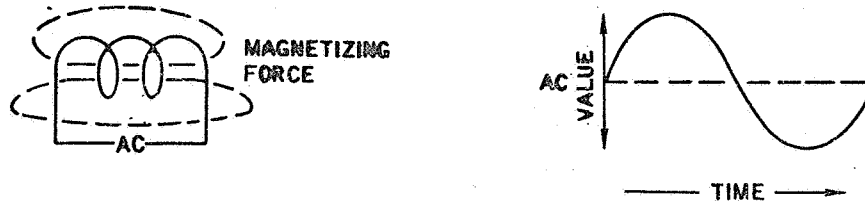

An alternating current (ac) is an electrical current that varies. Its value starts at a center value and increases to a maximum in one direction; then it decreases to a center value and reverses its direction to a maximum in the opposite direction; and then it returns to the center value to start the cycle again. Since the magnetizing force depends upon the current flowing through the coil, this means that the magnetizing force varies as the current varies.

The term "magnetizing force" also applies to nonmagnetic materials. From what you have learned about the eddy current sequence and the magnetizing force, you can now say that the induced eddy current in a nonmagnetic material is:

A steady electrical current Page 4-20

An alternating electrical current Page 4-21

Your answer "A steady electrical current" is not correct. Eddy current is an alternating current, just like the alternating current applied to the test coil.

Eddy currents are developed by the magnetizing force applied to the specimen. If this magnetizing force (flux) varies, then you can expect the amount of eddy current to vary. And you just learned that the alternating current applied to the test coil does generate a magnetizing force that varies as the alternating current varies.

Turn to page 4-21.

Yes, you're right. Eddy current is an alternating electrical current. Let's look at it in more detail.

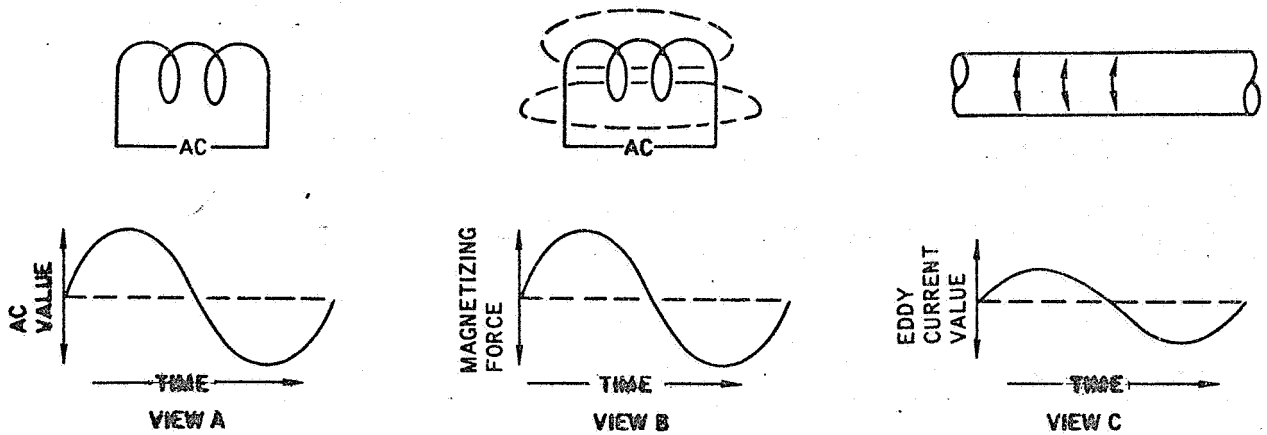

An alternating current is a varying electrical current (view A) that varies above and below a center value. This current will develop an alternating magnetizing force (view B). And this force will induce an alternating current (eddy current) into a specimen (view C).

When things happen in equal ways, we say the relationships are linear. This is the situation in views A, B, and C. Note that the three factors - ac value, magnetizing force, and eddy current value rise and fall in equal ways. In a moment you will see that this is true for nonmagnetic materials but is not true for magnetic materials. That's where permeability comes into the test system. Permeability is not linear.

In a linear system (views A, B, and C above), if the ac applied to the test coil is increased, will the eddy current:

Remain the same Page 4-22

Increase Page 4-23

No, you are wrong. In a linear system, if the ac applied to the test coil is increased, the eddy current will increase, rather than remain the same (your answer).

If you recall, I said that when things happen in equal ways, the relationships are linear. That makes a linear system. This also applies to eddy currents. As the ac applied to the test coil increases, the magnetizing force increases and this increases the value of the eddy currents.

Turn to page 4-23.

Naturally you're right. If the ac to the test coil increases, the magnetizing force increases, the flux in the specimen increases, and the eddy current increases. And they all happen in equal ways because the system is linear. Now let's look at something that is not linear. It's related to permeability.

A coil has a flux density which for our purposes we will call a magnetizing force. And to help us, we will use the letter H. H is our symbol for magnetizing force. As you have just learned, H varies as the alternating current applied to the coil varies. The magnetizing force (H) alternates back and forth, rising to a maximum value in one direction and then reversing to a maximum value in the opposite direction. To help us understand permeability, we will make a graph with H laid out on the horizontal scale. And we establish a center point and then say that the maximum value in one direction is H and the maximum direction in the opposite direction is H'. It looks like this:

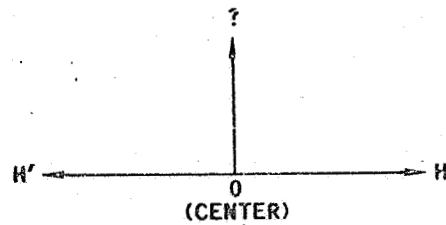
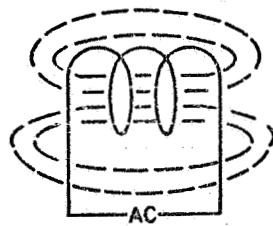

Of course, we also need a vertical scale so we will show this too; however, let's hold off talking about this vertical scale for a moment. Right now the important fact to know is that the horizontal scale is H and means:

- Magnetizing force Page 4-24
- Permeability Page 4-25

True, of course. The letter H means magnetizing force on our horizontal scale. And H means a maximum value in one direction while H' means a maximum value in the opposite direction.

Logically, we can't have a graph without a vertical scale with a value. So let's put it in and call the value B. The letter B will represent the flux density in a magnetic specimen. Since we know that the flux within a specimen alternates and depends upon the value of the magnetizing force (H), we better show B moving in both directions (B and B').

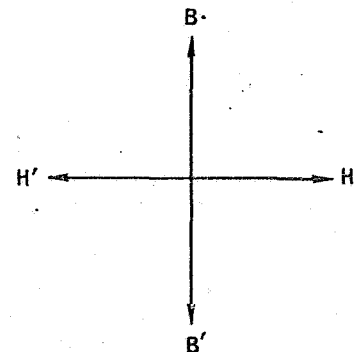
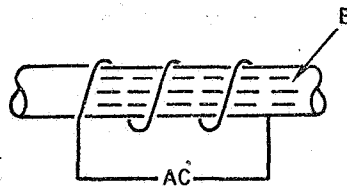
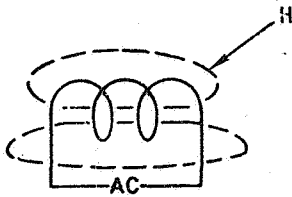

Now let's see what we have. B is the flux density in the magnetic specimen; H is the magnetizing force of the coil that establishes the flux density B in the specimen. For every value of H, there must be a corresponding value of B. We have the basis for a graph don't we? Of course, we don't have any units of measurements shown on our graph, but for our purposes we can leave these units out. Just realize that both H and B have units of measurement.

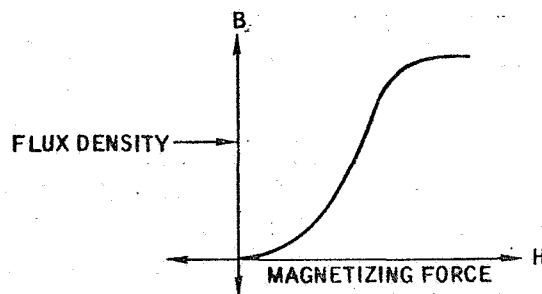

The above figure illustrates how B varies as H varies when a magnetic specimen is placed in the test coil. If the figure had actual units of measurement on it and we gave you a specific value H, could you find the corresponding value for the:

Magnetizing force Page 4-26

Specimen's flux density Page 4-27



Wrong. You said "permeability" and the answer is "magnetizing force." We will get to permeability in a minute.

The letter H means magnetizing force. And you have learned that it moves from a center point to a maximum in one direction (H) and then reverses to a maximum value in the reverse direction (H').

Return to page 4-23, read the page, and try the question again.

Perhaps you misunderstood the question for you are wrong. Let's review the question together.

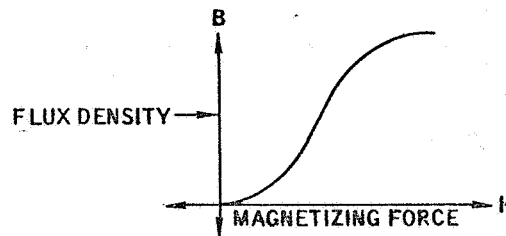

The above figure illustrates how B varies as H varies when a magnetic specimen is placed in the test coil. If the figure had actual units of measurement on it and we gave you a specific value H, could you find the corresponding value for the:

Magnetizing force

Specimen's flux density

You said "Magnetizing force;" the correct answer is "Specimen's flux density." We gave you a specific value for H and H is the magnetizing force. Using the curve, you can find this point on the horizontal scale, move vertically to the point where the value intercepts the curve, and then move horizontally to the vertical scale. There you will find the specific value for B which is the specimen's flux density. Recall that B is the specimen's flux density. H is the magnetizing force. Your problem was to find B, not H.

Turn to page 4-27.

Fine, you said "Specimen's flux density" and that's right. Let's review your procedure. You were given the value H and asked to find the value of B.

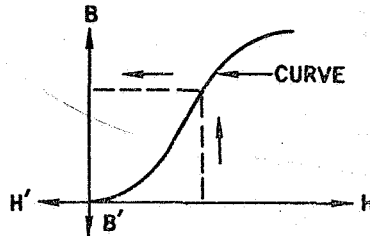

Given the value H (magnetizing force), you located this value on the horizontal scale. Next you moved vertically to the point where your value H intercepted the curve. Then you moved horizontally from this point to the point where you intercepted the vertical B scale. This gave you the specific value of the specimen's flux density (B).

The ratio of the value of B to the value of H has a name. It's called permeability (now you know what it means, don't you?). And for the specific example we used, there would be a definite permeability value. Notice that we used the curve to get this value. Again it is convenient to use a symbol. This time we will use the symbol (μ). It's pronounced MU. And MU (μ) means the ratio of the specimen's flux density to the coil's magnetizing force.

From this we can say that:

$$\text{MU } (\mu) = \frac{H}{B} \dots\dots\dots \text{Page 4-28}$$

$$\text{MU } (\mu) = \frac{B}{H} \dots\dots\dots \text{Page 4-29}$$

No, you have the ratio reversed. Permeability = B/H, not H/B.

Permeability is the ratio of the specimen's flux density to the coil's magnetizing force.

$$\text{Permeability } (\mu) = \frac{\text{specimen's flux density}}{\text{coil's magnetizing force}} = \frac{B}{H}$$

Got it? Good! Then let's move on. Turn to page 4-29.

You selected the proper ratio for permeability.

$$\mu = \frac{B}{H}$$

or

$$\text{PERMEABILITY} = \frac{\text{FLUX DENSITY}}{\text{MAGNETIZING FORCE}}$$

It's interesting to note the range of permeability.

Commercial Nickel	39
Wrought Iron	2,000
High Silicon Steel	9,000

It can extend to even higher values than shown. Visualize that you apply a magnetizing force to three specimens and note that each specimen had a different flux density. You use the same value of H on each of the three specimens.

H	μ
Specimen A	10
Specimen B	100
Specimen C	1,000

Would you say that the flux density of specimen B is:

Less than specimen A Page 4-30

More than specimen A Page 4-31

No, you are not correct when you say that the flux density of specimen B is less than specimen A. It's actually more.

$$\text{Permeability} = \frac{B}{H} .$$

$$\text{For specimen A, we had: } 10 = \frac{B}{H}$$

$$\text{For specimen B, we had: } 100 = \frac{B}{H}$$

And I said that H has the same value for both specimens. Since the permeability of specimen B is greater than that of specimen A and H is the same for both specimens, it's obvious that the flux density of specimen B is more than that of specimen A. In fact it's 10 times more, isn't it?

Turn to page 4-31.

Good! You recognized that the flux density of specimen B is more than that of specimen A because the permeability of specimen B is more than that of specimen A.

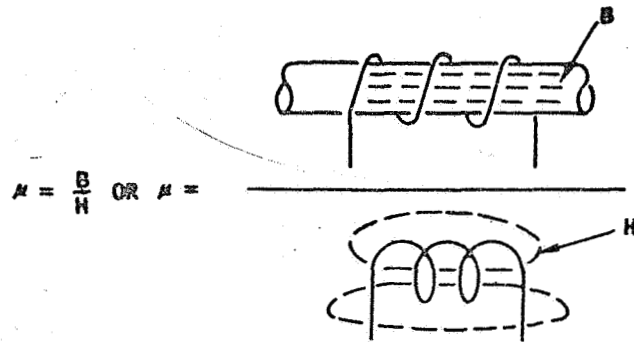

Notice what permeability really means. When a rod is placed in a coil, flux is developed in the rod. This flux has two parts. One part is the flux in the coil that is now in the rod. The other part is the flux developed in the rod because the rod has magnetic properties (recall the small magnets that are aligned by the external magnetizing force).

We can view the magnetizing force H as the flux density in the test coil. Thus we can say that we are dividing the flux density of the coil into the flux density of the rod. And since the rod generates additional flux density, we get big numbers (e.g. 39; 2,000; 9,000; 1,000,000).

So far you have learned that the flux density of the specimen varies as the flux density of the coil varies. And you have learned that the flux density of a magnetic specimen in a coil is:

Greater than the flux density of the coil Page 4-32

Less than the flux density of the coil Page 4-33

Right! To get permeabilities like 2,000 (9,000; etc.), the magnetic specimen's flux density B must be greater than the flux density of the coil.

Consider now what this means. Eddy currents develop when flux changes take place within a specimen. For a nonmagnetic material, the only source of flux is the test coil. This means that there is a direct relationship between the flux of the coil and the flux in the specimen. The amount of eddy current is directly related to the coil's flux and the conductivity of the specimen.

You have just learned that the coil's flux also enters a magnetic material. Like a nonmagnetic material, eddy currents will be induced into the magnetic material. Again, the amount of eddy current is directly related to the coil's flux and the conductivity of the specimen.

In the case of a magnetic material, an additional factor exists. Since the material also generates its own flux and this flux changes within the material, additional eddy currents will be generated. These currents are directly related to the magnetic properties of the material.

From this we can conclude that the magnetic properties of a specimen:

Will not affect the flow of eddy currents Page 4-34

Will affect the flow of eddy currents Page 4-35

No, you missed the concept. Perhaps you misread the question. You said that the flux density of a magnetic specimen in a coil is "Less than the flux density of the coil." We're sure you don't believe that.

As you recall, a magnetic material generates additional flux when the material (e.g., a rod) is placed in a coil. The rod therefore has two sources of flux. One is the flux generated by the rod's material. The other is the flux that has entered the rod from the test coil. That's why the total flux density in the rod must be greater than the flux density of the coil.

Turn to page 4-32.

You have missed a very important point. You said that the magnetic properties of a specimen will not affect the flow of eddy currents. Perhaps the term "magnetic properties" caused you to select the wrong answer.

We used the term "magnetic properties" to designate the ability of the material to generate flux. This is the property of a magnetic material. You have just learned that this flux generates additional eddy currents into the material. This flux is in addition to the flux generated by the test coil. The amount of additional flux generated by the magnetic properties is added to the flux generated by the coil and the total value is related to the generation of eddy currents in the material. That's why we can say that the magnetic properties of the specimen will affect the flow of eddy currents. If these magnetic properties vary, the eddy current will vary.

Turn to page 4-35.

We agree. The magnetic properties of a specimen will affect the flow of eddy currents. In eddy current testing, this presents a problem; for permeability is not linear.

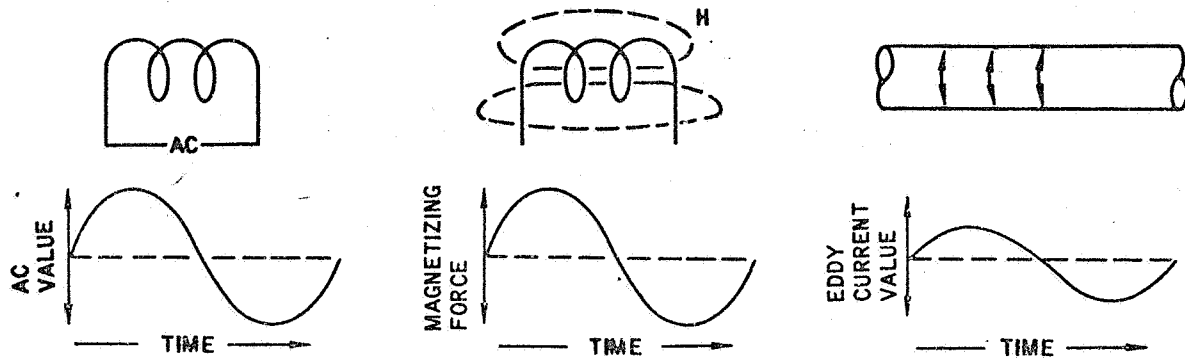

As you recall, the current applied to the test coil is an alternating current that varies above and below a center value. This current produces an alternating magnetic force which, in turn, produces an alternating eddy current within the specimen. Since the system is linear, equal changes in alternating current produce equal changes in eddy current. Such a condition is only true for nonmagnetic materials.

For a magnetic material, equal changes in magnetic force (or AC) do not produce equal changes in flux density (B). This can be seen in the following figure.

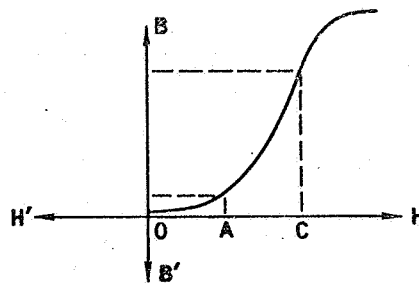

If the magnetizing force moves from O to the value A, only a small value of B is developed. If the force now moves from A to C, B rises to a large value (has more flux density doesn't it?). For our purposes we have used two equal changes in magnetizing force (i. e., $OA = AC$).

Since equal changes in magnetizing force produced unequal changes in flux density, we can say that the system is:

Not linear Page 4-36

Linear Page 4-37

• ~~XXXXXXXXXX~~

Yes, that's right. The system is not linear. Equal changes in magnetizing force are producing unequal changes in flux density. Note what this means.

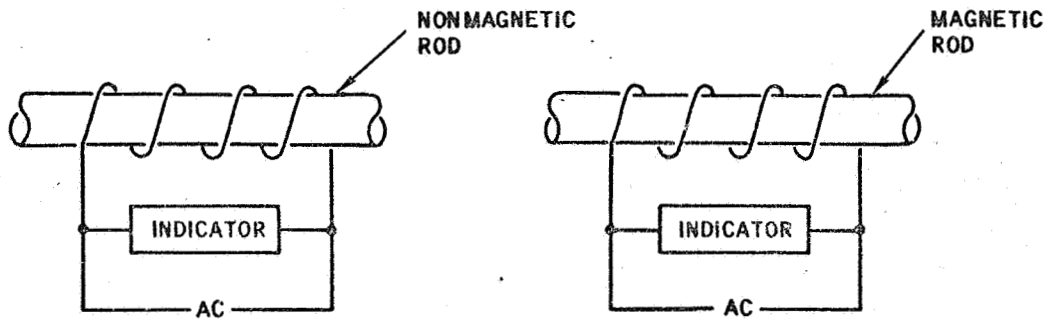

A nonmagnetic rod passing through a test coil will affect the coil. An indicating device connected across the coil can sense the rod's affect on the coil. If we disregard the dimensional changes of the rod, the output indication will change as the eddy current changes. These changes are related to the rod's conductivity. The total system that we have is essentially a linear system.

The use of a magnetic rod changes the picture. Since the flux density in the rod is not linear with relationship to the magnetizing force, we now have a varying value in the output indication. Such a value interferes with our eddy current indication. And since the magnetic effects are much stronger than the conductivity effects, we can't see the conductivity effects.

Suppose that we handed you a rod and did not tell you whether it is magnetic or non-magnetic. We told you to test the rod. Before you test it, must you know if the rod is magnetic or nonmagnetic?

No Page 4-38

Yes Page 4-39

We don't agree. You said that if equal changes in magnetizing force produced unequal changes in flux density, then the system is linear. Not true. The system is not linear.

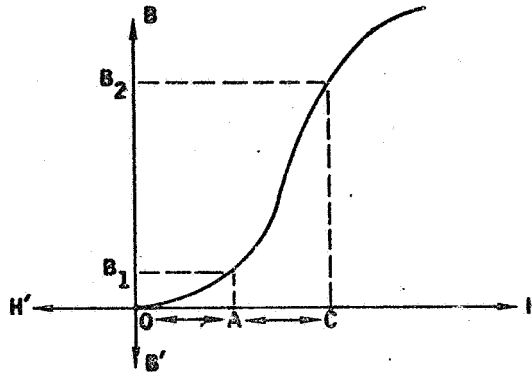

In the above figure, the magnetizing force is H and the flux density is B . The value OA represents a specific change in the magnetizing force H . This change produces the flux change OB_1 .

If now, a second change in magnetizing force is made (e.g., AC) then a change in the flux density B will occur. The change AC produces the change to B_2 . Note that the flux change B_1 to B_2 is greater than the flux change O to B_1 .

Since the magnetizing force change AC is the same as OA , this means that equal changes in magnetizing force produced unequal changes in flux density. This means the system is not linear.

Turn to page 4-36.

You said "No". The correct answer is "Yes". Apparently you don't feel you need to know if the specimen is magnetic or nonmagnetic before you test it. You're wrong.

You have just learned that the output indication is reflecting changes in the specimen. One source of change is the specimen's conductivity. Another source is the specimen's magnetic properties. For a magnetic specimen, both sources exist. In a nonmagnetic specimen only the conductivity source exists. Since the magnetic properties produce stronger effects than the conductivity property and since the magnetic properties are not linear, it's important to know if the specimen is magnetic or nonmagnetic. Otherwise, you can't really know what a change in the output indication means.

Turn to page 4-39.

Perfectly true! You need to know if the specimen is magnetic or nonmagnetic before you test it. You also need to know that permeability varies with the value of the magnetic force applied to the specimen.

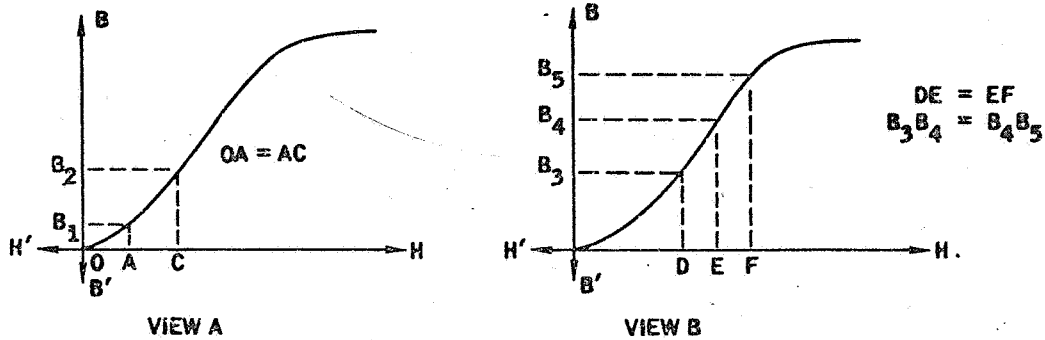

View A illustrates that equal changes in the magnetizing force can produce unequal changes in the flux density. The change from O to A produces the value B_1 ; therefore, the flux change is OB_1 . The change from A to C produces the flux change B_1B_2 . Since the change B_1B_2 is greater than the change OB_1 , we can say that the permeability is not constant.

View B illustrates that equal changes in H can produce equal changes in B. This means that the permeability is the same over this change area of the curve shown in views A and B. Note that change $DE =$ change EF and that change $B_3B_4 =$ change B_4B_5 .

Note that in views A and B the curve is actually a straight line over a portion of the curve. And we have seen that in this straight line portion the permeability is constant.

If the curve shown in views A and B is the magnetizing curve for a specific specimen, would you say that the permeability of the specimen:

- Is constant Page 4-40
- Varies with the range of the magnetizing force Page 4-41

Incorrect. Permeability of the specimen is not constant. It varies with the range of the magnetizing force.

If you recall, view A illustrated that the permeability varied over one portion of the curve. View B illustrated that the permeability was constant over a portion of the curve. Whether permeability is variable or constant depends upon where you are operating on the curve. It also depends on how wide a range of change in magnetizing force you are using. If your range is small and you are in the straight-line portion of the curve, permeability is a constant value. If your range is wide and you are operating over the bent portion of the curve, then the permeability will vary.

Turn to page 4-41.

Again, you are correct. Permeability varies with the range of the magnetizing force. If you select a small range of change and use a range in the straight portion of the curve, the permeability is constant. On the other hand if you use a range that extends into the bent portion of the curve, then the permeability varies.

Since permeability changes present a problem in eddy current testing, let's see if we can't make the permeability factor a constant. We can do this by saturating the specimen.

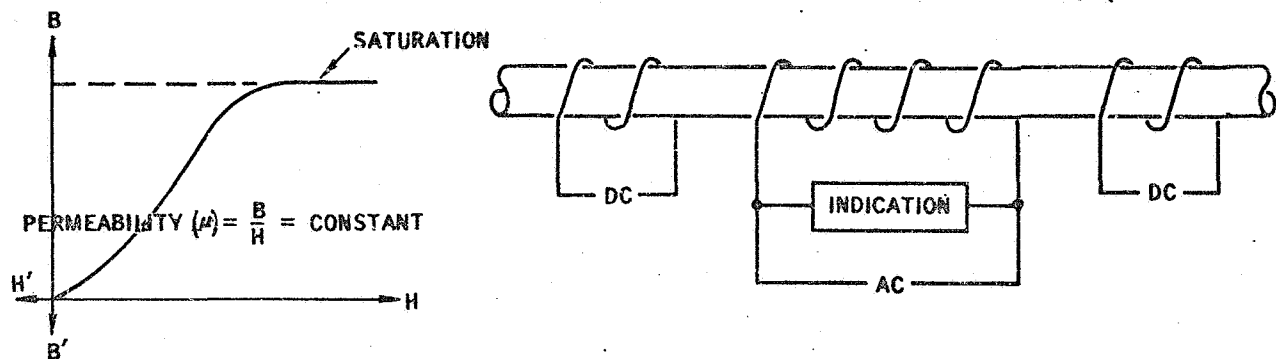

Notice in the above curve that the magnetizing curve becomes flat or horizontal at the top of the curve. This means that further changes in magnetizing force (H) will not produce changes in flux density. When such a condition exists, we say the specimen is saturated. And under such a condition, the permeability is constant. One way to saturate the specimen is to use a direct current (dc). Note that a dc coil is positioned on each side of the ac coil used in the rod under test.

When a specimen is saturated, the magnetic properties of the specimen will not generate further flux changes. The remaining flux changes will be caused solely by the test coil.

If you saturated a magnetic specimen, would you say that the output indication expresses:

Both the magnetic properties and conductivity properties of the specimen... Page 4-42

Only the conductivity properties of the specimen Page 4-43

You don't quite have the idea. If the specimen is saturated, only conductivity properties will be reflected in the output indication. You apparently believe you will have magnetic properties in the output indication as well.

The purpose of saturating the specimen is to eliminate magnetic effects. When a specimen is saturated by applying a strong direct current (dc) to a coil, a strong magnetic field (magnetizing force) is developed. This causes the specimen to become fully magnetized. Or we can say that the specimen develops all the flux density it can develop. If more magnetizing force is applied, nothing else happens. The specimen has developed its maximum amount of flux. That's why it can't affect the output indication.

Turn to page 4-43.

Good! You have a major point to your credit. By saturating a magnetic specimen, you can get rid of the specimen's magnetic effects from the output indication. That leaves only the conductivity effects in the specimen.

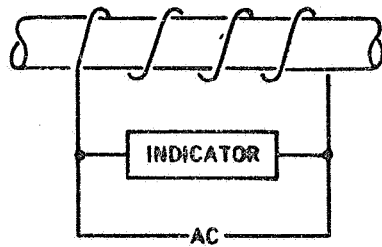

ELECTRICAL	MAGNETIC
CONDUCTIVITY	DIMENSIONAL CHANGES AND PERMEABILITY CHANGES

You started this chapter learning that a specimen had both electrical and magnetic effects. The electrical effect is conductivity; the magnetic effect is permeability (μ) (pronounced MU). In terms of an output indication, we can say that we have electrical effects and magnetic effects.

When we say that by saturating a specimen we can end up with only the conductivity effect in the output indication, we are not quite right. The dimensional changes of the specimen still appear in the output indication. Such changes we classify as magnetic effects. Notice that we have three factors: conductivity, dimensional changes, and permeability. Two of these are in the class called magnetic; the other is in the class called electrical. (See illustration above)

A moment ago you responded to a question that said that if you saturated a specimen, you would say that the output indication reflected only the conductivity properties of the specimen. For this to be true we assumed that the dimensional factor was constant.

Turn to page 4-44.

In eddy current testing, it is important to know if the specimen is magnetic or non-magnetic. Since this is so, let's take a moment to define what is magnetic and what is not magnetic.

You have seen that the application of a magnetizing force to some materials causes the material to generate a magnetic flux density that is greater than the flux density applied to the material. A material that does this is called a magnetic material. This condition can be established in a material by applying a direct current to a coil while the material is in the coil. When the material is removed from the coil, the material will still be magnetized (has permanent flux density) and will act like a magnet.

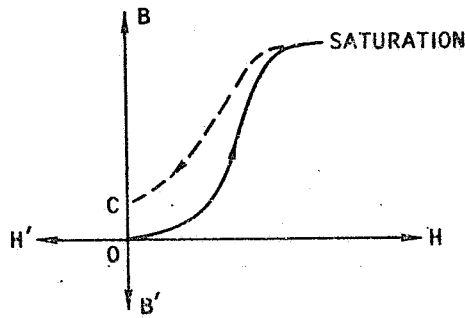

The above figure illustrates how a material reacts to a magnetizing force which is applied first in one direction and then decreased to a zero magnetizing force. Note that as the magnetizing force is increased, the material's flux density (B) increases to a maximum value and becomes saturated. If now the magnetizing force is reduced to zero, the material's flux density decreases (dotted curve) but does not return to zero. The vertical distance OC represents the value of flux density still remaining in the material. Would you say the material is:

- Nonmagnetic Page 4-45
- Magnetic Page 4-46

Your answer "Nonmagnetic" is not correct. The material is magnetic.

A magnetic material is a material that has residual magnetism after the magnetizing force is removed. This is the condition you had in the previous illustration. First a magnetizing force was applied to a material. This force generated flux density (B) within the specimen. Next the magnetizing force was reduced to zero. Under this condition, the flux density decreased; but it did not reduce to zero. A flux density represented by the distance OC still remained in the material and this is the residual magnetism. Since the material will still act like a magnet, we say the material is magnetic.

Turn to page 4-46.

We agree. The material is magnetic. This is true because the material acts like a magnet after you remove the magnetizing force.

Consider now that you reverse the magnetizing force while the material is still in the coil. As you do so, you have a means of watching what happens to the flux density in the material.

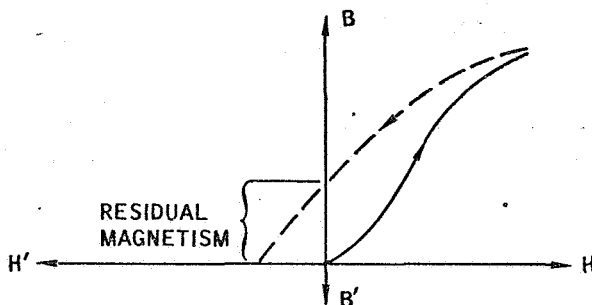

When the magnetizing force is reversed, the flux density will decrease to zero. The force required to reduce the flux density to zero is called the coercive force. It's not important that you remember this name. Just remember that the residual magnetism of the material can be eliminated by reversing the magnetizing force polarity.

In eddy current testing, alternating current (ac) rather than direct current (dc) is used; therefore, it's important to know how the flux density varies with the ac. You have just seen that the flux density decreases to zero when the magnetizing force is reversed. If you continued increasing the magnetizing force in the reverse direction, would you expect that the flux density:

Would rise to a maximum value in the reverse direction Page 4-47

Remain at zero flux density Page 4-48

You have the concept. The flux density reverses direction and rises to a maximum value in the reverse direction.

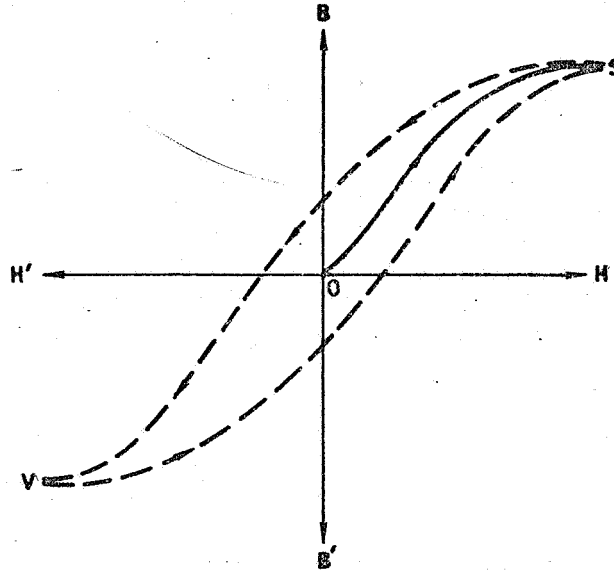

The above figure illustrates one complete cycle. Starting with an unmagnetized material, the flux density (B) increases to a maximum value (point S). The magnetizing force is then reversed (H') and the flux density decreases to zero and rises to a maximum value in the opposite direction (point V). If the magnetizing force is now reversed again, the flux density will decrease to zero and increase to point S. Note that the result is a loop. Such a loop is called a hysteresis loop (hiss-ter-e-sis). Try pronouncing it. Also note that the initial magnetizing curve OS will not appear after the first cycle.

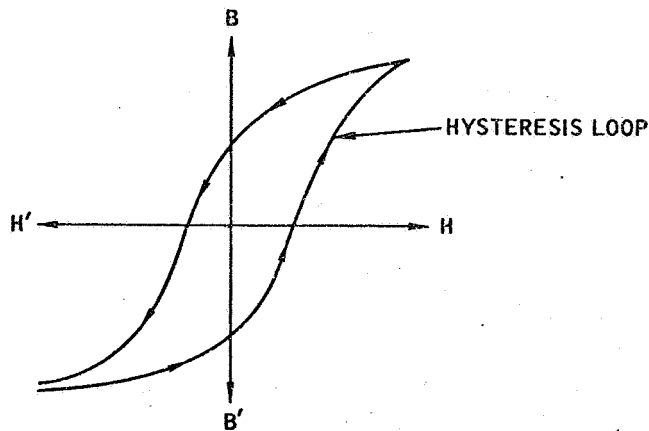

Turn to page 4-49.

No, you are not right. The flux density will not remain at zero. Instead, it will increase to a maximum value in the reverse direction.

A magnetic material will respond to a magnetizing force in either direction. If the direction of the force is reversed, the flux density will decrease to zero and then rise to a maximum in the opposite direction. If you recall, earlier you learned that the flux density within a material is alternating, first in one direction and then in the opposite direction. Thus we can expect that the flux density will rise to a maximum in one direction, then fall to a zero value and rise to maximum in the other direction.

Turn to page 4-47.

It is convenient to classify materials as magnetic or nonmagnetic. Most magnetic materials are called "ferromagnetic" which means of or relating to a class of substances characterized by abnormally high magnetic permeability, definite saturation point, and appreciable residual magnetism and hysteresis. The term "hysteresis" means that the material has a large hysteresis loop.

Using this definition, which of the following materials would you say is the ferromagnetic material:

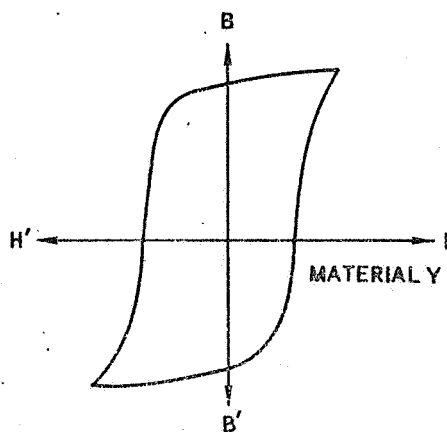
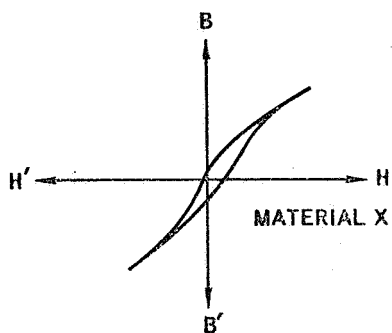

Material X Page 4-50
Material Y Page 4-51

You don't quite have the idea. The correct answer is material Y. Let's try again.

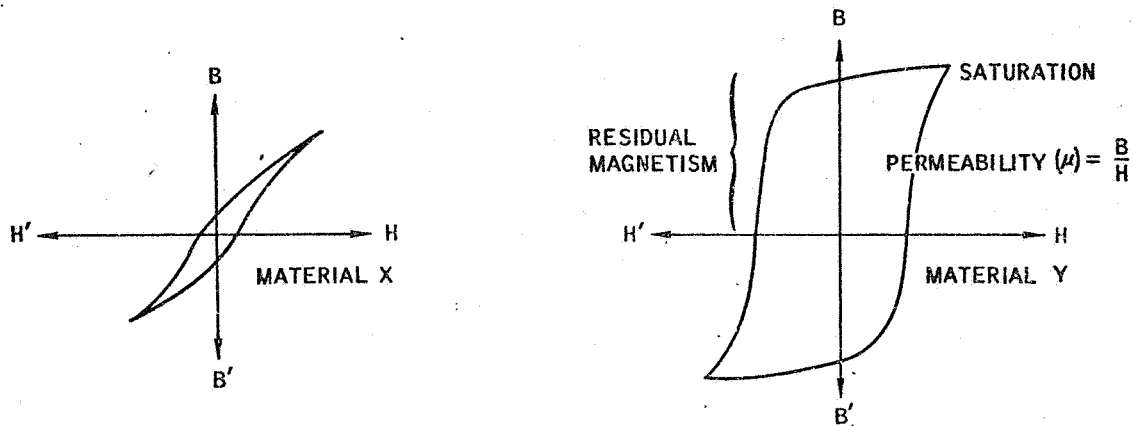

To be a ferromagnetic material (magnetic material), the material must have an abnormally high permeability, a definite saturation point, and appreciable residual magnetism and hysteresis. This is the condition we have in material Y.

Permeability is the ratio of Y to H. Note that the slope of the curve in material Y is steeper than that of material X. That means its permeability is higher.

Also note that material Y has a definite saturation point while material X is more gradual. Residual magnetism is the flux density remaining in the material when the magnetizing force is reduced to zero. Note the height of the flux density in material Y under this condition.

And finally, the larger the loop (hysteresis), the more magnetic the material is. Again, note that the loop in material Y is larger than the loop in material X.

For these reasons, you can say that material Y is the ferromagnetic material.

Turn to page 4-51.

You're right. Material Y is the ferromagnetic (magnetic) material. Now let's review what we know about magnetic and nonmagnetic materials.

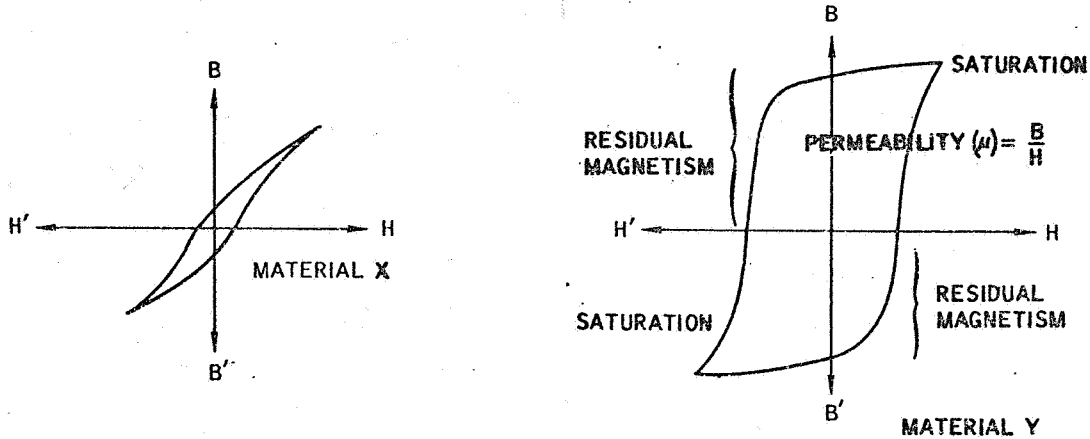

We have said that a material is magnetic (or ferromagnetic) if it has:

1. abnormally high permeability
2. a definite saturation point
3. appreciable residual magnetism
4. hysteresis (large loop)

And that's the condition we have in material Y, shown above.

It's important to realize that the line between magnetic and nonmagnetic is one of degree or how much of each characteristic. Some materials may be strongly magnetic, some only mildly so, and others so slightly magnetic that the characteristics can't be measured. Which really means that the effect is so small that the material can be treated as a nonmagnetic material. Actually it can be proved that all materials have some magnetic characteristics. It's just a matter of degree.

Turn to page 4-52.

One of the factors that can affect the results of eddy current testing is heat. Earlier you learned that the flow of eddy currents generates heat. Current flow always generates some heat. As this heat develops, it can change the conductivity in the area of the test coil and cause an incorrect output indication.

The hysteresis property of a magnetic material also is a source of heat. As you have seen, a magnetic material has residual magnetism and work is required to reduce this to zero before the flux density can be increased in the opposite direction. The force required to overcome the residual magnetism was called the coercive force. Note that the size of the hysteresis loop is related to this coercive force. The width of the loop increases as the value of the coercive force increases. And the larger the loop is, the greater the amount of heat generated. Again, this heat will affect the conductivity of the material.

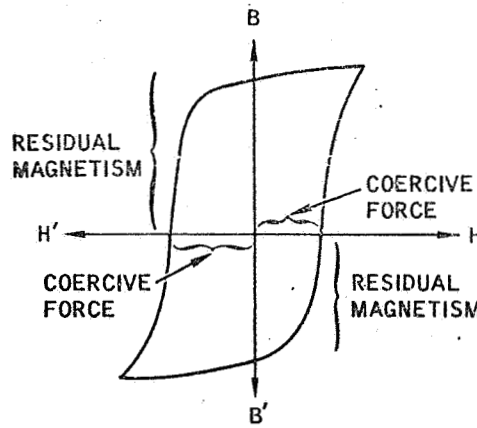

If you were inspecting both magnetic and nonmagnetic materials, you would normally expect more heat to be generated in:

- Nonmagnetic materials Page 4-53
- Magnetic materials Page 4-54

You're wrong when you say that more heat will be generated in a nonmagnetic material. Of course, it all depends upon the material; however, in general you can expect more heat from a magnetic material.

Heat comes from two sources: (1) eddy currents and (2) hysteresis effects. Since hysteresis effects only exist in magnetic materials, more heat will be generated in the material. This is added to the normal heat generated by the eddy currents.

Remember that work is required to overcome the residual magnetism and this work generates heat.

Turn to page 4-54.

#

Certainly. Magnetic materials will generate more heat because you have hysteresis heating effects as well as eddy current heating effects.

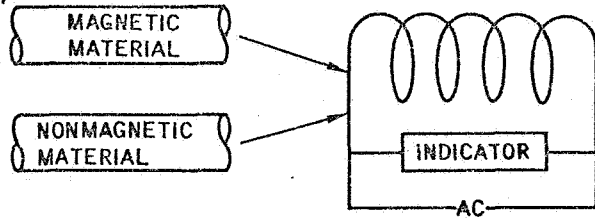

ELECTRICAL	MAGNETIC
σ CONDUCTIVITY	μ PERMEABILITY D DIMENSION
HEAT	HEAT

To successfully interpret eddy current output indications, you must learn to view the indication in terms of the variables in the eddy current testing system. One variable is conductivity. Its symbol is σ which means SIGMA. SIGMA stands for the electrical conductivity of the material. And of course electrical conductivity exists in both magnetic and nonmagnetic materials.

The second variable is permeability (μ) (MU) which is the ratio B/H. This, you have learned varies with the material and the value of the magnetizing force applied to the material.

The third variable is dimensional changes of the specimen within the coil. This is the fill-factor variable which we will represent by the letter D. D means dimensional changes. For the probe coil, this would be the lift-off factor. D applies to both magnetic and nonmagnetic materials.

It's important to know which variables apply to which materials (magnetic or non-magnetic). Would you say that σ :

Applies only to nonmagnetic materials Page 4-55

Applies to both magnetic and nonmagnetic materials Page 4-56

You are wrong. σ applies to both magnetic and nonmagnetic materials. You seem to feel that it only applies to nonmagnetic materials.

The symbol σ (means SIGMA) stands for the electrical conductivity of the material. This conductivity exists for both magnetic and nonmagnetic materials and is the variable directly related to eddy current testing. Recall that you learn something about the material through changes in conductivity. And the symbol for conductivity is σ (SIGMA).

Turn to page 4-56.

Right! The symbol σ (SIGMA) stands for conductivity and conductivity applies to both magnetic and nonmagnetic materials.

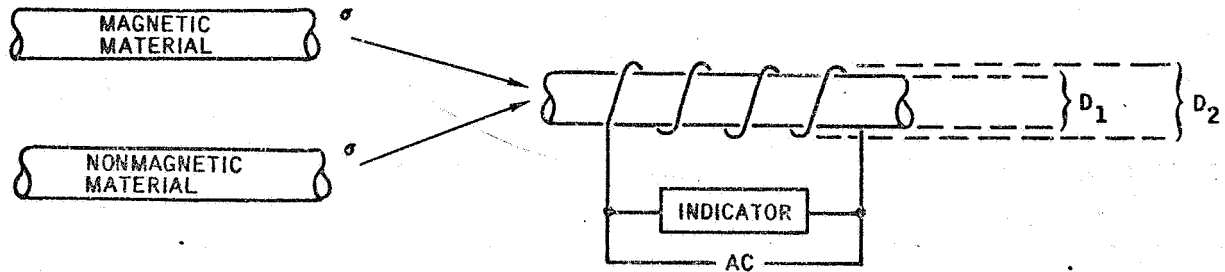

We agreed that we would use the letter D to denote dimensional changes. This means that the diameter of a rod passing through a test coil is varying.

The fill-factor, you learned, was a factor that tells you how well the rod fills the area inside a coil. This was defined as

$$\text{FILL-FACTOR} = \frac{D_1^2}{D_2^2} \text{ OR } \left(\frac{D_1}{D_2}\right)^2$$

Since the rod is magnetically coupled to the coil, the fill-factor really represents the coupling between the rod and the coil. And if the diameter of the rod varies, the fill-factor varies. This, in turn, changes the output indication.

If D represents dimensional changes, would you say that D:

Applies to both magnetic and nonmagnetic rods Page 4-57

Only to magnetic rods Page 4-58

Fine, you recognize that dimensional changes (D) apply to both magnetic and non-magnetic materials. The same is true for conductivity (σ) (SIGMA). That leaves only the permeability factor, doesn't it.

The permeability factor (μ) (MU) you learned:

Applies to both magnetic and nonmagnetic materials. Page 4-59

Applies only to magnetic materials Page 4-60

No, you are not correct when you say that D (dimensional changes) applies only to magnetic rods. D applies to both magnetic and nonmagnetic rods.

After all, D is a dimensional change which is related to the magnetic coupling between the coil and the rod. The coil is a magnetic field; the rod fills this field inside the coil. How well it fills the field depends upon the size of the rod. That's what the fill-factor is all about. The factor applies to both magnetic and nonmagnetic rods placed inside the coil. And if the rod's dimension changes, you can expect a change in the output indication. This is true for both magnetic and nonmagnetic rods. Got it? Good.

Turn to page 4-57.

Something happened that time; for you are wrong. Permeability applies only to magnetic materials. It does not apply to nonmagnetic materials.

Permeability (μ) (MU) is the ratio of the specimen's flux density to the coil's magnetizing force. And when the specimen's flux density is more than the magnetizing force, you get large numbers such as 2,000; 9,000; etc. When the ratio is 1/1, the material is not a magnetic material.

Perhaps, you recalled that the dividing line between a magnetic material and a nonmagnetic material is a thin one and when you talk about permeability you know it's just a question of degree or how much. Recall, however, that a magnetic material was defined as a material with an abnormally high permeability.

Actually, permeability exists in nonmagnetic materials; but the value is so small that it's not significant. When we speak of permeability in relationship to magnetic materials, we mean abnormally high permeability.

We will adopt the convention of saying that when the ratio is 1/1 the material is nonmagnetic and that the material does not have permeability.

So you see you were right; but in terms of significant changes, you were wrong. For our purposes, permeability is only significant for magnetic materials.

Turn to page 4-60.

Yes, for all practical purposes, permeability (μ) (MU) applies only to magnetic materials. Permeability is a question of degree or how much. It exists in all materials; however, it's only significant in magnetic materials. Recall that a magnetic material is defined as one with an abnormally high permeability. It is in this sense that we use the term permeability. That's why we say that permeability applies only to magnetic materials.

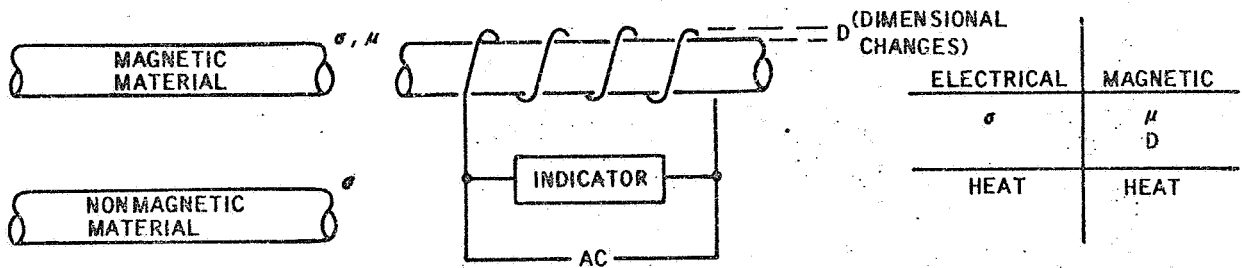

We can summarize what we have learned by saying -

1. Conductivity (σ) (SIGMA) applies to both magnetic and nonmagnetic materials.
2. Dimensional change (D) (fill-factor) applies to both magnetic and nonmagnetic materials.
3. Permeability (μ) (MU) applies only to magnetic materials and varies with the material and the value of the magnetizing force applied to the material.

We can also say that heat is generated in both magnetic and nonmagnetic materials. Eddy currents generate heat in both magnetic and nonmagnetic materials. Hysteresis generates heat in magnetic materials.

Turn to page 4-61.

From page 4-60

1. In this chapter you have learned to look at eddy current testing in terms of variables. These variables can be divided into two classes. One class is electrical; the other class is _____.



6. permeability

7. The permeability variable, as we use the term, only applies to _____ materials.



12. B, H

13. Or we can say that permeability = _____ divided by the _____.



18. residual magnetism

19. The residual magnetism in a magnetic material can be reduced to zero by reversing the m _____ f _____.



1. magnetic

2. For the electrical variable, we used the symbol σ (SIGMA) which represents the _____ variable.

7. magnetic

8. The symbol μ (MU) is used to denote the _____ variable.

13. flux density,
magnetizing force

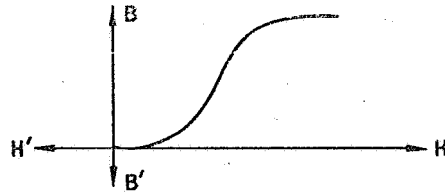

14. The relationship between B and H can be shown by a graph. As the magnetizing force (H) is increased, the specimen's flux density (B) increases. A point is finally reached where further increases in H do not cause an increase in B. This point is called the _____ point.

19. magnetizing force

20. A material is said to be magnetic if it has abnormally high permeability, a definite saturation point, hysteresis, and _____ .

2. conductivity

3. The conductivity variable (σ) (SIGMA) appears in both _____ and _____ materials.



8. permeability

9. Permeability (μ) is a ratio of two values. One value is the magnetizing force of the coil; the other value is the f_____ d_____ of the specimen.



14. saturation

15. Permeability is a variable; its specific value depends upon the value of the magnetizing force. It can be made a constant by using a direct current applied to a coil. This will increase the flux density to the point of _____. Under this condition, further changes in H will not change B.



20. residual
magnetism

21. Each time the magnetizing force is reversed, work must be done to reduce the residual magnetism to zero. Such work generates h_____.



3. magnetic,
nonmagnetic

4. We are working with three basic variables: conductivity, permeability, and d _____ changes of the rod in the test coil.

9. flux density

10. Again, we use symbols in expressing permeability. For the specimen's flux density we use the letter _____.

15. saturation

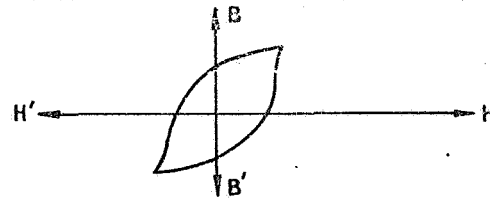

16. If an alternating magnetizing force is applied to a magnetic material, the material's flux density will vary as shown above. The resulting loop is called a h _____ loop.

21. heat

22. A second source of heat in both magnetic and nonmagnetic materials is _____.

4. dimensional

5. The dimensional changes apply to both _____ and _____ materials.

10. B

11. This gives us two symbols: μ (MU) for permeability and B for flux density. The letter H is used for our third value which is called the m _____. f _____. For our purposes, we view H as the flux density of the test coil.

16. hysteresis

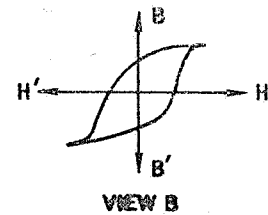
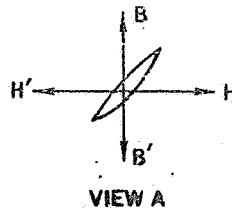

17. The size and shape of a hysteresis loop varies with the specific magnetic material. Two loops are shown above. View___ illustrates the material with the strongest magnetic properties.

22. eddy currents

23. We can summarize what we know by saying that the _____ variable applies only to magnetic materials and the two variables c _____ and d _____ changes apply to both magnetic and nonmagnetic materials.

5. magnetic,
nonmagnetic

6. Thus we have two variables (conductivity and dimensional changes) that apply to both magnetic and nonmagnetic materials. Our third variable is _____.

Return to page 4-61, frame 7,
and continue with the review.

11. magnetizing force

12. Using the three values μ , B, and H we then define permeability (μ) as the ratio of _____ to _____.

Return to page 4-61, frame 13,
and continue with the review.

17. B

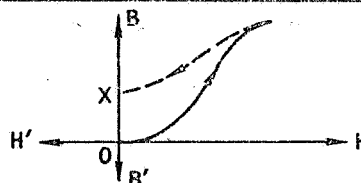

18. As H increases, B rises to a maximum value. If H is now decreased to zero, B decreases to point X. The distance OX on the graph represents the r_____ m_____ left in the material.

Return to page 4-61, frame 19,
and continue with the review.

23. permeability, conductivity,
dimensional

This completes the review of Chapter 4. Turn to page 5-1.



The purpose of this chapter is to present to you the basic electrical concepts directly related to eddy current testing. In doing so, we will assume that you have a rudimentary understanding of basic electrical principles; therefore, we will only present these concepts to the depth needed to refresh your memory and only as they relate to eddy current testing.

In eddy current testing, information about the specimen is obtained through the characteristics of the test coil. The output indication can be obtained directly across the primary coil or it can be obtained across the secondary coil.

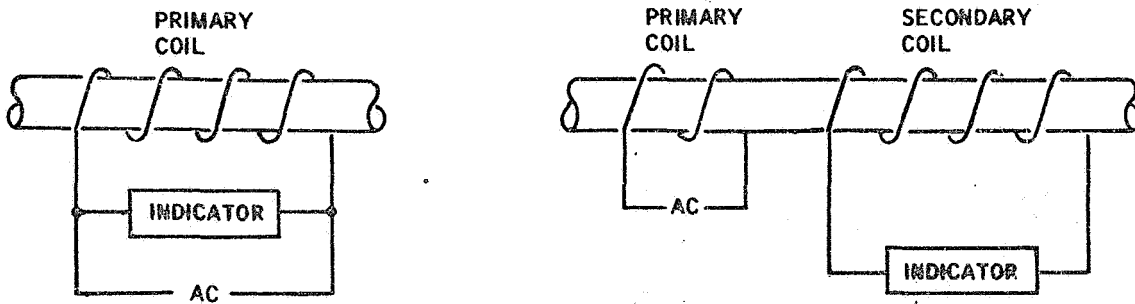

A coil provides two basic factors: Current (we will use the symbol I) and a voltage (we will use the symbol V). These two factors can be in phase or out of phase with each other. The total opposition of the coil to the flow of current is called impedance. Starting with these facts, we have three basic approaches to learning something about the specimen. These are:

1. Impedance testing
2. Phase analysis
3. Modulation analysis

This chapter will provide the background needed to understand the use of these approaches.

Turn to page 5-2.

The basic power source used in eddy current testing is an electrical generator (or electronic oscillator) which provides a range of test frequencies. Frequencies can range from a few cycles per second to 150,000 cycles per second. The generator's output provides two values: a varying current (I) and a varying voltage. These can be seen on a cathode ray tube (CRT). If a coil is not connected to the generator, the generator's current and voltage can be shown to be in phase with each other. This means that the current will rise as the voltage rises and will fall as the voltage falls. And this will happen during the same increment of time.

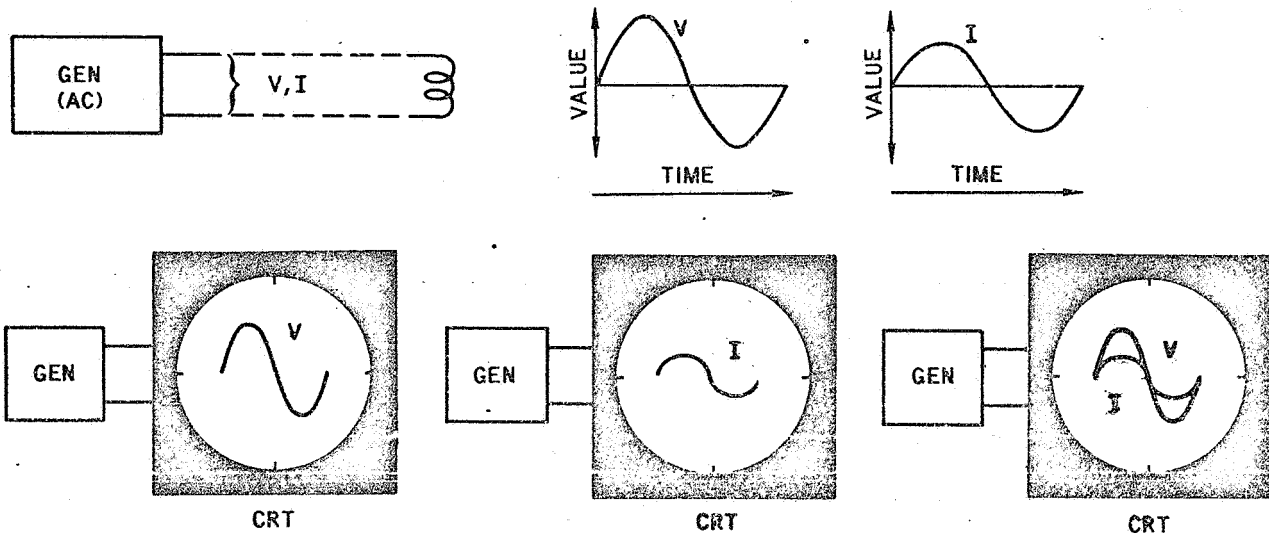

In the following figure, one complete voltage cycle is shown. Note that V varies above and below a center value and this occurs over a period of time. As this voltage increases, note that the current does not increase at the same time. The distance OX represents a time lag. Would you say that:

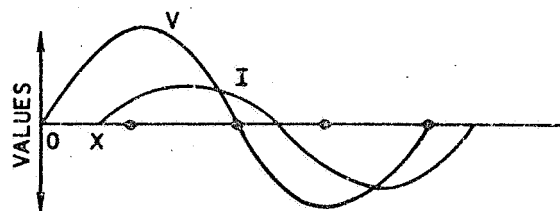

The current is in phase with the voltage Page 5-3

The current is out of phase with the voltage Page 5-4

No, you are not correct. Perhaps you are not too familiar with the concept of phase. You said the current is in phase with the voltage. This is not true. The current is out of phase with the voltage. Let's look at the concept.

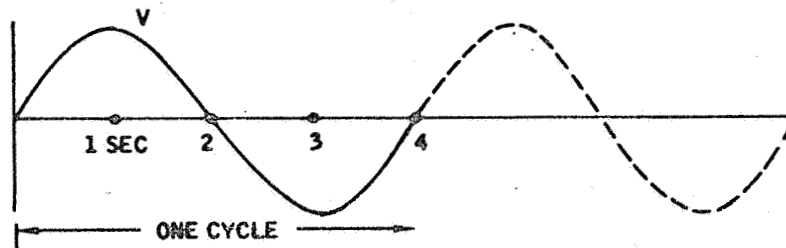

Consider that you have a voltage that varies above and below a center value. One complete variation as shown above is called a cycle. Note that it took 4 seconds to complete the cycle and that maximum values are obtained at 1 second and at 3 seconds. Visualize that this cycle will be repeated at the end of 4 seconds.

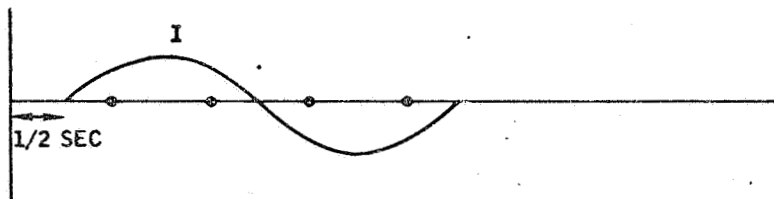

Now consider that you have a current that varies above and below a center value; however, the variation starts 1/2 second later than the voltage. This means that the current is lagging the voltage by 1/2 a second. Or we can say that the current is out of phase with the voltage.

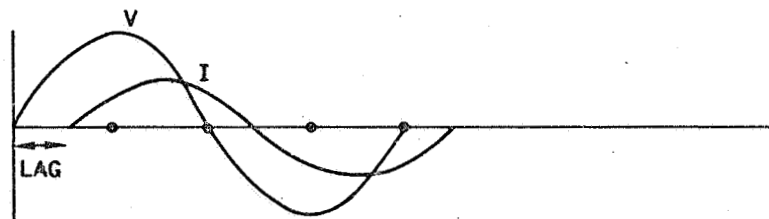

In electrical circuits, changes in voltage produce changes in current. The current may lag the voltage; thus instantaneous changes in voltage do not produce instantaneous changes in current. Such is the case shown above. In this case, the current lags the voltage by 1/2 second. And so we say the current is out of phase with the voltage.

Turn to page 5-4.

Fine! Apparently you are familiar with the ideas of phase (in phase and out of phase).

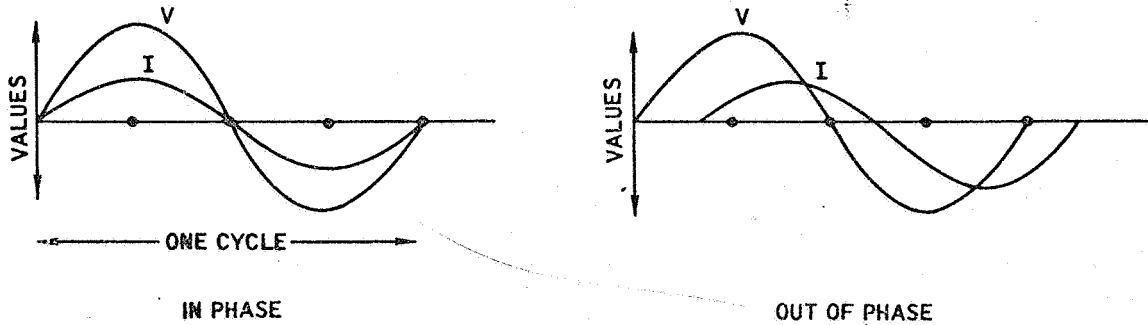

You are probably familiar with the electrical component called a resistor. This is, of course, simply a component that has resistance and resists the flow of current. If we connect a resistor across our ac (alternating current) generator and insert a current measuring device in series with the resistor, we can find out how much current is flowing through the resistor. Then, if we use different values of resistance, we can learn how the amount of current flow varies with the specific value of the resistor. From this, we learn that as the resistance is increased, the current flow is decreased. Or in other words, the higher the resistance, the less the current.

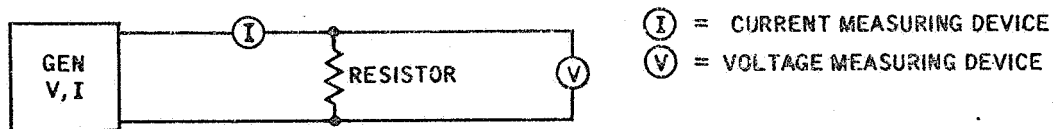

To determine how the current is related to the voltage applied to the resistor by the generator, we connect a voltage measuring device across the resistor. It can be shown that for a resistor, the current will be in phase with the voltage. It can also be shown that the current will not be in phase with the voltage when a coil is used in place of the resistor.

Since this is a review of what you should already know from your basic understanding of electrical principles, let's move on.

Turn to page 5-5.

Since we are really interested in test coils, let's put one across our generator and see what we can do.

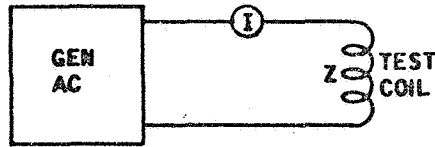

Z = IMPEDANCE

When a coil is connected across an ac generator, a current will flow through the coil. The value of the current will depend upon the coil's opposition to current flow. For alternating currents (ac) the coil's opposition to current flow is called impedance. The letter Z is used to denote this impedance. Note that for a resistor we used the term resistance and for a coil we used the term impedance.

It can be shown that each coil has a unique impedance characteristic which is determined by the coil's properties. And we can also show that the coil's impedance (Z) is related to the frequency of the ac applied to the coil. Thus if you wanted to know the impedance of a coil, you would need two facts: the frequency of the ac and the coil's characteristics. Together they give you the impedance of the coil.

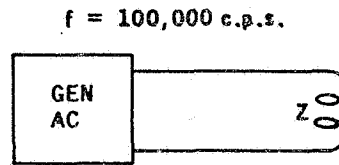
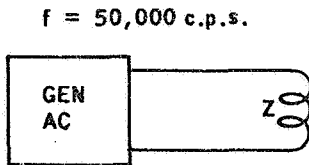

Visualize that you have a test coil connected to an ac generator and you are using a test frequency of 50,000 cycles per second (c.p.s.). You then change the test frequency to 100,000 c.p.s. Does the test coil's impedance:

Change Page 5-6

Remain the same Page 5-7

Absolutely right. If you change the frequency, the coil's impedance will change. In a moment, we will see that there is another way we can change the impedance. However, before we get into that let's see what a change in impedance means.



A moment ago, you learned that a certain amount of current (I) will flow through a resistor connected across a generator. If the resistance varies, the current varies. For each value of resistance, there will be a corresponding value of current.

The same is true for impedance. Impedance may be viewed as a form of resistance. Impedance is defined as the coil's opposition to the flow of current. If the impedance varies, the current varies. And you have just learned that one way to change the impedance is by changing the frequency. It is also true that an increase in resistance or an increase in impedance will decrease the current flow.

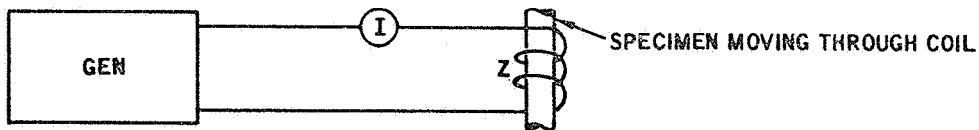

Visualize that you have a specimen passing through a coil. Let's agree that the specimen affects the impedance of the coil. If the specimen's properties change, can we say:

The current flow through the coil will not be affected Page 5-8

The current flow through the coil will be affected Page 5-9

Sorry, but you are not right. We asked you if the frequency applied to a coil is changed, will the coil's impedance change. You said that the impedance will remain the same. This is not true. The impedance will change.

To determine the coil's impedance, you need two things: (1) the electrical values of the coil and (2) the frequency applied to the coil. The coil's specific impedance depends upon the frequency applied to the coil and this impedance will change as the frequency is changed. That's why we said that if you changed the frequency from 50,000 c.p.s. to 100,000 c.p.s. then the impedance will change.

Turn to page 5-6.

We don't agree. You say the current flow through the coil will not be affected by a change in the specimen's properties. We say it will. Here's why.

The current will change if the coil's impedance changes. One way to change the impedance is to place a specimen in the coil. Under these conditions, the coil's impedance will change to a new value and the current flow will stabilize at this new value of impedance. If now the specimen is moved through the coil at a steady rate, the impedance will remain steady, providing the specimen's properties do not change. If the specimen's properties do change, that means we get a new value of impedance. In turn, this means the current flowing through the coil will change. Now do we agree? Fine!

Turn to page 5-9.

Good! You're right. And you realize that we are getting closer to eddy current testing when you say that the specimen's properties will affect the flow of current through the coil.

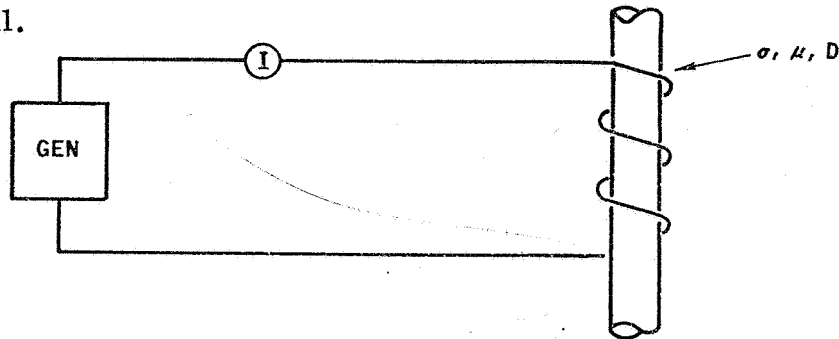

In fact we can say that we have a basis for detecting changes in conductivity (σ), permeability (μ), and dimensions (D). All we have to do is watch the current indicating device.

We started this chapter by saying that there were three approaches to eddy current testing.

1. Impedance testing
2. Phase analysis
3. Modulation analysis

Would you say that the testing system we have been using is based on:

Phase analysis..... Page 5-10

Impedance Page 5-11

You seem to feel that the testing system we have been using is based on phase analysis. Sorry but you are wrong. Our testing system is based on impedance.

If the impedance changes, the current flow through the coil changes. And we just saw that the properties of the specimen affect the coil's impedance. Since our system is based on changes in impedance, we can say that we are performing eddy current testing by the use of an impedance system. We will cover phase analysis later.

Turn to page 5-10.

We agree. The testing system we have been using is based on impedance. Phase analysis is a technique we will cover later and is based on the fact that the current is not in phase with the voltage.

The concept of impedance applies to any coil and the coil need not be the primary coil.

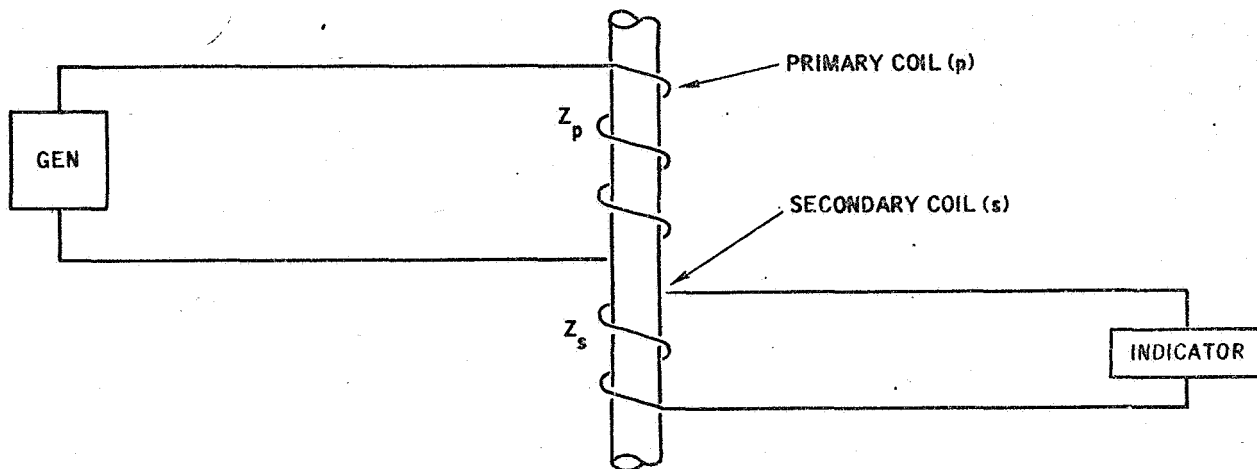

For example, as shown above, the primary coil can be used to apply current to the test specimen while a secondary coil can be used to obtain an output indication. The secondary coil will also have an impedance and this will be affected by the specimens properties.

When a secondary coil is used, the primary coil induces a current into the secondary coil. The changing flux within the specimen also affects the current flow in the secondary coil. The amount of current flow depends upon the impedance of the secondary coil. And this changes as the properties of the specimen change.

Turn to the next page.

BACKGROUND INFORMATION

Some readers may be interested in the electrical circuits related to eddy current test equipment. The following information is presented for these readers and need not be remembered. If you wish you may jump to page 5-13.

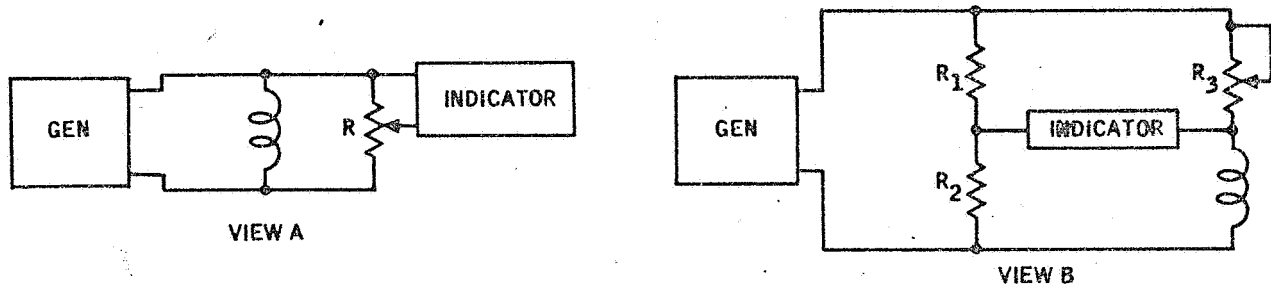

View A illustrates an alternate way to get an output indication. In this case the generator's current flows through two parallel paths. One path is through the test coil; the other path is through an adjustable resistor. The indication is obtained across a portion of the resistor. Total current flow depends upon the combined effect of the coil's impedance and the value of the resistor. If the coil's impedance changes, current flow through both the coil and the resistor will change. Since a flow of current through a resistor develops a voltage across the resistor, a portion of this voltage can be used to obtain an output indication.

View B illustrates a bridge circuit with current flowing through both branches. Resistors R_1 and R_2 form one branch; resistor R_3 and the test coil form the other branch. Note that an indicating device is connected between the two branches. When the current flow through both branches is the same, the bridge is balanced and no voltage difference exists between R_2 and the coil. An output indication is obtained when the test coil's impedance changes and the bridge becomes unbalanced. Under this condition, a voltage difference is developed and the indication will denote this change in balance. Resistor R_3 is adjustable and provides a means of initially balancing the bridge when a specimen is placed in the test coil.

Turn to page 5-13.

The term impedance also applies to coils connected as shown below.

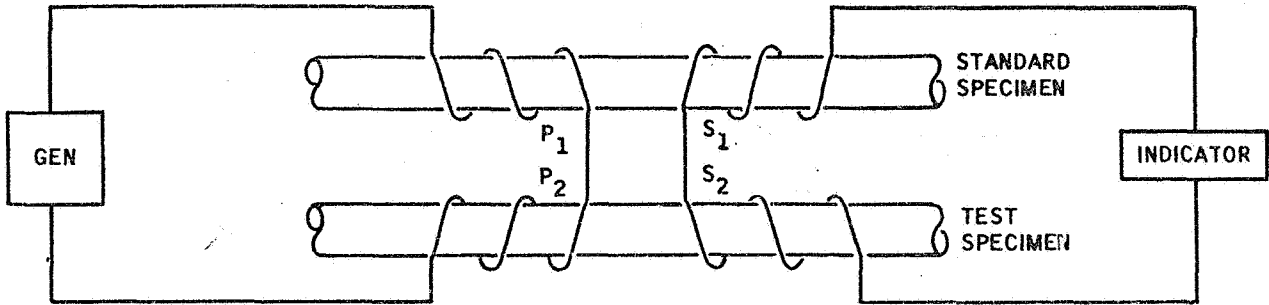

In this case, two sets of coils are used and the test specimen is compared against a standard specimen. The secondary coils (S_1 and S_2) are connected together in such a way that the output of one coil opposes the output of the other coil. If the test specimen's properties are the same as the standard specimen's properties, no output voltage is developed. On the other hand, if the properties are not the same, an output is obtained. This output is related to the impedance of the coils. If the test specimen's properties change, the impedance will change.

Visualize that you have a test setup as shown above, with the specimens positioned in the coils. No output indication is obtained. If you removed the standard specimen from the test coil, would the impedance across the two coils connected to the output indication:

- Remain unchanged Page 5-14
- Change Page 5-15

Your answer is not correct. You said that the impedance would remain unchanged if the standard test specimen is removed from the test coil. The impedance would change.

An empty test coil has a specific impedance. This impedance will change if a test specimen is placed in the coil. In the test system we were using, a standard specimen was contained on one coil and a test specimen was located in a second coil. The coils were connected so that the effect of one coil off set the effect of the other coil. This was also true with both specimens in the coils. Since the specimen's properties were the same, no output indication was obtained.

If the standard specimen is removed, the impedances are no longer balanced and an output will be indicated. Removing the specimen changes the impedance. Got it? Fine! Let's move on.

Turn to page 5-15.

Fine, you have the idea. The specimen placed in the coil affects the impedance and if you remove the specimen you change the impedance.

For many eddy current test purposes, impedance testing is adequate; however, it does have limitations. For example, all specimen effects are reflected in the impedance; thus, it is not possible to separate conductivity effects from permeability or dimensional changes.

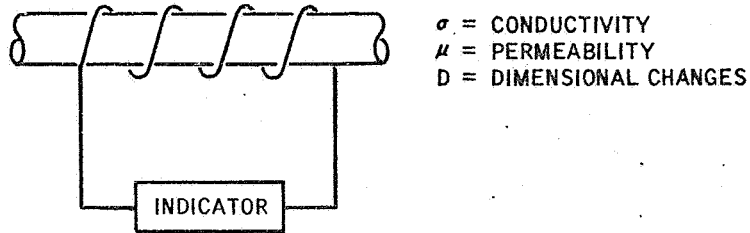

Of course, for many applications this is not a problem. If the specimen is nonmagnetic and dimensional changes are minor, then one can say that the impedance changes are being caused by conductivity changes. A change in the indication means a change in conductivity.

Visualize that you are using a surface coil on a nonmagnetic specimen. Through a lift-off control on your equipment and through the use of a spring-loaded surface coil, you have cancelled out the lift-off effect. The purpose of the test is to measure conductivity. Do you think that you could use impedance testing for measuring the conductivity?

Yes Page 5-16

No Page 5-17

Excellent! You have the idea. Since lift-off and permeability are not affecting the coil's impedance, we can use impedance testing for measuring the conductivity.

As shown below, there are three variables being reflected in the coil's impedance which, in turn, appears in the output indication. Earlier you learned that two of these variables are magnetic and one variable is electrical.

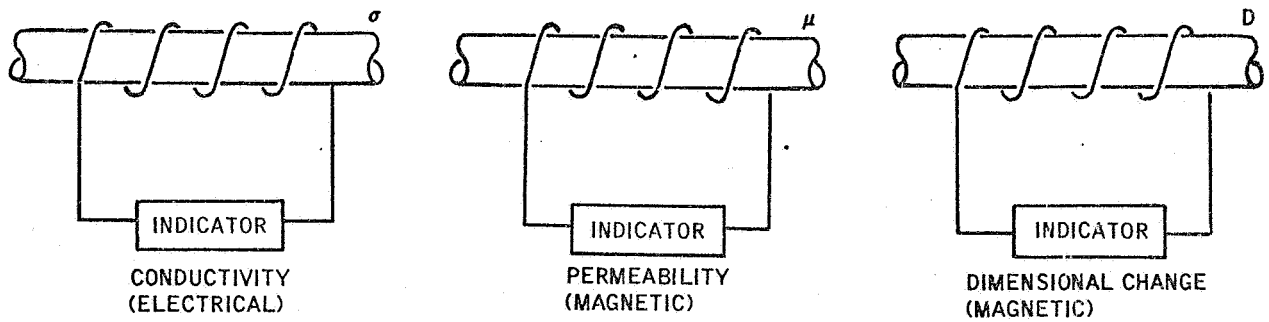

It can be shown that a coil's impedance can be separated into magnetic and electrical properties. This fact can be used to separate the three variables conductivity, permeability, and dimensional changes.

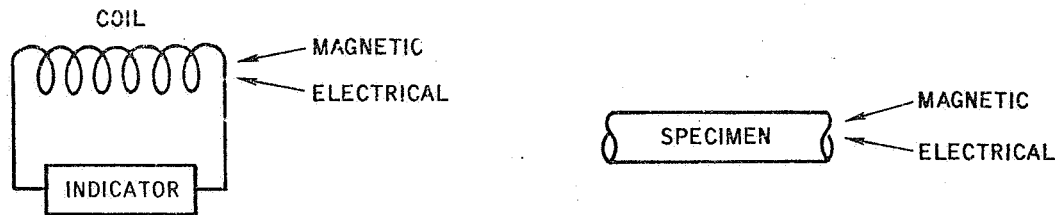

To do this, we need to know more about the coil.

Turn to page 5-18.

Your answer "No" is not correct. You should have said "Yes."

Using a surface coil, you were measuring the conductivity of a nonmagnetic specimen. The lift-off effect was not a factor. And since the specimen was not magnetic, permeability was not a factor. Under these conditions, a change in impedance was the result of a change in conductivity. That's why you could use impedance testing for measuring the conductivity.

Turn to page 5-16.

If a piece of wire is connected across an alternating current (ac) generator, a current will flow through the wire. The value of the current will depend upon the resistance of the wire. Since the wire has resistance, it can be considered to be a resistor. The letter R stands for both resistance and the electrical component called a resistor.

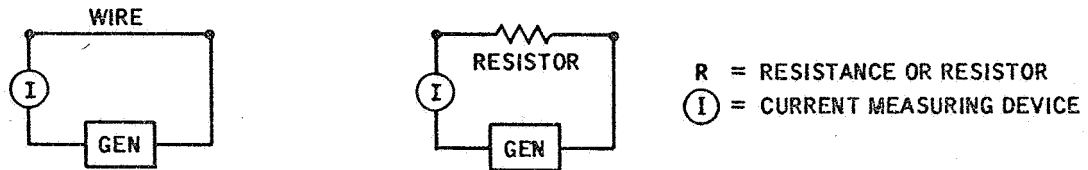

If now the same piece of wire is wound into a coil and connected across the generator, a different current will flow through the coil. The fact that the two currents are not the same is caused by something called inductance. The letter for inductance is L. The coil can be represented as an inductance and a resistance. Note that the wire's original resistance is still present. Resistance is an electrical property.

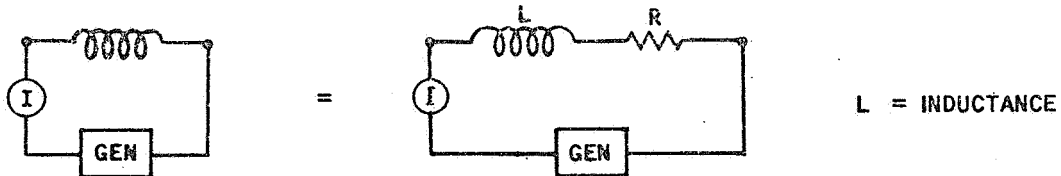

A coil's opposition to current flow is called impedance. Would you say that impedance is related to:

Only the coil's resistance Page 5-19

Both the coil's resistance and inductance Page 5-20

You have missed the idea. You said that the impedance is related only to the coil's resistance. You should have said that it's related to both the coil's resistance and inductance.

A coil's opposition to current flow is called impedance. This opposition has two parts. One part is the coil's resistance; the other part is the coil's inductance. Recall that the piece of wire had only resistance; however, when it was formed into a coil it also had a property called inductance. And you knew that the coil was not the same as the piece of wire because the current flow was not the same.

Turn to page 5-20.

Naturally you're right. A coil's opposition to current flow is called impedance and this is composed of the coil's resistance and inductance.

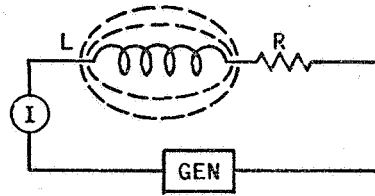

The property of inductance is based on the magnetic field established around the coil when a current flows through the coil. Without getting into the details, let's look at this for a moment. Current flow generates a magnetic field. This field will, in turn, react on the windings of the coil and will generate an effect that opposes the original current change. That's why the current through the coil will be less than when the coil is only a straight piece of wire. Keep in mind that an alternating current is being used and the current is changing.

For our purposes, the important thing to remember about inductance is that it is a magnetic property and the field around the coil affects the flow of current within the coil.

When a specimen is placed in a test coil, the coil's magnetic field is changed. Would you say that the specimen affects the coil's:

Inductance Page 5-21

Resistance Page 5-22

Yes, that's right. The specimen affects the coil through the coil's inductance. This is true because inductance is a magnetic effect.

Inductance (L) is a particular property of the coil and is determined by the number of turns, the spacing between turns, coil diameter, kind of material, type of coil winding, and the overall shape of the coil. Each coil has a unique value of inductance (L).

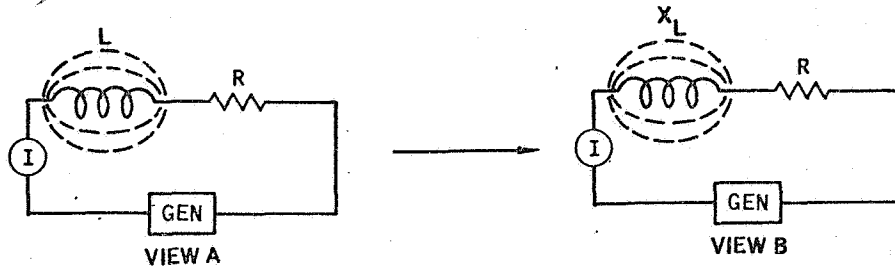

In eddy current testing, we are not directly interested in the coil's inductance. What we are interested in is something called the inductive reactance (X_L). This is the coil's opposition to current flow based on the coil's inductance and is determined by the coil's inductance and the frequency applied to the coil. $X_L = 6.28fL$; where f = the frequency of the alternating current applied to the coil and L = the coil's inductance. It is not important that you remember the formula for the inductive reactance and that $6.28 = 2\pi$. Just remember that the inductive reactance is determined by the frequency as well as by the coil's inductance.

View A above shows the coil's inductance; view B shows the coil's inductive reactance X_L. The inductive reactance and the coil's resistance determine the total impedance of the circuit.

In view B, a certain amount of current will flow when the generator frequency is 1,000 c.p.s. If the frequency is changed to 50,000 c.p.s. the amount of current will change. The factor that is causing the change in current is the coil's:

Inductance Page 5-23

Inductive reactance Page 5-24

Incorrect. The specimen is affecting the coil's inductance, not its resistance.

Inductance is a magnetic property; resistance is not. As you saw, a straight piece of wire has resistance, and this still exists when the wire is formed into a coil. Inductance, on the other hand, only exists when the wire is formed into a coil. Under this condition, a magnetic field is established and is related to the coil's inductance. The specimen, through the coil's field affects this inductance.

Turn to page 5-21.

You said that the factor that is causing the change in current is the coil's inductance. You should have said the inductive reactance.

A current change is caused by a change in the opposition to current flow. There are two sources of opposition: the coil's resistance and the coil's inductive reactance. This reactance is determined by the coil's inductance and by the frequency applied to the coil.

Note that for a given coil, the coil's resistance is constant. This is also true for the coil's inductance. What changes is the coil's inductive reactance (X_L). And $X_L = 6.28 fL$.

Turn to page 5-24.

Right! The factor that is causing the current change is the coil's inductive reactance. The coil's inductance is a constant. It's the coil's inductive reactance that varies with frequency.

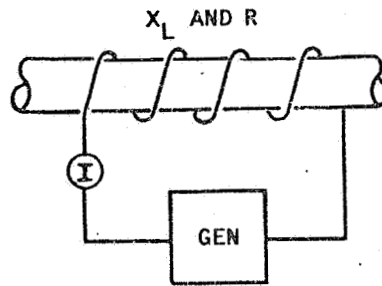

However, the coil's inductance is not always constant. It depends upon what's happening in the coil's magnetic field. For example, if a specimen is placed in the coil the current flow will be changed. Note we didn't change the frequency so this means the inductance must have changed.

Now let's add up our facts. To learn something about a specimen, we need a current change. A change in the coil's impedance will cause a change in current. The coil's impedance consists of two parts. One part is the coil's resistance; the other part is the coil's inductive reactance. If this inductive reactance (X_L) changes, the current changes. The inductive reactance has two variables of interest to us. Either one can cause a change in impedance. One variable is the frequency applied to the coil; the other variable is the coil's:

- Resistance Page 5-25
- Inductance Page 5-26

Perhaps you misunderstood the question. You said "resistance." The correct answer is "Inductance."

We were talking about the inductive reactance and said that it had two variables of interest to us. One variable is the frequency applied to the coil; the other variable is the coil's inductance. Resistance is not a part of the inductive reactance.

Turn to page 5-26.

You said "inductance" rather than "resistance" and you are right. The inductive reactance has two variables (inductance and frequency) and either one can change the inductive reactance which in turn will change the impedance.

BACKGROUND INFORMATION

It's not necessary for you to remember formulas; however, it might help you understand where we are by noting the following relationships.

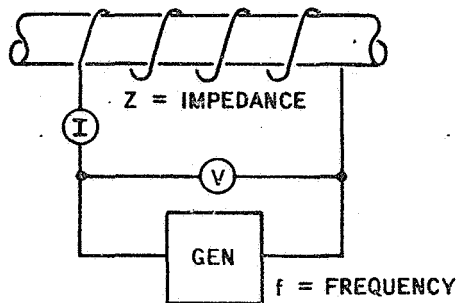

$$Z = \sqrt{X_L^2 + R^2}$$

$$I = \frac{V}{Z}$$

When an alternating voltage (V) from the generator is applied across a coil, an alternating current (I) will flow through the coil. The coil's opposition to this current flow is called impedance (Z). If you knew the value of Z and the voltage (V), the actual current value could be calculated by the formula shown above. ($I = V/Z$). The impedance can also be calculated by the formula shown above.

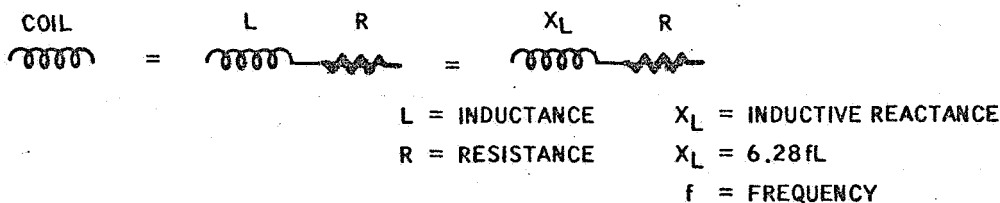

Impedance, we have seen is made up of two factors: the coil's resistance (R) and the coil's inductive reactance (X_L). The inductive reactance, in turn, is determined by two variables: frequency and the coil's inductance. Changing either the frequency or the coil's inductance (L) will change the inductive reactance.

And finally, we have learned that the inductance (L) will change if the magnetic field around the coil is changed.

Turn to page 5-27.

When the impedance method of eddy current testing is used, three variables can appear in the output indication and it is not possible to know which variable is causing a change in indication.

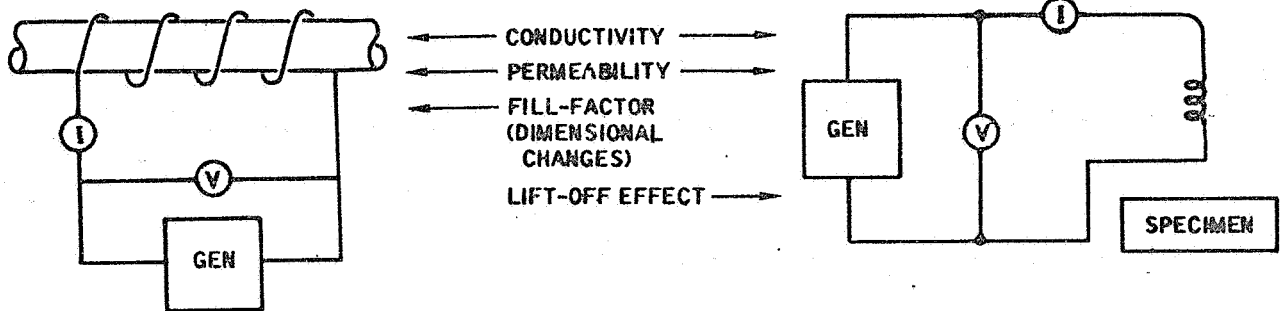

For example, when the specimen is placed within the coil, three variables can cause a change in the current through the coil. If two variables are constant, then we can assume that the third variable is causing the change. If the specimen is non-magnetic, the permeability variable is eliminated or can be considered to be a constant and only conductivity and the fill-factor (dimensional changes) can affect the output indication. When the surface coil system is used, the lift-off effect takes the place of the fill-factor.

In making the decision to use impedance testing, one must realize that:

Impedance testing can separate the variables Page 5-28

Impedance testing cannot separate the variables Page 5-29

You missed that one when you said that impedance testing can separate the variables. That's the limitation on impedance testing. Impedance testing cannot separate the variables of conductivity, permeability, and coupling factors such as fill-factor and lift-off effects.

Impedance testing is a gross approach. You only know one thing. The impedance has changed. You don't know what has caused that change unless you assume that certain variables are constant.

Turn to page 5-29.

We agree. Impedance testing cannot separate the variables. This may or may not be a problem. It depends upon the test situation.

If we are inspecting a nonmagnetic specimen, permeability is not a factor; therefore, we reduce our variables to two: conductivity and dimensional changes for a specimen in a coil; and conductivity and lift-off for a surface coil arrangement.

Of course, if we are using a specimen within a test coil, we use guides to keep the fill-factor constant; but this does not cover actual changes in the dimension of the rod (specimen). Under some conditions, the dimensional changes may be so small compared to conductivity changes that we can disregard the dimensional changes. In other cases, the discontinuities may be so small that the resulting change is small. If the dimensional change is also present, this may override and mask the discontinuity change. Under such a condition, impedance testing would not provide adequate inspection results.

Since impedance testing does not separate the variables, alternate methods must be used. As you recall, we have three methods or approaches.

1. Impedance testing
2. Phase analysis
3. Modulation analysis

Let's look into the phase analysis approach.

Turn to page 5-30.

We started this chapter with a generator which supplied an alternating voltage and current. Then we learned that this current (I) will flow through an external circuit at a rate that is determined by the external circuit. If the external circuit is a coil, then the opposition to current flow will be an impedance (Z) which will change if the generator's frequency is changed or if the magnetic field around the coil is changed. Testing through a change in impedance we have called impedance testing.

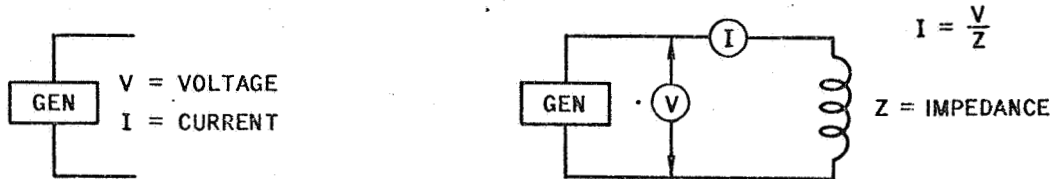

You have learned that the disadvantage of impedance testing lies in the fact that it can't separate the variables. All we get is a change in current (I) as the impedance changes. Since we are measuring a quantity (current) and getting specific values of current, impedance testing is sometimes called impedance-magnitude testing.

To separate the variables, we need to find another relationship. Such a relationship exists between the voltage (V) and the current (I). Our original relationship was between the current (I) and the impedance (Z) and we saw that the current changed as the impedance changed.

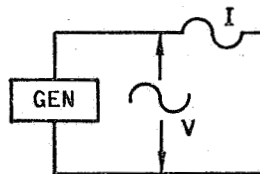

At the beginning of this chapter we learned that the voltage (V) alternates above and below a center value and this occurs over a period of time. As the voltage changes, the current also changes. If the current rises and falls with the voltage over equal increments of time, we say that the current is:

In phase with the voltage Page 5-31

Out of phase with the voltage Page 5-32

Right! When the current (I) rises and falls in time with the voltage (V), we say that the current is in phase with the voltage.

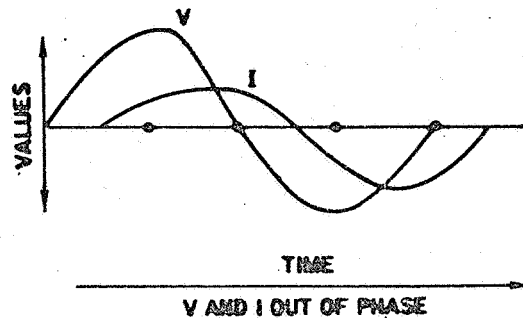
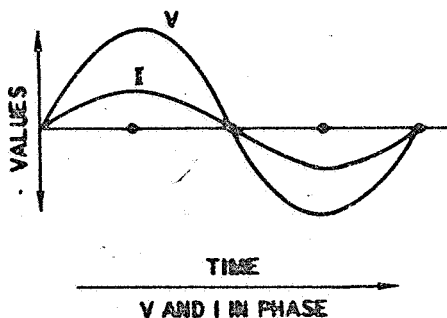

Phase analysis is based on the fact that the current (I) is out of phase with the voltage (V) when a coil is connected across a generator. This phase relationship will change as the specimen's properties change. To understand how phase changes can be used in eddy current testing, let's start with a resistor across the generator.

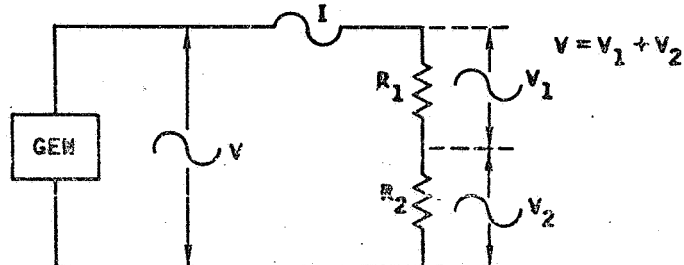
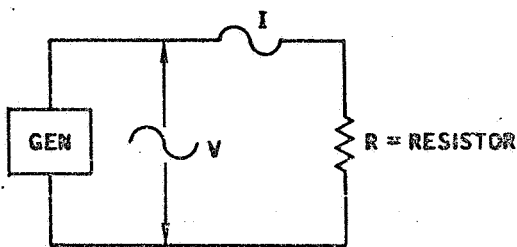

When a resistor is used across the generator, the current will be in phase with the voltage. It can be shown that this relationship also is true when two resistors (R_1 and R_2) are used in place of only one resistor. Current flowing through a resistor causes a voltage to appear across the resistor. Thus resistor R_1 will have a voltage (V_1) across it; the same is true for resistor R_2 . The sum of the two voltages (V_1 and V_2) will equal the voltage of the generator. These two voltages will also be in phase with the current. It is also true that these two voltages will be in phase with the generator's voltage.

Before we consider the phase relationships in a coil, it's important to recognize that when only resistance is in the circuit, the current will be:

Out of phase with the voltage Page 5-33

In phase with the voltage Page 5-34

You're wrong when you say that the current is out of phase with the voltage when the current rises and falls with the voltage over equal increments of time. Actually the current is in phase with the voltage. Let's look at the idea together.

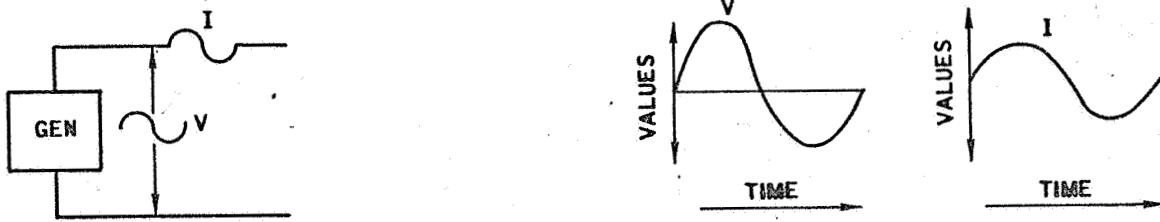

The generator produces a voltage that rises above and below a center value. This occurs over a period of time. One complete rise and fall sequence is called a cycle. The time required to perform the cycle is the period. And the number of cycles per second is called the frequency.

As the generator voltage changes, the current changes. Like the voltage, the current will rise and fall over a period of time. If the current rises as the voltage rises and falls as the voltage falls, then the possibility exists that they are in phase. This is true if they both rise and fall in the same increments of time. Thus we get a picture that looks like this.

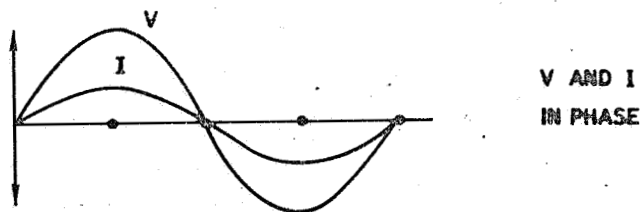

And if they are not in phase, we get a picture like this.

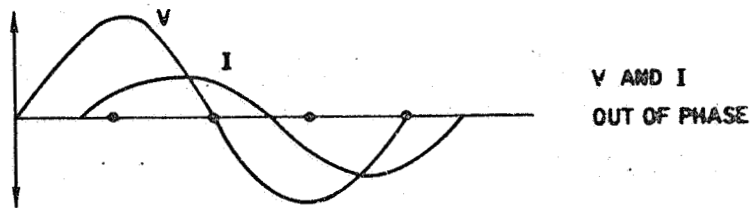

Do you think you have the idea now? Good! Turn to page 5-31.

No, you are wrong. When a resistor is connected across a generator, the current will be in phase with the voltage. You said that it will be out of phase.

Our problem is to get more information about the specimen through the test coil.

Initially, we used impedance and found that this did not separate the variables. So we tried to find another relationship. This we find exists between the current (I) and the voltage (V). When a resistor is connected across the generator, we find that the current is in phase with the voltage; this is not the case when we use a coil. And that's why we have a means of learning more about the variables. The phase relationship will do something the impedance relationship can't do.

Let's look at this. Turn to page 5-34.

Certainly true. When a resistor is connected across the generator, the current will be in phase with the voltage.

Now let's replace the resistor with a coil. And for our purposes, let's also assume that the coil does not have any resistance, only the inductance (L).

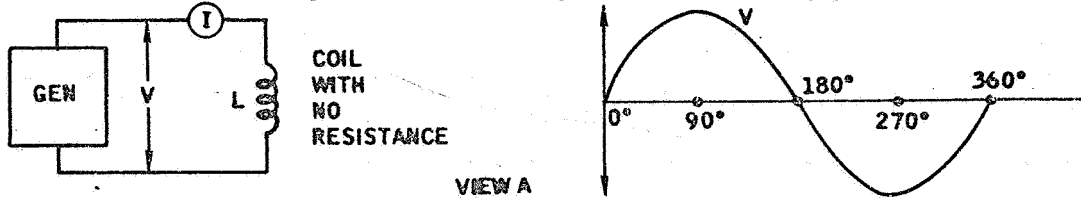

Inductance has a unique property that opposes a change in current. For example, if a sudden change in voltage is applied to a coil, the current will not immediately change. Instead, it lags the voltage. To get a better feel for this, visualize that the voltage rises above and below a center value as shown in view A. To give us a time base, let's use a circle with 360 degrees. Then let's agree that the voltage first rises to a maximum value in one direction. At this point we have used 90 degrees of "our time." Now let the voltage fall to the center value (180 degrees) and rise to a maximum value in the opposite direction (270 degrees). And finally let's let the voltage return to the center value (360 degrees). Visualize that this 360 degree cycle is repeated again and again. The result is an alternating voltage.

If we have a means of measuring how the current (I) varies as the voltage (V) varies, and if we plot this on our time base (360 degrees), we get the following result. This shows us that the current (I) is lagging the voltage (V) by 90 degrees. Keep in mind that the sequence from 0 degrees to 360 degrees is time. Note that as the voltage rises to a maximum at 90 degrees, the current is decreasing to the center value.

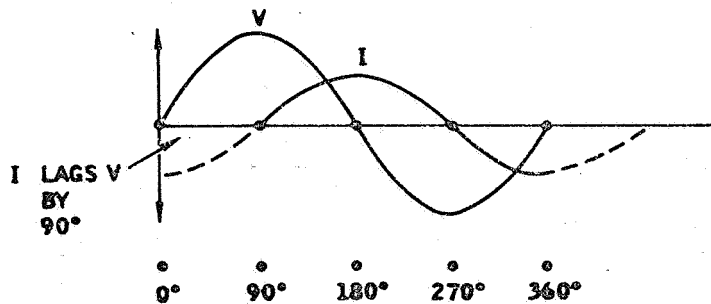

Turn to page 5-35.

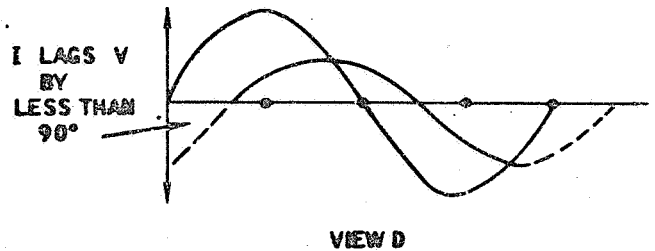
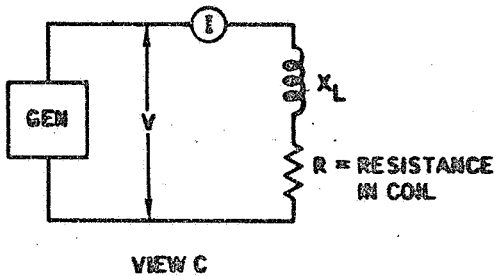
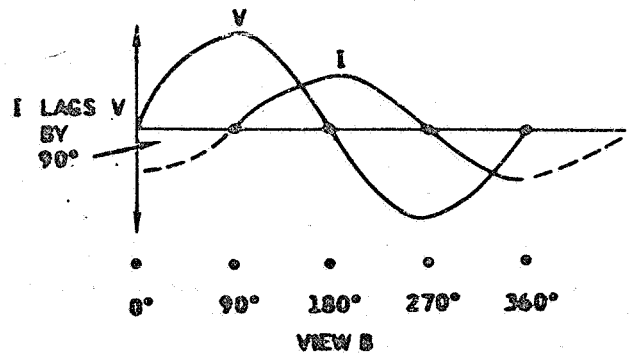
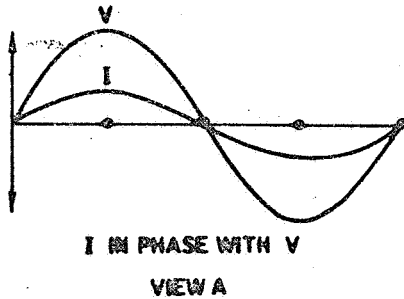

When a resistor is connected across a generator, the current (I) will be in phase with the voltage (V) as shown in view A. If the resistor is now replaced by a coil, the current will no longer be in phase with the voltage. The coil as you have seen has both resistance and inductance (L). The inductance in turn is expressed as the inductive reactance (X_L) which you have learned is determined by the inductance (L) and by the frequency applied to the coil. ($X_L = 6.28 fL$)

In some cases, the inductive reactance (X_L) is so much greater than the coil's resistance that we can disregard the resistance. Under these conditions, it can be shown that the current (I) lags the voltage (V) by 90 degrees as shown in view B. It can also be shown that when the resistance is a significant value (views C and D) the current will lag the voltage by a value less than 90 degrees. The current lag shown in view D represents the effect of both the coil's inductance reactance and the resistance. A change in either value will change the lag between the current and the voltage.

If a change in the coil's magnetic field is made by the presence of a specimen, will the lag between the current and the voltage:

Change Page 5-36

Remain the same Page 5-37

Fine! You have the idea. If the coil's magnetic field is changed by the presence of a specimen, then the coil's inductance changes. This, in turn, changes the lag between the current and the voltage.

In eddy current testing, our problem is to get more information out of the test coil. You have seen that with impedance testing, all we get is a change in current. This change is based on the fact that the coil's impedance varies and this causes the current to change.

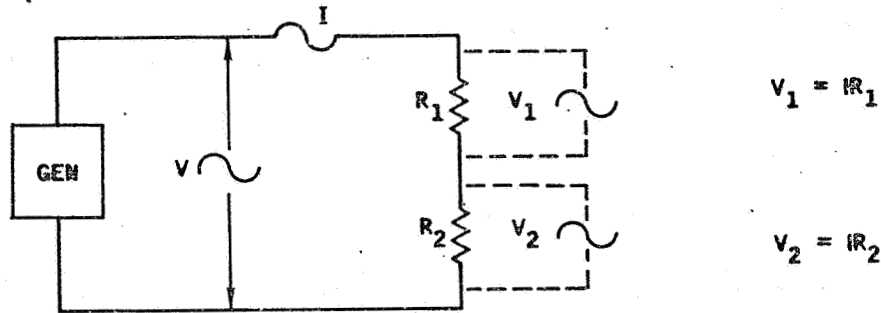

To see how we can get more information from a test coil, let's return to the case where we have two resistors connected across a generator. We learned that the current flow through a resistor will cause a voltage to exist across the resistor. The actual voltage across the resistor is the product of the specific value of the resistor and the current flowing through the resistor. Or we can say that $V_1 = IR_1$ and $V_2 = IR_2$. The sum of the two voltages ($V_1 + V_2$) will equal the applied voltage. Also note that the two voltages will be in phase with the applied voltage (V).

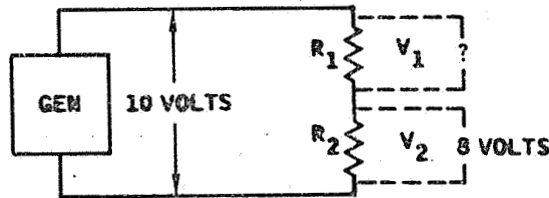

In the above figure, 10 volts is applied across resistors R_1 and R_2 and a voltage of 8 volts is measured across resistor R_2 . The voltage across R_1 is:

18 volts Page 5-38

2 volts Page 5-39

Sorry, but you are not right. You said that the lag between the current and the voltage will remain the same when the coil's magnetic field is changed by the presence of a specimen. This is not true. If the field changes, the coil's inductance will change. This change will also cause the inductive reactance (X_L) to assume a new value. Since the current lag is determined by the coil's inductive reactance and the coil's resistance, the current lag will change if the inductive reactance changes.

The fact that the lag between the current and the voltage changes as the magnetic field around the coil changes provides a basis for separating the variables in an eddy current testing system.

Turn to page 5-36.

When you said "18 volts" you missed the concept. Let's take another look at the concept.

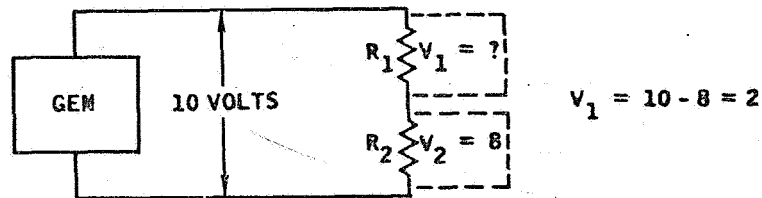

In the above figure, 10 volts is applied across resistors R_1 and R_2 and a voltage of 8 volts is measured across resistor R_2 . The voltage across R_1 is 2 volts (not 18 volts).

When the circuit connected across the generator contains only resistors, then the voltages across the resistors will add up to the voltage applied across the circuit.

This means that the voltage across R_1 must be the applied voltage (10 volts) less the voltage (8 volts) across resistors R_2 . That leaves 2 volts, doesn't it?

Turn to page 5-39.

Your answer of 2 volts is correct. The voltages across the resistors must add up to the value of the applied voltage; thus, we get $10 - 8 = 2$ volts.

Now consider the case where a coil replaces one of the resistors. Again we get two voltages; one across the resistor (R) and one across the coil. This time, however, the voltages do not add up to the applied voltage. And the reason for this lies in the fact that the voltage across the coil leads (not lags) the voltage across the resistor. Or we can say that the two voltages are out of phase.

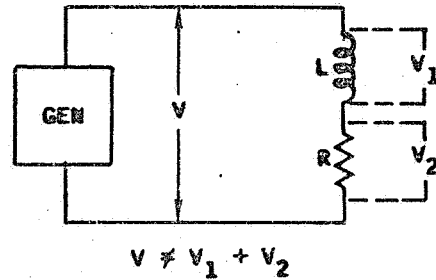
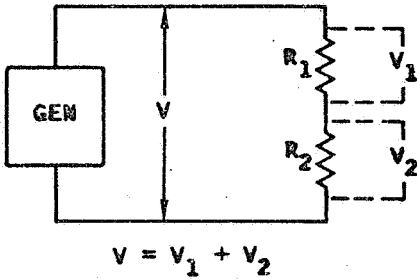

NOTE
≠ MEANS
NOT EQUAL

The fact that the voltage across a coil (or the inductance within the coil) is out of phase with the voltage across a resistor provides the basis for phase analysis and also provides a means of separating the variables. Before we get into this, let's stop for a moment and look at a cathode ray tube (CRT).

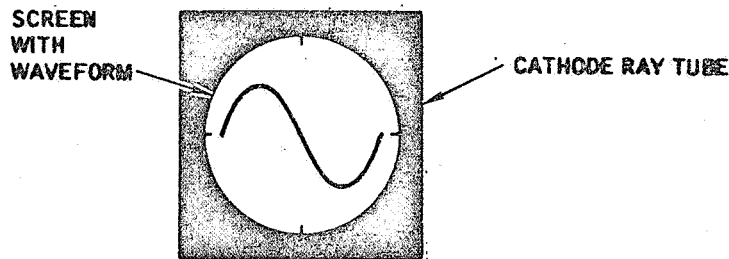

In eddy current testing, you will frequently be using a cathode ray tube and will see a waveform on the CRT screen. This waveform will change its shape and will shift back and forth. To properly interpret these indications, you need to understand how waveforms are changed. Many of these changes are based on the fact that the voltage across a coil (L) is:

In phase with the voltage across a resistor Page 5-40

Out of phase with the voltage across a resistor Page 5-41

Not true. The voltage across a coil is not in phase with the voltage across the resistor. You should have recognized the fact that the voltage across a coil is out of phase with the voltage across the resistor.

You just saw that the voltage across the coil and the voltage across the resistor do not add up to the voltage applied across the coil and the resistor. The reason for this lies in the fact that the two voltages are out of phase. Let's look into this a little further.

Turn to page 5-41.

Correct! The voltage across the coil is out of phase with the voltage across the resistor. Let's take a look at this.

Before we put the coil and the resistor together in the same circuit, let's recall the fact that the voltage and current are in phase when only a resistor is in the circuit.

This is shown in view A.

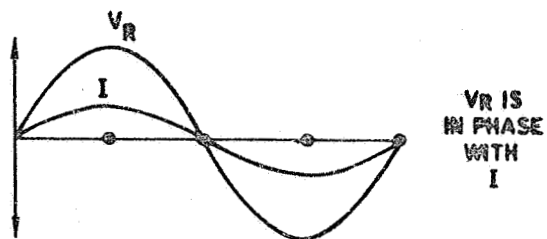

V_R IS
IN PHASE
WITH
 I

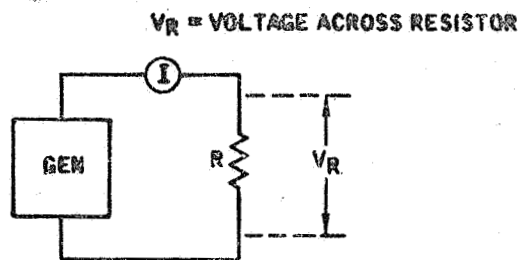

VIEW A

Then let's look at the case where only a coil is in the circuit. We will assume that the coil does not have any internal resistance. Earlier you learned that a coil causes the current through the coil to lag the voltage applied across the coil. If no resistance is present, the lag will be 90 degrees. This is shown in view B. Another way to say this is to say that the current and the voltage are out of phase and the phase difference is 90 degrees. We can also use either the voltage or the current as a reference. For example, we can say that the current lags the voltage or we can say that the voltage leads the current. View B illustrates the case where the current is the reference; thus in looking at this view you would say that the voltage leads the current. Note that the voltage is at a maximum value when the current is at the zero position at the start of the current cycle.

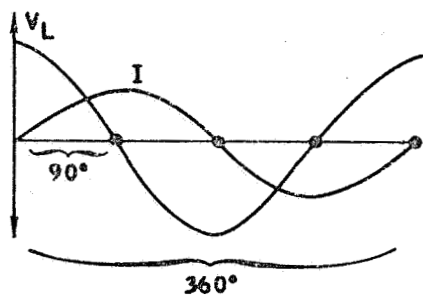

V_L IS
OUT OF
PHASE
WITH
 I

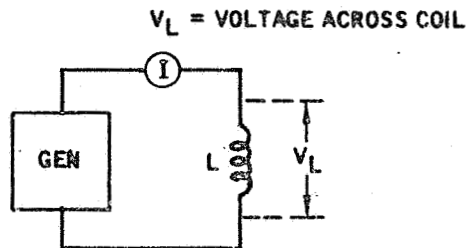

VIEW B

Turn to page 5-42.

The following figure shows a coil with no resistance connected in series with a resistor which is external to the coil. Note that the voltage across the coil (represented by L) leads the current through the coil by 90 degrees while the voltage across the resistor (R) is in phase with the current.

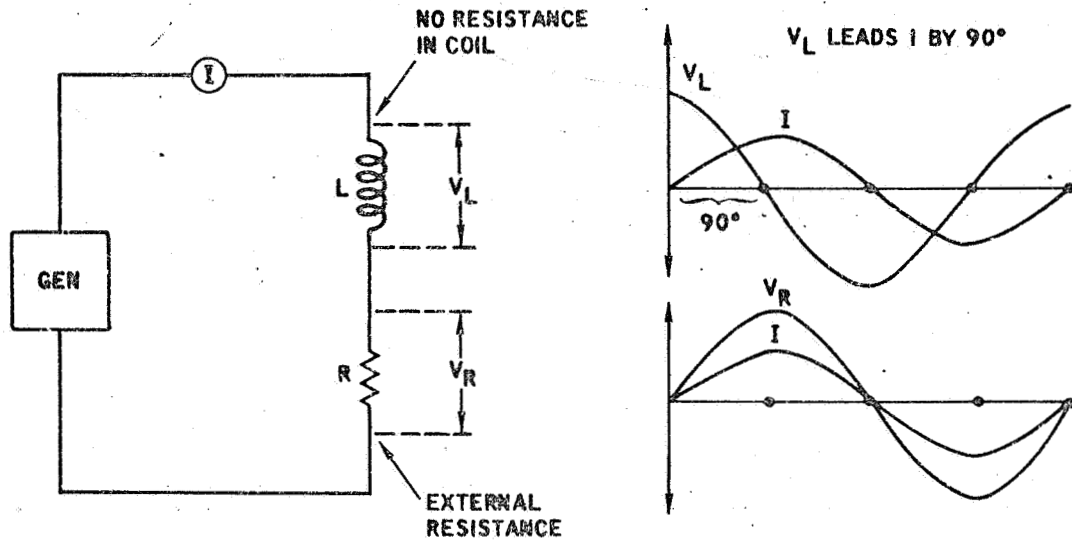

Since the current is common to both the coil and the resistor, it is possible to use the current as a point of reference. If we do this, and if we show both voltage waveforms on the same graph, then we can see that the voltage across the coil leads the voltage across the resistor by 90 degrees.

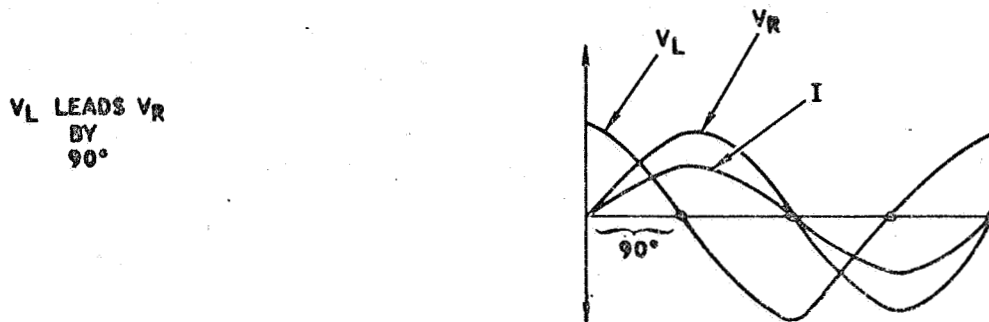

Turn to page 5-43.

You have just learned that the voltage across a coil leads the voltage across a resistor by 90 degrees. We assumed that the coil did not have any resistance. Now let's throw away the external resistor and recognize that a coil does have resistance (R).

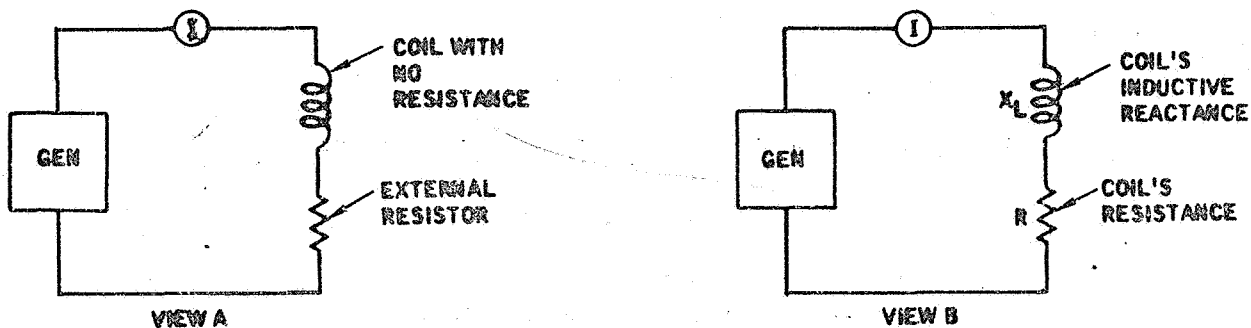

In view B, a coil and a resistance (R) are shown. The coil represents only the coil's inductive reactance (X_L). Recall that $X_L = 6.28 fL$; where f is the frequency of the generator voltage; and where L is the inductance of the coil. Inductance, as you learned, is the property of the coil which opposes a current change and causes the voltage to lead the current.

Visualize that it is possible to measure or observe the voltage across the coil's resistance separately from the voltage across the coil's inductive reactance (X_L). If this is done, you would find that the voltage acts just like the voltage across a resistor outside the coil. In like manner, if the voltage across the inductive reactance (X_L) were measured separately from the coil's resistance, you would find that this voltage acts like the voltage across a coil with no resistance. Because this is true, we can say that the voltage across the inductive reactance (X_L) is:

Out of phase with the current flowing through the coil Page 5-44

In phase with the current flowing through the coil Page 5-45

Good! You got the point. The voltage across the coil's inductive reactance (X_L) is out of phase with the current flowing through the coil. Actually, the voltage leads the current by 90 degrees. A lead of 90 degrees only occurs, however, if no resistance is in the circuit. In the practical situation, resistance is always present; so the lead will be less than 90 degrees. We will get to this in a moment.

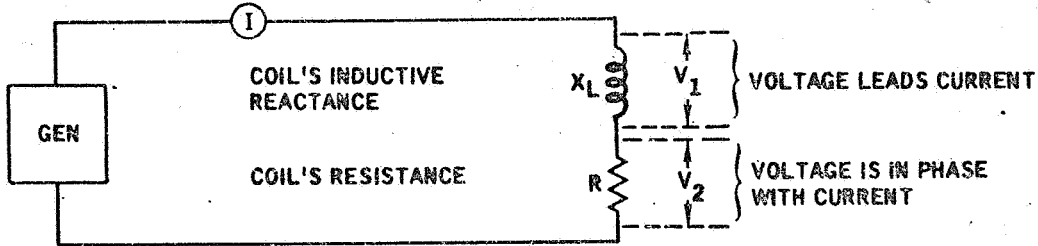

In the above view, the coil is shown as an inductive reactance (X_L) and a resistance (coil's resistance). Note that the current flows through both values. You have just seen that the voltage across the inductive reactance (X_L) leads the current (I). And previously you learned that the voltage across the resistance is in phase with the current. Since the current is common to both values, this means that the voltage across the inductive reactance (X_L):

Is in phase with the voltage across the resistance Page 5-46

Leads the voltage across the resistance Page 5-47

Your answer is wrong. You said that the voltage across the inductive reactance (X_L) is in phase with the current flowing through the coil. The opposite is true. The voltage across the inductive reactance (X_L) is out of phase with the current by 90 degrees and actually leads the current.

The inductive reactance (X_L) of the coil acts like a coil without resistance. And such a coil, you just saw, has a voltage that leads the current by 90 degrees. Or we can say the current lags the voltage by 90 degrees. The following figure applies to both a coil without resistance and the inductive reactance (X_L).

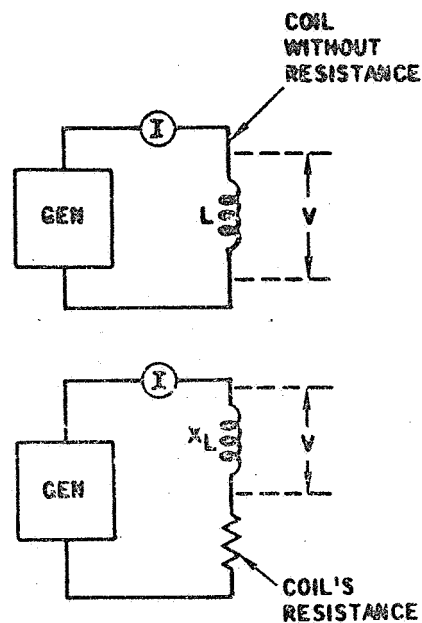
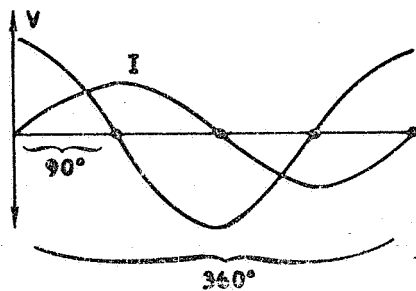

Turn to page 5-44.

Incorrect! The voltage across the inductive (X_L) leads the voltage across the coil's resistance. You said that the inductive voltage was in phase with the resistance's voltage.

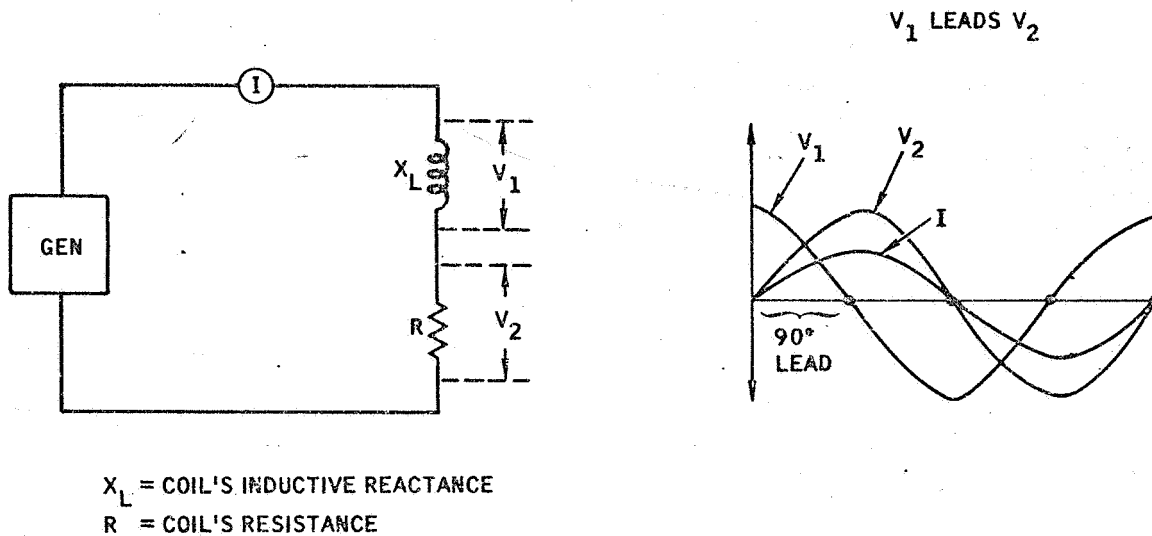

The above figure illustrates the voltage conditions. Note that the current (I) is common to both the inductive reactance (X_L) and the coil's resistance. As you remember, the inductive reactance voltage leads the current while the voltage across the coil's resistance is in phase with the current. Since the current is common to both the inductive reactance and the resistance, it is possible to use the current as a point of reference for both voltages. When this is done, you can see that the voltage across the coil's inductive reactance (X_L) leads the coil's resistance (R).

Turn to page 5-47.

Right again! The voltage across the inductive reactance (X_L) leads the voltage across the coil's resistance.

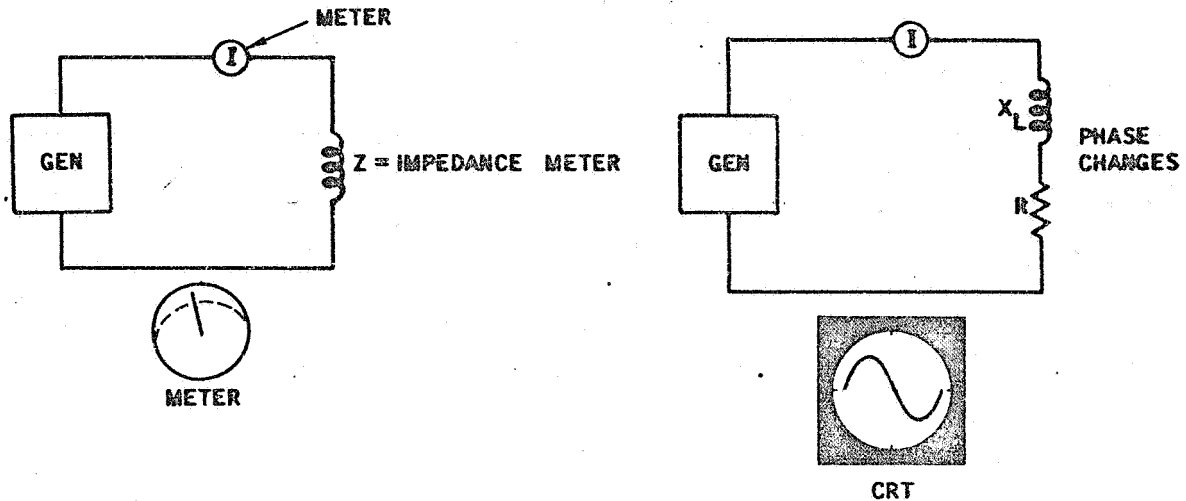

Before we move on with the idea of phase analysis, let's review your progress. We started with impedance testing and learned that impedance was the coil's opposition to current flow. Since the coil's impedance is affected by a specimen, it is possible to learn something about the specimen through changes in impedance. These impedance changes produce current changes which can be indicated on a meter. Unfortunately, since the three variables of permeability, dimensional changes (or lift-off effects), and conductivity all affect the impedance, it is not possible to determine which variable is producing a change in a given test situation. A change in meter indication simply means that the impedance has changed.

To get more information from the test coil, we use a cathode ray tube (CRT) and observe an indication on the CRT screen. This indication will change if the impedance changes. What's important to us, is that through the CRT indication it is possible to separate the variables. This is based on something called the impedance phase angle. If this angle changes, the waveform moves and that's the basis for phase analysis. Let's see what this means.

Turn to page 5-48.

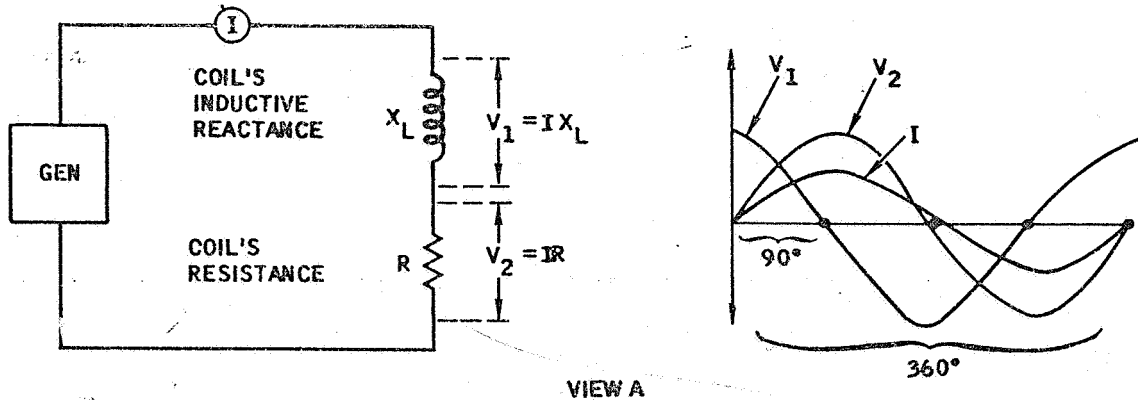

In a practical circuit, impedance is a combination of both the inductive reactance and the coil's resistance. A circuit with only the inductive reactance and with no resistance does not exist. This means that the waveforms shown in view A are not correct. It is true that the voltage V_1 will lead the voltage V_2 but this lead will be less than 90 degrees because resistance also exists in the circuit.

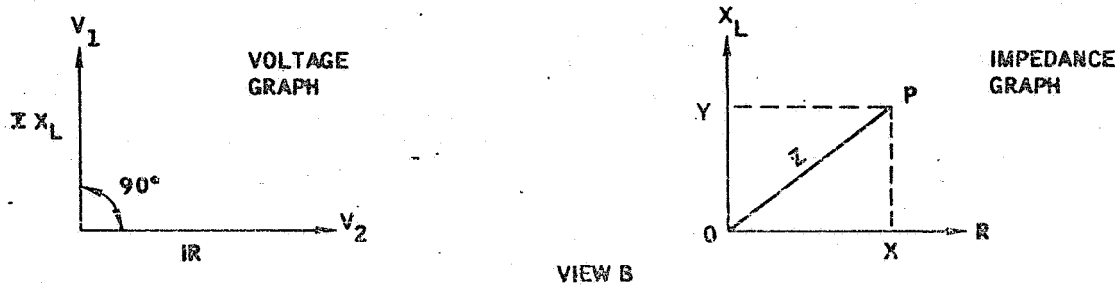

This can best be understood by using a graph which shows voltage V_1 perpendicular (90 degrees) to V_2 . The voltage V_1 is the voltage across the inductive reactance and is obtained by multiplying X_L by the current (I). In like manner, $V_2 = IR$. Since the current (I) is common to both terms, this can be removed and the graph can present only the inductive reactance (X_L) and the resistance (R). Note that these would be shown as 90 degrees apart.

In a practical circuit, both X_L and R would have real values. For a given circuit, the values for X_L and R can be located on a graph and these two points extended to a point of intersection as shown in view B. This point defines the impedance of the circuit. The length of OP is the actual value of the circuit's impedance (Z). This could also have been calculated as follows:

$$Z = \sqrt{X_L^2 + R^2}$$

Turn to page 5-49.

We have moved rapidly over several ideas so that you could see how these ideas are interrelated. Now let's break these ideas into smaller pieces. As we do so, keep in mind that our objective is to understand what we see on the cathode ray tube.

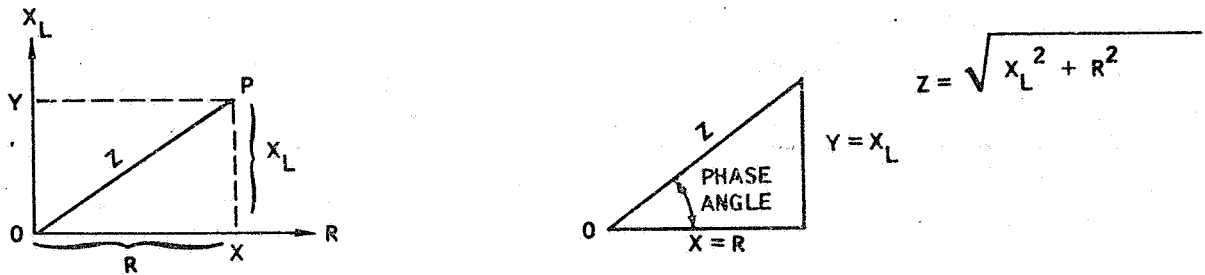

Impedance is the total opposition to the flow of current and is composed of two values: the coil's resistance (R) and the coil's inductive reactance (X_L). Because of the voltage relationships of these two values, we can represent the two values in a graph and show that they are 90 degrees apart. The actual impedance of a circuit is some combination of these two values.

One way to determine the impedance is to calculate the value. This formula is based on the relationships of the sides of a right triangle as shown above.

Another way is to locate the given value of the inductive reactance on the vertical scale of the graph and the given value of the resistance on the horizontal scale. The value on the vertical scale is then extended to the right while the value on the horizontal scale is extended upwards. The intersection of the two extensions gives us a point. A line drawn from this point to the start of the vertical and horizontal scales (point O) gives us the actual value of the impedance. This line can be related to a scale that gives us the real value in the same way that the calculated value was a real value.

Note in the above figure that the three values form a triangle with angles. Also note which angle is called the phase angle. Do you think this angle will change if the impedance changes?

- No Page 5-50
- Yes Page 5-51

Sorry, You don't quite have the feel for the phase angle. You said that you didn't think the phase angle would change if the impedance changes.

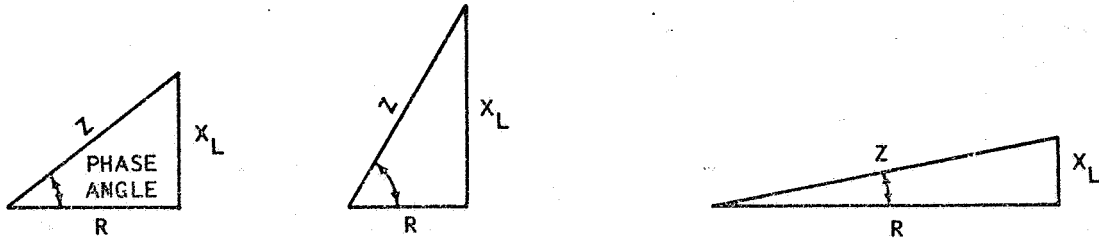

Impedance is a combination of the inductive reactance (X_L) and the resistance (R). Either of these two values can have many specific values. For example, X_L may be high, while R is low. Or, on the other hand, the inductive reactance (X_L) may be low and the resistance (R) can be high. For each set of X_L and R values, a unique phase angle will exist. Note the three examples shown above.

That's why you should have recognized that the phase angle will change if the impedance changes. After all, impedance is a unique combination of X_L and R .

Of course, you might feel that both X_L and R could change at the same time and the specific values might keep the phase angle unchanged. You would be right; however, in a practical circuit this is very uncommon. For example, if R is the coil's resistance, this is a fixed value; thus the phase angle must change since only X_L will change.

Turn to page 5-51.

Very good. You recognized that when the coil's impedance changes, the phase angle changes.

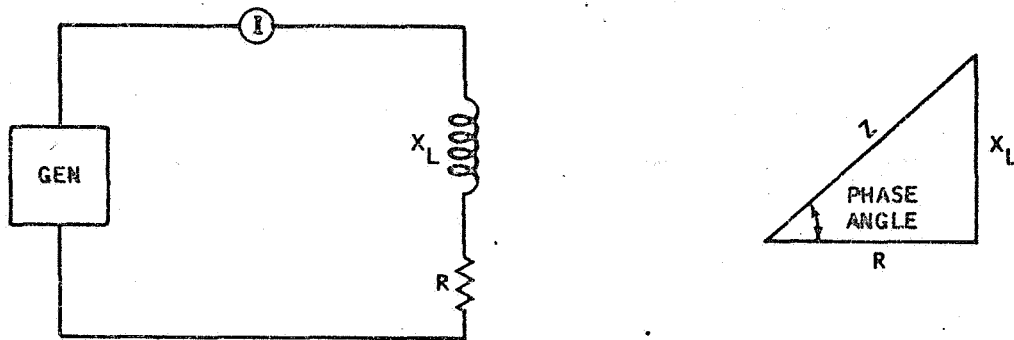

It's important for you to get a feel for how this phase angle can be changed. For a given value of X_L and R , a definite phase angle will exist. If the inductive reactance (X_L) increases, the phase angle increases. In fact if we didn't have any resistance, this phase angle would be 90 degrees, wouldn't it? Of course, since resistance is always present, the phase angle will be something less than 90 degrees.

Naturally, some test coils may not have very much inductive reactance (X_L) so this means that X_L is small. The result is a small phase angle. Or one can say that the current lag in the circuit is small. Recall that it is the coil's inductive reactance which causes a current lag.

Visualize that a specimen is passing through a test coil. Do you think that the specimen's properties:

Will not affect the phase angle Page 5-52

Will affect the phase angle Page 5-53

You seem to have forgotten an important point when you said that the specimen's properties will not affect the phase angle.

The phase angle depends upon the coil's inductive reactance (X_L). This reactance, in turn, is changed by the properties of a specimen. So if the specimen's properties change, then the inductive reactance (X_L) will change. And you just learned that a change in the inductive reactance will change the phase angle.

You should have said that the specimen's properties will affect the phase angle.

Turn to page 5-53.

Certainly true. If the specimen's properties change, the phase angle will change. Now let's see what this means in terms of phase analysis.

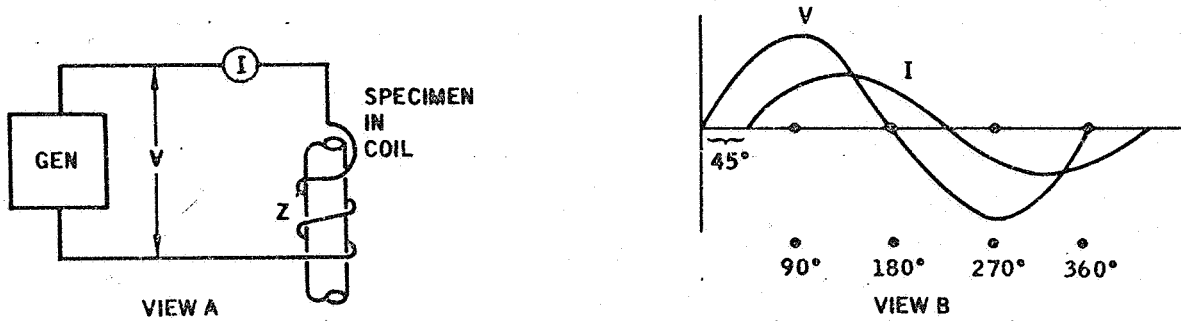

View A shows a test coil connected across a generator. The voltage is across the generator's alternating output voltage. This voltage will cause an alternating current to flow through the test coil. Since the coil has inductance, the current will lag the generator voltage by some phase angle. It can be shown that this angle is the impedance phase angle.

In view B, we see the generator voltage (V) and the current (I) flowing through the circuit. Note that the current lags the voltage. Let's say that this is 45 degrees. This is the impedance phase angle.

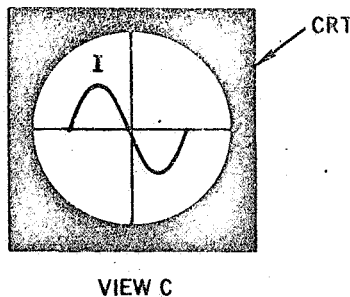

In view C, the current (I) which is shown in view B is shown on a cathode ray tube. The waveform is positioned so that half the waveform is on each side of a vertical line on the cathode ray tube's screen. If we told you that this waveform will shift sideways (either right or left) if the phase angle changes, then do you feel that the waveform will also shift sideways if the specimen's properties change:

Yes Page 5-54

No Page 5-55

Yes, you're right. If the specimen's properties change, the waveform on the cathode ray tube (CRT) will change.

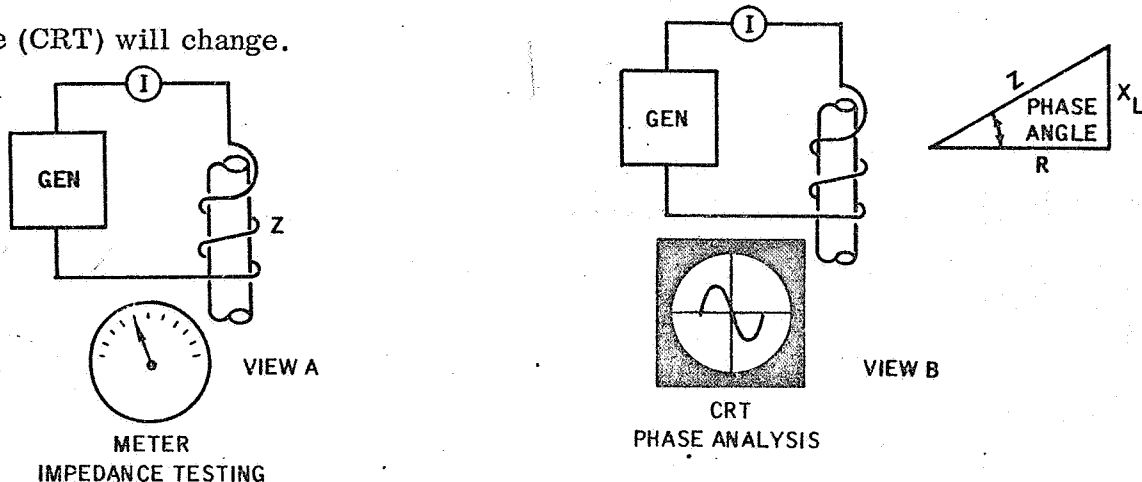

Note that we now have two ways of observing changes in a specimen's properties.

View A illustrates the impedance testing approach. In this approach, we get a meter indication which tells us how much current is flowing through the circuit. This value will change as the coil's impedance changes.

In view B, we use the phase analysis approach. Here we are not interested in the value of the current. Instead, we are concerned with the shift in the waveform for this tells us that the phase angle has changed.

Perhaps you are wondering why you need to understand the phase analysis approach. If you recall, our problem was to separate the variables; permeability, dimensional changes (or lift-off), and conductivity. And we could not solve our problem with impedance testing. With phase analysis, we can solve this problem and the solution is based on the fact that conductivity changes parallel resistance in the coil while permeability and dimensional changes parallel the inductive reactance (X_L).



Turn to page 56.

You said "No." The correct answer is "Yes" to the question do you feel that the waveform will also shift sideways if the specimen's properties change.

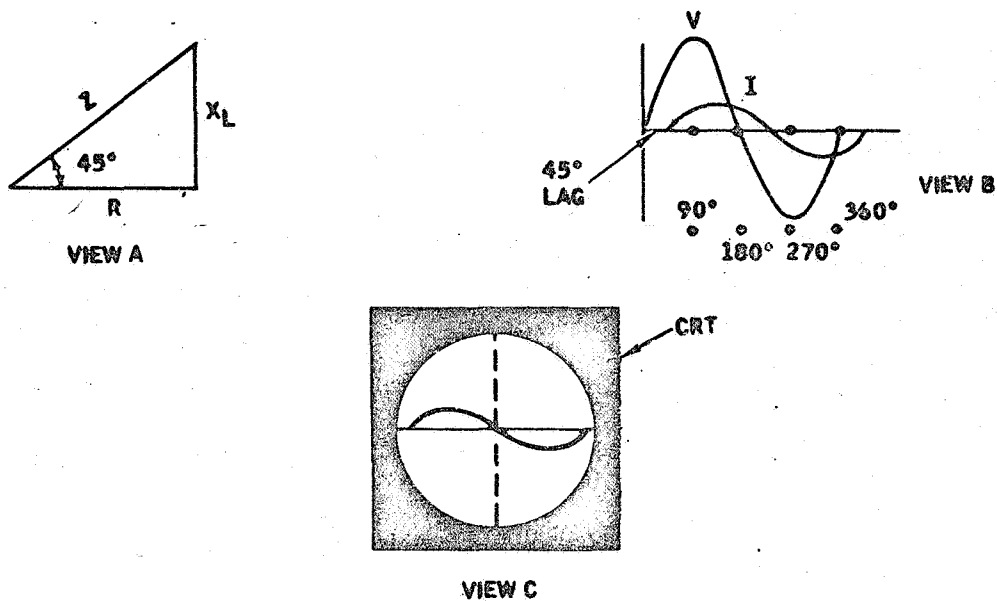

View A shows an impedance angle of 45 degrees. This angle will change if the inductive reactance (X_L) changes. Earlier you learned that X_L can be changed if the specimen's properties change.

In view B, you see the current (I) lagging the voltage (V) by 45 degrees and, of course, this is the impedance phase angle. The waveform will shift to the right or to the left as the phase angle changes.

View C puts the current waveform in view B on a cathode ray tube (CRT). CRT circuits permit us to position this waveform so that the center of the wave (180 degree position) is aligned with a vertical mark on the CRT screen. As you recall, you learned that this waveform will shift to the right or to the left on the screen if the phase angle changes.

Since you know that the phase angle will change if the specimen's properties change, you should also realize that the waveform on the CRT will change if the specimen's properties change.

Turn to page 5-54.

In phase analysis, the output indication is often taken from the secondary coil as shown below.

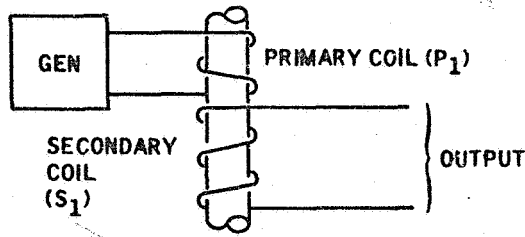

The primary coil (P₁) is used to apply a magnetic field to the rod. This field will induce eddy currents into the rod and will also induce currents into the secondary coil (S₁). The flow of eddy currents in the rod will generate a magnetic field which will affect both the primary and secondary coils. The resulting current flow in the secondary coil (S₁) is therefore the result of the primary coil field, the eddy currents, and the impedance of the secondary coil.

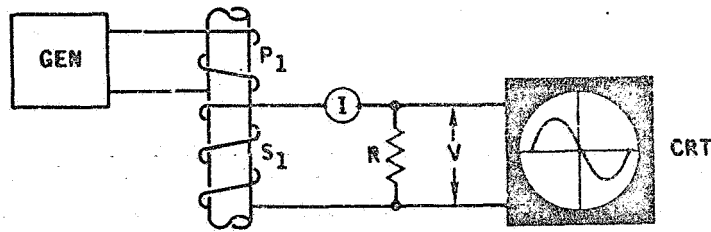

In the above view, the secondary coil's current is passed through a resistor. You have learned that a current flow through a resistor will generate a voltage across the resistor. This voltage (V) will be the product of the current (I) and the value of the resistor (R). Or $V = IR$. The voltage across the resistor can be applied to a cathode ray tube (CRT) for observation. Is this voltage:

Out of phase with the current through the resistor Page 5-57

In phase with the current through the resistor Page 5-58

You have forgotten a point that you learned previously. You said that the voltage across a resistor is out of phase with the current flowing through the resistor. Look at the following figure.

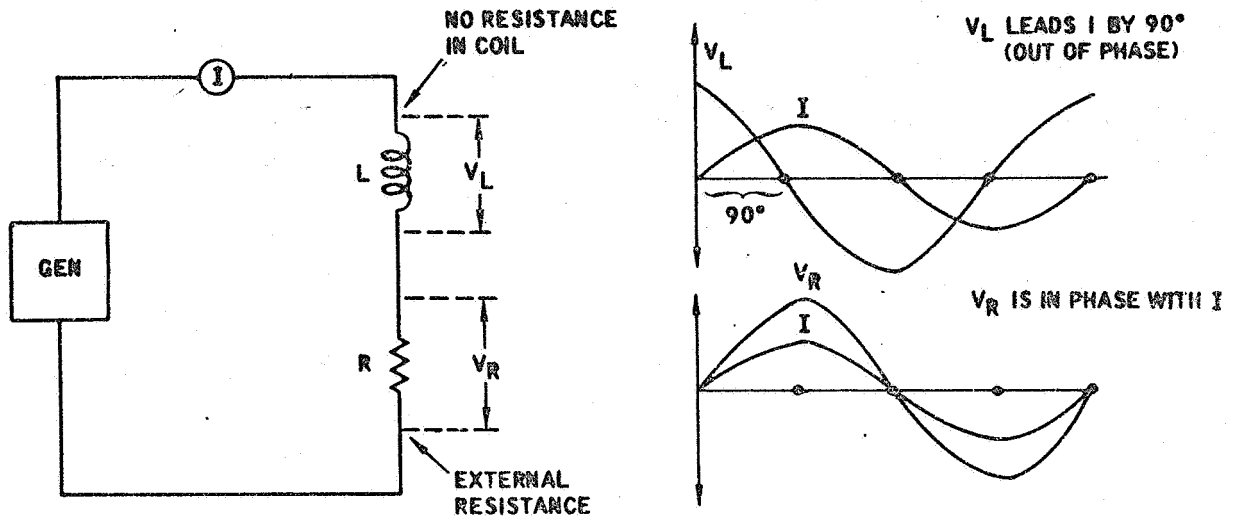

Note that a generator is applying a voltage through a coil with an external resistor. The voltage across the coil leads the current by 90 degrees (out of phase with the current). The voltage across the resistor is in phase with the current. That's why you should have said that the voltage in the previous question was in phase with the current through the resistor.

Turn to page 5-58.

That's right. The voltage across the resistor is in phase with the current flowing through the resistor. And the voltage waveform shown on the CRT can be viewed as the current waveform flowing through the resistor.

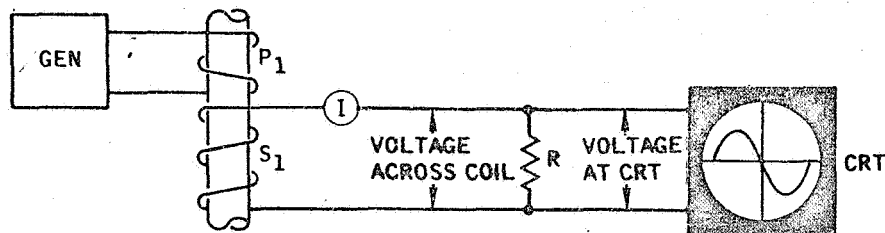

In the above circuit, the voltage across the resistor (R) is the voltage applied to the cathode ray tube (CRT). Note that the secondary test coil (S_1) is also connected across the resistor. This means that the voltage across the coil is the same as the voltage applied to the CRT.

You have learned that a coil consists of an inductive reactance (X_L) and a resistance ($R_L = \text{coil's resistance}$). And we have seen that when a current flows through either the inductive reactance (X_L) or the coil's resistance (R_L) a voltage is developed. For the inductive reactance, this voltage (V_1) is equal to the product of the current and the inductive reactance. Or we can say that $V_1 = IX_L$. In the same way, we can say the voltage across the coil's resistance is $V_2 = IR_L$. Since these two voltages are out of phase by 90 degrees, it is not possible to simply add the two voltages to obtain the total voltage across the coil. Instead, a special method must be used to add these voltages (we cover this in a moment).

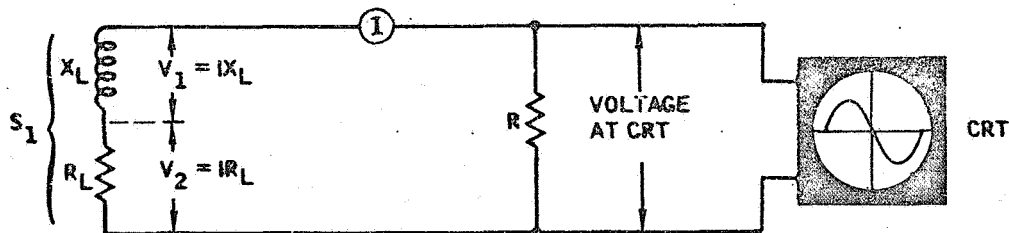

Turn to page 5-59.

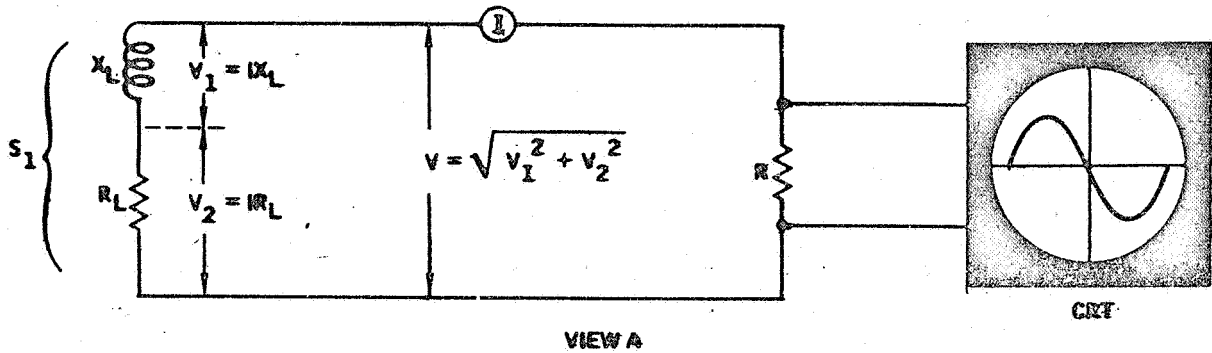

Since the voltage across the coil is the voltage applied to the cathode ray tube (CRT), it is interesting to see how this voltage is obtained. View A shows that this voltage (V) consists of two values (which are out of phase by 90 degrees). The actual voltage across the coil can be calculated by the formula shown above. Of course, you would need to know the amount of current (I) and the values X_L and R_L .



An alternate way would be to use two scales positioned as shown in view B. For a given current (I), V_1 and V_2 would have specific values. For example, V_1 could have a value that could be the distance OY on the scale shown in view C. In like manner, V_2 could have the value shown by distance OX. If these two values were extended as shown in view C, the point of intersection (point V) would represent the combination of the two voltages. The distance OV could then be compared to a scale to determine its actual voltage.

Would you say that the voltage V (distance OV) in view C:

Is the voltage applied to the cathode ray tube Page 5-60

Is not the voltage applied to the cathode ray tube Page 5-61

Of course, you're right. The voltage V (distance OV) in view C is the voltage applied to the cathode ray tube.

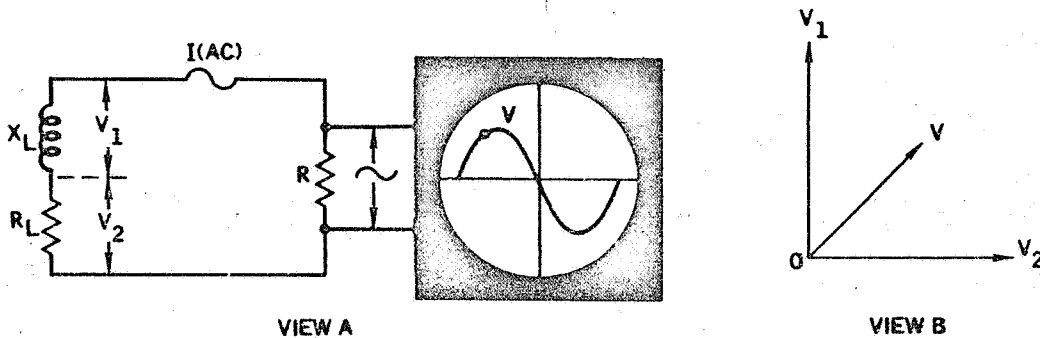

Since the current in the secondary coil is an alternating current (AC), the voltage developed across the resistor is an alternating voltage. That's why you see an alternating voltage in the CRT shown view A. In the example we used, a single point on the waveform shown on the CRT was selected as illustrated in view B.

Another way we can look at this concept of showing a point on a waveform as two separate voltages is described as follows:

1. Select a point on the waveform.
2. Show this point on a graph with V_1 and V_2 scales.
3. Extend the point horizontally to get the value of V_1 .
4. Extend the point vertically to get the value of V_2 .
5. The value OY is the voltage across the inductive reactance (X_L).
6. The value OX is the voltage across the coil's resistance.

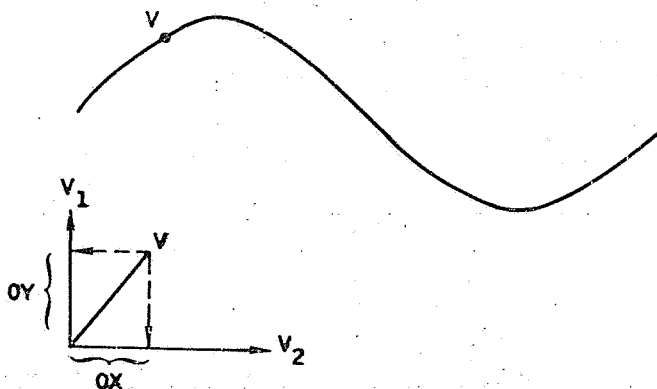

Or we can work the other way. If we knew every voltage value for X_L and R_L over one complete cycle of alternating current, we could plot the curve shown on the cathode ray tube.

Turn to page 5-62.

Something happened that time for you should have recognized that the voltage V (distance OV) in view C is the voltage applied to the cathode ray tube.

The distance OV in view C is the result of adding the voltages across the coil's inductive reactance (X_L) and the coil's resistance (R_L). The total voltage (V) added in this special way (through view C) is the voltage applied to the cathode ray tube.

Return to page 59, read the page, and try the question again.

A cathode ray tube (CRT) is a device which displays dots of light when particles of electricity (electrons) strike the CRT's screen. The electrons are generated at one end of the tube and pass through the tube to the screen. The material on the screen will display a dot of light when the electron strikes the screen and the display will continue for a short period of time before it disappears. Thus it is possible to get a pattern of dots on the screen and to see a waveform.

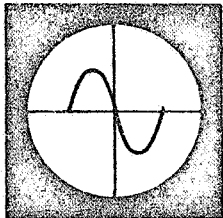

CRT

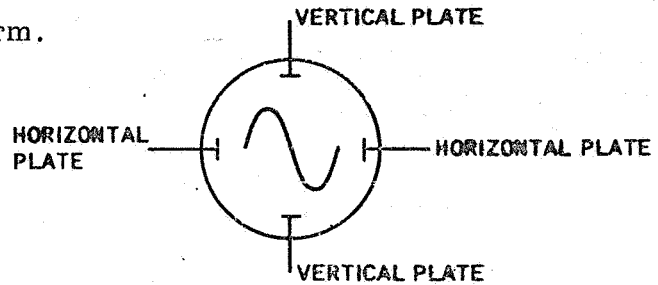

The position of a dot of light is changed by vertical and horizontal plates within the tube. These plates affect the electrons as they pass through the tube. The vertical plates move the dot up and down while the horizontal plates move the dot sideways (left to right as you observe the screen).

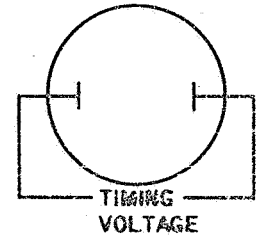
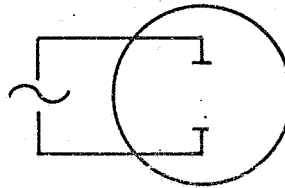
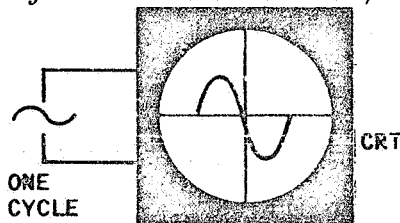

If one cycle of alternating voltage is applied to the CRT, a vertical line will appear on the screen. To get the dots to move across the screen, a second voltage is applied to the horizontal plates. This voltage will move the dots across the screen at a steady rate. The voltage is normally called a timing voltage or sweep and can be set to have a time period which is the same as the period of the alternating voltage applied to the vertical plates. A period is the time required to complete one cycle. Circuits within the CRT provide a means of blanking out the screen after one cycle so that the cycle can start again at the left side of the screen. In this way you can get a continuous picture of one waveform.

The input to a CRT is a series of identical cycles. What you see on the CRT:

Is one cycle of the alternating voltage applied to the vertical plates Page 5-63

Is an alternating voltage applied to the vertical plates and displayed as one complete cycle of the alternating voltage Page 5-64

You are not right. The input to the CRT is a series of identical cycles. You said that you would see one cycle of the alternating voltage applied to the vertical plates. This is not true. What you actually see is an alternating voltage applied to the vertical plates and displayed as one complete cycle of the alternating voltage.

Look at it this way. A series of identical cycles is being applied to the vertical plates. When the first cycle is applied, this is displayed on the screen. Remember that the horizontal plates through the timing voltage move this pattern of dots across the screen. After one complete cycle, the timing voltage jumps back to the left side of the screen and starts a second movement across the screen at the same time as the second cycle is applied to the vertical plate. This happens again and again. That's why you see one complete waveform continuously displayed on the screen.

Turn page 5-64.

Again you're right. The input to the CRT vertical plates is a series of identical voltage cycles; however, you only see one complete cycle on the CRT screen because the timing voltage is set to show only one complete cycle. After one complete cycle, the timing voltage returns to the left side of the screen and repeats the display. Thus you see only one cycle at a time.

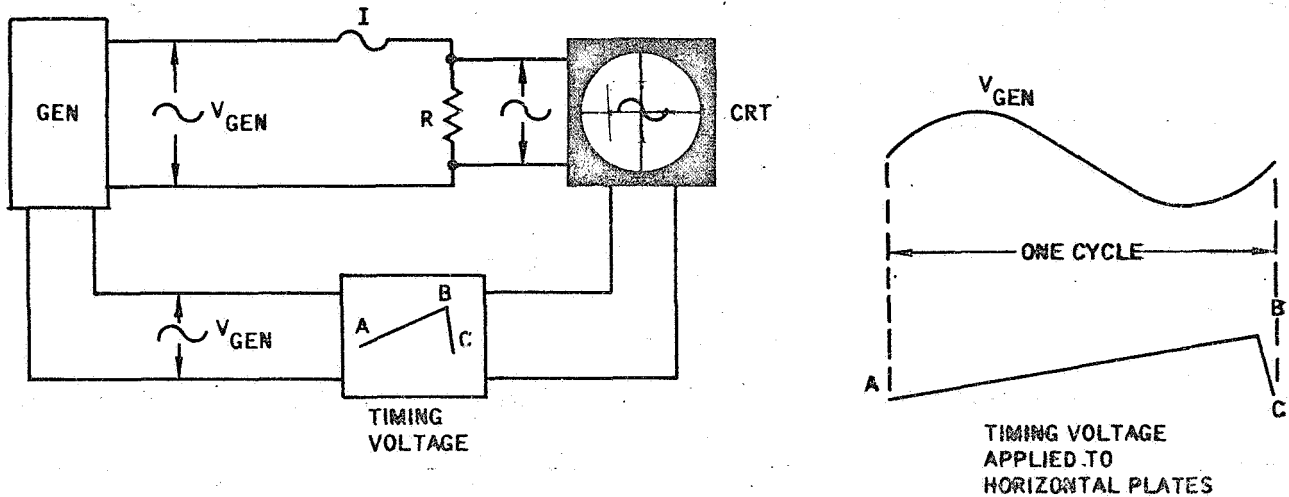

Let's get a better feel for how we can use the cathode ray tube. In the above figure, a CRT is connected to an AC generator. The CRT's vertical plates will receive the alternating voltage appearing across a resistor. This voltage will be the same as the generator's voltage (V_{GEN}). The CRT's horizontal plates are connected through a timing voltage circuit to the generator. The purpose of the timing voltage circuit is to convert the generator voltage (V_{GEN}) to a voltage that rises at a steady rate to a specific value (A to B) and then falls to zero (C). The voltage rise (A to B) causes the dot on the CRT to move horizontally across the screen. The voltage from B to C is used to return to the dot to the left side of the screen. Since the timing voltage cycle is the same as the cycle for the generator's voltage, the display on the CRT's screen will be the same as the waveform produced by the generator. Under these conditions, one can say that the generator's voltage is in phase with the timing voltage.

Turn to page 5-65.

It is important to know that the CRT display may change as a result of changes in the testing circuits.

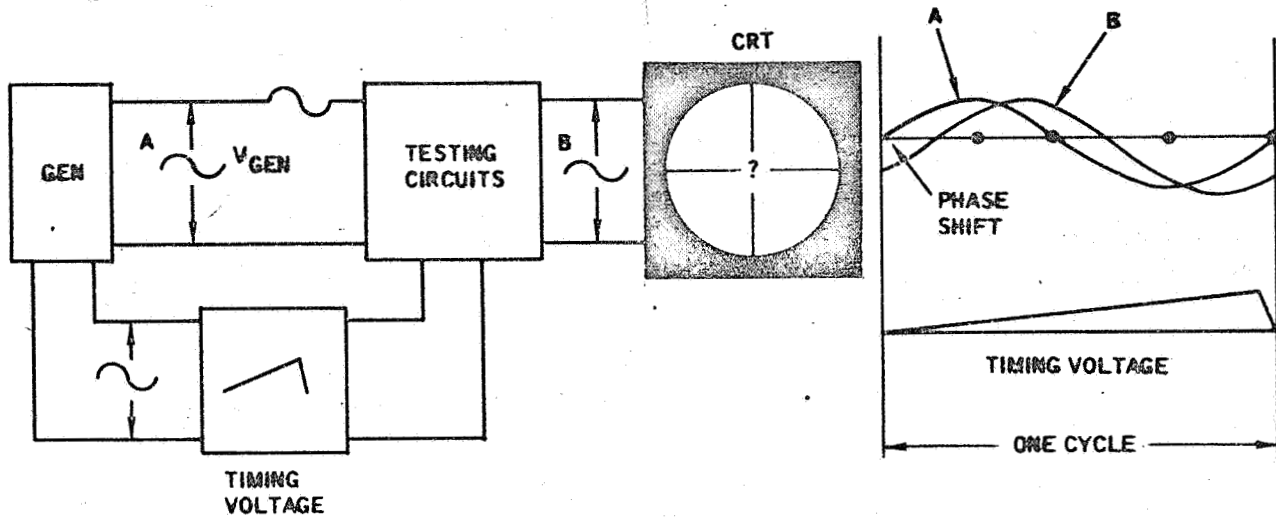

In the above figure, the timing voltage is adjusted to the same period as the generator's voltage (waveform A). Waveform A will appear on the CRT's screen. Now consider that the testing circuits cause a phase shift. This means that waveform A will now become something else (example; waveform B). Note that this waveform B still has the same period as waveform A; but it is lagging waveform A. The entire waveform B will appear on the screen. It will now look differently than waveform A. One form of eddy current testing is based on this change in display as a result of a phase shift.



View A illustrates a typical display as a series of identical specimens are passed through a test coil. If the display suddenly changed to that shown in view B, would you say that the phase of the voltage applied to the vertical plates:

Has not changed Page 5-66

Has changed Page 5-67

Let's try it again for you selected the wrong answer. You said that the phase of the voltage applied to the vertical plates has not changed.

As a series of identical specimens are passed through a test coil, we get the display shown in view A. Suddenly the display changes to that shown in view B.

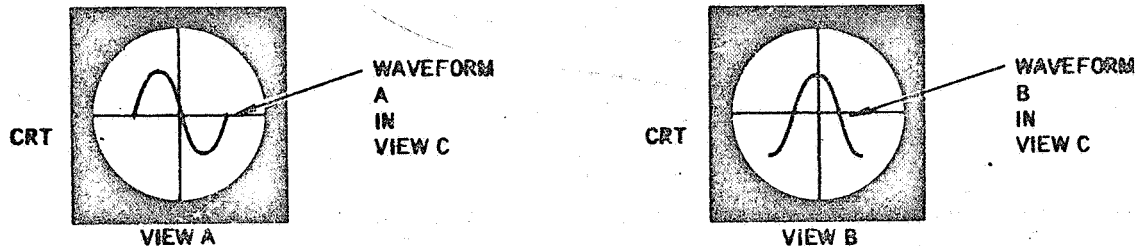

A change in the display tells us that the properties of one of the specimens passing through the test coil is not the same as the other specimens. What has happened is that the non-normal specimen has caused a phase shift. This means that the voltage applied to the vertical plates of the cathode ray tube has shifted its phase. The period of the voltage is unchanged; however, the phase has changed.

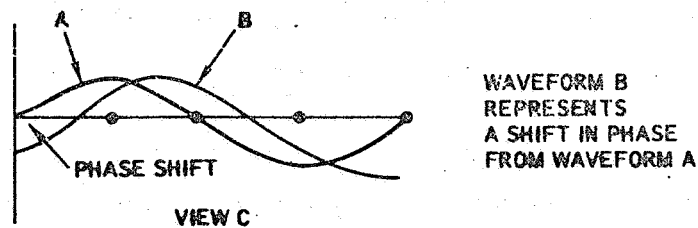

In view C, the original voltage waveform is shown by waveform A. This is the waveform shown in view A. When a phase shift occurs, a new display appears on the cathode ray tube. This is shown as waveform B in view C and displayed in view B. Since the timing voltage cycle is the same as the voltage applied to the vertical plates, the entire waveform B will be displayed; however, it will not appear the same as waveform A. This is caused by the fact that the waveform starts and stops at a different point because of the timing voltage.

Now let's move on. Turn to page 5-67.

Fine! You have seen that the testing circuits may cause a phase shift and the waveform display on the CRT will show this change.

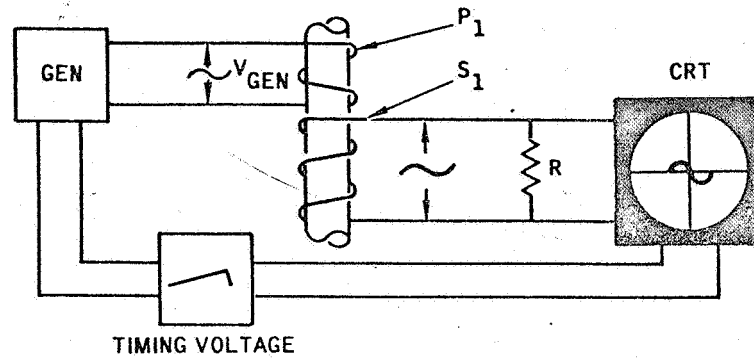

The above figure illustrates a typical testing arrangement. The generator voltage (V_{GEN}) is applied to a primary coil (P_1) and to a timing voltage circuit. The voltage applied to the primary coil causes a current to flow through the coil. This current establishes a magnetic field which induces eddy currents into the specimen and also induces currents into the secondary coil (S_1).

The current in the secondary coil is an alternating current and the resulting voltage across the secondary coil will be an alternating voltage. This voltage will have the same frequency and period (time required for one cycle) as the generator voltage (V_{GEN}).

When the secondary coil (S_1) is connected to a CRT, a display will appear on the CRT. This display will be an alternating voltage. If the timing voltage is adjusted to show one complete cycle, will the waveform on the CRT have the same period as the period of the generator's voltage (V_{GEN}):

No Page 5-68

Yes Page 5-69

Your answer "No" is not correct. You should have said "Yes." The question was "If the timing voltage is adjusted to show one complete cycle, will the waveform on the CRT have the same period as the period of the generator's voltage (V_{GEN})?"

The generator voltage is an alternating voltage. This means that the voltage rises and falls above and below a center value. One complete sequence as shown below is a cycle.

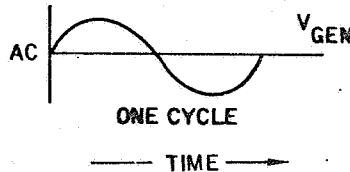

The time required to complete one cycle is called the period. Frequency is the number of cycles per second. The generator voltage is applied to the primary coil and the resulting current in the coil will be an alternating current. This too will have a cycle and a period which will be the same as the voltage. The magnetic field in the primary coil induces eddy currents into the specimen and also induces currents into the secondary coil. The alternating current in the secondary coil will have the same period as the generator voltage. The current flowing through the secondary coil will generate a voltage in the secondary coil and this voltage will have the same frequency and period as the current. Since this is the voltage applied to the CRT, we can say that the CRT waveform will have the same period as the period of the generator's voltage (V_{GEN}). That's why you should have said "Yes."

Turn to page 5-69.

Correct! The waveform on the CRT will have the same period as the period of the generator's voltage. Now let's see why the waveform on the CRT will not have the same phase as the phase of the generator's voltage.

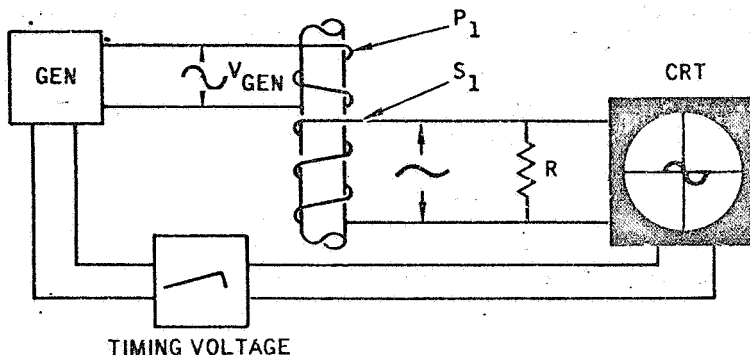

Previously you learned that a coil has inductance (L) and this causes the current through the coil to lag the voltage applied to the coil. Thus we can say that the current is out of phase with the voltage. In the above figure, the generator's voltage (V_{GEN}) is applied to the primary coil; however, the resulting current in the primary coil lags the voltage. Since this current, through the primary coil's magnetic field, induces currents into the secondary coil (S_1) we can also say that the secondary coil's current lags the generator voltage. And finally, since the secondary coil's voltage depends on the current in the secondary coil, we can say that the coil's voltage is out of phase with the generator voltage.

In the above view, the CRT display represents the voltage from the secondary coil. Through the timing voltage, the display is adjusted to show one complete cycle. As various specimens are passed through the coil, the waveform will shift phase if the specimen properties change. Initially, a group of acceptable specimens are passed through the coil and controls on the CRT are adjusted to display this normal waveform. Will this CRT waveform:

Be in phase with the generator voltage Page 5-70

Be out of phase with the generator voltage Page 5-71

You missed the point when you said that the CRT waveform will be in phase with the generator voltage. The CRT waveform will be out of phase. Let's look at it again.

When the generator's voltage (V_{GEN}) is applied to a coil, the coil's current (I) will lag the voltage as shown below.

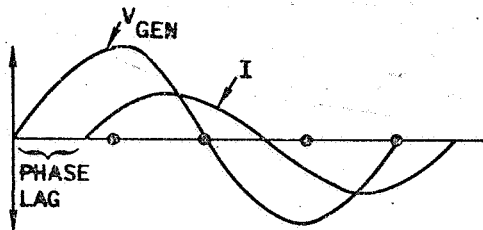

The current lag is caused by the inductance (L) of the coil. Since this current generates a magnetic field which causes a current to flow in the secondary coil, we can say that the current in the secondary coil also lags the generator voltage. In turn, the secondary coil current generates a voltage which is applied to the CRT. Because this voltage depends upon the secondary current (which is out of phase), this voltage will be out of phase with the generator voltage. That's why we can say that the CRT waveform will be out of phase with the generator voltage.

Turn to page 5-71.

Certainly true! The CRT waveform will be out of phase with the generator voltage. This, however, is not a problem for we are really interested in a shift in phase at the CRT after the waveform has been established at the CRT.

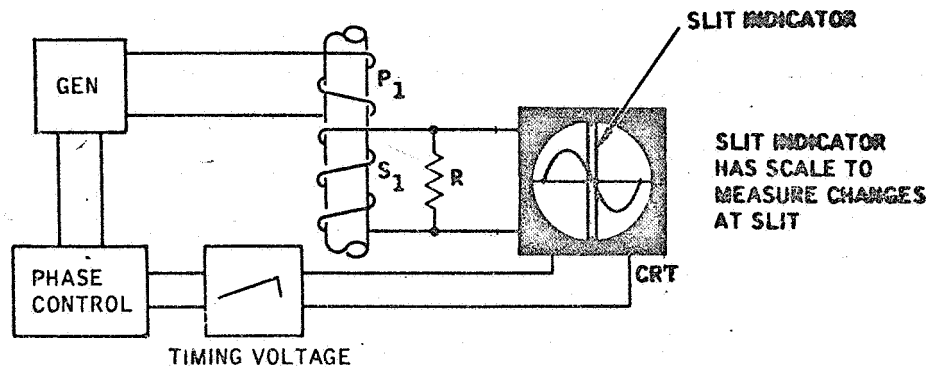

To help you detect a phase change by observing the CRT, the CRT is equipped with special features. One of these is a vertical "line" on the front of the CRT screen. This is normally a piece of transparent material with a slit and has a scale to measure the height of the waveform at the slit.

To position the waveform on the CRT screen, the CRT is equipped with a phase control (generally on the front panel). In the above view this is shown outside the CRT. Note that the phase control (also called a phase shifter) is positioned between the generator and the timing voltage circuit. The purpose of this control is to shift the phase of the waveform on the CRT so that the waveform can be positioned properly with respect to the slit. How this is done by the circuits is not important to us. It is only necessary to know that by using the phase control, you can position the waveform sideways. You can move it to the left or to the right. In the above view it is centered so that the middle (180 degree position) is at the center of the slit.

Imagine that you have an acceptable specimen in the test coil and have adjusted the phase control so that you have the display shown above. Now you place an unacceptable specimen in the test coil. Will an indication appear at the slit:

- Yes Page 5-72
- No Page 5-73

Good! You recognize how the slit can be used to sense a change in phase. You also recalled that the specimen's properties affect the phase of the voltage applied to the CRT. If the properties change, the phase of the waveform on the CRT will change.

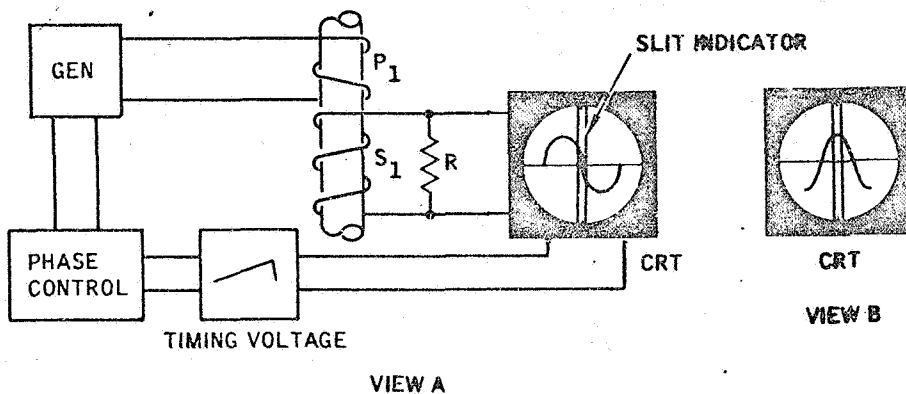

It is equally important to know that the initial waveform on the CRT can take many shapes. For example, the initial waveform can be as shown in view A. A phase change can then cause this waveform to appear as shown in view B. Of course, it can also work the other way. View B can be the initial waveform as set by the phase control. A change in the specimen's properties can cause this waveform to change to that shown in view A. It's all a question of how you establish your initial waveform.

If a series of acceptable specimens are passed through a test coil, it can be shown that some variation will still exist. For this reason, it is necessary to establish upper and lower slit value limits at the slit. As long as the waveform remains within the tolerances at the slit, one can say that the specimen's are acceptable.

Oftentimes eddy current testing is performed by watching the value at the CRT slit.

For a series of specimens passing through the test coil, will the slit value:

- Be constant Page 5-74
- Vary Page 5-75

The question was "Will an indication appear at the slit?" You said "No." You should have said "Yes."

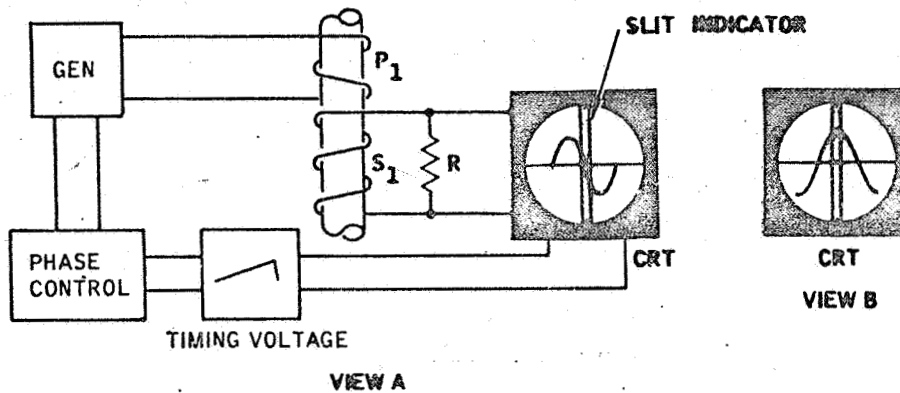

A change in the specimen's properties will change the phase of the voltage across the secondary coil (S₁). Initially an acceptable specimen was placed in the test coil and through the phase control the phase was adjusted to show the display in view A. The value at the center of the slit is zero.

If an unacceptable specimen is now placed in the test coil, the phase of the voltage across the secondary will change. View B shows this new waveform. Note that the value at the slit has some value other than that shown in view A. That's why you should have recognized that the indication will appear at the slit.

You should keep in mind the fact that the specimen's properties change the impedance of the coils (both the primary and the secondary coils). This means that the phase will change as the specimen properties vary. Such a phase change will cause the display on the CRT to change. This is the basis for phase analysis.

Turn to page 5-72.

Perhaps you misread the question for you are wrong. The question was "For a series of specimens passing through the test coil, will the slit value: (Be constant) or (Vary)."
You said "Be constant" and you should have said "Vary."

A change in the value at the slit denotes a change in phase. Since all acceptable specimens have some variability, we can expect that the slit value (value at the slit) will not be constant. That's why a slit value tolerance must be included in the inspection procedure. The value at the slit can be expected to vary. What's important is that the variability remain within acceptable tolerances.

Turn to page 5-75.

Right! If you were watching the slit, you could expect that the slit value will vary. And this variation is caused by property variations in the specimens passing through the test coil.

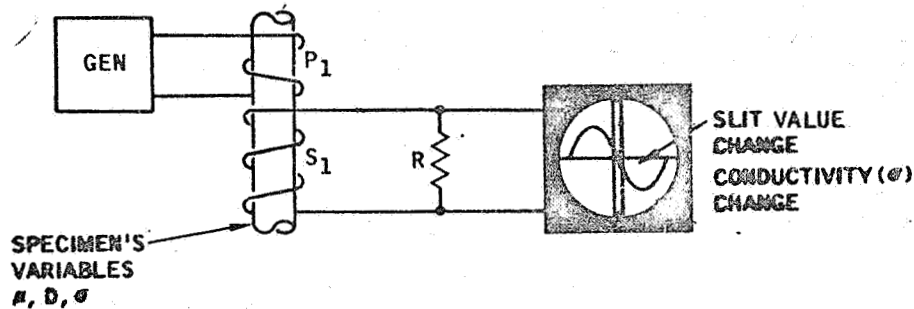

The phase analysis method of eddy current testing provides a means of separating the conductivity variable (σ) from the permeability (μ) and dimension (D) variables. For example, through proper adjustments, the value at the slit can represent only conductivity changes. Or the adjustments can be changed so that the slit value represents permeability and dimension changes. By saturating the specimen, the permeability variable can be suppressed; thus, only the dimension changes are displayed at the slit.

The fact that the variables can be separated is based on how the specimen affects the coil. You should keep in mind the idea that the specimen is seen through the coil and it is the coil's voltage which is being applied to the cathode ray tube (CRT).

Before you can understand how variables are separated, you need to briefly review the nature of the voltages "generated within the secondary test coil"

Turn to page 5-76.

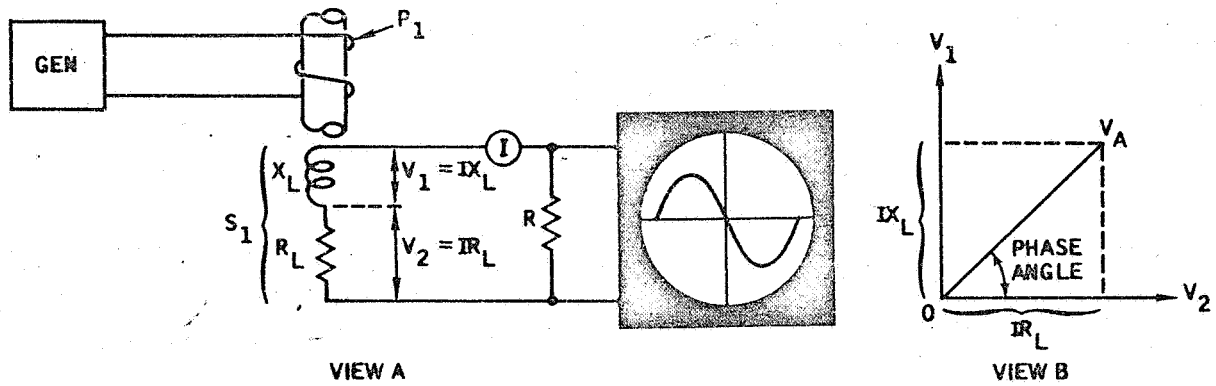

In view A, an alternating current flows through the secondary coil (S_1) as a result of the primary coil and the specimen acting on the secondary coil. This current will develop separate voltages (V_1 and V_2) within the secondary coil and these two voltages will be 90 degrees out of phase. View B illustrates this condition.

Imagine that a particular moment is selected during a cycle of alternating current. At this moment, the current will have a specific value. Let's call this I . The voltage at this moment can be determined by multiplying the current by the coil's inductive reactance (X_L) and by the coil's resistance (R_L). These two values can be located on the vertical and horizontal scales in view B. If these two values are then extended as shown in view B, the actual voltage across the coil can be obtained. This is point V_A in view B. The distance OV_A represents the voltage across the coil and the voltage applied to the CRT.

In view B, a phase angle is shown. This is the angle by which the voltage will lead the current flowing through the resistor (R). Note that this phase angle will change if the value of the inductive reactance (X_L) changes. The angle will also change if the value of the coil's resistance (R_L) were to change. Recall that $V_1 = IX_L$ and $V_2 = IR_L$.

A specimen in a test coil will change the secondary coil's inductive reactance (X_L).

If the specimen's properties changed, would you expect the phase angle in view B:

To remain unchanged Page 5-77

To change Page 5-78

No, you are not correct. You said that the phase angle would remain unchanged if the specimen's properties changed. Just the opposite is true. If the specimen's properties change, the phase angle will change.

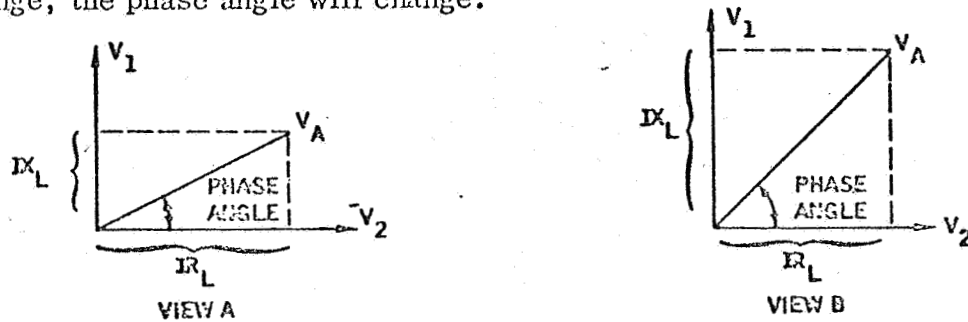

As shown above, the phase angle depends upon the value of the coil's inductive reactance (X_L) and the coil's resistance. If either of these values change, the phase angle will change. In the example we used, the specimen's properties changed the coil's inductive reactance (X_L). View B illustrates this condition. As you can see, this will change the phase angle.

Turn to page 5-78.

Fine! You recognize that the phase angle varies if the coil's inductive reactance (X_L) or the coil's resistance (R_L) varies. You're ready to separate the variables.

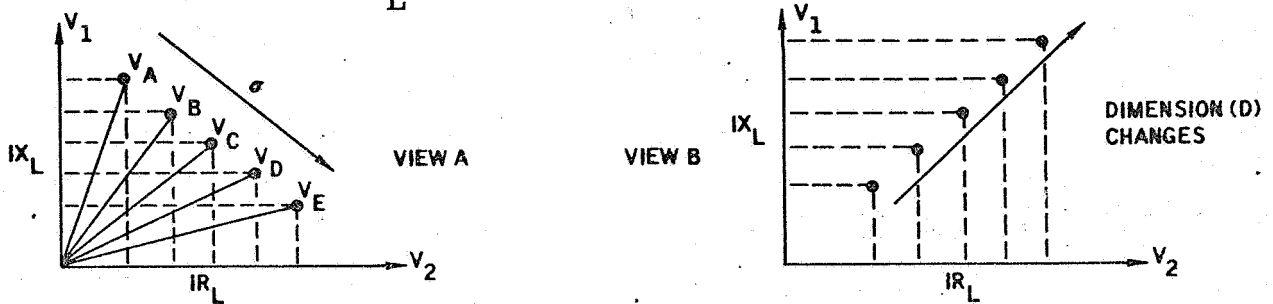

In view A, you see the two voltages (V_1 and V_2) again. This time, however, you see five different voltages (V_A through V_E). These voltages were obtained from five specimens with the same permeability and dimension values. The only difference between the samples is the conductivity (σ). V_A represents the specimen with the lowest conductivity. The specimen with the highest conductivity is represented by V_E . Note that for each specimen a distinct phase angle exists. Thus we can say that the phase angle varies as the specimen's conductivity varies.

View B illustrates another set of five specimens. In this case all specimens have the same conductivity and all specimens are saturated to make permeability a constant. Under these conditions, the only variable is the specimen's dimension. View B shows five voltages, one for each change in dimension.

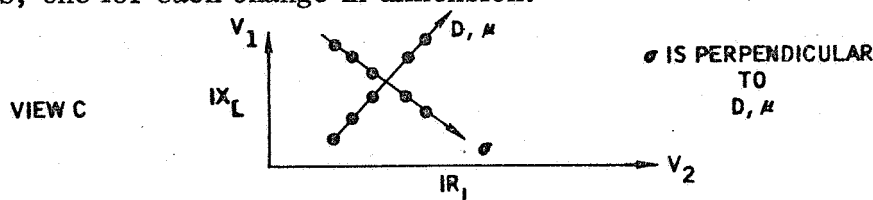

If we now compare view A with view B (as shown in view C), an interesting fact arises. Note that the conductivity variable is perpendicular (90 degrees out of phase) to the dimension variable. It can also be shown that permeability and dimension move in the same direction; therefore, we can say that the permeability and dimension variables are perpendicular to the conductivity variable. Let's look at this further.

Turn to page 5-79.

This concept of the conductivity variable being perpendicular to the permeability and dimension variables is difficult to see.

You should realize that the specimen is seen through the coil and that the coil has two voltages which are perpendicular. The actual voltage across the coil is some combination of these two voltages (V_1 and V_2) View B illustrates these two voltages and the combination voltage (V) for a specific current through the coil. You should recall that the current is an alternating current and that we are only considering one value of the current during the complete current cycle.

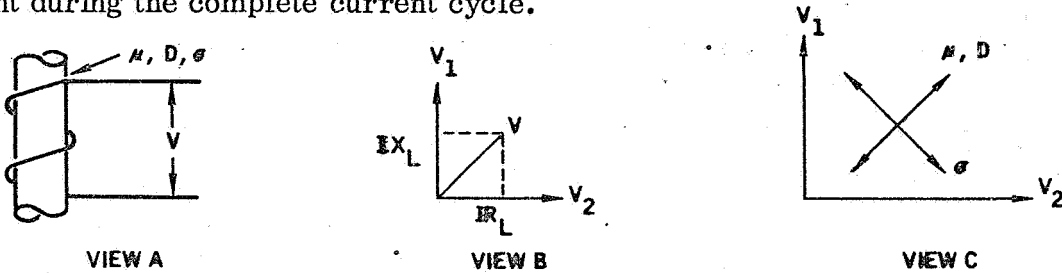

In view C, we see that variations in conductivity (σ) cause the voltage (V) to change. This voltage change has a direction. In like manner, variations in permeability (μ) or dimension (D) also cause the voltage (V) to change. The direction of this voltage change is perpendicular (90 degrees out of phase) with the direction of voltage change caused by conductivity variations. For this reason, we say that the conductivity variable is perpendicular to the permeability and dimension variables.

Throughout this book, we have been talking in terms of three variables: conductivity, permeability, and dimension. In impedance testing, you have seen that it is not possible to separate these variables. On the other hand, phase analysis provides a means of separating the variables. This separation is based on the fact that:

The permeability variable is 90 degrees out of phase with the conductivity and dimension variables Page 5-80

The conductivity variable is 90 degrees out of phase with the permeability and dimension variables Page 5-81

Wrong! You said that the permeability variable is 90 degrees out of phase with the conductivity and dimension variables. This is not true.

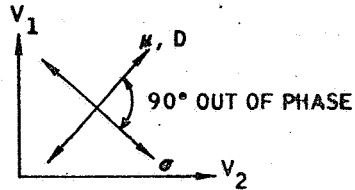

In the above view, you can see that the conductivity variable is perpendicular (90 degrees out of phase) to the permeability and dimension changes. Note that permeability (μ) and dimension (D) changes move in the same direction.

Return to page 5-79, review the page, and select another answer.

Good! You recognize that the conductivity variable (σ) is 90 degrees out of phase (perpendicular) with the permeability (μ) and dimension (D) variables.

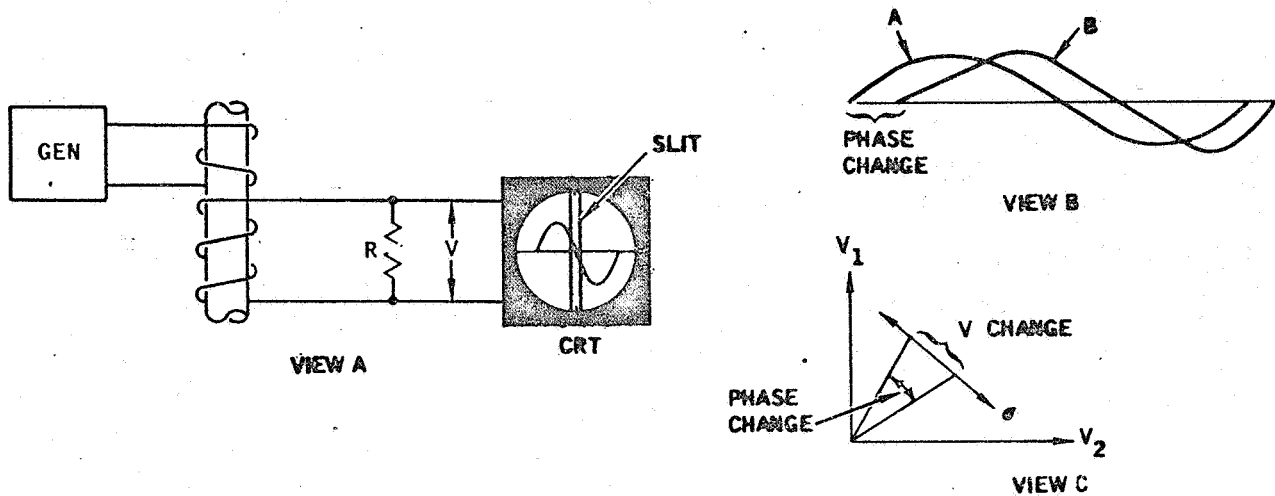

View A illustrates a specimen in a test coil and the resulting display on the CRT. The timing voltage circuits and the phase control are not shown. The CRT display is the waveform A in view B.

View C illustrates how the phase angle changes as the conductivity of the specimen changes (only two values are shown). Note that the voltage (V) changes as the conductivity changes. For each voltage change, there is a corresponding phase angle change. View B illustrates how the phase angle changes from waveform A to waveform B as the conductivity changes.

Imagine that you have a specimen with a specific conductivity in the test coil shown in view A. You have adjusted the CRT phase control so that a zero (minimum) indication appears at the CRT slit. If you now replace the specimen with one that has a different conductivity, would you expect the value at the slit to:

Change Page 5-82

Remain unchanged Page 5-83

Yes, you're right. If you replace the specimen with one that has a different conductivity, you would expect the value at the slit to change. After all, if the specimen's properties change, the phase changes and this will change the value at the CRT slit.

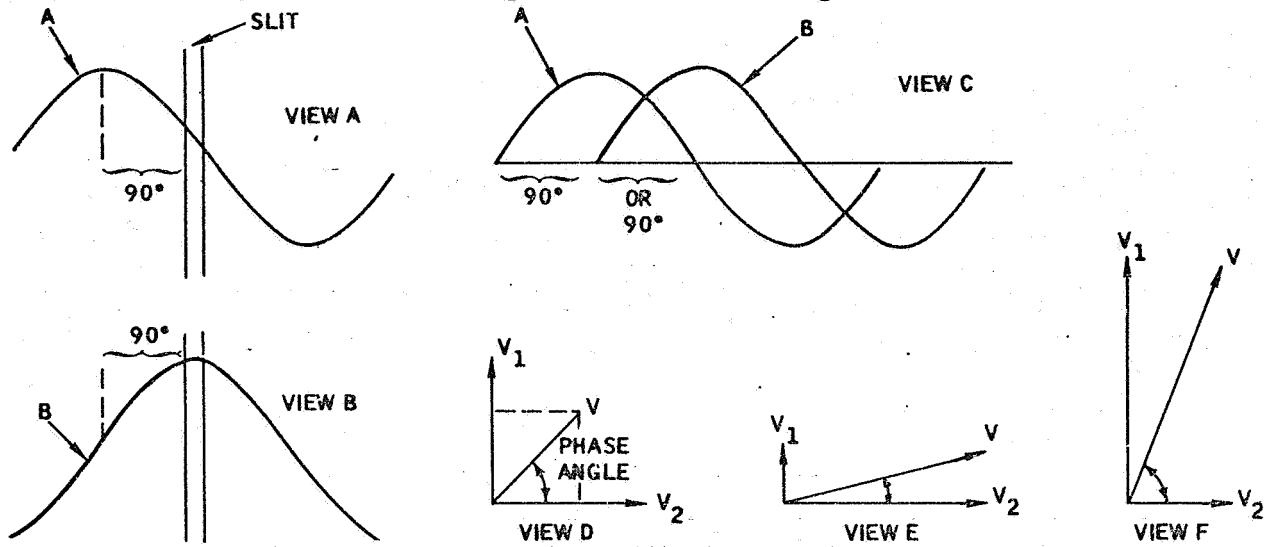

To understand how the variables are separated, you need to recognize the meaning behind the change in waveforms from view A to view B. The change from view A to view B is a 90 degree phase change. View C shows this on a common scale.

To get a 90 degree phase change, either V_1 or V_2 (the voltages in the coil) must change (view D). Note how the phase angle changes in views E and F when different voltages exist.

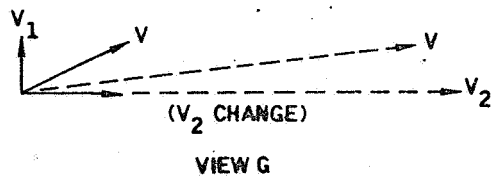

In view G, you can see what happens when V_1 remains unchanged while V_2 increases. The phase angle becomes smaller, doesn't it? Another way to say this is to say that some property of the specimen which is perpendicular to voltage V_1 has produced a change in V_2 .

Turn to page 5-84.

Not right! You said that the value at the slit would remain unchanged. You should have recognized that the slit value would change.

As the specimen's properties change, the voltage across the secondary coil will change and this will cause a shift in the waveform displayed on the CRT. Initially, through the phase control, you had adjusted the control so that the waveform was positioned with a minimum (zero) value at the CRT slit. When a second specimen with different conductivity is placed in the test coil, a shift in phase will occur at the CRT display. This will change the value at the slit. Remember that a change in the slit value means a change in phase angle.

Turn to page 5-82.



In looking at view A, you should realize that the voltage V is one point on the waveform you see on the CRT. The phase angle you see is the angle by which the voltage leads the current through the coil. If the value of voltage V changes, the waveform on the CRT will move sideways. This movement will change the value at the CRT slit.

You should also realize that the three variables (σ , μ , D) will change the value of voltage V . In view B, you see how the three variables can change the value of voltage V .

By now, you should realize that:

Only the conductivity variable produces a phase change Page 5-85

Any one of the three variables (σ , μ , D) can produce a phase change Page 5-86

Perhaps you should look at the following view for you are wrong.

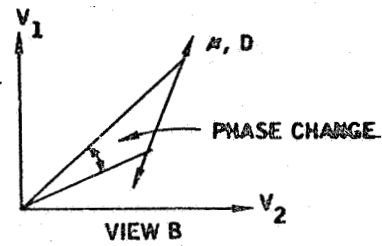
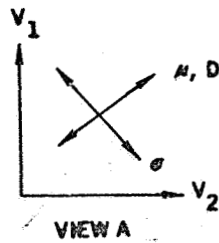

You said that only the conductivity variable produces a phase change. This is not true. Permeability and dimension changes also produce phase changes. Note in view B that a change in either the permeability or the dimension can change the phase angle.

In view B, the direction of the permeability and dimension changes has been rotated from that shown in view A. This has been done to help you see that a phase angle does occur. The actual position of the two perpendicular directions in view A varies with the specific material of the specimen, the fill-factor, and the test coil frequency.

Turn to page 5-86.

That's right. Any one of the three variables (σ , μ , D) can produce a phase change.
And all three variables can be producing phase changes at the same time.

Two of the three variables produce phase changes in the same direction. These two variables are:

- Permeability (μ) and dimension (D) Page 5-87
- Permeability (μ) and conductivity (σ) Page 5-88

Fine! You remembered that permeability and dimension changes produce phase changes in the same direction. Now let's get back to the CRT slit and put these facts to work.

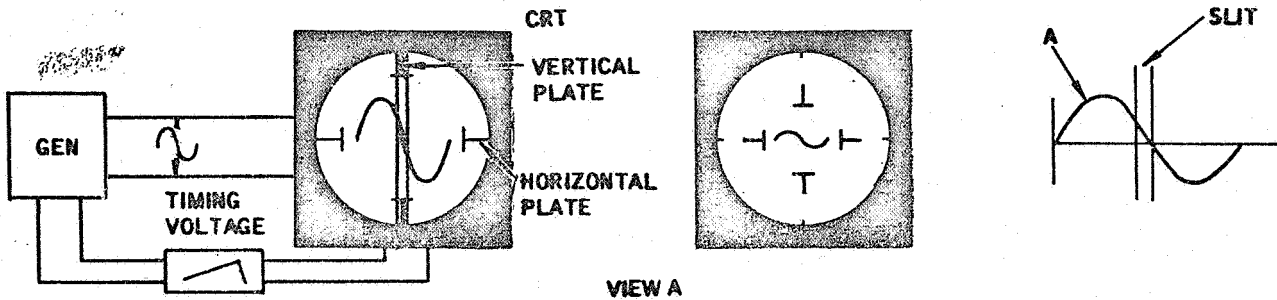

In view A, the generator voltage is applied directly to the vertical plates of the CRT and to a timing voltage that converts the generator voltage to a straight line voltage which moves the vertical plate dots horizontally across the CRT screen. Keep in mind that the CRT plates are perpendicular to each other (90 degrees apart). Because no phase changes exist, the CRT waveform will be the same as the generator voltage waveform and the CRT waveform will be centered at the slit as shown in view A.

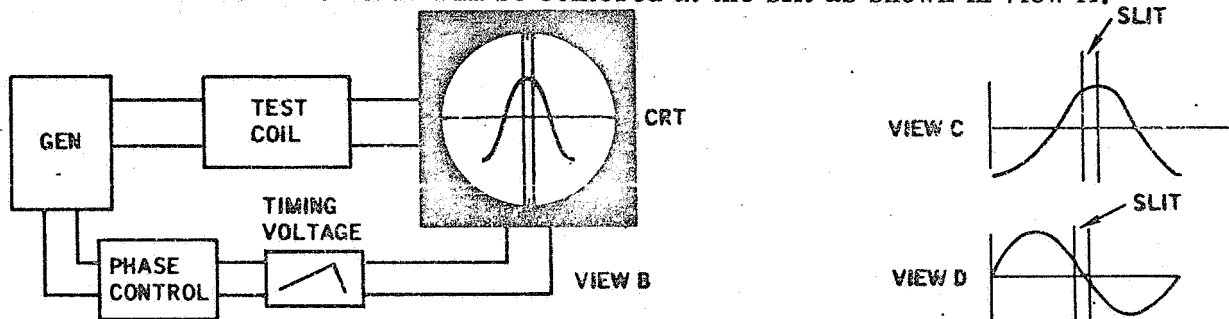

View B illustrates the condition of a test coil with a specimen placed between the generator and the CRT. Under this condition the CRT waveform will change to that shown in view C. This means the voltage applied to the vertical plates has shifted phase and, of course, this phase shift has been caused by the test coil and the specimen. Since the timing voltage is now out of phase with the voltage applied to the vertical plates, the display will be as shown in view C rather than like the display shown in view A. By operating the phase control which controls the timing voltage, the CRT display can be changed to that shown in view D. Note that view D is now the same as view A.

Turn to page 5-89

No, you're wrong. Look at the illustration below. Note that the variables permeability (μ) and dimension (D) are in the same direction while conductivity (σ) is nearly perpendicular (90 degrees out of phase) to the other two variables.

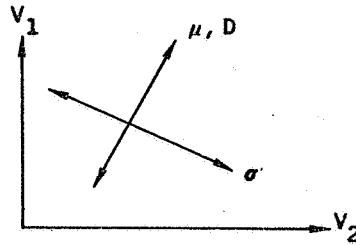

Now you can see why your statement that permeability (μ) and conductivity (σ) produce phase changes in the same direction is wrong. Permeability produces phase changes in the same direction as dimension changes. Got it? Good! Let's move on.

Turn to page 5-87.

You have just seen that the phase control provides a means for changing the display on the CRT.



For example, view A illustrates a typical CRT display. View B illustrates a change in display which was obtained by operating the phase control. Both views represent the same waveform. The difference between the two displays lies in the fact that the waveform is starting and stopping at different points on the CRT.

The phase control changed the CRT display:

By changing the phase to the vertical plates Page 5-90

By changing the phase of the timing voltage applied to the CRT's horizontal plates Page 5-91

Not correct! You said that the phase control changed the CRT display by changing the phase to the vertical plates. This is not true. The vertical plates are connected to the test coils. The test coils and the specimen change the phase to the vertical plates.

The phase control affects the phase of the timing voltage which is applied to the horizontal plates. Thus, when you operate this control, you change the timing voltage phase. This, in turn, changes the display on the CRT. Remember, it's still the same waveform on the CRT. You just see a different form of the same wave.

Turn to page 5-91.

Right again! When you operate the phase control, you change the phase of the timing voltage applied to the CRT's horizontal plates.

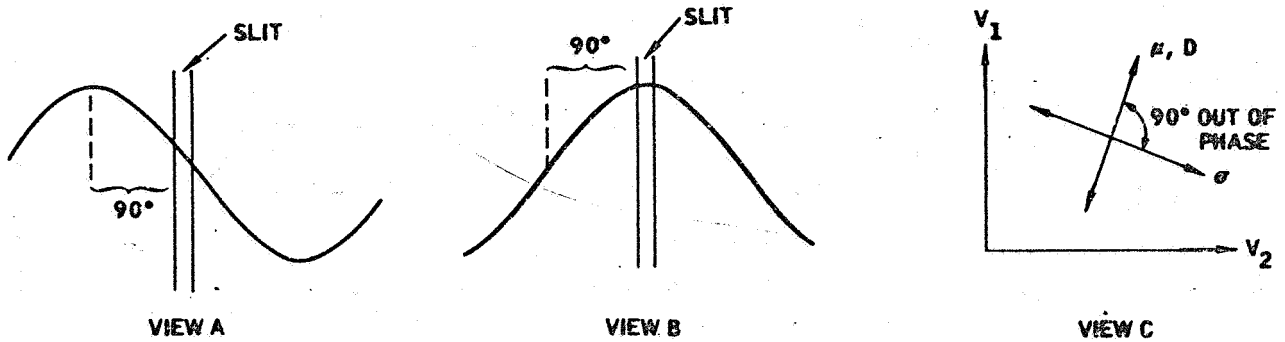

A change in display from view A to view B represents a 90 degree phase shift. Now note in view C that the permeability (μ) and dimension (D) variables are 90 degrees out of phase with the conductivity variable. And then recall that any of these three variables can cause a phase shift.

By the use of the phase control it is possible to shift the phase so that the direction of phase change for the permeability and dimension variables is the same as the timing voltage applied to the horizontal plates of the CRT. If this is done, permeability and dimension changes would not appear on the CRT at the slit and only the conductivity variable would be indicated at the slit. Such a condition is shown in view A. If now a conductivity change occurs, then a value is obtained at the slit. This is represented by a change in display from view A to view B.

Actually what has happened is that a conductivity change has caused a phase shift from the waveform shown in view A to the waveform shown in view B. In the views shown above, a phase shift of 90 degrees has taken place; however, in normal testing the phase shift can be less than 90 degrees.

Under the above conditions, we can say that a change in the slit value represents:

A change in conductivity Page 5-92

A change in permeability or dimension Page 5-93

Correct! Under the conditions we established, the slit value represents a change in conductivity. Now watch this.

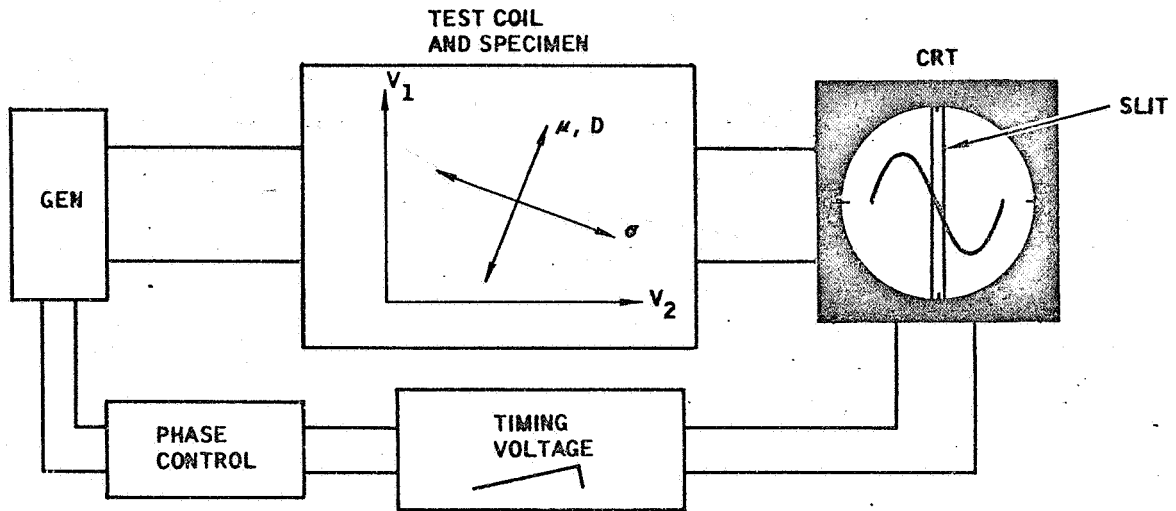

The value at the slit depends on how we establish our initial conditions. For example, it may be desirable to have the slit represent changes in dimension. We will assume that the specimen is a nonmagnetic material. Under these conditions, the phase control would be changed so that the direction of phase change for the conductivity variable is in the same direction as the timing voltage applied to the CRT's horizontal plates. If we did this, then only changes in dimension would be represented at the CRT's slit. We will assume that permeability is a constant.

From what you have learned, would you say that the value at the slit depends on how you establish the initial conditions for the variable which is in the same direction as the timing voltage applied to the CRT's horizontal plates:

No Page 5-94

Yes Page 5-95

No, you are not right when you say that a change in the slit value represents a change in permeability or dimension.

Under the conditions we established the slit value represented a change in conductivity.

Recall that the phase control was adjusted so that the direction of permeability and dimension phase changes was the same as the direction of the timing voltage. This means that these changes will not appear at the slit. On the other hand, conductivity changes will appear at the slit because the conductivity phase direction is 90 degrees out of phase with phase direction for the permeability and dimension variables.

Turn to page 9-92.

You said "No." You should have said "Yes." We asked if you would say that the value at the slit depends on how you establish the initial conditions for the variable which is in the same direction as the timing voltage applied to the CRT's horizontal plates.

The initial conditions established for the slit determine what you will see at the slit. If you want to see the conductivity variable, then you must make the permeability and dimension variables cause phase changes in the same direction as the timing voltage. That way you will not see these changes at the slit. On the other hand, if you want to see the dimension changes at the slit, then you must make the conductivity variable move in the same direction as the timing voltage. In both cases, this is done by operating the phase control.

Turn to page 5-95.

Perfectly true. The value at the slit depends on how you establish the initial conditions. The process of learning something about the specimen through a phase change is called phase analysis. There are several forms of phase analysis. The form we have been covering is called the linear time-base method. The timing voltage is the time base. Since the timing voltage moves the CRT dot across the screen at a steady rate, the voltage is called a linear voltage. The idea of time we get from the fact that time is required to move the dot across the CRT screen. This time is the period for one complete cycle and is the same period as the period of the voltage cycle applied to the CRT's vertical plates.

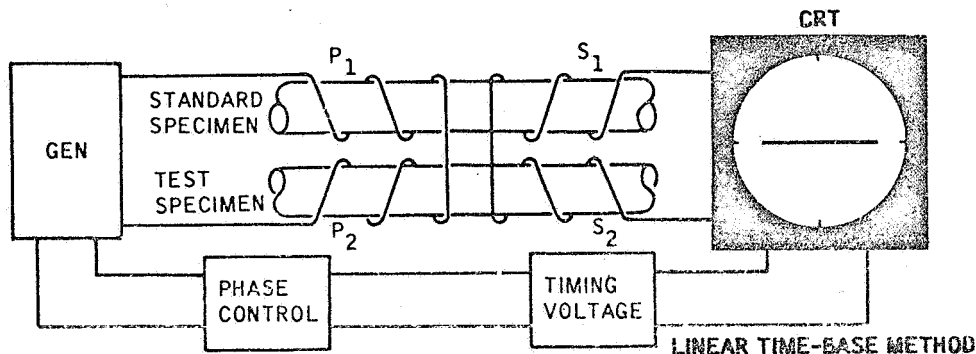

The above figure illustrates a typical linear time-base method using two sets of test coils. Notice that the secondary coils are connected together. Under this coil arrangement, the voltage developed by coil S_1 opposes the voltage developed by coil S_2 . This means that no output voltage will be developed across the secondary coils S_1 and S_2 when the test specimen has properties identical to the properties of the standard specimen. For this case, the CRT display will be a straight horizontal line which is the timing voltage. No voltage will be applied to the vertical plates.

In the above figure, if the properties of the test specimen are not the same as the properties of the standard specimen, will the CRT display be:

A straight horizontal line. Page 5-96

A waveform like the waveform of the generator voltage Page 5-97

You have missed a point when you say that the CRT display will be a straight horizontal line.

Recall that a straight horizontal line is obtained when no voltage is applied to the vertical plates of the CRT. This condition exists when the test specimen's properties are the same as the properties of the standard specimen. Under this condition, the voltage of secondary coil S_1 opposes and cancels the voltage of secondary coil S_2 .

In the case we were considering, the test specimen's properties were not the same as the properties of the test specimen. This means that the voltage from coil S_1 will not cancel the voltage from coil S_2 . The result will be an output voltage which is applied to the CRT's vertical plates. The display on the CRT will be a waveform which will be similar to the waveform from the generator. Note: The waveform may not be identical because the specimen's properties may change the waveform. This is particularly true if the specimen is magnetic.

Turn to page 5-97.

You have the idea. If the test specimen's properties are not the same as the properties of the standard specimen, then the CRT display will be a waveform rather than a straight line.

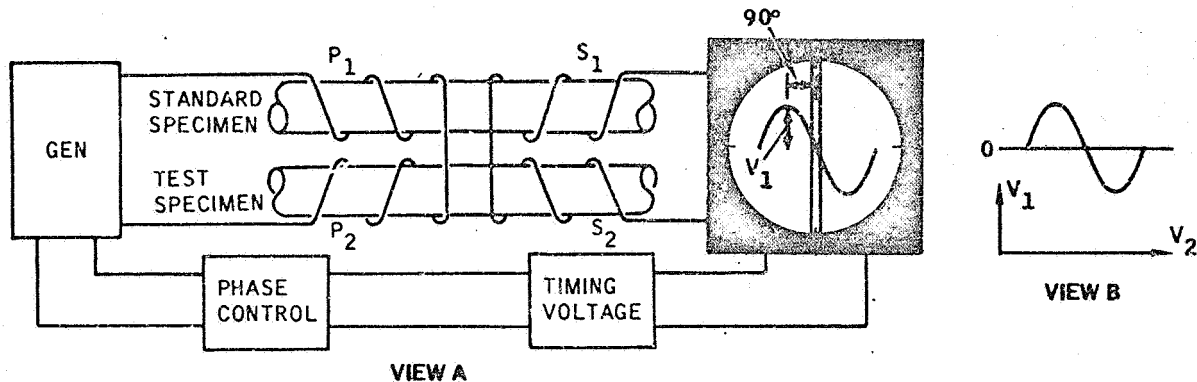

In view A, imagine that the test specimen has the same permeability and conductivity properties as the standard specimen. The only difference between the two specimens is a change in dimension. Under these conditions a waveform will appear on the CRT screen. The CRT display can be any of a number of different displays; however, by using the phase control the waveform is adjusted as shown in view A.

View B illustrates the voltage waveform applied to the CRT's vertical plates. You have learned that any point on this waveform can be shown to be two voltages (V_1 and V_2) which are 90 degrees apart. For any point on the waveform, V_1 and V_2 will have a particular set of values.

Now look at view A and notice that the maximum value of V_1 is 90 degrees from the slit and that the value of V_2 is zero at the slit. Would you say that V_1 in view A:

Represents the dimension variable in the test specimen Page 5-98

Represents the conductivity variable in the test specimen Page 5-99

That's right. The value V_1 in the CRT display represents the dimension variable. After all that is the variable that caused the waveform to appear on the CRT.

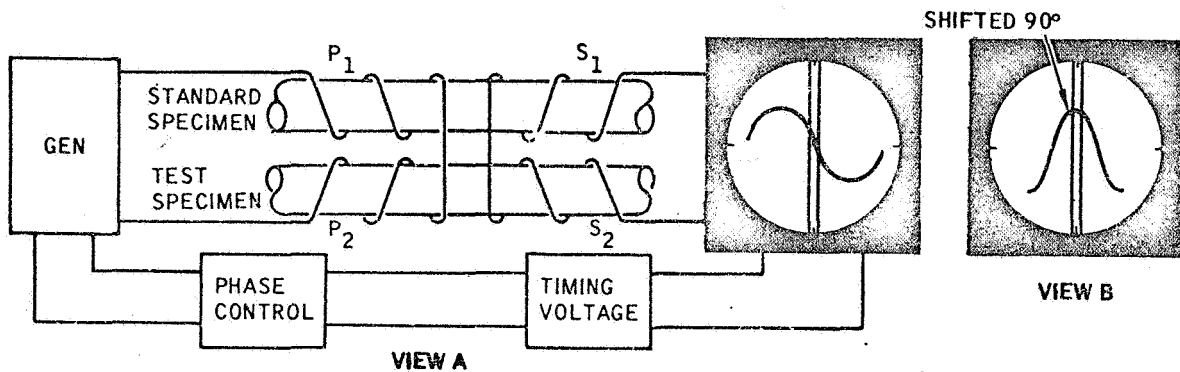

View A indicates the display we obtained when a dimension difference exists. Visualize that the test specimen is now removed and a test specimen is used in which the permeability and dimension variables are the same for both specimens; however, the conductivity of the test specimen is not the same as that of the standard specimen.

Under these conditions a new display will appear on the CRT screen. This is shown in view B. Now let's see what has happened. Since conductivity causes a change in phase that is 90 degrees out of phase with the permeability and dimension changes, the phase of the voltage applied to the CRT's vertical plates will be 90 degrees out of phase with the initial setting of the phase control. Recall that the original setting made a zero value at the slit (view A). Because a 90 degree phase change has occurred, a maximum value will appear at the slit as shown in view B.

The value at the slit in view B:

Represents the permeability and dimension variables Page 5-100

Represents the conductivity variable Page 5-101

Sorry, but you are wrong. The voltage value V_1 represents the dimension variable, not the conductivity variable.

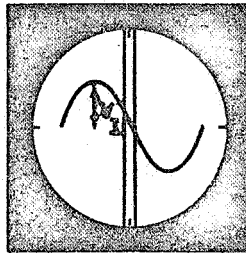

WAVEFORM REPRESENTS
DIMENSION VARIABLE.

The waveform on the CRT is the result obtained when the dimension property of the test specimen is not the same as that of the standard specimen. Recall that all other variables are identical for both specimens. Also recall that the display would be a straight line if all variables in the test specimen were the same as those in the standard specimen.

The fact that the dimension properties are not the same is the reason why a waveform appears on the CRT. When the phase control is operated so that the value at the slit is zero, the maximum value of the waveform is shown 90 degrees out of phase from the slit. The maximum value is the voltage value V_1 . Since the dimension variable caused the waveform to appear on the CRT, V_1 represents the dimension variable.

Turn to page 5-98.

Not that's not right. The value at the slit represents the conductivity variable, not the permeability and dimension variables.

Let's review the procedure. First a test specimen was used which had a dimension property that was not the same as the standard specimen. This gave us an output voltage from the secondary coils. When this voltage was applied to the CRT's vertical plates, we got a waveform. Using the phase control, the waveform was changed so that the maximum value of the waveform was 90 degrees out of phase with the slit.

Next we replaced the test specimen with one that had a conductivity property that was not the same as the standard. This means that the voltage applied to the CRT's vertical plates is 90 degrees out of phase with the original voltage applied to the vertical plates. Under this condition, the new waveform on the CRT will have a maximum value at the slit. Thus the value at the slit represents the conductivity variable.

Turn to page 5-101.

Correct. The value at the slit represents the conductivity variable.

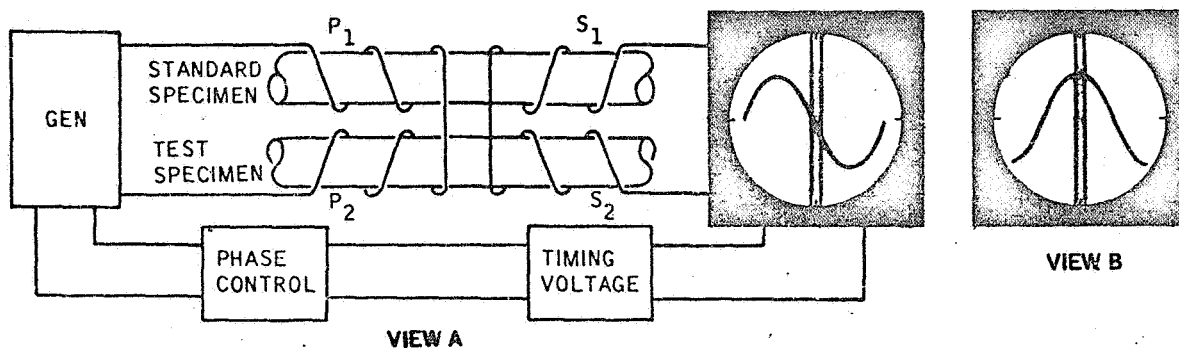

Now let's review the procedure. To indicate a change in conductivity at the CRT slit, a test specimen is selected with a dimension property that is not the same as the dimension property of the standard specimen. All other variables are the same for both specimens. Under these conditions, an output voltage will appear across the secondary coils S_1 and S_2 and this will cause a waveform to appear on the CRT screen. This waveform can be any of a number of different displays, depending upon the setting of the phase control.

Using the phase control, the waveform is adjusted so that a zero value appears at the slit. This means that the maximum value of the waveform is 90 degrees out of phase with the slit. To cause this maximum value to appear at the slit will now require a voltage that is 90 degrees out of phase with the voltage being applied to the CRT's vertical plates.

The test specimen is now removed from the test coil. If a test specimen with identical properties to the standard specimen is placed in the test coil, the CRT display will be a straight line. On the other hand if a specimen with a difference in conductivity is placed in the test coil, the waveform in view B will be obtained. This represents a 90 degree phase shift and the slit value is now indicating a change in conductivity.

Turn to page 5-102.

The linear time-base method has the ability to separate the conductivity variable from the permeability and dimension variables. Let's consider the case where both the conductivity and dimension of the test specimen are not the same as the standard specimen. In other words, two variables are changing and are affecting the CRT display.

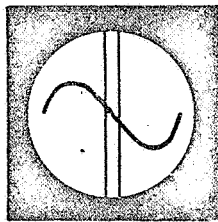

VIEW A

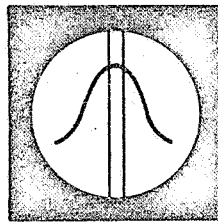

VIEW B

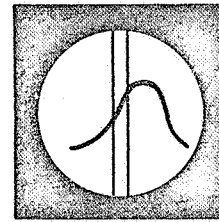

VIEW C

View A shows the display caused by the dimension variable. We will assume that the permeability is the same for both specimens. Note that the slit value is zero. View B illustrates the condition that is obtained when only the conductivity variable is present. Recall that the phase control is adjusted to obtain the display shown in view A. Under these conditions, view A will be obtained if only the dimension variable is present (not the same as the standard specimen) and view B will be obtained if only the conductivity variable is present.

View C illustrated a typical display that is obtained when both the conductivity and dimension variables are present. As you can see, the display is very nearly the same as view B. What's important to us is the value at the slit. Does it represent the conductivity variable or the dimension variable? The answer is that the slit value indicates the conductivity variable. Because the phase control was initially set as shown in view A to obtain a zero value at the slit for changes in dimension, we get only conductivity changes at the slit.

Based on what you have just learned, you can now say that the linear time-base method:

Can separate the dimension variable from the permeability variable Page 5-103

Can separate the conductivity variable from the dimension variable Page 5-104

Not right! You said that the linear time-base method can separate the dimension variable from the permeability variable. This is not true. Recall that the dimension variable and the permeability variable produce phase changes in the same direction. Since the linear time-base method is a phase-sensitive method, it is not possible to separate two variables that produce phase changes in the same direction.

On the other hand, the linear time-base method can separate the conductivity variable from the dimension variable (or from the permeability variable). This can be done because the conductivity variable produces a phase change that is 90 degrees out of phase with the phase change produced by the dimension and permeability variables.

Turn to page 5-104.

Fine! You have the idea. The linear time-base method can separate the conductivity variable from the dimension variable because the linear time-base method is a phase-sensitive method.

It's important to keep in mind that the display on the CRT screen will be a straight horizontal line when the properties of the test specimen are the same as the properties of the standard. It's also necessary to realize that when the properties of the two specimens are not the same, the CRT display may be any of a number of displays, depending upon the nature of the variation. For example, the value at the slit may be a maximum value or a minimum value. It all depends upon the property in the test specimen that is not the same as the similar property in the standard specimen.

The following figure illustrates the use of the linear time-base method of phase analysis. If the properties of the test specimen are not the same as the properties of the standard specimen, the resulting indication on the CRT screen will be as illustrated in:

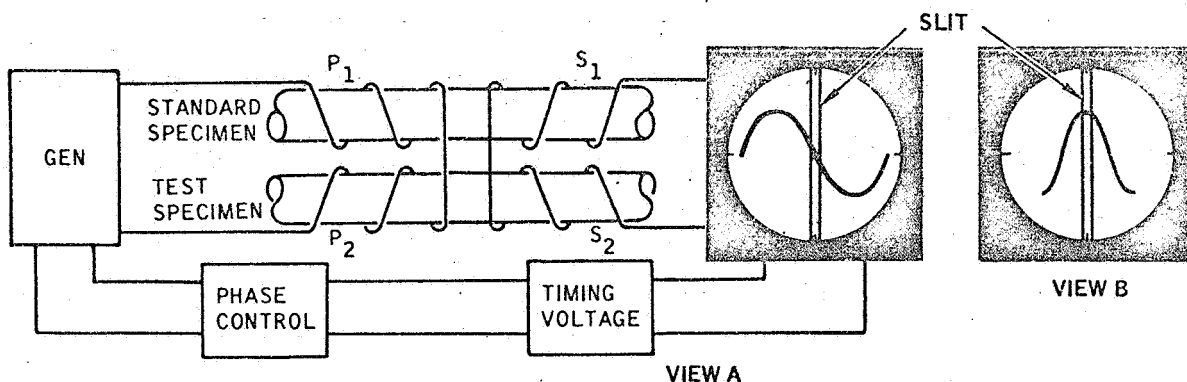

Either view A or View B Page 5-105

View A Page 5-106

View B Page 5-107

Excellent! You got the idea and it's an important one too. As an operator, you will be looking at the CRT display. Your task will be to interpret the display. It's important to realize that this display will change as changes take place in the test specimens passing through the test coil. You have just seen that the display may be centered with a minimum value at the slit or a maximum value at the slit. It can also be some value in between these two values.

A change in the CRT display can be changed by either the specimen or by the phase control. Either one will change the display. Once the phase control is initially set, changes are normally caused by the specimen. Such specimen changes produce a phase change which is applied to the CRT's vertical plates. The result is a phase change in the CRT display.

Views A and B illustrate two possible displays on the CRT screen, using the linear time-base method of phase analysis. The display can be changed from view A to view B by:

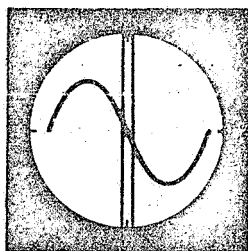

VIEW A

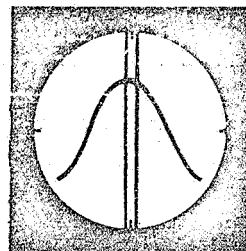

VIEW B

Changing the phase control on the CRT equipment Page 5-108

Changing the phase of the voltage applied to the CRT's vertical plates Page 5-109

By changing either the phase control on the CRT equipment or the phase of the voltage applied to the CRT's vertical plates Page 5-110

You have missed a concept. Your selection of view A means that you have failed to realize that the resulting indication on the CRT screen can be any waveform. You should have said that the indication could be either view A or view B.

When the properties of the two specimens are not the same, a waveform will be displayed on the CRT screen. This waveform may be positioned so that the value at the slit is a minimum value (view A) or a maximum value (view B). The specific display depends upon the specific property. For example, view A might mean that the dimensional variable is present and the test specimen's dimension is not the same as that of the standard specimen. And view B could represent the fact that the conductivity of the two specimens is not the same.

The important fact to keep in mind is that the waveform can be as shown in view A or view B or even some other display. It all depends upon which variable is present and where the phase control has been positioned. Turn to page 5-105.

You have missed a concept. Your selection of view B means that you have failed to realize that the resulting indication on the CRT screen can be any waveform. You should have said that the indication could be either view A or view B.

When the properties of the two specimens are not the same, a waveform will be displayed on the CRT screen. This waveform may be positioned so that the value at the slit is a minimum value (view A) or a maximum value (view B). The specific display depends upon the specific property. For example, view A might mean that the dimensional variable is present and the test specimen's dimension is not the same as that of the standard specimen. And view B could represent the fact that the conductivity of the two specimens is not the same.

The important fact to keep in mind is that the waveform can be as shown in view A or view B or even some other display. It all depends upon which variable is present and where the phase control has been positioned.

Turn to page 5-105.

You did not select the best answer. You are correct when you say that the display can be changed by repositioning the phase control on the CRT equipment; however, you should also realize that the display can be changed by the phase of the voltage applied to the CRT's vertical plates. This phase change is being caused by the specimen. Thus there are two ways to produce a change in CRT display. That's why you should have selected the answer which said that the display change can be accomplished by changing either the phase control on the CRT equipment or the phase of the voltage applied to the CRT's vertical plates.

Turn to page 5-110.

You did not select the best answer. You are correct when you say that the display can be changed by changing the phase of the voltage applied to the CRT's vertical plates; however, you should also realize that the display can be changed by the phase control on the CRT equipment. That's why you should have selected the answer which said that the display change can be accomplished by changing either the phase control on the CRT equipment or the phase of the voltage applied to the CRT's vertical plates. Of course, the specimen causes the phase change applied to the CRT's vertical plates.

Turn to page 5-110.

You are correct! The display on the CRT can be changed by changing either the phase control on the CRT equipment or the phase of the voltage applied to the CRT's vertical plates.

Earlier you learned that the conductivity variable produces a phase change that is 90 degrees out of phase with the phase change produced by the dimension and permeability variables. Now let's see if you can apply this fact.

In the following figure, imagine that a test specimen with a dimension property that is not the same as the standard specimen is placed in the test coil. Through the operation of the phase control, the display is adjusted to provide the indication in view A. If the test specimen is now replaced by one that has permeability and conductivity properties that differ from those of the standard specimen, the value at the slit:

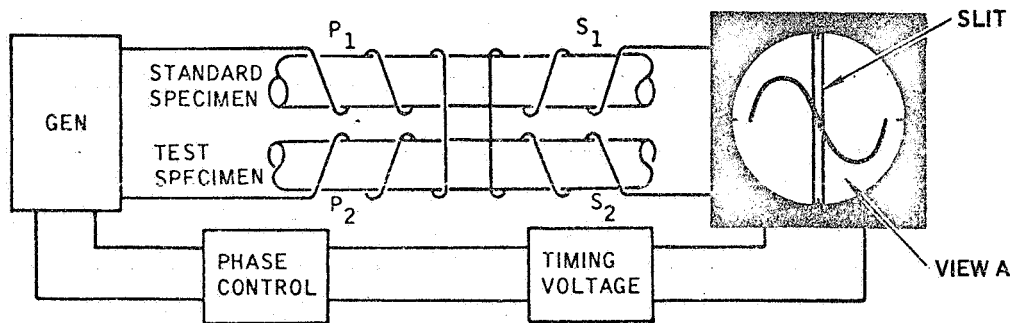

- Will represent the permeability variable Page 5-111
- Will represent the conductivity variable Page 5-112
- Will represent both the permeability and conductivity variables Page 5-113

Incorrect! You said that the value at the slit will represent the permeability variable. You should have said that the value at the slit will represent the conductivity variable.

Recall that the dimension and the permeability variables produce phase changes in the same direction and that we used the dimension variable to obtain our initial display.

This display, through the phase control, was positioned so that the maximum value of the waveform was 90 degrees from the slit value. This means that any dimension or permeability change will not appear at the slit. If now a test specimen with permeability and conductivity properties that differ from those of the standard specimen is used in the test coil, the permeability change will not appear at the slit. Only the conductivity variable will appear at the slit, even though both variables are present.

Turn to page 5-112.

Certainly true! Even though we have a test specimen with two variables (conductivity and permeability) only the conductivity variable will appear at the slit. This ability to separate two variables is one of the advantages of phase analysis.

You should also realize that a similar condition exists when the test specimen has dimension and conductivity variables that are not the same as the standard specimen. Again, only the conductivity variable will appear at the slit.

In this chapter, we have been emphasizing the linear time-base method of phase analysis. The linear time-base method can separate the dimension variable from the permeability variable:

- True Page 5-114
- False Page 5-115

Incorrect! You said that the value at the slit will represent both the permeability and the conductivity variable. You should have said that the value at the slit will represent the conductivity variable.

Recall that the dimension and permeability variables produce phase changes in the same direction and that we used the dimension variable to obtain our initial display. This display, through the phase control, was positioned so that the maximum value of the waveform was 90 degrees from the slit value. This means that any dimension or permeability change will not appear at the slit. Only the conductivity variable will appear at the slit. If now a test specimen with permeability and conductivity properties that differ from those of the standard specimen is used in the test coil, the permeability change will not appear at the slit. Only the conductivity variable will appear at the slit, even though both variables are present.

Turn to page 5-112.

Stop! Perhaps you read the question too quickly. The question was "The linear time-base method can separate the dimension variable from the permeability variable." You said that this statement was true. You should have recognized that this statement is false.

The dimension and permeability variables produce phase changes in the same direction. This means that it is not possible to separate these two variables by using the phase analysis techniques of the linear time-base method. It is possible to separate the conductivity variable from the other two variables, but it is not possible to separate the dimension variable from the permeability variable by the linear time-base method. Normally, separation is accomplished by using direct current saturation to make the permeability variable a constant.

Turn to page 5-115.

Fine! You recognized that the linear time-base method cannot separate the dimension variable from the permeability variable. It takes direct current saturation to accomplish separation of these two variables. Now let's review our facts. Recall that we started with three methods:

1. Impedance testing
2. Phase analysis
3. Modulations analysis

You learned that the impedance testing method was based on the fact that the test coil's impedance would vary as the specimen's properties varied. As the impedance varied, the current flowing through the test coil would vary. This gave us a basis for getting an indication. Unfortunately, this method could not separate the three variables conductivity, permeability, and dimension. All we get is a gross change in impedance.

You then learned that the current through a coil was out of phase with the voltage across the coil. This fact provided a basis for using a method based on phase changes. The phase changes were based on characteristics of the coil. You saw that the voltage across a coil was based on two voltages within the coil that were 90 degrees out of phase. Next you picked up the idea that each of the three variables produced a phase change; however, two of these variables (permeability and dimension) produced phase changes in the same direction. The remaining variable (conductivity) produced a phase change that was 90 degrees out of phase with the other two variables.

Based on these facts, we covered the linear time-base method. This is a phase-sensitive method. The process of interpreting the CRT display can be called one form of phase analysis. The other forms will be covered in volume II of this handbook.

Using the linear time-base method, we finally learned that it is possible to separate the conductivity variable from the permeability and dimension variables. It is not possible to separate the permeability variable from the dimension variable because these two variables produce phase changes in the same direction.

Now let's look at modulation analysis. Turn to page 5-116.

Modulation is the process of applying a variable effect to something that is constant.

We can use your automobile as an example. Imagine that you are riding along in your automobile which is moving over a road with a constant surface. You, of course, feel a certain amount of vibration which is caused by the automobile and by the road's surface. This vibration is your constant and you are the indicating device.

Next imagine that your right front tire picks up a large stone. What happens? You get a change in the vibration and this happens each time the tire rotates. One can say that the tire with the stone is the modulating factor or device. If you like, we can call this "stone modulation."

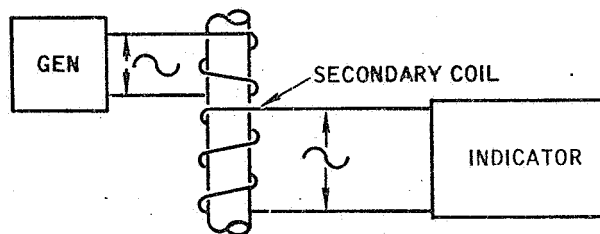

In the above view, a generator is providing an alternating voltage to a test coil.

Through a secondary coil, this voltage is being applied to an indicating device. Now imagine that the specimen passing through the test coil is a long rod which has a conductivity variation that occurs at regular intervals along the rod. Would you say that the conductivity effect is modulating the voltage supplied by the secondary coil:

No Page 5-117

Yes Page 5-118

Wrong. You said "no." You should have said "Yes" to the question "Would you say that the conductivity effect is modulating the voltage supplied by the secondary coil."

The secondary coil contains the constant effect produced by the generator. The coil also contains the effects produced by the specimen. The specimen is modulating the secondary coil's voltage. In our example, the modulating factor was conductivity which was periodically changing and causing a change in the secondary coil's output voltage. That's why we can say that the conductivity effect is modulating the secondary coil's voltage. Recall that modulation is the process of applying a variable effect to something that is constant.

Turn to page 5-118.

Good! You have the feel for modulation. A periodic change in conductivity is modulating the secondary coil output voltage.

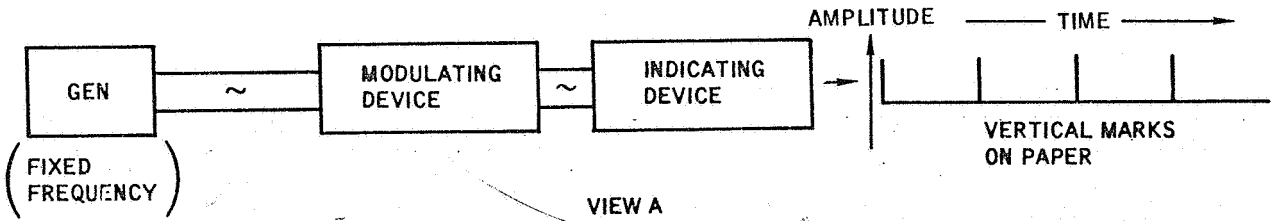

View A illustrates a typical arrangement for modulation analysis. A generator supplies an alternating voltage with a fixed frequency to a modulating device. For our case, this device is a test coil with a long rod passing through the coil. The output indicating device is a strip of paper moving at a steady rate and a pen that provides a means of marking indications on the paper. Circuits related to the indicating device are arranged so that only the modulations from the standard output of the secondary coil are shown in the paper. These modulations are also treated so that only vertical marks in one direction are used. Thus we get a series of vertical lines moving from a baseline as shown in view A.

In view A, each vertical mark represents something about the specimen that is causing a variation. For example, the marks in view A could represent periodic changes in conductivity. Note that these marks are evenly spaced. One can say that the distance between two adjacent marks represents one cycle. Frequency is defined as the number of times something happens in one second. The marks in our example thus represent a frequency. If four marks appear in one second, we can say the frequency of the modulation is four cycles per second.

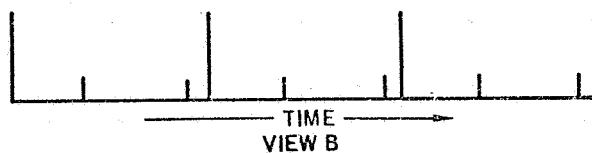

View B illustrates a typical display. Note that two factors are causing modulations.

Would you say that the indication shows:

Two frequenciesPage 5-119

One frequencyPage 5-120

No problem! You're right. Two frequencies are shown in the display. If we assume a time interval of one second, we can say that one frequency is four cycles per second while the other frequency is six cycles per second.

A number of factors related to the coil and the specimen can modulate the test frequency applied to the test coil. These are listed as follows:

1. Chemical composition.
2. Changes in coupling between the specimen and the coil (fill-factor).
(Vibrations as the specimen passes through the test coil).
3. Dimension changes of the specimen.
4. Discontinuities (flaws, porosity, inclusions, etc.).
5. Internal and applied stresses.
6. Heat treatment condition (phase, grain size, distribution of impurity atoms, etc.).
7. Crystal orientation.
8. Lattice dislocations (such as those due to heavy working).
9. Temperature.
10. Noise pick-up (electrical interference).

It is not necessary for you to remember these factors; however, it is important to realize that many of these factors can occur periodically (at regular intervals).

Based on these facts, do you think the display on the paper would be:

One frequency Page 5-121

A group of frequencies Page 5-122

Your answer is not correct. Look at the following view again.

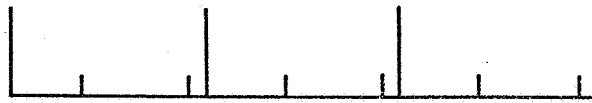

You said that this indication shows only one frequency. Actually two frequencies are shown. One frequency is the four vertical marks. This is a frequency of four cycles per second (we will assume the distance in the view represents one second). Now note that you also have six other marks that are equally spaced. This shows that we have a frequency of six cycles per second. Thus there are two frequencies present in the indication. Got it! Good! Turn to page 5-119.

Let's look at the concept again. You don't quite have the idea. Apparently you feel that the display on the paper would be one frequency.

The main problem in eddy current testing is that we have too many factors affecting the test coil. You saw that we had three basic variables: conductivity, permeability, dimension changes. Then you learned that we actually have a group of individual factors which can influence the coil.

When the modulation analysis method is used, many of these factors can appear separately in the set of indications appearing on the paper. This means that we get a group of frequencies, not just one frequency.

Let's see how we can separate these factors. Turn to page 5-122.

You're right. We get a group of frequencies. For example, the display might look like this.

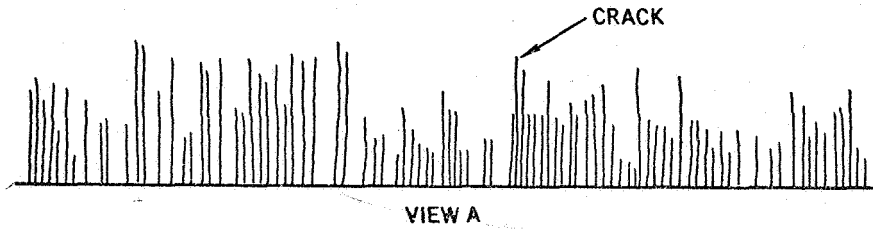

The main problem in eddy current testing lies in the fact that too many factors affect the test coil. Modulation analysis offers a solution to this problem by the use of electronic filters.

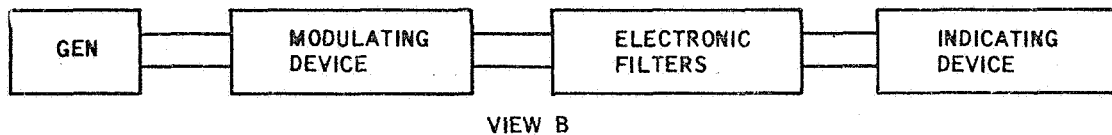

View B shows electronic filters which provide a means of removing certain frequencies or bands of frequencies from the indicating device. Using these filters, it is possible to obtain an indication as shown in view C.

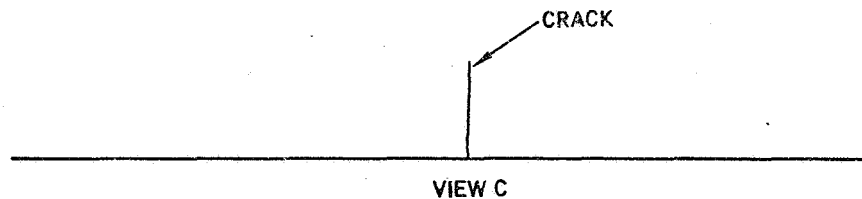

Modulation analysis provides the means of removing unwanted variables from the output display. It thus becomes possible to separate the desired variable from the unwanted effects which are producing variations. An electronic filter will pass only certain frequencies through the filter. Thus, by using the proper filter, one can suppress all frequencies except those in a narrow band of frequencies. Using this technique, the display can then show only very low frequencies, low and very low frequencies, intermediate frequencies, or very high frequencies. Turn to page 5-123 to see an example of how filters have been used to isolate a defect.

Turn to page 5-123.

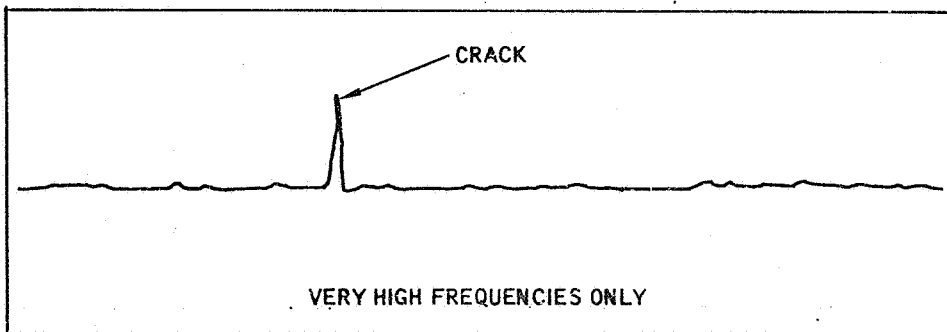
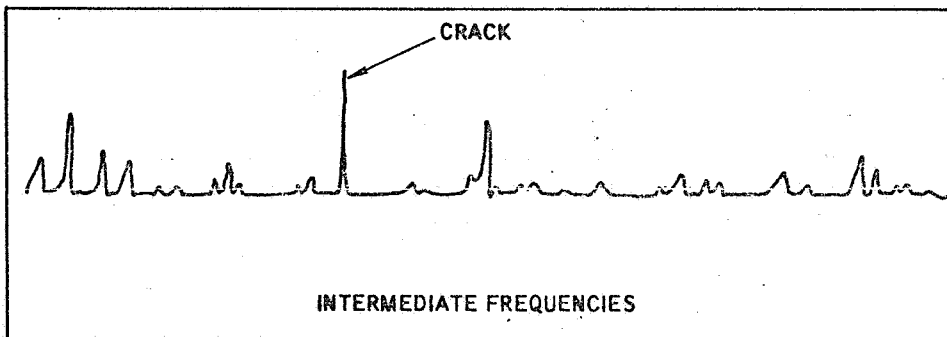
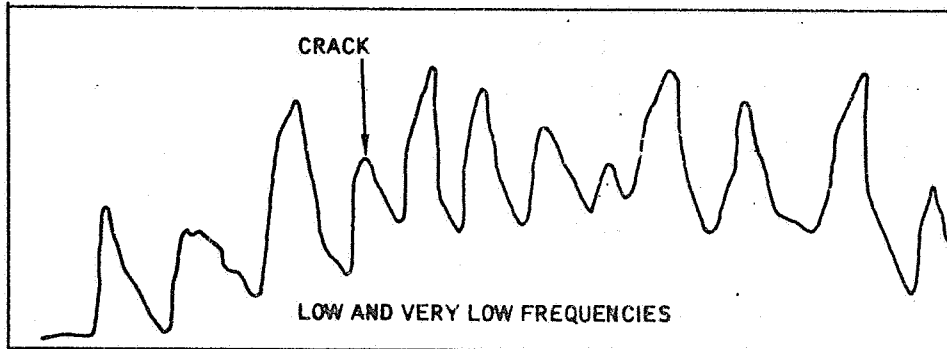
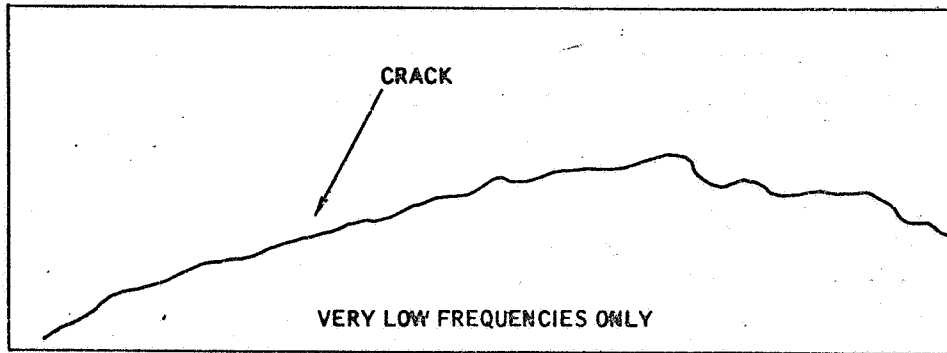

In the last view, only very high frequencies are being displayed. Note that these have very little height; thus, the line is almost horizontal. Under these conditions, the appearance of a crack can be clearly seen.

Turn to page 5-124.

You have just seen how the output changes when different electronic filters are used in the modulation analysis method. In the first view, only very low frequencies were being displayed. This meant that a crack could not be detected. The gradual change you see in the first view might represent a variation in the specimen as a result of a change in heat treatment.

In the next view, a number of effects are seen and one of these is the crack. The presence of the other factors makes it impossible to detect the crack. In the last view, all low and intermediate frequencies are filtered out and only high frequencies are being displayed. Under this condition, the crack can be detected.

In the modulation analysis method, the specimen is moving through the coil at a constant rate. A speed between 40 and 300 feet per minute is normally used. For a given test, the speed must be constant.

Imagine that you are testing a specimen for cracks by using the modulation analysis method. A slight wobble exists as the specimen passes through the test coil and this is causing an output indication. Do you think that this wobble effect can be eliminated from the output indication by the use of the proper electronic filter:

No Page 5-125

Yes Page 5-126

Sorry but you are wrong. You should have recognized that it is possible to eliminate the wobble effect from the output indication by the use of an electronic filter.

Keep in mind that the modulation analysis method has the capability of eliminating unwanted effects from the output indication and this is done through filters.

The wobble effect in our example is modulating the coil's output voltage. Normally, this is a constant effect which varies above and below a center value. The output indication will show this effect and will tend to make it impossible to see other effects (for example, a crack). That's why a filter is used to eliminate the unwanted effect.

Turn to page 5-126.

Of course you're right. That's the advantage of the modulation analysis method. By the use of filters, you can eliminate unwanted effects in the output indication.

This chapter has covered three basic methods or approaches to the task of performing eddy current testing. These are:

1. Impedance testing
2. Phase analysis (linear time-base method)
3. Modulation analysis

You learned that impedance testing is based on the fact that the current through a coil will change if the coil's impedance changes and, of course, the specimen will change the coil's impedance. Impedance was defined as the coil's opposition to a flow of electrical current.

Next, we looked at phase analysis. In this method, you saw that the coil's properties caused the current through the coil to be out of phase with the voltage applied across the coil. You also learned that the voltage across a secondary coil will be out of phase with the current induced into the secondary coil by the primary coil and by the specimen. The phase changes as the specimen's properties change.

And finally, we examined the modulation analysis method. In this case, the coil's fundamental frequency is being modulated by a number of effects. This means that the output voltage is a family of frequencies. By the use of filters, we can separate the variable we are interested in and eliminate the unwanted effects.

Turn to page 5-127.

The purpose of this chapter has been to establish the basic electrical concepts related to eddy current testing. These concepts were presented in terms of three test methods and only to the depth needed to understand the methods.

Before you close the cover on this volume, three facts must be reviewed. These are directly related to the test methods. The three facts were covered in chapter two and are summarized as follows:

1. Depth of eddy current penetration
2. Effect of frequency on eddy current penetration
3. Effect of conductivity on eddy current penetration

When eddy currents are induced into a specimen, the amount (density) of eddy current varies with the distance from the surface. The maximum value lies near the surface and this value decreases with distance from the surface. Thus at a certain distance from the specimen's surface, the amount of eddy current present in the specimen will be less than at the specimen's surface. The depth of penetration is defined as the distance from the specimen's surface where the amount of eddy current is only 37 per cent of the value at the surface. It is not necessary to remember the value 37 per cent. It is only necessary to realize that the density of the eddy current decreases with the distance from the surface.

The depth of eddy current penetration can be changed by the test frequency or by the conductivity of the specimen. As you learned in chapter two, the depth of penetration decreases:

If the test frequency is decreased Page 5-128

If the test frequency is increased Page 5-129

You have forgotten an important point when you said that the depth of eddy current penetration decreases if the test frequency is decreased. Just the opposite is true.

High frequencies cause eddy currents to stay near the specimen's surface. Thus the depth of eddy current penetration decreases if the test frequency is increased.

Since many pieces of eddy current test equipment have means of changing the test frequency, it's important to know how a change in frequency affects the depth of penetration. If you are looking for cracks near the specimen's surface, you use a high frequency. This puts most of the eddy current near the surface. On the other hand, if you are looking for cracks deep within the specimen then you use a low frequency. This increases the depth of penetration and puts more eddy current deep within the specimen.

So remember! THE DEPTH OF EDDY CURRENT PENETRATION DECREASES AS YOU INCREASE THE TEST FREQUENCY.

Turn to page 5-129.

Good! You have not forgotten an important point. The depth of eddy current penetration varies with the test frequency. High frequencies cause the eddy currents to stay near the specimen's surface. Low frequencies make the eddy currents penetrate deeper into the surface. Or we can summarize the fact by saying THE DEPTH OF EDDY CURRENT PENETRATION DECREASES AS YOU INCREASE THE FREQUENCY.

Now, what about the specimen's conductivity. Can we use the rule THE DEPTH OF EDDY CURRENT PENETRATION DECREASES AS THE CONDUCTIVITY INCREASES:

No Page 5-130

Yes Page 5-131

Stop! You failed to recall an important idea. You said the following rule was not true.

THE DEPTH OF EDDY CURRENT PENETRATION DECREASES AS THE
CONDUCTIVITY INCREASES.

The rule is true.

Conductivity affects the depth of penetration. Let's see why the rule is true. Eddy currents depend on the conductivity of the specimen. As the conductivity increases, more eddy currents can be induced into the specimen. Recall that conductivity is the specimen's willingness to conduct electrical currents.

Now realize that as more currents flow within the specimen, stronger magnetic fields are generated by the eddy currents. These oppose the test coil's magnetic field and thus make the test coil's magnetic field less effective on the specimen. Or to put it another way, as conductivity increases, the coil's magnetic field becomes weaker. That means the depth of eddy current penetration decreases as the specimen's conductivity increases. Do you think you can remember the rule now? Fine! Turn to page 5-131.

Right! The rule is true. The depth of eddy current penetration decreases as the conductivity increases. This means that if you are using a specific test frequency and you switch from a rod with a low conductivity to a rod with a high conductivity, you will need to change the test frequency. If you don't, then you will not be inspecting to the same depth in both rods.

As you perform eddy current testing, you must constantly keep in mind the idea of how deep you are penetrating into the specimen. Depth of penetration varies with the frequency and the conductivity. The rule is:

THE DEPTH OF PENETRATION DECREASES:

1. If you increase the frequency
- or
2. If you increase the conductivity

Turn to page 5-132.

From page 5-131

1. In this chapter, we have covered three basic methods or approaches to eddy current testing. These three methods are _____ testing, phase analysis, and modulation analysis.



10. inductive reactance

11. Impedance is a combination of the coil's resistance (R_L) and the coil's inductive reactance (X_L). It can be shown that separate voltages are developed across the inductive reactance (X_L) and the coil's resistance (R_L). These two voltages are _____ with each other.



20. period

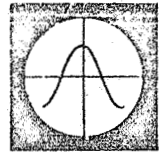
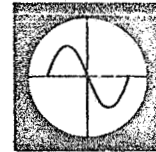
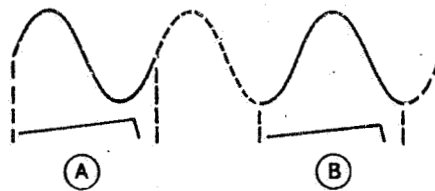

21. As shown above, any portion of a series of identical cycles can be selected for display on the CRT. In the linear time-base method, the control used to make this selection is called a _____ control.



30. slit

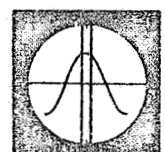
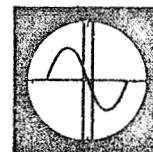
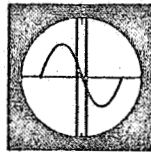

31. View A represents a dimension variable. If the test specimen is replaced by one with a conductivity variable, the display shown in view _____ will be obtained.



1. impedance

2. Eddy current testing is based on the properties of the test coil. The coil's opposition to the flow of an alternating electrical current is called i.



11. out of phase

12. And you learned that these two voltages are 90 degrees out of phase.



21. phase

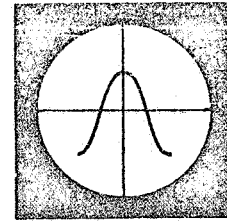
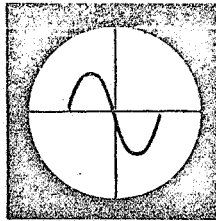

22. By using a phase control related to the timing voltage applied to the horizontal plates, any portion of one complete cycle can be selected for display. The important fact to remember is that the display still represents one complete c of the voltage applied to the vertical plates.



31. C

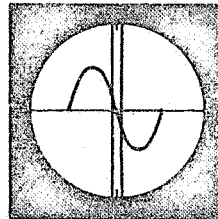

32. The above view represents the display for a dimension variable. If a test specimen with both conductivity and dimension properties that are not the same as the standard specimen is used, the slit value will display only the _____ variable.



2. impedance

3. A test coil has a magnetic field and a specimen placed in the coil will affect this field. Through this field, the specimen affects the coil's i.

12. no response is required

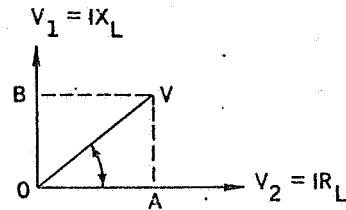

13. The above view shows the two voltages in the coil. $V_1 = IX_L$ and $V_2 = IR_L$. The voltage V represents the addition of these two voltages. This voltage V will lead the current (I) through the coil by some _____ angle which is represented by the angle AOV .

22. cycle

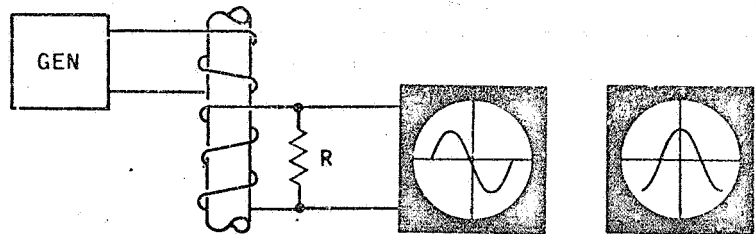

23. The shape of the waveform shown on the CRT can be changed by the specimen. This is based on the fact that the specimen causes p changes. Thus we can expect the waveform shape to change as the specimen's properties change.

32. conductivity

33. The linear time-base method is one form of phase analysis and can separate the _____ variable from the _____ and _____ variable.

3. impedance

4. As a specimen's properties change, the coil's impedance changes. This, in turn, changes the flow of current through the coil. Testing based on measuring or sensing this current change is called _____.

13. phase

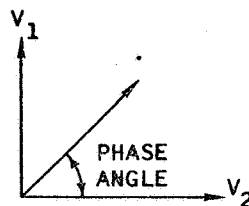

14. The phase angle in the above view represents the angle by which the current (I) through the coil lags the voltage (V) across the coil or the angle by which the voltage (V) across the coil _____ the current (I) flowing through the coil.

23. phase

24. The linear time-base method is based on the fact that the specimen causes _____.

33. conductivity,
permeability,
dimension

34. The linear time-base method can not separate the _____ variable from the _____ variable.

4. impedance testing

5. The main problem in eddy current testing is to separate the variables: conductivity, permeability, and dimension changes. The method called _____ can not separate these three variables.

14. leads

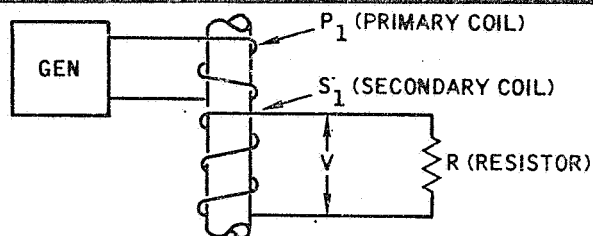

15. In the above view, the primary coil (P_1) and the specimen induce a current (I) into the secondary coil (S_1). This current will generate an output voltage (V) across the secondary coil. This voltage (V) will _____ the current (I) flowing through the coil.

24. phase changes

25. The phase changes caused by the specimen can be shown to have two directions. Of the three variables conductivity, permeability, and dimension it can be shown that the permeability and _____ variables produce changes in the same direction.

34. permeability, dimension

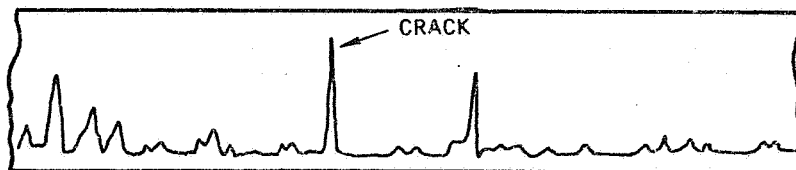

35. The above view represents a display of indications over a period of time. Certain indications occur over and over again and thus represent a frequency. Since several frequencies are present, we can say that several v _____ are appearing in the output display.

5. impedance testing

6. Since impedance testing can not separate the three variables, another method is needed. For help, we can turn to the fact that the current flowing through a coil is _____ with the voltage applied to the coil.

15. lead

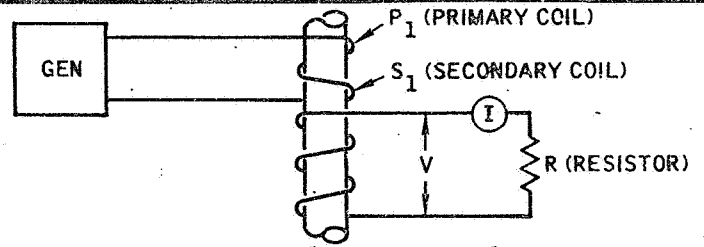

16. The specimen's properties affect the phase of the voltage (V) in the above view. If the specimen's properties change, you can expect that the phase angle will _____.

25. dimension

26. It can also be shown that the conductivity variable is _____ degrees out of phase with the other two variables.

35. variables

36. A testing system which uses electronic filters to remove frequencies that represent unwanted variables is called _____.

6. out of phase

7. It can be shown that the current through a coil lags the voltage across the coil. This current lag is caused by something in the coil called the coil's i _____.

16. change

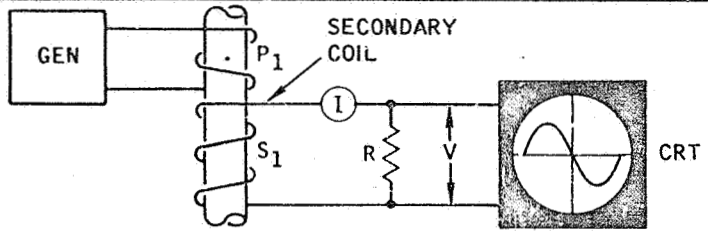

17. A cathode ray tube (CRT), which has both horizontal and vertical plates, can be used to display the output voltage (V) from the secondary coil. The voltage (V) is applied to the CRT's _____ plates.

26. 90

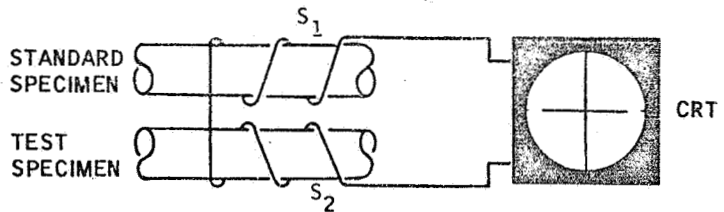

27. Secondary coils S_1 and S_2 are connected so that the output of S_1 opposes the output of S_2 . If both specimens have the same properties, no voltage will be applied to the CRT's vertical plates. That means the CRT display will be a s _____ l _____ which represents the timing voltage.

36. modulation analysis

37. The depth of eddy current penetration varies with f _____ and c _____.

7. inductance

8. Inductance is a property that causes the current through the coil to _____ the voltage applied across the coil.

17. vertical

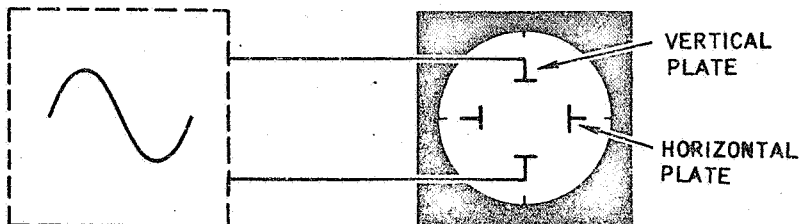

18. The secondary coil's output voltage is a voltage value that alternates above and below a center value over a period of time. One complete alternation is called a c _____.

27. straight line

STANDARD
SPECIMEN

TEST
SPECIMEN

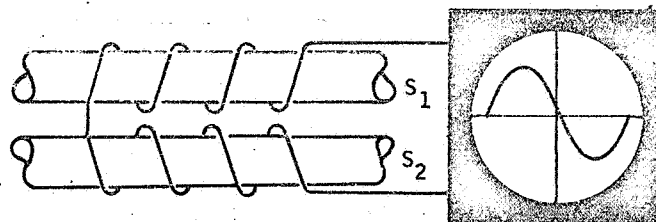

28. On the other hand, if we get a display as shown above, this means that the specimen properties are not the s _____.

37. frequency,
conductivity

38. The depth of eddy current penetration varies with frequency and will increase or decrease as the frequency is changed. If the frequency is increased, the depth will _____.

8. lag

9. A coil's inductance is related to the magnetic field established by the coil. When we say that a specimen affects a coil's impedance, we realize that this is being done through the coil's _____.

18. cycle

19. The time required to complete one cycle is called the p_____.

28. same

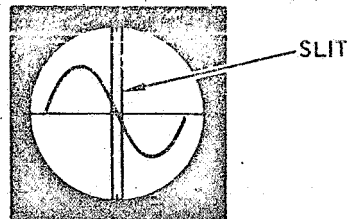

29. If a test specimen with a dimension that is not the same as the standard specimen dimension is used, a CRT display will be obtained. This can be positioned as shown above by the use of the CRT's p_____ c_____.

38. decrease

39. The depth of eddy current penetration also varies with conductivity, and will increase or decrease as specimens with different conductivities are used in the test coil. If the conductivity increases, the depth will _____.

9. inductance

10. A coil can be shown to consist of two electrical values which combine to form the coil's impedance. One value is the coil's resistance (R_L); the other value is a combination of the coil's inductance and the frequency applied to the coil. This value is called the i _____ r _____ (X_L).

Return to page 5-132, frame 11, and continue with the review.

19. period

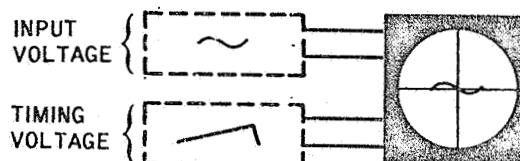

20. To see one cycle of voltage (V) on the CRT's vertical plates, the voltage value must be moved steadily across the CRT's screen. This is done by applying a timing voltage to the horizontal plates. To see one cycle, the timing voltage must have the same p _____ as that of the voltage applied to the vertical plates.

Return to page 5-132, frame 21, and continue with the review.

29. phase control

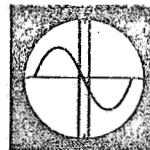

30. The above view represents a dimension variable. The maximum value of this variable is shown to be 90 degrees out of phase with the CRT's s _____.

Return to page 5-132, frame 31, and continue with the review.

39. decrease

40. This completes your review of this chapter. Turn to page 5-142.

You have just completed the first volume of the programmed instruction course on eddy current.

Now you may want to evaluate your knowledge of the material presented in this handbook. A set of self-test questions are included at the back of the book. The answers can be found at the end of the test.

We want to emphasize that the test is for your own evaluation of your knowledge of the subject. If you elect to take the test, be honest with yourself - don't refer to the answers until you have finished. Then you will have a meaningful measure of your knowledge.

Since it is a self evaluation, there is no grade - no passing score. If you find that you have trouble in some part of the test, it is up to you to review the material until you are satisfied that you know it.

Rotate the book 180° and flip to page T-1 at the back of the book.

EDDY CURRENT TESTING - VOLUME I

Self Test

HOW TO USE THIS SELF TEST

Use this self test as follows: (1) read the question, (2) read all possible answers, and (3) circle the letter preceding the answer you feel is the best answer for the question.

1. An alternating current (ac) applied to a coil generates an alternating magnetic field around the coil. If a conductor with an external circuit (view A) is placed in the field, a current will flow within the conductor. If the external circuit is removed (view B)

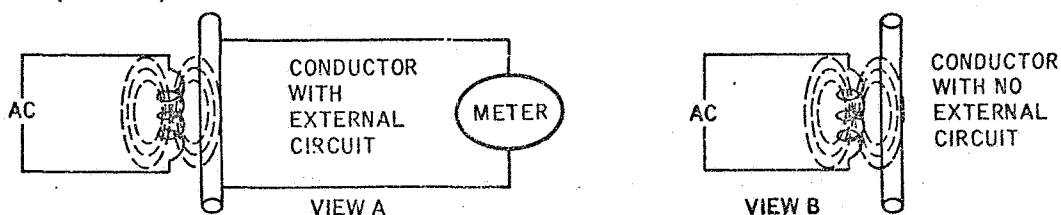

- a) alternating current will not flow within the conductor.
 b) alternating current will still flow within the conductor.
2. Eddy currents generate a magnetic field
 a) True b) False
3. Conductivity can be defined as:
 a) The willingness of a material to conduct an electrical current.
 b) The unwillingness of a material to conduct an electrical current.
4. An eddy current can be defined as a circulating alternating current induced into an isolated conductor by an alternating magnetic field.
 a) True b) False
5. Eddy currents generate a magnetic field that
 a) opposes the coil's magnetic field.
 b) aids the coil's magnetic field.
6. The flow of electrical current through a test coil
 a) is affected by the magnetic field around the coil.
 b) is not affected by the magnetic field around the coil.

7. In the following view, a test coil induces eddy currents into a test specimen. The presence of eddy currents in the specimen

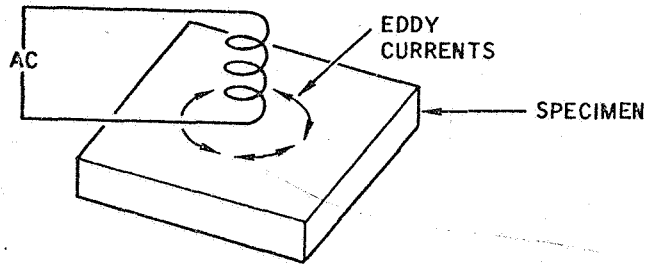

- a) will not affect the current flowing through the test coil.
 b) will affect the current flowing through the test coil.
8. Eddy currents exist
- a) only conductive materials.
 b) only nonconductive materials.
 c) both conductive and nonconductive materials.
9. A test coil's magnetic field will not pass through a nonconductive material (for example, paint).
- a) True b) False
10. Changes in a material's chemical composition will affect the flow of eddy currents.
- a) True b) False
11. An inclusion in a material will not affect the flow of eddy current.
- a) True b) False
12. A crack within a material will affect the flow of eddy current.
- a) True b) False
13. A test coil's magnetic field has an intensity. In eddy current testing (not magnetic particle testing), this intensity is assumed to be constant across the inside diameter of the test coil.
- a) True b) False
14. A test coil's magnetic field intensity outside a test coil
- a) increases with distance from the coil.
 b) decreases with distance from the coil.

15. The following figure shows two points in the magnetic field extending from the end of the coil.

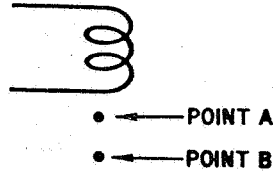

- a) Point B has a greater magnetic field intensity than point A.
 b) Point B has less magnetic field intensity than point A.
16. The path of eddy currents is related to the windings of a coil. For an encircling test coil, the correct eddy current path is shown by

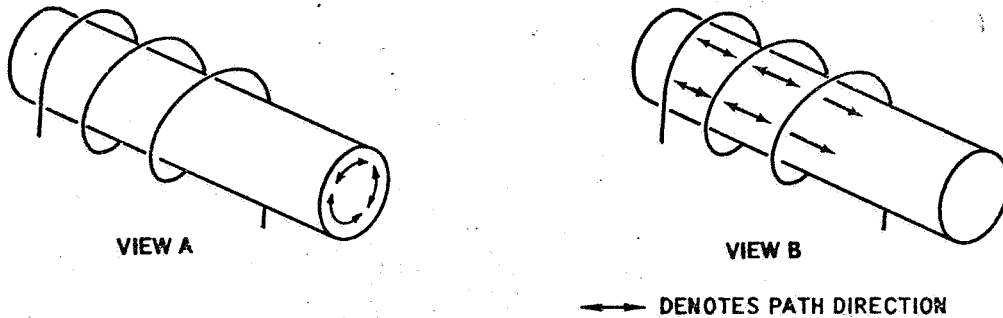

- a) view A
 b) view B
17. In the following view, ac flowing through a primary coil establishes a magnetic field and causes eddy currents to be induced into a rod. A secondary coil encircling the rod

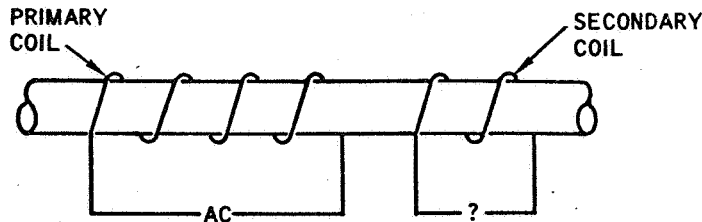

- a) will not be affected by the eddy current flow.
 b) will be affected by the eddy current flow.
18. When a rod is placed in a test coil, the density of the induced eddy currents will vary within the rod. The greatest density (the most current) will exist
- a) near the surface of the rod.
 b) near the center of the rod.

19. When a rod is placed in a test coil, the density of the induced eddy currents will vary within the rod. No eddy currents will exist
- at the center of the rod.
 - near the surface of the rod.
20. When a surface test coil is placed on a specimen, the depth of eddy current penetration into the specimen varies with
- test frequency applied to the coil.
 - conductivity of specific specimen.
 - both the test frequency and the conductivity of the specimen.
21. The depth of eddy current penetration decreases as the test frequency
- increases.
 - decreases.
22. The depth of eddy current penetration decreases as the conductivity
- increases.
 - decreases.
23. The term "lift-off" applies to
- a surface coil.
 - an encircling coil.
24. The term "fill-factor" applies to
- a surface coil.
 - an encircling coil.
25. In the following view, a surface coil is positioned above the surface of a specimen. If the distance between the coil and the specimen's surface varies, the output indication will

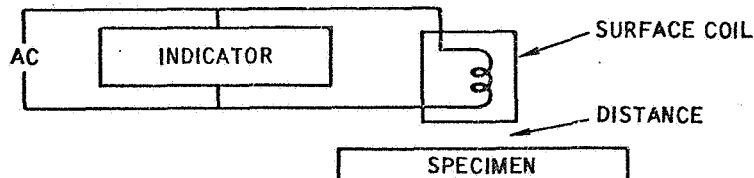

- remain unchanged.
- vary.

26. The following view shows a rod passing through a test coil. If the diameter of the rod varies, the indicating device output indication will

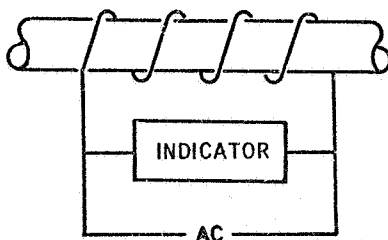

- a) vary.
b) remain unchanged.
27. Lift-off is defined as a change in output indication as the distance between the coil (surface coil) and the specimen's surface is varied.
- a) True b) False
28. The following view shows a surface coil positioned on the surface of a nonconductive coating. Below the coating is a conductive material. If the surface coil is moved across the surface and the thickness of the nonconductive coating varies, the indicating device output indication will

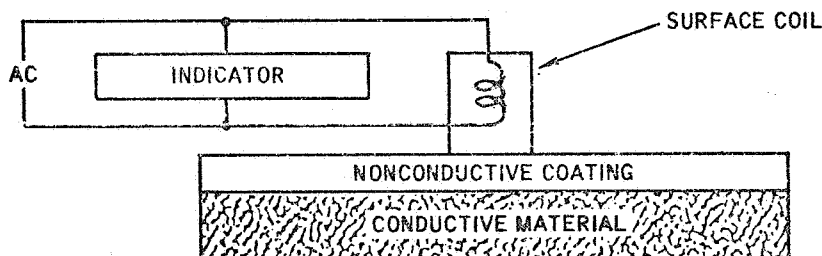

- a) remain unchanged.
b) vary.
29. A specimen may be viewed in terms of three variables: conductivity, dimension, and permeability. The conductivity variable appears in
- a) only magnetic materials.
b) only nonmagnetic materials.
c) both magnetic and nonmagnetic materials.
30. A specimen may be viewed in terms of electrical and magnetic effects. Conductivity is
- a) an electrical effect.
b) a magnetic effect.

31. A specimen may be viewed in terms of three variables: conductivity, dimension, and permeability. A specimen may also be viewed in terms of electrical and magnetic effects. The dimension variable is

- a) an electrical effect.
- b) a magnetic effect

32. Permeability is

- a) an electrical effect.
- b) a magnetic effect.

33. The ratio of the flux density (B) of a specimen to the magnetizing force (H) of the test coil is called

- a) residual magnetism.
- b) permeability.
- c) hysteresis.

34. Permeability varies as the magnetizing force applied to the specimen is increases

- a) True
- b) False

35. A substance which is characterized by an abnormally high permeability, definition saturation point, and appreciable hysteresis is called

- a) a magnetic substance.
- b) a nonmagnetic substance.

36. The hysteresis loop for two specimens is shown below. The magnetic material is

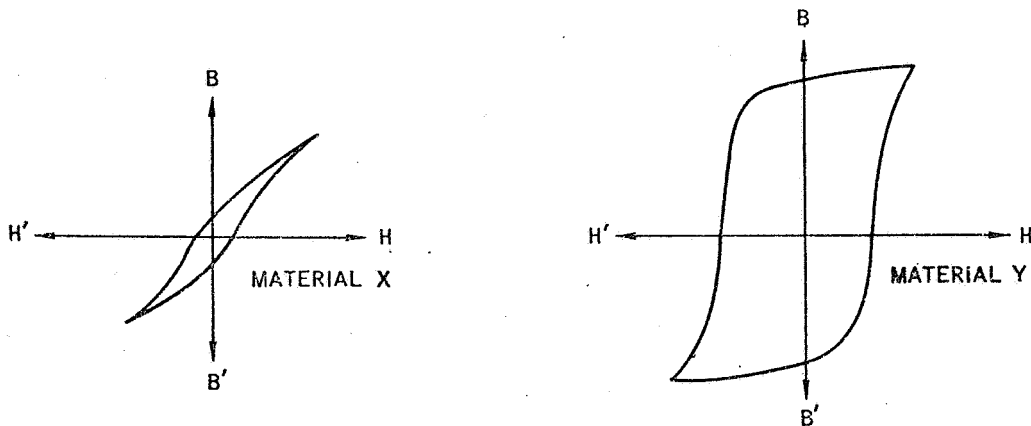

- a) material X.
- b) material Y.

37. The process of applying a direct current through a coil for magnetic saturation of a specimen is related to
- a) conductivity.
 - b) permeability.
38. A coil's opposition to the flow of an alternating current is called
- a) impedance.
 - b) inductance.
 - c) inductive reactance.
39. A specimen's properties will not affect a test coil's impedance.
- a) True b) False
40. If a coil's impedance changes, the coil's current
- a) remains unchanged.
 - b) changes.
41. Impedance testing can separate the conductivity variable from the dimension and permeability variables.
- a) True b) False
42. Current flowing through a test coil is
- a) in phase with the voltage across the coil.
 - b) out of phase with the voltage across the coil.
43. Phase analysis is based on the fact that
- a) a coil's impedance changes.
 - b) the current through a coil lags the voltage across the coil.
 - c) the frequency response of the coil changes.
44. Phase analysis can separate the dimension variable from the
- a) permeability variable.
 - b) conductivity variable.
45. Each of the three variables (conductivity, permeability, and dimension) produce phase changes in the test coil.
- a) True b) False
- 

46. The two variables which produce phase changes in the same direction are

- a) conductivity and dimension.
- b) conductivity and permeability.
- c) dimension and permeability.

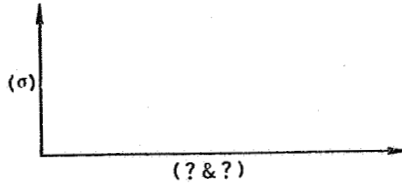

47. The permeability and dimension variables produce phase changes that are

- a) the same direction as the conductivity variable.
- b) 90 degrees out of phase with the direction of the phase change produced by the conductivity variable.

48. The following figure illustrates the use of the linear time-base method of phase analysis.

Does the display on the CRT indicate

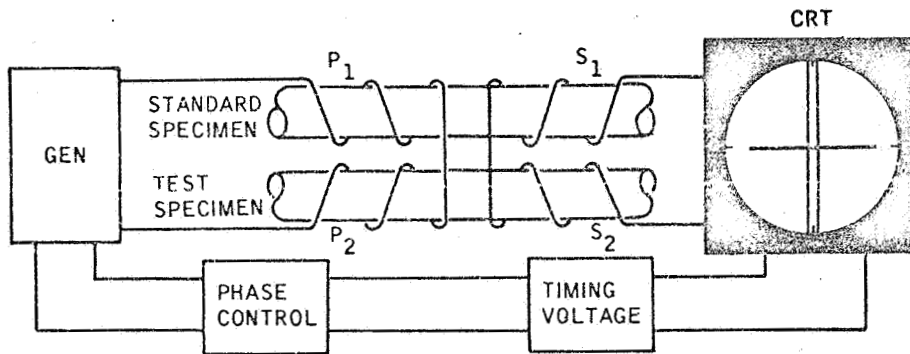

- a) the specimens are the same
- b) the specimens are not the same
- c) one of the specimens has been removed.

49. Views A and B illustrate two possible displays on the CRT screen, using the linear time-base method of phase analysis. The display can be changed from view A to view B by

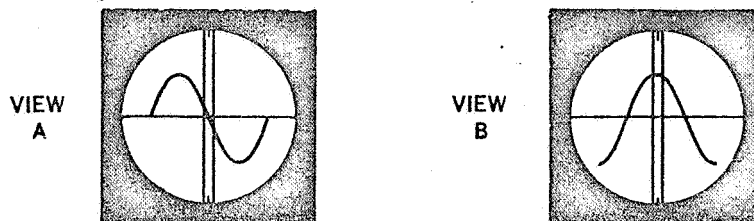

- a) changing the phase control on the CRT equipment.
- b) decreasing the amplitude of the signal.
- c) either "a" or "b."

50. The following figure illustrates the use of the linear time-base method of phase analysis. If the two specimens are not the same the resulting indication on the CRT screen will be as illustrated in either

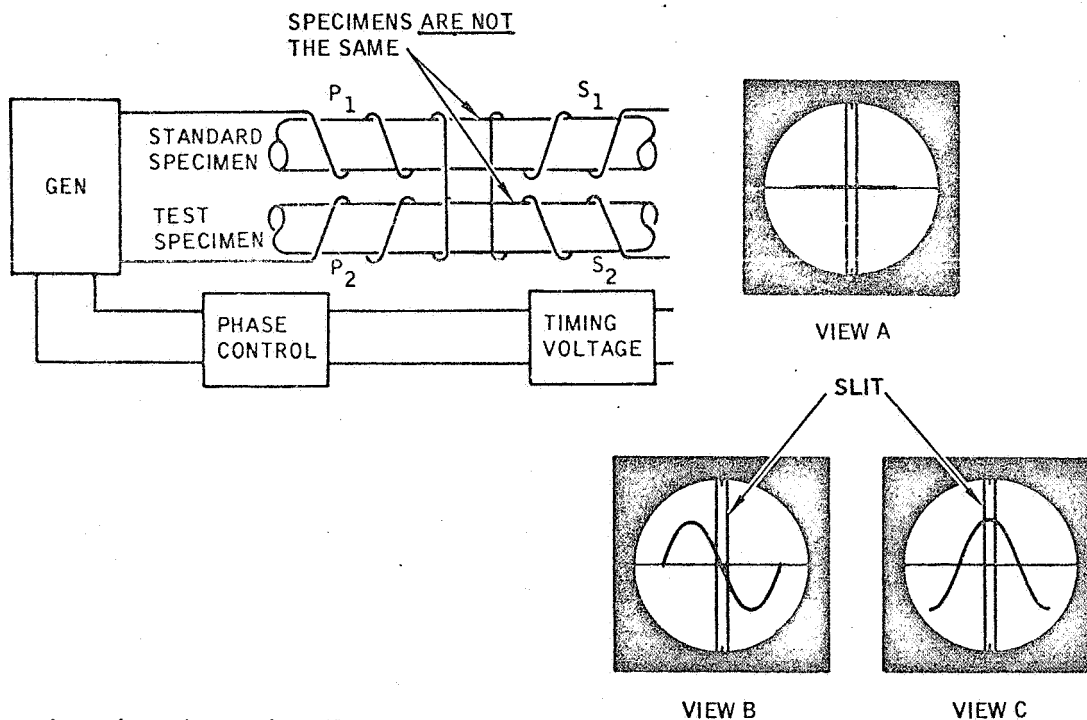

- a) view A or view B
- b) view B or view C
- c) view A or view C

51. In the following figure, imagine that a test specimen with a dimension property that is not the same as the standard specimen is placed in the test coil. Through the operation of the phase control, the display is adjusted to provide the indication in view A. If the test specimen is now replaced by one that has conductivity properties that differ from those of the standard specimen, the value at the slit will represent

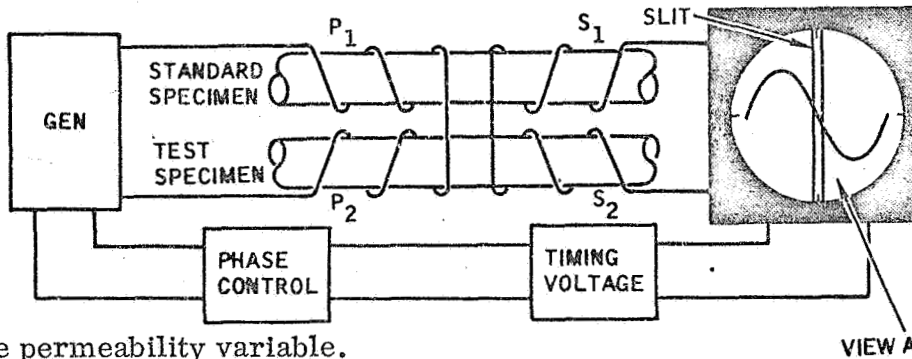

- a) the permeability variable.
- b) the conductivity variable.
- c) both the permeability and conductivity variables.

52. The value at the slit can represent either the conductivity variable or the dimension variable, depending upon how the display is originally established on the screen.

- a) True
- b) False

53. The linear time-base method can without magnetic saturation, separate the dimension variable from the permeability variable.

- a) True
- b) False

54. The following view shows a series of indications on a chart recorder. These indications represent changes in a test coil as a result of a rod passing through a test coil. This type of indication is applicable to

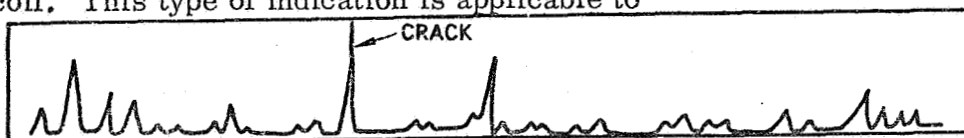

- a) impedance testing.
- b) phase analysis.
- c) modulation analysis.

55. Modulation analysis is based on

- a) impedance.
- b) phase changes.
- c) generation of frequencies.

56. A testing system which uses electronic filters to remove frequencies that represent unwanted variables is called

- a) modulation analysis.
- b) impedance testing.
- c) phase analysis.

END OF SELF TEST

This completes the self test. Do not turn the page until you have completed the self test. Then turn to page T-12 to evaluate your performance.

ANSWERS TO SELF TEST

	<u>Page No.</u>		<u>Page No.</u>
	<u>Ref.</u>		<u>Ref.</u>
1. b	1-2	27. a	3-2
2. a	1-4	28. b	3-3
3. a	1-8	29. c	4-60
4. a	1-2	30. a	4-1
5. a	1-4	31. b	4-6
6. a	1-4	32. b	4-6
7. b	1-4	33. b	4-27
8. b	1-8	34. a	4-27
9. b	1-9	35. a	4-49
10. a	1-12	36. b	4-49
11. b	1-13	37. b	4-41
12. a	1-13	38. a	5-1
13. a	2-7	39. b	5-6
14. b	2-7	40. b	5-6
15. b	2-7	41. b	5-15
16. a	2-9	42. b	5-2
17. b	1-21	43. b	5-10
18. a	2-14	44. b	5-79
19. a	2-10	45. a	5-84
20. c	2-14	46. c	5-84
21. a	2-14	47. b	5-78
22. a	2-17	48. a	5-95
23. a	3-2	49. a	5-101
24. b	3-8	50. b	5-104
25. b	3-2	51. b	5-110
26. a	3-13	52. a	5-105

53. b	5-115
54. c	5-118
55. c	5-116
56. a	5-122