

ELECTRO-OPTICAL SYSTEMS, INC.
A XEROX COMPANY
PASADENA, CALIFORNIA 91107 • 213/351-2351

FACILITY FORM 602

ACCESSION NUMBER N68 28816 (THRU) _____

63 (PAGES) _____

CR-95623 (NASA CR OR TMX OR AD NUMBER) _____

_____ (CODE) _____

_____ (CATEGORY) _____





Annual Progress Report

CONTACT ION ENGINE SYSTEM
FOR ATS SATELLITES D AND E
Contract NAS5-10380

Prepared for
National Aeronautics and Space Administration
Goddard Space Flight Center
Greenbelt, Maryland 20771

Contracting Officer: Mr. Kent Cockerham
Technical Officer: Dr. Robert E. Hunter, 734

EOS Report 7202-A-1

24 May 1968

Prepared by

RM Worlock

R. M. Worlock
Program Manager

Approved by

J. Davis

Jack Davis
Manager
Plasma Systems Division



ELECTRO - OPTICAL SYSTEMS, INC.
A XEROX COMPANY

PRECEDING PAGE BLANK NOT FILMED.

ABSTRACT

This report covers the first twelve months effort on a program to fabricate and test ion microthruster systems for Applications Technology Satellites D and E, provide appropriate ground support equipment, and provide technical support of spacecraft integration and launch. During the reporting period, March 22, 1967 to March 22, 1968, the majority of the effort required in support of ATS-D was completed. The microthruster system design was finalized and a qualification model system was built and subjected to a qualification test program. Necessary test equipment was designed and fabricated. Two flight model ion microthruster systems were fabricated, flight acceptance tested and delivered to the spacecraft contractor. As a result of spacecraft integration tests, microthruster system modifications were made to ensure compatibility with spacecraft equipment. The most important modification consisted of the addition of an external filter box which provided transient filtering on all telemetry, power and command lines. With the completion of these modifications it is concluded that system design is basically sound and that the delivered units have a high probability of performing as anticipated in space operation.

PRECEDING PAGE BLANK NOT FILMED.

CONTENTS

1.	Introduction and Program Summary	1
2.	Microthruster System Description	2
2.1	General	2
2.2	Thruster Subsystem	3
2.3	Control Logic/Power Conditioning Unit (CLPC)	10
2.4	Electronic Packaging	23
2.5	External RFI Filter	24
3.	Ground Support Equipment	28
4.	Design Qualification Testing	36
4.1	Qualification Test Procedure	36
4.2	First Qualification Series	38
4.3	Second Qualification Series	45
4.4	RFI Filter Qualification	47
5.	Flight Acceptance Testing and Spacecraft Integration	48
5.1	Acceptance Test Procedure	48
5.2	Flight System SN 03	49
5.3	Flight System SN 04	50
5.4	Flight System SN 05	51
5.5	Filters	53
6.	New Technology	53
7.	Program for Next Reporting Period	53
8.	Conclusions and Recommendations	54

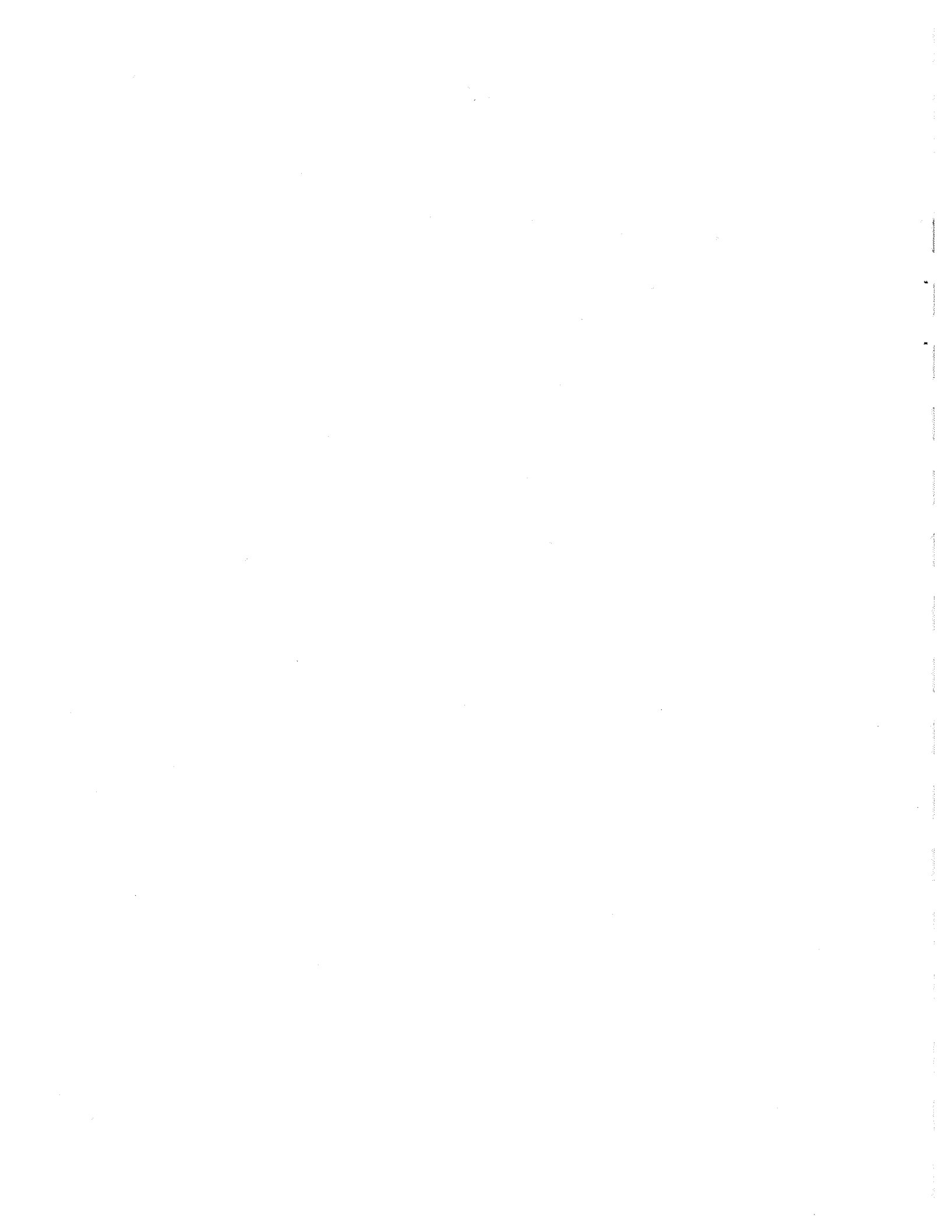

PRECEDING PAGE BLANK NOT FILMED.

ILLUSTRATIONS

1.	Microthruster System with RFI Filter	4
2.	Thruster Subsystem Schematic	5
3.	Accelerator Installation	7
4.	Reservoir Assembly Components	8
5.	Bimetal Valve	11
6.	Block Diagram of CLPC	13
7.	Block Diagram of Ionizer Converter	15
8.	Block Diagram of Main Converter	16
9.	Block Diagram of Beam Deflection System	18
10.	Block Diagram of Thrust Level Control	19
11.	Block Diagram of Command Control System	21
12.	Welded Module A3 before Potting	25
13.	Installed Welded Modules	26
14.	High Voltage Compartment	27
15.	External RFI Filter Schematic	29
16.	Filter Box with Covers and Bracket	30
17.	Test Console	32
18.	Air/Vacuum Thruster Subsystem Simulator	35
19.	Beam Probe Assembly	37
20.	Typical Beam Probe Data	41

PRECEDING PAGE BLANK NOT FILMED

TABLES

Table I	Power Supply Output Specifications	14
Table II	Telemetry System	22
Table III	Sinusoidal Vibration Schedule Component Design Qualification	39
Table IV	Random Excitation Vibration Schedule Component Design Qualification	39

1. INTRODUCTION AND PROGRAM SUMMARY

This program covers the first twelve months effort on a program to fabricate and test ion microthruster systems for Applications Technology Satellites D and E, provide appropriate ground support equipment, and provide technical support of spacecraft integration and launch.

Microthruster system development was begun in December 1966 under sponsorship of the Air Force Aero Propulsion Laboratory, Wright Patterson Air Force Base. Initial design work was carried out and breadboard and prototype systems were fabricated and tested. The subject program began March 22, 1967. The existing design was modified slightly as the result of a design review held at GSFC, and fabrication of a qualification model microthruster was begun. At the same time, procurement of long lead time screened electronic components for flight hardware was begun. For conducting checkout and operational testing of the microthruster systems, three test consoles were designed and fabricated. Appropriate models were fabricated and delivered to the spacecraft contractor. Thruster subsystem simulators were designed and fabricated for testing the electronic portion of the systems under circumstances when it would be inconvenient or impossible to operate a thruster.

The qualification model microthruster system was completed in September 1967 and qualification testing began immediately. As dictated by the program schedule, fabrication of the flight model microthruster systems was carried on concurrent with the qualification testing.

By the end of the first twelve months qualification testing had been completed and two flight model systems had been fabricated, successfully acceptance tested, and delivered to the spacecraft contractor for integration on the ATS-D satellite. As a result of spacecraft integration tests, microthruster system modifications were made to ensure compatibility with spacecraft equipment. The most important modification consisted of the addition of an external filter box which provided transient filtering on all telemetry, power and command lines.

Section 2 of this report contains a description of microthruster system design and construction. Section 3 describes the ground support equipment designed and fabricated for the program. Section 4 covers testing conducted on the qualification system, while Section 5 covers acceptance testing and spacecraft integration of the flight model microthrusters.

2. MICROTHRUSTER SYSTEM DESCRIPTION

2.1 General

This section describes the cesium contact ion microthruster system designed as an experiment for the ATS-D and E satellites. The microthruster also serves as an operational backup system for east-west station keeping of the satellite. The microthruster is qualified as flightworthy with total power requirement of 32W, thrust range of 0 to 15 μ lb, and two-axis beam deflection. Thrust vectoring of $\pm 10^\circ$ is achieved in $2/3^\circ$ increments. The propellant feed system is the zero-g surface tension type and carries 51g of cesium, enough for two years full-thrust operation at 60% duty cycle. A valve at the vaporizer surface maintains the reservoir in a sealed and evacuated condition when the system is not operating. The valve is actuated by vaporizer

temperature, permitting operation without additional power or control circuitry. Figure 1 is a photo of the complete microthruster system, including RFI filter.

2.2 Thruster Subsystem

The thruster is a single aperture cesium contact ion engine. It has a segmented accelerating electrode for thrust vectoring and redundant thermionic electron emitters for ion beam neutralization. Cesium propellant is supplied by a surface tension type zero-g feed system with a thermally actuated valve. Thrust is adjustable in 5 μ lb steps between 0 and 20 μ lb and may be vectored in incremental steps between 0° and 10° in the +X and/or +Y directions. Undelected thrust is along the Z axis. The thruster is housed in a cylindrical shroud that isolates it from the spacecraft and from the system power conditioning. A schematic of the thruster subsystem is shown in Figure 2.

The ionizer is made from porous tungsten sintered from spherical powder and machined to shape. It is electron-beam welded to a molybdenum crucible which is in turn electron-beam welded to a molybdenum-rhenium feed tube. A sheathed rhenium heater is brazed to the crucible and the feed tube is brazed to a stainless steel flange with a copper nickel alloy which has proven compatibility with hot cesium vapor. The ionizer assembly is heat shielded with alternate layers of thin metal foil and ceramic felt. The ionizer assembly is sealed to the cesium reservoir and vaporizer assembly with a copper gasket.

The accelerating geometry consists of contoured ionizer, beam forming electrode, accelerating and decelerating electrodes and neutralizers. The copper accelerator electrode is cut into four segments to permit beam deflection for thrust vectoring. Deflection is produced by

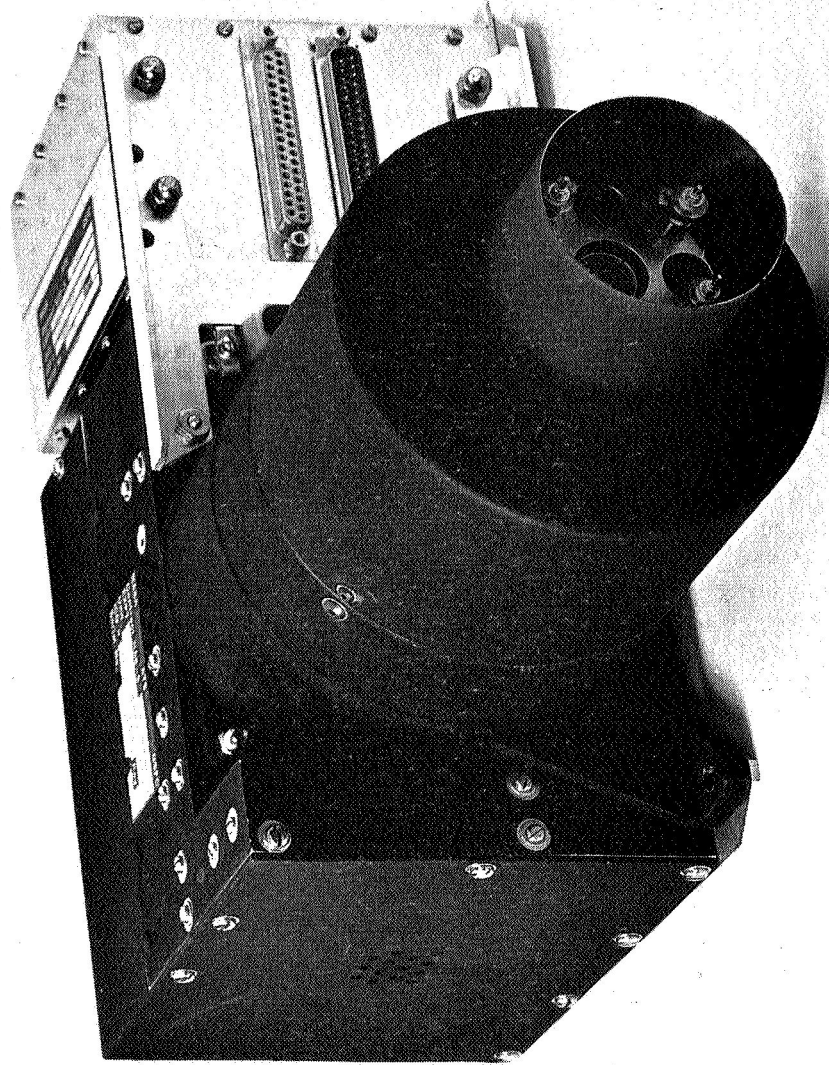

Figure 1. Microthruster System with RFI Filter

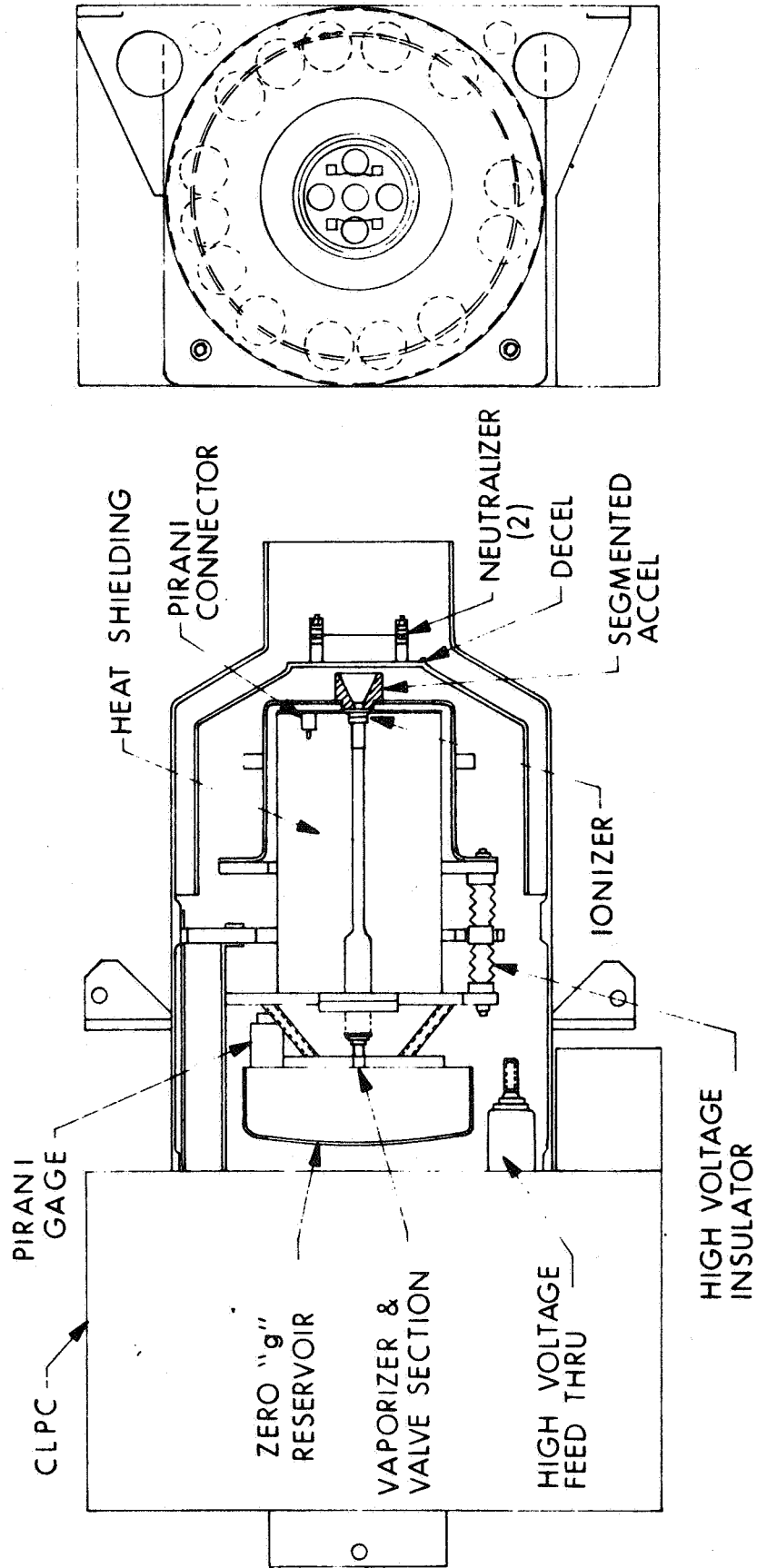

Figure 2. Thruster Subsystem Schematic

symmetric biasing of opposing pairs of quadrants; one quadrant is positive and the other negative with respect to the nominal accelerating potential. This scheme results in adequate deflection sensitivity and produces no significant spreading of the deflected beam. The electronic circuitry required is considerably more complicated than for a postacceleration deflection system, but postacceleration produces more beam spreading than can be tolerated in this application. The accelerator segments are supported by two alumina rings and the accelerator assembly is mounted on four alumina support insulators which isolate the accelerator and the ionizer from thruster common (ground potential). Figure 3 shows an accelerator electrode being installed on a thruster subsystem. The decelerator electrode is to one side.

The decelerator electrode is mounted to thruster common and provides support for the two hot-wire neutralizers. These neutralizers are 0.007 in. diameter tantalum doped with 50 ppm yttrium to retard grain growth. One neutralizer operates and one remains as back-up. The thruster is connected electrically to its power conditioning by a wiring harness that is hardwired to all thruster components; connecting lugs are secured to feedthrough insulators with nuts and lock washers. The shroud (in two parts to permit easy access) completes the thruster subsystem.

The propellant system is a modified version of systems previously developed and tested by EOS. These systems utilize surface tension forces to establish and maintain stable liquid-vapor interfaces. These same forces are used for transporting the liquid from the reservoir to the vaporizing area.

The reservoir, shown disassembled in Figure 4, consists of a cylindrical volume enclosing a fin array. The area between fins tapers from the outside toward the central axis of the reservoir. There are 120 fins

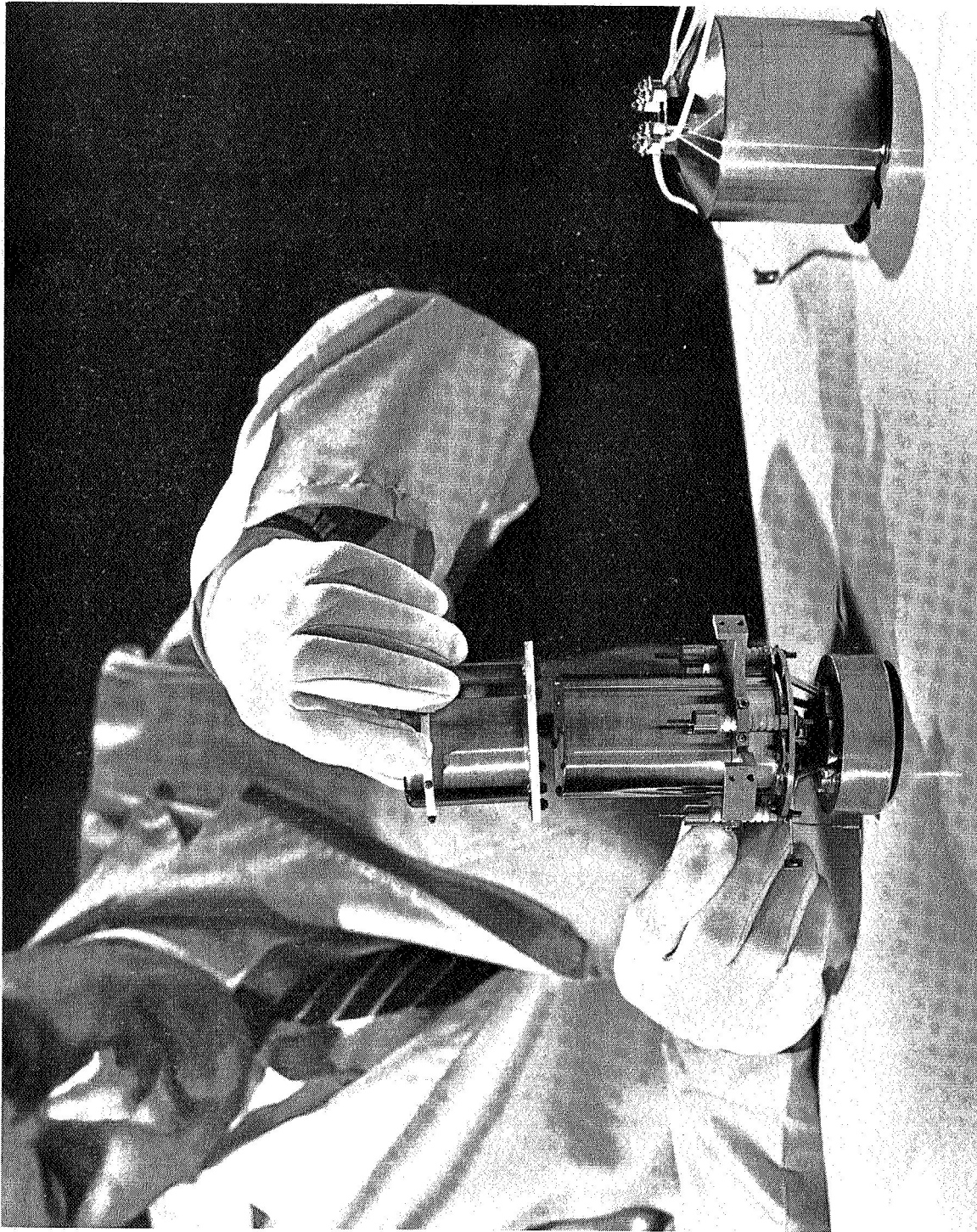

Figure 3. Accelerator Installation

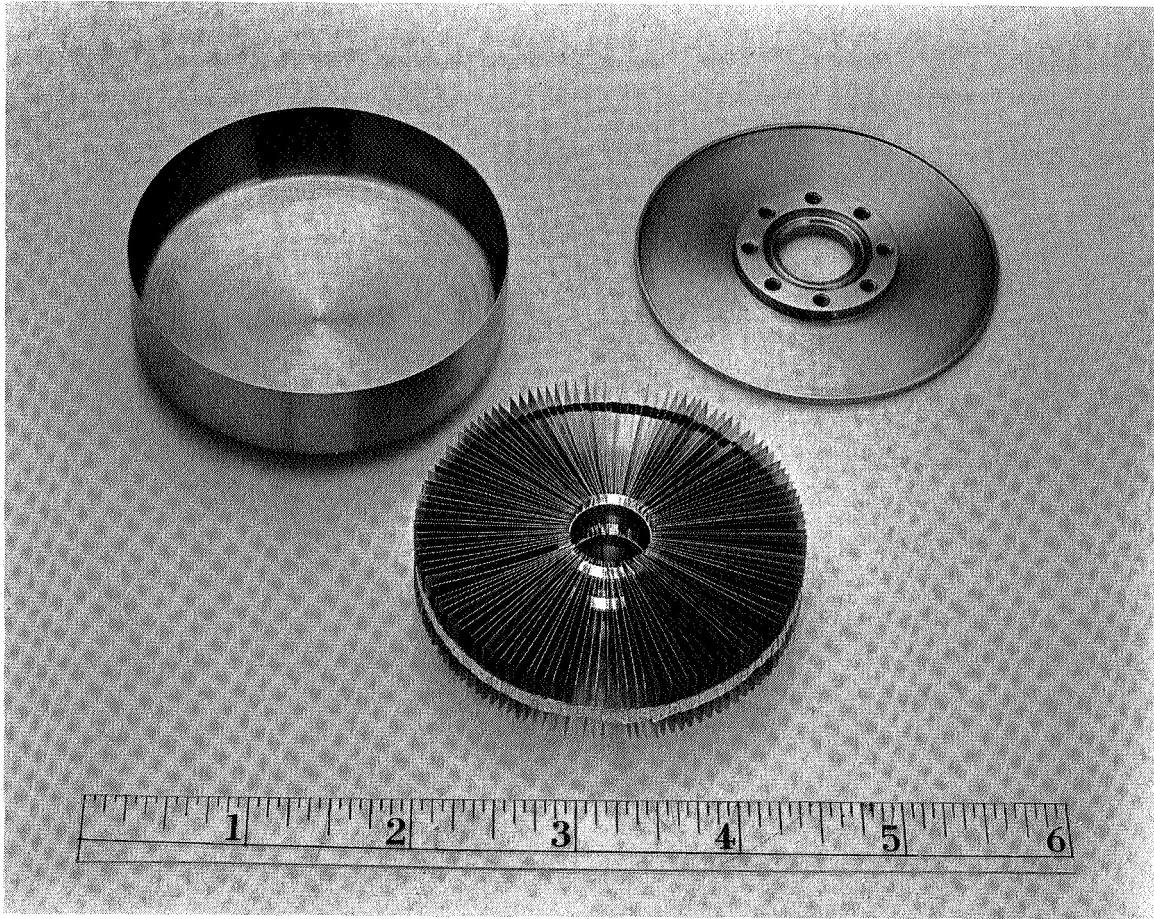

Figure 4. Reservoir Assembly Components

with a spacing of 0.064 inch between fins at the outside edge of the array. During operation, liquid cesium in the area between fins is forced toward the central axis of the reservoir and into contact with a porous nickel rod which carries the cesium to the vaporizing surface. A fill tube and a pressure transducer (not shown) are welded to the reservoir shell. All parts of the propellant system are fabricated from 347 stainless steel except as noted below.

A vaporizer assembly is attached to the reservoir by machine screws, and is sealed by a copper gasket crushed between machined seal surfaces. The porous nickel rod is press-fit into the vaporizer and terminates in the area heated by a sheathed heater brazed around the outside of the tube. The vaporizer feed tube has been made re-entrant into the reservoir to reduce the overall length of the propellant system and still maintain adequate thermal isolation between vaporizer and reservoir.

The propellant system is designed to be evacuated, loaded with cesium, and then sealed. The entire loading and sealing operation is performed under vacuum in the chamber of an electron beam welding machine. The evacuated and sealed system has three features considered vital to successful operation of flight hardware: (1) the cesium is protected from contamination during the period between reservoir filling and launch, (2) the cesium is kept in the reservoir and restrained from moving into the ionizer region under the influence of launch vibration, and (3) the cesium is prevented from flowing out of the reservoir due to differential pressure between the reservoir and feed tube regions. Sealing of the propellant system is accomplished by placing a sealed valve at the end of the vaporizer (liquid-vapor interface) and by sealing the fill tube after loading.

Since maintenance of vacuum within the reservoir is crucial to satisfactory system operation, a miniaturized Pirani pressure sensor was

designed, tested, and incorporated into the system design. When the sensor is operated in a constant temperature mode by an automatic bridge circuit developed for the purpose, excellent sensitivity is achieved in the pressure region of interest, 0.01 to 1 torr.

Terminals from the pressure sensor are brought out to the thruster focus electrode, and are accessible through openings in the accelerator and decelerator electrodes. Thus, by inserting a probe through the 2-inch diameter opening at the thruster end of the package, the condition of the propellant system can be determined whenever desirable, from the time of assembly on. Periodic monitoring of the pressure can be used to develop very high confidence in the integrity of a particular system.

The valve developed to seal the feed system operates by differential thermal expansion of dissimilar materials. It consists of an Invar tube inside a stainless steel tube. Attached to the Invar tube is a nickel tip which seats in an orifice in the vapor feed line. Power is conducted to the valve area from both the ionizer and the vaporizer. The difference in expansion between the Invar tube and the stainless tube is sufficient to move the tip away from the seat, opening the valve. Figure 5 shows a schematic of the valve. When sealed this valve has a leak rate of less than 3×10^{-10} STD cc He/sec and reseals in the presences of cesium six or more times. The valve begins to open at 60°C and reseals at 40°C; normal operation temperature is 300°C.

2.3 Control Logic/Power Conditioning Unit (CLPC)

The CLPC system provides the various power forms needed to operate the cesium contact microthruster. The power conditioning system is designed to operate from a -24V dc regulated power bus. If the bus should fall

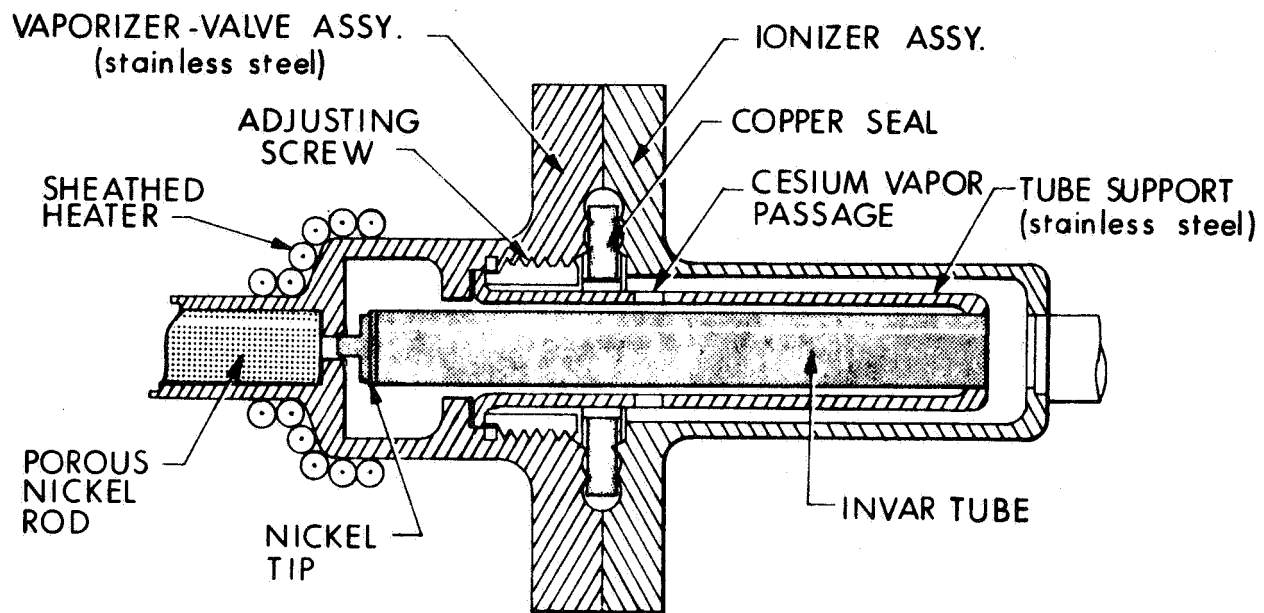

Figure 5. Bimetal Valves

below -19V dc the CLPC will shut down and can only be restarted by ground command.

A block diagram of the entire system is shown in Figure 6. This diagram shows the relationships between the two converters, the command system, telemetry system and the beam deflection and thrust level circuitry. Table I lists the output specifications of the various CLPC supplies which operate the engine.

The ionizer converter supplies power to heat the ionizer and neutralizer as well as power for operating the logic and control circuitry. A block diagram is shown in Figure 7. The converter is a self-saturating, push-pull type operated at a 10 kHz switching rate. The ionizer heater current is limited by a saturable reactor in series with one of the power leads to prevent excessive current flow into the cold element when power is initially applied. A separate secondary winding supplies power to the neutralizer heater elements. A current sensor provides telemetry voltage readout of the neutralizer and ionizer heater currents.

A neutralizer select circuit connects heater power to either of two neutralizer filaments selected by ground command. If a filament burns out, the heater current drops to zero, and the neutralizer select circuit automatically switches power to the remaining filament.

The main converter supplies power to the ion beam, accelerator electrode and vaporizer heater; a block diagram is shown in Figure 8. The converter is a self-saturating, push-pull type operated at a 10 kHz switching rate. Positive and negative high voltages are obtained from voltage doublers driven by separate windings on the converter transformer. Currents are sensed by resistors in the low potential side of each doubler. Signals from these two resistors

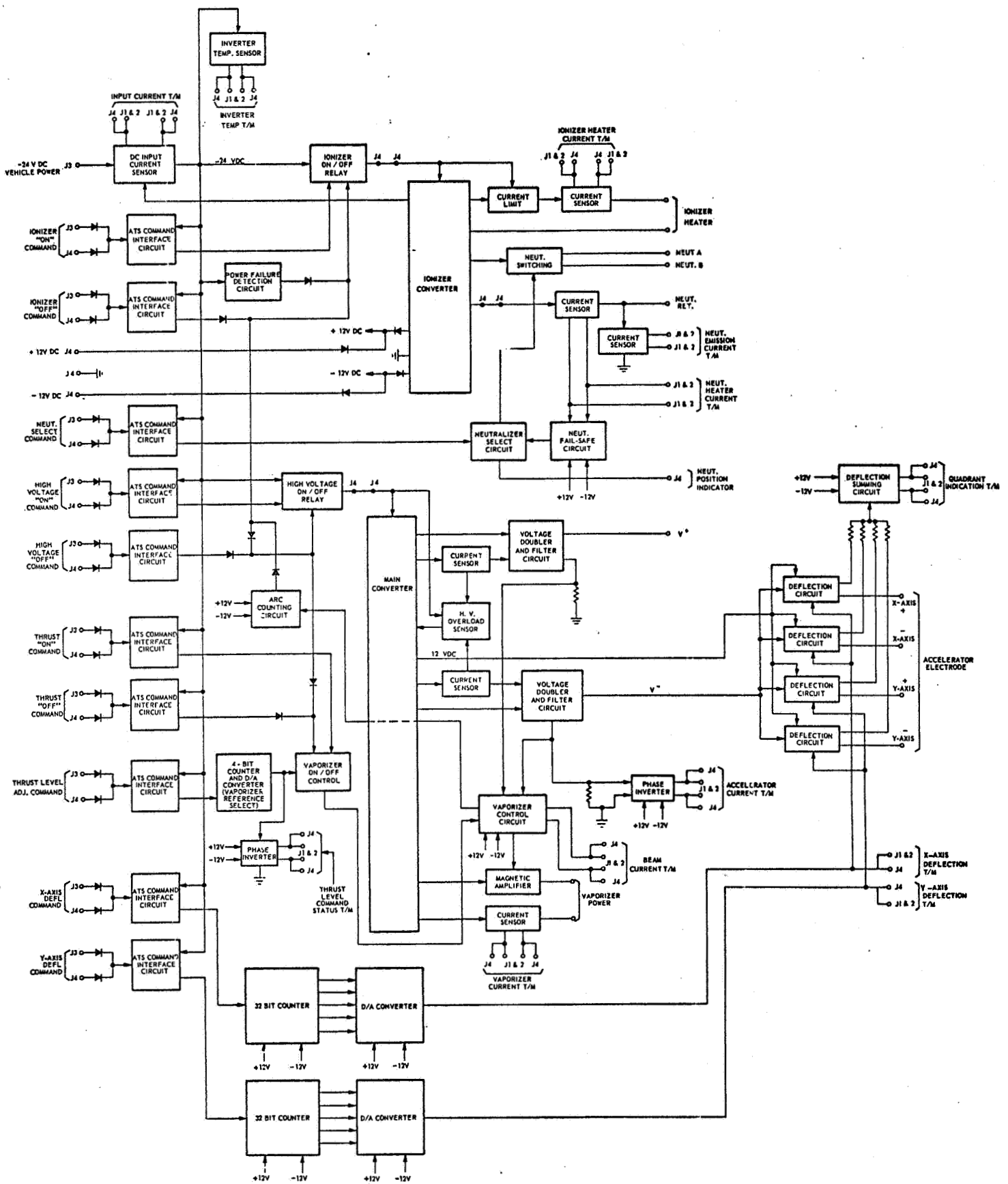

7202-A-1

Figure 6. Block Diagram of Control Logic/Power Conditioning Unit

TABLE I
POWER SUPPLY OUTPUT SPECIFICATIONS

<u>Supply</u>	<u>Rated Output</u> *			<u>Remarks</u>
	<u>Voltage</u>	<u>Current</u>	<u>Power</u>	
Beam	+3000V dc	1000 μ A	3.0W	
Accelerator	-2000V dc **	< 200 μ A	0.4W	
Ionizer	4.4V ac	2.3A	10.1W	
Vaporizer	3.5V ac	1.3A	4.6W	Controlled by beam current
Neutralizer	1.5V ac	2.4A	3.6W	
Deflection	<u>+250V dc</u>	250 μ A	<u>0.1</u>	
			21.8W	

*For nominal -24V dc input voltage conditions and 20 μ lb thrust
 **Beam deflection voltages are superimposed on accelerator voltage

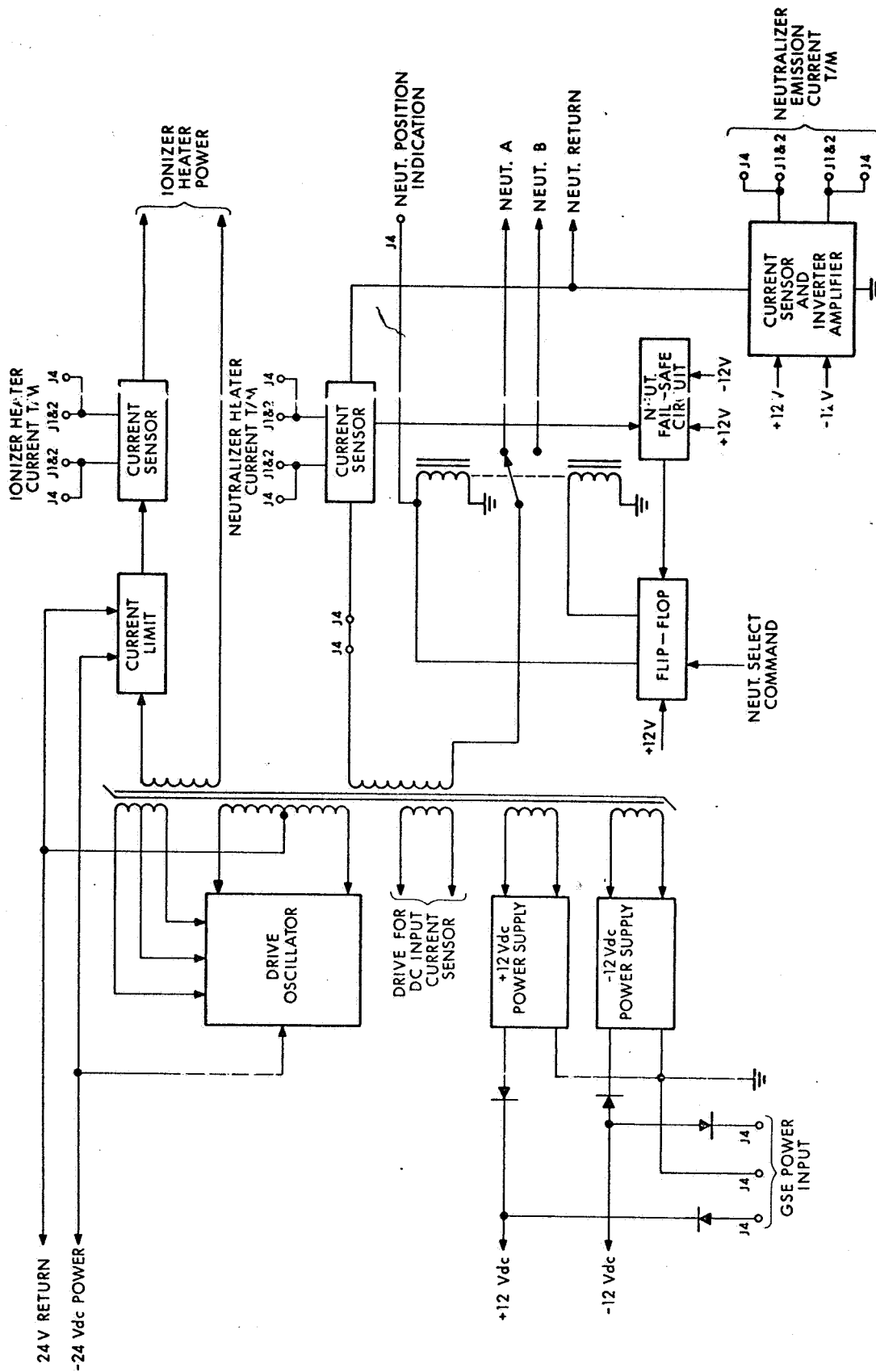

Figure 7. Block Diagram of the Ionizer Converter

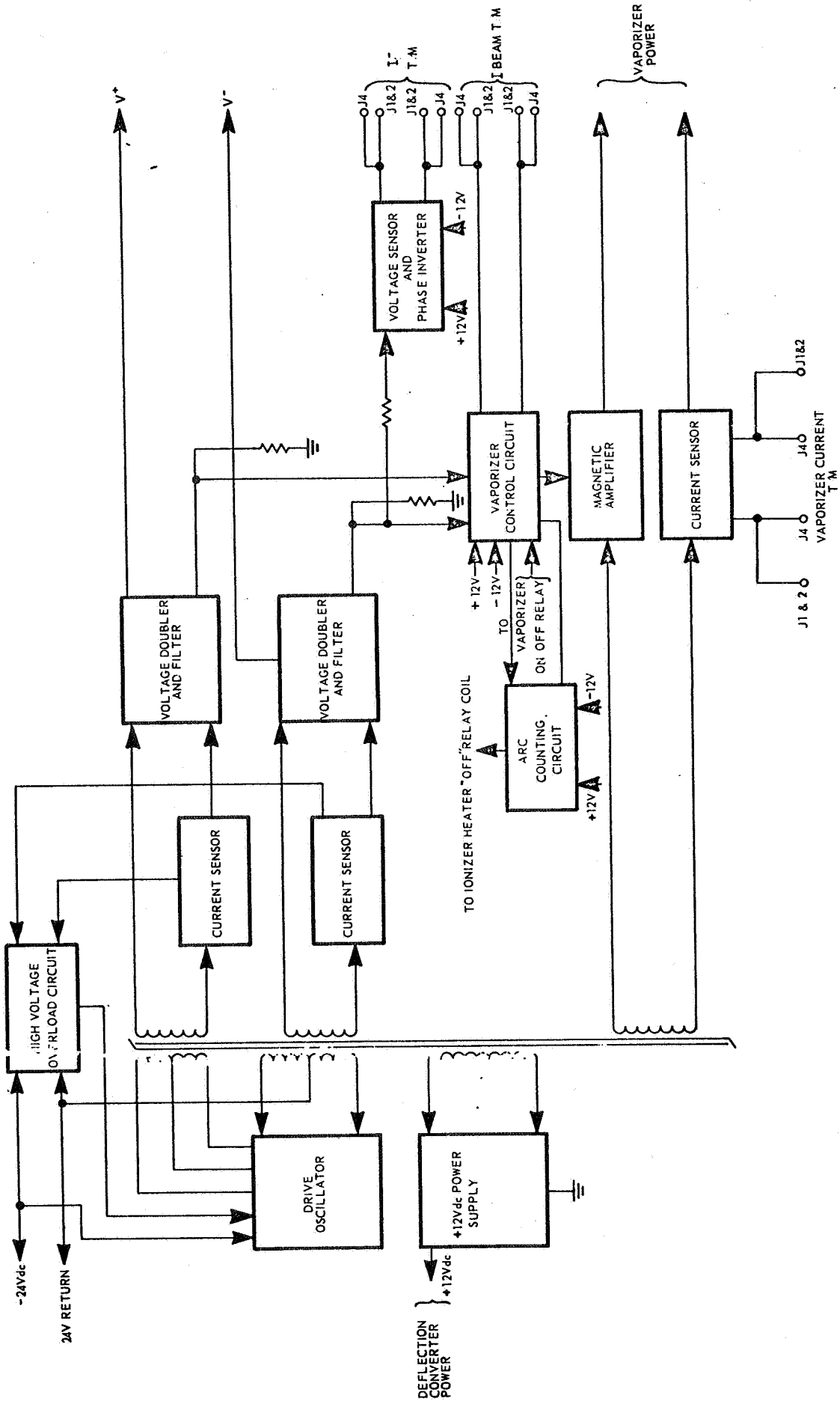

Figure 8. Block Diagram of Main Converter

are added in an operational amplifier; the sum is taken to be the best available measure of beam current and is used as the feedback signal in the vaporizer control loop.

High voltage overloads are sensed by current transformers in series with the high voltage secondaries. When a sufficiently large signal is produced by either transformer, a discriminator is triggered and the inverter is temporarily disabled. After approximately 5 milliseconds, the inverter is restarted; if the overload is still present, the inverter will again be shut off. This process is repeated until the fault has corrected itself. If the overloading continues for approximately 40 seconds, the system is turned off by an arc-counting circuit. This circuit accepts the overload shutdown signals described above and connects them to an active integrator; if the arcing persists, the output of the integrator trips a circuit giving high voltage off, thrust off, and ionizer off commands. Ionizer on, high voltage on, and thrust on can then only be applied by ground command.

Two-axis beam deflection is achieved by adding differential voltages to a segmented accelerator electrode. A block diagram of the beam deflection system is shown in Figure 9. Deflection command pulses drive a 4-stage binary counter which drives a digital-to-analog converter. The 16-level analog signal controls the deflection converter which applies the deflection potential differences to the accelerator electrode quadrants. Three telemetry outputs are provided; the first two indicate the magnitude of the X and Y deflections while the third indicates the quadrant in which deflection is being produced.

The control of engine thrust is achieved by ground command as shown in Figure 10. The "thrust level select" command pulse from the spacecraft feeds a two stage binary counter; the output of the counter goes to a digital-to-analog converter which provides the reference

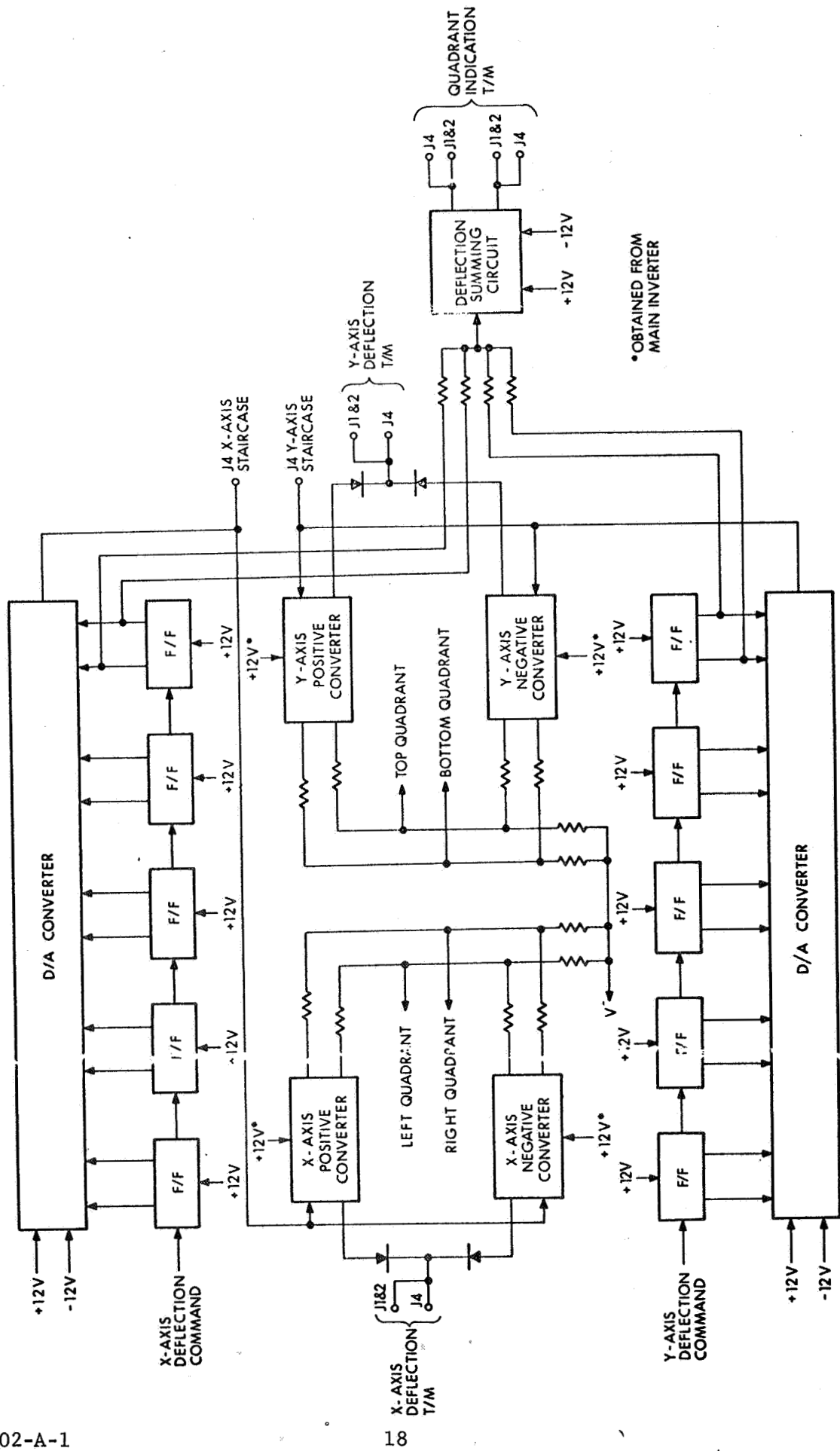

Figure 9. Block Diagram of Beam Deflection System

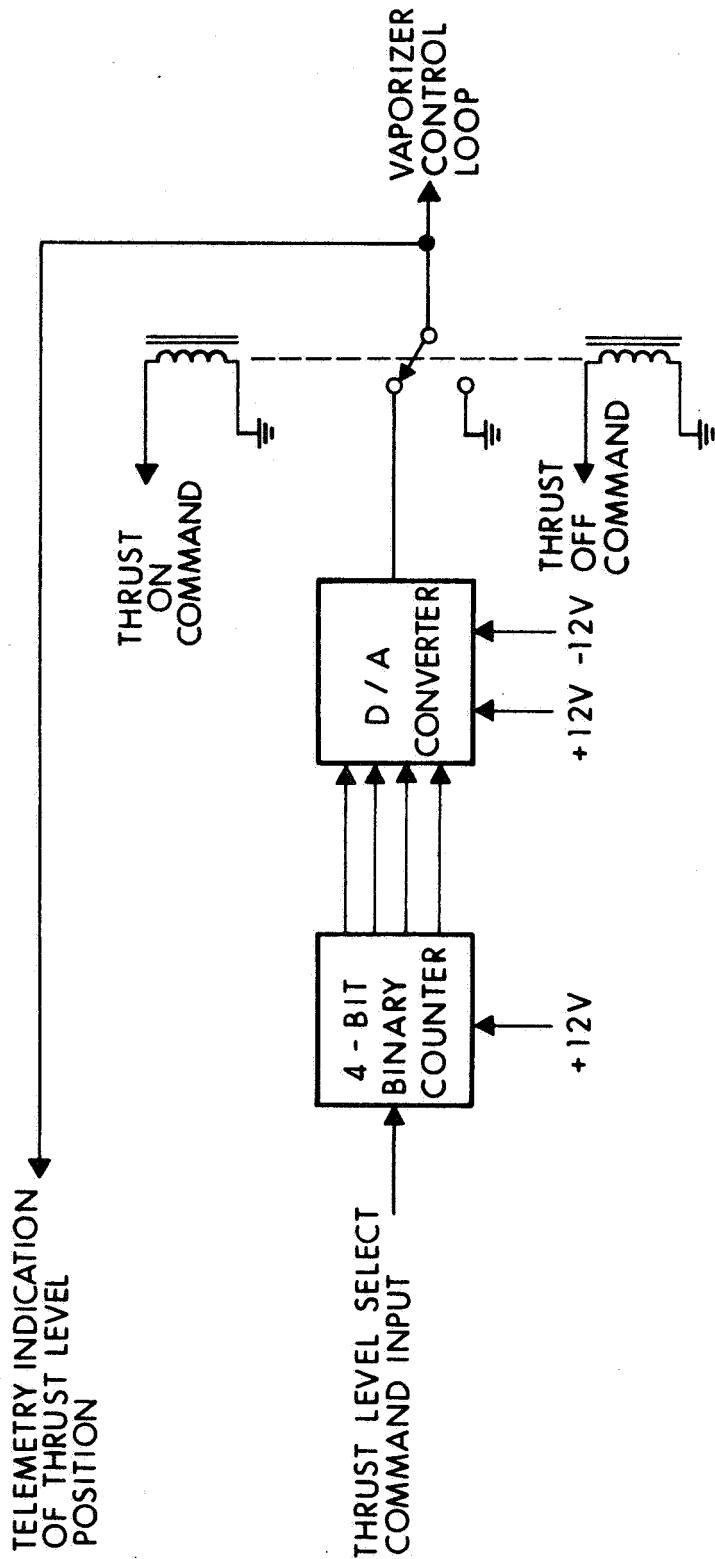

Figure 10. Block Diagram of Thrust Level Control

signal for the vaporizer control loop. Application of the reference signal is governed by thrust on and off commands. In the reset position the D/A converter has an output reference signal corresponding to 5 μ lb thrust. When a "thrust level select" command pulse is received, the counter steps one position and the output of the D/A converter changes the reference to 10 μ lb. Subsequent command pulses step the thrust reference to 15 μ lb, 20 μ lb and back to 5 μ lb.

The microthruster command system is designed for the maximum flexibility of engine operations through the use of ground commands. A total of 10 command channels are provided. A block diagram of the command control system is shown in Figure 11.

Important off commands are interlocked together. For example, an ionizer heater off command also gives a high voltage and thrust off command. This interlocking prevents any undesirable engine operating condition from occurring due to a missent ground command. A power failure detection circuit gives an ionizer heater off command, a high voltage off command and thrust off command whenever the regulated bus falls below -19V dc. An arc counting circuit also gives ionizer heater, high voltage, and thrust off commands if engine arcs have occurred continuously for approximately forty seconds.

The telemetry system monitors the microthruster engine and power conditioning functions necessary for determining thrust level, beam deflection, system performance and selected diagnostics.

The twelve telemetry channels carry negative going signals in the range of 0 to 5.0V dc. Zener diodes are provided to limit the output of the telemetry channels to -5.5V dc. All telemetry channels are referred to spacecraft ground potential and have output impedances of 5000 ohms or less. A list of telemetry channels is shown in Table II.

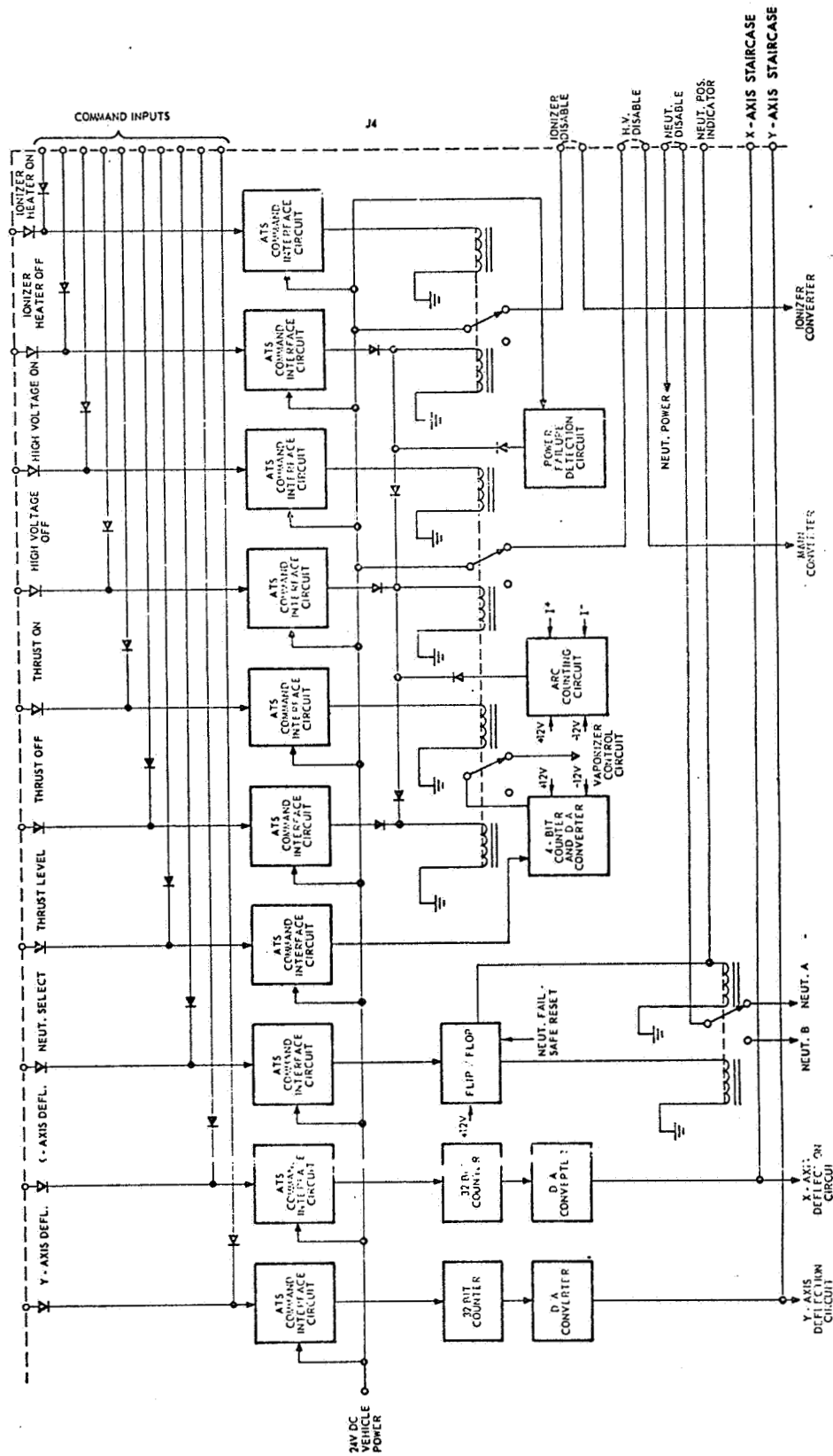

73025153

Figure 11. Block Diagram of Command Control System

TABLE II
TELEMETRY SYSTEM

<u>Function</u>	<u>Units</u>	
Beam current	0 - 1.25 mA	
Accelerator current	0 - 200 μ A	
Neutralizer heater current	0 - 3.0A	
Neutralizer emission current	0 - 1.25 mA	
Vaporizer heater current	0 - 2.0A	
Ionizer heater current	0 - 3.0A	
Inverter temperature	-50 $^{\circ}$ C - +150 $^{\circ}$ C	
Inverter input current	0 - 1.5A	
X-axis deflection	0 - 10 $^{\circ}$	
Y-axis deflection	0 - 10 $^{\circ}$	
Quadrant indication	I	
	II	
	III	
	IV	
Thrust level command status	0 μ lb	
	5 μ lb	4 μ lb*
	10 μ lb	8 μ lb*
	15 μ lb	12 μ lb*
	20 μ lb	16 μ lb*

* applies to systems in which the thrust levels have been scaled down to the values shown by addition of a resistor in the reference circuitry

2.4 Electronic Packaging

Two factors combined to make the electronic packaging task a formidable one: the basic package dimensions had been frozen before the circuit development was begun, and the comprehensive command, control, and telemetry requirements imposed required that the circuitry be rather elaborate. The result was that a densely packed package had to be developed; 1100 components are contained in approximately 100 cubic inches, giving a component density of 11 components per cubic inch.

The electronic package chassis consists of three parts: main chassis, to which all components are mounted, main outer cover which opens to expose three sides of chassis interior, and high voltage compartment cover. The main chassis forms the basic structure of the microthruster assembly. This chassis carries one of the attaching flanges and supports most of the load of the assembled unit. It is made from 0.090 aluminum sheet, composition 6061, and was dip brazed as a unit to make an integral piece. Subsequent heat treating brought the yield strength to 35,000 psi (T6 condition). The chassis was largely self-jigging to minimize tooling for the brazing process.

Structural adequacy was a primary concern during chassis design. Structural analysis was conducted to insure that the brazed joints would support both the static and dynamic loads imposed upon the chassis. The self-jigging tabs were located to reinforce those joints which were most heavily loaded and so have the lowest margins of safety.

The main outer cover was also brazed. The cover is a secondary structural member and is designed to stiffen the assembly and to carry part of the structural load. The cover also dampens the vibrational response of the chassis.

The chassis and cover are nickel and gold plated and then painted with 3M Black Velvet (Series 400). The engine/chassis interface is left unpainted as is the chassis/spacecraft interface surface.

The welded modules mate with the main chassis assembly and are of standard construction with plug-in bases and a fitting on top of each for ease of removal. Figure 12 shows a typical welded module before potting. All bases have guide pins located to assure that each module will only plug into its own socket. The board onto which the modules mount is constructed of glass epoxy and has printed conductors on the bottom side where interconnections are required between modules. All wiring from modules is dressed to one edge of the board. This edge is mounted on a hinge which permits the module board to be rotated to one side for access to module wiring and high voltage box. The board is held in the closed position with two screws. Modules are shown installed in Figure 13. Modules requiring RFI shielding are enclosed by a mumetal box. The mumetal box is attached to the board by means of tabs passing through the board then bent over and soldered on the opposite side.

All high voltage components are mounted inside a separate compartment. This compartment is located under the module mounting board. The high voltage compartment is readily accessible by rotating the hinged module board assembly and removing the cover; it may be seen in Figure 14.

2.5 External RFI Filter

During testing of the microthrusters on the ATS-D spacecraft the need for RFI filtering was discovered. Section 4.3 describes the situation

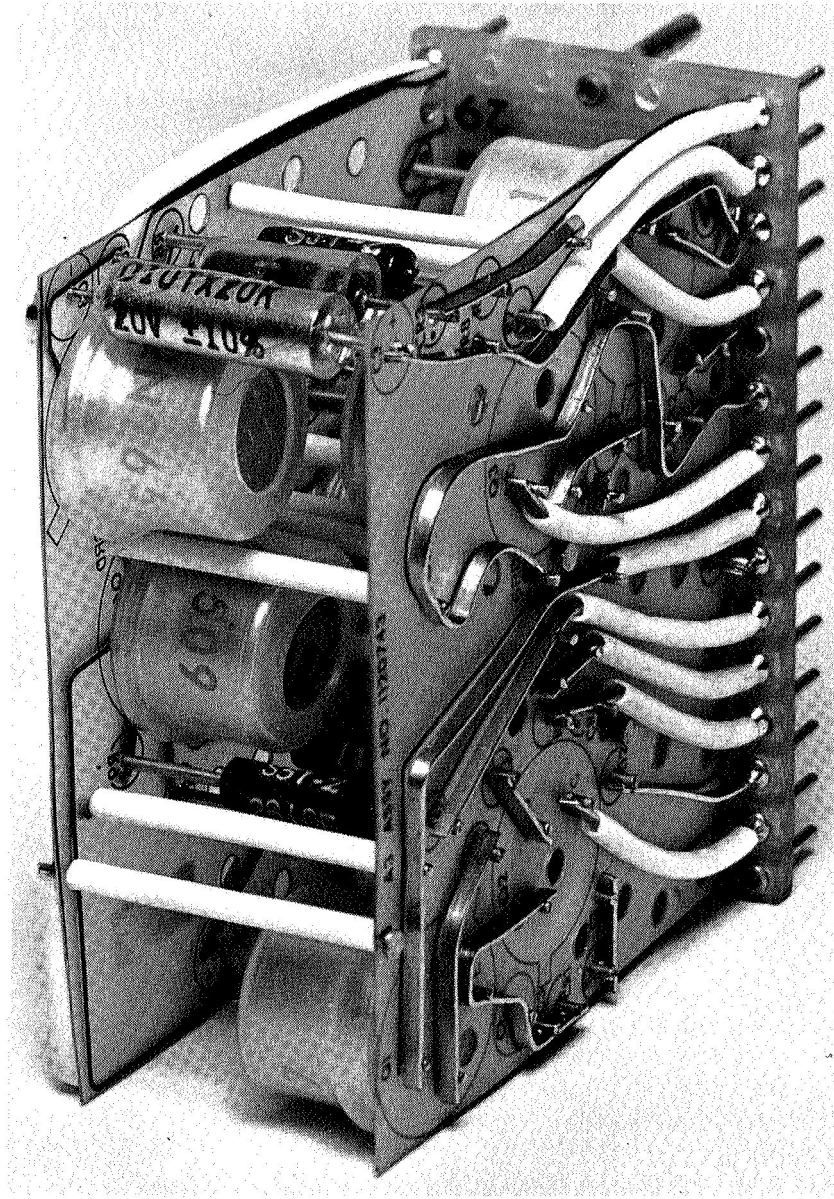

Figure 12. Welded Module A3 Before Potting

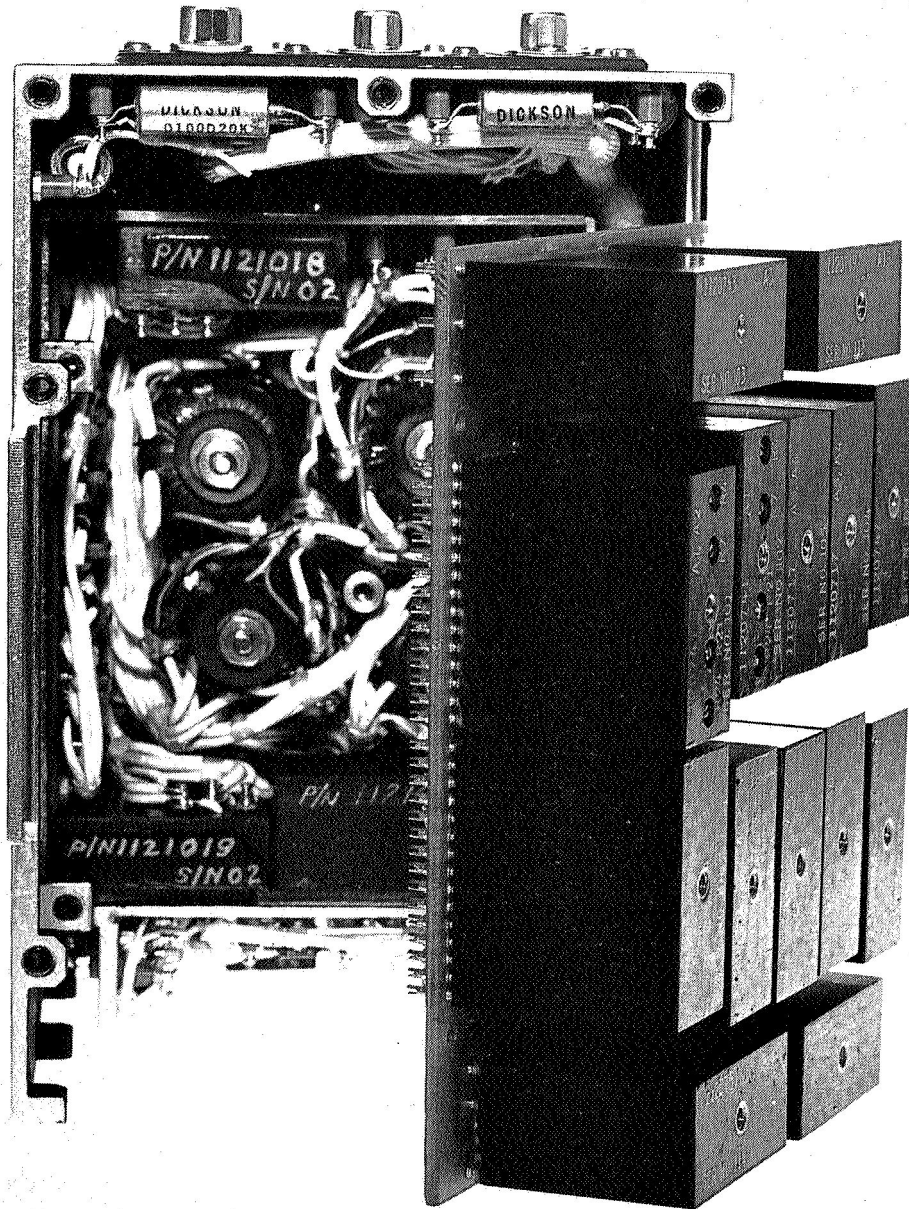

Figure 13. Installed Welded Modules

EP-967119

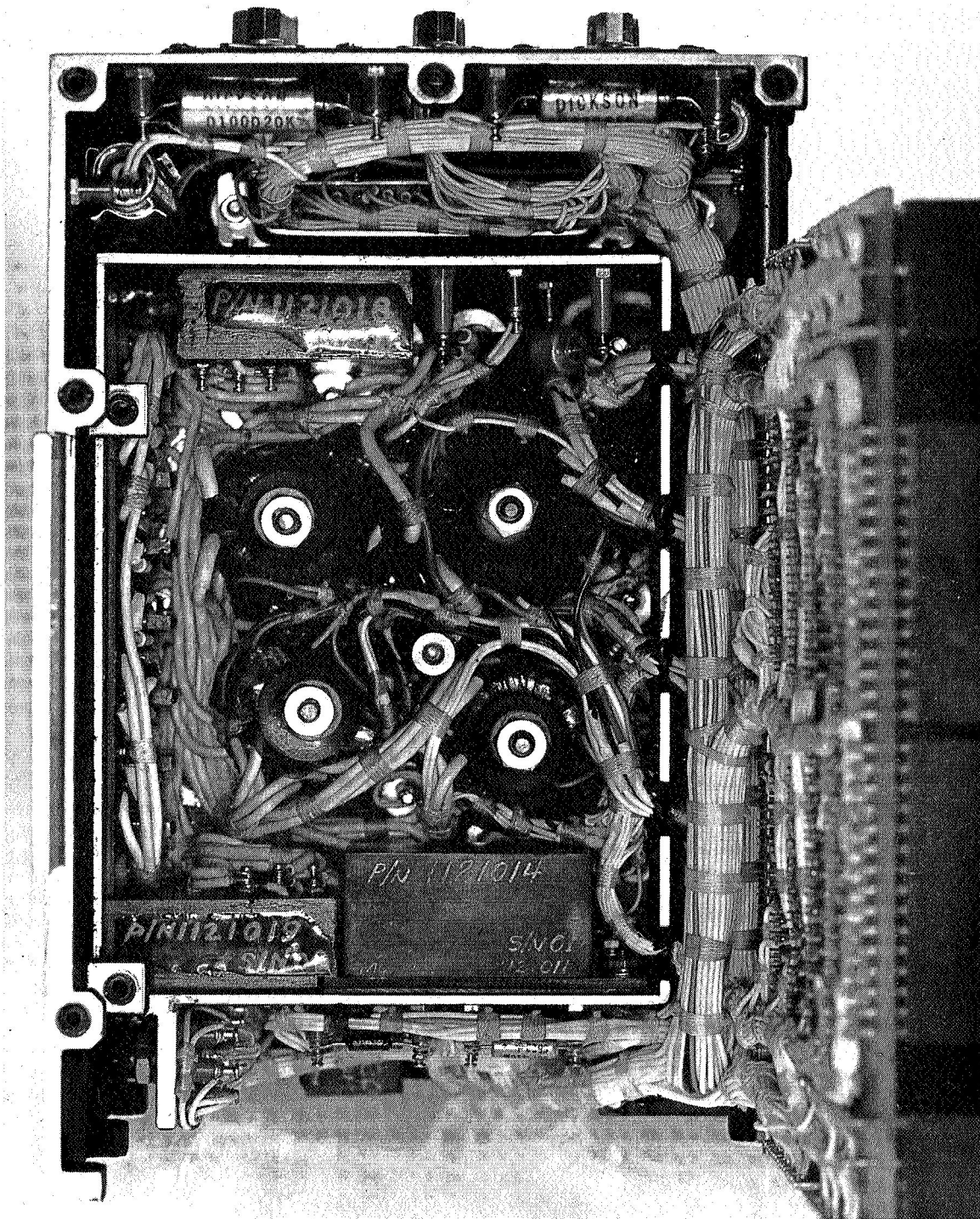

Figure 14. High Voltage Compartment

leading to the decision to add an externally mounted filter; this section describes the filter that was built to meet the need.

Fabrication was already completed on the microthruster and all available space in the existing envelope had been utilized. A new interface specification was developed with Hughes Aircraft Company to provide space for a filter chassis mounted externally to the existing microthruster system.

A filtering scheme was then devised to fit into the new envelope. This scheme consisted of commercially available in-line filters bulkhead mounted in a box mounted directly on the existing microthruster system. All power, command and telemetry lines are filtered, and additional suppression on TM lines is provided by capacitors installed between signal and ground lines. A schematic of the filter box is shown in Figure 15. The chassis is machined from one piece of aluminum and gold plated. A main cover and two side covers provide access to the four separate compartments. Figure 16 shows the filter box with covers removed and with the mounting brackets which attach the filter to the microthruster system.

3. GROUND SUPPORT EQUIPMENT

A variety of equipment was designed and used in support of microthruster system fabrication, testing, and spacecraft integration. Included in this category are harness models, mass models, test consoles, Pirani gauge controllers, and two types of thruster subsystem simulators.

The harness models were wooden models of the complete microthruster system. They duplicated the size, shape, mounting arrangement, and connector location of the microthruster and were used on a mockup

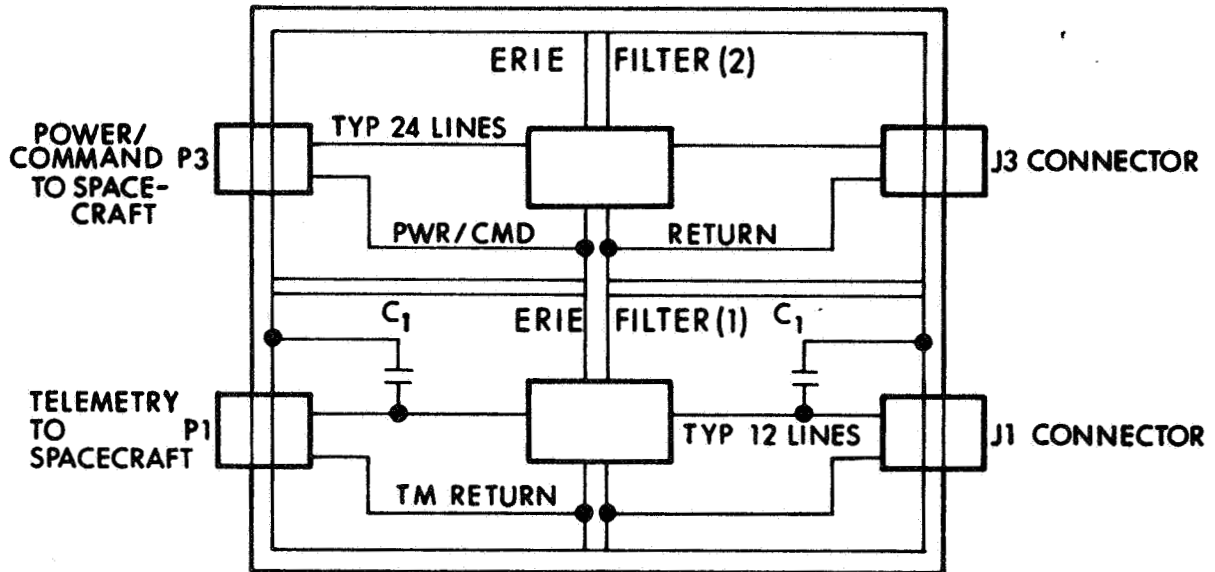

SPECIFICATIONS:

CANNON CONNECTORS DCM-37 S/P-NM

ERIE FILTER PN 1212-502

US CAPACITOR $.01\mu\text{F}$

ATTENUATION AT 10MHz: 500V IN,
10V OUT

Figure 15. External RF Filter Schematic

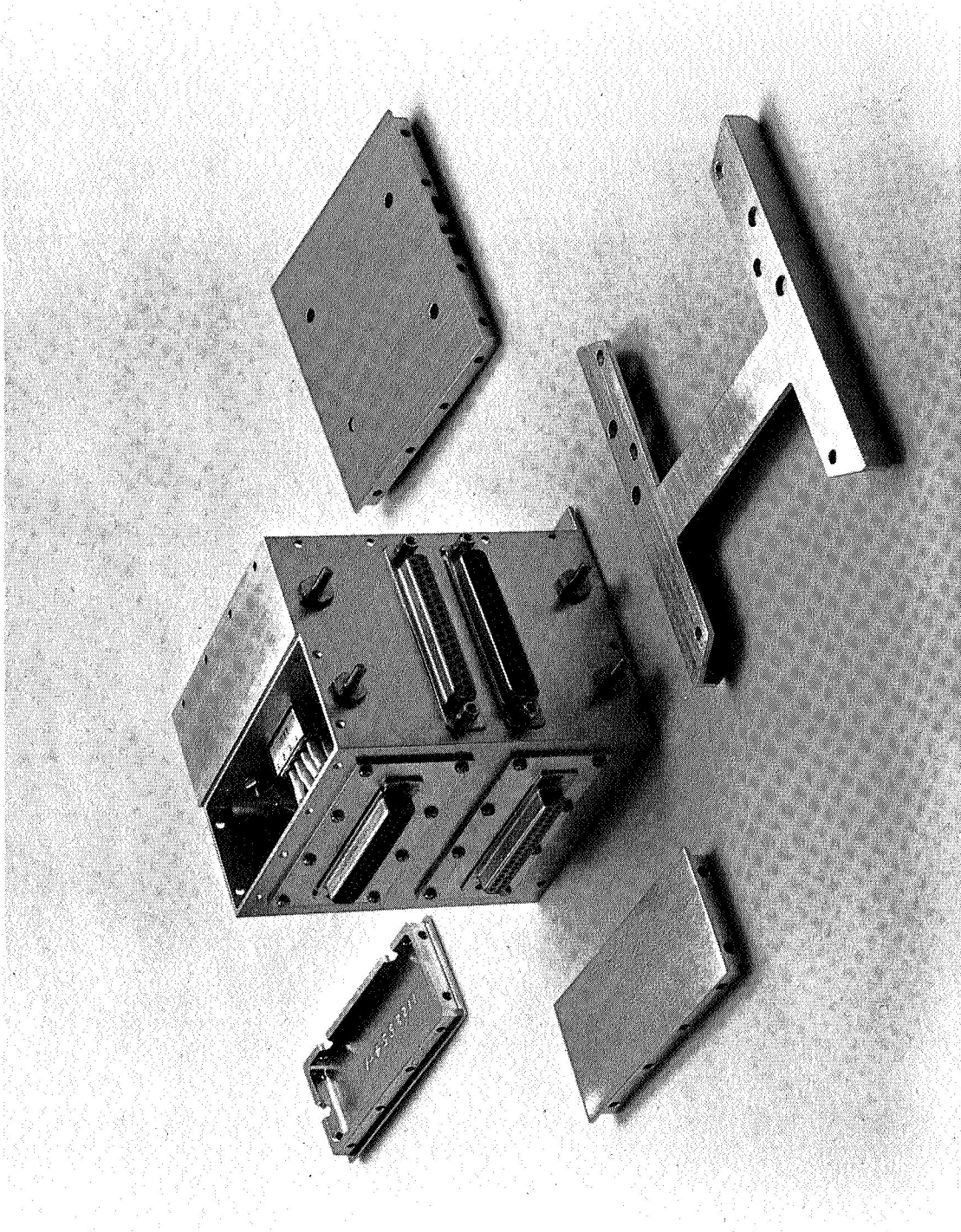

Figure 16. Filter Box with Covers and Bracket

spacecraft for determining mounting arrangement and layout out wiring harnesses.

The mass models were constructed of blocks of aluminum and duplicated the mass and center of mass (but not moments of inertia) of the micro-thruster. Their function was to provide simulation of the microthrusters during environmental testing of the T6 prototype spacecraft.

In the early planning stages of the program a distinction was made between checkout consoles which would be used to verify operational readiness of the system and test consoles which would be used during full system operation. Thus, both types are specified as deliverable hardware. As the program progressed it became clear that it would be most practical to build only one type of console, one that could perform all required functions. The resulting test console is shown in Figure 17. The top portion of the panel is associated with telemetry readout. Telemetry signals from the CLPC are available for driving a strip chart recorder and may also be monitored, one at a time, by the digital voltmeter on the test console panel. Calibration signals of 1.25, 2.50, 3.75, and 5.00 volts may be substituted for any telemetry signal by means of the small toggle switches shown. The lower portion of the main panel is associated with commands and command status. Operating commands are given by depressing the buttons shown. Wherever possible, telemetry signals are used to drive indicator lamps. Thus, when the ionizer heater is on, a green lamp under the ionizer on button is illuminated. Since it is impractical to drive indicators from the x and y deflection telemetry signals, the indicators shown in the upper right hand corner of the command panel register the number of command pulses issued.

The buttons under the transparent hinged panel in the lower right corner are reserved for checkout of the fully assembled microthruster



EF-568171

Figure 17. Test Console

system using the CLPC test connector, J4. Since the thruster subsystem must not be operated in air, the air checkout procedure includes:

1) verification of power relay operation, 2) verification of ionizer heater and vaporizer heater integrity through momentary (1/2 second) operation, 3) verification of high voltage converter operation through momentary (1/2 second) operation, 4) verification of neutralizer integrity through individual resistance measurements, 5) verification of operation of thrust control and beam vector control circuitry.

Three identical consoles of the type shown were fabricated and have received extensive use on the program.

As a necessary adjunct to the Pirani pressure transducers incorporated into the microthruster cesium reservoirs, two Pirani gage controllers were designed and fabricated. The Pirani element is connected into an automatically balanced bridge circuit and a measurement is made of the power dissipation required to maintain the Pirani element at a predetermined resistance value (and thus at a predetermined temperature since the Pirani element is temperature sensitive). A separate measurement is made of the Pirani housing temperature by means of a temperature sensitive resistor (sensistor) attached to the housing. From these two measurements and the appropriate calibration curves, the reservoir pressure may be determined with satisfactory accuracy in the range between 10 and 1000 microns.

The first thruster subsystem simulator built on the program is a laboratory device used in checking out and measuring characteristics of CLPC units. Meters are included for measuring all significant voltages and currents. The ionizer heater is simulated by a fixed resistor. Neutralizer filaments are also simulated by fixed resistors. Each resistor is connected through a switch which may be actuated to verify CLPC action in case of neutralizer failure. The negative high voltage load is simulated by a resistor. Any one of four resistors

may be selected. By making measurements with all resistors, voltage regulation and overload tripoff characteristics are determined. The positive high voltage load is simulated by a vacuum diode operated in the temperature limited mode. The diode filament is heated by the vaporizer heater supply. This arrangement provides both simulated loads and allows operation of the ion beam control feedback loop since the required relationship between vaporizer power and beam current is simulated by the diode.

As the program progressed it became clear that a thruster simulator which could be attached directly to the CLPC and fit inside the thruster housing would be extremely valuable. Accordingly, the contract was modified to cover the design and construction of two such simulators capable of operating satisfactorily either in air or in vacuum. Figure 18 shows the construction of a simulator.

The basic design of the air/vacuum simulators is the same as that of the larger simulator. The ionizer heater and negative high voltage loads are simulated by resistors. Positive high voltage load, vaporizer heater load, and the functional relationship between heater power and beam current are simulated by a vacuum diode. One neutralizer is simulated by a resistor. The other is simulated by a transformer-rectifier which drives a high voltage vacuum relay. The relay contacts are connected across the negative high voltage supply. When this neutralizer position is selected, the relay is energized and a short circuit load is applied to the negative supply. This provision was incorporated to permit overload testing during times (such as spacecraft solar-vacuum testing) when the microthruster system is inaccessible. For testing during times when the simulator is accessible, two switches are provided for producing high voltage sparks. One switch connects negative high voltage to ground while the other connects negative high voltage to positive high voltage; these are the predominant high voltage breakdown modes.

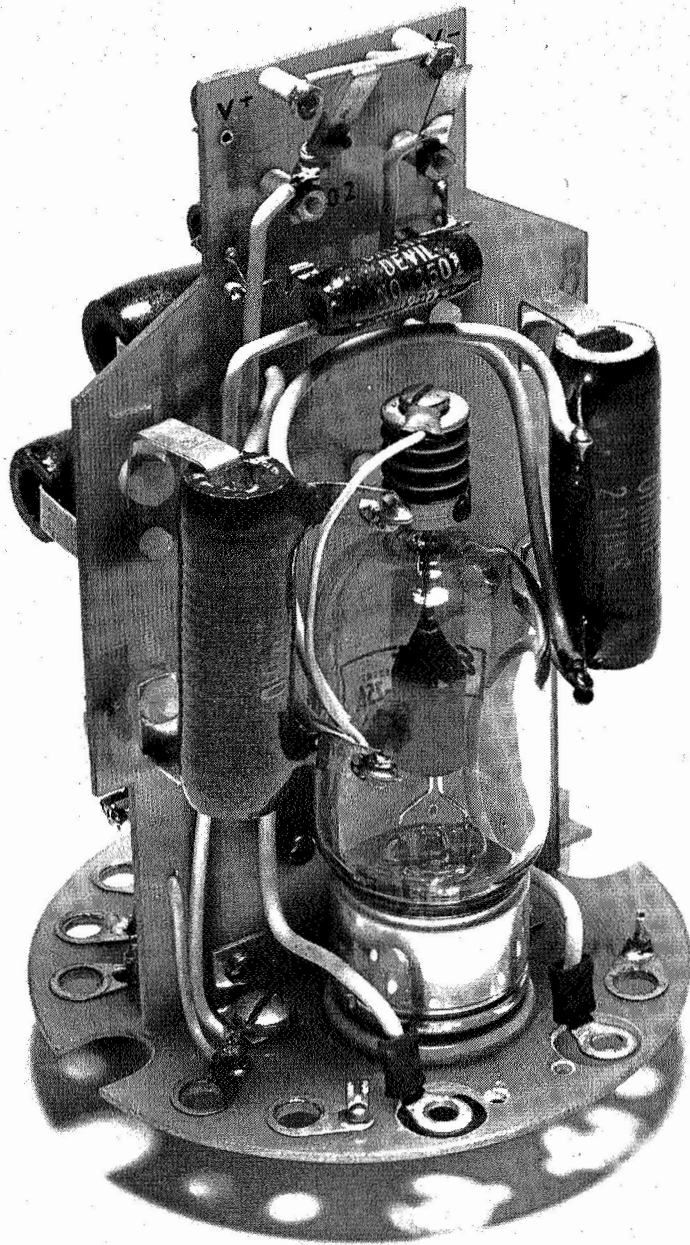

Figure 18. Air/Vacuum Thruster Subsystem Simulator

The air/vacuum simulators have found a number of applications on the program. The most important of these is substitution for the thrusters during spacecraft solar-vacuum testing, a test during which it is highly desirable to exercise the electronic portion of the system but undesirable to operate the thruster. Other applications have involved RFI investigations and retesting of modified power conditioning units.

4. DESIGN QUALIFICATION TESTING

4.1 Qualification Test Procedure

Design qualification testing for the microthruster system was based on ATS Technical Requirement S2-0102, Environmental Qualification and Acceptance Test Specification Component Testing. Modifications were incorporated to take into account unique characteristics of ion thrusters, which require a vacuum environment for operation. In qualification testing the unit is stressed to levels exceeding those expected in actual operation; the sequence includes hot and cold storage, humidity, vibration, acceleration and thermal vacuum. The qualification test program is described and significant results reported.

The qualification test sequence begins with an operational check of the microthruster system in vacuum. The unit is operated at each thrust level (nominal 0, 5, 10, 15, 20 μ lb) and beam deflection circuitry is exercised at each level. Beam deflection data is obtained with the moveable Faraday cup probe assembly shown in Figure 19. The slit aperture allows collecting complete beam position data with one sweep of the probe. By rotating the microthruster system about its thrust axis, both beam deflection directions may be mapped. After operational testing has verified performance, the unit is removed from the vacuum chamber, cleaned, and put into hot and cold storage, six hours each of +50°C and -10°C. After hot and cold storage, humidity is raised to

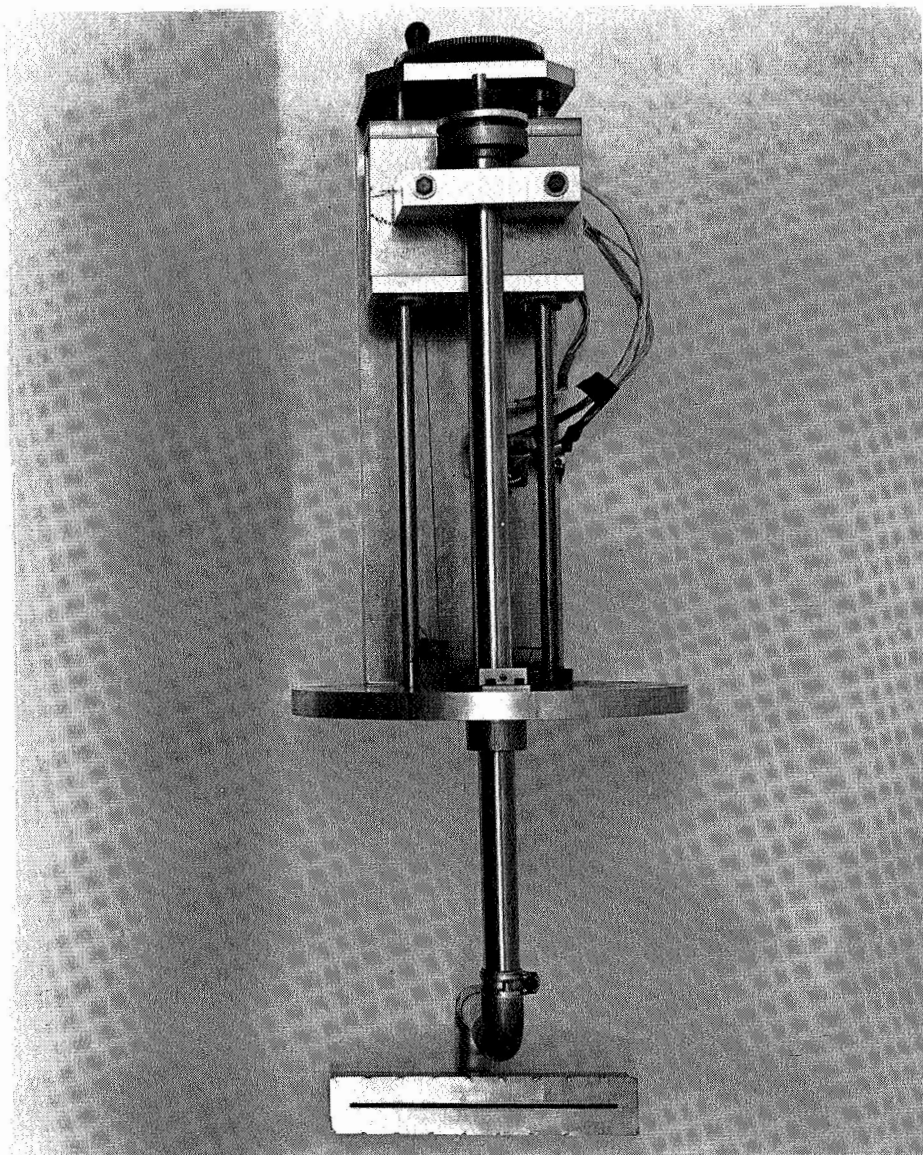

66838

Figure 19. Beam Probe Assembly

90% at 30°C and held for 24 hours. Sinusoidal vibration is next, followed by random vibration. Vibration specifications, from TR S2-0102 are given in Tables III and IV. After vibration the unit is subjected to 23g static acceleration for 3 minutes. The final test, thermal-vacuum is the most extensive, consisting of 20 days operation. This test includes 25 on-off cycles to demonstrate start-restart capability. Three cycles each are performed at maximum and minimum temperature extremes of -5°C and +38°C for the thermal enclosure around the micro-thruster. The remaining 19 cycles are performed at 20°C. After the 25 cycles have been completed the unit is operated continuously for 14 days, then 25 more on-off cycles are performed at ambient temperature. Throughout the test, thrust level and beam deflection are exercised regularly.

4.2 First Qualification Series

Testing began with qualification model microthruster SN 01-01. The first number identifies the CLPC subsystem, the second the thruster subsystem. The first step consisted of bench checkout of the CLPC. Output voltage-current curves for the power supplies were plotted and telemetry channels were calibrated. Breakdown of a high voltage transformer to a washer was eliminated by adding H-film insulation under the washer and it was discovered that a failed operational amplifier in one of the welded modules made the accelerator voltage telemetry channel inoperative.

The system was assembled and put into Operational Test on September 8, 1967. Initial operation was satisfactory. After a few hours, however, repetitive overloading of the high voltage converter was observed. After continued experimentation, it was established that the overloading was closely correlated with the CLPC temperature sensor output and did not appear to be correlated with thruster parameters. The

TABLE III

SINUSOIDAL VIBRATION SCHEDULE
COMPONENT DESIGN QUALIFICATION

Frequency	Axis	Level (0-Peak G)
10-25	Thrust	± 2.3
25-250	Z-Z	± 11.5
250-400		± 18.5
400-2000		± 7.5
10-17	Lateral	0.50 in. double ampl.
17-250	X-X	± 7.5
250-400	and	± 15.0
400-2000	Y-Y	± 7.5

TABLE IV

RANDOM EXCITATION VIBRATION SCHEDULE
COMPONENT DESIGN QUALIFICATION

Frequency	Acceleration (g + rms)	Test Duration	PSD Level (g^2/Hz)
20-150	9.2	4 Min. per axis	0.0225
150-300			Increasing from 150 Hz at a con- stant rate of +3.0 dB per octave.
300-2000			0.045

test was terminated and the system disassembled. Further experimental operation with the CLPC and a thruster simulator revealed that a high voltage resistor used in a voltage divider to provide the accelerator voltage telemetry was shorting intermittently in vacuum operation. Several replacement resistors were successfully tested under vacuum and high voltage for approximately ten hours. One of these was used to replace the faulty resistor. The repaired CLPC was checked, and the system reassembled. In the course of system operation the same intermittent overloading was again encountered. Diagnostic operation was repeated; this time both V+ and V- high voltage resistors were found to be failing. By direction of the Technical Officer the resistors were removed from the circuit and V+ and V- were removed from the telemetry list.

Also during this test the thruster appeared to suffer ionizer contamination; the cesium flowrate was adequate but the ionizer could not produce the appropriate number of ions. This condition had been seen during system development which was undertaken on another program and was thought to have been eliminated at that time by isolating the thruster subsystem from the CLPC subsystem. However, it continued to be a problem throughout the present program.

The qual unit was assembled with a new thruster as SN 01-02 and put through operational test. The system was fully exercised at each thrust level including 20 μ lb and beam deflection was measured with the scanning probe. Typical probe data are shown in Figure 20. The test was generally successful although a few anomalies were observed. On several occasions spurious thrust step commands were generated and on several occasions the deflection command circuitry in the test console operated intermittently.

At the conclusion of the Operational Test, the thruster was cleaned and the system was subjected to qualification level hot and cold

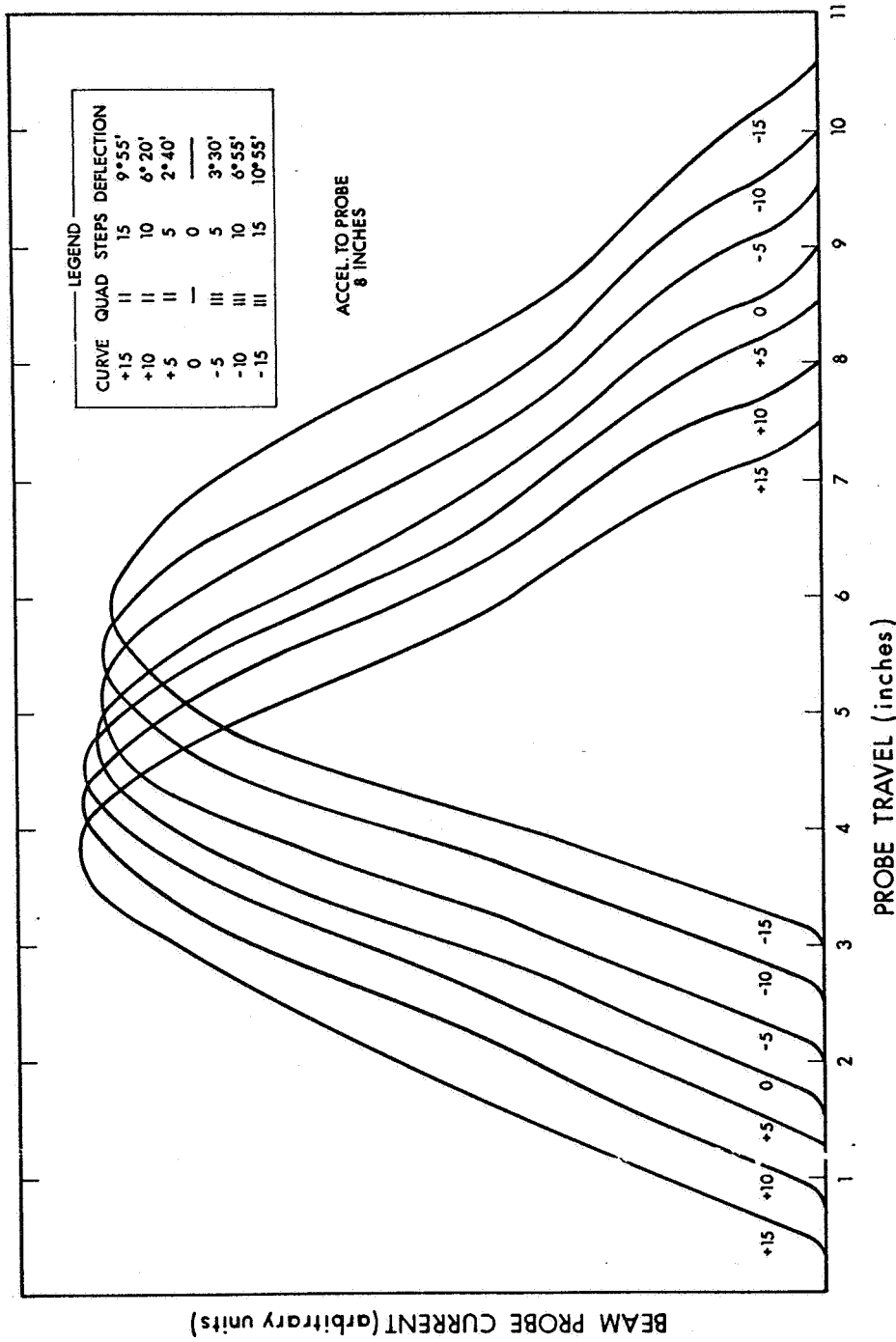

Figure 20. Typical Beam Probe Data

storage and humidity tests. All were passed successfully and were not repeated in subsequent test series.

On September 29, vibration testing was conducted. During sinusoidal vibration some resonance occurred in the thruster subsystem between 250 and 400 Hz. The ionizer, beam former, accelerator and decelerator electrodes all experienced excursions of from 0.05 to 0.1 in. All except the ionizer returned to their original positions. The ionizer remained misaligned about 0.01 in., but this did not degrade performance. During sinusoidal vibration a nut was vibrated loose. It was replaced (with a new lock washer) and the test proceeded to random vibration. Since the apparent cause of the loose nut was inadequate torquing, torque specifications were imposed on all subsequent assemblies. With the exception of the loose nut and slight ionizer misalignment produced by the sinusoidal vibration, the test was successful.

On September 30 acceleration testing was conducted uneventfully, leaving the system ready for thermal-vacuum testing in October. Acceleration test was not repeated in subsequent test series.

On October 2 the Thermal Vacuum qualification test was started. System operation at 5, 10, and 15 micropound thrust levels was normal. When the command was given for 20 micropound operation, the ion beam collector current rose from 670 μA to 840 μA and then decreased instead of rising further. This type of operation is not well understood but is widely attributed to ionizer contamination and is referred to as "rollover" after the appearance of the chart recorder trace. Operation at the 15 micropound level was resumed. Subsequent attempts to achieve 20 micropound operation were similarly unsuccessful. Several times during this phase of the test the thrust command status changed spontaneously to the 20 micropound level. Spurious thrust adjustment commands are usually associated with thruster sparks.

During this phase of the test two 0.003 dia neutralizer filaments being tested in a separate vacuum system failed. The original thruster design incorporated two 0.003-in diameter tantalum wires operating in parallel and a redundant pair as standby with automatic switch-over in case both of the primary filaments failed. This scheme provided fourfold redundancy since a single filament provided adequate beam neutralization. The literature predicts a life of 10,000 hours for the filaments as used, but failures were occurring between 100 and 300 hours. Subsequent investigation showed that failure was due to either evaporation or crystal-slippage (offsetting), a well known phenomenon in high temperature filaments. Because of the poor performance of the 0.003 inch diameter filaments, one pair was replaced on qualification thruster SN 02 by a single 0.007 inch diameter tantalum filament. Performance of the single filament was satisfactory both in system tests and in bell-jar lifetime tests; this design was ultimately approved for incorporation in flight hardware. No further neutralizer failures occurred after the design change. A neutralizer life test is being conducted under an Air Force program; 0.007 inch diameter tantalum filaments doped with 50 ppm yttrium have logged over 4000 hours continuous operation with no failures.

On October 4, the high temperature part of the thermal vacuum test was started with the system operating at the 15 micropound level. The following equilibrium temperatures (in °C) were measured: Thermal-Vac test enclosure, 40; CLPC mounting point, 51; Thruster mounting point, 60; Thruster housing, 82; CLPC case, 60; Main Converter transformer, 73. After equilibrium was attained, three off-on cycles were performed. At this time trouble was experienced in turning on high voltage and unexpected interaction of commands was observed. After some diagnostic operation these problems were traced to a faulty relay in the CLPC and the test was continued. Equilibrium temperature data was taken at several combinations of thermal enclosure and mounting point

temperatures. When the high temperature portion of the test was complete, the low temperature portion was conducted; the system was then subjected to 19 on-off cycles, each consisting of approximately 1-1/2 hours of power on and 1 hour of power off. The on-off cycles were completed without incident and the 14-day operational period was started. After encountering some trouble with HV turn-on, the system was stabilized at 15 micropounds. Several hours later, a spurious thrust adjustment command was generated. Operation at 20 micropounds was not achieved; instead the "rollover" phenomenon occurred. Since the 14-day test was not supervised on a 24-hour basis, this condition persisted until discovered by an operator several hours later. By this time the power supplies were overloaded and were cycling on and off continuously. During the next 48 hours the system was operated in an attempt to achieve stable 15 micropound operation once again. This attempt was unsuccessful. After a few additional hours of operation to investigate anomalies in CLPC operation, the system was turned off and removed from the test chamber.

On 25 October the Qualification System was reassembled with a new ionizer as SN 01-03 for further testing. During Operational Test spurious thrust commands were again observed and it was discovered that the beam probe mechanism was inoperative. The Qualification System was removed from the test chamber, the probe was repaired, and the Operational Test was repeated. On October 30 the Qualification System was successfully subjected to vibration testing and was installed in the test chamber for thermal vacuum testing. When energized the ionizer heated to 800°C. Since it did not reach the expected temperature of 1080°C, the test was terminated for investigation.

The ionizer lead was found adjacent to the beamformer bulkhead. A short circuit was suspected so the lead was centered in its clearance hole and the thruster retested. Again the ionizer temperature did

not exceed 800°C. When the unit was reexamined, cesium was found on the ionizer and in the feed tube, a condition caused by air pressure in the feed system. The feed system had successfully undergone six operational cycles previous to this test and a seventh cycle was known to have only a reasonable chance of success. The low ionizer temperature observed was probably a result of the cesium in the tube providing conduction away from the ionizer area. It should be mentioned for completeness, however, that continued investigation revealed several layers of 0.001 in thick molybdenum heat shielding were in contact with the ionizer heater connector. This would result in some heat conduction away from the ionizer but could not account for the large temperature drop observed. Nevertheless the condition was undesirable so the heat shielding design was modified to preclude its recurrence.

Since the essential qualities of the microthruster system had been proven and the flight schedule was pressing, attention was turned to flight hardware for a time. After delivery of the first two flight units attention was again returned to qualification testing.

4.3 Second Qualification Series

On December 14 qualification testing began with system SN 01-08. During operation test considerable arcing was observed but the test was completed including beam probe data. The unit moved to vibration test. Information from accelerometers installed on the spacecraft structural model (T6) indicated actual vibration levels were considerably lower in the 70-400 Hz range than indicated by specification S2-0102. In order to present a more realistic test, qualification vibration was run at the reduced value of 5g in the above range. Resonant effects in this test were very minor. Electrode excursions were much smaller than on previous tests. However, ionizer misalignment of approximately 0.005 inch still occurred. Thermal vacuum was started but ionizer contamination effects were evident very early. The unit achieved 15 μ lb

thrust but later would not maintain even 10 μ lb. The test was discontinued and a new ionizer installed. Since the system had been operating normally before beam probing, probing was eliminated from the test procedure. Although the evidence did not strongly point to the probe as a source of contamination, eliminating its use did decrease the amount of material sputtered back to the ionizer.

On January 2, 1968 a qualification test series using system SN 01-09 was started. The system configuration was the same as had been tested previously except that transient suppression resistors had been installed in the accelerator quadrant leads. At the time, it was being proposed that 10K metal film resistors be used for suppression, so resistors of this type were installed. (Subsequent simulated thruster sparking tests indicated that the 10K metal film resistors used on the qualification system could not be expected to survive in this service. Also additional transient suppression associated with a larger resistance value proved desirable. A 300K carbon composition resistor was finally chosen for flight units.) The operational test was successfully conducted as directed by the Technical Officer with operation through 15 micropounds. The system was then subjected to qualification level vibration testing to the levels indicated by T6 spacecraft tests. No problems were encountered except that after the test it was found that one of the metal film resistors had failed, probably from sparking during operational test. The resistor was replaced and thermal vacuum testing was started. Operation of the system during this test was generally satisfactory. During the first few hours of the test the vaporizer control loop exhibited oscillations. This effect, attributed to feed system characteristics, disappeared after the 25 on-off cycles. Hot and cold cycles were completed uneventfully and a 14-day period of unattended operation was started. During this period 7 spurious commands from 15 micropounds to 20 micropounds were observed. When this occurred, the test console,

which had been modified since the last test, automatically commanded thrust off and summoned an operator. During the last day of this period the thruster sparked sufficiently on two occasions to activate the arc counter which shuts down the system. Upon completion of the 14 day test, on-off cycling was again conducted. After about 10 cycles it was observed that the vaporizer power required to achieve 15 micropound operation was increasing. Finally it was impossible to achieve 15 micropounds in normal cycling. However, if the system were operated at 10 micropounds for approximately four hours, vaporizer power gradually decreased to a normal value and several normal on-off cycles could be performed. After 16 on-off cycles the test was terminated on January 26. With the possible exception of the anomalous feed system behavior, qualification testing was considered acceptable.

4.4 RFI Filter Qualification

During tests with the Experimental Package Console (EPC) at Hughes Aircraft it was discovered that high voltage arcing in the microthruster was inducing transients on telemetry lines that could damage the spacecraft encoder. As noted earlier, spark suppression resistors were added to the accelerator leads and bench tests indicated this was sufficient to protect the encoder. A set of accel leads with 300K carbon resistors was subjected to qualification level vibration and thermal-cycling to verify the design change. This was necessary as 10K metal film resistors were used during the microthruster qualification test.

With resistors installed, delivered units passed EPC but a unit was misassembled causing a spark that damaged the F-4 spacecraft encoder. Subsequent examination resulted in tighter control on assembly and the decision to add an RFI filter assembly external to the microthruster system. This filter was fabricated and subjected to

qualification vibration and thermal cycling to qualification level temperatures to verify the design. Three thermal cycles were conducted; each cycle consisted of one half hour at -5°C and one half hour at 40°C . Transient suppression was monitored during hot and cold cycles. Peak to peak transients of 500 volts at 10 MHz were reduced to 10 volts. Qualification testing ended with the above test. The microthruster system had demonstrated successful operation through 15 μlb thrust level. Indications of adequate life were good, although test time was limited by the program schedule. Three items remained incompletely explained: Ionizer contamination, slow vaporizer response during cycling, and spurious thrust level commands. But none of these appear to prevent the microthruster system from performing its mission on ATS. The superior vacuum environment available on the spacecraft should improve ionizer performance allowing satisfactory operation at 20 μlb . The microthruster system is flight qualified for 15 μlb and has 20 μlb thrust potential.

5. FLIGHT ACCEPTANCE TESTING AND SPACECRAFT INTEGRATION

5.1 Acceptance Test Procedure

Flight acceptance testing is performed at the levels expected in operation to verify functional integrity of the particular unit tested. For the microthruster system this requires random vibration at levels specified in TR S2-0102 and operation at each thrust level except 20 μlb as directed by the Technical Officer. Thermal-vacuum testing consists of 12 hours operation at the highest anticipated spacecraft temperature, 30°C , and 12 hours at the lowest, 5°C . Three on-off cycles are performed at each temperature and thrust vectoring capability is exercised at each thrust level.

5.2 Flight System SN 03

On 6 November the first flight model, SN 03-04, was completed and started through acceptance testing. Vibration testing was completed satisfactorily and the thermal vacuum test was begun. Initial operation was satisfactory with the exception of failure to operate at 20 micropounds thrust. Operation in the cold environment was completed. During the hot environment portion of the test the system again failed to operate at 20 micropounds. From this point, thruster operation deteriorated further and the test was terminated.

A new thruster subsystem was assembled and installed in the system now denoted SN 03-05. Acceptance testing was started on 14 November. At the direction of the Technical Officer operation at 20 micropound thrust was deleted from the procedure. The vibration test was completed satisfactorily. During thermal vacuum the unit experienced high drains and rollover at 15 μ lb thrust. The system recovered however and passed the test. The unit was determined to be acceptable, and was delivered to Hughes Aircraft Company on 17 November.

The performance of the SN 03-05 flight system had been barely satisfactory. In addition, following procedures then in effect, the thruster had not been cleaned after acceptance testing. Also accel leads with resistors were to be retrofitted. Since it was agreed that a more satisfactory unit would result from retesting with a new thruster subsystem, the 03 system was returned from HAC, fitted with new accel leads and the SN 07 thruster and put into acceptance test. The system performed well during acceptance test. At the end of the test, however, the ionizer temperature fell dramatically. This malfunction was traced to a faulty electron beam weld in the ionizer heater lead. Since the weld in question was uninspectable, all previously completed welds had to be reworked. A design change was made to prevent recurrence of

this problem. The 07 thruster subsystem was replaced with SN 11 and the system was prepared for flight acceptance testing. This test was terminated when the ionizer temperature began to fluctuate. The problem was traced to contact between ionizer and vaporizer leads. Additional clearance was provided and the unit was reassembled with thruster SN 10. Flight unit SN 03-10 passed acceptance test without incident and was redelivered to Hughes Aircraft Company.

5.3 Flight System SN 04

In checking out the next flight model CLPC (S/N 04) it was discovered that the unit exhibited the symptoms of an overload condition on the negative high voltage supply. Initially it was felt that the negative high voltage current transformer might be defective. Further investigation showed, however, that neither the current transformer nor the rectifier module was faulty. The overcurrent signal was apparently produced by capacitive current associated with stray wiring capacity. SN 04 was put in operating condition by rerouting some of the high voltage wiring and by adding a resistor in parallel with the secondary of the current transformer to bring the overload trip point to the desired level. Further bench testing showed that two resistors in the deflection circuitry also had failed. These were replaced.

Because of potential problems in recovering from rollover, one thruster on ATS-D was to be limited to 15 μ lb thrust. Thus, Flight System SN 04-11 was modified to 15 μ lb maximum thrust as directed by the Technical Officer. This was done by attenuating the thrust reference signal to make each level 75% of its original value. Flight acceptance testing was begun. After three hours into the hot cycle of thermal vacuum the high voltage converter began to cycle on and off. Investigation showed the overload circuit was temperature sensitive. CLPC SN 04 was set aside for the time being.

5.4 Flight System SN 05

The complete microthruster system was assembled on 27 November and started into acceptance testing as SN 05-06. Vibration testing was completed uneventfully and the thermal-vacuum test started. It was found that accelerator drains were excessively high from the beginning of the test. This condition was attributed to the fact that the thruster electrodes and insulators had not been cleaned after the thruster conditioning run. The test was terminated, the system was removed from the test chamber, and the electrodes were cleaned. It was at this time posttest cleaning procedures were reinstated for all thrusters. The thermal vacuum test was restarted on November 30. Operation of the thruster was less than satisfactory; the system failed to achieve 15 micropound operation upon command due to occurrence of the "rollover" phenomenon. System operation was continued; on December 1, 15 micropound operation had been achieved and the cold cycle portion of the thermal vacuum test was conducted. The following day the hot cycle portion was started. Thruster operation deteriorated with repeated failure to operate at 15 micropounds observed. Late on December 2 the test was terminated. Thruster 06 was removed from the CLPC and operated with laboratory supplies. Operation at elevated temperature restored the ionizer to proper operation. After cleaning and reassembly the thruster was reinstalled on the CLPC and system SN 05-06 was subjected to acceptance thermal vacuum test. The test was completed without incident and the system was delivered on December 12.

The delivered flight system SN 05-06 was subjected to testing on the Experiment Package Console (EPC) at Hughes. In the course of this testing it was observed that, during simulated thruster sparking, large transients (>100 volt) were introduced on telemetry lines. These transients were correlated with encoder malfunctions. Analysis by HAC revealed that transients of amplitude greater than 45 volts were

potentially damaging so the task of reducing the amplitude of the transients was undertaken. An experimental investigation showed that adding a 300K resistor in series with the lead to each accelerator quadrant limited current flow during sparking and reduced the transients on telemetry lines to an acceptable level of a few volts. This design change was approved and qualification testing of resistor assemblies was conducted. At the direction of the Technical Officer, further investigations were conducted to reduce telemetry line noise associated with inverter operation. It was found that a worthwhile reduction in noise could be produced by adding a 6800 pF capacitor between collectors of the ionizer inverter and by adding 2700 pF across the input power line for high frequency by-passing; these modifications were approved and incorporated into the design.

Flight System SN 05-06 was returned from Hughes Aircraft for addition of the modifications described above. After modification the unit was subjected to the flight acceptance vibration schedule and the CLPC with simulator put through a modified thermal vacuum schedule comprising testing four hours at the high temperature and four at the low temperature specified for flight acceptance.

The unit was redelivered to Hughes for EPC and spacecraft tests. By technical direction the unit was again returned to EOS and modified by reducing maximum thrust to 15 μ lb; SN 05-06 was again returned to Hughes. While at Hughes the simulator was removed and thruster installed by EOS personnel as part of the spacecraft test procedure. The unit was mounted on the spacecraft for testing. During high voltage arcing the spacecraft encoder was damaged. System 05-06 was returned to EOS for analysis which showed the thruster had been misassembled allowing a positive to negative high voltage arc to bypass the 300K suppression resistors. To prevent the situation from recurring, an assembly and disassembly procedure was prepared

for EOS personnel operating away from the EOS plant. Inspection points for cognizant quality assurance inspectors were clearly indicated. The unit was redelivered to Hughes Aircraft Company.

5.5 Filters

As a result of the encoder failure, effort was directed toward developing an RFI filter to act as a buffer between microthruster system and spacecraft encoder. A filter was designed and qualified as reported in Sections 2.5 and 4.4. Acceptance testing for the filters consisted of vibration to flight-spare specifications, 3 axis random, 3 axis sine. The units were mounted on a microthruster system in the same manner that they are to be mounted on the spacecraft. Thermal testing consisted of 3 cycles each consisting of one-half hour at 5°C and one-half hour at 30°C. Transient suppression was monitored.

Two flight units were acceptance tested. The qualification unit and one flight unit were delivered to Hughes Aircraft and installed on the microthrusters there. The third unit is the flight spare.

6. NEW TECHNOLOGY

There are no reportable items as defined by the New Technology Clause.

7. PROGRAM FOR NEXT REPORTING INTERVAL

During the next reporting interval the following tasks will be undertaken:

- 1) Conduct flight spare acceptance testing on microthruster system SN 06-11.
- 2) Complete fabrication and acceptance testing of filter units SN 04 and 05.

- 3) Complete fabrication and acceptance testing of microthruster systems SN 04, 07, and 08.
- 4) Continue spacecraft integration and test support.
- 5) Provide spacecraft pre-launch and post-launch support.
- 6) Refurbish qualification microthruster system SN 01 and deliver to GSFC with test console.

8. CONCLUSIONS AND RECOMMENDATIONS

As a result of the development and testing described in the main body of the report, we conclude that the microthruster systems are flight qualified and have an excellent chance of performing as anticipated aboard the satellite.

However, during the program a number of problems arose, which, because of the press of time, could be dealt with only in a very limited way. Extended investigations into the source of the problem or solutions involving significant changes in system design were not compatible with the program which was strictly geared to flight hardware fabrication and acceptance testing on a rapid schedule.

In most cases, an acceptable if not completely satisfactory solution to the problem was arrived at in the limited time available, allowing the program to proceed. We feel that these solutions are not the best solutions and that it would be highly desirable to conduct further investigations, determining the cause of the problem wherever possible, and presenting the available solutions.