

Presented at the
1968 IEEE National Telemetry Conference
April 11, 1968, Houston, Texas

An Analysis of the Effect
of a Particular Class of
PFM on Noise Inputs*

C. E. Hutchinson
Y. T. Chon

Electrical Engineering Department
University of Massachusetts
Amherst, Massachusetts 01002

GPO PRICE \$ _____

CSFTI PRICE(S) \$ _____

Hard copy (HC) _ _

Microfiche (MF) _ _

ff 653 July 65

*The research reported herein was partially supported by NASA
under Grant NGR 22-010-018.

FACILITY FORM 602	ACCESSION NUMBER	NO 84565	(THRU)
	(PAGES)	21	(CODE)
	(NASA CR OR TMX OR AD NUMBER)	CR-96822	(CATEGORY)
			07

PFM with Random Inputs - Hutchinson, et. al.

LIST OF SYMBOLS

$E[\cdot]$	Expected value of $[\cdot]$
f_c	Effective cutoff frequency of band-limited white noise
K	Bandwidth of Σ PFM
$m_n(x_0)$	Defined as $E[T^n x_0]$
$p(t)$	Output of PFM integrator
$P[\cdot]$	Probability of $[\cdot]$
$p(x_0, t_0; x, t)$	Transition probability density
$R_{SS}(\tau)$	Autocorrelation function of the impulse process and defined as $E[S(t+\tau)S(t)]$
r	PFM reset threshold level
$S(t)$	Impulse process
S_0	Spectral density of a white noise
$S_{SS}(\omega)$	Spectral density of the impulse process
$\text{sgn}(\cdot)$	Sign of (\cdot)
T_k	Instantaneous impulse period
t_n	Impulse occurrence times
$u(t)$	Input of a PFM system
$\text{Var}[\cdot]$	Variance of $[\cdot]$
$X(t)$	Random process
$y(t)$	Output of a PFM system
α_n	Random intensity of impulse
β	Average number of random impulses per unit time interval
$\delta(\tau)$	Dirac delta function
$\theta(x_0)$	Infinitesimal mean
$\rho(n)$	Defined as $E[\alpha_j \alpha_{j+n}]$
$\phi(x_0)$	Infinitesimal variance
ω	Angular frequency, i.e., $\omega = 2\pi f$

Number of pages - 13

Number of Tables - 0

Number of Figures - 5

ABSTRACT

Because Pulse Frequency Modulation (PFM) provides a high degree of immunity to noise, it is presently of interest in many modern communication and control systems. This paper presents a quantitative statistical analysis of PFM systems with a noise input (namely, white noise). Some concepts of the Impulse process and the first passage time problems of diffusion process are introduced, which are analogous to the noise transmission of PFM systems. The autocorrelation and spectral density functions are determined for the output of the PFM system with a white noise input. A comparison between the analytical and experimental results is presented.

I. INTRODUCTION

During recent years communication and control engineering have merged in many related research areas, one of which is the application of Pulse Frequency Modulation (PFM). In a PFM system the information carrier is the time between the emission of two rectangular pulses with identical width and amplitude. The pulses are generally assumed to be impulses for analytical purposes. This practice will be followed herein.

It has been demonstrated that PFM presents many advantages in engineering applications [Farrenkopf, Sabroff, and Wheeler, 1963]. Most important among these advantages is a high degree of noise immunity. However, little is known about the actual degree to which PFM systems are immune to noise and/or the responses to random inputs in a statistical sense.

In this paper, a statistical analysis of the responses to a PFM system is developed, with particular attention given to the cases of Integral Pulse Frequency Modulation, IPFM [Li, 1961] and Sigma Pulse Frequency Modulation, Σ PFM [Pavlidis and Jury, 1965].

Integral Pulse Frequency Modulation is defined as one that emits an impulse whenever the magnitude of the integral of the input signal reaches a given threshold value. The integrator is reset after each pulse so that the successive integration always starts from zero. The output is then a train of impulses whose instantaneous frequency increases linearly with the input signal magnitude. In this work, only one type of IPFM, namely double-signed IPFM which can generate impulses of both signs depending upon the sign of the time integral of the activating signal is considered. A block diagram of IPFM is shown in Fig. 1.

If $u(t)$ denotes the input, $y(t)$ the output, $p(t)$ the output of the

integrator, and r the threshold value, the following two equations describe the behavior:

$$\frac{dp(t)}{dt} = u(t) - r \operatorname{sgn}(p) \delta(|p|-r) \quad (1)$$

$$y(t) = \operatorname{sgn}(p) \delta(|p|-r) \quad (2)$$

where $\operatorname{sgn}(p) = \pm 1$ depending on the sign of p and δ is a unit impulse (a Dirac delta function). The second term of the right hand side of (1) represents a resetting of p to the zero value immediately after an output pulse occurs.

A more general scheme of PFM is to feed the signal to a low-pass filter and emit an impulse when the output reaches a certain level. One of the cases where the filter is of first order and linear has been presented as Σ PFM, the block diagram of which is shown in Fig. 2.

If $u(t)$ denotes the input, $y(t)$ the output, r the threshold value and K the bandwidth of Σ PFM, the following two equations describe the behavior:

$$\frac{dp(t)}{dt} + Kp(t) = u(t) - r \operatorname{sgn}(p) \delta(|p|-r) \quad (3)$$

$$y(t) = \operatorname{sgn}(p) \delta(|p|-r) \quad (4)$$

where $p(t)$ is the integral of the sum of the input plus a function, Kp , of the integrator output.

The Σ PFM systems present many advantages over the IPFM system such as improved stability and ease of physical implementation. It is obvious that IPFM is a special case of Σ PFM which occurs when $K = 0$.

II. PROBLEMS AND ASSUMPTIONS

When the input $u(t)$ to a PFM unit is a random function of time, the output of the modulator will be an impulse train whose instantaneous impulse period T_k is a random function of different distribution. If the statistical properties of T_k can be found through the statistical properties of the input $u(t)$, the autocorrelation function of the modulator output $y(t)$ and hence its power spectral density can be determined. Thus a quantitative measure of the effect of PFM will be available.

The approach taken is to first determine properties of T_k for both IPFM and Σ PFM driven by random processes. Then the autocorrelation functions and the power spectral densities will be determined. Some initial assumptions are in order, however, and these are given below.

Assumption I: The input of the PFM unit is white noise (pure random process) which has:

- a) constant spectral density, S_0 , for all frequencies,
- b) stationary, normally distributed magnitude, and,
- c) zero mean.

Assumption II: The resetting of the integrators after each impulse is effected instantaneously.

Assumption III: The emitted impulses at the output have unit area.

III. IMPULSE PROCESS

When attempting to discuss the statistical performance of PFM, the problem of determining the spectrum, and the autocorrelation of a random impulse train arises. The problem involves the study of a random process consisting of an infinite train of impulses occurring at random times with random intensities. As in Lenemen[1966] the impulse process $S(t)$ is defined as:

$$S(t) = \sum_{n=-\infty}^{\infty} a_n \delta(t - t_n) \quad (5)$$

where the firing times t_n constitute a stationary point process [Beutler and Leneman, 1966], and the intensity modulating coefficients α_n a stationary random process which is independent of the point process. That is, the impulse process consists of an infinite train of delta-functions occurring randomly in time and having random intensities (areas).

In the same reference it was shown that the autocorrelation for $S(t)$ is

$$R_{SS}(\tau) = \beta \rho(0) \delta(\tau) + \beta \sum_{n=1}^{\infty} \rho(n) f_n(\tau) \quad \tau \geq 0 \quad (6)$$

where

β = average number of pulses per unit time

$$\rho(0) = E[\alpha_n^2]$$

$$\rho(n) = E[\alpha_j \alpha_{j+n}]$$

$$f_n(\tau) = \int_0^\tau f_1(\tau-u) f_{n-1}(u) du$$

and $f_1(\tau)$ is the probability density function for the interval between two consecutive firing times. $f_n(\tau)$ therefore, denotes the probability density function associated with n consecutive intervals.

The intensity of output impulses of PFM, α_n , constitute a stationary random process which is independent of the stationary point process $\{t_n\}$ and has outcomes of +1 or -1. In addition, it can be noted that in case of PFM with a white noise input,

$$\rho(0) = E[\alpha_n^2] = 1 \quad (7)$$

and

$$\rho(n) = E[\alpha_j \alpha_{j+n}] = 0 \quad n \geq 1 \quad (8)$$

Consequently, the autocorrelation function and the power spectral density become simply

$$R_{SS}(\tau) = \beta \delta(\tau) \quad (9)$$

and

$$S_{SS}(\omega) = \beta \quad (10)$$

In the following Section g will be evaluated in both the IPFM and EPFM cases with a white noise input using the techniques of first passage time problems of homogeneous normal diffusion processes, following the

approach of Darling and Siegert [1953] as presented in Cox and Miller [1965].

IV. THE FIRST PASSAGE TIMES OF DIFFUSION PROCESSES

If the input to the PFM unit is a gaussian, white noise process the output of the integrator, $p(t)$, is a normal diffusion process which is time homogeneous. In the theory of the diffusion process if x_0 denotes the state at time t_0 and x that at a later time t then the transition probability density $p = p(x_0, t_0; x, t)$ satisfies the Kolomogorov equations (diffusion equations). There are two of these equations, a forward and backward one. However, if the first passage time distribution to a fixed state r as a function of the initial position x_0 , is desired, then the backward equation provides the appropriate method. For the time homogeneous process the Kolomogorov backward equation becomes

$$\frac{1}{2} \phi(x_0) \frac{\partial^2 p}{\partial x_0^2} + \theta(x_0) \frac{\partial p}{\partial x_0} = \frac{\partial p}{\partial t} \quad (11)$$

where

$$p = p(x_0, x; t) \text{ and}$$

$$\theta(x_0) = \lim_{\Delta t \rightarrow 0} \frac{E[x(\Delta t) - x_0]}{\Delta t}$$

$$\phi(x_0) = \lim_{\Delta t \rightarrow 0} \frac{\text{Var}[x(\Delta t) - x_0]}{\Delta t} \quad (12)$$

The functions of $\theta(x_0)$ and $\phi(x_0)$ are sometimes called the infinitesimal mean and variance of the process. A precise explanation of these equations may be found in Gnedenko [1962].

For a process $x(t)$ starting at x_0 with mean zero and variance parameter S_0 , the first passage time T of $X(t)$ to the point $r > x_0$ is defined by

$$\begin{aligned} X(0) &= x_0 \\ X(t) &< r \quad (0 < t < T) \\ X(T) &= r \end{aligned} \quad (13)$$

If there is an absorbing barrier* at r and $p(x_0, x; t)$ is the probability density that $X(t) = x$ and that the process does not reach the barrier in time $(0, t)$ then

$$\begin{aligned} & P\{X(\tau) < r \text{ for } 0 < \tau < t, X(t) \leq r | X(0) = x_0\} \\ &= \int_0^t p(x_0, y; t) dy \\ &= P(x_0, r; t) \end{aligned} \quad (14)$$

$P(x_0, r; t)$ is the probability that absorption has not yet occurred by time t , i.e.,

$$P(x_0, r; t) = P(t \leq T) \quad (15)$$

The above comments concerning first passage times is significant since if

$$m_1(x_0) = E[T | x_0] \quad (16)$$

then

$$\beta = \frac{1}{m_1(0)} \quad (17)$$

It is straight forward, using Laplace Transform techniques to show that

$$\frac{1}{2} \phi(x_0) \frac{d^2 m_1}{dx_0^2} + \theta(x_0) \frac{dm_1}{dx_0} = -1 \quad (18)$$

The appropriate boundary conditions for the PFM problem are

$$m_1(r) = m_1(-r) = 0 \quad (19)$$

If $u(t)$ is assumed to have zero mean and spectral density S_0 , then for IPFM

$$\phi(x_0) = S_0 \quad (20)$$

$$\theta(x_0) = 0 \quad (21)$$

and for Σ PFM

$$\phi(x_0) = S_0 \quad (22)$$

$$\theta(x_0) = -Kx_0 \quad (23)$$

* A point r is called an absorbing barrier if when the process $X(t)$ starting at x_0 reaches that point, the motion ceases.

Utilizing these values in Eq. (18) yields

$$m_1(o) \Big|_{\text{IPFM}} = \frac{r^2}{S_o} \quad (24)$$

$$m_1(o) \Big|_{\Sigma\text{PFM}} = \frac{1}{2K} \sum_{n=1}^{\infty} \frac{(4r^2K/S_o)^n}{(2n)(2n-1)\cdots(n)} \quad (25)$$

V. ANALYTICAL AND EXPERIMENTAL RESULTS

An experimental study was conducted to verify the analytical results of the previous sections. The ΣPFM equipment used in the experimental study was built by R. A. Leuchs [1967]. A laboratory noise generator was used to provide the input*. In reality this generator was not truly "white", rather it was "band-limited".

True white noise has constant power spectral density, i.e.,

$$S(\omega) = S_o \quad (26)$$

$$R(\tau) = S_o \delta(\tau) \quad (27)$$

In the experimental work that follows, the input is a band-limited white noise which has spectral density and autocorrelation such as,

$$S(\omega) = \begin{cases} S_o & |\omega| < \omega_c \\ 0 & |\omega| > \omega_c \end{cases} \quad (28)$$

$$R(\tau) = S_o \frac{\sin \omega_c \tau}{\pi \tau} \quad (29)$$

where $\omega_c = 2\pi f_c$ and f_c is the frequency band.

For the particular noise generator used

$$S_o = 0.33 \text{ (volts)}^2/\text{cps}$$

$$\omega_c = 2\pi(150) \text{ rad/sec.}$$

* Manufactured by Elgenco Inc. (Santa Monica, California), Model 321 A.

It is possible, however, to change the magnitude of the power spectral density by increasing or decreasing the input gain to the PFM system.

The autocorrelation function and the spectral density function of the response of PFM to a true white noise input were determined in Section III as

$$R_{SS}(\tau) = \beta \delta(\tau) \quad (30)$$

$$S_{SS}(\omega) = \beta \quad (31)$$

The calculation of the number of pulses per unit time, β , is given in Section IV, for IPFM

$$\beta = \frac{S_o}{2r} \quad (32)$$

and for Σ PFM

$$\beta = \frac{1}{\frac{1}{2K} \sum_{n=1}^{\infty} \frac{(4r^2K/S_o)^n}{(2n)(2n-1)\cdots n}} \quad (33)$$

From Eqs. (32) and (33), it can be seen that β is a function of both threshold value, r , and the bandwidth of Σ PFM, K . For the IPFM case, $K = 0$.

To compare the analytical and experimental results, several experiments were conducted. The results of three such experiments are shown in Figs. 3, 4, and 5. In Fig. 3, the system is IPFM and the plot is β versus threshold, r . In Fig. 4, the system is Σ PFM with constant K but variable r while Fig. 5 is constant r with variable K .

For low threshold values the experimental results do not agree with the analytical results as shown in the figures because the white noise input was band-limited.

VI. CONCLUSIONS

The statistical properties of random impulse trains from pulse frequency modulators (IPFM and Σ PFM) have been studied for a random input (namely, white noise). It was found that the response of the PFM

system to a white noise input has certain characteristics such as:

- 1) The autocorrelation, $R_{SS}(\tau)$, is an impulse with intensity β (pulses per second).
- 2) The spectral density, $S_{SS}(\omega)$, is constant with magnitude β
- 3) β depends upon the spectral density, S_o , of the white noise input, the threshold value, r , and the bandwidth of Σ PFM, K .
- 4) β decreases nonlinearly when r and/or K are increased.

BIBLIOGRAPHY

- E. J. Beutler and O. A. Z. Leneman, "Random Sampling Processes," *Information and Control*, vol. 9, 1966, pp. 325-346.
- D. R. Cox and H. D. Miller, *The Theory of Stochastic Processes*, (book) John Wiley & Sons, New York, 1965, Ch. 5.
- D. A. Darling and A. J. F. Siegert, "The First Passage Problem For A Continuous Markov Process," *Ann. Math. Statist.*, 24, 624-39, 1953.
- R. L. Farrenkopf, A. E. Sabroff, and P. C. Wheeler, "Integral Pulse Frequency ON-OFF Control", Preprint 63-328, presented at AIAA Guidance and Control Conference, Cambridge, Massachusetts, August 12-14, 1963.
- B. V. Gnedenko, *The Theory of Probability*, (book), Chelsea, New York, 1962, p. 344.
- C. C. Li, "Integral Pulse Frequency Modulated Control Systems", Ph.D. dissertation, Northwestern University, Evanston, Illinois, 1961.
- T. Pavlidis and E. I. Jury, "Analysis of a New Class of Pulse-Frequency-Modulated Feedback Systems", *I.E.E.E. Transactions on Automatic Control*, vol. AC-10, No. 1, January, 1965, pp. 35-43.
- O. A. Z. Leneman, "Random Sampling of Random Processes: Impulse Processes", *Information and Control*, vol. 9, 1966, pp. 347-363.
- R. A. Leuchs, "A Circuit Design for a Pulse Frequency Modulator", M.S.E.E. Thesis, University of Massachusetts, June, 1967.

Figure Legends

- Fig. 1. Block Diagram of IPFM
- Fig. 2. Block Diagram of Σ PFM
- Fig. 3. Frequency of Pulses vs Threshold Value Holding
 $K = 0$ (IPFM); $S_o = 15.7 \frac{(\text{volts})^2}{\text{cps}}$
- Fig. 4. Frequency of Pulses vs Threshold Value Holding
 $K = 50$; $S_o = 15.7 \frac{(\text{volts})^2}{\text{cps}}$
- Fig. 5. Frequency of Pulses vs Bandwidth of Σ PFM, K
Holding $r = 1.0$ Volts; $S_o = 15.7 \frac{(\text{volts})^2}{\text{cps}}$

Figure (1)

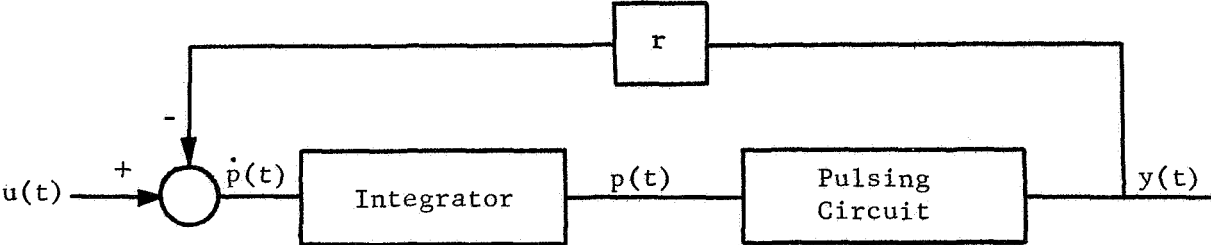

Figure (2)

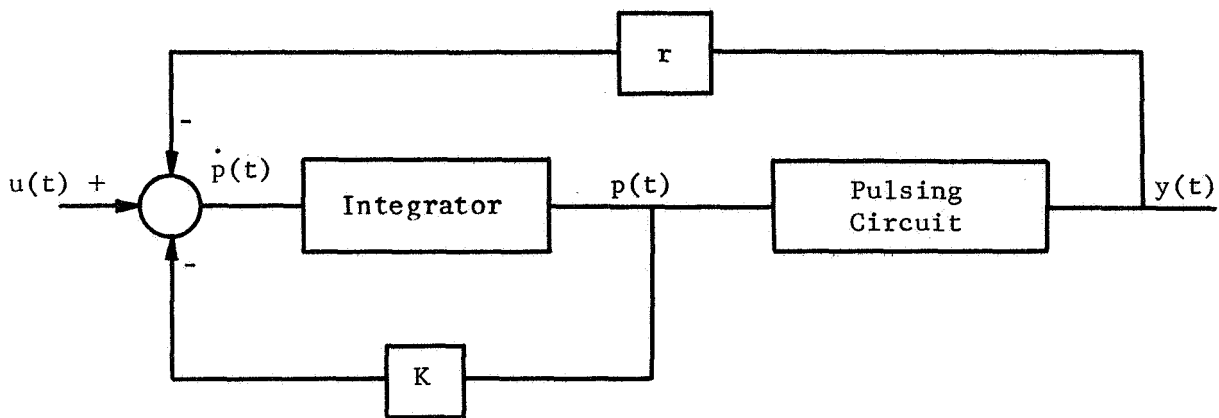

Figure (3)

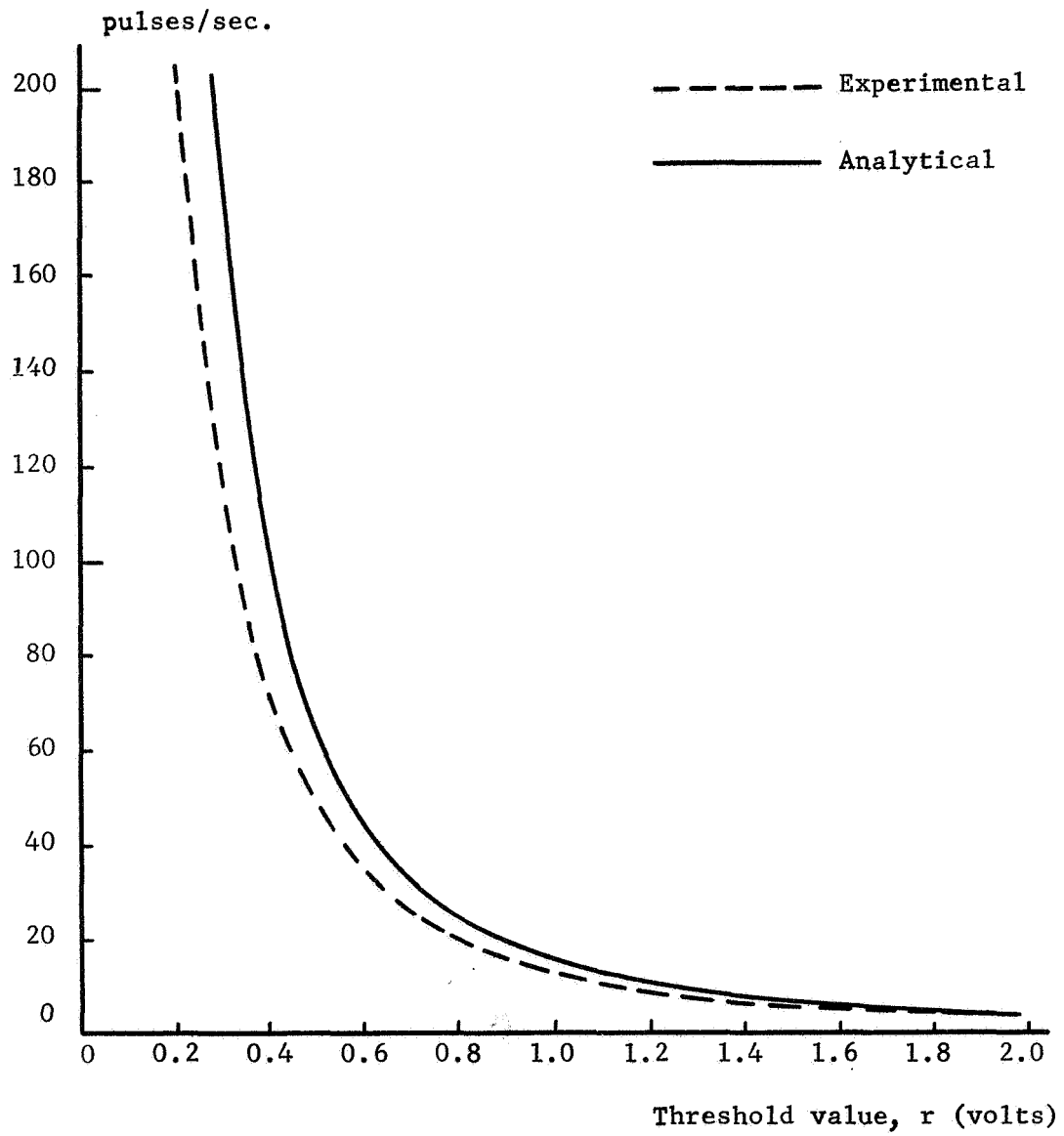

Figure (4)

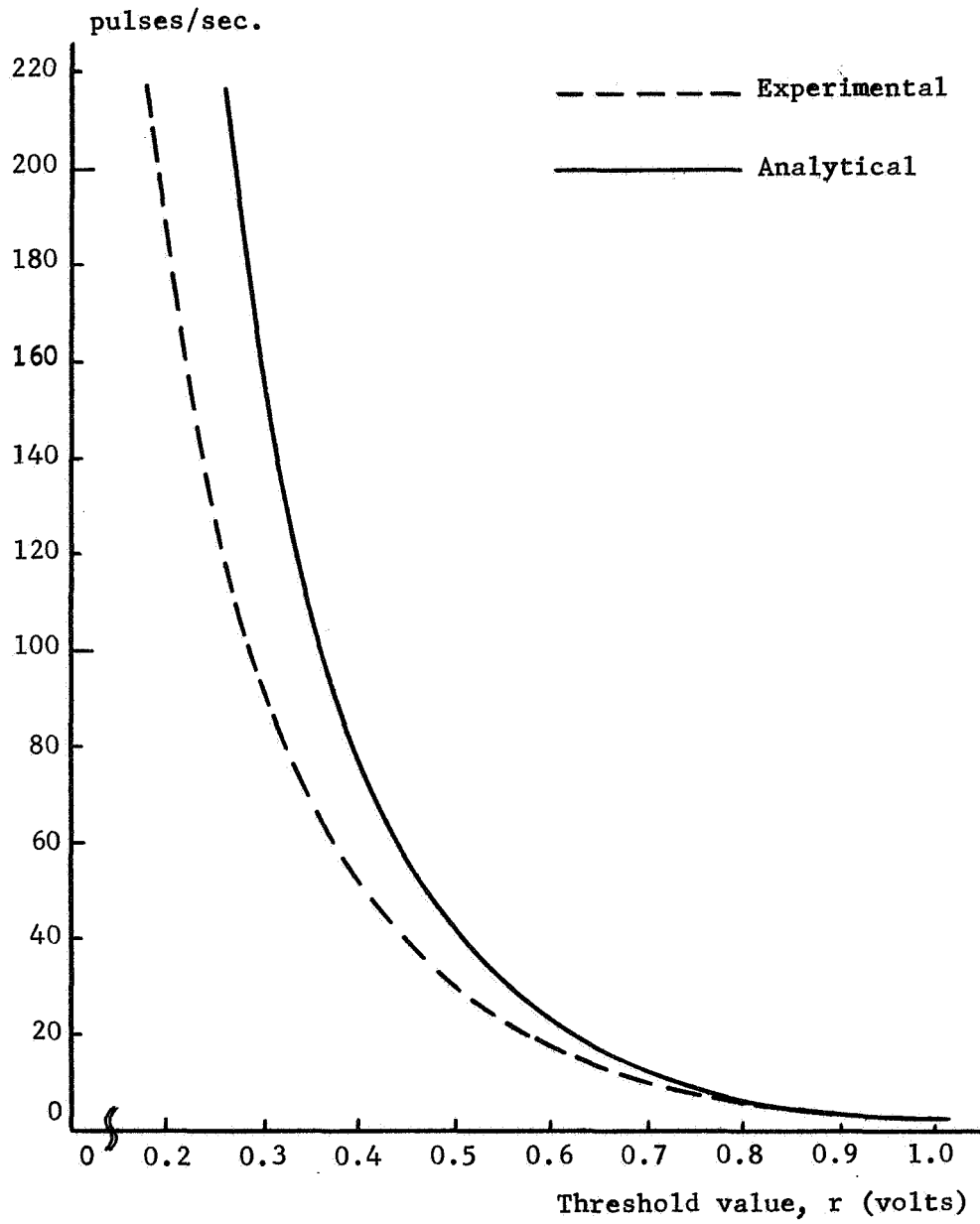

Figure (5)

