

CONCEPT FOR A LARGE MULTIPURPOSE LAUNCH VEHICLE

By Edward W. Gomersall* and John G. Brunk**

Mission Analysis Division, CART
Ames Research Center, NASA
Moffett Field, Calif. 94035

*Research Scientist.

**Advanced Vehicle System Manager, Launch Systems Branch, Space
Division, The Boeing Company.

GPO PRICE \$ _____

CSFTI PRICE(S) \$ _____

Hard copy (HC) 3.00

Microfiche (MF) .65

ff 653 July 65

N 68-34587

FACILITY FORM 602

(ACCESSION NUMBER)

(THRU)

29

(PAGES)

1

(CODE)

TMX 61237

(NASA CR OR TMX OR AD NUMBER)

31

(CATEGORY)

ABSTRACT

The key results of a NASA-sponsored study of a large multipurpose launch concept are summarized. The study evolved, through parametric performance and detailed design analyses, the characteristics of an attractive launch vehicle approach for consideration in future mission planning studies. The reported vehicle system has only two stages - a LOX/LH₂ main stage and a solid-motor strap-on stage. The main stage has the performance capability to fly single stage to orbit and the structural capability to accommodate strap-on stages to achieve a broad range of payload flexibility. The salient features of the vehicle system, sized to deliver one to four million pounds to low earth orbit, are described. The major resource and technology implications of the system are discussed.

Gomersall and Brunk

THIS PAPER PRESENTS the major results of a launch vehicle systems study conducted by The Boeing Company, Space Division, under NASA contract NAS2-4079. The study evolved, through parametric and design analyses, the design characteristics of an effective multipurpose launch vehicle. The purpose of the study was primarily to provide data to on-going technology programs, but also to investigate alternate approaches to launching the payloads desired in future missions.

The multipurpose large launch vehicle idea (Fig. 1) was the starting point of the study. The concept is a "building-block" vehicle system that features a main stage capable of single-stage-to-orbit operation and add-on stages, either boost assist or upper stages, that afford a broad range of payload capability.

A potential application of this launch vehicle concept is for launching future manned interplanetary, extended lunar, and large space station payloads. For many missions, the payload versatility of the launch vehicle system could be used to orbit the total payload requirements in a single launch, obviating the need for orbital assembly. Previous mission analysis information indicated that a payload capability from one to four million pounds to low earth orbit would adequately cover the range of these mission requirements.

Thus, the system size selected for this study was set at one million pounds payload capability for the single-stage-to-orbit configuration.

The study was organized to first conduct a series of performance and conceptual design investigations to explore the design and performance of each stage element and how they complement or compromise each other. With this parametric and trade-off design data, a reasonably optimized or representative configuration was selected and worked to a level of sufficient detail to substantiate its feasibility and performance capabilities.

CONFIGURATION DERIVATION

The logic employed to evolve the representative configuration was a step-by-step process whereby first the main-stage flight mode was established, and then, through a series of design trade-off studies of the major independent variables, a main-stage concept was chosen. The evaluation of the strap-ons and injection stage was then approached by defining representative designs that matched the main stage and then establishing their mass fractions and performance values. Performance trades were conducted for

Gomersall and Brunk

each logical configuration option to determine the payload gains possible and to select basic flight modes. Load, stress, and weight analyses were performed for each major configuration option to define the structural changes required in the main-stage design.

MAIN-STAGE PERFORMANCE OPTIMIZATION - The preferred single-stage-to-orbit flight mode and payload capability were determined through a series of trajectory optimization studies which varied both engine throttling and the amount of propellant consumed at each engine thrust level.

Single-stage vehicles that directly ascend to orbit have a relatively short burn time. This short burn time forces the vehicle to fly a steep trajectory and results in a large thrust-vector loss when the velocity vector is turned to meet the orbital flight-path-angle requirement. Throttling the stage increases the burn time, which reduces the thrust-vector loss. The optimization problem was then to determine the trajectory that minimizes the combination of gravity and thrust-vector losses.

Figure 2 shows the longitudinal acceleration as a function of flight time for the unthrottled case and a typical single-step throttling case. The unthrottled trajectory has a burn time of only 263 seconds with a burn-out acceleration of 14 g. The throttled case shows that throttling increased the burn time and reduced the burn-out acceleration. The optimization study varied the amount of throttling and the amount of propellant consumed at each thrust level. The ratio of propellant consumed with the engine throttled to the propellant consumed in the unthrottled portion of the flight is referred to as the burn ratio. The amount by which the engine thrust was reduced is referred to as percent throttling.

The results of the core optimization studies, which include engine performance penalties for throttling, are shown in Fig. 3. The data show that there is an optimum burn ratio for each percent of throttling, and that the optimum burn ratio decreases and the payload becomes more sensitive as the percent of throttling is increased. The largest thrust reduction considered (95 percent) resulted in the largest payload. Two additional cases were determined for comparison: in one case, the vehicle was flown to 100 nautical miles with no throttling, which resulted in a 27-percent payload penalty; in the other, a Hohmann transfer-type trajectory was flown with the vehicle coasting from 50 to 100 nautical miles followed by reignition of the engines and injection into orbit. No penalty was assumed for engine reignition. This case resulted in a

Gomersall and Brunk

payload essentially the same as for the 95-percent throttling case.

Additional trajectory parameters that influence the vehicle optimization are the maximum dynamic pressure and the maximum longitudinal acceleration. The data show that the maximum longitudinal acceleration increases as the percent of throttling increases, and reaches a maximum of 8.2 g at 95-percent throttling. For the no throttling and Hohmann transfer case, the maximum acceleration was 14.0 g. The variation in maximum dynamic pressure with and without throttling was not significant (620 to 650 lb/ft²).

A 10:1 throttling trajectory offers near maximum performance and is considered to be a likely capability for advanced engines. Therefore, 90-percent throttling was selected for the main-stage operation, although deeper throttling results in a slight gain in payload.

STRAP-ON PERFORMANCE AUGMENTATION - The payload performance of the main stage can be increased by adding strap-on stages. Pump-fed or pressure-fed liquid propellant stages or solid motors could be employed. This study considered N₂O₄/UDMH pressure-fed and solid-motor systems, as shown in Fig. 4, over a range of diameters and thrust levels. The pressure-fed system considered in the study incorporated a single engine with a liquid injection thrust-vector control and a hot-gas pressurization system. Both systems offer approximately the same payload capabilities as measured by payload-to-launch-weight ratios. Final selection between the liquid and solid propellant strap-on stages requires cost studies as well as technology confidence appraisals. These were not included in this study. At this time, more data are available on solid motors, therefore, these were chosen for the final study configuration.

The solid rocket motor strap-on (SRM) performance investigation considered the effects of strap-on thrust levels for both parallel-burn and zero-stage flight modes. For the parallel-burn case, both the strap-ons and the main stage are ignited at launch; the strap-ons are staged after burnout and the core continues burning to orbital insertion. In the zero-stage case, only the strap-ons are ignited at launch, and the main stage is ignited at SRM burnout and staging.

Figure 5 shows the payload gains offered by the solid-motor systems for both flight modes. In this figure, solid propellant weight is fixed; therefore, higher solid-motor thrusts correspond to shorter motor burn times. For the solid-to-core-propellant ratio shown, the zero-stage mode gave better payload performance. Lower maximum

Gomersall and Brunk

dynamic pressures and longitudinal acceleration are also encountered in the zero-stage mode. These trajectory parameters indicate that the structural loads imposed on the main stage would be less in the zero-stage mode than in the parallel-burn mode. The zero-stage performance plot shows that most of the payload gain possible can be achieved without exceeding a maximum dynamic pressure of 900 lb/ft².

UPPER-STAGE PERFORMANCE AUGMENTATION - The use of an upper stage to increase payload versatility and reduce configuration sensitivities was considered for both core and core-plus-strap-on configurations. A LOX/LH₂ stage with toroidal propellant tanks and an extendable nozzle high-pressure engine system was selected as a representative design solution for matching the core stage diameter (Fig. 6). This design also lends itself to a modularizing flexibility where a series of propellant tank wafers are stacked and additional engines mounted to a common thrust beam. A stage mass fraction of 0.82 was obtained for the single-wafer configuration shown and was improved to 0.88 when four wafers were stacked. Although technology problems are noted in the fabrication of the toroidal tank, the design can be considered representative for an advanced vehicle parametric study.

Performance studies using a range of thrust-to-weight ratios and core throttling modes were conducted to determine possible payload capabilities. For configurations with an upper stage added to the main stage (no strap-ons), the payload improvement is constrained by the practical low limit of vehicle liftoff thrust to weight (T/W_0). The main stage was sized for a liftoff thrust-to-weight ratio of 1.25. When an injection stage is added to the main stage, its weight plus the additional payload weight reduces the liftoff thrust-to-weight ratio. For this study, the limit was set at $T/W_0 = 1.18$. At this value, the payload increase offered by the injection stage was 18 percent for 100-nautical-mile orbit missions shown in Fig. 7. Maximum performance was determined with a trajectory mode without main-stage throttling. If the main stage had had a lower mass fraction, the injection stage would have displayed a better payload performance benefit.

When an upper stage is added to the main-plus-strap-on stage configuration, the minimum T/W_0 limit is not an influencing factor. The basic configuration has a T/W_0 greater than 1.6, and the addition of an optimum upper stage (third stage) weight is reached with a T/W_0 of 1.59. Stacking three wafers of the upper stage for the strap-on configuration provides nearly

Gomersall and Brunk

all the payload gain possible with an additional stage, a gain of 6 percent with three wafers compared with an optimum of 6-1/2 percent with four wafers.

For missions to higher earth orbits, for example, 300 nautical miles, the injection stage becomes more desirable since it is a practical approach for performing a Hohmann-transfer-type trajectory and provides a short coupling, high-response control system for accomplishing the final orbit injection maneuver. With the addition of the upper stage, the basic payload capability of the main stage can be injected into a 300-nautical-mile orbit, whereas, without the stage, a direct injection of only 78 percent of the basic payload is possible.

MAIN-STAGE DESIGN - After establishing the basic flight modes of the system, the main-stage design was evolved through a series of trade-off studies in which the influence of the major independent variables of mixture ratio, stage-length-to-diameter ratio, engine chamber pressure, number of modules, and tank pressures were investigated. Each trade-off considered the total consequence of the perturbed parameter and its effect on performance and weights. A complete set of vehicle loads was developed for each point studied. Stress analysis was repeated for each case and a new stage weight was estimated. Aerodynamic characteristics were adjusted for each case in which vehicle size was varied. Two engine systems were considered: the toroidal/aerospike and the multichamber/plug.

Figure 8 lists the range of each parameter that could be accepted without penalizing the payload by more than 1 percent from the maximum value determined.

The mixture ratio investigation considered both engine performance effects and stage weight changes. A mixture ratio of 5:1 resulted in the best effective engine specific impulses while higher mixture ratios gave lighter stage weights. An optimum value of 6:1 was determined for either propulsion system.

Stage-length-to-diameter (L/D) influence revealed that both the engine systems and stage design favored low L/D values until the LOX tank cylindrical section was eliminated. Then the weight penalties associated with the flatter bulkheads negated any further improvement in engine specific impulse obtained from the larger diameters. A value of 2.2 was selected.

The engine system chamber pressure studies investigated the effects of variations in both engine weight and performance. For the regeneratively cooled multichamber and toroidal systems, improvements in overall performance were noted

Gomersall and Brunk

until a chamber pressure of about 2000 psia was reached, then the payload benefit leveled. A high-pressure transpiration-cooled multi-chamber/plug system with hinged modules was also investigated. The payload performance of this system offered only slight improvement.

The number of module trade-off studies performed for the multichamber engine system showed that payload performance was independent of the number of modules used. Engine performance slightly favored fewer modules but the performance gain was offset by the accompanying engine and stage weight increase.

The trade study of LH₂ tank pressures showed that 28.0 psia ullage pressure gave the lightest stage weight. Stage structure, pressurization system, and gas weight effects led to the determination of this optimum value, which appears to be in accord with net positive suction head values currently considered possible by the engine contractors.

The LOX tank is forward. This selection was made on the basis of vehicle control. Figure 9 shows the estimated thrust-vector deflection angle required to control the vehicle while it experiences an assumed 10° angle of attack, as a function of fineness ratio. Vehicle static stability is changed appreciably by switching the relative position of the LOX tank from aft to forward of the LH₂ tank. Smaller control requirements exist when the LOX tank is forward because the vehicle center of gravity moves forward, resulting in a longer control moment arm and a shorter aerodynamic moment arm.

STRAP-ON STAGE EFFECTS ON MAIN-STAGE DESIGN - Designing the main-stage structure to accommodate strap-ons leads to weight increases that detract from its single-stage-to-orbit effectiveness. The effects on the skirts, tank sidewalls, and bulkheads of the stage were investigated and a means of minimizing the core weight penalties was found.

Increased load conditions on the cylindrical sidewalls result from the higher bending moments created by the longer payload and the higher dynamic pressures, as well as the higher longitudinal forces created by the strap-on thrust. Increased hydrostatic pressure loads in the tank bulkheads are created when the full tanks are subjected to the longitudinal acceleration of 3.1 g at the solid-motor cutoff flight condition.

An effective means of minimizing the sidewall structural loads is to react the solid-motor thrust into the forward skirt rather than into the thrust structure. Figure 10 plots the designing compressive load for both the aft and forward thrust take-out, with the loads encountered for

Gomersall and Brunk

the core-alone single-stage-to-orbit operation for reference. It is seen that the loads with forward thrust take-out are less than with core-alone operation for all stations aft of 2173. With aft attachment, the loads over this part of the vehicle are more than double the values for the core-alone operation. Forward of station 2173, the loads are essentially the same with either thrust take-out arrangement.

The effect of the structural beef-up required in the forward skirt (stations 2312 to 2630) can be minimized by using two forward skirt assemblies: a light-weight assembly for core-alone operation and a heavier one for use with the strap-on configurations.

The structural weight increases due to the thicker bulkheads needed to contain the higher fluid pressures are independent of the attachment concept used. This weight amounts to a 10 percent increase in stage inert weight. No scheme for designing around this penalty was uncovered.

The effects of the load increases on the main-stage size are shown in Fig. 11. A main stage designed for only single-stage-to-orbit flight can have a structural mass ratio, λ' , of 0.950 (λ' is defined as propellant weight divided by propellant weight plus inert weight) and would have a stage-to-payload-weight ratio of 10.6 (bar A on the figure). Beefing-up the stage to the load demands of strap-on operation would reduce the λ' to 0.936, which, as shown by bar D, would require the stage size to increase 20 percent. By using the forward thrust take-out design concept, the stage size increase could be reduced to 12 percent (bar C). By using separate forward skirt assemblies, the size increase could be further reduced to only 8 percent (bar B).

Another unique feature of the main stage and related to the forward strap-on thrust take-out is forward holddown and support for the single-stage-to-orbit mode. The use of the forward skirt for vehicle support minimizes ground wind and emergency shutdown loads. The forward skirt reaction point provides a short load path between the support connections and the large inertia payload and LOX tank elements. Although this system does necessitate a new type of launch stand design, it is significant in minimizing the structural weight of the stage. The forward skirt support posts are also the logical points for reacting the strap-on stage thrust.

Gomersall and Brunk

REPRESENTATIVE CONFIGURATION

8

The configuration, sized and designed using the results of the previously described trade-off

and parametric performance investigations, is shown in Fig. 12. It was analyzed in considerable depth in order to substantiate the predicted performance and design efficiencies. This analysis included:

- (a) Dynamic load analysis including a check on structural response to acoustics,
- (b) Control-system requirements and duty cycles including the effects of "scatter" terms,
- (c) Distributed aerodynamic characteristics,
- (d) Aeroheating and base heating environments and protection,
- (e) Pressurization system and schedules,
- (f) Stress analysis of each structural element including distribution from point load sources,
- (g) Weight statement and mass distribution properties,
- (h) Main-stage drawings to show structural details,
- (i) Finalized performance with optimized burn ratios.

The technical details of the finalized version of the system, after the trade-offs and detail studies were completed, are given along with the vehicle schematics in Fig. 13. The predicted performance for this selected configuration is shown in Fig. 14 for each possible flight configuration. The upper payload capability of 3.5 million pounds could be increased if larger-diameter solid motors are used. For example, ten 372-inch solid motors would have resulted in a payload of 4.2 million pounds. The increased payload or additional flexibility offered by the addition of an upper stage is minimal compared to the versatility available with strap-on stages. Therefore, for low earth orbit applications the requirements can be met with only two stages - the main stage and a solid-motor stage.

RESOURCE IMPLICATIONS - A survey of development, production, and launch requirements for this system suggested that the vehicle implementation would be possible with contemporary manufacturing and facility technology. The following statements provide a summary of the study findings in the resource area:

(a) Main-stage fabrication is possible at the NASA Michoud site (or its equivalent located on a navigable waterway). A new factory building would be necessary.

(b) Development testing of the main-core stage and any possible injection state would probably require new dynamic and structural test facilities constructed adjacent to the factory building.

Gomersall and Brunk

(c) Injection-stage fabrication could be accomplished in the existing factory building at Michoud.

(d) Transportation by ocean going towed barges appears favored for all vehicle elements from factory to launch site.

(e) The system can be launched at Cape Kennedy (KSC), but new facilities are required. An off-shore launch area at the Atlantic Test Range may be required based on standard acoustic siting criteria. New specially designed hoisting devices are required to handle the 2000-ton solid motors and 400-ton main stage.

The new launch facility is envisioned (Fig. 15) to consist of a raised platform. The vehicle would be launched from a large hole in the platform. The vehicle would be supported by holddown and support fittings mounted on the deck. Separate sets of holddown fittings would be required. One set would be used to hold the main stage for single-stage-to-orbit vehicle configurations and the other to support the core plus solid strap-on configurations. The entire vehicle would probably be assembled and checked out in the launch position.

The flame deflector might be a special barge that could be submerged in the proper location. If required, a portion of the canal could be sealed off and the water pumped out similar to the operation of a shipyard drydock. The flame deflector might be cooled by pumping water through coils during the engine firing.

The location of the launch site would probably be required to be 15 miles from unprotected personnel, assuming a 120-dB sound pressure level criterion. Relaxing the decibel tolerance criterion to 125 dB would allow siting on shore at KSC. The 0.4-psi blast over-pressure standoff distance is approximately 4 miles.

CONCLUSION

Performance and design analysis indicates that a multipurpose launch vehicle system employing only two stages offers a practical approach for transporting large payloads to earth orbit. Recent technology developments now indicate the feasibility of an advanced single-stage-to-orbit system. The system analyzed in this study was sized to deliver 1 million pounds to low earth orbit. The system was found to have an inert weight roughly 40 percent greater than a two-stage Saturn V vehicle (S-IC/S-II), but four times the payload capability. A vehicle system of this efficiency, coupled with a minimization of stages and the payload flexibility to handle a

Gomersall and Brunk

broad range of missions, is expected to have inherent economic and reliability attributes.

The specific size of the study vehicle was for payloads from 1 to 4 million pounds. Smaller versions of this advanced concept could be attractive for near-earth payload delivery systems.

The study results are available in two NASA reports. The summary report (1)* provides a concise account of the objectives, methods of investigation, and significant results. The technical report (2) provides a comprehensive record of the analyses conducted with their detailed results.

ACKNOWLEDGMENTS

All the propulsion systems data used in the performance of the study were provided by Rocketdyne, Division of North American Rockwell Corporation; Pratt and Whitney Aircraft, Division of United Aircraft Corporation; Aerojet-General Corporation, Space Booster Division; and Lockheed Propulsion Company, Division of Lockheed Aircraft Corporation. Their cooperation in contributing engine or motor data significantly enlarged the scope and value of the study results.

REFERENCES

1. The Boeing Company, "Study of Advanced Multipurpose Large Launch Vehicles - Summary Report (U)." Prepared under NASA Contract NAS2-4079, NASA CR-73154, 1968.
2. The Boeing Company, "Study of Advanced Multipurpose Large Launch Vehicles - Technical Report (U)." Prepared under NASA Contract NAS2-4079, NASA CR-73155, 1968.

Gomersall and Brunk

*Numbers in parentheses designate References at end of paper.

FIGURE LEGENDS

Fig. 1 - Multipurpose launch vehicle concept

Fig. 2 - Acceleration profile

Fig. 3 - Core trajectory optimization

Fig. 4 - Strap-on systems

Fig. 5 - Solid-motor strap-on performance

Fig. 6 - Upper-stage design

Fig. 7 - Upper-stage performance

Fig. 8 - Core stage parameter effects

Fig. 9 - Core control requirements

Fig. 10 - Strap-on attachment loads

Fig. 11 - Core size penalties

Fig. 12 - Representative configuration

Fig. 13 - Representative design parameters

Fig. 14 - Predicted design performance

Fig. 15 - Launch facility concept

Gomersall and Brunk

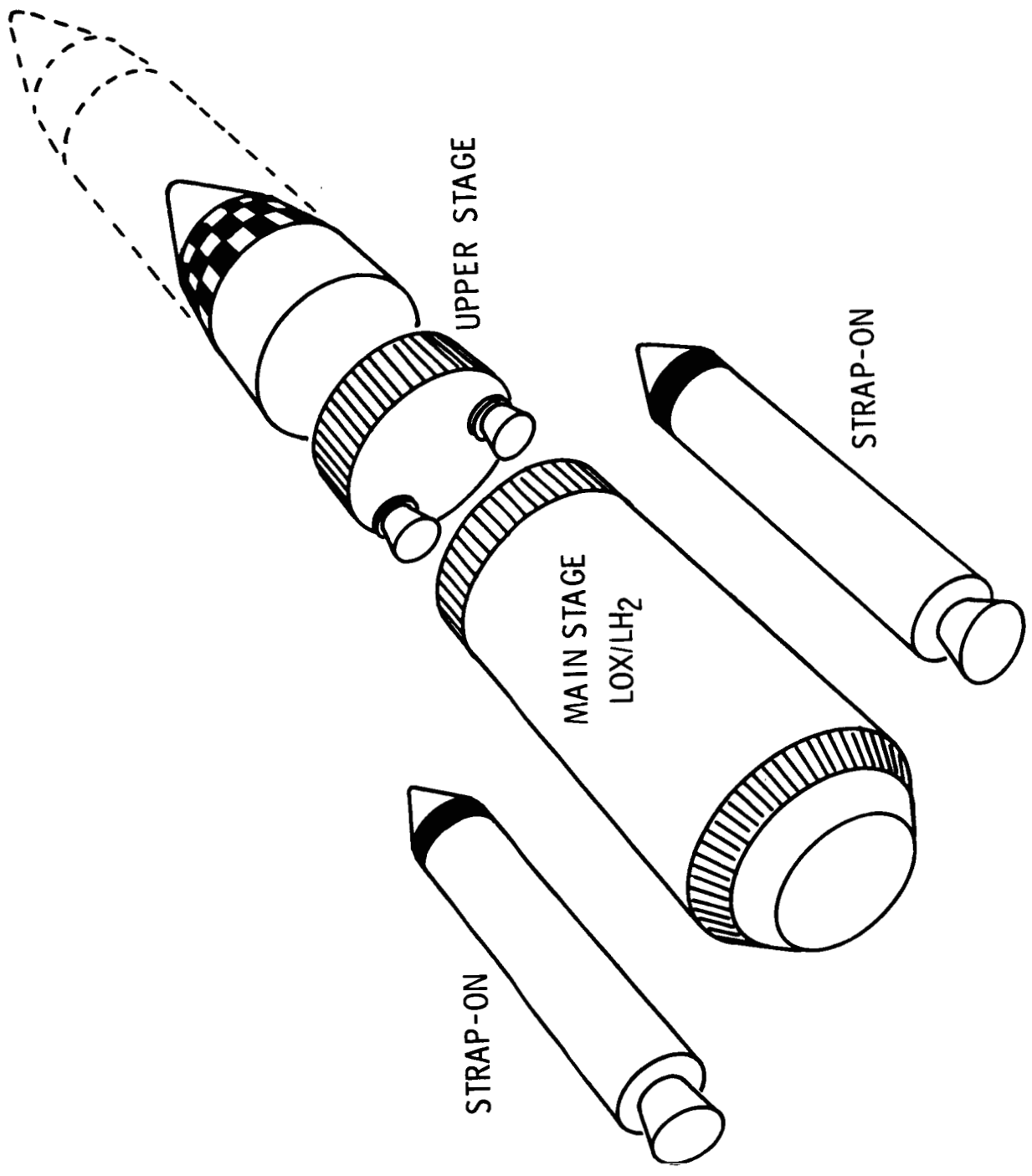

Figure 1.

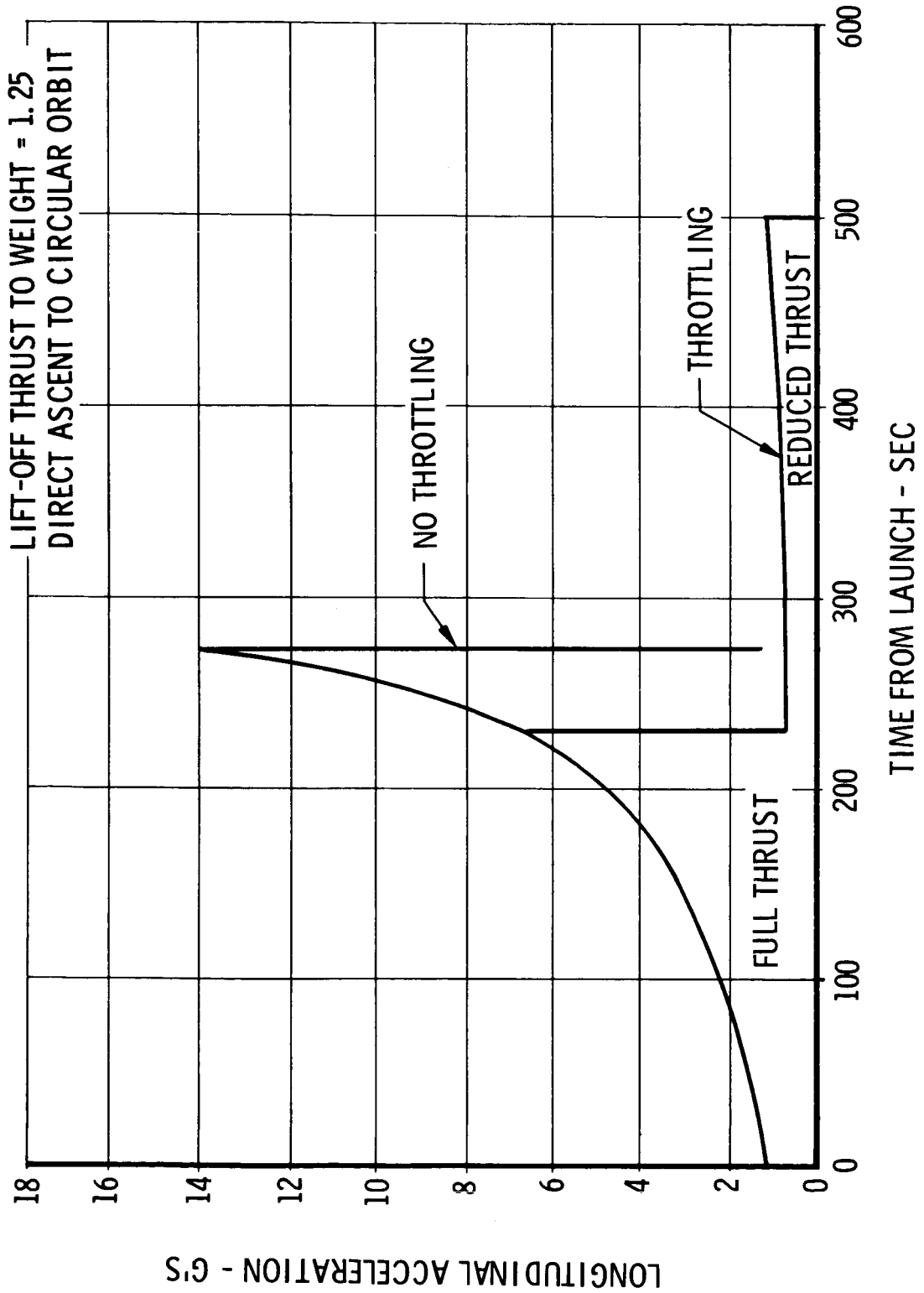
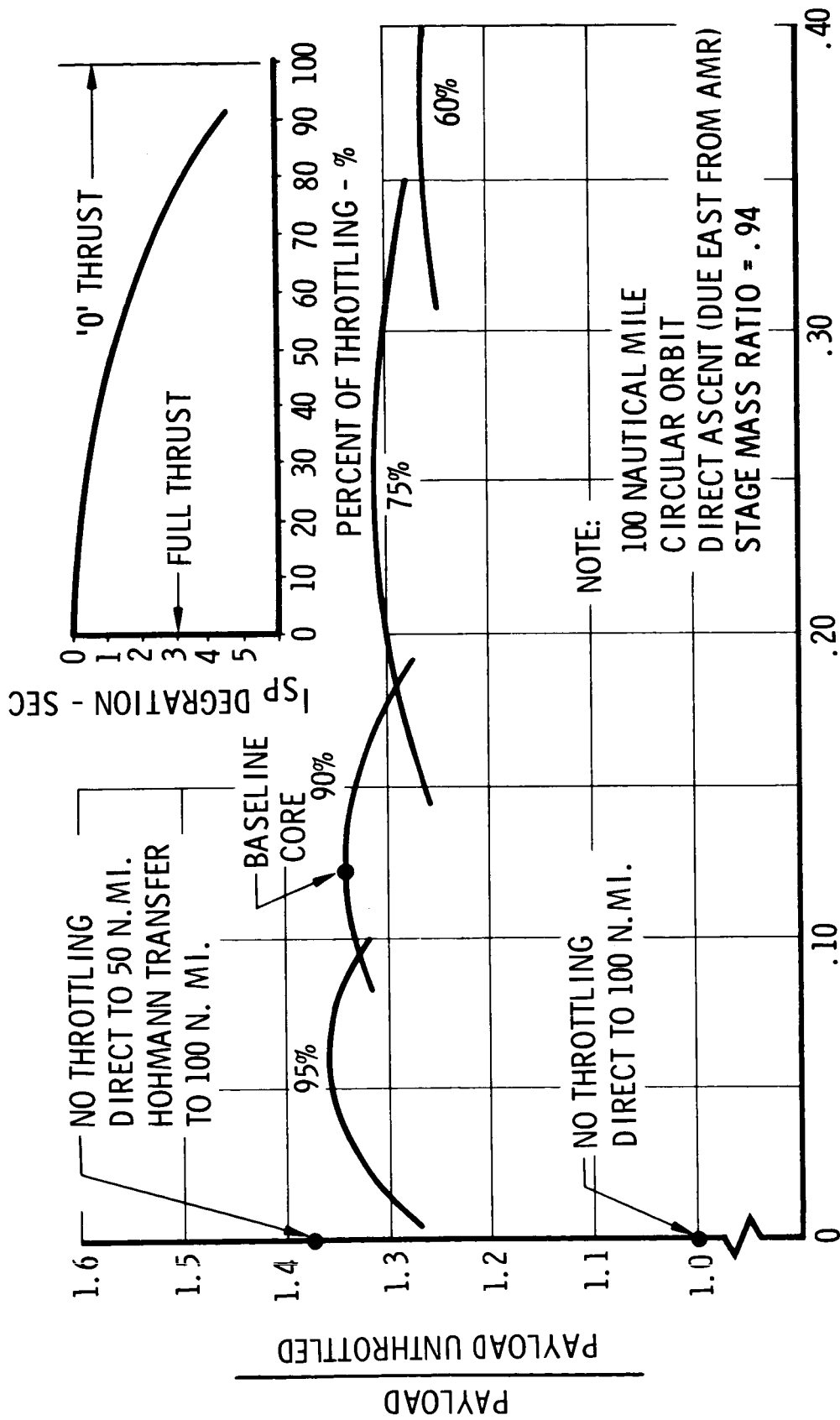
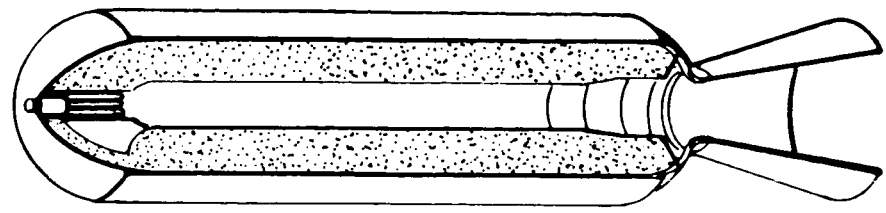
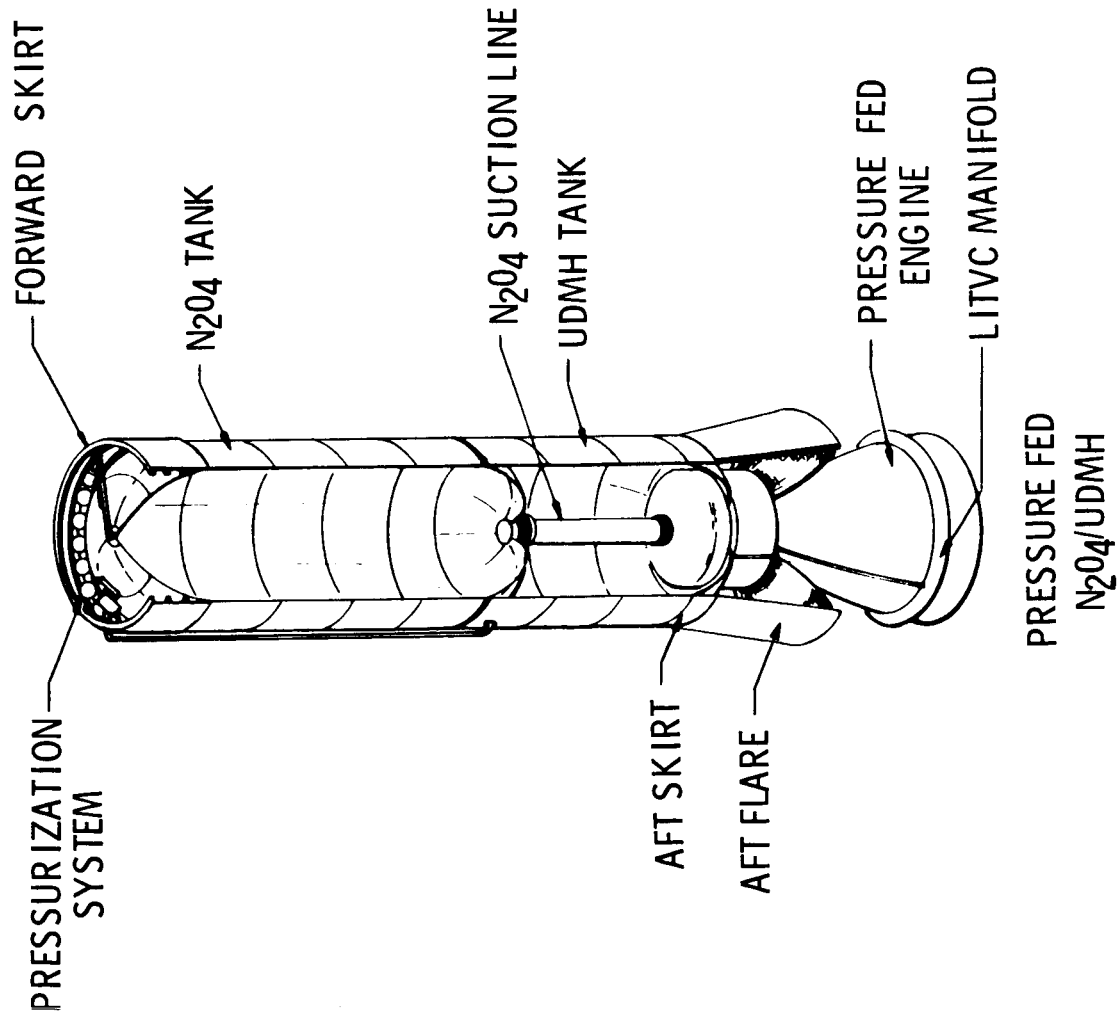

Figure 2.



$$\frac{B_2/B_1}{\text{PROPELLANT CONSUMED @ FULL THRUST}} = \frac{\text{PROPELLANT CONSUMED @ REDUCED THRUST}}{\text{PROPELLANT CONSUMED @ FULL THRUST}}$$

Figure 3.



SOLIDS
 156"
 260"
 300"

Figure 4.

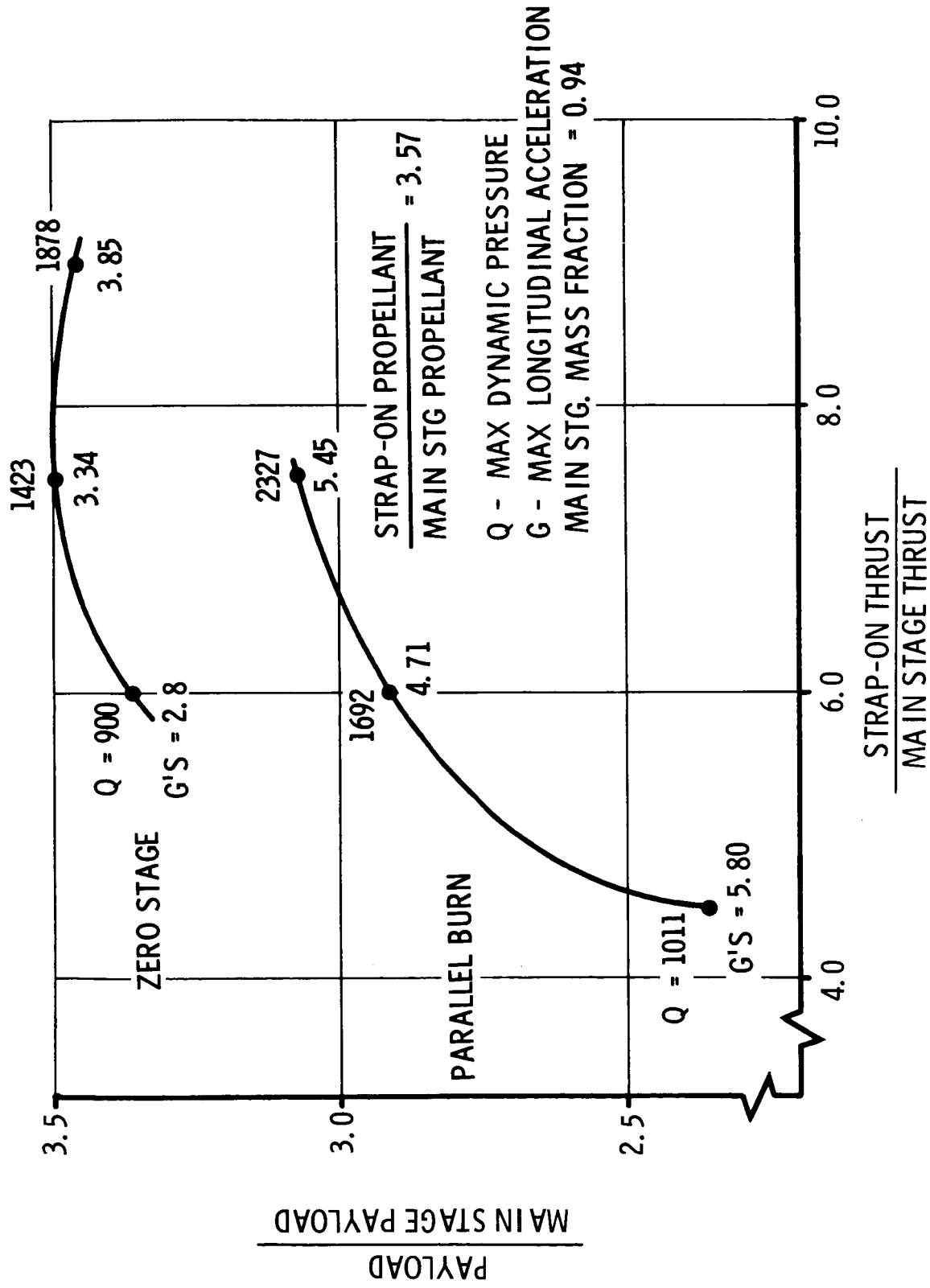

Figure 5.

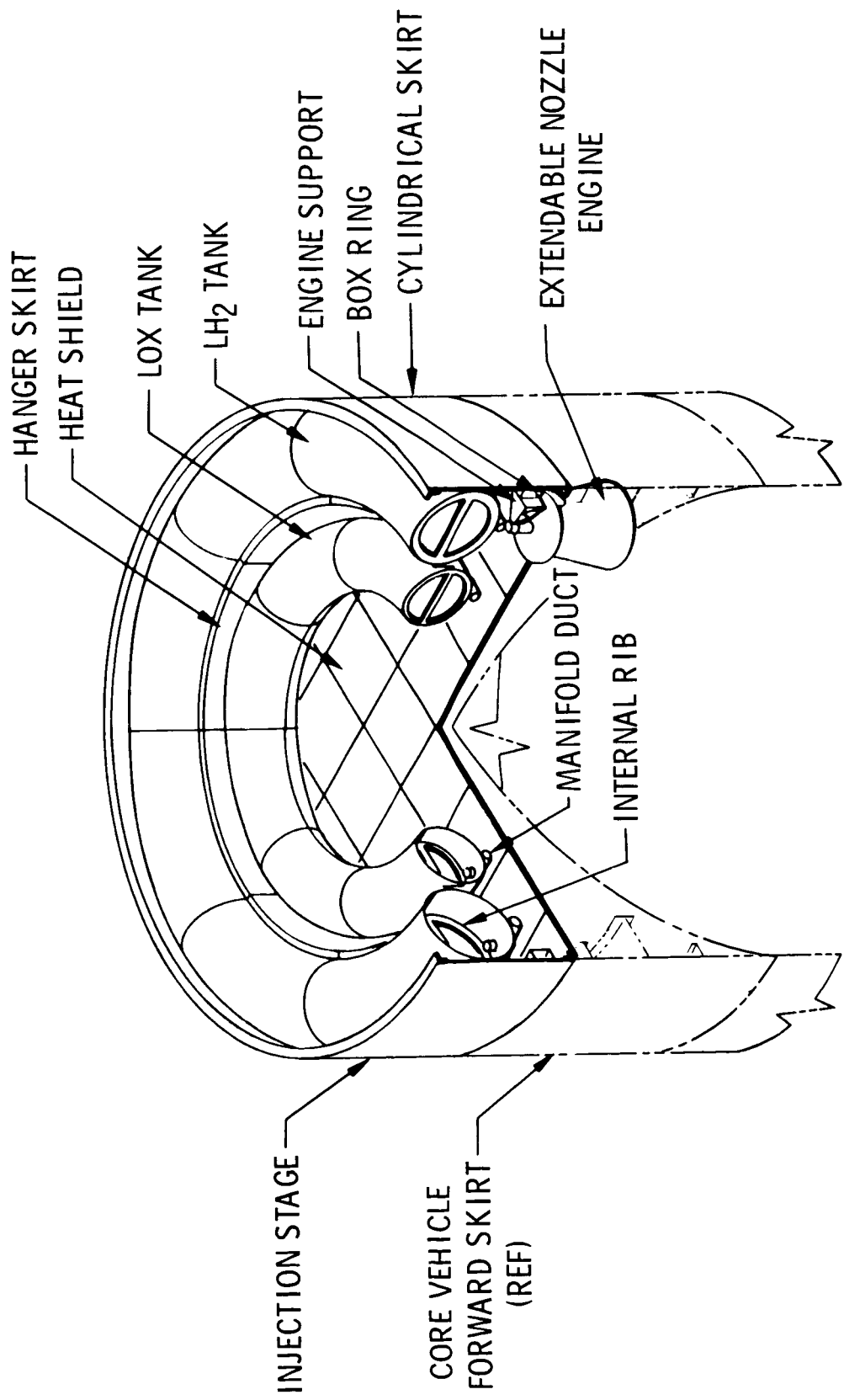

Figure 6.

DUE EAST LAUNCH FROM AMR
100 N. MI. CIRCULAR ORBIT

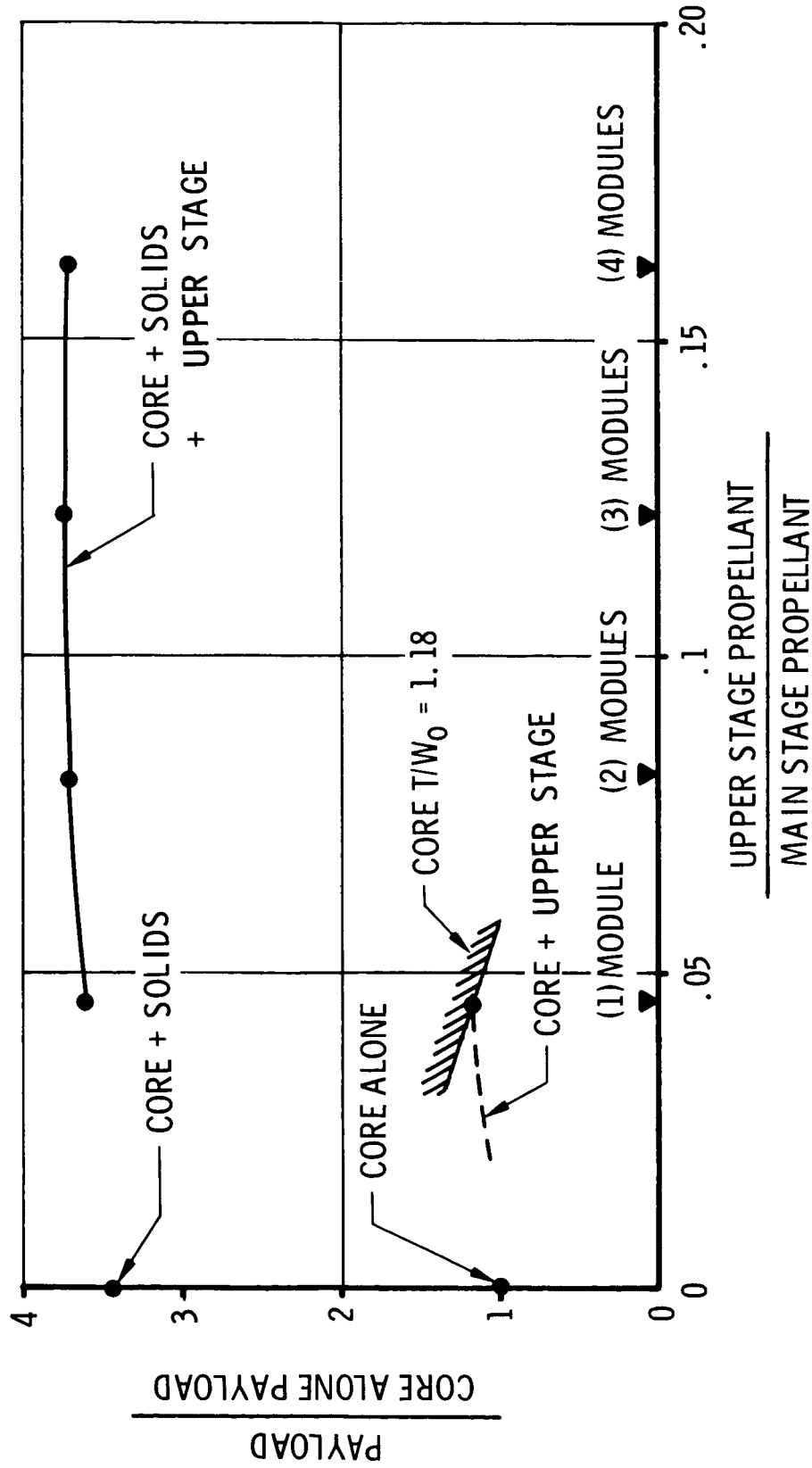

Figure 7.

VARIABLE	RANGE OF VARIABLE WITHIN 1% OF MAX GROSS PAYLOAD	
	MULTICHAMBER	TOROIDAL
MIXTURE RATIO	5.2:1 —→ 6.4:1	5.65:1 —→ 6.6:1
STAGE LENGTH/DIA RATIO	2.24 —→ 2.80	2.20 —→ 2.78
CHAMBER PRESSURE (PSIA)	2000 —→ 3000	1950 —→ 2800
NO. MODULES		
ROCKETDYNE ($P_c = 2000$ PSIA)	8 —→ 16	
PRATT & WHITNEY ($P_c = 3000$ PSIA)	12 —→ 24	
LH ₂ ULLAGE PRESSURE (PSIA)	18.2 —→ 35.0	18.2 —→ 35.0

Figure 8.

NOTES:

$T/W_0 = 1.25$

$P/L = 4.5\% W_0$

$P/L \text{ DENSITY} = 5 \text{ LB/FT}^3$

WIND ANGLE = 10 DEGREES

MAX Q = 750 LB/FT²

- - - STAGE DIAMETER (FT)

— SEA LEVEL THRUST (10⁶ LBS)

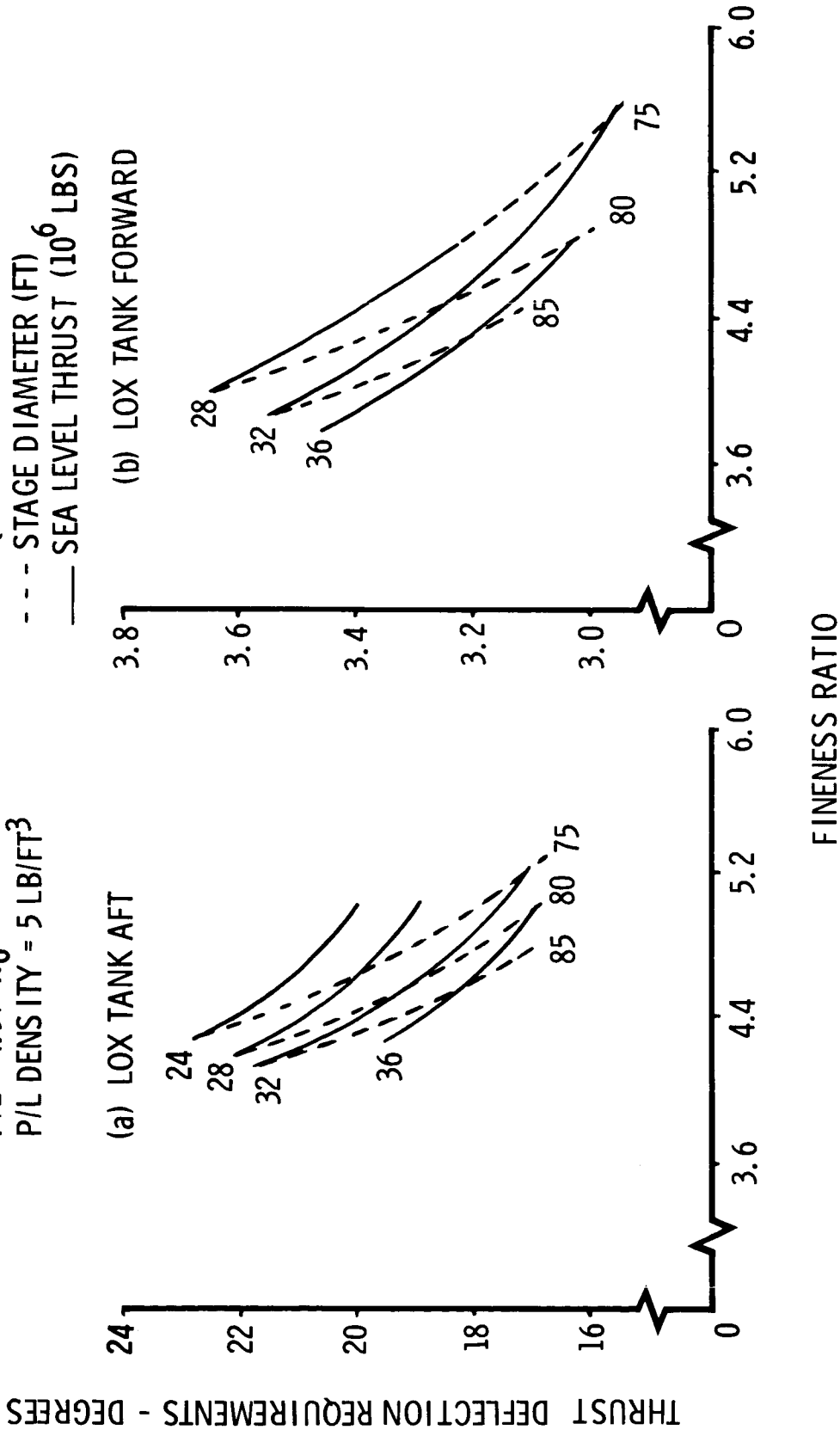

Figure 9.

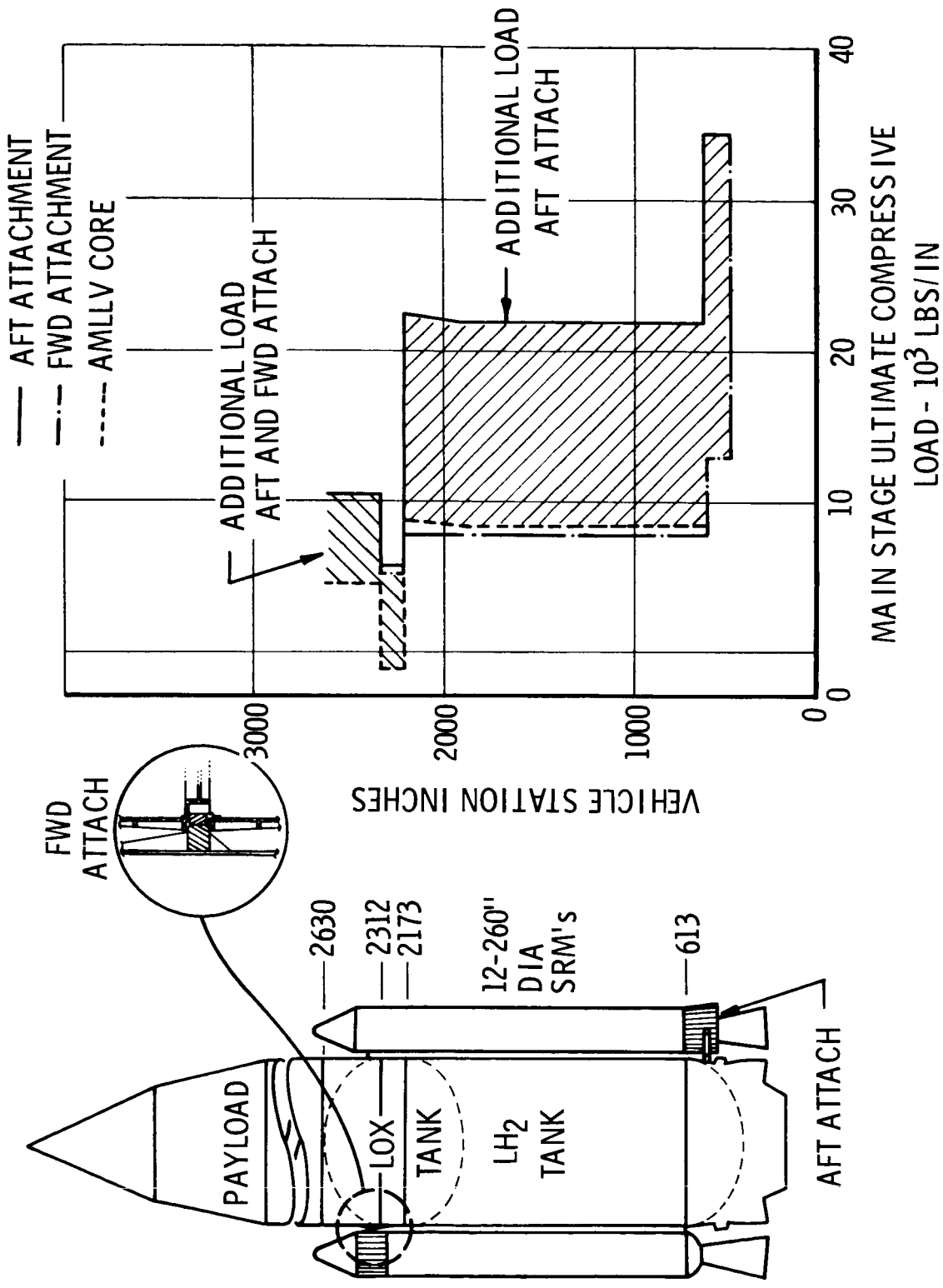
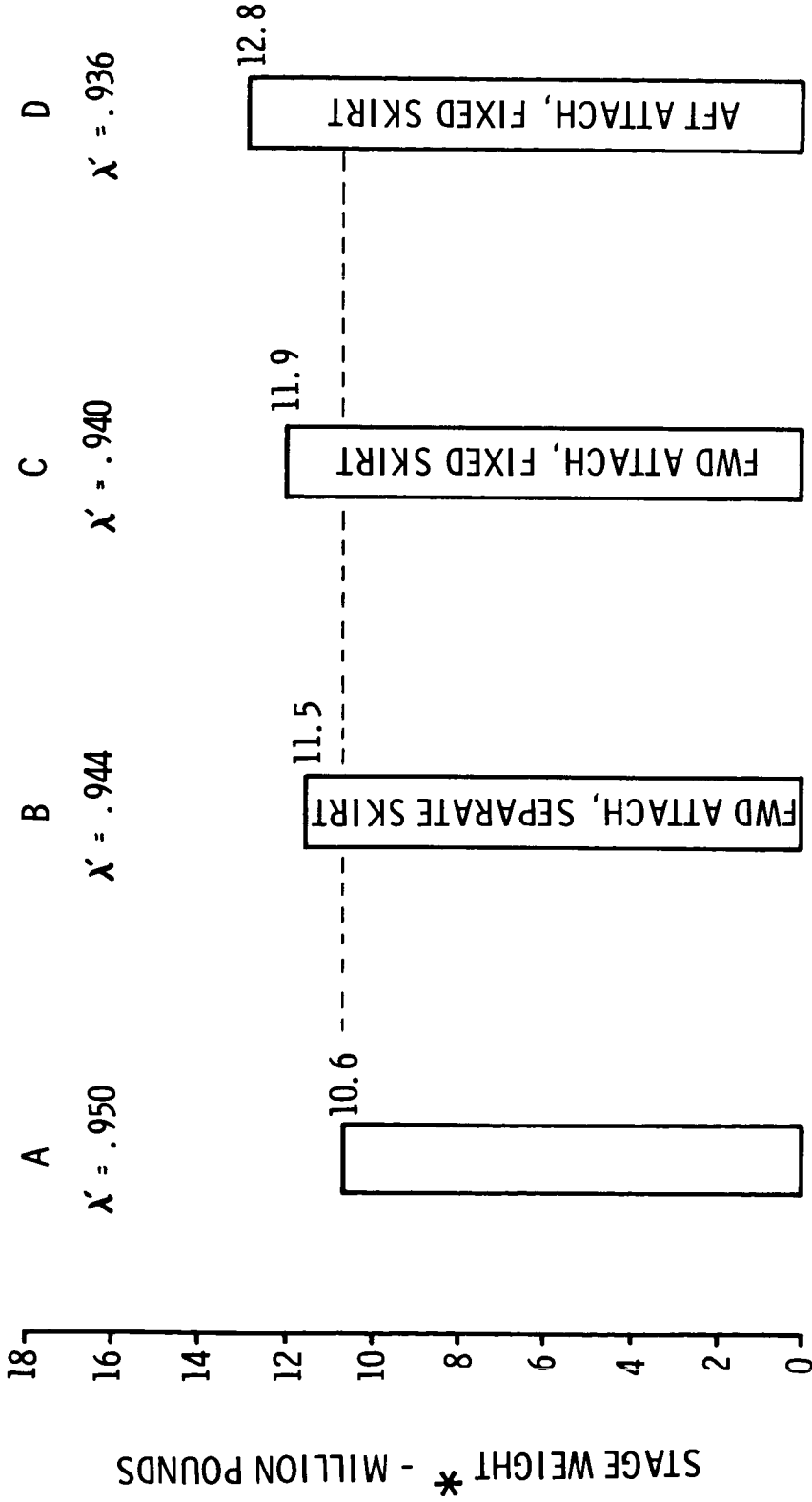

Figure 10.

1 MILLION POUND PAYLOAD
 TO 100 N.MI. ORBIT
 DUE EAST FROM AMR
 $\chi' = \text{MASS FRACTION}$



SINGLE STAGE-TO-ORBIT ONLY

MODIFIED TO ACCEPT STRAP ON STAGES

* LAUNCH WEIGHT, FUELED

Figure 11.

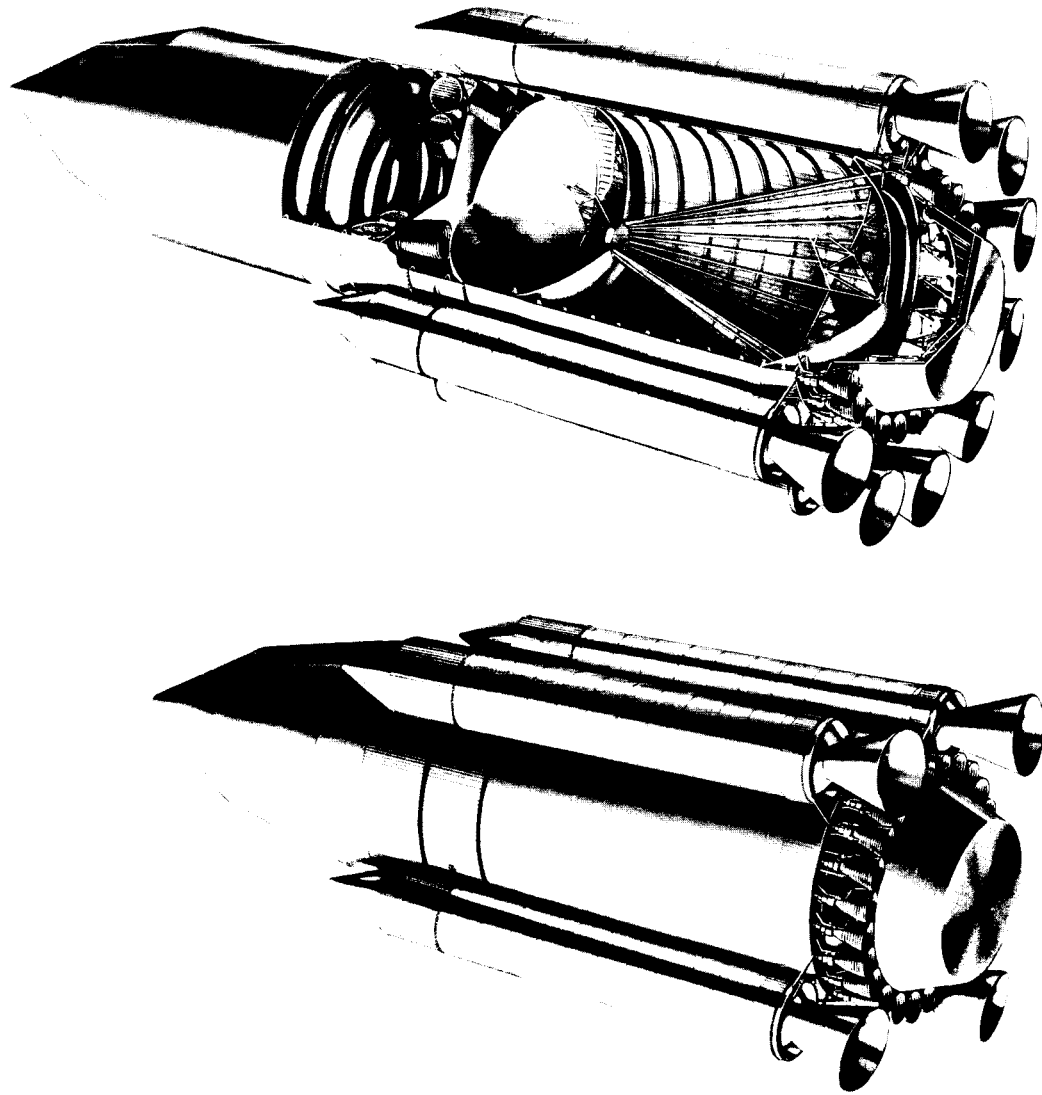
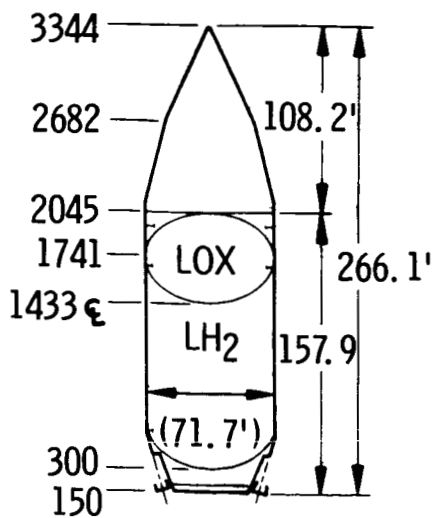

Figure 12.

GROSS PAYLOAD \approx 1,000,000 LBS.
 LIFTOFF WEIGHT = 12,800,000 LBS.
 LIFTOFF THRUST/WEIGHT = 1.25

CORE

LENGTH/DIAMETER = 2.20
 MASS FRACTION \approx 0.94
 SEA LEVEL THRUST
 = 16,000,000 LBS.
 USEABLE PROPELLANT
 = 11,110,169 LB.
 LOX = 9,514,460 LBS
 LH₂ = 1,585,700 LBS.
 RES IDUAL PROPELLANT = 1% LH₂
 = 0.1% LOX
 ULLAGE VOLUME = 3%



CORE VEHICLE

GROSS PAYLOADS \approx 3,500,000 LBS.
 LIFT-OFF WEIGHT = 66,257,000 LBS.
 LIFT-OFF THRUST/WEIGHT = 1.63

CORE

MASS FRACTION \approx 0.94

STRAP-ON MOTORS

NUMBER = 12 -260" DIA.
 MASS FRACTION = 0.90
 USEABLE PROPELLANT =
 3,810,000 LBS/MOTOR
 SEA LEVEL THRUST =
 9,000,000 LBS/MOTOR

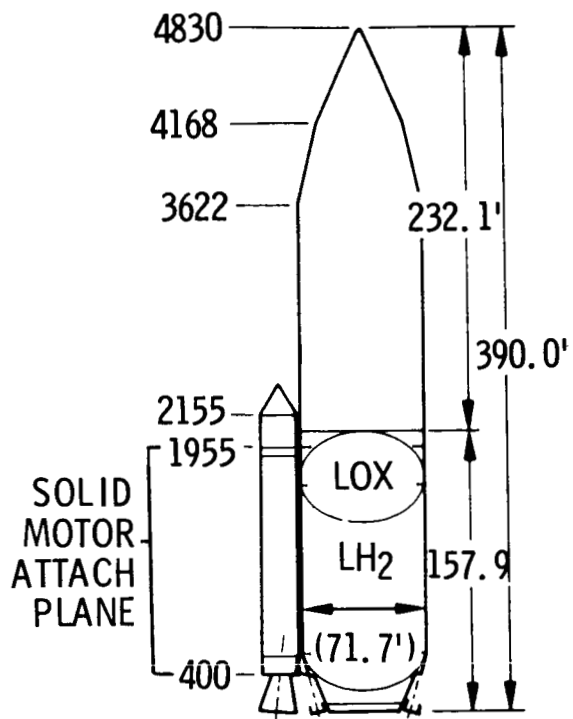

CORE + STRAP-ON'S

Figure 13.

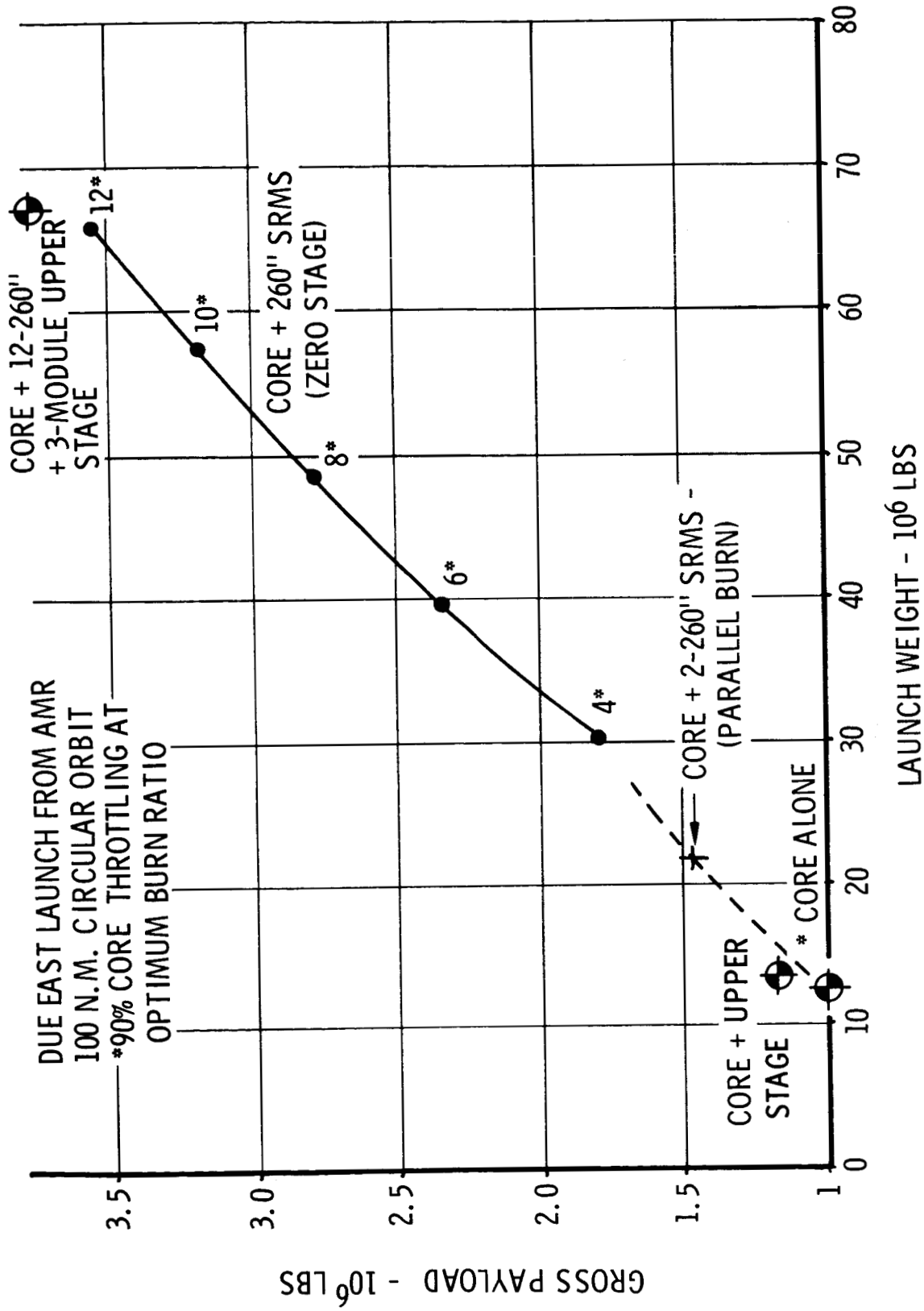

Figure 14.

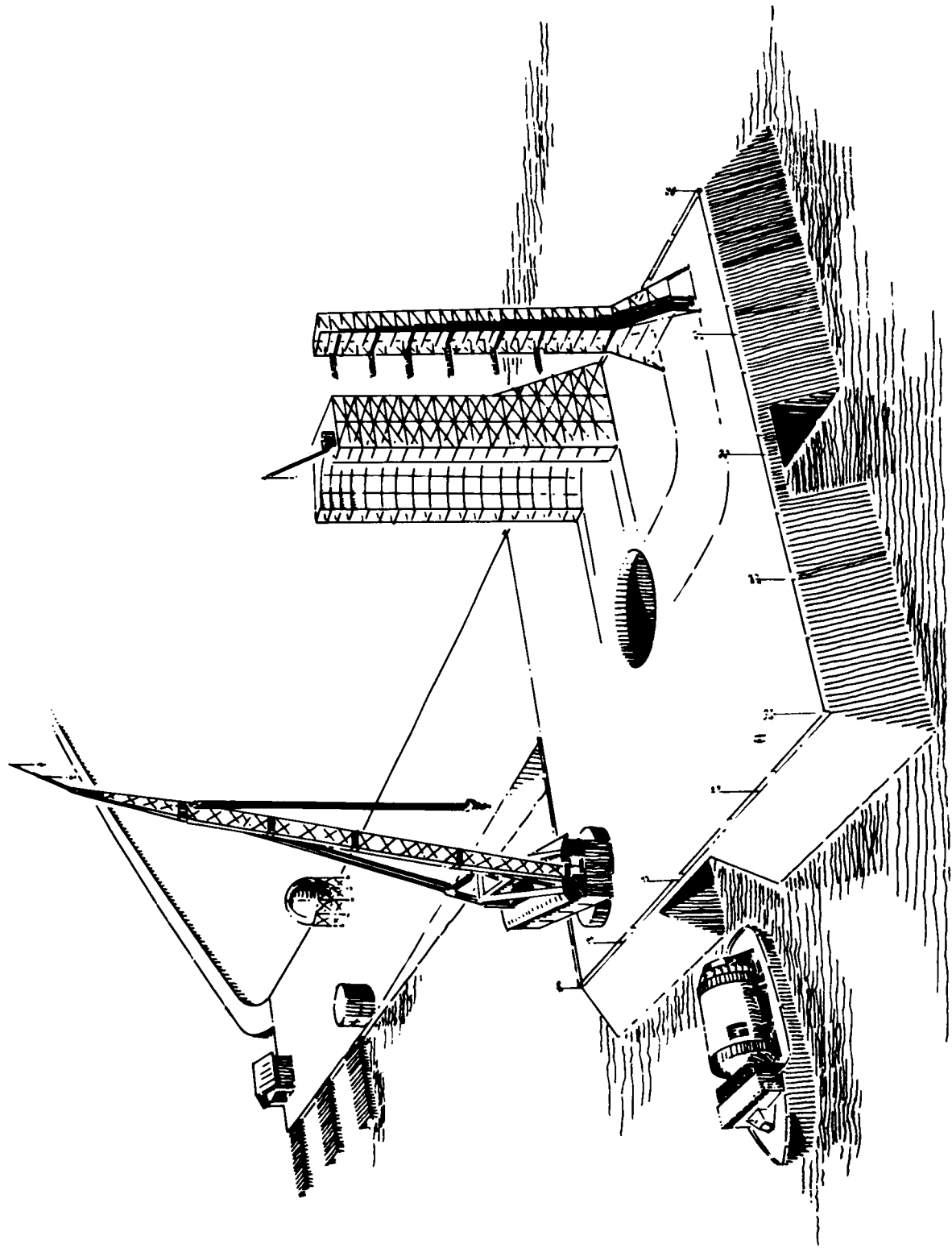

Figure 15.