

NASA TECHNICAL  
MEMORANDUM

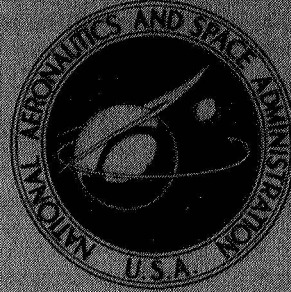

NASA TM X-1670

NASA TM X-1670

GPO PRICE \$ \_\_\_\_\_

CSFTI PRICE(S) \$ \_\_\_\_\_

Hard copy (HC) \_\_\_\_\_

Microfiche (MF) \_\_\_\_\_

ff 653 July 65

FACILITY FORM 602	N 68-36076	
	(ACCESSION NUMBER)	(THRU)
	28	17
	(PAGES)	(CODE)
	TMX 1670	
	(NASA CR OR TMX OR AD NUMBER)	(CATEGORY)

CAVITATION DAMAGE OF STAINLESS STEEL,  
NICKEL, AND AN ALUMINUM ALLOY IN WATER  
FOR ASTM ROUND ROBIN TESTS

by Stanley G. Young  
Lewis Research Center  
Cleveland, Ohio



NASA TM X-1670

CAVITATION DAMAGE OF STAINLESS STEEL, NICKEL, AND AN  
ALUMINUM ALLOY IN WATER FOR ASTM ROUND ROBIN TESTS

By Stanley G. Young

Lewis Research Center  
Cleveland, Ohio

NATIONAL AERONAUTICS AND SPACE ADMINISTRATION

---

For sale by the Clearinghouse for Federal Scientific and Technical Information  
Springfield, Virginia 22151 - CFSTI price \$3.00

## ABSTRACT

Cavitation damage was determined for AISI type 316-stainless steel, nickel 270, and 6061-T6 aluminum as part of an ASTM round robin test program. A vibratory apparatus was used and tests were conducted in water at 75° F (23.9° C) under 1 atmosphere pressure. Volume loss, volume loss rate, and mean depth of penetration were determined, and metallographic studies were made of the damaged specimens.

# CAVITATION DAMAGE OF STAINLESS STEEL, NICKEL, AND AN ALUMINUM ALLOY IN WATER FOR ASTM ROUND ROBIN TESTS

by Stanley G. Young

Lewis Research Center

## SUMMARY

The results of NASA cavitation damage studies for an ASTM round robin cavitation test program are described. AISI type 316-stainless steel, nickel 270, and 6061-T6 aluminum were tested for resistance to cavitation damage in water at 75° F (23.9° C) under 1 atmosphere pressure. A magnetostrictive transducer was used to vibrate the specimens at a frequency of approximately 25 000 hertz with a total displacement amplitude of 0.00175 inch ( $4.45 \times 10^{-2}$  mm).

The stainless steel was the least damaged and the aluminum alloy showed the heaviest damage. On the basis of volume loss and mean depth of penetration after 160 minutes of test, aluminum sustained damage approximately 45 times greater than stainless steel.

Metallographic examination of damaged specimens showed that undercutting and random surface attack occurred with all three materials. Some subsurface deformation was indicated by slip lines in the 316 stainless steel specimen.

## INTRODUCTION

Of the many methods used to evaluate materials for resistance to cavitation damage, the vibratory method is probably the most universally accepted. Various types of magnetostrictive test facilities designed to impose accelerated cavitation damage on materials by subjecting them to high frequency vibration in a fluid are described in references 1 to 6. Because of differences in test conditions such as amplitude and frequency of vibration, temperature, etc., employed by investigators using vibratory tests, it is difficult to compare the results from one laboratory with those of another.

During 1967, the ASTM committee G-2, on Erosion by Cavitation or Impingement, initiated a round-robin test program in which comparative tests were to be made with vibratory test facilities available at different laboratories. The NASA was invited to

participate in this program in which, as far as possible, test conditions were to be standardized. Thus, specimens from the same original batch of material were tested in each laboratory. The three materials chosen for the program were type 316 stainless steel, nickel 270, and 6061-T6 aluminum. The major requirements of the G-2 committee were that the specimens be tested in distilled water at 75<sup>0</sup> F (23.9<sup>0</sup> C) and atmospheric pressure. The specimen surface was to have a surface finish of 32 microinches rms or better. Tests were to be carried out to at least 0.003 inch (0.076 mm) mean depth of penetration based upon total specimen surface area. It was suggested that where possible a total displacement amplitude of 0.002 inch (0.051 mm) be used.

This report describes the results of the tests made at the NASA Lewis Research Center with these materials using a magnetostrictive apparatus. Cavitation damage for each material is presented in terms of cumulative mass loss, cumulative volume loss, volume loss rate, and mean depth of penetration. The results of metallographic studies of damaged specimens are also presented.

## MATERIALS, APPARATUS, AND TEST CONDITIONS

### Materials

The materials tested for resistance to cavitation damage were AISI type 316-stainless steel, nickel 270, and 6061-T6 aluminum. The nominal chemical compositions of these materials are listed in table I. Mechanical properties of the test materials as reported by the ASTM Committee G-2, are listed in table II, and the hardness measurements made by NASA for each test material are summarized in table III. Micrographs at 250X and grain size determinations of each material in the as-received condition are presented in figure 1. All three materials were tested in the as-received condition; the stainless steel and nickel had been annealed, while the 6061 aluminum had been solution treated and aged to the T6 condition.

### Specimens

The two types of specimens used for these tests are shown in figure 2. The externally threaded specimen design which has been used previously is suitable for most materials. The internally threaded specimen was intended for weak materials that would be susceptible to failure in the neck region. Both types of specimens were used for 316-stainless steel to compare the cavitation damage obtained with each of the two specimen designs. The surfaces of all the specimens were polished metallographically before test.

## Cavitation Apparatus

A schematic diagram of the apparatus is shown in figure 3. A photograph of the transducer, specimen holder, and test chamber is shown in figure 4. The test chamber consisted of a glass beaker containing 2 liters of distilled water.

As shown in figure 3 a magnetic pickup was used to monitor the vibration amplitude. A feedback signal from the magnetic pickup was used to control the transducer input signal to match the natural resonant frequency of the transducer-specimen assembly.

## Test Conditions

All tests were made in distilled water at  $75^{\circ} \pm 1^{\circ}$  F ( $23.9^{\circ}$  C). The initial dissolved oxygen content of the water was 7 parts per million, and the pH, as measured by Hydrion paper was 5.5. Local atmospheric pressure was  $29.17 \pm 0.25$  inches of mercury ( $1 \times 10^5$  N/m<sup>2</sup>). The total displacement (double amplitude) of vibration was  $0.00175 \pm 0.00005$  inch ( $4.45 \times 10^{-2}$  mm). The suggested amplitude for the round-robin tests was 0.002 inch ( $5.1 \times 10^{-2}$  mm). The amplitude of 0.00175 inch ( $4.45 \times 10^{-2}$  mm) was used in these tests because of limitations of the equipment at the high frequencies used.

An oscillogram of the specimen wave form is presented in figure 5. The nominal frequencies of vibration ( $\pm 50$  Hz) experienced by each of the materials in our test facility were as follows: steel, internally threaded, 25 240 hertz; steel, externally threaded, 25 675 hertz; nickel, internally threaded, 25 190 hertz; and aluminum, externally threaded, 25 890 hertz.

## Test Procedure

Each test period was preceded by a 15 minute run with a dummy specimen (Stellite 6B) to obtain uniform test bath conditions. Two specimens of each material were tested. The specimens were cleaned in distilled water and alcohol and air dried, then they were photographed, weighed, and subjected to cavitation damage by vibration for varying intervals. After each period of operation, the specimens were again cleaned, weighed, and photographed. At least eight measurements of mass loss were made for each specimen during a complete test. Mass loss was divided by density to obtain volume loss, which in turn was divided by total specimen area to determine mean depth of penetration.

## RESULTS AND DISCUSSION

### Cavitation Damage Data

Cavitation damage for all materials is expressed in terms of mass loss, volume loss, and mean depth of penetration in table IV. Mass loss and volume loss for all three materials are plotted in figures 6 and 7, respectively. On both a mass loss and volume loss basis, aluminum showed the heaviest damage, and stainless steel the least damage. On the volume loss plot of figure 7, the line of mean depth of penetration equal to 0.076 millimeter, the minimum requirement for test duration, is shown. The aluminum reached this level after 30 minutes, the nickel after 140 minutes, and the stainless steel after 620 minutes of testing. Figures 6 and 7 show that extremely close agreement was obtained with the duplicate test specimens with each material. There was essentially no difference between the results obtained with the internally and externally threaded stainless steel specimens.

Volume loss rate curves for the three test materials are presented in figure 8. These curves were obtained by dividing the volume loss between successive points where weight measurements were taken by the measurement of time between them, and plotting the data point midway between the two weighing times. The points so calculated are shown on figure 8 for 2 specimens of each material, and a single curve has been faired through the data for each material. The curve for the heavily damaged aluminum specimen passed through a damage rate peak and appeared to be approaching a steady-state damage rate at the conclusion of the test (160 min). The nickel curve showed a definite steady-state damage rate region after 230 minutes of test. The stainless steel curve showed a very gradual increase in loss rate and appears to have reached a plateau. This material shows a relatively steady damage rate after about 300 minutes.

It is of interest to compare the cavitation damage observed in these tests in water with that observed in liquid sodium (ref. 4). Such a comparison was made for type 316-stainless steel, the only material common to both studies. On the basis of volume loss after 240 minutes, the damage sustained in water at 75° F (23.9° C) was about one-fourth that sustained in liquid sodium at 800° F (527° C). On a steady state volume loss rate basis the damage in water was about one-third that in sodium.

### Metallography

Macrographs of tested specimens are shown in figures 9 and 10. Figure 9 shows the damaged surfaces of the specimens at various times during test. All of these macrographs were taken using uniform lighting, and except for the higher magnification, the specimens appear approximately as they would to the naked eye in daylight. However,

oblique lighting was used to obtain the macrographs of the specimens of each material after completion of the test (fig. 10). This was done to accentuate the jagged surface appearance of the tested specimens. Figure 10 also illustrates the striking similarity of the damage patterns for the two duplicate specimens of each material.

Micrographs were taken of axially sectioned specimens after completion of the cavitation damage tests for the three materials and are shown in figure 11.

On a macroscale damage was observed over the entire specimen surface except for a narrow rim where cavitation did not occur. On a microscopic scale channeling or undercutting was observed at random locations in specimens of all three materials. No preferential erosion with respect to the grain boundaries was observed for these materials. Grain boundaries were not visible in the aluminum, but the character of the damage appeared similar to that of the other two materials. Some evidence of subsurface deformation was noted in the form of slip lines in the stainless steel sample. Also just below the damaged surface of the nickel a slightly "mottled" effect was observed; this suggests that the material near the surface was worked.

## SUMMARY OF RESULTS

The following results were obtained from accelerated cavitation damage tests in a vibratory apparatus at the NASA Lewis Research Center with AISI-type stainless steel, nickel 270, and 6061-T6 aluminum. The materials were tested in distilled water at  $75 \pm 1^\circ \text{F}$  ( $23.9^\circ \text{C}$ ) at one atmosphere pressure.

1. The ranking of the materials in order of decreasing resistance to cavitation damage was stainless steel, nickel, and aluminum. On the basis of volume loss and mean depth of penetration after 160 minutes of test, the aluminum alloy sustained cavitation damage approximately 45 times greater than the stainless steel.

2. Despite possible differences in the ultrasonic vibratory mode of specimens of stainless steel due to different methods of attachment to the transducer (internal against external threads), the degrees of damage sustained were nearly identical.

3. Metallographic examination of damaged specimens showed that undercutting and random surface attack occurred with all three materials. Some subsurface deformation was indicated by slip lines in the 316 stainless steel specimens.

Lewis Research Center,  
National Aeronautics and Space Administration,  
Cleveland, Ohio, July 5, 1968,  
129-03-03-03-22.



## REFERENCES

1. Robinson, L. E.; Holmes, B. A.; and Leith, W. C.: Progress Report on Standardization of the Vibration-Cavitation Test. Trans. ASME, vol. 80, no. 1, Jan. 1958, pp. 103-107.
2. Hobbs, J. M.; Laird, A.; and Brunton, W. C.: Laboratory Evaluation of the Vibratory Cavitation Erosion Test. NEL Rep. 271, National Engineering Lab., Glasgow, Jan. 1967.
3. Plesset, Milton S.: Pulsing Technique for Studying Cavitation Erosion of Metals. Corrosion, vol. 18, no. 5, May 1962, pp. 181t-188t.
4. Young, Stanley G.; and Johnston, James R.: Accelerated Cavitation Damage of Steels and Superalloys in Liquid Metals. NASA TN D-3426, 1966.
5. Garcia, R.; Hammitt, F. G.; and Nystrom, R. E.: Correlation of Cavitation Damage with Other Material and Fluid Properties. Erosion by Cavitation or Impingement. Spec. Tech. Publ. No. 408, ASTM, 1967, pp. 239-283.
6. Thiruvengadam, A.; and Preiser, H. S.: Cavitation Damage in Liquid Metals. Rep. TR 467, Hydronautics, Inc. (NASA CR-72035), Nov. 29, 1965.

TABLE I. - NOMINAL CHEMICAL COMPOSITIONS OF TEST MATERIALS

Material	Composition, wt. %											
	Fe	Ni	Al	Cr	Mo	C	Mn	Si	P	S	Cu	Mg
AISI type 316 stainless steel <sup>a</sup>	Bal- ance	13	----	18	2.5	0.08	1.25 to d2.0	b <sub>1</sub>	b <sub>0.04</sub>	b <sub>0.03</sub>	b <sub>0.50</sub>	---
Nickel 270 <sup>c</sup>	----	99.98	----	----	---	0.005	----	----	----	----	----	---
6061-T6 aluminum <sup>d</sup>	b <sub>0.7</sub>	-----	Bal- ance	0.25	---	-----	b <sub>0.15</sub>	0.6	-----	-----	0.25	1.0

<sup>a</sup>AMS specification 5648C.

<sup>b</sup>Maximum.

<sup>c</sup>Huntington alloy bulletin 5000 7-63 S25, INCO, Huntington, W. Va., 1963.

<sup>d</sup>ASM Metals Handbook, Vol. I, 1961, pp. 945-946.

TABLE II. - MECHANICAL PROPERTIES OF TEST MATERIALS

[Data furnished by ASTM committee G-2.]

Material	Yield strength (0.2 percent)		Tensile strength		Elon- gation, percent	Reduc- tion in area, percent	Impact strength	
	Psi	N/m <sup>2</sup>	Psi	N/m <sup>2</sup>			ft-lb	J
AISI type 316 stainless steel	31 310	2.16×10 <sup>8</sup>	81 250	5.6×10 <sup>8</sup>	69.0	76.9	136.0	184.1
Nickel 270	8 000	0.55×10 <sup>8</sup>	48 750	3.36×10 <sup>8</sup>	61.0	91.5	91.0	123.5
6061-T6 aluminum	40 680	2.81×10 <sup>8</sup>	47 260	3.28×10 <sup>8</sup>	21.5	44.0	5.5	7.47

TABLE III. - ROCKWELL B HARDNESS MEASUREMENTS OF TEST MATERIALS

Material	Readings	Rockwell B hardness	
		Range	Average
AISI type 316 stainless steel	23	71.8 to 76.6	74.8
Nickel 270	30	20.1 to 30.8	24.9
6061-T6 aluminum	20	58.1 to 62.0	60.1

TABLE IV. - CAVITATION DAMAGE RESULTS FOR TEST MATERIALS IN WATER AT 75° F (23.9° C)

(a) AISI type 316 stainless steel

Time, min	Specimen 1 <sup>a</sup>	Specimen 2 <sup>b</sup>	Specimen 1 <sup>a</sup>	Specimen 2 <sup>b</sup>	Specimen 1 <sup>a</sup>	Specimen 2 <sup>b</sup>	Specimen 1 <sup>a</sup>	Specimen 2 <sup>b</sup>	Specimen 1 <sup>a</sup>	Specimen 2 <sup>b</sup>
	Mass, g		Mass difference, mg		Cumulative mass loss, mg		Cumulative volume loss <sup>c</sup> , mm <sup>3</sup>		Mean depth of penetration <sup>d</sup> , mm	
0	6.9494	9.9950	----	----	----	----	----	----	----	----
5	6.9488	-----	0.6	----	0.6	----	0.08	----	0.0005	----
20	6.9488	-----	0	----	.6	----	.08	----	.0005	----
40	6.9484	9.9944	.4	0.6	1.0	0.6	.13	0.08	.0008	0.0005
80	6.9443	9.9910	4.1	3.4	5.1	4.0	.65	.51	.0041	.0032
160	6.9321	9.9779	12.2	13.1	17.3	17.1	2.19	2.16	.0137	.0135
240	6.9191	9.9645	13.0	13.4	30.3	30.5	3.83	3.86	.0239	.0241
320	6.9049	9.9510	14.2	13.5	44.5	44.0	5.63	5.56	.0352	.0348
480	6.8763	9.9225	28.6	28.5	73.1	72.5	9.24	9.17	.0578	.0573
640	6.8454	9.8929	30.9	29.6	104.0	102.1	13.15	12.91	.0823	.0807

(b) Nickel 270

Time, min	Specimen 1 <sup>b</sup>	Specimen 2 <sup>b</sup>	Specimen 1 <sup>b</sup>	Specimen 2 <sup>b</sup>	Specimen 1 <sup>b</sup>	Specimen 2 <sup>b</sup>	Specimen 1 <sup>b</sup>	Specimen 2 <sup>b</sup>	Specimen 1 <sup>b</sup>	Specimen 2 <sup>b</sup>
	Mass, g		Mass difference, mg		Cumulative mass loss, mg		Cumulative volume loss <sup>e</sup> , mm <sup>3</sup>		Mean depth of penetration <sup>d</sup> , mm	
0	11.2273	11.4771	----	----	----	----	----	----	----	----
20	11.2200	11.4704	7.3	6.7	7.3	6.7	0.82	0.75	0.0051	0.0047
40	11.2021	11.4541	17.9	16.3	25.2	23.0	2.82	2.57	.0176	.0161
80	11.1647	11.4178	37.4	36.3	62.6	59.3	7.00	6.63	.0438	.0414
120	11.1300	11.3840	34.7	33.8	97.3	93.1	10.88	10.41	.0680	.0651
160	11.1010	11.3520	29.0	32.0	126.3	125.1	14.13	13.99	.0883	.0874
200	11.0759	11.3251	25.1	26.9	151.4	152.0	16.93	17.00	.1058	.1063
260	11.0459	11.2969	30.0	28.2	181.4	180.2	20.30	20.16	.1269	.1260
320	11.0159	11.2689	30.0	28.0	211.4	208.2	23.65	23.29	.1478	.1456

(c) 6061-T6 aluminum

Time, min	Specimen 1 <sup>a</sup>	Specimen 2 <sup>a</sup>	Specimen 1 <sup>a</sup>	Specimen 2 <sup>a</sup>	Specimen 1 <sup>a</sup>	Specimen 2 <sup>a</sup>	Specimen 1 <sup>a</sup>	Specimen 2 <sup>a</sup>	Specimen 1 <sup>a</sup>	Specimen 2 <sup>a</sup>
	Mass, g		Mass difference, mg		Cumulative mass loss, mg		Cumulative volume loss <sup>f</sup> , mm <sup>3</sup>		Mean depth of penetration <sup>d</sup> , mm	
0	3.2550	3.1785	----	----	----	----	----	----	----	----
1	3.2548	3.1781	0.2	0.4	0.2	0.4	0.07	0.15	0.0004	0.0009
5	3.2536	3.1770	1.2	1.1	1.4	1.5	.52	.55	.0033	.0034
10	3.2506	3.1741	3.0	2.9	4.4	4.4	1.62	1.62	.0101	.0101
20	3.2383	3.1637	12.3	10.4	16.7	14.8	6.16	5.46	.0385	.0341
40	3.1951	3.1267	43.2	37.0	59.9	51.8	22.10	19.12	.1381	.1195
60	3.1574	3.0818	37.7	44.9	97.6	96.7	36.01	35.68	.2251	.2230
80	3.1206	3.0375	36.8	44.3	134.4	141.0	49.59	52.03	.3099	.3252
120	3.0505	2.9685	70.1	69.0	204.5	210.0	75.46	77.49	.4716	.4843
160	2.9920	2.9090	58.5	59.5	263.0	269.5	97.05	99.45	.6066	.6216

<sup>a</sup>Externally threaded.

<sup>b</sup>Internally threaded.

<sup>c</sup>Cumulative mass loss divided by density. (Density of stainless steel, 7.91 g/cm<sup>3</sup>.)

<sup>d</sup>Cumulative volume loss divided by area of specimen. (Total area of specimen, 160 mm<sup>2</sup>.)

<sup>e</sup>Cumulative mass loss divided by density. (Density of nickel, 8.94 g/mm<sup>3</sup>.)

<sup>f</sup>Cumulative mass loss divided by density. (Density of aluminum, 2.71 g/cm<sup>2</sup>.)

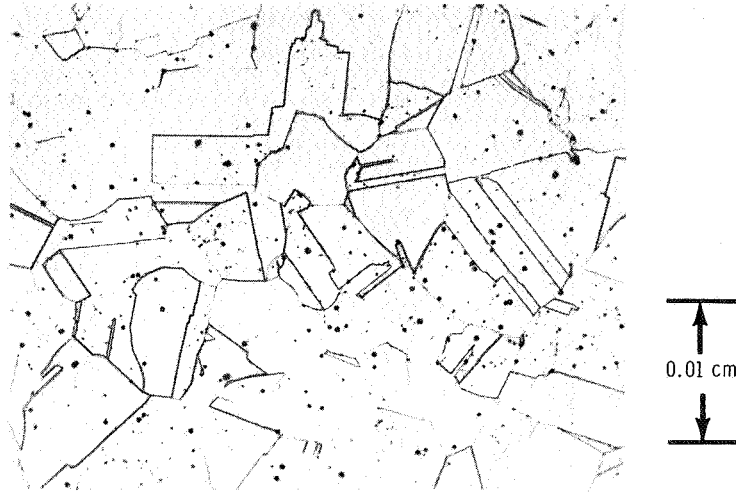

(a) AISI type 316 stainless steel. Etchant, 30 milliliters HCl, 30 milliliters glycerine, 10 milliliters HNO<sub>3</sub>, and electrolytic. Grain size 4 (8 grains/in.<sup>2</sup> at X100).

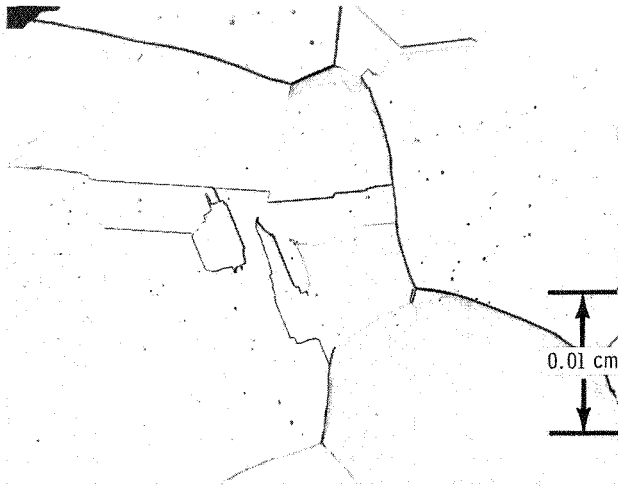

(b) Nickel 270. Etchant, 92 percent HCl, 5 percent H<sub>2</sub>SO<sub>4</sub>, and 3 percent HNO<sub>3</sub>; two grain sizes, approximately 60 percent grain size 0 (1/2 grain/in.<sup>2</sup> at X100), approximately 40 percent grain size 2 (2 grains/in.<sup>2</sup> at X100).

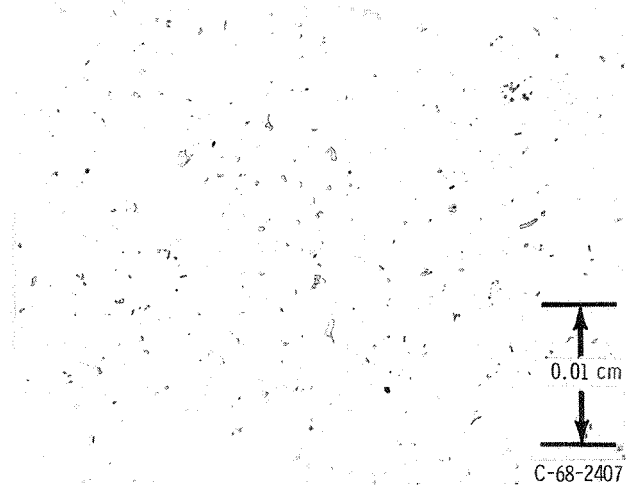

(c) 6061-T6 aluminum. Etchant, 30 milliliters glycerine, 20 milliliters HNO<sub>3</sub>, and 10 milliliters HF. No grain boundaries visible.

Figure 1. - Metallographic studies of specimen materials. ASTM Austenite grain size standard, measured by use of grain-size-measuring eyepiece and comparison of X100 photomicrograph with ASTM standard grain size charts.

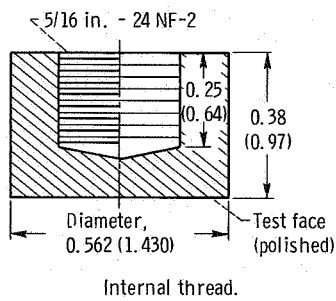
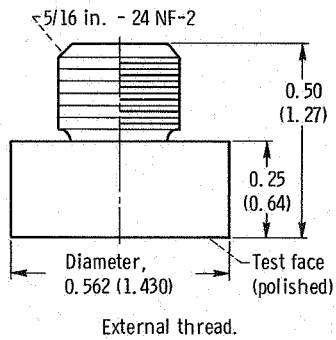

Figure 2. - Cavitation test specimens.  
(All dimensions are in inches (cm).)

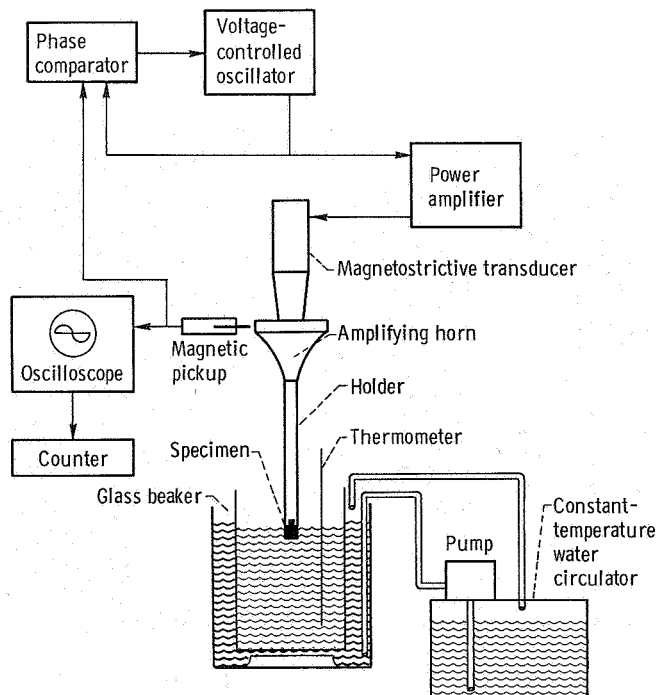
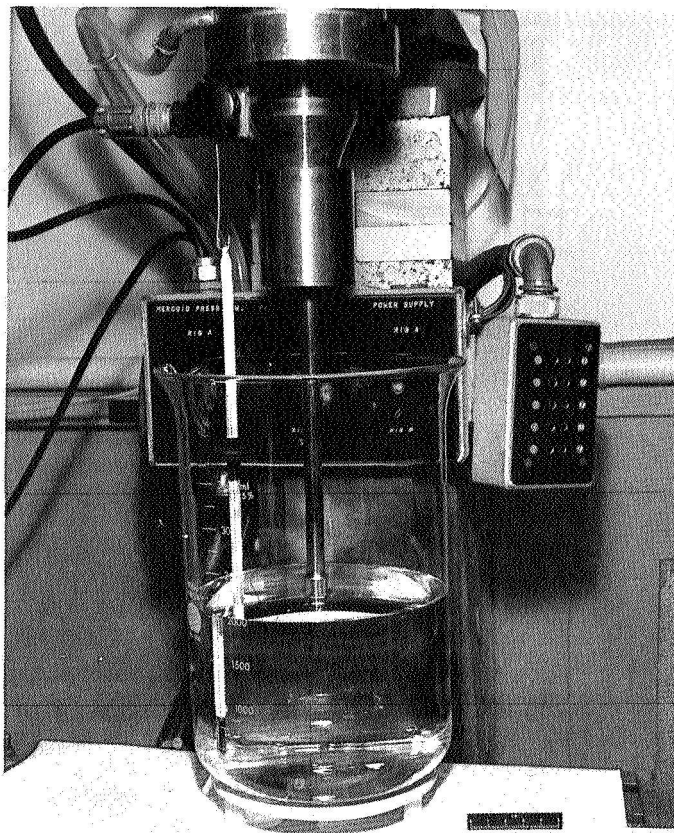
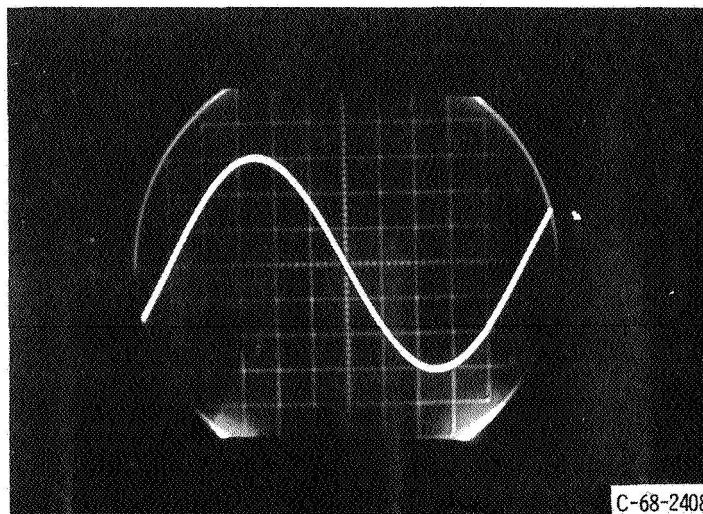

Figure 3. - Schematic diagram of NASA magnetostrictive cavitation facility used in ASTM round robin tests.



C-67-3726

Figure 4. - Cavitation apparatus (water jacket removed).



C-68-2408

Figure 5. - Oscillogram of specimen waveform in apparatus.

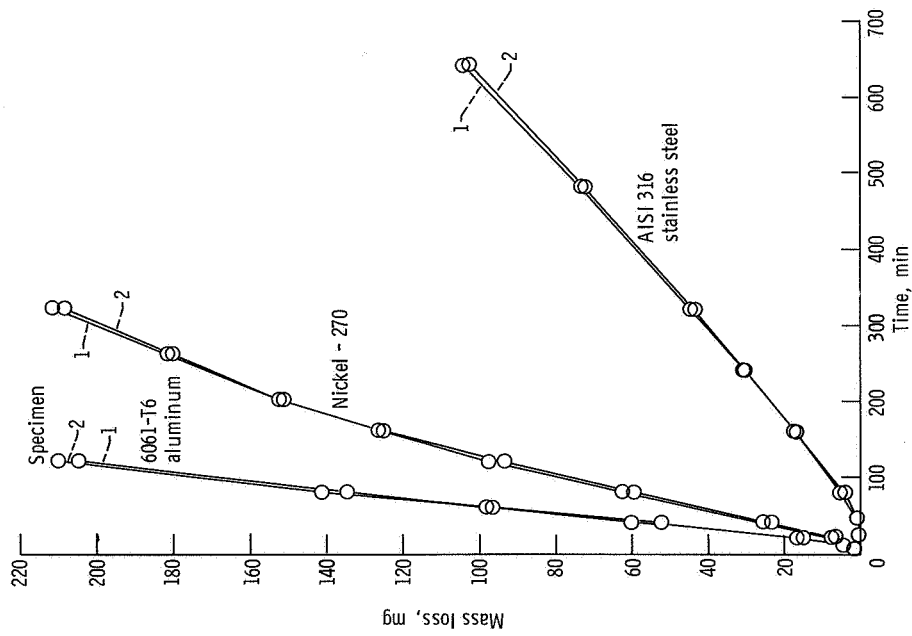

Figure 6. - Cavitation damage (mass loss) of round robin test materials in water at 75°F (23.9°C).

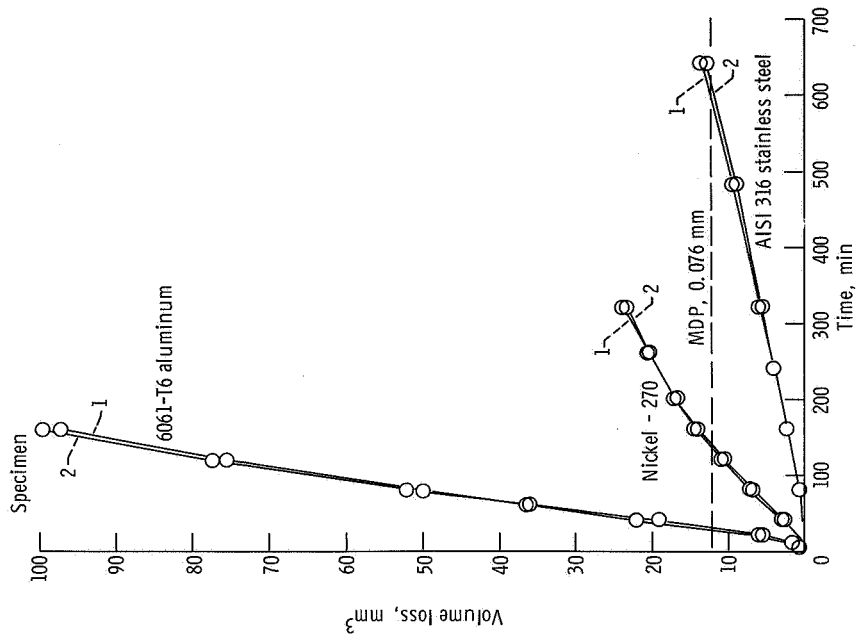

Figure 7. - Cavitation damage (volume loss) of round robin test materials in water at 75°F (23.9°C).



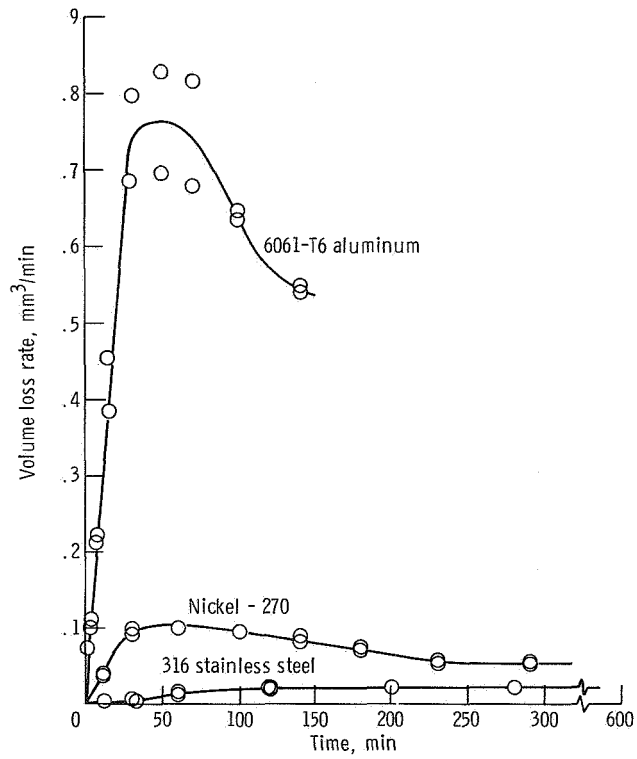
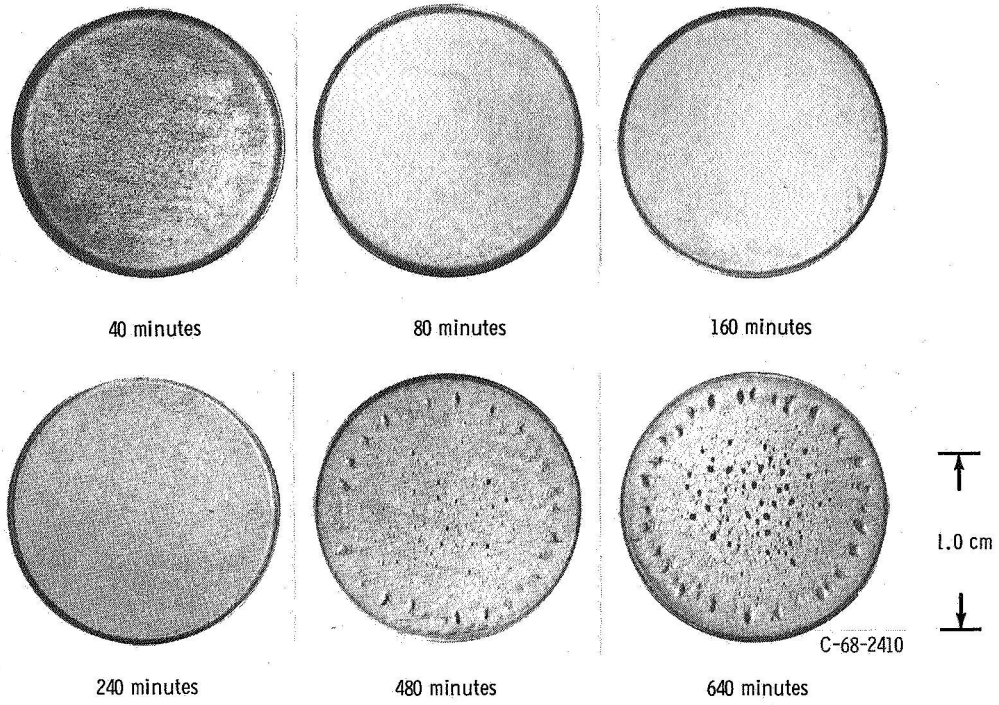
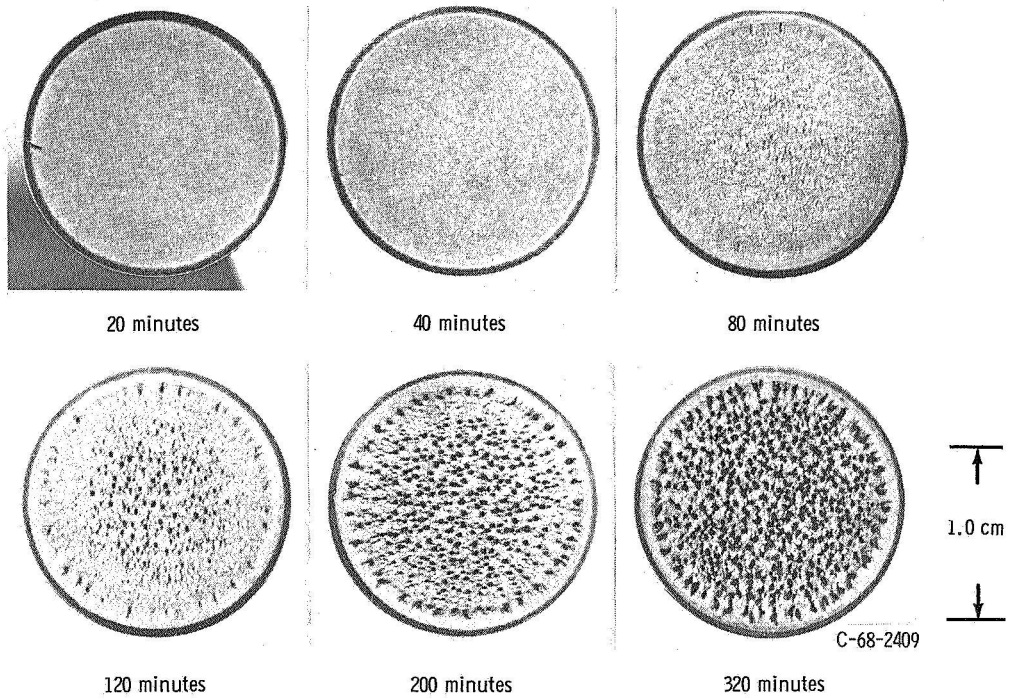

Figure 8. - Cavitation damage rate curves of round robin test materials in water at 75° F (23.9° C).



(a) AISI type 316 stainless steel.



(b) Nickel 270.

Figure 9. - Cavitation damage to materials in 75° F (23.9° C) water at various times as viewed under uniform lighting.

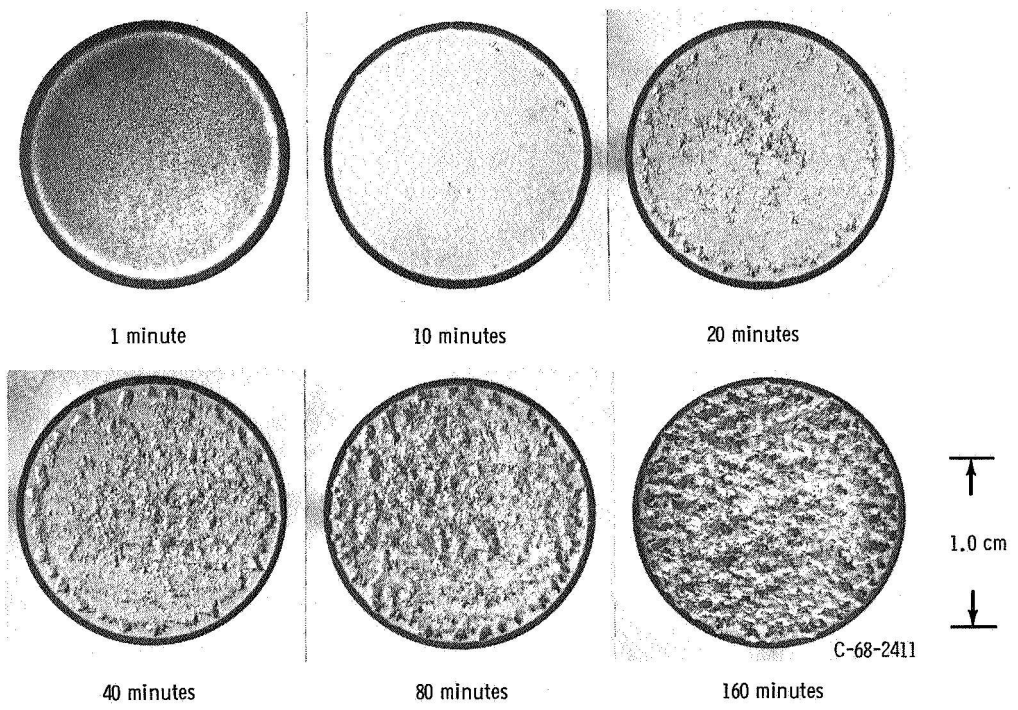

(c) 6061-T6 aluminum.  
Figure 9. - Concluded

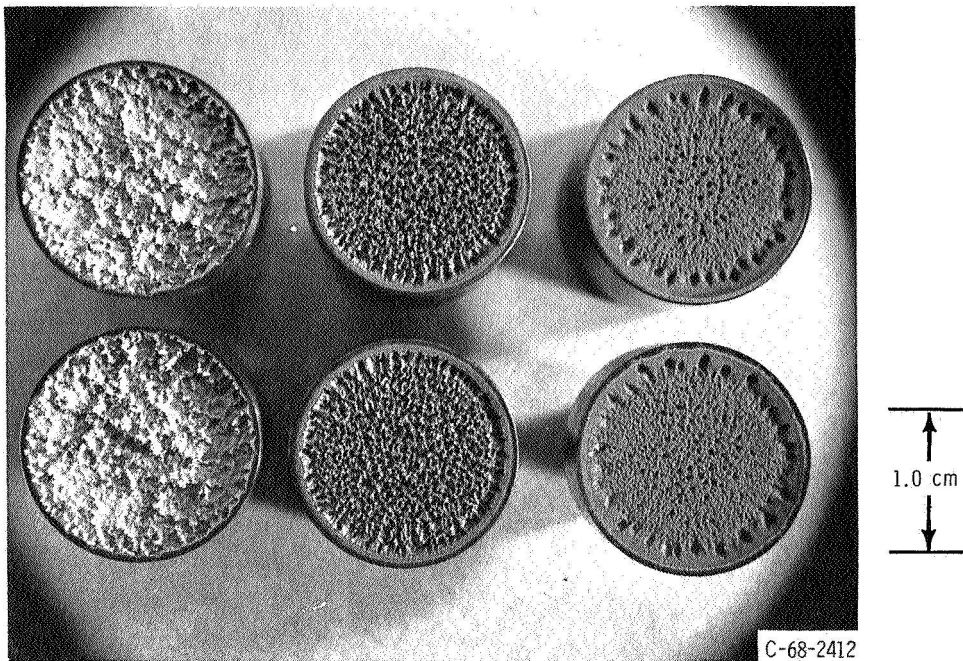

6061-T6 aluminum  
(160 min)

Nickel-270 (320 min)

316 stainless steel  
(640 min)

Figure 10. - Cavitation damage in duplicate test specimens of each material as viewed under oblique lighting. X2.

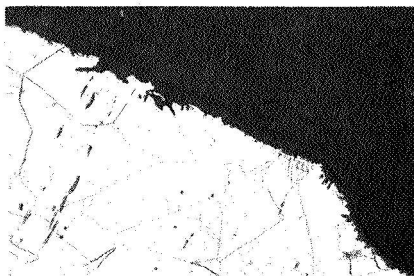

316 stainless steel (640 min).

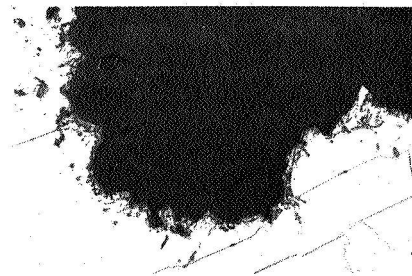

Nickel 270 (320 min).

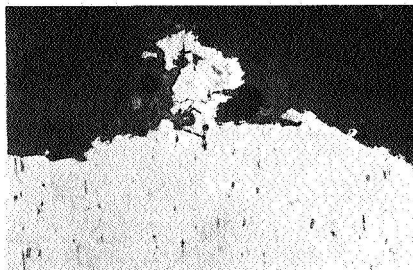

6061-T6 aluminum (160 min).

0.01 cm

C-68-2413

Figure 11. - Photomicrographs of sectioned specimens after exposure to cavitation in water at 75° F (23.9° C). X250.

NATIONAL AERONAUTICS AND SPACE ADMINISTRATION  
WASHINGTON, D. C. 20546  
OFFICIAL BUSINESS

FIRST CLASS MAIL

POSTAGE AND FEES PAID  
NATIONAL AERONAUTICS AND  
SPACE ADMINISTRATION

POSTMASTER: If Undeliverable (Section 158  
Postal Manual) Do Not Return

*"The aeronautical and space activities of the United States shall be conducted so as to contribute . . . to the expansion of human knowledge of phenomena in the atmosphere and space. The Administration shall provide for the widest practicable and appropriate dissemination of information concerning its activities and the results thereof."*

— NATIONAL AERONAUTICS AND SPACE ACT OF 1958

## NASA SCIENTIFIC AND TECHNICAL PUBLICATIONS

**TECHNICAL REPORTS:** Scientific and technical information considered important, complete, and a lasting contribution to existing knowledge.

**TECHNICAL NOTES:** Information less broad in scope but nevertheless of importance as a contribution to existing knowledge.

**TECHNICAL MEMORANDUMS:** Information receiving limited distribution because of preliminary data, security classification, or other reasons.

**CONTRACTOR REPORTS:** Scientific and technical information generated under a NASA contract or grant and considered an important contribution to existing knowledge.

**TECHNICAL TRANSLATIONS:** Information published in a foreign language considered to merit NASA distribution in English.

**SPECIAL PUBLICATIONS:** Information derived from or of value to NASA activities. Publications include conference proceedings, monographs, data compilations, handbooks, sourcebooks, and special bibliographies.

**TECHNOLOGY UTILIZATION PUBLICATIONS:** Information on technology used by NASA that may be of particular interest in commercial and other non-aerospace applications. Publications include Tech Briefs, Technology Utilization Reports and Notes, and Technology Surveys.

*Details on the availability of these publications may be obtained from:*

SCIENTIFIC AND TECHNICAL INFORMATION DIVISION  
NATIONAL AERONAUTICS AND SPACE ADMINISTRATION  
Washington, D.C. 20546