

NASA TECH BRIEF



NASA Tech Briefs are issued to summarize specific innovations derived from the U.S. space program, to encourage their commercial application. Copies are available to the public at 15 cents each from the Clearinghouse for Federal Scientific and Technical Information, Springfield, Virginia 22151.

Improved Table for Cutting and Welding

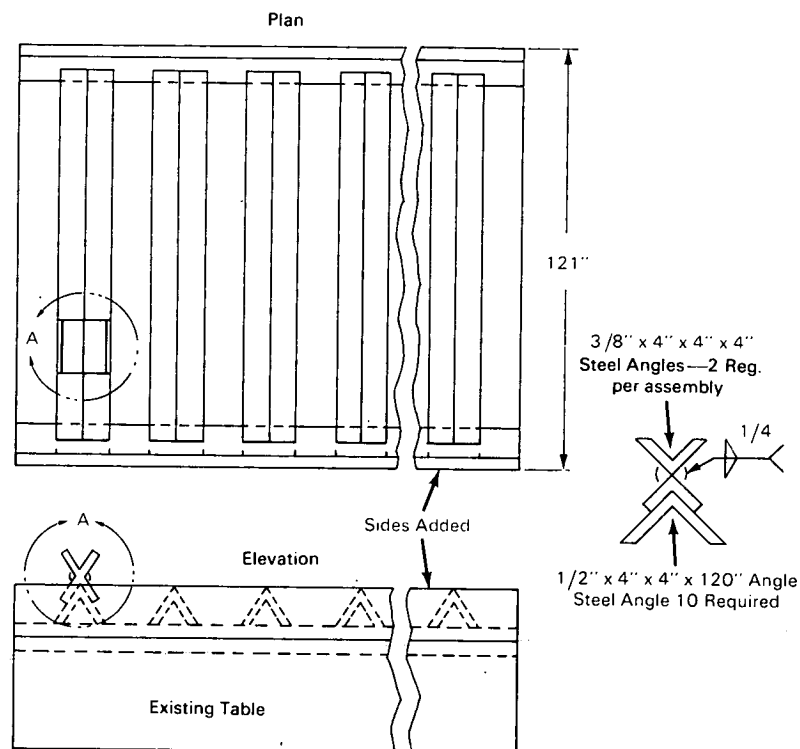

Fig. 1. Views of the Table (a) and a Sectional View of a Rider Astride a Table Angle (b)

The problem:

To design an improved welding table for torch cutting of metal of various types and thicknesses.

The solution:

A 10-foot-square welding table is much improved when covered with parallel inverted 10-foot steel angles ($\frac{1}{2}$ " by 4" by 4") centered about 9.25 inches

apart or as required. Surrounding them are box sides, tacked to the sides of the table, of the same height as the apexes of the angles (Fig. 1a).

Pairs of short lengths of angle approximately 4 inches long by $\frac{3}{8}$ " by 4"—are welded together, apex to apex, to form X-sectioned "riders" (Fig. 1b). These riders are placed astride the long angles (Fig.

(continued overleaf)

1a) and slid to their required locations.)

Very few riders are damaged when metal is cut on the table, and they can be replaced very cheaply—usually made from scrap. Cleanup of the table is minimal; it need not be swept meticulously before subsequent work will sit dead-level on the surface.

Note:

This Tech Brief is complete in itself. No additional information is available.

Patent status:

No patent action is contemplated by NASA.

Source: D. H. Oliver and M. Ramirez of
North American Rockwell Corporation
under contract to
Manned Spacecraft Center
(MSC-15537)