

5. DUCT-LINING MATERIALS AND CONCEPTS

By R. A. Mangiarotty,

The Boeing Company

Alan H. Marsh,

McDonnell Douglas Corporation

and Ernest Feder

Pratt & Whitney Aircraft

SUMMARY

This paper summarizes the experimental and theoretical studies conducted by The Boeing Company, McDonnell Douglas Corporation, and Pratt & Whitney Aircraft to evaluate the acoustical characteristics of various metallic and nonmetallic materials and lining concepts. The use of a flow-resistance apparatus and an impedance tube and their role in the initial determination of the suitability of a material are explained. A synopsis of the materials tested and the results obtained is presented. Concepts and guidelines developed for design of acoustically absorptive linings are also presented. A summary of the theoretical studies relating to duct linings is given. In addition, the flow-duct results are compared with full-scale-engine results.

INTRODUCTION

Presented herein is a discussion of some of the aspects of the studies that led to the choice of duct-lining materials and the basic concepts used in the development of acoustically treated inlets and fan ducts for flight tests. (See refs. 1 to 3.)

As an introduction to the subject, figure 1 shows the environment in which acoustic linings must operate. The high airflow velocities in the inlet and fan ducts generate turbulence pressures on the walls that require materials which will not disintegrate under such conditions. (For example, rock wool would not be suitable.) Also, the high sound pressure levels may cause structural damage; a sound pressure level of 170 dB represents a fluctuating pressure of 100 pounds per square foot.

Figure 2 shows a typical spectrum of the far-field sound pressure levels (SPL) generated by the JT3D turbofan engine at a landing-approach power setting. Below 800 Hz the spectrum is controlled by noise from the primary jet exhaust. The spectrum between 800 and 10 000 Hz contains several discrete frequency components that are the principal

E

cause of annoyance to airport neighbors. The duct-lining materials and concepts are to be selected to attenuate these discrete frequency components.

SYMBOLS

a	duct width (appendix A)
a_i	pressure amplitude constant
b	duct height (appendix A)
c	speed of sound
C_x, C_y	coefficients of mode function
d	cavity depth; lining depth
D	acoustic attenuation, decibels (dB)
f	frequency, hertz (Hz) or cycles per second (cps)
h	duct height; separation between linings
i	integer
$j = \sqrt{-1}$	
k	wave number, $2\pi/\lambda$
k_x, k_y, k_z	components of complex wave number
l	treatment length; duct length
L	acoustic admittance
m, n	duct-mode harmonic integers
M	Mach number
p	acoustic pressure

Δp	pressure drop across material
R	flow resistance, rayls (cgs system of units)
SPL	sound pressure level, decibels (dB)
S_x, S_y	coefficients of mode function
t	time
u	acoustic particle velocity
V	airflow velocity through material
x, y, z	rectangular coordinates (subscripts 1 and 2 indicate stations along duct)
T, X, Y, Z	variable functions
Z	acoustic impedance
α	wave-number propagation constant
α_N	acoustic absorption coefficient
β	wave-number phase constant
λ	acoustic wavelength
ω	angular frequency

Double primes denote second derivatives and the notation ∇^2 denotes the nabla squared.

EXPERIMENTAL STUDIES

The three steps that were taken to evaluate and test various duct-lining materials and concepts are outlined as follows:

- (1) Search for materials suitable for use as acoustical linings.
- (2) Evaluate the materials and the concepts using a flow-resistance apparatus and an impedance tube.
- (3) Test the materials (and the concepts) as duct linings in a flow-duct facility.
(In a few cases, some lining concepts have been tested in a full-scale-engine fan duct.)

The desired characteristics of porous sheet materials for potential use as duct-lining treatments are summarized in table I. These characteristics were evolved on the basis of previous experience in the development of lining technology and were modified in view of current work. The candidate materials considered in the program and a list of the evaluation methods are given in table 11. Part of the process of material selection and evaluation depends upon the type of lining concept. The three basic kinds of lining concepts that were studied are shown in figure 3, and their acoustic lining mechanisms are outlined in figure 4. The perforated plate and honeycomb combination resembles an array of Helmholtz resonators. As indicated by the solid curve for the lining mechanism, the attenuation spectrum is that of a sharply tuned resonator effective over a narrow band of noise when used as a duct lining in an environment of low airflow velocities and low sound pressure levels, and resembles an array of Helmholtz resonators. This concept can also provide a broader bandwidth of attenuation (see dashed curve in fig. 4) at very high noise levels or by the addition of a fine wire screen which provides acoustic resistance. The addition of the wire screen, however, complicates manufacture and adds weight to such an extent that other concepts are more attractive. The homogeneous absorber blanket is effective over a wide frequency range, but the materials available are not suitable for an engine environment because of their tendency to absorb and retain fluids and because of their fragility when exposed to airflow and high sound pressure levels. The broadband-resistive-resonator concept shown at the bottom of figure 3 was selected because it provides substantial acoustic attenuation over a wide frequency range and was judged, in particular, the most suitable concept for use in an engine environment. This concept incorporates the basic principles of the other two types of linings.

An extensive search was made for metallic and nonmetallic materials suitable for the broadband-resistive-resonator concept. Over 40 materials were evaluated. Most of these materials turned out to be unsuitable for use as lining materials because of their structural brittleness, for example, or their low acoustic performance.

Flow-Resistance Tests

Potentially suitable materials were screened for their flow-resistance properties by means of the flow-resistance apparatus illustrated schematically in figure 5. The

quantity measured is the acoustic flow resistance of the porous material, which is defined as

$$R = \frac{\Delta p}{V} \quad (1)$$

where Δp is the pressure drop across a sample of porous material and V is the air-flow velocity through the material. The flow resistance of a porous material is related to the acoustic resistance of the material when it is used as a duct lining. The steady airflow velocity may be related to the root-mean-square (rms) particle velocity, over a range of frequencies, of the sound waves incident on the lining. The variation of flow resistance with airflow velocity for different materials may be roughly defined as turbulent or laminar to indicate the type of flow through the material. In general, the flow resistance should vary as little as possible for materials used to attenuate a narrow band of frequencies, but the variation may be of less importance where a broadband of frequencies is to be attenuated.

Impedance-Tube Tests

If the flow resistance of a sample of material was between about 1 and 100 rayls (cgs), the material was then evaluated with a normal-incidence acoustic-impedance tube to measure acoustic-impedance characteristics, as indicated in figure 6.

The normal-incidence acoustic impedance of a material Z is defined as the complex ratio of the rms acoustic pressure p at the surface of the sample to the rms acoustic particle velocity u at the same surface:

$$Z = \frac{p}{u} \quad (2)$$

This impedance has a resistive component $\text{Re}(Z)$ that is analogous to the flow resistance defined in equation (1) and a reactive component $\text{Im}(Z)$ that is dependent upon the resonance of the air cavity behind the material as well as the resonance characteristics of the air in the linings. Thus,

$$Z = \text{Re}(Z) + j \text{Im}(Z) \quad (3)$$

For the purpose of evaluating the acoustic properties of materials before they are used as part of a duct lining, the resistive part of the impedance is of prime interest because it provides an indication of the change of flow resistance with frequency. The reactive impedance of a material alone is small compared with the impedance of a lining on the wall of a duct.

The designation "small pores" in figure 6 indicates woven or felted types of materials, whereas "large pores" indicates coarsely woven or perforated plate materials. In the flow-resistance tests, the airflow through the woven or felted types of materials is generally laminar or turbulent with a fine-grain scale of turbulence. The airflow

through the perforated plate materials is generally fully developed turbulent flow. The small-pore materials show much less variation of the real part of the impedance with frequency and therefore are more desirable for applications as acoustical duct linings in turbofan engines.

The acoustic absorptivity of a material can also be determined from the data obtained with the impedance tube. The absorption coefficient, as shown in figure 7, serves to indicate the relative acoustic efficiency of a material as a function of the frequency of the incident sound waves. The depth of the cavity d behind the sample determines the frequency of peak absorption of the lining. The smaller the cavity, the higher the frequency of peak absorption.

To supplement the standard impedance-tube tests in which there is no airflow over the surface of the sample, a study was conducted to measure the acoustic impedance of materials with one surface of the sample exposed to airflow. The study was done by mounting an impedance tube on the side of a flow duct so that one surface of the sample was exposed to the airstream in the duct and the other was exposed to sound waves in an impedance tube. A preliminary analysis of the results indicated, as expected, that increasing the airflow generally increased the acoustic impedance in a manner similar to that indicated in figure 6, or, by using the analogy between the flow resistance and the real part of the impedance, in a manner similar to that shown in figure 5.

Flow-Duct Tests

After evaluating many candidate materials and concepts in the flow-resistance apparatus and the impedance tube, a few of the candidates were tested as part of a duct lining by fabricating panels for installation in a flow-duct facility. A diagram of this type of facility is shown in figure 8. Materials are exposed to high sound pressure levels, as well as to high airflow speeds similar to those in an engine. By measuring the sound levels in the source chamber and the receiving chamber for lined and unlined test ducts, the acoustic attenuation of a lining treatment in the test duct is obtained. The configuration shown in figure 8 simulates an exhaust duct configuration where the directions of the sound propagation and airflow are the same; however, by reversing the direction of either the airflow or the sound through the system, an inlet configuration can be simulated. Typical airflow Mach numbers through the test duct ranged from 0 to 0.6.

Typical results obtained with a lining configuration tested in the flow-duct facility for the exhaust mode only are shown in figure 9. The value of the peak attenuation and the peak frequency at which the peak attenuation occurs are functions of many quantities, the most important of which are presented here. Firstly, however, it should be noted that a conclusion from the study is that materials with the same acoustic characteristics (i.e., flow resistance R and acoustic impedance Z) in a given set of duct environmental

conditions yield the same acoustic performance. This result means that once the proper values for R and Z are determined the resultant acoustic attenuation of a lining treatment is determined by the geometry of the configuration.

The attenuation of individual lining configurations typically varies with the airflow velocity in the duct and the nominal flow resistance as illustrated in figure 10. The nominal flow resistance is the average flow resistance from measurements made at several points on a sheet of material at an airflow velocity of 0.2 meter/second. As the airflow velocity is increased, the nominal flow resistance must be adjusted in order to maintain a high level of attenuation. It is therefore necessary to design a treatment for the flow regime in the duct in which it will be used. The influence of the boundary layer over the lining surface was included in the data in figure 10, but it was not studied separately.

As mentioned previously, the attenuation produced by a duct lining depends on the geometry of the duct in which it is installed. Figure 11 shows the large change in attenuation that can result from variation of only the duct height or separation between treated surfaces; that is, the closer the lined walls are to one another, the greater the attenuation for a given type and area of treatment. The results presented in figure 11 indicate how critical this duct height parameter is. In the example shown, the same treatment with the duct height increased from 6 inches to 12 inches resulted in a decrease of 15 dB in the peak attenuation.

A parametric study of a large quantity of experimental data from flow-duct facilities has shown that the three quantities of (1) treatment cavity depth d , (2) duct height h , and (3) frequency of peak attenuation f are highly correlated, as indicated in figure 12. The information presented in figure 12 is useful in selecting a cavity depth for a treatment for a duct with particular duct height and a particular noise spectrum to be attenuated. The speed of sound c was used to obtain nondimensional parameters.

The attenuation of a fixed length of duct lining increases, as to be expected, with the number of surfaces treated (i.e., as the treated area is increased). The typical relative increase obtained by treating the various sides of a duct is shown in figure 13. It is evident that treating a second and opposite surface of a duct produces a substantial increase in attenuation. The small increase in attenuation obtained by adding linings on walls C and D when linings are already on walls A and B is due to the smaller surface areas of the short walls and to the greater separation between them. The aspect ratio between the length of walls A and B and the length of walls C and D was varied from 1 to 4.

Attenuation of noise also increases, as expected, with an increase of treatment length, and figure 14 shows some of the typical results obtained. The initial portion of the treatment is more effective because, at the beginning of the duct, there are many more

acoustic modes (high orders) that are attenuated more rapidly than the remainder of the propagating modes. Since the remaining modes are predominantly of plane-wave type, they attenuate less rapidly with lining length. Sufficient length of treatment is necessary, of course, to attenuate broadband noise which generates both kinds of duct modes.

Full-scale Test

Two fan-exhaust lining materials and configurations were evaluated in the ducts of a full-scale JT3D engine with good results. Figure 15 shows a sample of the correlation achieved between flow-duct data and full-scale-engine data, after adjustments had been made to account for the differences between the sound pressure levels and the duct heights in the engine and in the flow duct.

Summary of Experimental Results

A summary of the test results on porous surface materials that can be used as part of acoustic lining concepts is as follows:

- (1) A large variety of porous materials, metallic and nonmetallic, were tested.
- (2) The general result, for a given set of duct environmental conditions, was that the same acoustic performance could be obtained from any of the materials examined provided that the flow resistance and acoustic impedance of the lining were identical under the particular environmental conditions. This result means that each type of thin porous surface material considered (i.e., perforated plate, resin-coated fiber-glass cloth, fiber metal, and woven wire screen) can be made to work. Hence, the selection of the material for use as an acoustical duct lining is more concerned with weight, cost, strength, and manufacturing requirements. Each type of material, however, requires certain adjustments to the acoustical and geometrical variables of the material and its support structure to achieve equal levels of noise reduction and compliance with mechanical and economic constraints.
- (3) Perforated-plate material requires the greatest amount of adjusting and full-scale development testing to realize the full potential of the mechanical and economic features.
- (4) Both resin-coated cloth and fiber-metal material require about the same amount of adjustment, but advantage can be taken of developments in duct-lining technology to minimize the time and cost of the development program.
- (5) Fiber-metal material, with low nominal flow resistance and low nonlinearity factor, is desirable when contamination is not serious or when effective methods can be devised to clean contaminated surfaces.

(6) Resin-coated fiber-glass cloth, with low nominal flow resistance and high non-linearity factor, is desirable when contamination is a serious problem or when it is undesirable or difficult to devise effective cleaning methods.

A chart showing the types of tests that have been conducted in the various test facilities is shown in figure 16. Of the nonmetallic materials, the fiber-glass — polyimide resin was the most successful, although the other two materials shown had similar acoustical properties. Of the metallic materials, the first two were about the same in acoustical performance. The perforated plate required the largest amount of parametric adjustment to perform acoustically in a similar way to other materials. The NASA-developed lining (NASAMET) was also satisfactory but bulkier than the other three.

THEORETICAL STUDIES

Theoretical studies have been conducted by The Boeing Company (and also by Pratt & Whitney Aircraft) to develop methods for predicting the acoustic performance of duct linings. Thus far, the studies have been successful in developing mathematical equations and an associated computer program for predicting attenuation of a treatment in a duct without airflow. Figure 17 shows a comparison of the attenuation predicted for a two-wall lining treatment without air flowing through the duct and that measured for the same configuration with air flowing through the duct at a Mach number of 0.1. The theoretical prediction is considered to be accurate if allowance is made for the small airflow in the duct.

A summary of the theoretical work is given in appendix A.

CONCLUDING REMARKS

It was concluded from the overall study of material and lining concepts that, for a given duct environment, the same acoustic performance could be obtained from any of the materials examined provided that the flow resistance and acoustic impedance of the lining treatments were the same. In view of this conclusion, a material for lining a duct to produce a given attenuation can be selected by giving primary consideration to other factors, such as the weight, strength, and total cost of the installed lining.

The most important parameters for a duct treatment are the duct height (separation of the treated surfaces), the cavity depth (which controls the principal frequencies to be attenuated), the lining length, and the area treated.

A prediction theory for the condition of no airflow has been successfully developed, but requires extension to cover the case when airflow is present.

APPENDIX A

THEORETICAL ANALYSIS

A theoretical analysis was made to develop a method for predicting the attenuation of sound in ducts, with particular application to turbofan engines. The theory is for straight sections of duct with various cross sections ranging from rectangular to concentric cylindrical segments. The method developed also includes duct-lining optimization on the basis of maximum reduction in perceived-flyover-noise level depending on the shape of the input spectrum.

The transmission of sound through lined ducts has been treated by many investigators. The treatment of the problem as described in this appendix follows most closely that of reference 4, but with an extensive broadening of concepts and applications. A brief outline of the analysis is presented to indicate the principal assumptions in the prediction method.

The sound pressure in the duct is assumed to be low enough for the linear wave equation to be valid; thus,

$$\frac{1}{c^2} \frac{\partial^2 p}{\partial t^2} - \nabla^2 p = 0 \quad (\text{A1})$$

By using the method of separating the variables to obtain a solution in terms of the normal modes of the duct, the following equation is obtained:

$$p(x,y,z) = X(x)Y(y)Z(z)T(t) \quad (\text{A2})$$

If harmonic waves are assumed to be traveling in the positive z -direction along the duct, equation (A2) leads to a solution of the form

$$X(x) = C_x \cos k_x x + S_x \sin k_x x \quad (\text{A3})$$

$$Y(y) = C_y \cos k_y y + S_y \sin k_y y \quad (\text{A4})$$

$$Z(z) = \exp(-jk_z z) \quad (\text{A5})$$

$$T(t) = \exp(j\omega t) \quad (\text{A6})$$

A general solution as a superposition of these solutions is as follows:

$$p = \sum_{i=1}^{\infty} a_i X_i Y_i Z_i T_i \quad (\text{A7})$$

where the constants a_i are chosen in such a way that any particular sound pressure distribution at the sound-source end of the duct can be accurately described.

Expanding equation (A1) yields

$$\frac{1}{c^2} \frac{\partial^2 p}{\partial t^2} - \frac{\partial^2 p}{\partial x^2} - \frac{\partial^2 p}{\partial y^2} - \frac{\partial^2 p}{\partial z^2} = 0 \quad (\text{A8})$$

but $\frac{\partial^2 p}{\partial x^2} = \frac{\partial^2 X}{\partial x^2} YZT$, and similarly for the other variables. Denoting $\frac{\partial^2 X}{\partial x^2} = -X''$ leads to

$$\frac{1}{c^2} \frac{T''}{T} - \frac{X''}{X} - \frac{Y''}{Y} - \frac{Z''}{Z} = 0 \quad (\text{A9})$$

By means of separation constants, equation (A9) is transformed into a number of ordinary differential equations.

A solution that represents a wave propagating in the z-direction, restricted to a single frequency component, is

$$Z(z) = \exp(-jk_z z) \quad (\text{A10})$$

where $k_z^2 = k^2 - k_x^2 - k_y^2$ is the axial wave number and k is the complex wave number of a wave propagating in free air.

Boundary equations are derived from equations (A2) to (A7) and (A9). Each solution corresponds to a mode of propagation in a duct of width a and height b . In order to solve a particular problem, a combination of modes with different values of the modal order numbers m and n must be taken with different amplitude and phase. They must be made to match the sound pressure distribution at the sound-source end of the duct, where

$$x = a, \quad \sin k_x a = 0, \quad k_x = \frac{m\pi}{a} \quad (m = 0, 1, 2, \dots)$$

$$y = b, \quad \sin k_y b = 0, \quad k_y = \frac{n\pi}{b} \quad (n = 0, 1, 2, \dots)$$

The solution is applied to the calculation of sound attenuation in a duct with broadband-resistive-resonator linings by introducing boundary conditions representing the

acoustic admittances $L(0,a)$ and $L(0,b)$ of linings in a duct of width a and height b . (Note that $b = h$ in the experimental studies described previously.) The attenuation of sound per unit length of duct in the positive z -direction can be determined from equation (A10) for the pressure by introducing $k_z = a + j\beta$. Thus,

$$Z(z) = \exp(-j\alpha z) \exp(\beta z) \quad (\text{A11})$$

The attenuation along the duct between stations at z_1 and z_2 , expressed in decibels, is then

$$D_{(z_2-z_1)} = 20 \log_{10} \left| \frac{p(z_1)}{p(z_2)} \right| = -8.68\beta(z_2 - z_1) \quad (\text{A12})$$

Thus, the attenuation per unit length is

$$D = 8.68\beta \quad (\text{A13})$$

The wave number k_z (and thus the phase constant β) is solved from the wave number equation

$$k_z = \pm \left(k^2 - k_x^2 - k_y^2 \right)^{1/2} \quad (\text{A14})$$

Because the influence of the convective velocity of the gas in the duct is small compared with the influence of airflow turbulence, the solution was obtained for a zero velocity. The influence of airflow turbulence, boundary layers, and other aerodynamic effects can be taken into account by using experimentally derived lining characteristics obtained under the actual conditions of flow.

A computer program was developed which provides duct-lining design characteristics for optimum attenuation. Inputs to the program are the experimentally determined characteristics of a selection of previous materials, constraints on lining thickness, and the geometry of the duct. Optimization of the attenuation can be performed for any number of modes of sound propagation in the duct. A merit function allowing optimization over any frequency range is used to weight the sound spectrum for subjective response so that linings can be selected to provide optimum attenuation in perceived noise.

REFERENCES

1. Pendley, Robert E.: Design Concepts. Conference on Progress of NASA Research Relating to Noise Alleviation of Large Subsonic Jet Aircraft, NASA SP-189, 1,968. (Paper No. 9 herein.)
2. Drakeley, George T.; and McCormick, Ralph B.: Treated Inlets. Conference on Progress of NASA Research Relating to Noise Alleviation of Large Subsonic Jet Aircraft, NASA SP-189, 1968. (Paper No. 14 herein.)
3. McCormick, Ralph B.: Fan-Duct Development. Conference on Progress of NASA Research Relating to Noise Alleviation of Large Subsonic Jet Aircraft, NASA SP-189, 1968. (Paper No. 15 herein.)
4. Cremer, Lothar: Theorie der Luftschall-Dämpfung im Rechteckkanal mit schluckender Wand und das sich dabei ergebende höchste Dämpfungsmass. *Acustica*, vol. 3, no. 2, 1953, pp. 249-263.

TABLE I.- DESIRED CHARACTERISTICS OF POROUS SHEET MATERIALS

- ACOUSTIC FLOW RESISTANCE
 - Producible with mean values between 1 and 100 rays (cgs)
 - Uniform over sheet or controlled gradation
 - Nonlinear increase in flow resistance with increasing airflow velocity should be small
- WEIGHT
 - Not over approximately 0.4 lb/ft²
- THICKNESS
 - Between approximately $\frac{1}{8}$ and 0.02 in
- STRENGTH
 - Effective ultimate tensile strength not less than 10 000 lb/in²
 - Effective yield tensile strength not less than 4000 lb/in²
 - Breaking strength no less than 200 lb/in.
- ENVIRONMENTAL FACTORS
 - High airflow velocity (up to Mach number 0.6)
 - High sound pressure levels (up to 170 dB)
 - Subject to contamination - dust and oils
 - May need use of cleaning solvents
 - Anti-icing considerations
 - Exposed to rain - wetting, freezing, erosion, and corrosion
 - Exposed to sunshine and heat from engine
 - Should be able to withstand environment for rest of design life of airplane
- MANUFACTURE
 - Formable into compound curved shapes
 - Should be available in large sheets, nontoxic and nonflammable
- COST OF RAW MATERIAL
 - Approximately \$15/ft² or less, in 1000-ft² production lots

TABLE II.- CANDIDATE MATERIALS AND ACOUSTICAL EVALUATION METHODS

- POROUS SURFACE MATERIALS
 - Metallic
 - Felted wire fibers - sintered
 - Layers of woven-wire screen - sintered
 - Sintered powders
 - Perforated plate
 - NASAMET
 - Nonmetallic
 - Layers of woven fiber-glass cloth - resin or rubber impregnated
- HONEYCOMB-SUPPORT STRUCTURES
 - Metallic
 - Stainless steel or aluminum - welded or brazed
 - Nonmetallic
 - Heat-resistant phenolic-resin-impregnated fiber-glass cloth (bonded)
 - Phenolic-resin-impregnated nylon-coated paper
 - Polyimide-resin-impregnated fiber-glass cloth (bonded)
- ACOUSTICAL EVALUATIONS
 - Laboratory Tests
 - Flow resistance
 - Standing-wave tube with and without airflow
 - Duct-Model Tests
 - Full-Scale-Engine Tests

TREATMENT ENVIRONMENT

MACH	0.2 TO 0.6	0.3 TO 0.5
SPL, dB	120 TO 160	120 TO 170
AIR TEMP, °F	-85 TO 140	0 TO 700

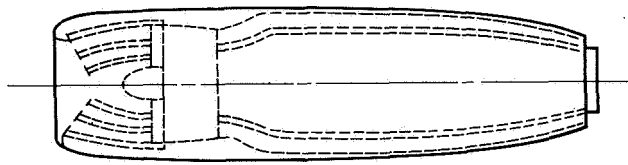

Figure 1

ENGINE SPECTRUM APPROACH POWER

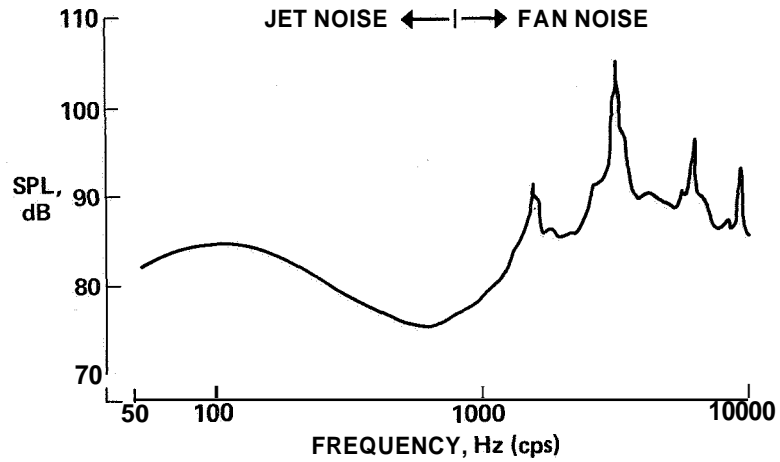

Figure 2

ACOUSTIC LINING CONCEPTS

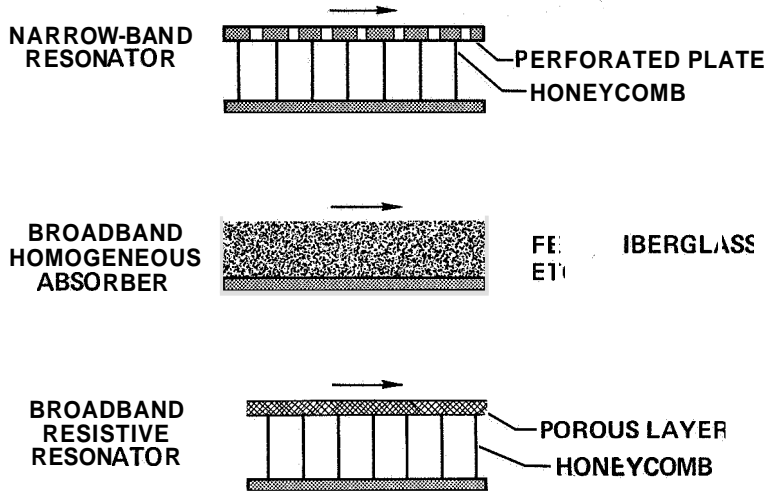

Figure 3

LINING MECHANISMS

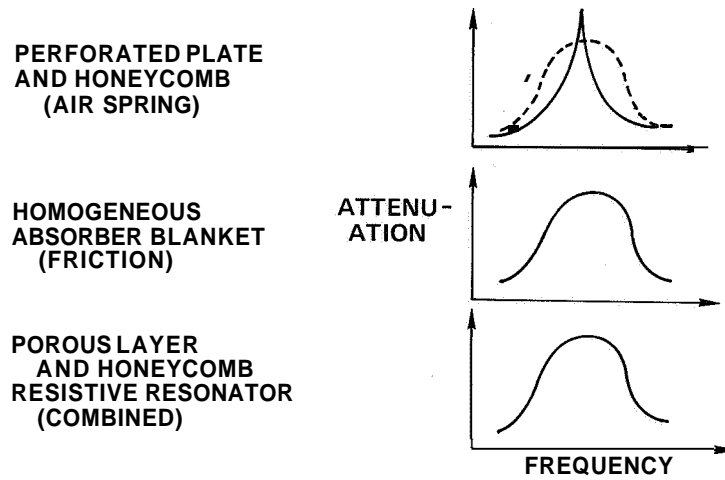

Figure 4

ACOUSTIC FLOW RESISTANCE

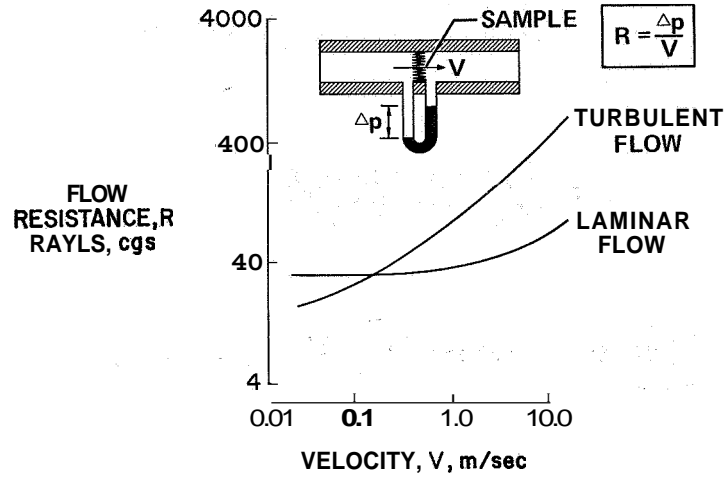

Figure 5

ACOUSTIC IMPEDANCE

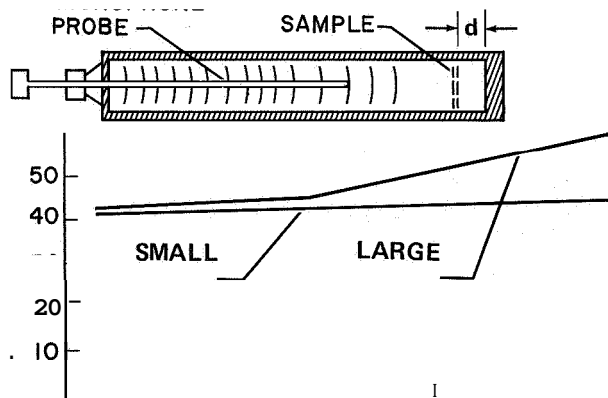

Figure 6

ABSORPTION COEFFICIENT

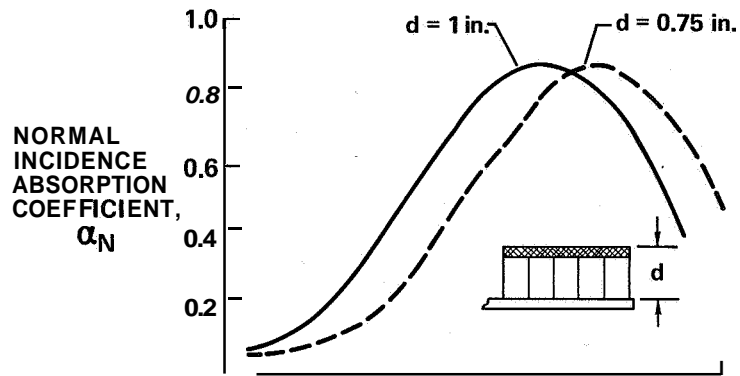

Figure 7

FLOW-DUCT MODEL TESTS

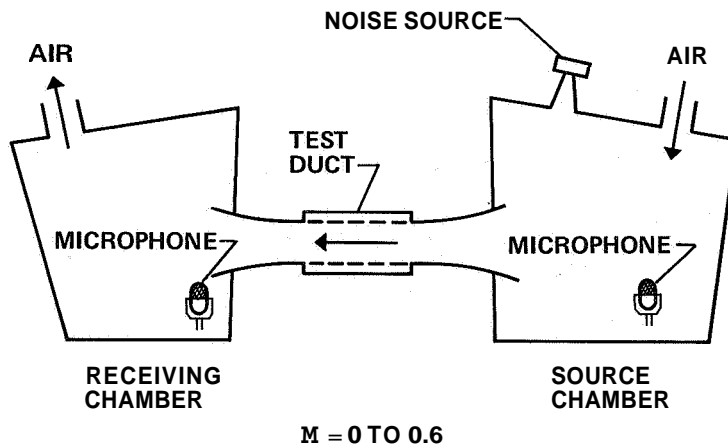

Figure 8

DUCT ATTENUATION BROADBAND NOISE SOURCE

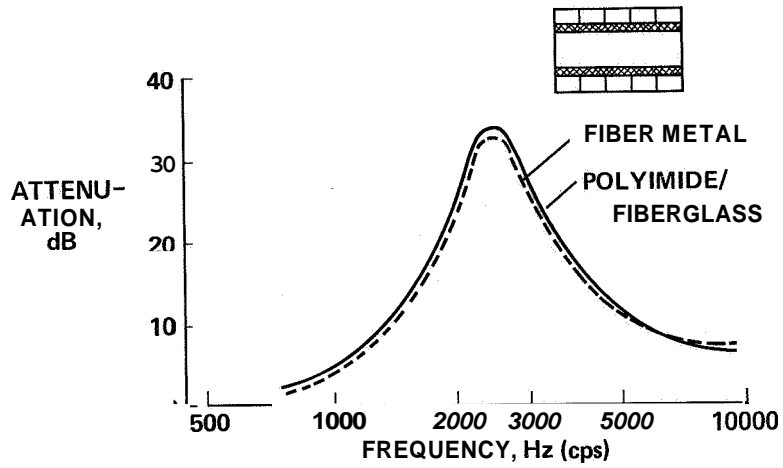

Figure 9

EFFECT OF FLOW VELOCITY

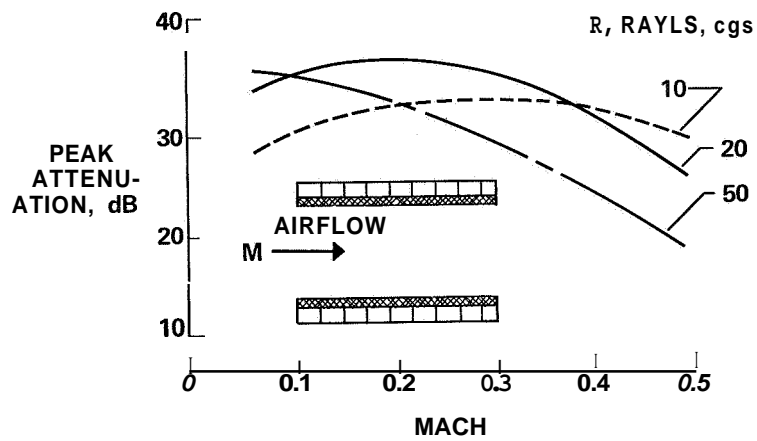
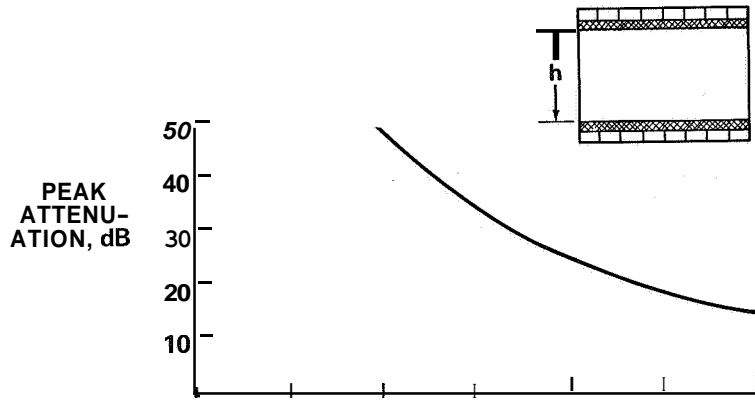

Figure 10

EFFECT OF DUCT HEIGHT



RELATION BETWEEN LINING DEPTH AND DUCT HEIGHT

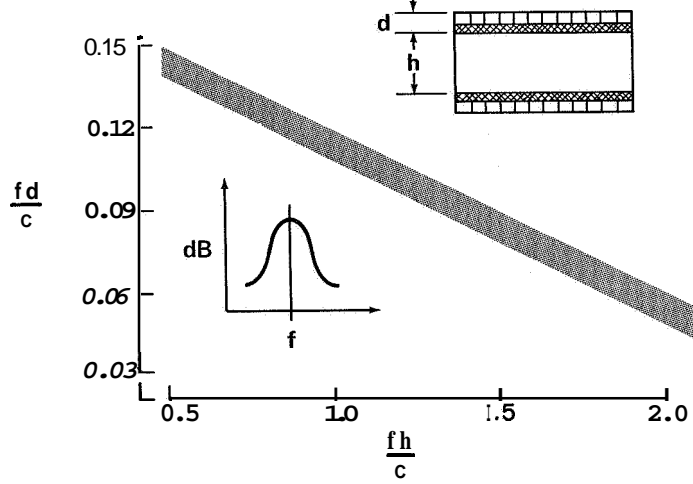

Figure 12

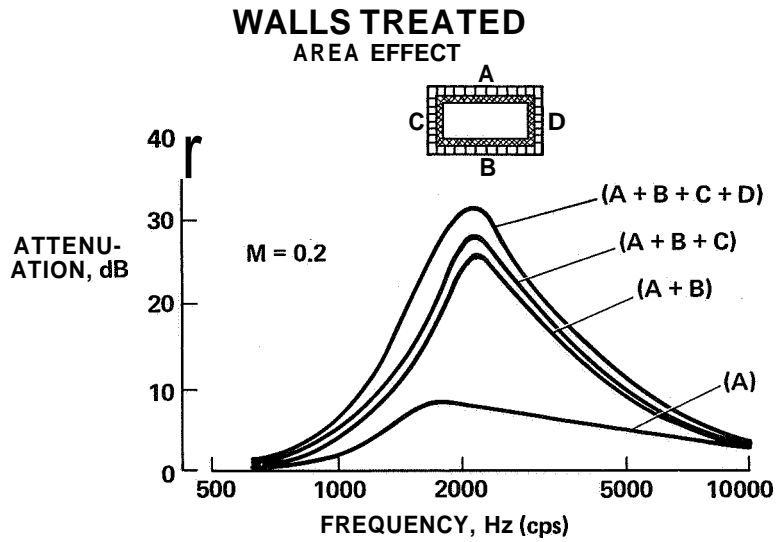

Figure 13

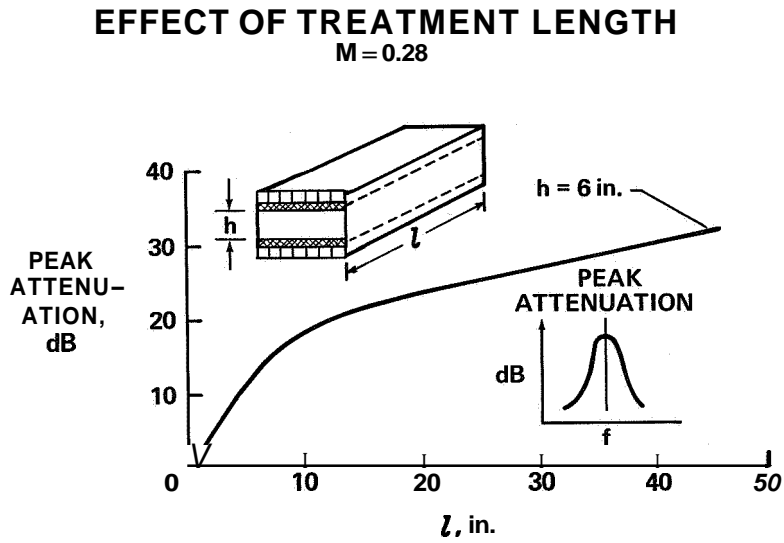

Figure 14

COMPARISON OF ACOUSTICAL DUCT LINING IN JT3D FAN-EXHAUST DUCTS AND IN MODEL FLOW DUCT

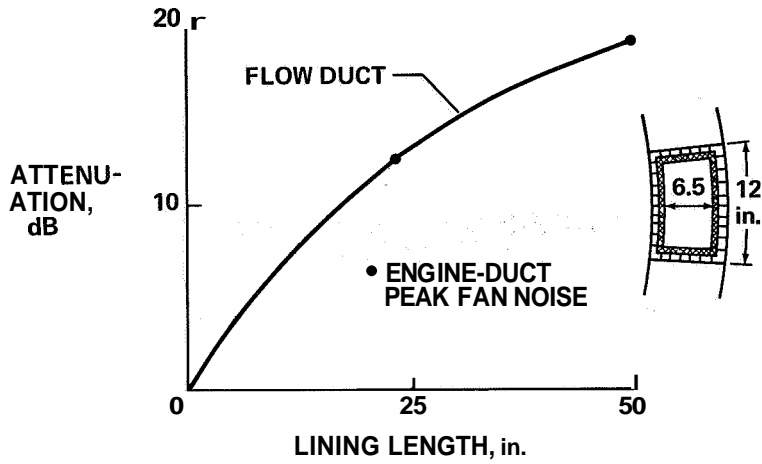

Figure 15

MATERIALS

	FLOW RESISTANCE	IMPEDANCE TUBE	FLOW DUCT
<u>NONMETALLIC</u>			
FIBERGLASS-POLYIMIDE	e	•	•
FIBERGLASS-CARBORAZOLE	•	•	
TEFLON	e	•	
<u>METALLIC</u>			
METAL FELT	e	•	•
WOVEN METAL	•	•	•
PERFORATED PLATE	e	•	•
NASAMET	e	•	•

Figure 16

COMPARISON OF EXPERIMENT AND THEORY

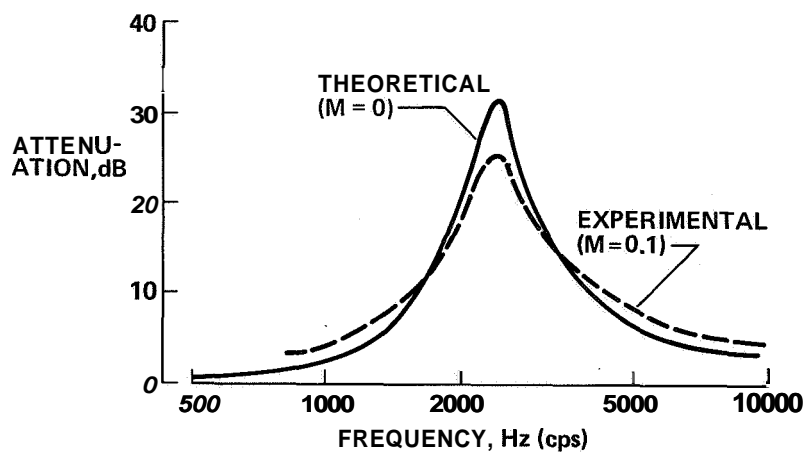

Figure 17