

N 69-11817

Torsionally Rigid and Thermally Stable Boom*

F. C. Rushing, A. B. Simon, and C. I. Denton
Westinghouse Defense and Space Center
Aerospace Division
Baltimore, Maryland

The Torsionally Rigid and Thermally Stable boom uses a unique pattern of windows or perforations, in combination with selected thermal coatings on both inside and outside surfaces, to produce equal thermal distortions on opposite sides of the boom in sunlight and therefore eliminate thermal bending. A typical boom is made of 0.002-in.-thick beryllium copper and is ½ in. in diameter. An interlocked seam maximizes torsional and bending rigidities and makes them more predictable. A special deployer has been developed for the boom. Production facilities have been set up, and the boom is now in the flight qualification state.

I. Introduction

Long erectable tubular members (booms) for space applications are required to be immune to sunlight influences on thermal bending, while possessing a maximum of bending and torsional rigidity. Such erectable members are commonly stored in a cylindrical roll and are deployed and retracted on command.

The erectable boom has been particularly applicable in space, where small stored volume and light weight are desirable. Furthermore, in gravity-free space flight, a low-strength, low-rigidity (by earth standards) boom has

filled a need for antennas and gravity-gradient attitude control systems. However, thermal bending and rigidity characteristics have presented serious limitations. In an effort to overcome these limitations, the torsionally rigid and thermally stable boom has been developed by the Westinghouse Defense and Space Center for the NASA Goddard Space Flight Center.

II. Design Principles

A. Thermal Design

The geometric and thermal configuration of this boom controls the rate of absorption of heat on opposite sides of the boom, thus producing equal thermal expansions on opposite walls and avoiding thermal bending. This

*Information for this paper was developed on NASA contracts NAS 5-9598 (Westinghouse G. O. 51340) and NAS 5-10130 (Westinghouse G. O. 51360).

condition is required for all incident angles of the sun. Although the amount of heat absorption changes with the sun's angle, it produces no adverse effects as long as the relationship from side to side is maintained constant. The required thermal stability is achieved by (1) a pattern of windows or perforations in the boom and (2) coatings of different absorptivities on the inside and outside surfaces.

1. Window pattern. A unique window pattern (Fig. 1) is used to produce the same proportionality of inside to outside exposure for all incident angles of the sun. The pattern consists of small circular holes arranged in a double helix pattern. One helix is a left-hand "thread" with a very large lead angle, and the other (intersecting) helix is a right-hand thread with a small lead angle. The holes are kept small to minimize stress concentrations and thermal resistance and maximize bending strength. With this pattern, the incremental lengths which experience the equal exposure ratio can be controlled by the helix angles. Increments less than 1 in. long have been found to be practicable. The window pattern is disrupted by the seam, since there is an overlap of about 30 deg, but the disruption is minimized by having holes in the overlapping tabs and by having the tabs bear hard against adjacent sides of the seam.

2. Coatings. Regardless of the amount of material removed by the holes, the side of the boom nearest the

sun (the front side) is completely exposed to the sun, whereas the back side is always partially shadowed by the front side. In order to absorb the same amount of heat on the back side, the inside surface is given a higher absorptivity than the outside surface.

Moreover, to minimize the cut-out area of the tube wall, the absorptivities inside and outside need to be as widely different as feasible. If the outside is covered with a low-absorptivity coating, the amount of heat involved for either side can be reduced, and thus only small perforations are required to allow sunlight to fall on a high-absorptivity surface inside. As a rough rule of thumb, the ratio of absorptivities outside to inside is equal to the fractional area of wall cut out for windows. Practically, it can be as low as 8 to 15%. By using window areas on the high side of this range, or even higher, the use of extreme and difficult-to-maintain surface absorptivities can be avoided.

To meet the requirements described above, a beryllium copper alloy with an aluminum coating vacuum-deposited on the outside and a dark oxide coating on the inside is used for the boom and gives attractive results. Solar absorptivities of these coatings are approximately 0.12 and 0.85 respectively. The reflection from the outer surface is predominantly specular, and that from the inner surface is diffuse. The proportion of holes to solid wall is adjusted to be compatible with these coatings.

B. Seam Design

The edges of the strips from which the boom is formed have V-shaped notches, and the tabs between the notches of each edge alternately go inside and outside of tabs on the opposite edge. The tabs that go inside are given a slightly inward curvature in advance. Thus, as the seam comes together, the curved tab passes under its mating uncurved tab (Fig. 1).

The shapes and spacings of the V notches can be controlled to predetermine the amount of backlash in the seam under the longitudinal shearing action which accompanies torsion. The backlash can be varied from 0 deg up to 20 deg or more per foot.

The number of Vs per unit length affects the torsional rigidity and strength of the boom. A spacing of $\frac{3}{4}$ in. has been found feasible for a $\frac{1}{2}$ -in.-diameter gravity gradient boom.

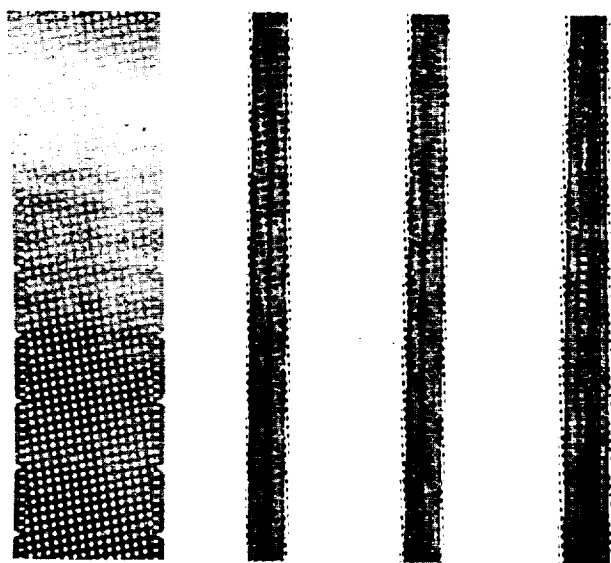

Fig. 1. From left to right: chemically milled strip; boom with double helix window pattern; boom showing joined seam; and detail of seam joining

The seam can be circumferentially preloaded. By forming the boom to a smaller diameter than its working diameter, the seam is held together by elastic strain in the boom. For a 1/2-in.-diameter boom, a formed diameter of 0.4 in. produces an attractively tight seam.

Because of the seam tightness and the hard bearing of the tabs against the opposite edges, coulomb friction is produced for any torsional backlash that is built into the boom. Friction torques in the range of 2 to 3 oz-in. have been measured under laboratory ambient conditions.

III. Thermal Bending Analysis

While elimination of thermal bending is the sole purpose of the hole pattern and thermal coatings, the achievement of exact relationships is required for optimum results. If the optimum is not achieved, the radius of curvature can be analytically computed using the following assumptions:

- (1) The window pattern distributes the radiation to the back side uniformly regardless of boom orientation.
- (2) The temperature variations along the boom's surface at any instant are small (say 10°F) so that every element radiates about the same amount of energy.
- (3) The inside surface coating reflects diffusely (according to Lambert's cosine law).
- (4) The conductivity across the seam is the same as elsewhere.

The first three assumptions have been easily justified. In the case of the fourth, the actual conductivity across the joint is relatively good because of the elastic forces pressing the interlocking tabs of the seam together; furthermore, analysis has shown that the effect of even zero conduction across the seam is relatively small.

The equation for the curvature of the boom due to thermal bending is derived as follows:

- (1) The heat balance for a differential strip running the length of the boom is obtained. This includes radiation from the sun, radiation to space, and internal reradiation and reflections.
- (2) Step 1 leads to an equation giving the temperature distribution around the boom.

- (3) The strain energy due to the thermal gradients is minimized when the boom is allowed to bend. Therefore, the curvature is found by writing an expression for the strain energy due to bending and thermal gradients and finding the curvature required to make it a minimum.

The curvature thus found is given by

$$\frac{1}{R_s} = \frac{erJ_s}{2k't} (1 - A_w) (\alpha_o - A_w\alpha_i) \sin \theta_s \quad (1)$$

where

R_s = radius of curvature due to solar irradiation

e = coefficient of thermal expansion of boom material

r = radius of boom

J_s = solar radiation flux

k' = effective conductivity of boom material considering effect of hole pattern

A_w = fractional window area of holes

α_o = solar absorptivity of outer surface

α_i = solar absorptivity of inner surface

θ_s = angle between boom axis and solar flux

t = constant wall thickness

Thermal bending can then be eliminated, in theory, by choosing the window area so that

$$A_w = \frac{\alpha_o}{\alpha_i} \quad (2)$$

In case α_o , α_i , and A_w are not related according to Eq. (2), Eq. (1) can be used to predict the curvature of the boom.

For near-earth orbits, the infrared radiation from the earth can also cause bending, although this energy is an order of magnitude less than the sun's. Equation (1) is still applicable for predicting this curvature, except that the terms J_s , α_o , α_i , and θ_s must be changed to similar terms for earth radiation instead of solar radiation.

The principles described in this paper are applicable to a wide range of boom diameters such as are required for space applications. Theoretically, Eqs. (1) and (2)

apply, and where Eq. (2) is not satisfied, there will be thermally induced bending. The curvature will be proportional to τ/t , which is approximately independent of size. The result is that for larger-diameter booms the practical length will still be limited to that of existing small-diameter booms if it is based on the criterion of straightness.

IV. Strength and Rigidity Analysis

A. Bending

Tests have been conducted on existing patterns with window areas ranging from 15 to 50%, and an empirical relationship that closely predicts the average bending strength is

$$M_{cr} = \left(\frac{S - D}{S} \right) M_{scr} \quad (3)$$

where

M_{cr} = bending strength of boom with hole pattern

S = hole spacing

D = hole diameter

M_{scr} = buckling moment for a solid-wall tube

The bending strength for the Westinghouse 1/2-in.-diameter beryllium copper boom with 15% window pattern is about 8 in.-lb. Equation (3) is shown plotted in Fig. 2.

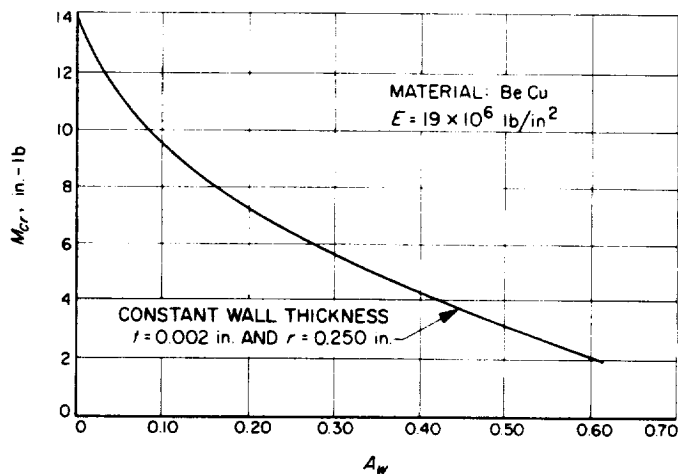

Fig. 2. Bending strength of booms as a function of A_w

B. Torsion

The shear strength of the seam determines the torsional strength for most applications. The shear strength of the seam is dependent on the number of interlocking tabs per unit length because the torsional mode of failure begins with compressive buckling at a tab. By increasing the number of tabs per unit length of boom, the tab is strengthened by being shortened and the shear load is distributed along more tabs.

For a current Westinghouse design of a 1/2-in.-diameter boom with a tab length of 3/4 in., the specified torsional strength requirement was that it exceed 16 in.-oz. This requirement was exceeded by booms with window areas ranging from 15 to 50%. The boom with a 15% window area successfully carried over 50 in.-oz of torsional load.

V. Deployer

The deployer, shown in Fig. 3, provides positive drive both for extension and retraction and contains a simple mechanism for joining the seam. The model shown was made for a special application of a 150-ft-long, 1/2-in.-diameter boom. The end connection was provided for an 8-lb tip mass. It is a compact, rugged design which has successfully withstood vibration testing at space qualification levels.

VI. Production

Production facilities available for the booms are specifically adapted to 1/2-in. beryllium copper booms up to 200 ft long and can be modified for greater lengths and diameters. The window pattern and the edge Vs are produced by chemical milling. Figure 1 shows a chemically milled strip.

VII. Conclusions

A method of minimizing the thermal bending of long tubular members has been developed and applied in the development of the torsionally rigid and thermally stable 1/2-in.-diameter beryllium copper extendible boom for NASA Goddard Space Flight Center. This boom employs an interlocked seam to yield improved torsional rigidity and strength. A flight model deployer has been built and tested. This deployer and boom development can lead to new space applications where longer booms with improved strength and straightness are needed.

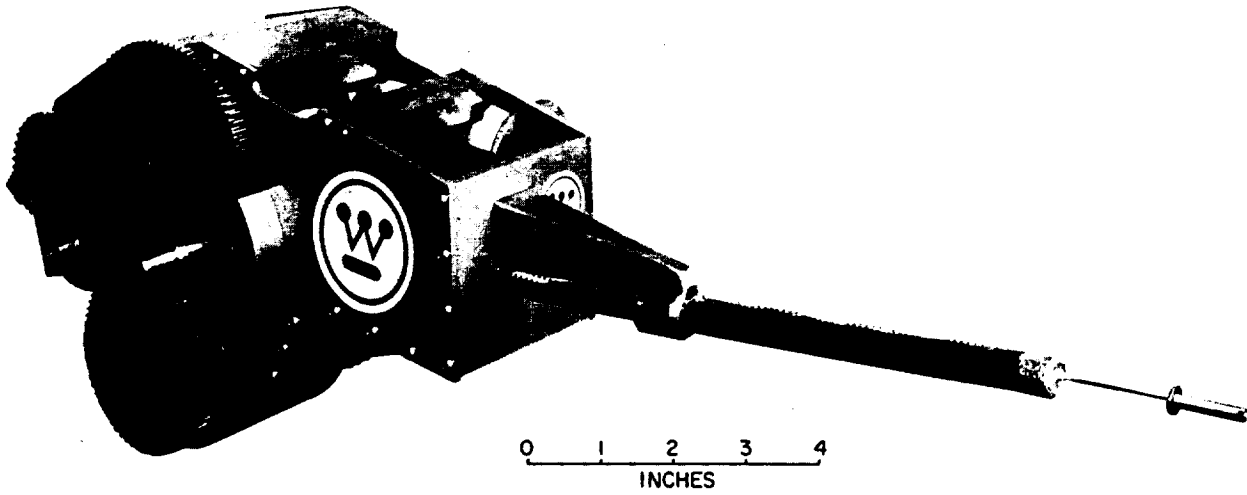

Fig. 3. Deployer for 150-ft-long boom, with provision for tip mass

