

General Disclaimer

One or more of the Following Statements may affect this Document

- This document has been reproduced from the best copy furnished by the organizational source. It is being released in the interest of making available as much information as possible.
- This document may contain data, which exceeds the sheet parameters. It was furnished in this condition by the organizational source and is the best copy available.
- This document may contain tone-on-tone or color graphs, charts and/or pictures, which have been reproduced in black and white.
- This document is paginated as submitted by the original source.
- Portions of this document are not fully legible due to the historical nature of some of the material. However, it is the best reproduction available from the original submission.

BRL

AD

REPORT NO. 1415

**PICKET MEASUREMENTS OF ELECTRON DENSITY,
ELECTRON TEMPERATURE AND THE EARTH'S MAGNETIC FIELD
ABOVE FORT CHURCHILL**

by

H. T. Loontjens

August 1968

This document has been approved for public release and sale;
its distribution is unlimited.

DDC
OCT 16 1968
RECEIVED

U.S. ARMY ABERDEEN RESEARCH AND DEVELOPMENT CENTER
BALLISTIC RESEARCH LABORATORY
ABERDEEN PROVING GROUND, MARYLAND

62

B A L L I S T I C R E S E A R C H L A B O R A T O R I E S

REPORT NO. 1415

AUGUST 1968

ROCKET MEASUREMENTS OF ELECTRON DENSITY, ELECTRON
TEMPERATURE AND THE EARTH'S MAGNETIC FIELD ABOVE FORT CHURCHILL

H. T. Lootens

Signature & Propagation Laboratory

This document has been approved for public release and sale;
its distribution is unlimited.

This research was partially supported by National Aeronautics
and Space Administration, R-82, Project NTF-99

RDT&E Project No. 1T014501B53A15

A B E R D E E N P R O V I N G G R O U N D , M A R Y L A N D

BALLISTIC RESEARCH LABORATORIES

REPORT NO. 1415

HTLootens/san
Aberdeen Proving Ground, Md.
August 1968

ROCKET MEASUREMENTS OF ELECTRON DENSITY, ELECTRON
TEMPERATURE AND THE EARTH'S MAGNETIC FIELD ABOVE FORT CHURCHILL

ABSTRACT

This report describes the results obtained from two Nike-Apache and two Javelin (Argo D-4) rockets launched in mixed pairs at Fort Churchill, Canada in November 1964. These rockets were instrumented with two-frequency propagation beacons, Langmuir probes and proton precession magnetometers. The project objectives, vehicle and payload configurations, and field operations schedule are given. Electron density and electron temperature profiles, earth magnetic field measurements and propagation beacon frequency stability values are presented.

TABLE OF CONTENTS

	Page
ABSTRACT	3
LIST OF ILLUSTRATIONS	7
I. INTRODUCTION	9
II. PROJECT OBJECTIVES AND THEORY	10
A. Primary Objectives	10
B. Secondary Objectives	10
C. Theory	10
III. VEHICLE AND PAYLOAD STRUCTURE	11
A. Nike-Apache	11
B. Javelin (Argo D-4)	13
C. Payload Structure	13
IV. PAYLOAD INSTRUMENTATION	17
A. Two-Frequency Beacon	17
B. Langmuir Probe	22
C. Proton Precession Magnetometer	25
D. Tracking, Telemetry and Aspect Units	26
E. Javelin Antennas	27
V. FIELD OPERATIONS	29
A. Launch Schedule	29
B. Tracking and Support	29
C. Ground Station and Data Recording	31
VI. RESULTS	33
A. Vehicle and Instrumentation Performance	33
B. Electron Density	38
C. Electron Temperature	41
D. Magnetic Field	41
E. Two-Frequency Beacon Frequency Stability	53

TABLE OF CONTENTS (Continued)

	Page
VII. SUMMARY	57
REFERENCES	59
DISTRIBUTION LIST	61

LIST OF ILLUSTRATIONS

	Page
1. Dimension Drawing for Nike-Apache NASA 14.104 and 14.105 . . .	12
2. Dimension Drawing for Javelin NASA 8.19 and 8.20	14
3. Expandable Boom Assembly	16
4. Payload for Nike-Apache NASA 14.104 with Expandable Boom Extended	18
5. Payload for Nike-Apache NASA 14.104 with Expandable Boom Compressed	19
6. Payload for Javelin NASA 8.20 with Expandable Boom Compressed (Frnt View)	20
7. Payload for Javelin NASA 8.20 with Expandable Boom Compressed (Back View)	21
8. Two-Frequency Propagation Beacon	23
9. Block Diagram of Two-Frequency Propagation Beacon	24
10. Antenna Configuration for Javelin NASA 8.19 and 8.20	28
11. Rocket and Payload for Javelin NASA 8.19 in Horizontal Position on Launcher with Environmental Cover Retracted . .	30
12. Block Diagram of Ground Station for Two-Frequency Propagation Beacon Data	32
13. Trajectory for Nike-Apache NASA 14.104	34
14. Trajectory for Nike-Apache NASA 14.105	35
15. Trajectory for Javelin NASA 8.19	36
16. Trajectory for Javelin NASA 8.20	37
17. Electron Density Profile from Javelin NASA 8.19	39
18. Electron Density Profile from Javelin NASA 8.20	40
19. Electron Temperature Profile from Javelin NASA 8.19	42
20. Electron Temperature Profile from Javelin NASA 8.20	43

LIST OF ILLUSTRATIONS (Continued)

	Page
21. Magnetic Field Data as a Function of Altitude from Nike-Apache NASA 14.104 and Javelin NASA 8.19	45
22. Magnetic Field Data as a Function of Altitude from Nike-Apache NASA 14.105 and Javelin NASA 8.20	46
23. Magnetic Field Data as a Function of Rocket Flight Time from Nike-Apache NASA 14.104 and Javelin NASA 8.19	47
24. Magnetic Field Data as a Function of Rocket Flight Time from Nike-Apache 14.105 and Javelin NASA 8.20	48
25. Smoothed and Unsmoothed Magnetic Field Data as a Function of Altitude from Nike-Apache NASA 14.104	51
26. Smoothed and Unsmoothed Magnetic Field Data as a Function of Altitude from Nike-Apache NASA 14.105	52
27. Frequency Drift of the Two-Frequency Propagation Beacon Flown in Javelin NASA 8.19	55
28. Frequency Drift of the Two-Frequency Propagation Beacon Flown in Javelin NASA 8.20	56

I. INTRODUCTION

In an effort to gather information related to the composition of the ionosphere, the Ballistic Research Laboratories (BRL) have sponsored and conducted basic and applied research in ionospheric physics for many years, utilizing experimental techniques such as the monitoring of satellite radio transmissions and the launching and tracking of instrumented rockets.

Recently, BRL participated jointly with NASA and the University of Michigan in an experimental rocket program conducted at Fort Churchill, Canada. The objectives of this program were to measure electron density, electron temperature and the earth's magnetic field to an altitude of approximately 800 km. The project culminated in November 1964 with the launching of two Nike-Apache and two Javelin (Argo D-4) rockets instrumented with dual-frequency propagation beacons to measure electron density and temperature, and proton precession magnetometers to measure the earth's magnetic field. For tracking and data transmission purposes, the payloads carried DOVAP transponders, S-band radar beacons and VHF telemetry units. Miscellaneous instrumentation consisted of aspect magnetometers and longitudinal accelerometers.

This project marked the first launching of a Javelin rocket at the Fort Churchill range. Range safety personnel were understandably concerned about these flights because of the higher altitude and greater horizontal range normally attained by the Javelin vehicle. Fortunately, both these Javelins impacted well within the designated area. Hence, it should be much easier to obtain permission to launch Javelin rockets at Fort Churchill in the future.

For this program, NASA provided the rocket vehicles as well as partial funding, and was responsible for dynamically balancing and shock testing the completed payloads. The University of Michigan, under contract to NASA, was responsible for the design and fabrication of the Langmuir probes, and for post-flight reduction and analysis of probe data. BRL was responsible for payload structure design, fabrication of the

remaining payload instrumentation, payload integration and the reduction and analysis of electron density and magnetic field data.

This report outlines the project objectives and theory, describes the vehicles and instrumentation, discusses the field operations and launch schedule, assesses rocket and payload performance, and presents electron density, electron temperature, magnetic field and propagation beacon stability data.

II. PROJECT OBJECTIVES AND THEORY

A. Primary Objectives

To measure day-night electron density values at Fort Churchill using a phase-coherent, harmonically related, two-frequency propagation beacon transmitting at 36.44 and 145.76 MHz and carried aloft in Javelin (Argo D-4) rocket payloads.

To measure day-night electron temperature and electron density values at Fort Churchill using a Langmuir probe in the Javelin payloads.

To measure day-night earth magnetic field values at Fort Churchill using a proton precession magnetometer mounted on the forward end of an expandable boom in the Javelin payloads and in Nike-Apache payloads launched 90 seconds before the Javelins.

B. Secondary Objectives

To compare the doppler frequencies received from the two-frequency propagation beacon and the DOVAP transponder in an effort to determine the frequency stability of the two-frequency propagation beacon. Though we have been using a multi-frequency propagation beacon for many years, this program marked the first time that the beacon and a DOVAP transponder were flown on the same rocket, thus providing us with an ideal opportunity to experimentally determine beacon frequency stability.

C. Theory

The theory underlying the magnetic field measurement program deserves comment. As noted, the Javelin and Nike-Apache payloads each carried a

proton precession magnetometer. We selected the trajectories and launch times of the vehicles such that the Javelin payload would be moving past the Nike-Apache payload when the Apache was at or near apogee. The reason for this unique spatial placement of the payloads was an attempt to differentiate between temporal and spatial changes in the ionospheric geomagnetic field. Since there is little correlation of the high altitude field with the field as measured at ground level, the temporal characteristics of high altitude perturbations cannot be determined from ground-based measurements. Furthermore, it is not possible to separate spatial and temporal variations in magnetometer data obtained from only a single rocket payload. By gathering data from two payloads simultaneously, however, spatial and temporal values may be identified.

Appropriate trajectories were chosen and each Nike-Apache rocket was launched 90 seconds prior to each Javelin. With this arrangement, the Nike-Apache payload was essentially stationary at apogee in the E-region of the ionosphere (measuring only temporal magnetic field variations) as the Javelin payload passed nearby traversing a path from the E-region to above the F-region (measuring both temporal and spatial field changes). We believed this launch timing and payload placement would make it possible to (1) differentiate between temporal and spatial changes in the ionospheric magnetic field, (2) investigate the flow of current systems in the ionosphere, and (3) correlate magnetic field variations with ionospheric electron densities.

III. VEHICLE AND PAYLOAD STRUCTURE

A. Nike-Apache

The Nike-Apache rocket and payload, shown in Figure 1, is a two-state, solid-propellant rocket combination consisting of (1) a Nike booster and (2) an Apache. Both stages are fin-stabilized and nominal spin rates for the first and second stages are 2 and 5 rps, respectively. Typically, the first stage motor burns for 3.5 seconds and drag-separates at burnout. The second stage coasts for 16.5 seconds, ignites at T+20 seconds and burns for 6.4 seconds. At burnout, the second stage reaches a velocity of 5500 feet per second. At T+60 seconds, the expandable

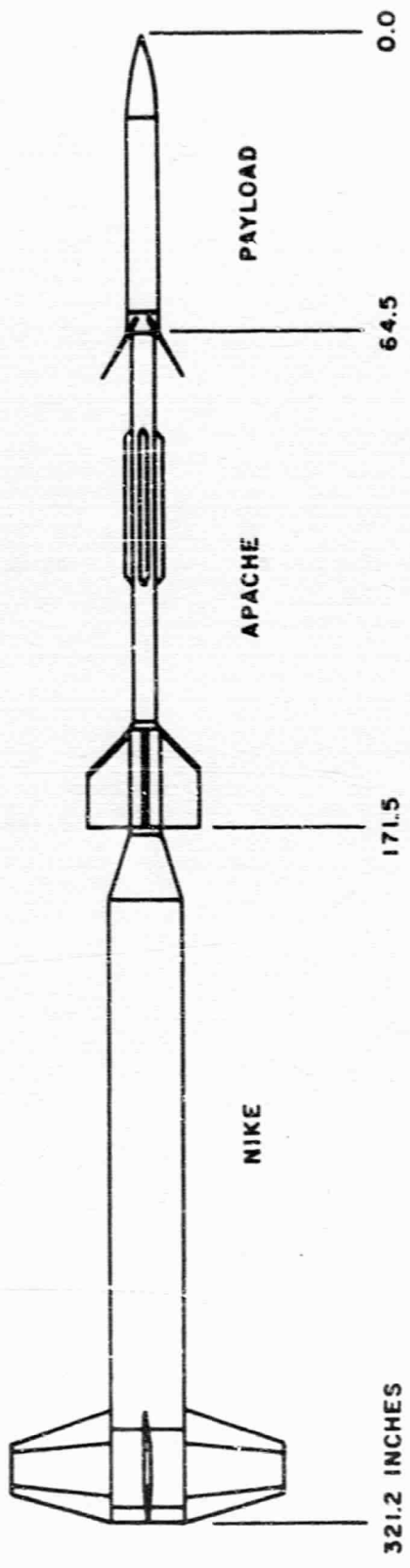

Figure 1. Dimension Drawing for Nike-Apache NASA 14.104 and 14.105

boom is released, thrusting the payload ogive (and the proton precession magnetometer sensing heads) forward approximately three feet. Maximum payload altitude achieved is approximately 150 km. Nominal length of the two stages and payload is 47 feet, and total weight is approximately 1500 pounds. The payloads described in this report were 64.5 inches in length, 7 inches in diameter and weighed 80 pounds. They were designated Nike-Apache NASA 14.104 and 14.105.

B. Javelin (Argo D-4)

The Javelin (Argo D-4) rocket and payload, shown in Figure 2, is a four-stage, solid-propellant rocket combination consisting of (1) an Honest John, (2) a Nike, (3) a Nike and (4) an X-248. The first three stages are fin-stabilized; the fourth stage has no fins and is spin-stabilized. Typically, the Honest John burns until T+5 seconds and then drag-separates. The remaining stages coast until T+9.7 seconds when the second stage ignites. This stage burns until T+13 seconds and then drag-separates. The third and fourth stages coast until T+25 seconds when third stage ignition occurs. The third stage burns until T+26.3 seconds, and then coasts with the fourth stage until fourth stage ignition at T+58 seconds, at which time the third stage is blast-separated by a blowout diaphragm. The fourth stage burns until T+100 seconds, attaining a burn-out velocity of 12,000 feet per second. The payload ogive is ejected and the expandable boom is extended at T+120 seconds. The burned out fourth stage and the payload, now spinning at a nominal rate of 8 rps, coast on a ballistic trajectory to a peak altitude of approximately 900 km. For this project, the fourth stage including the payload was not despun after burnout. Nominal length of the four stages and payload is 48 feet, and total weight is approximately 7300 pounds. The payloads described in this report were 51.3 inches in length, 19 inches in diameter and weighed 140 pounds. They were designated Javelin (Argo D-4) NASA 8.19 and 8.20.

C. Payload Structure

1. General. The Nike-Apache payload skins were constructed of 3/8-inch wall thickness fiberglass tubing. The payload supporting structures

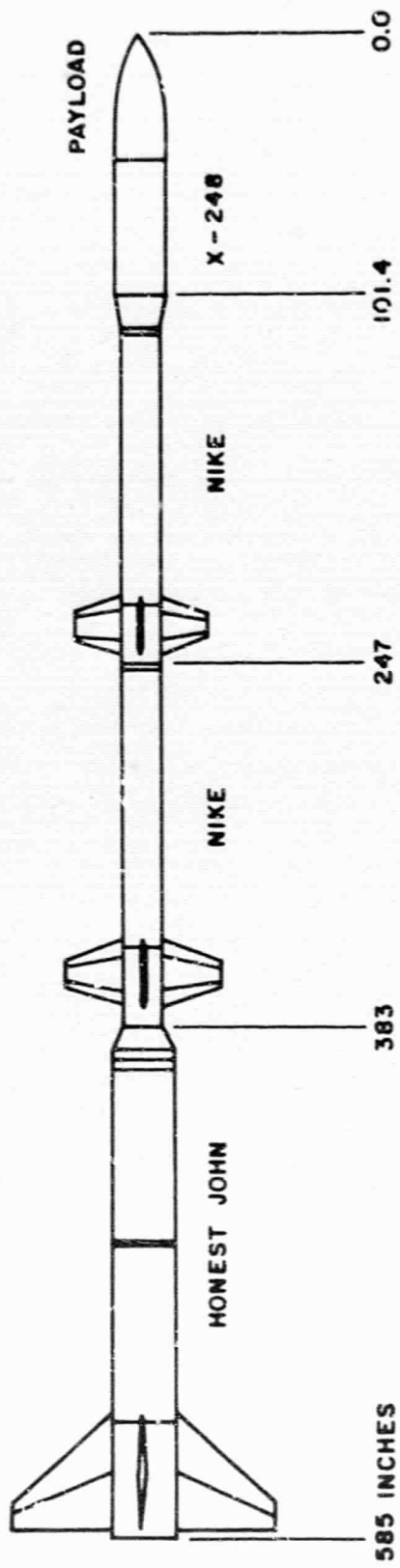

Figure 2. Dimension Drawing for Javelin NASA 8.19 and 8.20

were also fabricated entirely of fiberglass. The ogives were filament-wound fiberglass, built-up to a wall thickness of 1/4 inch. The Javelin payload internal structures were made entirely of fiberglass plate, held together with non-magnetic epoxy and a few metal screws. The Javelin ogives were constructed of two layers of molded fiberglass with a foam resin core. Finished ogive skin thickness was approximately 1/2 inch. To minimize payload residual magnetism and eddy currents, all metal structures inside the payloads were made of thin, aluminum sheeting. Fasteners were nylon, teflon or stainless steel and were as short as possible. Wherever possible, we removed the metal fasteners in the various instrument housings and replaced them with non-magnetic fasteners. All power leads were routed in twisted pairs and all radio frequency cabling was copper conductor. Payload batteries were non-magnetic and were located at the rear of the instrumentation section.

Each payload incorporated an expandable boom with two magnetometer sensing heads mounted in the forward end of the boom. Following boom extension, the heads were thus isolated from the residual magnetism and magnetic influence of the payload. The Nike-Apache boom was released at T+60 seconds when a parachute reefing-line cutter, known as a "guillotine", severed a nylon restraining rope. This allowed the entire payload and ogive to move forward approximately three feet along the rocket longitudinal axis. In the Javelin payload, a "G" actuated timer released the ogive at T+120 seconds, and a BRL-designed fiberglass spring assembly ejected the ogive and permitted the magnetometer boom to extend.

2. Expandable Boom. Each of the four payloads was fitted with an expandable boom mechanism, designed and built at BRL, to minimize the possibility of contamination of the magnetometer data as a result of payload-induced magnetism or magnetic fields. The boom, shown expanded in Figure 3, consisted of four telescopic fiberglass cylinders, each closed at one end. It was nominally 6 inches in diameter at the base and 4 inches in diameter at the tip. When compressed, the boom was approximately 13 inches long; when fully extended it was approximately 45 inches long.

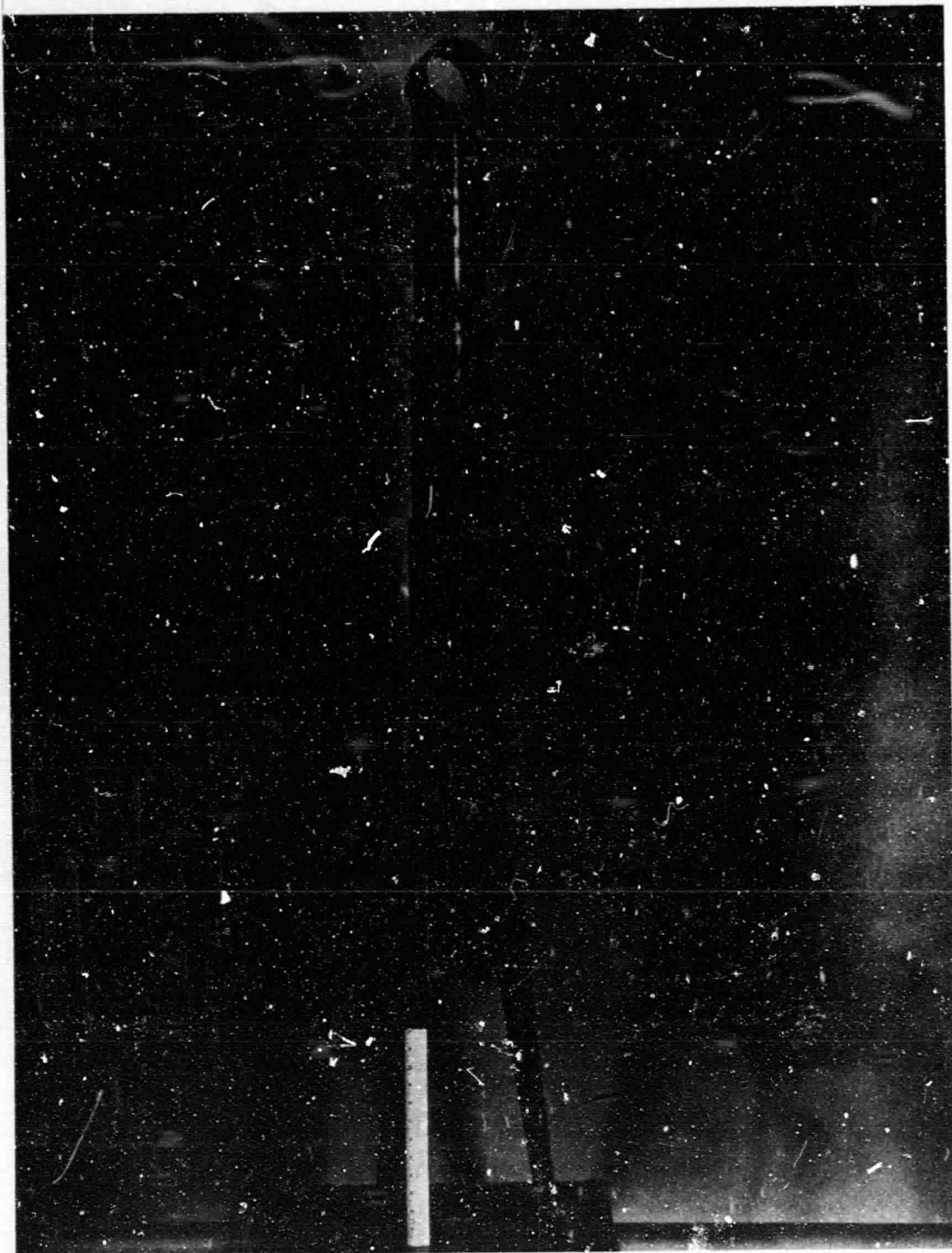

Figure 3. Expandable Boom Assembly

We mounted the magnetometer sensing heads perpendicular to each other at the forward end of the boom, one in the open cylinder at the tip of the boom and the other adjacent to the tip in the cylindrical section of the boom. In use, the boom assembly was compressed inside the payload ogive at atmospheric pressure and restrained during the early portion of the flight with a nylon rope (Nike-Apache) or by the ogive itself (Javelin). Following ogive release or ejection, the boom automatically extended as a result of the pressure differential and locked in the extended position. Extension time was adjustable and for these payloads was set for 0.3 second.

Figure 4 shows the payload for Nike-Apache 14.104 with the boom extended, while Figure 5 is the same payload with the boom compressed. Figures 6 and 7 show two views of the payload for Javelin 8.20 with the boom compressed.

IV. PAYLOAD INSTRUMENTATION

Payload instrumentation is listed in Table I and described in the succeeding paragraphs. The antenna system for the Javelin payloads is also explained in this section.

Table I. Payload Instrumentation

<u>Nike-Apache</u>	<u>Javelin (Argo D-4)</u>
Proton precession magnetometer	Two-frequency beacon
DOVAP transponder	Langmuir probe (2 per payload)
VHF telemetry system	Proton precession magnetometer
Aspect magnetometer (2 per payload)	DOVAP transponder
	S-band radar beacon
	VHF telemetry system
	Aspect magnetometer (2 per payload)
	Accelerometer

A. Two-Frequency Beacon

The BRL propagation experiment is based on a modification of Seddon's

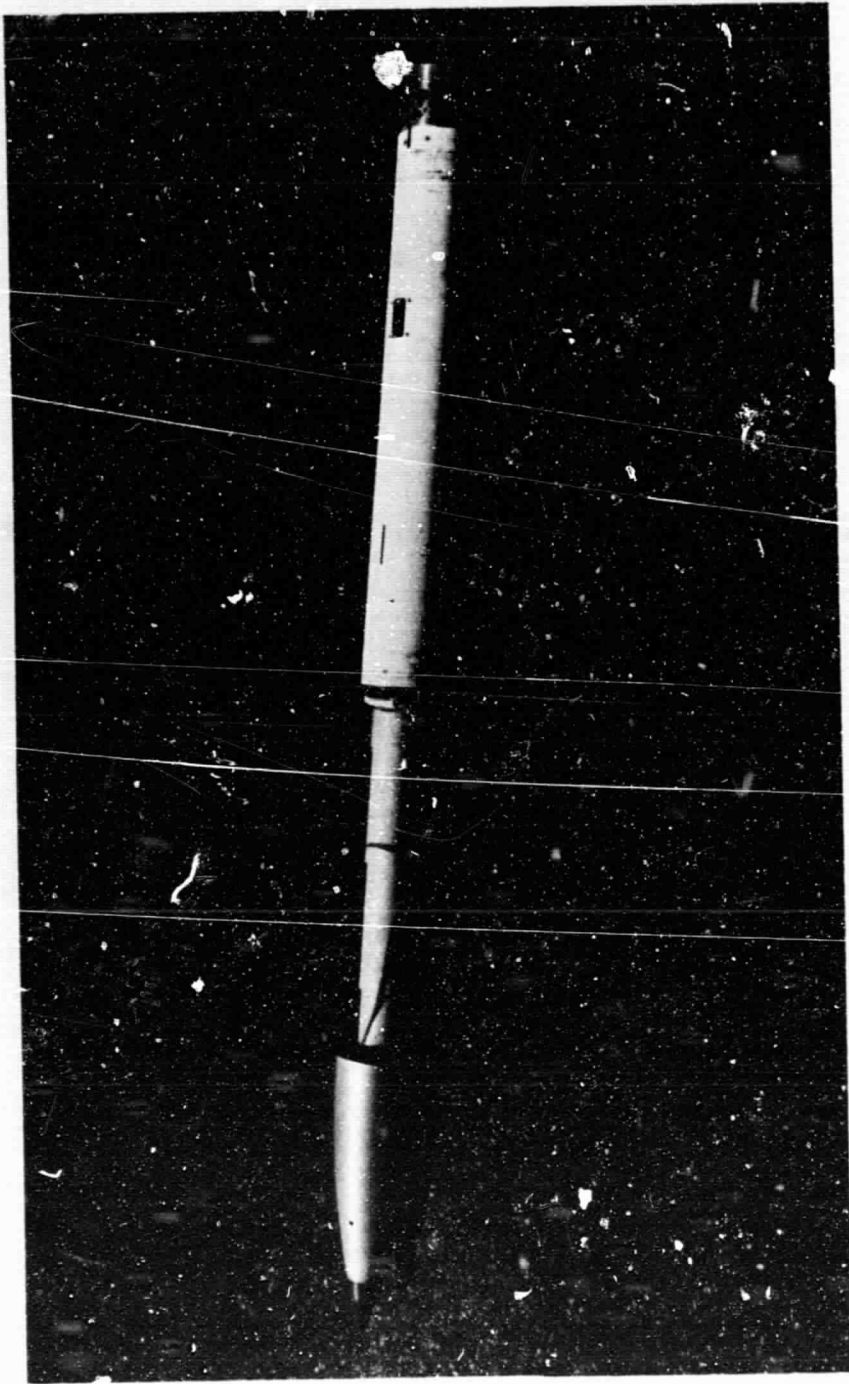

Figure 4. Payload for Nike-Apache NASA 14.104 with Expandable Boom Extended

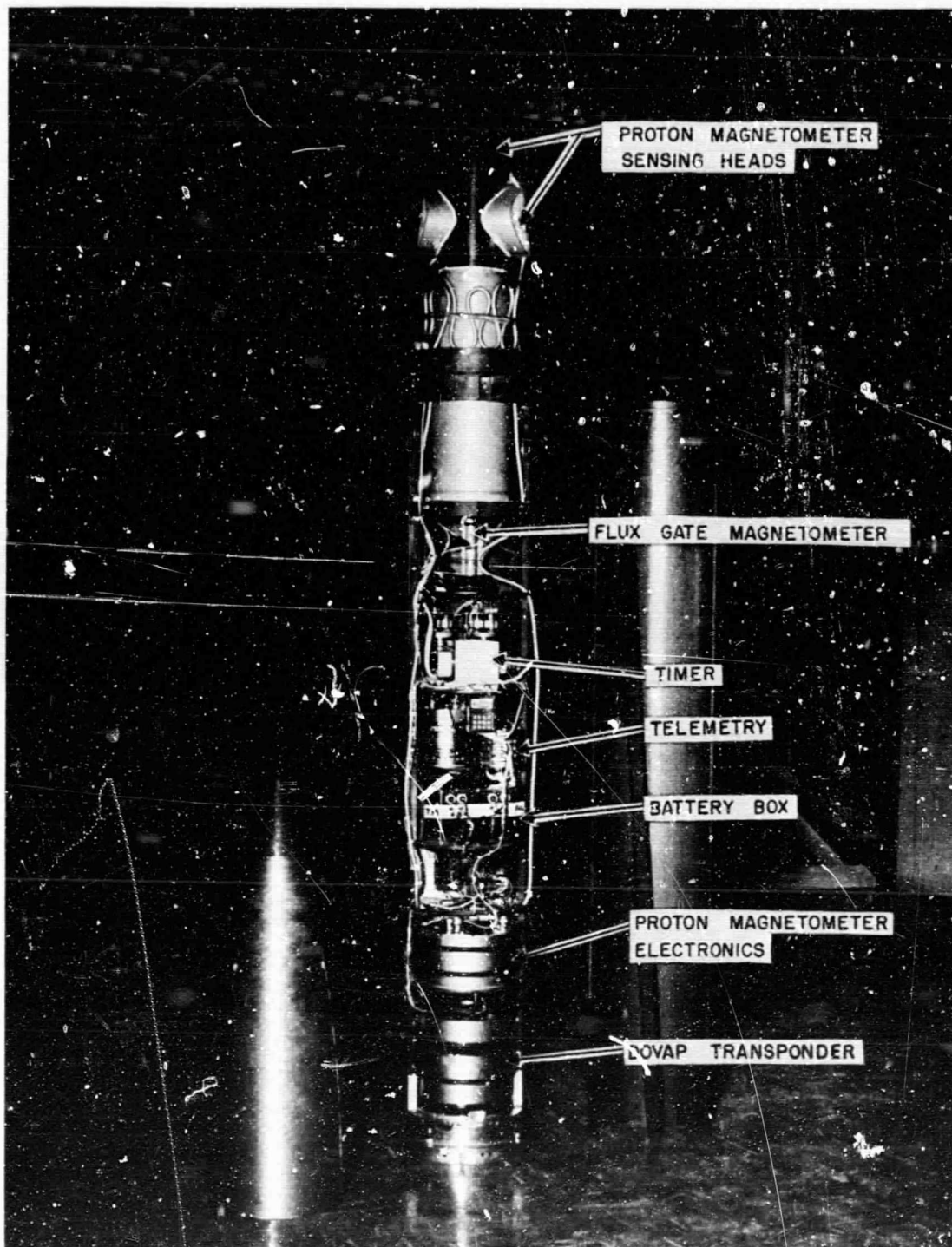

Figure 5. Payload for Nike-Apache NASA 14.104 with Expandable Boom Compressed

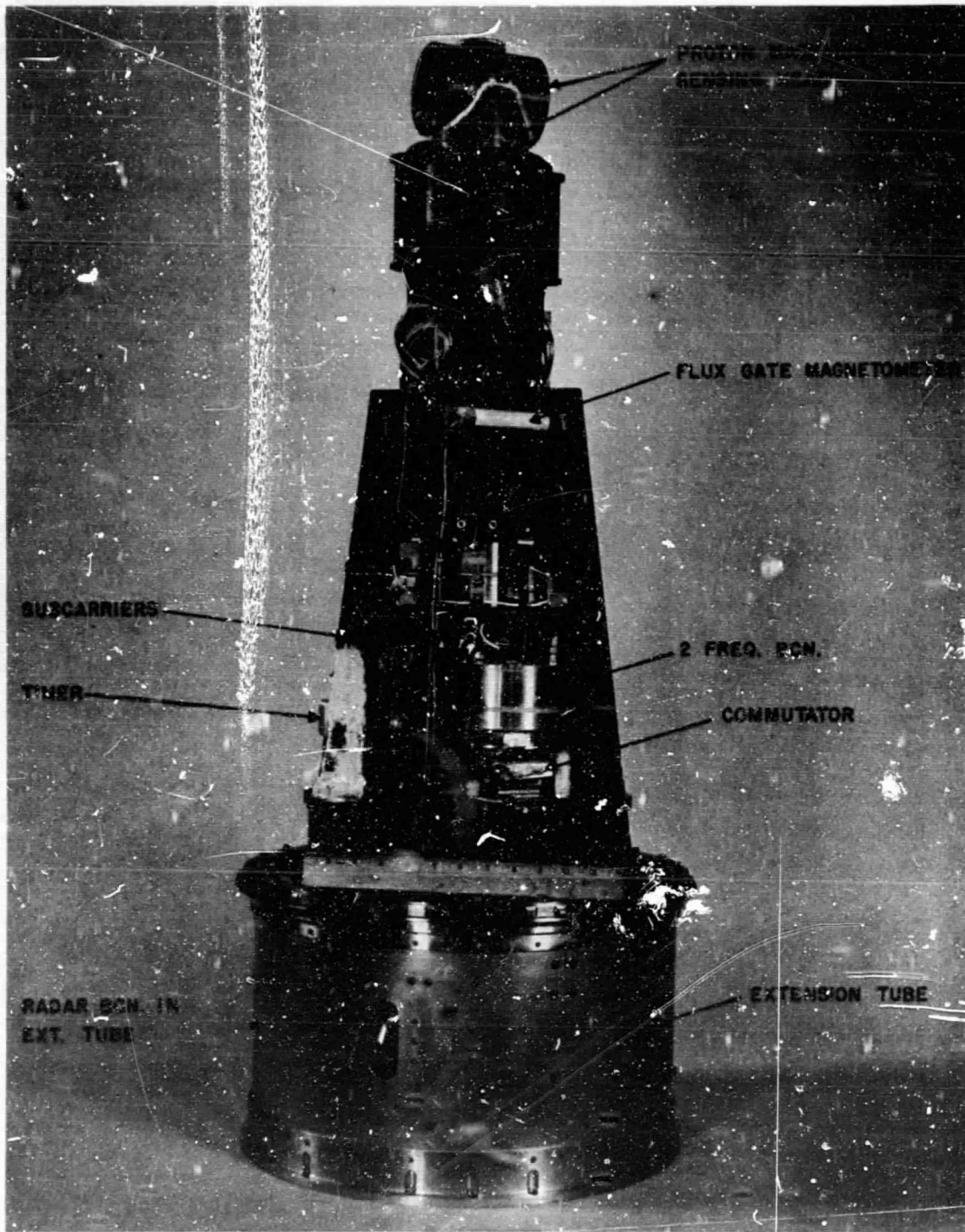

Figure 6. Payload for Javelin NASA 8.20 with Expandable Boom Compressed (Front View)

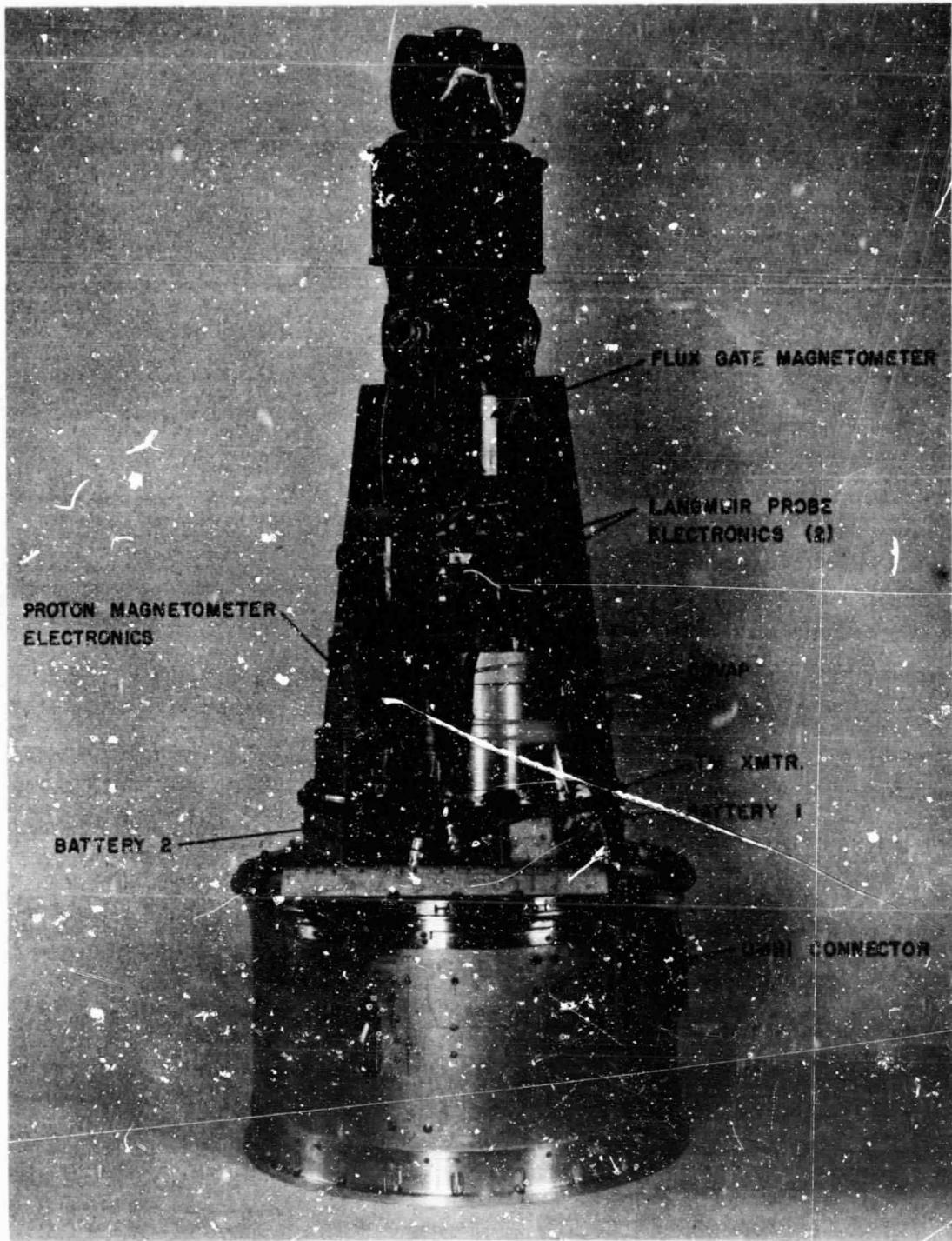

Figure 7. Payload for Javelin NASA 8.20 with Expandable Boom Compressed (Back View)

method.^{1*} The dispersive doppler technique used to determine ionospheric electron density utilizes the measurement of the differential (dispersive) phase shift between two widely separated frequencies transmitted through the ionosphere. We electronically mix the transmitted frequencies at our ground receiving station and obtain a dispersive doppler frequency, from which we derive the desired electron density values.²

The BRL propagation beacon, shown in Figure 8, is a solid state unit designed to transmit two harmonically related, phase-coherent frequencies of 36.44 and 145.76 MHz. Nominal beacon output power is 150 milliwatts at 36.44 MHz and 100 milliwatts at 145.76 MHz. The fundamental 36.44-MHz frequency is generated by a transistorized, crystal-controlled oscillator, temperature regulated to maintain a frequency stability of 1 part in 10^8 . This stability is measured under expected in-flight temperature conditions, but without shock or vibration stress. Figure 9 is a block diagram of the beacon.

Physically, the beacon is a cylinder containing a radio frequency section and a power supply section. The radio frequency section includes the basic oscillator, as well as the 36.44- and 145.76-MHz frequency multipliers and amplifiers. Amplifier circuitry is potted with foam resin to enable the beacon to survive the shock and vibration forces encountered during rocket launch. The beacon is $5\frac{1}{2}$ inches in diameter and 5 inches high including connectors.

During payload testing, it was discovered that spurious radiation generated by the beacon at 36.44 MHz was sufficiently strong to drive the 38.0305-MHz DOVAP transponder. This interference was eliminated by inserting a low-pass filter at the 36.44-MHz frequency output and reducing beacon output power from 150 to 30 milliwatts.

B. Langmuir Probe

The Langmuir electrostatic probe, used here to measure electron temperature and density, is a thin, cylindrical, conducting probe whose potential is continuously varied. The resulting current flow to the probe

*References are found on pages 59 and 60.

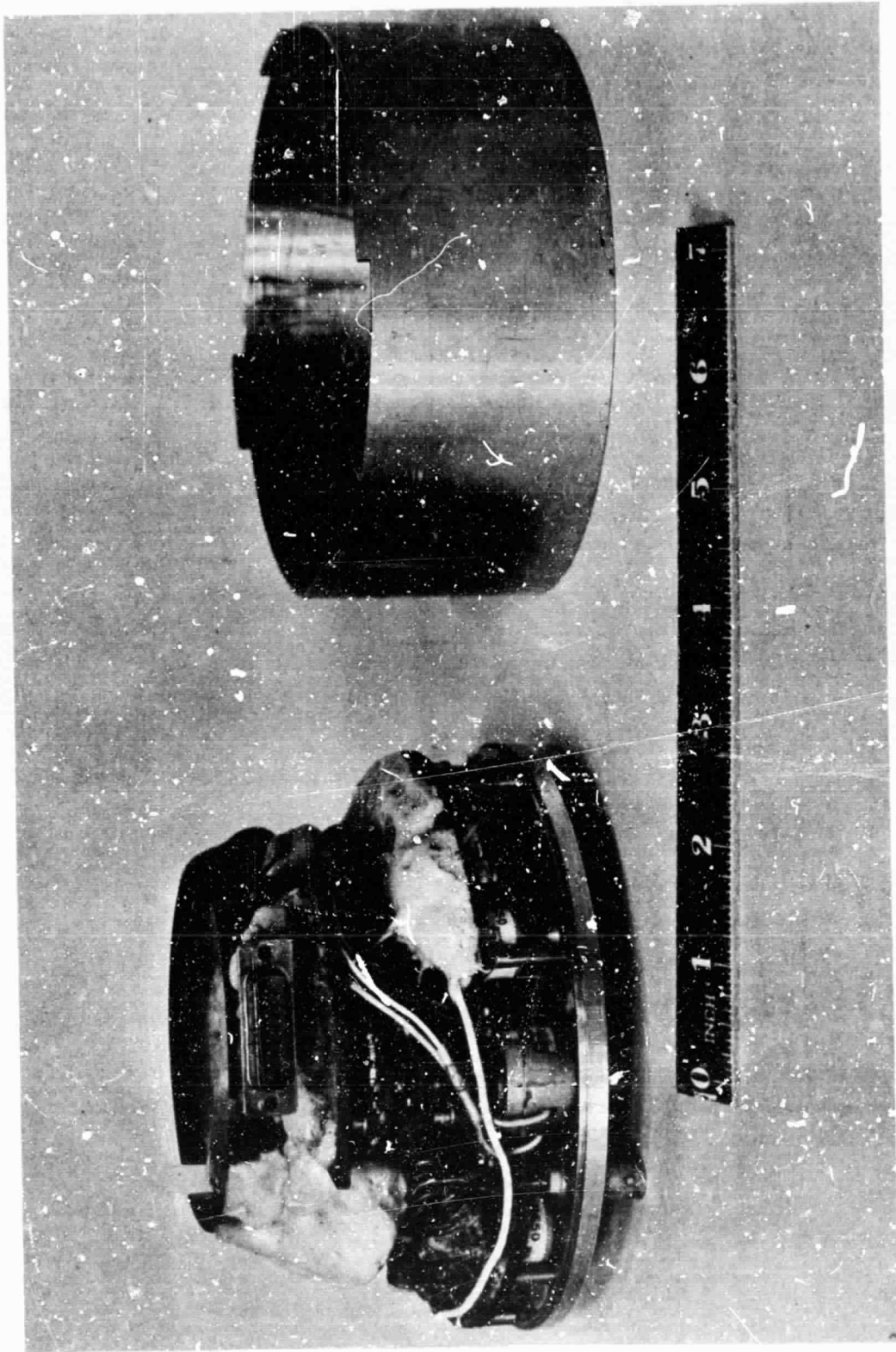

Figure 8. Two-Frequency Propagation Beacon

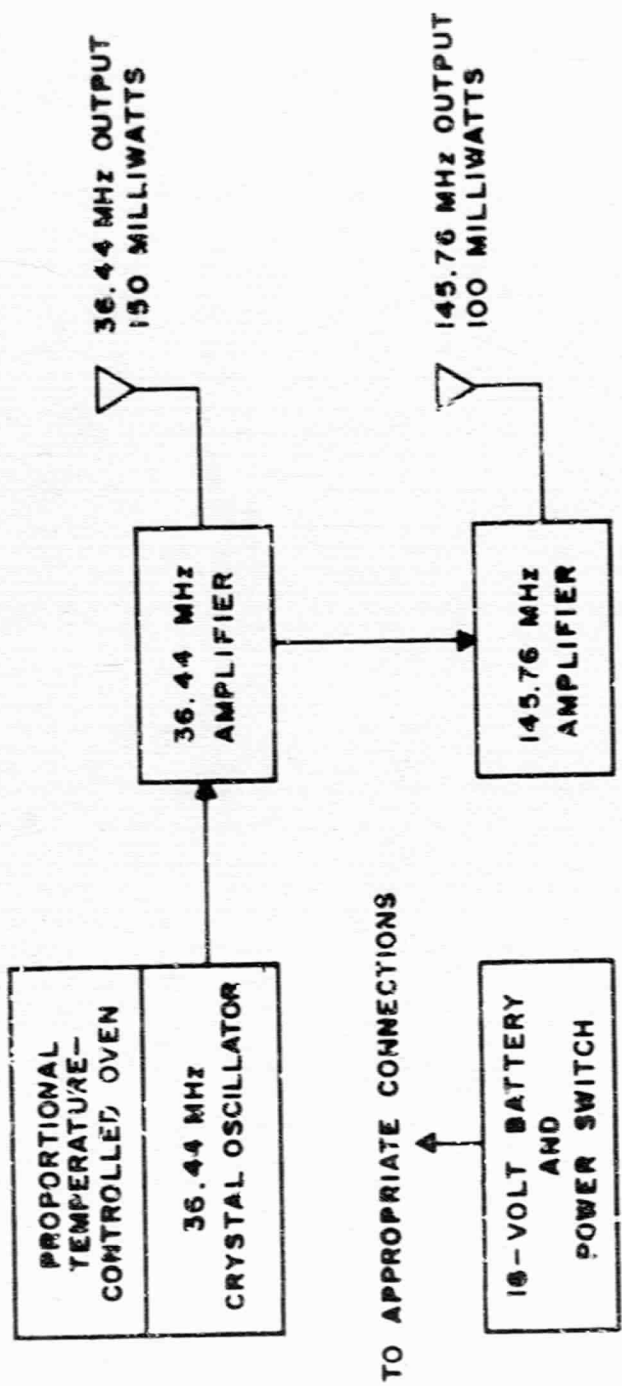

Figure 9. Block Diagram of Two-Frequency Propagation Beacon

is measured, and the current-voltage relationship is analyzed to yield electron temperature and electron density data. The exact relationship from which the desired data are obtained is highly dependent on payload configuration, and must be calculated for each application.

Each Javelin payload was instrumented with two probes. The probes each had a different current sensitivity range. For Javelin 8.19, probe current sensitivity ranges were 0.05 to 0.5 and 0.25 to 1.5 microamperes. For Javelin 8.20, the probe sensitivities were 0.01 to 0.1 and 0.04 to 0.25 microamperes.

The probes were approximately 18 inches long and 1/8 inch in diameter. They were located 180 degrees apart on opposite sides of the payload. One end of each probe was spring-hinged to the conical antenna ground plane, and the probes were held flat along the ground plane surface by the ogive during the early portion of the flight. When the ogive was ejected, the probes snapped outward to a position approximately perpendicular to the ground plane.

C. Proton Precession Magnetometer

Two proton precession magnetometers were used in each payload to measure the local magnetic field strength. Operation of this type of magnetometer depends on the fact that a spinning nucleus (proton) possessing a magnetic moment will precess in the presence of a magnetic field whenever the proton polarizing current is disconnected. This proton precession represents a time dependent variation of magnetic moment, and induces a signal in the polarizing coil. The frequency of this induced signal is proportional to the strength of the ambient magnetic field (in this case, the earth's magnetic field).^{3,4}

We used two magnetometer sensing heads in each payload to insure data at all rocket attitudes, since the output voltage of the magnetometer is zero when the earth's magnetic field vector is parallel with the magnetometer axis. The heads were oriented at right angles to each other. With this arrangement, the output of one head was frequency modulated, while the output of the other head was amplitude modulated. This modulation was created

as a result of rocket spin. Output from each magnetometer head was a series of 150-millisecond data bursts, spaced approximately 0.5 second apart. The two outputs were sampled alternately and telemetered on a common telemetry channel.

The two magnetometer heads were mounted in the forward end of each expandable boom in order to isolate the heads as much as possible from the magnetic influence of the rest of the payload. We installed the magnetometer electronics in the aft end of each payload, and turned them on with a "G" actuated timer at final stage burnout.

D. Tracking, Telemetry and Aspect Units

1. DOVAP. Each payload carried a UDT-A DOVAP transponder which transmitted at a frequency of 76.061 MHz. The fundamental ground-based DOVAP transmitter operated at 38.0305 MHz. The DOVAP antennas for the Nike-Apache payloads were shrouds fastened to the rocket motor casing in the conventional manner.

2. S-Band Radar Beacon. No radar beacon was flown in the Nike-Apache payloads. The Javelin payloads carried a Vega Model 201-S radar beacon which received on a frequency of 2800 MHz and transmitted on a frequency of 2900 MHz.

3. VHF Telemetry System. A standard IRIG, FM/FM, VHF telemetry system was installed in all four payloads. In the Nike-Apaches, the system operated at 244.3 MHz with a nominal transmitter power of 3 watts. A solid state, 6 x 15, 50 percent duty cycle, non-standard IRIG commutator was used in Nike-Apache 14.104. No commutator was used in Nike-Apache 14.105. Turnstile stub antennas were used on the Nike-Apache payloads. They protruded approximately 10 inches from the rocket body and were swept back at a 45-degree angle. This arrangement produced right-hand circular polarization with maximum signal radiated to the rear of the rocket.

The Javelin telemetry system transmitted at 234.0 MHz with a nominal power of 4 watts from launch until T+95 seconds, at which time the power output was increased to a nominal 8 watts. A solid state, 30 x 5, 50 percent duty cycle, standard IRIG commutator was flown in both Javelin payloads.

4. Aspect Magnetometer. Each of the four payloads was instrumented with two Schonstedt Model RAM-3 aspect magnetometers, one mounted parallel with the rocket longitudinal axis and the other mounted perpendicular to the rocket longitudinal axis.

5. Accelerometer. The Nike-Apache payloads carried no accelerometer. The Javelin payloads each had one accelerometer oriented parallel with the rocket longitudinal axis to measure longitudinal acceleration.

E. Javelin Antennas

The severe aerodynamic heating which the Javelin payloads would be subjected to precluded locating rocketborne antennas on the outside of the payload skin. For this reason, we experimented with rectangular loop DOVAP antennas, made of thin copper foil, mounted on the fourth stage motor casing. The radiation pattern of these antennas was good, but, during two static test firings of the motor, it was discovered that motor burning produced considerable noise on the carrier frequency and severely degraded the antenna mismatch from 1.5 to 1 to approximately 6 to 1.⁵ Project scheduling did not permit further experimentation with this type of antenna so the effort was discontinued.

The final antenna configuration used on the Javelin payloads is shown in Figure 10. The antennas were mounted on a conical ground plane that slipped over the outside of the payload structure and fastened to it with screws. The ogive then enclosed the entire antenna and ground plane structure. We tested both the shroud and quadraloop type of antenna for voltage breakdown, and found that this phenomena would not be a problem at the transmitter power we planned to use.^{6,7}

The two-frequency beacon, DOVAP and S-band radar beacon antennas transmitted linear polarization, while the telemetry antennas transmitted right-hand circular polarization. All of the antennas were designed to radiate maximum signal off the tail of the rocket.

The DOVAP antennas consisted of three shrouds, one for the 38.0305-MHz frequency, and two similar-sized ones for the 76.061-MHz frequency. The two-frequency beacon antennas were shrouds also, one for the 36.44-MHz

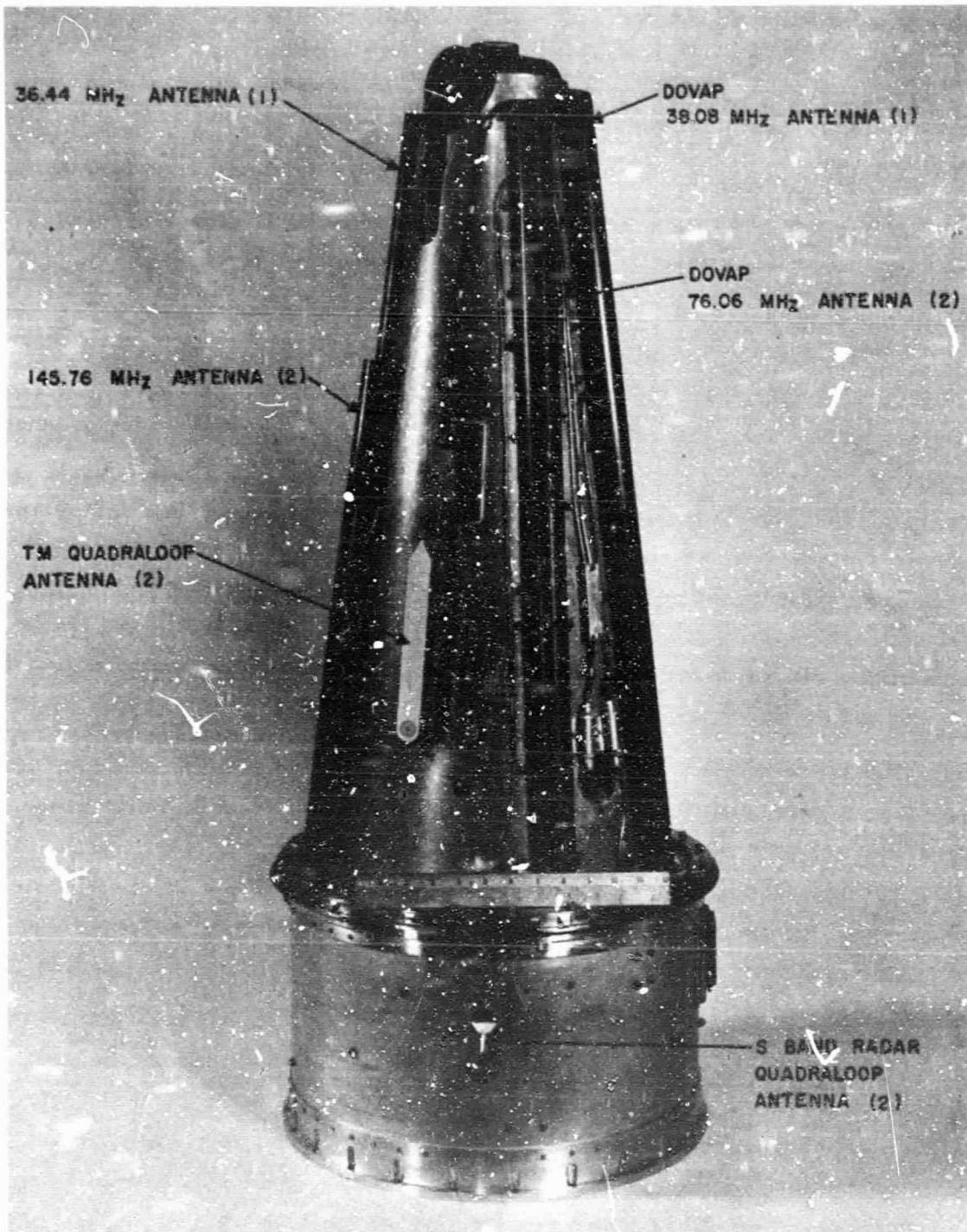

Figure 10. Antenna Configuration for Javelin NASA 8.19 and 8.20

channel and two shorter ones for the 145.76-MHz channel (see Figure 10). We found, during initial antenna tests, that only one shroud antenna was required at the lower DOVAP and beacon frequencies to yield a satisfactory radiation pattern aft of the rocket, whereas at the higher DOVAP and beacon frequencies two antennas were necessary. The DOVAP and beacon antennas were all mounted on the conical ground plane.

The telemetry and S-band radar beacon antennas were quadraloops, with two used for each function. The two telemetry antennas were mounted on opposite sides of the conical ground plane, 180 degrees apart, while the radar beacon antennas were similarly spaced but mounted on the sides of the Argo D-4 extension section rather than on the conical ground plane. One of each of these antennas is visible in Figure 10.

V. FIELD OPERATIONS

A. Launch Schedule

The four rockets were launched in mixed pairs, with a Nike-Apache preceding a Javelin by 90 seconds, followed by another Apache-Javelin pair approximately 36 hours later. The first pair, Nike-Apache 14.104 and Javelin 8.19, was launched on 5 November 1964 at 1438:00 and 1439:30 CST, respectively. The second pair, Nike-Apache 14.105 and Javelin 8.20, was launched on 6 November 1964 at 2313:00 and 2314:30 CST, respectively. Figure 11 shows Javelin 8.19 on the launcher prior to firing.

The purpose of the 36-hour spacing between rocket pairs was to observe diurnal variations in the parameters being measured. The reason for the 90-second spacing between rockets and the unique spatial distribution of the payloads is explained in Section II-C of this report.

B. Tracking and Support

1. DOVAP. The DOVAP transponder in the Nike-Apache payloads operated from launch until T+60 seconds. At that time, it was turned off by means of a "G" actuated timer to allow the DOVAP unit in the Javelin payloads to be turned on.

2. Radar. The radar beacon in the Javelin payloads was turned on

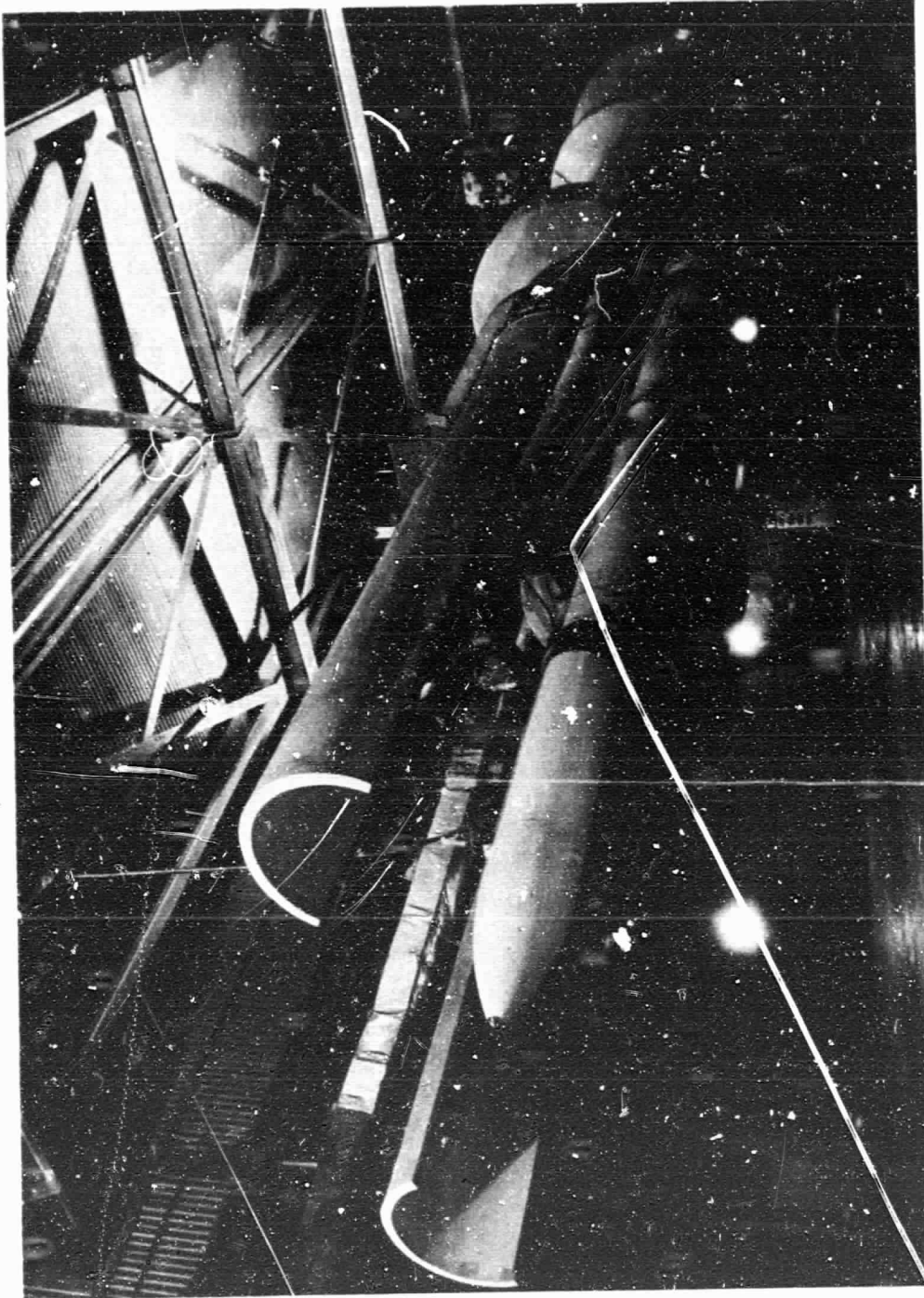

Figure 11. Rocket and Payload for Javelin NASA 8.19 in Horizontal Position on Launcher with Environmental Cover Retracted

at launch and tracked by the Fort Churchill MPS-19 radar until T+120 seconds, at which time both the DOVAP and the radar beacon were turned off by means of a pyrotechnic switch actuated by the ogive ejection circuit. The beacons were turned off to avoid possible interference with the operation of the scientific instrumentation. The Prince Albert radar skin-tracked the Javelin payloads throughout the entire flight.

3. Ionosonde. The Fort Churchill ground-based ionosonde furnished ionograms according to the following schedule centered around rocket launch times:

- a. One sounding every hour from T-2 to T+2 weeks.
- b. One sounding every 15 minutes from T-2 to T+2 hours.
- c. One sounding every 2 minutes from T-5 to T+30 minutes.

4. Miscellaneous Support. The Fort Churchill range provided ground-based instrumentation support with the flux gate magnetometer, auroral radar, riometer, all-sky camera, and photometer (3914 Angstrom). Range and contractor personnel furnished normal operational support including magnetic tape and oscillographic recordings of telemetry data, communications, timing and countdown services, payload impact predictions, launcher settings, weather information, photographic coverage and miscellaneous logistical support.

C. Ground Station and Data Recording

The ground-based antennas for the two-frequency experiment were crossed dipoles for the 36.44-MHz frequency and helices for the 145.76-MHz frequency, with right- and left-hand circular polarization at each frequency. Receiving and recording equipment was housed in a trailer-type instrumentation van, and featured special receivers (designed and built at BRL) used in conjunction with commercial, phase-locked, tracking filters. This arrangement produced real-time outputs of signal strength, doppler, dispersive doppler, Faraday rotation and rocket spin data. These data were recorded on analog charts or magnetic tape. Figure 12 is a block diagram of the ground station equipment.

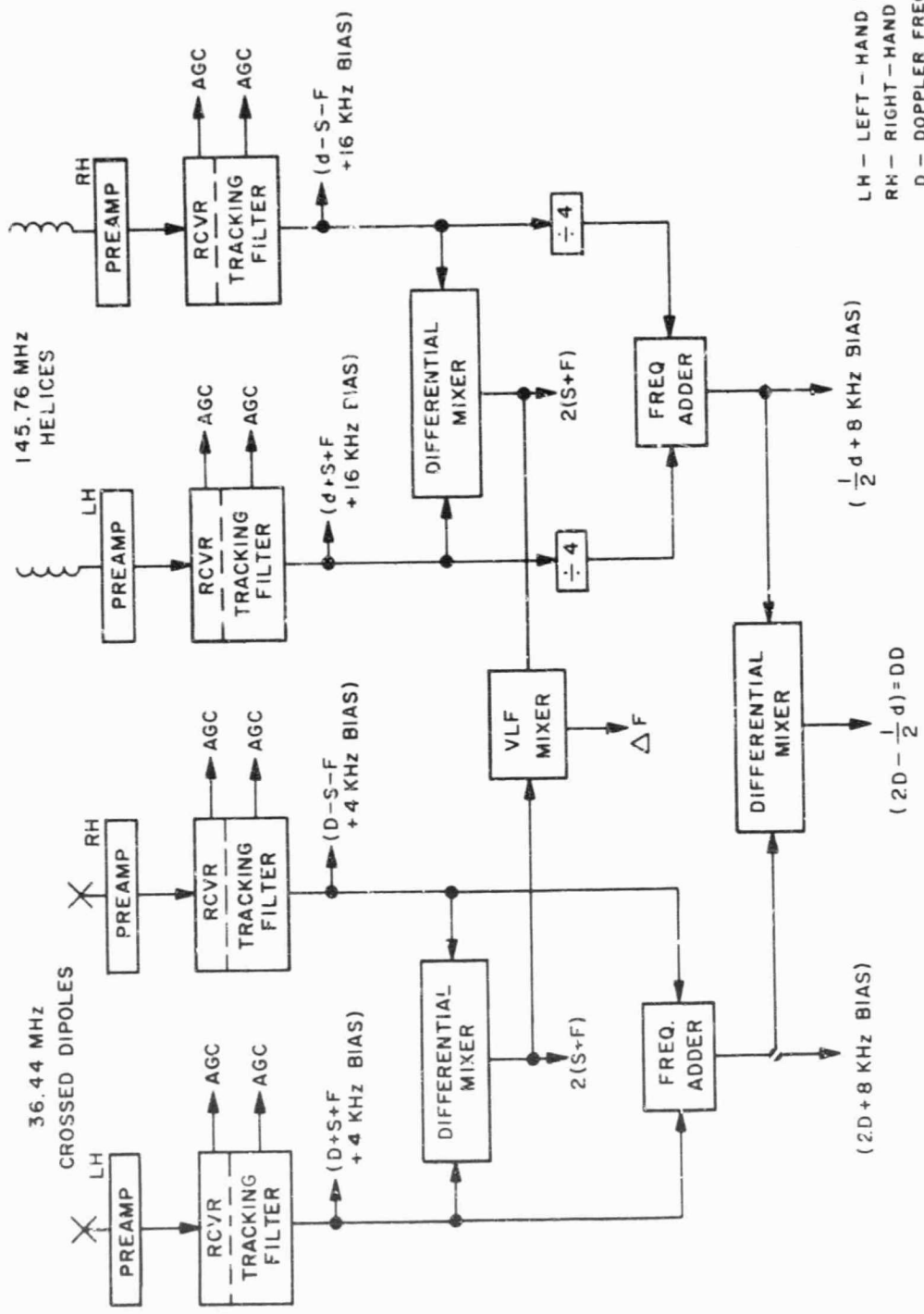

LH — LEFT — HAND POLARIZATION
 RH — RIGHT — HAND POLARIZATION
 D — DOPPLER FREQUENCY AT 36.44 MHz
 d — DOPPLER FREQUENCY AT 145.76 MHz
 DD — DISPERSIVE DOPPLER FREQUENCY
 S — ROCKET SPIN FREQUENCY
 F — FARADAY ROTATION FREQUENCY
 ΔF — DELTA FARADAY FREQUENCY

Figure 12. Block Diagram of Ground Station for Two-Frequency Propagation Beacon Data

VI. RESULTS

A. Vehicle and Instrumentation Performance

All vehicles performed as expected with the exception of Javelin 8.20. This rocket suffered a partial malfunction in the fourth stage motor and, as a result, attained a peak altitude of only 715 km, approximately 17 percent lower than predicted. Rocket trajectories are shown in Figures 13-16 and Table II summarizes vehicle performance.

Table II. Summary of Vehicle Performance

<u>Vehicle Designation</u>	<u>Date Launched</u>	<u>Time (CST)</u>	<u>Peak Altitude (Km)</u>	<u>Impact Range (Km)</u>	<u>Flight Time (sec.)</u>
Nike-Apache 14.104	5 Nov 64	1438:00	136	70	356
Javelin 8.19	5 Nov 64	1439:30	885	229	1012
Nike-Apache 14.105	6 Nov 64	2313:00	149	53	373
Javelin 8.20	6 Nov 64	2314:30	715	428	898

With minor exceptions, all instrumentation functioned excellently. The two-frequency beacon yielded good dispersive doppler throughout the upleg and a portion of the downleg for Javelin 8.19, and throughout the entire flight for Javelin 8.20. There were numerous rocket spin-induced phase reversals in the data from Javelin 8.20, but these did not seriously degrade the data.

The DOVAP transponders in all payloads operated superbly, transmitting high quality data and adhering perfectly to the ON/OFF sequencing. Radar data from the Javelin rockets were somewhat degraded because of ground instrumentation difficulties, but we did not consider this serious since we used DOVAP data for prime trajectory input. The DOVAP data were corrected for ionospheric errors and used to compute initial conditions for vacuum trajectory computations. Vacuum trajectories were calculated for the Nike-Apache rockets after T+58 seconds of flight time, and for the Javelin rockets after T+120 seconds.

The telemetry data were excellent for all rockets except Javelin 8.19, where we observed frequency shifts in the subcarrier oscillators during

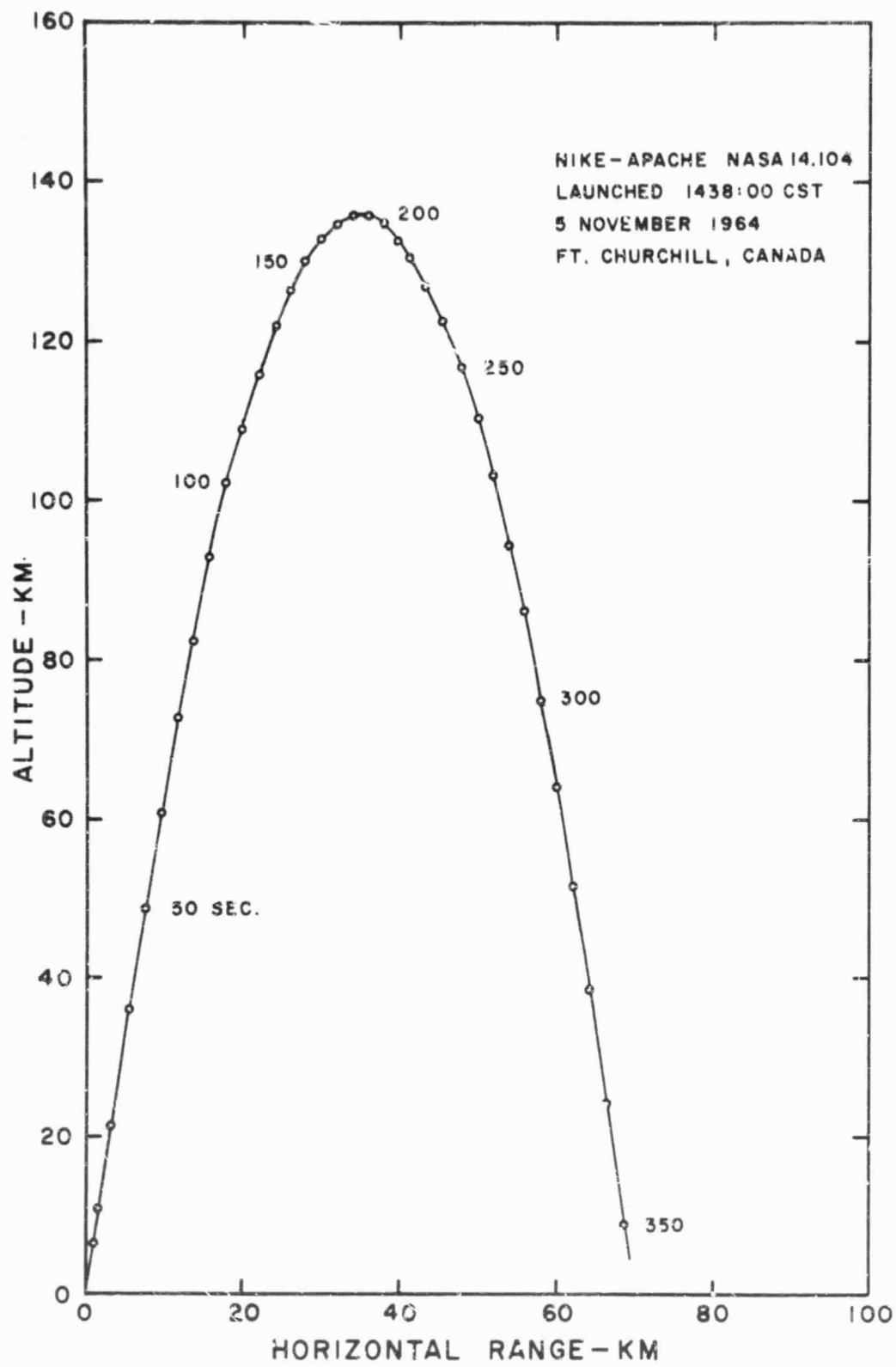

Figure 13. Trajectory for Nike-Apache NASA 14.104

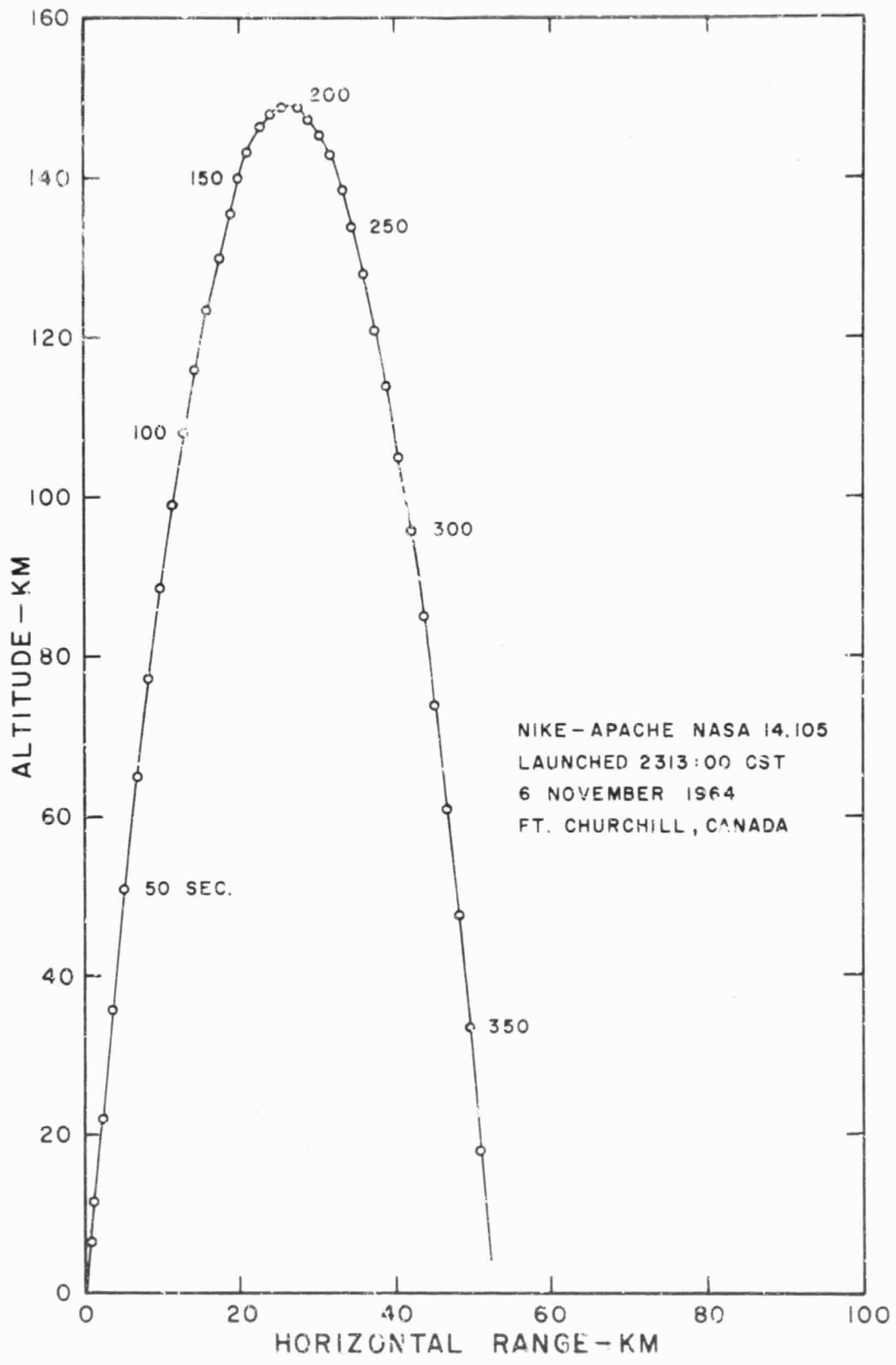

Figure 14. Trajectory for Nike-Apache NASA 14.105

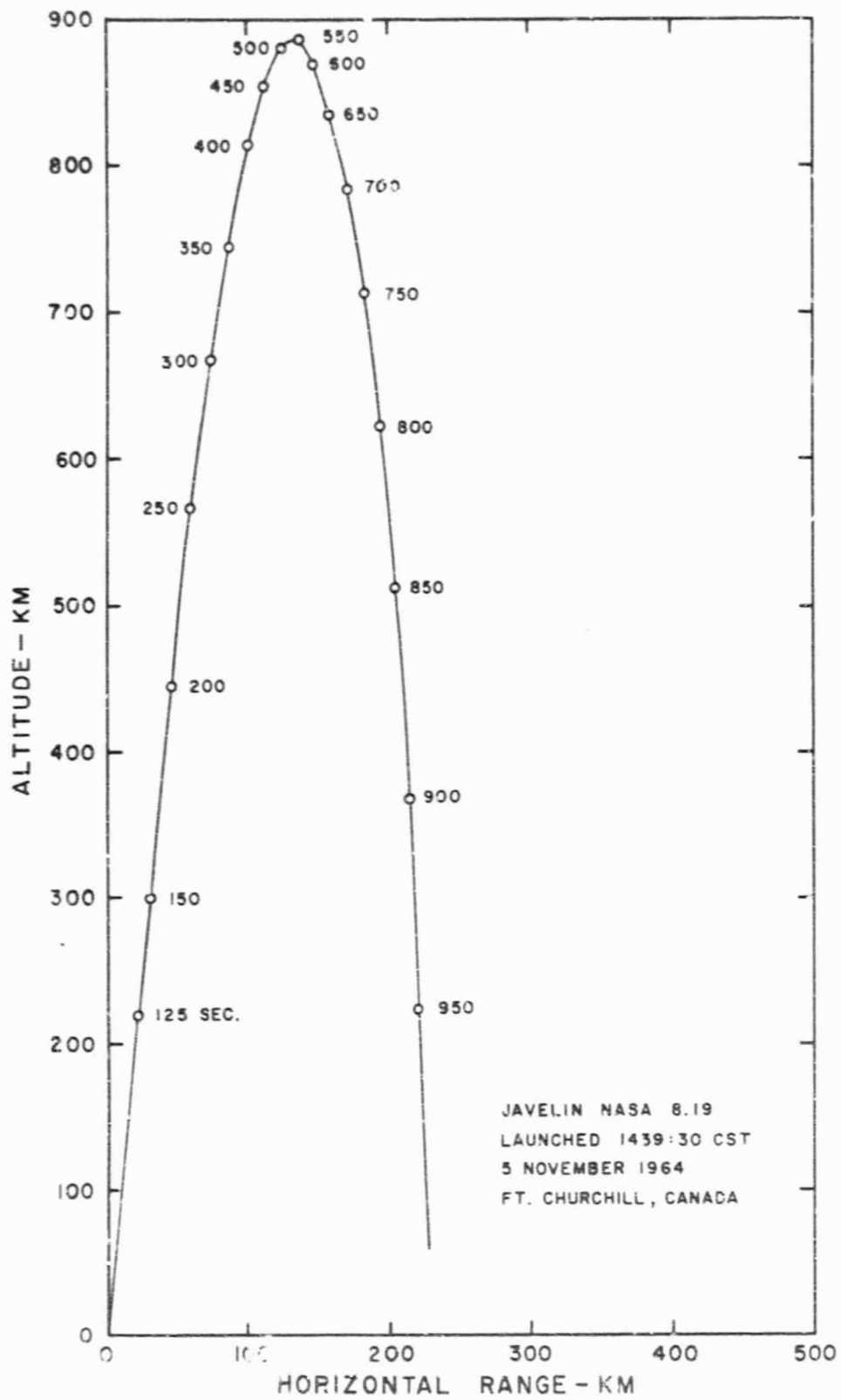

Figure 15. Trajectory for Javelin NASA 8.19

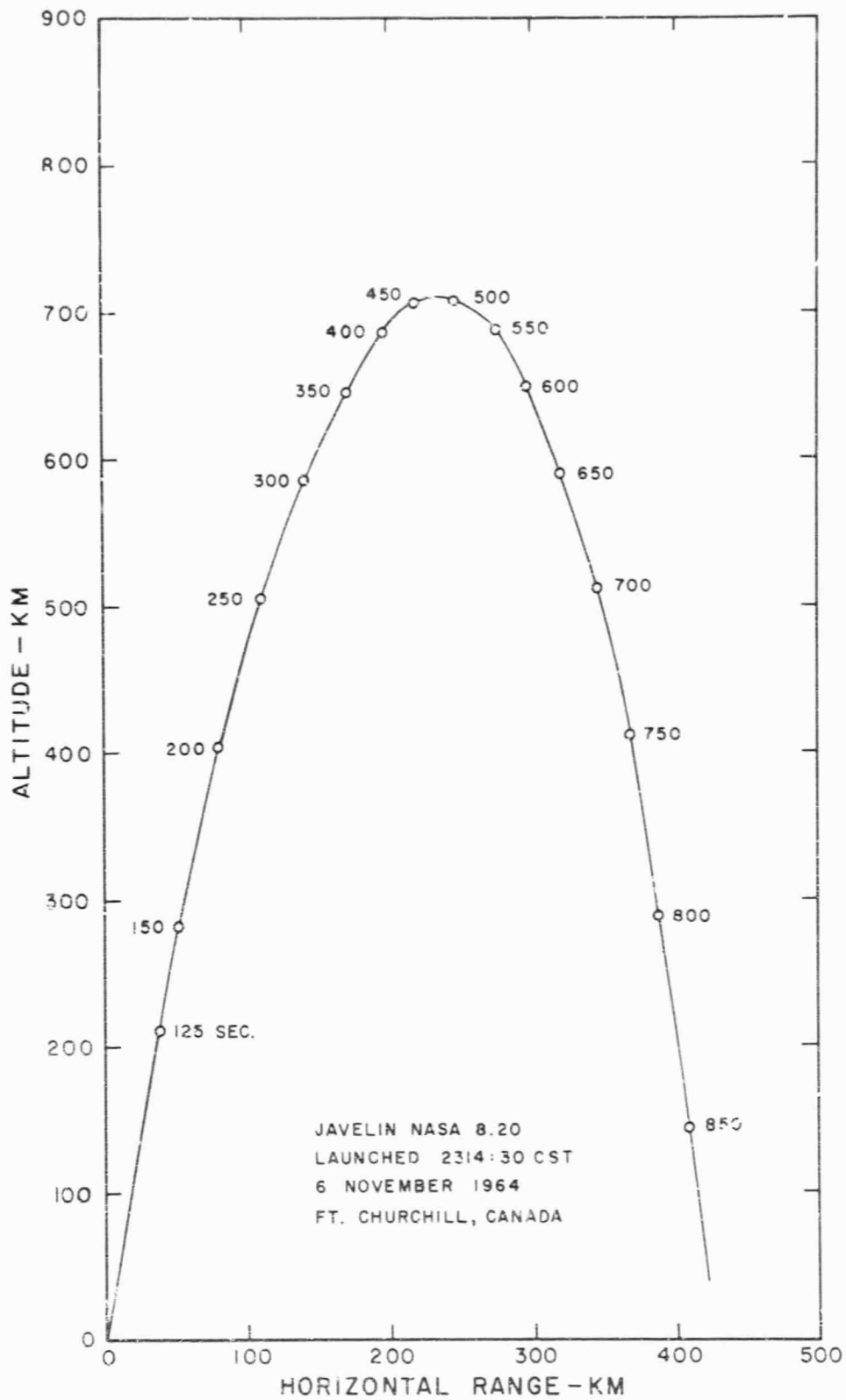

Figure 16. Trajectory for Javelin NASA 8.20

approximately 10 percent of the flight. With the exception of this minor flaw, the telemetry subcarriers were stable throughout the ionospheric portion of the trajectories, and telemetry signal levels never dropped below 4 microvolts (FM signal threshold was approximately 1 microvolt).

B. Electron Density

Figure 17 shows the electron density profile obtained from Javelin 8.19. The flight took place at 1440 local time, and produced a normal, auroral zone, early afternoon, winter profile. The solid curve represents data from the BRL propagation beacon, the dashed curve is data from the University of Michigan Langmuir probe, and the dotted curve is data from the Fort Churchill ionosonde sounding taken at 1446 local time. All three sources of data agree favorably.

The electron density profile from Javelin 8.20 is shown in Figure 18. This rocket was launched at 2315 local time, under very quiet geomagnetic conditions. There was no visible aurora at launch time. Under these circumstances, one would expect to observe a broad, smooth maximum in electron density occurring between 300 and 400 km altitude. The flight results, however, show a maximum electron density at an altitude between 150 and 200 km. Here again, the solid curve is BRL propagation beacon data, the dashed curve is Langmuir probe data, and the dotted curve is ionosonde data taken at 2317 local time. These Langmuir probe data were reduced and previously reported by Dr. Andrew F. Nagy of the Space Physics Research Laboratory at the University of Michigan.^{8,9} Though this profile is not typical of what one would expect in the auroral zone during a November night, the data do substantially support each other, indicating a peak density below 200 km.

We at BRL have never before measured a nighttime ionization peak at such a low altitude. Similar results have been reported, however, from the Alouette "topside sounder" satellite.¹⁰ The existence of such low altitude ionization requires a continuing energy input at or near that altitude. It has been suggested that one possible source of this energy input might be incoming electrons with energies of 1-2 Kev. Particles of

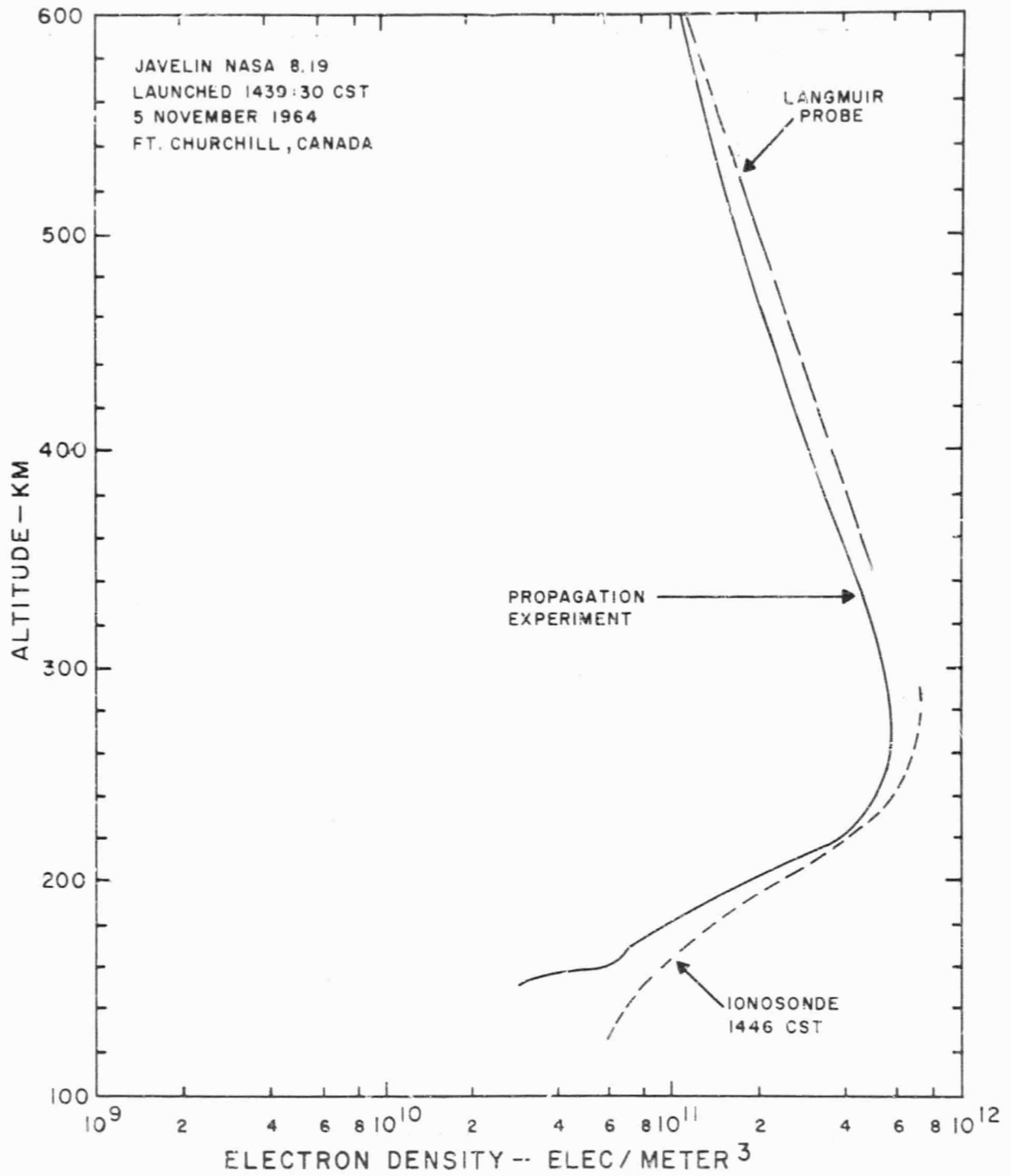

Figure 17. Electron Density Profile from Javelin NASA 8.19

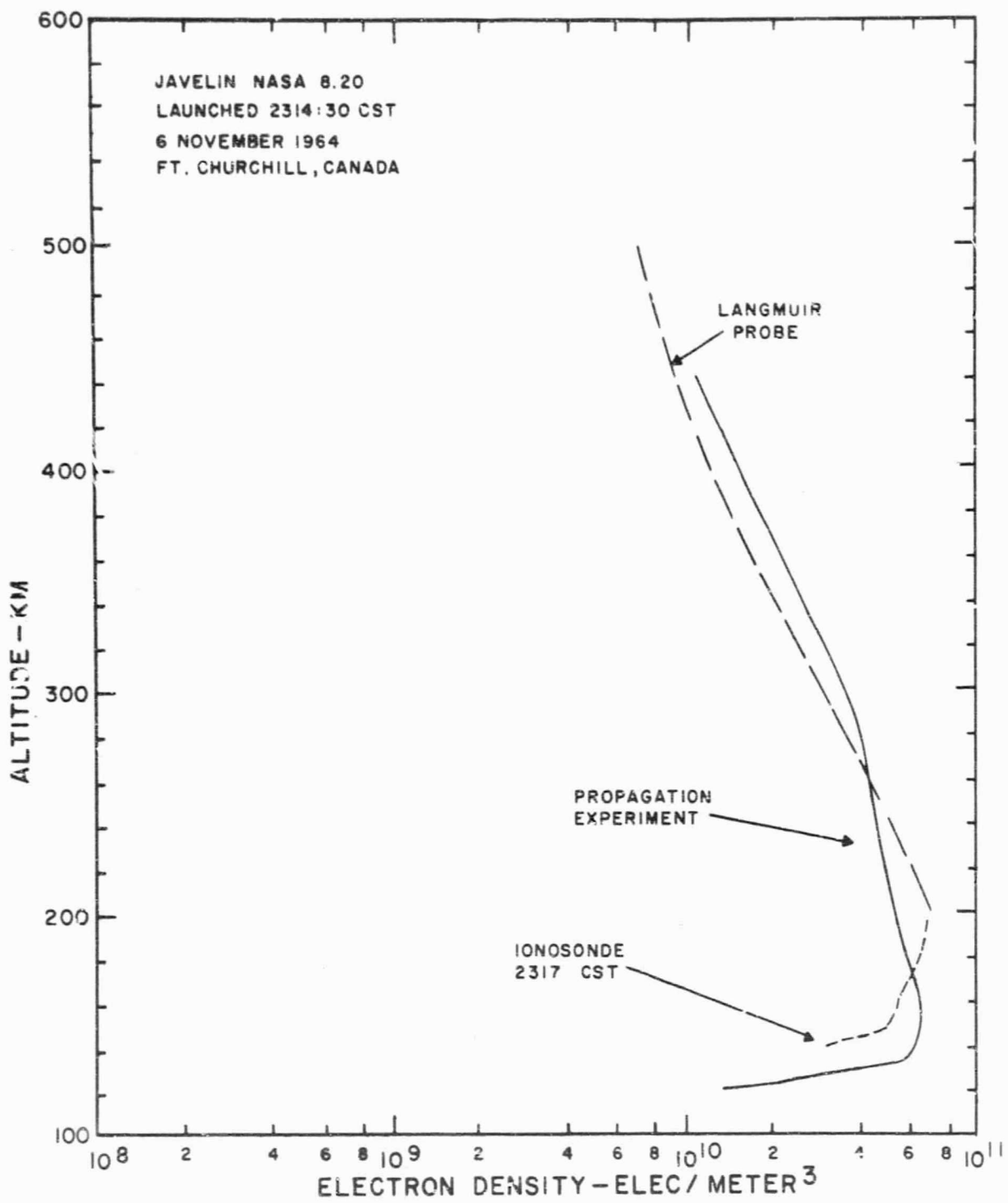

Figure 18. Electron Density Profile from Javelin NASA 8.20

this type have been theoretically shown to produce strong ionization in the altitude region between 150 and 200 km.¹¹

C. Electron Temperature

Electron temperature profiles for Javelin 8.19 and 8.20 are presented in Figures 19 and 20, respectively. These smooth curves were drawn through a large number of rather scattered data points (more than 1000 points per flight). The standard deviation of the data points about the curves is indicated by the horizontal bars. This deviation is considerably larger than is common for this measurement technique, mainly because of unfavorable probe orientation with respect to the magnetic field, and the high payload spin rate (8 rps). This is a higher spin rate than the Langmuir probe experiment normally encounters. These data were also reduced and reported earlier by Dr. Nagy.¹²

D. Magnetic Field

As stated in Section IV-C of this report, the output from the magnetometer heads was in the form of frequency modulated and amplitude modulated data bursts. In the interests of reducing computer costs, we treated only the frequency modulated data, since each data point required approximately two minutes of computer time on the BRLESC.

The raw data were quite noisy, a condition which precluded the use of analog tracking filters for noise removal. As an alternate method of removing noise from the data, we used a computer program that incorporated correlation techniques.¹³ The tabulated output of this program, in the form of proton precession frequency versus time, was converted to total scalar magnetic field strength (H) using the relationship

$$H = f/23.486 \quad (1)$$

where H is in gammas and f is in Hertz.⁴

We then compared these measured magnetic field values with various computed magnetic field profiles. Each computed profile was derived from a different set of magnetic field coefficients using a FORTRAN subroutine.¹⁴ The magnetic field profile computed from the GSFC (12/66)-1 coefficients¹⁵

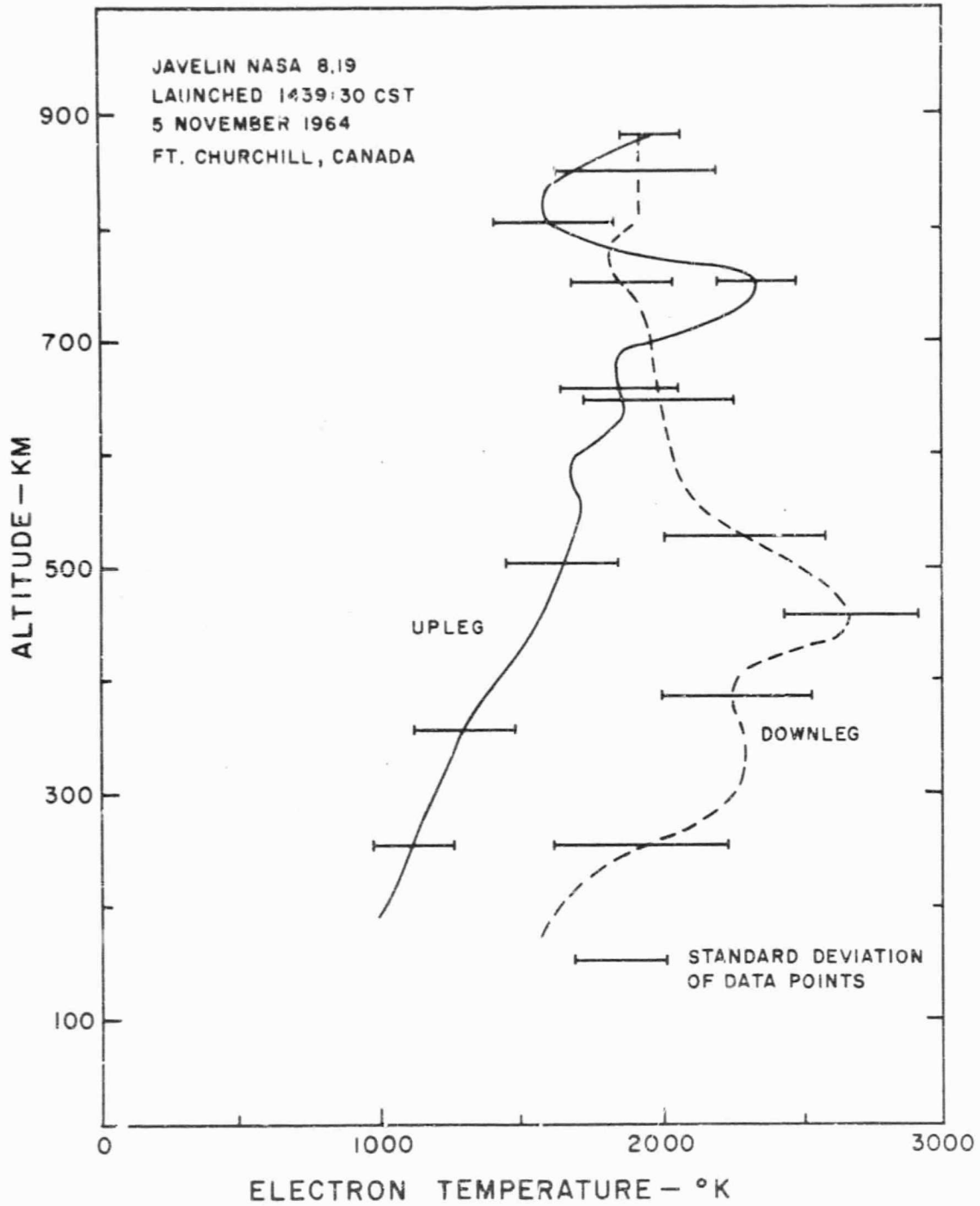

Figure 19. Electron Temperature Profile from Javelin NASA 8.19

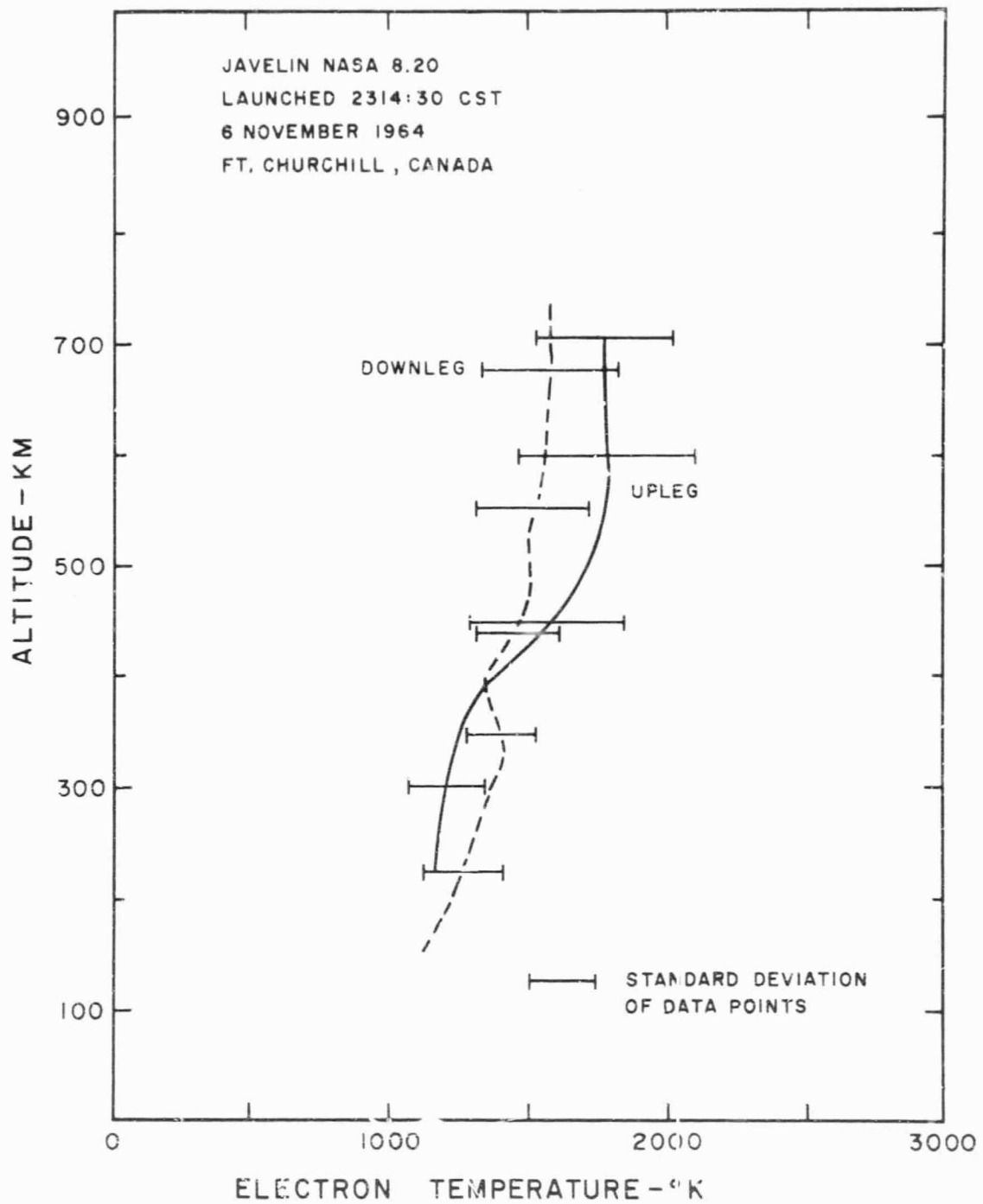

Figure 20. Electron Temperature Profile from Javelin NASA 8.20

represents a good fit (although not the best fit) to the experimental data. We decided to use the GSFC (12/66)-1 field as our standard reference field, however, because it is the most recent and probably is the most accurate when averaged on a worldwide basis. A comparison of the measured magnetic field values with the computed reference field values is given in Table III. As an interesting comparison with the current data, we have included some magnetic field values that were obtained from a BR. rocket (OB 6.15) flown at Fort Churchill in November 1958.

Table III. Measured Magnetic Field Minus
Computed Magnetic Field (gammas)

<u>Vehicle Designation</u>	<u>Launch Date and Time (CST)</u>	<u>Mean Value</u>	<u>Standard Deviation</u>	<u>RMS Local Scatter</u>
Nike-Apache 14.104	5 Nov 64 - 1438:00	77.3	8.1	5.5
Nike-Apache 14.105	6 Nov 64 - 2313:00	58.0	5.9	3.5
Javelin 8.19 ^a	5 Nov 64 - 1439:30	-9.1	34	10.5
Javelin 8.19 ^b	5 Nov 64 - 1439:30	-5.4	32	7.2
Javelin 8.20	6 Nov 64 - 2314:30	-59.9	81.1	7.2
Nike-Cajun OB 6.15	30 Nov 58 - 1627:00	44	35	-----

^aData after 860 seconds not usable.

^bData after 770 seconds omitted.

Figures 21 and 22 present the individual data points for Nike-Apache 14.104 and Javelin 8.19, and Nike-Apache 14.105 and Javelin 8.20, respectively, plotted as a function of altitude. As in Table III, these plotted data represent the difference between the measured field and the computed reference field. Figures 23 and 24 show similar data for the same rocket pairs plotted as a function of rocket flight time.

The Javelin raw data contained a good deal of noise, a substantial portion of which was structured spike noise from an unknown source.¹³ For Javelin 8.19, the data after 860 seconds was not usable at all because of excessive noise. The data between 770 and 860 seconds was only barely reducible. The poor quality of this particular portion of the data is

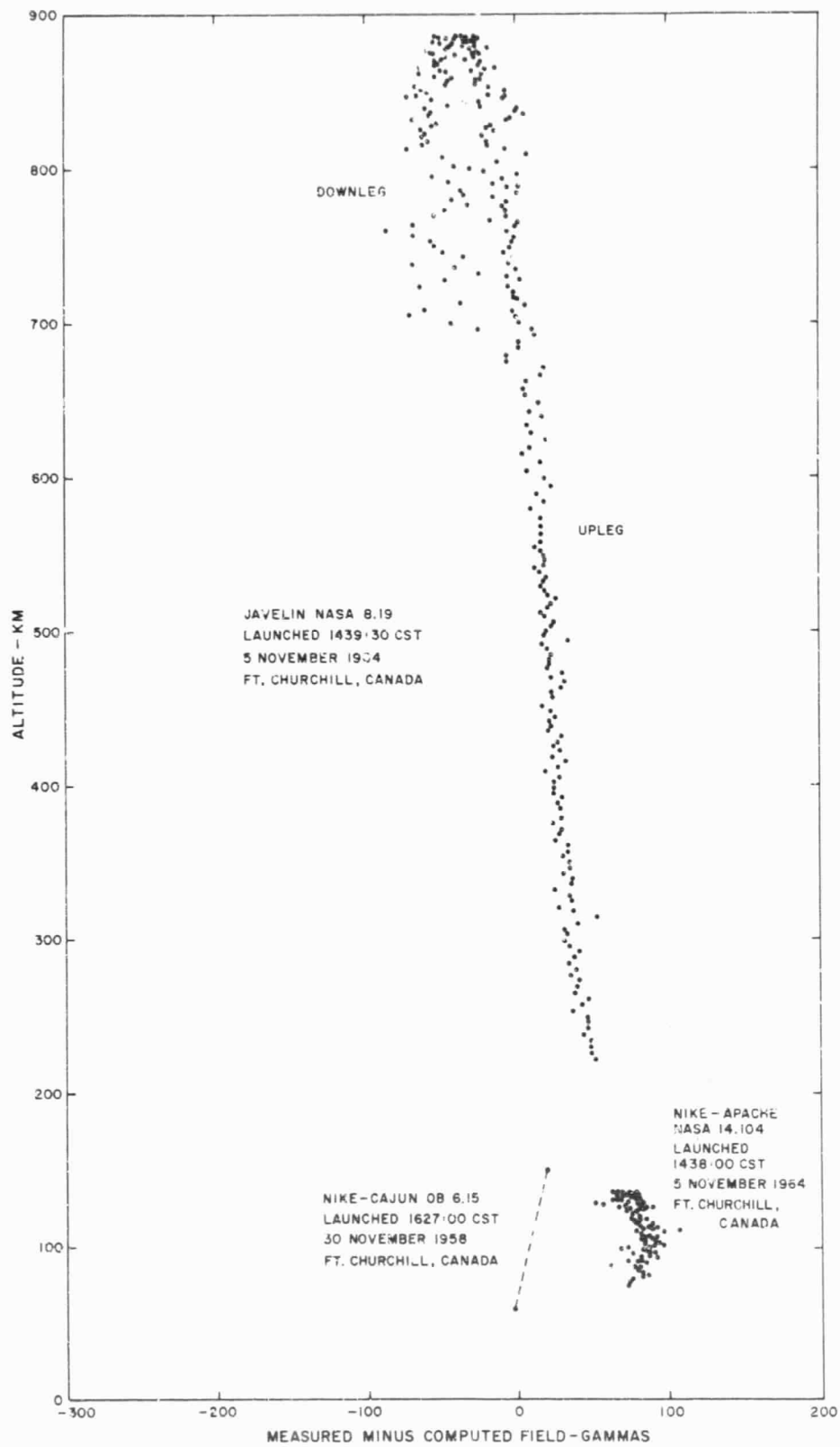

Figure 21. Magnetic Field Data as a Function of Altitude from Nike-Apache NASA 14.104 and Javelin NASA 8.19

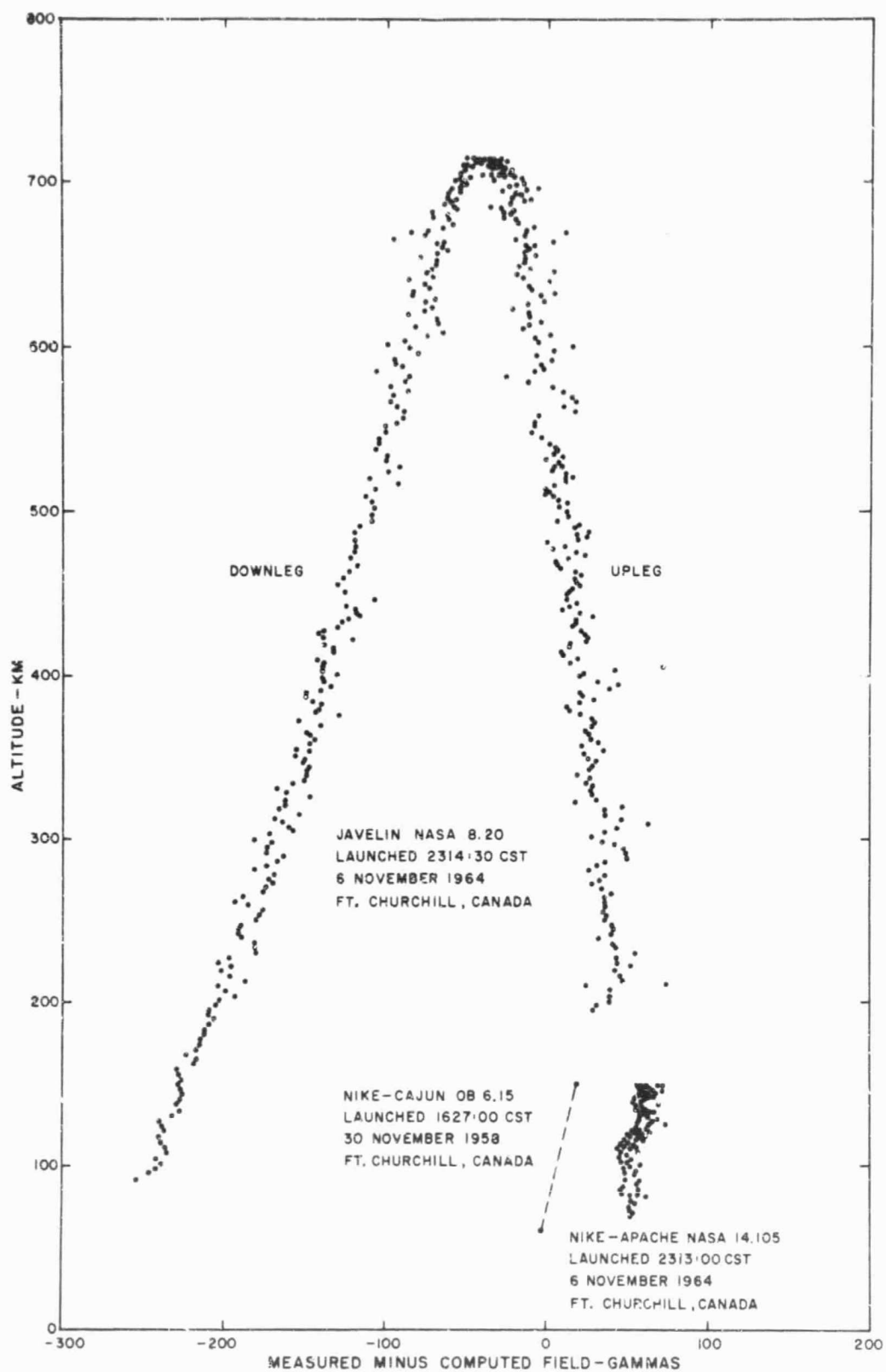

Figure 22. Magnetic Field Data as a Function of Altitude from Nike-Apache NASA 14.105 and Javelin N/ SA 8.20

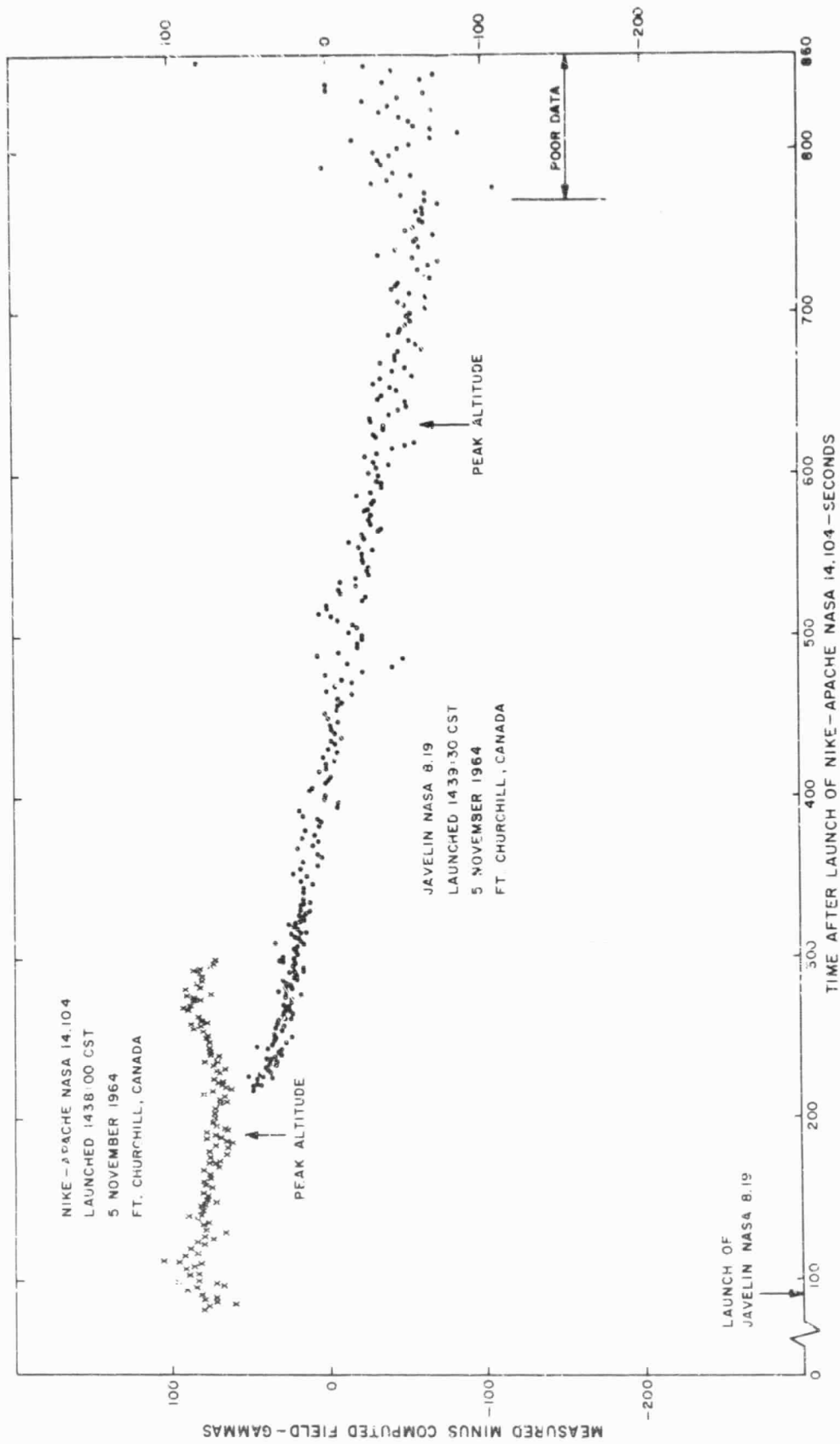

Figure 23. Magnetic Field Data as a Function of Rocket Flight Time from Nike-Apache NASA 14.104 and Javelin NASA 8.19

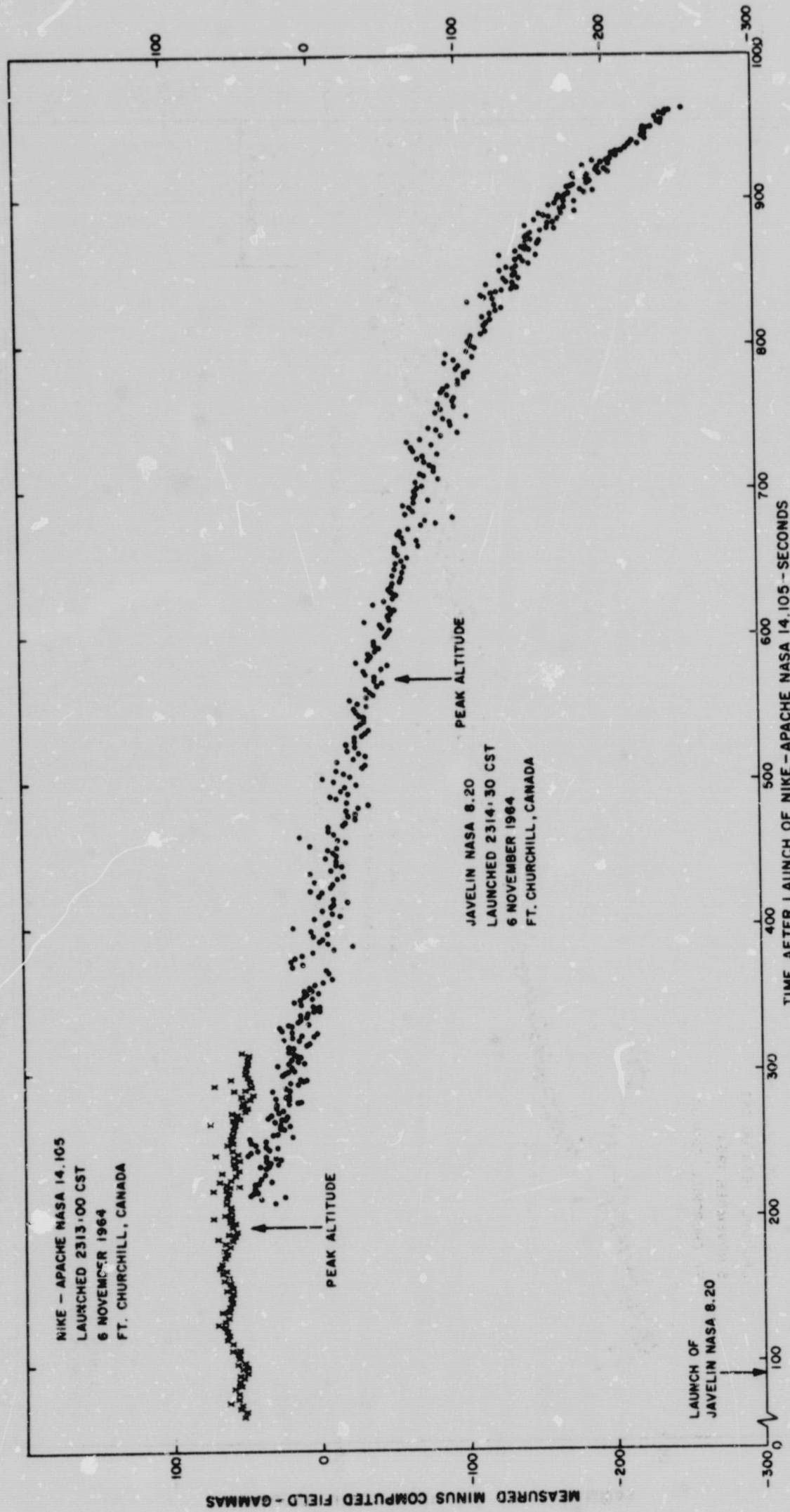

Figure 24. Magnetic Field Data as a Function of Rocket Flight Time from Nike-Apache NASA 14.105 and Javelin NASA 8.20

reflected in the increased scatter of the reduced data points in Figure 23. As shown in Table III, when we used the entire 860 seconds of raw data, the mean difference between the measured and the computed field was -9.1 gammas. When we discarded the data after 770 seconds, however, the mean difference was reduced to -5.4 gammas.

The slope of the Javelin data in Figures 21 and 22 is such that these data can easily be extrapolated downward in altitude to merge with the Nike-Apache data shown on the same graphs. This agreement suggests that the temporal variation in the measured data is small. The Javelin data do exhibit a significant and steady drift from plus to minus, as a function of both altitude and time (Figures 21-24). This drift is not caused by horizontal displacement of the rocket since the GSFC (12/66)-1 reference field takes spatial variations into account. We believe this drift is the result of errors in rocket trajectory, in view of the fact that a 3.5-km error in trajectory will produce a 100-gamma error in magnetic field.

By contrast, the Nike-Apache raw data were much less noisy than the Javelin data. In addition, we believe the Nike-Apache trajectories to be more accurate than those for the Javelins, primarily because the former traversed a much shorter flight path. It is not surprising, therefore, that the upleg-downleg agreement is quite good for the Nike-Apache data (Figures 21-24). Furthermore, rather than steadily drifting as the Javelin data do, the Nike-Apache data show an essentially constant offset from the computed reference field values. For Nike-Apache 14.104, this offset ranges from +60 to +90 gammas, while for Nike-Apache 14.105 it varies from +45 to +70 gammas.

The cyclic variations in the Nike-Apache data in Figure 24 possess a constant period of 47 seconds, which corresponds to the precession rate of the rocket vehicle. This agreement suggests that these variations may be the result of residual magnetism in the Nike-Apache payload. As the payload precesses, the residual magnetic field associated with it would alternately enhance and degrade the local magnetic field, and would tend

to produce a record such as that seen in Figure 24.

In order to display more structure in the data, the Nike-Apache results were replotted on an expanded scale as a function of altitude. To reduce scatter in the data, we applied a 5-point, triangular smoothing technique with 1-2-3-2-1 weighting. Both the smoothed and unsmoothed data are shown in Figures 25 and 26.

We reduced the Fort Churchill ground-based flux gate magnetometer records to obtain local magnetic field values for the two-hour interval centered around the launch time of each rocket pair. For Nike-Apache 14.104 and Javelin 8.19, this interval was one of moderate magnetic disturbance, with the flux gate magnetometer data showing peak-to-peak variations in the X, Y and Z components of 120, 110 and 55 gammas, respectively. The period of these variations ranged from 3 to 5 minutes. For the launch of Nike-Apache 14.105 and Javelin 8.20, the local magnetic field was much quieter, with flux gate magnetometer values for the X, Y and Z components being 15, 10 and 40 gammas, respectively. The period of these variations ranged from 2 to 4 hours.

Within the limits of analysis imposed by scatter in the rocketborne magnetometer data, there was no visible evidence of magnetic discontinuities or current sheets in the ionosphere. To investigate the presence of traveling disturbances in the ionospheric magnetic field, we tried to cross-correlate the overlapping portions of the data shown in Figures 23 and 24, but found no correlation.

The results of Nike-Cajun OB 6.15, flown at Fort Churchill in November 1958, are included in this report to provide a comparison with the current data. We believe this comparison is valid, since the Nike-Cajun was launched from the same site and at the same season of the year as the rockets reported here. In the original documentation of the flight results for this Nike-Cajun, an empirical expression for the earth's main magnetic field above Fort Churchill in November 1958, derived from the Nike-Cajun data, is given as

$$F = F_0 \left[\frac{a}{a+h} \right]^3 \pm 20 \text{ gammas} \quad (2)$$

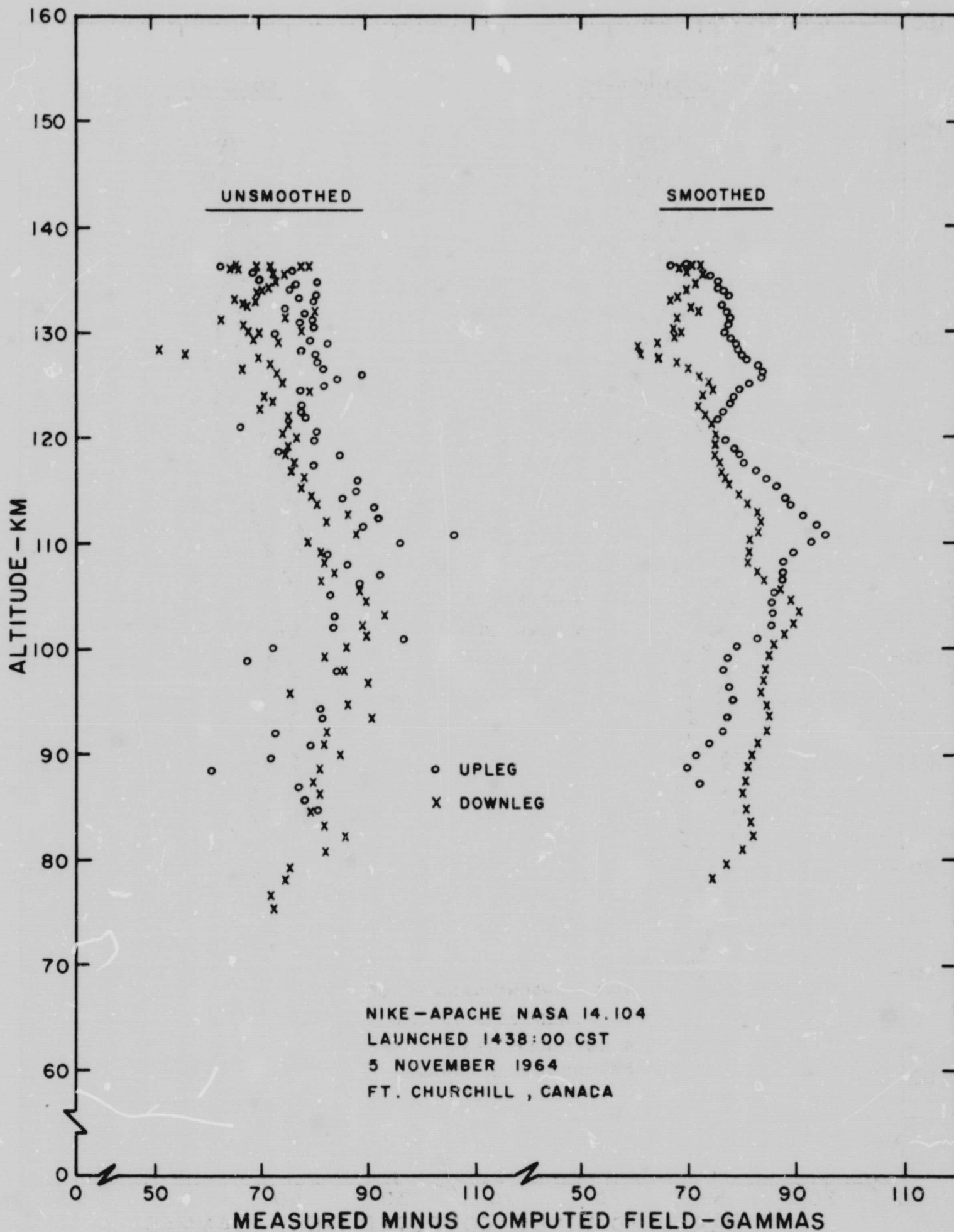

Figure 25. Smoothed and Unsmoothed Magnetic Field Data as a Function of Altitude from Nike-Apache NASA 14.104

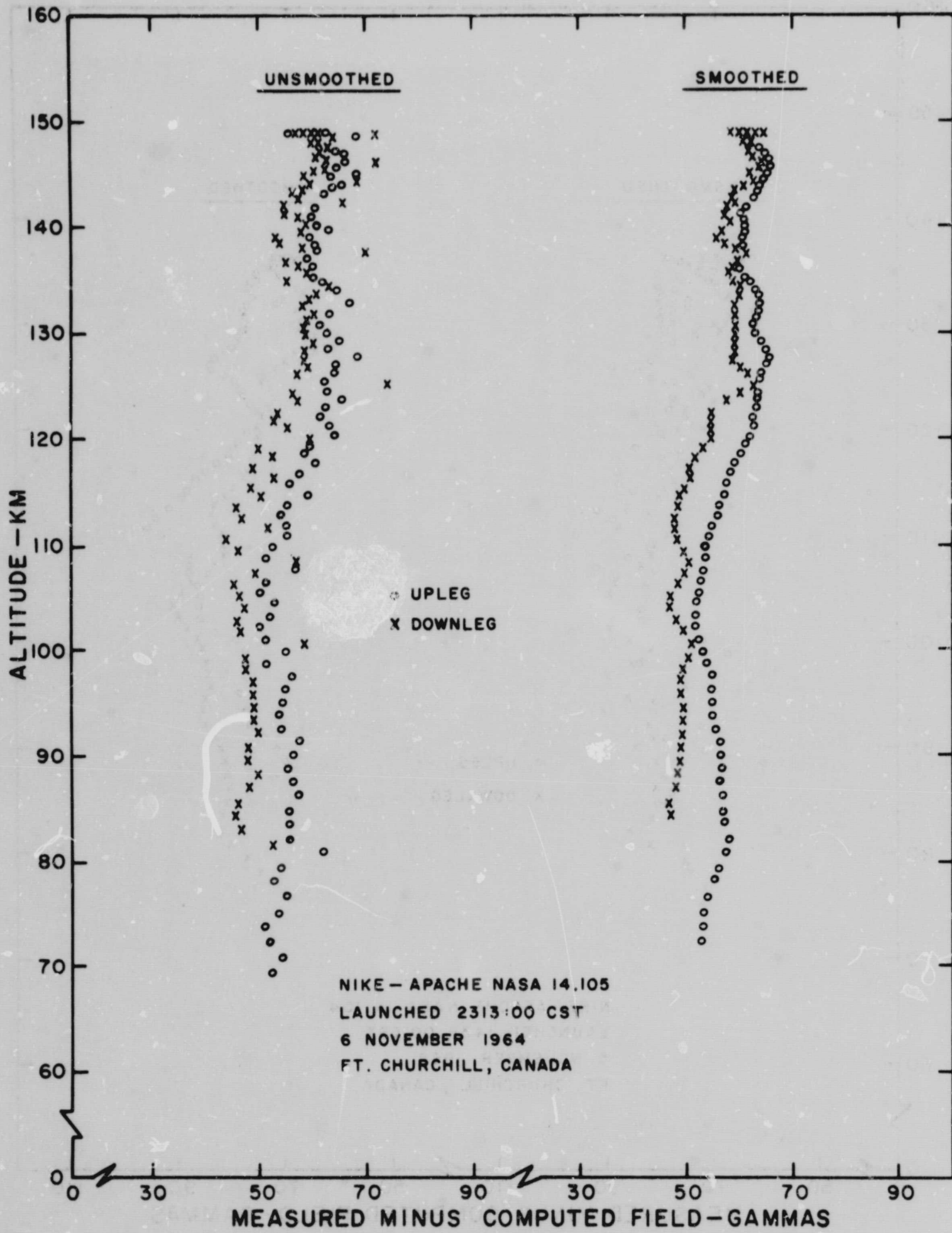

Figure 26. Smoothed and Unsmoothed Magnetic Field Data as a Function of Altitude from Nike-Apache NASA 14.105

where $F_0 = 61,240$ gammas, $a = 6,065$ km and $h =$ altitude above sea level. This expression is valid only up to 150 km altitude.¹⁶

The magnetic field represented by Equation (2) compares well with the reference field we computed for that date and location using the GSFC (12/66)-1 coefficients. Differences between the Nike-Cajun data and the computed field vary from -3 gammas at 60 km altitude to +18 gammas at 150 km altitude (Figures 21 and 22). Note that the altitude variation displayed by the Nike-Cajun data is opposite to the altitude variation shown by the Javelin data. Of course, the Nike-Cajun data encompass only about 20 percent of the altitude region covered by the Javelin data. Hence, any significance attached to variations between the two sets of data must take this fact into account.

E. Two-Frequency Beacon Frequency Stability

BRL has been using a two-frequency beacon for many years to yield propagation data from which electron densities are derived. We have also used a DOVAP transponder to obtain input data for the computation of rocket trajectories. This rocket project marked the first time, however, that BRL flew both the two-frequency beacon and DOVAP transponder on the same rocket, thus providing an ideal opportunity to use the DOVAP data to determine the frequency stability of the two-frequency beacon. The method used to compute beacon frequency stability is described below.

During a normal rocket launch sequence, the two-frequency beacon is operated for several minutes prior to rocket launch. This permits an accurate measure of the pre-flight beacon frequency, f , from which the wavelength is determined using the relationship

$$\lambda = c/f$$

To determine the frequency that would be observed at a ground receiver in the absence of any frequency drift, we use the DOVAP and vacuum vacuum trajectories and proceed as follows:

If R , the slant range to the rocket, is represented by the expression

$$R = (x^2 + y^2 + z^2)^{1/2}$$

where x, y and z are position coordinates of the rocket, then the change in slant range over a one-second interval is represented by the expression

$$\Delta R_t = R_t - R_{t-1}$$

where t is time.

The calculated received frequency, f_c , for a drift-free beacon averaged over a one-second interval is

$$f_{c_t} = f - \Delta R_t / \lambda$$

The quantity derived from the two-frequency beacon data is the phase, ϕ_t , of the received signal. Hence, the frequency of the observed signal, f_{o_t} , averaged over a one-second interval is

$$f_{o_t} = f + \Delta \phi_t \quad \text{where } \Delta \phi_t = \phi_t - \phi_{t-1},$$

and the frequency drift of the beacon, Δf , averaged over a one-second interval can be expressed as

$$\Delta f_t = f_{o_t} - f_{c_t}$$

Because the two beacon frequencies are harmonically related and both derived from the same basic crystal, this analysis of beacon frequency drift was performed for the 37-MHz frequency only. Figures 27 and 28 show frequency drift for the beacons flown in Javelin 8.19 and 8.20, respectively. For Javelin 8.19, the maximum frequency drift is approximately 13 cycles per second, while for Javelin 8.20 it is about 15 cycles per second. The violent frequency drift oscillations, evidenced in the early portion of each flight, are the result of rocket stage burnings.

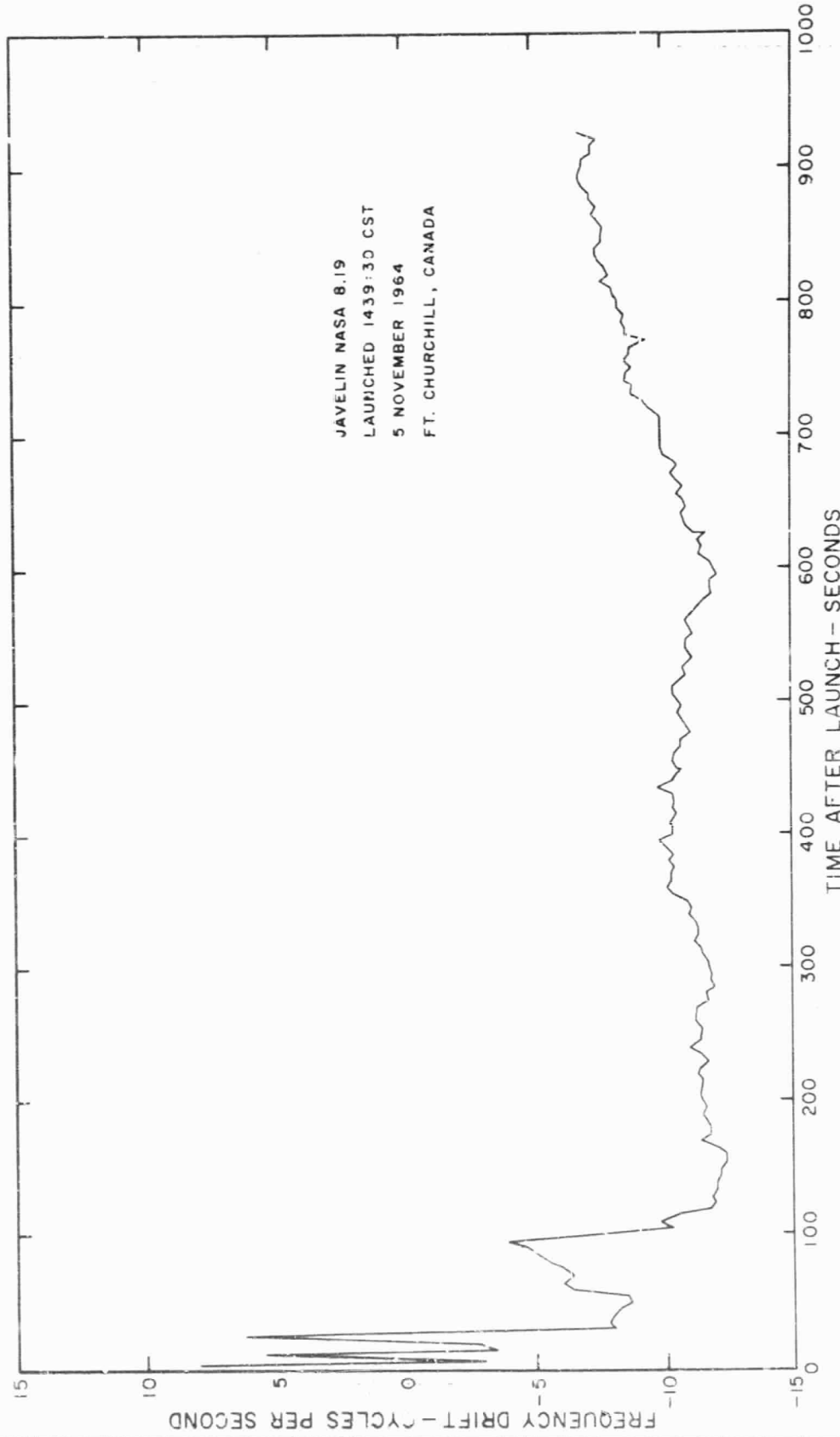

Figure 27. Frequency Drift of the Two-Frequency Propagation Beacon Flown in Javelin NASA 8.19

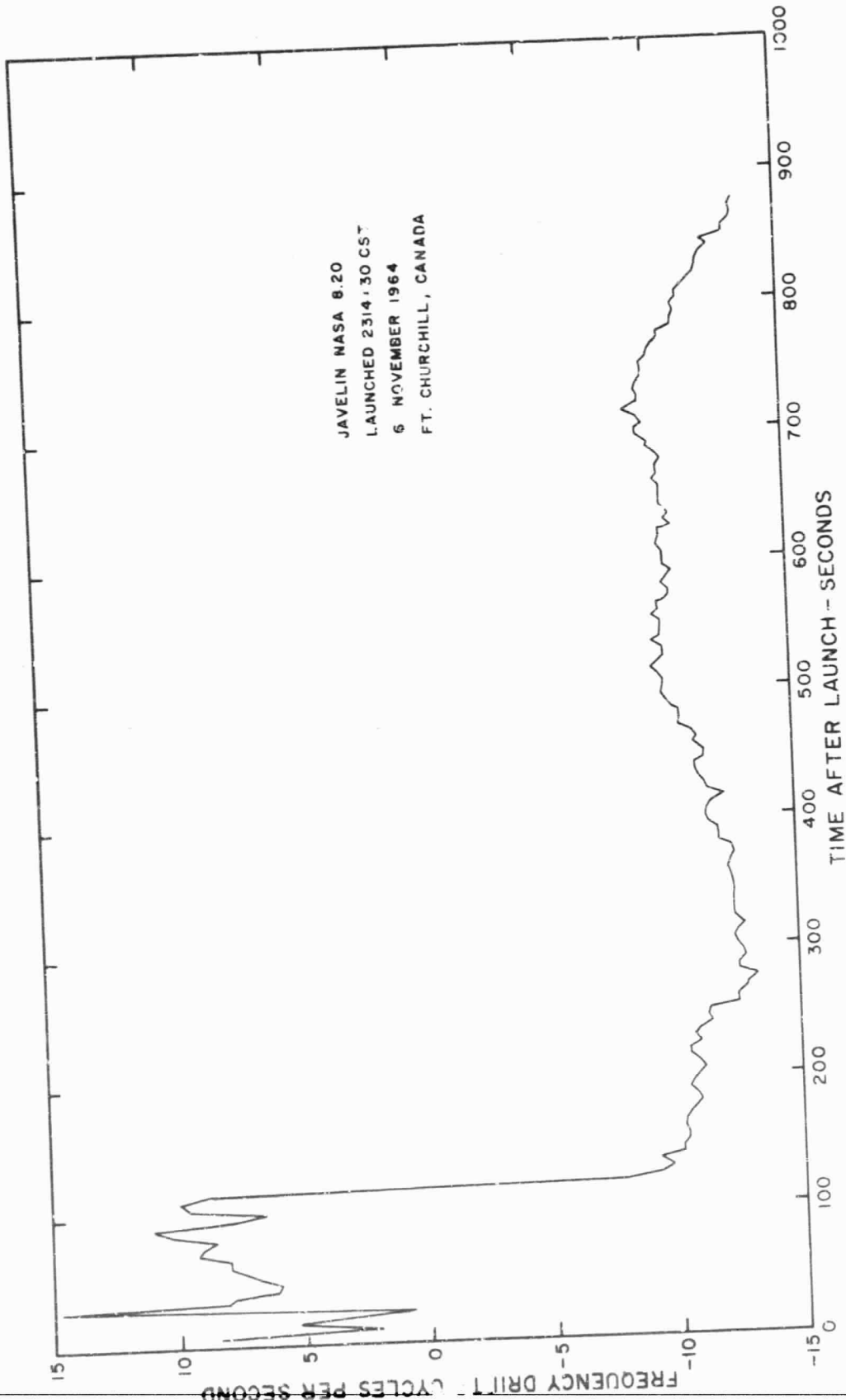

Figure 28. Frequency Drift of the Two-Frequency Propagation Beacon
Flown in Javelin NASA 8.20

The decrease in frequency drift near 100 seconds, particularly sharp for Javelin 8.20, is caused by the severe mechanical shock of payload ogive ejection.

We calculated the frequency stability of the beacon from the expression

$$\text{Frequency Stability} = \Delta \bar{f}_{\text{max}} / f$$

For Javelin 8.19, the frequency stability thus determined was 3.5 parts in 10^7 , while for Javelin 8.20 it was 4.1 parts in 10^7 . These frequency stability figures are poorer than those quoted in Section IV-A of this report (1 part in 10^8). This difference is attributable to the shock and vibration forces that the beacon undergoes during flight.

VII. SUMMARY

Three of the four rockets launched during this project performed as planned, and the fourth was only slightly below expectations. All instrumentation operated well. The exacting launch operations, requiring that the rockets in each pair be fired 90 seconds apart and that the payloads be placed in close proximity spatially, was implemented perfectly.

The electron density profile from Javelin 8.19, launched in the afternoon, was a normal profile for that location and that season of the year. The profile from Javelin 8.20, launched near midnight, was far from normal, however. It showed a peak density well below 200 km altitude, approximately 100 km lower than we expected under the given conditions. The source of this high electron density at such a relatively low altitude is not clear, but one possibility might be incoming electrons with energies of 1-2 Kev.

Electron temperature results derived from Langmuir probe data were quite scattered, primarily as a result of poor probe orientation with respect to the magnetic field and the high payload spin rate.

Excessive noise in the magnetometer data made the reduction and

analysis of these data much more difficult than anticipated. Despite this drawback, however, we managed to obtain magnetic field values that agreed reasonably well with the GSFC (12/66)-1 reference field.

The frequency stability of the propagation beacons flown in the Javelin rockets varied from 3.5 to 4.1 parts in 10^7 . These values were poorer than previously measured stabilities (1 part in 10^8), with the degradation resulting from the severe shock and vibration stress that the beacon was subjected to during flight. The purpose of measuring the beacon frequency stability was to determine the magnitude of the flight-induced drift.

ACKNOWLEDGEMENTS

The very successful completion of this multiple rocket project was a direct result of the high degree of technical competence and dedicated effort displayed by all personnel involved. However, since these Javelin rockets were the first of this type to be launched at the Fort Churchill range, and because the project objectives required closely-timed vehicle launches and critical spatial payload placement, the Fort Churchill range support personnel and Mr. Norman E. Peterson, NASA Vehicle Manager, deserve special recognition for a difficult and painstaking job well done.

I wish to express personal appreciation to several of my colleagues who contributed to this report; namely, to Mr. R. E. Prenatt who derived the electron density profiles from BRL propagation beacon data, to Mr. I. L. Chidsey who reduced the magnetometer data and provided material for Section VI-D, and to Mr. W. A. Dean who furnished the propagation beacon frequency drift computations in Section VI-E.

REFERENCES

1. J. C. Seddon, "Propagation Measurements in the Ionosphere With the Aid of Rockets," J. Geophys. Res., Vol. 58, September 1953, pp. 323-35.
2. S. T. Marks, et al., "Summary Report on Strongarm Rocket Measurements of Electron Density to an Altitude of 1500 Kilometers," Ballistic Research Laboratories Report 1187, January 1963.
3. L. J. Cahill and J. A. Van Allen, "High Altitude Measurements of the Earth's Magnetic Field with a Proton Precession Magnetometer," J. Geophys. Res., Vol. 61, September 1956, pp. 547-58.
4. J. P. Heppner, J. D. Stolorik and L. H. Meredith, "The Earth's Magnetic Field Above WSPG, New Mexico, from Rocket Measurements," J. Geophys. Res., Vol. 63, June 1958, pp. 277-88.
5. R. Pinamonti and C. L. Wilson, "Javelin DOVAP Antenna System," Ballistic Research Laboratories Technical Note 1511, August 1963.
6. R. Leong, "Voltage Breakdown Measurements on Quadraloop, Shroud and Rectangular Slot Antennas at High Altitudes," Ballistic Research Laboratories Memorandum Report 1514, August 1963.
7. V. W. Richard, "The Shroud Antenna," Ballistic Research Laboratories Memorandum Report 1283, June 1960.
8. A. F. Nagy, Direct Electron Temperature and Density Measurements in the Polar Ionosphere, Paper presented at the URSI meeting, Dartmouth College, Hanover, New Hampshire, October 1965.
9. A. F. Nagy and J. C. G. Walker, "Direct Measurements Bearing on the Question of the Nighttime Heating Mechanism in the Ionosphere," Planet. Space Sci., Vol. 15, January 1967, pp. 95-101.
10. D. H. Jelly, "Some Remarks on the Valley Between the F-Layer and Thick E_s (Night E) Determined from Simultaneous Bottomside and Topside Ionograms," Proceedings of the Conference on Ground-Based Radio Wave Propagation Studies of the Lower Ionosphere, Defense Research Telecommunications Establishment, Shirley Bay, Ottawa, Ontario, Canada, 1966.
11. H. Kamiyama, Ionization and Excitation by Precipitating Electrons, unpublished memorandum, Geophysical Institute, Tohoku University, Sendai, Japan, 1966.
12. A. F. Nagy, "Direct Measurements in the Ionosphere," Report 05671-6-F, Space Physics Research Laboratory, University of Michigan, Ann Arbor, October 1965.

REFERENCES (Continued)

13. O. K. Goodin and J. V. Lanahan, "Cross Correlation Filtering Using a Digital Technique," Ballistic Research Laboratories Memorandum Report (in press).
14. J. C. Cain, et al., "Computations of the Main Geomagnetic Field from Spherical Harmonic Expansions," NASA Report X-611-64-316, October 1964.
15. J. C. Cain, et al., "A Proposed Model for the International Geomagnetic Reference Field--1965," NASA Report X-612-67-173, July 1967.
16. J. M. Conley, "Earth's Main Magnetic Field to 152 Kilometers Above Fort Churchill," J. Geophys. Res., Vol. 65, March 1960, pp. 1074-5.

Unclassified
Security Classification

DOCUMENT CONTROL DATA - R & D		
<i>(Security classification of title, body of abstract and indexing annotation must be entered when the overall report is classified)</i>		
1. ORIGINATING ACTIVITY (Corporate author) USA Aberdeen Research & Development Center Ballistic Research Laboratories Aberdeen Proving Ground, Maryland 21005		2a. REPORT SECURITY CLASSIFICATION Unclassified
		2b. GROUP
3. REPORT TITLE ROCKET MEASUREMENTS OF ELECTRON DENSITY, ELECTRON TEMPERATURE AND THE EARTH'S MAGNETIC FIELD ABOVE FORT CHURCHILL		
4. DESCRIPTIVE NOTES (Type of report and inclusive dates)		
5. AUTHOR(S) (First name, middle initial, last name) Harold T. Lootens		
6. REPORT DATE August 1968	7a. TOTAL NO. OF PAGES 64	7b. NO. OF REFS 16
8a. CONTRACT OR GRANT NO.	9a. ORIGINATOR'S REPORT NUMBER(S) Report No. 1415	
b. PROJECT NO. RDT&E 1T014501B53A15	9b. OTHER REPORT NO(S) (Any other numbers that may be assigned this report)	
c. NASA R-82, NTF-99		
d.		
10. DISTRIBUTION STATEMENT This document has been approved for public release and sale; its distribution is unlimited.		
11. SUPPLEMENTARY NOTES	12. SPONSORING MILITARY ACTIVITY USAMC, Washington, D. C. NASA, Washington, D. C.	
13. ABSTRACT This report describes the results obtained from two Nike-Apache and two Javelin (Argo D-4) rockets launched in mixed pairs at Fort Churchill, Canada, in November 1964. These rockets were instrumented with two-frequency propagation beacons, Langmuir probes, and proton precession magnetometers. The project objectives, vehicle and payload configurations, and field operations schedule are given. Electron density and electron temperature profiles, earth magnetic field measurements, and propagation beacon frequency stability values are presented.		

DD FORM 1473
1 NOV 66

REPLACES DD FORM 1473, 1 JAN 64, WHICH IS
OBSOLETE FOR ARMY USE.

Unclassified
Security Classification

14. KEY WORDS	LINK A		LINK B		LINK C	
	ROLE	WT	ROLE	WT	ROLE	WT
Ionosphere Electron Density Electron Temperature Earth's Magnetic Field Two-Frequency Propagation Beacon						