

**NASA CONTRACTOR
REPORT**



NASA CR-1255

C.1



0060544

TECH LIBRARY KAFB, NM

NASA CR-1255

LOAN COPY: RETURN TO
AFWL (WLIL-2)
KIRTLAND AFB, N MEX

**AN INVESTIGATION OF THE SUITABILITY
OF WHITE RATS FOR SUB-ORBITAL STUDIES
OF BEHAVIOR IN A GRAVITY FIELD**

by A. B. Broderson and K. O. Lange

Prepared by
UNIVERSITY OF KENTUCKY
Lexington, Ky.
for

NASA CR-1255
TECH LIBRARY KAFB, NM



0060544

AN INVESTIGATION OF THE SUITABILITY OF WHITE
RATS FOR SUB-ORBITAL STUDIES OF BEHAVIOR
IN A GRAVITY FIELD

By A. B. Broderson and K. O. Lange

Distribution of this report is provided in the interest of
information exchange. Responsibility for the contents
resides in the author or organization that prepared it.

Prepared under Grant No. NsG-456 by
UNIVERSITY OF KENTUCKY
Lexington, Ky.

for

NATIONAL AERONAUTICS AND SPACE ADMINISTRATION

For sale by the Clearinghouse for Federal Scientific and Technical Information
Springfield, Virginia 22151 - CFSTI price \$3.00

ABSTRACT

An Investigation of the Suitability of White Rats for Sub-Orbital Studies of Behavior in a Gravity Field

Techniques were developed for evaluating the Sprague Dawley rat as a subject for the first of four "In-Flight Gravity Preference Experiments" to be launched into sub-orbital trajectories by Aerobee 150A rockets. Special configuration centrifuges were developed and used to experimentally determine the locomotion behavior of rats in fields of simulated gravity. Techniques were developed for investigating the effect of rocket launch stress on this behavior, and an environmental simulation system was developed and used to routinely prepare rats for the confinement, acceleration, spin, noise, and vibration of an Aerobee launch. The suitability of the subject and the effectiveness of the environmental simulation routine were verified by the satisfactory behavior demonstrated in the first flight experiment.



TABLE OF CONTENTS

INTRODUCTION	1
CHAPTER I. SELF-SELECTION OF GRAVITY BY RATS WHICH LOCOMOTE THROUGH FIELDS OF CENTRIFUGAL ACCELERATION ABOVE 1G	
Introduction	5
Apparatus and Basic Procedures	5
Preliminary Test Results	8
Computer Studies of Motion in a Gravity Field	17
Conclusions and Recommendations	32
CHAPTER II. AN INVESTIGATION OF THE ABILITY OF THE WHITE RAT TO PERFORM A GRAVITY PREFERENCE TASK AFTER EXPOSURE TO SIMULATED ROCKET LAUNCH STRESS	
Introduction	34
Flight Environments of the Aerobee Gravity Preference Payload.	35
Simulation of the Launch Environments	43
Effect of Launch Simulation on Preference Behavior	61
Training Procedures for Suborbital Flight	66
Flight Verification of the Effectiveness of the Training Program	81
Conclusions and Recommendations	85
BIBLIOGRAPHY	87

LIST OF ILLUSTRATIONS

Figure	Page
1. Paraboloid, Parabolic Track, and Spiral-Type Centrifuges	6
2. Mean Percentage of Time Spent by 20 Naive Rats at 1.0g and 2.0g as a Function of Time into a 48-hour Test in a Spiral Centrifuge	10
3. Mean Gravity Preference of 52 Naive Rats during a 48-hour Test in a Parabolic Track Centrifuge	10
4. Percentage of 52 Naive Rats which Experienced Each Gravity Region in a Parabolic Track Centrifuge during a 48-hour Test	12
5. Mean Percentage of Time Spent by 9 Naive Rats at 1.0g in a Spiral Centrifuge for Consecutive Tests of Decreasing Lengths	12
6. Mean Gravity Preference of 12 Naive Rats during a 24-hour Test in a 1.0g-1.3g Spiral Centrifuge	14
7. Comparison of Gravity Preference of Rats in Spiral, Paraboloid, and Parabolic Track Centrifuges	14
8. Mean Position in the Gravity Field, Versus Time, of 4 Rats during 63 Tests of 5- Minute and 30-Second Duration in a 1.3g-2.3g Spiral Centrifuge, with Re- lease at both High and Low Gravity	16
9. Automated Paraboloid and Control System for Detailed Observation of Locomotion Behavior in a Gravity Field	18

10.	Parameters Describing Locomoting Motion in a Parabolic Gravity Field Centrifuge	22
11.	Median Position in the Gravity Field, Versus Time, of 4 Rats during 5 Tests in the Automated Paraboloid	25
12.	Median Running Speed and Coriolis Acceleration, Versus Gravity, of 4 Rats during 5 Tests in the Automated Paraboloid	26
13.	Relative Paths Followed by a Golf Ball when Expelled at 10 ft/sec by a Spring at 2.0g in the Automated Paraboloid (45 rpm)	28
14.	Typical Patterns of Locomotion of Rats in the Automated Paraboloid	29
15.	The Effect of Centrifuge Reversal on the Response Time of 2 Rats, Compared with 2 Rats whose Direction of Rotation was Not Reversed	31
16.	Payload Centrifuge to be Launched by Aerobee Rocket for Investigating Gravity Preference of 2 Rats Between 0.35g and 1.60g during 5 Minutes of Free Fall	36
17.	Spin (Roll Rate) Profile of the Aerobee 150A Sounding Rocket	39
18.	Longitudinal Acceleration Profile of the Aerobee 150A with 200-Pound Payload	39
19.	Calculated Spectrum of Noise Intensity Internal to the Aerobee Gravity Preference Payload at 37 Seconds into Flight	42
20.	Parameters Describing a Gravity Preference Centrifuge Profile where Slope is Modified from that of a True Parabola	46
21.	Track Profiles for Gravity Preference Centrifuges which Incorporate a 9.6° Slope	48

22.	Gravity Preference Centrifuge with One Track of True Parabola Configuration and One Track whose Slope is Modified by 9.6°	48
23.	Acceleration Components and Drag Force Distribution Resulting from Angular Velocity and Angular Acceleration of a Cylindrical Centrifuge Arm	51
24.	Torque Profiles Required to Simulate the Aerobee Boost Acceleration Profile on a Centrifuge of 13.8-Foot Radius for Various Moments of Inertia (ft lb sec^2)	55
25.	Configuration of Shock Cord System for Applying Torque to a Centrifuge for Boost Acceleration Simulation	57
26.	Torque Profile Attainable from a Centrifuge with an Undamped Shock Cord Power System, Compared with the Profile Required for Boost Acceleration Simulation	57
27.	Centrifuge for Simulating the Boost and Sustainer Acceleration and Spin Profile of the Aerobee 150A	59
28.	Simulated Boost Acceleration Profile Achieved Compared with the Profile of an Aerobee 150A with 200-Pound Payload	59
29.	Simulated Sustainer Acceleration Profile Achieved Compared with the Profile of an Aerobee 150A with 200-Pound Payload	62
30.	Simulated Spin Profile Achieved Compared with the Profile of an Aerobee 150A	62
31.	Mean Preference of 6 Rats for 1.0g and 2.0g as a Function of Time into Test Before and After Boost Acceleration Simulation	64
32.	Set of Confinement Capsules Used to Prepare Rats for a 4-Hour Hold in Launch Procedure	68

33.	Animal Caging System Employed in the Runway of the Aerobee Gravity Preference Payload	68
34.	History of Air Temperature Internal to the Confinement Capsule During a One Hour Rat Confinement, With and Without External Fan Cooling	70
35.	Acceleration Simulation Centrifuge for Routine Preparation of Rats for an Aerobee Flight	70
36.	Apparatus for Routinely Exposing Rats to Simultaneous Simulations of the Aerobee Spin, Noise, and Vibration	72
37.	Spiral Gravity Preference Centrifuge Simulating the Gravity Range, Track Length, Slope Angle, and Angular Velocity of the Aerobee Gravity Preference Payload	72
38.	Number of Good and Poor Performers Out of 20 Rats Routinely Prepared for Aerobee Launch Compared with Standard Deviation, σ , of Position in the Gravity Field at Five Minutes Into Test	78
39.	Improvement of Gravity Preference Behavior of 20 Rats during Repeated Testing after an Initial Performance Decline Upon Transfer from Lexington, Kentucky to Wallops Island, Virginia	79
40.	History of Running Time to Low Gravity of Subject 3A during a Program of Routine Exposure to Simulated Aerobee Launch Environments.....	82
41.	Typical Gravity Preference Behavior of Subject 3A during Gravity Preference Testing at Wallops Island, Virginia	83
42.	Centrifuge Location, Versus Time, of Subject 3A during a 5-Minute Test in a Non-Rotating Spiral Centrifuge at Wallops Island, Virginia	83
43.	Gravity Preference Payload Carrying Two Trained Rats Launched by Aerobee 150A Rocket from Wallops Island, Virginia on December 5, 1967	84

INTRODUCTION

Before long-term space flight can become safely routine, the extent of man's physiological requirement for gravity must be more firmly established. Medical studies during simulated weightlessness and during short-term orbital weightlessness have revealed that man's physiological processes undergo potentially harmful adaptations to the weightless state; examples of gross adaptations are cardiovascular deconditioning, muscle atrophy, diuresis, and bone decalcification.^{7, 14, 16, 24, 26, 27, 41, 60, 69, 75, 82, 87} Theoretical studies have revealed what are possibly more profound changes at the cellular level relating to structure, metabolism, and mitosis.^{6, 46, 58, 72, 78} While these adaptations may not be harmful in themselves, they probably constitute a lessening of man's ability to withstand the stresses imposed by gravity and may contribute to biological collapse when he is exposed to the acceleration stresses associated with reentry.

A number of proposals have been advanced for alleviating the potential hazard; in essence, they fall into two groups which are fundamentally distinct in their approach:

1. Provide artificial, inertial gravity by space vehicle rotation,⁸⁰ eliminating the problems of weightlessness per se, but necessarily introducing the problems of adaptation to the motion sickness and disorientation which accompany rotation.^{28, 32, 36, 51, 85}

2. Treat the symptoms of adaptation to weightlessness with drugs, muscular and cardiovascular exercise, or devices to maintain cardiovascular tone such as pressure cuffs on the extremities, elastic leotards, positive pressure breathing, and "lower body negative pressure".^{31,48,55}

Each viewpoint has its own merits, but neither is completely satisfactory. The non-inertial approach has met with only limited success and cannot guarantee protection against deconditioning at the cellular level; the inertial approach requires an excessive vehicle radius if rotation rate is to be held within limits easily tolerable to the vestibular system. One proposed compromise would incorporate features characteristic of each viewpoint; that is, centrifugation on a short radius would be provided periodically, with non-inertial measures for maintenance during the alternating periods of weightlessness.^{77,86} Such compromises offer a temporary solution but may be suitable only for flights of short to intermediate duration; the means of protection for long-term space flight cannot be designed until we establish how much gravity, if any, is necessary for proper functioning of physiological processes.

The biosatellite program now in progress is expected to expand existing knowledge on the morphological and physiological response of organisms to weightlessness; it is not intended to investigate gravity requirements. The Wenner-Gren Aeronautical Research Laboratory of the University of Kentucky has proposed that the gravity requirements of earth organisms be investigated by behavioral experiments in orbit; experimental animals would vary the amount of gravity experienced, thereby demonstrating a preference for gravity level.⁴⁹

Such a behavioral approach would complement biomedical investigations and would seem a logical sequel to the pioneering studies of Henry and Rohles in the Aerobee-mice and Mercury-chimpanzee programs.^{42,64,65,73}

In preparation for studies in orbit, basic laboratory investigations have been underway since 1963 to establish the gravity preference behavior of earth organisms as influenced by gravity above 1.0g and by the dynamic environments associated with its simulation on the centrifuge. These studies are under the direction of Dr. K. O. Lange and are funded by grant NsG-456 from the National Aeronautics and Space Administration.

Two purposes of the research program are: 1) to develop suitable techniques for measuring gravity preference, and 2) to identify species which readily demonstrate gravity preference and which might, therefore, be suitable organisms for orbital investigations below 1.0g. One technique was developed around operant conditioning methods and allows restrained animals control over the radius and/or angular velocity of the centrifuge; in the other technique, unrestrained animals vary gravity by locomoting to various radii along the surface of a special configuration "gravity-field" centrifuge.

A number of species have been studied using both techniques; the male Sprague Dawley rat performed well in early tests with the gravity-field centrifuge, suggesting that this species might prove suitable for orbital studies. Accordingly, plans were made to evaluate both the species and the technique by suborbital experiments using gravity field centrifuges lofted by Aerobee rockets from Wallops Island, Virginia.

In preparation for these suborbital studies, investigations were conducted into the gravity preference behavior of the rat and the stability of that behavior after exposure to simulated rocket-launch stress. This paper reports on these investigations.

CHAPTER I

SELF-SELECTION OF GRAVITY BY RATS WHICH LOCOMOTE THROUGH FIELDS OF CENTRIFUGAL ACCELERATION ABOVE 1.0g

Introduction

The Wenner-Gren Aeronautical Research Laboratory has investigated the gravity preference behavior of a number of species, and papers by Lange, Belleville, McCoy, Broderson, and Martin have reported the results of preliminary studies with mice, rats, and squirrel monkeys. 5,10,11,13,49,50,54,56

As the Sprague Dawley rat was considered a potentially suitable subject for orbital studies, a detailed study of the behavior of that species in a gravity field above 1.0g was considered a necessary prerequisite. This chapter describes the techniques developed and presents the results of that investigation.

Apparatus and Basic Procedures

Three types of gravity-field centrifuge have been developed: the paraboloid, the parabolic track, and the spiral. Examples of each are shown in figure 1; full descriptions are given elsewhere.^{13, 49} The paraboloid is a surface of revolution of the form $Z = Ar^2$ in cylindrical coordinates [or $Z = A(x^2 + y^2)$ in cartesian coordinates]

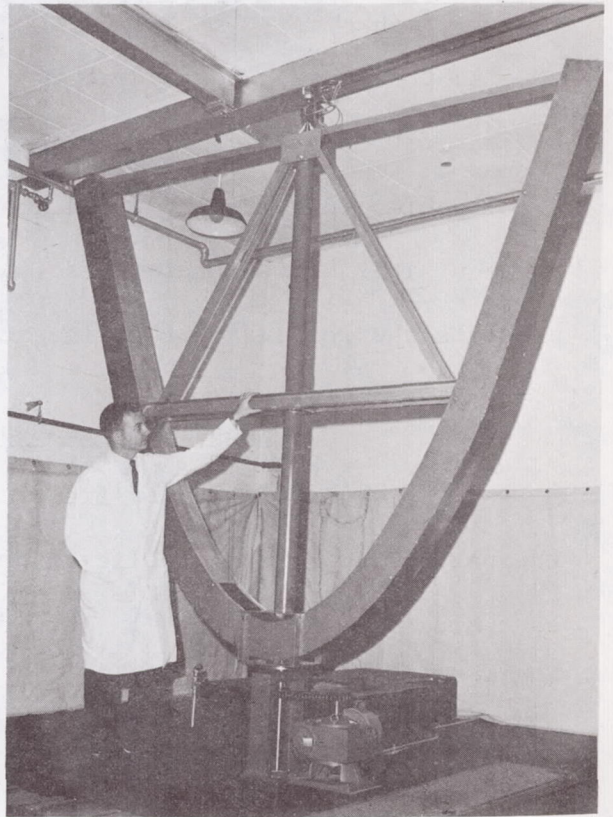
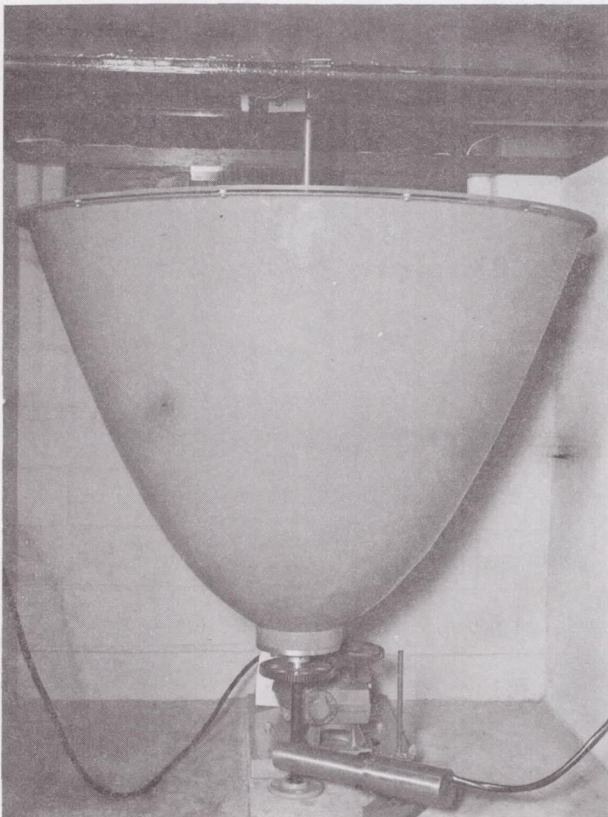

Figure 1. Paraboloid, Parabolic Track, and Spiral-Type Centrifuges.

where A is the constant necessary to generate a surface which is normal to the gravity vector at any radius, r, and height, Z. The parabolic track is of the form $Z = Bx^2$ and resembles a "slice" from a paraboloid. The spiral centrifuge is of the form $r = e^{C\theta}$ where C is a constant which determines how rapidly the spiral surface unfolds. In the spiral centrifuge, the track in which the animal runs is in the horizontal plane, whereas in the parabolic track centrifuge, subjects run in the vertical plane; in the paraboloid, subjects may move in both planes.

In each type of apparatus, the subject effects a change in gravity by locomoting inward or outward along the surface, changing radius. As used in this paper, the term "gravity preference test" refers to the procedure whereby the subject is allowed to locomote freely within the centrifuge for a specified period of time during which the investigator measures the percentage of time spent in each of several, arbitrarily-bounded gravity regions. Measurement of this position is achieved by any of several methods, such as by providing floor switches in each gravity region which are closed by the subject's weight, or by radiation or photographic tracking; detailed descriptions of these systems are presented in the previously cited papers.

The particular value of acceleration which results from the vector addition of earth gravity and centrifugal acceleration, and to which a subject is exposed at any given time, is herein referred to as "gravity level" and is expressed in g's; all gravity levels

are taken to act at the estimated center of gravity of the subject. The more general term "gravity region" is used herein to denote the small range of gravity in the neighborhood of a particular gravity level. For purposes of this investigation, the word "gravity" shall always indicate centrifugally-simulated gravity.

It is important to recognize that an animal reacts to the total environment of the centrifuge, of which gravity level is only one part, others being angular velocity, Coriolis acceleration, air currents, temperature gradients, etc. Gravity is assumed to have the predominant effect; rigorously, however, a statement such as "the subject preferred 2.0g" should actually indicate that "the subject preferred a centrifuge environment which the investigator chooses to characterize by 2.0g's of resultant acceleration." The terms "g-preference" and "gravity-preference" are used interchangeably, that is, it is assumed that the subject cannot distinguish between a gravity force and a linear inertia force.

Preliminary Test Results

A number of tests were conducted with the three types of centrifuge in order to establish basic trends of gravity preference behavior. The following section presents the results of those tests.

Learning.

Twenty naive rats were each exposed for 48 hours to the gravity field of a spiral centrifuge (46 rpm, 1.0g - 2.0g) such

as that shown in figure 1 in order to establish how quickly they learn to show a preference for gravity region. Figure 2 shows the mean percentage of time spent at the 1.0g and 2.0g regions as a function of time into the test. Less than 60% of the time was spent at 1.0g during the first 6 hours; about 20% was spent at 2.0g, and the remaining 20% was spent at other locations and in locomotion between gravity regions. As the test progressed, the rats spent an increasing amount of time at 1.0g and, correspondingly, a decreasing amount of time at 2.0g, demonstrating that the rat can effectively learn to manipulate gravity by locomotion.

Gravity Preference.

The parabolic track centrifuge, shown in figure 1 (46.7 rpm, 1.0g - 3.67g), was equipped with weight-actuated floor switches in each gravity region of each track; activation by the rat switches on a corresponding elapsed-time indicator and thus records the total time the rat spends in each of 9 gravity regions. Figure 3 shows the results of 48-hour tests on 52 naive rats; all subjects were placed in the centrifuge at the 1.0g location. Over 50% of the time was spent at 1.0g, less than 10% being spent at any other gravity. This is taken to indicate that rats prefer 1.0g to any higher gravity once they have learned to manipulate gravity magnitude by locomotion.

Aversive properties of high gravity.

Figure 4 is a frequency distribution of the data of figure 3, showing the number of subjects (expressed as a percentage of the

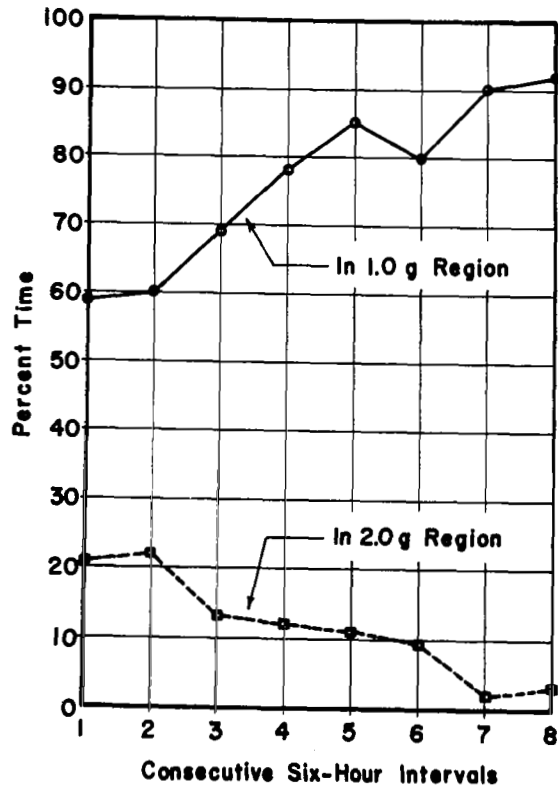

Figure 2. Mean Percentage of Time Spent by 20 Naive Rats at 1.0g and 2.0g as a Function of Time into a 48-hour Test in a Spiral Centrifuge.

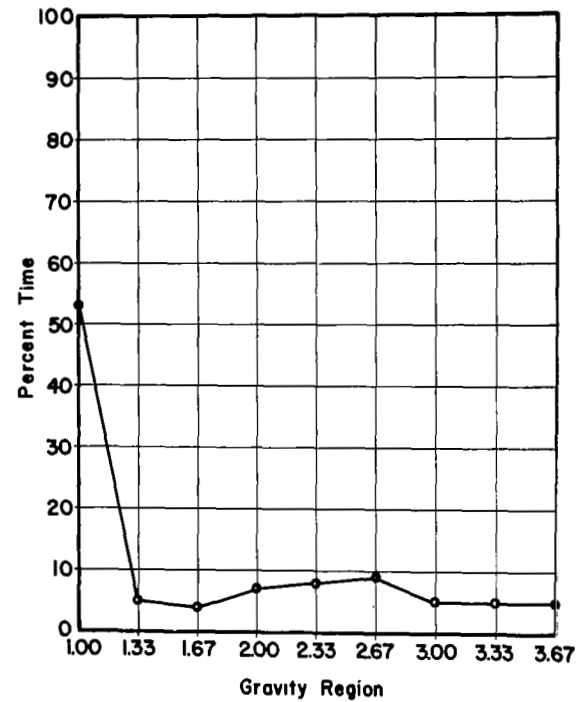

Figure 3. Mean Gravity Preference of 52 Naive Rats during a 48-hour Test in a Parabolic Track Centrifuge.

total) which had experienced each gravity region. Only 29% experienced as much as 3.67g; the negative slope of the curve indicates the degree of aversiveness of the higher gravity regions. It is also known that high gravity is noxious, and this was evident in the poor physical condition of subjects which spent considerable time at 3.67g; this gravity level was noticeably burdensome for the rats and some found it impossible to escape. A small percentage suffered from eye protrusion and nose bleeding, and one subject was found dead after 48 hours at 3.67g.

Increase and stability of preference for 1.0g with repeated testing.

Nine naive rats were given tests in the spiral centrifuge on 12 consecutive days with durations decreasing from one hour to five minutes. As shown in figure 5, over 40% of the time was spent at 1.0g during the first 1-hour test, and by the second test this had risen to about 75%. Beyond this point, preference for 1.0g remained relatively stable between 65% and 80%, even though test duration was reduced to only five minutes. Note the slight downward trend in preference for 1.0g beginning with the ninth day. In many cases, this trend will continue as though the rats were beginning to adapt to the higher gravities; experience has indicated, however, that a reduction in test frequency to once in every three or four days will maintain stability through months of testing.

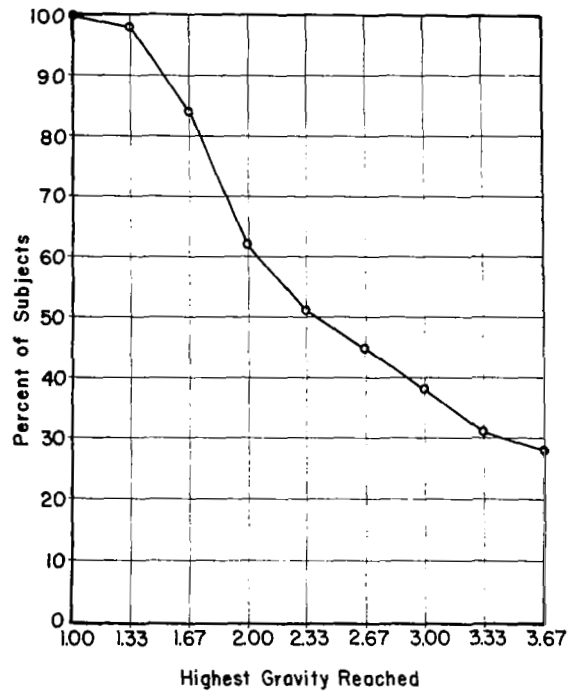

Figure 4, Percentage of 52 Naive Rats which Experienced Each Gravity Region in a Parabolic Track Centrifuge during a 48-hour Test.

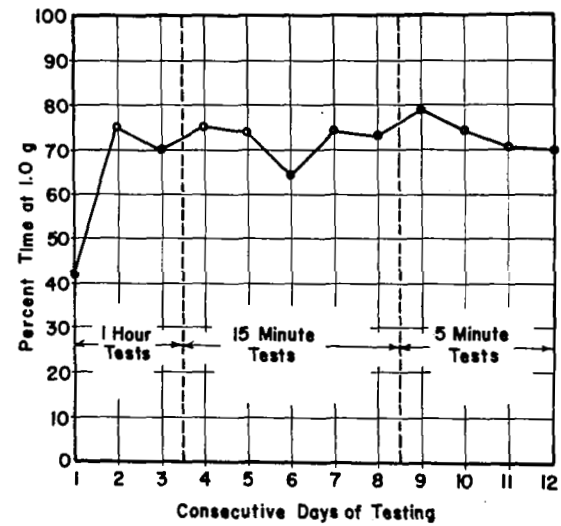

Figure 5. Mean Percentage of Time Spent by 9 Naive Rats at 1.0g in a Spiral Centrifuge for Consecutive Tests of Decreasing Lengths.

Ability to discriminate gravity magnitude.

There is evidence that rats can discriminate angular velocity⁸⁴ and the question arises whether or not they can also discriminate gravity. The gravity field centrifuge does not readily lend itself to measurements of discrimination since gravity exposure is not under the direct control of the investigator; operant techniques are preferred.⁵⁶ Nevertheless, studies with centrifuges having a small gravity range over a standard track length can give an indication to the extent that the subject does or does not respond to the reduced gravity gradient. Figure 6 shows the gravity preference of 12 naive rats during 24 hours in such a spiral centrifuge (36.1 rpm, 1.0g - 1.3g). The peak in the curve at 1.05g is an artifact due to the position-sensing method employed (tracking of radioactive cobalt on the subjects' tails); visual observation confirmed that subjects rested with their heads near the center of rotation, tail outward. About 70% of the time was spent in or near the 1.0g region. That the subjects respond to gravity, and not to other stimuli, is demonstrated by the random preference for position in the spiral centrifuge when rotation (and thus gravity) is withheld; documentation will be presented in Chapter II. Note that the spiral centrifuge is the only type which permits subjects to roam the entire surface (without the necessity for negotiating a steep incline) while rotation is withheld.

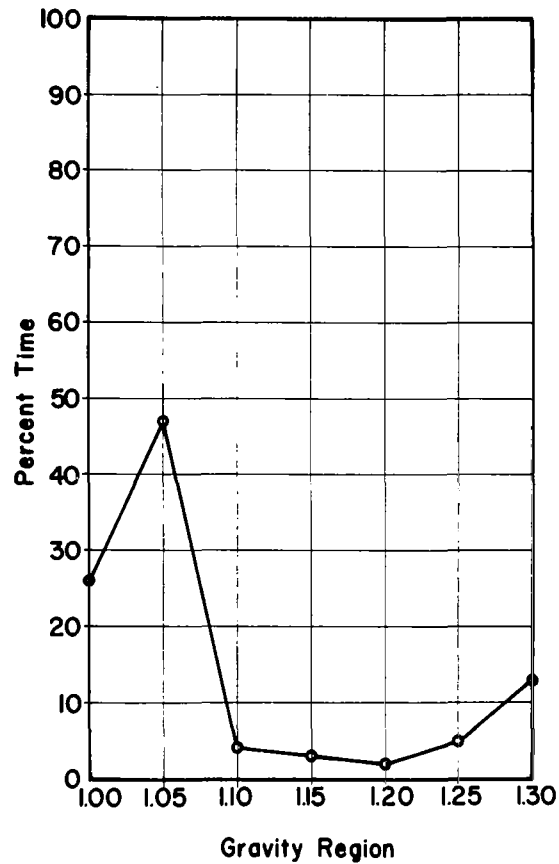

Figure 6. Mean Gravity Preference of 12 Naive Rats during a 24-hour Test in a 1.0g - 1.3g Spiral Centrifuge.

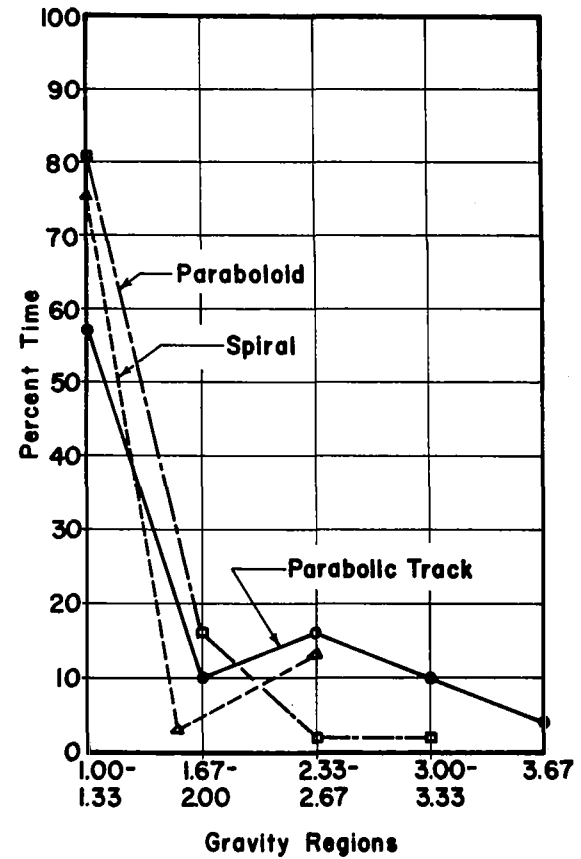

Figure 7. Comparison of Gravity Preference of Rats in Spiral, Paraboloid, and Parabolic Track Centrifuges.

Similarity of preference in different apparatus.

Figure 7 compares the gravity preference of 20 rats in the spiral, 8 in the paraboloid, and 52 in the parabolic track centrifuge; gravity regions have been grouped to minimize the effect of different apparatus size. The paraboloid test represented here was of 24-hour duration while the other two were 48-hour tests. In spite of differences in number of subjects, test duration, apparatus geometry, and angular velocity, similar preference is indicated in the three types of centrifuge.

Response time of trained rats.

As shown previously in figure 5, a high preference for 1.0g is indicated by a trained rat during a five-minute test. In an effort to establish the minimum time necessary for a valid gravity preference indication, 4 rats were tested extensively (63 tests) for both five-minute and 30-second durations in a 1.3g - 2.3g spiral which was equipped with centrifugally-actuated, spring-loaded starting gates at each end of the track; the gates were designed to open as soon as full speed was attained. To guard against the possibility that subjects might inadvertently be trained to run away from the starting gate rather than to a preferred gravity, starting positions were alternated between 1.3 g and 2.3g.

Figure 8 shows the mean position in the gravity field, versus time, for both test durations and starting positions. When released from the 2.3g end, subjects ran quickly to the 1.3g end; when

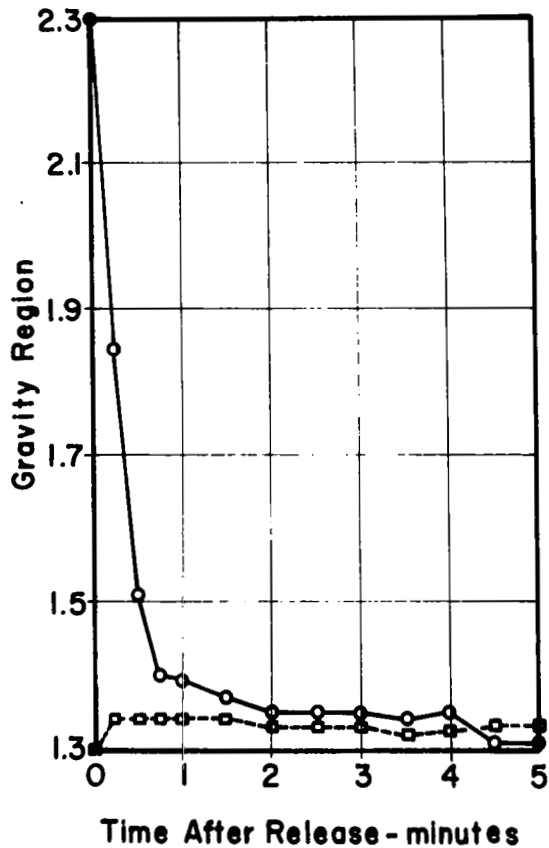

(a) Five Minute Tests.

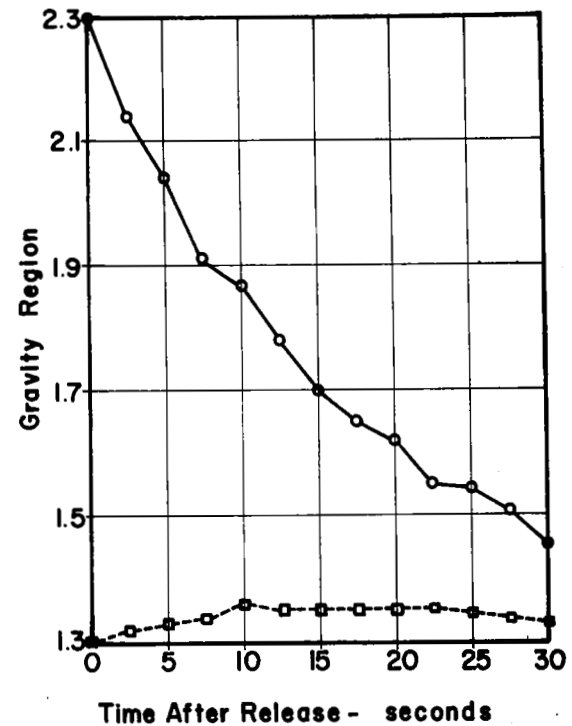

(b) Thirty Second Tests.

Figure 8. Mean Position in the Gravity Field, Versus Time, of 4 Rats during 63 Tests of 5 Minute and 30 Second Duration in a 1.3g - 2.3g Spiral Centrifuge, with Release at both High and Low Gravity.

released at the 1.3g end, little or no change in position occurred, demonstrating that rats do escape high gravity, not merely the starting gate. These tests also indicate that one minute is sufficient for all subjects to reach the low-g region and that 30 seconds is sufficient to indicate the trend of preference in a trained rat; individual subjects frequently reached the low-g end within 10 seconds.

Computer Studies of Motion in a Gravity Field

After establishing these basic trends of behavior, it was desirable to devise a technique for automated testing of rats and other species, to include investigation of 1) patterns of locomotion in a three-dimensional gravity field, particularly as influenced by Coriolis acceleration^{33,70} and 2) changes in those patterns, or symptoms of vestibular disturbance which might arise from reversing the direction of rotation. Accordingly, a new testing system was devised for investigating the motion of a rat within a rotating paraboloid by reducing his successive positions to polar coordinates for computer analysis. From 12 subjects being used in a related investigation, 4 were chosen for a pilot study to evaluate the technique.

Apparatus.

Figure 9 shows the "automated" paraboloid and related equipment. The body of the centrifuge is constructed of layers of expanded polystyrene. The interior was scooped out to form a paraboloid and provided with a black epoxy resin running surface.



Figure 9. Automated Paraboloid and Control System for Detailed Observation of Locomotion Behavior in a Gravity Field.

This centrifuge has a 1/4" thick plexiglass lid which serves to eliminate internal air currents and to permit photography. A solenoid-actuated animal start box at the highest gravity is controlled to permit release of the subject at a preset time after rotation is initiated. A maximum gravity level of 2.0g is created at a radius of 2.51 feet by rotation at 45 rpm. The centrifuge motor is reversible.

Photographic position detection is accomplished by single-frame operation of a special Bolex movie camera, mounted on the floor at eye level for ready servicing; it photographs the rats in the paraboloid through a mirror mounted overhead. Illumination is provided by a 40-Watt, circular fluorescent lamp, shaded and mounted just under the plexiglass lid. A black curtain surrounds the centrifuge to mask out room light.

Control over the sequence of test events is achieved with a system of Foringer clocks, relays, and predetermining counters which receive actuation pulses from the periodic closing of a cam-actuated microswitch on the centrifuge drive assembly. Pushing the start button initiates the following automatic sequence of controlled events:

1. The paraboloid, with rat confined at 2.0g, starts rotating.
2. The subject is released from the start box after a preset number of centrifuge revolutions, as controlled by predetermining counter.
3. Photographic coverage is simultaneously initiated at a preset frame rate, controlled by a second predetermining counter.

An electric frame counter, mounted in the camera's field of view, is actuated as each frame is photographed and serves to identify successive frames during data reduction.

4. After an additional, preset number of revolutions, photographic coverage is automatically stopped by a third predetermining counter; the centrifuge, however, continues to rotate.

5. At a preset time after the start of the test, a timer commands stopping of the centrifuge. Pushing a reset button then causes the frame counter and predetermining counters to recycle their original position, ready for the next test.

Dynamic measurements.

Data reduction is accomplished by projecting successive frames on a polar coordinate screen; the radius and angular displacement of each successive position are then punched onto IBM data cards for analysis on the Laboratory's IBM 1800 digital computer.

Three parameters were calculated; gravity level, running speed along the paraboloid surface, and the magnitude of whole body Coriolis acceleration. Since position was determined at finite intervals, the accuracy of speed and acceleration calculations is limited and therefore approximate expressions for speed and Coriolis acceleration were considered adequate.

Gravity level. The gravity level at each position is determined by vectorially adding centripetal acceleration with earth

gravity. Therefore gravity level, expressed in gs, is given by,

$$n = \frac{\sqrt{g^2 + (r\omega^2)^2}}{g} \quad (1)$$

Surface running speed. The average speed occurring during the time period between each two frames is calculated from the distance traveled (a straight-line approximation) and time elapsed (from the fixed frame rate). As shown in figure 10, the straight-line distance, s , between points 1 and 2 on the paraboloid surface ($Z = Ar^2$) is equivalent to the diagonal of the rectangle subtended by a scalene wedge of angular width, $\Delta\theta$, and height, ΔZ . Therefore:

$$s = \sqrt{(\Delta\vec{r})^2 + (\Delta Z)^2} = \sqrt{(r_1^2 + r_2^2 - 2r_1r_2\cos\Delta\theta) + A^2(r_1^2 - r_2^2)^2} \quad (2)$$

where $\Delta\vec{r}$ refers to a change in the position vector, \vec{r} , not a change in radius. The approximate surface speed is found by dividing this distance by the elapsed time, Δt :

$$V_{\text{surface}} = \frac{s}{\Delta t} = \frac{\sqrt{r_1^2 + r_2^2 - 2r_1r_2\cos|\theta_1 - \theta_2| + A^2|r_1^2 - r_2^2|^2}}{\Delta t} \quad (3)$$

Coriolis acceleration. Whenever any mass moves relative to a rotating system with a component of velocity in the plane of rotation, it is acted upon by Coriolis acceleration which tends to deflect its path in a direction perpendicular to the velocity;^{12,30,34,40,57} Coriolis acceleration is defined as the cross product, $2\vec{\omega} \times \vec{V}_r$, where \vec{V}_r is the vector velocity relative to the rotating system

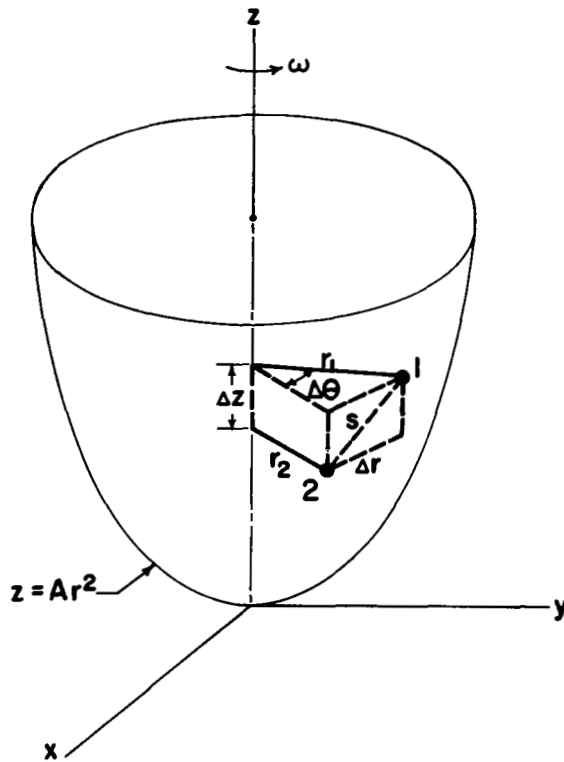

Figure 10. Parameters Describing Locomoting Motion in a Parabolic Gravity Field Centrifuge.

and $\bar{\omega}$ is the vector angular velocity of the rotating system. The magnitude is $2\omega V_r \sin\gamma$ where γ is the angle between the relative velocity and "omega" vectors. In the case of a rat moving along the surface of a paraboloid, the quantity $V_r \sin\gamma$ is simply the component of relative velocity in the plane of rotation:

$$V_{\text{plane}} = \frac{\Delta r}{\Delta t} = \frac{\sqrt{r_1^2 + r_2^2 - 2r_1 r_2 \cos\Delta\theta}}{\Delta t} \quad (4)$$

therefore, the magnitude of Coriolis acceleration is twice the product of the centrifuge angular velocity and the velocity in the plane of rotation,

$$A_{\text{cor}} = \frac{2\omega \sqrt{r_1^2 + r_2^2 - 2r_1 r_2 \cos\Delta\theta}}{\Delta t} \quad (5)$$

Test Procedures.

Four rats were given a 15-minute test in the automated paraboloid every weekday (M-F) for six weeks. A test duration of 15 minutes was estimated to be the minimum required for rapid training; only the first 5 minutes was photographed since most activity of a trained rat occurs within this period. Subjects were placed on food deprivation one week after testing began. Each subject was released from the 2.0g location 13 seconds (10 revolutions) after rotation was initiated, and was photographed at a rate of one frame per revolution.

For the first four weeks, the subjects were rotated in the counter-clockwise direction, establishing a rapid response to 1.0g. During the following two weeks, two of the subjects were exposed to rotation in the opposite, or clockwise direction while for the other two the direction of rotation was unchanged.

Results of the pilot study.

Dynamic analysis. The dynamic parameters accompanying locomotion were calculated for a five-day period of stable behavior just prior to the date in which the direction of rotation was reversed. Figure 11 shows the median position of the 4 subjects in the gravity field for the first 35 seconds of the test. These four subjects consistently reached low gravity within about 20 seconds.

Figure 12 shows the median running speed as a function of gravity level; consideration was given only to data points in each gravity region where motion was present. Speeds up to 8 in/sec were recorded, the median being nearly 5 in/sec. Typically, the highest speeds occurred between 1.2g and 1.4g; subjects slowed considerably as they approached 1.0g. Not surprisingly, running speed above 1.2g decreased with increasing gravity.

Figure 12 also shows the median Coriolis acceleration experienced by the rats while running, plotted versus gravity. At the point of highest speed, the median Coriolis acceleration was 3.5 ft/sec^2 , or slightly over 0.1g. Being a function of running speed,

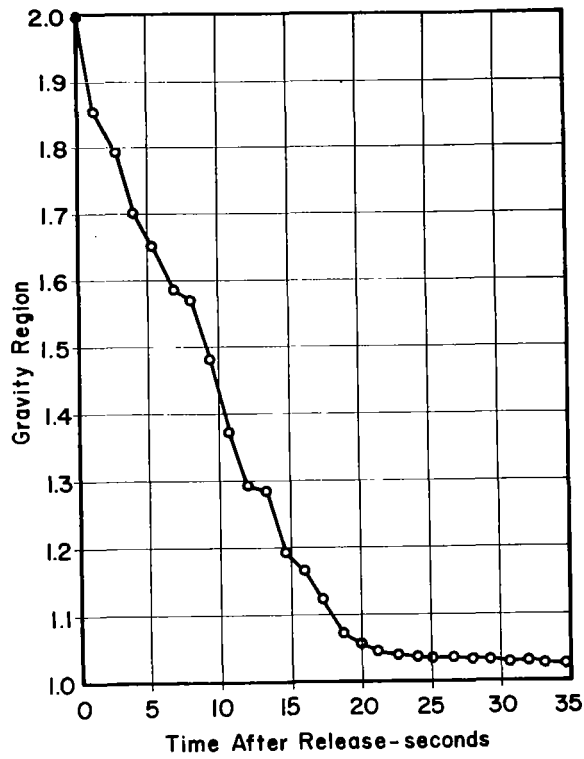
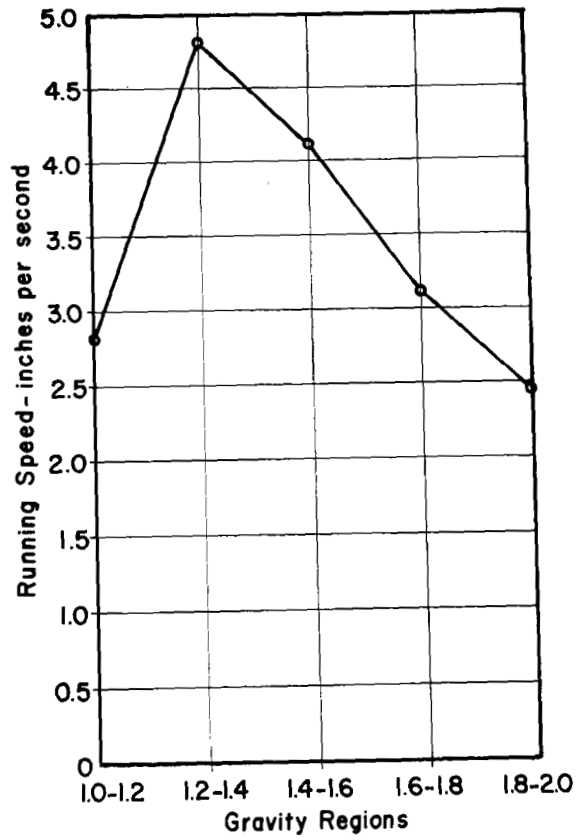
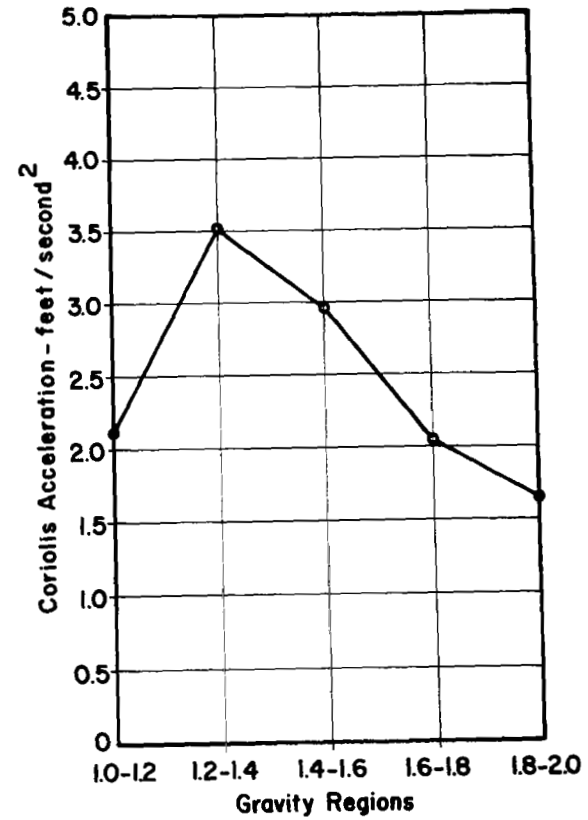

Figure 11. Median Position in the Gravity Field, Versus Time, of 4 Rats during 5 Tests in the Automated Paraboloid.



(a) Running Speed.



(b) Coriolis Acceleration.

Figure 12. Median Running Speed and Coriolis Acceleration, Versus Gravity, of 4 Rats during 5 Tests in the Automated Paraboloid.

the magnitude of Coriolis acceleration above the 0.2g gravity region also decreases with increasing gravity. The ratio of Coriolis acceleration to speed is not constant, however, since a given speed induces proportionately greater Coriolis acceleration near the 1.0g region where velocity is nearly perpendicular to the axis of rotation.

The influence of Coriolis acceleration on the pattern of locomotion is more readily appreciated by first considering the effect on an inanimate object which moves relative to the rotating paraboloid under the influence of aerodynamic and frictional forces alone. To demonstrate the effect, the motion of a golf ball was photographed in the paraboloid after being expelled by a spring from a constraint at 2.0 g. The initial velocity was approximately 10 ft/sec; in a few seconds, this velocity decreases to a value representative of a locomoting rat. Expulsion was triggered by the animal-release solenoid after a constant angular velocity had been attained. The resulting motion, photographed at a rate of 24 frames per second, is shown in figure 13. Since Coriolis acceleration is always perpendicular to the velocity, the ball follows a spiral path and, as shown in figure 13, the path spirals, in this case, in a direction opposite to the direction of paraboloid rotation.

Figure 14 shows three patterns of locomotion representative of rats in the paraboloid. Of the 20 patterns examined (four subjects, five tests each), all resembled one of these three types, although some entailed smoother changes of direction than those shown; in

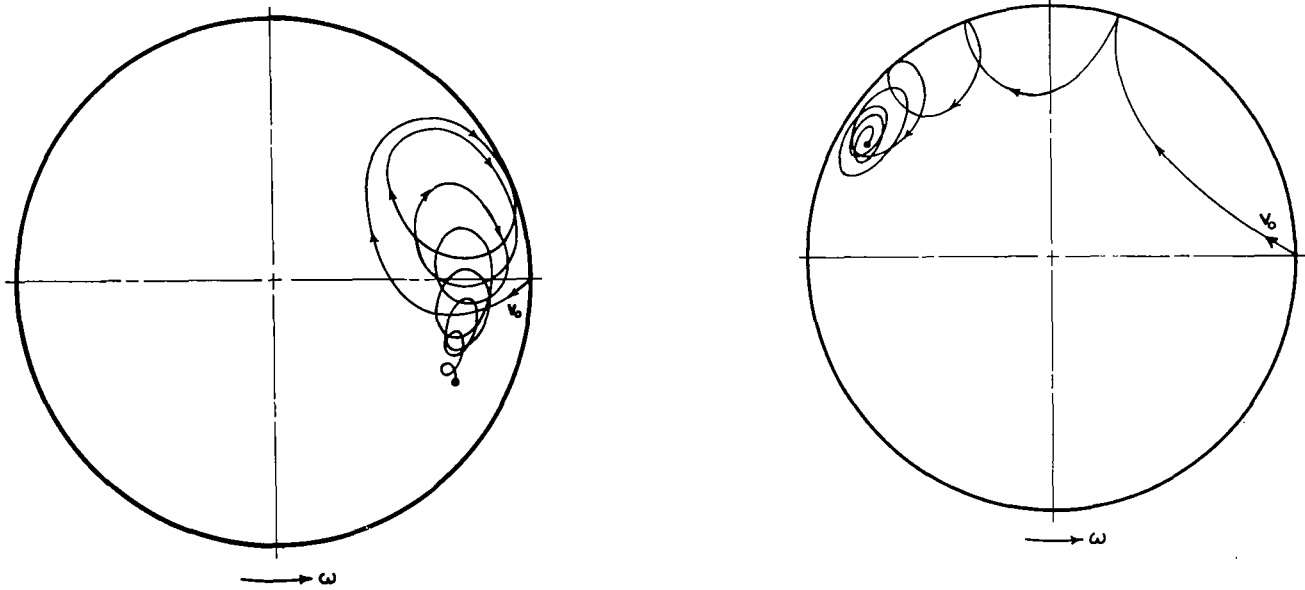

Figure 13. Relative Paths Followed by a Golf Ball when Expelled at 10 ft/sec by a Spring at 2.0g in the Automated Paraboloid (45 rpm).

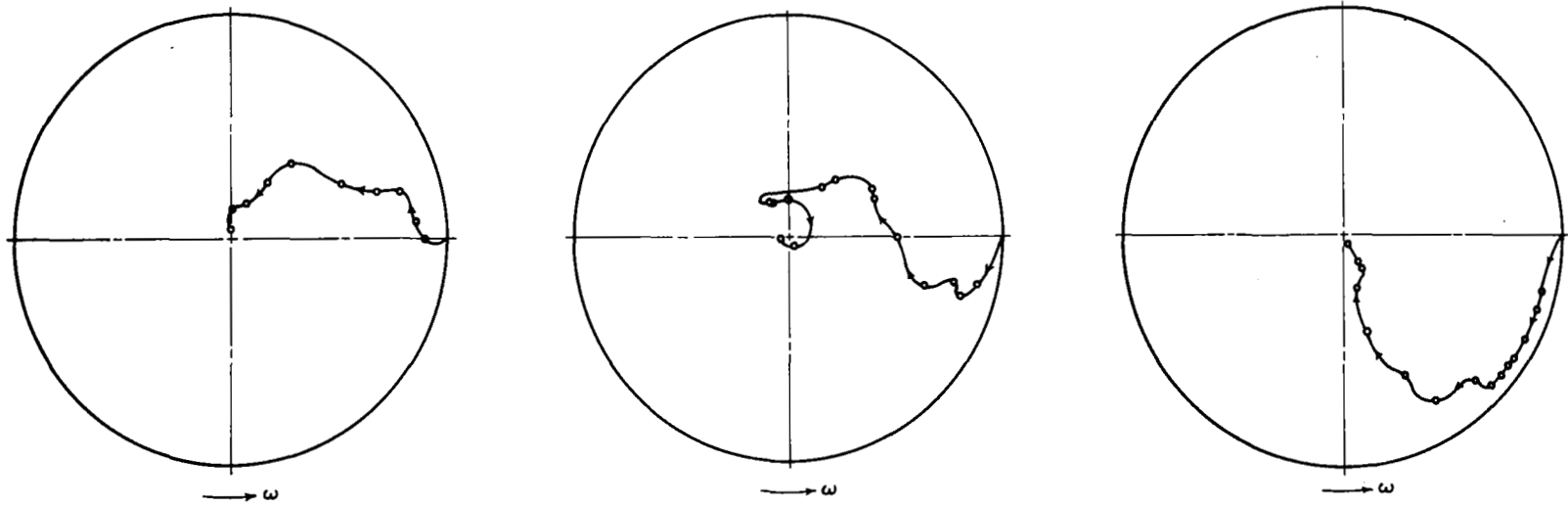

Figure 14. Typical Patterns of Locomotion of Rats in the Automated Paraboloid.

10 instances, the initial motion was in a counterclockwise direction, while in 5 instances it was clockwise and in 5 more it was directly toward the center. The tendency toward spiraling in a clockwise direction under the influence of the 0.1g or less of Coriolis acceleration is evident in about 3/4 of these patterns; apparently, as the rat runs toward the center, he tends to be displaced in the direction of the Coriolis force, and must occasionally correct his direction in order to reach the center by the shortest path.

Effect of reversal of direction. After four weeks of training, the direction of rotation was permanently reversed for 2 of the subjects; Figure 15 shows the response times (time to reach 1.0g) of these two subjects, compared with response times of the two for which direction was not reversed, both before and after the date of reversal. Unexpectedly, the 2 subjects which experienced a reversed direction of rotation immediately ceased to respond to the gravity field and did not respond throughout the remaining two weeks of testing; no significant change occurred in the behavior of the other two subjects.

Since only 4 subjects were tested, statistically meaningful conclusions are not justified. Nevertheless, these results strongly suggest that reversal of the direction of rotation is disturbing to the rat which has been trained in one direction only, a plausible conclusion in view of evidence that the vestibular system adapts

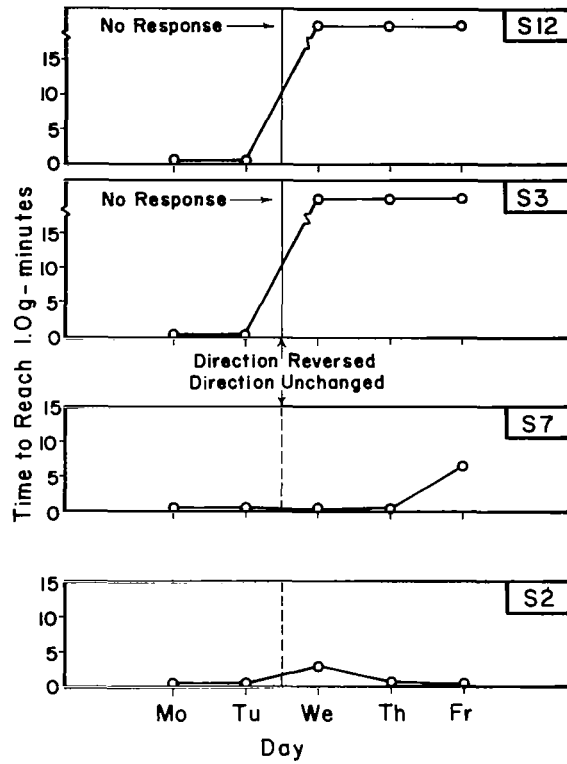

Figure 15. The Effect of Centrifuge Reversal on the Response Time of 2 Rats, Compared with 2 Rats whose Direction of Rotation was Not Reversed.

to rotation in a given direction 17,20,21,67,68 but that the adaptation does not transfer to stimulation in the opposite direction. 18,19,35,63

Conclusions and Recommendations

On the basis of these studies of the behavior of rats in fields of simulated gravity, the following conclusions and recommendations are forwarded:

1. Gravities above 1.0g appear to be aversive to rats; they can discriminate gravity magnitude and, given the opportunity to change it by locomotion in a gravity field, learn to demonstrate a pronounced preference by locomoting to and remaining at 1.0g.

2. In all types of apparatus, experienced rats consistently run from high to low gravity within 30 seconds; pilot tests in the paraboloid suggest that rats typically travel at speeds up to 5 in/sec and experience whole body Coriolis accelerations up to 0.1g, lower values being indicated at the higher gravities.

3. Preference behavior in a gravity field becomes more pronounced and stable with repeated training and varies little between spiral, paraboloid, and parabolic track centrifuges, but there are indications that the rats eventually begin to adapt to the higher gravities unless test frequency is then reduced.

4. The magnitude of simulated gravity appears to be the predominant stimulus in the gravity field centrifuge. Rats will

escape from high gravity to reach lower gravities but will not escape from low gravity when only higher gravities are available; when the gravity gradient is completely absent, a random preference for position is demonstrated.

5. Rats running from high to low gravity in the paraboloid tend to follow a spiral path under the influence of Coriolis acceleration and must intermittently correct their direction to account for it.

6. Reversing the direction of centrifuge rotation appeared, in the pilot study, to extinguish the learned gravity preference response in rats which had been adapted to one direction only, perhaps due to lack of vestibular adaptation in the other direction. Where a reversal of direction is a possibility, training should incorporate alternate exposure to both directions.

7. The rapid, stable, and predictable gravity preference behavior of Male Sprague Dawley rats make them suitable subjects for basic investigations of behavior in a gravity field, and it is recommended that they be considered for more detailed investigations leading to studies of gravity preference below 1.0g using in-space gravity field centrifuges.

CHAPTER II

AN INVESTIGATION OF THE ABILITY OF THE WHITE RAT TO PERFORM A GRAVITY PREFERENCE TASK AFTER EXPOSURE TO SIMULATED ROCKET LAUNCH STRESS

Introduction

The Wenner-Gren Aeronautical Research Laboratory of the University of Kentucky has established that the white laboratory rat can be trained to locomote through a centrifugal gravity field to a preferred level of gravity, and it is planned to utilize this method to obtain guidelines relevant to man's gravity requirements during space flight. This is to be accomplished by observing the gravity preference behavior of experimental animals during orbital flight and requires the establishment of techniques particularly suitable for use in rocket-launched experiments. Such flight techniques are now being evaluated utilizing rats in gravity-field centrifuges which are lofted by Aerobee 150A rockets into sub-orbital trajectories from NASA Wallops Island, Virginia.

One of the major obstacles to successful evaluation of animal experiments in space is the stress imposed by the mechanical, thermal, and acoustic environments of powered rocket flight. These combined

stresses seem to cause short-term functional changes in physiological systems^{2,4,38,47,53} as well as decrements in the performance of behavioral tasks,^{64,65,73} making it difficult to isolate those responses which are due solely to the space experiment.⁵²

Therefore, in preparation for the suborbital studies with the Aerobee, an investigation was conducted into the effect of rocket launch stress on learned gravity preference behavior. This paper reports the results of that investigation; it also describes the apparatus and procedures developed for routinely adapting rats to these stresses prior to flight and suggests improvements in the routine in light of the results of the first flight.

Flight Environments of the Aerobee Gravity Preference Payload

The Aerobee Gravity Preference Payload, shown in figure 16, was designed and constructed by NASA Wallops Station in accordance with criteria established by the Wenner-Gren Aeronautical Research Laboratory. The payload centrifuge was designed to create a field of centrifugal acceleration between 0.35g and 1.60g. Upon reaching a state of free fall at an altitude of 270,000 feet, two 80-inch-long tunnel runways unfold from the payload body to an angle of 15° with the longitudinal axis; the resulting increase in moment of inertia is counted on to reduce the roll rate to the required 45 rpm.

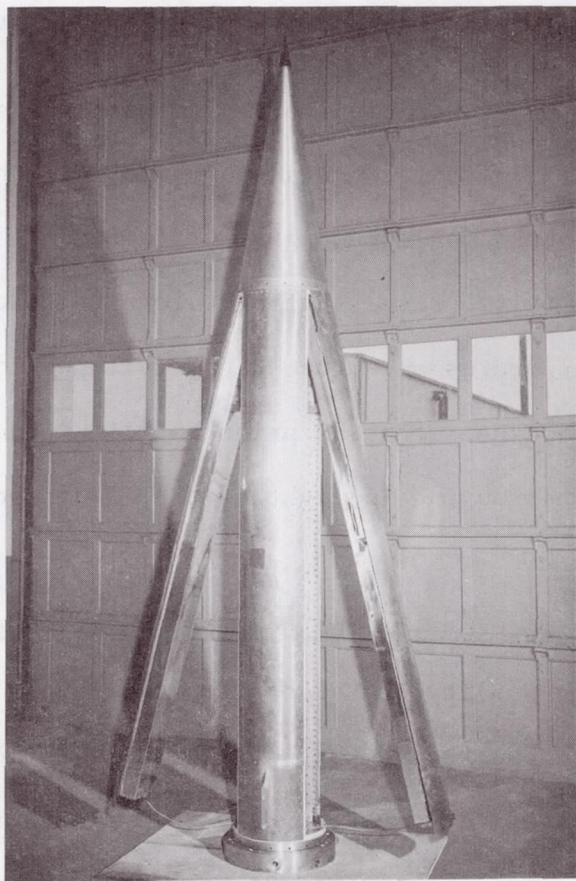

Figure 16. Payload Centrifuge to be Launched by Aerobee Rocket for Investigating Gravity Preference of 2 Rats Between 0.35g and 1.60g during 5 Minutes of Free Fall.

One rat is caged in each runway, one at the 0.35g end and the other at the 1.6g end. When the runways are fully extended, the cages are opened and the rats are free to select magnitude of centrifugally simulated gravity by locomotion along the runway. Position is sensed by a photoelectric detection system and telemetered to the monitoring ground station along with environmental data including track temperature, three-axis acceleration, and roll rate. Approximately five minutes of free-fall weightlessness are available for the experiment.

Since the test period begins only 30 seconds after powered flight, gravity preference demonstrated by locomotion might be affected by exposure to any of the environments which exist from the time the rats are first housed in the rocket until they are released into the runways during flight. Confinement, acceleration, spin (roll rate), noise, and vibration were considered capable of affecting behavior; coning motions, having a period of 70 seconds, were considered negligible.^{44,71}

Confinement.

The rats are caged in the runway for protection against jostling during powered flight. This confinement occurs no later than one hour before launch and a "hold" in launch procedure for an additional three hours may be anticipated.

Confinement is known to be generally stressing to the rat; moreover, it may introduce secondary stresses associated with inadequate heat transfer. During the 1965 NASA Bio-Space Training Program, rats in the payload of Arcas Rockets were closely constrained so as to minimize pickup of interference by the attached electrodes;^{22,62} this restraint, and the resulting inability of the rat to properly dissipate heat, was responsible for a large increase in skin temperature. Restraint for a few hours, then, might be expected to affect locomotion behavior.

Spin: Angular velocity and acceleration.

Although the Aerobee is aerodynamically-fin stabilized, spin is incorporated to reduce the effects of misalignments and to reduce dispersion of the impact point.⁷¹ The anticipated spin profile (time history) is shown in figure 17; it is characterized by a very rapid rate of onset to 120 rpm and an equally rapid decline, followed by a more gradual return to 120 rpm. Angular velocities and angular accelerations of the magnitudes indicated contribute to motion sickness and disorientation and might, therefore, contribute to a rat's inability to perform a gravity task.

Longitudinal acceleration.

The Aerobee 150A is a liquid-fueled rocket with a solid-fueled booster for supplementing thrust during exit from the launch tower. Figure 18 shows a typical longitudinal acceleration profile

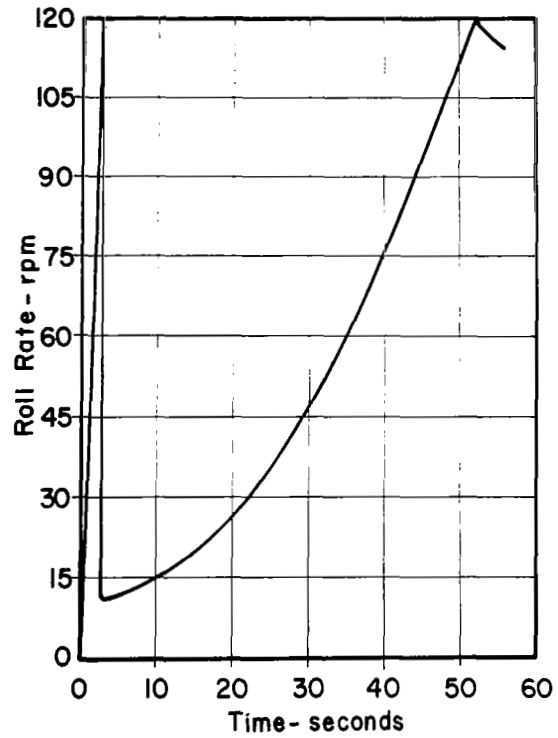

Figure 17. Spin (Roll Rate) Profile of the Aerobee 150A Sounding Rocket.

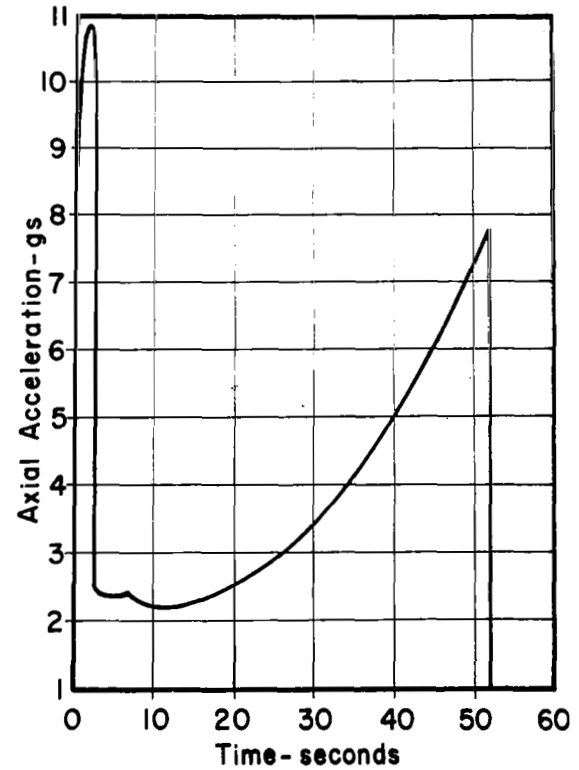

Figure 18. Longitudinal Acceleration Profile of the Aerobee 150A with 200 Pound Payload.

assuming a 200-pound payload.^{61,71} The booster contributes a nearly square wave, 11g pulse of acceleration for 2.5 seconds; this is followed by a gradual buildup to nearly 8 g during the 50 seconds of sustainer thrust.

The biological and behavioral effects of acceleration have been studied for a number of years. Stapp and von Gierke have studied biological response to various mechanical force environments and found not only the magnitude, but the rate of onset and pulse duration to be significant determinants of biological damage; ^{76,81} Herrick found decreases in lever-press response rate of rats during acceleration.⁴³ Such evidence indicates that the stresses of acceleration might affect the performance of a gravity preference task.

Vibration.

The vibration environment of the Gravity Preference Payload is unknown, although launch tower, aerodynamic, and rocket motor vibrations are certainly present. Vibration has been measured during one previous, though unrelated Aerobee flight; an accelerometer attached to the mounting plate of the attitude control system revealed a wide spectrum of frequencies and amplitudes.⁶⁶

A vibration environment can be quite harmful if the natural frequency of any major body organs is applied for a time sufficient for overcoming system damping; ^{23,29,74} even in the general area of the natural frequency, severe discomfort is common. Unrestrained

rats die at 20-25 cps,³ though they can adapt to higher and lower frequencies; ¹⁵ rectal temperature drops ⁵⁹ and plasma steroids rise ^{8,9} during vibration. Vibration is also disrupting to behavior and is known to "drive" the EEG at certain frequencies.¹ Therefore, even though little specific information existed on the amplitudes and frequencies to which rats in the Gravity Preference Payload were to be exposed, some simulation of vibration was considered desirable.

Noise.

Jacobson has estimated the attenuated sound pressure level internal to the Gravity Preference Payload by considering motor noise, aerodynamic noise, and Helmholtz resonator noise from the hole used to ventilate the internal support structure.⁴⁵ The maximum sound pressure level exterior to the payload is estimated to be 157 db and to occur at 37 seconds into the flight; figure 19 shows sound pressure level-versus-frequency distribution estimated to occur internal to the payload at that time. An over-all sound pressure level of 102 db can be expected, with a peak of 123 db at 37.5 cps, the resonant frequency of the vent hole.

High noise levels are known to be stressing to the rat. Geber reports that only 73-93 db causes a reduction of plasma white cells and adrenal ascorbic acid in the white rat,²⁵ and thus, sound pressure levels below the painful can produce physiological stress reactions. Stress induced by high noise levels, therefore, appeared to

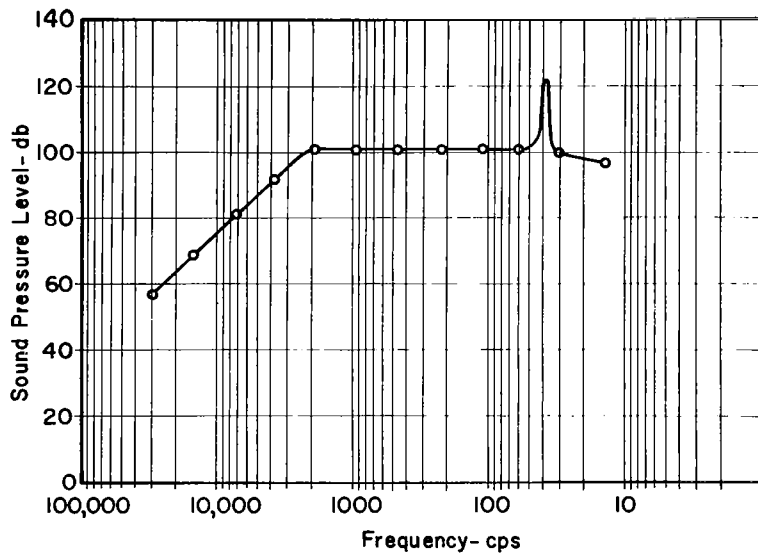

Figure 19. Calculated Spectrum of Noise Intensity Internal to the Aerobee Gravity Preference Payload at 37 Seconds into Flight.

be potentially detrimental to the successful demonstration of gravity preference in the Aerobee investigations.

Simulation of the Launch Environments

The flight stresses which affect subsequent behavior occur simultaneously and the question arose whether or not it is justifiable to simplify a simulation program by successively exposing subjects to individual stresses. The effects of combined stress may be quite different from the total effect of each considered singly; combined stresses may be either additive or antagonistic.⁸³ For example, body heat transfer may be aided by vibration,⁵⁹ and cold may decrease tolerance to acceleration.⁸³

But, even though a simultaneous simulation would be more precise, a complex apparatus would be required to subject a rat to a simultaneous simulation of the spin, vibration, noise, and acceleration profiles of the Aerobee and simplification was almost mandatory for economic reasons alone. Moreover, since the noise and vibration conditions are relatively unknown, an exact simulation is impossible from the outset. Consequently, it was decided to first investigate whether rats could tolerate two of the more well-defined environments, spin and acceleration, without pronounced effects on subsequent gravity preference behavior. Then, if behavior were still acceptable, the other environments would be added, either singly or in combinations, so as to establish a sequence of all environments to which subjects could be routinely subjected and adapted prior to flight.

Following is a description of the techniques and apparatus used in the first phase, that is, the investigation of tolerance to spin and acceleration; the apparatus described consists of:

1) a gravity field centrifuge which geometrically and dynamically resembles the tunnel runways of the Aerobee payload, and 2) a large radius centrifuge and supporting equipment for exposing rats to simulation of the spin and acceleration profiles.

Gravity-field centrifuge.

The parabolic-track centrifuge then in routine use was modified by replacing the "floor" of the runways with one-eighth-inch diameter aluminum rods spaced one-half inch on center, as in the Aerobee payload, and the position of the rat in the track was recorded through an overhead mirror by single-frame operation of a special Bolex movie camera.

Another modification was to simulate the slope of the payload runway. Unlike the parabolic centrifuge where the resultant acceleration vector is normal to the runway surface at every point, the Aerobee runway must be slanted in order to produce the gravity field (see figure 16). Consequently, the rat must negotiate an "uphill" slope in order to reduce the level of simulated gravity. A 9.6° slope was envisioned at the time and so the surface configuration of the parabolic centrifuge was redesigned to be 9.6° "off" of a true parabola.

In a parabolic centrifuge, the resultant acceleration vector, "a", lies along the normal to the surface curve, displaced from the earth's gravity vector, "g", by some angle, β (see figure 20). But if the surface is to be sloped by some angle, θ , then the angular displacement between the "a" and "g" vectors must be increased to the angle, $\beta + \theta$. In this configuration, the angle β is given by:

$$\beta = \left(\arctan \frac{r\omega^2}{g} \right) - \theta \quad (6)$$

The slope of the desired curve is the negative reciprocal of the slope of the normal and is given by:

$$\frac{dy}{dr} = \frac{-1}{-\tan(90^\circ - \beta)} = \frac{1}{\tan[90^\circ - (\arctan \frac{r\omega^2}{g} - \theta)]} \quad (7)$$

The equation of the desired curve is then found by integrating y with respect to r, that is:

$$y = \int_0^r \frac{dr}{\tan [90^\circ - (\arctan \frac{r\omega^2}{g} - \theta)]} \quad (8)$$

This equation may be rendered integrable by substitution of the three trigonometric identities, $\tan (90^\circ - \alpha) = \cot\alpha$, $1/\cot\alpha = \tan\alpha$, and $\tan (\alpha - \gamma) = (\tan\alpha \tan \gamma) / (1 + \tan\alpha \tan\gamma)$, to yield:

$$y = \int_0^r \frac{r\omega^2 - g \tan \theta}{g + r\omega^2 \tan\theta} dr \quad (9)$$

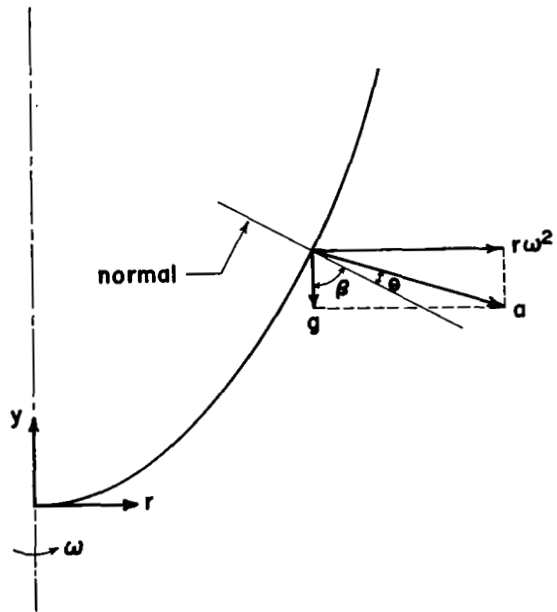

Figure 20. Parameters Describing a Gravity Preference Centrifuge Profile where Slope is Modified from that of a True Parabola.

Since θ is a constant, then $\tan\theta$ is also constant ($\tan\theta = K$), and equation (9) may be resolved into two integrals:

$$y = \int_0^r \frac{r\omega^2 dr}{g + Kr\omega^2} - \int_0^r \frac{Kg dr}{g + Kr\omega^2} \quad (10)$$

The first expression may be integrated directly from tables; the second may be written in the form $\int \frac{du}{u}$ and may then be integrated by elementary methods. The resulting expression is:

$$y = \frac{r}{K} - \frac{g}{K^2\omega^2} \ln (Kr\omega^2 + g) - \frac{g}{\omega^2} \ln (Kr\omega^2 + g) + C =$$

$$\frac{r}{K} - \frac{g}{\omega^2} \left[\frac{1}{K^2} + 1 \right] \ln (Kr\omega^2 + g) + C \quad (11)$$

The constant of integration, C, is found by substituting the condition that $r = 0$ when $y = 0$, and this yields the equation in final form:

$$y = \frac{r}{K} - \frac{g}{\omega^2} \left[\frac{1}{K^2} + 1 \right] \ln \left[\frac{Kr\omega^2 + g}{g} \right] \quad (12)$$

Substituting the desired slope of $\theta = 9.6^\circ$, and limiting the gravity field of the centrifuge to a maximum of $2g$, yields the family of curves shown in figure 21, one curve for each of five different angular velocities.

The configuration with a six-foot radius was chosen in order that the track length be comparable with the anticipated length of the payload runway; figure 22 shows the modified parabolic centrifuge used in the laboratory. One track is constructed according to equation (12) and the other is a true parabola; both create a

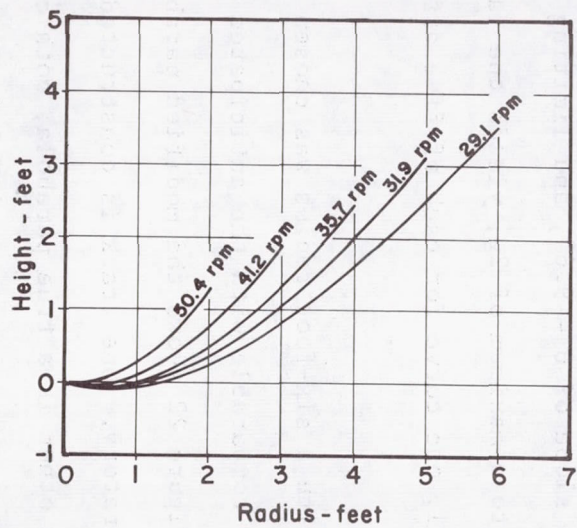

Figure 21. Track Profiles for Gravity Preference Centrifuges which Incorporate a 9.6° Slope.

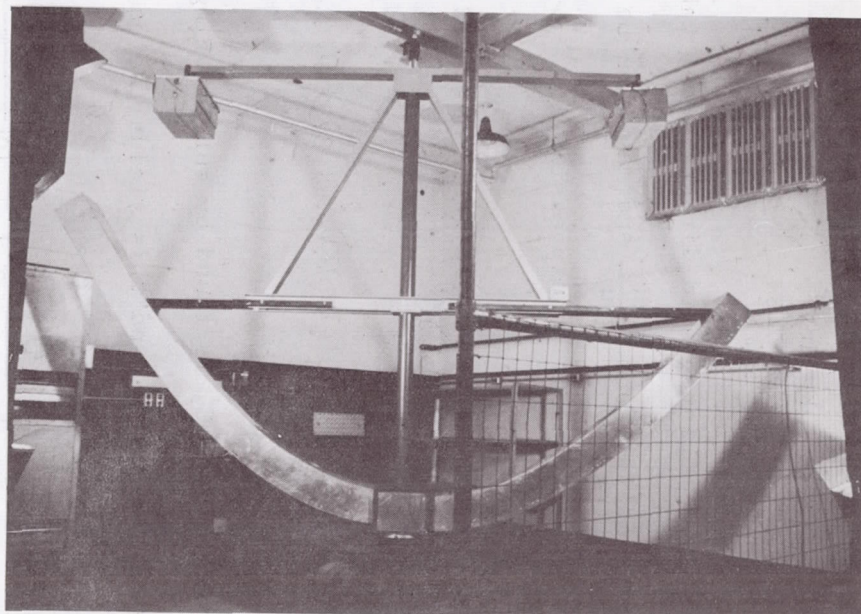

Figure 22. Gravity Preference Centrifuge with One Track of True Parabola Configuration and One Track whose Slope is Modified by 9.6° .

maximum of 2 g at a radius of 6 feet by rotation at 29.1 rpm.

Simulator for launch acceleration and spin.

The purpose of the launch acceleration simulator is to expose rats to the profile of acceleration of an Aerobee flight, preferably without introducing extraneous environments. Accordingly, the following design constraints were reached:

1. A unidirectional, one-minute application of the specified acceleration profile would require a prohibitive amount of space and would terminate in an undesirably high velocity; therefore, centrifugation was considered the only practical technique.

2. The only important angular velocity characteristic of the Aerobee, from a behavioral standpoint, is the roll rate, which is about an axis coincident with the longitudinal acceleration vector. On the other hand, the angular velocity of a simulation centrifuge would be about an axis which is nearly perpendicular to the resulting acceleration, that is, to the vector sum of earth gravity and centrifugal acceleration. To reduce this artifact, the angular velocity of the centrifuge should be minimized, that is, the centrifuge radius should be as large as practical and any simulated roll rate should be about the axis of resultant acceleration.

3. It is impossible to accurately simulate the square wave, boost acceleration of the Aerobee on a large radius centrifuge without an abundance of finely controlled power. Therefore, simple power and control systems were acceptable so long as they could supply a very rapid rate of onset of acceleration.

Boost acceleration simulation. The approach to design of a boost simulation system was to establish the required torque profile, compare that with the capabilities of several simple systems, and then choose the most satisfactory compromise. Figure 23 illustrates the configuration of the simulation centrifuge and the parameters used to derive an equation for the required torque profile; the rat is placed at the end of the centrifuge arm and is exposed to acceleration as a result of the combination of gravitational, centrifugal, and tangential forces.

At any instant, the torque applied to the centrifuge is equal to the sum of the inertial torque and the torque resisting motion, the latter due principally to aerodynamic drag, that is:

$$T_{\text{applied}} = I \frac{d\omega}{dt} + T_{\text{drag}} \quad (13)$$

where T is torque, I is the centrifuge moment of inertia, and $\frac{d\omega}{dt}$ is the instantaneous angular acceleration required to produce the desired simulation of longitudinal acceleration. Determination of the torque-time profile then requires that expressions be developed for both aerodynamic drag torque and angular acceleration.

The aerodynamic drag torque may be simply expressed as the product of the total drag force, F_{drag} , and the effective radius at which it acts; refer again to figure 23. The total drag force is found by integrating the differential drag force over the total arm length, R , yielding:

$$F_{\text{drag}} = \int_0^R d(F_{\text{drag}}) = \int_0^R C_D (1/2\rho V^2) dA \quad (14)$$

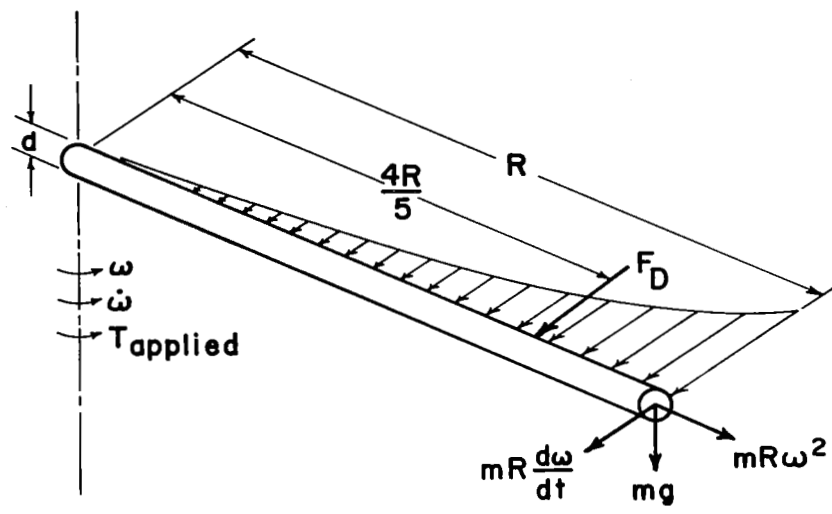

Figure 23. Acceleration Components and Drag Force Distribution Resulting from Angular Velocity and Angular Acceleration of a Cylindrical Centrifuge Arm.

where C_D is the drag coefficient, ρ is the air density, V is the tangential velocity, and A is the cross-sectional area of the arm.

The drag coefficient, being dependent upon the Reynolds number (N_R), is a function both of centrifuge angular velocity, ω , and distance along the arm, r , that is:

$$N_R = \frac{\rho dV}{\mu} = \frac{\rho dr\omega}{\mu} \quad (15)$$

where d is the thickness of the arm and μ is the viscosity of the surrounding air. Assuming a maximum radius of 15 feet, a 0.5-foot arm height, a maximum angular velocity of 4 radians/second, and values of $\rho = 0.002377$ slugs/foot³ and $\mu = 3.737 \times 10^{-7}$ pound seconds/foot², the maximum Reynolds number would be:

$$N_{R,max} = \frac{(0.002377)(0.5)(15)(4)}{(3.737 \times 10^{-7})} = 1.9 \times 10^5 \quad (16)$$

For Reynolds numbers between this value and 100, the drag coefficient⁷⁹ of a cylindrical arm varies between 0.9 and 1.4 and for purposes of this approximate analysis is taken to be a constant equal to 1.0. This permits simplification of equation (14), which now becomes:

$$F_{drag} = 1/2\rho C_D \int_0^R V^2 dA \quad (17)$$

Substituting the values of ρ and C_D given above, and the relations $V = r\omega$ and $dA = (d)(dr)$ gives:

$$F_{drag} = 0.00032\omega^2 r^3 d \quad (18)$$

Since this distribution is cubic with respect to r, the total drag force, F_{drag} , acting at any speed, ω , may be taken to act at a radius of $4R/5$ and, therefore, the aerodynamic drag torque is:

$$T_{\text{drag}} = \frac{4RF_{\text{drag}}}{5} = .0.00026\omega^2 R^4 d \quad (19)$$

Having an expression for drag torque, an expression for $\frac{d\omega}{dt}$ is required in order to evaluate equation (13) for applied torque. As shown in figure 23, the resultant acceleration, a, which acts upon the rat is the vector sum of the centripetal, $r\omega^2$, the tangential, $r \frac{d\omega}{dt}$, and the gravitational acceleration, "g"; the angular acceleration, $\frac{d\omega}{dt}$, may be solved for from this vector sum, assuming that an expression for "a" may be written. It is desired that "a" be approximately equal to the time-varying, Aerobee boost acceleration as shown in figure 18, and considerable mathematical simplification may be achieved by approximating this profile by a linear increase from 9.3g to 10.4g over a 2.5 second period. Setting this equal to the vector sum of the components yields:

$$a = \sqrt{r^2\omega^4 + r^2(d\omega/dt)^2 + g^2} = (9.3 + .44t)(32.2) \quad (20)$$

and solving for $\frac{d\omega}{dt}$ yields:

$$\frac{d\omega}{dt} = \sqrt{5.45[(9.3 + .44t)^2 - 1] - \omega^4} \quad (21)$$

The torque-time profile which must be applied to the centrifuge for boost acceleration simulation is found by substituting

equations (19) and (21) into equation (13), which yields:

$$T_{\text{applied}} = 0.000263\omega^2 R^4 t + I\sqrt{5.45[(9.3 + .44t)^2 - 1]} - \omega^4 \quad (22)$$

This equation was solved on the University of Kentucky's IBM 7090 digital computer for various moments of inertia, using the PACTOLUS digital-analog simulation technique and assuming a centrifuge radius of 13.8 feet; the resulting family of torque profiles, shown in figure 24, will produce resultant acceleration profiles which increase linearly from 9.3g to 10.4g in 2.5 seconds. Note that a high initial torque is required since nearly all of the resultant acceleration at time zero is in the tangential component. After 0.3 seconds, however, very little torque is required since the centripetal component is of sufficient magnitude to supply nearly all of the required acceleration.

Several simple systems were examined for their ability to produce this type of torque profile. The system chosen utilizes a stretched rubber shock cord to apply a tangential force to a drum concentric with the centrifuge axis; figure 25 is a schematic diagram of this type power system. The shock cord, with spring constant, K , is stretched so as to pull with an initial tension, F_0 . The equation for torque applied as a function of drum displacement, θ , is:

$$T = 2(F_0 - Kx) r \cos\theta = 2(F_0 - Kr \sin\theta)r \cos\theta \quad (23)$$

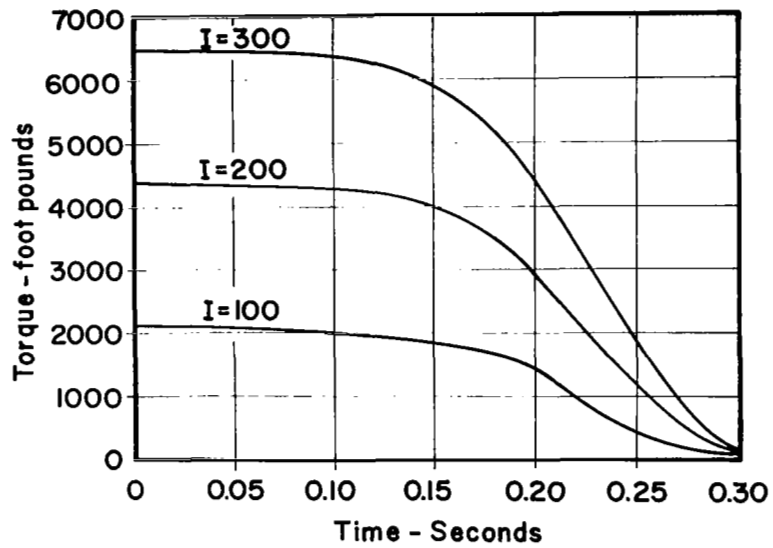

Figure 24. Torque Profiles Required to Simulate the Aerobee Boost Acceleration Profile on a Centrifuge of 13.8 Foot Radius for Various Moments of Inertia (ft lb sec²).

The value of F_0 is determined by the required tangential acceleration (i.e., at time zero) and equals $300I/2rR$ for 9.3g acceleration substituting, with values of $R = 13.8$ feet, $r = 1$ foot, and $I = 300 \text{ ft lb sec}^2$ yields:

$$T = 2[3260(1 - \sin\theta) + F_{\min} \sin\theta] \cos\theta \quad (24)$$

where $F_{\min} = F_0 - Kr$. This equation yields a family of torque-angular displacement curves for various spring constant, K . If damping is neglected, the dynamic response of the system (i.e., versus time) is found by numerical integration according to the following outline:

1. Given that momentum is the time integral of work, then $\omega = 1/I \int T d\theta$. Substituting T as a function of θ from equation (24) yields $\omega = f(\theta)$.

2. Given that displacement is the time integral of velocity, then $t = \int \frac{d\theta}{\omega}$. Substituting $\omega = f(\theta)$ from step (1) yields $t = f(\theta)$.

3. Then by inverting, that is by relating θ to $1/\omega$, θ can be found as a function of time.

4. Knowing $T = f(\theta)$ from equation (24) and $\theta = f(t)$ from step (3) permits a matching of torque to time at each value of θ , yielding $T = f(t)$.

If the centrifuge is wound up against the shock cord (which has an initial tension of F_0) through some angle greater than 90° ,

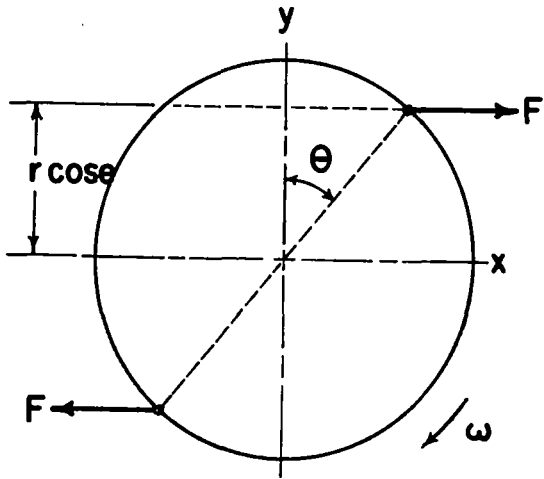

Figure 25. Configuration of Shock Cord System for Applying Torque to a Centrifuge for Boost Acceleration Simulation.

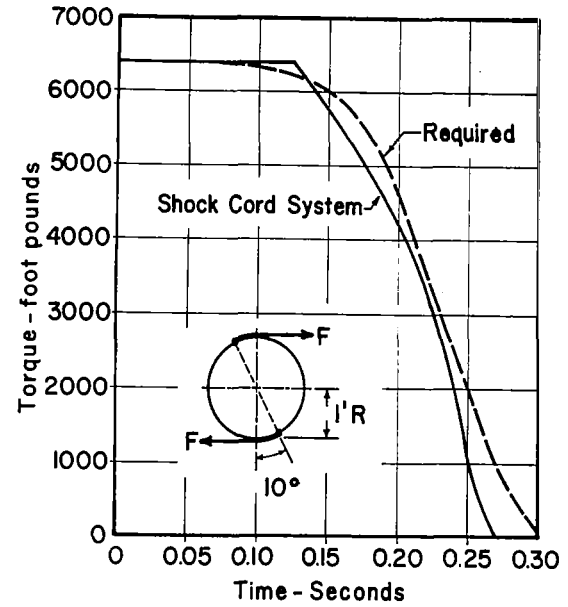

Figure 26. Torque Profile Attainable from a Centrifuge with an Undamped Shock Cord Power System, Compared with the Profile Required for Boost Acceleration Simulation.

the first part of the torque-time curve is flattened, but drops off rapidly after a " θ " of 90° is reached; this is because at angles greater than 90° , the pulling radius is constant, resulting in a nearly constant torque. By rotating an additional 10° before release, an acceptable profile is theoretically obtainable. Figure 26 compares the required torque profile with that attainable from an undamped shock cord system ($K = 100 \text{ lb/ft}$) operating on a centrifuge of radius 13.8 feet and moment of inertia of 300 ft lb sec^2 .

Figure 27 shows the centrifuge which utilizes the shock cord system for boost simulation. The moment of inertia was reduced considerably below the anticipated value by using a 6-inch diameter aluminum tube for the centrifuge arm; consequently, the required torque is less than anticipated. A 34-foot length of 1/2-inch rubber shock cord is doubled and stretched with block and tackle to an initial tension of 400 pounds; the arm is then "walked around" about three-quarters of a turn to store the additional energy necessary for initial acceleration, and released. After three-quarters of a turn of powered motion, the centrifuge is braked by rewinding against the stretched shock cord; the centrifuge is allowed to reverse and move through one additional cycle so as to dissipate sufficient energy to permit stopping by hand.

Sustainer acceleration and spin. Figure 27 does not show the electric motor drive which subsequently powers the sustainer acceleration simulation; a 1/2 horsepower motor and v-belt drive is used.



Figure 27. Centrifuge for Simulating the Boost and Sustainer Acceleration and Spin Profile of the Aerobee 150A.

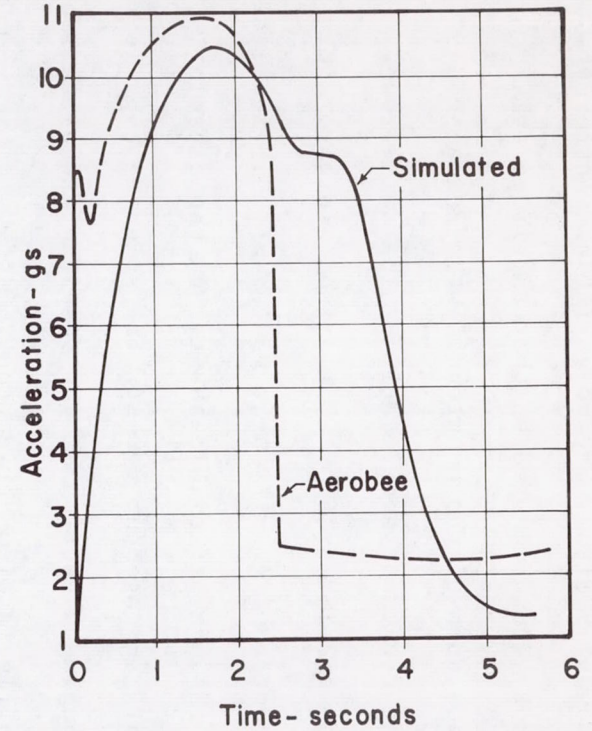

Figure 28. Simulated Boost Acceleration Profile Achieved Compared with the Profile of an Aerobee 150A with 200 Pound Payload.

Speed is controlled manually with a Variac variable transformer. A 1/15 horsepower motor, shown mounted on the centrifuge arm, simultaneously provides spin of the counterweighted animal capsule about the axis of resultant acceleration. The animal capsule is fashioned from a 3-1/2" x 6" x 8" aluminum Minibox, and is mounted with its center of gravity at a radius of 13.8 feet. Power is transmitted through a flexible shaft, and the capsule is gimble mounted; this arrangement permits the spinning capsule to align with the changing direction of the resultant acceleration vector. The spin profile is also Variac controlled.

Performance of the acceleration and spin simulation apparatus.

Figure 28 shows the simulated boost acceleration profile compared with that of the Aerobee with a 200-pound payload. Acceleration was measured with a CEC model 4-202-0001 unbonded strain gage accelerometer mounted on the bottom of the gimble animal capsule, and recorded on a Sanborn 350 strip chart recorder. Since only 1-1/2 turns of the centrifuge was necessary, the transmission cable was allowed to twist, eliminating the necessity for slip rings. The curve shown is the mean resultant acceleration for three tests. Shock cord damping is probably responsible for the fact that acceleration starts at 1.0g rather than 8g.

Figure 29 shows the simulated sustainer acceleration profile, compared with the Aerobee profile with 200-pound payload. In the absence of slip rings, the sustainer acceleration was calculated

from measurements of angular velocity. A cam-operated micro-switch closes once during each centrifuge revolution, producing a timing mark on the Sanborn strip chart from which the average angular velocity for that revolution is calculated. From this, centripetal acceleration is calculated for each revolution and, neglecting tangential acceleration, is vectorially added to earth gravity to obtain the resultant acceleration. The curve shown is the mean of six tests.

Figure 30 shows the simulated spin profile compared with that of the Aerobee. Spin rate was measured in the same manner as centrifuge angular velocity except that the reference timing marks are produced by voltage fluctuations from a continuous rotation potentiometer driven by the spinning capsule.

It is felt that the achieved simulations of sustainer acceleration and spin are satisfactory since both magnitude and rate of onset are comparable with the corresponding Aerobee characteristic. The simulated boost profile is quite inaccurate only during the first several milliseconds in that a step function was not achieved.

Effect of Launch Simulation on Preference Behavior

Six naive rats were routinely trained in the preference centrifuge in preparation for evaluation of tolerance to the simulated launch environment; each subject was released at 2.0g and tested for ten minutes. After 21 training sessions, a stable pattern of preference behavior was achieved; five of the six subjects

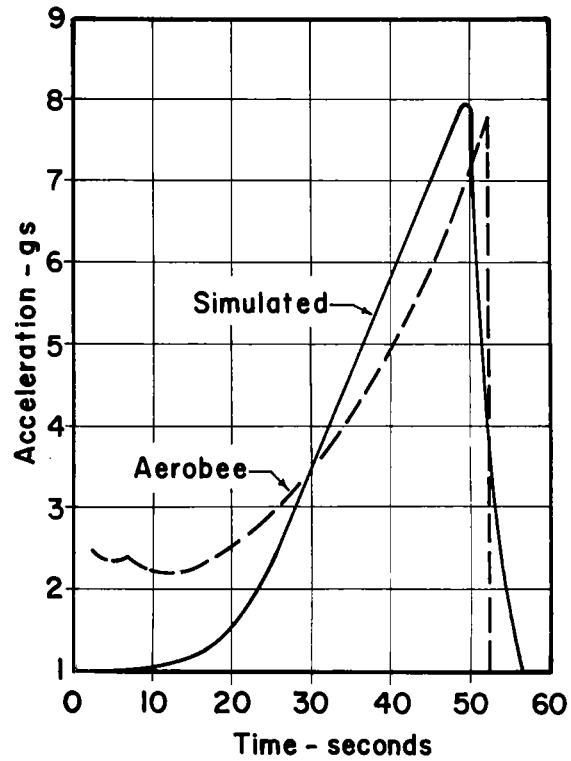

Figure 29. Simulated Sustainer Acceleration Profile Achieved Compared with the Profile of an Aerobee 150A with 200 Pound Payload.

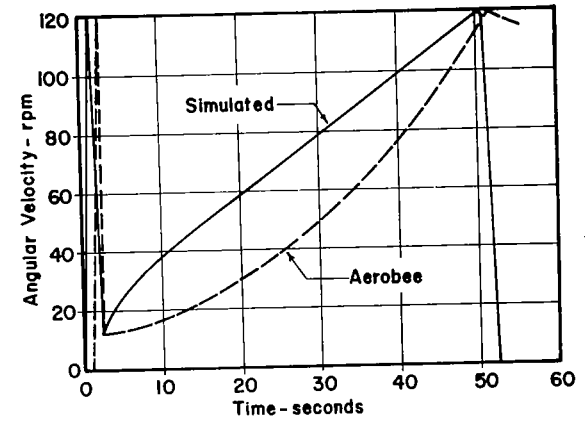

Figure 30. Simulated Spin Profile Achieved Compared with the Profile of an Aerobee 150A.

reached 1.0g within 15 seconds, while one spent a large proportion of each test at 2.0g. The five subjects with rapid response also demonstrated normal exploratory behavior after reaching 1.0g, that is, short trips away from the 1.0g region occurred two or three times in each test.

The effect of each environment was evaluated by first exposing a subject to that environment, and then immediately transporting him to the gravity field centrifuge for a routine preference test. Behavior of the subject while in transport from the simulation was examined for any unusual symptoms such as excitement, rapid breathing, excessive urination and defecation, or disorientation; also, gravity preference behavior was compared with that demonstrated in the 21 training tests with respect to both response time and exploratory behavior. If no unusual behavior was demonstrated during transport, and response time and exploration were normal during the preference test, then the environment was considered to have no significant effect on gravity preference behavior.

Effect of simulated boost acceleration.

Figure 31 shows the mean percentage of time spent at 1.0g and 2.0g by the six rats as a function of time into the preference test, both after exposure to simulated boost acceleration and during prior training; the one subject which spent considerable time at 2.0g accounts for the fact that a mean of only 80% of each minute was

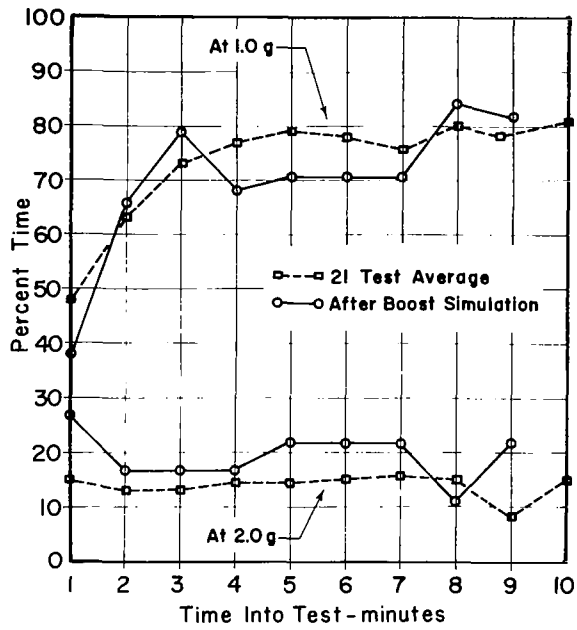

Figure 31. Mean Preference of 6 Rats for 1.0g and 2.0g as a Function of Time into Test Before and After Boost Acceleration Simulation.

spent at 1.0g. No unusual symptoms were observed during transport of any subject from the environmental simulation; exploratory behavior of each was normal during preference testing and response time was not significantly changed. Following boost evaluation, routine preference training was resumed so as to maintain stable behavior until evaluation of tolerance to spin was initiated.

Effect of simulated spin.

Before the rats were exposed to a simultaneous simulation of spin and acceleration on the boost simulator centrifuge, the effect of spin alone was evaluated. This separate spin simulation was accomplished by rotating the capsule through the spin profile about a vertical axis, using the Variac speed control technique previously described.

Preference behavior was identical to that observed after exposure to simulated boost except that all six subjects reached 1.0g within 15 seconds; again, no unusual symptoms were observed during transport. After evaluation of the effect of spin, subjects resumed routine preference training for one week to maintain behavior until evaluation of tolerance to sustainer acceleration was initiated.

Effect of simulated sustainer acceleration.

Preference behavior after exposure to simulated sustainer acceleration remained unchanged except that the one subject who acquired a rapid response after spin simulation returned to his

previous pattern of behavior, spending considerable time at 2.0 g. Normal exploratory behavior was demonstrated by all subjects during preference training and no unusual symptoms were observed during transport. After evaluation of sustainer acceleration, subjects resumed preference training for two weeks until evaluation of simultaneous spin and acceleration was initiated.

Effect of simultaneous simulation
of spin and sustainer acceleration.

Again, normal preference and exploratory behavior were observed after simulation and no unusual symptoms were recognized during transport. It is concluded that rats are able to tolerate exposure to the simulated spin and acceleration profiles of the Aerobee 150A, either singly or in combination, without adverse effects on locomotion-demonstrated gravity preference behavior.

Training Procedures for Suborbital Flight

Having established the capacity of the trained rat to maintain learned gravity behavior after undergoing two of the environments characteristic of an Aerobee launch, it remained to establish techniques for routinely preparing subjects for the many environments anticipated on the actual rocket-launched experiment. It was decided that training sessions should entail sequential exposure to: 1) confinement, 2) boost and sustainer acceleration, and 3) simultaneous spin, noise, and vibration, followed by 4) a gravity

preference test. This section describes the apparatus and procedures developed, and the results of the training program.

Apparatus.

Confinement. Twenty aluminum capsules, such as the one shown in figure 32, were fashioned to simulate the caging system of the Aerobee runway, shown in figure 33. The rat is confined in a portion of the simulation capsule measuring 2-3/4" x 6-1/4" x 3" by an aluminum rod gate. Each two of the capsules are attached to a mounting plate which is modified for rapid attachment to both the acceleration simulation centrifuge and spin-noise-vibration apparatus, permitting exposure of the rats to all environments without removal from the confinement capsule. One capsule of the set is inverted relative to the other so that the rats may become accustomed to sitting either on the rod gate or the opposite floor, just as they would in the payload depending upon whether they were released at high or low gravity.

Early experience showed that the internal temperature and humidity of the capsule rose significantly during confinement. To investigate means of improving this, one capsule was modified by drilling six small ventilation holes in each side to permit cooling externally with an electric fan. Temperature was measured in both a modified and an unmodified capsule with a mercury thermometer inserted through a rubber grommet into the empty space opposite the rat; as shown in figure 34, the temperature rise in

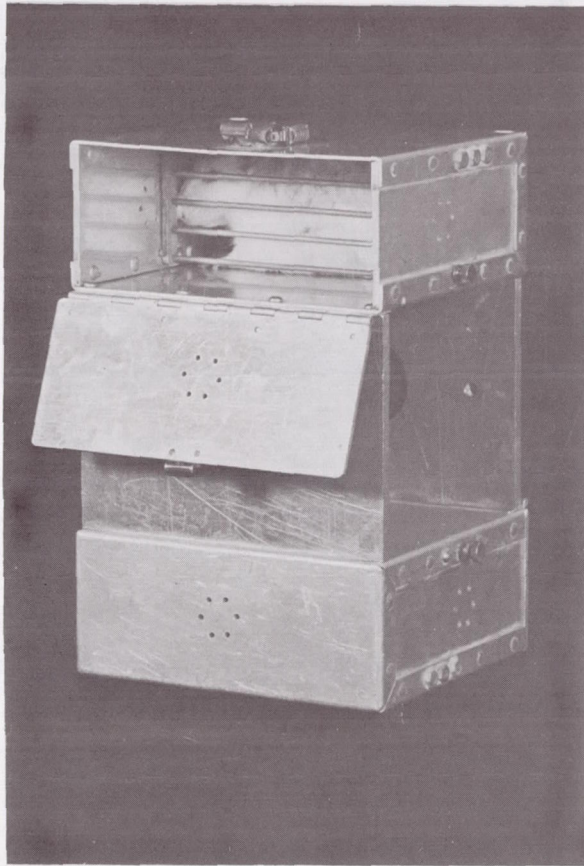

Figure 32. Set of Confinement Capsules used to Prepare Rats for a 4 Hour Hold in Launch Procedure.

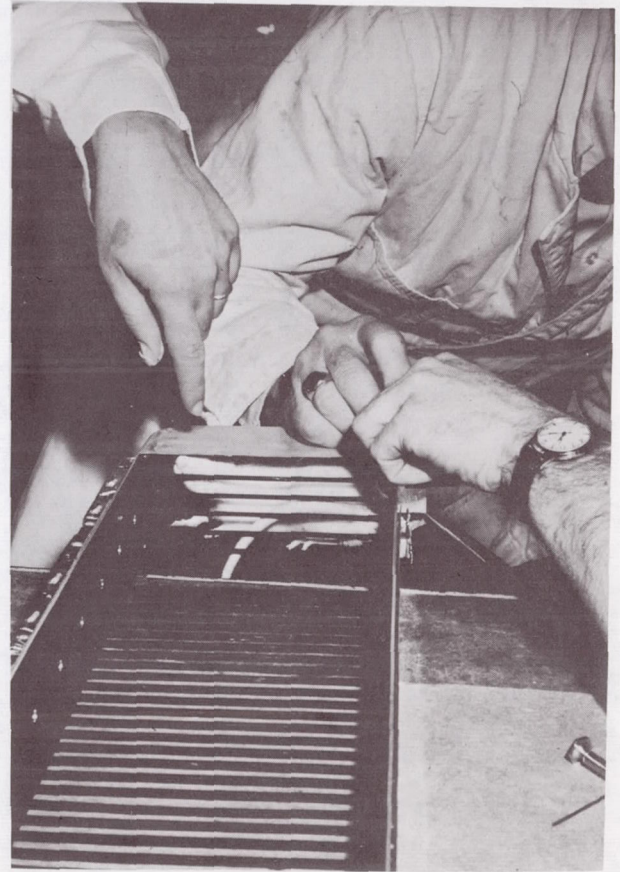

Figure 33. Animal Caging System Employed in the Runway of the Aerobee Gravity Preference Payload.

the ventilated capsule was limited to 4°F as compared to a 10°F rise in the unventilated system. Humidity was not noticeably reduced at first since the confined rats tended to urinate heavily. All confinement capsules were subsequently ventilated in the fashion described.

Acceleration. The existing acceleration simulation centrifuge was modified for more precise and automatic operation; see figure 35. A 1/4 horsepower winch motor provides the initial shock-cord tension by pulling the centrifuge arm backwards against the shock cord through an angle of about 30° . Upon reaching this point the winch cord detaches automatically, permitting the shock cord to accelerate the arm; the shock cord also drops after expending its stored energy, and allows the centrifuge to continue rotation in the same direction. After slowing considerably, the centrifuge is powered through the sustainer phase under the control of a Data-Trac curve-following programmer. Performance is considerably improved with these modifications since the drive motor assists the shock cord in a programmed manner during the boost phase, and increased smoothness and repeatability of the sustainer phase are achieved. No capsule spin motor is used; however, spin is induced aerodynamically during centrifuge rotation.

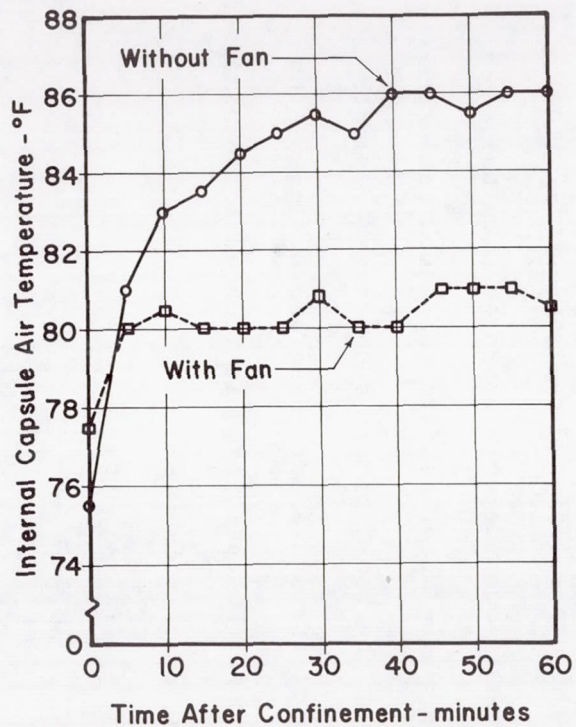

Figure 34. History of Air Temperature Internal to the Confinement Capsule During a One Hour Rat Confinement, With and Without External Fan Cooling.

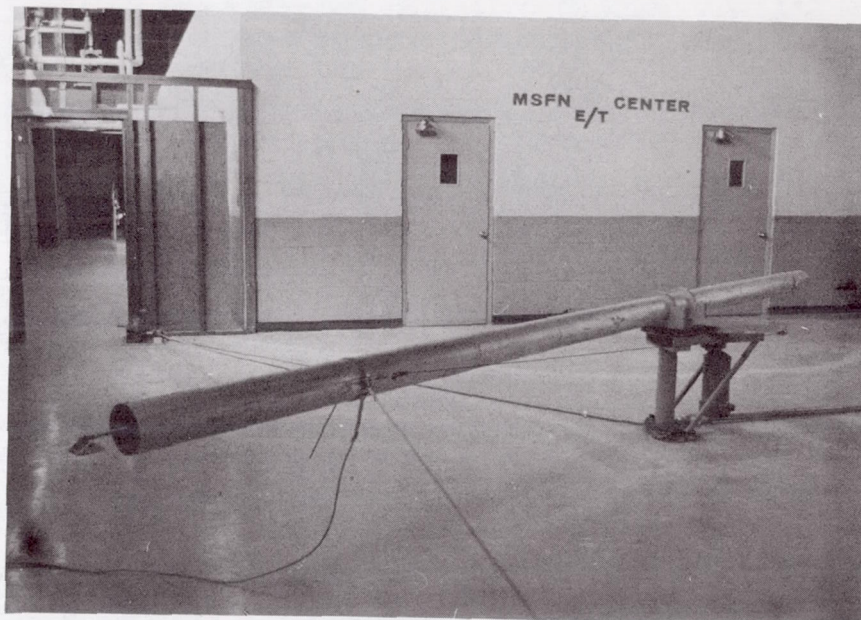

Figure 35. Acceleration Simulation Centrifuge for Routine Preparation of Rats for an Aerobee Flight.

Spin, noise, and vibration. While it would be desirable to simulate all the launch environments simultaneously, the increase in moment of inertia which would result from adding the necessary devices to the end of the arm of the acceleration simulation centrifuge would be prohibitive to high rates of onset; consequently, the simulated spin, noise, and vibration environments were created simultaneously, but apart from the centrifuge, and the apparatus is shown in figure 36. A mechanical shaker vibrates the spinning capsule assembly between two acoustic speakers through which is played a tape recording of rocket noise.

The mechanical shaker is the crank-and-eccentric rod type with a variable pivot position on the eccentric rod to supply amplitudes up to 1/16 inch. It is driven electrically and manual frequency control up to 15 cps is achieved by means of a hand crank on a model 30M Graham variable speed transmission. In view of the limited information on the payload flight vibration, the choice of amplitude and frequency was somewhat arbitrary, the goal being to familiarize the subjects with the idea of vibration rather than to accurately simulate anticipated conditions. The frequency was set at 10 cps, about half the natural frequency of the major body systems of a rat, so as not to cause serious injury with repeated exposure; the amplitude was set at 1/16 inch which, at 10 cps, corresponds to 0.32g peak acceleration.

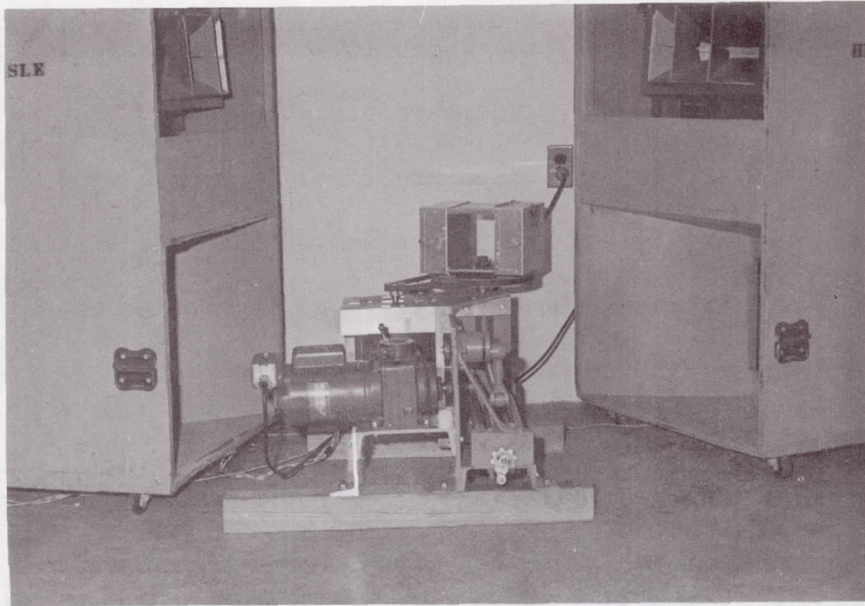

Figure 36. Apparatus for Routinely Exposing Rats to Simultaneous Simulations of Aerobee Spin, Noise, and Vibration.

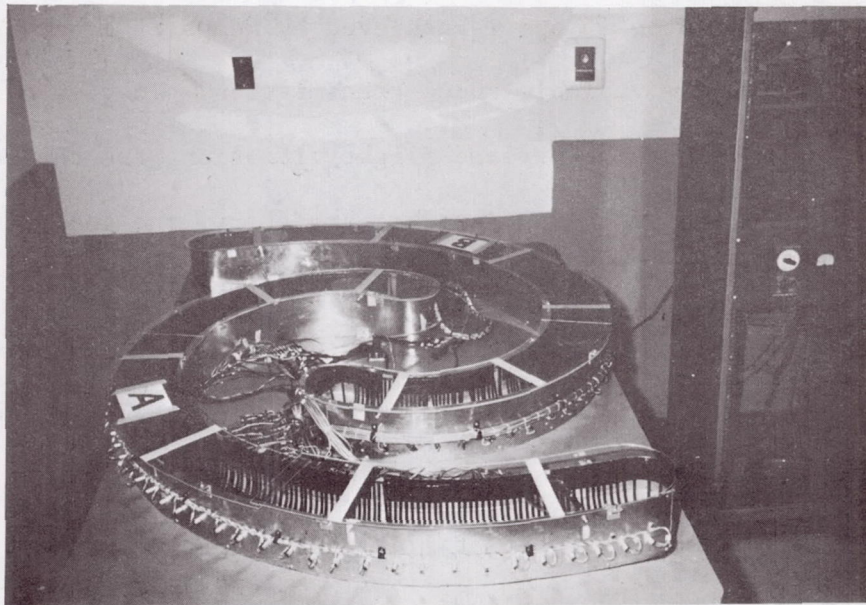

Figure 37. Spiral Gravity Preference Centrifuge Simulating the Gravity Range, Track Length, Slope Angle, and Angular Velocity of the Aerobee Gravity Preference Payload.

The spin portion of the apparatus consists of a 1/12 horsepower, variable-speed motor with v-belt drive to a pulley which is collared to, but free to rotate about, the output shaft of the mechanical shaker. The spin profile is manually adjusted with a Boston R12 motor speed controller.

The noise facility consists of a 100-Watt, Altec Lansing model 1570B audio amplifier, a Webcor "Compact" tape recorder, and two Altec "Voice of the Theater" speaker cabinets. This matched system is capable of producing 130 db of broadband noise at the capsule assembly with a frequency response which is "flat" within ± 1 db between 20 and 20,000 cps. The noise recording was made in the Aerobee launch tower at Wallops Island, Virginia during a routine launch. Based upon the Wallops estimate,⁴⁵ and assuming a 3 db attenuation through the capsule, the intensity at the capsule was adjusted to 106 db with a calibrated General Radio model 759 db meter.

Gravity field centrifuge. A spiral configuration centrifuge was chosen over the parabolic type since it seemed to permit a closer compromise between the geometric and dynamic parameters of the payload centrifuge; at 45 rpm (the angular velocity of the payload after arm deployment), a parabolic track centrifuge with proper gravity gradient would be only a few feet long. Figure 37 shows the two-track, spiral apparatus. It duplicates the track length (80 inches), slope angle (15°), and angular velocity

(45 rpm) of the payload centrifuge; the 1.3g-2.4g gravity field approximates the 0.35g-1.60g gradient of the payload centrifuge. Centrifugally-actuated starting gates are provided at both ends of each track to permit subjects to be given both high-g and low-g starts so as to prepare them for either task in the actual Aerobee flight. Position detection was achieved initially by visual observation and later by a photoelectric system developed by Wallops engineers for use in the payload. This system consists of an electro-luminescent tape-light on one wall of the spiral, and a series of photoconductors on the opposite wall. Activation by the rat causes a pen deflection on an event recorder corresponding to the particular gravity region.

Procedures.

Training schedule. Training sessions were conducted during a three-month period, beginning with 31 subjects and gradually reducing to 8 subjects. All subjects were mature, male Sprague Dawley rats maintained on food deprivation at 80% (300 grams) of normal body weight. The schedule of training proceeded as follows:

1. Twenty-two days of preference training within a 30-day period using the spiral centrifuge at the University of Kentucky.
2. Fifteen days of preference training during the next 22 days while spin, vibration, acceleration, and noise exposures were gradually added.

3. Two days of preference training without launch simulation during the next week while equipment was transferred to Wallops Island, Virginia.

4. Transport of subjects to Wallops Island by private airplane for 12 days of additional preference training during the next 33 days. Full launch simulation was employed, including confinement which began with one-hour sessions and was gradually increased to four-hour sessions. The photoelectric spiral centrifuge was first used here.

Sequence of a single training session. When the complete simulation routine was established, all subjects were tested once each test day and the following sequence was maintained in each test on two rats:

1. Four hours of confinement in the capsule assembly with exterior fan cooling; subjects were alternately confined in the upright and the inverted capsule.

2. Attachment of the capsule assembly to the acceleration centrifuge where subjects received exposure to a one-minute simulation of the complete boost and sustainer acceleration profile.

3. Attachment of the capsule assembly to the spin-noise-vibration facility for a one-minute, simultaneous exposure to 10 cps of mechanical vibration, 106 db of taped rocket noise, and a spin profile reaching 120 rpm.

4. Removal of subjects from the capsule and placement in the

spiral centrifuge for performance of a 20-minute gravity preference test. Subjects were alternately started from the high-g and low-g ends of the track.

Behavior during the training routine.

Visual observation during launch simulation. The confinement routine initially produced a pronounced deterioration of the physical appearance in all subjects. After four hours in the capsule, subjects were listless and had excreted a large amount of urine and feces, indicative of the stressfulness of the environment. It is noteworthy that these symptoms gradually disappeared with continued training; toward the end of the training schedule, nearly all subjects were relatively dry, active, and much improved in general appearance when inspected after four hours of confinement.

The acceleration profile produced no visible detrimental effects, in agreement with the findings of the preliminary study on tolerance to spin and acceleration.

Simultaneous spin, noise, and vibration initially caused subjects to excrete and urinate heavily and to struggle vigorously to escape confinement; in general, this appeared to be the most stressing of the simulated environments, though it too seemed to adapt readily and few signs of struggling or excitement were recognized toward the end of the training schedule.

Preference performance of the group. Only 20 of the 31 rats trained in Lexington were taken to Wallops Island for continued training. Figures 38 and 39 summarize the gravity preference behavior of these 20 subjects up until the time the final 8 were selected; points plotted represent only those tests in which all subjects were released at the high-g end of the track. The following points are noteworthy:

1. Throughout the three months of training, the number of "good" subjects (those which ran immediately to their preferred gravity) increased steadily while the number of "poor" subjects (requiring 5 minutes or more) decreased until just prior to the Wallops transfer when 17 of the 20 were reaching low gravity within 30 seconds and none required 5 minutes.

2. Preference performance, when first tested at Wallops Island, had sharply deteriorated. It is speculated that this was due to one or more of the following factors:

- a. The four-hour airplane flight to Wallops.
- b. The change in circadian rhythms involved in the geographical shift.
- c. The absence of launch simulation during the equipment transfer.
- d. The use of the spiral centrifuge, equipped for the first time with the electroluminescent tape-light.
- e. The addition of confinement to the environmental simulation routine.

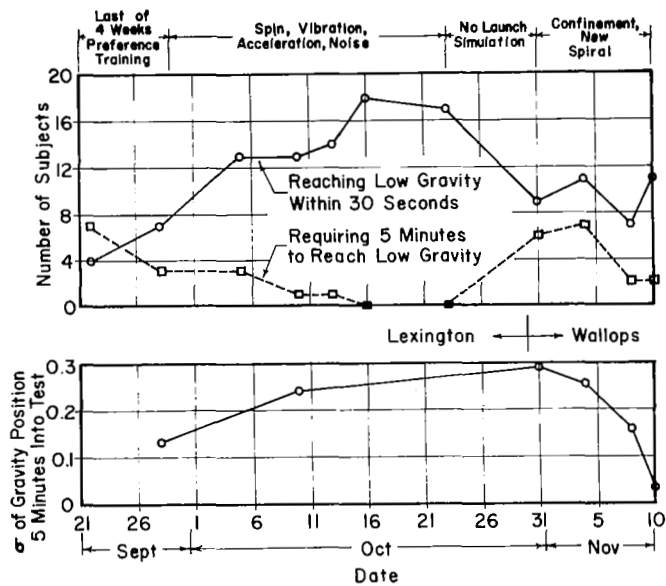

Figure 38. Number of Good and Poor Performers out of 20 Rats Routinely Prepared for Aerobee Launch, Compared with Standard Deviation, σ , of Position in the Gravity Field at 5 Minutes Into Test.

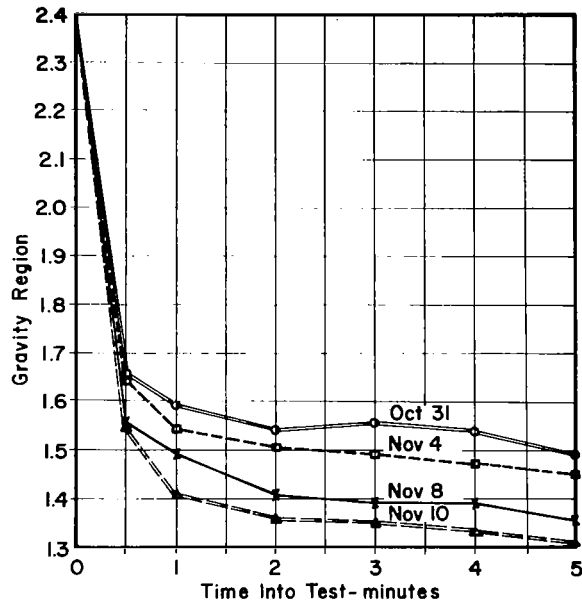

Figure 39. Improvement of Gravity Preference Behavior of 20 Rats during Repeated Testing after an Initial Performance Decline upon Transfer from Lexington, Kentucky to Wallops Island, Virginia.

3. Continued training improved preference performance of the group, reducing the number of poor performers to two, and reducing group variability (standard deviation, σ , of position at 5 minutes into the preference test).

4. A special test was conducted in which rotation was withheld from the preference centrifuge to establish that the preference being demonstrated was still for gravity and not for position in the runway; no launch simulation occurred on that day. Position was completely random (see figure 42 in the following section), verifying that gravity continued to be the predominant stimulus in the preference centrifuge. It is noteworthy that preference performance was noticeably deteriorated in a few animals on the day following this test, but returned to an acceptable level in succeeding tests.

Preference performance of one of the "best" subjects.

Two subjects were chosen as first candidates for flight on the basis of their consistently good performance; the behavior of one of these subjects (Subject 3A) is summarized in figures 40,41 and 42. Figure 40 shows the history of response time, figure 41 a typical response pattern, and figure 42 the random location preference in the nonrotating spiral. The same random behavior was demonstrated during laboratory familiarization with the actual Aerobee runway.

Flight Verification of the Effectiveness of the Training Program.

Subjects 3A and IE were launched into a suborbital gravity preference experiment from Wallops Island on December 5, 1967, on the first of four such flights planned; figure 43 shows the Aerobee with payload, in-flight. The results of this flight and their interpretation are beyond the scope of this paper; however, the general ability of the subjects to perform in flight is relevant to this treatment.

Regretably, the spin rate of the payload after runway deployment was considerably higher than anticipated, resulting in a gravity field from 0.85g to nearly 4g. However, both rats did move from the starting gates and locomote smoothly in the direction of the center of the track. This is particularly noteworthy for the subject released at nearly 4g since he had not previously experienced such a high magnitude of acceleration in a centrifuge in which he was free to locomote.

To the extent that this was the first attempt to train rats for an in-flight experiment of this nature, and that the subjects were able to and did locomote within an in-space gravity field after rocket flight, it may be considered that the established training procedures were generally effective.*

* The second Gravity Preference Payload was launched on June 24, 1968. The design roll rate was precisely achieved through use of a gas de-spin system. Animal training procedures were somewhat revised and both subjects were able to locomote effectively.

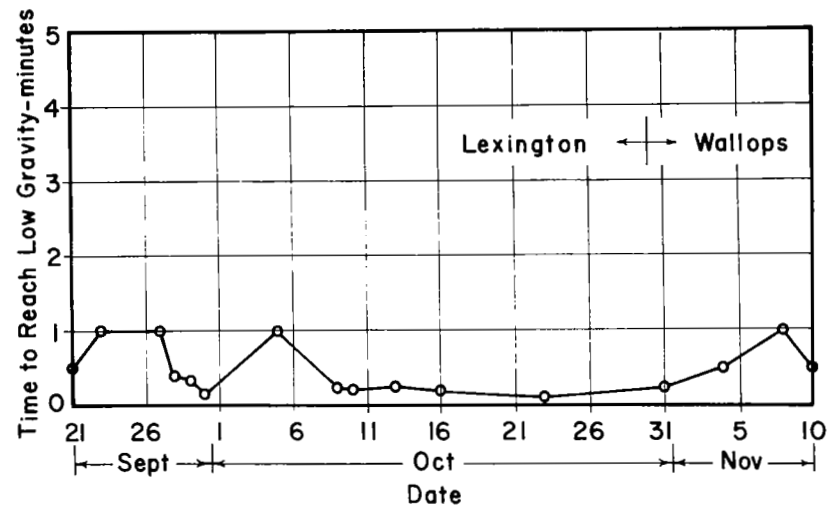

Figure 40. History of Running Time to Low Gravity of Subject 3A during a Program of Routine Exposure to Simulated Aerobee Launch Environments.

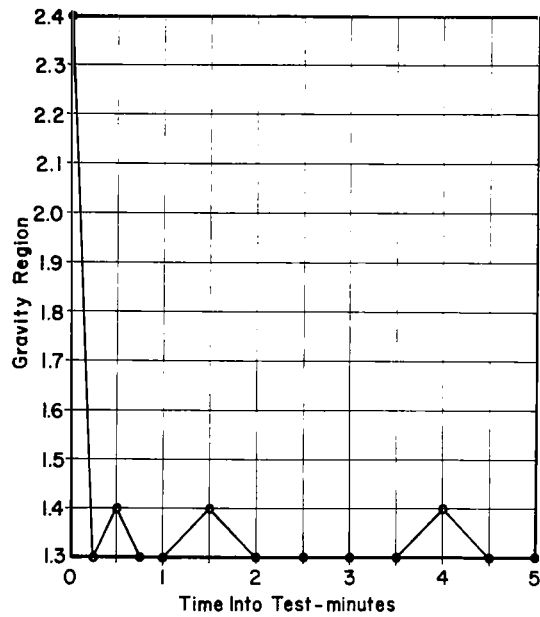

Figure 41. Typical Gravity Preference Behavior of Subject 3A during Gravity Preference Testing at Wallops Island, Virginia.

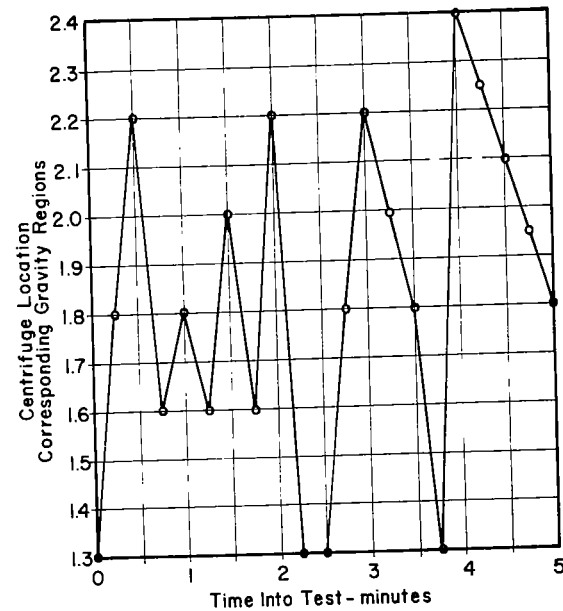

Figure 42. Centrifuge Location, Versus Time, of Subject 3A during a 5 Minute Test in a Non-Rotating Spiral Centrifuge at Wallops Island, Virginia.

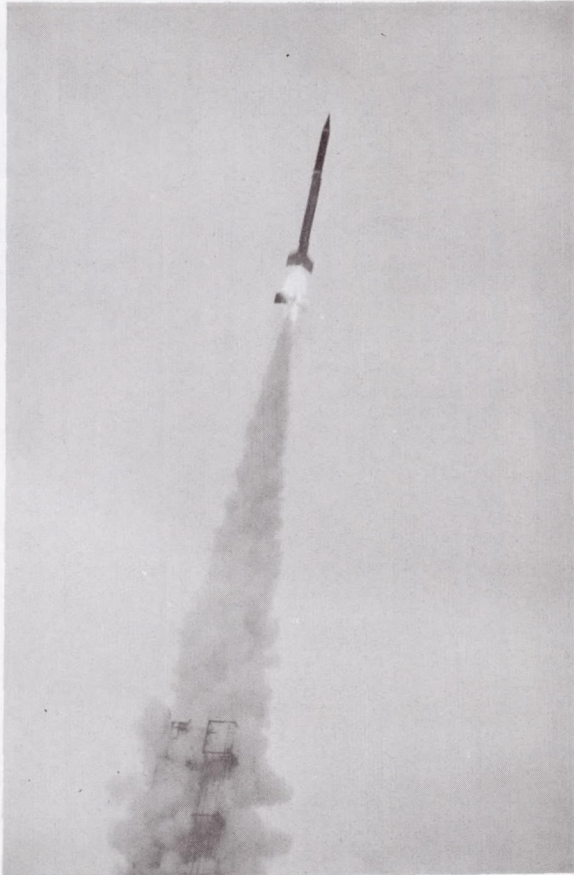

Figure 43. Gravity Preference Payload
Carrying Two Trained Rats Launched by
Aerobee 150A Rocket from Wallops Island,
Virginia on December 5, 1967.

Conclusions and Recommendations

On the basis of these studies into the ability of rats to tolerate simulations of a rocket launch environment, the following conclusions and recommendations are forwarded:

1. Male, Sprague Dawley rats, trained to demonstrate gravity preference, are capable of emerging without detrimental effects on preference behavior from a routine program of confinement, spin, acceleration, noise, and vibration environments which simulate, in part, the powered flight of an Aerobee 150A rocket; prospects are good that they will be suitable for orbital experiments launched by rockets whose flight environments are similar to those of the Aerobee.

2. A training group of 30 subjects is more than adequate to produce two good candidates for rocket flight into a suborbital gravity preference experiment.

3. Simultaneous spin, noise, and vibration, as presented in this investigation, appears to be the most stressing environment; it is highly desirable to know the characteristics of the payload vibration in more detail to permit more precise simulation. Confinement for four hours appears to be nearly as stressing as simultaneous spin, noise, and vibration. Rats appear to be able to adapt to all simulated environments with repeated training. The acceleration profile utilized does not appear to produce as much stress, though it is recommended that it be included as part of the total simulation program in order to avoid presentation of a

novel environment during flight.

4. The cause of the significant deterioration in group performance observed after the transfer from the base laboratory to the launching station should be more thoroughly investigated; adequate time should be allowed for recovery from such a performance decline prior to flight.

5. More sophisticated behavioral techniques, such as operant conditioning, should be considered in preparation for orbital flight.

6. Physiological techniques should be introduced to complement behavioral evaluation of the effects of the various launch environments on the "over-all" state of the rat.

7. Whenever possible, simulations of the launch environment should be made simultaneously; it would be especially desirable to present environments to the subject while confined in the gravity field centrifuge.

8. The smooth locomotion of the trained rats during the two suborbital gravity preference experiments suggests that the training program conducted is an adequate base from which to develop refined techniques in preparation for orbital investigations.

BIBLIOGRAPHY

1. Adey, W. R., et al., "EEG in Simulated Stresses of Space Flight with Special Reference to Problems of Vibrations", Electroenceph. Clin. Neurophysiol., v 15, 1963.
2. Antipov, V. V., et al., "Some Results of Medical and Biological Investigations in the Second and Third Satellites", Problems of Space Biology - Vol. 1, NASA TT-F-174, 1962.
3. Ashe, William F., et al., "Some Responses of Rats to Whole Body Mechanical Vibration", Archives of Environmental Health, V 2, April, 1961.
4. Balakhovskiy, I. S., et al., "Results of Experiments Carried Out in Satellites", Problems of Space Biology - Vol. 1, NASA TT-F-174, 1962.
5. Belleville, R. E., Clark, F. C., and Lange, K. O., "Uber das Verhalten kleiner Tiere unter raumfahrtbedingen Beschoeunigungen", German Rocket Society Tagungsbericht No. 36, 1964.
6. Bender, M. A., Gooch, P. C., and Kondo, S., "The Gemini-3 S-4 Spaceflight-Radiation Interaction Experiment", Radiation Research, v 31, 1967.
7. Berry, Charles A. and Catterson, Allen D., "Pre-Gemini Medical Predictions Versus Gemini Flight Results", Gemini Summary Conference, NASA SP 138, February, 1967.
8. Blivaiss, Ben B., Magid, Edward B., and Litta-Modignani, Renato, "Effects of Whole-Body Vibrations on Plasma and Urinary Corticosteroid Levels in Man", AMRL-TDR-64-53, June, 1964.
9. Blivaiss, Ben B., and Litta-Modignani, Renato, "Endocrine and Metabolic Response of Dogs to Whole-Body Vibration", AMRL-TDR-64-54, June, 1964.
10. Broderon, A. B., and Lange, K. O., "The Behavior of Small Animals in Fields of Simulated Gravity", Preprints, Annual Scientific Meeting, Aerospace Medical Association, Washington, D. C., 1967.

11. Broderson, A.B., "Centrifuge for Measuring Gravity Preference in Mice", Paper presented at the Annual Student Conference of the American Institute of Aeronautics and Astronautics, Atlanta, Georgia, 1963.
12. Broderson, A.B., "Coriolis Acceleration in the Rotating Environment: Understanding the Coriolis Phenomenon", Submitted for publication.
13. Broderson, A.B., "The Measurement of Gravity Preference in Small Animals", Masters Thesis, University of Kentucky, 1964.
14. Busby, Douglas, E., Clinical Space Medicine, NASA CR-856, July, 1967.
15. Carter, Earl T., et al., "Some Responses of Rats to Whole Body Mechanical Vibration - Part II", Archives of Environmental Health, V 2, April, 1961.
16. Catterson, A.D., et al., "Aeromedical Observations", Mercury Project Summary Including Results of the Fourth Manned Orbital Flight, NASA SP-45, May, 1963.
17. Cramer, Robert L., et al., "The Changing Parameters of the Habituating Vestibular System", USAF Sch. Aerosp. Med. SAM-TR-67-85, 1967.
18. Crampton, George H., "Directional Imbalance of Vestibular Nystagmus in Cat Following Repeated Unidirectional Angular Acceleration", Acta Oto-Laryng, V55, 1962.
19. Crampton, George H. and Brown, James H., "Repeated Vertical Semi-Circular Canal Stimulation Does Not Habituate Horizontal Nystagmus in Cat", Acta Oto-Laryng, V 58, 1964.
20. Dodge, Raymond, "Habituation to Rotation", Journal of Experimental Psychology, V6, February, 1923.
21. Dowd, Patrick J., "Induction of Resistance to Motion Sickness Through Repeated Exposure to Coriolis Stimulation", USAF Sch. Aerosp. Med. SAM-TR-64-87, December, 1964.
22. Early, Larry J., Development of a Small Animal Payload and Integration with a Sounding Rocket, NASA SP-109, 1966.
23. Edwards, Richard G. and Lange, K.O., A Mechanical Impedance Investigation of Human Response to Vibration, AMRL-TR-64-91, October, 1964.

24. Gzenko, O. G. and Gyudzhian, A. A., Physiological Effects of Gravitation, NASA-TT-F-376, August, 1965.
25. Geber, William F., Anderson, Thomas A., and Van Dyke, Bruce, "Physiologic Responses of Albino Rat to Chronic Noise Stress", Archives of Environment Health, V 12, June, 1966.
26. Generales, Constantice D. J., "Weightlessness: Its Physical, Biological, and Medical Aspects", in Medical and Biological Problems of Space Flight, Edited by Geoffrey H. Bourne, Academic Press, 1963.
27. Gerathewohl, Siegfried J., Principles of Bioastronautics, Prentice Hall, 1963.
28. Gillingham, Kent K., "A Primer of Vestibular Function, Spatial Disorientation, and Motion Sickness", USAF Sch. Aerosp. Med: Aeromedical Review 4-66, June, 1966.
29. Goldman, David E. and Von Gierke, Henning E., "The Effects of Shock and Vibration on Man", Lecture and Review Series, No. 60-3, Naval Research Institute, Bethesda, Maryland, January 8, 1960.
30. Goldstein, Herbert, Classical Mechanics, Addison-Wesley, 1965.
31. Graveline, Duane E., "Maintenance of Cardiovascular Adaptability During Prolonged Weightlessness", in Medical and Biological Problems of Space Flight, Edited by Geoffrey H. Bourne, Academic Press, 1963.
32. Graybiel, Ashton, et al., "The Effects of Exposure to a Rotating Environment (10 rpm) on Four Aviators for a Period of 12 Days", The Role of the Vestibular Organs in the Exploration of Space, NASA SP-77, January, 1965.
33. Greening, Charles P., "Coriolis Effects on Operator Movement in Rotating Vehicles", Aerospace Medicine, V 33, May, 1962.
34. Greenwood, Donald F., Principles of Dynamics, Prentice Hall, 1965.
35. Guedry, Fred E., "Comparison of Vestibular Effects in Several Rotating Environments", The Role of the Vestibular Organs in the Exploration of Space, NASA SP-77, January, 1965.
36. Guedry, Frederick E. and Crocker, Jeremy, "Vestibular System", Bioastronautics Data Book, Section 19, NASA SP-3006, 1964.

37. Guedry, Fred E. and Montague, E.K., "Quantitative Evaluation of the Vestibular Coriolis Reaction", Aerospace Medicine, V 32, June, 1961.
38. Gyurdgzian, A.A., et al., "Biochemical Investigations of the Blood and Urine of Animals that Flew in Satellites", Problems in Space Biology - Vol. 1, NASA TT-F-174, 1962.
39. Harrs, E.A. and Newsom, B.D., "A Manned Revolving Space Station Simulator", Proceedings, Annual Technical Meeting, Institute of Environmental Sciences, Chicago, 1965.
40. Hartog, J.P. Den, Mechanics, Dover Publications, 1961.
41. Henry, James P., Biomedical Aspects of Space Flight, Holt-Rhinehart, 1966.
42. Henry, J.P., et al., "Animal Studies of the Subgravity State During Rocket Flight", Journal of Aviation Medicine, October, 1952.
43. Herrick, Robert M., "Accuracy of Lever-Displacement Behavior of Rats Following Exposure to Accelerations", Journal of Aerospace Medicine, September, 1961.
44. Jacobson, Ira D., et al., Feasibility and Preliminary Design Study of a Small Animal Gravity Preference Payload, NASA Wallops Station, Wallops Island, Virginia, July, 1966.
45. Jacobson, Ira D., "Noise Level Determination for In-Flight Gravity Preference Project Payload (IFGPP)", Wallops Station Memorandum, NASA Wallops Station, Wallops Island, Virginia, June 7, 1967.
46. Jenkins, Dale W., "Environmental Biology", Significant Achievements in Space Bioscience, 1958-1964, NASA SP-92, 1966.
47. Kas'yan, I.I., Yaganov, Ye M., and L'vova T.S., "Changes in Certain Morphological and Biochemical Indices of the Peripheral Blood of Animals after Rocket Flights", Problems of Space Biology- Vol. 1, NASA TT-F-174, 1962.
48. Lamb, Lawrence E., "Influence of Lower Body Negative Pressure on the Level of Hydration During Bed Rest", USAF Sch. Aerosp. Med. TR 65-282, December, 1965.

49. Lange, K.O. and Broderson, A.B., "Animal Behavior in Fields of Simulated Gravity", Proceedings, Annual Scientific Meeting, Institute of Environmental Sciences, Chicago, 1965.
50. Lange, K.O., Broderson, A.B., Martin, R.C., and Richardson, W.K., "Chronic Centrifugation of Small Animals", Paper presented at the American Physiological Society Meeting, Los Angeles, 1965.
51. Lansberg, M.P., "The Function of the Vestibular Sense Organ and the Construction of a Satellite", Aeromedica Acta, V 4, 1955.
52. Levin, G. and Saunders, J.F., "Environmental Biology", Significant Achievements in Space Science, 1966, NASA SP-155, 1967.
53. Luk'yanova, L.D., "Observations on the Conditioned Reflex Activity of White Rats Some Considerable Time after Traveling on the Second Soviet Satellite", Problems in Space Biology-Vol. 1, NASA TT-F-174, 1962.
54. Martin, R.C., Richardson, W.K., and Martin, W.L., "Simulted Gravity: The Aversive Stimulus in an Escape and Punishment Situation", Journal of Engineering Psychology, V 5, N 1, 1966.
55. McCally, Michael and Shropshire, Spenser, "Relative Effectiveness of Selected Space Flight Deconditioning Countermeasures", Preprints, Annual Scientific Meeting, Aerospace Medical Association, Washington D.C., April, 1967.
56. McCoy, D.F. and Lange, K.O., "Stimulus Generalization of Gravity", Submitted for publication.
57. McCuskey, S.W., Introduction to Advanced Dynamics, Addison-Wesley Publishing Co., 1962.
58. McKinney, Ramon, Montgomery, Phillip O'B, and Gell, Charles F., "A Study of the Effects of Zero Gravity on Cell Physiology", in Physical and Biological Phenomena in a Weightless State, Second AAS Symp. Phys. Biol. Phenomena Under Zero Gravity Conditions, E.T. Benedift and R.W. Halliburton, Editors, Adv. Astronaut. Sci., V 14, 1963.
59. Megel, Herbert, Keating, Frederick M., and Stern, Joseph A., "Effect of Elevated Ambient Temperature on the Restrained Rat", Journal of Aerospace Medicine, December, 1961.

60. Miller, Perry B., "Medical Problems of Weightlessness", USAF Sch. Aerosp. Med. SAM- TR-66-200, October, 1965.
61. Miles, George M., Personal Correspondence.
62. Miles, George M., "Report on Biological Testing in Support of the Bio-Space Technology Training Program", NASA Wallops Station Inter-Office Report, Wallops Island, Virginia, Fall, 1965.
63. Money, Kenneth E., "Vestibular Problems in Rotating Space-Craft", The Role of the Vestibular Organs in the Exploration of Space, NASA SP-77, January, 1965.
64. Mosely, John D. and Henry, James P., "Summary of the Results of the MR-2 Flight", Results of the Project Mercury Ballistic and Orbital Chimpanzee Flights, NASA SP-39, 1963.
65. Mosely, John D. and Henry, James, "Summary of the Results of the MR-5 Flight", Results of the Project Mercury Ballistic and Orbital Chimpanzee Flights, NASA SP-39, 1963.
66. Nagy, James A. and Coble, Gomer L. Jr., Flight Vibration Data of the Aerobee 150A Sounding Rocket, NASA Goddard Space Flight Center, 1964.
67. Newsom, B.D. et al., "Adaptation to Prolonged Exposures in the Revolving Space Station Simulator", Aerospace Medicine, V 37, N 8, August, 1966.
68. Newsom, B.D. and Bradey, James F., "Observations on Subjects Exposed to Prolonged Rotation in a Space Station Simulator", The Role of the Vestibular Organs in the Exploration of Space, NASA SP-77, January, 1965.
69. Nungesser, William C., "Factor Influencing the Renal Regulation of Calcium - Implications of Prolonged Weightlessness", USAF Sch. Aerosp. Med. Aeromedical Review 2-65, May, 1965.
70. O'Laughlin, T.W., Brady, J.F., and Newsom, B.D., "Reach Effectiveness in a Rotating Environment", Preprints, Annual Scientific Meeting, Aerospace Medical Association, Washington D.C., April, 1967.
71. Performance Summary for the Aerobee 150A Sounding Rocket Vehicle, Report No. AST/EIR-13319, Vought Astronautics, April 18, 1961.

72. Pollard, Ernest C., "Theoretical Studies on Living Systems in the Absence of Mechanical Stress", Journal of Theoretical Biology, V 8, 1965.
73. Rohles, Frederick H., Grunzke, Marvin E., and Reynolds, Herbert H., "Chimpanzee Performance During the Ballistic and Orbital Project Mercury Flights", Journal of Comparative and Physiological Psychology, V 56, N 1. 1963.
74. Roman, James A., Coermann, Rolf, and Ziegenrucker, Gerd, "Vibration, Buffeting, and Impact Research", Journal of Aviation Medicine, February, 1959.
75. Slager, Ursula T., Space Medicine, Prentice Hall, 1962.
76. Stapp, J.P., Analysis and Biodynamics of Selected Rocket-Sled Experiments, USAF Sch. Aerosp. Med. Report, Prepared under Contract No. AF41(609)-2317 by Northrop Space Laboratories, Hawthorne, California, July, 1964.
77. Stone, Ralph W., Letko, William, and Hook, W. Ray, "Examination of a Possible Flight Experiment to Evaluate an On-board Centrifuge as a Theapeutic Device", Second Symposium on the Role of the Vestibular Organs in Space Exploration, NASA SP-115, January, 1966.
78. Tyler, Albert, "A Model Illustrating Possible Instability of Cellular Structure under Conditions of Weightlessness", Journal of Theoretical Biology, V 11, 1966.
79. Vennard, John K., Elementary Fluid Mechanics, John Wiley and Sons, 1961.
80. Von Braun, Wernher, "What Ever Happened to the Manned Space Station?", Popular Science, February, 1965.
81. Von Gierke, Henning E., "Biodynamic Response of the Human Body", Applied Mechanics Reviews, December, 1964.
82. Voris, Frank E., "Medical Aspects of Space Flight", NASA FP-17, 1964.
83. Webb, Paul, "Combined Stresses", Bioastronautics Data Book, NASA SP-3006, 1964.

84. Weissman, Norman W., "Response Differentiation in Slow Rotation", Paper presented at the Third Symposium on the Role of the Vestibular Organs in Space Exploration, Pensacola, Florida, 1967.
85. Wendt, G.R., "Vestibular Functions", in Handbook of Experimental Psychology, Edited by S.S. Stevens, John Wiley and Sons, 1962.
86. White, William J., "Space-Based Centrifuge", The Role of the Vestibular Organs in the Exploration of Space, NASA SP-77, January, 1965.
87. Wunder, Charles C., Life Into Space, F.A. Davis Co., 1966.