

NASA TECHNICAL  
MEMORANDUM

NASA TM X-58024  
January 1968



SPACE SCIENCE WRITING AT A DOWN TO EARTH LEVEL

A One-Day Seminar  
Held at Fondren Library  
Rice University, Houston, Texas  
Saturday, January 20, 1968

NATIONAL AERONAUTICS AND SPACE ADMINISTRATION  
MANNED SPACECRAFT CENTER  
HOUSTON, TEXAS

44

45

46

47

## FOREWORD

A 1-day technical communications seminar on space science writing is necessarily limited; at best only a quick survey of this vast subject matter can be presented. Realizing this limitation, the Houston Chapter of STWP and Rice University proceeded to present such a seminar with a space technical art exhibit. The emergence of Houston and Rice University as a space center in recent years admirably qualified the choice of both this subject array and location.

The Houston Chapter of STWP has recently become quite involved in educational problems and procedures to reach scientists and engineers.

As a result, the chapter has compiled an enviable record of participation and involvement. This seminar has been one of the most important chapter undertakings for three reasons:

(1) We reached the largest number of people ever for our chapter; there were 160 in attendance.

(2) The success of this seminar gave us the impetus to plan further seminars: a 1-week seminar at Rice in June 1968; a day-long graphics seminar at Rice, planned for January 1969.

(3) The completed critiques from those attending have directed our attention and have made a valuable contribution to our plans and activities for the future.

I extend my sincere appreciation to all those participating with us in this growing program.

*David N. Holman*

David N. Holman  
NASA Manned Spacecraft Center

Chairman, Houston Chapter,  
Society of Technical Writers  
and Publishers, Inc.

## A One-Day Seminar

**For:** Technical writers, illustrators, engineers, scientists anyone involved in communicating technical ideas in space science and engineering.

**Offering:** Practical instruction in the what, why, and how of writing, editing, illustrating and producing space-related technical information with time for dialogue and afternoon workshops.

**By:** Experienced, top-notch editors, writers, illustrators, and publications specialists in industry, news media, and government.

**At:** Rice University, Fondren Library, Houston, Saturday, January 20, from 9:00 A.M. to 6:00 P.M.

### PROGRAM SCHEDULE

#### *Morning*

- Registration and coffee 8:15-9:00
- Welcoming Remarks 9:00-9:05  
Dr. Kenneth S. Pitzer, President, Rice University
- Introductions 9:05-9:10  
David Holman, NASA-MSC, Chairman, Houston Chapter, Society of Technical Writers & Publishers;  
Joe A. Rice, Ph.D., Dept. of English, Houston Baptist College
- Space Coverage—Perils, Problems, and the Payoff 9:10-9:45  
Jules Bergman, ABC Science News Editor
- News Coverage of Manned Space Missions 9:45-10:15  
Paul Haney, NASA-MSC Public Affairs Officer
- Coffee break—dialogue 10:15-10:40
- Earth Resources Information Systems 10:40-11:20  
Charles M. Grant, Chief, Technical Information Programs, NASA-MSC
- Space Documentation 11:20-12:00  
Joseph Godfrey, Manager of Technical Services, IBM Houston and President-elect of STWP
- Lunch at Rice Faculty Club 12:00-1:30  
Address by Astronaut F. Curtis Michel, Ph.D. Physics, Rice University  
(Space Science Researcher and Teacher)

#### *Afternoon*

- News Stories and Publicity (Panel Session) 1:30-2:15  
Moderator: Lee Estes, Rice University Development Office; Louis Alexander, University of Houston; Jules Bergman, ABC Science News Editor; Paul Haney, NASA-MSC Public Affairs Officer
- Space Science Writing for the General Public 2:15-2:45  
Bill Sexton, Editor, World Book Encyclopedia Science News Service
- Coffee break 2:45-3:00
- Workshops
  1. Preparing Art for Mission Evaluation Reports 3:00-4:00  
Roy Magin, Reproduction Services Manager, NASA-MSC
  2. Information Retrieval 4:00-4:30  
John Stout, Senior Engineer, Federal Electric Corporation
  3. Stylistics 4:30-5:15  
Louis Alexander, Correspondent, Wall Street Journal, Houston free-lance writer and educator
- Tour—Rice University Space Science Department facilities 5:15-6:00

LIST OF REGISTRANTS

NASA-MSC

Lockheed Electronics  
Company  
Houston Aerospace  
Systems Division  
16811 El Camino Real  
Houston, Texas 77058

ITT/Federal Electric  
Corporation  
1115 Vanguard Building  
Gemini Avenue  
Houston, Texas 77058

Allyn, Charles F.  
Burton, Mary S.  
Chapman, William B.  
Cline, Rex B.  
Cordiner, David H.  
Coston, Charles L.  
Edwards, Thomas J.  
Fielder, Dennis E.  
Friis, David J.  
Goodson, F. D.  
Goodwin, Mary Ann  
Hendrickson, D. R.  
Hess, N. Jean  
Holman, David N.  
Hooper, Carol  
Jackson, Bradford J.  
Jackson, Estelle G.  
Lyons, Gerald J.  
Magin, Roy L.  
Meade, Eston F.  
Moon, Jamie L.  
Mounce, Boyd E.  
Murtagh, Thomas B.  
Normand, Ann E.  
Painchaud, Lois  
Reed, Lettie B.  
Robinson, Alice  
Shaw, Ena B.  
Strahl, Pete  
Taub, Willard M.  
Whitley, Sidney L.  
Grant, Charles M.  
Haney, Paul  
Jones, Robert M.

Kates, B. L.  
Knox, T. L.  
DeGeorge, W. F.  
Forsberg, F. C.  
Vela, Roland R.  
Jennings, J. E.  
Cogen, W. M.  
Lockett, J. L.  
French, A. J.  
Schutt, J. R.  
Carey, G. A.  
Wehner, A. E.  
Johnson, J. III  
Richardson, A. E.  
Mersereau, A.  
Korowski, S. M.  
Lamb, M. E.  
Shankle, R. O.  
Stuckum, G. C.  
Backus, K. D.  
Blanchard, G. F.  
Rowe, R. I.  
Carhart, Tom  
Walsh, James  
Garland, Lloyd H., Jr.

Acres, R.  
Appenbrink, J.  
Atkins, R.  
Braden, A.  
Brinsa, E.  
Brooks, W.  
Burttschell, T.  
Clark, C.  
Cox, M.  
Cox, W.  
Crysler, R.  
Emery, G.  
Fox, B.  
Gauldin, E.  
Green, G.  
Hafenmaier, H.  
Hilton, A.  
Hreha, A.  
Hughes, T.  
Jackson, F.  
Johns, C.  
Jones, J.  
Kernaghan, H.  
Latour, C.  
Macha, S.  
Mathews, E.  
McCracken, W.  
Osborne, B.  
Pilling, G.  
Polansky, J.  
Reid, T.  
Reis, D.  
Robinson, S.  
Ruhlen, R.  
Sandy, D.  
Shore, J.  
Smith, H.

ITT/Federal Electric  
Corporation -  
Concluded

Spivey, H.  
Stout, John M.  
Taber, J.  
Thibodeau, M.  
Walker, J.

---

Philco-Ford Corporation  
1002 Gemini Avenue  
Houston, Texas 77058

N. Johnson  
F. Miles  
A. Bray  
E. Tenholder  
F. Bobo  
E. White  
L. Pierce  
R. L. Runnels

IBM - Federal Systems  
Division  
1322 Space Park Drive  
Houston, Texas 77058

Godfrey, Joseph  
Autrey, Ramon T.  
Backhaus, Agnes M.  
Crosby, John B.  
Crow, Frank H.  
Fodor, John E.  
Fuller, William A.  
Hagedorn, Karen L.  
Halloran, Bernard J.  
Jones, Clyde R.  
Kemlage, Michael B.  
Lundin, Raymond W.  
Stark, Herschel L.  
Waldo, Juanna G.  
Whittaker, Jessie P.

Bonner & Moore  
Associates  
500 Jefferson Bldg.,  
Suite 112  
Houston, Texas 77002

Currie, Cullen W.  
Jones, Harry F.  
Long, Forrest R.  
Radez, Frank  
Short, Ross E.  
Silvey, William A.  
Wuelfing, Ronald A.

---

General Electric Company  
P. O. Box 58408  
Houston, Texas 77058

Glenn, T. M.  
McCabe, E. R.  
Brooks, Jan

TRW Systems Group  
P. O. Box 58327  
Houston, Texas 77058

Gary E. Dinsmore  
Lanny P. Burkhalter

---

Raytheon-Autometric  
P. O. Box 58038  
Houston, Texas 77058

B. Crittenden  
R. Donaldson  
D. Kinsler  
A. Valentine  
R. Weber

---

Brown & Root, Inc.

Boring, Sue Ellen  
Brown, Frances

---

Esso Production Research  
P. O. Box 2189  
Houston, Texas 77001

J. B. Colby  
Lynne Muller

## INDIVIDUAL REGISTRATIONS

Mrs. Donna Kaye Gibson, Hahn and Clay

Miss Jean E. Kernahan, University of Houston

Mary Louise Morse, University of Houston

Mrs. Linda Thompson, ITT/FEC

Eloise A. Rochelle, Southwest Research Institute, Houston, Texas 77007

Leland L. Estes, Jr., Associate Director of Public Relations, Rice  
University, P. O. Box 1892, Houston, Texas 77001

Speakers not listed with company groups: Louis Alexander, University of  
Houston  
Jules Bergman, American  
Broadcasting  
William C. Sexton, World Book  
Science News Service

Dr. Christine V. Brannan, Publications Consultant

Louis Dartez, Dart Cold - Type Service

Victor Ehrlich, Bechtel Corporation

A. F. Fukal, Graphics Consultant

Marx Isaacs, Fluor Corporation, Ltd.

Loyd B. Keel, Texas A&M University

James R. Moss, Action Printers, 205 East 19th St., Austin, Texas, 78701

Marshall E. Parker, Consulting Engineer

Dr. Joe A. Rice, Houston Baptist College

## HOUSTON STWP SEMINAR COMMITTEE CHAIRMEN

General Chairman - Victor Ehrlich

Program - Dr. Joe A. Rice

Arrangements, Registration, and

Accommodations - Dr. Christine V. Brannan

Technical Art Exhibit - Roy L. Magin, Jr.

Publicity - John B. Colby

Entertainment - Marx Isaacs

Finance - Harry F. Jones

## HOUSTON CHAPTER STWP

1967-68

David N. Holman	Chairman
Eston F. Meade	Vice Chairman
Howard D. Cole	Director
Alfred F. Fukal	Director
Harry F. Jones	Treasurer
John B. Colby	Secretary
Dr. Christine V. Brannan	Program
Louis A. Dartez	Membership
Marx Isaacs	Publicity
Eston F. Meade	Arrangements

CONTENTS

	Page
INTRODUCTIONS . . . . .	1
SPACE COVERAGE — PERILS, PROBLEMS, AND THE PAYOFF . . . . .	3
By Jules Bergman	
NEWS COVERAGE OF MANNED SPACE MISSIONS . . . . .	14
By Paul Haney	
THE ROLE OF THE TECHNICAL WRITER IN THE EARTH RESOURCES SURVEY PROGRAM . . . . .	20
By Charles M. Grant, Jr.	
SPACE DOCUMENTATION — A BOON TO THE CONTRACTOR . . . . .	45
By Joseph Godfrey	
LUNCHEON REMARKS . . . . .	51
"TODAY AND TOMORROW" . . . . .	51
By Dr. F. Curtis Michel	
SPACE NEWS STORIES AND PUBLICITY (PANEL DISCUSSION) . . . . .	56
Moderator: Lee Estes	
SPACE SCIENCE WRITING FOR THE GENERAL PUBLIC . . . . .	72
By William C. Sexton	
GRAPHICS PARTICIPATION IN THE MISSION EVALUATION REPORT AT THE MANNED SPACECRAFT CENTER . . . . .	78
By Roy Magin	



	Page
INFORMATION RETRIEVAL — DEFINITION AND PERSPECTIVE . . . . .	109
By John M. Stout	
STYLE IN TECHNICAL WRITING . . . . .	124
By Louis Alexander	

## INTRODUCTIONS

Dr. Joe Rice: It's my pleasure at this time to introduce Dr. Kenneth S. Pitzer, a distinguished chemist, educator, advisor to the President on science, former member of the Atomic Energy Commission, and a man who's been involved in technical writing in one way or another most of his life. The President of Rice University, Dr. Kenneth Pitzer.

Dr. Pitzer: Thank you, Dr. Rice. It's certainly a great pleasure to welcome you all here and I feel pleased to see such a large group. I suspect whoever in the Society of Technical Writers and Publishers has a problem of balancing the budget is especially pleased to see such a large group here. I join that view also. I do think that Space Science Communications is a very important subject and one that has concerned me a good deal in various aspects through the years. To see such a fine group giving serious attention to it in this, as well as in many other frameworks, is certainly most worthwhile and most pleasing.

Science becomes more and more complex and has more and more interactions with the everyday life of our whole community, as was pointed out vividly last night in a conference also going on this morning on urban problems, in relationship to the possible establishment of an urban problems research center here in Houston. The whole urban life is running into difficulties which we hope science will have some contribution towards solving. We're sure it will, but the problem of combining possible contributions from various areas are not normally within the professional expertise of a given individual. This comes back again to the question of reasonably accurate, reasonably profound, deep communication with explanations about the advances in one area of science that are helpful in assisting either scientists specializing in other areas, or educated, intelligent and concerned citizens generally, in applying scientific matters and scientific knowledge to problems of our community, both urban as well as national and international.

I'm pleased to see that you will hear Dr. Curtis Michel at the luncheon. I think he should make an excellent contribution to the program in that he is really a scientist of great distinction and yet in his present role has undoubtedly had a particular set of experiences in communicating science to a broader audience. It seems to me that this should be a particularly appropriate contribution. As I say, we're certainly very happy to have this group on the Rice campus. We wish you a most successful conference today and again, welcome to our campus. Thank you.

Mr. David Holman: Thank you, Dr. Pitzer and good morning. On behalf of the Houston Chapter of Society of Technical Writers and Publishers, our participants and guests, I'd like to express our appreciation

to Dr. Pitzer and Rice University for being our host today. I'd especially like to thank Lee Estes of the Rice University Development Office for his help in the arrangements. The Houston Chapter of the Society of Technical Writers and Publishers would like to give Rice's Fondren Library this Annotated Bibliography of Technical Publications.

I want to thank all of you for taking time from your busy schedules to be here today to discuss and consider technical communications in the space sciences. You know, in Houston basketball, today is "super Saturday" but right here it's "Seminar Saturday." An "in" word these days is "synergetic" which means working together. This seminar can thus be called a "synergetic seminar" because of the many elements working together to make this meeting possible. To mention a few, at the risk of omitting many, these elements include Rice University, of course, Brown & Root, Esso Production Research, Gulf Publishing Company, the Manned Spacecraft Center of the National Aeronautics and Space Administration or NASA — we usually refer to it as NASA — Bonner & Moore Associates, Redactory Services, American Photo Copy, and the following NASA contractors: Federal Electric Corporation, Lockheed, General Electric, IBM, Philco-Ford, Raytheon, and TRW. The contributors to the technical art exhibit are listed on a placard in the lobby at the exhibit. Our seminar chairman is Victor Ehrlich of the Bechtel Corporation. Our program chairman is Dr. Joe Rice of Houston Baptist College. It's now my pleasure to introduce Dr. Joe Rice.

Dr. Joe Rice: We have a full day lined up for you, and I'm going to waste very little time of it on introductions as we go along. These are prominent men; you've read about them in "Dateline Houston" or your programs, and in a case of a number of them, you recognize their work and are familiar with it. They have quite a bit to say, so we're going to give them full opportunity.

## SPACE COVERAGE — PERILS, PROBLEMS, AND THE PAYOFF

By Jules Bergman, Science Editor  
American Broadcasting Company

Mr. Jules Bergman: I'm not going to try to talk to you professionals about space writing techniques or methodology. I think sometimes too much has been said about that and not enough about the purpose of it all. I want to try to talk instead rather about some of the problems our society and the perils that it faces, and where science fits in and sometimes doesn't fit in. Science today, as you here full well know, has hurdled obstacles thought not merely impossible but insane a few years ago. Yet it walks a tightrope, trying to help a society that is beset by population explosions, food shortages, and unbelievable death rates in two-thirds of the world and slums everywhere. In short, science is faced with the challenge of transforming misery- and poverty-ridden mankind into decency before it faces extinction.

The two dramatic breakthroughs of the last few months — and we'll come back to that word "breakthroughs" a little later on — were the first human heart transplant and creating the basic molecule of life in a test tube; both point the way to much that lies ahead for all of us. The creating of DNA, deoxyribonucleic acid, pushes medicine toward the making and controlling of viruses and toward controlling the genetic formative structure of life itself. In themselves, these will lead to conquering at least the simpler forms of cancer that are virus-induced, and toward possibly controlling congenital birth defects by altering the faulty genetic strain.

As for the heart transplants, you won't see lines of people waiting to get a parts change at the neighborhood Chevy dealer soon, but we're not far off. Transplanting human hearts, once the human rejection mechanism is fully understood and controllable, will be the great interim step in saving many thousands of lives. And since five to six hundred thousand people each year in the U.S. alone die of heart disease, you can see that there will never be enough hearts for all who need them. But human heart transplants will save the first group, until a true artificial heart is perfected within the next three to five years. After that, thousands will be saved and at the same time we'll be moving toward routine transplanting of most other vital organs — liver and pancreas, as well as kidney and lungs, and ultimately limbs as well.

Medicine today is crossing a threshold into a new era with almost unbelievable promise. The critics who say it's too soon to transplant human hearts — that we don't know enough about the rejection factor — are the same kind of people who didn't think the airplane would ever get

anywhere. Well, the time is right for transplantations. Of course, there are unknowns in space as well as in science; there will always be. But medicine had about reached the limit with animal research, and we had to start with humans. Will there be a high death rate in these first heart transplants? It's too soon to say, but there may well be, and small wonder. It will hardly be unusual. The patients are all terminal, with only a few days or weeks to live at best. They invariably have liver, kidney and lung disease as well as heart disease. If they weren't so sick, doctors would be unable to attempt the transplant for fear that if a patient died medicine would be morally condemned. But a few years from now when transplantation techniques and methods are perfected, doctors will be able to tackle heart disease patients earlier, when there is a much better chance of their surviving. So let's not forget that in the hysteria that's about to ensue with the death of many of these people.

But what about the other problems we're now deeply aware of — the hovels, the slums in most of our cities that need rebuilding, the new planned cities that must be started fresh, the crises of our transportation system from crowded city streets to expressways that have become giant parking lots, to the air traffic congestion overhead, to building airports where we can fly and not wait? They are deep and searching crises and questions such as: Where are we going and why? Is this the best way to get there? We are besetting the people by confusion and controversy. There are multiple points of views for single questions, but seldom single answers for our multiple crises. Too often we wait too long for too many answers while the crises deepen. There are so many points of views on any given issues that we despair. I'm reminded of a recent letter to a close friend of mine, a gynecologist which read: "Dear Dr. Greely: Please send me some pink pills to prevent people. Signed: Isodora End." So Dr. Greely sent the pills to Isodora End. The follow-up letter then declared: "They're fine, but are they habit-forming?" Well, the trouble with our era is that we're finding pink problem-solving pills at a record rate but they're always habit forming. The sudden awareness of today's crises and the knowledge that we can solve them springs, I believe, in the Space Age itself and the ability it has given us to solve huge problems systematically.

Six years ago, what I call the third revolution began in our nation. One that saw many existing concepts and theories overturned, this technology revolution followed the earlier industrial and scientific revolution. We call that revolution Apollo, strangely enough, without anyone being aware of what it really was, and has proved that not only are things not as they seemed, but they don't end the way they started, or turn out the way they were planned, which is kind of a basic rule of science.

Stated another way, you could say in science it's what does not fit that counts. Amidst great confusion and controversy, as we all recall, the late President John F. Kennedy created Apollo to race the Russians and to land an American on the moon. To insure our preeminence of this space-faring nation, "to set sail," as he put it, on this new sea, we still found, while the Russians, our opposition, had flashy single car entries, we were alone in entering a big team on the track. And a funny thing happened to us on the way to the launch pad. Apollo cost so much that it made us examine deeply its worth and our goals and where we were going.

It also caused a national consciousness in exactly how much our science and technology was capable of achieving in any given field, be it space, medicine, or whatever. It will be a year next week, since the tragic saga of Apollo I ... pad 34, and though the smashing success of the first Saturn 5 flight has gotten us on the recovery road, there are many more tough hurdles ahead. The old days of heady confidence born of 16 straight Mercury and Gemini successes are gone. Things will never again be quite the same. Apollo I taught us, I believe, that men must be inspired as well as ordered, must be motivated as well as commanded. Those are axioms that ring true to those of us both in big corporations and large federal agencies. And somehow in the drive to get Apollo going, some of those basics were forgotten. We will get to the moon, of course, and I think it matters not whether it once had been targeted for late 1968, '69 or '70. The dates do not matter nearly as much as knowing why we are going.

It will be a hollow victory indeed if we land there and most of our people don't know why we really made the journey. This past year has seen an era pass in our space program and a new one begin. The era of promising better frying pans out of the space program is gone, thank goodness, and I hope I never see another technology utilization brief that cites "new methods of electronically arc welding titanium has a benefit to the overall civilian economy." It just isn't so, as we all know. Instead of making false claims, let us recognize the real value of the space program to our people in our nation: the technological revolutionizing of U.S. industry and the upgrading of engineers and scientists everywhere. And, a further, and an ironic spinoff of the Apollo safety improvements will, I believe, be safer fabrics, materials, and structures in aircraft, autos, and high speed conveyances, as well as the dedication to safety that has emerged from our subconscious for all time.

What about the Russians, you may ask. Well, we know they've had their troubles, no one knows exactly what they intended to do in space from the first place, but we do know our space program has forced them to try harder. The Soyuz I tragedy has taught them some lessons too, and we can expect the Soyuz II flight soon with the same objectives very

shortly now, as soon as Siberia begins to thaw out a bit. Another three-man spacecraft, it would seem, may be taken out by a single pilot and joined by a second spacecraft in rendezvous with perhaps a crew transfer. After perhaps two all-out missions, many of our people expect them to try circumlunar flights around the moon and back, perhaps by late next summer, long before we're able to, on the third Saturn 5 manned flight in Apollo perhaps. But again who gets to land on the moon first is anybody's guess. We still stand a slim 50/50 chance. They have now demonstrated rendezvous and finally docking. But both sides face massive technological hurdles and great risks over the next two years.

Landing on the moon, however, is no longer their goal or the end in space flight. The moon is a symbol of the technological excellence of our society. It is a beginning, a way station on a road where we've begun to notch out the first trailmarkers and have no idea where, if anywhere, we'll ever notch out the last. The real question is how we'll use space, if not for profit, then to advance our way of life and improve it. At the beginning of any new technology, such as ours, its ultimate goals and usefulness are beyond the reach of even our most imaginative minds and the history of science and technology is covered with underestimates, shortsightedness and repeated skepticism. I'm reminded of an old issue of "Popular Science" magazine. A famous engineer has written a review of the first flight of the Wright brothers at Kitty Hawk. Half of the newspapers neglected the event, thinking the Wrights pure "nut hatches" and the story too ludicrous to even deserve mention. If we'd had television, they wouldn't have covered it either. The famous engineer, a man named Chanute, of whom you may have heard, looked deeply into his crystal ball and predicted, "This machine may even carry mail in special cases, but the useful loads carried will be very small. The machines will eventually be fast, they will be used in sport, but they are not to be thought of as commercial carriers." That magazine issue was March 1904. And any hard-headed engineer would have laughed at aviation, even as some now laugh at manned space flight as having a really serious future. People were fresh from reading H. G. Wells, then 38 years old, or Jules Verne, then 76. Verne in a novel called "Master of the World" had written of a heavier-than-air machine that actually hovered or rose and landed vertically. A few years back Verne in another book called "Anticipation" had the sheer idiocy to suggest that airplanes might be major influences in warfare by the year 1950.

The point is simple: who among us can truly predict the value of what we've started in manned space flight, how space will be used, or how valuable it will be? The value of space flight is as impossible to predict now as aviation was back then 60 years ago. We do know its value already in terms of Comsat, Metsat and reconnaissance, but many of those functions, as we full well know, can be performed by unmanned vehicles as easily and sometimes better than manned spacecraft are able

to do them. The future uses of space are uncertain, and how we'll develop them is unknown in many ways.

First approaches in many fields are primitive and changeable. The point of all this is that, though we talk of manned flights, tomorrow it is Venus, even Jupiter flights lasting two years and even longer, and some skeptics even talk of bringing along female pilots because men can't be trusted alone that long. The point is that no one knows for sure just what we want to do, or must do. We'll only find out, not only by a great deal of difficult work, but by trying some of these things as well.

Sooner or later, when you aim to fly, you've got to get the bird off the runway. Well, sooner or later we will travel to the planets, and I submit we will get there in ways that will seem amazingly quick and cheap. Perhaps navigating to Mars within two to three weeks will be possible instead of the five months it takes by present projection. And while automated machines, as witness Lunar Orbiter, Surveyor and Mariner, can tell us many things, they cannot yet think and answer real riddles. They can suggest answers that man himself is the only one who can solve. As yet, we're not even sure, as you here full well know, which planet we should seek to explore first. Mars was once the favorite, then Venus, then Mars again. Now lunar scientists are intrigued by Jupiter, far off course in this cruel solar system. Too far off but showing many tantalizing signs of color that suggest possibly the gaseous state that harbors a species of life. And some think Jupiter may be more hospitable to life than any other planets, even Earth itself.

Many of the people I speak to around this country, including the television audience, believe we're moving too fast in space exploration. Well, I tell them that they remind me of Mark Twain's old river boat captain complaining of the hazards of the brand new-fangled steam propulsion. Twain, you may recall, after listening to the man's complaint looked up and declared, "All of this may be very true, but when it's steamboat time, you steam." Well, I submit this then is spaceship time — the exploration and exploitation of this solar system will be one of the two great technological feats and challenges in the next century. Somewhere or another I think we'll cap the process of the human race itself maturing from its present adolescence by answering the puzzle of how life began, where else it flourishes, or may, and in itself that will make space exploration worthwhile. Well, so much for the long look and the philosophy of space.

Now, a short quick portrait of today in our nation, where we argue about cuts in the space program — and the cuts should not have been made, while we worry about where we're going to go in space. It doesn't take much to realize how sadly we have neglected this strained and



tormented planet of ours, this young tired nation. Let the road to the stars be littered with the burned out hulks of the nation that was once called the United States. Much has to be done and I submit that we can do both: explore space and save our planet.

Let us tackle oceanography for example, another area I have to cover. Twenty-four federal agencies now share a pitiful 462 million dollars this current fiscal year for their total oceanographic research budget. Much more is obviously needed. This explosive planet, as some of you know, is already deep into the starvation gap; the protein foods, fish and plants in the seas, will soon be a necessity for our Western, as well as the Eastern, world. The pioneering fish flour work done by a small group of U.S. scientists points the way to the worldwide effort needed. Though the President declared the other night in his State of the Union speech that he proposed an international program to tap the oceans' wealth, I'm a skeptic so I'll wait until I see the funding. I've seen too much of a proliferation of programs that are never really funded, much less have the people to administer them. We need a large-scale program to farm the oceans now, using a new type of ship, a new technology. Two-thirds of this planet is water, and like the man who ignored his wife because she was there, we've largely ignored the oceans because they were there. The race to conquer inner space is now even more critical, I submit, than that to conquer outer space. Many people talk of mining the moon, and we may well one day, tapping what may be hydrogen gas there for fuel, or possibly recovering gold or valuable metals if they are there.

But mining the oceans right here is not only far cheaper to do, but much more essential to our survival. The cost by the time you get through bringing back one ounce of lead or iron from the Moon, if they are there, will be more than a pound of platinum costs here on Earth. And we know our oceans contain usable and commercially valuable deposits of manganese, zinc, gold, and other metals, as well as oil, and materials we're fast running out of here on the surface of the Earth. The development of efficient, practical ocean mining devices and methods has become a high priority national objective. It is interesting to note, by the way, that in budget and manpower the Soviet Oceanographic Program far exceeds ours. Russia long ago recognized the vital importance of the seas for food as well as research.

The real key to both exploring and harnessing the ocean will, I suspect, be man himself. We need and are heading toward inner space stations, if you will, with men living in them for months at a time, doing research in science, tracking fish schools, and even protecting our security. The "continental shelf" concept, which you may have heard of, and you'll hear much more of soon, explains the ideas of inner space stations along the continental shelf on the East, Gulf and Western coasts, holding perhaps up to a dozen men, a mixed group of scientists,

engineers, and medical and electronics experts. The Navy is interested because of their obvious value as early warning stations against ballistic missile submarine attack. They could at the same time research the seas as they have never before been examined. We need to conquer the oceans fully to live in them and to use them, and it will take an aggressive program to do it.

What about medicine, for example? We talk about cuts in the space program, we talk about not having a big enough oceanographic program. Well, if you'd look at the figures on U.S. medicine, as I've recently done, you find we're critically short of medical researchers. We need perhaps 25,000 more researchers, and 100,000 nurses, as well as 50,000 more doctors, if U.S. medical care is to be upgraded, as it must be merely to keep pace. And breakthroughs don't just happen, they're mostly preplanned. Without those researchers there'll be fewer and fewer breakthroughs. One researcher, perhaps after 20 years working on a single narrow thread of one facet of one problem, may untangle one small piece of the knot. That is a "breakthrough," that much maligned word in the popular press.

And we need more hospitals, along the way; part of the irony of today in this country is that scores of millions can't even be given the advantage of present-day medical care, because of the lack of hospitals. The decline of the U.S. hospital, especially in our big cities, is shocking. Try getting sick sometime at two o'clock in the morning in a major city when you can't find your own doctor: it happened to me once about three months ago. And it isn't just ordinary hospitals we need any more, it's a new kind of hospital, equipped with computers to record and diagnose ailments, and with biomedical sensors, those little body-attached radio sensors we developed in manned space flight, that transmit full-time radio signals to a central station the patients' temperature, heart rate, and blood pressure. Such hospitals would see the nurse and medics always able to watch every patient by using electronics. This is already underway in some hospitals, including one right here in Houston which was the pioneer. The medic feeds all the patient's readings and symptoms into a central computer bank that helps do the diagnosis and someday will both speed and make that diagnosis more accurate. Well, the automated electronic hospital is obviously the key to better medical care for more people at lower cost. They are technology's answer, the space program's answer, one of the real answers to the population explosion and along the way more medical schools are needed and more teachers and doctors are needed.

In education a similar problem, as the one in medicine, exists. We're midway in a painful gap, if you will, between the tried older methods and the newer methods relieving the teacher shortage. It's clear to us at the start that we need many more teaching colleges and teacher's salaries need upgrading to higher professionalism. At the same time, program teaching using computers and closed-circuit TV is

needed to expand and upgrade the quality of teaching. Witness the revolt of the teachers across the nation this past fall, and their fights for professional dignity. Think of our children, and you wonder what is really important. I asked myself the other day, "why doesn't the teacher in junior high school or high school earn as much as a bank vice-president or the highest paid engineers we have?" I couldn't find the answer to that question.

In aviation, also neglected now curiously enough in the last five years as you here full well know, we need not only the supersonic transport to guarantee our air superiority but even more desperately a practical VSTOL transport to operate from city center to city center. To help conquer the transportation crisis that's choking our cities to death, VSTOL is obviously the answer for the Boston — New York — Washington corridor, the Los Angeles — San Francisco corridor and for Dallas to Houston someday soon. And at the same time our air traffic control system — which is better than anybody else's by the way — but far more clogged, is not being automated rapidly enough. Most of our airports are hopelessly outdated. Houston International downtown here is a disgrace, and so are most of the airports in New York and Washington. The traffic tieup nowadays at JFK, Washington, or O'Hare, most of our major terminals, is not in the air. It's on the ground getting to the airport and on the taxiways waiting for the active runway. Black Friday, as we used to call it at JFK and O'Hare, is now black most every day between 5 and 7 p.m. Traffic is stacked up upstairs waiting to land, and on the runways waiting for the clearance to roll.

Even more major problems are ahead. The arbitrary cut in the air safety funds of the FAA recently made by the White House and the Budget Bureau cutting back the number of new radars and controllers are going to lead directly to more crashes. This is a nation that lives, breathes, and survives in the air. Cutting FAA funds was the greatest single mistake that could have been made. There were other places to cut, not in air safety, no matter how short we are of money because of Viet Nam.

And in transportation itself, besides in aviation, the United States is choking itself to death on a carpet of concrete and blacktop. We desperately need a national system of high speed and true transports or monorail in or under our major cities to prevent those cities from choking themselves any further with auto congestion. To get to the airport for example, the new form of Russian roulette in New York, is not seeing how long it takes to get to the airport, but in seeing whether you can make it at all. The old ways won't do any more. We need to use our technological genius, that same genius that Apollo triggered, that same genius that points the way to solving future perils.

And in housing, the most single neglected area of our technology, our cities are going downhill at an incredible rate. We need plastics and low-cost material to end the corrosive slums that are eating away at the heart of the strength of our democracy. And some experts think slums may ultimately lead to a revolution in this country. We need low-cost materials, with new types of answers using sandwich construction perhaps. With the insulation built into plastic walls, that may offer a potential solution to higher labor costs and provide decent places to live for all our people. Is the revolt in our cities any wonder to any of us, — really, when 40% of our people live in hovels, it's not going to end anytime soon. And in people, in ourselves, by the end of the century, there will be 6 billion of us on this planet. Well, assuming we find the food and the seed by more efficient methods than in farming and by using hydrocarbons for protein so that we all can survive, man himself will find it harder than ever to discover his own identity, and it's already a struggle in this society.

We have now, or know how to acquire, as one top scientist puts it, the technical capability to do very nearly anything we want to. We'll soon be able to chemically control our personalities as well as to transplant human hearts and order the weather we want. Not so far off we'll be able to get to Mars or Venus — but will we be able to live with ourselves here on Earth? The conquest of technology obviously offers us the opportunity to do most anything, so the question will be: what should we do? How shall we best use that science and technology?

Well, this has been characterized by the philosophers as the age of overact and underthink, the jet age, the space age, the computer age; in an age of nothingness, there's a limitless demand for instant everything — from instant sex, to instant encyclopedias on instant sex. The point is man himself must somehow prevail in this confusion. If we lose track of that, we lose ourselves. So the study of man himself, perhaps a new science, and the art and science of the individual must be given far more attention than it now receives. Why we do what we do is perhaps more important sometimes than what we do. The tasks of the future in these perilous years ahead are awesome. We have to push our science and technology to save our planet and our society, and push ourselves to discover what we really are and can be. Oceanography, space travel, housing, medicine, all of these things must be pushed.

The work that lies ahead for engineers and scientists and even writers is awesome, yet immensely promising. And there has to be a closer interaction, by the way, between those three groups. Some interesting definitions have been ricocheting around. The engineer is a man who learns more and more, somebody says, about less and less. The writer learns less and less about more and more. And the scientist thinks he's learning more and more, but sometimes he's really learning less and less. Sometimes in fact we've learned, as Charlie Allyn expressed it last night,

everything about nothing. That's one of the perils that meets us. The philosopher and planner, Louis Mumford, looking on a strangulation of New York, commented recently, "I am an optimist about possibilities, a pessimist about probabilities." Well, the glib word of years past seems hollow indeed when confronted with the awful reality as to what we have to do. But the key is there again, using technology, and we hardly do now. Those who potshot at the space program should remember the space race by dramatic counterpoint showed us what had to be done on this Earth and what could be done.

If we move now, if we accept some of the challenges during the remaining third of the century, there's immense promise ahead by the year 2000 A.D. The promise many of you have read about, — 5,000-miles-per hour hypersonic transports to take us anywhere in the world within three hours — will be a problem of not getting there but adjusting to time changes. We may need drugs to conquer the time barrier. Consider these promises, the vertical transports we've spoken of, the underground high-speed tube transport, underwater colonies for mining and explorations, the use of reinforced plastics and composites precast or molded on the spot to solve the home and housing problem.... Nuclear power for electricity and drinking water everywhere and to reclaim all the world's deserts for farming and new cities.... Nuclear power to drive underground trains and nuclear engines, by then, may propel ultrasonic aircraft.... Certainly thermal nuclear energy will have triggered interplanetary space travel giving us low-cost, long-life engines to get us anywhere. And I submit this should be our number one project. Since if all else gets shelved by Viet Nam or budgetary problems, the Earth by then will be uninhabitable and nuclear spaceships will enable us to escape.

In genetics, we will by then put the code to work, perhaps ending congenital birth defects, and eliminating many inherited diseases. All dread diseases will have been eliminated most everywhere by the year 2000 except for the remaining villain, of course, the common cold and hay fever. The normal life span should be by then 85 to 90 years and anybody suggesting retirement by age 65 will face unthinkable punishments. What that longer life span will make possible, one researcher suggests, is two or more careers for most of us. At age 40 or 50 we might go back to school and retrain ourselves for another career. Just think of the possibilities. Politicians could become statesmen. Statesmen could become politicians. Nasser would gain the time to retrain the Egyptian army and lead them to certain disaster again. Well, those are some of the promises of 2000 A.D. — the promises distilled by top researchers. But our real goal in research, one told me recently, is to reduce chaos to mere disorder.

Rodger Rossel summoned up the peril of this era recently in this way: "This Earth," he declared, "is all we've got and we better learn

to cherish it; it's probably man's only home," or as another top scientist put it: "The world has become too dangerous for anything less than Utopias." Thank you.

## NEWS COVERAGE OF MANNED SPACE MISSIONS

By Paul Haney, Public Affairs Officer  
NASA Manned Spacecraft Center

Thank you very much, Joe. Jules, that was very heady stuff. Who's writing your material now? I think it is an interesting twist of assignments this morning: to produce a portion of his remarks Jules Bergman looked to appraise NASA which he is certainly able to do and I'm assigned to appraising what he might be better able to do because I find particularly during interesting missions I'm so caught up in the activity of the mission that I'm really not too much aware of how the coverage is going or who's writing what. It's all by an incidental kind of thing that I've become aware of it when somebody will say in my one good ear that: "Boy, you ought to hear what Bergman is saying." I've got a monitoring set and punch up my monitoring set. You know, in the next announcement we will try to clear it up. All in all, it starts out, and through the good efforts of our librarians and our group I did become aware of what people said, at least after the fact.

I think to really appreciate our topic we ought to go back in time this morning, go back to the late 50's and even before NASA, and certainly at the beginning of NASA, to get an impression of what news coverage is like. Some of you may have been involved, I don't know, I don't see too many familiar news faces here. I know Jules Bergman was, so if he's the only one aboard, I'll press on. But in the late 50's the Department of Defense, up until the fall of 1958, had the major responsibility for missile and space activity, and they had a news coverage policy that was without a doubt the most ridiculous policy that this dear old government of ours ever concocted. I never understood it, but it went something like this. We were obviously getting into a very active era of rockets and missiles and we knew it would take a fair portion of the public's support to do or fund these projects, but somehow we were to do it without letting the public know about it, or let them in any way understand it. Furthermore, we were going to fire them off the East Coast of Florida, and with some of the larger experiments, knowing full well that they could be seen 200 miles north and south of the Cape. Now that's really an interesting assignment: how you can keep a bushel basket over something like that. But a succession of people tried, I guess Morie Synder was the last one to have to try it and the Vanguard happened in his time. Vanguard ebbed and flowed and the policy literally changed from day to day. One day they would reserve the Patrick Air Force Base theater and have a really detailed and good solid briefing, and the next day word would go out that the Cape was closed to all newsmen. The policy of Vanguard normally was exasperating more than anything else but it vacillated similarly on the early rocket tests in '56-'57 and '57-'58. On the Thor, Jupiter, and

Atlas programs, more often than not, the press would find itself huddled out on a little sand strip looking across a canal into the Cape area itself and if they had done their homework and paid someone properly, they might get a call saying maybe in about 5 minutes. It was all very mysterious and if I might sound overly sympathetic, it's because I was still an "honest" newspaper man myself at that point, having not gone over to the other side. But in the fall of 1958, NASA came into being and when I went to work there in December of '58, we still had interesting little policies that were all hangovers from the Vanguard days which went like this: All launching dates were classified up until T zero until the rocket actually launched. This I suggest is an interesting assignment too. How can you convey to people that there is going to be this launch only if you do convey it and violate security? I believe very firmly in the national security. I know there is a very urgent need for it and I defend it, and even defended it for two years in the uniform of the U.S.A., but I defend it also and I think enough of it that I don't like to see people abuse it willy-nilly. I'm afraid that's one of my favorite sayings. But on this I think you'll agree, it was certainly a ridiculous kind of arrangement — but it persisted for fully the first year and a half at NASA — that we would go right down to T zero before everything was released. I can remember the flight of two little monkeys (Rhesus monkeys) on a Jupiter which was an experiment inherited from the Army, which went sometime in early '59 and again the old policies at T zero: "It's all releasable or anything you can get your hands on." I can remember sitting in my office in Washington and passing pictures across the desk to people all of which were stamped "Secret" but, as of that moment, they were no longer "Secret."

Well, finally, it did change and it took a tremendous stride forward sometime in late '59 where at T minus 4 days we could publicly announce the launching date. That certainly was a great improvement over T zero but if it did tie up too many phones at that critical T-0 but T minus 4 obviously wasn't the ultimate solution, it was primarily a case of getting people more used to the fact that these things were going on and perhaps people could understand them. When we went into the Mercury days, and started the Mercury flight, the other in December of 1960, as a matter of fact, another very significant happening in the information program of NASA occurred, wherein the first administrator of NASA, T.G. Glennon, at what I consider an historic meeting one day in December of 1960, approved the formation of a pool to cover the Mercury flight. The pool would be drawn from all the media and would man the key locations where space and time were small and they then would feed their products in the common area of the news center from which all the other interested reporters could draw. This made a tremendous difference and it was also about the biggest, and the single greatest geographically, newspool ever attempted because we literally pooled the whole world. We had people out on the recovery ships, people in special locations should



trouble develop, and we had people at key points around the pad. We've gotten so used to it today, we do take it for granted but still, it's not without its important features.

The coverage, to make a few remarks, the coverage during Mercury is very hard to recall just what to portray this feeling of people during the Shepard flight. Which I think was sort of a pinnacle of all this coverage at least as far as reporters were concerned. The day that Alan flew there were about 400 people at the Cape which was all we could take in the first place. Even among the reporters, certainly among the public the impact of space was never more clear. People were glassy-eyed, they were crying, they were laughing, they didn't care what they were doing. The drama was so much. Naturally, this has settled down, fortunately, but it was very apparent during that period. It didn't just stop there with the Shepard flight, another curious thing about Shepard flight, that I recall very vividly, was the parade, the only parade we had that marked the Shepard flight as unusual. We really got into the parade mood there for a while after Cooper's flight we had seven parades in six cities in six days, starting in Honolulu and ending in Oklahoma. But in Al Shepard's case we had a parade in Washington, as we went down from the White House, up to the Capitol, down Pennsylvania Avenue, the people on the street applauded. I've lived in Washington for 10 years and covered an awful lot of visiting potentates and people who would acquire crowds along the curb, but I've never seen one where the people applauded. This gives you also an idea of the headiness of news coverage area and what it can do to some people if you let it.

A favorite recollection of mine happened after the Glenn flight: I went into New York for the first of two ticker tape parades and as usual, it seemed like in those early Mercury flights, wherever we flew some other, very natural news story broke and that day was certainly no exception. To give you an example during one of the early Mercury tests just as we got down to about T minus 15 minutes, the carrier exploded in a drydock in Brooklyn, (I remember) killing a lot of people. It was almost as if we were competing for Page 1 with the natural news of the disaster. In any case, the day of the Glenn flight, 45 minutes before the parade was to begin, a big American jet went in on takeoff at Idlewild, about 5 miles away from where we were circling at La Guardia. This had the effect of pulling about 3 or 4 thousand police out of the lines in downtown Manhattan where they were really urgently needed. There were an awful lot of people out there that day and the parade went ahead, of course.

The festivities were fantastic over a two-day period and it got to where if somebody wanted to go get a pack of cigarettes it always meant a police motorcade and you began to routinely to get into the sixth car

or seventh car it was just automatic, like reaching for a fork when you eat. This, believe me, was pretty heady stuff for us dear mortals, but I've often thought if you have enough elevators held for you, or if your picture's in the paper often enough, it's going to have an effect after awhile.

Well, as I say, this went on for two days and finally on the third morning we were headed back for La Guardia over the same Triborough bridge over which we had come in from La Guardia a trifle 48 hours earlier, and by this time for once there was not a huge throng of people outside the Waldorf. And we started across the Triborough bridge and naturally whizzed right through the turnstile. There were about 12 cars in the motorcade and people were looking back remembering the fireboats and how they were squirting water 2 days ago in the river. All of a sudden the Triborough bridge commission truck hailed us, stopped us in the middle of the bridge and the fella said, "that'll be a quarter a car and the gentlemen (in the front seat) from the Mayor's office, said, "No, you don't understand. This is the NASA party, Col. Glenn and all those wonderful heros?" and the fella said "Look, I don't give a damn who they are. Just give me a quarter a car!" And so help me, high above the East River, we paid a quarter a car. I think that's the greatest.

So you can't let that stuff go to your head or it will, really. That always brings me back to Earth whenever I need to be brought back, believe me, it's better than a reentry.

Where's all of our news coverage headed? Well, I don't know. In space we have been successful beyond our fondest dream, I think, in manned space flight and like any good news story, I understand this, but I'm not sure everybody in NASA does. It begins to go down as the news item if it is all that successful. You know, the Post and the Chronicle don't write stories about all the little children who get home safely every day from school, but if one of them gets squashed under the back of a truck that's unusual and that becomes a news story. If you understand that, then you can better understand a million words went into the fire last January by way of the coverage. That's probably three or four times as many words as ever went into our greatest days, Shepard's flight, or John's flight or things like that. This will be the rule from here on in and there will be some single peak kinds of achievements that will provoke great coverage, but from now on the coverage will increasingly be on the negative side. There was only a small amount of coverage the day the B-70 flew the first time. But when Joe Walker and those other good souls got clobbered out there in the desert, there was quite a bit of coverage. And that, I think we all need to remember, is a fundamental news approach.

Within NASA itself we've got a lot to do in the information area, I think, an awful lot to do, both within and without. We have

fundamentally to deal with a very conservative fellow called an engineer. He's extremely conservative, which is part of our success, of course. But he has never taken a course much in news and how it operates. He would much prefer, I think, to let something happen a few times and know that it's going to work before he wants to share his expertise with even the fellow down the hall, much less the outside world. I don't know where this terrible fear of failure starts, but I think it's the fear of failure (or putting it positively, honest conservatism) but it certainly is there. It manifests itself in many ways, I've called it frequently in-house, and again today actually, in discussing a few things, and I'm not trying to make headlines, and rather hopefully I won't.

But I think there is an importance to convey some information here, if we are to achieve a better understanding. One of my biggest criticisms are people, who within NASA and within industry (there is no difference), who invoke national security when they're really talking about job security, their own job security. Or in the case of industry, they invoke proprietary information. And if anything, it is probably more difficult in industry because within the government itself, there are other things happening, the new information law last July, that is certainly no cure-all for all the difficulties. In fact, it's probably going to start some big nasty fight that will put the whole information system in retrogression for a few years, but so be it. It wasn't getting any better in and of itself. That's a personal problem, I think, and we need to do a lot more work with Mr. Engineer.

Another device that occurs more all too often at NASA is something called, (I think it is particularly devious), is the RTQ's (the response to query). I don't know how many of you are really concerned with this, but obviously if you have an opinion or position on something, I think you should make it known and not come in and just wait for somebody to ask you the critical question. They play games with this in Washington and people would call in and say where (it's a device used more in Washington than anywhere else, I will say that) but they would call in and say, "Well, what RTQ's do you have today?"

I recall another favorite posture that occurred one day when a fellow called in and asked how business was. I said, "Well, it's so slow that we haven't denied anything all day." The denial of RTQ is a very interesting thing. There still is within our great agency a tremendous amount of indecision that I think we need to do better on, both internal and external. I think we need this largely for outside inspirational purposes. I think any agency needs at least to give the appearance that it knows exactly what it's doing.

Even if you go a little bit astray, I'm afraid you're in deep trouble. I don't think it helps much when we get into a situation like we

did back last summer the day we scrubbed the famous scrub and launched 201 in a matter of minutes. We had one almost like it last night where we put out a scrub announcement. I got a call at home around 10:00 p.m. that this LM flight was scrubbed off, at least until Tuesday, probably till Wednesday. This is something you learn to live with in the business and you just automatically let everything slide and certain things get out of kilter. And 45 minutes later, I got another call: "Well, we're not too sure of that, maybe we are going to change it, maybe we will try Monday after all." And that's bad, you know. Particularly for the poor fellow who has called up and cancelled his reservations and his plane ticket.

Another fundamental problem we have, that we have dealt with very well to date, and in fact it is going to become more of a problem, is the scientist in NASA and his right to publish in a professional journal. This is the issue that we should publish first in a professional journal. It is an issue I used to go around vigorously with Homer Newell who ran and still runs the science program back in Washington. We finally reached a policy which said that NASA would release the news the day that the publication came out. Like "Science magazine" or whatever. That is certainly as much as I think the agency should back off. I can understand an individual researcher operating under a grant, not necessarily from NASA, who might be able to strike a better bargain. But I think if he is operating under NASA funds that it should be made generally available and not go directly into a magazine. Not everybody shares my view of that within NASA.

Finally, as an apology or kind of an explanation of our job out there, despite the beautiful introduction that Dr. Rice gave us, I look upon us not as public relations people as such, although we certainly get into those areas and touch a lot of them. But we in fact do not have a PR mission; we are enjoined by law from going out and aggressively selling space and marketing it, if you will. Which is probably just as well, because a lot of people are confused and I think this is our principal job. In the information department I look upon our job very much as you would a librarian. I think we ought to have the information and I think we ought to be able to bring it up to the window or counter and if you want it, I think you should come and get it. It would be well worth your trip. Thank you very much.

THE ROLE OF THE TECHNICAL WRITER IN THE  
EARTH RESOURCES SURVEY PROGRAM

By Charles M. Grant, Jr.

INTRODUCTION

One of the most interesting programs currently being developed by NASA and one which perhaps offers the greatest scientific and economic potential to the world is the Earth Resources Survey Program. The technical writer's role in the Program will be comprehensive — from the early planning stage to final data utilization. He will be expected to take what is termed a "systems approach" to his writing. This means that he will not only be familiar with the hardware and the data collected by it but he will also understand the system as an entity and its place in the total program.

A factor of importance to the writer is the large family of documents with which he will work. These documents may include everything from long-range plans through ground-truth survey reports to detailed evaluation reports of a specific location or discipline. Such a diversity of documents will demand the best from a technical writer.

It is anticipated, then, that working in the Earth Resources Survey Program will be both a challenging and rewarding experience for the writer. In addition to his more traditional role of technical writer and editor, he will have an opportunity to act as an observer, a researcher, and an aide to the scientist or engineer.

In the following sections we shall examine the Program itself, the equipment and test sites, the users, and the way in which the technical writer will interface with the Program.

EARTH RESOURCES SURVEY PROGRAM

The earlier space programs have demonstrated that certain earth phenomena can be more easily interpreted when viewed from space. NASA is currently supporting research into remote-sensing equipment and techniques having possibilities for the detection and identification of earth resources.

Earth resources may be defined as such naturally occurring materials as mineral deposits, fish resources, timberstands, crops, land, and cultural resources of value to mankind. The combination of a rapidly expanding population and an increasing use of technology is causing an enormous demand for earth resources of all kinds. In order to step up the surveying and investigation of these resources, NASA has initiated the Earth Resources Survey Program. A comprehensive study of the earth's surface from space is a complex problem requiring the application of many different disciplines and technologies. It is only by adopting a coordinated and integrated approach that the ultimate objectives can be achieved. As we shall see, the technical writer's part in helping achieve the Program's objectives can be significant.

### Program Objectives

The objectives of the Earth Resources Survey Program are shown in figure 1:

1. Development of the best combination of instrumentation, procedures, and interpretational methods for gathering resource data and testing these in experimental spacecraft
2. Discovery and delineation of those earth resources from space which will be of economic value to the nation and the world

At the present, five broad areas of earth resources have been identified as potentially suitable for the applications of space technology: agriculture and forestry; geology and minerals; hydrology; geography, cartography, and cultural resources; and oceanography and marine resources. Figure 2 shows some typical earth-resources data applications in each of these five areas.

### Major Phases of the Program

The Manned Spacecraft Center at Houston has been designated as the lead NASA Center with respect to the Earth Resources Survey Program. A large number of Federal agencies, universities, and research institutions are also participating. The overall Program, as currently planned, can be divided into three major stages or phases, as shown in figure 3:

1. Feasibility phase. During this phase, aircraft flights over carefully selected and controlled test sites are being flown, employing a number of airborne photographic and electronic remote sensors. Using data obtained from these over-flights, the correlation and relative value of each sensor to the phenomena in question are being studied. Data from current suborbital and orbital flights, such as Nimbus and

Gemini, are also being used to obtain some limited sensor responses. These data are being analyzed and used as a basis for relating aircraft-obtained to spacecraft-obtained signatures or patterns. In addition, several experiments related to the collection of surface earth-resources data by Apollo spacecraft will be initiated during this phase.

2. Spacecraft testing phase. Space flight missions will be made for the primary purpose of acquiring data for extensive studies of the earth's resources. These Apollo Applications Program (AAP) flights will use manned spacecraft and be capable of carrying a large number of remote sensors. On these flights, coverage will be of areas such as the United States where ground controls will be used to verify the conclusions derived during the feasibility phase. A number of earth-based sensors, such as buoys and stream gages placed on or near the earth's surface, for detecting, recording, and transmitting, via spacecraft, may be used to collect a variety of earth-resources data.

Also during the test phase, several unmanned Earth Resource Satellites may be flown. These satellites, with an expected life in orbit of a year, could be an outgrowth of current spacecraft. The Earth Resource Satellites are expected not only to acquire data using sensors in the spacecraft but also to collect and relay data gathered by sensors on the earth's surface.

3. Operation phase. After the testing phase, the scope and magnitude of the Program will depend on the results of the earlier phases. Indications are that it will be multidiscipline in nature, global in extent, and more or less continuous, as many of the important phenomena associated with resources are time variant.

#### Flight Equipment

In support of the objectives of the Earth Resources Survey, NASA is currently sponsoring an airborne program to define those sensor systems which will be of greatest value for recording earth phenomena. It is recognized that the airborne flights are not the final Program objective, but do serve to calibrate the instruments over known areas. Those instruments and techniques found successful in the airborne flights will later be utilized in the space flight missions.

The experience gained from this airborne program is providing a basis for planning the space flights. The Program calls for the installation, in various airborne vehicles, of appropriate electronic and electro-optical sensors covering selected parts of the electromagnetic spectrum.

The airborne program has been subdivided into three major phases: low altitudes (1500 to 20 000 feet), intermediate altitudes (20 000 to 40 000 feet), and high altitudes (above 40 000 feet). To satisfy the objectives of the low-altitude phase, a Convair 240-A, based at the NASA Manned Spacecraft Center, has been equipped with a number of sensors and data have already been gathered over a number of test sites. Figure 4 shows the instrument locations on the Convair 240-A. Additional work in this phase is being carried out by aircraft assigned to other government agencies.

The intermediate phase will use the Lockheed P3A (also useful in the low-altitude phase) and, perhaps, the NASA/Ames-based Convair 990 over the same test sites. The vehicles proposed for high altitudes may include aircraft, drones, balloons, sounding rockets, and spacecraft. Information on the nature and extent of the high-altitude phase is still in the planning stage.

#### Remote Sensors and Their Uses

Many types of instruments have been developed for use as remote sensors. Each sensor, including the photographic types, does nothing more than store or record data from some portion of the electromagnetic spectrum. The sensors measure radiated energy emitted from the earth's surface and modified by the atmosphere. The intensities of radiation that are actually measured by the various sensors are compared with theoretically found intensities. Deviations from the theoretical, of course, are of interest.

Of the many types of remote sensors, aerial, panoramic, and multi-band cameras seem to have considerable promise. Similarly, the optical-mechanical scanner, side-looking radar, and gamma ray spectrometer appear to have sensing value. Figure 5 shows several of these sensors.

A number of full-time research projects in each instrument area are being carried out by scientists in Government agencies and private organizations. These studies are directed at establishing feasibility and at advancing the "state of the art" in instrument design, data acquisition and data reduction relative to airborne and spaceborne remote sensors as they apply to the various user disciplines.

The present sensor systems are all experimental in nature. Their purpose is to determine the feasibility of applying the space sensors for use in earth studies. Because of some of the complexities involved, the systems are initially being developed for manned flight. However, as problems are solved and experience gained, the various sensor systems may ultimately be developed for unmanned flights as well.



## Program Test Sites

Earth Resources Survey Program test sites are of two types: instrument-calibration sites and data-acquisition sites. The instrument-calibration test sites should be areas which have been studied in great detail in one or more of the intended sciences.

At present, the Program policy calls for the establishment of a test-site committee empowered to select and set priorities for the study of test sites. This committee consists of a chairman for each instrument team, a manager of each discipline, a NASA representative, the aircraft project manager, and a representative from the Office of International Affairs.

Data-acquisition test sites should be suitable for the purpose intended; that is, for the field of study in which the data will be used. They should not be larger than necessary or in inaccessible terrain.

To date, 160 test sites of both types have been selected in the continental United States. In addition, approximately 60 sites have been tentatively selected for flights abroad. Figure 6 shows the location of test sites in the United States.

Site descriptions have been prepared for 63 of the U.S. test sites. These descriptions are prepared by investigators supporting the Earth Resources Survey Program and give in considerable detail the facts of the particular site. They are used to verify and correlate the flight data taken over the site. For this reason, the site descriptions form part of what is called "ground-truth" surveys. As the Program progresses, additional sites are expected to be selected, both in the United States and abroad.

## POTENTIAL USERS OF THE PROGRAM

The potential users of the wealth of data expected to be acquired during the Program's life may be divided into four categories: other government agencies, private industries, universities, and foreign governments.

The Department of Agriculture, for instance, plans to use remote-sensing equipment to make large area surveys of land use, monitor wild-life migrations, predict future crop yields, warn of insect infestations, locate reclaimable land, and make several other types of surveys. Figure 7 is an excellent illustration of the use of remote sensing to identify soil and crop types.

The Treasury Department has shown considerable interest in determining the spectral signatures of various types of narcotic-producing plants. For instance, if poppy fields could be detected readily, the Department would have an excellent tool for the control of the illicit trade in opium and heroin.

The Forest Service is investigating the use of remote sensors in detecting and locating forest fires. When developed, these devices will enable the Service to provide continuous coverage over the millions of acres of forest lands within the United States.

The U.S. Geological Survey plans to use spaceborne remote sensors to provide advance warning of earthquakes and volcanoes, such as the Kilauea Volcano shown in figure 8.

Orbital data evaluations will be useful to private industries in many ways. For instance, the shipping industry, by even a small improvement in routing techniques, will be able to realize significant dollar savings. These improvements can be expected to be derived from orbital data concerning wave heights, channel shoaling, iceberg location, et cetera. Other uses of commercial value would include the detection of underground rivers, fast and accurate topographic mapping, and the location and delineation of mineral deposits. For example, figure 9 provides a striking illustration of the superiority of multi-spectral photography to conventional photography in charting the ocean floor.

At present some 31 universities located across the country are cooperating with NASA in the Earth Resources Survey Program. Many of the principal investigators who carry out ground-truth surveys of test sites are from these universities.

As the spaceborne phase becomes a reality, the scope of the program is expected to broaden. Relationships with other nations and their governments on many aspects of the Program will become commonplace. The data obtained will be useful to many nations, yet each will have its own particular problems and priorities regarding utilization of the Program's data.

#### THE TECHNICAL WRITER AND THE PROGRAM

The technical writer will play a challenging and rewarding part in the Earth Resources Survey Program. His participation will be needed from the planning phase through the final report preparation phase. He will find that the tasks he is called upon to do require a varied background of education and experience. He will need to be versatile and

intelligent. His part in contributing to the success of the program will be significant.

#### Current Role

At present, only a few writers are working in the Earth Resources Survey Program. These few people are engaged in preparing air flight mission summary reports. Approximately 150 of these flights have been completed to date with more planned. Each of the flights is documented with a mission summary report. This report covers the mission objectives, equipment status, and flight-log data. No attempt is made in these reports to discuss the data taken or its evaluation.

Although the total number of technical writers engaged either directly or indirectly in the Earth Resources Survey Program is presently quite small, as the Program advances, the need for technical writers will undoubtedly multiply due to the increasing number of people working in the Program and to the increase in the data flow.

#### Future Role

Now let us examine the future role of the technical writer in the Program. Currently, nine types of technical documents are being issued under the Program (figs. 10 and 11). You will note that the documents are divided into phases, which we shall discuss later.

Under the planning phase (fig. 10), mission requests which cover the reasons and plans for air or space flights are shown, along with site maps showing the pertinent features of selected test sites.

Within the data collection phase (fig. 10), we have listed both mission reports, which detail flight conditions and instrument performance, and site descriptions of the test areas.

No documentation is carried in the data cataloging phase.

The most important documents are issued by the various investigators and scientists and are seen under the data dissemination and utilization phase (fig. 11). These documents cover detailed reports of sensors and resources and progress reports of various projects being conducted under the Program.

Figures 12 and 13 illustrate the data flow, including several of the documents just discussed. You will note that the flow is divided into four phases.

1. Planning Phase. This section would include short- and long-term plans for both air and space flights, as well as ground-truth surveys of test sites. Technical writers would assist in the preparation of all types of planning documents.

2. Data Collection Phase. In the flight portion of this phase, the technical writer would act as observer and aide on the flight and later help in writing the mission summary report. On the ground portion, the writer would act as observer and aide on the ground-truth survey of the test site. Later he would work on the preparation of the technical report covering the survey. Also during this phase, the writer might be expected to aid in the matching of the ground-truth and flight data. Perhaps he will help in the library research and preliminary interpretation of the data itself.

3. Data Cataloging Phase. This phase will encompass the classification, preliminary evaluation, and cataloging of both the raw data and the reports prepared in the earlier phase. The writer who has the proper background could be expected to help here with the preliminary evaluation.

4. Data Dissemination and Utilization Phase. The final phase concerns the dissemination of the raw data, mission and technical reports, and any preliminary evaluation reports which have been prepared previously. This material will be distributed to a university or to a principal investigator. Again the writer might participate in any or all of these areas, helping with the necessary research and data evaluation for preparation of final reports. These final reports would form the basis for a proposal to explore or develop a specific resource. They would return to the MSC document file for release to other government agencies and private industry users.

#### Requisites for the Ideal Technical Writer in the Program

What type of technical writer is needed in this Program? We have discussed some of the documentation he would be concerned with and also how he might fit into Program operations. Now let us examine the educational and experience requirements of an ideal technical writer.

To date, the technical writer's education has widely varied from individual to individual. Successful technical writers have entered the field from other professions, and a lesser number have entered the field from other areas of writing. Only a few writers have received

formal university training in technical writing as such. Reflecting this general pattern is the background of a typical technical writer engaged in writing for the aerospace industry at MSC. For example, the technical writing group of a single NASA contractor has writers with degrees in 17 different disciplines.

Although almost any discipline might be represented by a writer in the Program, figure 14 illustrates an optimum educational background for the more successful technical writers entering the field. Such a background would include a degree in an earth science or engineering with courses in physics or chemistry. Graduate work in science or technical communications would be helpful.

As in the case of educational backgrounds, writers have come to the Manned Spacecraft Center with widely varying backgrounds of experience. They have come from other industries, from the aerospace industry at other locations, and from universities and schools. Length and type of experience seem to follow no common pattern. Yet most of the people have found aerospace fascinating and have contributed significantly to technical writing in this field.

Again, as with the educational background, it does not appear that a particular kind of experience in a restricted area is necessary. We have observed, however, that industry experience per se is important, either as a professional technical writer or as a practicing professional in a scientific area. Service with some type of government survey would also be of invaluable help to a technical writer working in the Program.

Figure 15 is an example of the complexity and interrelationships of the disciplines involved in just one possible use of the Program. We have indicated here five major disciplines: geology, physics, chemistry, engineering, and economics. We have also shown the secondary disciplines arising from the blending of the primary disciplines. All of these sciences are necessary for the proper exploration and development of a single type resource — in this example, a mineral deposit.

## CONCLUSIONS

We believe, basically, we can make four conclusions concerning the Earth Resources Program and the technical writer's role in that Program.

1. The Program results to date have shown that the rate of data collection has accelerated tremendously compared to earlier efforts. Similarly, the types of data being collected have multiplied. The

aerial camera has been replaced by more and better types of photographic and electronic sensors. There is simply more data being collected.

2. As a result, the time required by the Program engineers and scientists in planning, interpretation, and evaluation has been increased many-fold. Also, the correlation and coordination of the wealth of data acquired is more exacting and time-consuming.

3. Of necessity, with the increase in the workload imposed upon the engineers and scientists, it will fall upon the technical writer to relieve them of the burden of preparing the data and seeing that it is disseminated to the scientific community and to the ultimate users.

4. Although in the past, the writer's task has often ceased when a document was published, we envision a much broader role for him in the Program. Not only will he relieve the scientist of the burden of data preparation and dissemination, but he will also help the cataloger in providing identification keys for each document. Finally, as the mass of data grows, the writer will be required to interface with data storage and retrieval systems.

## **OBJECTIVES**

- **DEVELOPMENT OF THE BEST COMBINATION OF INSTRUMENTATION, PROCEDURES AND INTERPRETATIONAL METHODS FOR GATHERING RESOURCE DATA AND TESTING THESE WITH EXPERIMENTAL SPACECRAFT**
- **DISCOVERY AND DELINEATION FROM SPACE OF THOSE EARTH RESOURCES WHICH WILL BE OF ECONOMIC VALUE TO THE NATION AND THE WORLD**

Figure 1.- Objectives of the Earth Resources Program.

## **SOME POSSIBLE APPLICATIONS BY AREA**

- **AGRICULTURE AND FORESTRY PRODUCTION**  
**GATHERING OF DATA ON PLANT VIGOR AND DISEASE FOR INCREASING PLANT PRODUCTION**
- **GEOLOGY AND MINERAL RESOURCES**  
**GATHERING OF DATA TO AID IN DISCOVERY AND DEVELOPMENT OF MINERAL RESOURCES**
- **HYDROLOGY AND WATER RESOURCES**  
**GATHERING OF DATA TO AID IN LOCATION AND UTILIZATION OF WATER**
- **GEOGRAPHY, CARTOGRAPHY, AND CULTURAL RESOURCES**  
**GATHERING OF DATA TO PERMIT BETTER USE OF RURAL AND METROPOLITAN LAND AREAS**
- **OCEANOGRAPHY AND MARINE RESOURCES**  
**GATHERING OF DATA TO AID IN OCEAN TRANSPORTATION AND UTILIZATION OF FISHERIES**

Figure 2.- Some applications of the Earth Resources Survey Program.



## PROGRAM PHASES

- **FEASIBILITY PHASE - EXPERIMENTATION FROM AIRCRAFT TO ACQUIRE SIGNATURES OF EARTH RESOURCES PHENOMENA AND HOW TO INTERPRET THEM**
- **SPACECRAFT TESTING PHASE - FROM 1970 TO 1980, SPACE FLIGHT MISSIONS WILL BE MADE, FOR THE PRIMARY PURPOSE OF ACQUIRING DATA FOR EXTENSIVE STUDIES OF THE EARTH'S RESOURCES**
- **OPERATIONAL PHASE - BEYOND 1980, THE SCOPE AND MAGNITUDE OF THE PROGRAM WILL DEPEND ON THE RESULTS OF THE EARLIER PHASES. INDICATIONS ARE THAT IT WILL BE MULTIDISCIPLINE IN NATURE, GLOBAL IN EXTENT AND MORE OR LESS CONTINUOUS**

Figure 3.- Program phases.

NASA-S-67-644

# NASA EARTH RESOURCES SURVEY AIRCRAFT CONVAIR 240-A SHOWING INSTRUMENT LOCATIONS

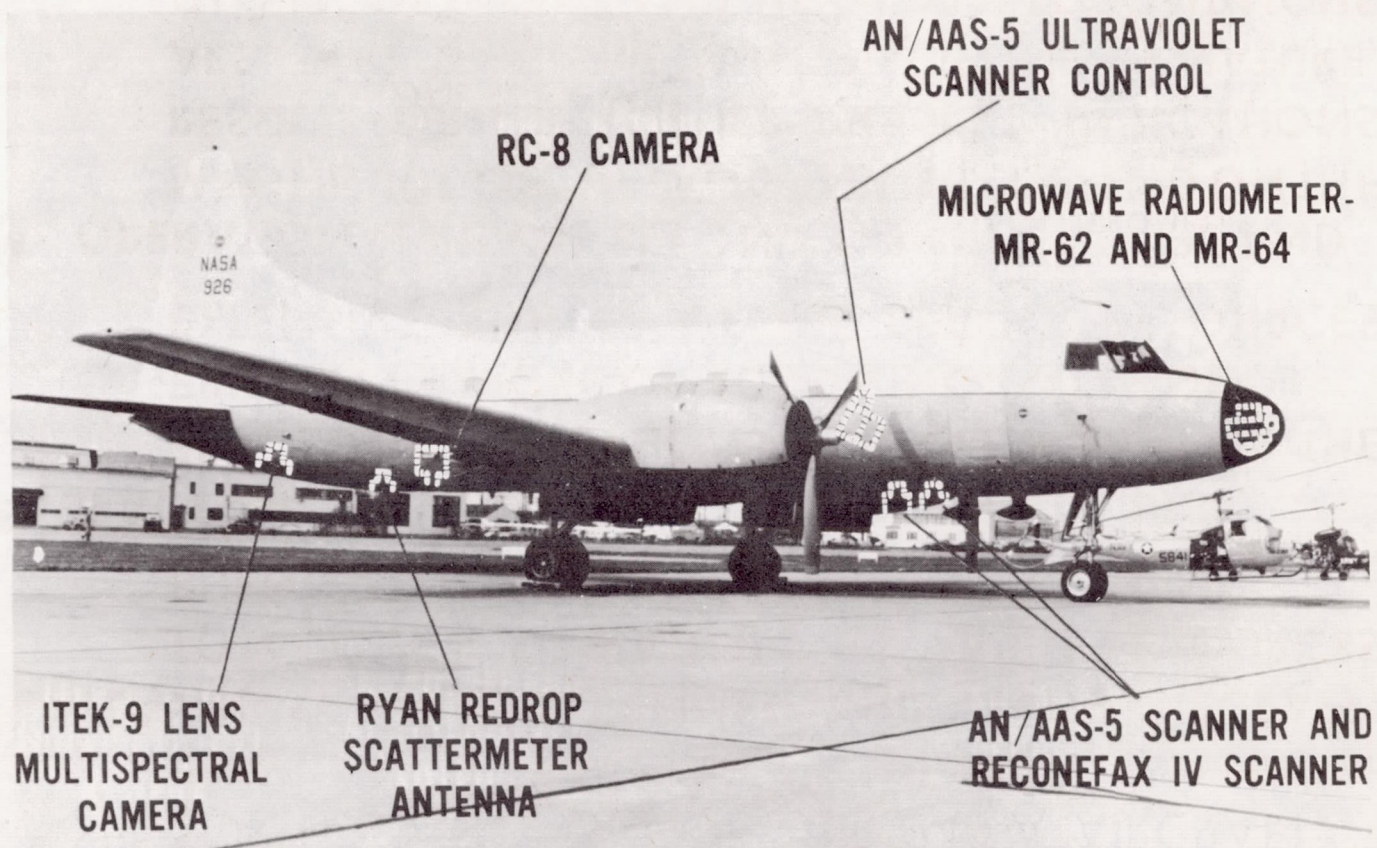

Figure 4.- Instrument locations on aircraft.

# SENSOR LOCATIONS - CONVAIR 240-A AIRCRAFT

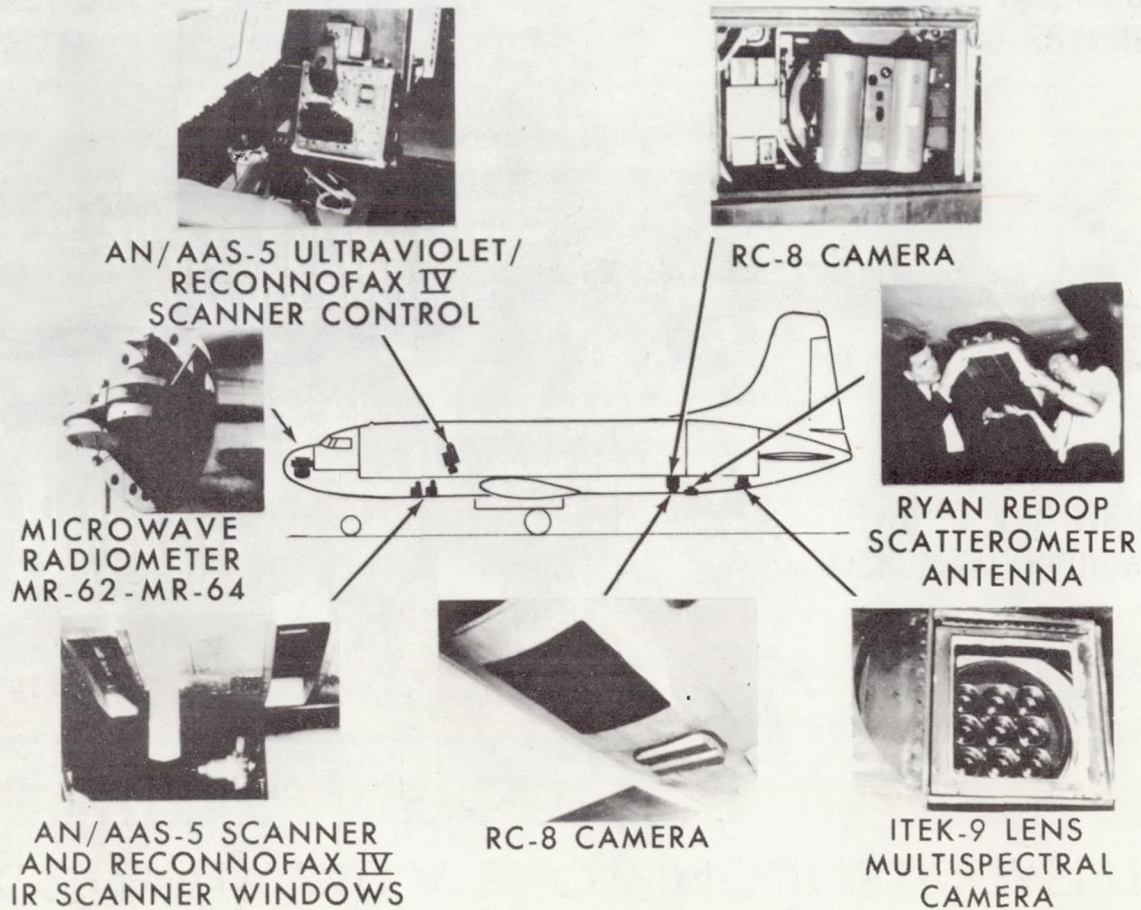

Figure 5.- Sensor locations.

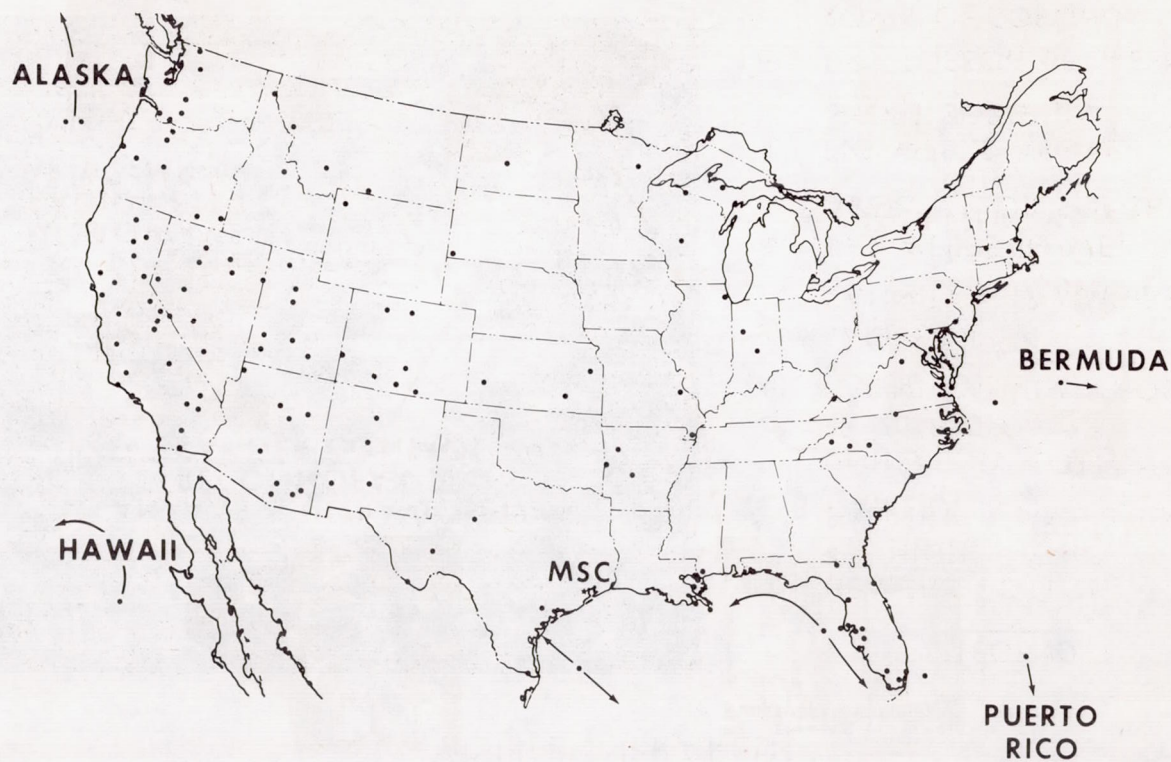
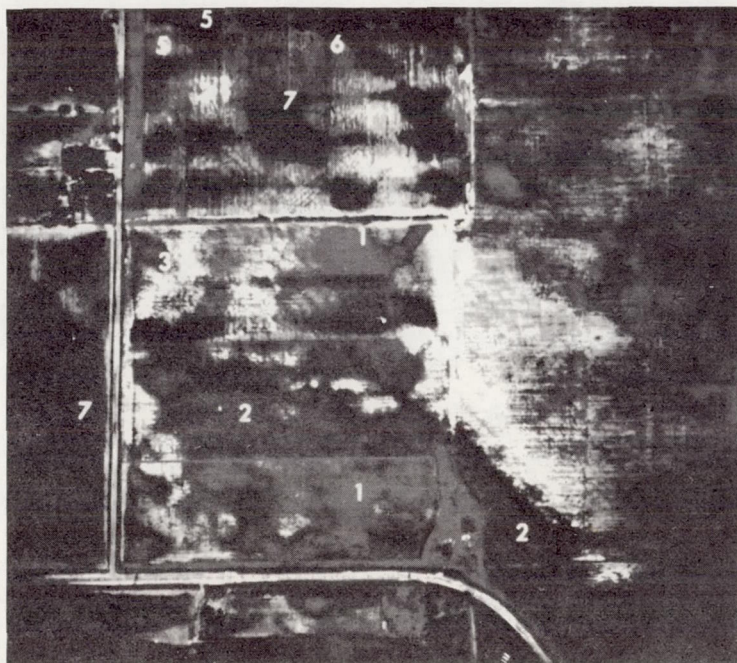

Figure 6.- U.S. Test Site Map.

# IDENTIFICATION OF SOIL AND CROP TYPES BY DIAGNOSTIC COLOR SIGNATURES USING AERIAL EKTACHROME FILM (VISIBLE INFRARED)



PHOTOGRAPHY TAKEN IN SEVERAL WAVELENGTH BANDS  
SIMULTANEOUSLY YIELDS SIGNATURES WHICH WHEN  
COMBINED WILL PROVIDE POSITIVE IDENTIFICATIONS

## LEGEND

1. HEALTHY COTTON  
48" HIGH  
SALINITY: 1 MMHO/CM
2. UNHEALTHY COTTON  
12" 16" HIGH  
SALINITY: 7-10 MMHOS/CM
3. BARE SOIL  
SALINITY: > 12 MMHOS/CM
4. PIG WEEDS IN WET  
AREA, MINOR SORGHUM
5. PIG WEEDS ABOVE  
SHORT SORGHUM
6. DRY TOPSOIL BETWEEN  
ROWS OF SORGHUM
7. BARE SOIL BETWEEN  
ROWS OF SORGHUM  
HIGH MOISTURE CONTENT

Figure 7.- Identification of soil and crop types.

# KILAUEA VOLCANO, HAWAII

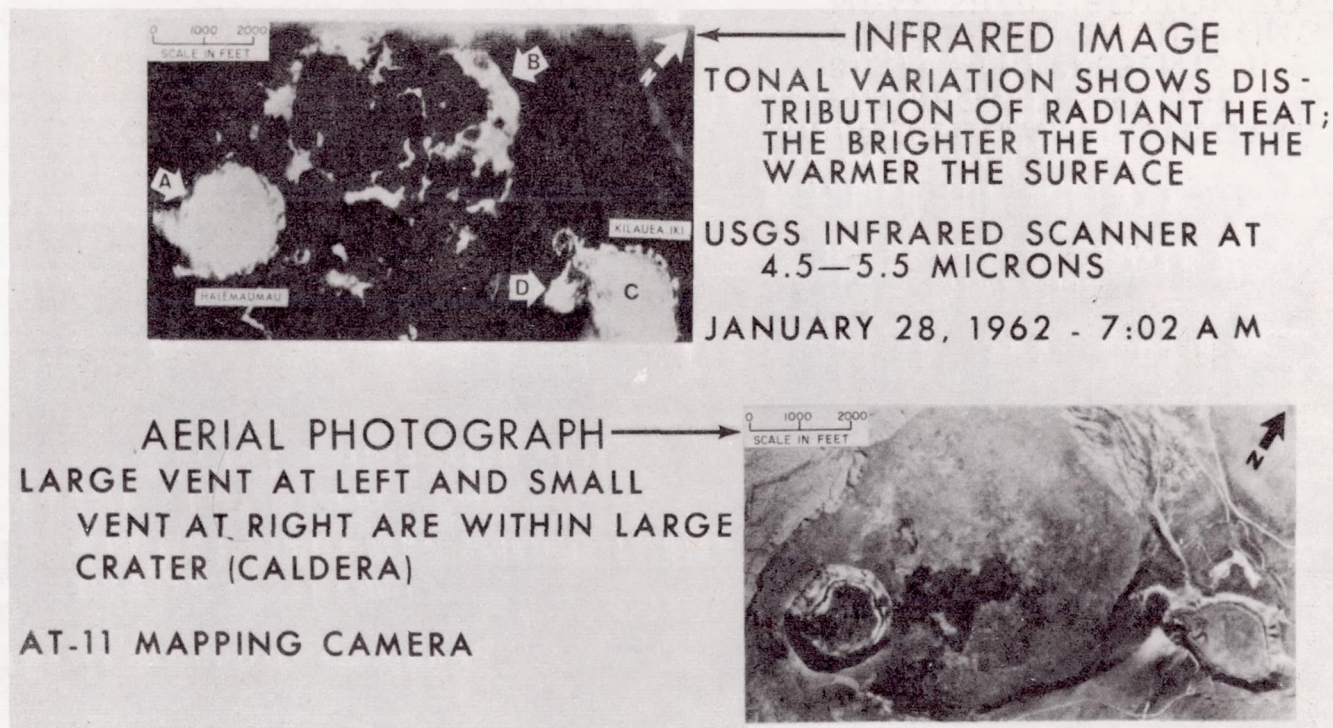

Figure 8.- Kilauea Volcano.



CONVENTIONAL COLOR  
PHOTOGRAPHY  
SCALE 450 FT/IN.



MULTISPECTRAL PHOTOGRA-  
PHY PROVIDES BETTER VISI-  
BILITY AND PRESENTS THE  
POSSIBILITY OF CHARTING  
NEAR SHORE BOTTOM TO-  
POGRAPHY AT DEPTHS OF  
30 FEET OR MORE

Figure 9.- Water depth penetration by photography.

- **PLANNING PHASE**
  - **MISSION REQUESTS - REQUESTS FOR AIR OR SPACE FLIGHTS**
  - **SITE MAPS - MAPS OF TEST SITES SHOWING FEATURES**
- **DATA COLLECTION PHASE**
  - **MISSION REPORTS - REPORTS OF FLIGHT CONDITIONS & INSTRUMENT PERFORMANCE**
  - **SITE DESCRIPTIONS - OF TEST AREA DESCRIPTION**
- **DATA CATALOGING PHASE**
  - **NO DOCUMENTATION**

Figure 10.- ERSP documents.



- **DATA DISSEMINATION & UTILIZATION PHASE**
  - **TECHNICAL LETTER REPORTS - PAPERS BY USGS ON SENSORS & GROUND STUDIES**
  - **TECHNICAL REPORTS - EVALUATIONS OF RESOURCE SITES & SENSOR USE**
  - **MISCELLANEOUS DOCUMENTS - PAPERS ON A VARIETY OF ERSP SUBJECTS**
  - **PROGRESS REPORTS - REPORTS ON ERSP PROJECTS BY USGS & UNIVERSITIES**
  - **SUMMARY REPORTS - REPORTS ON EARTH RESOURCES SPACECRAFT**

Figure 11.- ERSP documents, continued.

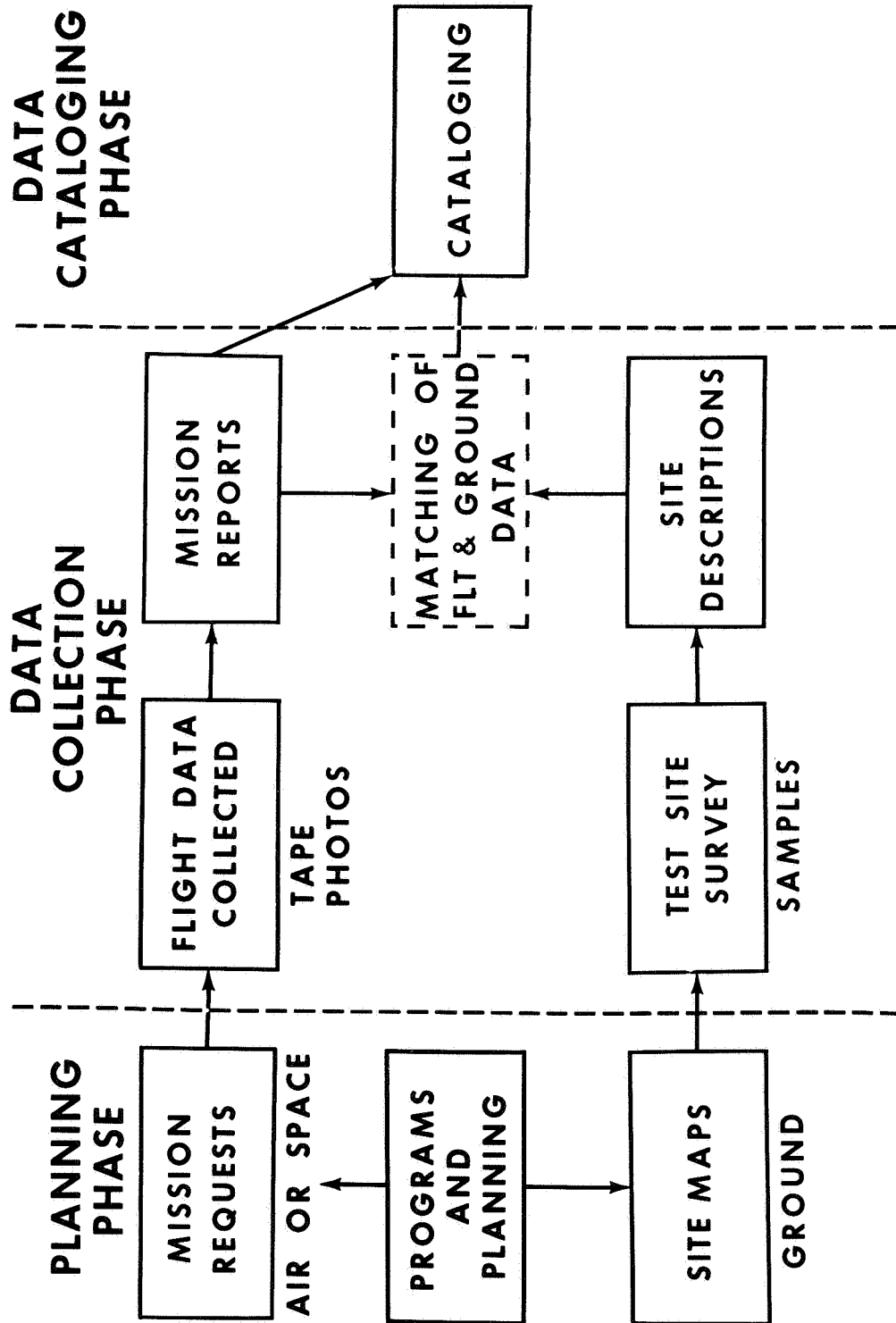

Figure 12.- ERSP data flow.

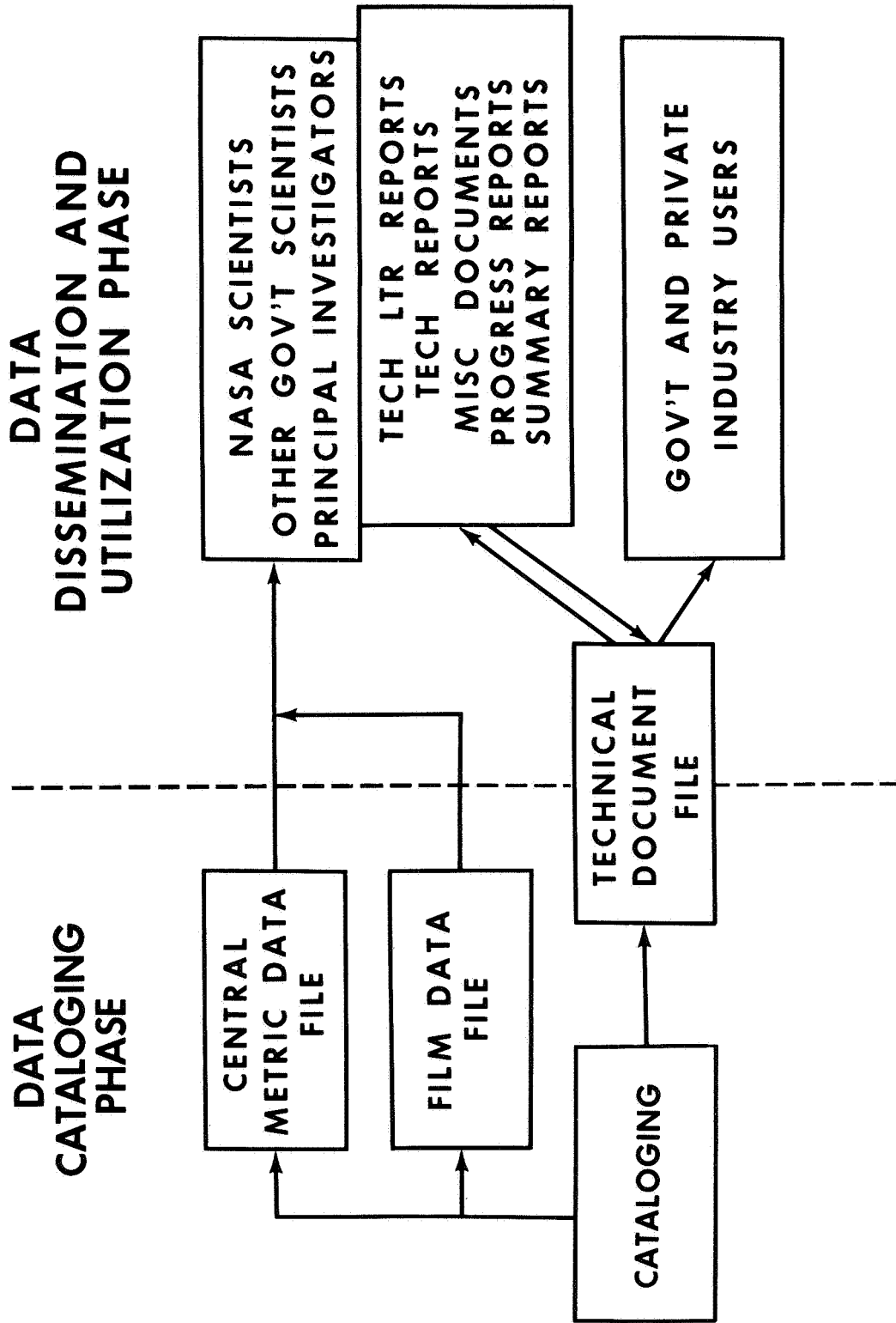

Figure 13.- ERSP data flow, continued.

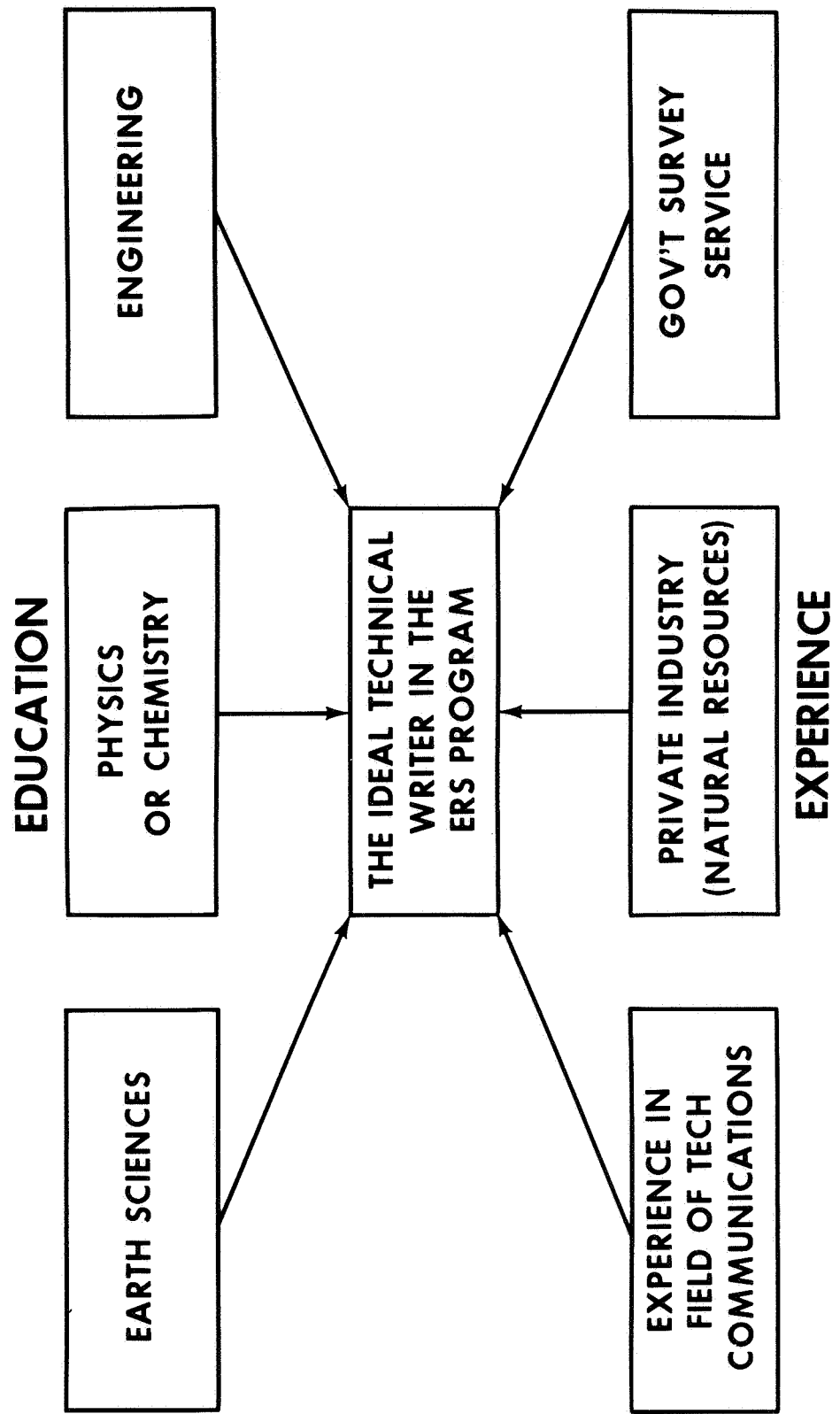

Figure 14.- Requisites for the ideal technical writer in the ERSP.

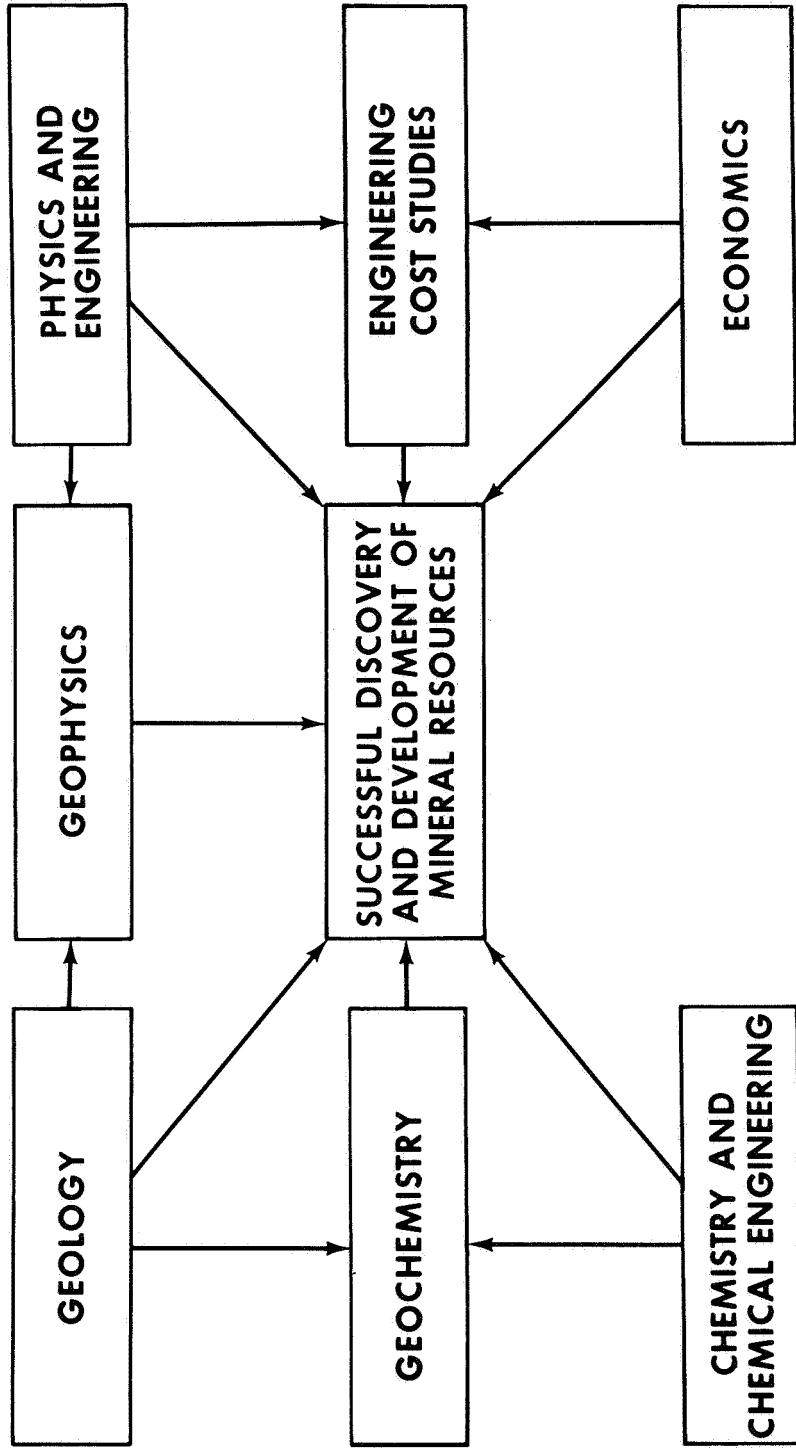

Figure 15.- Typical example of interrelationship of four disciplines.

## SPACE DOCUMENTATION — A BOON TO THE CONTRACTOR

By Joseph Godfrey  
IBM Corporation  
Federal Systems Division  
Houston Operations  
Houston, Texas

I understand that NASA now controls more than a half-million aerospace documents. And, over 300,000 of these were published since 1962. From what I can gather, this file is growing at the rate of considerably more than 70,000 documents per year.

These publications come from various sources: some come from NASA employees and the industrial firms who serve as NASA prime and subcontractors. Others come from places like the Department of Defense, private industry, universities, and foreign sources. I'm told the number of titles coming from NASA and its contractors is only a small percentage of the total; but, from experience with NASA reporting requirements, I'll bet the percentage of pages isn't small.

NASA provides the central storehouse for all of the aerospace documentation. Collection and distribution comes under the Office of Technology Utilization. This office has two separate, though coordinated operating divisions: the Scientific and Technical Information Division which is oriented toward supplying the information requirements of the aerospace community, and the Technology Utilization Division which concentrates its efforts on supplying information to users outside of the aerospace environment.

Aerospace publications generated by NASA and its contractors are aimed primarily at assisting the space program to achieve a manned moon landing as soon as possible. The manuals, reports, papers, and articles that are written by NASA, its contractors, and other sources have provided information on assembling our space ships, trouble-shooting the one in millions component that is bad; on maintaining and operating the computers, display units, controls, tracking devices, cameras; they contain procedures, techniques, devices; engineering, physics, math, and programming.

The publications that many of you are producing are getting wide distribution, are being read, and are being used to contribute to all of our efforts in space. Millions of pages of documentation are written, and hundreds and even thousands of copies of these pages are distributed and read to make our space missions possible.

In a tremendous volume information bank, such as the one I am describing, getting the right information to the right people is a tough assignment. The user can't possibly read everything that pertains to his field of interest and can't guess which ones of a half million documents he needs or wants. He needs help. So indexes and computers are used. The indexes provide subject and author categories and abstracts of all current available publications.

Even the indexes, though most helpful, are not the end all. They are voluminous when available, and are not always available. So computers are used too. Indexes allow users to find their required documents that match their needs; and the computers to find the users that match the documents. Between these two methods, distribution of publications reaches many people who need the information. Our excellent technical editors are making a real contribution to the readability of the information by reducing the word count considerably while still keeping the meaning clear.

I've been talking about the documentation that is written and is available. Many good innovations and techniques are never put on paper. Then the finding becomes useful only at the source.

A new technology utilization program now aims at this extremely valuable information that is non-communicated. The object of this program is to get every good idea documented and available.

Each NASA contract has a new technology clause which obligates the contractor to report any new technology found under that contract. Such a clause is only effective when a strong guiding hand is provided. Why? - because many capable people don't like to write or have not been expected to document their work. Education and motivation are provided to contractor personnel in why, what, and how to report.

Education is provided through direct contact with the contractor to set systems and procedures and establish operating standards. Publications on the program explain NASA requirements under the new technology clause, the scope of the program, and reporting requirements. Motivation is provided through incentives and by stressing the values of the program. Some of these values are shown to contractors through movies which show practical application of space technology. These activities motivate us contractors and our personnel into full cooperation with the Technology Utilization Program.

IBM has established New Technology Representatives for each of its Federal Systems Division locations which operate in a NASA contract environment. The New Technology Representative is on the alert for any uses of inventions, discoveries, improvements, and innovations made under NASA contracts. He must get the people involved to report or he must do the

reporting. I'm sure other contractors have effective procedures to achieve the desired end results.

Though the ultimate responsibility for discovery of technologies, techniques and so forth, and their reporting is that of the Technical Utilization Officers and contractor appointed representatives, the success of the program rests with the individuals on the job.

Each person, and this includes the design engineer, mechanic, tool maker, and the technician, must ask himself is the work I've done worth exploiting? Is there a better way of doing it? When he determines yes, he reports - the problem, the solution, and how it works. At IBM, the report is made to the New Technology Representative who evaluates the item for possible submission to the Technology Utilization Program. One example of an IBM new technology report under this effort is a computer program designed to analyze waveforms of an astronaut's electrocardiogram automatically in real time, and without the benefit of highly skilled specialists. This innovation should have potential for use in the medical industry.

Naturally contractors, in addition to reporting information to NASA on the contract, take advantage of their own developments for the space program to make improvements in their own products and procedures; to make new products; to develop new applications, and to establish new markets. These developments are often forerunners to profitable company developments.

In a sense, information does not always have to be distributed to be useful; you can bring the people to the information. Houston Operations of the IBM Federal Systems Division sponsored a two-and-a-half day seminar on Real Time Systems in the fall of 1966. This seminar presented 22 papers by IBM engineers, programmers, mathematicians, systems and management people, most of them involved in the space program, to IBM people and customers and potential customers.

Six hundred and forty-six people attended this seminar - 335 IBM'ers from various locations and job disciplines and 291 people representing military and civilian government agencies, industry, education, and the press. The purpose of the seminar was twofold: first, to let our customers and potential customers know of our accomplishments and capabilities in Real Time Systems; and to provide valuable information to IBM people for their use in development programs, sales, and systems application. The papers provided useful data to Federal Systems Division people for use in space technology, and the other divisions for commercial applications.

I said that we brought the people to the information, but they didn't leave empty handed. We gave them proceedings of the Real Time



Systems Seminar which consisted of 550 pages. We printed 1,800 copies; more than 1,200 have gone; and they are still in demand.

The value of the seminar publications cannot be overemphasized. The hectic activities of our entire publications department for several months was worth the effort. Writers, editors, typists, reproduction people, and often overlooked people in publications, the artists, played a large part in the success of the Real Time Systems Seminar. They assisted all of the authors in their presentations: on their papers, flipcharts, slides, and films - and most important prepared the papers and graphics for the permanent documentation.

The information presented at the seminar reached a limited number of people, with the retention of the information also limited. The printed documentation continues to be of value to all of these people and many others who did not attend the seminar, as shown by the continued requests for the proceedings.

There is little doubt that our efforts in the space program that were documented from this seminar have benefitted and will continue to benefit the company in new ideas and better programs.

IBM calls these things we learn from our efforts in government work precursors. Precursors are those techniques or technologies which have actual value or potential in development and application of commercial products. Precursors break the ground for the future and provide the solution to problems which could otherwise be many years in the solving. IBM has benefitted from these precursors to the extent of new programs and new paths.

Contractor documentation of space technology in relation to the contract and their documentation for commercial programs works two ways for the contractor - the documentation of commercial developments helps us establish programs and technology for use in proposals for new government and commercial contracts; the NASA contract documentation will assist contractors in finding precursors and the space program in achieving the manned moon landing.

We all know that very little in any of our space and company projects is completely new. Even in our space program, where our accomplishments are astounding, most of the developments are based on previous technology and know-how. Most of our technological breakthroughs are based on previous discoveries.

Our space vehicles, each one larger, stronger, and more capable have had the benefit of knowledge from each forerunner vehicle, and before that advances in rocketry and aeronautics, metallurgy, fuel development, electronics, and chemistry.

IBM developed onboard computers for the Gemini and Saturn programs. Though these computers were different - special purpose - tiny in comparison to the large systems - say the Real Time Computer Complex which supports Mission Control, I'm sure every bit of available experience gained from the time of the IBM 701 on down and whatever may have been on the drawing board was used in the development of the onboard computers. Sure there were advances and breakthroughs, but control logic, input/output, storage, programming, and design and packaging technology and techniques from many locations were all used in the development of the onboard computers.

From a realistic point of view, starting from scratch on each special purpose project is impractical for any company. It is time consuming and costly to the developer; and therefore time consuming and costly to the buyer. The availability of technology is the key.

Documentation of every phase of every program from each location, and its availability to everyone with a need at every location, is really the only possible way to bring together all of the required information for any company development. Every type of publication: engineering specifications, manuals for operation, procedures, and maintenance; reports for technology, techniques, and administration; papers, articles, and films, is essential for optimum program function.

An excellent example of the use of forerunner technology in the development of a new computer system by IBM is the IBM System/4PI. You'll remember that I said that I was certain that many previous technologies had been brought together and used in the development of the onboard computers for our spacecraft. IBM executives decided that we should take advantage of our knowledge of computers - commercial and space programs - and develop a family of computers for airborne use. The purpose of this was so that a special purpose computer would not have to be built, every time an aircraft company or government agency had a compact computer requirement.

As a result, the IBM system/4PI computer family now is an announced development of the IBM Federal Systems Division. It consists of three very compact, highly reliable models for airborne and spaceborne use. These computers can also be used on shipboard and for military field use. Precursor technology from the onboard computers developed by IBM for the Saturn rockets and Gemini space vehicle was undoubtedly a forerunner for the development of the System/4PI program. Publications of all types on the spaceborne computers in the Saturn and Gemini programs provided much information that assisted in the development of the System/4PI family.

Publications on the 4/PI systems are also needed at many IBM locations. These locations many miles apart are engaged in making systems proposals using IBM System/4PI computers. To be successful in these

proposals, the people involved in the proposal effort must have the facts - engineering and application. The publications and their availability and accessibility play a large part in winning the business. Some of the onboard uses for the 4/PI system are data acquisition and management, target identification, missile site warning, and weapons delivery.

Publications - reports, manuals, and papers on the IBM System/4PI program are extremely valuable in providing the information to all IBM locations for use of these computers in direct proposals. They are also extremely valuable to the commercial divisions for use in their programs of techniques, innovations, and applications that come as a result of this program.

The System/4PI computer family is compact and I think most important, has extremely high reliability. There is little doubt that the IBM commercial product divisions will be using reliability and compactness techniques evolved from this program. The documentation and dissemination of all pertinent information will play a large part in the ability to do so.

Documentation of IBM technology from all of its programs through the years surely contributed to the company's efforts in the space program. In the same way, documentation on IBM's space program projects have shown the way to new company programs and will continue to do so.

Much of what has been achieved by the space program in space and on earth has come about through the written word. Those of you who have a hand in producing the vitally important publications - the manuals, reports, articles, speeches, films, and whatever else goes into making up this fantastic aerospace information bank know that you are making a real contribution.

You will be producing tens-of-thousands of documents each year for the NASA document center; and that doesn't include the articles and speeches you'll write or assist someone else in writing, that will find their way into the center through periodicals and conference proceedings. You'll also be involved in the generation of information for technology utilization by finding reportable items on your writing and editing projects, writing some, encouraging innovators to report their findings, and helping those people who have things to report, to write and edit their documents.

## LUNCHEON REMARKS

Dr. Joe Rice: The man I want to introduce to you now has promised me that he won't talk more than 30 seconds. He wasn't even scheduled to be on the program at all at the beginning, but we prevailed on him to give us a little time. He is the man who Victor gave the award to a minute ago, who is responsible for gathering and displaying all that art, the paintings, the graphics that you have been looking at from time to time throughout the day, and he wants to give credit to some of the people who have helped him with this display, which we think is a very nice one. Roy Magin, come on up here. Roy is Reproduction Services Manager for NASA's Manned Spacecraft Center, I don't need to remind you.

Roy Magin: Thank you, Joe. Ladies and gentlemen, I would like to extend my welcome to all of you and it is needless to say that we could never have put on such a fine exhibit unless we had such excellent artists in the area. This is an excellent representation of the technical competence of the illustrators available here in the Houston area. I would like to single out Mr. Fukal, who has been most cooperative and very helpful working with me on this exhibit. Mr. Fukal. Needless to say there were many others, and I would also like to identify the cooperation we got from Rice University from Mr. Estes and his staff. The technical art exhibit, we feel, is a fine representation of the technical art that is available here in Houston, and without any more ado, we would like to say, that those of you who haven't seen it, please take an opportunity to stop by and look at it. Thank you very much.

Dr. Joe Rice: The problem was getting through the crowds this morning to see it, and I think everybody was trying to see the exhibit. This brings us to our luncheon speaker and this is the man you have been waiting to hear. He has a Ph.D. in physics from Cal Tech, is a former F-86 pilot, a member of the Rice faculty, and since June 1965 he has been a scientist-astronaut. The title of his speech is "Today and Tomorrow." Dr. F. Curtis Michel.

## "TODAY AND TOMORROW"

By Dr. F. Curtis Michel  
Scientist-Astronaut  
NASA Manned Spacecraft Center

Dr. Michel: When they needed a technical writer to address this luncheon, I unfortunately qualified in a sense; that is, I am a technical writer but I am afraid that the journal I write for most frequently, the "Journal of Geophysical Research," won't be found next to

the "Ladies' Home Journal" or any of the larger circulation magazines. In fact, probably I would guess that if it reaches the hands of say 10 000 people, that is a big circulation, and, of those people, perhaps 100 are interested in the subject you are writing about. That's a pretty good audience. And if of those, 10 people read the article, then you have really done a good job there. So, as far as mass media goes, I am a little out of my depth; I have tried on one occasion to write a popular article and so now I am back writing for JGR.

I have nothing but compliments to say about people who do write technical work for the public as a whole. Especially since ours every year becomes an increasingly technical society, and every year there are more difficult concepts to be gotten across to the public. Of course, some concepts like heart transplants are pretty easy to get across. I watch Channel 13 every Saturday night and they are always chopping up and putting people back together there and so that is easy to get across on the Late Weird Show. But to get something across like elementary particle physics, or plasmas in space, or something like this, this is very hard for somebody who is embroiled in it, because you want to be precise and you want to say everything exactly right. What you really want to do for popularizing this thing is to get the flavor of the idea and where it fits into the world as a whole. And that is very hard for someone who is embroiled in it.

Of course, on the other hand, I am also a part-time teacher. You can always tell the effectiveness of what you try to get across by asking questions or being asked questions. I must say, as far as the space program goes, John Glenn running down the beach has really gotten across, of all the things in the program that's really gotten across.

I get asked frequently by academic friends about my training program, and how much exercise I get out at MSC. I would like to say that the physical part of the training program is really very small. For most of us it consists of hand-ball instead of lunch a couple of times a week and that is just about it. There are exceptions and you can have a more elaborate program if you want. The men who have done extra-vehicular activity (EVA) and have EVA responsibilities, must train quite hard for the physical requirements, but for most of us it is not a big factor of our time.

Then, of course, we have a lot of academics. The Apollo Program is probably about an order of magnitude more complicated than the Gemini Program in both scope and systems involved, and this requires quite a bit of classroom time. And then we all fly, and even to get the 100 hours a year required by FAA requires a bit of our time. But most of our work (if you are not on the flight crew, of course) goes into what is called corollary duties, and in my case it is watching after the Apollo Telescope Mount, which is an astronomical project to be launched

in the Apollo Applications Program. And, of course, there are all the public appearances which take a little of our time. For us, as far as being a scientist or being a pilot, our activities are just the same, which is just what we want.

Now, within this program, as you know, the program has certain financial restrictions of late, and for example, it cancelled presently the follow-on lunar explorations, which I read about in the newspapers. I appreciate that. I thought I was just not very attentive. We were in Boulder, Colorado, the other day for an ATM meeting. I was there with Joe Engle reading the newspaper at lunch and I read where they had cancelled the X-15 program and Joe Engle already has his astronaut wings. We are going above 50 miles in the X-15, and he didn't know about that either, so he was happy for me to show him the newspaper. So we really depend on you guys that write and keep track of the space program for us. And, of course, they have cancelled 1-A (I got the jump on this, my office-mate works on 1-A), which would have been the first Apollo Applications Flight. So you see the program is being modified considerably for financial reasons, and this is painful to everybody involved.

I think one of the most unfortunate things about having to cancel parts of the program is that it breaks up highly trained teams, for example, the team that made the Lunar Orbital vehicles. There are no more Lunar Orbiters so that's the end of that and there are no more jobs. So that is pretty much the end of that team. And, it is too bad to see highly successful and well trained and accomplished teams be dissolved. The same goes for Surveyor and Huntsville, who, of course, have been marvelously successful in building boosters and there are no more boosters to be built.

Ultimately, I think these projects and requirements will be reinstated, but it will be difficult, I think, to get good men back to work on what will have proven in the past to be part-time jobs. Now, that's not a policy statement. I am not qualified in any way to weigh the administrative difficulties and problems; if you don't have enough money, you just can't do anything about it. But one is permitted I think, to analyze the effect of such cuts. I think again, in this business, it is going to lead us pretty much to a certain gap in the space program, probably shortly following a landing on the moon. In fact, we will probably be in somewhat an ironic position of landing on the moon and pretty much eliminating manned space exploration at just about the same time, at least for a few years. The reason for this is a desperate need for planning and this is where Today and Tomorrow enters (actually, I could have said yesterday, but I am not much of a historian). Yesterday is when you have to do the planning, Today is when you build the spacecraft, and Tomorrow is when you fly it. And, when I speak of one day, that's just sort of a literary way of putting it. It's years and years. Say, some-

thing like five years to develop the spacecraft, and depending, of course, on what the spacecraft does, that may be conservative.

And, we don't have very much on the drawing boards today in proposed Apollo hardware, and yet we are going to the moon tomorrow, so to speak, in any way, in about a year. In scientific payloads for my interest, of course, the big thing about exploring space, when you talk about putting up scientific payloads like 10 to 20 tons, is a lot of science and that's a lot of equipment and even if it were just TV sets latched together, that would be quite a bit of money. To have them all developed and scratched takes time, a lot of thought, and a lot of effort. I think we will have a reasonable gap. What we do have is ATM which I have worked on, Apollo Telescope Mount, (that is the alphabet habit in the government) and I have been working on that ever since I got in the program, about three years ago, and it will be at least another two years before that gets launched. And we have high expectations that this will be a very scientifically productive program.

Now, as far as I am concerned, and I think it is true that space is here to stay, I would expect that we will develop a stable ongoing program. I think this will come about really when the hiatus becomes more clearly defined, the fact that we are not really progressing as much as we are going to need to in the program. And, particularly I think the scientists have been bad in sort of taking the program for granted. I have just recently noticed that Van Allen has started taking a positive role in complaining and worrying about the lack of space activities. I think, if nothing else, the scientific requirements are going to keep rising and having an accelerated effect on the program. We have learned so much that we didn't expect to learn. A couple of years ago if you had asked an astronomer what they thought about Mars or the Moon or Venus, they would have said, "Well, it's round and not very interesting and very far away." In absolute ignorance, of course, you can be content to stay that way, but now things are starting to be known about these planets, that Venus rotates the wrong way, whatever that means, the way nobody expected, and it has a much hotter atmosphere than anybody expected. It has a much more interesting and curious body than anybody expected. Mars isn't a giant irrigation project apparently, but it looks much like the Moon. Of course, we are still not sure what we will find on the Moon itself, which is an excellent reason for going there.

I am sure, just like so many things have been learned about Mars and Venus without even going there, that when we finally get a man on the Moon, we will find exciting and tantalizing things. I think the tantalizing aspect is what is going to keep people from stopping, from losing interest, because it is going to be a constant force. There is always going to be the next little step. What's the next question? What's the next answer? Science and people as a whole have never been content to be given part truth and then go home and forget about it.

They have always insisted on knowing the next answer, asking the next question, and getting the next answer.

In closing, I want to emphasize and make clear to you that we are only thinking of you people, not of ourselves, but of you people because we want you to have plenty to write about. Thank you.

Mr. Ehrlich: Many of you have seen this morning, frantically setting up signs and I just made it in time, about three minutes before nine. All of the signs are up, some of them belatedly. I think I will say something now, make another announcement although belatedly, just about the last moment. I would like to recognize the hard work and the cooperation of three of our members in the society without whose diligence this seminar couldn't have been successful, in fact it could not have been done at all. First of all, my thanks and appreciation goes to John Colby. Please stand up John. John has prepared and has produced the assistance of Esso Production Research and his attractive editor Lynne Muller who is also a member in our society chapter. I think the people would like to see you too. Lynne, why don't you stand up? She produced the program guide which was used for the initial contact for you people. Without this program guide, you wouldn't have known about the meeting, and without this program guide, your employer wouldn't have decided on financing your way, many of you, many of the members had an opportunity to put this in on your expense accounts, so your employer wouldn't have been able to decide whether the seminar was worthwhile enough to finance the reimbursement for it. And then Marx Isaacs who was very effective in putting this announcement through the newspapers, radio and television channels to the general public. Marx works for Fluor Corporation as a technical writer and has been a very effective publicity man in our chapter. Marx. And then, last but not least, Dr. Christine Brannan, who has been working hard to take care of your advance registrations and was instrumental in setting up the registration lines here in the morning. You will remember her; please stand up Dr. Brannan. With these concluding remarks, I want to thank you again for your appearance and hope that the afternoon sessions will be enjoyable again. Thank you very much.



## SPACE NEWS STORIES AND PUBLICITY

## (PANEL DISCUSSION)

Moderator: Lee Estes,  
Rice University Development Office

DR. JOE RICE: I would like to introduce to you now one of this afternoon's panel members, Mr. Louis Alexander. I would like to use his words. He describes himself in a letter to me in these words: "I teach magazine and newspaper writing and editing at the University of Houston. I served as area correspondent for the Wall Street Journal and the National Observer. As a free-lancer I also helped 'Time,' 'Newsweek,' and 'Fortune.' I wrote for the ABC radio and television network, sometimes on special assignments, and occasionally write for other publications." He is a man of broad experience and background, as you can see. The other member of the panel is Lee Estes of Rice, whom you have also met briefly, and he will be our panel moderator. He is associate director of public relations for Rice University's Development Office, a University of Houston graduate, and again a man who has worked in a variety of media. So set off between these two versatile gentlemen are the two specialists, Jules Bergman at one end and Paul Haney at the other. We didn't separate them for any reason except that we have our soft speakers in the middle and our louder speakers at the end.

LEE ESTES: Thank you very much. I asked Mr. Haney if he would lead off the discussion because most panel members really do not prepare anything for this session; this would allow us all to fire at him. He said that it was a position that he occupies quite often and it really wouldn't disturb him as long as he got a rejoinder after Jules Bergman speaks. In all seriousness, many of us have watched the growth of scientific news coverage over the past ten years with some interest. I think we have evolved past the "gee whiz" school of science writing now, and most of our major scientific efforts are complicated with political issues, with highly technical matter, scientific matter, engineering problems, and rather complex administrative and fiscal operations. Frankly, as I have observed it, NASA grew up very rapidly and had to formulate scientific news coverage policies that would accommodate mass media coverage. As Mr. Haney knows, several hundred reporters were all banging away at the same time, all on split-second time schedules. Now frankly, this has never been done in the world. Older more traditional governmental agencies have not been faced with this problem. I would like seriously to lead off with Mr. Haney describing some of the problems that are faced within the agencies, preparation for these mass onslaughts, the policies that the government is faced with, the demands of interpretation and the philosophical rules that they have to stand by under fire.

MR. HANEY: I appreciate your opening with this, it gives me something to talk about. Very fundamentally, the reason why NASA got heavily into the public information business, as obviously as heavy as it is, is because of the NASA Space Act of 1958, which is our charter. It was the first such act in the history of our government which directed the agency to make known the results of its experiments. It is since then that several other agencies have been formed that have similar words or similar charters. But NASA was the first which was specifically directed to do so and it sort of put the public affairs office in business, if you will. And of course, the man who wrote that act is not totally unaware of the public affairs department (although some people think he is at times). I am of course referring to Lyndon Johnson, who was the Senator in charge of the committee who wrote the Act of 1958.

A couple of other points need to be made, I think. If you are not already aware of it, I believe fiercely, perhaps even passionately, in the business of informing the public in what we do. To me it is like perhaps religious prejudice or race relations to other people. I think it starts, if not in the home, in the office, and it radiates outward depending on how much and how we deal individually with this specific task of informing the public. I think if we tend to clam up or try to cover up, or make judgment on matters in which we are neither competent nor have any business in making judgment, then we are probably going to have a poor public information program.

Last July Fourth a new information law took effect in the government, and we referred to it this morning. I do not want to dwell on it overlong, but it has occurred to me more than once in the last nine years at NASA. I wonder why there are not violations for suppressing information. There are violations for security infractions. If you leave your safe unlocked at night you are liable to all sorts of minor or major punishments, and up to several years in prison if you are found passing information of a confidential or higher nature to other people. I really wonder why, and I think maybe we ought to explore that in some point in NASA or elsewhere, we don't have at least some violations for suppressing information (oh, it ought to be at least as bad as parking in someone else's reserved stall. Perhaps worse).

I also believe that any agency of the government, just as a company, has the right to meet and to ponder its future in private and not in front of the world. I think that reporting of the results of your experiments is one thing, but reporting how you are going to do those experiments is quite another thing. Now this has come into question at least in some of the local quarters here, without very much resolution, I'm afraid.

Finally, I also believe very strongly in the First Amendment to our Constitution wherein it deals with the freedom of the press and its

right to acquire information. I take great issue with my colleagues or people who work in the business in which I used to work, newspapering, who would use the First Amendment as a subpoena rather than a freedom. It is precisely a freedom and it gives the newspaper the right to go out and ask questions, ask you if you were in orbit or not, and you the answerer have the right of answering the question or not answering the question. And it is precisely that. It is a freedom and not a subpoena or in any way an indictment. Your witness, counselor.

LEE ESTES: We have arranged for Mr. Bergman to come up with this second speech.

MR. BERGMAN: I don't know if I am supposed to play Perry Mason here or not, but now that you have made those noble comments, Paul, out of the hard knocks of experience, out of covering 16 manned Mercury and Gemini flights (every one of them, I believe), and out of covering virtually every major missile task we have had, some abundant lessons have been learned by the press. Lessons, that in many cases, we feel NASA has insufficiently digested. The Defense Department has digested them even less so we do not indict NASA too much on that score.

I think Paul's suggestion of perhaps a punishment for suppressing information inside a federal code is a good idea. Some people think that I have attacked NASA at times. And at times I have attacked NASA, but I don't think I am exactly in the lead in that class. (I may be running a close second to Bill Hines or people like that.) But I attack NASA on the way it handles information at times. I have never yet attacked it, Paul, and I think that bears out, in terms of operational capability. I have infinite respect, not only for the astronauts and the flight controller people and engineers, many of whom I number among my personal friends, but for the goals of the space agency, as I thought I tried to make clear this morning. But, now comes the interface, as we engineer types like to call it. When Bergman has to report back to his producers in New York and explain why we can't get a picture of the frammis valve. Or why we can't interview Dr. Blotz about his death ray or whatever it might be.

I might bring up a couple of peculiar things, to digress slightly to the side about television's peculiar problems. Much more so than newspapers or magazines, we have no page 48 or 64. We have what is essentially a front page and a front page only, even on our half-hour evening news shows. And when we started out on Mercury and Gemini shots and did hours and hours of live programming, as Paul explained partially this morning, we could watch the curve of public interest go down against time. You know you could only dare fake so many times with John Glenn and his flying trapeze, before, or the Carpenter flight or the Schirra flight or the Cooper flight or on whatever flight the public curve did lessen. Television coverage, with that lessening of interest,

tapered off in terms of the amount of time we dedicated to it. Familiarity, you might say, breeds "no news." Today's bulletin, in news terms, is an item on tomorrow's news show. I challenge any one in this audience to remember who the sixth transplant heart case may be. We know maybe about the first five and no one will ever remember the seventh, eighth, or ninth heart transplant case, much less the seventh, eighth, or ninth man to fly in space unless you happened to have covered the event yourself or worked on his team. The Ranger-Surveyor-Lunar Orbiter shots proved that. I, as a matter of fact, debated in my own organization and among the other networks just the other week that we should cover the Surveyor VII landing in toto, live. It was the final windup shot in the Surveyor series, and it was the end of our lunar unmanned exploratory program which has been a wild success, a tremendous success. And it was new terrain, new dramatic terrain. I got shot down in flames by my own management and by the other networks' management who felt public interest had tapered off and said, "Unless you can show me little green men running around up there, kiddo, forget it. We ain't gonna do it live." Well, that is part of the problem; familiarity does breed "no news." How many times can you show craters on the moon?

Well, our problem in communicating is communications and translation, and NASA has made a tremendous effort, literally, to help the media, all media. We in radio and television feel that NASA, even to this day does not sufficiently understand our strange needs. Paul Haney and Julian Scheer and NASA's Public Affairs Office (PAO) people come to us and say, "We give you people more consideration than anybody else, much more so than the wire services," and we say, "The hell you do." Some of the other network types, not I, say, "We've boosted the space program by carrying it all live, we have helped build national interest in it." Well, I don't want to get into that part of it. But I would point to some of the gaps and there are gaps that I have brought up before. I led a little one-man band, starting about three years ago, that screamed, "Give me public relations or public affairs guys," (they aren't public relations men as Paul mentioned this morning) "Give me public affairs men who are technically oriented. You complain about my taking up your flight controller's time in interviews or engineer Frammis' time, or somebody else. Well, give me a PAO who is technically oriented enough to explain to me what triple sigma is when I go crash land on Ascension Island or whatever the heck it might be." NASA still has very few PAO's who are technically able to be the interface, if you will, between the newsman and the NASA project man when the project man is too busy to see the newsman. There are still confusions that take place.

The classic one I can recall is the strange case of Gemini VIII, which is so funny I bring it up briefly. I recall on that case that Neil Armstrong and Dave Scott had successfully pulled off the docking with the Agena at roughly 7:02 p.m. Eastern Standard Time (the figures

are indelibly inscribed in my mind). Back in our huge theater in New York, they said, "O.K., put on that astronaut suit, kiddo, we are going to put you up on a wire because we are doing a video tape thing of what EVA is all about." It was a preview of the next flight. So Bergman hoisted on this crazy astronaut suit that some idiot had made up, and they put him up on the wires and there he was thirty feet above the floor dangling from his — the attitude is indescribable — it was a spin, a spiral, and a Dutch roll all mixed up. And fortunately I had left the speaker on in my little control console there at ABC Space Central, and the voice of Paul Haney, known familiarly to us as "Mumbles," came through crystal clear, 84 stage hands earning golden time were in back lapping up the ginger ale and cigars and there I was screaming on top there when this voice came through, "This is Gemini Control, it is 4 hours 12 T into the mission. We seem to be experiencing a little trouble. Neil Armstrong and Dave Scott seem to be in a slight roll and we don't quite understand it." That was perhaps the most understated comment of the mission. I began to sense it, when Paul said little trouble, so I interpreted it as being deep trouble. That is because I am an old amateur pilot type and am afraid of everything. So I started screaming, "Let me down," and of course, there was no one there to let me down — they were all in back having cokes and cigars. Finally, I pulled the wire down by myself and fell the last 10 feet, changed out of this astronaut suit, and got back into a blue shirt and all that nonsense. Meantime Paul was saying, "This mission may have to be terminated" so this was at roughly 7:29 p.m. now, and we had a new show coming up, which at that point was No. 1 in all the national ratings called "Batman." And as I recall several high news executives said, "You're going to break into what?" So I said, "But chief, but chief....you know these guys are in deadly peril." So finally when the facts became clear, there was a long information gap in there, which I think was quite genuine. It was some time before they were in a position to get to an AGC station, Paul, as I recall. Well, finally it became clear what had happened with the thruster hanging up et cetera and finally how they stopped the roll by kicking in the reentry yaw thrusters et cetera. It was around 7:52 or 7:53, and as I recall we lopped off the last five minutes of "Batman" for Bergman's ugly mug on 185 stations, which prompted 1800 phone calls to the ABC switchboard in New York, and were they mad! The one I like best was: (I have three or four allegedly classified phone numbers there for emergency missions, and one of them rang and my researcher picked it up and you know, was it James E. Webb, was it Robert McNamara, or was it God calling with some urgent message?) And the woman said, "My name is Sadie Glass from Tulsa, Oklahoma, and I have twelve teenagers in my living room. What do I do now?" To this day I don't know how she ever found my phone number. My own wife doesn't know it.

What ensued afterward was the really interesting thing. We stayed live on the air from 8:00 p.m. EST to nearly 2:00 a.m. the next morning.

It wasn't that I haven't got a strong voice and it wasn't that I couldn't do the stint alone, as I had to. It was that precious little information and aid of any kind that came through from mission control or anywhere else in NASA. Then one of the most absurd frammisses of all history started, the air-to-ground tape of Neal and Dave's conversation with mission control, which was really reasonably routine when I finally heard it. Paul, was it not? There was nothing exciting, classified or obscene on it, as I recall. That air-to-ground tape was suppressed. Promptly a large corps of the press began to scream, "Freedom of information being violated: censorship!" What really happened was a kind of bureaucratic confusion of classification, where, as I recall, Bill Schneider, the mission director, I think, made the decision in that case. He just wanted all his guys to hear it and review it before releasing it. Well, it was finally released about 2:00 p.m. the next afternoon, as I recall, and it proved to be one of the biggest duds in history. There was nothing on it besides a lot of noises and finally the decision to come on down fellows, get out of there, which they did beautifully.

But meantime the thing I object to was that for six hours we had the whole American public on three networks, and 80 million people, hung up wondering what the hell had happened until they plunked down 500 miles east of Kwajalein or wherever it was. There was a terrible information gap.

Well, one of the things that concerns us at the networks most, when we go live is it not only costs us very large sums of money and sponsors who get angry and who have to be rebated, and audiences who call up and want to know why their favorite show is off or why they are not seeing whatever it is. One of the things we at the networks would like to see is a real interface where NASA full-time advises us. Paul tries, and the people in Houston try much harder for my money than the people in some other areas who perhaps should remain nameless. But Houston does not always have the final decision power. So, I maintain that evening the space agency for all its great work looked pretty ludicrous in failing to supply people to comment on what was happening, live, for all the networks. Well, that was the main case I wanted to bring up.

I think there is still an information gap also that exists. For example, we spent a lot of money at ABC News. I don't know exactly what our budget figures are, but it is somewhere above 35 million dollars a year, which is most of the profit of our corporation, and our brass gets pretty upset when that money is wasted and they want to know how to schedule events in advance and to deploy people and cameras and remote trucks and things like that. So one of the things that is very important to us is knowing flight schedules on a planning basis, not to go out and trumpet it. Well, perhaps Paul can tell me why, at some point, it is that NASA's flight schedules and target dates are marked

"Confidential" when NASA is an agency that handles almost nothing that is truly secret, and by congressional statute is supposed to disseminate information at the widest possible point. In the end we get the dates we want but it is a struggle to do it. So those are the main points I want to bring up.

Let me make this point in finishing, lest it seems that I have overweighted the case. NASA is far better than the Defense Department, much better. The Defense Department on the other hand has to deal with genuine cases of security, with new weapons, new airplanes, new satellites. NASA has very little classified material, truly classified material that it is dealing with. We think there should be a better interface with the press. We think there should be closer cooperation, although Paul and the people in his shop try all the time; NASA is a large organization. To go back to the point, the Defense Department in the last year or two is the prime leader of what I call bureaucratic or political classification that has nothing to do with genuine security. Thus, I might bring up one instance stemming from that new information law of July 1, Paul, or whenever it went into effect. I did a show about two months ago on the F-111 swing-wing airplane and the Defense Secretary himself, Mr. McNamara, who said, "Henceforth the Defense officials are free to talk without a public affairs man being present." Which is one of the prime things that the news profession had been irked about. So, I went in to interview various generals, admirals, people at the Pentagon and elsewhere, and in every case there were two, three, four, or five, public relations men present. Unfortunately, they were all friends of mine so I couldn't very well say, "Hey, Charlie, do you mind going out and having a smoke, while I interview Dr. Blotz?" Because I felt deeply in my heart that their presence inhibited Dr. Blotz's freedom of response, so when I brought up the point in a kind of joking fashion, I said, "Gee, I thought that new law was supposed to change all this." They said, "Well, yes, it does, but if this general or that admiral requests our presence, we have to be there." So that's the way around the law in this case. It inhibits the freedom of expression of a lot of people. So there you are, Lee.

LEE ESTES: I think Jules has left a few problems from the ones he had left over with "Batman." Mr. Louis Alexander has worked in both print media and broadcast research with NASA and he will now give one response before we go to the second round for rejoinders.

LOUIS ALEXANDER: Mr. Bergman has posed a number of problems for the print media, and one he has posed for me is how to take issue with him on behalf of the news media and still work for him later on the space missions for the broadcast media. I'm going to do my best.

JULES BERGMAN: Go ahead and take issue. Everybody else does, Louie.

LOUIS ALEXANDER: I'm going to have to see if I can walk a tight-rope up here similar to the wire he was on during Gemini VIII, and tell you a little bit about where I was at that moment. The best recommendation I can offer you for talking about the newspapers' problems and what the newspapers seek to do is the fact that Dr. Michel and Joe Engle get their news from the newspaper about the space program, as they told you at lunch. And this perhaps illustrates one point I would like to make about the function of the newspapers in this business of space writing. Television (T.V.), I tell my students at the University of Houston, seeks to entertain primarily and to inform secondarily, so I will throw that to you, Jules. Whereas newspapers....

JULES BERGMAN: You are in deep trouble already.

LOUIS ALEXANDER: Whereas newspapers seek to inform first and then to entertain secondarily, and maybe that is why some of the newspaper people are not such good entertainers as most of the television people. But, at any rate they take their information function rather seriously. I suspect the T.V. people do too, but it is a really serious problem for newspapers. What they seek to do primarily is to tell you everything that goes on and the word "truth" therefore has a very special meaning for a newspaper person. Just as the goal of NASA and Paul Haney personally is to take a passionate interest in informing, the newspapers take a passionate interest in making sure what they inform is the truth. This is not to throw a curve at Paul, but to point out a very special problem of the newspapers.

Well, in doing this they run into one obstacle which causes a lot of criticism and, I think, among people perhaps like those here. Among the readers of newspapers are many professors, many engineers, but perhaps they are outnumbered though; there is no question, they are outnumbered by the clerks, the sales people, those with high school educations and those with less. Now the more mass a media is, the more it has to seek to cater to the needs, the information needs of these clerks and salesmen, as well as the engineers and the professors. I think this is one of the reasons we have given a lot of people the impression that the space program, at least at its onset, consisted of John Glenn running along the beach. But at the same time, we have to fill page 48 and page 64, and we have our obligations to give these readers the truth and to inform them. We have a second obligation, which T.V. has also, which an editor takes rather seriously. Somehow or other, he has to walk a line between giving them his own personal opinion of what they ought to have and somehow, nevertheless, educate them.

If this space program is to have any meaning to the general public, and if they are to make decisions such as whether or not to approve a tax increase, whether or not to participate in it, if they are to



understand this, they have got to know what it is all about. So somehow or other, the newspaper with its page 48 and the Chronicle and the Post with their page 64 have room and time and an obligation to explain to a much greater degree and with a little more time than does T.V. or radio. This gets us into a number of problems that I would like to pose to you.

One is how to explain this business. Not only do we need technically oriented people at NASA to explain to us, we have to somehow or other explain these things to the general public, as does Jules. And our problem is complicated a little bit by the tension on the scientists and the engineer to give the exact term and the exact number to the exact situation. And one result, which is not ludicrous to them, but is somewhat funny to us, is what we used to call retrofire during the Gemini mission, we are going to have to call the deorbit during the Apollo mission. Now it is not the same thing to the engineer or the scientist, but how are we going to explain to the general public? All they know is that the darn spaceship is going to come out of orbit and land. So we will have to get this new vocabulary and we'll have to explain it, but it will mean different things to the scientists. We have this problem on the press of explaining these things, and somehow or other getting a new word across to the general public. Multiply this by the frammis valve, by the command and service module, by the lunar module, and the many other things we have to explain.

The other problem we have in a little different degree, just to give you another sampling of problems, is the problem of time. NASA means well, NASA does very well, and I think Jules Bergman put it very well, that never before has an organization had to rise to such a challenge in information, in that it has to give technical information, and it has to give it to a broad range of media, and that it has to give it fast. NASA has done a wonderful job in rising to that; nevertheless, the major problems remain, and after two or three or four or five years they ought to be better solved.

One of them is the time it takes to get an interview. If I want to interview an astronaut, I can interview him on Friday if he is not busy. And this is understandable because those people really have their time crammed. Now so does every other person at NASA as far as I can ascertain, especially the major people; but, should it take that long for a representative of a major medium to get his interview? Should he have to call three or four or eight times or wait a day or several days or a week? It is the problem of that Gemini VIII mission multiplied many times over and over again. It just takes too long and too much effort on the part of the media to get these interviews.

Now there are several good answers for that and I am perfectly willing not to attempt them, but to leave the way open for Paul if he

cares to talk about it and cover that point. I want to cover one other point, which is back at this idea of informing the "truth" to the general public, and a special obligation that the newspaper editors and the newspaper reporters feel (not that T.V. reporters do not feel it). But I am going to risk Jules' wrath by saying that, in general, newspaper reporters feel it even more strongly than do broadcast media people, in general. I think Jules and I are among the exceptions, aren't we, Jules? We are both pretty serious about this. I don't want you to jump on me until after the next mission paycheck comes in.

JULES BERGMAN: Playing a quadruple agent is pretty dangerous, Louie.

LOUIS ALEXANDER: So my point then about the special effort of the news media to get at the truth is aimed at two situations. One, is the kind of thing that Jules described to you, and the other is exemplified by one other simple-to-describe problem. The control room in NASA has 14 people who are very much on edge and very much responsible for everything that goes on during a mission. It's where the mission is run. Behind it is a viewing room with seats for 70 people. They call it the V.I.P. room, and they call it the viewing room. Before a mission begins, the news media can come in and go through a rehearsal and see how this thing runs. During a mission, they are not allowed in the V.I.P. or the viewing room; the controllers who run the mission do it without the presence of the press. Congressmen can get in there, and representatives of contractors can get in there. I have never verified this, and therefore I can not tell you that it is so, but Jim Maloney of the Houston Post has stated that secretaries can get in there but the news media can't.

Now the news media are represented there by Paul himself or by one of the other public affairs officers, very well informed, who takes a lot of time in advance to brief himself and know what is going on. He is on a microphone and he has a television camera at his disposal, and a closed circuit public-address system which informs the press of everything that the public affairs officer sees and thinks we should get in our effort to inform the public. Fortunately, people like Paul are there who are interested in seeing that the public learns as much as they possibly can. I think that, in general, they succeed very well in giving to us the things we need to pass along to you and to everybody else. But there is one thing that I learned when I worked for the Chronicle, and that has been repeated when I worked for the Wall Street Journal, and I remember it when I worked for Jules. That is there is nothing like first-hand information. If you are going to inform somebody else of how things are, you want to know how they are yourself, you want to be there, and not take it from anybody else. It may be right but how do you know? You didn't see it. It may be all there was that happened, but how do you know? You weren't there. And this just

irks the hell out of the newspapers and it irks the hell out of T.V., and it may even irk the hell out of Paul Haney who has to abide by this rule. But it is a major problem in this business of truth. They say that a democracy operates successfully because everybody knows what is going on. Therefore, to the degree that they know what is going on is this democracy a successful operation. Well, I pose that not in microcosm, but at least in smaller scale as the problem of reporting on space.

LEE ESTES: The time is running short. Mr. Haney, do you care to dig into a couple of these problems?

PAUL HANEY: I thought you would never ask. Well, very quickly, I won't take the 20 minutes that he took but ....

LOUIS ALEXANDER: He's paid by the hour.

PAUL HANEY: But I will deal with Jules first in the Gemini VIII situation. The trouble on that flight did develop at 7:02 EST and it occurred when the spacecraft was not in contact with any station. The Coastal Sentry — (whatever else I've got, I've got a good memory and for this one I don't have to look at any notes) — The Coastal Sentry Quebec acquired Gemini VIII at about 7:06. At 7:12 an announcement was made by the Public Affairs Officer, the first line of which was: "Trouble has developed in the flight of Gemini VIII." Not a little trouble, not a lot of trouble, but trouble. He further said that the spacecraft had come up on CSQ, it was undocked, and it was tumbling at an undetermined rate. That announcement was repeated at 7:14, and every 15 minutes thereon through the night there was an announcement made. The tape, as Jules said, was suppressed till the following day at noon. That, I think, covers that, although, we did, I believe, in the second announcement after that initial one, we did indicate that there was a strong possibility of an early termination of the flight and that's what started people scrambling. Again, I am telling you what happened and I'll show you the transcript if there's any doubt in anybody's mind.

But Jules, and Louie to a certain extent, and lots of other people who are far less informed, used phrases like "information gap" and "information blackout" and those illusions, statements, or what have you, are patently false, in my opinion, and I have the transcripts to back it up, both tape and written, and I'll stand on it.

Now in the case of Louie's comments about the viewing room, on this I'm afraid he touched a delicate nerve in a couple of amplifying remarks that I would like to make there. It is true, and I don't honestly know; I've never been able to decipher the logic that goes into the population of the viewing room during a mission. I've seen

the President of the United States, the Vice-President on more than one occasion, the heads of major committees, various members of the Cabinet, the Chief Justices — boy, you name 'em and we've really had them in the various viewing rooms here and at the Cape. And yet for some reason we've never been able to accommodate a pool. Now, the reason, (the reason has always wandered around, for various reasons), and finally the statement is: "We don't want to bring undue pressure on the flight controllers. They have enough to do." Well frankly, given a choice of Louie Alexander and Jules Bergman, I would much rather have them looking over my shoulder than Lyndon Johnson or Hubert Humphrey. But, obviously my feelings aren't much considered.

The other factor is that Louie says the viewing room would be the ideal spot. Well, I don't happen to agree with that. I happen to think that the ideal arrangement would be to just patch the picture out across the street and then everybody gets a look at everybody. Then those who want to be subjective and read undue strain on the face of Chris Kraft when he says those immortal words can do that, if they like. I don't think the viewing room would be any solution at all. I think that if we had a pool or the total press corps in the viewing room during a mission, (we could certainly put a press corps in there in recent missions), if we had them in there, then there would be another hurdle. We would have to build some stands around the flight director's console and it's just that it would be a progressive thing. Or finally, we would have to occasionally give the microphone to one of the correspondents who would say, "O.K., execute a right roll." Or, "Why didn't you execute a right roll?" You see? And this is part of the agency doing business that I think should be observable, certainly reportable, but it is under a finite point. The press should stop and should simply let NASA run it and report what NASA did. That is about all I would like to say.

JULES BERGMAN: Well, no one in the press, least of all me, has ever tried to tell NASA how to fly a mission, nor would any of us, I think, seriously ever attempt such a thing. To go back to the Gemini VIII case, I was not trying to question the validity of your first bulletins or announcements; they were pretty fast and were in actually real time. The major point I brought up that was handled wrong was what ensued after that (after the decision to bring them down). That is where the information gap really came into being. Let's replay the tape now, as they say; let's go back to the action byplay of that night of Gemini VIII for just one second and let us see how it might have been.

Let's see how the information gap might have been cleared, Paul, without interfering with the way NASA flew the flight or anything else, and I submit that it can be done very simply. We could have had a patch into the NASA video-vidicon cameras and mission control, and the

picture could have been brought across the street for the press to see it with audio so they could hear it. No need for the press to be in the viewing room. I don't believe, for one, that the camera being on or the audio lines being up for room sound, short of getting Chris or Gene Kranz or any controller's actual remark, I don't believe that would bother. I don't believe the picture of the guys in the control room being on network T.V. would bug them for a second. Let's say we had those live cameras in there the night of Gemini VIII when the whole nation was on tenterhooks so, waiting to find out what happened to Neil and Dave. O.K., and let's say my other suggestion, which has gone unpicked up by NASA for the last four years, was taken up. That is, mainly, that one of the flight controllers on the team — if Kraft is in charge, not him, not Kranz, not John Hodge, not Glynn Lunney, but the guy who is off-duty at that moment and is standing by — were available. There is a little vidicon camera in a booth to the right of the V.I.P. room or the viewing room, whatever you want to call it, and he comes on every ten or fifteen minutes or something, maybe every half-hour, to give a progress report.

All right, Paul does his homework and does a good job of it, in some cases nearly as good as a lot of those guys. But it still would carry more authority if one of the men who was actually flying the mission or running the control portion of the mission came on. That whole night would have been different, Paul, if we could have had live pictures in there and could have had an actual spokesman, one of the flight controllers come on, and I maintain that it could have been done on a noninterference basis.

No need for live network cameras in the control center itself, near the monitors, no need for live T.V. cameras in the V.I.P. room, just a patch running through the switching center on across the street to Building 6. And no need to bug the audio (which some people have attempted in the past, by the way) by getting what the controllers say to the astronaut. That whole night would have been different. That is the thing that the networks would like to see, by the way, as we move into Apollo manned flights. With that kind of thing, the interest curve may still be down at that point, but it would certainly make for far better, more accurate reporting and television viewing by the whole nation. That, I think, would help solve the problem.

LEE ESTES: Do we have any specific question from the audience? Yes sir?

Audience: Why wasn't the Gemini VIII for sending out?

PAUL HANEY: So we could find out, perhaps, why the incident happened. Incidentally, I think it was a mistake now, and NASA and other people within NASA thought it a mistake, but on that particular

evening the reason it was held up, or suppressed, or censored, or whatever word you care to use, was specifically so that it could be re-played in line with certain other telemetry events to try and understand what did happen. As a matter of fact, it took three days to figure out that the No. 8 thruster had stuck open. It was three days later before that came out, and that was after —

Audience Question: With such extremes with that thing, it looks to me like it would be very simple to duplicate it and let them have it.

PAUL HANEY: Oh, it is very simple, but I don't think, you know, with such extremes that it should be necessary to do it. In this case, I think we made a mistake and we should have gone on out with it, in the normal course of events. I think also that something else important is that when NASA makes a mistake, I think they ought to admit it, and I admit it.

LEE ESTES: Let me point out, because in my present position, I come in contact with various types of scientific research. The opportunity to ponder in private is guarded far more jealously by researchers in almost every other field than you find in NASA and space science research. Air Force research, and such. Medical doctors, by the same token, feel no obligation to have a T.V. camera bearing down on their shoulder; they choose to bring it in and quite often they have the opportunity to elect to leave it out.

Frankly, our professors, honestly and sincerely are pretty nervous when they know that their first reaction, their first thought, is going to several hundred million people and their opportunity to ponder in private is seriously invaded at the moment. Most people do not have to work under that strain. I think that it is the people in control who are conditioned to it, but this is one of the dilemmas that we are faced with in future scientific reporting. I think that it is instantaneous duplication of events, and analyses of them are difficult to bring together. Yes sir?

Audience Question: I wonder why is it that the news media, and all the television media, claim to be trying to serve the public and communicate, rather than being a commercial product? Why don't they join together and have a pool? (There is no reason to have three major networks stand by for six hours or twelve hours or whatever it was with dead air-time.) Why not have one network standing by with dead air-time and join together like AP and UP does by putting everything out for everybody to pick up?

LEE ESTES: Give that man a network. What dead air-time are you referring to?

Audience Question: Well, he said that they had to stand by all night and they weren't getting any information.

LEE ESTES: Oh, well, he conveyed that, so he'll want to correct it because that is not a true statement, is it, Jules?

JULES BERGMAN: There is a misunderstanding. What I said was that all three networks had dropped regular programming and were doing nothing except live coverage of Gemini VIII until we could determine that Neil and Dave were safely down. (Now, you could extrapolate your thought, which is: "Why did all three networks do it, why not just one that is pooled?") O.K. The free enterprise competitive system is the answer. We have debated among ourselves, certainly we at ABC News have, as to why we don't pool. For example, we could carry Apollo 7, let NBC carry Apollo 8, and CBS Apollo 9. And the way the interest curve has gone down, we might beat the other ones on ratings by carrying regular programming. Who knows? But we have chosen, as a public service commitment, and because of the free enterprise competitive system, to carry it. The same rule by the way (the question by the way) may be asked of political conventions and elections, you know. Some people feel that the networks have sated them. They have overdone it that way. I don't know how to answer it. We pool facilities, technical facilities, cameras, trucks, et cetera, for major space shots and conventions, but nobody has been willing to make the other move, which is to say, "O.K. we're not going to carry it, Apollo 7 kids, you can carry it, we take the next one."

LEE ESTES: You see, really the same arguments you have about social responsibility of the network changes place. "Batman" would have picked up the rating because there are more kids, there is no question about it.

Audience: I would like to ask: "Mr. Bergman, do you think the media are meeting their responsibility in general in assigning more technically oriented people to cover the space program?"

JULES BERGMAN: I'm sorry, more technically oriented program to what?

Audience: Really attempting to train more technically oriented people to cover the space program.

LEE ESTES: Could all of you hear that question? Are the news media fulfilling their responsibility to the people by assigning more technically oriented reporters to space coverage. Is that right?

Audience: Yes.

Jules Bergman: I will not attempt to answer that for the other two networks because to do so would obviously be prejudicial. I think my network has met its commitment in assigning me as a full time specialist, at great cost, by the way. There are plenty of people who say, "Why are they sending him to Cape Kennedy covering that shot when we could use him to cover the Newark race riots or whatever else?" O.K., I think the newspapers and wire services have done largely a superb job of reporting science news. In the seven years since I became a full-time science-news specialist on the Sloan Kettering Fellowship, I've seen, not a double and tripling, or quadrupling, but perhaps a twenty-fold increase in the number of science writers and reporters in the nation's newspapers and wire services. And I think, by and large with small exceptions, the product we are turning out is highly accurate and very well done. I think some days by reading the newspapers that we're overdoing it.

LOUIS ALEXANDER: May I answer that very briefly, Lee? I'd like to say that the newspapers and broadcast media are increasing their efforts but there just aren't enough well-qualified people to go around.

LEE ESTES: We're just running out of time now; we're overtime really. We don't have another question, so we are closed down. Thank you very much.



## SPACE SCIENCE WRITING FOR THE GENERAL PUBLIC

By William C. Sexton  
Editor, World Book Encyclopedia  
Science News Service

I thought I had wandered in on a family argument here in the last few minutes. I want to start today by getting revenge on the previous speakers for using up half of my time. And it seems to me the way to do this is to tell a little story that actually happened once. A fellow came in from out of town to speak to an organization which he knew really couldn't afford to pay his fee. I think that it is appropriate now that we have a picture of the budget for next year to tell this story. And so when he had finished speaking he said to the chairman of the group that he wanted to hand back his check if they had some good use to which they could put it. The chairman was very grateful. He said, "Oh, yes, I'll put it into our earmarked fund." The speaker asked, "Oh, what is it earmarked for?" "Well, it is a fund we are putting together to get better speakers next year."

I'm rather eminently concerned with the coverage of space, the technology, the engineering and the pure science, which I haven't heard mentioned yet today, or this afternoon, at any rate. My concern is a little bit different from that of the gentlemen you heard before. I keep thinking that a lot goes on in the space program between flights. I keep thinking that there are responsibilities which NASA has to cover, this great research effort in terms other than astronauts, missions, tensions before the launch and the pressures during the flight. This hasn't been mentioned. I suppose I could talk all afternoon about the things that don't get coverage because NASA doesn't bother to have a public relations program dealing with the serious side of space. Unfortunately, though, that is not really the purpose of this seminar today — to argue today whether NASA is doing something right or the networks are doing something wrong. It is a much more serious issue that deserves about 10 minutes of consideration. That is the communication of science, partially, the techniques of communicating it, and more important, the purpose of blocking the other. This is a many-sided discussion. There are two audiences here today at least; one, perhaps writers, who are looking for specific ideas that can be put into news when they get back to the job. There is another set of people, and it may overlap, who have management or public relations, engineering or other responsibilities, and to keep this split going, I — you, really, — have two speakers here. With one hat, I pretend to represent the reader as a listener, as a viewer. Very little has been said on his behalf today, so far. The other hat I wear is that of the newspaper man or the broadcaster, the reporter primarily who is trying to get the information, and to carry this double situation

further I am going to have to make two speeches. I hope to make a very short one on writing, and a very short one on the purpose of writing, the philosophy, the real mission.

Now, there are a lot of people in this audience who are completely up-to-date and completely equipped on both these scores, the techniques of science writing and the purpose and philosophy of science writing. Unfortunately, their bosses have different ideas, sometimes they don't get to write the story, or to use the clear language, or to go right to the kernel of the issue, or to speak plainly rather than to obfuscate the information. Well, there is something that has to be said to their bosses, if the policies of communicating scientific information are shaped nearer to serve the specific narrow purposes of administrators, or engineers, or contractors, or offices, or administration. They have only themselves to blame when the public loses interest in what they are doing and appropriations dry up. And that, my friends, is what happened to the space program. It has not been a question of the public losing interest, it is the question of the program losing touch with the public. Administrators with fairly guaranteed salaries are not taking the trouble to make their policies clear, to frame their policies, to phrase their statements, to make their plans with any recognition whatsoever that I'm paying the bill and I'm going to be heard from sooner or later. And because of this disdain to communicate to me, "I ain't paying anymore." And that is where the contracts went. That's exactly where they went. There is the great drama of manned space flight.

Well, the purpose of space exploration is not to put on a bull fight in the sky. It is scientific research, it is the pursuit of knowledge, it is the developing of information systems of new types of technological organizations which can solve vast problems, not just of engineering, but of social engineering, not just of spacecraft architecture, but of urban architecture. We are developing these things but we are neglecting to look at them and present them in this larger view and this is where the money went. We lost interest, and I have to say I think the reason for it was lack of attention to detail at every level of public relations, and at every level of engineering, and at every level of politics. And when I mean attention to detail I mean things like someone losing his life on a flight on earth, and calling up to find out how far he was trying to fly, to discover that the flight distance between Cape Kennedy and Houston is classified. That's ridiculous. But again, it was inattention to detail, lack of thinking, and the ready excuse not to go and find out a piece of information. This is where you lose friends. You lose the friends of the newspaper men who try like mad to popularize the program, you lose the friends of the people who read newspapers and watch television and are seriously interested in it. Pretty soon they quit trying and this is where we are today. Now that is the end of my sermon on the philosophy of the space program.

But it does have a bearing on the philosophy and purpose of communicating science. The real information gap in this country today is not one of credibility, it is not one of people not reading the right newspaper or looking at the right television shows, it's really the way that those of us who are concerned with science and research and development and technology have somehow lost touch with all the other publics which make up our society. It is easy enough to see why it happened. The things we are working in today are so complicated we don't even understand what the guy next door in Building 6 is doing. And yet, unless we can make the effort, find the skills, the techniques of breaking down these barriers of understanding, how in the world can we mobilize a nation and the world to find some practical use for the information we are pursuing? I think it is wonderful to know what the atmosphere of Venus is; I'd like to know what is a thousand meters underground, it might be important to us a little sooner. But, unfortunately, we are not communicating.

The people that were involved with Project Mohole didn't communicate very well and it killed the project. The people involved in the Apollo Applications Program (AAP) didn't communicate very well, and God knows that one's probably gone for two or three years. All because we are not taking the trouble to break down the real information barrier, which is just one guy talking to another guy and speaking English. This is the problem. It is more than an appropriations problem, more than a political problem, it is certainly much more than a battle between the T.V. networks, as to who sits where down at mission control. We've got so much information, so many solutions to problems, so many skills, and so few of them are actively being put to work, because of inability to communicate the answers to the problems that surround us. So when we complain about urban sprawl, lack of housing codes, poor transportation, air pollution, all of this in a time when we have all kinds of solutions to air pollution, all kinds of solutions to transportation, there has got to be something wrong, and it seems to come down to a simple communications channel. Something is missing between the guy that knows the answer and the guy who has the problem.

Now this comes back to science writing. It comes back very intimately to science writing and very directly. There has got to be built up within our society (I hate to talk like a professor, but, this is really what it comes down to), we've got to establish a new interface, a new profession of people who know enough about the engineering and enough about the common man to dig into the interests of one and the knowledge of the other and keep it pulling back and forth. It is a two-way street. So technical writing, if it is used as a larger skill, not just the producing of reports, and proposals, and captions for engineering drawings, but is enlarged and looked at from the view of

communicating technical information to people who do not know quite as much about the subject as the man who did the original work, then we really have a job to do.

I think that is why I'm here today, not to talk about the philosophy, but about some specific things that can be done. And it is so simple. It's as simple as the nail that wasn't in the shoe that wasn't on the horse that lost the war. It's as simple as that. We've got to go back to some very simple techniques of communicating and I have to say to you that I met a charming English teacher at lunch today and she is the one who should be making the speech because that is the problem, plain English. If you are writing for people, not for engineers, even the engineers are people, and I find in reading scholarly literature these days that the biggest complaint about lousy technical writing is now coming from editors of such journals as: "Nature," "Science," "Journal of the American Medical Association," and for some reason, "The Journal of Micromolecular Biology," which had a grim editorial, damning people who were writing papers that microbiologists couldn't understand.

All right, a couple of techniques. First, in writing for a semi-popular audience, whether this audience is in "Roundup," or a general scientific publication as opposed to an in-house paper, try to put yourself in the place of the reader. I suppose everybody sets out with this in mind, but we keep forgetting that while most people are trying to read even the "Journal of Microbiologists" or the "Annals of Microbiology," the telephone is ringing. If it is like most of the professionals I know, they are having to do it at home at night and the electric train is still running in the next room; he has got 97 magazines he has to get to tonight because you are going off to a seminar at the University tomorrow and you don't know which question you are going to get asked so you have to look real smart in a hurry. All these interruptions, so the main advice is for the writer to put himself in the reader's place.

Now this breaks down into several subheadings. One is to write about people, not about things, because people are inevitably interested in other people and seldom as interested in things. I suppose this sounds like treason in front of a technical gathering to say that the names or a little bit about the actual human beings that are carrying out a project deserve to be in the report on it. Listen, the question inevitably comes up: "Who did it?" "How did he manage it?" "Where did he come from?" All of these things which we, somehow, learned to leave out of the scientific report and made it dull.

The second important element in the semi-popular presentation of science (and I am not talking about "Popular Mechanics") is to avoid the temptation to present every fact to an accuracy of .0001 to the minus 17th, for a reader who really wants to know whether the man's sum

really comes out a green or blue. Is there anything that is more appalling to people in a hurry for important information to be confronted with a mass spectrogram when they want to know whether it was white or black? You don't use an electron microscope to see if it's time to put your fertilizer on your lawn, and yet in our writing of science we've been trained to be so exact that we kill the customer with details. And this is one of the hardest lessons that research and technological people have to learn, and it's communicating.

The third point is telling and communicating the information in terms familiar to the audience. Often that involves finding analogies that are not 100 percent accurate, which represent over-simplifications, but which at least leave your audience understanding what you are talking about. Surely an over-simplification in an analogy is more important, more tolerable, than total lack of understanding at all.

Finally, I want to say something in favor of the short sentence. I think that the technical writing in the United States could be improved 100 percent between now and noon tomorrow if we doubled the number of periods on typewriters. It sounds facetious to stand up in front of a bunch of educated people, many of whom have advanced degrees and all of whom handle sensitive and important, significant information. But there is some sound neurological, physiological Claude-Shannon type of communication research behind this. The mind takes information in sentences. The gate through which these sentences go is just so wide, and if you make the sentence about as wide as that gate circuit in there, you are going to get through. If you don't, the reader has to stop and break the sentence down, consciously into increments that will fit through the gate. It is as simple as that.

Now, I hope I haven't said anything treasonous this afternoon and, since I am almost within the allotted time without using all of the coffee break, I want to get in a commercial. I wish to deny that NASA is the most misunderstood organization in the United States. It is only the second most misunderstood. The most misunderstood is the organization which allowed me to come here this afternoon. It bears the name of an encyclopedia but it does not have very much to do with an encyclopedia. It works very hard on space programs, but it is not by any means limited to covering space. And so perhaps you can forgive me for unloading a bit of the frustration by giving me one minute of explanation of what something could possibly be which bears the unlikely name of "World Book Encyclopedia Science Service, Incorporated," or as we pronounce it "Weebeca." We're a charitable division of Field Enterprises of Chicago. We have that in common with NASA; in being a charitable organization, we know what budget cuts are. And we are the only organization in this whole rich country which is dedicated to the communicating of serious news of science to newspaper readers. We're not a branch office of "Batman" or a part-time science writer on a wire

service; we are a very small compact news organization. We are four years old and have about a hundred newspapers in this country and quite a few outlets overseas which look to us for illustrated, serious coverage of all types of science. One of my colleagues is sitting back there this afternoon, and he's off tomorrow on what may prove to be the absolutely impossible mission of popularizing X-ray diffractions. But the fact of the matter is, laugh though you may, one of these many techniques in the exploration of this microworld we live in is X-ray diffractions and we got a hot tip that they are about to map a new protein out at the California Institute of Technology. I don't care what NASA's problems are, with hanging over a flight controller's tense shoulders, we are going out and we are going to do a story about tracking down another protein. If Krommy is as skillful as he usually is and if the photography is as dramatic as we hope it is, and the cut lines and illustrations are very carefully put together, we will be able to put this story into — oh, we can get it into 80 of the newspapers that buy our service. Eighty of them, if it is the right 80, we will have a circulation of between 10 and 12 million. We know statistically that one newspaper goes through the hands of between two and one-half and three and one-half persons, so maybe in the next couple of weeks for the first time, as many as 25 or 30 million people will be given the opportunity to understand what X-ray diffractions are and why it is important. Well, I don't know if that is important to the future of America or not.

But I do know this, that unless some of these complicated concepts and developments and techniques and inventions which are absolutely and unquestionably determining the whole shape of the world we are going to live in tomorrow and the next day, if all of these complicated things are to be understood, somebody has to do the hard job of trying to explain it. Not only to the high school kids who are taking advanced science, but also to their dad, who is making out the income tax return and writing the congressman and going down to the club and making nasty remarks about the fool grants that go out to the California Institute of Technology or to Rice University or the University of Houston or the Manned Spacecraft Center; these are the people we are trying to talk to.

And I'll tell you a secret, we are not getting one bit of help out of the National Aeronautics and Space Administration because they are too busy publicizing their manned space flights. We are getting very little help out of contractors because they are too busy writing proposals. We get precious little help out of the actual space researchers themselves because they are so busy. It is such a terrible thing to have to explain what you are doing until you're good and ready to do it. That's fair enough. We never ask anyone to reveal his work until his paper is accepted for publication. But would you please take an extra five minutes and tell us in English? Thank you.

## GRAPHICS PARTICIPATION IN THE MISSION EVALUATION

## REPORT AT THE MANNED SPACECRAFT CENTER

By Roy Magin  
Manned Spacecraft Center  
Houston, Texas

From May 1964 to December 1966, the NASA Manned Spacecraft Center flew 12 Gemini missions, 10 of which were manned. The data obtained from these missions are indispensable in the planning of future missions. An adequate and timely system of data reduction was established to accommodate an effective evaluation and to adequately document the evaluation for future reference.

The main objectives of a mission evaluation are:

To reveal all anomalies

To determine their cause

To recommend corrective action

Because of the relatively short interval between the Gemini missions, the evaluation had to be accomplished in a timely and efficient manner. It is imperative that an evaluation be completed and a report generated in sufficient time to apply the knowledge gained to future missions.

The main objective of a Mission Evaluation Report is to assimilate all facts and figures from each mission evaluation and thoroughly document them for future reference. It is in this capacity that Graphics and Reproduction Support Services play an indispensable role.

Each Gemini Mission Evaluation Report is divided into 13 major sections which are subdivided to accommodate the complexities of a particular mission. For example, in the Gemini V Mission Evaluation Report, the vehicle-description section (section 3.0) was divided into three subsections (fig. 1).

3.0 — Vehicle description

3.1 — Gemini spacecraft

3.2 — Gemini launch vehicle

3.3 — Gemini V weight and balance data

In the Gemini XII Mission Evaluation Report, section 3.0 was expanded to include:

- 3.4 — Gemini Agena target vehicle
- 3.5 — Target launch vehicle
- 3.6 — Gemini Atlas-Agena target-vehicle weight and balance data

Each section or subsection is divided into three categories: text, figures, and tables (fig. 2).

A typical Mission Evaluation Report team consists of the following members (fig. 3):

Team Manager

Chief Editor

Editorial Staff Head (NASA and contractor)

Data Support Group Head

Graphics Support Group Head (NASA and contractor)

Senior Editors and Staff for all major sections

A Mission Evaluation Report team consists of personnel previously responsible for the design, testing, and qualification of the vehicle and its systems and of personnel previously responsible for conducting the flight. Support services such as Writing, Editing, Graphics, and Typing supplement the team.

The team is program oriented and consists of both NASA and contractor personnel. These personnel work independently of normal administrative lines of authority and, with some exceptions in the support areas, report directly to the Gemini Program Manager. Personnel working as part of the Mission Evaluation Report team are relieved of their regular duties to the maximum extent possible but are released when they complete their particular Mission Evaluation Report assignment or responsibility.

Graphics Support, both consultation and art production service, is available to the entire Mission Evaluation Report team from the beginning of the evaluation through final printing. Graphics Support is available to other support services (such as Writing, Editing, Typing, and Math Aids) on a consultant basis throughout the preparation of the report.



The average production schedule for a Mission Evaluation Report is 35 days from end-of-mission and includes review copies, rework, final printing, and distribution. This rigid schedule must be met with a minimal, predetermined amount of overtime. Allotted time for the Graphics production is about 30 days (26 when Sundays are discounted). During this time, an average of 265 inputs have to be scheduled through Graphics in addition to the regular workload (fig. 4). The Graphics workflow is shown on figure 5.

Each graphic input received five quality-control checks from (fig. 6):

The Quality Control man at Graphics (contractor)

The Graphics coordinator on the Mission Evaluation Report team (contractor)

The NASA Graphics coordinator on the Mission Evaluation Report team

Initiator of the input

Chief Editor

Figures for a Mission Evaluation Report include charts, graphs, photographs, technical illustrations, and/or combinations of any of these (fig. 7).

The basic format for a report figure is a 3-to-4 ratio of length to width. The image area (in printed form) is 6 inches by 8 inches. To insure conformity and to expedite production of art and printing, four format sizes were selected (fig. 8).

100 percent — 6-inch by 8-inch image area

75 percent — 8-inch by 10-1/2-inch image area

60 percent — 10-inch by 13-1/4-inch image area

50 percent — 12-inch by 16-inch image area

By limiting the format sizes, the copy preparation was greatly simplified. For expediency, "cold-type" typewritten copy on "sticky-back" paper is used. The copy using IBM registry and directory type best complemented the selected format sizes.

The initial purpose of the Gemini Mission Evaluation Report (to document the facts and figures for future reference) necessitated production of the most clear, concise figures possible within the allotted time

frame. It is for this reason that all figures in the Mission Evaluation Report are reproduced either full page (fig. 9) or as full page-height foldouts (fig. 10). Foldouts are used to graphically portray data and/or equipment too complex for a 6-inch by 8-inch image area. Foldouts are particularly adaptable to accommodate a lengthy time scale (fig. 11).

Review copies of the Mission Evaluation Report are distributed to the Program Manager and to the Senior Editors 30 days after end-of-mission. Only 15 copies are required; therefore, cheaper and faster printing methods are used to accommodate this limited short-deadline printing requirement. Xerox, Ozalid, and Itek types of reproduction equipment have been adequate to accomplish this task.

For the final printing requirement, offset lithography is used. Plates are prepared from camera negatives. Because of the short deadlines imposed on printing, the final copy is handled as an in-house printing requirement.

To reduce reproduction costs and to accommodate existing press size, foldouts are printed on either 17-inch or 22-inch paper (no trimming). Illustrations are planned accordingly by the Graphics coordinator assigned to the Mission Evaluation Report team. When illustrations require a continuous presentation of data that exceeds these limitations, a left-hand, right-hand foldout spread is prepared (figs. 12 and 13).

Distribution of the final printed Mission Evaluation Report is documented in section 13.0 of each Mission Evaluation Report. Physical distribution is handled by the responsible Program Office. Approximately 550 copies are required for each Mission Evaluation Report.

The first Gemini Mission Evaluation Report required a total of 212 pages, of which 88 were figures. The Gemini XII Mission Evaluation Report contained 520 pages, of which 164 were figures. The percentage ratio shows 68 percent text and tables to 32 percent figures (fig. 14). As the missions became longer and more complex, the demand for Graphics Services increased accordingly.

The biggest problem facing Graphics on a Mission Evaluation Report is the quantity of work involved within the short timespan. The average workload for Graphics is 1760 pieces within a 30-day time interval. A Mission Evaluation Report adds an average of 265 pieces to the workload. A typical Mission Evaluation Report workload breaks down approximately as follows (fig. 15):

Total number of pieces initiated	— 160
Change requirements	— 85

Corrections	— 20
Total inputs to Graphics	— 265

Many resources are employed by Graphics to meet growing Mission Evaluation Report requirements. Resources employed in MER art production are shown in figure 16. Existing art stored in the repository is updated when possible, rather than preparing an entirely new figure. This is especially beneficial in the preparation of the highly technical illustrations for the vehicle-description section (fig. 17).

Math Aid plots are utilized as original art whenever possible. A light-green grid paper with a black major grid is used. Pencil plots are prepared heavy enough to adequately reproduce in combination with the major grid (fig. 18). Preprinted maps are utilized for presenting data which involve orbital tracking (fig. 19), and photograph/artwork combinations are used to simplify illustrations (fig. 20).

Preprinted forms are designed and used when applicable to display vehicle time histories and actual flight plans. Figure 21a is an example of a preprinted form and figure 21b shows the form completed to illustrate a spacecraft test history. Similarly, figure 22a shows a preprinted form for a flight plan, while 22b is an example of the form filled in for a particular flight.

Machine plots are frequently utilized as original art (fig. 23). As you can see by the example, these data would have been difficult and costly to hand-plot and graphically reproduce. The technical accuracy would be most difficult, if not impossible, to maintain.

Production of the figures is planned with maximum flexibility to accommodate numerous changes. Flexibility is acquired through the use of overlays and by utilization of "cold-type" typewritten copy on removable "sticky-back" paper (fig. 24).

One NASA and one contractor Graphics coordinator are assigned to the Mission Evaluation Report team. The coordinators' familiarity with the Chief Editor's and/or Senior Editors' desires, plus the flexibility built into the figures, enable the coordinators to make numerous minor changes and corrections to the figures, thus eliminating a recycle back through Graphics. The coordinators are also thoroughly familiar with NASA figure standards.

With the beginning of the Apollo Missions (which have more complex systems and vehicles, larger crews, and longer and more complicated flights), it is only reasonable to expect the talents and resources of Graphics Services to be taxed more and more. In anticipation of this, we are continually seeking better and more efficient ways to meet these demands.

# GEMINI MER

## SECTION THREE BREAKDOWN

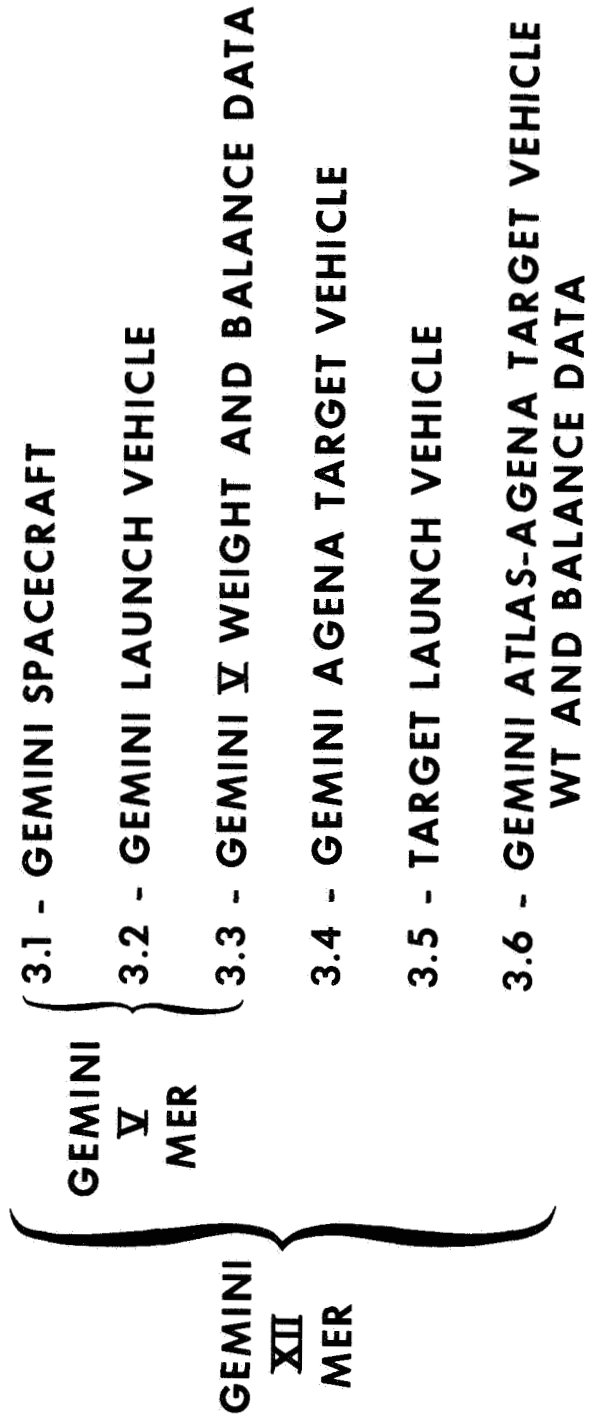

Figure 1

# GEMINI XII MER PAGE BREAKDOWN

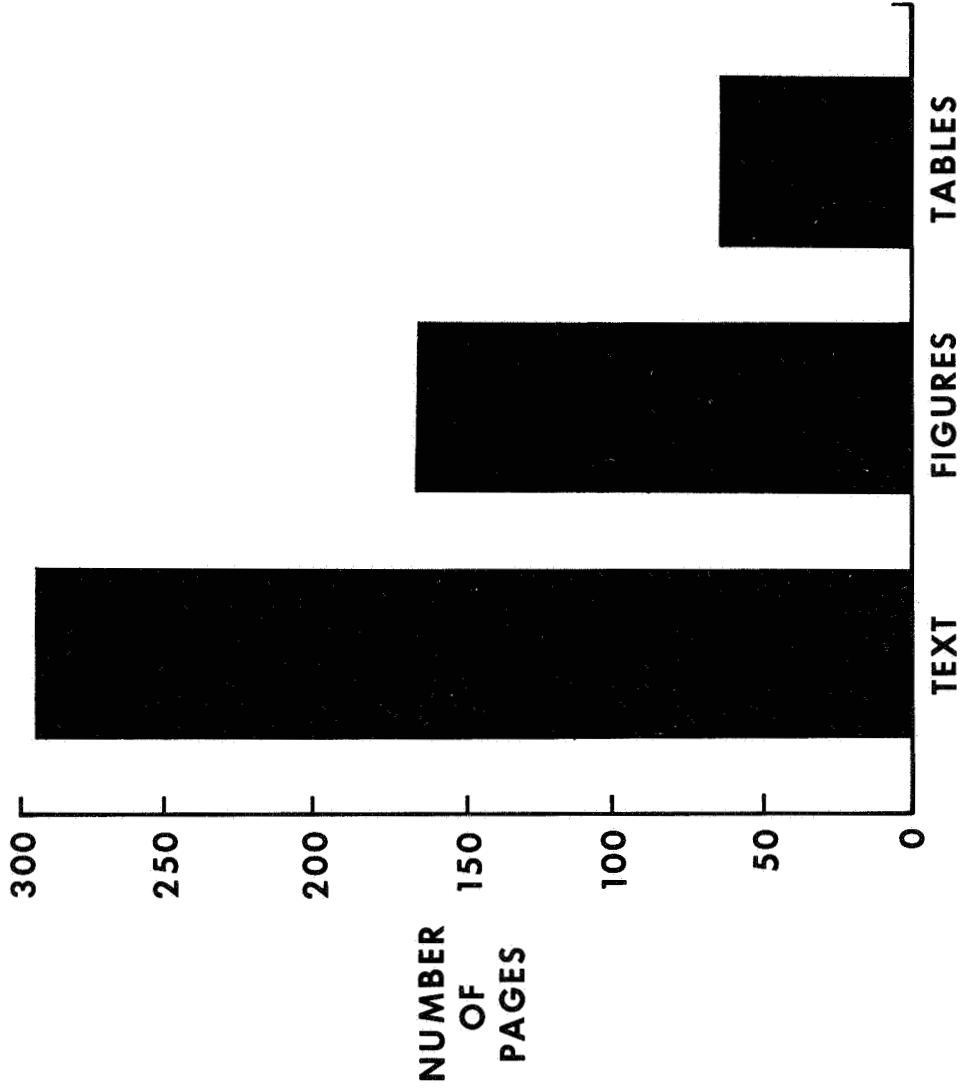

Figure 2

# MER TEAM

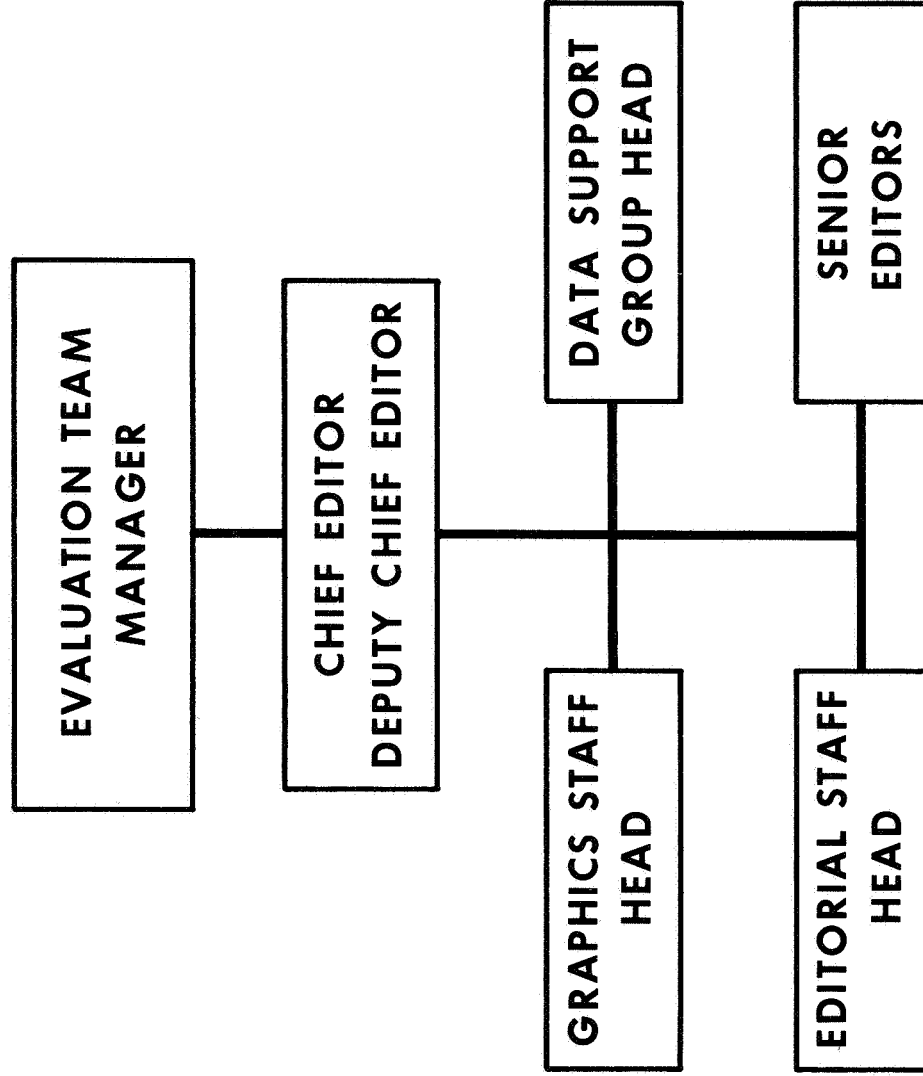

Figure 3

NASA-S-68-95

# GEMINI MISSION REPORTING SCHEDULE

END OF MISSION

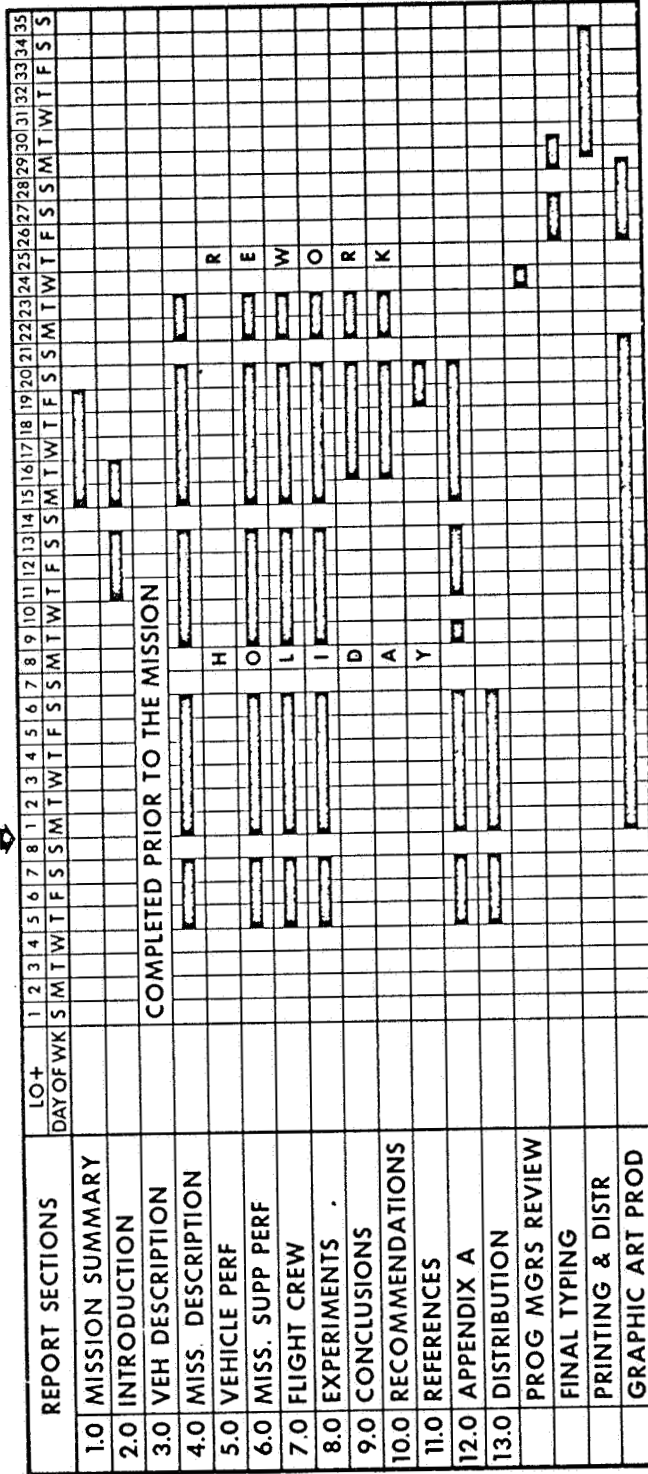

Figure 4

# GEMINI MER GRAPHICS WORKFLOW

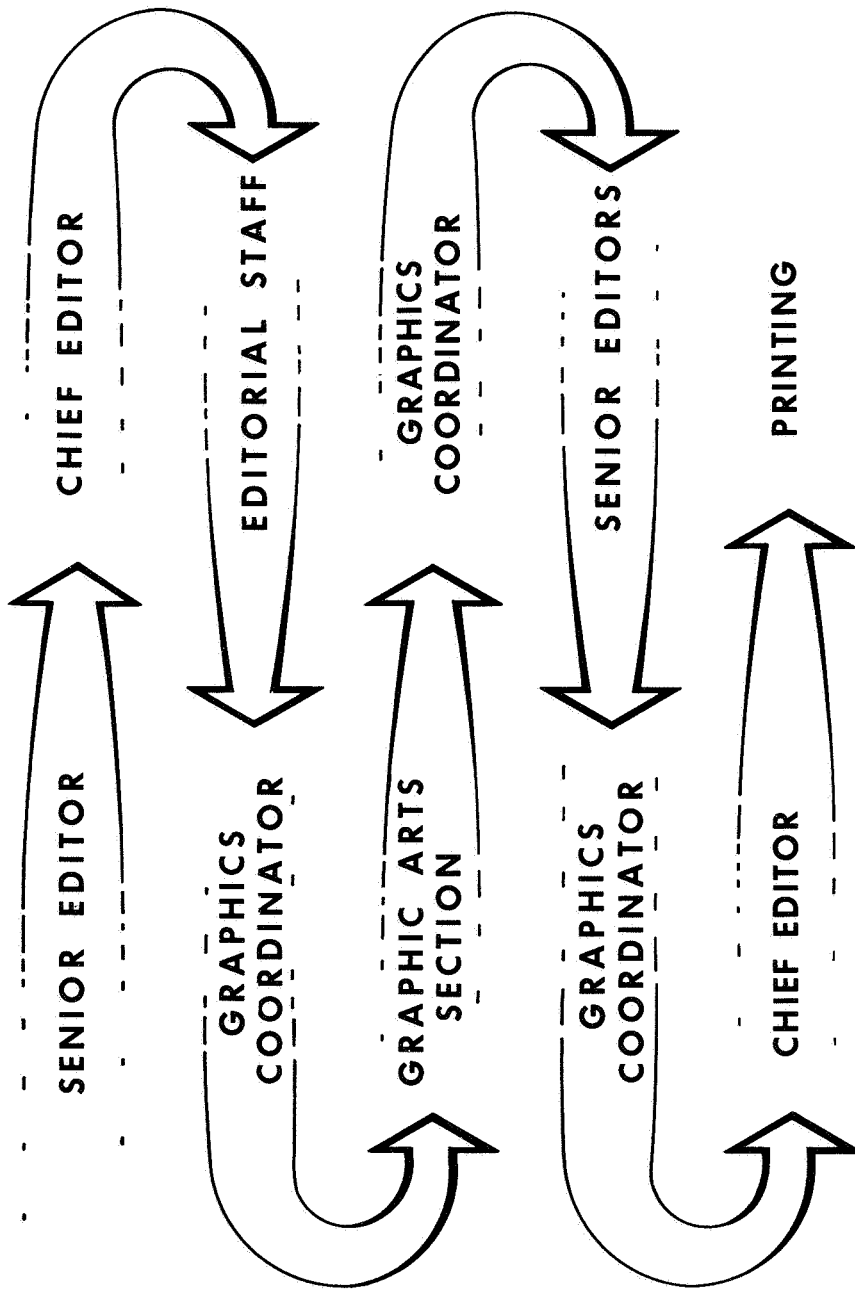

Figure 5



# GRAPHICS QUALITY CONTROL POINTS

- QC MAN AT GRAPHICS (CONTRACTOR)
- GRAPHICS COORDINATOR ON MER  
TEAM (CONTRACTOR)
- GRAPHICS COORDINATOR ON MER  
TEAM (MSC)
- INITIATOR
- CHIEF EDITOR

Figure 6

3-24

UNCLASSIFIED

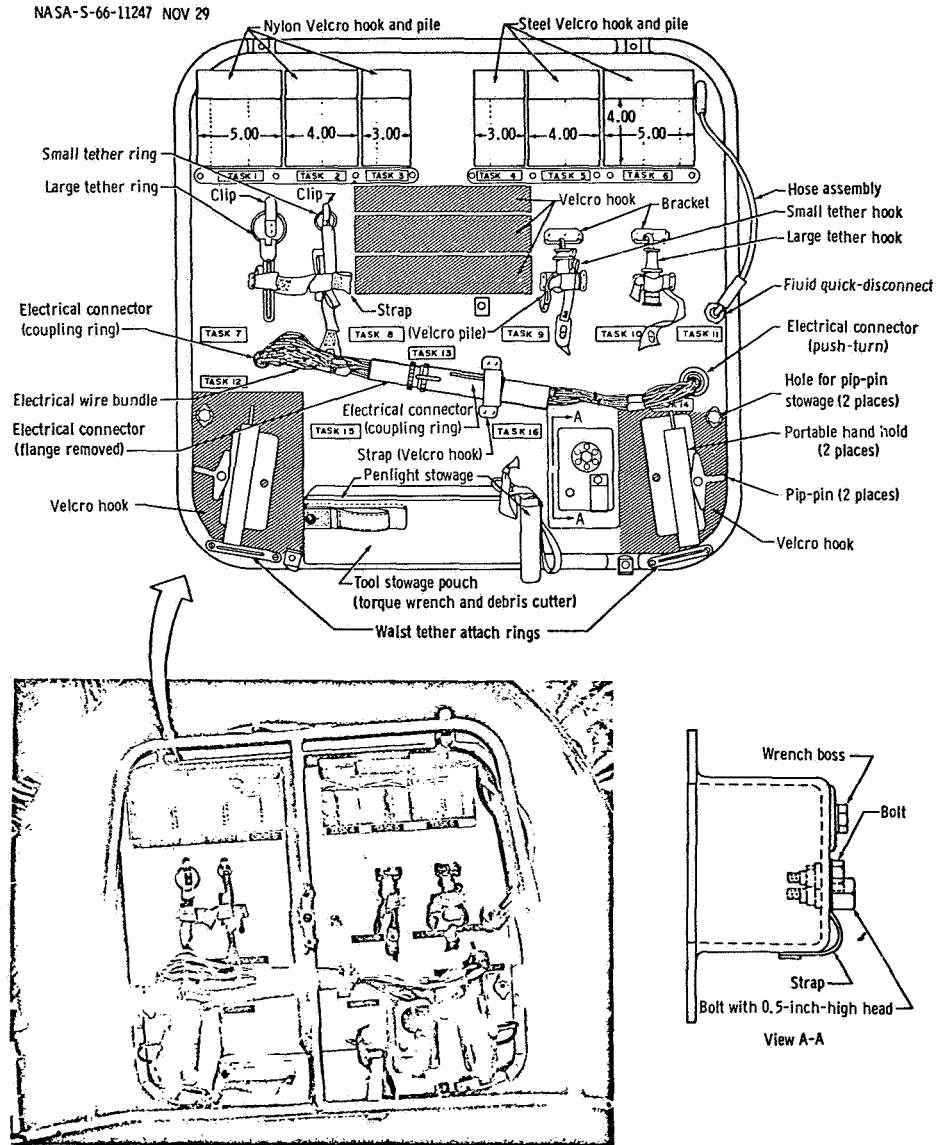

Figure 3.1-6. Adapter work station.

UNCLASSIFIED

Figure 7

NASA-S-68-579

UNCLASSIFIED

TOP OF HORIZONTAL PAGE

USE THIS SIDE OF THIS SHEET ONLY

UNCLASSIFIED

REDUCE TO 50% OF SIZE

Figure 8

UNCLASSIFIED

4-49

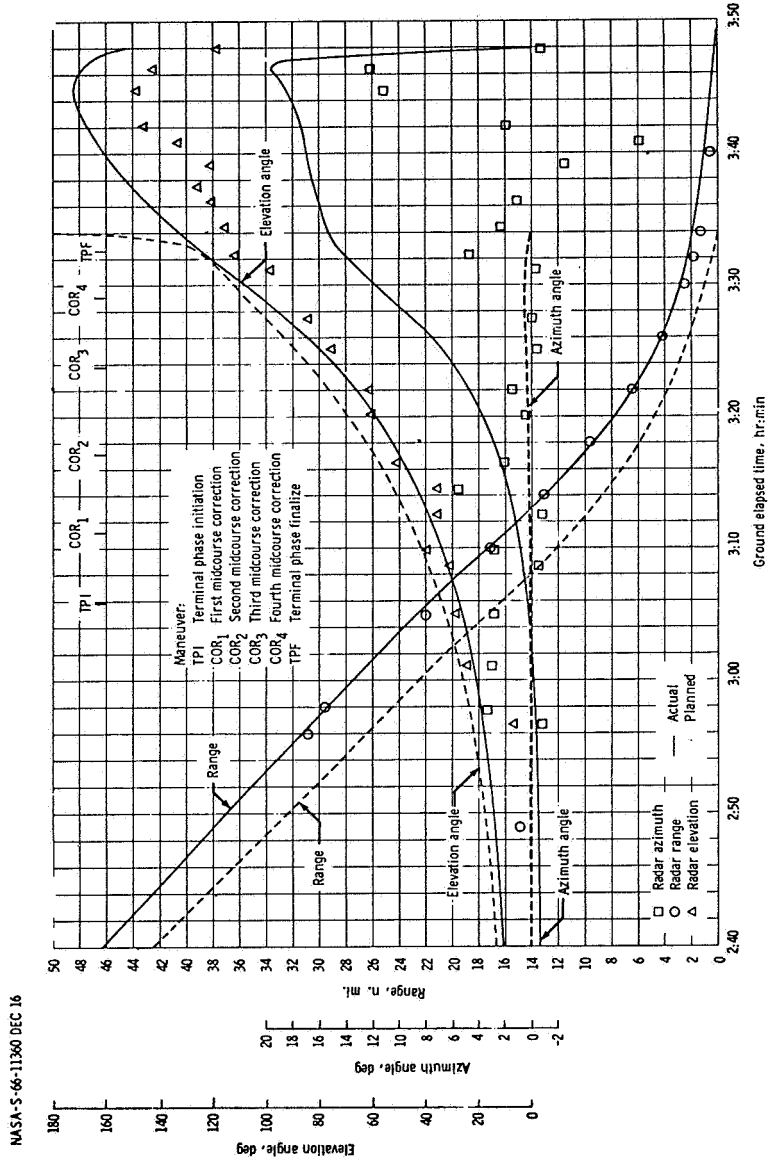

(b) Relative range, azimuth, and elevation from Spacecraft 12 to Gemini XII GATV during terminal phase maneuvers.

Figure 4.3-4.: Continued.

UNCLASSIFIED

Figure 9

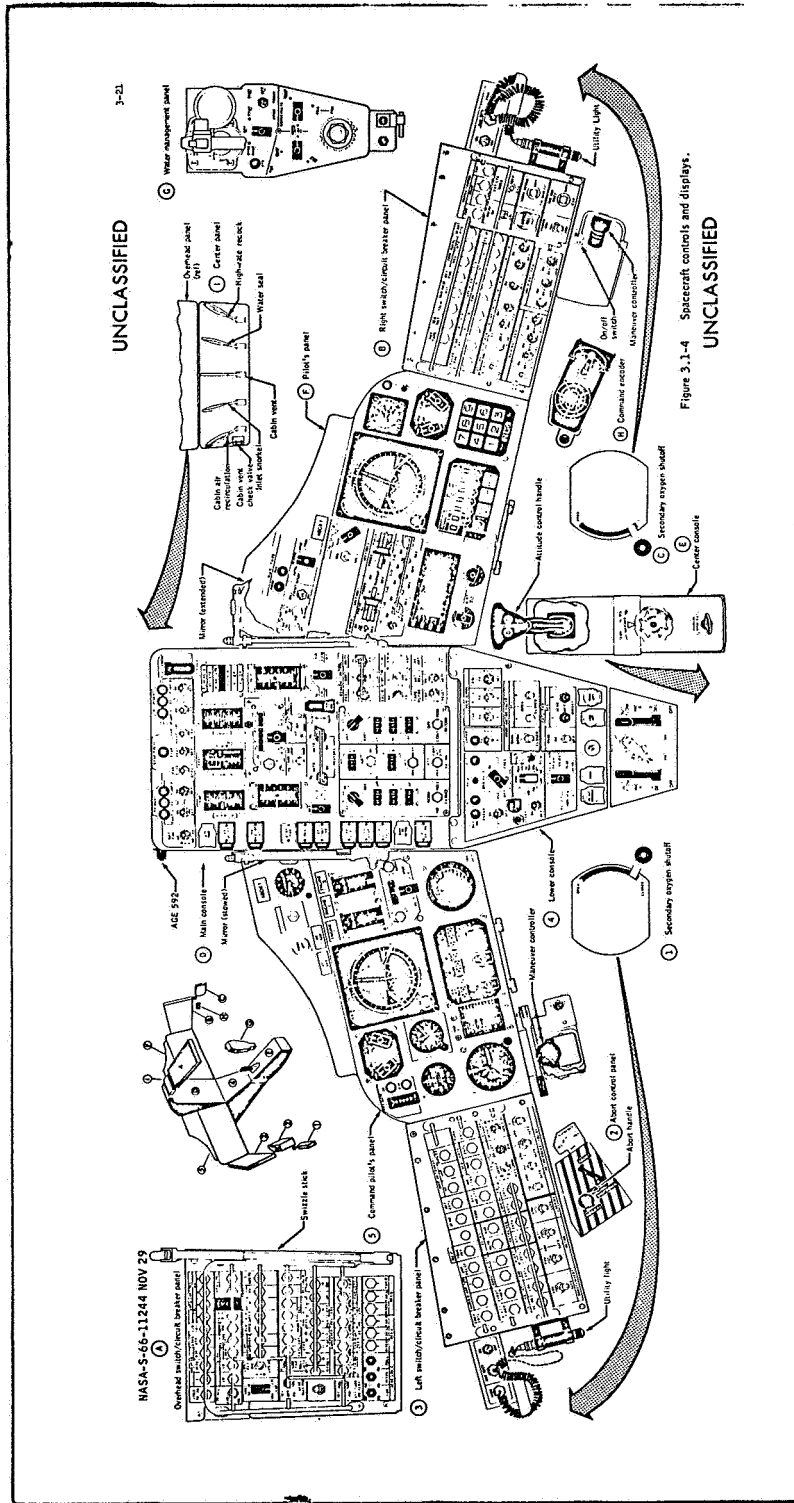

Figure 3.1-4 Spacecraft controls and displays.

Figure 10

UNCLASSIFIED

5-55

MA5A-5-66-1374 DEC 17

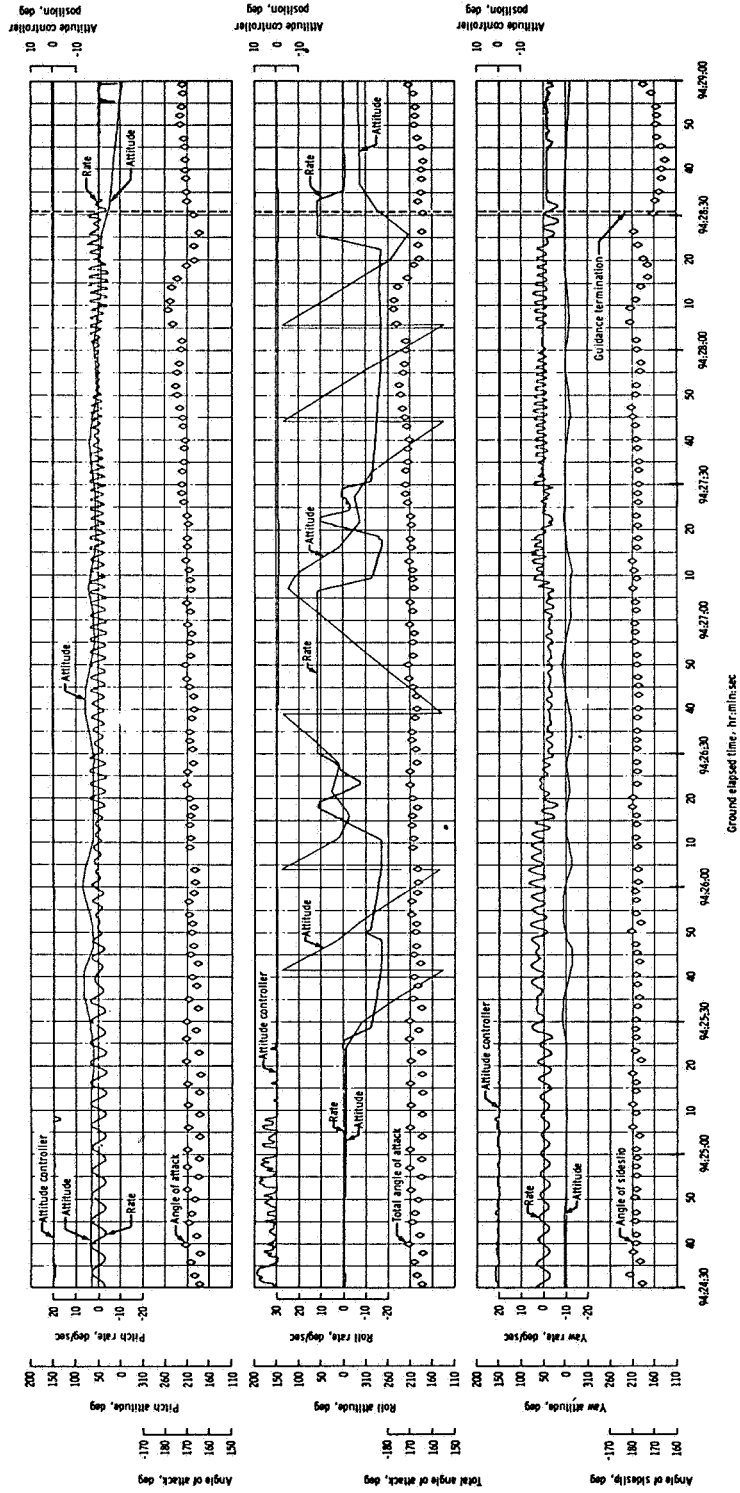

(b) 94:24:00 to 94:29:00 g.s.t.  
Figure 5.1.5-10. Concluded.

UNCLASSIFIED

Figure 11

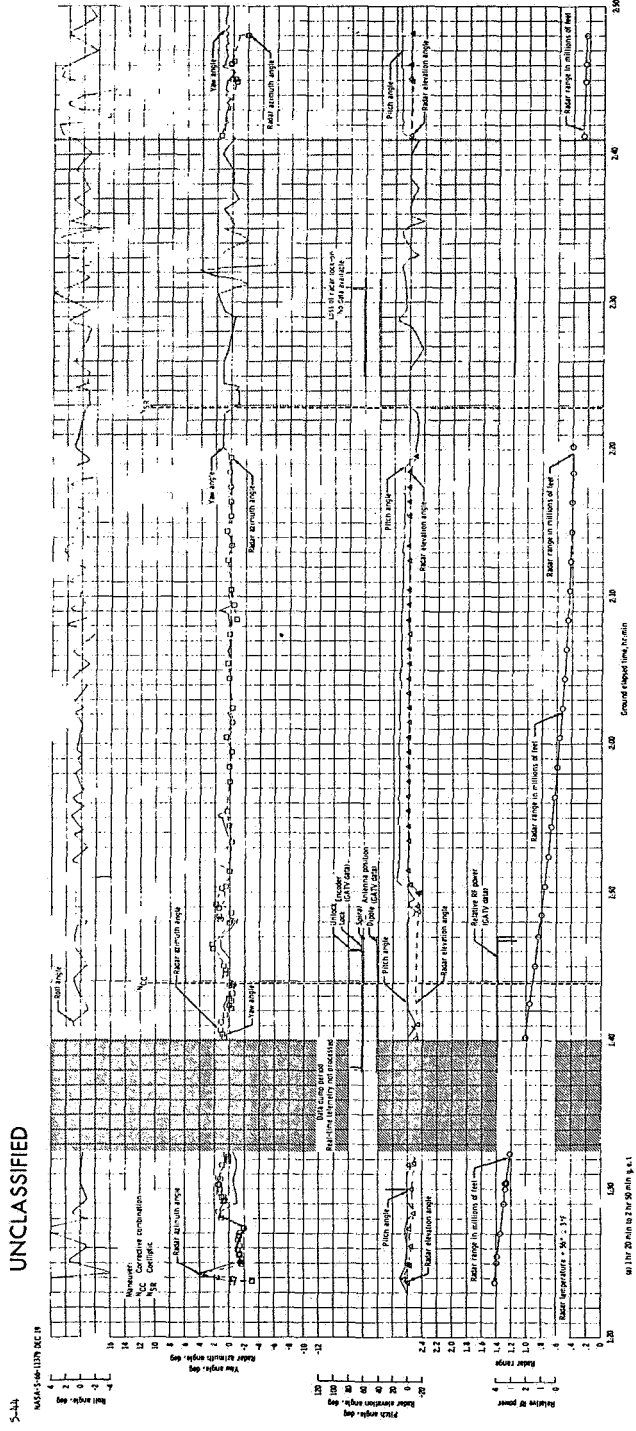

Figure 12

UNCLASSIFIED

UNCLASSIFIED

UNCLASSIFIED 5-45

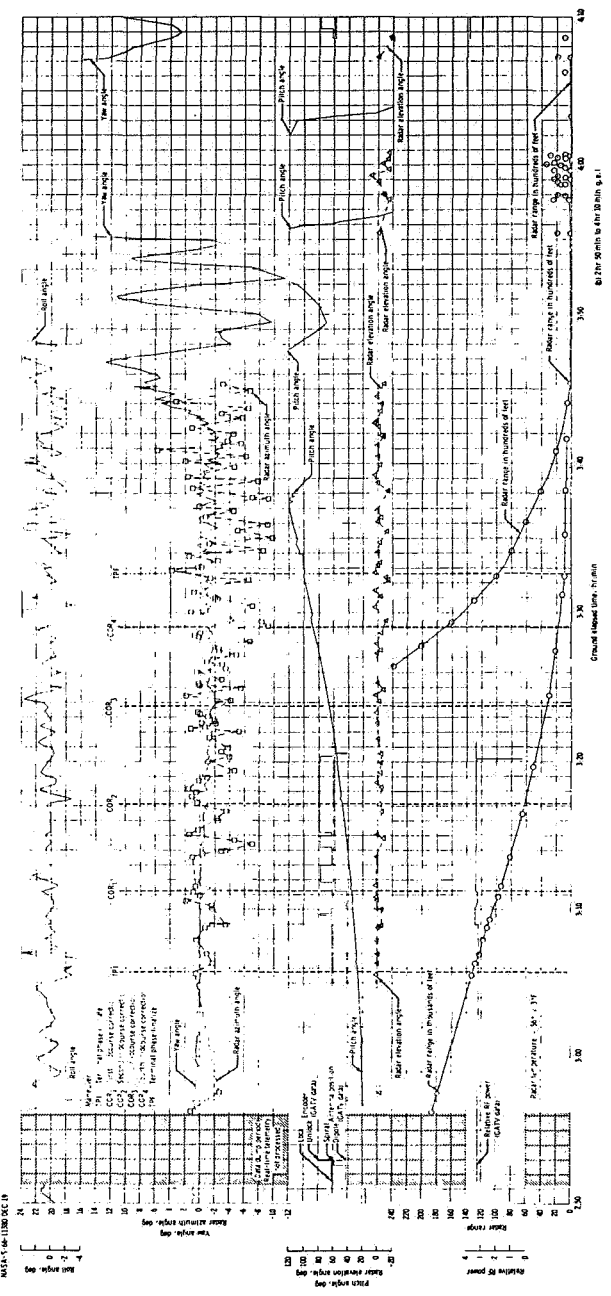

Figure 13



# GEMINI MER FIGURES VS TEXT AND TABLES

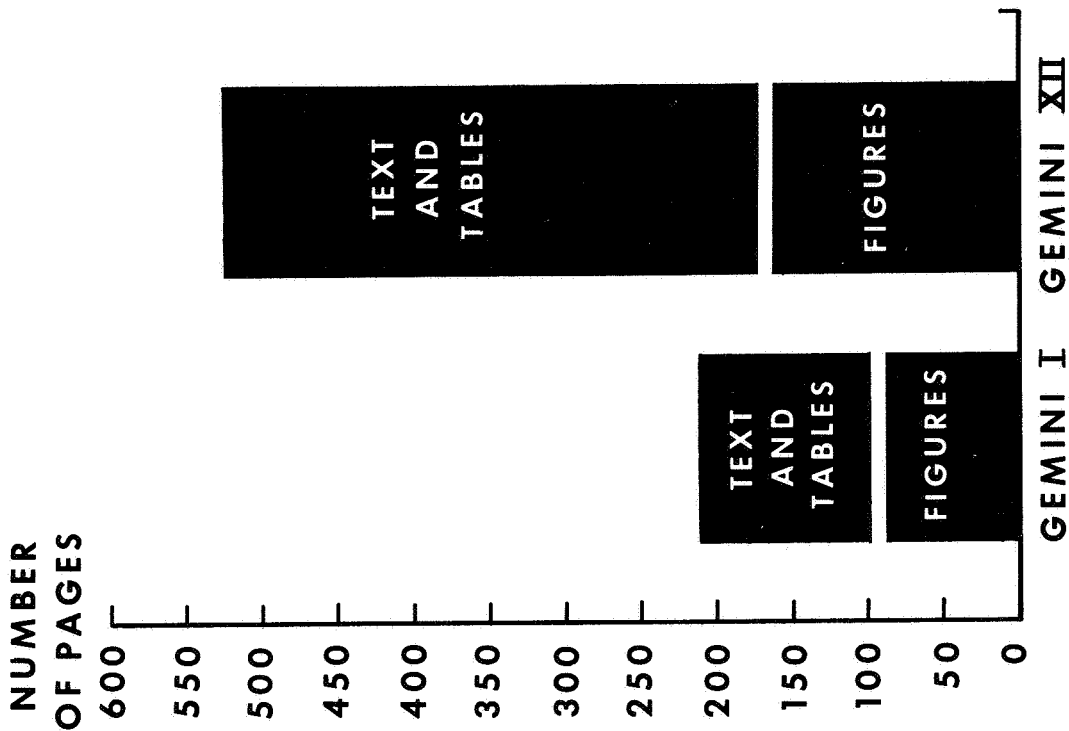

Figure 14

## TYPICAL MER WORKLOAD

● TOTAL NUMBER OF PIECES INITIATED . . . .	160
● CHANGE REQUIREMENTS . . . . .	85
● CORRECTIONS . . . . .	20
	<hr/>
<b>TOTAL INPUTS TO GRAPHICS . . . . .</b>	<b>265</b>

Figure 15

NASA-S-68-92

## RESOURCES EMPLOYED IN MER ART PRODUCTION

- UPDATE EXISTING ART
- UTILIZATION OF MATH AID PLOTS AS ORIGINAL ART
- UTILIZATION OF PREPRINTED MAPS
- USE PHOTOGRAPH/ARTWORK COMBINATIONS TO  
SIMPLIFY ILLUSTRATIONS
- DESIGN PREPRINTED FORMS TO DISPLAY CERTAIN DATA
- UTILIZATION OF MACHINE PLOTS AS ORIGINAL ART
- PLAN PRODUCTION OF FIGURES WITH MAXIMUM FLEXIBILITY
- ASSIGN ONE NASA AND ONE CONTRACTOR GRAPHIC  
COORDINATOR TO THE MER TEAM

Figure 16

UNCLASSIFIED

3-19

NASA-S-66-11285 DEC 7

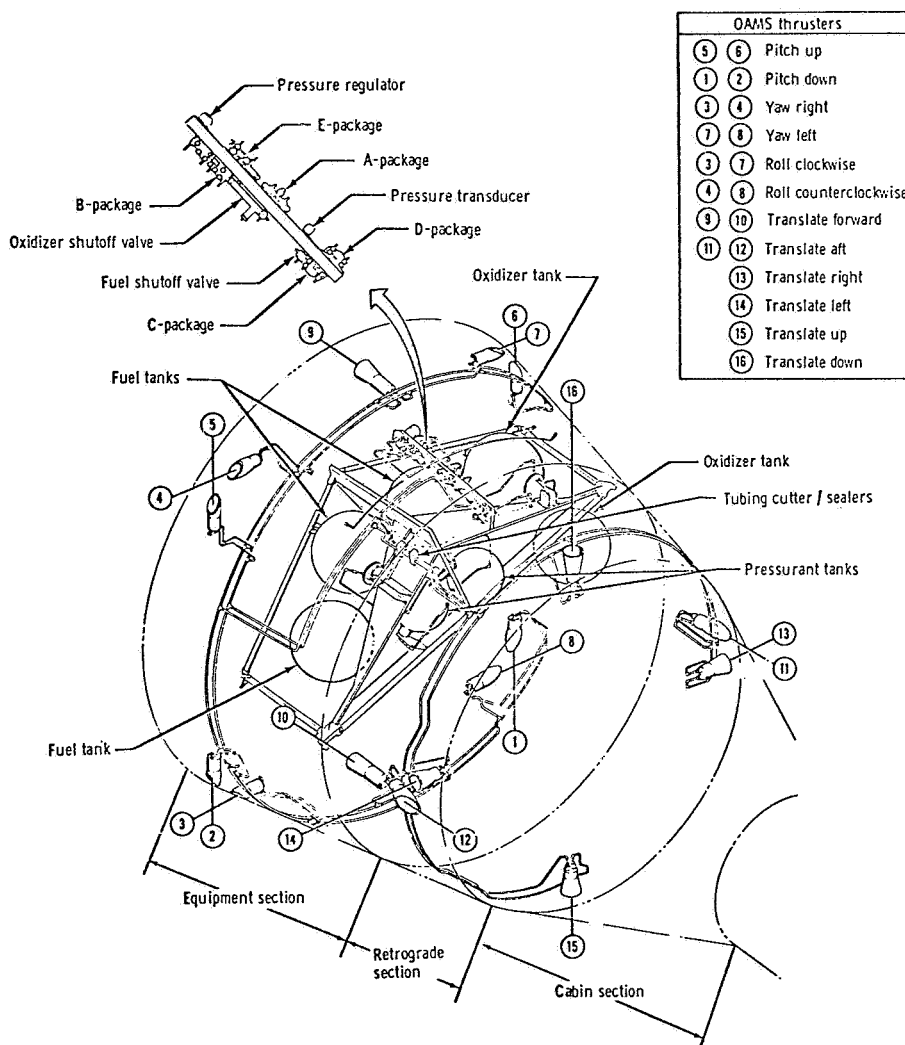
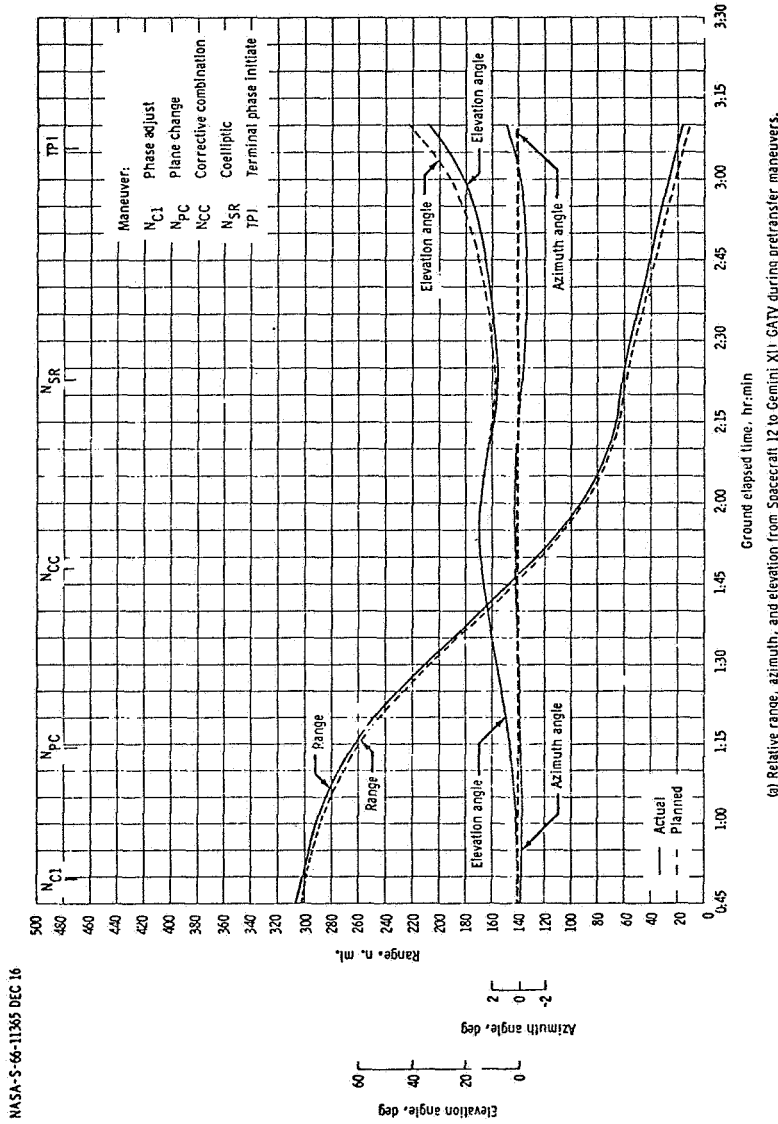

Figure 3.1-3. Orbital Attitude and Maneuver System.

UNCLASSIFIED

Figure 17

UNCLASSIFIED



NASA-S-66-11363 DEC 16

(a) Relative range, azimuth, and elevation from Spacecraft 12 to Gemini XII GATV during pretransfer maneuvers.

Figure 4.3-4. Rendezvous during the Gemini XII mission.

UNCLASSIFIED

Figure 18

UNCLASSIFIED

4-39

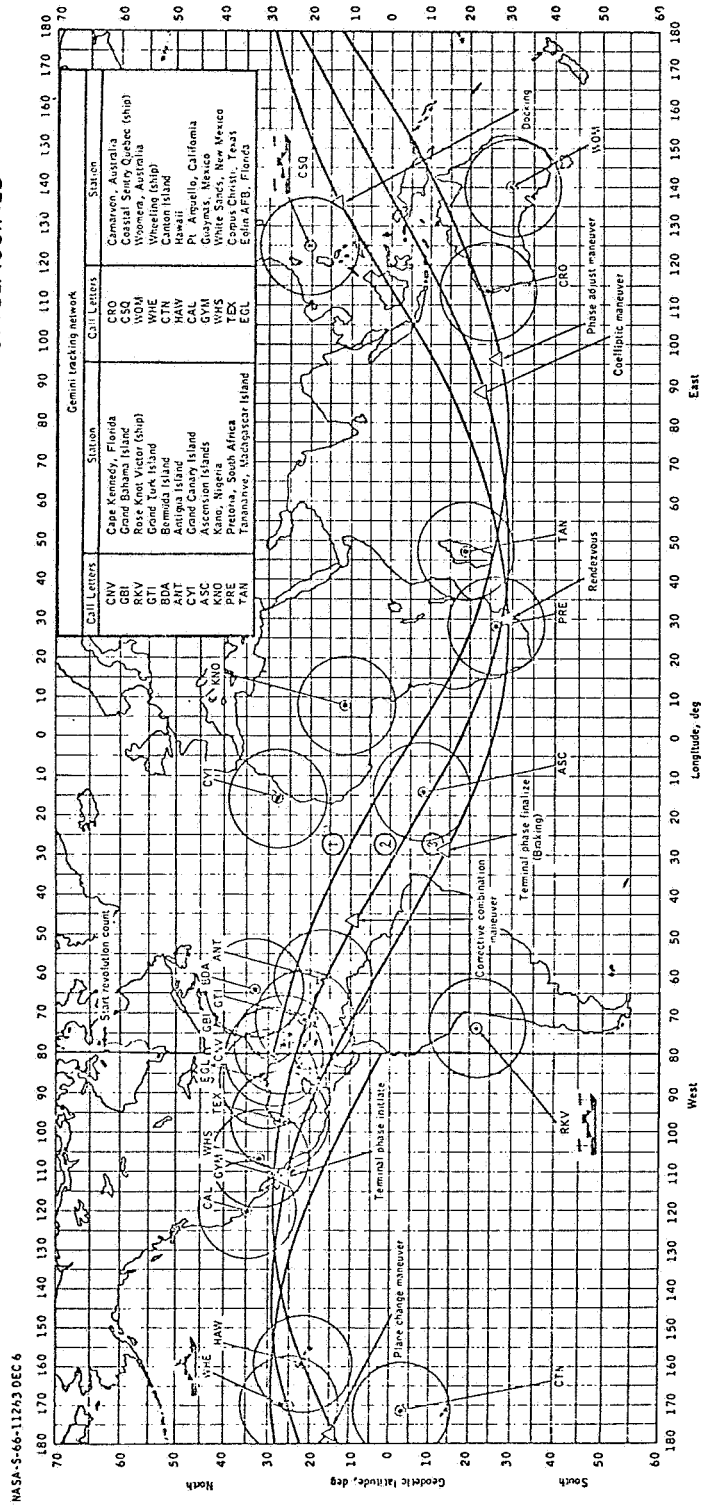

(a) Revolutions 1 through 3.

Figure 4.3-1.- Ground track for the Gemini XII orbital mission.

UNCLASSIFIED

Figure 19

3-16

UNCLASSIFIED

NASA-S-66-8969 SEP 29

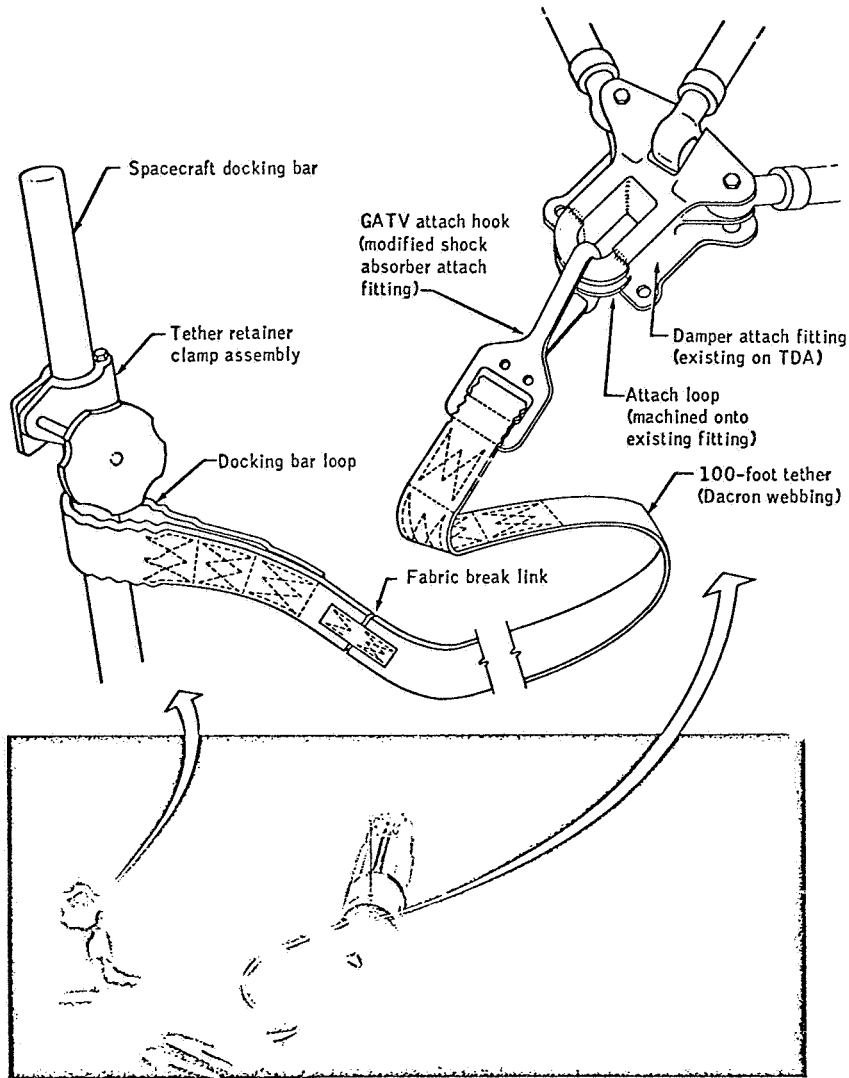
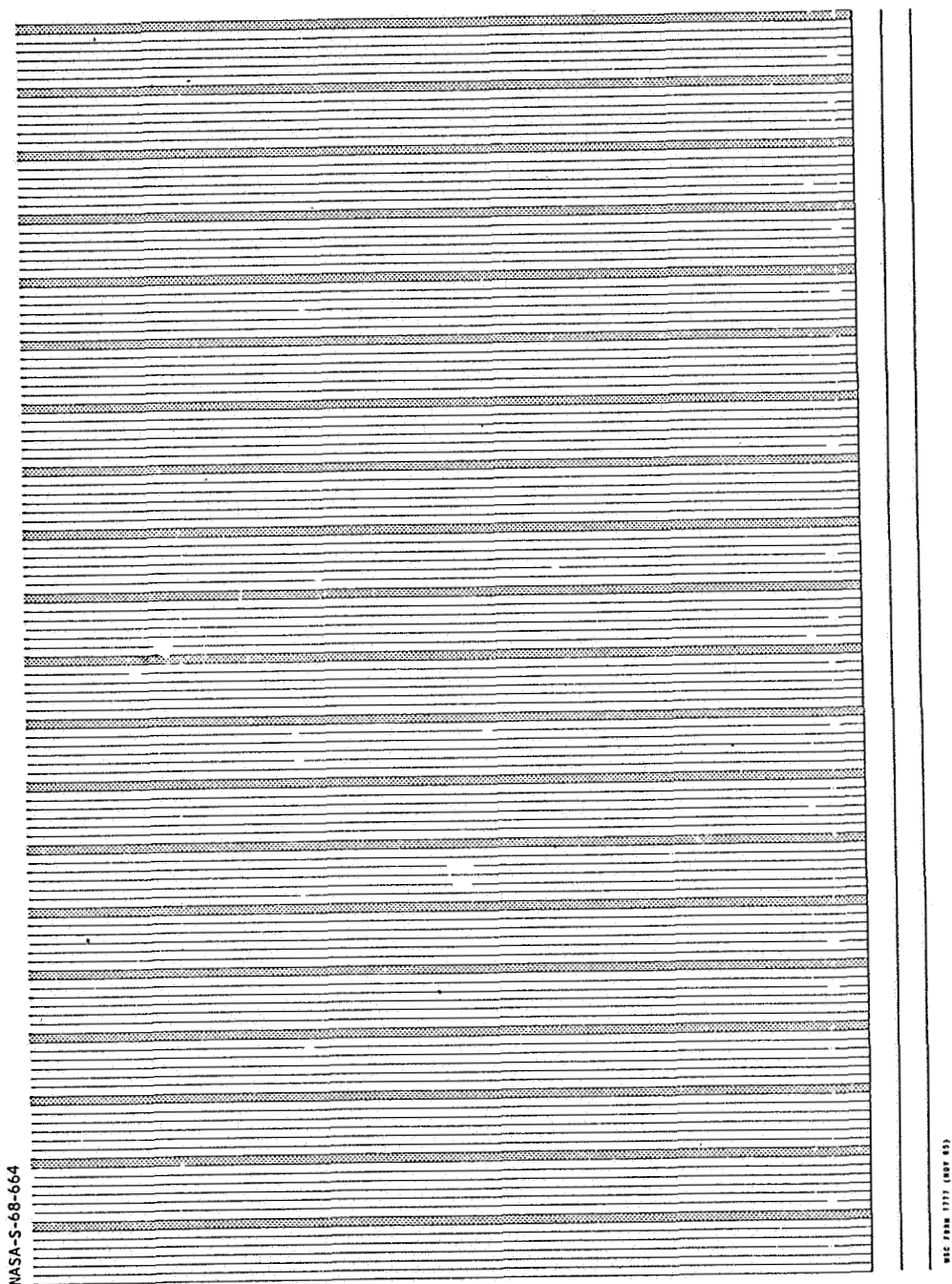

Figure 3.1-2. - Tethered vehicle evaluation equipment.

UNCLASSIFIED

Figure 20



NASA-S-68-664

MIC FROM 1171 (ORF 65)

Figure 21 (a)



UNCLASSIFIED

12-3

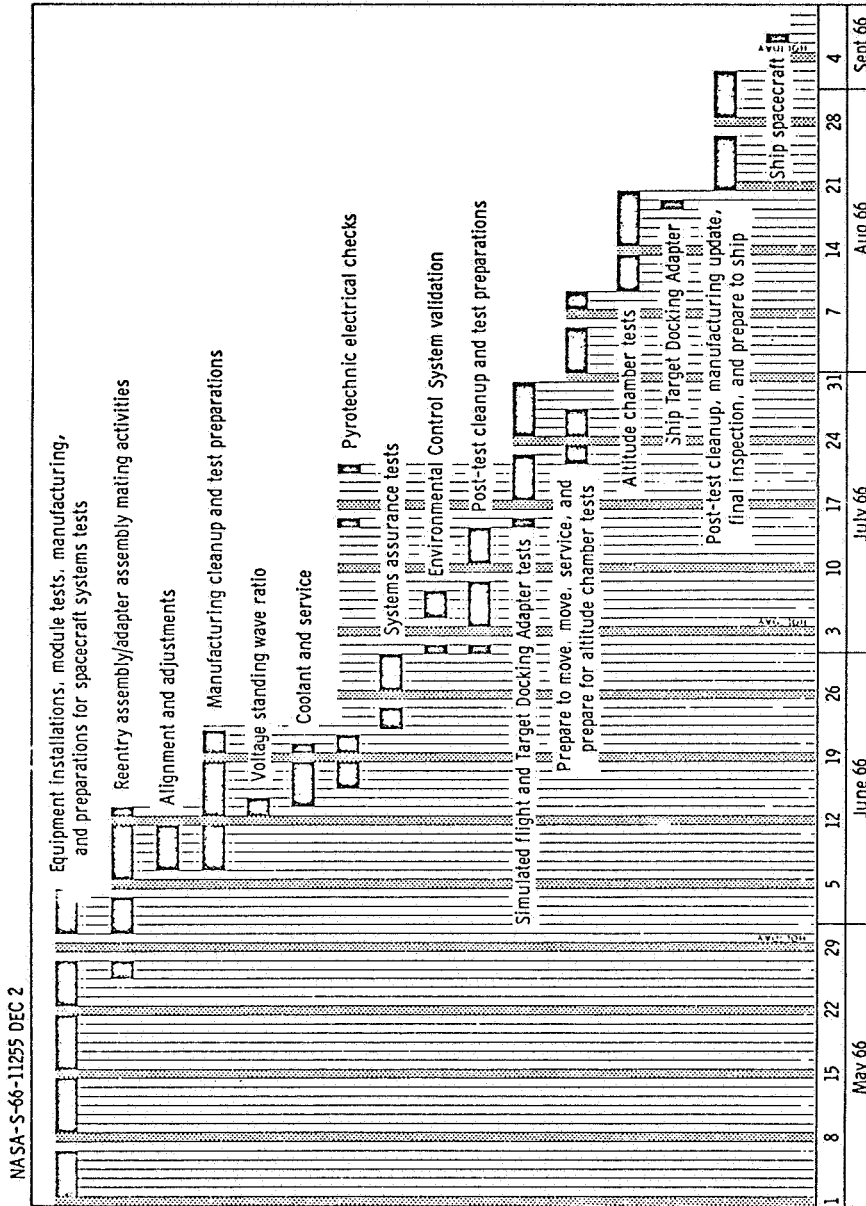

Figure 12.1-1. - Spacecraft 12 test history at contractor facility.

UNCLASSIFIED

Figure 21 (b)

NASA-S-68-662

UNCLASSIFIED

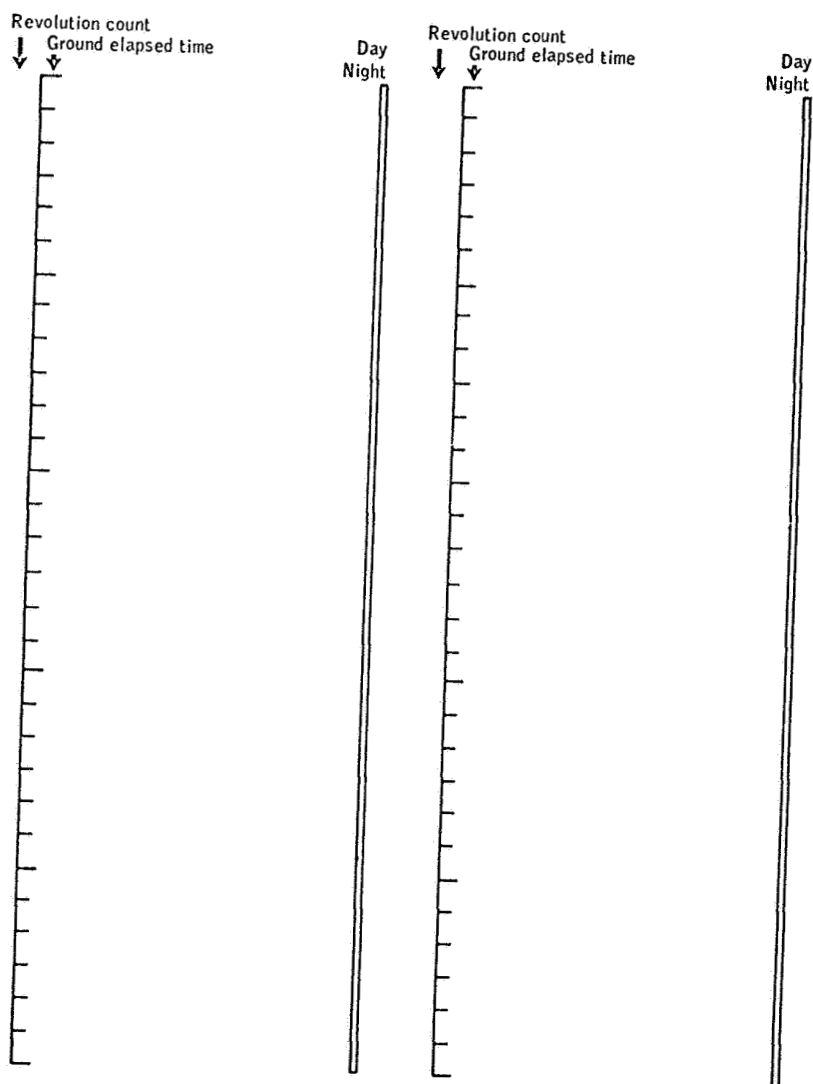

UNCLASSIFIED

Figure 22 (a)

UNCLASSIFIED

7-13

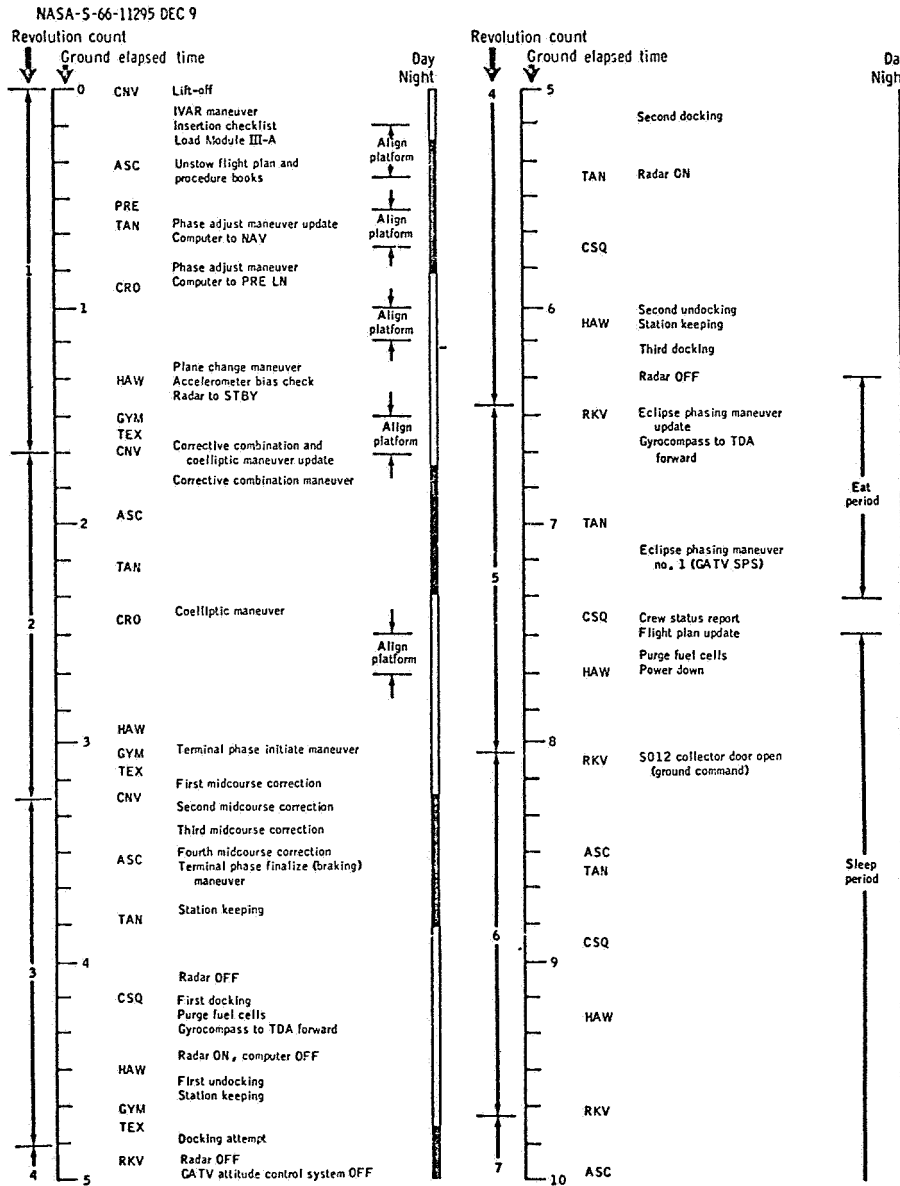

(a) 0 to 10 hours g.e.t.  
Figure 7.1.1-1. Summary flight plan.

UNCLASSIFIED

Figure 22 (b)

UNCLASSIFIED

NAACP-4-100-1100-1001

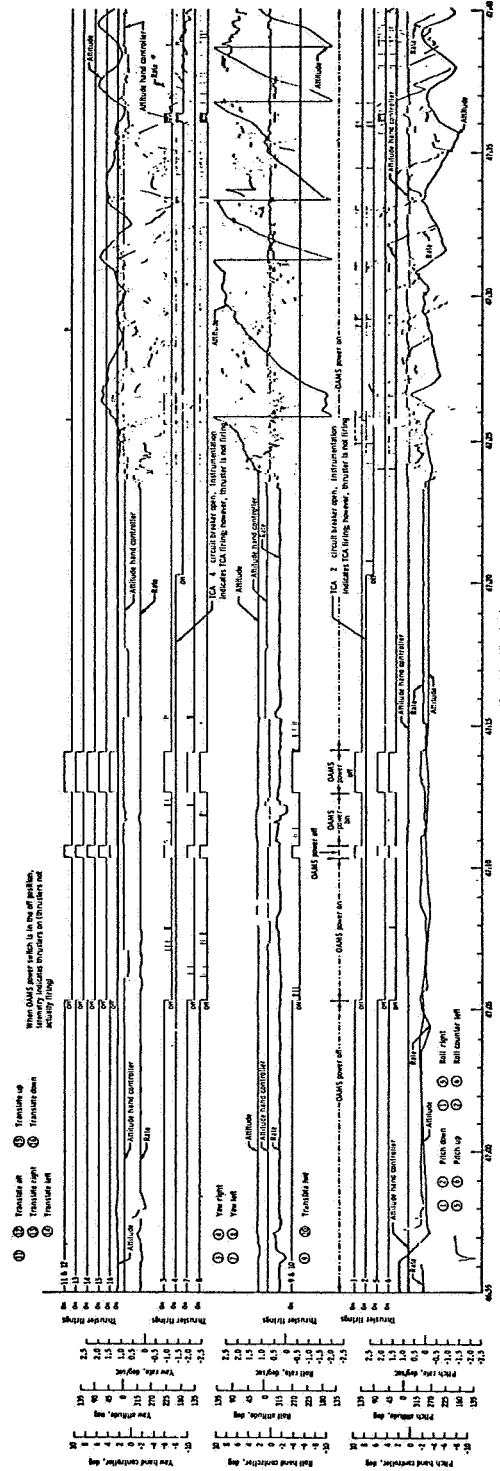

Figure 23 - Aircraft performance during the initial reduction speed-up sequence.

UNCLASSIFIED

Figure 23

UNCLASSIFIED

7-37

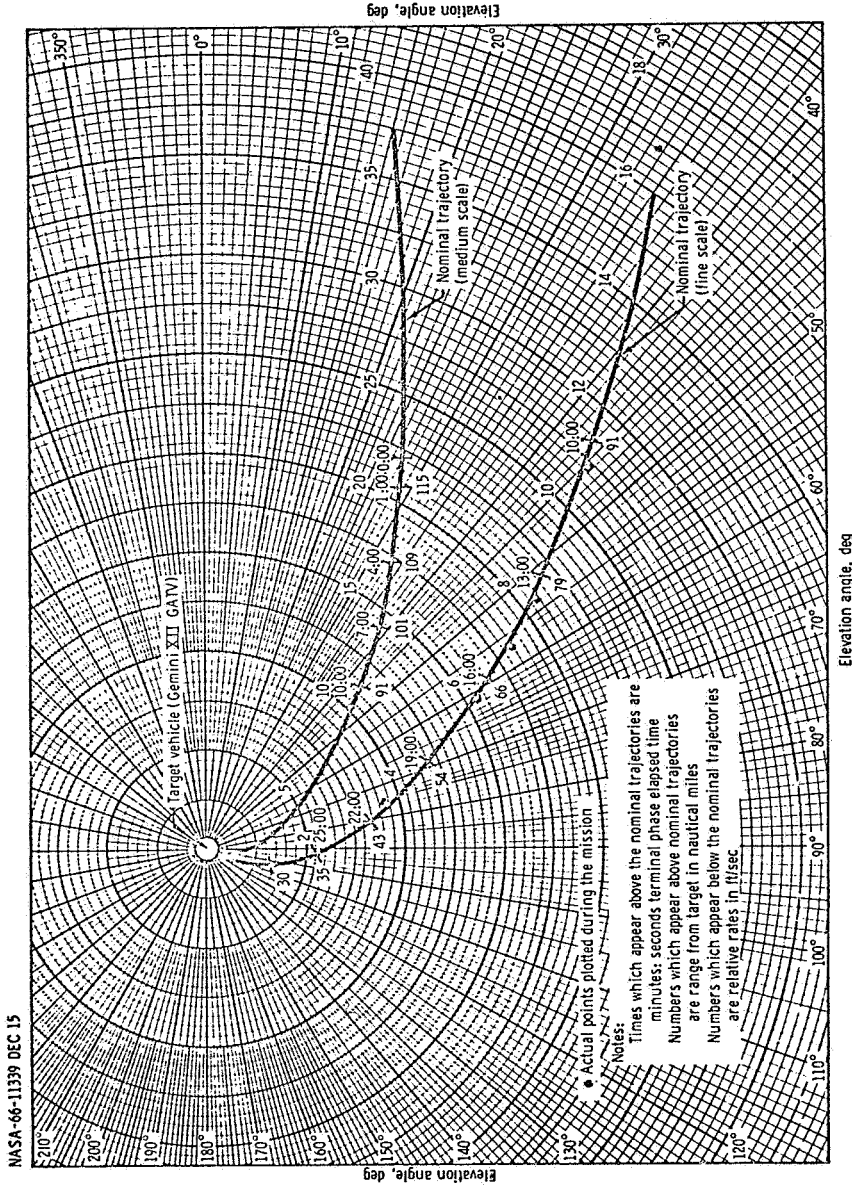

Figure 7.1.2-1. Onboard target-centered coordinate plot of rendezvous.

UNCLASSIFIED

Figure 24

## INFORMATION RETRIEVAL — DEFINITION AND PERSPECTIVE

By John M. Stout, Senior Engineer  
Federal Electric Corporation, ITT

## INTRODUCTION

Many involved in the writing and recording of information are not aware of what happens to their information after the specifications of the initiating job order have been satisfied. The product generated is not just a document, nor is it merely a chunk of information. Rather, it is — or should be — a contribution to knowledge. Knowledge is accumulative — always increasing. It also can create more knowledge, in a chain reaction, so to speak, but only if it is made accessible and if it is used.

An anthropologist would say that a stroke of lightning struck the ground next to a primitive man. He leaped back and growled a response which was heard and remembered by another. From that initial bit of recorded information — which evolutionists feel must have taken millions of years to produce — man has primarily been occupied with the recording, transmission, and use of information in almost explosively increasing quantities, so that today up to 3,000,000 documents per year, containing almost immeasurable quantities of information, are being produced.

This enormous input into man's storehouse of knowledge is a result of three basic revolutionary milestones in the art of information exchange — one of which has occurred in our time. The first must be the recording of information into concrete form, thus marking the end of the prehistoric era. The second was the invention of the printing press more than 500 years ago. This was one of the primary contributing factors to the Renaissance — a time when man began to explode with ideas which he wanted to communicate to other men. The third milestone was the invention of the technical report, which became a recognized necessity immediately following World War II. This has been one of the essential ingredients in the modern technological revolution which at the present rate is changing 90 percent of our technology every 10 years and which some have estimated will double the entire store of human knowledge in the next 25 years. This technological revolution is further exemplified by the increase from 765 special libraries in 1941 to

to approximately 15,000 today in the United States, and the creation of the technical writing profession, as well as the science devoted to the study of information, that is, information science.

Returning to a basic premise that knowledge to be used must be made accessible — must be ordered and stored — so that eventually it can be economically retrieved, we find that only in the past 100 years has man learned to process information so it can be effectively stored for retrieval.

In 1876 Melvil Dewey proposed a hierarchical classification scheme in which all knowledge was put into 10 broad classes, each divided into 10 divisions, then 10 subdivisions, and so on. Hundreds of classification schemes followed. Regardless of the scheme used, the purpose of classification is to make each volume in the collection readily available — to lead a potential user to the material he wants.

In 1950 Mortimer Taube noticed that it was becoming increasingly difficult to classify certain topics, such as liver-disease. Should the classification be liver-disease or disease-liver? He suggested that the term be coordinated into liver and into disease in a proposed coordinate scheme of indexing. The response to coordinate indexing was overwhelming. Uses of library collections increased, and in some cases more than doubled. A test was conducted at the Air Force Eastern Test Range technical library to determine the usage that two sets of documents had after each had been in the collection for the same period of time. One set, cataloged according to a subject classification scheme, showed only a 25-percent probability of usage during the first year in the collection. The other set, being cataloged by coordinate indexing, and with fewer terms, indicated a 60-percent probability of usage.

An increase in concepts results generally in increased usage. However, increased concepts may result in decreased usage, if inadequate selection of concepts is made.

Information Retrieval, as it is generally thought of today, is less than 10 years old. It is still in its inventive stage. It is developing so fast that by the time a person reads about a system in a document, that system might be obsolete.

The purpose of the paper is to formulate a descriptive definition of Information Retrieval as it exists today, and then to show how the various programs of an Information Retrieval System interface with each other to establish an intelligence network.

This description will limit itself to (1) the processing steps in Information Retrieval which will give us a working knowledge of the

operation itself, (2) the types of information retrieved which will define the system to be used, and (3) the purpose of the information retrieved which will guide us in our approach to the system.

### PROCESSING STEPS IN INFORMATION RETRIEVAL

Information Retrieval used to be known as Information Storage and Retrieval, perhaps because storage is an essential part of the system. However, there are three basic interdependent processing steps: (1) adequate screening of the input into the system; (2) adequate storage in the system; and (3) effective retrieval from the system.

The total Information Retrieval System is essentially a series of devices for screening out the information which the user wants. Input screening selects only those documents applicable to the project, mission, or goal of the system. The retrieval process, accomplished by the computer as it searches through thousands of documents in the storage, selects only those documents which satisfy the selection program dictated to the computer. Finally, the user, after receiving the printout from the computer, selects those documents relevant to his needs which he cares to examine in closer detail.

#### Screening

Information cannot be retrieved if that information is not in the system. Someone has the responsibility for the aggressive screening of the world's production of literature to select materials responding to the needs of the system. Passive screening takes place when documents appear that were not previously selected for the system. When the effective capacity of the storage has been exceeded, or the information in the system has become obsolete, additional screening must retire documents. The cost of storage and retrieval operations must be weighed against the value of the information content of the document, keeping in mind that the usefulness of information decreases geometrically in proportion to its age.

#### Storage

In the storage step, the material is cataloged for accessibility as a unit of information and is stored in its full text either in the original hard-copy form or in a magnetic or optical micro form. The material is processed into an abstract. This may include an abstract narrative, title, source, writer, journal, publisher, availability, and



an index of concepts which define the content. This abstract is then stored on magnetic tape. One full reel of tape may contain 20,000 documents. Figure 1 is an example of a magnetic tape printout.

## Retrieval

Retrieval operations have developed from the perusal of card files to mechanical card selectors, to coordinating devices in which document numbers responding to the coordinates of two or more concept terms would be selected, and finally to the use of computers.

In a computerized Information Retrieval System (fig. 2) the computer searches for identifying symbols which correspond to the programmed logic put to the computer. When a positive response, or match, occurs, the information on the master storage tape is transferred to an internal storage area of the computer and is ultimately printed out for the user. The search speed is approximately 55 documents per second for 150 simultaneous searches.

## TYPE OF INFORMATION RETRIEVED

The type of information needed determines which retrieval system might satisfy the request of the user. What does the user want? Does he want a specific piece of data, a fact, regardless of its source? Does he want extracts of information? Will he require an exhaustive search, or is he only wanting to keep abreast in a very broad field of interest? All of these are possible in Information Retrieval, but the systems used would be different.

### Micro Information (Data Retrieval)

Micro Information Retrieval attempts to find data, wherever data may exist. Data may appear in the file as a symbol, a word, a chart, a record, or in a narrative. Data Retrieval attempts to find a unique answer to a specific question.

### Macro Information (Information Retrieval)

Macro Information Retrieval is concerned with the retrieval of information, as opposed to documents, about a certain topic. A document may contain information about many different topics, but Information Retrieval attempts to locate and extract only that information which was requested.

Document no.	Author	Narrative	Title	Source	Concepts	Coded concepts
222G 05 67A 17154 087211 063 2 111 0449 0687			0012665 0111205 41	08340003		0045
0137 0229 0437			0012665 0111205 41	08340003		0045
YDROGEN AND NITROGEN IN HIGH EXPLOSIVES. \$RAPID MICRO COMBUSTION DETERMINATION O FCARBON, H						
EN AND NITROGEN IN HIGH EXPLOSIVE \$15WRIGHT, H.						
ND DEVELOP MEN T17*ESTABLISHMENT, WALTHAM ABBEY, ESSEX ,19*ENGLAND/ .20075 940EXPLOSIVESTOFFE, VOL. 14						
, DEC. 1966, P. 274-276 .413 REFS . \$						
ICHEMISTRY 3COMBUSTION 1CONTRCL 1DECOMPOSITION						
GH EXPLOSIVE 3HYDROGEN 3MICROANALYSIS 3NITROGEN 3ORGANIC 3SULFUR 3THERMAL						
IWEIGHT \$ 1 .ULFU 3 , (R=7 1 DGAN 3 X5 0 1 'ULCG 3 01/RO 1 C6JOR 1 DRY 1 E4 G 1 J\$(1) 3 JE						
BUA 1 K,ERM 1 LILLY 3 S*FRO 1 V5NTR 3 WAR80 1 5EIGH 3 7N 0+\$ .05 67A 17155 058211 053 1 221						
0000665 0111205 42 0153						
75\$BIOENGINEERING AND FOOD PROCESSING, AMERICA N INSTITUTE OF CHEMICAL ENGINEERS, NATIIONA L ME						
ETING, 57TH, MINNEAPOLIS, MINN. , SEPTEMBER 26-29, 1965, PAPER\$ . \$BIOENGINEERING AND FOOD PROCESS						
ING - AIC E MEETING, MINNEAPOLIS, SEPTEMBER 196 5\$20075 740CHEMICAL ENGINEERING PROGRESS, SYMPOSI						
U M41SERIES, NO. 69, 1966. 153 P .70MEMBERS, \$4.50, NONMEMBERS, \$15 . \$ 3BIOENGINEERING ICELL						
3CONFERENCE 3FOOD IPOPOPULATION\$ 3 *10G 1 CELL 3 DT 5 3 FOOD 1 WE 86\$ 05 67A 17156 C						
76911 051 2 121 0000665 0111200 41 02 0013 C045 0099 0148 042						
2 0483 0510 0638\$STATISTICS AND DYNAMICS CF MICRCBIAL CEL LPOPULATIONS . \$MICROBIAL CELL PO						
PULATION STATISTICS AN ODYNAMIC \$15TSUCHIYA, H. M./MINNESOTA, U. , MINNEAPOLIS ,16*MINN./ .20075 740						
/AMERICAN INST. OF CHEMICAL ENGINEERS, NATIONA L41MEETING, 57TH, MINNEAPOLIS, MINN., SEP. 26-29 ,421						
965, PAPER./ CHEMICAL ENGINEERING PROGRESS ,43SYMPOSIUM SERIES, NO. 69, 1966, P. 37-49. 2 644REFS						
.\$ EAKMAN, J. M. FREDRICKSON, A. G. TSUCHIYA, H. M. \$ NASA G-24-005/056/ \$ 1						
AGE 3BIOTECHNOLOGY ICELL 3CELL DIVISICN 1CONFERENCE 1DIVISION 3MICROR						
IODOLOGY IPOPOPULATION 1STATISTICS\$ 1 8-\$ 3 + TDS 1 . 1S 1 AGE 1 CELL 1 DT 5 3 JYVO 3 P						
F,EW 1 WE 86\$						
256F 05 67A 17157 087111 073 2 221 0007665101121053 41 740008 0045						
0142 0268 0525 0567 0728\$REDUCTION OF DIFFRACTION PROBLEMS ON NON-CLOSE DSURFA						
CES TO INTEGRAL EQUATIONS OF THE SECON DKIND . \$REDUCTION OF PROBLEMS OF DIFFRACTION OF SCALER AN DVE						
CTOR WAVES AT OPEN CURVILINEAR SCREEN T OINTEGRAL EQUATIONS OF SECOND KIN C\$20076 540/RADIOTEKHNIKA						
I ELEKTRONIKA, VOL. 11, JUL .411566, P. 1159-1158./ RADIO ENGINEERING AN D42ELECTRONIC PHYSICS, VOL						
. 11, JUL. 1966, P. 431017-1024. 7 REFS. TRANSLATICN. JFO R44ABSTRACT SEE ISSUE 20, PAGE 3518, AC						
CESSIO N45ND. A66-37992 J\$ FELD, IA. N. SUKHAREVSKII, I. V. \$ 1CURVILINEAR 1D						
IFFRACTION IEQUATION 1INTEGRAL 3INTEGRAL EQUATION 1SCALER 1SCREEN 1SURFACE						
1VECTOR 1WAVE 3WAVE DIFFRACTION \$ 1 U EG 1 .CALE 1 JECTO 1 -ONCC 3 N10. 1 '=AAAT						
3 F. C 1 GCREE 1 I)'-8 1 JJRFA 1 WAVE \$ 05 67A 17158 088511 073 2 221 0007665101121053						

Figure 1.- Printout of the magnetic tape file used in storage.

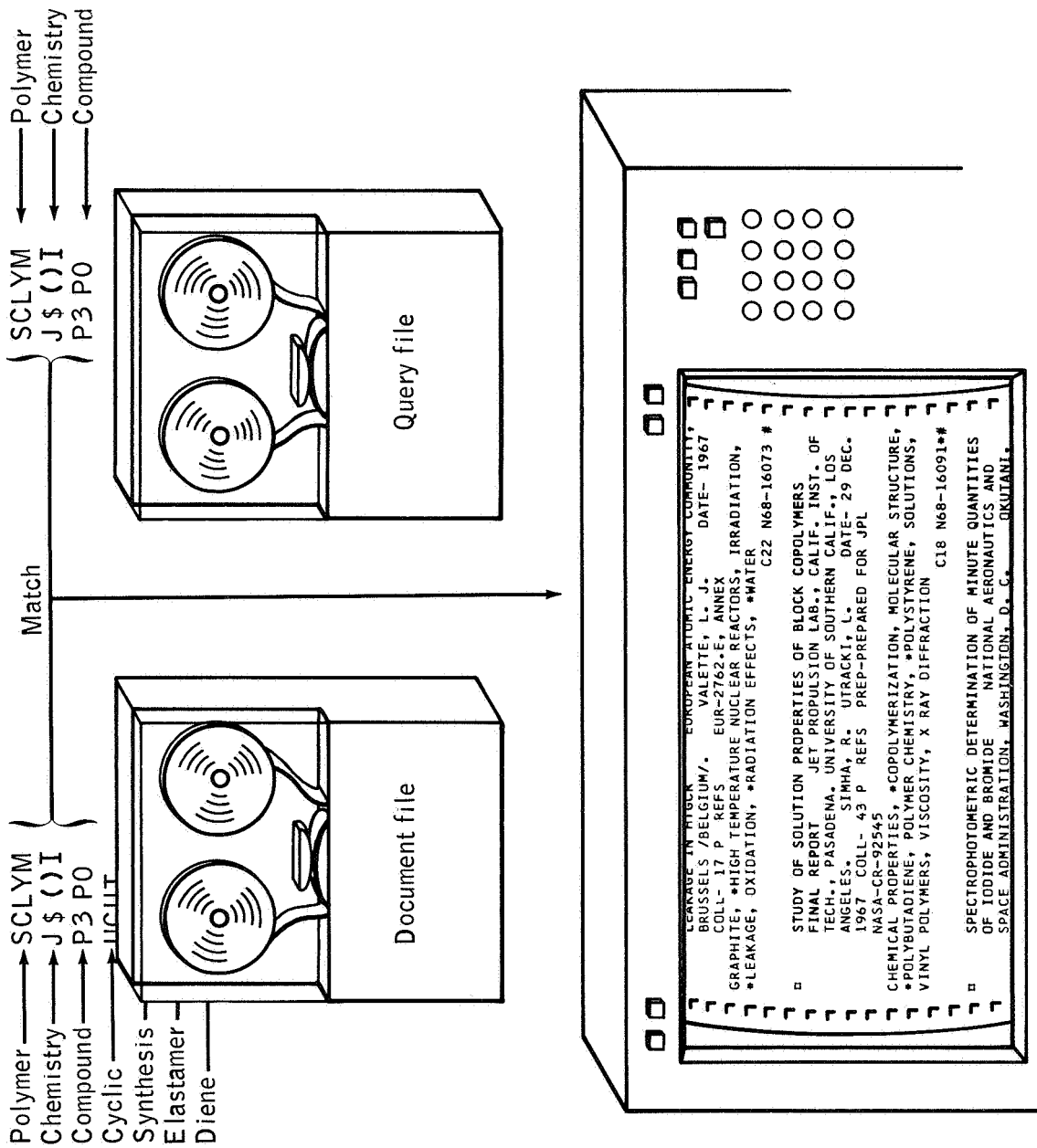

Figure 2

### Document Information (Document Retrieval)

In Document Retrieval, references about documents related to specific queries are retrieved. This abstract form of the document is printed out to assist the user in making his decision to read the document.

Table I compares the three retrieval systems. Document Retrieval is an established process; Data Retrieval is in its development stage; and Information Retrieval is in its experimental phase of development.

TABLE I.- TYPES OF INFORMATION RETRIEVED

	Analytic Retrieval	Abstract Form	Concrete Form
Document Information	Dialog	Abstract	Document
Macro Information	Information	Information	Extract
Micro Information	Data	Fact	Record

### PURPOSE OF INFORMATION RETRIEVED

The purpose of the information retrieved will dictate the type of searching to be done. If a user has been assigned a topic to study in preparation for the presentation of a report upon existing research in a particular field, a passive retrieval approach, or retrospective searching, would be used. This is known as a literature search. The entire file would be searched in an attempt to answer the query. If the user wants to keep abreast of current developments in a particular field, an aggressive retrieval approach might be used. This is current awareness, and the program is commonly referred to as the Selective Dissemination of Information (or SDI) Program.

### Retrospective Searching

An appreciation for retrospective searching can be developed by using the Fondren Library of Rice University as a starting point. There are approximately 550,000 volumes in the library, each being classified

into one of approximately 100,000 different categories of information. The collection is supported by three sections of card catalogs containing approximately 3,000,000 catalog cards. This is, for all practical purposes, the only aid that a user has to retrieve the information he is looking for. To obtain desired information the user goes through the following processes.

1. Describe. He must generate a description of the kind of information he is looking for, such as "something that tells me how to brace a strut," or "all I can find about cadmium batteries," or "something about ion exchange resins in chemical analysis."

2. Categorize. The user then transforms this description into a set of categories under which the information might be indexed according to the system of indexing and filing used by the library. For example, for "ion exchange resins," the user may try "ion exchange;" "Analytical Chemistry;" "Chromatography;" "Electro-Chemistry;" "Corrosion;" and so on. "Bracing Struts" may be found under "Aeronautics," "Aerodynamics," "Aircraft Structures," "Wing Theory," "Stability and Control," and "Aircraft Design."

3. Screen and Categories. The user by now probably finds himself with an abundance of references and, depending upon his patience and time availability, will attempt to reduce the number of categories by screening them. He screens them, however, at the expense of losing part of the collection which may be relevant to his problem — especially since he generally does not understand the filing system. His journey through the card catalog should generate many other categories which had escaped his mind during the formulation of his search scheme.

4. Screen the Abstracts. The user proceeds to examine each card for abstract information about the content of the material. The necessity of examining all of the cards under a given category is so burdensome that for a given level of desperation the number of categories searched is kept to a minimum. Filing categories may be only incidentally related to the user's needs and adequate information may not be available, even if the material requested is retrieved. Limitations upon added entries of the cards and inadequate cataloging may be an insufficient guide as to content. Extensive inspection may be required before a relevant decision can be made.

5. Screen the Material. The user finally selects and receives those materials judged probably relevant, provided they are available. Considerable searching through the materials received may still be required in order to identify relevant information.

Given the amount of searching required to locate the material, and given the amount of searching required after the material has been received, and considering that during each screening process relevant information may be lost, the traditional use of the library is very costly, not only in terms of hidden and unaccessible information in the collection, but also in terms of the wasted time and useless machine like effort of the user. The user is drastically limited in the amount of information he can afford to acquire, or else he is discouraged from approaching the collection at all.

Computerizing the card catalog offers only a very limited solution — and this is being studied at the Fondren Library. Information content which is not under the categories searched cannot be made available for retrieval, regardless of the sophistication of the system.

Coordinate indexing has increased the usage of small collections and does have the capability for retrieving more relevant information; however, such indexing might be impractical. For the same collection, this multimillion dollar operation would require 20 sections of card catalogs occupying 6000 square feet of floorspace, or if the files were lined up in a single row the files would have a length of 720 feet. If the cards were stacked one on top of the other the top card would be 9.5 miles high, or if the cards were placed end to end, they would reach from coast to coast, 4750 miles. This playing with numbers is only to emphasize the fact that if retrieval of a noncoordinate indexed collection contained an element of discouragement, the user of a coordinate indexed system would be overwhelmed by sheer exhaustion in attempting to locate the right card from which to handwrite his notations.

A normal search in the card catalog referencing 20 volumes and requiring approximately 8 hours could be accomplished in a prorated minute of computer time, thus releasing the user for that productive work which can more economically be done by man. How does the computer go about doing this?

Although it is possible, the computer does not furnish the user with, say, 200 volumes in which may appear relevant information. The computer furnishes the user with enough abstract of each volume so that he can readily ascertain whether or not he should read a specific volume in more detail.

If a user wanted information about concept A, the computer would search through the magnetic tape file of the collection, and print out for the user abstract information about each volume found which was indexed under concept A. This is represented by a Venn diagram (fig. 3) in which information relevant to concept A is represented by a circle which represents the set of documents relevant to concept A. The total collection would constitute set U, or the universe of the system.

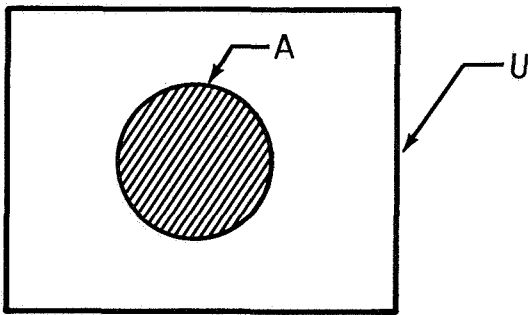

Figure 3.

Retrieval by single concepts, however, will not satisfy the majority of the queries put to the system, as in the liver-disease case mentioned previously. Any concept may be modified by a second concept, thereby generating a third concept. This can be shown by the intersection of two circles (fig. 4(a)) representing set A concepts and set B concepts, in which case the solution would be the mutually inclusive segment of the two circles. Concepts may be modified

as much as needed, within the limitations imposed by the system, until the desired degree of specificity or volume is achieved. This modification may be either in a positive restrictive manner or in a negative restrictive manner, as in the case when a user wants concept A, but not anything of concept B (fig. 4(b)).

As a matter of economy, synonymous, associated, or even mutually exclusive terms may appear in the same set, as in the case when the user wants either concept A or concept B (fig. 4(c)). There are many other possible combinations. The Venn diagrams in figure 4 may be represented in algebraic form by Boolean equations written in a specific computer language.

$$A \cdot B \$$$

$$A - B \$$$

$$A + B \$$$

Examples of more complex problems follow:

$$(A+B+C) \cdot (D+F) \$$$

$$(A+B+C+D+F+F) \cdot (H+I+J) - K - L \$$$

$$(A+B+C+D+F+F+G+H) \cdot (I+J+K+L+) \cdot (M+N) \$$$

$$A \cdot (B+C+D)+E+F+G \$$$

$$A \cdot (B+C) \cdot (D+F+F+G) \cdot (H+I+J) \$$$

$$(A \cdot B+C) \cdot (D \cdot (E+F)+G) \$$$

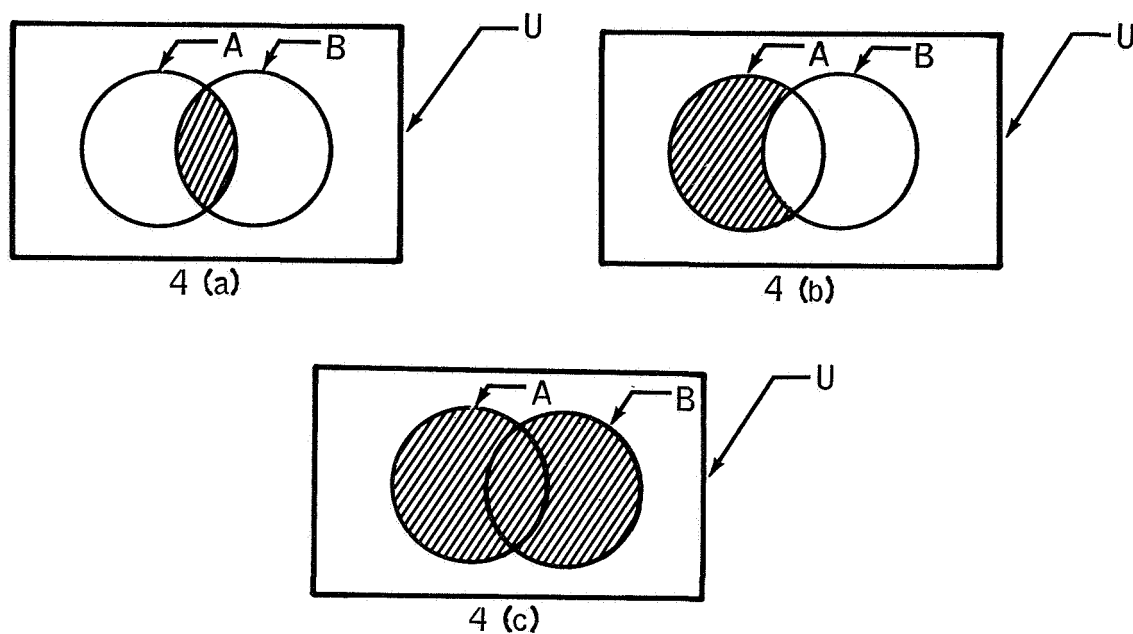

Figure 4

A model of Information Retrieval (fig. 5) may consist of a circle representing the set of documents retrieved and another circle representing all of the relevant documents in the file. The mathematical relationships existing between various components of the model establish the mathematical effectiveness of the retrieval system.

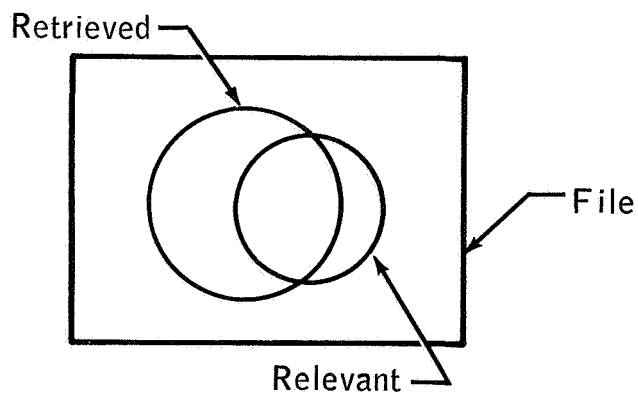

Figure 5



### The SDI Program

Let us turn our attention to some of the problems involved when a scientist or engineer tries to keep abreast of developments in his particular field.

We have in recent years heard much about the population explosion. In 1900 there were 1.8 billion people on earth. In 1960 there was an estimated 3.0 billion — an increase of 2.8 percent per year. In 1900 there were 1.25 million scientists being supported by 10,000 scientific journals. In 1960 4.0 million scientists were aided by 60,000 journals. The point is that if there is a population explosion of people, there certainly is a scientific explosion, since the number of scientists has increased at about twice the world population growth rate. And if there is a scientific explosion, there certainly is a scientific journal population explosion, since the number of journals has increased at about two times that of the scientists — this, without taking into account the increase in the size and information content of the journals. If there is a scientific journal explosion, we might add, there must also be a tremendous amount of garbage being produced in an equally explosive manner. Man's reading ability has not basically changed in the past hundred years.

If this causes concern, it should cause even more concern for American scientists, for the growth rate of scientists in the United States is 16.5 percent a year as compared to 5.0 percent worldwide. And, with the anticipated breakthrough in machine translation, that is, the translation from one language to another by computer, the picture is made even more complicated with the dumping of enormous quantities of technical reports in English translation on the desks of American scientists.

How can the individual scientist keep up with this massive paper explosion? What can be done to help him against these overwhelming odds?

The ideal solution would be to have a journal, or publication of some kind, which would publish the literature only in the subject areas of one's interests. For a chemist, why not a journal of chemistry — for the mathematician, a journal of mathematics — for the life sciences, a journal of life sciences?

The problem is that not only is one journal of chemistry published, but literally hundreds of them. In life sciences alone there are an estimated 18,000 journals. Three problems are apparent to the scientist: (1) he cannot afford the time or the money to read all of the journals in his own discipline (2) there is much overlapping of content in various journals, as well as much interdisciplinary reporting — thus creating

a waste of the reader's valuable time, and (3) there is much trash, or unwanted and useless information, in any literature published from an individual's point of view.

The area of interest of a user does not correspond to the area of interest of the journals. The user has areas of interest which are not covered by the journals. The question may now be asked, then, "Why not create a journal designed specifically for an individual user or user group?" Briefly, this is exactly what is done in the SDI Program. The program fills in the voids, cuts out duplicate reporting, and throws away the trash (fig. 6).

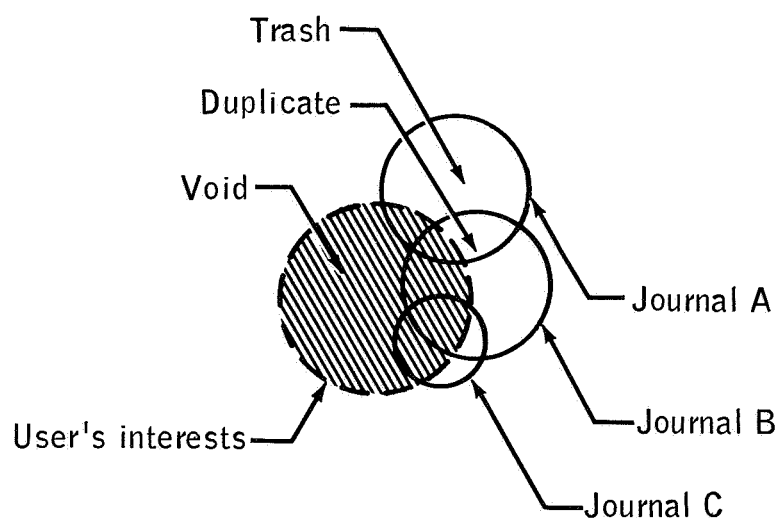

Figure 6

By controlling the quality and the quantity of the material the user receives, it would not be necessary to spend more than 1 minute per day — as compared to the 2 hours or more per day to manually accomplish the same thing — for the scientist to be aware of what is going on in his areas of interest.

In order to accomplish this, there must first be constructed a profile of the user's interests. A user may have very broad interest in some topics and a very specific interest in other topics. In addition, he may be interested in the social, economic, legislative, or administrative aspect of his scientific research. He may be primarily concerned with applied research, or may want to keep up with what a certain company or individual is doing. He has many peripheral interests in his career development.

Information of any kind, in this program, can be tailored to the individual or group needs. Contrary to normal library operations, the user does not have to come and procure information about documents; rather, information about documents is automatically selected and disseminated to the user according to his needs.

In an adaptive SDI Program there is a constant feedback of the user's response to the program — his dialog with the computer. This response is analyzed and modifications are made in the profile to reflect variations of interest (fig. 7).

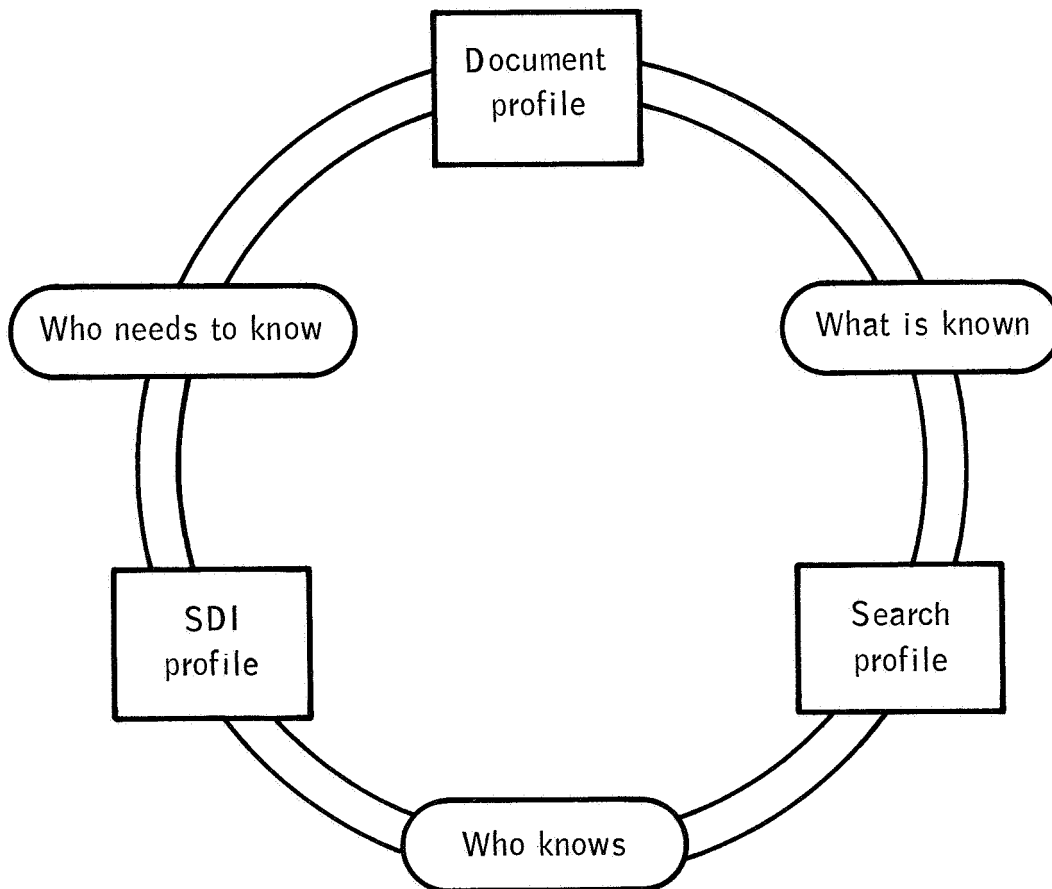

Figure 7

Dr. Hunt at the Air Force Cambridge Research Laboratory (AFCRL) has said, "I have been very favorably impressed by the results of the SDI Program. On the basis of man-hour savings alone, the dollar value of SDI to AFCRL is estimated to be at least 10 percent of the total payroll of the using scientists and engineers. I am not aware of any pertinent reports published during the period covered that the SDI search procedure missed. This system has thus proved workable, easy-to-use, reliable, and accurate ..."

Query profiles from the retrospective searching and the SDI Program are matched against each other and against administrative records, resulting in the computer matching of individual scientists to each other (thus permitting the oral exchange of information between individuals) and in the computer matching of scientists to project assignments (thus encouraging more effective management).

#### CONCLUSIONS

An Information Retrieval Intelligence System, interfacing its various subsystems, will inform the user or management of who needs to know what, who knows or is working on what, as well as what is known. This computer-controlled network of intelligence which constantly feeds back into itself permits a company, agency, or individual to keep abreast of the rapid changes in modern technology, in spite of the volume of scientific literature in the world.

## STYLE IN TECHNICAL WRITING

By Louis Alexander

University of Houston and Wall Street Journal

I'm a "bug" about language. I take a great interest in making myself clear — in written stories and letters and articles and manuals — and I know clear language makes a big difference in the ability of another person to understand what is on my mind.

I think it started way back when my father used to take delight in pursuing a word through the dictionary — and he took me along with him. We found out what the word meant; and along the way we found out a lot about other words related to it, and how to make the word mean what it says.

One big problem of a technical writer is to mean what he says. It's not that he doesn't know what he means. Of course he knows what is in his mind when he writes a word and a sentence and a technical paper. If he had to please only himself when he writes the paper, he succeeds very well; and he understands every bit of it.

But the trouble is that when you write a paper — or a memo, or a letter, or anything — you are not writing it to please yourself. You are writing it to convey some information to someone else. And the "someone else" doesn't always speak your language. This someone else can't always tell what you mean. Very few technical writers, and practically no engineers or scientists, really set out from the beginning to put down on paper what someone else should know about their work. They put down what they think is important — and they wind up with what is important to themselves.

So I maintain that the real problem of doing any technical writing whatsoever is not an engineer's unfamiliarity with spelling, or a scientist's apathy toward grammar, or a businessman's impatience with punctuation. It's the practice of every one of them to write down what he personally is doing, what he wants; let the other guy meet him halfway — more than halfway, and somehow figure out what is important to that other guy, in order to understand his writing.

And the real solution to any of these problems of writing starts at the same point: ask yourself what there is about your work that matters to the guy to whom you are writing. You know a lot about him. You know who he is. You know what he is interested in — the results of the project, the cost, the need for equipment, what your activity can be used for. When you learn to write about that — instead of

writing about what you have been doing — then you're bound to be a successful technical writer.

A lot of things about the way in which technical and scientific papers are written contribute to the ability of an engineer to "beat around the bush" and the ability of a scientist to obscure the subject matter. The very first one is that famous — and important — emphasis on objectivity. The report must be objective. All the language in the report must contribute to the report remaining completely objective, so as not to influence the guy who receives the report and reads it.

Now, most engineers and scientists take that admonition to mean that you must "tell the facts, sir, just the facts, nothing but the facts." And in a report of an experiment, or an activity, that may be true. Maybe. You write down just what you did, just what happened; and no more.

What you are doing in those cases is writing a diary, or writing a log. But in most cases, the guy for whom you are writing the report does not want a play-by-play account. He wants to know, "What did you accomplish?" "What can this reaction be used for? What can you make with it?" Maybe he wants to know, "How much will it cost? And do you really need all that money to accomplish that goal?" And you don't answer him; you duck the responsibility by resorting to a play-by-play account of the work you went through.

He doesn't need to know that. He needs to have you draw some conclusions about the work, summarize it, explain it. And not in terms of what you do; but in terms of what's important to him. The money. The equipment. What things can be used for.

So I maintain that every description of what you have been doing needs to be preceded by an explanation of what it's all about, and ended with a statement of what you want, what you have accomplished. In addition to a selective description of what you did.

The objective language of scientific writing enables you to duck responsibility. When you say, "The valve is turned to the 'on' position" — the use of passive voice, "is turned," enables you to confuse the reader as to whether the valve turns automatically at a certain pressure, or whether a workman has to watch the dials and then turn it by hand. You don't even indicate whether the valve ought to be turned at that point; only that it is turned. How objective can you get? You've managed to be objective at the price of evading an explanation of whether the operation is automatic or human, whether it was right or just necessary.

Now of course there are ways of indicating those things. You can say at the beginning of a paragraph that the process is automatic, or that things went wrong when the valve was turned prematurely. But you rarely do. In fact you rarely put a person, a subject, into a sentence, when you use the passive voice — "the valve is turned....." By whom? "The reaction was determined to be negative....." By whom? Anybody? Nobody?

It makes a difference. If the new worker on the job came in at quitting time and said, "By the way, that reaction didn't work," that means one thing to an investigator. If the engineer in charge of the operation says it, it means considerably more. But as long as you use the passive voice, the reader will never know. You have to say, "The investigator determined that the reaction was negative." And, really, if you write the report, and the reader knows who you are — maybe he assigned you to carry out the experiment — you should write, "I determined that the reaction was negative." Take the responsibility in writing. You have the responsibility anyway. Make it simple in writing.

Of course, if you don't want the responsibility, go back to the passive voice. And, I must say also, in all fairness, that if the policy of your company or your department is to write in the passive voice, you must follow policy — until you become the boss and change it to a policy of using the active voice whenever possible, so you can follow the writing easily and tell who does what.

It may be modesty, it may be the natural reticence of an engineer or the deliberate nature of a scientist not to take credit for anything, and to prefer the passive voice. But you must at some times use the active voice and take the credit or the blame. People will understand what you have to say, and that's important to the success of every project. Use active voice whenever you can. Use "I" or "we" whenever it is appropriate. You'll be understood more frequently. The boss will approve your reports and okay your projects more often, the sooner.

Direct sentences, short sentences are very important to good writing. The simple declarative sentence is the easiest to understand. "I did this." "We need that." This is a major problem to an engineer and a scientist because of two reasons: One, engineers and scientists have retentive minds, and they can hold a lot of ideas together in their minds at one time. This leads to writing long sentences with lots of ideas in them. And two, they are always thinking in terms of cause and effect, action and reaction and result.

The trouble comes when an engineer puts more than one cause and effect in one sentence. He puts side causes into it, too, and side effects. He goes on to the second result, beyond the first one. Stop a moment and notice how easy it is to follow the sentences in this paragraph. Each one contains one thought. The first thought leads to

the one in the next sentence. It would be easy to put them together, and you would still understand — as you do this sentence. But this (foregoing) sentence contains three ideas, and you had to stop and consider a bit before you got the import of it and got the relationship of everything in the right place. Make it easy on the other guy. Even if the writing becomes choppy. He won't think it's choppy and too simple. Because it's all new to him. You're writing about something he doesn't know; or you wouldn't have to write it down in the first place. You know it, so it seems simple to you. That's why you're the one who should write it; you understand it. But the other guy welcomes short sentences and simple ideas, so that he can digest this new thing a little bit at a time. Maybe even argue with it. But he can't digest it, much less agree with it or disagree, if he has to bite off big hunks of sentences, long chains of actions and results, causes and effects and digressions and conclusions. Make it easy for the other guy.

We make it hard for the other guy because of another American habit — the use of long, complicated nouns. I call that the practice of using two-pound, heavyweight, compound-collective nouns. It really means using nouns as adjectives to modify a major noun — collecting a whole lot of facts that relate to something and tacking them all in advance of the something, as "the transistorized, subordinate-circuit, 25-watt transmitter-receiver." I show my ignorance of electricity and communications in that collection of nouns. But doesn't it sound like something you often read or write? You're trying to make clear just what, and which, item you're talking about. You want to prepare the reader for what it does. And you stuff it all down his throat till he can't sort out all the facts at all. He gets no picture except a picture of something that is so big, so important, so hard to understand — that he'll put off reading it till he really has time for it. And you know when that will come! Maybe never.

What should you do? When you have a lot of facts that relate to one big fact, spread them out — throughout a whole sentence. "The equipment is a combination transmitter and receiver. Despite being transistorized it requires 25 watts power. Now, the subordinate circuit model ....."

Sure it takes more space to say it this way. But the reader understands it, easily. And when did length ever matter in a technical report? Especially as compared with comprehensibility.

Some people like to stack up verbiage on purpose. Using big words and lots of them makes the report look important. Sure it does. Too important to read. Too difficult. If you want to impress the boss, that's one way to do it. But of course, he may be unable to understand all those big words; and then he can't approve your project or your promotion to senior engineer.



I blame high school English teachers for this trouble. It's one of my beefs about them; and I hope the good teachers of English will forgive me, because I don't mean to include them. Also, even the bad teachers of English had a good purpose in mind.

In high school, a teacher of English is working very hard to increase your vocabulary. One way to do this is to require you to use a different word — a synonym or a word which offers an interesting variation to the original word — when you have the same thing to say again. You say, "the book" the first time. The next time you refer to "the volume." The third time it's "that reference" and maybe later on it's "the 353-page manual." But never again is it the "book."

You sure do demonstrate your vocabulary and your versatility. But what if the reader says, "Now somewhere in this report he mentioned a book. Let me find it. It can't be this thing, because here he's talking about a manual ....." and so on.

I think you've had the experience of walking in late on a conversation, after your friends have begun talking about someone. They say "he" and they say "his" — but they never again refer to him by name. You don't know if it's John or Fred or Bill, and you're either confused or embarrassed. That's what happens to your reader when you vary the language. It's known as "elegant variation" when you use big words to avoid repeating yourself. It's considered vagueness when you use pronouns instead of specifics.

Take a tip, instead, from your speech teacher. Your speech teacher made a big point of the importance of repetition. Repetition drives home an idea. Don't be afraid to repeat the idea. Repeat, repeat, repeat. Drive it home. Make sure the other guy knows what you're talking about. Make sure he understands what to do. Make sure he knows what you want him to give you. Notice how you remember repetition? There's nothing wrong with it. There's nothing wrong with using a specific word over and over again. If it's a pressure vessel call it a pressure vessel. Call it a pressure vessel every time. Don't call it a tank, a boiler, a container, and then something else — unless it really makes a difference. Take advantage of language, specific language, to drive your report home.

Each of these specific suggestions is aimed at showing you how to make the most of a specific practice in writing reports and memos. Each one is aimed at showing you how to avoid weaknesses in technical writing.

Now you need to take a look at one overall recommendation that will show you how to make a report clearer, shorter, more effective. That one recommendation is easy to state and difficult to carry out:

Write one more draft of your report — and before you start it, ask yourself what you want the other guy to get out of it. Then change the report around so that everything in it helps that guy to get the message and take the action you want.

I say this because most people write reports in a form of organization that tells what they have to say. If you're a chemist talking about an experiment, you tell it in the order you did it, and you report the results. If you're a construction engineer, you start with the equipment and materials, go to the foundation, and step by step finish the construction project.

But you rarely realize that the organization of your report would be different if the chemist realizes that he's writing this report in order to get approval to continue his experiment, and enough money and time to carry on — if the engineer realizes he is writing the report so the operations department can begin to schedule the movement of machinery into the building, and then the movement of personnel, and finally the start of operations. If you realize that you are really writing for that reason, wouldn't you organize your report differently? Wouldn't you choose certain things to emphasize, and leave out other things? And wouldn't you add some comments or explanations or conclusions to the straight report of the facts? Of course you would. You do it when the boss phones you, and says, "Now I have your report on my desk. Very clear. What do you want me to do about it?"

If you wrote that report for his use, instead of summarizing it for you use, the boss would know what you want. The boss knows what he can do, and what he can't do. You know, too. If you include that, you enable the boss to phone you and say, instead, "I thought you'd like to know I've recommended that you get another six months to work on that experiment, and all the chemicals you asked for." Or, "The plant manager wants me to thank you for speeding up the construction job." And you didn't speed it up; you merely went to the trouble of including a paragraph explaining that if all goes reasonable well, the movers can start shipping in the machinery in 30 days, start personnel training in 60 days, and have everything in operation in 90 days.

And so I maintain that a sense of purpose helps a technical writer — the boss's purpose, or the subordinate's purpose, whoever is to receive and use the report. I maintain that directness and simplicity help them to understand the writing. I maintain that active voice is usually better than passive voice.

And always, offer explanations as well as facts. Remember the other fellow doesn't know where your report is leading him. He may draw different conclusions from the facts than you intended — or he may not get the point at all. So tell him what it's all about, and then give him the specific facts.

I like this outline and guide which was given to me by my instructor in the Air Force. When you're writing a report, he told me, "First, tell 'em what you're going to tell 'em. Then tell'em. Then, tell 'em what you've told 'em."

The instructor was talking about writing for everybody, not just dumb recruits, but for everybody up to the rank of general, or even Secretary of Defense. Everybody writes that middle part, the "tell 'em" part. But a good technical writer should help his reader know what to expect by, first, telling him what is to come — what this report is all about, what he wants the other guy to get out of it. Then, the main part, the extensive report, the details. In such a way that the details bear out what the writer said he was going to tell 'em. And finally, after the reader has gone through all this new information, and is trying to sort it out in his mind, tell him what you've told him — sum it up, explain where it leads, re-state what you want him to do about it.

And I hope I've done that, myself. I trust you can make use of some of these practices in good technical writing. I trust you can understand how you get into some difficult spots, and how to get out of them. Some of you are doing these things already, and having good success in your writing. I look forward to more of you doing more good writing, and having more success with it.