

MFS 20075

AWARDS ABSTRACT

STORAGE CONTAINER FOR ELECTRONIC DEVICES

The invention is a storage container for channel carriers having miniature electronic components such as field effect transistors mounted thereon. Channel carriers like that designated by 38 in FIGURE 6 are commercially available.

The container includes cover 10, and a base 12 with several groups (FIGURE 3) of three closely spaced slots 24 cut therein; each group of slots receiving a channel carrier 38. Each slot has a spring conductor 32 (FIGURE 5) mounted therein that includes an elongated member terminating at one end in a point 34 and at the other end in a tab 40. The spring conductor has a post 42 extending from about the middle thereof that passes through the base and is soldered to one of a number of printed circuit paths 28 on the outside of the base. The printed circuit paths extend to one side of the base member to form a male plug portion 30 that makes it possible to plug the storage container into an instrument and perform electrical tests on the component while the channel carrier is sealed in the storage container.

The novelty of the invention lies primarily in the spring conductors and their arrangement with the base.

Inventor: George L. Filip
Employer: Marshall Space Flight Center
Evaluator: ~~W. Angele~~

Patent Application Serial No. 835,059

Filing Date June 20, 1969

NOTICE

The invention disclosed in this document resulted from research in aeronautical and space activities performed under programs of the National Aeronautics and Space Administration. The invention is owned by NASA and is therefore available for licensing in accordance with the NASA Patent Licensing Regulation (14 Code of Federal Regulations 1245.200).

To encourage commercial utilization of NASA-owned inventions, it is NASA policy to grant nonexclusive, royalty-free, revocable licenses to any company or individual desiring to use the invention while the patent application is pending in the U.S. Patent Office and within a specified period, presently two years, after issuance of the patent to NASA. If commercial use of the invention does not occur during this period, NASA may grant a limited exclusive, royalty-free license thereby adding an incentive to further encourage commercial development. Any company desiring to make, use, or sell this invention is encouraged to obtain a royalty-free license from NASA.

Address inquiries and all requests for licenses to Assistant General Counsel for Patent Matters, Code GP-1, National Aeronautics and Space Administration, Washington DC 20546.

NASA Case No. 20075

Charles C. Wells

APPLICATION FOR LETTERS PATENT

TO ALL WHOM IT MAY CONCERN:

BE IT KNOWN THAT George L. Filip, citizen of the United States of America, employee of the United States Government, and resident of Huntsville, Madison County, Alabama, has invented certain new and useful improvements in STORAGE CONTAINER FOR ELECTRONIC DEVICES of which the following is a specification:

ORIGIN OF THE INVENTION

The invention described herein was made by an employee of the United States Government and may be manufactured and used by or for the Government of the United States of America for govern-
5 mental purposes without the payment of any royalties thereon or therefor.

BACKGROUND OF THE INVENTION

The invention relates to storage containers for miniature electronic components. More particularly it relates to such con-
10 tainers wherein provision is made for testing of the components while sealed within the storage container.

The use of miniature electronic circuits is expanding rapidly and one commonly used device in such circuits is a channel carrier. A channel carrier is a device on which one or more miniature
15 electronic components, like a field effect transistor for example, are mounted. The channel carrier includes conductive surfaces which are connected by suitable leads to the terminals of the mounted components. When it is desired to use the mounted com-
ponent in fabricating a circuit, the component is hooked into the circuit by connecting leads from the circuit to the conductive
20 surfaces of the channel carrier..

It is desirable, and sometimes necessary, to test the component prior to use or during storage periods and it is this testing that has caused a problem in the past. To test the com-
25 ponent requires the welding of wires to the conductive surfaces of the channel carrier and gluing or otherwise attaching the

Page intentionally left blank

Page intentionally left blank

channel carrier to a printed circuit board. The wires welded to the channel carrier are connected to conductive paths on the circuit board which in turn are connected to some electrical device used for testing the components.

5 This is not a desirable test procedure because it is time consuming and often the component being tested is damaged during handling or while setting up or tearing down the test hook up. The channel carrier is particularly susceptible to damage when being removed from the circuit board after test.

10 OBJECTS AND SUMMARY OF THE INVENTION

BRIEF DESCRIPTION OF THE DRAWINGS

FIGURE 1 is a pictorial view of the container with the cover assembled on the base.

15 FIGURE 2 is a cross-sectional view of the assembled container taken along lines 2-2 of FIGURE 1.

FIGURE 3 is a view of the base looking at that surface which would face the cover when assembled.

FIGURE 4 is a view of the base looking at that surface thereof which would be an exterior surface when assembled.

20 FIGURE 5 is a cross-sectional view illustrating how the spring conductors are mounted in the slots cut in the base.

FIGURE 6 is an enlarged pictorial view, broken away and in cross-section of how the spring conductors engage the conductive surfaces of the channel carrier.

DETAILED DESCRIPTION OF THE INVENTION

FIGURE 1 of the drawing illustrates an assembled storage container having a cover 10 mounted on a base 12 by means of screws 14. Cover 10 has a rectangular recess 16 formed in the center thereof and a groove 18 is cut around the periphery of this recess. A seal 20 is positioned therein so that when cover 10 is assembled upon base 12 the interior of recess 16 will be sealed. The cover and base can be made of any suitable non-conducting material such as plexiglass or other suitable plastic or ceramic material.

FIGURE 3 is a plan view of the base looking at surface 22 thereof which is that surface which will be facing recess 16 in the cover when the container is assembled. Eight groups of closely spaced slots 24, three slots per group, have been formed in surface 22 of the base. These slots can be formed in any desirable manner but a preferred method is by making saw cuts with a small precision saw. Surface 26 of the base has a plurality of printed circuits paths 28 formed thereon and these paths are directed over to side 30 of the base which has been reduced in thickness (see FIGURE 2) so as to form a male plug portion whose purpose will be described hereafter.

Referring now to FIGURE 5 of the drawing wherein an enlarged view illustrates how spring conductor 32 is mounted in each of the slots 24. Spring conductor 32 is a forked member that terminates at one end in a pointed portion 32 and a tab 36 closely adjacent thereto. Pointed section 34 engages a conductive surface on channel carrier 38, described in more detail hereafter, and tab 36 forms an abutment against which the channel carrier

can be placed. The other end of the spring conductor terminates in a tab portion 40 which can be manually depressed to cause upward movement of pointed portion 34. The conductor spring has a post 42 extending therefrom that extends through the base and connects to one of the printed circuit paths 28 formed on the base.

In order to assure that the operation and significance of the storage container is fully set forth a brief discussion of the channel carrier is believed appropriate. Channel carrier 38 is typical of many such devices that are commercially available. It is composed of a ceramic material and has a small rectangle 44 of silicon or other suitable semiconductor material sweated thereon. Material 44 in turn supports a three terminal field effect transistor 46 that has been grown or otherwise formed thereon. It will be noted that the channel carrier has three horizontal surfaces 48, 50 and 52, and each of these surfaces is coated with a conductive material. Surfaces 48 and 52 are connected to the terminals of the field effect transistor by wires 53 and 55 connected between the terminals of the field effect transistor and surfaces 58 and 52. The third terminal of the transistor is electrically connected to surface 50. As is readily apparent from FIGURE 6, pointed sections 34 of the spring conductors contact the conductive surfaces of the channel carrier to form an electrical connection carried through to the outside of the container by post 40 which is connected by solder to the printed circuit paths formed on the outside of the container. Thus it is possible to plug the loaded container into some type instrument and perform tests on the component mounted on the channel carrier. This, of course, can be accomplished without removing the channel carrier from the container or breaking the seal between the cover and base of the container.

It will be seen in FIGURE 5 that the upstanding rib members 50 and 56 formed when the slots are cut into the base have been cut away to some extent so as to form a recessed area that the channel carrier will drop into when inserted under the conductor springs in a slot group. This recessed area along with the tab portions 36 formed on the spring member function as a guide and stop to assure proper alignment of the channel carrier beneath pointed section 34 of the spring conductors.

This completes the detailed description of the invention. While a preferred embodiment has been described many modifications will occur to one skilled in the art. For example, it would be a simple matter to increase the number of slots in each slot group and thereby make it possible to accommodate an electronic component with more than three input and output terminals.

What is claimed is:

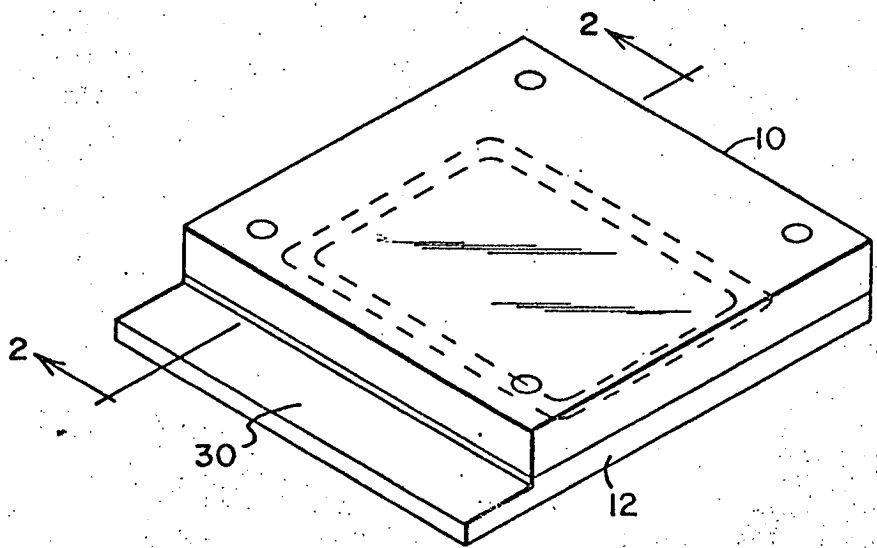

FIG. 1

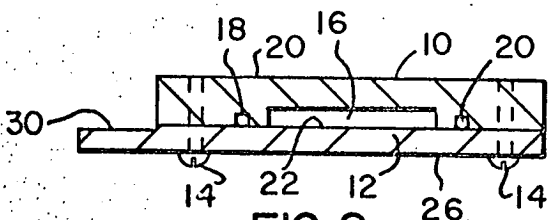

FIG. 2

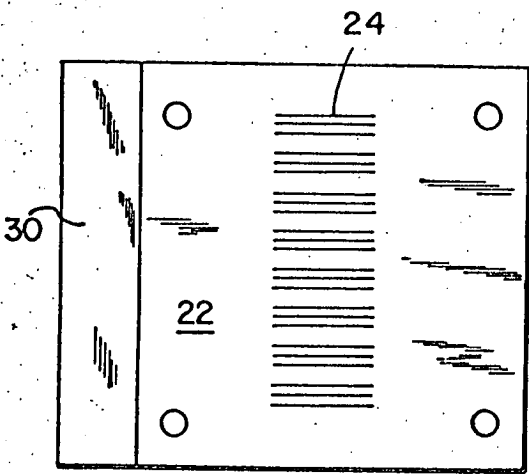

FIG. 3

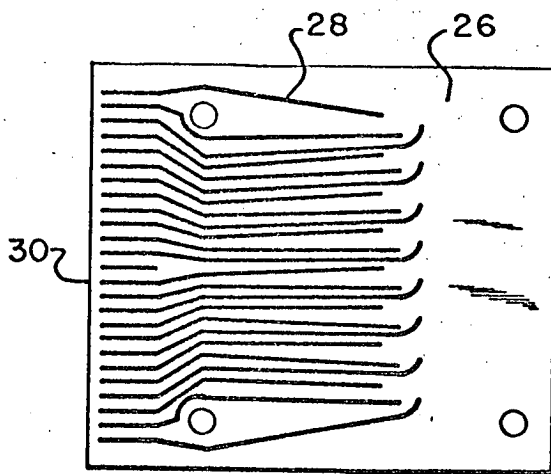

FIG. 4

INVENTOR
 GEORGE L. FILIP

BY

ATTORNEYS

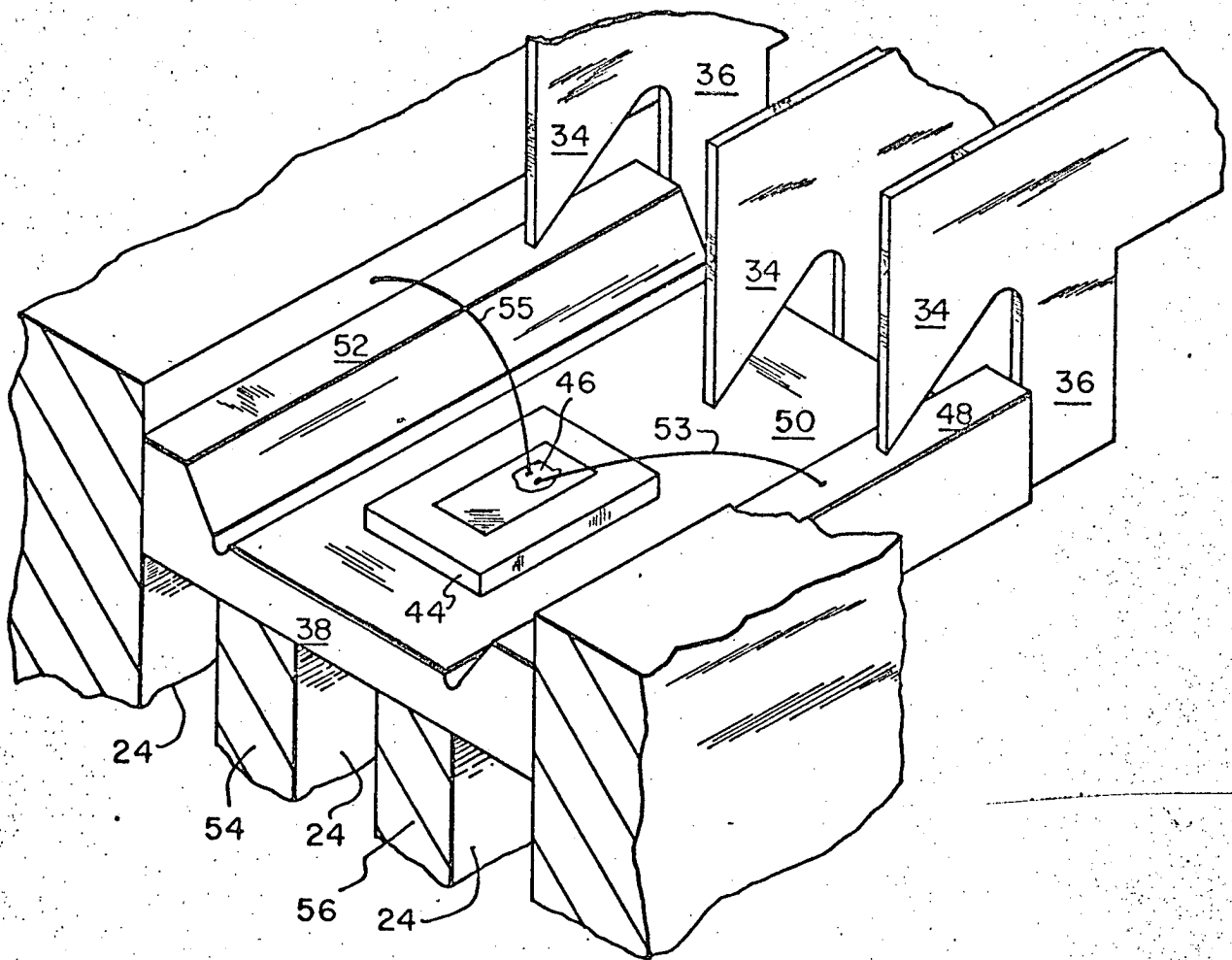

FIG. 6

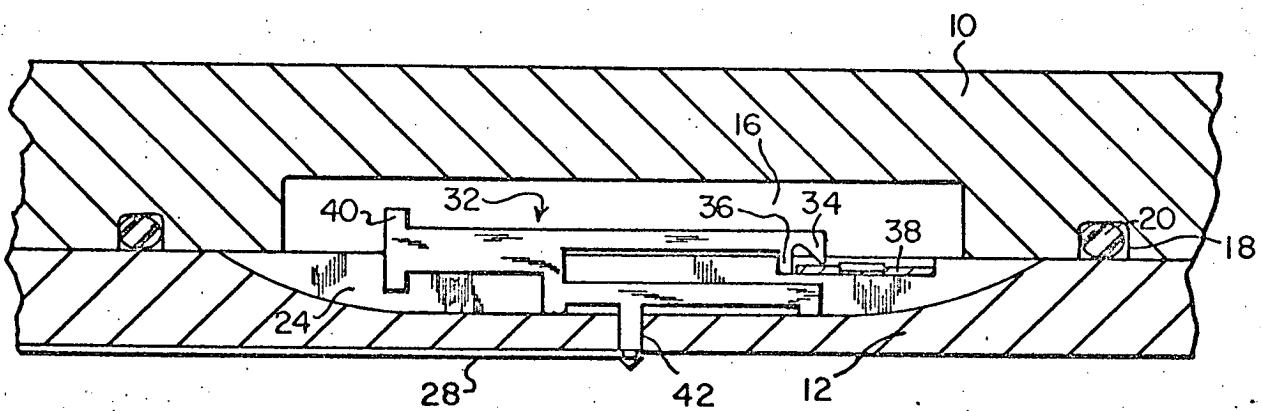

FIG. 5

INVENTOR
 GEORGE L. FILIP

BY

ATTORNEYS