

N 69 27 15 5

NR 10 1228



SEMIANNUAL STATUS REPORT
(Millimeter-Wavelengths Propagation Studies)

The Ohio State University

ElectroScience Laboratory

(formerly Antenna Laboratory)

Department of Electrical Engineering

Columbus, Ohio 43212

**CASE FILE
COPY**

Semiannual Status Report 2374-3
15 April 1969

Grant Number NGR 36-008-080

National Aeronautics and Space Administration
Office of Grants and Research Contracts
Washington, D.C. 20546

NOTICES

When Government drawings, specifications, or other data are used for any purpose other than in connection with a definitely related Government procurement operation, the United States Government thereby incurs no responsibility nor any obligation whatsoever, and the fact that the Government may have formulated, furnished, or in any way supplied the said drawings, specifications, or other data, is not to be regarded by implication or otherwise as in any manner licensing the holder or any other person or corporation, or conveying any rights or permission to manufacture, use, or sell any patented invention that may in any way be related thereto.

The Government has the right to reproduce, use, and distribute this report for governmental purposes in accordance with the contract under which the report was produced. To protect the proprietary interests of the contractor and to avoid jeopardy of its obligations to the Government, the report may not be released for non-governmental use such as might constitute general publication without the express prior consent of The Ohio State University Research Foundation.

REPORT
by
THE OHIO STATE UNIVERSITY ELECTROSCIENCE LABORATORY
Columbus, Ohio 43212

Sponsor National Aeronautics and Space Administration
Office of Grants and Research Contracts
Washington, D.C. 20546

Grant Number NGR 36-008-080

Investigation of Millimeter-Wavelengths Propagation Studies

Subject of Report Semiannual Status Report

Submitted by ElectroScience Laboratory
Department of Electrical Engineering
The Ohio State University

Date 15 April 1969

ABSTRACT

Preparations for ElectroScience Laboratory participation in the NASA ATS-E millimeter wave propagation experiment are described. Two receiving terminals, one fixed in location and one transportable, are under construction and will be essentially complete for the planned August, 1969 launch of the satellite.

CONTENTS

	Page
INTRODUCTION	1
TRANSPORTABLE TERMINAL	1
FIXED TERMINAL	6
FACTORS COMMON TO BOTH TERMINALS	9
<u>The Corrugated Horn Feed</u>	9
<u>Radiometer</u>	9
<u>Beacon</u>	12
<u>Rain Fall Rate Gauges</u>	13
WEATHER RADAR	13
CONCLUSIONS	13

SEMIANNUAL REPORT

INTRODUCTION

This report covers the work completed through February, 1969, under NASA Grant NGR36-008-080 which provides for the construction and instrumentation of two K_u band receiving terminals. The terminals, one fixed in location and the other transportable, will provide a space diversity capability and are being prepared for participation in the NASA millimeter wave propagation experiment which will utilize the ATS-E satellite. This synchronous satellite will provide a modulated 15.3 GHz signal during a period of one or more years for propagation studies through the atmosphere.

In addition to a NASA phase locked loop (PLL) receiver, signal processor and calibration and test set, each terminal will have a radiometer operating at 15.1 GHz. If available, a K_u band radar (15.5 GHz) will be operated at the fixed terminal to provide insight into local weather patterns.

TRANSPORTABLE TERMINAL

The transportable terminal has been designed to enable changes in location to be made in a few days time. The terminal consists of a 15 foot parabola and pedestal mounted on a dropped flat bed trailer, and a trailer mounted control and equipment van. These two units are presently located near the satellite communications facility which is used as a base of operations for equipment and man power.

The antenna trailer and pedestal are mechanically and electrically nearly complete. The antenna has been mounted and the subreflector with its supporting tripod and Cassegrainian feed silo are under construction, see Figs. 1 and 2. The feed silo for this antenna consists basically of two concentric cylinders; the outer cylinder being fixed and the inner rotatable. The R-F portions of both the PLL receiver and the radiometer are located in the rotatable cylinder along with the antenna feed. The cylinder is motor driven and allows complete rotation of polarization of the feed horn (see Fig. 3). The rotation will be monitored electrically.

The pedestal pointing vector is variable plus or minus 185 degrees in azimuth and from 0° to 98° in elevation. It has 36 to 1 positional synchros and maximum azimuth and elevation slew rates of about 1.4 degrees per second. No auto track capabilities are provided, however provisions for slaving to the fixed antenna terminal or to some preplanned program can be added if necessary.

The antenna consists of a 15 foot diameter paneled aluminum reflector, a 2 foot diameter hyperbolic ($e = 1.67$) subreflector and a corrugated horn feed. The maximum deviation of reflecting surfaces is approximately $d/20$

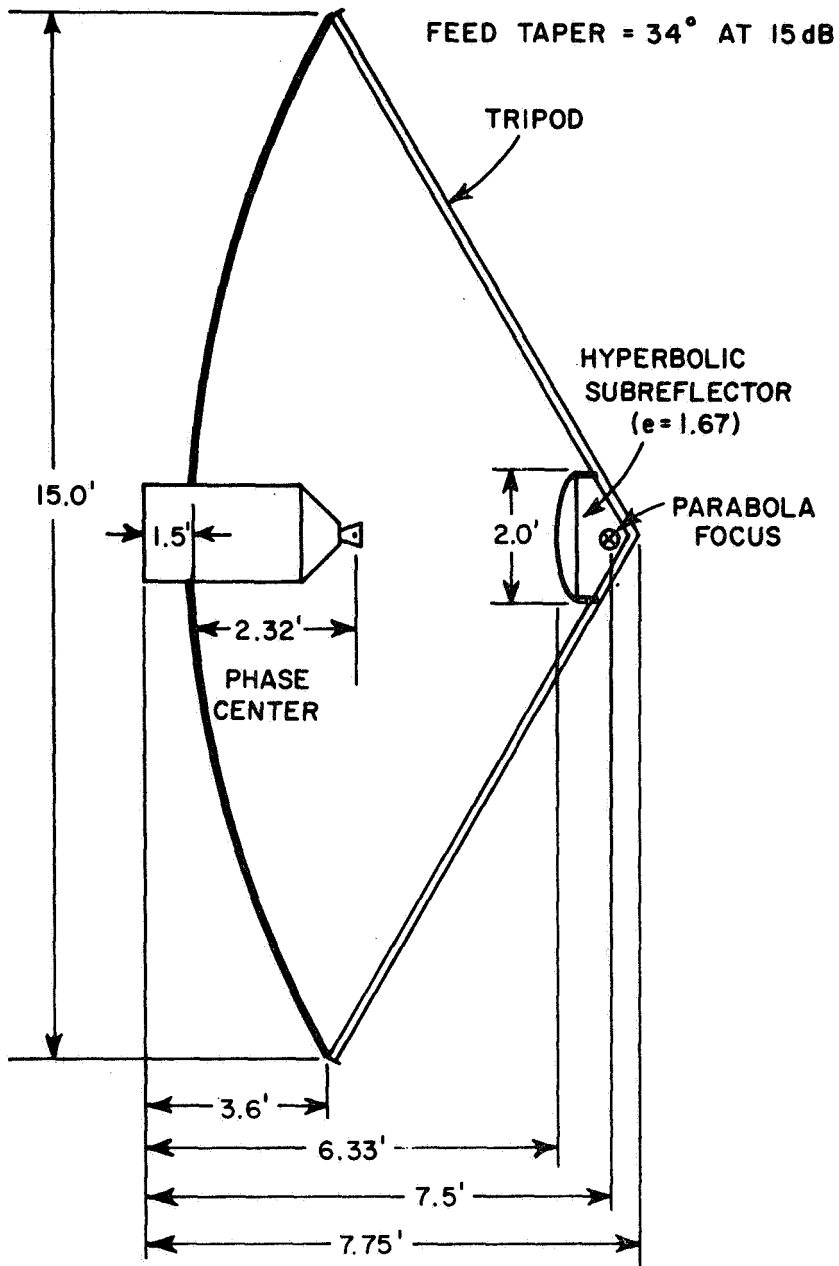

Fig. 1. Transportable antenna cross section.

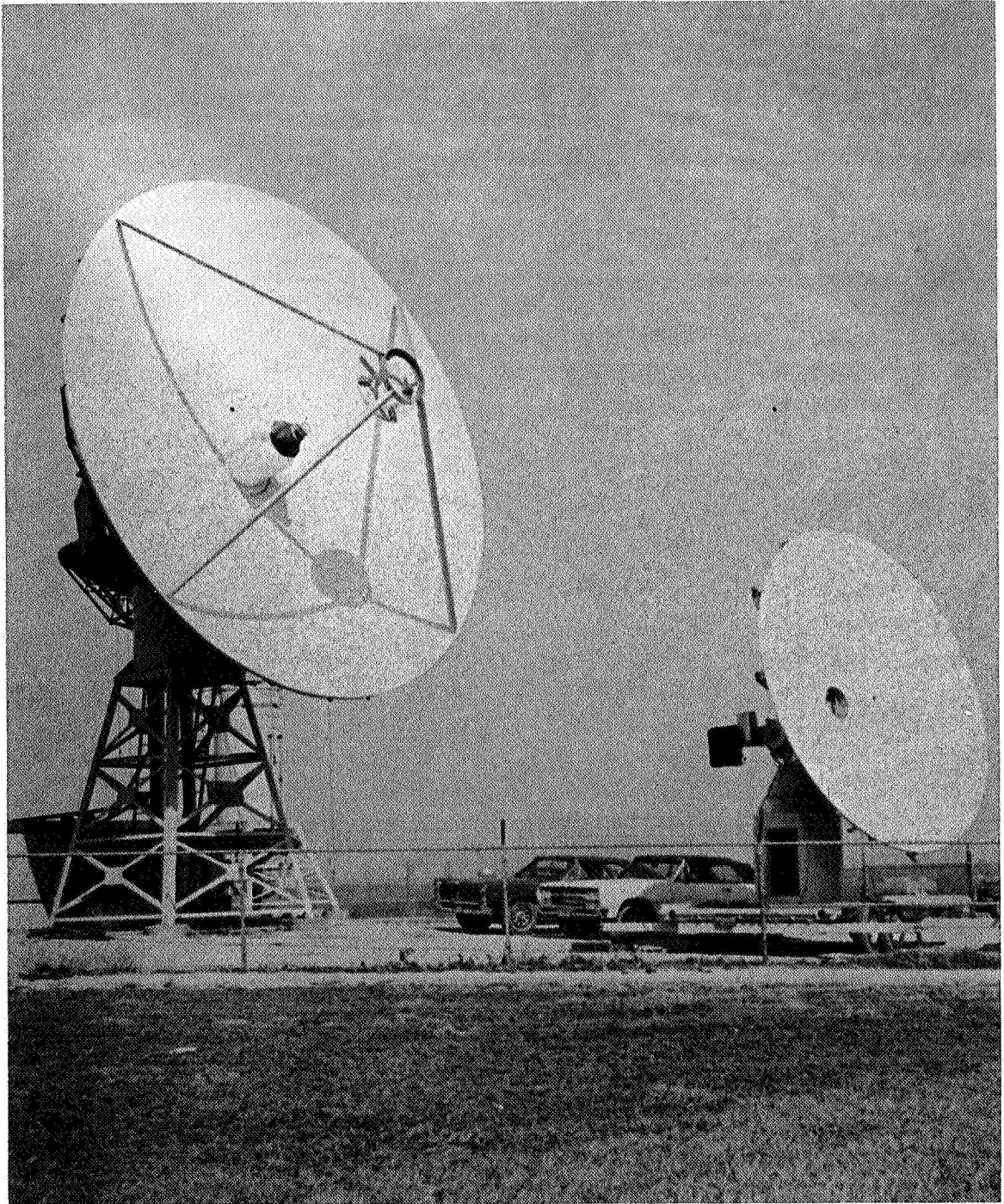

Fig. 2. Photo - transportable antenna.

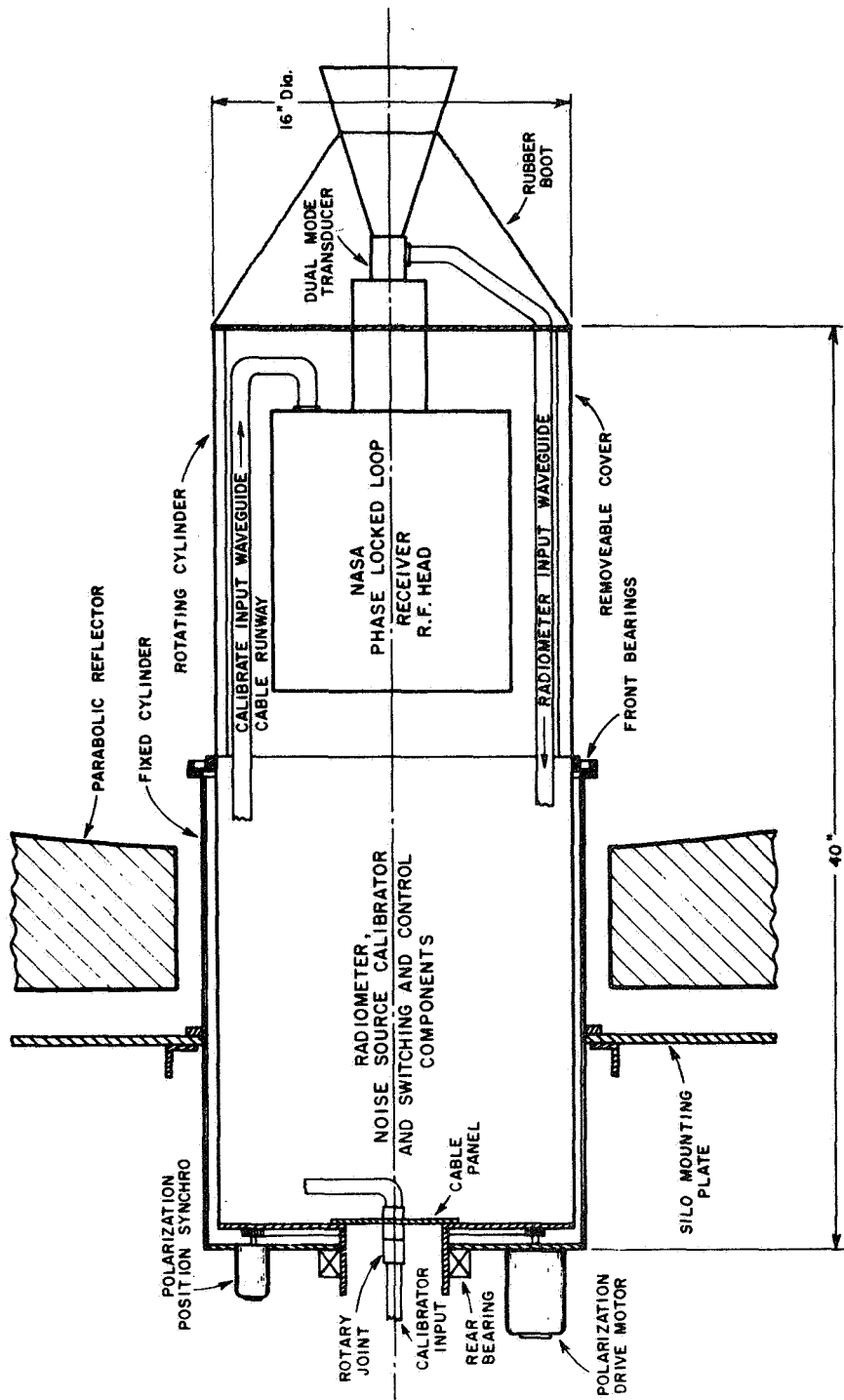

Fig. 3. Transportable antenna feed silo.

at 15.3 GHz. The philosophy of design was to optimize the signal-to-noise ratio at the antenna output. This requires a taper of approximately 15 dB at the subreflector edges. The corrugated feed horn, discussed in a later section, has very low side lobe levels which, along with the Cassegrainian feed, should reduce temperature contributions from the ground to a minimum for elevation angles above 20 degrees.

Thermal noise is nonpolarized. This fact permits the coupling of receivers with orthogonal polarizations to the antenna with no appreciable loss to either receiver. The nearly identical E and H plane patterns of the corrugated horn assures similar antenna patterns for both receivers.

The control van is a modified Nike system van complete with heaters, lights, work bench and storage lockers. It is mounted on a trailer that is suitable for travel on public roads at low speeds. The floor plan is shown in Fig. 4. Four or five equipment racks are planned; they will carry the following; PLL receiver, magnetic tape recorder, paper chart recorder, control panel (radiometer, mount control, power supplies, etc.), and auxilliary equipment (WWV receiver, time code generator, etc.).

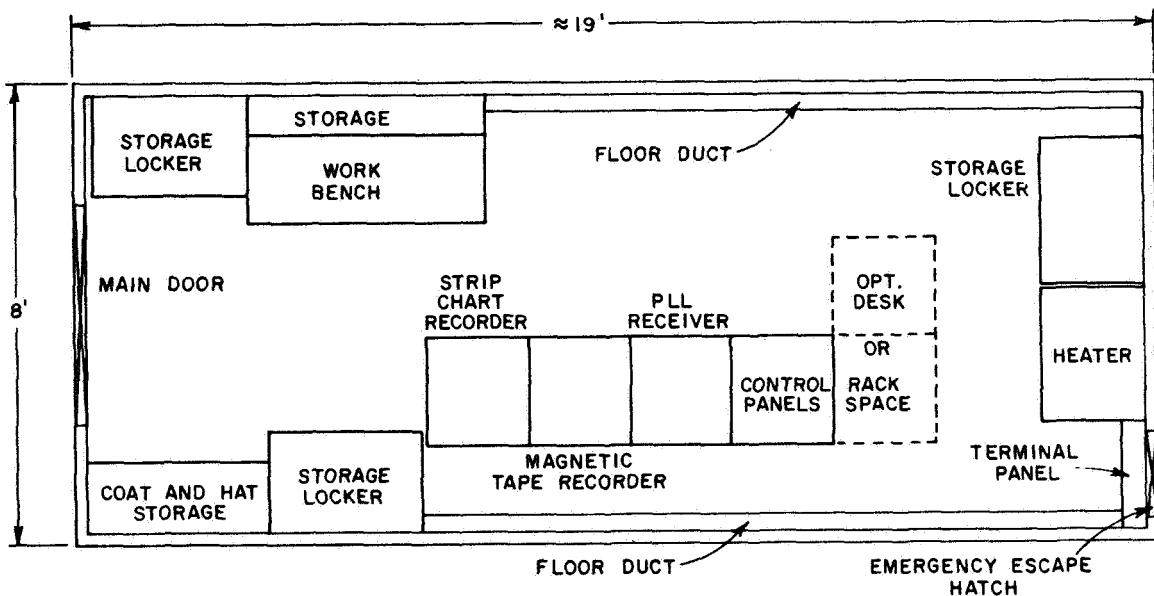

Fig. 4. Transportable terminal control van.

The initial location for this terminal has not as yet been determined. It is felt that, for this early "shake down" period, a location near the fixed terminal and a commercial power source would be desirable.

A possible location would be near the ElectroScience Laboratory building at 1320 Kinnear Road, approximately 1200 feet south of the fixed terminal. This location would have the advantage of simple wire interconnections between sites, quick transfer of man power and equipment between

sites, elimination of portable power problems during initial phases, and very similar weather patterns over both terminals for comparison of variables unique to each terminal.

At present the maximum portable power available to us is limited to 5 kw. Although an accurate determination of the power requirements of the terminal has not yet been possible, 5 kw may not be adequate and additional generators may be required

FIXED TERMINAL

The fixed terminal, located at 40°00'10" N latitude, 083°02'30" W longitude will consist of the South Antenna of the 4 antenna array of the Satellite Communications Facility, its control system and sufficient space in the terminal building for 5 racks of control, calibration and recording equipment. This 30 foot diameter antenna is presently operating at X-band. Its Cassegrain feed package is undergoing modification, shown in Fig. 5, to place the PLL receiver R-F head and radiometer directly behind the corrugated feed horn. Design parameters for feeding this antenna are essentially the same as for the transportable terminal (see Fig. 6). Although the tolerances of the outer panels of the main reflector of this antenna are not small enough to contribute to overall gain, the X-band feed design will be used. This design will permit the use of the existing subreflector and feed silo. The 15 dB taper planned will illuminate these main reflector outer panels weakly so that the resultant loss in gain should be small.

The feed package will be electrically identical to the transportable antenna, although not rotatable (see Fig. 9).

No modification of the antenna pedestal or its control system is expected to be necessary. It is capable of plus or minus 185 degrees of rotation in azimuth and elevation angles of from zero to 92 degrees both at rates up to two degrees per second. Capability exists or can be added to handle most externally generated tracking programs. Positional synchros used are of the 36 to 1 type and pointing accuracy is plus or minus 0.1 beamwidth.

This antenna will be left in its present operational condition until the mechanical portions of the K_u band feed system are complete. The X-band feed will then be replaced with the K_u band feed and patterns taken. This modification should take place sometime in April or May. In preparation for the addition of the electrical portions of the feed package, wiring from the terminal building to the existing silo has been completed. Waveguide sections to couple the test and calibration signal to the R-F head are partly assembled and will be installed shortly. Space in the terminal building has been allotted and the first PLL receiver installed. Tests on this system have started and will continue as additional equipment is received.

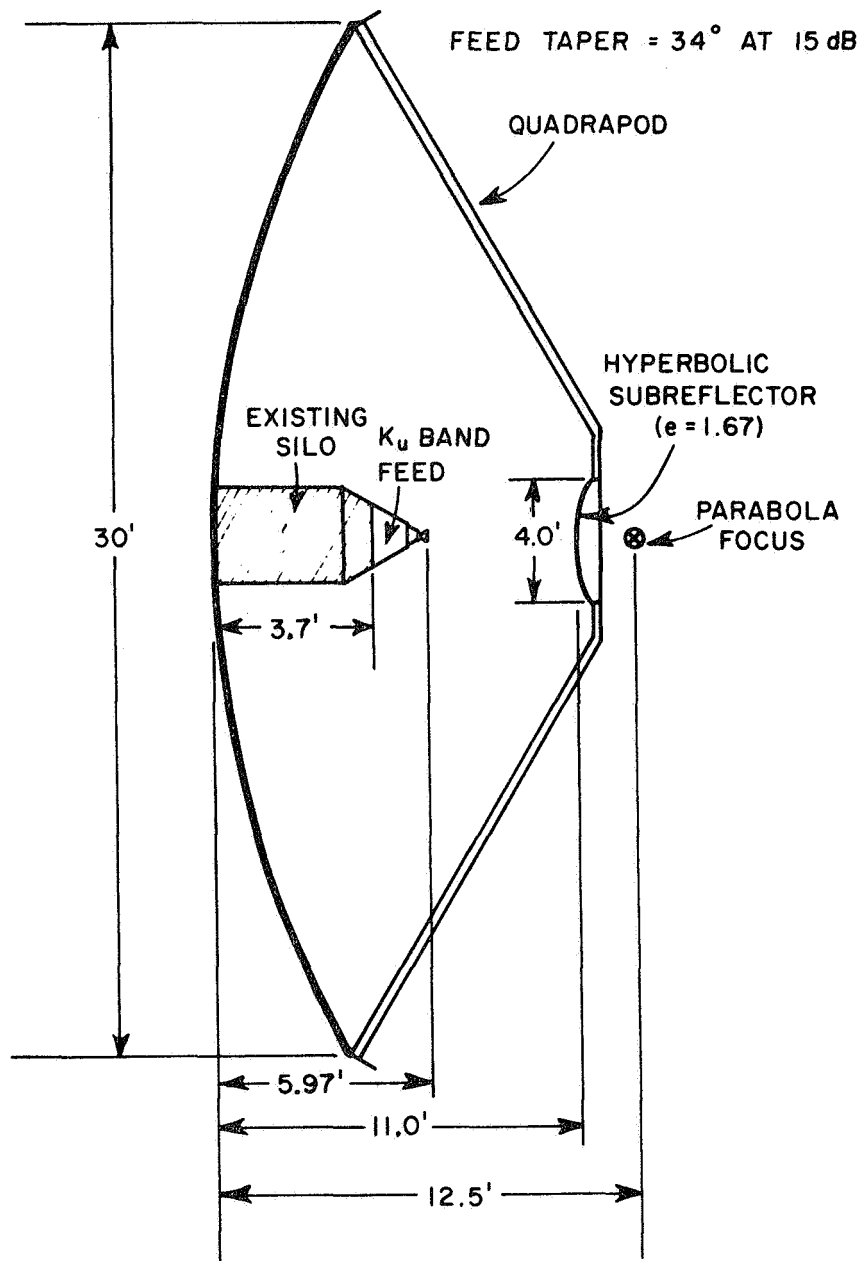

Fig. 5. Fixed antenna cross section.

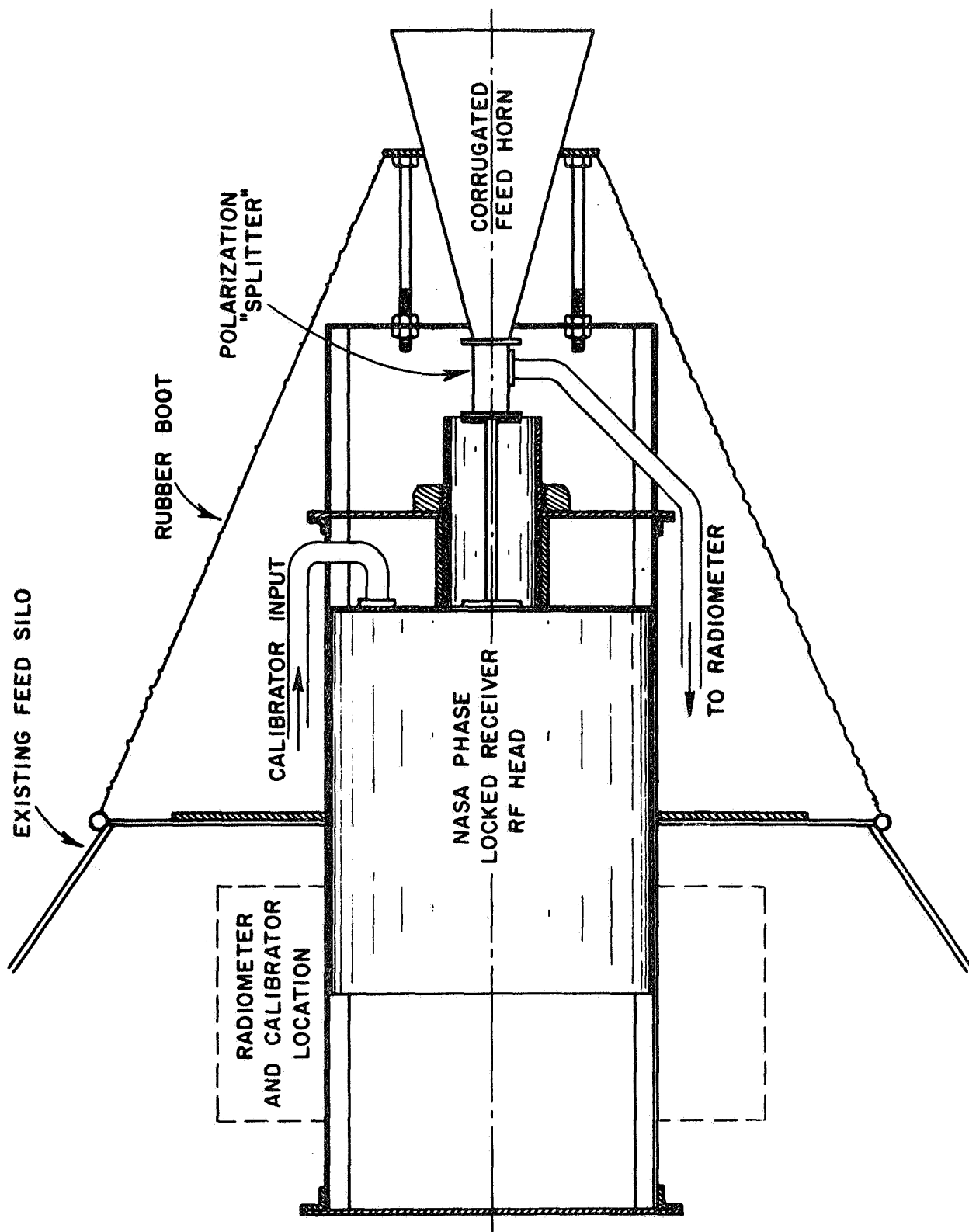

Fig. 6. Fixed antenna silo crosssection.

A weather transducer panel has been designed that will provide, at low output impedance, wind direction, wind speed, ambient temperature and relative humidity. These parameters will be recorded initially, at the fixed terminal only. Similar instruments will be provided for the transportable terminal when it operates at a sufficient distance from fixed terminal to be required.

FACTORS COMMON TO BOTH TERMINALS

The feed horns and R-F packages for both terminals will be electrically identical and consist of corrugated feed horn, PLL R-F front end, radiometer, and noise source calibrator. The basic silo shape is approximately 16 inches in diameter and 40 inches long with a shaped rubber cone to weather seal the back of the feed horn. The feed horn aperture will be sealed by a thin teflon sheet and the entire wave guide system pressurized slightly with nitrogen to eliminate condensation problems.

The Corrugated Horn Feed

The corrugated feed horn can assume several configurations. Basically it consists of a series of transverse corrugations (6 or more per wavelength) along the walls of a conventionally shaped horn. The result is to force the propagating energy away from the horn sides so that little is diffracted at the edges. This results in very low side lobe levels which will reduce the contribution to the antenna feed from the "hot" ground. It was decided to couple this feed to both the PLL receiver and radiometer by "polarization splitting". Here the vertical polarization will go to the PLL receiver and the horizontal to the radiometer. This type of coupler introduces 0.2 dB or less insertion loss and is reasonably broad band allowing some degree of freedom in changing radiometer frequency. In order to produce nearly identical E and H plane patterns so that both the horizontally and vertically polarized beams will look at the same volume, a square horn with four corrugated sides was chosen. The resultant patterns of the prototype are shown in Fig. 7.

The vertically polarized signal is coupled directly to the PLL receiver and processed as detailed in NASA Report X-733-68-196.

Radiometer

The horizontally polarized signal is coupled through a mechanically operated switch to the radiometer. This Dicke type radiometer uses a latched ferrite circulator switch with typical insertion loss and isolation of 0.3 dB and 20 dB plus, to connect first, the antenna and then a load at ambient temperature to a mixer-preamplifier, post amplifier combination. It has a noise figure of 10 dB, a bandwidth of 20 mhz, and a 60 mhz I-F frequency. The local oscillator is a Gunn diode, tunable from 15 to 15.5 GHz.

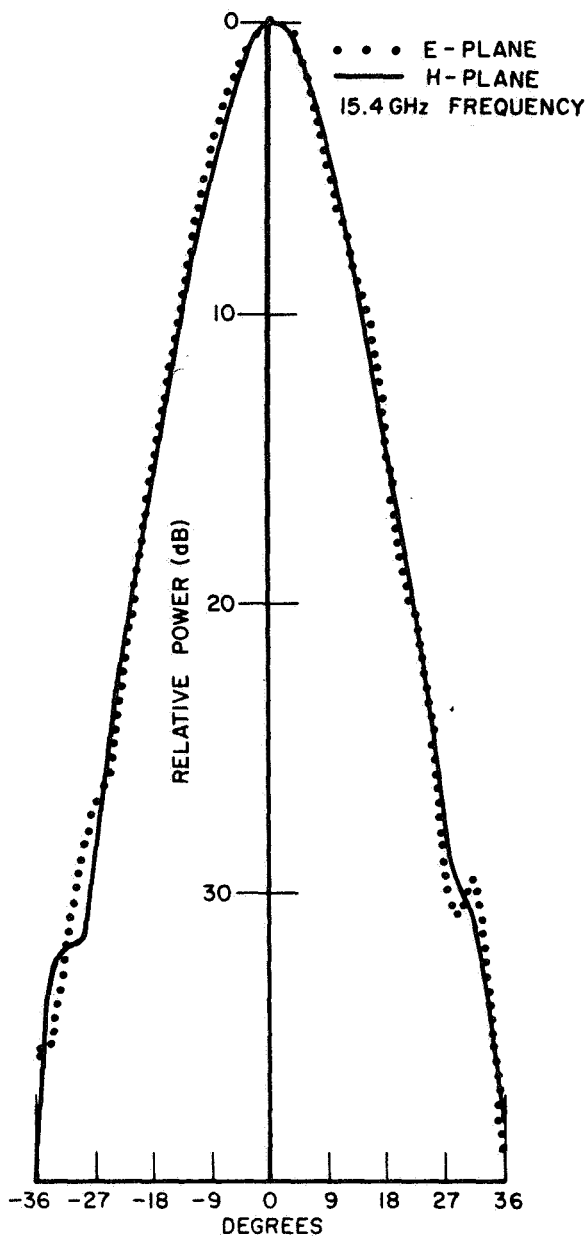

Fig. 7. Prototype corrugated horn - E plane pattern.

The output of the I-F amplifier is carried by coaxial cable to the control console where it is video detected and amplified by a selective amplifier tuned to the ferrite switch driver frequency (see Fig. 8).

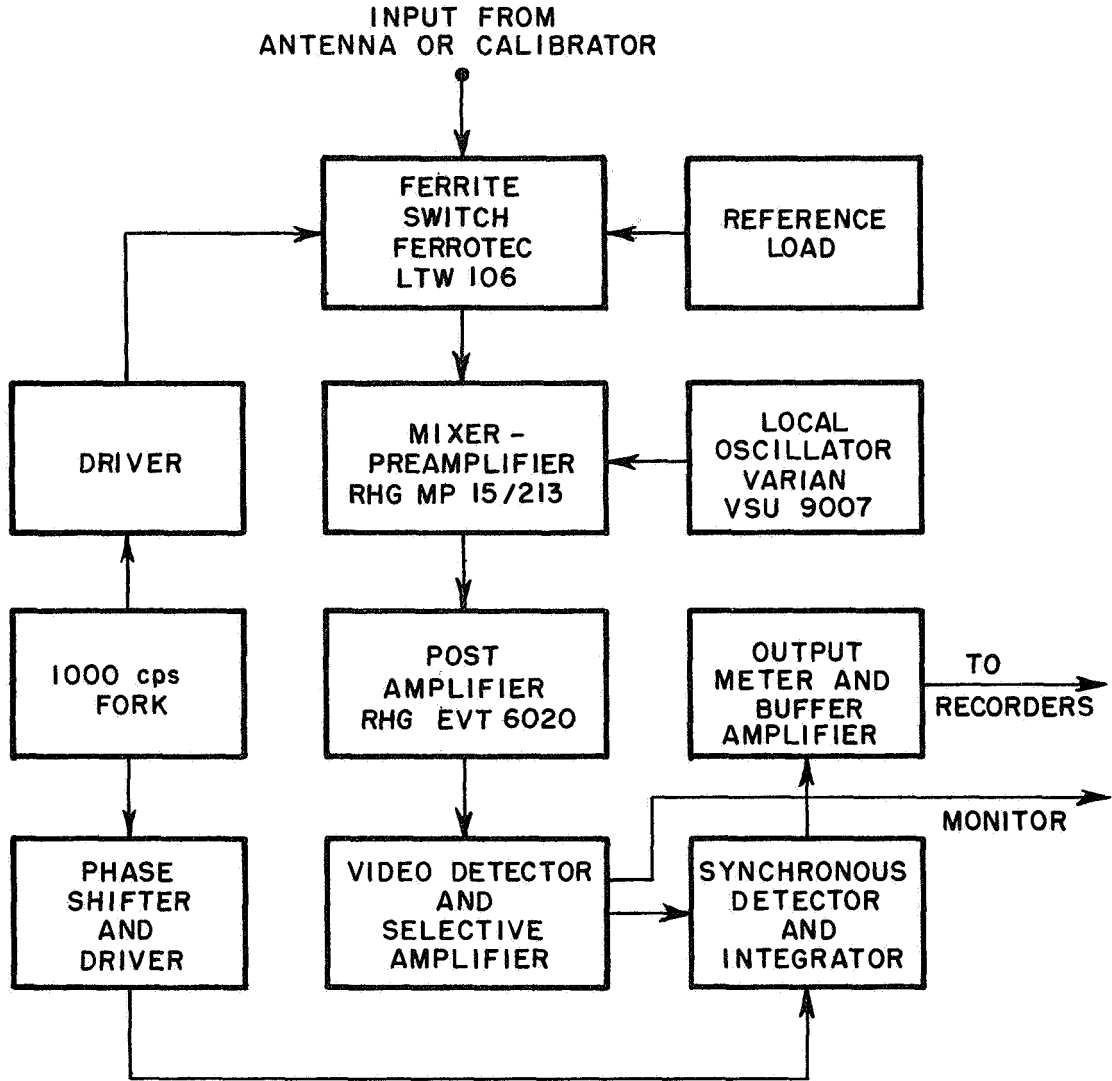

Fig. 8. Radiometer-block diagram.

This signal is then synchronously detected, integrated and fed through buffering amplifiers to a panel meter and paper and tape recorders. The output will be calibrated directly in degrees Kelvin and should need only small correction for system and antenna side lobe noise contributions. Calibration of this system is accomplished by periodically switching, via the electrically operated mechanical switch mentioned earlier, to a calibrated noise source so that gain adjustment can be made if necessary. This source will be padded so that a calibration temperature of 600 degrees is

produced. Predicted delta T is 1 to 2 degrees while absolute accuracy is expected to be within plus or minus 5 degrees. The other end of this same noise source will be coupled to the PLL receiver either through a switch or calibrated directional coupler as a further check on the PLL receiver system calibration (Fig. 9).

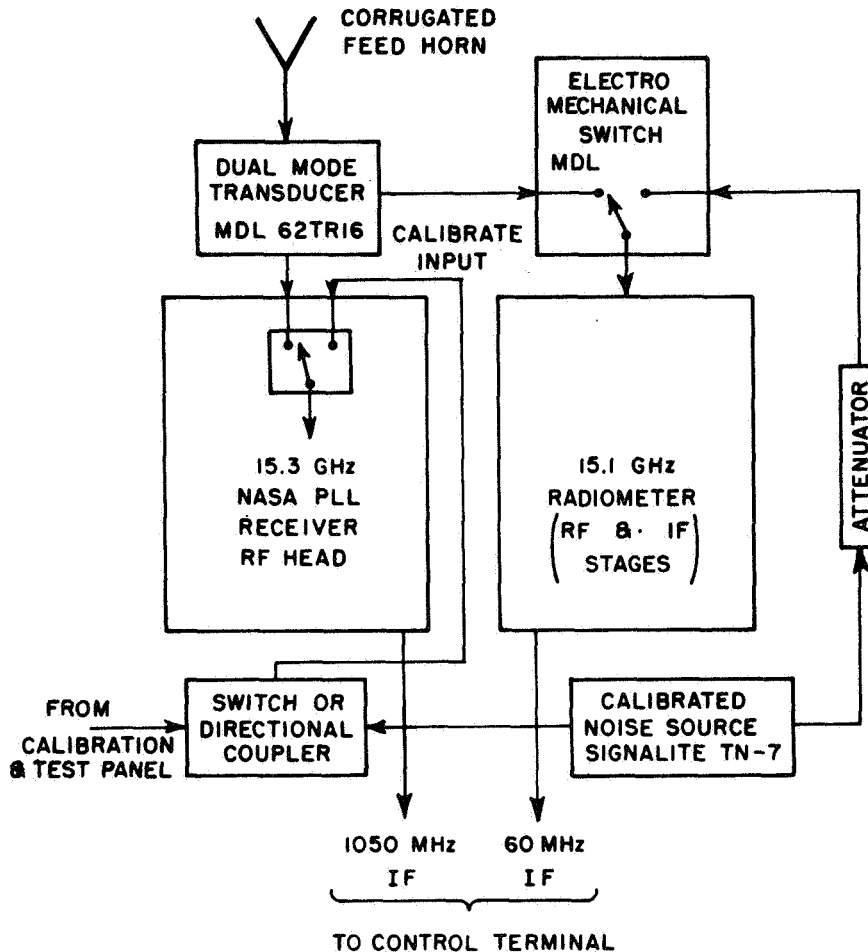

Fig. 9. Feed silo instrumentation block diagram.

The radiometer is in the breadboard stages with the control and drive circuitry under construction, and is expected to be operational by May.

Beacon

Presently two beacon locations are used for boresight and pattern measurements for the four antenna array at X-band. One beacon is located near the top of a 500 foot television tower, 7700 feet from the array and 28.02 degrees from true north. The elevation angle to this beacon is

2.9 degrees. It is planned to add a K_u -band source and antenna to this location that will be viewable at the fixed terminal and all proposed locations of the transportable terminal. The second beacon location, also to be modified for K_u -band operation is located at the top of a 100 foot tower on the ElectroScience Laboratory roof, 1200 feet south of the fixed terminal. Due to the ease of operation of this beacon, it will be used for initial calibrations and adjustments.

Rain Fall Rate Gauges

Each terminal will have at least one rainfall rate gauge whose output will be directly recorded. The total number of rainfall rate gauges used will depend on such factors as the location of the transportable site, the difficulty of locating such gauge sites in highly populated areas, and the availability of gauges.

WEATHER RADAR

Some time has been spent reviewing radar meteorology so that maximum benefit may be obtained from the K_u -band radar which may be available. Presently, it is planned to mount the unit on a gun director mount near the fixed terminal. This mount would be modified so that the radar could be slaved to the fixed antenna or driven independently. The Bendix K_u band radar is capable of 90 degree sector scan only, however by rotating the entire mount, a 360 degree PPI presentation of 160 miles diameter could be displayed. The display could be photographically recorded by any of several methods now under study. Photographs taken every few minutes as a storm develops and/or travels through the vicinity of the two receiving sites should, at the least, provide information as to the gross relative rainfall densities in the area. This information would show whether "worst case" conditions were seen over a space diversity receiving system for a given weather event. Depending on such factors as storm size, attenuation rates, velocity, etc., it may be possible to graphically translate a storm system to produce gross "worst case" conditions for a given pattern of antenna locations. Basically, the usefulness of this approach depends upon the ability of the radar to locate iso-contours of rainfall rate within a storm system. If the approach appears feasible to a reasonable degree, these radar control and photo systems may be implemented.

CONCLUSIONS

The construction of two K_u band receiving terminals is proceeding with no unusual problem expected. Present scheduling indicates a nominal completion date as July 1969. Modifications and adjustments, however, are expected to continue through the first few months of operation of the satellite.

Investigations into methods and techniques of weather sensing by radar to provide support to and enlargement of, data from these terminals should provide information as to the level of effort to be expended in this area. Presently, 360 degree PPI photographs of the radar return appears desirable and a system to produce them will probably be implemented.