

## **General Disclaimer**

### **One or more of the Following Statements may affect this Document**

- This document has been reproduced from the best copy furnished by the organizational source. It is being released in the interest of making available as much information as possible.
- This document may contain data, which exceeds the sheet parameters. It was furnished in this condition by the organizational source and is the best copy available.
- This document may contain tone-on-tone or color graphs, charts and/or pictures, which have been reproduced in black and white.
- This document is paginated as submitted by the original source.
- Portions of this document are not fully legible due to the historical nature of some of the material. However, it is the best reproduction available from the original submission.



NATIONAL AERONAUTICS AND SPACE ADMINISTRATION

TECHNICAL LETTER NASA-121  
APPLICATION OF ULTRAVIOLET REFLECTANCE  
AND STIMULATED LUMINESCENCE TO  
THE REMOTE DETECTION OF NATURAL MATERIALS

September 1968

Prepared by the U. S. Geological Survey for the  
National Aeronautics and Space Administration (NASA)  
under NASA Work Order No. T-65757

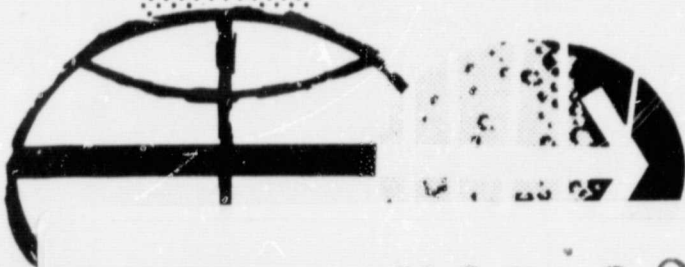

MANNED SPACECRAFT CENTER  
HOUSTON, TEXAS

FACILITY FORM 602

N69-28327	
(ACCESSION NUMBER)	(THRU)
41	1
(PAGES)	(CODE)
TMX-#61915	14
(NASA CR OR TMX OR AD NUMBER)	(CATEGORY)

Earth Resources Aircraft Program  
Data Bank, BM5



UNITED STATES  
DEPARTMENT OF THE INTERIOR  
GEOLOGICAL SURVEY  
WASHINGTON, D.C. 20242

Interagency Report  
NASA - 121  
September 1968

Mr. Robert Porter  
Acting Program Chief,  
Earth Resources Survey  
Code SAR - NASA Headquarters  
Washington, D.C. 20516

Dear Bob:

Transmitted herewith is one copy of:

INTERAGENCY REPORT NASA-121  
APPLICATION OF ULTRAVIOLET REFLECTANCE  
AND STIMULATED LUMINESCENCE TO THE  
REMOTE DETECTION OF NATURAL MATERIALS\*

by

William R. Hemphill\*\*

The U.S. Geological Survey has released this report in open files. Copies are available for consultation in the Geological Survey Libraries, 1033 GSA Building, Washington, D.C. 20242; Building 25, Federal Center, Denver, Colorado 80225; 345 Middlefield Road, Menlo Park, California 94025; and 601 E. Cedar Avenue, Flagstaff Arizona 86001.

Sincerely yours,

A handwritten signature in cursive script, appearing to read "W.A. Fischer".

William A. Fischer  
Research Coordinator  
EROS Program

\*Work performed under NASA Work Order No. T-65757

\*\*U.S. Geological Survey, Washington, D.C.

UNITED STATES  
DEPARTMENT OF THE INTERIOR  
GEOLOGICAL SURVEY

INTERAGENCY REPORT NASA-121

APPLICATION OF ULTRAVIOLET REFLECTANCE  
AND STIMULATED LUMINESCENCE TO THE  
REMOTE DETECTION OF NATURAL MATERIALS\*

by

William R. Hemphill  
U. S. Geological Survey  
Washington, D. C.

Presented at the  
1968 American Society of Photogrammetry Convention  
March 11-15, Hilton Hotel Washington, D. C., March 12,  
Session B, Application of Remote Sensing

\*Work performed under NASA Work Order No. T-65757

## CONTENTS

	Page
ABSTRACT-----	1
INTRODUCTION-----	3
ULTRAVIOLET REFLECTANCE-----	4
Laboratory studies-----	4
Ultraviolet photography and imagery-----	7
ULTRAVIOLET STIMULATED LUMINESCENCE-----	14
Ultraviolet imaging system-----	15
Ultraviolet laser-----	22
Fraunhofer line-depth method-----	26
SUMMARY-----	34
REFERENCES-----	35

## ILLUSTRATIONS

- Figure 1. Curves showing ultraviolet and visible spectral reflectance of some common rocks.
2. Curves showing transmission of specific ultraviolet and visible filters, and the quantum efficiency of the S-13 photocathode.
  3. Multiband imagery acquired with the University of Michigan's 18-channel scanner over Paoha Island, Mono Lake, California.
  4. Computer print-out of part of Paoha Island, Mono Lake, California showing bedrock and surficial materials symbolized by letter.
  5. Diagram showing operational components of an active ultraviolet imaging system.
  6. Photograph showing ultraviolet imaging system set up in laboratory. Transmitter, A; receiver, B; oscilloscope, C; and video monitor, D.
  7. Video monitor image indicating luminescence of deweylite in a quarry near Baltimore. Distance from the transmitter to the quarry face is 64 feet.
  8. Conventional photograph of same area shown in figure 7.
  9. Ultraviolet laser.
  10. Diagram showing position of laser, sample, and photomultiplier detector for measurement of luminescent decay time.
  11. Oscilloscope traces for a suite of five feldspars.
  12. Diagram illustrating the Fraunhofer line depth method.
  13. Schematic showing design of the optical unit of the line-discriminator prototype.
  14. Prototype line-discriminator showing the optical unit and the control console.
  15. Excitation and emission spectra of Rhodamine dye.

APPLICATION OF ULTRAVIOLET REFLECTANCE  
AND STIMULATED LUMINESCENCE TO THE  
REMOTE DETECTION OF NATURAL MATERIALS 1/

by

William R. Hemphill  
U. S. Geological Survey

ABSTRACT

Carbonate rocks and evaporite deposits commonly exhibit relatively high reflectance in the ultraviolet ( $<3600\text{\AA}$ ), and some outcrops of these materials are selectively shown on ultraviolet imagery. Other materials which are commonly strongly imaged on ultraviolet imagery and photography include water, snow, concrete, and metallic objects, particularly aluminum.

Outdoor tests of an active ultraviolet imaging system have demonstrated the feasibility of imaging ultraviolet stimulated luminescence of such minerals as talc, dolomite, and deweylite along quarry faces from distances of several hundred feet. The system features a cathode ray tube transmitter, an image dissector receiver, and a video monitor on which the distribution of luminescent material is imaged as the outcrop is scanned.

A pulsed ultraviolet laser emitting at  $3371\text{\AA}$  has been used successfully in the laboratory to stimulate phosphorescence of selected rock and mineral specimens and to discriminate between them on the basis of decay time which ranges from less than three to more than 10 microseconds. Initial results suggest that sodic feldspars have

---

1/ Presented at the 1968 American Society of Photogrammetry Convention, March 11-15, Hilton Hotel, Washington, D. C., Session E, Application of Remote Sensing.

longer decay periods than calcic feldspars. Some granites also appear to have decay periods significantly different from other types of granite in the same locality.

Outdoor tests with a high-resolution grating spectrometer were successful in detecting luminescent materials by means of the so-called "Fraunhofer line-depth method". This method is advantageous because it uses the sun as an ultraviolet source and therefore is independent of low-powered artificial sources such as cathode ray tubes, lasers, and mercury vapor lamps. A Fraunhofer line-discriminator suitable for aircraft operation has been constructed, and initial on-the-ground tests are being performed on Rhodamine WT, a luminescent dye used by hydrologists and oceanographers in studies of current dynamics in streams and estuaries.



## INTRODUCTION

The Geological Survey and NASA are jointly sponsoring a program aimed at determining the application of the ultraviolet spectrum in discriminating natural materials. The Survey is interested in the terrestrial applications of detecting and mapping selected rocks and other materials, both in surface and airborne studies, and from orbital altitudes. NASA is interested in similar applications for study of the earth and moon, as well as other planetary bodies.

This paper discusses the program in terms of the two properties to be detected and measured. These properties are ultraviolet reflectance and ultraviolet stimulated luminescence.

## ULTRAVIOLET REFLECTANCE Laboratory studies

Most materials show a gradual reduction in spectral reflectance with reduction in wavelength from the visible into the ultraviolet. Exceptions to this generalization include snow, concrete, aluminum, and certain other materials which strongly reflect ultraviolet energy.

Spectral reflectance of more than a hundred rock specimens and common rock forming minerals have been measured in the laboratory (Watts, 1966; Watts and Goldman, 1967; Thorpe and others, 1966), and figure 1 typifies the spectral distribution patterns of most of them. Carbonates, evaporites and some phosphate rocks commonly show comparatively high reflectance values in both the ultraviolet and visible region; this response is exemplified by the curve for the limestone specimen. Acidic rocks also tend to have high reflectance values in the visible region and low values in the ultraviolet, as, for example, the granite specimen shown in figure 1. Basic rocks such as the basalt specimen seen in figure 1 commonly show low reflectances which are nearly the same in both the visible and ultraviolet. A few materials such as the monzonite in figure 1 and asphalt show more reflectance in the UV than in the visible, but these are exceptions and although a higher UV response is fairly common for asphalt, it is not necessarily typical for monzonite and intermediate rocks.

The limestone and granite specimens, with reflectances on the order of 35 to 40 per cent in the visible region, would appear on a photograph at nearly the same density or grayness, and only slightly brighter than the rhyolite with a reflectance of 25 to 30 per cent. At best, image brightness in the visible for these three specimens would tend to be similar.

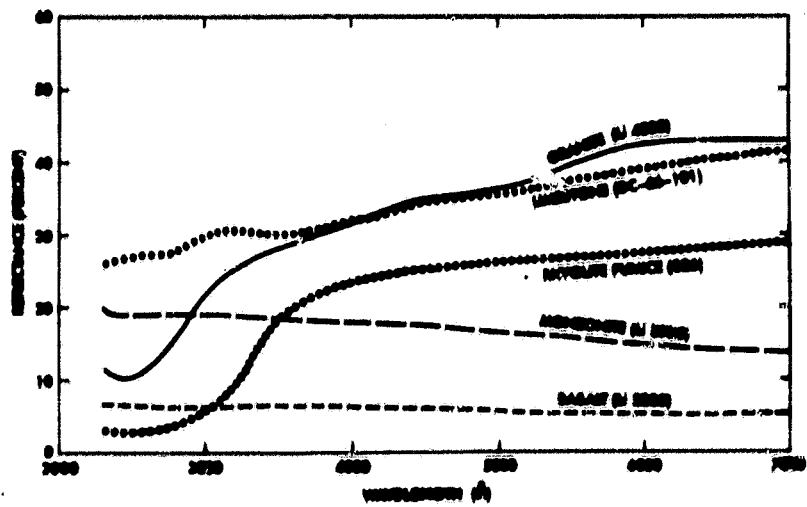

Figure 1. Curves showing ultraviolet and visible spectral reflectance of some common rocks

At 2500Å in the ultraviolet, less energy is reflected by these three specimens. However, limestone shows more than 2 1/2 X the reflectance of the granite, and more than 10 X the reflectance of the rhyolite. Despite the fact that there is less total energy, image contrast would be greater in this part of the ultraviolet than at longer wavelengths. This possibility of achieving greater contrast for some materials is the single most important advantage of imaging in the ultraviolet.

In lunar orbit, this contrast property can be exploited to the utmost by imaging in the 2500Å band where contrast is at maximum. However, earth applications are more limited because nearly all ultraviolet energy shorter than 3000Å is absorbed by ozone and oxygen in the atmosphere and does not reach the earth's surface. Ultraviolet energy at longer wavelengths is extremely scattered. Nevertheless, the 3000 to 3500Å band is particularly interesting, because this is where abrupt changes in spectral reflectance begin to occur.

## Ultraviolet photography and imagery

To date, two systems have been used to acquire ultraviolet imagery. One is a 35 mm photographic system and the other is a line-scanner similar to that used for infrared imaging, except that a UV sensitive photomultiplier has been substituted for the cooled IR detector.

Several instrumentation problems plague operations in the near ultraviolet. Most severe is the fact that all filters transmitting near ultraviolet light also leak light in the red and near infrared, where photomultipliers retain marginal sensitivity.

Red leakage of filters is shown in extreme right hand part of figure 2. The response curve of the S-13 photocathode commonly used in the UV photomultiplier also extends into this area. Many early attempts to image in the ultraviolet using line-scanners resulted inadvertently in red or infrared imagery. This red leakage can be reduced to tolerable levels, but at the sacrifice of the spatial resolution.

A neat way of avoiding this filter leakage problem is to use a camera with a special UV film that has a longwave limit of about 5500Å. However, conventional camera lenses have little or no transmittance in the 3000-3500Å band of interest. Ultraviolet transmitting lens elements composed of quartz and lithium fluoride are available, but they are expensive, and generally a lens-film system has a slower response time than a photomultiplier.

Another disadvantage of the camera approach is that rays striking an interference filter at angles of more than five to 10 degrees off the axis are tuned to wavelengths longer than the center frequency of the filter.

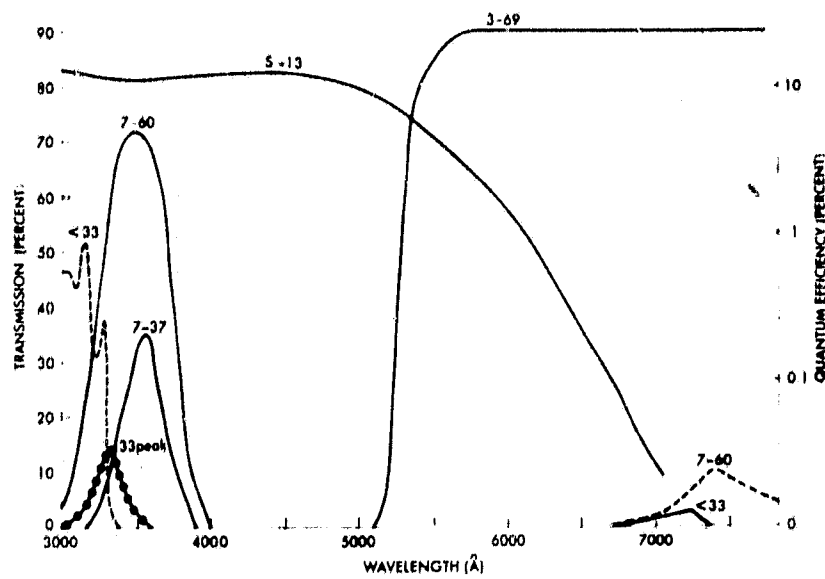

Figure 2. Curves showing transmission of specific ultraviolet and visible filters, and the quantum efficiency of the S-13 photocathode

This precludes the use of wide angle lenses in an ultraviolet camera system. Still another disadvantage is the fact that surface texture of some components in the ultraviolet filter stack approaches the center wavelength of the filter pass-band; consequently, a significant amount of energy in the filter pass-band is scattered by the filter, thus reducing photographic contrast and resolution. Thus, although an ultraviolet camera and a selected film neatly avoids the problem of red leakage of UV filters, there are other disadvantages that must be weighed against a photomultiplier line-scan system.

To date, the most successful results have been achieved with the line-scanner system from altitudes of less than 6000 feet above terrain.

Figure 3 shows some imagery taken by the University of Michigan over the Paoha Island, Mono Lake, California. Their scanner is an elaborate device of some 18 channels, 12 of which are time-coincident. Three of the 18 channels are shown here; on the left is ultraviolet limited to wavelengths shorter than  $3750\text{\AA}$ , blue is in the middle, and red is on the right. The spectral range for all 18 channels is from  $3000\text{\AA}$  to 14 micrometers.

All channels are tape recorded and have the same format. This permits playback and printout of the tape in the laboratory. Those bands which are time-coincident can be integrated electronically in various combinations. Image density data can be stored and collated by means of a computer.

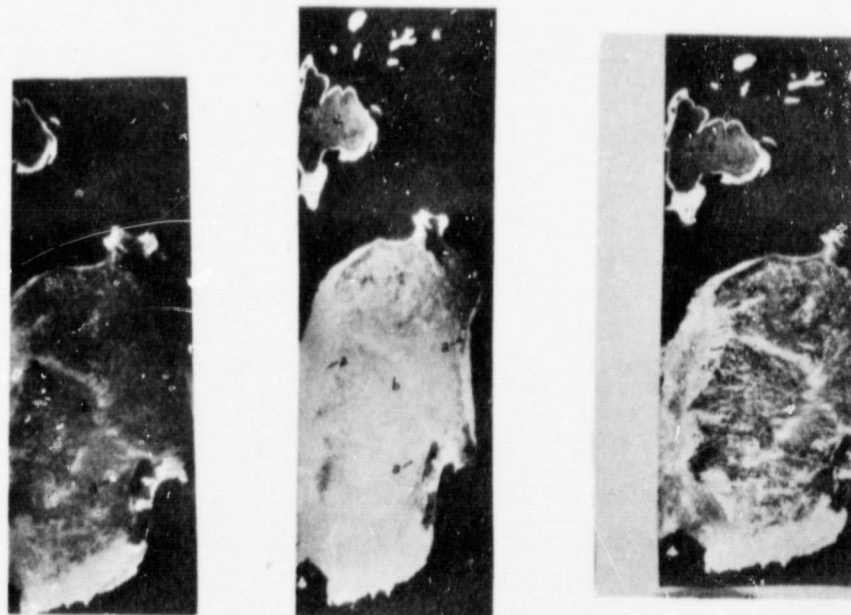

Figure 3. Multiband imagery acquired with the University of Michigan's 18-channel scanner over Paoha Island, Mono Lake, California



This imagery was taken at an altitude of about 5000 feet above terrain. Evaporite deposits at a appear with marked contrast on the ultraviolet band, but are less apparent in the blue and red. Other materials, however, for example, basalt lava flows at c on the north end of the island appear more clearly in the blue or red. Each band contributes its own unique spectral contrast. This appears to be the most significant application of the ultraviolet reflectance; that is, in a truly multispectral approach in which several bands in the ultraviolet, visible, and infrared are used simultaneously to discriminate natural materials.

An instrument that produces 18 channels of imagery simultaneously puts a user in the dangerous position of being innundated or overwhelmed with data. At best, attempting to collate 12 or 18 channels of imagery by simple inspection and channel to channel comparison is inefficient and generally ineffective.

Figure 4 also shows Paoha Island. For comparison, one of the film printouts is shown on the right. On the left is a composite made from three channels in the blue, red, and near infrared. The UV could not be included because it is not a part of the 12 channel spectrometer, and therefore is not time-coincident. This composite of three channels was made with the aid of Purdue University's IBM 360-44 computer using a program designed to use data from Michigan's 12 channel imaging spectrometer. This program involves determining the probability description of two or more classes (for example, rock types) in two or more channels. Each data point in the imagery is then analyzed and classified on the basis of its similarity or nonsimilarity to

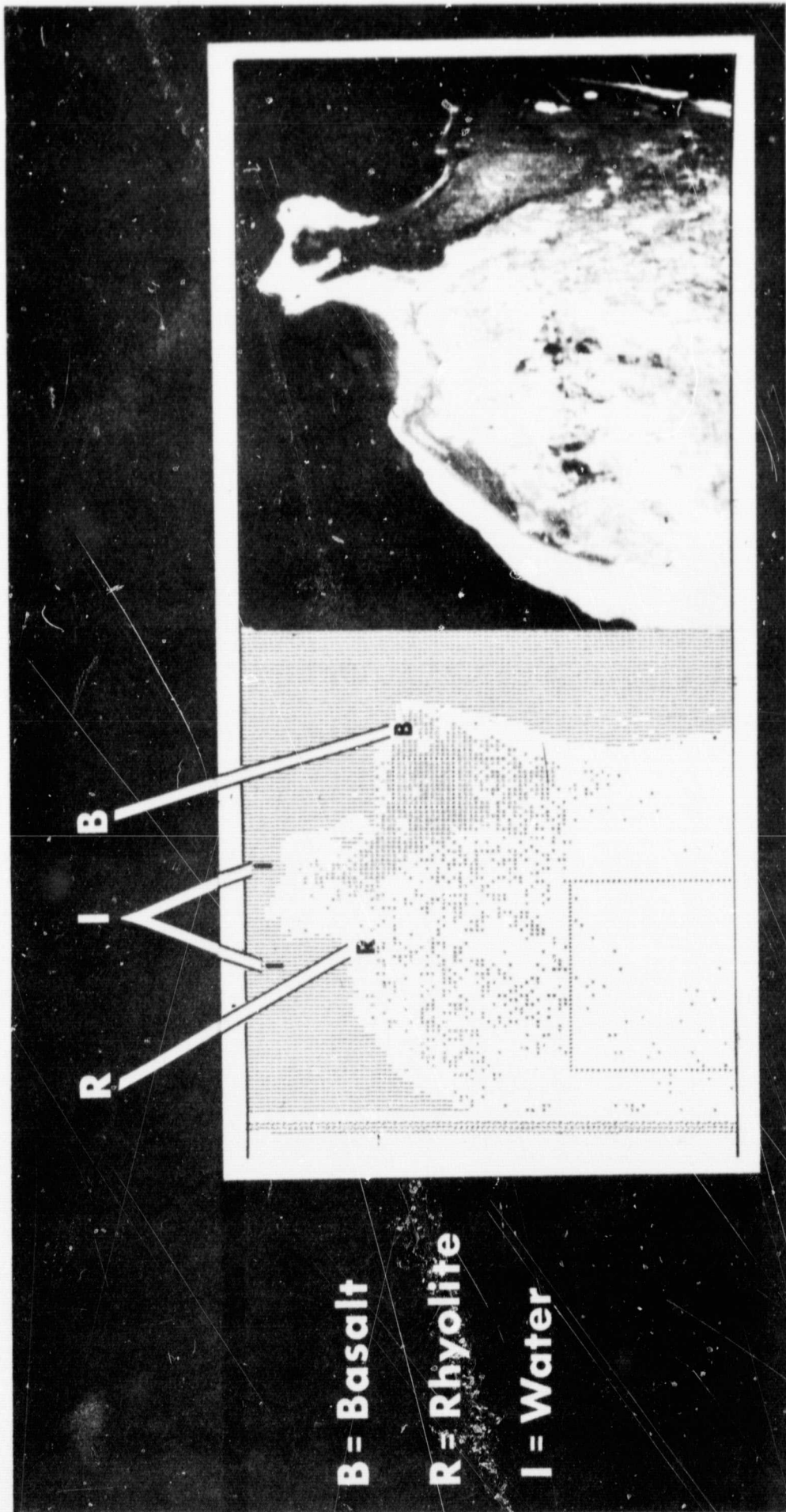

Figure 4. Computer print-out of part of Paoha Island, Mono Lake, California showing bedrock and surficial materials symbolized by letter. (Prepared in cooperation with the Department of Agriculture and Purdue University.)

previously determined probability descriptions. Automatic data processing as applied to the classification of agricultural crops is reported by Landgrebe (1967) and Purdue University (1967).

The computer output shown in figure 4 is actually a two-dimensional plot on which different materials are symbolized by letter. Water appears as "I", basalt as "B", rhyolite as "R", and lake and surficial deposits as "blank". The false alarm rate for "R", rhyolite, is probably quite large in the northern part of the island. The basalt, "B" at the north end of the Paoha Island and the adjacent island is surprisingly accurate, however, as are the surficial deposits and water. The area shown covers about one square mile; ground distance of the entire computer print-out is more than 12 miles, and it was produced in less than two minutes.

Neither the ultraviolet nor the infrared are time-coincident, but it is believed that the example shown in figure 4 illustrates a technique of data handling which has a lot of promise. These are very crude attempts; more sophisticated computer programs hopefully will be even more effective in discriminating between materials, particularly with the addition of ultraviolet ( $<3500\text{\AA}$ ) and infrared (8-14 micrometers) channels.

## ULTRAVIOLET STIMULATED LUMINESCENCE

The other property that we propose to detect and to measure is luminescence; that is, the property of some materials to emit energy at longer wavelengths when illuminated by ultraviolet light.

Ultraviolet stimulated luminescence is a property that has been used for a number of years in detecting and discriminating between some natural materials. Small hand-carried ultraviolet lamps have been used in the exploration for luminescing minerals. However, these portable ultraviolet sources are low powered and are rarely effective more than a few feet from the outcrop.

### Ultraviolet imaging system

The ultraviolet imaging system shown in figure 5 was designed originally for a military application but was later modified by Westinghouse Aerospace Division for use by the Survey (Hemphill and Carnahan, 1965). Basic components of this system include an ultraviolet transmitter and an image dissector receiver.

The transmitter consists of a cathode ray tube with an ultraviolet phosphor and a raster scan. Electron bombardment of the phosphor stimulates an ultraviolet emission peaking at  $3700\text{\AA}$ . This radiation is projected by means of the optics and instantaneously illuminates a spot in the subject field. The raster scan enables the UV transmitter to sequentially illuminate all elements in the target field.

The receiver consists of an image dissector sensitive to visible light. This device provides a scannable aperture slightly larger than the transmitter flying spot and synchronized with the transmitter beam. The small instantaneous spot size or field of view of both the transmitter and receiver reduces the amount of ultraviolet back scatter normally encountered in floodlight ultraviolet systems, thereby extending useful range and improving contrast of imaged features (Horn and Hubbard, p. 5 and 36, 1967).

Figure 6 shows the components of the system--the transmitter A, the receiver, B, both of which are directed toward the subject in the background. The receiver output is connected to an oscilloscope, C, and television monitor, D, for simultaneous measurement and observation of the intensity of luminescence in the visible region of the spectrum.

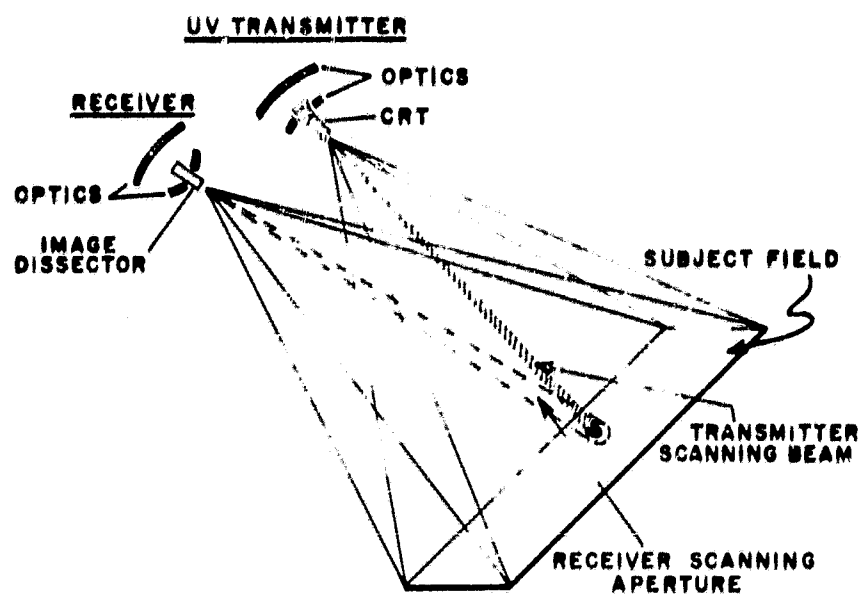

Figure 5. Diagram showing operational components of an active ultraviolet imaging system

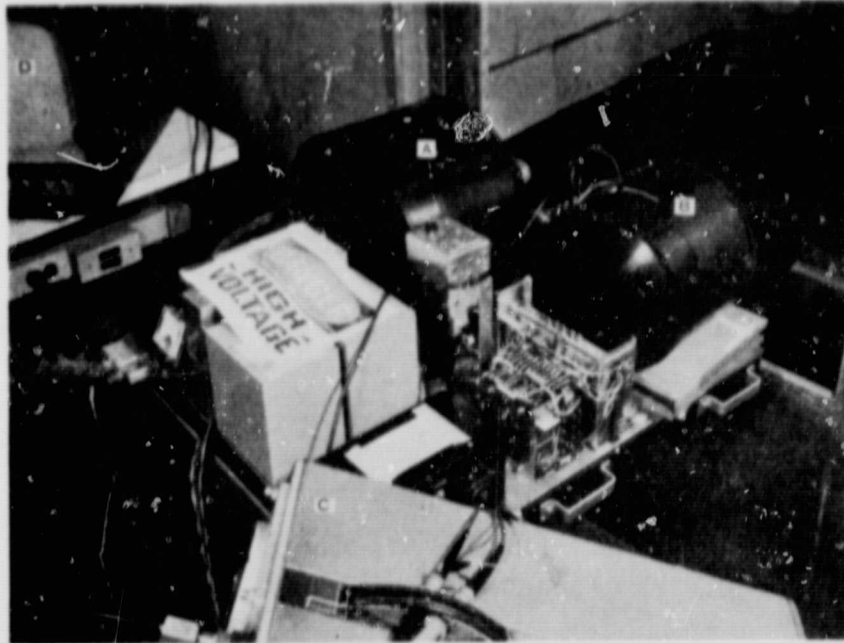

Figure 6. Photograph showing ultraviolet imaging system set up in laboratory. Transmitter, A; receiver, B; oscilloscope, C; and video monitor, D

The Geological Survey originally became interested in this imaging system to evaluate its application in the exploration for materials such as scheelite, phosphate, and other materials which are known to luminesce in some localities. It was also hoped that by using the device in a pulsed mode that the decay time of phosphorescent materials could be measured, but preliminary tests in the laboratory showed that design limitations of the prototype instrument precluded measurement of decay time.

The instrument was used successfully, however, to image luminescing materials in outcrops and along quarry faces from distances as great as 200 feet in the Baltimore, Maryland area. The transmitter-receiver was transported in a small delivery truck and positioned in such a way that it could be directed toward the rock exposure to be imaged. The tests were conducted at night in order to avoid solar illumination.

Figure 7 is a photograph of the television monitor. The three bright areas in the upper half are due to the luminescence of deweylite, a mineral of the serpentine group which crops out along a fracture set in a quarry near Baltimore. Other bright spots in the image are merely electronic noise in the system. Distance between the imaging system and the quarry face is 64 feet; distance across figure 7 is about 20 feet. For comparison, figure 8 shows the same area photographed during daylight with a camera. Although the photograph is rather nondescript, the television image indicates luminescing areas that could be of interest to the geologist. Discrimination of deweylite and several other minerals with an ultraviolet imaging system is little more than a scientific curiosity; however, the study does serve to demonstrate the technique.



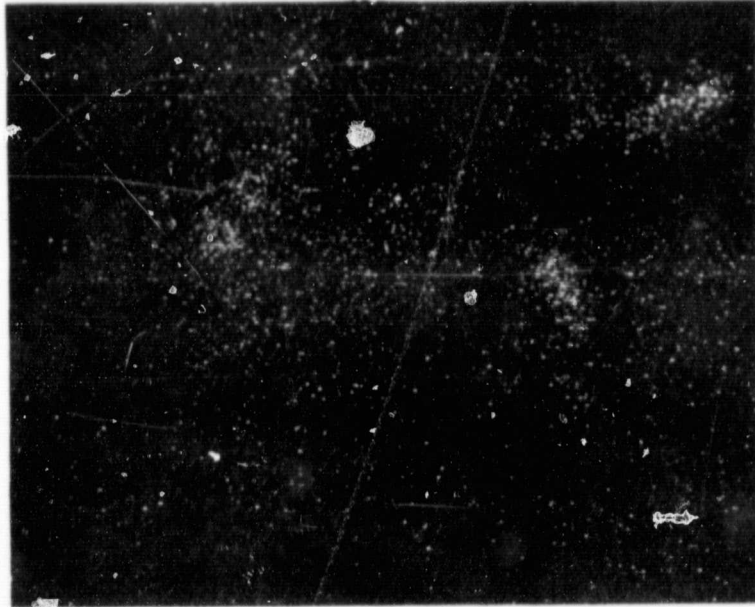

Figure 7. Video monitor image indicating luminescence of deweylite in a quarry near Baltimore. Distance from the transmitter to the quarry face is 64 feet.

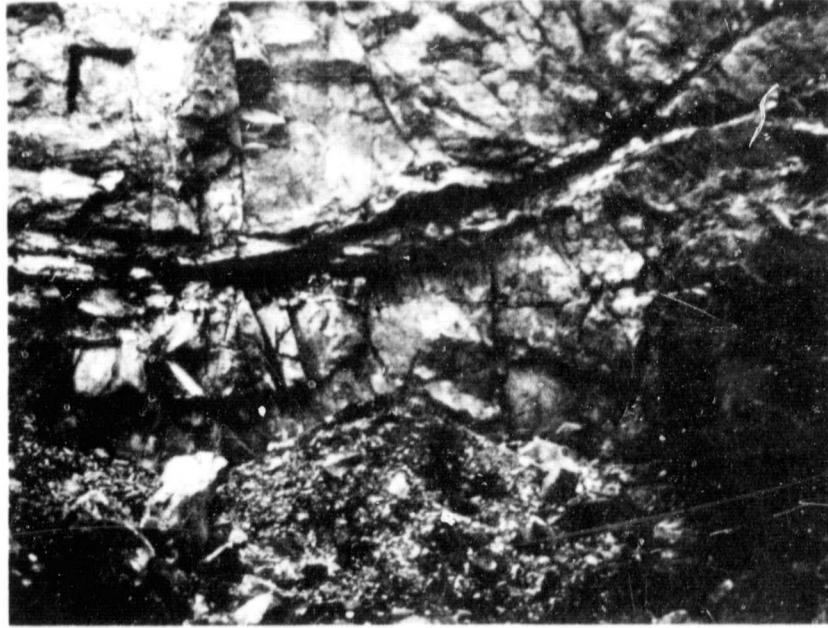

Figure 3. Conventional photograph of same area shown in figure 7

A possible application of an ultraviolet imaging system concerns the discrimination of limestone along inaccessible faces in quarries in central Indiana (Watts and Goldman, 1967). Spectral measurements in the laboratory show that peak excitation for most of the limestones is in the  $2600\overset{\circ}{\text{A}}-2800\overset{\circ}{\text{A}}$  region, a part of the ultraviolet which does not receive solar illumination. The spectral measurements also show that these limestones differ in their luminescence intensities and that some of these differences could be used to distinguish varying grades of quarriable limestone, if a suitable field device were available. This work was done as a cooperative effort by the U. S. Geological Survey and the Geological Survey of Indiana.

### Ultraviolet laser

In 1966 Avco-Everett laboratories in Boston perfected a nitrogen gas laser emitting at 3371A in the ultraviolet. The laser, shown in figure 9, can only be operated in the pulsed mode, but this feature is considered to be ideal for the type of source that is required to measure luminescence decay time. Pulse rate can be as fast as 100pps, and output power is extremely high, as much as 200KW.

Recently 75 samples of selected rocks and rock-forming minerals were illuminated with 3371A light, using the Avco laser and an S-11 photomultiplier arranged in the simple configuration shown in figure 10. Filters effectively block all UV light reflected from the sample so that the photomultiplier sees only the time dependent emission in the visible. Some early results of the work are encouraging.

Figure 11 shows the oscilloscope trace for a suite of five feldspars. In each trace, the laser pulse is followed by a relatively high fluorescence peak on the left, and then a gradual decay or decrease in intensity toward the right. Peaks displayed on the decay curves are due to ringing in the output signal, which is caused by the photomultiplier responding to the high voltage discharge of the laser power supply. Horizontal sweep is one-half micro-second per square. Thus, decay time ranges from less than two microseconds for bytownite to more than five microseconds for oligoclase. Of feldspar specimens measured to date, decay time tends to be the longest for sodic feldspars--on the order of 5 to 10 microseconds. Similar work suggests that measurement of decay time of laser stimulated luminescence may be useful in distinguishing between some granites of different mineralogic composition, and between oils which are secreted by schools of some commercial fish and which may form a thin layer on the surface of the water.

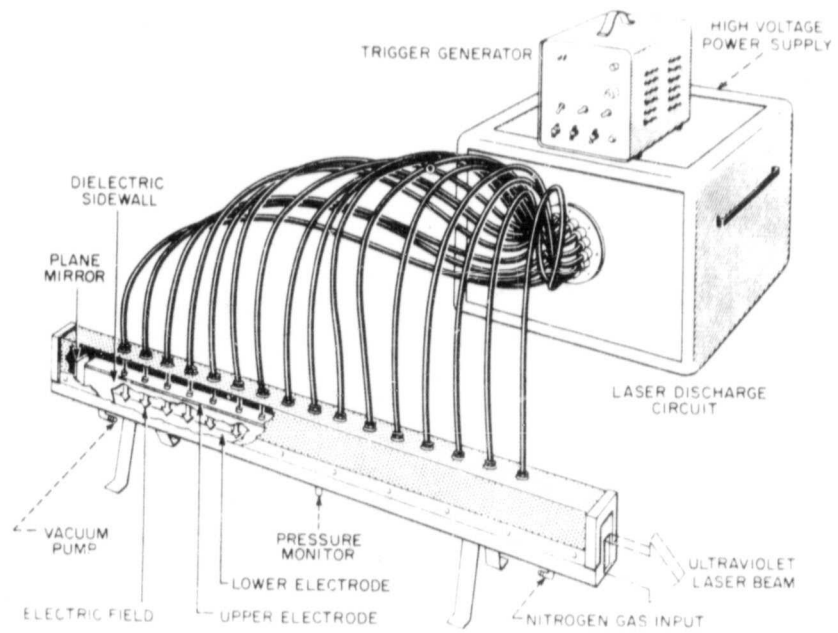

Figure 9. Ultraviolet laser (courtesy of the Avco Everett Research Laboratory)

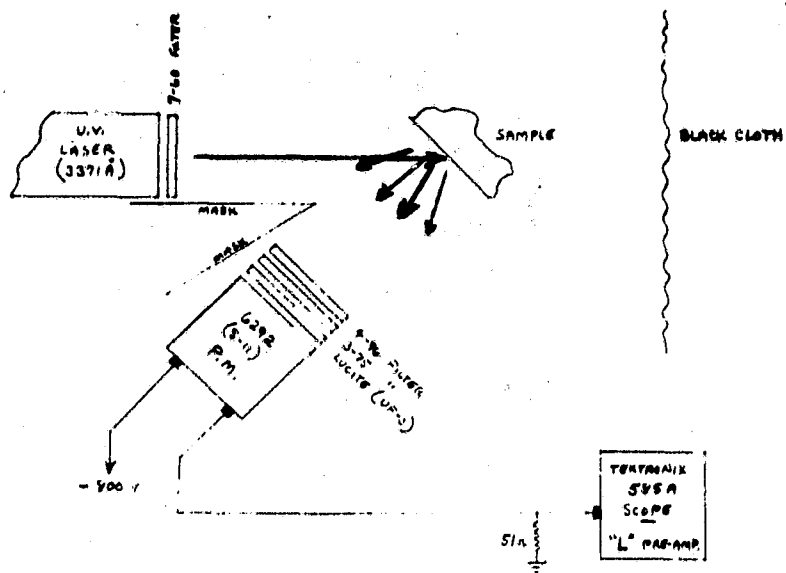

Figure 10. Diagram showing position of laser, sample, and photomultiplier detector for measurement of luminescent decay time

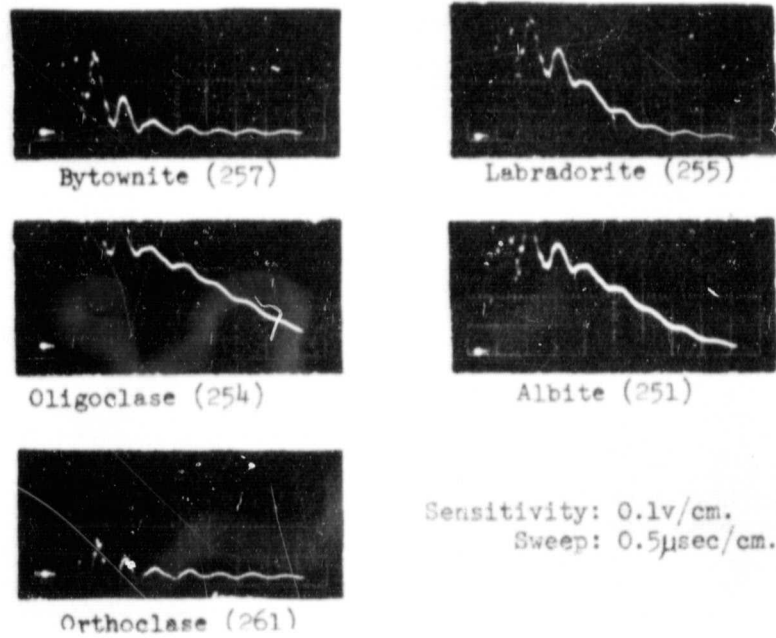

Figure 11. Oscilloscope traces for a suite of five feldspars

### Fraunhofer line-depth method

Both the UV imaging system and the pulsed laser sources are significant improvements compared to the portable mercury vapor lamps of 10 or 20 years ago. However, compared to the sun both these systems are low powered and rarely would be effective more than a few hundred feet from the outcrop. Also, it is imperative that the work be done at night in order to avoid obscuring the luminescence by daytime solar background.

During the 1950's, the Russian astronomer Kozyrev (1956), detected luminescence on the lunar surface by means of an earth-based spectrometer and a method that has since become known as the "Fraunhofer line-depth method" or "Method of line-depths".

This method involves observing a selected Fraunhofer line reflected from the lunar surface and measuring the ratio of the central intensity to the continuum and also comparing this ratio with its conjugate observed in the solar spectrum directly. Diagram 1 in figure 12 is an idealized Fraunhofer line in the solar spectrum wherein the central intensity or minimum,  $\underline{B}$ , constitutes a narrow region, less than one angstrom wide where solar emission is absorbed or occluded by gases in the solar atmosphere. Typically, the central intensity,  $\underline{B}$ , is 10 to 20 percent of the continuum,  $\underline{A}$ . Thus, Kozyrev looked at the sun, scanned across the Fraunhofer line in question, and obtained a profile and a  $\underline{B}$  over  $\underline{A}$  ratio, that is,  $\underline{R}_S$  such as is shown in diagram 1.

Then he looked at a small area on the moon, scanned the same spectrum, and obtained  $\underline{R}_m$  shown in diagram 2.



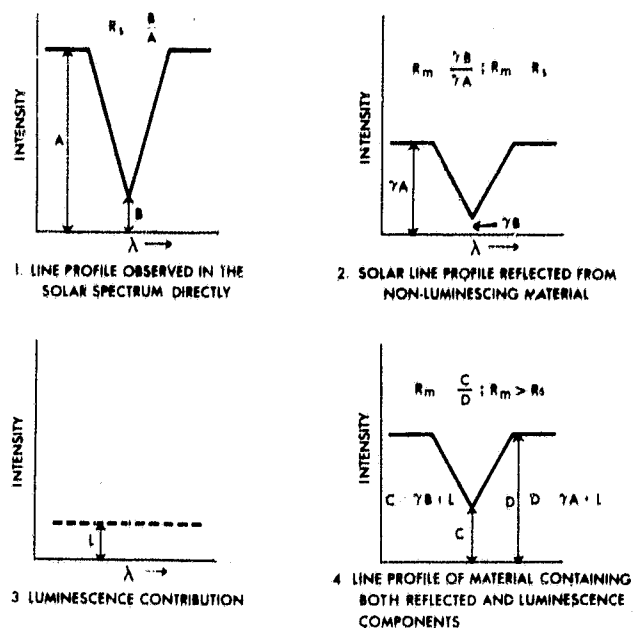

Figure 12. Diagrams illustrating the Fraunhofer line depth method

If there is no luminescence, both ratios will be equal. If there is luminescence, as shown in diagram 3, then both the central intensity and the continuum will be increased an equal amount as shown in diagram 4. However, the ratio  $\underline{R}_m$  will then exceed  $\underline{R}_s$  by an amount proportional to the amount of luminescence.

This method is amazing in its simplicity and in the past 10 years has been used successfully by a number of astronomers to detect luminescence in specific areas on the lunar surface (Kozyrev, 1957; Grainger and Ring 1962a, 1962b; Spinrad, 1964; Kopal, 1965; Noxon and Goody, 1965; McCord, 1967 ).

About two years ago, in cooperation with the IIT Research Institute, Chicago, Illinois, outdoor tests of the "Fraunhofer line-depth method" were performed on hand specimens of colemanite, phosphate, and calcite, using the sun as a source and an Ebert grating spectrometer. The tests were successful and demonstrated the feasibility of detecting UV stimulated luminescence of natural materials during the day against a high solar background. These tests also pointed out that the crude instrumentation that was used was inadequate outside the lab. For example, rapid fluctuations of the solar ultraviolet flux, probably caused by pollutants in the atmosphere, commonly exceeded the scan rate of the grating spectrometer. It was obvious that instrumentation with a faster response would be required. Additional basic design requirements of a more elaborate instrument are described by Hemphill (1968).

Early this year the Perkin-Elmer Corporation completed design and construction of a prototype Fraunhofer line-discriminator that will be adequate for trial field use, perhaps from an aircraft.

Figure 13 is a schematic showing the optical unit. The instrument has two entrance apertures. One is directed upward toward the skylight and sunlight, and the other, with a one-degree field of view, is directed downward toward ground.

The key components of the Perkin-Elmer design are two glass-spacer Fabry-Perot filters with half-widths of less than one angstrom and a peak transmission of more than 50 per cent. This extremely narrow bandwidth and high peak transmission represents a state-of-the-art advance in filter fabrication. Center wavelength of the filters may be tuned by a precision thermostatic control.

In the configuration shown in figure 13, one filter is tuned to the central intensity of the Fraunhofer line and the other filter is tuned to a convenient point on the continuum adjacent to the line. Low noise photomultipliers are located behind each filter. A system of lenses, beamsplitters, and choppers permits the instrument to "look" alternately downward at the ground and upward toward the sky, and to monitor the ratios of the central intensity to the continuum in each look. An analog computer compares the ratios in the solar look and ground look and converts any difference that may be present into a signal that is proportional to the amount of luminescence in the ground target. This signal is plotted as a function of time on a strip chart recorder.

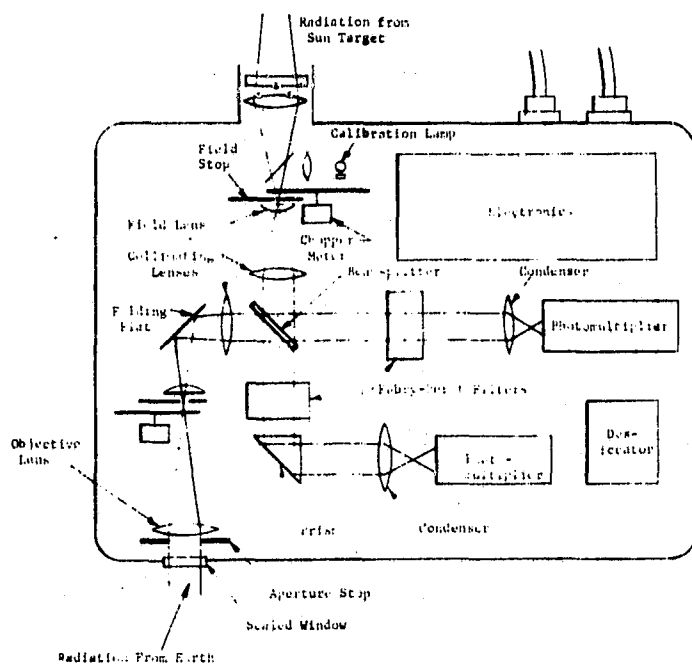

**Figure 13.** Schematic showing design of the optical unit of the line-discriminator prototype (courtesy of the Perkin-Elmer Corp.)

Figure 14 shows the completed prototype. This prototype instrument is designed to detect Rhodamine dye in concentrations of 20 ppb or less.

Luminescent dyes such as Rhodamine WT are used by hydrologists and oceanographers to monitor current dynamics in rivers and estuaries. The reason for selecting Rhodamine dye as a design target for this first prototype instrument is one of convenience (Hemphill, 1968). First, Rhodamine dye is readily available and lends itself ideally to quantitative testing of the instrument. Second, conventional dye monitoring methods are extremely laborious and awkward; it is believed that if this airborne semi-automated method were successful, it would be of immediate practical benefit in dye studies (Betz, 1968).

Figure 15 shows the excitation and emission spectrum of Rhodamine dye. Peak excitation occurs near  $5400\text{\AA}$ . Peak emission is near  $5800\text{\AA}$ ; accordingly, the prototype instrument is filtered to look at the nearby sodium Fraunhofer line at  $5890\text{\AA}$ .

Following completion of initial tests on Rhodamine WT, it is tentatively planned to modify the instrument to operate at shorter wavelengths, specifically the calcium Fraunhofer line at  $3868\text{\AA}$  in the ultraviolet where a variety of materials are known to luminesce, notably oil slicks, detergents, and other water pollutants, as well as some phosphate rocks and other minerals. Potential role of the instrument appears to be especially promising in water pollution studies, although it is realized that the emission spectra of materials may vary widely with locality and occurrence. Because of this and other factors, specific applications of the technique are difficult to predict at this time.

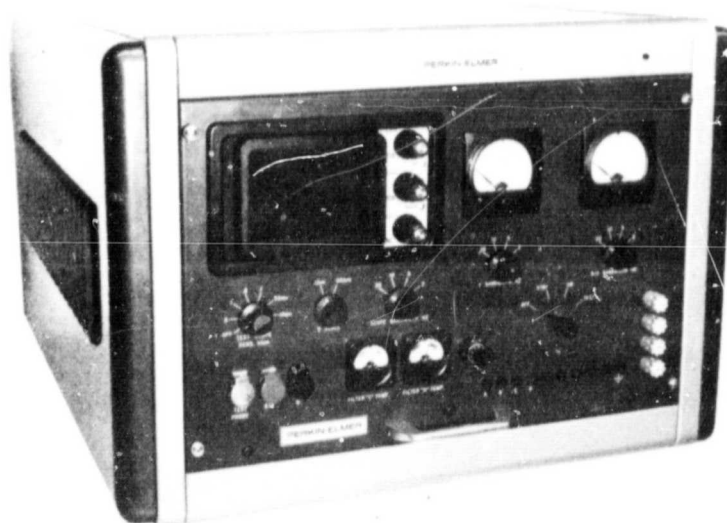
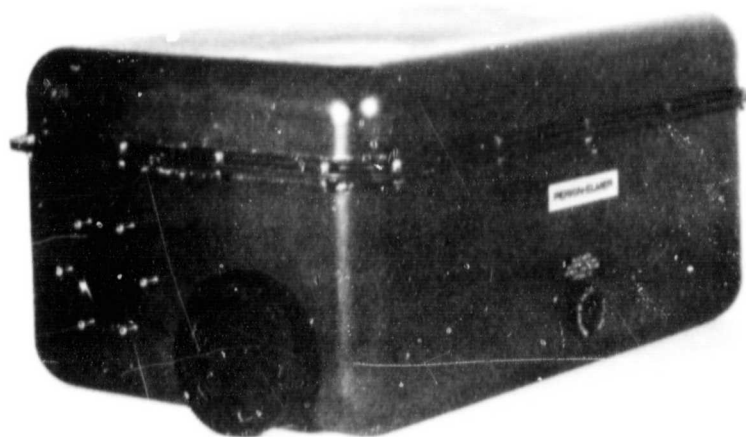

Figure 14. Prototype line-discriminator showing the optical unit and the control console (courtesy of the Perkin-Elmer Corp.)

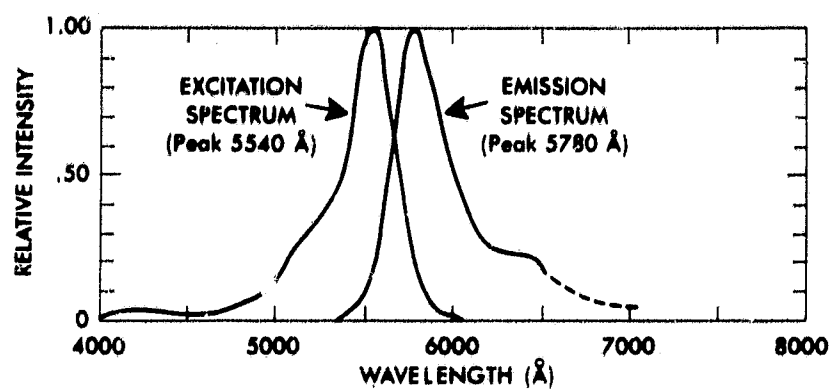

Figure 15. Excitation and emission spectra of Rhodamine dye (after spectrofluorometric analyses furnished by G. K. Turner Associates, Palo Alto, California)

## SUMMARY

Work to date shows that some materials exhibit more contrast when imaged in the ultraviolet than at longer wavelengths. Michigan's 18-channel imaging spectrometer is a promising research tool because its spectral range extends from the ultraviolet to the far infrared. Output is tape recorded and can be computer processed.

Active ultraviolet systems permit both imaging of luminescing materials and measurement of luminescing decay time.

The Fraunhofer line-depth method is the only technique that permits detection of luminescence during daylight against a high solar background, and shows great promise particularly in water resource and pollution studies.



## REFERENCES

- Betz, H. T., 1968, The remote measurement of Rhodamine B concentration when used as fluorescent tracer in hydrologic studies: U. S. Geol. Survey open-file report, Tech. Letter NASA-101, 48 p., 9 figs., 8 tables.
- Grainger, J. F., and Ring, J., 1962a, The luminescence of the lunar surface: Physics and astronomy of the moon, ed. by Z. Kopal, Academic Press, New York, p. 385-405.
- Grainger, J. F., and Ring, J., 1962b, Anomalous Fraunhofer line profiles: Nature, v. 193, p. 762.
- Hemphill, W. R., and Carnahan, S. U., 1965, Ultraviolet absorption and luminescence investigations, progress report: U. S. Geol. Survey Tech. Letter NASA-6, 27 p., 53 figs., Appendix.
- Hemphill, W. R., 1968, Ultraviolet absorption and luminescence studies; Progress report for the period from April to December, 1967: U. S. Geol. Survey open-file report, Tech. Letter NASA-100, 57 p. (incl. Appendix), 12 figs., 1 table.
- Horn, E. F., and Hubbard, R. N., 1967, Considerations for the application of an ultraviolet illuminator to night aerial photographic reconnaissance (unpub): U. S. Air Force Tech. Report AFAL-TR-67-205, 87 p., 33 figs., 7 tables.
- Kopal, Zdenek, 1965, The luminescence of the moon: Scientific American, v. 212, n. 5., p. 28-37.
- Kozyrev, N. A., 1956, The luminescence of the lunar surface and the intensity of the solar corpuscular radiation: Izvestia Krymskoi Astroizitcheskoy Observatorye, v. 16, p. 148-161.
- Landgrebe, David A., and staff, 1967, Automatic identification and classification of wheat by remote sensing: Purdue University Laboratory for Agricultural Remote Sensing, Information Note 212567, Research Progress Report 279, 7 p., 8 figs.
- McCord, Thomas B., 1967, Observational study of lunar visible emission: Journ. Geophys. Res., v. 72, n. 8, p. 2087-2097.
- Noxon, J., and Goody, R. M., 1965, Noncoherent scattering of skylight: Izvestiya, Atmospheric and Oceanic Physics Series, v. 1, n. 3, p. 275-281.
- Purdue University, 1967, Remote multispectral sensing in agriculture: Laboratory for Agricultural Remote Sensing (LARS), v. 2, n. 832, 75 p., 79 figs.

Spinrad, H., 1964, Lunar luminescence in the near ultraviolet, *Icarus*, v. 3, p. 500-501.

Thorpe, A. N., Alexander, C. M., and Senftle, F. E., 1966, Preliminary ultraviolet reflectance of some rocks and minerals from 2000Å to 3000Å: U. S. Geol. Survey Tech. Letter NASA-37, 5 p., 1 fig., 1 table.

Watts, H. V., 1966, Reflectance of rocks and minerals to visible and ultraviolet radiation: U. S. Geol. Survey Tech. Letter NASA-32, 57 p. (including Appendices), 1 fig., 1 table.

Watts, H. V., and Goldman, H. J., 1967, Visible and ultraviolet reflectance and luminescence from various Saudi Arabian and Indiana limestone rocks: U. S. Geol. Survey open-file report, 33 p., 34 data curves, 8 figures, 4 tables.