

RARE EARTH FLUORIDES AND OXIDES - AN EXPLORATORY STUDY OF
THEIR USE AS SOLID LUBRICANTS AT TEMPERATURES TO
1800° F (1000° C)

By Harold E. Sliney

Lewis Research Center
Cleveland, Ohio

NATIONAL AERONAUTICS AND SPACE ADMINISTRATION

For sale by the Clearinghouse for Federal Scientific and Technical Information
Springfield, Virginia 22151 - CFSTI price \$3.00

ABSTRACT

Powdered lanthanide trifluorides such as LaF_3 and CeF_3 , when used as solid lubricants, significantly reduced the wear of Inconel 600 riders in sliding contact with Inconel 750 during lubrication experiments in air and in argon at temperatures up to 1800°F (1000°C). Rare earth oxides were poor lubricants compared to the fluorides. Fluoride powders were good film-formers; they were smeared into adherent film on the wear track by the stresses in the zone of sliding contact. The oxides were not film-formers. It was also shown that fusion-bonded LaF_3 and CeF_3 coatings, containing CaF_2 - BaF_2 eutectic or LiF as melting point depressants, have possibilities as solid lubricant coatings.

RARE EARTH FLUORIDES AND OXIDES - AN EXPLORATORY STUDY OF
THEIR USE AS SOLID LUBRICANTS AT TEMPERATURES TO
1800⁰ F (1000⁰ C)

by Harold E. Sliney
Lewis Research Center

SUMMARY

Powdered lanthanide trifluorides such as LaF₃ and CeF₃, when used as solid lubricants, significantly reduced the wear of Inconel 600 riders in sliding contact with Inconel 750 during variable temperature lubrication experiments in air and in argon atmospheres. At a sliding velocity of 6 feet per minute (0.03 m/sec), the friction coefficients in air were about 0.5 at room temperature, gradually decreased to 0.2 at 1000⁰ F (540⁰ C), and remained at that level to 1800⁰ F (1000⁰ C). In argon, friction coefficients were generally lower (0.4 at room temperature to 0.08 at 1800⁰ F (1000⁰ C)). Rare earth oxides had little or no lubricating ability under most of the experimental conditions employed.

The fluoride particles readily deformed under the compressive stresses in the zone of sliding contact and were smeared over the wear track to form an adherent film. The oxides had no film-forming tendencies in these experiments.

Adherent, fusion-bonded coatings of LaF₃ and CeF₃ containing CaF₂ - BaF₂ eutectic or LiF showed some lubricating ability, but compositions and coating procedures were not optimized in this study.

INTRODUCTION

The need for solid lubricants which can be used at temperatures up to 1800⁰ F (1000⁰ C) or higher exists in some turbojet engine applications and many other applications. Two examples are the lubrication of variable pitch turbine blades and abradable blade tip seals.

Some of the fluorides and oxides of the lanthanide elements have characteristics which suggest they may have potential as solid lubricating materials for use to at least 1800⁰ F (1000⁰ C). Some of these characteristics are (1) fairly low hardness (the trifluorides have a hardness at room temperature of about 4.5 on the Moh scale); (2) hexagonal crystal structure; (3) melting points above 2200⁰ F (1200⁰ C); (4) thermal

expansion coefficients which match those of metals such as the nickel base super alloys and stainless steels; and (5) water insolubility.

In addition to these advantageous physical properties, the lanthanide trifluorides and sesquioxides are resistant to thermal dissociation and to chemical reduction; that is strongly indicated by the exceptionally large, negative free energies of formation of the lanthanide compounds (ref. 1).

The objectives of this study were (1) to experimentally determine if the rare earth fluorides or oxides have any potential as solid lubricant pigments or binder materials, especially at elevated temperatures; and (2) to formulate bonded lubricating coating of lanthanide fluorides on metal surfaces.

The scope of this work encompassed a study of the lubrication of an age-hardenable nickel-base alloy (Inconel 750) with loose powders of the fluorides and oxides of La, Ce, Nd, and Gd at temperatures up to 1800° F (1000° C). Coating formulations and bonding procedures for solid lubricant coatings containing cerium trifluoride (CeF₃) or lanthanum trifluoride (LaF₃) were also investigated. The lubricating properties of successfully bonded coatings were evaluated in air from room temperature to 1300° F (700° C).

TABLE I. - PHYSICAL PROPERTIES OF SOME RARE EARTH TRIFLUORIDES AND OXIDES

Compound	Melting point		Specific gravity	Crystal structure	Hardness		Thermal expansion		Reference	
	°F	°C			Moh's scale	Knoop, kg/mm ²	in./in./°F	cm/cm/°C	Hardness	Other
LaF ₃	2714	1490	5.94	Hexagonal	^a 4.5	---	8.3×10 ⁻⁶	15×10 ⁻⁶	12	9
CeF ₃	2620	1437	5.99	Hexagonal	↓	---	-----	-----	↓	↓
NdF ₃	2505	1374	6.37	Hexagonal	↓	---	-----	-----	↓	↓
GdF ₃	2242	1228	7.05	Orthorhombic	↓	---	-----	-----	↓	↓
Y ₂ O ₃	4370	2410	5.03	^b bcc	5	---	4.5	8.1	4	↓
La ₂ O ₃	4172	2300	6.51	Hexagonal	---	---	-----	-----	---	↓
CeO ₂	3542	1950	7.20	^c fcc	5	---	6.7	12.1	4	↓
Nd ₂ O ₃	4118	2270	7.24	Hexagonal	---	---	-----	-----	---	↓
Sm ₂ O ₃	-----	-----	7.43	Monoclinic	---	438	6.0	10.8	4	↓
Eu ₂ O ₃	3722	2050	7.28	bcc	---	435	-----	-----	↓	↓
Gd ₂ O ₃	4262	2350	7.41	Cubic	---	486	-----	-----	↓	↓
Dy ₂ O ₃	4244	2340	7.81	bcc	---	700	4.5	8.1	↓	↓
^e CaF ₂	2480	1360	3.18	Cubic	4	163	7.8	^d 14	13	13
^e Graphite	-----	-----	2.25	Hexagonal	1 to 2	---	-----	-----	12	12
^e PbO	1620	888	9.53	Tetragonal	2	---	-----	-----	12	12

^aEstimated by assuming hardness of pure trifluorides is at lower end of hardness range for rare earth mineral fluorides such as fluocerite ((Ce, La, Di)F₃), yttrifluorite (CaF₂ - YF₃), and ytrocrite (CaF₂ - (Y, Ce)F₃) all of which have a Moh hardness of about 4.5 to 5.0.

^bBody-centered-cubic.

^cFace-centered-cubic.

^dRef. 12.

^eReference material.

MATERIALS

The lanthanide series of the chemical elements is the first of the two rare earth series of elements and is known as the "first inner transition series." It contains elements of the atomic numbers 57 to 71. The first member of this series (atomic number, 57) is lanthanum, and the individual elements are known in accepted chemical terminology as lanthanide elements or lanthanons (ref. 2). The physical and chemical properties of the lanthanons and lanthanide compounds are well-documented (e.g., in refs. 1 to 9). Some of the physical properties of representative compounds are given in table I.

Crystal Structure Considerations

Most of the well-known solid lubricants have a lamellar or layer lattice crystal structure to which their lubricating properties have been partially attributed. Layer lattice crystal structures can be referred to as infinite two-dimensional complexes because bonds between the cations and anions extend in two dimensions to form layered networks whose length and width are limited only by the faces of the crystal. The layers are held together only by weak van der Waals forces (refs. 10 and 11). This type of structure is readily sheared in the direction parallel to the layer orientation. Such a structure occurs for some compounds of the MX_2 or MX_3 type, where M represents a metal and X represents a halide and the components assume a hexagonal crystalline form.

Some of the rare earth oxides and fluorides have a hexagonal crystal allotrope, but none of them are, strictly speaking, of the true layer lattice type. However, a group of trifluorides which includes LaF_3 , CeF_3 , and NdF_3 adopt the so-called tysonite structure which approximates a layer lattice.

The LaF_3 structure is shown schematically in figure 1. In this structure, the layers consist of hexagonal nets of alternate La^{+3} and F^{-1} ions with additional F^{-1} ions on each side of the layers (fig. 1(a)). Each La^{+3} ion is surrounded by five equidistant, nearest-neighbor F^{-1} ions, which are designated A-type in the illustration. The inter-ionic spacing between La^{+3} and F^{-1} is 2.36 Å. The F^{-1} ions can be considered at the apices of a bipyramid with La^{+3} in the center as drawn in figure 1(b). The next-to-nearest neighbors of La^{+3} are six more F^{-1} ions, three of which are associated with each of the layers on either side of the layer under consideration. These ions are at the apices of a prism (fig. 1(c)) with La^{+3} at the center. The La-F distance is 2.70 Å - only slightly longer than the nearest-neighbor spacing. Therefore, ionic bonding occurs not only between La^{+3} and nearest-neighbor F^{-1} ions but, because of their close proximity, some ionic bonding although weaker, also occurs with the next-to-nearest-

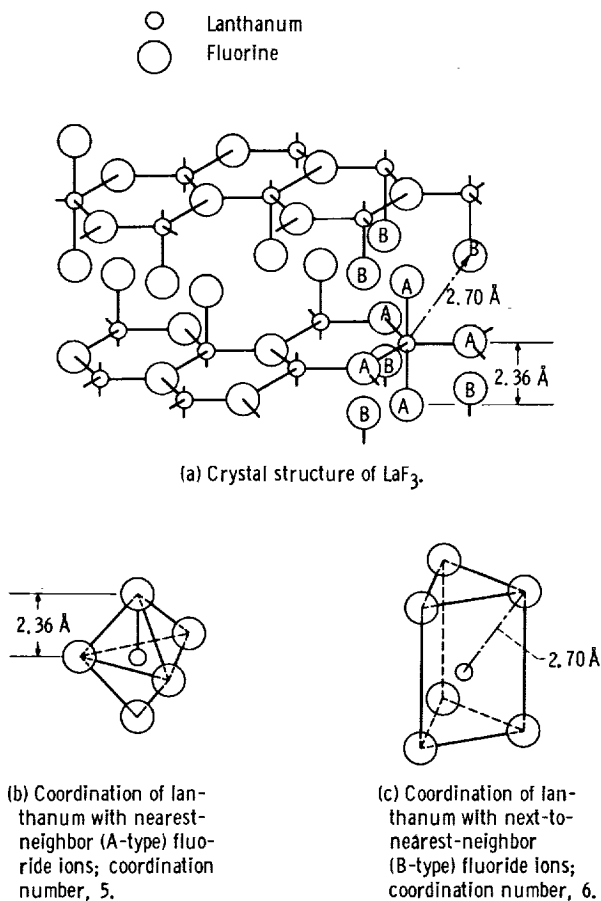

Figure 1. - Modified layer lattice structure of lanthanum trifluoride.

neighbor F^{-1} ions. In such a case, ionic bonding is to a degree, three dimensional. This structure can therefore be considered a transition between the three-dimensional ionic and the two-dimensional layer lattice types (ref. 10). Nevertheless, the similarity to the layer lattice structures and the other desirable properties make LaF_3 type compounds worthy of study as possible solid lubricants.

Hardness of Lanthanide Fluorides and Oxides

In figure 2 the correlation of the Moh's hardness and Knoop hardness scales is plotted from the data of references 4 and 12 to 14. The approximate hardness levels of the rare earth fluorides and oxides are compared to the hardnesses of some well-known materials. The rare earth trifluorides have a Knoop hardness at room temperature of around 280 kilograms per square millimeter. The rare earth sesquioxides have a Knoop hardness of about 400 kilograms per square millimeter (ref. 4). Materials in the hard-

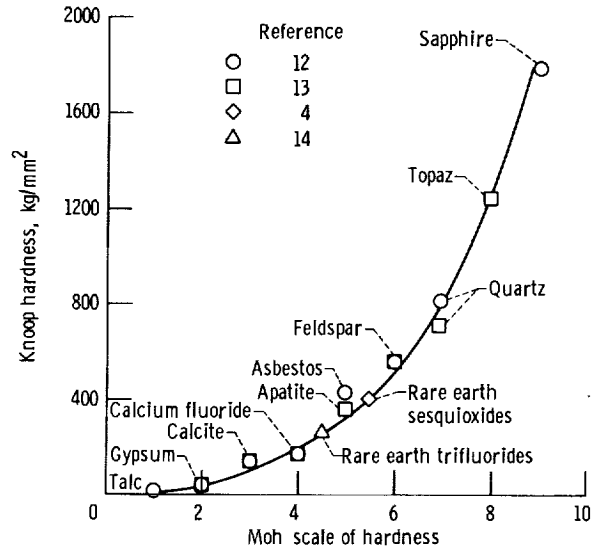

Figure 2. - Hardness of rare earth trifluorides and sesquioxides relative to some standard materials used in correlation of Moh and Knoop hardness of inorganic compounds.

ness range of the trifluorides will not scratch mild steel. Materials in the hardness range of the sesquioxides may be expected to be slightly abrasive to mild steel but will not scratch hardened steel.

Chemical Considerations

The tripositive oxidation state is the commonest form of most lanthanide fluorides and oxides. A notable exception is tetravalent cerium as found in CeO_2 . However, the most stable cerium fluoride is the trifluoride (CeF_3) (ref. 3). Although chemical reduction of the sesquioxides and trifluorides is difficult, some substitution reactions are known which may limit the usefulness of these compounds in certain environments. For example, the trihalides can be converted to oxyfluorides by means of hydration followed by heating (ref. 3).

Purity of Materials

All rare earth compounds used were nominally 99.5 percent pure. The compounds CaF_2 , BaF_2 , and LiF were reagent grade. The results of X-ray diffraction examination of the rare earth compounds in the as-received condition are included in table II. The

TABLE II. - PHASES DETECTED BY X-RAY DIFFRACTION EXAMINATION OF RARE EARTH
COMPOUNDS AFTER HEATING^a

(a) Fluorides in air

Condition	Nominal powder			
	LaF ₃	CeF ₃	NdF ₃	GdF ₃
As received	LaF ₃ hexagonal	CeF ₃ hexagonal	NdF ₃ hexagonal	GdF ₃ orthorhombic
After friction tests in air to - 1200° F (650° C) 1800° F (1000° C)	----- No change	----- No change	No change	No change
After being in air furnace for 2 hours at - 1500° F (800° C)	LaOF tetragonal + LaF ₃ hexagonal	-----	-----	-----
2000° F (1090° C)	LaOF tetragonal + LaO ₃ hexagonal	-----	-----	-----

(b) Oxides in air or hydrogen

Condition	Nominal powder			
	La ₂ O ₃	CeO ₂	Nd ₂ O ₃	Gd ₂ O ₃
As received	La(OH) ₃	CeO ₂ (fcc)	Nd(OH) ₃	Gd ₂ O ₃ cubic
After friction tests in air to - 1200° F (650° C)	La(OH) ₃	CeO ₂ (fcc)	Nd ₂ O ₃ orthorhombic + Nd ₂ O ₃ hexagonal	Gd ₂ O ₃
1800° F (1000° C)	La(OH) ₃ + La ₂ O ₃ hexagonal	CeO ₂ (fcc)	-----	-----
After being in air furnace for 1 hour at - 1500° F (800° C)	La ₂ O ₃ hexagonal	CeO ₂ (fcc)	Nd ₂ O ₃ hexagonal	Gd ₂ O ₃ cubic
2000° F (1090° C)	La ₂ O ₃ hexagonal	CeO ₂ (fcc)	Nd ₂ O ₃ hexagonal	Gd ₂ O ₃ cubic
2500° F (1370° C)	La ₂ O ₃ hexagonal	CeO ₂ (fcc)	Nd ₂ O ₃ hexagonal	Gd ₂ O ₃ monoclinic
After 2 hours in hydrogen at 2000° F (1090° C)	-----	No reduction	-----	-----

^aExposure to high temperatures was of shorter duration during friction tests than in furnace treatments.

In friction tests, specimens were held for 10 minutes at each 100° F temperature interval from 100° F to maximum temperature.

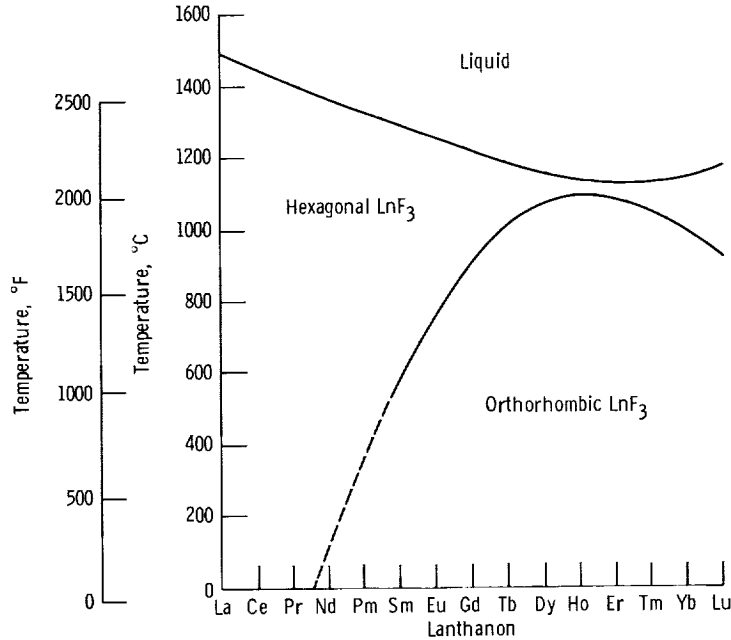

Figure 3. - Crystal transformation temperatures and melting points of lanthanide series of rare earth trifluorides. (Data from ref. 3.)

diffraction patterns of the trifluorides conform to the nominal compositions and to the crystal structures predictable from the reference data in figure 3; LaF_3 , CeF_3 , and NdF_3 were of a hexagonal crystal structure and GdF_3 was orthorhombic. Figure 3 indicates that a hexagonal to orthorhombic transformation of NdF_3 should occur below about 100°C . However, the curve is extrapolated in this area. Further, as indicated in reference 3 the inversion reaction (at the lower temperatures) probably occurs so slowly that "... it will not be detected in conventional equilibration experiments."

Two out of the four oxides in table II were received in a hydrated condition. Compounds labeled La_2O_3 and Nd_2O_3 were identified as $\text{La}(\text{OH})_3$ and $\text{Nd}(\text{OH})_3$. Lanthanum hydroxide was not readily converted to the oxide. As indicated in table II, no change occurred in $\text{La}(\text{OH})_3$ after exposure to temperatures up to 1200°F (650°C), and only partial conversion to the oxide occurred after exposure to temperatures up to 1800°F (1000°C) in friction tests. However, the high-temperature exposure was relatively short (10 minutes at each 100°F (56°C) interval) in these tests. Complete conversion of $\text{La}(\text{OH})_3$ to La_2O_3 occurred during a 1-hour exposure to air at 1500°F (800°C); $\text{Nd}(\text{OH})_3$ was completely converted to Nd_2O_3 during friction tests at temperatures up to 1200°F (650°C). Both orthorhombic and hexagonal Nd_2O_3 were detected. However, a 1-hour furnace treatment of 1500°F (800°C) completely converted $\text{Nd}(\text{OH})_3$ to a single reaction product, hexagonal Nd_2O_3 . Face-centered-cubic CeO_2 did not undergo any changes in crystal structure or chemical composition when exposed for 1 hour to air at

2500^o F (1370^o C) or for 2 hours to hydrogen at 2000^o F (1100^o C). This oxide is somewhat unique among the lanthanide oxides in that it is more commonly found as the dioxide rather than the sesquioxide.

Slider Specimens

In this program, the rider specimens were Inconel 600. The hardness was Rockwell B 90. Disk specimens were Inconel 750. The hardness of age-hardened Inconel 750 was Rockwell C 38.

EXPERIMENTAL APPARATUS AND PROCEDURE

Cleaning Procedure

Disk and rider specimens were cleaned by washing with anhydrous ethyl alcohol. Next, they were cleaned with a paste of levigated alumina and water until all surfaces were readily wettable with distilled water, then water-rinsed and scrubbed with a clean brush to remove all particles of alumina. The specimens were rechecked for water wettability and dried.

Friction Apparatus for Powdered Solid Lubricants

The low-speed, 6 feet per minute (0.03 m/sec), friction experiments with powdered lubricants were conducted in an apparatus with the friction specimen configuration shown in figure 4. The lower specimen is a stationary Inconel 750 disk. The upper specimens are Inconel 600 riders with 0.1875-inch (0.475-cm) hemispherical radii on the contacting ends. Three riders are mounted in a disk-shaped plate which rotates at the end of the drive shaft. The riders are equally spaced on a 1.0-inch (2.5-cm) radius from the centerline of shaft rotation. The specimens are mounted in a suitable cylindrical Inconel chamber (not shown in the figure) for the maintenance of a controlled atmosphere by continuous purging with the cover gas. Small vanes on the rider holder continuously plow lubricant powder in front of the riders in order to maintain a lubricant supply to the wear track. Sufficient clearance is provided between the vanes and the disk specimen to prevent contact as the specimens wear. The specimens are heated by radiation and convection from the hot chamber wall which functions as a susceptor for an induction coil. The specimen loading system and alignment features are the same as for a similar apparatus which is described in detail in reference 15.

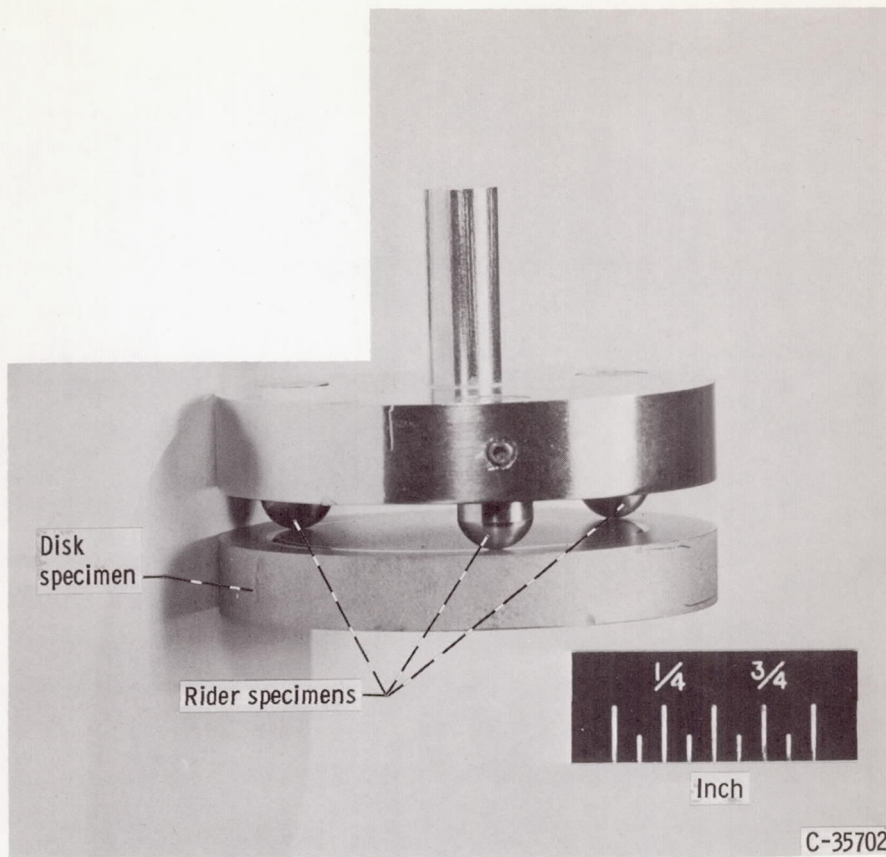

Figure 4. - Friction specimens.

Procedure for Variable Temperature Friction Experiments

The friction coefficient was measured during 10-minute periods at 100°F (56°C) intervals of temperature from room temperature to 1800°F (1000°C). Rider wear was measured after each complete test and was expressed as the average wear volume per rider per unit distance of sliding over the entire temperature range. A composite average of this sort does not give any indication of the influence of temperature on wear, but does provide some measure of the relative wear-reduction capabilities of the various lubricants over the entire temperature range.

Procedure for Applying Bonded Coatings

The powdered experimental lubricants were ground to pass a 325-mesh screen, then mixed with enough distilled water to produce a slurry. The disks were sandblasted to a

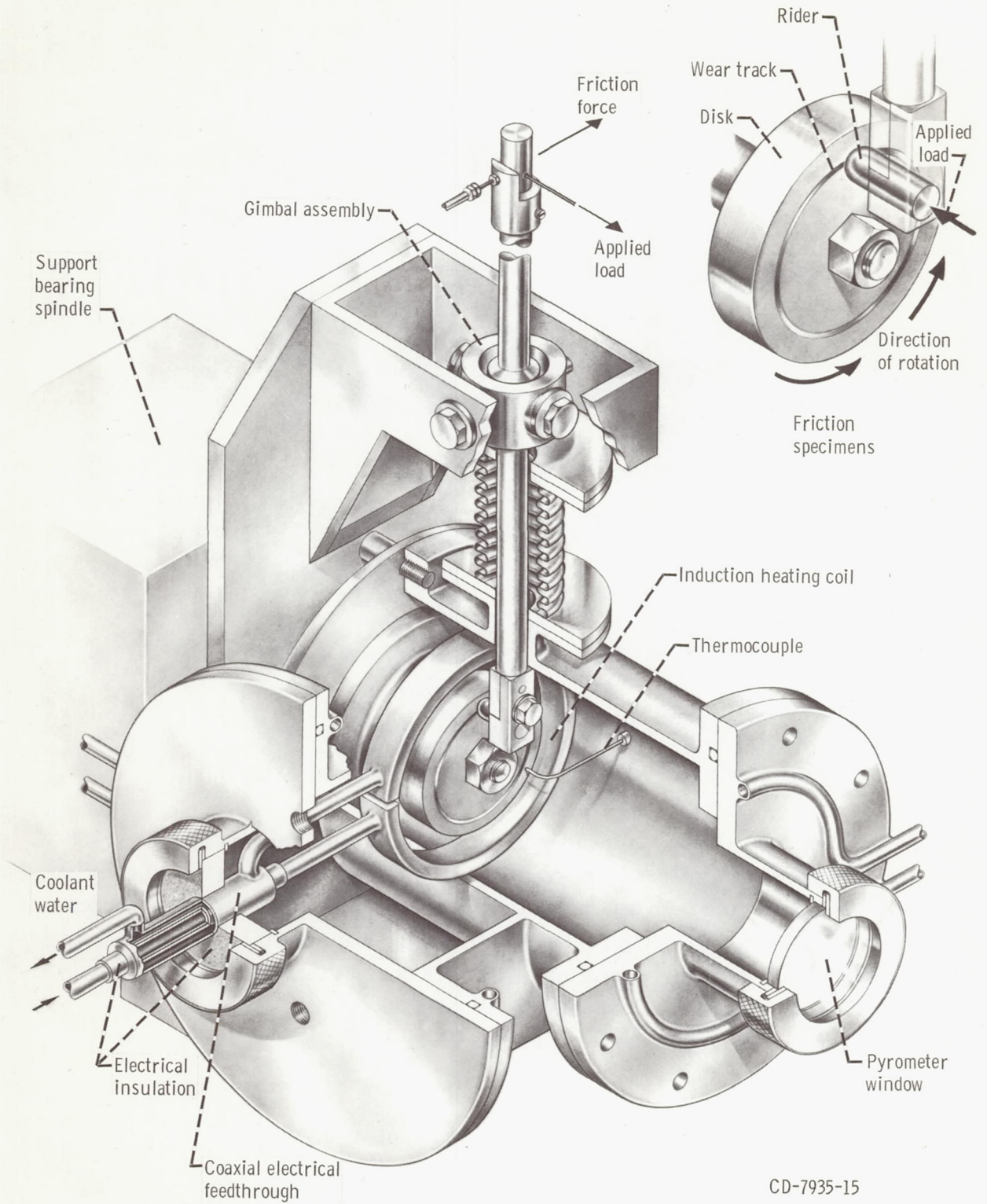

Figure 5. - High-temperature friction apparatus.

40-microinch ($1\text{-}\mu\text{m}$) finish, then cleaned. The disks were preheated to 160°F (70°C), then the slurry was sprayed onto the disk with an air brush. The coating thickness was built up to 0.001 inch (0.003 cm) by repeated spraying. The coated disks were heated above their melting point (fused) for a prescribed period of time in a tube furnace containing an atmosphere of dry hydrogen, then transferred from the furnace hot zone to a hydrogen-filled chamber which was cooled with a water jacket. The specimens were allowed to cool to about 200°F (90°C) before removal from the furnace.

Friction Apparatus and Experimental Procedure for Coatings

The solid lubricant coatings were evaluated in the friction apparatus shown in figure 5. The friction specimens consist of a rotating disk in sliding contact with a hemispherically tipped rider 0.1875 inch (0.475 cm) under a normal load of 500 grams. The rider slides on a 2-inch (5-cm) diameter wear track on the disk. Sliding is unidirectional, and the sliding velocity can be continuously varied and closely controlled over a range of 200 to 2500 feet per minute (1 to 13 m/sec). The specimens are heated by an induction coil around the disk specimen. Temperature is monitored by an infrared pyrometer capable of indicating surface temperatures from about 200°F (90°C) to over 4000°F (2200°C). Suitable corrections are made for the viewing window by calibrating the pyrometer against a thermocouple welded to a stationary dummy disk mounted in place of a friction disk. Target diameter for the pyrometer is $1/8$ inch (0.3 cm) at a distance of 6 inches (15 cm). Surface temperature is monitored on the wear track, 90° of rotation ahead of the point of contact between rider and disk.

RESULTS AND DISCUSSION

Lubrication with Rare Earth Trifluoride Powders

The influence of temperature on the friction coefficients of Inconel alloys lubricated with four rare earth trifluorides is shown in figures 6(a) (dry air atmosphere) and (b) (dry argon atmosphere). The friction coefficients of Inconel 600 sliding on unlubricated Inconel 750 are given for comparison.

As might be expected, the friction coefficients for the unlubricated metals are high, around 0.7 for the unoxidized metals. In air, the friction coefficient begins to decrease at about 1200°F (650°C), it levels out to a value of 0.4 at about 1500°F (800°C). This value (0.4) is constant to the maximum temperature of the experiment, 1800°F (1000°C). This decrease in friction at 1200°F (650°C) occurs simultaneously with the formation of a clearly visible oxide on the metal surfaces. At about 1500°F (800°C),

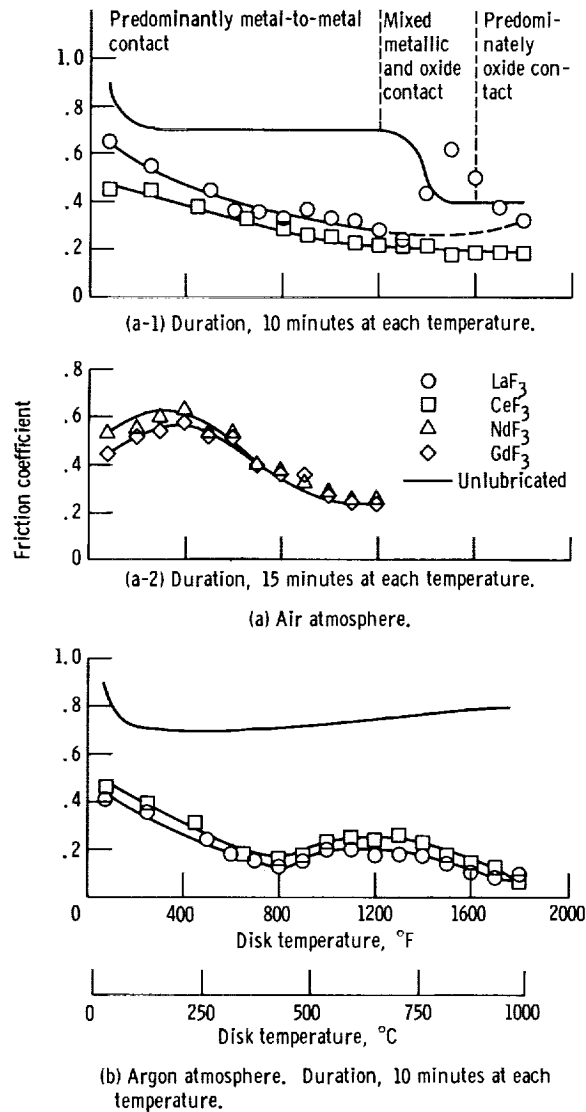

Figure 6. - Friction of rare earth fluorides in air and argon. Sliding velocity, 6 feet per minute (0.03 m/sec); load, 2 kilograms per rider; riders, Inconel 600 pins with 0.1875-inch (0.475-cm) hemispherical radii; disks, Inconel 750.

oxidation occurs at a rate sufficient to compensate for wear, and the friction coefficient of 0.4 can be considered representative for a stably oxidized Inconel sliding surface with no significant metal-to-metal contact through the oxide film.

In argon, by contrast, the friction coefficient remains high to 1800° F (1000° C). In fact, in argon, the friction coefficient gradually increases with temperature, probably because of thermal softening of the metal with a resulting increase in the mechanical deformation component of the friction force.

In air, either powdered LaF₃ or CeF₃ reduced the friction coefficient over the entire

temperature range of room temperature to 1800° F (1000° C) with the exception of scattered high friction coefficients for LaF₃ in the 1300° to 1800° F (700° to 1000° C) temperature range. These high friction coefficients probably indicate metal to metal contact rather than any intrinsic high friction coefficient of LaF₃ in this temperature range. The general trend in both atmospheres was toward lower friction at the higher temperatures, although there were some undulations in the friction-temperature curves. For example, in the case of LaF₃ in an argon atmosphere, the friction coefficient rose gradually from a value of about 0.15 at 750° F (400° C) to about 0.25 at 1200° F (650° C), then decreased to 0.10 at 1800° F (1000° C). The general frictional behavior of GdF₃ and NdF₃ in air was similar to the behavior of LaF₃ and CeF₃, with the exception of a maximum in the friction-temperature curves at about 350° F (175° C).

Results with LaF₃ and CeF₃ were better in argon than in air. The friction coefficients at room temperature were of the order of 0.4 to 0.5, but were 0.3 or lower from 200° to 1800° F (90° to 1000° C) and as low as 0.08 at 1800° F (1000° C).

The average wear rates (wear volume per meter of sliding per rider) of the Inconel 600 riders used in these experiments are given in figure 7. These rates are averages based on measurements of wear after the variable temperature experiments, and therefore indicate the relative wear protection provided by the rare earth fluoride over the entire temperature range of the experiments. Wear rates, averaged in this

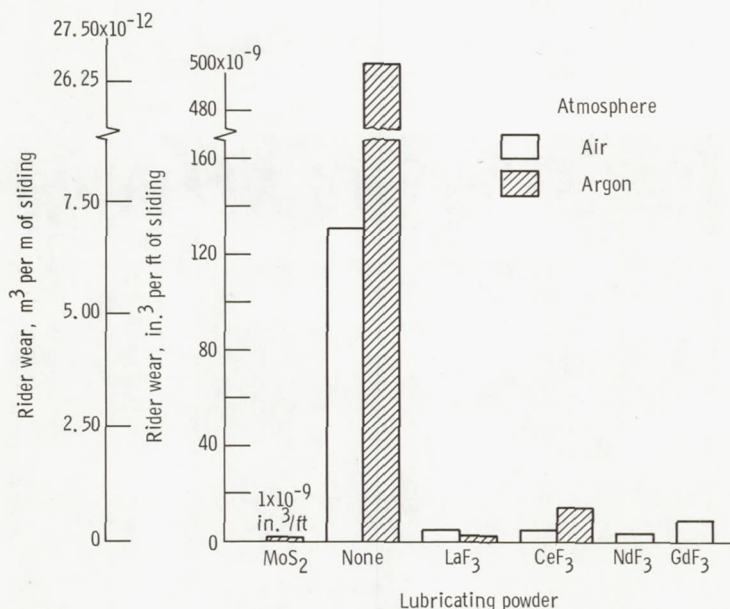
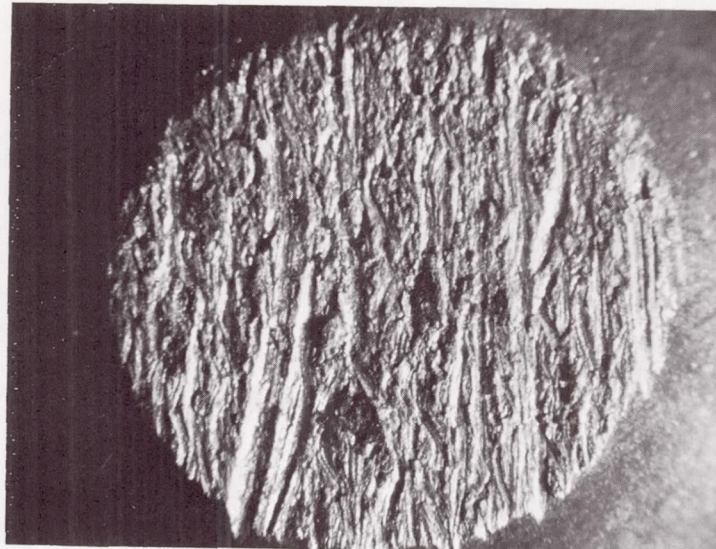
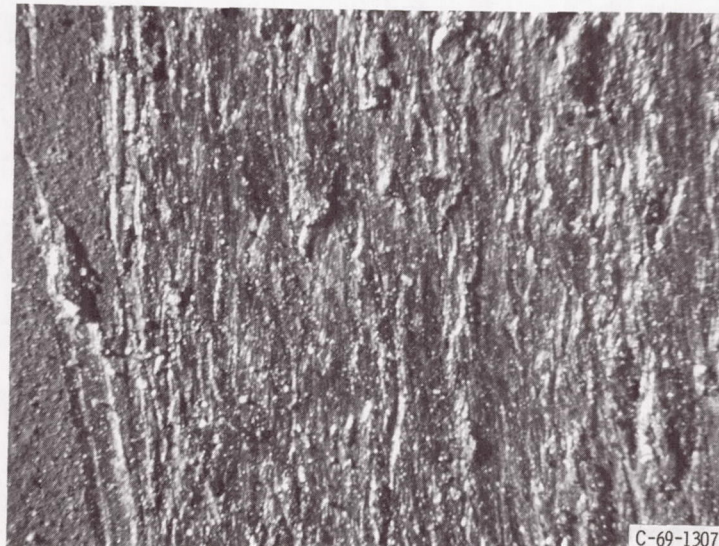

Figure 7. - Average rider wear rates during variable temperature friction studies of some rare earth trifluorides. Temperature range, room temperature to 1800° F (1000° C) except NdF₃, GdF₃, and MoS₂ control which were room temperature to 1200° F (650° C); sliding velocity, 6 feet per minute (0.03 m/sec); load, 2 kilograms per rider.



(a) Inconel 600 rider.



(b) Inconel 750 disk.

Figure 11. - Wear surfaces on Inconel 600 rider and Inconel 750 disk after sliding in argon with La_2O_3 powder on disk surface. Temperature range, room temperature to 1800° F (1000° C); load, 2 kilograms per rider; duration, 180 minutes.

the contact area. This can be seen in the photographs of wear areas on the disk and riders which are shown in figure 8. These specimens were lubricated in argon with LaF_3 during an experiment in which the temperature was increased from 25° to 1000° C. The rubbing surfaces of both the rider and the disk are completely covered with a layer of LaF_3 , which prevented metal-to-metal contact. In areas where the fluoride was chipped away from the wear track, the original sandblasted surface was still intact.

Average rider wear rates for Inconel lubricated with LaF_3 in argon and in air atmospheres from room temperature to 1800° F (1000° C) were higher but of about the same magnitude as wear rates with MoS_2 lubrication in argon. Similar results were obtained with CeF_3 , NdF_3 , and GdF_3 .

In general, the data show that the rare earth trifluorides are effective in reducing metallic wear in air or in argon during experiments in which the specimen temperature is increased from room temperature to 1800° F (1000° C). In both atmospheres and over a large temperature span, the friction coefficients were within the range of 0.1 to 0.4, which is typical of the friction coefficients obtained with many grades of mechanical carbons in commercial use as sliding contact bearing and seal materials (ref. 16). This suggests that rare earth fluorides such as LaF_3 may be useful as adjuvants or lubricating fillers for mechanical carbons, especially for high-temperature applications.

Lubrication with Rare Earth Oxide Powders

The influence of temperature on the friction and wear of Inconel lubricated with rare earth oxide powders in air and in a slightly reducing atmosphere (90 percent N_2 and 10 percent H_2) is given in figures 9 and 10. In 90 percent N_2 - 10 percent H_2 atmosphere, friction coefficients were 0.4 or higher from room temperature to 1800° F (1000° C), and rider wear rates were high. Lubrication in air was also poor up to about 1200° F (650° C). Others have also observed similar poor lubricating ability with La_2O_3 and Nd_2O_3 in air at 1300° F (700° C) (ref. 17). However, the friction coefficients in air decreased with further heating to a low of 0.17 at 1800° F (1000° C) for La_2O_3 and CeO_2 . Rider wear was lower with La_2O_3 and CeO_2 lubrication than for the corresponding unlubricated conditions. Therefore, although the oxides were relatively poor in these experiments, there is some indication that La_2O_3 and CeO_2 may have lubricating ability at very high temperature beyond the scope of the present studies.

The poor lubricating properties of the rare earth oxides under most of the experimental conditions employed can be attributed to the following two factors: (1) The oxide powders had very little tendency to adhere to the metal surface or to flow plastically even under the high compressive loads in the contact zone. Therefore, gross metal-to-metal contact occurred, as is apparent from the severe damage to the metal surfaces

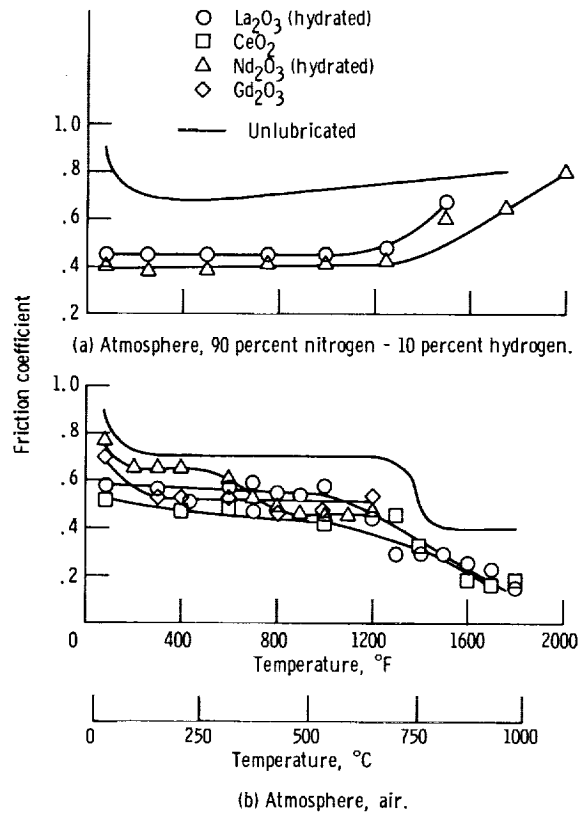

Figure 9. - Friction of rare earth oxides in nonoxidizing and oxidizing atmospheres. Sliding velocity, 6 feet per minute (0.03 m/sec); load, 2 kilograms per rider; riders, Inconel 600 pins with 0.1875-inch (0.475-cm) hemispherical radii; disks, Inconel 750; duration, 10 minutes at each temperature.

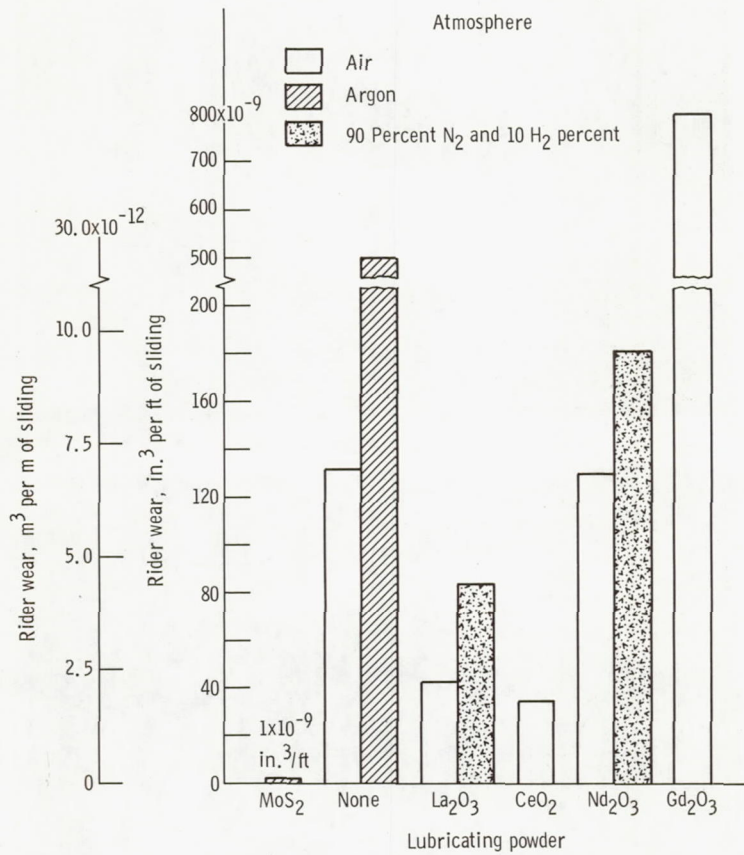
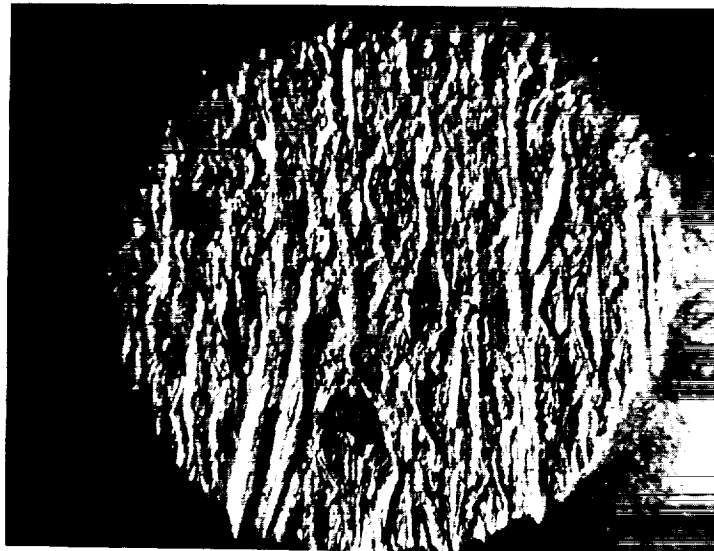

Figure 10. - Average rider wear rates during variable temperature friction studies of some rare earth oxides. Temperature range, room temperature to 1800° F (1000° C); sliding velocity, 6 feet per minute (0.03 m/sec); load, 2 kilograms per rider; La₂O₃ and Nd₂O₃ were in hydrated form at beginning of tests.



(a) Inconel 600 rider.



(b) Inconel 750 disk.

Figure 11. - Wear surfaces on Inconel 600 rider and Inconel 750 disk after sliding in argon with La_2O_3 powder on disk surface. Temperature range, room temperature to 1800°F (1000°C); load, 2 kilograms per rider; duration, 180 minutes.

and the total absence of rare earth oxide film formation. (See fig. 11 and compare to the mild surface damage and characteristic film formation in the case of the rare earth trifluorides (fig. 8).) (2) The oxides were harder and more abrasive than the trifluorides.

Bonded Coatings Containing Rare Earth Trifluorides

Some preliminary attempts were made to formulate and apply adherent, fused coatings of rare earth trifluorides to Inconel 750 disks. The coatings were applied by spraying water slurries of the fluorides on the disks, then heating the sprayed specimen in hydrogen to produce melting of the coating material. The procedure was described previously. The maximum firing temperature used in these attempts was 2200°F (1200°C), which is the solution anneal temperature of Inconel 750. The formulation of coatings containing rare earth fluorides is difficult because of the scarcity of phase diagrams for systems containing these compounds. Therefore, most compositions and firing procedures, of necessity, were based on empirical judgement.

No single-component fluoride coatings were prepared because the high melting points of the rare earth fluorides (2242°F (1228°C) for GdF_3 to 2714°F (1490°C) for LaF_3 ; see table I). Binary mixtures in 1 to 1 weight ratios of the trifluorides did not melt after 15 minutes at 2200°F (1200°C), and bonding did not develop between the metal and the coating material.

Lower melting point fluorides which are known to have lubricating ability at high temperatures (refs. 18 and 19) were then introduced in an attempt to depress the melting point below 2200°F (1200°C). The addition of 5 weight percent LiF to a 1 to 1 GdF_3 - LaF_3 composition resulted in a formulation which melted during a 20-minute heat treatment at 2100°F (1150°C). However, all of the coatings of this type spalled off the metal substrate during cooling to room temperature.

LaF_3 with 25 weight percent of a CaF_2 - BaF_2 eutectic was readily melted during a 15-minute heat treatment at 2200°F (1200°C). The resulting coatings were well-fused and were adherent to the substrate metal. The results of friction experiments with this coating composition are shown in figure 12(a). From room temperature to 1300°F (700°C), and at a sliding velocity of 2000 feet per minute (10 m/sec), the friction coefficient was nearly constant at 0.3. At a lower sliding velocity (450 ft/min (2.25 m/sec)), the friction coefficient was almost as high as that of the unlubricated metal.

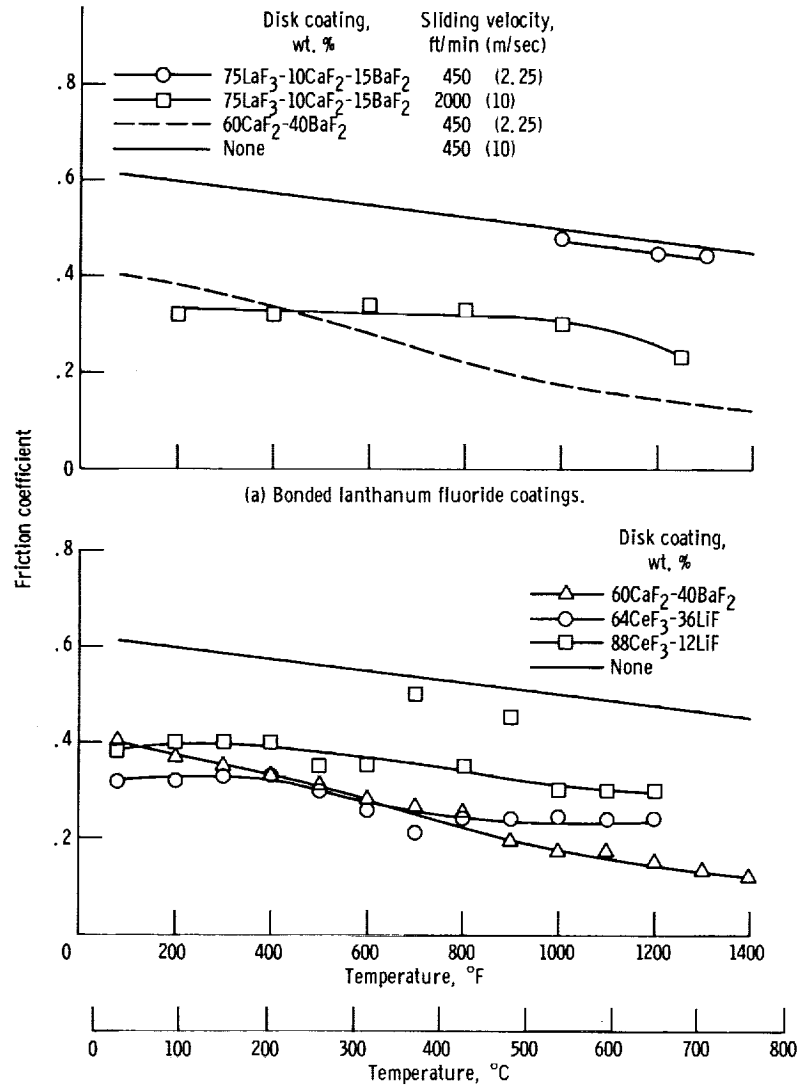

(b) Bonded cerium fluoride - lithium fluoride coatings. Sliding velocity, 450 feet per minute (2.5 m/sec).

Figure 12. - Friction of bonded lanthanum fluoride and bonded cerium fluoride - lithium fluoride coatings compared to calcium fluoride - barium fluoride coatings and to uncoated metal. Load, 500 grams; riders, cast Inconel pins with 0.1875-inch (0.475-cm) hemispherical radii (uncoated); coating thickness, 0.0010 to 0.0015 inch (0.003 to 0.004 cm) on Inconel 750 disks.

The best results were obtained with bonded coatings of CeF_3 and LiF . The phase diagram for the CeF_3 - LiF system has been published (refs. 3 and 20). A simple eutectic composition exists at 19 molecular weight (64 wt. %) CeF_3 . The eutectic melting point is 1380°F (750°C). Coatings of the eutectic composition and of 88 weight percent CeF_3 - 12 weight percent LiF were prepared. The liquidus temperature for the latter composition is 2012°F (1100°C). Both compositions were successfully bonded to Inconel 750 by firing in hydrogen for 15 minutes at 1600°F (870°C).

The results of friction experiments with both composition are given in figure 12(b). At a sliding velocity of 450 feet per minute (2.25 m/sec), both CeF_3 - LiF compositions had lower friction coefficients than the LaF_3 coatings. The friction coefficient of the 88 weight percent CeF_3 - 12 weight percent LiF coating was not very sensitive to temperature in the range of room temperature to 1200°F (650°C); the friction coefficient was 0.4 at room temperature and gradually decreased to 0.3 at 1200°F (650°C). Approximately the same behavior occurred with the eutectic composition, but the friction was lower, 0.30 at room temperature to 0.23 at 1200°F (650°C). Comparison with results for 60 weight percent CaF_2 - 40 weight percent BaF_2 coatings show that the CeF_3 eutectic provided a more uniform friction coefficient over the temperature range with lower friction at room temperature and higher friction at 1200°F (650°C) than the CaF_2 - BaF_2 coatings.

The results of these studies indicate that the rare earth trifluorides have some possibilities as solid lubricants. Friction coefficients tend to be higher than desirable for many purposes, but the compounds do exhibit antiwear properties and fairly constant friction coefficients over a large temperature range. These considerations, in addition to good chemical stability and melting points above 2200°F (1200°C), make these materials interesting as potential solid lubricants for special applications. For example, the moderately high friction coefficient combined with good antiwear characteristics suggests possibilities of rare earth trifluorides for use in power transmission devices such as clutch plates and brakes. They also should be of interest as fillers in mechanical carbons.

CONCLUDING REMARKS

An evaluation of the lubricating properties of the rare earth trifluorides indicated that powdered CeF_3 and LaF_3 can lubricate nickel-base superalloys in air and in argon at temperatures to at least 1800°F (1000°C). Friction coefficients were 0.4 to 0.3 from room temperature to about 500°F (260°C), but were in the range of 0.2 to 0.1 at higher temperatures. The total rider wear in variable temperature friction experiments (room temperature to 1800°F (1000°C)) was low compared to the wear of the unlubricated metals under the same conditions.

Rare earth oxide powders showed no promise as solid lubricant materials below 1300° F (700° C).

The rare earth fluorides were excellent film-formers. The powders readily flowed plastically when subjected to the contact stresses in the sliding interface and were smeared to thin, adherent films on the sliding surfaces. The oxide powders formed no films and had no tendency to adhere to the metal surfaces.

Fused, adherent coatings composed of CeF₃ and LiF were prepared. Friction coefficients were not particularly sensitive to temperature. The friction coefficients of a eutectic CeF₃ - LiF composition were 0.3 at room temperature and 0.23 at 2100° F (650° C).

Lewis Research Center,
National Aeronautics and Space Administration,
Cleveland, Ohio, April 10, 1969,
126-15-02-27-22.

REFERENCES

1. Glassner, Alvin: The Thermochemical Properties of the Oxides, Fluorides, and Chlorides to 2500° K. Rep. ANL-5750, Argonne National Lab., 1957.
2. Moeller, Therald: Inorganic Chemistry. J. Wiley & Sons, Inc., 1952, p. 891.
3. Thoma, R. E.: Rare Earth Halides. Rep. ORNL-3804, Oak Ridge National Lab., May 1965.
4. Anon.: Engineering Properties of Selected Ceramic Materials. Am. Ceram. Soc., 1966.
5. Stecura, Stephan: Crystallographic Modifications and Phase Transformation Rates of Five Rare-Earth Sesquioxides: Lanthanum Oxide, Neodymium Oxide, Samarium Oxide, Europium Oxide, and Gadolinium Oxide. Rep. BM-RI-6616, U.S. Bureau of Mines, 1965.
6. Wilfong, Roy L.; Domingues, Louis P.; Furlong, LeRoy R.; and Finlayson, Joseph A.: Thermal Expansion of the Oxides of Yttrium, Cerium, Samarium, Europium, and Dysprosium. Rep. BM-RI-6180, U.S. Bureau of Mines, 1963.
7. Domingues, Louis P.; Wilfong, Roy L.; and Furlong, LeRoy R.: Pyrolysis of Five Salts of Yttrium, Lanthanum, and Cerium. Rep. BM-RI-6029, U.S. Bureau of Mines, 1962.

8. Spedding, F. H.; and Doane, A. H., eds.: *The Rare Earths*. John Wiley & Sons, Inc., 1961, p. 78.
9. Gibson, John A.; and Harvey, Gifford S.: *Properties of the Rare Earth Metals and Compounds*. Battelle Memorial Inst. (AFML-TR-65-430, DDC No. AD-479391), Jan. 1966.
10. Wells, Alexander F.: *Structural Inorganic Chemistry*. Third ed., Clarendon Press, Oxford, 1962.
11. Gould, Edwin S.: *Inorganic Reactions and Structure*. Rev. ed., Holt, Rinehart, and Winston, 1962.
12. Weast, Robert C., ed.: *Handbook of Chemistry and Physics*. 45th ed., The Chemical Rubber Co., 1964-65, p. F-15.
13. Anon.: *Metals Handbook*. 1948 ed., Am. Soc. Metals, Cleveland, Ohio, p. 102.
14. Lange, N. A.; and Forker, G. M., eds.: *Handbook of Chemistry*, Tenth ed., McGraw-Hill Book Co., Inc., 1961.
15. Peterson, M. B.; and Johnson, R. L.: *Factors Influencing Friction & Wear with Solid Lubricants*. *Lubr. Eng.*, vol. 11, no. 5, Sept.-Oct. 1955, pp. 325-331.
16. Strom, Thomas N.; Allen, Gordon P.; and Johnson, Robert L.: *Wear and Friction of Impregnated Mechanical Carbons at Temperatures to 1400^o F (760^o C) in Air or Nitrogen*. NASA TN D-3958, 1967.
17. Peterson, M. B.; Murray, S. F.; and Forek, J. J.: *Consideration of Lubricants for Temperatures above 1000^o F*. *ASLE Trans.*, vol. 2, 1960, pp. 225-234.
18. Sliney, Harold E.; Strom, Thomas N.; and Allen, Gordon P.: *Fused Fluoride Coatings as Solid Lubricants in Liquid Sodium, Hydrogen, Vacuum, and Air*. NASA TN D-2348, 1964.
19. Olson, Katherine M.; and Sliney, Harold E.: *Additions to Fused-Fluoride Lubricant Coatings for Reduction of Low-Temperature Friction*. TN D-3793, 1967.
20. Levin, Ernest M.; Robbins, C. R.; and McMurdie, Howard E.: *Phase Diagrams for Ceramists*. Am. Ceram. Soc., 1964.

