

*Ed...  
(right-hand page)  
back is left blank*

NASA CR-72521

FINAL REPORT

DEVELOPMENT OF DUCTILE CLADDING  
FOR TD-NICKEL TURBINE VANE APPLICATIONS

by

L. Sama, D. D. Lawthers and G. T. Pepino

SYLVANIA ELECTRIC PRODUCTS INC.

Chemical & Metallurgical Division

High Temp. Composites Lab.

Hicksville, N. Y. 11802

Prepared for

NATIONAL AERONAUTICS AND SPACE ADMINISTRATION

December 31, 1968

CONTRACT NAS 3-10489

Technical Management  
NASA Lewis Research Center  
Cleveland, Ohio  
Materials & Structures Division

R. E. Oldrieve, Project Manager  
S. J. Grisaffe, Research Advisor

*inside of cover*

## NOTICE

This report was prepared as an account of Government-sponsored work. Neither the United States, nor the National Aeronautics and Space Administration (NASA), nor any person acting on behalf of NASA:

- A.) Makes any warranty or representation, expressed or implied, with respect to the accuracy, completeness, or usefulness of the information contained in this report, or that the use of any information, apparatus, method, or process disclosed in this report may not infringe privately-owned rights; or
- B.) Assumes any liabilities with respect to the use of, or for damages resulting from the use of, any information, apparatus, method or process disclosed in this report.

As used above, "person acting on behalf of NASA" includes any employee or contractor of NASA, or employee of such contractor, to the extent that such employee or contractor of NASA or employee of such contractor prepares, disseminates, or provides access to any information pursuant to his employment or contract with NASA, or his employment with such contractor.

Requests for copies of this report should be referred to

National Aeronautics and Space Administration  
Scientific and Technical Information Facility  
P. O. Box 33  
College Park, Md. 20740

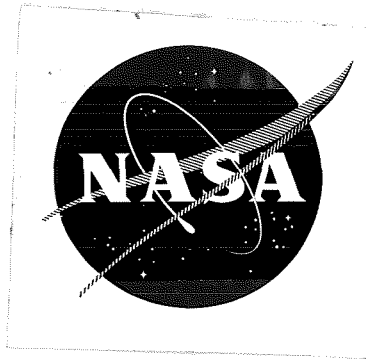

# DEVELOPMENT OF DUCTILE CLADDING FOR TD-NICKEL TURBINE VANE APPLICATIONS

by

L. Sama, D.D. Lawthers, and G.T. Pepino

SYLVANIA ELECTRIC PRODUCTS INC.

Chemical & Metallurgical Division

Hicksville, N.Y.

High Temperature Composites Lab.

11802

prepared for

NATIONAL AERONAUTICS AND SPACE ADMINISTRATION

Technical Management

NASA Lewis Research Center

Cleveland, Ohio

Materials & Structures Division

Contract NAS 3-10489

R.E. Oldrieve, Project Manager

S.J. Grisaffe, Research Advisor

December 31, 1968

**Page intentionally left blank**

## FOREWORD

This is the final report on National Aeronautics and Space Administration Contract No. NAS3-10489 administered by the Lewis Research Center, Cleveland, Ohio. The NASA Project Manager for this contract is Robert Oldrieve and the NASA Research Advisor, for the first period reported, was Michael A. Gedwill, Jr. Present Research Advisor is Salvatore Grisaffe. This report covers the period from July 5, 1967 to December 31, 1968.

Sylvania and GT&E Laboratory personnel contributing to the experimental work and to the writing of this report were:

Dean D. Lawthers	-	Principal Investigator
G. Pepino	-	Technical Associate
L. Sama	-	Program Manager
P. Lublin	-	Electron-Microprobe Analyses
H. Woods	-	Metallography
E. Rittershaus	-	X-ray Diffraction

**Page intentionally left blank**

## ABSTRACT

Slurry techniques were used to apply ductile 5 mil thick Ni-Cr-Al-Si coatings to TD-Ni and TD-NiCr. Single step coatings could not be fused uniformly thick around edges and corners. A two-step process, Ni-Cr-Si in the first and Al-20Co in the second, was developed and proved more successful in protecting TD-Ni and TD-NiCr from oxidation. The systems protected TD-Ni for over 200 hours and TD-NiCr for over 350 hours at 2300°F. Coatings on TD-Ni were brittle as-coated but caused no substrate embrittlement. Coatings on TD-NiCr embrittled the substrate. After 100 hours at 2300°F, both coated materials could be bent cold over a 4 T radius. Electron probe analyses were obtained before and after exposure to argon diffusion or oxidation at 2300°F.

## TABLE OF CONTENTS

	<u>Page No.</u>
I. SUMMARY	1
II. INTRODUCTION	2
III. EXPERIMENTAL WORK - TASK I	
3.1 Background	3
3.2 Materials	3
3.3 Coating Development and Alloy Compositions	3
3.4 Oxidation Testing at 2300°F, Screening Studies	5
3.5 Bend Tests	6
3.6 Metallographic Examination	20
3.7 Oxide Scale Analysis	31
3.8 Electronmicroprobe Chemical Analysis of Screening Coating Compositions	31
3.9 Microhardness Values	34
3.10 Conclusions Based on Screening Tests	34
3.11 Modification of Coating Compositions	35
3.12 Torch Tests	45
3.13 Additional Coating Modifications	45
3.14 Oxidation Tests on Two-Step Coatings	50
IV. EXPERIMENTAL WORK - TASK II	
4.1 Introduction	56
4.2 Materials	56
4.3 Coating Development and Compositions	56
4.4 Oxidation Testing	82
4.5 Bend Tests	90
4.6 Metallographic Examination	90
4.7 Diffusion Studies	102
4.8 X-Ray Diffraction Studies	107
4.9 Electronmicroprobe Analyses	109
4.10 Microhardness Values	128
V. PREPARATION OF EROSION BAR SAMPLES	130
VI. DISCUSSION OF RESULTS	133
VII. CONCLUSIONS	135
VIII. REFERENCES	136

## LIST OF TABLES

<u>Table</u>	<u>Title</u>	<u>Page</u>
I	Coating Alloy Compositions	4
II	Bend Test Results on Coated and Oxidized TD-NiCr Samples	19
III	Electronmicroprobe Chemical Results on Coated and Oxidized TD-Nickel Samples	32
IV	Electronmicroprobe Chemical Results on Coated and Oxidized TD-NiCr and Uncoated TD-NiCr Samples	33
V	Bend Test Results on Coated and Oxidized TD-Ni and TD-NiCr Samples	42
VI	Metallographic Measurements of the Thinnest Areas of the Coatings at Edges on As-Coated Samples	49
VII	Bend Test Results on Coated and Oxidized Single and Two-Step Coatings on TD-Ni	55
VIII	Diffusion Treatments to Eliminate Incipient Melting of Aluminized Coatings on TD-Ni Substrate	57
IX	High Temperature Aluminum Coating Trials on TD-Ni and TD-NiCr.	63
X	Slow Heating Experiments to Eliminate Tunneling.	63
XI	Results of #2 and #3 Diffusion Heat Treatments on TD-Ni and TD-NiCr Substrates	66
XII	Fusion Range Determinations for Ni-Cr-Si Alloy First-Step Coatings Fired in Vacuum	67
XIII	Effect of Substrate, First Step Coating Composition, Aluminum Composition and Slower Heating on Tunnel Formation and Oxidation Behavior	68
XIV	Effect of Diffusion Heat Treatment #5 on TD-Ni and TD-NiCr Samples with 15-20 mg/cm <sup>2</sup> of Al-20Co Slurry Coating	72
XV	Effect of Lower Al-20Co Compositions on Cyclic Oxidation	74
XVI	Effect of Additives to Al-20Co Slurry and Al <sub>2</sub> O <sub>3</sub> Diffusion Pack on "Dusting" of Coating after Diffusion Treatment	77
XVII	Effect of Minor NH <sub>4</sub> Cl Additive to Al <sub>2</sub> O <sub>3</sub> Diffusion Pack on Al Weight Losses during Diffusion Treatment #5.	79
XVIII	Effect of Coating Composition on 2300°F Oxidation Behavior	79
XIX	Calculated Average Overall Coating Compositions for Typical Combined First and Second Coatings	81
XX	Bend Test Results on Two-Step Coated and Oxidized TD-Ni and TD-Ni-Cr Samples	91

List of Tables (Continued)

<u>Table</u>	<u>Title</u>	<u>Page</u>
XXI	X-Ray Diffraction Results on As-Coated Samples of TD-Ni and TD-NiCr	108
XXII	Electronprobe Analyses of TD-Ni Substrates Coated with Ni-30Cr-1Si and 10 mg/cm <sup>2</sup> Al-20Co	110
XXIII	Electronprobe Analyses of TD-Ni Substrates	111
XXIV	Electronprobe Analyses of TD-NiCr Substrates	112
XXV	Electronprobe Analyses of TD-Ni Substrates	113
XXVI	Electronprobe Analyses of TD-Ni Substrates	114
XXVII	Electronprobe Analyses of TD-NiCr Substrates	115
XXVIII	Slurry Coating Data for TD-Ni and TD-NiCr Erosion Bars	132

## LIST OF FIGURES

<u>Figure</u>		<u>Page</u>
1	Oxidation behavior at 2300°F of uncoated TD-NiCr sample	7
2	Oxidation behavior at 2300°F with coated TD-Ni and TD-NiCr samples (Coating Alloy 1)	8
3	Oxidation behavior at 2300°F with coated TD-Ni and TD-NiCr samples (Coating Alloy 1A)	9
4	Oxidation behavior at 2300°F with coated TD-Ni and TD-NiCr samples (Coating Alloy 2)	10
5	Oxidation behavior at 2300°F with coated TD-Ni and TD-NiCr samples (Coating Alloy 3)	11
6	Oxidation behavior at 2300°F with coated TD-Ni and TD-NiCr samples (Coating Alloy 4)	12
7	Oxidation behavior at 2300°F with coated TD-Ni and TD-NiCr samples (Coating Alloy 5)	13
8	Oxidation behavior at 2300°F with coated TD-Ni and TD-NiCr samples (Coating Alloy 6)	14
9	Oxidation behavior at 2300°F with coated TD-Ni and TD-NiCr samples (Coating Alloy 7)	15
10	Oxidation behavior at 2300°F with coated TD-Ni and TD-NiCr samples (Coating Alloy 8)	16
11	Oxidation behavior at 2300°F with coated TD-Ni and TD-NiCr samples (Coating Alloy 9)	17
12	Oxidation behavior at 2300°F with coated TD-Ni and TD-NiCr samples (Coating Alloy 10)	18
13	Uncoated TD-NiCr oxidized at 2300°F	21
14	Coating Alloy 1 on TD-NiCr oxidized at 2300°F	22
15	Coating Alloy 2 on TD-Ni oxidized at 2300°F	23
16	Coating Alloy 3 on TD-Ni oxidized at 2300°F	24
17	Coating Alloy 3 on TD-NiCr oxidized at 2300°F	25
18	Coating Alloy 4 on TD-Ni oxidized at 2300°F	26
19	Coating Alloy 7 on TD-NiCr oxidized at 2300°F	27
20	Coating Alloy 9 on TD-Ni oxidized at 2300°F	28
21	Effect of vacuum homogenization heat treatment on TD-Ni substrate	29
22	Effect of vacuum homogenization heat treatment on TD-NiCr substrate	30

List of Figures (Continued)

<u>Figure</u>		<u>Page</u>
23	Oxidation behavior at 2300°F with coated TD-Ni Samples 359N and 264N	36
24	Oxidation behavior at 2300°F with coated Td-Ni Samples 266N and 271N	37
25	Oxidation behavior at 2300°F with coated TD-Ni Samples 275N and 280N	38
26	Oxidation behavior at 2300°F with coated TD-NiCr Samples 283 and 287	39
27	Oxidation behavior at 2300°F with coated TD-NiCr Samples 239 and 244	40
28	Oxidation behavior at 2300°F with coated TD-NiCr Samples 232 and 255	41
29	Coating Alloy 13-3 on TD-NiCr oxidized at 2300°F	42
30	Coating Alloy 14-3 on TD-NiCr oxidized at 2300°F	44
31	Flame tests at 2300°F with Coating Alloy 7 on TD-Ni	46
32	Flame tests at 2300°F with Coating Alloy 3 on TD-NiCr	47
33	Flame test at 2300°F on uncoated TD-NiCr showing sample after 100 hours	48
34	Oxidation behavior at 2300°F with coated TD-Ni two step coating	51
35	Ni-20Cr-3Si coated TD-Ni oxidized at 2300°F	52
36	Two-step coating on TD-Ni oxidized at 2300°F	53
37	As coated and diffusion heat treatments of Ni-20Cr-3Si plus pack Al on TD-Ni substrate	58
38	As coated and diffusion heat treatments of Ni-20Cr-3Si plus slurry Al-20Co on TD-Ni substrate	59
39	Two-step coating on TD-Ni as diffusion treated at 2200°F	61
40	Two-step coating on TD-Ni	62
41	Various Al or Al-20Co diffusion treatments used during Task II coating development	64
42	As coated TD-Ni samples with Ni-30Cr-1Si first step coating and Al-20Co second step showing edges and surface structure	69
43	As-coated TD-NiCr samples with Ni-20Cr-3Si first step coating and Al-20Co second step showing edge and surface structure	70
44	As-coated TD-Ni and TD-NiCr samples after #5 diffusion treatment	73
45	Structural changes during #5 diffusion treatment on Sample 70	76

List of Figures (Continued)

<u>Figure</u>		<u>Page</u>
46	Edges of two step coated TD-Ni and TD-NiCr	80
47	Oxidation behavior in non-standard test at 2300°F	83
48	Oxidation behavior in standard test (Samples 331 and 335)	84
49	Oxidation behavior in standard test (Samples 7, 11, 26, 36)	85
50	Oxidation behavior in standard test (Samples 52, 43, 47, 57)	86
51	Oxidation behavior in standard test (Samples 103, 110, 115)	88
52	Comparison of two-step coated TD-Ni and TD-NiCr with uncoated TD-NiCr in oxidation test at 2300°F	89
53	TD-Ni with Ni-20Cr-3Si first coat and 5 mg/cm <sup>2</sup> slurry Al-20Co second coat with #1 diffusion treatment and oxidized at 2300°F	93
54	TD-Ni with Ni-20Cr-3Si and 5 mg/cm <sup>2</sup> pack Al with diffusion treatment and oxidized at 2300°F	94
55	TD-Ni with Ni-20Cr-3Si and Al-20Co with diffusion treatment and oxidized at 2300°F	95
56	TD-Ni with Ni-25Cr-1Si and Al-20Co diffusion treated and oxidized at 2300°F	96
57	TD-Ni with Ni-30Cr-1Si and Al-20Co diffusion treated and oxidized at 2300°F	97
58	TD-NiCr with Ni-20Cr-3Si and Al-20Co diffusion treated and oxidized at 2300°F	98
59	TD-Ni with Ni-30Cr-1Si and Al-20Co diffusion treated and oxidized at 2300°F	99
60	TD-Ni with Ni-20Cr-3Si and Al-20Co diffusion treated and oxidized at 2300°F	100
61	TD-NiCr with Ni-20Cr-1Si and Al-20Co diffusion treated and oxidized at 2300°F	101
62	Uncoated TD-NiCr and coated TD-Ni and TD-NiCr oxidized in automated one hour cycles at 2300°F	103
63	Structure of argon diffusion treated samples and oxidized sample coated with Ni-30Cr-1Si and Al-20Co	104
64	Structure of argon diffusion treated samples and oxidized sample coated with Ni-20Cr-3Si and Al-20Co	105
65	Structure of argon diffusion treated samples and oxidized sample coated with Ni-20Cr-3Si and Al-20Co	106
66	Location of EMP analyses on TD-Ni substrates coated with Ni-30Cr-1Si and Al-20Co	116
67	Location of EMP analyses on TD-Ni substrates coated with Ni-20Cr-3Si and Al-20Co	117

List of Figures (Continued)

<u>Figure</u>		<u>Page</u>
68	Location of EMP analyses of TD-NiCr substrates coated with Ni-20Cr-3Si and Al-20Co	118
69	Location of EMP analyses of TD-Ni substrates coated with Ni-30Cr-1Si and Al-20Co	119
70	Location of EMP analyses of TD-Ni substrates coated with Ni-20Cr-3Si and Al-20Co	120
71	Location of EMP analyses of TD-NiCr substrates coated with Ni-20Cr-3Si and Al-20Co	121
72	EMP analyses of TD-Ni and TD-NiCr substrates for Si and Al as coated and after oxidation at 2300°F	122
73	EMP analyses of TD-Ni and TD-NiCr substrates for Cr as coated and after oxidation or argon diffusion at 2300°F	123
74	EMP analyses of TD-Ni and TD-NiCr substrates for Si and Al after argon diffusion treatments at 2300°F	124
75	The Nickel-Chromium-Aluminum Phase Diagram: Isothermal Section for 2100°F	125
76	Erosion Bar Samples	131

## I. SUMMARY

This experimental program was established to develop oxidation resistant coatings for TD-Ni and TD-NiCr (Ni-20%Cr) alloys. The target service condition was for jet engine turbine vanes with a 2300°F maximum material temperature. The major objective was to develop slurry coating techniques for applying dense, adherent oxidation resistant and ductile coatings 5 mils thick per side. The program was divided into two major tasks. In Task I ten coating compositions were studied and screened by oxidizing for 100 hours at 2300°F. The coating compositions were nickel base with from 16 to 30% chromium and 2 to 8% aluminum. About 0.75% silicon was added to the powder slurries to lower the fusion temperatures of the Ni-Cr-Al alloys. The coating compositions Ni-25Cr-8Al-0.75Si on TD-Ni and Ni-20Cr-6Al-0.75Si on TD-NiCr were found to give the best oxidation behavior. No improvement was obtained with 0.5 and 1.0% additions of columbium, yttrium and thorium to these two compositions. No compositions showed potential in cyclic furnace tests for protecting TD-Ni for longer than 100 hours at 2300°F. In furnace testings none appeared superior to uncoated TD-NiCr.

The major problem in Task I was the tendency for the coatings to thin out at edges during the fusion treatment. The TD-Ni substrate oxidizes rapidly at these locations to form NiO. On TD-NiCr the Cr<sub>2</sub>O<sub>3</sub> formed spalls too fast to give long term protection. Accordingly in Task II a two step slurry coating process was developed which resulted in similar average coating compositions but gave superior protection. The first step coatings were Ni-(20-30Cr)-(1-3Si) which fused on uniformly. Second step coatings were either pack Al or Al and Al-20Co slurries. The optimum first step for TD-Ni was Ni-30Cr-1Si. Only Ni-20Cr-3Si was used for TD-NiCr. The major problem in Task II was to optimize the maximum amount of Al or Al-20Co which could be applied without forming low melting phases or porous interfaces. A slow incremental temperature diffusion treatment was developed for this purpose. Optimum average coating compositions for the two steps were Ni-2Co-27Cr-9Al-1Si for TD-Ni and Ni-2Co-18Cr-9Al-2.5Si for TD-NiCr. The latter coating was better than uncoated TD-NiCr. Protective lives obtained were 240-260 hours for TD-Ni and 340-360 hours for TD-NiCr. Erosion bars were fabricated and coated with these compositions for NASA evaluation.

Electron probe analyses showed rapid diffusion of Al, Cr and Si into the substrates and preferential oxidation of Al. Al is also lost by vaporization in argon, particularly from TD-NiCr. All coatings were ductile after 2300°F exposure as measured by a 4T bend at room temperature.

## II. INTRODUCTION

Nickel base alloys are the main materials being used in the high temperature sections of aviation gas turbines today. For at least ten years the material specialist has believed that superalloys had reached their maximum use temperature as turbine blades and vanes. The design engineer has increased the turbine inlet temperature by air cooling these components. Recently oxide dispersion strengthened metals, such as TD-Ni and TD-NiCr, have become available that retain mechanical strength to temperatures above 2000°F. But they do not have adequate oxidation resistance above 2000°F to be useful for long time use in a jet engine. These materials can be protected from oxidation for long time periods with a relatively simple aluminum base coatings, but the coatings are relatively brittle since they are NiAl type intermetallics. About the only research work reported to date are the excellent summaries by DuPont.<sup>1, 2</sup> They have partially developed a Cr-Al coating system for TD-Ni for use at 2200° and 2400°F, which will be referred to often in this report. Other sponsored work is presently being performed by other groups, such as IIT Research Institute (Contract NAS3-10494).

The purpose of this NASA Contract NAS3-10489 is to develop coating systems which shall protect TD-Ni and TD-NiCr alloys from mechanical degradation, oxidation, and sulfidation for times up to 800 hours at temperatures up to 2300°F. Although TD-NiCr is normally considered oxidation resistant when furnace tested, in Mach 1 burner rig tests at NASA-Lewis Research Center it lost weight rapidly in 100 hours at 2000°F. Therefore it was included in the present program for further improvement. The program is divided into two tasks. Task I is to develop slurry coating techniques for applying dense, adherent, oxidation resistant, and ductile coatings 5 mils thick. Screening oxidation tests will be made on sixteen slurry compositions for times up to 100 hours. Task II is for advanced evaluation and improvement for times up to 800 hours at 2300°F. The slurry compositions are based on the Ni-Cr-Al system with silicon additions to lower the fusion temperature.

### III. EXPERIMENTAL WORK - TASK I

#### 3.1 Background

In response to the NASA request for ductile claddings for TD-Ni type materials, Sylvania suggested that the slurry approach for applying coatings be investigated. Sylvania had learned that it was feasible and potentially practical to apply Ni-Cr-Al type coatings to TD-Ni. The addition of 0.75 weight percent silicon to the elemental powders, Ni-(20-30Cr)-(2-8AL) results in a fusion temperature lower than that for the base Ni-Cr-Al compositions. The superiority in oxidation resistance of the ternary alloys over Ni-Cr alloys is fairly well known. Accordingly, the following program was adopted to apply coatings by slurry techniques.

#### 3.2 Materials

Two substrate materials, 0.060 inches thick, were used for application of the slurry compositions. The chemistry of each substrate as supplied by DuPont are given below:

	Cr	ThO <sub>2</sub>	Ti	Fe	Co	S	N	Bend C Radius
TD-Ni Heat 1473	0.01	2.6	0.001	0.01	0.01	0.0011		0.0018 1T
TD-NI Heat 1404-1	0.01	2.4	0.001	0.002	0.008	0.0034		0.0004 1T
TD-NiCr Heat 2453	21.63	2.3				0.0036	0.007	0.014 2.5T
TD-NiCr Heat 2789-1	19.31	1.9				0.0054	0.006	0.0195 1.5T

All elemental powders used in this investigation were of commercial purity and would pass through a -325 mesh screen. The nickel and chromium powders were 1 to 5 microns particle size. A prealloyed Ni-20%Cr powder of similar particle size was used later in the program.

#### 3.3 Coating Development and Alloy Compositions

All specimens were 1" x 1" by 0.060" thick. The samples were tumbled for 100 hours in a water slurry containing ceramic stones and powder that rounded the sample edges and corners to a 15 to 25-mil radius. The samples were lightly grit blasted to give a clean surface for slurry coating. The Ni-Cr-Al-Si slurry composition was sprayed onto the sample at room temperature. A nitrocellulose lacquer, Raffi and Swanson L-17, is used as a vehicle with a metal powder to lacquer ratio of 3 to 1 by weight. A coating weight of 80 to 100 mg/cm<sup>2</sup> would result in a 5-mil thick coating per side after fusion.

The first step in the experimental program was to determine the fusion temperature of each coating alloy composition on both substrates. The nominal chemistry of each coating is given in Table I. Also included

TABLE I

## Task I. Coating Alloy Compositions

Coating Alloy Designation	Initial Powder Composition (weight percent)				Other	Fusion Temperature on Substrate Indicated (°F)		No. of Trials
	Ni	Cr	Al	Si		TD-Ni	TD-NiCr	
1	79.25	16	4	0.75		2510	2500	12
1A	78.50	16	4	1.50		2480	2475	2
2	75.25	20	4	0.75		2460	2460	5
3	73.25	20	6	0.75		2425	2425	5
4	71.25	20	8	0.75		2330	2330	7
5	70.25	25	4	0.75		2430	2430	4
6	68.25	25	6	0.75		2350	2350	4
7	66.25	25	8	0.75		2350	2350	4
8	67.25	30	2	0.75		2455	2455	4
9	65.25	30	4	0.75		2415	2415	4
10	63.25	30	6	0.75		2365	2360	4
11-3	72.75	20	6	0.75	0.5Cb		2395	1
12-3	72.25	20	6	0.75	1.0Cb		2380	1
13-3	72.75	20	6	0.75	0.5 Y		2410	1
14-3	72.75	20	6	0.75	1.0 Y		2380	1
15-3	72.75	20	6	0.75	0.5 Th		2400	1
16-3	72.75	20	6	0.75	1.0 Th		2380	1
11-7	65.75	25	8	0.75	0.5 Cb	2340		1
12-7	65.25	25	8	0.75	1.0 Cb	2335		1
13-7	65.75	25	8	0.75	0.5 Y	2350		1
14-7	65.25	25	8	0.75	1.0 Y	2340		1
15-7	65.75	25	8	0.75	0.5 Th	2345		1
16-7	65.25	25	8	0.75	1.0 Th	2345		1

All above coatings vacuum fused for 15 minutes.

in this table are the fusion temperatures for each composition on each of the two substrates. Also noted are the number of fusion trials to determine the exact fusion temperature of each composition with each substrate. If the furnace temperature is 5°F below the fusion temperature, it was found that specimens were only partially sintered. If the furnace temperature is 5°F too high the coating was found to be too fluid, such that it ran down and formed a "blob" on the sample. The samples are held in a vertical position in a fused quartz slab with slots to hold the sample. All sintering and fusion treatments were performed in a cold wall tantalum resistance heated vacuum furnace, at pressures less than 0.1 torr, with the temperature measured by a Pt/Pt-10Rh thermocouple. Time at temperature was generally 15 minutes.

It was decided that the coating fusion temperature must be less than 2500°F. Coating Alloy 1 (Ni-16Cr-4Al-0.75Si) had a fusion point of about 2500°F. This is too high and too close to the melting point of TD-NiCr. Therefore the silicon content was doubled to 1.50% and the fusion temperature was only lowered slightly. From this experiment and from sintering trials, it was found that 0.75% silicon has a marked effect on lowering the melting point of Ni-Cr-Al compositions, but an excess does not lower the melting point much more. (Other experimental work with the basic Ni-Cr-Al compositions verified that the melting points were over 2600°F when no silicon was added. Many difficulties were caused by lack of chemical purity within the vacuum furnace used for this work.

As shown in Table 1, all coated samples were fused in a vacuum furnace for 15 minutes at the temperature given. The fusion temperature of certain coatings on TD-NiCr were slightly lower than on TD-Ni. No positive explanation can be given for this fact. As coated, the samples have a relatively smooth surface and may have a metallic shiny appearance. Usually, as the aluminum content increases, it results in a matte grey surface.

These coatings can be fused in a dry hydrogen atmosphere at the same or slightly lower temperatures than required in vacuum. Some of the silicon is lost by vaporization in the vacuum furnace. At atmospheric pressure no silicon or aluminum can be lost by vaporization. Therefore the fusion temperature in a hydrogen atmosphere is the same or lower. However, with the coatings reported here, all fusion was done in vacuum, since the equipment was more readily available.

A total of four samples for each substrate was prepared for each of the eleven (11) coating compositions from 1 to 10; one as-prepared, one bend test, and two for oxidation testing.

#### 3.4 Oxidation Testing at 2300°F, Screening Studies

Oxidation testing was done in a Globar-heated furnace with a hot zone 9" by 9" by 16" deep with flowing air at 30 standard cubic feet per hour. Weight changes were measured every two hours for the first 20 hours for

duplicate specimens and each twenty-hour cycle thereafter for one of the duplicate specimens (testing is terminated when  $11 \text{ mg/cm}^2$  is exceeded). The second sample was sectioned in thirds after 20, 60, and 100 hours total accumulated time at  $2300^\circ\text{F}$  to provide a record of the microstructural changes during exposure. Weight determinations were made both with exfoliated oxide and with the oxide brushed lightly from the specimen into a standard alumina crucible for retention until completion of the test. Duplicate uncoated TD-NiCr specimens were similarly tested and evaluated for control purposes.

For reference purposes the weight change behavior of an uncoated TD-NiCr sample oxidized in the manner described above is shown in Figure 1. Sixteen samples were tested with the weight change results all within plus or minus  $0.5 \text{ mg/cm}^2$ . At  $2300^\circ\text{F}$  the oxide formed on TD-NiCr is  $\text{Cr}_2\text{O}_3$  which will spall off with time. The two curves shown in this figure and all other figures of this nature are (1), weight change with sample only, and (2), sample weight change plus any and all spalled oxide(s). With uncoated TD-NiCr at  $2300^\circ\text{F}$  the sample is losing weight after a certain time period. The total weight change sample and spall is always positive and about  $2 \text{ mg/cm}^2$  after 100 hours at  $2300^\circ\text{F}$ . Thus, the load bearing area is always decreasing, a major reason for the coating requirement.

Curves giving the  $2300^\circ\text{F}$  oxidation behavior of each of the eleven screening coating compositions are shown in Figures 2 through 12 for both substrates. With many coating compositions the coated TD-Ni sample would fail by oxidation at an edge(s) due to extreme thinness of the coating at these areas. This is a serious practical coating problem. This phenomenon also occurs with coated TD-NiCr but is much more difficult to detect visually or any other practical method. When the TD-Ni substrate is exposed to oxidizing conditions at  $2300^\circ\text{F}$ , it is visually very easy to detect the glassy black NiO. Visual observations are quite critical and important in evaluating any oxidation resistant coating system.

The contract states that the selection of the most oxidation resistant coating composition will be made from oxidation, metallographic, diffusion, and bend test data. Coating Alloy 7 (Ni-25Cr-8Al-0.75Si) was selected for the TD-Ni substrate. Coating alloy 3 (Ni-20Cr-6Al-0.75Si) was selected for TD-NiCr. The reasons will be given after presentation of other test data.

### 3.5 Bend Tests

Bend testing was conducted at room temperature on all screening coating compositions with both substrates using MAB-176 procedures. Samples were tested both as-coated and after 100 hours (maximum oxidation time) at  $2300^\circ\text{F}$ . The ram speed was one (1) inch per minute with a 4T radius plunger. The test results are given in Table II. All of the samples withstood the  $90^\circ$  bend after oxidation. With the TD-Ni substrate all of the samples would withstand the bend test as-coated with some cracking of the coating on the tension side. Most of the as-coated TD-NiCr samples were completely brittle in this test. But note that this batch of TD-NiCr uncoated would only take a 2.5T bend as reported by DuPont. The coating made it notch sensitive.

(Text continued page 20)

UNCOATED TD-NiCr

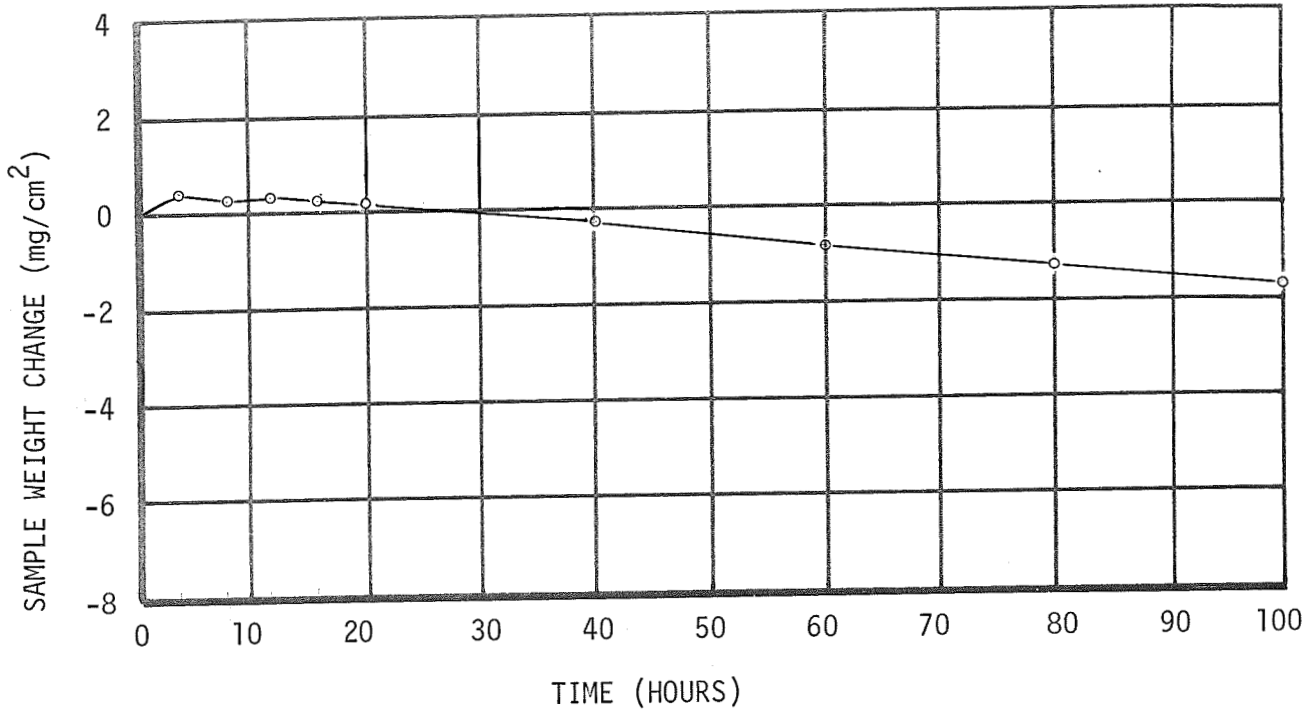

TD-NiCr - Control L

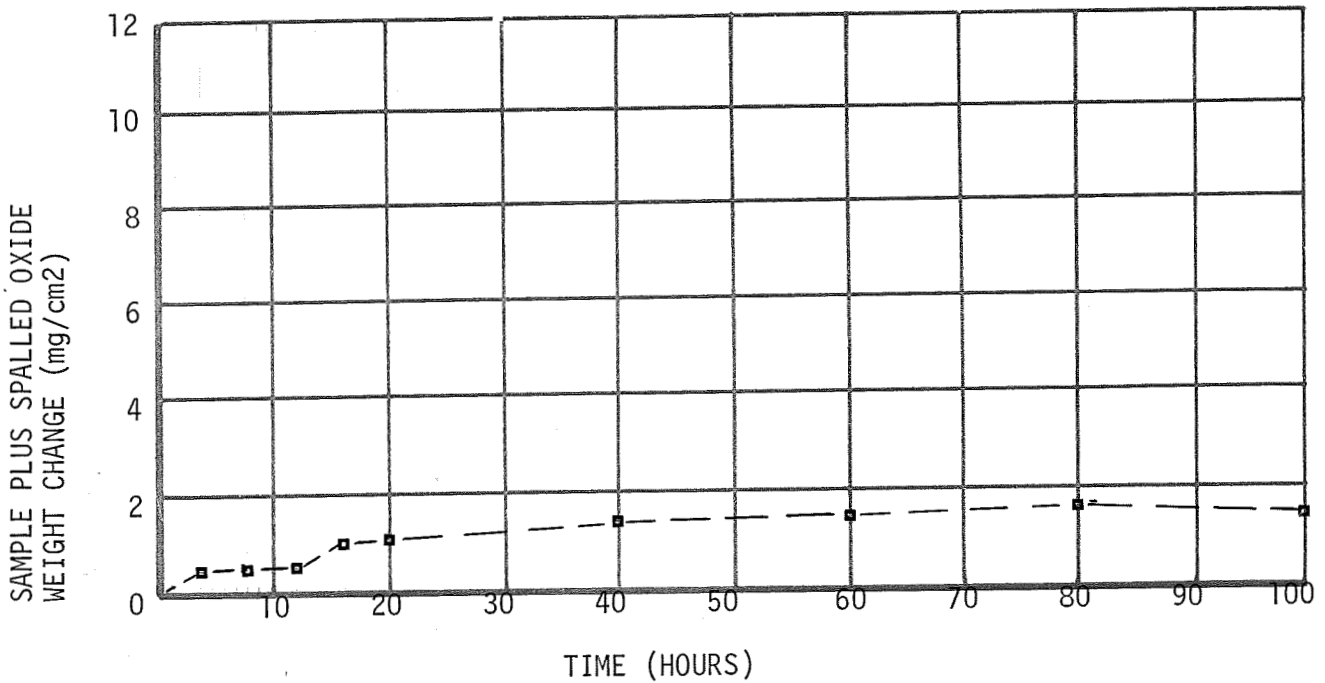

Oxidation Behavior at 2300°F of Uncoated TD-NiCr Sample

FIGURE 1

COATING ALLOY 1 (Ni-16Cr-4Al-0.75Si)

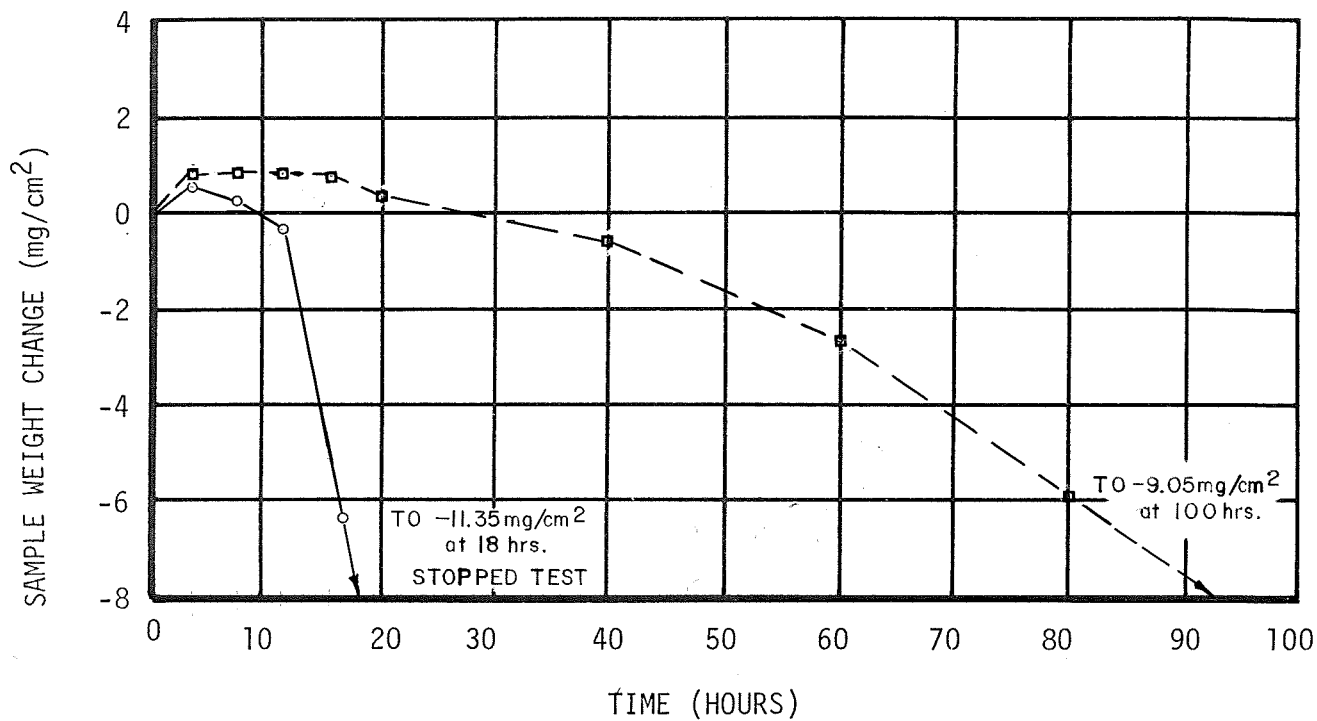

○ TD-Ni ————— #214 N  
 □ TD-NiCr - - - - - #219 N

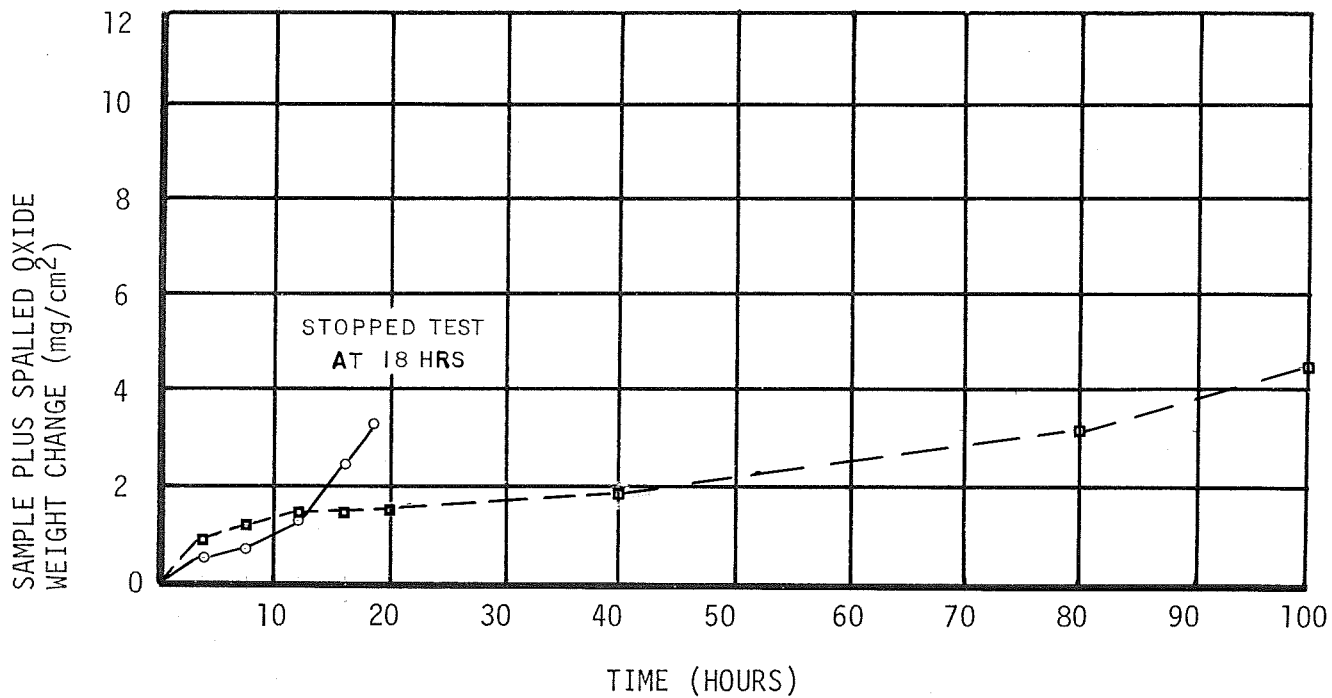

Oxidation Behavior at 2300°F With Coated TD-Ni and TD-NiCr Samples

FIGURE 2

COATING ALLOY 1A (Ni-16Cr-4Al-1.50Si)

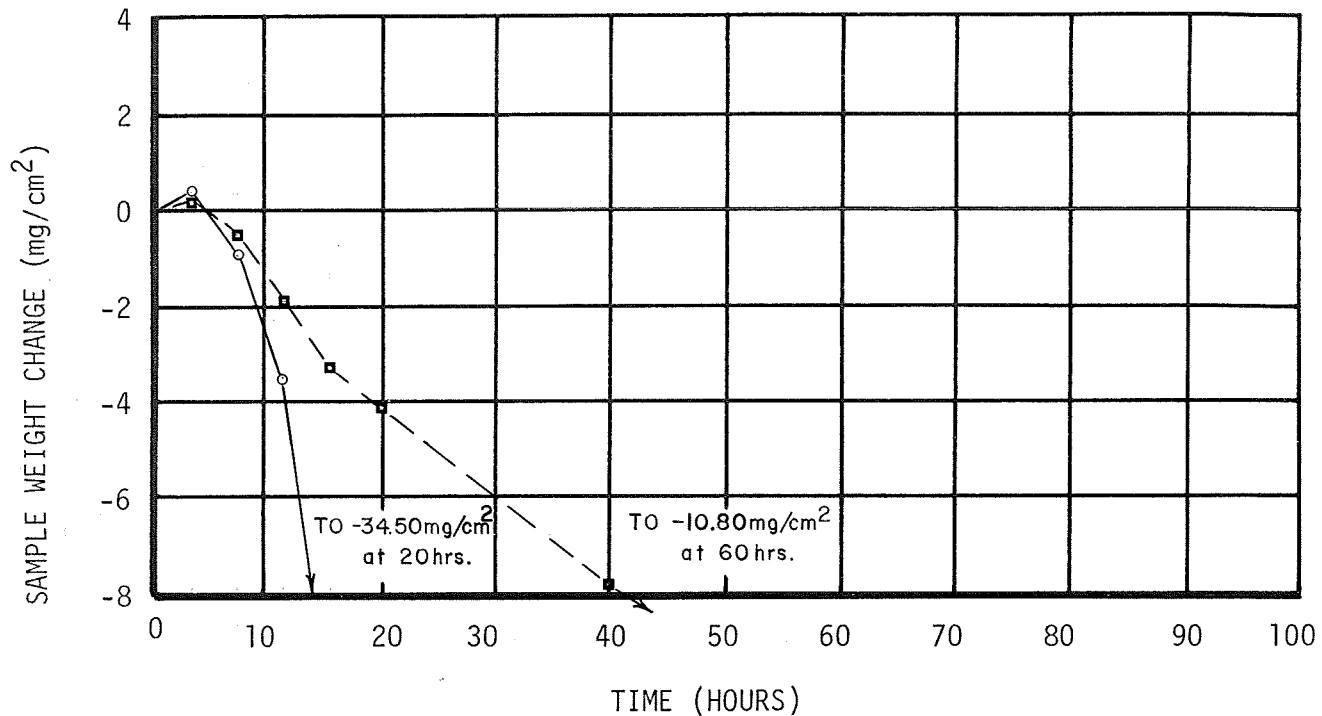

○ TD-Ni ————— #223 N  
 □ TD-NiCr - - - - - #229 C

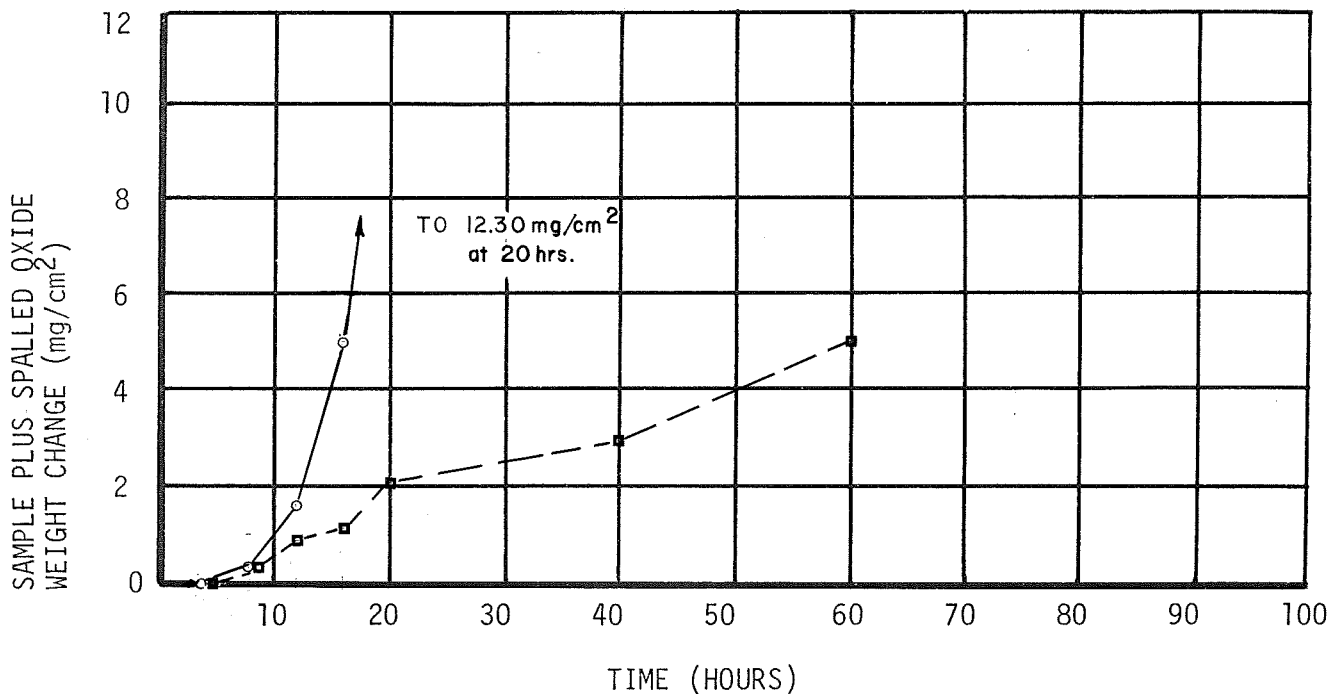

Oxidation Behavior at 2300°F With Coated TD-Ni and TD-NiCr Samples

FIGURE 3

COATING ALLOY 2 (Ni-20Cr-4Al-0.75Si)

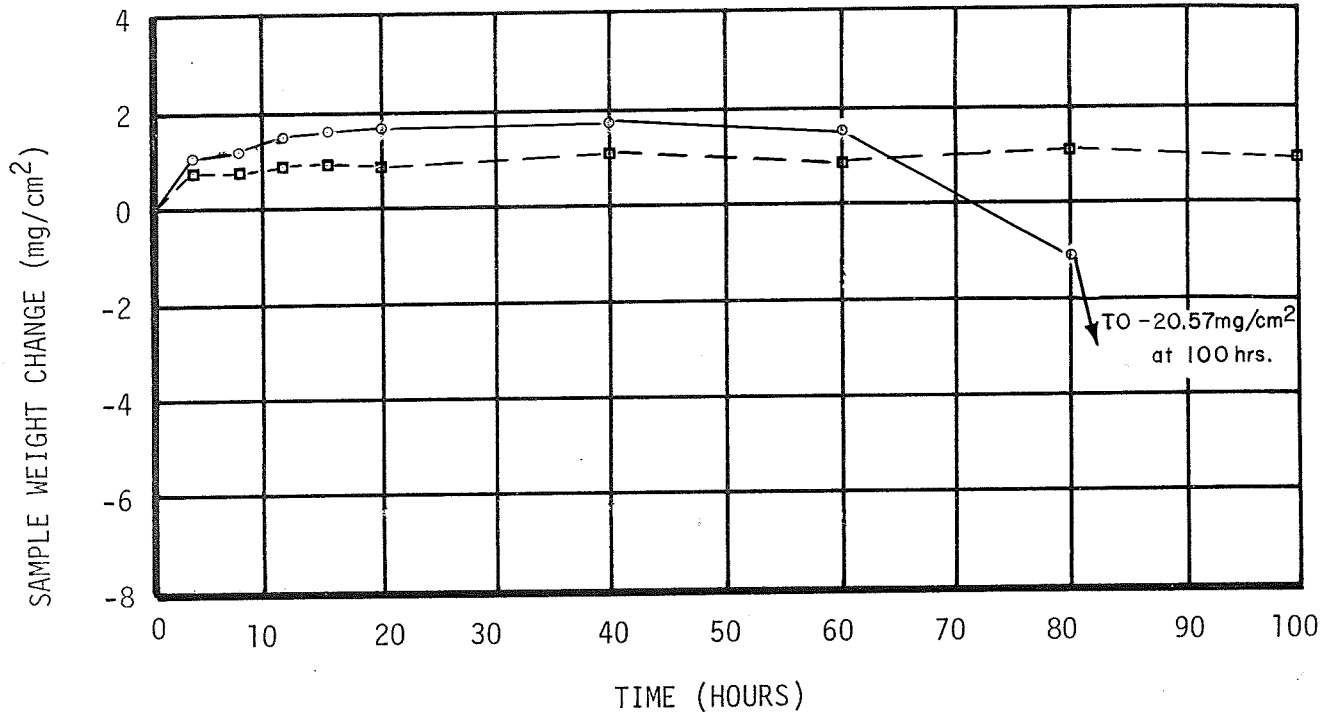

○ TD-Ni ——— # 128 N  
 □ TD-NiCr - - - # 133 C

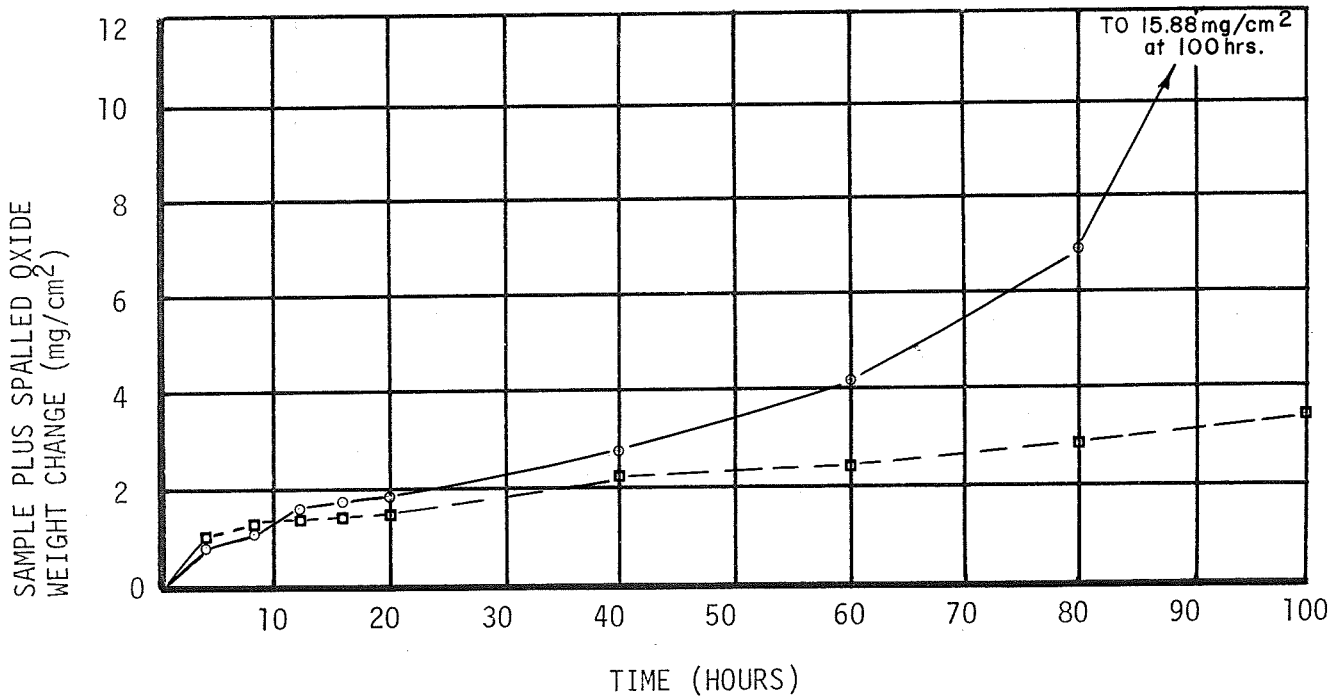

Oxidation Behavior at 2300°F With Coated TD-Ni and TD-NiCr Samples

FIGURE 4

COATING ALLOY 3 (Ni-20Cr-6Al-0.75Si)

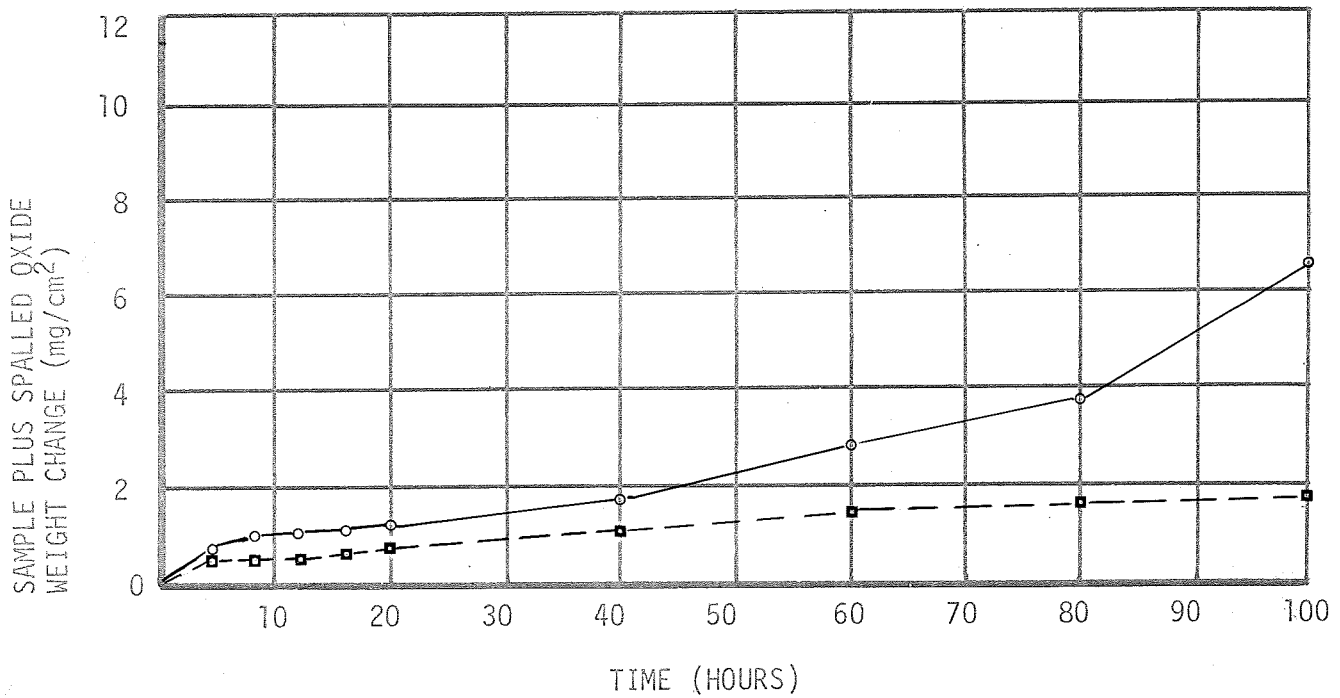
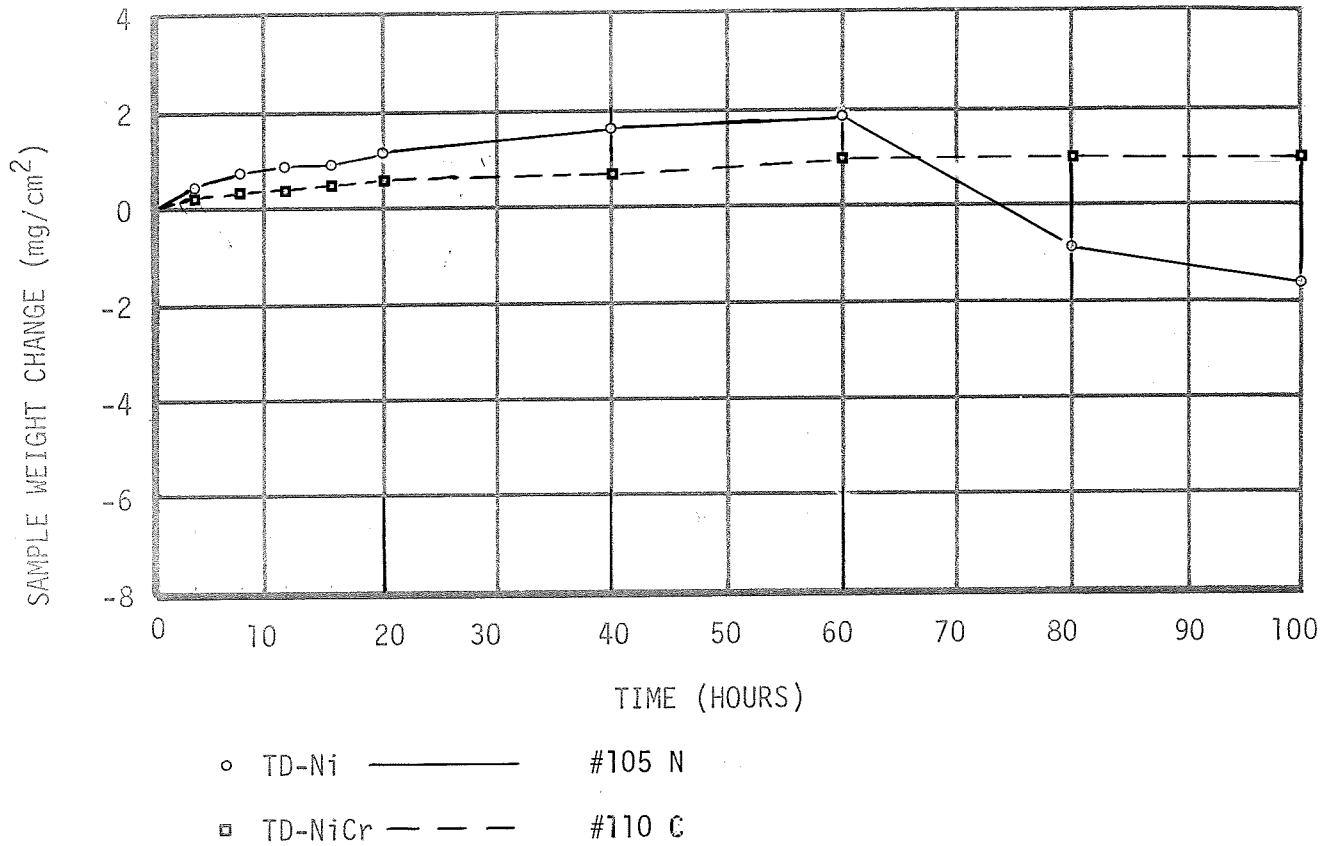

Oxidation Behavior at 2300°F With Coated TD-Ni and TD-NiCr Samples

FIGURE 5

COATING ALLOY 4 (Ni-20Cr-8Al-0.75Si)

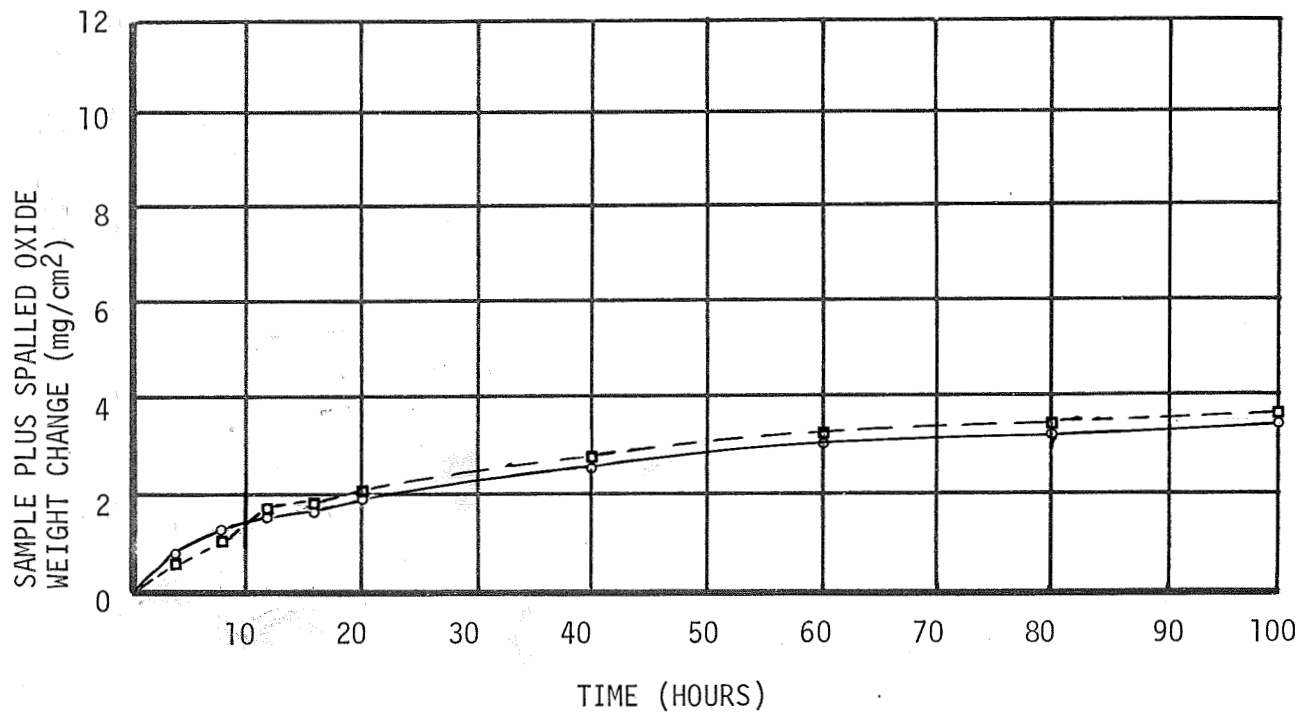
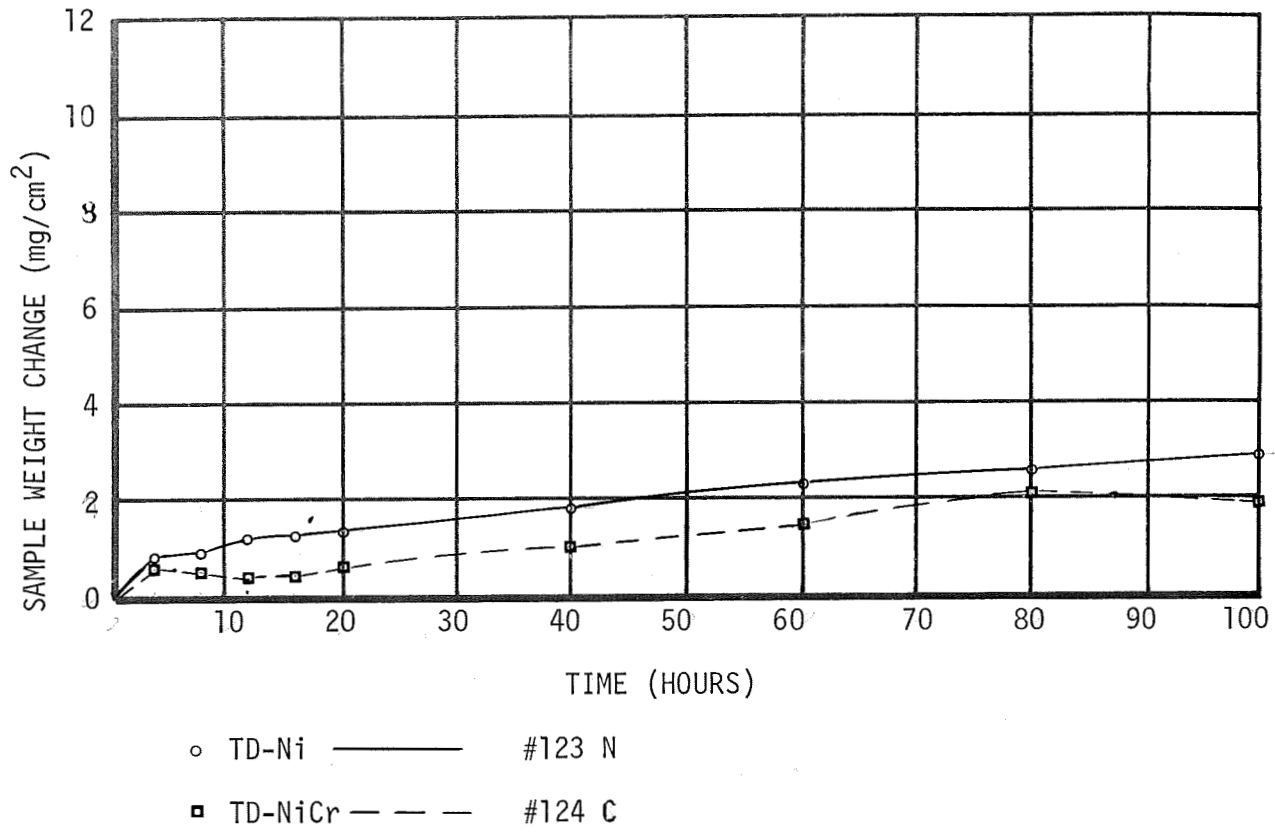

Oxidation Behavior at 2300°F With Coated TD-Ni and TD-NiCr Samples

FIGURE 6

COATING ALLOY 5 (Ni-25Cr-4Al-0.75Si)

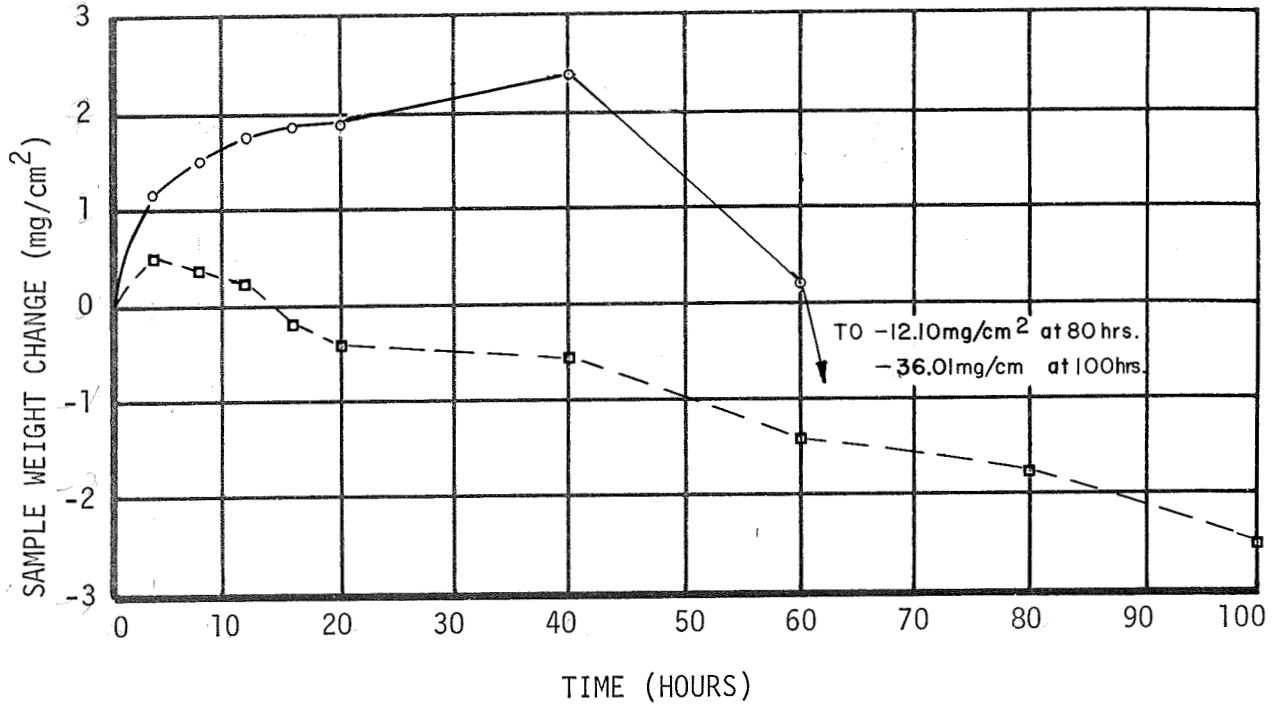

○ TD-Ni ——— #139 N  
 □ TD-NiCr - - - - #144 C

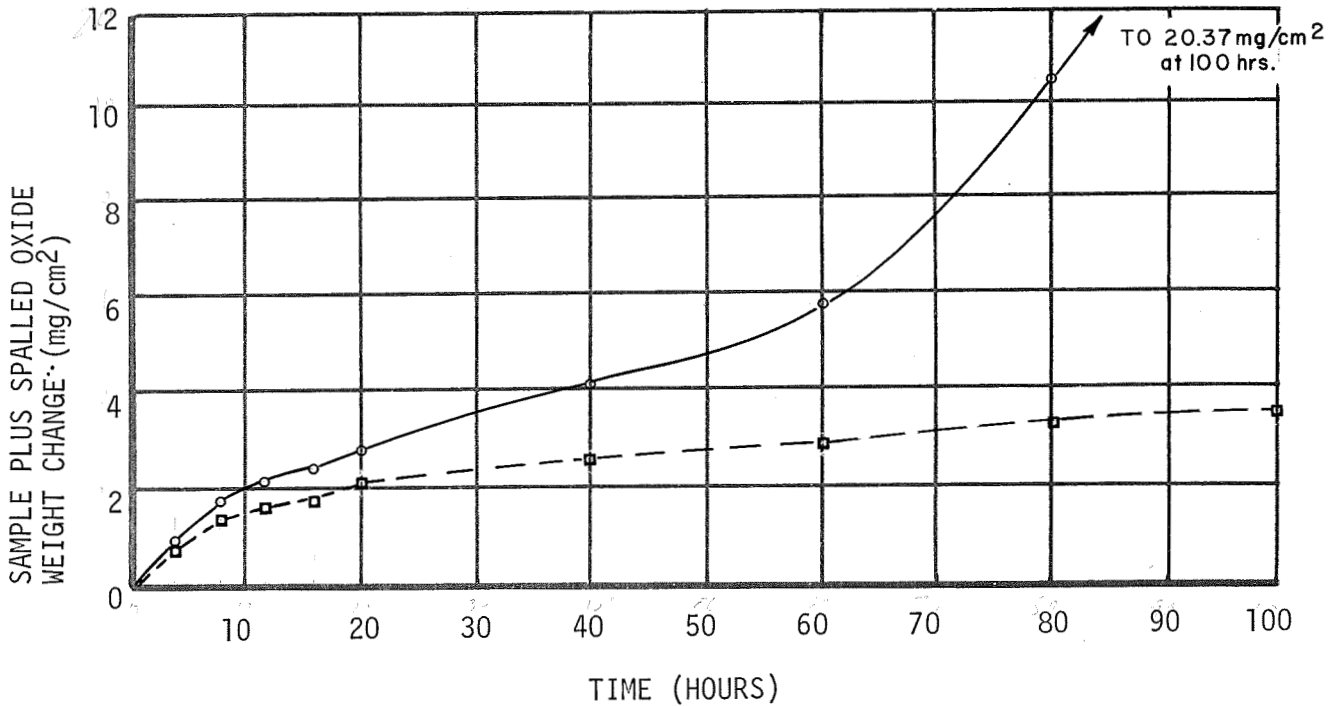

Oxidation Behavior at 2300°F With Coated TD-Ni and TD-NiCr Samples

FIGURE 7

COATING ALLOY 6 (Ni-25Cr-6Al-0.75Si)

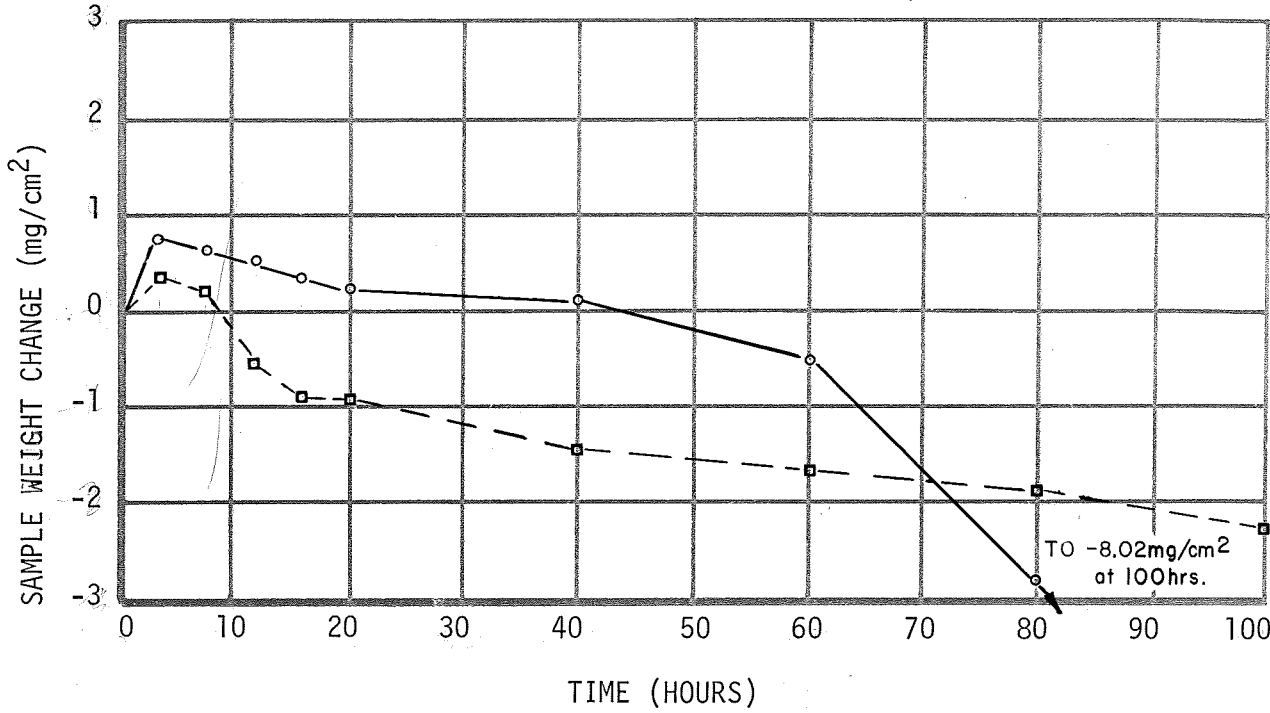

○ TD-Ni ——— #149 N  
 □ TD-NiCr - - - #154 C

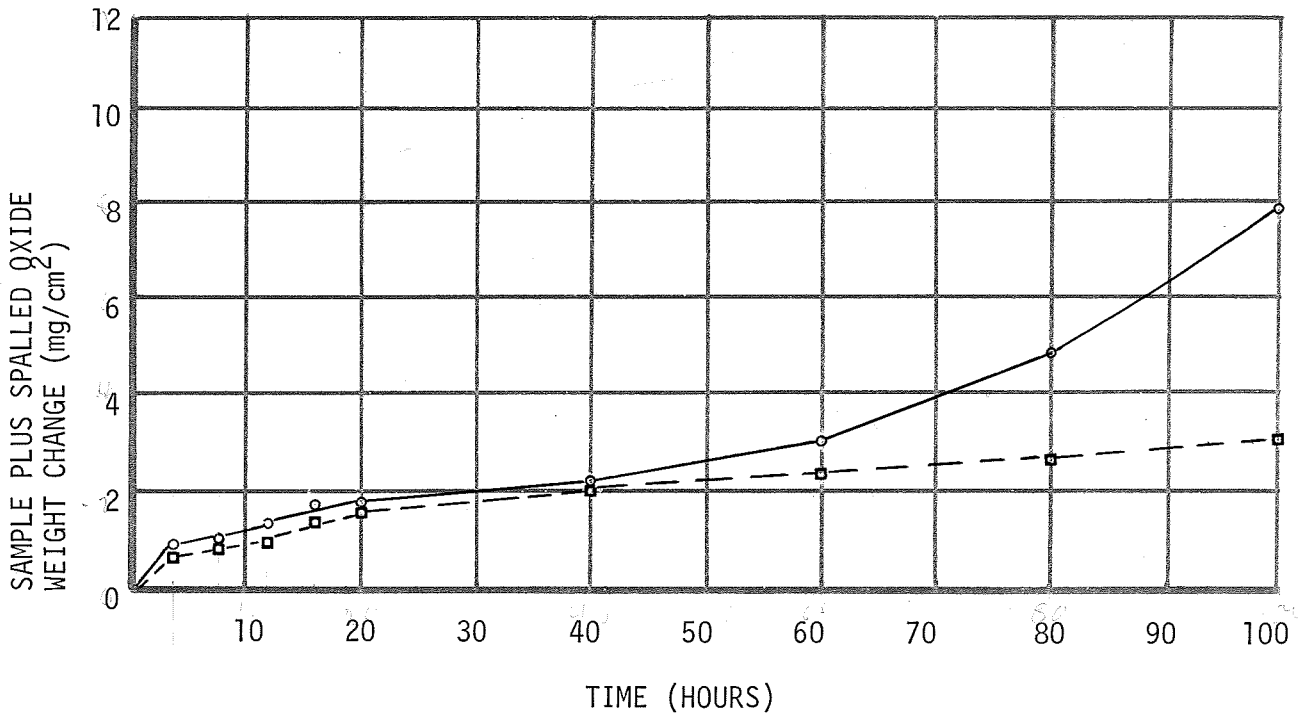

Oxidation Behavior at 2300°F With Coated TD-Ni and TD-NiCr Samples

FIGURE 8

COATING ALLOY 7 (Ni-25Cr-8Al-0.75Si)

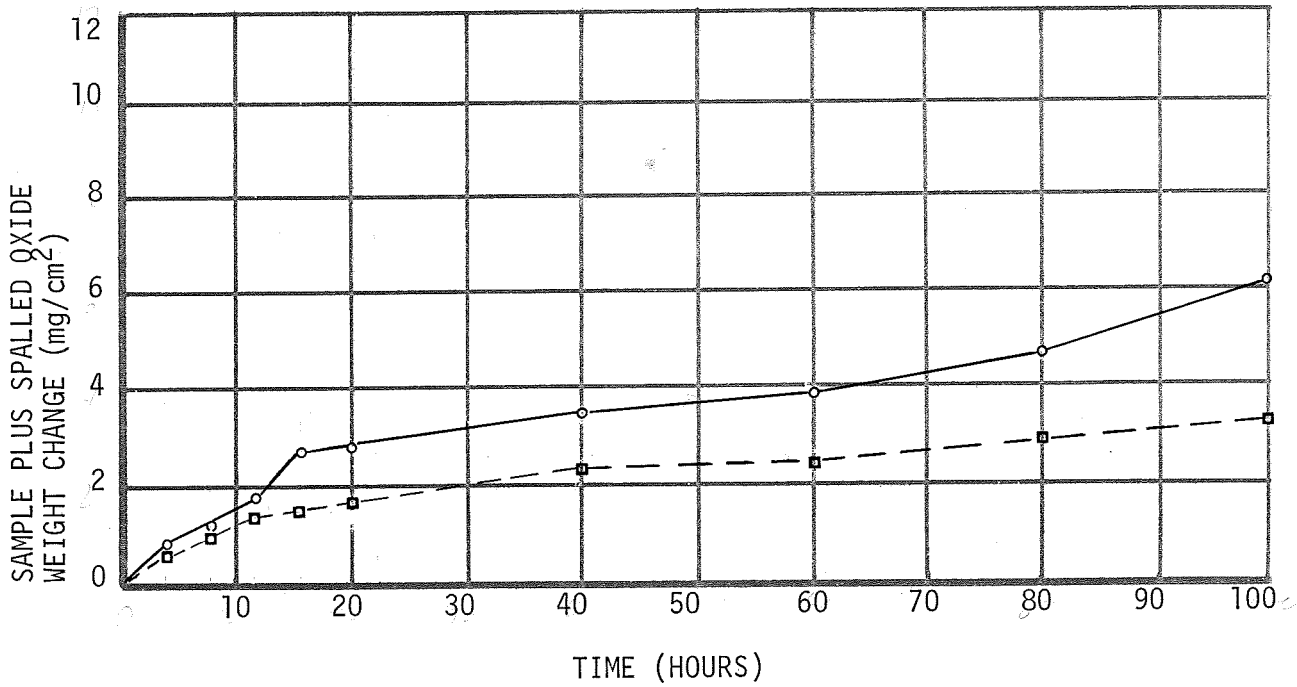
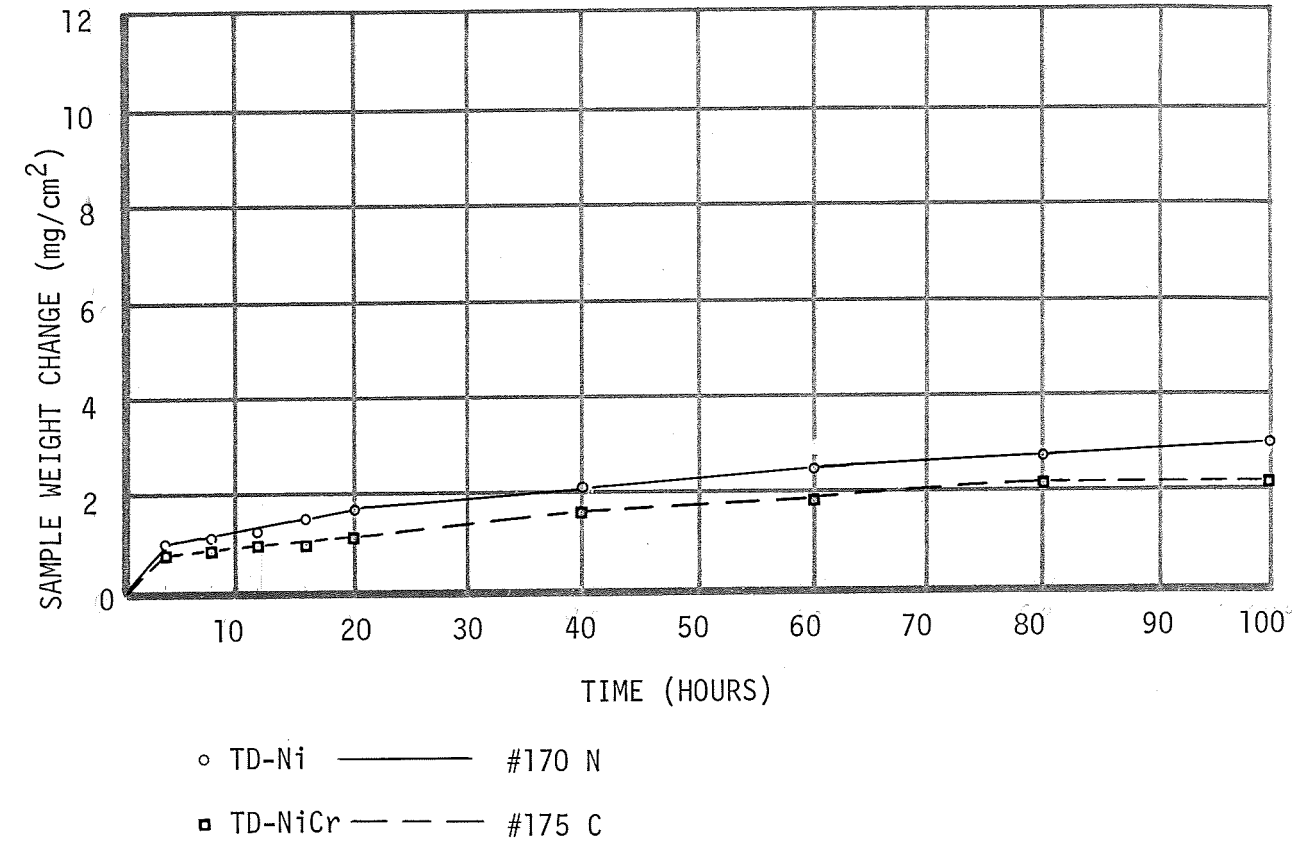

Oxidation Behavior at 2300°F With Coated TD-Ni and TD-NiCr Samples

FIGURE 9

COATING ALLOY 8 (Ni-30Cr-2Al-0.75Si)

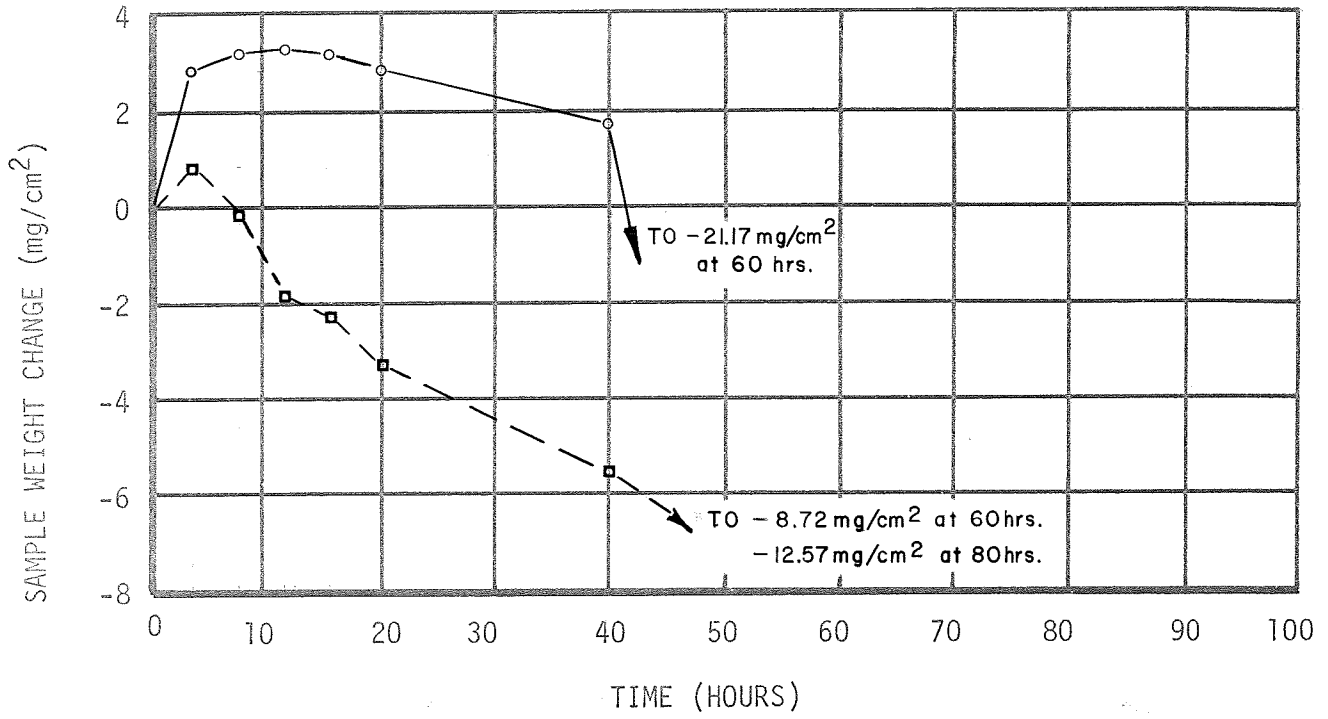

○ TD-Ni ——— #180 N  
 □ TD-NiCr - - - #185 C

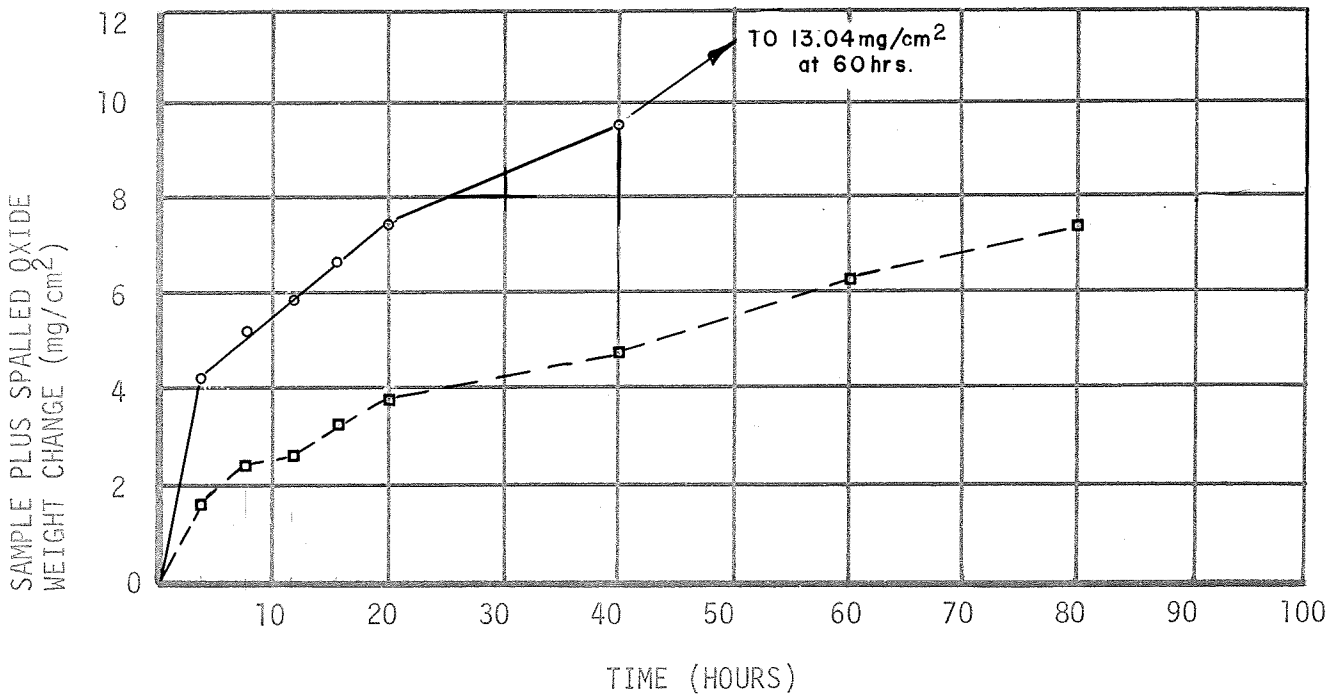

Oxidation Behavior at 2300°F With Coated TD-Ni and TD-NiCr Samples

FIGURE 10

COATING ALLOY 9 (Ni-30Cr-4Al-0.75Si)

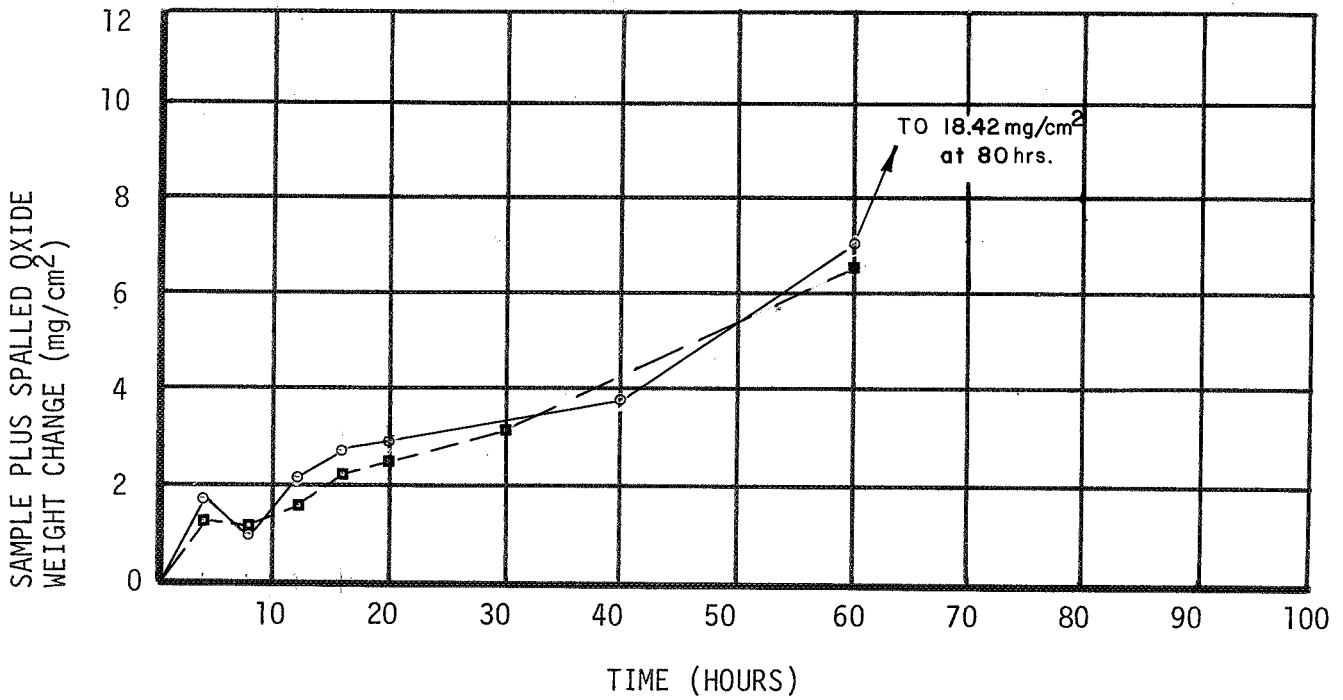
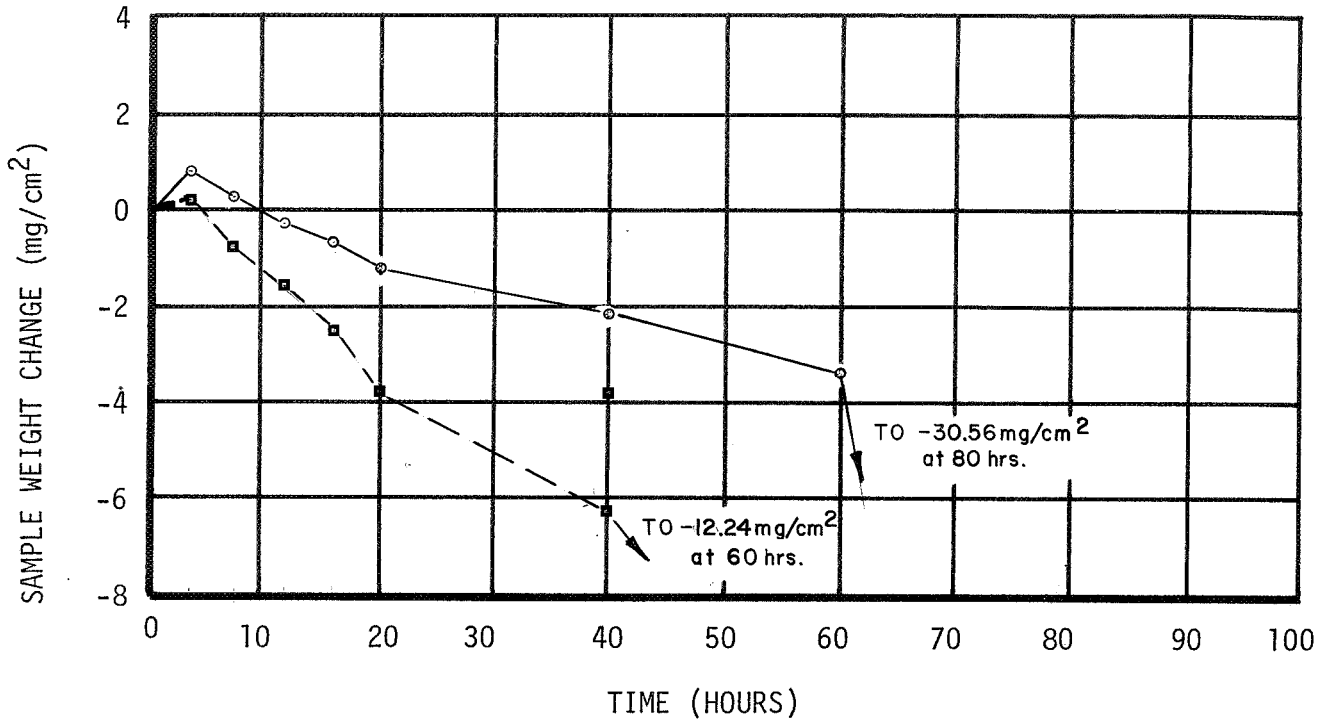

Oxidation Behavior at 2300°F With Coated TD-Ni and TD-NiCr Samples

FIGURE 11

COATING ALLOY 10 (Ni-30Cr-6Al-0.75Si)

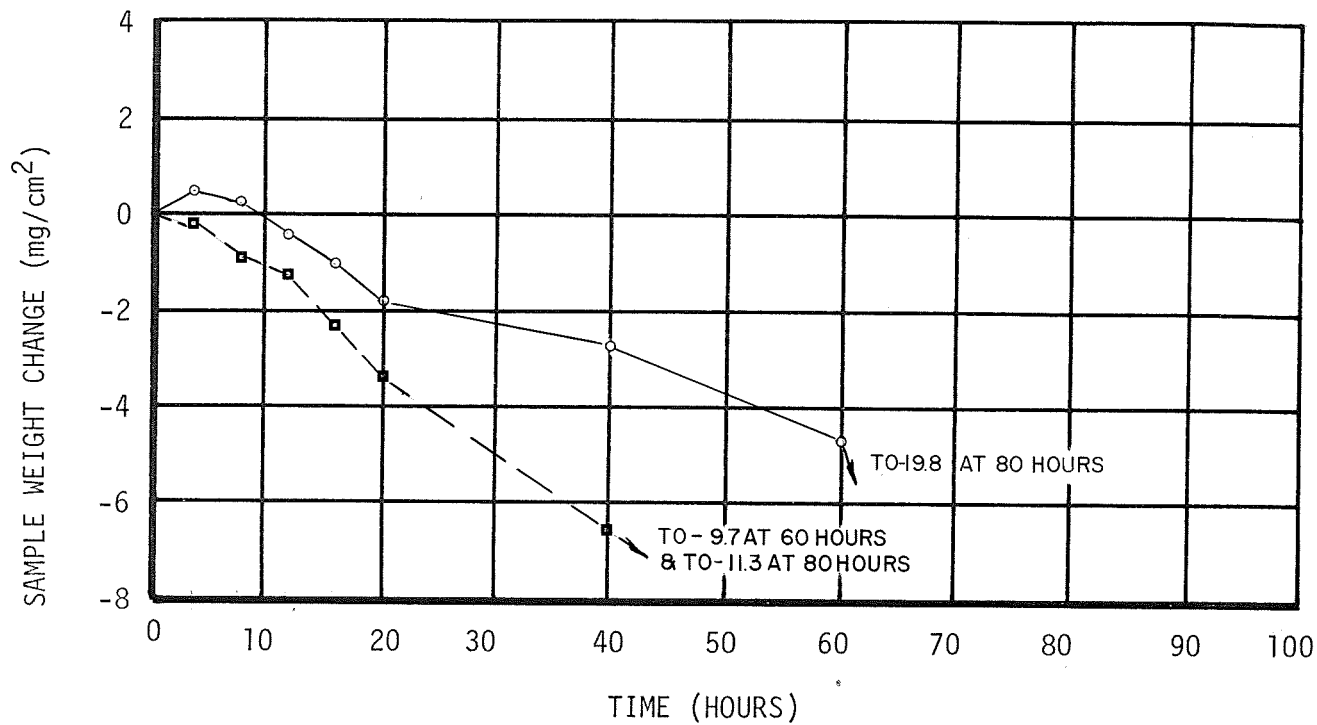

○ TD-Ni ————— #200 N  
 □ TD-NiCr - - - - - #205 C

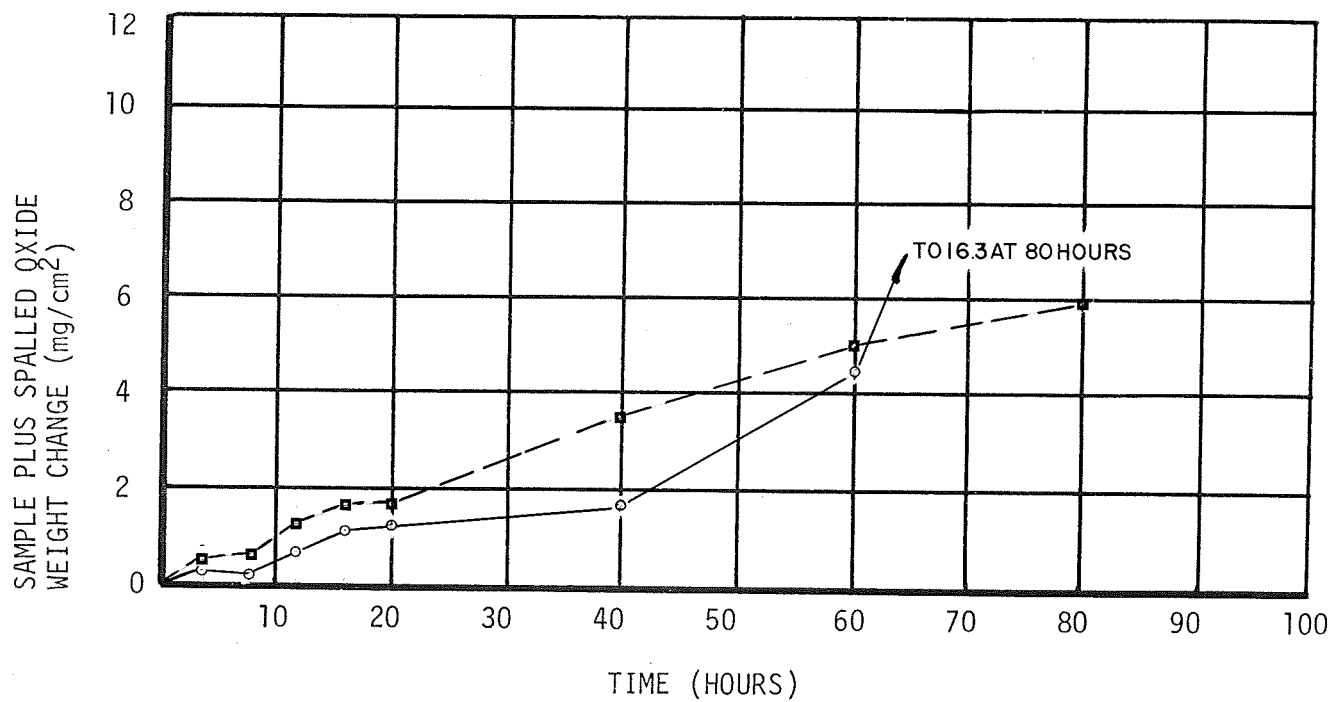

Oxidation Behavior at 2300°F With Coated TD-Ni and TD-NiCr Samples

FIGURE 12

TABLE II

Bend Test Results on Coated and Oxidized  
TD-Ni and TD-NiCr Samples

Coating Alloy	TD-Ni Substrate			TD-NiCr Substrate		
	As Coated Ductility*	Oxidized 2300°F Hours	Ductility	As Coated Ductility*	Oxidized 2300°F Hours	Ductility
1	Ductile	100	Ductile	Ductile	100	Ductile
1 A	Ductile			Ductile		
2	Ductile	100	Ductile	Ductile	100	Ductile
3	Ductile		Ductile	Ductile	100	Ductile
4	CC-S Be	100	Ductile	Broke	100	Ductile
5	Ductile	100	Ductile	Ductile	100	Ductile
6	Ductile	100	Ductile	Broke	100	Ductile
7	CC-S Be	100	Ductile	Broke	100	Ductile
8	Ductile	60	Ductile	Ductile	100	Ductile
9	Ductile	80	Ductile	CC-S Be	80	Ductile
10	CC-S Be	80	Ductile	Broke	80	Ductile

\*CC-S Be Coating cracked - sample bent

### 3.6 Metallographic Examination

All of the as-coated and oxidized samples were metallographically examined. Photomicrographs of fine screening coating Compositions 1, 2, 3, 7 and 9 on TD-Ni and TD-NiCr substrates as coated and after 20, 60, and 100 hours of oxidation at 2300°F are shown in Figures 13 to 20. Coating Compositions 4, 6, 7, 9, and 10 show a two-phase microstructure as typified by alloy 7 (Figure 28). This explains the brittleness of these coatings as shown by the bend test. Many of these two-phase coating microstructures are brittle. The second phase appears to be aluminum rich by chemical etching techniques. This was later proved by electronmicroprobe analysis.

Vacuum homogenization heat treatments were given to Compositions 4, 6, and 7 on both substrates. They were one and four hours at 2300°F. The microstructures are shown in Figures 21 and 22. As indicated, these coatings can be made single phase by a heat treatment. In addition, no sample had a second phase after 20 hours of oxidation at 2300°F. Although standard bend tests were not performed on these single phase coating samples, the samples could be bent by hand without cracking. This would indicate that solution treatments could be provided to improve the ductility and fabricability of metastable two-phase coatings. However, for many applications such treatments may not be necessary.

The gross porosity in the oxidized, uncoated TD-NiCr and the coatings themselves are due to the Kirkendall effect. DuPont also reported this finding (Reference 1, Pages 44 to 46). This phenomenon will be discussed further in the Task II section of the report.

The microstructures also make apparent the differences in smoothness of the external surface. This is caused by the very narrow temperature spread between just melting (rough surface) and enough temperature to result in a smooth surface without too much viscous flow to result in a "blob". This is a major weakness in this particular coating system. The presence of aluminum in the coating composition does not help to relieve this problem. The thickness of the coatings also shows too much of a spread. Another weakness is the lack of full thickness coverage at the edges of the samples. The thickness at the edge may be as little as 2 mils (0.002") thick. This results in comparatively early oxidation failure at the edges of coated TD-Ni samples. The same general trend is probably occurring with the coated TD-NiCr samples but is not as readily apparent.

The oxide is not seen on many of the metallographic figures presented because it either has spalled off during oxidation or requires examination at higher magnification. A thin oxide scale has been noted on many tested samples. A typical failed coating with gross oxidation evident is that of Alloy 9 on TD-Ni (Figure 20).

(Continue text on Page 31)

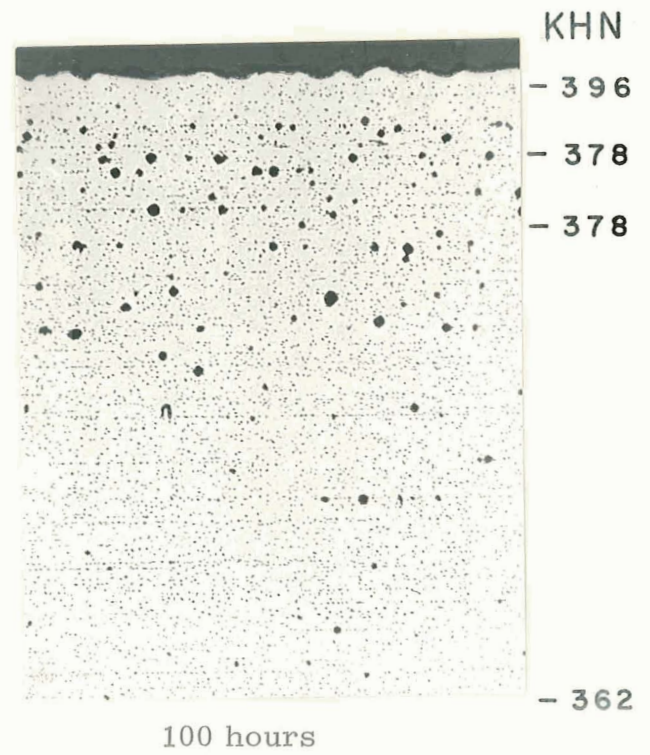
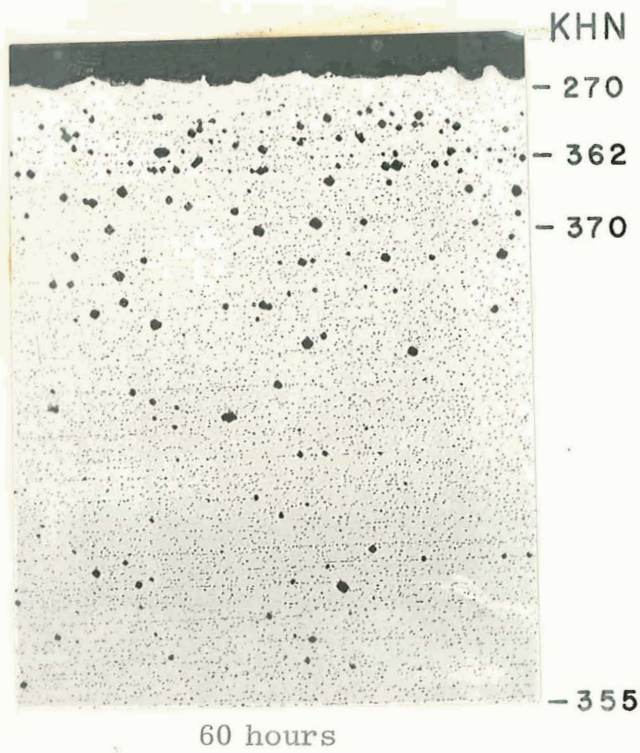
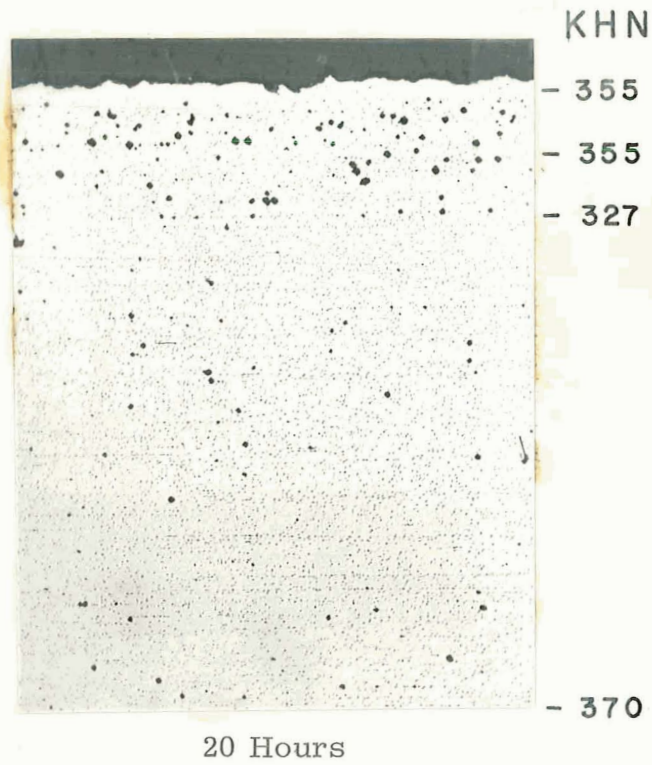
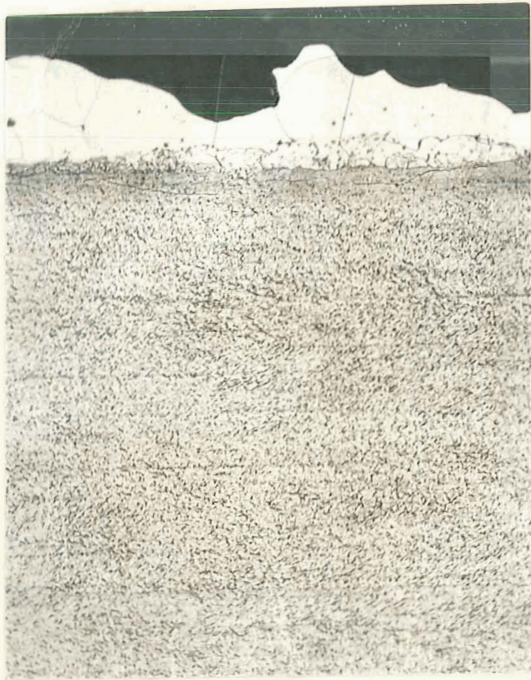
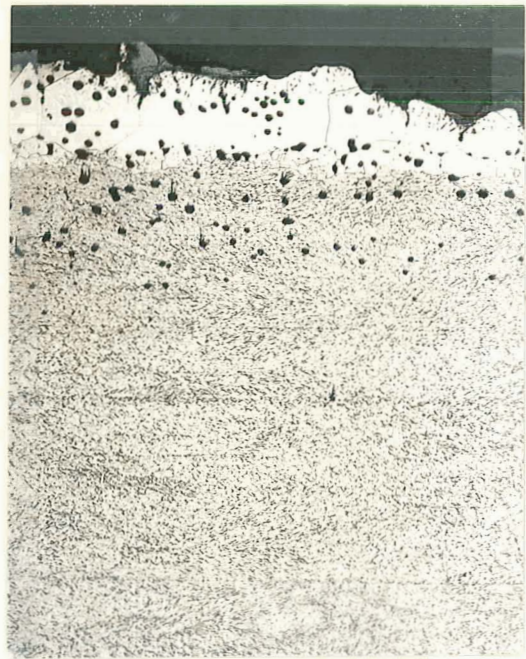

Figure 13. Uncoated TD-NiCr oxidized at 2300°F (100X)  
Microhardness tests made using 100 g load



As coated



20 Hours



60 hours



100 hours

Figure 14. Coating Alloy 1 on TD-NiCr oxidized at 2300°F (100X).



As coated

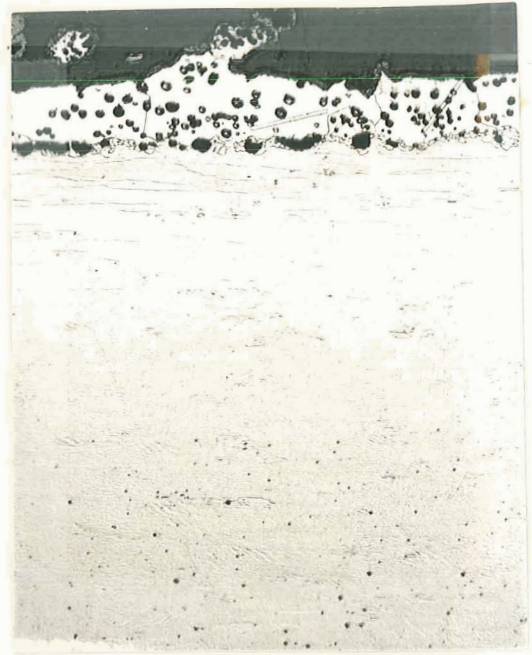

20 hours

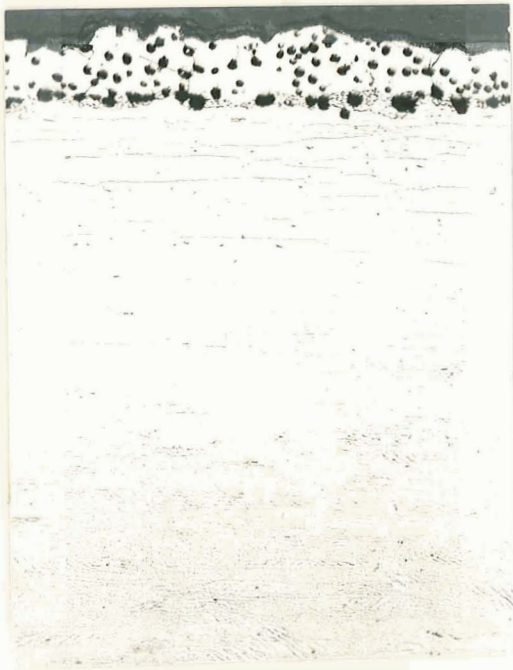

60 hours

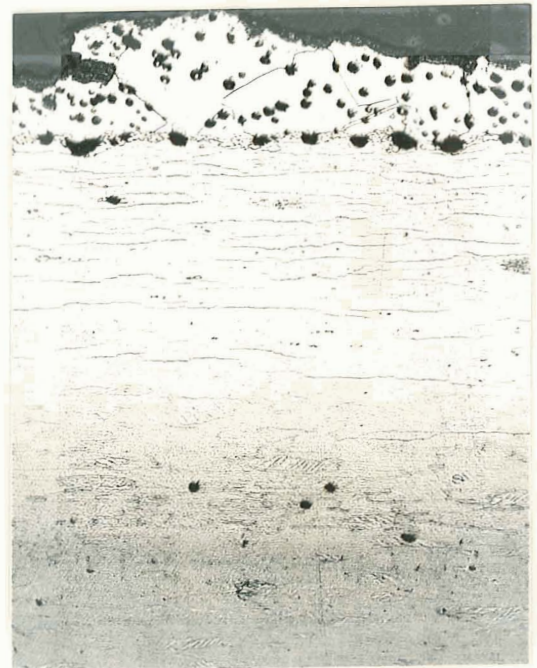

100 hours

Figure 15. Coating Alloy 2 on TD-Ni oxidized at 2300°F (100X)

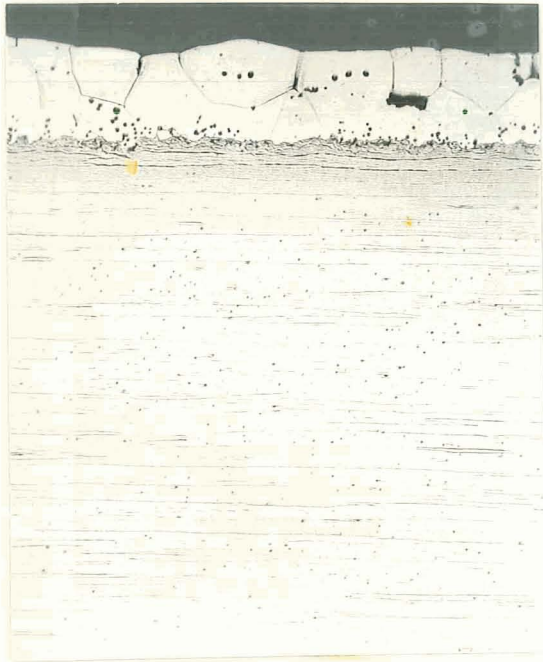

As coated

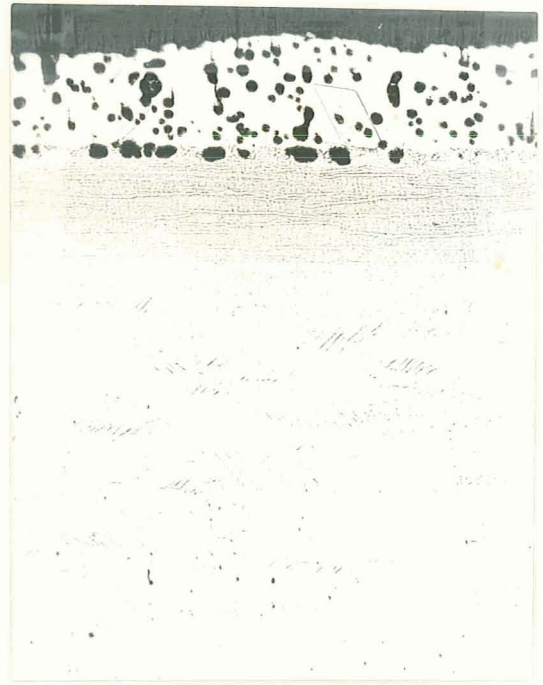

20 hours



60 hours

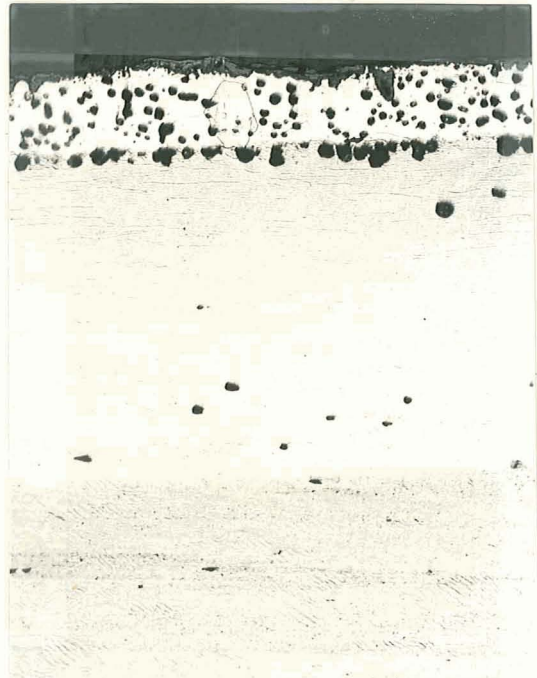

100 hours

Figure 16. Coating Alloy 3 on TD-Ni oxidized at 2300°F (100X)

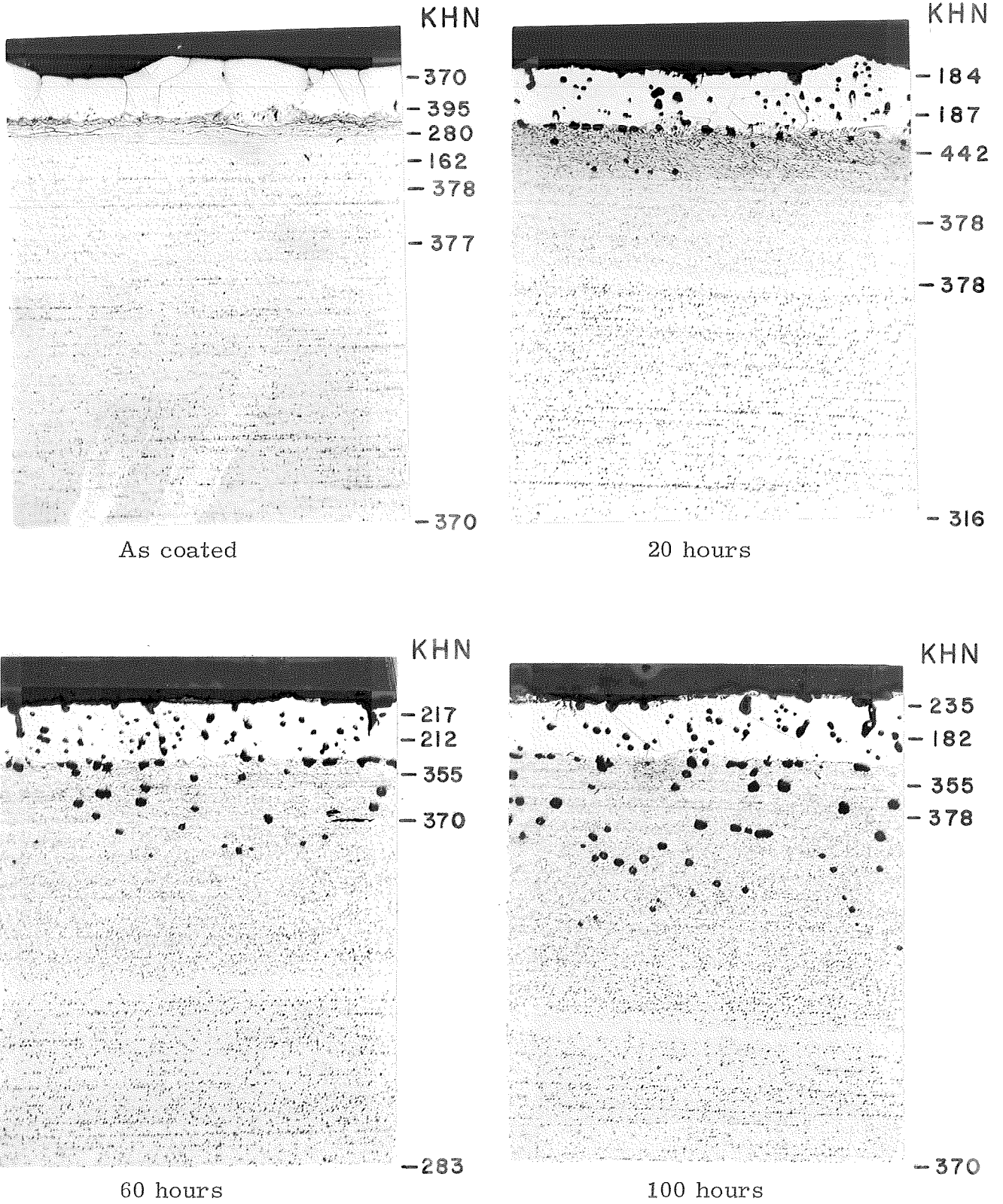
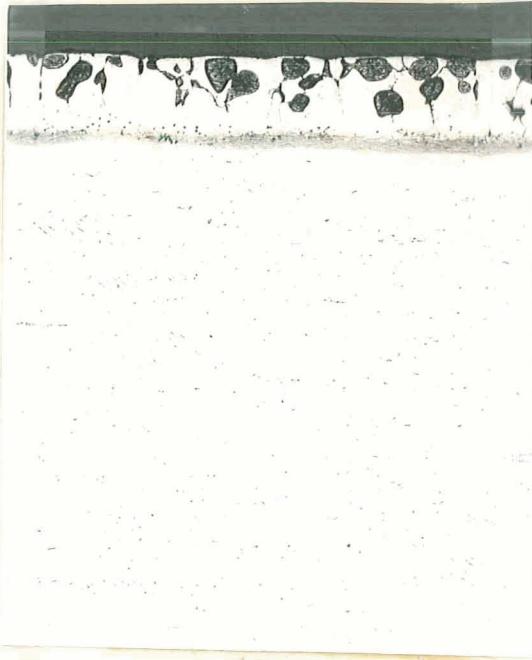

Figure 17. Coating Alloy 3 on TD-NiCr oxidized at 2300°F (100X)  
Microhardness tests made using 100 g load.



As coated



20 hours

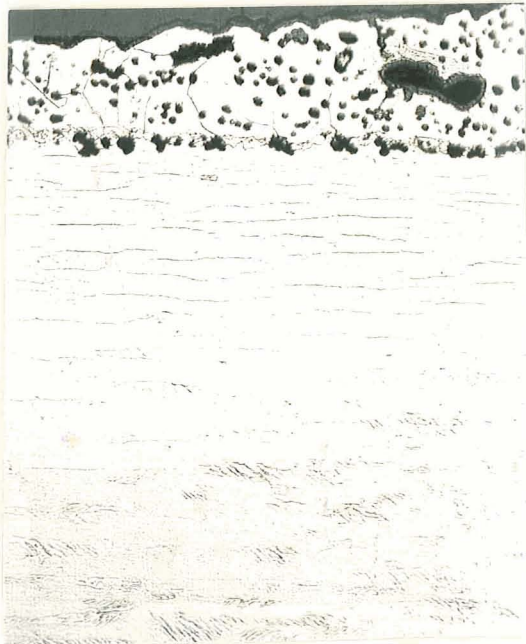

60 hours

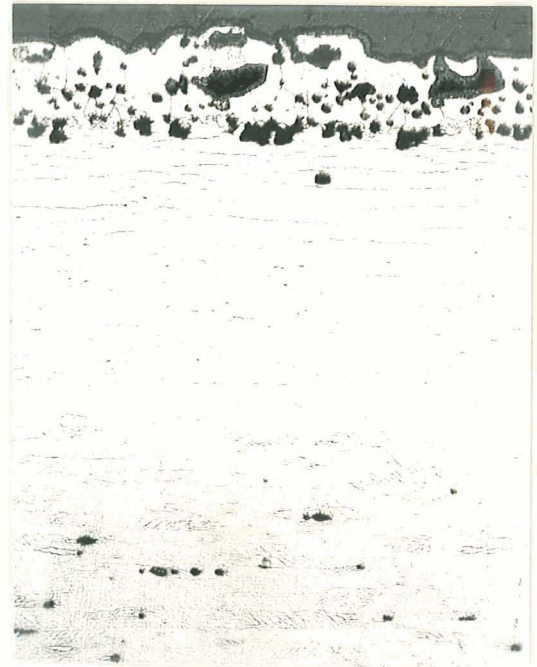

100 hours

Figure 18. Coating Alloy 4 on TD-Ni oxidized at 2300°F (100X)



As coated

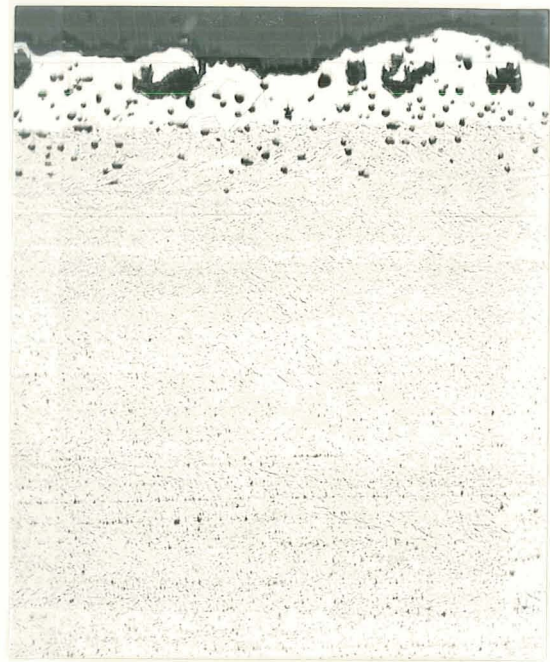

20 hours

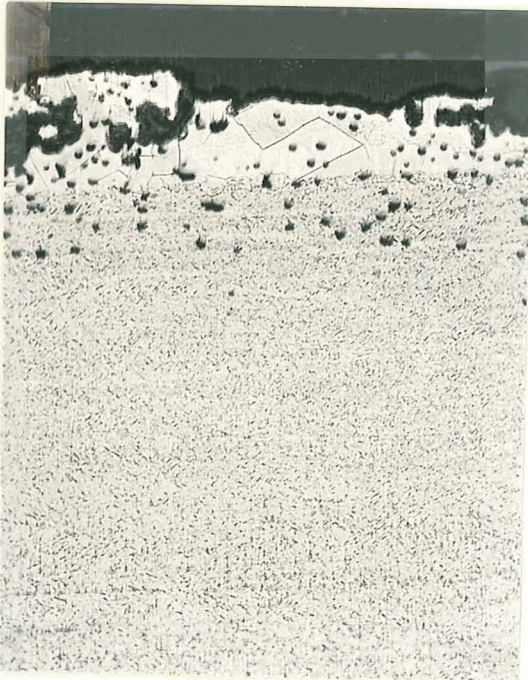

60 hours



100 hours

Figure 19. Coating Alloy 7 on TD-NiCr oxidized at 2300°F (100X)

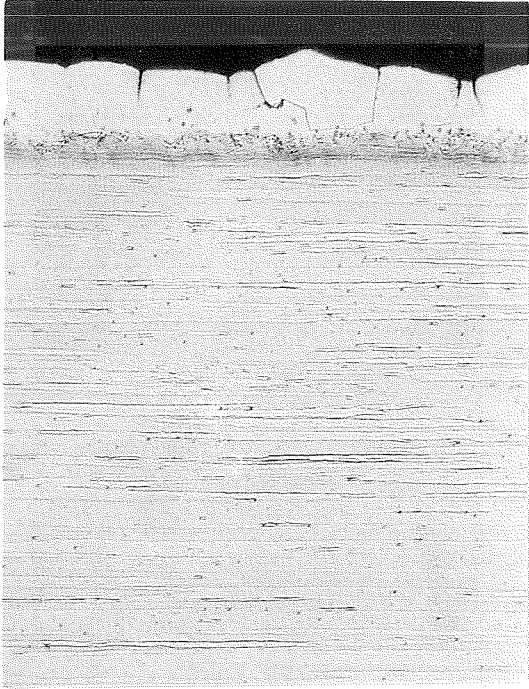

As Coated

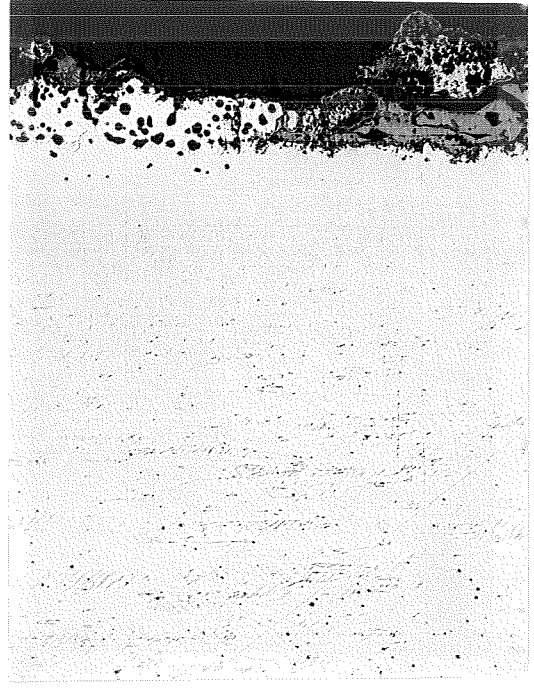

20 Hours

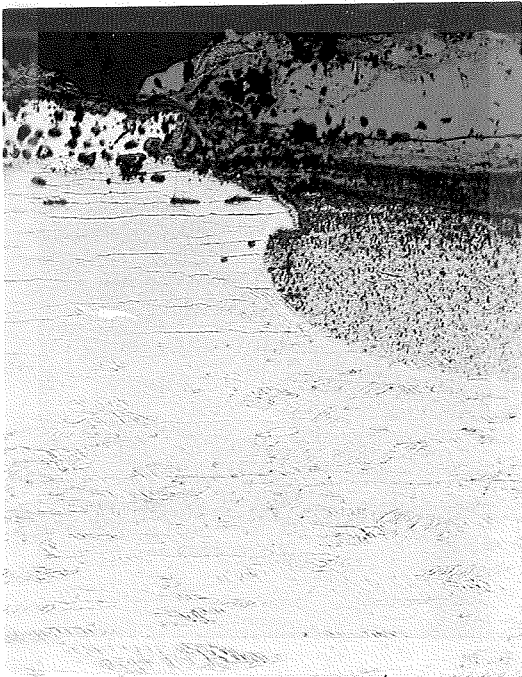

60 Hours

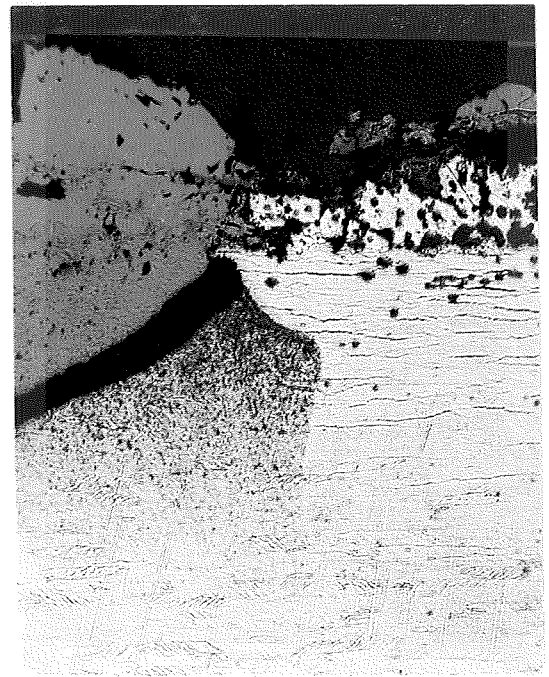

80 Hours

Figure 20. Coating Alloy 9 on TD-Ni oxidized at 2300°F (100X)

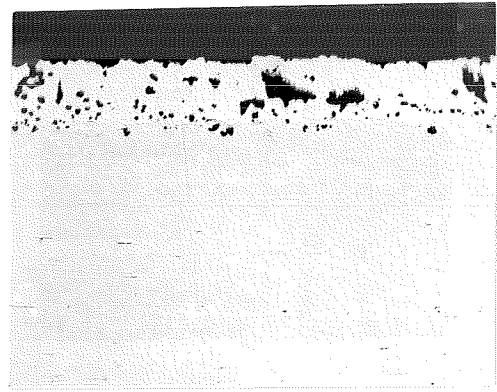
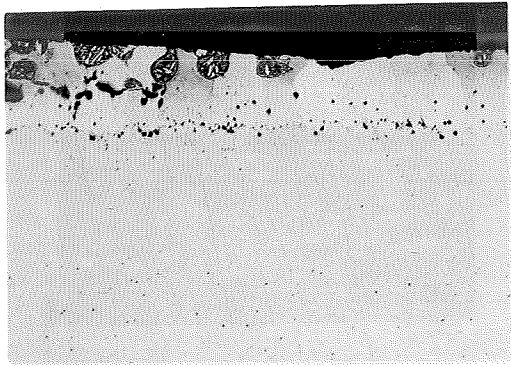

Coating Alloy 4

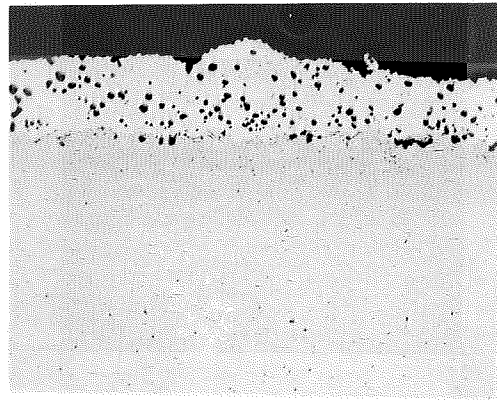
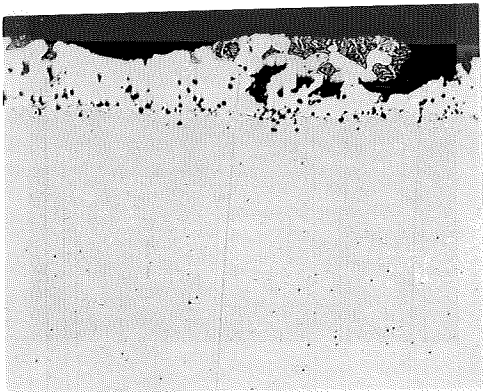

Coating Alloy 6

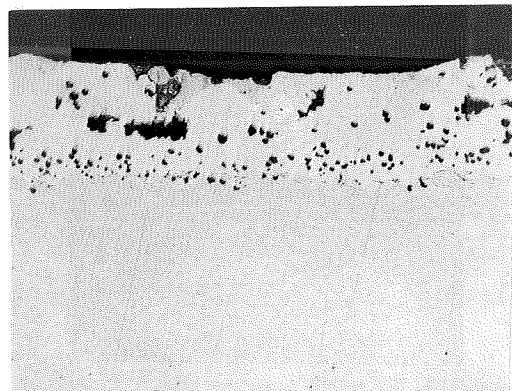
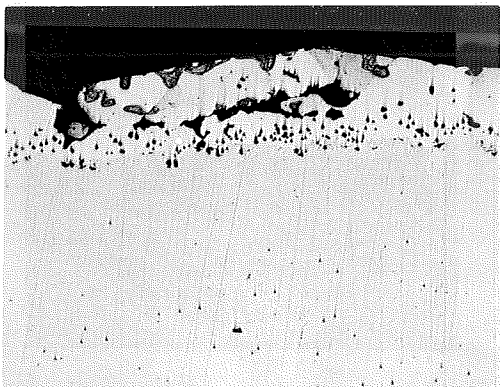

Coating Alloy 7

One Hour

Four Hours

Figure 21. Effect of vacuum homogenization heat treatment at 2300°F on coating alloys 4, 6, and 7 on TD-Ni substrate. (100X)

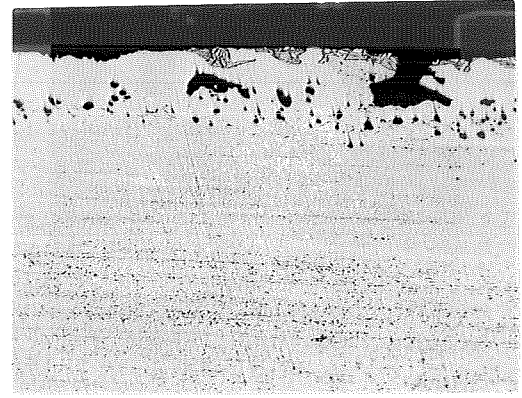
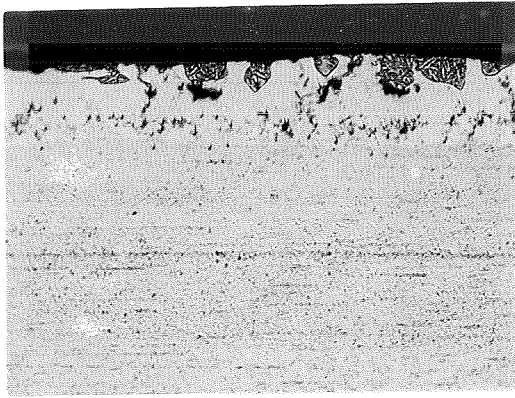

Coating Alloy 4

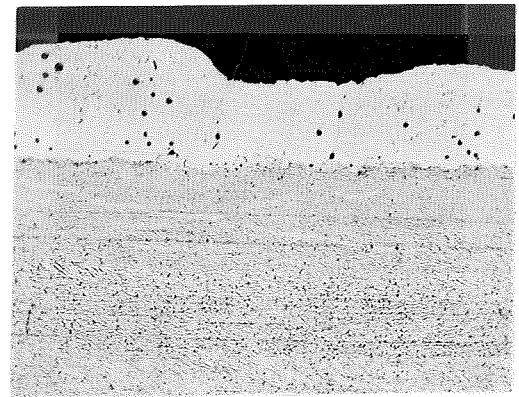
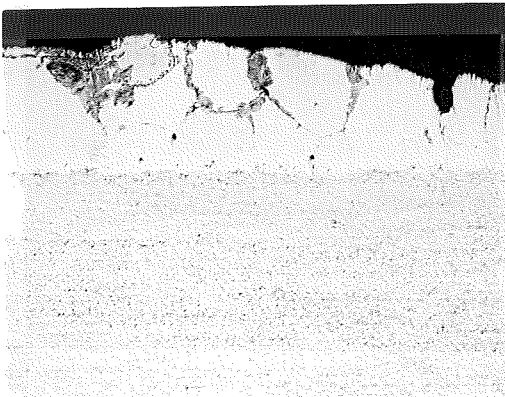

Coating Alloy 6

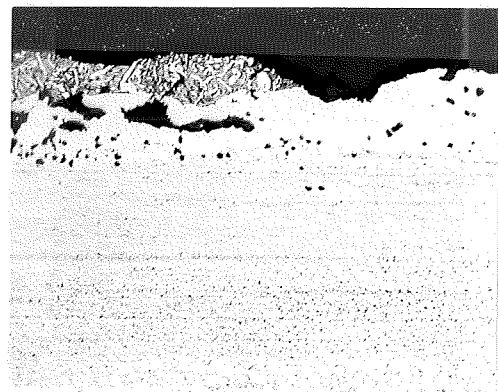
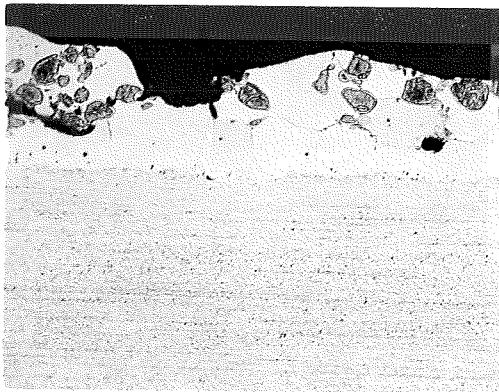

Coating Alloy 7

One Hour

Four Hours

Figure 22. Effect of vacuum homogenization heat treatment at 2300°F on coating alloys 4, 6, and 7 on TD-NiCr substrate. (100X)

### 3.7 Oxide Scale Analysis

X-ray diffraction data were obtained on the oxide produced after 100 hours of oxidation at 2300°F with coating alloys 2, 4, and 7 on both substrates. The oxide on the uncoated TD-NiCr control sample was  $\text{Cr}_2\text{O}_3$  as expected. With coating alloy 2 the main oxide phase was  $\text{NiAl}_2\text{O}_4$  with some alpha  $\text{Al}_2\text{O}_3$ . With coating alloys 4 and 7 the main oxide phase was  $\text{Al}_2\text{O}_3$  with some  $\text{NiAl}_2\text{O}_4$ . No  $\text{Cr}_2\text{O}_3$  phase was detected in solid solution with any of these coating alloys on either TD-Ni or TD-NiCr substrates.

### 3.8 Electronmicroprobe Chemical Analysis of Screening Coating Compositions

The extent of interdiffusion was investigated by electron microprobe techniques for coating compositions 4 and 7 on both substrates as coated and after 100 hours of oxidation at 2300°F. Uncoated TD-NiCr was examined in the oxidized condition. Between 13 and 19 points were probed for analysis on each of the nine samples. The values obtained are given in Tables III and IV. The presence of nickel, chromium, aluminum, and silicon was checked at each point. The precision of the Ni and Cr data should be within plus or minus 2%. The standard deviation for the Si data is 4.5%. The information reported in the tables has been normalized so that the total adds to 100%.

If possible, the EMP analysis was to be made at points close to the external coating surface, midway in the coating, in the coating at the coating-metal interface, in the substrate close to the coating, possibly a point close to the latter, in the center of the substrate, and of the second phase in the as-coated samples. With the oxidized uncoated TD-NiCr, the purpose was only to determine that chromium is lost by oxidation at the surface. This was shown. Apparently the Cr depleted zone extends inward about 10 mils. However the average Cr concentration in this region is only 1.0% lower than in the substrate; i. e. 18.8% vs. 20.9%. With the TD-Ni substrate it can be seen that the coating reservoir is very rapidly depleted of chromium and aluminum by inward diffusion and oxidation.

In both substrates an aluminum-rich, chromium-lean second phase is evident in the as-coated condition. As a result the chromium concentration is enriched in the matrix phase of the coating. Both depletion and homogenization occur as a result of 2300°F oxidation. Diffusion effects are quite noticeable with the TD-Ni substrate. The aluminum diffuses inward quite rapidly but the very low residual concentration found after 100 hours at 2300°F indicates it rediffuses outward and is consumed by oxidation. Accordingly, it appears that aluminum diffusion coatings can be effectively utilized in spite of the relatively rapid diffusion rate of aluminum in TD-Ni. Rough approximations indicate the major loss of chromium from the coating is by diffusion inward. Although its concentration is only a fraction of a percent at the center of the substrate after

*As noted*

TABLE III

Electronmicroprobe Chemical Results on Coated and Oxidized TD-Nickel Samples (Weight Percent)

Distance from External Surface (inches)	Nickel	Chromium	Aluminum	Silicon
<u>As Coated Alloy 4 (Ni-20Cr-8Al-0.75Si)</u>				
0.0003	68.36	26.10	4.44	1.04
0.0019	71.98	23.85	3.45	0.53
0.0038 Interface	79.41	16.99	3.20	0.40
0.005 Substrate	89.31	7.59	2.66	0.43
0.0055	89.31	0.86	2.66	0.35
0.034 Center	100.			
0.0005 Second Phase	74.79	10.24	13.84	1.12
<u>Alloy 4 Oxidized 100 Hours at 2300°F</u>				
0.0002	92.26	7.52	0.00	0.22
0.0025	92.68	7.10	0.00	0.21
0.0050 Interface	93.28	6.22	0.28	0.22
0.0060 Substrate	93.53	6.10	0.15	0.22
0.0080	93.97	5.73	0.15	0.15
0.035 Center	99.00	0.65	0.28	0.07
<u>As Coated Alloy 7 (Ni-25Cr-8Al-0.75Si)</u>				
0.0002	66.77	29.38	3.15	0.70
0.0025	68.30	27.46	3.92	0.35
0.0060 Interface	96.51	1.92	1.37	0.22
0.0070 Substrate	99.48	0.15	0.35	0.00
0.0080	100.			
0.035 Center	100.			
0.0006 Second Phase	72.03	14.23	12.84	0.50
<u>Alloy 7 Oxidized 100 Hours at 2300°F</u>				
0.0003	93.37	6.56	0.00	0.07
0.0025	93.29	6.84	0.00	0.07
0.0040 Interface	93.46	6.46	0.00	0.07
0.0045 Interface	93.72	6.21	0.00	0.07
0.0060	93.02	5.79	0.07	0.07
0.034 Center	99.98	0.02		

TABLE IV

Electronmicroprobe Chemical Results on Coated and Oxidized  
TD-NiCr and Uncoated TD-NiCr Samples (Weight Percent)

Distance from External Surface (inches)	Nickel	Chromium	Aluminum	Silicon
<u>As Coated Alloy 4 (Ni-20Cr-8Al-0.75Si)</u>				
0.003	79.09	26.11	2.91	0.89
0.0025	71.22	25.26	3.04	0.48
0.0050 Interface	73.35	23.99	2.23	0.43
0.0055 Substrate	73.61	24.05	1.97	0.37
0.0065	75.17	23.32	1.26	0.24
0.035 Center	80.02	19.98		
0.0019 Second Phase	78.78	10.56	9.79	0.87
<u>Alloy 4 Oxidized 100 hours at 2300°F</u>				
0.0006	77.43	22.39	0.00	0.18
0.0013	78.10	21.66	0.06	0.18
0.0045 Interface	79.24	20.39	0.19	0.18
0.0050 Interface	79.74	19.76	0.32	0.18
0.0075	79.67	20.49	0.24	0.18
0.0348 Center	78.85	21.15		
<u>As Coated Alloy 7 (Ni-25Cr-8Al-0.75Si)</u>				
0.0003	68.71	28.06	2.40	0.83
0.0020	68.58	28.83	2.18	0.41
0.0032 Interface	70.36	27.43	1.85	0.36
0.0038 Interface	71.31	26.97	1.42	0.30
0.0042	74.10	25.11	0.66	0.13
0.034 Center	79.37	20.63		
0.0005 Second Phase	76.01	13.53	9.67	0.79
<u>Alloy 7 Oxidized 100 Hours at 2300°F</u>				
0.0010	77.01	22.69	0.06	0.24
0.0025	77.86	21.88	0.13	0.12
0.0050 Interface	78.07	21.58	0.19	0.18
0.0070 Interface	77.68	22.01	0.18	0.12
0.035 Center	79.65	20.34		
<u>Uncoated TD-NiCr Oxidized 100 Hours</u>				
0.0005	81.58	18.42		
0.0020	81.63	18.37		
0.010	80.85	19.15		
0.030	79.10	20.90		

100 hours at 2300°F, the average substrate concentration is 5-7%. At this level the substrate is in danger of rapid attack by oxidation in the event of coating failure.

Depletion of aluminum in the TD-NiCr after oxidation is similar to the TD-Ni substrate. Naturally there is little depletion of chromium evident, only homogenization.

### 3.9 Microhardness Values

Knoop microhardness values were taken on as-coated Coating Composition 3 on TD-NiCr and Composition 7 on TD-Ni using a 100 gm load. Impressions were also made on these two coating systems plus uncoated TD-NiCr after 20, 60, and 100 hours of oxidation at 2300°F. The data obtained are given on Figures 13, 17, and 18. Sometimes hardness values could not be obtained in the oxidized coating area because of the extreme porosity. Usually hardness impressions were made one mil apart on a traverse from coating into the substrate plus in the middle of the substrate.

The oxidized uncoated TD-NiCr sample of Figure 13 had Knoop hardness numbers between 350 and 380 from the surface and four mils into the base alloy and including the center of the sheet sample. The one value of 270 KHN at the surface could be the result of chromium depletion by oxidation. The as-coated Alloy 7 on TD-Ni has a hardness of 345 to 415 with the second phase being 348 KHN. During oxidation the coating alloy softens with an increase in substrate hardness due to diffusion of Cr and Al into the TD-Ni. The same general statement applies to Coating Alloy 3 on TD-NiCr.

### 3.10 Conclusions Based on Screening Tests

After careful consideration and evaluation of all the test data, Coating Alloy 7 (Ni-25Cr-8Al) was selected as being best for TD-Ni and Alloy 3 (Ni-20Cr-6Al) for TD-NiCr. These coatings were then to be further modified by Cb, Y, and Th additives. Weight change measurements in themselves were not discriminating enough. Positive elimination based on the 11 mg/cm<sup>2</sup> weight change criterion can be made for Coating Alloys 1, 1A, 2, 5, 8, 9, and 10 on TD-Ni and for 1A, 8, 9, and 10 on TD-NiCr. With the TD-Ni substrate, little difference in oxidation weight change between Coating Alloys 4 and 7 is found. However, in order to provide a greater source of chromium in the coating, Coating Composition 7 was selected as being more suitable for the TD-Ni substrate.

With the TD-NiCr substrate it was found that Coating Composition 3 had a good combination of good coatability, lowest oxidation change, and good ductility.

### 3.11 Modification of Coating Compositions

Elemental additions of 0.5 and 1.0% Cb, Y, and Th were made to Coating Compositions 7 and 3 and deposited on TD-Ni and TD-NiCr substrates respectively. These additives had little effect on the fusion temperature of the coatings. Therefore only one trial run per additive per substrate was needed to determine the fusion temperature. The fusion temperatures are listed in Table I.

The oxidation weight change at 2300°F for each system is given in Figures 23 to 28. Only the 0.5% Y additive to Alloy 3 applied to TD-NiCr appeared to give any advantage over the base alloy. Comparison of Figure 27 with Figure 5 shows that the 0.5% Y additive gives slightly less sample weight gain but spalls slightly more than the base alloy. Of the modified systems tested this one was best but did not represent too significant an improvement. It is possible that additives of less than 0.5% Y might be more beneficial. It had been planned to develop these quaternary modifications further if the results were more promising. However no further work was done with these additives because it was felt other approaches discussed later would be superior.

The bend test results for the alloys with additives are given in Table V. The microstructures representative of the Y additions to TD-NiCr are shown in Figures 29 and 30. No unusual structure is seen. The description of torch testing for unmodified alloys 3 and 7 are presented on page 71. Further effort to provide suitable coatings is recommended in section 3.13 below.

(Text continues on page 45)

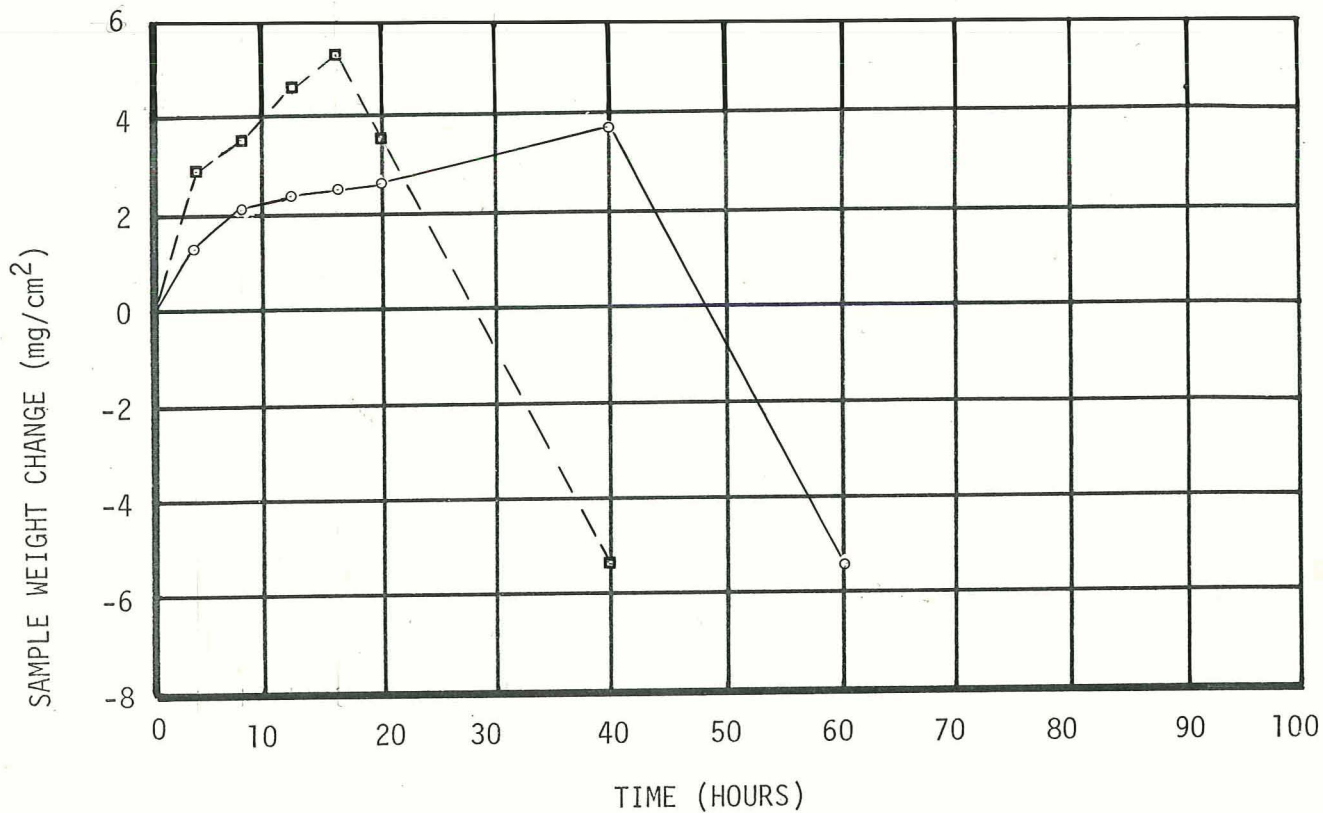

○ TD-Ni — Alloy 11-7 #259N  
 □ TD-Ni - - Alloy 12-7 #264N

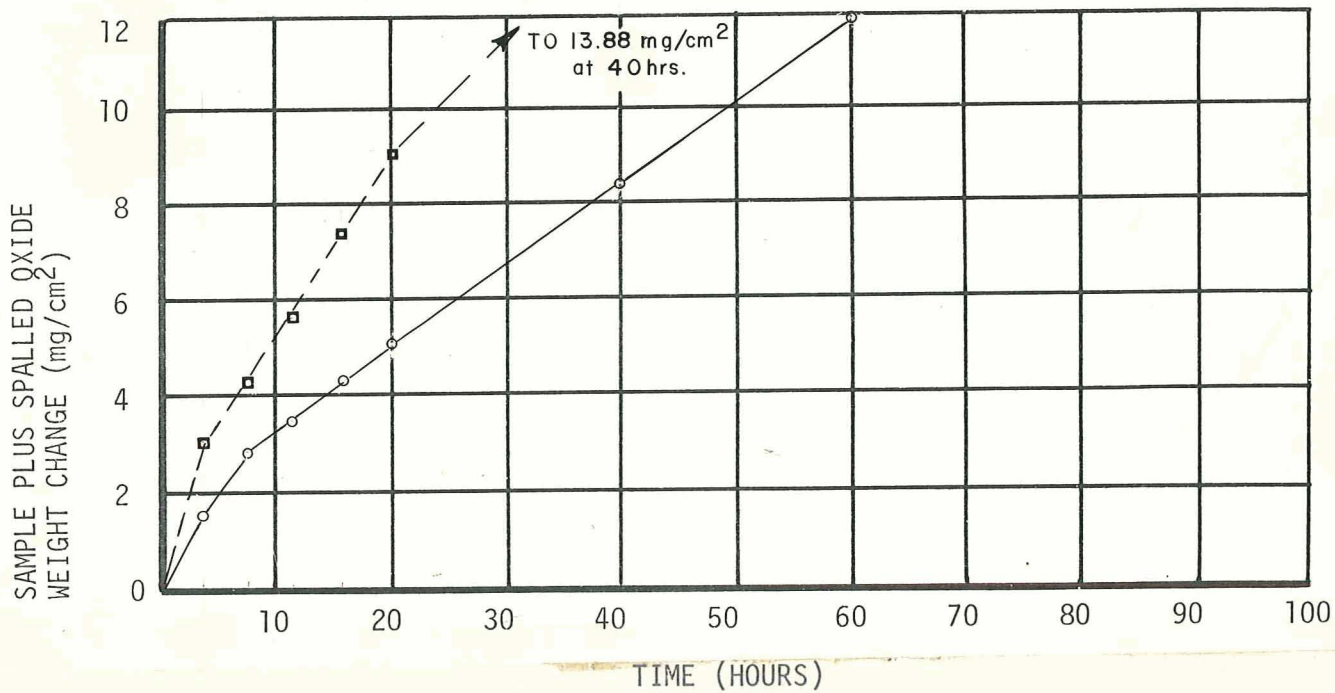

Oxidation Behavior at 2300°F with Coated TD-Ni Samples

FIGURE 23

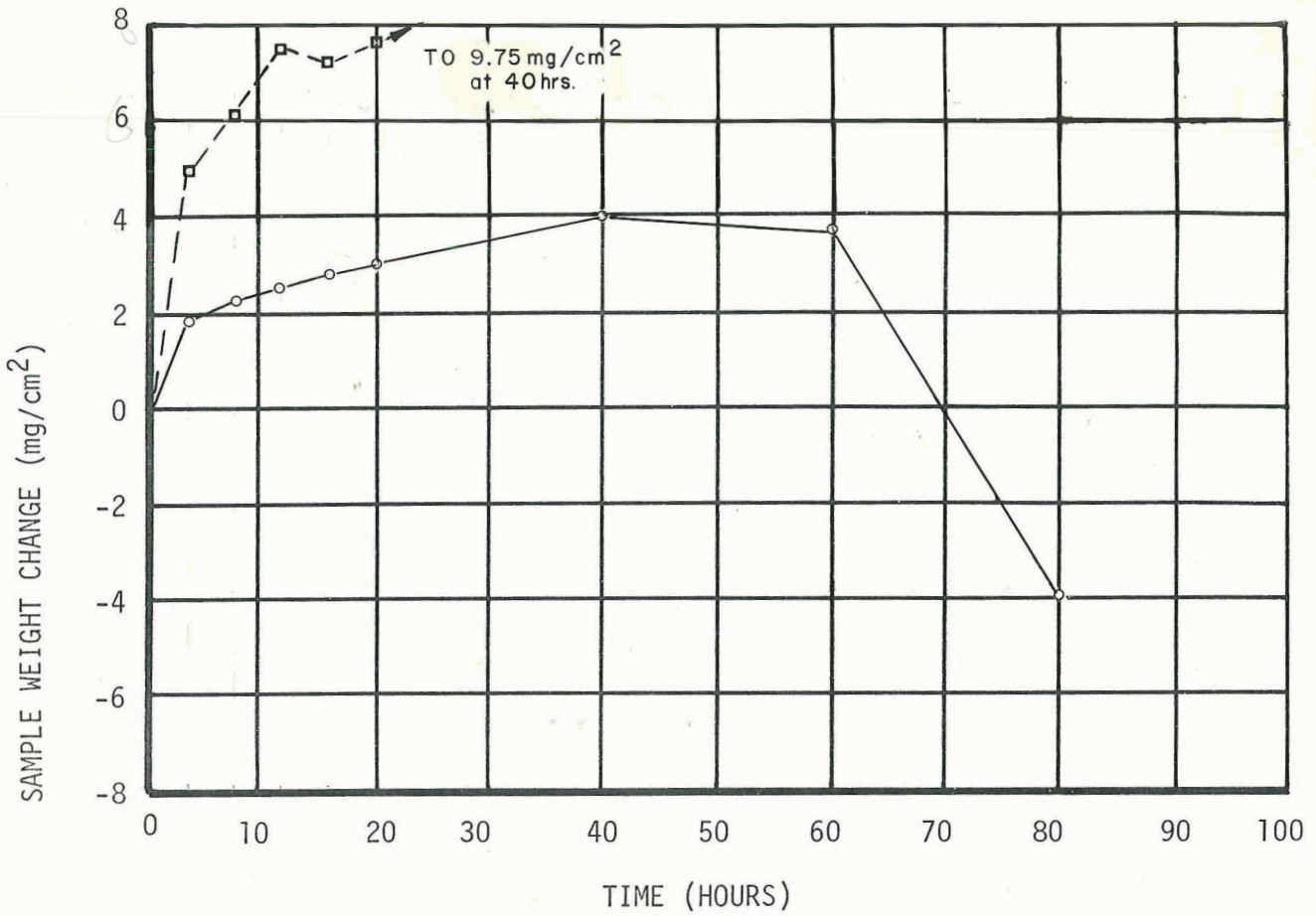

- TD-Ni Alloy 13-7 #266N
- TD-Ni Alloy 14-7 #271N

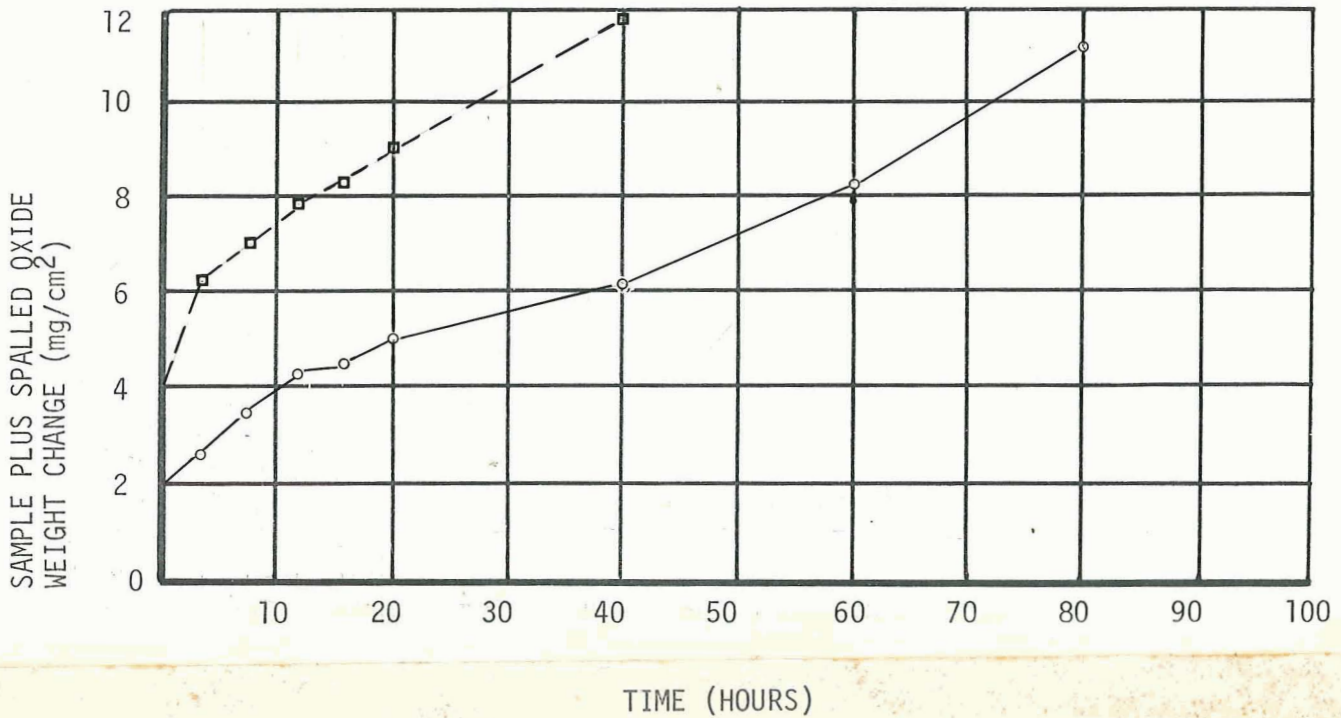

Oxidation Behavior at 2300°F with Coated TD-Ni Samples

FIGURE 24

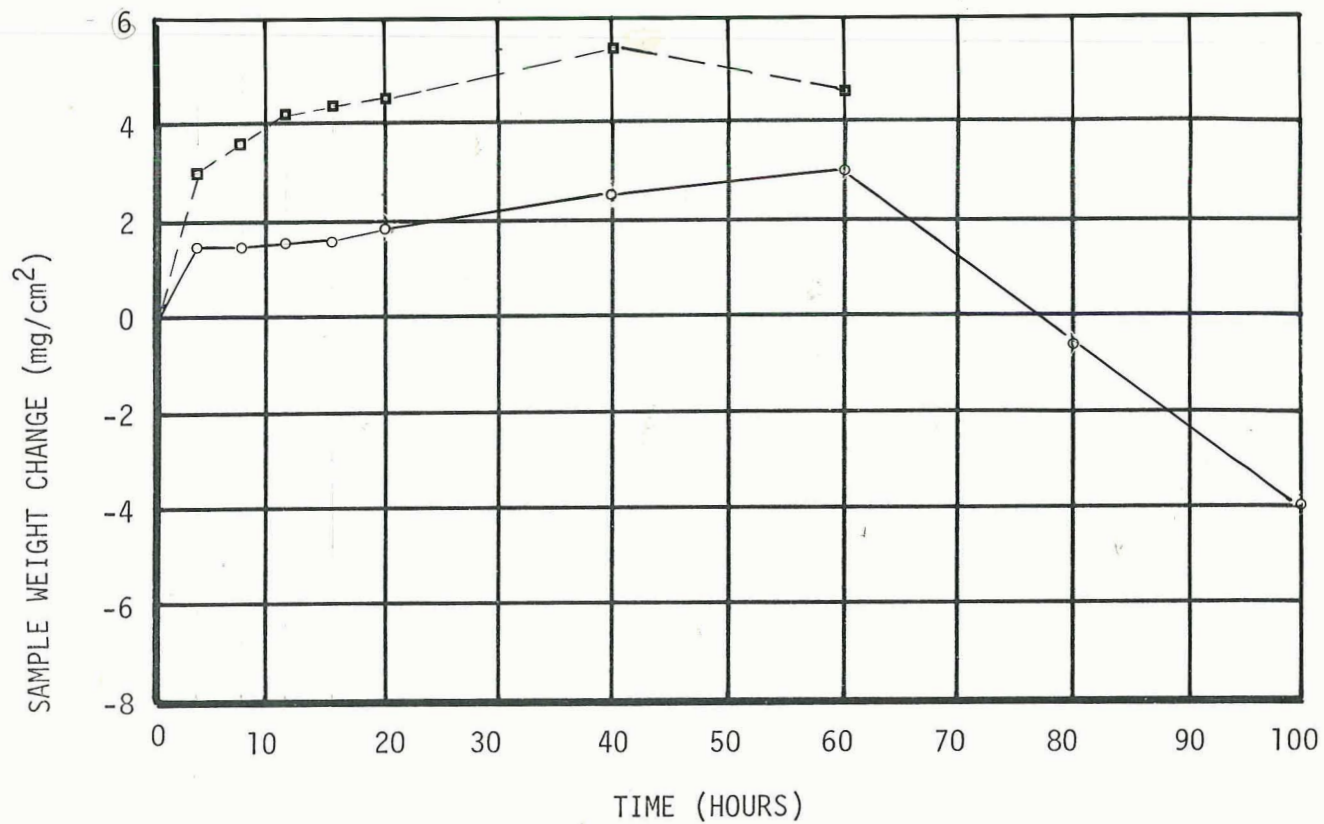

○ TD-Ni — Alloy 15-7 #275N  
 □ TD-Ni - - Alloy 16-7 #280N

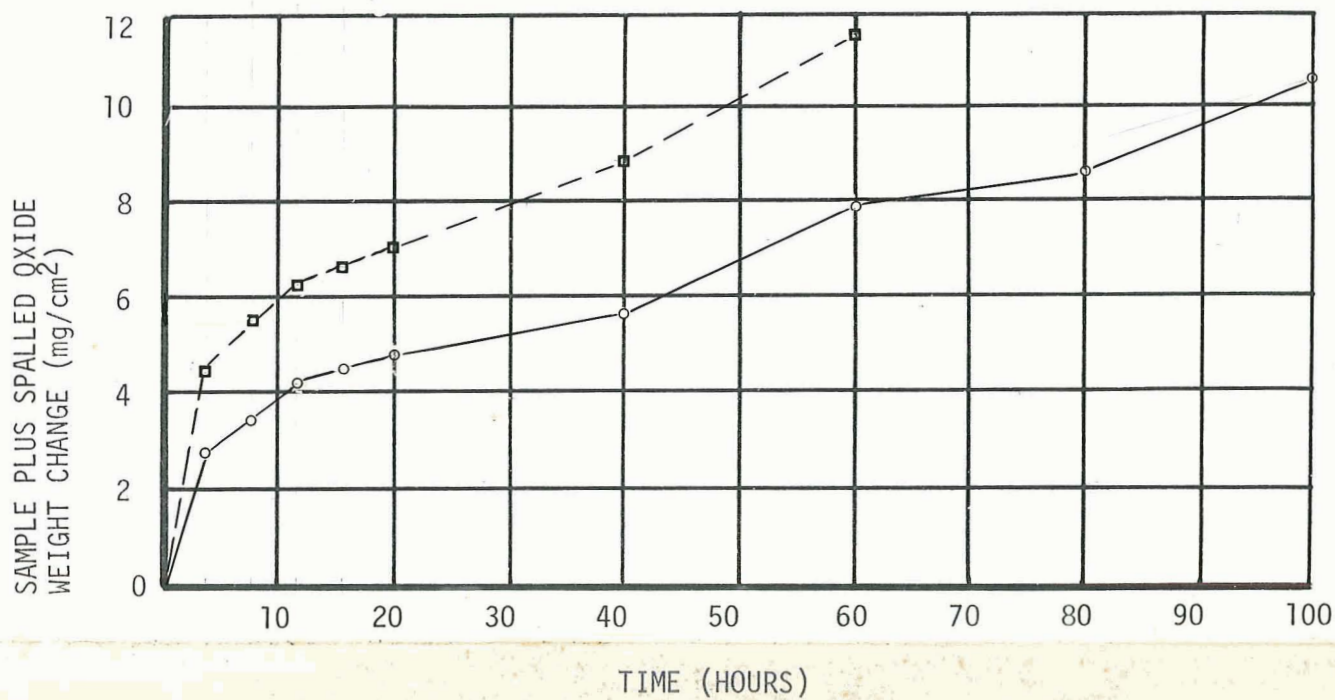

Oxidation Behavior at 2300°F with Coated TD-Ni Samples

FIGURE 25

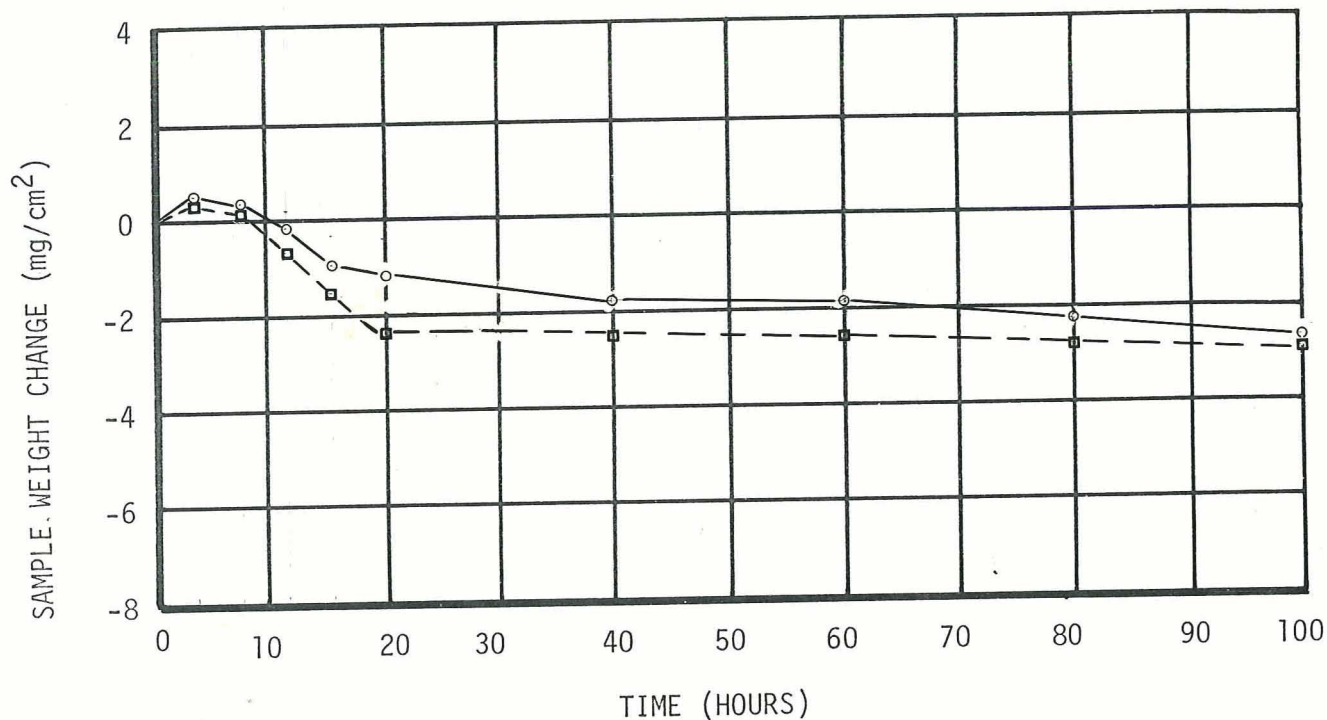

○ TD-NiCr — Alloy 11-3 #283  
 □ TD-NiCr - - Alloy 12-3 #287

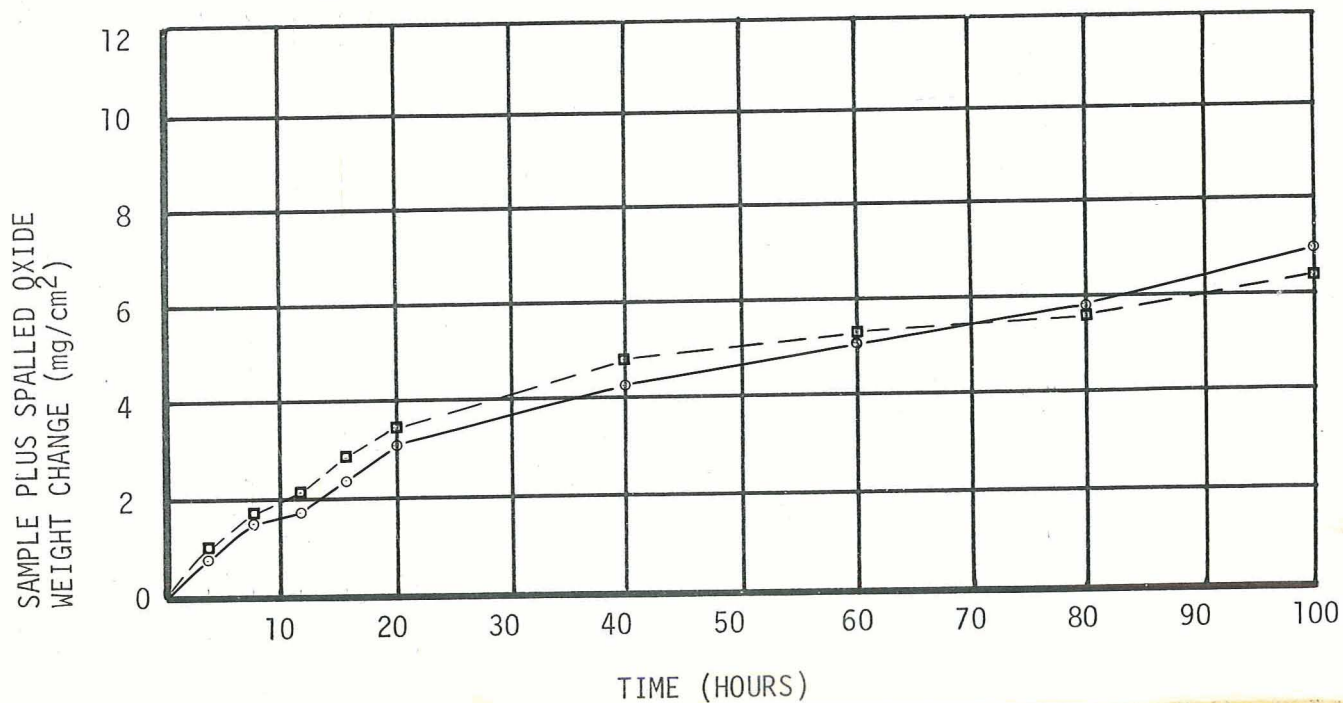

Oxidation Behavior at 2300°F with Coated TD-Ni Cr Samples

FIGURE 26

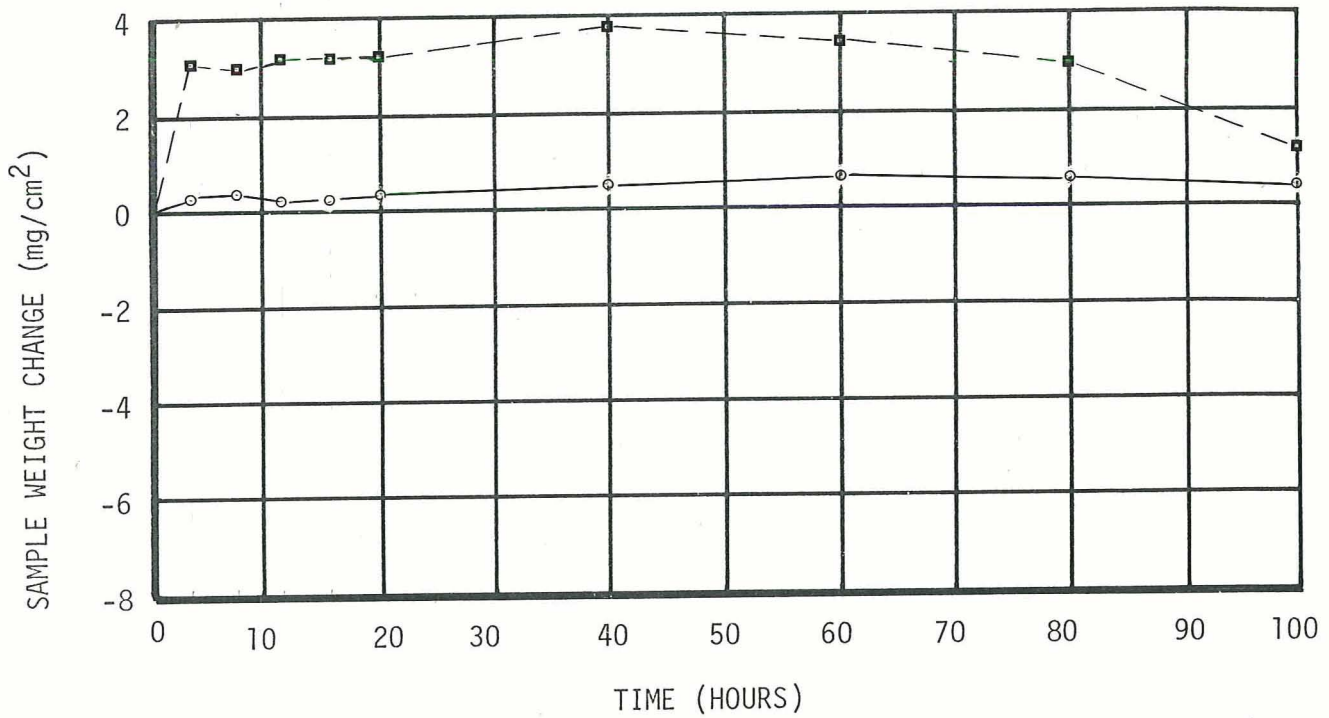

○ TD-Ni Cr Alloy 13-3 #239

□ TD-NiCr Alloy 14-3 #244

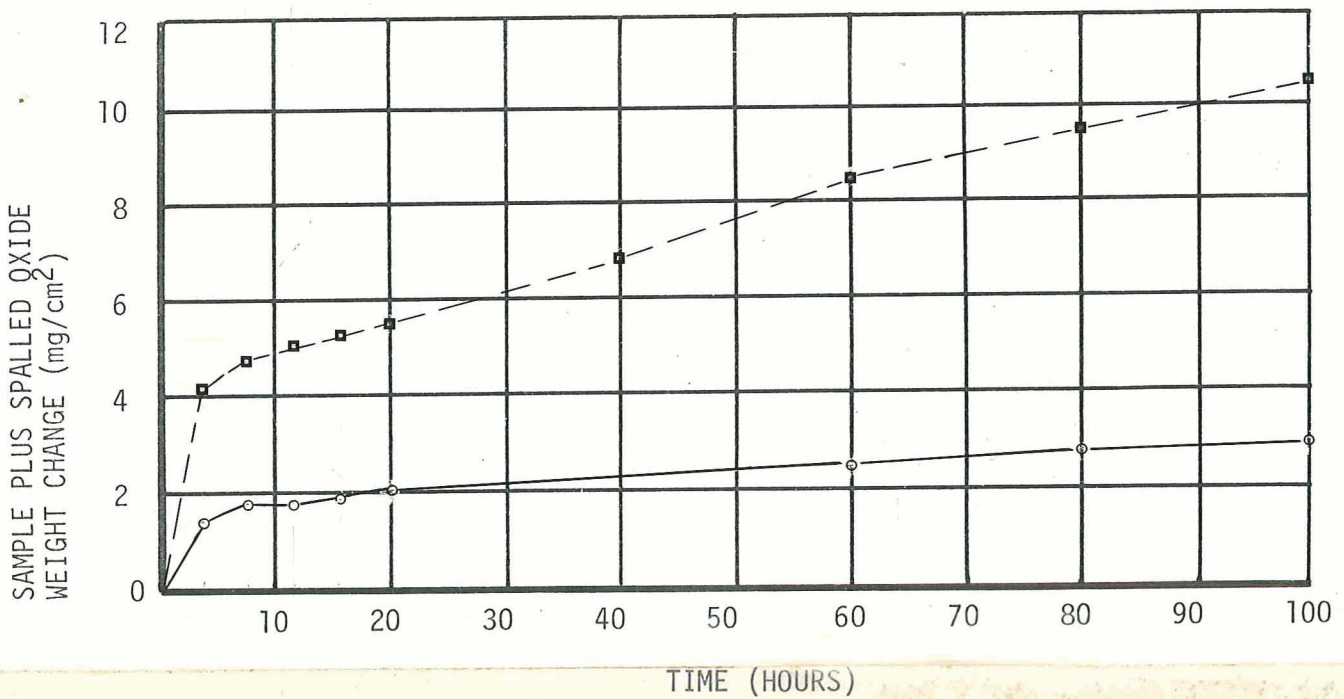

Oxidation Behavior at 2300°F with Coated TD-NiCr Samples

FIGURE 27

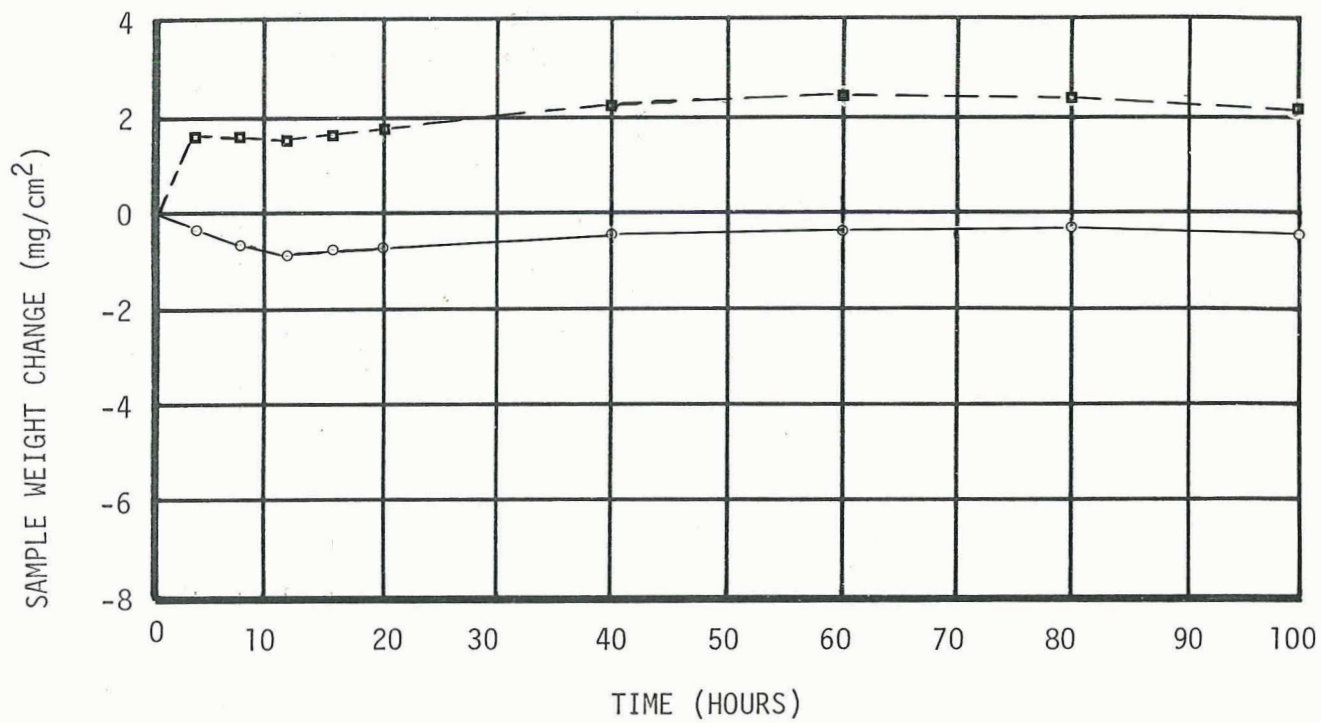

○ TD-NiCr — Alloy 15-3 #232  
 □ TD-NiCr - - - Alloy 16-3 #255

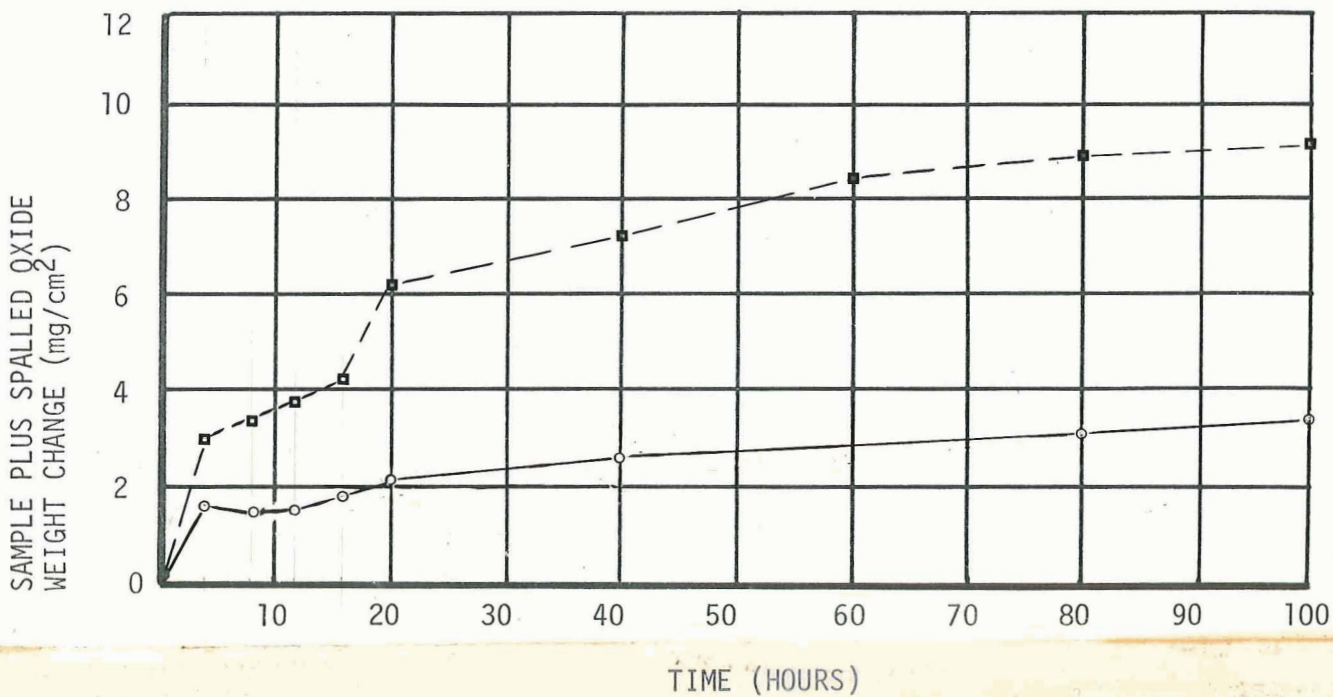

Oxidation Behavior at 2300°F with Coated TD-NiCr Samples

FIGURE 28

TABLE V  
Bend Test Results on Coated and Oxidized  
TD-Ni and TD-NiCr Samples

<u>Coating Alloy</u>	<u>Condition</u>		<u>Results</u>
	<u>As Coated</u>	<u>Oxidized, 2300°F (hours)</u>	
<u>TD-Ni Substrate</u>			
11-7	X		Coating cracked, sample bent
11-7		60	Ductile
12-7	X		Coating cracked, sample bent
12-7		40	Ductile
13-7	X		Coating cracked, sample bent
13-7		80	Ductile
14-7	X		Coating cracked, sample bent
14-7		40	Ductile
15-7	X		Coating cracked, sample bent
15-7		100	Ductile
16-7	X		Coating cracked, sample bent
16-7		60	Ductile
<u>TD-NiCr Substrate</u>			
11-3	X		Sample broke
11-3		100	Ductile
12-3	X		Sample broke
12-3		100	Ductile
13-3	X		Coating cracked, sample bent
13-3		100	Ductile
14-3	X		Sample broke
14-3		100	Ductile
15-3	X		Ductile
15-3		100	Ductile
16-3	X		Sample broke
16-3		100	Ductile

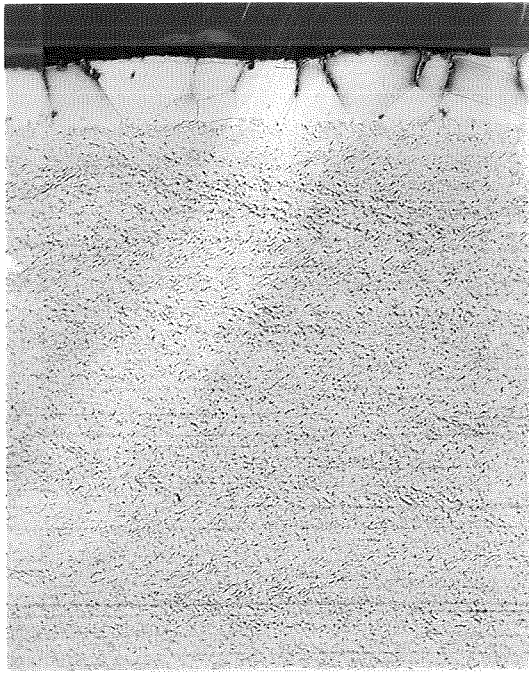

As Coated

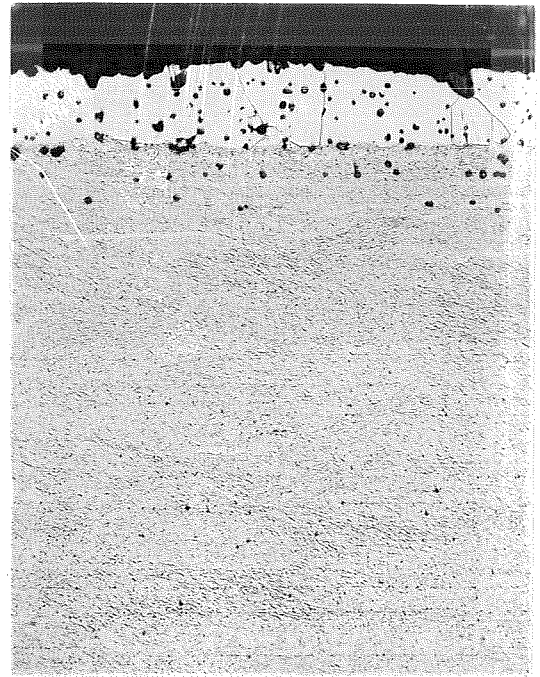

20 Hours

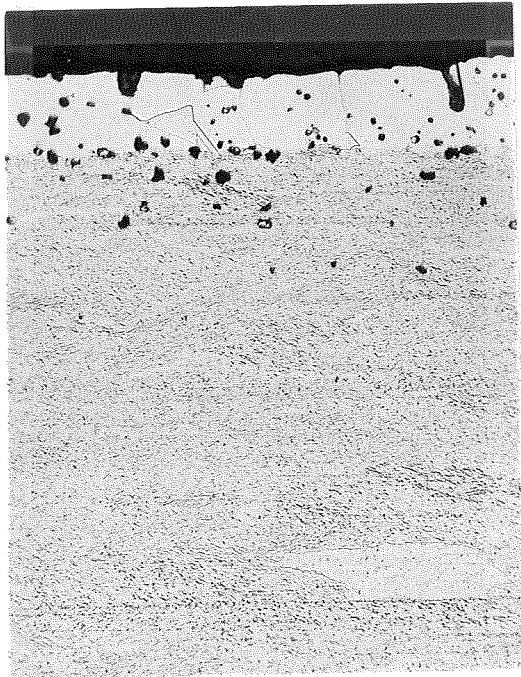

60 Hours

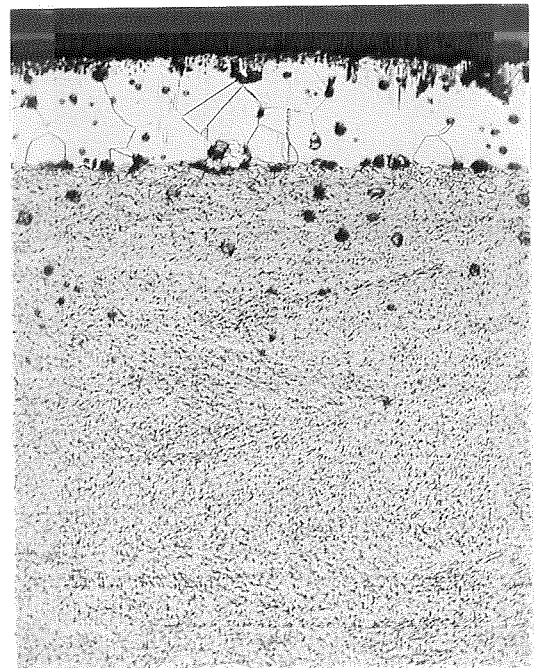

100 Hours

Figure 29. Coating Alloy 13-3 on TD-NiCr oxidized at 2300°F. (100X)  
See Figure 42 for oxidation data.



As Coated

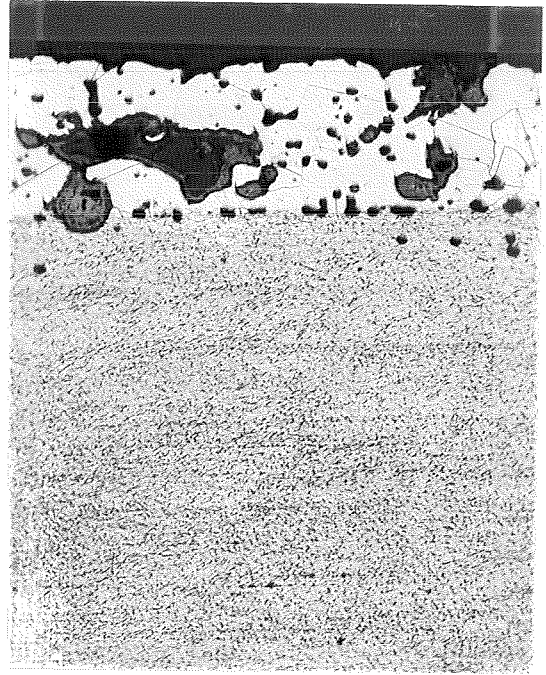

20 Hours

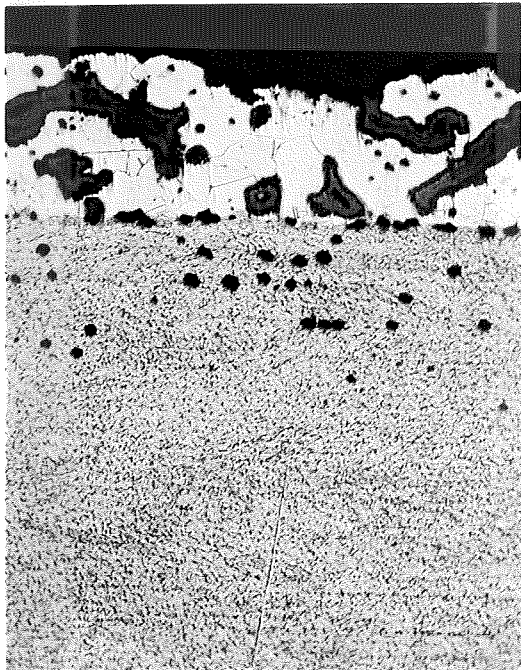

60 Hours

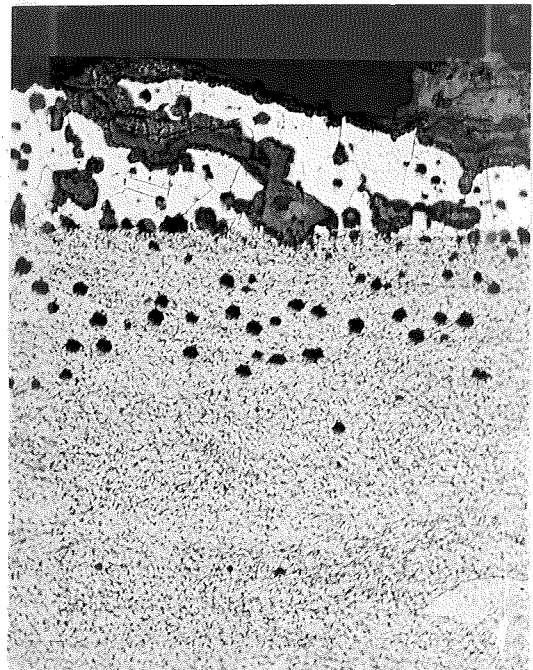

100 Hours

Figure 30. Coating Alloy 14-3 on TD-NiCr oxidized at 2300°F (100X)  
See Figure 42 for oxidation data.

### 3.12 Torch Tests

The best alloy compositions of those studied are #7 for TD-Ni and #3 for TD-NiCr. Therefore duplicate flame samples, 1" by 2", were prepared with each substrate. The test procedure consisted of two-hour cycles for the first 20 hours at 2300°F and eight-hour cycles until a total test time of 100 hours or failure occurred. Weight measurements were made with each cycle. With our oxygen-acetylene torch units a constant and uniform temperature was difficult to maintain. The flame gave about a 3/4" diameter uniform hot zone on the flame side but the temperature was 2200°F or lower on the opposite side. Therefore weight changes in mg/cm<sup>2</sup> cannot be used since the specimen temperature varied so much.

The two samples of Alloy 7 on TD-Ni were stopped after 16 and 100 hours at 2300°F. Metallographic examination, Figure 31, revealed substrate oxidation in both examples. With Alloy 3 on TD-NiCr flame samples, tests were stopped after 76 and 100 hours at 2300°F. Metallographic examination, Figure 32, showed apparent melting of the TD-NiCr substrate just under the coating of the 76-hour sample and gross oxidation attack with the 100-hour sample. An uncoated TD-NiCr sample was run for 100 hours at 2300°F and at least 10 mils of the alloy has been consumed by oxidation as shown by the microstructure in Figure 33. Microhardness values are also listed on Figure 32.

We have shown that the effectiveness and reproducibility of this kind of torch test is questionable. Our findings were discussed with NASA technical personnel. Accordingly, it was recommended that this type of test be discontinued.

### 3.13 Additional Coating Modifications

Certain processing limitations appeared to prevent the attainment of the full potential of the Ni-Cr-Al-Si screening compositions investigated above. Accelerated oxidation occurred in the vicinity of edges on the TD-Ni samples and was visually manifested by the formation of the characteristic black glassy nickel oxide phase; this oxide is indicative of substrate attack. Examination of metallographic samples showed the coatings to be thinner at the sample edges. Although the characteristic nickel oxide phase does not form on the more oxidation resistant TD-NiCr substrate during testing, the same nonuniformity in coating is usually present. Accordingly, rather than to attempt further direct modification of coating compositions, it was felt necessary to improve the application techniques of compositions already screened.

It was stated previously that the coatings during application thinned out at edges so that in some cases they were as thin as 2 mils. In general this was the tendency. However, a subsequent more detailed examination of as-coated sample edges showed there was a considerable range and variety of thin spots at edges. It is difficult to generalize on

(text continued on page 49)

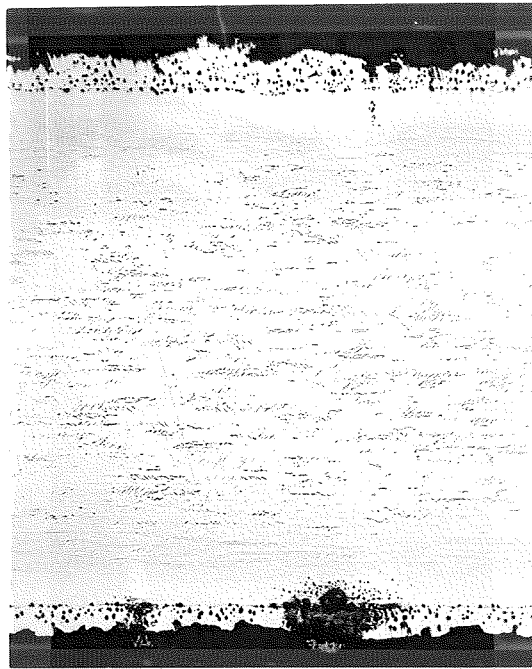

16 Hours

Flame side



100 Hours

Flame side

Figure 31. Flame tests at 2300°F with Coating Alloy 7 on TD-Ni.  
(40X)

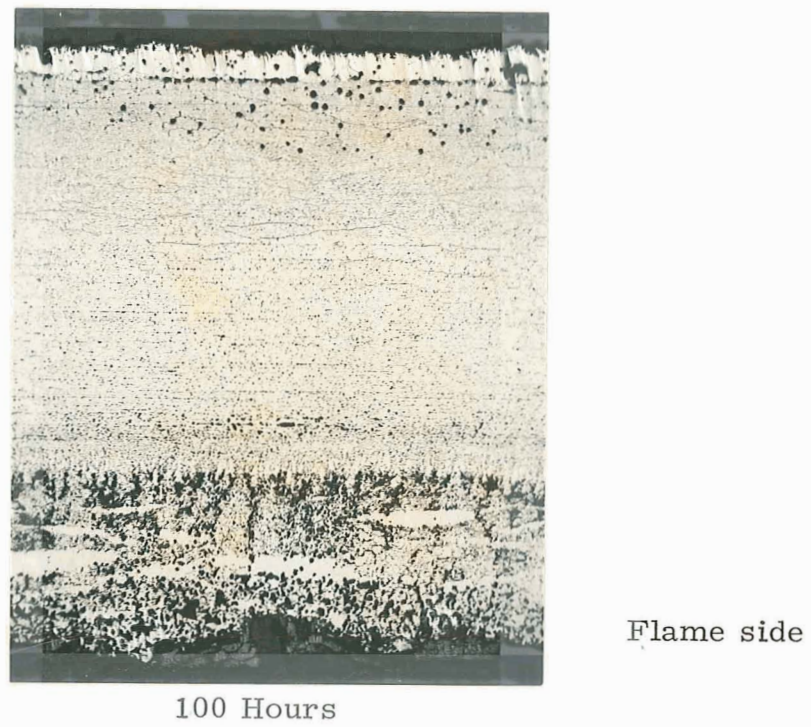
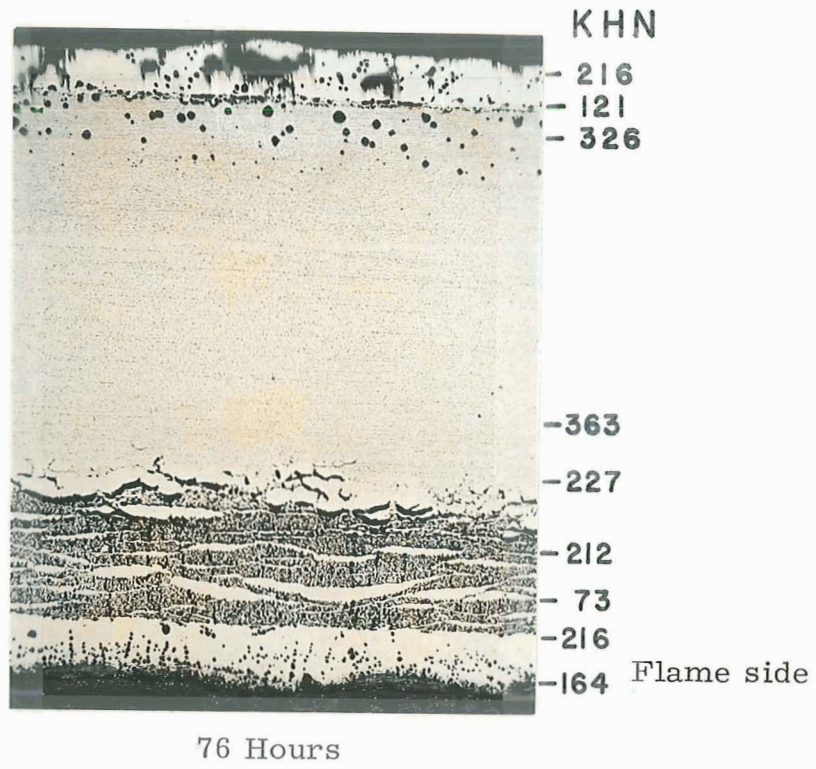
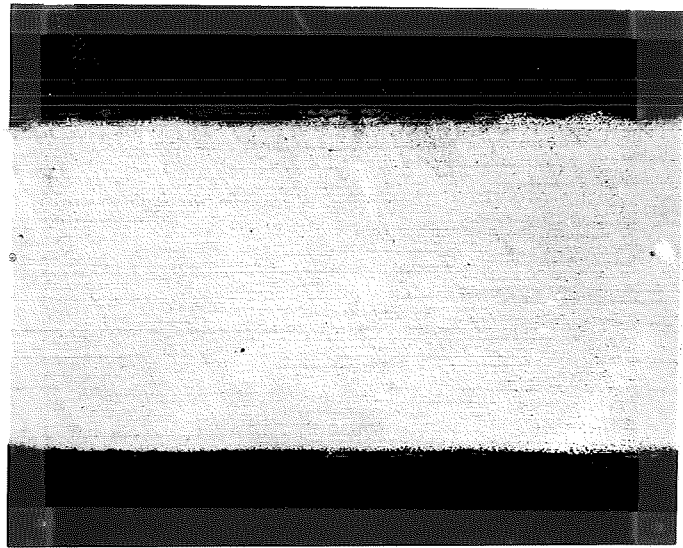
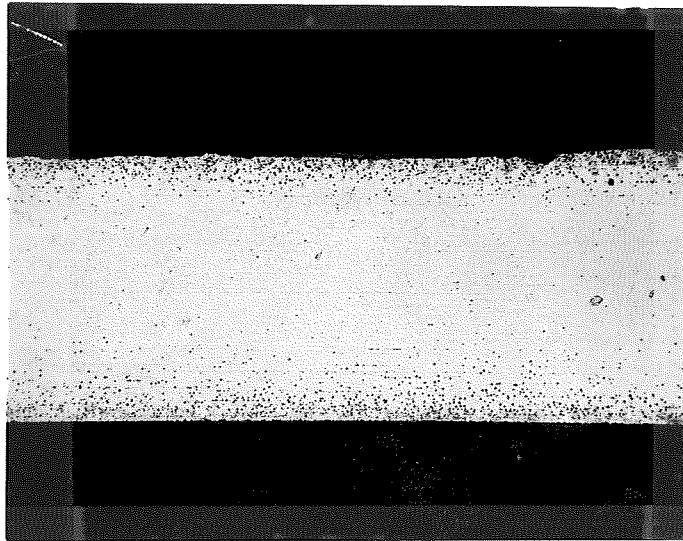

Figure 32. Flame tests at 2300°F with Coating Alloy 3 on TD-NiCr.  
 (50X)  
 Microhardness tests were made with 100 g load.



58 mils thick

Cool end



Flame side

46 mils thick

Hot Section

Figure 33. Flame test at 2300°F on uncoated TD-NiCr showing sample after 100 Hours. (30X)

the statistical tendency for any one coating alloy to be better or worse in this regard since only one sample of each composition could be checked and only one plane per sample was examined. However it is possible to state that at least one spot on one edge of each sample had some general thinning out of the coating; i. e. over a linear length equal to several coating thicknesses. These thicknesses ranged from 0.3 to 3.8 mils, as illustrated in Table VI. In all cases attempts had been made to provide "extra" coating slurry at edges. However the thin spots noted in Table 6 were formed in spite of these precautions. In one case, Alloy No. 14 on TD-Ni, the overall coating thickness was high but several large voids formed internally at one edge which was attributed to shrinkage and which reduced potential coating effectiveness in the same manner as a thinned out area.

TABLE VI

Metallographic Measurements of the Thinnest Areas  
of the Coatings at Edges on As-Coated Samples.  
Average coating thickness on samples approx. 5 mils.

Coating Alloy No.	Minimum Edge Thickness - mils	
	TD-Ni	TD-NiCr
1	1.25	1.25
1A	0.6	3.10
2	1.25	0.6
3	0.3	2.5
4	1.8	1.8
5	1.25	1.8
6	3.8	1.8
7	0.3	1.25
8	1.25	1.8
9	3.1	0.6
10	2.5	1.8
11	3.8	1.8
12	3.1	1.8
13	3.1	2.5
14	6.5*	1.25
15	4.0	1.8
16	2.5	3.1

\* Contained shrinkage pores

Since attempts to build up edge coverage were not successful, it was deduced that the fluidity and surface tension during fusion was responsible for thinning out of the coating. It was speculated that the lowest melting component, aluminum, might be most responsible for this behavior. Accordingly, it was deemed fruitful to apply the Ni-Cr-Si portion of the coating in one step and the Al in a second step. Theoretically it appeared

potentially feasible to provide more direct control over composition in this fashion. In addition, previous attempts to fuse the Ni-Cr-Al-Si compositions in hydrogen resulted in rather rough discolored surfaces and it was suspected that Al was responsible for this behavior. Therefore it was felt that the elimination of Al in the first coating step might give more latitude in processing.

Accordingly preliminary experiments were performed aimed at the development of a two-step coating process which would give superior performance. To provide additional assurance of homogeneity a 1-5 micron prealloyed Ni-20Cr powder was obtained and used as the basis for the first step coating. In order to obtain a reasonably low fusion temperature it was estimated that 3% Si be added as a maximum compositional starting point. Fusion experiments on TD Ni at 2360, 2380, 2400°F and 2500°F for 15 minutes indicated the fusion range to be from 2360°F to a little over 2380°F. The coatings appear bright and uniform in texture when properly fused. Equivalent behavior was later obtained in hydrogen and vacuum on TD-Ni and TD-NiCr. The reason for using this intermediate layer on TD-NiCr is discussed below.

In other work here it has been found that pack or slurry aluminide coatings when applied directly to TD-Ni or TD-NiCr have a tendency to spall off. It is speculated that the thoria particles in some way cause a plane of weakness to form which then fractures under stresses produced by the differential in thermal expansion between the aluminide layer and the substrate. Accordingly a thoria-free layer was deemed a necessary base for aluminum alloying, particularly on TD-NiCr.

Both a pack and two slurry coatings were utilized in the second or aluminizing step. A powder blend by weight of 5Al-0.5NH<sub>4</sub>Cl - balance Al<sub>2</sub>O<sub>3</sub> was used (as a pack) in hydrogen at 1900°F for 2 hours to obtain 12-13 mg/cm<sup>2</sup> of Al. Two slurries, one a pure Al and the other Al-20Co, were applied by spraying elemental powders in a lacquer vehicle and vacuum firing at 1900°F for 2 hours. Weight gains of 10-12 mg/cm<sup>2</sup> were obtained with the slurries. Therefore the average overall composition of the finished coatings is estimated to be 69.3Ni-18Cr-2.7Si-10Al or 69.3Ni-18Cr-2.7Si-8Al-2Co.

The Al-20Co slurry composition was included because of some past experience here in coating superalloys. It appeared to wet and cover well and therefore had superior future potential for practical processing.

### 3.14 Oxidation Tests on Two-Step Coatings

Oxidation tests at 2300°F (similar in schedule to previous tests) were performed on samples of the three, two-step coatings together with samples having only the first step coating for comparison. The weight changes with time are shown plotted in Figure 34 and the microstructures in Figures 35 and 36. The as-coated two step microstructures are very similar to one another and consist of a top layer of aluminides over an alloy layer. (Text continued on page 54)

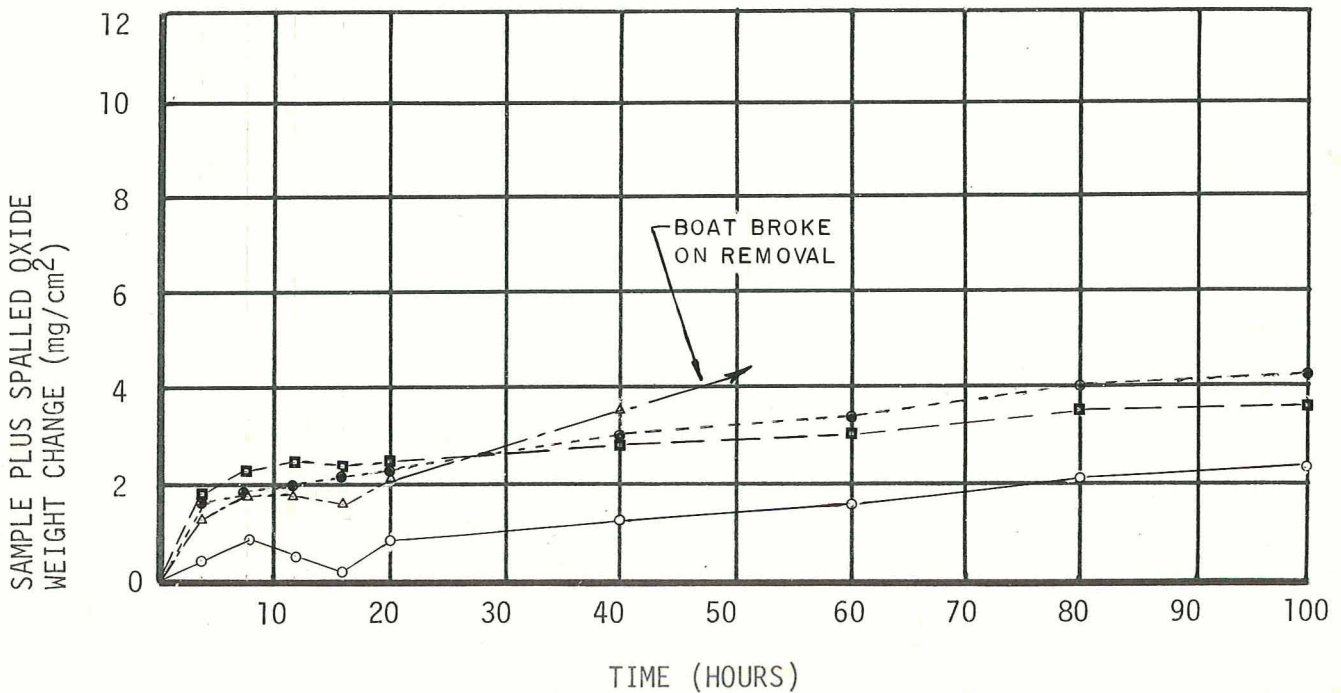
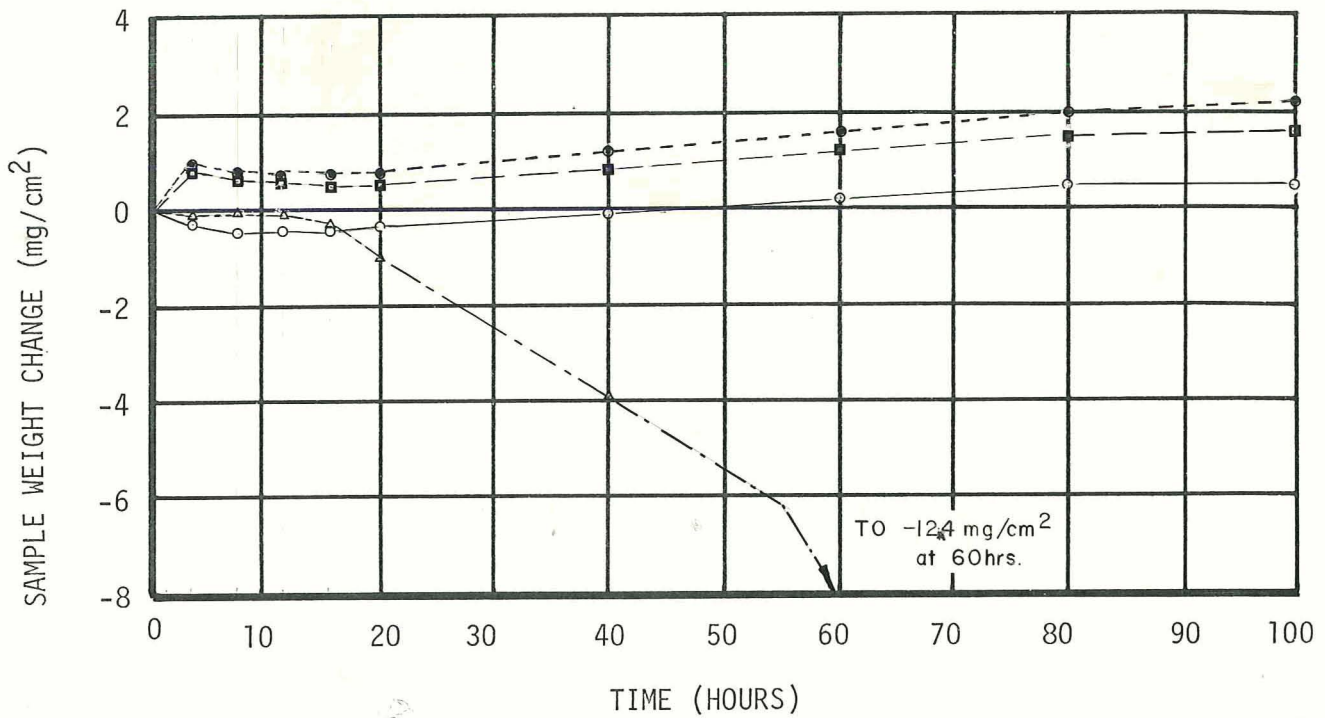

Oxidation Behavior at 2300°F with Coated TD-Ni Two Step Coating, Ni-20Cr-3Si plus Aluminum

FIGURE 34

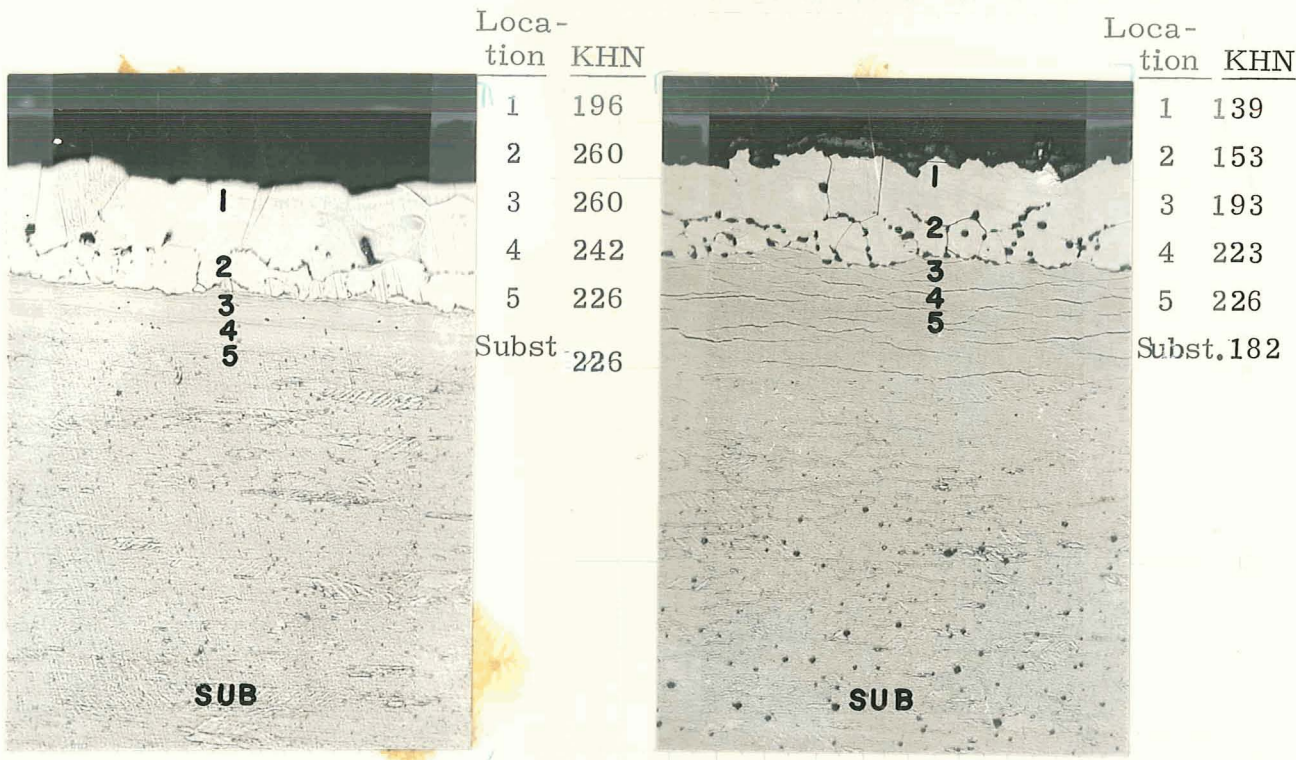

As Coated

20 hours

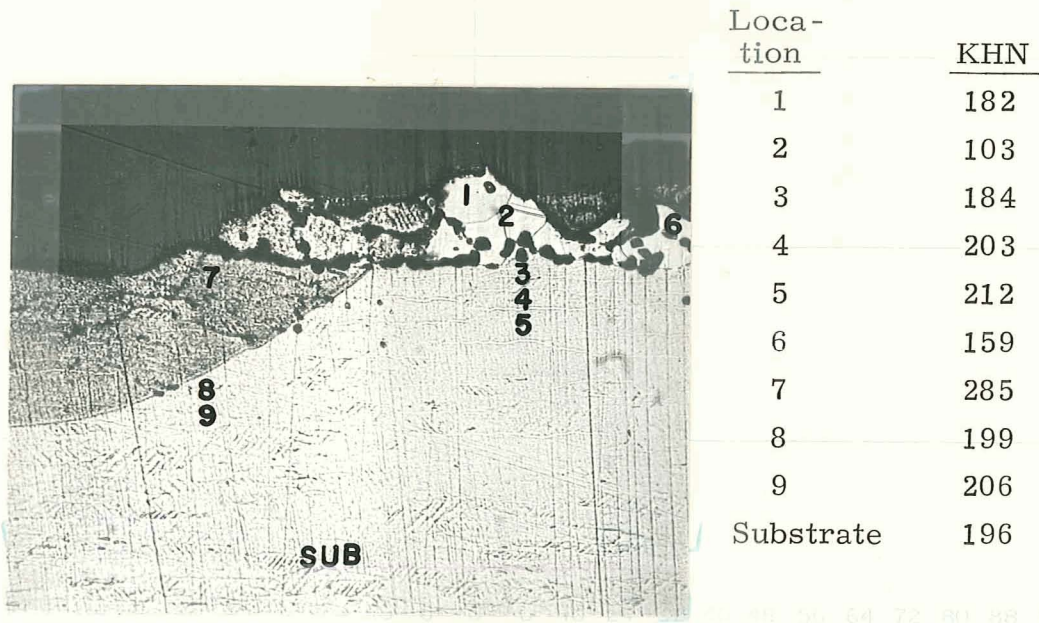

60 hours

Figure 35. Ni-20Cr-3Si coated TD-Ni oxidized at 2300°F. Microhardness tests made with 50 g load. (100X)

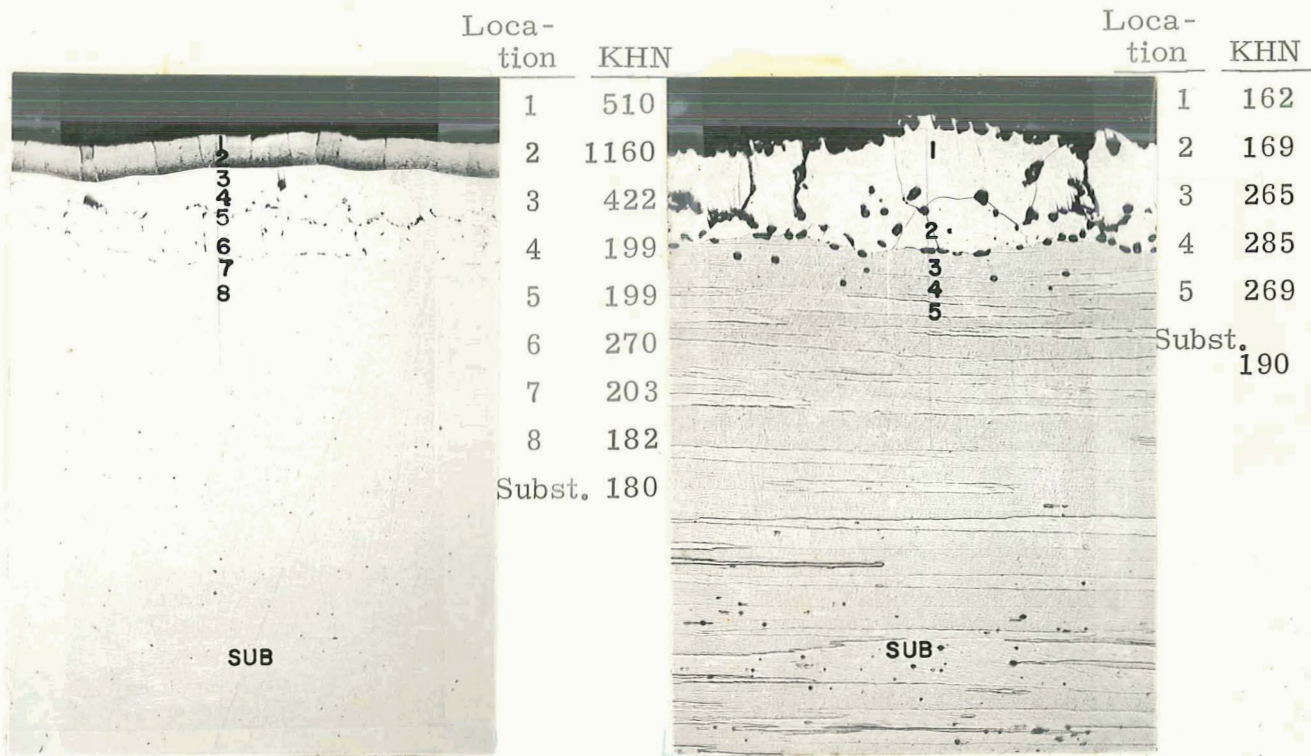

As Coated

20 hours

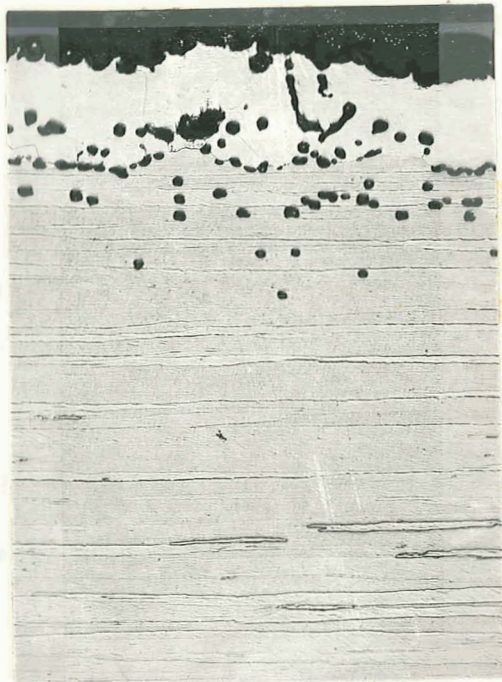

80 hours

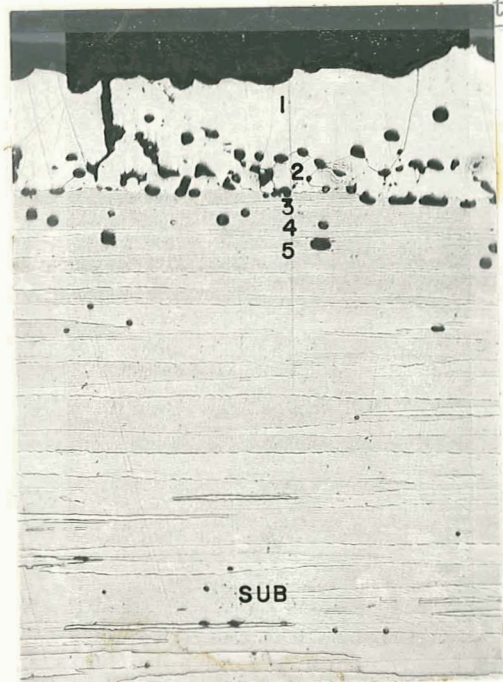

100 hours

Location	KHN
1	131
2	116
3	193
4	227
5	223
Subst. 205	

Figure 36. Two-step coating on TD-Ni oxidized at 2300°F. First step Ni-20Cr-3Si, second is Al-20Co slurry. Microhardness tests made with 50 g load. (100X)

The first step coating by itself forms a spalling oxide and after 20 hours or so starts to oxidize fairly rapidly. After 40 hours the coating has oxidized through in spots so that by 60 hours almost the entire coating spalls off and considerable attack has occurred on the substrate. Apparently once the coating is breached there is a porous interface zone, which forms concurrently and which provides the path for rapid undermining.

All of the aluminized two-step coating samples after the first 2-hour oxidation exposure at 2300°F had somewhat wrinkled surfaces indicative of a liquid phase in one of the coating layers. However, with continued oxidation no further anomalous effects were noted and oxidation behavior for the 100 hours was excellent with all three coatings. Very little spalling was noted visually and weight changes were quite low. No edge attack was noted and these systems appeared far superior to the alloy coatings tested previously.

Microstructurally, the three two-step coatings are very similar. After the first 20 hours of oxidation the coatings become single phase. While there is additional porosity formed with time there is little further consumption of coating by oxidation. Because of the excellent behavior of these coatings it was felt that the longer time samples would be more revealing. Therefore the 80 hour microstructures are shown instead of the 60 hour samples shown for previous coatings. The porosity developed at the coating-substrate interface during 100 hours is slightly less than for previously screened coatings and is probably caused by different diffusion rates of the chromium, aluminum and nickel, i.e. the Kirkendall effect. The porosity towards the center of the 0.060" thick TD-Ni substrate has been noted frequently and is an inherent feature of the substrate material and not a product of coating-substrate interactions.

Bend tests are listed in Table VII for both as-coated and 100 hour oxidation tested samples. The first step coating is completely ductile in the 90° 4T bend and all samples are ductile after the high temperature long term oxidation exposure. The as-coated two-step coated samples bent but had small surface cracks. These correlate with the presence of the aluminide surface layer.

Microhardness test data are tabulated together with the locations of the indentations in Figures 60 and 63 for the first step Ni-20Cr-3Si coating and for the Al-20Co slurry second step coating which is considered representative of the two other two-step coatings. The indents are not shown since the hardnesses were taken on another piece of equipment subsequent to the photographs. However the equivalent location of the hardness indentation is shown directly on the micrograph.

The first step coating and interface zone in Figure 60 are only slightly harder than the TD-Ni substrate in the as-coated condition. After 20 hours oxidation the coating softens considerably and the substrate and interface or diffusion zone somewhat less. There is a general further softening at 60 hours except in the failure zone which is appreciably harder.

The as-coated two step coating in Figure 63 has a hard intermetallic outer coating layer of KHN 510 which has a much harder thin layer, KHN 1160, just below it. The rest of the coating is quite soft with some increase in hardness at the diffusion zone. After 20 hours oxidation the single phase coating is quite soft, about KHN 160, but the diffusion zone has hardened slightly. After 100 hours oxidation the coating and diffusion zone have softened further and the substrate hardened slightly.

TABLE VII

Bend Test Results on Coated and Oxidized  
Single and Two-Step Coatings on TD-Ni

<u>Coating</u>	<u>R e s u l t s</u>	
	<u>As Coated</u>	<u>Oxidized</u>
Ni-20Cr-3Si	Ductile	
Ni-20Cr-3Si + Al Pack	Coating Cracks Sample Bends	100 hrs. - Ductile
Ni-20Cr-3Si + Al Slurry	Coating Cracks Sample Bends	100 hrs. - Ductile
Ni-20Cr-3Si + Al-20Co Slurry	Coating Cracks Sample Bends	100 hrs. - Ductile

As a result of the excellent oxidation protection obtained with the two-step coating it was decided to proceed into the Task II investigation with this basic system.

## IV. EXPERIMENTAL WORK - TASK II

### 4.1 Introduction

Although the two-step coating system appeared quite promising on TD-Ni it was necessary to eliminate the incipient melting which occurred in the first two-hour exposure to 2300°F. It appeared that this phenomenon was associated with a eutectic between the intermetallic phases initially formed and the Ni-Cr-Si coating layer. Both the cause and effect seemed to have disappeared during the first 20 hour oxidation exposure at 2300°F. Therefore the initial objective in Task II was to determine a reasonable time-temperature treatment which would develop a single phase structure without melting and prior to oxidation testing.

Concurrently it was planned to study other parameters such as the effect of varying the Cr and Al compositions and the coating of TD-NiCr. The overall goal of Task II was to develop and evaluate coatings for up to 800 hour oxidation protection at 2300°F.

### 4.2 Materials

The TD-Ni and TD-NiCr substrates used were 0.060" thick and the metal powders of 1-5 micron particle size. Prealloyed Ni-20Cr powder was used throughout Task II. To get higher chromium compositions elemental chromium was added to the prealloyed powder.

All of the samples in Task II were prepared from the second heats of TD-Ni and TD-NiCr listed in the materials section of Task I.

### 4.3 Coating Development and Compositions

The concept of applying a Ni-Cr-Si coating in the first step plus an aluminum coating in the second step followed by a diffusion treatment appeared relatively simple and straightforward. However, although an isothermal treatment eliminated obvious melting upon 2300°F oxidation exposure, a related but more subtle manifestation of this phenomenon was later encountered. Table VIII is a flow sheet type representation of the experiments performed.

In the first trial, TD-Ni substrates were used and a Ni-20Cr-3Si first step coating of 81-94 mg/cm<sup>2</sup> was applied, followed by 11-12 mg/cm<sup>2</sup> of Al by pack coating or Al-20Co by slurry coating. A diffusion treatment of 1900°F for 16 hours in argon resulted in a two-phase coating but 16 hours at 2200°F was sufficient to completely diffuse the Al and form a single phase coating. The structures of the broad surfaces as coated and after diffusion treating are shown in Figures 37 and 38; however edges were not examined closely. (text continued p. 60)

TABLE VIII

Diffusion Treatments to Eliminate Incipient Melting  
of Aluminized Coatings on TD-Ni Substrate.  
First Coating Ni-20Cr-3Si

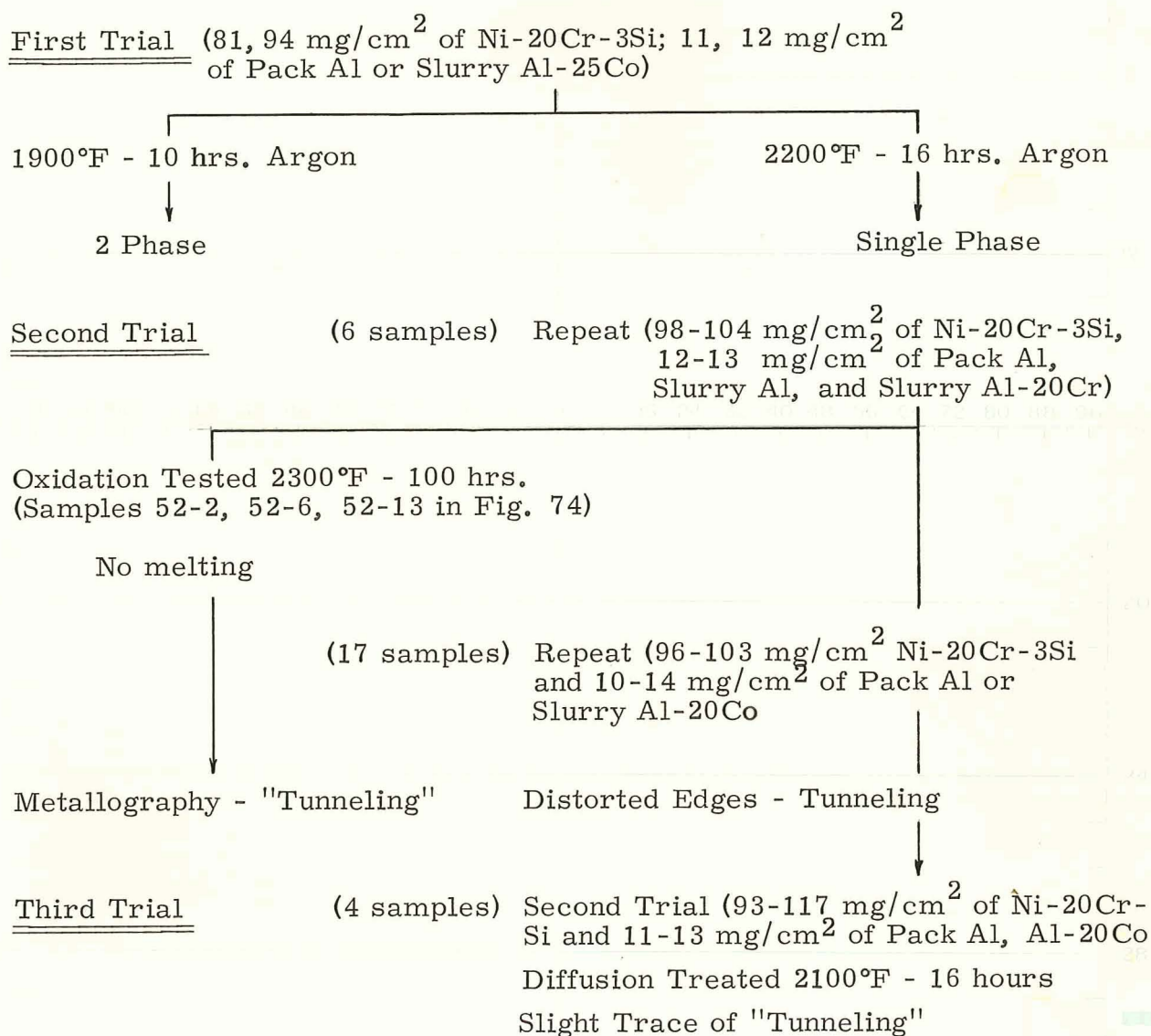

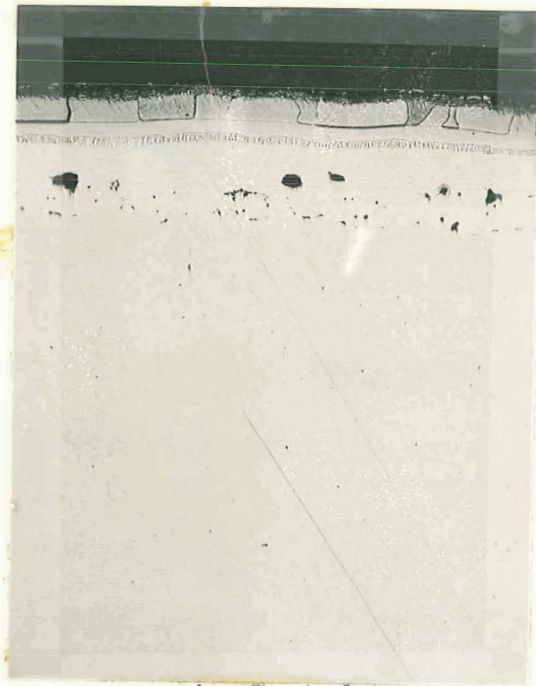

As Coated



16 hours, 1900°F



16 hours, 2200°F

Figure 37. As coated and diffusion heat treatments of Ni-20Cr-3Si plus pack Al on TD-Ni substrate. (100X)

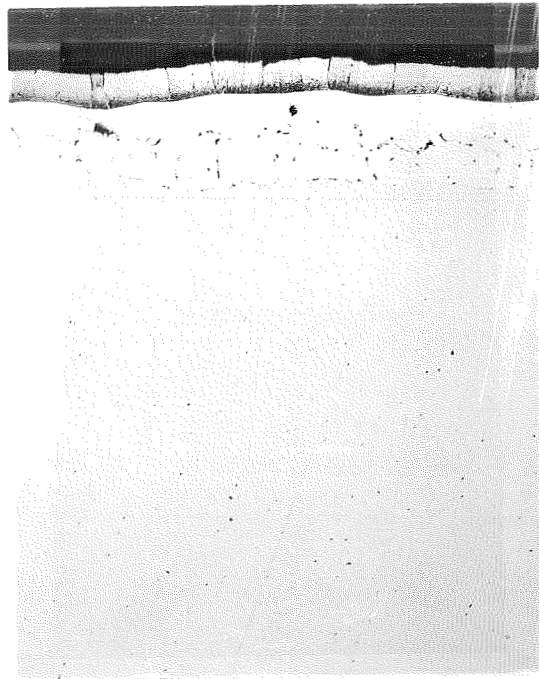

As Coated

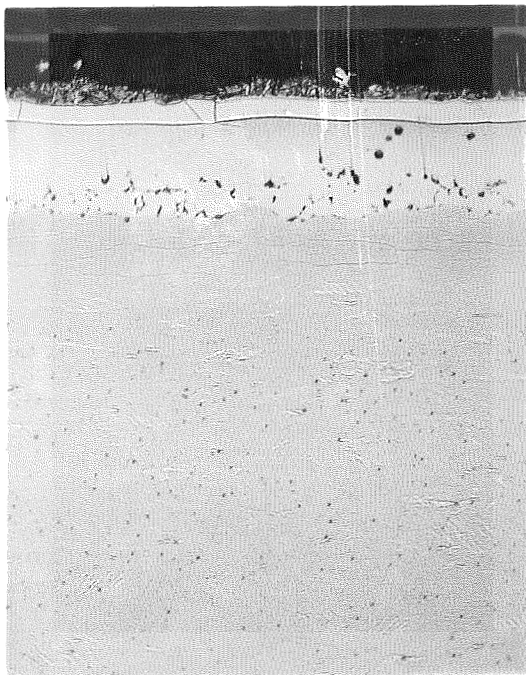

16 Hours, 1900°F

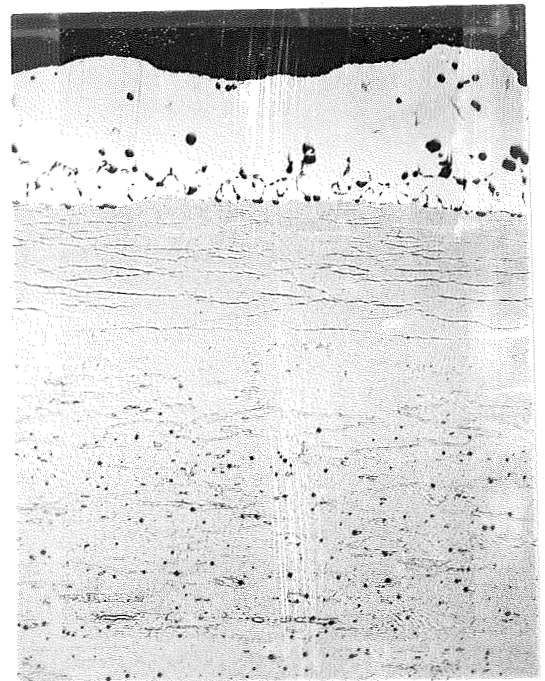

16 Hours, 2200°F

Figure 38 . As coated and diffusion heat treatments of Ni-20Cr-3Si plus slurry Al-20Co on TD-Ni substrate. (100X)

Accordingly additional samples were prepared for preliminary oxidation testing at 2300°F using the 2200°F - 16 hour treatment. These were tested for 100 hours without any apparent incipient melting and with excellent protection. Therefore in a second trial additional samples were prepared for longer time oxidation testing while metallography was performed on the 100 hour samples. Although the compositions and treatments were similar to the previous samples, the sample edges were distorted or roughened. A channel or "tunnel" was found in the coating running along the edge around the periphery of the samples. The micrographs in Figure 39 are illustrative of the hollow "tunnel" formed. Upon metallographic examination a similar structural defect was found in the oxidation tested samples. It appeared that a separation occurred between the Al-rich outer layer and the Ni-Cr-Si layer.

It was assumed that the 2200°F diffusion treatment may have been borderline and that some incipient melting still occurred between coating layer phases. It was also speculated that the tunnel may have been partially a result of volume changes during diffusion since the effect of this type of phenomenon could be magnified at an edge. Therefore in a third trial the diffusion treatment was lowered to 2100°F for 16 hours. Again "tunnels" were formed but they were considerably smaller, as shown in Figure 40 for one sample.

One effort was made to form a more stable aluminized coating system by applying the coating at 2300°F. The results are listed in Table IX. A pack with 2.5Al-0.25NH<sub>4</sub>Cl and a slurry of Al-20Co were fired for 2 hours, the pack in hydrogen and the slurry in vacuum. Both TD-Ni and TD-NiCr substrates were used. Much higher Al contents were obtained in the pack at 2300°F than previously at 1900°F, 17-18%. The nominal aimed at was 10%. With the slurries vacuum firing resulted in larger evaporation losses for some reason with the TD-NiCr samples leaving approximately 6% Al and on the TD-Ni, 9%. The slurry applied coatings gave massive melting and rundown of the coating but no "tunnels" were observed. In contrast the pack coatings were not melted but "tunneled". It can be speculated that aluminide phases and subsequent interdiffusion occur more slowly in the pack because of its relative insulating quality, thereby inhibiting the formation of a low melting outer phase. Later in oxidation tests the melted coatings showed an ability to remelt and run down when the samples were inverted during the early hours of 2300°F oxidation exposure.

It was felt that a proper balance of Al composition and controlled heating rate from 1900 to 2300°F was required to obtain a stable system for 2300°F oxidation. In order to facilitate the description of diffusion treatments a graphic representation has been made in Figure 41 of the six major incremental time-temperature diffusion treatments used in the balance of the program. These will be referred to by number for easy reference.

For the next series of experiments heat treatment #1 was used with TD-Ni substrates and the results are listed in Table X. During aluminizing  
(text continued page 65)

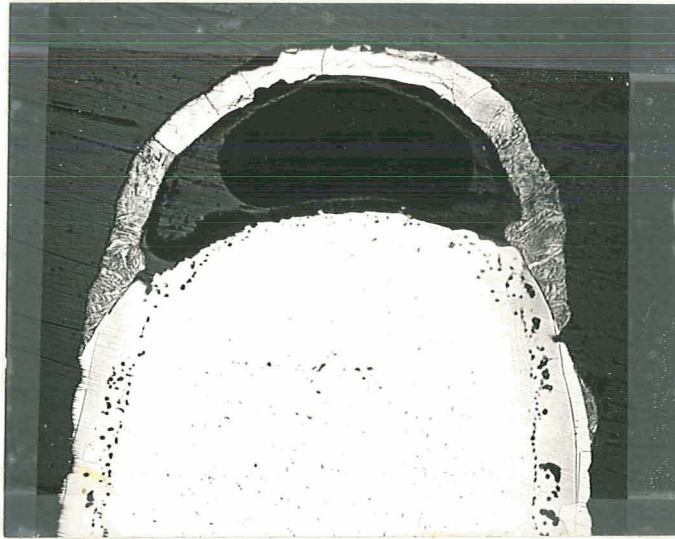

Pack Al

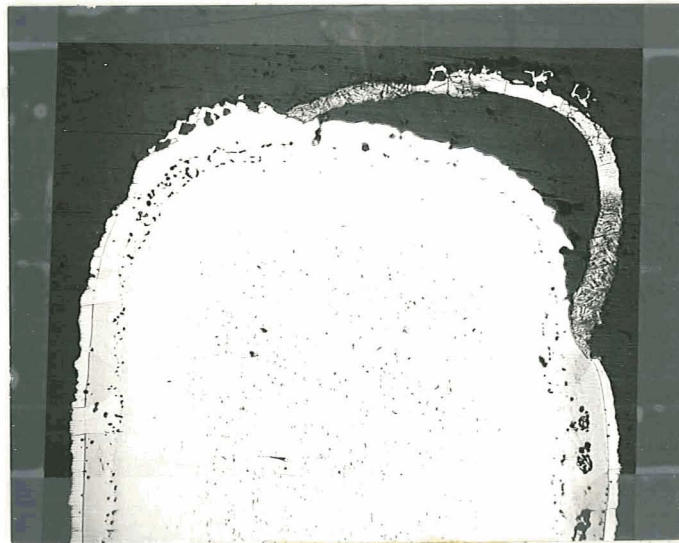

Slurry Al-20Co

Figure 39. Two-step coating on TD-Ni as diffusion t. treated at 2200°F for 16 hours. (40X)



As Coated



After Diffusion Treatment  
Note tunnel at edge.

Figure 40. Two-step coating on TD-Ni. First step Ni-20Cr-3Si and second step Al-20Co slurry. Showing as-coated structure and after a diffusion treatment of 16 hours at 2100°F. (100X)

TABLE IX

High Temperature Aluminum Coating Trials on TD-Ni and TD-NiCr. First coat 82-96 mg/cm<sup>2</sup> of Ni-20Cr-3Si. All coatings fired at 2300°F for 2 hours.

Sample	Coating	Substrate	Atmosphere	Al Wt. Gain (mg/cm <sup>2</sup> )	Results
324	Pack 2.5Al-0.25NH <sub>4</sub> Cl	TD-Ni	Hydrogen	17.3	Tunneled
323	"	TD-Ni	"	18.3	"
319	"	TD-NiCr	"	17.0	"
320	"	TD-NiCr	"	17.5	"
321	Slurry Al-20Co	TD-Ni	Vacuum	8.3	Melted-No Tunnel
322	"	TD-Ni	"	9.2	"
317	"	TD-NiCr	"	5.9	"
318	"	TD-NiCr	"	5.7	"

TABLE X

Slow Heating Experiments to Eliminate Tunnelling. Diffusion Treatment #1, TD-Ni Substrates and Ni-20Cr-3Si First Coat. Packs heated in hydrogen and argon, slurry in vacuum.

Sample	Ni-Cr-Si Wt. (mg/cm <sup>2</sup> )	Al Coating Type	Weight (mg/cm <sup>2</sup> )	Edge Appearance	2300°F-Oxid.
325	127	Pack 1*- hydrogen	10	Slight tunnel	16 hrs. -OK
326	115	Pack 1*- argon	6	No tunnel	"
327	111	Pack 2*-argon	6	No tunnel	"
338	107	Slurry Al-20Co**	3.6	Melted & ran	-
328	111	Slurry Al-20Co	3.1	No tunnel	-
330	102	"	4.1	"	-
331	94	"	4.8	"	60-80 hrs- Failed
332	98	"	5.3	"	"
333	95	"	3.9	"	-
334	93	Pack 2	5.2	"	-
335	92	"	4.8	"	60-80 hrs- Failed
336	100	"	4.8	"	"
337	85	"	4.7	"	-

\* Pack 1 - 1.7Al-0.17NH<sub>4</sub>Cl

\* Pack 2 - 1.0Al-0.1NH<sub>4</sub>Cl

\*\* Heated rapidly from 1900° to 2300°F

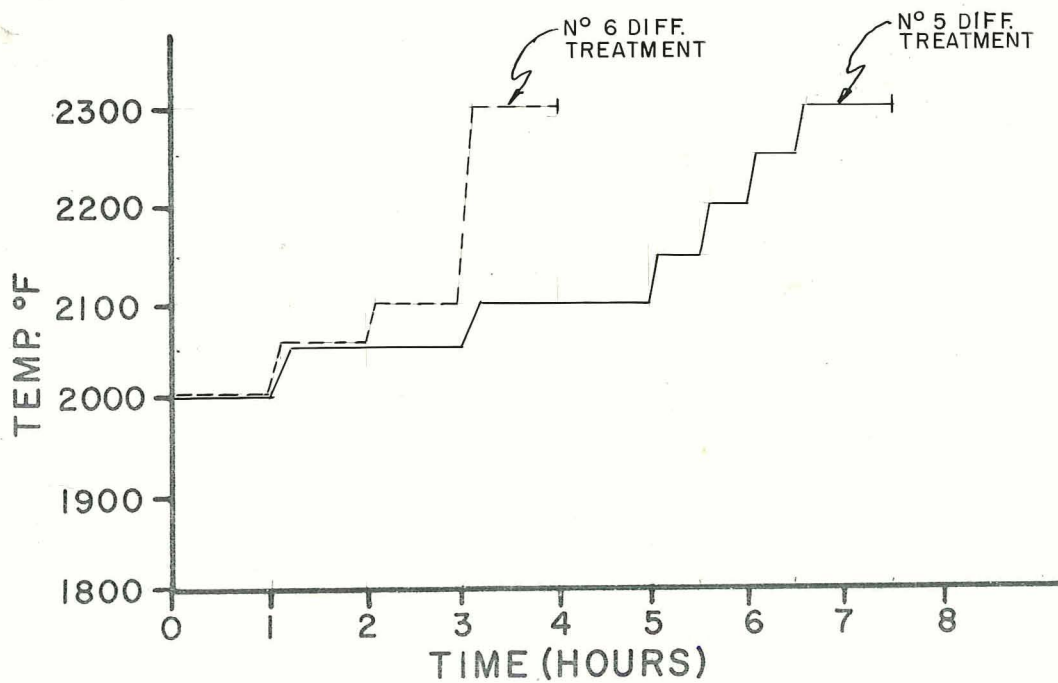
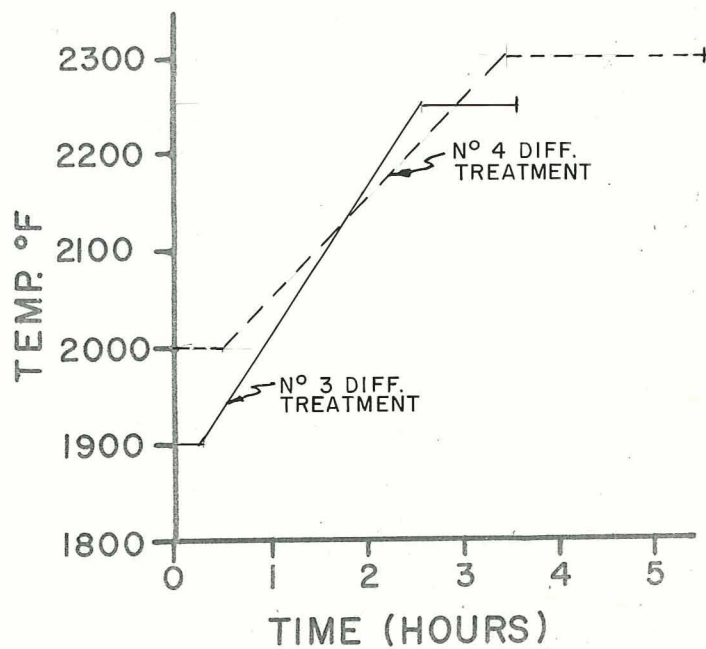
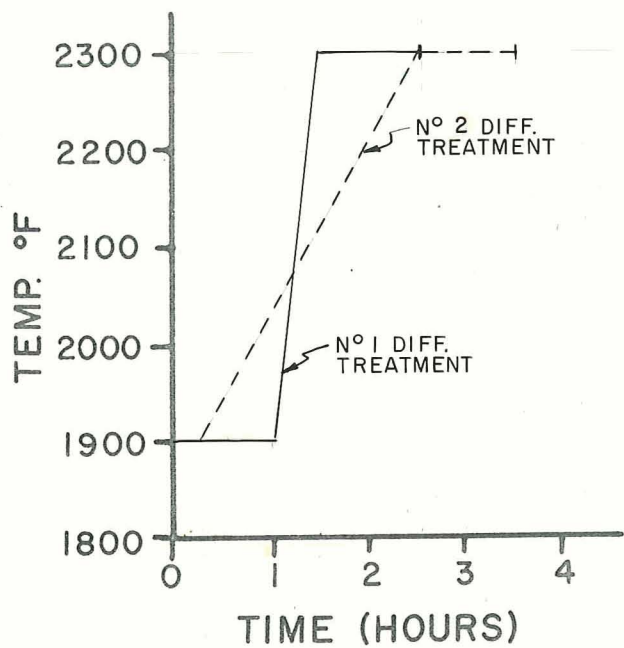

Figure 41. Various Al or Al-20Co diffusion treatments used during Task II coating development.

samples were held at 1900°F for an hour, heated to 2300°F in a half hour, and then held for one hour. In order to get lower Al compositions, the packs were diluted. With slurries the Al was directly controllable. In general the combination of low Al, 4 to 6%, and slow heating to 2300°F eliminated obvious melting or "tunneling". In contrast one slurry sample was heated rapidly to 2300°F and in spite of the low Al, melting occurred. Subsequent oxidation tests at 2300°F on representative samples revealed no "tunneling" tendencies but the coatings only gave 60-80 hours protection. The results were comparable to alloy coatings on TD-Ni evaluated in Task I with about 4% Al.

In order to improve protective life it was obviously necessary to increase the Al content and correspondingly it was felt necessary to provide a longer and slower diffusion treatment cycle to obtain a stable structure. Therefore attempts were made to increase Al to about the 10% level using diffusion treatments #2 and #3. The primary change was to decrease holding time at 1900°F and slow down the rate of heating from 1900 to 2300°F so that it took approximately 2 hours or more to reach 2250-2300°F. Resort was also made to a richer pack. The results are listed in Table XI. Both TD-Ni and TD-NiCr substrates were used. Since the first step coating was a little light on the last batch of TD-NiCr samples, less Al-Co was applied so that the same overall composition was attained as the other batches of samples. Although diffusion treatment #2 eliminated melting and tunneling for the TD-Ni substrates at this Al level, it was necessary to use the slightly lower heating rate of diffusion treatment #3 and to finish hold at 2250°F instead of 2300°F so that no "tunnels" were formed on the TD-NiCr samples. Considerable improvement in oxidation protection was obtained with the higher Al composition on TD-Ni but all of the TD-NiCr sample coatings melted and ran down during the first 2-hour oxidation cycle at 2300°F and the samples failed in 60-120 hours.

In order to improve stability with the TD-NiCr substrates and protective life for both the TD-NiCr and TD-Ni it appeared necessary to further modify the diffusion treatment cycle and increase the Al and/or the Cr in the first step coating for the TD-Ni substrate. Therefore considerable effort was devoted to the determination of fusion temperatures of potential higher chromium first step coating alloys. The results are listed in Table XII.

It was found that at chromium levels of 25 and 30% the silicon content could be dropped from 3% to the 1% level and still obtain reasonable fusion temperatures just a little above 2400°F. It was felt with the higher Cr alloys that the fusion temperatures with 3% Si additions, 2330 and 2345°F, was a little low, considering the problems being encountered in incipient melting and "tunneling" on subsequent aluminizing. Therefore with chromium contents above 20%, 1% Si additions were used as first step coatings in the ensuing development work.

TABLE XI

Results of #2 and #3 Diffusion Heat Treatments on TD-Ni and TD-NiCr Substrates with Ni-20Cr-3Si First Coat and 2.5Al-0.25NH<sub>4</sub>Cl Pack and Al-20Co Slurry Aluminized Second Step. First step fired in vacuum and second step in hydrogen.

Sample	Substrate	First Coat (mg/cm <sup>2</sup> )	Al Coating		Diff. Treat. No.	Edge Appear- ance	2300°F Oxid.
			Type	Weight (mg/cm <sup>2</sup> )			
9	TD-Ni	100	Pack	13	2	OK	Met. -Bend
10	"	101	"	14	"	"	Not Tested
11	"	106	"	13	"	"	160 hrs-failed
12	"	107	"	13	"	"	160 hrs-failed
13	"	95	"	13	"	"	160 hrs-failed
14	"	102	"	13	"	"	140 hrs-failed
15	"	98	"	13	"	"	20 hrs-Met.
16	"	89	"	13	"	"	100 hrs-Met.
25	TD-NiCr	78	"	13	"	Tunnel	120 hrs-failed
26	"	73	"	13	"	"	140 hrs-failed
27	"	95	"	12	"	"	Bend-Met.
28	"	91	"	12	"	"	Not tested
29	"	89	"	13	"	"	100 hrs-Met.
30	"	96	"	13	"	"	20 hrs-Met.
31	"	90	"	13	"	"	60 hrs-failed
32	"	92	"	13	"	"	80 hrs-failed
17 to 24	"	84-97	Slurry	12-14	2	Tunnels	Not tested
1	TD-Ni	95	Slurry	13	3	OK	Bend-Met.
2	"	100	"	13	"	"	Not tested
3	"	97	"	14	"	"	160 hrs-failed
4	"	95	"	14	"	"	160 hrs-failed
5	"	88	"	14	"	"	100 hrs-Met.
6	"	88	"	15	"	"	140 hrs-failed
7	"	88	"	14	"	"	160 hrs-failed
8	"	92	"	14	"	"	20 hrs-Met.
33	TD-NiCr	87	"	10	"	"	20 hrs-Met.
34	"	81	"	9	"	"	80 hrs-failed
35	"	79	"	9	"	"	120 hrs-failed
36	"	83	"	10	"	"	120 hrs-failed
37	"	77	"	10	"	"	80 hrs-failed
38	"	78	"	9	"	"	100 hrs-Met.
39	"	77	"	10	"	"	Bend-Met.
40	"	89	"	10	"	"	Not tested

Note: All TD-NiCr samples had surface melting and run-down of coating in first test cycle.

TABLE XII

Fusion Range Determinations for Ni-Cr-Si Alloy  
First-Step Coatings Fired in Vacuum

Alloy	Temperature - °F				Optimum Fusion
	Trial Runs				
Ni-20Cr-3Si	2630,	2380,	2400,	2500	2380
Ni-25Cr-1Si	2435,	2440,	2445		2440
Ni-25Cr-3Si	2315,	2340,	2350		2345
Ni-30Cr-1Si	2340 - 2450 (7 points)				2430
Ni-30Cr-3Si	2330,	2340,	2335		2330

To expedite the work and since slurry coatings were the main effort of the program, further development was restricted to the use of the Al-20Co slurry as an aluminizing step. The Al-Co composition was increased from the 12-15% level slightly to the 15-16% level and a Ni-30Cr-1Si first step coating was used on TD-Ni substrates while the Ni-20Cr-3Si remained a standard first step for the TD-NiCr substrate. Longer time, slower diffusion heat treatments #4 and #5 were used to effect stability. The results are listed in Table XIII. Many of the samples were used for metallography, representative structures of which are shown in Figures 42 and 43.

The added Al and the higher Cr first step on TD-Ni appeared to give a stable coating with the #4 diffusion treatment. However on subsequent oxidation exposure the tunnel effect was developed. Subsequently, as shown in Figure 42, signs of incipient tunneling were found on an as-coated sample. The #4 treatment was not as effective on the TD-NiCr substrate which developed tunnels in the as-coated condition. The somewhat lower Al ( $10 \text{ mg/cm}^2$ ) on TD-NiCr sample #87 showed no metallographic evidence of tunneling. Concurrently similar first coat samples had been prepared with very high Al second coat compositions,  $32-35 \text{ mg/cm}^2$ . Diffusion treatment #5 was used in an effort to further promote stability by introducing 2-hour holding periods at  $2050^\circ\text{F}$  and  $2100^\circ\text{F}$  and approximately half-hour holds every  $50^\circ\text{F}$  from  $2100^\circ\text{F}$  to  $2300^\circ\text{F}$ . The entire heat treat cycle was 7-1/2 hours. Although the #5 treatment resulted in apparently sound edges and no other visual defects, metallographic examination showed some evidence of void formation between coating phases at the edges of both substrates, as shown in Figures 42 and 43. Upon oxidation at  $2300^\circ\text{F}$  the TD-Ni developed massive blisters on

(text continued on page 71)

TABLE XIII

Effect of Substrate, First Step Coating Composition, Aluminum Composition and Slower Heating on Tunnel Formation and Oxidation Behavior. First coating step in vacuum and second in hydrogen.

Sample	Substrate	Ni Cr-Si* Weight (mg/cm <sup>2</sup> )	Al-20Co Coating		Edge Appear- ance	2300°F- oxid.
			Diff. Treat.	Weight (mg/cm <sup>2</sup> )		
61	TD-Ni	86	4	16	OK	111 hrs-tunnel
62	TD-Ni	69	4	15	OK**	-
71	TD-NiCr	76	4	16	Tunnel	-
72	TD-NiCr	78	4	16	Tunnel**	-
75	TD-NiCr	71	4	16	Tunnel**	-
76	TD-NiCr	72	4	10	OK**	-
63	TD-Ni	69	5	32	OK	70 hrs- blistered
64	TD-Ni	71	5	35	OK**	-
73	TD-NiCr	71	5	32	OK	111 hrs-tunnel
74	TD-NiCr	75	5	34	OK**	-

\* First step coating on TD-Ni was Ni-30Cr-1Si and on TD-NiCr, Ni-20Cr-3Si

\*\* Used for metallography

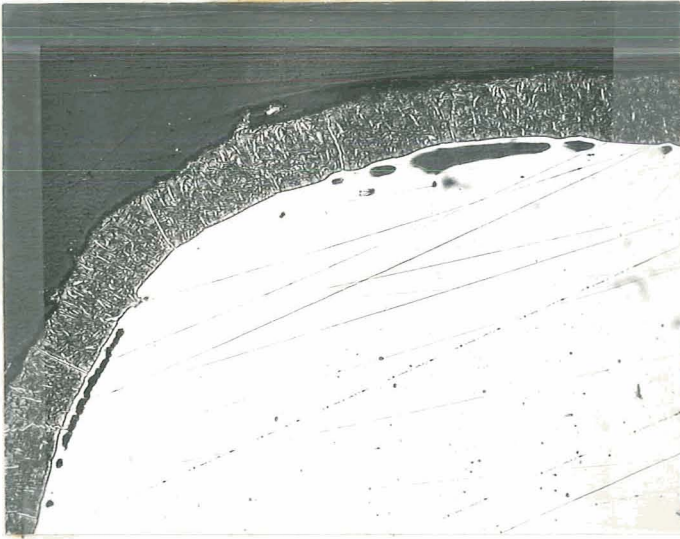

Sample 62 - Edge



Sample 64 - Edge

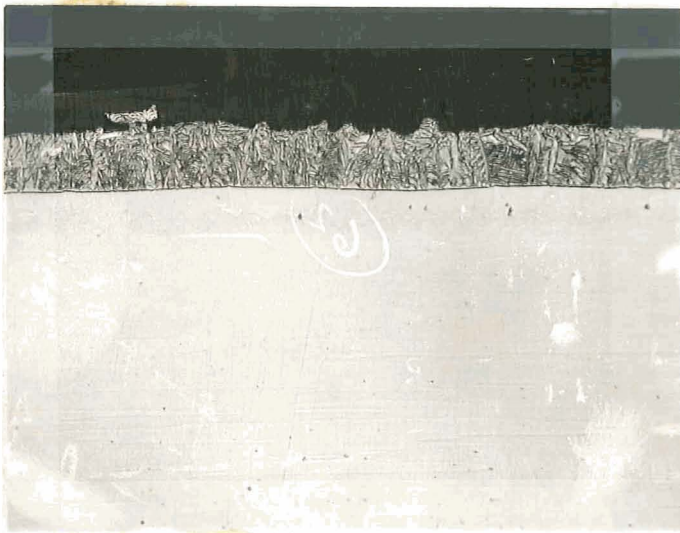

Sample 62 - Surface



Sample 64 - Surface

Figure 42. As coated TD-Ni samples with Ni-30Cr-1Si first step coating and Al-20Co second step showing edges and surface structure. Sample 62 had  $15 \text{ mg/cm}^2$  Al-20Co and the #4 diffusion treatment. Sample 64 had  $35 \text{ mg/cm}^2$  Al-20Co and the #5 diffusion treatment. (100X)



Sample 72 - Edge



Sample 74 - Edge

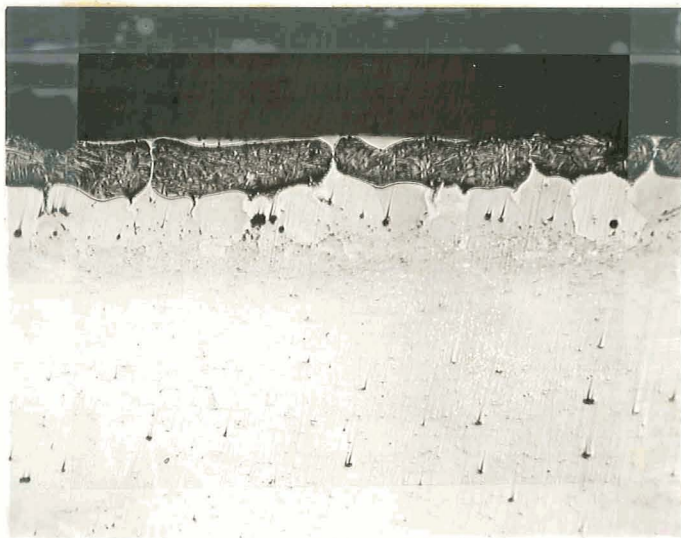

Sample 72 - Surface



Sample 74 - Surface

Figure 43. As-coated TD-NiCr samples with Ni-20Cr-3Si first step coating and Al-20Co second step showing edge and surface structure. Sample 72 had  $16 \text{ mg/cm}^2$  Al-20Co and the #4 diffusion treatment and Sample 74 had  $34 \text{ mg/cm}^2$  of Al-20Co and the #5 diffusion heat treatment. (100X)

one side and the TD-NiCr very definite tunnels along edges. The interface porosity responsible for blistering can be seen in Figure 42 in the as-coated condition.

At this point it was estimated that an Al content of about 20 mg/cm<sup>2</sup> might be tolerated by using the prolonged diffusion treatment #5. Accordingly samples of both substrates were prepared, the TD-Ni with three chromium levels 20, 25, and 30% in the first step coating and the TD-NiCr with a 20Cr first step coating. All samples were then aluminized by the Al-20Co slurry to obtain approximately 15-20 mg/cm<sup>2</sup> of coating and subjected to diffusion treatment #5. The results are listed in Table XIV.

Although the combination of long term diffusion treatment, 7-1/2 hours at 2000-2300°F, and 15-20 mg/cm<sup>2</sup> of Al-20Co gave no obvious visual evidence of melting or "tunneling" subsequent metallographic examination and oxidation testing revealed several problems. "Tunnels" of varying degrees of severity were noted metallographically in representative samples from each group of substrate-first coat combinations, as shown in Figure 44. These were relatively small on the TD-Ni substrate. In addition, although oxidation protection was good for up to 220 hours, the coatings tended to blister from one side, starting at times varying from 12 to 80 hours. No blisters were formed on TD-NiCr coatings but these coatings actually melted and ran down on the first several two hour oxidation exposures at 2300°F. However the coatings were otherwise protective to 180 hours in spite of this behavior.

The efforts to maximize Al composition and the theoretical coating life were not fundamentally successful since the problem of tunneling cropped up again and other problems such as melting and blistering were added. Therefore it appeared that coating compositions had to be limited to something above 5% but below 15% Al. Therefore the remaining effort on the program was placed on obtaining 5-10% Al in the coatings.

Before proceeding with the final major evaluation, some preliminary exploratory experiments were performed in order to determine feasibility and conserve effort and material. Samples were prepared from both substrates and the first coat was limited to one Cr composition for each, Ni-30Cr-1Si for TD-Ni and Ni-20Cr-3Si for TD-NiCr. Two Al-20Co levels were aimed at in the 5-10% range and the #5 diffusion treatment was applied during aluminizing. The results are listed in Table XV. To expedite the oxidation evaluation an automatic thermal cycling apparatus was used whereby the samples were cycled from 2300°F to room temperature once an hour.

Neither of the two as-coated aluminum levels resulted in any visible or metallographic evidence of tunneling, nor was there any sign of coating interface porosity which might precede blistering. There appeared to be some evidence of incipient grain boundary melting on the as-coated TD-NiCr sample with the high Al composition coating. The TD-Ni substrates were protected for 120 to 200 hours, depending on Al composition,  
(text continued on page 75)

TABLE XIV

Effect of Diffusion Heat Treatment #5 on TD-Ni and TD-NiCr Samples with 15-20 mg/cm<sup>2</sup> of Al-20Co Slurry Coating. First step coating fired in vacuum, second in hydrogen. Edge appearance visually OK in all samples as coated.

Sam- ple	Sub- strate	Ni-Cr-Si Coat- ing*	First Stop Wt. (mg/cm <sup>2</sup> )	Al-20Co Wt. (mg/cm <sup>2</sup> )	2300°F-Oxidation Testing
41	TD-Ni	2	81	19	20 hrs.** Blistered one side 12 hrs.
42	"	2	74	20	100 hrs.** Blistered one side 80- 100 hrs.
43	"	2	72	20	100 hrs. Blistered one side 40 hrs.
44	"	2	75	17	100 hrs. Blistered one side 40 hrs.
45	"	2	79	14**	Small tunnels edges-porous inter- face on one surface.
46	"	3	83	21	100 hrs.**Blistered one side 60 hrs.
47	"	3	81	21	Blistered one side 100 hrs-stopped.
48	"	3	79	18	20 hrs.**Blistered one side 12 hrs.
49	"	3	83	19	100 hrs. Blistered one side 40 hrs.
50	"	3	78	18**	Tunnel at edge.
51	"	1	79	16	20, 100 hrs* Blistered one side. 14 hrs.
52	"	1	83	21	220 hrs. Failed**
53	"	1	86	21**	Small tunnels edges.
54	"	1	79	16	160 hrs. Failed
55	"	1	77	15	160 hrs. Blistered one side 40 hrs.
56	TD-NiCr	1	83	18	180 hrs. Failed. X
57	"	1	82	19	200 hrs. ** X
58	"	1	83	14	180 hrs. Failed. X
59	"	1	79	17	20, 100 hrs. ** X
60	"	1	77	15**	Large tunnel one edge.

X First 4 hours melting and rundown of outer phase

\* 1) Ni-20Cr-3Si, 2) Ni-25Cr-1Si, 3) Ni-30Cr-1Si

\*\* Metallographic samples



Sample 45



Sample 50



Sample 53



Sample 60

Figure 44. As-coated TD-Ni and TD-NiCr samples after #5 diffusion treatment showing varying degrees of tunneling associated with 15-20 mg/cm<sup>2</sup> Al-20Co second step coating. Sample 45 - TD-Ni with Ni-25Cr-1Si first coat; Sample 50 - TD-Ni with Ni-30Cr-1Si first coat; Sample 53 - TD-Ni with Ni-20Cr-3Si first coat; Sample 60 - TD-NiCr with Ni-20Cr-3Si first coat. (100X)

TABLE XV

Effect of Lower Al-20Co Compositions on Cyclic Oxidation. TD-Ni substrates had Ni-30Cr-1Si first coat and TD-NiCr substrates Ni-20Cr-3Si first coat. All samples given #5 diffusion treatment during aluminizing.

<u>Sam- ple</u>	<u>Sub- strate</u>	<u>Ni-Cr-Si (mg/cm<sup>2</sup>)</u>	<u>Al-20Co (mg/cm<sup>2</sup>)</u>	<u>2300°F - 1 hr. Cyclic Tests</u>
65	TD-Ni	70	5.8	As coated metallographic sample
66	"	72	5.6	122 hrs. - Edge & surface failure
67	"	72	8.7	168-200 hrs. Failure-104 cy. corner chip
68	"	72	8.1	As coated metallographic sample
77	TD-NiCr	75	5.3	200 cycles- OK Metallography
78	"	73	5.3	As-coated metallographic sample
79	"	76	9.7	200 cycles - OK metallography
80	"	75	8.7	As coated metallographic sample
69	TD-Ni	58	6.2	*
70	TD-Ni	71	12.0	*

\* Used for studying structural changes during diffusion treatment #5.

and both TD-NiCr samples tested withstood 200 hours oxidation without failure or any visual signs of distress. There was no metallographic evidence of tunneling or blistering after oxidation.

Concurrently TD-Ni samples 69 and 70 in Table XV with coatings containing approximately 8 and 12% Al were examined for structural changes which occur during diffusion treatment #5. This was done by removing the samples from the diffusion furnace at four points in the heat treat cycle and sectioning a piece for metallographic examination at each point; i. e. after the cumulative 2000, 2050, 2100 and 2300°F periods. The microstructures in Figure 45 are representative of both Al levels. It appears the coatings start as a two-layered nonhomogeneous structure of possibly  $\text{Ni}_3\text{Al}$  which gradually homogenizes to single phase  $\text{Ni}_3\text{Al}$  by the time the sample has been exposed to the 2100°F part of the cycle; i. e. 5 hours total time. After the complete diffusion cycle the coating consists of a two-phase  $\text{Ni}_3\text{Al}$  plus solid solution layer over the Ni-Cr-Al alloy layer. There is little structural difference between the two Al compositions, the high Al taking somewhat longer to homogenize and also consuming more Ni-Cr-Si first coat to form a thicker Al-rich layer.

Since the feasibility of utilizing Al compositions up to about the 10% level was demonstrated it was planned to run a final series of comprehensive oxidation tests with 10% Al. However it appeared a slight modification in the aluminizing step would be beneficial. In all of the previous work after the Al-20Co slurry was applied, the samples were diffusion treated by laying them on top of an  $\text{Al}_2\text{O}_3$  powder layer in a steel boat. The resultant surfaces of the samples, usually the upper, coated with a very thin "dusty" deposit. While this condition did not appear to result in any marked effect on oxidation behavior, it was felt that the surface condition could and should be improved. Consequently a number of experiments were performed to put the proper finishing touches to the slurry aluminizing process.

Samples of both substrates were prepared with the now standardized first coat of Ni-Cr-Si for each followed by the application of an Al-20Co slurry of 5-8 mg/cm<sup>2</sup>. Various additives were made to the Al-20Co slurry and to the  $\text{Al}_2\text{O}_3$  powder in which the samples were submerged during the diffusion treatment. Abbreviated diffusion treatments of 1 and 4 hours at 1900°F and more extended time treatments as in the #5 and #6 diffusion cycles were used. Additives of 1%  $\text{NH}_4\text{Cl}$  were made to the  $\text{Al}_2\text{O}_3$  powder pack and of 0.5%  $\text{NH}_4\text{Cl}$  and 0.2  $\text{CaH}_2$  to the Al-20Co slurry. The results are listed in Table XVI.

All of the additives and treatments worked well in that they resulted in clean nondusting surfaces. However they also caused rather high coating losses of 30-50%. Samples were retained for metallography and for x-ray diffraction but did not reveal any significant structural or phase changes from those associated with 3-6% Al compositions. For the most part oxidation tests were carried out for 4 hours at 2300°F as a short time check for unusual visual behavior. Two samples of each substrate with 4-5% Al coatings were tested for longer times and had moderate  
(text continued page 78)

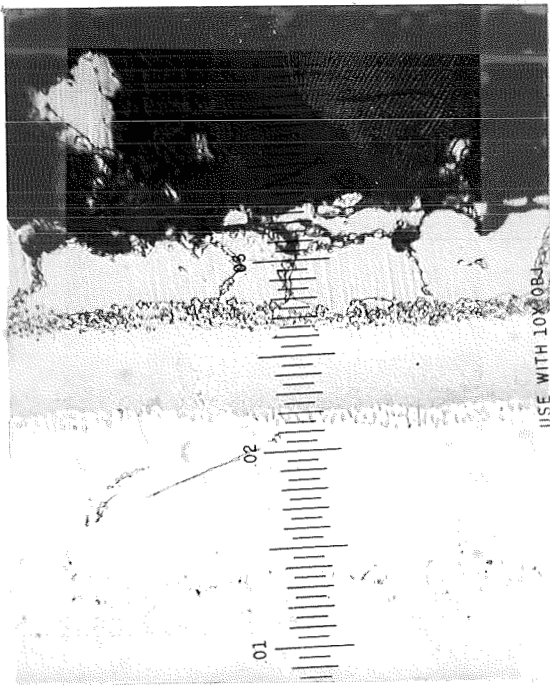

A

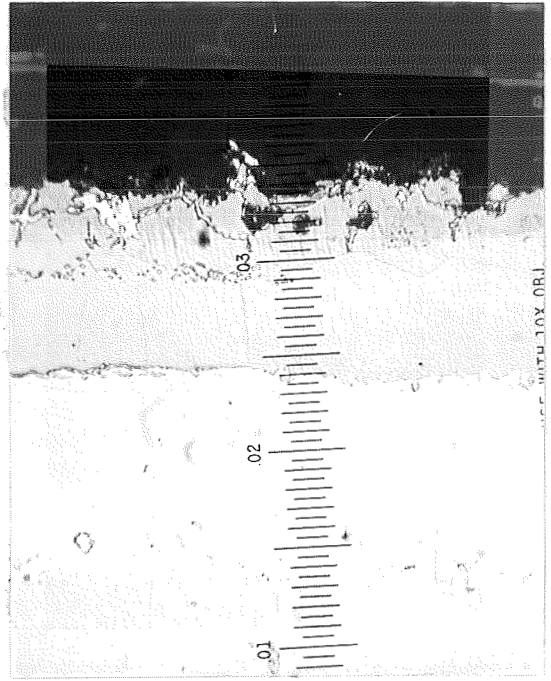

B

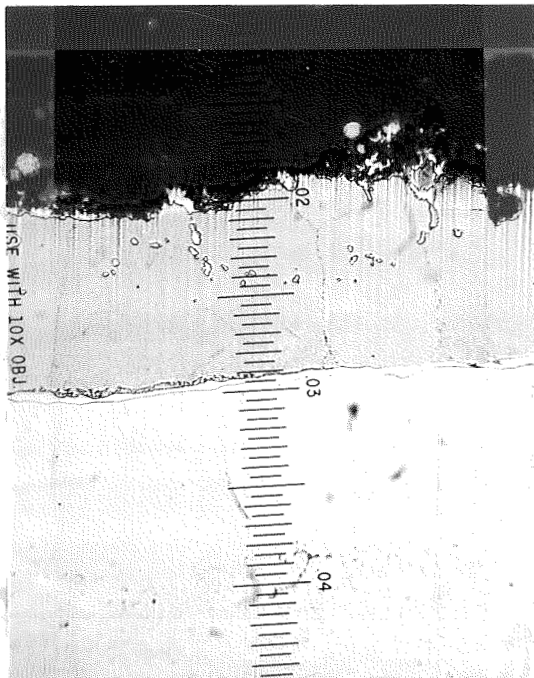

C

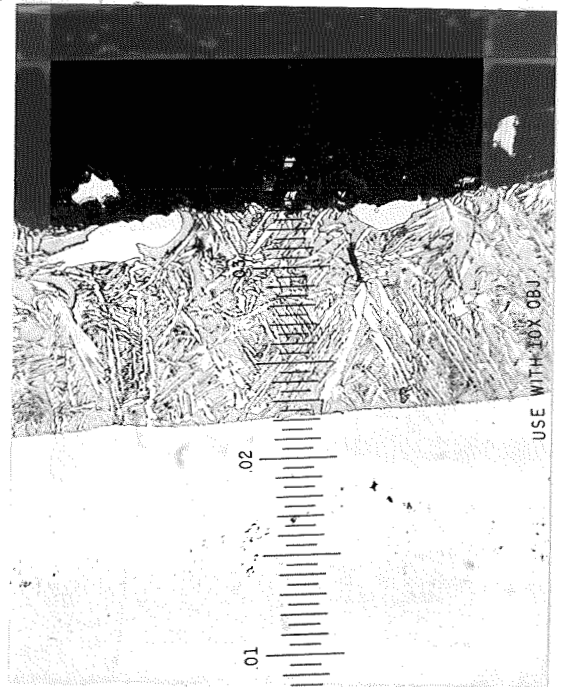

D

Figure 45. Structural changes during #5 diffusion treatment on Sample 70 TD-Ni coated with Ni-30Cr-1Si first step and 12 mg/cm<sup>2</sup> Al-20Co second step. (400X)  
 A) 1 hour at 2000°F, B) A plus 2 hours at 2050°F,  
 C) B plus 2 hours at 2100°F, D) C plus 1 hour at 2300°F.

TABLE XVI

Effect of Additives to Al-20Co Slurry and Al<sub>2</sub>O<sub>3</sub> Diffusion Pack on "Dusting" of Coating after Diffusion Treatment. Ni-30Cr-1Si first coat on TD-Ni and Ni-20Cr-3Si first coat on TD-NiCr. Second coat treatments in hydrogen.

Sam- ple	Sub- strate	Ni-Cr-Si (mg/cm <sup>2</sup> )	Al-20Co Wt. (mg/cm <sup>2</sup> )		Diff. Diff. Treat.*	Sample Disposition
			As Applied	Diffused		
81	TD-Ni	80	7.2	3.9	6	-
91	TD-NiCr	75	5.0	4.0	6	-
82	TD-Ni	79	7.2	5.9	A	Metallography
92	TD-NiCr	75	7.2	5.9	A	Metallography
83	TD-Ni	78	7.2	2.8	B	X-ray diff.
84	"	79	6.9	3.2	B	2300°F- oxid. 4 hours
85	"	79	6.5	2.4	6	X-ray diff.
86	"	77	6.4	3.1	6	2300°F- oxid. 4 hours
87	"	80	7.8	3.1	5	X-ray diff.
88	"	79	7.3	3.4	5	2300°F-oxid. 4 hrs.
93	TD-NiCr	75	6.6	3.4	B	2300°F-oxid. 4 hrs.
94	"	74	6.2	2.4	B	X-ray diff.
95	"	76	6.6	3.5	6	X-ray diff.
96	"	76	7.0	3.6	6	2300°F-oxid. 4 hrs.
97	"	76	7.0	3.8	5	2300°F-oxid. 4 hrs.
98	"	75	6.6	3.4	5	X-ray diff.
89	TD-Ni	78	8.4	4.0	6-1	2300°F oxid. 62 hrs. -fail.
90	"	77	8.5	5.0	6-1	"
99	TD-NiCr	76	8.2	5.4	6-1	2300°F-oxid. 167 hrs-fail.
100	"	75	8.1	4.5	6-1	"

\* #5, #6 - submerged in 1%NH<sub>4</sub>Cl-Al<sub>2</sub>O<sub>3</sub>, 6-1 - 0.2%CaH<sub>2</sub> added to Al-20Co  
 A - 1900°F - 1 hr. on top of Al<sub>2</sub>O<sub>3</sub>, 0.5% NH<sub>4</sub>Cl in Al-20Co  
 B - 1900°F - 4 hrs. submerged in 1% NH<sub>4</sub>Cl - Al<sub>2</sub>O<sub>3</sub>

lives of 62 hours for TD-Ni and 167 hours for TD-NiCr. These lives were not considered unusual at the Al level retained.

It was felt from the above tests that (1) increased slurry weight, (2) a smaller  $\text{NH}_4\text{Cl}$  additive to the  $\text{Al}_2\text{O}_3$  together with (3) the #5 diffusion treatment would be the most practical solution. Accordingly additional samples from both substrates were prepared and a comparison made between zero and 0.2%  $\text{NH}_4\text{Cl}$  added to the  $\text{Al}_2\text{O}_3$  pack in which the Al-20Co slurry coated samples were submerged during the diffusion treatment. The results are listed in Table XVII. Although the samples submerged in the pure  $\text{Al}_2\text{O}_3$  lost about 14% of the Al-20Co originally in the slurry they had "dusty" surfaces. The 0.2% salt additive gave about 30% losses which were still considered too high. Accordingly, for the final group of test samples the original slurry Al-20Co coating weight was increased to  $12 \text{ mg/cm}^2$  and the samples were submerged in a 0.1%  $\text{NH}_4\text{Cl}$  - Bal.  $\text{Al}_2\text{O}_3$  pack during the #5 diffusion treatment.

Results of the final coating run are listed in Table XVIII. Losses during aluminizing were about 20%, the surfaces did not "dust" and the target 10% Al was uniformly obtained from sample to sample. Therefore these samples were used in the final oxidation tests and for the argon diffusion studies. Lives of 200 to 260 hours were obtained on the TD-Ni substrates with the higher Cr first coating having slightly longer lives. The TD-NiCr samples had lives of 340-360 hours. No evidence of tunneling was found in the edges of as-coated samples as shown in Figure 46 or later on the samples which were tested.

The weights and compositions of first and second coating steps given in the foregoing description of process development were convenient numbers for working. However, due to the complexity of coating alloy compositions, i. e. three components in the first step and two in the second with varying weights of each, it was not practical to use average overall coating target compositions. For reference purposes and to summarize, various average compositions were calculated covering the broad ranges of first and second step coatings used in the investigation. These are listed in Table XIX. The optimum compositions found for the TD-Ni and TD-NiCr substrates are noted.

(text continues p. 82)

TABLE XVII

Effect of Minor  $\text{NH}_4\text{Cl}$  additive to  $\text{Al}_2\text{O}_3$  Diffusion Pack on Al Weight Losses during Diffusion Treatment #5. Ni-30Cr-1Si first step coating on TD-Ni and Ni-20Cr-3Si on TD-NiCr.

Sample	Substrate	Ni-Cr-Si Weight (mg/cm <sup>2</sup> )	Al-20Co (mg/cm <sup>2</sup> )		Al <sub>2</sub> O <sub>3</sub> Pack Additive	2300°F * Oxid.
			Applied	Diffused		
116	TD-Ni	81	10.5	6.9	0.2% $\text{NH}_4\text{Cl}$	136 hrs-failed
117	"	80	10.0	6.9	" <sup>4</sup>	136 hrs-failed
118	"	80	10.0	8.6	None	140 hrs-failed
119	"	80	10.0	8.5	None	Not tested
121	TD-NiCr	81	10.0	6.9	0.2% $\text{NH}_4\text{Cl}$	471 hrs-failed
122	"	80	10.6	7.3	" <sup>4</sup>	471 hrs-failed
123	"	80	10.0	8.6	None	500 hrs-failed
124	"	78	10.0	8.6	None	Not tested

\* Automated one hour cyclic test.

TABLE XVIII

Effect of Coating Composition on 2300°F Oxidation Behavior. Diffusion Treatment #5 used for aluminizing. Samples buried in a 0.1%  $\text{NH}_4\text{Cl}$  pack during diffusion treatment.

Sample	Substrate	Ni-Cr-Si Coating Weight (mg/cm <sup>2</sup> )		Al-20Co (mg/cm <sup>2</sup> )		2300°F Oxidation Tests
		Type *	Weight (mg/cm <sup>2</sup> )	Applied	Diffused	
101	TD-Ni	1	80	12	9.3	Argon diffusion study
102	"	1	80	12	9.3	As coated bond sample
103	"	1	79	12	9.3	260 hrs. failed
104	"	1	79	12	9.3	200 hr. Met.
105	"	1	79	12	9.4	20, 100 hr. Met.
106	"	2	80	12	9.8	Argon diffusion study
107	"	2	80	12	10.6	As coated bend sample
108	"	2	80	12	10.3	20, 100, 200 hr. Met.
109	"	2	80	12	10.4	200 hrs. Failed
110	"	2	80	12	10.0	240 hrs. Failed
111	TD-NiCr	2	79	12	9.3	Argon diffusion study
112	"	2	79	12	9.9	As coated bend sample
113	"	2	79	12	9.9	20, 100, 200 hr. Met.
114	"	2	79	12	10.1	340 hrs. failed
115	"	2	78	12	9.9	360 hrs. failed

\* 1) Ni-30Cr-1Si

2) Ni-20Cr-3Si

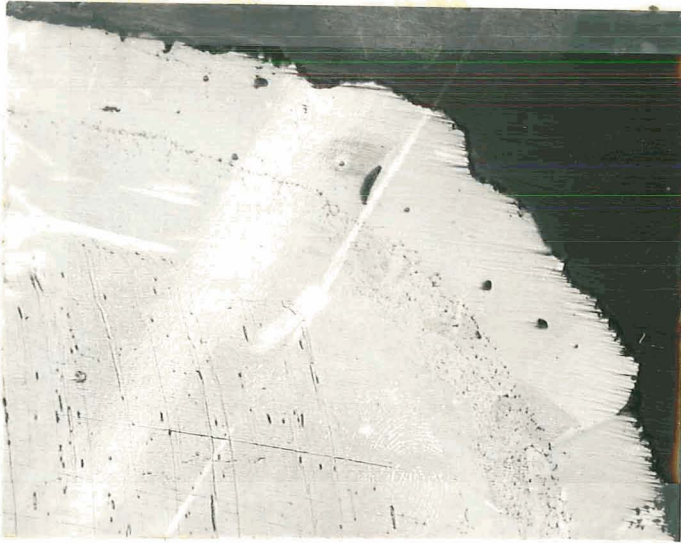

TD-Ni - Ni-20Cr-3Si  
First Step Coating  
Sample #106



TD-Ni - Ni-30Cr-1Si  
First Step Coating  
Sample #101



TD-NiCr - Ni-20Cr-3Si  
First Step Coating  
Sample #111

Figure 46. Edges of two step coated TD-Ni and TD-NiCr with  $10 \text{ mg/cm}^2$  of Al-20Co in the second step and given the #5 diffusion treatment. (100X)

TABLE XIX

Calculated Average Overall Coating Compositions  
for Typical Combined First and Second Coatings.

First Coat	Weight (mg/cm <sup>2</sup> )	Second Coat	Weight (mg/cm <sup>2</sup> )	Overall Average Composition				
				Ni	Co	Cr	Al	Si
Ni-20Cr-3Si	100	Al	5	73	-	19	5	3
"	"	"	15	67	-	17.5	13	2.5
"	90	"	15	66	-	17	14.5	2.5
"	100	Al-20Co	3	75	0.5	19	2.5	3
"	"	"	5	73	1	19	4	3
"	"	"	15	67	2.5	17.5	10.5	2.5
"	90	"	5	73	1	19	4	3
"	"	"	10	69	2	18	8	3
"	"	"	15	66	3	17	11.5	2.5
"	80	"	8	70	2	18	7.3	2.7
"	"	"	10*	68	2.3	18	9	2.7
"	"	"	15	65	3	17	12.5	2.5
"	"	"	20	61.5	4	16	16	2.5
"	75	"	5	72	1	19	5	3
"	"	"	10	68	2	18	9.4	2.6
"	70	"	15	63.5	3.5	16.5	14	2.5
"	"	"	35	51	7	13	27	2
Ni-25Cr-1Si	80	"	15	62.5	3	21	12.6	0.9
"	"	"	20	59.2	4	20	16	0.8
Ni-30Cr-1Si	80	"	5	65.4	1	28	4.7	0.9
"	"	"	8	63	1.8	27	7.3	0.9
"	"	"	10*	61.5	2	26.7	8.9	0.9
"	"	"	15	58	3	25.5	12.6	0.9
"	"	"	20	55.2	4	24	16	0.8

\* Considered optimum from test results.

#### 4.4 Oxidation Testing

Except where noted during the discussion of coating development above, the oxidation tests were carried out at 2300°F in the same fashion as Task I. It was originally planned to run a series of six samples of each coating-substrate combination and remove a sample after 20, 100, 200, 400, 600 and 800 hours of test. However it became apparent that lifetimes would not be long enough and since substrate material was being consumed rapidly in development work, the number of samples put in test were gradually decreased to three for each system. Nevertheless the samples were utilized to obtain the originally desired information. Except for one test series no uncoated TD-NiCr control samples were run.

After 20 hours of testing a piece was cut from one sample and the balance of the sample piece run for an additional 80 hours or a total of 100 hours and stopped. A second sample was removed at 200 hours and the third sample at 400 hours or failure, whichever was shorter. In many of the development phases samples 1/2" x 1" or 1" x 1" were used but most of the samples prepared were 1/2" x 2".

Weight change data for the uncut specimens are plotted in Figures 47 to 52. In all cases the data shown are for those samples which had the longest lives. Figure 47 covers samples referred to in Table VII where the feasibility of utilizing a 2200°F - 16 hour diffusion treatment was checked with 1" x 1" samples of TD-Ni. Comparison was made among pack and slurry Al and slurry Al-20Co at the 12-13 mg/cm<sup>2</sup> of Al level. Weight gain measurements were made every 24 hours on the samples only and it can be seen there was a continuous weight gain in all three cases with very little difference between the pack and Al-20Co slurry. As discussed previously, "tunneling" was later noted in these samples. However the oxidation behavior was excellent.

The standard Task I schedule of testing was applied to TD-Ni samples with much lower Al levels, 4-6 mg/cm<sup>2</sup>, listed in Table IX. Figure 48 is a weight gain plot for the samples and samples plus oxide. Both the pack and slurry second step coatings behaved similarly with an increase in oxidation rate at 60 hours followed by failure in 80 hours.

The effect of slower heat treatments on pack Al and slurry Al-20Co second step coatings at higher Al levels, 10-14 mg/cm<sup>2</sup>, are shown plotted in Figure 49. Standard testing was used. Total weight gain curves are similar in shape for both the TD-Ni and TD-NiCr substrates but oxide spalling was much greater for the TD-NiCr. However the results on the TD-NiCr must be assessed with the fact in mind that considerable surface melting and rundown occurred on these samples during the first test cycles. The overall life for the TD-Ni samples was double that of equivalent samples tested previously with the lower 4-6 mg/cm<sup>2</sup> of Al.

Figure 50 shows the effect of Al-20Co at the 18-20 mg/cm<sup>2</sup> level on both substrates with the slow #5 diffusion treatment and with TD-Ni the  
(text continued page 87 )

- - TD Ni SAMPLE 6 - (Ni-20Cr-3Si) plus 13 mg/cm<sup>2</sup> Al slurry
- - TD Ni SAMPLE 2 - (Ni-20Cr-3Si) plus 12.7 mg/cm<sup>2</sup> Al-20Co slurry
- △ - TD Ni SAMPLE 13 - (Ni-20Cr-3Si) plus 11.7 mg/cm<sup>2</sup> Al pack

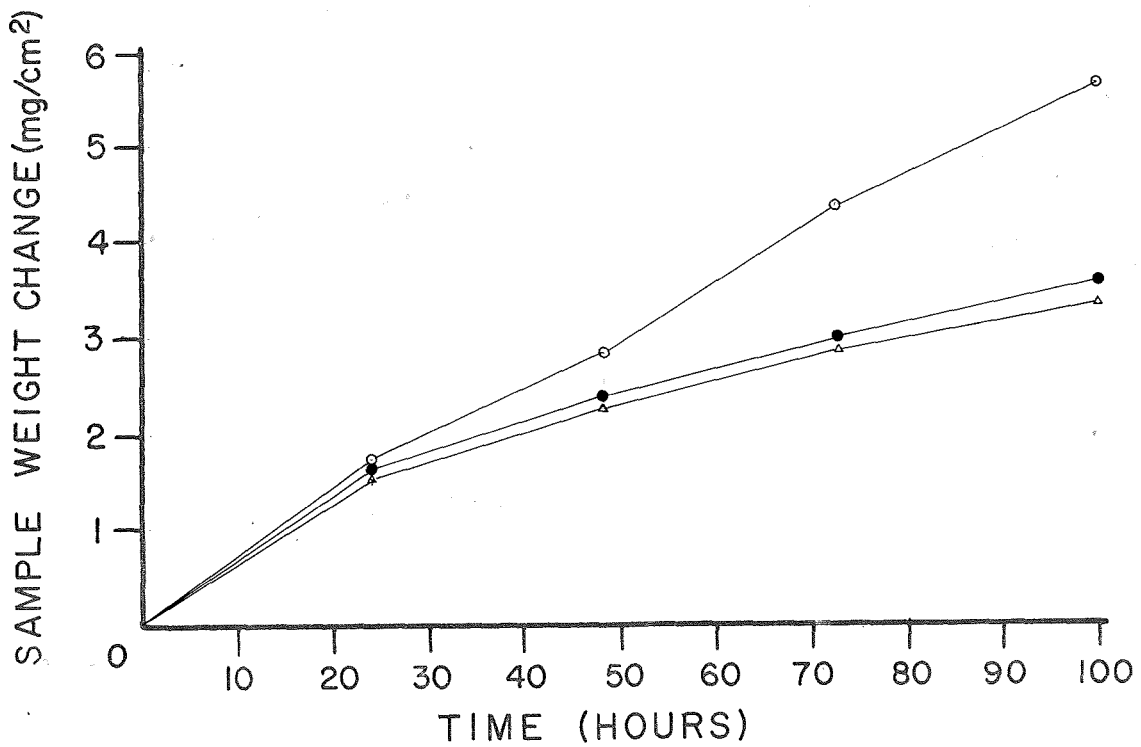

Figure 47. Oxidation behavior in non-standard test at 2300°F. Comparison of slurry and pack second coats applied at 1900°F for 2 hours and diffusion treated 16 hours at 2200°F.

# DIFFUSION TREATMENT N° 1

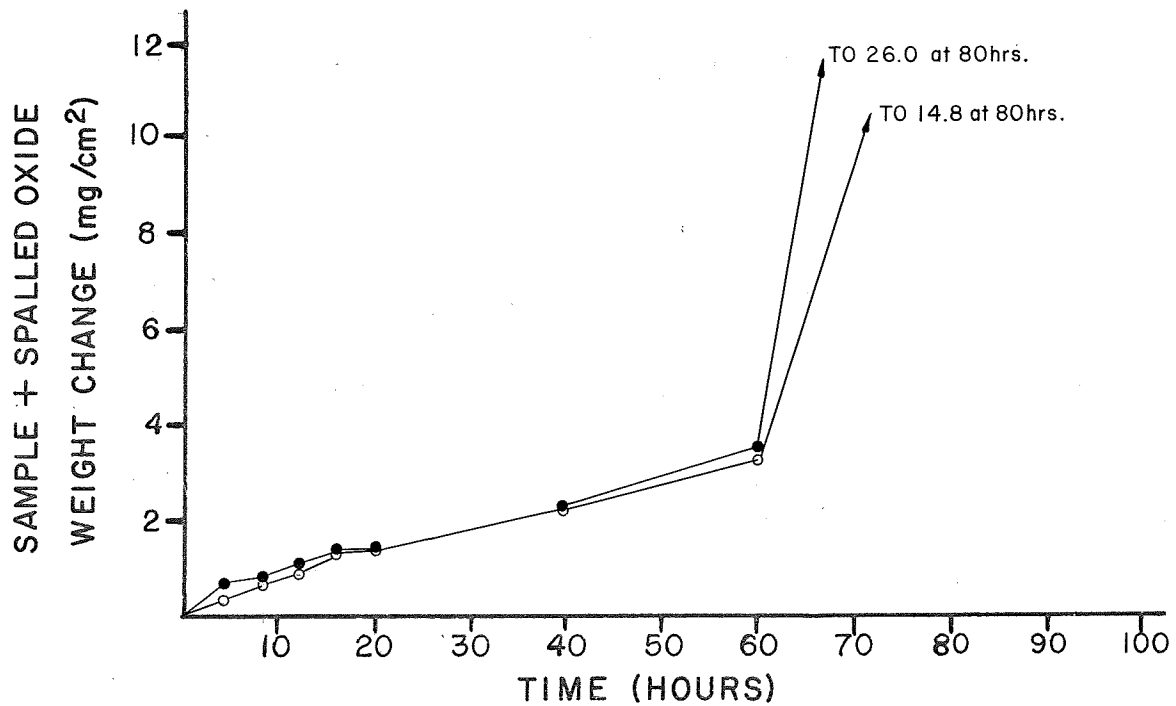
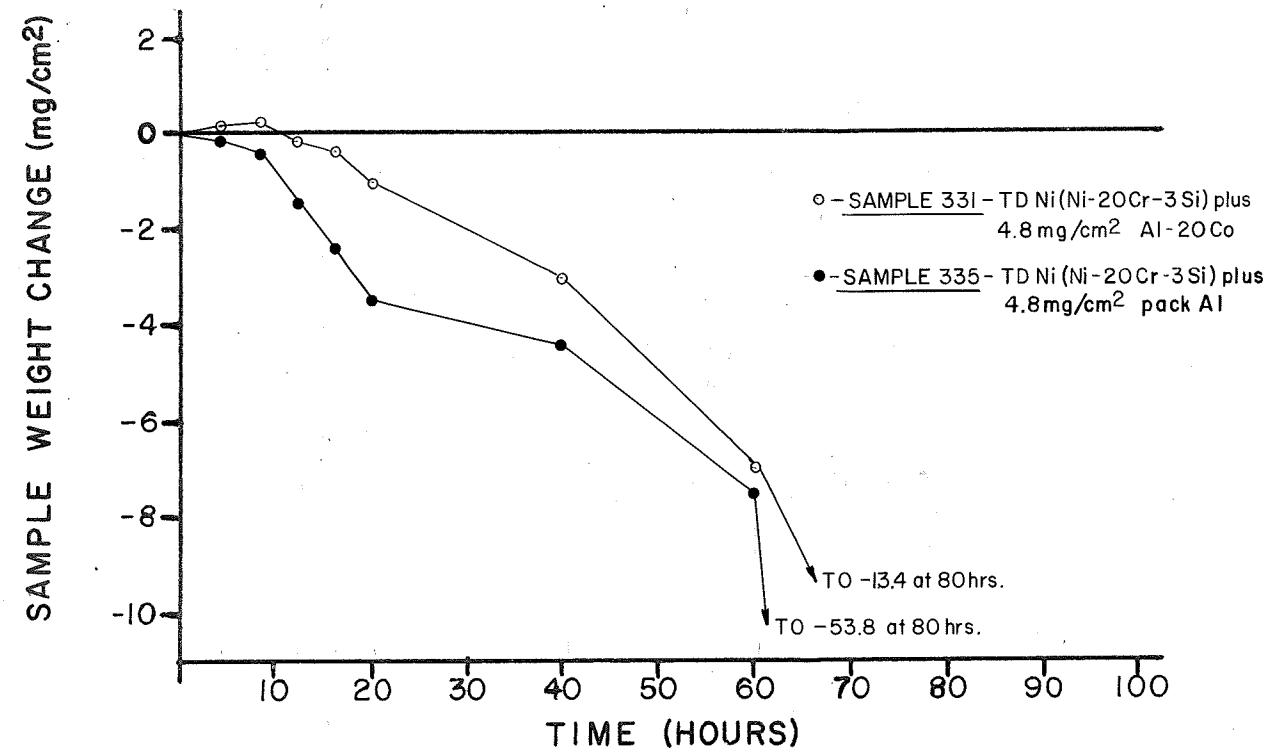

Figure 48. Oxidation behavior in standard test at 2300°F.

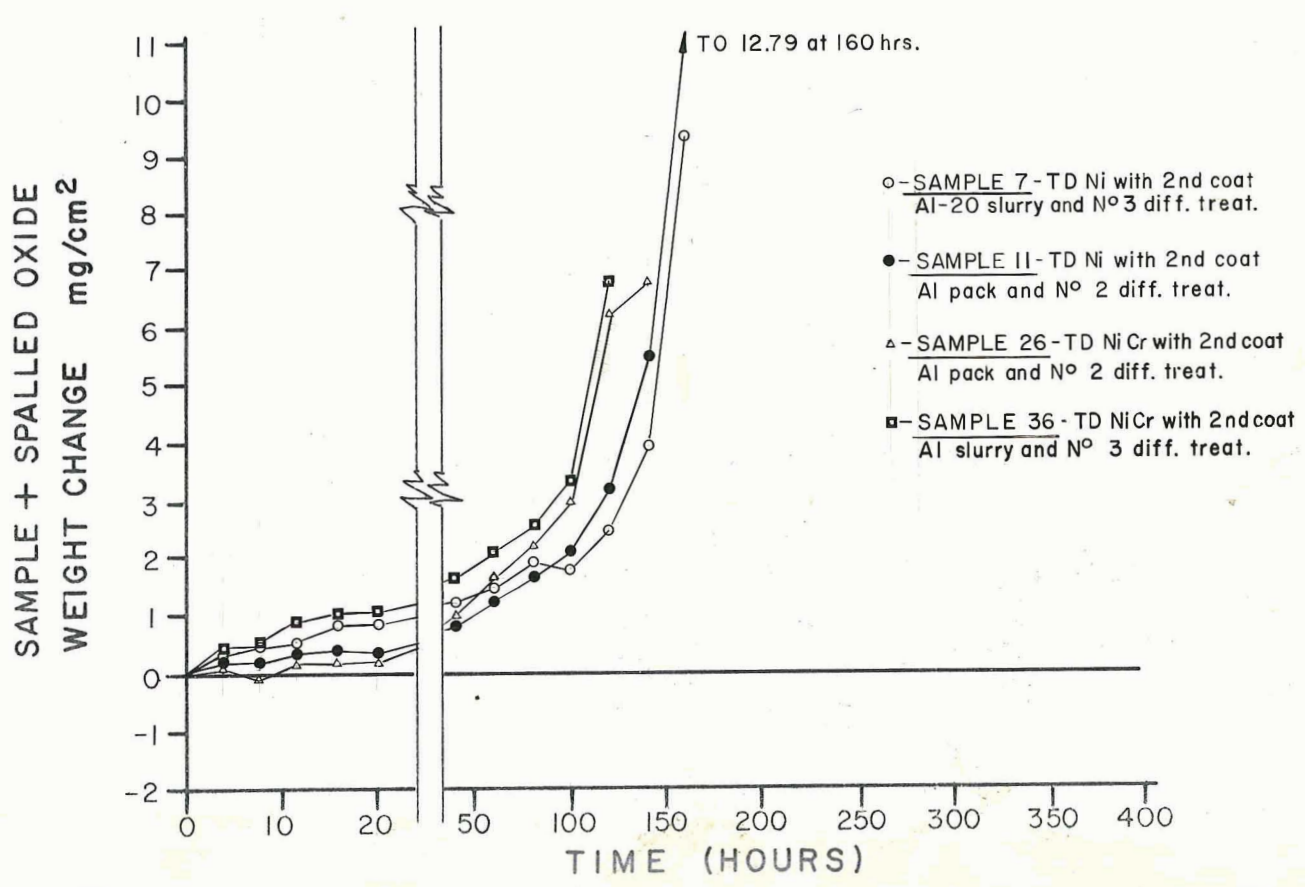
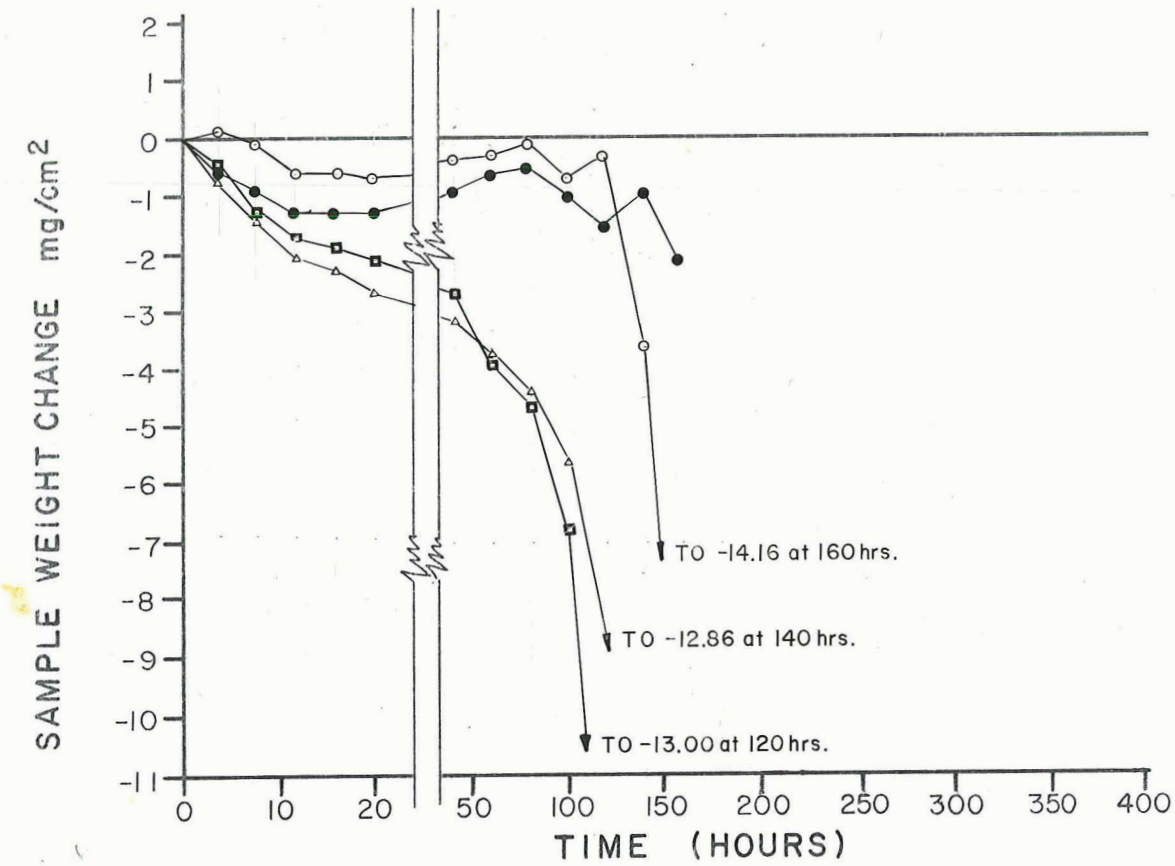

Figure 49. Oxidation behavior in standard test at 2300°F. First coat on all samples Ni-20Cr-3Si. Second coat 13 mg/cm<sup>2</sup> pack Al or 10-14 mg/cm<sup>2</sup> slurry Al-20Co.

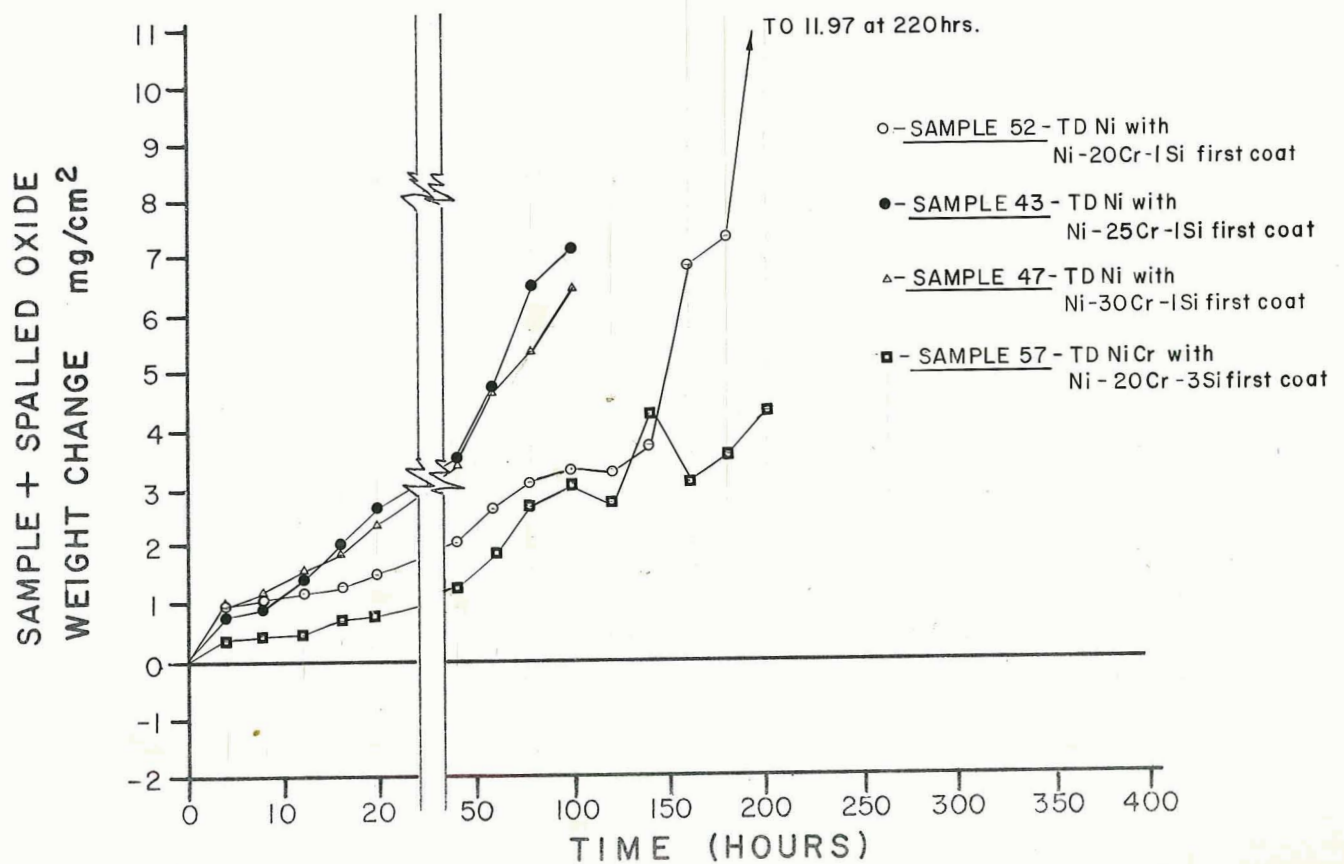
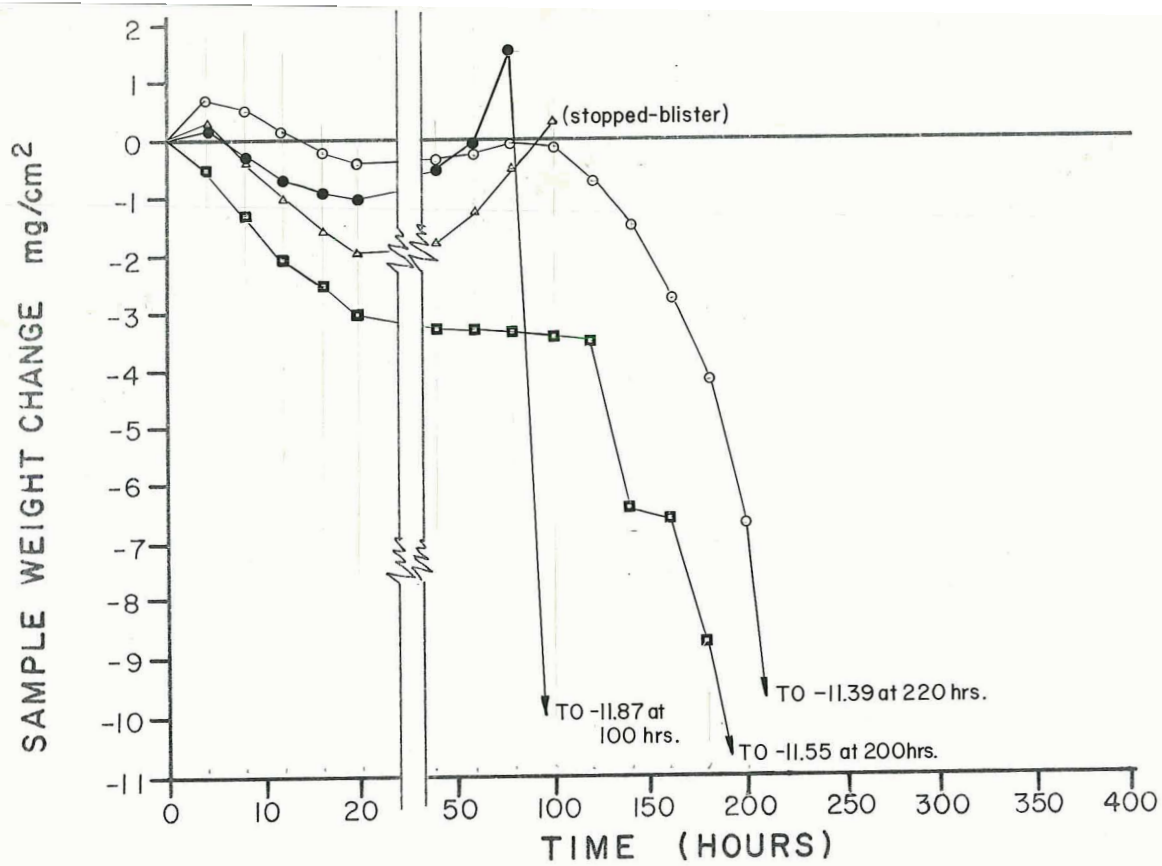

Figure 50. Oxidation behavior in standard test at 2300°F. Second coat on all samples was 18-21 mg/cm<sup>2</sup> of Al-20Co with #5 diffusion treatment.

effect of different Cr levels in the first step coating. The high incidence of blistering on the TD-Ni samples makes it difficult to deduce anything too significant from the weight changes. All of these systems show rather erratic sample weight change behaviors after 50 hours with relatively rapid weight losses. The Ni-20Cr-1Si first step coating was similar in behavior on both substrates and the Ni-25Cr-1Si and Ni-30Cr-1Si first step coatings were similar in behavior on the TD-Ni. Although blisters were prevalent on the TD-Ni substrates, testing was continued until failure occurred on two TD-Ni samples and the TD-NiCr as defined primarily by the 11 mg/cm<sup>2</sup> sample weight loss.

Much more uniform and improved behavior was obtained on both substrates with 10 mg/cm<sup>2</sup> Al-20Co second step coating as shown in Figure 51. In fact all three systems shown behaved quite similarly. Sample and total weight changes were very small for about 200 hours with little oxide spalling occurring. Then spalling commenced to take over with a sharp increase in sample weight loss and total weight gain for all three systems. Failure of both TD-Ni systems was at 240-260 hours using both the sample weight loss and total weight gain criteria of 11 mg/cm<sup>2</sup>. The TD-NiCr system failed in 360 hours by the sample weight loss criterion. However it should be noted that visually the major spalling occurs at corners and edges. Also in the TD-Ni substrates a few small spots of NiO were noted with both coatings on the broad surfaces and at two corners on the 20Cr first step coating at 200 hours.

All three systems were far superior to any of the alloy coatings tested in Task I. In fact the two-step coated TD-NiCr with 10 mg/cm<sup>2</sup> of Al-20Co appeared superior to uncoated TD-NiCr. However, no uncoated TD-NiCr samples were run as controls in Task II and since Task I samples were not run more than 100 hours it is not possible to compare longer time behavior. Reference to Figure 1 in Task I for uncoated TD-NiCr shows sample losses close to 2 mg/cm<sup>2</sup> for 100 hours, whereas the two step TD-NiCr coating in Figure 51, shows very little if any sample loss in 100 hours.

Some further verification in the superiority of the two-step coating over the uncoated TD-NiCr was obtained by accelerated testing in an automated cyclic test unit. Samples were held for one hour at 2300°F, withdrawn from the furnace for 5 minutes to cool, and then the cycle repeated until failure, which was defined by sample weight loss of 11 mg/cm<sup>2</sup>. The samples were not weighed each cycle but at various intervals of 24 to 48 hours. Before weighing they were brushed as per standard test procedure. Sample weight change plots are shown in Figure 52 for uncoated TD-NiCr and two-step coated TD-Ni and TD-NiCr. The TD-Ni sample has a continuous positive weight gain but was stopped because of an obvious corner failure where black glassy NiO became evident. The two-step coated TD-NiCr did not fail until 500 hours as compared to 240 hours for the uncoated TD-NiCr. The major difference between the coated and uncoated TD-NiCr is in the first 350 hours during which a positive weight gain

(text continued p. 90)

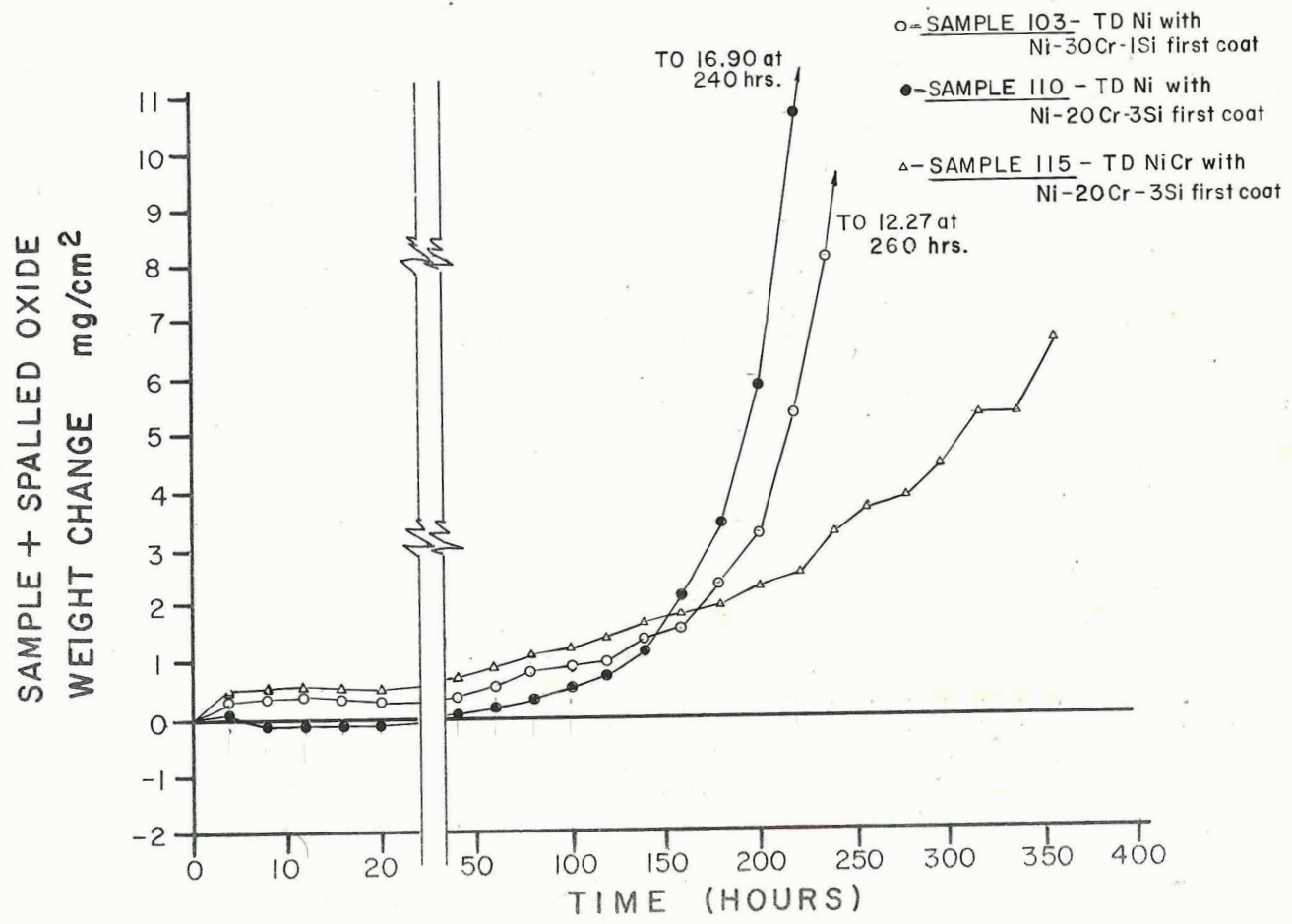
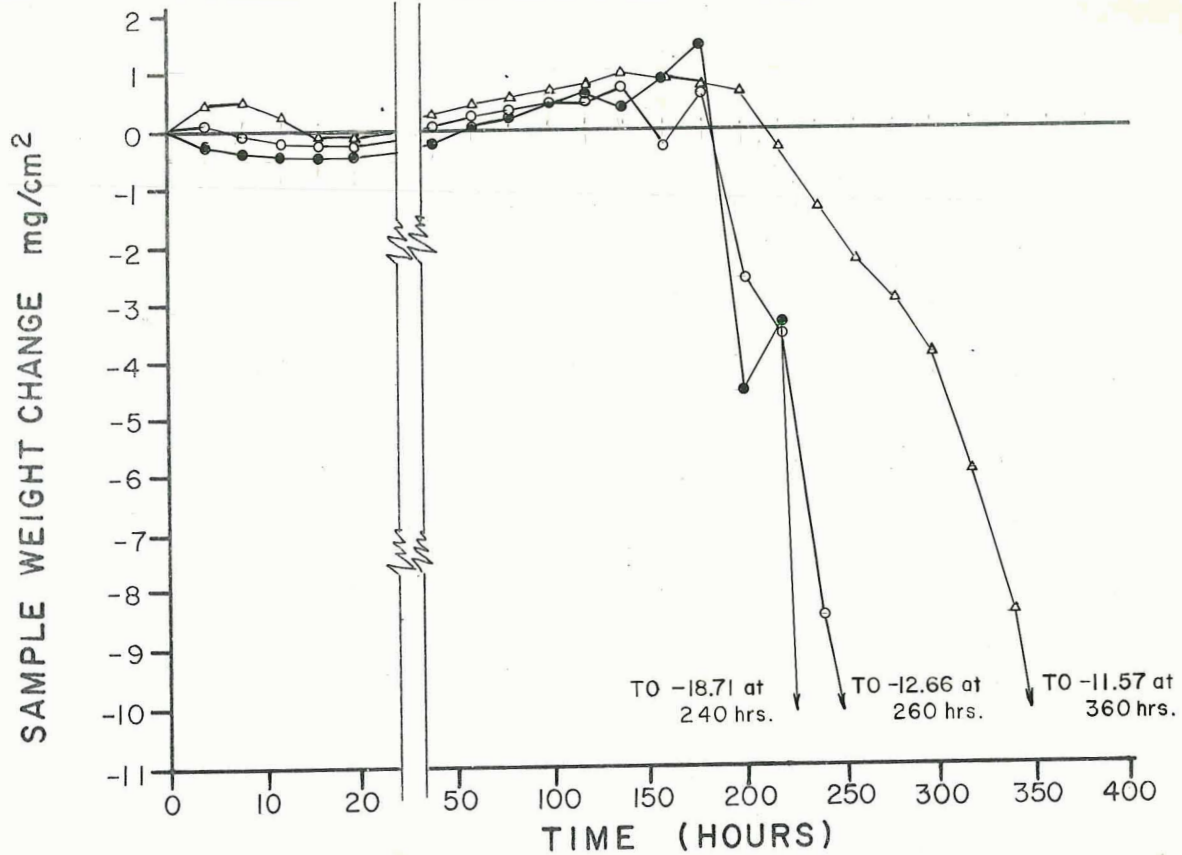

Figure 51. Oxidation behavior in Standard Test at 2300°F. All samples with 10 mg/cm<sup>2</sup> Al-20Co second coat and #5 diffusion treatment.

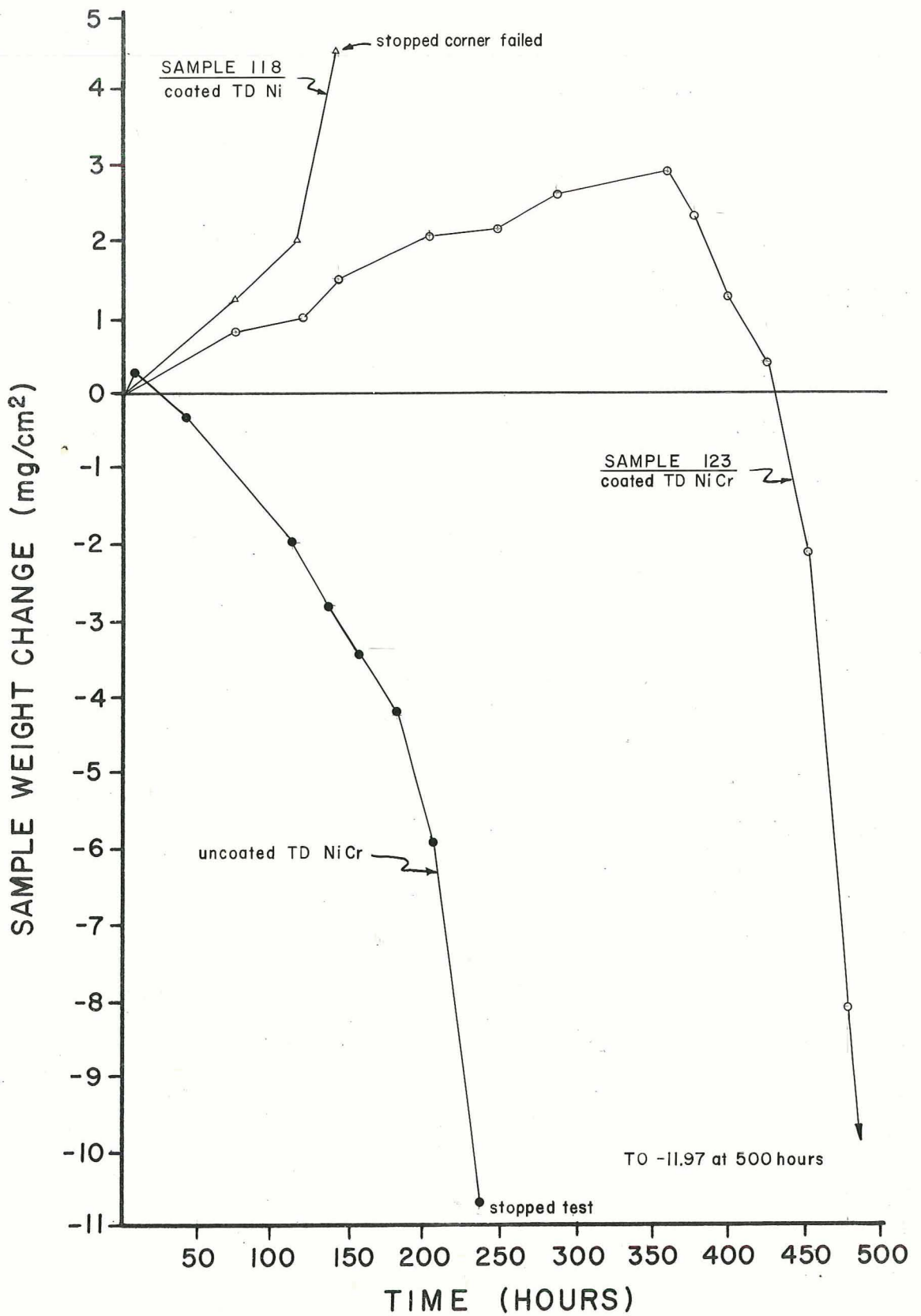

Figure 52. Comparison of two-step coated TD-Ni and TD-NiCr with uncoated TD-NiCr in automated one hour cyclic oxidation test at 2300°F. TD-Ni coated with Ni-30Cr-1Si and TD-NiCr coated with Ni-20Cr-3Si in first step. Both coated with 8.6 mg/cm<sup>2</sup> of Al-20Co in second step.

occurs on the coated TD-NiCr. After this time a weight loss occurs which is at about the same rate as the uncoated TD-NiCr which starts to lose weight early in the test.

It appeared peculiar that the coated TD-NiCr samples cycled at the higher rate of once per hour lasted longer compared to the standard once in 20 hour samples. This behavior may be explained by the fact that the automated test samples are not brushed every cycle but only when weighed. Therefore they were brushed only a dozen times compared to the two dozen times for the two step coated TD-NiCr standard test sample which lasted 360 hours. Apparently although the scale can be brushed off by a stiff brush it can still offer a measure of protection before spalling off naturally.

#### 4.5 Bend Tests

Results of the bend test are listed in Table XX for as-coated samples and for those with maximum 2300°F test times. It is readily notable that all oxidation tested samples of both substrates with three different Cr level first step coatings and 4-21 mg/cm<sup>2</sup> second step coatings were completely ductile. The only completely ductile as-coated samples were TD-Ni substrates with 4-10 mg/cm<sup>2</sup> second coats. Only one TD-Ni substrate broke in a brittle fashion, Sample #1 having the 13 mg/cm<sup>2</sup> second step slurry coating and the relatively short #3 diffusion treatment. Higher Al second step coatings together with the longer #5 diffusion treatment resulted in cracking or chipping of the coating but a ductile TD-Ni substrate. First step coating Cr levels had no noticeable effect on bend ductility.

All as-coated TD-NiCr samples broke in a brittle fashion regardless of second-step coating weight in the 10-15 mg/cm<sup>2</sup> range or final diffusion treatment. However it should be reemphasized that all as-coated systems could be made ductile as a result of further homogenization as indicated by the excellent ductility of oxidation tested samples. Generally speaking the TD-Ni substrate is resistant to notches and therefore can arrest cracks which occur in the coating whereas the TD-NiCr appears notch sensitive. On the other hand the bend tests are rather severe and are more indicative of fabricability rather than resistance to impact or damage during service. It should be noted that these coating systems are much more like alloys and tougher than intermetallic compound coatings and should be more resistant to flying object damage and particularly impact at elevated temperatures.

#### 4.6 Metallographic Examination

Figures 53 to 62 are presented as representative of 13 major coating-substrate systems which were oxidation tested and show the coatings in the early and late stages of testing compared to as-coated samples.

*Pluce*

TABLE X X  
 Bend Test Results on Two-Step Coated and Oxidized  
 TD-Ni and TD-Ni-Cr Samples

Sample	Substrate	Coating		Diff. Treat. #	Bend Ductility **	
		First Step Alloy *	Second Step Type Weight mg/cm <sup>2</sup>		As Coated	Oxidized Time (hours) Ductility
333	TD-Ni	1	Slurry 3.9	1	D	
331	"	1	" 4.8	1		80 D
337	"	1	Pack 4.7	1	D	
335	"	1	" 4.8	1		80 D
1	"	1	Slurry 13	3	Broke	
9	"	1	Pack 13	2	CC	
26	TD-NiCr	1	Pack 12	2	Broke	
39	"	1	Slurry 10	3	Broke	
4	TD-Ni	1	Slurry 14	3		160 D
11	"	1	Pack 13	2		160 D
26	TD-NiCr	1	Pack 13	2		140 D
35	"	1	Slurry 9	3		120 D
45	TD-Ni	2	Slurry 14	5	CCC	
50	TD-Ni	3	" 18	5	CCC	
53	TD-Ni	1	" 21	5	CCC	
60	TD-NiCr	1	" 15	5	Broke	
44	TD-Ni	2	" 17	5		100 D
47	TD-Ni	3	" 21	5		100 D
52	TD-Ni	1	" 21	5		220 D
57	TD-NiCr	1	" 19	5		200 D
102	TD-Ni	3	" 9.3	5	D	
107	"	1	" 10.6	5	D	
112	TD-NiCr	1	" 9.9	5	Broke	
103	TD-Ni	3	" 9.3	5		260 D
110	"	1	" 10.0	5		240 D
115	TD-NiCr	1	" 9.9	5		360 D

\* (1) Ni-20Cr-3Si, (2) Ni-25Cr-1Si, (3) Ni-30Cr-1Si

\*\* CC - Coating Cracked, D - Completely Ductile, CCC - Coating Cracked and Chipped Off.

Figures 53 and 54 are representative of the shorter time heat treatments #1 to #3 and cover the effect of aluminum or Al-20Co levels in the 5-14 mg/cm<sup>2</sup> range. Most of the as-coated structures have a two-phase outer layer over the residual first step coating except for the structure in Figure 54 at the 5 mg/cm<sup>2</sup> Al level, which is single phase. However, within 20 hours at 2300°F all coatings have been converted to single phase structure. For various reasons, as discussed above, none of these samples lasted much more than 140 hours or so, or were defective in other ways.

With the TD-Ni substrates pores develop primarily within the coating and in the vicinity of the coating substrate interface. There is also a tendency for the pores to line up at the interface. With the TD-NiCr substrates porosity is more general and spreads well into the substrate.

At the higher Al-20Co levels, 14-21 mg/cm<sup>2</sup>, and with the longer time diffusion treatment #5, the outer coating layer consists of a solid aluminide, probably Ni<sub>3</sub>Al, with the 25 and 30 Cr first step coatings as shown in Figures 56 and 57. With the 20Cr first step coating on both substrates, as shown in Figures 55 and 58, there is a considerable amount of aluminide in the outer layer but the layer is two-phased. There is surprisingly little porosity developed in any of these coatings for up to several hundred hours. However a line of pores develops at the coating-substrate interface on the TD-Ni substrate and in the TD-NiCr substrate in general. There is little difference in structures between the 25 and 30Cr first step coatings on the TD-Ni.

The superior coatings developed by a combination of 10 mg/cm<sup>2</sup> of Al-20Co and the #5 diffusion treatment are shown in Figures 59 to 62. With the 20Cr first step coatings the as-coated structures are practically single phase as coated on both substrates. With the 30Cr first step coating on TD-Ni the coating is two phased at the same Al-20Co level. In general a little more porosity develops in these coatings during oxidation than with higher Al-20Co levels but on the TD-Ni substrates there is the same tendency to develop a line of porosity at the coating-substrate interface. The 20Cr first step coating on the TD-Ni was slightly thinner and more irregular than the 30Cr first step coating but lasted slightly longer.

The localized attack shown in the 240 hour sample in Figure 60 is not typical of all areas of the sample but occurred at a few locations on both the 20Cr and 30Cr first step coatings on the TD-Ni substrate. It is shown to illustrate the isolated type of attack which occurs and is probably associated with the small NiO areas noted at 200 hours on these samples.

The TD-NiCr coating structures in Figure 61 show the usual development of substrate porosity which increases with time. There is little or no evidence of localized attack. The coating oxide appears to spall preferentially but uniformly in the vicinity of edges where the coating becomes thinner with time. This is true in general for all coatings on both substrates. Therefore the residual coating thicknesses shown on the flat  
(text continued on p.102.)



As coated  
Sample 330



20 hours  
Sample 332



60 hours  
Sample 332



80 hours  
Sample 332

Figure 53. TD-Ni with Ni-20Cr-3Si first coat and  $5 \text{ mg/cm}^2$  slurry Al-20Co second coat with #1 diffusion treatment and oxidized at 2300°F. (100X)

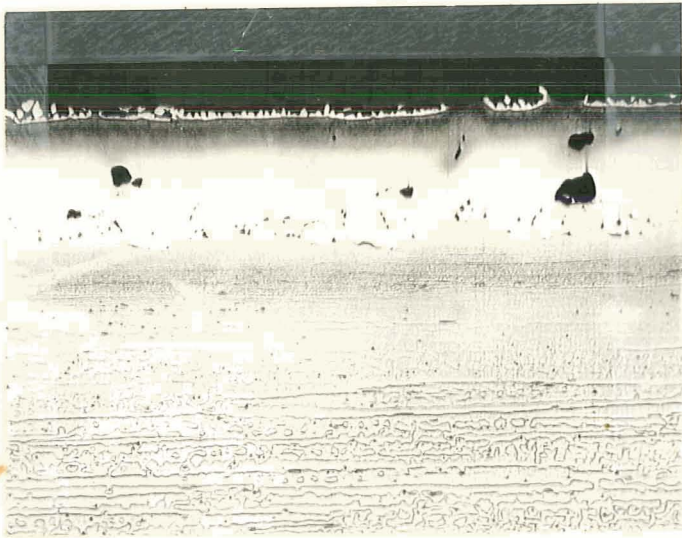

As coated  
Sample 334

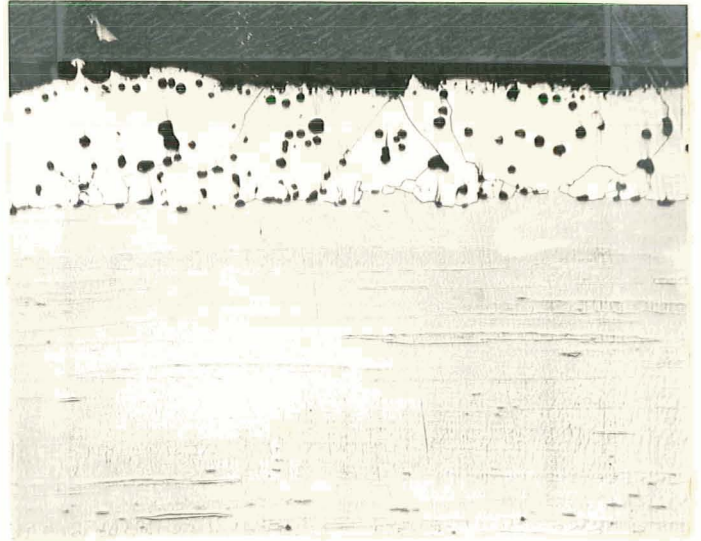

20 hours  
Sample 336

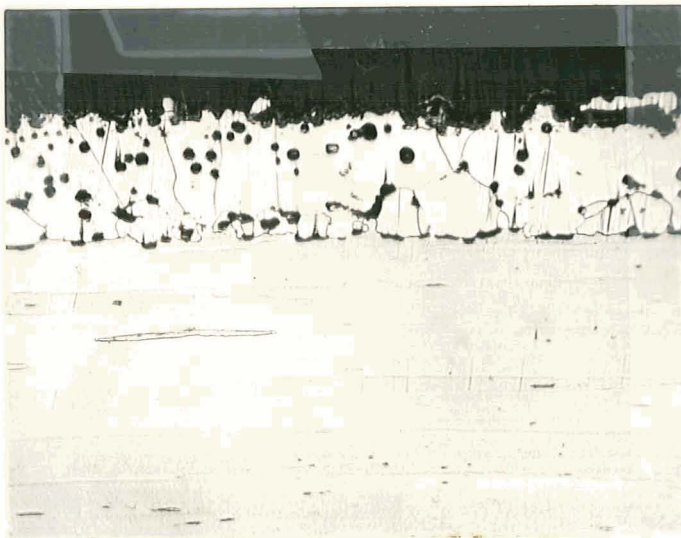

60 hours  
Sample 336

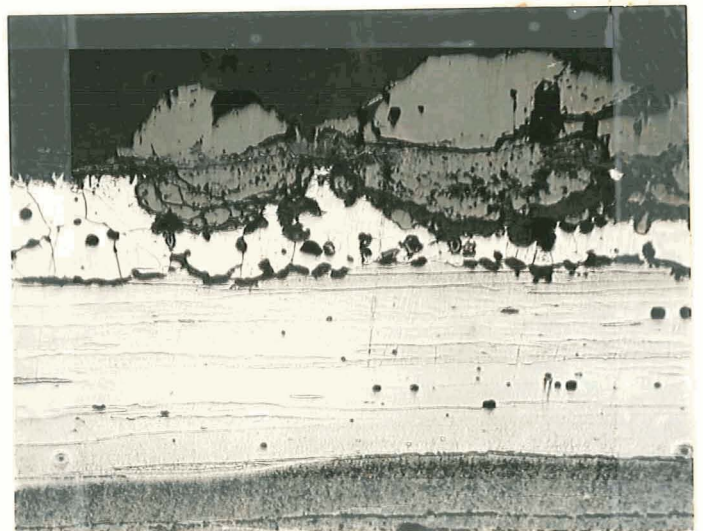

80 hours  
Sample 336

Figure 54. TD-Ni with Ni-20Cr-3Si first coat and  $5 \text{ mg/cm}^2$  pack Al second coat with #1 diffusion treatment and oxidized at  $2300^\circ\text{F}$ . (100X)

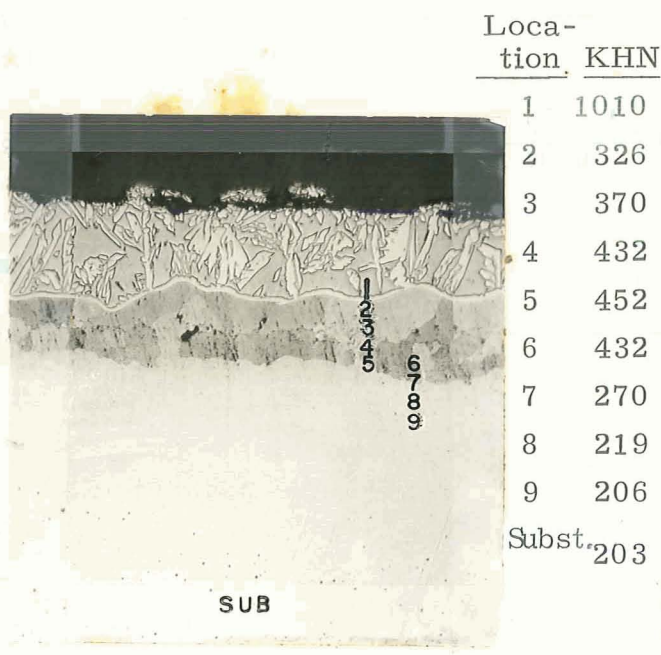

As coated  
Sample 53

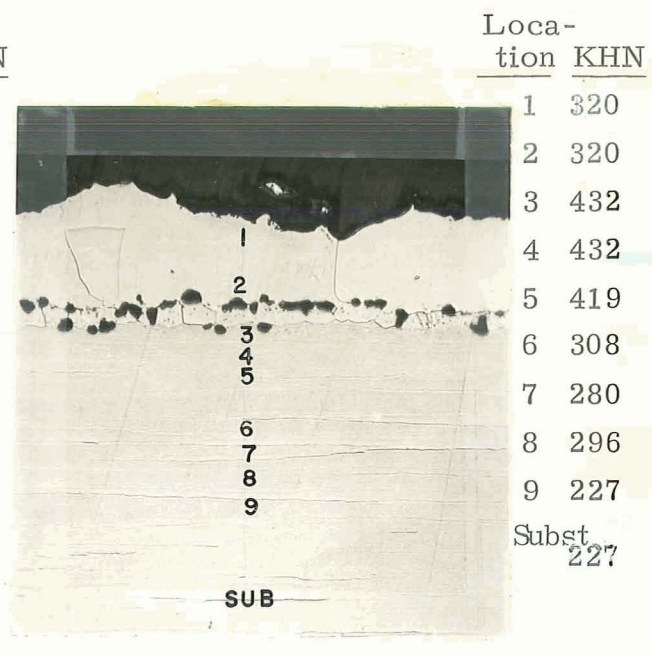

20 hours  
Sample 51

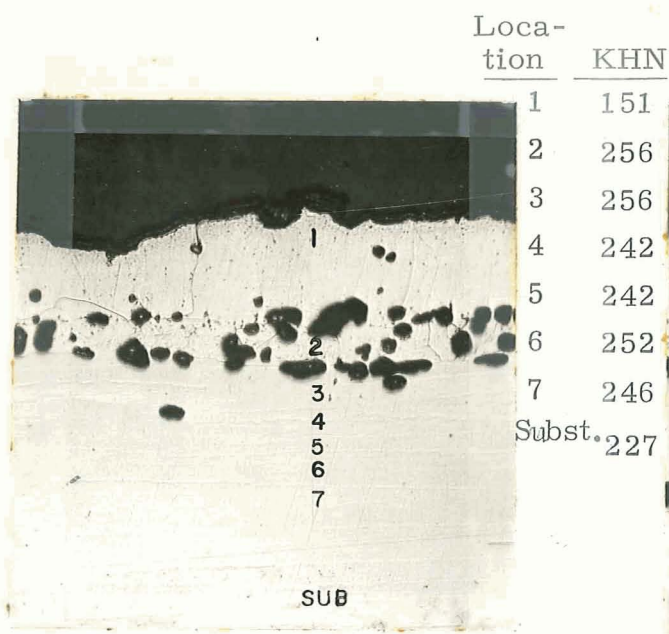

100 hours  
Sample 51

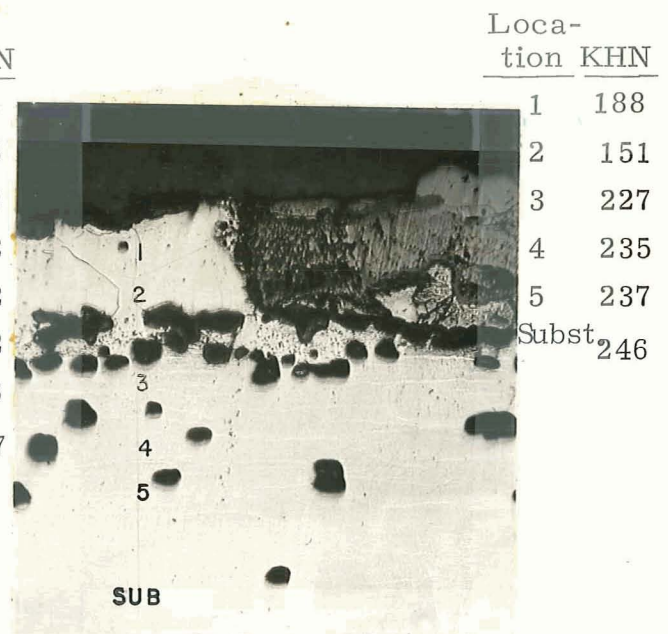

220 hours  
Sample 52

Figure 55 . TD-Ni with Ni-20Cr-3Si first coat and 16-21 mg/cm<sup>2</sup> of Al-20Co second coat with #5 diffusion treatment and oxidized at 2300°F. 50 g load used in microhardness (100X) tests.

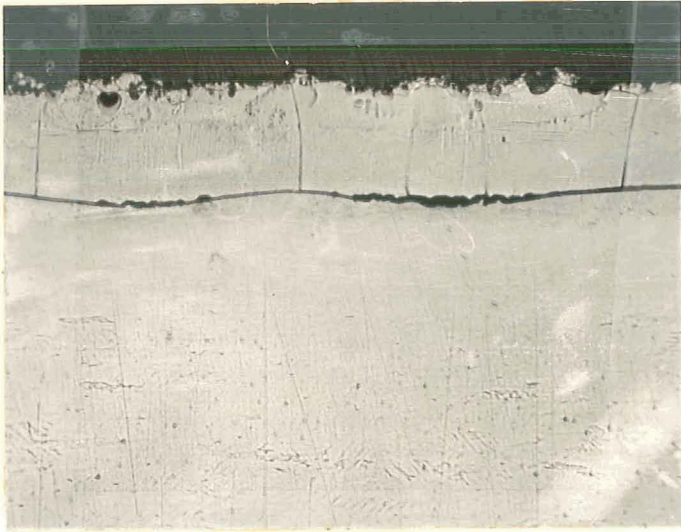

As Coated  
Sample 45



20 hours  
Sample 41

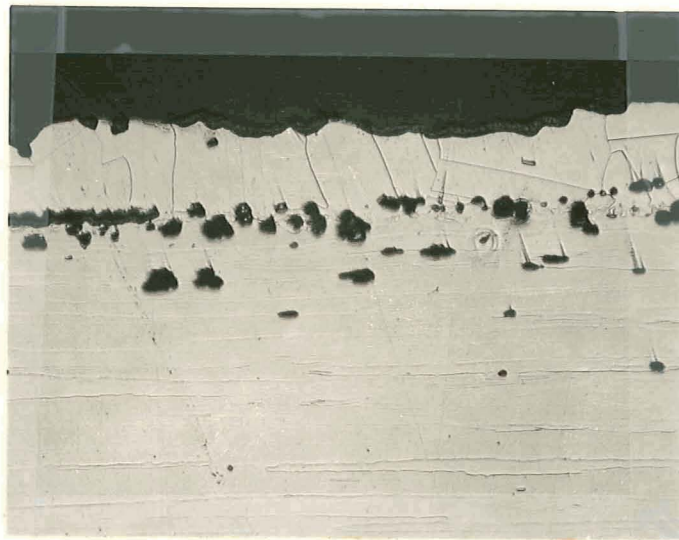

100 hours  
Sample 42

Figure 56. TD-Ni with Ni-25Cr-1Si first coat and  $14-20 \text{ mg/cm}^2$  Al-20Co second coat with #5 diffusion treatment and oxidized at  $2300^\circ\text{F}$ . (100X)

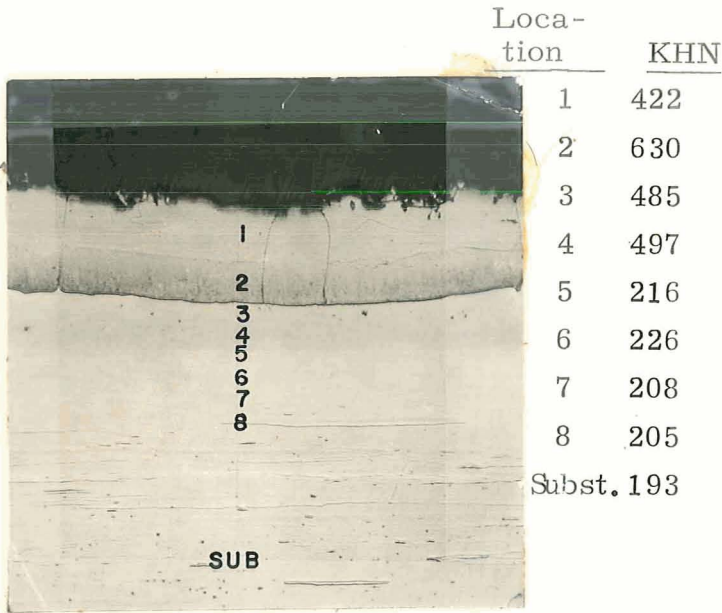

As coated  
Sample 50

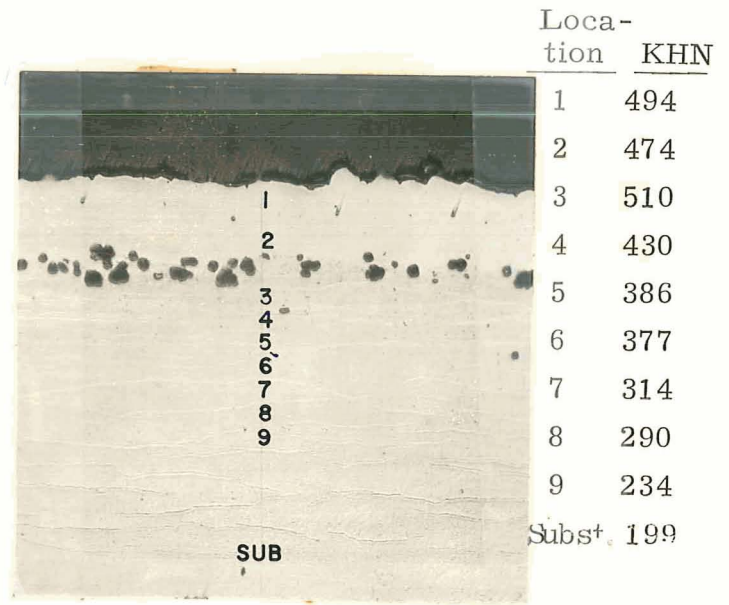

20 hours  
Sample 48

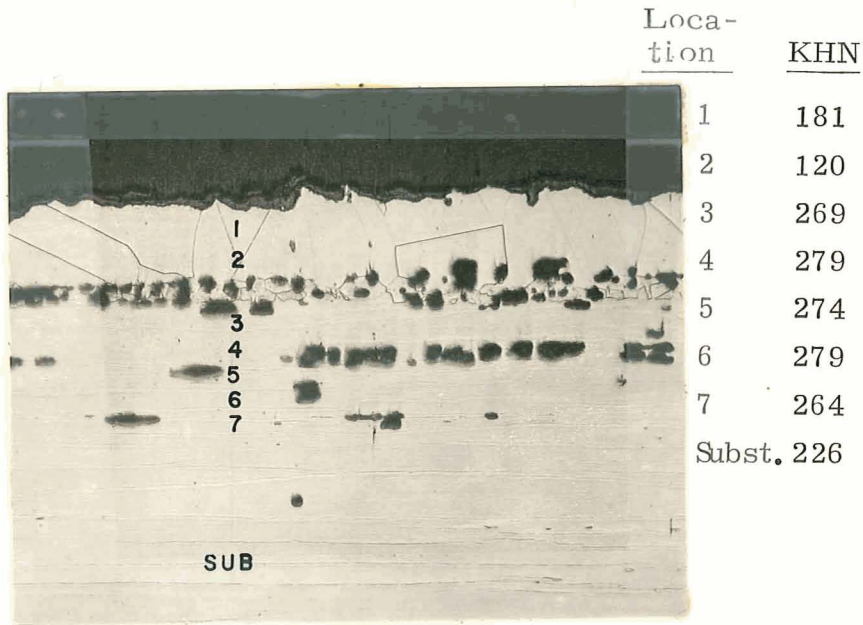

100 hours  
Sample 46

Figure 57.

TD-Ni with Ni-30Cr-1Si first coat and 18-21 mg/cm<sup>2</sup> of Al-20Co second coat with #5 diffusion treatment and oxidized at 2300°F. 50 g load used in (100X) microhardness tests.

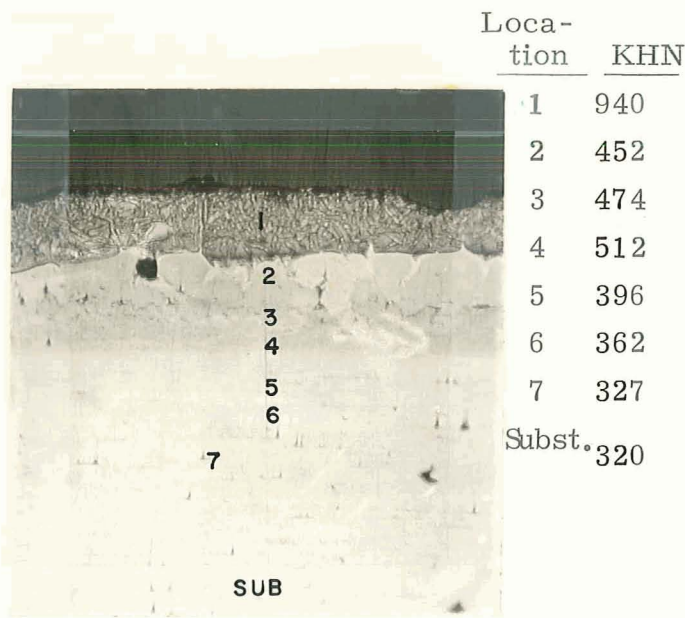

As coated  
Sample 60

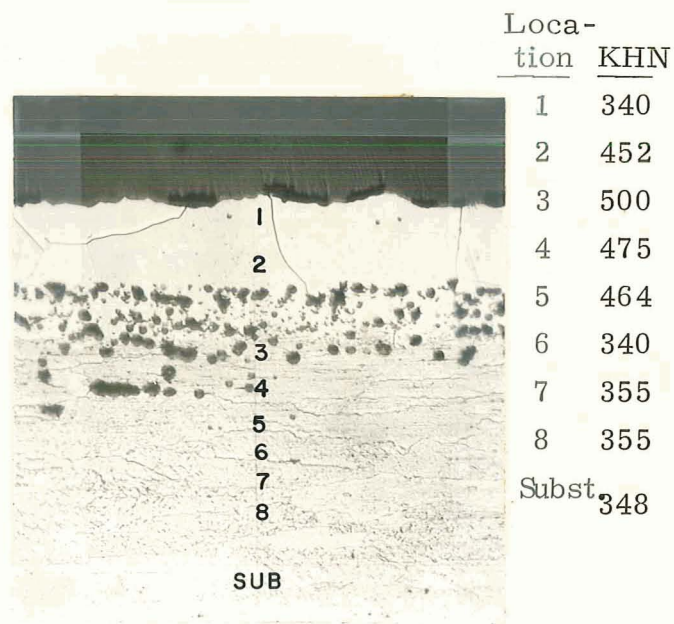

20 hours  
Sample 59

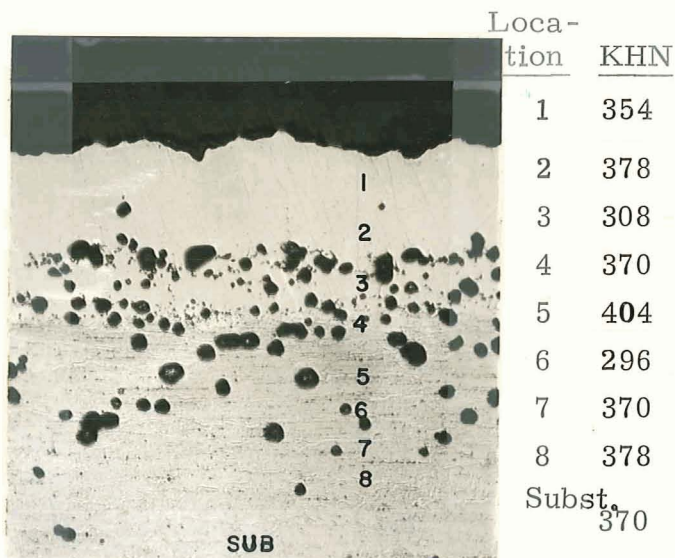

100 hours  
Sample 59

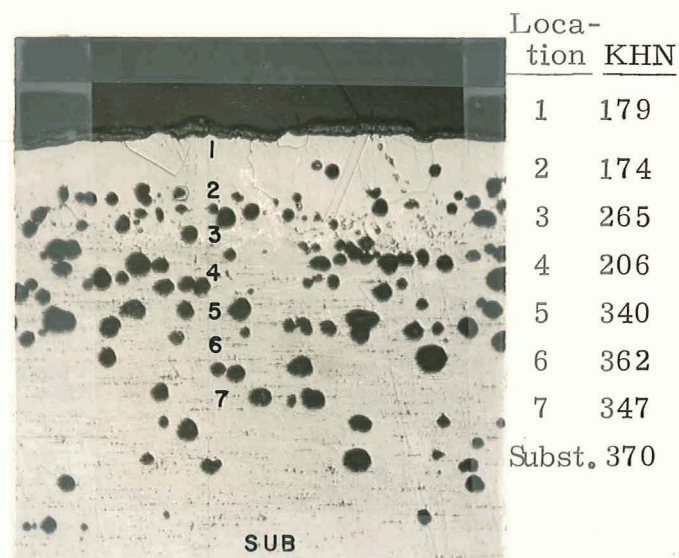

200 hours  
Sample 57

Figure 58. TD-NiCr with Ni-20Cr-3Si first coat and 15-19 mg/cm<sup>2</sup> Al-20Co second coat with #5 diffusion treatment and oxidized at 2300°F. 50 g load used in micro-hardness tests. (100X)

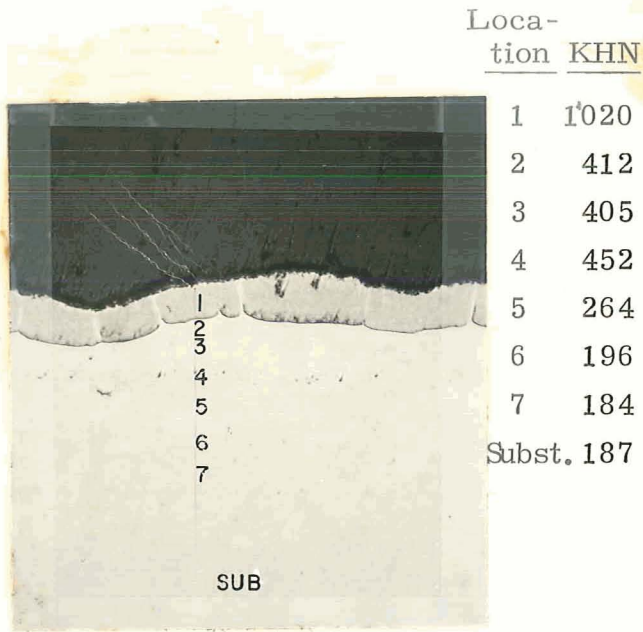

As coated  
Sample 101

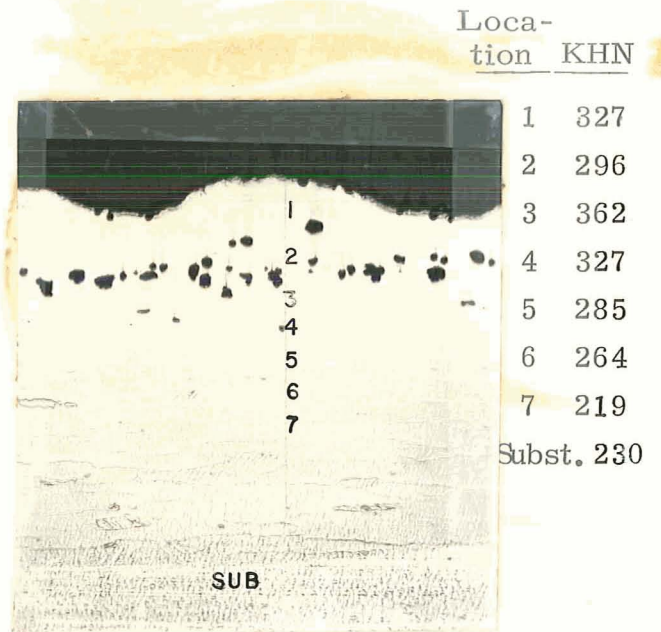

20 hours  
Sample 105

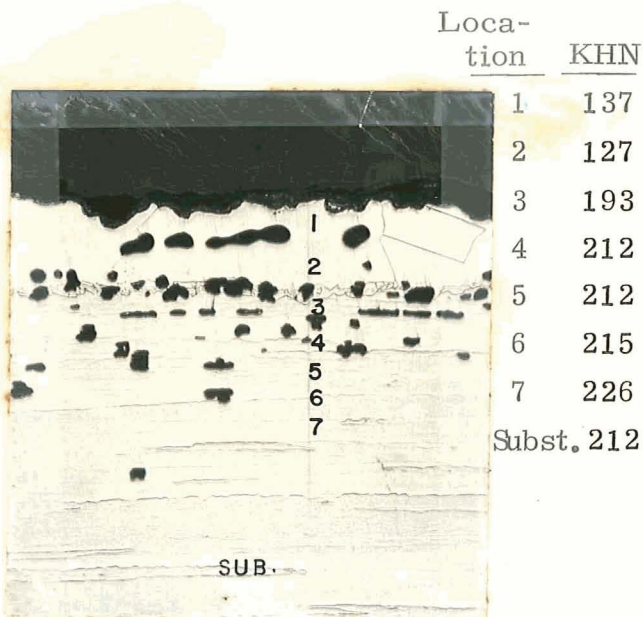

200 hours  
Sample 104

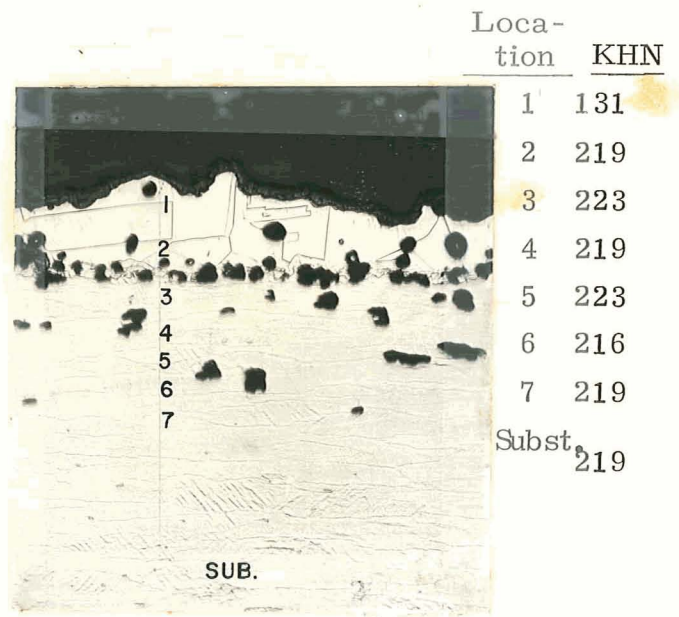

260 hours  
Sample 103

Figure 59. TD-Ni with Ni-30Cr-1Si first coat and  $10 \text{ mg/cm}^2$  Al-20Co second coat with #5 diffusion treatment and oxidized at 2300°F. 50 g load used in microhardness tests. (100X)

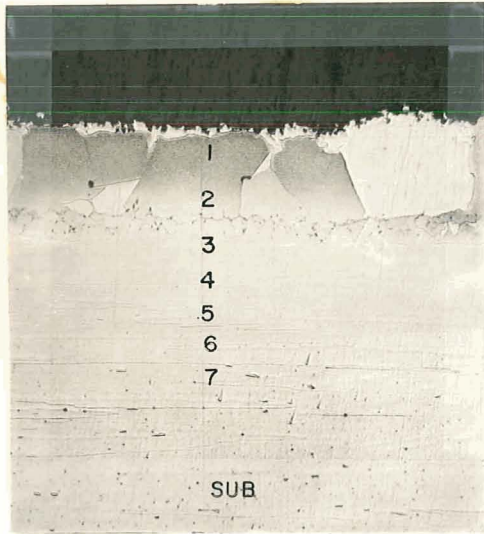

Location	KHN
1	370
2	362
3	420
4	280
5	205
6	190
7	179
Subst. 179	

As coated  
Sample 106

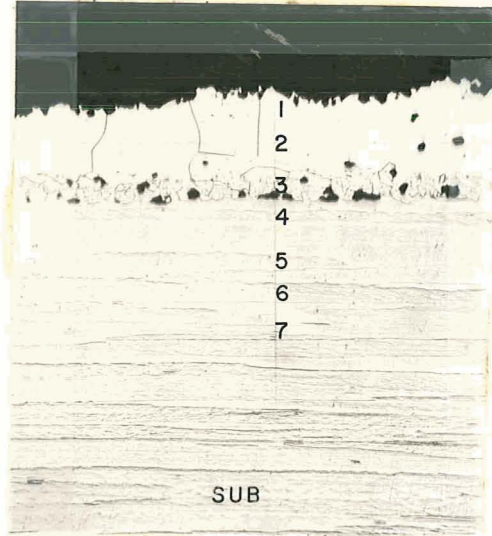

Location	KHN
1	269
2	246
3	208
4	327
5	301
6	255
7	219
Subst. 199	

20 hours  
Sample 108

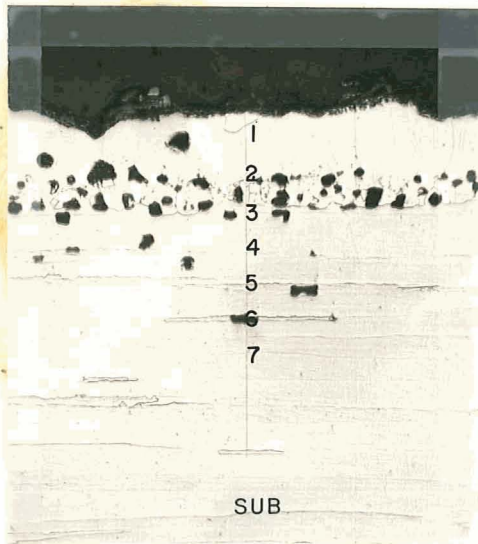

Location	KHN
1	124
2	141
3	212
4	212
5	226
6	216
7	219
Subst. 212	

200 hours  
Sample 108

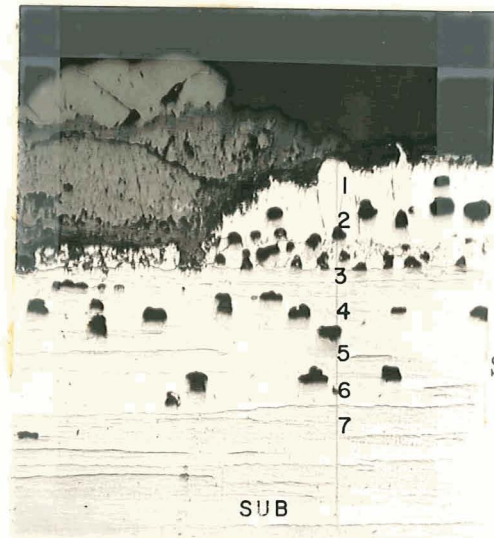

Location	KHN
1	122
2	82
3	196
4	212
5	215
6	215
7	215
Subst. 208	

240 hours  
Sample 110

Figure 60.

TD-Ni with Ni-20Cr-3Si first coat and  $10 \text{ mg/cm}^2$  Al-20Co second coat with #5 diffusion treatment and oxidized at  $2300^\circ\text{F}$ . 50 g load used in (100X) microhardness tests.

Note: Localized attack not prevalent in Sample 110.

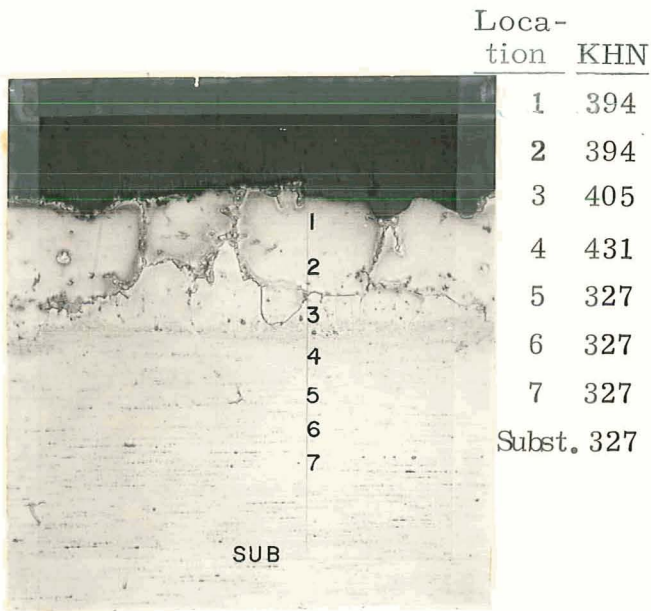

As coated  
Sample 111

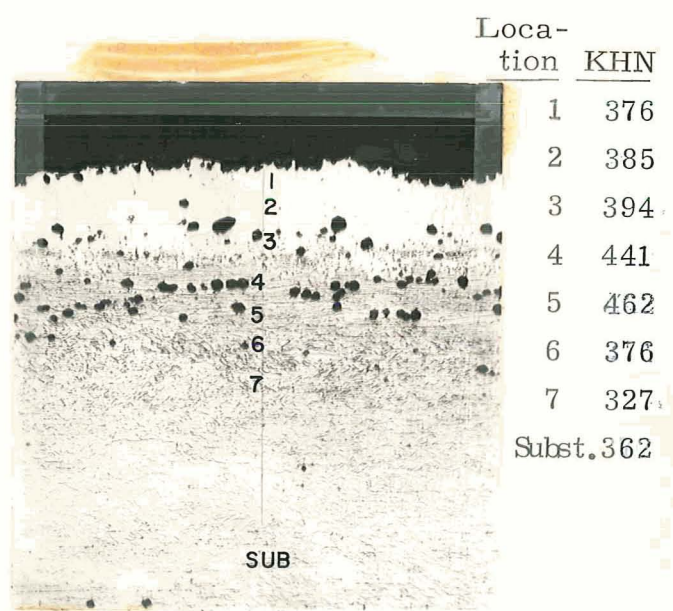

20 hours  
Sample 113

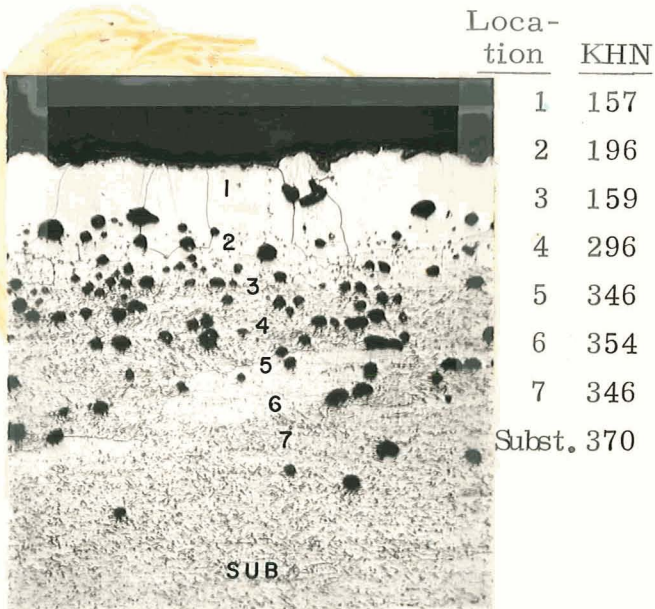

200 hours  
Sample 113

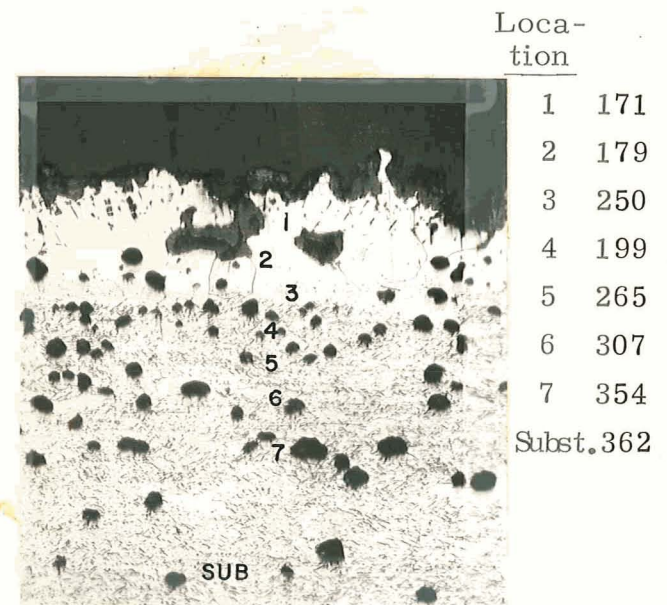

360 hours  
Sample 115

Figure 61. TD-NiCr with Ni-20Cr-1Si first coat and  $10 \text{ mg/cm}^2$  Al-20Co second coat with #5 diffusion treatment and oxidized at 2300°F. 50 g load used in (100X) microhardness tests.

surfaces of the best coatings should not lead one to expect additional considerable life. At edges there is only 1-2 mils of the original 5 mils of coating remaining and in a few places on the broad surfaces there are also very thin areas, particularly on the TD-Ni substrates. Therefore in order to obtain longer lives it will be necessary to thicken the coatings or make additional compositional changes.

The effects of increased thermal cycling rate are shown in the coated structures in Figure 62. The one-hour cycled coating surfaces shown here are much rougher than on samples cycled every 20 hours shown in the previous figures. In contrast, the uncoated TD-NiCr has a very smooth structure. However it must be kept in mind that the coated TD-NiCr was exposed for over twice as many cycles.

#### 4.7 Diffusion Studies

In order to differentiate somewhat between oxidation and diffusion effects samples of the three coating-substrate systems tested in the final stages of the program were subjected to heat treatment at 2300°F in argon. The structures of these samples after 10 hours and 100 hours at 2300°F in argon can be compared with similar samples after 100 hours oxidation in air at 2300°F. Micrographs are shown in Figures 63 to 65. As coated microstructures for the same systems can be referred to in Figures 59, 60 and 61.

Several notable observations can be made. First, the TD-Ni substrate with the Ni-30Cr-1Si first coat in Figure 63 becomes completely single phase in 10 hours at 2300°F, compared to the two-layered as-coated structures in Figure 59. Second, coating-substrate interface porosity develops after 10 hours in argon. This is further evidence of the Kirkendahl diffusion effect. Third and most notable and somewhat surprising is the generally greater amount of porosity developed in the 100 hour argon diffused samples compared to the 100 hour oxidation samples. This effect is more pronounced in the coatings of both systems on the TD-Ni substrates. There is also generally less porosity in the TD-NiCr substrate oxidized at 100 hours than in the 100 hour argon sample. The tendency for pores to line up and connect at the coating-substrate interface is not as great on the TD-NiCr substrate as it is with the TD-Ni samples.

Weight changes were measured on several argon diffusion treated samples after 10 and 100 hours. The results compared to oxidized samples were tabulated below:

Time (hours)	Weight Changes (mg/cm <sup>2</sup> )			
	TD-Ni (Ni-30Cr-1Si first coat)		TD-NiCr (Ni-20Cr-3Si first coat)	
	<u>Argon</u>	<u>Air</u>	<u>Argon</u>	<u>Air</u>
10	-0.20	-0.11	-0.08	+0.20
100	-0.49	+0.43	-0.57	+0.73

(text contd. p.107)

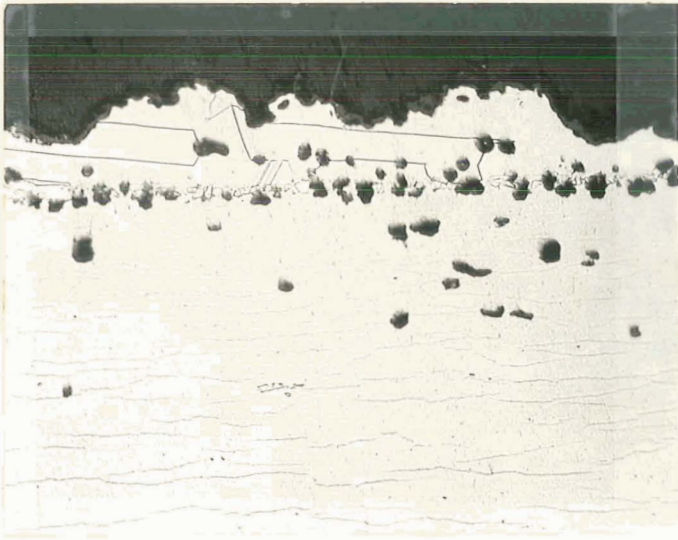

Coated TD-Ni  
Sample 118  
140 hours

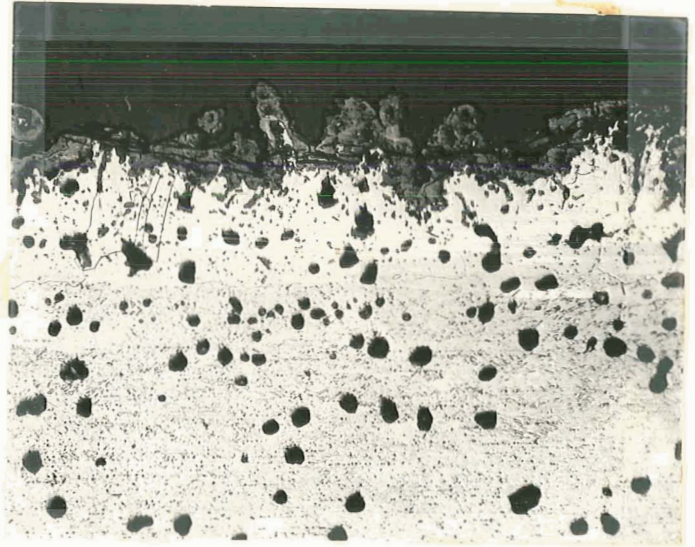

Coated TD-NiCr  
Sample 123  
500 hours



Uncoated TD-NiCr  
230 hours

Figure 62. Uncoated TD-NiCr and two step coated TD-Ni and TD-NiCr oxidized in automated one hour cycles at 2300°F. TD-Ni coated with Ni-30Cr-1Si and TD-NiCr with Ni-20Cr-3Si first step and both with 8.6 mg/cm<sup>2</sup> of Al-20 second coats and #5 diffusion treatment. (100X)

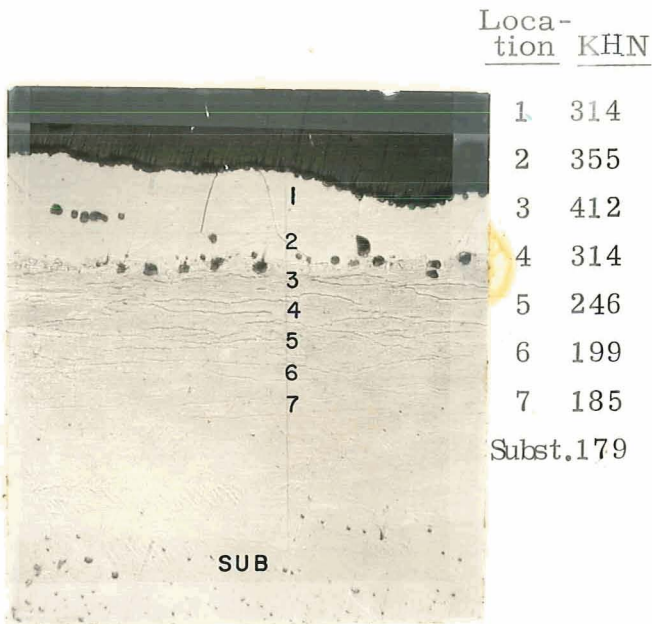

Argon - 10 hours  
Sample 101

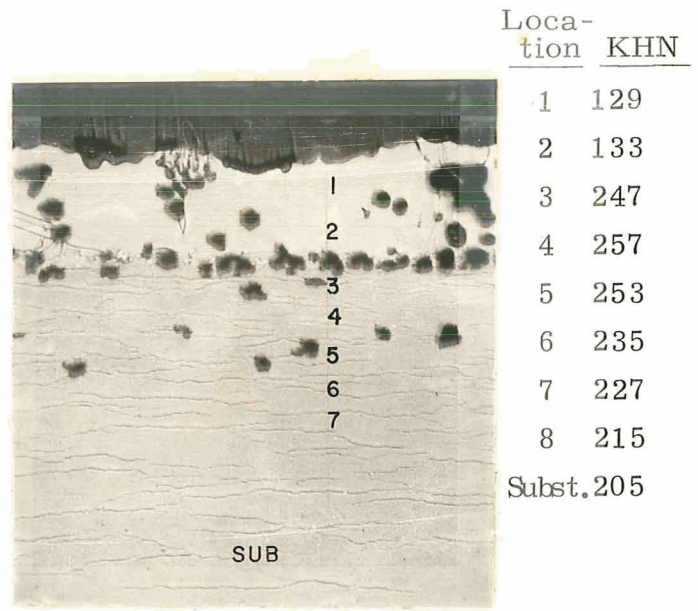

Argon - 100 hours  
Sample 101

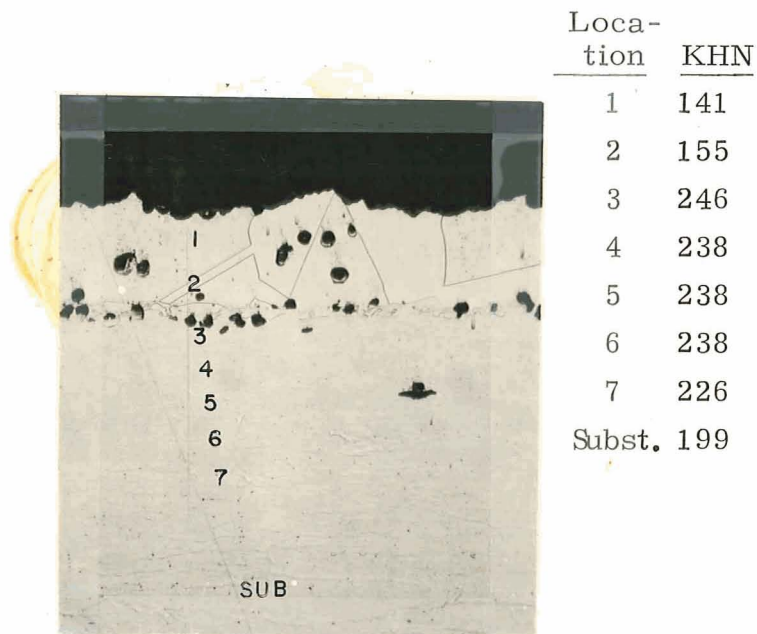

Oxidized - 100 hours  
Sample 105

Figure 63. Structure of 2300°F argon diffusion treated TD-Ni samples and 2300°F oxidized sample. Ni-30Cr-1Si first coat and Al-20Co second coat. 50 g load used in (100X) microhardness tests.

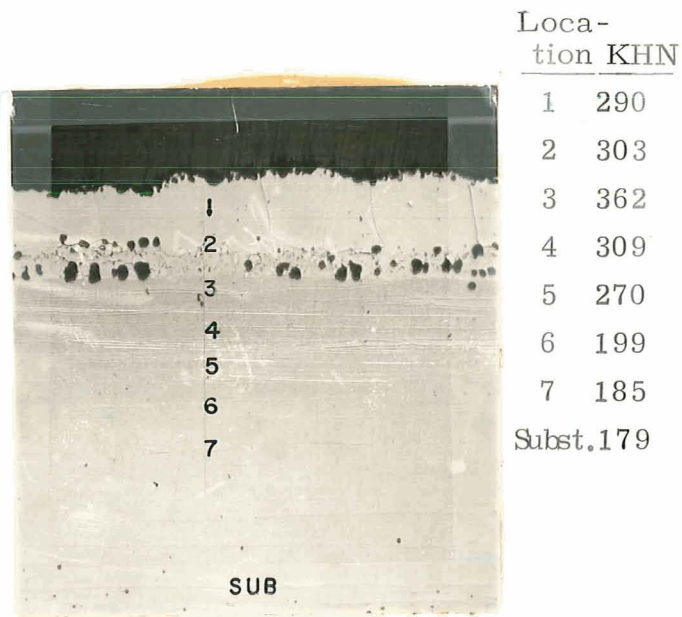

Argon - 10 hours  
Sample 106

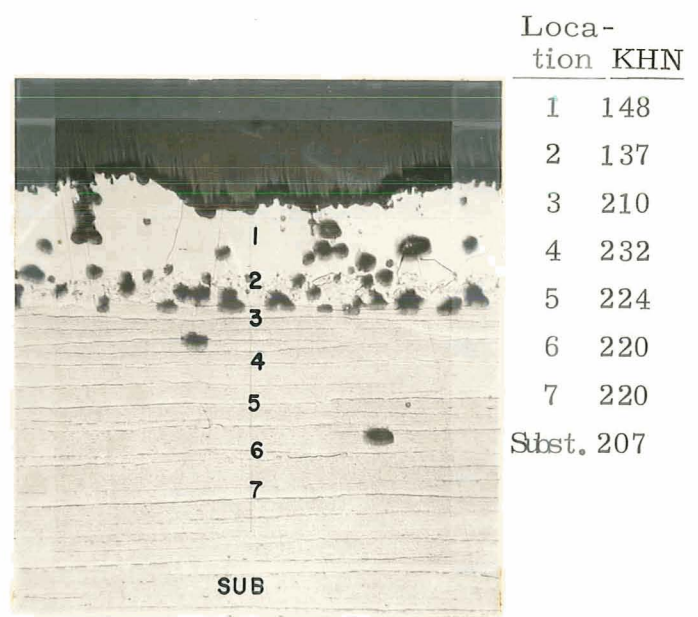

Argon - 100 hours  
Sample 106

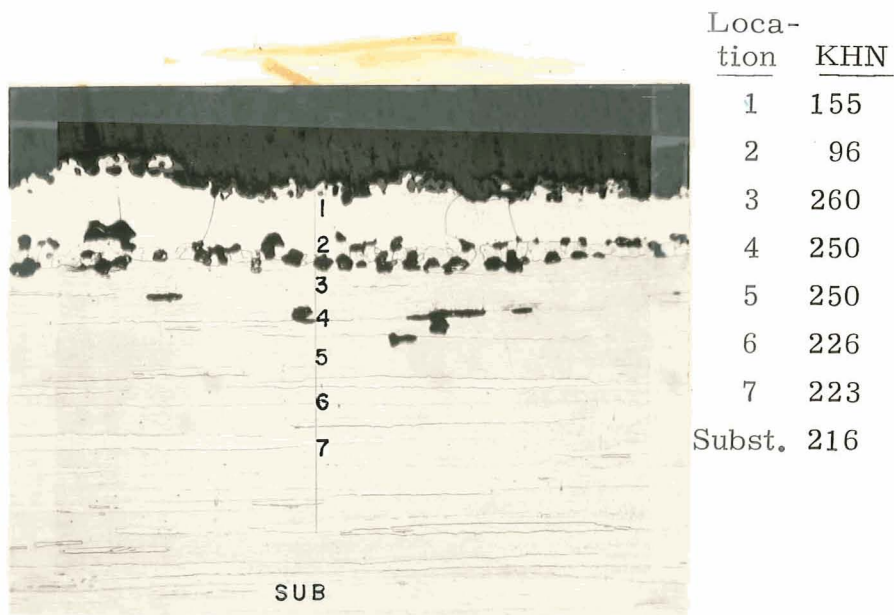

Oxidized - 100 hours  
Sample 108

Figure 64.

Structure of 2300°F argon diffusion treated TD-Ni samples and a 2300°F oxidized sample. Ni-20Cr-3Si first coat and Al-20Co second coat. (100X)  
50 g load used in microhardness tests.

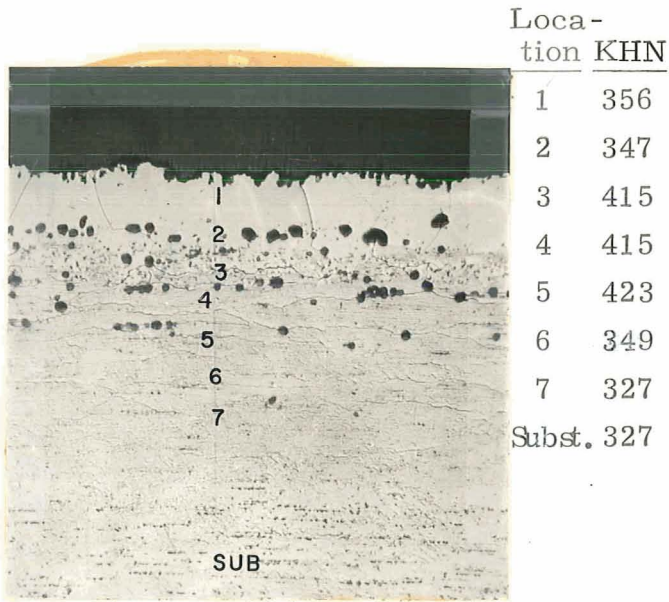

Location	KHN
1	356
2	347
3	415
4	415
5	423
6	349
7	327
Subst. 327	

Argon - 10 hours  
Sample 111

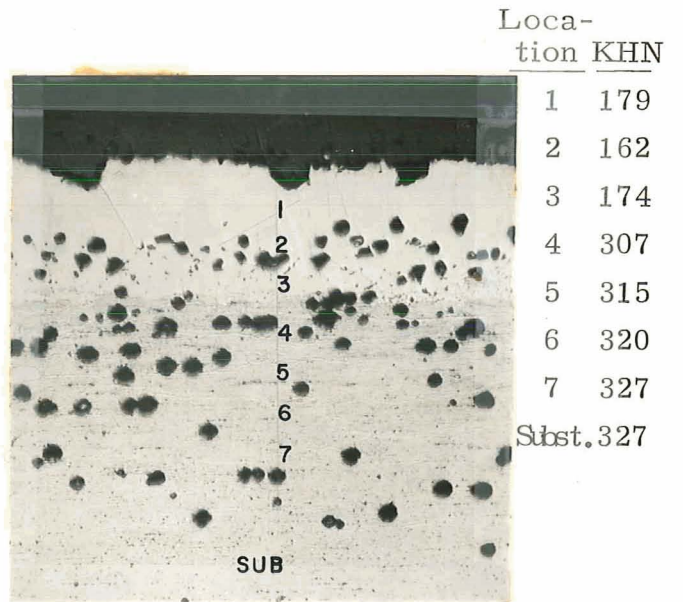

Location	KHN
1	179
2	162
3	174
4	307
5	315
6	320
7	327
Subst. 327	

Argon - 100 hours  
Sample 111

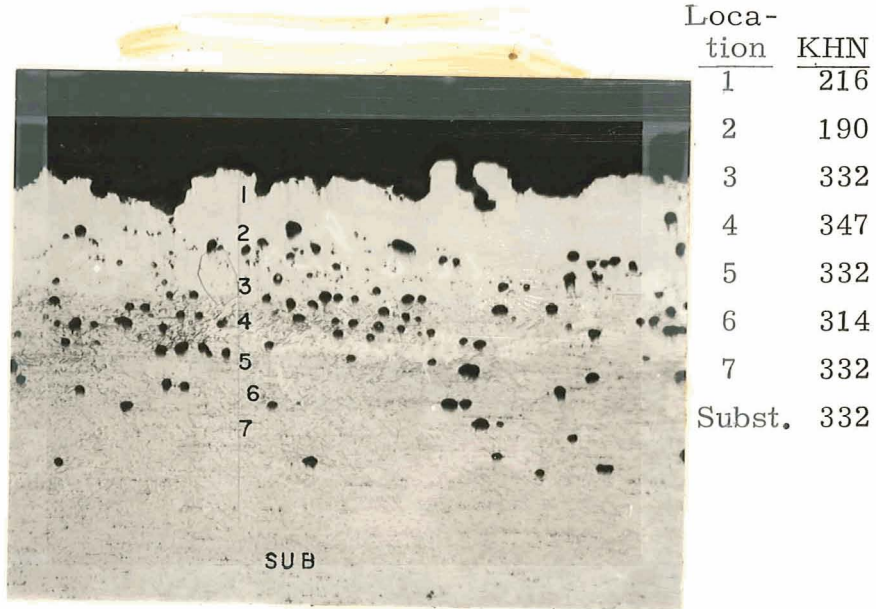

Location	KHN
1	216
2	190
3	332
4	347
5	332
6	314
7	332
Subst. 332	

Oxidized - 100 hours  
Sample 113

Figure 65. Structure of 2300°F argon diffusion treated TD-NiCr samples and a 2300°F oxidized sample. Ni-20Cr-3Si first coat and Al-20Co second coat. (100X)  
50 g load used in microhardness tests.

It is evident and understandable that the samples lose weight continuously in argon at 2300°F since volatilization is the only mechanism available to produce weight changes. The higher Cr coating appears to lose weight faster initially but the weight losses of the lower Cr coating on the TD-NiCr become equivalent after 100 hours. The figures shown for the oxidized samples are sample weight changes and reflect primarily a net weight gain due to oxidation, particularly after 100 hours.

Compositional changes during diffusion can only be speculated upon from metallographic and weight changes. Since the metallographic samples were subjected to microprobe analyses, discussion of diffusion and oxidation effects on compositions are covered in a later section below.

#### 4.8 X-Ray Diffraction Studies

A few analyses were made to verify the phases present in as coated samples given the #5 diffusion treatment but with different first step coating compositions and a range of Al-20Co weights. The results are tabulated in Table XXI and appear to correlate with metallographic structures and microhardness tests.

The two major phases present appear to be a function of the Al and Cr contents in the coating. The combined 30Cr and 18 mg/cm<sup>2</sup> Al-Co give an outer layer of NiAl and an inner layer of Ni<sub>3</sub>Al or Ni solid solution. At lower Al and/or Cr levels the solid solution layer is the major phase with some NiAl present also. With lower Al contents of about 10 mg/cm<sup>2</sup> and a 20Cr first step the coatings are nickel base solid solution.

Since only poor powder diffraction data is available for Ni<sub>3</sub>Al, it is not possible to state positively whether this phase is present or any line shifts occur as usually happens when a third element is present in solid solution. However the metallographic structures and later electronprobe data and reference to the Ni-Cr-Al ternary diagram show that the 10 mg/cm<sup>2</sup> Al coatings and 20Cr first step coatings are single phase nickel base gamma solid solutions and contain up to 8-9% Cr.

The presence of an aluminum oxide film on all samples is not too surprising since no particular care is taken to prevent the samples from cooling in air after the second coating step.

Because of the preferred orientation of the coating it was difficult to completely identify the NiAl phase. However it is reasonable to deduce from the reflections and the other information available that NiAl is likely to be present on the higher Al second step coatings.

TABLE XXI

X-Ray Diffraction Results on As-Coated Samples of TD-Ni and TD-NiCr. All samples given Al-20Co coating and #5 diffusion treatment in second coating step.

Sample	Substrate	First Coat	Al20Co Wt. (mg/cm <sup>2</sup> )	Coating Phases Present		
				Solid Solution	NiAl*	Al <sub>2</sub> O <sub>3</sub>
53	TD-Ni	Ni-20Cr-3Si	21	S	M	W
45	"	Ni-25Cr-1Si	14	S	M	W
50	"	Ni-30Cr-1Si	18	M	S	W
102	"	Ni-30Cr-1Si	9.3	S	M	M
107	"	Ni-20Cr-1Si	10.6	S	-	M
60	TD-NiCr	Ni-20Cr-1Si	15	S	M	W
112	"	Ni-20Cr-1Si	9.9	S	-	M **

\* Probable

M Medium Intensity

S Main Phase

W Weak Intensity

\*\* Two extra reflections of Medium Intensity.  
Possibly a solid solution of unknown (Ni, Cr, Al, Co) composition.

All samples show a few additional weak reflections of unknown identity.

#### 4.9 Electronmicroprobe Analyses

The probe analyses were obtained on as-coated, 100 hour oxidation tested and 10 and 100 hour argon treated samples. The three most successful two-step coating-substrate systems used for final evaluation were analyzed: (1) Ni-30Cr-1Si and (2) Ni-20Cr-3Si first step coating on TD-Ni and (3) the Ni-20Cr-3Si first step coating on TD-NiCr. All three had 10 mg/cm<sup>2</sup> of Al-20Co as the second step coating with the #5 heat treatment.

The analyses and location points for as-coated and oxidation tested samples are listed in Tables XXII through XXIV. Argon treated sample analyses are in Tables XXV through XXVII. Figures 66 through 71 show the location points for the analyses on each of the microstructures. The data are plotted for easier reference study in Figures 72 through 74. Comparison of the two as-coated TD-Ni samples in Figure 73 shows that in the Ni-20Cr first step coating the surface chromium content is dropped to the 7-9% level by the relatively long #5 second step coating heat treatment while the Ni-30Cr coating is only lowered to 22-26% Cr in the layer under the outer aluminide phase. As shown in Figures 72 and 73, the aluminide phase is much higher in Al and lower in Cr than the inner layer and corresponds closely to beta (NiAl) plus gamma (Ni solid solution) in the ternary Ni-Cr-Al diagram (4) at 2100°F; see Figure 75. The average Al content in the as-coated TD-NiCr coating is slightly lower than in either TD-Ni coating and somewhat higher at equivalent points in the substrate, thus indicating inward diffusion of Al is slightly greater in TD-NiCr. There is also very little Al composition gradient in the TD-NiCr coating compared to the TD-Ni. The single phase portions of all three coatings fall in the gamma field of the Ni-Cr-Al diagram at 2100°F.

After 100 hours oxidation at 2300°F, Al and Cr levels have decreased considerably in both TD-Ni coatings and the Al in the TD-NiCr coatings. Although not shown here, the plots for the Al distribution in the Ni-20Cr-3Si systems on TD-Ni and TD-NiCr were used to approximate the overall Al contents before and after oxidation exposure by simple graphic integration of the areas under the curves. About 40-50% of the original Al appears to be consumed by oxidation. There is a further surface depletion by diffusion inward. About 10% of the Cr in the Ni-30Cr coating on TD-Ni is depleted by oxidation and about 25% of the Cr in the Ni-20Cr coating on TD-Ni. It is interesting that both of the TD-Ni coatings withstood further oxidation to over 200 hours at the very low surface percentage levels of 0.6 - 1.0% Al and 8-9% Cr for one coating and 1.1 - 1.4% Al and 5.7 - 3.9% Cr in the other. Since samples with over 100 hours oxidation were not analyzed, it is impossible to state the levels of Al and Cr which coincide with a sharp increase in weight loss leading to failure. Since there is a similar sharp increase in loss with the TD-NiCr but at a longer time, i.e. 300-350 hours, it must correlate with an extremely low Al content.

(text contd. on page 126 )

Please reduce

TABLE XXII

Electronprobe Analyses of TD-Ni Substrates Coated with Ni-30Cr-1Si First Step and 10 mg/cm<sup>2</sup> Al-20Co Second Step

Point	Area	Distance from Surface (mils)	Composition (w/o wt. percent)					
			Cr	Ni	Al	Co	Si	O*
Sample #101, As Coated								
1	Surface oxide		0.7	0.4	40.49	0.1	0.3	57.95
2	Band (A)	1.2	12.5	71.8	13.9	0.2	1.5	
3	Band (A)	2.2	11.9	70.8	15.0	0.2	1.9	
4	Band (B)	3.4	24.0	67.7	6.5	0.4	1.16	
5	Band (B)	4.6	25.0	68.1	5.3	2.9	1.25	
6	Band (B)	5.6	22.0	72.2	4.2	0.1	1.36	
7	Substrate	6.8	18.2	76.7	3.5	0.0	1.6	
8	Substrate	7.8	12.5	83.9	2.0	0.0	1.6	
9	Substrate	8.6	7.3	90.3	0.8	0.0	1.5	
10	Substrate	9.8	3.5	95.3	0.3	0.0	0.9	
11	Substrate	10.8	0.7	98.2	0.3	0.0	0.7	
12	Substrate	13.0	0.0	99.7	0.2	0.0	0.1	
Sample #105 after 100 hours oxidation at 2300°F								
1	Surface oxide		1.3	0.8	50.0	0.0	0.0	47.9
2	Band (A)	1.2	9.0	89.5	0.7	0.1	0.7	
3	Band (A)	2.4	8.8	90.0	5.8	0.1	0.5	
4	Band (A)	3.5	8.6	90.0	0.6	0.1	0.7	
5	Band (A)	4.5	8.3	90.0	1.0	0.1	0.6	
6	Substrate	5.6	8.0	90.5	0.7	0.1	0.7	
7	Substrate	6.8	7.5	91.1	0.7	0.1	0.5	
8	Substrate	12.8	5.4	93.4	0.6	0.0	0.6	
9	Substrate	18.4	3.0	96.0	0.5	0.0	0.5	
10	Substrate	24.0	1.2	98.4	0.2	0.0	0.2	
11	Substrate	29.8	0.3	99.6	0.0	0.0	0.1	

\* Oxygen by difference

TABLE XXIII

Electronprobe Analyses of TD-Ni Substrates Coated with  
Ni-30Cr-1Si First Step and 10 mg/cm<sup>2</sup> Al-20Co Second Step

Point	Area	Distance from Sur- face (mils)	Composition (w/o wt. percent)					
			Cr	Ni	Al	Co	Si	O*
<u>Sample #106, As Coated</u>								
1	Band (A)	0.6	4.3	83.5	8.6	0.4	3.0	
2	Band (A)	1.6	7.2	82.2	7.6	0.5	2.5	
3	Band (A)	2.6	7.2	83.2	7.2	0.5	1.9	
4	Band (A)	3.8	8.1	83.0	6.6	0.5	1.9	
5	Band (B)	4.8	9.0	83.8	5.0	0.3	2.0	
6	Band (B) Substrate	5.9	9.0	84.5	4.1	0.2	2.3	
7	Substrate	6.8	7.9	86.6	2.8	0.1	2.5	
8	Substrate	8.0	6.0	89.5	1.8	0.0	2.7	
9	Substrate	9.2	3.6	93.1	1.1	0.0	2.2	
10	Substrate	10.4	1.3	96.6	0.4	0.0	1.7	
11	Substrate	13.8	0.0	99.9	0.0	0.0	0.1	
12	Substrate	19.0	0.0	100.0	0.0	0.0	0.0	
<u>Sample #108, after 100 hours oxidation at 2300°F</u>								
1	Surface Oxide		0.0	0.4	49.5	0.0	0.0	50.1
2	Band (A)	0.8	3.8	94.0	1.1	0.3	0.9	
3	Band (A)	2.0	3.8	94.0	1.1	0.3	0.9	
4	Band (A)	3.0	3.5	94.1	1.3	0.3	0.7	
5	Interface	4.2	3.5	94.4	1.2	0.3	0.7	
6	Substrate	5.2	3.4	95.8	1.4	0.2	0.8	
7	Substrate	6.2	3.3	94.4	1.4	0.2	0.8	
8	Substrate	7.2	3.1	95.0	1.1	0.2	0.7	
9	Substrate	12.8	2.2	96.2	0.9	0.1	0.7	
10	Substrate	18.4	1.2	97.6	0.6	0.0	0.6	
11	Substrate	24.0	0.5	98.7	0.3	0.0	0.5	
12	Substrate	29.8	0.2	99.3	0.0	0.0	0.5	

\* Oxygen by difference

TABLE XXIV

Electronprobe Analyses of TD-NiCr Substrates Coated with Ni-20Cr-3Si first step and 10 mg/cm<sup>2</sup> of Al-20Co second step

Point	Area	Distance from Surface (mils)	Composition (w/o wt. percent)					O *
			Cr	Ni	Al	Co	Si	
<u>Sample #111, As Coated</u>								
1	Band (A)	0.3	17.5	74.7	5.1	0.3	2.9	
2	Band (A)	0.3	15.5	75.8	5.0	0.3	3.4	
3	Band (A)	1.2	16.4	76.2	4.8	0.3	2.3	
4	Band (A)	2.3	16.6	76.2	4.8	0.4	2.0	
5	Band (A)	3.4	16.5	77.0	4.8	0.3	2.0	
6	Band (A)	4.6	16.5	76.2	4.6	0.3	2.4	
7	Substrate	5.8	16.9	76.1	4.5	0.3	2.1	
8	Substrate	6.9	17.1	76.1	4.7	0.3	1.8	
9	Substrate	8.0	19.1	76.1	2.7	0.1	2.0	
10	Substrate	8.9	20.2	76.6	1.6	0.1	1.6	
11	Substrate	12.4	20.5	79.4	0.0	0.0	0.1	
12	Substrate	17.8	20.7	79.3	0.0	0.0	0.0	
<u>Sample #113 after 100 hours oxidation at 2300°F</u>								
1	Surface Oxide		0.3	1.2	50.0	0.0	0.0	48.5
2	Band (A)	1.2	17.1	80.8	0.9	0.2	1.3	
3	Band (A)	2.4	16.4	81.5	0.9	0.1	1.2	
4	Band (A)	3.6	16.7	81.2	0.9	0.2	1.0	
5	Band (A)	4.8	16.8	81.0	1.0	0.2	1.0	
6	Band (A)	5.8	16.8	81.0	1.0	0.2	1.0	
7	Substrate	6.8	16.6	81.2	1.0	0.2	0.9	
8	Substrate	7.8	16.7	80.8	1.5	0.2	0.8	
9	Substrate	13.2	17.8	80.5	0.9	0.1	0.8	
10	Substrate	19.0	18.3	80.7	0.5	0.0	0.5	
11	Substrate	24.8	19.1	80.4	0.2	0.0	0.3	
12	Substrate	30.6	18.5	81.4	0.0	0.0	0.1	

\* Oxygen by difference

TABLE XX.V

Electronprobe analyses of TD-Ni Substrates Coated with  
Ni-30Cr-1Si First Step and 10 mg/cm<sup>2</sup> Al-20Co Second Step  
and Diffusion Treated in Argon

Point	Area	Distance from Sur- face (mils)	Composition (w/o wt. percent)					O*
			Cr	Ni	Al	Co	Si	
Sample #101 after 10 hours in argon at 2300°F								
1	Surface Oxide		3.9	23.5	63.4	0.1	0.3	8.8
2	Band (A)	0.8	9.7	82.3	6.8	0.4	0.8	
3	Band (A)	2.4	10.5	82.1	6.1	0.5	0.7	
4	Band (A)	3.6	11.4	82.1	5.4	0.4	0.7	
5	Band (A)	4.8	12.2	82.1	4.7	0.3	0.8	
6	Interface	6.0	12.1	82.8	4.0	0.2	0.8	
7	Substrate	7.2	11.3	84.4	3.4	0.1	0.8	
8	Substrate	8.4	10.3	86.1	2.7	0.1	0.8	
9	Substrate	9.6	8.2	88.3	2.4	0.0	1.1	
10	Substrate	10.8	5.9	91.5	1.7	0.0	0.9	
11	Substrate	12.0	3.7	94.5	1.2	0.0	0.6	
12	Substrate	16.6	0.1	99.5	0.0	0.0	0.4	
13	Substrate	22.6	0.0	99.9	0.0	0.0	0.1	
14	Substrate	28.4	0.0	99.8	0.0	0.0	0.2	

Sample #101 after 100 hours in argon at 2300°F

1	Surface Oxide		0.0	0.0	52.7	0.0	0.1	47.2
2	Coating	1.2	8.2	9.0	1.1	0.3	0.6	
3	Coating	2.4	9.0	89.2	1.1	0.3	0.4	
4	Coating	3.5	8.5	89.4	1.3	0.2	0.4	
5	Coating	4.8	7.9	90.3	1.1	0.2	0.4	
6	Substrate	5.9	7.8	90.2	1.2	0.2	0.5	
7	Substrate	7.2	7.4	90.9	1.2	0.2	0.4	
8	Substrate	8.2	7.0	91.4	0.9	0.2	0.4	
9	Substrate	9.6	7.1	91.6	1.4	0.2	0.3	
10	Substrate	10.8	6.3	92.0	1.2	0.2	0.3	
11	Substrate	16.4	4.1	94.5	0.9	0.1	0.3	
12	Substrate	22.2	2.1	96.9	0.6	0.1	0.3	
13	Substrate	28.0	0.7	98.6	0.3	0.1	0.3	
14	Substrate	33.8	0.3	99.4	0.0	0.1	0.2	

\* Oxygen by difference

TABLE XXVI

Electronprobe Analyses of TD-Ni Substrates Coated with  
Ni-20Cr-3Si First Step and 10 mg/cm<sup>2</sup> Al-20Co Second Step  
and Diffusion Treated in Argon

Point	Area	Distance from Sur- face (mils)	Composition (w/o wt. percent)					O *
			Cr	Ni	Al	Co	Si	
Sample #106 after 10 hours in argon at 2300°F								
1	Surface Oxide		0.8	4.4	49.3	0.1	0.0	45.4
2	Coating	1.2	6.1	88.1	3.4	0.5	1.8	
3	Coating	2.4	6.2	88.3	3.4	0.5	1.6	
4	Coating	3.1	6.2	88.4	3.2	0.5	1.7	
5	Coating	3.6	6.1	88.7	3.2	0.4	1.6	
6	Coating	4.2	5.9	89.1	3.0	0.4	1.6	
7	Substrate	5.4	5.8	89.3	3.0	0.3	1.5	
8	Substrate	6.6	5.5	90.2	2.3	0.2	1.8	
9	Substrate	7.8	4.8	90.0	2.3	0.2	1.6	
10	Substrate	9.0	4.2	92.3	1.6	0.1	1.7	
11	Substrate	14.6	0.3	98.8	0.0	0.1	0.8	
12	Substrate	20.6	0.0	99.8	0.0	0.1	0.1	
13	Substrate	26.6	0.0	99.8	0.0	0.1	0.1	

Sample #106 after 100 hours in argon at 2300°F

1	Surface Oxide		1.0	0.1	52.6	0.0	0.1	46.3
2	Coating	1.2	4.0	93.2	1.1	0.2	0.9	
3	Coating	2.4	4.2	93.6	1.2	0.2	0.8	
4	Coating	3.4	4.0	93.9	1.1	0.2	0.7	
5	Coating	4.5	4.1	93.7	1.0	0.2	0.9	
6	Coating	5.8	3.9	93.4	1.6	0.2	0.8	
7	Substrate	6.8	3.8	94.2	0.9	0.2	0.8	
8	Substrate	8.0	3.7	94.2	1.2	0.2	0.7	
9	Substrate	9.2	3.5	94.6	0.9	0.2	0.7	
10	Substrate	10.6	3.4	94.7	0.9	0.2	0.7	
11	Substrate	16.4	2.4	95.7	0.9	0.1	0.8	
12	Substrate	22.2	1.4	97.3	0.5	0.1	0.6	
13	Substrate	28.0	0.6	98.3	0.3	0.1	0.6	
14	Substrate	33.4	0.4	98.8	0.1	0.1	0.5	

\* Oxygen by difference

TABLE XXVII

Electronprobe Analyses of TD-NiCr Substrates Coated with Ni-20Cr-3Si First Step and 10 mg/cm<sup>2</sup> Al-20Co Second Step and Diffusion Treated in Argon

Point	Area	Distance from Sur- face (mils)	Composition (w/o wt. percent)					
			Cr	Ni	Al	Co	Si	O *
<u>Sample #111 after 10 hours in argon at 2300°F</u>								
1	Surface Oxide		5.00	24.6	63.4	0.2	0.4	6.5
2	Coating	1.2	15.1	77.9	4.6	0.4	2.0	
3	Coating	2.4	15.2	77.6	4.9	0.4	1.9	
4	Coating	3.6	16.1	77.1	4.5	0.4	1.8	
5	Interface	4.8	16.4	77.1	4.4	0.3	1.6	
6	Substrate	6.0	17.6	76.4	4.2	0.3	1.5	
7	Substrate	7.0	18.6	76.3	3.5	0.2	1.4	
8	Substrate	8.2	19.3	74.9	4.3	0.2	1.3	
9	Substrate	9.2	20.3	75.4	3.0	0.1	1.2	
10	Substrate	10.4	21.3	75.4	2.2	0.0	0.9	
11	Substrate	16.4	21.8	78.1	0.0	0.0	0.1	
12	Substrate	22.0	20.4	79.6	0.0	0.0	0.0	
13	Substrate	27.8	20.9	79.0	0.0	0.0	0.1	
<u>Sample #111 after 100 hours in argon at 2300°F</u>								
1	Surface Oxide		9.0	2.6	55.6	0.0	0.0	32.8
2	Band A	1.2	16.2	82.3	0.22	0.22	1.1	
3	Band A	2.2	16.2	80.9	0.5	0.2	1.3	
4	Band A	3.4	16.9	81.3	0.4	0.2	1.1	
5	Band A	4.4	17.2	81.1	0.4	0.2	1.2	
6	Band A	5.6	16.8	81.5	0.4	0.2	1.2	
7	Band A	6.6	18.0	80.4	0.2	0.2	1.2	
8	Interface	7.8	18.3	80.2	0.2	0.2	1.1	
9	Substrate	9.0	18.0	80.3	0.4	0.2	0.9	
10	Substrate	10.2	18.3	80.3	0.2	0.2	0.9	
11	Substrate	16.0	18.6	80.1	0.4	0.2	0.5	
12	Substrate	21.8	22.1	77.5	0.0	0.1	0.3	
13	Substrate	27.6	20.2	79.6	0.0	0.1	0.1	

\* Oxygen by difference

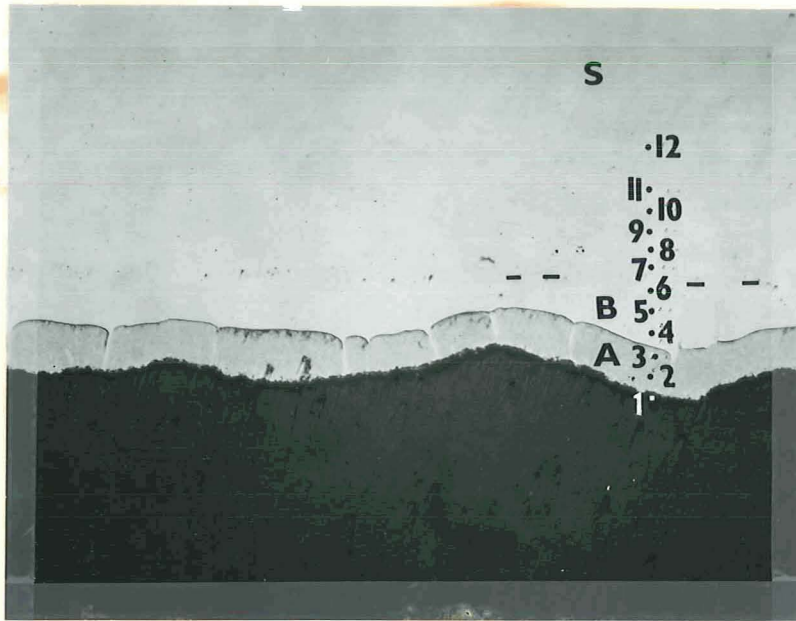

Sample #101 as coated

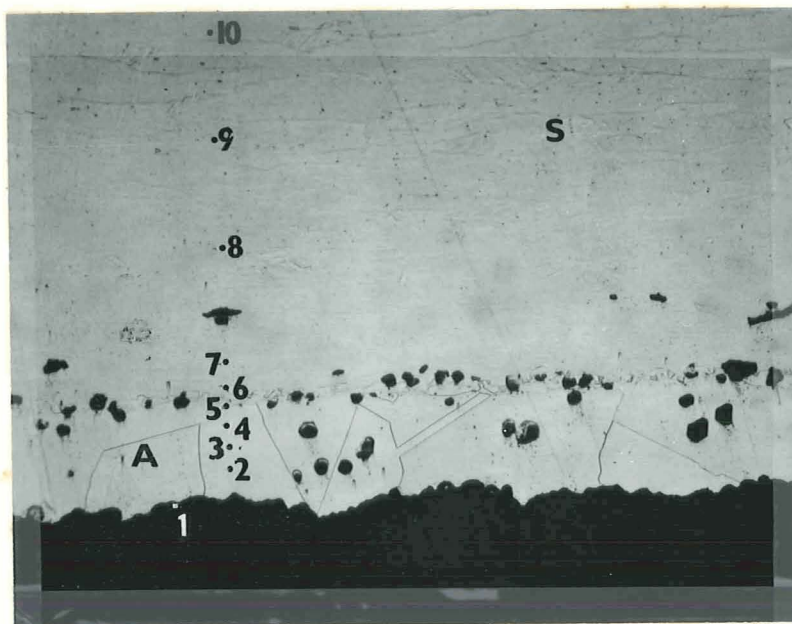

Sample #105 oxidized 2300°F- 100 hrs.

Figure 66. Location of electronprobe analyses on TD-Ni substrates coated with Ni-30Cr-1Si first step and  $10 \text{ mg/cm}^2$  Al-20Co second step (100X)

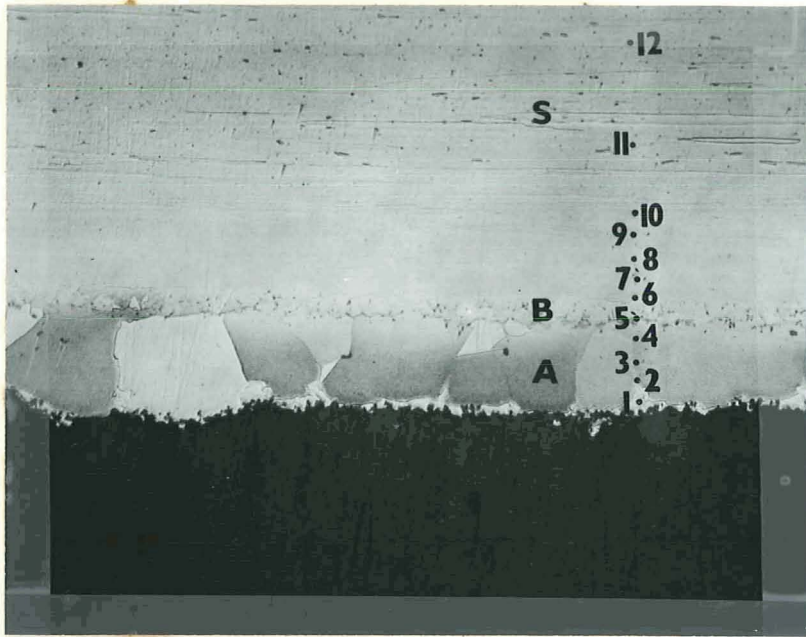

Sample #106 as coated

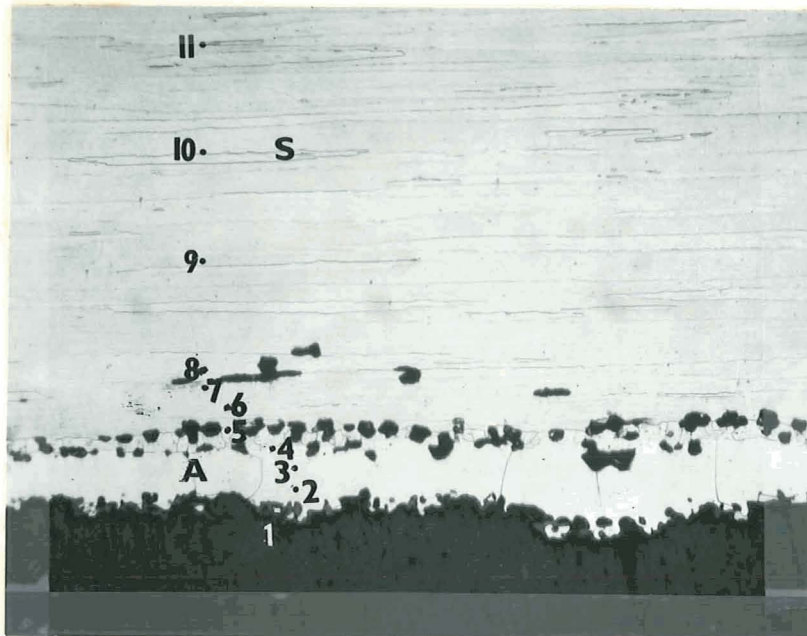

Sample #108 oxidized 2300°F - 100 hours

Figure 67. Location of electronprobe analyses on TD-Ni substrates coated with Ni-20Cr-3Si first step and  $10 \text{ mg/cm}^2$  Al-20Co second step (100X)

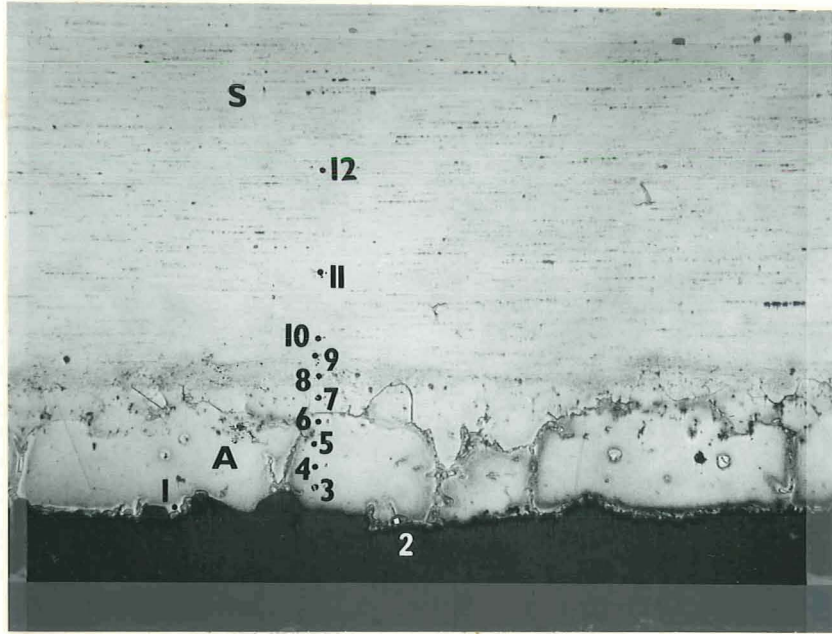

Sample #111 As coated

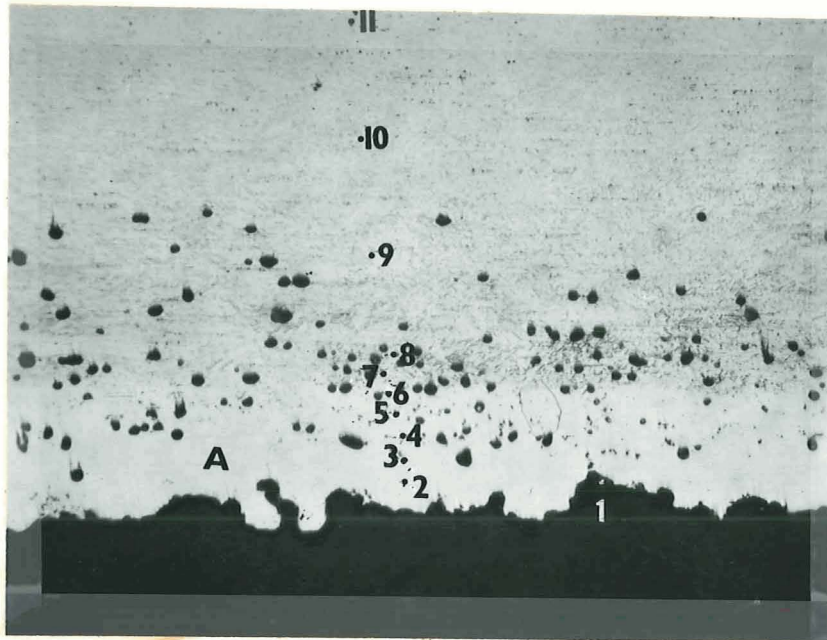

Sample #113 oxidized 2300°F - 100 hours

Figure 68. Location of electronprobe analyses of TD-NiCr substrates coated with Ni-20Cr-3Si first step and  $10 \text{ mg/cm}^2$  Al-20Co second step (100X)

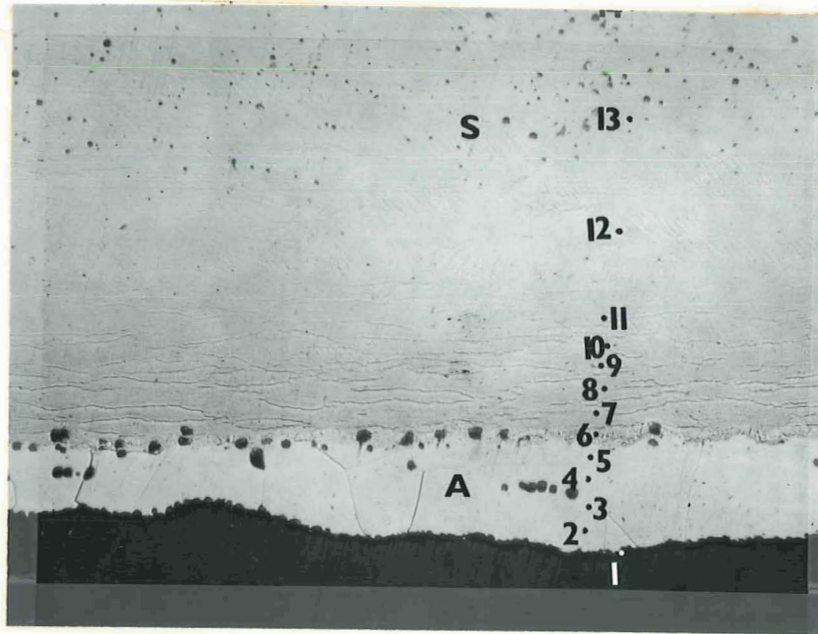

Sample #101 - 10 hours argon

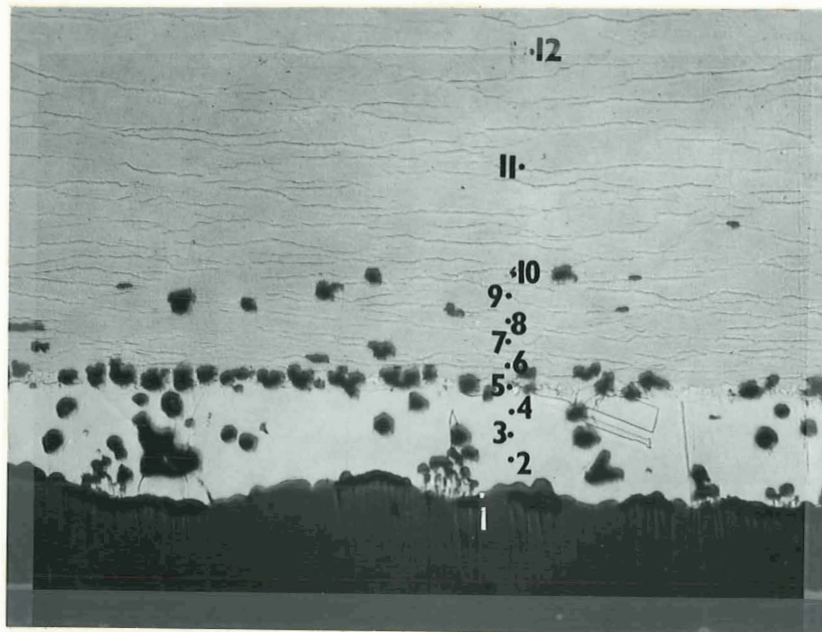

Sample #101 - 100 hours argon

Figure 69. Location of electronprobe analyses of TD-Ni substrates coated with Ni-30Cr-1Si first step and  $10 \text{ mg/cm}^2$  of Al-20Co second step and diffusion treated in argon at  $2300^\circ\text{F}$  (120X)

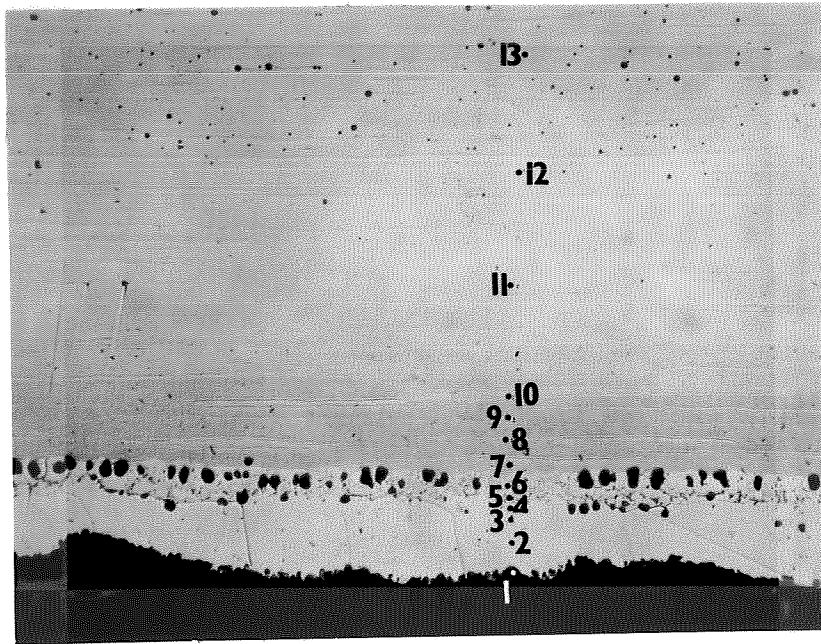

Sample #106 - 10 hours argon

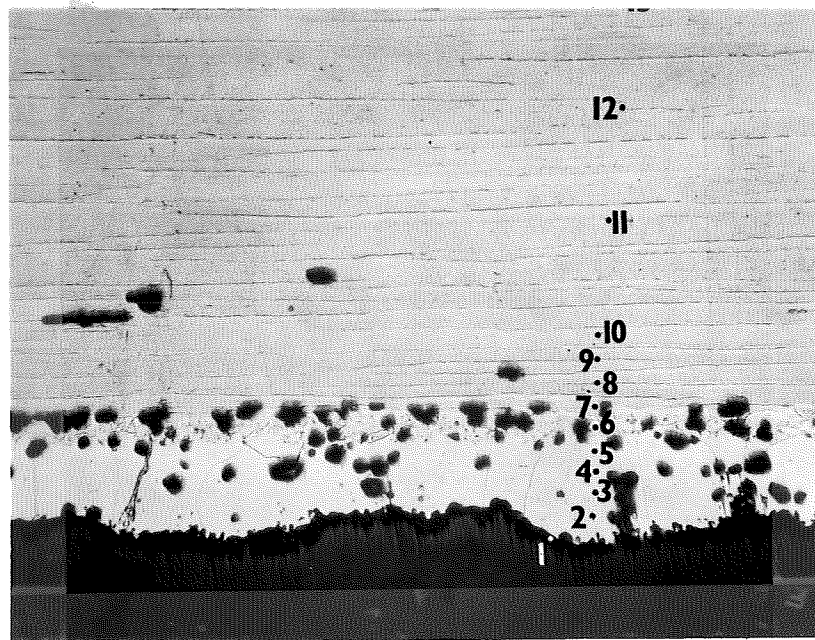

Sample #106 - 100 hours argon

Figure 70 . Location of electronprobe analyses of TD-Ni substrates coated with Ni-20Cr-3Si first step and  $10 \text{ mg/cm}^2$  Al-20Co second step and diffusion treated in argon at  $2300^\circ\text{F}$  (100X)

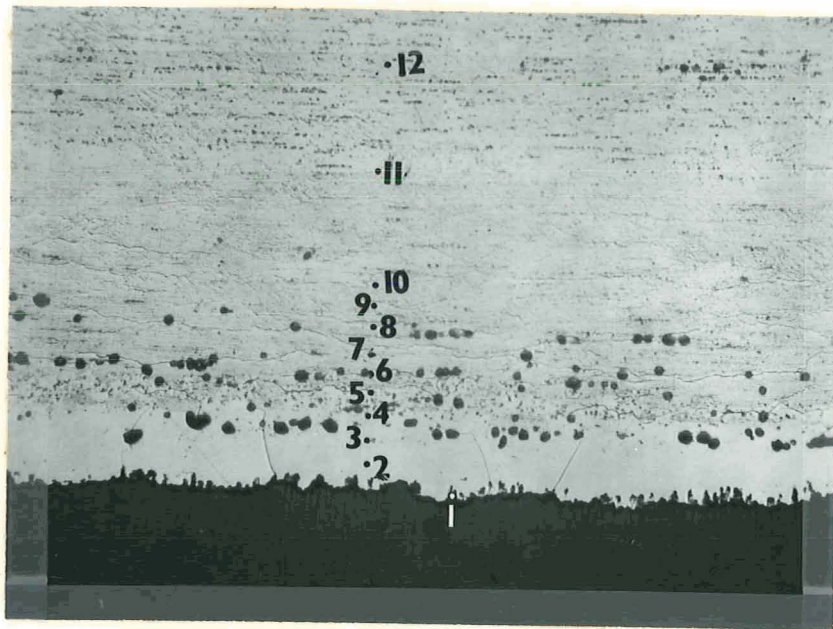

Sample #111 - 10 hours argon

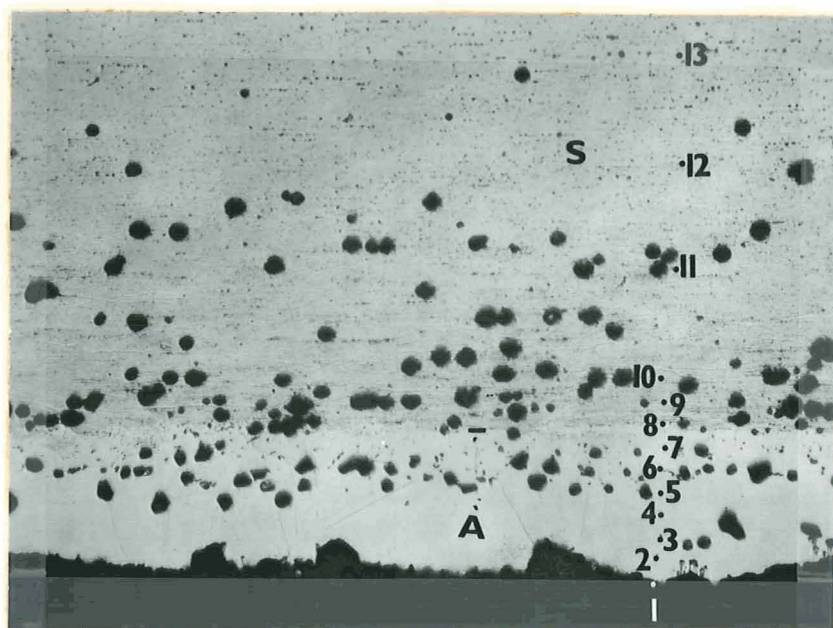

Sample #111 - 100 hours argon

Figure 71. Location of electronprobe analyses of TD-NiCr substrates coated with Ni-20Cr-3Si first step and  $10 \text{ mg/cm}^2$  of Al-20Co second step and diffusion treated in argon at  $2300^\circ\text{F}$  (100X)

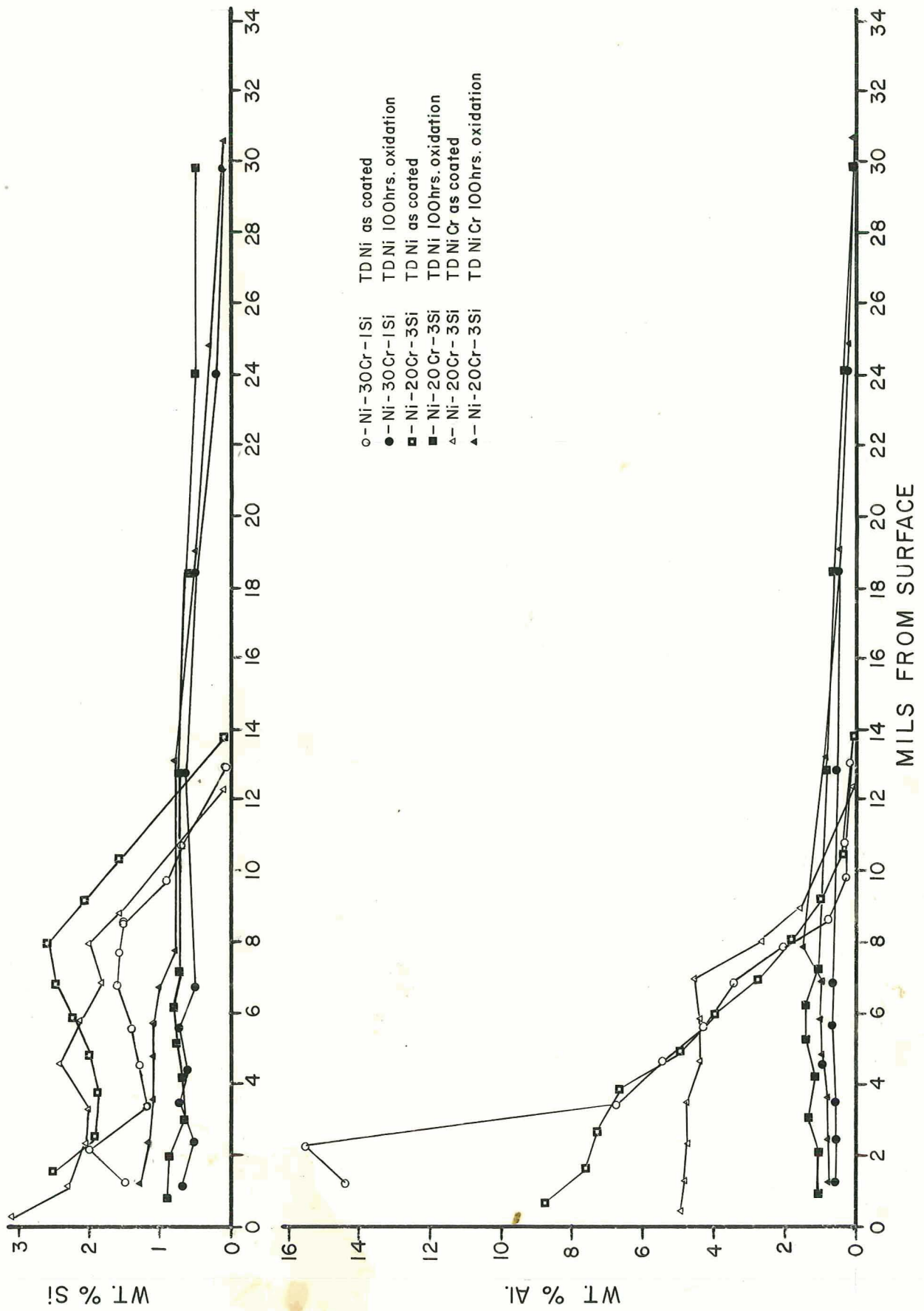

Figure 72. Electronprobe analyses of TD-Ni and TD-NiCr substrates for Si and Al as coated and after oxidation at 2300°F.

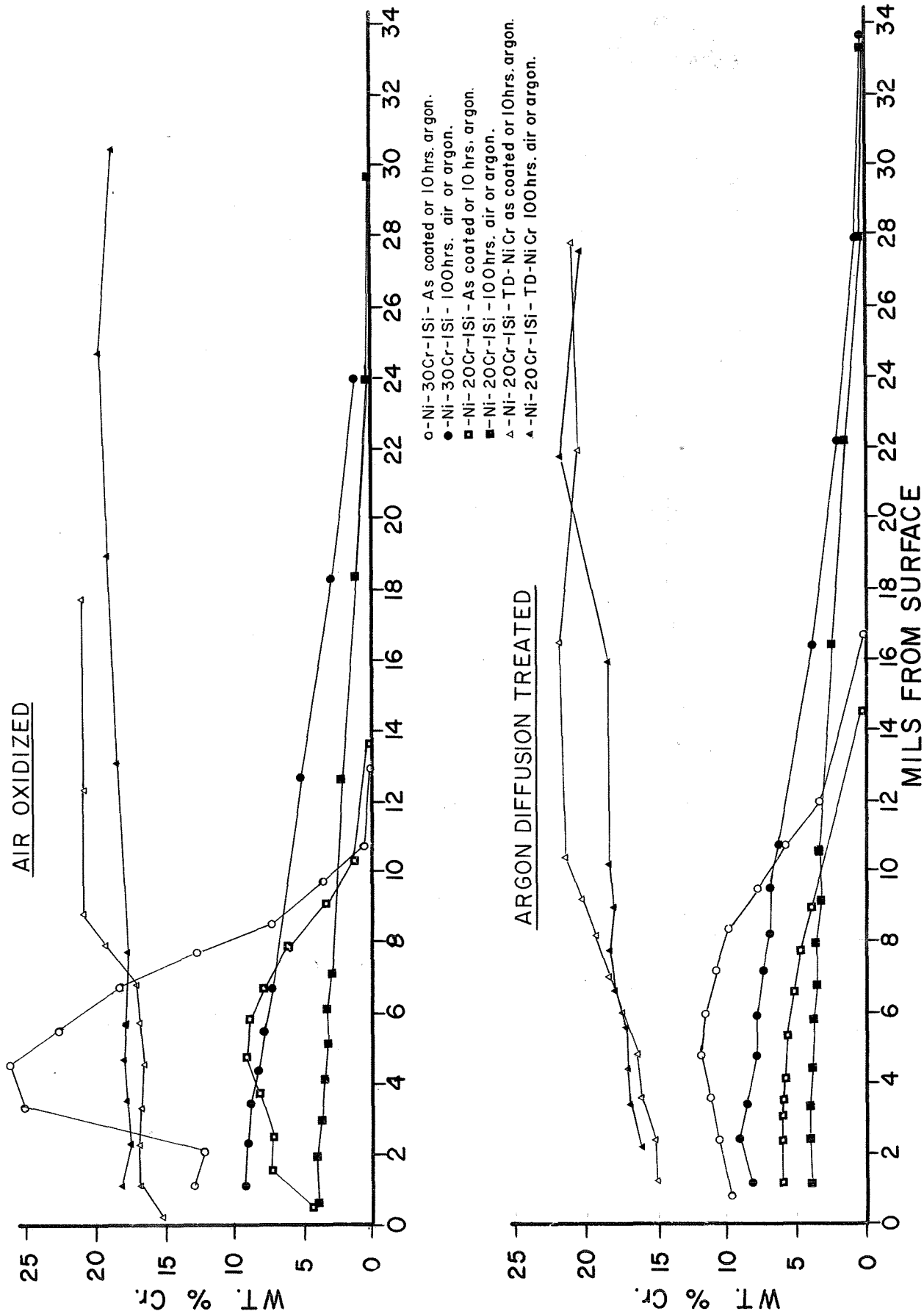

Figure 73. Electronprobe analyses of TD-Ni and TD-NiCr substrates for Cr as coated and after oxidation or argon diffusion at 2300°F

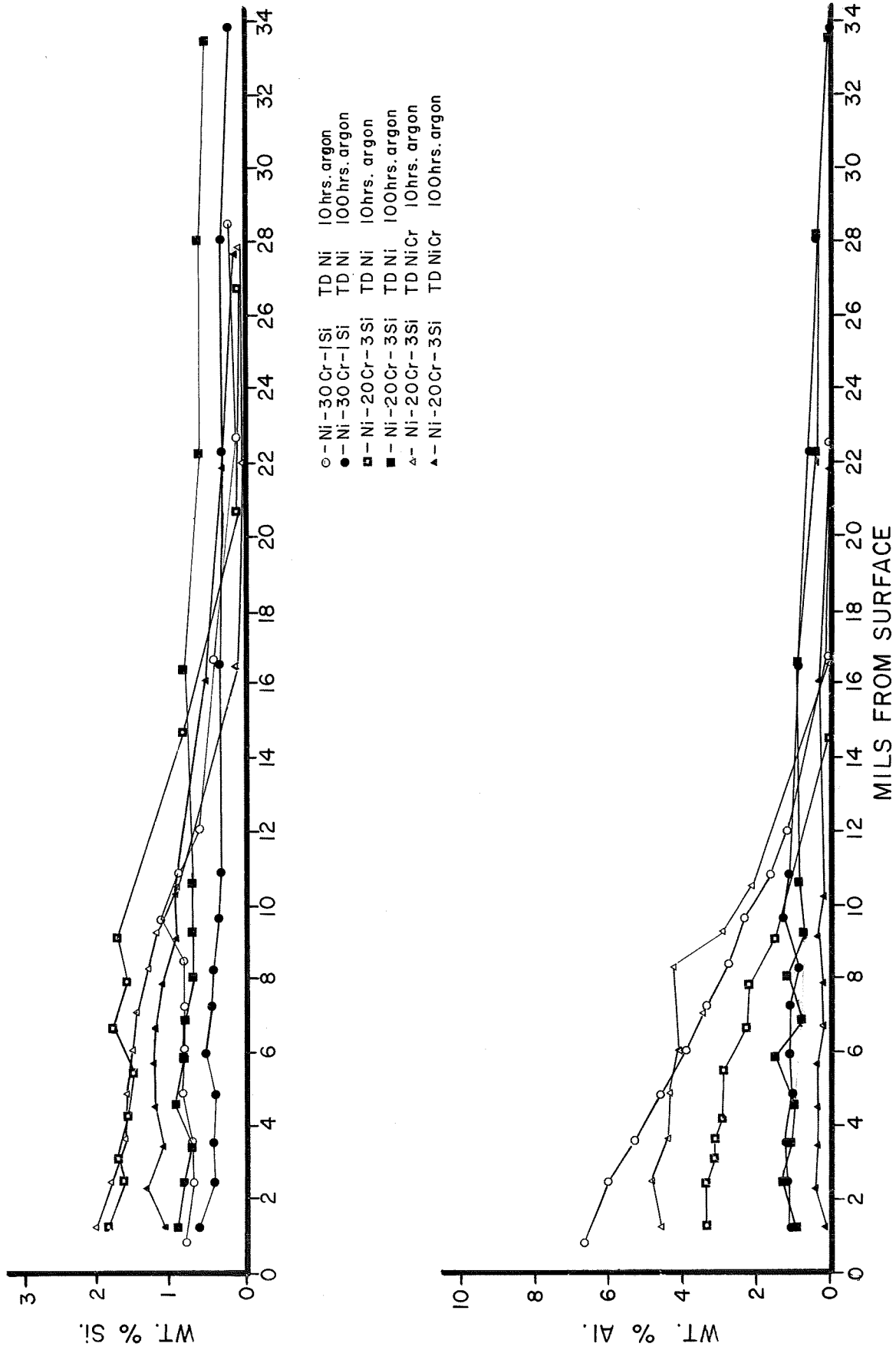

Figure 74. Electronprobe analyses of TD-Ni and TD-NiCr substrates for Si and Al after argon diffusion treatments at 2300°F

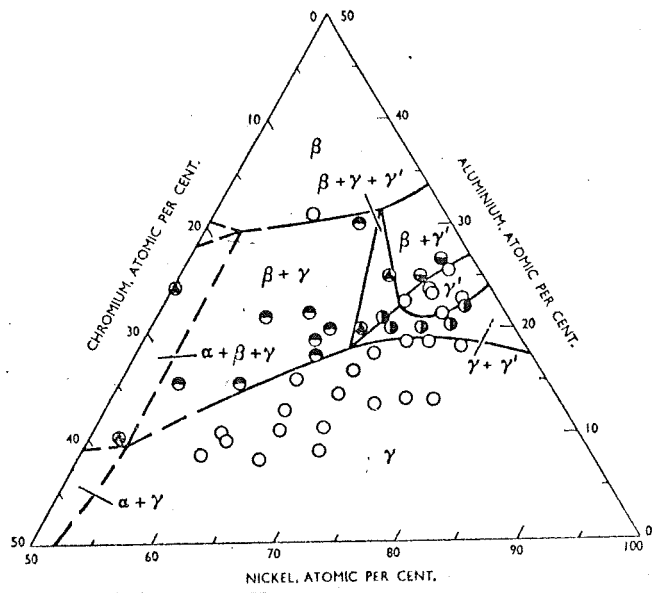

Figure 75. The Nickel-Chromium-Aluminum Phase Diagram: Isothermal Section for 2100°F. (Ref. 4)

Rather extensive inward diffusion takes place with silicon in all three coating-substrate systems with only 10-20% of the original as-coated silicon apparently being consumed in the oxidation process. However no silicon was detected in the oxide on those oxidized samples in which the oxide was analyzed. Due to the rough approximations which were made from the curves, it is possible very little silicon is lost by oxidation.

The argon treated sample curves shown in Figures 73 and 74 do not yield as consistent analyses when the areas under the curves are integrated graphically. The estimate indicates very little Al is lost in 10 hours from the Ni-30Cr coating on TD-Ni and the Ni-20Cr on TD-NiCr. However the Ni-20Cr coating on TD-Ni loses about 20% of the Al in the first 10 hours. After 100 hours the Ni-20Cr on TD-Ni has lost only another 10% whereas the same coating on TD-NiCr has lost 90% of the original Al and the Ni-30Cr has lost 50%. As a result there is apparently more diffusion into the TD-Ni than into the TD-NiCr.

From the areas under the silicon curves there appears to be more silicon present in all cases than was originally added to the coating and with the TD-NiCr substrate this amount appears to increase further after 100 hours. It should also be noted that silicon is found to a considerable depth in all substrates after the 100 hour diffusion treatment. Somewhat higher concentrations are found after 100 hours in the TD-Ni substrates than in the TD-NiCr, with a 0.2 - 0.5% Si composition at the center of the samples.

It is difficult to state whether there is any difference in chromium content in the TD-NiCr coating between the 10 and 100 hour argon exposures. A smoothly increasing concentration appears to develop from surface to substrate with perhaps a slightly lower overall content in the 100 hour sample. The 15% Cr at the coating surface is puzzling since the weight losses noted in these samples is far too low to account for this low a Cr concentration.

With both TD-Ni coatings measurements of the areas under the Cr curves show an overall higher total Cr content in the 100 hour argon samples compared to the 10 hour samples. The Ni-30Cr coated samples had 10-20% less than the original as-coated Cr content and the Ni-20Cr coated samples 20-35% less. Here again actual weight losses are far too low to account for this difference; there must be some inconsistency in actual composition or due to the method of graphically estimating.

A comparison of the 100 hour oxidized and 100 hour argon diffusion treated sample curves shows one outstanding difference. The Ni-20Cr coating on TD-NiCr shows a much lower overall Al concentration in the argon sample than the oxidized sample. It may be inferred from this that it is Al that is lost by vaporization. The Si and Cr in this coating-substrate system and the Al, Si and Cr in the other two systems show very little difference in overall concentration levels between oxidized and argon treated samples.

Before summarizing the analyses a number of mitigating factors should be kept in mind. In the as-coated samples it is possible that complete homogenization takes place at the coating temperature but that some precipitation or phase dissociation or "coring" takes place on cooling which may account for some irregularities in composition when plotted. The ternary diagrams from (4) at temperatures lower than 2100°F show considerable phase field shifts. Also the points analyzed do not line up at 90° to the sample surfaces. Although it may not be too widespread, it is likely that some lateral composition gradients do exist; it must be kept in mind that accelerated spalling and depletion occurs at edges. How the presence of pores affects the analyses is not known but efforts were made to direct the beam at solid areas of the coating and substrate. There is some difference in coating thicknesses, particularly between oxidized samples; since the data plots are based on distances from the coating surface, they may be slightly displaced from the original or other sample plots. Since the composition gradients inward are rather gradual it is not possible to have a fixed reference point suitable for all samples. Nor is it really possible to determine where the original coating substrate interface was. Where it was deemed possible, an analysis of the surface oxide was made. However in many cases this film was extremely thin and difficult to hit without surrounding metal interference.

Accordingly the following generalizations must be made with the above limitations in mind. Silicon appears to be retained to a considerable degree whether under oxidizing conditions or in argon, and diffuses readily to the center of both substrates. Aluminum is consumed preferentially either by oxidation or by vaporization in argon, the latter process being more pronounced with the TD-NiCr substrate. Diffusion of aluminum inward occurs rather rapidly with both substrates. Chromium diffuses quite readily into the TD-Ni substrate but it is difficult to tell whether it is lost to any appreciable degree by vaporization in argon, since there is so much of it present in all cases. The calculated losses in argon of both Al and Cr do not correlate quantitatively with the weight losses noted in the diffusion work.

Both the Al and Cr surface concentrations are relatively low after 100 hours at 2300°F on TD-Ni. According to reference (1) if these compositions were to be freshly prepared and tested they would oxidize rapidly. The data are for ternary Ni-base alloys with 2-8% Cr and 1% Al and show that at 2200°F these alloys gain over 11 mg/cm<sup>2</sup> in 15-20 hours oxidation in air. This is the same approximate surface composition range of the two coatings on TD-Ni shown here after 100 hours oxidation at 2300°F. Yet these coatings are able to sustain an additional 100 hours oxidation without reaching the same weight change even though they are 100°F hotter. Therefore the prior formation of an aluminum oxide film on the as-coated Cr and Al surface compositions may provide primary protection as a coating with the residual concentrations after 100 hours at 2300°F being sufficient for repair and replenishment of local fissures and spalling for at least another 100 hours.

Reference to the oxidation curves in Figure 51 shows a total weight gain in all three coating-substrate systems of no more than 1 mg/cm<sup>2</sup> in 100 hours. Calculations indicate this much oxygen pickup would consume only 1 mg/cm<sup>2</sup> of Al in 100 hours, which is roughly only 10% of the total Al content. Since the analyses are consistent in showing 50% of the Al consumed by oxidation, or approximately 4-5 mg/cm<sup>2</sup>, there must be loss of some other coating component to balance the extra 3-4 mg/cm<sup>2</sup> of oxygen weight pickup. The analyses of the TD-Ni samples indicate about 10-20% of the Cr is lost during oxidation, or 2-6 mg/cm<sup>2</sup>, depending on the coating. Very little Cr is found in the aluminum oxide. Accordingly the major portion of the Cr is lost through an oxidation-evaporation process.

#### 4.10 Microhardness Values

Microhardness impressions were made using a 50 g. load and a Knoop indenter. Reference can be made to Figures 55, 57, 58, 59, 60, and 61, which cover six major coating-substrate systems in the as-coated and oxidized conditions. Two levels of Al-20Co coating weight and two Cr levels in the first coat are covered for TD-Ni and the two Al-20Co coating weights for the TD-NiCr substrate. Similar tests were also made on the 10 and 100 hour argon diffusion treated samples and compared with the 100 hour oxidized samples in Figures 63 to 65.

A number of the metallographic mounts contained samples which were also used for electronprobe analyses. Also most of the micrographs for the report were taken in one laboratory and the microhardnesses for part of Task I and all of Task II were taken at another laboratory. This was done because of the inherent efficiencies for each of these specialties at each laboratory. It was not practical to make hardness impressions until all of the metallography and probe analyses work was completed. Therefore the actual hardness impressions are not shown on the figures cited above but their locations are referenced by number on the areas of the microstructure in which they were made.

Comparison of the as-coated structures in Figures 55, 57 and 58 show that at the Al-20Co 15-21 mg/cm<sup>2</sup> coating weight level the two phase outer layer on both the TD-Ni and TD-NiCr has a very hard constituent, KHN 1000, whereas the single phase outer layer on the 30Cr first step coating on TD-Ni in Figure 57 is considerably softer. The inner coating layer and the diffusion zone in all three cases is considerably harder than the substrate. In general, after 20 hours oxidation the hardness level in the outer layer drops considerably and after 100 hours oxidation the outer zone of the coating is softer than the substrate and the diffusion zone is somewhat harder than the substrate. After 200 hours or so the substrate appears to have hardened perceptibly over its original hardness and the hardness decreases gradually from substrate to the outer surfaces.

At the lower Al-20Co coating weight level of 9-10 mg/cm<sup>2</sup>, as shown in Figures 59 to 61, the coating hardnesses in the as-coated condition are somewhat lower except for the two phase 30Cr first step coating on TD-Ni in Figure 59; it is equivalent in hardness to the two-phase coating structure of Figure 55. However the hardnesses of coatings in all three coating-substrate systems drop off with time of oxidation exposure at 2300°F. On the TD-Ni substrates after 250 hours or so there is a very soft outer coating layer but the diffusion zones and substrate are practically homogeneous in hardness at or slightly higher than the original substrate hardness level. After 360 hours at 2300°F the coating and diffusion zone on the TD-NiCr are considerably softer than the substrate which has hardened only slightly over its original value.

The 10 hour argon diffusion treatments of the 9-10 mg/cm<sup>2</sup> coatings of Al-20Co in all three major coating-substrate systems has not only homogenized but also softened the coatings to the 300-350 KHN level. After 100 hours in argon the coatings have softened further; to 130-150 KHN on TD-Ni and to 160-180 KHN on the TD-NiCr. A similar softening of the coating occurs during oxidation of the TD-Ni samples but not as much on the oxidized TD-NiCr. In general the diffusion zone to substrate hardness gradients are similar in the 100 hour argon and 100 hour air samples.

In general the microhardness correlate with bend ductility behavior. Where there are very hard outer coating layer phases there is a tendency to crack on bending. After only 10-20 hours at 2300°F, whether in argon or air the coating structures homogenize, hardness drops and bend ductility is enhanced.

## V. PREPARATION OF EROSION BAR SAMPLES

As part of the contract requirements, it was necessary to fabricate, coat and deliver 24 erosion bars to NASA. The bar design is shown in Figure 76.

In the late stages of Task I, two TD-NiCr bars were coated with Alloy #3, Table I, and delivered to NASA. These have not been tested there as yet.

An additional 24 bars were later fabricated, coated with the two-step process and delivered. These consisted of 12 each of TD-Ni and TD-NiCr. Coating weight and weight change data for these are listed in Table XXVIII. There was little or no problem in coating the TD-Ni bars. The Al-20Co coating losses during the #5 diffusion treatment were a little high in batch 4 but there was no unusual behavior.

Both coating steps gave problems with the TD-NiCr. Samples 14 to 19 had considerable rundown of the first step coating when fused at 2365-2370°F. There was only slight runoff with 20 to 25 at 2360°F. Therefore 15 to 19 were stripped back, recoated and fired at 2355°F with 26 and 27. In the Al-20Co coating step losses in firing in a trial run brought some coating weights down to below 8 mg/cm<sup>2</sup>. Therefore the green slurry weight was increased to 14 mg/cm<sup>2</sup>. Although this worked well with the TD-Ni, considerable melting occurred in TD-NiCr samples 18 and 19. Therefore the green slurry weight was lowered to 11-12 mg/cm<sup>2</sup> on the balance of the samples. After firing the coating weights retained were lower than originally desired, 5.1 - 7.7 mg/cm<sup>2</sup> instead of 8-10 mg/cm<sup>2</sup>. In addition there were still areas on each bar that looked as though incipient melting had occurred, particularly on 27.

Since the TD-NiCr erosion bars were obtained from a third batch of material, it is possible some slight difference in chemistry from previous stock was responsible for the difficulties in coating. However it is also likely the scale-up in part size and weight from test coupons may have been responsible; i.e. due to temperature uniformity limitations in first step coating, for example.

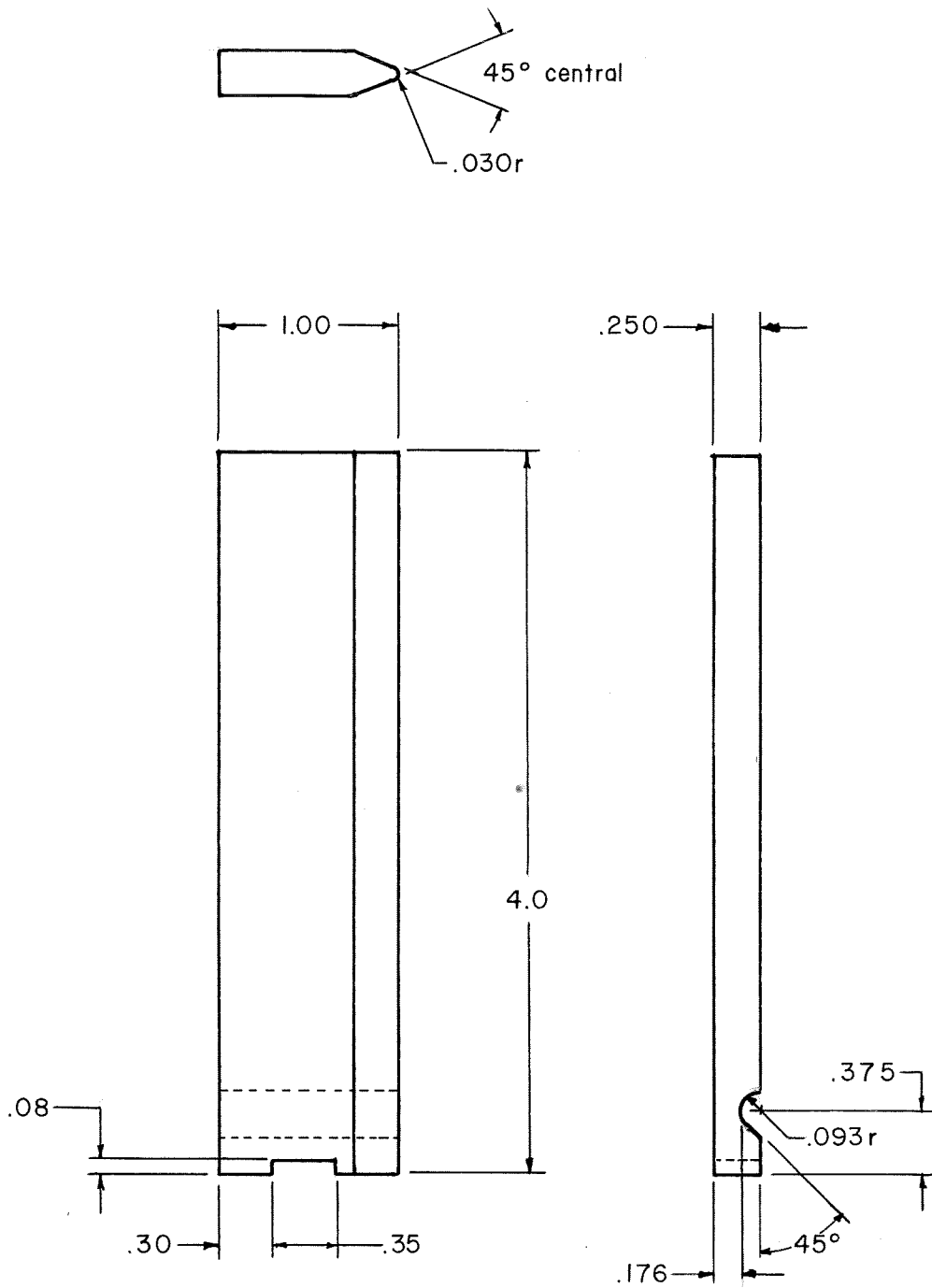

Figure 76. Erosion Bar Samples

TABLE XXVIII

Slurry Coating Data for TD-Ni and TD-NiCr Erosion Bars

Bar No.	Substrate	Composition	1st Step Coating		Al-Co Batch No.	Al-20 2nd Step Coating	
			Wt. (mg/cm <sup>2</sup> )			Wt. (mg/cm <sup>2</sup> )	
			Before Firing	After Firing		Before Firing	After Firing
1	TD-Ni	Ni-30Cr-1Si	89	80	(2)	14	10.4
2	"	"	89	80	(2)	14	8.9
3	"	"	89	80	(2)	14	8.9
4	"	"	90	82	(1)	12	7.9
5	"	"	89	80	(3)	14	8.9
6	"	"	90	81	(3)	14	8.8
7	"	"	89	80	(3)	14	9.0
8	"	"	89	80	(3)	14	10.1
9	"	"	89	80	(3)	14	8.3
10	"	"	89	79	(4)	14	8.4
11	"	"	89	80	(4)	14	8.3
12	"	"	89	80	(4)	14	8.1
15	TD-NiCr	Ni-20Cr-3Si	85	82	(1)	12	7.7
17	"	"	85	77	(5)	11	6.4
18	"	"	85	81	(2)	14	9.4
19	"	"	85	82	(2)	15	9.5
20	"	"	85	81	(4)	12	5.9
21	"	"	85	82	(4)	11	5.1
22	"	"	86	82	(5)	11	6.7
23	"	"	85	81	(5)	11	7.3
24	"	"	85	80	(5)	11	6.8
25	"	"	86	81	(5)	11	7.7
26	"	"	85	80	(5)	12	7.3
27	"	"	85	80	(3)	14	9.1

## VI. DISCUSSION OF RESULTS

It is apparent that the coating alloy compositions chosen from the Ni-Cr-Al system for Task I were in the correct range since the more successful two-step coatings of Task II were also within this range, if averaged over the coating thickness. The critical factor is aluminum composition, although it is necessary for the coating to also contain 10-20% Cr.

It also appears that the Al-20Co second coating step can lead to high Al intermediate compositions with the Ni-Cr-Si first layer, which contain low melting regions resulting in porous and weak coating layer interfaces. Therefore a carefully controlled diffusion treatment must be used so that incipient melting does not occur. The treatment must be balanced against the Al content; i. e. the higher the Al the more prolonged the treatment. However the first step coating-substrate interface is a second potentially weak region if sufficient Al is applied to reach a critical concentration at this interface. With a 4 mil thick first step coating of Ni-(20-30Cr)-(1-3Si), it appears that a maximum finished composition of 8-10% Al can be attained without incipient melting or other problems.

Although an incremental temperature diffusion treatment was used, this does not preclude the use of long term isothermal treatments. Isothermal treatments longer than 16 hours were not investigated at or below 2100°F in order to use chronological time more effectively on the program.

The coating process was only refined to the point where meaningful test data could be obtained. It is not suggested that a completely practical coating system has been developed to coat actual gas turbine hardware. In fact it appears that considerably more compositional and process development work can and should be done to obtain improved coating protection.

Major limitations in protection at 2300°F appear to be associated with the starting aluminum composition at the coating surface and the total aluminum available for oxidation during the life of the coating. Unfortunately the 200 hour test samples were not analyzed by electron probe. Therefore the lower critical concentration of Al prior to the onset of rapid oxide spalling can only be the subject of speculative estimating.

Since about 50% of the Al is consumed in the first 100 hours of oxidation at 2300°F and the oxidation rate is roughly parabolic, it is reasonable to estimate that another 25% is consumed in the second 100 hours, which then reduces the overall content to about 25% of the starting composition. However the average surface concentration at 100 hours is approximately 1% and diffusion has proceeded extensively into the substrate. Therefore it is probable that little further depletion by diffusion occurs and in the ensuing 100 hours the average surface concentration drops to about 0.5% because of oxidation; i. e. the "critical" concentration for the repair and replenishment of the  $Al_2O_3$  film.

Depletion of protective alloying elements and more rapid oxidation attack appears to develop preferentially at edges and corners on both substrates. However general surface "wear out" behavior does occur on the TD-Ni substrates at 200-250 hours and therefore the chain of events discussed is a reasonable approximation.

It can be hypothesized from the foregoing that if an Al surface concentration of 1% or greater can be maintained longer, i. e. by inhibiting diffusion, then additional protective life is attainable. The alternate approach of increasing the initial Al concentration at the same coating thickness would appear quite difficult in view of the incipient melting problem. Although a thicker overall coating should also give longer life, an average 5 mil thick coating appears to be a reasonable maximum at this time. On the other hand, a 25% increase in coating thickness may be sufficient to increase the Al enough to double the protective life; i. e. 500 to 700 hours instead of 250 to 500 hours, using the 11 mg/cm<sup>2</sup> weight loss as the failure criterion.

The present substrate materials were approximately 60 mils thick and diffusion of Al was sufficiently high to reach an easily detectable composition level at the center of the samples in 100 hours. Since the substrate acts as a diffusion sink, the thicker the substrate the more effective it will be in lowering the Al concentration to below that required for continued protection. Accordingly it might be expected that substrates thicker than 60 mils would be protected for somewhat shorter times than reported here and thinner substrates for longer times.

A secondary but important interdiffusion effect also requires consideration. As has been noted in both Task I and Task II, a line of interconnected porosity usually develops at the coating-substrate interface as a result of long term exposure at elevated temperatures. Similar observations have been noted elsewhere (1) with Cr-Al pack coatings on TD-Ni. This phenomenon has been described as the Kirkendahl (4) effect after the original work done by the author on Cu-brass diffusion couples.

The subject of diffusion is a complex one and particularly so where one of the couples is a four or a five-component system such as in the present case. The additional operative mechanisms of oxidation and vaporization here help to complicate matters further. It must be emphasized that the electron probe data obtained here were not and could not be intended for anything so complex as the determination of diffusion coefficients but only to assist in following compositional changes during oxidation or diffusion.

Accordingly the development of interface porosity by the coatings and its relationship to the Kirkendahl effect can not be discussed here too extensively. Roughly speaking the effect occurs in a diffusion couple where there is a differential in component diffusion rates resulting in a net mass flow across the couple interface. Vacancies can be initiated, migrate and coalesce. In the present case it is possible with the TD-Ni substrates that Al, Cr and Si are diffusing inward and/or outward from

the coating faster than Ni is diffusing into the coating with the net result that vacancies form in the vicinity of the interface. However this explanation is a gross oversimplification of the case.

The important aspect of the interface porosity is a mechanical one. When the pores develop and migrate sufficiently to become interconnected they form a plane of weakness which can, as a result of thermal stresses imposed by cycling, induce spalling of the coating. An immediate loss of oxidation protection is to be expected. Naturally any inhibition imposed on diffusion could also inhibit the formation of interface porosity. No evidence of gross coating spalling over the sample surfaces was noted in the present case with the best two-step coatings. However it is possible that "wear out" by oxidation has barely preceded the onset of this phenomenon. It is also possible that an increase in thermal cycling rate may precipitate failure by spalling when gross interface porosity has accumulated but before "wear out" by oxide spalling has occurred.

In any event it appears necessary that to increase oxidation life of the two-step coating system a higher Al and Cr surface concentration must be maintained by: (1) slightly higher starting compositions, (2) thicker coatings or (3) inhibition of diffusion of Al and Cr. On TD-NiCr it is necessary to conserve or increase only Al but by similar means. Substrates thinner than 60 mils may automatically have increased life over those reported here because of a diminished diffusion sink effect.

Some additional increase in life may be obtained by slowing down oxide spalling through the further alloying of the coating with additives such as originally attempted in Task I; i. e. Y, Th and Cb. It is likely the true effect of these additives in Task I was masked to some extent by practical coating problems discussed previously.

Naturally coating life could be expected to be considerably longer at temperatures lower than 2300°F. Depletion of Al by diffusion and oxidation should be sufficiently decreased as to readily afford 500-1000 hours protection in the 2000-2200°F range.

## VII. CONCLUSIONS

1. Slurry coatings in the Ni-Cr-Al system are protective to TD-Ni at 2300°F. Two-step slurry coating processes were developed which protect 60 mil TD-Ni and TD-NiCr for over 250 to 500 hours at 2300°F with 5 mil coatings.
2. The coatings have good potential service ductility.
3. Protective life is limited by oxidation and diffusion of Al and Cr into the substrates.

4. Total aluminum content and surface composition are the major life limiting factors for both substrates but chromium is also important for TD-Ni.
5. The maximum effective aluminum content obtainable in solid solution was limited to about 8%.

#### VIII. REFERENCES

1. Monson, L. A., and Pollock, W. I. "Development of Coatings for Protection of Dispersion Strengthened Nickel from Oxidation", AFML-TR-66-47, Part I, March 1966.
2. Baker, F. R., and others, "Further Development of Coatings for Protection of Dispersion Strengthened Nickel from Oxidation", AFML-TR-67-230, August 1967.
3. Williams, D. N., and others, "Development of Protective Coatings for Chromium-Base Alloys", NASA Contract NAS3-7612, Mar. 1968.
4. Taylor, A. and Floyd, R. W. "The Constitution of Nickel-Rich Alloys of The Nickel-Chromium-Aluminum System", Journal of the Inst. of Metals, 1952-53, Vol. 81, pp. 451-464.
5. Kirkendall, E. O., "Diffusion of Zinc in Alpha Brass", Transactions, Amer. Inst. of Mining and Metallurgical Engineers, Vol. 147, 1942, p. 104.