

## **General Disclaimer**

### **One or more of the Following Statements may affect this Document**

- This document has been reproduced from the best copy furnished by the organizational source. It is being released in the interest of making available as much information as possible.
- This document may contain data, which exceeds the sheet parameters. It was furnished in this condition by the organizational source and is the best copy available.
- This document may contain tone-on-tone or color graphs, charts and/or pictures, which have been reproduced in black and white.
- This document is paginated as submitted by the original source.
- Portions of this document are not fully legible due to the historical nature of some of the material. However, it is the best reproduction available from the original submission.

NASA CR-73345

**STUDY OF TECHNOLOGY REQUIREMENTS  
FOR  
STRUCTURES OF LARGE LAUNCH VEHICLES**

**FINAL REPORT  
VOLUME 3 OF 3  
SURVEY OF ADVANCED STRUCTURES TECHNOLOGIES**

1 JULY 1969

**PREPARED FOR:**

**National Aeronautics and Space Administration  
Office of Advanced Research and Technology  
Contract NAS2-5047**

**By:**

**APOLLO SYSTEMS DEPARTMENT  
MISSILE AND SPACE DIVISION  
GENERAL ELECTRIC COMPANY  
DAYTONA BEACH, FLORIDA 32015**

N69-31623

FACILITY FORM 608

(ACCESSION NUMBER)	(STHRU)
164	1
(PAGE)	(CODE)
NASA-CR-73345	32
(NASA CR OR TRX OR AD NUMBER)	(CATEGORY)

**"This report was prepared as an account of Government-sponsored work. Neither the United States, nor the Administration, nor any person acting on behalf of the Administration:**

- a. Makes any warranty or representation, expressed or implied, with respect to the accuracy, completeness, or usefulness of that information contained in this report, or that the use of any information, apparatus, methods, or process disclosed in this report may not infringe privately owned rights;**
- b. Assumes any liability with respect to the use of any information, apparatus, methods, or process disclosed in this report."**

**As used in the above, "Person acting on behalf of the Administration" includes any employee or contractor of the Administration, or employee of such contractor to the extent that such an employee or contractor of the Administration, or employee of such contractor prepares, disseminates, or provides access to any information pursuant to his employment or contract with the Administration or his employment with such contractor.**

NASA CR-73045

**STUDY OF TECHNOLOGY REQUIREMENTS  
FOR STRUCTURES OF LARGE LAUNCH VEHICLES**

**FINAL REPORT  
VOLUME 3 OF 3**

**SURVEY OF ADVANCED STRUCTURES TECHNOLOGIES**

**1 JULY 1969**

**Prepared For  
NATIONAL AERONAUTICS AND SPACE ADMINISTRATION  
OFFICE OF ADVANCED RESEARCH AND TECHNOLOGY  
CONTRACT NAS2-5047**

**By  
APOLLO SYSTEMS DEPARTMENT  
MISSILE AND SPACE DIVISION  
GENERAL ELECTRIC COMPANY  
DAYTONA BEACH, FLORIDA**

## FOREWORD

This report presents the results of a survey of structural technologies applicable to an overall Study of Technology Requirements for Structures of Large Launch Vehicles. This study is being performed for the National Aeronautics and Space Administration under Contract NAS 2-5047, monitored by Mr. Kenji Nishioka and Mr. Harry Hornby of the Mission Analysis Division of the Office of Advanced Research and Technology.

We wish to acknowledge many organizations and individuals who provided us with data pertinent to this study. A list of these organizations and individuals is included at the end of this report.

## TABLE OF CONTENTS

<u>Section</u>	<u>Title</u>	<u>Page</u>
	SUMMARY	xiii
SECTION 1—INTRODUCTION		
1.1	BACKGROUND	1-1
1.2	STUDY APPROACH	1-2
SECTION 2—METAL STRUCTURAL TECHNOLOGY—STATUS		
2.1	INTRODUCTION	2-1
2.2	CONVENTIONAL STRUCTURAL TECHNOLOGY	2-1
2.3	ADVANCED ALUMINUM STRUCTURES	2-2
2.3.1	GENERAL REMARKS	2-2
2.3.2	CORE MATERIAL	2-5
2.3.3	FACE SHEETS	2-5
2.3.4	ADHESIVE BONDING	2-6
2.3.5	OTHER FABRICATION METHODS	2-8
2.3.6	MANUFACTURE OF ALUMINUM HONEYCOMB CORE	2-8
2.3.7	FABRICATION OF SANDWICH STRUCTURES	2-9
2.3.8	AVAILABILITY AND COST OF MATERIALS	2-11
2.3.9	PROBLEM AREAS	2-11
2.4	BERYLLIUM STRUCTURES	2-12
2.4.1	GENERAL REMARKS	2-12
2.4.2	PROPERTIES	2-14
2.4.3	FABRICATING WITH BERYLLIUM	2-15
2.4.3.1	Introduction	2-15
2.4.3.2	Forming	2-15
2.4.3.3	Extrusion	2-18
2.4.3.4	Machining	2-19
2.4.3.5	Drilling	2-20
2.4.3.6	Joining	2-20
2.4.3.7	Toxicity	2-21

## TABLE OF CONTENTS (Cont.)

<u>Section</u>	<u>Title</u>	<u>Page</u>
2.4.4	CORROSION OF BERYLLIUM	2-21
2.4.5	EXAMPLES OF AEROSPACE APPLICATIONS OF BERYLLIUM	2-22
2.4.5.1	Introduction	2-22
2.4.5.2	Mechanically Fastened Sheet	2-23
2.4.5.3	Large Cylindrical Structure	2-26
2.4.5.4	Beryllium Honeycomb Sandwich	2-26
2.4.5.5	Roll Diffusion Bonding	2-31
2.4.5.6	Other Sheet Applications	2-31
2.4.6	AVAILABILITY OF BERYLLIUM SHEET	2-36
2.4.7	COST OF BERYLLIUM	2-36
2.4.8	PROBLEM AREAS	2-38
2.5	TITANIUM STRUCTURES	2-38
2.5.1	GENERAL REMARKS	2-38
2.5.2	PROPERTIES OF TITANIUM SHEET	2-39
2.5.3	FABRICATING TITANIUM	2-40
2.5.3.1	Introduction	2-40
2.5.3.2	Machining	2-40
2.5.3.3	Joining	2-40
2.5.3.4	Forming	2-41
2.5.4	AEROSPACE APPLICATIONS OF TITANIUM	2-42
2.5.4.1	Introduction	2-42
2.5.4.2	Saturn Booster	2-43
2.5.4.3	SST (Super Sonic Transport) Application	2-47
2.5.4.4	Other Applications	2-49
2.5.5	CHEMICAL COMPATIBILITY OF TITANIUM	2-49
2.5.6	AVAILABILITY OF TITANIUM	2-50
2.5.7	COST	2-55

## SECTION 3—COMPOSITE STRUCTURAL TECHNOLOGY

3.1	INTRODUCTION AND GENERAL COMMENTS	3-1
3.2	STATUS OF REINFORCING FIBERS AND MATRIX MATERIALS	3-5
3.2.1	ADVANCED FIBERS	3-10
3.2.1.1	Boron Filaments	3-11

TABLE OF CONTENTS (Cont.)

<u>Section</u>	<u>Title</u>	<u>Page</u>
3.2.1.2	Graphite Filaments	3-13
3.2.1.3	Silicon Carbide Filaments	3-15
3.2.1.4	Other High Modulus, Non-Metallic Filaments	3-15
3.2.1.5	Beryllium Wires	3-16
3.2.1.6	High-Strength Steel Wires	3-16
3.2.1.7	Short Fibers	3-16
3.2.1.8	Fiber Price Trends	3-17
3.2.2	MATRIX MATERIALS	3-19
3.3	STATUS OF FIBER COMPOSITES	3-21
3.3.1	RESIN MATRIX COMPOSITES	3-21
3.3.1.1	Glass-Resin Composites	3-21
3.3.1.2	Boron-Resin Composites	3-26
3.3.1.3	Graphite-Resin Composites	3-30
3.3.1.4	Beryllium-Resin Composites	3-32
3.3.1.5	Short-Fiber Reinforced Resins	3-32
3.3.1.6	Mixed-Fiber Resin Composite	3-32
3.3.1.7	Fiber-Resin Tapes and Prepregs	3-33
3.3.2	METAL-MATRIX COMPOSITES	3-35
3.3.2.1	General	3-35
3.3.2.2	Boron-Aluminum	3-39
3.3.2.3	Silicon Carbide-Aluminum Composites	3-42
3.3.2.4	Boron-Titanium Composites	3-43
3.3.2.5	Beryllium-Aluminum Composites	3-44
3.3.2.6	Graphite-Metal	3-44
3.3.2.7	Other Fiber-Metal Combinations	3-44
3.4	APPLICATIONS OF FIBROUS COMPOSITES	3-46
3.4.1	FILAMENT WINDING OF LARGE STRUCTURES	3-48
3.4.2	BORON-RESIN COMPONENTS	3-53
3.4.3	GRAPHITE-RESIN COMPOSITES	3-59

SECTION 4—LIST OF PLACES AND PERSONS CONTACTED  
OR QUERIED 4-1

SECTION 5—REFERENCES 5-1

TABLE OF CONTENTS (Cont.)

<u>Section</u>	<u>Title</u>	<u>Page</u>
<b>APPENDIX A—PROPOSED WORK PROCESSES FOR MATERIAL PREP- ARATION, FABRICATION, AND INSPECTION OF INTE- GRALLY STIFFENED SKIN STRUCTURES BY MARTIN NOVA STUDIES</b>		
A.1	GENERAL	A-1
A.2	WORK PROCESSES FOR MAJOR TANKAGE	A-1
A.2.1	STIFFENED TANK-SKIN PANELS	A-2
A.2.2	CONICAL SKIN PANELS	A-3
A.2.3	GORES	A-4
A.2.4	BULKHEAD CAPS	A-5
A.2.5	TANK TO BULKHEAD TRANSITION SECTIONS	A-6
A.2.6	FRAMES	A-7
A.2.7	PREWELD PREPARATION	A-7
A.2.8	POSTWELD OPERATIONS	A-8
A.2.9	SUBASSEMBLY WELDING—LONGITUDINAL AND MERIDIONAL	A-8
A.2.10	BULKHEAD SUBASSEMBLY WELDING—LONGITUDINAL AND MERIDIONAL	A-9
A.2.11	SUBASSEMBLY WELDING—CIRCUMFERENTIAL	A-10
A.2.12	LH <sub>2</sub> TANK SUBASSEMBLY TEST	A-11
A.2.13	ASSEMBLY WELDING—LH <sub>2</sub> TANK	A-11
A.2.14	ASSEMBLY WELDING—LOX TANK	A-12
A.2.15	HYDROSTATIC TEST—LH <sub>2</sub> TANK	A-13

## LIST OF ILLUSTRATIONS

<u>Figure</u>	<u>Title</u>	<u>Page</u>
2-1	Typical Dimensions of the Base Vehicle Components	2-3
2-2	Typical Dimensions of Aluminum Honeycomb Components	2-4
2-3	Bloomingtondale	2-9
2-4	Hexcel	2-9
2-5	Steps in Production of Adhesive Bonded Structures	2-10
2-6	Face Sheet Doubler Joint Technique	2-11
2-7	Typical Dimensions of Beryllium Constructions	2-13
2-8	Cross-Rolled Beryllium Sheet Compression Buckling Tests of Simply Supported Panels	2-16
2-9	Cross-Rolled Beryllium Sheet Typical Modulus and Elongation	2-16
2-10	Cross-Rolled Beryllium Sheet Bearing and Shear Strength	2-17
2-11	Cross-Rolled Beryllium Sheet Typical Stress Strain Curves	2-17
2-12	Typical Tensile Strength and Elongation of Hot Extruded Beryllium	2-18
2-13	Extruded Beryllium I Beams	2-19
2-14	Minuteman Guidance and Control Compartment	2-23
2-15	Two Beryllium Assemblies for Minuteman: the Spacer (Top) and the Guidance Control Compartment (Bottom)	2-24
2-16	Beryllium Box Beam	2-25
2-17	Integrally Heated Ceramic Die	2-25
2-18	Beryllium Box Beam Subassemblies	2-25
2-19	MOL Use of Beryllium for Rigidity	2-27
2-20	Beryllium Honeycomb Core	2-28
2-21	All-Beryllium Honeycomb Sandwich	2-29
2-22	Honeycomb Sandwich Joints Using Beryllium Foils	2-30
2-23	Assembling Pack for Roll-Diffusion Bonding	2-32
2-24	Design Configurations for a Vertical-Rib Structure	2-32
2-25	A View of One Surface of Beryllium Panel 66-5 After Leaching	2-33
2-26	Photograph of Beryllium Panel 67-1 After Sectioning and Leaching	2-33
2-27	Beryllium Conical Frustum Brazements	2-34
2-28	Stiffened Beryllium Cylinder Brazement	2-35
2-29	Projections of a Beryllium Producer as to Price Trend as a Function of Volume for Six Thicknesses of Sheet	2-37

LIST OF ILLUSTRATIONS (Cont.)

<u>Figure</u>	<u>Title</u>	<u>Page</u>
2-30	Titanium S-IC Y-Ring Segment	2-44
2-31	Full Scale Y-Ring After Machining Operation	2-44
2-32	Fabrication Layup Design Used to Prepare Y-Ring Structure	2-45
2-33	Stiffener-to-Facing Joint Obtained in Ti-8Al-1Mo-1V Chamfered Filler Bar Pack	2-45
2-34	Completely Processed Subscale Y-Ring Segment	2-45
2-35	Integral Tee-Configuration Stiffeners Inside Cylinder	2-46
2-36	Final Production Panel	2-46
2-37	Titanium Conjugate Tankage Structure	2-48
2-38	Standard Ti-6Al-4V Panel Design	2-48
2-39	Lower Tank Panel, Trimmed and Machined	2-49
2-40	Mercury Capsule	2-50
2-41	Aft Fuselage Sections	2-51
2-42	Ti-6Al-4V Plates	2-51
2-43	Titanium Fuel and Oxidizer Tanks	2-52
2-44	7000 Gallon Tank	2-52
3-1	The Relative Structural Efficiency of Various Filament-Wound Composites Compared to some Conventional Isotropic Materials	3-3
3-2	Specific Strengths (Strength-to-Weight Ratios) of Various Structural Materials over the Period 1900 to 1980	3-3
3-3	Identifiable DOD Materials Research and Development Projects on Fiber Composite Materials	3-4
3-4	Strength Characteristics of Reinforcing Fibers	3-7
3-5	Elastic Modulus Characteristics of Reinforcing Fibers	3-8
3-6	Relative Size (Cross-Sectional Area) of Several Reinforcing Fibers	3-9
3-7	Strength Retention at Elevated Temperature of Various Commercially Available Fibers	3-12
3-8	Projected Prices for Advanced Fibers for the Next Seven Years	3-18
3-9	Process Flow Diagram for Glass Fiber-Reinforced Resins	3-25
3-10	Process Flow Diagram for Boron Fiber-Reinforced Resins	3-27
3-11	S-N Curves Comparing Fatigue Data of Boron-Epoxy Composites with Glass-Reinforced Plastic and 2024-T3 Aluminum	3-29
3-12	Process Flow Diagram for Carbon/Graphite-Reinforced Resins	3-31
3-13	Some Basic Methods Used to Fabricate Inorganic Fibrous Composite Materials	3-38

LIST OF ILLUSTRATIONS (Cont.)

<u>Figure</u>	<u>Title</u>	<u>Page</u>
3-14	Uniaxial Al-B Tensile Test Data Fabricated and Tested by the Marquardt Corp.	3-41
3-15	Selectively Placed Unidirectional Filament	3-43
3-16	Methods Used to Fabricate Graphite-Reinforced Metals	3-45
3-17	Major Fabrication Operations for 260-Inch Diameter Case (3 Sheets)	3-49
3-18	Construction of Large Filament-Wound Composite Storage Tanks	3-52
3-19	Boron-Fiber Reinforced F-111 Tail Section	3-54
3-20	Rib Enforced Structure With Instrumentation	3-56
3-21	Prototype Glass-Boron/Epoxy First-Stage Compressor Disc	3-57
3-22	Adhesive-Bonded End Tabs for Tension Loads	3-57
3-23	Design and Major Dimensions of Advanced Composite Box Beam Test Specimen	3-58
3-24	Fabrication Sequence of T-39 Wing Box Section	3-58
3-25	Procedures for F-5A Wing Tip Fabrication	3-62
3-26	The Filamentary Graphite F-5A Wing Tip Leading Edge Part Is Shown From the Rear	3-63
3-27	Application of Graphite/Epoxy Composites to Typical Advanced Aircraft Structures Illustrated on Northrop F-5A	3-64
3-28	Filament Winding of "Thornel" Graphite Yarn and an Epoxy-Resin on a Mylar-Covered Mandrel	3-65
3-29	Hat-Shaped Stringer Stiffened Plate of "Thornel" 40/ERL 2256 Composite	3-65

LIST OF TABLES

<u>Table</u>	<u>Title</u>	<u>Page</u>
I	Advanced Constructions and Materials Considered	xiv
II	Metal Technology	xv
III	Filaments Technology	xvi
IV	Resin-Matrix Composites Technology	xvii
V	Metal-Matrix Composites Technology	xviii
2-1	Properties of Typical Sandwich Facing Materials	2-6
2-2	Typical Strengths and Forming Temperatures for Beryllium Sheets	2-14

LIST OF TABLES (Cont.)

<u>Table</u>	<u>Title</u>	<u>Page</u>
2-3	Cross-Rolled Beryllium Sheet Properties	2-14
2-4	Ambient Temperature Properties of Various Joining Processes	2-20
2-5	Corrosion of Beryllium	2-22
2-6	Properties of Titanium Alloys at Room Temperatures	2-39
2-7	Comparison of Titanium, Aluminum, and Steel	2-39
2-8	Machinability	2-40
2-9	Forming Pressure Considerations	2-41
2-10	High-Speed-Forming Considerations	2-42
2-11	Titanium Alloy Sheet	2-53
2-12	Extrusion Press Capabilities for Titanium	2-54
2-13	Titanium Composite Price Index	2-56
3-1	Cost Effective Analysis of Using Boron/Epoxy Composites in the Horizontal Tail Section of the F-111	3-2
3-2	Properties of Fibrous Reinforcements for Composite Materials	3-6
3-3	Data on High Modulus Graphite Fibers	3-14
3-4	Assessment of Matrix Resins	3-20
3-5	Combinations of Fibers and Matrices Currently under Investigation	3-22
3-6	Room Temperature Tensile and Specific Strengths for Some Fiber-Reinforced Epoxies	3-28
3-7	Properties of Prepreg Boron-Epoxy Tape	3-34
3-8	Test Results on Surface Treated Morganite Graphite Fiber/Epoxy Resin Prepreg and Composite	3-34
3-9	Suppliers of Composite Tapes and Prepregs	3-35
3-10	Metal-Matrix Composites Currently Available in Sample Quantities and Limited Size	3-37
3-11	Effect of v/o Boron and Matrix Temper on Ultimate Tensile Strength (ksi)	3-40
3-12	Properties of Panels Approximately 12 by 24 Inches with 45 - 50 v/o Boron During First Three Months of Production, 1968	3-40
3-13	Properties of Metals Reinforced with Various Fibers	3-47
3-14	Prototype Programs on Boron Fiber-Reinforced Resin Composites	3-60

## SUMMARY

This report presents the results of surveying the field of advanced structural technologies completed during the Phase I portion of the study entitled, "Study of Technology Requirements for Structures of Large Launch Vehicles."

The advanced constructions and materials evaluated in this survey are summarized in Table I. Information relevant to each of these areas was obtained through the listed references and through personal contacts and discussion, as tabulated in Section 5. Summary data on materials, fabrication and costs are presented in Sections 2 and 3. For simplicity of reference, a summary of findings on the current status and prediction for the future of metal technology, filament materials as well as fiber-reinforced composites is tabulated in Tables II, III, IV and V.

Over one hundred references have been reviewed and digested; and nearly as many contacts with industry and government agencies were reviewed to insure that the data in this report provides the latest information on today's structural technologies. Drawing on talents within several General Electric Departments, including the Space Science Laboratory and Re-Entry Systems, these data, plus in-house related information have been screened and refined to produce this summary report of these technologies. Hence, this report provides a unique compilation of today's status of large launch vehicle advanced materials and structural configurations; nevertheless, it is emphasized that limitations of time and expense have necessarily precluded the possibility of providing complete coverage of the subject and there are undoubtedly many other applicable documents which have not been included or reviewed. However, the material in Tables II through V is a reasonably accurate compilation of today's state of the art and material cost projections where available.

A potentially attractive method of combining metal technology with composite technology through the use of unidirectional composite stiffeners with metallic shell structure is discussed briefly in Section 2 of this report. Structural reliability, test and inspection technologies are considered briefly in Section 3.

Table I  
Advanced Constructions and Materials Considered

Materials and Construction	Primary Source of Data for This Study
1. Aluminum—Brazed Honeycomb, Bonded Honeycomb	Battelle, Hexcel, MSFC, Goodyear, GE, MDAC, NAR
2. Beryllium—Brazed Honeycomb, Bonded Honeycomb, Roll-Bonded Double Wall	AFML, Brush Beryllium, Berylco, Harvey, MSFC, Solar, Republic, Materials Advisory Board, GE/RS, GE/MOL, MDAC
3. Titanium—Brazed Honeycomb, Roll-Bonded Shapes, Stitch-Welded Shapes	MSFC, AFML, Solar, GE, MDAC, NAR
4. Resin Matrix Composites  <u>Principal Filaments</u>  a. Boron-Epoxy b. Graphite-Epoxy c. Beryllium-Epoxy d. Glass-Epoxy  <u>Other Filaments</u>  $Al_2O_3^*$ , $SiC^*$ , $Si_3N_4^*$ , $BeO^*$ , $B_4C^*$ Stainless Steel	MSFC, AFML, Battelle, GE/RS, GE/SSL, GE/AEG, plus 72 contacts of Reference 49
5. Metal Matrix Composites  <u>Principal Filaments</u>  a. Boron-Aluminum b. Boron-Titanium c. Carbon-Aluminum d. Beryllium Wire-Aluminum  <u>Other Filaments</u>  Steel, $SiO_2$ , $Al_2O_3^*$ , $B_4C^*$ , $CuAl_2$ , $Al_3N_i^*$	MSFC, AFML, Battelle, United Aircraft, GE/AEG, GE/RS, GE/SSL, Harvey, MDAC, plus 72 contacts of Reference 49

\*Whiskers

Note: Secondary sources of data include many other companies and agencies as noted in the references.

Abbreviations: AFML—Air Force Materials Laboratory, GE—General Electric, GE/AEG—General Electric Aircraft Engine Group, GE/MOL—General Electric Manned Orbiting Laboratory, GE/RS—General Electric Re-Entry Systems, GE/SSL—General Electric Space Sciences Laboratory, MDAC—McDonnell-Douglas Aircraft Corporation, MSFC—Marshall Space Flight Center, NAR—North American Rockwell.

Table II  
Metal Technology

Materials	Data Availability	Current Status	Cost		Comments
			Now	Projected (1975)	
Aluminum - Conventional Construction	Excellent	Production		\$16-\$27 per pound**	Typified by integrally stiffened skin construction. Heavier than advanced construction.
Aluminum - Advanced Construction	Good	Limited Production	Al-core: \$1.00-\$2.00 per board foot (12"x12"x1") Al-sheet: \$0.50-\$2.00 per pound	\$16-\$30 per pound**	Represented by honeycomb construction. Efficient N. D. T. is needed.
Beryllium - ISS	Limited	Limited Production		\$150-\$300 per pound**	Lightweight, stiff, brittle, toxic.
Beryllium - Honeycomb	Limited	Limited Production	Be-Sheet: \$200-\$700 per pound	Be-Sheet: \$120-\$220 per pound	Cost reduction is important for wider potential application.
Titanium - Honeycomb	Limited	Limited Production	\$200 per Sq. Ft.*	Not much change expected	Good compatibility with most pollutants. Excellent strength to weight properties.
Metal Shells with Unidirectional Filamentary Stiffeners	Not Available	Conceptual Stage		\$25-\$33 per pound***	High load carrying efficiency.

\*For "Stressskin" Titanium Honeycomb

\*\*Based on design of Vehicle 201

\*\*\*Based on design of Vehicle 201 for B/epoxy stiffeners on aluminum shell

Table III  
Filaments Technology

Materials	Data Availability	Current Status	Cost		Comments
			Now (\$/lb.)	Projected (1975) (\$/lb.)	
Glass	Excellent	Production	0.30 - 5.00	0.30 - 5.00	Low cost; temperature - sensitive.
Boron	Good	Limited Production	320	200	Low density; high reactivity with metals.
Graphite	Good	Limited Production	260 - 340	30 - 50	High strength even at high temperature; poor oxidation resistance.
Silicon Carbide	Limited	Least Developed of Synthetic Fibers	1800 - 3000	400	Good oxidation and corrosion resistance; suitable for metal matrix composites.
Other Non-Metal Fibers*	Limited	Limited Production	Not Available	Not Available	Early stage of development.
Beryllium Wires	Limited	Limited Production	2000 - 3000	200	High specific modulus; low ductility.
Steel Wires	Good	Production	3.50	3.50	Low specific modulus; relatively inexpensive.

\*e.g., B/SiO<sub>2</sub>, Asbestos

Table IV

## Resin--Matrix Composites Technology

Materials	Data Availability	Current Status	Cost		Comments
			Now (\$/lb.)	Projected (1975) (\$/lb.)	
Glass-Resin	Good	Production	less than 5	less than 5	Low cost: standard technology.
Boron-Resin	Good	Production	450-550*	100*	High specific properties: excellent fatigue and environmental resistance.
Graphite-Resin	Limited	Limited Production	450-550*	100*	Graphite filaments have potentially high modulus and high strength.
Beryllium-Resin	Limited	Developmental Stage	Not Available	Not Available	Suitable for use in joints, cut-outs and attachments in structures.
Short Fiber-Resin	Limited	Limited Production	Not Available	Not Available	Various whiskers and asbestos fibers are used as reinforcements.
Mixed Fiber-Resin	Limited	Developmental Stage	Not Available	Not Available	Potentially high strength and high modulus.

\*L: Tape-Form

Table V

## Metal-Matrix Composite Technology

Materials	Data Availability	Current Status	Cost		Comments
			Now (\$/lb.)	Projected (1975) (\$/lb.)	
Boron-Aluminum	Limited	Development Stage	2000 - 3000	\$140 per pound	Superior strength at elevated temperature; good oxidation and corrosion resistance.
Silicon Carbide-Aluminum	Limited	Developmental Stage	550 - 1150	Not Available	Typified by silicon carbide coated boron filaments in aluminum matrix.
Boron-Titanium	Limited	Developmental Stage	Not Available	Not Available	Primarily in compressor blade applications.
Beryllium-Aluminum	Limited	Developmental Stage	Not Available	Not Available	Strong; lightweight; high modulus; previous high cost of beryllium wire has delayed development.
Graphite-Metal	Limited	Developmental Stage	Not Available	Not Available	Properties still inferior to boron-metal composites - might improve with larger diameter filaments or improved carbon coating.
Other Fiber-Metal Combinations*	Limited	Developmental Stage	Not Available	Not Available	The process of unidirectionally solidifying eutectic alloys shows promise.

\*e.g., Silicon Carbide Whisker-Reinforced Aluminum

In conclusion, metals and fibrous composites which were found to be attractive in previous studies <sup>(1,2)\*</sup> for weight reduction have been researched. Many of these attractive materials appear to be technically feasible for use in large launch vehicle structures, including:

- a. Beryllium honeycomb
- b. Boron/Epoxy and Carbon/Epoxy honeycomb
- c. Unidirectionally stiffened metal sheets with Boron/Epoxy Stringers
- d. Boron filaments in aluminum matrix

In addition, titanium honeycomb appears to be an excellent candidate for pressurized fuel tank walls and titanium monocoque equally attractive for fuel tank heads.

These then were the materials chosen for study in Phase II and compared with conventional aluminum construction. The results are presented in Volume 2 for the evaluation of relative cost effectiveness of the advanced materials and construction technologies.

---

\*Numbers in parentheses refer to references listed in Section 5.

## SECTION 1

### INTRODUCTION

#### 1.1 BACKGROUND

Economics will be one of the most important criteria for the second-generation launch vehicles. Therefore, incorporation of new structural technology into future launch vehicles will be influenced by this economic criterion also. In order to fulfill the requirements of such a criterion, new structural technologies must be assessed as to their technical desirability, technical feasibility, and economic feasibility. The question of technical desirability has been answered in past studies<sup>(1,2)</sup>. This study is addressed to the questions of technical feasibility and economic feasibility.

This volume summarizes the work done in Phase I of the study, the exploration of the question of technical feasibility. The question of economic feasibility is discussed in Volume II, for selected promising technologies which were studied in Phase II.

The study entitled, "Study of Structural Weight Sensitivities for Large Rocket Systems," performed by General Electric Company under contract N S2-3811 formed the basis for this study. The study showed potential weight savings of 60 percent, and more could be realized from the judicious (proper construction methods) use of advanced materials such as composites, beryllium and titanium. As a part of the economic evaluation of these promising technologies selected in Phase I, the potential weight savings of these technologies were traded against factors of safety, and/or enhanced reliability and reduced program costs through lowered test requirements in Phase II.

Continuing technological advances in advanced materials have enjoyed a growing interest such that research efforts have increased markedly in the last decade. For example, in the area of composites, the expansion in research by both government and private organizations has grown from \$500,000 in 1958 to \$12,000,000 in 1967<sup>(4)</sup>.

This vigorous research effort promises that data used in a study of this type has a high risk of becoming obsolete quickly. Thus, the bases of decisions in this study have been carefully weighed so that the effect of obsolescence on the results will be minimized.

## 1.2 STUDY APPROACH

This study has been divided into two phases, covering a period of eight months. Phase I, performed during a three-month period, was primarily addressed to the examination of technological areas of interest and the determination of technical status in detail. The Phase I work is summarized in this report.

The principal activities in Phase I were oriented toward the collection, identification, and sifting through latest available data on advanced structures and materials technologies. To achieve this goal, competent authorities were assembled from several departments within the General Electric Company to assist in the survey and evaluation. The following individuals were principal contributors to this survey:

N. E. Munch—Apollo Systems Department  
W. Postelnek—Re-Entry Systems  
Dr. W. H. Sutton—Space Sciences Laboratory  
R. W. Snyder—Space Sciences Laboratory  
Dr. L. S. Shu—Space Sciences Laboratory

In addition, numerous individuals within the General Electric Company and Dr. J. J. Burns of the University of Florida provided supporting help and consultation as required.

The study provides a comparative evaluation of advanced structures and materials against conventional state-of-the-art structures. The comparison baseline was established from the detailed data on structural configurations described by the Martin Company<sup>(5,6)</sup>. The comparative analysis baseline for construction was 2219-T87, aluminum integrally stiffened skin cylindrical sections and monocoque heads.

Material properties have been collected and tabulated for the materials of interest to this study. Since the properties have been derived from numerous references, small differences exist in the values reported in the tables and charts. No attempt was made to produce a single set of values, rather, the values have been quoted directly from the indicated references.

## SECTION 2

### METAL STRUCTURAL TECHNOLOGY—STATUS

#### 2.1 INTRODUCTION

Metals structural technology is considered in this section through a review of costs, feasibility, and status of fabrication and inspection of three metals:

- a. Aluminum.
- b. Beryllium.
- c. Titanium.

Each metal is considered separately. Examples of current or planned application are included with the discussion of each metal. Other related factors such as corrosion resistance, availability, and fabricability are included.

Aluminum Integrally Stiffened Skin (ISS) construction is discussed first, briefly, to provide a basis of comparison with the more advanced constructions.

#### 2.2 CONVENTIONAL STRUCTURAL TECHNOLOGY (Represented by Aluminum Integrally Stiffened Skin Structure)

Conventional structural technology is that which is based upon proven structural concepts for which developed fabrication techniques exist. It is perhaps best exemplified by the Saturn family of launch vehicles. Conventional technology has also been used in several studies of advanced launch vehicles, either as a basis for comparison in optimization studies<sup>(1,2,7,8)</sup> or as the basis for vehicle design<sup>(5,6,9)</sup>.

Today's conventional technology in launch vehicles is typified by the use of aluminum, primarily in one of several alloy forms such as 2014-T6, 2024-T4, 2219-T87, and 7075-T6, although titanium, stainless steel, magnesium, and several other metals have also been used. The types of construction used in conventional technology include monocoque, semi-monocoque (skin, stringers, and rings or frames), waffled skin, corrugated skin, integral rings and stringers, and, to a lesser extent, honeycomb.

For the purpose of this study, a typical example of conventional technology has been taken to be aluminum skin, integrally stiffened with rings and stringers, referred to as integrally stiffened skin (ISS). This type of construction has been studied for use

in a large, two-stage, million-pound-to-orbit launch vehicle, selected from a post-Saturn vehicle study performed by the Martin Company<sup>(5,6)</sup>. This vehicle was used as one of the baseline vehicles in a study performed by the General Electric Company on structural weight sensitivities<sup>(1,2)</sup>, and will also be used as a baseline vehicle for this study. Typical vehicle construction details and dimensions for the baseline vehicle are shown in Figure 2-1. Work processes for material preparation, fabrication, and inspection of conventional technology (represented by integrally stiffened skin) are presented in Appendix A.

### 2.3 ADVANCED ALUMINUM STRUCTURES (Represented by Aluminum Honeycomb)

#### 2.3.1 GENERAL REMARKS

Aluminum honeycomb sandwich construction has been used to some extent in practically every aircraft or missile flying today. The technology has been developed to the point where it is now possible to fabricate many complex shapes and large size honeycomb sandwich structures. The large-scale (33 feet) common bulkhead fabricated for use between the liquid hydrogen and oxygen tanks on the S-II stage of the Saturn V, while having a plastic honeycomb core, demonstrated the technological advances in fabricating such large structures from segmented components<sup>(10)</sup>.

An analysis performed during a prior study and reported in References 1 and 2 showed that honeycomb construction resulted in the lightest weight of the aluminum wall configurations considered for large launch vehicles. Therefore, aluminum honeycomb was selected for this study as representative of advanced structures achievable within foreseeable advances of the state-of-the-art. Preliminary design calculations during this study indicated that dimensions shown in Figure 2-2 are reasonable for large post-Saturn launch vehicles using aluminum honeycomb. These dimensions are not intended to constrain this survey, but rather to establish typical sizes and shapes as a basis for technology evaluation.

This section will discuss the general material and fabrication considerations for aluminum honeycomb. Summary information is provided for selection of core materials, face sheets, and bonding adhesives; specific design details may be found in the several references noted. Fabrication processes, costs, and availability are briefly discussed.

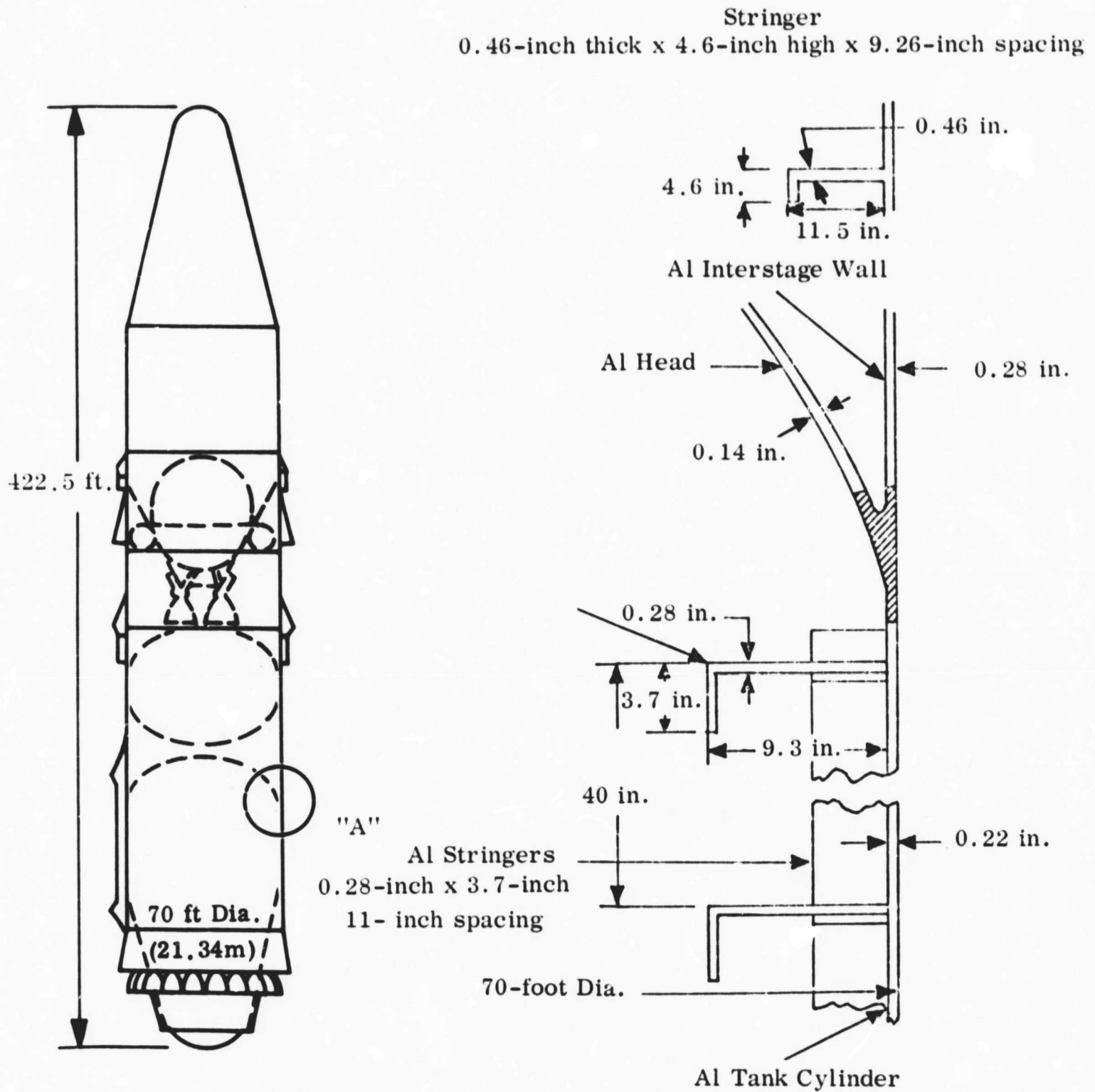

Figure 2-1. Typical Dimensions of the Base Vehicle Components (Not to Scale)<sup>(1, 2, 5, 6)</sup>

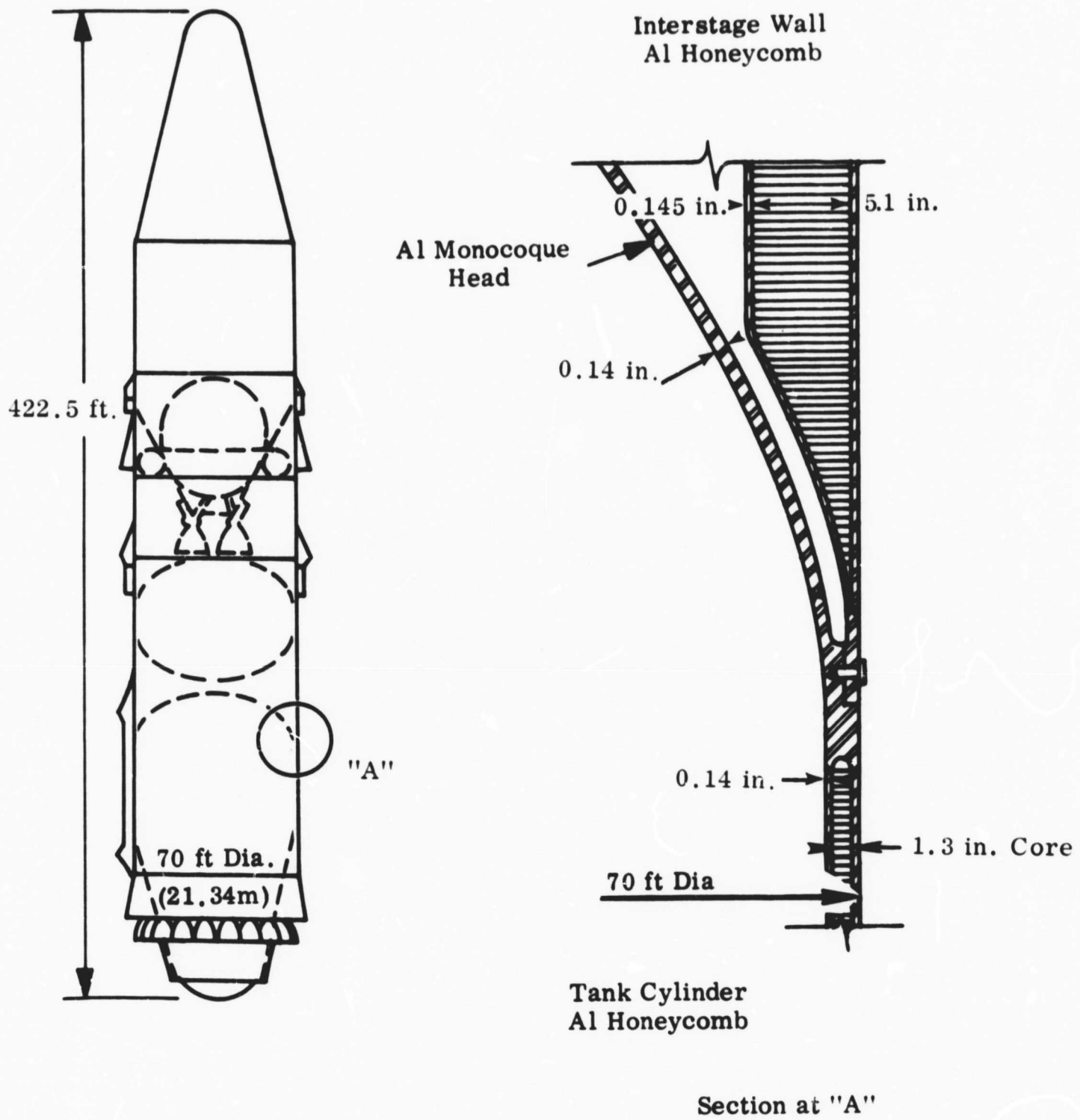

Figure 2-2. Typical Dimensions of Aluminum Honeycomb Components<sup>(1,2)</sup>

### 2.3.2 CORE MATERIAL

Honeycomb cores have been produced from a variety of materials, including paper, glass-reinforced plastic, aluminum, and many other materials. For this application, cores made of aluminum and fiber glass will be discussed as typical of potentially feasible materials.

The design formulas for analysis of honeycomb, as described in Reference 7, note the relationship of core shear modulus  $G_{lt}$  to density. For most materials, this relationship is nearly linear and can be represented by the equation

$$G_{lt} = C_1 \rho_c$$

Where  $G_{lt}$  is the core shear modulus in psi,  $C_1$  = constant for each type of material in psi/lb/ft<sup>3</sup> and  $\rho_c$  = apparent core density in lb/ft<sup>3</sup>. Values of  $C_1$  vary from approximately  $4 \times 10^5$  psi/lb/ft<sup>3</sup> for nylon and simple glass resinous material cores to  $14 \times 10^5$  psi/lb/ft<sup>3</sup> for aluminum and steel. Thus, for a given shear modulus  $G_{lt}$ , a core made of resinous materials would be over three times as heavy as an aluminum core.

Aluminum core is readily available in four alloys, 3003-H19, 5052-H39, 5056-H39, and 2024-T81. Densities vary from 1 to 12 lb/ft<sup>3</sup>. The 5052 material yields approximately 20 percent higher compressive and shear strength than the 3003 of equal density; 5056 and 2024 provide the highest compressive and shear strength of available aluminum alloys.

Reinforced plastic core is also available using glass fiber in resin fiber matrices. Shear strength-to-density ratio is less and the fiber glass is more expensive than the aluminum honeycomb. Advantages of the fiber glass result from elevated temperatures where some types of glass fiber plastic are stronger than some types of aluminum honeycomb. Fiber glass also provides good insulating qualities and is generally resistant to many corrosive environments.

### 2.3.3 FACE SHEETS

Properties of aluminum face sheets used in honeycomb sandwich construction are shown in Table 2-1<sup>(12)</sup>. Selection of the proper alloy will depend upon design criteria for sandwich application.

Table 2-1  
Properties of Typical Sandwich Facing Materials<sup>(1)</sup>

Facing Material	Yield Strength psi	Ultimate Strength psi	$E_f$ psi	Weight per Mil Thickness Lbs/Ft <sup>2</sup>	Comments
Aluminum 1100-H14	17,000	NA	$10 \times 10^6$	0.0143	Low cost, weldable
Aluminum 2024-T4	47,000 42,000 (clad)	63,000	$10.6 \times 10^6$	0.0144	Combines good strength with reasonable cost
Aluminum 2219-T87	50,000	62,000	$10.4 \times 10^6$	0.0144	Best combination of strength and weldability
Aluminum 6061-T4	19,000	30,000	$10.0 \times 10^6$	0.0141	Lowest cost heat treatable, weldable
Aluminum 7075-T6	73,000 67,000 (clad)	77,000	$10.4 \times 10^6$	0.0145	High strength

#### 2.3.4 ADHESIVE BONDING

The bond between the core and the facings must sustain approximately the same shear stresses as the core. It must resist failure in rupture or creep over the entire range of service temperatures and must also be consistent with other loading and service requirements. It must be appropriate in cost and process techniques in order to fit in with the production contemplated.

High peel strength is a desirable property of structural adhesives for sandwich construction but is not usually a factor in panel design. In actual practice, panels should be designed to eliminate most or all peeling forces. High peel strength, however, is nearly always an indication of an improved impact characteristic, and resistance to the propagation of local failures and good resistance to normal service abuse. In spite of this, however, adhesives having only moderate peel strength, but high shear, fatigue, and creep strengths, are being successfully utilized in aircraft and commercial construction. Sandwich bond strengths are influenced not only by the type of bonding material but also by weight and distribution of the material; the time, temperature, and pressure variables in the bonding cycle; the cell size of the core; and subsequent environmental exposure.

Some adhesives are available as partially cured films, usually embodying a light weave scrim cloth and furnished in large rolls. The use of adhesives in this form is helpful in several ways. It assures uniform distribution of adhesive over the area to be bonded and facilitates close control of adhesive weight and thickness. The presence of a carrier fabric also improves the peel characteristics and toughness of an adhesive bond in a sandwich. In using a dry-tape adhesive it is usually necessary to apply a light prime coat of the same adhesive in liquid form to both core and skins if maximum adhesive strength is desired.

It is important that a fillet of bonding material be developed between the facings and the honeycomb walls. The filleting action of an adhesive is usually governed by the flow behavior during the cure. Metallic bonds respond to variations of the brazing cycle in a similar manner. The satisfactory performance of a bonding system (either resin adhesive or metallic braze) in an overlapped metal joint is not necessarily an indication that it will perform well in a sandwich joint.

Several distinct types of adhesives have been developed for the use of honeycomb panel fabricators:

- a. Rubber base cements. These are usually in the form of solvent solutions, and cured by the release of solvents, either at room temperature or slightly above. Some types are adapted to pinch-roll assembly methods, which makes for extremely low production costs where this type adhesive is acceptable.
- b. Combinations of thermosetting resins and elastomeric polymers. Phenolformaldehyde resins modified by vinyl polymers, rubber, or nylon are representative of this class of adhesive. These may be in the form of solvent solutions or supported films (no scrim cloth).
- c. Epoxy resins. These are normally thick liquid or paste-type adhesive, formulated without solvents.
- d. Epoxy-phenolic systems. These have been developed especially for high-temperature service. Fillers and carriers are used, and the use of solvents is usually avoided. This type of adhesive may be supplied as an extruded film, as a supported film, as a paste, or as a thick putty.
- e. Duplex tapes. Recent trends in primary aircraft structural bonding has been toward use of duplex tapes in all honeycomb sandwich where maximum peel and structural integrity are desired. The duplex tapes consist

of a support film of B-stage adhesive of type b above, with a film of semi-liquid epoxy on one side only. The epoxy side is placed next to the honeycomb, which results in excellent filleting action of the epoxy combined with the superior toughness of the phenolic-elastomer tape.

Adhesive formulations of the same type may display widely different properties and must be evaluated separately. Adhesive manufacturers are usually able to recommend specific products for any given purpose. Furthermore, there are government specifications covering types of adhesives for various applications, and a qualified products list listing the adhesives which are currently qualified for use in each particular case. Beyond this it is up to the designer and process engineer to select the material which best suits a specific design. Frequently the evaluation of some test panels is accomplished as an aid in this selection.

#### 2.3.5 OTHER FABRICATION METHODS

Fabrication of aluminum honeycomb by several methods other than adhesive bonding have been identified, but are in the experimental stage. Brazing of aluminum honeycomb can be performed for small sections by dip brazing, but such methods do not appear applicable for the large structures required for launch vehicles. Experimental brazing of aluminum honeycomb has been achieved at GE Re-Entry Systems by local heating of pre-prepared sheet having brazing alloy sandwiched between the face sheet and the honeycomb core; but this method is considered to be too early in its development phase for consideration for large launch vehicles.

Other methods of fabrication include resistance welding, and roll-bonding. Resistance welding appears to be expensive with weld strengths below required values for this installation. Roll bonding has been used on commercial aluminum construction, such as refrigerator cores, and might be appropriate for multi-wall construction, though inappropriate for honeycomb fabrication.

#### 2.3.6 MANUFACTURE OF ALUMINUM HONEYCOMB CORE

The two principal producers of honeycomb core are Hexcel and Bloomingdale Division of American Cyanamid Company. In general, both processes use adhesive bonding to form the HOBE (honeycomb before expansion). The Bloomingdale process prepares the HOBE by laying down adhesive strips parallel to the aluminum coil length, Figure 2-3, and the Hexcel process uses adhesive strips perpendicular to the coil length, Figure 2-4.

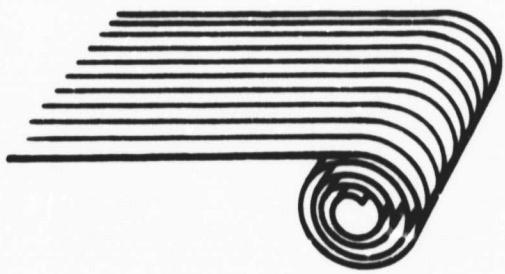

Figure 2-3. Bloomingdale<sup>(14)</sup>

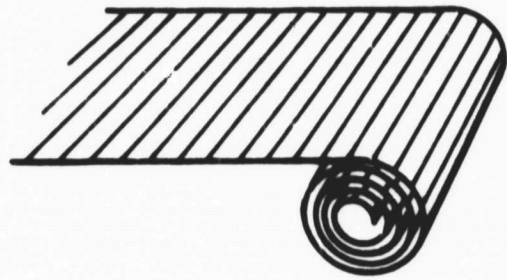

Figure 2-4. Hexcel<sup>(14)</sup>

The sheets are cut and stacked so that the adhesive strips on each layer are equally displaced from the adhesive strips on the next layer. The stack of sheets is then bonded in a press and cut into convenient HOBE sizes, or as ordered.

#### 2.3.7 FABRICATION OF SANDWICH STRUCTURES

In the fabrication of the bonded structure, the HOBE is mechanically expanded, trimmed, or machined, and the structure is assembled as shown in Figure 2-5<sup>(14)</sup>. Curing is accomplished at about 250° F under 20-40 psi pressure.

Various techniques have been developed for joining honeycomb panels and shapes. The design of edge attachments and closeouts depends upon an analysis of the structure. For the large launch-vehicle tankage, bonding of doublers on both sides of the face sheet joint is a technique that is available and has been used on the C-5A Cargo door and on the Boeing 747, Figure 2-6. The honeycomb core can be spliced to form a continuous core.

The major problem in fabrication of a large launch vehicle from aluminum honeycomb would be in the joining of large panels to form the structure. A minimum pressure of 30 psi is required for adhesive bonding and current epoxy-base adhesives require a curing temperature of 250° F. Adhesively bonded doublers require tooling and large autoclaves. Research and Development on adhesives is continuing at the major adhesive producers: Shell, 3M, Whittaker and American Cyanamid, as well as at Hexcel.

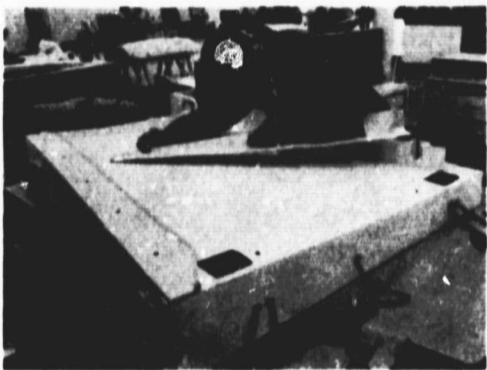

1. Precision buildup of plaster tool.

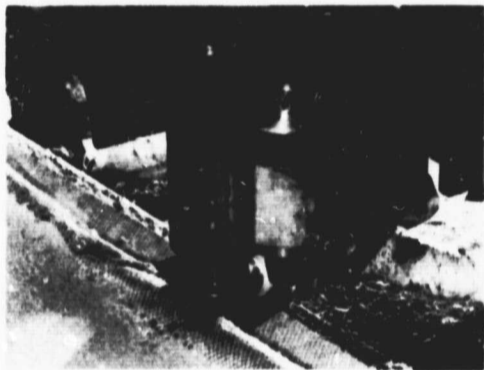

2. Core undergoes careful machining operation.

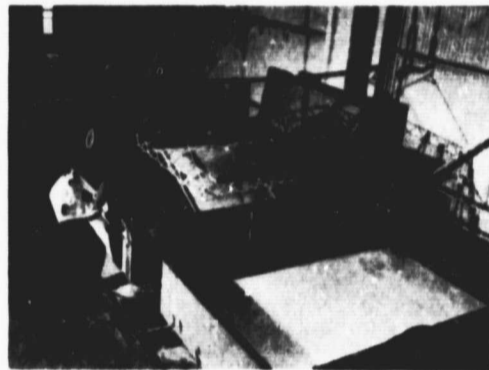

3. Detail parts are thoroughly cleansed.



4. Adhesive for bonding is applied, either in semiliquid form . . .

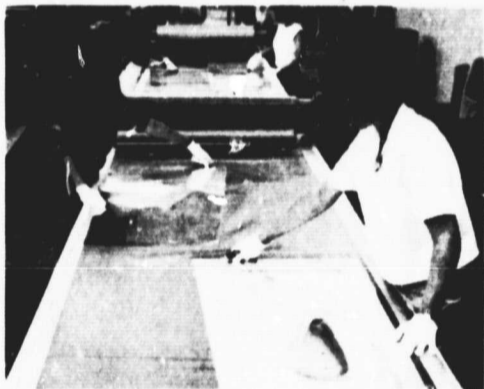

5. . . . or as adhesive tape.

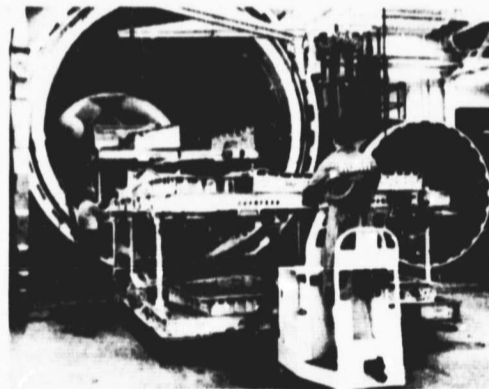

6. Layup of bonded structures is placed in the autoclave for adhesive cure.

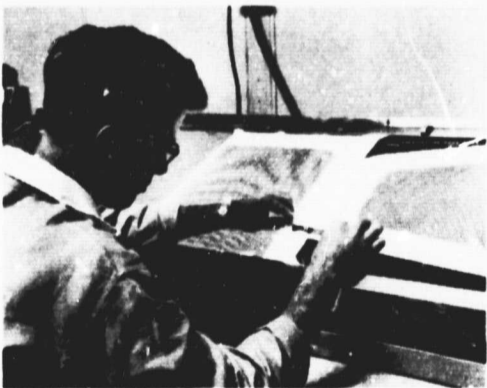

7. The structure receives detailed x-ray . . .

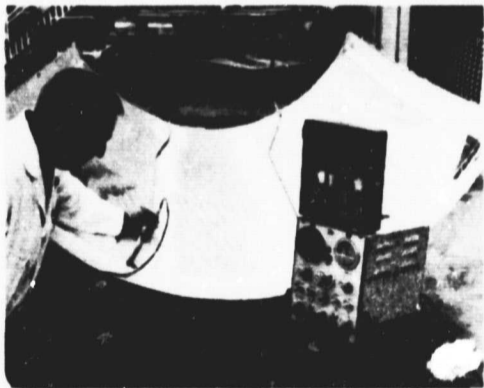

8. . . . and ultrasonic inspection before final inspection O.K.

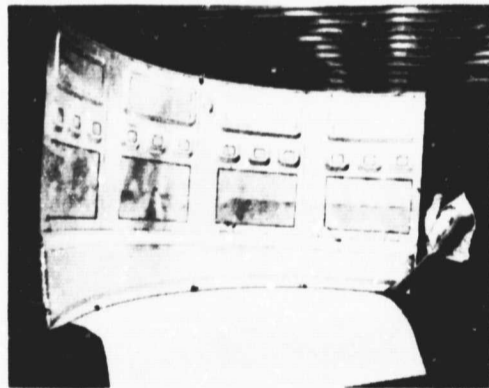

9. Mechanical assembly completes the operation.

Figure 2-5. Steps in Production of Adhesive Bonded Structures<sup>(14)</sup>

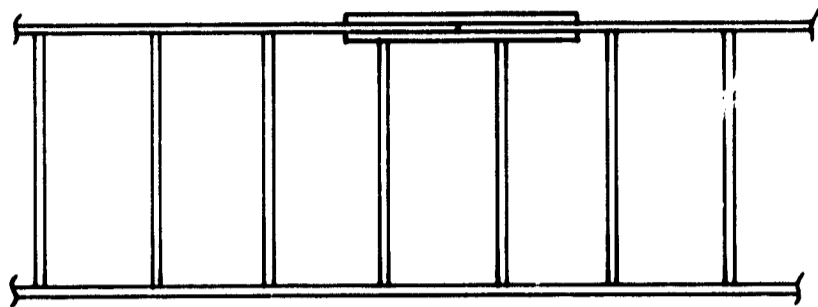

Figure 2-6. Face Sheet Doubler Joint Technique

Some experimental adhesives now cure at  $160^{\circ}$  -  $180^{\circ}$  F. It is generally felt that research and development toward development of room-temperature curing adhesives with the same properties as the current high-temperature cured materials are in the picture within the next five years. This also includes curing by sonic energy or radiation.

As an alternative to construction of a large autoclave to develop 30 psi for bonding panels into a large structure the development of room temperature curing adhesives, along with vacuum bonding procedures engineered with adjunctive tooling for bonding doublers locally would be a desirable goal.

#### 2.3.8 AVAILABILITY AND COST OF MATERIALS

Aluminum honeycomb core can be produced in expanded sizes up to 96 inch  $\times$  144 inch  $\times$  12 inch. Aluminum face sheets are available in sizes up to 72"  $\times$  240" in thicknesses ranging from 20 to 64 mils. The cost of aluminum core runs between \$1 to \$2 per board foot (12"  $\times$  12"  $\times$  1"). Aluminum alloy sheet costs between \$.50 to \$2 per pound. There is little likelihood of future price reductions of either the core or face sheet. On the contrary, if the general inflationary trend continues there is a good likelihood of a price increase within the next 10 years, as with most metals.

#### 2.3.9 PROBLEM AREAS

In fabricating large tankage using aluminum honeycomb sandwich construction, the main problem areas involve the design and fabrication of large tooling, the lack of large autoclaves, or the lack of room temperature curing adhesives. Large complex sections such as bulkheads might create special problems in tooling. Another important problem is the inspection of large surfaces. Present NDT techniques do not allow efficient testing of these large areas. Other related minor problems such as skin scales also require attention.

## 2.4 BERYLLIUM STRUCTURES

### 2.4.1 GENERAL REMARKS

The primary property of beryllium which makes it attractive for aerospace applications is its high modulus-to-density ratio, which is approximately six times that of aluminum, titanium, superalloys, and ferrous alloys.

The use of beryllium for primary load carrying structural applications can still be considered controversial and generally has resulted in a polarization of opinions by various people in the aerospace industry and the government. There is general agreement that the unique mechanical properties of beryllium makes it a prime candidate where stiff, lightweight structures are required and where buckling is the primary mode of failure. Partisanship emerges when the following parameters are considered: brittleness, toxicity, fabrication, cost, and handling. Practically every aerospace company has utilized beryllium in one application or another. Solar, McDonnell-Douglas, and Aeronca have successfully produced beryllium honeycomb structures.

Although sheet beryllium is susceptible to brittle failure when subjected to out-of-plane loads, this tendency is reduced somewhat in honeycomb construction. In applications where buckling is the criterion and compression is the method of loading, beryllium is very efficient. In the Aeronca tests on beryllium face sheet/inconel core honeycomb, it was demonstrated that beryllium develops the theoretical buckling stress prior to buckling and brittle failure of the face sheets.

Some of the disadvantages of beryllium are the strict design limitations imposed by the lack of slip planes in its crystalline structure. Proper joint design and joint formation are essential for structural reliability, more so than for any other metal. At room temperature, it is highly notch sensitive and the surface must be free from cracks and defects.

As with aluminum honeycomb in paragraph 2.3, preliminary designs during a previous study<sup>(1)(2)</sup> indicated that dimensions shown in Figure 2-7 are representative of the range for post-Saturn vehicles using beryllium construction. Here also, the dimensions shown establish typical sizes and shapes and are not intended to form constraints on the study.

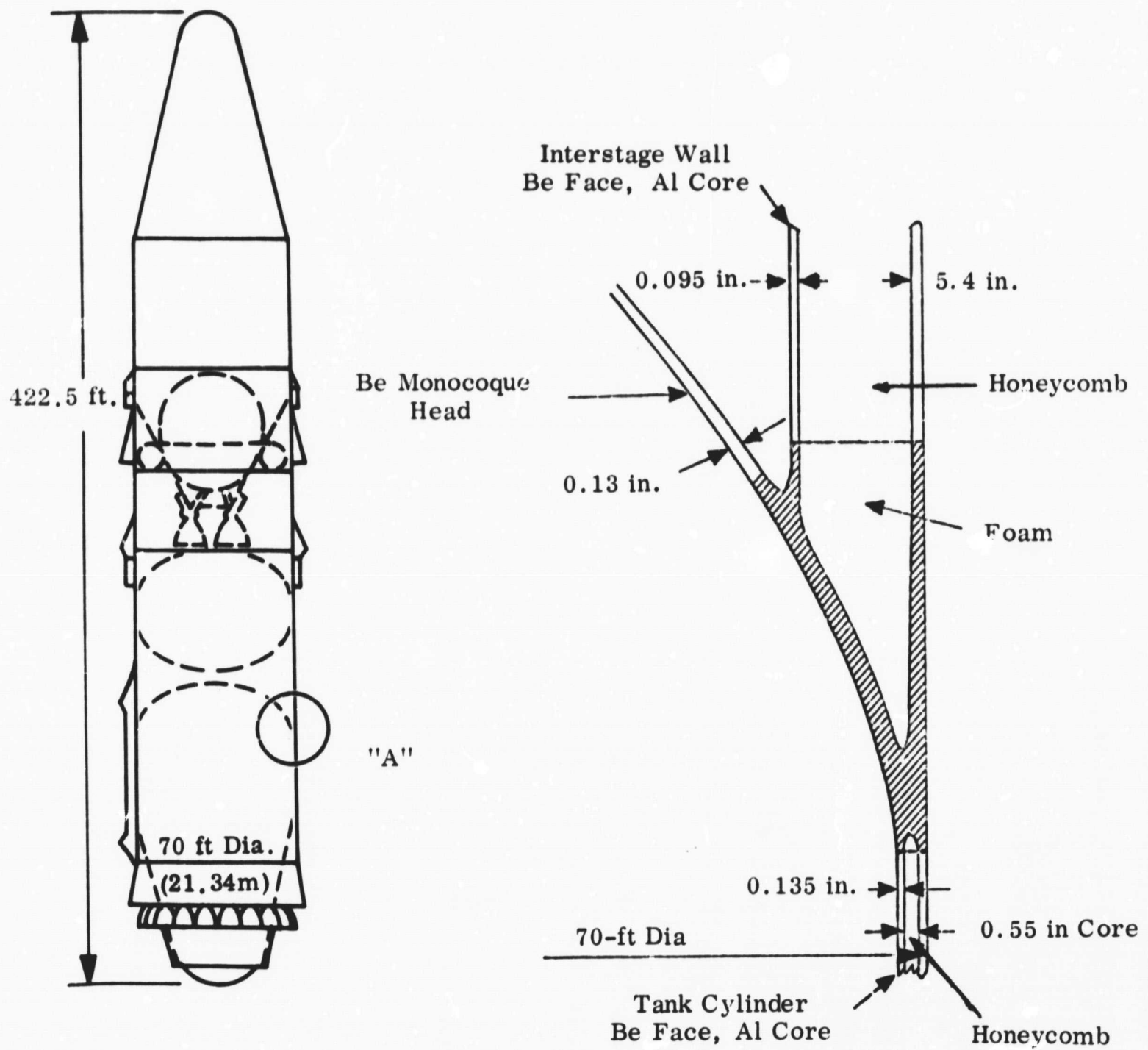

Figure 4-7. Typical Dimensions of Beryllium Constructions<sup>(1,2)</sup>

### 2.4.2 PROPERTIES

Two types of beryllium sheet are presently available—powder cross-rolled sheet and ingot sheet. Cross-rolled sheet is prepared by hot pressing a billet from beryllium powder containing 1.5 to 2.0 percent beryllium oxide, then rolling. Ingot sheet is rolled directly from a refined cast ingot having 0.1 percent BeO, which is vacuum melted, thus eliminating powder metallurgy techniques. In general, the powder sheet has higher tensile strength than the ingot sheet, but lower elongation, especially at higher temperatures. Thus, the ingot sheet can be formed at lower temperatures than the powder sheet. Table 2-2<sup>(17)</sup> compares the typical properties and forming temperatures of the two types of beryllium sheet.

Table 2-2  
Typical Strengths and Forming Temperatures for Beryllium Sheets<sup>(17)</sup>

Types of Beryllium Sheets	Typical Strengths (at Room Temperature) ksi		Recommended Forming Temperature °F
	F <sub>tu</sub>	F <sub>ty</sub>	
Ingot Sheet IS-2	45	31	500-600
Ingot Sheet IS-3	49	40	600-700
Powder Sheet HPS-12	70	49	1300-1400
Powder Sheet HPS-20	75	54	1300-1400

Cross-rolled beryllium powder sheet, the more common of the two materials, has the range of room temperature mechanical properties shown in Table 2-3<sup>(18)</sup>.

Table 2-3  
Cross-Rolled Beryllium Sheet Properties<sup>(18)</sup>

Temperature Range, °F	F <sub>tu</sub> (ksi)		F <sub>ty</sub> (ksi)		Elongation (‰ in 1.0 in)		E(× 10 <sup>6</sup> psi)
	Longitudinal	Transverse	Longitudinal	Transverse	Longitudinal	Transverse	
1300	78.4	70.0	51.3	50.3	10.0	6.5	42
1400	85.0	86.2	63.3	61.1	24.0	25.0	

Figures 2-8 through 2-11<sup>(19)</sup> show variations of physical properties versus temperature, as well as stress-strain curves. Figure 2-12 shows typical properties of hot extruded beryllium.

Beryllium sheet, even when cross-rolled, exhibits some degree of anisotropy, especially in the thermal expansion property. While the coefficient of thermal expansion in the longitudinal and the transverse directions vary slightly at ambient temperatures, the short transverse (through the thickness) thermal expansion coefficient may be as much as 15 percent less.

### 2.4.3 FABRICATING WITH BERYLLIUM

#### 2.4.3.1 Introduction

A substantial experience has been developed over the past decade for fabricating and handling beryllium. Earlier uses of beryllium were primarily as an alloying element. Full use of beryllium emerged perhaps twenty years ago for use in nuclear energy shields and more recently as re-entry vehicle heating shields. Standard texts, such as References 117 and 122 are now available for handling and fabrication of this material in pure and alloy forms.

The following sections provide a summary discussion of manufacturing technology, including the forming, machining, extrusion, drilling, joining, and toxicity of beryllium.

#### 2.4.3.2 Forming

Beryllium sheet can generally be formed above 800° F, although successful forming temperatures in the case of powder sheet is limited to 1000° to 1400° F. Spinning and drawing are also carried out in this temperature range. Sheet and plate can be shaped, bent, shear formed, and creep formed. In all forming operations, temperature, rate of forming, tool design, and surface effects are important considerations<sup>(20)</sup>. Cylindrical shapes can be formed at room temperature in a 3-roll bender, or by creep forming at 1300° F. The advantages of creep forming are uniformity of contour, elimination of spring back<sup>(19)</sup>, and the absence of residual stresses<sup>(19)</sup>.

Forming parameters for cross-rolled beryllium sheet have been studied<sup>(18)</sup>. Conclusions drawn from this study are as follows: the optimum forming temperature is

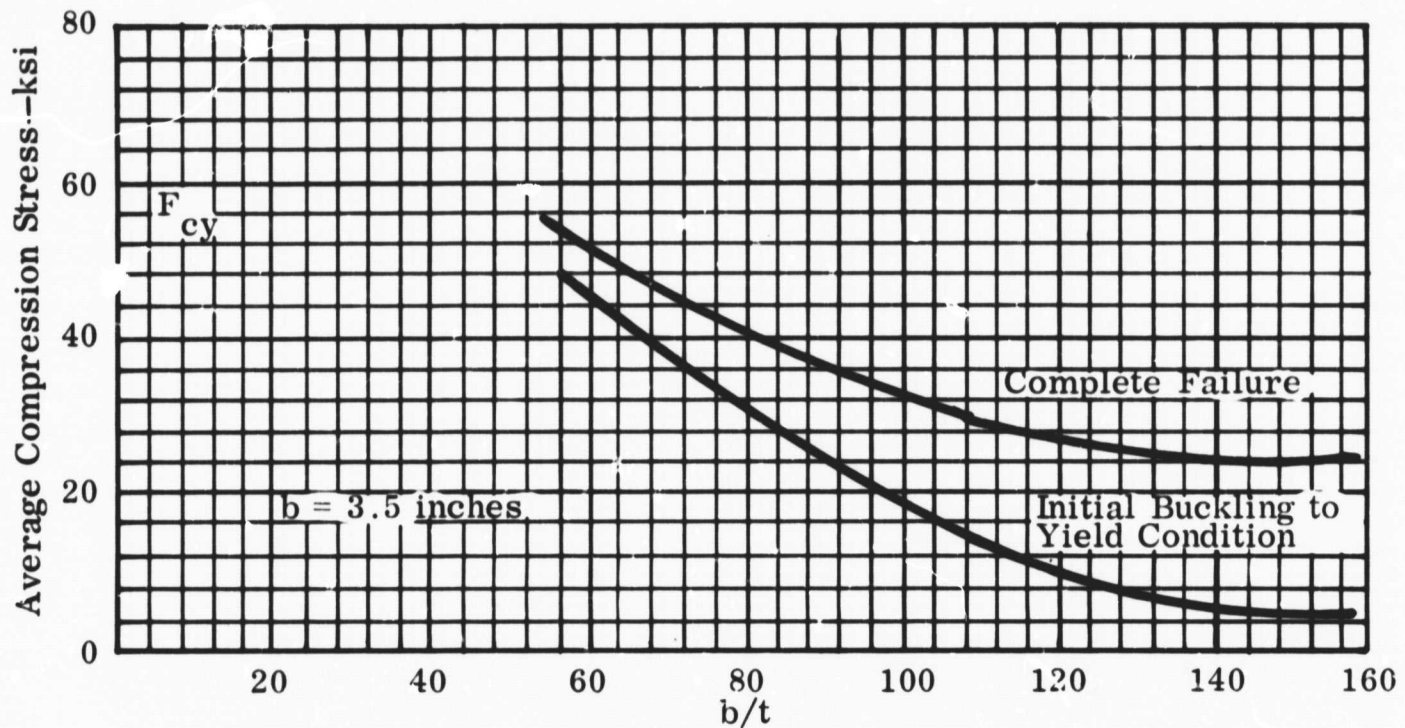

Note: Tests were at room temperature.

Figure 2-8. Cross-Rolled Beryllium Sheet Compression Buckling Tests of Simply Supported Panels<sup>(19)</sup>

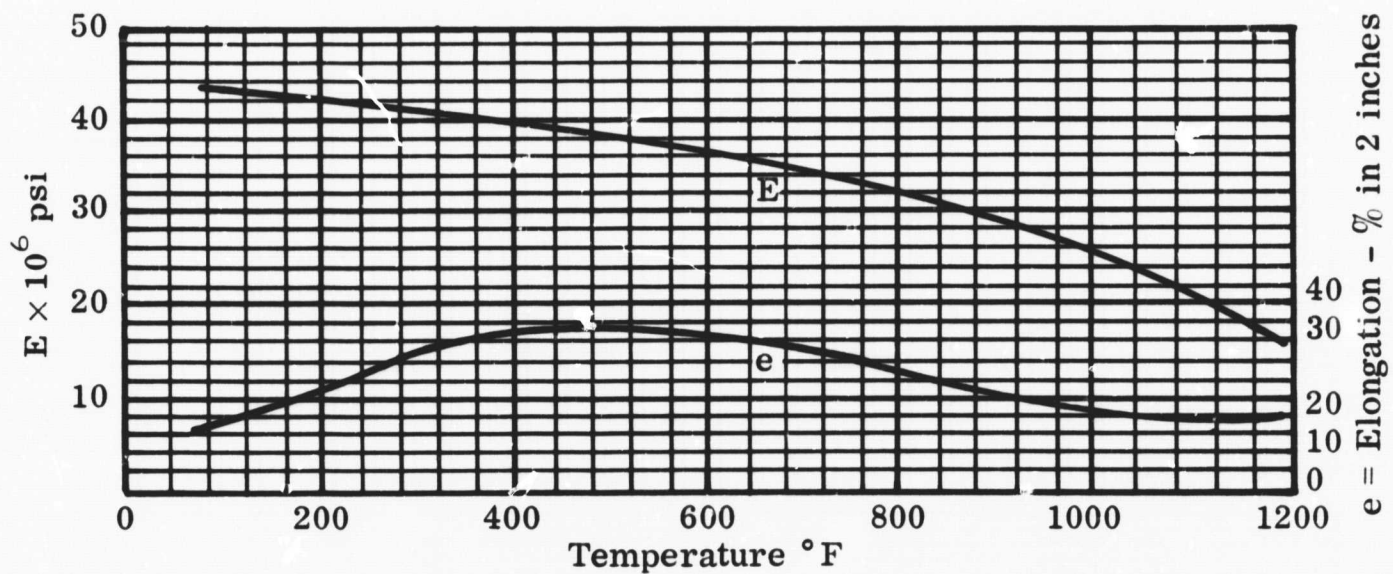

Figure 2-9. Cross-Rolled Beryllium Sheet Typical Modulus and Elongation<sup>(19)</sup>

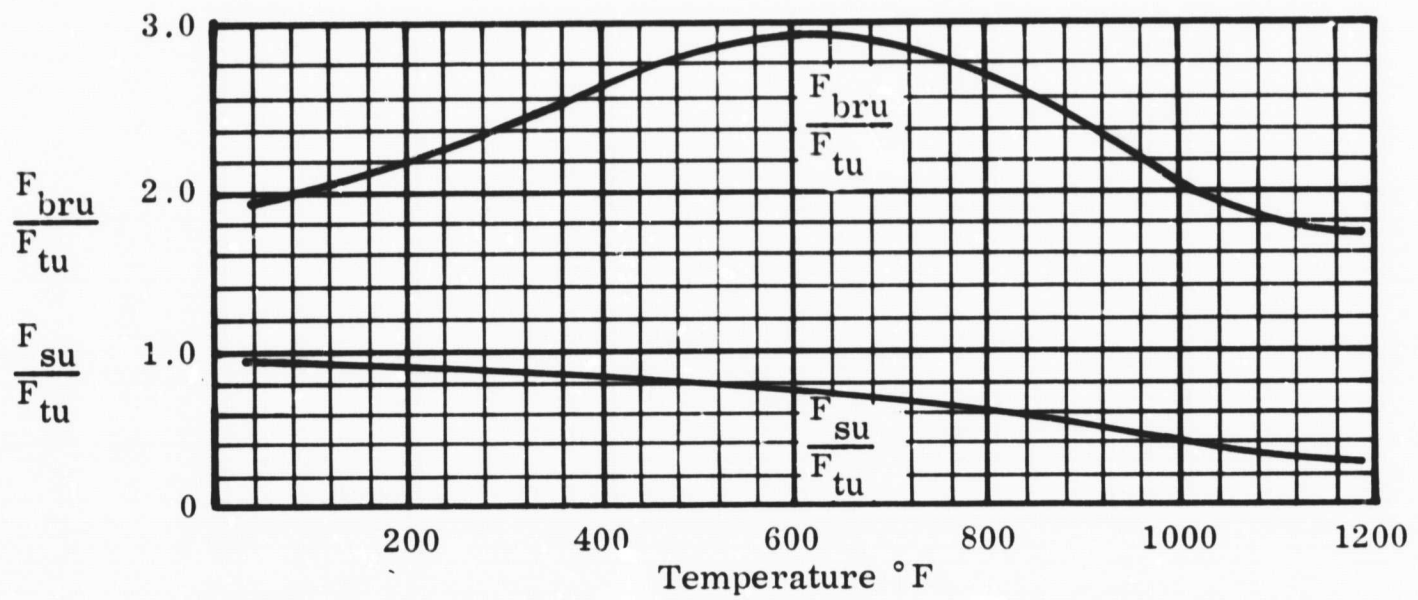

Figure 2-10. Cross-Rolled Beryllium Sheet Bearing and Shear Strength<sup>(19)</sup>

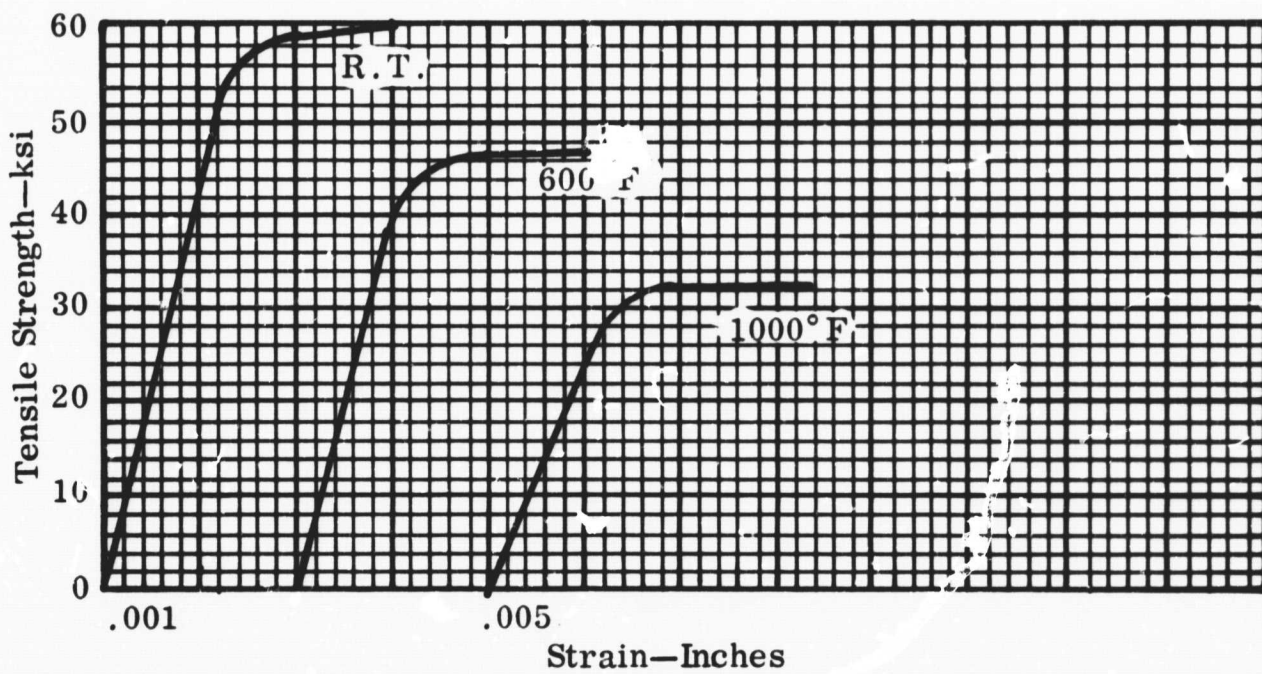

Figure 2-11. Cross-Rolled Beryllium Sheet Typical Stress Strain Curves<sup>(19)</sup>

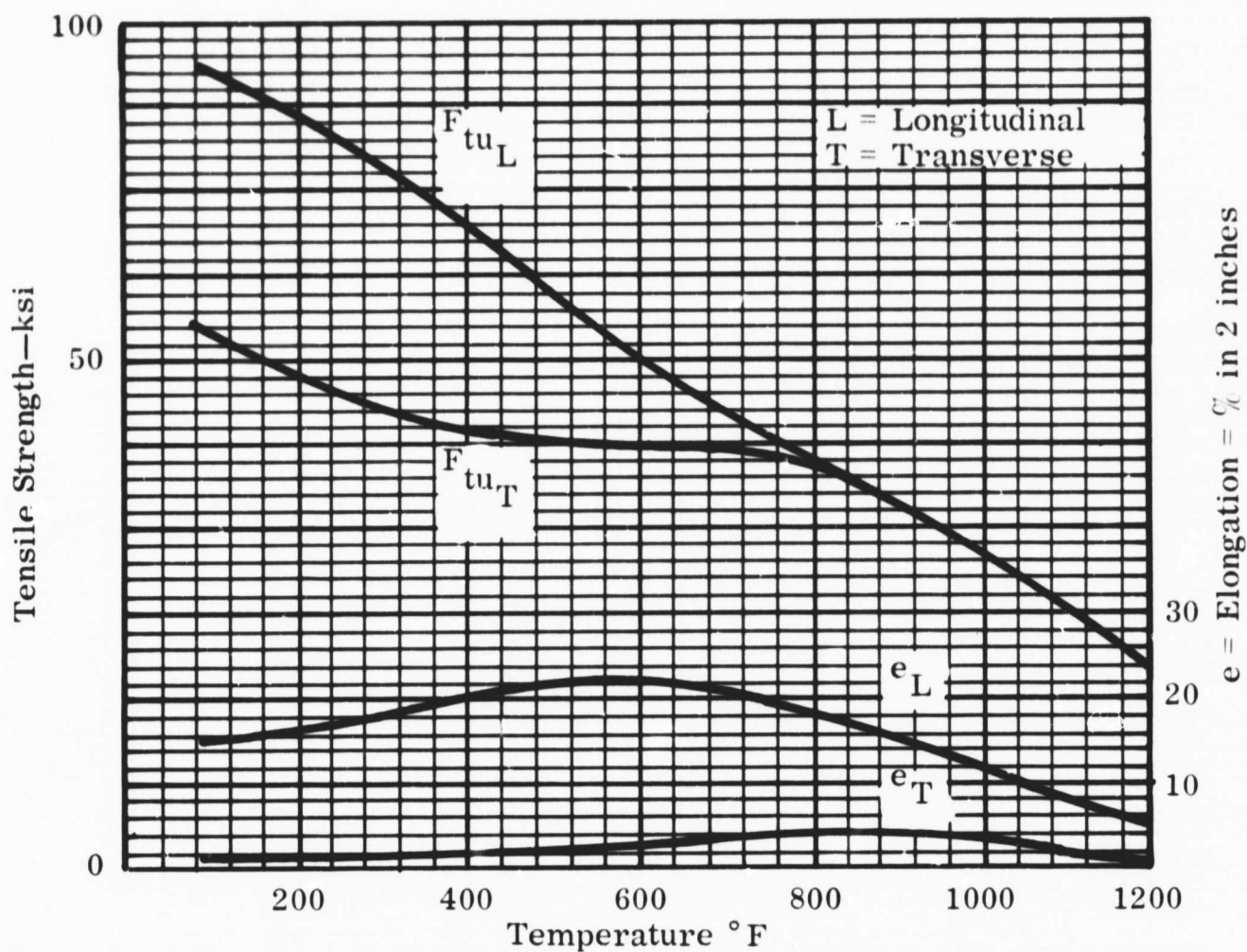

Figure 2-12. Typical Tensile Strength and Elongation of Hot Extruded Beryllium<sup>(19)</sup>

1350°F, and the minimum bend radius is five times the thickness. The temperature distribution in tool and workpiece is critical if distortion is to be avoided.

Forming of ingot sheet can be accomplished at 500° to 700°F (Table 2-2).

#### 2.4.3.3 Extrusion

Beryllium has been extruded into various cross-sectional shapes. Difficulties are encountered due to its tendency to gall and stick to the tooling as well as washing away of the die. Good results have been obtained by jacketing beryllium in a metal (mild steel or copper) which can later be removed by chemical means<sup>(20)</sup>. Tubes, U-channels, T-channels, hat channels, etc., have been successfully extruded. Figure 2-13<sup>(19)</sup> shows I-beam shapes formed by hot extrusion.

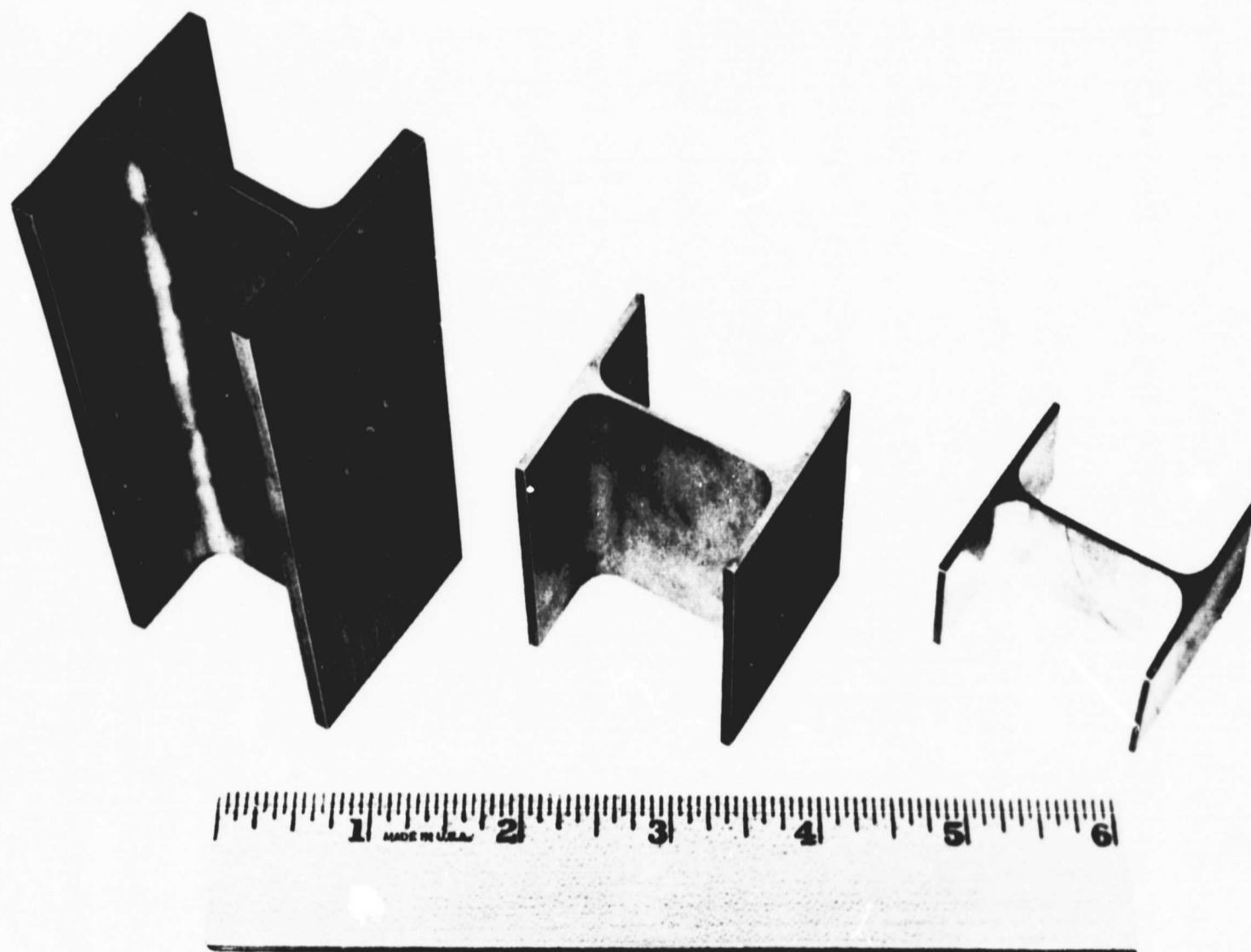

Figure 2-13. Extruded Beryllium I Beams<sup>(19)</sup>

#### 2.4.3.4 Machining

Machining of beryllium presents some minor engineering problems. In order not to contaminate beryllium chips which are valuable as scrap, coolants are generally not used in machining. Contaminated chips undergo a 75 percent devaluation. Localized heating during the machining operation may reach 1600° F, depending upon tool speed. As a result, machining, as well as other mechanical operations, results in the formation of microcracks, which must be removed either by chemical etching or annealing at 1400-1450° F, or both.

### 2.4.3.5 Drilling

Because of the brittle nature of beryllium, special techniques are necessary for drilling, in particular the feed rate must be closely controlled, and drill points which minimize tool pressure must be used. The use of Tornetic drilling has been successful in regulating the feed rate by automatic torque control. Finished holes are etched to prevent crack propagation.

### 2.4.3.6 Joining

Table 2-4<sup>(20)</sup> shows the room temperature properties of beryllium joints made by conventional and advanced methods.

Table 2-4  
Ambient Temperature Properties of Various Joining Processes<sup>(20)</sup>

Joining Process	Method	Filler Material	Ultimate Strength (psi)
Fusion welding	Automatic tungsten-arc inert-gas	Beryllium wire	40,000-50,000 <sup>a</sup>
Fusion welding	Electron Beam	None	40,000-50,000 <sup>a</sup>
Braze welding	Automatic tungsten-arc inert-gas	Fine silver	32,000-42,000 <sup>a</sup>
Braze welding	Automatic metal-arc inert-gas	Aluminum - 12% Si	18,000-28,000 <sup>a</sup>
Furnace brazing	Pressure and vacuum	Fine silver plus 0.5% Li	39,000-42,000 <sup>b</sup>
Soldering	Torch	Tin	4,500- 8,500 <sup>c</sup>
Soldering	Furnace	Zinc	12,000-15,000 <sup>c</sup>
Adhesive bonding	Temperature cured	Epoxy resin	3,000- 5,000 <sup>c</sup>
Diffusion welding	Pressure and furnace	None	20,000-45,000 <sup>b</sup>
Diffusion welding	Resistance-butt	None	40,000-60,000 <sup>b</sup>
Ultrasonic welding	Spot	None	12,000-18,000 <sup>d</sup>
Reference properties of parent beryllium material (See Fig. 2-12)			60,000-86,000 <sup>a</sup>
<sup>a</sup> Sheet tensile test. <sup>b</sup> Butt tensile test. <sup>c</sup> Joint shear strength-load divided by joint area. <sup>d</sup> Shear strength.			

In addition, mechanical fastening using bolts, screws, and rivets made from various metals has been employed. In general, the joining of beryllium by any of the techniques illustrated in Table 2-4 can be accomplished if proper precautions are observed. Certain of these techniques are preferred over others, depending upon the final application of the assembled components.

#### 2.4.3.7 Toxicity

Because of the toxic nature of beryllium, special precautions must be observed in fabricating with beryllium, especially in the machining and drilling operation. Beryllium mist, dust, and fumes cause delayed pneumonitis, which can be fatal, and soluble beryllium compounds can cause dermatitis. The beryllium industry and beryllium fabricators employ special precautions specified by the AEC, which include proper ventilation during machining, personal hygiene, and frequent medical examinations.

#### 2.4.4 CORROSION OF BERYLLIUM

In general, the corrosion resistance of beryllium is similar to that of aluminum in most environments. Corrosion testing of beryllium has not produced consistent results, which has been attributed to impurities in the metal. The effect of various environments upon beryllium is summarized in Table 2-5<sup>(21)</sup>.

Beryllium, like aluminum, undergoes stress-corrosion cracking, but the problem has not been well defined as yet, and no failures due to this phenomenon have been observed.

Surface treatments have been developed to protect beryllium from corrosive environments. Chromate and fluoride coatings offer protection. Various metal coatings, such as "electrodeless" nickel, can be applied. Anodizing has been very effective in protecting beryllium from corrosion. The coatings are generally applied in a bath containing various chromate salts by means of an electric current. The details are proprietary. However, the anodized beryllium is resistant to moisture, salt solutions, and salt fog.

Table 2-5  
Corrosion of Beryllium<sup>(21)</sup>

Pure Water	Resistant (pH = 4-11)
Tap Water	Pitting (pH = 4, 11-14)
Humid Air	Resistant
Salt Water	Corroded - Pitting
Salt Fog	Pitting
Halogen Acids	Reacts
Dilute HNO <sub>3</sub> , H <sub>2</sub> SO <sub>4</sub> , Acetic Acid	Reacts
Concentrated HNO <sub>3</sub>	Violent Reaction
Dilute Alkalai	Reacts
Air	Forms Protective Film
Dry O <sub>2</sub>	Forms Protective Film
Moist O <sub>2</sub>	Corrodes above 1200° F
CO <sub>2</sub> and CO	Reacts at 1382° F
Alcohols, Ketones, and Halogenated Solvents	Reacts
Trichlorethylene	Passive

#### 2.4.5 EXAMPLES OF AEROSPACE APPLICATIONS OF BERYLLIUM

##### 2.4.5.1 Introduction

The primary use of beryllium for aerospace components to date has been in the form of pressed block, forgings, and sheet. Examples of space applications include several cases where beryllium has been substituted in designs to reduce excessive weight, including the Minuteman assembly, Agena D Upper Stage, MOL (Manned Orbiting Laboratory), and several classified projects. A beryllium rudder has been flown experimentally on the McDonnell-Douglas F-4. Experimental use of beryllium has also been investigated in advanced airplanes and helicopters where weight reduction is of critical importance.

As can be noted from the following discussion, beryllium is gradually emerging from R&D to experimental use in the aerospace field. Development has progressed slowly, however, and unless there is a significant investment in research and application, it will be many years before beryllium is accepted and used on a day-to-day basis as an aerospace metal.

#### 2.4.5.2 Mechanically Fastened Sheet

The interstage spacer and the guidance and control compartment of the Minuteman were fabricated from hot-formed beryllium. Mechanical fasteners were used in the assembly, shown in Figures 2-14 and 2-15<sup>(19)</sup>.

A box beam 10 inch  $\times$  10 inch  $\times$  96 inch made for NASA Marshall Space Flight Center by Republic-Fairchild is a large mechanically-fastened beryllium sheet-metal structure made in the United States<sup>(22)</sup>. The beryllium sheets in this box beam are 0.050 and 0.100 inch thick. Special forming techniques and tooling were devised for fabricating the parts economically to a tolerance of 0.005 inch. All of the parts were hot-formed (at 1350°F) in one integrally heated ceramic die designed and built by Republic. The holes were drilled with torque-sensitive Tornetic drills to avoid spalling and cracking. See Figures 2-16 through 2-18.



Figure 2-14. Minuteman Guidance and Control Compartment<sup>(19)</sup>



Figure 2-15. Two Beryllium Assemblies for Minuteman: the Spacer (Top) and the Guidance Control Compartment (Bottom)<sup>(19)</sup>

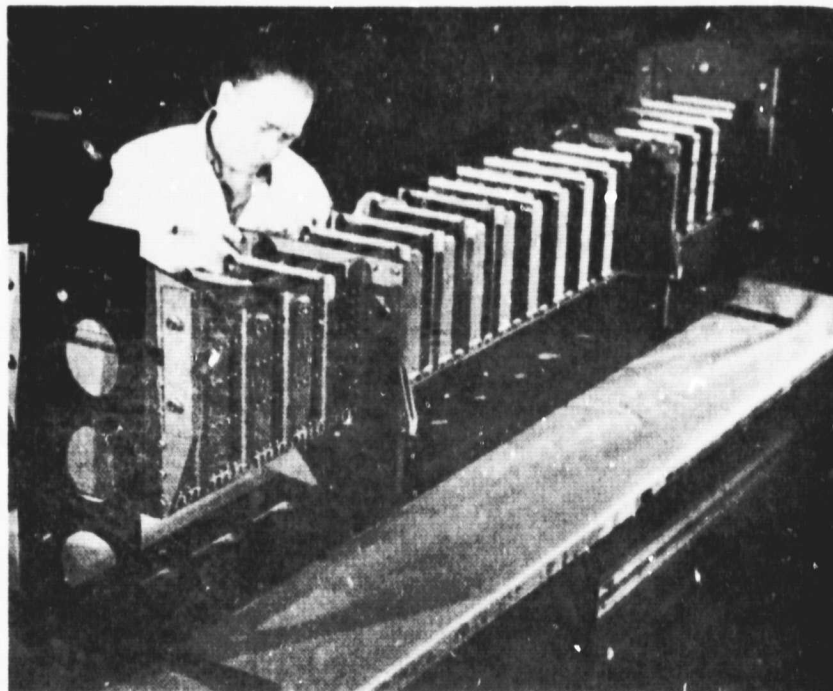

Figure 2-16. Beryllium Box Beam<sup>(22)</sup>

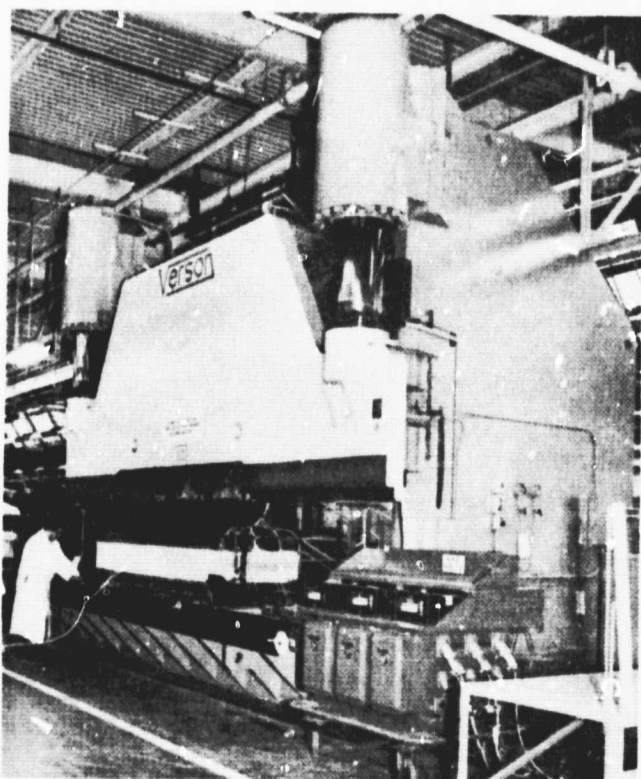

Figure 2-17. Integrally Heated Ceramic Die<sup>(22)</sup>

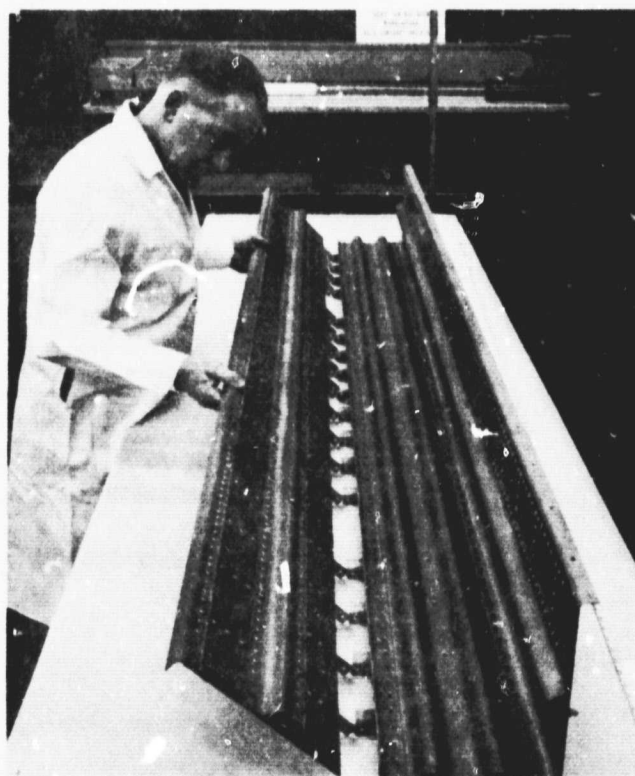

Figure 2-18. Beryllium Box Beam Subassemblies<sup>(22)</sup>

#### 2.4.5.3 Large Cylindrical Structure

As noted in a recent SAE meeting <sup>(118)</sup>, the MOL project is evaluating the use of Beryllium in a large cylindrical structure. As illustrated in Figure 2-19, the beryllium is mechanically riveted, using a squeeze rivet technique, with corrugated sheets attached to a ring frame structure. As noted in Reference 118, the required rigidity could not have been obtained without the use of beryllium or the modification of these constraints imposed on the design of this station using aluminum. The confidence exhibited by the McDonnell-Douglas Company in their willingness to consider beryllium for a manned application speaks for the degree of acceptance that beryllium has achieved today.

#### 2.4.5.4 Beryllium Honeycomb Sandwich

The Solar Division of International Harvester has successfully fabricated an all-beryllium honeycomb panel on a NASA/MSFC sponsored program <sup>(23)</sup>. The panel was 18" x 18" x 0.5" and a follow-on program calls for a 31" x 52" size. The fabrication sequence consists of automatically crimping 0.006 inch foil ribbons, and spot welding these into a 1/4 inch cell-size core. The sandwich panel is fabricated by brazing in argon at 3 psi and 1450°F. No post-braze heat treatment was required. The brazing alloy, Ag-Cu-Sn in wire form, was selected as optimum after screening several newly developed alloys. The core and panel are shown in Figures 2-20 and 2-21 <sup>(24)</sup>.

The honeycomb panel, using 0.020 inch face sheet, had a density of 5.28 pounds per cubic foot. The weight of one square foot was 0.71 pounds, comprised as follows: <sup>(24)</sup>

Core Weight	0.22 pounds
Braze Alloy	0.11 pounds
Face Sheet	<u>0.38 pounds</u>
Total	0.71 pounds

The high weight percentage contributed by the brazing alloy is due to the large T joints, core to facing, as shown in Figure 2-22 <sup>(25)</sup>.

All-beryllium honeycomb panels are joined by brazing beryllium edge attachments and mechanically fastening these panels to each other. For applications where high temperature is not important (under 700°F), and shear strength requirements are under 5000 psi, beryllium honeycomb core can be adhesively bonded to beryllium face sheets, and joined by adhesively bonded doublers.

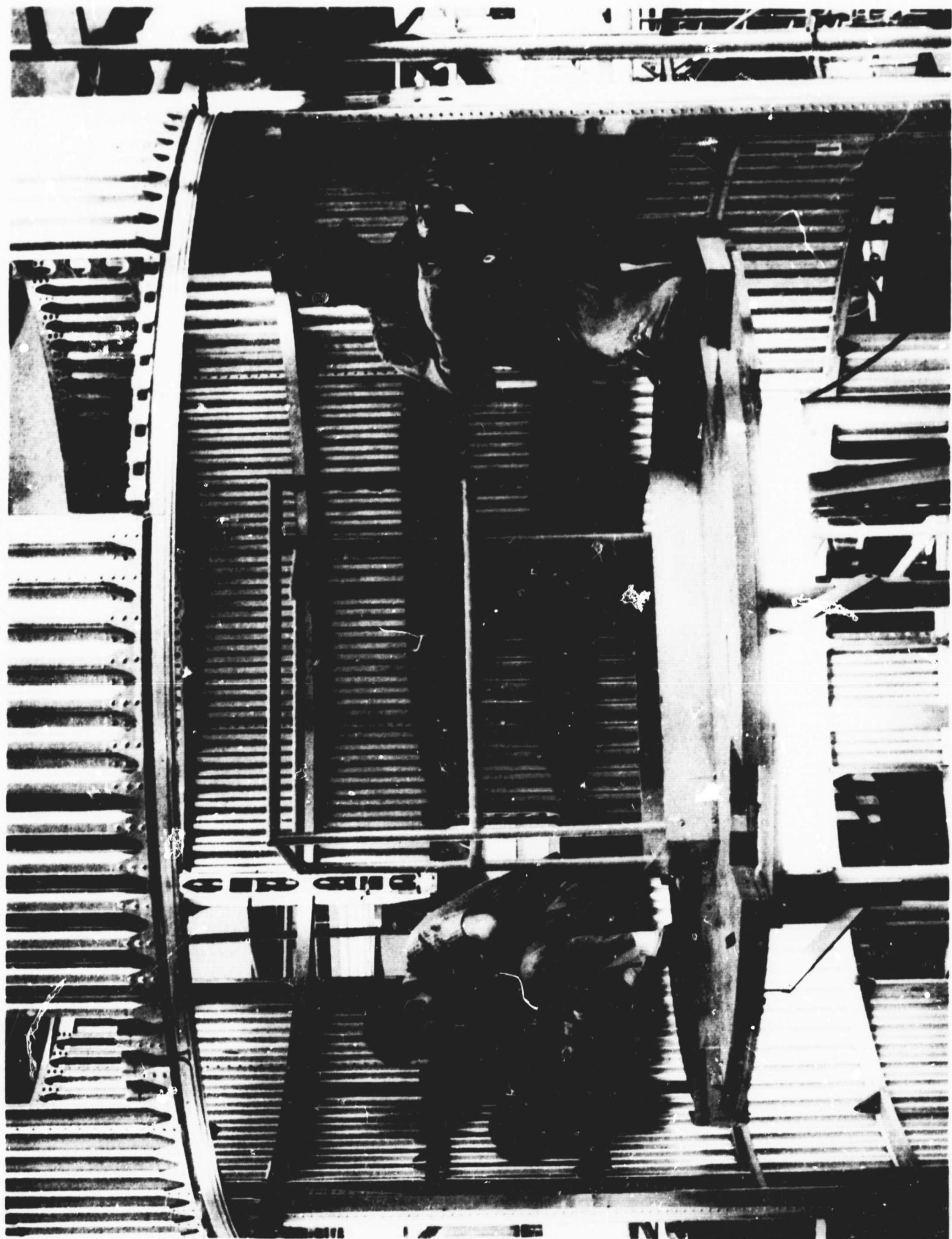

Figure 2-19. MOL Use of Beryllium for Rigidity<sup>(118)</sup>

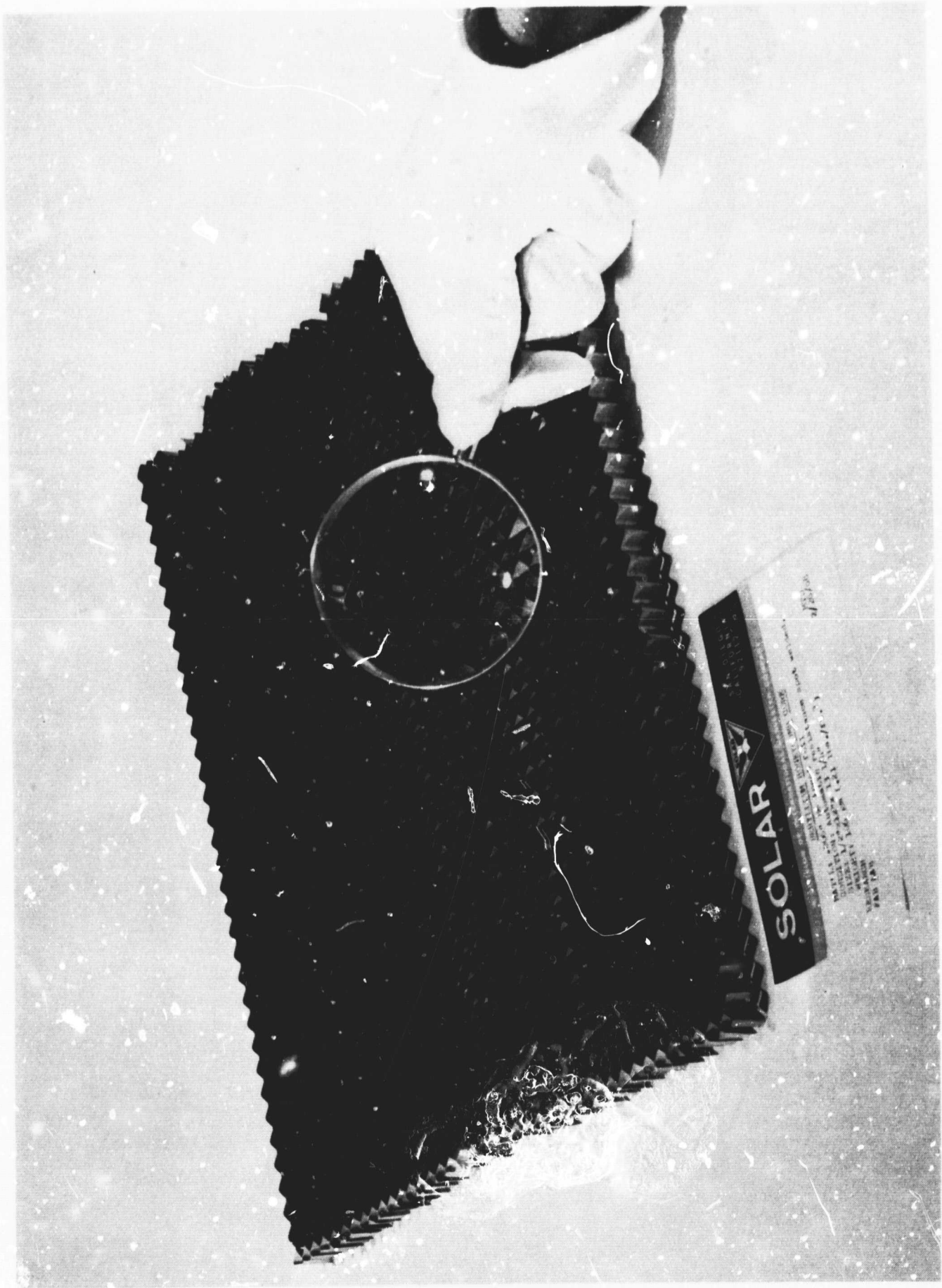

Figure 2-20. Beryllium Honeycomb Core (24)

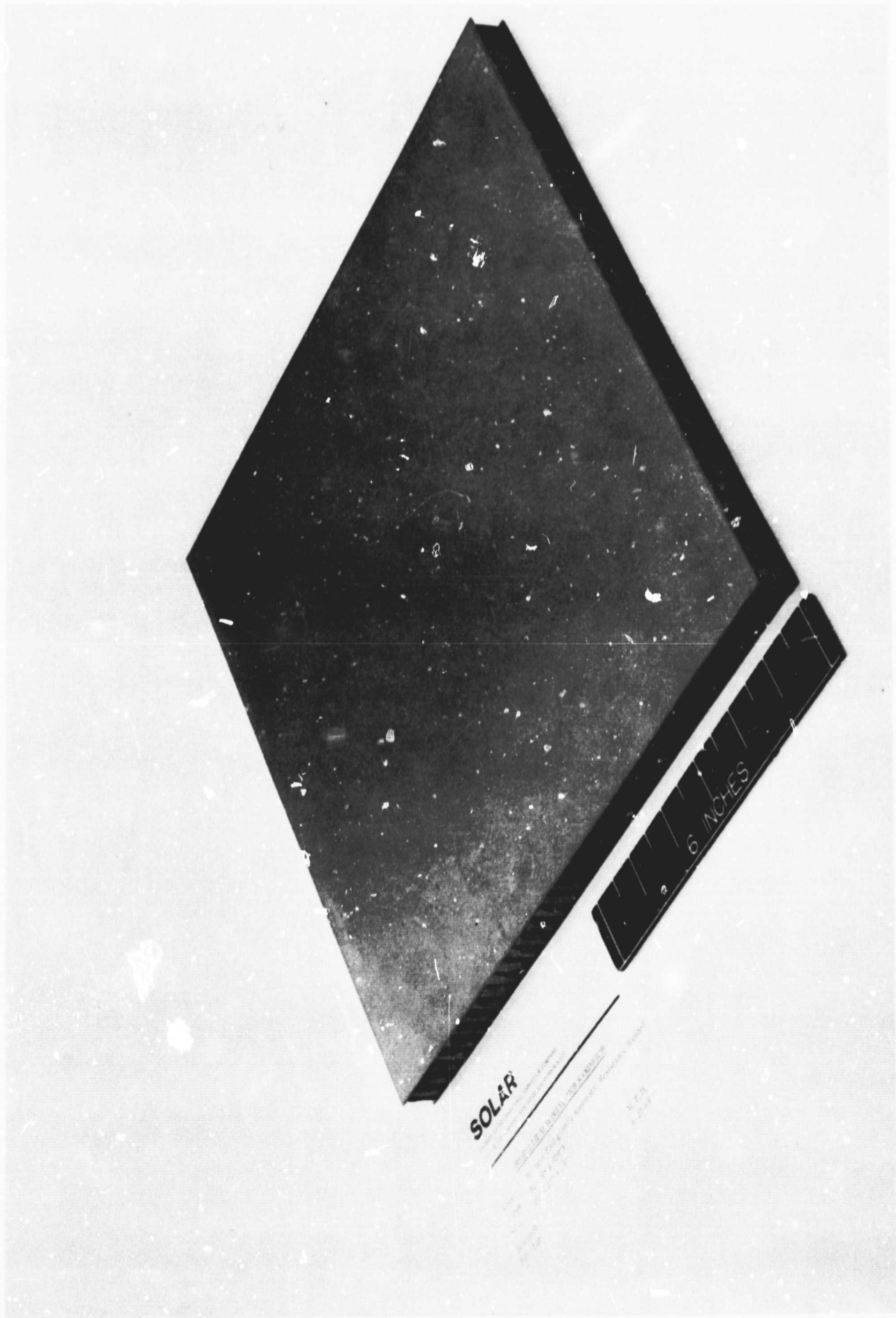
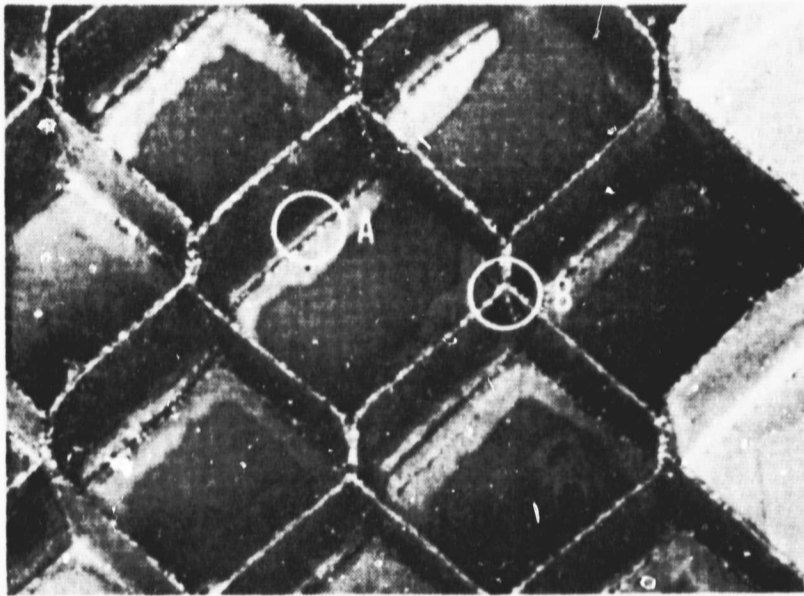
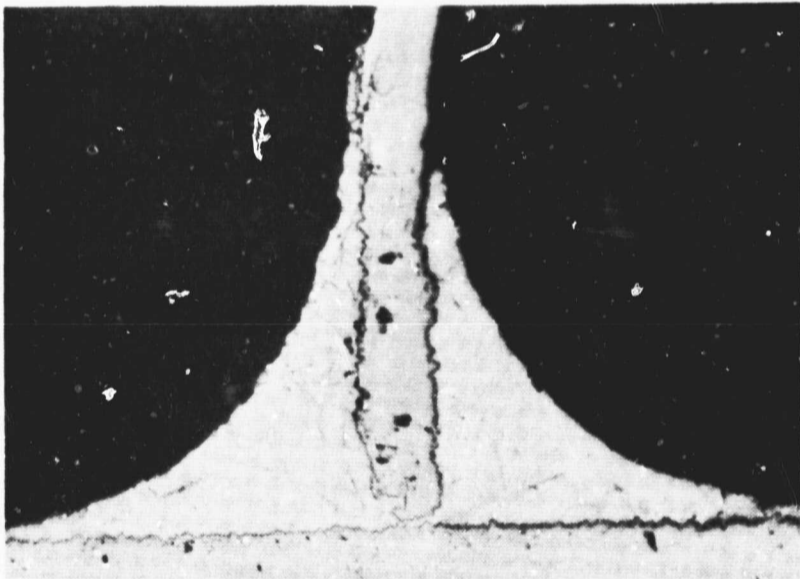

Figure 2-21. All-Beryllium Honeycomb Sandwich (24)



A. OPEN FACE



B. TYPICAL T-JOINT, CORE-TO-FACING

0.003-Inch Ingot Foil Brazed to  
0.020 CRS Beryllium Face With  
Experimental Braze Filler.

Magnification: 100X

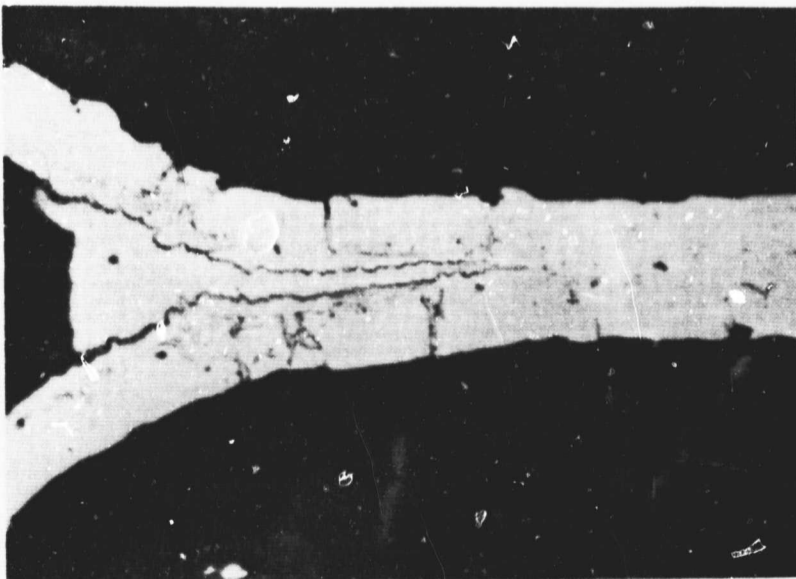

0.003-Inch Ingot Foil Brazed With  
Experimental Braze Filler.

Magnification: 100X

Figure 2-22. Honeycomb Sandwich Joints Using Beryllium Foils<sup>(25)</sup>

McDonnell-Douglas<sup>(26)</sup> built a rudder for the F-4 aircraft, using beryllium face sheet with an aluminum honeycomb core, adhesively bonded. The core was 5052-H39 alloy, 1/4" cell size, 1 mil foil thickness. The weight saving in the primary rudder structure was 34.5 percent. The overall weight saving compared to aluminum on the entire rudder assembly was 46.7 percent, due to a reduction in balance weights and the elimination of the upper damper assembly. The torsional stiffness increase was 500 percent and bending stiffness was increased 150 percent. Where high temperature application is not indicated, aluminum core beryllium sandwich construction would be acceptable.

#### 2.4.5.5 Roll Diffusion Bonding

As an alternate concept to beryllium honeycomb, roll diffusion bonding might be considered. In the roll bonding process a preformed core is fabricated either in the truss, vertical rib, or T-stiffener configuration. Face sheets are positioned on the core, and filler bars are placed in the voids (usually copper, but for beryllium structures, mild steel is generally used). The assembly is placed in a yoke on which cover sheets are welded and the entire assembly, called a pack, is evacuated. The pack is hot rolled on a steel mill and the thickness is reduced as desired. The diffusion bonded assembly is removed from the pack and the filler core is chemically removed leaving the resulting structure. Figure 2-23<sup>(27)</sup> shows how the diffusion bonding pack is assembled. Figure 2-24<sup>(27)</sup> shows the type of reduction in thickness occurring during the diffusion bonding of a typical rib structure.

Douglas Aircraft Company and the Battelle Memorial Institute<sup>(27)</sup> fabricated several small stiffened beryllium panels (10" x 5" x 1/4") including vertical rib, truss core, and T-stiffened skins. Bond quality was excellent but the major fabrication problem resulted from the low biaxial ductility of beryllium at ambient temperatures. This can be minimized by proper selection of process variables. Figures 2-25 and 2-26 show the truss-core and vertical rib panels after leaching.

#### 2.4.5.6 Other Sheet Applications

Solar has produced a variety of structural shapes by roll forming sheet and diffusion bonding<sup>(25)</sup>. Conical frusta and stiffened cylinders are some of the shapes produced in this manner. See Figures 2-27<sup>(24)</sup> and 2-28<sup>(25)</sup>.

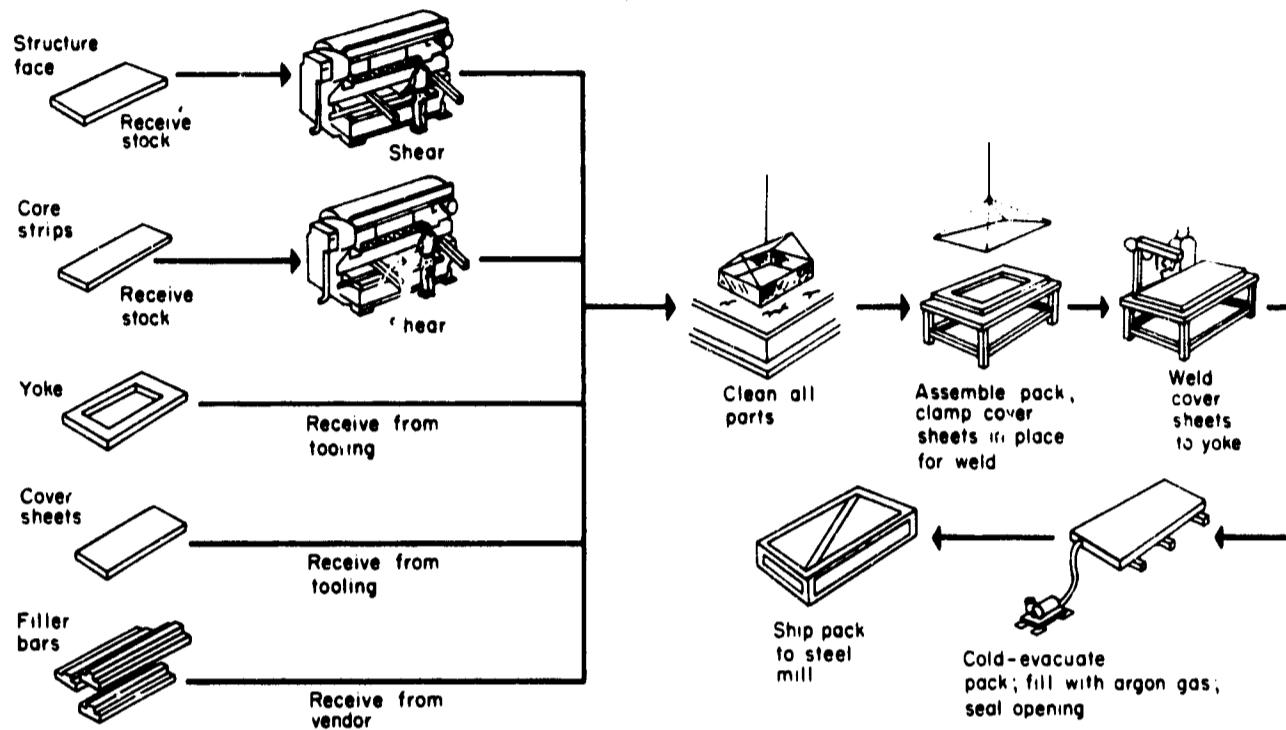

Figure 2-23. Assembling Pack for Roll-Diffusion Bonding<sup>(27)</sup>

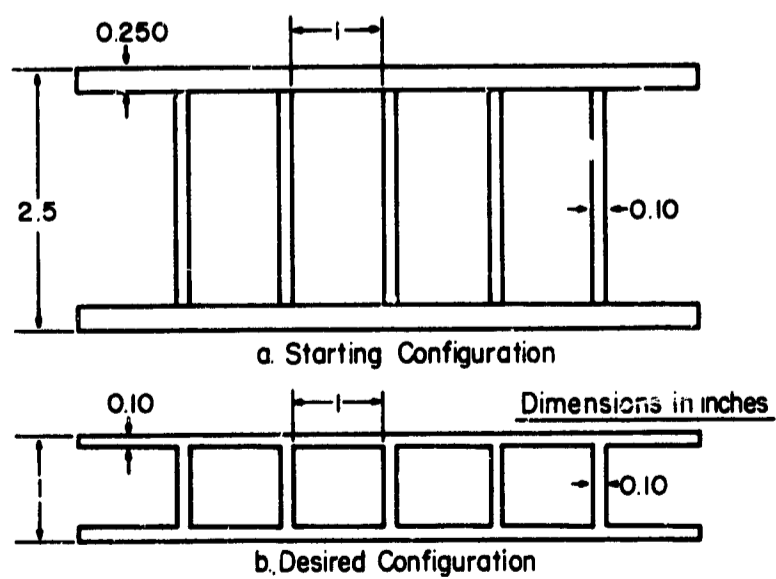

Figure 2-24. Design Configurations for a Vertical-Rib Structure<sup>(27)</sup>

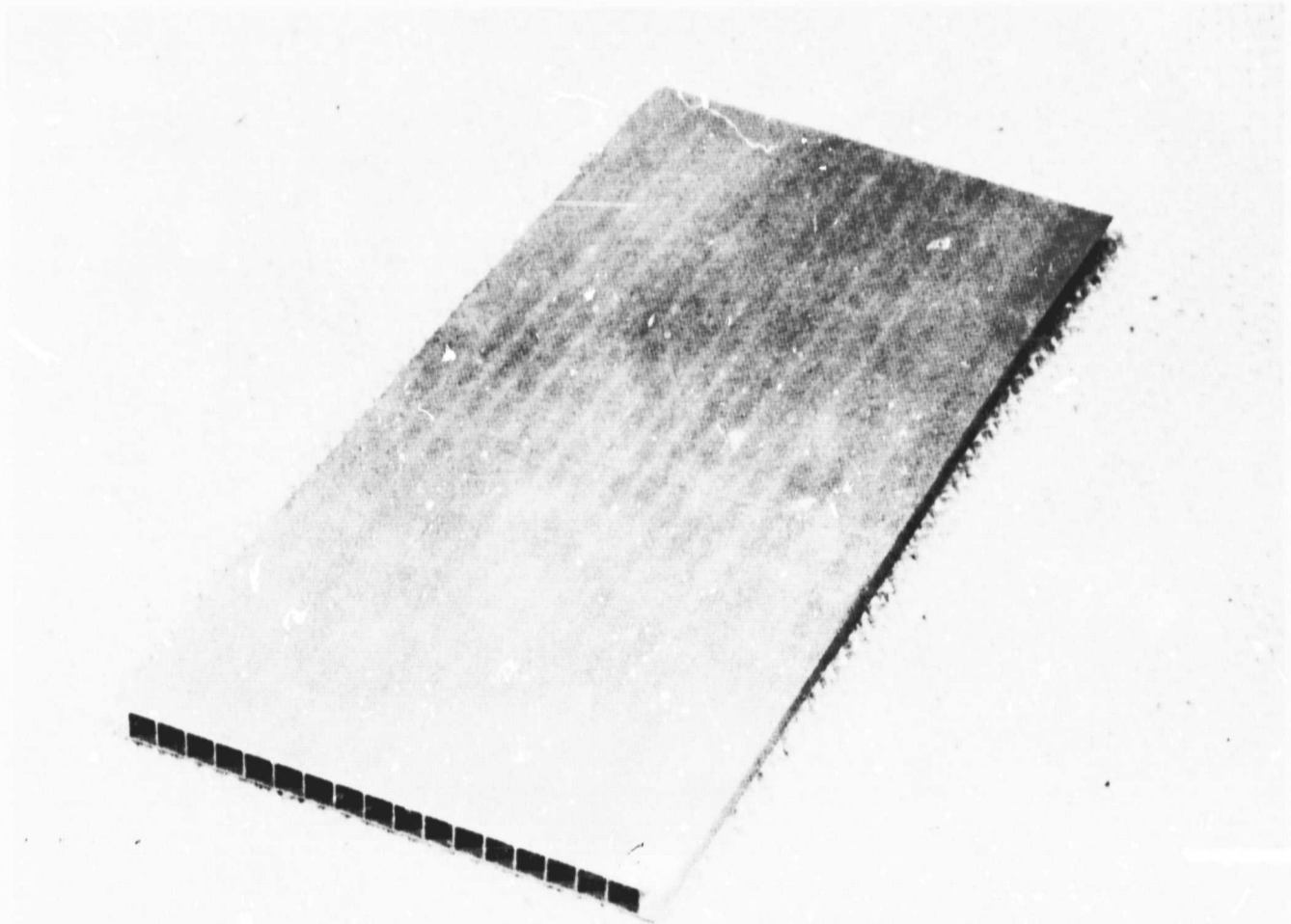

Figure 2-25. A View of One Surface of Beryllium Panel 66-5 After Leaching<sup>(27)</sup>

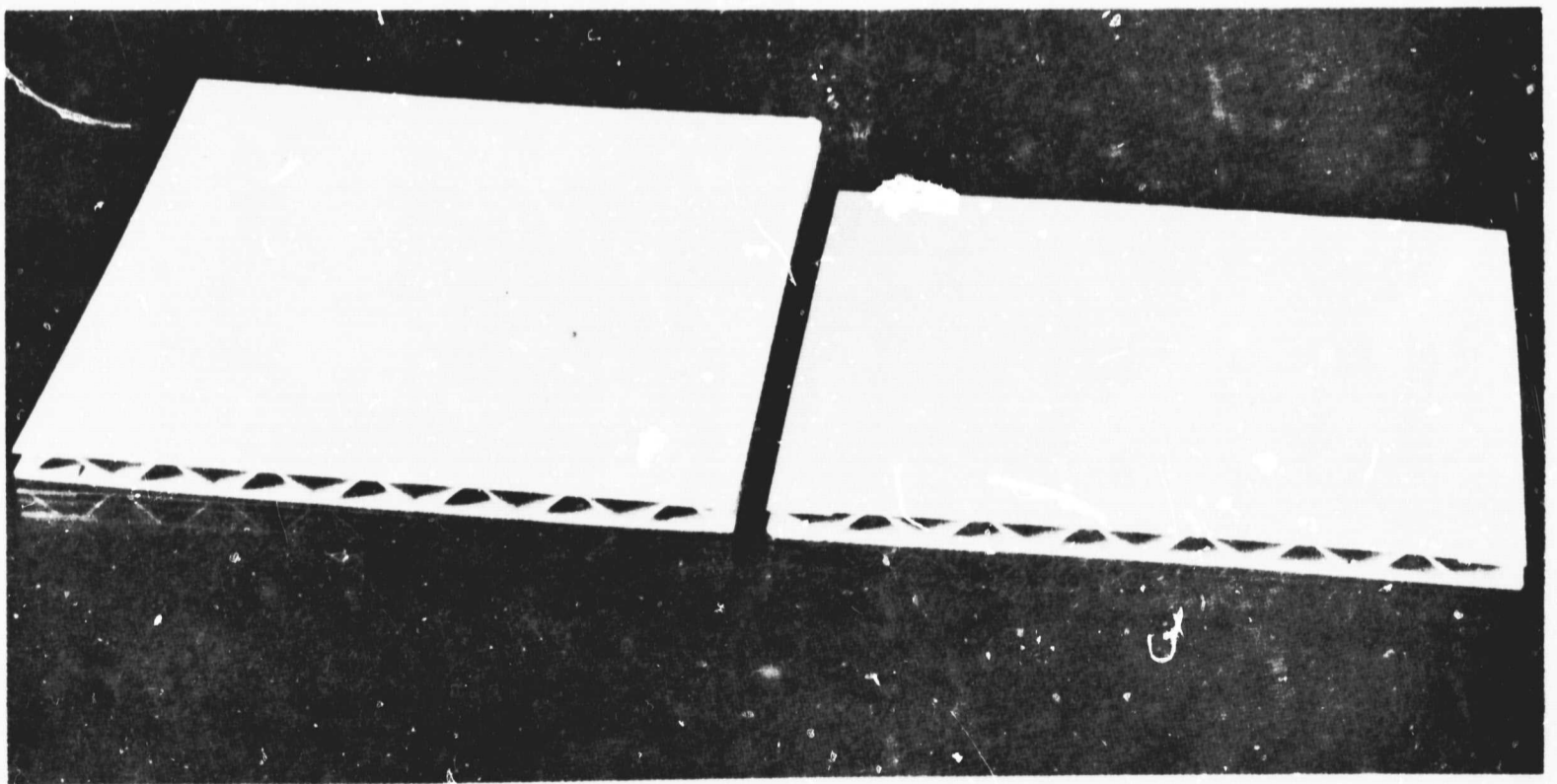

Figure 2-26. Photograph of Beryllium Panel 67-1 After Section and Leaching<sup>(27)</sup>

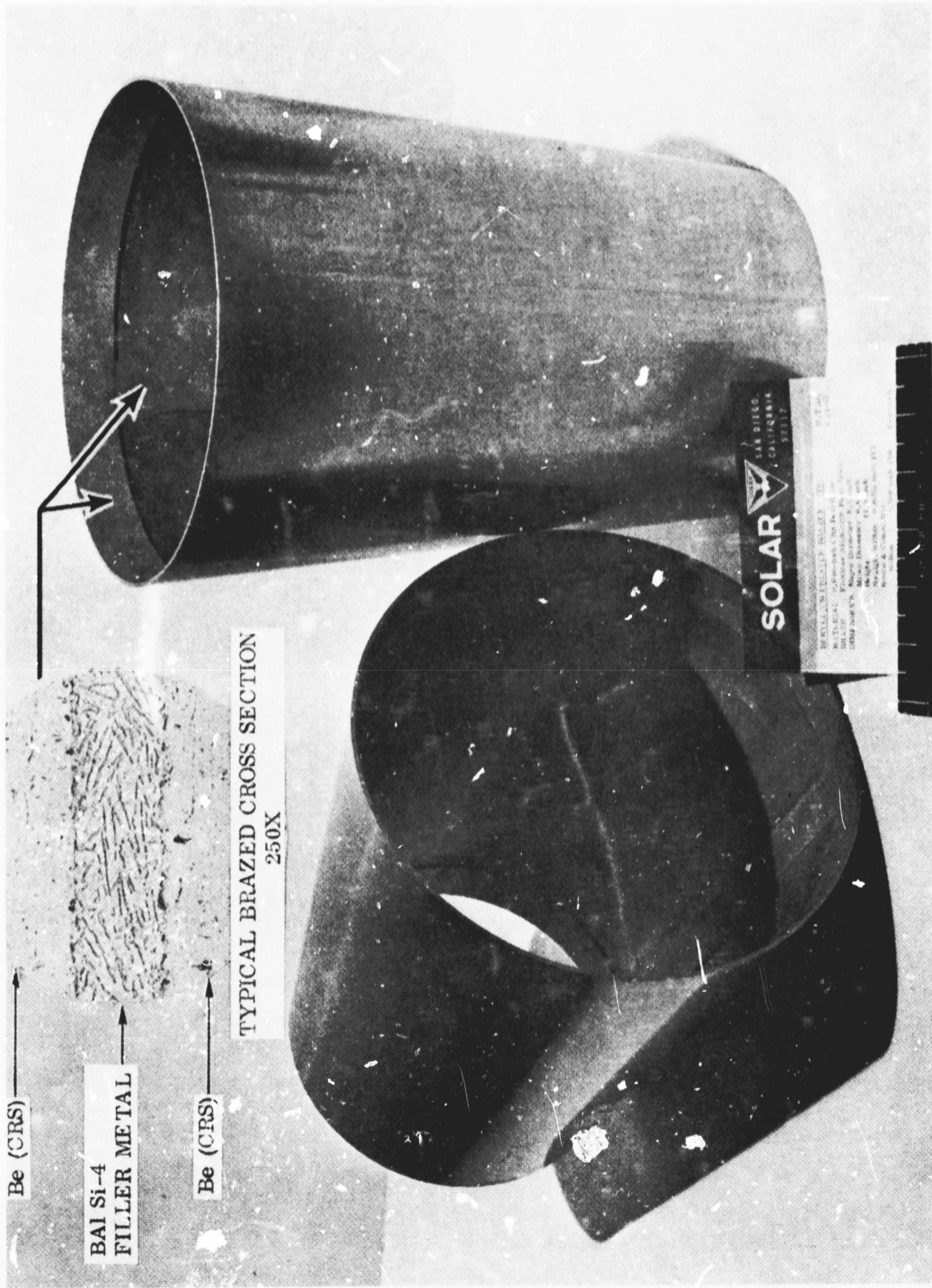

Figure 2-27. Beryllium Conical Frustum Brazements (24)

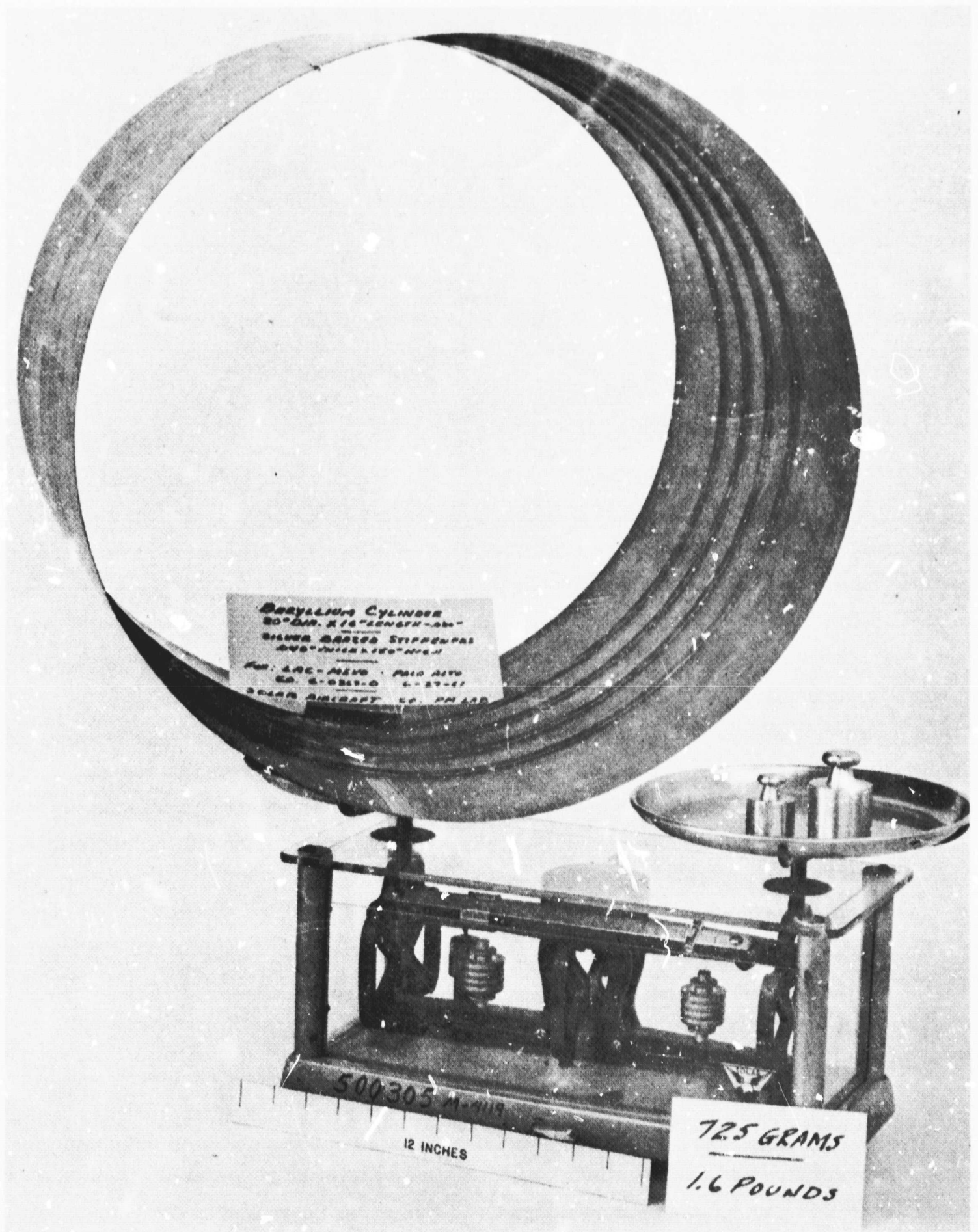

Figure 2-28. Stiffened Beryllium Cylinder Brazement<sup>(25)</sup>

#### 2.4.6 AVAILABILITY OF BERYLLIUM SHEET

Cross-rolled beryllium sheet is produced by Brush Beryllium and Berylco. Berylco also produces ingot sheet, and the AEC produces ingot sheet and foil at the Rock Flats plant. Cross-rolled sheets from 0.020 - 0.250 inch thick can be specially ordered at premium prices.

Foil of the quality required for honeycomb core is not readily available from existing commercial sources. An acceptable grade of beryllium foil was produced by the AEC in sheets 42" x 45", approximately five mils thick. This foil was used by Solar in producing all-beryllium honeycomb; similar quality foil is unobtainable through the commercial beryllium producers.

#### 2.4.7 COST OF BERYLLIUM

The price of cross-rolled beryllium sheet is usually quoted in dollars per square inch. The base price of sheet runs from \$0.80 to \$2.26 per square inch for standard sheets 20 inches by 60 inches, depending on thickness. Commercial foil, even if it could be obtained, would cost between \$8 and \$15 per square inch for foil of less than acceptable quality. The cost of the AEC-furnished foil for the NASA honeycomb program was \$0.50 per square inch, but this cost is not considered to be a realistic value for commercially produced foil.

The high cost of beryllium sheet must be considered in relationship to the way it is currently produced. Beryllium powder, which costs \$70.00 to \$90.00 per pound, is hot pressed into rolling billets costing \$80.00 to \$100.00 per pound. The billets are skinned, cleaned, machined, ultrasonically and radiographically inspected, etched, and then welded into a steel jacket for initial roll breakdown in 12-18 passes at 1450° F, and final rolling is accomplished at 1400° F in 10-12 passes. The case is removed, followed by stress relief, flattening, etching, trimming, and surface grinding. It is estimated that 40-60 percent of the starting block ends up as scrap worth about \$25-30 per pound.

As illustrated in Figure 2-29, current sheet prices range between \$200 to \$700 per pound, inversely proportional to thickness. By 1980, when sheet production is forecast to be 20,000 pounds per month, instead of the current 1000 pounds per month, sheet prices would range from \$120 to \$220 per pound<sup>(28)</sup>.

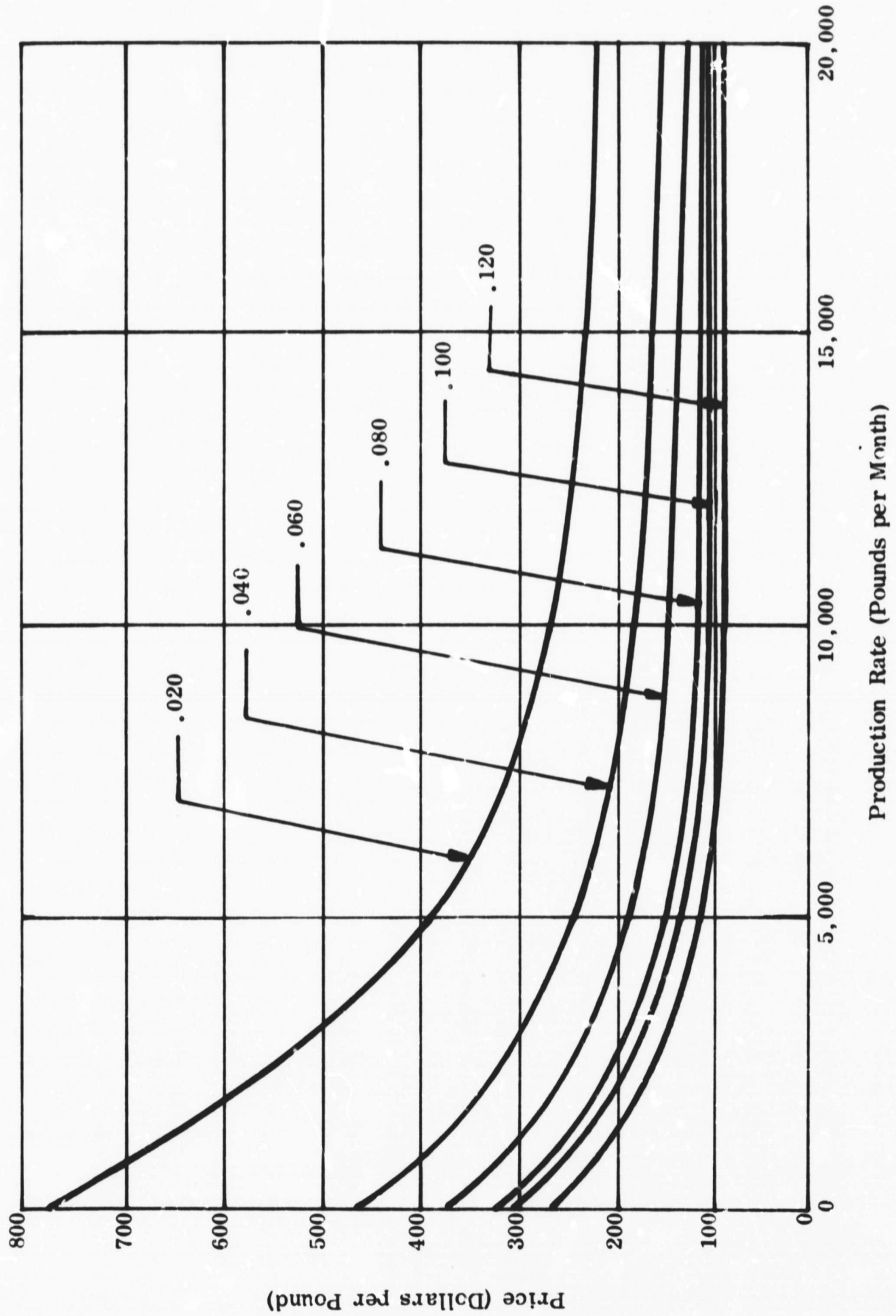

Figure 2-29. Projections of a Beryllium Producer as to Price Trend as a Function of Volume for Six Thicknesses of Sheet<sup>(2F)</sup>

#### 2.4.8 PROBLEM AREAS

Improvements are needed in basic fabrication techniques for mill products such as sheet and extrusions, in order to reduce the cost. Beryllium producers, in general, feel that the market is not large enough for a large expenditure of private research and development funds toward this end. The Government has not been willing to spend large amounts of money in this area until a determination is made that the use of beryllium will provide a major benefit to DOD, NASA, or AEC. However, DOD has provided funds for the development of the cross-rolled sheet program and the ingot sheet program, as has the AEC. Thus, the key problem is how to reduce the cost so that wider potential applications can be studied—creating a larger demand, which would lower the price further, etc. The DOD is presently conducting a beryllium survey of the aerospace industry to determine current and future interest in beryllium.

#### 2.5 TITANIUM STRUCTURES

##### 2.5.1 GENERAL REMARKS

The domestic use of titanium sheet, extrusions, and forged products has doubled between 1964 and 1967. Mill shipments in 1964 and 1967 were 7,708 and 15,000 short tons respectively<sup>(29)</sup>. The principal attributes of titanium are its superior elevated temperature properties, strength, and strength-to-weight ratios as compared to aluminum and steel. For missile and aerospace applications, annual usage in 1966 was 2,100 tons, principally in sheet form. Reference 29 reports that 85 percent of all pressure vessels made for various space vehicles were fabricated from titanium; this is interpreted to refer to high pressure gas storage pressure vessels.

This section of the report will provide a summary of information related to the properties, fabrication, corrosion resistance, availability and cost of titanium. Aerospace applications of titanium are noted and several of the advanced experimental uses are discussed. The general acceptance of titanium by the aerospace industry marks the use of this metal, as today's state of the art. As noted in Reference 118, today's acceptance has been possible through the multi-million dollar investment by the U.S. in titanium development. Similar investments are not foreseen for other materials; rather, it is anticipated that the research and development will progress more slowly as in the case of beryllium or the boron composites.

## 2.5.2 PROPERTIES OF TITANIUM SHEET

Four titanium sheet alloys, which can be considered as candidate materials for large launch vehicle structures, are Ti-6Al-4V, Ti-8Al-1Mo-1V, Ti-5Al-2.5Sn, and Ti-6Al-6V-2Sn. There is also a grade of the first alloy, designated Ti-6Al-4V ELI (Extra-low-inclusions) which is recommended for high pressure cryogenic vessels. The properties of these alloys are summarized in Table 2-6<sup>(30)</sup>.

Table 2-6  
Properties of Titanium Alloys at Room Temperatures<sup>(30)</sup>

	Ti-6Al-4V	Ti-8Al-1Mo-1V	Ti-5Al-2.5Sn	Ti-6Al-6V-2Sn	Ti-6Al-4V ELI		
					RT	-328° F	-423° F
Ult. T.S. (psi)	130,000	135,000	120,000	150,000	130,000	220,000	265,000
Yield T.S. (psi)	120,000	125,000	115,000	140,000	120,000	205,000	250,000
% Elongation	10	10	10	10L, 8T	10	14	6
Density (#/in <sup>3</sup> )	0.160	0.158	0.153	0.164	---	---	---
E (10 <sup>6</sup> psi)	16.5	18.5	14.9	16.5 (aged)	---	---	---

When compared to steel and aluminum, titanium offers an advantage on a strength-to-weight basis, but not on a modulus-to-weight basis, as shown in Table 2-7<sup>(31)</sup>.

Table 2-7  
Comparison of Titanium, Aluminum, and Steel<sup>(31)</sup>

	Ti-6Al-4V	7075 Aluminum	4130 Steel
Strength to Weight (10 <sup>3</sup> inches)	963	700	565
Modulus to Weight (10 <sup>6</sup> inches)	102	105	104

Titanium sheet is annealed at the mill, but forming and welding introduce residual stresses which must be relieved by further annealing, or mechanical stress relieving.

## 2.5.3 FABRICATING TITANIUM

### 2.5.3.1 Introduction

The fabrication and use of titanium has become relatively well understood with widespread usage in the aerospace industry. Numerous difficulties still exist, particularly in the machining, joining, and forming of this metal, but suitable techniques have emerged for these processes as discussed in the following sections.

### 2.5.3.2 Machining

Titanium alloys may be machined by both conventional and newer techniques. A machinability rating has been developed, comparing titanium to aluminum and steel, Table 2-8. This rating indicates the relative speed of metal removal with constant feed and tool wear.

Table 2-8  
Machinability<sup>(31)</sup>

Alloy	Machinability Rating
A12017 T4	300
Steel B-1112	100
Ti-5Al-2.5Sn	30
Ti-6Al-4V	22
Ti-9Al-1 Mo-1V	22

Metal cutting can be routinely performed with titanium. Milling, drilling, tapping, and boring techniques have been developed for successful operations in these areas. Chemical milling techniques have been developed for titanium removal in order to control hydrogen pickup by the metal.

### 2.5.3.3 Joining

Fusion welding of titanium can be accomplished by TIG (tungsten-inert gas), MIG (metal-inert gas), and EB (electron beam) techniques<sup>(32)</sup>, but post-weld heat treatments are required. A combination of mechanical and thermal stress-relief treatments can be accomplished. The order of weldability of titanium alloys is as follows: Ti-5Al-2.5Sn, Ti-8Al-1Mo-1V, Ti-6Al-4V, and Ti-6Al-6V-2Sn. Mechanical fastening has been accomplished with promising results. Diffusion bonding has been utilized

In the development of titanium sandwich structures and integrally stiffened panels and some brazing of titanium has been achieved. Titanium-faced aluminum honeycomb core and fiberglass-plastic core sandwich construction has been made by adhesive bonding for the SST program by Boeing. In semi-monocoque construction, stiffeners have been adhesively bonded. Adhesively-bonded lap joints have also been successfully demonstrated.

#### 2.5.3.4 Forming

Forming of titanium is best performed at elevated temperature in the absence of air, generally in the temperature range of 1200-2000° F. Using a single operation and one-tool setup, forming can be accomplished with certain curvature limitations. Brake forming, stretch forming, and deep drawing were accomplished and forming limit parameters have been established<sup>(34)</sup>. Other potential forming methods involving high pressure and high speed are listed in Tables 2-9 and 2-10. These tables indicate those areas of development required in general for these methods.

Table 2-9  
Forming Pressure Considerations<sup>(35)</sup>

Potential High Pressure Forming Methods	Development Needed
Room Temperature Forming Water Air Solid (Rubber) Elevated Temperature Forming Hot Fluid (Molten Metal) Inert Gas Fluidized Solids (Sand)	High Pressure Press Systems Tonnage to 100,000 Tons Pressure to 50,000 psi Temperatures to 3000° F Sealing Methods Safety Material Behavior of Equipment Effect of High Pressure on Rubber Corrosive and Other Damaging Effects of Hot Fluids Insulation Methods

Table 2-10  
High-Speed-Forming Considerations (a)

Potential High-Speed-Forming Methods	Development Needed
Explosive Capacitor Discharge Combustible Gas High Temperature Combinations of these	Mechanized Press to 10-Foot Diameter Cycle Time of 5 Minutes Closed System High Pressure to 50,000 psi Versatile (Form Variety of Part Shapes) Good Safety Features Semi-Mechanized System to 50-Foot Diameter Open System Cycle Time of 1 Hour

High pressure forming by the Guerin rubber process normally operates in the 2000 psi range. A rubber-bag technique is designed to utilize direct hydraulic pressure up to 10,000 psi

For improvement in high-temperature forming techniques, development is required in high temperature tooling, atmospheric control of part, heating methods and insulation methods. For improvements in high-pressure forming methods, development is required in press design to develop pressures up to 50,000 psi and temperatures up to 3000° F. High-velocity forming has been studied at velocities up to 1000 ft/sec. A significant increase in ductility occurs in a number of metals at forming velocities of 700 ft/sec. Further development is required before this method can be commercially feasible. These high velocities can be accomplished by means of explosion, capacitor discharge, combustible gas, high temperature, or a combination of these.

#### 2.5.4 AEROSPACE APPLICATIONS OF TITANIUM

##### 2.5.4.1 Introduction

The general acceptance of titanium as an aerospace material can be seen from the range of applications which are discussed briefly in the following section. These applications range from commercial aircraft to launch vehicles and spacecraft of the Apollo Program.

#### 2.5.4.2 Saturn Booster

Several development programs have been carried out by NASA in the roll diffusion bonding of titanium structural elements in an effort to assemble simulations of anticipated Saturn S-IC structures. The general details of the roll bonding process are discussed under Beryllium Structures (paragraph 2.3) in this report.

Several elements of a titanium thrust ring were fabricated using Ti-8Al-1Mo-1V alloy<sup>(33)</sup> by roll diffusion bonding process. These included the following:

- a. Four 10.5" x 42" panels, each carrying two 1.75" high T stiffeners with 1" wide flanges.
- b. Two 5" x 5" x 30" overall thrust-post simulations.
- c. Two 10.5" x 42" panels, each carrying two 1.75" high by 1" wide hat-section stiffeners.
- d. One 24" x 80" stepped-thickness skin panel carrying seven 1.75" T stiffeners with 1" wide flanges.

The quality of all these items was unsatisfactory. This was largely attributed to inadequacy in the encapsulation design which resulted in excessive internal distortion during the rolling portion of the roll-bonding process. This distortion collapsed the support intended to position the Ti-8Al-1Mo-1V components for rolling-pressure application. Thus, bonding pressures were inadequate and resulted in unbonded or partially bonded items.

A simulated titanium Y-ring segment for the S-IC fuel tank was also fabricated<sup>(33)</sup>. Analytical studies have shown that substitution of titanium for aluminum in the Y-ring fabrication for the Saturn V vehicle would allow for a 32 percent weight saving or 780 pounds per vehicle. Two full scale Y-ring segments were fabricated, as shown in Figures 2-30 through 2-34<sup>(33)</sup>. These Y-rings were of excellent appearance; the results of test and experimental use have not yet been reported.

The current S-IC skin-stiffened panels are made from aluminum. Six subscale panels were fabricated by North American Aviation Inc. to evaluate the potential of producing titanium Ti-8Al-1Mo-1V panels by roll diffusion bonding. The major problem in this program was the development of post-rolling cracks. Two full scale panels of good quality were produced. Details of these panels are illustrated in Figures 2-35 and 2-36<sup>(33)</sup>.

TITANIUM S-IC Y-RING SEGMENT

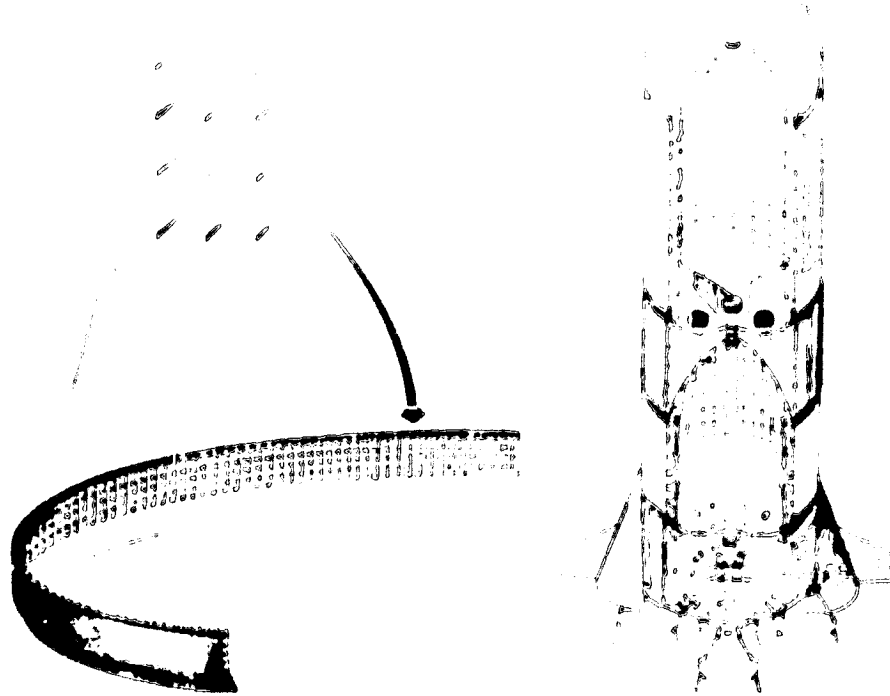

Figure 2-30. Titanium S-IC Y-Ring Segment<sup>(33)</sup>

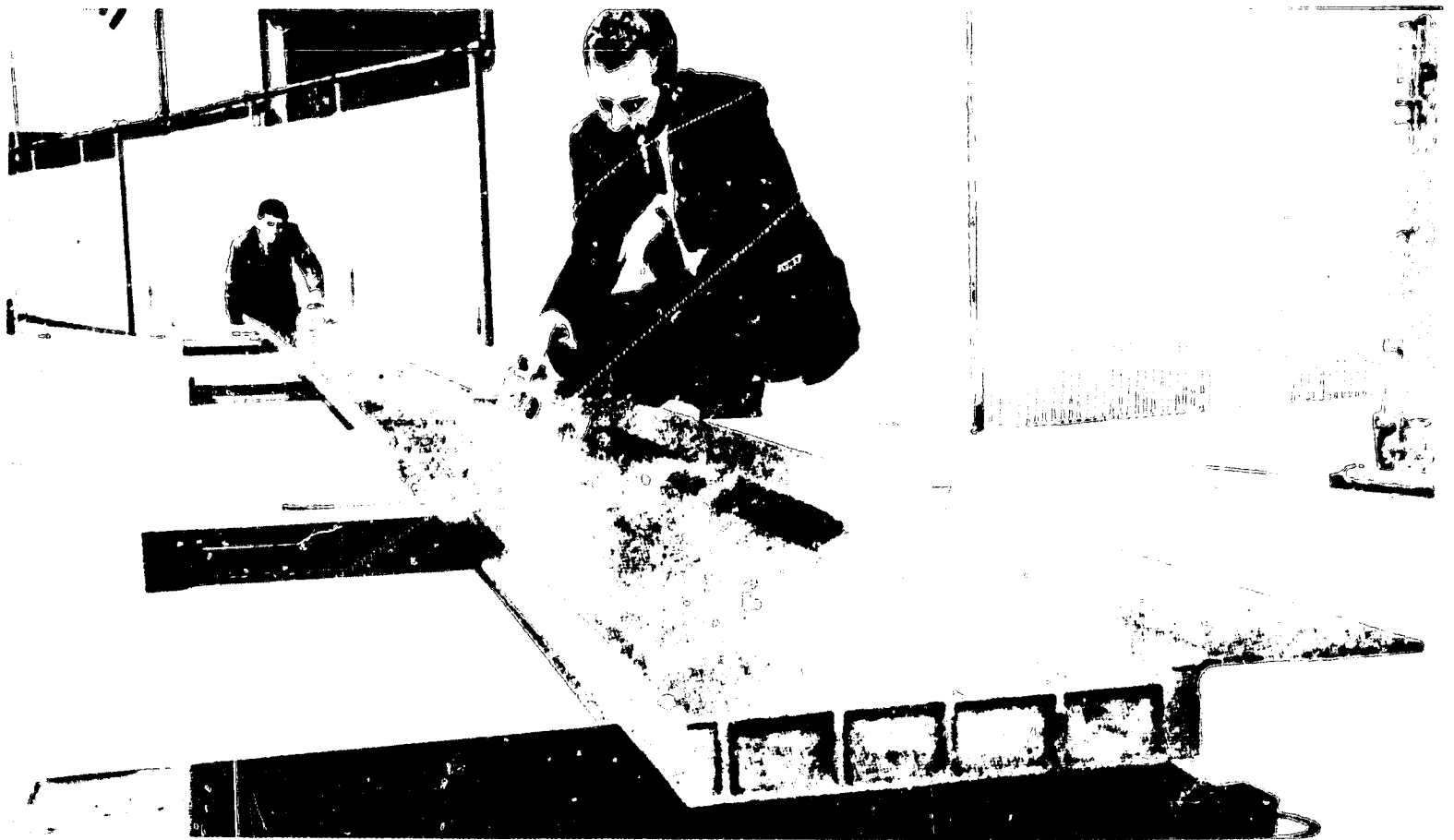

Figure 2-31. Full Scale Y-Ring After Machining Operation<sup>(33)</sup>

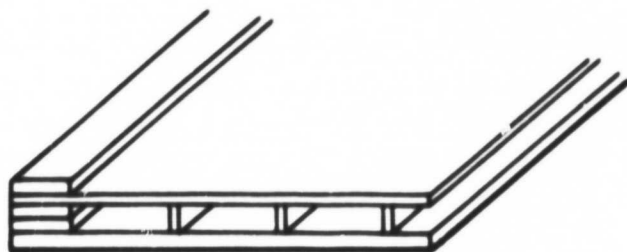

Figure 2-32. Fabrication Layup Design Used to Prepare Y-Ring Structure<sup>(33)</sup>



Figure 2-33. Stiffener-to-Facing Joint Obtained in Ti-8Al-1Mo-1V Chamfered Filler Bar Pack<sup>(33)</sup>

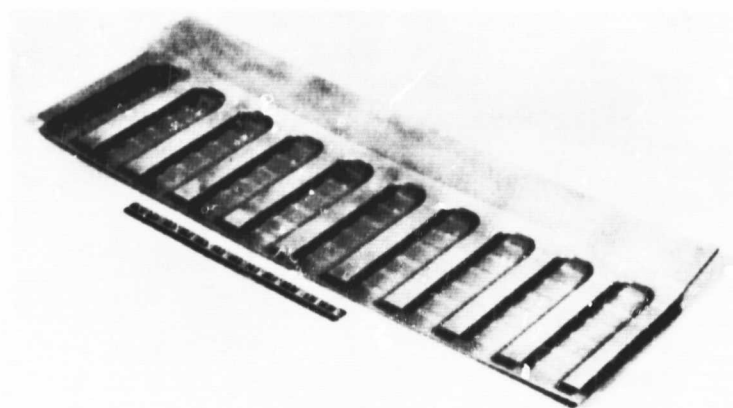
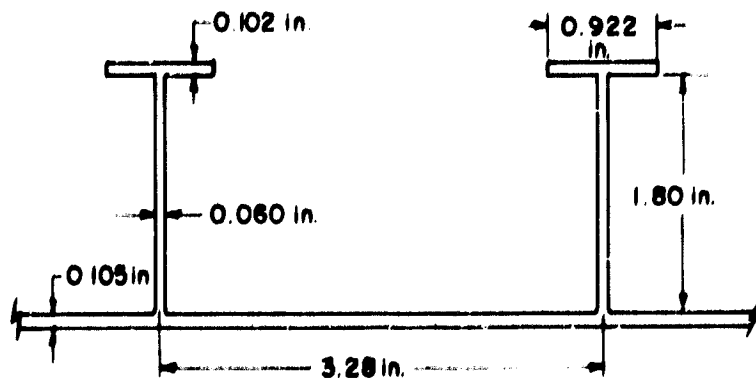

Figure 2-34. Completely Processed Subscale Y-Ring Segment<sup>(33)</sup>



Material: Ti-8Al-1Mo-1V duplex annealed

Figure 2-35. Integral Tee-Configuration Stiffeners Inside Cylinder<sup>(33)</sup>

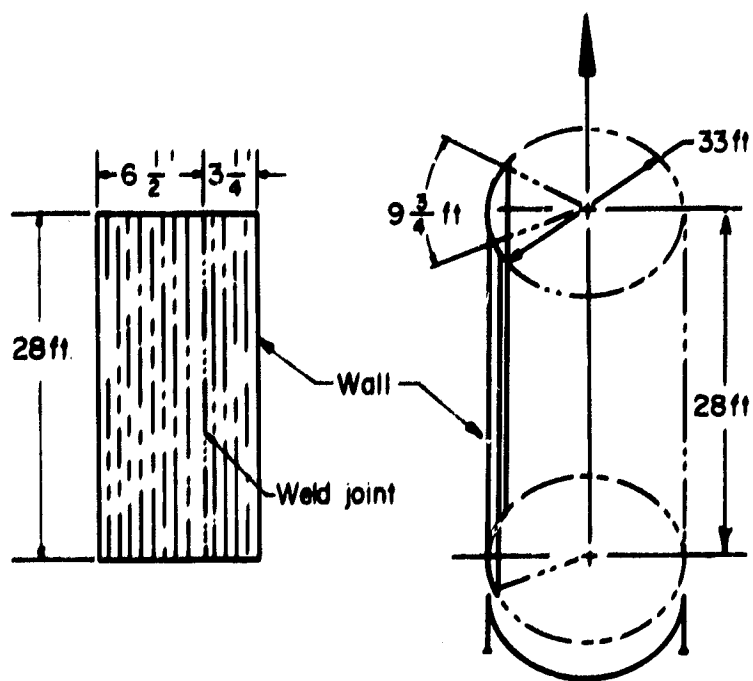

Figure 2-36. Final Production Panel<sup>(33)</sup>

A redesigned fuel tank calls for a Ti-6Al-4V truss core design, fabricated by the roll diffusion-bonding process. A total of 23 full scale truss core panels were produced in sizes up to 48" x 90" and one special panel in 48" x 120" size. Details of this truss core panel are shown in Figures 2-37 through 2-39.

#### 2.5.4.3 SST (Super Sonic Transport) Application

The new fixed wing design for the SST has shifted emphasis from titanium sheet stringer construction to primarily that of titanium honeycomb. Three primary all-titanium honeycomb processes are being evaluated at Boeing, among other materials concepts<sup>(34)</sup>.

The Stressskin Products Division of Tool Research and Engineering Corporation has a new process of making diffusion bonded all-titanium honeycomb<sup>(25)</sup>. In this process, crimped ribbons of titanium foil with small edge flanges are micro spot welded to form the core at the same time the core is spot welded to the skin. The sandwich is then diffusion bonded at 1600°F. The foil is Ti-35A, 0.0035 inch thick, and the face sheet is 0.012 inch Ti-6Al-4V. At the present time, this process can produce panels only up to 48 inch x 96 inch due to the furnace size. Panel thickness capability is 1/4 inch to 4 inches. Only flat panels have been produced thus far, but panels can be creep formed. Edge attachment techniques have not been fully developed as yet.

Brazed honeycomb panels are being made by Aeronca using 0.016 inch Ti-6Al-4V face sheets of Ti-A-70 core, using Aluminum 1100 for brazing alloy. This process has the disadvantage of being very sensitive to processing temperature. Changes of 30-40°F during the brazing can adversely affect the brazing.

Norair is diffusion bonding titanium honeycomb and titanium truss core sandwich using copper foil as the bonding element.

Composite core titanium sandwich is also being studied by Boeing-Hexcel for the SST application. Panels 48 inches x 120 inches have been made with a fiberglass-polyimide honeycomb core and Ti-6Al-4V face sheets, adhesively bonded. The use of titanium and of polyimide core with titanium face sheets is primarily designated for high temperature applications. For launch-vehicle applications, aluminum-core titanium-sandwich construction would have advantages in material cost and fabrication costs. However, this concept must be considered with regard to the stiffness-to-weight ratio in relation to an all-aluminum sandwich construction.

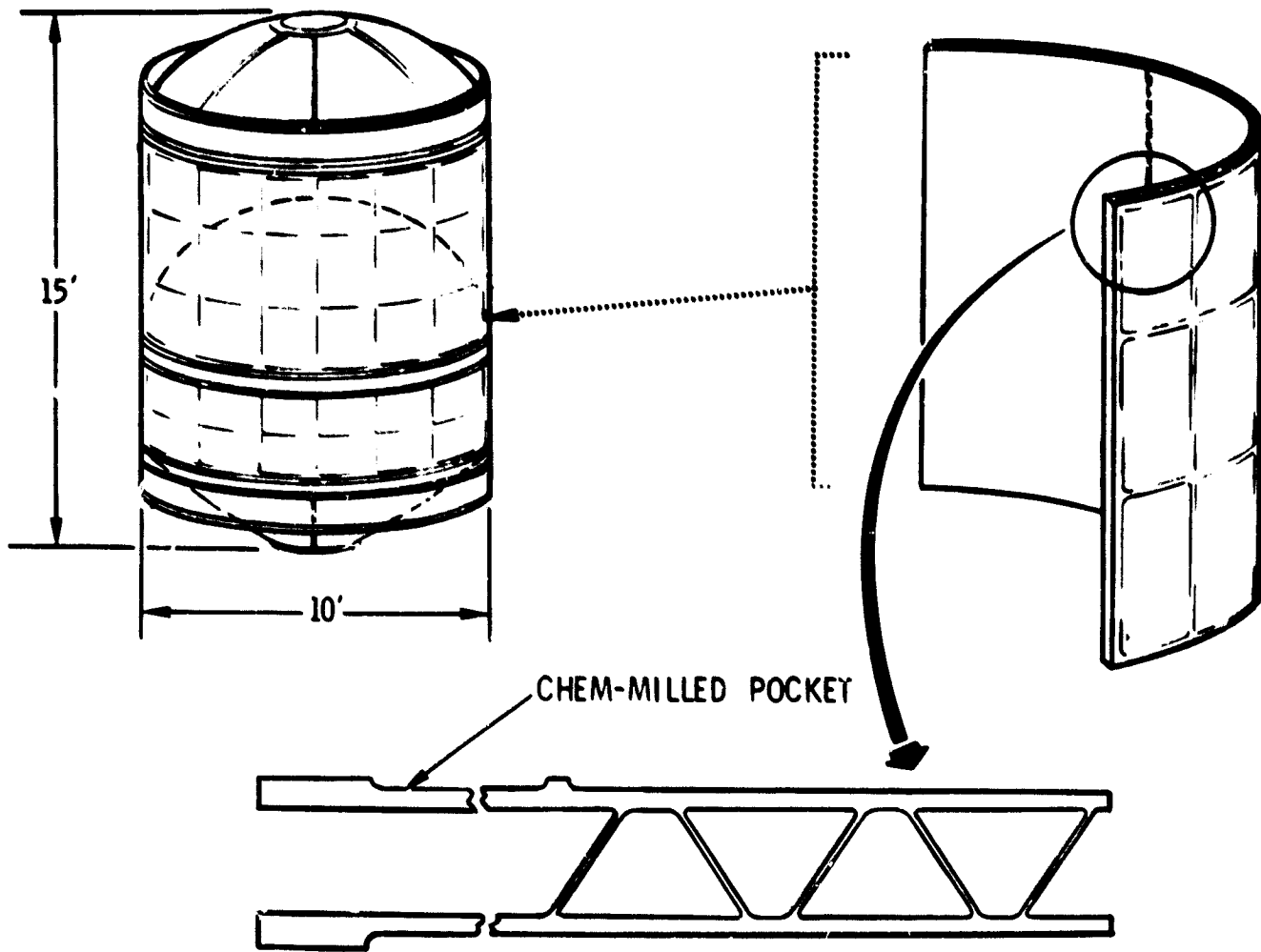

Figure 2-37. Titanium Conjugate Tankage Structure<sup>(33)</sup>

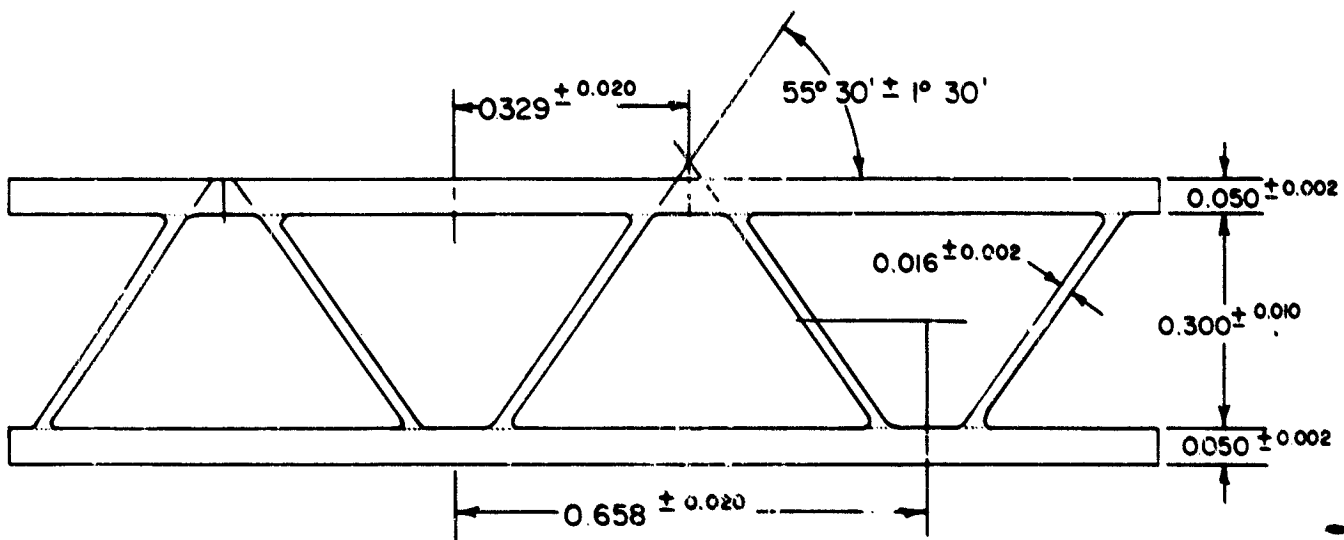

Figure 2-38. Standard Ti-6Al-4V Panel Design<sup>(33)</sup>

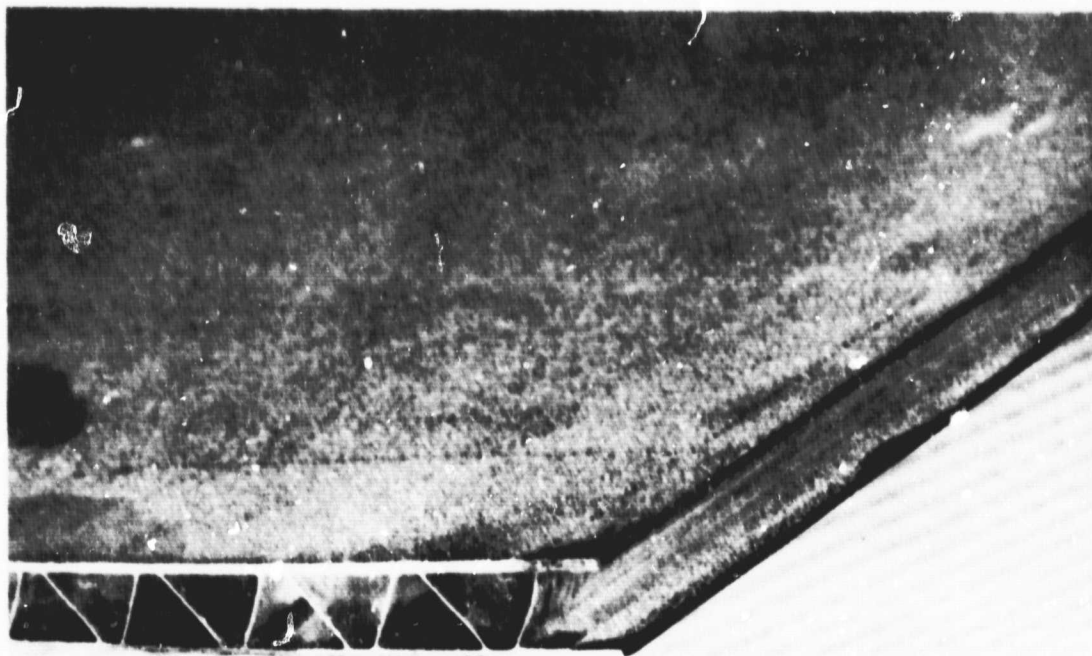

Figure 2-39. Lower Tank Panel, Trimmed and Machined<sup>(33)</sup>

#### 2.5.4.4 Other Applications

Some examples of other applications of titanium for aerospace use are shown in Figures 2-40 through 2-44<sup>(38)</sup>.

#### 2.5.5 CHEMICAL COMPATIBILITY OF TITANIUM

Unalloyed titanium is completely resistant to all natural environments. Hot salts, nitric acid, wet halogens, etc., have no effect. On the other hand, acid salts such as aluminum chloride and calcium chloride, and hot acids such as sulphuric, hydrochloric and phosphoric acids are damaging, as is red fuming nitric acid and 90 percent hydrogen peroxide, dry halogens, and fluorine salts. Ti-8Al-1Mo-1V and Ti-6Al-4V exhibit stress corrosion susceptibility in seawater, but their sensitivity is somewhat reduced by judicious temperature control during heat treatment. The failure of the Apollo Spacecraft 101 tank, made from Ti-6Al-4V, due to stress cracking in the presence of methanol was intensively studied. During the study, organic halogen compounds also produced stress corrosion cracking in both alloys<sup>(37)</sup>.

Several instances have been reported<sup>(119)</sup> of violent reaction of titanium in liquid oxygen. The ignition of titanium occurs under impact where fresh metal is exposed and gaseous oxygen is formed at point of impact. Ignition has been observed in gaseous oxygen at liquid oxygen temperatures at pressures of 100 psi and above. At ambient temperatures this critical pressure is lowered only slightly.

#### 2.5.6 AVAILABILITY OF TITANIUM

Titanium alloy sheet is produced only by Reactive Metals Incorporated (RMI) and Titanium Metals Company of America (TMCA), although Carlson and Crucible Steel produce titanium plate. Oremet Metallurgical Corporation, Harvey Aluminum Company, Crucible Steel, RMI and TMCA are basic producers of titanium ingots.

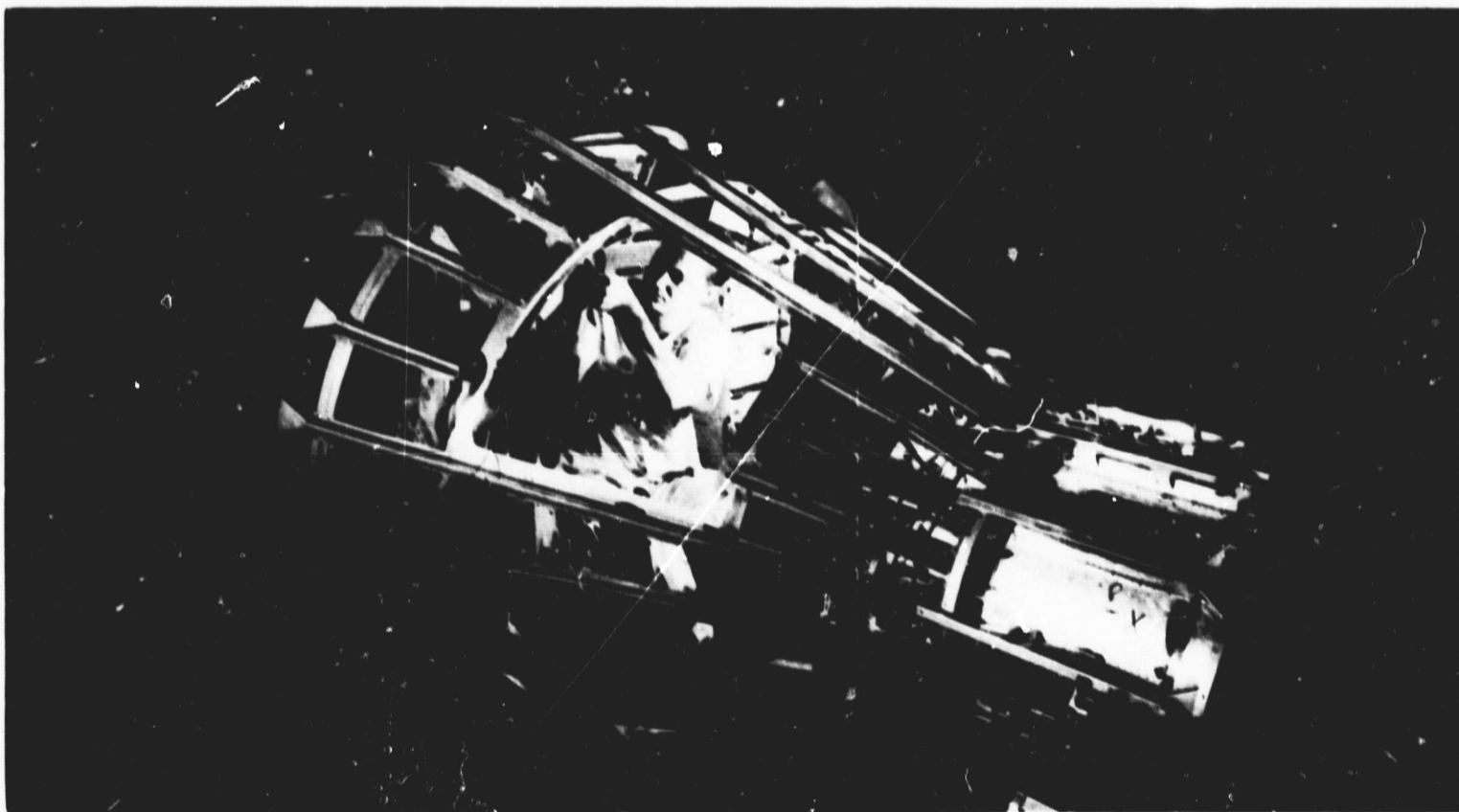

Figure 2-40. Mercury Capsule Has a Ti-5Al-2.5Sn Frame Built by McDonnell Aircraft, Mercury Capsule's antenna and parachute housings and the adapter section mating it to the booster consist of titanium inner skin (commercially pure) attached to framework of titanium (Ti-5Al-2.5Sn) stringers and machined rings. Outer skin is Rene 41. The stringers reach 600° F during re-entry: There are 45,000 inches of spot and seam weld in each capsule. Reliability has been proved in the most rigorous use devised by man—in every down-range and orbital space shot completed in the United States. (38)

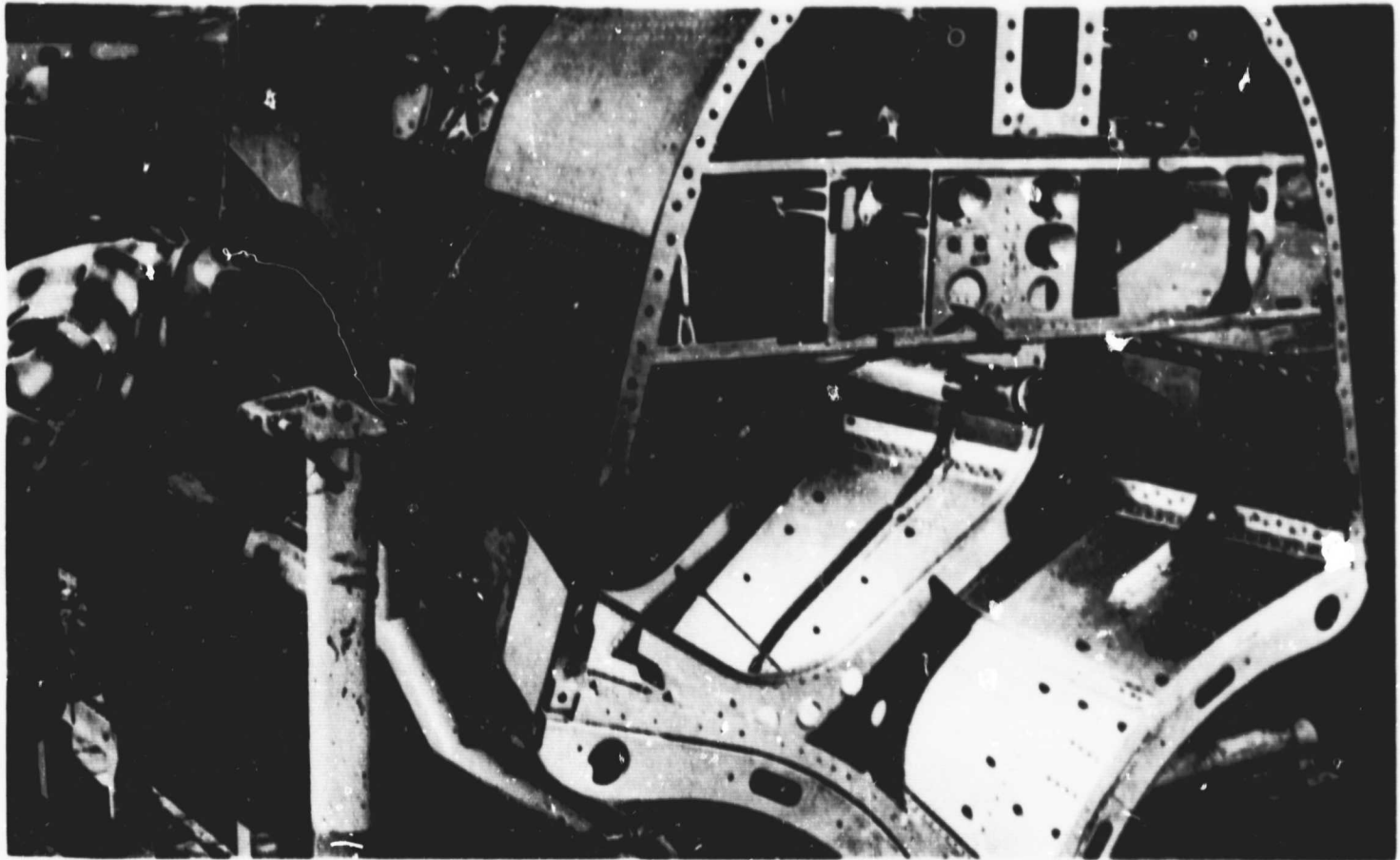

Figure 2-41. Aft Fuselage Sections. The tail assembly shown above is a titanium structure—the basic part of the aft fuselage section of the McDonnell F4C being assembled at Republic Aviation Corporation. Titanium comprises more than 25 percent of the flyweight of this portion of the aircraft, and 90 percent of it is load-bearing. (38)



Figure 2-42. Ti-6Al-4V plates, 0.390-inch thick, machined by Altamil Corporation and bent and stress relieved at Twigg Industries, Martinsville, Indiana, for use in stabilator torque box in F4B/F4C. Bending is performed on standard brake press. (Above)(38)

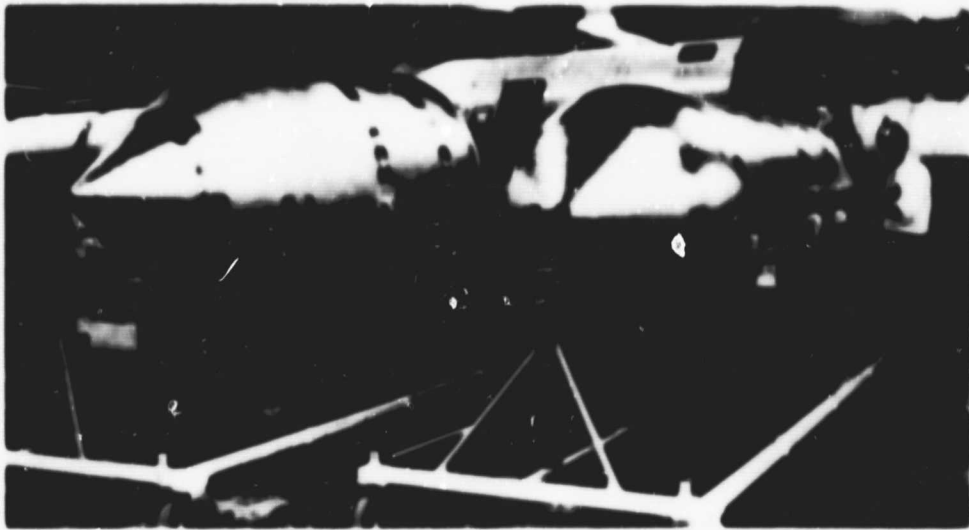

Figure 2-43. Inspector at Martin Company's Denver Division checks fuel and oxidizer titanium tanks which will hold liquid propellants for the Transtage engine of the Air Force Titan III space launch vehicle. The fuel tank, right, is almost four feet in diameter by 13 1/2 feet in length, the oxidizer tank, five feet in diameter and 11 feet long. (38)

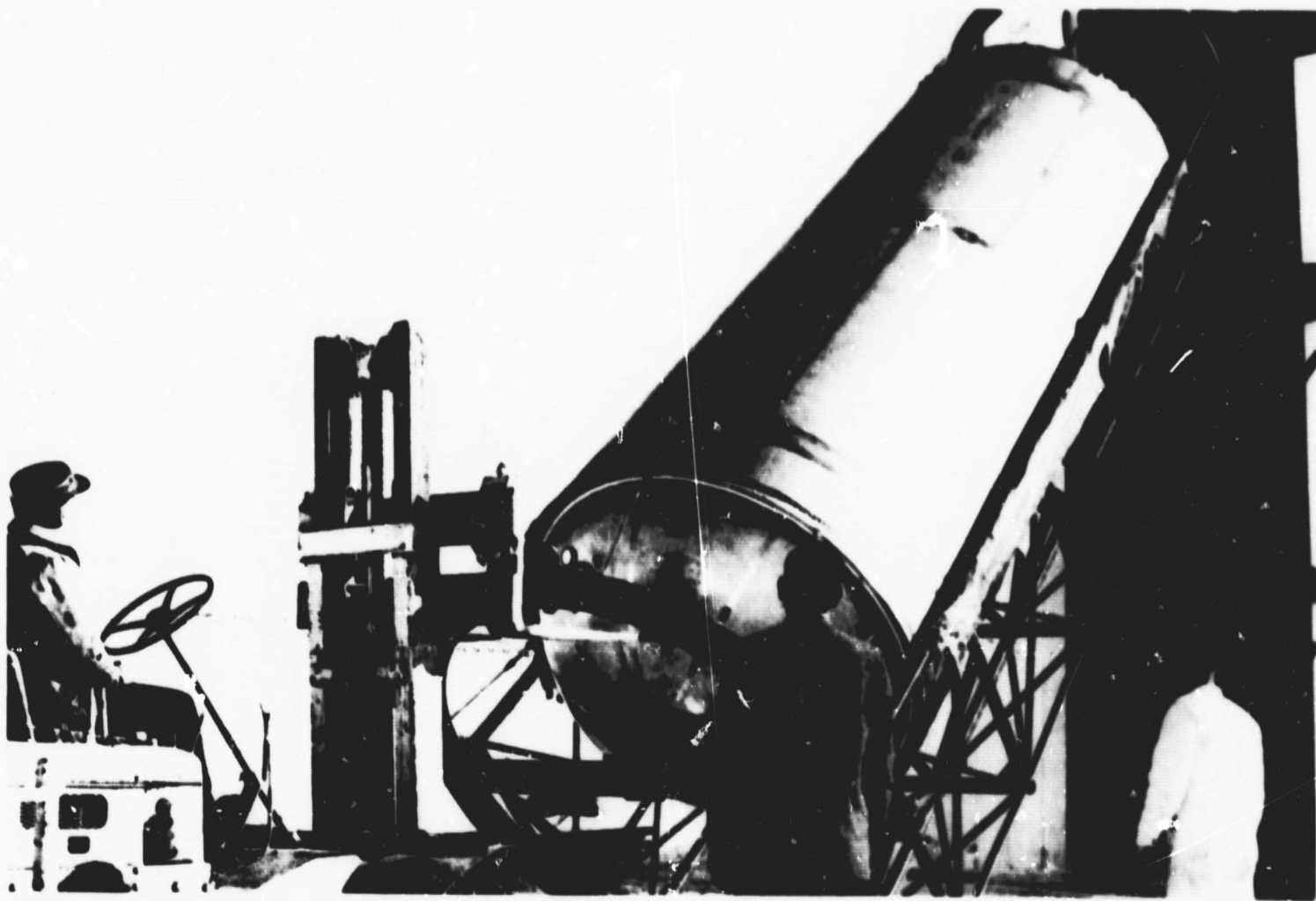

Figure 2-44. 7000 Gallon Tank, 8' Diameter x 24' Length, Produced from 0.025" Titanium Alloy Ti-6Al-4V ELI(38)

Titanium metal is produced by the Kroll process from titanium ore (rutile). The process consists of leaching the ore with hydrochloric acid and purifying the titanium tetrachloride by distillation. Titanium sponge is then produced which is mixed with alloying ingredients, vacuum melted, and cast into billets for rolling or forging. Titanium sheet is available in the sizes shown in Table 2-11<sup>(29)</sup>.

Table 2-11  
Titanium Alloy Sheet<sup>(30)</sup>

Thickness (inches)	Maximum Width (inches)	Maximum Length (inches)
0.008-0.012	26	Coil
0.012-0.016	30	Coil
0.016-0.020	36	Coil
0.020-0.032	44	Coil
	48	120-144
0.032-0.060	44	Coil
	48	144
0.060-0.187	48	144

Titanium foil availability is a problem. The major titanium producers are not making foil. Rodney Metals and Hamilton Watch Company are the principal suppliers. Ti-75A foil is generally available, but Ti-6Al-4V foil is difficult to obtain.

Extruded shapes are currently supplied in a wide variety of configurations, mostly angles, tee, or channel shapes. Most cross-sections fit within a 3 to 5 inch diameter circle; however, some cross sections have been made within circumscribing circles from 1-1/2 to 11 inches. Section thicknesses generally vary from 1/8 to 1-1/4 inches.

Integrally-stiffened extruded panels of Ti-6Al-4V have been made by Curtiss-Wright using a 12,000-ton press. A small four-ribbed panel was made with 0.4 inch thick stiffeners and it is expected that larger panels will eventually be produced on this program. Extrusion press capability for titanium is shown in Table 2-12<sup>(29)</sup>. Canton Drop Forge and Babcock and Wilcox are included, but are not actively extruding titanium at this time. All titanium extrusions are currently machined prior to use because of surface contamination or surface roughness. A utilization factor has been computed for titanium which is the number of pounds of titanium required for one pound

Table 2-12  
Extrusion Press Capabilities for Titanium<sup>(2e)</sup>

Company and Location	Extrusion Press Capacity, Tons	Maximum Billet Length Inches	Maximum Circumscribing Circle	Minimum Cross Sectional Area, in <sup>2</sup>	Extruded Length, Capability, Feet
Curtiss-Wright Corporation Buffalo, New York	12,000	66	21-1/2	5	75 Annealed 40 STA <sup>(e)</sup>
Harvey Aluminum Company Torrance, Calif.	3,850	36	11	1.0	60 Annealed 30 STA
	12,000 <sup>(a)</sup>	44 <sup>(b)</sup>	21	N.A. <sup>(c)</sup>	60 Annealed 30 STA
H. M. Harper Company Morton Grove, Illinois	1,900	27	5-3/8	0.5	60 Annealed 30 STA
	1,200	20	4-3/8	0.125	60 Annealed 30 STA
TMCA (Allegheny-Ludlum Steel Corporation) Watervliet, New York	2,000	26	5-1/4	0.5	N.A.
Babcock & Wilcox Company <sup>(d)</sup> Beaver Falls, Penna.	2,500	28	6-1/2	N.A.	N.A.
Canton Drop Forging & Mfg. Co., <sup>(d)</sup> Canton, Ohio	5,500	44	12	N.A.	N.A.

(a) Available on special inquiry only.

(b) Based on ingot-casting capabilities.

(c) Not available.

(d) Has equipment capabilities but is not now active in supplying titanium extrusions.

(e) Solution heat-treated and annealed.

of finished military airframe component. For Ti-6Al-4V sheet, the utilization factor is 2.7, and for extrusions, 1.2.

#### 2.5.7 COST

Types of titanium alloy sheets of interest for large launch vehicle applications cost between \$6.00 and \$6.50 per pound in thicknesses up to 0.1875 inch as a base price. If heat treatment is required over and above the mill annealed condition, such as duplex annealing or solution treated and aged, the price can be increased by \$0.50 to \$2.25 per pound, depending upon the thickness. The price increases with increased width and for cut lengths by as much as \$6.65 per pound, depending upon thickness. The maximum available width is 48 inches. As an example, a sheet of Ti-6Al-4V, 0.025 inch thick, 48 by 96 inches, duplex annealed is calculated as follows on a per pound basis:

Base Price	\$6.00
48" Width	6.65
144" Long	0.50
Duplex Anneal	1.00
Less than 200 lbs	<u>1.00</u>
Total	\$15.15

Future price forecasts could not be obtained. Past price history for sheet is not available, but a composite price index consisting of:

- a. Ti-75A plate 0.30" x 36" x 96"
- b. Ti-75A coil strip 0.016" x 20"
- c. Ti-5Al-2.5Sn 1" rod, centerless ground
- d. Ti-6Al-4V 8-1/2" diameter billet, rough turned

has been calculated from 1954 to 1967 and is shown in Table 2-13<sup>(29)</sup>.

The cost of Stressskin titanium honeycomb sandwich in development panels runs about \$200 per square foot, independent of core thickness. Production runs would be priced at \$50-\$70 per square foot<sup>(35)</sup>.

The leveling off of the composite price may indicate a technology barrier in present methods of metal refining and mill operations, particularly in the mill-heat treatment and post-heat treatment handling. Producer sponsored research in these areas is being conducted, and a price break will depend upon the results of these efforts. There is a good possibility that very large quantity utilization of a particular alloy in a standard size and heat treatment could result in some price decrease.

Table 2-13  
Titanium Composite Price Index<sup>(2)</sup>

Year	Composite Price Index
1954	\$15.25
1955	13.41
1956	11.75
1957	10.55
1958	8.66
1959	7.22
1960	6.97
1961	6.10
1962	5.90
1963	5.90
1964	5.90
1965	5.90
1966	--
1967	5.95

## SECTION 3

### COMPOSITE STRUCTURAL TECHNOLOGY

#### 3.1 INTRODUCTION AND GENERAL COMMENTS

The keen interest in fiber-composite materials results largely from their exceptionally high structural efficiencies; viz., very high strengths and elastic moduli at relatively low densities. Furthermore, they offer the designer great flexibility in both the design and the selection of materials. This proves to be a mixed blessing, however, because he now has an opportunity to use anisotropic (tailor-made) materials which have significant structural advantages over metals and alloys, but he also is faced with the difficult task of designing and using more costly, and certainly far more complex, materials. Indeed, while cost is a major consideration of the new composite materials, the real advantages will be seen in the "installed" material (i.e., the final structure itself). For example, the cost of aluminum alloy sheet runs from \$0.50 to 2.00 per pound, while an equivalent boron/epoxy composite sheet (containing about 50% boron by volume) may cost over \$175 per pound. On these grounds, there would seem to be little advantage in using the composite material on a direct substitution basis. However, when the performance requirements of specific structural components are considered, the conclusions drawn may be completely different. This was illustrated early in the case of an analysis undertaken under Air Force sponsorship involving the application of boron/resin composites to the horizontal tail section of the F-111<sup>(43, 44)</sup>. The results are summarized in Table 3-1. In the fabricated form, the boron/epoxy structure (a boron/epoxy face sheet on aluminum honeycomb) costs about \$175 per pound, while a comparable aluminum structure costs about \$90 per pound. On this basis, there is no saving (except that the prices of these composite materials are expected to decrease dramatically as the technology matures). However, in terms of the total weight saved on the aircraft, the composite material becomes cost effective.

In general, the designer is faced with an infinite number of combinations of materials, material configurations, and geometrical arrangements, which must be considered in the design of a structural system if it is to be truly cost-effective. Thus, optimum design studies involving cost effectiveness, weight penalties, materials fabricability, and other factors become mandatory. This means that computer technology will play an increasingly important role in the development of the new fiber composite materials.

This section is concerned primarily with a brief state-of-the-art review of current fiber composite materials showing the greatest promise.

Table 3-1

Cost Effective Analysis of Using Boron/Epoxy Composites in the Horizontal Tail Section of the F-111 (from Ref. 43,44)

Boron/Epoxy Material and Fabrication Costs	\$131,000
Costs when Fabricated from Aluminum	\$ 98,000
Aluminum Tail Weight	1100 lbs.
Boron Tail Weight	750 lbs.
"Cascade" Savings in Tail Support Structure	200 lbs.
Cost of Saving 550 Pounds	\$ 33,000
Cost per Pound	\$ 60
Estimated Cost/Effectivity/Pound	\$ 200

Historically, the use of glass fibers was essentially uncontested as reinforcing fibers until about 1960. The relatively low elastic moduli of these fibers became a major limitation for use in large structures, such as rocket motor cases, space vehicles, aircraft wings, or when used in rotating members (turbine blades, rings, etc.). In the late 1950's, a search was on for strong but higher-modulus fibers. By 1960, some new high modulus fibers were just becoming available for evaluation as reinforcements. These included whiskers, boron and other vapor-deposited filaments, and beryllium wire. High-modulus graphite fibers became available in limited quantities about five years later.

The structural merits of filament-wound resins using the new fibers are compared with other structural materials in Figure 3-1. It is readily seen that the specific strengths (strength/density ratio) of glass reinforced plastics are entirely satisfactory, but the specific moduli are no match for the materials reinforced with graphite, boron, or beryllium fibers. All metals and alloys (except beryllium) have low specific properties, which result primarily from their greater densities. The specific strengths of the fiber composites are compared with those of conventional alloys for an 80-year period in Figure 3-2. The emergence and future potential of the fiber composite materials are clearly evident.

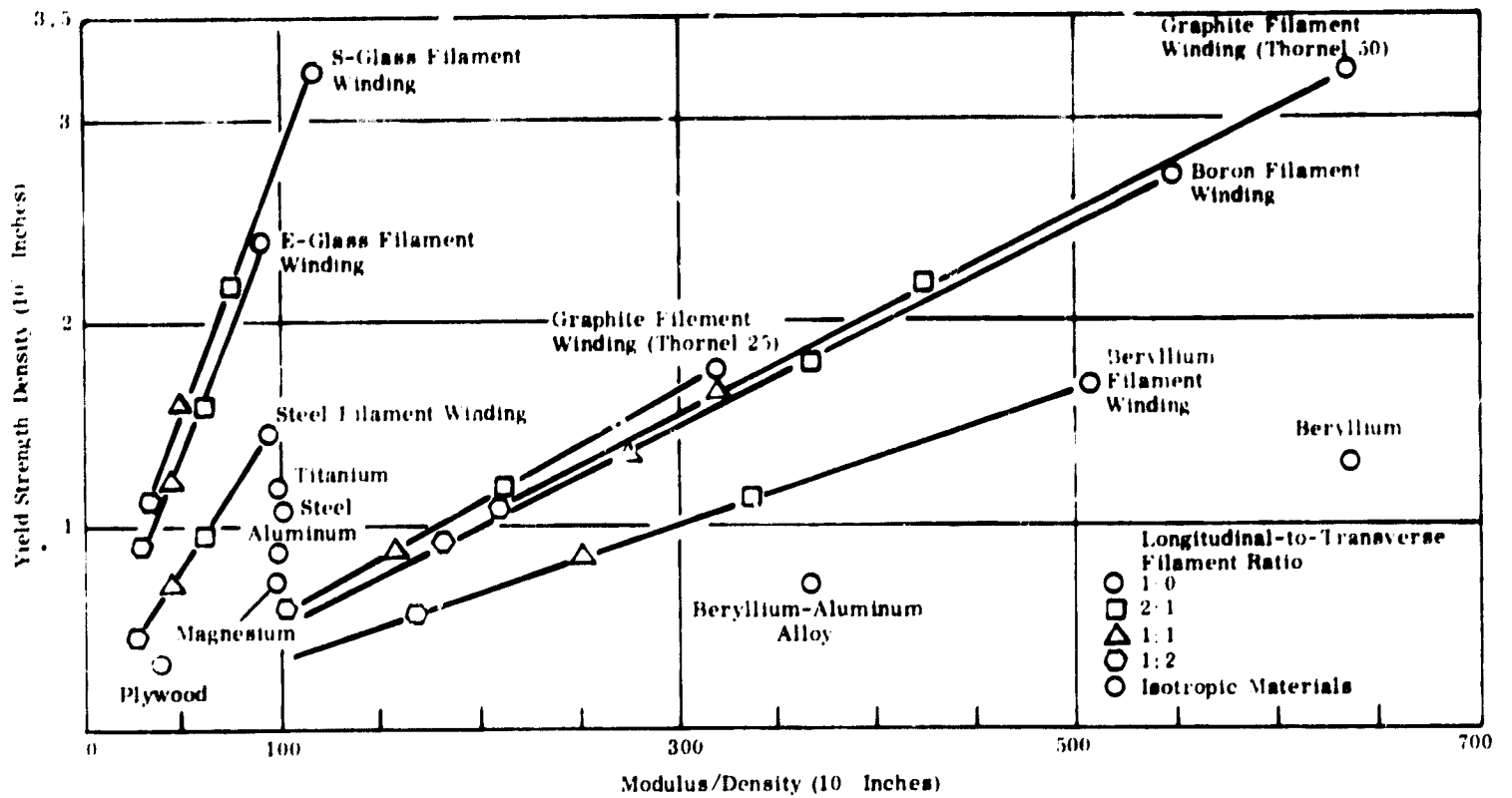

Figure 3-1. The Relative Structural Efficiency of Various Filament-Wound Composites Compared to some Conventional Isotropic Materials<sup>(114)</sup>

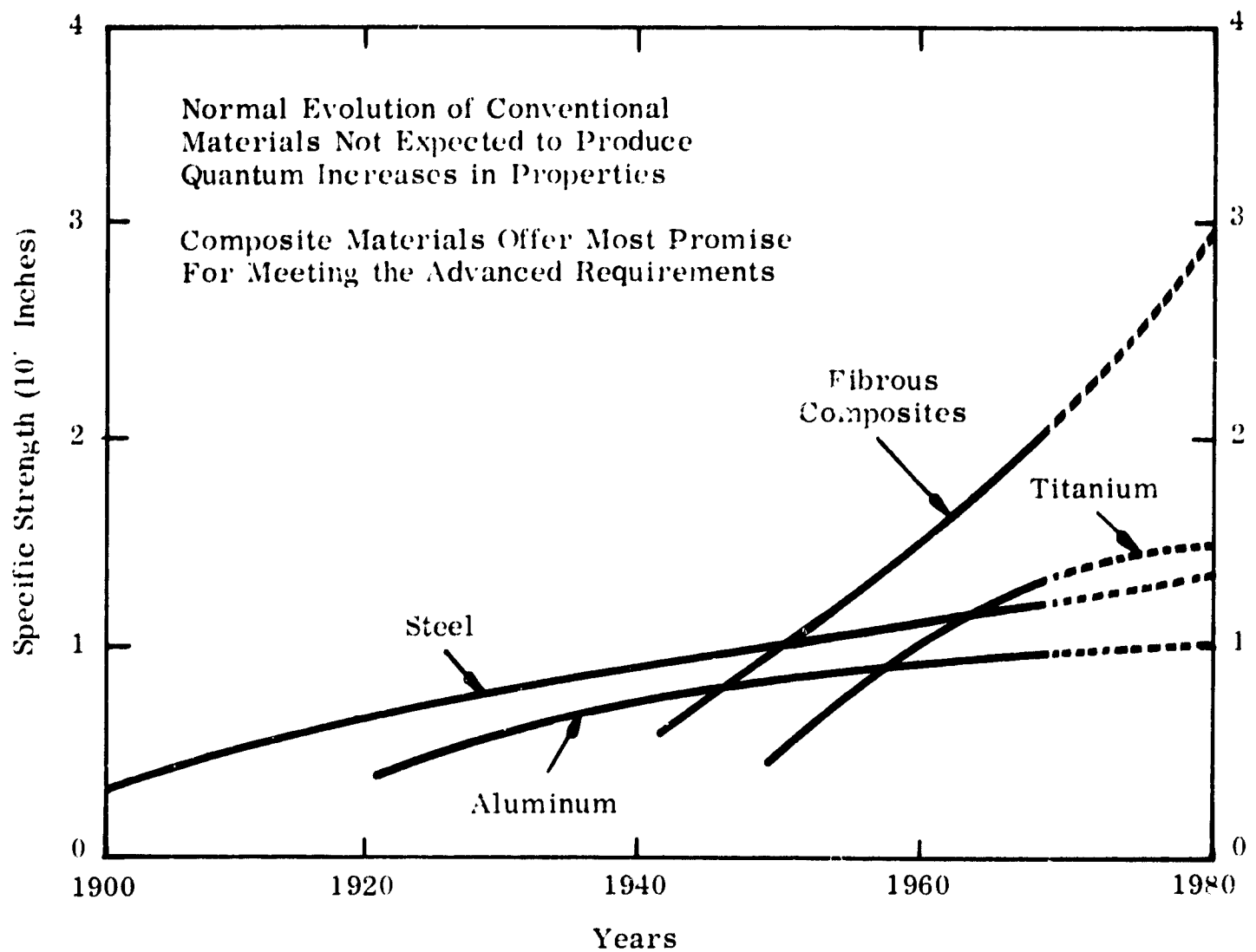

Figure 3-2. Specific Strengths (Strength-to-Weight Ratios) of Various Structural Materials over the Period 1900 to 1980<sup>(115)</sup>

During the past five years, the progress in fiber-development, in composite technology, and in producing and testing prototype hardware has been particularly outstanding. This progress has largely resulted from the stimulation and support by Government agencies (DOD and NASA). The increasing support provided by the Department of Defense during the past 10 years is shown in Figure 3-3. The data used in this figure are based on identifiable DOD Research and Development projects, and are thus conservative. The increase in effort on a national level is evident.

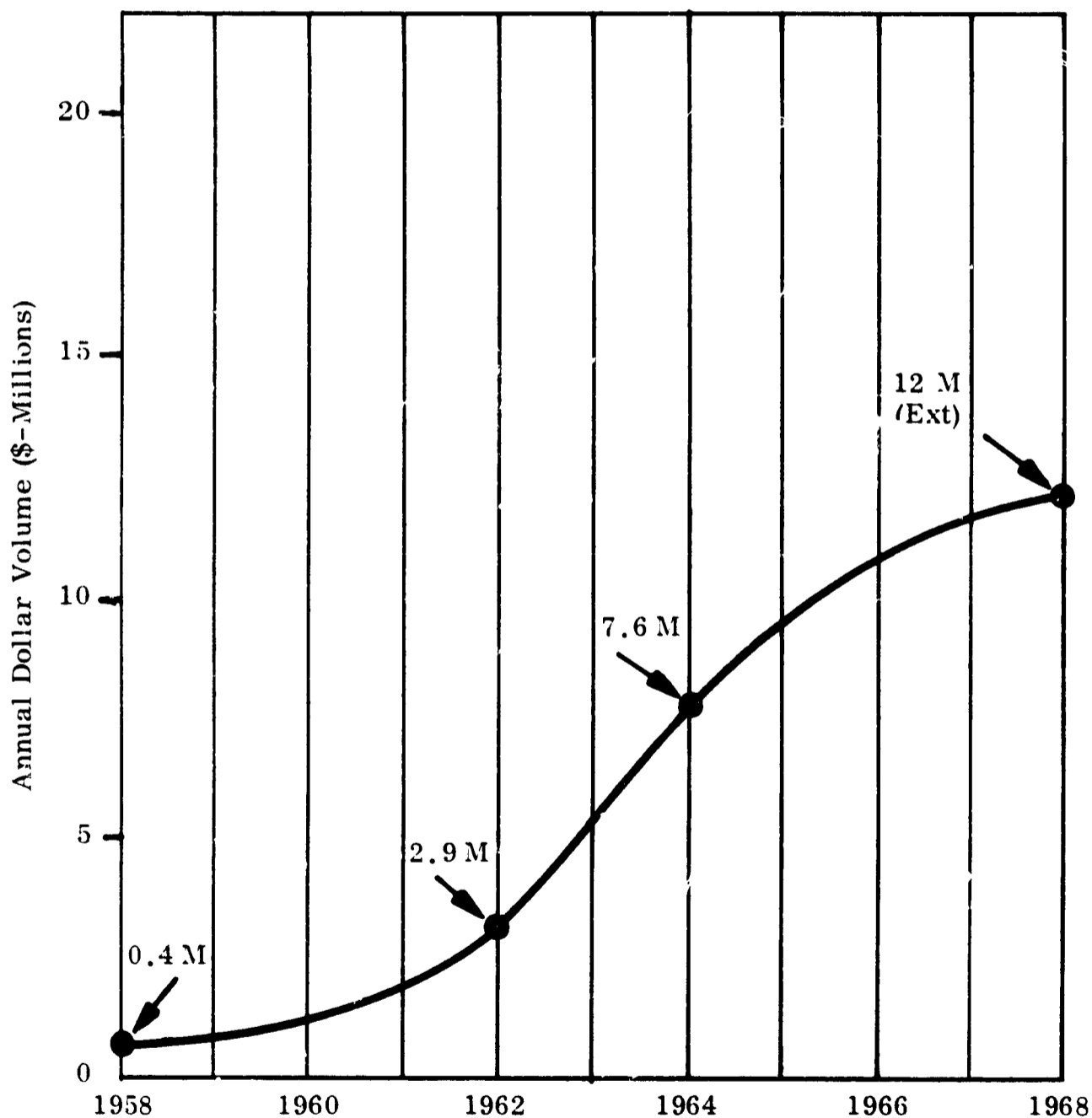

Figure 3-3. Identifiable DOD Materials Research and Development Projects on Fiber Composite Materials<sup>(4)</sup>

In the following sections, current progress in fibers, in structural composites and their applications will be discussed.

### 3.2 STATUS OF REINFORCING FIBERS\* AND MATRIX MATERIALS

Since 1959, a variety of new reinforcing fibers have become available. As mentioned earlier, the higher elastic modulus of these new fibers, compared to that of glass fibers, was a major factor behind their development. Structural elements reinforced with these new fibers should exhibit 5 to 10 times greater stiffness than comparable glass filament-reinforced materials. Furthermore, the new fibers have many other desirable features: lower sensitivity to mechanical damage, greater corrosion resistance, higher strength retention at elevated temperatures, and for some, lower density than glass (i.e., 0.06 lb/in<sup>3</sup> versus 0.09 lb/in<sup>3</sup> for graphite and glass fibers, respectively). The properties and potential of these fibers have been reported in detail<sup>(45-48)</sup>. Some of the mechanical properties of the fibers of interest are compared in Table 3-2. These include the fibers formed by chemical vapor deposition on hot filamentary substrates, such as boron deposited on fine tungsten wires (B/W), boron deposited on fused silica (B/SiO<sub>2</sub>) etc., the glass fibers, the graphite fibers (which have about the same diameter as the glass fibers) and the single crystal fibers, or whiskers.

Figure 3-4 compares the strength and strength-to-density ratios (specific strengths) of several fibers. Only the tensile strength of the whiskers exceeds that for the glass filaments\*\*. On a strength-to-weight basis, the values for the other fibers are nearly that for glass. However, on the basis of either the elastic modulus or the specific modulus, Figure 3-5 shows that all of the newer fibers are far superior to the glass fibers. In terms of specific modulus, one of the graphite fibers currently exceeds that for all the other fibers shown in Figure 3-5. Recently, maximum modulus values exceeding  $100 \times 10^6$  psi and tensile strengths exceeding 500,000 psi have been reported for graphite fibers under current development in the laboratory<sup>(4, 50)</sup>.

Figure 3-6 shows the relative cross-sectional sizes of some of the high modulus fibers compared with glass fibers. It is readily evident that the range of sizes is very great. This also has a bearing on the ease with which the fibers can be handled and processed.

---

\* The term "fibers" is used generically to describe all types of fibers, whiskers, etc. The term "filament" is defined as a continuous-length fiber, while a "whisker" is a single crystal (usually short) fiber.

\*\*The average strength of the vapor-deposited filaments are shown in Figure 3-4. However, some tensile values are exceeding 650,000 psi (1-inch gage lengths)<sup>(51)</sup>. See also Reference 50 on graphite fibers.

**Table 3-2**  
**Properties of Fibrous Reinforcements for Composite Materials<sup>(4)</sup>**

Fiber Type	Fiber Material	Density lb/in <sup>3</sup>	Tensile Strength <sub>3</sub> psi × 10 <sup>3</sup>	Specific Strength <sup>c</sup> in × 10 <sup>6</sup>	Young's Modulus <sub>1</sub> psi × 10 <sup>6</sup>	Specific Modulus <sub>1</sub> in × 10 <sup>7</sup>
<b>CONTINUOUS FILAMENTS</b>						
Glass	E-Glass	0.092	500	5.4	10.5	11.4
	S-Glass	0.090	650	7.2	12.6	14.0
	4H-1	0.096	730	7.6	14.5	15.1
	SiO <sub>2</sub>	0.079	850	10.8	10.5	13.3
Polycrystalline	Al <sub>2</sub> O <sub>3</sub>	0.114	300	2.6	25	21.9
	ZrO <sub>2</sub>	0.175	300	1.7	50	28.6
	<sup>a</sup> Carbon-Graphite (Th 40)	0.057	250	4.4	40	70.0
	<sup>b</sup> Carbon-Graphite (RAE)	0.069	320	4.6	62	89.9
	Boron Nitride	0.069	200	2.9	13	18.8
Multiphase	Boron/Tungsten	0.095	400	4.2	55	57.8
	Boron/SiO <sub>2</sub>	0.085	330	3.9	53	62.5
	B <sub>4</sub> C/Boron/Tungsten	0.095	390	4.1	62	65
	SiC/Tungsten	0.125	300	2.4	67	52
	TiB <sub>2</sub>	-	15	-	7	-
Metal	Tungsten	0.697	380	0.8	59	8.5
	Molybdenum	0.369	320	0.9	52	14.1
	Rene 41	0.298	290	1.0	24	8.1
	Steel	0.280	600	2.1	29	10.3
	Beryllium	0.066	185	2.8	35	53.0
<b>WHISKERS</b>						
Ceramic	Al <sub>2</sub> O <sub>3</sub>	0.143	3000	21.2	62	43.4
	B <sub>2</sub> O <sub>3</sub>	0.103	1900 <sup>c</sup>	18.4	50	48.5
	B <sub>4</sub> C	0.091	2000	21.9	70	76.9
	SiC	0.116	3000	26.1	70	60.8
	Si <sub>3</sub> N <sub>4</sub>	0.115	2000	17.4	55	47.8
	Graphite	0.060	2845	47.4	102	170.0
Metal	Chromium	0.260	1290	5.0	35	13.4
	Copper	0.322	475	1.3	18	5.6
	Iron	0.283	1900	6.7	29	10.2
	Nickel	0.324	560	1.7	31	9.6

<sup>a</sup>U.S. Supplier

<sup>b</sup>British Supplier

<sup>c</sup>Flexure Test

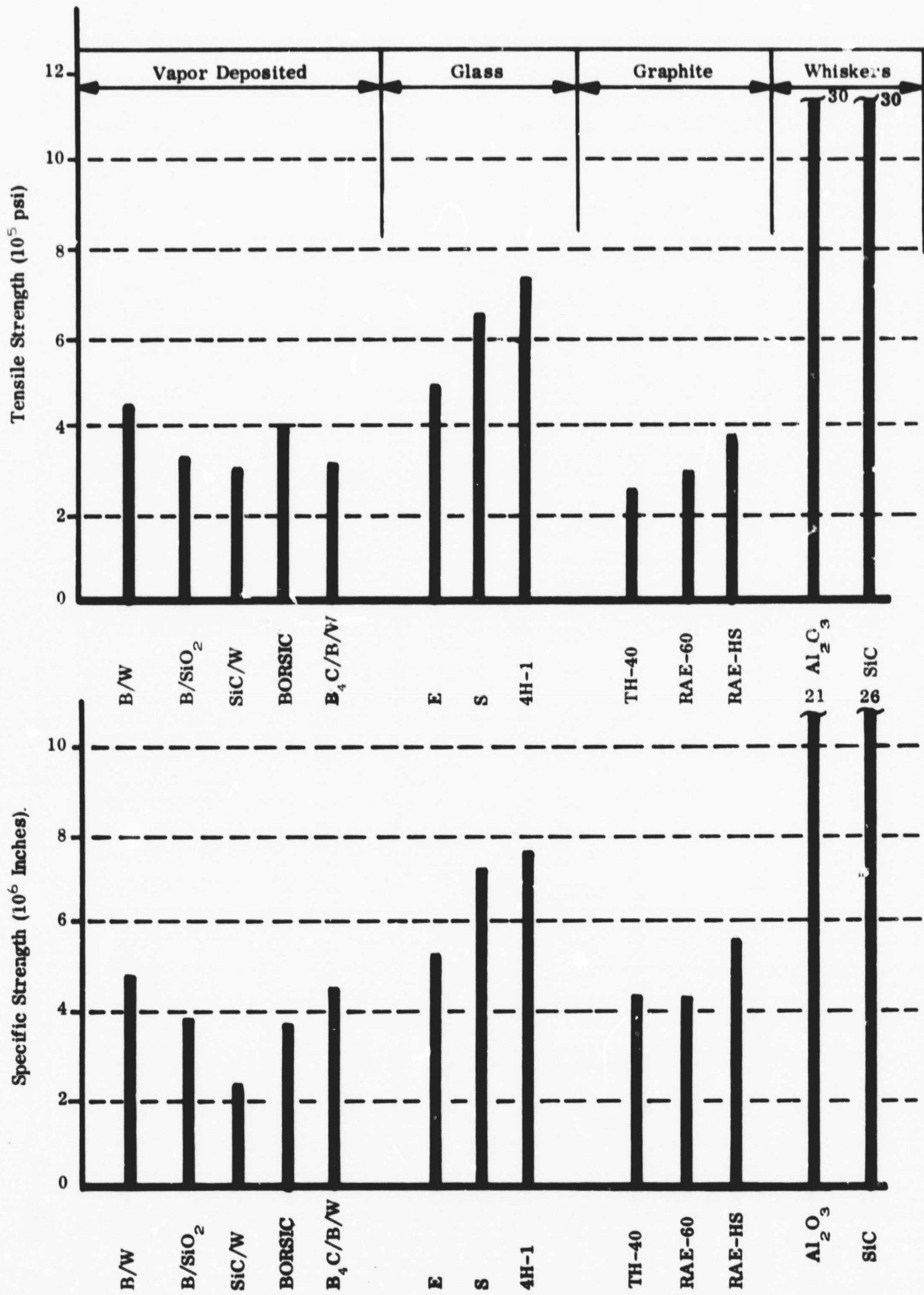

Figure 3-4. Strength Characteristics of Reinforcing Fibers<sup>(4, 50)</sup>

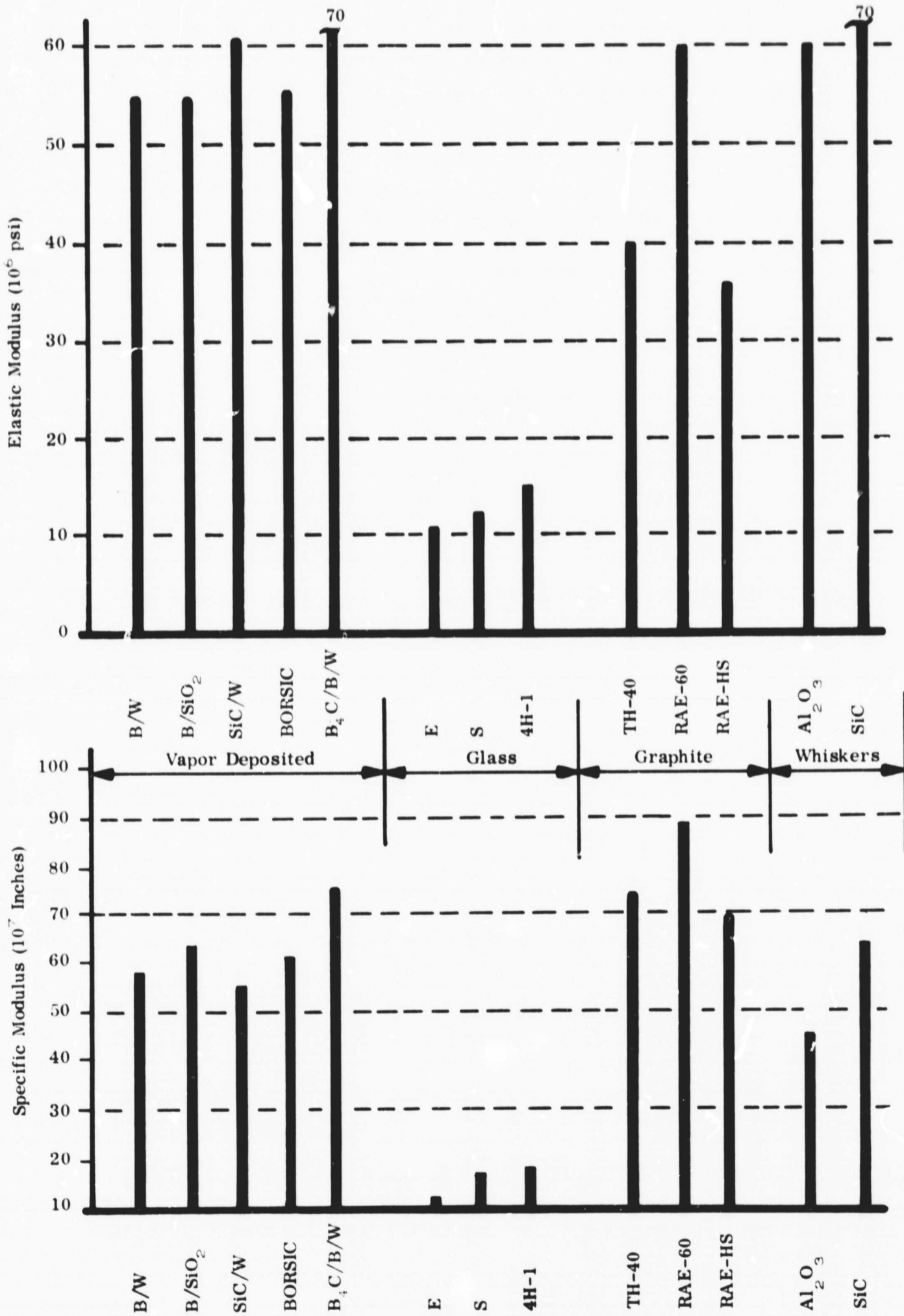

Figure 3-5. Elastic Modulus Characteristics of Reinforcing Fibers<sup>(4, 50)</sup>

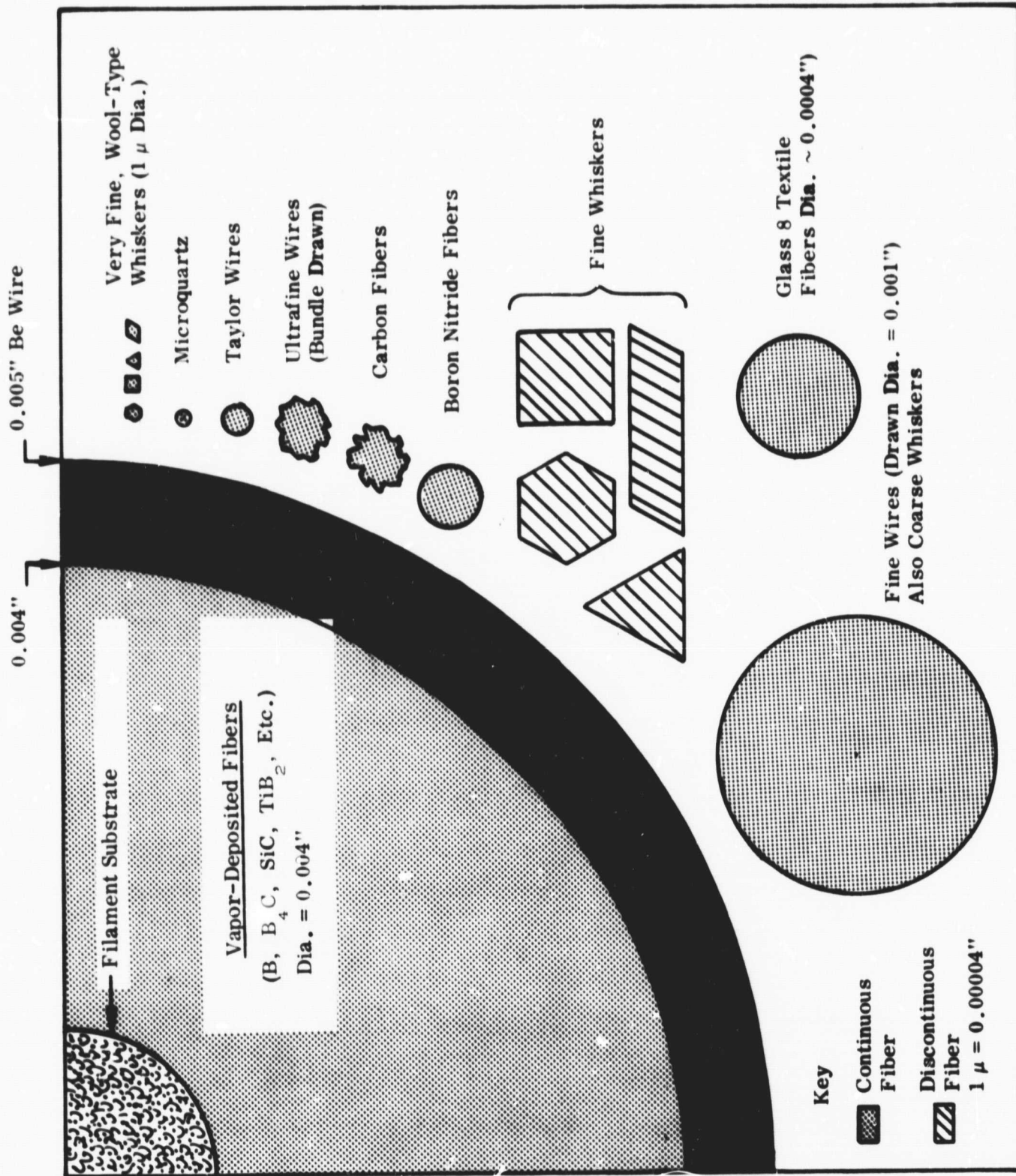

Figure 3-6. Relative Size (Cross-Sectional Area) of Several Reinforcing Fibers (Adapted from Reference 46, 47)

For example, nearly 10,000 1-micron diameter whiskers would be required to occupy the cross-section of one 0.004-inch diameter boron fiber in a composite. Of the various fine diameter fibers (diameters less than 0.001 inch), the graphite types are receiving the greatest attention because of superior specific moduli ( $70$  to  $90 \times 10^7$  in) compared to boron ( $60 \times 10^7$  in) or alumina whiskers ( $43 \times 10^7$  in).

In assessing the full merits of the newer filaments, it is obvious that many other factors must be considered in addition to the strength, modulus, and density. These factors include the ease (and cost) of fabrication, handling, long-term stability, resistance to moisture and abrasion, and other properties such as thermal expansion coefficient, the stress-strain behavior, internal structures (anisotropy, residual stresses, etc.). For example, the chemical compatibility between these new, high-performance fibers and the various materials in which they are incorporated is another very important consideration. Resin-matrix composites are relatively free of this problem, compared to metal-matrix systems. Many fiber-metal combinations are severely weakened because of chemical reactions and diffusion between the fiber and the matrix (51-54). In other fiber-metal systems, there may be so little reaction between the fiber and the matrix that inadequate bonding results. Thus, the use of coatings either to prevent, or minimize fiber-matrix reaction or to promote adherence between these components may be necessary in many cases. On the other hand, the strength of glass fiber reinforced resins decreases considerably after prolonged exposure to even moderate temperatures. Although the new, high-performance fibers are considerably less temperature-sensitive than glass fibers, their use to reinforce resin matrices does not overcome the temperature limitations of the resin matrix. For this reason, the development of many new resins with higher temperature capabilities is being pursued. However, some of the greatest payoffs in terms of high temperature applications will be the use of some of these advanced filaments to reinforce metals and alloys. Therefore, the strength retention of these fibers at elevated temperatures is an extremely important property.

### 3.2.1 ADVANCED FIBERS

The present status and potential of various types of fibers are discussed individually below. Some of them have been used extensively while others are still in the developmental stage. Fiber prices are recorded for the historic and future trends.

### 3.2.1.1 Boron Filaments

Boron filaments are the most developed of the new, high-performance fibers. Currently, this fiber is being produced by passing a resistively-heated tungsten wire through a reactor containing boron trichloride and hydrogen. Thermal decomposition of the gaseous boron compound occurs when it contacts the hot wire and causes the boron to deposit onto the heated tungsten surface. This process is amenable to quantity production, and currently there are two major suppliers of these filaments: Hamilton Standard and AVCO. The use of a tungsten substrate has certain disadvantages, however. Foremost is the very high density ( $0.695 \text{ lb/in}^3$ ), followed closely by the rather high cost of tungsten. Interaction between the tungsten core and the boron deposit<sup>(53)</sup> occurs but it does not seem to be a problem and many thousands of feet of high-strength, high-modulus B/W filament have been produced by this technique. Current production is on the order of a few thousand pounds\* per year. Nominal properties of 4-mil diameter boron/tungsten filament are: 400,000 psi minimum average tensile strength,  $55 \times 10^6$  psi elastic modulus, and  $0.095 \text{ lb/in}^3$  density. This latter property, which is relatively low, gives the boron filament very attractive specific properties. (The actual and specific properties of boron and subsequently discussed fibers are listed in Table 3-2.) The cost of boron filaments in the commercial market is currently running about \$550 per pound (for 1 to 10-pound orders) and about \$310 per pound (for orders over 600 pounds), although some Government sponsored projects can procure these filaments at a reduced price; i. e., for the wing trailing edge panels of the F-111, 116 pounds of boron filaments were purchased for \$302 per pound<sup>(50)</sup>. At present, only two companies (AVCO and Hamilton Standard) are producing these fibers. Work has also been directed toward the preparation of boron fibers through the deposition of boron on cheaper substrates than tungsten; i. e., on fused silica and other glasses, and more recently on "large" diameter carbon fibers (diameters of about 0.001 inch).

Boron filaments retain an appreciable amount of their strength to about  $1000^\circ \text{F}$ <sup>(49, 50)</sup> in air but weaken rapidly beyond this temperature. Figure 3-7 illustrates this behavior along with similar data for other commercially available fibers. A more serious problem than the loss of strength at elevated temperatures, however, has been the reactivity of boron filaments with various metals<sup>(51-54)</sup>. In fact, this reaction is so

---

\*One pound of boron filament is equal to about 70,000 feet of filament.

extensive that many boron-metal combinations are impractical as structural materials at temperatures above 1000°F. The use of protective coatings on boron filaments may be able to prevent or minimize these reactions.

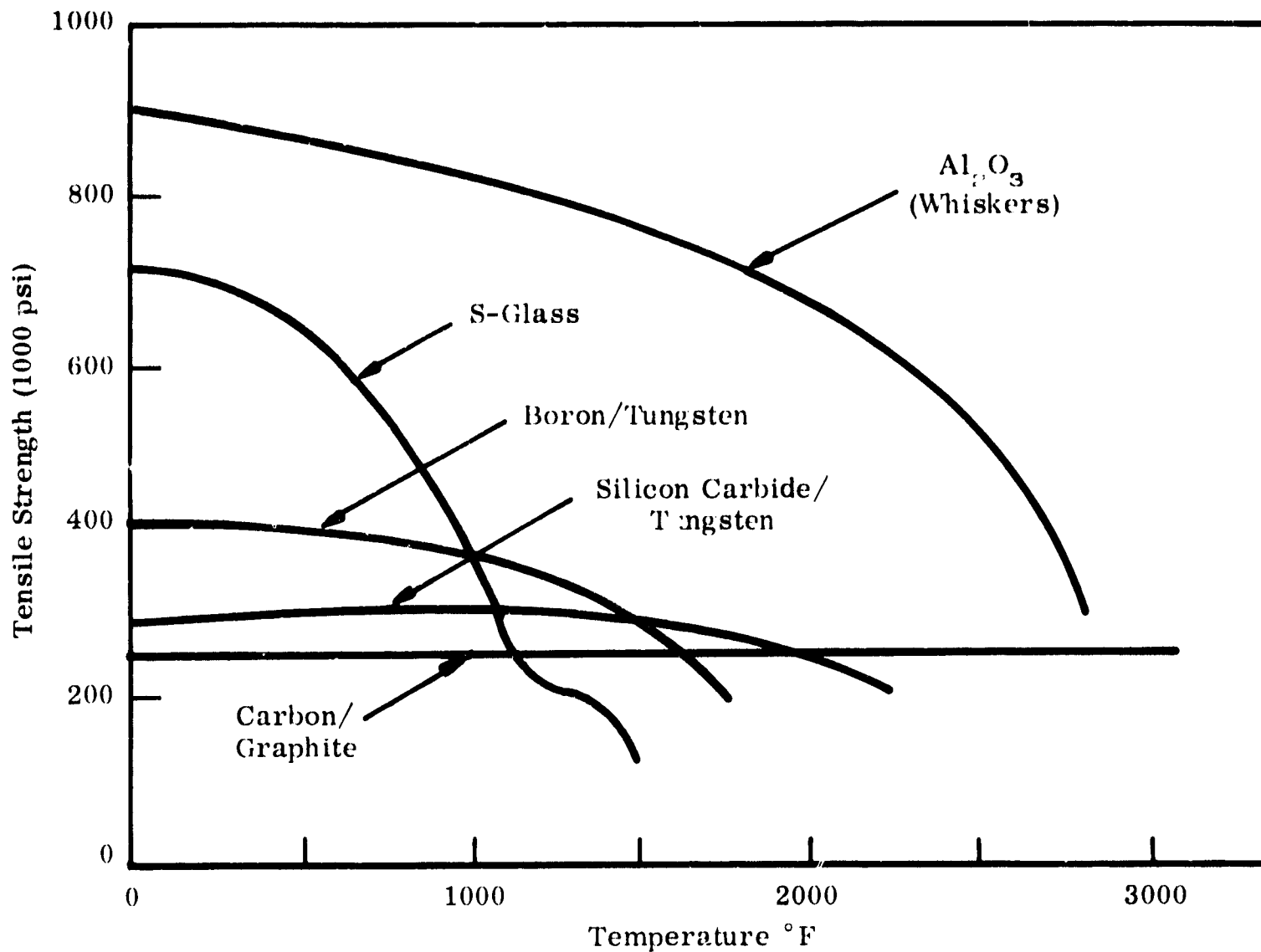

Figure 3-7. Strength Retention at Elevated Temperature of Various Commercially Available Fibers<sup>(49)</sup>

At least three companies <sup>(57, 58, 59)</sup> have developed a process for coating boron filaments. Hamilton Standard now coats the fibers with SiC, and these soon should be available in relatively large scale <sup>(57)</sup> production. The coated fiber has essentially the same mechanical properties as the boron filament. However, its chemical behavior is quite different. Most of its strength is retained even after 1000 hours at 1100°F in air and after contact with 2024 aluminum alloy or titanium at 1100°F for 500 hours. <sup>(58)</sup>

### 3.2.1.2 Graphite Filaments

Graphite filaments are the second most developed of the new high performance fibers. Although low-modulus carbon and graphite fibers have been commercially available for many years, it is only within the last three years that high-strength, high-modulus varieties have been produced in any quantity. The most common production method is the pyrolysis of an organic precursor filament. Numerous compositions have been used for this purpose, but viscose rayon and polyacrylonitrile (PAN) are the precursors being most widely used. Thermal treatment of the fibers requires precisely controlled temperatures as high as 5350°F. The furnace atmosphere must be controlled, and means for applying tension to the precursor fibers must be available. This last process feature is important in aligning the graphite crystals, which in turn determines the fibers' elastic modulus (i.e., the greater the degree of alignment, the higher the elastic modulus). Tension is usually applied to the precursor prior to, and maintained during pyrolysis, or the precursor may be stretched only during heat treatment. High-modulus fibers have been produced in England and in the United States by both processes, although the rayon precursor material is primarily used in the U.S. and the PAN material is used in England. Fibers produced by either technique are about seven microns in diameter, and are either circular or irregular in cross-section, depending on the precursor fiber. They are not generally available as single filaments; instead, the material is supplied as yarn, consisting of as few as 720 (rayon process) or as many as 10,000 (PAN process) single filaments per ply. The former are available in continuous lengths, and the latter can be purchased now in 1100-foot lengths. The prices vary considerably, depending on the starting material and on the desired modulus. Some of the prices and properties are summarized in Table 3-3. The Japanese, who were early pioneers in the PAN process, are now planning to produce high-modulus graphite filaments by using pitch as the starting material <sup>(60)</sup>. They are presently producing a fiber having a  $20 \times 10^6$  psi modulus. Next year it is planned to market a  $40 \times 10^6$  psi filament having strengths of about 300,000 psi for about \$100 per pound <sup>(60)</sup>. However, the quantity will be limited until full-production capacity is achieved. The total graphite filament production last year was about 4000 pounds in the U.S. <sup>(61)</sup> and this was probably exceeded in England.

The strength retention of the graphite fibers is excellent even at very high temperatures (Figure 3-7), but the poor oxidation resistance may be a disadvantage. Furthermore, these fibers tend to recrystallize and weaken in metals such as nickel at temperatures above 1600°F <sup>(62)</sup>. Another problem is the inert chemical surface of the

Table 3-3  
Data on High Modulus Graphite Fibers (Diameters 6.9 to 7.8 Microns)<sup>(b)</sup>

Fiber	Precursor Material	Density (lb/in <sup>3</sup> )	Modulus 10 <sup>6</sup> psi (Avg)	Strength 10 <sup>3</sup> psi (Avg)	Cost/Pound	Manufacturer
Th 40	Rayon (720 fil/tow)	0.056	40	250	325 (Ref. 50)	Union Carbide Corp.
Th 50 <sup>(a)</sup>	Rayon (720 fil/tow)	0.059	50	285	350 (Ref. 68)	Union Carbide Corp.
Th 60	Rayon (720 fil/tow)	0.061	60	315	-	Union Carbide Corp. (Ref. 63)
Type I	PAN (10,000 fil/tow)	0.072	61	250	280 <sup>(c)</sup> (310)	Morganite, Ltd.
Type II	PAN (10,000 fil/tow)	0.063	40	400	-	Morganite, Ltd.
Type A	PAN (10,000 fil/tow)	0.065	30	320	140 <sup>(d)</sup> (400) <sup>(e)</sup>	Courtaulds, Ltd.
Type B	PAN (10,000 fil/tow)	0.070	56	290	200 <sup>(d)</sup> (580) <sup>(e)</sup>	Courtaulds, Ltd.
Type C	PAN (10,000 fil/tow)	0.067	35	370	180 <sup>(d)</sup> (500) <sup>(e)</sup>	Courtaulds, Ltd.

(a) In the laboratory, filaments with moduli over  $100 \times 10^6$  psi and tensile strengths of 500,000 psi have been made and tested (Reference 50).

(b) 1 micron = 0.00004 inch; data based on manufacturer's information sheets and discussions with company representatives.

(c) Surface of fiber chemically treated to provide improved shear strength in resins composites.

(d) Available in 48-inch lengths.

(e) Available in lengths up to 1000 feet.

graphite fibers, which hinders the development of strong bonds between the fibers and resin matrices. This results in poor interlaminar shear strength in graphite/resin composites<sup>(3)</sup>.

### 3.2.1.3 Silicon Carbide Filaments

Of the two manufacturers now producing SiC/W filaments, one offers commercial quantities in 6-mil diameter only; the other produces these filaments in a range of diameters from 2 to 5 mils, but selects 4-mil diameter as the standard size. Properties of the 6-mil diameter filament are:

- Tensile strength, 350,000 to 650,000 psi.
- Elastic modulus, 60 million psi.
- Density, 0.125 lb/in<sup>3</sup>.

The 4-mil filament has the following properties:

- Tensile strength, 300,000 psi minimum.
- Elastic modulus, 70 ± 5 million psi.
- Density, 0.127 lb/in<sup>3</sup>.

The relatively high density of SiC/W filaments (Table 3-2) results in lower specific properties than either B/W or graphite filaments. However, this disadvantage may be compensated for by the good oxidation and corrosion resistance of SiC/W. Withers et al<sup>(5)</sup> report good stability of SiC/W filaments in contact with liquid aluminum and magnesium. Other investigators<sup>(4-7)</sup> report successful reinforcement of metal matrices with SiC/W. The use of this filament to achieve significant reinforcement in resins has been demonstrated<sup>(7-8)</sup>, but the good chemical stability of this filament suggests that it will be of greater value in metal-matrix composites.

Although silicon carbide filaments are the least developed of the new fibers, the improved chemical stability of silicon carbide-coated boron may force a change in this status. These filaments are produced by the same general technique used for boron filament (i.e., chemical vapor deposition of SiC on a heated tungsten core). The current costs are high because these filaments are in a relatively early stage of development. The prices vary from \$1800 to \$3000 per pound<sup>(4)</sup>.

### 3.2.1.4 Other High Modulus, Non-Metallic Filaments

Numerous other filaments have been investigated, including vapor deposited B<sub>4</sub>C/W, TiB<sub>2</sub>/W, B/SiO<sub>2</sub>, and polycrystalline Al<sub>2</sub>O<sub>3</sub>, BN, SiC, ZrO<sub>2</sub><sup>(4)</sup>. However, these

filaments formed by vapor deposition are in the very early stages of development, and it does not seem likely that they will receive any significant research and development effort at present. Many of the polycrystalline fibers are available commercially, but their specific properties do not compare favorably with those fibers shown in Figures 3-4 and 3-5. Continuous single-crystal fibers of alumina are now being produced in very limited quantities and they will probably be used mainly for reinforcing high temperature metal/alloys.

#### 3.2.1.5 Beryllium Wires

Of the commercially available wires, beryllium shows the greatest reinforcing potential in terms of its low density ( $0.066 \text{ lb/in}^3$ ) and high modulus. However, its low ductility makes it difficult to draw in wire form, and in 0.005-inch diameter, the price still runs above \$4000 per pound. The General Electric Company has recently been able to produce beryllium wire by a new process where the price of 0.005-inch diameter wire in lengths up to 1000 feet is running about \$2220 per pound (1 to 10 pound orders) and \$1700 per pound in larger quantities <sup>(70)</sup>. The properties include: 130,000 psi yield strength, 160,000 psi ultimate strength, and a modulus of elasticity of  $42 \times 10^6$  psi.

#### 3.2.1.6 High-Strength Steel Wires

Harvey Aluminum Company is using high-strength steel to reinforce aluminum <sup>(71)</sup>. Although the density of the steel wires is about 4.2 times greater than that of the Be wires, it is three times stronger, and thus possesses nearly the same specific strength. Although its chief limitation is a relatively low specific modulus (one-fifth that of beryllium), it is available as a relatively inexpensive fiber, viz., \$3.50 per pound <sup>(71)</sup>.

#### 3.2.1.7 Short Fibers

Many fibers are available only in short lengths, such as whiskers (single-crystal fibers) or natural varieties, such as asbestos. The whiskers are particularly attractive because of their high-specific strengths, but at present further development is required before they can be used in large structures. Perhaps their most promising future lies in reinforcing high-temperature metals and alloys—since in this area they have no serious competitors (when high specific properties are desired at temperatures above  $2000^\circ\text{F}$ ). The status of whiskers has been reviewed in References 45-49, and some properties are presented in Table 3-2.

Continuing interest is being generated in the asbestos fibers for reinforcing resins, because they have some properties approaching the whiskers (i.e., strengths over 600,000 psi and elastic moduli over  $27 \times 10^6$  psi). The main advantages of these fibers are low cost (as low as \$1.40 per pound—see p. VII - 46, Reference 49), availability, and a reasonable resistance to heat. Both in the U.S. (under Air Force support)<sup>(4, 72)</sup> and in England (p. VII - 45 to VII 46, Reference 49) major strides have been made in producing composites with high volume fractions of oriented asbestos. Bending strengths of composites exceed 90,000 psi, and moduli range between 9 to  $12 \times 10^6$  psi<sup>(4, 41)</sup>.

Continuous filaments of graphite and boron have also been chopped to reinforce resins<sup>(4)</sup>. Being short, they are amenable to a variety of fabrication techniques, such as use of molding compounds, or they can be used as secondary reinforcements for improved interlaminar strength in resins containing continuous boron or other large diameter continuous fibers.

#### 3.2.1.8 Fiber Price Trends

One of the key factors affecting the future progress of the advanced composites is the production volume and the cost of the raw material—the fibers themselves. Because these fibers are still in a developmental stage, it is difficult to predict reliable cost data a few years hence. However, for the purposes of predicting cost of future composite materials, it is instructive to estimate what the market might be and its effect on the price of fibers.

Figure 3-8 shows the current prices and the estimated future price trends. While the 1968 prices are still very high (compared to steel wires; and glass, which costs between \$0.30 to \$5.00 per pound) a steady decrease in price can be expected over the next seven years. The carbon fibers cost about the same as the boron fibers; however, it seems likely that the B/W fibers cost will not fall much below the \$200 per pound level, because of the high cost of the W-substrate (unless a breakthrough is achieved during this period). Filaments of boron using a cheaper substrate, such as glass, would be expected eventually to be about half this price, viz., \$75 to \$100 per pound. On the other hand, the precursor material of the graphite fibers is inexpensive, and as the process costs are reduced, the price of the graphite fibers may be expected to fall to the \$20 to \$60 per pound range, depending on the modulus and strength desired and on the specific process and precursor material. Deposition of SiC onto W is more complex than is boron on W, so that it is expected that these filaments will always be more expensive. The SiC-coated boron filaments will probably

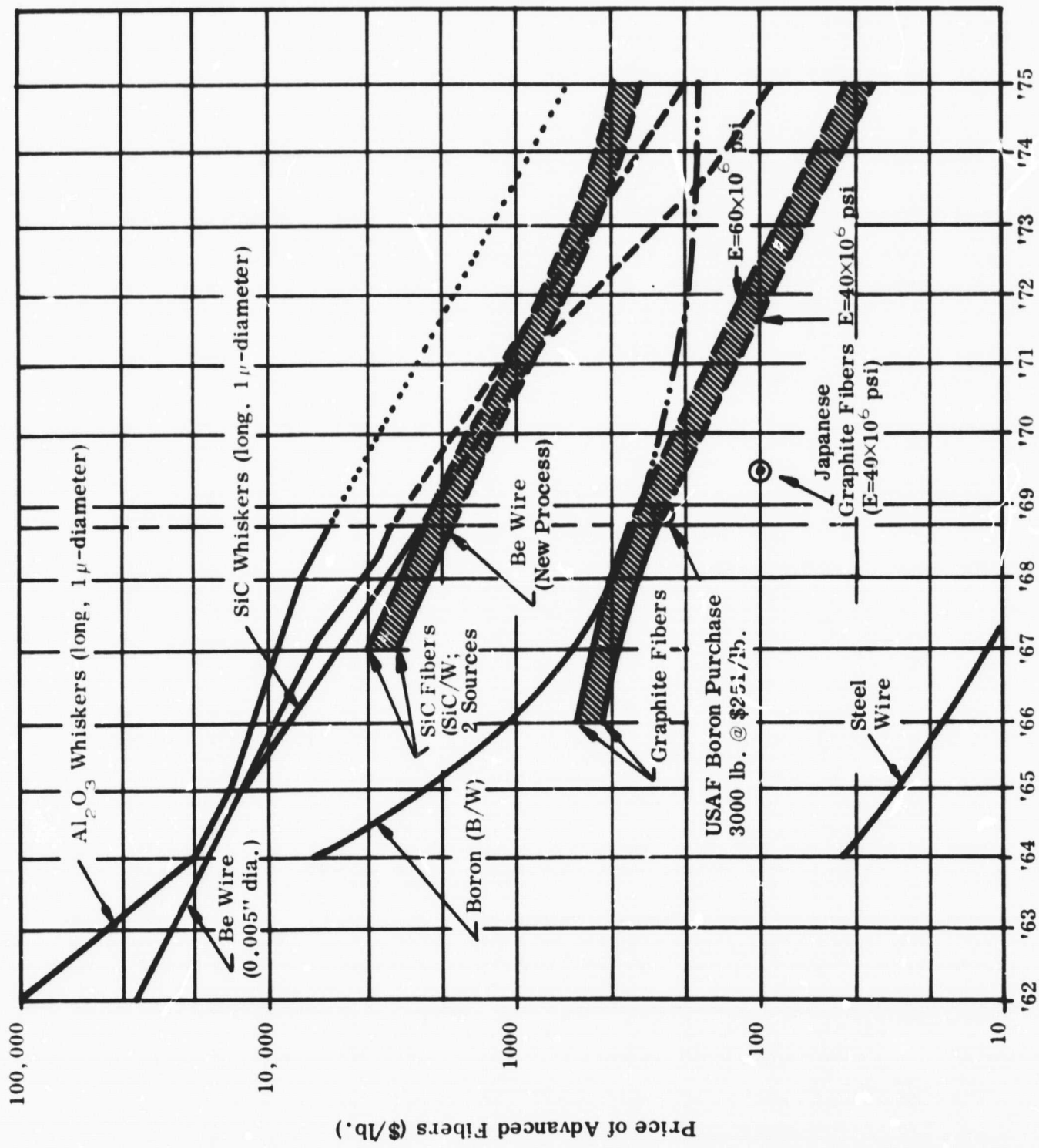

Figure 3-8. Projected Prices for Advanced Fibers for the Next Seven Years

cost only a small fraction more than the uncoated filaments. Beryllium wires have been very expensive, and will probably remain so until further major changes in processing are achieved. Already some breakthroughs have been made, and if this trend continues, the price may drop to the order of \$200 per pound by 1975.

### 3.2.2 MATRIX MATERIALS

Both resins and metals are used as matrix materials for fiber-reinforced composites. While the technology of reinforcing resins is more fully developed than that of reinforcing metals, resin materials are inferior to metals in certain applications aspects such as high-temperature environments as mentioned at the beginning of this subsection.

Five types of resins, polyester, epoxy, phenolic, silicone and polyimide, have been used in nearly all the filament-winding applications. Table 3-4 qualitatively compares the five types of resins. Epoxy resins are used extensively in the aerospace industry. Polyester resin has better electrical properties and is slightly lower in cost, but its mechanical properties are much inferior to epoxy resins.

Silicones are low-strength specialty resins, used primarily for thick radomes for supersonic aircraft requiring long-term heat resistance and excellent dielectric properties. If the strength requirements at elevated temperature are too high for silicones, the phenolics may be the suitable alternative choice.

The polyimides are a more recent development in matrix systems. They have good thermal resistance for both short- and long-term exposure and are used almost exclusively for their thermal properties. The polyimides are difficult to process since they require high cure temperatures and release volatiles (water and solvent) during the curing process.

It should be noted that for applications below 350° F none of the other resins shown in Table 3-4 is competitive with epoxy for structural applications.

Aluminum is the most commonly used metal matrix material. Titanium, magnesium, nickel, etc., are also used in composites. Properties and current status of production of these materials are discussed in Section 2. For more information, readers are referred to available conventional metal handbooks and related literature.

Table 3-4  
 Assessment of Matrix Resins  
 (113)

Resin	Mechanical Properties	Processability	Long-Term Heat Res.	Short-Term Heat Res.	Electrical Properties	Chemical Resistance	Cost
Polyester	Good	Very Good	Poor	Fair	Very Good	Good, Esp. Acids	Low
Epoxy	Very Good	Very Good	Poor	Fair	Good	Good, Esp. Alkalis	Low
Phenolic	Very Good	Good	Fair	Good	Fair or Good	Good, Esp. Acids	Low
Silicone	Fair or Poor	Fair	Good	Very Good	Very Good	Good	Moderate
Polyimide	Good	Fair or Poor	Good	Very Good	Fair or Good	Good, Esp. Acids	High

### 3.3 STATUS OF FIBER COMPOSITES

The development of reinforced polyester laminates during World War II and the subsequent sophisticated achievements in reinforced plastics have contributed more than anything else to the current attitude toward fibrous composites in general as a highly promising class of structural materials <sup>(73)</sup>. The growth of the reinforced resin industry has been outstanding and every indication suggests that it will continue. One forecast <sup>(8)</sup> predicts that 860 million pounds of glass fiber-reinforced polyester composites will be produced in 1975. Of that total, about 86 million pounds will find application in aircraft and missiles. These estimates do not include the new advanced fibrous composites, which are likely to be widely used in aerospace applications in a few years.

The availability of the high-modulus fibers has made it possible to greatly extend the number and types of matrices that can be reinforced. The low-modulus and high-chemical reactivity of the glass fibers has almost exclusively limited their use as reinforcements to resin matrices. However, the newer, advanced filaments are more stable in metallic matrices, so that a much greater range of fiber-matrix combinations can be investigated. Some composite systems currently under study are listed in Table 3-5. The more promising combinations for structural applications will be discussed subsequently.

#### 3.3.1 RESIN MATRIX COMPOSITES

Various resin-matrix composites that have promising future in structural application are discussed in the following section. Properties, methods of fabrication as well as status of production are presented in detail for individual composites.

##### 3.3.1.1 Glass-Resin Composites

The most commonly used resins today are polyesters, epoxies, and phenolics. Glass, because of its availability, and low cost, continues to be the most widely used reinforcement, but the increasing availability and the superior properties of the new, high-performance fibers will make possible resin-matrix composites of far better strength/density and stiffness/density ratios. However, the following discussion will be limited primarily to the advanced fibrous composites (e.g., boron-epoxy, graphite-epoxy, etc.) and will include some mention of glass-fiber-reinforced resins only for comparison.

Table 3-5  
Combinations of Fibers and Matrices Currently under Investigation

Fiber	Matrix			
	Al*	Ti*	Ni*	Resin
Boron	X	X		X
Graphite	X		X	X
Be	X	X		X
Stainless Steel	X	X		X
SiC**	X		X	X
SiC	X	X		
B <sub>4</sub> C**	X			
Al <sub>2</sub> O <sub>3</sub> **	X		X	X
Glass				X
Quartz	X			X
Asbestos				X

\* Metal or alloy

\*\*Whiskers

Fortunately, the fabricators of advanced fibrous composites have been able to rely heavily on the conventional methods used for many years in the glass fiber-reinforced resin industry. The Society of the Plastics Industry, Inc., has recently published a brochure in which these methods are described as follows:

- a. Hand lay-up: In the hand lay-up of resin matrix composites (often called contact molding), the reinforcement in the mat or fabric form is applied to the mold and saturated with resin, and the process repeated, layer by layer, until the laminate has been built to the desired thickness. Cure is at room temperature and with pressure and/or heat.
- b. Spray-up: Both reinforcement and resin are applied by specially designed dual-nozzle or mixing-head spray guns linked mechanically to glass-roving choppers. These guns mix resins and catalyst and project the mixture with chopped reinforcements onto the mold surface. Curing is usually performed in an oven.
- c. Matched die molding: Preforms of resin-matrix composites are held together by a small amount of binder resin prior to placing in matched metal die molds. After the binder resin has been cured, the preform

is placed in the mold. Molding resin is then poured on the preform and the mold is closed. Heat and pressure are used to polymerize the resin and to shape the final product to close tolerances.

- d. Filament winding: The reinforcement is pre-impregnated with resin and wound in predetermined patterns on a mandrel. The mandrel may be removable or may become a structural part of the molding. A variation of the filament winding process uses an impregnated tape instead of glass strands. This is known in the trade as "tape wrapping," and will be discussed later.
- e. Bag molding: Bag molding may be defined as a process in which a flexible bag or blanket is used to apply pressure against a manual wet lay-up while polymerization is taking place. This type of molding lends itself to parts whose size or complex shape preclude the use of any other molding method.
- f. Pultrusion: Flat sheets of resin-matrix composites as well as profile stock with high unidirectional strengths can be produced economically by impregnating continuous strands of reinforcement with resin and pulling the strands through a steel die. The die sets the shape of the stock and controls the ultimate resin content. Final cure is in an oven.
- g. Centrifugal molding: Round objects such as pipe can be produced by centrifugal casting. This method has the advantages of low labor costs, adaptability to automation, low tooling costs, uniform void-free wall thickness, and production of good inside and outside surfaces. In centrifugal molding, the reinforcement and the resin are positioned either separately, or as a premix inside a hollow mandrel and held in place by the centrifugal action of rotation prior to and during the cure cycle.
- h. Continuous laminating: In the continuous laminating process for making flat or corrugated resin-matrix-composite sheets, the reinforcement in fabric or mat form is impregnated by dipping, rolls exert pressure, and the sheet is cured in an oven.

This wide variety of manufacturing techniques has undoubtedly been an important factor in the steady growth of the fiber-reinforced resin industry and will very likely exert considerable influence on the progress of advanced fibrous composites. In fact, certain prototype hardware programs which will be discussed later have been using filament winding, tape winding, or continuous laminating processes to make various aerospace components. The unidirectional fiber alignment in the composites produced

by these methods results in structures having excellent physical and mechanical properties <sup>(74)</sup>. In addition, the winding and wrapping techniques are extremely useful for fabricating complex shapes of revolution and for obtaining very high (60 to 80 v/o) fiber fractions in the final composite <sup>(75)</sup>. Thus, it appears that filament winding, tape wrapping, and continuous laminating are also becoming established as methods for producing advanced fibrous composites. However, some of the other methods may become just as useful. One program (Reference 49, p. VII-100) is studying the feasibility of molding short-fiber, resin-matrix, aircraft structural components.

While there are an infinite variety of process steps that can be used to fabricate resin-matrix composites, the details and decisions to specify specific procedures will depend largely on the fabricability of the materials, on the design, and on the service requirements. A general series of steps for producing glass fiber-reinforced resins are shown in Figure 3-9. Here, the fibers may be in continuous lengths (usually in multi-filament rovings), in some woven form, or in a staple or chopped form.

Although fiber-reinforced resins can be produced by a variety of forming methods, the temperature limitations of resins in general have been a disadvantage. The inability of the commonly used resins (polyesters, epoxies, and phenolics) to remain structurally stable at temperatures approaching 400°F has restricted the use of fiber-reinforced resins to relatively low-temperature applications. This deficiency becomes even more pronounced with the realization that the proposed, advanced flight vehicles, such as the supersonic transport, will develop skin temperatures as high as 450°F to 500°F for extended time periods, and possibly as high as 600°F for short times <sup>(76)</sup>.

Fortunately, significant progress has been made recently in developing more thermally stable resins for use as matrices <sup>(76-81)</sup>. Perhaps the most familiar of these new resins are the polyimides (PI) and the polybenzimidazoles (PBI) <sup>(82)</sup>. However, other resins such as the diphenyl oxides and the polybenzothiazoles, now under development, also appear promising for high-temperature applications.

While the excellent thermal behavior of both PI and PBI composites is desirable, these resins are not without shortcomings. During the cure cycles, large quantities of volatile matter (water and phenol) are evolved, leaving many voids in the matrix. The present high strength of these materials could be increased even further, if the void content can be reduced. Thus much effort is being devoted to improving both the cure cycles and the resins themselves to overcome this current deficiency.

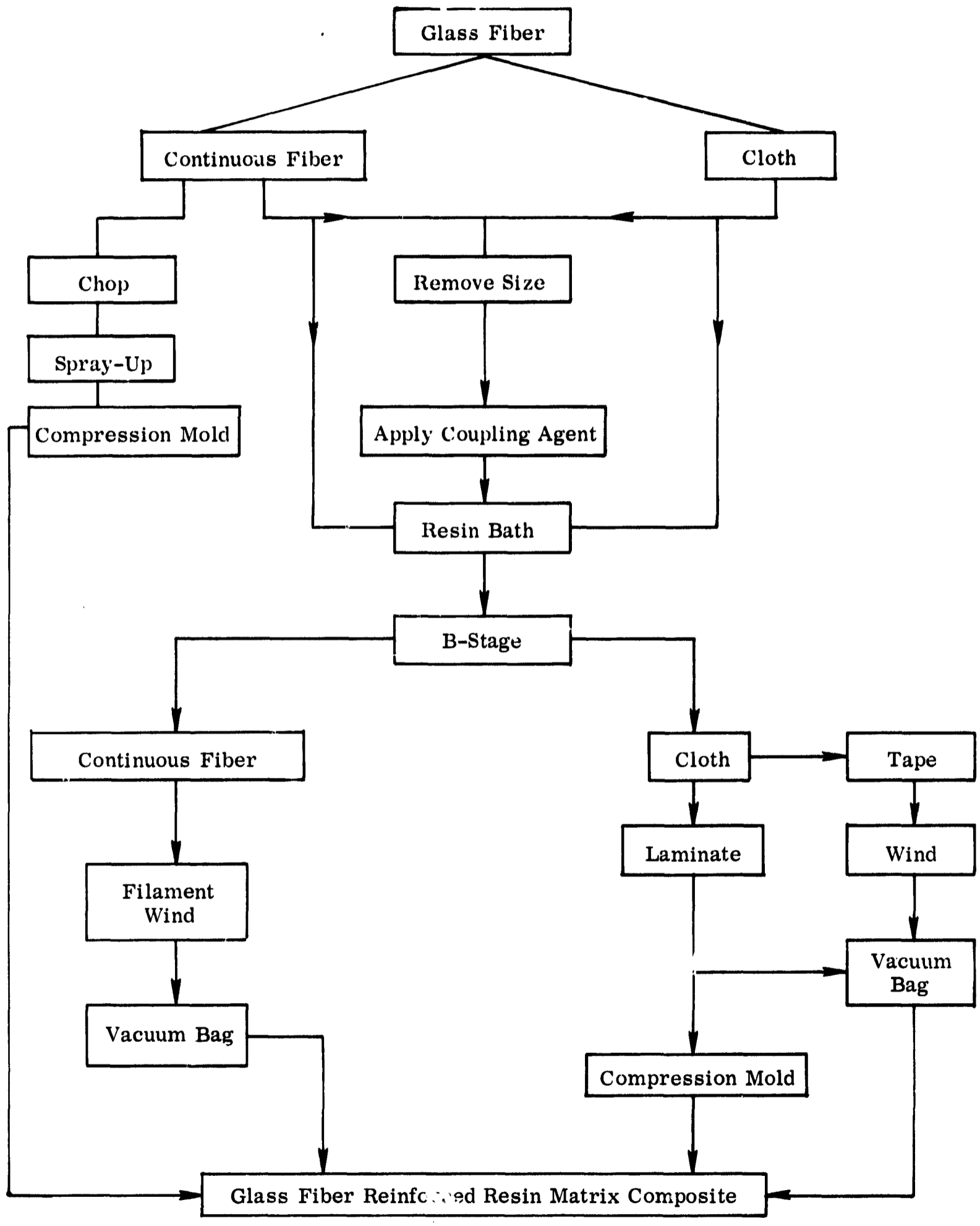

Figure 3-9. Process Flow Diagram for Glass Fiber-Reinforced Resins

### 3.3.1.2 Boron-Resin Composites

Of all the new, high-modulus fibers, the boron fibers have received the main emphasis in the United States. Graphite fibers are gaining substantially, and nearly all the work in England has been devoted to the development of these fibers and hardware components, which will be discussed later. However, it seems likely that some balance of effort will be obtained in the future, depending on the performance requirements, on the design, and on the economics involved. It may be that a cheaper substitute will be used for boron deposition (such as glass or even inexpensive carbon/graphite filaments having low modulus).

Much of the technology used in the glass-reinforced plastics (GRP) has been adapted to make boron composites (BRP). The boron fibers are not nearly as susceptible to damage from mechanical abrasion or environmental exposure (such as water vapor). However, their diameters are considerably larger (0.004 versus 0.0004 inch for the glass fibers) as shown in Figure 3-6 so that they should not be bent (or filament wound) over curves having small radii (say less than 1/2 inch). In addition, the surface chemistry is different, so that surface treatments (cleaning, sizing, coupling agents, etc.) are usually different. Figure 3-10 shows a flow diagram for various process steps that are being used to fabricate boron composites. The general procedures are similar to those shown in Figure 3-9 for the GRP composites. In some cases the boron fibers may be cleaned (by etching) before the resin or coupling agent is added, but this is not usually done in current practice.

The boron/epoxy composites are attractive structural materials because of their high specific properties, excellent fatigue and environmental resistance.

The room-temperature data for boron/epoxy composites are compared in Table 3-6. On a specific strength basis (S/D), the boron/epoxy composites have values about 65 percent of those for the glass-reinforced composites. However, on a specific modulus basis, the boron composites are more than four times better.

Some fatigue data <sup>(83)</sup> on boron/epoxy face sheets (adhesively bonded to an aluminum core) which were stressed in beam bending at the North American Aviation Laboratories are shown in Figure 3-11. A completely reversing mode was used, thereby placing the composite face sheets alternately in tension and compression. The data are compared with those for 2024-T3 aluminum and for GRP composite. The boron

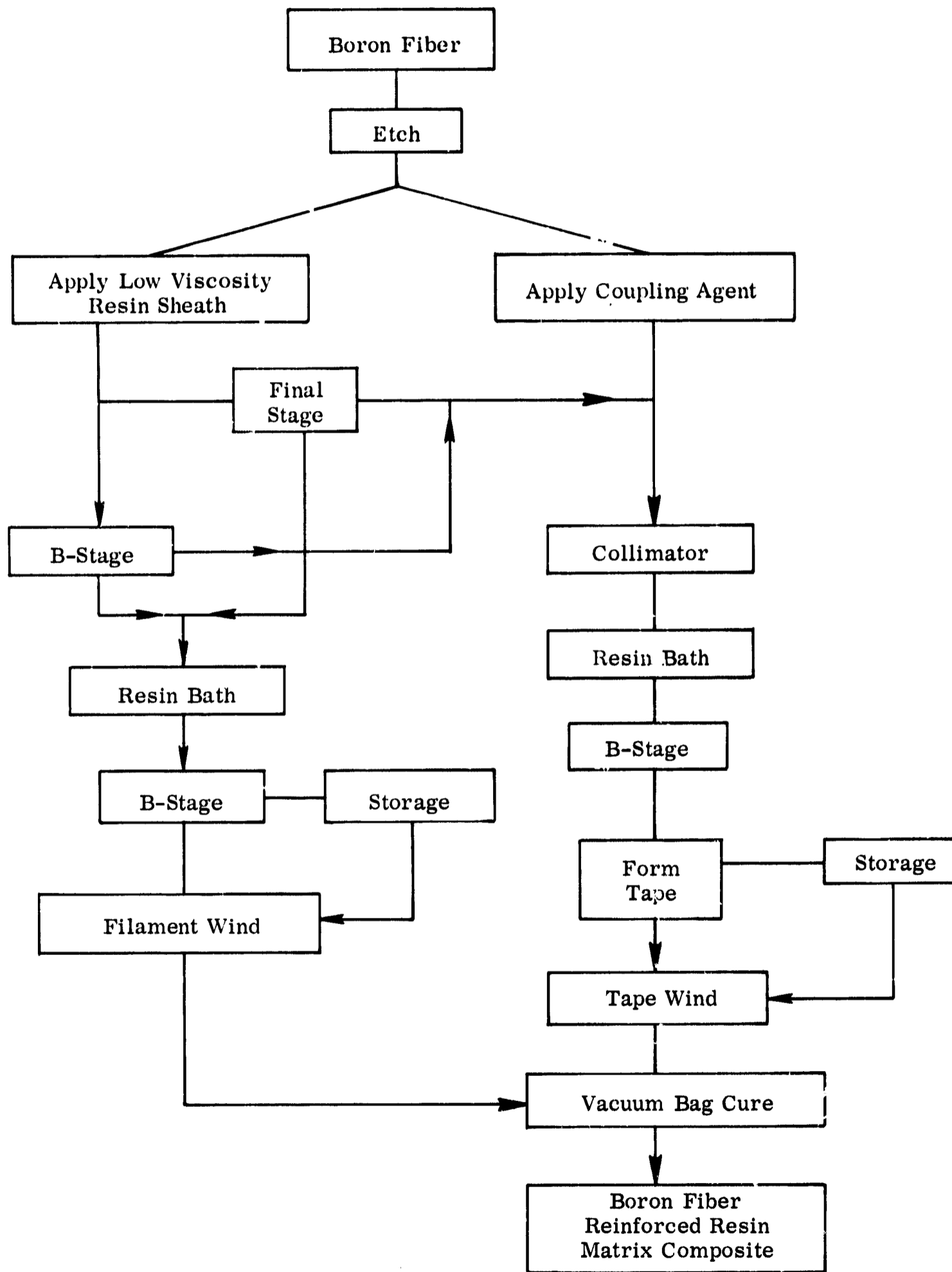

Figure 3-10. Process Flow Diagram for Boron Fiber-Reinforced Resins

Table 3-6  
 Room Temperature Tensile and Specific Strengths for Some Fiber-Reinforced Epoxies  
 (from Reference 46, 49)

Type	Fiber*		Composite**				
	Density (lbs/in <sup>3</sup> )	Volume Percent	Density**, D (lbs/in <sup>3</sup> )	Strength, S (10 <sup>3</sup> psi)	Modulus, E (10 <sup>6</sup> psi)	S/D (10 <sup>3</sup> inches)	E/D (10 <sup>6</sup> inches)
S-Glass	0.090	60	0.072	290	7.4	4000	100
B/W	0.095	67	0.076	200	33.1	2630	436
Be	0.067	73.3	0.061	150	33	2500	540
Graphite	0.072	nr	nr	90	40	1500	660
Graphite	0.072	40	0.055	105	22	1900	400
Al <sub>2</sub> O <sub>3</sub> §	0.143	44	0.063	72	24	810	380
Al <sub>2</sub> O <sub>3</sub> §	0.143	14.2	0.059	113	6.0	1920	102

\* Unidirectional Orientation

\*\* Density of Resin = 0.046 lb/in<sup>3</sup>

nr = not reported

§ Whiskers

composite was able to withstand significantly higher stresses (expressed in terms of percent UTS) over the range tested (in excess of  $200 \times 10^6$  cycles).

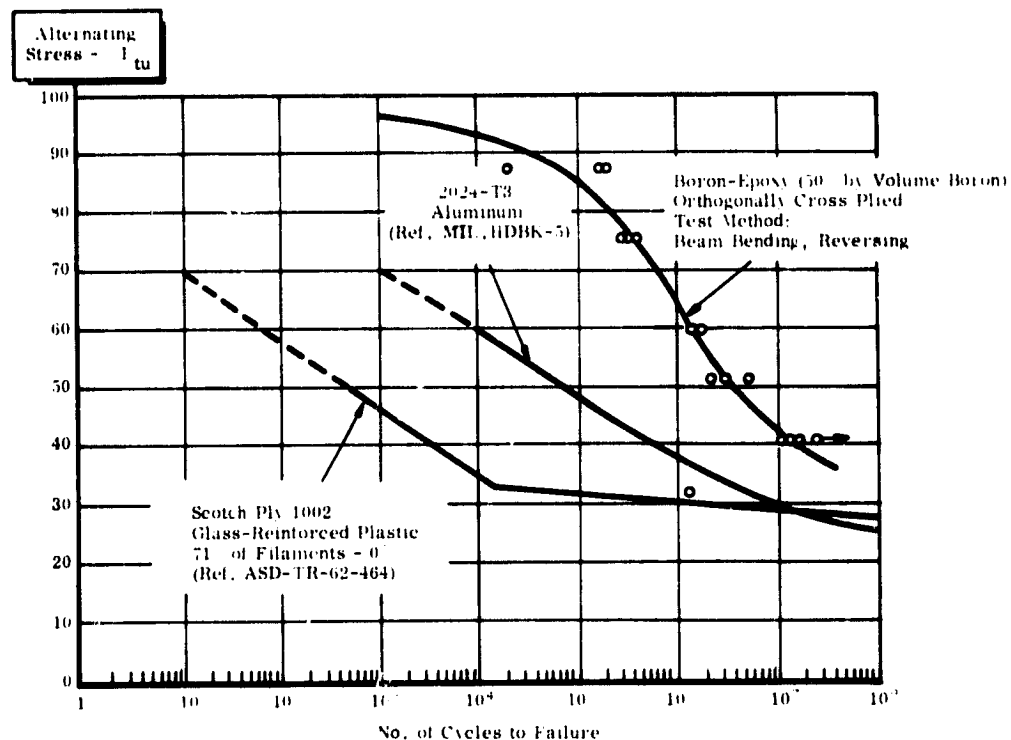

Figure 3-11. S-N Curves Comparing Fatigue Data of Boron-Epoxy Composites with Glass-Reinforced Plastic and 2024-T3 Aluminum<sup>(83)</sup>

Much of the current effort on boron-resin systems is directed toward:

- a. Better control of fiber spacing (through the use of sheathing coatings).
- b. Preparation of collimated tapes.
- c. Optimizing processing methods.
- d. Scaling up equipment.
- e. Developing automated processes (including tape laying).
- f. Developing higher temperature resin-tape systems.
- g. Working on joining methods.
- h. Quality control and NDT.
- i. Design and demonstration of hardware.

In summary, there is now a vast amount of information that has been (and is continuing to be) generated on a wide variety of boron composite materials. Current emphasis is on further developing and demonstrating the potential of these materials primarily for flight hardware. Much of the composites are being prepared by tape winding or by lamination of broad-goods (i. e., woven materials).

### 3.3.1.3 Graphite-Resin Composites

There is a widespread feeling that the graphite-resin composite will eventually be one of the most widely used of all the forthcoming advanced composite materials. This results from the outstanding potential of the carbon filaments for reinforcement available in continuous lengths and having exceptional structural efficiencies, highest modulus-to-density ratios, coupled with the fact that its future price will be relatively low among the advanced filaments, i. e., on the order of \$12 per pound <sup>(84)</sup>.

In comparison to the boron or glass composites, the tensile properties have been somewhat lower (as shown in Table 3-6), but recently high-strength fibers have become available in suitable quantities for composite evaluation. This high modulus for the graphite-resin composites has been achieved in several laboratories <sup>(49)</sup>. Thus, a material now exists which has a density 50 percent of that of aluminum and a modulus (in one direction) that is greater by 30 percent than steel.

Like the boron-resin composites, much effort is directed toward the application of these materials to hardware. This aspect will be discussed later. A process used to fabricate carbon-fiber-resins composites is shown in Figure 3-12.

One of the limitations of these composites has been the low interlaminar shear strength. For example, an interlaminar shear strength of 6000 psi is not unusual for a glass fiber-reinforced resin, compared to about 3400 psi for a similar composite reinforced with graphite fibers <sup>(85)</sup>. Preliminary investigations with interfiber dispersions of whiskers showed some promise, but greater improvement was needed. A recent technique described as "whiskerizing" reportedly provides this improvement <sup>(86)</sup>. The process results in the radial growth of silicon carbide whiskers on the surface of a graphite filament. The whiskers apparently provide additional bonding surfaces and form a mechanical interlock between the graphite fibers and the matrix. Shear strength improvements of 300 percent have been described for epoxy-resin composites utilizing "whiskerized" filaments as reinforcements. "Whiskerizing" reduces fiber strength somewhat and appears to be expensive. However, other methods have also been employed for improving interlaminar shear. Herrick <sup>(87)</sup> used a combination of chemical oxidation with nitric acid followed by a polymeric coating to improve the shear strength of graphite-fiber-reinforced epoxy composites. Air oxidation at 875° F of graphite fibers has been used for increasing the interlaminar shear strength of graphite fiber-reinforced epoxy composites <sup>(49)</sup>. These techniques have been demonstrated to more effectively utilize the reinforcing potential of the new fibers, but as Herrick <sup>(87)</sup> points

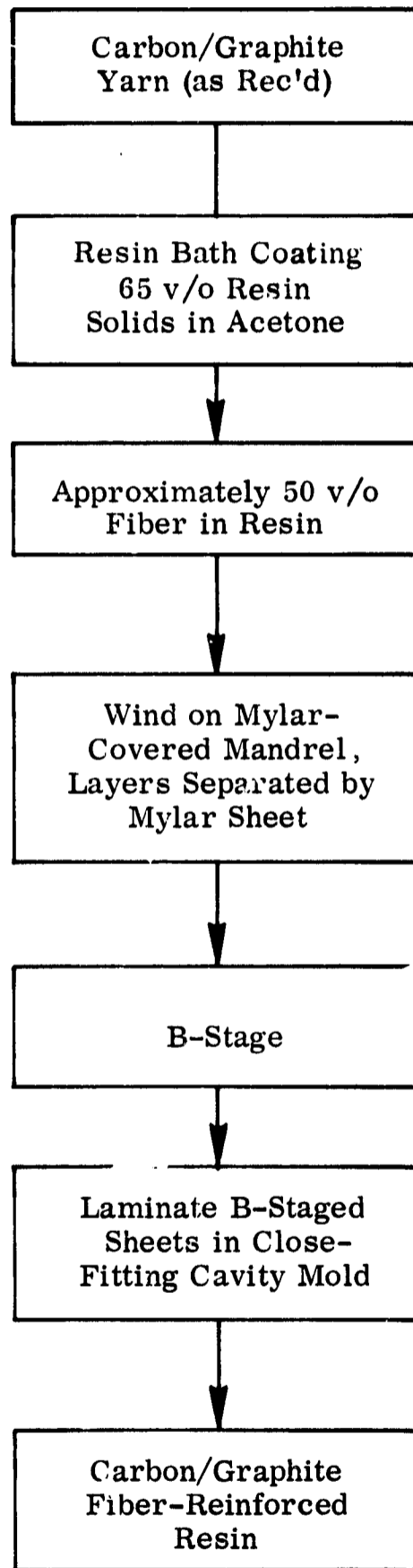

Figure 3-12. Process Flow Diagram for Carbon/Graphite-Reinforced Resins

out these same techniques can also reduce the composite tensile strength. However, surface treatments of the carbon filaments by a variety of chemical means are now producing composites in the laboratory having interlaminar shear strength in the 6000 to 12,000 psi range <sup>(49)</sup>.

The current sandwich constructions using the high-modulus graphite (Thornel 50 and Morganite II) epoxy combinations are surpassing mechanical properties of the boron/epoxy sandwich structure <sup>(4)</sup>. Because the graphite fibers can also be woven into various cloths and fiber patterns, work is also being conducted on these systems <sup>(49, 62)</sup>.

#### 3.3.1.4 Beryllium-Resin Composites

Although in the early stages of development, the Be-epoxy composites are unique, since the reinforcements exhibit ductile deformation prior to composite rupture. Thus, these composites exhibit a definite yield characteristic in the stress-strain curve. This type of phenomenon could perhaps be used to advantage in resins where structural discontinuities occur, such as at joints, cut-outs, or attachments <sup>(4)</sup>. Some tensile properties of these composites (based on a NOL ring test) are also shown in Table 3-6. The specific properties compare favorably to both boron- and graphite-epoxy composites.

#### 3.3.1.5 Short-Fiber Reinforced Resins

Both whiskers <sup>(49)</sup> and asbestos fibers <sup>(4, 84)</sup> are being used to reinforce a variety of thermosetting and thermoplastic resins. Some properties of  $Al_2O_3$  (whiskers)-epoxy composites are shown in Table 3-6. Work on asbestos fiber-reinforced resins is progressing well in both the United States (AFML) and in England, especially in the area of collimating the fibers and achieving high fiber loadings in the composites <sup>(4, 49)</sup>.

When in highly aligned configuration, the whiskers or asbestos fibers are best utilized in processes which utilize tape or laminating methods. However, they can be used in randomized orientations for molding processes.

Work is also being performed on resins reinforced with chopped fibers of boron and carbon, again molding processes are used <sup>(4, 49)</sup>.

#### 3.3.1.6 Mixed-Fiber Resin Composite

As the technology of fiber composites matures, the level of understanding and sophistication also increases. More recently, combinations of fibers are being utilized so that a greater number of properties may be optimized. For example, small-diameter

fibers can be added to composites containing large diameter fibers; this could aid in fabrication (glass fibers woven normal to parallel arrays of boron fibers)<sup>(83)</sup>, aid in fiber spacing<sup>(83)</sup>, fill interstices between the large fibers, improve composite transverse properties, etc. There are numerous combinations that can be considered. AVCO, for example, developed a 3-D weave whereby silica, carbon, and boron fibers were each woven into three mutually perpendicular directions (Reference 49).

The Air Force Materials Laboratory has also shown the advantages that can be gained through the use of mixed-fibers. For example, a molded Be-wire resin composite had a flexural strength of 150,000 psi<sup>(4)</sup>. When high strength S-glass fibers were used along with the Be-wires in a 1.75:1 ratio, the flexural strength was increased to 245,000 psi. However, the composite flexural modulus was reduced from  $26 \times 10^6$  psi (no glass) to  $16 \times 10^6$  psi. On the other hand, by adding Be, B, or graphite fibers to glass fiber reinforcements, the composite modulus of the GRP material can also be increased in a predictable manner.

#### 3.3.1.7 Fiber-Resin Tapes and Prepregs

When one considers that there are 70,000 feet (over 13 miles) of boron filaments in a pound, and that there are over 3000 miles of graphite filaments\* in one pound, it is obvious that single-filament winding will not be practical for large structures. However, much effort is being devoted to producing these fibers in tape form. Both boron-epoxy and graphite-epoxy tapes are now available (the boron tapes in lengths up to 500 feet).

Currently Narmco, 3-M, and Hercules, Inc., are producing boron tape. The properties of the 3-M tape are shown in Table 3-7 and the properties of Narmco graphite prepreg and composite materials are shown in Table 3-8. A list of some of the leading suppliers of graphite and boron tapes is shown in Table 3-9.

Several companies, including General Dynamics and McDonnell-Douglas are designing and using numerically controlled tape machines to fabricate boron-epoxy structural components<sup>(61)</sup>. Thus, as automatic processes become operational, the fabrication costs for producing the composite structural components would be expected to drop drastically.

---

\*Graphite fibers are available only in yarn form which contains either 720 or 10,000 fibers/yarn (tow).

Table 3-7  
 Properties of Prepreg Boron-Epoxy Tape ("Scotch Ply" SP-272) <sup>(111)</sup>

Tape	Boron fibers unidirectionally oriented in an epoxy resin which can be cured in an autoclave.
Size	3 inches wide (212 boron filaments per inch) 0.0051 to 0.0054 inch thick per ply
Matrix	32 percent by weight
Glass Carrier	Style 104 Series
Length/Pound	67 feet
Length/Reel	500 feet
Density	0.074 lb/in <sup>3</sup>
Tensile Strength	206,000 psi (114,000 0°/90° fiber orientation)
Tensile Modulus	33.1 × 10 <sup>6</sup> (19.1 × 10 <sup>6</sup> 0°/90° fiber orientation)
Compression Strength	250,000 psi
Shear Strength	17,000 psi (horizontal beam)

Table 3-8  
 Test Results on Surface Treated Morganite Graphite  
 Fiber/Epoxy Resin Prepreg and Composite\* <sup>(112)</sup>

Type Test (Temperature)		Type I		Type II	
		Average Strength 10 <sup>3</sup> psi	Average Modulus 10 <sup>6</sup> psi	Average Strength 10 <sup>3</sup> psi	Average Modulus 10 <sup>6</sup> psi
Flexural	(RT)	92.8	29.1	146.6	17.2
	(350° F)	75.0	27.3	107.0	16.0
Compression	(RT)	63.2	25.2	104.3	15.9
	(350° F)	40.5	26.7	50.6	15.2
Tensile	(RT)	73.2	30.2	104.2	16.8
Transverse Flex	(RT)	9.73		18.7	
	(350° F)	5.18		7.14	
Beam Shear	(RT)	8.75		16.5	
	(270° F)	8.20		10.2	
	(350° F)	6.01		7.07	
	(420° F)	3.45		3.54	

\*Resin Content, %/W—Type I (32.9%/W)  
 Type II (26.2%/W)

Table 3-9  
Suppliers of Composite Tapes and Prepregs\*

Manufacturer	Fiber	Matrix	Cost
Hamilton-Standard	(SiC coated B-filaments)	6061 Al	\$100/ft <sup>2</sup>
3-M (XP-272)	Boron	Epoxy	**
(XP-263)	Graphite	Epoxy	**
Narmco	Boron	Epoxy	**
	Graphite	Epoxy	**
	Boron	Al Alloy	**
Hercules, Inc.	49% Boron	Epoxy	**
Goodyear	Glass and Boron	Epoxy	**
Courtaulds, Ltd.	Graphite	Epoxy	**
Morganite R&D, Ltd.	Graphite	Epoxy	**
HITCO	Graphite	Epoxy	**

\* Data from Suppliers' Literature.

\*\*Available from manufacturer, prices of epoxy tapes generally range from \$450 to \$550 per pound at present.

### 3.3.2 METAL-MATRIX COMPOSITES

Metal-matrix composites are still in the early developmental stage. It is known that their potential in structural applications rely on various factors such as methods of fabrication and selection of combination of constituents. Basic methods of fabrication are described below. Different types of metal-matrix composites are discussed with regard to their potentiality, availability, price, as well as sources of supply.

#### 3.3.2.1 General

The increasing interest in fiber-reinforced metals and alloys arises from several advantages possessed by these materials when they are strengthened with the new high-modulus filaments and whiskers. Some of these benefits include:

- a. Improved, superior strengths at elevated temperature for a wide variety of metals and alloys, including improved stress-rupture life and improved creep resistance.
- b. Major improvements in specific strength, by virtue of the high strength and lower density of the reinforcing fibers.
- c. Major increases in the actual and specific elastic moduli of lightweight metals.

- d. A high degree of anisotropy by virtue of the fiber orientation, thereby offering greater latitudes in the design of high-performance structures.
- e. Added flexibility in the selection of materials for use in corrosive or oxidizing environments. The matrix metal or alloy can be chosen on the basis of its resistance to this type of environment, while the fibers (which are protected by the matrix) provide the major strength and stiffness to the structure.

The outlook for fiber-reinforced metals and alloys is optimistic in terms of these great potential advantages, and some predictions indicate that these materials will be used in aircraft in the early 1970's (see, for example, 30).

However, it should be emphasized that the fiber-reinforced metals are still in an early stage of development (compared with fiber-reinforced resins) and many problems remain to be solved before their full potential can be realized. Chief among the problems are those of composite fabrication and chemical compatibility between the fibers and matrix, since fabrication or service temperatures may be high. Furthermore, the direction and degree of plastic deformation of the matrix around the fibers due to pressure-forming processes (such as extrusion, hot pressing, rolling, etc.) must be very carefully controlled to avoid breaking or otherwise mechanically weakening the fibers. Many times, working or secondary forming of the composite material is necessary in order to reduce matrix porosity.

Numerous fiber-metal combinations are currently being investigated, including some model systems in a continuing effort to better understand the factors which affect the properties of fiber-reinforced metals. Most of the work, however, is devoted to systems which have engineering potential. Several metal-matrix composites can now be purchased in sample quantities for testing and evaluation. Some of these materials are listed in Table 3-10.

Since the fabrication of metal-matrix composites is complex, the properties of the final material will be greatly affected by the forming method. There are numerous methods and variations in techniques which have been used to produce fiber-reinforced materials. Five of them are schematically shown in Figure 3-13.

In the first example shown in Figure 3-13, a coating is applied directly to the fibers. This coating, if sufficiently thick, may also serve as the matrix, so that dense composites can be formed directly by hot pressing parallel arrays of coated fibers.

Table 3-10  
Metal-Matrix Composites Currently Available in Sample Quantities and Limited Size<sup>(4t)</sup>

Matrix	Reinforcement	Source
Aluminum	Boron Silicon Carbide Beryllium Alumina* Silicon Carbide*	General Technologies Corp.
Aluminum Alloys	Boron	Marquardt Co.
	SiC Coated Boron	Hamilton Standard Division, UAC
	Boron or NS 355 Stainless Steel	Harvey Aluminum, Inc.
Magnesium	Boron or Silicon Carbide	General Technologies Corp.
Nickel	Boron Silicon Carbide Tungsten Alumina* Silicon Carbide*	General Technologies Corp.
Titanium	Silicon Carbide	General Technologies Corp.

\*Whiskers, all others continuous fibers.

The first method shown in Figure 3-13 is the application of the matrix as a coating to the fiber. This may be accomplished by drawing the fiber through a melt, by plasma spraying, by electroplating or by other techniques. The coated filaments are then aligned or wound onto mandrels and then hot-pressed to form a compacted structure.

A second approach (in Figure 3-13) is to place single layers of aligned fibers between alternate sheets of the matrix materials and then diffusion bond all these layers in order to consolidate them into one solid composite sheet. Another approach is similar, where the sheets of the matrix can be replaced by the matrix in powder form, and then the fibers plus matrix can be hot-pressed into a dense composite.

When the matrix is liquid (melted), it may be infiltrated into an aligned bundle of fibers and then solidified, or if it is an alloy of suitable composition (such as an eutectic alloy), it can develop a structure of aligned fibers or platelets in the direction of

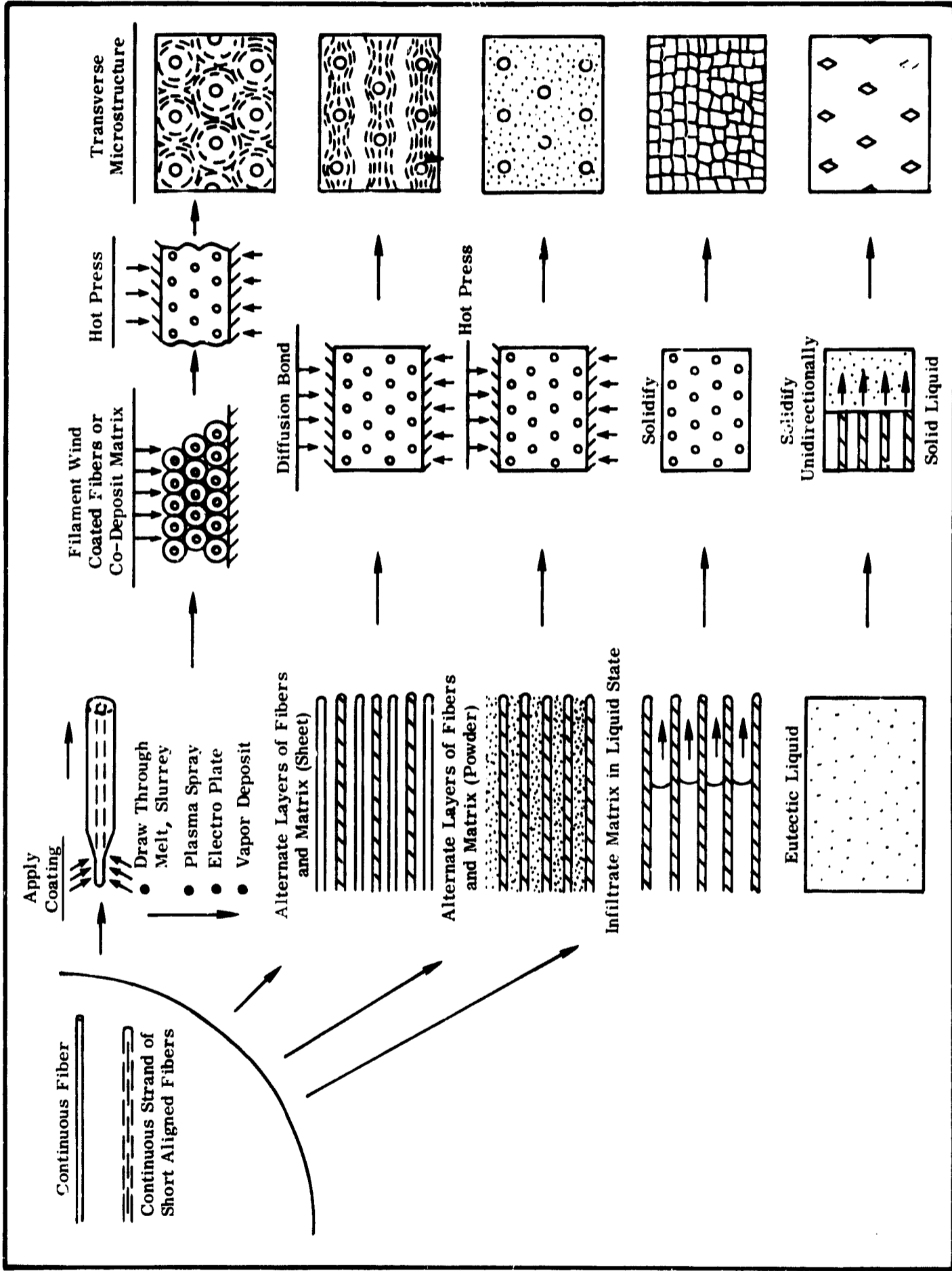

Figure 3-13. Some Basic Methods Used to Fabricate Inorganic Fibrous Composite Materials (49)

solidification. This latter approach has the advantage of not having to handle or align the fibers separately; they are formed in situ during the solidification process. On the other hand, the composition and volume fraction of the fibers is fixed for a given alloy.

Two other forming methods have been receiving increasing attention recently. One is the co-deposition of fibers and matrix by electroplating techniques<sup>(84-86)</sup>; the other is a high-energy-rate forming (HERF) process<sup>(87, 88)</sup>.

### 3.3.2.2 Boron-Aluminum

Of all the metal matrices, aluminum and aluminum alloys have received by far the greatest emphasis.

Strong composites of boron/aluminum and steel/aluminum have been made by diffusion bonding alternate layers of aligned boron filaments and thin sheets of aluminum or aluminum alloys<sup>(71, 89-100)</sup>. Fiber degradation is avoided by using moderate temperatures and pressures for fairly long periods of time. Relatively large specimens have been produced and excellent control over the fiber packing and spacing has been achieved.

Today, about 90 percent of the production of boron/aluminum composites involves hand labor. The production rate was 100 pounds per year in early 1968 and has risen to 1,000 pounds per year since. A forecast of production rate predicts 10,000 pounds per year in 1969 and 100,000 pounds per year in 1970<sup>(61)</sup>.

The major producer of the aluminum composites is Harvey Aluminum Co. They currently are producing a wide variety of composites having different alloys as the matrix. The properties of some of these composites are listed in Table 3-11. Much of the recent effort has been to reduce the scatter in the strength data, and Table 3-12 illustrates the minimum and maximum values obtained during the first three months of 1968. Current costs are running about:

2024 Aluminum foil	\$5 per pound
Boron filament	\$300 to \$350 per pound
Composite	\$2000 per pound

Table 3-11

Effect of v/o Boron and Matrix Temper on Ultimate Tensile Strength (ksi) (1)

Type Matrix	v/o Boron	No. Tests	Average	90% Range Between	Coefficient of Variation
6061-F	20 - 25	40	78.3	64.4 and 111.7	23.6
6061-F	37	28	130.0	106.0 and 155.0	24.5
6061-O	50	35	152.9	121.0 and 199.5	38.8
6061-F	45 - 50	244	156.3	134.0 and 205.0	35.5
6061-T6	50	12	125.9	102.0 and 170.5	33.8

Table 3-12

Properties of Panels Approximately 12 by 24 Inches with 45 - 50 v/o Boron During First Three Months of Production, 1968 (1)

Month (1968)	Ultimate Tensile Strength (ksi)		
	Minimum	Maximum	Average
Jan	123.2	140.5	130.5
Feb	124.0	187.0	150.4
Mar	130.8	177.1	154.9

The reduction in price with increasing production is estimated as follows (1):

Material	Time	Cost per Pound
Aluminum-boron	Today	\$2000 - \$3000
	1970	\$500
	1973	\$200
	1978	\$100
Aluminum-carbon	1978	\$ 50
Titanium-silicon carbide	1978	\$125

The Marquardt Co. is also producing boron-aluminum composites for sale. They are also working on reducing the strength scatter of the composites. Some of their data are plotted in Figure 3-14.

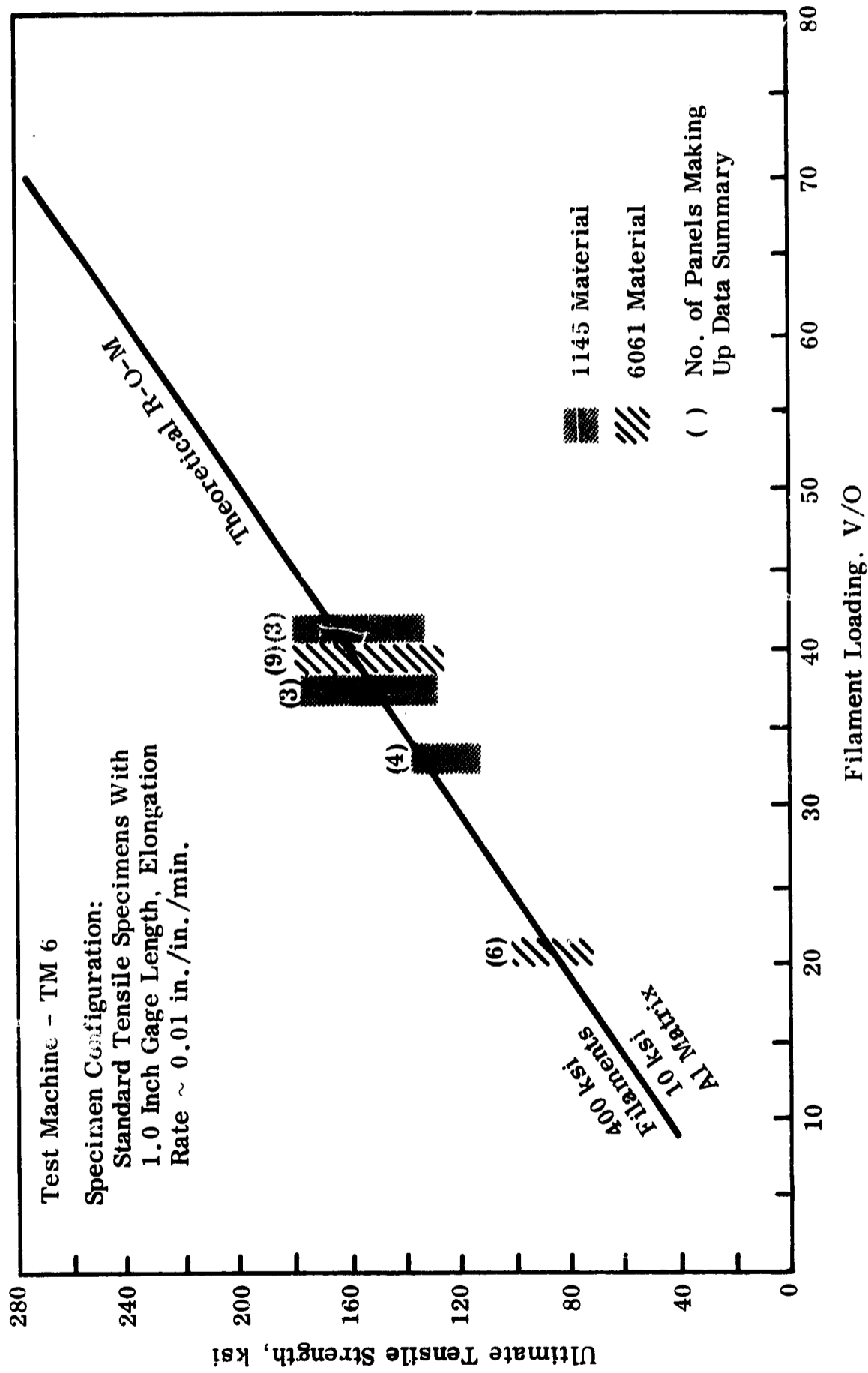

Figure 3-14. Uniaxial Al-B Tensile Test Data  
 Fabricated and Tested by the Marquardt Corp.  
 (1145 & 6061 Al Matrix Material, Diffusion Bonded)

The Convair Division of General Dynamics and Harvey Engineering Laboratories in their current programs (sponsored by the Air Force Materials Laboratory) are making integrally stiffened panels of boron-aluminum composites. The purpose of this work is to construct a payload adapter for the PRIME vehicle, 60 inches in diameter and 41.5 inches long. Using this construction, it is anticipated that a 41 percent weight saving will result over sheet stringer aluminum construction. The boron fibers may be either uncoated or coated with either silicon carbide or boron nitride. Aligned fibers are layered between aluminum sheets, 2.5 mils thick (Al 2025) in 50 volume percent. They are bonded in a modified hydraulic forging press at 900°F in an enclosed, evacuated can. Thus far, 48 by 48 inch sheets have been made and the strength and elastic properties approach predicted values. In the case where stringers are made the boron reinforcements are omitted in the curved areas as shown in Figure 3-15. Thus hat sections can be formed from the sheet materials. Stringers are attached either by mechanical fastening or spot welding. The sheets are fastened by lap-joint riveting, but continuous spot welding is being studied. Development work continues on the pressing operation so that the canning operation can be eliminated. This involves building a vacuum chamber within the press. Harvey estimates that adaption of a press to accommodate a 48 by 96 inch panel would cost \$200,000 <sup>(101)</sup>.

Problems which require further effort are better methods of joining and better methods of forming shapes.

Boron-aluminum has been used as face sheets for aluminum core honeycomb panels by North American, Downey <sup>(101)</sup>.

### 3.3.2.3 Silicon Carbide-Aluminum Composites

Alternate methods for making aluminum-boron composites, such as vacuum casting, liquid metal infiltration, etc., do not show as much promise as the hot pressing due to the degradation of the properties of the boron fiber. Hamilton Standard Division of United Aircraft Corporation is making Borsic (silicon carbide coated boron) and aluminum tapes by plasma spraying aluminum onto the boron filament. To fabricate shapes, the tapes are layered and then diffusion bonded into the desired curvature.

The tape is currently selling for \$1150 per pound in one-pound orders, and for less than \$550 per pound for orders exceeding 100 pounds.

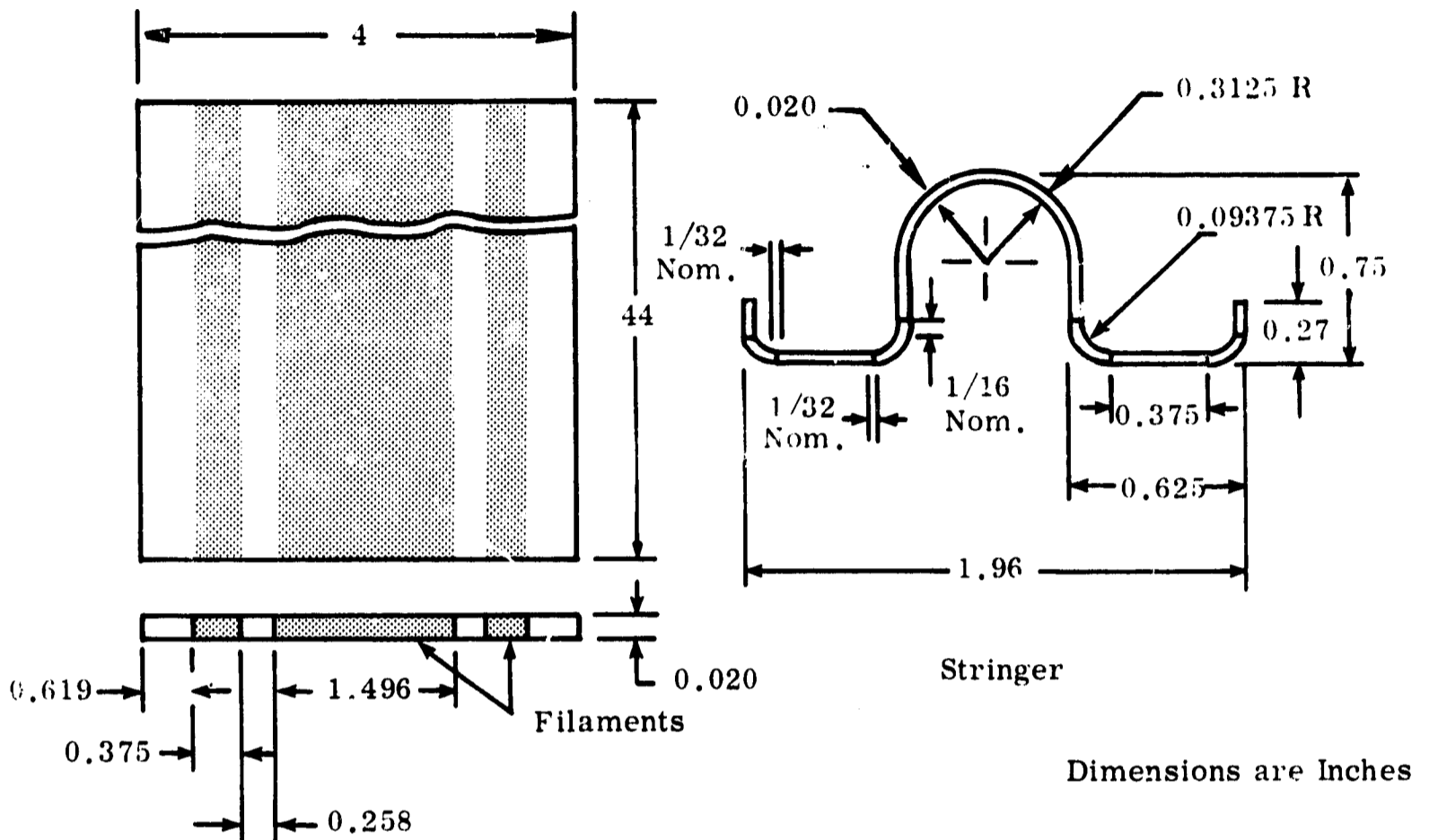

Figure 3-15. Selectively Placed Unidirectional Filament<sup>(101)</sup>

#### 3.3.2.4 Boron-Titanium Composites

Continuous boron-titanium tapes are being made by Solar<sup>(46)</sup> under an AFML program. The 0.5-inch-wide tapes are made by inscribing thin grooves in 4 to 6 mil-thick Ti-75A foil, inserting the boron fibers in the grooves and then covering with another strip of titanium foil. The assembly is diffusion bonded at 1800°F for one second using a roll-bonding technique.

Properties of a tape containing 25 volume percent of boron are as follows:

Ultimate tensile strength	= 122,000 psi
Young's modulus	= $26 \times 10^6$ psi
Ultimate strain	= 5500 $\mu$ inch/inch

The tapes are joined by diffusion bonding into shapes, primarily for compressor blade applications. However, it does not appear that this type of composite could be applicable to large structures because of possible degradation of fibers due to interaction between titanium and boron fibers in diffusion bonding.

#### 3.3.2.5 Beryllium-Aluminum Composites

These composites are made by diffusion bonding beryllium wire and aluminum foil. Another method of preparation is by coating the beryllium wire with aluminum followed by diffusion bonding. In general, theoretical properties are approached. However, this composite has not received much attention due to the high cost of beryllium wire, about \$4200 per pound. The Lamp Division of the General Electric Company now can produce 5-mil beryllium wire in ten-pound lots for \$2200 per pound and it is estimated that this can be reduced to \$1700 per pound in larger quantities.

#### 3.3.2.6 Graphite-Metal

These composites are in an earlier stage of development, and the properties (strength and modulus) are still considerably lower than the boron-metal composites.

Graphite fiber-reinforced composites have been fabricated by electrocladding nickel onto the individual graphite fibers and then hot-pressing bundles of these coated fibers<sup>(102)</sup>. The forming pressure and temperature were found to be critical since the maximum tensile strength was observed to occur at the minimum pressure required for optimum densification. Porembka and co-workers<sup>(103)</sup> and Niesz and co-workers<sup>(104)</sup> described the use of electrodeless plating techniques to metal-coat graphite fibers, which were then hot-pressed into composites. Both cobalt and nickel-matrix composites, formed by this method, showed no evidence of fiber-matrix interaction. These fibrous composites offer good potential for high-temperature service. For example, the strength-to-weight ratio of a 60 v/o Thornel-cobalt composite would be four times higher than Inconel at 1800°F, and two times higher at 1600°F<sup>(103)</sup>. The fabrication procedure is summarized in Figure 3-16. The figure also shows a process used for preparing graphite/aluminum composites by liquid-phase sintering. These composites have not received nearly as much attention as the boron/aluminum composites to date.

#### 3.3.2.7 Other Fiber-Metal Combinations

The use of short, high-modulus fibers and whiskers present additional problems in fiber handling, in fiber alignment, and in composite fabrication. Automated processes need to be developed and are currently receiving much attention. Furthermore, short, discontinuous fibers must be adequately bonded to the matrix because of the peak interfacial shear stresses that occur near the fiber ends. Since short fibers also have regions that are ineffectively stressed, the fibers should have the largest possible aspect

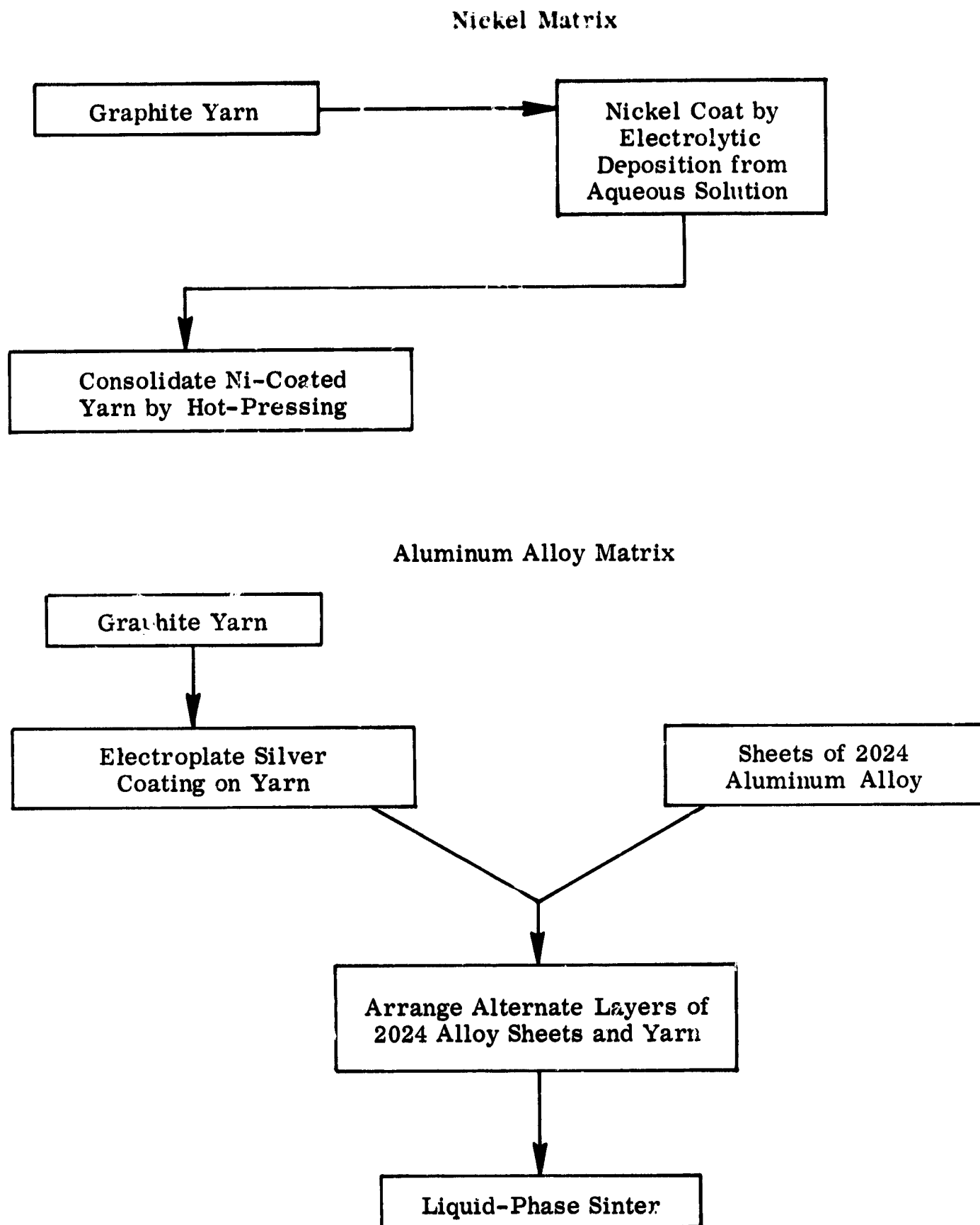

Figure 3-16. Methods Used to Fabricate Graphite-Reinforced Metals<sup>(103)</sup>

ratios (length-to-diameter ratio). However, with all these difficulties, several methods have been developed for utilizing whiskers as reinforcements.

Liquid-metal infiltration <sup>(105)</sup>, liquid-phase hot-pressing <sup>(106)</sup>, co-precipitation, and electroforming <sup>(116)</sup> techniques have been used to fabricate whisker-reinforced metal matrix composites. Silicon carbide whisker-reinforced aluminum tape has been produced in which very good alignment of the whiskers has been achieved <sup>(107)</sup>.

The process for unidirectionally solidifying eutectic compositions to form aligned, single-crystal fibers is also showing promise. The chief advantages are that the fibers do not have to be handled separately, are uniformly spaced, and are strongly bonded to the matrix. Thus, this method produces a desired, uniform, micro-structure containing strong fibers in a ductile matrix. However, the whisker volume fraction in these composites is essentially fixed, and the number of desired compositions yielding a high fiber fraction is somewhat restricted. Also, the size of the specimen may be limited by the thermal conductivity of the material and by the thermal gradients, which must be carefully controlled in order to achieve a continuous fibrous microstructure <sup>(108, 109)</sup>.

In summary, it should again be emphasized that all of these metal-matrix composites are chemically and mechanically complex. In order to achieve the full potential advantages of these new materials, each of the constituents, the fiber, the matrix, and the interface, must perform several functions. Thus the constituents must be combined in such a way that all of the required functions are satisfactorily performed. Otherwise, the reinforcing strength and stiffness of the fibers will not be effectively utilized. Some of the high strengths achieved in some of the metal-matrix systems are shown in Table 3-13. Much progress has been made, but much also remains to be accomplished before reproducible and reliable metal-matrix composites attain the status of present-day conventional structural materials.

#### 3.4 APPLICATIONS OF FIBROUS COMPOSITES

The largest use of fibrous composites to date is in the form of resin-matrix composites. Metal-matrix fibrous composites are still in the early stage of development. Some basic problems concerning fabrication, chemical compatibility between fibers and matrix, high temperature effects, and control of plastic deformation of matrix around fibers have to be solved before extensive application of metal-matrix composites can be made. So far as applications of resin-matrix composites are concerned, nearly all

Table 3-13  
Properties of Metals Reinforced with Various Fibers <sup>(46)</sup>

Composition		Fiber v/o	Composite	
Matrix	Fiber		Tensile Strength* 1000 psi	Strength/Density 1000 inches
Al	B	50	200	3,380
	Steel	25	173	1,210
	Be	40	80	830
	SiO <sub>2</sub>	46	140	1,930
	Al <sub>2</sub> O <sub>3</sub> **	35	161	1,425
	B <sub>4</sub> C	10	29	302
	CuAl <sub>2</sub> ***	50	39	307
	Al <sub>3</sub> Ni***	10	48	470
Cb	Cb <sub>2</sub> C***	31	172	570
Ni	B	75	384	1,470
	W	9.4	61.4	173
	Al <sub>2</sub> O <sub>3</sub> **	19	171	600
	C	48	49.7	260
Al-10.2 Si	Al <sub>2</sub> O <sub>3</sub> **	15	40.7	395
Ni-20 Cr	Al <sub>2</sub> O <sub>3</sub> **	9	255	870
Fe	Al <sub>2</sub> O <sub>3</sub> **	36	22	1,017
Ta	Ta <sub>2</sub> C***	29	155	267
	Ta <sub>2</sub> C***	29	118	203
Ag	Si <sub>3</sub> N <sub>4</sub> **	15	40	119
	Al <sub>2</sub> O <sub>3</sub> **	24	232	720

\* Highest reported values

\*\* Whiskers

\*\*\*Unidirectionally solidified

of the effort on applying the advanced filament composites is in the aerospace industries at the present time. Much of the technology, as was mentioned earlier, was derived from the GRP industry. Although filament winding of glass-resin composites represents about 15 percent of the total market, it is still a large volume (55,000 pounds last year)<sup>(49)</sup>, and most of this is in the aerospace industry.

#### 3.4.1 FILAMENT WINDING OF LARGE STRUCTURES

Fabrication of filamentary fiberglass composites into pressure vessels is considered state of the art and will not be covered here in any detail. However, it is of interest to consider the fabrication techniques for some recent large tanks fabricated from fiberglass epoxy composites since these techniques are of interest for the study.

Aerojet-General<sup>(88)</sup> developed the manufacturing technology for fabrication of a 260-inch diameter fiberglass composite rocket motor case. Processes shown in Figure 3-17 illustrate the following major operations in fabrication of a filament wound chamber:

- a. Mandrel assembly
- b. Liner application
- c. Filament winding
- d. Skirt fabrication
- e. Case cure
- f. Mandrel disassembly

Large filament wound glass cylinders, 40 feet in diameter, have been made by the Rohr Corporation. These were storage tanks, such as shown in Figure 3-18. They were air cured and used an upright, expandable air mandrel. The windings were oriented at  $90^\circ$  to the cylinder axis. Rohr feels that tanks up to 75 feet in diameter and 30 feet in height can be made by this method.

For large launch vehicle tankage and interstages this technique could be modified to allow for windings oriented at  $90^\circ \pm 30^\circ$  to the cylinder axis. As envisioned, the inside skin would be wound first with a preimpregnated yarn, the honeycomb core set in place, and the outside skin wound. Curing would present a problem considering present technology. The largest autoclave, 28 feet  $\times$  55 feet, is at Boeing, Seattle. As an alternative, large panels of composite honeycomb can be fabricated and joined by adhesively bonded doublers. However, new autoclaves and other tooling development would be required for joining.

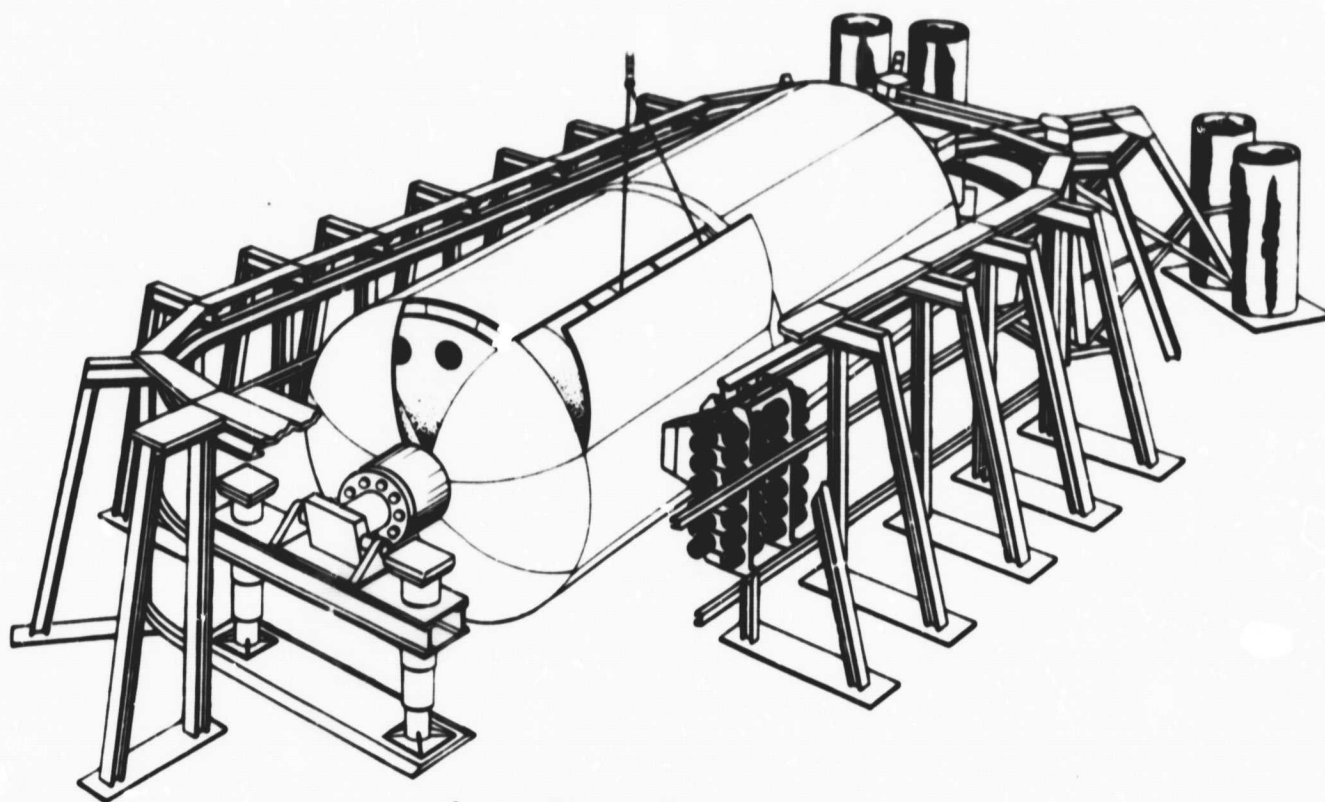

1 MANDREL ASSEMBLY

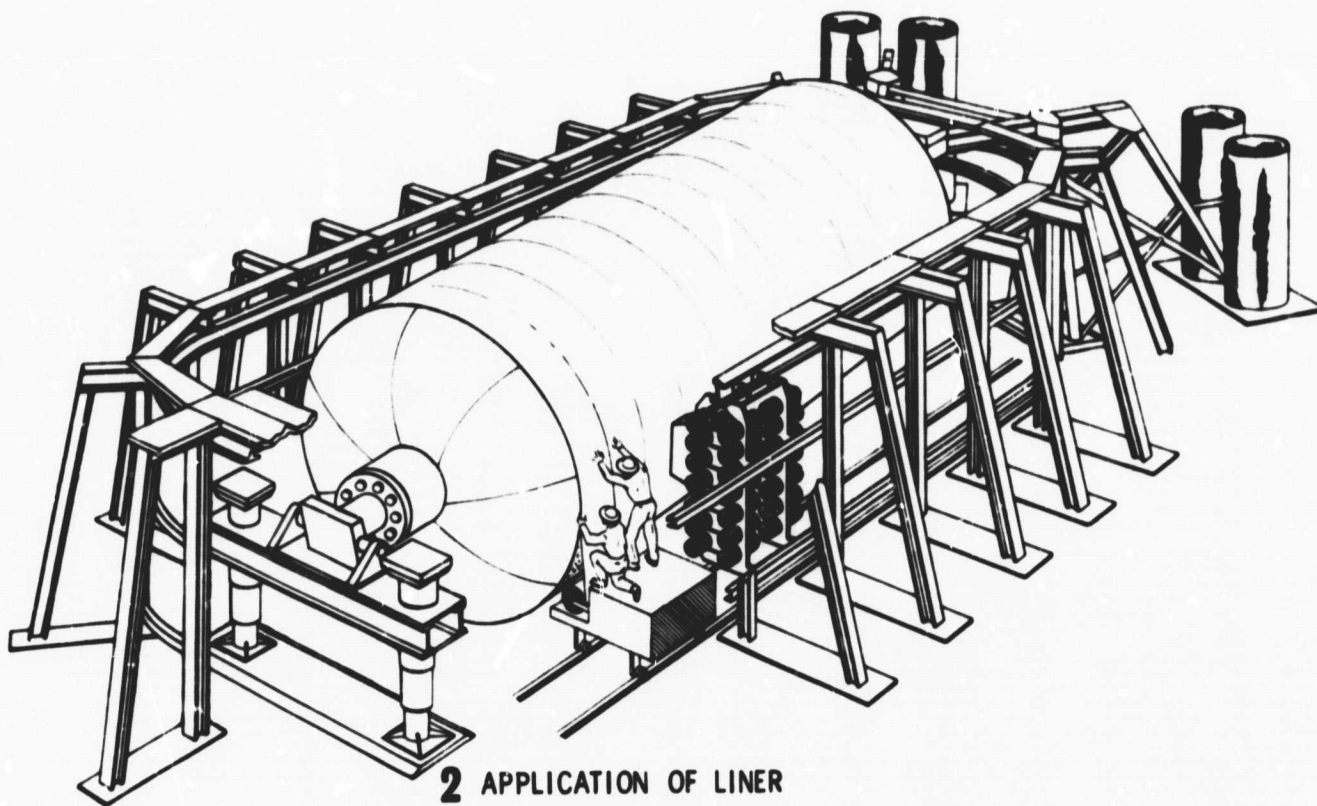

2 APPLICATION OF LINER

Figure 3-17. Major Fabrication Operations for 260-Inch Diameter Case<sup>(88)</sup>  
(Sheet 1 of 3)

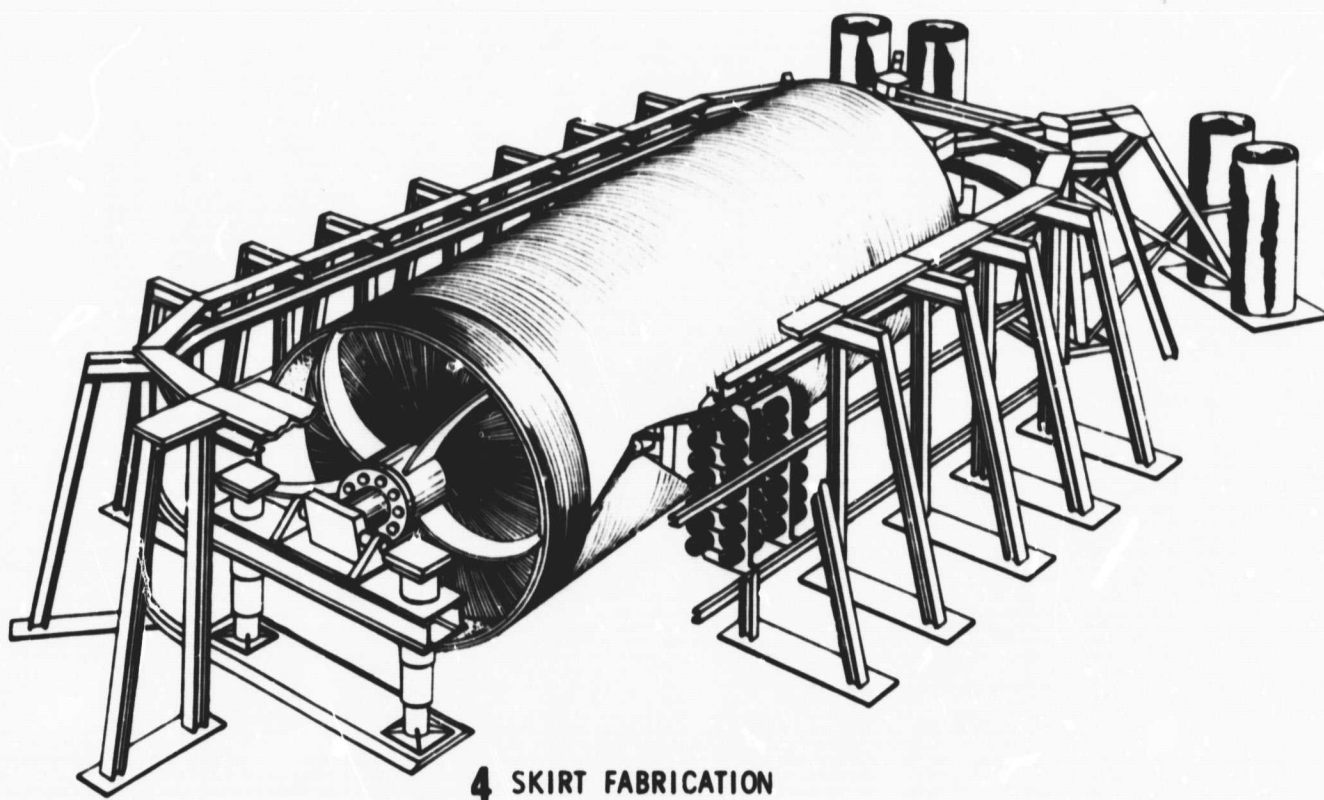
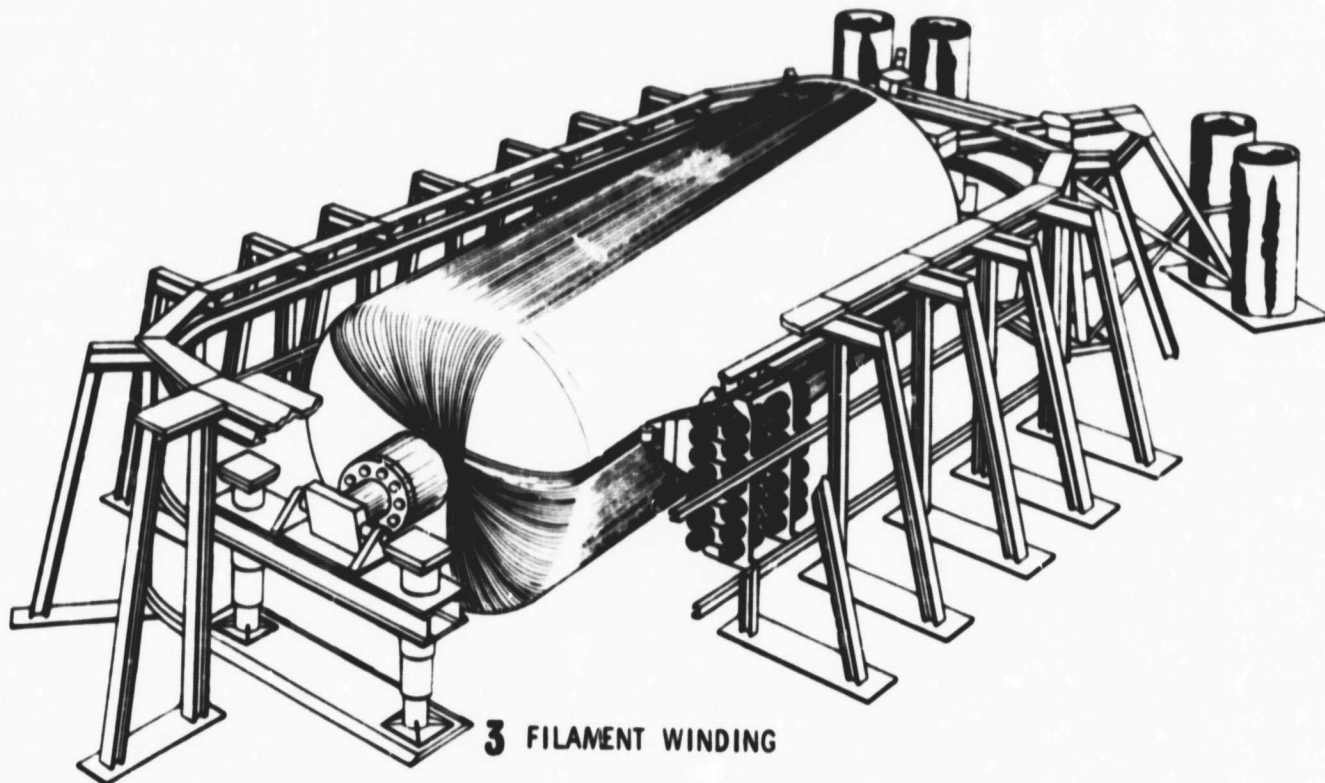

Figure 3-17. Major Fabrication Operations for 260-Inch Diameter Case<sup>(88)</sup>  
(Sheet 2 of 3)

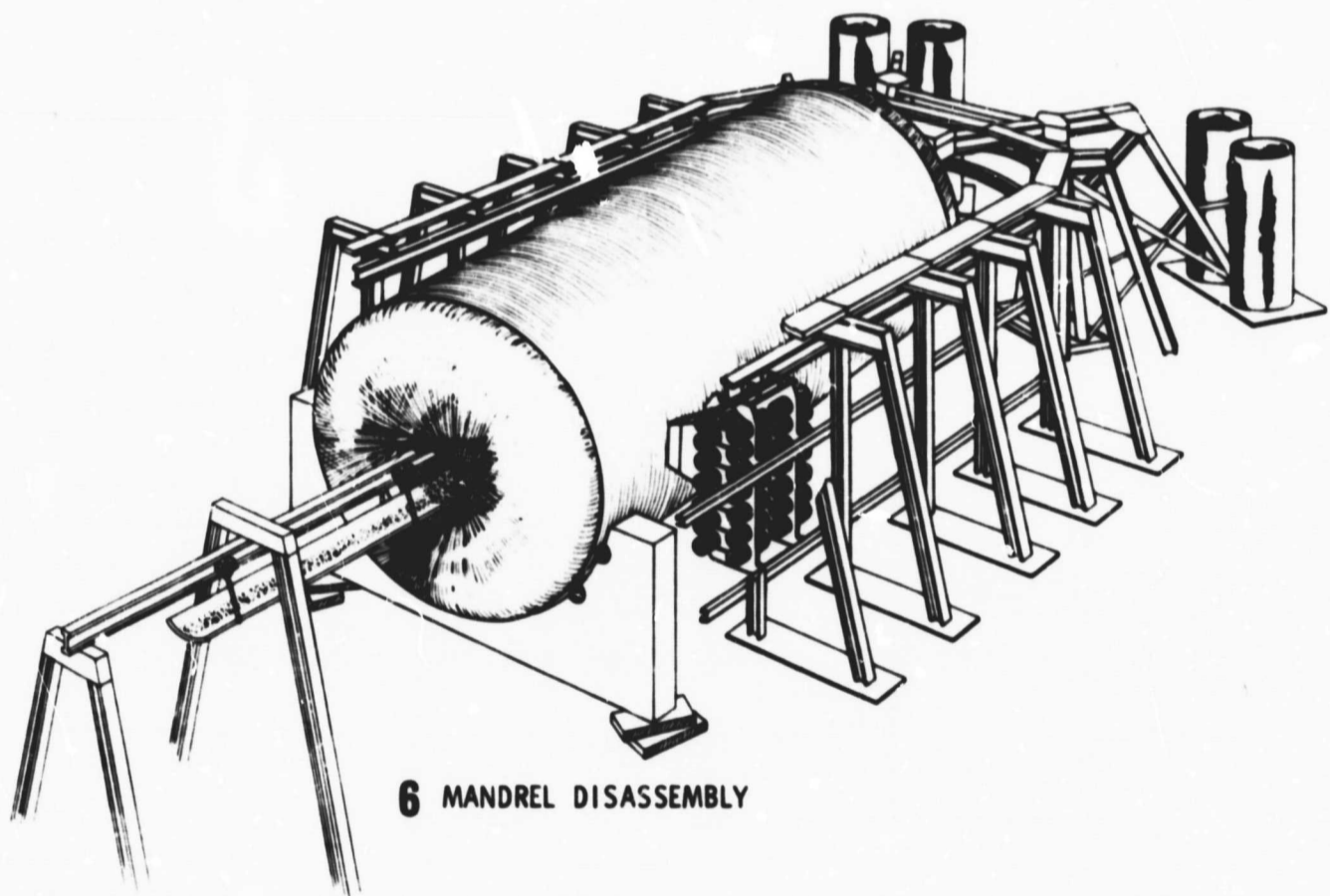
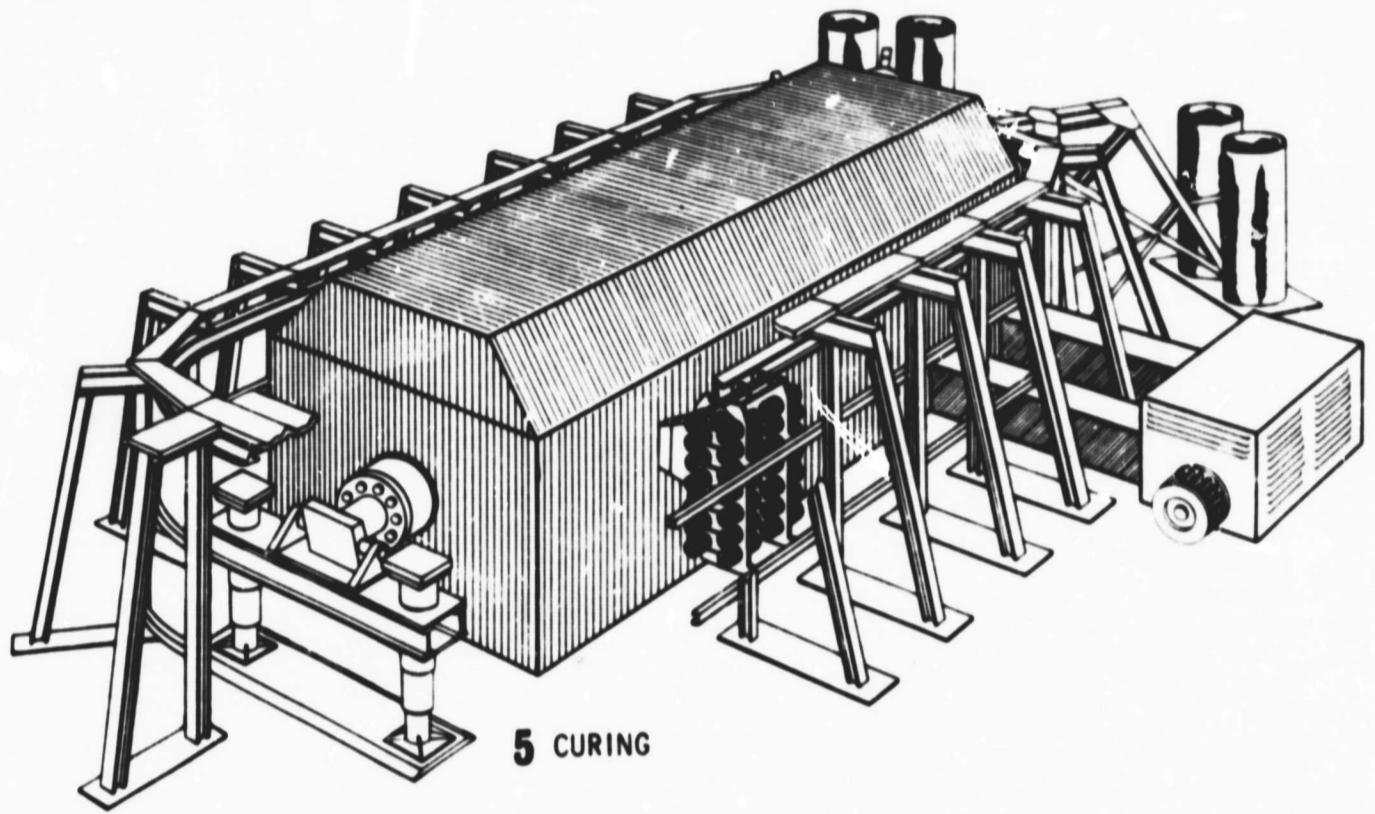

Figure 3-17. Major Fabrication Operations for 260-Inch Diameter Case<sup>(8a)</sup>  
(Sheet 3 of 3)

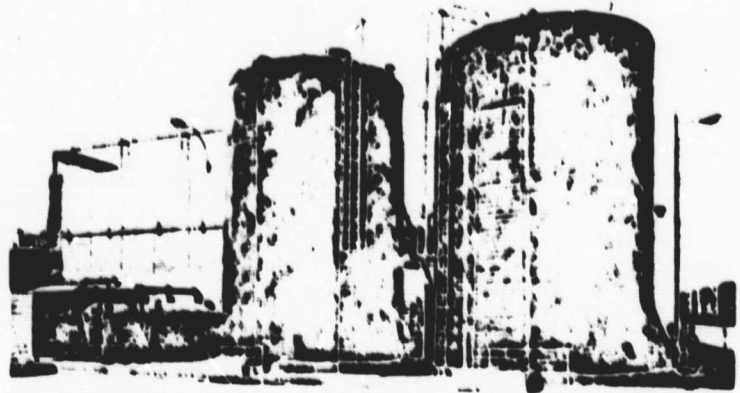
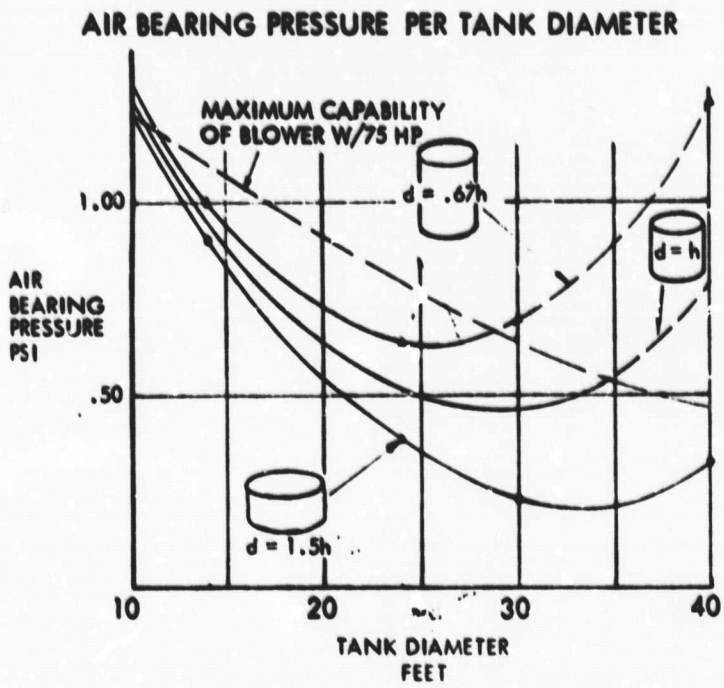
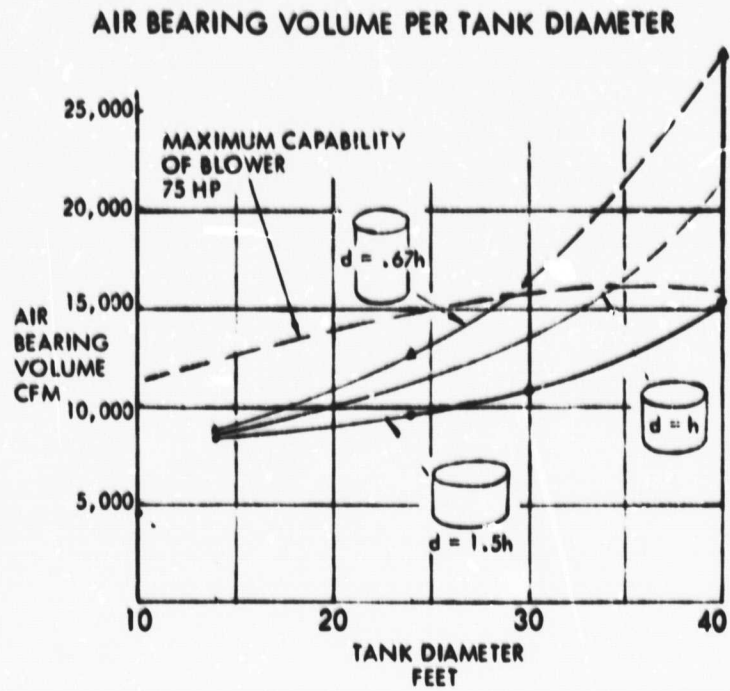
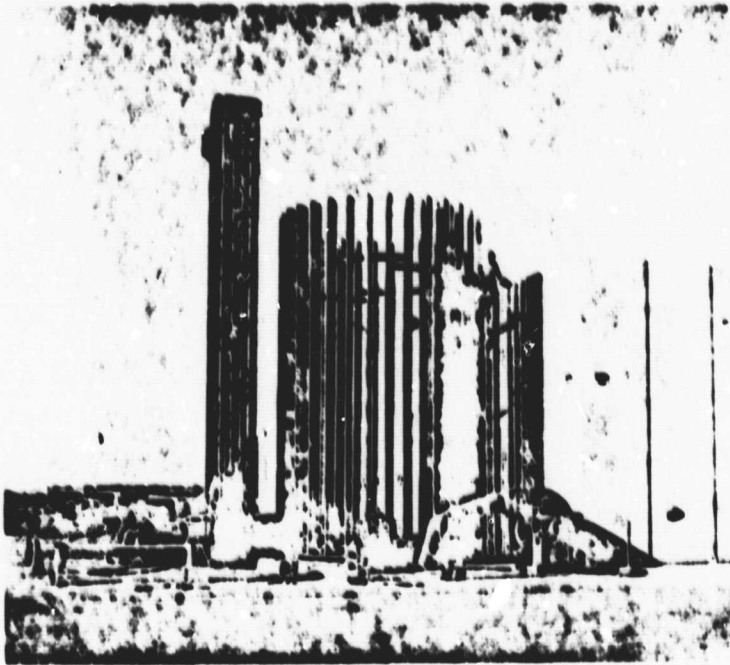

Figure 3-18. Construction of Large Filament-Wound Composite Storage Tanks<sup>(76)</sup>

### 3.4.2 BORON-RESIN COMPONENTS

The Advanced Composites Division of the Air Force Materials Laboratory has been responsible for the development of the boron fibers and has sponsored several major programs devoted to the application of these composites to aircraft and space hardware. Initially, five contracts were awarded, based on the use of boron-resin composites. These included:

- a. General Dynamics Corporation, Ft. Worth Division; a structure representing the major portion of the structural box section of the F-111 horizontal stabilizer.
- b. General Electric Company, Re-Entry Systems Department; a ring-stiffened cylinder representative of a re-entry vehicle structure.
- c. General Electric Company, Advanced Engine and Technology Division; engine components consisting of a compressor blade, an integrally bladed disk, and a stator vane.
- d. Whitaker Corporation and Bell Helicopter Company; helicopter rotor blade components.
- e. North American Aviation, Inc., Los Angeles Division; a section representative of a portion of the T-39 center section wing box.

All of these structures have been built and tested. Additional contracts have been awarded to General Dynamics for further work on aircraft structure, and Boeing-Vertol for further work on helicopter blade structure.

The General Dynamics program was to build, test and evaluate a relatively first generation composite component—the F-111 horizontal stabilizer—which is a primary load bearing structure. This program provided the technology base (in materials development and in design and fabrication procedure to make a flight worthy structure; the potential weight savings were discussed earlier (see Table 3-1). A photograph of the stabilizer, consisting of boron-epoxy face sheets over aluminum honeycomb, is shown in Figure 3-19.

The total saving over the existing F-111 structure of equal size would be over 300 pounds (or 26.3 percent) of the original weight of 1140 pounds. Non-critical components (lower-wing, air-flow deflector door; a fixed, upper surface trailing edge panel; and a curved, main landing gear door—all bonded on a conventional honeycomb structure sandwiched between boron-epoxy face sheets have been flight tested<sup>(ea)</sup>.

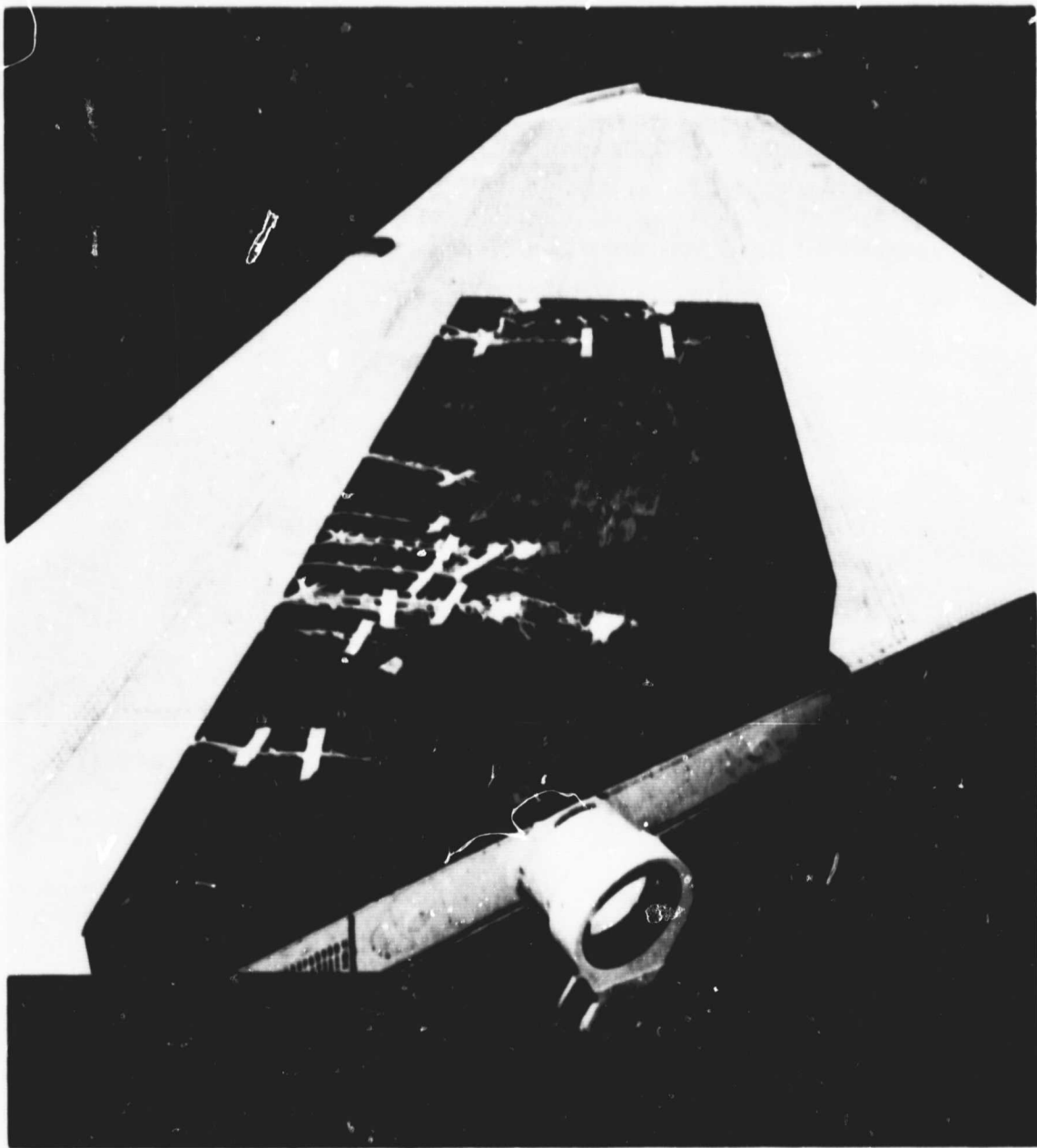

Figure 3-19. Boron-Fiber Reinforced F-111 Tail Section<sup>(89)</sup>

The Re-Entry Systems, General Electric Co. worked on a ring-stiffened cylinder representative of a re-entry vehicle. A cylinder instrumented for testing is shown in Figure 3-20. The cylinder was 18 inches in diameter and 26 inches long. The boron-epoxy component was fabricated by Hercules, Inc., and the unique feature was the filament winding of the stiffeners integrally with the cylinder <sup>(20)</sup>.

The Aircraft Engine Group of General Electric was studying the application of a combined glass and boron-reinforced resin rotating assembly. This was a subscale 20-inch diameter integrally wound, first-stage compressor disc for a gas turbine. This experimental prototype offers a 25 percent weight reduction and is shown in Figure 3-21.

The Boeing-Vertol study was concerned with the fabrication and flight testing of an aft set of boron-epoxy rotor blades for the CH-47 helicopter (the front rotor blades are of GRP <sup>(42)</sup>). Sikorsky Aircraft (using its own funds) is developing a set of boron-epoxy blades for the tail rotor of a helicopter <sup>(21)</sup>.

The Advanced Composites Division of AFML believe that they may be on the verge of a breakthrough in the aeropropulsion area, since other higher temperature matrices (other than epoxy) are being investigated. Recently the Aircraft Engines Group at General Electric has been working, under Air Force contract, to use boron reinforced aluminum in some of the engine components <sup>(21)</sup>.

North American Aviation has been conducting studies on the application of composites in advanced strategic aircraft (AMSA). They are studying the cost-weight-performance of these composites in specific applications (for both resin and metallic matrices). One specific item was the wing-box beam structure of the T-39 aircraft <sup>(23)</sup>. Part of the program was concerned with the technology of fabrication, determining properties, and predicting properties for structural analysis and design. Several schemes were investigated for bonding specimens to tabs, so that they could be gripped for tensile testing, as shown in Figure 3-22. The problem was to get the loads applied to the entire specimen and not at the points of attachment. The tests led to the improved attachment techniques used in Figure 3-23. The fabrication sequence for producing the box-structure is shown in Figure 3-24.

McDonnell-Douglas has fabricated boron-epoxy rudders for testing on its F-4 phantom aircraft. The first rudder was made to check the basic design and the tooling.

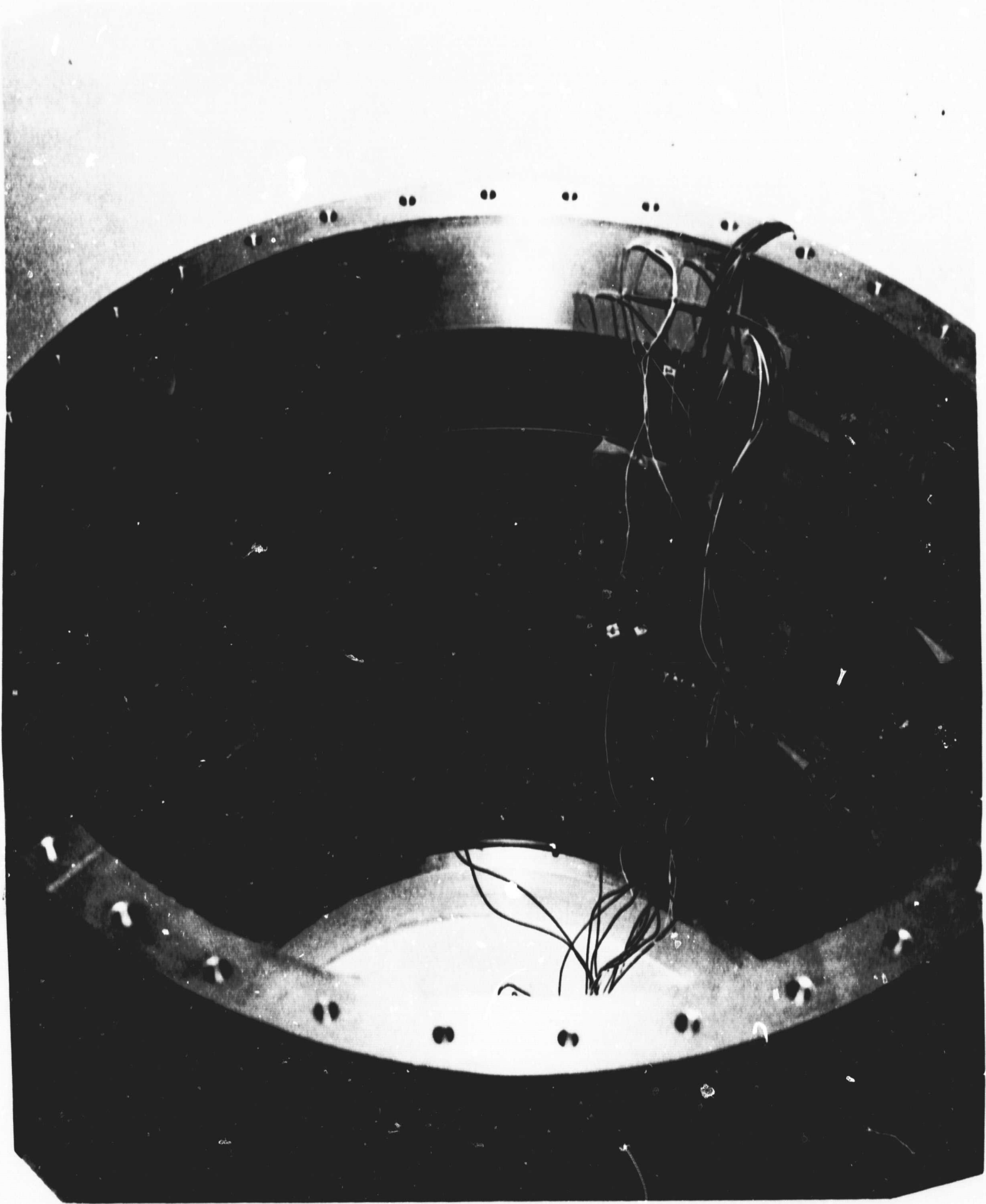

Figure 3-20. Rib Enforced Structure With Instrumentation<sup>(90)</sup>

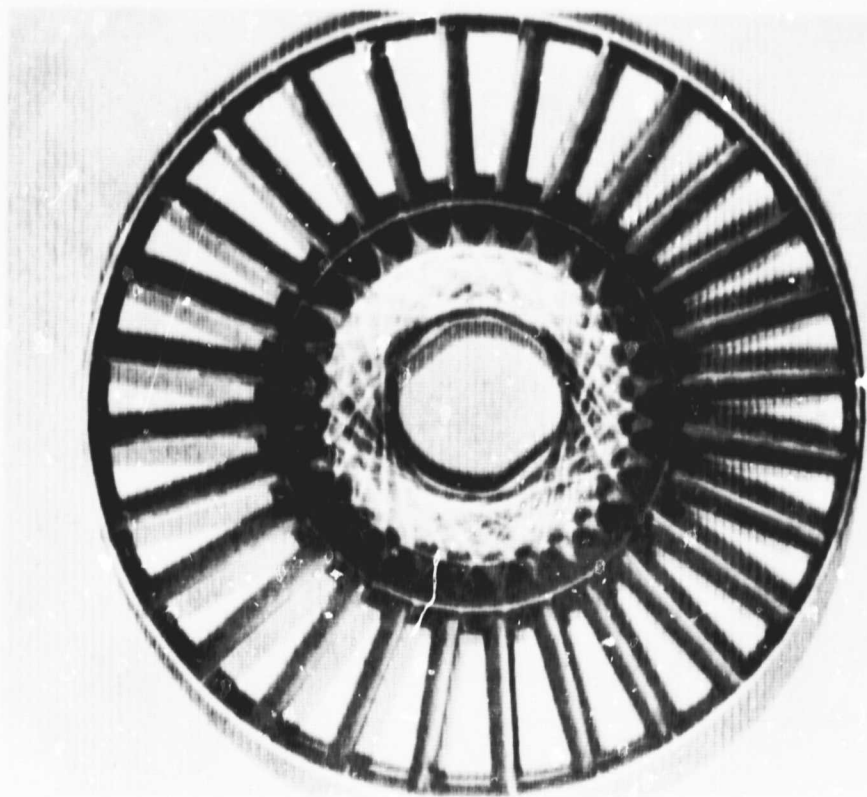

Figure 3-21. Prototype Glass-Boron/Epoxy First-Stage Compressor Disc<sup>(B1)</sup>





TYPE	FILAMENT ORIENTATION		FAILURE TYPE	COMPOSITE STRESS	FILAMENT STRESS
SPECIAL TAPER	UNIDIRECTIONAL		IN COMPOSITE	146,000	269,000
FEADED AND TAPERED	0 DEG - 90 DEG CROSSPLYED		IN COMPOSITE	62,000	243,000
DOUBLE TAPER - 'FISHTAIL'	UNIDIRECTIONAL		IN COMPOSITE	125,000	250,000
WIDE 'FISHTAIL'	±25 CROSSPLYED		IN COMPOSITE	97,000	—

Figure 3-22. Adhesive-Bonded End Tabs for Tension Loads<sup>(B3)</sup>

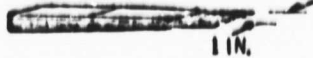
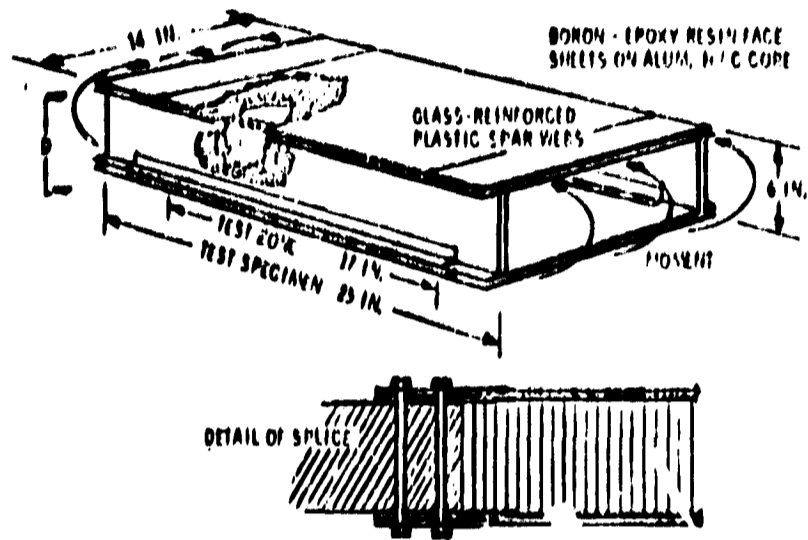

Figure 3-23. Design and Major Dimensions of Advanced Composite Box Beam Test Specimen (83)

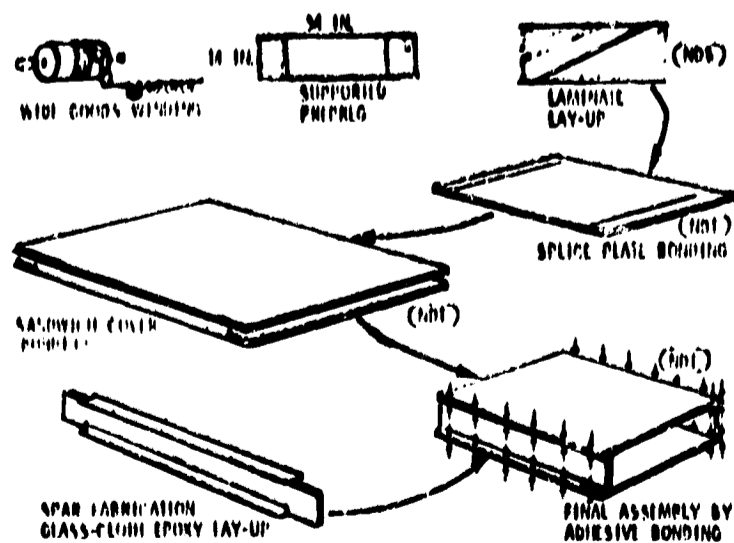

Figure 3-24. Fabrication Sequence of T-39 Wing Box Section (83)

The second rudder went through extensive vibration and proof static ground tests before being installed into the aircraft. Also the company made an experimental beryllium rudder. According to Aviation Week & Space Technology, September 30, 1968, both rudders have been installed in aircraft and will shortly be tested. Other components (a flap and landing-gear strut) are also being designed for boron-resin composites.

The Air Force has a cooperative program with 28 companies <sup>(63)</sup> for using boron filaments in various aerospace applications. The Air Force will provide the filaments to these companies which will provide the Research and Development effort. Some of the areas being investigated by this program and also others through direct contracts are summarized in Table 3-14.

In summary, it is evident that a very large effort is being devoted to the application of boron-resin composites to a wide variety of aircraft and space structures. The results of these and other programs are clearly showing the trend towards the use of such composites in aerospace structures. For example, at Boeing's Commercial Airplane Division, Seattle, Washington, more than 50 percent of the total in-house composite research is directed toward boron-epoxy systems <sup>(21)</sup>. Currently, the firm is developing three flight quality aircraft floor beams using composites. Compared with a conventional aluminum beam, a boron composite component is expected to reduce weight by about 40 percent.

Boeing is also fabricating a flap component for its 707, utilizing a boron-epoxy composite with 5052 aluminum honeycomb core. The company hopes to have the part (which is 6 feet long, 15 inches wide, and 5 inches deep) flying by the end of the year <sup>(21)</sup>.

#### 3.4.3 GRAPHITE-RESIN COMPOSITES

Rolls-Royce has been conducting an extensive Research and Development program on graphite-reinforced resins for several years and probably has the greatest experience to date in the preparation (of filaments and composites), design, and testing of these composites materials <sup>(22)</sup>. They call their material HyFil. Much of the effort has gone into the development of fan blades for the advanced RB211 engine. These blades are nearly three feet long and have a chord of over one foot. The design, fabrication, and testing of these blades represent a major advance in the state of art. Currently the RB211 production program (HyFil) is underway.

Table 3-14

## Prototype Programs on Boron Fiber-Reinforced Resin Composites

Component Company	Stabilizer and Rudder Parts	Landing Gear Parts	Rotor Blades and Rotor Hub Structures	Re-Entry Structures	Engine Parts	Trailing Edge Flaps, Leading Edge Slats, Other Lift Surfaces	Internal Wing Parts	VTOL COWLS and Ducts	Cryogenic Tanks
Allison Division (GM)					X			X	
AVCO Corporation				X					
Bell Aerosystems								X	
Bendix		X							
General Dynamics	X								
General Electric				X	X				
Grumman Aircraft Engineering							X		
Lockheed			X			X			
Martin									X
McDonnell Douglas	X	X				X			
Northrop Norair		X							
Ryan Aeronautical						X			
Vertol Division (Boeing)			X						

The Northrop Company will be the first to flight test a graphite-epoxy tip leading edge of an F-5A wing. The part was designed by Northrop Norair using Thronel 50 graphite supplied by Union Carbide Corporation's Carbon Products Division, impregnated with its resin by U.S. Polymeric Inc.'s Santa Ana, California Division and fabricated by the Allegany Ballistics Laboratory of Hercules Inc., Cumberland, Maryland.

The procedure to fabricate the wing tip is shown schematically in Figure 3-25 and the final piece is shown in Figure 3-26. Future plans for the application of graphite/epoxy composites to typical advanced aircraft structures are shown in Figure 3-27.

Although the Northrop program used single yarn prepreg for filament winding, and drum winding unidirectional tape for hand lay-up, U.S. Polymeric is marketing graphite in the form of continuous multi-strand tape for filament winding applications, continuous unidirectional tape up to 3 inches wide and in sheets from 11 inches and 27 inches long. An ARPA coupling effort has been underway which involves Union Carbide's Carbon Products Division and includes Bell Aerosystems Company and Case Western Reserve University. This association came into being in May 1965, sponsored by ARPA and administered through the Air Force Materials Laboratory.

The objective was to create an integrated approach to research and design with graphite fiber composite materials. One of the many results of this collaboration to date is the fabrication of a six-inch ring-stiffened cylinder using UCC Thronel filament.

This cylinder has been undergoing various tests and is chiefly an exercise in design and fabrication to develop techniques while characterizing graphite as an engineering material. The filament winding of such a cylinder is shown in Figure 3-28. Also, an exploratory effort is underway to fabricate angle, tee, hat-shaped, and box-beam shapes <sup>(63)</sup>. A typical hat-shaped stringer is shown in Figure 3-29.

If the fabrication of large cylinders of honeycomb construction using graphite-epoxy composite face sheets is considered, the present state of the art can be utilized. Experimental samples of honeycomb core have been made with graphite fibers. Filament wound cylinders and pressure vessels have been made with graphite-epoxy. However, the matter of scaling up to large-diameter structures requires engineering development.

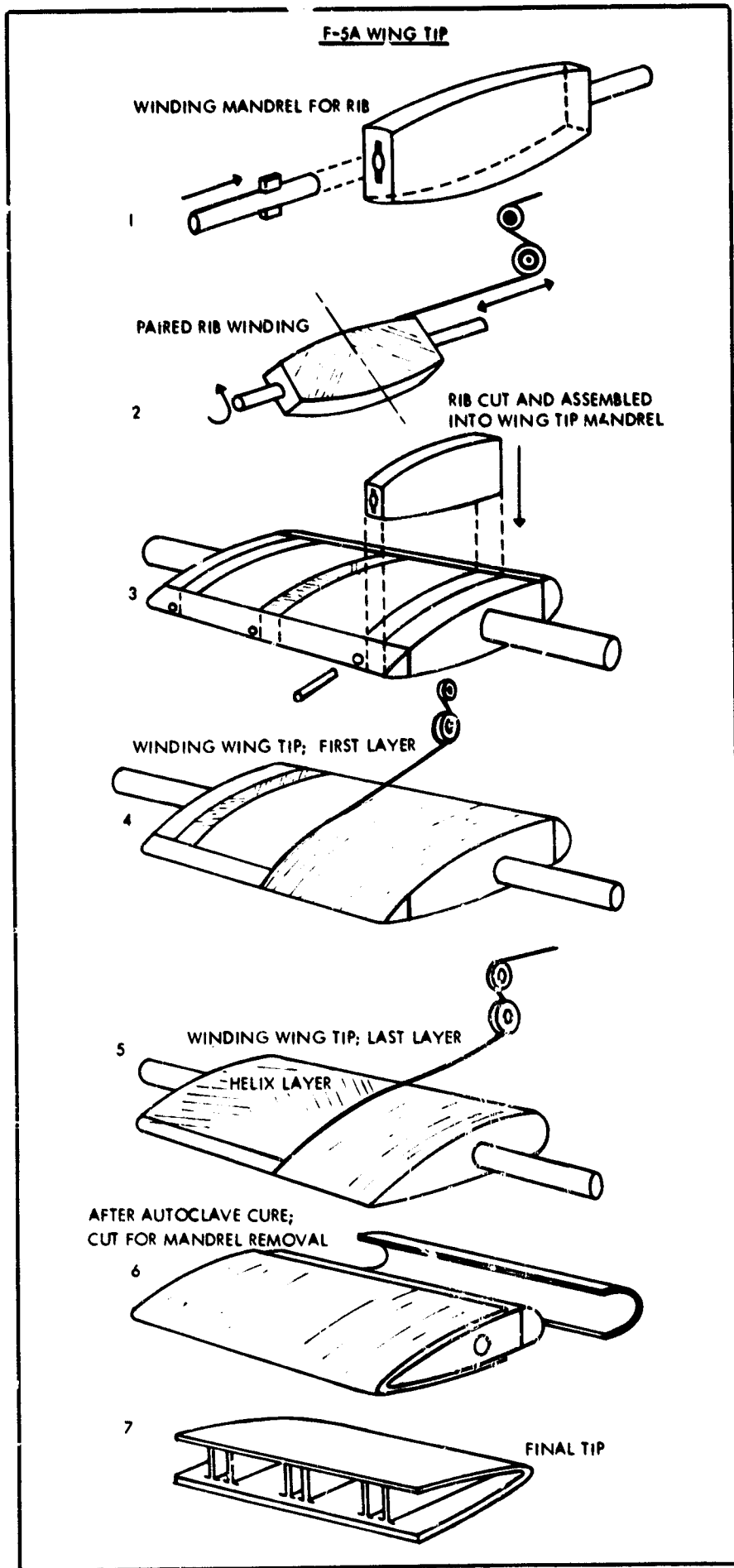
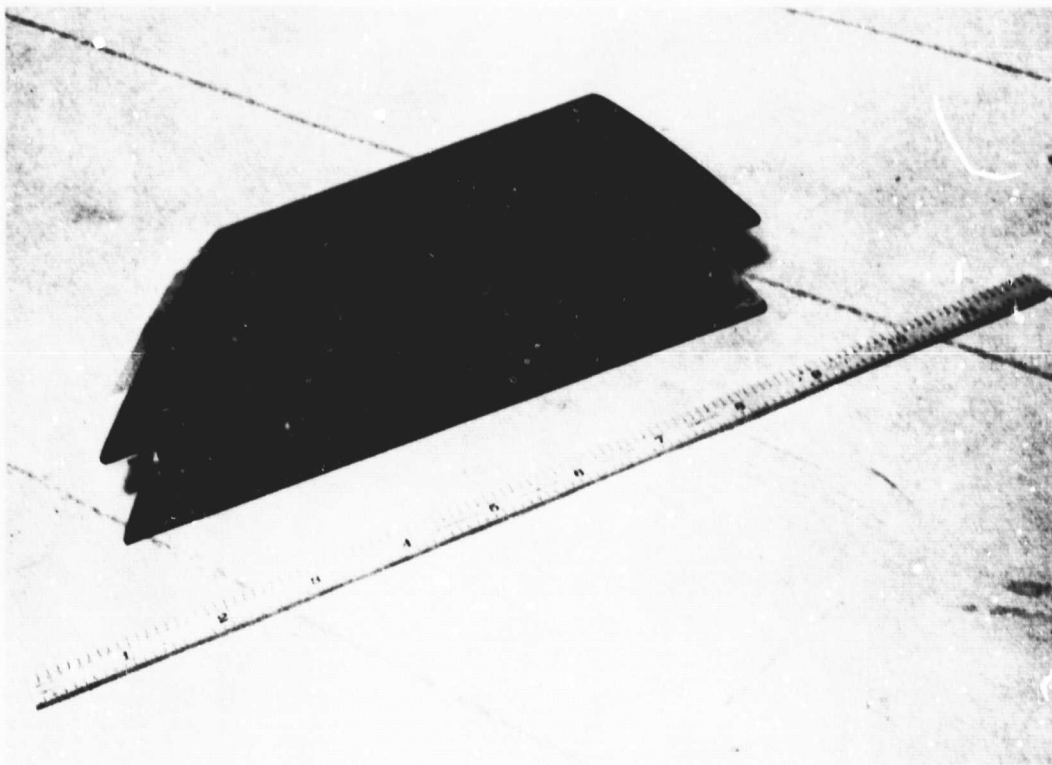

Figure 3-25. Procedures for F-5A Wing Tip Fabrication<sup>(93)</sup>



**Figure 3-26.** The filamentary graphite F-5A wing tip leading edge part is shown from the rear. Titanium strips have been bonded to the part to interface with the rest of the F-5 wing. The integral ribs are not visible but the sharp curvature of the leading edge is apparent. The program was a joint effort by Northrop Norair, Hercules Inc., Union Carbide and U.S. Polymeric. No Government contract is involved but the development is known to the Air Force and data are being transmitted to the military. <sup>(92)</sup>.

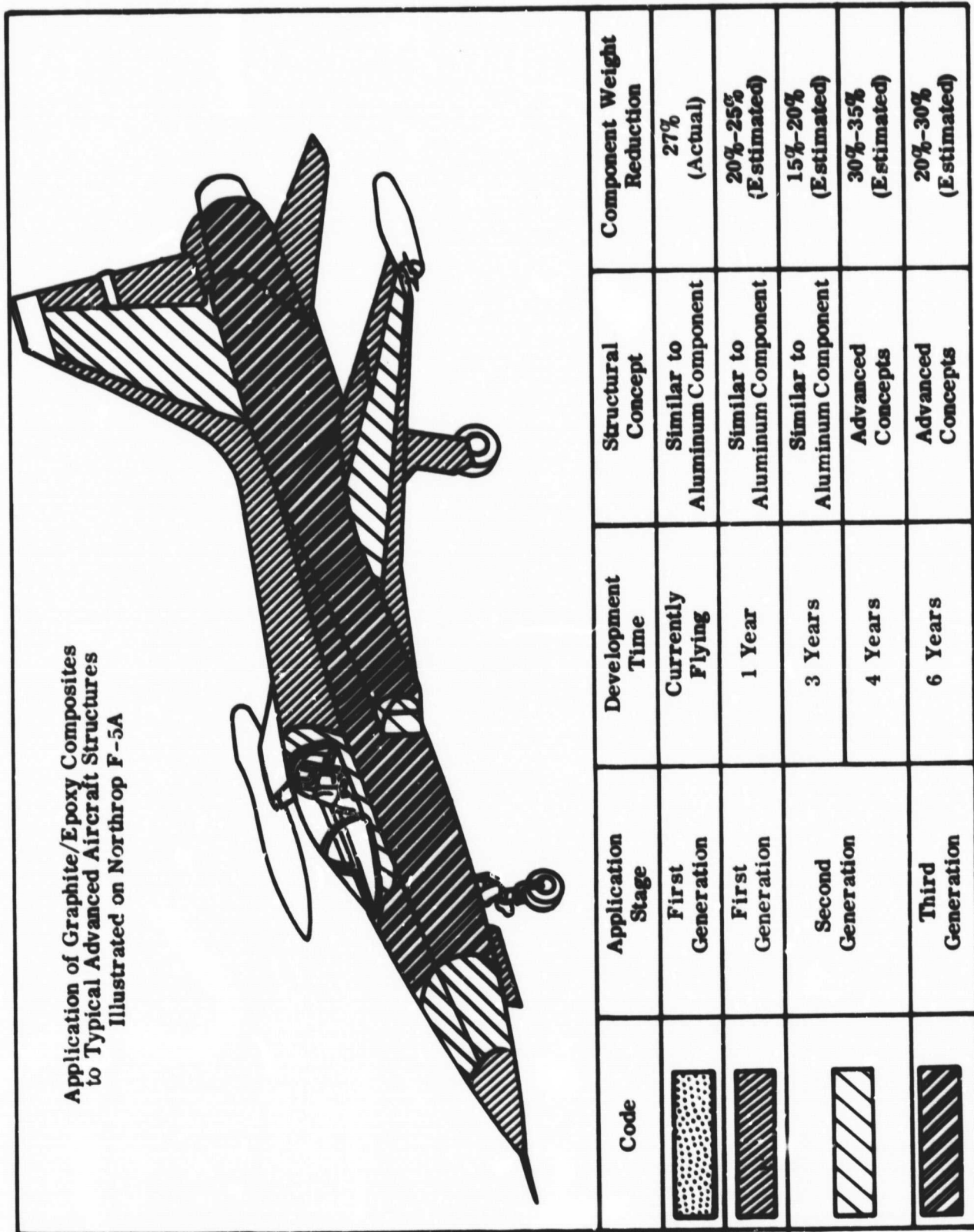
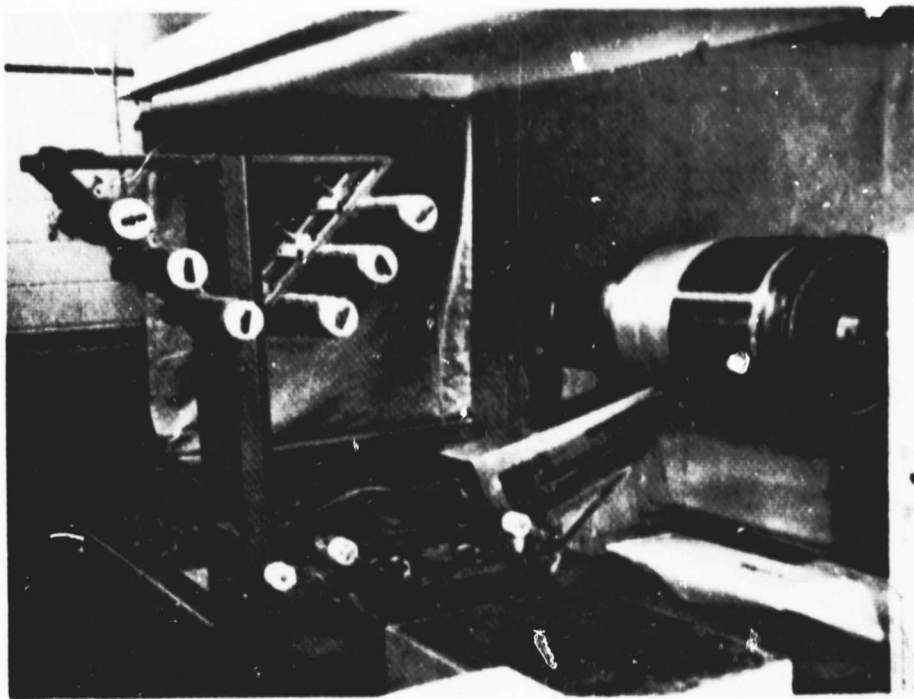

Figure 3-27. Application of Graphite/Epoxy Composites to Typical Advanced Aircraft Structures Illustrated on Northrop F-5A(1.1.0)



**Figure 3-28.** Filament Winding of "Thornel" Graphite Yarn and an Epoxy-Resin on a Mylar-Covered Mandrel (63)



**Figure 3-29.** Hat-Shaped Stringer Stiffened Plate of "Thornel" 40/ERL 2256 Composite (63)

SECTION 4

LIST OF PLACES AND PERSONS CONTACTED OR QUERIED

<u>NAME</u>	<u>TITLE</u>	<u>SUBJECT</u>
<b>Battelle Memorial Institute, Columbus, Ohio</b>		
Dr. Dale F. Niesz	Senior Research Ceramist	C - Al
K. F. Meiners	Engineer	Be
F. L. Foster, Jr.	Advisor	Be
Dr. R. F. Keith	Assoc. Fellow	Al Honeycomb
R. F. Badertscher	Chief, Aerospace Mechanics	Be
R. Runck	Director, DMIC	Be, Ti
<b>Air Force Materials Laboratory, W-P AFB, Ohio</b>		
G. Peterson	Chief, Composite Div.	B-Epoxy, C-Epoxy
Capt. W. Schultz	Eng. Composite Div.	B-Al
R. T. Schwartz	Chief, Non-Metallics Div.	C-Al, C-Epoxy
H. Schwartz	Consultant, Non-Metallics Div.	Carbon Comp.
K. Kojala	Eng. Metals Div.	Be
Lt. W. Starke	Eng. Metals Div.	Metal Matrix
H. Johnson	Mfg. Tech. Div.	Be Sheet
Lt. Col. Broch	Chief, Mfg. Tech Div.	Be Sheet
<b>Hexcel Products, Dublin, California</b>		
A. C. Marshall	V. P., Applications	Honeycomb
Dr. E. Vickers	V. P., R & D	Honeycomb
<b>Brush Beryllium, Eastern Sales Office, Fairfield, N. J.</b>		
W. Estess	Manager	Be
<b>Harvey Aluminum, Los Angeles</b>		
L. Harvey	Chairman of Board	B - Al
L. W. Davis	Chief Research Metallurgist	B - Al
<b>Solar, San Diego, California</b>		
W. Compton	Asst. Director of R & D	Be
L. Grant	Engineer	Be
Dr. A. G. Metcalfe	Consultant	B - Ti
<b>Materials Advisory Board, Nat. Acad. of Science, Washington, D. C.</b>		
N. Promisel	Executive Secretary	Be

<u>NAME</u>	<u>TITLE</u>	<u>SUBJECT</u>
General Electric Co., Re-Entry Systems, Philadelphia, Pa.		
R. J. Michalak	Supervising Engineer	Be, Composites
G. Bainton	Mgr. Adv. Comp. & Process Dev. Lab.	Filament Wound Strut.
T. F. Hess	Mgr. Struct. Synthesis & Test Lab.	Adv. Matl.
K. Kuhl	Producibility Engineer	Be
F. R. Gianforte	Engineer	Be
General Electric Co., Aircraft Engine Group, Cincinnati, Ohio		
C. F. Dantorth	Mgr. Advanced Mechanics	Adv. Struct. & Matls.
W. L. Chambers	Mgr. Long Life Struct. Methodology	Adv. Struct. & Matls.
Marshall Space Flight Center, NASA, Huntsville, Alabama		
F. Engler	Engineer - Structures, P&VE	Be, Composites
A. J. Verble	Chief - Structures, P&VE	Be, Composites
W. Huber	Chief - Adv. Systems	Adv. Structures
H. Wuenscher	Dep. Dir. - Manuf. Engrg.	Adv. Manuf.
T. Hollingsworth	Engineer - Manufacturing	Adv. Manuf.
P. Maurer	Project Engineer	Adv. Manuf.
C. Wood	Engineer - Manufacturing	Be
W. Wilson	Chief, Methods Development Branch	Be, Boron-Epoxy
F. Brown	Dep. Chief, Methods Development Branch	Be, Boron-Epoxy
General Electric Co., MOL Dept., Radnor, Pa.		
N. Hess	Mgr. - Design Engineering	
General Electric Co., Space Systems, Valley Forge, Pa.		
R. Peck	Mgr. - Materials	Adv. Matls.
W. Englehardt	Engineer - Manuf.	Adv. Matls.
McDonnell-Douglas Aircraft Corporation, St. Louis, Missouri		
L. McCay	Project Manager	NAS2-5022
L. Kock		Be
R. Newcomer		Ti, Roll Bonding
C. LaMaster		Thin Gage Fabrics
W. Jakway		Metal Matrix Compos.
R. Jackson		Refractory Metals
Department of Transportation, FAA/SST, Washington, D. C.		
F. R. Barthalomew		Ti Honeycomb
F. Peck		Ti Honeycomb

<u>NAME</u>	<u>TITLE</u>	<u>SUBJECT</u>
Nippon Kayaku Company, Limited, Tokyo, Japan		
Dr. M. Kimura	Chief of R & D	Carbon fibers
H. Bessho	Mfg. Rep.	Carbon fibers Carbon fibers
AFML Advanced Composites Status Report Conference, Marietta, Georgia		
R.C. Tomashot	Conference Director	Advanced Composites
E.H. Jaffe	Conference Chairman	Advanced Composites
Conference Attendees		Advanced Composites

## SECTION 5

### REFERENCES

- (1) "Study of Structural Weight Sensitivities for Large Rocket Systems," Final Report (Vol. 1), NAS2-3811, General Electric Company, Missile and Space Division, Apollo Support Department, July 7, 1967.
- (2) "Study of Structural Weight Sensitivities for Large Rocket Systems," Final Report (Vol. 2), NAS2-3811, General Electric Company, Missile and Space Division, Apollo Support Department, July 7, 1967.
- (3) Anon, "Industry Evolution - From RP to Composites", Reinforced Plastics and Composites World 6, (8), 14-16, 18, 1967.
- (4) Rineharts, T., "Composite Materials for Use in Advanced Aerospace Systems," presentation at University of Tennessee Space Institute - Course on Composite Materials, August 5, 1968.
- (5) "NOVA Vehicle Systems Study - Part I, Vol. III Configurations, (U)" Martin Company Report, April 3, 1963 (NAS9-5135) (Confidential).
- (6) "NOVA Vehicle Systems Study - Part II, Vol. III Configurations, (U)" Martin Company Report, September 1963 (NAS8-5135) (Confidential).
- (7) "Structural Systems and Program Decisions, " Vol. 1, NASA SP-6008, Apollo Program Office, NASA, Washington, D.C.
- (8) "Structural Systems and Program Decisions" Vol. 2, NASA SP-6008, Apollo Program Office, NASA, Washington, D.C.
- (9) "Study of Advanced Multipurpose Large Launch Vehicles - Technical Report (U)," NAS2-4079, Boeing Company, January 1968 (Confidential).
- (10) Douglas Missile & Space System, "Methods of Fabricating and Joining Large Sandwich Segments for Forming Common Domes," DAC-60847, December 1967.
- (11) Anon, "Structural Design Guide for Advanced Composites Applications," Southwestern Research Institute, San Antonio, Contract AF33(615)-5142, September 1967.
- (12) Hexcel Corporation, "Design Curves for Honeycomb and Sandwich Core," TSB121, June 1966.

- (13) "Manufacturing Plan Outline, Post Saturn Vehicle Study," Contract NAS8-11123, Martin Company, October, 1964.
- (14) Hexcel Corporation, "Design Handbook for Honeycomb Sandwich Structures," TSB123, October 1967.
- (15) Structural Safety Under Conditions of Ultimate Load Failure and Fatigue, Freudenthal & Shinozuka, Columbia University, October, 1961, WADD Report 61-177.
- (16) Engineering Applications of Reliability, Lipson, Kekawalla & Mitchell, University of Michigan, 1963.
- (17) Beryllium Corporation, "Beryllium Ingot Sheet," Berylco Technical Bulletin No. 2210, Reading, Pa.
- (18) Ingels, S.E., "Ductility of Cross Rolled Beryllium Sheet-Barrier or Challenge," SAE, NAE Meeting, April 1966, New York, N.Y.
- (19) Brush Beryllium Company, "Beryllium in Aerospace Structures," Cleveland, Ohio.
- (20) Hausner, H.H. (Editor), "Beryllium, Its Metallurgy and Properties," University of California Press, Berkley, 1965.
- (21) Defense Metals Information Center, "Corrosion of Beryllium," DMIC Report 242, December 1967.
- (22) Republic Aviation Division of Fairchild Hiller - Brochure on Beryllium, December 1967.
- (23) Solar Division, International Harvester Company, "Beryllium Honeycomb," NAS8-2125.
- (24) Solar Division, International Harvester Company, Private Communication, September 1968.
- (25) Cremer, G.D., Woodward, J.R., Grant, L.A., "Beryllium Brazing Technology," SAE Paper No. 670805, Aeronautic & Space Engineering & Manufacturing Meeting, Los Angeles, California, October 2-6, 1967.
- (26) McDonnell-Douglas Corporation, "Design, Fabrication, and Flight Test of F-4 Beryllium Rudder," AFFDL TR 67-68.

- (27) Defense Metals Information Center, "The Roll Diffusion Bonding of Structural Shapes and Panels," DMIC Report S-17, October 1967.
- (28) Materials Advisory Board - National Academy of Science, "Structural Beryllium and the Beryllium Industry," MAB-199-M (10), June 1967.
- (29) Defense Metals Information Center, "Current and Future Trends in the Utilization of Titanium," DMIC Memo 226, October 1967.
- (30) Reactive Metals Inc., "Basic Facts About Titanium," Niles, Ohio.
- (31) Defense Metals Information Center, "The Ti-8A1-1MO-IV Alloy," DMIC Report S-10, April 1965.
- (32) Defense Metals Information Center, "Joining of Titanium," DMIC Report 240, November 1967.
- (33) Defense Metals Information Center, "The Roll Diffusion Bonding of Structural Shapes and Panels," DMIC Report S-17, October 1967.
- (34) Private Communication, E.R. Bartholomew and F.J. Peck, Jr., SST Office, Federal Aviation Authority, Washington, D.C., September, 1968.
- (35) Private Communication, C. Conn, Stresskin Products Company, Santa Anna, California, September, 1968.
- (36) Defense Metals Information Center, "Titanium 1966," DMIC Memo 215, September, 1966.
- (37) Defense Metals Information Center, "Accelerated Crack Propagation of Titanium by Methanol, Halogenated Hydrocarbons, and Other Solutions," DMIC Memo 228, March, 1967.
- (38) Titanium Metals Corporation of America, "Titanium Data for the Aerospace Industry," New York, N.Y.
- (39) Titanium Metals Corporation of America, "Titanium Buyers Guide," New York, N.Y.
- (40) Rosen, B.W., Snyder, R., and Dow, N.F., "Application of Fibrous Composite Materials to Large Rocket Systems," GE/SSL, TIS-R67SD57, October, 1967.

- (41) Rosen, B.W., and Dow, N.F., "Structural Design Concepts for the Efficient Utilization of Fibrous Composite Materials," GE/SSL, February, 1968.
- (42) Dow, N.F., Rosen, B.W., and Kingsbury, H.G., "Evaluation of the Potential of Advanced Composite Materials for Aircraft Structures," AFML-TR-66-144, May, 1966.
- (43) Alexander, J., "Inner Strength for Man's Materials," Fortune, April, 1966.
- (44) Anon, "The Whisker Metals - Science Fiction Comes True," The Magazine, Wall Street, November 25, 1967.
- (45) McCreight, L.R., et al, "Ceramic and Graphite Fibers and Whiskers; A Survey of the Technology," Academic Press, 1965, p 395.
- (46) Rauch, H.W., Sr., et al, "Survey of Ceramic Fibers and Fibrous Composite Materials," AFML-TR-66-365, October, 1966.
- (47) Sutton, W.H. and Rauch, H.W., Sr., "Review of Current Developments in New Refractory Fibers and Their Utilization As High Temperature Reinforcements," Advanced Fibrous Reinforced Composites, SAMPE Volume 10, November, 1966.
- (48) Rauch, H.W., Sr., "What's New in Fibers for Strong, Lightweight Composites," Materials Eng. 66(4), pp 74-76, 1967.
- (49) Rauch, H.W., Sr., Sutton, W.H., and McCreight, L.R., "The Fabrication, Testing and Application of Fiber-Reinforced Materials - A Survey," AFML-TR-68-162, May, 1968.
- (50) Materials Engineering, p 49, August, 1968.
- (51) Alexander, J.A., "The Elevated Temperature Reactivity of Boron Matrix Composites Materials," Technical Report AFML-TR-67-101, June, 1967.
- (52) Alexander, J.A., et al, "The Elevated Temperature Reactivity in Boron-Metal Matrix Composite Materials," F91 - F104, Advanced Fibrous Reinforced Composites, 10th SAMPE Symposium, San Diego, California, November 9 - 11, 1966.
- (53) Jackson, C.M., and Wagner, H.J., "Fiber-Reinforced Metal-Matrix Composites: Government Sponsored Research 1964-66. Part I, Low Density Matrices," Battelle Memorial Institute, Columbus, Ohio, DMIC Tech. Memo, August, 1967.

- (54) Jackson, C.M., and Wagner, H.J., "Fiber-Reinforced Metal-Matrix Composites: Government Sponsored Research 1964-66. Part II, High-Density Matrices," Battelle Memorial Institute, Columbus, Ohio, DMIC Tech. Memo, August, 1967.
- (55) Galasso and Paton, A., "The Tungsten Borides in Boron Fibers," Trans. AIME 236(12) pp 1751 - 1752, 1966.
- (56) Withers, J.C., and Alexander, J.A., "High Modulus Filaments for Metal Matrix Reinforcements," American Society for Metals, Metals Park, Ohio, Report WES 7-75, March, 1967.
- (57) Basche, Borsic Data
- (58) Vidoz, A.E., Coons, W.C., Camahart, J.L., and Hansen, A.R., "Effectiveness of Boron Nitride Coating in Boron Composites," 14th Refractory Composites Meeting, May 13 - 15, 1968; AFML-TR-68-129, 1. 68, pp 257 - 269.
- (59) Mehan, R.L., and Sutton, W.H., "Review of Research on Composite Materials," 14th Refractory Composites Meeting, May 13 - 15, 1968, AFML-TR-68-129, pp 370 - 371.
- (60) Japanese trip visit by Flom and Sutton.
- (61) Advanced Composites Status Report, Meeting sponsored by the Advanced Composites Division, held at Lockheed Aircraft Co., Marietta, Georgia.
- (62) Nature, Recryst. of Graphite.
- (63) "Graphite Fiber Composites," Symposium presented to ASME, Pittsburgh, November, 1967, sponsored by the Rubber Plastic Div., p 73, 1967.
- (64) Compton, W.A., et al, "Metal-Matrix Composite Materials for Aircraft Compressor Blades," Advanced Fibrous Reinforced Composites, 10th SAMPE Symposium, November 9 - 11, 1966, San Diego, California.
- (65) Metcalf, A.G., and Schmitz, G.K., "Development of Filament Reinforced Titanium Alloys," Paper No. 670862, Aeronautic and Space Engineering and Manufacturing Meeting, Society of Automotive Engineers, Los Angeles, California, October 2 - 6, 1967.

- (66) Schneidmiller, R.F., and White, J.E., "A Compatibility Study of SiC and B. Fibers in Be, Fe, Co and Ni Matrices," Advanced Fibrous Reinforced Composites, 10th SAMPE Symposium, San Diego, California, November 9 - 11, 1966.
- (67) Technical Report AFML-TR-67-167, November, 1967.
- (68) McCandless, L.C., et al, "High Modulus-To-Density Fiber-Reinforcements for Structural Composites," Technical Report AFML-TR-65-265-Part 2, Sept. 1966.
- (69) Schwartz, H.S., and Spain, R.G., "Development of Structural Plastic Composites Incorporating New High Modulus Reinforcement," Proceedings of AIAA/ASME 8th Structures, Structural Dynamics and Materials Conference, Palm Springs, California, March 29 - 31, 1967.
- (70) Phone conversation with R. Fellman, GE/RSD.
- (71) Davis, L., and Margan, "New Metal-Metal Composite Materials," Journal Spacecraft and Rockets 4(3), pp 386 - 391, March, 1967.
- (72) Paper No. 1, SAMPE, Volume 12.
- (73) Anon, "The Age of Composites," Reinf. Plastics & Composites World 6(3) pp 14 - 16, 18, 21, 24, 1967.
- (74) Morris, E.E., et al, "Filament-Wound Structures," Space/Aeronautics 47(2), pp 86 - 92, 1967.
- (75) McGarry, F.J., "Composite Structural Materials," Engineering Mechanics 6(6) pp 33 - 1336, 1966.
- (76) SAMPE Symposium No. 12, Advances in Structural Composites, Western Periodical Publishing Company, North Hollywood, California.
- (77) Bandaruk, W., "Polymers for the Space Age," Sect. 18D, pp 1 - 8, Proceedings 22nd ANTEC, Soc. Plastics Ind., New York, N.Y., 1967.
- (78) Carlson, R.G., "Orientation Effects on Metal Matrix Composites," General Electric Company, Cincinnati, Ohio, Report R67FPD159, March 30, 1967.
- (79) Moorefield, S.A., and Beeler, D.R., "An Evaluation of New and Potentially Heat Resistant Glass Reinforced Plastics," Tech. Report AFML-TR-66-380, December 1966.

- (80) Steg, L., "Whisker and Short Fiber Reinforcements," Paper 660640, Aeronautic and Space Engineering and Manufacturing Meeting, SAE, Los Angeles, California, October 3 - 7, 1966.
- (81) Shyne, J.J., and Shaver, R.G., "Whisker Composite Technology," Advanced Fibrous Reinforced Composites, 10th SAMPE Symposium, San Diego, California, November 9 - 11, 1966.
- (82) Plueddemann, E.P., "Silane Coupling Agents for High-Temperature Resins," Sect. 9A, pp 1 - 10, Proceedings 22nd ANTEC, Soc. Plastics Ind., Inc., New York, N.Y., 1967.
- (83) Atkin, H.P., "Boron-Filament Reinforced Plastic Composites for Aircraft Structures," Met. Eng. Atly, pp 17 - 22, February 1967.
- (84) "U.K. Process Promises Low-Cost Whiskers," C and E News, pp 35 - 36, August 26, 1968.
- (85) Phillips, L.N., "Carbon Fiber-Reinforced Plastics - An Initial Evaluation," Royal Aircraft Establishment, Farnborough, England, Report RAE-TR-67088, April 1967 (AD655890).
- (86) Anon, "Shear Strength Improved 300 percent in Graphite-Fiber Composites," Reinforced Plastics and Composites World 6 (5) p 20, 1967.
- (87) Herrick, J.W., "Surface Treatments for Fibrous Carbon Reinforcements," Technical Report AFML-TR-66-178, Part I, June 1967.
- (88) "Manufacturing Technology for Large Nonolithic Fiberglass Reinforced Plastic Rocket Motor Case - Volume 1 - Basic Text." Final Technical Documentary Report NR AFML-TR-65-436, November, 1965.
- (89) Aviation Week and Space Technology, p 47, October 30, 1967.
- (90) V.N. Saffire, "Application of Advanced Fibrous Reinforced Composite Materials," AFML-TR-66-272, Volume I and II, 1966.
- (91) "Space Age Composites Are Flying," Steel, pp 47 - 51, August 5, 1968.
- (92) "Applying Hybrid to Aero-engineers," The Engineer, 225, pp 698 - 699, May, 1968.
- (93) J.F. Judge, "Aerospace Use of Graphite Composites Expands Aerospace Technology," May 6, 1968.

- (94) Ahmad, I., et al., "Electroforming of the Composites of Nickel Reinforced with Some High Strength Filaments," Watervliet Arsenal, New York, Report WVT-6709, January 1967.
- (95) Buschow, A.G., et al., "Electroforming Aluminum Composites for Solar Energy Concentrators," Final Report NASA CR-66322, May 1967.
- (96) Cooper, G.A., "Electroformed Composites Materials," J. Mtl. Sci., 2 (5) 409-414, 1967.
- (97) Hodge, W. and Bartlett, E.S., "Summary of the 12th Meeting of the Refractory Composites Working Group, Battelle Memorial Institute, Columbus, Ohio, Report DMIC-Memo-222, April 1967.
- (98) Robinson, R.K., "Fiber-Reinforced Metal Matrix Composite Studies," Battelle Northwest Laboratory, Richland, Washington, Report BNWL-SA-550, November 1966.
- (99) Davis, L.W., "Development of Aluminum-Boron Composites," presented at the 13th Ref. Comp. Wkg. Grp. Mtg., Seattle, Washington, July 18 - 20, 1967.
- (100) Davis, L.W., "Stainless Wire + Aluminum Matrix = Strong, Light Composite Plate", Met. Progr. 91 (4), pp 105 - 106, 108, 110, 112, 114, 1967.
- (101) Private Communication with Harvey Engineering Laboratories,
- (102) Sara, R.V. & Winter, L.L., "Preparation of Carbon Fiber-Nickel Composites," presented at the 13th Refr. Comp. Wkg. Grp. Mtg., Seattle, Washington, July 18 - 20, 1967.
- (103) Porembka, S.W., et al, "Control of Composite Microstructure Through the Use of Coated Filaments," Paper 67 - 175, Aerospace Sciences Meeting, AIAA, New York, N.Y., Jan. 23 - 26, 1967.
- (104) Niez, D.E., et al, "Development of Filament-Reinforced Metals," Contract NOW-65-0615, Final Report, January 1967 (AD649509).
- (105) Mehan, R.L., "Fabrication and Evaluation of Sapphire Whisker Reinforced Aluminum Composites," presented at the 70th Annual Meeting of ASTM, Boston, Mass., June 25 - 30, 1967.
- (106) Hahn, H., "Progress in Preparation and Working of Whisker Reinforced Metal Composites," Paper 67-DE-35, presented at Design Eng. Conf., ADME, May 15 - 18, 1967, New York, N.Y.

- (107) Barr, H.N., "Silicon Carbide Whisker Reinforced Metallic Matrix Continuous Tapes," Technical Report AFML-TR-67-296, November, 1967.
- (108) "Fiber-Reinforced Metal-Matrix Composites, Government Sponsored Research 1964 - 1966," Battelle Report DMIC Report 241, September 1, 1967.
- (109) "Fiber-Reinforced Metal-Matrix Composites, Government Sponsored Research 1967, Battelle Report DMIC-S21, June 1968.
- (110) Hieronymus, Wm., "Composite Use in Aircraft," Metal Working News 9 (412), June 10, 1968.
- (111) Technical Data Sheet No. 5, 3M Co., Scot Ply Reinforced Plastics, February, 1968.
- (112) Technical Data Sheet, Graphite Fiber/Epoxy Resin Prepreg. and Composite, Whittaker Corp., Narmco R&D Div., Sept. 24, 1968.
- (113) H. Lin. "Filament Winding: Its Progress and Future in the Aerospace Industry," *Plastics and Polymers*, 36 (123) pp 249 - 259, October, 1967.
- (114) E.E. Morris, M.J. Sanger & F.J. Darms, "Filament Wound Structures," *Space/Aeronautics*, pp 86 - 92, February, 1967.
- (115) Grimes, D.L., "Why Develop Composite Materials Now?", *Res/DW* 16 (9), p 29, 1965.
- (116) Ahmad, I., "Contributions to the Development of the Whisker Reinforced Composites", presented at the 13th Refractory Composites Working Group Meeting, Seattle, Washington, July 18 - 20, 1967.
- (117) "Beryllium Technology," Vol. 1 and Vol. 2, edited by L. McDonald Schetky and Henry A. Johnson, 1966, Gordon and Breach Sciences Publishers, Inc., New York, N.Y.
- (118) J.S. Bleymaier, "Systems Considerations for Aerospace Beryllium Applications," Speech for SAE Manufacturing Forum Meeting, Los Angeles, California, October 8, 1968.
- (119) "Compatibility of Materials with Rocket Propellants and Oxidizers", DMIC Memo 201, January 1965.
- (120) "Carbon Fiber Development in U.K. Part I," *Aviation Week*, November 8, 1968.

- (121) "Review and Evaluation of Recent Structural Development Program," MSFC Internal Note R-ME-IT-10044, Vol. I., August 15, 1966 (U).
- (122) White, Jr., D.W. and Burke, J.E., "The Metal Beryllium," The American Society of Metals, Cleveland, Ohio, 1955.
- (123) Grimes, G.C. et al, "Investigation of Structural Design Concepts for Fibrous Aircraft Structures," Southwestern Research Inst., Tech. Report AFFDL-TR-67-29, Vol. III, November 1967.
- (124) Simcox, T.A., "Cholesteric Liquid Crystals—Their Application to Non-destructive Testing," General Electric Apollo Systems Department, Cocoa Beach, Florida.
- (125) Anon, "Integrated Test Plan (Preliminary)," Space Systems Division, Martin Company, NOVA TN-20, Contract NAS8-5135, March, 1963.
- (126) NOVA Vehicle Systems Study, Part 1, Conceptual Design Study, General Dynamics, Report AC 63-0096.
- (127) Burns, H.D., "Saturn V Test Plan and Status Summary," NASA Marshall Space Flight Center, Saturn V Test Management Office, January 15, 1968, Revision B.
- (128) Anon, "Test Verification Summary AS 501 Launch Vehicle, NASA Apollo Program Office, 27 January 1967.
- (129) Ackley, J.B. and Wharton, J.D., "S-II-4 Test: Forward Skirt/LH<sub>2</sub> Tank Assembly - Forward, Structural Qualification Test Requirement, Rev. 3," Brown Engineering Company, October 1, 1967.
- (130) The Engineering Safety Factor - How Valid Is It? S. Demskey - 18th Annual Convention ASQC, May 1964.
- (131) Structural Subsystem Reliability Prediction Analysis, General Electric, TEMPO, July 31, 1964.
- (132) NOVA Vehicle Systems Study - Reliability - Cost - Schedule Trade-offs, Martin Company, NTN 58, September, 1963.
- (133) Post Saturn Launch Vehicle Study, PSTN-III-37(R), Martin Company, September, 1964.
- (134) Structures Reliability Report, ER 11862, Martin Company, December, 1961.

- (135) Dow, N.F. and Rosen, B.W., "Structural Efficiency of Orthotropic Cylindrical Shells Subjected to Axial Compression," AIAA Journal, Volume 4, Number 3, pp 481 - 485, March 1966 (U).
- (136) Haskin, Z. and Rosen, B.W., "The Elastic Moduli of Fiber Reinforced Materials," J. of Applied Mechanics, Series E, Vol. 31, No. 2, 1964.
- (137) Shu, L. and Rosen, B.W., "Application of The Methods of Limit Analysis to The Evaluation of The Strength of Fiber-Reinforced Composites," to be published.
- (138) Rosen, B.W., "Mechanics of Composite Strengthening," Fiber Composite Materials, ASM, Metals Park, Ohio, 1965.
- (139) "Study of Technology Requirements for Structures of Large Launch Vehicles" Phase I Report "Survey of Advanced Structures Technologies", General Electric Company, Missile and Space Division, Apollo Systems Department, January 31, 1969.
- (140) "Titanium S-1c Skin Section," Phase III Report, (NASA George C. Marshall Space Flight Center), North American Aviation, Inc., 6 September 1967.
- (141) Anonymous, "Design of Bonded Sandwich Intertank Structure for Saturn V Vehicle," Gdys Code 25500, Contract NAS8-11553, 18 May 1966.
- (142) Keller, B., "Application of High Modulus Composites to Space Vehicles," Hughes Aircraft. A paper presented at an Air Force Symposium on Advanced Composites for Space and Missile Structures at Aerospace Corporation on 13 January 1969.

APPENDIX A

PROPOSED WORK PROCESSES FOR MATERIAL PREPARATION,  
FABRICATION, AND INSPECTION OF INTEGRALLY STIFFENED  
SKIN STRUCTURES AS DEFINED BY MARTIN NOVA STUDIES

## APPENDIX A

### PROPOSED WORK PROCESSES FOR MATERIAL PREPARATION, FABRICATION, AND INSPECTION OF INTEGRALLY STIFFENED SKIN STRUCTURES AS DEFINED BY MARTIN NOVA STUDIES

#### A.1 GENERAL

The work processes by which aluminum integrally stiffened-skin structures might be fabricated have been investigated by the Martin Company in their Post-Saturn Vehicle study<sup>(5, 6)</sup>. As a part of this study, an outline of a manufacturing plan was prepared<sup>(14)</sup>. The processes and parts presented in this appendix were taken from that manufacturing plan outline in order to show the manufacturing requirements as originally planned for the baseline vehicle used in this study.

As pointed out by the Martin Company in their study, industry capabilities are insufficient for manufacturing vehicles of this size, particularly because of the large diameters. Development work is required in welding, sheet processing, forging and production of larger sheet and plate sizes. Current machining capability is sufficient for this size vehicle if constructed using conventional technology.

#### A.2 WORK PROCESSES FOR MAJOR TANKAGE

The work processes which follow are presented on a step-by-step basis, with illustrations and materials where applicable, for the liquid hydrogen and liquid oxygen tanks of the baseline vehicle. The work processes, though by no means complete or indicative of the precise sequence of operations, begin with the fabrication of components from mill stock or rough forgings and proceed through welding to hydrostatic test. It should also be noted that in many instances there are alternate processes to the ones presented. The work processes shown are indicative of the methods and procedures used in conventional technology, associated with the baseline vehicles.

### A.2.1 STIFFENED TANK-SKIN PANELS

#### SKETCH

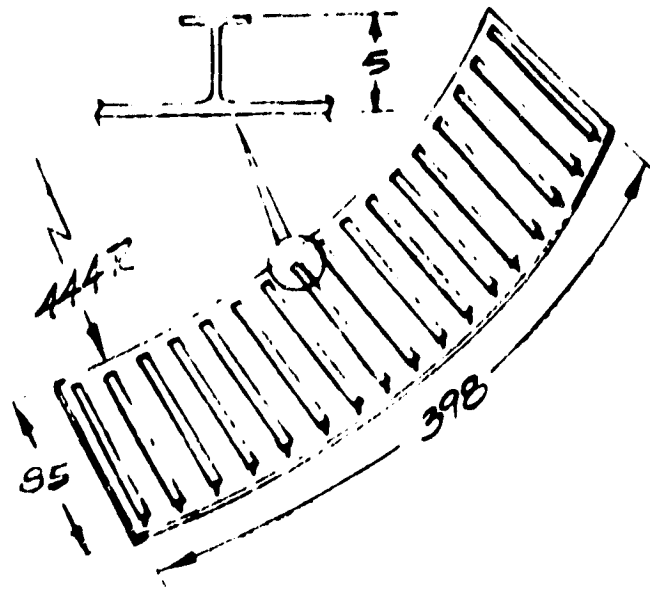

#### Material

Type as received	2219T37
Maximum gage	5.25 inch Plate
Maximum size	85 inch × 398 inch
Final condition	2219T87

#### WORK PROCESSES

- Machining of "T" stringers, pockets, and weld lands to final dimensions, preliminary edge preparations for welding, using numerically controlled skin mills, control tapes, cutting tools and vacuum holding fixtures.
- Dimensional and surface checks using vidigage and standard gages.
- Contour forming to radius using mobile age-forming fixture and aging furnace.
- Contour check using template (final check in assembly weld fixture).

## A.2.2 CONICAL SKIN PANELS

### SKETCH

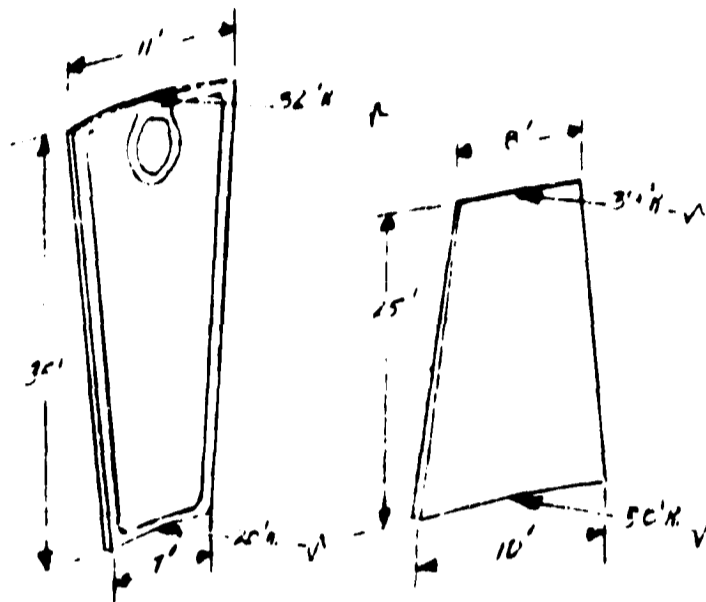

<u>Material</u>	<u>Tanks</u>	<u>Skirts</u>
Type as received	2219-T37	7075-T6
Approximate gage	.750 inch	.500 inch
Approximate size	13 ft × 36 ft	12 ft × 26 ft
Final condition	2219-T87	7075-T6

### WORK PROCESS

- a. Machine outline, tapers, and weld lands using numerically controlled skin mill, control tapes, cutters, and holding fixture.
- b. Degrease.
- c. Form conical contour with mobile age-forming fixture and aging furnace at 500°F.
- c. Contour check using check fixture.

### A.2.3 GORES

#### SKETCH

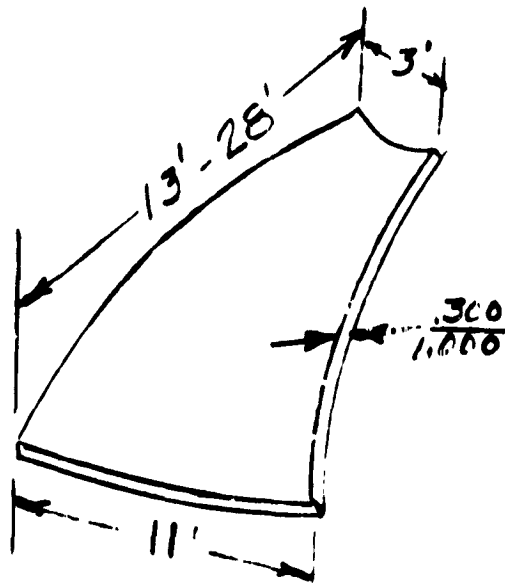

#### Material

Type as received	2219-T37
Maximum gage	1.000 inch
Maximum size	12 ft x 30 ft
Final condition	2219-T87

#### WORK PROCESS

- Machine outline, tapers, and weld lands using numerically controlled skin mills, control tapes, cutting tools, and holding fixtures.
- Degrease.
- Roll-form contour in one direction using forming rolls and template.
- Bulge form ovate contour using hydrodynamic bulge-form die with plastic-faced cavity and steel backup in 25,000-ton capacity press.
- Oversize trim and deburr in selfcontained trim fixture with traversing heads for trimming and deburring.
- Age-size in mobile aging-fixture with multiple capacity and clamping provisions in aging furnace at 500°F.
- Check contour in check fixture with provisions for indicating contour of peripheral trim line.

#### A.2.4 BULKHEAD CAPS

#### SKETCH

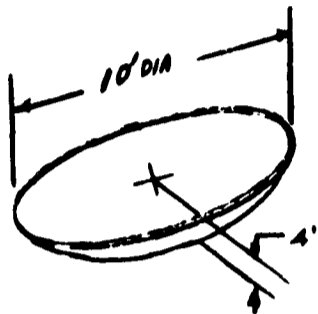

#### Material

Type as received	2219-T37
Approximate gage	.750 inch
Maximum size	11 feet diameter
Finish condition	2219-T87

#### WORK PROCESS

- a. Machine taper and weld lands using numerically controlled skin mills, control tapes, cutting tools, and holding fixtures.
- b. Degrease.
- c. Bulge-form ellipsoidal shape using hydrodynamic bulge-form die with plastic-faced cavity and steel backup in 16,000-ton capacity press.
- d. Trim outline using vertical boring mill.
- e. Supplemental sizing using mobile age-sizing fixture with clamping provisions in aging furnace at 500° F.
- f. Check contour in check fixture with provisions for indicating contour of peripheral trim line.

A.2.5 TANK TO BULKHEAD TRANSITION SECTIONS

SKETCH

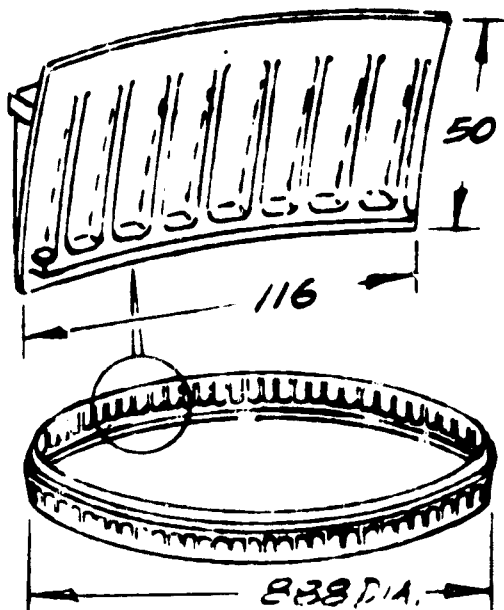

Material

Type as received	2219 as forged
Maximum size	50 in × 116 in
Finish condition	2219-T6

WORK PROCESS

- a. Internal and external contour and pocket machining to final dimensions prior to welding and preliminary preparation for welding using numerically controlled 5-axis profile mills, control tapes, cutting tools and holding fixtures.
- b. Heat treat after rough machining.
- c. Contour, dimensional, and surface checks using check fixtures and standard gages.

## A.2.6 FRAMES

### SKETCH

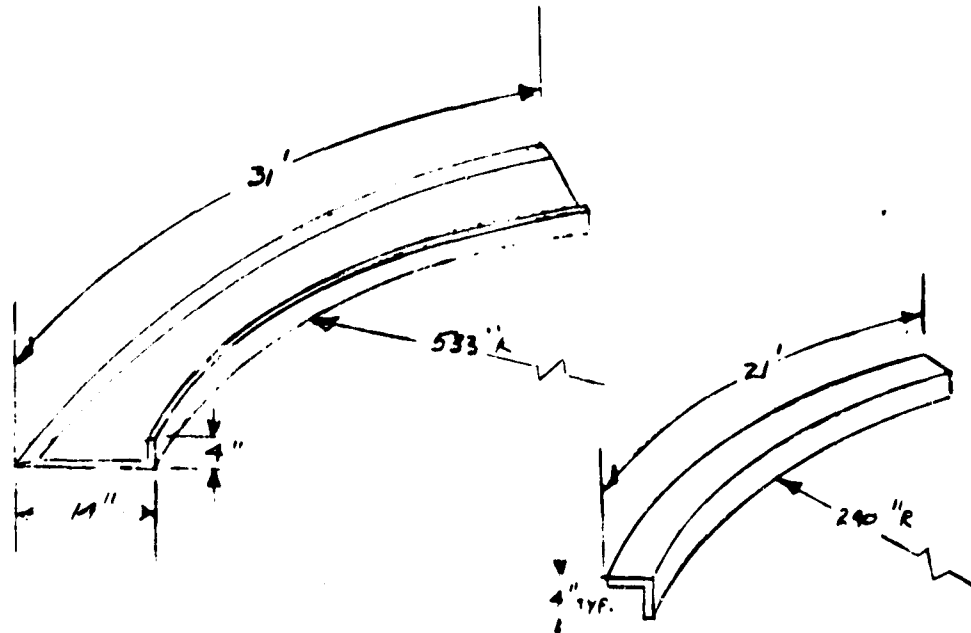

### Material

Type as received	7075-0
Approximate area	12 sq. in.
Approximate length	32 ft.
Final condition	7075-T6

### WORK PROCESS

- Form basic contour using aluminum stretch die with reinforced plastic "snake" inserts in 400-ton capacity extrusion stretch wrap press.
- Solution heat treat in drop-bottom quench furnace at 1100° F.
- Refrigerate.
- Age size in mobile aluminum age-size fixture in aging furnace.
- Check on universal check table with contour templates.
- Trim ends on universal saw fixture with traversing heads.

## A.2.7 PREWELD PREPARATION

### WORK PROCESS

- Weld joint edge preparation simultaneously with trimming of welded subassemblies.
- Preweld joint cleaning.
- Joint alignment and clamping.

## A.2.8 POSTWELD OPERATIONS

### WORK PROCESS

- a. Weld verification performed progressively and simultaneously with the welding or
- b. Weld verification performed progressively in increments after subassembly or assembly is welded but prior to removal from fixture.

## A.2.9 SUBASSEMBLY WELDING—LONGITUDINAL AND MERIDIONAL

### SKETCH

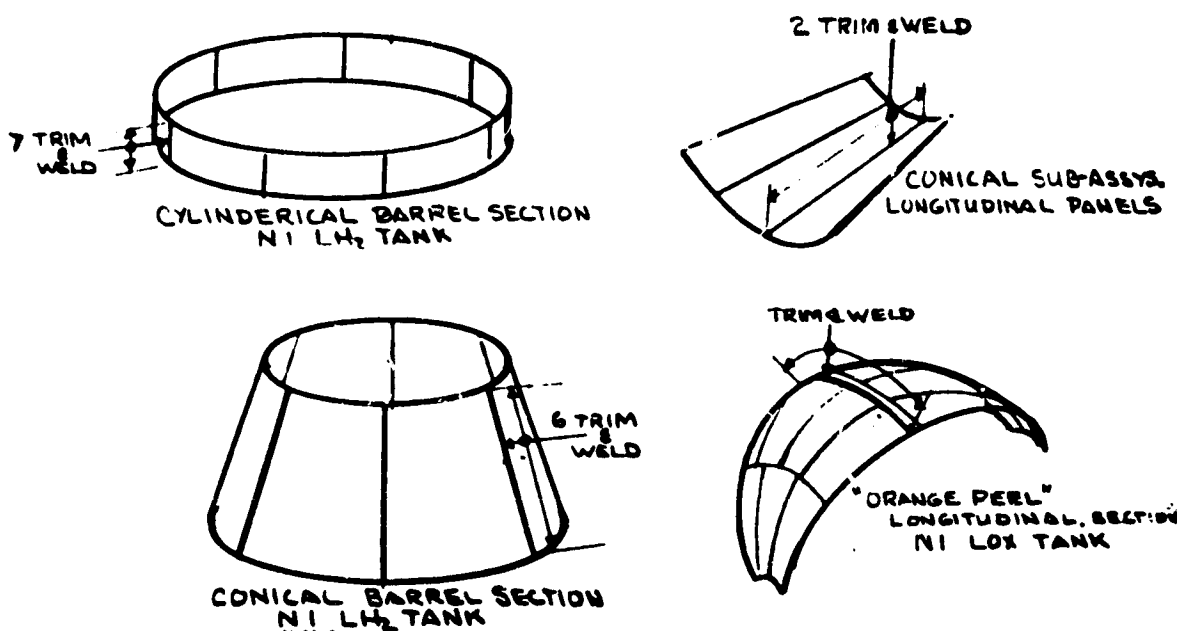

### WORK PROCESS

- a. Use of progressive weld and trim operations to assure maximum tolerance control and minimum joint gaps.
- b. Cylindrical barrel section: barrel segments located to proper diameter in heavy-duty fixtures, vertical welding stations align and clamp segments along 100 percent of joint for trimming and welding, portable trackage at each station transport automated trimming and welding equipment.
- c. Conical barrel sections: longitudinal panel subassemblies use flat welding in heavy-duty fixtures with clamping of segments along 100 percent of joint. fixed horizontal trackage for automated trimming and welding equipment, conical barrel assemblies made up of 1/6 segment subassemblies will be welded similarly to cylindrical barrel sections in b above.

- d. "Orange peel" longitudinal sections: forward and aft bulkhead panel subassemblies trimmed and welded at equator, assembly positioned with centerline horizontal for flat position welding, trim and weld equipment traverses circumferential segment weld joint, supporting structure detachable from weld fixture base and remains with welded subassembly during handling and locating in assembly fixture, support structures coordinated to mate and form final assembly weld fixture.

#### A.2.10 BULKHEAD SUBASSEMBLY WELDING—LONGITUDINAL AND MERIDIONAL

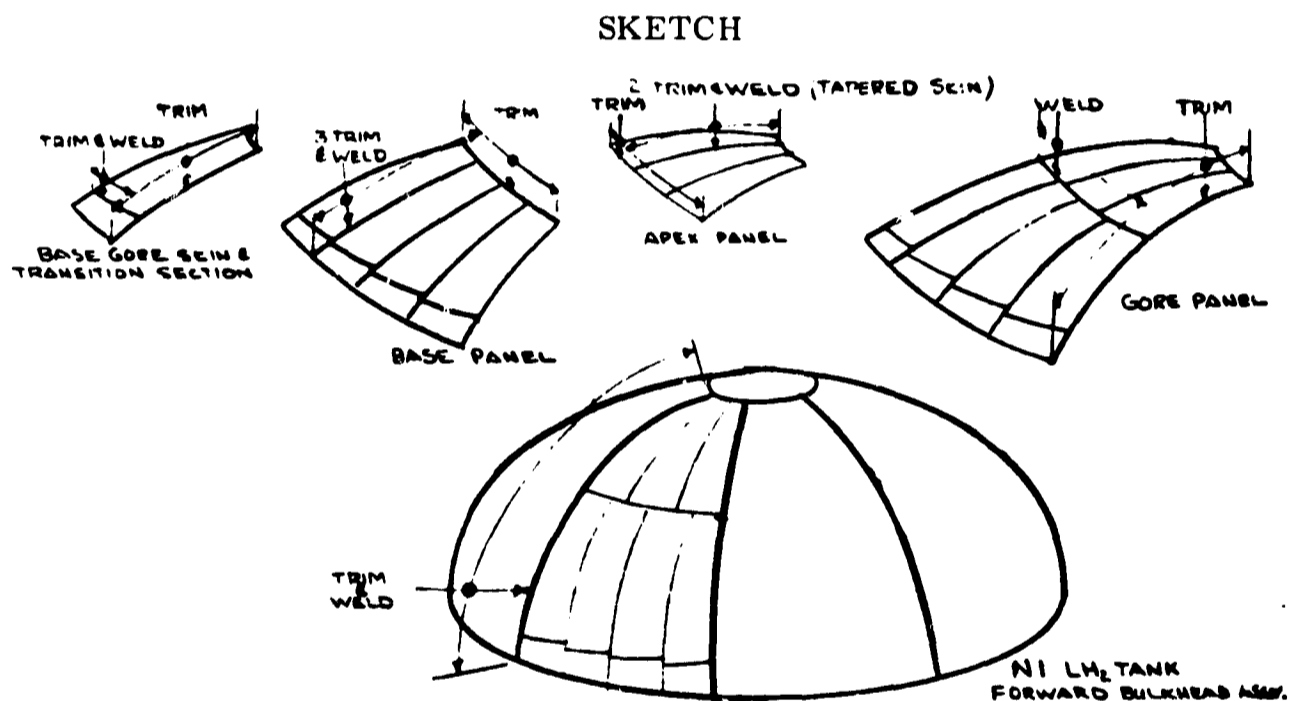

#### WORK PROCESS

- a. Use of progressive weld and trim operations to assure maximum tolerance control and minimum joint gaps.
- b. Details and subassemblies located in proper alignment and position in heavy-duty fixtures, tools provide clamping and alignment along 100 percent of joint.
- c. Subassemblies up to and including  $1/6$  arc segments will be positioned for maximum flat welding on coordinated weld and trim fixtures.

## A.2.11 SUBASSEMBLY WELDING—CIRCUMFERENTIAL

### SKETCH

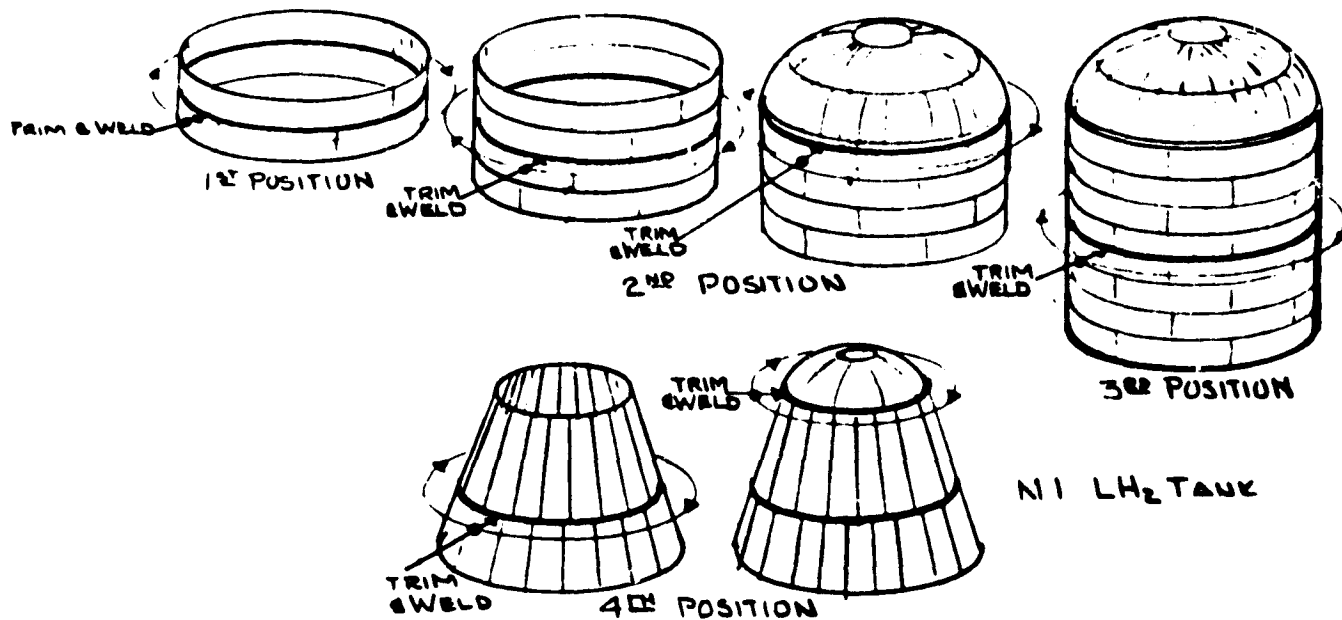

### WORK PROCESS

- Use of progressive weld and trim operations to assure maximum tolerance control and minimum joint gaps.
- Configuration support skeleton fixtures employing local clamping to be used.
- Reduced clamping pressure requires the utilization of the "critical speed" of welding to attain the minimum movement during welding.
- Cylindrical barrel to barrel: barrel assemblies positioned with center-line vertical and held in proper relation with local aligning tools attached to coordinated longitudinal integral-skin stiffeners, trim and weld equipment circumnavigates the weld splice on trackage supported by the tank structure.
- Conical barrel to barrel: forward and aft conical barrel assemblies positioned with vertical centerlines, local aligning tools hold assemblies for trimming to matched circumferential lengths, trim and weld equipment circumnavigates weld splice on trackage supported by the tank structure.
- Bulkhead to barrel (cylindrical and conical): barrel and bulkhead positioned with center lines vertical and held in proper relation with local aligning tools attached to barrel stiffeners and coordinated to bulkhead,

trim and weld equipment circumnavigates weld splice on trackage supported by the tank structure.

#### A.2.12 LH<sub>2</sub> TANK SUBASSEMBLY TEST

##### WORK PROCESS

- a. Test performed on completed subassemblies while in welding fixture, during manufacture.
- b. Double wall vacuum cup applied to one side of weld, inner compartments flooded with pressurized tracer gas, vacuum cup applied to other side of weld to check for leakage using tracer-gas leak detector.

#### A.2.13 ASSEMBLY WELDING—LH<sub>2</sub> TANK

##### SKETCH

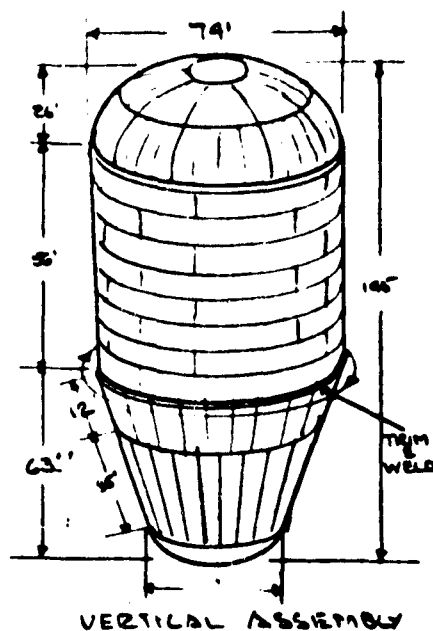

##### WORK PROCESS

- a. Use of progressive weld and trim operations to assure maximum tolerance control and minimum joint gaps.
- b. Configuration support skeleton fixtures employing local clamping to be used.
- c. Reduced clamping pressure requires the utilization of the "critical speed" of welding to attain the minimum movement during welding.

- d. Employ "launch position" assembly, conical aft section subassembly supported by knuckle ring, forward cylindrical section mated and aligned with conical section, local supporting and clamping tools attached to longitudinal skin stiffeners to guide and align sections, trim and weld equipment circumnavigates weld splice on trackage supported by tank structure, local clamping and self-aligning weld joint geometries hold splice for welding.

#### A.2.14 ASSEMBLY WELDING—LOX TANK

##### SKETCH

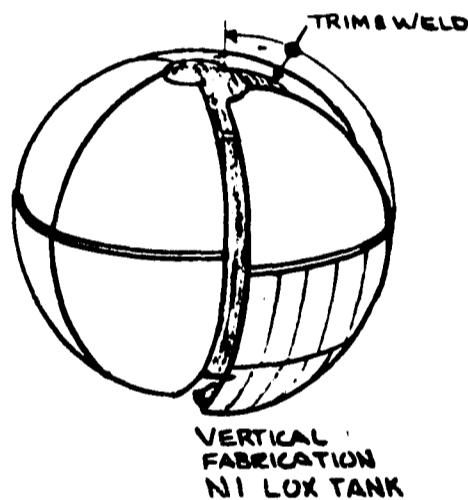

##### WORK PROCESS

- a. Use of progressive weld and trim operations to assure maximum tolerance control and minimum joint gaps.
- b. Configuration support skeleton fixtures employing local clamping to be used.
- c. Reduced clamping pressure requires the utilization of the "critical speed" of welding to attain the minimum movement during welding.
- d. Longitudinal subassembly sections with their respective supporting structure aligned around center supporting column, pedestal-mounted ring clamp surrounds the tank, transition section mates to ring and achieves alignment of assembly, trim and weld equipment trackage attaches to center column at the poles of the assembly and guides the trim and weld equipment along the meridional splice, equipment must be capable of

welding tapered material thicknesses and making transition from vertical to flat welding position, major interior supporting structure removed following meridional welding but prior to fitting and welding caps.

#### A.2.15 HYDROSTATIC TEST—LH<sub>2</sub> TANK

##### WORK PROCESS

- a. Fill tank and test silo simultaneously with water, keep ullage area flooded with tracer gas and "sniff" as water ascends inside and outside tank, equipment carried up outside of tank on floatation gear, large leaks detected by bubbler.
- b. Apply hydrostatic proof pressure to filled tank.
- c. Drain water slowly and pressurize with tracer gas, "sniff" all welds as floatation gear descends.