

Neurosciences Research Program
Bulletin

Volume 6, Number 3

December 20, 1968

NEURAL CODING

A Report based on an NRP Work Session

CASE FILE
COPY

DONALD H. PERKEL

and

THEODORE HOLMES BULLOCK

PARTICIPANTS

W. Ross Adey
Horace B. Barlow
Michael V. L. Bennett
Marguerite Biederman-Thorson
Theodore H. Bullock
Jack D. Cowan
John W. Evans
James D. Frost, Jr.
Michael G. F. Fuortes

Will Gersch
George L. Gerstein
Leon D. Harmon
Donald Kennedy
Nelson Y.-S. Kiang
David Lange
Donald M. MacKay
Frank Morrell
Vernon B. Mountcastle

Lloyd D. Partridge
Donald H. Perkel
Gardner C. Quarton
Wilfrid Rall
Francis O. Schmitt
José P. Segundo
Richard B. Stein
Samuel Sutton
Donald M. Wilson

NEUROSCIENCES RESEARCH PROGRAM

280 Newton Street, Brookline, Massachusetts 02146
Telephone: Area Code 617, 522-6700; Cable: NEUROCENT

NRP CENTER STAFF

Chairman
Francis O. Schmitt

Program Director
Gardner C. Quarton

Communications Director
Theodore Melnechuk

Business Manager
L. Everett Johnson

Managing Editor & Librarian
George Adelman

Administrative Officer
Katheryn Cusick

Assistant to the Chairman
Harriet E. Schwenk

Resident Scientists
Arnold L. Leiman
Jacques Mouret
John R. Smythies

Staff Scientists
Richard Hirsh
Frederick E. Samson, Jr.

Secretaries
Carla Byrne
Julie S. Tholander
Jane I. Wilson

Writer-Editors
Yvonne M. Homsy
Catherine M. LeBlanc

Library Assistant
Linda T. Knowles

Audio-Visual Technician
Wardwell F. Holman

SPONSORSHIP AND SUPPORT

The Neurosciences Research Program, sponsored by the Massachusetts Institute of Technology, is an interdisciplinary, interuniversity organization the primary goal of which is to facilitate the investigation of the physical basis of mental processes including memory and learning. To this end the NRP, as one of its activities, conducts scientific meetings to explore crucial problems in the neurosciences and publishes the results of these Work Sessions in this *Bulletin*. NRP is supported in part by National Institutes of Health Grant No. GM10211-07, National Aeronautics and Space Administration Grant No. Nsg 462 Amendment 5, Office of Naval Research Grant Nonr(G)-00014-68, The Rogosin Foundation, and Neurosciences Research Foundation, Inc.

Work of the authors of this *Bulletin* was aided by grants from NIH, NSF, ONR, and AFOSR.

NEURAL CODING

A Report based on an NRP Work Session
organized by Theodore Holmes Bullock
and held on January 21-23, 1968

written by

Donald H. Perkel
The Rand Corporation
Santa Monica, California

and

Theodore Holmes Bullock
Department of Neurosciences
University of California
San Diego

with the editorial assistance of
Dorothy W. Bishop
NRP Writer-Editor

CONTENTS

List of Participants	223
Preface	225
I. Introduction	227
The Notion of "Coding"	228
Coding in the Nervous System	232
Formal Properties of Neural Codes	232
Biological Significance	234
Candidate Codes	236
Scope and Limitations	237

II. Nerve Impulses and Trains in Single Channels	239
Labeled Lines	240
Time of Firing: "Go!"	241
Frequency or Rate	242
Variance of Interpulse Intervals	254
Temporal Pattern	256
Number or Duration Codes	261
Statistical Features of Impulses in a Single Channel	262
III. Nerve Impulses and Trains in Parallel Channels	266
Impulse Coding in Pairs of Fibers	267
Impulse Coding in Many Channels	272
Stimulus-Related Codes	277
Who Reads Ensemble Codes?	284
IV. The Representation of Information in Nonimpulse Carriers	287
Subcellular Nonimpulse Codes	290
Nonimpulse Codes Between Neurons	295
Slow Waves	297
V. Summary	307
VI. Appendix: A Table of Candidate Neural Codes	310
Bibliography	329
Index	344

LIST OF PARTICIPANTS

Dr. W. Ross Adey
Department of Anatomy
University of California
Los Angeles, California 90024

Dr. Horace B. Barlow
Department of Physiology
University of California
Berkeley, California 94720

Dr. Michael V. L. Bennett
Department of Anatomy
Albert Einstein College of Medicine
Yeshiva University
1300 Morris Park Avenue
Bronx, New York 10461

Dr. Marguerite Biederman-Thorson
Department of Neurosciences
School of Medicine
University of California, San Diego
La Jolla, California 92037

Dr. Theodore H. Bullock
Department of Neurosciences
School of Medicine
University of California, San Diego
La Jolla, California 92037

Dr. Jack D. Cowan
Chairman, Committee on
Mathematical Biology
University of Chicago
5753 Drexel Avenue
Chicago, Illinois 60637

Dr. John W. Evans
Department of Aeromechanical
and Engineering Sciences
University of California, San Diego
La Jolla, California 92037

Dr. James D. Frost, Jr.
Department of Physiology
Baylor University
College of Medicine
1300 Moursund Avenue
Houston, Texas

Dr. Michael G. F. Fuortes
Ophthalmology Branch
National Institute of Neurological
Diseases and Blindness
National Institutes of Health
Bethesda, Maryland 20014

Dr. Will Gersch
School of Aeronautical and
Engineering Sciences
Purdue University
Lafayette, Indiana 49707

Dr. George L. Gerstein
Department of Biophysics and
Physical Chemistry
School of Medicine
University of Pennsylvania
Philadelphia, Pennsylvania 19104

Mr. Leon D. Harmon
Bell Telephone Laboratories
Murray Hill, New Jersey 07971

Dr. Donald Kennedy
Department of Biological Sciences
Stanford University
Stanford, California 94305

Dr. Nelson Y.-S. Kiang
Eaton Peabody Laboratories
Massachusetts Eye and Ear Infirmary
243 Charles Street
Boston, Massachusetts 02114

Dr. David Lange
Department of Neurosciences
School of Medicine
University of California, San Diego
La Jolla, California 92037

Dr. Donald M. MacKay
Department of Communication
University of Keele
Keele, Staffordshire
England

Dr. Frank Morrell
Division of Neurology
Stanford University
School of Medicine
Stanford Medical Center
Palo Alto, California 94304

Dr. Vernon B. Mountcastle
Department of Physiology
Johns Hopkins University
School of Medicine
725 North Wolfe Street
Baltimore, Maryland 21205

Dr. Lloyd D. Partridge
Department of Physiology and Biophysics
University of Tennessee
Memphis, Tennessee 38103

Mr. Donald H. Perkel
The Rand Corporation
1700 Main Street
Santa Monica, California 90406

Dr. Gardner C. Quarton
Mental Health Research Institute
University of Michigan
Ann Arbor, Michigan 48104

Dr. Wilfrid Rall
Mathematical Research Branch
National Institute of Arthritis
and Metabolic Diseases
National Institutes of Health
Bethesda, Maryland 20014

Dr. Francis O. Schmitt
Neurosciences Research Program
280 Newton Street
Brookline, Massachusetts 02146

Dr. José P. Segundo
Department of Anatomy
University of California
Los Angeles, California 90024

Dr. Richard B. Stein
Department of Physiology
University of Alberta
Edmonton, Alberta, Canada

Dr. Samuel Sutton
Biometrics Research
722 West 168th Street
New York, New York 10032

Dr. Donald M. Wilson
Department of Biological Sciences
Stanford University
Stanford, California 94305

PREFACE

What do we know about coding in the nervous system? Is the code of the brain about to be broken? These and related questions are too important and timely to be avoided out of timidity or neglected because terms and concepts are not agreed upon.

Another reason for this meeting and report is the "news" now rapidly attracting attention that the nervous system does not employ one code, or a small number, or an infinity of codes, but many. The new situation we are in raises questions such as: What is meant by a code in the context of the nervous system? What modes of representation are theoretically plausible? How is a candidate code established? What correlates are themselves signals, and which are either inevitable concomitants or actual noise? Are there rules or principles about the kinds of codes and the domains in space and time where they are used? About tradeoffs in dynamic range, resolution, noisiness, ambiguity, redundancy, reliability, plasticity, and other properties?

Planning for discussions in depth to deal with such problems began at the NRP several years ago. A prolegomenon by Bullock was included in the 1966 Boulder "Intensive Study Program" (Bullock, 1967). In January 1968, a Work Session on this topic was organized by Bullock and held at the NRP Center in Brookline, and this report is based on that meeting, departing freely from it in various ways. It is hoped that the subject will progress rapidly and can be treated again at the 1969 Boulder "Intensive Study Program" (see also Bullock, 1968). In this apparently initial attempt to treat systematically the forms of representation of information in nervous systems, a wide range of possible codes is considered and formally defined (see Appendix).*

*After this paper went to press, the Tallahassee symposium volume *The Skin Senses*, edited by Kenshalo (1968), appeared. Among other relevant papers, that of Littal and Krissoff (1968) deserves special mention for essaying a general scheme of sensory coding.

Y A A M E
Y A A M S
Y A F

P A A M E
P A A M S
P A S

But natural and experimental history is so varied and diffuse, that it confounds and distracts the understanding unless it be fixed and exhibited in due order. We must, therefore, form tables and co-ordinations of instances, upon such a plan, and in such order, that the understanding may be enabled to act upon them.

Bacon, *Novum Organum*

I. INTRODUCTION

The nervous system is a communication machine and deals with information. Whereas the heart pumps blood and the lungs effect gas exchange, whereas the liver processes and stores chemicals and the kidney removes substances from the blood, the nervous system processes information.* It gathers, transforms, stores, retrieves, generates, and distributes information, whatever other functions it may also perform. The information gathered by the nervous system impinges in the form of various energies and substances—sound waves, electromagnetic radiation, pressures, temperature gradients, and samples of specific kinds of molecules impinging at specific locations on and within the body. But these energies and substances are not found inside the nervous system; the information they convey is converted into a form that the nervous system can handle. The transformed impinging information is augmented by, and mingles with, information generated by on-going spontaneous activity; built-in tendencies and patterns interact with environmental events to generate streams of information even under steady-state conditions. The once-transformed information undergoes many further internal transformations at many stages and levels within the nervous system before the effects of peripherally directed information finally manifest themselves in externally observable behavior. The problem of neural “coding” is that of elucidating the transformations of information effected by the nervous system: the representation of impinging and intrinsic energies and substances by some internal coin, and the successive transactions and conversions of that coin as it passes through and is acted upon by the neural apparatus.

Just as the anatomy of the nervous system can be studied at several levels—the molecular structure of membranes and organelles, the structure of individual neurons, the histology of particular neural tissues, and the more global structures and connectivities of the organs comprising the nervous system—so the coding of information by the nervous system can, and indeed must, be studied at several levels of detail and concept. The intimate electrochemical physiology of receptors and junctions, of dendrites and axons, is relevant to the physical substrate of the elementary informational transactions. The analysis of neural “circuits” and their functional properties represents an essential part of the coding story at another level. Specific control systems, such as those regulating respiration

* “Information” is used here and throughout this report, except as explicitly noted, in its more colloquial non-Shannon sense; the information we discuss is not necessarily measurable in bits.

or pupil diameter, represent still another level in which many circuits come into play. Finally, there are the higher levels of representation in the nervous system such as those typified by cognitive processes, problem solving, and the use of language by humans. In the Work Session reported, the emphasis lay at the intermediate, supramolecular, but relatively microscopic levels: the main concern was with coding in individual cells and small groups of cells; only occasionally did a participant venture to discuss on a more speculative level the information-processing potentialities of larger masses of neural tissue. Investigations of neural coding at the diverse levels are complementary and mutually relevant, even though the kinds of description found appropriate at the several levels may at first appear hopelessly disparate.

The Notion of "Coding"

The term "coding," like so many notions used to describe aspects of the functioning of nervous systems, is borrowed from common discourse and technology where it has several clusters of meanings, some quite dissimilar. Such borrowed metaphors, if they are to contribute more understanding than confusion in their adaptive realm of application, must be carefully defined and qualified in their new context. In order to fix ideas at the outset, we must digress briefly to discuss what "coding" means in other contexts and then extract explicitly those features of the notion that seem most useful for describing information transactions and representations in the nervous system.

Among cryptologists (Kahn, 1967), the term "code" refers to a substitution scheme where each phrase, word, syllable, or letter in the "plaintext," or message to be encoded, is replaced by a "codegroup," a special set of symbols. There may be alternative codegroups called "homophones" by which a given word, etc., in plaintext may be encoded; but the decoding table by which a given codegroup is reinterpreted to give the corresponding plaintext gives a unique inverse. A code with homophones is then a one-to-many mapping from plaintext onto a set of codegroups, together with a unique inverse mapping from codegroups onto plaintext elements. If the plaintext elements are individual letters rather than larger text units, the scheme is called a "cipher" rather than a code. If the codegroups are in the same alphabet as the plaintext, the code is called monoalphabetic; if different, it is called polyalphabetic.

The genetic code, then, falls into this scheme without difficulty; it may be described accurately as a substitution code (or cipher) that is

bialphabetic and homophonic. The plaintext consists of strings of amino acids selected from a repertoire of 20 that may be considered as the elements of a 20-symbol alphabet; in this view, the genetic code is a cipher. The codegroups consist of ordered trios of nucleotides comprising a list of 4^3 (that is, 64) possibilities; the "degeneracy" or existence of alternative possibilities of nucleotide trios for encoding a particular amino acid corresponds to homophony in the cipher. Although certain details complicate this picture, it is clear that the genetic "code" is aptly named and that the metaphor from cryptology is useful even though there is no element of secrecy in the use of the code by the protein-synthesis mechanisms.

However, the cryptologist's "code" seems to be a far weaker metaphor for representation of information in the nervous system. First of all, substitution ciphers or codes are essentially static; encoding, transmission, and decoding take place according to certain fixed rules, but with no particularly critical temporal considerations. In the nervous system, on the other hand, time sequences, delays, relatively precise coincidence relationships, and considerations of resolving time seem to be critically important aspects of many information-processing applications. Second, there rarely seems to be a small fixed set of symbols to be encoded or "decoded" in the nervous system. Further, problems of random variation, noise, and reliability arise almost universally in the nervous system and are not dealt with explicitly in the cryptological scheme. Finally, the change of medium between the plaintext and the encoded message as seen in the genetic code is not clearly seen in the nervous system except in primary receptors and in effectors.

Some of the defects in the metaphor are filled in the concept of "coding" as developed by Shannon in his mathematical theory of communication, often referred to as "information theory." Shannon describes the encoding process as performed by a transducer, which receives a sequence of input symbols and produces blocks of output symbols. "The transducer may have an internal memory so that its output depends not only on the present input symbol but also on the past history" (Shannon and Weaver, 1949; p. 26). Thus, the "code" employed is more complicated than the "code" of the cryptographer. However, Shannon's encoding and decoding schemes are embedded within a functioning "general communication system" comprising specific parts: information source, transmitter, noise sources, receiver, and destination.

The case against the facile application of the concepts and techniques of information theory to the working of the nervous system has been stated by Moore, Perkel, and Segundo (1966; pp. 507 et seq.):

At best, in fact, the concepts and constructs of information theory are metaphors when applied to the nervous system, and the questionable aptness of these metaphors lies at the heart of the difficulty [that the promise of information theory to students of the nervous system has been realized to a disappointingly small extent]. It is thus important to exercise great caution in the identification of the formal entities defined by information theory (e.g., the source, the source alphabet, the channel, etc.) with the realities encountered in neurophysiological investigation. ... The decoding process has usually involved an attempt on the part of the experimenter to infer the identity of a stimulus by observing a given neuronal response, employing the calculus of probabilities. ... The experiments do not imply that the assumptions and methods used by the investigators in their decoding efforts bear any resemblance to processes employed by the nervous system itself.

Nevertheless, we take an important cue from Shannon by using his initial procedure to specify precisely the formal components and functions of a general communication system and apply them to information transformations in the nervous system. We shall define and describe the formal aspects of a general neural "coding" scheme, which must apply to any scheme considered as exemplifying a "neural code" that is actually used.

As pointed out by Cowan and MacKay in the Work Session, neural pathways are more than just communication channels; something akin to computation is going on. Therefore, the term "code" may be inappropriate, and the term "logic function" as used in describing computer networks might be more suitable. Terms such as "mappings" and "correlates" were also suggested at the Work Session as substitutes for "codes." The suggestion of "correlates" is based on the belief that a probabilistic aspect is frequently inherent in the transformations used in the nervous system.

In the field of the digital computer, the terms "code" and "coding" have several disparate, rather loosely conceived meanings. In one usage, the "code" or "command code" is the repertoire of elementary instructions that the computer can be called upon to execute. The "code" may also refer to the customary set of abbreviations by which the programmer refers to elements in this repertoire. Second, the term "code" is sometimes used as a synonym for "program," an organized set of instructions to the computer for performing a specific task; for example, a "criticality code" is a program for calculating the rate of neutron multiplication in a nuclear reactor. Third, a "code" or "coding scheme"

may designate the set of rules by which numerical quantities, instructions, alphabetic symbols, and other pieces of data are represented electrically within the workings of the computer; most digital computers, for example, use one of a number of "binary codes" in which quantities, etc., are represented by strings of binary digits (zeros and ones) of fixed or variable length. Such codes are used in the transmission and storage of information in the computer. Only in this third sense is there a valid analogy between computer "codes" and neural "codes," though an imperfect one.

The appropriateness and sense of the term "code" for transformations in the nervous system derives less from the discrete, substitutive technological usage than from the broader meanings in common English. One, for example, is a system of principles or rules of behavior relevant to a certain context, whether of physicians, gentlemen, outlaws, or nerve cells. Another is a system of understood signals, whether by smoke, drums, whistles, flags, lights, or other means for mechanically conveying information between separate points.

All of the technological examples of coding schemes display a rigid, mechanical aspect. The technological codes, like the genetic code, can be "cracked." We do not believe that there is a single "neural code" of the sort that can be cracked. The representation and transformation of information in nervous systems goes on continually, and any division of the "message" into discrete "symbols" is arbitrary, doing a greater or lesser degree of violence to the physiological reality. Moreover, many different kinds of representations and transformations are employed by different parts of the nervous system, by different species, and perhaps to some extent by different individuals within a species, or by a given individual at different times (labile coding). It also seems clear that various "encoding" and "decoding" schemes are adaptive; they are especially suited to their individual roles in the functioning of the organism. It follows, then, that we cannot investigate "coding" or representation of information in nervous systems in general but must begin by studying a multitude of specific examples with sufficient thoroughness and compass to provide a strong foundation for subsequent generalization about modes and properties of "neural coding." Most of the assertions and propositions in this paragraph are believed by the authors to be achievements of modern neurophysiology; they do not agree with the "classical" and still-prevalent textbook picture. However, it is not clear how general this view is even among the Work Session participants.

Coding in the Nervous System

On balance, then, we retain the term “coding” for the nervous system, keeping in mind its metaphorical use and the caveats just mentioned. The working definition of neural coding as “the representation and transformation of information in the nervous system” allows the application of the concept at various levels of neural organization and does not commit us prematurely to any particular classes of coding schemes.

We can distinguish two fundamental approaches by which neural coding may be investigated and described. The first, or functional, approach works more or less as follows: We consider, for example, sounds reaching an organism; we distinguish the relevant properties of those sounds—frequency, intensity, phase relationships, and the temporal aspects of these properties, such as those that give rise to rhythm and melody in musical sounds—and we then investigate how each of these is represented in turn at the receptors, in the auditory fibers, at various “relay” nuclei, and so on, as far centrally as these representations can be followed. Although the functional approach has important advantages, and in fact is an indispensable part of the biological picture of neural coding, it generally requires far more detailed information about neural processing of information than is known at present. Another difficulty is that the relevant properties of physiological stimuli may not be known at all, or may be known very poorly, as in the case of the lateral line organs of fish. These properties may have to be discovered experimentally, as in the case of the property extractors in the frog’s eye.

The other approach, particularly heuristic once we have realized the multiplicity of neural codes, is to set out and deal with the properties or aspects of each code in a formal manner.

Formal Properties of Neural Codes

Partly for expediency, then, and partly for the furtherance of rigor, we discuss specific examples of neural coding in terms of their formal properties. Under the general concept of a neural code as a working scheme of representation in the nervous system, we distinguish four interdependent formal aspects of the individual code: (1) the *referent*, (2) the *transformation* process, (3) the *transmission* of the transformed information, and (4) the *interpretation* process, whereby the transmitted information is “read” or integrated or retransformed by the target units.

1. The *referent*, as in any scheme of representation, is that which is being extracted and represented. In the case of receptors, the referent is some aspect of a physical "signal," such as the wavelength of illumination, the intensity of a sound, and the like. The modality is of course an essential formal property of encoding in receptors. The referent, then, may be some aspect of an external physical quantity, of an internal physiological variable, or of internal neural events. The description of the referent must also include its domain, the region in time, space, or other relevant dimensions within which the quantity or feature extracted varies under experimental or physiological conditions.

2. The *transformation* or encoding process is the scheme by which the input "signals" or referents are represented by output signals. For receptors, the equivalent engineering term is transduction, whereby one physical quantity generates a corresponding signal in another form, often electrical; effectors as well as receptors are transducers. Most often in nervous systems of higher organisms the referent in a neural coding scheme is not an external physical stimulus but is in itself a neural signal; however, the transformation of that signal is still a transduction when considered at the mechanistic level of chemical transmitters as stimuli. At the level of communication science it is tantamount to the input-output relationship of the neuron or group of neurons involved. A description of the transformation must in general include: (1) the carrier or vehicle in which the output information is represented, (2) the precise scheme of modulation or, more generally, the mode of representation of the information in the carrier, (3) the mechanism by which the representation is effected insofar as this physiological substrate of the encoding is known, and (4) relevant considerations as to the fidelity or reliability of the representation process.

3. *Transmission* of the encoded signal must, of course, be discussed in the context of the transformation scheme itself. Among the necessary items of description are the spatial and the temporal aspects of transmission. The spatial aspects include questions as to the anatomical substrate of transmission: whether single or parallel lines are used (for impulse transmission), convergence and divergence of fibers, diffusion of ions or other chemical carriers of information, and so on. The temporal aspects include questions about conduction times and, in the case of transmission along parallel lines, about temporal coherence among the various "channels." Reliability of transmission may also be extremely important.

4. The set of neurons receiving the encoded and transmitted information must then interpret it. The process of *interpretation* can be pictured as one in which the target neuron is continually evaluating the oncoming stream of information and continually “deciding” whether and how much to alter its own activity. To a large extent the “interpretation” of coded information by one or more neurons is synonymous with “integration” as ordinarily understood in neurophysiology. Here we avoid the term “decoding,” which implies rather too closely an operation inverse to encoding. Whereas in cryptographic schemes the end product after decoding is the original message, the sequence of transformations in a nervous system can almost never be interpreted as yielding, either ultimately or at an intermediate stage, a mere copy of the information impinging on the periphery. A description of interpretation in a neural code must include a specification of the target sites (e.g., a set of higher-order neurons); the rules, if not also the mechanism of interpretation; and considerations of noise and reliability.

In many circumstances, the interpretation of encoded information generated at one stage in the nervous system will simply be the transformation or encoding scheme at the next; instead of interpretation or “decoding,” we may often speak of “recoding” at the next level. However, the nervous system is not just a bundle of parallel, jointed segments with encoding and recoding accomplished at each junction; divergence and convergence in the transmission pathways drastically complicate this picture by changing the meaning of the messages; moreover, the existence of recurrent or re-entrant pathways makes the numbering of levels ambiguous (MacKay, WS)* and muddies further the analogy with simple communications systems. Although interpretation may simply be recoding by another location, it must be included in a description of a neural code because transformed and transmitted signals do not constitute a bona fide neural code unless that information is appropriately acted upon—interpreted—by appropriate parts of the organism.

Biological Significance

In addition to the formal aspects of a neural code as outlined here, there are the questions of biological significance, including the specific functional aspects of a code under examination. One obvious question, for which the answer is by no means trivial or easy to establish, is whether a

*Surnames followed by WS refer to comments made at the Work Session.

proposed coding scheme whose formal properties can be worked out is actually used at all, or in the way proposed, by the living organism under more or less natural conditions. Another consideration, which can be investigated quantitatively, is the reliability of a particular neural code, or set of codes, as it operates in a given information-processing subsystem in the living organism. For example, is the proposed scheme sufficiently sensitive to accomplish its supposed purpose? Is its operation sufficiently free from false alarms and from overlooked signals? Is the coding scheme under discussion the only such scheme used by the organism, or the principal one, or merely a supplemental or emergency system?

Other biological questions arise at a level somewhat more removed from any particular instance. For example, a given encoding scheme embodies a rule or set of rules by which input events or properties are represented by output events or properties. Any single "mapping" of this sort is one among a large number of logically possible (if not physiologically possible) schemes where the same set of input properties could be mapped onto the same set of output properties, including of course the temporal aspects. The question then arises as to whether the particular observed scheme is uniquely chosen among the theoretically possible ones, and if so, why; what are the anatomical, physiological, physical, or chemical constraints determining or limiting the choice? For example, now that the representational rules of the genetic code have been unraveled, questions still remain as to whether these rules are unique among all organisms, and why the particular rules observed have evolved and persisted. The explanation might be historical or evolutionary, or it might be purely physicochemical; the point being made here is that these questions are on a different level of inquiry from those relating to the existence and the particulars of the genetic code itself. With neural codes, completely analogous considerations apply; the reasons why a particular neural code, rather than alternative possibilities, is in fact used in a particular instance is a question that must be answered in biophysical, physiological, developmental, or evolutionary terms. Intelligent investigation of these higher-order problems must, in all prudence, await the solution of the more immediately factually based problems of establishing the existence and properties of individual coding schemes.

Adaptive coding or labile coding is part of this problem. In engineering uses of codes, the rules for the representation of information are sometimes changed at a suitable stage in the use of the system. We know of no examples as yet demonstrated in the nervous system, but it is obviously a possible corollary of learning and of normal maturation, or even of change of attention or mood.

Candidate Codes

Experimental findings that establish a particular kind of transformation of information by a portion of a nervous system constitute suggestive evidence for the physiological reality of a particular neural code. We shall refer to such a presumptive or putative code as a *candidate code* in the sense that it is a candidate for our further consideration. In order to establish a candidate code as a bona fide neural code, it is necessary both (1) to elucidate its formal properties, showing that the observed mechanisms and relationships fall within the rubric of a coding scheme, and (2) to demonstrate the circumstances in which the coding scheme is used functionally by the organism.

These requirements are difficult to meet in any complete fashion. For example, in order to establish the existence of appropriate interpretation processes (the fourth of the formal properties), it is necessary to investigate the relevant "higher-order" neurons ($n+1$) as well as those that perform the encoding (n), having first assumed that the input is supplied by lower-order neurons ($n-1$). Few experiments have encompassed simultaneous observations of neurons of order $n-1$, n , and $n+1$; this would be required for rigorous establishment of a neural code (Segundo, WS), yet it may be impossible or impractical in cases of interest (Gerstein, WS). Even in those instances in which the formal properties have been fairly well worked out, the biological significance is a separate and frequently more difficult problem. A cautionary example was provided by Wilson (WS), demonstrating that phasic information about wing position in the locust is accurately encoded but that the insect apparently makes no use of this information (Figure 10, p. 261).

A criterion that may help in establishing a candidate code as a real, neurophysiologically utilized code was suggested by Barlow (WS). That criterion is the efficiency measured as signal-to-noise ratio in the neural output compared to the signal-to-noise ratio of the input. Of two candidate codes, the one that carries the information the more efficiently is likely to be the biological one. A code for which the signal-to-noise ratio is low might be questioned if one could show that the whole animal does much better; that is, the use of parallel channels by the animal may overcome some limitations.

There is a related, more subtle aspect of the study of information transformation in the nervous system; it has its own dualism problem. In any investigation of neural coding, the information encoded in, say, a train of neural spikes may be interpreted by a higher-order neuron, and it

may also be interpreted by the neurophysiologist. There need not be any direct correspondence, qualitative or quantitative, between these two interpretations. Wilson's example shows that information relevant to the physiologist may not be relevant to the organism; on the other hand it is entirely conceivable that signals that "make sense" to the nervous system—which convey functionally useful information—may be indistinguishable from random noise to the investigator with his limited range of tools. However, under the assumption that a particular coding scheme well understood by us is being used, the rate of extraction of information of a given level of reliability by the experimenter, with access to the appropriate mathematical and computational techniques, cannot be exceeded by the nervous system's rate of extraction from the same channel. The experimenter's "decoding" capability in this case represents an upper bound on that of the nervous system; if an apparent contradiction should be encountered, it would be appropriate to look for additional channels of information used by the nervous system or for the operation of a different, more powerful, neural code.

We may think of a candidate code as one that has been perceived by the neurophysiologist, while an "established" code must in addition be shown to have significance for the animal. The majority of the examples presented at the Work Session remain in the former category.

Scope and Limitations

Although the topic of the Work Session was "neural coding" in general, certain subtopics were excluded from discussion in order to narrow the compass of the meeting to workable bounds.

The most elementary, yet pervasive, form of neural coding is that accomplished by "labeled lines," in which, for example, a train of impulses carried by an auditory fiber is interpreted as a sound, whereas a similar train on an optic fiber is interpreted as a visual event. That is, the "meaning" of a sensory neural signal is dependent on its central connection—an idea enunciated over a century ago as the doctrine of "specific nerve energies" (Müller, 1833 and 1840) and brought up to date by Adrian (1928). The concept of labeled lines is a generalization of this notion to any nerve fibers, not necessarily or exclusively sensory. This form of coding and the associated problems of modality, ambiguity, and specificity were excluded from the Work Session. (A few basic comments are found on p. 240 et seq.) Considerations of what information is encoded were also in general excluded. In order to concentrate on how

the information is represented, we omitted investigation of the meaning of signals, and therefore did not discuss recognition or property detection in the detailed manner of Maturana, Lettvin, McCulloch, and Pitts (1960) for frog visual units, or of Hubel and Wiesel (1962) for cat cortical units.

Also beyond the scope of the meeting were the chemical and physical events that underlie the signals—the mechanisms effecting changes in potential and details of transmitter actions. Higher organization of information processing was likewise off limits, including the related matters of attention, central modification of afferent input, plasticity, and instinctive and learned behavior. The important carriers of information, the hormones and neurosecretions, were regarded for purposes of this Work Session as effector-exciters when released by nerve action, or as sensory stimuli when acting upon neurons.

Some uneven attention was devoted to slow and lasting representations of input and experience such as altered excitability in its various forms, electrotonic spread, intercellular channels, neuroglial influence, and diffuse and field effects. Finally, we mention certain forms of representation of information only in the list that comprises the Appendix.

In the remainder of this report, the material covered in the Work Session is given more nearly in logical than in chronological order. Not all the material presented at the Work Session is represented, and additional material has been introduced. We discuss first candidate codes that employ impulse trains on single channels, then those that involve multiple channels of pulse information, and finally nonimpulse codes. The Appendix consists of a catalog of candidate codes described or alluded to in the Work Session; the formal properties are outlined briefly, and some indication is given, where possible, as to the biological significance and supporting evidence for the utilization of the code. Although comments and corrections have been solicited from the Work Session participants, responsibility for the statements and interpretations made in this report lodges with its authors.

II. NERVE IMPULSES AND TRAINS IN SINGLE CHANNELS

When trains of nerve impulses (spikes) are propagated along a fiber, a number of features of the spike trains are available as carriers of information, and there is a corresponding number of possible coding schemes. Because of the all-or-none character of spikes, the amplitude of the impulse is not ordinarily available for carrying information; in special cases at high frequency the amplitude goes down appreciably at local regions of low safety factor, e.g., near axon terminals. (Spike amplitude as recorded by electrodes external to the active neuron varies widely according to the amount of short-circuiting of the tissue and may be exploited by the neurophysiologist in distinguishing impulses that arise from different fibers in the signal recorded with a single electrode.) Because of the nearly uniform duration of spikes along a given fiber and their brevity relative to the time intervals between them, the spikes may be considered to be point events in time; therefore it is only the times of occurrence of spikes (or the intervals between them) that embody the information conveyed (Moore et al., 1966; Perkel et al., 1967a). Afterpotentials, to be sure, vary in a graded manner; but much, if not all, of this activity is a function of the recent history of spike activity, so that it has perhaps no additional information content. If it has, e.g., representing long-term states of the axon, afterpotentials belong in Chapter IV (p. 287).

The most obvious and perhaps most universal kind of neural coding is that of the labeled line. "Line" will be used freely here as equivalent to axon and nerve fiber. The mere presence of electrical activity in a particular fiber or group of fibers, and its absence in other fibers, conveys the most important message to the nervous system about the type of environmental event that has transpired and where it has impinged. Although labeled lines were excluded from detailed treatment in the Work Session, a brief reference to them is given here because the variety, number, and specifications of differently labeled lines could have a profound effect on the requirements for the coding of information in each line. (Some treatment of labeling appears in the Appendix.)

Of the many characteristics of sequences of nerve impulses on a single fiber that can in principle be used to carry information, and hence may be considered as candidate codes, the simplest is the precise time of a spike (its moment of occurrence), or the instant of onset or cessation of a train. Such a code (Go!) may be used as a command to initiate motor activity. This and several other types are treated here in turn in a generic

way. The Appendix lists candidate codes more systematically, though still quite tentatively.

Any quantitative statistical measure of a spike train might carry a message, and a large class of possible information-carrying aspects of a train of impulses corresponds to the statistical features of a spike train such as, for example, those described by Perkel et al. (1967a). Among the statistical parameters available are the mean rate of impulse repetition, the variance of intervals between impulses, and others, such as the serial correlation coefficients of interval length, which may well be used more by the physiologist than by the nervous system.

Beyond the features of nerve-impulse sequences that interest the statistician are the more transient, labile characteristics of spike trains that are believed to convey information more directly within the nervous system. These include such possibilities as (a) the duration of a burst of impulses, (b) the number of impulses within a burst, (c) rhythms or temporal patterns on a relatively small time scale, and (d) the occurrence of particular, precise timing relationships between impulses, imbedded in a noisy background of ongoing impulse traffic along the same channel.

Finally, the latency relationships between impulses on one channel and those of another impulse-carrying channel under observation have been considered as important information-bearing characteristics. Although codes involving time relationships of spikes in a single channel with stimulus events might be considered as single-channel spike codes, the probabilistic nature of most observed responses argues for a multiple-channel or parallel decoding of these codes. These are therefore discussed along with codes involving time relationships between two or more spike-bearing channels in Chapter III.

Labeled Lines

For the central decoding mechanism or analyzer in the brain, the most important feature of an arriving spike train is the identity of the particular line it is on; the information stored in the system then tells the quality and location of the stimulus. The labels on each neuron and axon may be more or less ambiguous, more or less permanent, more or less independent of experience and of activity in other channels. These important matters are beyond the present scope. Line labels are the background for coding within lines and can affect the requirements for such coding. If there is a large number of differently labeled lines, there is less need in single lines for accuracy, dynamic range, resolution, stability,

and the like. This is because some information that can be encoded and transmitted along a single axon can also be represented by separate lines. For example, intensity of stimulus can be represented by some reliable statistic of the single train or by a less clearly specified response in each of a series of lines with different thresholds.

The system apparently knows a large number and variety of labels. We are most familiar with the broad modalities (smell, touch, etc.), the submodalities (hues, tastes, etc.), the topographic localizing signs (receptive fields of cutaneous, retinal, proprioceptive, and cochlear units, for example), the overlapping channels for thin and thick fibers, and the channels of different sensitivity. But these are only the peripheral sensory nerve fibers. We know much less about the labels on central lines after integrative processing has altered the meaning of the messages (Hubel and Wiesel, 1962; Maturana et al., 1960), but presumably the number of different types of label known to the system is large.

Those single neurons that trigger widely spread muscles in behaviorally important motor acts—Mauthner's cell, for example—or that show sensory feature extractions, like the hyper-complex visual cells in area 19 of the cortex, are the most extreme examples of labeled-line code carriers. These cells perform routine neuronal integration, but because of their position they are responsible for relatively high-level decisions; their labels are complex in terms of the input requirements for firing. (See p. 284 for further discussion of decision cells.)

Time of Firing: "Go!"

The simplest representation scheme involving spikes does not deal with mean rates of firing or with time intervals between spikes; it simply records the time of occurrence of the impulse itself. For instance, in some insect systems studied by Wilson (WS), a single nerve spike (or a short burst) reaches a muscle and produces a twitch that in turn results in a wing beat. It is the precise timing of this impulse relative to others that ensures that the wing beats properly. Other examples of the relevance of exact spike timing may occur in the binaural spatial localization in the auditory system of mammals and in command neurons that trigger complex normal movements. Instead of a single spike, the time signal may represent the onset or cessation of a buzz—a train of spikes whose frequency is not critically involved in the signal but is a marker.

Frequency or Rate

Frequency is not an adequate specification for a candidate code; it is really a class of codes. The information relevant to the decoder may be represented by the value of the most recent interval, i.e., frequency measured with the maximum temporal resolution. Or the representation may be in the frequency averaged over some period; this period makes quite a difference and might be widely divergent. Often there is a no-stimulus background of higher or lower frequency, and here the information may in some instances be more properly considered to be the increment (or decrement) of impulses per unit time and invariant with changes in background, while in other examples it may be a function of the absolute frequency. It is even possible that in some instances a background frequency is like a carrier that is without information until modulated, and the modulating frequency represents the signal.

In the classic neural code, investigated most extensively in sensory afferents, stimulus intensity is represented by mean firing rate (or impulse frequency). Because the word "frequency" connotes a periodic process or regular firing, we prefer the term "rate," without connotations of regularity. The term "frequency" is widely used, however, and we will employ both. A rate code may be used either tonically or phasically; the quantity represented may vary slowly or rapidly when compared with the typical interval between impulses. Quantitative questions relating to information capacity, precision of transmission, and "decoding" depend to a great extent on the relative regularity of intervals between impulses and on the mode of decoding, i.e., whether by time measurement, or by a count of the number of impulses in a fixed time.

Segundo and Partridge (WS) suggested that in the decoding of a signal that embodies a mean rate code, more recent information may be given relatively more weight than slightly less recent information. A specific scheme of this type is one in which each received impulse has an exponentially decaying effect with time in an arrangement essentially similar to a counting-rate meter. This is a plausible mechanism inasmuch as the membrane potential of a simple neuron, to a first approximation, behaves in such fashion when integrating EPSP's (excitatory postsynaptic potentials). A system of this sort has distinct advantages over the simple "fixed-window" moving average, and the balance between responsiveness of the system and chance of "false alarms" can be adjusted by varying the time constant and the firing threshold. Another example of this kind of decoding is the muscle responding to motor nerve impulses.

There are two dissimilar but reasonable rules that might be used in the representation of a continuous signal as a pulse train: in one, the "instantaneous rate" (the reciprocal of the current interval between successive pulses) is proportional to the instantaneous value of the input signal at the time of generation of the pulse completing the interval; in the other, the reciprocal of interval length is proportional to an average value of the input signal. According to Partridge (WS), both types of representation can be generated using physiologically reasonable processes in receptors; but both of these schemes of representation introduce typical distortions, including phase lags.

The implementation of the first type of coding scheme would involve a threshold that rises to infinity immediately after an impulse is fired and then falls along a k/t curve (where k = a time-scale determining coefficient and t = time) toward an asymptotic threshold level. When threshold and signal curves intersect, a new pulse is generated and the cycle repeats. In effect, this mechanism produces an instantaneous sampling of the signal and has been proposed for generating repetitive firing in receptors (Adrian, 1928). This coding method could not produce a response at any time during which the input signal dropped faster than k/t ; its performance thus depends on the values of the two parameters, k and the asymptotic threshold.

The second type of signal generation is equivalent to the integration of the signal until the time integral reaches criterion value, whereupon a pulse is fired and the integrator is reset. A possible mechanism would be the accumulation of ions driven by a current proportional to the signal. This type of pulse-rate representation of a signal is used in several neuron and receptor models, including those of Harmon (1961) and Partridge (1962), and is suggested by the response characteristics of lobster joint receptors. This type of representation employing a noninstantaneous sampling introduces its own types of distortion; in particular, transient maxima and minima will not be adequately represented. If the signal is a sinusoidal variable, both phase lag and distortion of the wave form are introduced. These effects are only partially mitigated by introducing several parallel channels (Partridge, 1967).

Partridge (WS) gave an example in which a mean pulse-rate code is apparently used by a whole system but not by the individual components. In experiments done with J.H. Kim (Partridge and Kim, 1968), a branch of the vestibular nerve (from one cupula or macula) was stimulated electrically, and the response of a leg muscle (triceps surae) was measured. When the stimulation was a sinusoidally rate-modulated pulse train, the

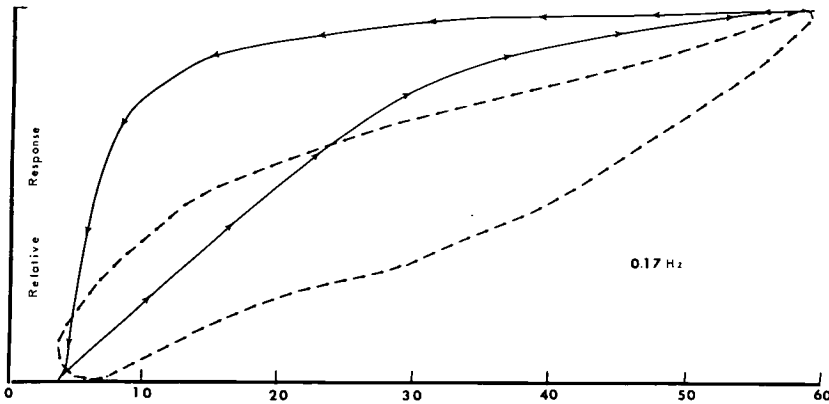

Figure 1. Comparison of triceps surae response to sinusoidally modulated stimulus rate delivered to: ipsilateral lateral canal branch of vestibular nerve (dashed line), and to the cut muscle nerve (solid line). For comparison, both are graphed as force relative to total response range, but the direct maximal stimulus to the muscle nerve produced much larger forces than did the reflex stimulus. In both curves time progresses in a counterclockwise direction indicating that the response lags behind stimulus. In the direct response a marked hysteresis appears. Since the reflex response shows very little hysteresis in the same muscle it would appear that the reflex signal to the muscle must have been significantly different from that delivered by the stimulator in either case. The motor nerve signal might be expected to carry a component in some way inversely related to the hysteresis of the muscle, a fact which might complicate the identification of the code used. [Partridge]

response of the whole leg was a sinusoidal movement with low distortion. However, the response of any single motor unit observed was not sinusoidal and had no clearly visible relation to the stimulus pattern. Direct application of a rate-modulated stimulation to the motor nerve produced a muscle response that was less nearly linear than the response of the whole system (Figure 1). The conclusion was that the whole system, including feedbacks, can compensate for nonlinearities in the components, and in addition it can handle signals at frequencies higher than can be handled when delivered directly to the motor nerve. In discussion two caveats were made: (a) It was pointed out that it is sometimes difficult to pick out correlations by eye when there is considerable cycle-to-cycle variability, even though such correlations may exist. A correlated response might be apparent, for example, in the massed discharge of the ventral root fibers. (b) The relevance and physiological meaning of the motor-nerve stimulation experiment were questioned because the factors that determine firing of the units and distortion of the compound resultant are artificial in the experiment. Partridge (WS)

suggested that the complex pattern in the motor-unit response might represent an error signal in the feedback system, and therefore would not be expected to correlate highly with the command signal. He has encountered this complication in studies of the stretch reflex in an experimental arrangement that combines hardware components and live cat muscle. Even when such a system employs a simple pulse-rate code and carries a simple signal, the unit activity is often complex, like that seen in the vestibular-stimulus experiments. In this case, knowing the meaning of the signal (i.e., whether it is feedback or command) is essential to understanding the coding scheme.

Stein (WS) described some difficulties arising from the assumption that frequency codes are used by single units. On the basis of calculations according to the Hodgkin-Huxley equations, an infinite or semi-infinite cable with a current applied at one point shows no adaptation or variability. Furthermore, the frequency of steady discharge is not a monotonic function of stimulus current but rises to a maximum and then falls slowly. At some well-defined current frequency halving occurs, sometimes followed by further frequency division, and finally the response drops to zero. Also, there is a limit to the range of frequencies obtainable, normally between about 50 and 100 impulses per second at 6°C. The range of frequencies was only marginally increased by changing various equation parameters such as calcium concentration or temperature. Therefore some longer time constants must be involved, such as those described by FitzHugh (1962).

Stein (WS) also made the point that an observed linear relation between two variables does not necessarily allow one to apply linear analysis to the system. For example, experimentally a receptor potential is often related linearly to the frequency of nerve impulses generated in the sensory fiber. Both these quantities result from receptor currents generated by the sensory stimulus. This process can be simulated on a computer by applying current in the absence or in the presence of a regenerative sodium system. In the absence of a regenerative sodium system the current produces no spikes but a steady voltage (analogous to the receptor potential) that is related nonlinearly to the current. In the presence of a sodium system a rate of nerve impulses results that is also nonlinearly related to the current. By apparent coincidence these two nonlinearities cancel when the steady frequency produced in the presence of a regenerative sodium system is plotted against the steady voltage produced in its absence. The linearity between frequency and receptor potentials observed experimentally may simultaneously hide basic

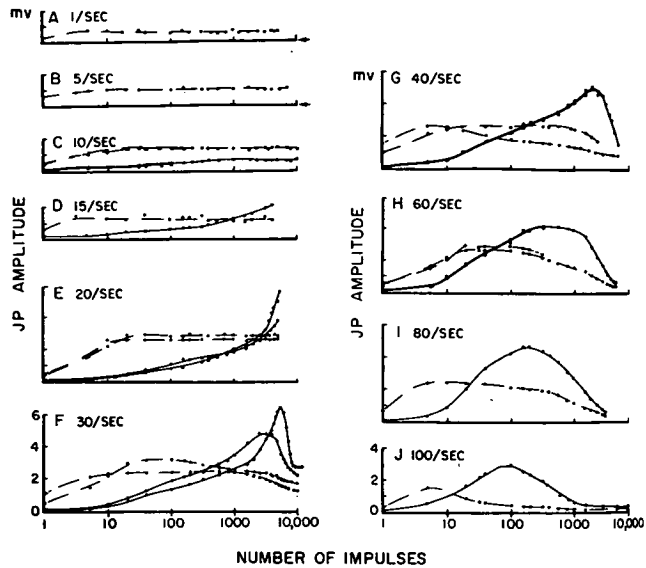

Figure 2. Two kinds of junction potentials (JP) in two populations of muscle fibers in the crayfish claw; one is shown by dashed lines (SD fibers), the other by solid lines (SC fibers). At low frequencies (1/sec, 5/sec) of stimulation of the single, common exciter axon the SC potentials were about 0.05 mv and therefore too small to show on this ordinate scale. At high frequencies these became larger and SD potentials became smaller, perhaps by failure of impulses to penetrate axon terminals. Filled circles: first time stimulus frequency was presented. Open circles: second time frequency was presented. [Bittner, 1968]

nonlinearities that cancel out under some stimulus conditions. When stimuli with other temporal patterns are applied, cancellation need not occur and predictions based on a linear model may not be obeyed.

A rate code is compatible with sharply discontinuous, threshold-type control. Bittner (1968) described a case in which a change in rate has the effect of a switch. A single excitatory motoneuron to the crayfish claw opener muscle innervates a large number of muscle fibers. There are two kinds of neuromuscular junctions, and each is specifically effective at a different range of rates. A simple change of the arrival rate from one range to another will shift the contraction from one group of muscle fibers to the other (Figure 2). A somewhat similar behavior has long been known in the sea anemone (Pantin, 1950, 1952; Batham and Pantin, 1954), but it is not known whether the mechanism is the same.

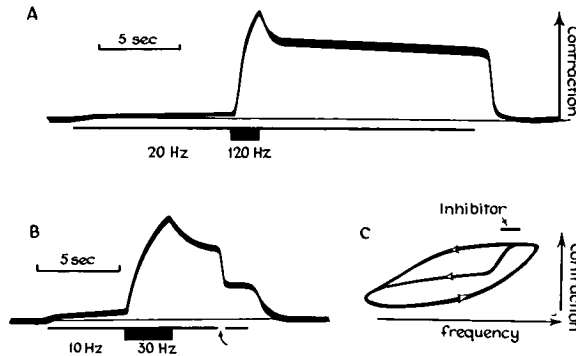

Figure 3. Frequency-coded input is read quite differently according to the recent history of the receiver. This example is from the "catch" property of muscle.

(A) Isotonic contraction of crayfish claw opener muscle. Stimulation at 20 Hz produces only a slight movement. A brief increase to 120 Hz results in a long-lasting reset to a much increased degree of contraction.

(B) A similar record for the claw closer muscle stimulated by its slow axon. During the "after" plateau brief interruption of the low-frequency stimulation again catches the contraction.

(C) Brief stimulation of inhibitor axon causes relaxation and length reset similar to that caused by pause in excitation in B. Hysteresis loop shows the effect of history by modulating the stimulus frequency of the motoneuron. [Wilson and Larimer, 1968]

Pattern-sensitive systems, best known on the motor side, depend upon rise times and decay rates of facilitation, and this often occurs in short- and long-term forms in the same junction. Frequency of motoneuron discharge does not necessarily determine a unique state of contraction but may indicate quite different states depending on the recent history of frequencies (Figure 3). For example, if a certain contraction is maintained by motoneuron impulses at low frequency, then a short burst at high frequency, or even a single extra impulse intercalated, will cause a prolonged increase in contraction in some systems (crayfish claw opener muscle). Similarly, a given frequency approached from above or below causes quite different contractions for a long time (Wilson and Larimer, 1968).

Bennett (WS) described a similar frequency coding scheme in a final common pathway in the electric eel. It has two classes of electroplaques: (1) caudally, a weak electric organ (Sach's organ) that is presumably used for electrolocation, and (2) the main electric organ in the middle of the body that generates large discharges. The two organs are run by the same system—the same medullary relay nucleus and the same spinal nucleus—and a frequency code is used for discharging the two organs. A

single neural volley that arises in the head and travels down the spinal cord is relayed to motoneurons running out the ventral roots to all electroplaques. However, a single volley produces only small PSP's in the main organ, while large PSP's and firing are produced at the Sach's organ. Two or more stimuli at a high frequency are needed to fire the main electric organ, again because of a threshold requirement for facilitation. The "price" paid for this simplicity of neural circuitry is latency. The fish cannot produce a main electric organ discharge earlier than two or three impulse intervals following the initiation of a signal from the pacemaker nucleus.

Stein (WS) reported data showing that even a simple frequency code may not indicate the fidelity of transfer of information through a system. Convergence or irregularity introduced at an intermediate stage may reduce fidelity for the unit channel. Experiments done by Stein and P.B.C. Matthews at the Physiology Laboratory, Oxford, illustrated some limitations on the transmission of information. The coefficient of variation for the discharge of muscle spindle cells is only 1 to 2% for the secondary endings, and 3 to 5% for the primary ones; i.e., both are so small that they are transmitting accurate information about the length of the muscle at any time. There is a strong synaptic connection in the spinal cord to cells of the dorsal spinocerebellar tract, with a convergence of about 15:1, and the second-order cell shows the same change in impulse rate per millimeter change in muscle length shown by the first-order cells. But the second-order cells activated by the muscle-spindle afferent fibers have coefficients of variation of 30 to 60% (Jansen et al., 1966), so that the information capacity in bits per second is decreased to about half. In the presence of tonic gamma efferent activity, the coefficient of variation of spindle afferents is much larger, and relatively less information is lost at the synapse in this case.

Mountcastle (WS) believes that in many receptors, especially in the skin, the variability is lower than in the corresponding central neuron, and therefore much information probably is lost.

Stein elaborated on probabilistic aspects of frequency coding. Figure 4 depicts an idealized spike train with spontaneous frequency ν_{\min} . During a time period of duration t a stimulus is produced (a generator potential, presynaptic spikes, etc.) which changes the rate to ν . The average number of spikes resulting from the stimulus is x . The actual number y produced by a particular stimulus will be a random variable, because of intrinsic variability in the spike train, phasing differences between the stimulus and the spikes, or changes in the central state of the neuron.

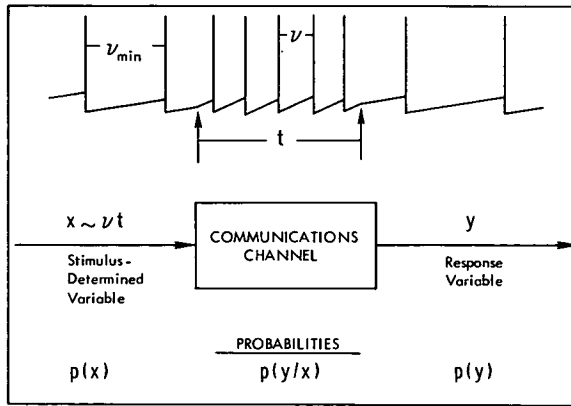

Figure 4. An idealized spike train with spontaneous frequency, a period of stimulation and the associated probabilities. [Stein]

Three probabilities are associated with x and y : $p(x)$ is the probability that on any given trial the stimulus is such that the expected (or mean) response is x ; $p(y)$ is the probability of a response y ; and $p(y/x)$ is the probability of y given the stimulus which on the average produces x . The probability $p(y/x)$ can be used to specify the channel in information-theoretical terms (see Segundo et al., 1966, for a similar scheme).

Barlow and Levick (1968, 1969) have addressed themselves to the application of frequency coding to the detection of threshold stimuli. They deal with cat retinal ganglion cells with irregular background activity that respond to maintained stimuli by augmenting the number of spikes in a given period of time. Threshold is defined as the amount of light required to change significantly the background noise caused by the maintained discharge. The threshold depends primarily on the relation between stimulus amplitude and response amplitude, in this case called quantum:spike ratio. This is measured as the number of spikes in some period and proves to be linear with stimulus intensity to a level well above threshold (Figure 5). This figure also shows that it is linear below threshold, i.e., down to zero incremental stimulus, which elicits zero extra impulses. Although not illustrated here, they also found it was linear below the maintained discharge for decremental stimuli that reduce the number of impulses to nearly zero. The slope of the line defines the quantum:spike ratio, i.e., the average number of extra quantal absorptions required to elicit an extra impulse.

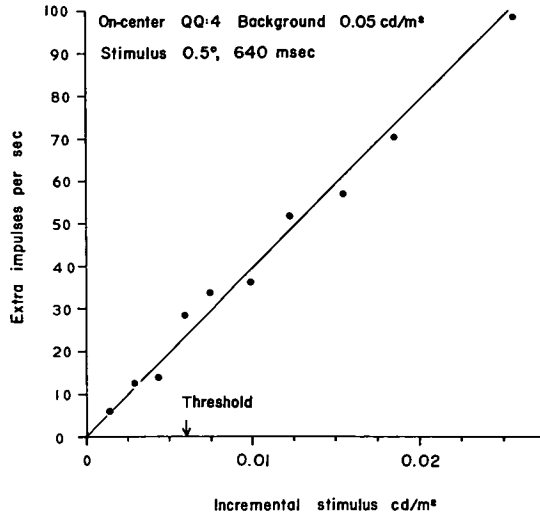

Figure 5. Linearity of near-threshold responses in cat retina. The number of extra impulses is proportional to incremental stimulus intensity, in this case up to at least four times the threshold as determined by the method of Figure 6. The slope defines the quantum:spike ratio. [Barlow and Levick, 1968]

The question as to whether the response is significant can be answered most easily in that case in which one knows the exact time during which the response will occur, if it is to occur, although this is admittedly a special case. The number of extra impulses required to achieve significance in this case depends upon the variance in the number of impulses occurring during a control period, i.e., in the absence of a stimulus. For all but very brief analysis periods, these pulse number distributions in the ganglion cells studied can be well fitted by Gaussian distributions (Figure 6). (Stein suggested that this is a necessary consequence of the central-limit theorem.) The variance of the pulse number is linearly related to the mean, but the constant varies with adaptation level and from unit to unit. Having established the mean and standard deviation of impulse number from control observations, using the relevant analysis time, one then can define a response criterion in terms of a number of standard deviations away from that mean. For example, in Figure 6, a significant response is arbitrarily defined as the occurrence during the analysis time of a number of impulses equal to or greater than the mean of the pulse-number histogram plus 2.9 standard deviations. The strength of stimulus necessary to obtain this number of impulses is derived from the quantum:spike ratio.

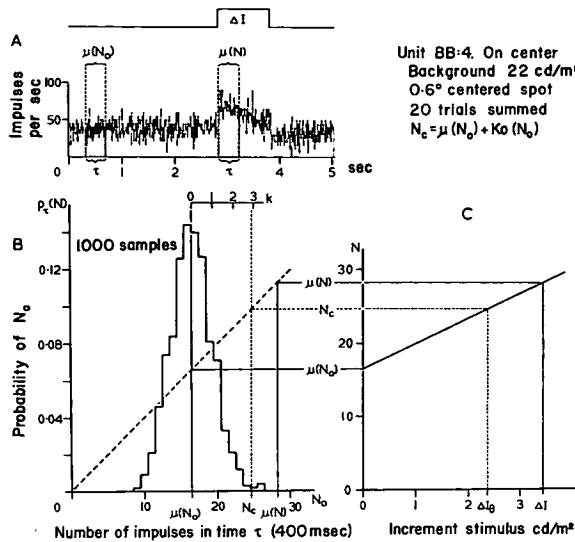

Figure 6. Detecting a light-evoked response in the noisy maintained discharge of a retinal ganglion cell of the cat. The poststimulus-time histogram at top shows how the number of extra impulses within a certain analysis period τ was measured. The distribution at bottom left is for the numbers of impulses within periods τ in the absence of stimulation. For 0.2% false positive responses the number of impulses following a stimulus must lie 2.9 standard deviations beyond the mean of this distribution, and the intensity required for this is obtained by linear extrapolation or interpolation of the result obtained from the poststimulus-time histogram. [Barlow and Levick, 1968]

If the physiologist uses this scheme for determining threshold from the spike data (as was done by FitzHugh, 1957), his thresholds often differ from those established classically, i.e., by subjectively judging the response, especially for brief responses (50 msec or less). However, the difference rarely will exceed a factor of 2, and this is rather unimportant. The absolute threshold so computed for five on-center units in the cat averaged about 50 quanta at the cornea, which is lower than the estimated human psychophysical threshold of 100 quanta. Furthermore, for the two most sensitive units only 6 and 10 quanta were required. It must be kept in mind that this threshold is defined for a single trial in a single cell according to the criterion that false negative responses occur on 50% of occasions when a threshold stimulus is delivered at 0.2% of trials at the same intensity.

There are obvious limitations to this analysis. Only single ganglion cells were examined, whereas the cat has about 100,000 in each eye. It was assumed that the time of the response and its duration would be known to the cat, whereas the cat is presumably interested in stimuli

occurring at any time. These limitations cut both ways. On the one hand, with possible responses in many channels at any moment of time, one should presumably demand a criterion higher than one that leads to a 0.2% false alarm rate in each channel at all times. This would increase the thresholds, but not by very much, because the tails of the pulse number distributions are not very long. On the other hand, it might be argued that the whole cat could do much better, behaviorally, than any single unit, by averaging the results from all its ganglion cells. Barlow made the following points about this: (1) Parallel pathways help (with regard to threshold) only if the individual channels are independently noisy, but the experiments indicate that some of the cat ganglion cells add surprisingly little noise. (Parallel pathways may help in other ways, e.g., in pattern coding.) (2) It is the channel with the lowest threshold that counts; if one channel gives a threshold response by the proposed criterion, other nonresponding channels can be disregarded. (3) When acuity requirements are taken into account, there do not appear to be many redundant channels; therefore there cannot be many parallel paths to average over, at least for small stimuli.

The question of how well the whole cat's threshold agrees with the threshold of his most sensitive ganglion cells has not been resolved, but two things are clear: (1) The threshold of some ganglion cells is so low that it seems unlikely that the whole cat can do any better. (2) Information about the number of quanta absorbed in the retina is efficiently coded onto the mean rate of ganglion cells; consequently this is a promising candidate code and one does not have to seek a more efficient alternative in this particular case. Efficiency is considered to be high because the signal-to-noise ratio in the ganglion-cell output (extra impulses per unit time:standard deviation of background discharge) is nearly the same as that of the input (extra quanta in stimulus period:standard deviation in quanta for unstimulated background state).

The code about which these statements are made is not the simple frequency representation of stimulus intensity.

Customarily one supposes that the referent of impulses in the optic nerve is light absorbed in receptors, and this is clearly adequate and appropriate if one is trying to analyze the physiological mechanism of excitation. Barlow's suggestion (1968) is that one should regard a more complex property of the light as the referent when one is interested in the code as a step in the neural processing of visual information. For on-center units this new referent would be the probability that there has been no local increase in the light in a defined epoch; for off-center units it would

be the probability that there has been no local decrease. The response is of course some decreasing function of these probabilities, expressed as $-\log p$; that is, very low probabilities give big responses. The merit of this suggestion is that the referent becomes invariant; an extra impulse always has the same meaning irrespective of changes in the input (e.g., the adaptation level) or of the output (e.g., the presence of other impulses in the same or other fibers). The probability value represented by an impulse could be a common currency having the same freely convertible value in different modalities or at different levels of sensory integration. Of course this can only be regarded as an ideal to which the biological system approaches, but the constancy of output noise and the square-root law for the quantum:spike ratio suggest this ideal. Furthermore, the supra-threshold responses of ganglion cells approximate the performance calculated for this ideal model.

On the basis of this formulation of the frequency code Barlow proposes that the signal sent by the retinal ganglion cell to the brain is a measure of statistical confidence (such as might be provided by a statistician) about the null hypothesis, i.e., that there is no local change in illumination in a particular portion of the visual field. This proposal he feels is supported by the finding that the adaptation process provides a fairly constant noise level of maintained discharge over changes in adapting luminance, i.e., an additional impulse always has about the same significance. In addition, the quantum:spike ratio for a small, brief, central flash, when plotted against log luminance, has a slope not far from 0.5; thus an additional impulse also has a constant significance in terms of a change in quantal flux.

Instead of analyzing discrete segments of the spike train, one might use a sliding observation window and plot reliability as a function of intensity and window width. This might be a valuable tool for finding out the observation time. The cat might do this using a number of parallel pathways with different window widths, perceiving not only that a stimulus had occurred but also how long it lasted. There is a balance between speed of response and sensitivity in this system analogous to that in monitoring neutron flux in a nuclear reactor in which a "trade-off" is made between speed of detecting runaway "excursions" of power and the false-alarm probability.

It was also pointed out that one might relax the requirement for a stimulus-locked starting time for the observation window by using a moving window or a time-weighted scheme (as Segundo proposed above). This would require a correspondingly higher significance level but would affect the required stimulus amplitude only to a minor degree.

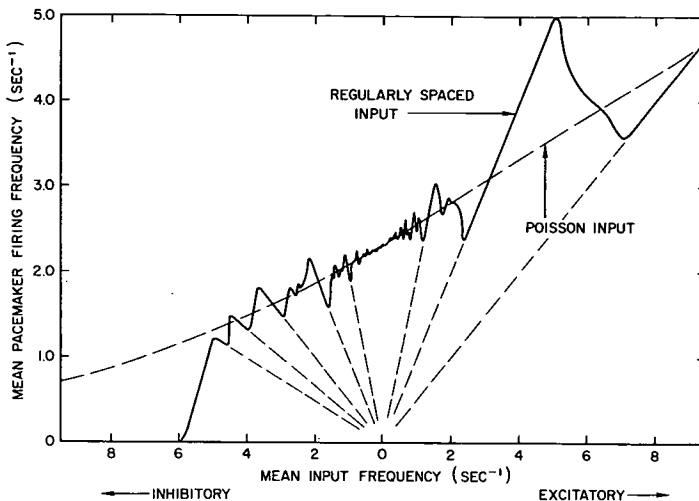

Figure 7. Sensitivity of a postsynaptic neuron to interval variance in a presynaptic impulse train. Both regularly and randomly spaced postsynaptic potentials are supplied to a computer-simulated *Aplysia* pacemaker neuron over a wide range of input rates. The two curves are remarkably different. For example, for IPSP's arriving at random at a rate of 6/sec, the postsynaptic cell fires at about 1 impulse per second; regularly arriving IPSP's at the same rate completely inhibit the cell. EPSP's at 5/sec produce pacemaker impulses at 5/sec or 3.5/sec, for regular or random arrivals respectively. [Perkel et al., 1964]

In comparing psychophysical and physiological thresholds, the issue of whether the thresholds are absolute or are indefinitely reducible by prolonged averaging over many trials becomes important. This topic is beyond the scope of the present session, but it is of interest because, if the apparent psychophysical threshold goes down with number of trials, the behavior is similar to that of the unit neuron with background activity when it responds to weak stimuli by slightly increased probability of firing.

Variance of Interpulse Intervals

In principle, a train of point processes could encode information by some function of the probability distribution of interval lengths. This obvious possibility was overlooked for many years and still cannot be satisfactorily evaluated. A variety of interval distributions has been found in recorded nerve-impulse trains and should therefore be examined as candidate codes. Variance is but one parameter of a distribution. Other parameters not yet explicitly investigated include symmetry about the

mode, relation of mean to mode, and more complex measures of the form of the interval histogram; consideration is limited here to distributions without regard to sequential ordering. The finding of multimodal histograms and those with "long tails" and different slopes suggests nonrandom processes and possible meaning, but one difficulty is that changes in the form usually occur with changes in mean rate. New efforts to distinguish the two interrelated types of change are needed. One method is to impose controlled trains to see whether, and how, the isolated parameter affects a postsynaptic neuron, i.e., whether the candidate code is readable (see Redman and Lampard, 1968).

Perkel pointed out some examples of the sensitivity of a postsynaptic pacemaker cell to the variance of interval lengths in an imposed train of presynaptic impulses. In computer simulations, as well as in experiments in visceral-ganglion pacemaker neurons in *Aplysia* and in thoracic tonic stretch-receptor neurons in the crayfish, both the mean rate and the distribution of intervals in the postsynaptic cell were in some circumstances highly sensitive to the standard deviation of impulse intervals in the synaptic input. This sensitivity was combined with a sensitivity to mean input rate (Figure 7) (Perkel et al., 1964.)

Lange (WS) described some results obtained in collaboration with Ratliff and Hartline that showed that the coefficient of variation of interspike intervals in the discharge of a dark-adapted *Limulus* eccentric cell is larger for a given mean frequency than that for a light-adapted cell (Figure 8). The cell is therefore capable of transmitting information not only about light intensity but also about the state of adaptation, assuming that there is a decoder for the coefficient of variation (Ratliff et al., 1968).

Stein (WS) recalled that a similar conclusion could be drawn from his data; i.e., the muscle-spindle fiber potentially contains information not only about muscle length but also about the amount of gamma bias (the centrally initiated set point). Barlow pointed out that something similar happens in the cat retina; the discharge is more regular at high adaptation levels than at low. Burns and Pritchard (1964) suggest that bursting, without change in mean frequency, is the proper code for edge detecting in certain units of the visual cortex.

In some preparations, then, the code is readable (by receiving cells) but is not known to be used. In others, information is encoded in a normally available parameter but is not known to be read by a decoder. Thus, although it is possible that interval variance is used as code, it remains a candidate only.

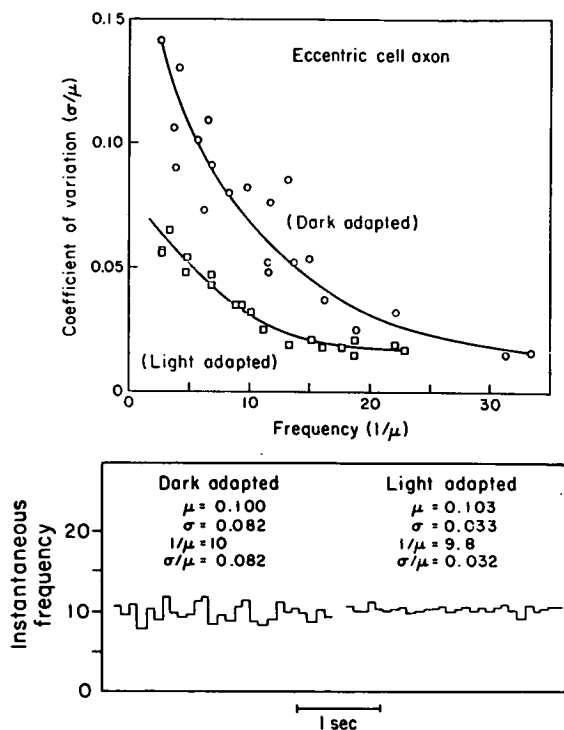

Figure 8. A case of systematic change in the coefficient of variation for the same mean frequency. Impulse trains in an eccentric-cell axon of the *Limulus* eye in the light and dark adapted conditions. [Ratliff et al., 1968]

Temporal Pattern

This heading covers those trains of impulses in which information is carried not simply by the array of intervals but by their sequence. So far we have dealt with parameters and measures that ignore sequential ordering; but in principle a powerful addition to the carrying capacity of a line is available if the system can encode and decode different micro-patterns at each mean rate. Here we shall limit consideration to relatively fine temporal structure, because very coarse or long repeat-time sequences become indistinguishable from individual messages composed of changes in frequency.

Some trains that occur naturally have been found to have different degrees of serial correlation or tendency to nonrandom order. This raises the question of the significance of such correlations and whether they can be "read" by a postsynaptic cell. To test this, controlled trains of stimuli

have been experimentally imposed on a presynaptic fiber, with the mean rate and sometimes also the interval distribution and variance held constant, while looking for postsynaptic response in synaptic potential amplitude or spike probability.

The first such experiment, reported by Wiersma and Adams (1950), showed that some neuromuscular junctions in crustaceans are highly sensitive to pattern, the contraction being many times greater for a train of alternately long and short intervals than for one of uniform intervals at the same mean rate. Other junctions do not distinguish between these. Segundo et al. (1963) found ganglion cells of the central nervous system of *Aplysia* to be pattern sensitive, using three spikes in the same total time but shifting the position of the middle one, or using long trains of random or differently ordered sequence. Schulman found that different patterns of stimulation of the inhibitor to the crayfish tonic stretch-receptor neuron change its output (Perkel et al., 1964).

Bullock reported unpublished results showing a similar pattern discrimination in the lobster cardiac ganglion when its single inhibitor axon is stimulated at a constant mean rate, either with uniform or with long and short intervals alternating. Such findings are rare, not because null results have been frequently found (see Wiersma and Adams, above, and Wilson, below) but because the demands are stringent for suitable preparations. There must be no internuncial neurons interposed or reverberating, and the presynaptic fibers should be few and synchronous, not dispersing. The integration time for determining output should not be so short that the cell follows every input volley.

Partly because of these experimental limitations, computer simulation has been used. Perkel et al. (1964) obtained results like those from *Aplysia* and from the crayfish with a model neuron. Fehmi and Bullock (1967) found that a realistic simulation of the minimally specified coelenterate nerve net could distinguish some temporal patterns.

In experiments by Segundo et al. (1966) long trains of stimuli to the presynaptic fibers of *Aplysia* cells were driven by a Poisson process with a dead time (refractory period), and the probability of a postsynaptic spike as a function of the recent history of intervals was examined in detail. The authors calculated both the prospective probability, which gives the likelihood of a postsynaptic spike as a function of the input timing, and the retrospective probability, which gives the probabilities of various input timings given that a postsynaptic spike has occurred. Corresponding contour diagrams illustrate the notion that probabilistic treatment of input-output relationships in neurons can be quantified and measured (Figure 9).

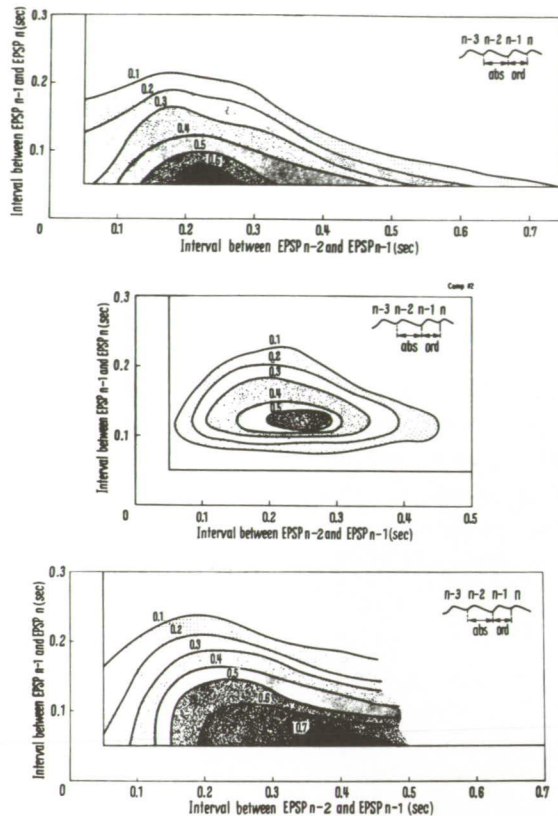

Figure 9. Contour diagrams estimating the prospective probability that a postsynaptic spike will be triggered, given the antecedent input timing. The input timing is determined by two intervals in a trio of impulses; the abscissa corresponds to the length of the first interval, the ordinate to that of the second. The three diagrams correspond to three facilitation rules at the computer-simulated synapse: invariant EPSP amplitude, reducing or antifacilitatory interaction between closely spaced EPSP's, and augmenting or facilitatory interaction. Each case gives rise to a distinct set of coding rules, as delineated by the corresponding contour diagram. [Segundo et al., 1966]

Do neurons then normally encode some of their information in the form of serially correlated or structured sequences? In general, these sequences are not common, but they have been encountered.

Kiang (WS) gave an example of a pattern change without mean rate change in single auditory nerve fibers that have high rates of spontaneous discharges. In response to low-frequency tones, there can be a temporal grouping of spikes so that statistically there is a time locking to a particular phase of the tone. Rupert et al. (1962) reported doublets of

spikes in primary vestibular units whenever the mean frequency rose above 10/sec; the patterning encodes stimulus strength *pari passu* with the mean frequency, therefore not uniquely, because the interval between the spikes of a doublet remains fixed while the interval between doublets varies. Thus the long:short interval ratio varies with mean frequency. Pattern seems unlikely to be the relevant code with respect to that information which is represented by frequency, but it might be signaling some other, probably cruder information.

Biederman-Thorson (WS) found an abrupt change from approximately uniform intervals to doublets at the same mean rate in certain crayfish interneurons when temperature is lowered to a critical level. Possibly this is a case where change of pattern itself has a meaning, but further study would be necessary to decide.

Although microstructure codes are readable and available here and there, it is still an open question as to whether they are generally useful. In order to be valuable, they require that a different dimension of information be represented by this code than by the mean rate. So far, in the experimental tests of readability, an alteration in response caused by a change in pattern only can be completely imitated by changing mean rate. It may be that nerve cells in a particular situation encode, say, intensity as mean rate and some other parameter, say, color, as a ratio of long-to-short interval, but as yet there is no specific evidence of this. Another reason for questioning how widely pattern codes may be used is that, inherently, they make high demands on precision of timing and are therefore susceptible to deterioration by noise.

Kennedy (WS) gave two examples of how patterned discharges arise. One way is in a motoneuron innervating crayfish abdominal muscle that fires regularly in triplets or sometimes in longer bursts under the drive of the command fibers, which fire at a regular frequency; the neuron also fires in bursts in response to stimulation with a constant current (Gillary and Kennedy, in preparation). Furthermore, if the command fiber is stimulated at a frequency too low to produce an output, antidromic spikes caused by stimulation of the axon tend to elicit orthodromic spikes to complete the triplet pattern. These experiments show that the pattern generator is the motoneuron membrane. But the response of the next-order cell (muscle) differs by only about 10% in equivalent average frequency for triplets as compared with a constant discharge. Another case of triplet formation has been described in mormyrid electric fish motoneurons (Bennett et al., 1967).

The second example referred to some interneurons in arthropods that collect input in a number of different segments of the animal so that one has a conducting axon with a number of sites of synaptic impingement (Kennedy and Mellen, 1964). If sensory fibers coming to each of these loci are stimulated, spikes are produced that propagate in both directions; the sequencing of inputs therefore becomes quite important in that it can determine various patterns. One of the interesting results is that on recording from both ends when natural stimuli are delivered, the temporal patterns at the two ends are observed to be different.

Wilson's experiments on the control of wing motion in the locust, reported at the Work Session, show that pattern can be available but not used. The central nervous system receives 4 input fibers and delivers wing motor output signals along 80 channels simultaneously. As a consequence of the elasticity and other mechanical properties of the thorax, each stretch receptor fires from two to four times toward the end of the upstroke of the wings when the wing-beat frequency is low; when the frequency is high, each stretch receptor fires only once, somewhat later in the cycle, and sometimes misses entirely. When the locust is flying, the experimenter, by recording from one of the input fibers, can tell the wing-beat frequency and amplitude, and if the correlation between phase and amplitude has previously been calibrated, he can also find phase information. The locust, however, does not appear to use anything but frequency information. If the nerve is cut and a surrogate input signal is provided electrically, the wings continue to beat at the proper frequency so long as the artificial input is at the correct rate; nearly any kind of temporal pattern in the substituted input, including random, will serve as well as the physiological, phasic input (Figure 10). The microstructure of the output pattern, however, must be precisely maintained because these impulses directly control the contractions of specific wing muscles.

Psychophysically it has been found that the temporal pattern of events can be decisive in respect to quality of sensation. MacKay (WS) referred to the Benham effect of color production by rhythmically patterned light stimuli. He also mentioned a related effect where a sequence of patterned and blank flashes, presented at a critical time-interval ratio, can produce sensations of motion and spurious structure (Wilson, 1960; MacKay, 1965; Fiorentini and MacKay, 1965). But it is not at all clear what relation there may be between such phenomena and coding in single axons.

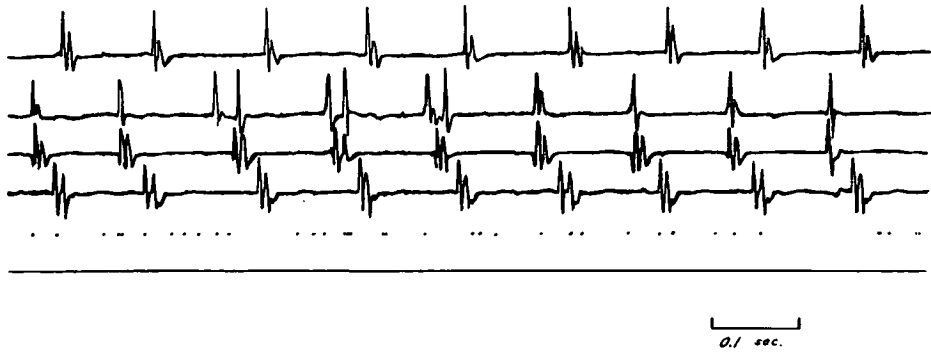

Figure 10. Irrelevance of the normal temporal pattern of sensory input for patterned output in the case of locust flight. The normal proprioceptive innervation has been interrupted, and the central stump of the sensory nerve is stimulated with an abnormal temporal pattern, a random train of shocks. The coordinated response of four flight muscles remains rhythmic and well patterned even when stimuli are absent during whole cycles of output. From top to bottom the traces represent activity in a depressor muscle, an elevator muscle, an elevator, another depressor, and the stimulator. [Wilson and Wyman, 1965]

Number or Duration Codes

There is a class of fibers, represented by well-studied examples in the lateral line nerve of electric fish, that forms a burst of impulses for each adequate stimulus—and the stronger the stimulus, the greater the number of impulses (Bullock et al., 1961; Hagiwara et al., 1962; Hagiwara and Morita, 1963). In one form of response there is no systematic change in interval between spikes, so that the information about intensity is represented by the number of spikes or by the duration of the burst (Figure 11). The authors cited give input-output curves over a useful

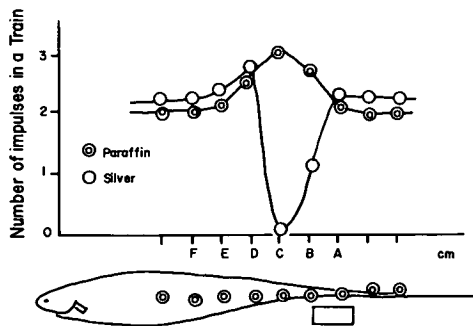

Figure 11. Number or duration coding. The response of a unit in the lateral line nerve of a gymnotid electric fish that cannot be coding by mean frequency and apparently codes the intensity of the adequate stimulus—presence of an object in its field—by the number of nerve impulses at a nearly fixed frequency. Note the steep function of position and opposite effect of dielectric and conducting objects. [Hagiwara and Morita, 1963]

dynamic range. The case is valuable because it permits exclusion of mean rate as the code. The adequate stimulus in this instance is an electric organ discharge whose field in the water, distorted by objects, affects the electroreceptors. But the mean rate of sensory impulses is largely determined by the frequency of electric organ discharges, which are commanded by a center in the fish's own brain.

Burst duration is also the relevant variable in controlling certain effectors like the electric organ discharge of *Torpedo* and sound production in cicadas where impulse interval does not change, but impulse number, and hence burst length, determines the amount of response.

Statistical Features of Impulses in a Single Channel

Information about the characteristics of a synapse is represented on a statistical basis in the time relationships between pre- and postsynaptic impulses. These relationships were illustrated by Perkel (WS) in examples drawn from computer simulations and in experiments in *Aplysia* performed in Segundo's laboratory. It was very difficult to see how the nervous system could extract the demonstrably present information in a useful manner, although the relationships may for other reasons be valuable to the neurophysiologist. The first example (Figure 12) shows how a portion of the cross-correlation histogram, as constructed from the simultaneously recorded impulses of a pre- and postsynaptic pair of neurons, furnishes a representation of the waveform of the postsynaptic potential produced at the junction. An excitatory synaptic event gives rise to a peak in the histogram, an inhibitory one produces a valley. The amplitude of the peak or valley is related to the mean amplitude of the postsynaptic potential, and its width corresponds to the duration of the potential. The mapping of waveform into a feature in the cross-correlation histogram is not linear, nor, in most cases, is it severely nonlinear. By monitoring the two channels of impulses in a favorable preparation and performing the appropriate statistical calculations, the experimenter can infer many features of the unobserved synaptic potential: its sign, its direction, an approximation of its amplitude, and the time constant of its decay. One of the requirements for observation of the mapped waveform is the presence of "noisy" background impulse activity in the postsynaptic cell.

Other features of pre- and postsynaptic discharges may be revealed in the cross-correlation histogram. In the presynaptic neuron, rhythmicity evidenced by oscillations in its autocorrelation histogram is represented in

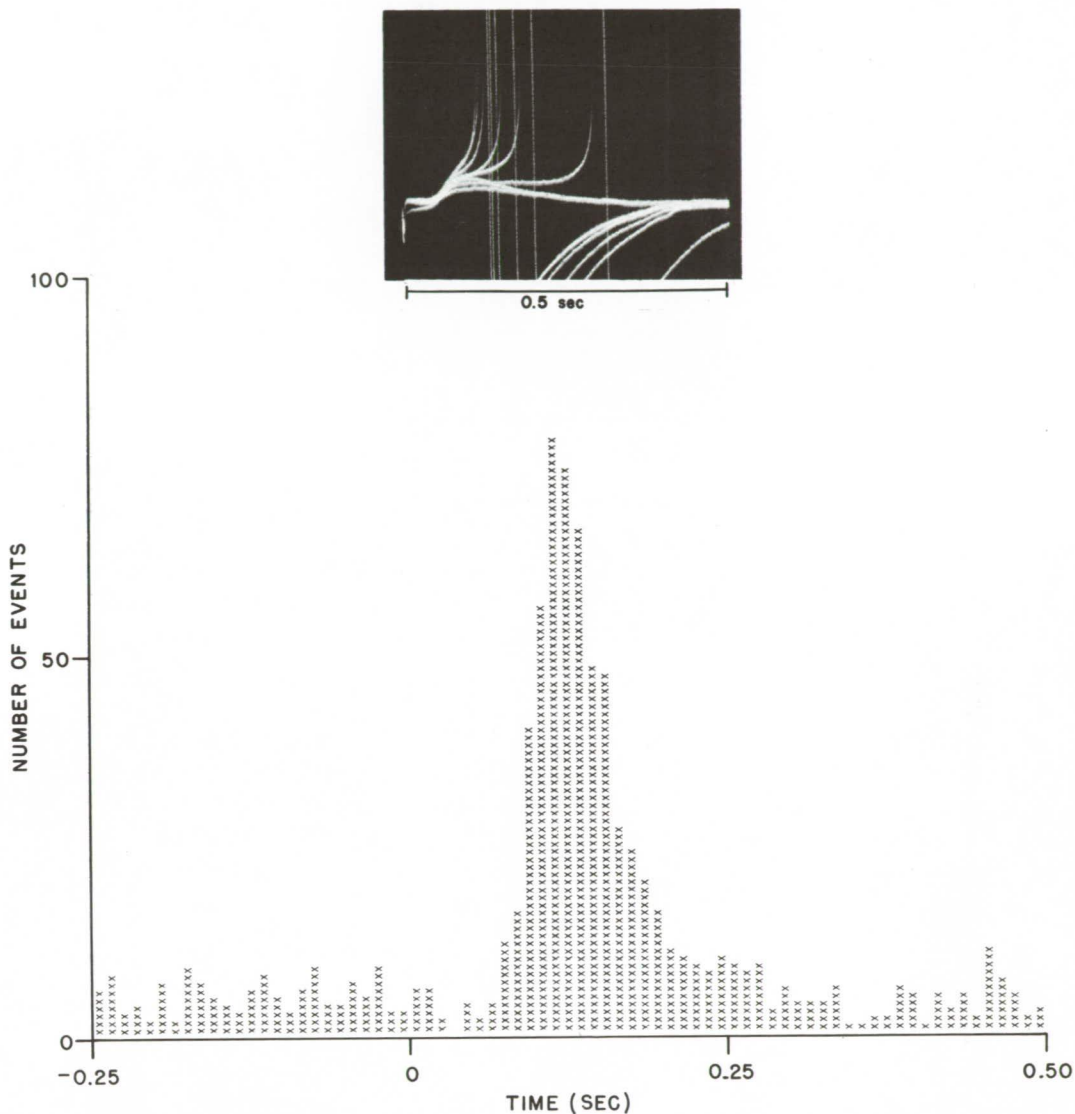

Figure 12. Mapping of waveform of postsynaptic potential by cross-correlation histogram.

Above: Superimposed tracings of intracellular records of a visceral ganglion neuron of *Aplysia californica*. Stimuli were randomly timed shocks to a connective governed by a Geiger counter. Records show EPSP's that occasionally trigger impulses.

Below: Cross-correlation histogram between presynaptic events (shocks) and postsynaptic spikes. Note that the latency, rise, and fall times of the peak in the histogram map those in the direct recordings of the EPSP's. [Levitán, unpublished data]

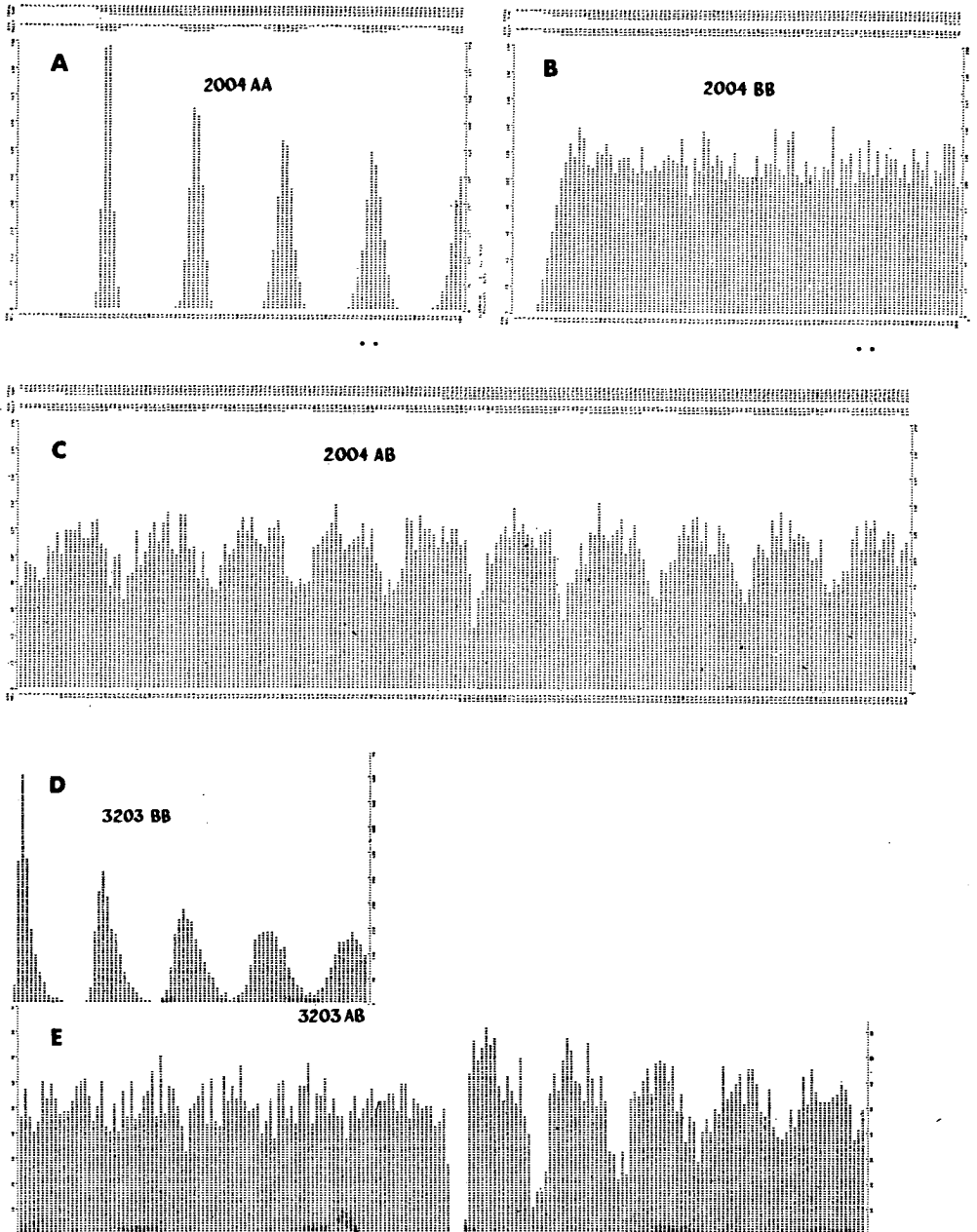

Figure 13. Rhythmicity of discharge reflected in cross-correlation histogram between pre- and postsynaptic neurons. (a) Control autocorrelation of presynaptic neuron. (b) Control autocorrelation of postsynaptic neuron. (c) Cross correlation. Note that presynaptic rhythmicity gives rise to a series of valleys bilaterally located about the central valley produced by synaptic inhibition. (d) Another case: autocorrelation of postsynaptic cell; presynaptic train was random (Poisson). (e) Cross correlation. Note that *postsynaptic* rhythmicity is represented unilaterally only. [Perkel]

the cross-correlation histogram between pre- and postsynaptic impulse trains in a bilateral, symmetric fashion (Figure 13). The peaks in the autocorrelation are mapped as peaks in the cross correlation if the synapse is excitatory, and as valleys if it is inhibitory. Postsynaptic rhythmicity, on the other hand, is represented only on the right-hand branch of the cross correlation, and the extent to which it appears is proportional to the mean effect of a presynaptic impulse in resetting the rhythm of the postsynaptic cell. Thus, if the postsynaptic cell is an autonomous pacemaker, its autocorrelation will be mapped maximally in the right-hand branch of the cross correlation. If postsynaptic rhythmicity is due to external driving or some other mechanism that is not influenced by an arriving presynaptic impulse, the autocorrelation will not be mapped at all.

These analyses have been extended to cases in which the two monitored neurons are not members of a pre- and postsynaptic pair but receive synaptic input from a common source, and to more complicated circuits. The statistical relationships furnish a method whereby the physiologist can infer features of synapses and neuronal connections from the impulse-train statistics. However, it remains to be shown—or suggested—how the nervous system might make empirical use of such information.

III. NERVE IMPULSES AND TRAINS IN PARALLEL CHANNELS

It has become a truism that the nervous system processes information "in parallel," i.e., simultaneously along many pathways and through the simultaneous, coordinated functioning of large numbers of units. It follows that the possibility at least exists that there are modes of representation and transformation of information in the nervous systems in which the cooperative action of two or more impulse-carrying pathways is of central importance. Investigation of such multiple-channel impulse codes, however, has not progressed far; there are significant difficulties at both the experimental and conceptual levels.

The experimental problem of recording from several "lines" simultaneously requires either the use of multiple electrodes or the resolution of the electrical signal from a single electrode into the impulse contributions from two or more neurons. Multiple electrodes require multiple amplifiers and recording systems, and the practical difficulties of placement of electrodes in the tissue increases rapidly with the number of electrodes. Separation of signal sources from a single electrode using computer techniques (e.g., Gerstein and Clark, 1963) is limited to the number of channels that can be reliably separated (five or six—with unusually favorable signals), can seldom be done "on line" while the experiment is in progress, and is subject to "coincidence loss." That is to say, impulses from separate channels that occur nearly simultaneously produce overlapping waveforms that frustrate automatized as well as "eyeball" methods of identification; also inherent is the problem of knowing where the records come from in terms of the connectivity of the units, i.e., in tracing the precise source of the impulse.

Conceptually, the underlying theory of representation of information by impulses in a plurality of channels, not necessarily independent, is nearly nonexistent. Statistical techniques for analyzing multiple-channel impulse records are in early stages of development, and several important problems, such as those of statistical significance of observed features of interaction, remain unsolved except in highly specific cases. The very wealth of possible multiple-channel codes represents an embarrassment of riches among which to find those—if any—used by the nervous system.

Despite these difficulties, neural coding through impulses in multiple pathways is being investigated, both experimentally and theoretically, the latter approach often aided by computer simulations. Understanding of multiple-channel codes would seem to be essential to a comprehensive, quantitative theory of coordinated, complex behaviors.

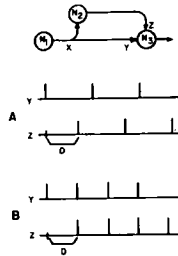

Figure 14. A simple model network with two lines in parallel designed to achieve an input frequency-band detection.

Upper: A pulse produced by the input neuron N_1 splits at the branch point X ; one pulse travels to the excitatory terminal Y , while the other passes through N_2 to its excitatory terminal Z , arriving D msec later. Neuron N_3 is a T-neuron that fires if, and only if, two pulses arrive within a period T . *Lower:* Regular pulse trains produced by N_1 , arriving at terminal Y and Z in the network. The fundamental period of the trains is greater than the net delay D , and no two pulses arrive in coincidence at N_3 . The fundamental period is equal to D , and three pairs of pulses arrive in coincidence, each pair causing N_3 to fire. [Reiss, 1964]

The preponderance of work done on multiple impulse-carrying channels has been directed more toward extraction of information by the physiologist than by the nervous system. The problem of establishing the actual use of a candidate code of the multiple-channel variety is considerably more difficult than for a single-channel code in that convergence, and integration in a population of "higher-level" neurons must be studied if one is to investigate the interpretation of the encoded signals. The opinion was expressed that in the face of such intransigent difficulties some physiologists retreat to a position of defeat, insist that matters must be simpler, and continue to ignore the real problems; the effort of this challenge was to smoke out into the discussion new contributors and new (or old) ideas.

Impulse Coding in Pairs of Fibers

A provocative theoretical study has been made (Reiss, 1964) of how precise timing relationships can be encoded and retrieved with high reliability and selectivity in pairs (and large groups) of parallel fibers. The several schemes described all depend on the detection of multiple coincidences of input synaptic events by postsynaptic neurons and on fixed, rather slow, conduction velocities in the fibers involved. The selectivity of the coding enables some of the properties of a large set of labeled lines to be accomplished using a relatively small number of actual fibers, the target cells being "tuned" to respond only to "messages" intended for them (Figure 14). Although these studies have not been adequately followed up by further theoretical or simulation studies or by

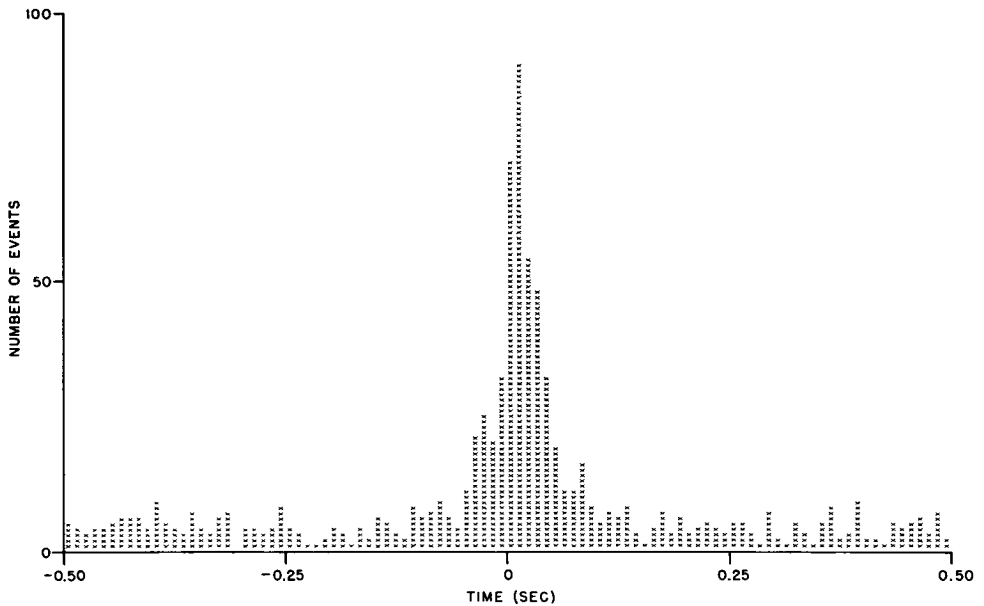

Figure 15. Shared synaptic input. Cross-correlation histogram between two *Aplysia* visceral ganglion neurons in each of which EPSP's are elicited by randomly applied shocks to a connective. The peak is symmetrically shaped and extends on both sides of the origin. The dips on either side of the peak reflect refractoriness of the cells. Compare with the cross correlation in Figure 12, taken from a similar experiment, but calculated between pre- and postsynaptic impulses. Note that the peak in Figure 12 is displaced from the origin and is noticeably more skewed than in the shared-excitation case above. [Levitan, unpublished data]

experiments in nervous systems, they do demonstrate that multiple-channel coding schemes are feasible and realizable within the physiological constraints of real neurons. Other modeling and theoretical studies have shown the wide range of possible behavior of minimal nets of neuronlike units (Reiss, 1962; Crane, 1964; Harmon, 1961, 1962a,b; Harmon and Lewis, 1966; Jenik, 1962; Perkel et al., 1964; Perkel, 1965).

A problem that arises in the experimental investigation of coding in pairs of parallel fibers is the establishment of the circuitry of the fibers under electrical observation: Are the two fibers in fact parallel, are they in series (pre- and postsynaptic), or are they independent? One potentially useful approach is through statistical analysis of the relative times of occurrence of impulses in the two records, chiefly through the cross-correlation histogram. In all but exceptionally unfavorable cases (Perkel et al., 1967b), units that fire independently yield a flat cross-correlation

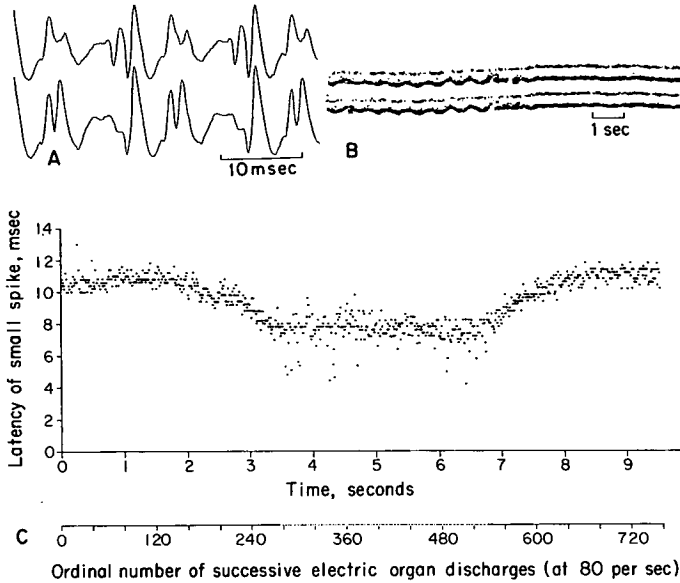

Figure 16. Latency or phase coding.

(A) Spike response of a bundle of a few units of synchronous type, before and after introduction of metal rod at critical anteroposterior level; average response computer records synchronized to electric organ discharge. Note shift of certain deflections (average position of one spike) relative to others.

(B) Two units, one phase-stable, the other phase-shifted, by about 2/sec waving of a metal rod back and forth 1 cm through critical level. Peaks of spikes brightened the cathode-ray beam.

(C) Time difference between small, phase-shifted spike and larger, stable spike during 2-sec movement of rod by 1 cm into and then out of critical region. The small unit misfired often during this stimulation as shown by the gaps in the lower abscissa. [Bullock and Chichibu, 1965]

histogram. If the two units constitute a pre- and postsynaptic pair, a pattern of peaks and valleys will appear, as described in the previous chapter. If the two units are "in parallel" and receive synaptic input from a common source, there will be a peak near the center of the histogram, whether the shared input is excitatory or inhibitory. Moreover, the shape of this peak will be much more nearly symmetrical than in the case of pre- and postsynaptic units in which the central peak maps the waveform, typically skewed, of the postsynaptic potential (Figure 15). In the shared-input case, the valleys and peaks extending to the left and right of the central peak to a large extent reflect the refractoriness and rhythmicities of the two monitored units and can therefore be related quantitatively to their respective autocorrelations. Examples of the effects of shared excitatory input in neighboring cerebellar Purkinje cells on cross-correlation histograms are given by Bell and Grimm (1968).

UNIT 50-3 FROM UNIT 50-2

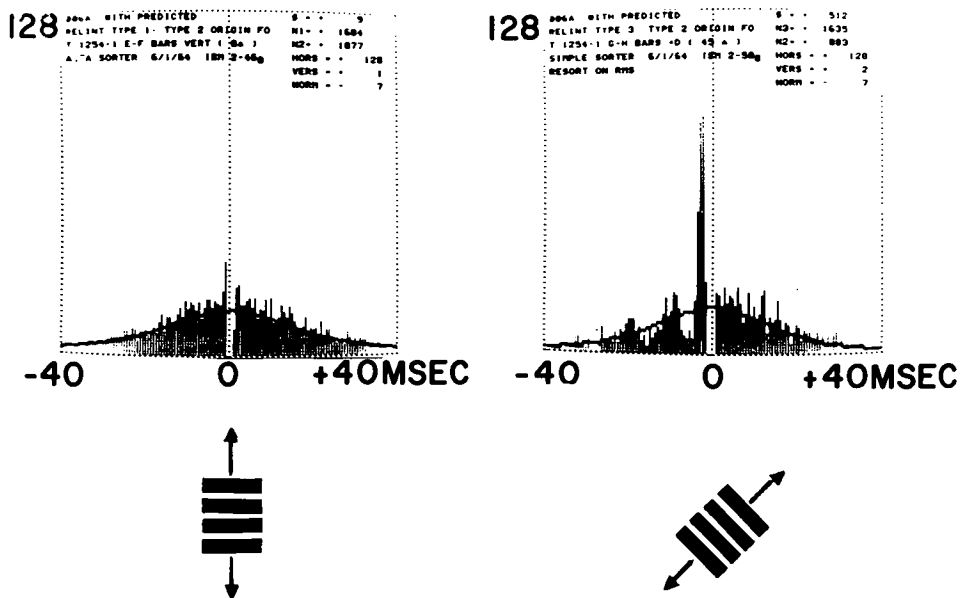

Figure 17a. Two-channel coding as displayed by the cross-interval histogram. Two cells in the visual cortex of an unanesthetized cat; stimuli were equal moving stripes in direction indicated. PST histogram did not show change of direction but CIH did. [Gerstein]

A clear-cut, experimentally investigated case of coding by latency differences between impulses in two sets of fibers was brought up by Bullock (WS). In the electric organs of electric fish there is one set of afferent fibers that fire in a one-to-one fixed relationship with the discharge of the organ. One of the classes of afferent fibers from the receptors apparently codes intensity by shift in latency of impulses with respect to discharges of the electric organ; there are also other afferent fibers that do not shift latency. The machinery is thus available in two classes of parallel fibers for the coding of intensity by latency and for "decoding" by comparison of these latencies between discharges (Figure 16). It was suggested that a similar latency coding among fibers might be operative in the mammalian auditory nerve.

A demonstration of the complex kinds of signals that can be generated for propagation along two parallel channels was provided by Harmon (WS), using his well-known electronic neuron models, or "neuro-

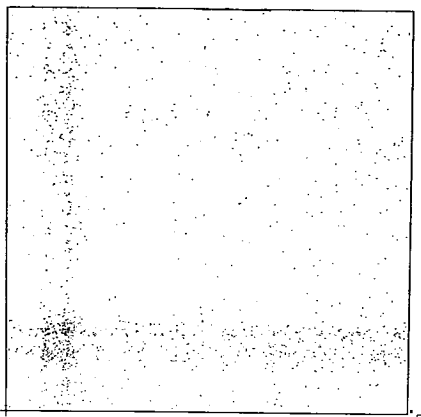

Figure 17b. Joint poststimulus-time scatter diagram. Abscissa is time from stimulus to a given spike in neuron A, ordinate is time from stimulus to a given spike in neuron B. All A-B spike pairs are included if their corresponding points fall within the range of the diagram. Stimulus excites both neurons through several parallel pathways, each with somewhat different latencies. Otherwise there is no interaction between the observed neurons. [Gerstein and Perkel]

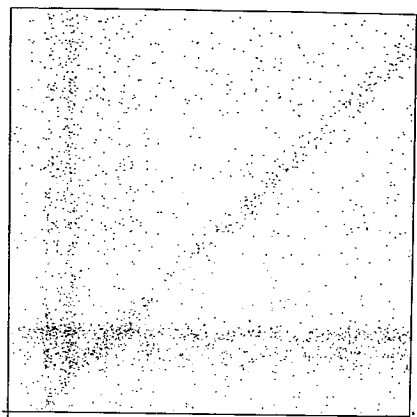

Figure 17c. Similar to (b), but neuron A excites neuron B through parallel synaptic pathways. Note that the diagonal region of increased density is displaced down from and to the right of the principal diagonal, indicating the direction of the interaction; synaptic excitation from B to A would give rise to a similar feature to the left and above the principal diagonal. [Gerstein and Perkel]

mimes." Using a simple circuit of two reciprocally inhibiting neurons supplied with a common source of excitation, he demonstrated how a wide variety of output pulse patterns could be obtained through variations in certain parameters of the neuromimes and in input rate. Phasic and tonic responses, dominance of one unit over the other, hysteresis effects, and alternation of firings in the two output channels all could be produced (Harmon, 1964). Model studies of this sort show clearly that encoding mechanisms are available in nervous systems for multiple-channel impulse codes. Such demonstrations of feasibility, of course, cannot of themselves show that such codes are in fact operative in specific organisms, although in some cases accurate predictions have been made (Harmon and Lewis, 1966).

Gerstein (WS) provided an example of a candidate two-channel code in which information can be extracted statistically through use of the cross-interval histogram (CIH, the histogram of times from an impulse in one train to the immediately preceding or following impulse in a second train; see Perkel et al., 1967b). Two cells recorded simultaneously in the visual cortex of the unanesthetized cat responded to a moving set of

stripes. The PST (poststimulus time) histograms of the cells did not change as the direction of movement of the stimulus was changed. However, the cross-interval histogram was different for two orientations of the stimulus (Figure 17a). When the stimulus moved back and forth in one direction, the cross-interval histogram was that of the null case consistent with independent discharge of the two cells; with preferred orientation of stimulus movement, the cells came into a specific temporal relationship with each other, as seen in the oscillatory shape of the left-hand side of the cross-interval histogram. The shape of this histogram has no obvious relation to the detailed temporal structure of the stimulus. It is the relationship between the two cells that is modified by the preferred stimulus, which appears to potentiate an excitatory pathway from the second cell to the first. The precise coding mechanism is not known, nor is there any detailed notion as to how such encoded information might be extracted by the nervous system, but the information can clearly be extracted by the observer with the aid of his computer. A generalization of the cross-correlation technique to two or more trains of impulses in the presence of stimulation has also been used by Gerstein and Perkel. The basic technique involves a joint poststimulus-time scatter diagram. Characteristic signatures of stimulus-locked effects, interactions, and common input are apparent in the scatter diagram. Some examples, drawn from computer simulations, are shown in Figures 17b and 17c.

Impulse Coding in Many Channels

A well-known theorem in stochastic point processes (Cox and Smith, 1954) states approximately that a large number of independent channels of impulses, with quite arbitrary (stationary) temporal distributions in the individual channels, give rise, when pooled, to a sequence of impulses that closely resembles a Poisson process, i.e., the sequence of events from a completely random source, such as emissions from a long-lived radioactive source. As applied to nerve impulses converging from many channels on an integrating neuron, this result implies that for independent (excitatory) input channels, any information coded temporally in single channels will be lost, and the many parallel channels (with the same amplitude of postsynaptic effects) could be replaced by a single random (Poisson) channel with no observable difference in the statistical behavior of the postsynaptic cell.

This result can be illustrated by computer simulation studies (Segundo et al., 1968). As the number of input channels was increased

and the amplitudes of excitatory postsynaptic potentials were decreased proportionally (so that the net excitation rate remained constant), the firing of the postsynaptic cell became more and more regular, with little change in its mean rate, irrespective of the irregularity or regularity of impulse sequences in the individual input channels.

When the input channels were made dependent, however, through temporal coherence among the impulses in subsets of the input channels, the situation changed rapidly. The statistical features of the postsynaptic train were now greatly influenced by those of the presynaptic trains, regular presynaptic trains giving rise to regular postsynaptic trains and irregular (Poisson-like) presynaptic trains giving rise to irregular postsynaptic trains. From these and related results it can be concluded that, under conditions of extreme convergence, it is unlikely that multiple-channel codes involving interchannel coherence are used if the postsynaptic output is highly regular. On the other hand, presynaptic temporal coherence among channels is likely if the postsynaptic cell fires irregularly, with the further possibility of multiple-channel coding governing the presynaptic input. Cat motoneurons, for example, receive a great deal of convergence and fire very regularly, consistent with the first case. In many sensory systems, on the contrary, increasing the number of channels tends to increase the irregularity of the integrating cell; this would imply the second case, i.e., temporal coherence in the input.

These results do not apply without qualification to cases in which the postsynaptic cell is a pacemaker or in which part of the input to this cell is inhibitory; computer studies are currently under way to elucidate these more complicated conditions.

The classical assumption about parallel-channel coding is shown in Figure 18. In the general case the receptive fields of the separate units overlap, whether this means area of the skin for topographic information coding, or sound frequency for pitch coding, or molecular specificity for taste and smell coding. The distinguishable stimuli are then represented by individual profiles of the relative activity in the separate channels.

Some of the advantages of multiple pathways for impulse-bearing channels have been discussed by Bayly (1968a,b). He investigated on a quantitative basis the characteristics of pulse-frequency modulation, using the technique of small-signal analysis and spectral analysis. The use of many independent parallel channels can increase the effective sampling rate of the decoder and hence significantly extend the effective frequency range of the system. The inherent distortions of the signal in pulse-frequency modulation schemes (see considerations brought up by

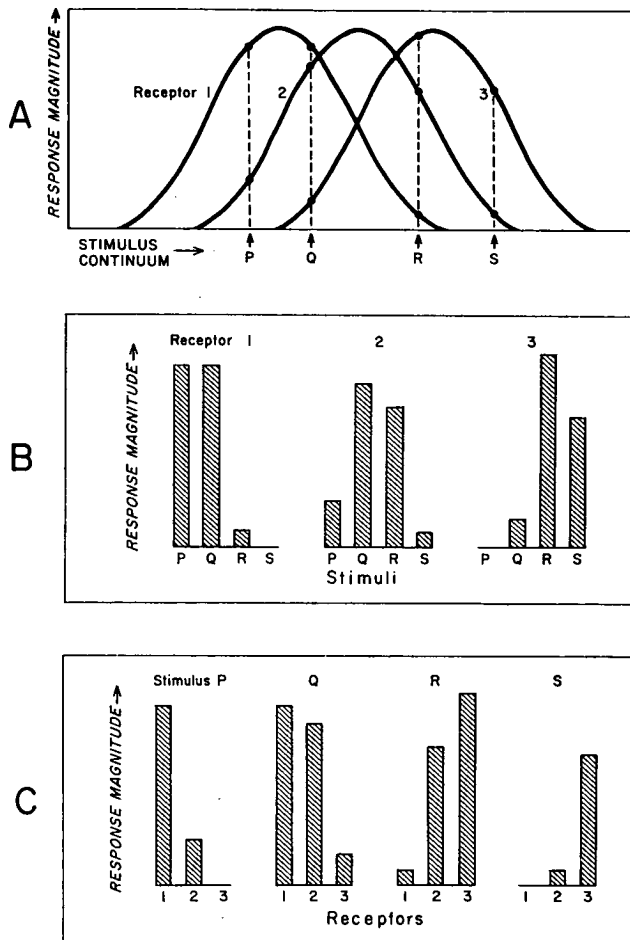

Figure 18. Parallel fiber coding with overlapping receptive fields: a hypothetical case.

(A) Receptive fields of three units (afferent fibers or central neurons). Curves 1, 2, and 3 represent the response areas of three hypothetical fiber types along the relevant stimulus continuum; this may be topographic distance or wave length of light, frequency of sound, etc. P, Q, R, and S represent four stimuli along this stimulus continuum. The responsiveness of a fiber type to one of these stimuli is indicated by the intersection of the response curve and the ordinate erected at the stimulus.

(B) Responsiveness of the three fiber types to the four stimuli in A. In each of the bar graphs is shown the responsiveness of one of the fiber types to each of the stimuli in A. If recordings were obtained from one of the fiber types shown in A using these stimuli, one of these three "response profiles" would be obtained, depending upon which fiber type was being sampled. There would be as many "response profiles" as fiber types.

(C) Across-fiber patterns. In these bar graphs are shown the patterns of activity across the three fiber types produced by the four stimuli in A. Each stimulus produces a characteristic pattern across the three fiber types. There would be as many across-fiber patterns as stimuli. [Erickson, 1963]

Partridge (WS), pp. 242-245) can be largely removed by use of multiple channels converging to a common decoder.

Returning to experimental studies, a clear-cut case of latency coding in many parallel channels was investigated by Gray and Lal (1965). The coding scheme is, in a sense, a generalization of the two-channel latency coding in electric fish, as described above. In the footpad of the cat there are extensively overlapping receptive fields of a class of rapidly adapting mechanoreceptors that fire a single impulse for each stimulus. A normal stimulus sets up an array of impulses in a set of afferent axons. Those fibers from the central or most strongly depressed part of the skin have the shortest latency spikes; the peripheral or liminally stimulated fibers have long latency spikes; a flying wedge of spikes represents the information about area and intensity profile of the stimulus (see Figure 19).

Another example of parallel-channel latency coding was described by Bennett (WS). The problem is to send a motor signal from a command center in the brain along many channels of different length so as to reach all parts of a target organ—the 1-meter-long electric organ in the electric eel—at the same time. The typical conduction velocity in the fibers is 50 m/sec, implying a time of 20 msec to traverse the length of the organ. Simultaneity of arrival of impulses along the organ is accomplished through compensatory delays for the more anterior segments within the spinal cord together with appropriate additional delays at the periphery, with about half the required delay taking place in each. The use of systematic delays to encode the desired time relations of the effector action, for example with changing length or age of the animal (e.g., kitten to cat), is probably a general principle of parallel line or ensemble coordination.

Investigation of large networks of interacting neurons on a unit basis has not been feasible in living systems. The work in this field has largely been carried out on a theoretical basis, either mathematically (e.g., Beurle, 1956) or through computer simulations (e.g., Farley and Clark, 1954, 1961; Andersen et al., 1966; Fehmi and Bullock, 1967). The behavior of various ensembles has typically been examined with very simplified models of neurons, often omitting inhibitory action. A later study by Beurle (1962) and the Fehmi-Bullock study were concerned with coding in a population of simple, artificial neurons. Fehmi and Bullock simulated a coelenterate nerve net subjected to various temporal patterns of stimulation. A principal finding was that the spatial spread of excitation described different patterns for certain classes of stimuli in such

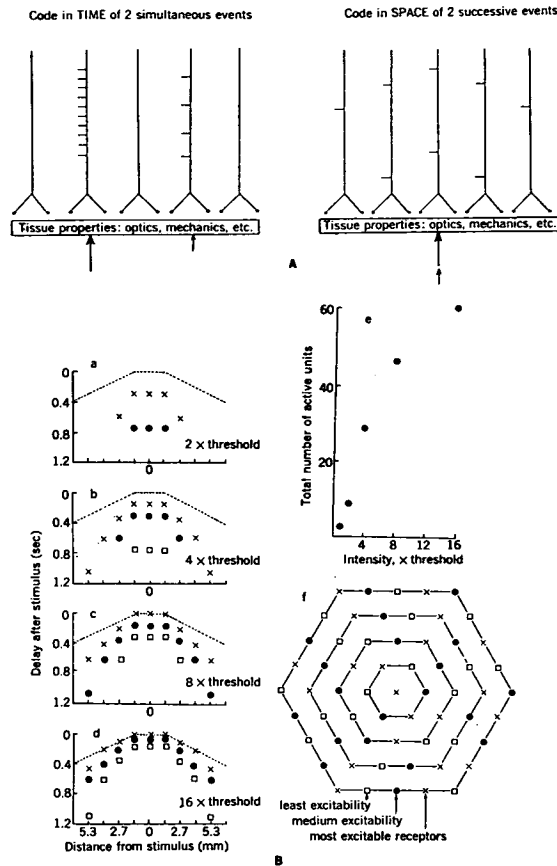

Figure 19. Coding intensity and locus in parallel fibers.

(A) Two types of "coding": frequency (left) and spatial (right) representations. Impulses are shown traveling upward from receptor ends to central nervous system.

(B) The spatial representation as found in tactile afferents from the cat's footpad when excited by mechanical pulses at one point; diagram based on quantitative experimental data. Assuming a number of equidistant receptors of three levels of excitability (f), a stimulus twice threshold will give the number of impulses at the distances from the stimulated point and at the time after stimulus shown in (a). The dotted line is the latency due to the traveling time of the mechanical wave in the pad. Stronger stimuli bring in responses shown in (b) to (d). The total number of impulses at each stimulus strength is given in (e). [Gray and Lal, 1965]

a way that the entire network transformed temporal information into a spatial representation.

Most of the other theoretical studies of large populations of interacting neurons confine themselves mainly to working out the spatio-temporal behavior of impulse traffic in such networks. A typical finding in these studies is that waves of impulses are produced under a wide variety of conditions, spread through the network, and in some cases and in a limited region of tissue give rise to maintained oscillations in the number

of impulses present from moment to moment. Attempts have been made to relate these waves with slow waves and EEG signals recorded from brain tissue, although these theoretical studies differ in that they describe nerve impulses rather than a continuous electrical signal transmitted through bulk tissue. The relationships between impulses and wave activity in the brain are discussed in the next chapter; but if there is in fact a connection between waves of impulses (which may perhaps carry information of use to the nervous system) and the continuous electrical waves, then the latter may likewise carry similar information.

One such theoretical study of interacting populations of neurons was presented at the Work Session by Cowan. In Cowan's system, significant characteristics of the entire network's structure and function can be inferred from time-averaged observations of individual units.

Conversely, given some knowledge of network structure and function, significant characteristics of the network's activity may be predicted. The theory in fact provides observables that can help to relate activity to structure and ultimately to function. As to whether the nervous system itself uses such observables, that is an open question. Because the observables are all obtained by correlational and convolutional operations in the time domain, it is suggested that analogous observables are computed within the nervous system, mainly in the spatial domain.

Stimulus-Related Codes

An indirect but relatively easy way of investigating impulse codes in more than one channel is through single-channel recordings in preparations subjected to brief repeated stimuli. The response, i.e., the number and temporal spacing of impulses observed after onset of the stimulus, typically varies, apparently at random, from trial to trial. Underlying regularities in response probabilities are brought out by summing or averaging over many stimulus trials. The resulting poststimulus time (PST) histogram estimates the probability of an impulse as a function of time after stimulus onset. One of the many unsolved problems presented by this kind of statistical measurement is that of establishing a priori confidence limits on features in the PST histogram suspected of having meaning, i.e., of carrying information about the stimulus. The problem is not easy inasmuch as the observation of an impulse at a particular poststimulus time renders shortly subsequent observation of an impulse during the same trial unlikely because of the refractoriness of the neuron.

Successive observations of impulses, then, are not independent trials, and the usual apparatus of Bernoulli trials and binomial statistics fails us. In the absence of a sufficiently powerful statistical theory, the only remedy is the collection of longer samples or, roughly equivalently, replication of the experiment. Longer samples, however, entail the risk of non-stationarity; Morrell (1967) has demonstrated the plasticity of the PST histogram.

The problem of detecting and measuring putatively meaningful signals "buried" in noise and complicated by lability or plasticity in the response arose again and again in the course of the Work Session; the problem is inherent not only in the investigation of impulse codes but also in the wavelike, continuous electrical signals in the brain. Discussion of the relationships between impulse activity and EEG or slow waves is found in the next chapter, but the methodological problem is conceptually the same for multiple-channel impulse codes: What is the appropriate time period over which to pool or average signals? Too brief a period results in a random scatter of observations, not amenable to interpretation. The "right" period optimally displays the sought-after relationship. Too long a period encompasses changes in the "state" of the organism and seems often to involve a change in the coding scheme or in the information encoded, at least in the units under observation, so that meaningful features in, say, a PST histogram may be obscured by other features or by noise. It seems clear that at least in central portions of the nervous system, in the awake animal, the functional relationships among information-transforming units do not remain fixed and that hypotheses of coding that rely on "soldered circuits" and invariant information pathways are at best incomplete. Even with fixed circuitry, rules of representation may change on a dynamic basis as in the case of the digital computer provided with microprogramming, whereby the meaning of the commands are stored in memory and can be altered by the programmer.

Gerstein (WS) presented some examples of different kinds of information that can be extracted from the PST histograms of single-cell discharges in the cochlear nucleus. The stimulus consisted of frequency-modulated tones: the tone swept linearly downward in frequency for 0.5 sec and then upward for the same time. In some units, the PST histogram for this V-shaped stimulus was mirror-symmetric about the center line (Figure 20); thus the response (pooled over many trials) followed the actual stimulus and could convey information about the order of occurrence of frequencies. In other units, the PST histogram was translation symmetrical, i.e., the same for descending as for ascending frequencies.

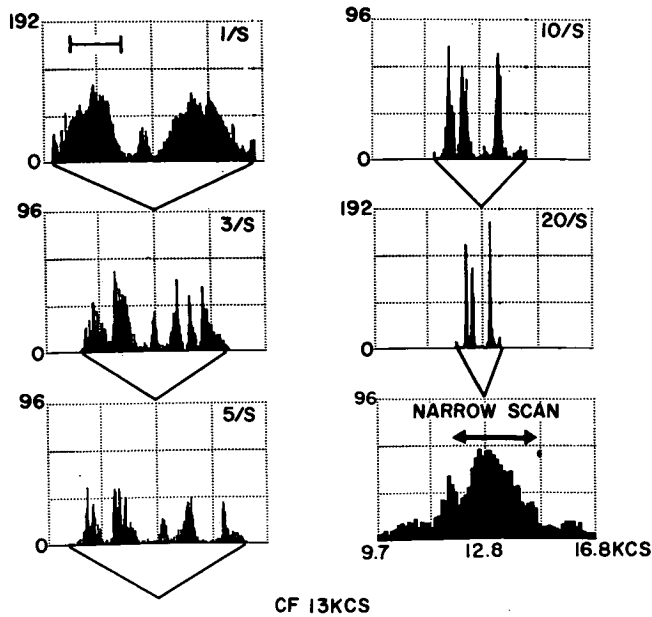

Figure 20. Three different types of response of auditory neurons in the cochlear nucleus to downward- and upward-sweeping frequency-modulated tones; PST histograms. [Erulkar et al., 1968]

The information contained is related to the change in frequency—possibly to its absolute rate of change—but does not include the direction of the change. In a third class of cells, the PST histogram was asymmetrical, giving essentially different “signals” for a given frequency depending on whether the frequencies were ascending or descending; i.e., information as to both the frequency and its time derivative is contained in this class of histograms. Once more, examination of any individual trial, i.e., the impulses observed in any 1-sec down-up sweep of frequencies, was incapable of conveying the information recoverable in the PST histogram, the result of many replicate trials.

In these experiments the investigator must average over many trials not only in order to elucidate the code but also to “read” the response of the cell. But the nervous system obviously does not require many repeated trials. We are therefore forced to the conclusion that, if the nervous system makes use of information encoded in this way, i.e., as observed through PST histograms, it must be using several channels simultaneously. In other words, the nervous system must utilize something like an ensemble average obtained simultaneously over a population

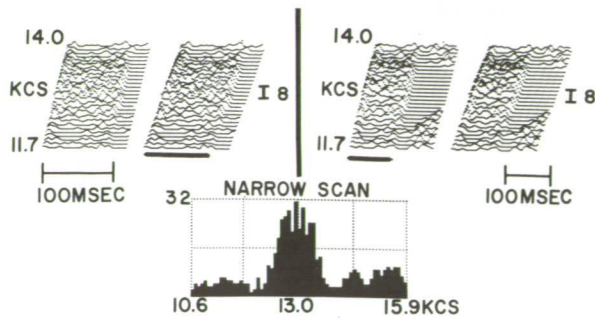

Figure 21. Poststimulus-time histograms of the discharges of a single unit in the cochlear nucleus of a cat to a succession of brief tone bursts at different frequencies. In enlargement at right of picture, time between initial burst and resumption of firing is related to logarithm of stimulus frequency. If the activity of this cell aids in the recognition by the central analyzer of what frequency of sound occurred, the latency-frequency characteristic of the cell must be "known" to the system. [Gerstein et al., 1968]

of neurons rather than the experimenter's time average that is obtained serially in time from a single representative of such a population.

In a related set of experiments described by Gerstein (WS), a series of PST histograms was obtained for individual cochlear-nucleus neurons, in which the stimuli consisted of short (50- to 100-msec) tone bursts at a series of frequencies. The corresponding series of "stacked" histograms (Figure 21) shows how tone-burst frequency is reflected in PST histograms. In one example there is an initial period of high likelihood of encountering impulses of essentially constant duration at all frequencies represented followed by a silent period of variable duration that is in turn succeeded by another period of relatively uniform activity. The length of the silent period is related to the tone frequency in such a way that the stacked histograms yield a configuration resembling the letter K; the length of the silent period is an increasing linear function of the absolute difference of the log of the tone-burst frequency from that of a reference frequency. Such a relationship is compatible with the kinds of relationships found in psychophysical experiments. On the other hand, it is difficult to visualize how this kind of representation can be utilized by the nervous system. If it is, it is clear that the interpretation mechanism must involve simultaneous processing along several channels.

An example of classical conditioning of the PST histogram was presented by Morrell (WS). He recorded discharges of units in the peristriate cortex of cat without general anesthesia. Some of these cells responded both to particular (preferred) visual stimuli and to trains of clicks; each type of stimulus lasted about 50 msec. A PST histogram was collected for each set of 20 trials of light or click or paired light and click; the results of one such experiment are shown in Figure 22. It is seen that

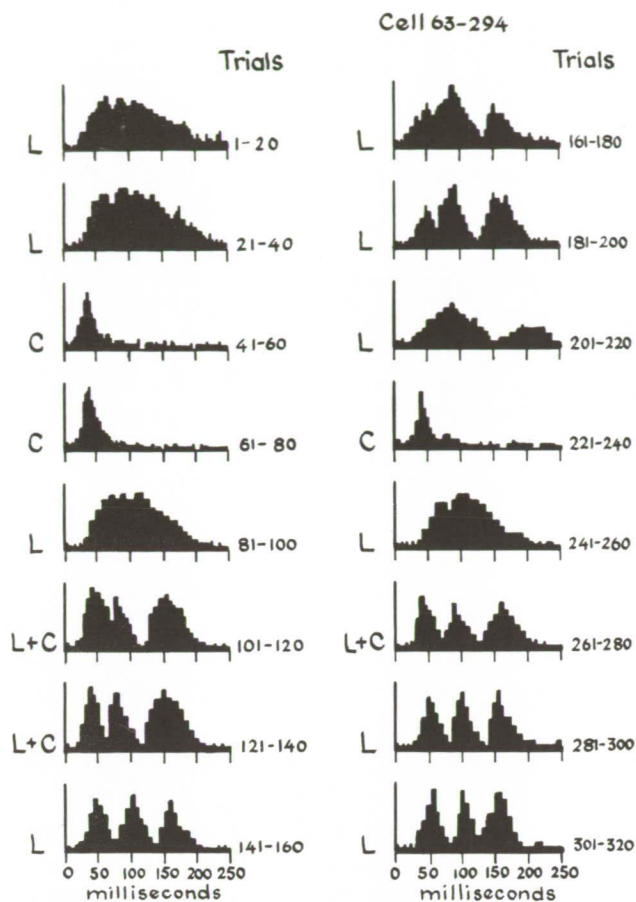

Figure 22. Altered response of a single unit in the peristriate cortex of a cat encoding its recent history of pairing of stimuli. PST histograms for successive blocks of 20 trials. L = light flash stimuli; C = click train stimulus. [Morrell, 1967]

light alone and click alone give quite different, unimodal PST histograms. When the stimuli were paired, a third type of histogram was obtained, different from either of the unpaired types. Furthermore, after 40 paired-stimulus trials, the trimodal histogram was now elicited by light alone (but not by click alone, as in other experiments). Continued stimulation by light alone resulted in the gradual deterioration of the trimodal character of the histogram and consequent reversion to the original light-only unimodal histogram. This extinction was not interfered with during the interposition of 20 click stimuli, after which 20 light stimuli gave the original light histogram. Another 20 trials of paired

stimuli gave the original light histogram. Still another 20 trials of paired stimuli reestablished the trimodal histogram, which once again was elicited by light alone. It must be emphasized that the poststimulus temporal pattern of impulses varied from trial to trial and that it is impossible to infer even the gross features of the 20-trial PST histogram from the impulse pattern in a single trial.

In a variation of this experiment, the two classes of stimuli consisted of stimulation of left and right eyes separately. Cells were found that responded to stimulation in one eye (the left) but not the other. Paired stimuli—to both eyes simultaneously—produced a histogram that was different from that produced by the left-eye-only stimulus and that was subsequently elicited by a left-eye stimulus alone. Stimulating the right eye continued to produce no response (negligibly few poststimulus impulses). This represents an example of a stimulus that itself is ineffective (for the cell under observation) yet carries significant information because it drastically modifies the response to a different stimulus when paired with the latter.

Another example of the anatomical complexity underlying these responses and the corresponding coding schemes was given by Morrell (WS). In studies with K.L. Chow in his laboratory, cortical cells were found that responded to a visual stimulus with a very short (monosynaptic) latency following the response of a geniculate cell. Electrical stimulation of that site in the cortex produced an antidromic response in the geniculate cell, showing that they were probably pre- and postsynaptic cells. Left-eye stimulation produced a response in the geniculate and also in the cortex, but stimulation of the right eye produced a response in the cortex only. Pairing the stimuli caused different responses in both areas. The cortical response pattern was not merely a reflection of that in the geniculate, but was more complex and of longer duration. However, it did not begin much later than the primary response and certainly was not delayed until after the geniculate response had run its course. The altered response was extinguished concurrently in both cells under unpaired stimulation. It seems clear that the information in these experiments is represented by a spatiotemporal code that must involve several simultaneously operating but not redundant pathways. Neither the encoding scheme nor the method of interpretation has been worked out.

Another example of data suggesting coding along multiple channels is contained in experimental results obtained in the cochlear nucleus by Kiang. These results reported by Kiang (WS) also give indirect evidence of coding mechanisms more complicated than impulses in

discrete channels. If threshold is defined as the intensity at which there is a specified change in rate, then all auditory nerve fibers "tuned" to a particular frequency exhibit thresholds within a narrow range of about 20 db. The dynamic range in the rates of discharges of these neurons is only about 20 or 30 db for tones at the characteristic frequency. The psychophysical function for loudness, however, is a power function with a dynamic range of 120 to 140 db. It is difficult to ascribe the mechanism of coding for stimulus intensity as used by the behaving organism to one employing only individual elements with similar thresholds and small dynamic range. Some form of integration across fibers for more than mere rates of discharge must be a part of the mechanism, but Kiang was at a loss to offer an explanation. Harmon referred to Van Bergeijk (1961) who provided a solution to the extension of dynamic range in an analog model of the cochlea and made an experimental prediction later tested and verified by Nomoto et al. (1964); see also Harmon and Lewis (1966).

It was suggested at the Work Session that such special mechanisms as biasing through efferent discharges might account for the psychophysical threshold function. Another suggestion was that an increase in synchronization of impulses among fibers might serve to encode intensity. In order to establish whether or not such interchannel coherence exists, it would be necessary to record simultaneously from two or more auditory fibers under a variety of combinations of tone frequency and intensity.

A final example giving indirect evidence for a multiple-channel code was described by Mountcastle (WS), involving stimulation of the skin with sinusoidally varying mechanical depression. In psychophysical experiments, the subjective estimation of intensity is clearly linearly related—in fact proportional—to the actual applied intensity (measured as inward skin displacement). In the first-order cutaneous sensory fibers whose frequency sensitivity and size are compatible with their being the responsible units, the impulses become phase-locked to the signal very low in the dynamic range (at about 10 to 12 μ displacement), a situation rather analogous to that of the auditory fibers described by Kiang. Recruitment is ruled out because there is only a narrow range of threshold. It is possible to approximate the psychophysical curve by a spatial integration of afferent fibers over the affected field around the stimulus—that is, by the grand total of impulses in a given period of time in the affected area of skin. This implies that the psychophysical relation is attributable to the first-order elements and to a linear translation of the integrated spike frequency for a population (but see Stein, p. 245).

Who Reads Ensemble Codes?

In the preceding chapter, the question of the identity of critical decision-making units in the nervous system was raised in connection with labeled-line codes (p. 240). The question now arises more crucially, as it applies to codes employing many channels. Are there single "pontifical" neurons or other kinds of defined units (e.g., deterministic circuits with sharp thresholds) that make crucial either/or decisions, just like those at low levels, e.g., neuromuscular junctions or motoneurons, but at higher and higher levels, like Mauthner's cells or the complex property-detecting units in the frog optic tectum (Maturana et al., 1960)? What is the upper limit? Or can such cells function in the final recognition of familiar sensory patterns (letters, faces, voices) and selection among motor actions (jump, speak, stay)?

An alternative is not usually made clear, but the popular answer is that such decisions are made by populations of neurons. On this point there was a marked and persistent divergence of opinion among the Work Session participants. Harmon asked, is there a Ted-Bullock-recognizer neuron? He felt certain that there is no single cell that lights up for the letter E. One principal objection to the critical importance of single cells is that accidental loss of or injury to the cell would be catastrophic to function. Some pointed out the striking recovery of animals from ablation operations and of humans recovering the ability to speak after suffering a lesion that caused aphasia. These facts, however, argue for the existence of residual capacities and do not necessarily speak to the issue or argue for a normally diffused decision process.

Other participants, including Bullock (1961b), felt that no limit can be set, at least on the dimension that makes important conscious decisions "high," to the upper level that single-unit thresholds may be responsible for. Some other functional ground may distinguish some decisions that could well rest on a unit (or a smaller or larger number of equivalent, equipotent units) from other decisions that depend in some sense on a population. Although at first impression this difference may appear to have no operational significance, the question is in fact extremely relevant to the search for neural codes. In what sense can a population be invoked to make a recognition or decision? In what way does the appeal to a population answer the argument from tolerance of lesions? Is the implausibility of decision units or pools of them based on the impression of unreliable, probabilistic behavior of higher brain units?

This question of "Who reads ensemble codes?" is one of the main unsettled issues of neural coding (Bullock, 1961a). Although the evidence is uneven for the various alternative solutions, we are persuaded of a pluralistic answer: At different locations in nervous systems, different ensemble codes are interpreted by different kinds of competent functional units of organized neural tissue. Four of the principal possibilities are sketched here.

1. The "pontifical" decision-making neuron is the first possibility and the only one directly demonstrated; several cases are known, e.g., Mauthner's and other giant cells and "command" cells in lower animals. Interpretation of incoming information along many pathways is the ordinary sort of neuronal integration, and the decision is registered by means of abrupt change in level of firing, triggered by the appropriate spatiotemporal configuration of synaptic input, perhaps under the additional influence of nonimpulse input. The neuron as now understood (Bullock, 1959) is fully capable of reliable decision-making and the complexity or sophistication of the decision can rest on sequential, hierarchically arranged converging units. A variant of this possibility, answering the objection of vulnerability of function to damage of a single cell, is that of a number of equivalent, redundant, decision-making neurons, perhaps anatomically separated, any of which, or the promptest of which, can trigger the response that registers the decision.

2. Another possibility, arising in final motor mechanisms, is that the "decision" is not made by neurons at all, but by the muscles and joints themselves. For example, efferent volleys to both agonist and antagonist muscles might be effectively continuously graded in intensity and the final comparison of the two would be accomplished mechanically, with the limb moving in one direction or the other according to the balance between the opposing neural signals.

3. The third possibility is that of a relatively large population of neurons acting as a unit. Beurle (1956, 1962) has treated this case theoretically. Bennett points out the resemblance to this of the pool of pacemaker cells that control electric organ discharge in the brain stem of gymnotid electric fish. Such a population of cells need not be anatomically contiguous and might be organized through rather unspecified quasi-random connections among the neurons or through highly specified connections, including feedbacks, to form a multistable network. It has been shown by Beurle and MacKay (see Bullock, 1961a) that masses of neurons, of either the relatively organized or unorganized type, can carry out the decision-making functions much as the single neuron can, and yet

with a "redundancy of potential command" so that no one neuron is crucial to the operation of the unit. The specificity of input and output connections and the need for sequential, hierarchical subgoal decisions are the same as for the first possibility.

4. The fourth possibility is somewhat of a mixture of the first and third: many parallel pathways, with some convergence but no ultimate funneling to a single unit, connect sensory to motor systems, with decision-making occurring as usual at many stages but primarily at the narrowest part of the funnel, yet with no point being identifiable as the locus of the decision. This fits current concepts of locomotor and similar events but seems unsatisfactory for recognition of faces, either/or commands, and the like.

These four possibilities are not, of course, exhaustive. It is essential to the satisfactory understanding of central coding and decision-making to establish experimentally which of such possibilities is in fact operative in a particular mode of performance.

IV. THE REPRESENTATION OF INFORMATION IN NONIMPULSE CARRIERS

The nerve impulse as a carrier of information has been investigated extensively in the periphery—in sensory and in effector systems—and is also a conspicuous and widely recorded feature of electrical records from the central nervous system in invertebrates as well as vertebrates. However, as we have seen in the preceding chapters, the role of impulses in the central nervous system in representing and transforming information has seldom been established and is nowhere investigated to a satisfactory degree of completeness. Moreover, several kinds of evidence, although somewhat indirect, point strongly to the importance of other, nonimpulse vehicles for carrying information in the brain according to their corresponding coding schemes; the importance of such nonimpulse codes may well surpass that of the “classical” nerve impulse.

The proposed nonimpulse vehicles are both electrical and chemical and include nonneuronal as well as neuronal elements. At the subcellular level, the potentially information-bearing neuronal electrical signals are perhaps the best known (Figure 23). They include dendritic potentials,

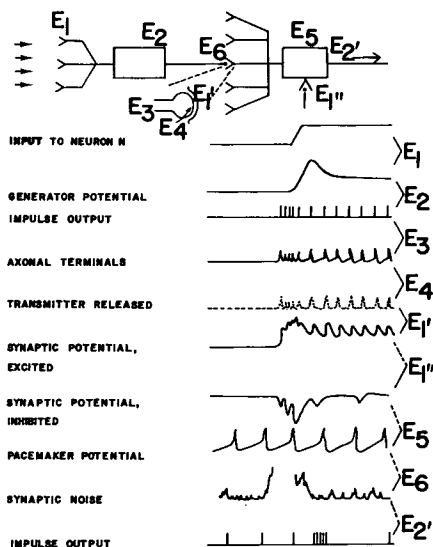

Figure 23. Diagrammatic sequence of processes within neurons, each process representing the integration of information up to that point. The coupling functions between successive events are symbolized by the letter E to emphasize that they are distinct excitabilities. The dashed lines in front of E_1'' , E_5 , E_6 and E_2' mean that these E's do not connect the immediately preceding and following events but integrate factors not shown or shown earlier. [Bullock, 1968]

both those originating subsynaptically and "spontaneously;" receptor, generator, and pacemaker potentials; and the related kinds of interactions within the nerve cell that have been recognized since the "quiet revolution" in the neuron doctrine (Bullock, 1959). Intracellular chemical and related processes have not been so well established as bearers of information (at least on a short time scale comparable with electrical effects and with synaptic transmission); an example is axoplasmic transport of materials, which was the subject of a recent NRP Work Session (Barondes, 1967). Intercellular effects that bear information are largely tied to impulses, e.g., chemical effects such as release of synaptic transmitter, neurosecretions, and influence of potassium ion on neighboring cells in closely packed tissue, and to such electrical effects as electrotonic coupling, ephaptic effects, and the modification of the conduction velocity in a nerve fiber by an impulse in an adjacent fiber. Dendro-dendritic influences between neurons, both synaptic and nonsynaptic, have been proposed; virtually nothing has been established about coding schemes in such pathways that might well be nonimpulsive in nature. Finally, there are the relatively large-scale, ensemble effects, electrical in nature, that encompass the continuous electrical signals known variously as extracellular slow potentials, evoked potentials (in experiments involving stimulation), and EEG waves. As discussed in the following paragraphs, the precise role of the ensemble effects in information processing is not yet established.

It has been argued that subcellular processes do not constitute examples of neural codes. One reply to this is that the question is of an empirical nature. It may be true, on the one hand, that the various chemical and electrical phenomena that take place inside the cell (and that convey information to the physiologist) are entirely ancillary to the production of impulses and are not made use of by the nervous system except as they are translated into impulse trains. Then the subcellular processes may, if convenient, be subsumed under the rubric of "impulse-production mechanisms," important in their own right, but relevant to the question of intercellular coding only as a set of input-output rules for the neuron. On the other hand, it may be established in some systems that the play of electrical activity on the neuronal membrane or chemical activity in the cytoplasm or on the membrane is sufficiently determinative to be an essential influence on impulse production, in which case, for a satisfactory description of information-handling the rules for impulse transformation must be supplemented with those of intracellular integrative mechanisms; i.e., subcellular neural coding is an important part of the

picture. That is, perhaps information processing is largely intracellular and continuous, whereas information transmission is intercellular and discrete (pulse coded). We hasten to add that these two cases are not dichotomous; while intracellular coding need not be considered in a McCulloch-Pitts conceptual neuron, and probably must be in a Purkinje cell of the cerebellar cortex, the question in some intermediate cases may certainly be determined by context and convenience.

The same problem arises in a less academic manner when one considers information processing in large aggregates of neural tissue. A considerable controversy has been simmering for some time as to the effective role of extracellularly observed slow waves and the electroencephalographic signals in general. There is no question that they are useful clues to the investigator of the nervous system and especially to the clinician. However, as we have reiterated to the point of tedium, it does not follow automatically that information for the physiologist is information for the organism; the question, "Are brain waves signals for the brain itself?" remains to be answered in a reasonably conclusive and comprehensive manner.

Two levels of questions must be considered in this regard, to be answered perhaps through two separate kinds of experiments. The first concerns the causal relationship between EEG and neuronal or sub-neuronal electrical potentials. How, where, by what mechanisms, and under what circumstances are EEG and evoked signals related to nerve impulses? To dendritic and other potentials? Do the neurons generate the EEG exclusively? Or does the EEG markedly influence the production of impulses, either through modulation of dendritic potentials or more directly? In other words, is the EEG merely a by-product of other activity, an epiphenomenon that can safely be ignored or used only where convenient in describing brain functioning?

If this question is answered in the negative, i.e., if the EEG plays a functional role and is not a mere reflection of underlying neuronal activity, the second set of questions then presents itself. What is the functional role of EEG and evoked waves in information handling in the brain or in relation to the impulse traffic? Are pattern recognition, discrimination, storage and recall of information, learning, consciousness, control of complex behavior, and the like mediated primarily through waves or through impulses? Or through both? If there is a mutually causal relationship between waves and impulses, there may be no logically compelling choice as to the primacy of one or the other; from the point of view of the egg, the chicken is a mere device for perpetuating the

production of eggs. From the point of view of the biologist, however, transcending the viewpoints of both chicken and egg, the choice is clear, despite the indispensability of both. The suggestion has been made—and must be entertained seriously—that it is the impulses that are best regarded as the epiphenomena (at least in some parts of the central nervous system) and that only through understanding the properties and interactions of the electrical waves with the anatomical substrate will we arrive at a satisfactory understanding of the higher behavioral and mental processes.

Unfortunately, answers to the first set of questions to date have been incomplete, fragmentary, and often seemingly contradictory. Some of the evidence for and against causal relationships between EEG and impulses or dendritic activity, brought up in the Work Session, is discussed in this chapter. Opinions were expressed concerning the second set of questions. Mountcastle, for example, asked for a clear statement of the thesis that slow-wave events recorded in a population of cells might be signaling agents in the nervous system independently of direct neuronal connections. A clear statement was not forthcoming, although in the ensuing discussion the point that had not yet been covered in the Work Session was made by Adey, i.e., that central transactions are rather different from those at the periphery, or from those in early stages of sensory systems, and that they relate to storage mechanisms. A more detailed discussion of the hypothesis of the efficacy of slow-wave activity in both information transformation and storage in the central nervous system appears in a recent book by John (1967), but the formal coding aspects of waves are not, however, covered explicitly.

In the remainder of this chapter, we discuss first some subcellular mechanisms effecting or affecting neural coding, then some nonimpulse intercellular candidate codes, and finally the relationship between EEG and impulses or dendritic activity, and some implications of these relationships to the possible role of the EEG in information transactions in the brain.

Subcellular Nonimpulse Codes

The principal candidate codes operating in the subcellular domain are enumerated and described in the Appendix. Little need be said to elaborate and comment on them; we summarize here some of the discussion at the Work Session concerning receptors and dendritic activity that is germane to their role in the representation and transformation of information.

Fuortes compared the properties of responses of visual cells in *Limulus* and in the bee. The eccentric cell in the eye of *Limulus* has a long axon and produces spikes following illumination. In the bee (as in many other insects) photoreceptor cells are less than 1 mm long and usually do not produce spikes. Apparently the generator potential itself is the signal that activates the synaptic endings in these cells. Evidence supporting this view has been obtained by Baumann (1968). He found that the peak height of a visual-cell response in the bee is about 45 mv when recorded from the outer segment and is still about 30 mv when recorded from the vicinity of the synaptic ending. This shows that the decrement due to passive spread is not large, so that an adequate electrical signal can reach the synaptic terminals of these cells even in the absence of spikes. Both in *Limulus* and in the bee, the steady-state response plotted as a function of the logarithm of light intensity gives a straight line over a considerable range. In *Limulus*, the relation between magnitude of the generator potential and frequency of firing is approximately linear in the steady state. In both animals, the nonlinearities responsible for the logarithmic relation arise only after some delay, with response approximately proportional to light intensity at the outset. One suggested interpretation of this effect is that the nonlinearity is brought about not by the light itself but the end product of a chain of processes, for instance, by a chemical substance formed as a consequence of a succession of chemical reactions initiated by light. According to this view, the features of visual cells are comparable to those of systems equipped with an automatic gain control. Systems of this type reproduce satisfactorily the early peak and lower steady state of the generator potentials found in many receptors. Similar responses have been seen in stretch receptors, which might be attributable there to visco-elastic effects rather than to the receptor membrane (Kennedy, WS). Such accommodation effects are found in a wide variety of receptors, and they affect the representation of sensory information at subsequent stages in processing.

Another linear but apparently unusual junctional coding scheme was reported by Bennett. The weakly electric fresh-water fish have electroreceptors distributed over the skin, visible as pigment-free spots. Some of these receptors can be classed as tonic. Morphologically, a hole in the skin leads to a long channel ending in an ampulla in whose wall receptor cells are embedded. Electric potential across the skin, which is the effective stimulus or referent, is probably represented with little loss across the presynaptic face of the receptor cell. There is good evidence that transmission from the receptor to the innervating nerve fiber is

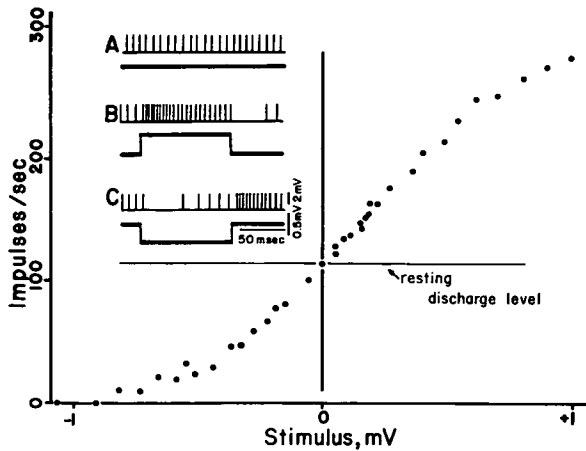

Figure 24. Linear input-output relation at a chemically transmitting synapse suggesting continuous transmitter release. Data from a tonic electroreceptor of *Gymnotus carapo*.

Inset: Upper trace, recording from the afferent fiber; lower trace, stimulating potential at the receptor opening. (A) Tonic discharge. (B) Response to a weak anodal stimulus. (C) Response to a weak cathodal stimulus.

Graph: Average impulse frequency during a stimulus of about 100 msec duration is plotted against stimulating voltage, anodal stimuli to the right and cathodal stimuli to the left. The frequency of resting discharge is indicated. [Bennett, 1968a]

chemically mediated. Apparently the transmitter is released continually, and its rate is either accelerated or retarded by appropriate stimulation. This is illustrated in Figure 24 where a small anodal stimulus is seen to cause a burst of impulses and a cathodal stimulus to slow the firing rate. The input-output curve is fairly linear at about zero voltage. This relation is of a different form from that occurring at most ordinary synapses. For example, at the neuromuscular junction or the squid giant synapse, transmitter release does not begin until there is considerable presynaptic depolarization, after which it rises very rapidly (Katz and Miledi, 1967a,b). A similar linear input-output relation might be of more widespread occurrence. It might be operative in the reciprocal (type 69) synapse found by Rall et al. (1966) in the olfactory bulb and by Dowling and Boycott (1965) in the retina. In these systems with two synapses side by side there is no need for an intermediate stage of spike encoding and the input-output relation need not be like that at synapses where the input is a presynaptic spike.

Rall has pointed out several properties of dendritic potentials that greatly affect their coding schemes. When synaptic activity occurs in dendritic terminals, the synaptic potentials have a relative slow time course, setting a limit on the frequencies that can be preserved, affecting

the interpretation of transmitted impulses, and, further, leading to a difference between synapses far out on the dendrites and those on the cell body. Dendritic synaptic activity produces a bias at the cell body. If it is of sufficient strength, a rhythmic firing is set up, as with a generator potential and in the simulations described above by Segundo (WS); the rhythmic firing can of course be modulated by somatic inputs. A weaker bias produced by dendritic activity brings the cell close to the firing level and makes the cell more susceptible to temporal patterns in the somatic input (Rall, 1959, 1964).

Dendritic potentials are recorded in the soma with lower amplitudes than occur in the dendrites themselves because of electrotonic conduction. Nonlinear effects can be significant in the dendrites even though the somatic voltages are at moderate levels (Rall, 1967).

Spatiotemporal patterns can be easily distinguished because an input first to the dendrite and then to the soma will give a waveform of potential at the soma different from that which appears when input is made first to the soma and then to the dendrite (Rall, 1964, 1965). Such spatiotemporal discrimination could contribute to the task of decoding an ensemble code.

Rall has also discussed the possibility of active membrane in some dendrites (including Purkinje cells, according to Llinás), although in motoneurons the evidence points to passive dendritic membrane. In "active" membrane the conductances are voltage dependent, giving rise to "local responses." In active dendritic trees, synaptic inputs at different branches might set up "fizzling" impulses that die out at branch points unless reinforced by well-timed impulses from other branches. The result would be very complicated logical properties of spatiotemporal patterning (Lorente de Nó and Condouris, 1959; Arshavskii et al., 1965). There is no direct evidence of this at present, but neither can the possibility be dismissed.

A significant insight is Lewis's demonstration that "electrically excitable" and "electrically inexcitable" properties of cell membranes are but two places on a continuum of membrane constants.

Another mode of representation of information within the nerve cell is the probability distribution of membrane potential in time. Some examples were shown by Adey. The intracellular distributions were always skewed (see Figure 25). Suggestions have been made as to how membrane-potential distributions can be used for information storage in nervous systems (Levitan et al., 1968).

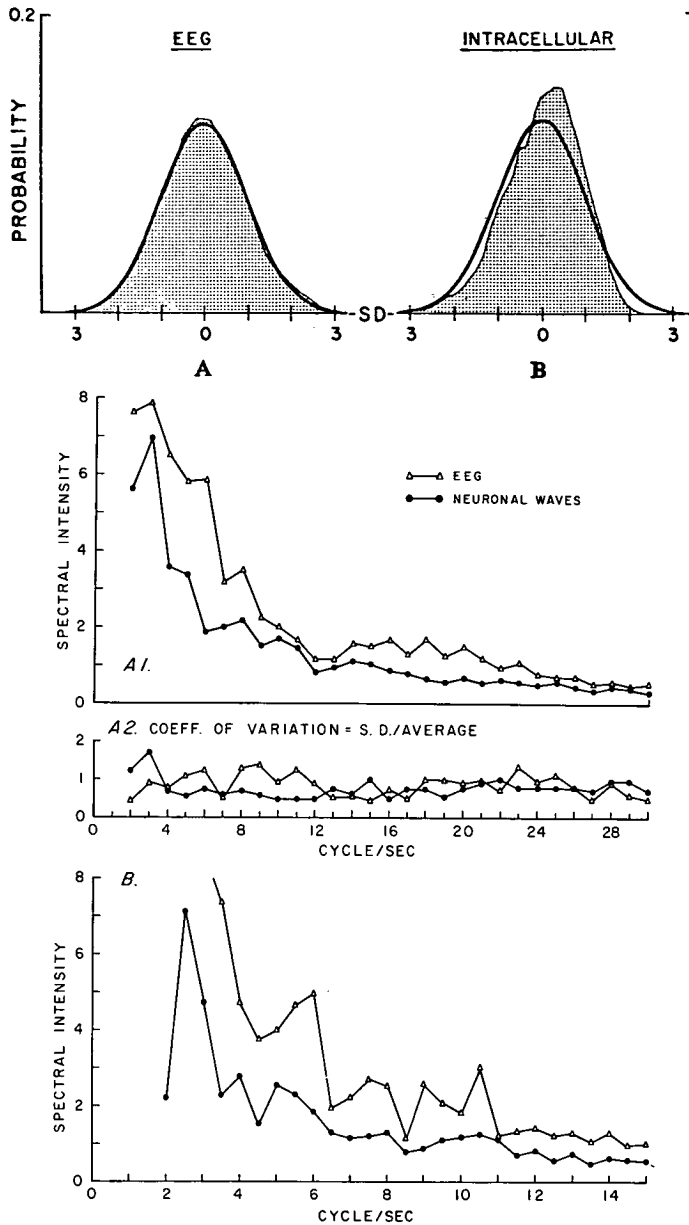

Figure 25. Intracellular and population forms of slow-wave activity.

Upper: Amplitude probability distributions of cortical EEG (A) and of neuronal wave activity (B) over the same period in same preparation. Histograms were computed for a 16-sec epoch at 400 sample/sec. Normal distributions with corresponding standard deviations are superimposed as a solid line. Note the striking similarity to the experimental plot of the EEG. The distribution of the neuronal waves (B), on the other hand, is clearly asymmetrical and deviates from the normal probability curve.

Lower: Power spectra of the EEG and of neuronal intracellular activity. The same data are computed again in (B) at higher resolution so as to cover the 0 to 15 Hz band containing most of the waves in both records. Plots are averages of consecutive analyses of 10 sec, each over a total period of 150 sec. Coefficients of variation of both EEG and neuronal waves are included in A2. [Elul, 1968]

Nonimpulse Codes Between Neurons

In addition to ordinary synaptic transmission, neurons can communicate through electrotonic coupling, release of potassium ion, and several other effects. Again, we confine our attention to certain modes; others are covered in the Appendix.

Rall (WS) recalled evidence for dendrodendritic synapses and their possible functions. Graded amounts of depolarization could produce graded amounts of inhibition, serving as part of a negative feedback loop in the olfactory bulb, where these studies were done (Rall et al., 1966; Reese, 1966; Rall and Shepherd, 1968). It was pointed out that this system for recurrent inhibition could contribute to the adaptive inhibition and the lateral inhibition in this sensory pathway; this would obviously contribute to the information processing in this sensory system.

A common observation in electric organ control systems is that cells that fire synchronously are electrotonically coupled (Bennett, WS). The significance of electrotonic coupling is that it causes the cells to fire synchronously and in a sense mediates rapid positive feedback between them. When, in the presence of a tonic input, a group of cells "decides" to initiate an effector act, reciprocal excitation between them is required. At neural levels below the decision nucleus, feedback between cells is not obviously necessary but presumably serves to increase or maintain synchrony. In most of the systems studied, it appears that the speed of electrotonic transmission is required. Reciprocal excitatory synapses that transmit chemically would not be able to mediate the observed degree of synchronization because of the delay associated with chemically mediated transmission.

The simplest effector system of the electric organ control systems is that of the electric catfish. Two neurons, one on either side of the first spinal segment, innervate the entire electric organ, each on its respective side. They are very large neurons and are electrotonically coupled. Electric current spreads between the cells by way of the presynaptic fibers that end on each of them, and there do not appear to be direct dendrodendritic connections between the cells. In this case and many others, the ultrastructure has been investigated by George Pappas and his collaborators, and they have found tight junctions between the coupled neurons. One has the strong suspicion that, where there are tight junctions, cells are electrotonically coupled (see Bennett et al., 1967).

Bennett has also found electrotonic coupling between the neurons controlling several muscle systems where contraction is synchronous; for

example, in sonic muscles of teleosts that act synchronously at high frequencies and in one rapid locomotor system. Bennett and his colleagues are now looking at the oculomotor system of several species of fish, and find there is electrotonic coupling between some of the oculomotor neurons. The physiological significance of the coupling has not been demonstrated, but it is reasonable to suggest that it is involved in the synchronization of neural activity leading to rapid eye movements.

If an organism requires cells to act together, electrical means of coupling might be superior to chemical means, even if the required degree of synchrony is low. This consideration should apply to mammalian systems as well as others, although no systems of this type have yet been adequately studied. We know now of several instances in mammals where electrotonic transmission apparently occurs. Tight junctions are found in the periphery of the primate retina (Dowling and Boycott, 1965), and there is evidence that coupling is not here related to synchronization but that it mediates recurrent inhibition as well as centripetal excitation (Ogden, 1966). In the vestibular system, the chalice endings show tight junctions between the receptor cells and the primary afferent fibers (Spoendlin, 1966). The occurrence of electrical transmission at these synapses appears to be required by the geometry (Bennett, 1964). Palay has reported lateral vestibular cells showing tight junctions (personal communication), and the cell bodies of some trigeminal muscle afferents have tight junctions between them (Hinrichsen and Larramendi, 1968). In none of these cases does there appear to be synchronous discharge like that in the effector systems we have studied. These examples do suggest that electrical transmission can mediate most kinds of neural interaction, a conclusion that also followed from some of the studies on synchronized systems (Bennett, 1968a).

Glial as well as neural cells might serve as nonimpulse communication pathways. Mountcastle (WS) brought up the example of a large astrocyte that embraces a large number of neurons. If it is depolarized by potassium ion at one of its processes, the depolarization would be transmitted electrotonically, probably affecting the excitability of other neurons surrounding the astrocyte. He suggested an experimental test of this idea. In the nerve of *Necturus* studied by Kuffler (1967) displaying potassium-mediated glial depolarization, it might be possible to block impulse transmission pharmacologically at some place along the nerve, leaving intact the electrotonically mediated glial depolarization, and seeing if the excitability of neurons at the next junction might be affected.

Adey stressed the importance of local, extracellular concentrations of potassium ion in altering spike-potential configurations as well as the concomitant afterpotentials. He suggested that potassium-ion concentration is relevant to the changing state of the tissue as induced by experience and that the effect on protein synthesis of excess potassium ion might lead to a long-term change in membrane structure, ultimately affecting the transmission of information. Such changes might act not only on glial cells but also on neuronal membranes themselves.

Wilson mentioned the long-known effect of nerve impulses on the conduction velocity in an adjacent axon. Such changes in conduction velocities have been proposed (MacKay, 1962) as useful candidates for information storage and modification in self-organizing networks; in principle, velocity changes could convey, modify, or store information in neural networks also (MacKay, 1954). No detailed hypothesis has been proposed for a neural exploitation of such a mechanism.

Barlow pointed out that information transfer of an important kind is taking place in the so-called trophic effects of nerves upon muscle, skin, and other neurons. The presence of nerves and the kind of nerve tells the postjunctional cell how to grow or to maintain itself or its sensitivity.

Slow Waves

The class of phenomena that can be said to carry information because they correlate with states of the organism or with external stimuli of behavioral significance is wide. Here we deal with the subclass of compound potentials in the brain, other than spikes. Typically we have no idea whether the observed variable is at all close to causal and hence to a code used by the nervous system. However, Adey, Bullock, and a few other authors find the causal possibility not only cannot be excluded but is a not unreasonable assumption and is at least heuristic. Harmon, on the other hand, regards the study of brain waves as equivalent to holding an oscilloscope probe 6 feet in diameter up to a computer and pronouncing from the resultant waveform on the underlying structure and function.

Almost since the discovery of the low-voltage, low-frequency signals observable at the scalp, on the surface of the brain, and within brain tissue, their role in brain functioning has been largely enigmatic. It is the current generally accepted belief that the on-going (i.e., not stimulus-bound) EEG signals do not represent simply the summed effect of nerve impulses in a large population but may also represent the resultant of graded, "slow" (meaning chiefly 0.1 to 100 cycles per second) dendritic potentials.

Greater success has been achieved in understanding the origin of that class of slow waves which are stimulus-bound, called evoked potentials (Brazier, 1967; Katzman, 1964). Detailed calculations of the electrical activity in time and space in the olfactory bulb by Rall and Shepherd (1968) have shown how certain experimentally recorded field potentials could arise from antidromic activation of the mitral cell population, followed by dendrodendritic synaptic excitation of the granule cell population.

Much effort has been expended on attempts to relate the ongoing EEG (not referred to specific times of stimulation) with nerve impulses and other facets of individual neuron activity. Those presented at the Work Session are summarized below together with some other examples considered relevant to the coding problem.

Adey discussed the relationship between intracellular slow processes and the EEG. In some instances the correlation between the two is suggestive; both "speed up" (show higher-frequency components), for example, during sleep as compared with the waking records. Spectral analysis shows that the intracellular waves and the EEG have the same general contour of frequency spectrum. It must not be concluded from this, however, that the two are related in a simple, linear way. Coherence calculations, which measure the extent of linear predictability between the two records as a function of ongoing time, show patches of significant coherence (Figure 26); but these are no greater in extent, over the entire frequency-time domain, than would be expected by chance. This has led Elul (1968) in Adey's laboratory to the conclusion that the population of cells which are the postulated generators whose activity is sampled by the two types of electrodes may be in great measure independent of each other. That is, the EEG is the sum of many units whose activity is independent, not synchronized as in the usual view. In these examples, the EEG is recorded on the suprasylvian cortex within a millimeter of the intracellular recording. The extracellular slow waves within the cortex also fail to display a linear relation with the intracellular records.

Gersch presented preliminary data that showed that in an 8-sec period, no linear coherence was found between EEG and intracellular slow waves; on the other hand, 1-sec segments of that record sometimes showed apparent coherence at least at some frequencies. This suggests that the linear relationship—and hence perhaps the causal relationship—between the two might be fleeting or that the significant loci of the relationships might shift about fairly rapidly in the tissue.

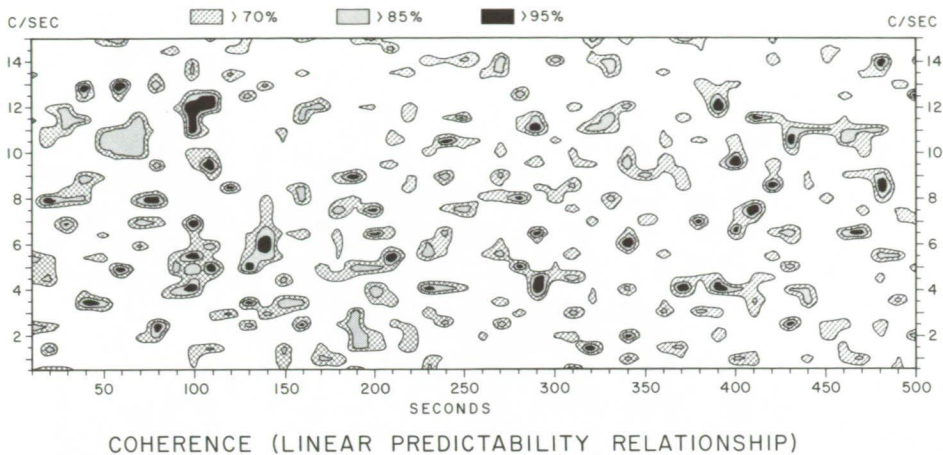
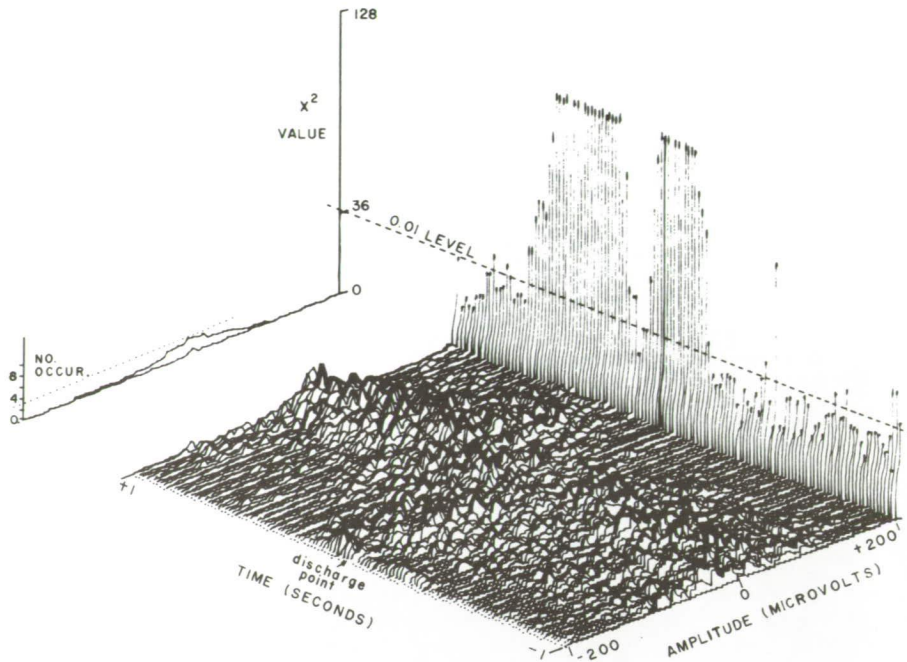

Figure 26. Coherence (linear predictability) between EEG and neuronal waves computed over a 500-sec continuous epoch. Each 10-sec epoch involves 30 separate measurements corresponding to each 0.5 Hz, and coherence at the 95% confidence level should therefore naturally occur 1.5 times in each 10-sec epoch so that even when the common frequency bands extend over 1 Hz (for example at 40, 60, 130 sec) or even over 2 Hz (at 290 sec) a chance occurrence cannot be excluded with confidence. When, however, high coherence level is found in the same frequency band over two adjacent 10-sec epochs, a chance occurrence becomes far less likely, and the probability of the coherence at the 100- to 120-sec period and at 11.5 to 12.5 Hz occurring by chance is $< 0.16\%$. [Elul, 1968]

Adey pointed out that cortical neurons may appear to show no fixed firing threshold with intracellular recording electrode in the soma. One possible explanation is that the microelectrode records local disturbances at a site removed from the impulse-triggering point; another explanation postulates multiple trigger points with different thresholds. Adey concludes that the wave processes and the spikes may be separate transforms of information; if not strictly independent they are at least not linearly related.

In contrast to the impression given by Adey, reports like that of Fox and Norman (1968) indicate very high functional congruence between unit spikes and slow waves in the ongoing, unanesthetized EEG. Extremely high correlations occur (from -0.98 to $+0.80$) between spike probability and amplitude of microelectrode-recorded EEG, with 90% of the cells studied showing significant correlation. But the degree of congruence varies, and some cells as well as some physiological states show much more rigidity than others. Such results are in agreement with those



A

Figure 27A. Three-dimensional selective amplitude histogram, demonstrating the relationship between ongoing EEG (cat) and single-unit spikes recorded from a nearby neuron. The stereogram is composed of 128 amplitude histograms (EEG voltage, probability density) displayed in three dimensions, each histogram representing a sampling time 16 msec later than the previous one. The entire time span is indicated on the longitudinal axis as time of sampling relative to the single-unit discharge point. The transverse axis is EEG voltage for each histogram, while the elevation indicates the number of occurrences of a particular voltage (probability density). Any point on the figure thus specified the frequency of occurrence of a particular EEG voltage at a particular point in time

of Frost, Morrell, Creutzfeldt, and others, and with similar studies on evoked potentials and spikes, as we shall see (Frost, 1967a,b; Frost, 1968; Frost and Elazar, 1968; Frost and Gol, 1966; Frost et al., 1966; Frost and Low, 1967).

Frost discussed the statistical sampling problem in determining relationships between EEG and single-unit activity and presented amplitude histograms of the EEG as a function of the time before and after single-unit impulses (Figure 27). He found that a typical cell tends to fire near a negative peak in the EEG and that the firing is sometimes followed by a positive EEG deflection. These relationships, however, differ from cell to cell. The statistical significance of the departures of the amplitude

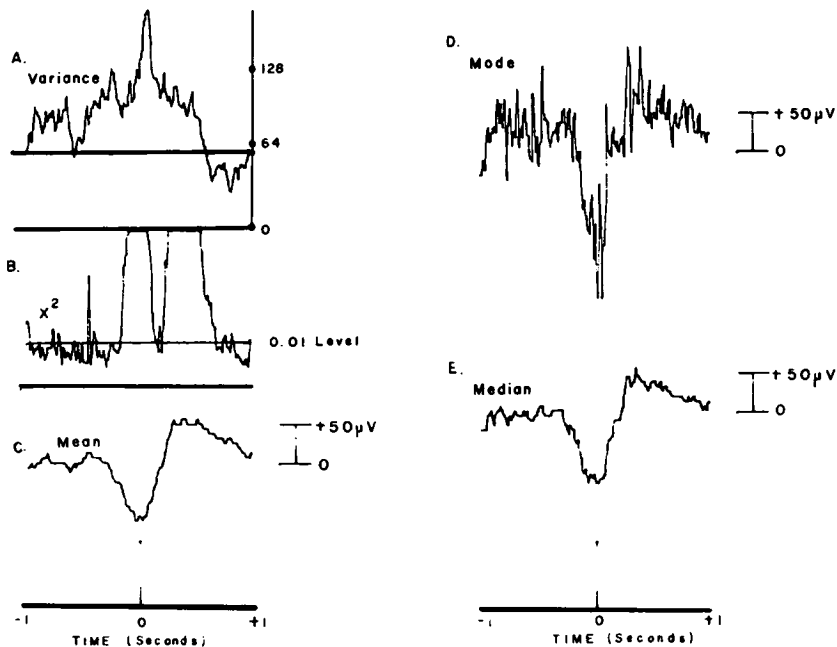

B

before or after neuronal discharge. The single histogram at the far left is a conventional amplitude histogram for a long sample of EEG activity, therefore random with respect to the spikes. Chi-square test for similarity of the random histogram with each selective histogram is shown at upper right. The evidence is strong in this example for a nonrandom relationship between EEG and spikes.

Figure 27B. Derived statistical plots from three-dimensional figure. Time base equivalent to longitudinal axis above. [Frost and Elazar, 1968]

histograms from the population average at each of the 128 time points was measured quantitatively by a chi-square value; these are also plotted in the figure and corroborate the visual impression of systematic departure of the EEG amplitude distribution from the population average at times systematically related to unit discharge.

An inverse approach to the same sort of problem was described by Morrell.* He first scanned the EEG record for specific wave shapes; three were selected, as shown in Figure 28: (A) a positive-negative sequence, (B) a monophasic negative sequence, and (C) a briefer positive-negative-positive sequence. For each shape, the manually separated waveforms were superimposed for a number of trials; the corresponding single-unit

*The same point was made and documented at an earlier Work Session by Creutzfeldt and Fujita (Adey, in press).

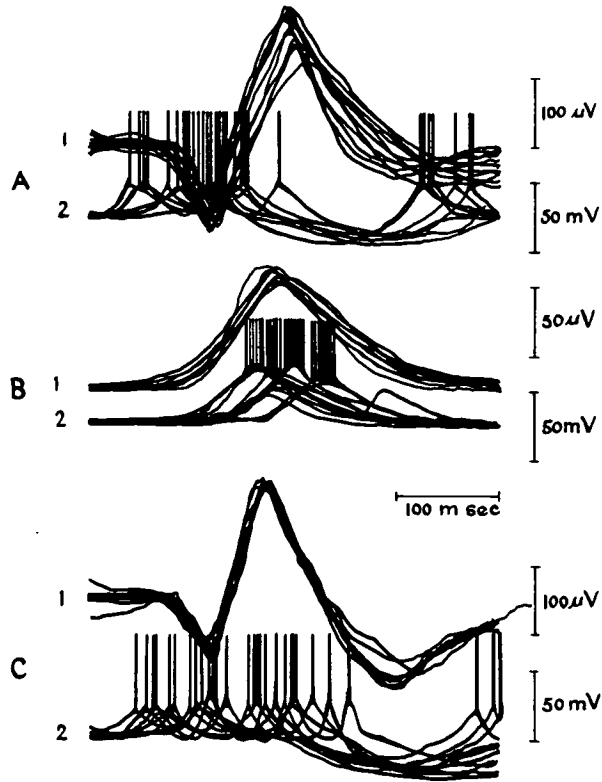

Figure 28. Relation of spikes to EEG waves of three naked-eye classified types. The macroelectrode record was scanned and waves superimposed that had the following illustrated form: (a) positive-negative, (b) monophasic negative, and (c) shorter positive-negative-positive. The corresponding unit records were superimposed accordingly, and there was a strong tendency to avoid certain phases while firing preferentially in other phases. [Morrell, 1967]

recordings were then superimposed. The figure shows clearly that there is a characteristic concentration of impulses for each waveform; e.g., in (A) the spikes are concentrated about the positive phase of the EEG, whereas in (B) they are concentrated about the negative phase. It is clear without recourse to extensive statistical analysis of the entire record that the separate kinds of relationships will obscure each other and perhaps yield no overall relationship whatever. Morrell also mentioned that the slow waves correlate with synaptic potentials so that the type of relationship between slow waves and impulse probability (in stimulated preparations) found by Gerstein (1961) and by Fox and O'Brien (1965) also holds in the absence of spikes.

One possible conclusion from these experiments is that the observed EEG is multiply caused, that different waveforms observed in

the EEG arise from different underlying single-unit events or from small populations. If these separate causal factors are isolated—through isolation of waveform in the EEG, through isolation of the spikes (as in Frost's experiments), or in stimulus events (Gerstein 1961; Gerstein and Kiang, 1964; Fox and O'Brien, 1965)—then the relationships between the two are rendered visible, either directly or through statistical computations. On the other hand, if a mixed spatiotemporal average is made by pooling all data in a given run, these distinctions are lost and may cancel out completely. Gersch said that a simple answer to the question of whether there is a causal relation between cell and population waves is possible. The Fourier transform of both the intracellular-to-gross EEG and the gross EEG-to-intracellular transfer functions would give the impulsive response between these two waves and a clear indication of causality relations between the two.

Even though the question is still unsettled of what the EEG actually is or what its cellular basis is, a great deal can be said about what information it encodes. Many clinical conditions and normal behavioral states are reflected in some aspect of the EEG. Some, like sleep stages, the inattentive waking state versus aroused concentration, petit mal and grand mal convulsions, are classical and useful. The number and range of such behavioral correlations increases with closer study and with additional methods of analysis of the recorded waves (Laursen, 1967).

An example cited by Adey (WS) is the more Gaussian-like form of amplitude histograms occurring in those stages of conditioning when stimuli cause orienting responses than when correct performance is fully established.

Another example is the cross spectral analysis of EEG activity in different parts of the brain (Figure 29), which Adey and Walter (1963) have found to correlate with the performances of correct versus incorrect responses in a conditioned cat, and with stage of learning. The coherence of gross EEG waves among widely separated regions is characteristic of similar behavioral states (Elazar and Adey, 1967a,b).

Definite signs in the EEG have been found to accompany readiness, attention, detection, and expectancy (Laursen, 1967; Sutton et al., 1966).

The large number of correlations between slow multiunit potentials and behaviorally significant states means that the potentials have encoded or represent the information about these states and are therefore candidate codes. But this does not establish that they are actual codes or tell the brain anything, as distinct from simply reflecting its state.

A.
CAT 15

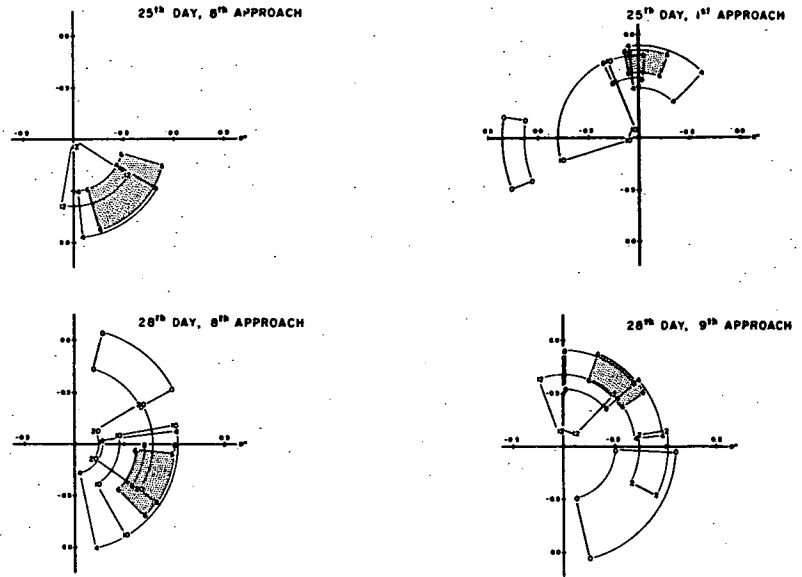

For the EEG or slow wave to be a functional vehicle for information transmission, a causal relationship must exist between unit activity and the EEG in both directions. Only if the EEG can significantly modify unit activity does it rise above the level of an epiphenomenon. What is needed, then, is to show the effects on single-unit impulse activity of slow waves known to be generated separately, and preferably remotely, perhaps through artificial means. Only in this way can interpretation rules be ascertained demonstrating how neurons "read" the wave activity in the surrounding bulk tissue. Some evidence of this type is at hand—Nelson's (1966), for example—to the effect that the field of current around a motoneuron reduces the threshold of an adjacent one. Furshpan and Furukawa (1962) obtained inhibition of the Mauthner cell in fish by passing extracellular current. Other references are given in Terzuolo and Bullock (1956).

Another whole category of slow waves that even more clearly embody information is that of evoked potentials, here meaning compound, multiunit responses, time-locked to a known stimulus. By their form, amplitude, progression, and locus they represent the time, nature, intensity, source, duration, and succession of stimuli and the state of many background factors such as distraction, anesthesia, conditioned

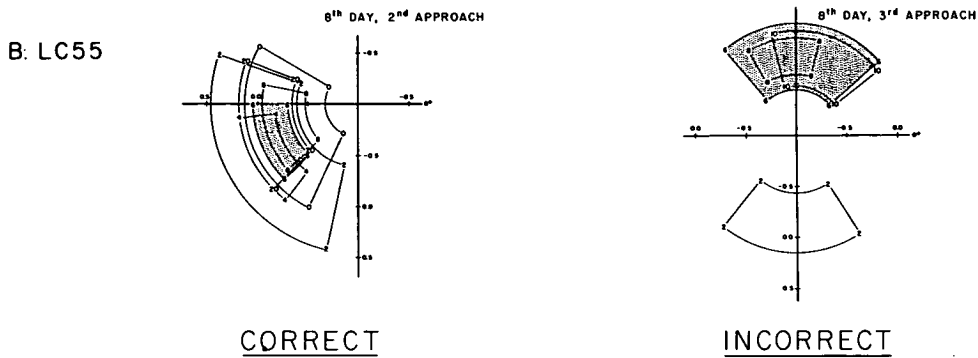

Figure 29. Examples of polar coordinate plots of probability bounds on complex amplitude transfer functions, dorsal hippocampus to entorhinal cortex. Phase angles are depicted on angular coordinates, and transfer functions are shown on radii. Shaded fans enclose 6-Hz portions of spectrum and are maximum energy zones. Note consistency between correct responses and differences from incorrect responses in one animal (left) and similar wide differences between correct and incorrect responses in another animal (right). [Adey and Walter, 1963]

significance of the stimulus, and so on. A very large literature exists; general or extensive treatments can be found for example in Brazier (1967), Katzman (1964), and Field et al. (1960). The evoked potential is typically recorded with macroelectrodes, in the presence of EEG waves not related to the stimulus and hence constituting noise from the point of view of recognizing the evoked response. The evoked response is often large enough to “see” every time a stimulus is given, but often it is quite invisible and is brought out only by averaging a number of responses. This averaging procedure may obscure inconsistent response. Its power, however, is so great that averaged responses have been found to reflect very subtle differences in the stimulus or the state of preparedness of the brain even when recorded at the scalp in a wide variety of situations described by Sutton (WS). A few examples will suffice to illustrate the class.

Averaged evoked potentials from the cortex rather quantitatively represent the stimulus luminance when flashes of constant duration but varying luminance are used and represent the product of luminance and duration when both are varied reciprocally (Wicke et al., 1964). Pairs of flashes are encoded such that the perceptual report of the subject is represented in the evoked potential; the second, brighter flash at the right interval blanks the perception of the first and its evoked potential seems to displace that to the first (Donchin et al., 1963).

Libet et al. (1967) found averaged evoked responses to stimuli in conscious man that were subthreshold for sensation. Pribram et al. (1967) found that evoked responses are different for a picture of a circle and for one of vertical stripes illuminated for one millisecond.

Shevrin and Fritzier (1968) report that the averaged evoked responses to tachistoscopically presented pictures "may contain a complex coding for both conscious and unconscious psychological processes of a symbolic nature...." The evoked potentials were different for two stimuli (one a picture of a knee and a pen, the other an abstract form of similar light and dark pattern), whether the duration of exposure was long enough to permit recognition or not.

Averaged evoked potentials show the effect of learning and of expectation of stimuli and of rhythm of previous stimuli (John, 1967; John and Ruchkin, 1967; Sutton et al., 1966; and further references given in these papers).

Just as in the discussion of ongoing EEG waves, we face the issue here of whether we are looking at what is merely an epiphenomenon or at some aspect of a causally significant process. The arguments cannot be reviewed here, but the present status appears to be inconclusive and to require new experimental design.

V. SUMMARY

The problem of neural coding is defined as that of elucidating the transformations of information in the nervous system, from receptors through internuncials to motor neurons to effectors.

The term and notion of "coding" has several meanings in common parlance as well as technical meanings in specialized fields: cryptology, genetics, computer technology, and statistical communication theory (information theory). The widespread use of "code" in neuroscience is congruent with the common core of meaning in these varied usages, in which a code is a representation, transformation, mapping, or correlate. For example, it is compatible with the use of "coding" by Shannon, even though information theory's universal components cannot be readily identified in nervous systems.

Typically, a neural pathway mixes inextricably its pure mapping and its computing or logic functions, for example in filtering or abstracting information relevant to the system. Four formal aspects of neural codes are distinguished, descriptions of which are essential to the acceptance of a proposed scheme of representation as a bona fide neural code. The *referent* consists of the relevant features abstracted from the stream of input signals and represented by means of the coding scheme. The *transformation* is the encoding process or set of rules (and underlying mechanisms) whereby the referents are represented by output signals. The *transmission* of the encoded information includes both anatomical and physiological substrates. Finally, the *interpretation* of the encoded information, typically consisting of its recoding by a higher-order set of neurons or of its "decoding" by an effector, corresponds largely to "integration" as ordinarily understood in neurophysiology.

This coding concept permits probabilistic, continuous, rate-sensitive, multiple, and mechanistically diverse codes, operating at intracellular, cellular, and ensemble levels. The present scope includes intermediate levels but omits membrane mechanisms at one end and cognitive processes at the other.

The requirements for establishing that a putative or candidate code is actually used in the way we imagine are in essence that the four formal aspects be shown to be operative in the living organism. These requirements have probably not been met in the case of any proposed code. What is usually lacking is demonstration that the relevant analyzer—whether a postsynaptic cell, receiving center, or circuit of neurons at the next level—"reads" or interprets the proposed parameter of the input. In

some cases it is shown that a candidate code is read but not that this occurs as a normal, systematic representation of information relevant to the organism.

The main thrust of modern evidence on neural coding is to the effect that there is not *a* neural code, but many. Some are sequential forms of representing the flow of information, for example within each neuron, from its input to its output. Others use alternative modes of representation, for example, employing different statistical properties of streams of impulses. The same stream may go to two analyzers that read different parameters and therefore use distinct codes.

The Appendix catalogs the candidate codes recognized; its table of contents should be considered a part of this Summary.

The most widely investigated class of neural codes is that in which information is carried by nerve impulses in single channels. The presence of impulse activity in one specific channel rather than another ("labeled lines") and the representation of stimulus intensity by means of rate of impulses comprise the "classical" neural codes. Many other parameters of a single-channel impulse train are available for use as codes, and many have been shown to be operative. The time of firing of an impulse or a short burst is used in motor systems as a "Go!" signal. The variance of interpulse intervals, and more generally the temporal patterns in an impulse train are features to which at least higher-order neurons are sensitive. Other features, such as number of impulses in a burst, or duration of a burst, have also been investigated as candidate codes.

Much greater capacity, sensitivity, and flexibility are furnished by the use of impulses in parallel channels. Proposed codes of this sort are intrinsically more difficult to investigate than those in single channels. Correlation measures of impulse activity, between channels or between a channel and a repeated stimulus event, have typically been more successful in providing the neurophysiologist with insight into underlying interaction patterns than in clarifying the operative coding schemes.

Nonimpulse carriers of information are employed by the nervous system at all levels, from subtle synaptic mechanisms to waves of electrical activity encompassing large portions of the brain. The microscopic nonimpulse mechanisms are more satisfactorily understood than the global phenomena as effective carriers of information. The causative role of the EEG, under "on-going" conditions as well as when systematically modified by a stimulus, is an active, unresolved problem. Much modern work has shown the kinds and varieties of information carried by "brain waves" as well as mechanisms that generate them, but serious gaps remain in our picture of how such information is interpreted and utilized.

Among the main unsettled issues collateral to the recognition of analyzers, and hence of codes, is the fourth of the formal aspects: the question, "Who reads ensemble codes?" applied to the multiple-channel impulse codes as well as to the EEG. In this, as in the broader question of how information is represented and transformed in nervous systems, the authors are persuaded of a pluralistic answer: in some cases the final motor action integrates converging inputs, in some cases a specific but large array of higher and descending neurons controls the final common paths, in some a smaller array acts as a funnel and may be either a defined circuit diffusing the responsibility for decisions by a sharing in series or an indefinite number of equivalent, parallel units ("decision cells") each capable of integrating all convergent inputs and triggering the divergent output array.

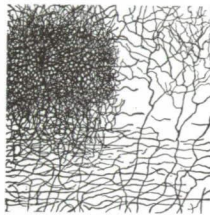

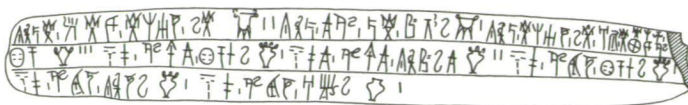

APPENDIX

A TABLE OF CANDIDATE NEURAL CODES OR FORMS OF REPRESENTATION OF INFORMATION IN THE NERVOUS SYSTEM

Again, it is clear that the more refined tissue
and conformation of things ... are neither
visible nor tangible.

Bacon, *Novum Organum*

In this Appendix, an attempt has been made to list systematically the chief candidates for consideration as neural codes together with a brief description of the formal properties of each and some comments as to the evidence, if any, for their functional role in living organisms. This is not a list of theoretically possible codes but of modes of representation for which there is some physiological evidence. The evidence is usually to the effect that information about the stimulus or state of the system is represented in the listed parameters, even though it may be read by the receiving cell in some other form or may not be read at all. This compendium should be considered more nearly a worksheet than an encyclopedic catalog.

I. NEURONAL EVENTS OTHER THAN IMPULSES

A. Intracellular Events

1. *Receptor potential: amplitude*
2. *Synaptic potential: amplitude*
3. *Synaptic conductance change: amplitude*
4. *Synaptic conductance change: spatial distribution*
5. *Membrane potential: spatial and temporal distribution*
6. *Graded potential in axonal terminals*

B. Intercellular Events

1. *Transmitter released*
2. *Potassium ion released*
3. *Neurosecretion released*
4. *Electrotonic coupling between specific cells*
5. *Electrotonic interaction via extracellular space*

II. IMPULSES IN UNIT NEURONS**A. Representation by Identity of Active Fiber**

1. *Labeled lines*

B. Codes Based on Temporal Properties of Impulses

1. *Time of occurrence*
 - a. *Instant of firing*
 - b. *Phase locking to stimulus*
2. *Interval statistics codes*
 - a. *Frequency: weighted average*
 - b. *Frequency: instantaneous*
 - c. *Frequency: increment above background*
 - d. *Frequency: rate of change*
 - e. *Frequency of firing/missing at fixed intervals*
 - f. *Coefficient of variation*
 - g. *Higher moments; interval histogram shape*
3. *Temporal pattern of impulses*
4. *Number of impulses or duration of burst*
5. *Velocity change in axon*

C. Codes Based on Other Properties

1. *Amplitude change in axon*
2. *Spatial sequencing*

III. ENSEMBLE ACTIVITY**A. Representation by Spatial Array**

1. *Topographic distribution of active fibers*

B. Codes Based on Temporal Relations Among Active Channels

1. *Latency distribution*
2. *Phase distribution*
3. *Probability of firing after stimulus: PST histogram shape*

C. Representation by Form of Composite of Multiunit Activity

1. *Evoked potential shape*
2. *Slow waves in ongoing EEG*

I. NEURONAL EVENTS OTHER THAN IMPULSES

A. Intracellular Events

Code: IA 1. *Receptor potential: amplitude*
Referent: Light intensity in the example of photoreceptor cells in *Limulus* or insect eye.
Transformation: Light elicits a voltage in the receptor that is propagated decrementally, without producing a spike; amount of depolarization is a linear function over some range of log light intensity.
Transmission: Electrotonically down the membrane of the receptor to influence the second-order neuron.
Interpretation: Small size of receptor permits non-spike voltage to remain sufficient for activating a synapse on the proximal portion of receptor; subsequent transmission of information is accomplished by ordinary postsynaptic effects.
Biological significance: Believed to be the significant output of the sensory transducer, encoding not only intensity but a time function of the stimulation. Bullock suggests that a similar signal—graded, decrementally spread, and without impulses—may be quite general in the abundant central short-axon cells.

Code: IA 2. *Synaptic potential: amplitude*
Referent: Transmitter impinging from presynaptic cell.
Transformation: Local, graded change of membrane potential occurs according to the particular properties of the given postsynaptic membrane in response to the given transmitter. There are several types: excitatory and inhibitory, slow and fast, facilitating and otherwise. Mechanism known in several cases; most common is change in ion conductances; another is electrogenic pump potential without change in conductance; in some cases unknown.
Transmission: Electrotonic spread to spike-initiating locus, sometimes augmented by some active local potential.
Interpretation: Determines firing. May also contribute to evoked potentials (*IIC1*) and slow waves (*IIC2*).
Biological significance: These synaptic responses are the equivalent of receptor potentials—representing the transduction of impinging events into a gradable, labile signal suitable for mixing with others to accomplish integration with weighting of inputs.

Code: IA 3. *Synaptic conductance change: amplitude*
Referent: Transmitter impinging from presynaptic cell.
Transformation: As above, IA2. Under some conditions the conductance increase occurs with little or no potential change. Distinguished from

potential-amplitude change by the relative importance in different cases of potential and conductance change, which are often unequal.

Transmission: Acts locally by shunting to reduce any potential change within range; also increases high-voltage threshold. Read-out by the receiving cell is therefore by potential change.

Interpretation: As for the preceding, *IA2*.

Biological significance: As for the preceding, *IA2*.

Code: *IA 4. Synaptic conductance change: spatial distribution*

Referent: Constellation of inputs within a brief time period.

Transformation: Topographic relations of the simultaneously active synaptic loci represent the array of presynaptic sources delivering input to this cell during that time.

Transmission: Mixing by decremental spread with delay and broadening, according to dendrite diameters, lengths, branching, etc., to influence spike initiation.

Interpretation: As for the preceding, *IA2*.

Biological significance: Provides spatial integration of many inputs. It may be a prime trend in evolution to increase the wealth and variety of synaptic endings per neuron.

Code: *IA 5. Membrane potential: spatial and temporal distribution*

Referent: Preceding synaptic events plus spontaneous activity, local potentials, and afterpotentials from antecedent spikes.

Transformation: These events sum and sometimes multiply. The processes responsible lose their identity and the membrane potential becomes a new measure to correlate empirically with such states as sleep, mental activity, epilepsy, etc. (Adey).

Transmission: As above, *IA2*.

Interpretation: As above, *IA2*. This is not the only determinant of firing; accommodative and other influences on threshold are not measured by the potential.

Biological significance: This is the first item of our catalog that includes the injection of a component representing the information that this cell has a certain intrinsic or autochthonous activity. Also, this complex resultant includes the afterpotentials from recent impulses. Here we call attention to the patterns in space and time that may represent important states of the organism.

Code: *IA 6. Graded potential in axonal terminals*

Referent: Antecedent activity, hence all the determinants of firing of that neuron, plus impinging presynaptic synapses (serial synapses), hence all the determinants of firing in those neurons.

- Transformation:** Spikes coming down axon become decremental under certain conditions and therefore gradable by by intrinsic factors (train frequency, length, etc.) and extrinsic influences (neighboring fibers, presynaptic inhibition, or facilitation).
- Transmission:** Presumably the amplitude of the acting potential in the terminal determines the effective quantity of transmitter produced. Certainly this is true for electrical synapses and probably for chemical, but with a nonlinear transfer function.
- Interpretation:** Postsynaptic potentials.
- Biological significance:** The degrees of freedom for control by throttling, filtering, facilitating, and the loci for lability are profoundly increased by having this gradable stage. Presynaptic inhibition is an example.

B. Intercellular Events

Code: IB 1. Transmitter released

- Referent:** Action potential in axonal terminals (above, *IA6*).
- Transformation:** In chemical synapses some function, as yet unknown, is to be presumed between these stages.
- Transmission:** Diffusion across intercellular cleft.
- Interpretation:** Postsynaptic potentials.
- Biological significance:** One of the stages and loci available for lability, fatigue, effects of age, experience, drugs, milieu.

Code: IB 2. Potassium ion released

- Referent:** Time of occurrence of an action potential or train of them.
- Transformation:** Temporary excess K^+ concentration in a restricted extracellular space can cause depolarizations and rhythmic oscillations in nearby membranes and may even induce spikes. It has been suggested that liberated K^+ might act on the same cell that liberated it. It may depolarize glial cell membranes that spread the signal passively but from cell to cell via low-resistance contacts and contribute to surface slow potentials.
- Transmission:** Unknown.
- Interpretation:** Unknown.
- Biological significance:** This is another mechanism whereby spikes in one cell may influence other neurons (besides synapses, direct electrical effects, etc.), but the effects are qualitatively similar to EPSP's.

Code: IB 3. Neurosecretion released

- Referent:** Unknown.
- Transformation:** It is usually assumed that action potentials resulting from synaptic input or from spontaneous activity cause release of the specialized

products that have been synthesized in the perinuclear cytoplasm and translated down the axon to a storage organ composed of swollen terminals of these axons. The need for spikes is not established.

Transmission: Via blood stream.

Interpretation: Target organ activity.

Biological significance: A mechanism for signaling remote or widespread target cells specifically without nerves to them by releasing chemical agents adapted to the target cells' responsiveness.

Code: IB 4. Electrotonic coupling between specific cells

Referent: Presynaptic impulse or other form of potential.

Transformation: Decremental, delayed, and sometimes low-pass filtered replica in the other cell, with low-resistance connections.

Transmission: Electrotonic transmission from pre- through postsynaptic membrane by low-resistance connections; sometimes rectifying.

Interpretation: Postsynaptic spikes or ease of bringing to firing threshold.

Biological significance: In fish, electrotonic coupling rather than chemically mediated synapse is found where speed or synchrony seem to be necessary in brainstem and spinal cord efferent pathways. Probably to be found in mammals. But does a simple interneural coupling, whether chemical or electric, constitute a neural code? The transformation rule seems too simple: presynaptic impulse followed by postsynaptic potential. However, some integrative phenomena are known in such cases. These mechanisms are treated here because they are part of the representation of information and constitute transfer functions that presumably are candidate sites for alteration by suitable conditions.

Code: IB 5. Electrotonic interaction via extracellular space

Referent: Current flowing diffusely through the tissue, mainly through the clefts between cells. The current may have various origins, including synchronized activity of nearby cells, standing or slowly changing potentials of remote or nonneuronal nature.

Transformation: Unknown processes determining current flow of extracellular patterns.

Transmission: Diffuse current flow following available channels, therefore mainly in extracellular space.

Interpretation: Bias of ongoing impulse discharge rate.

Biological significance: Not easily established. Many cases are known that show experimentally influenced activity via such current (see Slow Waves, pp. 297-306), but the normal role is not yet agreed upon.

II. IMPULSES IN UNIT NEURONS

A. Representation by Identity of Active Fiber

Code: IIA 1. *Labeled lines (spatial representation; see "specific nerve energies" of Müller, 1833, 1840)*

Referent: Tone frequency and intensity in the case of certain auditory fibers; light, color, or position in the case of optic fibers; each modality of stimulus in the case of other sensory fibers. The equivalent is true of central internuncial and of efferent neurons; they have referents in their normal input that label them.

Transformation: At several places in the cochlear nucleus, a gradient of sensitivity to tone frequency is preserved through divergent axons of auditory nerve fibers; optic nerve fibers are labeled visual; etc. "Labeled" connotes a pre-existing meaning for the organism of activity in the given fibers.

Transmission: Afferent and all central and all efferent axons whose messages have a predetermined meaning.

Interpretation: Modality-specific response.

Biological significance: Makes possible more than one receptor and one effector and behavioral pattern.

B. Codes Based on Temporal Properties of Impulses

1. *Time of occurrence*

Code: IIB 1a. *Instant of firing or onset; "doorbell" code (i)*

Referent: Time at which a movement is to be executed.

Transformation: Single spike or short burst on an otherwise silent motor fiber. Frequency within burst unimportant.

Transmission: Single motor fiber, or parallel ones, or divergent ones.

Interpretation: Wing muscles in locust; flight-initiating mechanism in fly; electric motoneurons in electric fish are examples.

Biological significance: Determines the precise initiation and sometimes the duration of maintained motor performance.

Code: IIB 1a. *Instant of firing (ii)*

Referent: Phase of locust wing beat.

Transformation: Stretch receptors in locust wing fire according to the phase of wing beat.

Transmission: Impulses in stretch-receptor axons, in a feedback loop to the locust brain.

Interpretation: Apparently none. When nerve is cut and the natural impulse activity is replaced by electrical stimulation, random or regular but at the same mean rate, wing beats and flying behavior remain normal. Whereas experimenter can detect phase, amplitude, and frequency of wing beat from these impulses, the locust apparently uses only rate information, not phase information.

Biological significance: None under experimental conditions studied. This example is listed to indicate that plausibility and the demonstrated presence of information in a nerve fiber are not reliable guides to the actual use of the impulse stream by the animal.

Code: *IIB 1b. Phase locking to stimulus*

Referent: Phase of tone in cat auditory fibers.

Transformation: In single auditory nerve fibers, frequency may not change from spontaneous discharge when a tone is given, but the spikes tend to group in phase with the tone, as shown in PST histograms. Nearly equivalent to latency code (*IIB2*).

Transmission: Spikes propagated along auditory nerve fibers.

Interpretations: Unknown. Possibly through parallel pathways and convergence.

Biological significance: Unknown.

2. *Interval statistics codes*

Code: *IIB 2a. Frequency: weighted average*

Referent: Decision as to which population of muscle fibers is to be activated, as in crayfish claw opener or sea anemone column; or as to what level of tetanic contraction is to be commanded in a given population.

Transformation: Curves of contraction rate or plateau tension versus frequency are characteristic for each population.

Transmission: Nerve impulses propagated along motor axon to many junctions per muscle cell.

Interpretation: One frequency of impulses activates one population of muscle fibers; another frequency, another population each to a degree dependent on the frequency. Mechanism presumably due to the presence of different types of neuromuscular junction.

Biological significance: Economy of motor units and motoneurons; peripheral integration; sometimes long latency; frequency code buys reduction in neural apparatus at the expense of latency.

Code: *IIB 2b. Frequency: instantaneous*

Referent: Intensity of adequate stimulus.

Transformation: The most recent interval or the interval from the last spike to the present determines the output. Because this code precludes temporal integration over several intervals, the frequency of stimuli must be no higher than the output of impulses. The crayfish stretch receptor neuron modulated by its inhibitor axon in a low frequency range is an instance. Crayfish muscle, although it does integrate incoming motor impulses, also responds to single short intervals interposed.

Transmission: Axon of inhibitor fiber to stretch receptor or, in second case, of motor neuron to muscle.

Interpretation: Time of next firing of stretch receptor cell; amplitude of muscle contraction.

Biological significance: Of special value in each case; all share the maximum promptness of response.

Code: IIB 2c. *Frequency: increment above background (i)*

Referent: Stimulus intensity in certain afferent neurons with background spontaneous activity, e.g., light in the eye for ganglion cells of cat's retina; acceleration of the head for some vestibular receptors in VIIIth nerve.

Transformation: The greater average frequency with stimulus can be treated as an increment over the spontaneous background, with some simplification of the function. Thus, so much stimulus per extra impulse per second has been found to hold for different levels of background.

Transmission: Axon of the cell in question.

Interpretation: Unknown.

Biological significance: This provides a constant signal for a given stimulus, even when the background changes.

Code: IIB 2c. *Frequency: increment above background (ii)*

Referent: In a case in cat retinal ganglion cells, change of illumination in a particular portion of visual field.

Transformation: During a particular time range after stimulus onset, a number of additional impulses occur over maintained adapted discharge level; these extra impulses appear to have a Poisson counting distribution as do the "background" impulses on which they are superimposed (Barlow).

Transmission: Retinal ganglion cell axons.

Interpretation: Unknown.

Biological significance: Detailed statistical analysis of experimental results indicates that this code is compatible with classical threshold curves. The requirement that the

time of onset must be known may be circumvented by a parallel channel from specialized ganglion cells, or by a change in the criterion level for deciding whether a significant change in luminance has occurred.

Code: IIB 2d. *Frequency: rate of change*
Referent: Unknown.
Transformation: Functions of change of frequency with time are theoretical candidates. No case has been identified, but it seems likely that some analyzer neurons receive impulse streams and respond with adaptation, therefore reading rate of change.
Transmission: Unknown.
Interpretation: Unknown.
Biological significance: Unknown.

Code: IIB 2e. *Frequency of firing/missing at fixed intervals*
Referent: In a class of electroreceptors in electric fish, the intensity of the electric field in the water, as distorted by objects.
Transformation: Some afferent fibers do not change latency with stimulus intensity but instead the proportion of the electric organ discharges to which they respond, each with a single spike. Intervals between spikes are therefore multiples of electric organ discharge interval. There is statistically significant tendency to nonrandom sequence, i.e., to negative serial correlation. Systematic encoding extends at least over the range of probability of missing, 0.1 to 0.9.
Transmission: Axons of lateral-line nerve fibers.
Interpretation: Unknown, but these or some other codes must contribute to the higher-order analysis of movement, direction, and object size, as reported by Enger and Szabo (1965).
Biological significance: Provides detection and estimation of presence, position, and size (integrating many channels) of objects or barriers; limited in dynamic range and resolution; places a premium on high frequency electric-organ discharge.

Code: IIB 2f. *Coefficient of variation; (i) occurrence*
Referent: State of adaptation of *Limulus* eccentric cell.
Transformation: Dark-adapted cell has larger coefficient of variation of discharge intervals than a light-adapted cell, for a given mean frequency (Ratliff et al., 1968).
Transmission: Impulses transmitted along eccentric-cell axon.
Interpretation: Unknown.
Biological significance: This is a possible mechanism for transmitting information about light intensity as well as adaptation state in the same train, along the same fiber, if a suitable interpretation mechanism exists. Stein's data (WS) also suggest that the

muscle spindle fiber potentially contains information about muscle length and also about the amount of gamma bias. Barlow states that similarly in the cat the retinal ganglion discharge is more regular at high adaptation levels than at low.

Code: *IIB 2f. Coefficient of variation; (ii) readability*
Referent: Irregularly spaced versus regularly spaced incoming impulses to a cell.
Transformation: According to the regularity of the input, changes occur in probability of firing or in mean firing rate of postsynaptic pacemaker cell, in pattern of its discharge (reflected in standard deviation of intervals, interval histogram, etc.), and in phase relationship with synaptic input. Different but analogous effects occur with EPSP's and IPSP's. Effect is due to a different influence on timing of next pacemaker discharge for early- versus late-arriving input impulses.
Transmission: Impulses along pacemaker axon.
Interpretation: Unknown.
Biological significance: None is established; systematic variation in regularity is not known in the cases studied for sensitivity to it. Effect is found in *Aplysia* visceral ganglion pacemaker neurons, in crayfish thoracic tonic stretch receptors, and in opener muscle of crayfish claw.

Code: *IIB 2g. Higher moments: interval histogram shape*
Referent: Unknown.
Transformation: Quite generally the histogram of interval lengths alters in shape as mean interval alters, becoming narrower (sometimes just proportionately, sometimes more than proportionately) with shorter intervals. Quasi-exponential distribution may become a gamma distribution of a lower order, or a gamma distribution may tend to become Gaussian; multimodal or long-tailed distributions may become simpler. But little is known of changes at the same mean interval (except as described above, *IIB2f.*). In a narrow range of temperature, crayfish interneurons change from a unimodal to a bimodal histogram with high negative serial correlation at the same mean (Biederman-Thorson).
Transmission: Axon of the given cell.
Interpretation: Unknown.
Biological significance: Unknown.

3. *Temporal Pattern of Impulses*

Code: *IIB 3(i). Temporal pattern recorded; generated by a neuron: joint interval histogram shape*
Referent: Unknown.

Transformation: Obvious pattern (repeated sequences of unequal intervals) can be detected by ear or by eye in a record. The histogram or scatter plot of each interval plotted against the preceding interval brings out weaker tendencies to serial correlation. Little is known of systematic changes in this plot with stimulation, in the absence of change in mean interval.

The crayfish interneuron example above (*IIB2g.*) is a possible case. A triplet pattern is produced by a ventral cord motoneuron that innervates crayfish abdominal muscle, irrespective of frequency of driving, by action of command fibers or in response to stimulation with a constant current. The pattern generator is shown to be in the motoneuron membrane. It is to be expected that many other examples will be found and possibly some that systematically encode certain inputs.

Transmission: Axon of the given neuron.

Interpretation: Unknown, but the experimental imposition of pattern (*ii*, next below) shows that neurons can read this code. In the case of the crayfish motoneuron, the abdominal muscle contraction in response to triplets is greater than to constant discharge by an amount equivalent to only a 10% increase in average frequency.

Biological significance: See (*ii*) next below.

Code: *IIB 3(ii). Temporal pattern of stimuli; imposed on a neuron: lobster*

Referent: Temporal pattern of incoming impulses: alternately long-short interspike intervals versus evenly spaced impulses.

Transformation: In pacemaker cells of lobster cardiac ganglion, regularly spaced incoming inhibitory impulses of suitable frequency inhibit cell almost completely, whereas long-short pattern with the same mean rate reduces the inhibitory effect to about one-half (Bullock, WS). Possibly based on the same properties that determine the nonalgebraic summation of inhibition and excitation. A similar sensitivity to pattern of timing of repeated sequences of intervals is seen in the Benham effect, as pointed out by MacKay.

Transmission: Spike discharge along axon of pacemaker cell.

Interpretation: Unknown, possibly not used by animal.

Biological significance: Unknown. In principle, if a neuron can read a pattern code in addition to a frequency code, the channel capacity is increased by making possible two separable estimates of aspects of the referent, e.g., pitch and loudness or color and intensity, at the same time. Pattern codes may be expected to have a relatively small dynamic range. Loss of pattern through successive synapses may be expected to limit the use of this device.

Code: *IIB 3(ii). Temporal pattern of stimuli; imposed on a neuron: Aplysia.*

Referent: Temporal pattern of incoming impulses: absolute and relative lengths of successive pairs of intervals (trios of spikes) in a continuing train applied to *Aplysia* ganglion cells.

Transformation: Postsynaptic firing probability is sensitive to the incoming temporal pattern over a trio of impulses at constant mean rate. Computer simulation corroborates experiments in *Aplysia* neurons using ordinary integration properties of postsynaptic neuron; transformation is shown to be modified drastically by changes in facilitatory properties of synapses (Segundo).

Transmission: Spikes propagated along postsynaptic-cell axon.

Interpretation: Unknown.

Biological significance: Unknown, see above.

Code: *IIB 4. Number of impulses or duration of burst.*

Referent: In weakly electric fish, change in the electric field due to introduction or removal of an object (dielectric or conducting) in the water near the fish.

Transformation: In *Hypopomus*, whose electric organ discharges 5 to 30 times per second, there are electroreceptor afferents that fire from 0 to 15+ times per electric-organ discharge, depending on the presence, proximity, size, and quality of objects in the receptive field of that unit. Some receptors show no systematic dependence of spike interval or latency but a systematic change in number and therefore duration of burst. Average frequency cannot be the code because it will depend chiefly on the electric organ discharge frequency commanded by the brain (Bullock).

Transmission: Lateral-line axon.

Interpretation: Unknown.

Biological significance: Similar to the "doorbell" code, above, *IIB1*. A very easy code to transmit and to read. In species that have medium frequency (50-per-sec electric organ discharge), the dynamic range is small and markedly quantal.

Code: *IIB 5. Velocity change in axon.*

Referent: Presence and time of occurrence of a nerve impulse in the same or an adjacent axon; also the same factors mentioned in *IIC1*, below.

Transformation: Change of conduction velocity in direction of decrease or increase. Velocity can be facilitated or depressed according to the interval between impulses in the same axon or the phase relation of neighboring fibers. After-potentials, recovery cycle, and catelectrotonus or anelectrotonus are probably adequate to explain the effects.

Transmission: Impulses in the same or neighboring fibers.

Interpretation: Possibly decrease or increase in dispersion of impulses. MacKay has pointed out the utility of adaptive changes in conduction velocity in a self-organizing automaton.

Biological significance: Unknown. Probably introduces a small amount of noise in the representation of information in spike trains.

C. Codes Based on Other Properties

Code: *IIC 1. Amplitude change in axon.*

Referent: Factors that determine frequency of impulses and at critical loci such as branch points or near terminals, factors in the milieu or history that determine the safety factor (ratio of spike height to threshold of next segment of axon).

Transformation: High-frequency bursts of impulses may cause local decrease in amplitude of action potentials.

Transmission: Impulses in the axon.

Interpretation: The probability of impulses passing branch points or reaching axon terminals may be affected. The transmitter released may be reduced.

Biological significance: This may be part of the presynaptic terminal lability and share significance with it (*IA6*, above).

Code: *IIC 2. Spatial sequencing.*

Referent: A sequence of inputs arrives at different points on certain interneurons in invertebrates, which collect input in a number of different segments of the animal so that a conducting axon has a number of sites of synaptic impingement.

Transformation: A rather complicated spatiotemporal transformation. Each sensory input fiber when stimulated produces a spike that propagates in both directions along the interneuron so that on recording from both ends under natural stimulation the patterns at the two ends are different (Kennedy).

Transmission: Spikes propagating in both directions down the axon of the interneuron.

Interpretation: Unknown.

Biological significance: Unknown. This is a mechanism for the production of temporal patterns, or a way in which spatial patterns may be converted into at least two temporal patterns.

III. ENSEMBLE ACTIVITY

A. Representation by Spatial Array.

Code: IIIA 1. *Topographic distribution of active fibers.*

Referent: (a) Locus of touch on body surface in crayfish, (b) Frequency of tone to ear in cat.

Transformation: (a) Local mechanical stimulation on the exoskeleton of a specific joint of a specific leg causes firing in a particular array of receptor axons some of whose receptive fields are the whole leg, others whose receptive fields cover different major portions of the leg, or this leg and adjacent legs, or legs on both sides, or legs and the abdomen. The stimulated locus is the common point of overlap (Wiersma). (b) A pure tone excites a certain battery of cochlear nerve fibers, whose response areas (with curves of frequency versus intensity at threshold) include the frequency and intensity of that tone.

Transmission: The indicated populations of axons.

Interpretation: Unknown in detail. Lateral interactions, convergence and divergence extract information from the channels of wide, overlapping receptive fields. The analysis depends on the a priori labeling of lines.

Biological significance: This system is thought to achieve a given degree of resolution of stimulus with fewer channels, to permit sense receptors with wide, overlapping fields, and to introduce emphasis on discontinuities.

B. Codes Based on Temporal Relations Among Active Channels

Code: IIIB 1. *Latency distribution; (i) electroreceptors.*

Referent: In a class of electroreceptors in electric fish the intensity of electric field in water as distorted by objects.

Transformation: Some afferent fibers change latency, with respect to electric organ discharges, as a function of stimulus intensity; others, which do not, provide reference signals, and the efferent discharges to the electric organ also provide reference signals. The latency shift is tonic and of the order of 2 msec for 1 cm of object movement. In *Sternopygus* there are 100 electric-organ discharges per second, and each is followed by one impulse in each latency-sensitive fiber and one impulse in each fixed latency fiber. Afferent fibers therefore have a fixed frequency and cannot code by the classical parameter (Bullock). Some mammalian auditory nerve fibers show similar behavior (Kiang).

Transmission: Axons of lateral-line nerve fibers.

Interpretation: Unknown. Presumably some kind of comparison (delayed coincidence analysis) between afferent (and possibly efferent) timings.

Biological significance: Unknown; presumably provides detection and estimation of the presence, position, and size (many channels) of objects or barriers.

Code: *IIIB 1. Latency distribution; (ii) touch receptors*

Referent: Intensity distribution of touch stimulus to cat's footpad.

Transformation: Tactile receptors fire once for each touch. Latency depends on strength of the tactile displacement and therefore on distance from the center of the touch. Thus an array of impulses in those fibers of the nerve, with the leading spike followed by others in surrounding fibers, represents the locus, size, intensity, and spatial gradient of the displacement.

Transmission: Cutaneous nerve.

Interpretation: Unknown.

Biological significance: Touch is accurately localized.

Code: *IIIB 2. Phase distribution; (i) width of phase histogram*

Referent: Intensity of tone, previously encoded in individual auditory fibers is ensemble-coded by a grouping around phases of the sound in parallel fibers.

Transformation: Same as described for single auditory fibers (Kiang) but done in parallel among a population of fibers. Nearly equivalent to the evoked potential.

Transmission: Spikes propagated along auditory fibers.

Interpretation: Convergence upon integrating (multiple-coincidence-detecting) neurons in the cochlear nucleus.

Biological significance: Not demonstrated; suggested as a way in which auditory thresholds can be explained in view of the limited dynamic range of phase locking in individual fibers. This represents a kind of ensemble averaging. Proposed code is verifiable only through simultaneous multiunit recordings.

Code: *IIIB .2. Phase distribution; (ii) two-neuron interaction (analog model)*

Referent: Input spike train exciting two reciprocally inhibiting neurons.

Transformation: Complicated input-output relationships can occur in models of such pairs of cells even in noise-free case. Both phasic and tonic responses are seen, and hysteresis and dominance effects are the rule. Major effects are due to change in input frequency but also occur with change in temporal structure of input. Behavior is quite sensitive to slight parameter variations, e.g., in interaction between inhibition and a nonlinear threshold (Harmon).

Transmission: Spikes propagated along axons of reciprocally inhibiting pairs of neurons.

Interpretation: Unknown, cannot be simple.

Biological significance: Unknown; experimentation done with analog model.

Code: III B 2. Phase distribution; (ii) two-neuron interaction (cat visual)

Referent: Two different orientations of moving parallel bars as visual stimuli.

Transformation: "Unfavorable" orientation shows no interaction (as shown by cross-interval histogram) between two cells in visual cortex of unanesthetized cat; with "favorable" orientation of stimuli, strong interaction seen. No significant change is seen in the PST histograms of the two cells under the two kinds of stimulus. Mechanism might be potentiation of a synaptic pathway between the two neurons, or, less likely, the sharing of common synaptic input, with a differential delay to the two observed units (Gerstein).

Transmission: Spikes propagated along axons of cortical neurons.

Interpretation: Unknown; presumably some form of coincidence detection.

Biological significance: Unknown. A case in which the appropriate statistical technique on the part of the experimenter can reveal the stimulus effect that is not otherwise obvious or even detectable.

Code: III B 3. Probability of firing after stimulus: PST histogram shape (i)

Referent: Presence of click or flash, and recent history of pairing between the two in neurons of peristriate cortex of cat.

Transformation: PST histogram recorded from units in cortex of unanesthetized cat responds differently to click, to flash, and to simultaneous combinations of the two. After repeated coincidences of pairing, flash alone elicits combined response. This conditioning is abolished and is easily reestablished. Mechanism unknown, but presumably does not reside solely in the single cell observed (Morrell).

Transmission: Spikes propagated down axon of peristriate cortical cell.

Interpretation: Unknown; interpretable by experimenter by time averaging of repeated presentations of stimuli. As in all PST work, because the nervous system interprets information in "real time," it must do ensemble averaging by means of parallel pathways.

Biological significance: Unknown. This is a classical conditioning situation.

Code: III B 3. PST histogram shape (ii)

Referent: Frequency of short tone burst.

Transformation: Smoothed PST histograms in the cat cochlear nucleus show peaks

whose time of onset is linearly related to the logarithm of the frequency of the tone or in some cases to the absolute value of the logarithm of the ratio of the tone frequency to a reference frequency (K-shaped feature in stacked histograms). Mechanism unknown; not well seen in individual trials (Gerstein).

Transmission: Unknown; parallel pathways.

Biological significance: Unknown.

Code: *IIIB 3. PST histogram shape (iii)*

Referent: Tone frequency in experiments in which tone sweeps upward in frequency and then downward.

Transformation: In cells in the cochlear nucleus (cat), some show mirror symmetry in PST histogram (following actual stimulus); other cells show translation symmetry (same curve for ascending as for descending frequency); and still other cells show asymmetry (therefore the PST histogram carries information as to the time derivative of tone). These symmetry types are seen in the PST histograms only, not in individual responses (Gerstein).

Transmission: Unknown; presumably in parallel fibers.

Interpretation: Performed by the experimenter through time averaging. If the cat interprets this information, it must be through some sort of ensemble averaging, i.e., through parallel channels and convergence. Possible mechanisms unknown.

Biological significance: Unknown.

C. Representation by Form of Composite Multiunit Activity

Code: *IIIC 1. Evoked potential shape*

Referent: Various aspects of stimuli, sometimes very subtle, or of the state of preparedness of the brain.

Transformation: Some parts of the cortex and subcortical structures give evoked potentials that are altered consistently in shape, without reduction in amplitude (during a given experiment) by slight changes: (a) in the physical stimulus, e.g., change of direction of frequency modulation of a short tone or slight distortion of the sound field by the presence of a slip of paper near the face (inferior colliculus of porpoise: Bullock); (b) in the state of the brain, e.g., with conditioning.

Transmission: Unknown.

Interpretation: Unknown. Because of the background of brain waves, observer must average several to many repeated responses to discern the characteristic shape.

Biological significance: Unknown, but bespeaks a population of units with a wide range of possible permutations of activity, probably units heterogeneous in properties, each with a certain degree of consistent behavior.

Code: *IIC 2. Slow waves in ongoing EEG (i)*

Referent: Unknown.

Transformation: Unknown. The class of waves intended here is not immediately referable to a stimulus (see evoked potentials). It is recorded with macro- or semimicroelectrodes, represents the activity of many cells and is equivalent to most of the electroencephalogram ("brain waves"). It is unknown whether such slow waves are the resultant of masses of dendritic potentials, relatively synchronized, or of some other form of activity.

Transmission: Unknown. Presumably through dendrites and therefore also through somata, proximal axons, glial cells, intercellular spaces—in short, the bulk tissue.

Interpretation: Unknown. Do slow waves influence dendritic potentials and thus alter firing probabilities of neurons? The occurrence of spikes in some units under some conditions is a function of the phase of slow waves and so also are some psychophysical judgments.

Biological significance: Unknown. Mountcastle asked for a clear statement of the thesis that slow-wave events recorded in a population of cells might be signaling agents in the nervous system independently of direct neuronal connections.

Code: *IIC 2. Slow waves in ongoing EEG (ii)*

Referent: Stimulus intensity; light in the eye.

Transformation: Adrian described slow waves in the optic nerve. Frequency of wave is independent of stimulus intensity, but amplitude is dependent on it. Mechanism may be the envelope of spikes in a class of optic nerve fibers that fire at the same frequency and in phase (observed by Lettvin and others).

Transmission: Optic nerve fibers; presumably the glial cells participate in spreading any synchronized slow potentials.

Interpretation: Unknown.

Biological significance: Unknown.

BIBLIOGRAPHY

The following is not an exhaustive bibliography of literature relevant to neural coding and the representation of information in nervous systems. It is, however, an extensive sample, especially of work by the participants in the Work Session and augmented by others. Works specifically cited in the text may be found on the pages listed in the right-hand column.

- | | Page |
|--|---------|
| Adey, W.R. (1967): Intrinsic organization of cerebral tissue in alerting, orienting, and discriminative responses. <i>In: The Neurosciences: A Study Program</i> . Quarton, G.C., Melnechuk, T. and Schmitt, F.O., eds. New York: The Rockefeller University Press, pp. 615-633. | |
| Adey, W.R. (1968): Spectral analysis of EEG data from animals and man during alerting, orienting and discriminative responses. <i>In: Neurophysiology of Attention</i> . Mulholland, R.B. and Evans, C., eds. London: Butterworth. (In press) | |
| Adey, W.R., Elul, R., Walter, R.D. and Crandall, P.H. (1967): The cooperative behavior of neuronal populations during sleep and mental tasks. <i>EEG Clin. Neurophysiol.</i> 23:88. (Abstr.) | |
| Adey, W.R., Kado, R.T., Didio, J. and Schindler, W.J. (1963): Impedance changes in cerebral tissue accompanying a learned discriminative performance in the cat. <i>Exp. Neurol.</i> 7:259-281. | |
| Adey, W.R., Kado, R.T., McIlwain, J.T. and Walter, D.O. (1966): The role of neuronal elements in regional cerebral impedance changes in alerting, orienting and discriminative responses. <i>Exp. Neurol.</i> 15:490-510. | |
| Adey, W.R. and Walter, D.O. (1963): Application of phase detection and averaging techniques in computer analysis of EEG records in the cat. <i>Exp. Neurol.</i> 7:186-209. | 305 |
| Adey, W.R., Walter, D.O. and Hendrix, C.E. (1961): Computer techniques in correlation and spectral analyses of cerebral slow waves during discriminative behavior. <i>Exp. Neurol.</i> 3:501-524. | |
| Adey, W.R., Walter, D.O. and Lindsley, D.F. (1962): Effects of subthalamic lesions on learned behavior and correlated hippocampal and subcortical slow-wave activity. <i>Arch. Neurol.</i> 6:194-207. | |
| Adrian, E.D. (1928): <i>The Basis of Sensation</i> . New York: Norton. | 237,243 |
| Andersen, P. and Andersson, S.A. (1968): <i>Physiological Basis of the Alpha Rhythm</i> . New York: Appleton, Century, Crofts. | |

	Page
Andersen, P., Gillow, M. and Rudjord, T. (1966): Rhythmic activity in a simulated neuronal network. <i>J. Physiol.</i> 185:418-428.	275
Arshavshii, Y., Berkinblit, M.B., Kovalev, S.A., Smolainov, B.B. and Chaylakhian, L.M. (1965): On the role of dendrites in the functioning of nerve cells. <i>Doklady Biophysics</i> 163:140-142 (trans.).	293
Babkoff, H. and Sutton, S. (1966): End point of lateralization for dichotic clicks. <i>J. Acoust. Soc. Amer.</i> 39:87-102.	
Barlow, H.B. (1964): The physical limits of visual discrimination. <i>Photophysiology</i> 2:163-202.	
Barlow, H.B. (1965): Optic nerve impulses and Weber's law. <i>Sympos. Quant. Biol.</i> 30:539-546.	
Barlow, H.B. (1968): Specificity of response in sensory neurones. <i>Ann. N.Y. Acad. Sci.</i> (In press)	252
Barlow, H.B., Blakemore, C. and Pettigrew, J.D. (1967): The neural mechanism of binocular depth discrimination. <i>J. Physiol.</i> 193:327-342.	
Barlow, H.B., Hill, R.M. and Levick, W.R. (1964): Retinal ganglion cells responding selectively to direction and speed of image motion in the rabbit. <i>J. Physiol.</i> 173:377-407.	
Barlow, H.B. and Levick, W.R. (1965): The mechanism of directionally selective units in rabbit's retina. <i>J. Physiol.</i> 178:477-504.	
Barlow, H.B. and Levick, W.R. (1968): Three factors limiting the reliable detection of light by retinal ganglion cells of the cat. <i>J. Physiol.</i> (In press)	249,250, 251
Barlow, H.B. and Levick, W.R. (1969): Coding of light intensity by the cat retina. <i>Proceedings of the International School of Physics "Enrico Fermi"</i> ; Varenna, 1968. New York: Academic. (In press)	249
Barondes, S.H. (1967): Axoplasmic transport. <i>Neurosciences Res. Prog. Bull.</i> 5(4):307-419.	288
Batham, E.J. and Pantin, C.F.A. (1954): Slow contraction and its relation to spontaneous activity in the sea-anemone <i>Metridium senile</i> (L.). <i>J. Exp. Biol.</i> 31:84-103.	246
Baumann, F. (1968): Slow and spike potentials recorded from retinula cells of the honey-bee drone in response to light. <i>J. Gen. Physiol.</i> (In press)	291
Bayly, E.J. (1968a): Small signal analysis of pulse frequency modulation. (Unpublished)	273
Bayly, E.J. (1968b): Spectral analysis of pulse-frequency modulation in the nervous system. <i>IEEE Trans. Biomed. Engrg.</i> (In press)	273
Bell, C.C. and Grimm, R.J. (1968): Discharge properties of cerebellar Purkinje cells recorded with single and double microelectrodes. (Submitted for publication)	269

	Page
Bennett, M.V.L. (1964): Nervous function at the cellular level. <i>Ann. Rev. Physiol.</i> 26:289-340.	296
Bennett, M.V.L. (1965): Electroreceptors in mormyrids. <i>Symp. Quant. Biol.</i> 30:245-262.	292,296
Bennett, M.V.L. (1966): Physiology of electrotonic junctions. <i>Ann. N.Y. Acad. Sci.</i> 137:509-539.	
Bennett, M.V.L. (1967): Mechanisms of electroreception. <i>In: Lateral Line Detectors.</i> Cahn, P.H., ed. Bloomington: Indiana University Press, pp. 313-393.	
Bennett, M.V.L. (1968a): Similarities between electrically and chemically mediated transmission. <i>In: Physiological and Biophysical Aspects of Nervous Integration.</i> Carlson, F.D., ed. Englewood Cliffs, N.J.: Prentice-Hall, pp. 73-128.	
Bennett, M.V.L. (1968b): Neural control of electric organs. <i>In: The Central Nervous System and Fish Behavior.</i> Ingle, D., ed. Chicago: University of Chicago Press. (In press)	
Bennett, M.V.L. and Grundfest, H. (1966): Analysis of depolarizing and hyperpolarizing inactivation responses in gymnotid electroplaques. <i>J. Gen. Physiol.</i> 50:141-169.	
Bennett, M.V.L., Pappas, G.D., Aljure, E. and Nakajima, Y. (1967): Physiology and ultrastructure of electrotonic junctions. II. Spinal and medullary electromotor nuclei in mormyrid fish. <i>J. Neurophysiol.</i> 30:180-208.	259,295
Bennett, M.V.L., Pappas, G.D., Giménez, M. and Nakajima, Y. (1967): Physiology and ultrastructure of electrotonic junctions. IV. Medullary electromotor nuclei in gymnotid fish. <i>J. Neurophysiol.</i> 30:236-300.	
Beurle, R.L. (1956): Properties of a mass of cells capable of regenerating pulses. <i>Phil. Trans. Roy. Soc., B</i> 240:55-94.	275,285
Beurle, R.L. (1962): Storage and manipulation of information in random networks. <i>In: Aspects of the Theory of Artificial Intelligence.</i> Muses, C.A., ed. New York: Plenum, pp. 19-42.	275, 285
Bittner, G.D. (1968): Differentiation of nerve terminals in the crayfish opener muscle and its functional significance. <i>J. Gen. Physiol.</i> 51:731-758.	246
Borsellino, A., Fuortes, M.G.F. and Smith, T.G. (1965): Visual responses in <i>Limulus</i> . <i>Symp. Quant. Biol.</i> 30:429-443.	
Brazier, M.A.B. (1967): A decade of development in knowledge of brain mechanisms. <i>J. Nerv. Ment. Dis.</i> 144:352-357.	298,305
Bullock, T.H. (1959): Initiation of nerve impulses in receptor and central neurons. <i>Rev. Mod. Physics</i> 31:504-514.	
Bullock, T.H. (1959): Neuron doctrine and electrophysiology. <i>Science</i> 129:997-1002.	285,288

- | | Page |
|--|---------|
| Bullock, T.H. (1961a): On the anatomy of the giant neurons of the visceral ganglion of <i>Aplysia</i> . In: <i>Nervous Inhibition</i> . Florey, E., ed. New York: Pergamon, pp. 233-240. | 285 |
| Bullock, T.H. (1961b): The origins of patterned nervous discharge. <i>Behaviour</i> 17:48-59. | 284,285 |
| Bullock, T.H. (1961): The problem of recognition in an analyzer made of neurons. In: <i>Sensory Communication</i> . Rosenblith, W.A., ed. Cambridge, Massachusetts: The M.I.T. Press, pp. 717-724. | |
| Bullock, T.H. (1965): Functional integration in nervous systems. Presented at the International Symposium in the Life Sciences, Massachusetts Institute of Technology, December 2-3. (Unpublished) | |
| Bullock, T.H. (1967): Signals and neuronal coding. In: <i>The Neurosciences: A Study Program</i> . Quarton, G.C., Melnechuk, T. and Schmitt, F.O., eds. New York: The Rockefeller University Press, pp. 347-352. | |
| Bullock, T.H. (1968): The representation of information in neurons and sites for molecular participation. <i>Proc. Nat. Acad. Sci.</i> 60:1058-1068. | 287 |
| Bullock, T.H. and Chichibu, S. (1965): Further analysis of sensory coding in electroreceptors of electric fish. <i>Proc. Nat. Acad. Sci.</i> 54:422-429. | 269 |
| Bullock, T.H., Hagiwara, S., Kusano, K. and Negishi, K. (1961): Evidence for a category of electroreceptors in the lateral line of gymnotid fishes. <i>Science</i> 134:1426-1427. | 261 |
| Bullock, T.H. and Horridge, G.A. (1965): <i>Structure and Function in the Nervous Systems of Invertebrates</i> . San Francisco: W.H. Freeman, 2 Vols. | |
| Burns, B.D. (1968): <i>The Uncertain Nervous System</i> . London: Edward Arnold. | |
| Burns, B.D. and Pritchard, R.H. (1964): Contrast discrimination by neurons in the cat's visual cerebral cortex. <i>J. Physiol.</i> 175:445-463. | 255 |
| Chow, K.L., Randall, W. and Morrell, F. (1966): Effect of brain lesions on conditioned cortical electropotentials. <i>EEG Clin. Neurophysiol.</i> 20:357-369. | |
| Cowan, J.D. (1964): Redundant automata as models of neuron assemblies. In: <i>Proceedings of the International Union of Physiological Sciences, XXIII</i> . Leiden (Symposium on Information Processing in the Brain) Gerard, R. and Duyff, J.W., eds. Amsterdam: Excerpta Medica. | |
| Cowan, J.D. (1965): The problem of organismic reliability. <i>Progr. Brain Res.</i> 17:9-63. | |
| Cowan, J.D. (1968): Statistical mechanics of nervous activity. In: <i>Neural Networks</i> . (Proc. School on Neural Networks, Ravello, June, 1967). Caianiello, E.R., ed. New York: Springer-Verlag. | |
| Cowan, J.D. (1969): Neuronal oscillators. (Proceedings of the Norbert Wiener Memorial Meeting on the Idea of Control. Genoa, 1965, Borsellino, A., ed.) (In press) | |

	Page
Cowan, J.D. (1969): Statistical mechanics of neural networks. <i>In: Mathematical Questions in Biology</i> . (Proc. 2nd Ann. Symp. 1967) Gerstenhaber, M., ed. Providence: American Mathematical Society. (In press)	
Cowan, J.D. (1969): Some remarks on neural cybernetics. (Proc. Int. Conf. on Theoretical Physics and Biology, Versailles,, 1967.) Marois, M., ed. Paris. (In press)	
Cowan, J.D. and Cohen, M.H. (1969): The role of statistical mechanics in neurobiology. <i>J. Phys. Soc. Jap.</i> 26(Suppl.) (In press)	
Cox, D.R. and Smith, W.L. (1954): On the superposition of renewal processes. <i>Biometrika</i> 41:91-99.	272
Crane, H.D. (1964): Possibilities for signal processing in axon systems. <i>In: Neural Theory and Modeling</i> . Reiss, R.F., ed. Stanford, California: Stanford University Press, pp. 138-153.	268
Donchin, E., Wicke, J.D. and Lindsley, D.B. (1963): Cortical evoked potentials and perception of paired flashes. <i>Science</i> 141:1285-1286.	305
Dowling, J.E., and Boycott, B.B. (1965): Neural connections of the retina: fine structure of the inner plexiform layer. <i>Cold Spring Harbor Symp. Quant. Biol.</i> 30:393-402.	292,296
Elazar, Z. and Adey, W.R. (1967a): Electroencephalographic correlates of learning in subcortical and cortical structures. <i>EEG Clin. Neurophysiol.</i> 23:301-319.	303
Elazar, Z. and Adey, W.R. (1967b): Spectral analysis of low frequency components in the hippocampal electroencephalogram during learning. <i>EEG Clin. Neurophysiol.</i> 23:225-240.	
Elul, R. (1967): Amplitude histograms of the EEG as an indicator of the cooperative behavior of neuron populations. <i>EEG Clin. Neurophysiol.</i> 23:87. (Abstr.)	294,298, 299
Elul, R. (1968): Brain waves: Intracellular recording and statistical analysis help clarify their physiological significance. <i>In: Data Acquisition and Processing in Biology and Medicine</i> , Vol. 5. New York: Pergamon, pp. 93-115.	
Enger, P.S. and Szabo, T. (1965): Activity of central neurons involved in electroreception in some weakly electric fish (<i>Gymnotidae</i>). <i>J. Neurophysiol.</i> 28:800-818.	319
Erickson, R.P. (1963): Sensory neural patterns and gustation. <i>In: Olfaction and Taste</i> . Zotterman, Y., ed. London: Pergamon, pp. 205-213.	
Erulkar, S.D., Butler, R.A. and Gerstein, G.L. (1968): Excitation and inhibition in cochlear nucleus. II. Frequency modulated tones. <i>J. Neurophysiol.</i> 31:537-548.	279
Evoy, W.H. and Kennedy, D. (1969): The central nervous organization underlying control of antagonistic muscles in the crayfish. <i>J. Exp. Zool.</i> (In press)	
Evoy, W.H., Kennedy, D. and Wilson, D.M. (1967): Discharge patterns of neurones supplying tonic abdominal flexor muscles in the crayfish. <i>J. Exp. Biol.</i> 46:393-411.	

	Page
Farley, B.G. and Clark, W.A. (1954): Simulation of self-organizing systems by digital computer. <i>IRE Trans. Inform. Theory</i> IT-4:76-84.	275
Farley, B.G. and Clark, W.A. (1961): Activity in networks of neuron-like elements. In: <i>Information Theory</i> . Cherry, C., ed. New York: Academic, pp. 242-251.	275
Fehmi, L.G. and Bullock, T.H. (1967): Discrimination among temporal patterns of stimulation in a computer model of a coelenterate nerve net. <i>Kybernetik</i> 3:240-249.	257,275
Field, J., Magoun, H.W. and Hall, V.E., eds. (1960): <i>Handbook of Physiology. Section 1: Neurophysiology, Volume II</i> . Washington, D.C.: American Physiological Society.	305
Fields, H.L., Evoy, W.H. and Kennedy, D. (1967): The reflex role played by efferent control of an invertebrate stretch receptor. <i>J. Neurophysiol.</i> 30:859-874.	
Fields, H.L. and Kennedy, D. (1965): Functional role of muscle receptor organs in crayfish. <i>Nature</i> 206:1235-1237.	
Fiorentini, A. and MacKay, D.M. (1965): Temporal factors in pattern vision. <i>Quart. J. Exp. Psychol.</i> 17:282-291.	260
FitzHugh, R. (1957): The statistical detection of threshold signals in the retina. <i>J. Gen. Physiol.</i> 40:675-692.	251
FitzHugh, R. (1962): Computation of impulse initiation and saltatory conduction in a myelinated nerve fiber. <i>Biophys. J.</i> 2:11-21.	245
Fox, S.S. and Norman, R.J. (1968): Functional congruence: an index of neural homogeneity and a new measure of brain activity. <i>Science</i> 159:1257-1259.	299
Fox, S.S. and O'Brien, J.H. (1965): Duplication of evoked potential waveform by curve of probability of firing of a single cell. <i>Science</i> 147:888-890.	302, 303
Freeman, W.J. (1968): Relations between unit activity and evoked potentials in prepyriform cortex of cats. <i>J. Neurophysiol.</i> 31:337-348.	
Frost, J.D., Jr. (1967a): Comparison of intracellular potentials and ECoG activity in isolated cerebral cortex. <i>EEG Clin. Neurophysiol.</i> 23:89-90.	300
Frost, J.D., Jr. (1967b): An averaging technique for detection of EEG-intracellular potential relationships. <i>EEG Clin. Neurophysiol.</i> 23:179-181.	300
Frost, J.D., Jr. (1968): EEG-intracellular potential relationships in isolated cerebral cortex. <i>EEG Clin. Neurophysiol.</i> 24:434-443.	300
Frost, J.D., Jr. and Elazar, Z. (1968): Three-dimensional selective amplitude histograms: a statistical approach to EEG-single neuron relationships. <i>EEG Clin. Neurophysiol.</i> 25:499-503.	300, 301

- Frost, J.D., Jr. and Gol, A. (1966): Computer determination of relationships between EEG activity and single unit discharges in isolated cerebral cortex. *Exp. Neurol.* 14:506-519. 300
- Frost, J.D., Jr., Kellaway, P. and Gol, A. (1966): Single-unit discharges in isolated cerebral cortex. *Exp. Neurol.* 14:305-316. 300
- Frost, J.D., Jr. and Low, M.D. (1967): An electronic method for determining time-locked changes in neuronal firing rate. *EEG Clin. Neurophysiol.* 23:176-178. 300
- Fujita, Y., Rosenberg, J. and Segundo, J.P. (1968): Activity of cells in the lateral vestibular nucleus as a function of head position. *J. Physiol.* (In press)
- Fuller, D.R.G. and Gray, J.A.B. (1966): The relation between mechanical displacements applied to a cat's pad and the resultant impulse patterns. *J. Physiol.* 182:465-483.
- Fuortes, M.G.F. (1959): Initiation of impulses in visual cells of *Limulus*. *J. Physiol.* 148:14-28.
- Fuortes, M.G.F. (1960): Inhibition in the *Limulus* eye. In: *Inhibition in the Nervous System and Gamma-aminobutyric Acid*. Roberts, E., Baxter, C.F., van Harrevelde, A., Wiersma, C.A.G., Adey, W.R. and Killam, K.F., eds. London: Pergamon, pp. 418-423.
- Fuortes, M.G.F. and Hodgkin, A.L. (1964): Changes in time scale and sensitivity in the ommatidia of *Limulus*. *J. Physiol.* 172:239-263.
- Furshpan, E.J. and Furukawa, T. (1962): Intracellular and extracellular responses of the several regions of the Mauthner cell of the goldfish. *J. Neurophysiol.* 25:732-771. 304
- Gersch, W. (1967): A stochastic model for real and simulated neural nets. *Trans. IEEE System Science and Cybernetics* SSC-3, No. 2.
- Gerstein, G.L. (1961): Neuron firing patterns and the slow potentials. *EEG Clin. Neurophysiol. Suppl.* 20:68-71. 302, 303
- Gerstein, G.L., Butler, R.A. and Erulkar, S.D. (1968): Excitation and inhibition in cochlear nucleus. I. Tone burst stimulation. *J. Neurophysiol.* 31:526-536. 280
- Gerstein, G.L. and Clark, W.A. (1963): Simultaneous studies of firing patterns in several neurons. *Science* 143:1325-1327. 266
- Gerstein, G.L. and Kiang, N.Y.-S. (1960): An approach to the quantitative analysis of electrophysiological data from single neurons. *Biophys. J.* 1:15-28.
- Gerstein, G.L. and Kiang, N.Y.-S. (1964): Responses of single units in the auditory cortex. *Exp. Neurol.* 10:1-18. 303
- Gerstein, G.L. and Mandelbrot, B. (1964): Random walk models for the spike activity of a single neuron. *Biophys. J.* 4:41-68.

	Page
Gerstein, G.L. and Perkel, D.H. (1968): Simultaneously recorded spike trains: analysis and functional interpretation. (Submitted for publication)	
Goldstein, J.L. and Kiang, N.Y.-S. (1968): Neural correlates of the aural combination tone $2f_1-f_2$. <i>Proc. IEEE</i> 56:981-992.	
Gray, J.A.B. and Lal, S. (1965): Effects of mechanical and thermal stimulation of cats' pads on the excitability of dorsal horn neurones. <i>J. Physiol.</i> 179:154-162.	275, 276
Hagiwara, S., Kusano, K. and Negishi, K. (1962): Physiological properties of electroreceptors of some gymnotids. <i>J. Neurophysiol.</i> 25:430-449.	261
Hagiwara, S. and Morita, H. (1963): Coding mechanisms of electroreceptor fibers in some electric fish. <i>J. Neurophysiol.</i> 26:551-567.	261
Hakerem, G. and Sutton, S. (1966): Pupillary response at visual threshold. <i>Nature</i> 212:485-486.	
Harmon, L.D. (1961): Studies with artificial neurons. I. Properties and functions of an artificial neuron. <i>Kybernetik</i> 1:89-101.	243, 268
Harmon, L.D. (1962a): Neural analogs. In: <i>Proceedings of the 1962 Spring Joint Computer Conference (A.F.I.P.S.)</i> , Vol. 21. Palo Alto, California: National Press, pp. 153-158.	268
Harmon, L.D. (1962b): Natural and artificial synapses. In: <i>Self-Organizing Systems 1962</i> . Yovits, M.C., Jacobi, G.T. and Goldstein, G.D., eds. Washington, D.C.: Spartan, pp. 177-202.	268
Harmon, L.D. (1964): Neuromimes: action of a reciprocally inhibitory pair. <i>Science</i> 146:1323-1325.	269, 271
Harmon, L.D. and Lewis, E.R. (1966): Neural modeling. <i>Physiol. Rev.</i> 46:513-591.	271,268,283
Hinrichsen, C.F.L. and Larramendi, L.M.H. (1968): Synapses and cluster formation of the mouse mesencephalic fifth nucleus. <i>Brain Res.</i> 7:296-299.	296
Hoy, R.R., Bittner, G.D. and Kennedy, D. (1967): Regeneration in crustacean motoneurons: evidence for axonal fusion. <i>Science</i> 156:251-252.	
Hubel, D.H. and Wiesel, T.N. (1962): Receptive fields, binocular interaction and functional architecture in the cat's visual cortex. <i>J. Physiol.</i> 160:106-154.	238, 241
Jansen, J.K.S., Nicolaysen, K. and Rudjord, T. (1966): Discharge pattern of neurons of the dorsal spinocerebellar tract activated by static extension of primary endings of muscle spindles. <i>J. Neurophysiol.</i> 29:1061-1086.	248
Jenik, F. (1962): Electronic neuron models as an aid to neurophysiological research. <i>Ergebn. Biol.</i> 25:206-245.	268
John, E.R. (1967): <i>Mechanisms of Memory</i> . New York: Academic.	290,306

	Page
John, E.R., Herrington, R.N. and Sutton, S. (1967): Effects of visual form on the evoked responses. <i>Science</i> 155:1439-1442.	
John, E.R. and Ruchkin, D.S. (1967): Average evoked responses and learning. <i>Science</i> 158:395.	306
Kahn, D. (1967): <i>The Codebreakers</i> . New York: Macmillan.	228
Katz, B. and Miledi, R. (1967a): A study of synaptic transmission in the absence of impulses. <i>J. Physiol.</i> 192:407-436.	292
Katz, B. and Miledi, R. (1967b): The release of acetylcholine from nerve endings by graded electric pulses. <i>Proc. Roy. Soc. B</i> 167:23-38.	292
Katzman, R., ed. (1964): Sensory evoked potentials in man. <i>Ann. N.Y. Acad. Sci.</i> 112:1-546.	298,305
Kennedy, D. (1966): The comparative physiology of invertebrate central neurons. <i>Adv. Comp. Physiol. Biochem.</i> 2:117-184.	
Kennedy, D. and Evoy, W.H. (1966): The distribution of pre- and postsynaptic inhibition at crustacean neuromuscular junctions. <i>J. Gen. Physiol.</i> 49:457-468.	
Kennedy, D., Evoy, W.H. and Fields, H.L. (1966): The unit basis of some crustacean reflexes. <i>Symp. Soc. Exp. Biol.</i> 20:75-109.	
Kennedy, D. and Mellon, DeF., Jr. (1964): Receptive-field organization and response patterns in neurons with spatially distributed input. In: <i>Neural Theory and Modeling</i> . Reiss, R.F., ed., Stanford, California: Stanford University Press, pp. 400-413.	260
Kennedy, D. and Takeda, K. (1965): The reflex control of abdominal flexor muscles in the crayfish. I. The twitch system; II. The tonic system. <i>J. Exp. Biol.</i> 43:211-227; 229-246.	
Kenshalo, D.R., ed. (1968): <i>The Skin Senses</i> . Springfield, Illinois: C.C Thomas.	
Kiang, N.Y.-S. (1965): Stimulus coding in the auditory nerve and cochlear nucleus. <i>Acta Oto-laryng.</i> 59:186-200.	
Kiang, N.Y.-S., Pfeiffer, R.R., Warr, W.B. and Backus, A.S.N. (1965): Stimulus coding in the cochlear nucleus. <i>Acta Otol. Rhinol. Laryngol.</i> 74:463-485.	
Kiang, N.Y.-S., Watanabe, T., Thomas, E.C. and Clark, L.F. (1965): <i>Discharge Patterns of Single fibers in the Cat's Auditory Nerve</i> . Cambridge, Massachusetts: The M.I.T. Press.	
Koerber, K.C., Pfeiffer, R.R., Warr, W.B. and Kiang, N.Y.-S. (1966): Spontaneous spike discharges from single units in the cochlear nucleus after destruction of the cochlea. <i>Exp. Neurol.</i> 16:119-130.	
Kuffler, S.W. (1967): Neuroglial cells: physiological properties and a potassium mediated effect of neuronal activity on the glial membrane potential. <i>Proc. Roy. Soc., B</i> 168:1-21.	296

	Page
Larimer, J.L. and Kennedy, D. (1966): Visceral afferent signals in the crayfish stomatogastric ganglion. <i>J. Exp. Biol.</i> 44:345-354.	
Laursen, M. (1967): Higher functions of the central nervous system. <i>Ann. Rev. Physiol.</i> 29:543-572.	303
Levitan, H., Segundo, J.P., Moore, G.P. and Perkel, D.H. (1968): Statistical analysis of membrane-potential fluctuations: relation with presynaptic spike train. <i>Biophys. J.</i> 8:1256-1274.	293
Libet, B., Alberts, W.W., Wright, E.W., Jr. and Feinstein, B. (1967): Responses of human somatosensory cortex to stimuli below threshold for conscious sensation. <i>Science</i> 158:1597-1600.	306
Littal, W.R. and Krissoff, M. (1968): Response of the somesthetic system to patterned trains of electrical stimuli. An approach to the problem of sensory coding. <i>In: The Skin Senses.</i> Kenshalo, D.R., ed. Springfield, Illinois: C.C Thomas.	
Lorente de Nó, R. and Condouris, G.A. (1959): Decremental conduction in peripheral nerve; integration of stimuli in the neuron. <i>Proc. Nat. Acad. Sci.</i> 45:592-617.	293
MacKay, D.M. (1954): Operational aspects of some fundamental concepts of human communication. <i>Synthese</i> 9:182-198.	297
MacKay, D.M. (1962): Self-organization in the time domain. <i>In: Self-Organizing Systems 1962.</i> Yovits, M.C., Jacobi, G.T. and Goldstein, G.D., eds. Washington, D.C.: Spartan, pp. 37-48.	297
MacKay, D.M. (1965): Visual noise as a tool of research. <i>J. Gen. Physiol.</i> 72:181-197.	260
Mandriota, F.J., Thompson, R.L. and Bennett, M.V.L. (1965): Classical conditioning of electric organ discharge rate in mormyrids. <i>Science</i> 150:1740-1742.	
Maturana, H.R., Lettvin, J.Y., McCulloch, W.S. and Pitts, W.H. (1960): Anatomy and physiology of vision in the frog (<i>Rana pipiens</i>). <i>J. Gen. Physiol.</i> 43:129-176.	238,241, 284
Moore, G.P., Perkel, D.H. and Segundo, J.P. (1966): Statistical analysis and functional interpretation of neuronal spike data. <i>Ann. Rev. Physiol.</i> 28:493-522.	229, 239
Moore, G.P., Segundo, J.P. and Perkel, D.H. (1963): Stability patterns in interneuronal pacemaker regulation. <i>In: Proceedings of the San Diego Symposium for Biomedical Engineering.</i> Paull, A., ed. La Jolla, California, pp. 184-193.	
Morrell, F. (1961): Microelectrode studies in chronic epileptic foci. <i>Epilepsia</i> 2:81-88.	
Morrell, F. (1963): Information storage in nerve cells. <i>In: Information Storage and Neural Control.</i> Fields, W.S. and Abbott, W., eds. Springfield, Illinois: C.C Thomas, pp. 189-229.	
Morrell, F. (1967): Electrical signs of sensory coding. <i>In: The Neurosciences: A Study Program.</i> Quarten, G.C., Melnechuk, T. and Schmitt, F.O., eds. New York: The Rockefeller University Press, pp. 452-469.	278, 281, 302

- Morrell, F. and Morrell, L.K. (1965): Computer aided analysis of brain electrical activity. *In: Symposium on the Analysis of Central Nervous System and Cardiovascular Data Using Computer Methods*. Proctor, L.D. and Adey, W.R., eds. Washington, D.C.: NASA SP-72, pp. 441-478.
- Mountcastle, V.B. (1967): The problem of sensing and the neural coding of sensory events. *In: The Neurosciences: A Study Program*. Quarten, G.C., Melnechuk, T. and Schmitt, F.O., eds. New York: The Rockefeller University Press, pp. 393-408.
- Müller, J. (1833): *Handbuch der Physiologie des Menschen*. vol. 1. Coblenz: Holscher. (English translation by William Baly, vol. 1, 1838)
- Müller, J. (1840): *Handbuch der Physiologie des Menschen*. vol. 2. Coblenz: Holscher. (English translation by William Baly, vol. 2, 1842)
- Nelson, P.G. (1966): Interaction between spinal motoneurons of the cat. *J. Neurophysiol.* 29:275-287. 304
- Nomoto, M., Suga, N. and Katsuki, Y. (1964): Discharge patterns and inhibition of primary auditory nerve fibers in the monkey. *J. Neurophysiol.* 27:768-787. 283
- Ogden, T.E. (1966): Intraretinal slow potentials evoked by brain stimulation in the primate. *J. Neurophysiol.* 29:898-908. 296
- Oyster, C.W. and Barlow, H.B. (1967): Direction-selective units in rabbit retina: distribution of preferred directions. *Science* 155:841-842.
- Pantin, C.F.A. (1950): Behaviour patterns in lower invertebrates. *Symp. Soc. Exp. Biol.* 4:175-195. 246
- Pantin, C.F.A. (1952): The elementary nervous system. *Proc. Roy Soc. B* 140:147-168. 246
- Pappas, G.D. and Bennett, M.V.L. (1966): Specialized junctions involved in electrical transmission between neurons. *Ann. N.Y. Acad. Sci.* 137:495-508.
- Partridge, L.D. (1962): Some potentialities of slow summing neural processes. *Fed. Proc.* 21:360. (Abstr.) 243
- Partridge, L.D. (1965): Modifications of neural output signals by muscles: a frequency response study. *J. Applied Physiol.* 20:150-156.
- Partridge, L.D. (1966a): A possible source of nerve signal distortion arising in pulse rate encoding of signals. *J. Theoret. Biol.* 11:257-281.
- Partridge, L.D. (1966b): Signal-handling characteristics of load-moving skeletal muscle. *Amer. J. Physiol.* 210:1178-1191.
- Partridge, L.D. (1967): Intrinsic feedback factors producing inertial compensation in muscle. *Biophys. J.* 7:853-863. 243

	Page
Partridge, L.D. and Huber, F.D., Jr. (1967): Factors in the interpretation of the electromyogram based on muscle response to dynamic nerve signals. <i>Amer. J. Phys. Med.</i> 46:1276-1289.	
Partridge, L.D. and Jones, R.F. (1965): A rate signal interpreter. <i>J. Applied Physiol.</i> 20:543-546.	
Partridge, L.D. and Kim, J.H. (1968): Some dynamic aspect of motor responses to vestibular signals. (M.S. Thesis, University of Tennessee, Memphis, Tennessee)	243
Perkel, D.H., Gerstein, G.L. and Moore, G.P. (1967a): Neuronal spike trains and stochastic point processes. I. The single spike train. <i>Biophys. J.</i> 7:391-418.	239, 240
Perkel, D.H., Gerstein, G.L. and Moore, G.P. (1967b): Neuronal spike trains and stochastic point processes. II. Simultaneous spike trains. <i>Biophys. J.</i> 7:419-440.	268, 271
Perkel, D.H., Schulman, J.H., Bullock, T.H., Moore, G.P. and Segundo, J.P. (1964): Pacemaker neurons: effects of regularly spaced synaptic input. <i>Science</i> 145:61-63.	254,255, 257,268
Pfeiffer, R.R. and Kiang, N.Y.S. (1965): Spike discharge patterns of spontaneous and continuously stimulated activity in the cochlear nucleus of anesthetized cats. <i>Biophys. J.</i> 5:301-316.	
Porter, R., Adey, W.R. and Kado, R.T. (1964): Measurement of electrical impedance in the human brain: some preliminary observations. <i>Neurology</i> 14:1002-1012.	
Pribram, K.H., Spinelli, D.N. and Kamback, M.C. (1967): Electro cortical correlates of stimulus reponse and measurement. <i>Science</i> 157:94-96.	306
Rall, W. (1955): Experimental monosynaptic input-output relations in the mammalian spinal cord. <i>J. Cell. Comp. Physiol.</i> 46:413-437.	
Rall, W. (1955): A statistical theory of monosynaptic input-output relations. <i>J. Cell. Comp. Physiol.</i> 46:373-411.	
Rall, W. (1957): Membrane time constant of motoneurons. <i>Science</i> 126:454.	
Rall, W. (1958): Mathematical solutions for passive electrotonic spread between a neuron soma and its dendrites. <i>Fed. Proc.</i> 17(1). Abstr. No. 503.	
Rall, W. (1959): Branching dendritic trees and motoneuron membrane resistivity. <i>Exp. Neurol.</i> 1:491-527.	293
Rall, W. (1960): Membrane potential transients and membrane time constant of motoneurons. <i>Exp. Neurol.</i> 2:503-532.	
Rall, W. (1962): Electrophysiology of a dendritic neuron model. <i>Biophys. J.</i> 2:145-167.	
Rall, W. (1964): Theoretical significance of dendritic trees for neuronal input-output relations. In: <i>Neural Theory and Modeling</i> . Reiss, R.F., ed. Stanford, California: Stanford University Press, pp. 73-97.	293

	Page
Rall, W. (1965): Dendritic synaptic patterns: experiments with a mathematical model. <i>In: Studies in Physiology</i> . Curtis, D.R., ed. Berlin: Springer-Verlag, pp. 238-243.	293
Rall, W. (1967): Distinguishing theoretical synaptic potentials computed for different soma-dendritic distributions of synaptic input. <i>J. Neurophysiol.</i> 30:1138-1168.	293
Rall, W., Burke, R.E., Smith, T.G., Nelson, P.G. and Frank, K. (1967): Dendritic location of synapses and possible mechanisms for the monosynaptic EPSP in motoneurons. <i>J. Neurophysiol.</i> 30:1169-1193.	
Rall, W. and Shepherd, G.M. (1968): Theoretical reconstruction of field potentials and dendrodendritic synaptic interaction in olfactory bulb. <i>J. Neurophysiol.</i> 31 (In press)	295, 298
Rall, W., Shepherd, G.M., Reese, T.S. and Brightman, M.W. (1966): Dendrodendritic synaptic pathway for inhibition in the olfactory bulb. <i>Exp. Neurol.</i> 14:44-56.	292, 295
Ratliff, F., Hartline, H.K. and Lange, D. (1968): Variability of interspike intervals in optic nerve fibers of <i>Limulus</i> : effect of light and dark adaptation. <i>Proc. Nat. Acad. Sci.</i> 60:464-469.	255, 256, 319
Redman, S.J. and Lampard, D.G. (1968): Monosynaptic stochastic stimulation of cat spinal motoneurons. I. Response of motoneurons to sustained stimulation. <i>J. Neurophysiol.</i> 31:485-498.	255
Redman, S.J., Lampard, D.G. and Annal, P. (1968): Monosynaptic stochastic stimulation of cat spinal motoneurons. II. Frequency transfer characteristics of tonically discharging motoneurons. <i>J. Neurophysiol.</i> 31:499-508.	
Reese, T.S. (1966): Further studies on dendro-dendritic synapses in the olfactory bulb. <i>Anat. Rec.</i> 154:408. (Abstr.)	295
Reiss, R.F. (1962): A theory and simulation of rhythmic behavior due to reciprocal inhibition in small nerve nets. <i>In: Proceedings of the 1962 Spring Joint Computer Conference (A.F.I.P.S.)</i> , Vol. 21. Palo Alto, California: National Press, pp. 171-194.	268
Reiss, R.F. (1964): A theory of resonant networks. <i>In: Neural Theory and Modeling</i> . Reiss, R.F., ed. Stanford, California: Stanford University Press, pp. 105-137.	267
Rodieck, R.W., Kiang, N.Y.S. and Gerstein, G.L. (1962): Some quantitative methods for the study of spontaneous activity of single neurons. <i>Biophys. J.</i> 2:351-368.	
Rupert, A., Moushegian, G. and Galambos, R. (1962): Microelectrode studies of primary vestibular neurons in cat. <i>Exp. Neurol.</i> 5:100-109.	258
Segundo, J.P., Moore, G.P., Stensaas, L. and Bullock, T.H. (1963): Sensitivity of neurons in <i>Aplysia</i> to temporal patterns of arriving impulses. <i>J. Exp. Biol.</i> 40:643-667.	257
Segundo, J.P., Perkel, D.H. and Moore, G.P. (1966): Spike probability in neurons: influence of temporal structure in the train of synaptic events. <i>Kybernetik</i> 3:67-82.	249, 257

	Page
Segundo, J.P. and Perkel, D.H. (1968): How does a post-synaptic nerve cell read a pre-synaptic spike train? In: <i>UCLA Forum in Medical Sciences, Number 11. The Interneuron</i> . Brazier, M.A.B., ed. Berkeley: University of California Press. (In press)	272
Segundo, J.P., Perkel, D.H., Wyman, H., Hegstad, H. and Moore, G.P. (1968): Input-output relations in computer-simulated nerve cells. Influence of the statistical properties, strength, number and inter-dependence of excitatory pre-synaptic terminals. <i>Kybernetik</i> 4:157-171.	
Shannon, C.E. and Weaver, W. (1949): <i>The Mathematical Theory of Communication</i> . Urbana, Illinois: University of Illinois Press.	229
Shevrin, H. and Fritzler, D.E. (1968): Visual evoked response correlates of unconscious mental processes. <i>Science</i> 161:295-298.	306
Smith, T.G., Bauman, F. and Fuortes, M.G.F. (1965): Electrical connections between visual cells in the ommatidia of <i>Limulus</i> . <i>Science</i> 147:1446-1447.	
Spoendlin, H. (1966): Some morphofunctional and pathological aspects of the vestibular sensory epithelia. In: <i>Second Symposium on the Role of the Vestibular Organs in Space Exploration</i> . Washington, D.C.: National Aeronautics and Space Administration (NASA SP-115), pp. 99-115.	296
Stein, R.B. (1967): The frequency of nerve action potentials generated by applied currents. <i>Proc. Roy. Soc., B</i> 167:64-86.	
Stein, R.B. (1967): The informational capacity of nerve cells using a frequency code. <i>Biophys. J.</i> 7:797-826.	
Stein, R.B. (1967): Some models of neuronal variability. <i>Biophys. J.</i> 7:37-68.	
Stein, R.B. and Matthews, P.B. (1965): Differences in variability of discharge frequency between primary and secondary muscle spindle afferent endings of the cat. <i>Nature</i> 208:1217-1218.	
Sutton, S., Braren, M., Zubin, J., and John, E.R. (1965): Evoked-potential correlates of stimulus uncertainty. <i>Science</i> 150:1187-1188.	
Sutton, S., Tueting, P., Zubin, J. and John, E.R. (1967): Information delivery and the sensory evoked potential. <i>Science</i> 155:1436-1439.	305
Szabo, T., Enger, P.S. and Bullock, T.H. (1968): Caractéristiques fonctionnelles des électrorécepteurs chez <i>Steatogenys</i> , poisson à décharge électrique de basse fréquence. <i>J. Physiol. (Paris)</i> 60:23-24.	
Takeda, K. and Kennedy, D. (1964): Soma potentials and modes of activation of crayfish motoneurons. <i>J. Cell. Comp. Physiol.</i> 64:165-182.	
Talbot, W., Kornhuber, H. and Mountcastle, V.B. (1965): Stimulus-response properties of mechanoreceptive first order afferents innervating the palmar skin of the monkey's hand. <i>Physiologist</i> 8:(Abstr.)	

	Page
Terzuolo, C.A. and Bullock, T.H. (1956): Measurement of imposed voltage gradient adequate to modulate neuronal firing. <i>Proc. Nat. Acad. Sci.</i> 42:687-694.	305
Van Bergeijk, W. (1961): Studies with artificial neurons. II. Analog of the external spiral innervation of the cochlea. <i>Kybernetik</i> 1:89-117.	283
Walter, D.O. and Adey, W.R. (1965): Analysis of brain-wave generators as multiple statistical time series. <i>IEEE Trans. Biomed. Engr.</i> BME-12:8-13.	305
Watanabe, A. and Bullock, T.H. (1960): Modulation of activity of one neuron by subthreshold slow potentials in another in lobster cardiac ganglion. <i>J. Gen. Physiol.</i> 43:1031-1045.	
Wayner, M.J. and Oomura, Y. (1968): Neuronal spike trains. <i>Science</i> 160:1025-1026.	
Werner, G. and Mountcastle, V.B. (1965): Neural activity in mechanoreceptive cutaneous afferents: stimulus-response relations, Weber functions, and information transmission. <i>J. Neurophysiol.</i> 28:359-397.	
Wicke, J.D., Donchin, E. and Lindsley, D.B. (1964): Visual evoked potentials as a function of flash luminance and duration. <i>Science</i> 146:83-85.	305
Wiersma, C.A.G. and Adams, R.T. (1950): The influence of nerve impulse sequence on the contractions of different crustacean muscles. <i>Physiol. Comp.</i> 2:20-33.	257
Wilson, D.M. and Davis, W.J. (1965): Nerve impulse patterns and reflex control in the motor system of the crayfish claw. <i>J. Exp. Biol.</i> 43:193-210.	
Wilson, D.M. and Larimer, J.L. (1968): The catch property of ordinary muscle. <i>Proc. Nat. Acad. Sci.</i> 61:909-916.	247
Wilson, D.M. and Wyman, R.J. (1965): Motor output patterns during random and rhythmic stimulation of locust thoracic ganglia. <i>Biophys. J.</i> 5:121-143.	261
Wilson, J.P. (1960): Perceptual anomalies associated with a single contour. <i>Nature</i> 187:137.	260
Winograd, S. and Cowan, J.D. (1963): <i>Reliable Computation in the Presence of Noise.</i> Cambridge, Massachusetts: The M.I.T. Press.	
Wyman, R.J. (1966): Multistable firing patterns among several neurons. <i>J. Neurophysiol.</i> 29:807-833.	
Zotterman, Y., ed. (1963): <i>Olfaction and Taste.</i> London: Pergamon.	

INDEX

- Adams, R.T., *cit.*, 257
 Adaptive (labile) coding, 231, 235
 Adey, W.R., 223, 290, 293, 297, 298, 299, 303, 312; *cit.* 301, 305
 Adrian, E.D., 328; *cit.*, 237, 243
 Afferent fibers, 242, 248, 270, 273, 274, 324; and latency, 270
 Amplitude histogram, EEG, and single-unit firing, 300-301, 303
 Andersen, P., *cit.* 275
Aplysia, cross-correlation histogram of, 262-265; visceral ganglion of, 254-255, 257, 262, 320, 322.
 Arshavskii, Y., *cit.*, 293
 Arthropods, 260
 Auditory nerves, cat, 258, 316; mammalian, 268; *see also* Cochlear nucleus
 Autocorrelation histogram, 262, 264, 265
- Bacon, F., 226, 309
 Barlow, H.B., 223, 236, 252, 253, 255, 297, 318, 320; *cit.*, 249, 250, 251, 252
 Barondes, S.H., *cit.*, 288
 Batham, E.J., *cit.*, 246
 Baumann, F., *cit.*, 291
 Bayly, E.J., *cit.*, 273
 Bee, eye of, comparison with *Limulus*, 291; photoreceptor cells in, 291
 Bell, C.C., *cit.*, 269
 Benham effect, 260
 Bennett, M.V.L., 223, 247, 275, 285, 291, 295, 296; *cit.*, 259, 292, 295, 296
 Bernoulli trials, 278
 Beurle, R.L., 285; *cit.*, 275, 285
 Bialphabetic code, 229
 Biederman-Thorson, M., 224, 259, 320
 Bittner, G.D., *cit.*, 246
 Boycott, B.C., *cit.*, 292, 296
 Brazier, M.A.B., *cit.*, 298, 305
 Bullock, T.H., 223, 225, 257, 270, 297, 311, 320, 321, 323, 326; *cit.*, 225, 257, 261, 269, 275, 284, 285, 287, 288, 304
 Burns, B.D., *cit.*, 255
 Burst duration, 240, 261-262, 307
- Candidate codes, 236-238, 239-265, 267, 272, 303, 306-307; comparison, single-channel to multiple channel, 267; formal properties of, 232-234, 236, 238, 306; subcellular non-impulse, 290-294; table of, 309-327
 Channels, parallel, 266-286; single, 239-265
 Chichibu, S., *cit.*, 269
 Chow, K.L., 282
 Cipher, 228-229
 Cicadas, 262
 Circuits, neural, analysis of, 227
 Clark, G.L., *cit.*, 266, 275
 Cochlear nucleus, 324, 325, 326; recordings from, 278-283; *see also* Auditory nerves
 Code, computer, 230-231; cryptology, 228-229; genetic, 228-229; information (Shannon), 229-230
 Codes *see under* specific name
 Coding, neural, 227-327; definition of, 228, 306
 Coding, theoretical studies of, 267-268, 275, 276; computer simulations, 275; mathematical models, 275
 Cognitive process, 228, 306
 Computer, 230, 245, 262, 266, 272, 297, 306; code, 230-231; studies, 271-273
 Condouris, G.A., *cit.*, 293
 Cortex, peristriate, cat, 280-282, 325; visual, 269, 280-282, 326
 Cowan, J.D., 223, 230, 277
 Cox, D.R., *cit.*, 272
 Crane, H.D., *cit.*, 268
 Crayfish, claw opener muscle, 246-247, 316-317, 319; model neuron (abdominal), 257, 259, 320; stretch-receptor neurons, 255
 Creutzfeldt, O.D., 300; *cit.*, 301
 Cross-correlation histogram, 262-265, 268-270
 Cross-interval histogram (CIH), 271, 326
 Cryptology, 306; code, 228-229
 Cutaneous sensory fibers, cat, 283
- Dendritic activity, 290, 292-293, 327; influences, 287-289, 292, 293
 Donchin, E., *cit.*, 305
 Dowling, J.E., *cit.*, 292, 296

- Duration (number) codes, 261-262
- Eccentric cell *see* *Limulus*
- EEG (electroencephalogram), functional
 role of, 289-290; and impulse activity, 278,
 290; and learning responses, 303; and
 neuronal and subneuronal activity, 289-290;
 role of in information transactions, 290; and
 slow waves, intracellular, 298-299, 304, 328;
 and waveforms, 293, 301-304.
- Elazar, Z., cit., 301, 303
- Electric fish *see* Fish
- Electrodes, multiple, 266; single, 266; and
 signal sources, 266
- Electroencephalogram *see* EEG
- Electroplaques, electric eel, 247-248
- Electrotonic coupling, 295-296, 315
- Electrotonic transmission, 315
- Elul, R., cit., 294, 298, 299
- Encoding process, cryptology, 228-229;
 genetic, 228-229, 231; Shannon
 (information theory), 229-230
- Enger, P.S., cit., 319
- Ensemble codes, 284-286, 306, 308, 323
- EPSP (excitatory postsynaptic potential), 242,
 254, 258, 263, 268, 313, 319
- Erickson, R.P., cit., 274
- Error signal, 245
- Erulkar, S.D., cit., 279
- Evans, J.W., 223
- Evoked potentials, 298, 304-305
- Excitatory postsynaptic potential *see* EPSP
- Farley, B.G., cit., 275
- Fehmi, L.G., cit., 257, 275
- FitzHugh, R., cit., 245, 251
- Fibers, afferent, 273, 274; computer studies of,
 271-272; experimental studies of, 269-271;
 and latency differences in, 270; overlapping
 receptive fields of, 273-275; pairs of parallel,
 266, 267-272; theoretical studies of, 267-268;
 and two types of coding, 276
- Field, J., cit., 305
- Fiorentini, A., cit., 260
- Fish, electric, 246, 247, 248, 259, 261, 270, 285,
 304; catfish, 295; electric eel, 247-248; electric
 organ; control of, 295, 318, 321, 323; electro-
 tonic coupling in, 314; fresh-water, 291-292;
 latency coding in, 270, 275; lateral line in,
 232, 261-262
- Footpad of cat, 275-276
- Fourier transform, 303
- Fox, S.S., cit., 299, 302, 303
- Frequency coding *see* Rate code
- Fritzler, D.E., 306
- Frog, 232, 238, 284
- Frost, J.D., 223, 303; cit., 300, 301.
- Fujita, Y., cit., 301
- Fuortes, M.G.F., 223, 291
- Furshpan, E.J., cit., 304
- Furukawa, T., cit., 304
- Gaussian distributions, 250; -like form, 303, 319
- Genetic code, 228-229, 231, 235, 306
- Geniculate cell, 282
- Gersch, W., 223, 298, 303
- Gerstein, G.L., 223, 236, 271, 278, 280, 325,
 326; cit., 266, 270, 271, 272, 280, 302, 303
- Gillary, H., cit., 259
- Go! time of firing, 239, 241, 307
- Glia, 296-297, 327
- Goldfish *see* Mauthner's cell
- Gray, J.A.B., cit., 275, 276
- Grimm, R.J., cit., 269
- Hagiwara, S., cit., 261
- Harmon, L.D., 223, 270, 271, 283, 284, 324;
 cit., 243, 268, 271, 283, 297
- Hartline, H.K., 255
- Higher order neuron, 236, 307, 308
- Himrichsen, C.F.L., cit., 296
- Histogram, 294, 300, 326; amplitude, 300-301,
 303; comparison, cross-interval to PST in cat,
 272; cross-correlation, 262-265, 268, 270;
 cross-interval, 270, 272, 325; experiment,
 recorded impulses in, 262-265, 268-270;
 interval, 255, 319, 320; multimodal, 255;
 PST, 251, 270, 272, 277-282, 310, 316, 325,
 326
- Hodgkin-Huxley equations, 245
- Homophones, 228-229
- Hubel, D.H., cit., 238, 241
- Impulse coding, in many channels, 272-277; in
 pairs of fibers, 267-272; through single-
 channel recording, 277-283
- Information theory (Shannon), 229-230, 306
- Information transformation in nervous system,
 227-327

- Inhibitory postsynaptic potential *see* IPSP
 Input channels, dependent, 273; independent, 272, 273
 Input-output relation, 324; linear, 291-292
 Intercellular events, 311; nonimpulse, 288, 290
 Interpretation process, 232, 234, 236, 306
 Interpulse intervals, variance of, 254-255
 Interval variance code, 254-255, 257
 Intracellular coding, 288, 289, 294, 306, 310, 312-314
 Intracellular slow process, and EEG, 298-299, 303-305
 IPSP (inhibitory postsynaptic potential), 254
- Jansen, J.K.S., *cit.*, 248
 Jenik, F., *cit.*, 268
 John, E.R., *cit.*, 290, 306
- Kahn, D., *cit.*, 228
 Katz, B., *cit.*, 292
 Katzman, R., *cit.*, 298, 305
 Kennedy, D., 223, 259, 291, 323; *cit.*, 259, 260
 Kenshalo, D.R., *cit.*, 225
 Kiang, N.Y.-S., 224, 258, 282, 283, 324, 325; *cit.*, 303
 Kim, J.H., 243; *cit.*, 243
 Krissoff, M., *cit.*, 225
 Kuffler, S.W., 296
- Labeled lines, 237, 239, 240-241, 266, 267, 284, 308, 311, 316; concept of, 237
 Labile (adaptive) code, 231, 235
 Lal, S., *cit.*, 275
 Lampard, D.G., *cit.*, 255
 Lange, D., 224, 255
 Larimer, J.L., *cit.*, 247
 Larramendi, L.M.H., *cit.*, 296
 Latency (phase) code, 263, 269-270, 275-277, 282, 311, 324, 325; and electric fish, 270, 275
 Lateral line, 261; of electric fish, 261-262
 Laursen, M., *cit.*, 303
 Lettvin, J.Y., 327; *cit.*, 238
 Levick, W.R., *cit.*, 249, 250, 251
 Levitan, H., *cit.*, 263, 268, 293
 Lewis, E.R., 293; *cit.*, 268, 271, 283
 Libet, B., *cit.*, 306
- Limulus*, eye of, comparison of response with bee, 291; eccentric cell, 255, 256, 291, 312
 Linear relation, of EEG and intracellular waves, 298-299; input-output, 291-292
 Littal, W.R., *cit.*, 225
 Llinás, R., 293
 Lobster, cardiac ganglion of, 257, 320; joint receptors in, 243
 Locust, wing, motion in, 236, 237, 241, 260, 261, 316-317
 "Logic function," 230
 Lorente de Nó, R., *cit.*, 293
- McCulloch, W.S., *cit.*, 238
 McCulloch-Pitts conceptual neuron, 289
 MacKay, D.M., 224, 230, 234, 260, 285, 321; *cit.*, 260, 297
 Matthews, P.B.C., 248
 Maturana, H.R., *cit.*, 238, 241, 284
 Mauthner's cell, 241, 284, 285, 304
 Mellon, DeF., Jr., *cit.*, 260
 Membranes, and electrical properties, 293; and time, 293
 Microstructure codes, 259, 260
 Miledi, R., *cit.*, 292
 Minimal nets, 268
 Monoalphabetic code, 228
 Moore, G.P., *cit.*, 229, 239
 Morita, H., *cit.*, 261
 Morrell, F., 224, 280, 282, 300, 301, 302, 326; *cit.*, 278, 281, 302
 Mountcastle, V.B., 224, 248, 283, 290, 296, 328
 Müller, J., *cit.*, 237, 316
 Multimodal histograms, 255
 Multiple channel impulse codes, 266-286, 308-309, 324-328; computer studies, 271-272, 273; experimental studies, 268-271; skin stimulation and mechanical depression, 283; theoretical study, 267-268
- Necturus*, 296
 Nelson, P.G., 304
 Nerve impulses, and multiple channels, 266-286; and single channels, 239-265
 Neural coding, 227-327; approaches to study of, 232-234; definition of, 228, 306; *see also* Code, Codes, Coding
 Neuromimes, 268, 270
 Neuron, higher-order, 236, 307, 308; doctrine, 288

- Noise, 229, 234, 259
 Nomoto, M., cit., 283
 Nonimpulse carriers *see* Nonimpulse codes
 Nonimpulse codes, 238, 287-305, 307; inter-cellular candidate codes, 288, 290; between neurons, 295-297; and slow waves, 297-305; subcellular, 290-294
 Norman, R.J., cit., 299
 Null hypothesis, 253
 Number codes, 261-262
- O'Brien, J.H., cit., 302, 303
 Ogden, T.E., cit., 296
 Olfactory bulb, 292, 295, 298
 Overlapping receptive fields, 273-275
- Pacemaker neuron, *Aplysia*, 254, 255
 Palay, S.L., 296
 Pantin, C.F.A., cit., 246
 Pappas, G.D., 295
 Parallel channels, nerve impulses and trains in, 252, 266-286, 307
 Partridge, L.D., 224, 242, 243, 244, 275; cit., 243, 244
 Pathways, parallel *see* Parallel channels
 Pattern codes, 252, 256-260, 269, 271, 320; change of, 258, 259
 Pattern-sensitive systems, 247
 Perkel, D.H., 224, 255, 262, 270, 272; cit., 229, 239, 240, 254, 255, 257, 264, 268, 271, 272
 Phase coding *see* Latency coding
 Phase lag, 243
 Photoreceptor cells, *see Aplysia*, bee, *Limulus*, Primate retina
 Pitts, W.H., cit., 238
 Poisson distributions, 257, 264, 272, 273, 318
 Polyalphabetic code, 228
 Postsynaptic cell, 254-258, 262, 264, 265, 272, 273
 Potassium ion, 297
 Pre- and postsynaptic impulses, time relationship of, 262
 Pribram, K.H., cit., 306
 Primate retina, 296
 Pritchard, R.H., cit., 255
 PSP (postsynaptic potential), 248
 PST (poststimulus time) histogram, 251, 270, 272, 277-282, 311, 317, 326-327; and cross-interval 272; experiments, 278-282
- Pulse-rate code, 243-245; frequency modulation, 275
 Purkinje cells, 269, 289, 293
 Putative code *see* Candidate code
- Quantum:spike ratio, 249, 250, 253
 Quarton, G.C., 224
- Rall, W., 224, 292, 293, 295; cit., 292, 293, 295, 298
 Rate code, 242-262; experiments and examples, 243-253, 255, 260; two types of, 243
 Ratio, signal-to-noise, 236
 Ratliff, F., 255; cit., 255, 256, 319
 Receptive fields, 321; overlapping, 273-276
 Receptors, 227, 243, 245, 248, 252, 270, 288, 290, 291, 306, 316, 322; cell, 291; electro-, 291, 292, 322, 324; sense, 324-325; stretch, 255, 260, 291, 316
 Redman, S.J., cit., 255
 Reese, T.S., cit., 295
 Referent, code, 232-233, 252, 253, 307
 Reiss, R.F., cit., 267, 268
 Reliability, 229, 234, 236
 Responses to learning, in cat, 303
 Retinal ganglion cells, *Aplysia*, 255, 257, 319, 321; cat, 249-252, 255, 318; threshold of, 249-252; two-channel code for, 271-274
 Ruchkin, D.S., cit., 306
 Rupert, A., cit., 258
- Sach's organ, 247, 248
 Schmitt, F.O., 224
 Schulman, J.H., 257
 Sea anemone, 246, 316-317
 Segundo, J.P., 224, 236, 242, 253, 262, 293, 322; cit., 229, 249, 257, 258, 272
 Shannon, C.E., 229, 230, 307; cit., 229; information theory, 229-230, 307; non-Shannon, 227
 Shepherd, G.M., cit., 295, 298
 Shevrin, H., 306
 Single channels (Single-channel spike codes), 238, 239-265, 267, 307-308; and multiple-channel recording, 278; statistics of impulses, 262-265; *see also* Candidate codes
 Slow waves, 289, 290, 293, 297-305, 315, 328; evoked potentials of, 298, 304-305; extra-cellular, 289; hypothesis, 290; and ongoing EEG, 298-300, 311, 328

- Smith, T.G., *cit.*, 272
"Specific nerve energies," doctrine of, 237, 317
Spectral analysis, 273, 298; of EEG activity, 303
Spike, and quantum:spike ratio, 249; and sodium system, 245; and rates of firing, 241, 242-245; and wave processes, 301-302
Spike time, example of, 241; intervals, 239, 241, 259; occurrence of, 241; relationships of, 239, 240
Spoendlin, N., *cit.*, 296
Squid, giant synapse of, 292
Stein, R.B., 224, 245, 248, 250, 255, 283, 319; *cit.*, 249
Stimulus-related codes, 277-283
Stochastic point processes, theorem, 272
Subcellular nonimpulse codes, 290-294
Sutton, S., 224, 305; *cit.*, 303, 305
Szabo, T., *cit.*, 319
- Temporal pattern *see* Pattern codes
Terzuolo, C.A., *cit.*, 304
Torpedo, 262
Transducer, 229
Transformation, property of code, 232, 233, 234, 307
Transmission of transformed information, 232, 233, 307
Trophic effects, 297
- Van Bergeijk, W., *cit.*, 283
- Walter, D.O., 304; *cit.*, 305
Waves and impulses, relationship of, 277, 278, 289, 290
Waveforms, neuronal, 266, 269, 293; in EEG, 297, 301-303
Weaver, W.W., *cit.*, 229
Wicke, J.D., *cit.*, 305
Wiersma, C.A.G., 323; *cit.*, 257
Wiesel, T.N., *cit.*, 238, 241
Wilson, D.M., 224, 236, 237, 241, 260, 297; *cit.*, 247, 260, 261
Wyman, R.J., *cit.*, 261

NRP ASSOCIATES AND THEIR INSTITUTIONAL AFFILIATIONS

Dr. W. Ross Adey
Professor of Anatomy
Center for the Health Sciences
University of California at Los Angeles

Dr. Leroy G. Augenstein
Professor of Biophysics
Biology Research Center
Michigan State University

Dr. David Bodian
Professor of Anatomy
The Johns Hopkins University
School of Medicine

Dr. Theodore H. Bullock
Professor of Neurosciences
University of California, San Diego
School of Medicine

Dr. Melvin Calvin
Professor of Chemistry
University of California at Berkeley

Dr. Leo C. M. DeMaeyer
Max-Planck-Institut für
Physikalische Chemie
Göttingen, Germany

Dr. Mac V. Edds, Jr.
Visiting Professor of Neurosciences
University of California, San Diego
School of Medicine

Dr. Gerald M. Edelman
Professor
The Rockefeller University

Dr. Manfred Eigen
Hon. Professor and Director
at Max-Planck-Institut für
Physikalische Chemie
Göttingen, Germany

Dr. Humberto Fernandez-Moran
Professor of Biophysics
University of Chicago

Dr. Robert Galambos
Professor of Neurosciences
University of California, San Diego
School of Medicine

Dr. John B. Goodenough
Research Physicist and Group Leader
Lincoln Laboratory
Massachusetts Institute of Technology

Dr. Holger V. Hydén
Director, Institute of Neurobiology
University of Göteborg
Göteborg, Sweden

Dr. Mark Kac
Professor
The Rockefeller University

Dr. Aharon Katchalsky
Director, Department of Polymer
Research
Weizmann Institute of Science
Rehovoth, Israel

Dr. Seymour S. Kety
Director, Psychiatric Research
Laboratories
Massachusetts General Hospital
Professor of Psychiatry
Harvard Medical School

Dr. Heinrich Klüver
Sewell L. Avery Distinguished
Service Professor Emeritus of
Biological Psychology
University of Chicago

NRP ASSOCIATES AND THEIR INSTITUTIONAL AFFILIATIONS [continued]

Dr. Albert L. Lehninger
DeLamar Professor and Director
Department of Physiological Chemistry
The Johns Hopkins University
School of Medicine

Dr. Robert B. Livingston
Professor and Chairman
Department of Neurosciences
University of California, San Diego
School of Medicine

Dr. Donald M. MacKay
Professor of Communication
The University of Keele
Keele, England

Dr. Harden M. McConnell
Professor of Chemistry
Stanford University

Dr. Neal E. Miller
Professor
The Rockefeller University

Dr. Frank Morrell
Professor of Neurology
Stanford University School of Medicine

Dr. Vernon B. Mountcastle
Professor and Director
Department of Physiology
The Johns Hopkins University
School of Medicine

Dr. Walle J. H. Nauta
Professor of Neuroanatomy
Massachusetts Institute of Technology

Dr. Marshall Nirenberg
Chief, Section on Biochemical Genetics
Laboratory of Clinical Biochemistry
National Heart Institute
National Institutes of Health

Dr. Lars Onsager
J. Willard Gibbs Professor of
Theoretical Chemistry
Sterling Chemistry Laboratory
Yale University

Dr. Detlev Ploog
Director, Klinisches Institut
Max-Planck-Institut für Psychiatrie
Munich, Germany

Dr. Gardner C. Quarton
Director
Mental Health Research Institute
University of Michigan

Dr. Werner Reichardt
Director, Max-Planck-Institut
für Biologische Kybernetik
Tübingen, Germany

Dr. Richard B. Roberts
Department of Terrestrial Magnetism
Carnegie Institution of Washington

Dr. Francis O. Schmitt
Institute Professor
Professor of Biology
Massachusetts Institute of Technology

Dr. William H. Sweet
Massachusetts General Hospital
Professor of Surgery
Harvard Medical School

Dr. Paul A. Weiss
Professor Emeritus
The Rockefeller University