

NASA TECH BRIEF

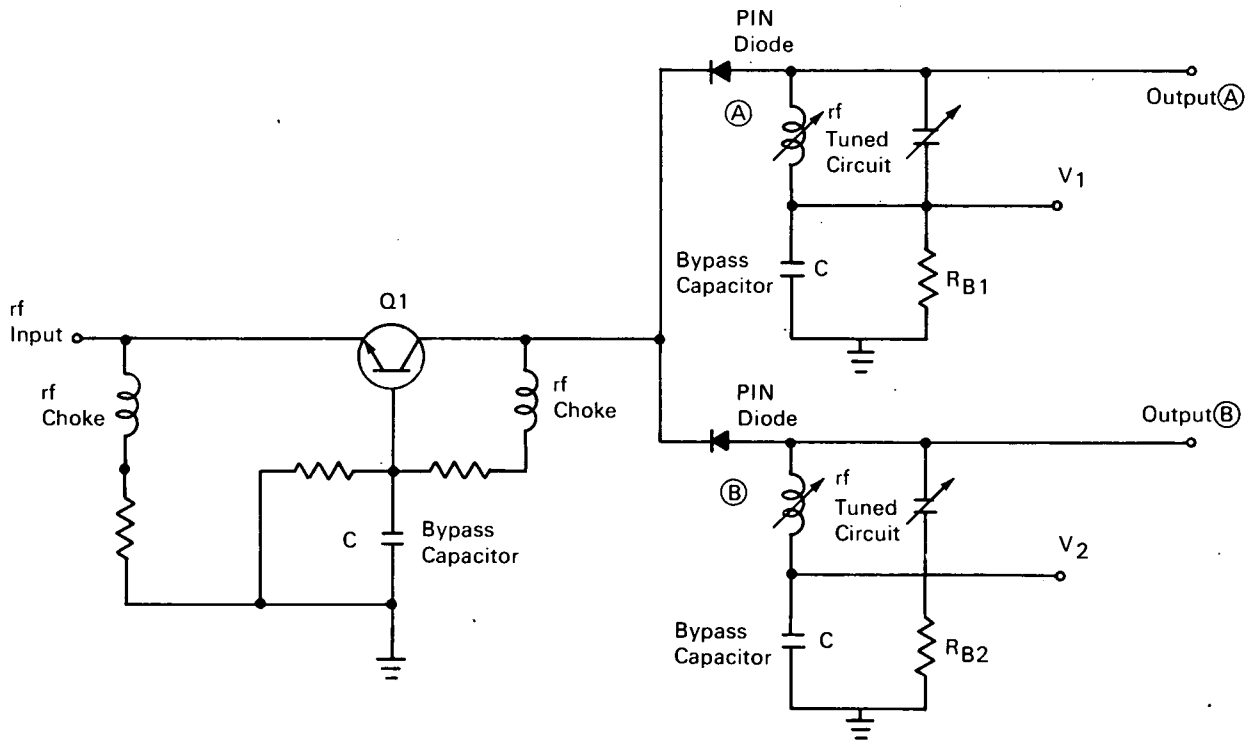

NASA Tech Briefs announce new technology derived from the U.S. space program. They are issued to encourage commercial application. Tech Briefs are available on a subscription basis from the Clearinghouse for Federal Scientific and Technical Information, Springfield, Virginia 22151. Requests for individual copies or questions relating to the Tech Brief program may be directed to the Technology Utilization Division, NASA, Code UT, Washington, D.C. 20546.

PIN Diode Switch



PIN Diode Switch

The problem:

Switch the output power of an rf amplifier to one of several outputs using solid-state switches requiring no special voltages and using minimum power.

The solution:

A PIN diode switch was designed using the same voltage and power supply as the rf amplifier.

How it's done:

A PIN diode has the property of attenuating rf power in proportion to the inverse logarithm of the

current flowing through it. The current required for full conduction is relatively high and the voltage drop is low. Normally, this would require either a separate power supply or a power loss in voltage-dropping resistors. The circuit shown in the figure requires neither a separate power supply nor voltage dropping resistors. The current needed to operate the diodes is obtained from the same power supply that powers the rf amplifier. The flow of rf power is determined by the point of application of the B⁺ voltage. For

(continued overleaf)

example, if B^+ voltage is applied to point V_1 , the rf power flows to output A, at the same time PIN diode B is kept in full attenuation by the lack of voltage at V_2 and by the 50k-ohm resistor R_{B2} .

Notes:

1. The use of PIN diode switching in rf amplifier stages simplifies circuit design and reduces the input power requirements. This innovation may be useful in mobile and fixed-base radio equipment, and in microwave communications systems.

2. No additional documentation is available. Specific questions, however, may be directed to:
Technology Utilization Officer
Goddard Space Flight Center
Greenbelt, Maryland 20771
Reference: B70-10278

Patent status:

No patent action is contemplated by NASA.

Source: Charles S. Vanek of
Goddard Space Flight Center
(GSC-10661)