

DEVELOPMENT AND EVALUATION  
OF AN IMPEDANCE CARDIOGRAPHIC SYSTEM  
TO MEASURE CARDIAC OUTPUT  
AND OTHER CARDIAC PARAMETERS

JULY 1, 1968 TO JUNE 30, 1969

N70-10001  
N70-10025

(ACCESSION NUMBER)  
465

(PAGES)  
NASA-CR-101965

(THRU)

(CODE)  
04

(CATEGORY)

FACILITY FORM 643

Performed under Contract No. NAS 5-4500

University of Minnesota  
Minneapolis, Minnesota

NATIONAL AERONAUTICS AND SPACE ADMINISTRATION  
Manned Spacecraft Center  
Houston, Texas

NASA CR 101965

N70-10001

DEVELOPMENT AND EVALUATION OF AN IMPEDANCE CARDIOGRAPHIC SYSTEM  
TO MEASURE CARDIAC OUTPUT AND OTHER CARDIAC PARAMETERS

July 1, 1968 to June 30, 1969

by

W. G. Kubicek, Ph.D., Principal Investigator

D. A. Witsoe, M.E.E., and R.P. Patterson, M.E.E.,  
and A.H.L. From, M.D. Co-Investigators

University of Minnesota College of Medical Sciences  
Minneapolis, Minnesota

Performed under Contract No. NAS 9-4500

by

University of Minnesota  
Minneapolis, Minnesota

for

NATIONAL AERONAUTICS AND SPACE ADMINISTRATION  
Manned Spacecraft Center  
Houston, Texas

## FOREWORD

Classical physiology texts describe the basic function of the heart as a blood pump. Ironically, after over three centuries of research since William Harvey's disclosure of the nature of the circulatory system in 1632 the pumping action of the heart remains an elusive parameter to measure without resorting to inconvenient, expensive, and somewhat traumatic procedures requiring sterile surgery to insert catheters into or near the heart. At the same time relatively simple, non-invasive methods are available to record other parameters related to myocardial function such as electrical activity, pulse rate and blood pressure. Obviously, a great need exists for a similarly simple non-invasive method to obtain information concerning the mechanical activity of the heart.

The data presented in these pages stand as testimony to the great dedication and desire by the participating investigators to contribute to the development of a non-invasive method to assess cardiac function and other parameters of the cardiovascular system.

The papers presented here were previously presented at the First Symposium on Impedance Cardiography held at the NASA Manned Spacecraft Center, Houston, Texas, June 2,3,4, 1969.

The investigators outside of the University of Minnesota had no support except to be supplied with a Minnesota Impedance

Cardiograph and some technical assistance through our NASA contract.

Special tribute must go to three groups who participated in the symposium without previous NASA support, but presented valuable data and excellent manuscripts for this report.

Dr. E. Kinnen, Drs. Richard Namon and Frank Gollan, and Dr. Robert D. Allison are to be commended for their good work.

Some frustration and understandable disappointment has been expressed by some in the variable results obtained in the measurement of the absolute value of stroke volume and cardiac output by the impedance method. On the otherhand, many investigators have been stimulated by the progress thus far and are vigorously exploring the use of the impedance system to obtain information in regard to other physiological parameters related to the cardiovascular system.

Transthoracic impedance has been shown to be a very sensitive indicator for the detection of pulmonary edema. Also, any other fluid accumulation in the chest, such as pleural effusion, is quickly sensed by observing transthoracic impedance changes. Likewise, the reversal of these conditions can be followed by this method.

Such basic determinations of myocardial function as cardiac contractility appear to be possible from thoracic impedance measurements. Several intriguing applications of impedance measurements in heart transplant patients and other cardiac patients are presented here. New research indicates that impedance measurements will be useful in certain peripheral vascular problems.

IIa

If another year produces as much progress as the last year, the use of electrical impedance determinations across various parts of the body appears to be insured of a wide spectrum of applications. A perusal of the index will confirm this.

Let us hope that acceptance will not take as long as the development of the electrocardiograph.

W. G. Kubicek, Ph.D.

### III

#### Index

	<u>Page</u>
1. Applications of the Minnesota Impedance Cardiograph. Kubicek <u>et al.</u>	1 ✓
2. The Use of the Minnesota Impedance Cardiograph in the Chronic Monitoring of Cardiac Transplant Patients at the Groote Schuur Hospital, Cape Town. David A. Boonzaier, and C. N. Barnard, M.D., M. Med., M.S., Ph.D., D.Sc. (Hon. Causa), F.A.C.S., F.A.C.C.	16 ✓
3. The Use of the Impedance Cardiograph in Assessing the Human Cardiac Transplant. Robert L. Kaster, B.E.E., C. Walton Lillehei, M.D., Ph.D., and Peter J. Starek, M.D.	43 ✓
4. Transthoracic Electrical Impedance as a Clinical Guide to Intrathoracic Fluid Volumes. Marvin Pomerantz, M.D. and Ben Eiseman, M.D.	67 ✓
5. Alterations in Transthoracic Electrical Impedance with Acute Intravascular Overload. Irwin R. Berman, MAJ, MC, USAR, Walter L. Scheetz, LTC, MC, USA, Edward B. Jenkins, B.S., and Howard V. Hufnagel, B.S.	78 ✓
6. Pulmonary Extravascular Water Volume. Potential for Measurement by the Minnesota Impedance Cardiograph. Joseph M. Van De Water, M.D., Jaen-Min Sheh, M.D., Nicholas E. O'Connor, M.D., and Francis D. Moore, M.D.	97 ✓
7. Clinical and Experimental Use of Thoracic Impedance Plethysmography in Quantifying Myocardial Contractility. John H. Siegel, M.D., Miklos Fabian, Charles Lankau, M.D., Andrew Cole, M.D., Michel Nahmad, M.D., and Michael Levine, M.D.	103 ✓
8. The First Derivative Thoracic Impedance Cardiogram A Useful Signal for Timing Events in the Cardiac Cycle. Zuhdi Lababidi, M.D., D. A. Ehmke, M.D., Ph.D., Robert E. Durnin, M.D., Paul E. Leaverton, Ph.D., and Ronald M. Lauer, M.D.	142 ✓
9. Physiological Correlates of the Cardiac Thoracic Impedance Waveform. James N. Karnegis, M.D. and William G. Kubicek, Ph.D.	162 ✓
10. Comparison of Methods for Calculating Stroke Volume from Aortic Pressure and Impedance Cardiograph. W. Sanford Topman, Ph.D., and Homer R. Warner, M.D., Ph.D.	175 ✓
11. The Development of a Transfer Function Between Aortic Blood Flow and the First Derivative of the Thoracic Impedance. Robert P. Patterson, MSEE., David A. Witsoe, MSEE., A.H.L. From, M.D. and W. G. Kubicek, Ph.D.	186 ✓

## IV

	<u>Page</u>
12. Evaluation of Thoracic Impedance Plethysmography as an Indicator of Stroke Volume in Man. Robert J. Bache, M.C., Alexander Harley, M.B., M.R.C.P., and Joseph C. Greenfield, Jr., M.D.	203 ✓
13. Studies Using the Impedance Cardiograph as a Potential Monitor During Treatment of Acute Dissecting Aneurysms. R. S. Eliot, Howard W. Ramsey, R. F. Palmer, and E. K. Prokop.	236 ✓
14. A Comparison of Cardiac Output Values by the Impedance Cardiograph and Dye Dilution Techniques in Cardiac Patients. Loren W. Heather, M.D.	247 ✓
15. Estimate of Cardiac Output with the Impedance Cardiograph During Postural Stress. James J. Smith, John E. Bush, V. Thomas Wiedmeier and Felix E. Tristani.	259 ✓
16. A Comparison of Changes in Stroke Volume and Cardiac output in Subjects Stressed by Upright Tilt and Lower Body Negative Pressure. Richard J. Gowen, Major, USAF, Ph.D., Richard D. Barnett, M.S., and Fred L. Zaebst, M.S.	267 ✓
17. Comparative Evaluation of the Thoracic Impedance and Isotope Dilution Methods for Measuring Cardiac Output. W. V. Judy, F. M. Langley, K. D. McCowen, D. M. Stinnett, L. E. Baker and P. C. Johnson.	296 ✓
18. Comparative Evaluation of the Thoracic Impedance and Electromagnetic Flow Probe Method for Measuring Cardiac Output. William V. Judy, Frank M. Langley, Karl D. McCowen, and Lee E. Baker.	301 ✓
19. Evaluation of Electrical Impedance Cardiographic Measurements of Heart Function in Comparison to Indicator Dilution and Pressure Gradient Methods. Ray T. Steigbigel, Henry Babbit, and J. Richard Warbasse.	314 ✓
20. Evaluation of Impedance Cardiographic Techniques for Measuring Relative Changes in Cardiac Output by Simultaneous Comparison with Indicator Dilution and Electromagnetic Flowmeter. David A. Witsoe, MSEE, Robert P. Patterson, MSEE., A. H. L. From, M.D., and W. G. Kubicek, Ph.D.	330 ✓
21. Impedance Stroke Volume. A Comparison in Dogs and Man with Electromagnetic Flowmeters and Dye Dilution Respectively. Wayne E. Martin, M.D.	357 ✓
22. Cardiac Output from Transthoracic Impedance Variations, Review of Experience with Heart Patients. E. Kinnen	385 ✓

23. Resistive and Reactive (Capacitive) Cardiac Impedance Pulses. Dr. Richard Namon and Dr. Frank Gollan.
24. The Potential Role of Impedance Plethysmography in Aerospace Medicine. Robert D. Allison, Ph.D.

404 ✓

422 ✓



W 70 10002

Applications of the Minnesota Impedance Cardiograph - Kubicek et al.

The measurement of thoracic impedance for use in estimating cardiac output (University of Minnesota method) or other cardiovascular or pulmonary functions requires a four electrode configuration. The placement of electrodes on a subject and the electrical and mechanical properties of electrodes are important to the obtaining of reliable data. The following paragraphs describe the electrode configuration developed at the University of Minnesota and some of the applications of the Impedance Cardiograph.

The four band electrode configuration is shown in Figures IV-1 and IV-2. Two conductive strip electrodes, approximately 6 mm wide, are placed, two around the neck and two around the abdomen. The outer two electrodes are spaced at least three centimeters away from the inner electrodes in order to obtain accurate readings and to avoid non-linearities in the electrical parameters involved. The inner two electrodes are placed, one around the base of the neck and the second at the level of the xiphisternal joint. The outer two electrodes are positioned as shown. The electrodes are numbered 1, 2, 3 and 4 from the neck down and are connected to the Impedance Cardiograph by the appropriate numbered clips on the patient connecting cable of the instrument.

A disposable electrode has been fabricated by the 3M Company, St. Paul, Minnesota\*. The electrode is constructed from one mil aluminum deposited on a polyester film and bonded to an adhesive

---

\*for availability see page 15.

PRECEDING PAGE BLANK NOT FILMED.

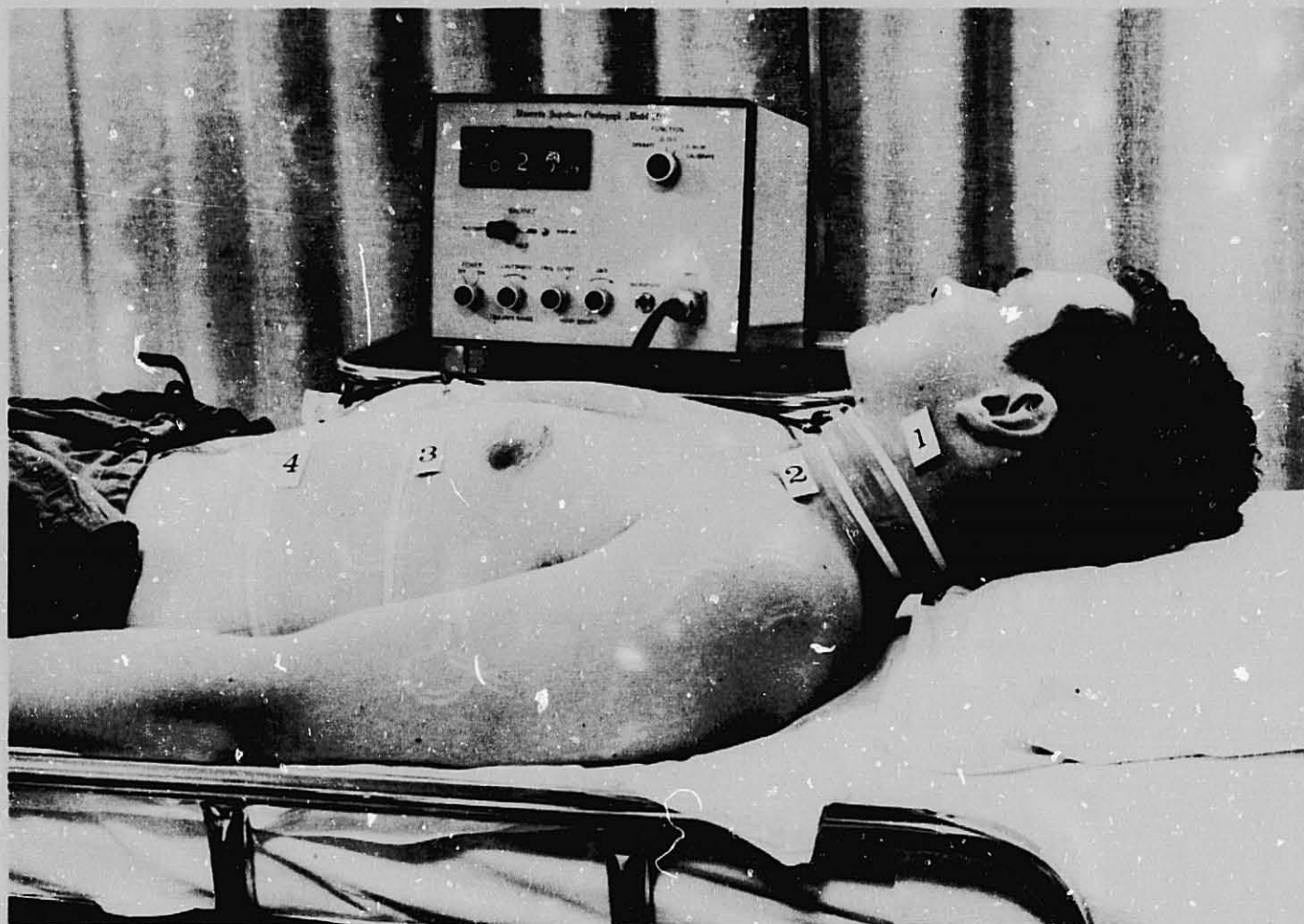

Figure IV-2

A photograph of the tape-on electrodes in place. It is important to maintain good separation between electrodes 1 and 2. This electrode configuration is used for obtaining (1) cardiac function data and (2) changes in total fluid in the chest by observing  $Z_0$  (the total impedance between electrodes 2 and 3). The  $Z_0$  measurement has been found to be a very sensitive indicator of the development or reversal of such conditions as pulmonary edema, pulmonary congestion and pleural effusion.

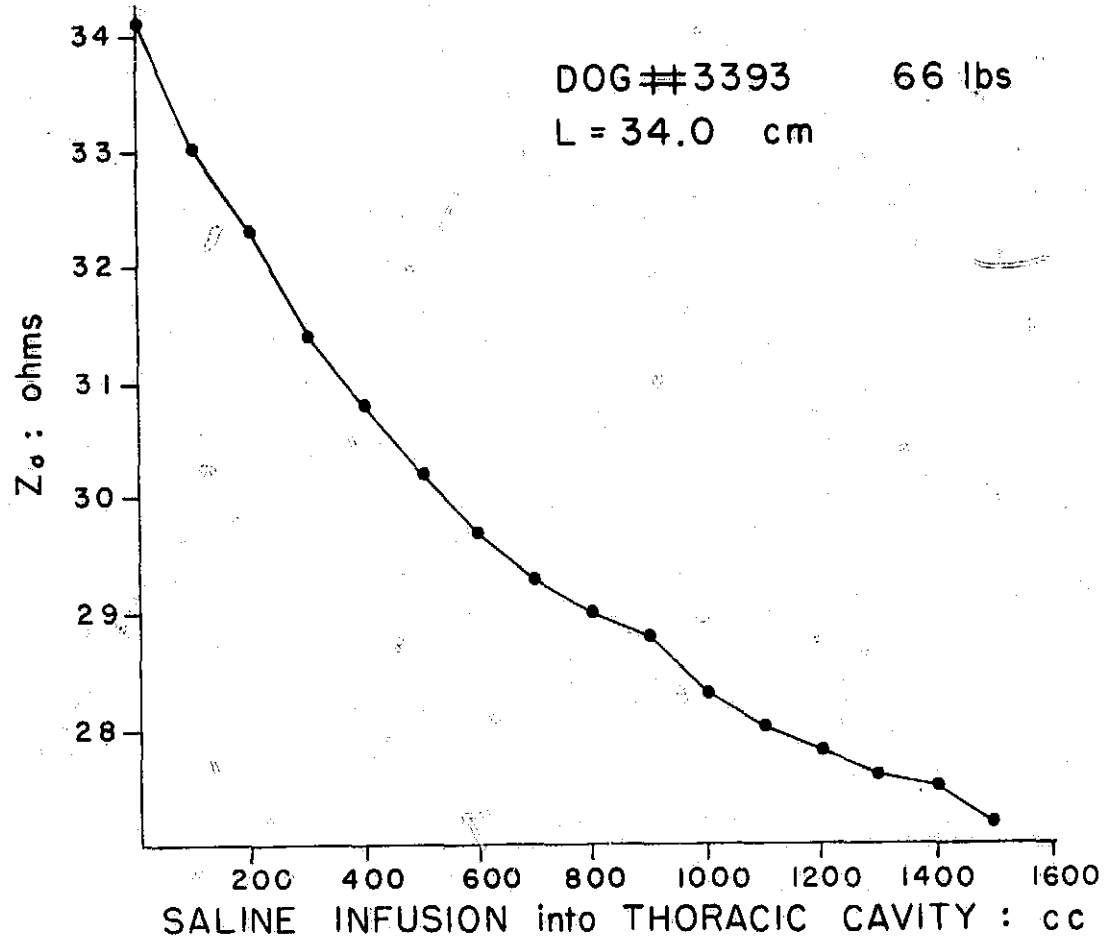

Figure IV-3

An example of the decrease in the value of  $Z_o$  resulting from a saline infusion into a dog's chest. Similar changes in  $Z_o$  have been observed by Pomerantz et al. (Surgery July 1969) during the development of experimental pulmonary edema. The reversal of these conditions then results in an increase in the value of  $Z_o$ .

Calculation of the Stroke Volume and Cardiac Output

This section describes the method for calculating the stroke volume and cardiac output using the first derivative waveform. It appears that the most reliable use of this method thus far

is to obtain ratios of change in cardiac output. For example, this would be the percentage change in cardiac output from a quiet resting condition to that of some standardized exercise.

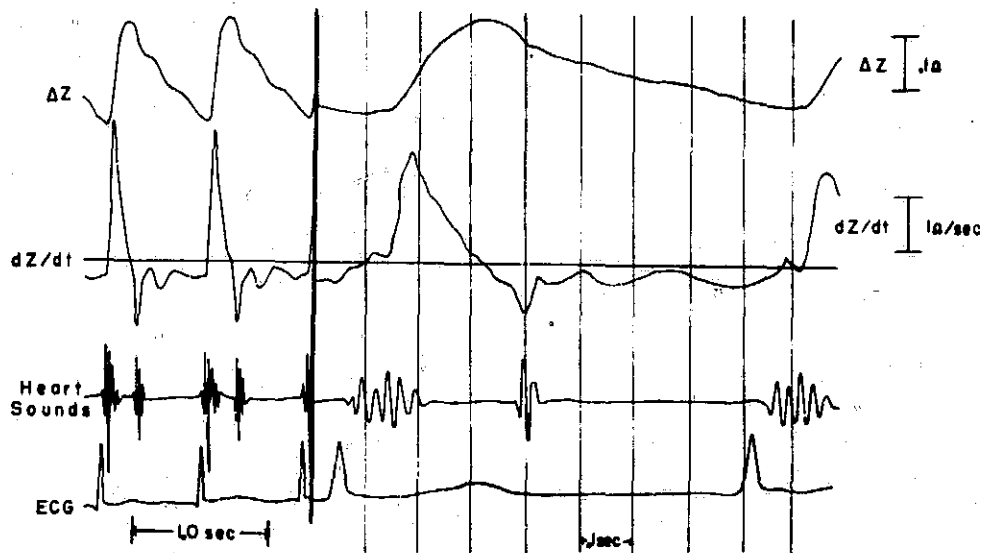

Figure IV-4

Figure IV-4 shows  $\Delta Z$ ,  $dZ/dt$ , heart sounds and ECG waveforms. From this figure the time relation of the impedance information with respect to the heart sounds and ECG can be seen. Negative is upward in both the  $\Delta Z$  and  $dZ/dt$  waveforms.

The stroke volume is calculated using the equation shown below

$$\Delta V = \rho \frac{L^2}{Z^2} T(dZ/dt)_{\min}$$

where

$\Delta V$  = ventricular stroke volume (cc)

$\rho$  = the electrical resistivity of blood at 100 kHz (average value 150 ohm-cm)

$L$  = the mean distance between the two inner electrodes (2 and 3) in cm.

$Z_0$  = the mean body impedance between the two inner electrodes in ohms.

$(dZ/dt)_{\min}$  = the minimum value of  $dZ/dt$  occurring during the cardiac cycle in ohms per second (see Figure IV-5).

$T$  = the ventricular ejection time in seconds as obtained from the  $dZ/dt$  waveform (see Figure IV-5).

Cardiac output is calculated from the stroke volume and pulse rate as shown below

$$C.O. = \Delta V \cdot PR / 1000$$

C.O. = cardiac output in liters/min

$\Delta V$  = stroke volume in cc

PR = pulse rate in beats/min determined by measuring the time interval between the beat used to calculate the stroke volume and the previous beat.

To obtain the value of  $L$ , measure the distance between the two inner electrodes (2 and 3) in the front and back

of the subject and then compute the mean value of the two measurements in cm.

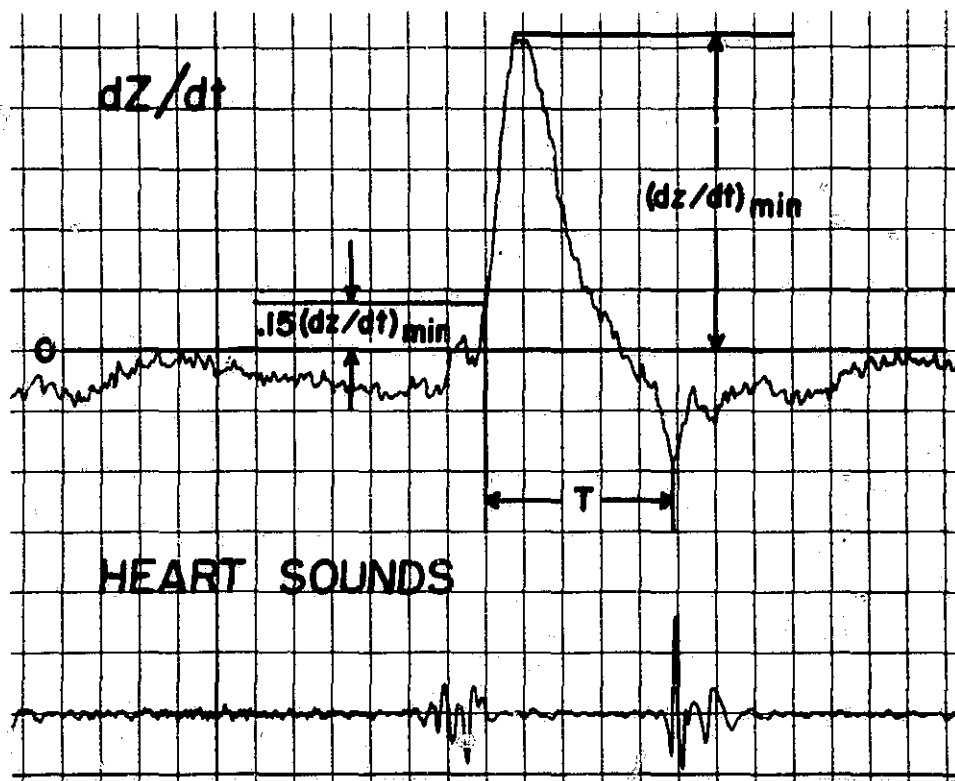

Figure IV-5

Figure IV-5 shows the  $dZ/dt$  waveform along with the heart sounds. The measurements of  $(dZ/dt)_{\min}$  and  $T$  are shown on the waveform. The value of  $(dZ/dt)_{\min}$  is measured from zero to the most negative point (negative is upward) on the waveform. The ejection time  $T$  is measured in time from  $.15(dZ/dt)_{\min}$  to the most positive peak of  $dZ/dt$ . The starting point for determining  $T$  is obtained by going back in time down the  $dZ/dt$  waveform from the negative peak to a point on the curve equal to  $.15(dZ/dt)_{\min}$ . The zero crossing of  $dZ/dt$  before the negative peak could also be used but because of small oscillations in the waveform before the large negative peak,  $.15(dZ/dt)_{\min}$  is a more reliable point.

The difference between the two is usually small. The end of T is usually determined from the sharp positive point in the  $dZ/dt$  waveform after  $(dZ/dt)_{\min}$  as shown in Figure IV-5. With some subjects no single sharp positive point is apparent. Therefore the  $dZ/dt$  waveform cannot be accurately used to determine the end of systole.

Figure IV-6 shows a waveform where there is not a positive point that clearly shows the end of the ventricular ejection. In such cases the beginning of the second heart sound is used to indicate the end of ventricular ejection.

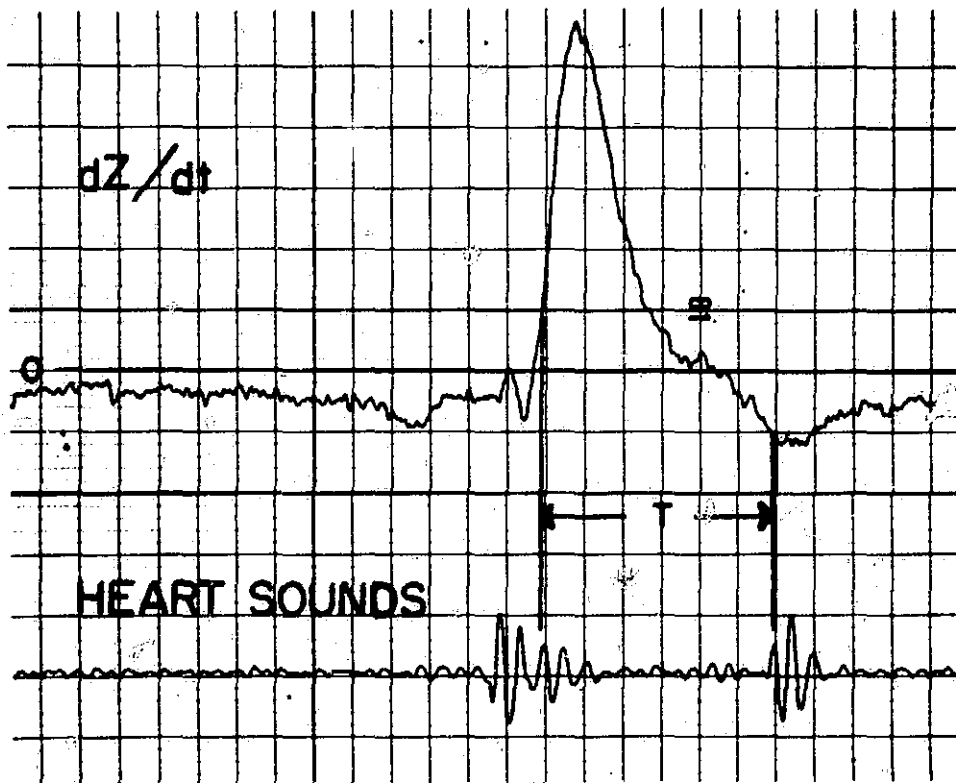

Figure IV-6

Calibration of the impedance waveform is obtained from the internal calibrator as described in Section III (Figure III-2).

The Impedance Cardiograph can also be used as a visual monitor of the mechanical action of the heart. The  $\Delta Z$  and  $dZ/dt$  recordings can indicate a variety of cardiac irregularities. An example of pulsus alternans in a dog is shown in Figures IV-7 and IV-8.

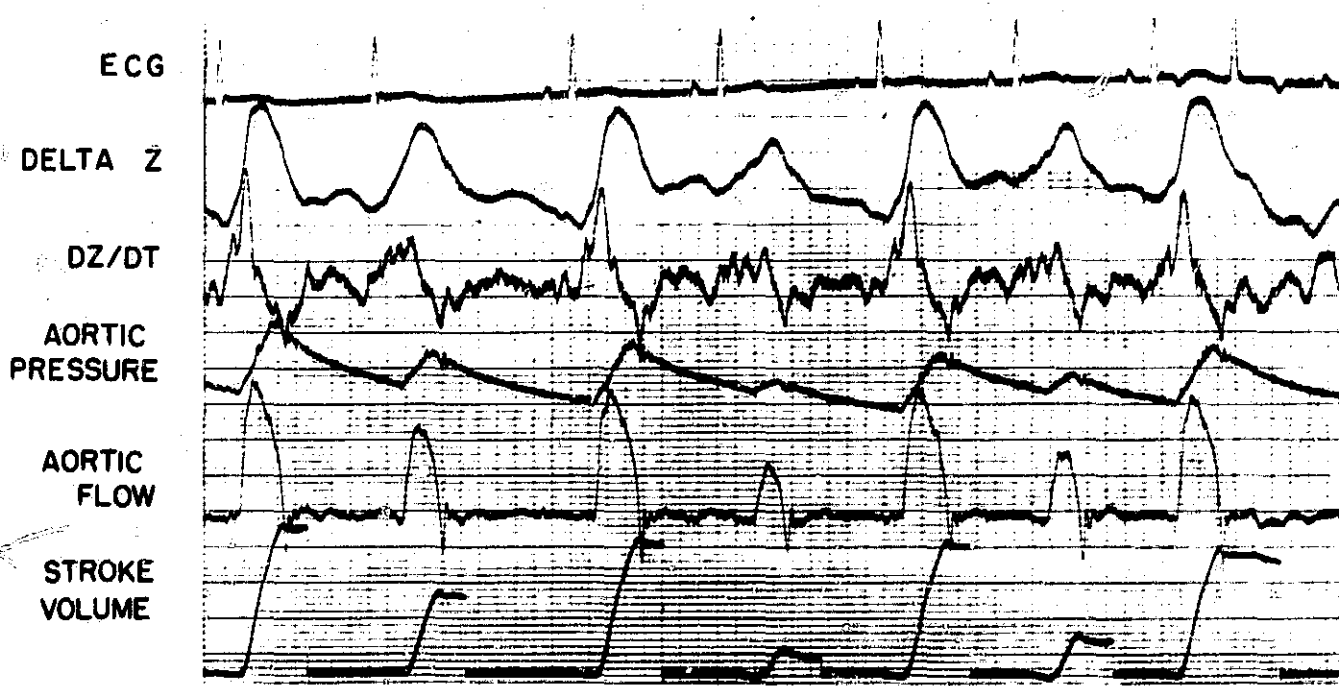

Figure IV-7 A record of the ECG,  $\Delta Z$ , ( $dZ/dt$ ), aortic pressure, ascending aortic flow and left ventricular stroke volume in an anesthetized dog. Note that the ECG record gives no hint of the pulsus alternans clearly indicated in the ( $dZ/dt$ ), aortic pressure, aortic flow and stroke volume tracings.





Figure IV-8 The same record as in Figure IV-7 except that only the ECG and (dZ/dt) tracings are included to illustrate the use of the (dZ/dt) output as a visual monitor of cardiac irregularities not evidenced by the ECG.

The Impedance Cardiograph has also been used to study circulation in the legs. An example of the unit in use as a venous occlusion plethysmograph is shown in Figure IV-9. The same electrode arrangement can be used to study leg volume changes (between electrodes 2 and 3) during the application of lower body negative pressure or gravitational forces. The valsalva

maneuver also results in leg volume changes. The instrument should also be useful in peripheral circulatory disease by observing the difference between recordings of  $\Delta Z$  and  $dZ/dt$  in normal and abnormal conditions. Figure IV-10 shows examples of the  $\Delta Z$  output recordings during venous occlusion and the valsalva maneuver. The  $\Delta Z$  Automatic Balance Range should be set to maximum and the balance switch should be turned to the manual position for about 0.1 seconds and then returned to the automatic position immediately preceding each recording.

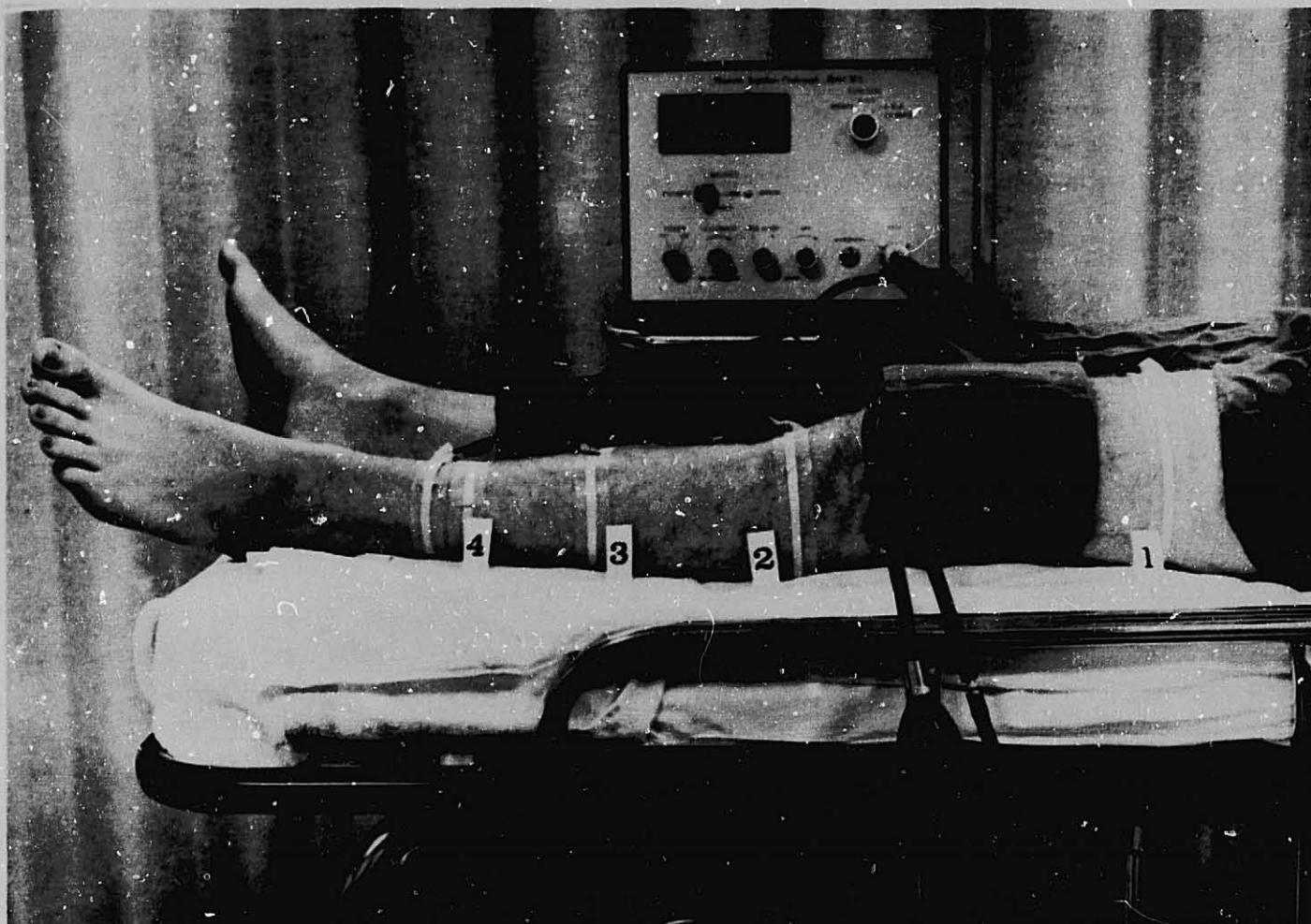

Figure IV-9 A view of the four electrodes in place to record leg volume changes between electrodes 2 and 3 as a result of inflating the blood pressure cuff between electrodes 1 and 2.

For best results it is recommended that ECG electrode paste be used for limb impedance recordings especially in cases where heavy hair is present. The circuits are designed primarily for transthoracic impedance recordings and therefore some precautions should be observed in attempting to use the system on the extremities. The  $Z_0$  reading should be maintained between 10 and 80 ohms. If the reading is below 10 ohms, the distance between electrodes 2 and 3 should be increased and if the  $Z_0$  reading is greater than 80 the distance between electrodes 2 and 3 should be decreased. Also note that electrode 4 is made up of two turns around the ankle to provide a larger surface area for the flow of current from the constant current oscillator. Again adequate (3 cm minimum) spacing should be maintained between electrodes (1 and 2) and (3 and 4).

The following formula has been used to calculate the leg volume change between electrodes 2 and 3

$$\Delta V = \rho \frac{L^2}{Z_0^2} \Delta Z = \text{cc}$$

where

$\rho$  = 220 ohm cm. (With more research this value may be changed slightly)

$L$  = the distance (cm) between electrodes 2 and 3

$Z_0$  = the total impedance between electrodes 2 and 3

$\Delta Z$  = the impedance change during the applied stress

The blood flow rate into the limb segment between electrodes 2 and 3 can be calculated from  $\Delta V/\Delta T$ , where  $\Delta T$  = the time interval for the impedance change  $\Delta Z$  to occur.

MINNESOTA IMPEDANCE CARDIOGRAPH

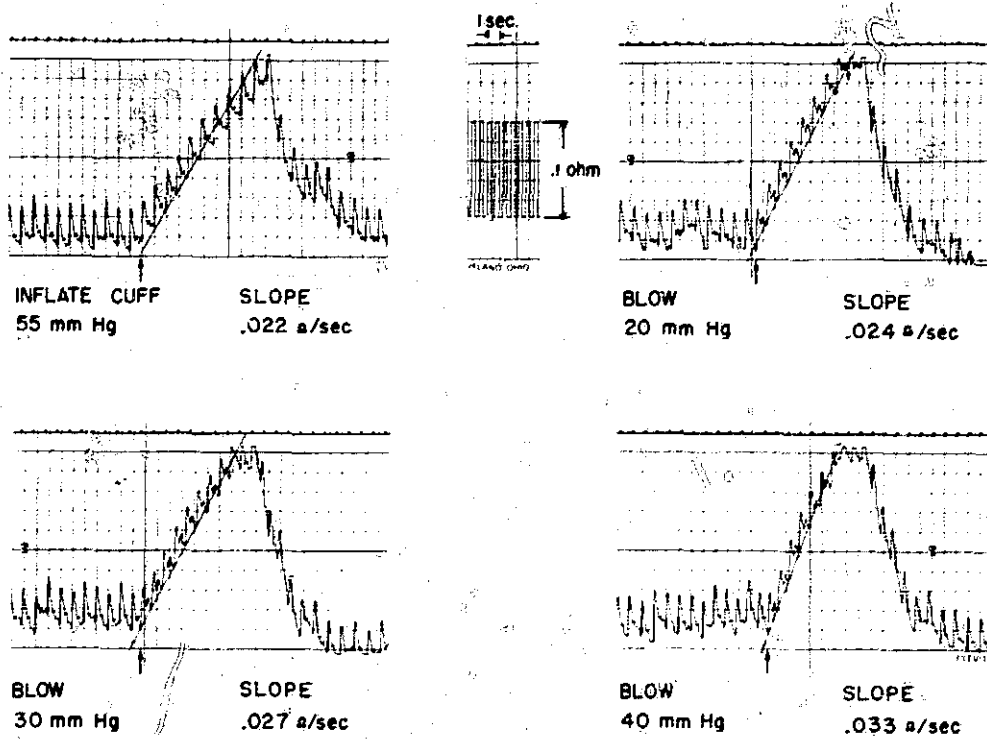

Figure IV-10 Records obtained from the electrode placement shown in Figure IV-9 by; (1) inflating the cuff to 55 mmHg and (2) after deflating the cuff the subject blew (with the glottis open) 20, 30 and 40 mm Hg.

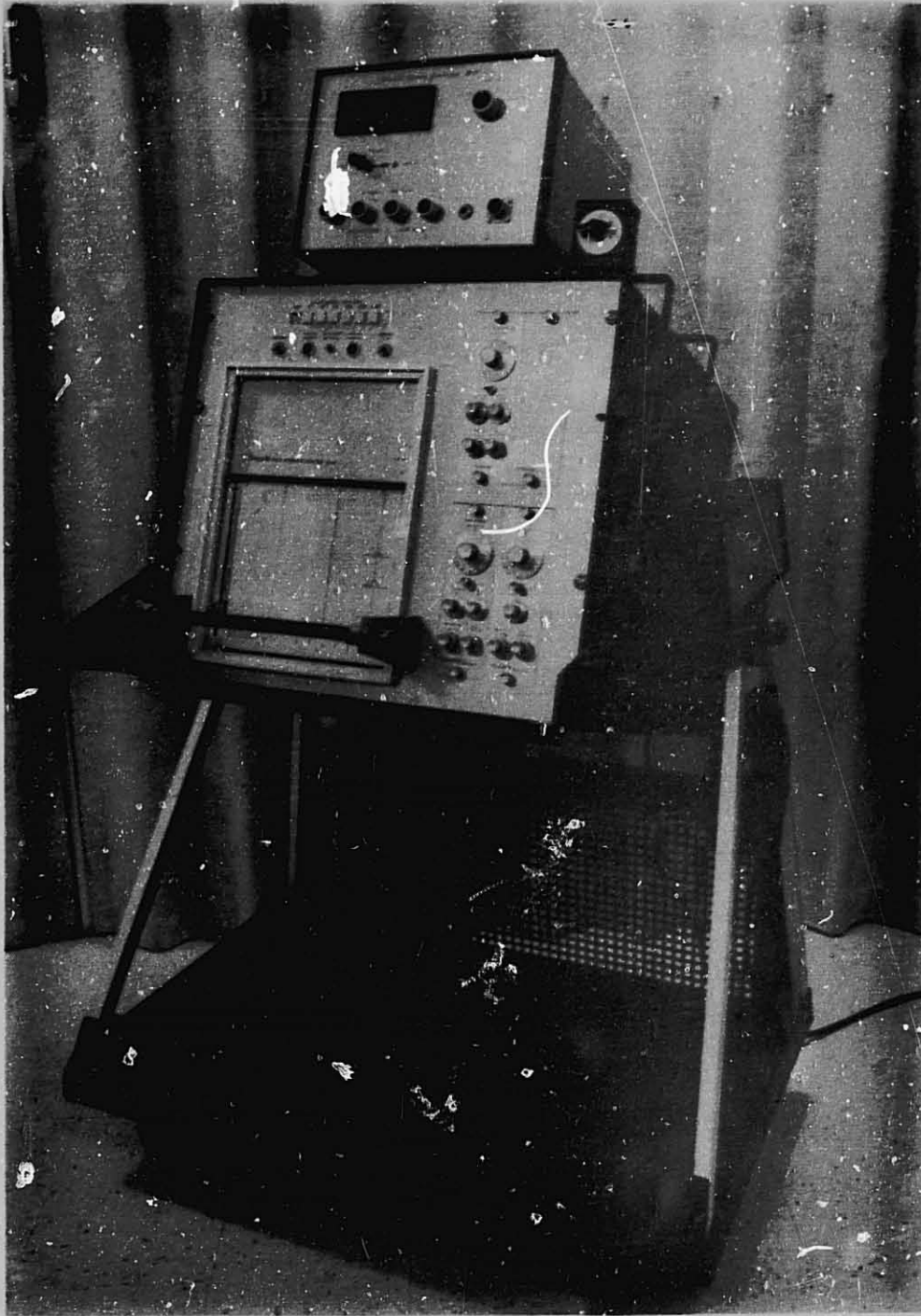

Figure IV-11 An example of the Impedance Cardiograph mounted on a recorder to form a mobile unit.

Inquiries regarding availability of 3M ELECTRODE TAPE  
should be directed to:

Mr. C. J. Anderson  
3M Company  
Medical Products Laboratory  
3M Center  
Building 218-3  
St. Paul, Minnesota 55101

Telephone #: (612) 733-2407

PRECEDING PAGE BLANK NOT FILMED.

The object of this report is to describe the utilization of the Minnesota Impedance Cardiograph in the chronic monitoring of cardiac transplant patients at the Groote Schuur Hospital, Cape Town. The work was carried out in the Surgical Research Laboratories of the University of Cape Town, South Africa, under Prof. C.N. Barnard. Since the first cardiac transplant, which was performed at the end of 1967 at the above centre, the need has existed for a reliable, noninvasive method of assessing not only output but also many other cardiac parameters.

The sphygmomanometer and electrocardiograph were previously the only two means available to us to assess cardiac performance, cardiac catheterization being contra-indicated because of the danger of infection. It is perhaps noteworthy that both this centre and NASA are interested in an instrument for assessing day to day variation in cardiac function without penetrating the skin and that the Minnesota Impedance Cardiograph is just such a device.

For these reasons the above instrument was eagerly accepted by our centre when offered for use, both for assessment of the practicability of its chronic use in terms of the machine itself and of the patients investigated.

The cardiac transplant patients studied in depth were Dr. Blajberg (No. 2) and Pieter Smith (No. 3).

In addition to Impedance Cardiograph (ZCG) parameters, other parameters studied were ECG voltage (summation of standard leads I, II + III), temperature, pulse, respiration, weight, intake/output, blood, and biochemical parameters as well as X-rays and special immunological techniques.

The object of all these measurements was both to establish baselines for cardiac transplants and to give early warning of rejection should it ensue. It is the firm belief at this centre that rejection should be vigorously treated with immunosuppressives at the earliest suspicion thereof, and if treatment is delayed the process might well become irreversible. It was therefore hoped that this device might give some pointer to rejection in its earliest stages, a phenomenon which undoubtedly occurs at cellular level, mechanical effects being a late manifestation.

With this in mind ZCG parameters were chosen and plotted alongside all the other parameters. The five were: Cardiac output (or an uncalibrated analogue thereof) ( $dZ/dt$ ), (R-Z) interval (R spike to max. eject. point), ejection time, and Patterson factor, (named after one of the designers of this machine). This is felt to be a more stable factor than is Cardiac Output and is derived from the formula for stroke volume:

$$\Delta V = \rho \frac{L^2}{Z_0^2} (dZ/dt) T$$

The reason why the Patterson factor is more stable is the fact that over the course of many readings it was found that T or ejection time showed large variations with acute changes in environment, namely: exercise, meals, mood, etc. and that the rest of the formula:-

$$\text{Patterson Factor} = \rho \frac{L^2}{Z_0^2} (dZ/dt)$$

is a truer representation of overall myocardial condition. This obviates having to standardize environmental conditions for every reading which is well-nigh impossible when patients attend as out-patients.



The five parameters were chosen so that not only the formula for cardiac output, but also factors thereof could be looked at to see which, if any, was a good index of cardiac function, or gave forewarning of rejection episodes. R-Z interval was looked at since it provides a useful index of cardiac contractility and it had been suggested by some that one of the first signs of rejection might be diminishing of the contractility of the heart, on the basis of infiltration and edema. Since vagal tone largely mediates the isometric phase of physiological contraction, it was felt that changes in R-Z interval might well be indicative of re-innervation should it occur.

It was decided to omit  $Z_0$  from the graph since very little variation in this was seen except in extreme fluid overload., viz. Blaiberg Fig. 2 \* day 487 when his  $Z_0$  dropped, only to rise again to normal levels after the energetic use of diuretics.

In this series, measurements commenced with both patients in the hospital. Dr. Blaiberg was recovering from a virus hepatitis, while Pieter Smith's readings started 5 days post-transplant.

The patients were monitored at first daily, while in the hospital, then three times a week and latterly twice a week, when they came in as outpatients. Measurements were made mainly in the supine, sitting and standing positions. Supine, since this offers a useful baseline and often the only position possible soon after transplant and in cases of collapse; standing, since this is the position of function and sitting, because they are mostly in this position in the recovery phase.

Figure 1 shows the ZCG parameters of E. Blaiberg beginning 254 days post-operatively.

The ZCG determined cardiac output was consistently highest in the sitting position (feet dangling), intermediate in the standing and lowest in the supine position.

The normal effect of sitting is to lower cardiac output so, whether this is an idiosyncrasy of the impedance cardiograph or a real finding has still to be determined.

In the period day 254 to day 360 negligible change in parameters was noticed. The small changes in evidence on the flow sheet are caused by variations in environmental conditions at the time.

It was impossible to standardize daily conditions, and factors such as room temperature, length of time resting before measurement; before or after physiotherapy, recent meals, etc. influenced both Smith and Blaiberg's figures. However, it should be pointed out that we were looking for a trend downward, i.e. two or more readings dropping progressively before looking upon the change as more than a day to day variation.

The R-Z interval was examined for signs of contractility change which might be indicative of reinnervation, but no significant change occurred. Over the course of the period after his discharge from hospital, his output progressively rose from a mean of  $\pm 4.0$  to  $\pm 6.5$  L/min.

His clinical course over this period was one of progressive improvement. Figure 2 shows parameters from day 366 to day 501. The scale on the x-axis is contracted for space reasons.

The P's at the bottom left show some days on which physiotherapy was given. This illustrates the influence of physiotherapy on parameters, i.e. a slight but obvious rise in

cardiac output.

Nothing significant occurred until day 422 when both on clinical and ECG voltage grounds rejection was suspected and the dosage of immunosuppressives was raised. The ZCG showed a slight but unconvincing drop at this point. If rejection was occurring it most certainly was not obvious on ZCG tracings and no change in ECG pattern besides a voltage drop was evident. Biochemical findings were non-contributory.

From this time onwards the steady rise in output which had occurred over the previous few months levelled off and output dropped as  $dZ/dt$  and ejection time decreased.

Again on day 457 rejection was treated for and this time the ZCG did show a previous downward trend with a dip on that day.

However, since  $dZ/dt$  did not drop significantly, the writer was not convinced that the rise in output which occurred after treatment for "rejection" would not have occurred anyway.

If rejection was occurring it had most certainly not progressed to the stage where the mechanical action of the heart was being severely interfered with.

After initial recovery there was at first slow and then appreciable drop in output,  $dZ/dt$ ; and ejection time, and an acute fall in  $Z_0$  of 2 ohms was experienced at day 487. Clinically, the patient was retaining fluid and failing. He was admitted to the hospital, given oxygen and vigorously treated for cardiac failure with digoxin and massive doses of diuretics. Rejection was not suspected since ECG voltage had actually risen. ( $dZ/dt$ ) had dropped precipitately as had ejection time and  $\Delta Z$ . This was the typical picture of a dilated failing heart.

Within 3 days the patient had lost 17 lbs. of oedema fluid and  $Z_0$  had risen by 8 ohms. Crepitations at the lung bases and gallop rhythm had disappeared. All the other parameters had risen towards normality and  $(dZ/dt)$  reached normality by the time he was discharged on day 501. The rise in R-Z at this time is unexplained.

Figure 3 shows Pieter Smith's ZCG parameters beginning day 5 after transplant. Initially there was a very large  $\Delta Z$  wave with a high  $(dZ/dt)$ . Concomitant with this was a low  $Z_0$  associated with fluid in the mediastinum. The cardiac output determination was therefore excessively high which might be partially due to high nor-epinephrine levels, isoprenaline infusion, or possibly a normal heart operating against the diminished peripheral resistance of a patient who had been in chronic failure. The precipitous drop at day 7 seems to have been caused by a sudden diuresis and rise in  $Z_0$ . Note the relatively small change in  $(dZ/dt)$ . Although ejection time was normal during this period, Patterson factor was extremely high showing that the high output was due to internal rather than environmental factors, since environmental factors largely change peripheral resistance thus altering blood pressure and ejection time.

Over the course of the next two weeks the hyperkinetic state subsided and normal parameters were recorded. The patient walked on day 7. His recovery was uneventful and he was discharged on day 38. Various peaks over this period were due to varying states of exercise. Changes in temperament were obvious on ZCG tracings, e.g., on day 35 the patient was extremely angry. When docile or depressed most parameters likewise showed a fall.

From discharge to day 61 no acute changes were evident. R-Z did not show any contractility changes.

Figure 4 Days 62 to 75 showed a rise in ejection time which has remained static since and is not regarded as significant. From day 82 to 108 no perceptible change was evident except that on day 90 he could not come in before breakfast and the boost associated with a large breakfast is quite obvious.

Figure 5 The P's on the bottom left are associated with physiotherapy on those dates and shown as spikes on the flow graph.

The patient was well until day 142 when he developed right renal colic diagnosed as a ureteric stone. Note that contractility increase preceded rise in other parameters. He was admitted to the hospital and treated with smooth muscle relaxants. During the next 4 days he writhed around in pain until he passed the stone. The passage of the stone is evident on the graph by the return of all ZCG parameters to normal.

On day 184 rejection was suspected on ECG and clinical grounds, and treated for. The ZCG showed no mechanical interference with heart action and the diagnosis was never conclusively established. Pieter Smith was, incidently, a very good tissue match and this is the probable reason for his uncomplicated progress.

It is amusing to note that when Dr. Blaiberg fell ill on 10th May, this was evident on Pieter Smith's graph by the flatness thereof. Smith was depressed and apprehensive and his readings until the 19th May can be regarded as basal, so little activity did he engage in over this period.

### Summary

Looking at the flow sheets from the beginning, perhaps the most significant finding was an insidious and progressive drop in function during the nine months studied as evidenced by  $(dZ/dt)$  falloff, and drops in output from a mean of 7 litres/min in October 1968 to 5.5 litres/min. in May 1969. Over the whole period studied, R-Z changes were non-contributory and no suggestion of reinnervation has been found. No episodes of unequivocal rejection were conclusively diagnosed in this patient and no changes in any of the ZCG parameters which might have been suggestive of rejection were seen in the nine months which followed.

Since the day to day measurements showed very little more than cardiac activity at rest, it was decided to assess the cardiac reserve of the transplant patients by measuring the same parameters after graded stress up to the patients' exercise maximum. Since no episodes of unequivocal acute rejection were seen either clinically or with the ZCG, it was felt that rejection, if it was occurring, was on a more chronic basis and would not be evident in basal measurements. This type of rejection could best be seen by reduction in effort tolerance and cardiac reserve. Another aspect of effort tolerance testing which interested us was the question of how the transplanted heart could increase its output without neurological connections with the rest of the body. Since the patients did not seem to suffer unduly in spite of a fairly fixed heart rate, it was obvious that some mechanism other than change in rate must be operative in increasing

cardiac output. Figures 6 and 7 show exercise tolerance studies of Smith and Blaiberg respectively.

The bicycle ergometer was used to grade exercise and measure work done. The ZCG tapes were applied at the usual sites and the harness as used by Kubicek and co-workers was utilized for the pick-up connections. ECG leads were applied proximally to the patient's legs and right arm (lead II) so as not to hinder him in pedalling. Resting measurements in the sitting position on the bicycle were used as a baseline for the run. In Figure 6 appears the results obtained on Pieter Smith in January 1969. The units of work were in kilo-pond-metres per minute. Blood pressure and respiration were monitored simultaneously but are ignored here since they are non-contributory. A resting set of measurements as well as four sets after four exercise periods were obtained. The first period of exercise was done under moderate load (400 kpm/min) until the patient could be seen to be slackening. Reading 1 was then taken. After 3.5 mins at the 400kpm/min rate changed from 95 to 125 min. It is interesting to note that during the exercise period, rate started rising only after 35 sec. from the initiation thereof whereas blood pressure started dropping almost immediately. After 35 seconds there was a sudden rise in rate up to ~~120~~ at 1 minute. In the following 2 1/2 minutes the rate rose by only 5 beats/min.

It is suggested that the delayed change in cardiac rate is caused by circulating catecholamine release mediated through the adrenal medulla and precipitated by the stress of dropping blood pressure, due to decreased peripheral resistance. No acute reflex changes in rate or contractility were seen. Over the whole study

no significant change in  $Z_0$  was seen. Contractility increased, (viz. R-Z drop to 80 m. sec.) either on the basis of elevated circulating nor-epinephrine rose or because of increased diastolic filling (Starling). It was not possible to determine levels of nor-epinephrine since blood samples were not taken during the experiment. Ejection time (T) shortened proportionately to rate change. Stroke volume doubled whereas rate increased by 30% only. This gave an increase in output of 200%.  $dZ/dt$  showed a rise similarly attributable both to raised catecholamine levels and/or increased venous return. Patterson factor allows us to look at the activity of the heart excluding ejection time as a function. Readings took only 20 seconds, whereupon exercise was recommenced. The patient was then asked to do one minute at 400 kpm/min.

Reading 2 showed little change from 1 except that rate crept up slowly to 130/min. and  $dZ/dt$  rose sharply, increasing stroke volume slightly and bringing cardiac output to 290% of the baseline level. For exercise 3 the load was increased to 500 kpm/min. for one minute. The patient became dyspnoeic about half-way through this period and complained of weakening of his legs.

Reading 3 showed cardiac decompensation as evidence by decrease in ejection time without rate change (i.e., probably not catecholamine mediated). His left ventricle was therefore tiring and his exercise maximum had been reached probably a little above 15.31 l/min.

At this point the patient's blood pressure also started dropping slightly. Stroke volume decreased, hence output also dropped. Interestingly enough, the  $dZ/dt$  rose still more to



2.50 showing that the heart could contract more forcefully but not for long enough to eject all the diastolic volume, and dyspnoea occurred, possibly on the basis of pulmonary congestion.

For exercise 4 the load was kept at 500 kpm/min. and the patient asked to maintain this as long as he could. This he managed for a further three-quarters of a minute: the signs of decompensation became more pronounced and stroke volume decreased to less than Reading 1. Note that  $dZ/dt$  nevertheless increased still further while ejection time dropped profoundly.

In summary, the results showed that the patient was capable of keeping up an average of 428 kpm/min. for 6.25 mins. and could increase his resting output by 290% which is well within normal limits.

Acute reflex changes in rate were absent but delayed changes suggestive of humeral agents were seen. The rise in output seen in exercise was accomplished by an abnormal means, namely mainly stroke volume increase and to a lesser degree rate changes.  $dZ/dt$  continued to rise in spite of cardiac decompensation and drop in output, as evidenced by appreciable drops in ejection time and blood pressure as well as subjective symptoms, e.g., dyspnoea.

In Figure 7 exercise tolerance for Dr. Blaiberg is reported (Jan. 1969). His performance, however, was not as good as Pieter Smith's. He never regained full power in his legs after his hepatitis four months before and the combined effects of this and of chronic administration of cortisone took their toll of leg muscle bulk. Nevertheless it was possible to determine his exercise maximum with the ZCG and bicycle ergometer. His resting

levels were established and a smaller load was used, namely i.e. 200 kpm/min. Looking at the (R-Z) interval contractility appeared first to increase and then decrease as decompensation occurred. It is interesting to note that  $dZ/dt$  rose only slightly beyond reading 2 thus suggesting that the contractility decrease was possibly due to dropping catecholamine levels. Ejection time showed a similar pattern to that seen in Pieter Smith. Rate, however, rose by only 4%. It is suggested that his heart was running at maximum rate and contractility and no increases on venous pressure and catecholamine levels could change this. This theory is supported by the fact that his resting venous pressure was  $\pm 19$  cm.  $H_2O$  and rose profoundly on exercise. In addition, stroke volume rose by only 154% in spite of obvious rises in venous pressure and profound dyspnoea. Since rate changed so little, changes in output very nearly paralleled stroke volume changes.  $dZ/dt$  rose very early to a maximum level and negligible change occurred after this.

In summary, little progressive contractility change occurred with exercise in this patient. Rate rose by 4% only and cardiac output was boosted by 160% with an exercise maximum of 8.15 l/min. and a work output one third that of Pieter Smith.

It is thought that at this centre this is probably an example of the chronic drug-modified rejection we can expect to see more of in patients who are so well-matched or well-treated as not to have acute manifestations. Slow insidious declines in function without punctuation by dramatic changes have been seen in Dr. Blaiberg over the past year.

It was thought that as venous pressure and/or right heart pressure rose there might be a significant drop in  $Z_0$ . In practice, if anything the reverse occurred, showing that  $Z_0$  was not so much a function of acute as chronic overload of the right heart. Where chronic retention of fluid occurred,  $Z_0$  did in fact show the expected drop. Perhaps in  $Z_0$  drops we are looking at extravascular water in the lung - either interstitial or intra-alveolar.

During day to day records on Pieter Smith an occasional nodal extra-systole was observed. What was remarkable about these beats was the fact that after the post-extra-systolic compensatory beat, normal  $\Delta Z$  and  $dZ/dt$  waves were observed. Out of interest, one such reading is included in this paper. In figure 8 we see a series of normal beats, an extra-systole, compensatory beat and again normal beats. Looking at  $\Delta Z$  we see that the extra-systolic beat scarcely opened the aortic valve while the compensatory beat was much larger and had a larger ejection time. From (R-Z) decrease we see that the contractility increased as a result of increased diastolic distension (Starling) during the compensatory beat. It seemed that all the blood which was not ejected by the extra-systole must have been cleared by the compensatory beat, and the sum of the stroke volumes of the extra beat plus the compensation beat should have been equal to two normal beats. From time obtained, stroke volumes were determined with the usual formula. Normal stroke volumes were  $\pm 52.3$  ml., while the extra and compensation beats volumes were 13.8 and 89.5 ml. respectively, giving a mean of 51.7 ml. thus confirming the hypothesis.

Another situation in which the ZCG has been used is in monitoring the cardiac condition of prospective donors for cardiac transplant. The most common presentation is one of head injury or cerebral hemorrhage with irreversible brain damage. Often no history is available and degrees of hypertension are present. It is helpful to know whether this hypertension and other cardiac changes are due to cerebral conditions or whether the heart is hypertensive and hypertrophied. In Figure 9 we see the three traces of donor, recipient before and recipient after the most recent transplant. The donor had had a cerebral hemorrhage and was mildly hypertensive. His rate was high as is frequently seen in cerebrovascular accidents and his blood pressure was up. The heart had a short ejection time which remained the same after transplant, while the ECG showed little change from donor to recipient. Over the course of the last few months since the transplant the ECG voltage has dropped somewhat, suggesting loss of some hypertrophied muscle bulk and ejection time is now over 200 m. sec. and approaching normality.

No work has been done to date on the correlation between ZCG and dye dilution methods of determining cardiac output at this centre. However, on the one occasion that Dr. Blaiberg was catheterized simultaneously with ZCG tracings, the impedance method overread by 11%.

No correlation for Mr. Smith has been established but on a subsequent cardiac transplant patient the ZCG overread by 26%. On a few dogs studied for various reasons and using thermodilution techniques of cardiac output, the ZCG measurements overread by between 10% and 35%.

In summary, the Minnesota Impedance Cardiograph was used for the chronic monitoring of cardiac transplant patients at this centre over the last eleven months. Two patients were studied in depth and a close watch was simultaneously kept on clinical, biochemical, serological, ECG and ZCG parameters.

Acute rejection was suspected and treated for on several occasions but since none of these episodes progressed to frank rejection the diagnosis was never conclusively confirmed. The ZCG showed signs of change more than one day in advance of other parameters but since more than one abnormal point on a graph was needed to establish a trend, it was not possible to diagnose and treat rejection on ZCG grounds alone. Nevertheless, the ZCG together with ECG and other tests has proved to be a valuable adjunct to diagnosis and an invaluable index of the efficiency of treatment and return of the cardiac transplant to normality.

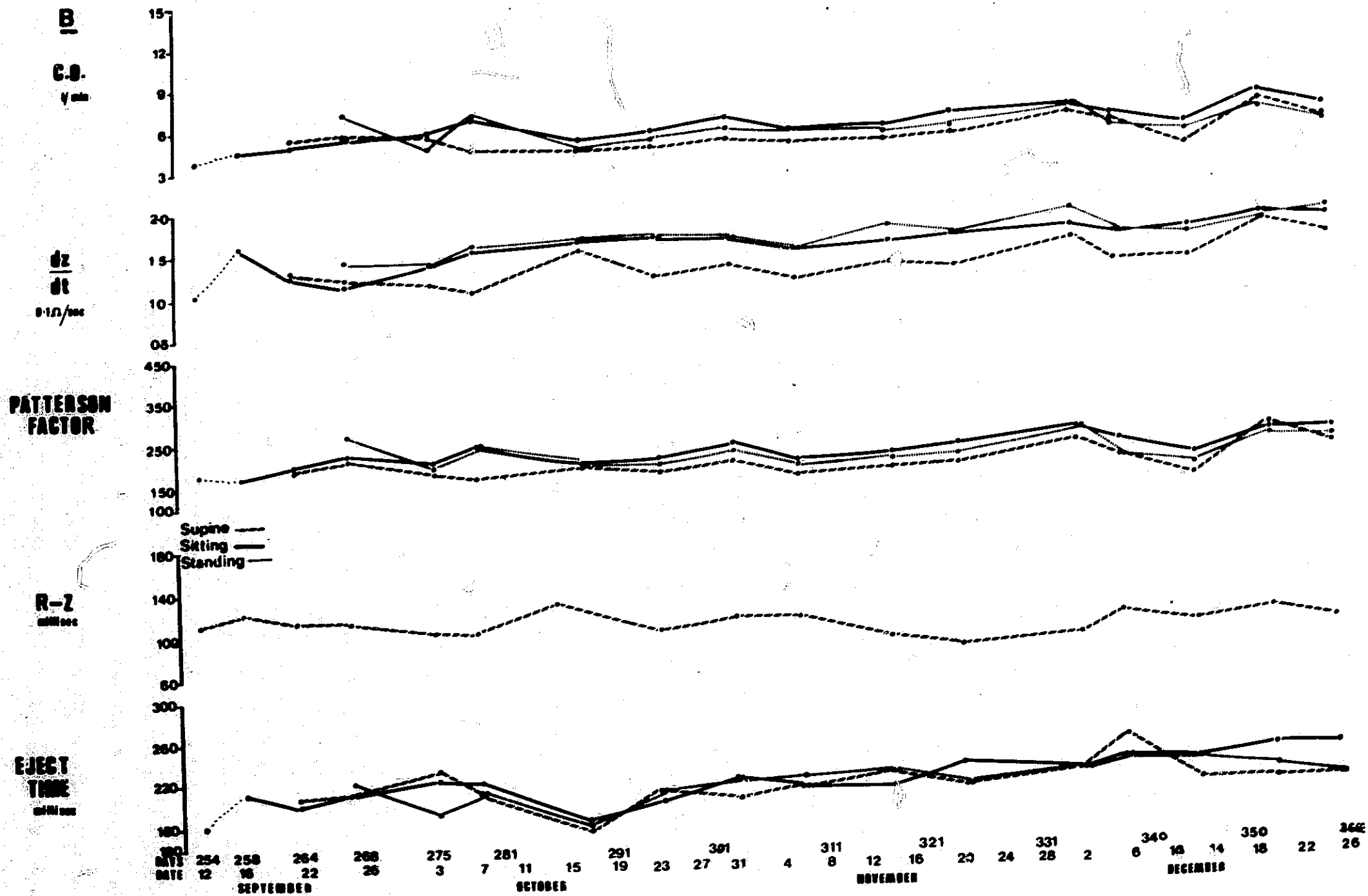

FIGURE 1 P. BLAIBERG (DAYS 254 - 366)

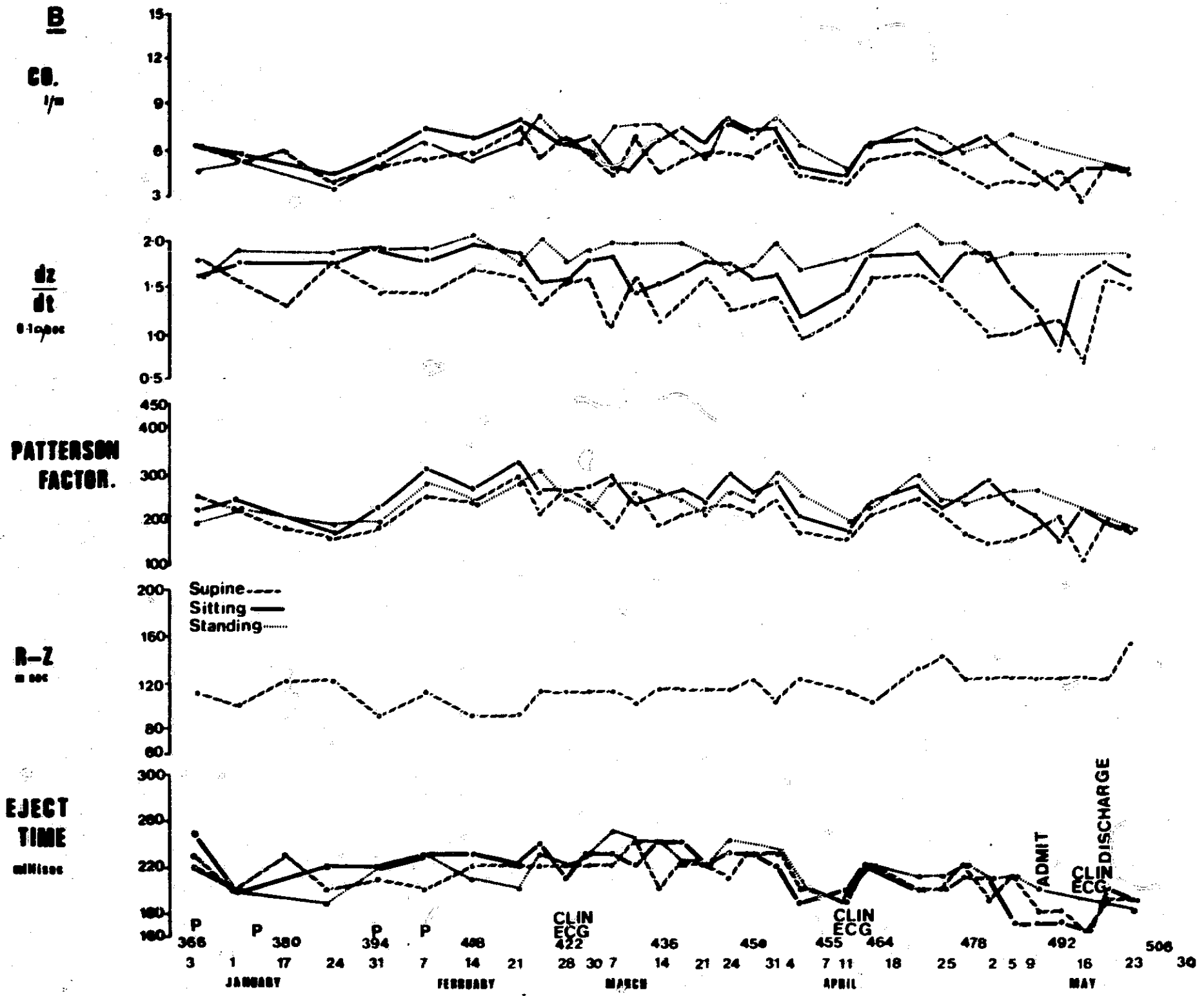

FIGURE 2 P. BLAIBERG (DAYS 366 - 497)

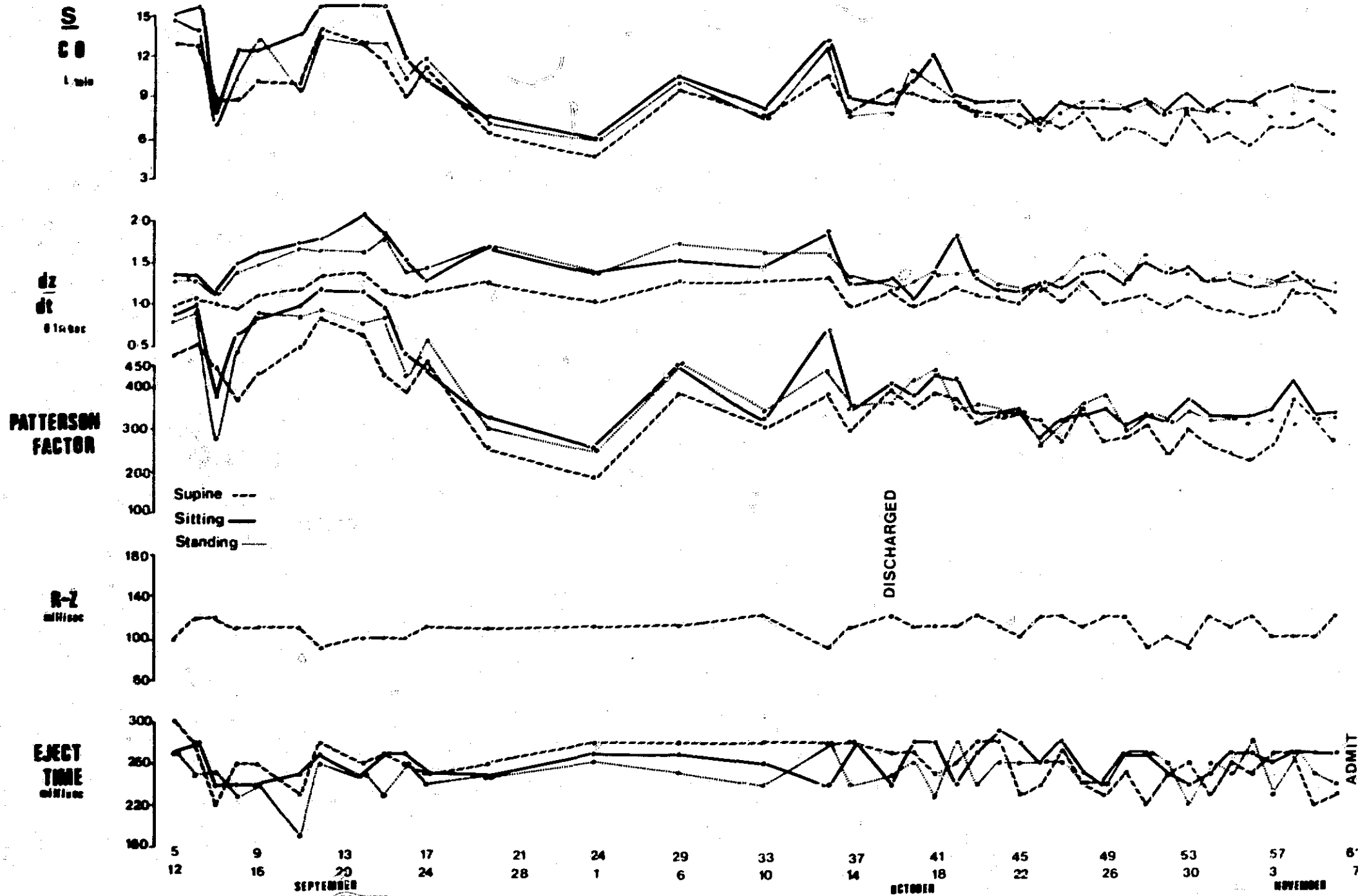

FIGURE 3 P. SMITH (DAYS 5 - 61)



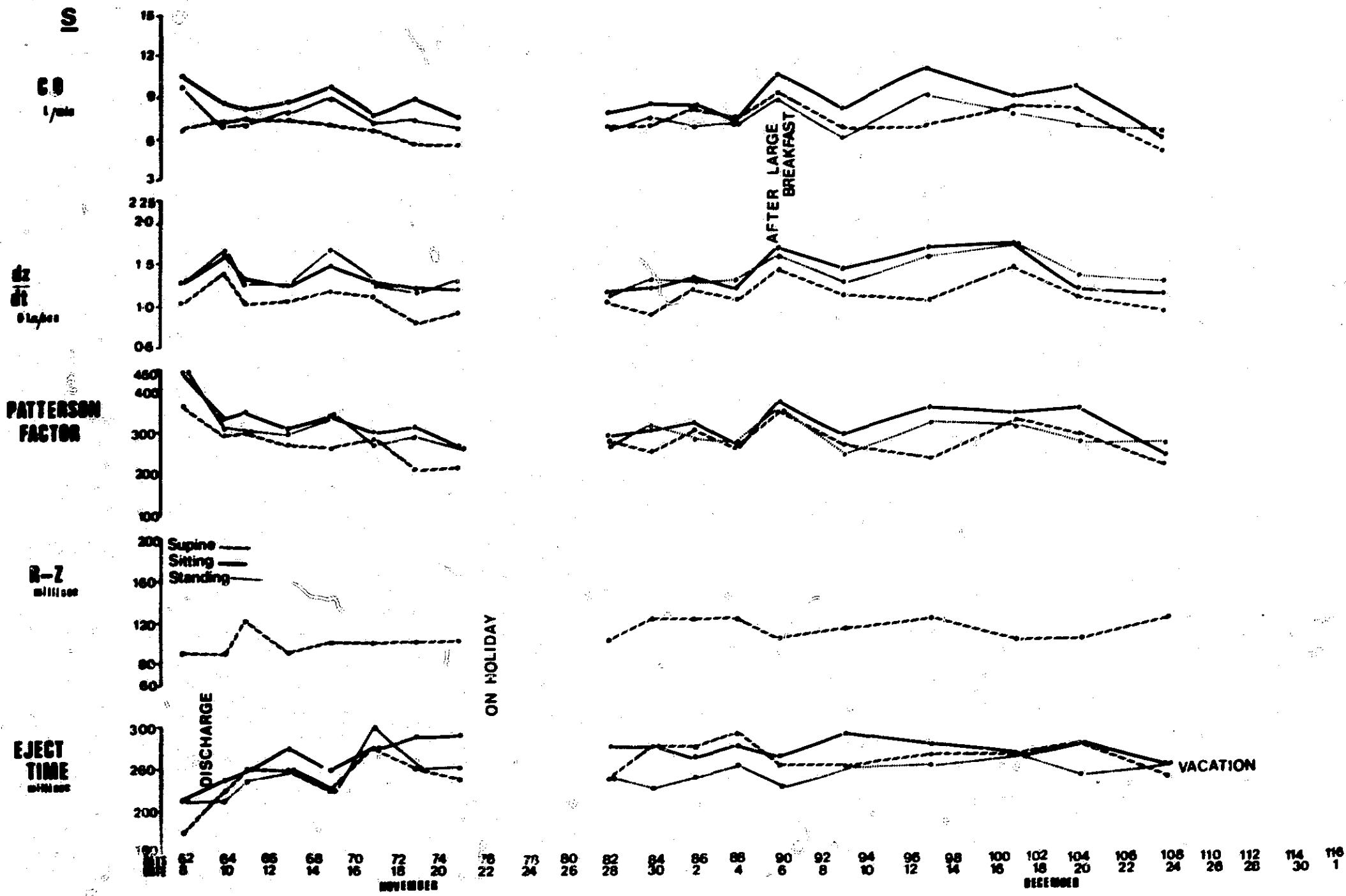

FIGURE 4 P. SMITH (DAYS 62 - 108)

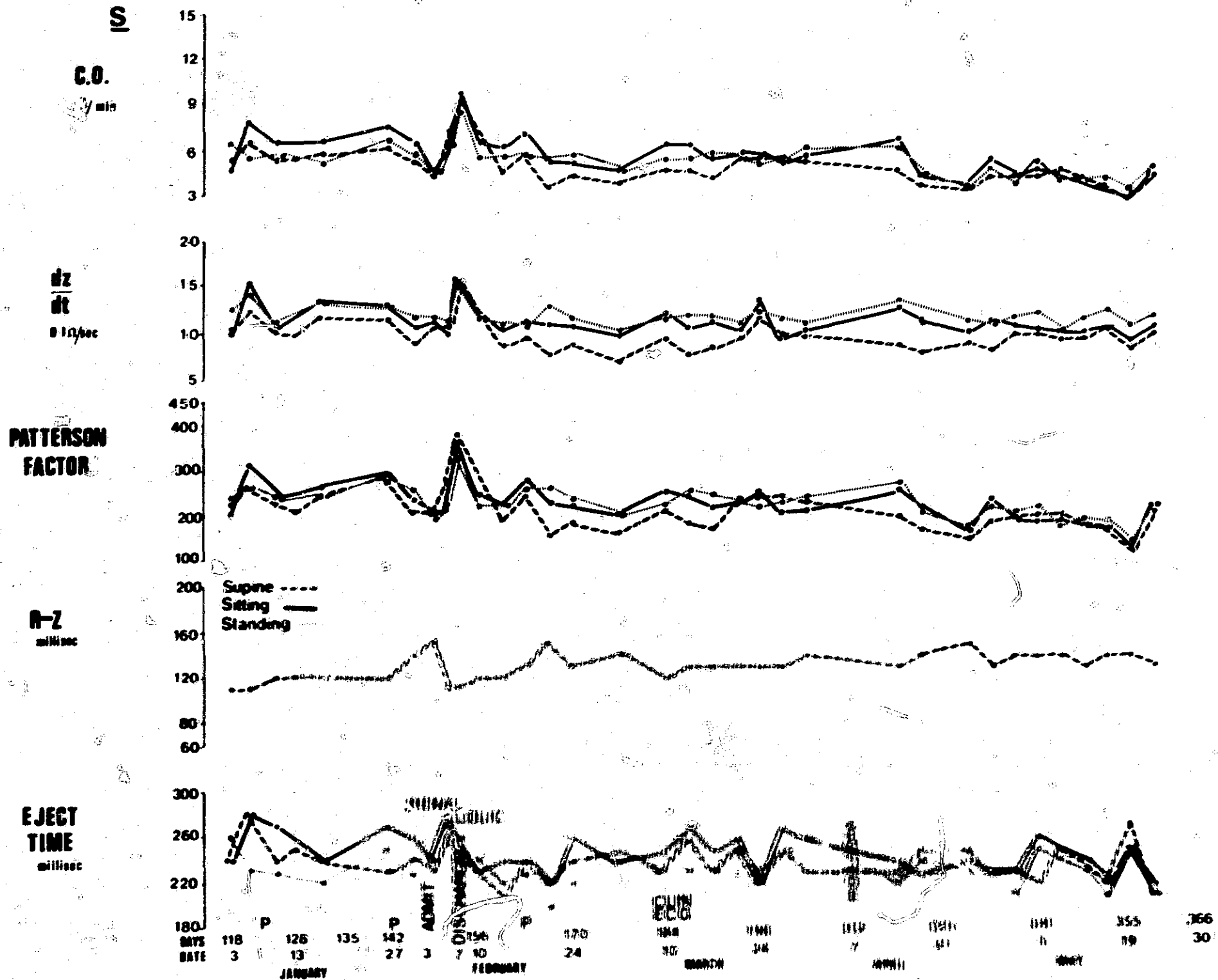

FIGURE 5 P. SMITH (DAYS 118 - 361)

P.S. (CARDIAC TRANSPLANT 6 MONTHS)  
 EXERCISE TOLERANCE STUDIES (ERGOMETER 13-1-69)

PARAMETERS	Rest	Ex. 1	Read 1	Ex. 2	Read 2	Ex. 3	Read 3	Ex. 4	Read 4
Zo (mean thoracic impedance-ohms)	27.0	3.5	26.7	1	27.0	1	27.1	$\frac{3}{4}$	27.3
R-Z m.sec (R wave to max.eject point)	150	min	80+	min	90-	min	80-	min	80+
T= ejection time(m.sec)	250	at	220	at	220	at	200	at	180
Pulse Rate/min	95		125		130		130		134
Stroke Vol.(ML)	56.4		111.9		117.9		111.2		103.2
Cardiac Output(L/min)	5.36	400	13.95	400	15.31	500	14.45	500	13.85
$\frac{dz}{dt}$ $\frac{\Omega}{sec}$ (max.eject rate)	0.96	$\frac{kpm}{min}$	2.22	$\frac{kpm}{min}$	2.39	$\frac{kpm}{min}$	2.50	$\frac{kpm}{min}$	2.61
$\frac{1z}{Zoz} \left( \frac{dz}{dt} \right)$ Patterson factor	215		509		535		556		572

Mean work done =  
 428  $\frac{kpm}{min}$  over 6.25 minutes.

FIGURE 6 P. SMITH EXERCISE TOLERANCE

P.B. (CARDIAC TRANSPLANT 14 MONTHS)  
 EXERCISE TOLERANCE STUDIES ( ERGOMETER: 17-1-69)

PARAMETERS	Rest	Ex.1	Read 1	Ex. 2	Read 2	Ex.3	Read 3	Ex.4	Read 4
Zo (mean thoracic impedance -ohms)	33.0	70	34.8	106	34.7	3	34.5	45	34.5
R-Z m.sec(R wave to max eject.point)	120	sec	110	sec	90	min	100	sec	100
T = Ejection time ( m.sec)	250	at	220	at	220	at	220	at	210
Pulse Rate/min	111	200	113	200	113	100	115	200	115
Stroke Vol (ml)	45.8		60.7		70.5		70.8		68.8
Cardiac output(l/min)	5.09		6.86		7.97		8.15		7.91
$\frac{dz}{dt}$ (sec) max. eject.	1.30		2.18		2.48		2.48		2.52
$\sqrt{\frac{1z}{Zoz}} \left(\frac{dz}{dt}\right)$ Patterson factor	183	$\frac{kpm}{min}$	276	$\frac{kpm}{min}$	320	$\frac{kpm}{min}$	322	$\frac{kpm}{min}$	328

mean work done =  $154 \frac{kpm}{min}$  over  $6\frac{3}{4}$  minutes

FIGURE 7 P. BLAIBERG EXERCISE TOLERANCE

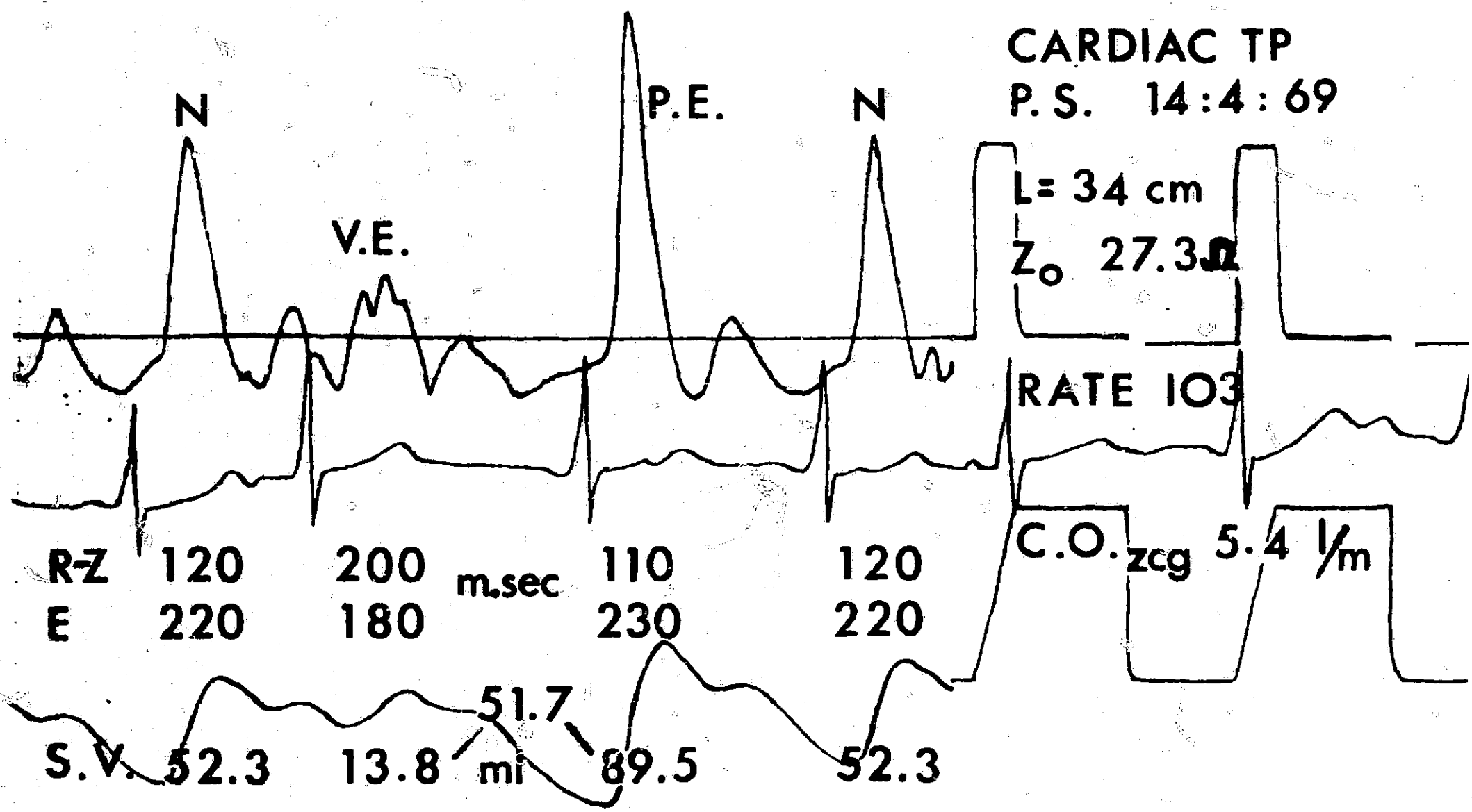
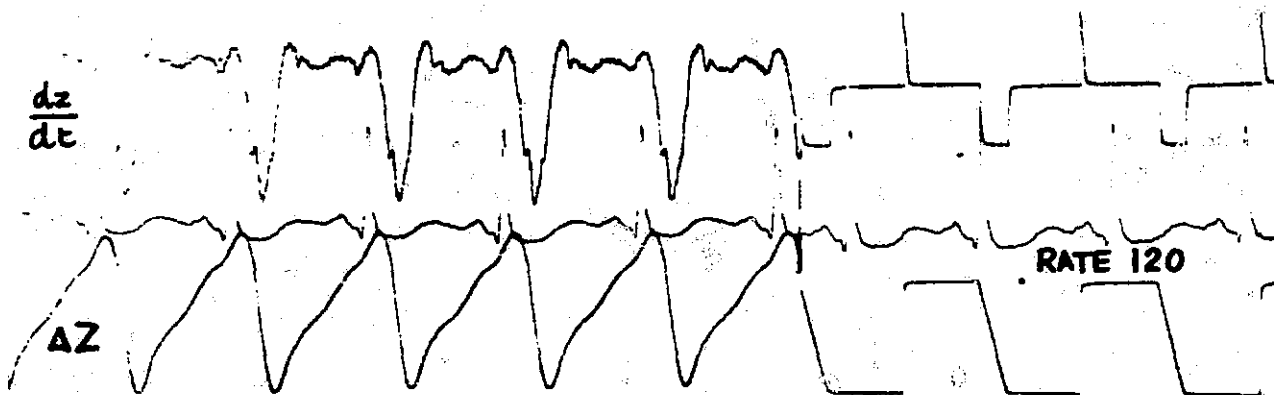

FIGURE 8 PIETER SMITH  
 N = NORMAL BEAT  
 V.E. = EXTRASYSTOLE  
 P.E. = POSTEXTRASYSTOLIC BEAT

Z<sub>0</sub> 29-2a



W.B. DONOR CVA

16-4-69

R-Z 130 m.sec

E 170 m.sec

C.O. 6.9 L/M

Z<sub>0</sub> 31-0a

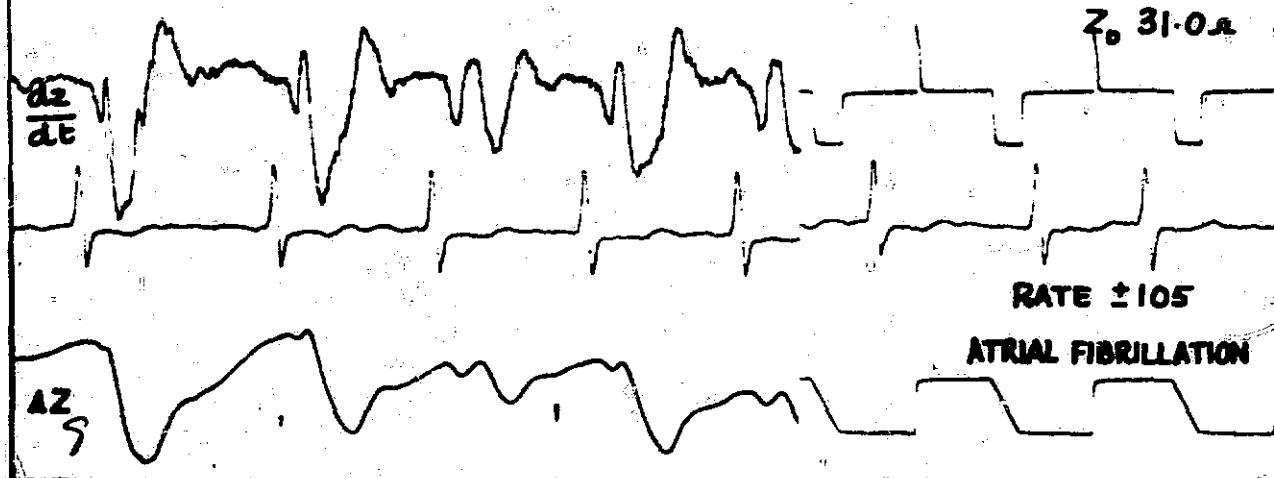

D.F. RECIPIENT PRE-OP

16-4-69 MS. MI. AF. 39 yrs.

C.O. 2.5 L/M

Z<sub>0</sub> 2i-2a

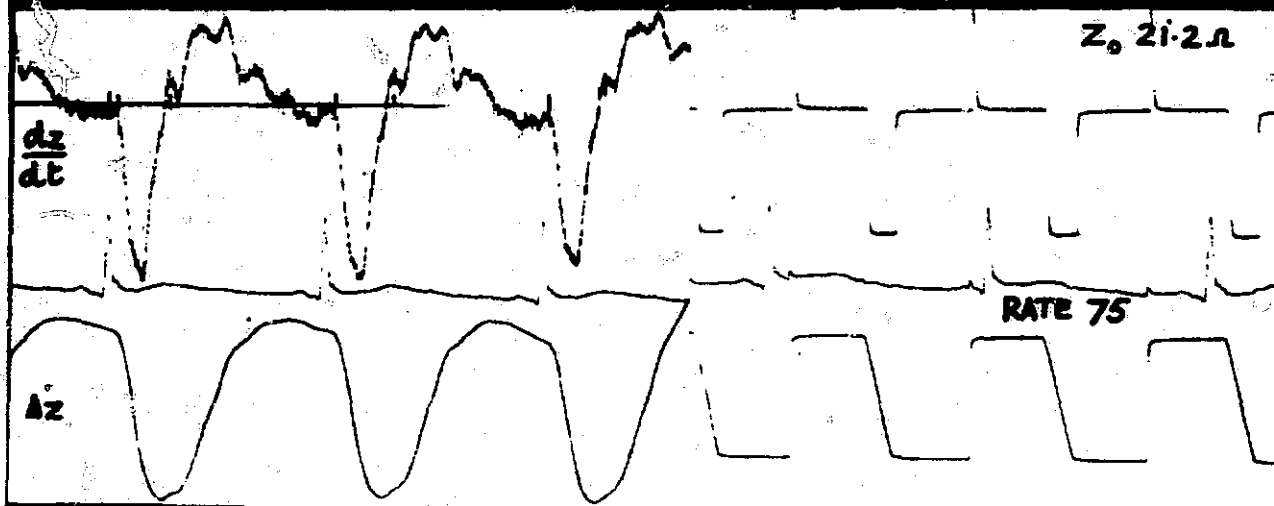

RECIPIENT POST-OP

24-1-69

R-Z 130 m.sec

E 170 m.sec

C.O. 6.0 L/M

-04-

FIGURE 9 MOST RECENT HEART TRANSPLANT DONOR BEFORE, RECIPIENT BEFORE, RECIPIENT AFTER TRANSPLANT

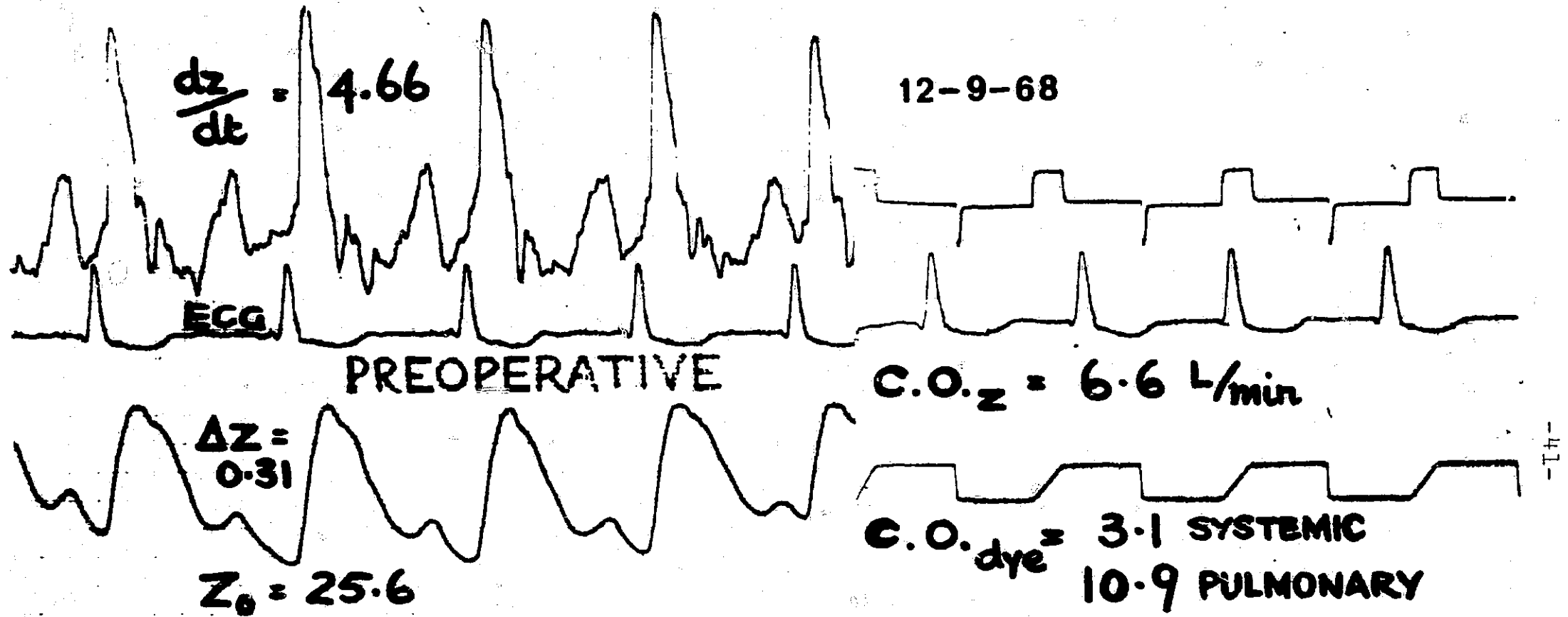

There apparently was a right heart and pulmonary component in the  $\Delta Z$  and  $(dz/dt)$  waveforms since  $(dz/dt)$  levels of this magnitude were not seen with a systemic flow of only 3L/min. Pulmonary congestion may have lowered the thoracic impedance and brought in a pulmonary component.

This unusual case is presented for general interest in addition to our work on heart transplant patients.

Figure A

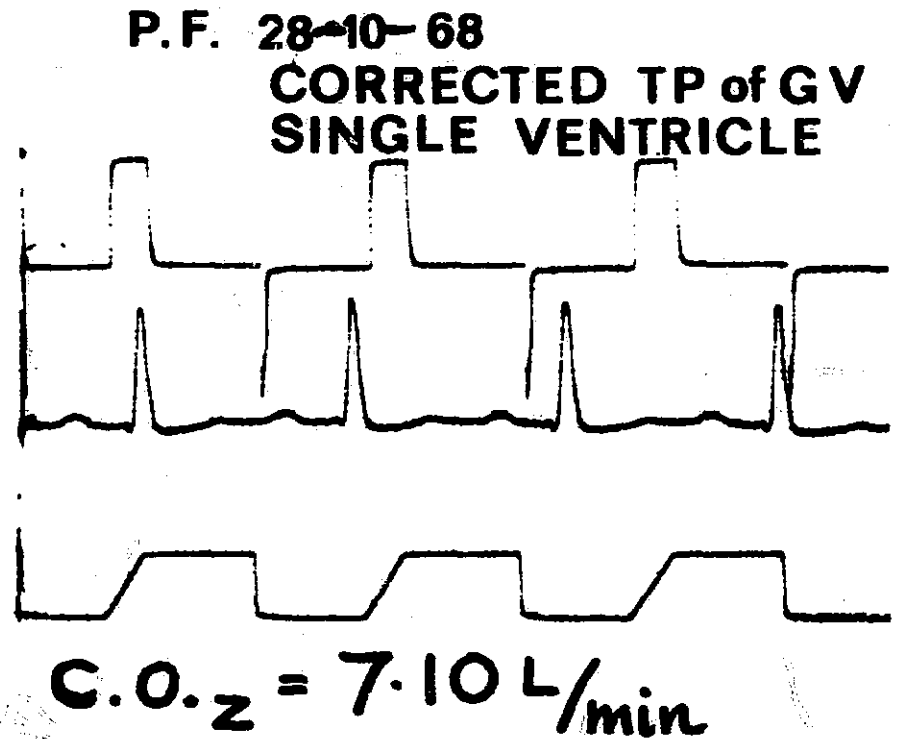
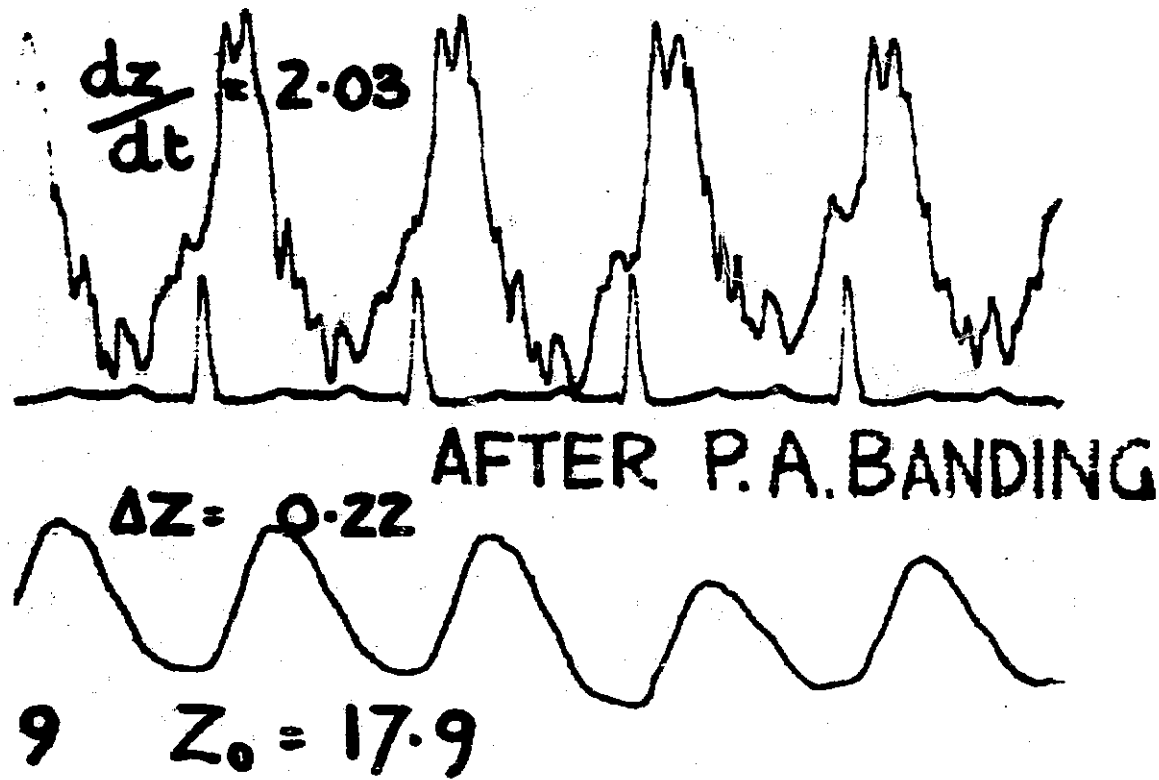

-42-

The pulmonary artery was banded ±60% -- note (dz/dt) drop, ΔZ drop, increased systemic flow

Figure B



N70-10004

THE USE OF THE IMPEDANCE CARDIOGRAPH IN ASSESSING  
THE HUMAN CARDIAC TRANSPLANT

Robert L. Kaster, B.E.E.  
C. Walton Lillehei, M.D., Ph.D.  
and  
Peter J. Starek, M.D.

Department of Surgery  
Cornell University Medical Center  
The New York Hospital  
New York, New York

Rejection of foreign tissue by the host environment is the single baneful complication presently associated with cardiac transplantation. An accumulative phenomenon and seemingly originating at the biochemical cellular level, rejection progresses with little or no outward indication of its existence. Chemotherapy (steroid) abates but does not prevent the advancing disruptive chemical alteration of the cells within the donor organ. Further, massive steroid therapy administered to offset clinically exhibited cardiac rejection often has a deleterious effect upon the normal routine physiologic functions of certain other systems and their associated organs. This is particularly evident in the case of an acute rejection episode or with one that is mild and persistent.

During the postoperative treatment of the transplant patient there is a need to understand the extent of rejection and more important its progression rate if it exists. The availability of this information would permit instituting an effective and more realistic program of anti-rejection drug therapy. To actually accomplish this, rejection must be detected at the sub-clinical level. Therefore, the rate of rejection could be controlled and without jeopardizing the patient's physiologic well-being.

Since cardiac rejection implies the incapacitation of cardiac muscle cells, it seems that the day-to-day measurement or determination of the hemodynamic capability of the transplanted heart would provide meaningful information of its pumping capacity. The

degree of reliability and the level of accuracy of intracorporeal information depends largely upon the test method employed. Transcutaneous or invasive methods of measurements by their inherent nature of direct sensing are known to provide more accurate and reliable data than non-invasive techniques. However, for the cardiac transplant patient, the indwelling devices of transcutaneous methods are a serious threat to the delicate balance between immunosuppressive therapy and infection. A non-invasive method of detecting rejection would be even more desirable in view of the patient's overall well-being.

Impedance cardiography is a non-invasive and readily reproducible method of measuring certain cardiac dynamic parameters. This report discusses our experience with impedance cardiography as a method to detect sub-clinical cardiac rejection; although at the outset it was not known which parameter provided information regarding rejection. Two cardiac transplant patients were monitored using impedance cardiography (ZCG) intermittently over periods of two and three months respectively.

#### METHODS

The four aluminized foil Mylar Electrodes\* were placed according to the method described by Kubicek et al<sup>(1)</sup>. A minimum separation of two centimeters was maintained with each placement of the two neck-encircling electrodes. The other two band-type electrodes encircled the torso at the xiphoid process and umbilicus

---

\*Supplied by Minnesota Mining & Manufacturing Co., St. Paul, Minnesota

levels respectively. In no instances was electrode paste or jelly used with electrode placement. The separation between the inner electrode numbers 2 and 3 (Figure 1) was measured along the sternal and spinal lines respectively. The average of these two measurements in centimeters corresponded to the separation distance "L". Except for a few isolated instances of the patient sitting in a chair, most measurements were made with the patient lying in bed with the torso inclined  $20^{\circ}$  (Figure 1).

An individual co-axial cable connected each of the encircling electrodes to the Minnesota Impedance Cardiograph (MIC), Model 202 instrument. For ease of handling, the four individual cables were banded together to constitute a single or master cable. The outputs of  $\Delta Z$  and  $dZ/dt$  from the MIC instrument were both connected with a shielded cable to a Sanborn Model 350-2700C, high-gain preamplifier in a Hewlett Packard Model 7712 thermal recorder. In addition, the patient's extremities were fitted with conventional electrocardiographic electrodes and in turn connected to a high-gain preamplifier. All instrumentation was turned on at least 45 minutes before performing the appropriate balancing and calibration procedures prior to recording data.

Both patients were instructed about the type of breathing activity they were to perform for this test. They were to consciously perform two passive oral respiratory cycles beginning with inspiration and ending with a prolonged period of relaxed

apnea maintaining an open glottis. Tidal volume was maintained at a level consistent with what they would normally experience during resting. They were asked not to move or talk throughout the test. As many as five runs but no less than three were taken for each test sequence. This was done to ascertain the reproducibility of the patient's performance and thereby assuring data reliability. Usually this produced stable data during a minimum of five heart beats after which time the patient was asked to voluntarily resume breathing. Following a 45-second delay, the patient was simply asked to initiate another conscious breathing sequence at his convenience. If  $Z_0$  changed more than 0.2 of an ohm between runs or exhibited instability during a run, the foregoing data was discarded and the test started over. A record of stable data was usually obtained after asking the patient to consciously participate, in addition to briefly instructing him on the proper breathing technique.

From the data of each recorded sequence certain relationships were routinely determined.

Thoracic Resistivity,  $Q$  (ohm-cm.)

This is a quality of the conducting properties<sup>(2)</sup> of the intracorporeal contents between the two inner electrodes relative to the two outer electrodes. This relationship is expressed as follows:

$$Q = \frac{C^2}{4\pi} \cdot \frac{Z_0}{L}$$

Where C represents the chest circumference in centimeters at the level of the second intercostal space,  $Z_0$  is the thoracic ohmic impedance between the two inner electrodes during prolonged apnea, and L is as defined above.

Interval R - Z, (M Sec.)

This period was measured between the R spike of the QRS complex and the maximum peak of the ensuing  $dZ/dt$  record. This point of the  $dZ/dt$  record is considered as the instant of maximum forceful ventricular contraction.

Interval T, (Sec.)

This relative determination of ventricular ejection time is obtained from the  $dZ/dt$  record. It is measured from the initial upswing of the  $dZ/dt$  record to the first major dip below the zero datum line which usually coincides with aortic valve closure.

$dZ/dt$  minimum (ohms/sec.)

The controlled minimum value of thoracic impedance occurs during the period of relaxed apnea. It is calculated by dividing the magnitude of the  $dZ/dt$  record by the positive amplitude of the resultant calibration record.

Stroke Volume, (ml/stroke)

The pulsatile volume of flow was calculated according to the formula in the preliminary instruction manual for the MIC Model 202 instrument as defined by the Minnesota group.

$$S.V. = \rho \frac{L^2}{Z_0^2} T (dZ/dt)_{\min}$$

Here,  $\rho$  is the electrical resistivity of blood at 100 kHz. Under normal hematologic conditions it is 150 ohm-cm. All other terms are as discussed above.

Heart Rate, (beats/min)

The series of R spikes of the electrocardiographic record during the prolonged period of apnea under consideration provide the determination of heart rate.

Cardiac Output, (liters/min)

It follows that the product of the previously calculated stroke volume and the heart rate gives a measure of minute flow volume.

In addition, certain sequential steps in the ultimate determination of stroke volume were performed, listed, and studied.

Two of these are as follows:

- a)  $L^2/Z_0^2$
- b)  $L^2/Z_0^2 \times dz/dt \text{ min}$

The contributory terms of these two determinations were discussed above. No particular relationship of these two parameters to the patient's clinical status is suggested at this writing. Finally, all of the above determinations were performed both by this investigator and by the Minnesota group which had at its disposal a pre-programmed computing facility.

RESULTS

Patient J.A. This cardiac transplant patient was first measured on his 23rd postoperative day. Since receiving the heart

of a man 16 years his junior (Table 1), he exhibited a satisfactory recovery. Between January 23, 1969 and April 25, 1969 a total of 31 ZCG tests were conducted. The results of the numerous determinations of these tests are listed in Table 2. The separation,  $L$ , of electrode numbers 2 and 3 ranged between a minimum distance of 24.0 centimeters to a maximum of 32 centimeters. From beginning to end, a slightly decreasing trend persisted (Figure 2). The spiking variations that occurred from one measurement to the next seemed the result of the patient's inability to sit erect for placement of electrode 3. The sticky tape electrodes were often troublesome which also contributed to variable placement of electrode 3. On other occasions electrodes 2 and 3 were placed to avoid intravenous cutdowns, chest tubes, and massive bandages. These differences in  $L$  did not produce consistent variations in other time variant or instrument outputs.

The thoracic impedance ( $Z_0$ ) data for the patient lying in bed ranged from 16.3 to 27.2 ohms. A single chest tube was implanted on January 23, when a bilateral pneumothorax was detected. It was removed on January 30 with clearing of the chest. During this period  $Z_0$  exhibited a moderately decreasing slope, which with the clearing of the pneumothorax reverted to a nearly flat plot of data points until February 20. The increasing value of  $Z_0$  beginning on February 26 was preceded on the day before with bilateral pleural effusion. Clinical indications on April 14 were



suggestive of right-sided heart failure. The square of the ratio of L to Z is seen in Figure 2 as the mirror image of the thoracic resistivity  $R$ . As seen in the relationship for  $R$  above, thoracic resistivity varies directly with  $Z_0$  on inversely with L.

Except for the January 23 measurement  $dZ/dt$  min. ranged from 0.9 to 2.45 ohms/sec. The approximate overall average was 1.4 ohms/sec. During the periods of February 3 to 10 and February 22 to 24,  $dZ/dt$  min. recorded least values during which there were no remarkable clinical notes. Note the generally increasing trend beginning with February 26 which was preceded on the day before with a bilateral pleural effusion. However, when a pneumothorax was noted for the period of January 23 to 30,  $dZ/dt$  min. varied markedly but without a trend.

The gradual decreasing graph of interval R-Z is marked by only two points of deviation from the beginning of the measurements until February 26 (Figure 3). During this period R-Z varied from a high of 95 milliseconds down to a low of 70 milliseconds. After February 26 R-Z became very erratic. This period was initiated with a bilateral pleural effusion which was noted to last until April 3.

During the period of March 6 to April 2 the patient did moderately well with no remarkable chart notes. Further, the patient's improved ambulatory condition in the hallways and about the hospital grounds made it difficult to find him for a ZCG

measurement. Thus no records were taken during this time. On April 16 he developed a sinus tachycardia which was followed in later days with additional episodes of tachycardia, atrial fibrillation, atrial flutter, spiking heart rates, and VPC's. These conditions were effectively controlled mainly with digitalis which returned the patient to normal sinus rhythm.

The interval T (or effective ventricular ejection time) seems to correlate most closely with the clinical status of this patient in regard to cardiac rejection. On February 3 and again on April 25 this patient exhibited acute episodes of cardiac rejection. Beginning January 25, T decreased consistently until it stabilized at a minimum on February 3. This is the period of pneumothorax which ended on January 30. At 2 a.m. on February 1, the patient went into paroxysmal atrial tachycardia which changed to atrial fibrillation at a pulse rate of about 150 beats per minute. Several hours later after digitalis, the rate dropped to 92 beats per minute - normal rhythm. This sequence of events occurred several times during the next 36 hours. In addition, prednisolone was increased from 200 mg. to 500 mg. daily. Late February 3 the patient stayed in normal sinus rhythm, but with continuous atrial flutter. Note the slightly erratic but steady increase in T after February 3. On the 12th normal sinus rhythm returned. The patient made slow but steady improvement until April 11 when the T value started to decrease. Two days later,

sinus tachycardia occurred, to be followed with atrial flutter on April 17. During the remaining days this patient complained of shortness of breath in addition to having an irritable heart which could usually be controlled with digitalis. On April 25 the patient suffered a cardiac arrest which was preceded by ventricular fibrillation. Following successful resuscitation the last ZCG measurement shown in Figures 2 and 3 was taken. Two hours later rates and multiple arrhythmias preceded ventricular fibrillation which resulted in irreversible cardiac arrest. Although the heart rate vacillated markedly during the days of these measurements, it was fortunate that data was always recorded during a period of stabilized heart rate which strengthens the validity of the T interval determinations (except for the very last occasion). Stroke volume and cardiac output (which follows from the heart rate) appeared to be somewhat high. Except for the single high value on February 14, all values remained high but with a consistency. A value of  $\rho = 150$  ohm-cm was used for the electrical resistivity of blood in these calculations. This  $\rho$  value of 150 is for a hematocrit of 41%. On several occasions the hematocrit was measured at 36% which would correspond to a  $\rho$  value of 135 and this if used would result in a considerable reduced but realistic value of stroke volume.

Patient J.H. This man received the heart of a man 21 years his senior (Table 3) and was measured initially with the ZCG method on his ninth postoperative day. Fifteen ZCG tests were performed on this patient between February 28, 1969 and April 24, 1969. The determinations of these tests are listed in Table 4. This patient

exhibited a very rapid recovery. The lack of data between March 10 and April 1 was a result of this man's mobility in the vicinity of the hospital. On April 12 he was discharged with re-admission on April 22.

Except for the high value of  $L$  on April 23 all others ranged between 22.70 and 29.20 centimeters (Figure 4). The largest value of  $L = 32.50$  centimeters resulted in the inability of the patient to move and thereby not assist in the proper placement of the electrodes. Indeed, the last three values are highest due to the numerous types of life-support equipment which were attached to sustain this patient in his condition of acute cardiac rejection. Electrode number 3 (Figure 1) is perhaps the single most difficult one to place under these conditions.

Thoracic impedance  $Z_0$  varied between 21.0 and 25.3 ohms for all measurements (Figure 4). For the latter two, the patient was supported by a respirator. Stable ZCG records were obtained by removing this respiratory support. Similar to patient J.A., the graph of thoracic resistivity  $\rho$ , is the mirror image of the square of the ratio of  $L$  to  $Z_0$  (Figure 4).

For all but the last three measurements,  $dZ/dt$  min. varied from 2.05 to 3.25 ohms/sec. This was slightly higher over all than for the patient J.A. During the postoperative period, this patient (J.H.) exhibited a more rapid recovery and a markedly greater capacity for physical activity. Recall that 36 year-old J.H. received his heart from a 57 year-old man (Table 3) and 63 year-old

J.A. received the heart from a man of 47 years (Table 1). Rather than the age of the transplanted heart, perhaps there is a direct relationship between the capacity for physical activity and  $\frac{dz}{dt}$  min. The final measurements of  $\frac{dz}{dt}$  min. (Figure 4) averaged .89 ohms/sec, which is less than half the value recorded for this patient while exhibiting a rapid recovery. During these latter measurements this patient was removed from the respirator at the time of respiratory apnea for up to ten seconds.

The R-Z interval graph displays an erratic pattern while ranging between 60.0 and 90.0 milliseconds (Figure 5). On March 3 the hematocrit dropped 9% from 47% on the day before. This is roughly equivalent to a loss of 1000 cc. of blood. The sudden jump in the R-Z record corresponding with this drop in hematocrit may be suggestive of a theory that a sudden loss of blood will result in a longer period of time between the R spike and the instant of maximum ventricular contraction which is believed to coincide with the peak of the  $\frac{dz}{dt}$  record. The ventricular ejection period, or T interval, during this period vacillated without any significant trend (Figure 5). Heart rate also remained stable but showed a slightly decreasing rate. In addition, stroke volume remained quite stable, averaging 100 ml while fluctuating over a range of 84 to 108 ml per stroke. During this period of early March (fluctuating hematocrit) and throughout the remainder of the month, the patient continued to do very well.

On April 1 the patient's urine turned dark which was followed two days later with an elevation in bilirubin to 2.7 mgm.%. A diagnosis of viral hepatitis was made at this time. Coincidentally the R-Z interval remained much the same as in the early postoperative series of measurements. The ventricular ejection duration showed a slight consistent increase in time which coincides with an increase in stroke volume - up 20 to 40 ml from an earlier average of 100 ml. The condition of viral hepatitis cleared up in a few days and the patient continued to do well. He was discharged on April 12 and re-admitted ten days later with a low blood pressure, a pulse rate of 120 beats/minute, temperature of 103° F, and complaining of weakness and chills. Two ZCG measurements were made 36 and 42 hours later. Note that prior to the day of discharge the T record was depressed and upon re-admission was even more markedly depressed. The greatly reduced stroke volume measurements which averaged 42 ml were apparently a result of the advanced condition of left ventricular failure.

#### DISCUSSION

These serial measurements were made on two patients who had undergone new revolutionary surgical procedures of cardiac transplantation. The impedance cardiograph method of measuring stroke volume and cardiac output as well as certain other parameters was used in hopes of detecting cardiac rejection. If cardiac rejection is detected before it reaches the advanced stage of an acute episode,

the attending physician can more effectively treat the patient. In these two patients three episodes of clinical cardiac rejection occurred, two in patient J.A. and one in patient J.H. In all three cases only the T interval graphs gave an early indication of something happening. For patient J.A., the T value began decreasing ten days before the first episode of rejection. It increased again only after the patient's condition stabilized and improved. Fifteen days before the sudden death of this patient which resulted from cardiac rejection, the T value began to decrease and continued this trend until the time of death. In the first case of rejection the heart rate was always constant when the ZCG data was recorded. During the second episode of rejection for J.A. the pulse rate varied moderately from one measurement to the next. Judging from the negative slope of the T graph for this episode, it appears that fluctuating pulse rate had little influence upon T.

With patient J.H. the ventricular ejection time T varied slightly more from one measurement to the next than for patient J.A. In this case the T value started to decrease the day before he was discharged to his home. This was 14 days before his demise. There is a 12-day break in the data from discharge to re-admission. Further, since there are only four measurements that make up this period of the graph, one must view this particular T plot and its relationship to cardiac rejection with reservation. Due to the spontaneous development and devastating effects of rejection, if a reliable test for such is available it should be performed daily.

Since this initial study of the impedance cardiogram method, four other cardiac transplant patients are under study with the Minnesota Model 202 instrument. Certain changes in technique have been initiated with these studies. All were studied within the first 24 hours following transplantation. Measurements were made daily with rare exceptions. Non-adhesive metal braid electrodes were substituted for the Mylar foil tape for electrode numbers 3 and 4 (Figure 1). A simultaneous heart sound record is routinely recorded which aids in pinpointing the exact instant of aortic valve closure, since in the deteriorating states of later patients this instant was masked by unusual  $dZ/dt$  records.

In all patients since this initial study, the hematocrit was recorded and used to arrive at a more realistic value for the electrical resistivity ( $\rho$ ) of blood. The resulting determinations of stroke volume and cardiac output have produced realistic values for cardiac output which range between five and six liters per minute.

It appears at this time that reliable and reproducible records can be obtained with a thorough understanding of the instrument and a certain operative proficiency. In addition, it is felt that the impedance cardiograph may lead to the understanding of other intracorporeal disturbances through improved techniques of data analysis.



Table 1

RECIPIENT

J.A. 112 68 27 White Male 63 Years

Diagnosis: Severe acquired coronary artery disease of all vessels with infarction of 50% of the left ventricle.

DONOR

M.B. 115 04 12 White Male 47 Years

Estimated Grade of Match: B

Preservation: Hypothermia, 17° C - Chilled  
Ringer's Lactate

Total Ischemia Time: 1 Hour

Implantation Date: January 1, 1969

Expiration Date: April 25, 1969

Duration: 16 Weeks

Cause of Death: Rejection - Cardiac Failure

PATIENT: J.A. 112 58 27 N.Y.H.

Table 2

DATE	DAY POSTOP	ELECTRODE SEPARATION L Cm	THORACIC IMPEDANCE Z <sub>o</sub> Ohms	INTERVAL R-Z M Sec	INTERVAL T SEC	THORACIC RESISTIVITY R Ohm-cm	dZ/dt <sub>1</sub> Ohm/sec	L/Z <sub>o</sub>	(L/Z <sub>o</sub> )dZ/dt	L <sup>2</sup> /Z <sup>2</sup>	(L <sup>2</sup> /Z <sub>o</sub> <sup>2</sup> )dZ/dt	STROKE VOLUME ml	HEART RATE Beats/Min	CARDIAC OUTPUT L/Min
1/22/69	22	0	31.50	0	.22	0	3.28	0	0	0	0	0	80.54	0
1/22/69	22	0	30.20	0	.22	0	3.67	0	0	0	0	0	80.54	0
1/23/69	23	32.00	29.60	0	.33	535.82	4.47	1.20	5.38	1.45	6.48	170.0	76.44	12.98
1/23/69	23	32.00	29.70	0	.28	598.27	4.15	1.08	4.47	1.16	4.82	205.82	76.92	15.83
1/24/69	24	31.00	24.50	95.00	.36	509.44	1.77	1.27	2.25	1.60	2.84	152.98	84.52	12.94
1/25/69	25	30.00	24.90	92.50	.31	535.02	2.05	1.20	2.47	1.45	2.98	140.77	84.21	11.85
1/27/69	27	31.00	27.20	90.00	.28	565.58	2.20	1.14	2.51	1.30	2.86	120.02	91.62	11.00
1/28/69	28	31.00	26.70	90.00	.25	555.18	3.25	1.16	3.77	1.35	4.38	167.43	102.13	17.09
1/29/69	29	31.00	21.10	90.00	.23	438.74	2.45	1.47	3.60	2.16	5.29	178.89	85.91	15.37
1/30/69	30	30.00	25.10	80.00	.24	539.31	1.51	1.20	1.81	1.43	2.16	77.78	85.12	6.62
2/3/69	34	28.00	19.90	82.50	.23	458.12	1.00	1.41	1.41	1.98	1.98	68.23	83.63	5.71
2/4/69	35	27.50	20.00	75.00	.27	468.80	1.32	1.38	1.82	1.89	2.51	102.38	85.11	8.71
2/5/69	36	31.00	20.30	72.50	.26	422.11	1.19	1.53	1.81	2.33	2.77	108.09	82.48	8.91
2/6/69	37	29.00	18.80	72.50	.25	417.88	1.17	1.54	1.80	2.38	2.78	102.05	82.48	8.41
2/10/69	41	24.00	16.30	92.50	.31	437.79	1.19	1.47	1.75	2.17	2.58	119.94	99.91	10.90
2/12/69	43	28.50	18.50	70.00	.28	418.42	1.48	1.54	2.29	2.37	3.52	148.95	83.63	12.43
2/13/69	44	28.75	18.90	70.00	.31	423.75	1.16	1.52	1.76	2.31	2.68	126.69	71.43	9.05
2/14/69	45	31.00	19.40	80.00	.33	403.39	2.05	1.60	3.23	2.55	5.23	260.83	73.17	19.09
2/17/69	48	27.30	18.90	70.00	.32	446.26	1.37	1.44	1.97	2.09	2.85	139.11	67.42	9.38
2/18/69	49	25.50	19.10	70.00	0	482.82	1.51	1.34	2.01	1.78	2.69	0	65.93	0
2/19/69	50	27.00	18.80	72.50	0	448.83	1.27	1.44	1.82	2.06	2.61	0	63.63	0
2/20/69	51	28.10	18.80	72.50	.31	431.26	1.07	1.49	1.59	2.23	2.38	111.68	75.00	8.38
2/22/69	53	25.30	17.60	70.00	.32	448.41	.92	1.44	1.32	2.07	1.89	92.97	67.04	6.18
2/24/69	55	25.80	17.00	72.50	.35	424.73	.91	1.52	1.38	2.30	2.09	109.09	78.69	8.63
2/26/69	57	25.70	18.30	72.50	.36	458.99	1.17	1.40	1.65	1.97	2.32	124.35	71.43	8.88
2/28/69	59	26.40	20.00	100.00	.34	488.33	1.44	1.32	1.90	1.74	2.51	129.11	68.62	8.86
3/3/69	62	33.70	20.30	82.50	.34	400.00	1.13			2.76	3.10	156.98	76.92	12.08
3/5/69	64	24.80	19.00	87.50	.35	493.81	1.44	1.66	1.87	1.70	2.46	130.80	78.43	10.20
3/6/69	65	23.10	20.30	80.00	.33	566.46	1.38	1.31	1.88	1.70	2.46	130.80	78.43	10.20
4/2/69	92	26.40	19.10	100.00	.35	400.36	1.14	1.14	1.29	1.29	1.79	89.44	90.91	8.13
4/11/69	101	29.00	19.90	82.50	.33	442.33	1.50	1.38	1.58	1.91	2.18	115.39	59.70	6.89
4/18/69	108	28.00	21.90	90.00	.32	504.17	1.97	1.46	2.19	2.12	3.19	157.68	62.02	9.78
4/23/69	113	29.00	23.30	105.00	.27	517.90	1.79	1.23	2.51	1.63	3.21	154.31	49.18	7.59
4/25/69	115	30.00	20.70	85.00	.18	444.77	1.57	1.24	2.23	1.55	2.78	114.32	79.46	8.95
								1.45	2.28	2.10	3.31	88.45	153.30	13.66

Table 3

RECIPIENT

J.H. 115 26 85 White Male 36 Years

Diagnosis: Cardiac myopathy

DONOR

E.R. 87 00 88 Negro Male 57 Years

Estimated Grade of Match: B

Preservation: Hypothermia, 17° C - Chilled  
Ringer's Lactate

Total Ischemia Time: 1 Hour, 30 Minutes

Implantation Date: February 19, 1969

Expiratory Date: April 24, 1969

Duration: 9 Weeks

Cause of Death: Cardiac Rejection

PATIENT: J.H. 115 26 85 N.Y.H.

Table #

DATE	DAY POSTOP	ELECTRODE SEPARATION L Cm	THORACIC IMPEDANCE $Z_0$ Ohms	INTERVAL R-Z M Sec	INTERVAL T SEC	THORACIC RESISTIVITY R Ohm-cm	$dZ/dt_m$ Ohm./sec	L/ $Z_0$	$(L/Z_0)dZ/dt$	$L^2/Z^2$	$(L^2/Z_0^2)dZ/dt$	STROKE VOLUME ml	HEART RATE Beats/Min	CARDIAC OUTPUT L/Min
2/28/69	9	25.65	20.90	87.50	.21	513.62	2.05	1.23	2.52	1.51	3.09	96.11	93.75	9.01
3/1/69	10	23.30	24.10	80.00	.23	651.99	2.65	.97	2.56	.93	2.48	83.77	94.49	7.91
3/3/69	12	26.25	23.30	95.00	.18	559.51	2.91	1.13	3.23	1.27	3.70	101.19	92.31	9.34
3/5/69	14	25.05	23.70	75.00	.20	596.38	3.25	1.06	3.44	1.12	3.63	107.54	96.39	10.37
3/6/69	15	24.05	22.10	77.50	.18	579.24	2.91	1.09	3.17	1.18	3.45	94.35	89.55	8.45
3/10/69	19	26.80	25.30	87.50	.25	595.07	2.57	1.06	2.73	1.12	12.89	107.26	78.69	8.44
4/1/69	41	22.70	25.05	85.00	.26	695.61	2.15	.91	1.95	.82	1.77	69.52	86.96	6.05
4/2/69	42	27.00	25.00	92.50	.27	583.66	2.50	1.08	2.70	1.17	2.92	117.00	84.51	9.89
4/4/69	44	28.30	24.10	92.50	.28	536.80	2.28	1.17	2.67	1.38	3.14	132.95	80.00	10.64
4/7/69	47	26.75	23.10	82.50	.29	544.34	2.39	1.16	2.76	1.34	3.20	138.06	83.33	11.51
4/11/69	51	27.50	24.90	85.00	.25	579.75	2.80	1.10	3.09	1.22	3.42	129.44	94.12	12.18
4/11/69	51	27.50	25.50	90.00	.24	584.51	3.00	1.08	3.24	1.16	3.49	122.90	96.77	11.89
4/23/69	63	32.50	22.60	100.00	.16	438.34	.98	1.44	1.40	2.07	2.02	49.17	122.45	6.02
4/23/69	63	29.20	21.60	80.00	.16	466.29	.77	1.35	1.05	1.83	1.42	34.56	109.60	3.79
4/24/69	64	28.70	21.30	65.00	.17	467.82	.93	1.35	1.25	1.82	1.68	44.09	86.96	3.83

Figure 1

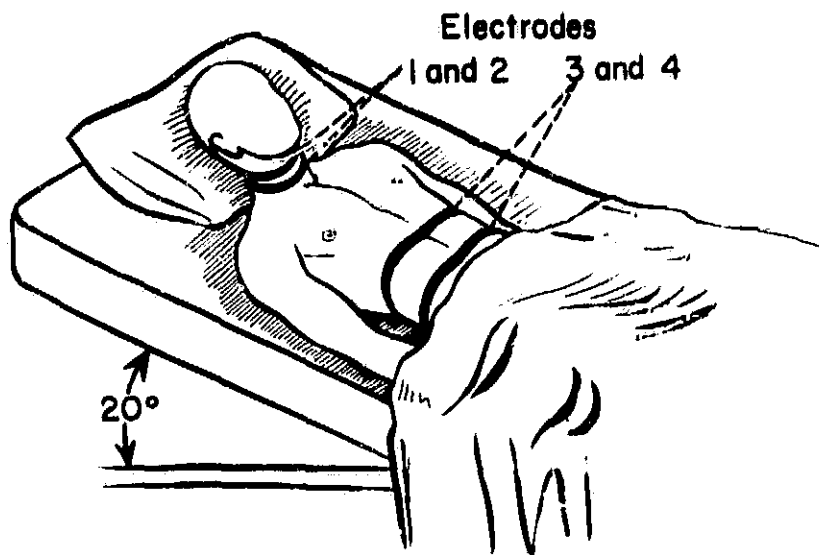

For each measurement the patients were fitted with aluminized Mylar foil electrodes. Electrode numbers 3 and 4 at the xiphoid process and umbilicus respectively proved the most difficult to place. This was because of the postoperative requirements resulting from the nature of the foregoing surgical procedure of this magnitude. All of the data points connected by a solid line on Figures 2, 3, 4, and 5 were a result of records taken while the patient was lying in bed and inclined 20 degrees.

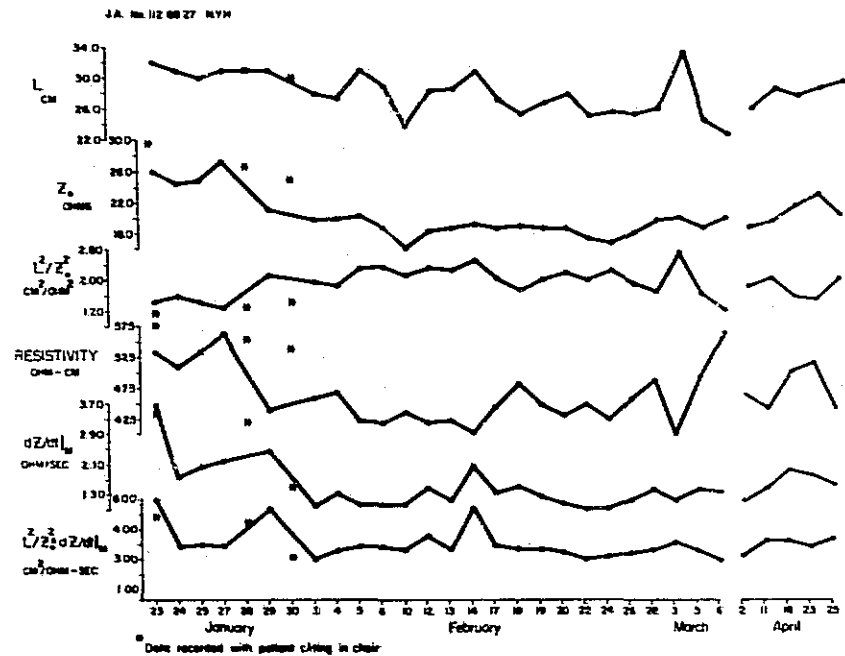

Figure 2

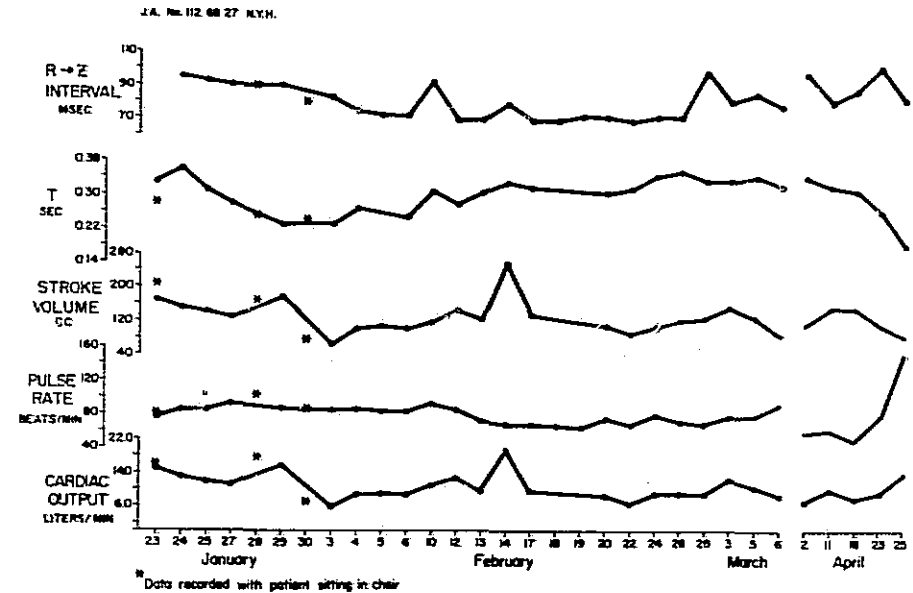

Figure 3

The data that appears in Table 2 is plotted in these two companion figures. The first record was taken on this patient's 23rd postoperative day. The last record was taken three hours before this patient's demise from acute cardiac rejection. The break in the graphs between March 6 and April 11 marks a period of 26 days in which no ZCG data was recorded.

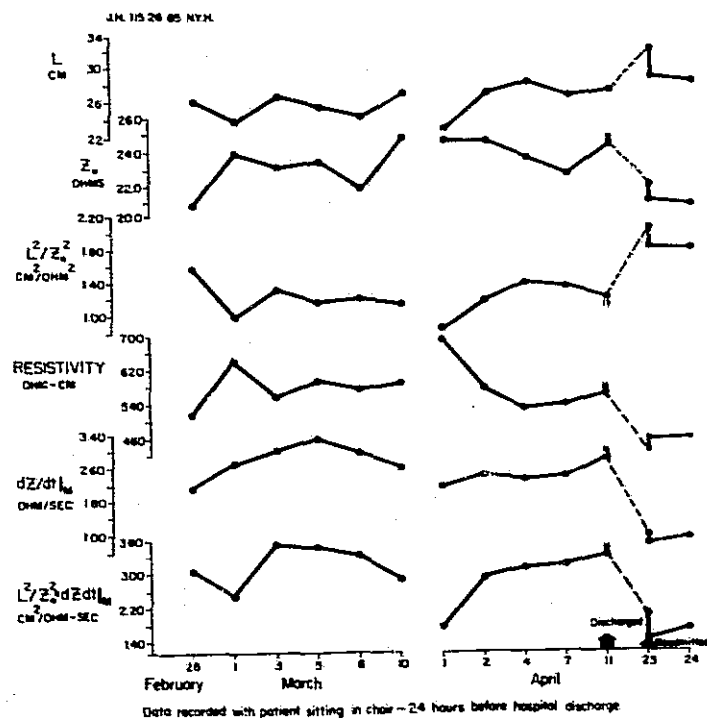

Figure 4

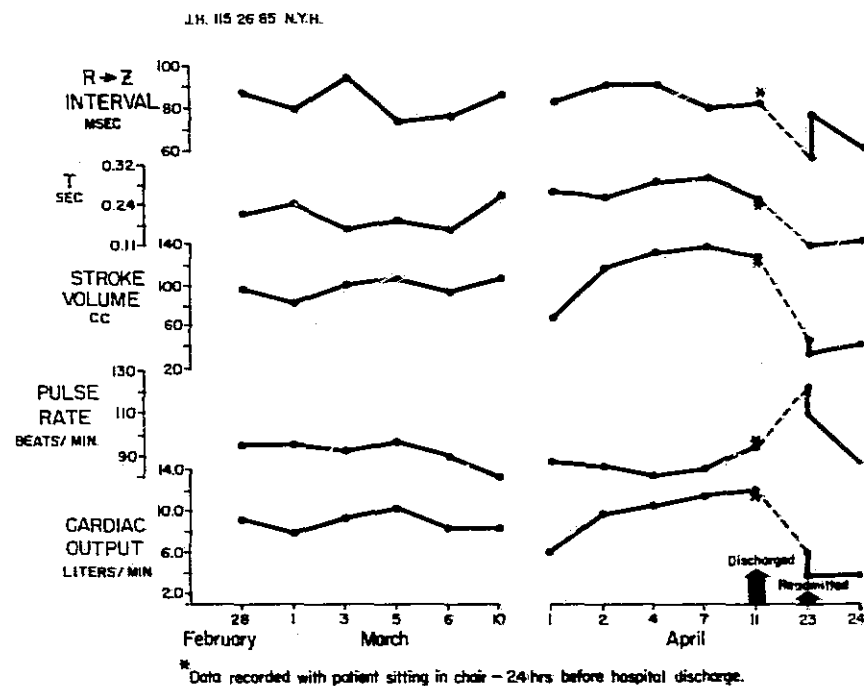

Figure 5

The data that appears in Table 4 is plotted in these two companion figures. The first ZCG measurement was recorded on this patient's ninth postoperative day. The last was recorded on his 64th postoperative day, about five hours preceding death from cardiac rejection. The break in the graphs between March 10 and April 1 marks a period of 21 days during which no ZCG measurements were recorded. The dates of April 11 and April 23 are the days of discharge and re-admission respectively. No records were taken during this time.

BIBLIOGRAPHY

1. Kubicek, W.G., Karnegis, J.N., Patterson, R.B., Witsoe, D.A. and Mattson, R.H.: Development and Evaluation of an Impedance Cardiac Output System. *Aerospace Medicine*, 37:1208, 1966.
2. Sears, F.W.: Electricity and Magnetism. Addison-Wesley Publishing Company, Inc., Cambridge, Massachusetts. pp. 92-94, 1956.

The authors wish to express their appreciation to Dr. William Kubicek, Mr. David Witsoe, and Mr. Robert Patterson and the technical staff of the Minnesota group for their patient guidance and assistance in the application of this instrument, the analysis of the records, and in performing the numerous computations involved.



**N70-10005**

**TRANSTHORACIC ELECTRICAL IMPEDANCE AS A CLINICAL GUIDE  
TO INTRATHORACIC FLUID VOLUMES**

by

**Marvin Pomerantz, M.D.  
Ben Eiseman, M.D.**

**Departments of Surgery  
The Denver General Hospital  
The University of Colorado School of Medicine  
Denver, Colorado**

**Supported in parts by a Grant from the USN N00014-69-  
A0078-0001 and NASA Contract No. NAS 9-4500.**

Transthoracic electrical impedance has been used as a noninvasive means for determining cardiac output (1) but inconsistent results have precluded its widespread clinical application for this purpose.

Recently we have employed transthoracic electrical impedance as a guide to the early detection of experimental pulmonary edema and insufficiency (2). Implicit in the system was the use of the Minnesota Impedance Cardiograph as described by Kubicek (1). These studies demonstrated that transthoracic impedance changed up to 45 minutes prior to standard measurements such as arterial blood gases, blood pressure, central venous pressure or compliance when experimental pulmonary edema was produced by the intravenous infusion of alloxan.

The current report presents preliminary clinical data concerning change in transthoracic impedance as it reflects intrathoracic fluid accumulation.

#### Materials and Methods

Twelve clinical studies have been carried out as summarized in Table I.

The impedance plethysmograph monitor as described by Kubicek was used in all studies. The four-electrode system was arranged so that the upper two electrodes encircling the neck were as far apart as possible, the third was at the level of the xiphisternum, and the fourth around the lower abdomen.

Electrodes at the upper neck and lower abdomen were excited by a 100 kHz sinusoidal current, and the impedance between electrodes two and three recorded as  $Z_0$ . Such a system measures impedance of a cylindrical core along the long axis of the thorax and is relatively uninfluenced by respiratory movement.

When repeat studies were performed or electrode bands replaced, care was taken to replace the electrodes in positions identical to the original placement. This kept the distance between electrodes two and three (L) as uniform as possible.

### Results

In all three patients with pleural effusions there was a linear relationship between impedance ( $Z_0$ ) and the amount of fluid removed by thoracentesis (Fig. 1). As little as 50 cc of fluid removed altered impedance readings.

Following extensive trauma and resuscitation, impedance values appeared to parallel changes in pulmonary dynamics. In one patient following a crush injury to both lower extremities requiring 6,500 cc of blood and 3,500 cc of crystalloid solutions for resuscitation, a decrease in impedance heralded a change in pulmonary dynamics. Approximately 30 hours after injury a drop in  $Z_0$  from 24.5 to 22.5 occurred. Arterial gases at this time revealed a  $PO_2$  of 35 mm Hg. Nasal oxygen (3-5 L/min) restored the  $PO_2$  to 75 mm Hg and impedance values gradually rose over the next eight hours.

In a second patient sustaining a gunshot wound to the abdomen requiring 17,000 cc of whole blood during resuscitation impedance values reflected her hospital course (Fig. 2). Baseline impedance measurements reached a high of 13.7 one day after injury and gradually declined to 12.00 on the eleventh post injury day when the patient died of progressive respiratory failure characterized by hypoxia and a progressive rise in pressures necessary for respiring the patient. At autopsy the lungs weighed 1000 and 900 grams respectively.

In another patient with hemorrhagic pancreatitis impedance values increased following diuresis and paralleled improvement of the arterial gases and clinical status (Fig. 3).

In the three cardiac cases impedance changes reflected the status of pulmonary fluid volumes. One patient with constrictive pericarditis, a right pleural effusion, and congestive heart failure, preoperatively had impedance values of 19.5 - 20.0, while postoperatively there was a gradual rise to 24.2 on the second postoperative day. At this time CVP, blood pressure and arterial gases were normal implying normal pulmonary hemodynamics.

The most striking change in impedance was recorded in a patient with a ventricular aneurysm and congestive heart failure. Admission impedance values were 20.0. Two weeks later after losing 20 pounds of fluid, impedance rose to 32.0.

### Discussion

The early detection of pulmonary edema is extremely difficult. Existing methods for its detection are insensitive. Once frank edema occurs a vicious cycle is begun which enormously impedes therapy. Edema begets ischemia of the alveolar membrane which in turn sponsors additional fluid leak. Difficulty in treating patients with established pulmonary insufficiency following nonspecific trauma represents only one need for an objective method for the early detection of pulmonary edema.

Electrolyte solution accumulation within the lung parenchyma or thorax theoretically should alter electrical impedance. Experimentally we have shown that electrical impedance changes up to 45 minutes prior to other standard measurements such as compliance, BP, CVP, or blood gases, when pulmonary edema is produced with intravenous alloxan (2). In our clinical studies impedance changes paralleled changes in blood gases, compliance, BP and CVP but at present it cannot be stated that it predates them. Using impedance measurements it does not appear possible to distinguish between fluid accumulation within the pleural cavity interstitial space, intra-alveolar space, or within the pulmonary vasculature.

Using the present system a relatively stable reading may be obtained. There are several drawbacks to the present system. In the agitated or restless patient impedance readings may vary considerably due to motion. Furthermore,

patients with bulky dressings or a tracheostomy may prevent accurate placement of electrodes, and if the distance between electrodes two and three (L) is not kept constant the baseline impedance ( $Z_0$ ) changes markedly. By altering (L) 6 cm in one patient the  $Z_0$  varied from 27 to 32. Finally, it is not yet clear whether a narrow normal range for  $Z_0$  can be established or whether each patient must serve as his own control. It appears, however, that impedances below 15 definitely indicate large amounts of intrathoracic fluid accumulations while those above 23 indicate relatively normal lungs or intrathoracic fluid volumes and are associated with normal blood gases and a normal CVP and BP.

The ratio of  $L/Z_0$  and  $L^2/Z_0$  was also calculated in an attempt to see if the impedance changes related to the distance between electrode two and three would give a more consistent normal or abnormal range. Preliminary data is inconclusive but this ratio does not appear to offer any advantage over direct impedance measurements.

### Conclusions

Twelve patients with a variety of clinical conditions either producing or suspected of producing increased intrathoracic fluid volumes were studied with the Minnesota Impedance Cardiograph System. Preliminary data indicate that  $Z_0$  changes are an accurate reflection of changes in intrathoracic fluid volumes.

TABLE 1

CLINICAL IMPEDANCE

<u>DISEASE</u>	<u>No.</u>
(1) TRAUMA	4
(2) PLEURAL EFFUSION	3
(3) CARDIAC SURGERY (PUMP)	2
(4) CARDIAC SURGERY (NO PUMP)	1
(5) PANCREATITIS	1
(6) CONG. HEART FAILURE	<u>1</u>
TOTAL	12

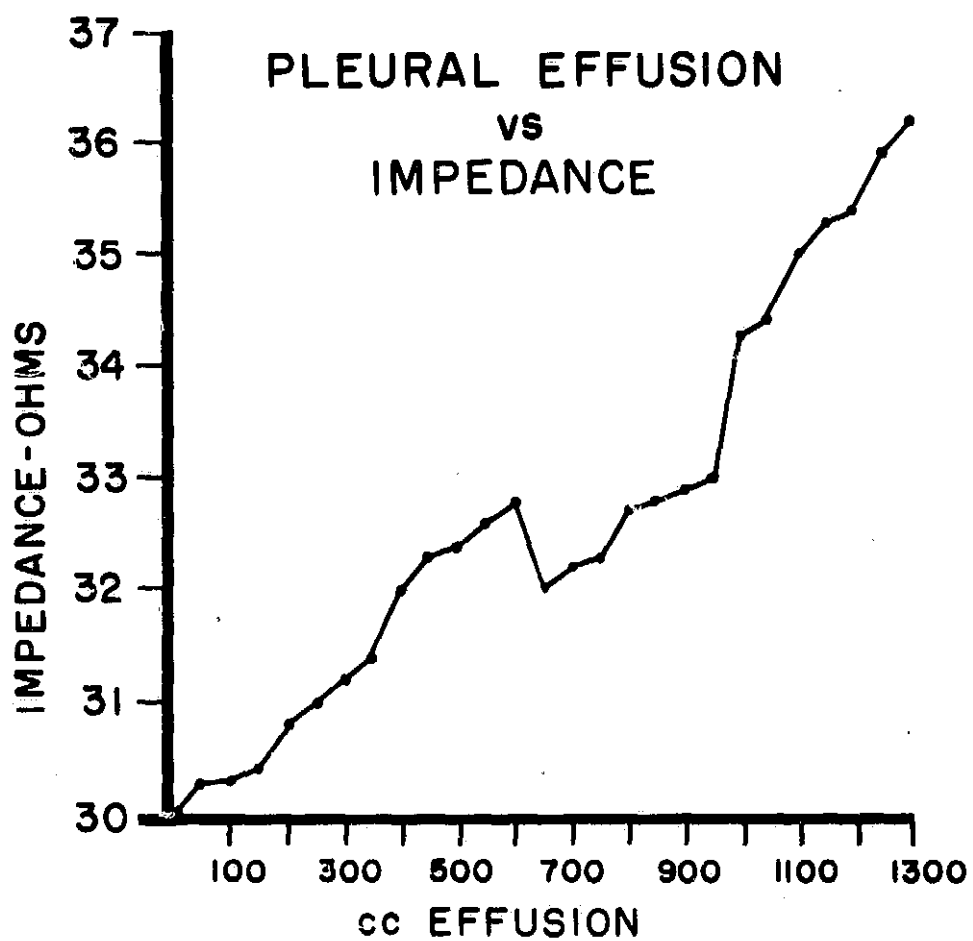

Figure 1 Impedance ( $Z_0$ ) plotted against cc of pleural effusion aspirated



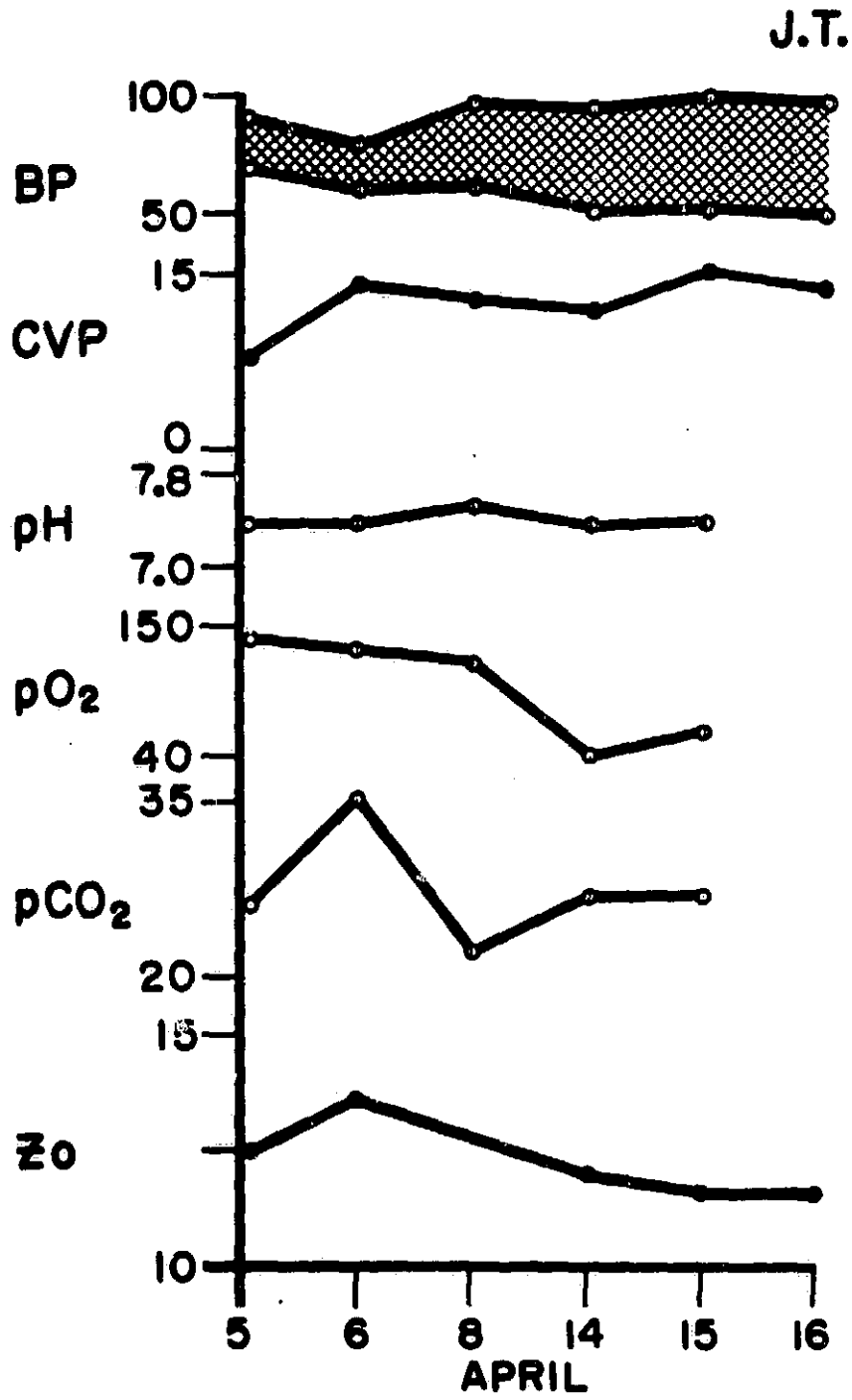

Figure 2 Continued low impedance readings in patient who died in respiratory insufficiency

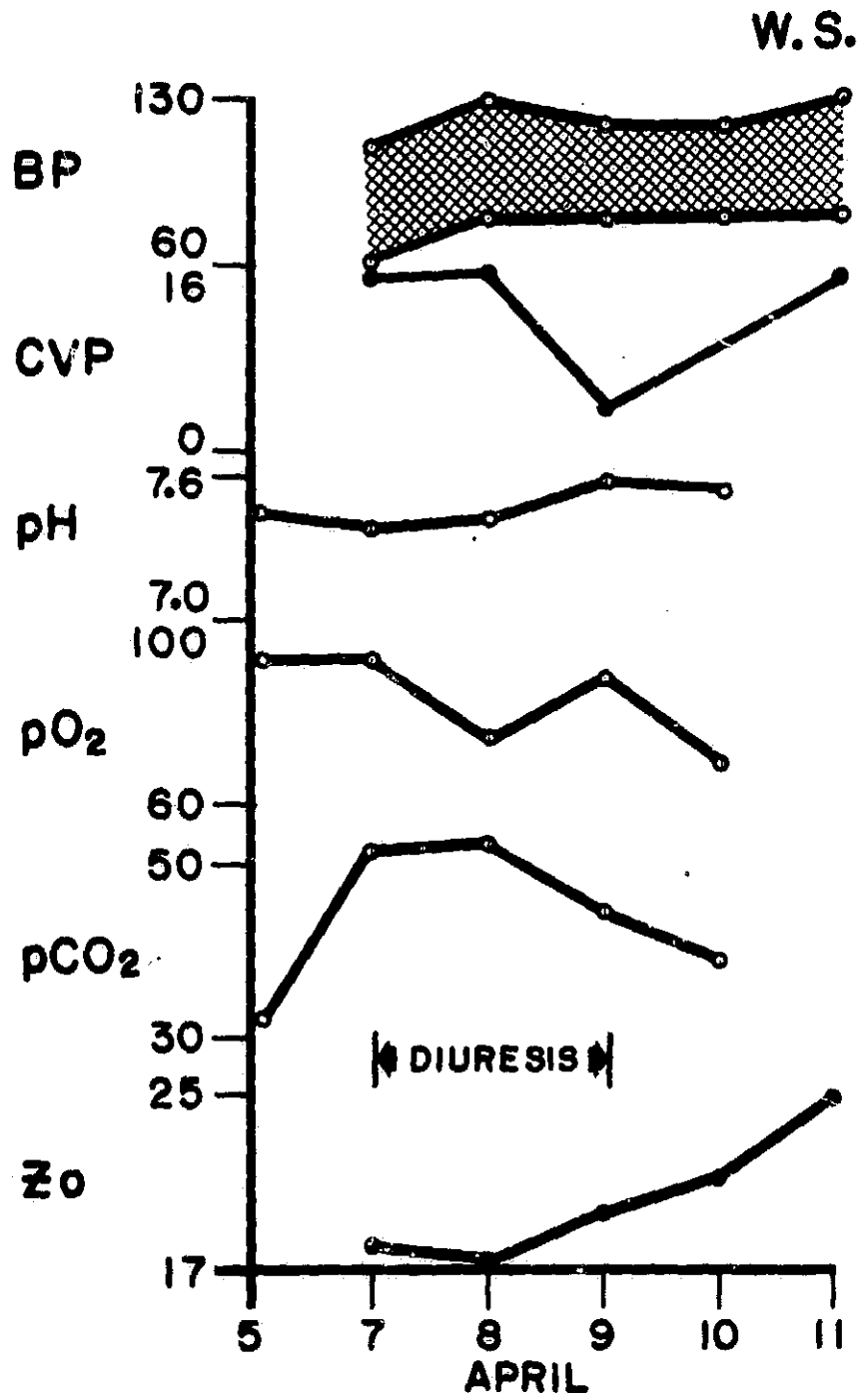

Figure 3 Rise in impedance paralleling improvement of blood gases following diuresis in a patient with pancreatitis

REFERENCES

1. Kubicek, W.G., Patterson, R.P., Witsoe, D.A., Castaneda, A., Lillehei, R.C. and Eiset, R.: The Impedance Cardiograph as a Noninvasive Means to Monitor Cardiac Function. Symposium on Development and Evaluation of an Impedance Cardiograph System to Measure Cardiac Output and other Cardiac Parameters. NASA Report No. NAS 9-4500, 1968.
  
2. Pomerantz, M., Baumgartner, R., Lauridson, J. and Eiseman, B.: Transthoracic Electrical Impedance for the Early Detection of Pulmonary Edema. In Press. Surgery.

N70-10006

ALTERATIONS IN TRANSTHORACIC ELECTRICAL IMPEDANCE  
WITH ACUTE INTRAVASCULAR OVERLOAD

-----

Irwin R. Berman, MAJ, MC, USAR\*  
Walter L. Scheetz, LTC, MC, USA  
Edward B. Jenkins, B.A.  
Howard V. Hufnagel, B.S.

From the Division of Surgery, Walter Reed Army Institute of Research,  
Walter Reed Army Medical Center, Washington, D.C. 20012

---

\*Current Address: Department of Surgery, New York University  
Medical School, 550 First Avenue, New York, New York 10016.

Post-traumatic pulmonary insufficiency is one of the major causes of morbidity and death in severely wounded combat casualties and in elderly patients who are subjected to major surgical procedures. Evidence is gradually accumulating that the syndrome of progressive pulmonary insufficiency after injury is partly attributable to interstitial pulmonary edema that is clinically inapparent.<sup>2</sup> The need is obvious for simple methods which might provide early detection of the accumulation of fluid in the lungs.

Lofgren's studies of the intact rat kidney demonstrated that increase in renal volume was accompanied by decrease in electrical impedance of the kidney.<sup>6</sup> He postulated that impedance methods would provide the basis for observing the development of edema in a complex tissue. More recently, Pomerantz demonstrated a fall in transthoracic electrical impedance with intratracheal or intrapleural instillation of fluid and with alloxan-induced pulmonary edema.<sup>9</sup> The present experiment was designed to determine changes in transthoracic electrical impedance that accompany intravenous overinfusion and pulmonary edema and to relate these changes to certain hemodynamic factors in control animals and in experimental models of hemorrhagic and septic shock. Emphasis was placed upon establishing the relationship between transthoracic impedance and conventional measurements which are used in the care of critically ill patients.

#### METHODS AND MATERIAL

In conducting the research described in this report, the investigators adhered to the "Guide for Laboratory Animal

Facilities and Care," as promulgated by the Committee on the Guide for Laboratory Animal Facilities and Care of the Institute of Laboratory Animal Resources, National Academy of Sciences - National Research Council.

Fifteen beagle dogs weighing 7.9 to 10.8 kg. were anesthetized with sodium pentobarbital 30 mg. per kg. Three mongrel dogs weighing 16-17.5 kg. splenectomized at least two months earlier were similarly anesthetized. The thorax, abdomen and neck were shaved and electrode tape (3M Company, St. Paul, Minn.) was applied circumferentially at four specified points (Fig. 1). Electrode 1 was placed at the upper cervical level, and electrode 2 just above the thoracic inlet. A thoracic strip, electrode 3, was placed at the xiphoid and a fourth at the umbilicus. These strips were applied using standard EKG electrode paste for improved skin contact and were attached to electrode leads 1-4, respectively, of a Minnesota Impedance Cardiograph Model 202. Total impedance between leads 2 and 3 (thoracic inlet to sternum) may be determined by this method and reflects electrical resistance of the entire intrathoracic content. Impedance measurements were read directly from the instrument during the course of the experiment, each impedance unit reflecting one ohm resistance.

Large catheters were placed in the femoral artery and femoral vein of one lower extremity and advanced to the upper abdomen. These were connected to appropriate pressure transducers attached to a Sanborn 350 recording instrument. Another catheter was placed in the opposite femoral vein and advanced until a right ventricular pressure pattern was obtained. The

catheter was withdrawn until the ventricular pattern disappeared and fluctuation occurred with respiration. The catheter was then assumed to be in the right atrium and was used to measure central venous pressure as well as cardiac output by the injection of indocyanine green. Animals were subdivided into three groups, each of which consisted of five normal dogs and one splenectomized animal.

All animals were subjected to the infusion of normal saline containing 25 g. human albumin per liter. This fluid was infused in a volume of 200 cc/kg. at a rate of 3.0-4.0 cc/kg/min. Group one animals served as controls and received this volume of fluid without pretreatment. Group two dogs were subjected to rapid arterial hemorrhage into a heparinized plastic collection bag prior to overinfusion. Systolic blood pressure was maintained at a level of 40-50 mm. Hg for 30 minutes, after which shed blood was reinfused and saline infusion started. Group three animals were given E. coli endotoxin, 2 mg/kg, 30 minutes prior to overinfusion with the saline-albumin solution. Two animals from each of the three groups were ventilated with 100% oxygen for calculation of alveolar-arterial oxygen gradient and pulmonary venoarterial shunting. One of these animals in each group was mechanically ventilated with a Harvard animal respirator at a minute volume sufficient to maintain arterial  $pCO_2$  of 35-45 mm. Hg.

Prior to each experiment plasma volume and red cell volume were determined by standard radioisotope dilution techniques using Iodine-125 labeled serum albumin and Chromium-51 labeled

autogenous red blood cells. Blood samples were obtained at 15-30, 45 and 60 minutes. Values were plotted on semilogarithmic paper and reverse extrapolated to obtain a value for the time of injection. Total blood volume was determined from the sum of red cell mass and plasma volume. Subsequent blood volumes were sequentially determined by calculation based upon starting red cell mass (corrected for measured withdrawals) divided by the observed large vessel hematocrit (corrected for the starting whole blood: large vessel hematocrit ratio).<sup>8</sup>

Transthoracic impedance, central venous pressure, and blood samples were obtained at baseline, after pretreatment in groups two and three, and after infusion of 50, 100, 150 and 200 cc/kg. of solution. At these intervals arterial and central venous blood were obtained for determination of partial pressure of oxygen, carbon dioxide and arterial hematocrit. Partial pressures of oxygen and carbon dioxide were determined using an Instrumentation Laboratories' blood Gas pH Analyzer Model 113. Cardiac output was computed at each of these points using dye dilution techniques. A bolus of indocyanine green was injected into the right atrium from the central venous pressure catheter and femoral arterial blood was sampled continuously using a Gilford Constant Withdrawal Pump. The dye dilution curve was transcribed on a Beckman cardiodensitometer from which cardiac output was calculated. Pulmonary shunt was calculated using alveolar-arterial oxygen gradient and arteriovenous oxygen difference incorporated into the standard shunt formula. The development of pulmonary edema was determined by auscultation of the chest



and endotracheal tube or by the efflux of frothy fluid from the endotracheal tube. At the termination of each experiment, animals were sacrificed. Weights of heart and lungs drained of blood were then determined and expressed as lung-heart weight ratio. Lung specimens from each dog were obtained for histologic examination.

### RESULTS

The effects upon impedance of the supine position were minimal and varied slightly with depth of anesthesia. Minimal fluctuation was also noted with normal respiration. The effects of hemorrhage and of endotoxin per se were also small. Although rise in impedance was anticipated with the hypotension that invariably accompanied both hemorrhage and endotoxemia, impedance rose no more than 2 units in either instance. In splenectomized animals this response was accentuated to only 3 impedance units. Likewise, forceful hyperinflation with a respirator failed to increase impedance more than 3 impedance units.

Results of overinfusion in the three experimental groups are expressed in Table 1 and Figure 2. Acute expansion of intravascular volume with saline-albumin solution resulted in immediate change of transthoracic electrical impedance. In fact, the first 30 cc infused was invariably accompanied by fall in electrical impedance. This change became progressively more pronounced as more fluid was infused. Mean final impedance fall was 16.08 in group one, 16.67 in group two and 14.49 in group three. In general, fall in impedance was less in individual animals of group two than in other animals. Expansion of

calculated blood volume of 416 to 809 cc was observed in control animals, 1059 to 1400 in hemorrhaged animals and 506 to 1664 in animals which had received endotoxin. Calculated central blood volume was increased approximately 200 cc in each group of animals. In splenectomized dogs of each group, calculated total blood volume greatly exceeded values of non-splenectomized animals. Concomitant with increase in plasma volume, large vessel hematocrit decreased 20.48 per cent in control animals, 23.25 per cent in hemorrhaged animals and 26.17 in animals receiving endotoxin.

Central venous pressure after infusion was elevated over 20 mm. Hg in all three groups of animals. Pulse rate remained remarkably steady, varying little once the infusion of fluid was started. Cardiac output was consistently elevated, however, accompanied by diminution in mean arterial blood pressure, peripheral resistance and arteriovenous oxygen difference. Maximum rise in cardiac output for control animals was 7.69 liters/min., 4.94 for hemorrhaged animals, and 3.69 for animals receiving endotoxin.

Progressive pulmonary shunting was evident in all animals subjected to overinfusion (Fig. 3). Shunt's were calculated on the basis of alveolar-arterial oxygen gradient while breathing 100% oxygen. Without mechanical ventilation, maximum shunt after infusion was 51% in control animals, 67.6% in hemorrhaged animals and 62.6% in animals which had received endotoxin. However, with mechanical ventilation and 100% oxygen, maximum shunt was always less than 35%. Likewise, fall in impedance of

animals in groups one and two was less in animals which received mechanical ventilation. This difference was not observed in group three animals which had received endotoxin. Cardiac output was initially lower in animals receiving mechanical ventilation than in those breathing spontaneously, but all outputs with infusion were elevated well above baseline values (Fig. 2).

Pulmonary edema developed in all animals subjected to acute volume expansion. This was usually detectable after 150 cc/kg had been infused by auscultation of breathing via the thorax or endotracheal tube. No alteration in the rate of impedance change was observed once pulmonary edema had become evident. At this time impedance usually continued to decrease steadily to lower levels while central venous pressure was erratic, frequently falling toward normal. Therefore, once full-blown pulmonary edema had developed, central venous pressure was less reliable as a volume index than was impedance change. In addition, while CVP frequently returned toward normal at the end of infusion (200 cc/kg), impedance usually fell to still lower levels at this time. Respiratory arrest occurred in one dog of each group. In splenectomized dogs, pulmonary edema usually developed earlier, was more severe, and was fatal in one dog. Lung-heart weight ratios were equivalent in all three groups of animals and regularly exceeded the normal ratios of 1.2:1. In fact, the lowest ratio obtained was 1.43:1. This ratio in splenectomized animals regularly exceeded 2:1. On cut section, frothy edema and areas of consolidation were evident. Microscopic examination revealed multiple areas of interstitial edema and

hemorrhage. Interstitial edema appeared greatest in animals of groups two and three.

#### DISCUSSION

These studies have demonstrated that transthoracic electrical impedance falls in a predictable manner with intravascular volume overload. This phenomenon may be related to several factors theoretically capable of altering conductivity (hence resistivity) of intrathoracic contents. Expansion of either pulmonary intravascular or extravascular volume may be responsible for decrease in impedance on the basis of an increase in conductivity which accompanies increased electrolyte containing fluid within the thoracic cavity. On the other hand, even in the face of constant intrathoracic volume, atelectasis may contribute to increased conductivity by elimination of the resistivity provided by air in previously expanded alveoli.

Impedance changes in these experiments paralleled the rise in cardiac output, fall in peripheral resistance and pulmonary and peripheral arteriovenous shunting that occurred regularly with hypervolemia. Differences in patterns of impedance change could not be fully explained on the basis of any one of these factors. Nevertheless, fall in cardiac output which accompanied hemorrhagic and endotoxin shock did produce a small rise in impedance. Similarly, transfusion of shed blood with restoration of cardiac output to normal resulted in a small drop in impedance toward basal levels. During the production of hypervolemia, maximal levels of cardiac output were obtained while impedance continued to fall to considerably lower levels,

thus mitigating against a major contribution of cardiac output to impedance changes.

Change in impedance was regularly observed with the rapid infusion of the first 30 cc of solution. This change occurred prior to detectable elevation in central venous pressure. In addition, central venous pressure measurements during infusion seemed to fluctuate with the state of cardiovascular compensation to the infused load, gradually falling off after reaching a given peak. In contrast, impedance measurements became progressively lower until the occurrence of pulmonary edema. Once the infusion was complete, and the animal was in frank pulmonary edema, impedance usually fell still further, while central venous pressure measurements were more erratic, frequently returning toward normal levels. These results would suggest that impedance measurements may be as sensitive as central venous pressure if a baseline value is known.

Pulmonary edema was documented in these animals by the occurrence of wet rales on auscultation, gross efflux of tracheobronchial fluid, and increased lung-heart weight ratio at post-mortem examination. In all animals wet rales were noted after the infusion of 150 cc/kg. All animals had lung-heart weight ratios in excess of 1.43:1. Splenectomized animals in each group seemed to develop pulmonary edema earlier than non-splenectomized animals and had the highest calculated blood volumes and lung-heart weight ratios (>2:1). These findings would suggest that the spleen may have served as a reservoir for some of the fluid infused in non-splenectomized animals.

The curious fact, however, is that fall in impedance was not significantly greater in splenectomized animals than in those without splenectomy.

The hemodynamic effects which accompanied acute volume overload in these experiments are not unexpected. Delivery of increased fluid volume to the right heart occurs primarily as the result of volume distention of peripheral vessels,<sup>3</sup> decreased viscosity due to hemodilution, and reflex vasodilatation.<sup>4</sup> Augmented venous return is then accompanied by increased cardiac output in all three experimental groups.

Hypervolemia administered after hemorrhagic and endotoxin shock, however, presents a somewhat different set of circumstances. Endotoxin in itself has been incriminated in the production of pulmonary hypertension and edema.<sup>5</sup> Hemorrhage and reinfusion may also result in increase in pulmonary arterial blood pressure and pulmonary blood volume.<sup>1</sup> In each group of animals it is likely that increase in pulmonary capillary hydrostatic pressure contributed to the transudation of fluid from the pulmonary vasculature. Increased capillary permeability may also have contributed to this end point in shocked animals. Impedance changes, however, did not contribute to differentiation between increased pulmonary intravascular and extravascular volume.

In the light of the above evidence, it is reasonable to assume that changes in transthoracic electrical impedance in these animals are at least in part the consequence of extravasation of fluid into the pulmonary parenchyma. Alterations of lung-heart weight ratios and histologic examination support this view. However, since lung-heart weight ratios were

equivalent in all three groups, differences in the degree of decrease in impedance among the three groups of animals are not clearly related to formation of interstitial edema. Indeed, as was emphasized earlier, expansion of intravascular volume per se may account for significant changes in impedance, as when the first 30 cc of fluid was infused. Therefore, differentiation between pulmonary engorgement and engorgement plus edema is difficult. It is anticipated that this problem may be partially eliminated by better electrode placement.

In general, individual animals in group two (hemorrhagic shock) showed a smaller fall in impedance than dogs in the other two groups. Although these experiments do not settle the question with certainty, a smaller change in impedance in animals which had been subjected to hemorrhagic shock would support the idea that pulmonary intravascular capacity may have reached an earlier maximum during overinfusion in these animals, with consequent reduced capacity for expansion by overload.

An additional factor of interest in these experiments is the difference in fall in impedance between animals ventilated with 100% oxygen with and without mechanical ventilation. Although shunting was slightly higher in animals without mechanical ventilation, impedance fall in both control and hemorrhaged animals was considerably greater in the absence of mechanical ventilation. It is possible that mechanical ventilation may have retarded the development of edema in these animals with consequent smaller impedance change. Also, microatelectasis is known to accompany prolonged inhalation of pure oxygen.<sup>7</sup> Microatelectasis may also contribute to fall in impedance by

the decrease in resistivity afforded by the collapse of previously air-filled alveoli. It would appear that in these animals, fall in impedance may be related to the magnitude of pulmonary venoarterial shunting.

#### SUMMARY AND CONCLUSIONS

Alterations in transthoracic electrical impedance are regularly observed with acute intravascular volume overload. Fall in the transthoracic impedance is accompanied by elevated cardiac output, fall in peripheral resistance and peripheral and pulmonary arteriovenous shunting. Impedance changes may occur as the result of increased conductivity due to decreased intrapulmonary aeration (atelectasis) or to increased intrathoracic fluid volume. Although relative changes in electrical impedance may be as sensitive as central venous pressure in detection of intrathoracic volume changes, differentiation between intravascular and extravascular volume has not been possible in these experiments. Nevertheless, the method appears to have merit as an investigative tool and as an additional means of better patient monitoring.

Additional studies are now in progress to determine the effects of unilateral pulmonary arterial occlusion and unilateral pulmonary edema upon transthoracic electrical impedance. Improved methods of electrode placement are being investigated to provide more direct measurement of lung impedance.



ACKNOWLEDGEMENT

The authors wish to acknowledge the technical assistance of Miss Constance Babcock in these studies.

Table 1. Values obtained for hemodynamic variables and transthoracic impedance during overinfusion. Values represent those for each individual animal of the three study groups. "A" indicates splenectomized animals.

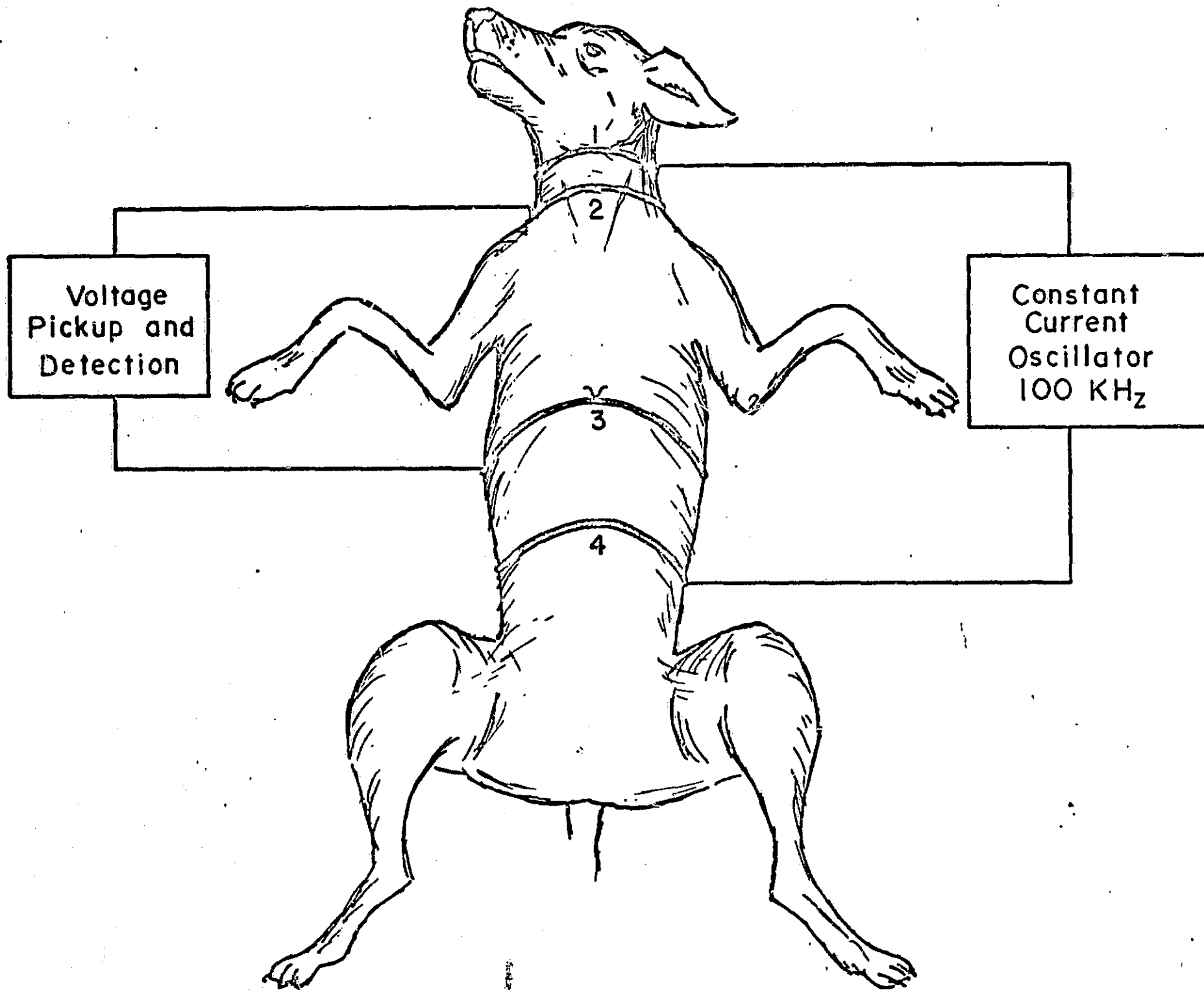
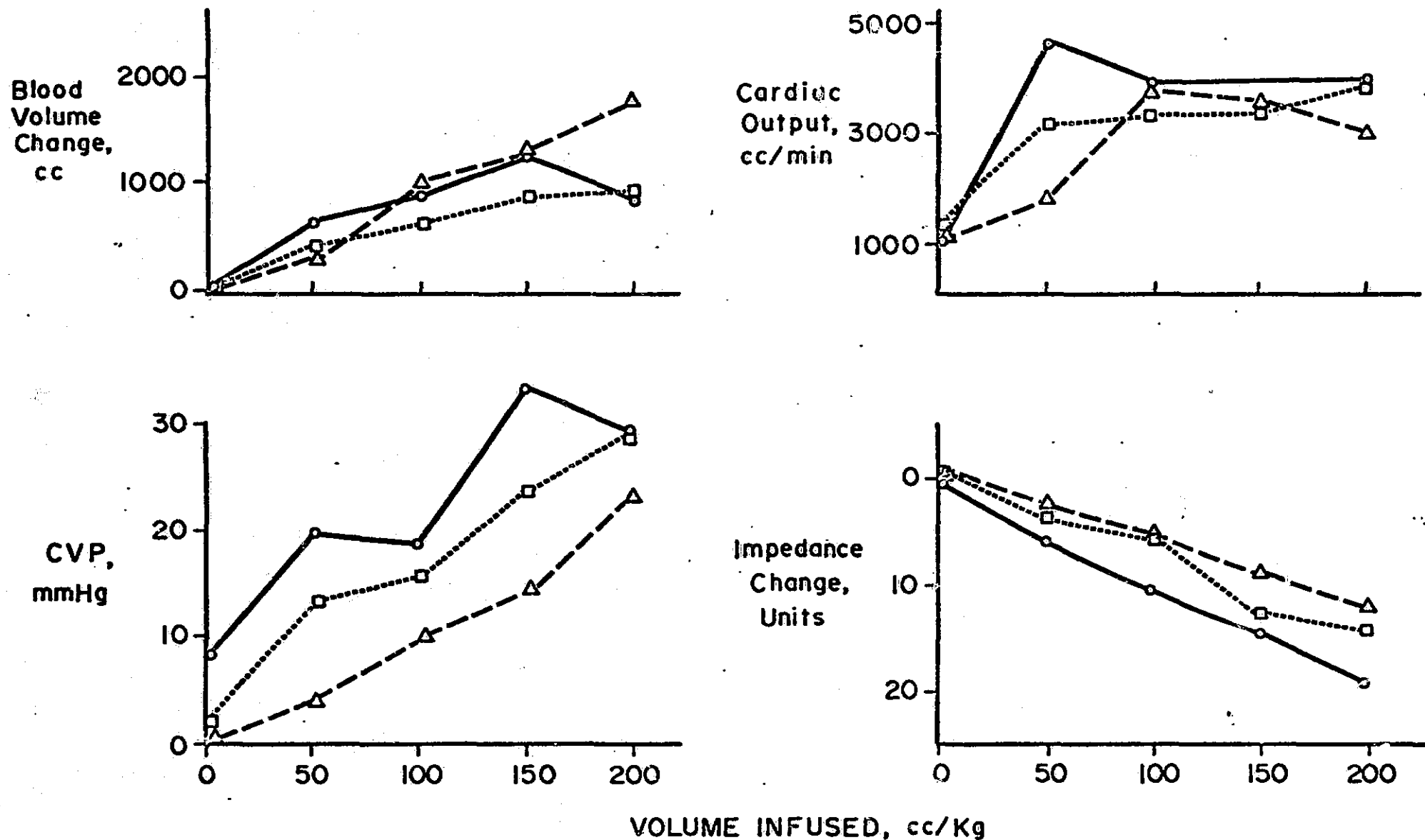

Figure 1 Diagrammatic representation of impedance apparatus and placement of electrode strips. Impedance is measured between electrodes two and three and read directly from the face of the Impedance Cardiograph.

## TRANSTHORACIC ELECTRICAL IMPEDANCE

# TRANSTHORACIC IMPEDANCE WITH ACUTE VOLUME OVERLOAD

## I. HEMODYNAMIC FACTORS



- Control (Hypervolemia alone)
- Hemorrhage + Hypervolemia
- △—△ Endotoxin + Hypervolemia

Figure 2 Typical alterations in cardiac output, central venous pressure and transthoracic electrical impedance in individual dogs subjected to acute intravenous overload.

TRANSTHORACIC IMPEDANCE WITH ACUTE VOLUME OVERLOAD

2. PULMONARY SHUNTING

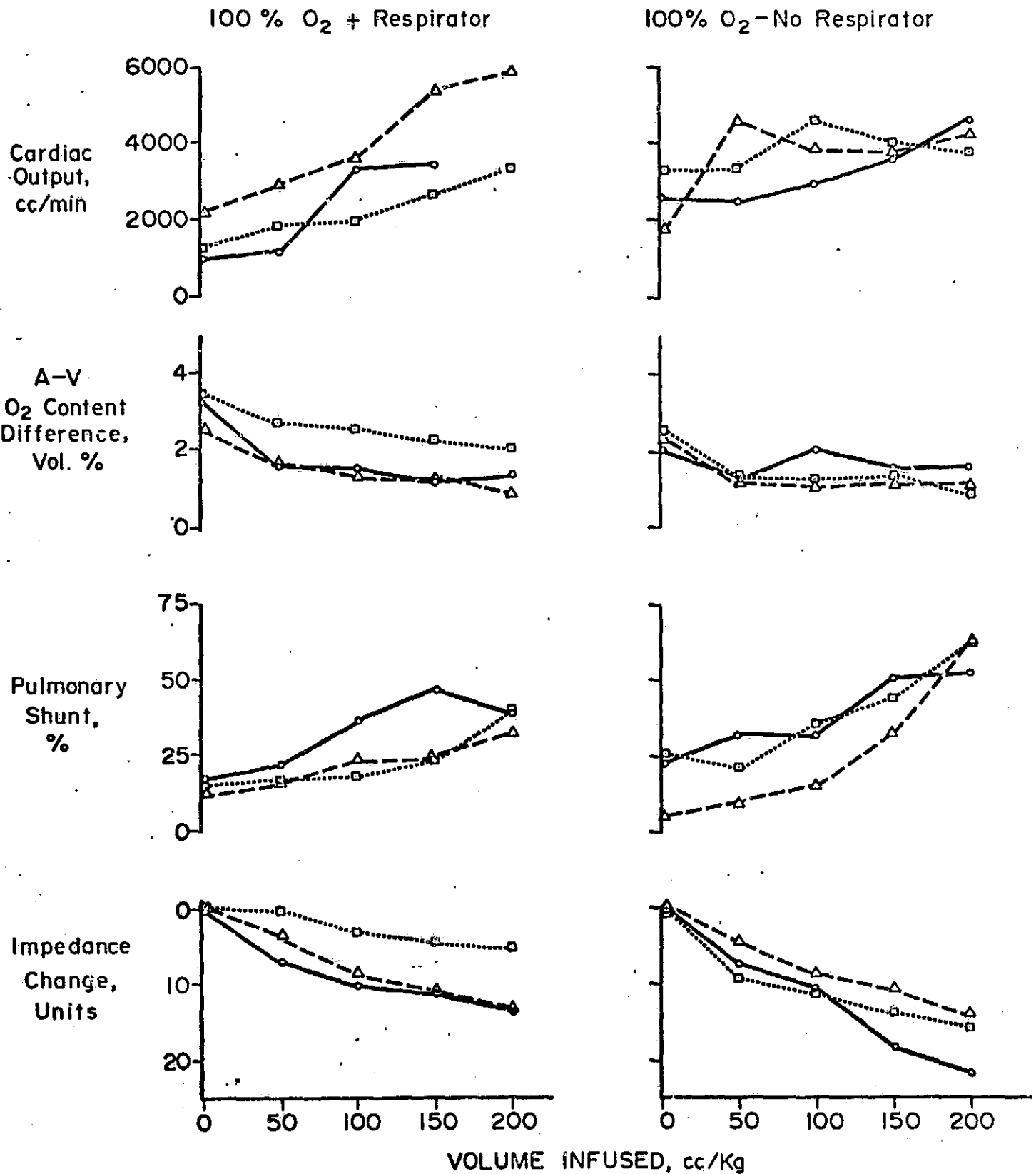

Figure 3 Alterations in transthoracic impedance, cardiac output and pulmonary arteriovenous shunting in individual animals undergoing acute intravascular overload while breathing 100% Oxygen

REFERENCES

1. Aviado, D. M.: The Lung Circulation. Vol. II. New York: Pergamon Press, 1965, p. 800.
2. Gutierrez, V. S., and Berman, I. R.: Role of diminished serum solids in post-traumatic pulmonary insufficiency. In preparation.
3. Guyton, A. C., Lindsey, A. W., Kaufman, B. N., and Abernathy, J. B.: Effect of blood transfusion and hemorrhage on cardiac output and on the venous return curve. Amer. J. Physiol., 194(2): 263, 1958.
4. Guyton, A. C., and Richardson, T. G.: Effect of hematocrit on venous return. Circ. Res., 9:157, 1961.
5. Kuida, H., Hinshaw, L. B., Gilbert, R. P., and Visscher, M.B., Effect of Gram-negative endotoxin on pulmonary circulation. Amer. J. Physiol. 192:335, 1958.
6. Lofgren, B.: The electrical impedance of a complex tissue and its relation to changes in volume and fluid distribution. Acta Physiol. Scand., 23:1, 1951.
7. Moore, F. D., et al.: Post-traumatic pulmonary insufficiency. Philadelphia: W. B. Saunders Co., 1969, p. 165.
8. Moore, F. D., Dagher, F. J., Boyden, C. M., Lee, C. J., and Lyons, J. H.: Hemorrhage in normal man: I. Distribution and dispersal of saline infusions following acute blood loss. Ann. Surg., 163:485, 1966.
9. Pomerantz, M., Lauridson, J., Baumgartner, R., and Eiseman, B.: Early detection of pulmonary edema using transthoracic electrical impedance. Surgery (in press).

PULMONARY EXTRAVASCULAR WATER VOLUME - POTENTIAL FOR  
MEASUREMENT BY THE MINNESOTA IMPEDANCE CARDIOGRAPH

by

N70-10007

Joseph M. Van De Water, M.D., Jaen-Min Sheh, M.D.,  
Nicholas E. O'Connor, M.D., and Francis D. Moore, M. D.

Department of Surgery, Harvard Medical School and Peter  
Bent Brigham Hospital, Boston

The work of Pomerantz and associates and Berman and associates as reported at this Symposium indicates a possible further application of the Minnesota Impedance Cardiograph. These investigators noted in both man and dog that the absolute impedance value ( $Z_0$ ) can be correlated with the volume of pleural fluid, the pulmonary shunt ( $Q_s/Q_t$ ) the arterial oxygen partial pressure ( $Pa_{O_2}$ ), and the central venous pressure (CVP). Thoracic impedance may indeed be a good measure of thoracic cavity fluid content. A fall in  $Z_0$  may herald early interstitial pulmonary edema before it can be recognized by the usual clinical parameters.

In our study of Post Traumatic Pulmonary Insufficiency, we have been interested in the detection and quantification of early pulmonary edema. Adapting a technique first described by Chinard<sup>1</sup> we have been measuring the pulmonary extravascular water volume (PEWV)<sup>2</sup> in critically ill and cardiac surgery patients at the Peter Bent Brigham Hospital. When normalized in terms of the patients's total lung capacity (cc/L of TLC) the PEWV has been found to correlate well with the clinical course, X-ray changes and  $Q_s/Q_t$  (see Figure 1).

The measurement of PEWV involves the simultaneous injection of tritiated water (THO) and Evan's Blue dye (T 1824). Blood samples are collected at one second intervals following a single passage through the lungs and analyzed to determine the respective curves of these two indicators (Figure 2). The



difference in mean transit times (MTT) multiplied by cardiac output is a measure of the PEWV. The method depends on the fact that there is rapid exchange of THO across the pulmonary capillaries, and that the recovery ratios of both indicators are the same.

It is our hope that a good correlation will be found between  $Z_0$  as measured by the Minnesota Impedance Cardiograph and our technique for measuring PEWV. If so, we will then have a continuous reading of the pulmonary status of our patients which will be of great help in therapy and an important addition to on-line non-invasive computer monitoring systems.

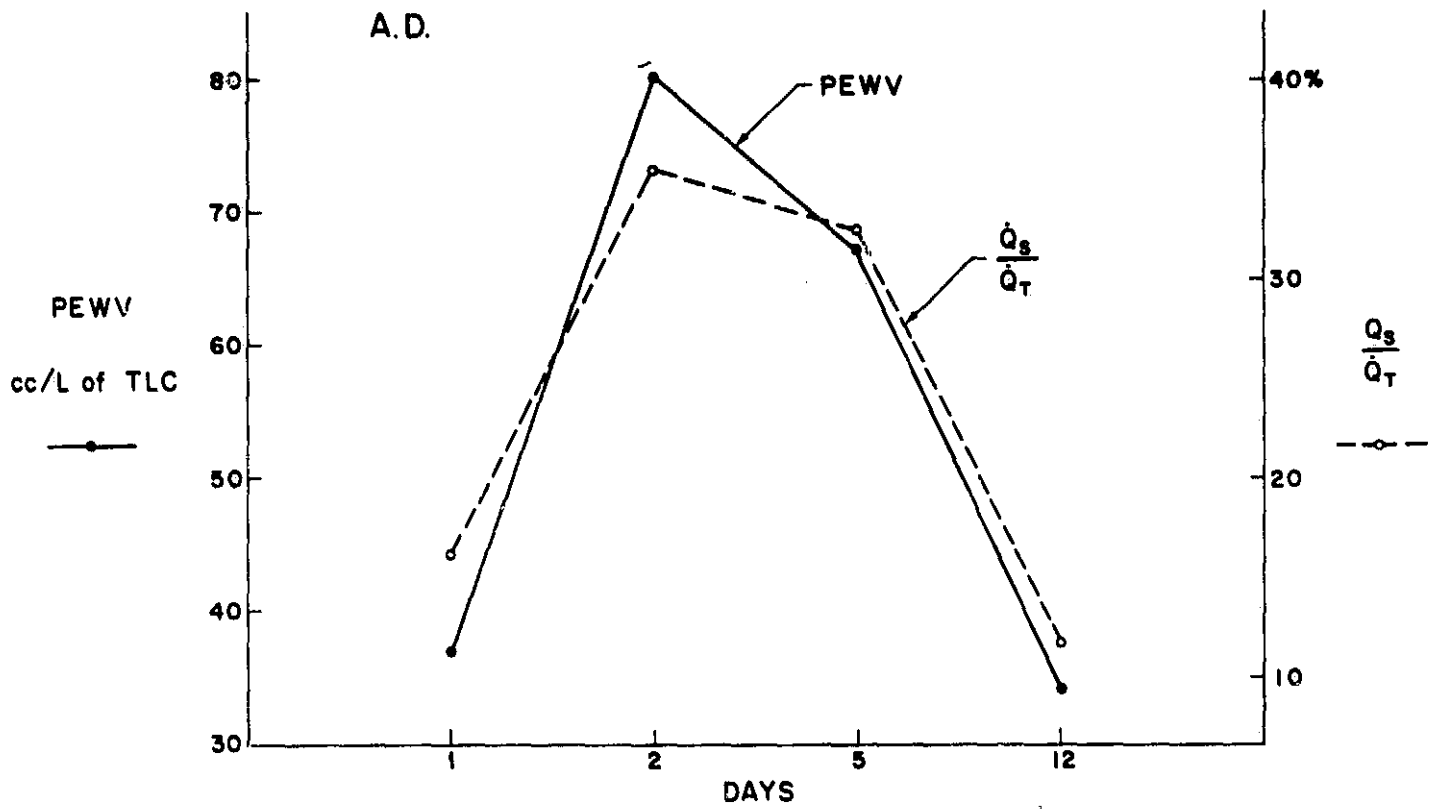
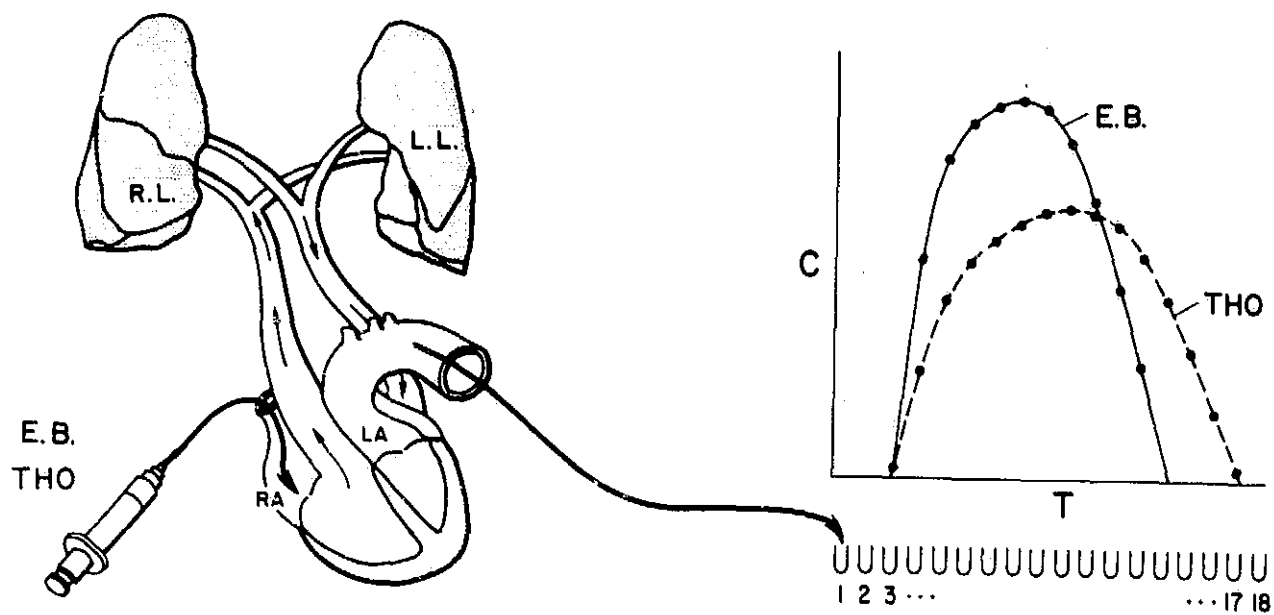

Figure 1 Correlation of PEWV and  $Q_s/Q_t$  in the post-operative course of a patient operated for a descending thoracic aortic aneurysm.



$$(1) F_{E.B.} = \frac{I_{E.B.} \times 60}{A}$$

$$(3) V_{E.B.} = F_{E.B.} \times MTT_{E.B.}$$

$$(2) MTT = \frac{\sum C \times T}{\sum C}$$

$$(4) V_{THO} = F_{E.B.} \times MTT_{THO}$$

Figure 2 Diagrammatic representation of PEWV measurement with calculations.  $PEWV = V_{THO} - V_{E.B.}$

REFERENCES

1. Chinard, F.: Capillary permeability. Bull. Hopkins Hosp. 88:489, 1951.
2. Sheh, J.-M., O'Connor, N.E., and Moore, F.D.: In vivo measurement of the extravascular water content of the lungs in pulmonary edema. Surg. Forum 19:259, 1968

CLINICAL AND EXPERIMENTAL USE OF THORACIC IMPEDANCE PLETHYSMOGRAPHY  
IN QUANTIFYING MYOCARDIAL CONTRACTILITY\*

by

N70-10008

John H. Siegel, M.D. Assistant Professor of Surgery  
Albert Einstein College of Medicine  
Career Scientist, Health Research Council of the City  
of New York

Miklos Fabian, Research Associate  
Albert Einstein College of Medicine

Charles Lankau, M.D., Michael Levine, M.D.,  
Andrew Cole, M.D. and Michel Nahmad, M.D.  
Department of Surgery,  
Albert Einstein College of Medicine

\*Supported by Grants HE 10033 and HE 10415 from the National  
Institutes of Health

One of the more difficult problems facing the physician responsible for the care of the critically ill patient is how to evaluate myocardial function in a rapid and reliable manner which does not hazard the patient to undue risk. It has become increasingly apparent that adequate care of such patients demands that the physician obtain an estimate of myocardial muscle function as distinguished from myocardial pump function, since in many critical illnesses it has been demonstrated that significant increases in cardiac output can occur at a time when myocardial contractility appears to be deteriorating (14). Indeed, there are a number of high output shock states such as that associated with septic shock (10,14), and the hyperdynamic state seen in severe hepatic cirrhosis with portal hypertension (15), in which a high output cardiac failure is often the event leading to the patient's demise.

Recently Kubicek (7) has suggested that the use of a newly designed impedance cardiograph may enable the computation of cardiac output by thoracic impedance plethysmography without percutaneous instrumentation. His studies both in canine preparations, and in young men, studied in the erect position suggested that quantification of cardiac output by this technique corresponds well with determinations obtained by standard indicator dilution techniques.

The present studies demonstrate that the clinical use of impedance plethysmography to measure cardiac output appears to

yield information about directional changes only. However, both experimental and clinical examination of the dynamic aspects of the thoracic impedance plethysmograph tracing reveal important relationships which appear to be a useful guide to the myocardial contractile state in the intact animal and in man using non-destructive or minimally destructive techniques.

### METHODS

#### Experimental Studies

A dog preparation anesthetized with light pentobarbital anesthesia (25 mg/kg) was used. An intracardiac micromanometer (Statham SF<sub>1</sub>) was positioned at the root of the ascending aorta, just above the aortic valve, and a second was placed into the left ventricular cavity via the apical dimple. This enabled the measurement of intraventricular dynamics simultaneously with the aortic pressure pulse, without interfering with aortic valve function. The heart was approached transabdominally through a diaphragmatic incision, so as not to violate the chest wall. After the intra-ventricular catheter tip manometer had been inserted, the chest was evacuated of air and maintained under a constant negative pressure of 14 cm of water. In some animals only the aortic catheter tip manometer was utilized so as not to alter intrathoracic dynamics in any way and to simulate the clinical situation. The animals were artificially respired with room air and all baro and chemoreceptors were left intact. The thoracic impedance changes were measured using the impedance cardiograph developed by Kubicek et al. (7). In this instrument,

two electrodes are placed circumferentially around the neck and two about the abdomen just below the xiphoid process. Alternating current is sent through the outer electrode of each pair and the change in voltage between the inner electrodes measured throughout the cardiac cycle. The change in impedance ( $\Delta Z$ ), indicated by the fluctuation in the voltage, corresponds to volume shifts between the two inner electrodes spanning the thorax. This technique measures pulmonary and cardiac volumes, but the slower respiratory cycle variations are electronically buffered, leaving only the rapid dynamic changes corresponding to events in the cardiac cycle. The ECG, the intraventricular pressure pulse, the aortic pressure pulse, and the impedance changes were recorded (Fig. 1). The change in impedance ( $\Delta Z$ ), and the first derivative of the impedance change ( $dZ/dt$ ) were compared with the first derivative of the intraventricular pressure pulse ( $dp/dt$ ), and the electrocardiogram. Myocardial contractility and vascular tone were altered by the use of an inotropic vasoconstrictor - norepinephrine, an inotropic vasodilator - isoproterenol, and a non-inotropic vasoconstrictor - methoxamine. In addition, two negative inotropic agents - pentobarbital, and E.coli endotoxin, were also used to challenge the animals.

#### Clinical Studies

Six high risk patients undergoing hemodynamic studies as part of a pre- or post-operative cardiovascular evaluation had



simultaneous determination of cardiac output by both thoracic impedance plethysmography (7,8) and indicator dilution techniques using cardiogreen dye. In order to evaluate the impedance cardiac outputs, they were compared to indicator dilution outputs computed by both the standard Stewart-Hamilton method which utilizes both the forward area under the dye curve plus an exponential replot of the downslope, and the gamma variate method of Thompson (24) which relies entirely on measurements made during the rising portion of the indicator dilution curve. In all instances the bolus of dye was injected into the right atrium and the arterial samples were taken from the femoral artery.

Four of the six were studied under a variety of conditions which frequently resulted in alterations in cardiac output, and one of these, a hyperdynamic cirrhotic patient (15) was re-evaluated on four different occasions during his post-operative recovery following portal venous decompression for portal hypertension.

In three additional patients using the Seldinger technique, a long teflon catheter was placed in the aortic arch via the femoral artery. Comparison of impedance and indicator dilution outputs were not done in this group, but determinations of impedance force-velocity relationships and the durational aspects of the impedance pulse were compared to more standard cardiovascular parameters; i.e., heart rate, central aortic blood pressure, and the Stewart-Hamilton cardiac output.

## RESULTS

### Experimental Observations

#### A. Myocardial Isometric Time-Tension Relations

Studies in ten animals revealed that there was a consistent relationship between the peak first derivative of the iso-volumetric portion of the ventricular contraction, ( $dp/dt$  maximum) and the inflection point in the impedance first derivative, ( $dZ/dt_{(I)}$ ). Both of these points occurred before the time of valve opening in the control non-stimulated animal (Fig. 1). The time from the peak of the r wave of the ECG to the peak first derivative of the pressure pulse ( $\Delta t dp/dt$ ) is shown below each panel, and has been compared with the time to the inflection point of the first derivative of the impedance pulse ( $\Delta t dZ/dt_{(I)}$ ), and the time to valve opening ( $\Delta t VO$ ). The calculated value of the first derivative of the isometric pressure ( $dp/dt$ ), and the first derivative of the impedance pulse ( $dZ/dt$ ) are shown, as well as the calculated stroke volume. Also, under each panel is the value of the computed Isometric Time-Tension Index  $\frac{dp/dt}{III}$ , which has been previously shown to also be an index of myocardial contractility independent of changes in fiber length (16,17). This index and the related  $\Delta t dp/dt$  are altered only by those interventions which also change the maximum velocity of shortening (16,17).

The administration of norepinephrine to this animal (Fig. 1) resulted in an increase in the peak pressure generated in the

ventricle as well as an increase in  $dp/dt$ . There was a corresponding shortening of the time from activation to the peak  $dp/dt$  ( $\Delta t dp/dt$ ), and this corresponded with a shortening in the  $\Delta t dZ/dt_{(I)}$ . With the increase in contractility produced by norepinephrine (or isoproterenol), there was a tendency for the time to valve opening ( $\Delta t VO$ ) to also shorten, and this tended to approach the time to maximum  $dp/dt$ , as is shown here. The Isometric Time-Tension relation  $\frac{dp/dt}{ITT}$  also increased. After the administration of norepinephrine had been stopped, all parameters of contractility tended to return to the control state, suggesting that this is a reproducible alteration and that it follows directionally the changes in myocardial contractility in the intact heart.

Figure 2 shows the inter-relation between the time to maximum  $dp/dt$  ( $\Delta t dp/dt$ ), and the time to the inflection point in the first derivative of the impedance pulse ( $\Delta t dZ/dt_{(I)}$ ). These data represent 150 observations in 7 animals and show a relationship between these two, such that increasing  $\Delta t dp/dt$  is associated with an increase in the  $\Delta t dZ/dt_{(I)}$ . This change is a function of the state of contractility of the myocardium. When isoproterenol or norepinephrine were used, there was a decrease in both of these values associated with an increase in contractility. When agents which produce a decrease in myocardial contractility, such as E.coli endotoxin or pentobarbital, were used, there was an increase in both values over the control range. The major departure from a linear relationship

between these values occurred with the use of methoxamine which, in these innervated preparations, resulted in a decrease in contractility, due to the reflex withdrawal of sympathetic activity to the myocardium associated with the increase in systemic pressures (2,18). There was also a marked disparity between the  $\Delta t$   $dp/dt$  and the time of valve opening, as the aortic diastolic pressure was raised progressively. Under these circumstances the period of electrical diastasis, represented by the  $\Delta t$   $dZ/dt$  inflection point, lengthened as valve opening and maximum  $dp/dt$  separated widely in time. The signal to noise ratio becomes significant during this period and it was somewhat difficult to ascertain the exact point of the inflection of  $\Delta t$   $dZ/dt$ . As a result of this and perhaps other factors which are less well defined, there was a tendency for the  $\Delta t$   $dZ/dt$ <sub>(I)</sub> to lengthen to values greater than the values of  $\Delta t$   $dp/dt$ . However, there still appears to be a good general correlation, even when all the points, including those produced by methoxamine, are taken as a whole. The best linear approximation is shown here by the calculated value for the linear regression line ( $R = 0.88$ ) with its standard error of estimate of the mean ( $\pm 0.01$ ).

Figure 3 shows the relationship between the time to maximum  $dp/dt$  and the time of valve opening. One can see that this also is reasonably linear in character, although it is shifted along the time axis. The abnormalities occurring with methoxamine, which raises the aortic diastolic pressure, become more pronounced with regard to their effect on  $\Delta t$   $V_0$ .

Figure 4 shows the inter-relationship between the  $\Delta t$   $dp/dt$  and the time to the peak first derivative of the impedance pulse  $\Delta t$   $dZ/dt$  (Peak). This part of the impedance pulse occurs after valve opening, appears to correspond to the time of peak aortic flow (5,6), and reflects the total hindrance to ventricular ejection. Again one can see that this relationship is further skewed along the time axis and that the abnormality produced by markedly increasing outflow resistance is further exaggerated, so that  $\Delta t$   $dZ/dt$  (Peak) becomes a relatively poor guide to alterations in myocardial contractility.

Figure 5 shows the linear regression slopes for these three curves plotted on the same axis and ordinate. Although these are only linear approximations to the functions shown previously, they show the inter-relationship between the mean values of the three with regard to the displacement in time of the  $\Delta t$  valve opening and the  $\Delta t$   $dZ/dt$  (Peak) compared to the  $\Delta t$   $dp/dt$  -  $\Delta t$   $dZ/dt$  (I) slope. This Figure also demonstrates that these functions are not parallel, but that there is an increasing disparity at the lower levels of contractility, suggesting that of the three, under ordinary circumstances, the  $\Delta t$   $dZ/dt$  (I) is the best guide to alterations in  $\Delta t$   $dp/dt$ , and by inference to alterations in the maximum velocity of the myocardial force-velocity relationship (16,17).

Table I shows the results of an experiment from a single animal in which all of the pertinent relationships have been compared following a variety of interventions. This table is

a representation of the reliability and reproducibility of these changes in an individual innervated preparation where baro and chemoreceptor reflex effects were possible. Increases in myocardial contractility effected by the use of the inotropic agent, norepinephrine, produced a substantial reduction in the  $\Delta t$   $dp/dt$ , an increase in  $dp/dt$ , stroke volume, and cardiac output, and a reflex mediated decrease in heart rate. The change in  $\Delta t$   $dp/dt$  was paralleled by the change in  $\Delta t$   $dZ/dt_{(I)}$ , and was generally followed by decreases in the time of valve opening and in the  $\Delta t$   $dZ/dt$  (Peak) in spite of an increase in systolic pressure. The values returned to control levels after discontinuation of norepinephrine. The administration of methoxamine, with its non-inotropic increase in aortic pressure and after-load (18), brought about a decrease in stroke volume and a reflex mediated fall in heart rate and in myocardial contractility, as reflected by an increase in  $\Delta t$   $dp/dt$ , and  $\Delta t$   $dZ/dt_{(I)}$ . A marked lengthening in the time to valve opening and time to peak  $dZ/dt$  also occurred, in contrast to the decrease in these values occurring with the vasoconstriction produced by the positive inotropic agent norepinephrine. That a persistent depression in myocardial contractility was produced by methoxamine is suggested by the fact that there was a failure to return to the control state even though the peak aortic pressure tended to be reduced towards the control level. This may be in part reflex induced, as evidenced by the persistent decrease in heart rate

at a time when the aortic diastolic pressure remained elevated. In this instance one can see that there was a disparity between  $\Delta t \, dp/dt$  and the  $\Delta t \, dZ/dt_{(I)}$ . However, the  $\Delta t$  valve opening and the  $\Delta t$  peak  $dZ/dt$  show an even greater disparity with  $\Delta t \, dp/dt$ , and only reflect the myocardial state in a qualitative way. The use of isoproterenol, with its beta adrenergic vasodilating activity as well as its inotropic action on the myocardium (13), was associated with a marked increase in contractility produced by both the inotropic and the chronotropic effects. There was a reduction in  $\Delta t \, dp/dt$  and in  $\Delta t \, dZ/dt_{(I)}$ . Following the use of this inotropic agent, the residual myocardial contractility seemed to be improved and there was a return to control levels. Finally, the use of a negative inotropic agent, E.coli endotoxin (13), produced not only a decrease in myocardial contractility, as reflected by the lengthening of the  $\Delta t \, dp/dt$ , but also a fall in the aortic outflow resistance as evidenced by a marked decrease in the level of systolic and diastolic pressures. It also produced a lengthening of the  $\Delta t \, dZ/dt_{(I)}$ , as well as a significant increase in the  $\Delta t$  valve opening and the  $\Delta t \, dZ/dt$  (Peak) value, demonstrating that decreases in contractility result in lengthening of the durational aspects of the contractile process even when aortic pressure falls.

From these data it appears that alterations in the  $\Delta t \, dZ/dt$  (Peak), which reflects the time course of ejection, can be influenced by the aortic outflow resistance, and also by changes in

contractility. However, alterations in the  $\Delta t \, dZ/dt_{(I)}$ , which occurs either before or at the time of valve opening, are only slightly influenced by these effects and correspond in the main rather closely to alterations in  $\Delta t \, dp/dt$ , and therefore to the duration of the active state of the myocardial contractile process. This index appears to provide an empiric correlate of the level of myocardial contractility and its directional changes without requiring intravascular instrumentation.

#### B. Myocardial Force-Velocity Relations

Using thoracic impedance plethysmography it is also possible to gain direct information concerning myocardial force-velocity relationships which delineate the velocity dependent aspects of contraction (19,20), provided that an accurate central aortic pressure pulse with a high frequency response, using a catheter tip micromanometer, can be obtained simultaneous with the impedance pulse. In this treatment the impedance pulse ( $\Delta Z$ ) is evaluated as a function of the aortic blood pressure at 10 msec intervals during the systolic ejection period (Fig. 6). The impedance pulse during early systole is directly related to the ejected volume (5-7), and the aortic pulse pressure to the resistance and capacitance factors opposing ejection. Together they reflect the after load against which myocardial shortening (ejection) is occurring (12). This afterload value in mm Hg. ohms is plotted against the instantaneous velocity of the impedance change ( $dZ/dt$ ) in ohms/sec at each corresponding 10 msec interval (Fig. 7) beginning from the point of valve opening. This portion of the  $dZ/dt$  pulse is related to the velocity of aortic flow (7,8).



By extrapolating the exponential portion of the downslope of this impedance force-velocity curve back to zero load based on the log-log slope occurring at peak  $dZ/dt$ , a function closely approximating a true myocardial force-velocity relationship is seen.

As many investigators have noted, the characteristic feature of the myocardial force-velocity relation is that while diastolic fiber length may change on a beat to beat basis, as a function of respiratory variation or volume infusion, so that the extrapolated  $P_0$  (maximum load) may change on the basis of a non-inotropic stimulus, the extrapolated  $V_{max}$  (maximum velocity of isotonic shortening) will be altered as a function of changing contractility only, and therefore this  $V_{max}$  serves as a measure of the contractile state of the myocardium (1,9,17 19-23). As this figure shows, neither alterations in end diastolic pressure in the control state, nor the use of a non-inotropic vasoconstrictor agent, methoxamine, produced an increase in the extrapolated maximum velocity of contraction in the experimental animal. However, both positive inotropic agents studied, norepinephrine and isoproterenol, effected major increments in the extrapolated  $V_{max}$ . While it is true that the full active state of the myocardial contractile element is diminishing during the period following the development of maximum  $dp/dt$ , it is still at a high level during the early systolic ejection phase (19), and probably permits determination of valid

force-velocity relationships during this period (1,9,19-23). Certainly, as Fig. 7 shows, the increase in the extrapolated  $V_{max}$  obtained from the impedance force-velocity curve changes in the same direction and to approximately the same degree as do other calculations of the maximum velocity of shortening derived from direct measurement of the force-velocity relation (19-23). It thus appears as if information concerning the velocity related aspects of the myocardial contractile state can also be obtained from impedance plethysmographic measurements.

#### Application to Man

##### 1. Cardiac output

The observations of Kubicek et al. (7,8) and Harley and Greenfield (5) have suggested that a correlation exists between cardiac output determinations performed in man by impedance cardiography and by indicator dilution or pressure pulse methods. Their observations were made on normal subjects (7) or on patients with chronic cardiac disease (5) studied in the erect position. In our hands simultaneously performed flow studies of high risk general surgical patients, evaluated in the supine position either pre- or post-operatively, revealed a poor quantitative correlation between cardiac output determined by impedance plethysmography and by standard indicator dilution techniques. However, there was a qualitative trend which suggested that directional changes might be validly indicated by the impedance technique (Fig. 8A). The quantitative aspects were improved if an initial impedance  $-CO/dye-CO$  ratio was used to correct subsequent

impedance outputs (Fig. 8B). Nevertheless, even this relationship tended to change with time and with some interventions which are known to alter myocardial function, perhaps as a function of alterations in pulmonary blood volume, or to differences in electrode placement on subsequent days (Table II). There was no consistent improvement in the  $\text{CO}_2/\text{CO}$  dye ratio if the gamma variate method of computation was used in preference to the Stewart-Hamilton for the indicator dilution curve.

In contrast to the difficulty in quantifying the flow related aspects of impedance plethysmography in man, the durational and velocity related aspects of individual myocardial contractions were more satisfactory delineated by this method. It was possible to evaluate relative change in  $\Delta t \, dZ/dt_{(I)}$  in all but one patient who showed ECG evidence of a right bundle branch block. In this patient the conduction defect produced abnormalities in the impedance pulse such that no clear cut inflection point could be determined. As is shown in Figure 9, when a central aortic pressure is also obtained, it is possible to evaluate both the  $\Delta t \, dZ/dt_{(I)}$  interval and the extrapolated impedance  $V_{\text{max}}$  provided no major conduction abnormality or ventricular asynergy exists.

In this Figure is shown the response of a 69 year old female studied pre-operatively prior to the resection of a recurrent sigmoid volvulus. The alteration in heart rate, cardiac output (via Stewart-Hamilton calculation of the cardio-green indicator dilution curve), blood pressure,  $\Delta t \, dZ/dt_{(I)}$ , and impedance  $V_{\text{max}}$  and  $P_0$  are presented in the box. The method

extrapolation of the impedance  $V_{max}$  is shown in the main part of the Figure. Very little change in the impedance force-velocity relation occurred during two control periods. A fifteen minute period of inhalation of 100% oxygen produced a fall in heart rate and cardiac output and a lengthening of the durational aspects of contraction,  $\Delta t \, dZ/dt_{(I)}$ . The impedance  $V_{max}$  fell. After re-equilibration on room air the cardiac output rose as did  $V_{max}$  and the duration of  $\Delta t \, dZ/dt_{(I)}$  shortened even though no significant increase in heart rate occurred. The intravenous administration of 4 mg of glucagon at this new control level produced a progressive increase in the impedance  $V_{max}$  and a decrease in  $\Delta t \, dZ/dt_{(I)}$  over a five minute period. These alterations in the contractile response were accompanied by a significant increase in the Stewart-Hamilton cardiac output 5 minutes after the administration of this inotropic agent. The increase in impedance  $V_{max}$  was increased to nearly 5 times the original control level after glucagon suggesting that at least a part of the increase in cardiac output was due to a true increase in myocardial contractility.

#### DISCUSSION

The studies of Sonnenblick (19-23) have indicated that the best description of myocardial contractility is contained in the myocardial force-velocity relationship which describes the alterations in the velocity of myocardial shortening as a function of the increasing afterload imposed on the myocardial fiber.

Siegel, Sonnenblick, Judge, and Wilson (17) evaluated the inter-relationships between the isometric and isotonic portions of contraction in papillary muscle fibers and in the intact heart. Their studies demonstrated that the temporal aspects of the isometric contraction are a function of the force-velocity relationships, in that alterations in the time from the onset of contraction to the peak isometric force ( $\Delta t P_0$ ), and to the maximum first derivative of isometric tension development ( $\Delta t dp/dt$ ) vary inversely with changes in the maximum velocity of isotonic shortening ( $V_{max}$ ). These interrelationships are shown in Table III. When myocardial contractility is unchanged but the fiber length is altered by increasing the diastolic volume (Panel A), each increase in fiber length increases peak potential isometric force ( $P_0$ ), and increases the maximum rate of isometric force development ( $dp/dt$ ), but fails to significantly alter the maximum velocity of isotonic shortening ( $V_{max}$ ). Of greater significance with regard to the present study was the fact that as long as the maximum velocity of shortening remained the same, the time from the onset of contraction to the maximum force in the isometric contraction ( $\Delta t P_0$ ) was also constant, as was also the time to the point of maximum  $dp/dt$  ( $\Delta t dp/dt$ ). These time relationships were independent of increasing fiber length, and could be used as a measure of the changes in the maximum velocity of shortening ( $V_{max}$ ). In a similar fashion when the fiber length was maintained constant and the contractile state

of the myocardium was altered either by increasing the rate of activation (Panel B), or by the use of an inotropic agent (Panel C), such as norepinephrine, etc., it was found that the maximum velocity of shortening ( $V_{max}$ ) increased and there was a corresponding increase in the absolute value of the first derivative of the isometric tension ( $dp/dt$ ). In addition, the time from the onset of contraction to the maximum peak isometric contraction ( $\Delta t P_0$ ), and to the maximum first derivative ( $\Delta t dp/dt$ ) also shortened substantially as an inverse function of the increase in the velocity of shortening. This suggested that alterations in the time from the onset of contraction to the maximum first derivative of the isometric portion of contraction ( $\Delta t dp/dt$ ) could be used as an index of alteration in the force-velocity relationship. These time relationships can also be measured in the intact normally functioning ventricle, both in animals and in man, and appear to enable the quantitative measurement of alterations in myocardial contractility (16-18).

It is not entirely clear why the alterations in thoracic impedance as measured by impedance plethysmography reflect the time course of isovolumetric contraction in the canine left ventricle, but it may be that the change in shape or relative position of the left ventricle occurring simultaneous with the development of maximum  $dp/dt$ , changes the relative volume, and thus the electrical impedance, between the two sensing electrodes. Observations of the heart during the period when maximum  $dp/dt$  is occurring suggest that it becomes more

spherical at this time, as the apex of the ventricle approaches the root of the aorta. This may produce a period of relative electrical impedance diastasis which can be observed in the plethysmographic tracing. Once valve opening occurs, the impedance trace reflects the volume of blood in the thoracic aorta (5,6), and the first derivative of the impedance pulse provides information regarding the velocity of ejection.

Although aortic run-off does occur during the early portion of systole, the major loss of volume from the thoracic aorta occurs in late systole and in diastole, so that the error of using volume rather than flow to compute the force-velocity relationship is probably small. Since the conversion factor utilized by Kubicek (5,6) to obtain volume from impedance is based on a theoretic approximation of the thorax as a cylinder (7) which may not be correct, it is probably wise to determine the maximum velocity in terms of ohms/sec as is shown in Figure 7, and to use the increase in maximum velocity as a relative index of increasing contractility rather than see a conversion to the absolute units of centimeters per second.

The disparity in the critically ill patient between cardiac output determinations computed by the standard Stewart-Hamilton treatment of the radiopaque indicator dilution curve and by the impedance plethysmographic method may be the product of a variety of factors. There are certainly errors inherent in the dye curve analysis, especially in high output states where early recirculation may occur. More important, however, are the assumptions on which the impedance

computation formula ( $\frac{L^2}{Z_0} 2P$ ) is based. This method of translating the impedance changes into volume changes depends on a theoretic consideration of the thorax as a cylinder with a uniform pattern of current flux and assumes that the sensory electrodes lie on equipotential lines and that the electrodes are pressure insensitive (7,8). Factors which independently alter the base impedance value ( $Z_0$ ) during the course of study will seriously interfere with volume quantification. Eiseman and his colleagues (11) have shown that alteration in the intrapulmonary fluid-air ratio, caused either by pulmonary edema or alterations in central blood volume will change the base impedance measurement. Changes in the resistivity of blood caused by hemodilution as well as some of the factors discussed by Hill et al. (6) may also help to explain the poor correlation between indicator dilution and impedance cardiac output determinations. The major value of impedance cardiac output measurements appears to be the delineation of important directional trends which may then be quantified by more accurate indicator dilution techniques. However, with regard to measurements designed to elucidate changes in the myocardial contractile state, none of the above factors appear to significantly interfere with the information revealed by impedance cardiographic measurements of the dynamic events related to the timing of the cardiac cycle. The time course of these events provides data which is related to alterations in the contractile state of the heart. As has been noted previously, increases in myocardial contractility are associated with increases in the maximum velocity of contractile



element shortening and with decreased in the duration of the active state of this contractile element (12). Information related to both of these factors is contained within the impedance tracing.

The importance of attempting to measure myocardial contractility in intact man has become obvious with the realization that stroke work and filling pressure relationships are "lumped" parameters of cardiovascular function. They do not solely reflect the contractile state of the heart since myocardial work is not only a function of intrinsic myocardial contractility, but is also a product of the ejected volume and the total peripheral resistance to flow (the afterload) (12,17-23). Since, at any contractile state, the absolute velocity of shortening decreases as a function of an increasing afterload (22,23), it means that to determine a change in contractility one must describe a substantial portion of the velocity-load curve in the contracting heart, so as to extrapolate the maximum velocity of shortening (1,3,4,9). The determination of this  $V_{max}$  permits one to establish on which force-velocity relationship the heart is operating. This is especially true when there are significant alterations in the resistance load against which the myocardium pumps (12,22), as may occur in shock states (10,14) where there may be wide alterations in outflow resistance and fiber length. With this in mind an attempt has been made to apply thoracic impedance plethysmography as a method of evaluating myocardial contractility which may be applicable to use in the critically ill

patient, where one hesitates to use catheterization of the left ventricle with an intracardiac micromanometer to determine the Isometric Time-Tension relationships (17), or the intra-ventricular injection of potentially dangerous volumes of contrast media to gain information about myocardial force-velocity relations (4).

Finally, the use of impedance methods to delineate the durational aspects of the myocardial contractile response by a totally non-invasive technique offers the possibility of being able to determine whether a decrease in myocardial contractile function precedes a clinically apparent rejection crisis in patients with cardiac allografts.

SUMMARY

Recent studies have suggested that thoracic impedance plethysmography may provide a method of measurement of cardiac output without transcutaneous instrumentation. These studies were directed toward ascertaining whether the dynamic aspects of the thoracic impedance pulse might also permit quantification of myocardial contractility. A canine preparation was used in which catheter tip micromanometers were inserted into the left ventricle and the proximal aorta. The aortic and intraventricular pressures, the first derivative of the intraventricular pressure pulse ( $dp/dt$ ), the change in impedance, and the first derivative of the impedance curve ( $dZ/dt$ ) were obtained. It has been shown that portions of the impedance pulse reflects events which occur prior to valve opening. These events mirror alterations in the time development of the isovolumetric pressure. A time relationship can be established on the basis of analysis of  $dZ/dt$  which bears a direct relationship to the time from the onset of contraction to the maximum  $dp/dt$ . In this way an estimate of myocardial contractility related to the Isometric Time-Tension Index can be obtained and quantified in the intact animal. By simultaneously evaluating the impedance pulse and the central aortic blood pressure as a function of  $dZ/dt$ , an impedance force-velocity relation can also be obtained. Both of these techniques have been applied to the estimation of myocardial contractility in the critically ill surgical patient.

Evaluation of the dynamic aspects of the thoracic impedance pulse appears to permit determination of the basic myocardial contractile state and enables quantification of the response of cardiac inotropic agents.

TABLE I

INTERVENTION	HR	STROKE VOL.	CO	dp/dt	Milliseconds				BP
					$\frac{\Delta t}{dp/dt}$	$\frac{\Delta t}{dZ/dt(I)}$	$\frac{\Delta t}{VO}$	$\frac{\Delta t}{dZ/dt(peak)}$	
CONTROL	151	16.90	2.55	3846	<u>45</u>	<u>45</u>	<u>60</u>	<u>87</u>	178/145
NOREPI	141	19.84	2.79	6250	<u>27</u>	<u>25</u>	<u>32</u>	<u>55</u>	220/148
CONTROL	142	19.43	2.75	3571	<u>45</u>	<u>47</u>	<u>62</u>	<u>82</u>	180/149
METHOXAMINE	116	13.78	1.59	1968	<u>62</u>	<u>82</u>	<u>107</u>	<u>147</u>	223/178
CONTROL	113	19.31	2.18	1960	<u>62</u>	<u>77</u>	<u>95</u>	<u>137</u>	177/153
ISUPREL	146	20.70	3.02	5952	<u>20</u>	<u>20</u>	<u>27</u>	<u>47</u>	150/102
CONTROL	144	15.47	2.22	3125	<u>45</u>	<u>45</u>	<u>62</u>	<u>112</u>	179/154
ENDOTOXIN	164	11.90	1.95	2173	<u>65</u>	<u>70</u>	<u>85</u>	<u>127</u>	87/76

TABLE II

Patient	Intervention	IMPEDANCE OUTPUT		INDICATOR DILUTION OUTPUT			
		CO <sub>Z</sub>		CO Stewart-Hamilton	Ratio Z/Dye	CO Gamma Variate	Ratio Z/Dye
132690 Male Pre-op	Control p 500 ml Plasmonate ly/min Isuprel p Isuprel	4.76		4.55	1.04	4.20	1.13
		4.71		4.81	0.97	5.25	0.90
		6.27		7.84	0.79	9.70	0.65
		5.82					
				MEAN 0.93		MEAN 0.89	
549038 Male Pre-op	Control Room Air 100% O <sub>2</sub> p 100% <sup>2</sup> O <sub>2</sub>	4.29		3.24	1.32	5.60	0.77
		4.11		3.73	1.10	4.80	0.86
		5.57					
				MEAN 1.21		MEAN 0.82	
373355 Female Pre-op	Control Room Air 100% C <sub>2</sub>	2.13		2.17	0.98	2.60	0.82
		2.43		2.55	0.95	5.20	0.47
				MEAN 0.97		MEAN 0.65	
552985 Male Post-op Cirrhotic	1) Control Room Air 100% O <sub>2</sub> (Po day 1) 2) Control Room Air 100% O <sub>2</sub> (Po day 2) 3) Control Room Air 100% O <sub>2</sub> (Po day 4) 4) Control Room Air 100% O <sub>2</sub> (Po day 10)	5.66		8.56	0.66	8.60	0.65
		6.11		10.03	0.60	9.20	0.66
		7.83		11.10	0.70	9.00	0.87
		8.22		12.67	0.64	12.20	0.67
		10.83		9.92	1.09	11.40	0.95
10.66		10.95	0.97	10.00	1.06		
7.42		5.33	1.39	4.60	1.61		
6.80		9.38	0.72	8.60	0.79		
				MEAN 0.85		MEAN 0.91	
557444 Male Pre-op	Control Room Air 100% O <sub>2</sub>	9.33		6.94	1.34	6.10	1.53
				6.27		5.05	
557048 Male Pre-op	Control Room Air	9.76		7.56	1.29	10.60	1.08

TABLE III

INTERVENTION	V Max	Po	dp/dt	Δt Po	Δt dp/dt
A.  Increasing Fiber Length (ΔL)	Constant  0	Increase Proportional to ΔL  +	Increase Proportional to ΔL  +	Constant  0	Constant  0
B.  Increasing Myocardial Activation Rate (ΔR)	Increase  +	No Change or Small Increase  0 or +	Increase  +	Decrease  -	Decrease  -
C.  Inotropic Agents NE, Isuprel, Digitalis	Large Increase  ++	Large Increase  ++	Large Increase  ++	Large Decrease  --	Large Decrease  --

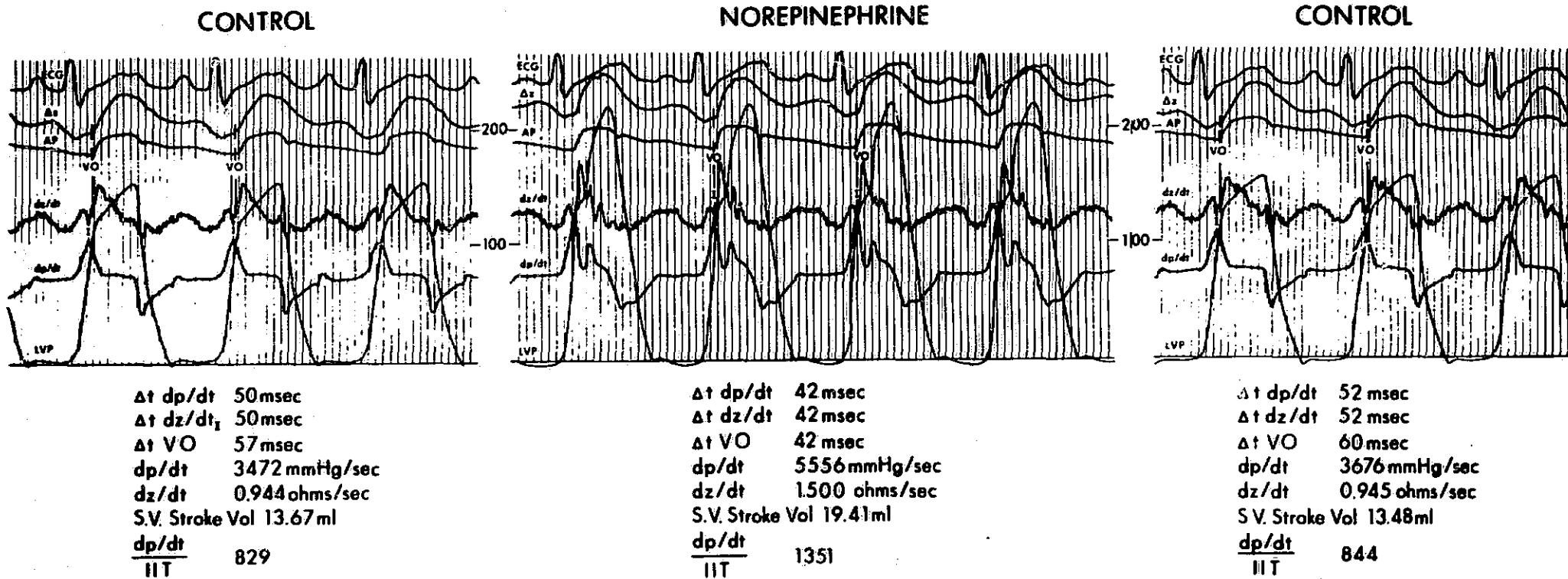

Figure 1 Simultaneous tracing of the intra-ventricular pressure pulse (LVP) and its first derivative with regard to time (dp/dt), the central aortic pressure (AP), the thoracic impedance pulse ( $\Delta Z$ ) and its first derivative with regard to time (dz/dt), and the ECG. Pressure scale applies to LVP only. The DC component of the aortic pressure (AP) is held constant and is used in this record for timing purposes only. Paper speed 200 mm/sec.



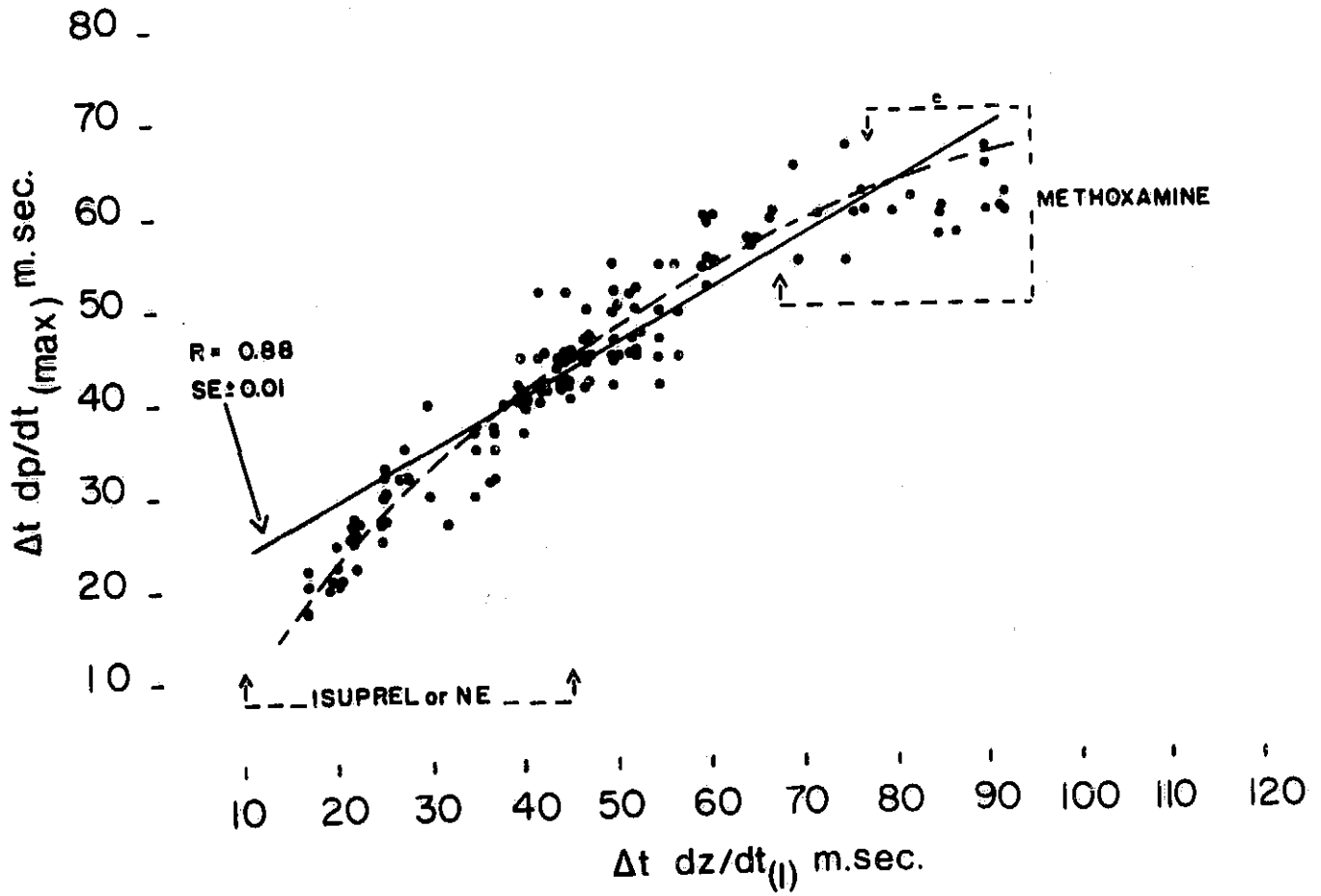

Figure 2 Temporal relation between maximum  $dp/dt$  ( $\Delta t \, dp/dt$ ) and the inflection point in the first derivative of the thoracic impedance ( $\Delta t \, dz/dt_{(I)}$ ).

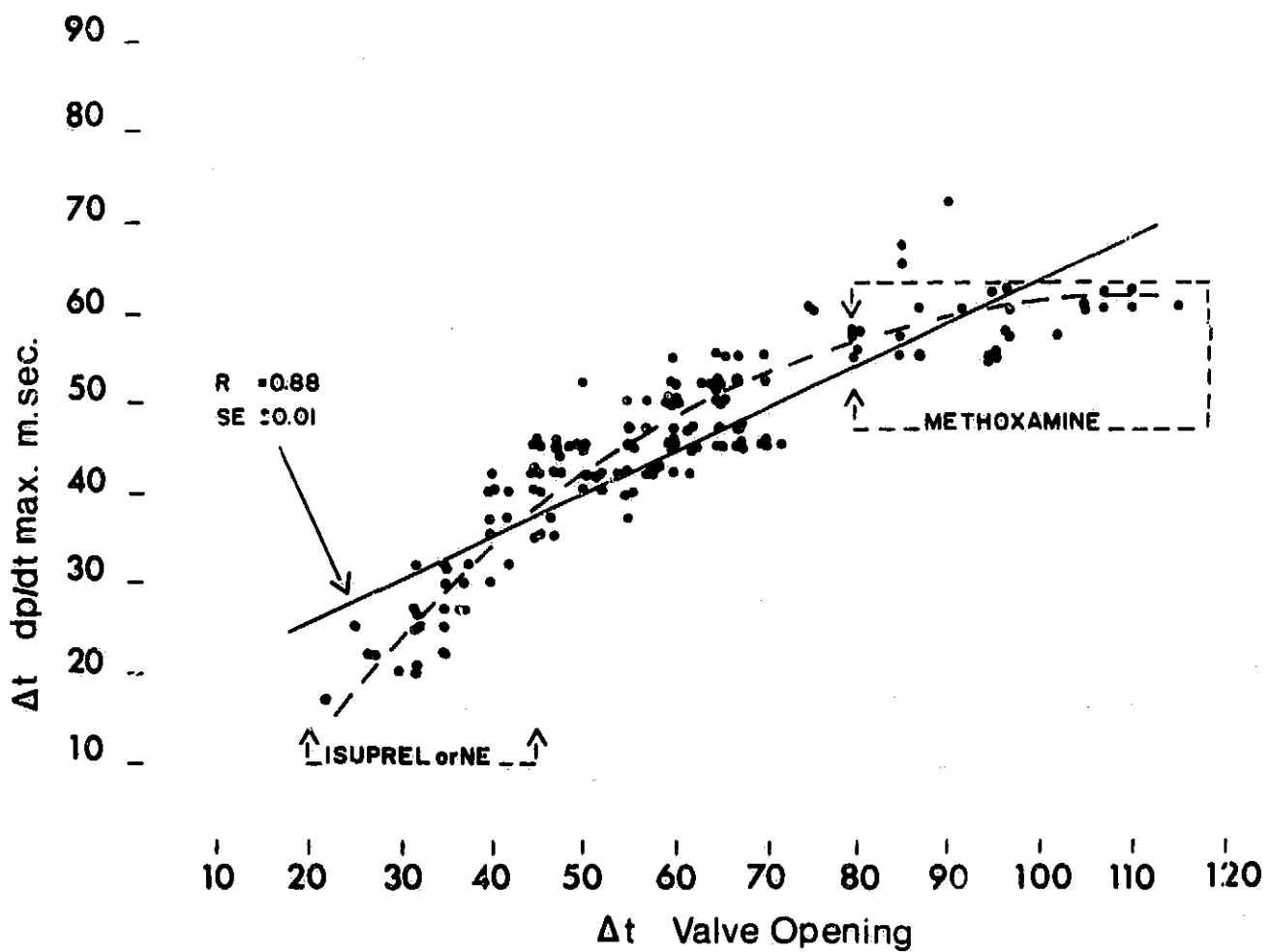

Figure 3 Temporal relation between maximum dp/dt ( $\Delta t \text{ dp/dt}$ ) and valve opening ( $\Delta t \text{ VO}$ ).

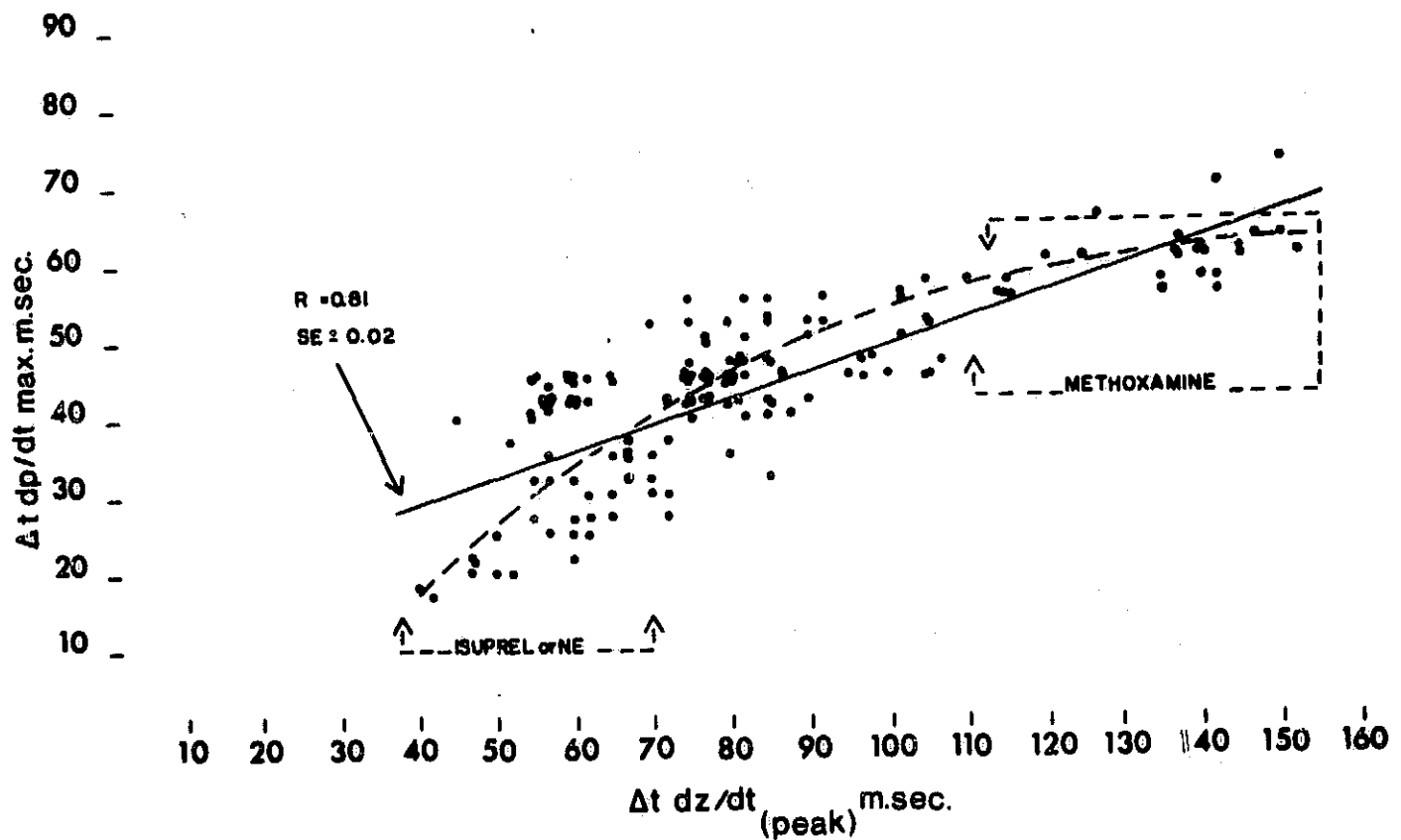

Figure 4 Temporal relation between maximum  $dp/dt$  ( $\Delta t dp/dt$ ) and the maximum first derivative of the thoracic impedance pulse ( $\Delta t dz/dt \text{ (peak)}$ ).

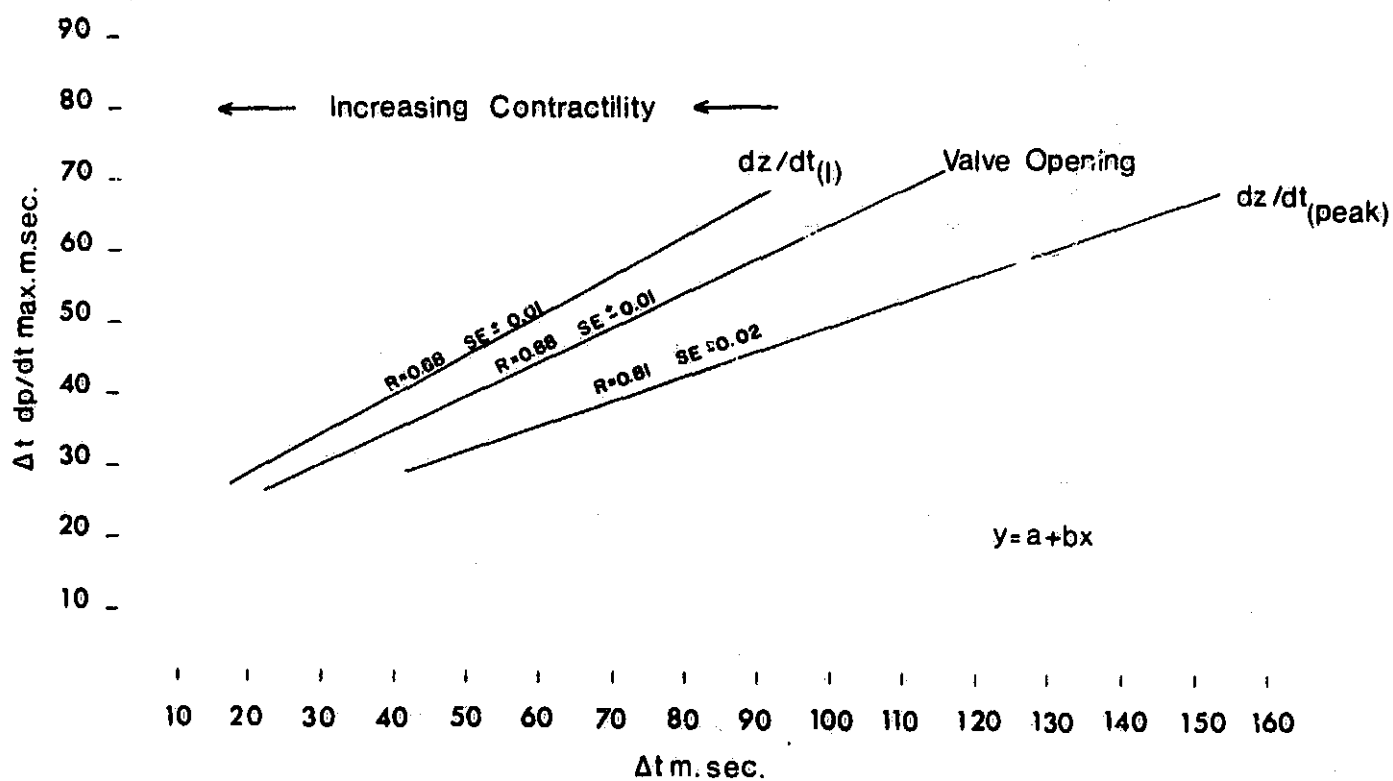

Figure 5 Comparison of regression lines for  $\Delta t \text{ dZ/dt}_{(I)}$ ,  $\Delta t \text{ VO}$ , and  $\Delta t \text{ dZ/dt}_{(peak)}$  with  $\Delta t \text{ dp/dt}$ .

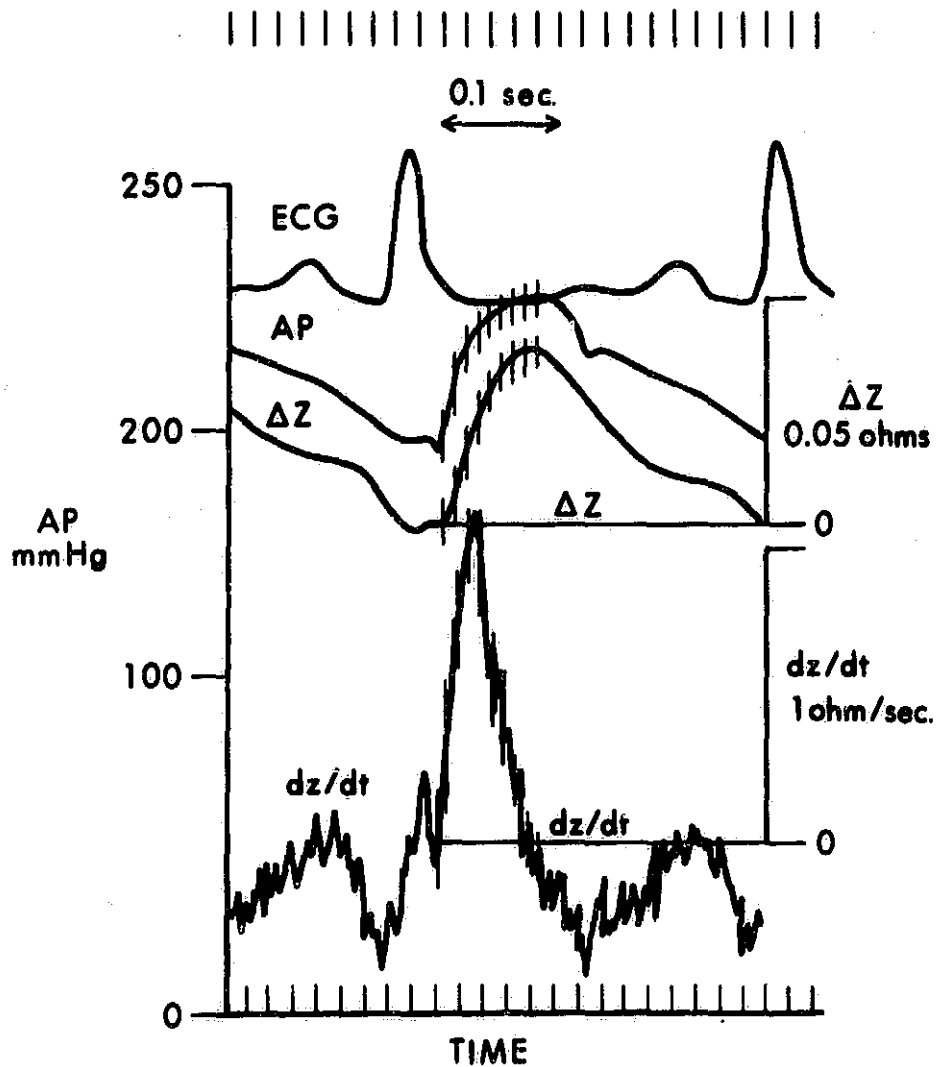

Figure 6 Method of computing impedance force-velocity relation on basis of single beat. Afterload; aortic pressure (AP) times change in impedance pulse ( $\Delta Z$ ) in mm Hg ohms; considered as function of the change in the velocity of the thoracic impedance pulse ( $dz/dt$ ) in ohms/sec, evaluated at 10 milliseconds intervals.

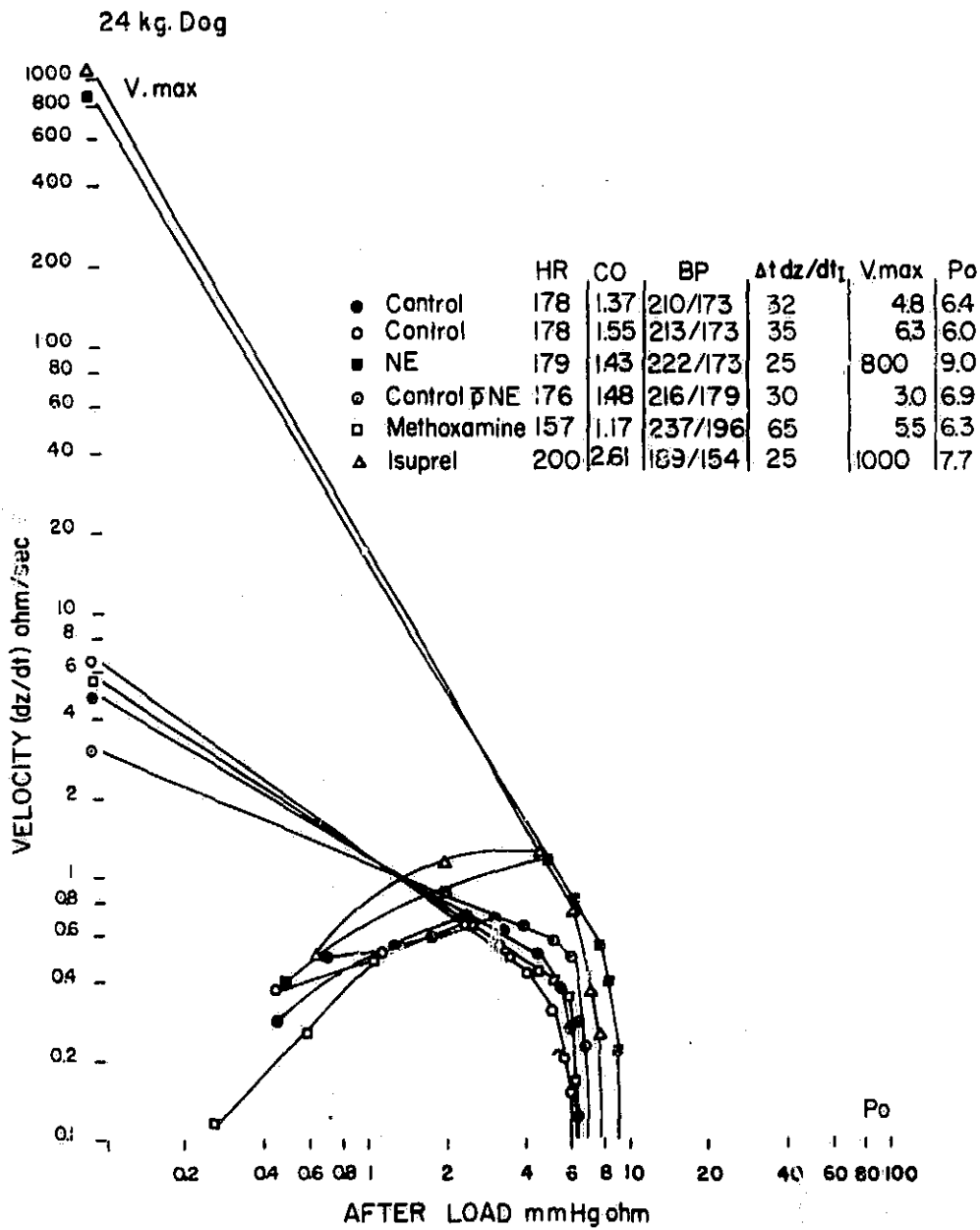

Figure 7 Impedance force-velocity relationship. Change in impedance velocity as function of increasing impedance afterload, in the presence of cardiac inotropic and non-inotropic interventions.

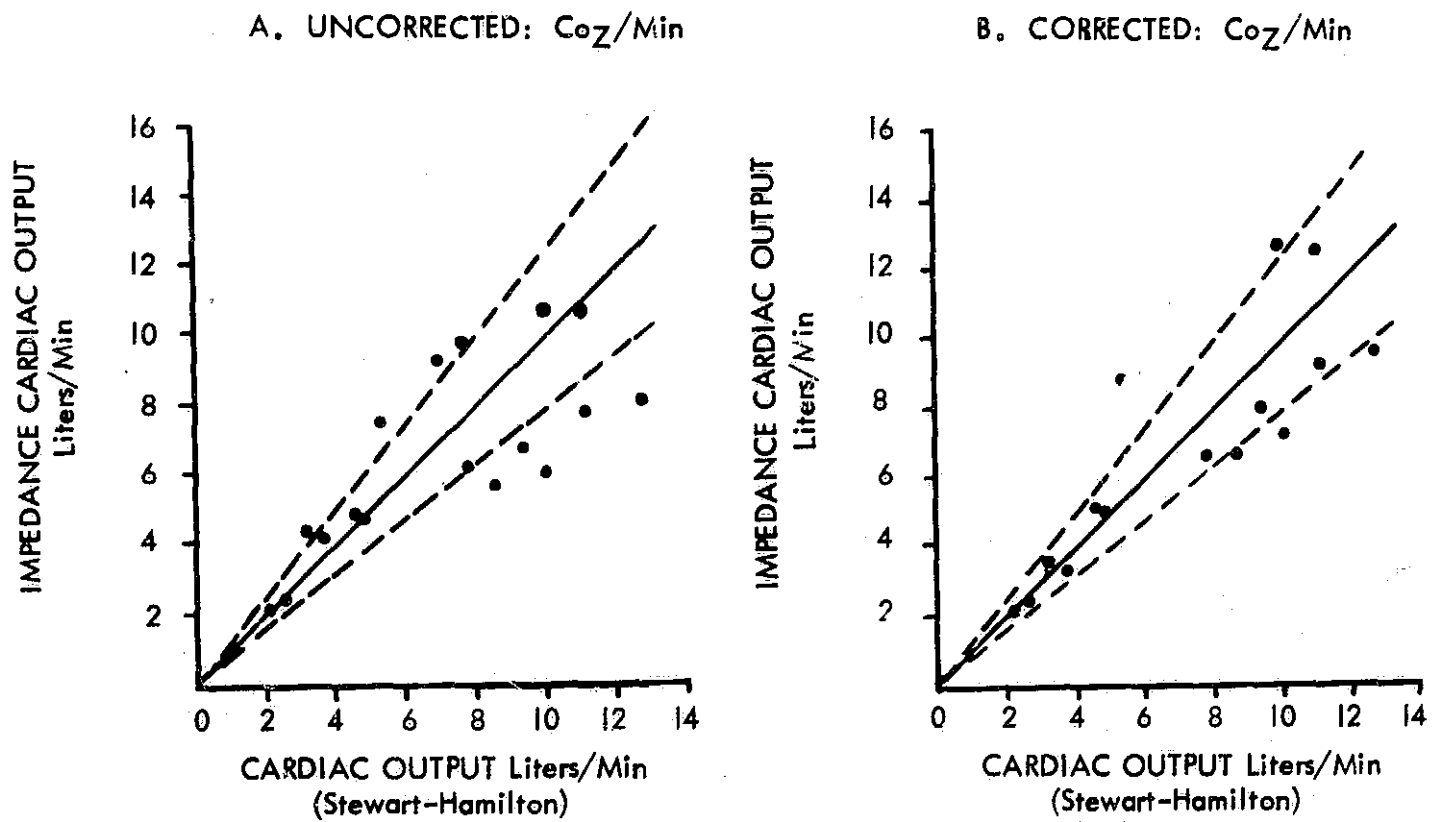

Figure 8A A graph of cardiac output values obtained by the impedance and indicator dilution techniques (Stewart-Hamilton computation).

Figure 8B A graph of corrected impedance cardiac output values plotted against the original indicator dilution values obtained by the Stewart-Hamilton method.

FR 560588 12-12-1968

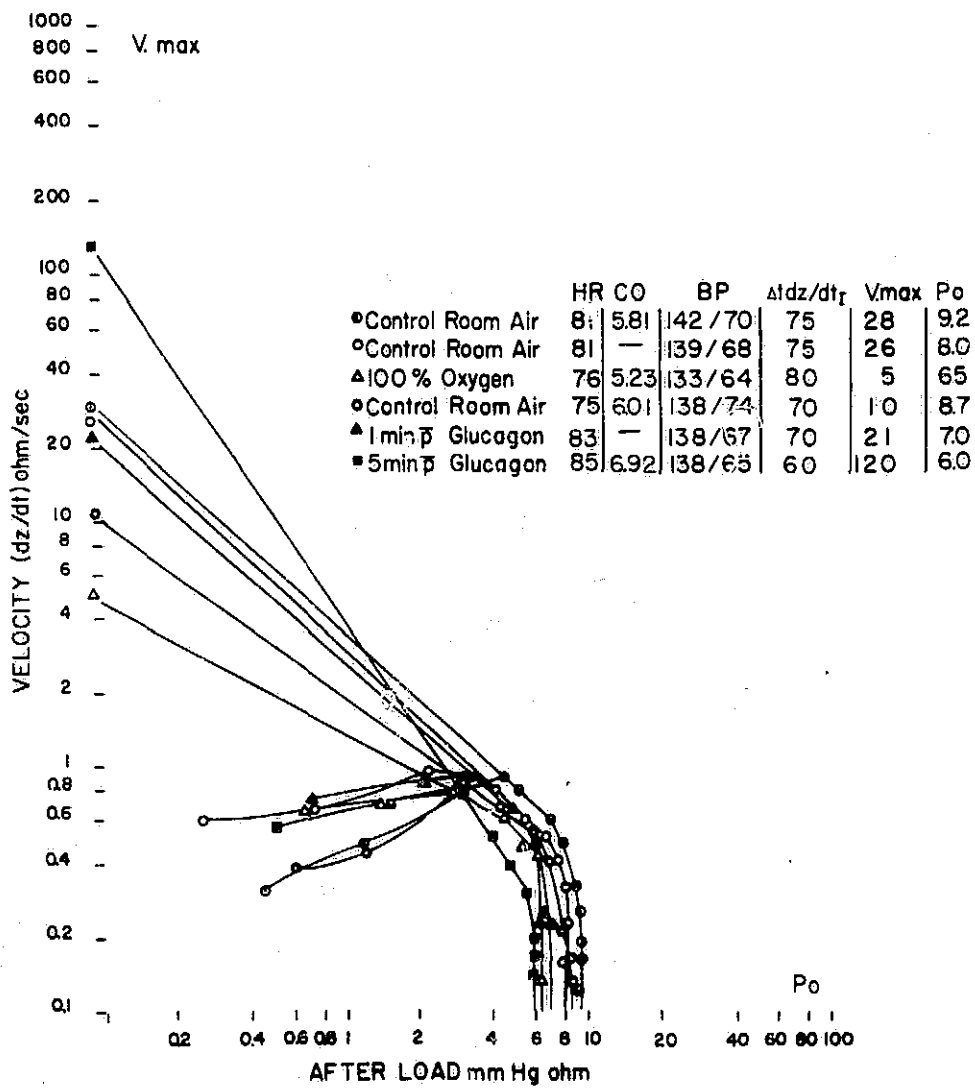

Figure 9 Determination of impedance force-velocity relation in man. Comparison with Stewart-Hamilton cardiac output.



REFERENCES

1. Covell, J.W., Ross, J. Jr., Sonnenblick, E.H., and Braunwald, E., Comparison of the force-velocity relation and the ventricular function curve as measures of the contractile state of the intact heart, Circulation Research 19:364, 1966.
2. Downing, S. E. and Siegel, J. H., Baroreceptor and Chemoreceptor influences on sympathetic discharge to the heart Amer. J. Physiol. 204: 471, 1963.
3. Fry, D. L., Greggs, D. M., and Greenfield, J. C., Myocardial mechanics: tension-velocity-length relationships of heart muscle, Circulation Research 4: 73, 1964.
4. Gault, J. H., Ross, J. Jr., Sonnenblick, E. H., and Braunwald, E., Characterization of myocardial contractility in patients with and without cardiac dysfunction by the instantaneous Tension-Velocity relation (P), Circulation 33: Suppl. III, 108, 1966.
5. Harley, A., and Greenfield, Jr., J. C., Determination of cardiac output in man by means of impedance plethysmography Aerospace Medicine, pp. 248, March 1968.
6. Hill, R. V., Jansen, J. C., and Fling, J. L., Electrical impedance plethysmography: a critical analysis, J. Appl. Physiol. 22: 161, 1967.
7. Kubicek, W. G., Karnegis, J. N., Patterson, R. P., Witsoe, D. A., and Mattson, R. H., Development and evaluation of an impedance cardiac output system, Aerospace Medicine 37: 1208, 1966
8. Kubicek, W. G., Witsoe, D. A. and Patterson, R. P., Development and evaluation of an impedance cardiograph system to measure cardiac output and other parameters. Report to National Aeronautics and Space Administration 1968, Contract No. NAS 9-4500.
9. Levine, H. J. and Britman, N. A., Force-velocity relations in the intact dog heart, J. Clin. Invest. 43: 1383, 1964.
10. MacLean, L. D., Mulligan, W. G., McLean, A.P.H., and Duff, J. H., The patterns of septic shock in man - a detailed study of 56 patients, Annals of Surgery 116: 543, 1966.

11. Pomerantz, M., Lauridson, J., Baumgartner, R. and Eiseman, B., Early detection of pulmonary edema using transthoracic electrical impedance Surgery (In Press) 1969.
12. Siegel, J. H., The role of the myocardial contractile state in the response to anesthesia and surgery. Anesthesiology 30:519, 1969.
13. Siegel, J. H., and Fabian, M. Therapeutic advantages of an inotropic vasodilator in endotoxin shock J.A.M.A. 200: 696, 1967.
14. Siegel, J. H., Greenspan, M., and Del Guercio, L.R.M. Abnormal vascular tone, defective oxygen transport and myocardial failure in human septic shock. Annals of Surgery 165: 504, 1967.
15. Siegel, J. H., Greenspan, M., and Del Guercio, L.R.M. The prognostic implications of altered physiology in operations for portal hypertension. S.G. & O. 126: 249, 1969.
16. Siegel, J. H., and Sonnenblick, E. H. Isometric Time-Tension relations as an index of myocardial contractility Circulation Research 12: 597, 1963.
17. Siegel, J. H., Sonnenblick, E. H., Judge, R. D., and Wilson, W. S. The quantification of myocardial contractility in dog and man. Cardiologia 45: 189, 1964.
18. Siegel, J. H., Sonnenblick, E. H., Judge, R.D., and Wilson, W.S. Occult myocardial failure and vasopressors in shock. Cardiologia 47: 353, 1965.
19. Sonnenblick, E. H. Implications of muscle mechanics in the heart. Fed. Proc. 21: 975, 1962.
20. Sonnenblick, E. H. Determinants of active state in heart muscle: force, velocity, instantaneous muscle length, time. Fed. Proc. 24: 1396, 1965.
21. Sonnenblick, E. H. Instantaneous force-velocity-length determinants in the contraction of heart muscle. Circulation Research 16: 441, 1965.
22. Sonnenblick, E. H. and Downing, S. E. Afterload as a primary determinant of ventricular performance. Am. J. Physiol. 204: 604, 1963.
23. Sonnenblick, E. H. Force-velocity relations in mammalian heart muscle. Am J. Physiol. 202: 931, 1962

24. Thompson, H. K., Jr., Starmer, C. F., Whalen, R. E. and McIntosh, H. D. Indicator transit time considered as a gamma variate. *Circulation Research* 14: 502, 1964.

N70-10009

THE  
FIRST DERIVATIVE THORACIC  
IMPEDANCE CARDIOGRAM:  
- - - -  
A Useful Signal for  
Timing Events in the Cardiac Cycle

by

Zuhdi Lababidi, M.D., D. A. Ehmke, M.D., Ph.D.  
Robert E. Durnin, M.D., Paul E. Leaverton, Ph.D.,  
and Ronald M. Lauer, M.D.

From The University of Iowa, Section of Pediatric Cardiology,  
Department of Pediatrics, and the Department of Biostatistics,  
University Hospitals, Iowa City, Iowa 52240.

AUTHOR INFORMATION

Zuhdi Lababidi, M.D. Fellow in Pediatric Cardiology,  
Department of Pediatrics, University Hospitals,  
Iowa City, Iowa.

D. A. Ehmke, M.D., Ph.D. Assistant Professor of Pediatrics,  
University Hospitals, Iowa City, Iowa.

Robert E. Durnin, M.D. Assistant Professor of Pediatrics,  
University Hospitals, Iowa City, Iowa.

Paul E. Leaverton, Ph.D. Associate Professor  
Department of Preventive Medicine and Environment Health,  
and Biostatistics, University of Iowa, Iowa City, Iowa.

Ronald M. Lauer, M.D. Professor of Pediatrics,  
Director, Section of Pediatric Cardiology,  
University Hospitals, Iowa City, Iowa.

Reprint request to:

Z. Lababidi, M.D.  
Department of Pediatrics,  
Section of Pediatric Cardiology  
The University Hospital  
Iowa City, Iowa 52240

Summary:

When an alternating current of high frequency is applied to the thorax, the first derivative of the impedance to this current is affected by the volumetric changes occurring during the cardiac cycle.

Phonocardiograms, ECG's and first derivative impedance cardiograms (ICG) were recorded simultaneously in 91 subjects. The ICG's were found to have sharply demarcated points which occur synchronously with the first heart sound, aortic second sound, pulmonic second sound, mitral opening snap, third heart sound and fourth heart sound.

The ICG may thus be used not only as a reference tracing to help identify heart sounds on the phonocardiogram, but also to directly time intervals within the cardiac cycle. Clinically it has proved to be useful in measuring the split of the second heart sound, recognizing  $S_3$ ,  $S_4$ , mitral opening snaps, systolic ejection clicks on the phonocardiogram, and identifying P waves in ECG's showing arrhythmia.

Additional Indexing Words:

Phonocardiogram

Impedance Cardiogram

First derivative impedance cardiogram

Temporal relationships of phonocardiogram

Introduction:

If two electrodes in a high frequency circuit are placed on the thorax, changes in impedance may be recorded which are synchronous with events in the cardiac cycle. Nyboer (1), Rushmer (2), Bonjer (3), and Kubicek (4,5) have noted that the impedance changes are related to cardiac volumetric changes.

A four electrode impedance cardiograph was developed by Kubicek et al. (4) for the recording of thoracic impedance changes during the cardiac cycle. This unit among other outputs allows the direct recording of impedance changes and its first derivative. Utilizing such an instrument, it was our observation that the first derivative of the impedance has a waveform which is synchronous with the cardiac cycle. The purpose of this report is to describe the waveform of the first derivative impedance cardiogram and its relationship to heart sounds and events in the cardiac cycle.

Methods:

A Minnesota Impedance Cardiograph\* Model 202 was used to record an impedance signal in 91 subjects (Table I). Four aluminized mylar strips\*\* attached to an adhesive tape backing were placed around the subjects as shown in Figure 1. The outer two electrodes were attached to a constant current oscillator supplying alternating current at 100 KHz and the impedance between the inner two electrodes was continuously recorded.

---

\*Manufactured by the Department of Physical Medicine & Rehabilitation, University of Minnesota.

\*\*Minnesota Mining & Manufacturing Company.

The impedance was markedly affected both by respiration and by the cardiac cycle. The impedance signal was also passed through a differentiator circuit, and the first derivative of the impedance was found to be less affected by respiratory movement.

The waveform of the first derivative impedance cardiogram was recorded simultaneously with a surface phonocardiogram and Lead II of the electrocardiogram on an Electronics for Medicine recorder (Model DR-12), at a paper speed of 150 mm. per second. The uniformity and accuracy of paper speed was measured from 0.04 second time lines generated within the recorder. The phonocardiograms recorded at the pulmonic area, lower left sternal margin, and apex of the heart were recorded with a frequency range from 100 to 500 cycles per second. Phonocardiograms at the apex were also recorded at a frequency range of 50 to 100 cycles per second.

The morphology of typical first derivative impedance cardiograms are shown in Figure 2. Note that decreasing rates of impedance change are recorded as upward deflections in the tracing. The points A, B, X, Y, O and Z are maximal deflections of waves on the first derivative of the impedance signal; and they were found to relate in time to events in the phonocardiogram: A, with the beginning of the fourth heart sound; B, with a maximal vibration (mitral component) in the first heart sound at the apex, X, with aortic closure; Y, with pulmonic closure; O with the mitral opening snap, Z with the maximal vibration in the third heart sound. Intervals were measured with a millimeter ruler to the closest 0.5 millimeter thus allowing measurements to be made to 0.004 seconds at 150 millimeter per second paper speed.



These phonocardiographic and impedance intervals were measured in a number of beats and the average of the phonocardiographic and impedance intervals were compared.

Ninety-one subjects were studied. Their ages and whether they had underlying heart disease are shown in Table I.

Results:

Impedance Cardiogram - A Point:

The records of 27 subjects were selected with both a well-recorded first heart sound on the phonocardiogram and a P wave on the ECG. Ninety-seven beats with an average of 4 beats per subject were examined. In these the A point occurred on the impedance cardiogram during the interval between the end of the P wave and the beginning of the QRS complex on the electrocardiogram. A fourth heart sound could be recorded in 9 of these 27 subjects. In all 9 patients the A point occurred simultaneously with beginning of the fourth heart sound. (See Table II).

Impedance Cardiogram - B Point:

The above 27 subjects were also selected to study the B point. Ninety-seven beats with an average of 4 beats per subject were examined. Data relating the B point to the first heart sound are shown in Table II. In all patients studied, the B point occurred during the first heart sound. In 19 of the 27 subjects, the B point was observed to occur synchronously with the maximal deflection of the first heart sound at the apex. In the remaining eight subjects, the B point occurred within 0.001 second of the maximal deflection of the first heart sound at the apex. The range of observations is shown in Table II.

Impedance Cardiogram - X & Y Points:

A group of tracings obtained from 37 subjects were selected because both components of the second heart sound were well recorded phonocardiographically. The time-interval between the electrocardiographic R wave and the maximal deflection of the aortic and pulmonic second heart sounds were independently measured and compared with the intervals between the electrocardiographic R wave and the X and Y points on the first derivative impedance cardiogram. One hundred and forty-six beats were measured with an average of 4 beats per subject. In all tracings the X and Y points occurred within the vibration of the aortic and pulmonic sounds, respectively.

In 28 of the 37 subjects, the X point occurred synchronously with the maximal deflection of the aortic second sound. In the remaining 9 subjects, the X point occurred within 0.01 second of the peak of the aortic second sound. The range of observations is shown in Table II.

In 25 subjects, the Y point occurred synchronously with the maximal deflection of the pulmonic second sound. In the remaining 12 subjects, the Y point occurred within 0.01 second of the peak of the pulmonic second sound. The range of observations is shown in Table III.

The X and Y points were found to vary with respiration in parallel with the splitting of the second heart sound. The duration between the X and Y points in the first derivative impedance cardiogram and the interval from the aortic second sound to the pulmonic second sound were averaged for each subject. In 19 of

the 37 subjects, the splitting of the second heart sound was the same as the X-Y interval, and in the remaining 18 subjects the difference was within 0.01 second (Figure 3).

#### Impedance Cardiogram - 0 Point:

The records of 10 subjects with mitral stenosis were chosen with a well recorded opening snap. An average of 4 beats per subject were measured. Data relating the intervals from electrocardiographic R wave to the impedance 0 point and the intervals between the electrocardiographic R wave and the maximal vibration of the phonocardiographic opening snap are shown in Table II. In 6 of the 10 subjects, the 0 point occurred synchronously with the opening snaps and in 4 subjects, the mean difference was 0.01 second.

#### Impedance Cardiogram - Z Point:

The records of 17 subjects were chosen with a well-recorded third heart sound and a first derivative impedance cardiogram Z point during held inspiration. Sixty-two beats with an average of 4 beats per subject were recorded. It was observed that inspiration enhances the Z point configuration. Data relating the intervals from the electrocardiographic R wave to the Z point and the intervals between the electrocardiographic R wave and the peak of the third heart sound are shown in Table II. In 13 of the 17 subjects, the Z point occurred synchronously with the maximal deflection of the third heart sound; and in all subjects the Z point occurred within the vibrations of the third heart sound.

#### Clinical Observations:

In clinical situations wherein the heart sounds are obscured

by murmurs or in which they are difficult to recognize, the first derivative impedance cardiogram has proved to be a useful tool in timing heart sounds. Figure 4A shows a phonocardiogram from a patient with pulmonic stenosis with an intact ventricular septum. Note that the pulmonic closure is difficult to discern on the phonocardiogram, but the first derivative impedance tracing shows both X and Y points, thus allowing the width of the split of the second heart sound to be estimated. Figure 4B shows the phonocardiogram of a patient with a patent ductus arteriosus. Note that the aortic and pulmonic second sounds are obscured by the murmur. The X and Y points allow their recognition and timing. Figure 4C shows the phonocardiogram from a patient with mitral stenosis. Note that the opening snap occurs after the first derivative impedance Y point at the 0 point. Note also that the Z point indicates the onset of the third heart sound. Figure 4D shows the impedance, phonocardiogram, and electrocardiogram of a patient with congenital complete heart block. Note that a negative deflection (A point) occurs on the impedance tracing following each P wave.

#### Discussion:

The first derivative transthoracic impedance cardiogram is recorded easily without the necessity of searching for pulsations. It has sharply demarcated points that relate in time to the four heart sounds. These points are consistent both in normal subjects and those with heart disease. Thus the impedance cardiogram can be used not only as a reference tracing for simultaneously recorded phonocardiograms, but also to time intervals within the

cardiac cycle directly. It may be particularly helpful when heart sounds are poorly recorded, obscured by murmurs, or very faint.

In 2 patients with complete heart block that we have studied, the A point occurred on the impedance cardiogram immediately following the P wave of the electrocardiogram, anywhere it occurred during the cardiac cycle. Thus it may be possible to utilize the impedance cardiogram to identify electrocardiographic P waves in certain atrial arrhythmias in which they are difficult to be recognized.

The X-Y interval is helpful in determining the width of the splitting of the second heart sound. It has been observed that the X-Y interval varies with the respiratory cycle in parallel with the splitting of the second heart sound. In clinical situations in which both components of the second heart sound can not be recorded phonocardiographically, the impedance cardiogram will allow an accurate measure of the interval between aortic and pulmonary closure. The impedance cardiogram Z point relates in time to the third heart sound and allows its timing and identification on the phonocardiogram.

In patients with mitral stenosis, the mitral opening snap can be recognized on the phonocardiogram by using the first derivative impedance cardiogram as a reference tracing. The opening snap occurs synchronously with the 0 point of the first derivative impedance cardiogram.

TABLE 1  
IMPEDANCE CARDIOGRAM: SUBJECT DATA

Phono	<u>EVENTS</u> Impedance	<u>NUMBER OF SUBJECTS</u>			Age (Yrs)	<u>SEX</u>	
		Total	Cardiacs	Normals		Male	Female
S <sub>4</sub> ,S <sub>1</sub>	A,B	27	14	13	1.5 - 33	15	12
A <sub>2</sub> ,P <sub>2</sub>	X,Y	37	16	21	3 - 40	19	18
S <sub>3</sub>	Z	17	8	9	3 - 25	7	10

TABLE II

PHONOCARDIOGRAM VS. IMPEDANCE CARDIOGRAM

	<u>(R TO S<sub>4</sub>) - (R TO A)</u>	<u>(R TO S<sub>1</sub>) - (R TO B)</u>	<u>(R TO A<sub>2</sub>) - (R TO X)</u>	<u>(R TO P<sub>2</sub>) - (R TO Y)</u>	<u>(R TO S<sub>3</sub>) - (R TO Z)</u>
NUMBER WITH IDENTICAL INTERVALS.	9	19	28	25	14
1)	—	-0.001	-0.001	-0.003	-0.01
2)	—	-0.001	-0.001	-0.003	-0.01
VARIATIONS BETWEEN PHONOCARDIOGRAM AND IMPEDANCE CARDIOGRAM (SECONDS)					
3)	—	-0.001	-0.002	-0.004	-0.01
4)	—	-0.001	-0.003	-0.004	—
5)	—	+0.001	-0.007	-0.005	—
6)	—	+0.001	+0.002	+0.002	—
7)	—	+0.001	+0.003	+0.002	—
8)	—	+0.001	+0.003	+0.005	—
9)	—	—	+0.010	+0.007	—
10)	—	—	—	+0.008	—
11)	—	—	—	+0.010	—
12)	—	—	—	+0.010	—
TOTAL NUMBER OF SUBJECTS	9	27	37	37	17

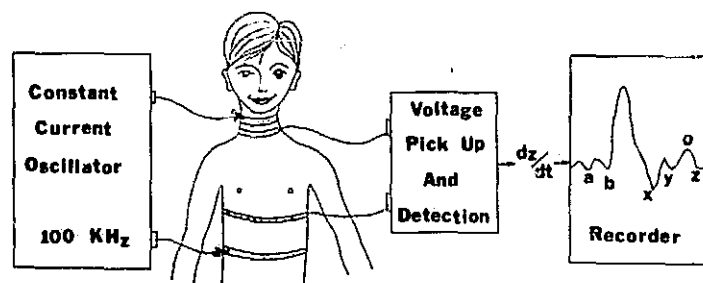
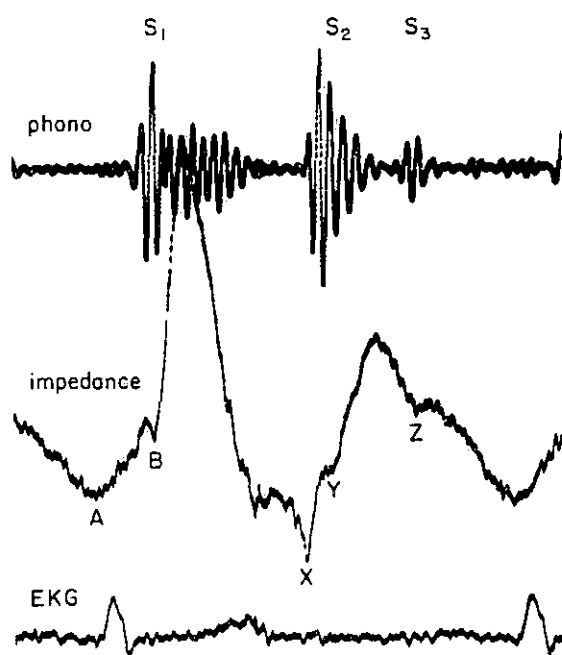

Figure 1 The position of the electrodes used to record the first derivative thoracic impedance cardiogram.

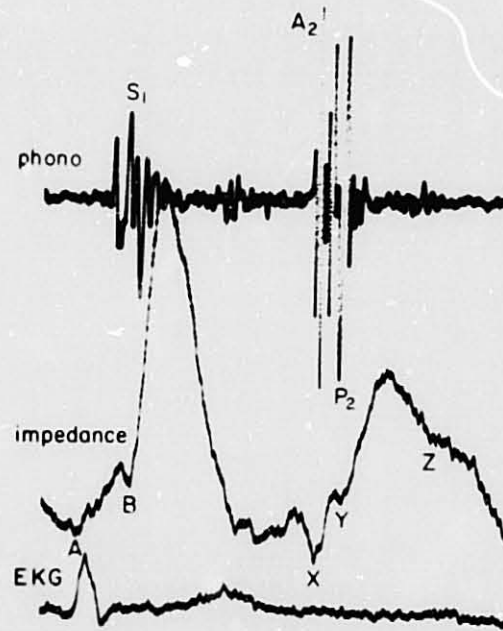

Figure 2: Simultaneously recorded phonocardiogram, electrocardiogram and first derivative impedance cardiogram.  
Legend: A, B, X, Y, and Z are points on the first derivative impedance cardiogram.



A. Note B synchronous with maximal deflection of first heart sound (S<sub>1</sub>) on phonocardiogram recorded at apex. Note also that point Z occurs synchronously with the third heart sound (S<sub>3</sub>).

Figure 2 (continued)



B. Phonocardiogram obtained at pulmonic area in normal subject. Note X & Y points of first derivative impedance cardiogram occur at the same time as the maximal deflection aortic ( $A_2$ ) and pulmonic ( $P_2$ ) second heart sounds.

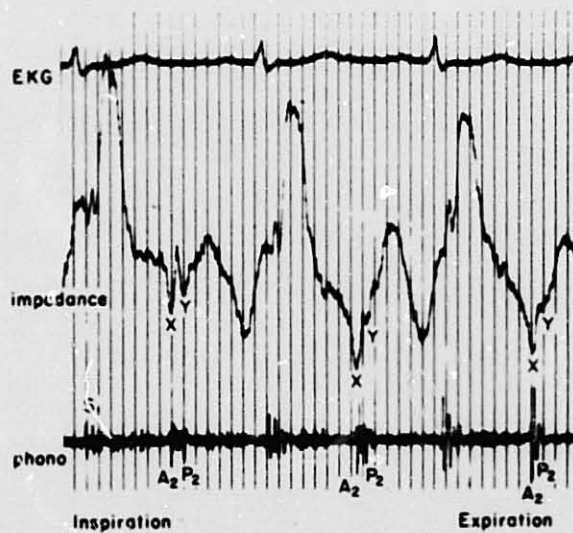

C. Note X & Y vary in their splitting the way that  $A_2$  and  $P_2$  vary in their splitting with respiration.

Figure 2 (continued)

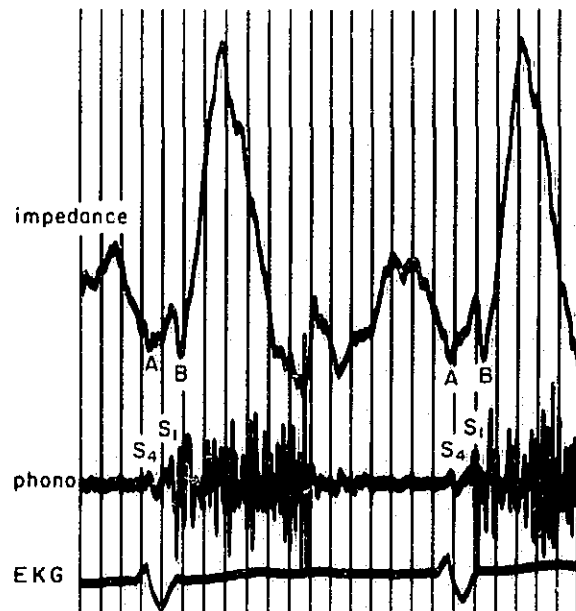

D. Phonocardiogram obtained at apex in a patient with Ebsteins Malformation. Note that the A point of the impedance cardiogram occurs synchronously with the fourth heart sound ( $S_4$ ).

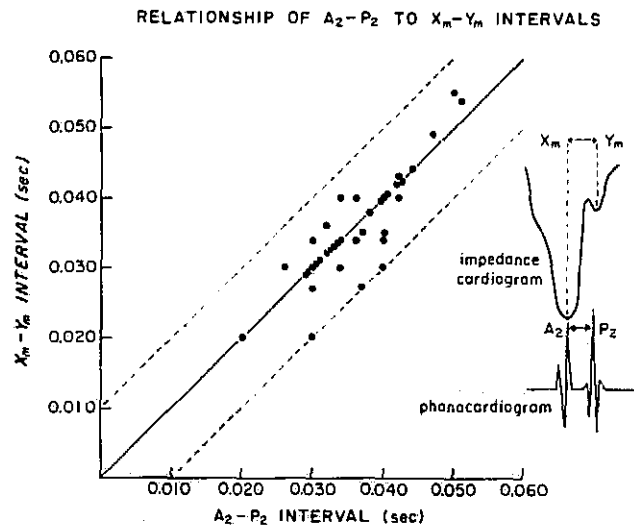
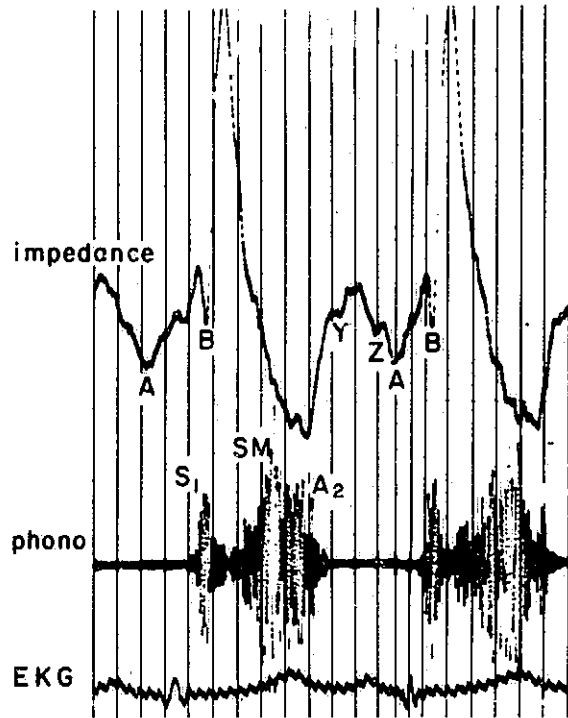
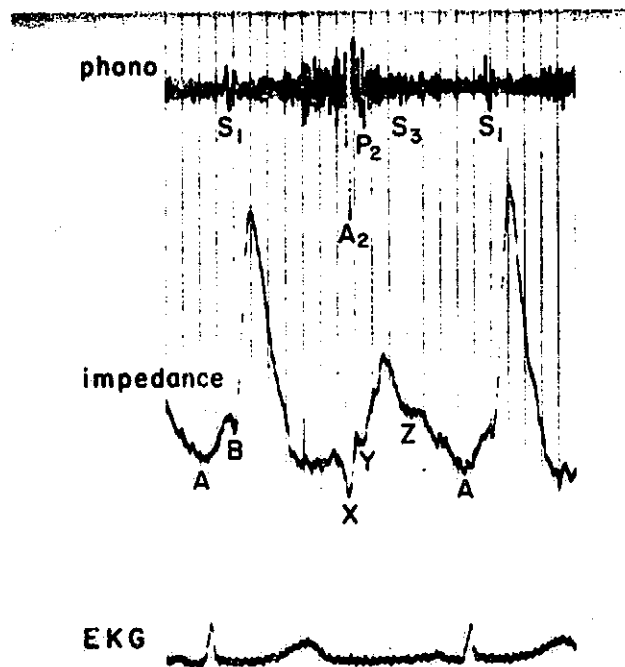

Figure 3 Relationship between the X - Y interval on the first derivative impedance cardiogram and the interval between the aortic ( $A_2$ ) and pulmonic ( $P_2$ ) second sounds in 29 subjects.<sup>2</sup> Dashed lines indicate 0.01 second limits.

Figure 4: Phonocardiograms (phono), first derivative thoracic impedance cardiogram (impedance), electrocardiograms (ECG). See text-clinical observations.



A. Patient with pulmonic stenosis



B. Patient with patent ductus arteriosus

Figure 4: (continued)

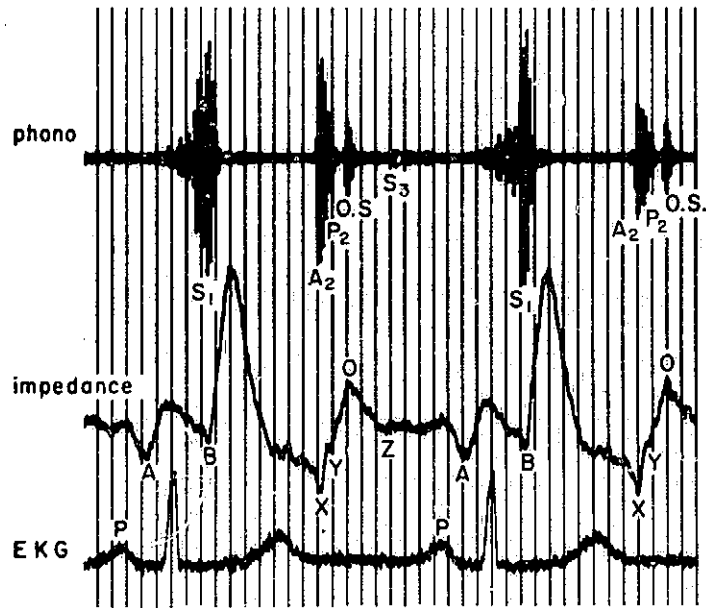

C. Patient with mitral stenosis

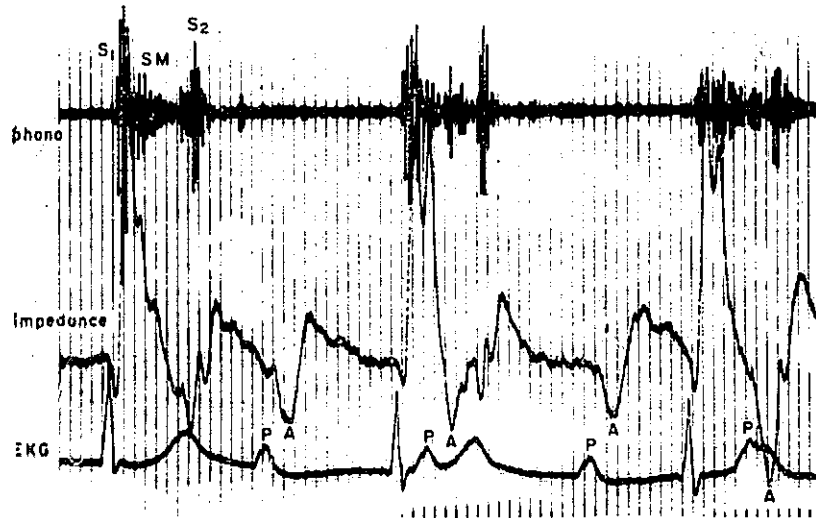

D. Patient with complete heart block. Note A point on impedance cardiogram follows P waves on the ECG

REFERENCES

1. Nyboer, J.S., Bagno, S., Barnett, A., and Halsey, R.M., J. Clin. Investigation 19:773, 1940.
2. Rushmer, Robert F., Crystal, D.K., Wagner, C., and Ellis, R.M. Intracardiac Impedance Plethysmography. American Journal of Physiology 174: 171, 1953.
3. Bonjer, F.H., Van Den Berg, J.W., and Dirken, M.N., Circulation 6:415, 1952.
4. Kubicek, W.G., Karnegis, J.N., Patterson, R.P., Witsoe, D.A., Mattson, R.H. Development and evaluation of an impedance cardiac output system. Aerospace Medicine 37:1208, 1966.
5. Kubicek, W.G., Patterson, R.P., Witsoe, D.D., Castaneda, A., Lillehei, R.C., and Ersek, R. The impedance cardiograph as a noninvasive means to monitor cardiac function. N.A.S.A. Report No. NAS 9-4500 1968.

PHYSIOLOGICAL CORRELATES OF THE CARDIAC THORACIC  
IMPEDANCE WAVEFORM

N70-10010

by

James N. Karnegis, M.D., Director  
Cardiac Diagnostic Facilities  
The Charles T. Miller Hospital  
St. Paul, Minnesota, and,  
Assistant Clinical Professor of Medicine  
University of Minnesota Medical School  
Minneapolis, Minnesota

and

William G. Kubicek, Ph.D., Professor  
Physical Medicine and Rehabilitation  
University of Minnesota Medical School  
Minneapolis, Minnesota



## PHYSIOLOGICAL CORRELATES OF THE CARDIAC THORACIC IMPEDANCE WAVEFORM

When a high frequency sinusoidal current is applied across the chest, changes in the thoracic impedance can be recorded (1). The thoracic impedance changes consist of deflections composing a waveform. The waveform appears to be related to the mechanical activity of the heart, and has been used to calculate the cardiac output (2).

The impedance change waveform is complex, and little is known about its composition. The purpose of this paper is to correlate the waveform deflections with physiological events.

### Materials and Methods

The thoracic impedance plethysmographic system used has been previously described (2), and will be summarized here. Four circular, flexible, metallic electrodes were used, two being placed around the neck, and two around the upper abdomen. One of the inner two electrodes was placed at the base of the neck, the other about two centimeters below the xiphoid process. The outer two electrodes were separated from the inner ones by about two centimeters.

An activating six milliampere, one hundred kilocycle sinusoidal current was passed through the outer two electrodes from a constant current source. The inner pair of the electrodes was connected to a high impedance amplifier and associated circuitry, to allow determination of the thoracic impedance changes. The resulting impedance change waveform, and its first

derivative, were recorded at a paper speed of fifty millimeters per second.

Impedance recordings were made on 58 patients. Diagnostic cardiac catheterization studies were done on 55 patients; of these, 6 were normal, 41 had cardiac valvular disease, 3 had congenital septal defects, and 5 had miscellaneous cardiovascular abnormalities. Atrioventricular conduction disturbances were present in three patients who did not have cardiac catheterization; two had complete heart block, and the other had the Wenckebach type of second degree atrioventricular block.

### Results

A typical normal thoracic impedance change waveform is shown in Figure 1, along with its simultaneously recorded first derivative, the left ventricular pressure, and lead two of the electrocardiogram. A decrease in impedance is shown by an upward deflection. The time lines on the abscissa indicate 0.04 second intervals.

The largest impedance deflection is upward, and is marked "C" in Figure 1. The C wave is immediately preceded by a downward deflection, marked "A", and is immediately followed by a second upward deflection marked "V". The upstroke of the C wave is steep, but after the peak is reached, the downstroke is not as rapid, and is interrupted by the second upward deflection, the V wave.

The C wave is a systolic event, since it is synchronous with the QRS complex of the electrocardiogram. This is confirmed by timing the C wave with the simultaneously recorded

left ventricular pressure. It can be seen in Figure 1 that the V wave occurs in protodiastole, and the A wave in presystole.

The impedance C wave appears to provide hemodynamic information. This is suggested by Figure 2 which shows a premature ventricular contraction followed by a compensatory pause. The amplitude of the C wave associated with the premature beat is smaller, and that associated with the postextrasystolic beat is greater, than those associated with the regular beats. The first derivative indicates the rate of change of the impedance waveform. The amplitude of the first derivative, and of the brachial arterial pulse pressure, are also similarly affected by the premature ventricular contraction. These observations are consistent with the known physiological fact that the stroke volume of a premature ventricular contraction is usually less, and that of the next beat is usually greater, than the stroke volume of the regular beats. An experimental method using the first derivative of the impedance C wave has been devised by which the stroke volume, and hence the cardiac output, can be calculated (2).

The impedance A wave follows the P wave of the electrocardiogram as is shown in Figures 1 and 2. This fact is more easily seen in those arrhythmias where there is a disturbance in atrioventricular conduction. The electrocardiogram in Figure 3 shows the Wenckebach type of second degree atrioventricular block. In this arrhythmia the PR interval progressively increases until a P wave impulse is not conducted to the ventricles, no QRS complex occurs, and a beat is dropped. The

sequence is then repeated. It can be seen that the impedance A wave and the electrocardiographic P wave move together as they shift position in the cardiac cycle. This relationship also pertains in complete atrioventricular heart block, as is shown in Figure 4.

In contrast to the A wave which is consistently associated with the P wave, the impedance C wave corresponds in timing with the QRS complex of the electrocardiogram. The C wave is followed by the V wave in the impedance cardiogram, and the C and V waves occur independently of the A wave. These relationships appear to be consistent regardless of the pathway by which ventricular depolarization is accomplished. This is demonstrated in Figure 5, which was recorded from the same patient who was presented with complete heart block in Figure 4. However, the heart is now being paced by a transvenous electrode positioned with its tip in the apex of the right ventricle. The impedance tracing shows the C and V waves follow the pacemaker produced QRS complexes, and that these waves are independent of the A waves which continue to follow the electrocardiographic P waves.

In atrial fibrillation the electrocardiogram does not show P waves, and it would be anticipated that A waves would also be absent in the impedance cardiogram. That this is true is illustrated in Figure 6. This figure also shows that the amplitude of the C wave and that of its first derivative appear to vary directly with the RR interval. This is consistent with the above described findings in premature ventricular contractions, and with the use of the impedance waveform in calculating the cardiac output (2).

## Discussion

It appears that the thoracic impedance change waveform provides hemodynamic information. The recording of the impedance cardiogram is easily accomplished and has the distinct advantage that a noninvasive technique is used. This may be of particular importance when it is desirable to avoid penetration of the skin, such as in cardiac transplant patients or space travelers.

The present study shows that the contraction of the atria and of the ventricles are associated with identifiable components in the impedance change waveform. Measurements from these recordings can be used to estimate the stroke volume (2). The impedance cardiogram may also be of value as a continuous monitor of cardiovascular function. It is probable that additional applications will be found for thoracic impedance measurements.

It is interesting to compare the thoracic impedance change waveform with other hemodynamic measurements. It has been demonstrated that the flow of blood in the venae cavae is pulsatile (3,4), and is similar to that in the pulmonary veins (5). The flow pattern in these vessels is composed of three major deflections and resembles closely the thoracic impedance change waveform. Following the P wave of the electrocardiogram, and at the time of atrial contraction, the flow of blood in the venae cavae and pulmonary veins slows, or briefly reverses. There then is an increase in blood flow toward the heart coincident with ventricular systole. This is followed by a second acceleration of blood toward the heart in ventricular diastole.

These three waves found in the pattern of blood flow in the venae cavae and the pulmonary veins appear to correspond well to the A, C, and V waves of the impedance cardiogram. It seems reasonable to speculate that the cardiac thoracic impedance changes may be related to the flow of blood through the venae cavae and/or pulmonary veins, and the heart.

### Summary

A high frequency, constant sinusoidal current can be passed through the chest by a noninvasive technique and pulsatile changes in the thoracic impedance recorded. These pulsations are related to the beating of the heart. Three major components are present.

One component shows an increase in impedance is associated with atrial contraction and consistently follows the P wave of the electrocardiogram. The other two waves show a decrease in impedance. The first is associated with ventricular systole and corresponds in time with the QRS complex of the electrocardiogram. The systolic wave is then followed by the third component, which also shows a decrease in impedance but occurs in diastole. In instances of arrhythmias the deflection associated with the P wave occurs independently of the other two deflections.

The impedance change waveform is similar to the pattern of blood flow in the venae cavae and the pulmonary veins. It is possible that the impedance changes are related to the flow of blood in these venous circuits and the heart.

BIBLIOGRAPHY

1. Nyboer, J. Electrical Impedance Plethysmography. Springfield, 1959. Charles C. Thomas Publisher.
2. Kubicek, W.G., Karnegis, J.N., Patterson, R.P., Witsoe, D.A., and Mattson, R.H. Development and Evaluation of an Impedance Cardiac Output System. Aerospace Medicine, 37:1208, 1966.
3. Guntheroth, W.G., Morgan, B.C., and Mullins, G.L. Effect of Heart Beat and Respiration on Flow Patterns in the Cavae, Pulmonary Artery, Pulmonary Vein, and Aorta in Intact Dogs. Science, 150:373, 1965.
4. Wexler, L., Gergel, D.H., Gabe, I.T., Markin, G.S., and Mills, C.J. Velocity of Blood Flow in Normal Human Venae Cavae. Circulation Research, 23:349, 1968.
5. Morgan, B.C., Dillard, D.H., and Guntheroth, W.G. Effect of Cardiac and Respiratory Cycles on Pulmonary Vein Flow, Pressure and Diameter. Journal of Applied Physiology, 21:1276, 1966.

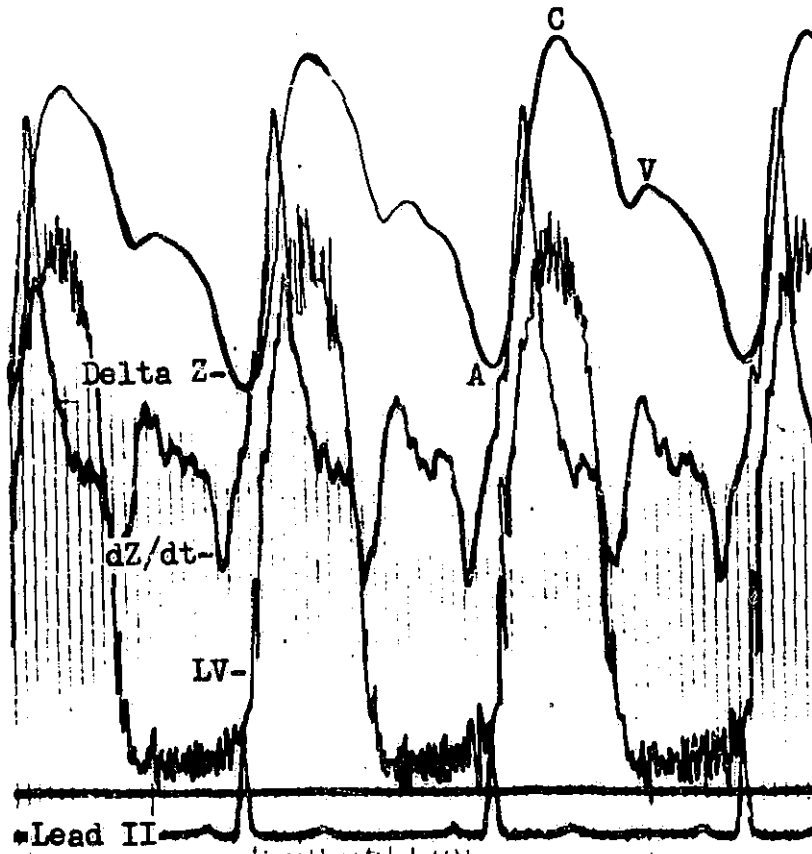

Figure 1 A recording from a patient without cardiac disease. From the top to the bottom, the tracings show the thoracic impedance change waveform, ( $\Delta Z$ ), its first derivative, ( $dZ/dt$ ), the left ventricular pressure, (LV), and lead two of the electrocardiogram. Decreasing impedance is upward. The major impedance deflections of the  $\Delta Z$  tracings are marked "A", "C", and "V". The time lines indicate 0.04 seconds.



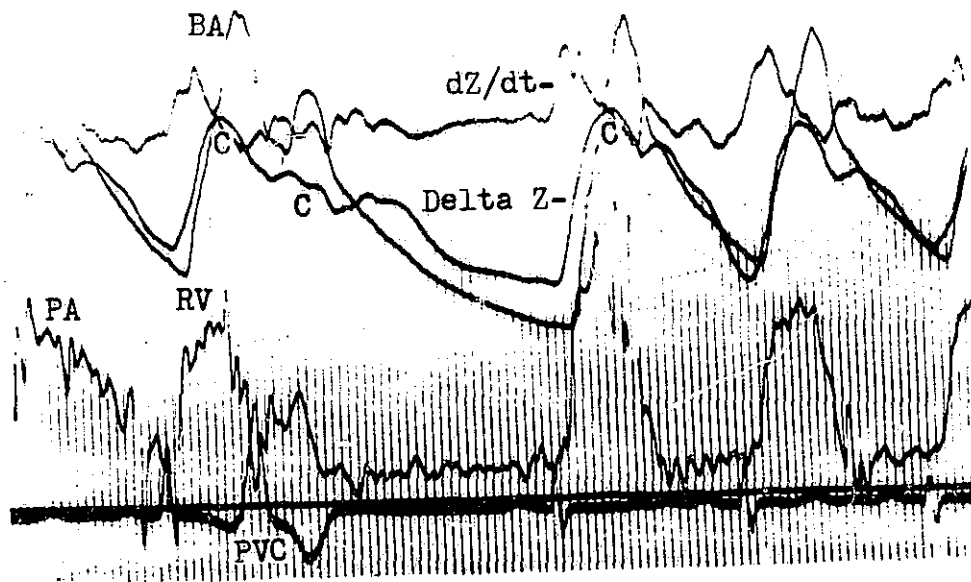

Figure 2 From the top to the bottom the tracings show the brachial arterial pressure, (BA), the first derivative of the impedance change, ( $dZ/dt$ ), the impedance change recording, ( $\Delta Z$ ), a pullback pressure from the pulmonary artery, (PA), to the right ventricle, (RV), and lead two of the electrocardiogram. The normal sinus rhythm was interrupted by a premature ventricular contraction, (PVC). See text.

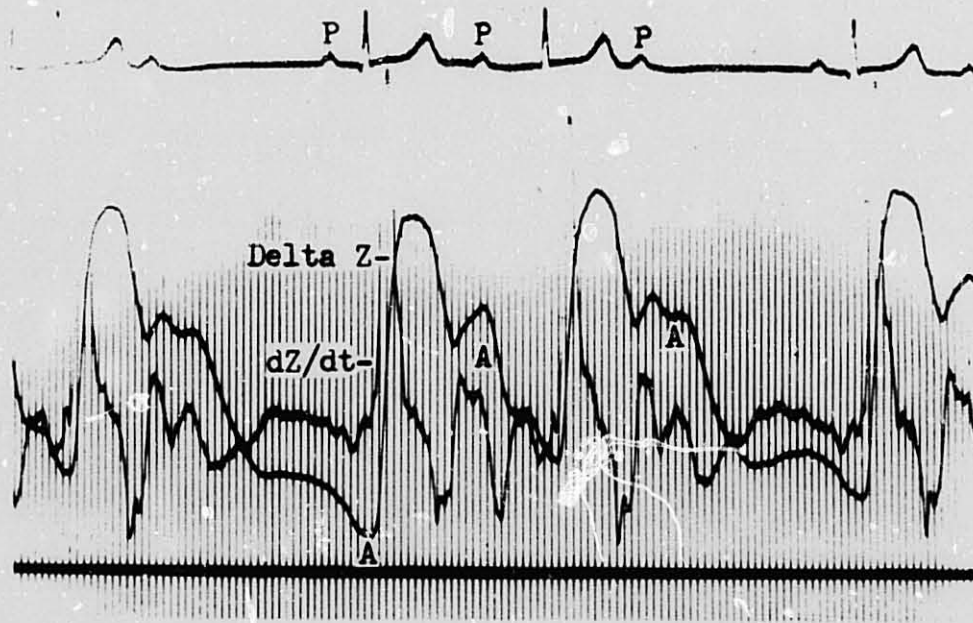

Figure 3 A recording to show the effect of the Wenckebach type of second degree atrioventricular block. The abbreviations are the same as in Figure 1. The A waves of the delta Z tracing are associated with the P waves of the electrocardiogram.

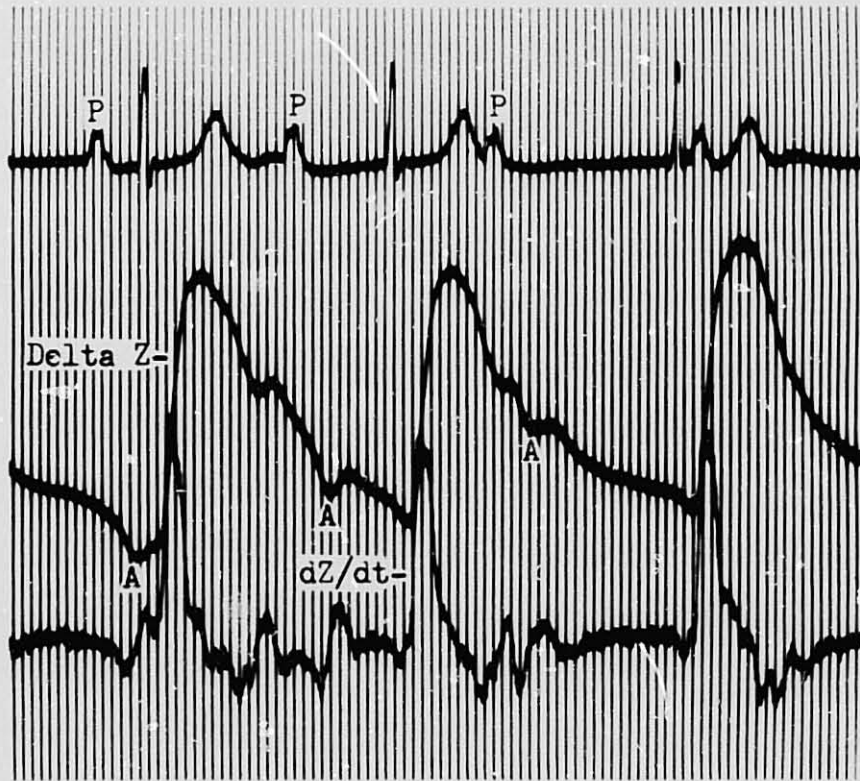

Figure 4 A recording to show complete atrioventricular block. The abbreviations are the same as in Figure 1

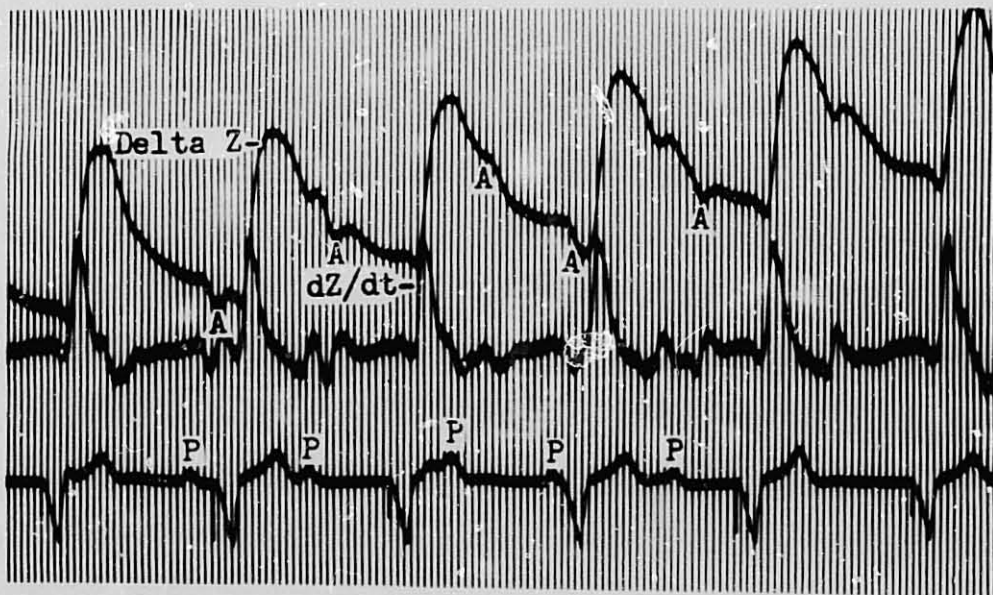

Figure 5 A recording from the same patient shown in Figure 4, who now has an artificial pacemaker.

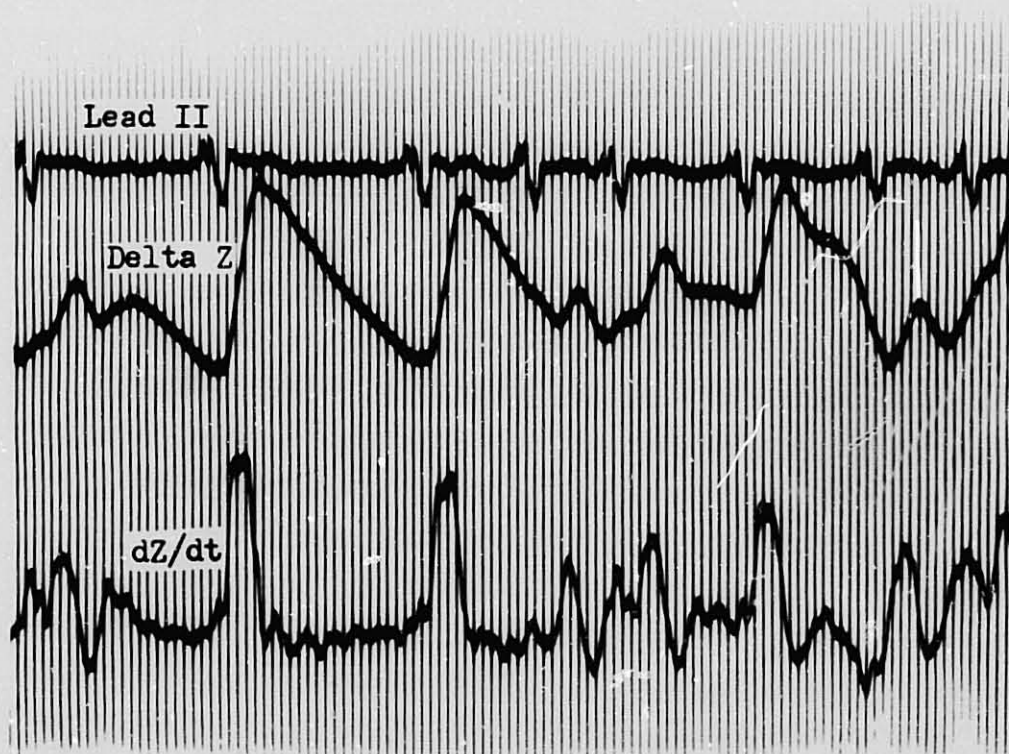

Figure 6 A recording to show atrial fibrillation. The abbreviations are the same as in Figure 1. The P waves of the electrocardiogram and the A waves of the delta Z tracing are absent.

COMPARISON OF METHODS FOR CALCULATING  
STROKE VOLUME FROM AORTIC PRESSURE  
AND IMPEDANCE CARDIOGRAPH

W. Sanford Topham, Ph.D., Homer R. Warner, M.D., Ph.D.  
Department of Biophysics and Bioengineering  
University of Utah  
Salt Lake City, Utah

N70-10011

Located at the Latter-Day Saints Hospital in Salt Lake City is a large computer facility which is being used for on-line, real-time monitoring of patients. One of the main programs which is used in the patient monitoring is a program which calculates stroke volume from a central aortic pressure. This method, developed by Warner (1,3), allows beat by beat calculations without the use of some flow measuring device. A small catheter is inserted through the radial artery to the level of the aortic arch to obtain the central pressure.

Because it is desired to be able to calculate central blood flow using non-invasive methods, the study described in this paper was undertaken to determine the accuracy and feasibility of using the impedance cardiograph for this purpose. Beat by beat comparison is made between stroke volume calculated from the pressure pulse method which has been previously verified (3,4) and stroke volume calculated by the impedance cardiograph.

The first experiment was done in a dog. The dog was anesthetized and an 18 gauge needle was inserted into the femoral artery. A small catheter was then inserted through the needle to the level of the aortic arch. To get variation in cardiac output levophed was injected intravenously. The dog was on a respirator and his breathing was maintained in expiration when the measurements were taken.

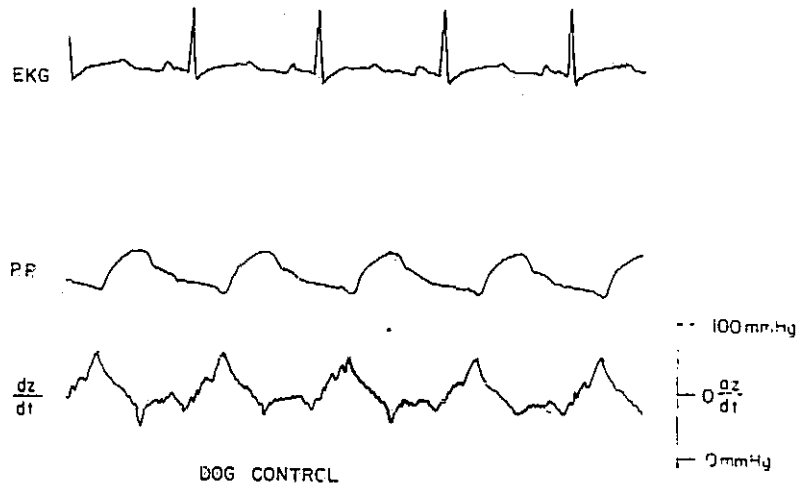

1-A

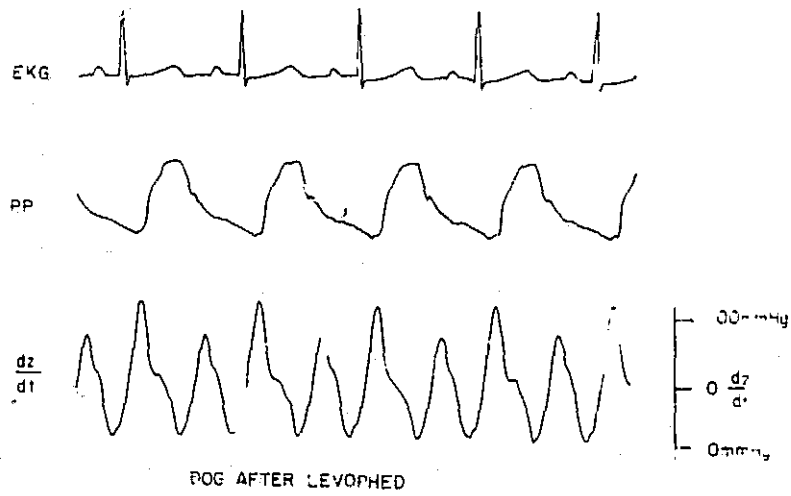

1-B

Figure 1 - EKG, Aortic Pressure and  $\frac{dz}{dt}$  obtained from a dog during control (A) and after the injection of levophed (B) breath held in expiration.

Figure 1-A shows the waveforms, EKG, aortic pressure, and dz/dt, that were recorded during the experiment. This is control with a peak systolic pressure of 140 mm Hg, diastolic pressure of 110 mm Hg and a heart rate of 120. The calibration and zero dz/dt are shown on the right-hand side of the figure. Figure 1-B shows the change in these waveforms after the injection of levophed. The systolic pressure increased to 240 mm Hg, the diastolic pressure to 173 mm Hg and the heart rate to 136. Notice that after the injection of levophed a very high second hump occurs in the impedance waveform during diastole. This was always prominent when levophed was given and the value of this peak was sometimes greater than the peak which occurred during systole. No explanation is evident for this change in waveform unless it is associated with atrial ejection.

To calculate beat by beat stroke volume from pressure and dz/dt, the EKG was used as a trigger and between two consecutive QRS complexes which were recognized by the computer, the data was stored. A pattern recognition was done on the pressure pulse to find the onset of systole and the dicrotic notch. From these reference points stroke volume was calculated. During the same period of time the peak dz/dt was obtained as well as the systolic period and stroke volume was calculated using the following equation:

$$SV = K \frac{L^2 T}{Z_o^2} (dz/dt)_{min}$$

Where,

- K was initially adjusted to obtain a stroke volume equal to that obtained from the pressure pulse,
- L is the distance between the two inner electrodes,
- Z<sub>o</sub> is the impedance between the two electrodes,
- T is systolic period and
- (dz/dt)<sub>min</sub> is the peak value which occurs during systole.

Eight beat by beat values were calculated at one time after which an average of the values was displayed back to the operator and the beat by beat values were stored on magnetic disc for further analysis.

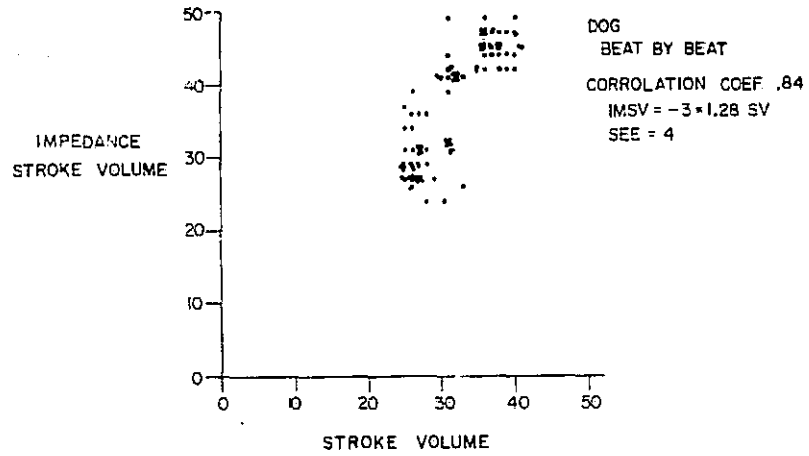

2-A

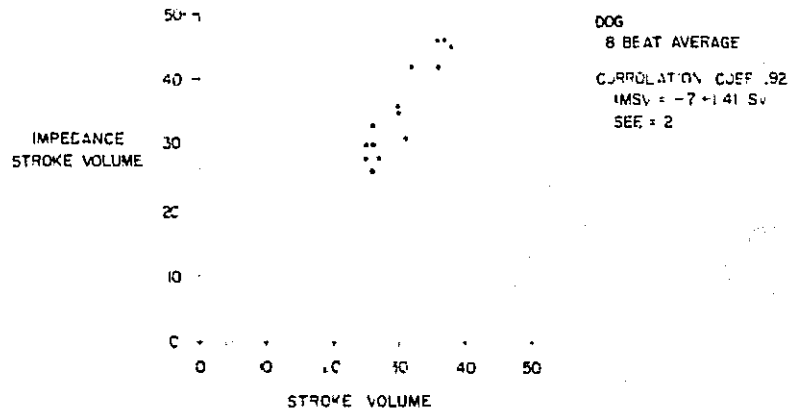

2-B

Figure 2 - Impedance Stroke Volume plotted against Stroke Volume calculated from aortic pressure pulse obtained from a dog (A) beat by beat values (B) eight beat averaged.



Figure 2-A shows the result of the beat by beat values calculated from the dog. The ordinate is impedance stroke volume; the abscissa is stroke volume calculated by the pressure pulse methods. These are actual stroke volumes. Both methods were calibrated using a dye curve. The correlation coefficient is .84 and a linear regression line can be drawn with an intercept of -3 and a slope of 1.28. The standard error of the estimate is 4 ml. Figure 2-B shows the values of eight beat averages from the data shown in Figure 2-A. This improves the correlation coefficient to .92 and reduces the standard error of the estimate to 2 ml with a slight change in the linear regression line equation. With the slope of the linear regression line equation greater than 1 the impedance stroke volume is overpredicting the pressure pulse stroke volume in both cases.

Next normal human subjects were used. In these subjects an 18 gauge needle was inserted into the radial artery. Through this needle a small catheter was inserted to the level of the aortic arch for obtaining central pressure measurement. With the patient in the supine position, an exercycle was wheeled to the foot of the bed and after a control measurement, he exercised vigorously for a period of 2 to 3 minutes and measurements were made of the increased cardiac output.

Figure 3-A shows the control waveforms, EKG, pressure pulse and  $dz/dt$  of the first normal subject. The mean pressure was 86 and he had a heart rate of 55. Figure 3-B shows the change in these waveforms after exercise. The diastolic pressure increased to 102 with a peak systolic pressure of 144 and a heart rate of 104. In both cases the subject was holding his breath when the measurements were made. However in Figure 3-B the change in the impedance waveform can be observed when the breath is released. Notice what appears to be two extra systoles in the impedance waveform although the EKG and pressure indicate that no contraction occurred. This type of artefact along with the drift of 0  $dz/dt$

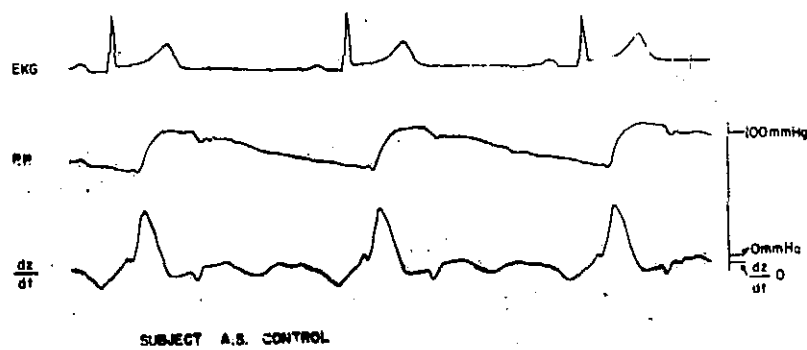

3-A

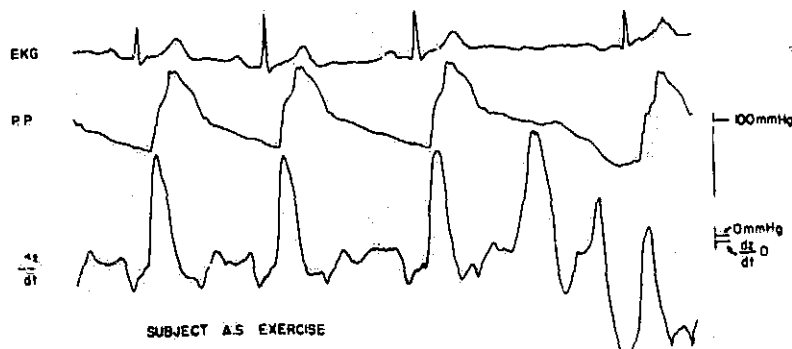

3-B

Figure 3 - Waveforms obtained from normal subject A.S. (A) control, breath held (B) after exercise, breath held for first three heart beats then released.

make automatic computer recognition almost impossible. If readings were taken while the subject was breathing, poor results were obtained. The beat by beat results obtained from this particular subject are shown in Figure 4-A. These are not calibrated values as it was assumed that at rest the subject had a cardiac output of 5 liters and the stroke volume calculated by both methods was adjusted accordingly. The correlation is .67. Impedance stroke volume overpredicts the pressure pulse stroke volume and the standard error of the estimate is 16.

Figure 4-B shows a plot of the average values of eight beats. The correlation coefficient increases to .84 and the regression line equation changes slightly with the standard error of the estimate reduced. The data in this figure was obtained using the pressure pulse systolic period. It was found that a better correlation could be obtained by using the systolic period determined from the pressure pulse pattern recognition because it was more accurate than that determined from the impedance cardiograph.

From a second normal subject the beat by beat correlation is .63 (see Figure 5). But contrary to the values obtained in the preceding data both in the dog and in the first normal subject, the impedance stroke volume seems to underpredict the stroke volume calculated by the pressure pulse method. The average values again increase the correlation to .76. Table 1 shows a summary of the correlations obtained from the dog and two normal subjects.

TABLE I  
Summary of Correlations Obtained

<u>Subject</u>	<u>Comment</u>	<u>Correlation</u>
dog	Beat by Beat	.84
dog	8 Beat Average	.92
A.S.	Beat by Beat using Impedance Systolic Period	.53
A.S.	Beat by Beat using Pressure Systolic Period	.67
A.S.	8 Beat Average	.84
J.G.	Beat by Beat	.63
J.G.	8 Beat Average	.76
J.G.	Beat by Beat Later in Experiment	.51

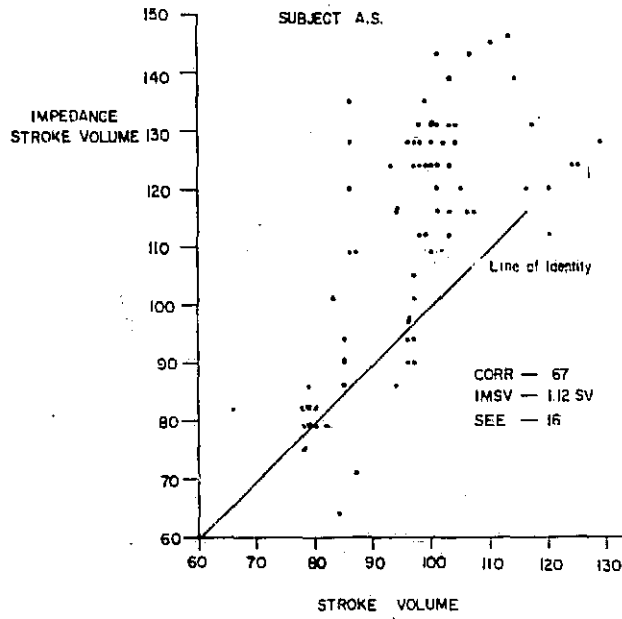

4-A

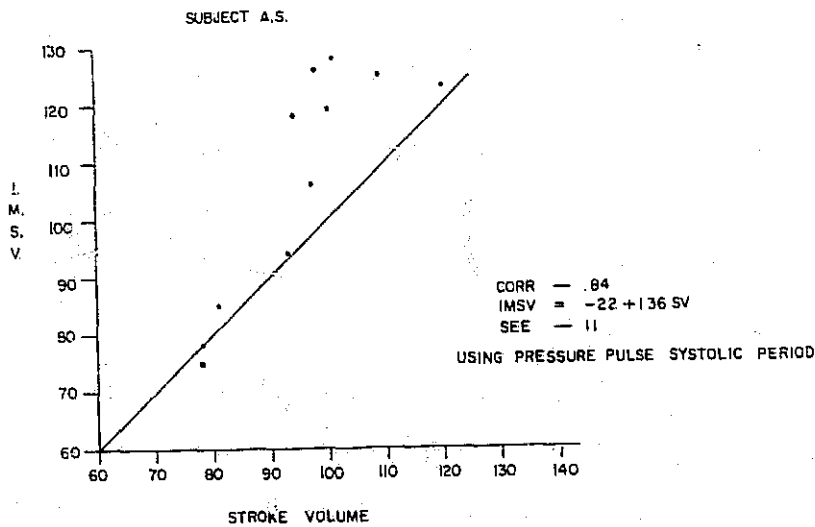

4-B

Figure 4 -- Impedance stroke volume versus pressure pulse stroke volume in normal human subject A.S. Line of identity shown (A) beat by beat (B) eight beat average.

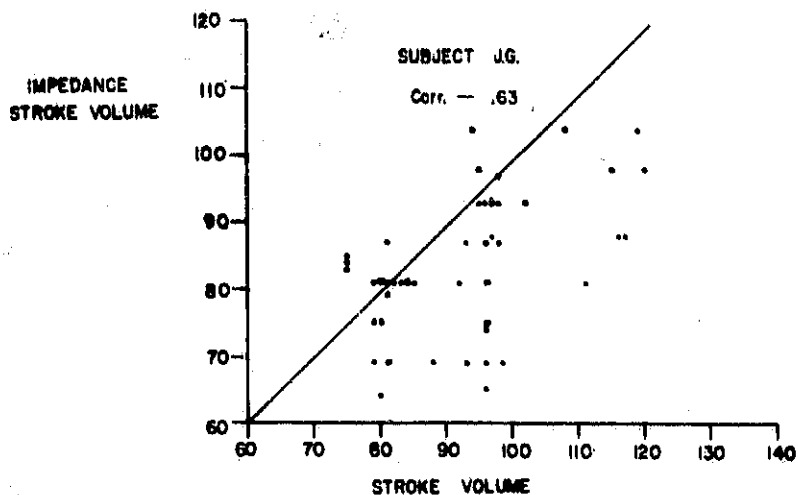

5-A

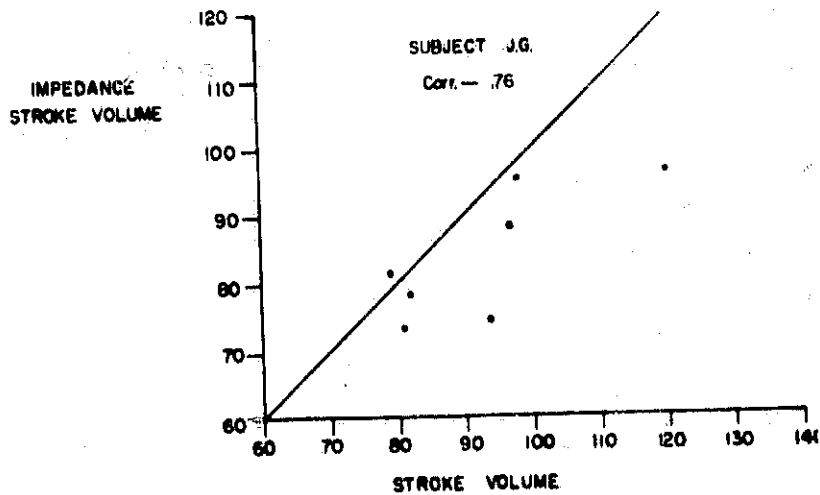

5-B

Figure 5 - Impedance stroke volume versus pressure pulse stroke volume. Normal subject J.G. line of identity shown (A) beat by beat (B) eight beat average.

From this table the following can be concluded: The correlations obtained from the dog are much better than those from the normal subjects. This perhaps agrees with the high correlations obtained between flowmeter measurements and the impedance cardiograph reported earlier (5). Computer calculation of the period of systole from the  $dz/dt$  waveform was difficult and much better correlations were obtained when a more accurate determination was made using the pressure pulse. The correlation changed through the experiment on the last subject because of a sudden change in  $dz/dt$  amplitude. The cause of this change could not be determined.

In summary, the main difficulty with using the computer to do this type of pattern recognition is that it is very hard, if not impossible, to determine when the impedance waveform changes due to respiration. With the inconvenience of making the subject hold his breath to make the measurements and because the correlation under these ideal situations are in the order of .65, it seems impractical that beat by beat calculations could be made in a patient monitoring situations using this non-invasive method of calculating stroke volume.

#### REFERENCES

1. H.R. Warner, etc; Quantitation of Beat-to-Beat Changes in Stroke Volume From the Aortic Pulse Contour in Man, Journal of Applied Physiology, 5: 495-507, March, 1953.
2. H.R. Warner, The Role of Computers in Medical Research; JAMA 196: 944-949, June 1966.
3. H.R. Warner, Experiences with Computer-Based Patient Monitoring: Anesthesia and Analgesia, 47: 453-462, Sept.-Oct., 1968.
4. H.R. Warner, R.M. Gardner, A.F. Toronto: Computer-Based Monitoring of Cardiovascular Functions in Post-operative Patients, Supplement II to Circulation, Vol. 37 and 38, pp II-68--II-74, April, 1968.
5. W.G. Kubicek, Development and Evaluation of an Impedance Cardiographic System to Measure Cardiac Output, Chapt. I, Sect. III, pp 34-42, July 1967, Report to NASA.

N70-10012

THE DEVELOPMENT OF A TRANSFER FUNCTION BETWEEN  
AORTIC BLOOD FLOW AND THE FIRST DERIVATIVE OF  
THE THORACIC IMPEDANCE

\* \* \* \* \*

by

Robert P. Patterson, MSEE.  
David A. Witsoe, MSEE.  
A.H.L. From, M.D.  
W. G. Kubicek, Ph.D.

Department of Physical Medicine & Rehabilitation  
University of Minnesota Medical Center  
Minneapolis, Minnesota 55455



Recent studies have been performed (1) to determine the usefulness of the thoracic electrical impedance measurements in determining cardiac stroke volume or cardiac output. These studies have shown that under some conditions the agreement between the impedance technique and the other standard techniques of measuring cardiac output such as the direct Fick or the dye dilution techniques have been reasonable, while under other conditions the two techniques have divergent results. It is the purpose of this paper to explain the development of a new technique used in calculating stroke volume from thoracic impedance measurement.

The technique used in this study involves finding the transfer function between aortic blood flow and the first derivative of the thoracic impedance signal. If a reasonably consistent transfer function can be found in dog or man for different functional states of the circulatory system it is possible to synthesize the transfer function with an electrical analog network if the system is linear time invariant. This would result, then, in an electrical network in which the input signal would be the first derivative of the thoracic impedance and the output would be a signal similar in contour to the aortic blood flow waveform. The area under this derived waveform during systole would then be proportional to left ventricular stroke volume.

#### Methods

Figure 1 shows one model of the system that we are attempting to analyze. Represented is a block diagram of the cardiovascular system showing the conversion of the cardiovascular

mechanical activity into an electrical impedance signal.

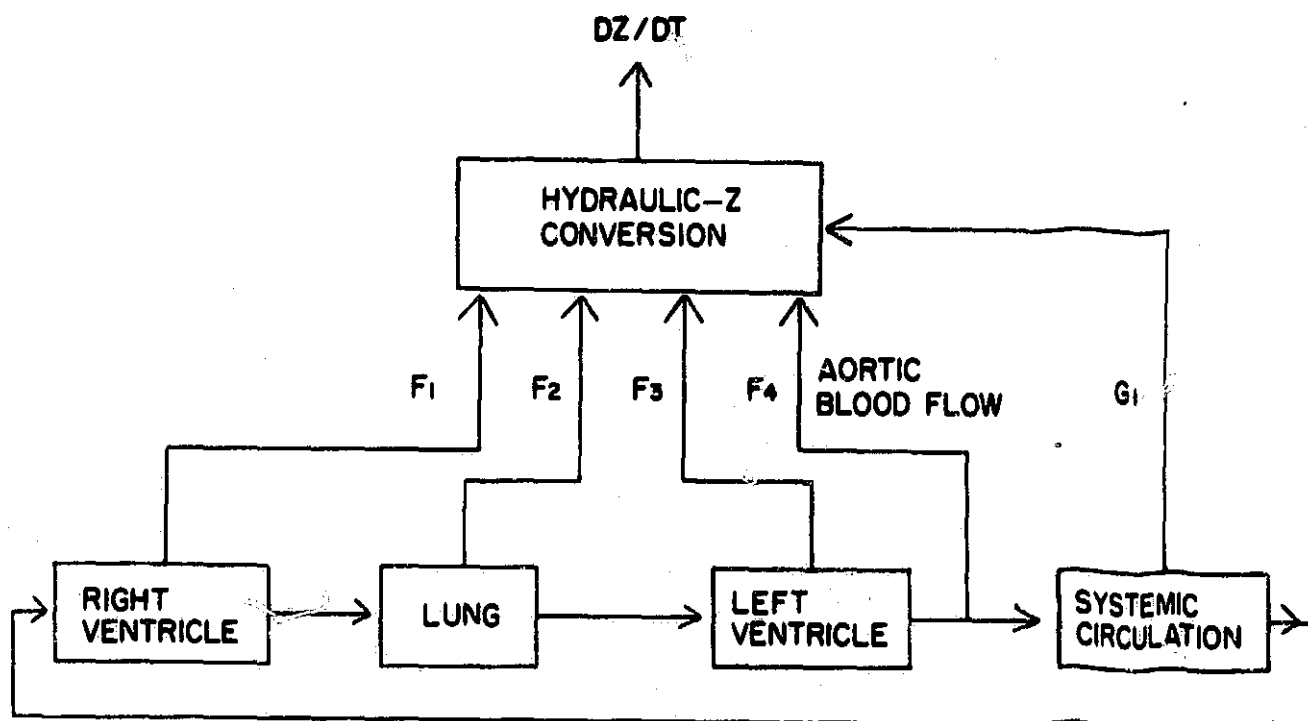

Figure 1 Model of circulatory system showing hydraulic-Z conversion

The lower half of the figure shows a diagram of the circulation with inputs into a block labeled hydraulic-Z convertor. As can be seen in the figure, signals from the right ventricle, lungs, left ventricle and systemic circulation feed into the hydraulic-Z convertor with its output as the first derivative of the electrical impedance signal. Since at the present time the exact origin of the impedance signal is not known, inputs from the various regions in the thorax are shown. In reality they may or may not be present but initially all possible inputs were considered.

In the analysis that was performed the transfer function was developed between the aortic blood flow and the output of the hydraulic-Z convertor which is the first derivative of the thoracic electrical impedance signal. The effects of the other inputs into the system would make the system nonlinear as far as the relationship between aortic blood flow and the impedance derivative signal. In order to make the transfer function valid and useful, for the purpose of this study it must be assumed that the other signals into the hydraulic-Z convertor are small or nonexistent. In the frequency analysis performed to determine the transfer function, the derivative signal was set equal to zero during diastole, thereby reducing the requirement for the other signals to be zero during diastole. This was felt to be reasonable because the systolic signal is of most importance in trying to quantitate the system for stroke volume.

Mongrel dogs were anesthetized with sodium pentobarbital (25 mg/kg), intubated, and placed on a positive pressure respirator. A left thoracotomy was performed and an appropriate electromagnetic flow transducer (Biotronex model 410) was placed around the ascending aorta. While the chest was open, a catheter for pressure measurements was positioned. The thoracotomy was then closed and air evacuated by continuous suction. The four electrode bands for impedance measurements were placed on the neck and lower thorax in the standard positions (2). The following parameters were recorded on magnetic tape: ECG, ascending aortic flow, ascending aortic pressure, thoracic impedance change,  $\Delta Z$ , and first time derivative of thoracic impedance,  $dZ/dt$ .

During the course of the experiment all parameters were monitored on a large screen oscilloscope. A total of three dogs were used in the experiment. All measurements were taken during periods of end-expiration apnea to eliminate respiration artifact from the impedance signals.

To obtain an increase in peripheral resistance with a minimal effect on contractility, methoxamine was infused at a constant rate by a Harvard Apparatus infusion pump. The levels of methoxamine infusion depended primarily upon the response of the particular animal as measured by the ascending aortic blood pressure. Infusion rates ranged from .25 mg/min to 1.0 mg/min.

Decreased peripheral resistance, increased contractility and increased heart rate were produced by infusion of isoproterenol at constant rates over several levels ranging from 0.25 micrograms to as high as 10 micrograms. Again the response of the individual dog controlled the infusion rate.

Two levels of bradykinin were infused at a constant rate of 25 and 50 micrograms per minute in an effort to decrease peripheral resistance without changing contractility.

The transfer function was developed by taking the Fourier series of both the impedance derivative signal with the diastolic portion set equal to zero and the aortic flow signal and dividing the magnitude of the frequency components of the impedance derivative signal into the aortic flow signal, harmonic by harmonic, and subtracting the phases of the derivative signal from the phases of the aortic flow signal. The Fourier Series was computed for 20 harmonics. All of the Fourier analysis was done on a Spear microLINC 300 digital computer. Both waveforms were sampled almost

simultaneously at a rate of 250 samples per second. The Fourier series for each of the waveforms was then determined and the division as explained above was done by the digital computer. The output from the computer was in both graphic and printed form.

An electrical network was then developed that approximated the transfer function. The impedance derivative signal was connected as the input and resultant output was the transformed impedance derivative.

The transformed impedance signal had a shape similar to the arterial blood flow waveform except during diastole. The diastolic portion of the waveform was not flat as is true of the ascending aortic blood flow waveform, therefore creating a problem in determining zero flow. In this study the early portion of diastole was assumed to represent zero flow on the transformed impedance waveform. The position of the assumed zero flow is shown in Figures 8 and 9. The cardiac stroke volume was computed by electrically integrating the flow meter signal during systole. The transformed impedance was integrated during systole using planimetry to determine stroke volume.

### Results

Figures 2, 3 and 4 show the transfer function between aortic flow and the first derivative of the thoracic impedance for one dog under three different conditions, control, isuprel, and methoxamine. On the left side of each of the figures are shown the two waveforms used in developing the transfer function. On the right is a plot of the transfer function. The magnitude is

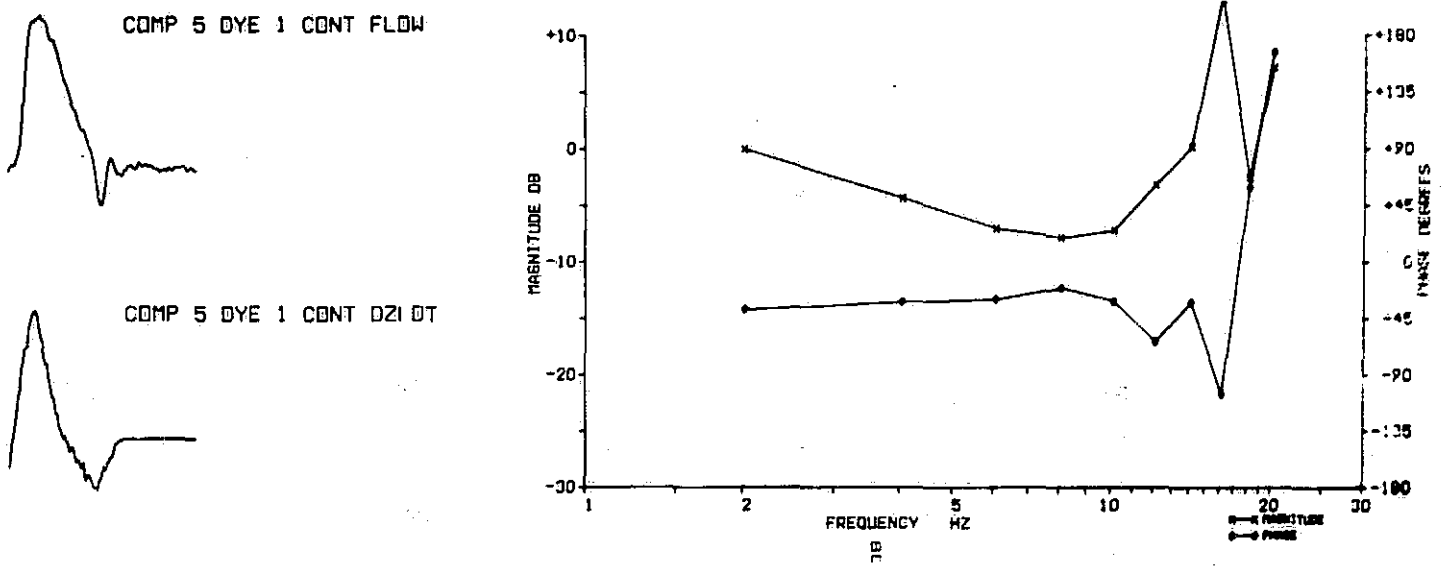

Figure 2 Transfer function between aortic flow and  $dZ/dt$  for control state

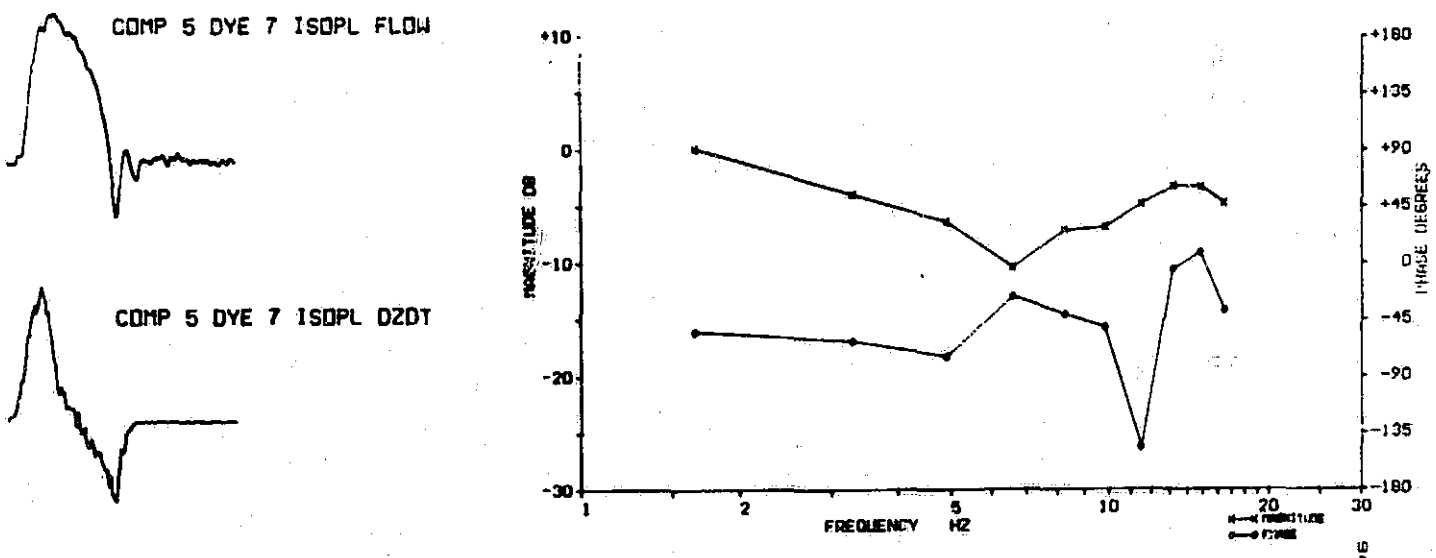

Figure 3 Transfer function between aortic blood flow and  $dZ/dt$  for isuprel infusion

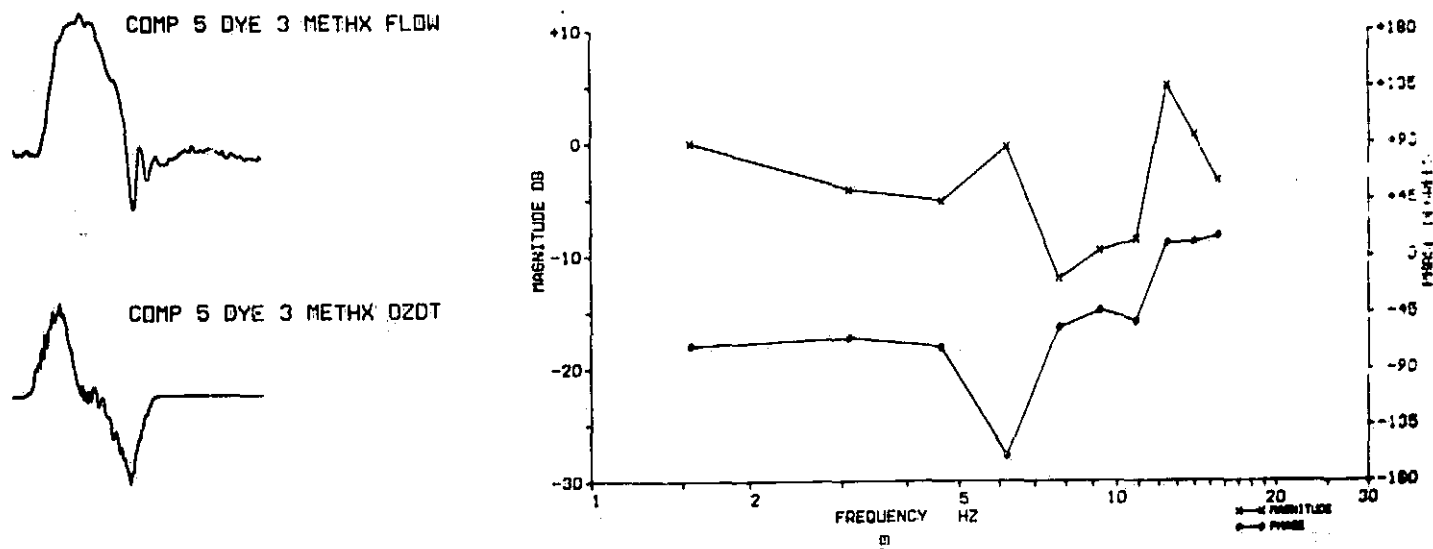

Figure 4 Transfer function between aortic blood flow and  $dZ/dt$  for methoxamine infusion

shown on the ordinate in DB and the log of the frequency is plotted on the abscissa. Figures 5 and 6 show the transfer function for another dog for the control state and with an infusion of methoxamine. The magnitude characteristics of the transfer function all have similar properties. They have a minimum between 5 and 10 cycles per second. They start out from the fundamental frequency and decrease until they reach the minimum and rise from the minimum usually at a faster rate than the initial decrease. All of the phase characteristics for the transfer function start at a negative value and show a slight increase in value with frequency, although there is more variation in the phase characteristics between the different drug conditions. The reliability of the information beyond 10 or 15 cycles per second is probably poor because of the noise present in the signal.

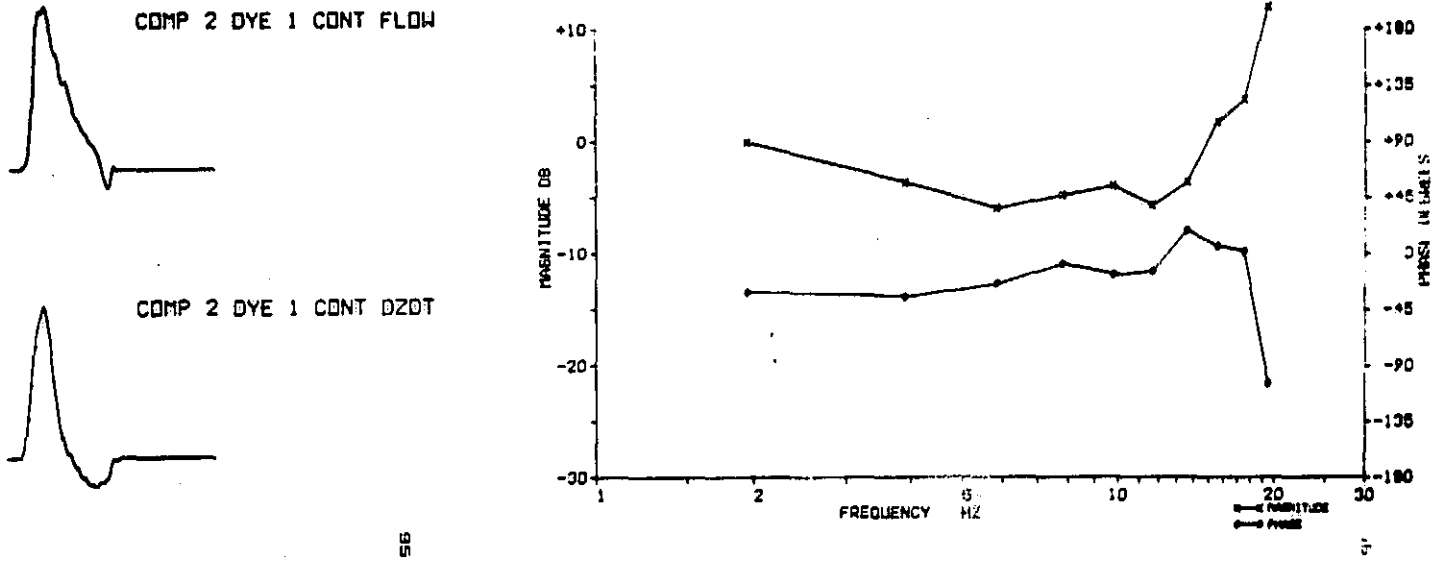

Figure 5 Transfer function between aortic blood flow and  $dZ/dt$  for control state

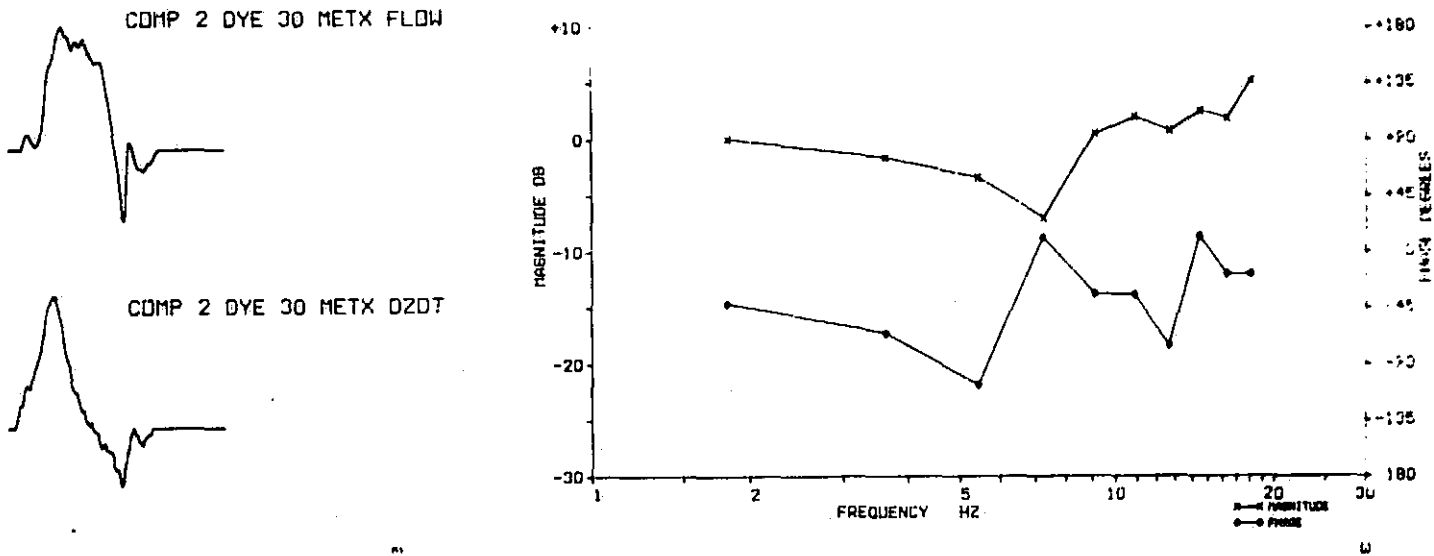

Figure 6 Transfer function between aortic blood flow and  $dZ/dt$  for methoxamine infusion



An electrical network was synthesized to approximate the transfer characteristics shown in Figures 2 through 6. It had a real axis pole adjustable between .1 and 1 Hz, a real axis zero adjustable between 4, 5 and 6 Hz and a fixed real axis zero at 10 Hz and also one real pole at 40 Hz and one at 160 Hz. The first pole adjustable between .1 and 1 Hz, allowed a slight change in the slope of the early descent in the magnitude function (1.5 Hz to 4 Hz). The zero adjustable at 4, 5 or 6 Hz allowed a change in the position of the minimum of the transfer function. A fixed zero at 10 Hz approximated the rise as seen in the transfer functions at approximately 10 Hz.

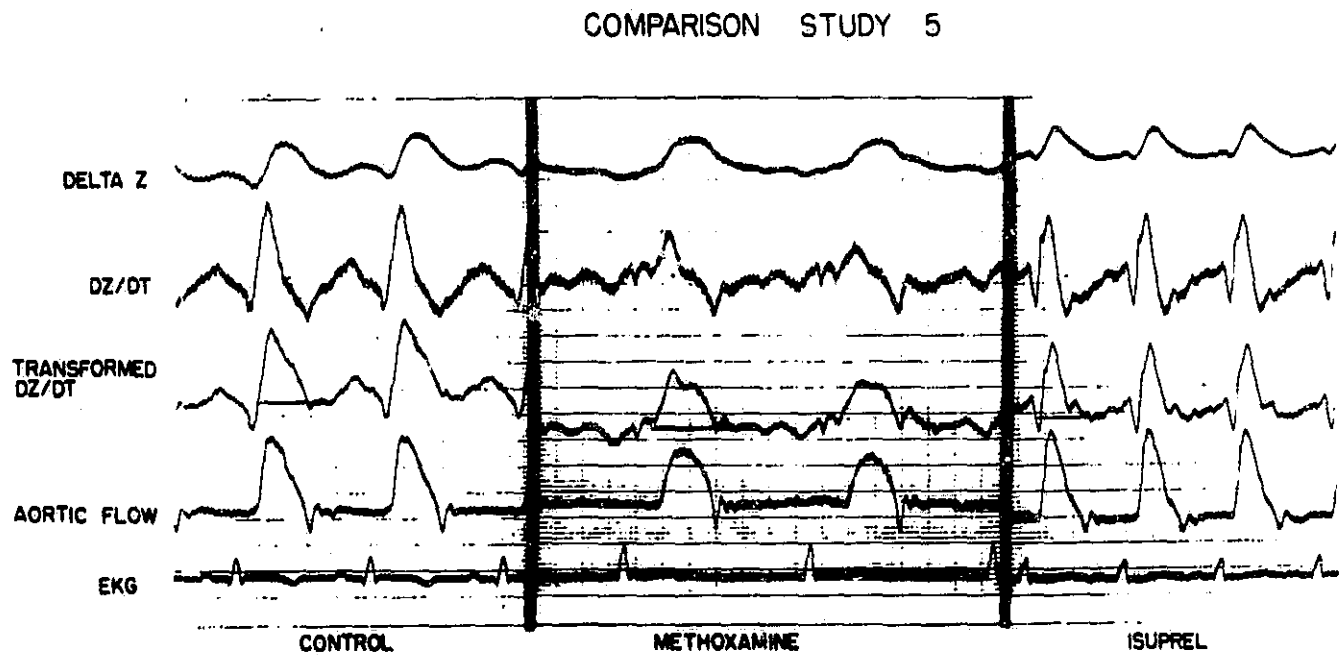

Figure 7 The resultant transformed impedance derivative signal under different drug conditions.

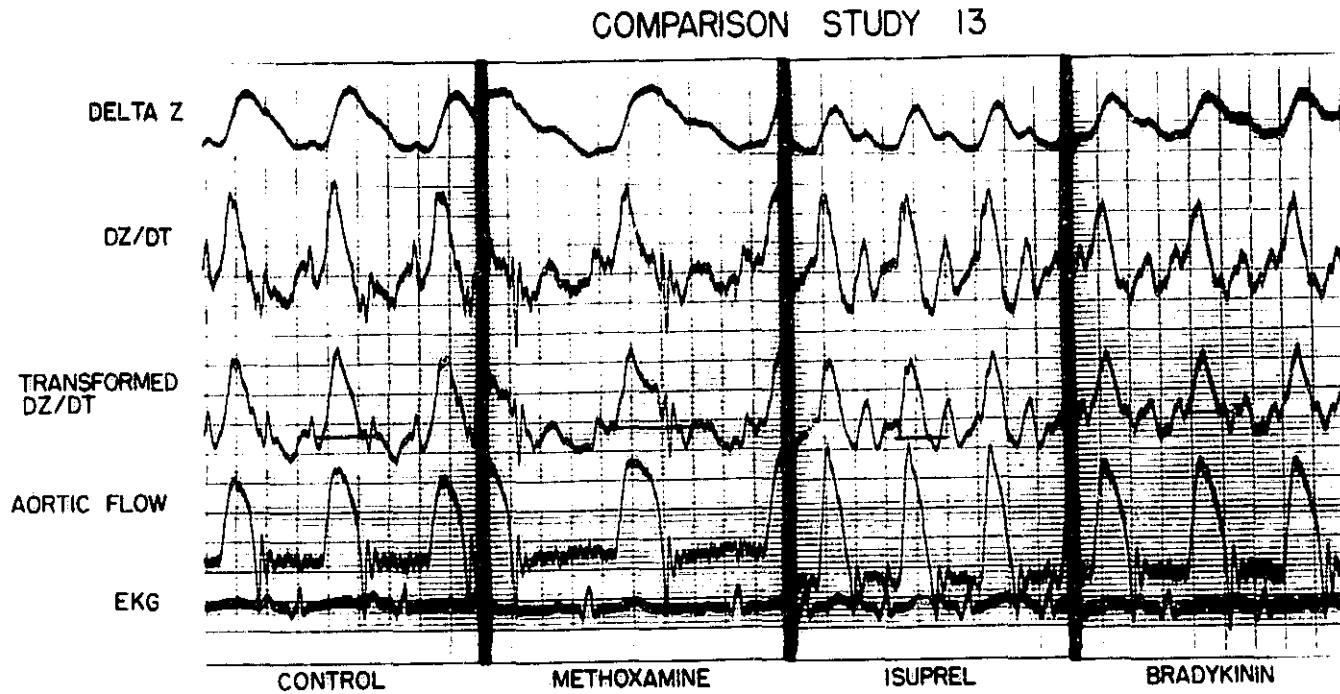

Figure 8 The resultant transformed impedance derivative signal under different drug conditions

Figures 7 and 8 show the resultant transformed impedance derivative signal for two different dogs under different drug conditions as indicated on the figures. The actual transfer function used was chosen by adjusting the low frequency pole between point .1 and 1 Hz and adjusting the zero until the control waveform appeared most like a flow waveform. The transfer function was then kept constant during the remainder of the experiment on a particular dog. Figures 9, 10 and 11 show the normalized stroke volume calculated (from one beat for each of the drug conditions). The stroke volume was calculated using the integrated electromagnetic flowmeter signal, the integrated transformed  $dZ/dt$  signal and using the standard impedance technique (1). Figure 12 shows the normalized stroke volume for the above mentioned variables for 7 consecutive beats on a dog with left mechanical alternans.

Pressure	145	160	111	107	76	106	89
Peripheral Resistance	2925	3339	1896	1785	1308	1896	4057
Cardiac Output	4.0	3.8	4.7	4.8	4.7	4.5	1.8
Pulse Rate	179	126	198	223	240	191	169

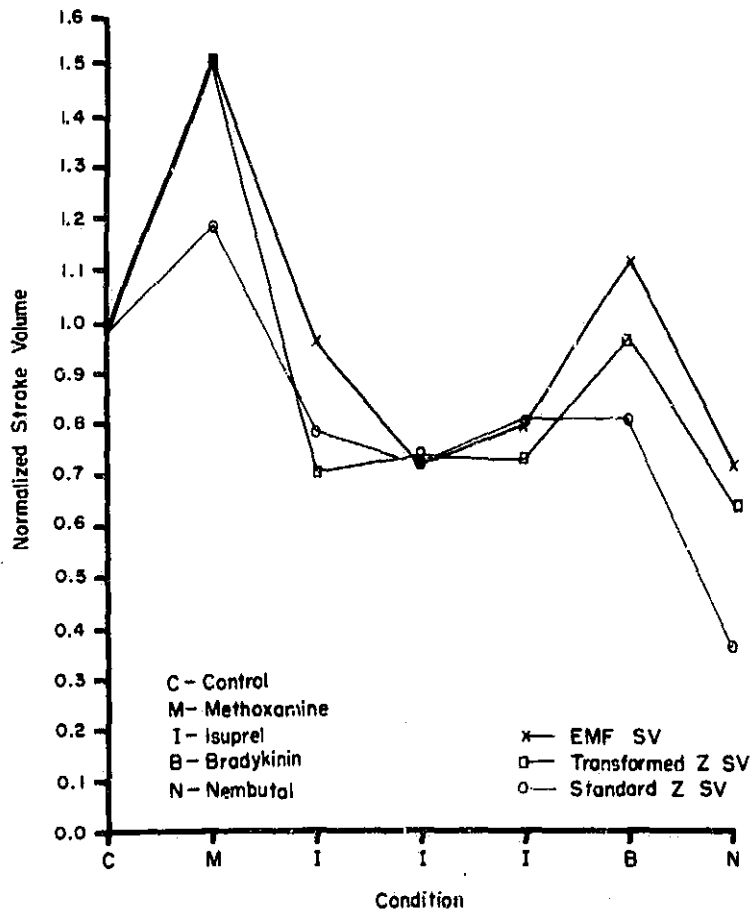

Figure 9 Normalized cardiac stroke volume vs. drug condition for one dog

Pressure	85	55	62	46	44	42	149	151
Peripheral Resistance	2889	2609	2436	1269	1114	579	9592	11100
Cardiac Output	1.8	1.7	2.0	2.9	3.1	5.8	1.2	1.1
Pulse Rate	120	150	147	196	204	211	112	109

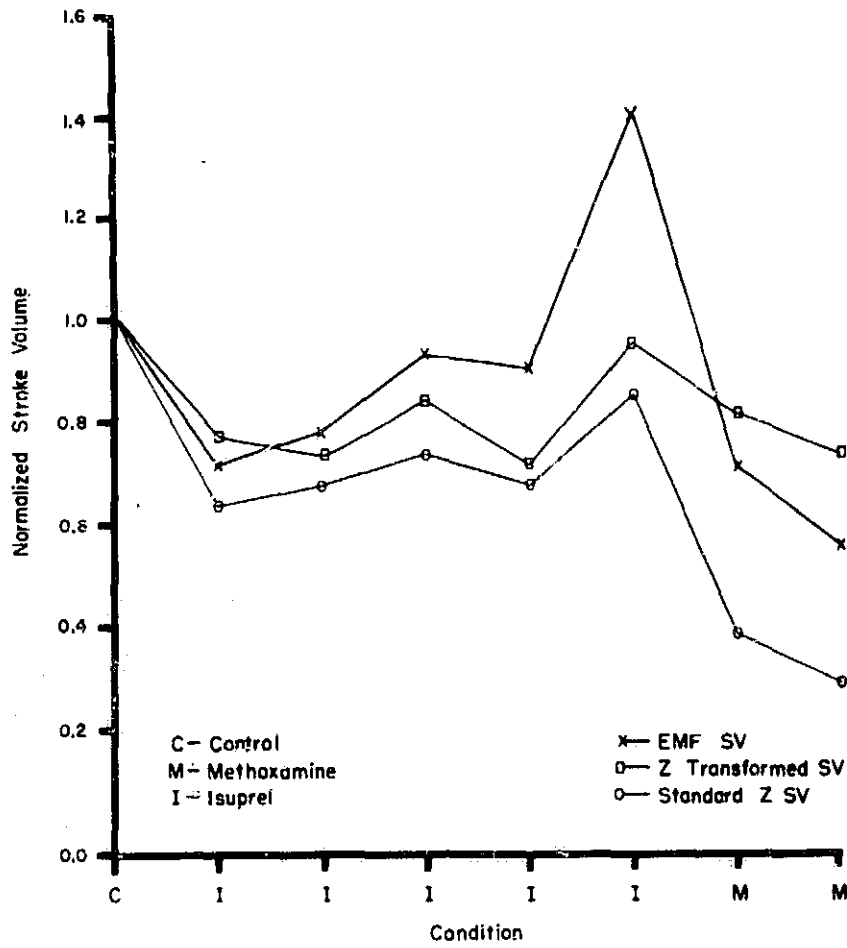

Figure 10 Normalized cardiac stroke volume vs. drug condition for one dog

Pressure	80	139	111	59	61	63	58
Peripheral Resistance	1978	5096	3012	1366	1204	959	856
Cardiac Output	3.2	2.2	3.0	3.5	4.1	5.3	5.5
Pulse Rate	121	90	99	145	174	169	150

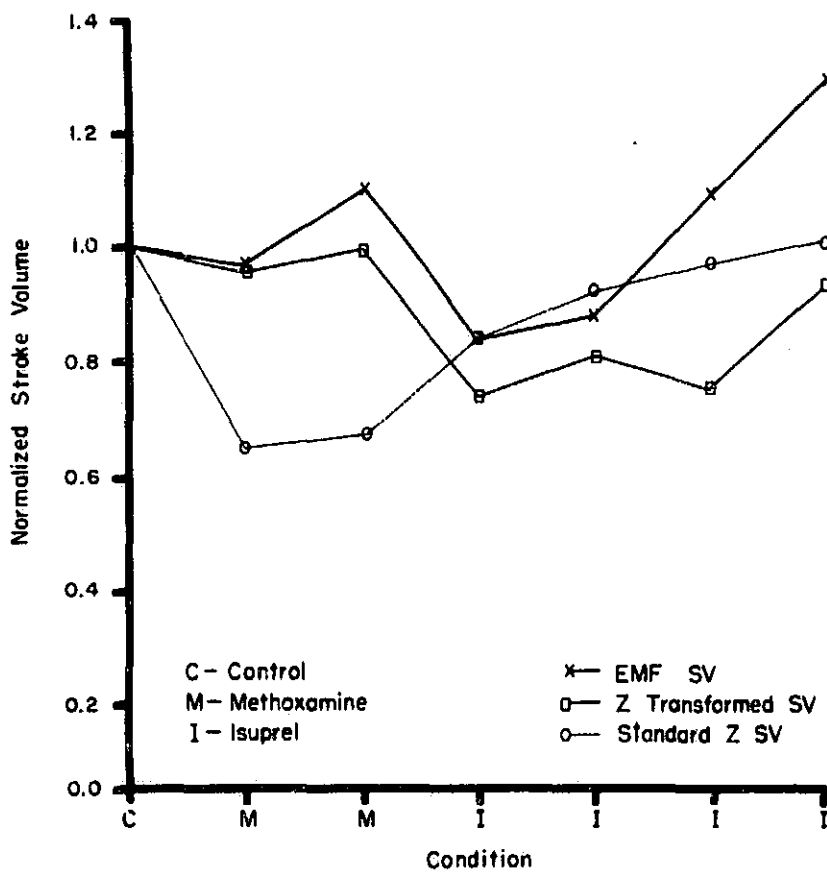

Figure 11 Normalized cardiac stroke volume vs. drug condition for one dog

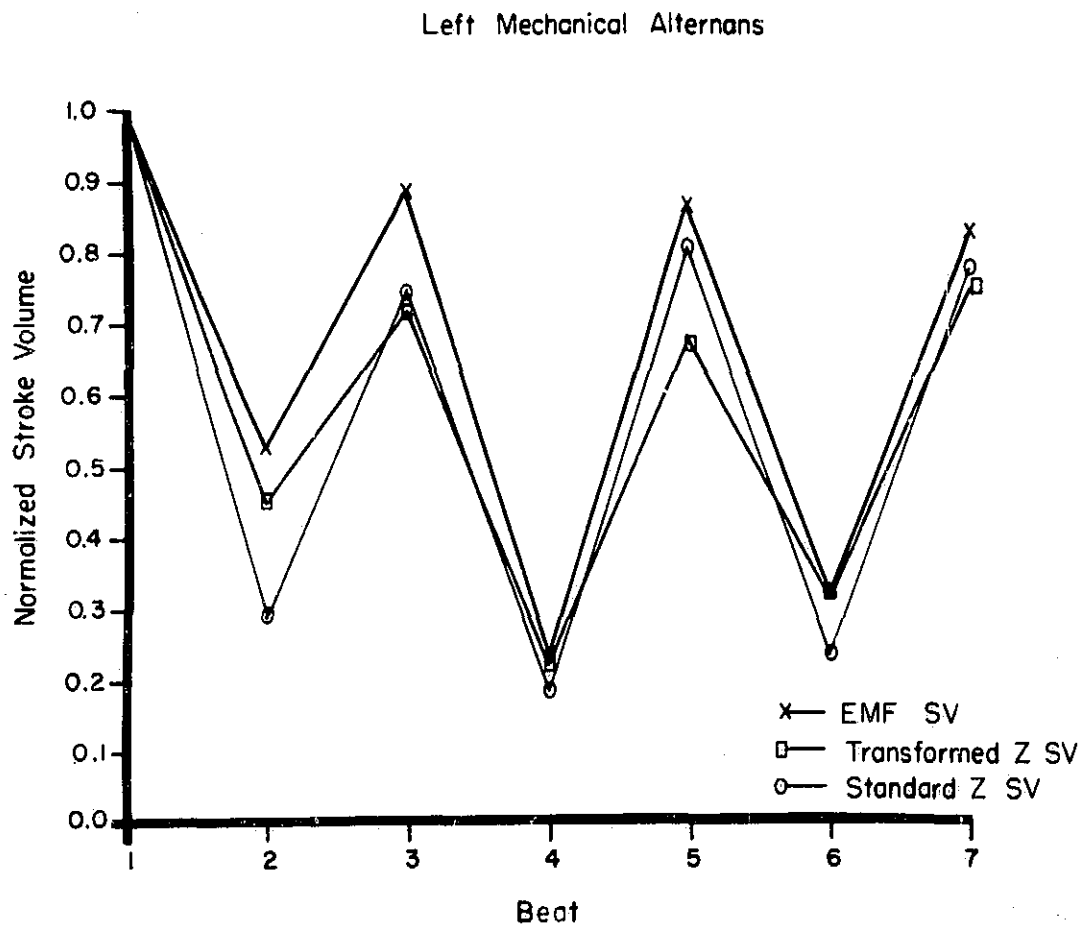

Figure 12 Normalized stroke volume for seven consecutive beats on a dog with mechanical alternans

### Discussion

One of the problems encountered in using the transformed impedance signal is that of determining the position of zero flow. In this study, points in early and in late diastole were used, but the point that gave the most consistent results is the notch in the waveform early in diastole as was shown in Figures 8 and 9.

Initially in this study a model of the system was considered that was nonlinear. In actuality, in performing the transfer function analysis it was of course necessary to assume a linear time invariant system. In this early phase of development the

above assumption was made and the results were evaluated to determine if any reasonable correlation could be made. It will be important in future experiments to explicitly study the effects of the nonlinearities.

The results from this study must be regarded as preliminary since only three dogs were analyzed. The general agreement between the transformed impedance calculated stroke volume and that calculated from the electromagnetic flowmeter was better than that obtained using the standard impedance technique.

The transformed impedance calculated stroke volume showed improvement over the standard impedance calculated stroke volume when compared against the electromagnetic flowmeter because it did not have the wide disagreements for certain circulatory states. This can be seen in Figure 9 for methoxamine and nembutal drug states and in Figure 11 for the methoxamine state.

The results of these studies indicate that the transformed impedance signal may improve the reliability of the thoracic impedance signal in determining relative change in stroke volume. More studies will be needed to evaluate the above hypothesis.

REFERENCES

1. Witsoe, D. A., R. P. Patterson, A.H.L. From, and W. G. Kubicek. Evaluation of impedance cardiographic techniques for measuring relative changes in cardiac output by simultaneous comparison with indicator dilution and electromagnetic flowmeter. (See index)
2. Kubicek, W. G., J. N. Karnegis, R. P. Patterson, D. A. Witsoe, and R. H. Mattson. Development and evaluation of an impedance cardiac output system. Aerospace Med. 37(12):1208-1212, 1966.



EVALUATION OF THORACIC IMPEDANCE PLETHYSMOGRAPHY AS AN  
INDICATOR OF STROKE VOLUME IN MAN

Running Head: Evaluation of Thoracic Impedance Plethysmography

N70-10013

Robert J. Bache, M. D.\*

Alexander Harley, M. B., M. R. C. P.\*\*

Joseph C. Greenfield, Jr., M. D.\*\*\*

From the Department of Medicine (Division of Cardiology)  
Duke University Medical Center and the Veterans Admini-  
stration Hospital, Durham, North Carolina, 27705, 27706

- \* Heart Disease and Stroke Control Officer, U. S. Public Health Service.
- \*\* Present Address: Manchester Royal Infirmary, Manchester 13, England
- \*\*\* Dr. Greenfield is the recipient of a Career Development Award (1-K3-HE-28, 112), from the U. S. P. H. S.

This work supported in part by Grant HE-09711, from the National Heart Institute, U.S.P.H.S. and by a grant from the North Carolina Heart Association.

ABSTRACT

The maximum negative first derivative of the systolic thoracic impedance change and duration of ejection were measured in 8 patients with cardiomegaly while stroke volume was computed continuously using the pressure gradient technique. Wide variations in heart rate and stroke volume were produced by atrial pacing and as pulsus alternans occurred spontaneously. Duration of ejection showed a close curvilinear relationship with stroke volume best expressed as a logarithmic function which was similar for all patients. A linear relationship existed between the maximum impedance derivative and stroke volume which was close in some patients but was poor or varied with heart rate in others. No independent characteristic could be found to predict in which patients the maximum impedance derivative reliably reflected changes in stroke volume. Wide variations in this relationship between individuals prevented its satisfactory description for all patients by any single equation. Computations employing the product of the maximum impedance derivative and duration of ejection did not reliably estimate absolute values for stroke volume and did not improve upon the simple relationship between duration of ejection and stroke volume.

Index Words: Impedance Plethysmography; Electrical Impedance; Blood Flow; Heart Rate; Pacemaker; Pulsus Alternans; Duration of Ejection; Isoproterenol.

It is well known that the impedance offered to passage of high frequency electrical current by limb or body segments of living organisms undergoes rhythmic changes synchronous with cardiac activity. These cyclic changes in tissue impedance appear to result from changes in the volume of blood within the segment under consideration (1) and alterations in the electrical resistivity of blood which occur with changes in blood velocity (2). These impedance changes may be readily measured using external skin electrodes and an appropriate impedance plethysmograph. The resultant waveform, which shows its major deflection simultaneously with cardiac systole, has been used as an indication of phasic blood flow. Although generally used to indicate only relative changes in blood flow, several workers have attempted to calibrate such impedance waveforms in terms of absolute volume blood flow for human extremities (1,3,4).

Recently, Kubicek et al. (5), have designed a system for measuring instantaneous transthoracic electrical impedance using circumferential electrodes around the neck and lower thorax. Because of the need for a nontraumatic method of estimating instantaneous cardiac output, we have studied their technique of transthoracic impedance plethysmography as an index of stroke volume in man. Instantaneous values of blood flow obtained using the pressure gradient technique in these subjects were used for comparison with the impedance measurements.

#### METHOD

Blood pressure and flow in the ascending aorta were continuously measured in 8 male patients with normal atrio-ventricular

conduction during the course of diagnostic cardiac catheterization (Group 1). Prior to study the informed consent of each patient was obtained. All patients had cardiomegaly of unknown origin and were receiving maintenance digitalis therapy at the time of study. Pertinent clinical data are listed in Table 1. No patient had evidence of pericardial, valvular, or arteriosclerotic heart disease, or evidence of subvalvular obstruction to aortic outflow. In 6 patients no etiology for cardiac disease could be found and a final diagnosis of idiopathic cardiomyopathy was made. The remaining 2 patients had known hypertension for 5 to 7 years and were presumed to have hypertensive heart disease. No cause for hypertension was found in either patient.

The four electrode impedance system described by Kubicek et al. (5), was used to obtain transthoracic impedance measurements. A pair of circumferential electrodes consisting of 6.5 mm wide aluminized Mylar strips backed with adhesive tape\* were applied around the neck 7 cm apart with the lower electrode at the base of the neck. A second pair of electrodes was similarly placed around the lower thorax, the upper electrode being 5 cm below the xiphisternal junction. The two outermost electrodes were attached to a constant current generator which supplied a 100 kHz alternating current at 4 ma. The voltage measured between the inner two electrodes was then proportional to the total impedance between them. In practice, the impedance bridge was balanced at the mean impedance ( $Z_0$ ) between the two inner electrodes and the superimposed impedance change consonant with the cardiac cycle and its first derivative ( $dZ/dt$ )

---

\*Kindly supplied by the 3M Company, St. Paul, Minnesota.

were continuously measured. Calibration was performed by stepwise application of known resistances from 25.5 to 25.7 ohms to the impedance bridge in 0.1 ohm steps. The differentiator was calibrated by applying a ramp function equivalent to an impedance change of 1 ohm/sec.

Phasic blood pressure and flow were estimated in the ascending aorta using the pressure gradient technique. A specially designed double lumen catheter having two sets of lateral pressure taps 4 cm apart was introduced percutaneously through a femoral artery and advanced under fluoroscopic control into the ascending aorta. Pressure from the distal lumen was recorded directly and the pressure difference between the two lumens computed continuously by electrical subtraction. This pressure difference, which represented the axial pressure gradient in the stream, was used to continuously compute the aortic flow with an analog computer. Detailed discussion of instrumentation techniques, calibration procedures, and manometric accuracy requirements are available elsewhere (6,7). The pressure derivative was obtained by electrical differentiation of the aortic pressure signal.

A bipolar pacing catheter inserted through the right cephalic vein facilitated control of heart rate by right atrial **pacing**. Lead II of a standard electrocardiogram was recorded continuously. Data were recorded on a Hewlett-Packard Model 4560 optical recorder at a paper speed of 100 mm/sec and a Hewlett-Packard Model 3520B magnetic tape recorder.

All recordings were made during end-expiratory apnea to eliminate respiratory artifacts from the impedance recordings. Data were recorded during sinus rhythm for 10 to 20 seconds. The heart rate was then increased 10 to 20 beats/min by atrial pacing and after allowing 60 to 90 seconds for equilibration, the measurements repeated. Additional increments in pacing rates were made so that 3-5 heart rates were available for study from each patient. In 3 patients the study was repeated during intravenous infusion of isoproterenol at a rate of 3 mcg/min. Similar studies were carried out using ventricular pacing in 5 patients with idiopathic complete heart block and transvenous right ventricular pacemakers. In 2 other patients recordings were obtained during interference dissociation produced by pacing the right ventricle faster than the sinus rate.

In evaluating the data, 6 to 22 heart beats were available at each heart rate, with a total of 20 to 81 beats for each patient. The systolic, diastolic and pulse pressures were measured directly from the pressure recordings. In evaluation of aortic blood flow, zero flow was assumed to be present at the end of diastole. Planimetric integration of the flow tracings was performed to obtain stroke volume. Cardiac output was computed as the product of mean stroke volume and heart rate. Peak flow was measured as the maximum amplitude of the flow recordings. The duration of ejection was taken

as the interval of forward flow. The mean transthoracic impedance ( $Z_0$ ) was read directly from a calibrated potentiometer on the impedance bridge. The maximum negative systolic first derivative of the transthoracic impedance ( $dZ/dt$ ) was measured directly from the recordings.

Computation of stroke volume from the maximum negative impedance derivative was carried out according to the method of Kubicek et al. (5):

$$ZSV \text{ (cm}^3\text{)} = \rho \cdot \frac{L^2}{Z_0^2} \cdot DE \cdot \left( \frac{dZ}{dt} \right)_{\max}$$

where ZSV is the theoretical stroke volume computed from the maximum negative impedance derivative,  $\rho$  is the blood resistivity (150 ohm/cm),  $L$  is the distance between the inner electrodes (cm),  $Z_0$  is the mean impedance between the inner 2 electrodes (ohms),  $DE$  is the duration of ejection (sec), and  $\left( \frac{dZ}{dt} \right)_{\max}$  is the absolute value of the maximum systolic impedance change (ohms/sec). Data analysis using standard statistical methods and plotting of data were performed on an International Business Machine Model 1130 digital computer (8).

In addition to the above studies, impedance plethysmograms alone were performed on several groups of patients without evidence of cardiovascular disease. Group 2 was composed of 6 patients in whom the distance between the neck and lower thoracic impedance electrodes was divided into equal thirds by two additional equally spaced circumferential electrodes placed around the thorax. Impedance measurements were then made

separately from each one-third of the thorax. Group 3 consisted of 6 patients in whom impedance plethysmograms were made with the neck electrodes replaced by 1 x 10 cm strips of aluminum foil applied to the forehead and chin, carefully placed to avoid palpable arterial pulsations. Group 4 included 10 patients in whom impedance measurements were obtained between pairs of circumferential electrodes applied to each forearm. Impedance recordings were made before and immediately after inflating blood pressure cuffs around both upper arms to 100 mm Hg above the systolic blood pressure.

#### RESULTS

Figure 1 shows a typical recording of aortic blood pressure and flow, and transthoracic impedance measurements obtained during sinus rhythm and atrial pacing at several heart rates. Throughout the ranges of heart rates studied cardiac output remained remarkably steady with standard deviations of  $\pm 3$  to  $\pm 18$  percent for individual patients. All patients except J. S. developed pulsus alternans at some time during atrial pacing. Since pulsus alternans tended to be unstable, continuous distributions of stroke volume from largest to smallest often resulted. The impedance and impedance derivative tracings in Figure 1 are typical of recordings obtained with this electrode configuration. An upward deflection indicates a decrease in transthoracic impedance. During sinus rhythm, the impedance reached a maximum prior to the onset of ventricular ejection and then began to decrease



rapidly reaching a minimum approximately consonant with peak aortic pressure. The maximum negative first derivative of the impedance occurred during early ejection prior to the attainment of peak aortic flow. Ventricular ejection was often followed by a smaller variable negative diastolic impedance deflection. During atrial pacing, first degree heart block frequently occurred and was accompanied by separation of the major impedance deflection into two components having different slopes by a brief slowing or transient reversal of the impedance change (Figure 1). This finding was also present in patients with spontaneous first degree heart block during sinus rhythm and is perceptible in Figure 2 A where the P-R interval was 0.22 sec. The first component of the systolic impedance deflection occurred prior to the onset of ventricular ejection and generally appeared to be about 0.05 sec in duration. The second component began with the onset of ventricular ejection and became minimum approximately consonant with peak aortic blood pressure. Consequently, during first degree heart block the impedance derivative showed two negative peaks for each ventricular systole. At rapid heart rates the pre-ejection peak often exceeded the peak which occurred during ventricular ejection. (Figure 1 D and E). Measurements of the maximum negative systolic impedance derivative in this study were made during the period of ventricular ejection.

Examination of 5 patients with complete heart block revealed that the first component of the usual systolic upstroke of the

impedance wave really represented the ascending limb of a negative deflection which accompanied atrial activity and could be seen independently of ventricular contraction (Figure 2). This same atrial deflection was also observed separately from ventricular activity in patients with interference dissociation produced by ventricular pacing at a rate more rapid than the sinus rate (Figure 1 F). If a P-wave fell on or within 0.05 sec prior to a QRS complex, summation of the upstroke of the atrial deflection and the ventricular deflection appeared to occur, factitiously exaggerating the maximum impedance derivative (Figure 1F, beats 1 and 6).

All data from all eight patients in Group 1 studied with the pressure gradient technique during sinus rhythm and atrial pacing (461 separate heart beats) were used to construct plots of maximum absolute impedance derivative, theoretical stroke volume computed from the maximum impedance derivative, and duration of ejection against stroke volume shown in Figure 3. It is apparent that the maximum absolute impedance derivative and its computed stroke volume both showed a much wider variation than duration of ejection for a given stroke volume. Linear regression of the maximum  $dZ/dt$  on stroke volume for each patient individually generally improved this relationship, as shown in Table 2 ( $r = 0.43 - 0.93$ ). Even when patients were considered individually, however, there was marked variation in the closeness of this relationship. In addition, the slopes and intercepts of these regression equations varied widely among the patients so that

combining the data from all patients was markedly detrimental to the overall correlation ( $r = 0.16$ ) (Table 2). Visual examination of plots of these data from all individual patients showed no evidence of a nonlinear relationship.

As shown in Figure 3 C, plotting duration of ejection on stroke volume resulted in a curvilinear relationship. Logarithmic plotting of these data produced an apparently linear relationship, and correlation coefficients between  $\text{Log}_e \text{SV}$  and  $\text{Log}_e \text{DE}$  ( $r = 0.70$  to  $0.96$ ) were higher than correlations computed directly from the corresponding linear data in 7 of 8 patients. The resulting logarithmic regression equations are shown in Table 2 C; the overall correlation coefficient was  $r = 0.83$ . Fitting the data to several other nonlinear curves including SV vs.  $\text{Log}_e \text{DE}$ ,  $\text{Log}_e \text{SV}$  vs. DE, SV vs.  $\text{DE}^3$ ,  $\text{SV}^3$  vs. DE, and  $\text{SV}^3$  vs  $\text{DE}^3$  resulted in poorer correlations than obtained from  $\text{Log}_e \text{SV}$  vs.  $\text{Log}_e \text{DE}$ .

Including the maximum impedance derivative with duration of ejection in order to compute a theoretical stroke volume provided an improvement over the simple relationship between duration of ejection and stroke volume in only one patient (C. P.) and was markedly detrimental to the overall correlation with stroke volume ( $r = 0.28$ ), (Table 2). Fitting these data to the same nonlinear curves tested for the SV vs. DE relationship did not improve upon the correlation coefficient obtained directly from the linear data. In addition, regression of the theoretical stroke volume on measured stroke volume tested only the linearity and fit of this relationship, and did not compare absolute values of computed versus measured stroke volumes. As may be seen in

Table 2 and Figure 3, the theoretical stroke volume was of little value in predicting actual stroke volume even in patients in whom a close linear relationship existed between these quantities.

Infusion of isoproterenol in patients A. H., E. A. and E. H. produced increases in sinus rates of 16, 15, and 7 beats/min with increases in cardiac output of 47, 23 and 18 percent, respectively. At this level of effectiveness isoproterenol produced no consistent changes in slopes or intercepts of regression equations between stroke volume and duration of ejection, maximum impedance derivative or theoretical stroke volume computed from the maximum impedance derivative, although standard errors of estimate of maximum impedance derivative were increased slightly (Figure 4).

In Table 3 results of regressions of the maximum impedance derivative on peak flow, pulse pressure, and the maximum aortic  $dP/dt$  are shown. In every case, visual examination of plots of these data showed no evidence of nonlinear relationships. The individual relationships of the maximum impedance derivative with peak flow were similar to those with stroke volume ( $r = 0.21$  to  $0.90$ ), with a poor overall correlation ( $r = 0.23$ ). Pulse pressure was moderately well correlated with maximum  $dZ/dt$  for individual patients ( $r = 0.55$  to  $0.93$ ), but the marked variation between individual patients in slope and intercept of the regression equations resulted in poor overall correlation ( $r = 0.19$ ). Regression of the maximum aortic  $dP/dt$  on maximum  $dZ/dt$  resulted in mediocre individual ( $r = 0.11$  to  $0.82$ ) and overall correlation coefficients ( $r = 0.47$ ).

Impedance measurements recorded from the upper, middle, and lower one-thirds of the thorax of patients in Group 2 are shown in Table 4. Most of the impedance, as well as most of the impedance change, was recorded by electrodes enclosing only the upper one-third of the chest. Impedance recordings obtained from the six patients in Group 3 with the upper two electrodes affixed to the forehead and chin to avoid obvious arterial pulsation produced a mean maximum absolute  $dZ/dt$  of 2.45 ohms/sec as compared with 1.80 ohms/sec using the usual neck electrode configuration ( $P < 0.01$ ). Mean impedance measurements from patients in Group 4 with electrodes attached to right and left forearms before and during arterial occlusions produced by inflating blood pressure cuffs around the upper arms are shown in Table 5. Completely eliminating arterial pulsation from the extremities to which the electrodes were attached produced no significant change in the maximum absolute  $dZ/dt$ .

#### DISCUSSION

Transthoracic impedance plethysmography provides a means for continuous measurement of the impedance encountered by a high frequency sinusoidal electrical signal as it passes through a segment of thoracic tissue. The present four electrode impedance plethysmograph described by Kubicek et al. (5) uses a 100 kHz constant current source to drive the two outer electrodes. Such a constant current source is essential for reliable impedance measurements in order to prevent variations in current flow even if artifactual changes in electrical

impedance result from physical changes at the skin-electrode interface (9, 10). Since current flow through the tissue segment is thus held constant, the voltage drop measured between the inner two sensing electrodes is proportional to the total tissue impedance between them (according to Ohm's Law, at a constant frequency voltage drop = current x impedance). Use of four-electrode system eliminates measurement of the region of increased impedance near the exciting electrodes where electrical field lines are concentrated as they pass into the interior of the body (inhomogeneous field resistance), unlike systems using only two electrodes (9).

Hill et al. (10) have emphasized that even small variations in mechanical pressure exerted on the sensing electrodes may produce major artifacts in the impedance signal. From studies on the extracorporeal bovine eye and intact human finger, they felt that the entire impedance signal extracted during pulsatile blood flow was artifact produced by changes in pressure on the sensing electrodes secondary to tissue volume changes which occurred with phasic alterations in blood content. Finding that most of the total transthoracic impedance change could be measured between sensing electrodes enclosing only the upper one-third of the thorax suggested that pulsatile neck vessels beneath the upper electrodes also might produce such skin electrode interface artifacts in the present study. Accordingly, the upper two neck electrodes were replaced with electrodes positioned on the forehead and chin to avoid palpable arterial pulsations. This electrode

placement actually increased the phasic impedance change accompanying cardiac systole, contrary to what would have been expected if neck pulsations had artifactually increased the impedance change by varying the pressure exerted on the electrodes. The additional finding that completely removing arterial pulsations from electrodes applied to the forearms by pneumatic arterial occlusion in the upper arm did not significantly decrease the measured impedance change substantiated the existence of a real, measurable transthoracic impedance change independent of possible electrode artifact.

In structures completely composed of incompressible tissue, any change in blood content which accompanys arterial pulsation must be transmitted to the surface as changes in total organ volume. This may account for the inability of Hill et al. (10) to measure electrical impedance changes independently of pressure artifact at the tissue-electrode interface in the eye and finger. In transthoracic plethysmography, however, the great vessels of the thorax are not completely surrounded by incompressible tissue but border on air containing lungs which may allow them to pulsate without transmission of their volume change to the exterior of the thorax, thus permitting measurement of electrical impedance changes independently of changes in pressure at the skin-electrode interface. Contrary to the findings of Hill et al. (10) however, other workers have reported that they were able to reliably measure the effective impedance of the human arm without significant electrode artifact using the four electrode impedance plethysmograph (9). No explanation for the disparity

between these reports is apparent.

In the present study, the pressure gradient technique, by permitting accurate estimation of beat to beat variations in stroke volume, provided a means for evaluating transthoracic impedance plethysmography. All patients studied with the pressure gradient technique had heart disease with cardiomegaly but none had valvular heart disease which has been previously suspected to invalidate cardiac transthoracic impedance measurements (11). Variations in stroke volume were produced by atrial pacing at several rates. In addition, all patients except one developed pulsus alternans during atrial pacing at one or more rates, further increasing the range of stroke volumes available for study. Pulsus alternans is commonly seen in patients with cardiomegaly associated with idiopathic cardiomyopathy and hypertensive heart disease (12,13) and is enhanced by rapid heart rates (14). With increasing pulsus alternans the correlation between stroke volume and heart rate decreased. In the absence of pulsus alternans stroke volume would be expected to have an inverse relationship with heart rate (as in patient J.S. without pulsus alternans), since within the physiologic range cardiac output is changed little by alterations in heart rate (15).

Previous studies which compared transthoracic impedance plethysmography with indicator dilution determinations as cardiac output was increased by exercise have been hampered by the small changes in stroke volume observed, since augmentation of cardiac output during exercise is accomplished chiefly by



an increased heart rate with little change in stroke volume (5). The present study showed that at a fixed heart rate the impedance plethysmogram could reflect alterations of ventricular activity produced by pulsus alternans, demonstrating a linear relationship between stroke volume and the maximum impedance derivative. Although this relationship was close and similar for all heart rates in some patients, in others it was only mediocre or varied with heart rate resulting in poor correlation when all rates were considered simultaneously. Unfortunately, no other characteristics could be found to distinguish between patients in whom this relationship was close and those in whom it was poor, so that no means were available to predict in which patients a reliable linear relationship could be expected. In addition, even among patients for whom this relationship was good, the slopes and intercepts of the regression equations were highly variable from one patient to another, so that no single equation could describe the relationship for all patients.

Greenfield et al. (16) have recently demonstrated a close logarithmic relationship between duration of ejection and stroke volume in a group of patients with atrial fibrillation and an irregular ventricular rhythm. Similar findings in the present study of patients having regular ventricular rates with alterations in stroke volume produced by atrial pacing further strengthens the validity of this relationship during supraventricular rhythms. The equation relating duration of ejection to stroke

volume in a group of patients during atrial fibrillation ( $\text{Log}_e \text{DE} = 0.34 \text{ Log}_e \text{SV} - 2.88$ ) provides remarkably similar solutions throughout the range of stroke volumes observed to the equation obtained in the present study ( $\text{Log}_e \text{DE} = 0.24 \text{ Log}_e \text{SV} - 2.56$ ). (In the original equation of Greenfield et al. (16) relating duration of ejection to stroke volume, DE and SV were interchanged and are shown here corrected).

In patients with complete heart block, during ventricular pacing, duration of ejection has been shown to have a direct linear relationship with stroke volume (17). The reason for the dissimilarity of this relationship between patients during ventricular pacing and those with regular or irregular supra-ventricular rhythms is not apparent. The range of heart rates studied in the patients with complete heart block (mean lowest rate = 84 beats/min; mean highest rate = 133 beats/min) was not greatly different from the range of heart rates observed in the present study (mean lowest rate = 91 beats/min; mean highest rate = 139 beats/min). Likewise, the ranges of stroke volume observed were not remarkably different. It appears that normal atrio-ventricular conduction may in some way result in a slightly different relationship between stroke volume and duration of ejection than that seen during ventricular pacing.

Employing the product of duration of ejection and the maximum impedance derivative in the formula proposed by Kubicek et al. (5) for computation of "impedance stroke volume" did not

improve upon the simple relationship between duration of ejection and stroke volume for individual patients, and was markedly detrimental to this relationship when all patients were considered simultaneously. Visual examination of these plots revealed no evidence of a nonlinear relationship. Examination of individual regression equations between "impedance stroke volume" and actual stroke volume showed that even when good correlation was observed, the "impedance stroke volume" did not reliably indicate absolute stroke volume. Had this been the case, regression equations between "impedance stroke volume" and actual stroke volume would have had intercepts at the origin and slopes of unity. Thus, this formula did not reliably predict absolute stroke volume and, under conditions of the present experiment, did not improve upon the simple relationship between duration of ejection and stroke volume.

Infusion of isoproterenol at a rate to produce 18 to 47 percent increases in cardiac output produced no consistent alteration of the relationship between stroke volume and the maximum negative impedance derivative. This is consistent with previous studies using indicator dilution determinations where the increased cardiac output produced by isoproterenol infusion was generally reflected by appropriate relative increases in the maximum negative impedance derivative (11). Of considerable interest was the relative lack of consistent effect of isoproterenol on the relationship between the duration of ejection and stroke volume, since positive inotropic stimuli are known to decrease the duration of systole. Although much of this decrease may occur in

the pre-ejection isovolumic contraction period due to increased contraction velocity, it is probable that at higher levels of inotropic stimulation the stroke volume - duration of ejection relationship would be altered as well.

Nyboer (18), using precordial electrodes, has previously noted a change in thoracic impedance corresponding to atrial activity. As in the present study, he found that the atrial deflection began 0.10 to 0.12 sec after the P-wave of the electrocardiogram. In our patients with atrioventricular dissociation this deflection was 0.10 to 0.20 sec in duration, generally being longer as the interval from the previous ventricular contraction lengthened. The source of this impedance change occurring with atrial activity is not known. Unfortunately, atrial pressure recordings were not available simultaneously with impedance measurements during atrioventricular dissociation. During atrioventricular dissociation, the maximum impedance derivative corresponding to ventricular systole may be artifactually increased by coincident atrial and ventricular contractions. Since during normal atrioventricular conduction the termination of the atrial and onset of the ventricular impedance deflections appear to merge, slight convergence or divergence of atrial and ventricular contractions might alter the maximum systolic impedance derivative. In the present study there was no consistent difference in the relationship between the maximum impedance derivative and stroke volume when patients went from normal atrioventricular conduction in sinus rhythm to first degree heart block with atrial pacing. It appeared that the atrial impedance change produced significant distortion of the maximum impedance

change corresponding to ventricular systole only with an obviously short P-R interval or coincidence of the P and QRS complexes.

Studies performed in anesthetized dogs by Witsoe and Kottke (19) showed that transiently occluding right ventricular output by inflating a balloon in the right atrium had little effect on the thoracic impedance waveform while similar occlusion of left ventricular output essentially abolished the impedance waveform. Further, ligation of all major branches of the thoracic aorta did not greatly alter thoracic impedance recordings. They concluded that in dogs the thoracic impedance waveform appeared to originate chiefly from the thoracic aorta with little contribution from the systemic arterial branches or from the pulmonary circulation. Because of these findings, hemodynamic measurements which might be expected to reflect aortic dynamics were made for comparison with the maximum impedance derivative. Regression of peak aortic flow rate, pulse pressure, and maximum  $dP/dt$  in the ascending aorta on the maximum impedance derivative, however, showed no closer correlation than observed with stroke volume. Similarly, the relationships of each of these quantities with the maximum impedance derivative varied between patients so that simultaneous consideration of the data from all patients was markedly detrimental to the overall correlation coefficient.

TABLE 1

## Clinical Data

Patient	Diagnosis	Age (yr)	Height (in.)	Weight (lbs.)	Blood Pressure (mm Hg)	Cardiomegaly	Previous CHF	N.Y.H.A. Classification
J. S.	IMH	54	68 1/2	164	130/90	+	+	2
A. H.	IMH	35	65 3/4	146	100/60	+	0	1
E. A.	HCVD	42	68 1/4	238	160/110	+	+	2
E. H.	IMH	34	67	162	100/70	+	+	3
J. G.	IMH	45	70	144	130/90	+	+	3
J. T.	HCVD	41	68 1/2	147	150/120	+	+	2
H. S.	IMH	44	69	142	120/80	+	+	2
C. P.	IMH	42	69	148	105/90	+	+	3

IMH = idiopathic myocardial hypertrophy; HCVD = hypertensive heart disease;  
 N.Y.H.A. = New York Heart Association Classification

TABLE 2: Correlations of Duration of Ejection, Maximum Derivative and Stroke Volume Computed from the Maximum Impedance Derivative with Stroke Volume Measured Using the Pressure Gradient Technique

Patient	Number of Beats	A Maximum Impedance Derivative			B Duration of Ejection			C Stroke Volume Computed from the Maximum Impedance Derivative			
		Stroke Volume -- Range (cm <sup>3</sup> )	Maximum dz/dt -- Range (ohms/sec)	Regression Equation	r	Duration of Ejection -- Range (sec)	Regression Equation	r	Z-SV -- Range (cm <sup>3</sup> )	Regression Equation	r
J. S.	60	10-29	0.500 - 1.350	DZDT = 0.354 + 0.0253 SV	0.85	0.130 - 0.190	Log <sub>e</sub> DE = -2.80 + 0.339 Log <sub>e</sub> SV	0.95	15-45	ZSV = 3.5 + 1.42 SV	0.94
A. H.	75	9-64	0.120 - 1.010	DZDT = 0.071 + 0.0132 SV	0.93	0.130 - 0.260	Log <sub>e</sub> DE = -2.93 + 0.386 Log <sub>e</sub> SV	0.94	6-101	ZSV = -5.8 + 1.42 SV	0.96
E. A.	58	8-45	0.120 - 1.010	DZDT = 0.287 + 0.0138 SV	0.88	0.115 - 0.210	Log <sub>e</sub> DE = -3.00 + 0.364 Log <sub>e</sub> SV	0.96	10-49	ZSV = 2.0 + 0.93 SV	0.91
E. H.	54	46-75	0.270 - 0.915	DZDT = 0.057 + 0.0069 SV	0.49	0.175 - 0.230	Log <sub>e</sub> DE = -2.94 + 0.320 Log <sub>e</sub> SV	0.78	12-47	ZSV = 5.3 + 0.44 SV	0.58
J. G.	56	13-39	0.310 - 0.795	DZDT = 0.331 + 0.0105 SV	0.43	0.130 - 0.210	Log <sub>e</sub> DE = -2.95 + 0.374 Log <sub>e</sub> SV	0.92	18-85	ZSV = 12.4 + 1.37 SV	0.62
J. T.	23	6-30	0.230 - 0.555	DZDT = 0.037 + 0.0155 SV	0.76	0.135 - 0.175	Log <sub>e</sub> DE = -2.31 + 0.147 Log <sub>e</sub> SV	0.79	7-20	ZSV = -1.0 + 0.65 SV	0.78
H. S.	74	9-24	0.205 - 0.635	DZDT = 0.095 + 0.0187 SV	0.57	0.105 - 0.180	Log <sub>e</sub> DE = -2.60 + 0.262 Log <sub>e</sub> SV	0.75	5-21	ZSV = 0.4 + 0.77 SV	0.68
C. P.	81	8-29	0.220 - 1.362	DZDT = 0.087 + 0.0374 SV	0.86	0.110 - 0.190	Log <sub>e</sub> DE = -2.72 + 0.283 Log <sub>e</sub> SV	0.70	5-95	ZSV = -5.5 + 1.53 SV	0.87
All	461			DZDT = 0.503 + 0.0030 SV	0.16		Log <sub>e</sub> DE = -2.56 + 0.240 Log <sub>e</sub> SV	0.83		ZSV = 18.3 + 0.76 SV	0.28

See = standard error of estimate; DZDT = maximum absolute impedance derivative; DE = duration of ejection

ZSV = stroke volume computed from the maximum impedance derivative.

TABLE 3: Correlation coefficients obtained by linear regression of various hemodynamic parameters and the maximum systolic transthoracic impedance derivative (dZ/dt).

Patient	Number of Beats	Heart Rates	Cardiac Output (cm <sup>3</sup> )	Heart Rate vs. Stroke Volume	Maximum dZ/dt vs. Stroke Volume	Maximum dZ/dt vs. Peak Flow	Maximum dZ/dt vs. Pulse Pressure	Maximum dZ/dt vs. Maximum dP/dt
				r	r	r	r	r
J. S.	40	78, 102, 115 128	1840 ± 325	0.90	0.85	0.87	0.66	0.11
A. H.	75	79, 94, 106 114, 125	2470 ± 405	0.79	0.93	0.90	0.93	0.78
E. A.	58	71, 85, 107 118, 140	2930 ± 215	0.66	0.88	0.80	0.55	0.44
E. H.	54	100, 104, 118 131, 145	7132 ± 1110	0.56	0.49	0.21	0.65	0.37
J. G.	56	94, 103, 126 137, 158	3000 ± 510	0.48	0.43	0.43	0.78	0.59
J. T.	23	105, 126, 133	2670 ± 85	0.39	0.76	0.80	0.80	0.74
H. S.	74	86, 92, 102 115	1810 ± 55	0.38	0.57	0.57	0.69	0.64
C. P.	81	97, 126, 141 165	2665 ± 200	0.08	0.86	0.71	0.93	0.82
All	461			0.20	0.16	0.23	0.19	0.47

Cardiac output is the mean for all heart rates obtained using the pressure gradient technique ± one standard deviation.



TABLE 4: Mean thoracic impedance and maximum systolic impedance derivative measured between circumferential electrodes enclosing the entire thorax, and the upper, middle and lower one-thirds of the thorax in 6 patients without known cardiovascular disease.

Patient	Age (yrs)	<u>Mean Thoracic Impedance</u> (ohms)				<u>Maximum Systolic Impedance Derivative</u> (ohms/sec)			
		Total	Upper 1/3	Middle 1/3	Lower 1/3	Total	Upper 1/3	Middle 1/3	Lower 1/3
R. P.	28	21.5	15.7	3.1	3.7	0.85	0.76	0.12	0.14
R. S.	27	22.5	15.8	4.2	2.9	2.08	1.45	0.61	0.10
M. W.	56	31.4	18.7	5.5	8.0	2.45	1.46	0.63	0.50
L. J.	58	32.6	18.9	10.2	4.4	1.22	1.03	0.71	0.10
H. C.	42	28.8	14.4	8.2	7.3	2.28	1.44	0.51	0.11
W. C.	22	24.2	17.3	3.7	3.4	1.88	1.47	0.63	0.10
Mean		26.8	16.8	5.8	4.9	1.79	1.27	0.53	0.17
SEE		2.1	0.8	1.2	1.0	0.28	0.13	0.09	0.07

TABLE 5: Maximum systolic impedance derivative measured between right and left arms of 10 subjects without known cardiovascular disease. Measurements were made prior to and immediately following inflation of pressure cuffs on the upper arms to 100 mm Hg above systolic pressure. There was no statistically significant difference between the means of the two groups.

<u>Age</u> (yrs)	<u>Maximum negative systolic impedance derivative</u> (ohms/sec)	
	Control	Cuffs inflated
44	0.83	0.87
44	0.77	0.59
34	1.08	0.93
45	1.55	1.65
48	1.85	1.82
48	1.17	1.21
46	1.89	1.49
42	1.74	1.72
47	2.62	2.45
51	1.19	0.94
Mean ± S. D.	1.47 ± 0.57	1.37 ± 0.56

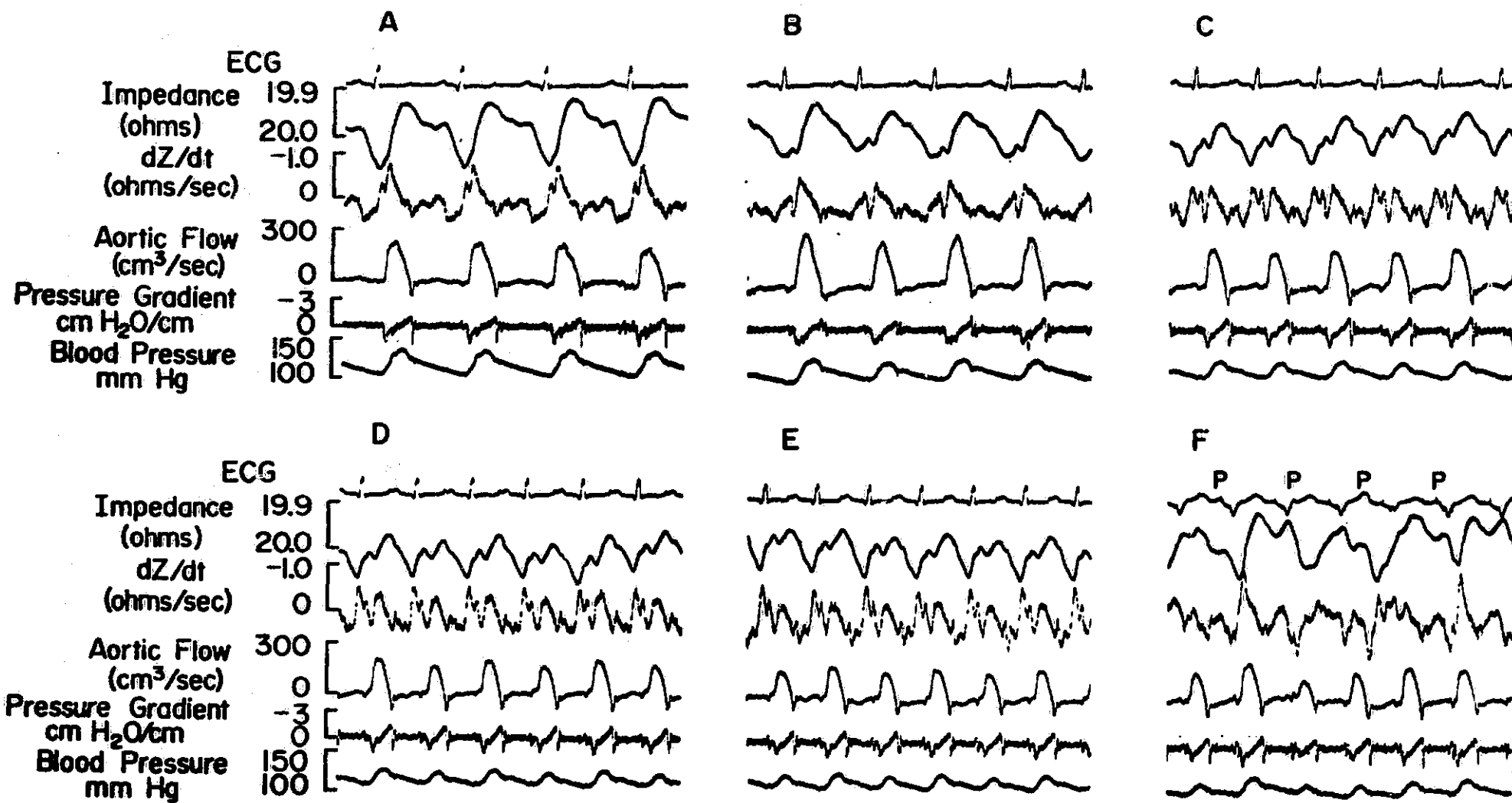

Figure 1 Data obtained from patient A. H. during sinus rhythm (A), during atrial pacing at 85 (B), 107 (C), 118 (D) and 140 beats/min (E), and during ventricular pacing at 136 beats/min (F). The position of P-waves is indicated on the electrocardiogram of panel F. Note the artifactual increase in maximum negative impedance derivative in beats 2 and 6 in panel F where a P-wave falls at the onset of a QRS-complex.

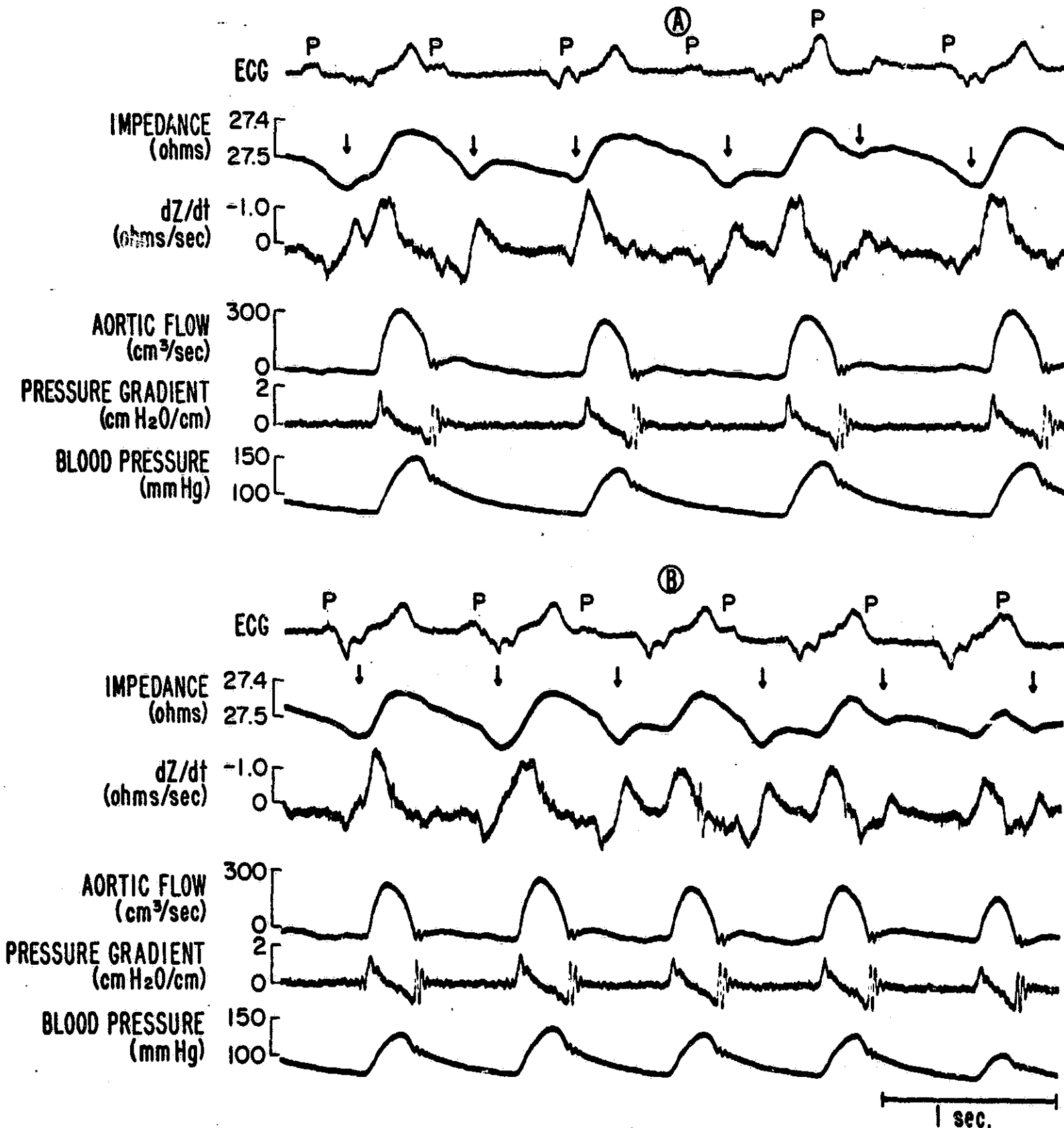

Figure 2 Data obtained from a 74 year old man with complete heart block during ventricular pacing at 50 and 70 beats/min. The position of the P-waves is indicated on the electrocardiogram and the increase in thoracic impedance following each P-wave indicated by arrows above the impedance tracing.

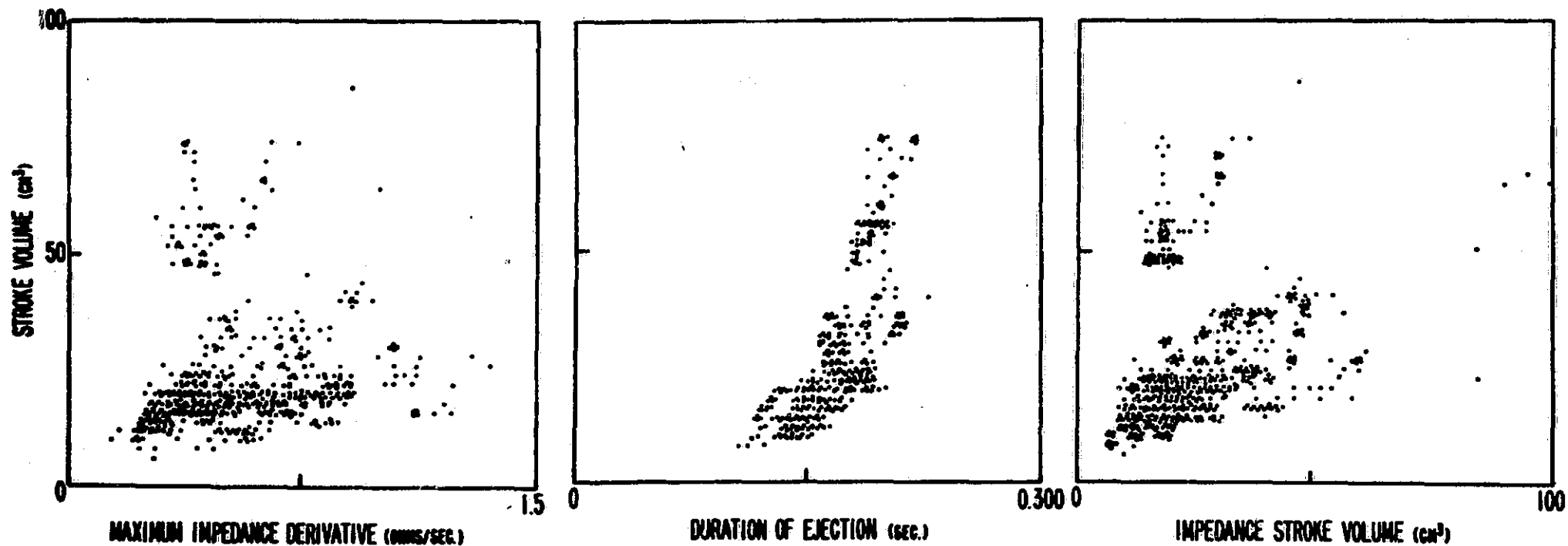

Figure 3 Plots of all data from 8 patients during sinus rhythm and atrial/pacing. Stroke volume is shown on the ordinate against maximum systolic impedance derivative in Panel A, duration of ejection in panel B, and stroke volume computed from the maximum systolic impedance derivative in panel C.

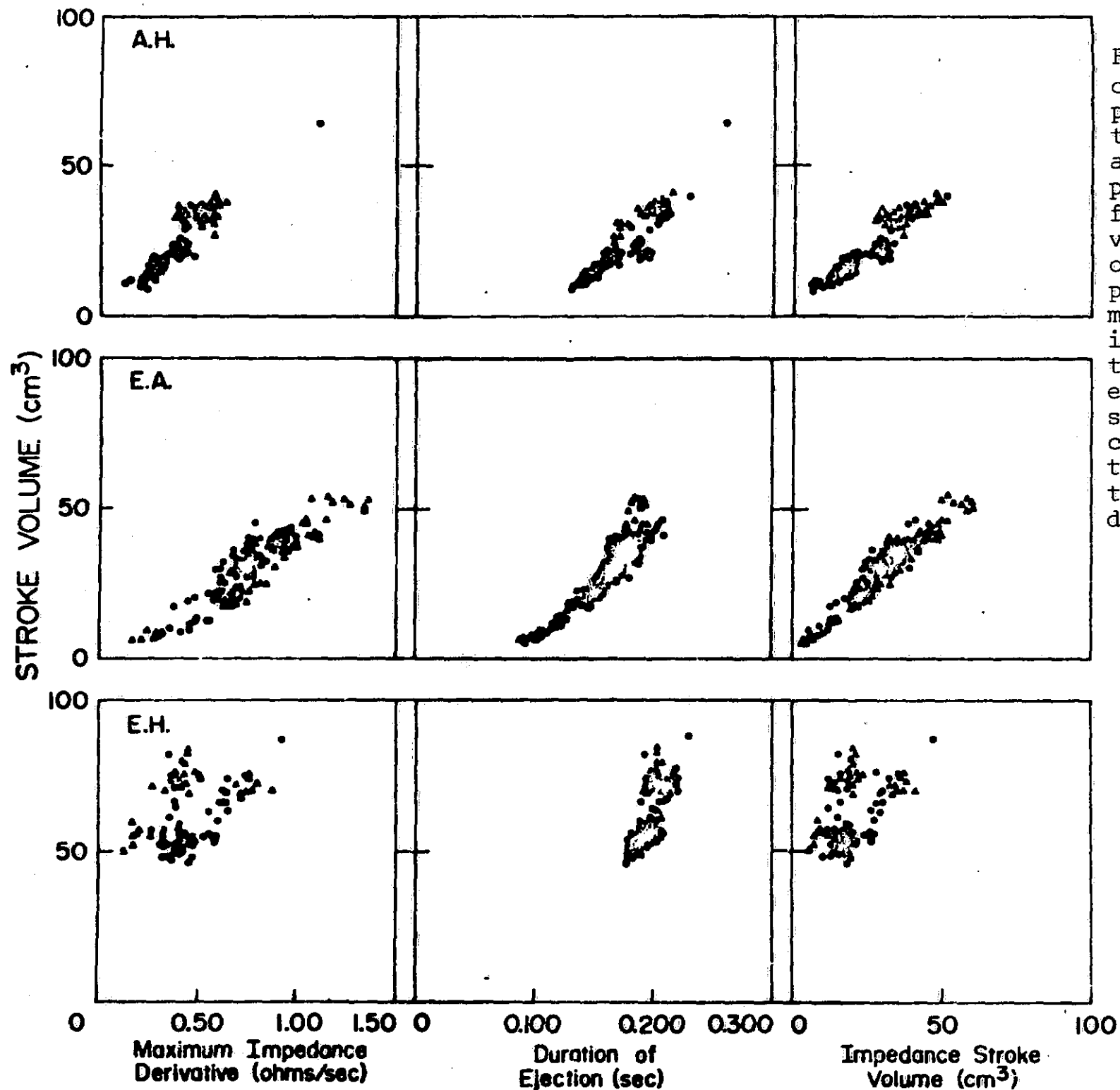

Figure 4 Plots of data from 3 patients for control conditions and during isoproterenol infusion. Stroke volume is shown on the ordinate plotted against maximum systolic impedance derivative, duration of ejection and stroke volume computed from the maximum systolic impedance derivative.

• Control  
 ▲ Isoproterenol

REFERENCES

1. Nyboer, J.: Electrical Impedance Plethysmography. Charles C. Thomas. Springfield, Ill., p. 37-37, 1959.
2. Liebman, F. M., Peart, J. and Bagno, S.: The electrical conductive properties of blood in motion. Phys. in Med. Biol. 7:177, 1962.
3. Nyboer, J.: Electrical Impedance Plethysmography. A physical and physiologic approach to peripheral vascular study. Circ. 2:811, 1950.
4. Bashour, F. A. and Jones, R. E.: Digital blood flow. I. Correlative study of the electrical impedance and the venous occlusive plethysmographs. Dis. Chest 47:465, 1965.
5. Kubicek, W. G., Karnegis, J. N., Patterson, R. P., Witsoe, D. A. and Mattson, R. H.: Development and evaluation of of an impedance cardiac output system. Aerospace Med. 37:1208, 1966.
6. Greenfield, J. C., Jr. and Fry, D. L.: Measurement errors in estimating the aortic blood velocity by the pressure gradient. J. Appl. Physiol. 17:1013, 1962.
7. Greenfield, J. C., Jr.: The pressure gradient technique. In Methods in Medical Research, Vol. 11, p. 83, edited by R. F. Rushmer. Chicago: Year Book Medical Publishers, 1966.
8. Snedecor, G. W.: Statistical Methods, 5th Ed. Iowa State College Press, Ames, Iowa, 1956.
9. Young, D. G., Jr., Cox, R. H., Stoner, E. K. and Erdman, W. J. II: Evaluation of quantitative impedance plethysmography for continuous blood flow measurement. I. Electrode systems. Am. J. Physical Med. 46:1261, 1967.
10. Hill, R. V., Jansen, J. C. and Fling, J. L.: Electrical impedance plethysmography: a critical analysis. J. Appl. Physiol. 22:161, 1967.
11. Harley, A., Greenfield, J. C., Jr.: Determination of cardiac output in man by means of impedance plethysmography. Aerospace Med. 39:248, 1968.
12. Harris, L. C., Nghiem, Q. Z., Schreiber, M. H. and Wallace, J. M.: Severe pulsus alternans associated with primary myocardial disease in children. Circ. 34:948, 1966.

13. Cohn, K. E., Sandler, H. and Hancock, L. E. W.: Mechanisms of pulsus alternans. *Circ.* 36: 372, 1967.
14. Saunders, D. E., Jr. and Ord, J. W.: The hemodynamic effects of paroxysmal supraventricular tachycardia in patients with Wolff-Parkinson-White Syndrome. *Amer. J. Cardiol.* 9:223, 1962.
15. Ross, J., Jr., Linhart, J. W. and Braunwald, E.: Effects of changing heart rate in man by electrical stimulation of the right atrium. *Circ.* 32:549, 1965.
16. Greenfield, J. C., Jr., Harley, A., Thompson, H. K. and Wallace, A. G.: Pressure-flow studies in man during atrial fibrillation. *J. Clin. Invest.* 47:2411, 1968.
17. Harley, A. and Greenfield, J. C., Jr.: Pressure-flow studies in man: an evaluation of the duration of the phases of systole. *J. Clin. Invest.*, in press.
18. Nyboer, J.: Electrical Impedance Plethysmography. Charles C. Thomas, Springfield, Ill., p. 167-169, 1959.
19. Witsoe, D. A. and Kottke, F. J.: The origin of cardiogenic changes in thoracic electrical impedance. *Fed. Proc.* 26:595, 1967.



#### ACKNOWLEDGEMENT

The authors wish to express their gratitude to Doctors S. M. Fox and A.H.L. From of the Heart Disease Stroke Control Program of the United States Public Health Service for consultation during the course of these studies, and to Dr. W. G. Kubicek of the University of Minnesota who provided the electrical Impedance Plethysmograph. We are also indebted to Miss Judith Rembert, Mrs. Kathleen Smith and Miss Debbie Hilliard for technical assistance. Assistance in preparation of illustrations was provided by the Durham Veterans Administration Hospital Medical Illustration Department.

STUDIES USING THE IMPEDANCE CARDIOGRAPH AS A  
POTENTIAL MONITOR DURING TREATMENT OF ACUTE  
DISSECTING ANEURYSMS

by

R. S. Eliot  
Howard W. Ramsey  
R. F. Palmer  
E. K. Prokop

\* \* \* \* \*

from the

Division of Cardiology and Department of  
Pharmacology  
University of Florida School of Medicine  
Gainesville, Florida

STUDIES USING THE IMPEDANCE CARDIOGRAPH AS A POTENTIAL  
MONITOR DURING TREATMENT OF ACUTE DISSECTING ANEURYSMS

R. S. Eliot, Howard W. Ramsey, R. F. Palmer, and E. K. Prokop

~~ABSTRACT~~

N70-10014

The purpose of this study was to attempt to correlate the impedance output,  $dz/dt$ , with the cardiac parameters  $dP/dt_{max}$  and contractility.  $dP/dt_{max}$  (in the ascending aorta) and the impedance output,  $dZ/dt$  were recorded before and after Isuprel administration in humans. The mean ratio for  $dP/dt_{max}$  after and before Isuprel administration was 2.0. The mean ratio for  $dZ/dt$  under the same conditions was 1.7. The impedance cardiograph was then used on dogs along with a catheter positioned in the ascending aorta, and a strain gauge attached to the left ventricle. Isoproterenol ( $4 \mu\text{gm}$ ), Arfonad (2 mg), and propranolol (1.5 mg/kg.) were given IV with an appropriate time interval between administration of each drug.  $dP/dt_{max}$  correlated with the height of the strain gauge recording. The impedance output,  $dZ/dt$ , did not correlate with either  $dP/dt_{max}$  or the height of the strain gauge recording.

## INTRODUCTION

Previous studies have indicated that the shape of the pulse wave is the most important factor in the extension and rupture of acute dissecting aneurysms. It was also shown that non-pulsatile flow would not cause a "standard model of an aorta" to dissect, whereas, pulsatile flow would cause dissection. The rate of dissection was related to  $dP/dt_{\max}$  in the fluid. There was a critical value for  $dP/dt_{\max}$  before dissection occurred.<sup>1</sup>

The above study supports the rationale for the use of drugs to decrease contractility and thus decrease  $dP/dt_{\max}$  as a mode of therapy in acute dissecting aneurysms.<sup>2</sup> However, during drug therapy there is no easy method to monitor  $dP/dt_{\max}$  unless a chronic indwelling catheter is placed in the aorta, which is certainly far from ideal therapy. Therefore, monitoring a person being treated with drugs for an acute dissecting aneurysm consists of following the ECG, blood pressure, pulses, urine output, and stools for blood.

Recent studies have suggested that thoracic impedance plethysmography may provide a non-invasive and easily adaptable method to estimate myocardial function.<sup>3,4</sup> This study was undertaken to evaluate the impedance cardiograph as a potential monitor of cardiac function during treatment of acute dissecting aneurysms.

## MATERIALS AND METHODS

Humans: A 7 French NIH catheter connected to a pressure transducer (P23 De-Statham) was placed in the ascending aorta. The impedance cardiograph was connected according to the Preliminary Instruction Manual for Minnesota Impedance Cardiograph Model 202. The outputs were connected to a recorder (Honeywell 1108 Visicorder).  $dP/dt_{\max}$  was determined by measuring

the slope at the steepest point on the pulse wave. The final value for  $dP/dt_{\max}$  was the average of five consecutive measurements. The height of the impedance wave for  $m \frac{dz}{dt}$  was measured.  $d^2Z/dt^2$  was also calculated by measuring the slope at the steepest point on the impedance wave,  $dZ/dt$ . The final value was the average of five consecutive measurements. It was decided to calculate the slope of  $dZ/dt$  along with the height of the impedance wave,  $dZ/dt$ , since there seemed to be some ambiguity as to where the baseline should be measured.

Dogs: Dogs (2) were anesthetized with 8 cc. of pentobarbital (50 mg/cc.). A polyethylene catheter connected to a pressure transducer (Siatham, model P23AC) was positioned in the ascending aorta via a femoral artery puncture. The dog was placed on a positive pressure respirator. The chest was opened on the left side, and a Walton-Brodie strain gauge was sutured to the left ventricle. The chest was then closed. The impedance cardiograph was connected. Two disposable electrode tapes (3M type) were placed around the neck of the dog. The No. 3 electrode was placed at the base of the sternum and the No. 4 electrode placed around the abdomen approximately 8 cm. below the No. 3 electrode. The outputs from the impedance cardiograph were connected to a Grass Polygraph (model 7).  $dP/dt_{\max}$  and  $dZ/dt$  were measured as above. The height of the strain gauge tracing was recorded.

## RESULTS

Humans: As can be seen in Table I the mean ratio for  $dP/dt_{\max}$  with isuprel and before isuprel administration was 2.0 (range 1.3 - 2.6). The mean ratio for  $dZ/dt$  under the same condition was 1.7 (range 1.1 - 2.2). There was an increase in  $d^2Z/dt^2$  in all cases except one (patient 4) where  $dZ/dt^2$  decreased after isuprel administration.  $dP/dt_{\max}$  and  $dZ/dt$  were slightly increased for this patient.

Dogs: Figure 1 shows the results of an IV injection of Arfonad ( 2 mg) on  $dP/dt_{max}$  and the height of the strain gauge tracing. A tracing of the shape of the pulse wave is also shown. There is initially an increase in  $dP/dt_{max}$  and then a decrease to 40% of the control value after 17 min. The height of the strain gauge tracing does not show an initial increase, but decreases to 50% of its control value after 17 min. Data on the other dog is not shown, but essentially showed the same trend. The impedance waveforms are shown in Figure 2. Tracings C and D (after injection of Arfonad) show changes from the control tracing, B. However, these impedance outputs were not interpretable.  $dP/dt_{max}$  and the strain gauge recordings did not show any changes.

The effects of an IV injection of Isoproterenol ( $4 \mu gm$ ) on  $dP/dt_{max}$  and the height of the strain gauge tracing is shown in Figure 3.  $dP/dt_{max}$  shows a ten fold increase over the control value after 2 min., and returns to control value in approximately 11 min. The height of the strain gauge tracing increased three fold in approximately 1 min. and had still not returned to control values after 11 min. Results of Isoproterenol injection on the other dog is essentially the same and is not shown. The same problem with the impedance output,  $dZ/dt$ , was encountered following isoproterenol injection as was following Arfonad.

#### DISCUSSION

These preliminary results in a small group of subjects indicate that there may be a relationship between  $dP/dt_{max}$  and  $dZ/dt$ ,  $d^2Z/dt^2$ . However, when the impedance cardiograph was used on dogs the findings were not consistent with those obtained from humans. In spite of careful attention to the details of the technique the same results were obtained when the impedance cardiograph was used on dogs on two separate occasions. In

studies performed by Siegel and Fabin<sup>4</sup>, they were able to show in canine preparations that  $dZ/dt$  bears a direct relationship to the time from onset of contraction to the maximum  $dP/dt$ . Kubicek<sup>3</sup> also reported that the magnitude of  $dZ/dt$  varied in a linear fashion with variations in peak ejection rate.

The reason for this discrepancy is not entirely clear. One source of difficulty might have been that the dogs chests were opened to attach the strain gauge and then closed. Kubicek<sup>3</sup> reports obtaining satisfactory signals from dogs which also had thoracotomies for placement of electromagnetic flowmeter probes. Placement of the electrodes may also have been responsible, but this study was only interested in relative changes. Therefore, once the electrodes were applied they were not moved during the course of the experiment. Clearly there is a discrepancy that exists between the human and dog data which cannot be readily accounted for. However, development of an atraumatic method to measure certain cardiac parameters during treatment of acute dissecting aneurysms would be extremely valuable. Since part of the data in this study does support the use of impedance cardiography in monitoring the cardiac parameter,  $dP/dt_{max}$ , it is felt that this method deserves further evaluation.

#### SUMMARY

The impedance output,  $dZ/dt$ , was compared with  $dP/dt_{max}$  measured in the ascending aorta of humans, and both  $dP/dt_{max}$  and contractility measured in dogs. The following results were obtained.

1. In humans there was a relationship between  $dZ/dt$ ,  $d^2Z/dt^2$  and  $dP/dt_{max}$  before and after Isuprel injection.
2. In dogs  $dZ/dt$  did not relate to either  $dP/dt_{max}$  or contractility.

TABLE 1. Values for  $dP/dt_{\max}$  measured in the ascending aorta and the impedance outputs  $dZ/dt$  and  $d^2Z/dt^2$  measured on 4 subjects before and after administration of 1.9  $\mu$  grams Isuprel for 3 minutes.

NAME	CONTROL			C ISUPREL			RATIO		
	$dP/dt(\max)$ Ascending Aorta	$dZ/dt$ Imped.	$\frac{d^2Z}{dt^2}(\max)$ Imped.	$dP/dt(\max)$ Ascending Aorta	$dZ/dt$ Imped.	$\frac{d^2Z}{dt^2}(\max)$ Imped.	$dP/dt \max$ ( $\bar{c}$ Isuprel)	$dZ/dt$ ( $\bar{c}$ Isuprel)	$d^2/dt^2 \max$ ( Isuprel)
							$dP/dt \max$ (control)	$dZ/dt$ (control)	$\frac{d^2}{dt^2} \max$ (control)
Patient 1 Dx ASD Pulmonic Stenosis	3.3	1.7	11.1	7.4	3.7	21.3	2.2	2.28	1.9
Patient 2 Dx Normal Heart s Coronary Disease	2.8	1.9	8.9	7.1	3.8	25.9	2.6	2.0	2.9
Patient 3 Dx Normal Heart	4.1	2.2	10.2		2.8	12.3		1.3	1.2
Patient 4 Dx CHF (Severe)	3.4	1.5	6.8	4.4	1.7	6.6	1.3	1.1	.91
MEAN	3.4	1.8	9.2	6.0	3.0	16.5	2.0	1.7	1.7



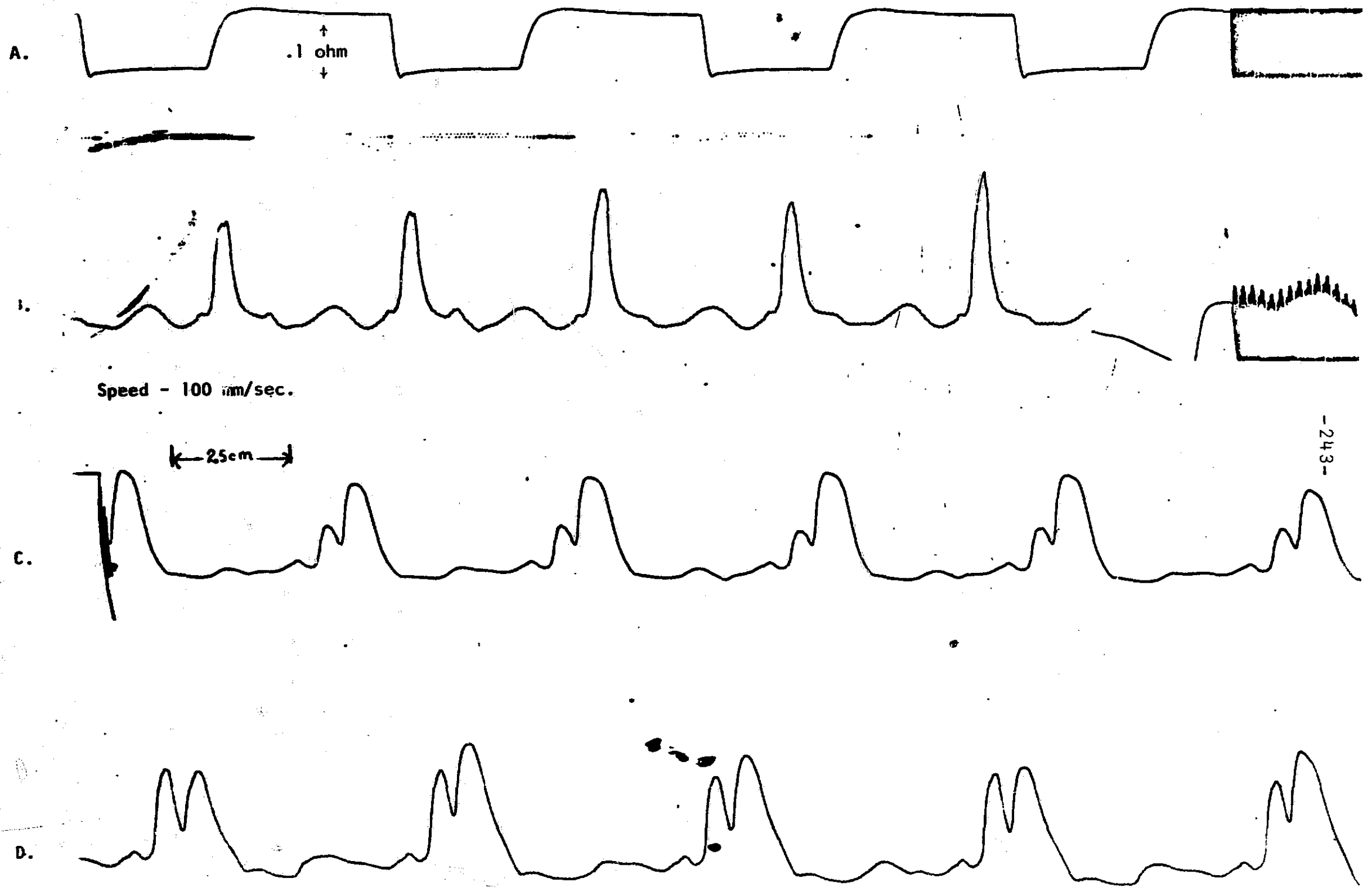
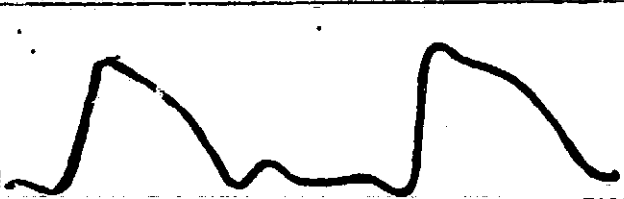

Figure 11. A. Calibration  
B. Control tracing for dz/dt  
C. & D. Tracing after IV injection of 2 mg. Arfonad (see text for discussion)



TIME (min)	STRAIN GAUGE	dP/dt	SHAPE OF PULSE WAVE
0	5.5	2.5	
	19.0	8.5	
2	--	25.0	
	13.5	15.0	
	13.0	2.9	
11	9.0	2.1	
	7.0	3.0	

Figure III. Changes in the height of the strain gauge recording and  $dP/dt_{max}$  (measured in the ascending aorta) when 4  $\mu$ gm. of isoproterenol was injected IV into a dog. A tracing of the shape of the pulse wave measured in the ascending aorta is also shown.

ISOPROTERENOL  
4  $\mu$  gm.

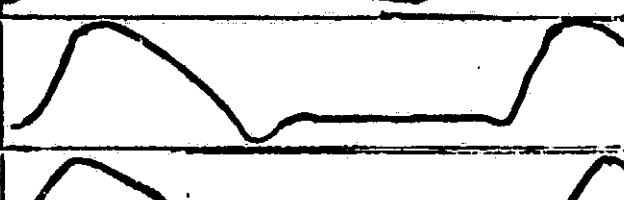
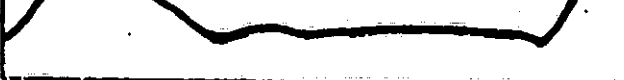
TIME (min)	STRAIN GAUGE	dP/dt	SHAPE OF PULSE WAVE
0	6.5	4.4	
	5.2	21.0	
5	3.5	4.5	
	2.8	2.4	
17	3.5	1.7	

Arfonad  
2mg.

Figure 1. Changes in the height of the strain gauge recording and  $dP/dt_{max}$  (measured in the ascending aorta) when Arfonad (2 mg.) was injected IV into a dog. A tracing of the shape of the pulse wave measured in the ascending aorta is also shown.

### BIBLIOGRAPHY

1. Prokop, E. k., M. W. Wheat, and R. F. Palmer. Hydrodynamic Forces in Dissecting Aneurysms. To be published.
2. Wheat, M. W., Palmer, R. F., Bartley, T. D., and Seelman, R. C. Treatment of Dissecting Aneurysms of the Aorta without Surgery. J. Thor. and Cardiovas. Surg. 50:364, 1965.
3. Kubicek, W. G., D. A. Witsoe, R. P. Patterson, M. A. Mosharrafa, J. N. Karnegis and A. H. L. From. Development and Evaluation of an Impedance Cardiographic system to Measure Cardiac Output and Development of an Oxygen Consumption Rate Computing System Utilizing a Quadrupole Mass Spectrometer. NASA Report No. NAS 9-4500, Houston, Texas, 1967.
4. Siegel, J. H. and M. H. Fabian. The Quantification of Myocardial Contractility by Impedance Plyethysmography. Fed. Proc. 27(2):445, 1968.

A COMPARISON OF CARDIAC OUTPUT VALUES BY THE  
IMPEDANCE CARDIOGRAPH AND DYE DILUTION  
TECHNIQUES IN CARDIAC PATIENTS

-----  
Loren W. Heather, M.D.  
Orange County Medical Center  
Orange, California

N70-10015

In clinical cardiology it is frequently of great practical necessity to obtain physiologic data by noninvasive and atraumatic techniques. Methods to obtain such data quickly and repeatedly without disturbance to the care of the patient will find wide acceptance in diagnosis, monitoring, and evaluation of therapy. It has been proposed that impedance methods may provide useful measurements of cardiovascular dynamics, particularly of stroke volume and cardiac output. Although such data are promising in normal individuals there is less information on the applicability of these techniques in patients with heart disease.

Therefore, we have attempted to correlate data obtained by the use of the Minnesota Impedance Cardiograph with simultaneous data obtained at cardiac catheterization and angiocardiography.

Methods:

38 patients were studied during cardiac catheterization. 36 underwent combined right and left heart catheterization by conventional techniques. One had right heart catheterization with simultaneous femoral artery puncture and one had only left heart catheterization with basilic vein cannulization. All had

cardiac output determination by using indocyanine green calculated by standard Stewart-Hamilton formulae.

**Material:**

Confirmed diagnoses of the 38 patients are listed in table #1.

Mitral Stenosis	3
Mitral Insufficiency	6
Mitral Stenosis and Insufficiency	3
Aortic Stenosis	2
Aortic Insufficiency	6
Combined Valvular Lesions	3
Congenital Heart Disease	5
Myocardopathy	2
Coronary Artery Disease	4
Miscellaneous	3
Normal	1

Table #1: Diagnoses of patients studied.

**Results:**

In all but one case waveforms satisfactory for interpretation were obtained with the Minnesota Impedance Cardiograph. This patient was a 33 year old male with severe hyposcoliosis, atrial and ventricular septal defects, bidirectional shunting and pulmonary hypertension.

Figure 1 shows comparison of cardiac output determinations by the two methods on all patients. The degree of scatter is considerable. Therefore, the patients were examined by diagnosis

to determine if specific hemodynamic abnormalities gave consistent alterations in these measurements.

Figure 2 includes all cases of aortic insufficiency. In all cases the output determined by Impedance exceeded that determined by indicator dilution. The one case of mild aortic insufficiency was closest to the isovalue line.

These findings are not surprising if, as has been postulated, the impedance method actually measures total aortic blood flow, while the indicator dilution technique measures only net forward flow. Further studies would be necessary to determine whether this comparison could be useful in assessing the severity of the regurgitation. If this were so, even on a relative basis, it might be a useful method of monitoring the course of the disease, particularly in patients with bacterial endocarditis and in those patients who develop leaks around prosthetic aortic valves.

In patients with mitral insufficiency our data suggest that the impedance technique underestimates cardiac output, and the degree of underestimation was greatest in those with moderate and severe insufficiency (Figure 3). The reason for this is not clear.

If cases of valvular insufficiency are excluded, correlation of cardiac output determination by the two methods is relatively good (Figure 4).

Although cardiac output determinations are very useful, it is frequently desirable to obtain additional physiological data specifically assessing myocardial contractility. Probably the

best such guide is the angiographic observation of the left ventricular emptying and calculation of ejection fraction. For clinical purposes non-invasive techniques for estimating left ventricular contractility have obvious advantages. Two currently used methods for estimating contractility are seen in Table 2. Both use phonocardiogram and carotid pulse tracings and are based primarily on the time required to generate adequate force to open the aortic valve.

In the impedance tracing the R-Z maximum interval has been suggested as a guide to myocardial contractility. This would appear to be reliable and somewhat similar to Weissler's pre-ejection period. Others have indicated that the height of  $dZ/dt$  related to maximum ejection velocity.

Therefore, it was considered that a combining of these measurements  $\frac{dZ/dt}{q - z}$  interval might be useful in the evaluation of left ventricular function (Figure 4). In a small number of cases where the ECG was recorded this appears to give an excellent separation of cases which on angiography have poor left ventricular function from those with good function (Figure 5). Patients with pure mitral stenosis are in the low normal range, possibly because of poor left ventricular filling.

In Conclusion:

- 1) 38 patients were studied and only one had inadequate waveform.
- 2) Aortic insufficiency results in increased impedance output, possibly in proportion to the severity of the insufficiency.
- 3) Mitral insufficiency, in moderate or severe degrees, gives



a falsely low impedance output by the impedance technique.

- 4) In other individuals impedance output seems to be relatively similar to dye dilution output.
- 5) An index is proposed for evaluation of left ventricular function.

TABLE 2

Non-Invasive Techniques for LV Contractility

Weissler Index: PEP (Pre-ejection Period)  
PEP = (Q-S2) - LVET (Left Ventricular ejection Time)  
Normal PEP: .09-.12 at rate of 70/min

Aranow's Index:  $\frac{\text{LVET}}{\text{EIVCT}}$

EIVCT (External Isovolumic Contraction Time) =  
(S1-S2) - LVET

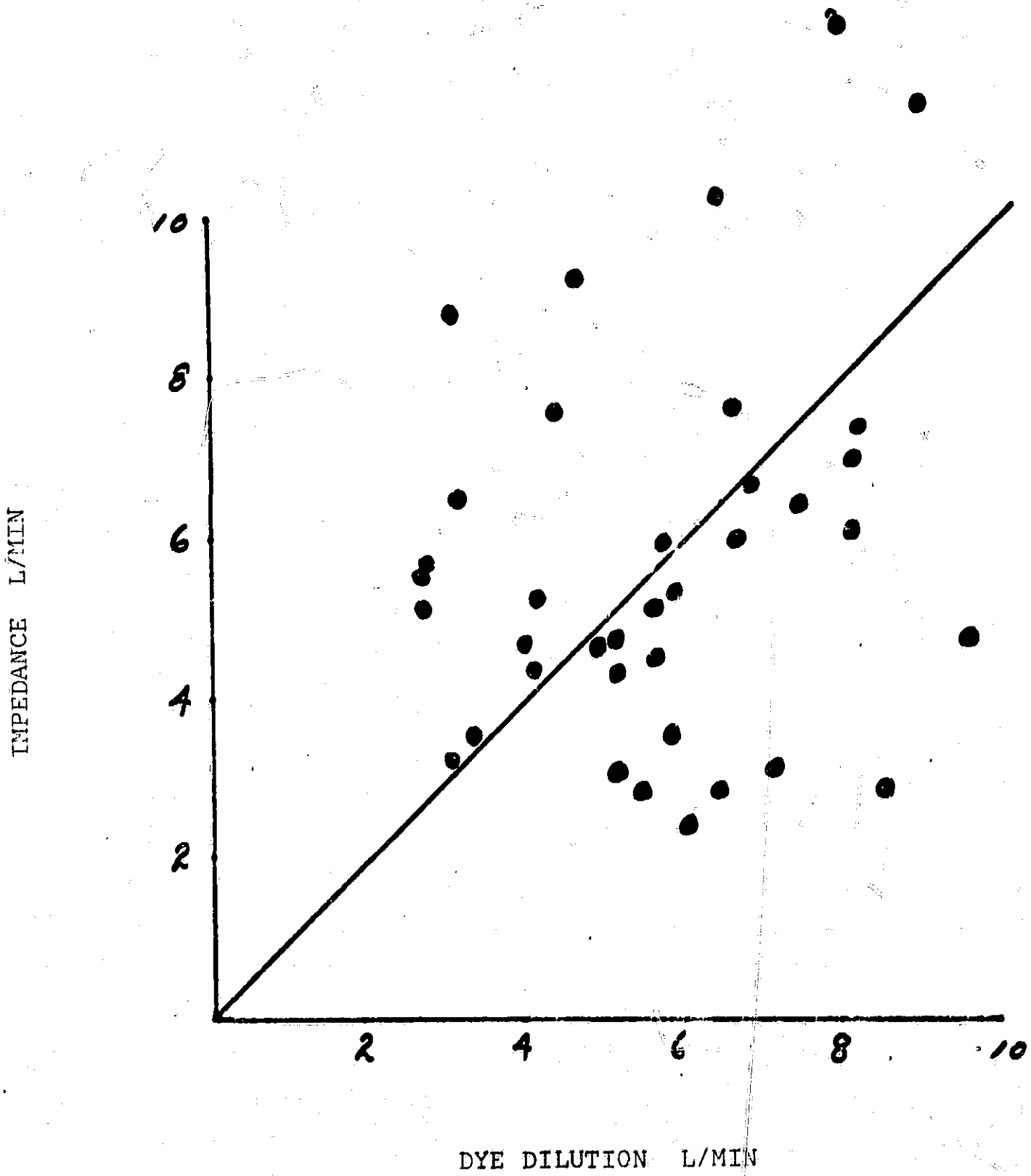

Figure 1: CARDIAC OUTPUTS, ALL PATIENTS

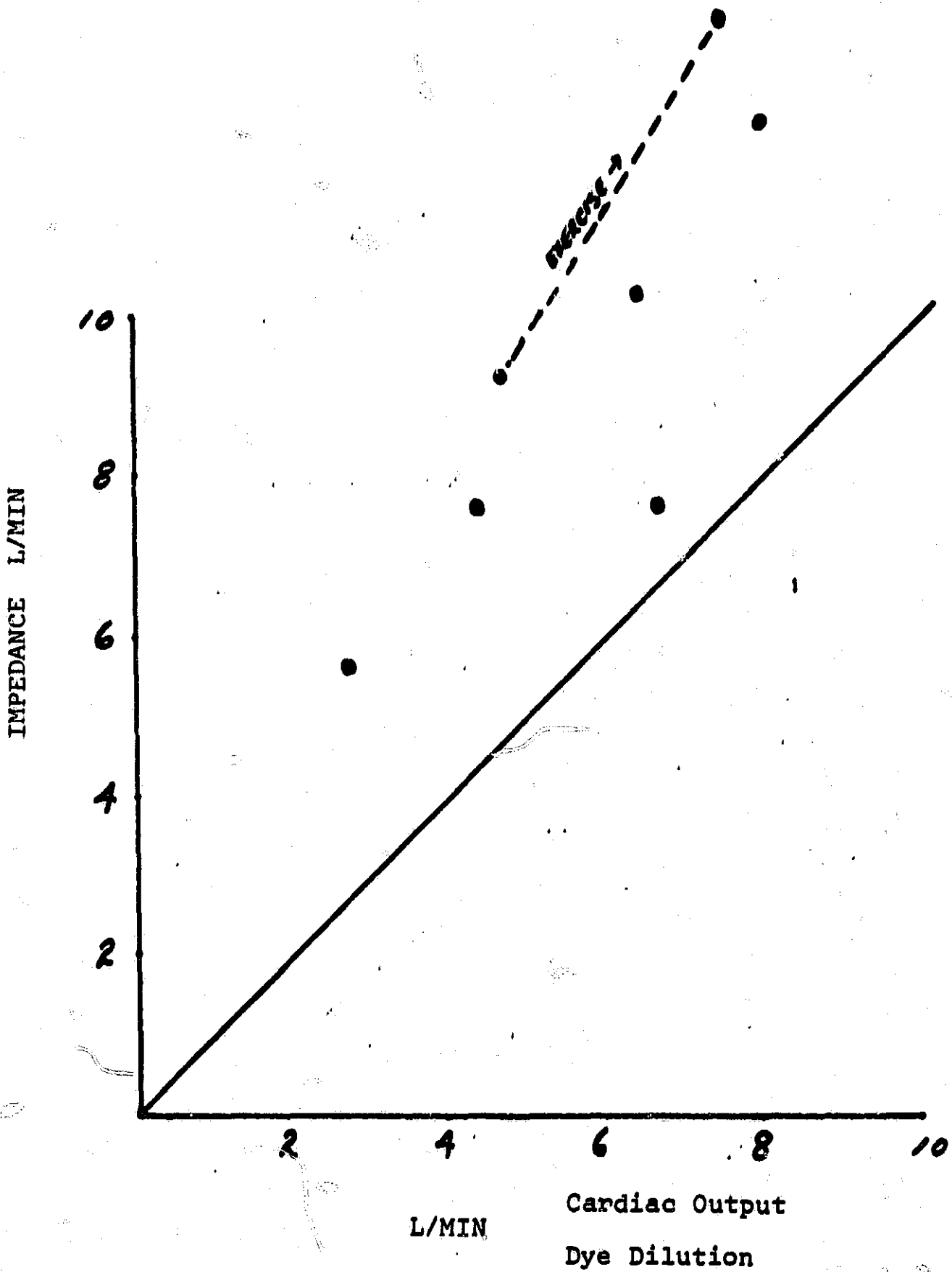
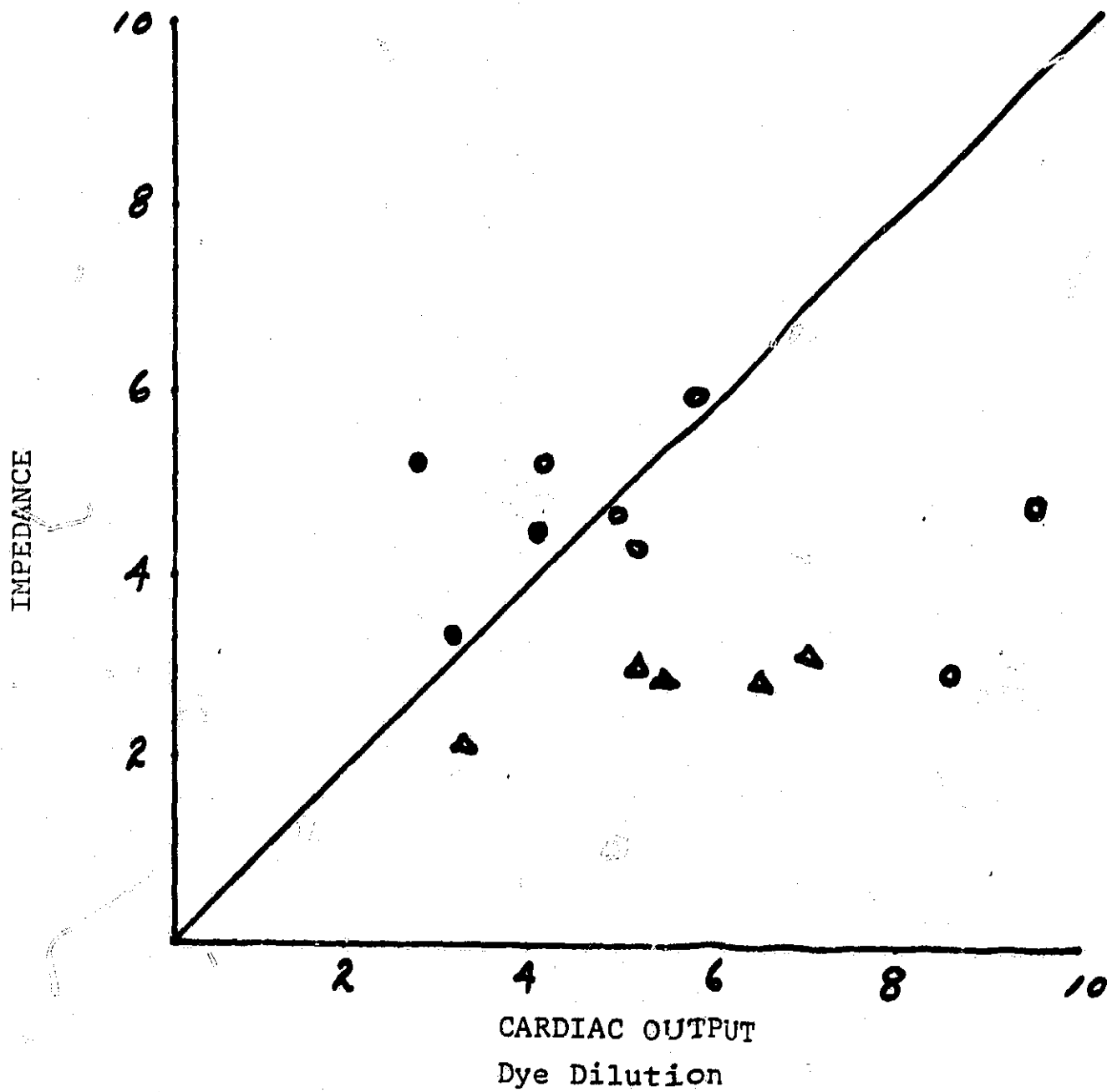

Figure 2: AORTIC INSUFFICIENCY



Mitral Stenosis

Mitral Insufficiency

Combined Stenosis + Insufficiency

Figure 3: Mitral Valve Disease

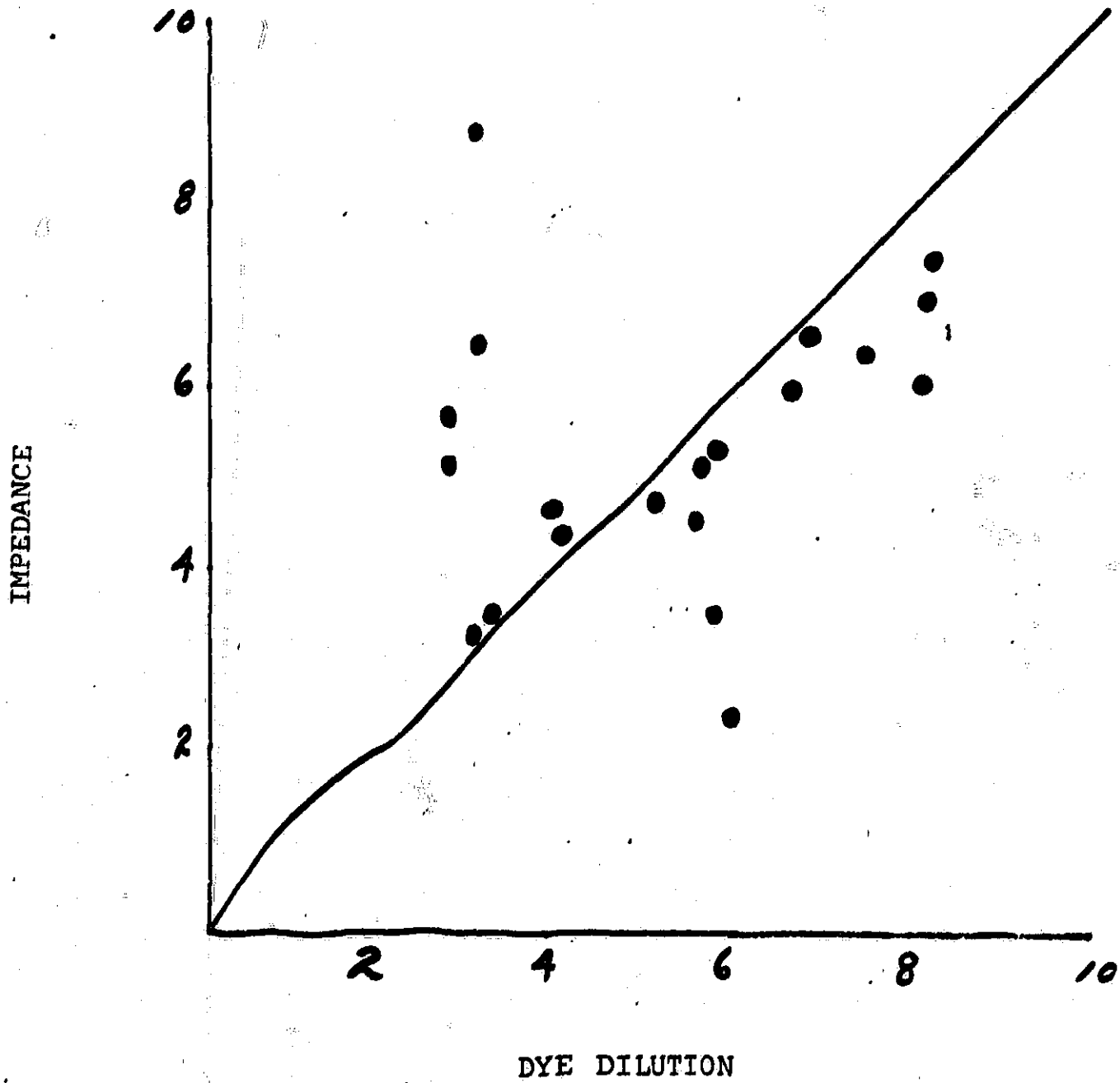

Figure 4: Patients without Valvular Insufficiency

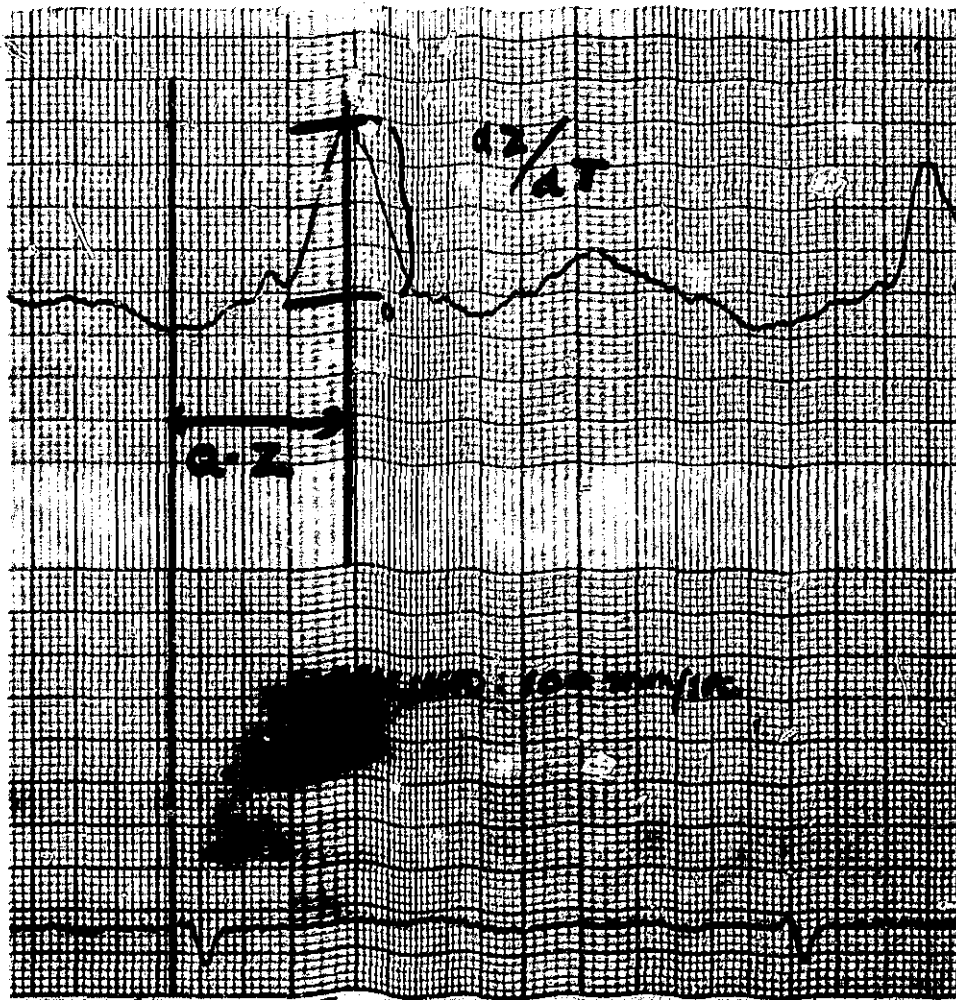
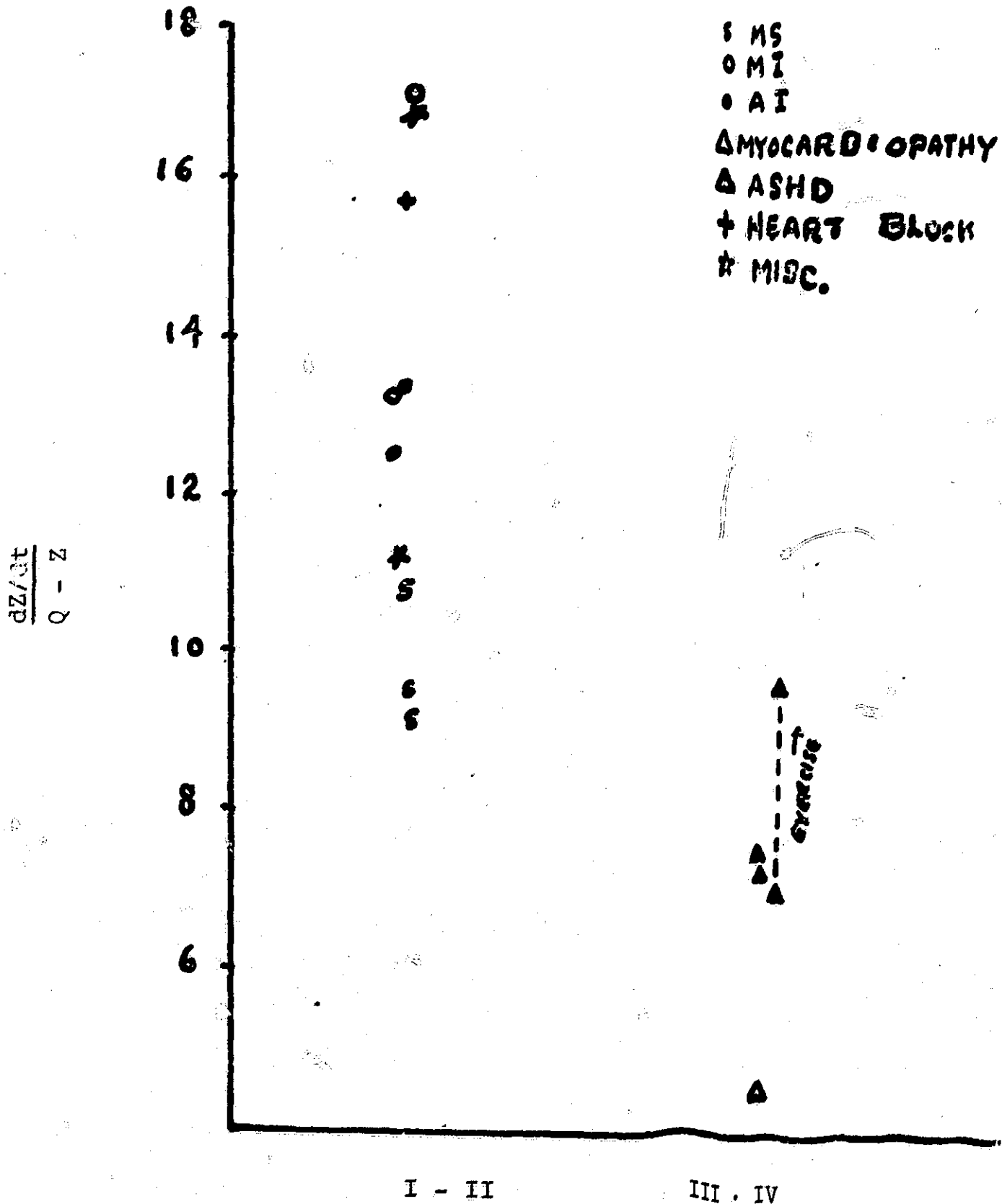

FIGURE 5



I - II III - IV  
MYOCARDIAL CONTRACTILITY - ANGIO

Figure 6



Estimate of Cardiac Output with the  
Impedance Cardiograph  
During Postural Stress

\* \* \* \*

N70-10016

James J. Smith, John E. Bush,  
V. Thomas Wiedmeier and Felix E. Tristani

From the Department of Physiology  
Marquette School of Medicine  
Milwaukee, Wisconsin

Department of Mechanical  
Engineering  
Marquette University  
Milwaukee, Wisconsin

Clinical Hemodynamics Laboratory  
Veterans Administration Hospital  
Wood, Wisconsin

Transthoracic impedance has been studied by Nyboer<sup>1</sup>, Geddes<sup>2</sup> and others and used mainly for measurement of respiratory ventilation. Recently, serious efforts have been made, particularly by Kubicek<sup>3</sup> and his associates, to adapt electrical impedance to the investigation of cardiac function. In dogs fitted with electromagnetic flowmeters, these investigators found good agreement between aortic flow and impedance-derived cardiac output; they also noted that the peak first derivative of the main impedance wave correlated with peak flow in the ascending aorta and that the second impedance derivative correlated with blood acceleration in the aorta.<sup>4</sup> Other reports on impedance cardiography have however been conflicting. Harley and Greenfield<sup>5</sup> found impedance measurements of cardiac output not too satisfactory, especially in certain cardiac disorders, and Hill<sup>6</sup> strongly questioned the basic validity of the impedance method itself on technical grounds. On the other hand, Coleman<sup>7</sup>, Siegel and Fabian<sup>8</sup>, Namon and Gollan<sup>9</sup>, and Krohn and associates<sup>10</sup> all found impedance cardiography to be useful technique.

During an investigation in our lab in which a non-invasive method was particularly advantageous, Dr. Kubicek kindly loaned us one of his instruments. Our objectives in the present study were (1) to assess the validity of the transthoracic impedance method for the measurement of cardiac output in the human and (2) to determine its possible usefulness in studying circulatory response to postural and other tests.

The investigation was done in two parts; in the first,

35 cardiac output determinations were done simultaneously with the dye-dilution and the impedance method during head-up tilt in 8 normal young male subjects. Indocyanine green was injected into an antecubital vein and blood withdrawn from a brachial artery through a Colson densitometer. The cardiac output calculations were done in the usual manner. In the second series, the Impedance Cardiograph was used to estimate stroke volume at frequent intervals during head-up tilt, but without the accompanying arterial cannulation.

The instrument used, the Minnesota Cardiograph, Model 202, is a four-electrode impedance system with two circular electrodes placed around the subject's neck, one around the lower thorax and the fourth around the lower abdomen as shown in figure 1. The upper and lower electrodes were excited by 100 KHz constant sinusoidal current and the resultant voltage (proportional to the magnitude of the impedance change) was monitored by the inner two electrodes.

The impedance signal is shown in figure 2. The upper tracing indicates the change in basic impedance upon heart contraction, the middle record is the first derivative of the impedance signal ( $dZ/dt$ ) and the lower shows the ECG. In the upper corner is shown the formula, partly empirical, proposed by Kubicek for the calculation of stroke volume:

$$\Delta V = \rho \frac{L^2}{Z_0^2} T \left| \frac{dZ}{dt} \right|_{\max}$$

$\Delta V =$  stroke volume

- $\rho$  = resistivity of the blood, which is assumed to be about 150 ohm/cm
- L = mean distance (cm) between the inner electrodes
- $Z_0$  = basic impedance between the two inner electrodes
- t = ventricular ejection time (msec)
- $\left| \frac{dZ}{dt} \right|_{\max}$  = magnitude of the peak value of the impedance derivative (ohm/sec)

Previous studies have shown that the beginning downsweep of the primary wave and its derivative appear to be synchronous with the beginning of ventricular ejection and the maximum deflection of the followup wave is synchronous with closing of the aortic valve. Thus the period between these two is the left ventricular ejection period (T) and the (R-Z) interval from R to the beginning of ejection represents the pre-injection period. Furthermore, as previously stated, the peak first derivative of the main impedance wave has been said to correlate with the maximum velocity of aortic blood. These additional variables--aside from cardiac output--provide useful information. However, further studies are needed to establish these relationships more precisely, particularly that of blood velocity and acceleration in the aorta to the impedance measurements.

The impedance stroke volumes (calculated according to the formula) and the dye stroke volumes are plotted in figure 3; the correlation coefficient (r) was +0.87. As you will note, the least square line, if extended, would produce a + intercept, i.e., impedance readings tended to be higher than dye readings. The cardiac output values when plotted gave very

similar results.

The stroke volume ratios ( $Z/\text{dye}$ ) were averaged for each individual and are shown in figure 5; the overall mean ratio was 1.10, i.e., the impedance readings were about 10% higher. If a correction is made for each individual using the respective ratio and the two values again plotted, the result is an improved correlation as shown in figure 4, suggesting that the impedance stroke volume may better serve as a relative measure of cardiac output for a given individual than as an absolute measure.

In subsequent experiments, impedance stroke volumes were estimated sequentially in a group of normal subjects during 70° head-up tilt and averaged results are shown in figure 6. These are mean values of cardiovascular determinations made before, during and after 70° head-up tilt. During tilt, heart rate increases, cardiac output decreases and stroke volume even more; there is a modest rise in diastolic blood pressure and a significant rise in peripheral resistance. These results are similar to those previously reported using other cardiac output methods.

A comparison of stroke volume, heart rate and peripheral resistance data in individual cases was very helpful in delineating physiological mechanisms involved in the response. In addition, other variables--such as  $dZ/dt$  and the ventricular pre-ejection and ejection times-- were derived from the impedance records and provided useful information. Data of this type is readily available during cardiac catheterization but its frequent recording via external electrodes represents an advantage in studies of this type.

Summary and Conclusions:

1. 35 simultaneous determinations of cardiac output in young male adults by the dye and impedance methods yielded a correlation coefficient of  $+0.87$  between the two methods. Using Kubicek's formula, the impedance readings averaged about 10% higher than the dye readings.

2. Aside from stroke volume, auxiliary data of hemodynamic value, such as  $dZ/dt$ , the (R-Z) interval and left ventricular ejection time, may be derived from the impedance record.

3. Our results suggest that the impedance cardiograph may have considerable potential for research and clinical use in cardiology. However, further study is needed not only with regard to its validity as a measure of cardiac output but also to further determine the basic factors governing the origin of the basic impedance waves and their precise relationship to key hemodynamic variables, such as velocity and acceleration of aortic blood.

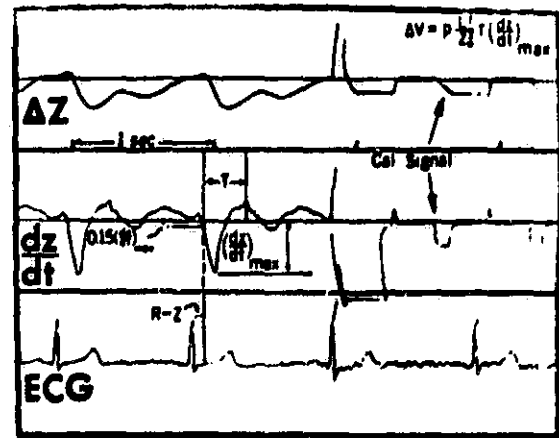
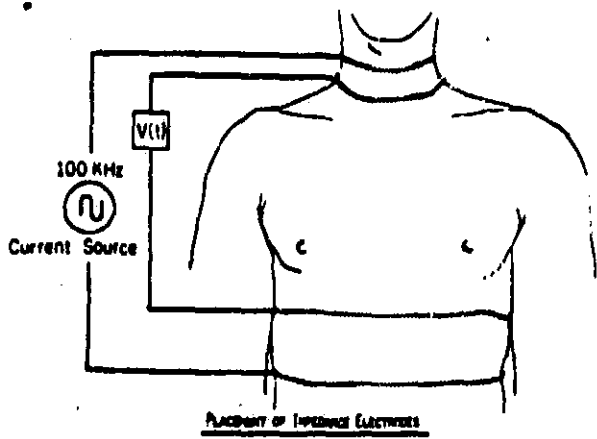
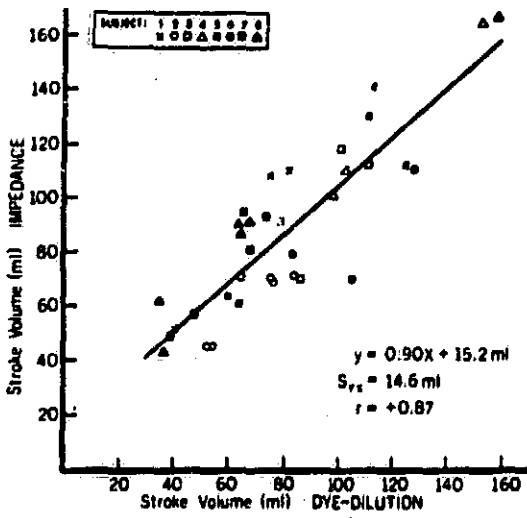

FIGURE 4. (A-D). Four Derivatives of Stroke Area (Z) and 22 Voltage (V) over 20 (ms)

1



Stroke Volume as Measured by Impedance vs. Intra-Aortic Volume

2

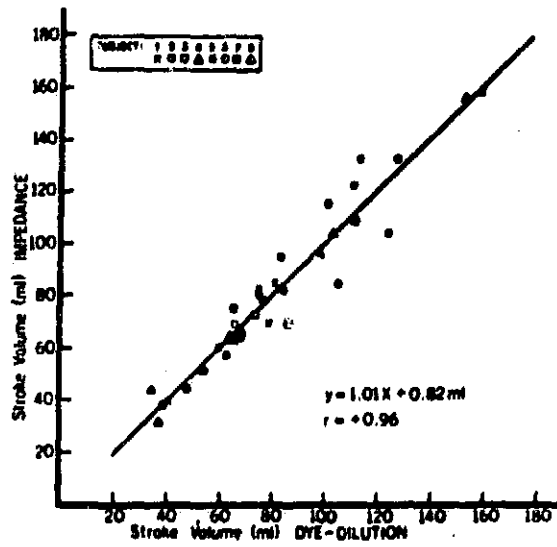

Stroke Volume as Measured by Impedance vs. Intra-Aortic Volume - Intra-Aortic Catheter

3

MEAN RATIOS OF Z-CALCULATED/DYE-CALCULATED CARDIAC OUTPUTS

SUBJECT No.:	1	2	3	4	5	6	7	8
MEAN RATIOS:	1.27	0.91	1.00	1.06	0.98	0.84	1.32	1.33

OVERALL MEAN RATIO:  $1.10 \pm 0.19$   
(N = 35)

5

4

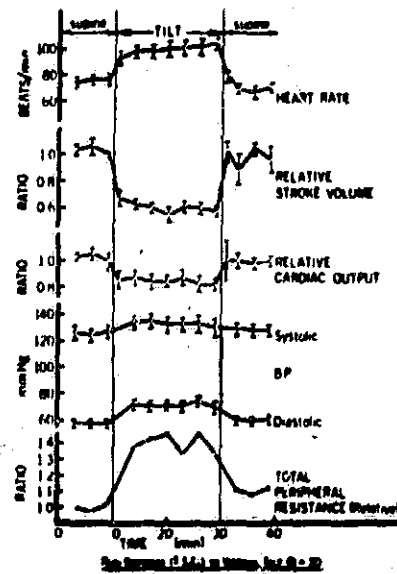

6

References:

1. Nyboer, J. "Electrical Impedance Plethysmograph," C.C. Thomas, Springfield, 1959.
2. Geddes and Baker. "Principles of Applied Biomedical Instrumentation," Wiley and Sons, New York City, 1968, p. 150.
3. Kubicek, W.G., J.N. Karnegis, R.P. Patterson, D.A. Witsoe and R.H. Mattson. Development and evaluation of an impedance cardiac output system. Aerospace Med. 37(12):1208-1212, 1966.
4. Kubicek, W.G., D.A. Witsoe, R.P. Patterson, M.A. Mosharrafa, J.N. Karnegis and A.H.L. From. Development and evaluation of an impedance cardiographic system to measure cardiac output and development of an oxygen consumption rate computing system utilizing a quadrupole mass spectrometer. NASA Report No. NAS 9-4500, NASA Manned Spacecraft Center, Houston, Texas, July 1967. 178 pp.
5. Harley, A. and J.C. Greenfield. Determination of cardiac output in man by means of impedance plethysmography. Aerospace Med. 39:248-252, 1968.
6. Hill, R.V., J.C. Jansen and J.L. Fling. Electrical impedance plethysmography: A critical analysis. J. Appl. Physiol. 22(1):161-168, 1967.
7. Coleman, B., J.W.M. Fletcher, and H.F. Bonfili. Human cardiodynamic responses to heat exposure: Impedance plethysmographic measurements of cardiac output. AMRL-TR-67-93.
8. Siegel, J.H. and F. Fabian. The quantification of myocardial contractility by impedance plethysmography. Fed. Proc. 27(2):445, 1968.
9. Namon, R. and F. Gollan. External monitoring of cardiac output by reactive electrical impedance. Fed. Proc. 27(2):325, 1968.
10. Krohn, B.G., E. Dunne, O. Magidson, H. Hanish, H.K. Tsuji, J.V. Redington and J.H. Kay. The electrical impedance cardiogram in health and disease. Am. Ht. J. 76:377-387, 1968.



N70-10017

A COMPARISON OF CHANGES IN STROKE VOLUME  
AND CARDIAC OUTPUT IN SUBJECTS  
STRESSED BY UPRIGHT TILT AND LOWER BODY NEGATIVE PRESSURE

by

Richard J. Gowen, Major, USAF, Ph.D.

Richard D. Barnett, M.S.

Fred L. Zaebst, M.S.

from the

Bioengineering Laboratory  
Department of Electrical Engineering  
USAF Academy, Colorado 80840

The Bioengineering Laboratory at the Air Force Academy is currently engaged in peripheral cardiovascular research which is jointly sponsored by NASA and the Air Force. Our present efforts are focused on two areas: The development of non-invasive peripheral cardiovascular instrumentation for use in the space program and the investigation of the physiology of the peripheral cardiovascular system. In order to study the dynamic activity of the cardiovascular system and to evaluate the fidelity with which prototype instrumentation developed in our laboratory responds to these changes, we are making extensive use of both orthostasis and lower body negative pressure (LBNP) stresses to produce controlled cardiovascular changes.

Historically, orthostasis has represented a major cardiovascular stress test for both clinical and experimental evaluations. Thus, there is now available in the literature a large body of data which documents the cardiovascular effects of orthostasis.

As an end point criterion for cardiovascular evaluation LBNP offers several distinct advantages over tilt table procedures: the rate and magnitude of physiological changes can be closely controlled by adjusting the vacuum applied; the subject and recording apparatus need not be moved, thus allowing continuity of observations; syncope may be induced without the use of vasodilator drugs; the subject remains supine during the entire experiment thereby eliminating the hydrostatic pressure differentials which occur with orthostasis and the subject discomfort frequently associated with tilt table saddle supports is eliminated.

As a result of these advantages, an increasing number of papers reporting the effects of lower body negative pressure on the cardiovascular system have appeared in the literature, and the adoption of this stress method by a number of laboratories has occurred. The existence of a variety of cardiovascular data obtained using these two similar but not previously equated stresses has emphasized the need for a study designed to compare the effects of lower body negative pressure and tilt on the cardiovascular system.

As a result of our common interest in both stresses, we have been confronted with an immediate need for such a comparative study. We have, therefore, initiated a series of experiments designed to determine the negative pressure stress which approximates that produced by tilt for a variety of cardiovascular parameters.

In order to avoid the cardiovascular stresses associated with intravascular instrumentation, such as those reported by Green et. al. (1961), Rushmer (1944) and Stevens (1966), all monitoring in our laboratory is restricted to the use of non-invasive techniques. This exclusion of invasive methodology has underlined the need for an indirect method for the monitoring of cardiac activity which has long been recognized by physicians and human physiologists.

The use of impedance techniques to measure changes in internal organs is a relatively recent development. This area was reviewed by Nyboer (1959). A number of investigators have recently applied this method to the study of both peripheral and central changes in the cardiovascular system. The development of the Minnesota Impedance Cardiograph by Kubicek and co-workers

has now made available a prototype device for the measurement of stroke volume. The availability of a standard instrument and method for evaluation in various laboratories should help to reduce the variability of results frequently reported and to focus attention on the repeatability, accuracy and reliability of the method and device rather than the differences in instrumentation and technique which occur from laboratory to laboratory.

Bush et. al. (1968) have reported the results of experiments in which both the Minnesota Impedance Cardiograph and dye-dilution methods were used to measure stroke volume and cardiac output changes in normal subjects during orthostatic stress. These workers found relatively high correlation between the two methods, correlations somewhat better than those reported by Harley and Greenfield (1968). Bush et. al. felt that this result could be explained in part by the fact that outputs measured in their study were all normal or below normal values produced by tilt, whereas those obtained by Harley and Greenfield were in the normal to above normal range produced by isoproterenol infusion.

The data presented in this paper document stroke volume, cardiac output and heart rate changes measured using the Minnesota Impedance Cardiograph during tilt table and lower body negative pressure comparison studies presently being carried out in our laboratory.

#### Materials and Methods

All experiments reported in this paper were carried out using an integrated tilt table-lower body negative pressure chamber developed in our laboratory. The negative pressure chamber is connected to a heavy-duty vacuum cleaner which provides sufficient vacuum to allow negative pressures

from 0 - 75 mm Hg to be achieved within the chamber. Subjects are sealed in the chamber at the level of the iliac crests by an inflatable waist seal.

The tilt table provides a 70° upright tilt with the subject supported by a specially constructed saddle.

The six volunteer subjects utilized in these experiments were all Air Force officers and members of the faculty of the Air Force Academy. They ranged in age from 24 to 36 with an average age of 30. All were certified to be in good health by an Air Force medical officer prior to each experiment. The subjects were acquainted with the LBNP and tilt table stresses and with the monitoring instrumentation during several preliminary experiments. Each subject followed a rigid protocol for 24 hours prior to his participation in an experiment. This protocol included abstinence from alcoholic beverages for 24 hours and from sexual intercourse, smoking, bathing, coffee and/or tea and undue physical exercise on the morning of an experiment. Breakfast was restricted to the drinking of one can of a nutrient beverage such as Metracal or Nutrient at 0700 hours.

All experiments were performed between 0800 and 1000 hours. The following parameters were recorded during each experiment:

Blood Pressure: Blood pressure readings were obtained using an automatically inflated brachial cuff on a one minute cycle. Korotkoff sounds were detected with a Spacelabs crystal microphone placed over the brachial artery.

ECG: Electrocardiograms were recorded from two sets of leads, one from a pair of axillary disc electrodes and the other from a similar pair

located over the xiphisternum and vertebral column.

Heart Sounds: Heart sounds were recorded using a Spacelabs crystal microphone placed over the third or fourth intercostal space just lateral to the sternum. All the above signals were processed by standard NASA biomedical signal conditioners similar to those used in the Gemini and Apollo programs.

Right and Left Leg Volumes: Right and left leg volumes were recorded using mercury-in-silastic strain gauges.

Stroke Volume, Heart Rate and Cardiac Output: The first derivative waveform was recorded at one minute intervals from a standard tetrapolar lead system using mylar strip electrodes supplied by the 3M Company. The first derivative output from the Minnesota Impedance Cardiograph and heart sound signals from the NASA signal conditioners were fed to a two channel Sanborn 302 recorder and recorded at a paper speed of 100 mm/second. Stroke volume, heart rate and cardiac output were calculated from these signals. All recordings were made during periods of apnea at one minute intervals.

Stroke volumes were calculated using the formula suggested by Kubicek (1967) for use with the derivative waveform.

The three experimental protocols utilized in this study are shown in Figure 1. All experiments covered a total of one hour and were designed to expose subjects to a sequence of ten minutes rest, ten minutes stress, fifteen minutes rest, ten minutes stress and final fifteen minute rest period. The initial low stress series of experiments was undertaken as a pilot study to evaluate cardiovascular responses to low levels of negative pressure followed by tilt. The results of these experiments indicated that

the 20-30 step profile was generally less stressful than the ten minute tilt. The second experimental series (high stress) which utilized a 40-50 mm Hg negative pressure step profile was then initiated. This series included profiles in which the order of stress was reversed for each subject. That is, each subject was exposed at least once to a profile in which the 40-50 mm Hg negative pressure profile preceded tilt and one in which the tilt stress preceded vacuum. Thus, all subjects were exposed at least once to each of the three experimental profiles.

### Results

Our initial objective was to determine if the Impedance Cardiograph did, in fact, produce repeatable results during the test profiles used in our laboratory. Therefore, we first evaluated the repeatability of results obtained from our subjects during recumbent rest in the tilt table-lower body negative pressure chamber. These data were obtained during several sessions spanning a two to three month period. Figure 2 is a plot of the results obtained during these experiments. In all cases, the means for the six subjects fall within reasonable values, and standard deviations were relatively small.

The repeatability of results obtained during dynamic testing is demonstrated in Figure 3 for the 20-30 mm Hg negative pressure stress and Figure 4 for the 40-50 mm Hg negative pressure stress. In each of these experiments a subject was exposed on three occasions to the same stress profile. Means and standard deviations were then calculated for each stress period from the data for the three experiments. The consistently small standard deviations obtained during test and stress support the conclusion that the results during stress were as repeatable as those obtained during

rest.

Minute to minute average relative percent changes in stroke volume and cardiac output for the six subjects are plotted in Figure 5.

Normalized percent changes for each subject were calculated as follows:

$$\text{Normalized \% change} = \frac{V_i}{V_{ave}} \times 100 \quad \text{where:}$$

$V_i$  = absolute value for the minute being calculated

$V_{ave}$  = average value for the first ten minutes of recumbent rest

While data such as those presented in Figures 3, 4 and 5 suggest certain relationships between the stresses utilized and their cardiovascular effects, we wanted to obtain a method which would yield more precise comparisons between the various cardiovascular responses recorded. We, therefore, used the Wilcoxon rank order test to evaluate each subject's stroke volume, heart rate and cardiac output responses under the following conditions:

1. Responses to 40 mm Hg vacuum versus responses to the initial 5 minutes of tilt. Comparisons were made for profiles in which vacuum was the initial stress and those in which tilt was the initial stress.

2. Responses during -40 mm Hg vacuum were then compared to the responses during the -50 mm Hg vacuum phase of the same stress. If no significant difference was found, the data for the entire vacuum period were pooled and compared to those occurring during the 10 minute tilt period of the same experiment. If there was a significant difference between the -40 and -50 mm Hg vacuum responses, the data obtained during



the -50 mm Hg vacuum phase were compared to the data obtained during the last five minutes of tilt. Vacuum responses treated in this way are referred to as "pooled data."

3. To evaluate the effect of LBNP and tilt, irrespective of the order in which the stress was applied during a run, each subject's responses to -40 mm Hg vacuum and to the first five minutes of tilt were grouped and evaluated without regard to the order of stress. The same procedure was then utilized to compare the "pooled" vacuum responses to the pooled tilt responses.

4. The effect of the initial stress on responses during the second stress period of an experiment was then investigated as follows: pooled responses during initial vacuum periods were compared to those during vacuum periods preceded by tilt and responses during initial tilt periods were compared to those during tilt stresses preceded by vacuum.

Tests yielding probabilities of less than five percent were accepted as being significantly different.

The results of these tests were then compiled in tables of the type illustrated in Table 1. This table summarizes results for six subjects for stroke volume, cardiac output and heart rate when vacuum responses were compared against tilt responses. Individual subject's responses were scored as: V: when the vacuum response was significantly greater than the tilt response, T: when the tilt response was significantly greater than the vacuum response and (-): when there was no significant difference between the two responses. The overall responses of all subjects were then summarized by calculations similar to those illustrated at the bottom of Table 1. In these calculations the number of times that one

stress was significantly greater than the other was divided by the total number of analyses for the three parameters to yield values reflecting the overall response of the six subjects.

The results of these analyses are shown in Figures 6, 7 and 8. In Figure 6, subject responses are outlined for comparisons between vacuum and tilt during the same protocol. These indicate that the five minute tilt stress produced significantly greater subject responses more frequently than the five minute -40 mm Hg pressure stress. However, when the 40-50 mm Hg negative pressure data were pooled and compared against the pooled tilt data, the vacuum stress was most frequently the greater stress. These results also suggest that responses during the second stress period may be influenced by the first stress.

In order to correct for this interaction, each subject's responses to vacuum and tilt were pooled and compared irrespective of the order of stress as noted above. Results of this analysis are revealed in Figure 7. When the response data for 40 mm Hg negative pressure were compared to the first five minutes of tilt, tilt was still found to most frequently represent the greater stress. The analysis of the pooled data yielded similar results showing that the entire vacuum period or the last five minutes of vacuum represented a greater stress than did tilt.

In order to elucidate the effect of the first stress period on the responses occurring during the second stress, vacuum responses when vacuum was the first stress were compared with those when vacuum was the second stress (Figure 8). There were no clear cut differences between

responses during the first and second vacuum periods. However, responses during the second tilt period were frequently greater than those recorded during the first tilt period.

The overall responses for all subjects for the three profiles completed are summarized for stroke volume and heart rate in Figures 9 and 10. Data plotted in Figure 9 indicate that stroke volume responses to the 40-50 mm Hg vacuum profiles were greater than those to the 20-30 mm Hg vacuum profile. Heart rate responses during tilt, however, were greater when preceded by the 40-50 mm Hg vacuum than when tilt was the first stress. A similar pattern of responses for heart rate is indicated in Figure 10. However, these data also indicate that the cardiovascular responses to 40-50 mm Hg negative pressure are increased when the stress is preceded by tilt.

#### Discussion

As is indicated by Figures 2, 3 and 4, the repeatability of data obtained from our subjects during recumbent rest and during stress was reasonably good. Standard deviations remained small and consistent during stresses indicating that the response of the instrument is not capricious during stress tests which reduce stroke volume in normal subjects. Minute by minute plots of average stroke volume and cardiac output (Figure 5) for all subjects again support the repeatability of results obtained during rest and stress conditions.

In addition, overshoots appear in both stroke volume and cardiac

output following termination of stress. This result agrees with observations made by Brown and co-workers (1966) who described overshoots in forearm blood flow, systolic and diastolic blood pressure and undershoots in heart rate in subjects following release of vacuum. The magnitude of the overshoot and the time of maximum change varied considerably from subject to subject in our experiments as is illustrated by the large standard deviations following release of stress. Some subject variability no doubt contributed to this phenomenon.

When the six subjects' stroke volume, heart rate and cardiac output responses to tilt and vacuum were compared, it was shown that there was a significant difference between responses to the two stresses, irrespective of order. The initial five minute tilt stress represented a greater stress than the five minute 40 mm Hg negative pressure period in 36% of the responses whereas vacuum was the greater stress in only 6% of the determinations. In contrast, when the pooled responses to the 40-50 vacuum profile were compared to the tilt responses, again irrespective of order, vacuum was found to represent the greater stress in 50% of the comparisons whereas tilt was the greater stress in only 8% of the comparisons. In addition, in 58% of the 40 mm Hg vacuum versus tilt comparisons there were no significant differences, whereas there were no significant differences in only 42% of the comparisons of the 40-50 mm Hg vacuum versus tilt responses. These observations all support the conclusion that the vacuum stress which most closely approximates tilt for the parameters measured lies between 40 and 50 mm Hg negative pressure and since the smallest number of significant differences occurred for the 40 mm Hg negative

pressure stress vs tilt that the equivalency point lies closer to 40 than to 50 mm Hg negative pressure for stroke volume, heart rate and cardiac output.

As noted above, the data presented in Figures 9 and 10 suggest that the initial stress in a test profile may influence cardiovascular responses during the second stress. For example, for the pooled 40-50 mm Hg vacuum versus tilt comparisons, vacuum was the greater stress for 39% of the comparisons when vacuum was the first stress but 61% of the time when vacuum was second. Conversely, tilt was the greater stress in 16% of the comparisons when vacuum was first but never when vacuum was second. The conclusion that the initial stress in a profile may influence cardiovascular responses during the second stress is further supported by the comparisons shown in Figure 8. In this analysis, pooled responses during the initial vacuum stresses were compared with those when vacuum was the second stress. In 28% of the analyses, the initial vacuum stress was greater than the second stress, while in 22% of the comparisons the responses during the second vacuum were greater, suggesting that the tilt stress prior to the 40-50 mm Hg vacuum stress had little or no effect. However, the analysis of responses during the first and second tilt stresses shows that in 11% of the comparisons, responses during the first stress were greater than those measured during the second stress, but in 44% of the comparisons cardiovascular responses during the second period were greater than those during the first. These data support the conclusion that tilt prior to vacuum has little or no effect on cardiovascular responses during the vacuum stress, but that the 40-50 mm Hg vacuum stress

prior to tilt does increase the cardiovascular responses observed during the tilt period.

This result may be due to the fact that the 40-50 vacuum profile presents a greater cardiovascular stress than does tilt. Now if the stability of the cardiovascular system is perturbed more severely by the vacuum profile, it may require a period of time for recovery which is longer than the fifteen minute rest period between the stresses. Since the tilt stress produces cardiovascular changes smaller than those produced by vacuum, the residual effects of the initial vacuum could then be detected during the following tilt period as increased cardiovascular responses.

The mean stroke volume and the heart rate responses for all subjects for each of these stresses which are plotted in Figures 9 and 10 also emphasize this effect. For both stroke volume and heart rate, tilt responses are greater when preceded by vacuum. However, stroke volume changes during vacuum preceded by tilt were less than when vacuum was the initial stress. The reason for this is not entirely clear. However, it may be that all parameters do not respond identically to vacuum and tilt stresses and that this observation is simply a reflection of this fact.

In general, the changes in stroke volume, heart rate and cardiac output obtained in our experiments during tilt stresses agree closely with those reported by Bush et. al. (1968) both in terms of the magnitude of the changes which occurred during stresses and the time course of events during the experiments. During tilt, the subjects showed a mean decrease in stroke volume of approximately 40% as compared to 38% in our

subjects for experiments in which tilt was the initial stress. Bush et. al. also reported overshoots in stroke volume and cardiac output for some subjects, although this effect is not reflected in their mean minute to minute plots for all subjects. This discrepancy may be explained by slight differences in methodology between their experiments and ours. In our experiments, all parameters were sampled each minute whereas determinations were made at 3 to 4 minute intervals in their experiments. Thus, they may have failed on occasion to detect overshoots which occurred between recordings.

#### Conclusions

We feel that the Minnesota Impedance Cardiograph, Model 202, is a useful tool for the evaluation of cardiac activity during stresses producing reductions in stroke volume and cardiac output. While it is clear that much work remains to be done in the areas of calibration and the elucidation of the physiological changes underlying the recorded impedance changes, the non-invasive nature of this technique makes it extremely attractive for both clinical and experimental use.

Bush, et. al. (1968) reported no adverse subject reactions to the 3M electrode tape. However, one of our subjects experienced some skin irritation following removal of the electrodes.

The repeatability of our results obtained when subjects were exposed on several occasions to the same profile was satisfactory, indicating the usefulness of the device in experiments designed to provide replicate data.

One of the major drawbacks inherent in the method is the requirement that the subject hold his breath during recordings. We have observed that heart rates may change rapidly in some subjects on the initiation of

breath holding. Clearly, this phenomenon would effect both stroke volume and cardiac output. In addition, breath holding would be impossible in an unconscious or heavily exercising individual.

#### Summary

1. The Minnesota Impedance Cardiograph, Model 202, was used to measure stroke volume, heart rate and cardiac output changes in six normal subjects during tests designed to compare the cardiovascular effects of -20, -30, -40 and -50 mm Hg lower body negative pressure with those produced by 70° upright tilt.
2. Repeatable stroke volume results were obtained from all subjects during recumbent rest and stress.
3. For the three parameters measured tilt was found to represent a greater stress than -20, -30 or -40 mm Hg pressure. -50 mm Hg or a combined -40,-50 mm Hg profile was found to represent a greater stress than tilt. It was concluded, therefore, that the equivalency point for negative pressure versus tilt lies somewhere between -40 and -50 mm Hg pressure.
4. When a tilt stress was preceded during the same experiment by a negative pressure stress, the responses were greater than those obtained when tilt was the initial stress. ]

#### Acknowledgements

We would like to express our thanks to Dr. R. L. Johnson of the NASA Manned Spacecraft Center, Houston, Texas, who made the Minnesota Impedance Cardiograph available to our laboratory. We are especially indebted to Dr. W. G. Kubicek, Mr. D. A. Witsoe and Mr. R. P. Patterson



for their valuable council and advice regarding the use and operation of the Impedance Cardiograph.

Further thanks are due Mrs. Norma Schlicht, Mr. Sidney Gillespie and Mr. John Skufca for their helpful technical assistance.\*\*

\*\* The research reported in this paper was jointly supported by the United States Air Force and by NASA Contract NDPR T-66344(G)

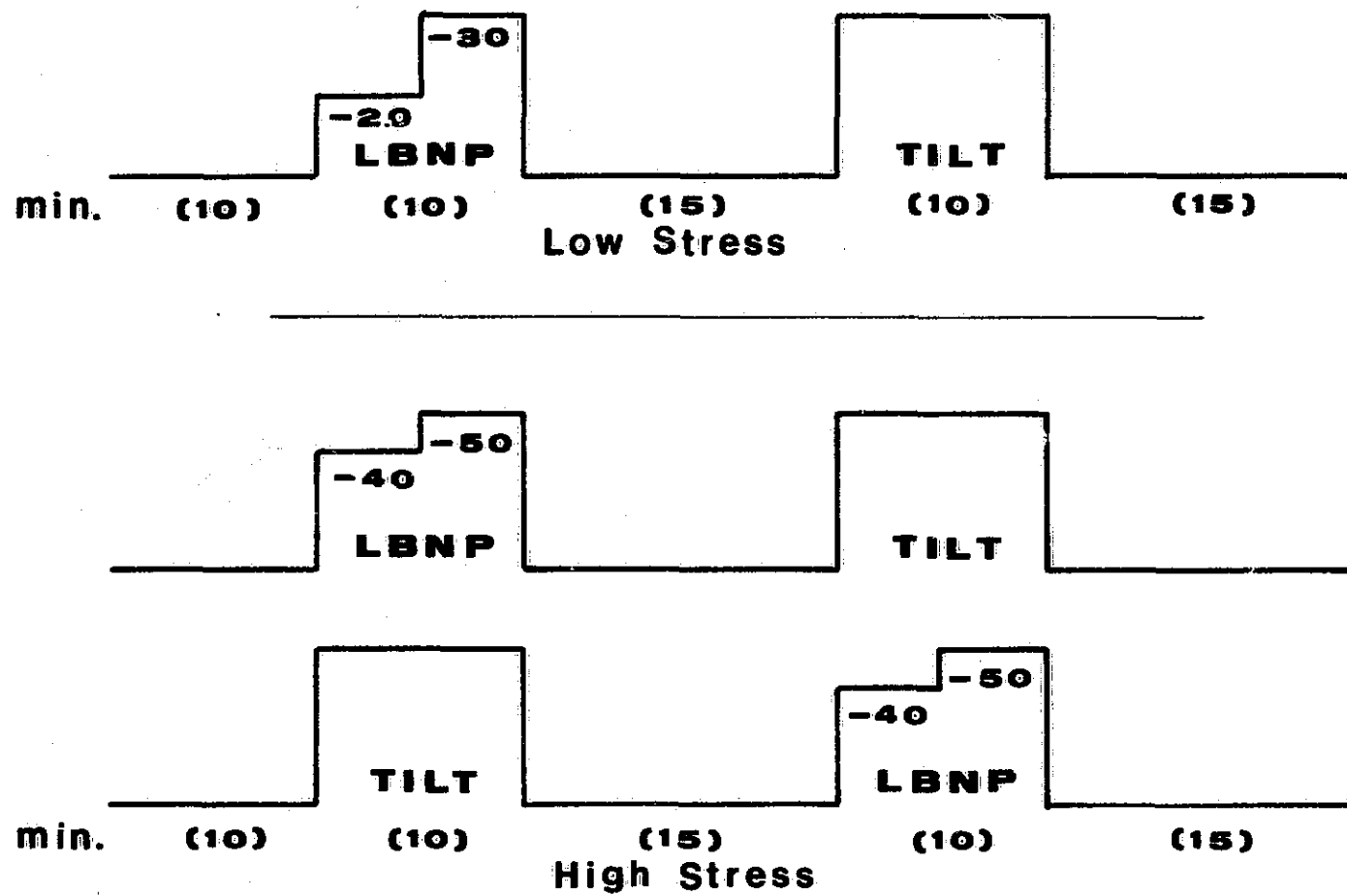

**EXPERIMENTAL PROTOCOLS**

FIGURE 1

Graphs representing the three stress profiles used in the experimental series reported in this paper.

### VARIATION IN STROKE VOLUME DURING REST

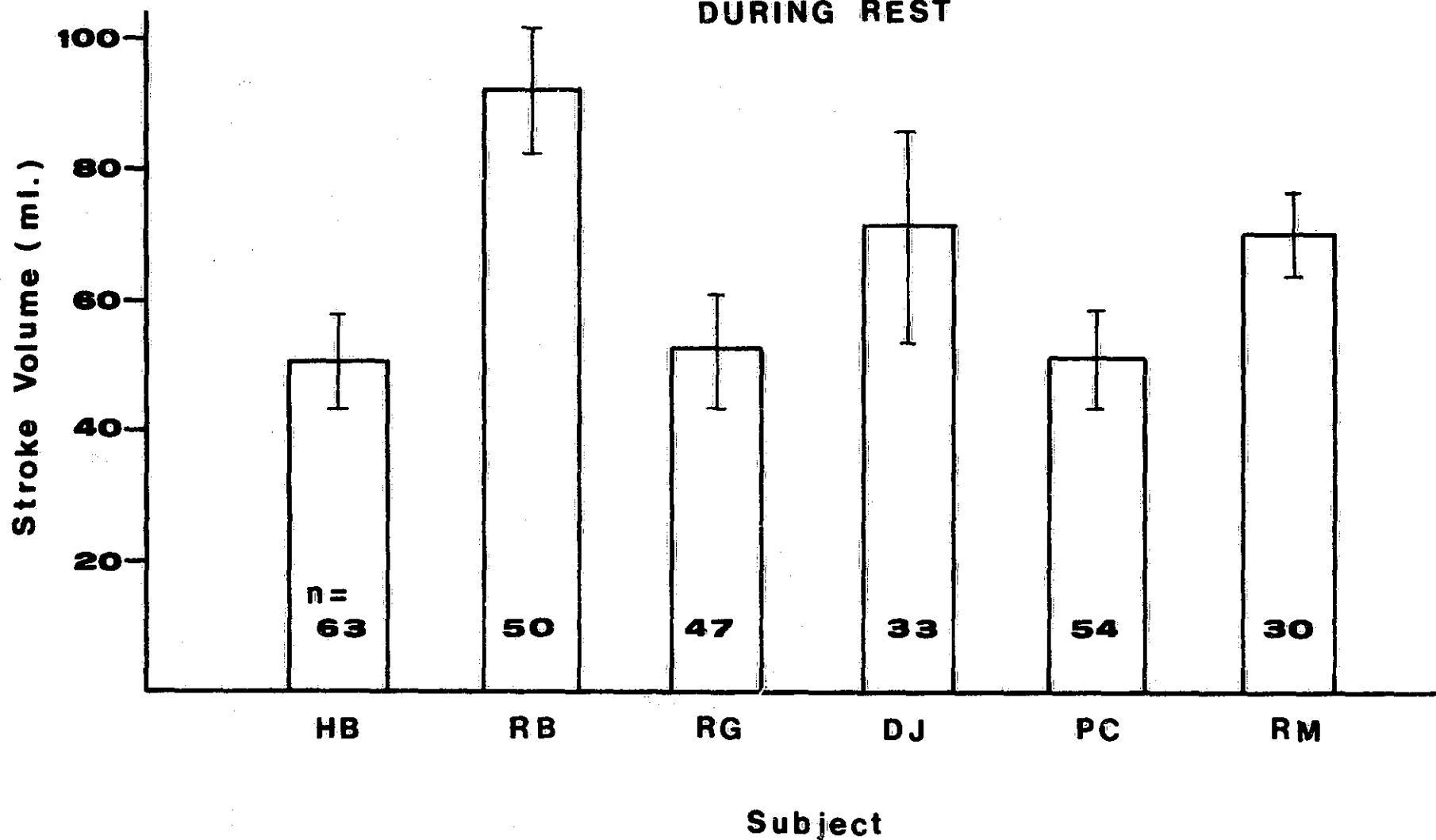
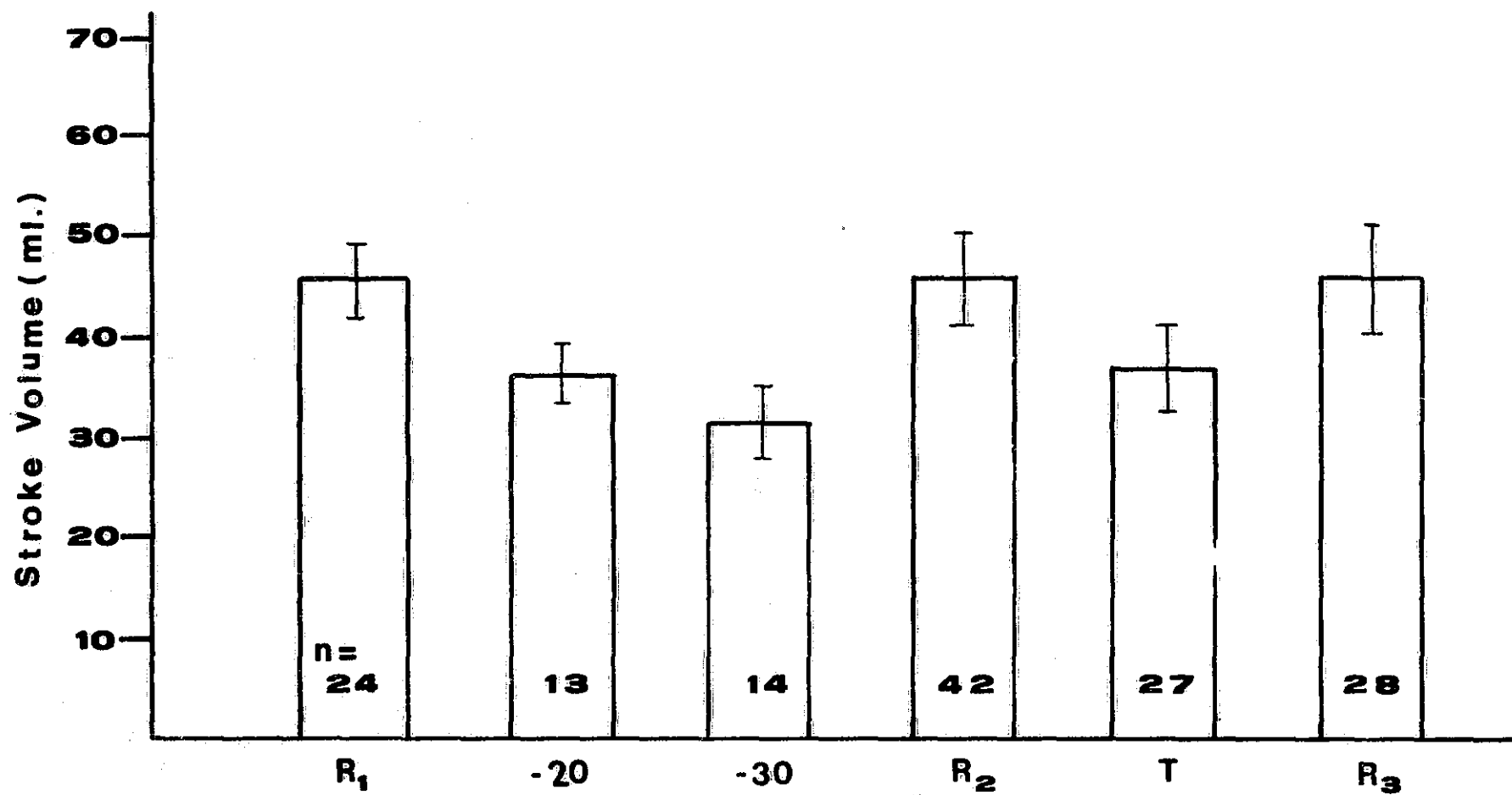

FIGURE 2

Mean stroke volumes obtained from each subject during recumbent rest. Means were calculated from data obtained on 3 to 7 separate sessions for each subject. Solid lines indicate standard deviations. Numbers at bottom of bars indicate total number of measurements.

### VARIATION IN STROKE VOLUME



3 Experiments, Subject HB

FIGURE 3

Changes in stroke volume during three exposures to the low charge profile for a single subject. (Mean and standard deviation)

### VARIATION IN STROKE VOLUME

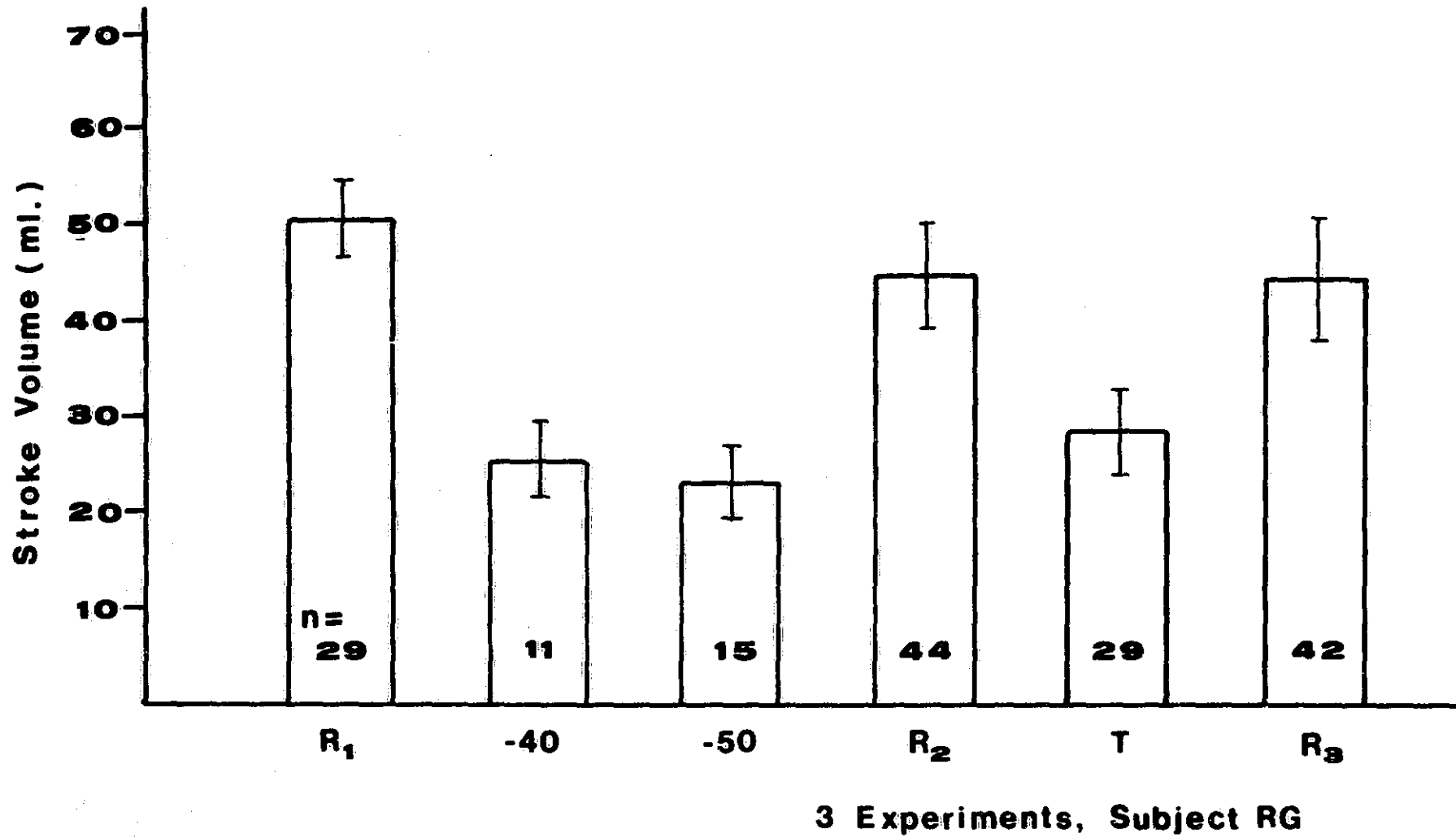

-287-

FIGURE 4

Changes in stroke volume during three exposures to the high stress profile for a single subject. (Means and standard deviations)

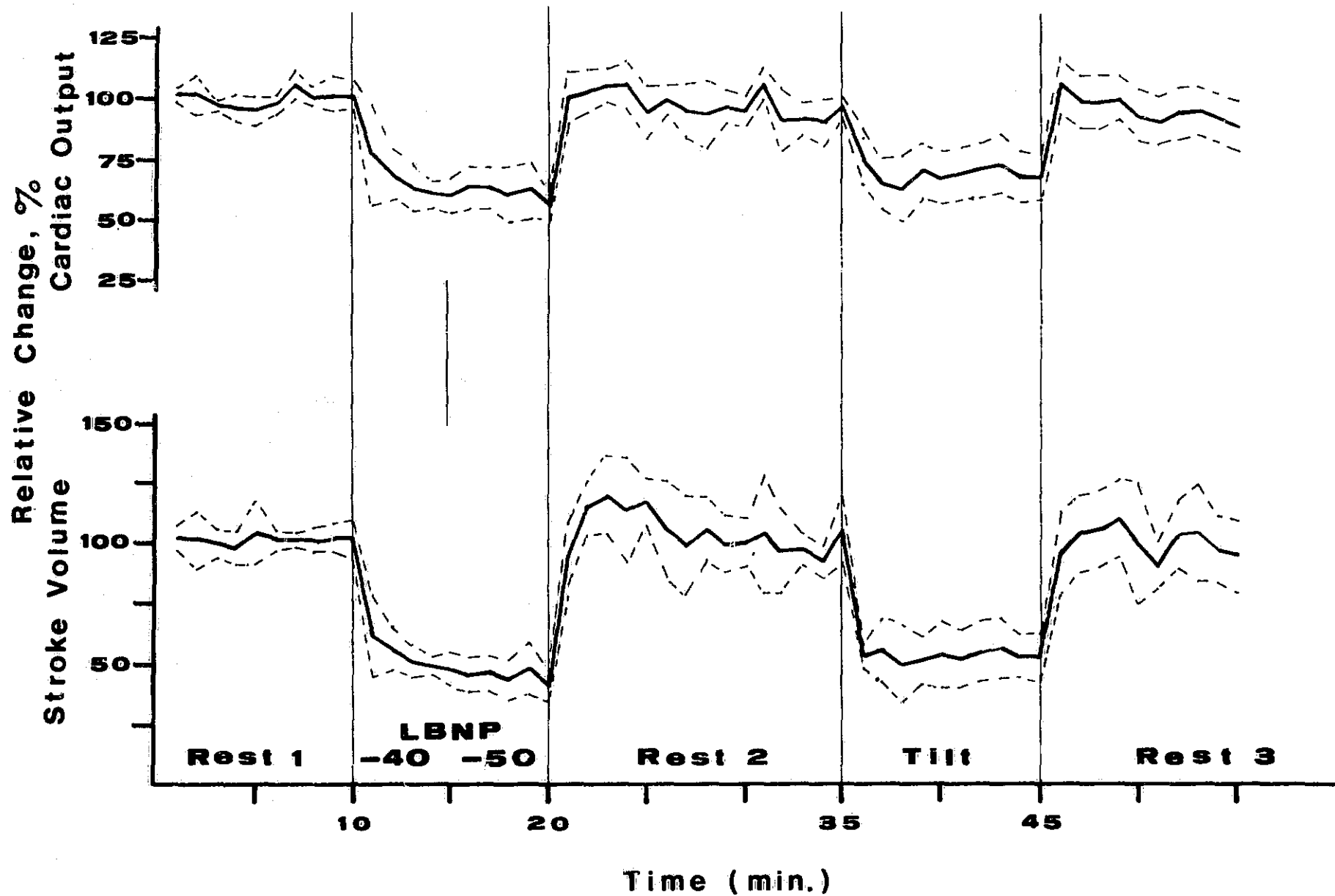
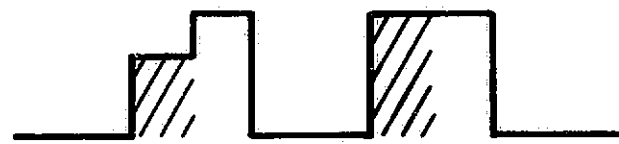

FIGURE 5

Minute by minute changes in cardiac output and stroke volume for six subjects during exposure to the high stress profile. (Solid lines represent means, dashed lines represent standard deviations.)



0 % Vac >  
39% Tilt >



39% Vac >  
16% Tilt >



11% Vac >  
33% Tilt >



61% Vac >  
0% Tilt >

### LBNP (40-50) Vs TILT

FIGURE 6

Comparisons of cardiovascular responses to the following stresses: 40 mm Hg vacuum vs 5 minutes tilt, pooled vacuum responses vs tilt, 5 minutes tilt vs 40 mm Hg, negative pressure and tilt vs pooled vacuum responses. (Hatched and/or stippled areas indicate periods during which comparisons were made.)

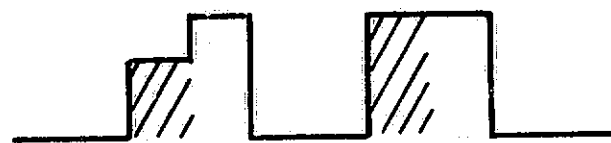

6 % Vac >

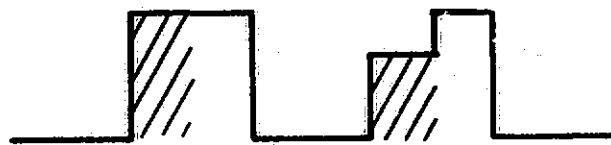

36 % Tilt >



50 % Vac >



8 % Tilt >

### COMPARISON OF POOLED DATA

FIGURE 7

Comparisons of responses to -40 mm Hg vacuum vs 5 minutes of tilt and of the pooled -40, -50 mm Hg vacuum responses vs tilt. (Hatched and/or stippled areas indicate periods during which comparisons were made.)



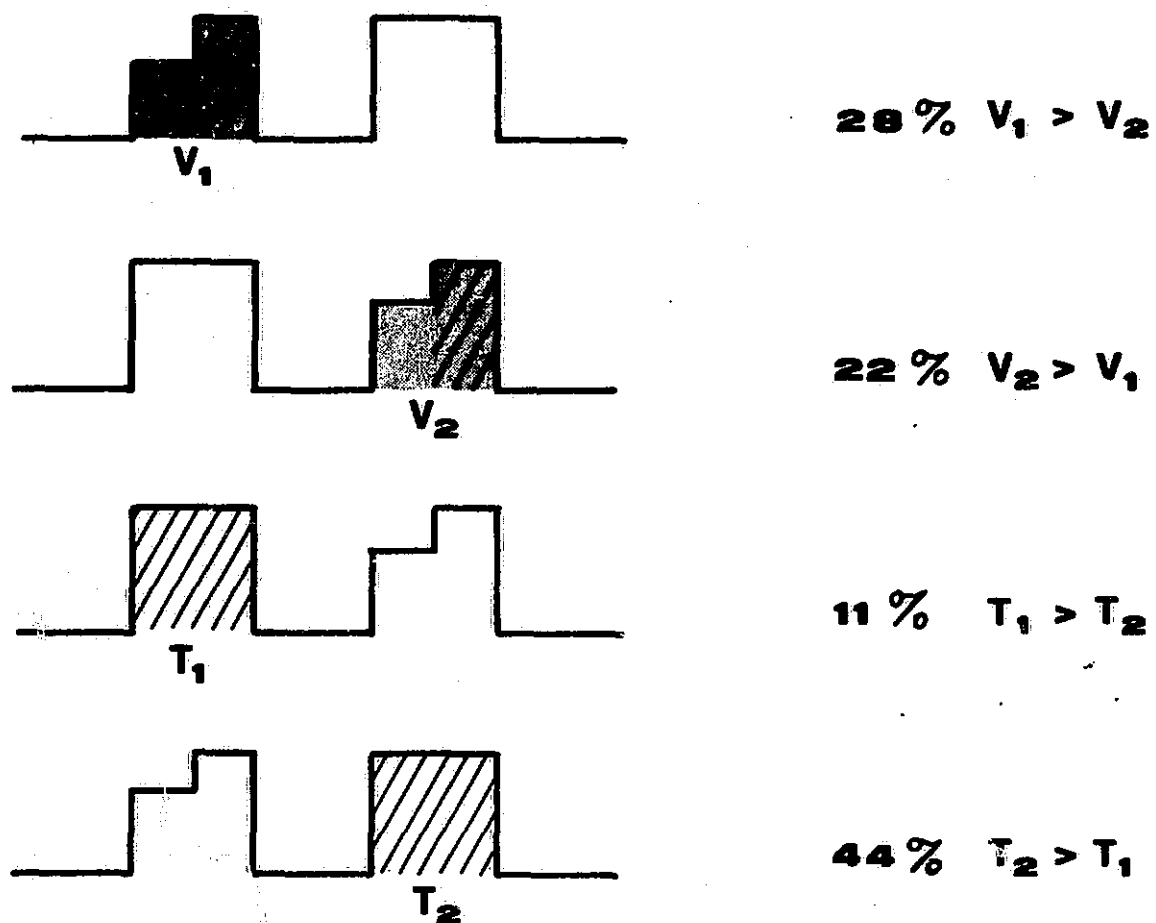

**STRESS SEQUENCE RELATIONSHIPS**

FIGURE 8

Comparison of responses to the 40-50 mm Hg vacuum stress when vacuum was the initial stress and when vacuum was preceded by tilt (upper comparison) and to tilt when tilt was the initial stress vs tilt when tilt was preceded by vacuum (lower comparison). (Hatched and/or stippled areas indicate periods during which comparisons were made.)

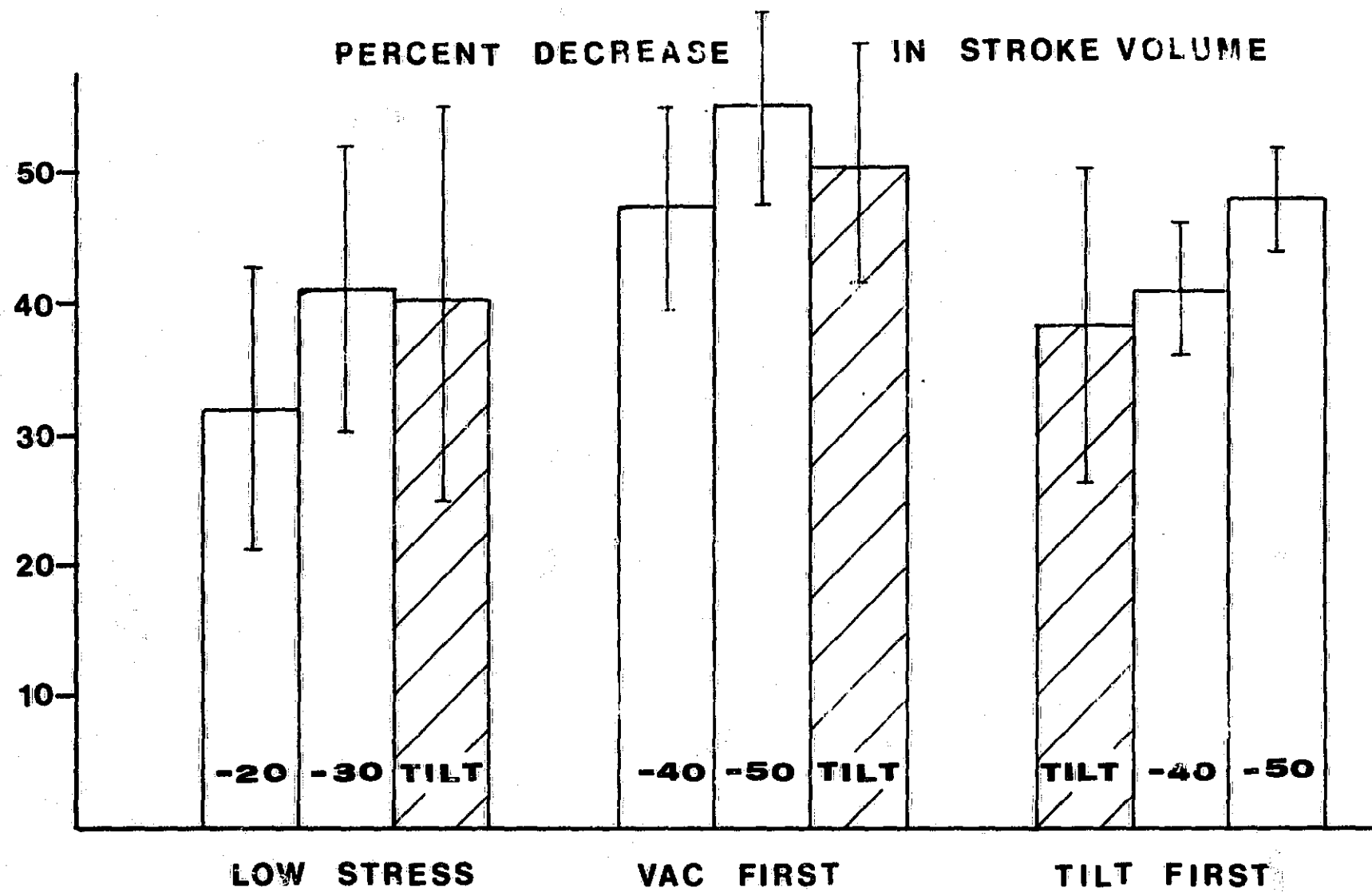

-292-

FIGURE 9

Stroke volume responses to the three stress profiles. (Means and standard deviations for six subjects)

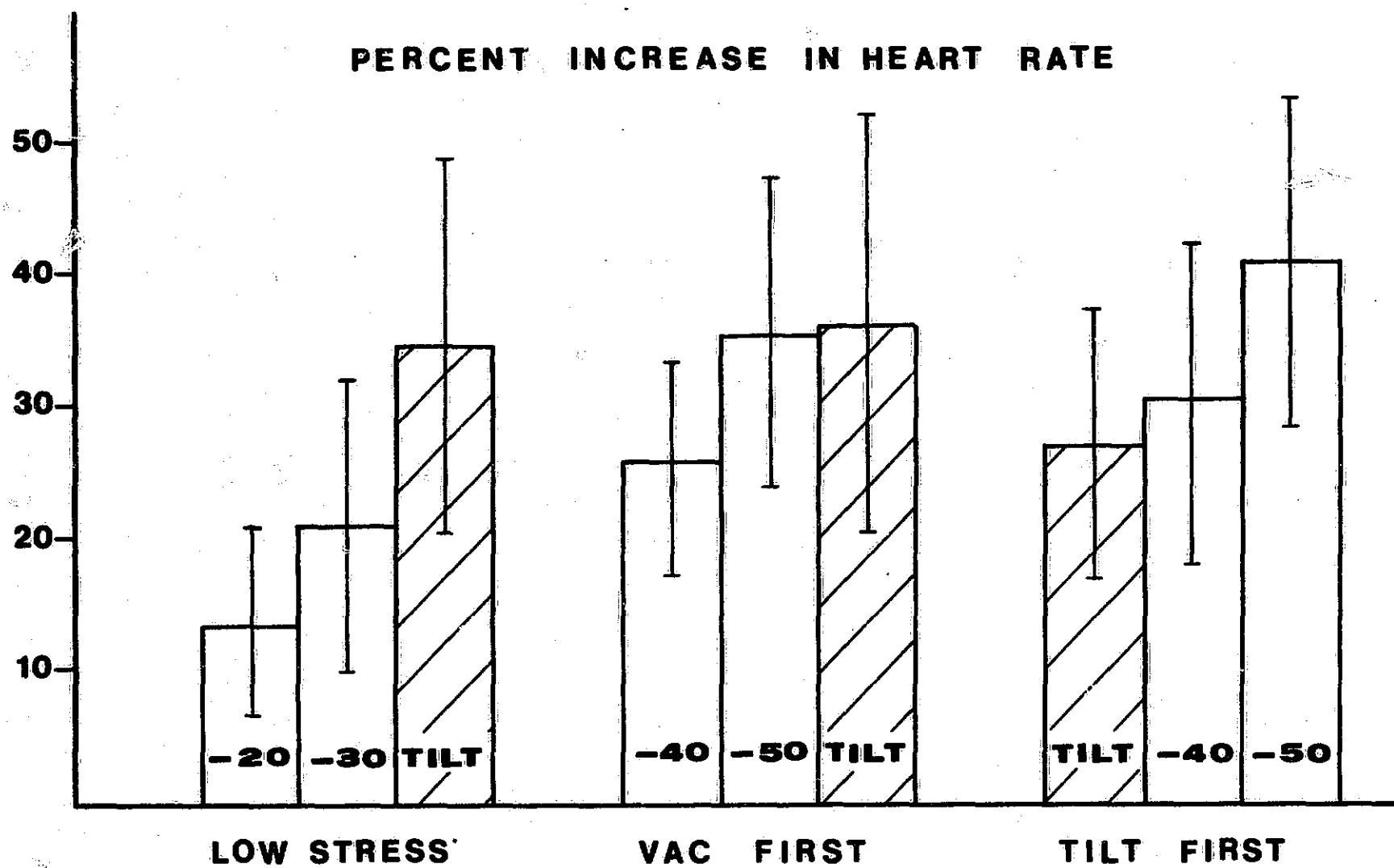

-293-

FIGURE 10

Heart rate responses to the three stress profiles. (Means and standard deviations for six subjects)

		HB	RG	RB	DJ	PC	RM
SV	Vac 1st	V	V	T	V	-	-
	Tilt 1st	V	V	-	V	V	-
CO	Vac 1st	-	V	T	V	-	-
	Tilt 1st	V	V	-	V	V	V
HR	Vac 1st	-	-	-	V	V	T
	Tilt 1st	V	-	-	V	-	-

-294-

**Observations:**

**Vac First:**

**Vac > Tilt  
Total**  $\frac{7}{18} \times 100 = 38\% \text{ Vac} >$

**Tilt First:**

**Vac > Tilt  
Total**  $\frac{11}{18} \times 100 = 64\% \text{ Vac} >$

TABLE 1

Sample comparison of six subjects stroke volume, cardiac output and heart rate responses to vacuum and tilt when vacuum was the initial stress and when tilt was the initial stress. Sample calculation shown at bottom of table.

References Cited

Brown, Ellen, The late J. S. Goei, A. D. M. Greenfield and G. C. Plassaras, 1966. Circulatory responses to simulated gravitational shifts of blood in man induced by exposure of the body below the iliac crests to sub-atmospheric pressure. J. Physiol. 183:607-627.

Bush, John E., V. Thomas Wiedmeier, Felix E. Tristante and James J. Smith, 1968. The application of impedance cardiography to the study of postural stress in the human. In: Development and evaluation of an impedance cardiographic system to measure cardiac output and other cardiac parameters, NASA Report No. NAS 9-4500, Houston, Texas.

Greene, M. A., A. J. Boltax and R. J. Ulberg, 1961. Cardiovascular dynamics of vasovagal reactions in man. Cir. Res. 9:12.

Harley, A. and J. G. Greenfield, 1968. Determination of cardiac output in man by means of impedance plethysmography. Aerospace Med. 39:248-252.

Kubicek, W. G., D. A. Witsoe, R. P. Patterson, M. A. Mosharrafa, J. N. Karnegis and A. H. L. From, 1967. Development and evaluation of an impedance cardiographic system to measure cardiac output and development of an oxygen consumption rate computing system utilizing a quadrupole mass spectrometer. NASA Report No. NAS 9-4500, Houston, Texas.

Nyboer, J., 1959. "Electrical Impedance Cardiography." C. C. Thomas, Springfield.

Rushmer, R. F., 1944. Circulatory collapse following mechanical stimulation of arteries. Am. J. Physiol. 141:722.

Stevens, P. M., 1966. Cardiovascular dynamics during orthostasis and the influence of intravascular instrumentation. Am. J. Cardiol. 17:211-218.

# Comparative Evaluation of the Thoracic Impedance and Isotope Dilution Methods for Measuring Cardiac Output

N70-10018

W. V. JUDY, F. M. LANGLEY, K. D. MCCOWEN, D. M. STINNETT,  
L. E. BAKER and P. C. JOHNSON

*Departments of Physiology and Medicine, Baylor University  
College of Medicine, Houston, Texas 77025*

JUDY, W. V., F. M. LANGLEY, K. D. MCCOWEN, D. M. STINNETT, L. E. BAKER and P. C. JOHNSON. *Comparative evaluation of the thoracic impedance and isotope dilution methods for measuring cardiac output.* *Aerospace Med.* 40(5):532-536. 1969.

Values of cardiac output determined simultaneously in 17 normal adult male human subjects by means of thoracic impedance changes and radioisotope dilution are compared. The absolute values of cardiac output determined by the impedance technique were 1.31 times higher than those measured by radioisotope with the subjects at rest and after moderate exercise. Even though the absolute values as found by the two methods were not the same, the changes in magnitude were comparable.

cardiac output were calculated. The formula used to compute these values was not given at the time, but was later published.<sup>6</sup>

Whitehorn and Perl<sup>8</sup> improved on the technique of Atzler and Lehmann by using electronic techniques for the detection of frequency modulated signals which had appeared during the intervening years. Those investigators calibrated their instrument by introducing known volumes of saline between the plates. On the basis of this calibration, calculated values of stroke volume, cardiac output, and cardiac indices fell within the range of normal values, but no conclusions were reached as to the validity of the method.

Kubicek, et al.<sup>3,4</sup> have postulated that the maximum rate of decrease in transthoracic impedance occurring during systole is related to ventricular stroke volume, and they have shown a reasonable comparative relationship between cardiac output as calculated from the impedance cardiogram, and values determined by Fick and indicator dilution techniques. More recently, however, Harley and Greenfield,<sup>2</sup> using dye dilution, have found a less favorable comparison in normal subjects and a poor comparison in clinical patients. This present report is a further evaluation of the impedance plethysmographic technique in which cardiac output values obtained by Kubicek's method are compared with values measured simultaneously using radioisotope dilution.

**T**HE FIRST GRAPHIC RECORDS of thoracic impedance changes associated with cardiac activity in the human appear to have been made by Atzler and Lehmann.<sup>1</sup> Their technique required placing the thorax of the subject between two fixed plates of a capacitor for which the thorax constituted the major portion of the dielectric. Using the capacitor as part of the tuned circuit of an oscillator (150 MHz), cardiac activity during periods of breathholding was sufficient to change the effective dielectric and, hence, the resonant frequency of the oscillator. These changes in frequency were detected, amplified and recorded with a string galvanometer or oscillograph. The records from subjects with healthy hearts were compared to those from subjects with diseased hearts, but no assessments of cardiac output were made.

Nyboer, et al.<sup>5</sup> reported records of impedance changes accompanying cardiac activity from which values of

## METHODS

Simultaneous isotope dilution and transthoracic impedance cardiac output wave-forms were recorded from 17 normal subjects in the supine position before and after exercise. The isotope dilution data constituted the standard to which the thoracic impedance data were compared.

The isotope, in the form of radioiodinated-human serum albumin ( $I^{131}$ ), was injected into the median cubital vein via intravenous saline flow. The passage of the radioisotope through the heart was recorded by placing a scintillator crystal (Packard, Model 1212-51)

Supported in part by USPH Grant HE 5125, National Heart Institute, National Institutes of Health, Bethesda, Maryland.

Present address of W. V. Judy is: Dept. of Physiology and Biophysics, University of West Virginia Medical School, Morgantown, West Virginia 26506.

Dr. F. M. Langley, K. D. McCowen, D. M. Stinnett, and L. E. Baker are in the Dept. of Physiology, Baylor University College of Medicine, Houston, Texas 77025.

Dr. P. C. Johnson is in the Dept. of Medicine, Baylor University College of Medicine, Houston, Texas 77025.

over the left ventricle. Graphic display of the isotope dilution curves were obtained with a pulse height analyzer (Technical Measurements Corp., Model 404C) and an X-Y plotting system (Moseley Model 7590-A). Isotope dilution cardiac output was calculated by the method described by Veall.<sup>7</sup> Transthoracic impedance data were obtained using four aluminized Mylar tape electrodes described by Kubicek, et al.<sup>4</sup> and the Impedance Cardiograph (Model 202) developed by the University of Minnesota. These data and the ECG were recorded using a Visicorder (Honeywell Model 1508) driven by direct coupled amplifiers (E & M Instrument Co., Mark VI).

Two tape electrodes were placed around the neck three or more centimeters apart. A third electrode was placed around the thorax at the level of the xiphoid process, and the fourth electrode ten centimeters caudal to the third. A constant current (6 milliamperes, 100 KHz) was applied to the outer two electrodes, and the potential changes during the cardiac cycle which reflect transthoracic impedance changes were measured between the two inner electrodes. Impedance data were taken over 5 to 7 heart beats while the subject was relaxed in end-expiratory apnea. Data from both isotope dilution and thoracic impedance were collected simultaneously during control conditions (supine and relaxed), and immediately after moderate exercise in the supine position which produced changes in heart rate from 3 to 30 percent. The values for cardiac output by impedance were calculated from the impedance data obtained during the time interval between the entrance of the isotope into the right side of the heart and the early ejection of the isotope from the left ventricle.

The maximum decrease in impedance change for each cardiac cycle measured was determined from the first derivative (dZ/dt) of the impedance waveform as shown in Figure 1. Stroke volume was computed by using the formula given by Kubicek, et al.<sup>3</sup>

$$\Delta V = \rho (L^2/Z_0^2) (dZ/dt)_m t.$$

In this expression  $\Delta V$  represents the stroke volume in  $cm^3$ ;  $L$  is the mean distance between the inner pair of electrodes in  $cm$ ;  $Z_0$  is the basal thoracic impedance (in ohms) measured between the inner two electrodes;  $dZ/dt$  is the time rate of change of impedance during the cardiac cycle measured in ohms/sec, and  $(dZ/dt)_m$  is the value at the negative peak;  $\rho$  is the resistivity of blood at 100 KHz; and  $t$  is the ventricular ejection time in seconds. Ventricular ejection time was taken as the interval between 15 percent of the negative peak of the  $dZ/dt$  waveform and the most positive peak as shown in Figure 1. The use of the 0.15  $(dZ/dt)$  point to establish the beginning of the time interval was chosen by Kubicek,<sup>4</sup> "To eliminate from the ejection time determination the slow decrease in impedance that occurs with some individuals at the start of systole." The resistivity of blood at 100 KHz used in calculating  $\Delta V$  was determined by measuring the subject's hematocrit, then reading the corresponding resistivity from a hematocrit-resistivity curve. Cardiac output per minute was obtained by multiplying mean stroke volume by minute heart rate.

## RESULTS AND DISCUSSION

Transthoracic impedance waveforms typical for the majority of the subjects are shown in Figure 1. Simultaneous measurements of transthoracic impedance and isotope dilution cardiac output before and after moderate exercise (termed passive and active respectively) in 17 subjects provided a comparison of the two methods in estimating resting cardiac output and a change in cardiac output. Complete impedance output data were obtained from all 17 subjects; however, because of

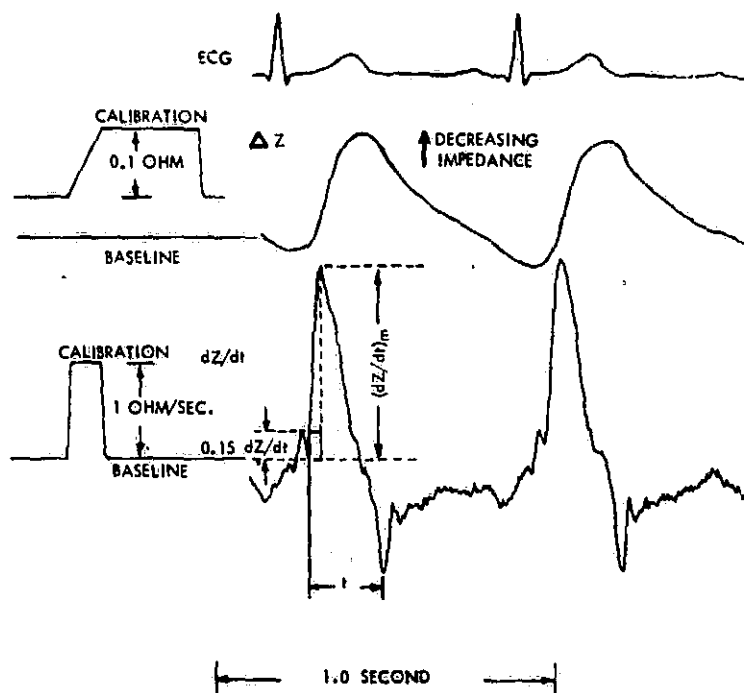

Fig. 1. Simultaneous records of ECG, ( $\Delta Z$ ) the thoracic impedance change during the cardiac cycle, and ( $dZ/dt$ ) the derivative of the ( $\Delta Z$ ) waveform.

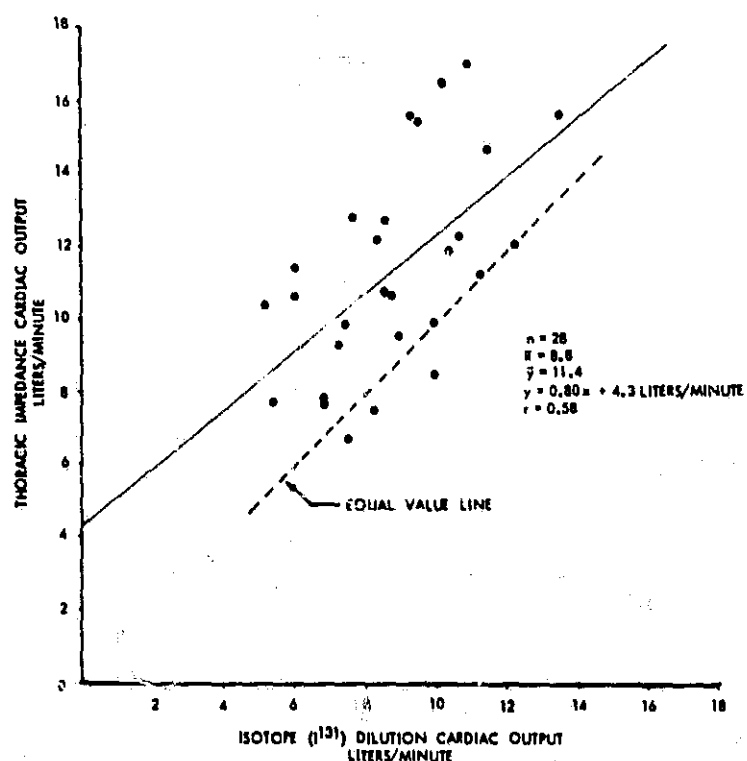

Fig. 2. Comparison of values of cardiac output determined by thoracic impedance change and radioisotope dilution.

EVALUATION OF METHODS FOR MEASURING CARDIAC OUTPUT—JUDY, et al.

technical difficulties the dilution data were not complete. The collected data, subject characteristics, impedance and dilution cardiac output, heart rate, and blood resistivity are shown in Table I.

As measured from the transthoracic impedance waveforms, the mean passive cardiac output (before exercise) for the 17 subjects was 9.92 liters/min and 11.47 liters/min after moderate exercise. The mean passive cardiac output for 15 subjects as measured by the isotope dilution method was 7.65 liters/min and the mean active cardiac output (after exercise) for 13 subjects was 9.39 liters/min. The change from passive to active states was 1.55 liters/min (15.6 percent) for the impedance method and 1.74 liters/min (22.7 percent) for the isotope dilution method.

The ratio of transthoracic impedance to isotope dilution cardiac output was 1.32 during passive conditions and 1.30 following exercise. These differences are not significant.

A comparison of passive and active impedance cardiac output values with isotope dilution (for 28 paired values) is shown in Figure 2. The mean of all passive and active cardiac output values was  $11.38 \pm \text{S.D. } 2.90$  liters per minute calculated by the impedance method and  $8.76 \pm \text{S.D. } 2.13$  liters per minute measured by isotope dilution. The correlation coefficient between the two sets of values was  $r = 0.58$ .

These data, comparing the transthoracic impedance and isotope dilution cardiac output, support the hypothesis that transthoracic electrical impedance changes during the cardiac cycle are indeed related in some way to cardiac function. Although the correlation ( $r$ ) between the transthoracic impedance and isotope dilution values was 0.58, the magnitude of changes (15.6 and 22.7 percent respectively) from passive to active were comparable. In a similar study by Harley and Greenfield,<sup>2</sup> comparing the indicator dye-dilution with the transthoracic impedance method, a correlation coefficient of 0.68 was found for 26 paired values. The ratios of mean impedance cardiac output values to mean isotope dilution values in this present study compare favorably with those reported by Harley and Greenfield. These investigators determined ratios of 1.34 during control and 1.26 after isoproterenol infusion, whereas in the present study a ratio of 1.32 during rest and a ratio of 1.30 after exercise were found. Although the ratios reported in both studies are comparable for the different methods, the correlation coefficients do differ slightly. There are at least two possible reasons for this difference in correlation coefficients, however slight. First, Harley and Greenfield determined the maximum slope of the  $\Delta Z$  waveform visually rather than electronically as was done in this present study. Secondly, Harley and Greenfield used the fixed value of 150 ohm-cms as the

TABLE I. THORACIC IMPEDANCE AND ISOTOPE (<sup>131</sup>I) DILUTION CARDIAC OUTPUT (Liters/min)

Subject	Age	Ht.	Wt.	$\rho^*$	Condition	Impedance C.O.	Dilution C.O.	Heart Rate
1	30	69"	175	167	Passive	9.33	7.20	70
					Active	10.83	.....	94
2	26	72"	188	156	Passive	7.49	8.20	71
					Active	8.48	9.90	88
3	22	73"	185	159	Passive	9.86	7.40	59
					Active	12.60	.....	80
4	21	74"	195	167	Passive	15.50	9.40	74
					Active	16.50	10.20	85
5	20	71"	162	152	Passive	10.75	8.50	63
					Active	12.30	10.60	71
6	23	76"	190	156	Passive	6.74	.....	54
					Active	9.55	8.90	78
7	23	73"	170	159	Passive	7.76	5.40	42
					Active	12.71	8.50	56
8	23	73"	157	146	Passive	11.88	10.30	85
					Active	14.66	11.40	109
9	22	75"	210	149	Passive	12.80	7.60	72
					Active	15.61	9.20	94
10	25	67"	135	140	Passive	10.39	5.10	48
					Active	10.61	6.00	52
11	22	72"	160	152	Passive	9.89	9.90	68
					Active	12.23	8.30	82
12	23	73"	178	163	Passive	11.80	.....	46
					Active	15.66	13.40	81
13	23	72"	167	140	Passive	10.67	8.70	62
					Active	11.18	11.20	78
14	22	73"	178	152	Passive	11.44	6.00	49
					Active	17.03	10.80	77
15	22	72"	160	159	Passive	7.76	6.80	61
					Active	12.06	12.20	83
16	23	69"	150	152	Passive	6.75	7.50	50
					Active	8.48	.....	70
17	22	72"	170	146	Passive	7.81	6.80	72
					Passive	6.35	.....	55

\* $\rho$  = Resistivity of blood at 100 KHz.



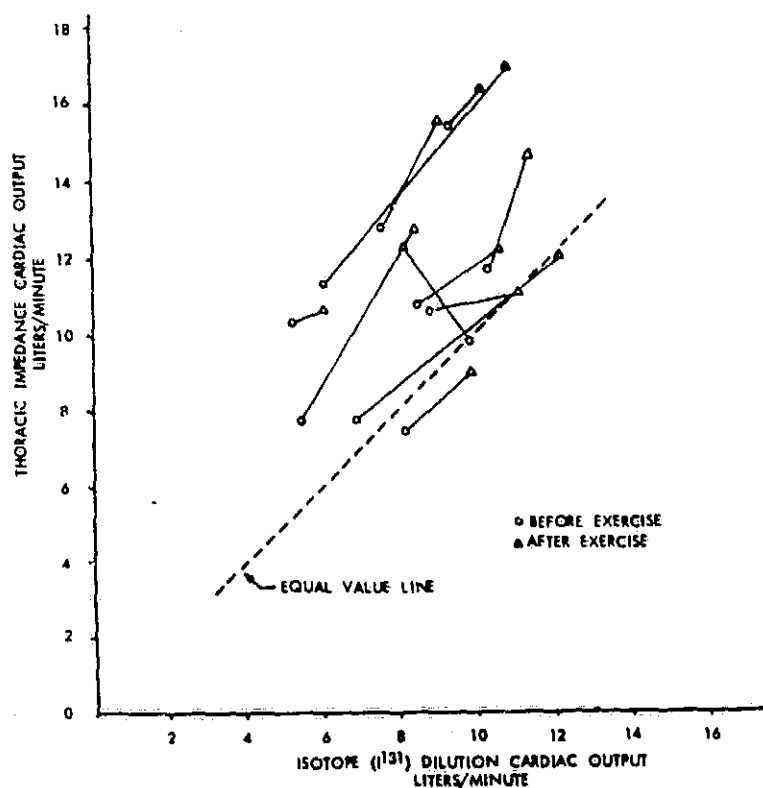

Fig. 3. Comparison of values of cardiac output determined by thoracic impedance changes and radioisotope dilution before and after exercise in the supine position.

resistivity of blood whereas in this present study the resistivity of the blood of each subject was determined from a functional relationship between the resistivity and the hematocrit. The resistivities of the blood samples ranged from 140 to 167 ohms with a mean value of 154 ohms.

Figure 3 shows a comparison of the values for cardiac output determined simultaneously by radioisotope dilution and thoracic impedance methods, before and after exercise, for the eleven subjects for which complete data were obtained as indicated in Table I. In each case, the impedance method showed an increase in cardiac output after exercise; however, the dilution method showed a decrease in cardiac output for one subject after exercise. The equal value line represents the ideal relationship which would be obtained if, when employed simultaneously, the two methods always indicated the same value of cardiac output. It is apparent that in almost all cases, the values of cardiac output determined by the impedance method exceed those found by isotope dilution. In the several instances for which the slopes of the lines approximate the slope of the equal value line, it is to be expected that the magnitude of the change in cardiac output, as found by both methods, would be essentially the same even though the absolute values were different.

As an additional study, the changes in cardiac output, stroke volume, and heart rate from the resting level (supine position) were determined by the impedance method alone for each of the following situations: (1) during moderate exercise, (2) immediately after moving from supine to sitting position, and (3) immediately after moving from supine to standing position. For each of the 17 subjects, the changes were

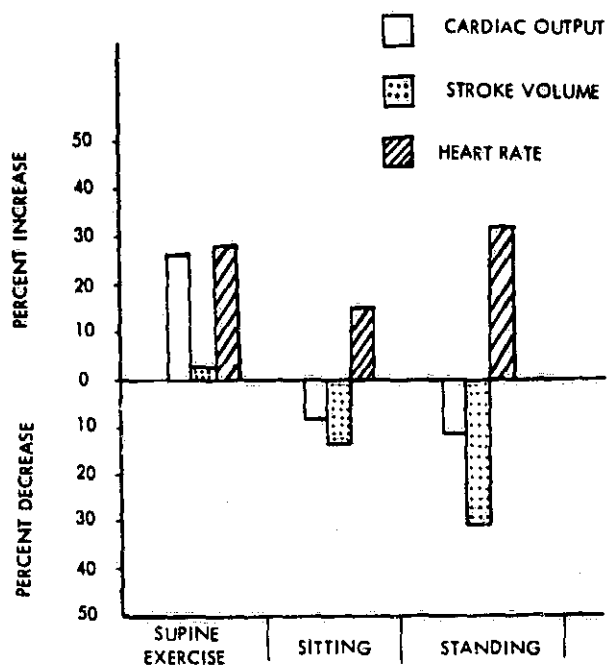

Fig. 4. Changes in cardiac output, stroke volume, and heart rate in response to exercise and body positional changes as calculated by the thoracic impedance method. The values shown represent the average of percentage changes from rest in the supine position for all 17 subjects.

expressed as a percent and all percentages averaged to arrive at the values shown in Figure 4. Cardiac output and heart rate increased during exercise (25 and 33 percent respectively), whereas stroke volume changed only slightly (+2 percent). Upon assuming the sitting position, both cardiac output and stroke volume decreased (9 and 14 percent, respectively), and heart rate increased 16 percent. Upon standing, cardiac output and stroke volume decreased (12 and 31 percent respectively), and heart rate increased (32 percent). Considering the simple averaging technique employed and the variation in physical conditioning among the subjects, these values are reasonable for the physical maneuvers described.

### CONCLUSIONS

Use of the impedance plethysmographic technique is simple, and does not require penetration of the skin or the introduction of indicator materials into the cardiovascular system.

The absolute values of cardiac output calculated from the impedance data for the subject at rest and after exercise were approximately 1.31 times greater than those determined by radioisotope dilution.

While the absolute values of cardiac output as determined by the two methods were not the same, for most of the subjects the magnitudes of the changes in cardiac output were comparable.

### REFERENCES

1. ATZLER, E., and G. LEHMANN: Über ein neues verfahren zur darstellung der herztätigkeit (dielektrographie). *Arbeitsphysiologie*. 6:636-680, 1932.
2. HARLEY, A., and J. C. GREENFIELD: Determination of cardiac output in man by means of impedance plethysmography. *Aerosp. Med.* 39:248-252, 1968.

3. KUBICEK, W. G., J. M. KARNEGIS, R. P. PATTERSON, D. A. WITSOE, and R. H. MATTSON: Development and evaluation of an impedance cardiac output system. *Aerosp. Med.* 37:1208-1212, 1966.
4. KUBICEK, W. G., D. A. WITSOE, R. P. PATTERSON, M. A. MOSHAIRAFI, and H. L. FROM: Development and evaluation of an impedance cardiographic system to measure cardiac output and development of an oxygen consumption rate computing system utilizing a quadrupole mass spectrometer. NASA Report Contract No. NAS 9-4500. July, 1967. 177 pp.
5. NYBOER, J., S. BAGNO, A. BARNETT, and R. H. HALSEY: Radiocardiograms—the electrical impedance changes of the heart in relation to electrocardiograms and heart sounds. *Am. Soc. Clin. Inv.* 19:773, 1940.
6. NYBOER, J.: *Electrical Impedance Plethysmography*. Springfield, Ill. Charles C. Thomas. 243 pp., 1959.
7. VEALL, N., J. D. PEARSON, T. HANLEY, and A. B. LOWE: A method for the determination of cardiac output. Radioisotope Conference; Proc. of the Second Conference (preliminary report), J. E. Johnston (editor), Oxford, July 19-23, 1954. Academic Press, New York, 1:183, 1954.
8. WHITEHORN, W. V., and E. R. PERL: The use of change in capacity to record cardiac volume in human subjects. *Science* 109:262-263, 1949.

COMPARATIVE EVALUATION OF THE THORACIC IMPEDANCE  
AND ELECTROMAGNETIC FLOW PROBÉ METHOD FOR MEASURING CARDIAC OUTPUT

by

William V. Judy, Frank M. Langley, Karl D. McCowen, and Lee E. Baker

INTRODUCTION:

N70-10019

Transthoracic electrical impedance changes associated with respiratory and cardiac function have been proposed and used by many investigators for the measurement of flow and volume (1-8). Recently, through the efforts of W. G. Kubicek and his colleagues, considerable advances have been made in designing and building a stable system for measuring transthoracic impedance changes associated with cardiac function (9,10,11). They have indicated that when a constant sinusoidal current is passed across the chest, impedance changes synchronous with the cardiac cycle, and the first derivative of these impedance changes seem to be indicative of left ventricular stroke volume or aortic blood flow (9). Good correlations between transthoracic impedance waveform and indicator-dilution calculated cardiac outputs have been found in dogs and satisfactory correlations have been found in humans by Kubicek et al. (9-11). Recently, comparison studies have been reported using the indicator dilution method in normal and clinical patients (12) and the isotope dilution method in normal patients (13). Correlation coefficients for normal subjects between the two output determining methods were  $r = 0.68$  for the dye-dilution method and  $r = 0.58$  for the isotope dilution method. However, a very poor correlation coefficient ( $r = 0.26$ ) was found for patients with various cardiac insufficiencies. Still other comparisons of the impedance calculated cardiac output with standard dilution methods in both normal human subjects and dogs have supported previously reported work (14-17). All of these efforts have compared the transthoracic impedance method, a beat-by-beat technique, with indicator dilution methods, which are averaging techniques.

Perhaps a more realistic or accurate assessment of the impedance method's validity of measuring cardiac output or stroke volume would be to compare its calculated value with another beat-by-beat measuring technique. Such comparisons have been made by Kubicek et al. using electromagnetic flow probes acutely implanted on the ascending aorta of dogs (11). They reported a much better comparison between these two methods than with the dye-dilution method in the same animal. Although good comparisons were found, considerable individual variations as to the regression coefficients were observed. These studies have recently been supported by additional dog studies, again showing good correlation between stroke volume and cardiac output but with considerable individual animal variations (15,18). Other beat-by-beat comparisons have been reported using the stroke volume and cardiac output values calculated by the aortic pressure pulse method (19). These studies also show mean correlations of approximately  $\bar{r} = 0.72 \pm 0.10$ .

This report is a continuation of the efforts to assess the validity of the impedance method to accurately measure absolute cardiac output as compared to the electromagnetic flowmeter. The purpose of this report is the presentation of results obtained from simultaneous impedance and electromagnetic flowmeter measured cardiac output of anesthetized mongrel dogs.

#### METHODS AND MATERIALS:

Simultaneous transthoracic impedance (ZCG) and electromagnetic flow probe (EMFP) waveforms were recorded and cardiac output determined in 11 mongrel dogs (6-17 kg). The EMFP cardiac output values constituted the standard to which the output values calculated from the ZCG waveform was compared.

Each dog was anesthetized with an intravenous injection of pentobarbital (30 mg/kg). The trachea was intubated with an intratracheal tube. Necessary body surfaces were trimmed of hair and these surfaces cleaned of body oils with ethyl ether. This method was used to achieve optimal impedance (dry) electrode

skin surface interface. Mid-sternal thoracotomy was performed during which time the lungs were ventilated with an E. & M. Instrument Co. Mark IV Respirator. All dogs were curarized to prevent voluntary respiratory movements which interfered with impedance signals. The ascending aorta was dissected free from surrounding adipose and connective tissue to allow optimal fit of the flow probe (Electromagnetic Probe Co.; Models EMP-435, -440, and -445). These probes were calibrated using a fresh aorta, of appropriate size, through which heparinized blood was pumped. The calibration system consisted of a constant pressure closed loop circuit through which variable flow rates were pumped (Harvard Apparatus Co.; Model 500-1200). Following the flow probe placement the thoracic cavity was cleansed of excessive exudate and the incision closed with a continuous suture pattern. The animal was maintained with the respirator following closure to facilitate controlled respiratory arrest for the collection of concurrent ZCG and EMFP data. Signals from the implanted flow probe were monitored by a square wave electromagnetic flowmeter (Carolina Medical Electronics, Model 321). Mean cardiac output values were taken from the calibrated output signals.

Thoracic impedance signals were obtained using four aluminum coated mylar electrodes (3 M Company, Minneapolis), described by Kubicek et al (10), and the Impedance Cardiograph Model 202. Two electrodes were placed around the neck at least 3 cm apart. One of the remaining two electrodes was placed around the thorax at the level of the xiphoid process and the other around the mid-abdominal area. A six mamp, 100 K Hz constant current was applied between the outer two electrodes, and the transthoracic impedance changes associated with the cardiac cycle were measured between the inner two electrodes.

Electrocardiograms (Lead II), EMFP and ZCG signals were recorded simultaneously on Kodak Direct Print light sensitive paper using a Honeywell Visocorder (Model 1508) driven by E. & M. Instrument Co. Mark IV Amplifiers.

A wide range of cardiac output values for comparison were obtained by changing heart rate and peripheral resistance by drug injections. Epinephrine, norepinephrine, acetylcholine and isoproterenol were injected intravenously in appropriate doses. Cardiac output and heart rate were allowed to return to pre-injection levels after each procedure. All data were collected simultaneously in the mid-expiratory apnea by cutting off the respirator during this interval.

The maximum negative impedance change for each cardiac cycle measured was determined from the first derivative of the impedance waveform. Stroke volume was computed using the formula given by Kubicek, et al (9).

$$\Delta V = \rho(L^2/Z_0^2)(dz/dt)_m t$$

In this expression  $\Delta V$  represents the stroke volume in  $\text{cm}^3$ ;  $L$  is the mean distance between the inner pair of electrodes in cm;  $Z_0$  is the basal thoracic impedance in ohms measured between the inner two electrodes;  $dz/dt$  is the time rate of change of impedance during the cardiac cycle measured in ohms/sec., and  $(dz/dt)_m$  is the value at the negative peak;  $\rho$  is the resistivity of blood at 100 K Hz, and  $t$  is the ventricular injection time taken as the interval between the point where the negative slope crossed the zero baseline and the most positive peak of the  $dz/dt$  waveform (Figure 1). The resistivity of blood ( $\rho$ ) at 100 K Hz was given a constant value of 150 ohms-cm for all dogs, and this value was based on the mean hematocrit for dogs. ZCG cardiac output was obtained by multiplying stroke volume ( $\Delta V$ ) by heart rate over the desired interval.

#### RESULTS AND DISCUSSION:

Transthoracic electrical impedance ( $\Delta Z$ ), time rate of change of this impedance ( $dz/dt$ ), mean electromagnetic flow probe (EMFP) and electrocardiograms (ECG) signals were recorded simultaneously. These data were taken from 11 dogs with flow probes on their ascending aortas. Representative signals collected are shown in Figures 1 and 2.

The ZCG calculated cardiac output changes were found to be directionally correct in that they followed the EMFP output. Representative individual dog comparisons between the ZCG and EMFP output values per minute are shown in Figure 3. This figure shows the scatter plots and regression lines for dogs 2,5,8 and 10 over a considerable range of outputs. This figure also shows the previously mentioned individual variation in regression lines and y-axis intercepts. The mean ZCG-EMFP mean output values, their ratios, regression analysis, and correction factors for each dog and for the total number of dogs are shown in Table 1. The mean output values ranged from 1022 to 3583 ml/min for the ZCG method and from 980-3492 ml/min for EMFP. Considerable variation between individual animal mean output values are evident. However, the output values from the two methods were very comparable for each dog. This is evident by the ZCG/EMFP ratio values which ranged from 0.83 to 1.18. Eight of the eleven animals showed a slightly greater ZCG mean output.

The regression analysis showed considerable individual variation with regression coefficient ranges (0.58 to 1.05), y-axis intercepts (-75 to 976) and positive correlation coefficients (0.58 to 0.98). The combined ZCG-EMFP output values for the total number (214 data points) are plotted in Figure 4. The regression equation obtained for this plot was,  $y = 0.91 x + 213$  ml., with a mean ZCG output value of 2345 ml and a mean EMFP value of 2353 ml. The ZCG-EMFP ratio from these mean values was 1.00 and the correlation coefficient  $r = 0.92$ . From the ratio of mean ZCG-EMFP output values one would believe that a one to one relation exists, however as shown by the regression coefficient this is not true; although the regression and correlation coefficients are close to unity for the total samples. The sample means and mean ratios in most cases indicate that the two methods measure equal outputs.

However, if a correlation factor is calculated from the EZC/EMFP ratio for each pair of values and the mean correlation value determined for each dog (Table 1),

It is evident that in most cases the ZCG values are greater than those of the EMFP. Mean correction values ranged from 0.87 to 1.26 with eight dogs having a correction value greater than one. The mean correction value for the total group was 1.05. This value is considerably less than the 1.18 value determined by Kubicek et al (10) using the dye-dilution as a standard. From these data it is evident that the use of the electromagnetic flowmeter as a standard for comparison with ZCG calculated cardiac output values is better than comparisons with averaging techniques. This is reflected by the correlation coefficients for absolute non-corrected values and the mean correction value determined in this study. These results agree with those of others (10,15,18) and again point out the relative equivalency of the cardiac output values measured by these two beat-by-beat techniques. In such a comparison however, one must be constantly aware of the inherent errors and discrepancies of each method. These errors and weak points are in all probability the influencing factors producing the different regression coefficients for each animal.

#### SUMMARY:

In this study it has been found that the transthoracic electrical impedance method's ability to estimate cardiac output compares very well with that of the electromagnetic flowmeter in dogs. A correction value of 1.05 was found between the two techniques as compared to 1.18 reported by Kubicek et al (10), 1.29 by Harley and Greenfield (12) and 1.31 previously found in this laboratory (13) in dilution method comparisons. The absolute values determined in this study correlated well ( $r = 0.92$ ) and a mean difference of 5 percent was found. It is felt that the characteristics of the ease of application, lack of invasive procedures or implants inherent to the ZCG method along with the knowledge gain in this study is sufficient to warrant continued use of this method. Many comparison studies with dilution and electromagnetic flowmeter methods have been



conducted and they all tell the same story for normal subjects. Additional studies must be designed to further delineate the actual origin of these impedance changes during systole before it can be clearly proven that the ZCG method is truly measuring pulsatile volume changes in the left ventricle or aorta. )

THORACIC IMPEDANCE AND ELECTROMAGNETIC FLOWMETER CARDIAC OUTPUT COMPARISON

Dog	Sample Size	Mean Cardiac Output (ml/min)		$\frac{\text{ZCG}}{\text{EMFP}}$	Regression Coefficient	Y-Axis Intercept	Correlation Coefficient	Correction Factor
		ZCG	EMFP					
1	12	2280	2233	1.02	0.58	976	0.58	1.09
2	13	2104	1769	1.18	0.93	450	0.78	1.26
3	10	1022	980	1.04	0.64	393	0.96	1.15
4	9	2481	2566	0.92	0.79	443	0.73	1.17
5	36	2867	2655	1.08	0.91	443	0.86	0.97
6	27	1337	1570	0.85	0.79	88	0.89	1.12
7	22	1926	1747	1.10	0.85	443	0.87	0.87
8	21	2735	3261	0.83	0.81	101	0.96	1.12
9	20	2906	2890	1.01	0.84	472	0.89	0.85
10	20	3583	3492	1.02	1.05	-75	0.98	1.03
11	24	1933	2018	0.95	0.78	361	0.88	1.01
<b>Total or Mean</b>	<b>214</b>	<b>2345</b>	<b>2353</b>	<b>1.00</b>	<b>0.91</b>	<b>213</b>	<b>0.92</b>	<b>1.05</b>

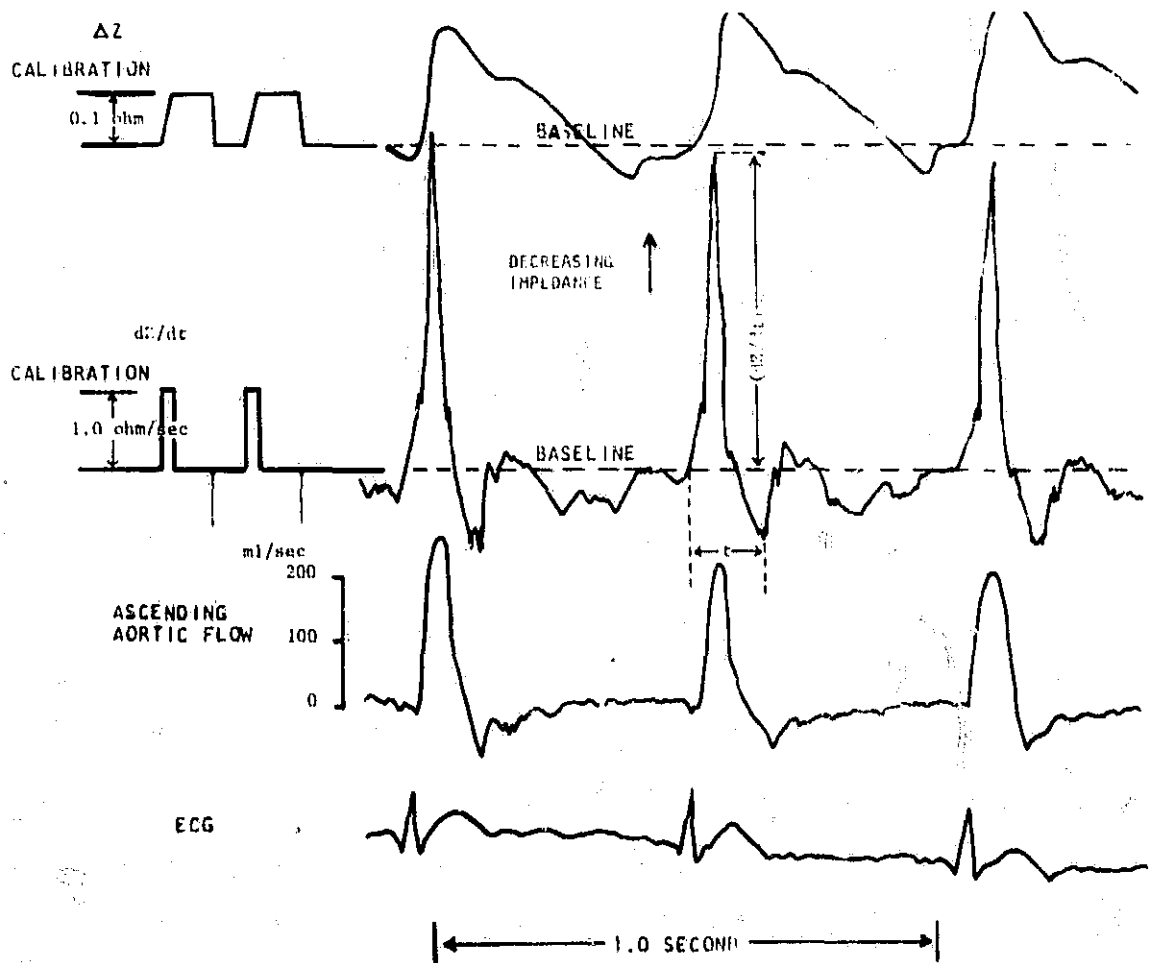
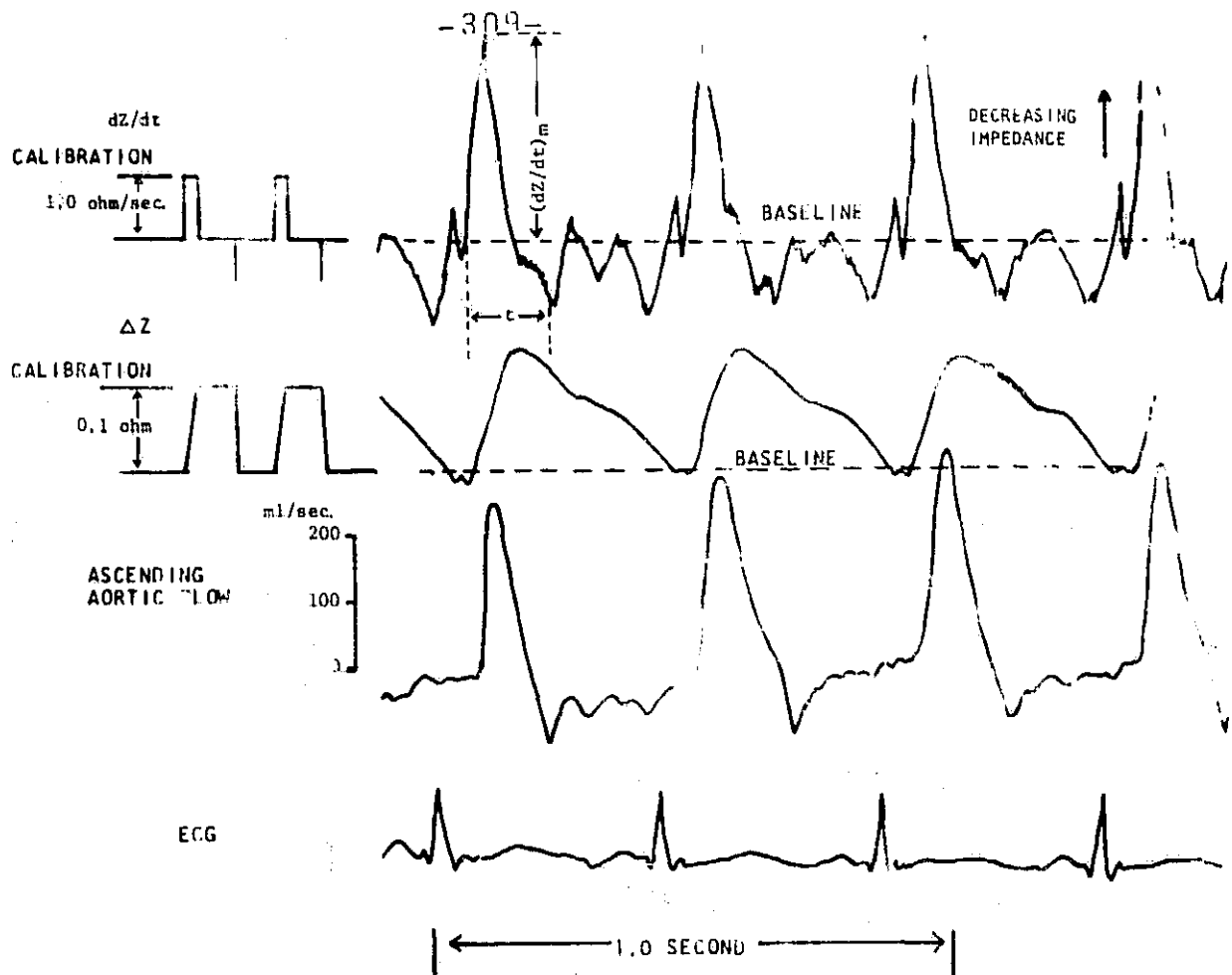

Figures 1 and 2 Characteristic waveforms recorded simultaneously from the dog. Thoracic impedance waveform ( $\Delta Z$ ), first derivative of thoracic impedance ( $dZ/dt$ ), aortic flow signal and ECG are shown.

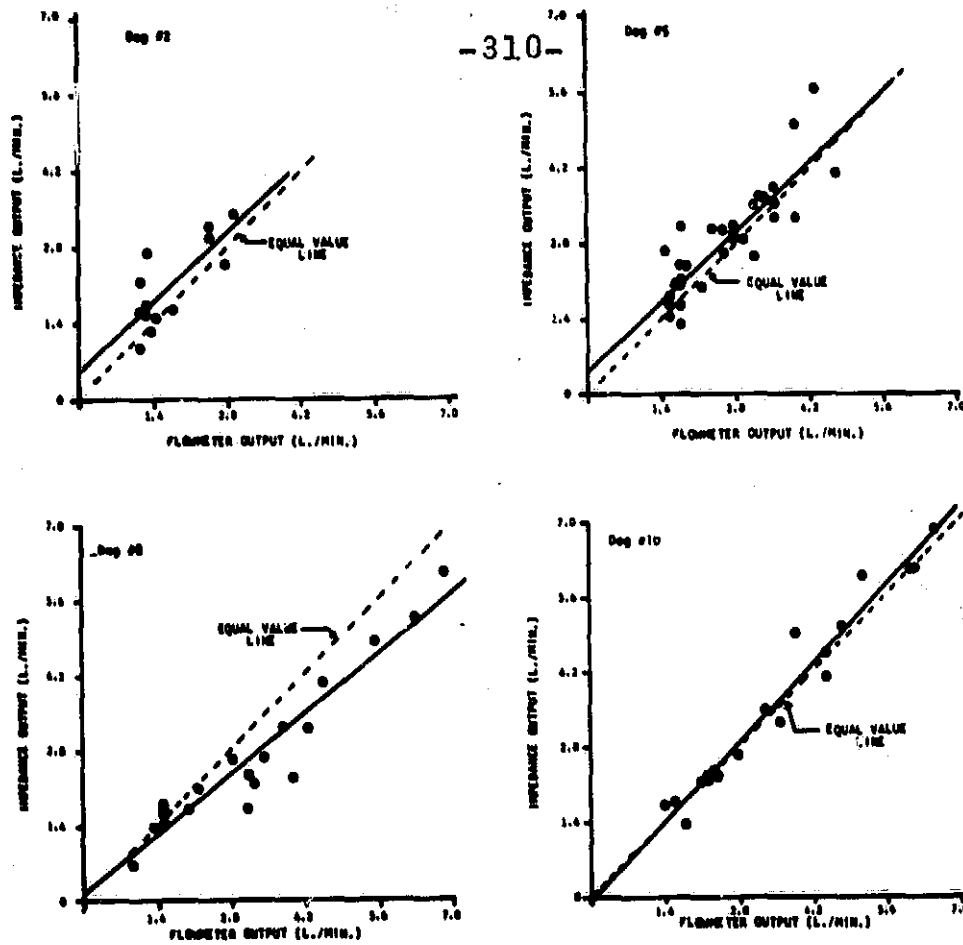

Figure 3 Comparison of paired absolute cardiac output values determined simultaneously by the ZCG and EMFP methods. Scatter plots and regression lines are shown for dogs 2,5,8, and 10. All graphs consist of non-corrected data points.

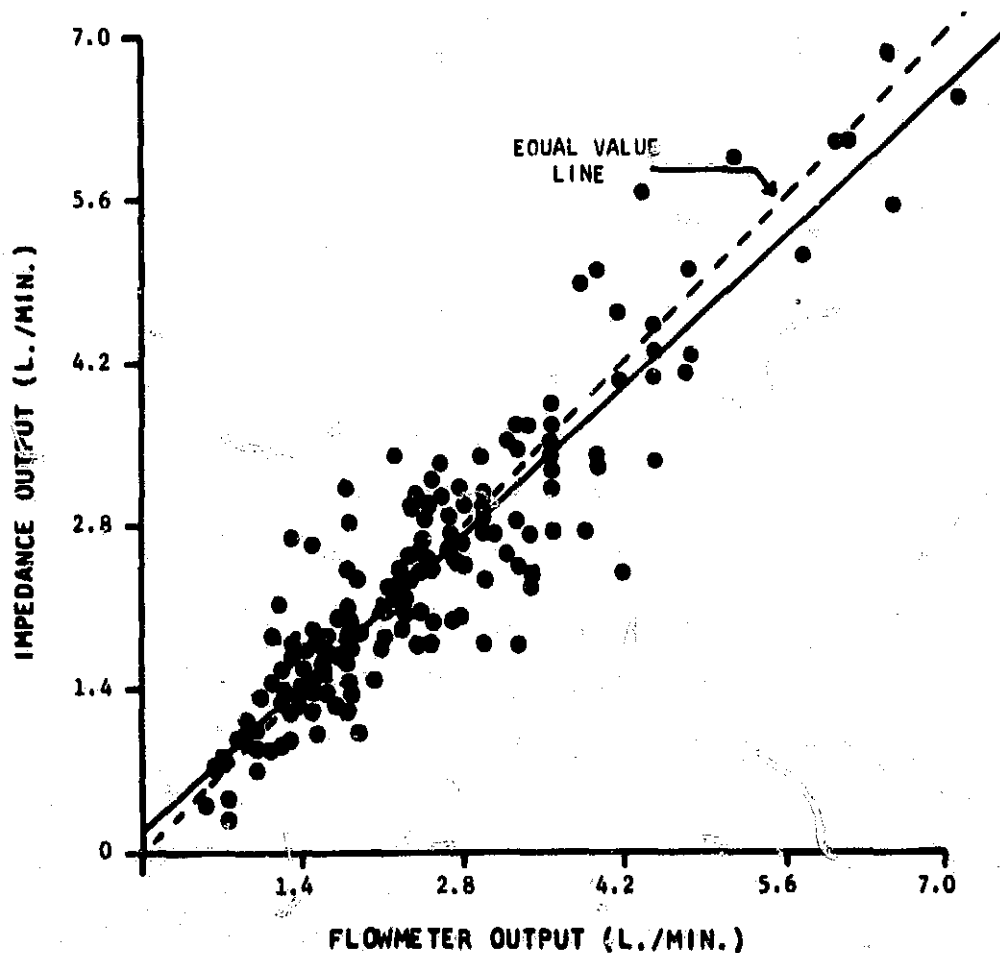

Figure 4 Comparison of 214 paired data points from 11 dogs. Scatter plots of ZCG vs EMFP absolute non-corrected values are shown.

REFERENCES:

1. Nyboer, J. Electrical Impedance Plethymography. C. C. Thomas, Springfield, 1959.
2. Nyboer, J., S. Bagno, A. Barnett, and R. H. Halsey. Radiocardiograms - the electrical impedance changes of the heart in relation to electrocardiograms and heart sounds. Am. Soc. Clin. Invest. 19: 773, 1940.
3. Hamilton, L. H., J. D. Beard, R. E. Carmean and R. C. Kory. An electrical impedance ventilometer to quantitate tidal volume and ventilation. Med. Res. Engn., First Quarter, Vol. 6, No. 1, 1967.
4. Baker, L. E. and L. A. Geddes. Transthoracic current paths in impedance spirometry. Proc. Symp. Biomed. Eng. 1: 181, 1966.
5. Kinnen, E. Estimation of pulmonary blood flow with an electrical impedance plethysmograph. USAF School of Aerospace Medicine, Report No. TR-65-81, December, 1965.
6. Lewis, F. J., V. K. Moses, M. L. Quinn and M. L. Petrovick: Automatic measurement of tidal volume in postoperative patients. J. Thoracic and Cardiovascular Surg. 56: 825, 1968.
7. Atzler, E. and G. Lehmann. Über ein neues verfahren zur darstellung der herztätigkeit (dielektrographie). Arbeitsphysiologie 6: 636-680, 1932.
8. Whitehorn, W. V. and E. R. Perl. The use of change in capacity to record cardiac volume in human subjects. Science 109: 262-263, 1949.
9. Kubicek, W. G., E. Kinnen and A. Edin. Thoracic cage impedance measurements. Calibration of an impedance pneumograph. USAF School of Aerospace Medicine, Report No. TDR-63-41, July, 1963.

10. Kubicek, W. G., J. N. Karnegis, R. P. Patterson, D. A. Witsoe and R. H. Mattson. Development and evaluation of an impedance cardiac output system. *Aerospace Med.* 37(12): 1208-1212, 1966.
11. Kubicek, W. G., D. A. Witsoe, R. P. Patterson, M. A. Mosharrafa, J. N. Karnegis and A. H. L. From. Development and evaluation of an electrical cardiographic system to measure cardiac output and development of an oxygen consumption rate computing system utilizing a quadrupole mass spectrometer. NASA Report No. NAS 9-4500, Houston, Texas, 1967.
12. Harley, A. and J. C. Greenfield. Determination of cardiac output in man by means of impedance plethysmography. *Aerospace Med.* 39: 248-253, 1968.
13. Judy, W. V., F. M. Langley, K. D. McCowen, D. M. Stinnett, L. E. Baker, and P. C. Johnson. Comparative evaluation of the thoracic impedance and isotope dilution methods for measuring cardiac output. *J. Aerospace Med.* Vol. 49, No. 5: 532-536, 1969.
14. Heather, L.. A comparison of cardiac output values by the impedance cardiograph and dye dilution, techniques in cardiac patients. First Symposium on Impedance Cardiography NASA-MSC, Houston, Texas, June, 1969.
15. Martin, W. E. Impedance outputs - a comparison in dog and man with electromagnetic flowmeters and dye dilution respectively. First Symposium on Impedance Cardiography, NASA-MSC, Houston, Texas, June, 1969.
16. Smith, J. J., J. E. Bush, V. T. Wiedmeier and F. E. Tristani. Estimate of cardiac output with the impedance cardiograph. First Symposium on Impedance Cardiography NASA-MSC, Houston, Texas, June, 1969.

17. Steigbigel, R. T., H. Babbit and J. R. Warbasse. Comparison of cardiac output as measured by impedance cardiogram and green dye method. First Symposium on Impedance Cardiography. NASA-MSC, Houston, Texas, June 1969.
18. Witsoe, D. A., R. P. Patterson, A. H. L. From and W. G. Kubicek. Evaluation of impedance cardiographic techniques for measuring relative changes in cardiac output by simultaneous comparison with indicator dilution and electromagnetic flowmeter. First Symposium on Impedance Cardiography. NASA-MSC, Houston, Texas, June, 1969.
19. Topham, W. S. and H. R. Warner. Beat-by-beat comparison of the calculation of stroke volume using the aortic pressure pulse and impedance cardiograph. First Symposium on Impedance Cardiography, NASA-MSC, Houston, Texas, June, 1969.

N70-10020

EVALUATION OF ELECTRICAL IMPEDANCE CARDIOGRAPHIC  
MEASUREMENTS OF HEART FUNCTION IN COMPARISON TO  
INDICATOR DILUTION AND PRESSURE GRADIENT METHODS

by

Ray T. Steigbigel  
Henry Babbit  
J. Richard Warbasse

★ ★ ★ ★ ★ ★ ★

from the

Clinical Investigations Service  
Cardiovascular Service & Laboratory  
U.S. Public Health Service Hospital  
3100 Wyman Park Drive  
Baltimore, Maryland 21211



EVALUATION OF ELECTRICAL IMPEDANCE CARDIOGRAPHIC  
MEASUREMENTS OF HEART FUNCTION IN COMPARISON TO  
INDICATOR DILUTION AND PRESSURE GRADIENT METHODS

Henry I. Babitt, Roy T. Steigbigel, J. Richard Warbasse

Evaluations have been made of electrical impedance cardiography<sup>1,2</sup> as a non-invasive means of estimating cardiac output in humans. Two different standards of reference have been used in an effort to validate the use of impedance cardiograph estimates of stroke volume from the empirically derived formula:

$$\Delta V = \rho \frac{L^2 T}{Z_0^2} (dz/dt) \text{ min.}^3$$

First, simultaneous cardiac output estimations comparing the Impedance Cardiograph to the indicator-dye-dilution technique<sup>4</sup> have been performed. Secondly, estimations of stroke volume and peak ascending aortic blood velocity are currently under investigation: simultaneous measurements are being made with the impedance cardiograph and with the pressure-gradient method of Fry and Fox.<sup>5,6</sup>

Evaluation of the Electrical Impedance Cardiogram with Indicator Dilution Method

Measurements were made on 11 patients who had either minor or no cardiovascular disease. Only one patient had valvular heart disease, i.e. mild mitral stenosis. All subjects were aware of the nature of the procedure, and an informed signed consent was obtained prior to the procedure in every case. These evaluations were performed in the

unsedated fasting state with the patient supine. The methods of electrode placement of the Minnesota Model 202 Electrical Impedance Cardiography System and cardiac output calculations utilizing the first derivative of the change in impedance ( $dZ/dt$ ) were those described by Kubicek.<sup>3</sup> The indicator-dye-dilution technique consisted of injecting a 1 cc bolus of 2.5 mg. of Indocyanine Green Dye followed by an immediate saline flush through a Gensini catheter which had previously been fluoroscopically placed in the superior vena cava. The injected dye was contained in a specially constructed volumetric one cc pipette syringe which was calibrated by weight to contain one cc of fluid with an error of less than 1%. The arterial sample was obtained through an 18 thin wall Cournand needle which had been percutaneously placed in the brachial artery. Sample withdrawal was accomplished with a Harvard pump at a rate of 25 cc/min. through a Gilford cuvette densitometer. The cardiac output was calculated utilizing the Steward-Hamilton method.<sup>7</sup>

The heart sounds, electrocardiogram, change in impedance, and first and second derivatives of change in impedance were recorded simultaneously with each indocyanine green dye injection on a Sanborn direct writing multi-channel recorder (Model 7708-09A) at a paper speed of 50 mm/second, and on electromagnetic tape (Sanborn, Model 2000). For each estimate of cardiac output from the impedance cardiogram,

average measurements were obtained from four consecutive  $dZ/dt$  deflections. These simultaneous determinations were made in the basal state, immediately after supine exercise on a bicycle ergometer, immediately after a 0.4 micrograms/cc isoproterenol infusion, during amyl-nitrate inhalation with tourniquets applied, and during recovery from these maneuvers. Not all of these modalities were used in all individuals studied.

The results of this comparative evaluation are as follows: of the eleven studies performed, 5 demonstrated quite acceptable agreement between the two techniques, whereas the other six did not. There was no consistent error and the results were scattered in a random fashion. Study number 10 is representative of results considered to be acceptable (Fig. 1). The slope of the regression equation is 0.84 with a standard error of estimate of 0.615 liters/minute, and a correlation coefficient of 0.907. By contrast, in study number 6 (Fig. 2) the impedance system markedly overestimated cardiac output at all levels, in a relatively consistent fashion. The slope of the regression equation is 0.565 with a standard error of estimate of 1.83 liters/minute, and a correlation coefficient of 0.771. The wave form of the change in impedance ( $\Delta Z$ ) and its first derivative ( $dZ/dt$ ) in study 6 are not significantly different from those in study 10. In study number 7 (Fig. 3) the impedance system

consistently underestimated cardiac output, resulting in a regression slope of 0.346, a standard error of estimate of 1.11 liters/minute and a correlation coefficient of 0.787. This patient had right bundle branch block on his electrocardiogram, but no clinical evidence of cardiovascular disease. Most of the studies showed very little scatter away from the regression line with standard errors of estimate ranging from 0.333 liters/minute to 1.20 liters/minute. However, three studies had rather marked scatter, this occurring predominantly at the higher cardiac output levels as demonstrated in study number 2 (Fig. 4). While the indicator-dye-dilution cardiac output ranged from 9 to 16.5 liters/minute, the cardiac output obtained from the first derivative of change in impedance did not change. However, later in study number 2, a cardiac output of 17.4 liters/minute was obtained utilizing the data from the impedance system while the simultaneous indocyanine green dye output was calculated to be 12 liters/minute.

When all 70 simultaneous determinations in 11 studies (Fig. 5) are combined the regression slope is 0.617. The standard error of estimate is 2.62 liters/minute. The correlation coefficient is 0.583. Efforts to develop a more accurate empirical formula to measure cardiac output utilizing the impedance cardiogram, e.g. the height of the

positive  $dZ/dt$  deflection above the baseline, the height times the width, the area of the positive deflection, etc., were not successful. However, in this evaluation of the impedance cardiogram, the potential errors in the dye dilution technique must be considered: lack of instantaneous indicator injection, lack of uniform mixing with the blood plasma, lack of uniformity of volume flow from injection to sampling site, lack of constant distribution of indicator dye during transversal time, presence of recirculation elements in the measured time concentration curve. Nevertheless, the theoretical validity and the approximate accuracy of properly performed indicator dilution measurements of cardiac output cannot be questioned.<sup>4,7</sup>

In summary, electrical impedance cardiography, using a previously developed empirical formula, in our experience produced variable results in the measurement of cardiac output when compared to measurements of cardiac output made simultaneously by the indicator dilution method.

Evaluation of Impedance Cardiogram with the Pressure Gradient Method of Measuring Instantaneous Blood Velocity and Flow

The indicator-dye-dilution method, described in the previous section, allows the measurement of only mean cardiac output over a number of heart beats. Since there is some experimental evidence<sup>8</sup> that the rate of change of the

electrical impedance measurement ( $dZ/dt$ ) reflects instantaneous changes in ascending aortic blood flow during breath holding, impedance cardiography may yield useful information on heart function. Therefore, the electrical impedance electrocardiogram was recorded simultaneously to instantaneous ascending aortic blood velocity and flow recorded by the pressure gradient method of Fry and Fox.<sup>5,6</sup>

The type of patients studied and the methods of electrical impedance cardiography are the same as those already described in this report. The methods utilized to measure instantaneous blood velocity and flow in the ascending aorta have previously been reported.<sup>9,10</sup> Briefly, lateral pressure is measured at 2 points 5 cm. apart along the axis of the ascending aorta with an 8F double lumen catheter, percutaneously introduced in the femoral artery and connected to two Statham P23DB pressure transducers. The difference between these two pressures over a finite distance is obtained by a subtraction circuit, and is used as an approximation of the pressure gradient at a point. The pressure difference serves as the input to an on line analog computer programed to instantaneously solve Fry's modification of the Navier-Stokes equation for blood velocity. Instantaneous ascending aortic blood flow is obtained by multiplying the recorded blood velocity by the cross-sectional area of the ascending aorta measured by biplane angiography (twelve 14" x 17" roll films/second) corrected for distance distortion by the

methods of Dodge.<sup>11</sup> The validity of the pressure gradient method of measuring instantaneous blood velocity and flow has been demonstrated by in vitro and in vivo studies.<sup>10,12,13</sup>

The studies comparing the electrical impedance electrocardiogram to pressure gradient methods are currently in progress and only very preliminary results are available to date. Figure 6 illustrates the recorded data of one such study. The impedance cardiogram determinations of cardiac output follow in direction the determinations made by the dye dilution and pressure gradient methods. Figure 7 illustrates simultaneous green dye, impedance cardiogram, and pressure gradient cardiac output determinations in four control situations, during an isoproterenol infusion, during recovery from the isoproterenol effect and during the performance of a Valsalva maneuver to a pressure of 40 mm Hg. The agreement between the cardiac output measurements by the impedance cardiogram and pressure-gradient methods is demonstrated by the correlation coefficient of 0.72 and the linear regression equation of  $y = 0.08 + 0.97x$ . (The cardiac output as determined by the pressure gradient technique is x and that determined by the impedance method is y.) The standard error of estimate is 0.91 liters/minute.

To examine instantaneous events, the peak of the first derivative of impedance change ( $dZ/dt$ ), expressed in ohms/second, was compared with the peak ascending aortic

blood velocity expressed in cm./second. In Figure 8, peak  $dZ/dt$  is plotted on the ordinate and peak blood velocity on the abscissa. Measurements were made during ventricular premature contractions, normally conducted beats, isoproterenol infusion, the Valsalva maneuver, and during rest and recovery periods. The correlation coefficient for this study is 0.94 for the simultaneous measurement by these two methods under these widely varying physiological circumstances. In the three other studies performed to date, the correlation coefficients were 0.94, 0.89 and 0.63. (Technical difficulties may account for the poor correlation coefficient in the last of these studies.)

In summary, preliminary data suggest that the impedance cardiogram may be a useful method to instantaneously evaluate mechanical heart function. It appears to provide information similar to that of more complicated procedures, to not require penetration of the skin, and to be easy to use. Further evaluation of electrical impedance cardiography is in progress.



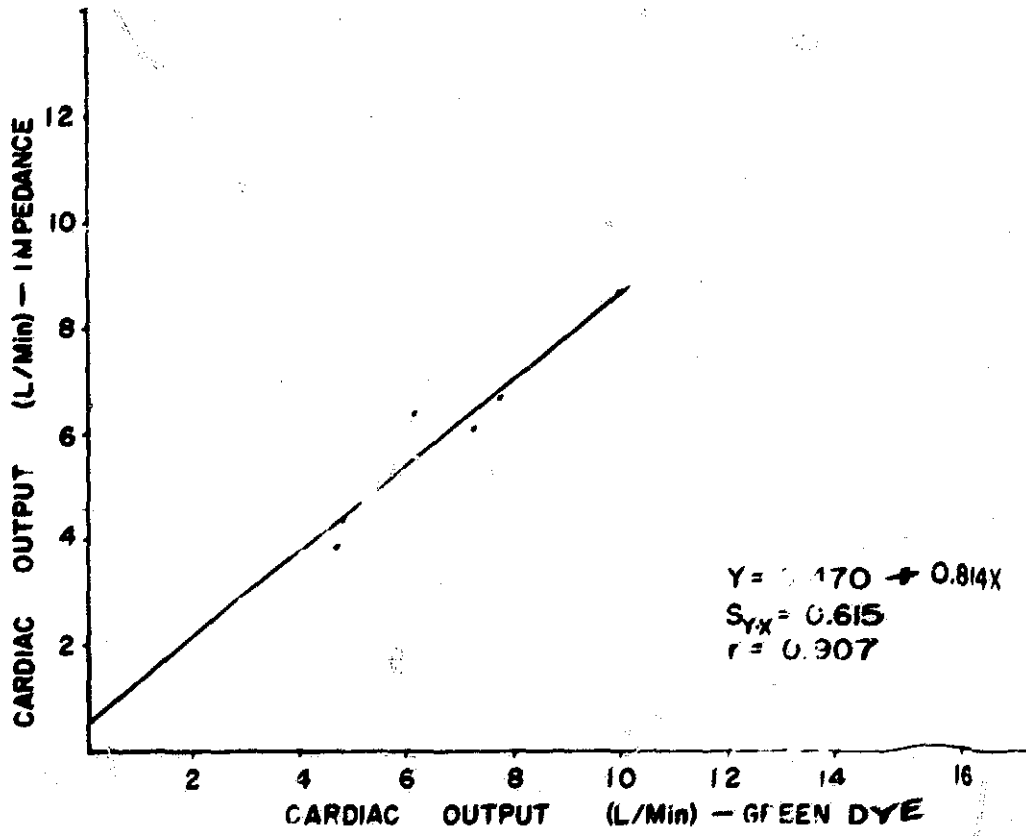

FIGURE 1

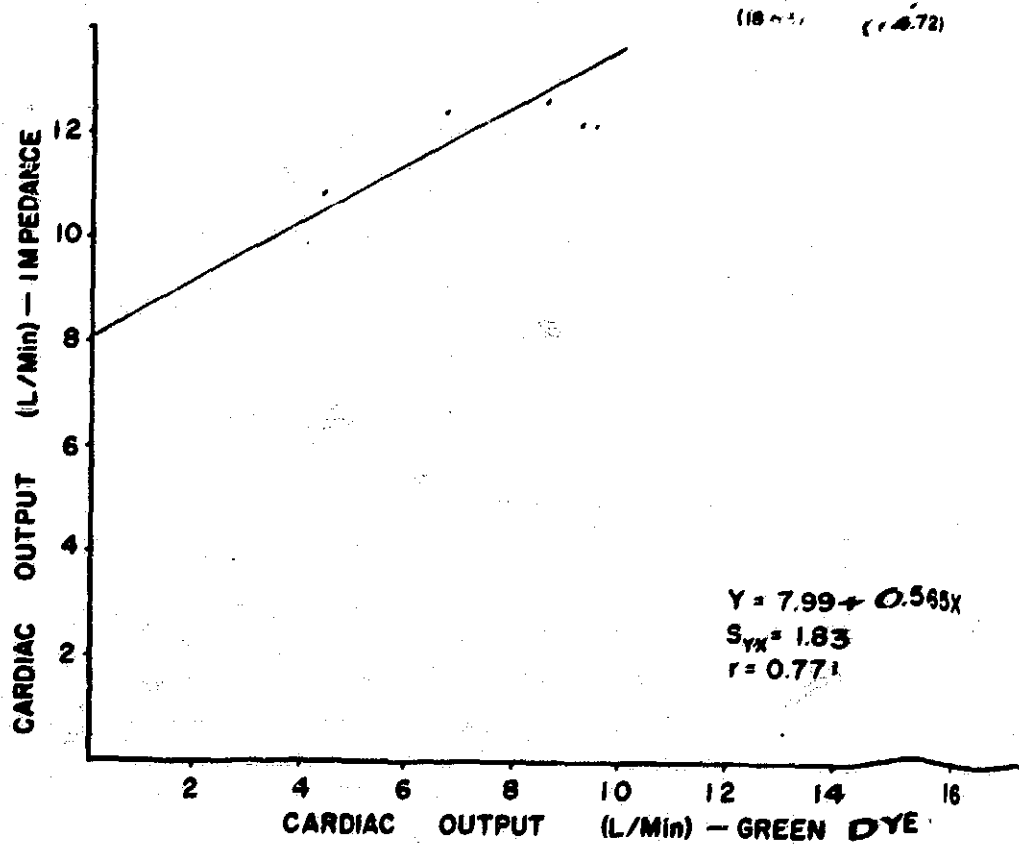

FIGURE 2

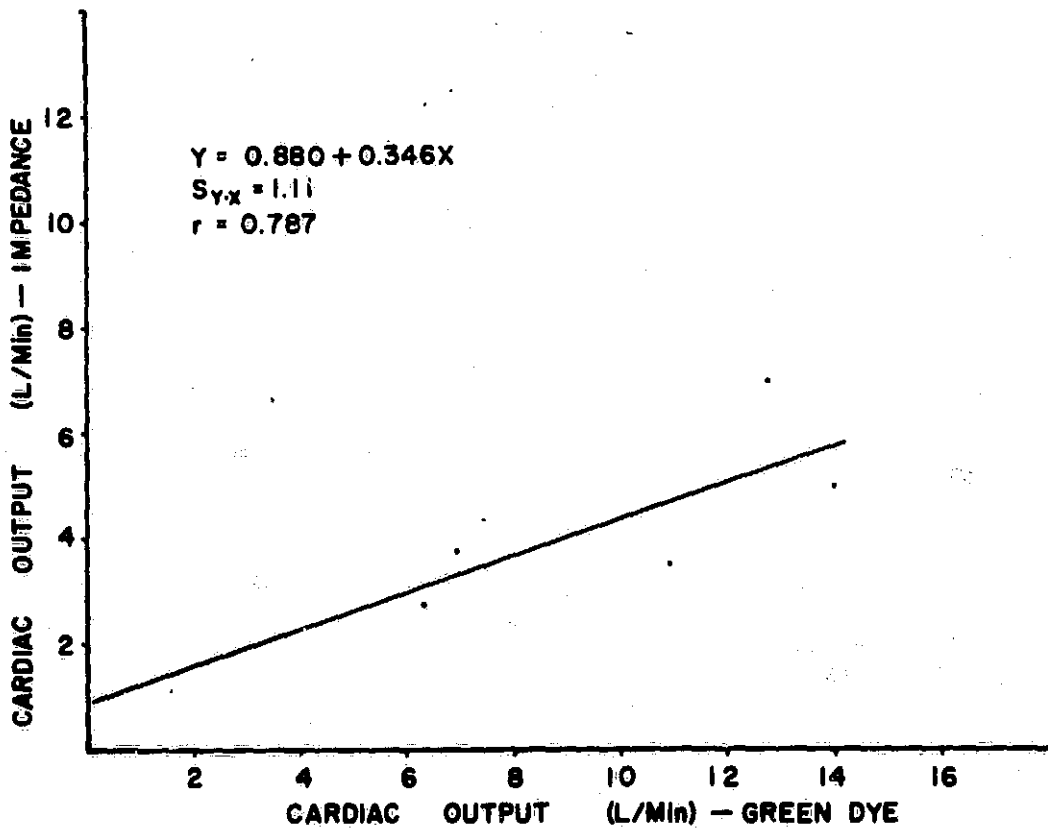

FIGURE 3

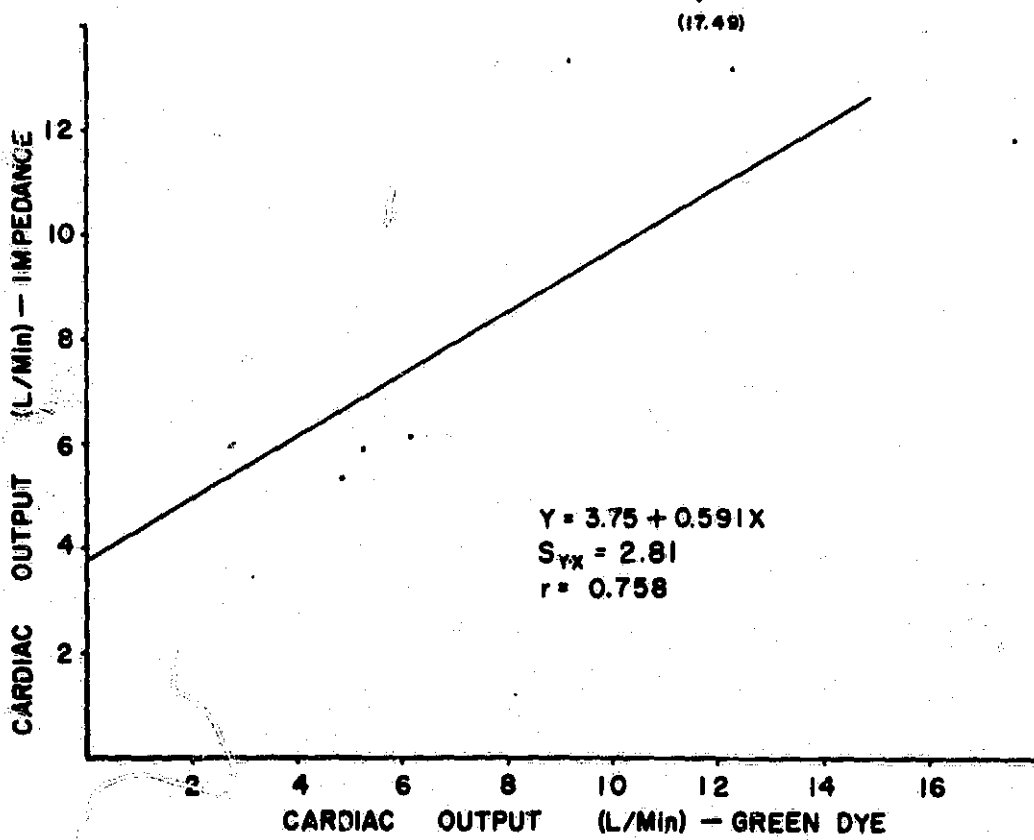

FIGURE 4

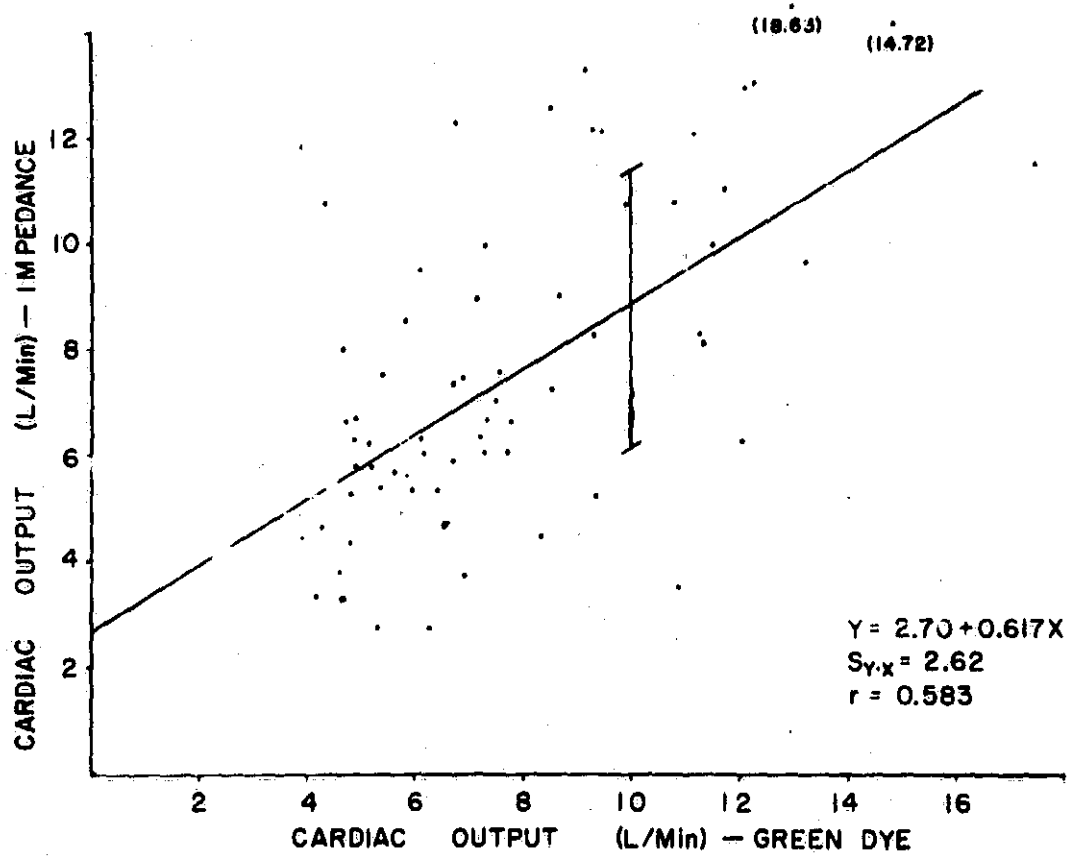

FIGURE 5

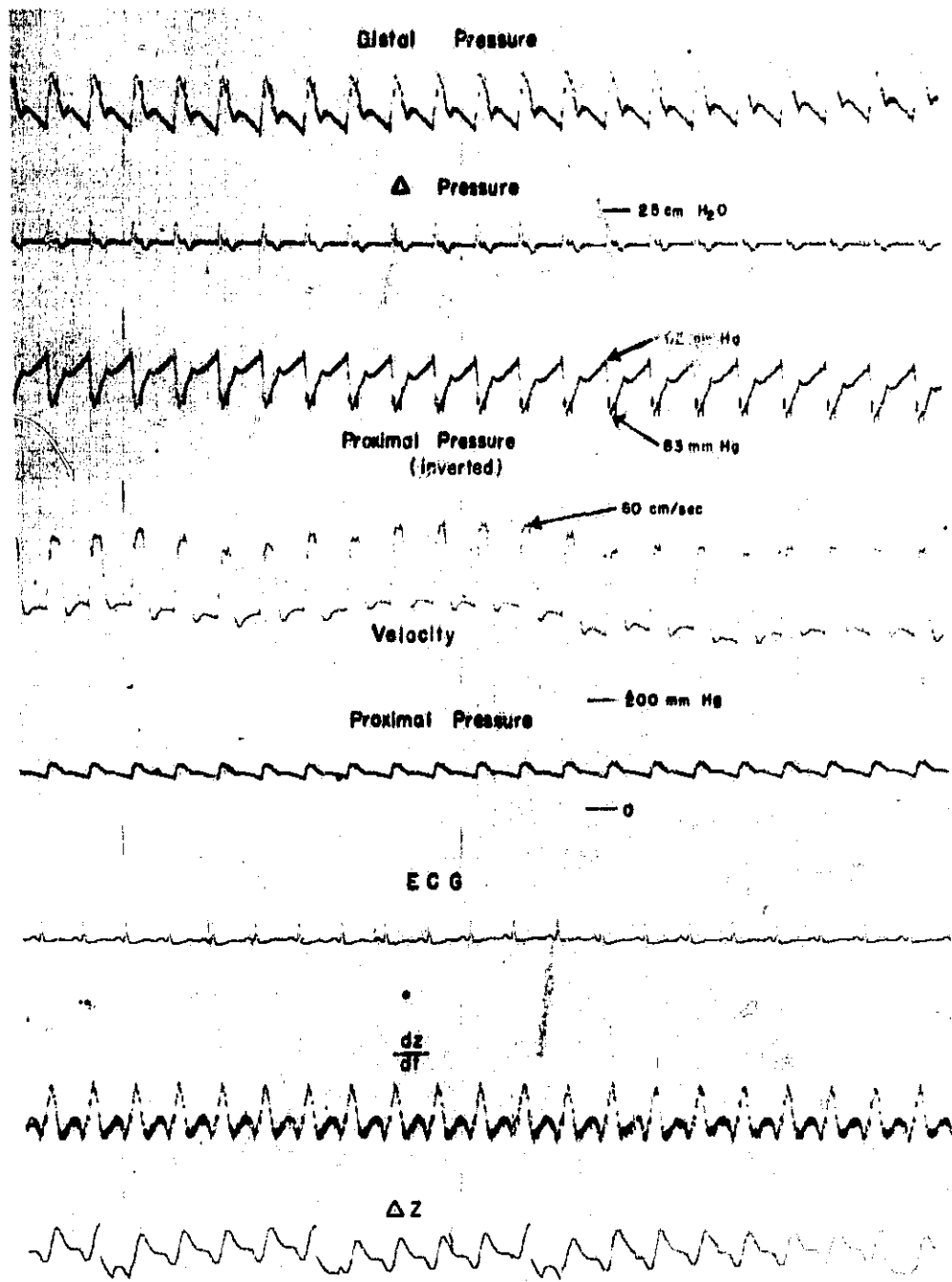

FIGURE 6

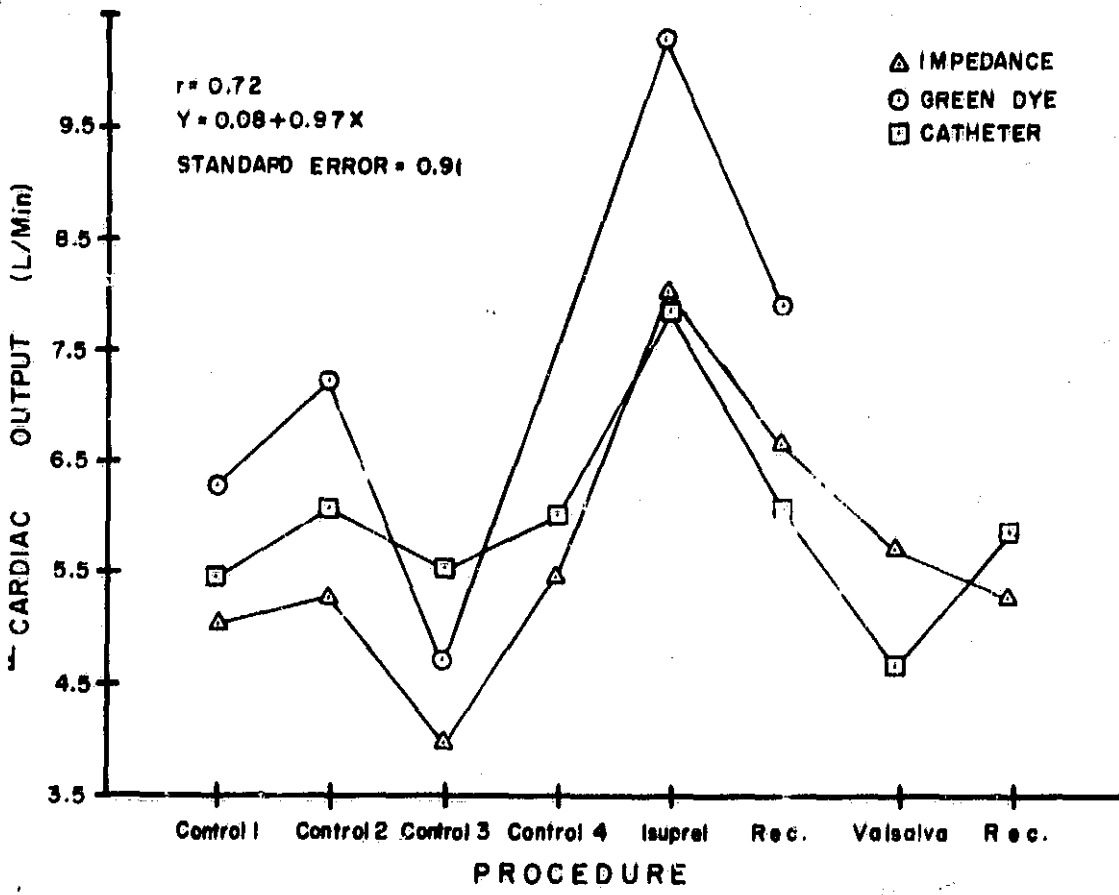

FIGURE 7

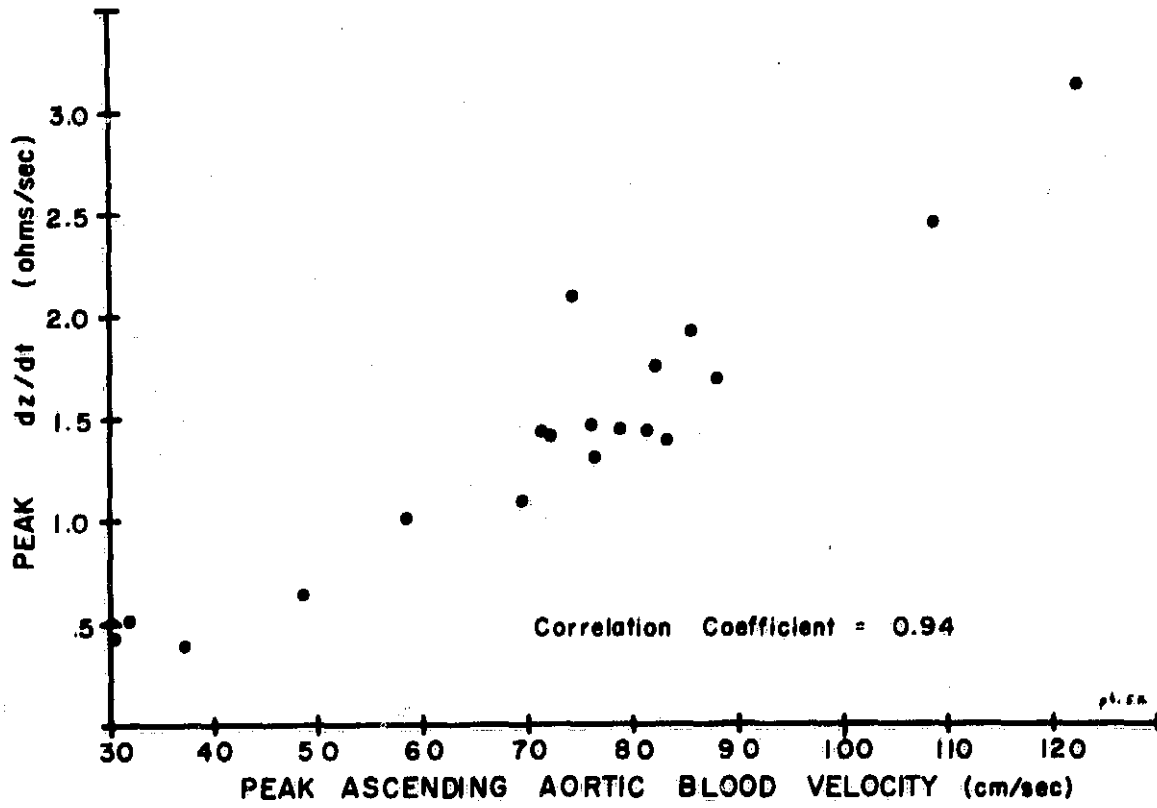

FIGURE 8

## REFERENCES

1. Krohn, B.G., Dunne, E., Magidson, O., Hanish, H., Tsuji, H.K., Redington, J.V., and Kay, J.H.: The electrical impedance cardiogram in health and disease. *Amer Heart J* 76: 377, 1968.
2. Geddes, L.A., Hoff, H.E., Mello, A., and Palmer, C.: Continuous measurement of ventricular stroke volume by electrical impedance. *Cardiovascular Research Center Bulletin* 4: 118, 1966.
3. Kubicek, W.G., Karnegis, J.N., Patterson, R.P., Witsoe, D.A., and Mattson, R.H.: Development and evaluation of an impedance cardiac output system. *Aerospace Medicine* 37: 1208, 1966.
4. Richardson, D.W., Wyso, E.M., Hecht, A.M., and Fitzpatrick, D.P.: Value of continuous photoelectric recording of dye curves in the estimation of cardiac output. *Circulation* 20: 1111, 1959.
5. Fry, D.L.: Measurement of pulsatile blood flow by the computed pressure gradient technique, *IRE Trans Biomed Electronics ME-6*: 259, 1959.
6. Barnett, G.O., Greenfield, J.C., and Fox, S.M., III: Technique of estimating the instantaneous aortic blood velocity in man from the pressure gradient. *Amer Heart J* 62: 359, 1961.
7. Hamilton, W.F., Riley, R.L., Attah, A.M., Cournand, A., Fowell, D.M., Himmelstein, A., Noble, R.P., Remington, J.W., Richards, D.W., Wheeler, N.C., and Withem, A.C.: Comparison of Fick and dye injection methods of measuring cardiac output in man. *Amer J Physiol* 153: 309, 1948.
8. From, A.: Applications of thoracic impedance variations during the cardiac cycle. In *Development and Evaluation of an Impedance Cardiographic System to Measure Cardiac Output and Development of an Oxygen Consumption Rate Computing System Utilizing a Quadrupole Mass Spectrometer*, National Aeronautics and Space Administration, 1967, p. 105.
9. Greenfield, J.C., Jr.: The pressure gradient technique. In *Methods in Medical Research*, vol. 11, edited by R.F. Rushmer. Chicago, Year Book Publishers, 1966, p. 83.

10. Snell, R.E., Clements, J.M., Patel, D.J., Fry, D.L., and Luchsinger, P.C.: Instantaneous blood flow in the human aorta. J Appl Physiol 20: 691, 1965.
11. Dodge, H.T., Sandler, H., Ballew, D.W., and Lord, J.D.: The use of biplane angiography for the measurement of left ventricular volume in man. Amer Heart J 60: 762, 1960.
12. Greenfield, J.C., Jr., Patel, D.J., Mallos, A.J., and Fry, D.L.: Evaluation of Kolin type electromagnetic flowmeter and the pressure gradient technique. J Appl Physiol 17: 372, 1962.
13. Greenfield, J.C., Jr., and Fry, D.L.: Relationship between instantaneous aortic flow and the pressure gradient. Circulation Research 17: 340, 1965.

EVALUATION OF IMPEDANCE CARDIOGRAPHIC TECHNIQUES FOR  
MEASURING RELATIVE CHANGES IN CARDIAC OUTPUT BY  
SIMULTANEOUS COMPARISON WITH INDICATOR DILUTION AND  
ELECTROMAGNETIC FLOWMETER

\* \* \* \* \*

N70-10021

by

David A. Witsoe, MSEE.  
Robert P. Patterson, MSEE.  
A.H.L. From, M.D.  
W. G. Kubicek, Ph.D.

Department of Physical Medicine & Rehabilitation  
University of Minnesota Medical Center  
Minneapolis, Minnesota 55455



## Introduction

The purpose of this paper is to describe the results of an evaluation of impedance cardiographic techniques (Section 1) for monitoring relative changes in cardiac output.

Previous comparison studies in our laboratories have included work on both human beings and animals. A study on 10 normal young adult healthy subjects was carried out under conditions of rest and exercise but only a fairly limited range of cardiac output and cardiovascular dynamics was achieved. Results of this study were described in our July 1967 Final Progress Report to the NASA and in reference number 1. Also reported at that time were results of studies on dogs in which stroke volume was varied by controlling pulse rate with paired pulse stimulation. Impedance stroke volume was compared on a beat by beat basis with that obtained from electromagnetic flowmeter information. Again this was very limited information since cardiac output and peripheral resistance remained essentially constant and only pulse rate and stroke volume were varied. The results of the experiments on animals showed a linear relationship between impedance and flowmeter stroke volumes over the limited range and also showed a linear relationship between the peak of ascending aorta flow and the peak of the first time derivative of the impedance waveform. These interesting results suggested that further work should be carried out to assess the applicability of impedance techniques over a wider range of dynamic cardiovascular conditions.

The major goal of the present study was to stress the cardiovascular system of the anesthetized dog as much as possible and monitor cardiac output with three techniques: the indicator

dilution method, the electromagnetic flowmeter, and the impedance technique. In order to achieve the aforementioned goals, several drugs were utilized to vary four parameters of cardiovascular function: the contractility of the heart, the peripheral resistance, the pulse rate and the stroke volume.

#### Methods:

Mongrel dogs were anesthetized with sodium pentobarbital (25 mg/kg), intubated, and placed on a positive pressure respirator. A left thoracotomy was performed and an appropriate electromagnetic flow transducer (Biotronex model 410) was placed around the ascending aorta. While the chest was open, three catheters for dye injection and sampling, and pressure measurements were positioned. Pressures were determined with a strain gauge transducer (Statham P23Db). Dye for the indicator dilution studies was injected into either the right atrium or main pulmonary artery and sampling was from the ascending aorta. The thoracotomy was then closed and air evacuated by continuous suction. The four electrode bands for impedance measurements were placed on the neck and lower thorax in the standard positions shown in Figure 1. The following parameters were recorded on magnetic tape: ECG, ascending aortic flow, ascending aortic pressure, thoracic impedance change,  $\Delta Z$ , first time derivative of thoracic impedance  $dZ/dt$ , and the indicator dilution curve (Waters Corp. densitometer system). Following the experiment, these parameters were reproduced on an oscillographic recorder (Honeywell Visicorder model 1508) for subsequent data reduction. During the course of the experiment all parameters were monitored on a large screen

oscilloscope and dye dilution cardiac output was computed on-line by our digital computer such that the trends of the experiment could be followed.

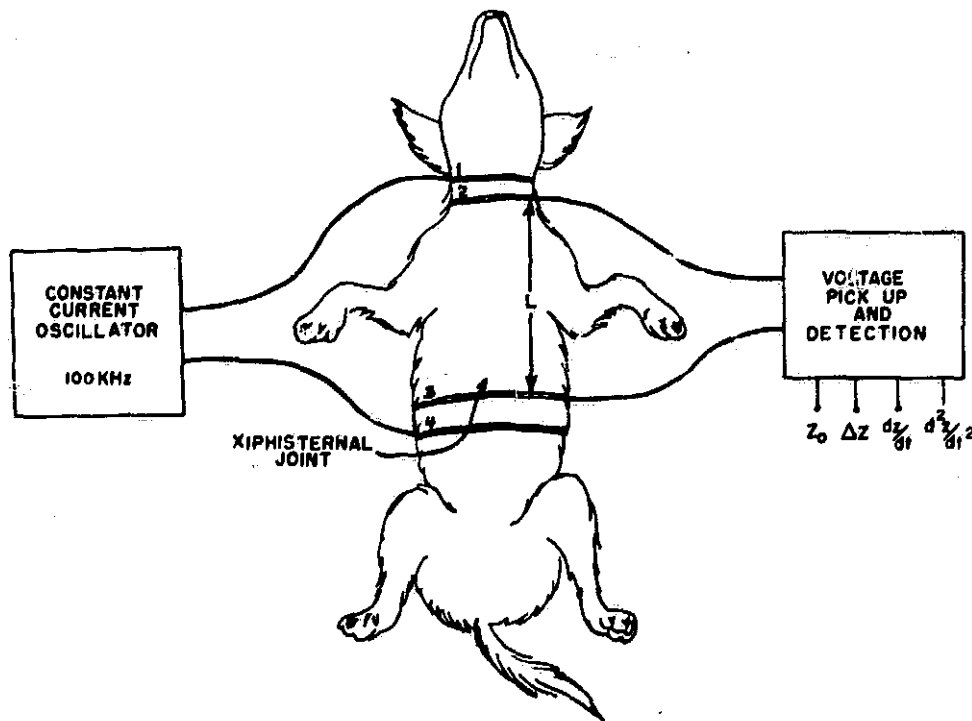

Figure 1 Electrode placement and Impedance Cardiograph components

A minimum of two dye dilution curves with simultaneous impedance and flowmeter measurements were obtained for each cardiovascular condition. All measurements were taken during periods of end-expiration apnea to eliminate respiration artifact from the impedance signals.

To obtain an increase in peripheral resistance with a minimal effect on contractility, methoxamine was infused at a constant rate by a Harvard Apparatus infusion pump. The levels of methoxamine infusion depended primarily upon the response of the particular animal as measured by the ascending aortic blood pressure.

Infusion rates ranged from 0.25 mg/min to 1.0 mg/min.

Decreased peripheral resistance, increased contractility and increased heart rate were produced by infusion of isoproterenol at constant rates over several levels ranging from 0.25 micrograms to as high as 10 micrograms. Again the response of the individual dog controlled the infusion rate.

Two levels of bradykinin were infused at a constant rate of 25 and 50 micrograms per minute in an effort to decrease peripheral resistance without changing contractility.

To lower heart rate and decrease contractility, dl-propranolol was given intravenously in one bolus at the rate of one quarter milligram per kilogram weight. In some instances sodium pentobarbital was given at the end of the experiment as a general system depressant.

Fourteen animal experiments were done. The drugs were not always administered in the order listed and in some cases not all drugs were given in a particular experiment. Figure 2 describes the parameter variations observed during a typical experiment.

After completion of the experiment the electrocardiogram,  $\Delta Z$ ,  $dZ/dt$ , ascending aortic flow, ascending aortic mean pressure, indicator dilution curve and stroke volume as computed by analog integration of the flow waveform were reproduced from magnetic tape for data reduction. For purposes of comparing the three cardiac output techniques, dye dilution, electromagnetic flowmeter and impedance, the beat by beat data of the electromagnetic flowmeter and impedance system were taken from eight beats under the dye dilution curve. Calculation of impedance determined stroke

volume was done as described in Section I.

Comparison Study 10

Typical Parameter Response

	Control	Methoxamine	Isuprel	Bradykinin	Propranolol
Pulse Rate :bpm	166	77	177	171	128
Cardiac Output : L/min.	2.74	2.50	5.87	4.22	2.32
Stroke Volume : cc	16	33	30	25	18
Aortic Pressure : mm Hg (mean)	119	171	111	100	149
Peripheral Resistance : $\frac{\text{Dyne} \cdot \text{sec}}{\text{cm}^2}$	3467	5429	1510	1895	5140

Figure 2 Typical cardiovascular parameter variations produced by drug infusions.

Indicator dilution curves were recorded and calibrated in the standard fashion and computed on-line with a small digital computer (Spear microLINC), and the technique utilized was similar to that of Hepner et al. (2). The validity of the computer calculations were established by hand calculation of selected curves using the Steward-Hamilton replot method (3). Fifty comparisons of the two methods of computation over a range of 2 to 11 L/min were characterized by the regression equation:

$$\text{Computer calculation} = 1.016 (\text{Hand calculation}) - .046$$

with a standard error of the slope = .0175 and a standard error of the intercept = .069.

The flowmeter probes were roughly calibrated with saline using a gravity feed system, stopwatch, and a graduated cylinder to measure flow volume.

Results:

Comparison of the dye and flowmeter cardiac output data is shown in Figure 3. There are 305 simultaneous comparisons from 14 dogs. The dogs are coded Dog 1 as A, Dog 2, B, etc. on to Dog 14 coded as N. The range of cardiac output was from one to 10 liters per minute. The flow probes utilized in these experiments previously had a rough calibration with saline but it was not considered accurate. Therefore, assuming that on the average the flowmeter and dye dilution cardiac outputs yield the same information, we divided each eight beat average flowmeter cardiac output value (rough calibration) by the corresponding dilution cardiac output and averaged all ratios for each experiment to derive a constant, then used this constant to correct the flowmeter data. Since the purpose of this study was to evaluate relative change predicting capabilities of the impedance technique, such a procedure for calibrating the flow probe is valid since one is only multiplying by a constant. Using this calibrating technique a 45° identity line and ±10%, ±15% and ±20% lines around the identity line can be drawn as shown in Figure 3. An analysis of these data shows that approximately 25% of the points lie outside the ±10% lines, approximately 10% lie outside the ±15% lines and approximately 4% lie outside the ±20% lines.

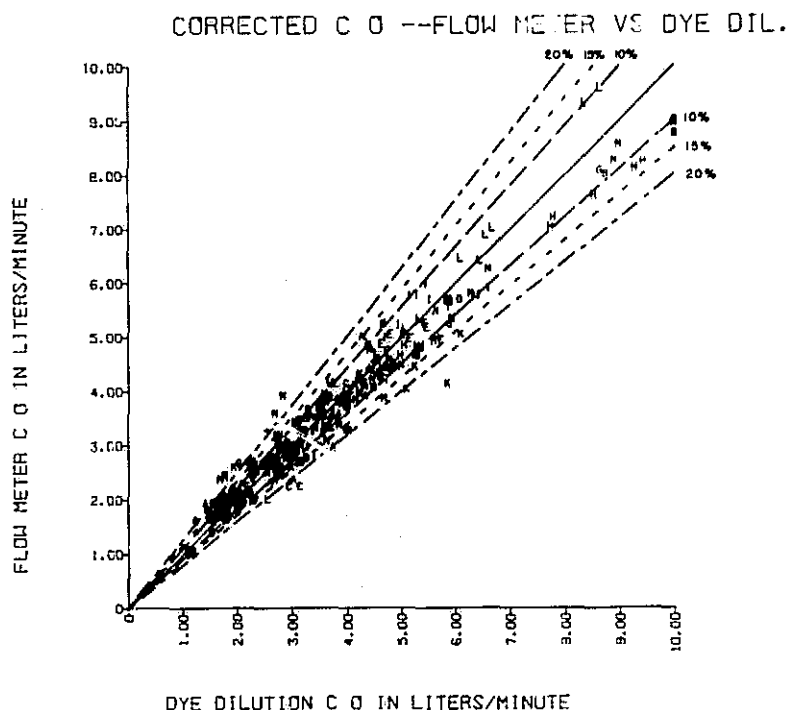

Figure 3 Comparison of corrected EM Flowmeter determined cardiac output with simultaneous dye dilution values for 14 dogs with 45° identity line and ±10%, ±15% and ±20% difference bands indicated (see text for correction method of flowmeter data).

To assess the quality of our dye dilution and flowmeter cardiac output information we can compare these data with results obtained by other investigators. For example, Miller et al. (4) did a dye dilution-Fick comparison on 15 patients with 34 simultaneous determinations. Their results indicated that 12% of their data fell outside a ±12 1/2% difference band. Sleeper et al. (5) carried out a study to evaluate the reproducibility of the indicator dilution system. To determine the errors inherent in the instrumentation and calculation of the indicator dilution curves they attached two densitometers to the same needle and results showed that two standard deviations were approximately 6% of the mean cardiac output. After determining the instrumentation error they measured cardiac output simultaneously from

two sites on the same patient; the brachial artery and the femoral artery. The results from this experiment showed that two standard deviations were equivalent to 1200 cc per minute or approximately 20% of the mean cardiac output. In light of the results of these other investigators we can conclude the following about our flowmeter and dye dilutions simultaneous comparison: There appears to be no greater spread of our data than when one compares the dye dilution with the Fick, both accepted techniques. There is an equivalent spread to the simultaneous dye dilution data on an individual from two separate sites. Thus the flowmeter and dye dilution information yield the same information within the accuracies suggested by other investigators for accepted cardiac output techniques. We may then use either the dye dilution data or the flowmeter data in assessing the quality of the impedance system for predicting relative changes in cardiac output.

Since the impedance technique is a stroke volume method, i.e., the basic calculation is for stroke volume, the comparison of the impedance system with the other techniques on a stroke volume basis is most meaningful. Figure 4 shows the relationship between impedance stroke volume and flowmeter stroke volume from 14 dogs and Figure 5 describes corresponding results for the dye dilution stroke volume. The coding is the same used in Figure 3. Since we were only interested in relative changes, the values of the impedance stroke volume have been corrected by determining the average ratio of the dye dilution stroke volume to the impedance stroke volume for each experiment and then multiplying the individual impedance stroke volumes by this correction factor.



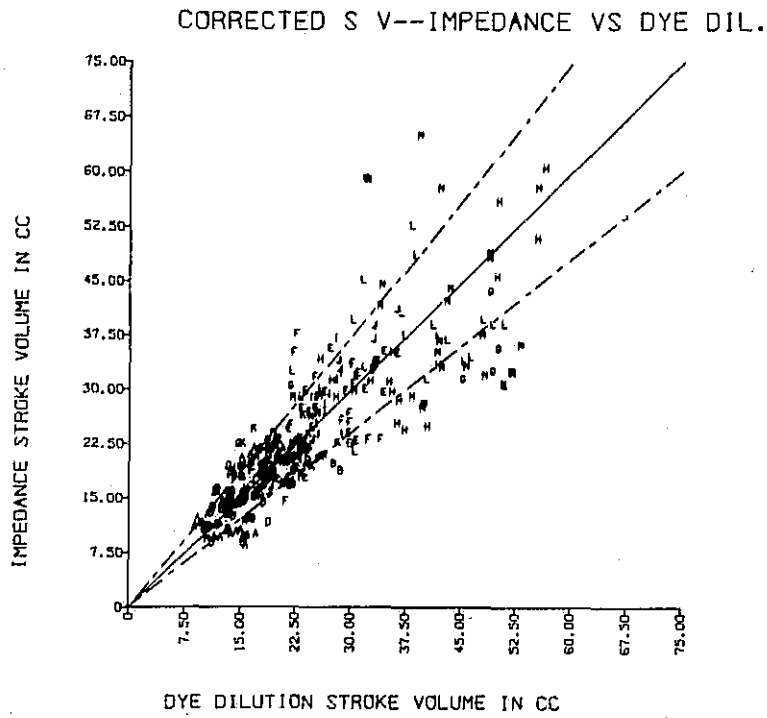

Figure 4 Comparison of simultaneous impedance and dye dilution stroke volume on 14 dogs with 45° identity time and ±20% difference band (see text for correction method of impedance data)

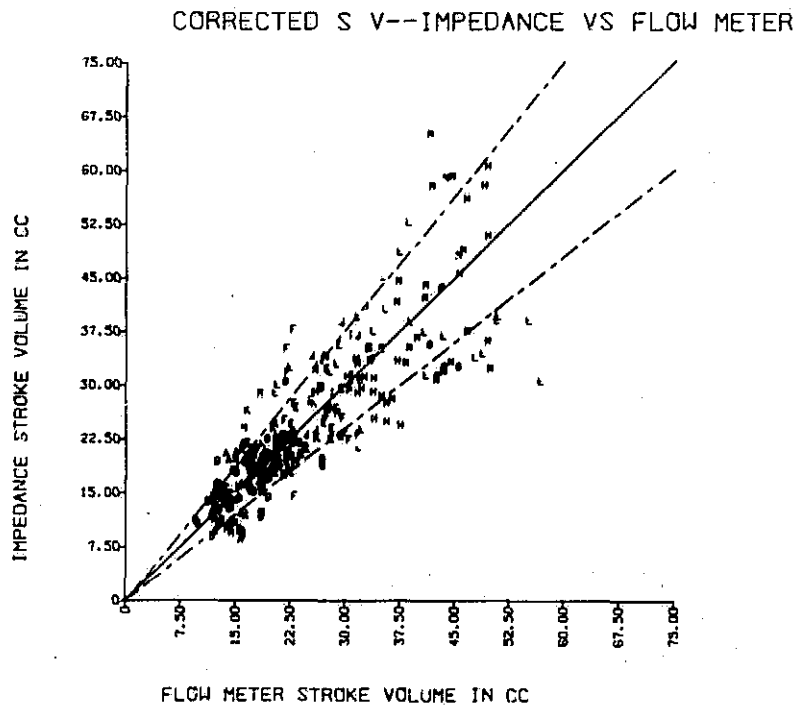

Figure 5 Comparison of simultaneous impedance and flowmeter determined stroke volume on 14 dogs. Dotted lines indicate ±20% off identity time.

Likewise, impedance vs. flowmeter stroke volume data were corrected in the same fashion. In both comparisons about 30% of the data are outside of a  $\pm 20\%$  band.

One vehicle for assessing the accuracy or the capabilities of the impedance method in predicting changes in relative stroke volume is through use of line graphs of normalized values of stroke volume. In Figures 6 through 9 normalized stroke volume by the three techniques are presented versus the condition of the experiment. Normalization was achieved by determining the average value stroke volume of the two or more control measurements for each method and dividing all other data by the respective average control value. The key for the data is shown in the upper right hand corner of the figure. These graphs are representative of the type of results that were obtained in this study, showing some of the best correlations and some of the poorest correlations of the 14 experiments (Appendix A contains the results of the remaining ten experiments). Figure 6, comparison study 12, shows the poorest fit of the impedance information to dye dilution and flowmeter information. On these graphs, C represents control, M indicates methoxamine infusion, R is recovery, I is isoproterenol, B is bradykinin, P is propranolol and N is Nembutal. Figure 7 is more typical of the type of data that were obtained on this series of 14 experiments. In comparison study 6 we see a fairly good correlation between the impedance and the other two methods during the isoproterenol and bradykinin injections but an overestimation of the methoxamine condition. In comparison, study 10 shown in Figure 8, the impedance system agreed fairly well with the flowmeter method during methoxamine,

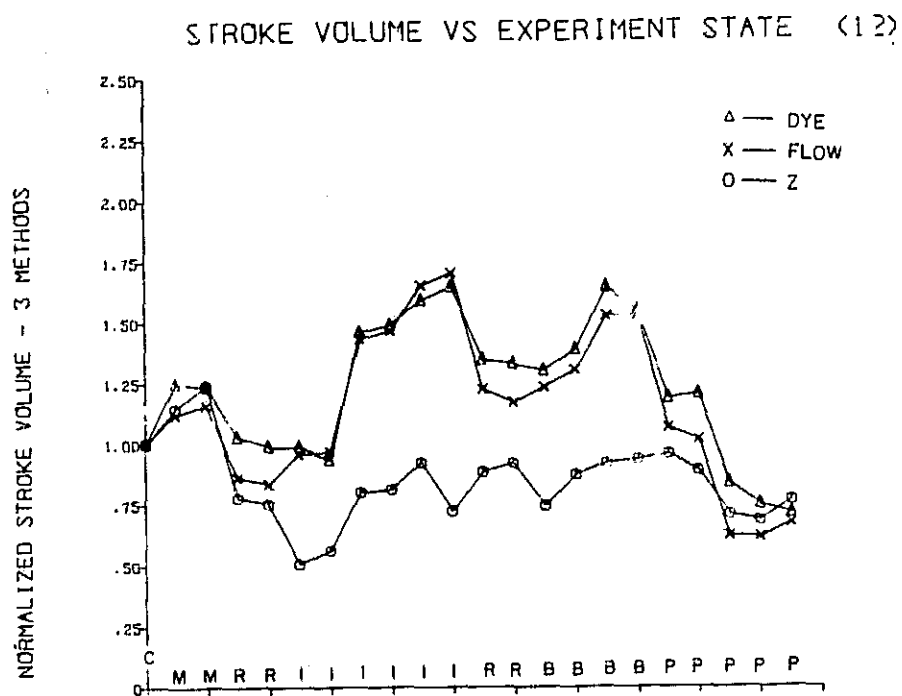

Figure 6 Three way comparison of stroke volume during experimental protocol of comparison study No. 12 (see text for normalization procedure and key to experimental state).

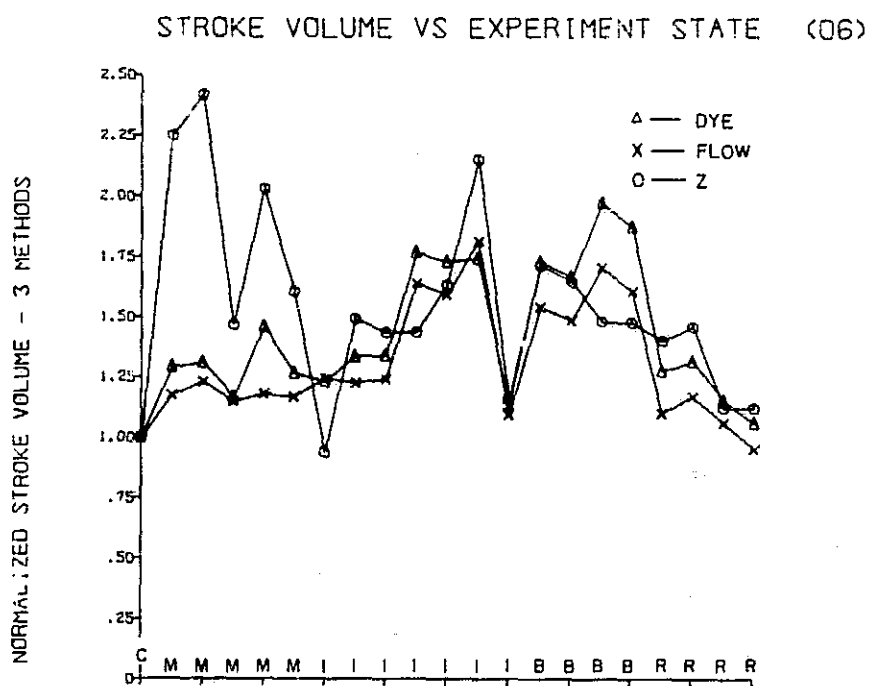

Figure 7 Normalized stroke volumes for comparison study No.6.

but overestimated during the remainder of the experiment while exhibiting the same directional changes as the other methods. During comparison study 8, Figure 9, the impedance system followed the other two measurement methods quite well.

As previously indicated, past studies in our laboratories have shown a linear relationship between peak amplitude of  $dZ/dt$  and the peak amplitude of the ascending aortic flow waveform over a limited range of cardiovascular condition. To determine if this relationship held over wide ranges, corresponding data were plotted for the current study. Figures 10 through 13 show the results of this comparison for the same experiments described by the stroke volume comparisons of Figures 6 through 9 (corresponding plots for the ten additional experiments are presented in Appendix A). The data were normalized by the same procedure used for normalizing the stroke volume line graphs. In addition to the plot of  $dZ/dt$  peak, a factor  $(L/Z_0)^2$  modifying  $dZ/dt$  peak is also shown. This factor is utilized in the computation of impedance stroke volume and it was of interest to see if it had any effect on the correlation of peak  $dZ/dt$  with peak flow.

#### Discussion:

It might be suggested that there are systematic reasons related to peripheral resistance, or a particular infusion media which explain why the impedance system may or may not follow the standard techniques, but Figures 6 through 9 suggest no obvious trend. In some cases cardiac outputs during infusion of isoproterenol were considerably overestimated. In some cases the cardiac output was underestimated while in several cases there

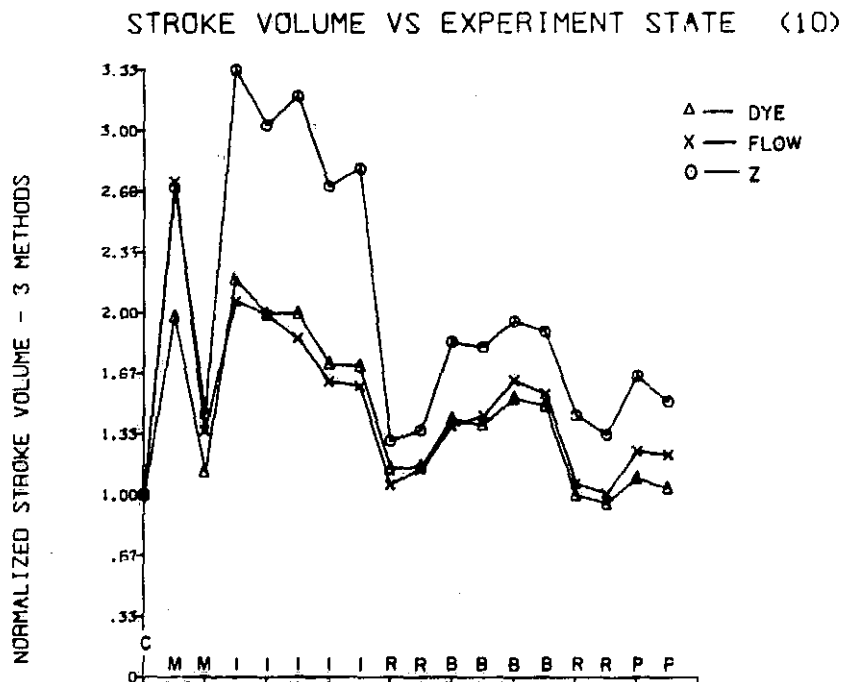

Figure 8 Normalized stroke volumes for comparison study No. 10.

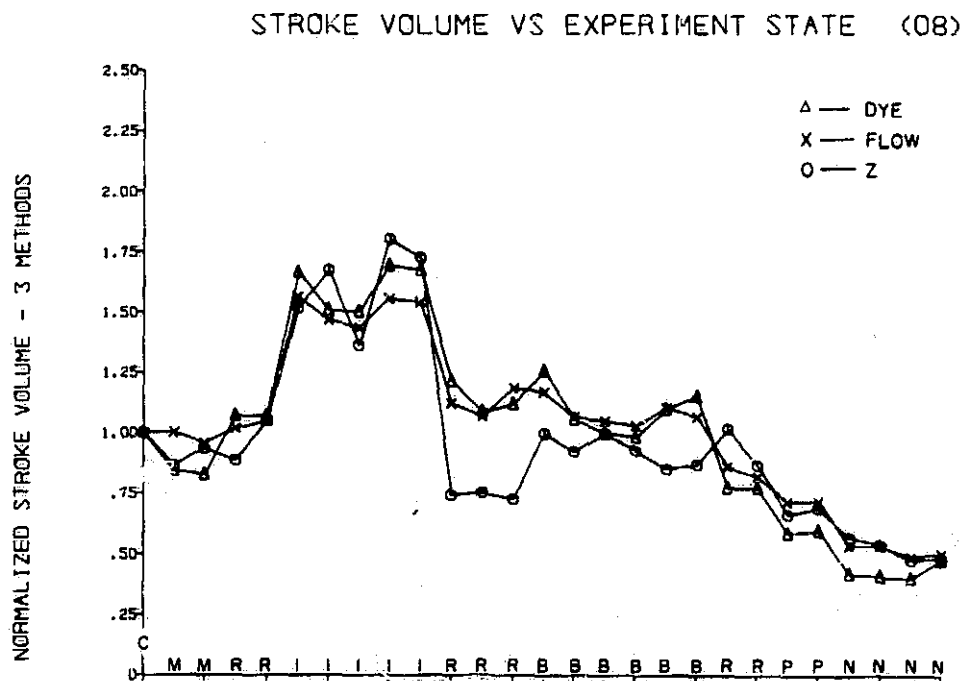

Figure 9 Normalized stroke volumes for comparison study No. 8.

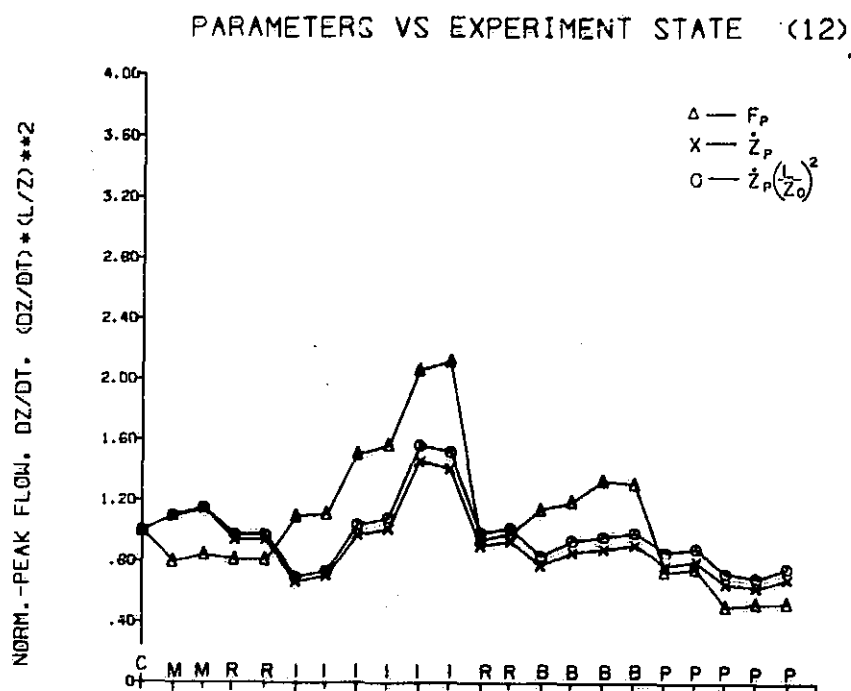

Figure 10 Comparison of normalized peak aortic flow ( $F_p$ ) with simultaneous peak  $dZ/dt$  ( $\dot{Z}_p$ ) and  $\dot{Z}_p (L/Z_0)^2$  during experimental conditions of comparison study no. 12 (see text for normalization method and key to experimental condition)

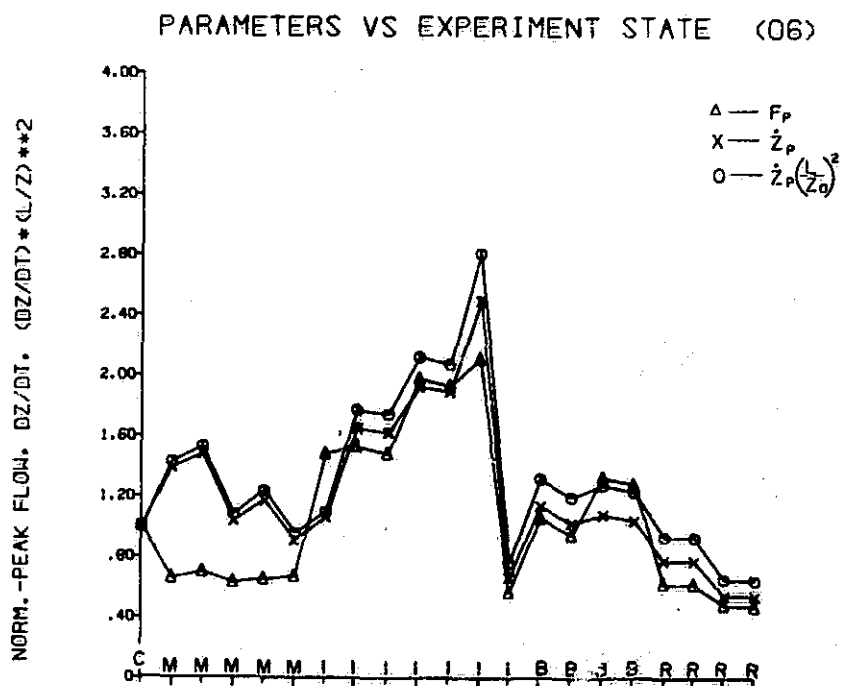

Figure 11 Comparison of normalized peak aortic flow, peak  $dZ/dt$  and  $\dot{Z}_p (L/Z_0)^2$  for comparison study no. 6.

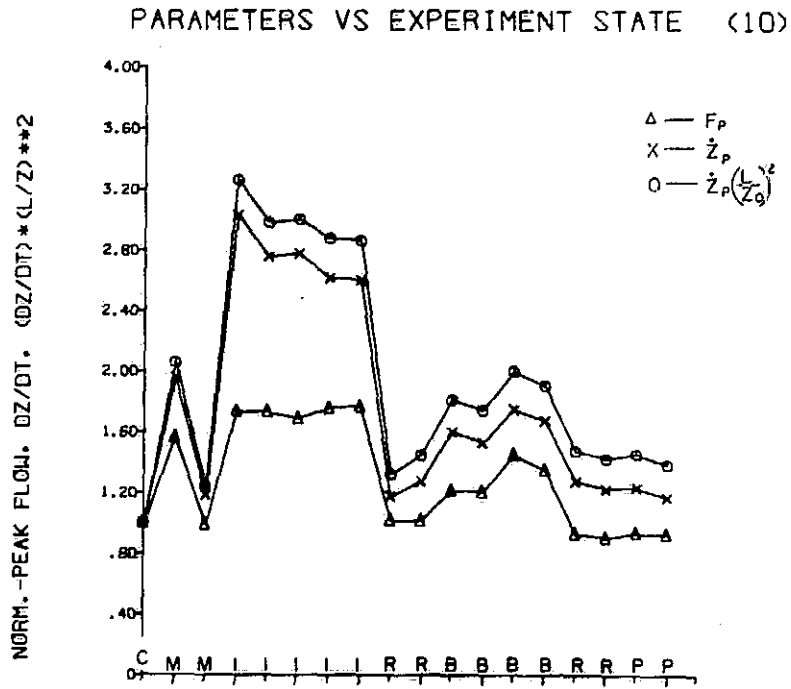

Figure 12 Comparison of normalized peak aortic flow, peak  $dZ/dt$  and  $\dot{Z}_p (L/Z_0)^2$  for comparison study no. 10.

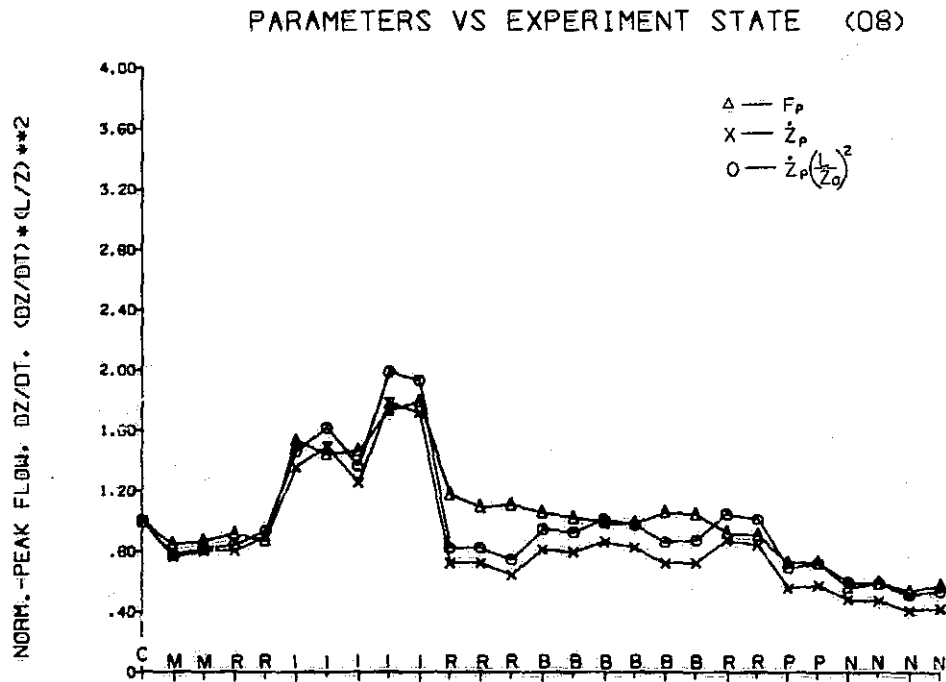

Figure 13 Comparison of normalized peak aortic flow, peak  $dZ/dt$  and  $\dot{Z}_p (L/Z_0)^2$  for comparison study no. 8

was a good correlation between the impedance method and the other two methods. Again, during bradykinin infusion, the impedance method underestimated or overestimated cardiac output in several experiments and agreed quite closely with the other two techniques in other experiments.

There are other possible explanations of the variability of the correlations found. Since the peak of the impedance waveform, along with ventricular ejection time, are involved in the impedance stroke volume computation formula, one can suggest that the formula is a triangular approximation of the ascending aorta flow waveform if linearity between the impedance time derivative peak and ascending aortic flow peak exists. Figures 10 through 13 suggest that the flowmeter peak value versus the impedance derivative peak value had a better correlation than the stroke volume by impedance technique versus stroke volume by the accepted techniques. If we assume for the moment that we have good correlation between flow peak and  $dZ/dt$  peak then the triangular approximation idea may show some indications of the errors in the impedance prediction of stroke volume. Under conditions of methoxamine the aortic flow profile waveform exhibits a flat top and is considerably wider than it is under normal peripheral resistance conditions but during isoproterenol the flow waveform becomes considerably narrower. If one would approximate the flow signal during methoxamine as a triangle a portion of the area under the waveform would be lost and therefore the stroke volume prediction would be much lower than the true value. If the triangle approximation is used during isoproterenol infusion one would expect to be more accurate because the flow profile fairly well approximates



a triangle during high activity isoproterenol conditions. From analysis of the impedance-flowmeter stroke volume data, we did not see this particular trend. Although there are examples of this type of behavior there is not enough of a trend to suggest that these are the errors inherent in the estimations of stroke volume by the impedance technique.

Reflecting upon the design of these experiments our goal was to stress as much as possible the cardiovascular system. Since there is sufficient data in the above figures to show a good correlation between impedance and dye dilution or flowmeter stroke volume one cannot disregard the possibility that the impedance system may be valid over a limited range only. The wide dynamic range imposed upon the animals in our series of experiments may be causing the impedance system to get into regions of nonlinearity.

One other possible clue to the disagreement between the impedance system and the other two techniques can be best explained by two figures that show waveforms from two of the experiments. Figure 14 shows  $\Delta Z$  and  $dZ/dt$  waveforms from comparison study 6 and are typical of those obtained from human subjects and from dogs whose chests are intact. Figure 15 from comparison study 12 shows some rather complex abnormal impedance tracings and it is this quality of waveform that appeared quite often throughout our series of experiments. Apparently, opening the chest of a dog to place the flow probes and catheters had some serious effects on the quality of the impedance waveforms that were obtainable after closure of the chest. During the course of these experiments every effort was made to evacuate all the air from the chest by continuous aspiration and repeated auscultatory checks were

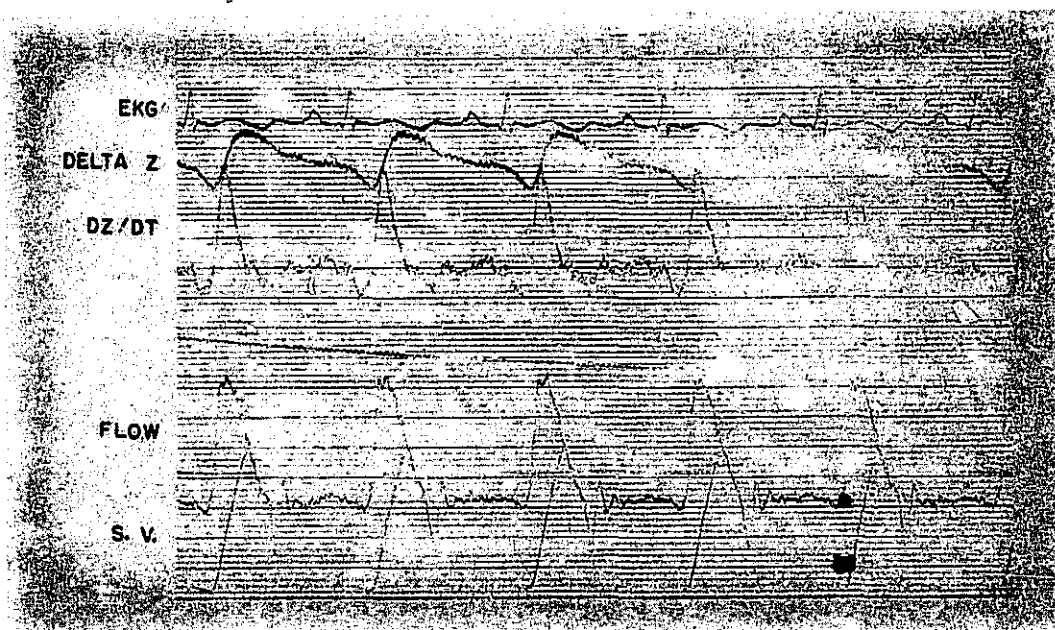

Figure 14 Impedance waveforms typical of those obtained from human subjects and dogs with intact chest. (Flow-ascending aortic flow, S.V. - stroke volume obtained by integration of flow).

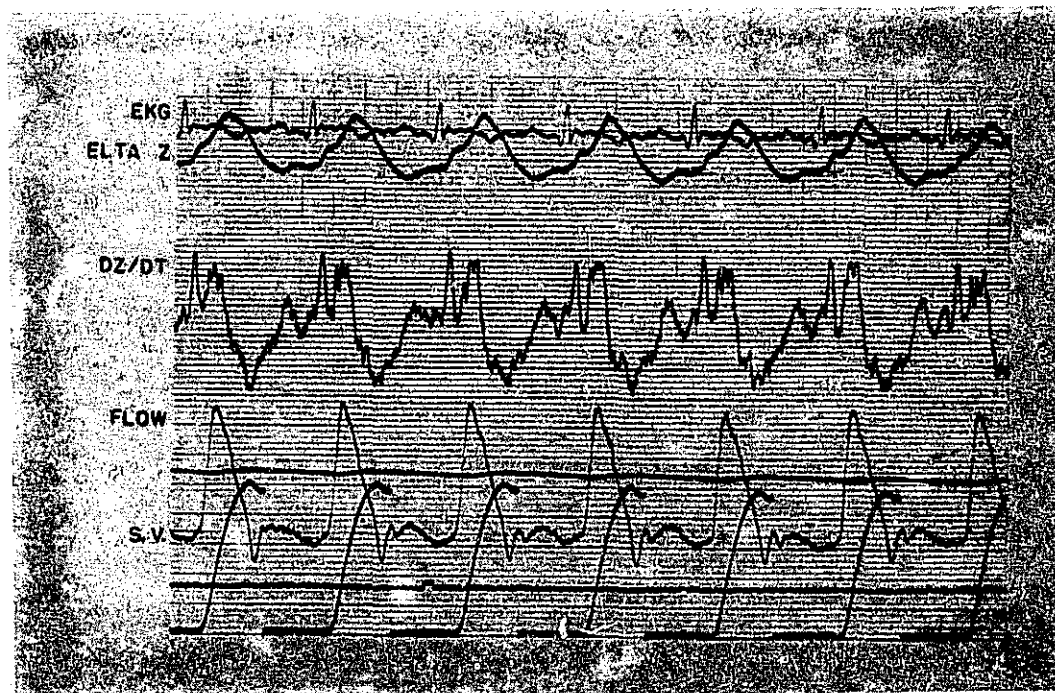

Figure 15 Abnormal impedance waveforms from dog possibly caused by opening and closure of chest.

made of the chest. We cannot ascribe all of the mismatch between the impedance data and the flowmeter and dye dilution data to problems that occurred because of the opening and closing of the chest but we consider it to be one contributor to the differences noted previously. As an example, comparison study 12 exhibited abnormal waveforms and poor correlation, while the more normal waveforms from study 6 were accompanied by better correlation. One obvious technic for assessing the effects of the surgery and acute experiments would be to utilize chronically implanted flow probes or a catheter tip flowmeter in order to avoid opening the chest. We are planning to utilize an electromagnetic catheter tip flowmeter and repeat some of these experiments to determine if the impedance waveforms retain a normal contour and examine the subsequent effect on the correlation of impedance stroke volume with accepted methods.

In summary, the cardiovascular system of 14 dogs was stressed over a wide dynamic range, and in some cases nearly to the point of destruction. The ability of the impedance system to predict relative changes in cardiac output was not as satisfactory as that achieved with the dye dilution and flowmeter methods. However there were sufficient conditions under which the impedance system did accurately predict relative changes in cardiac output to warrant further efforts in this area.

APPENDIX A

This appendix contains line graphs of stroke volume comparisons and impedance flowmeter parameter comparisons for the ten comparison studies not explicitly described in the text.

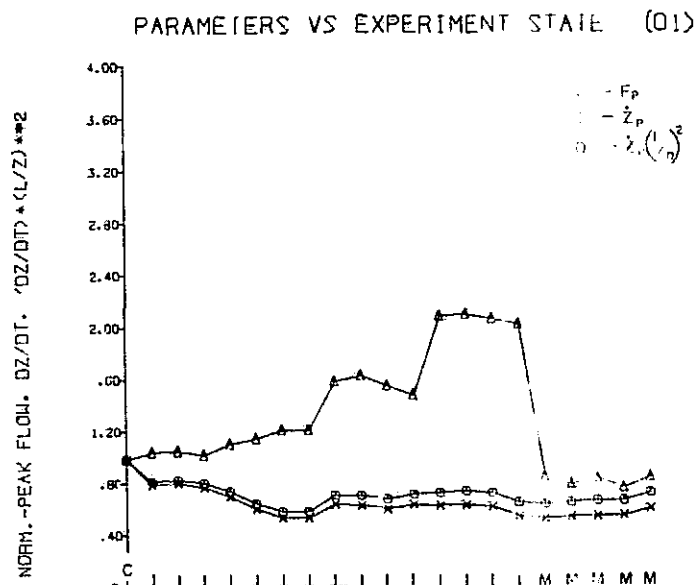
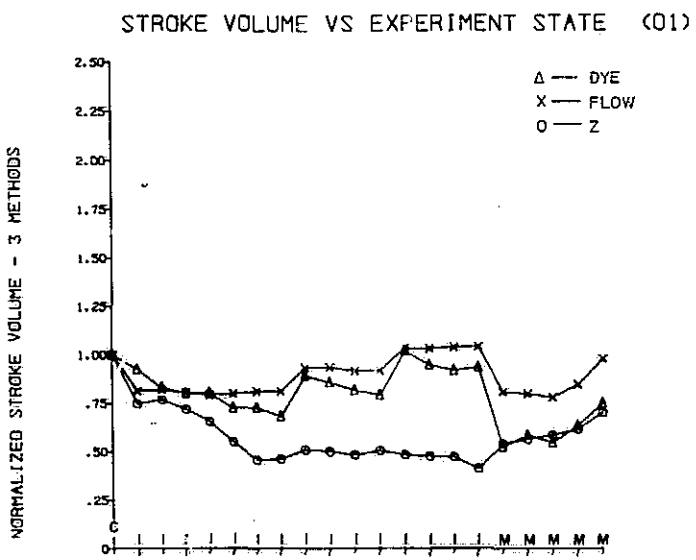

Comparison Study Number 1

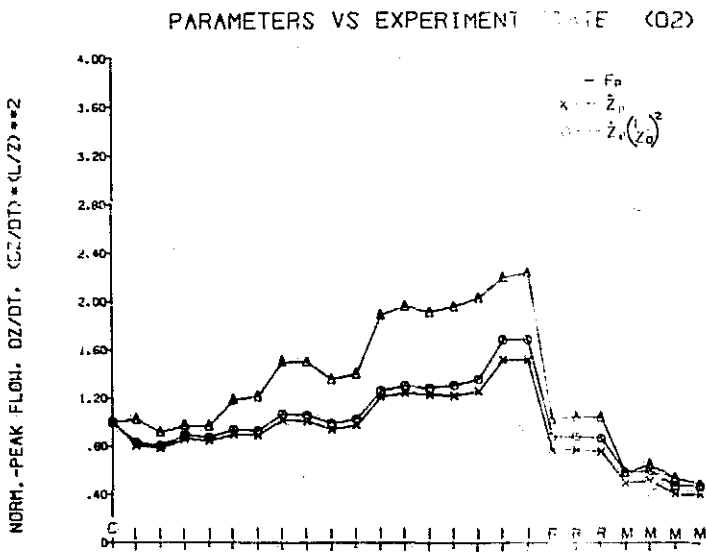
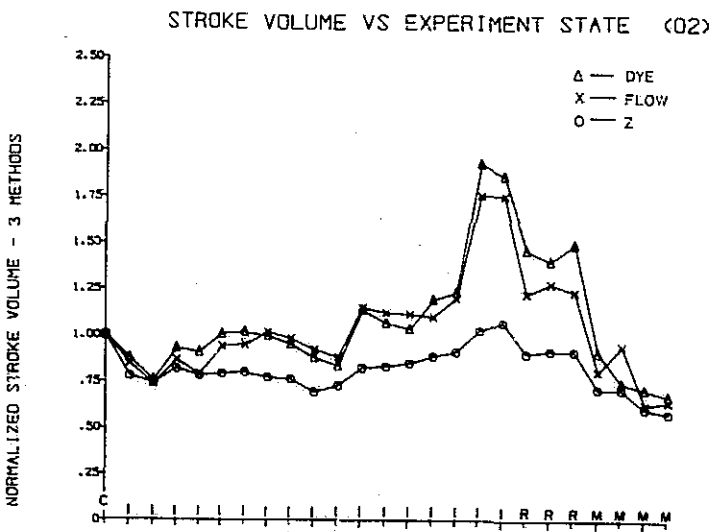

Comparison Study Number 2

STROKE VOLUME VS EXPERIMENT STATE (03)

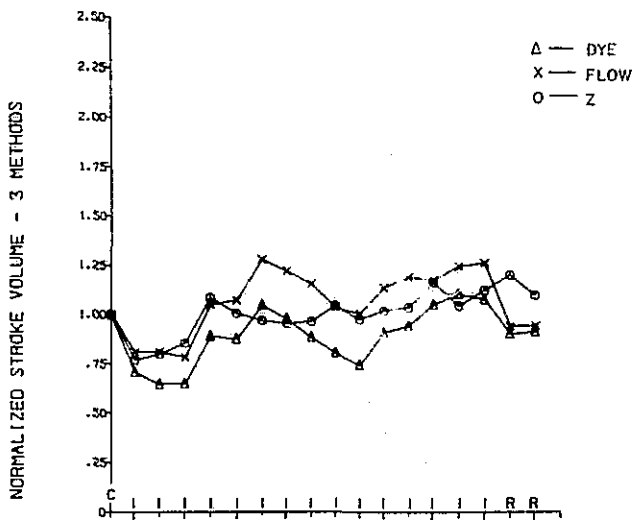

PARAMETERS VS EXPERIMENT STATE (03)

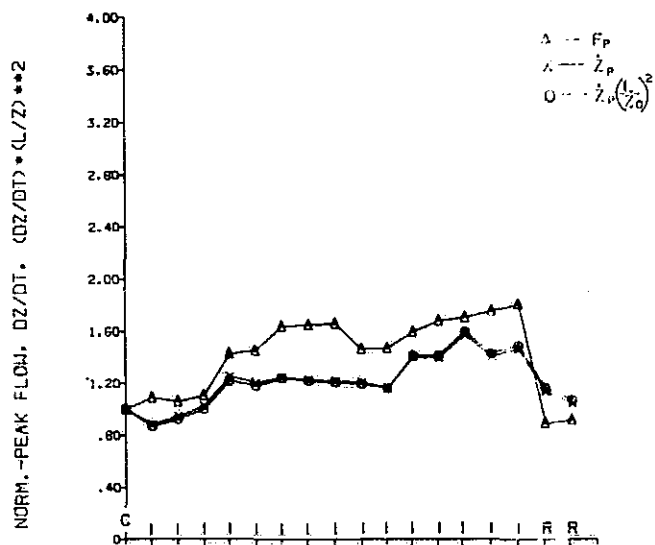

Comparison Study Number 3

STROKE VOLUME VS EXPERIMENT STATE (04)

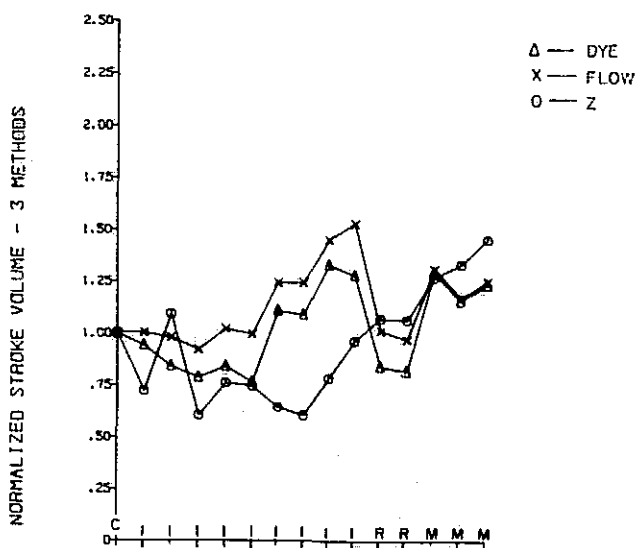

PARAMETERS VS EXPERIMENT STATE (04)

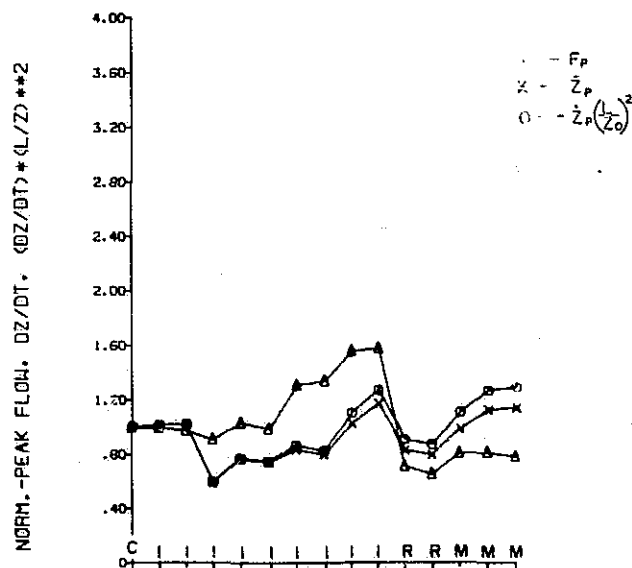

Comparison Study Number 4

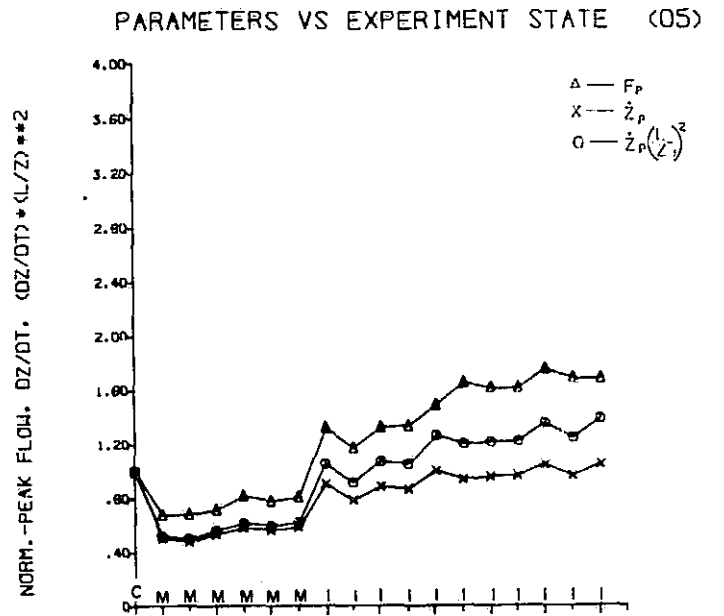
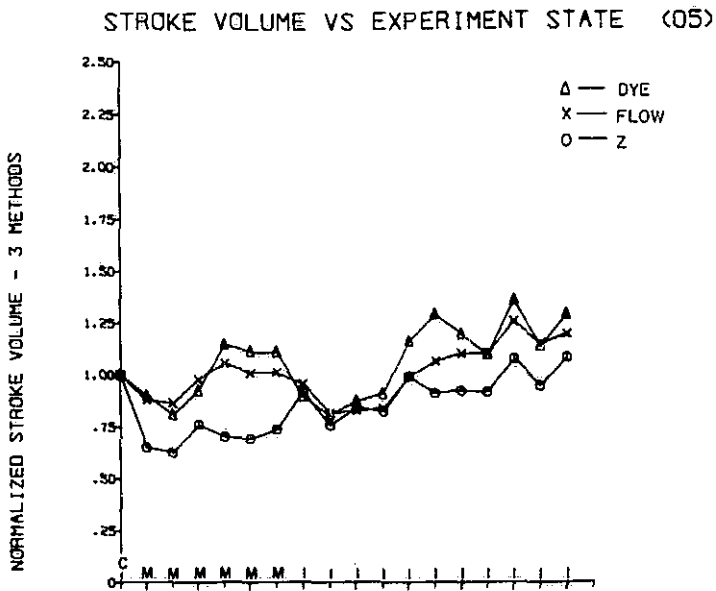

Comparison Study Number 5

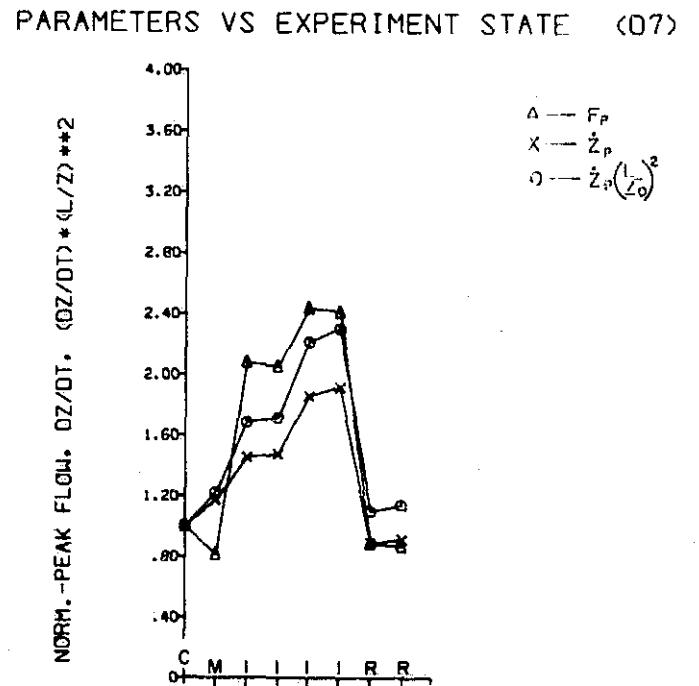
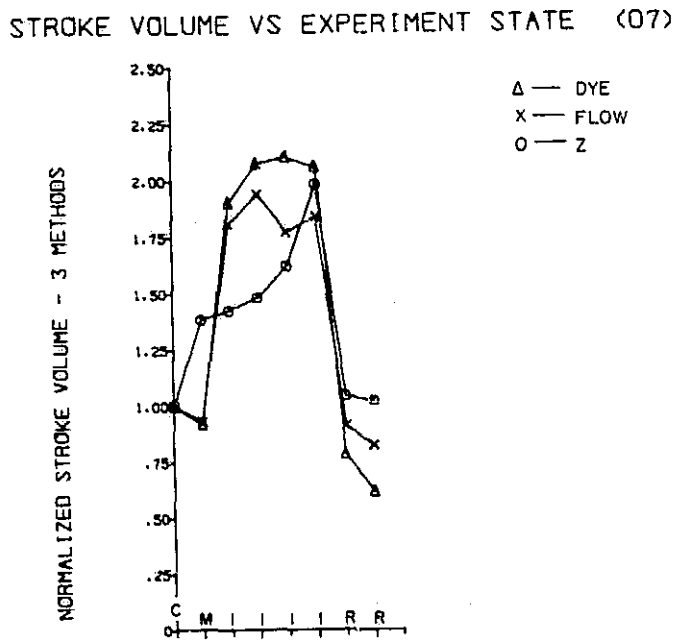

Comparison Study Number 7

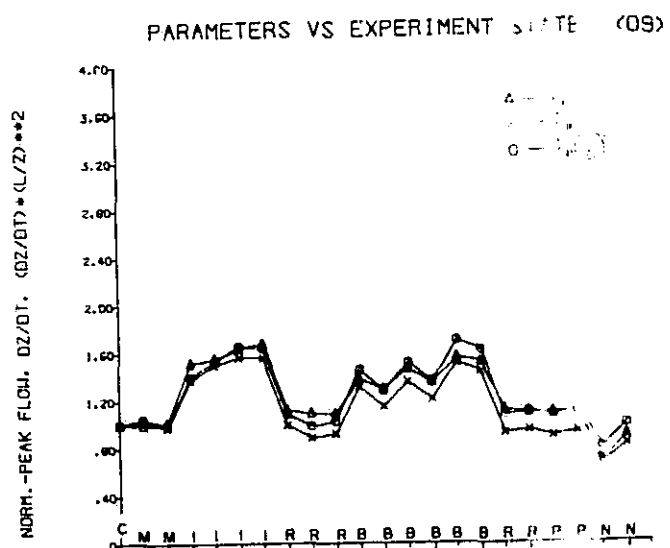
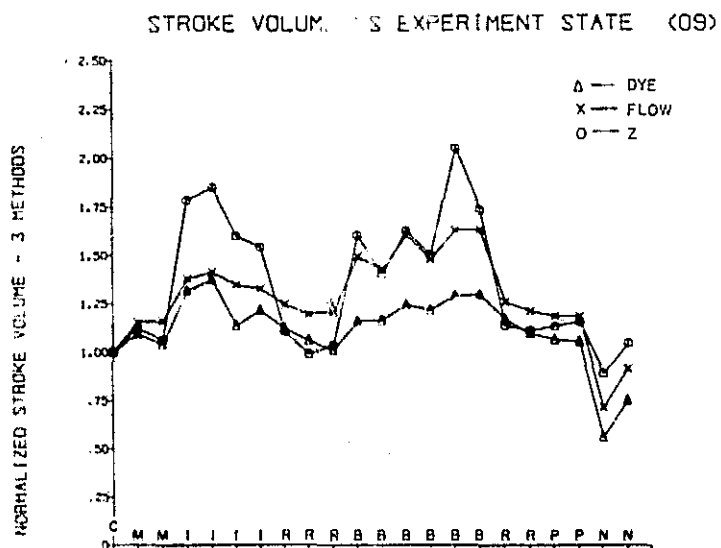

Comparison Study Number 9

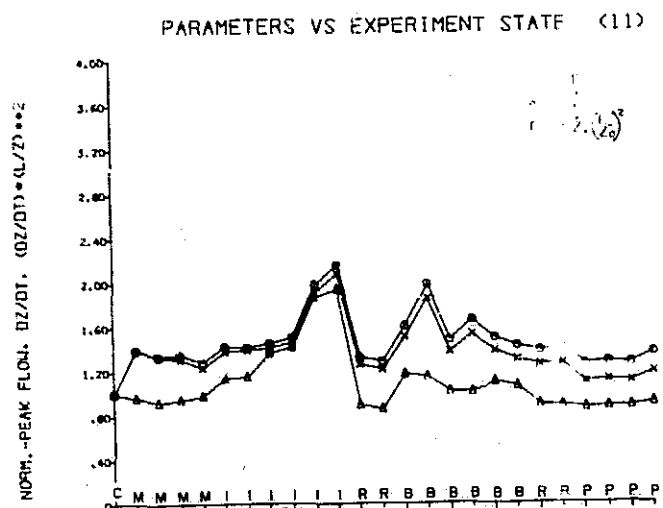
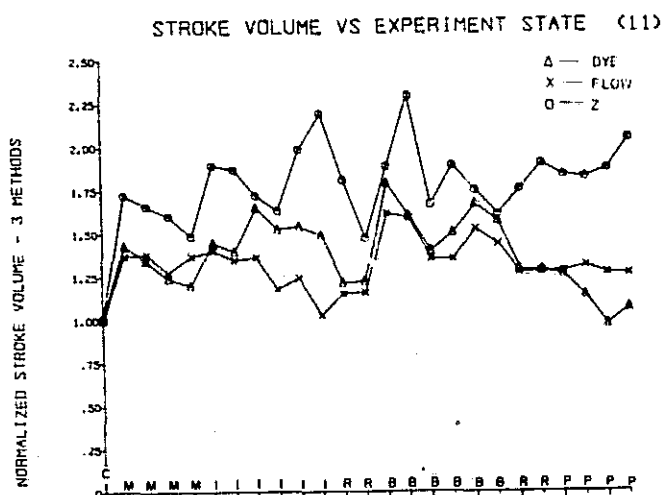

Comparison Study Number 11



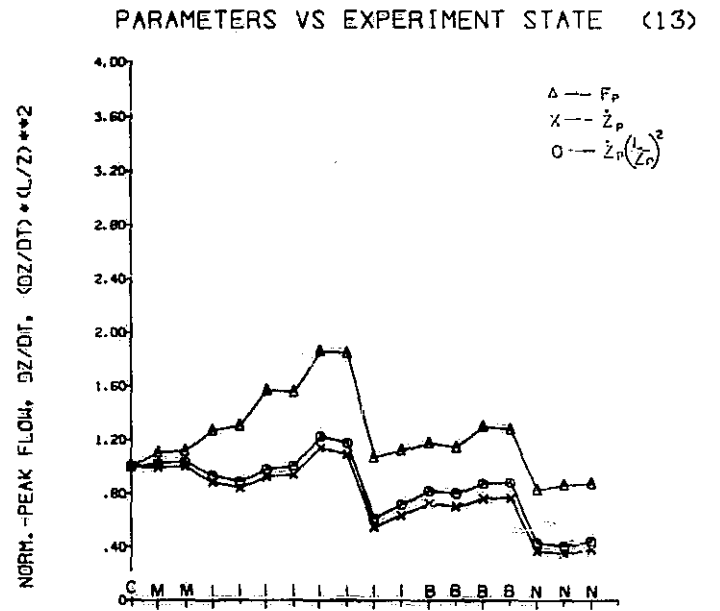
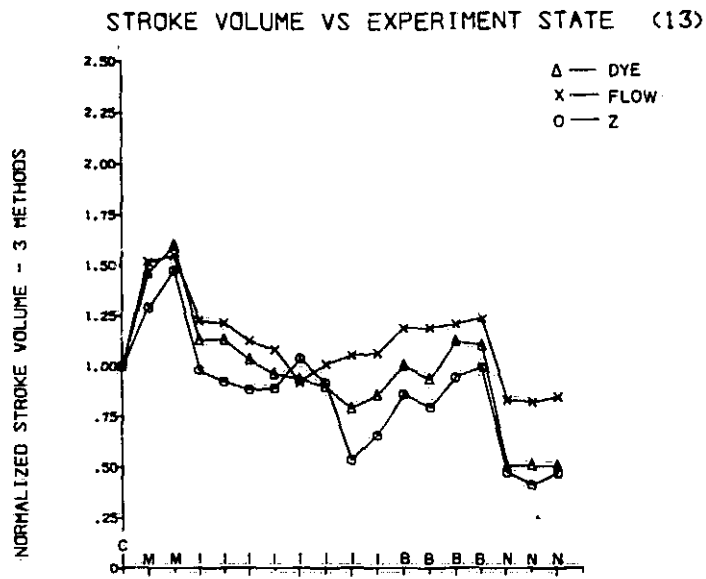

Comparison Study Number 13

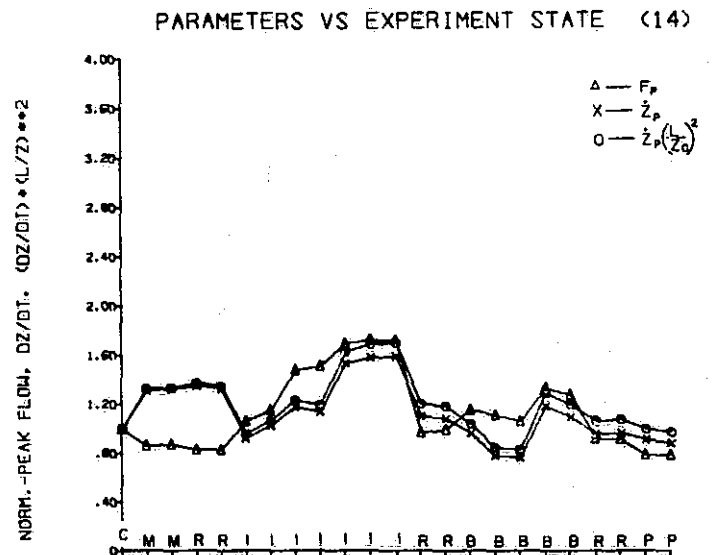
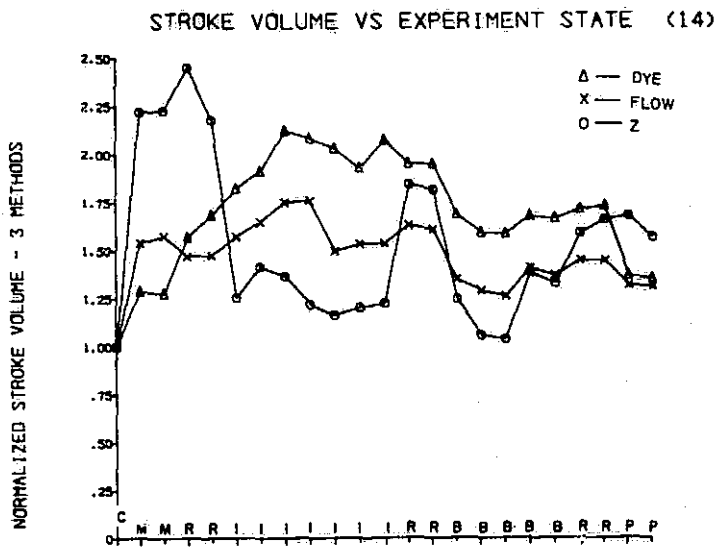

Comparison Study Number 14

PRECEDING PAGE BLANK NOT FILMED.

IMPEDANCE STROKE VOLUME -- A COMPARISON IN DOGS AND MAN WITH  
ELECTROMAGNETIC FLOWMETERS AND DYE DILUTION RESPECTIVELY

by

**N70-10022**

Wayne E. Martin, M.D.  
Assistant Professor

Department of Anesthesiology  
University of Washington School of Medicine  
Seattle, Washington

A technique for estimating cardiac output in man not requiring arterial and venous cannulation is badly needed by medicine. The Minnesota Impedance Cardiogram developed by Dr. Kubicek and his associates has been shown to reliably estimate changes in the stroke volume of dogs with bigeminy. Unfortunately the changes in cardiovascular dynamics in these animals were limited and little human data is available. These studies were designed to extend the observations on estimations of stroke volume over a wide variety of cardiovascular states, e.g., altered contractility, peripheral vasoconstriction and vasodilation and hypovolemia. In addition, measurements were obtained during another study in humans in which the cardiovascular system was depressed. A final group of measurements were taken in humans with more vigorous cardiovascular function. Unfortunately these data were not available at the time of this report.

Methods and Materials:

A. Animal Studies: Six small mongrel dogs were anesthetized with intravenous pentobarbital, intubated, and ventilated with room air via a Harvard animal respirator. The animals were clipped and a cannula placed in the femoral vein and #4 French cardiac catheter placed in the femoral artery, advanced to the arch of the aorta and connected to a Statham p23 d strain gauge.

A left thoracotomy was then performed and an electromagnetic flowmeter (Zepata model) placed tightly about the ascending aorta

(approximate 10% reduction in the diameter). The left thorax was filled with saline, the chest tightly closed and as much air and saline evacuated as possible. Two mylar electrodes were placed about the neck and two about the upper abdomen in the usual fashion. A microphone was placed on the anterior wall to record heart sounds for timing purposes. The electromagnetic flow, arterial pressure,  $Z_0$ ,  $\Delta Z$ ,  $dZ/dt$ , electrocardiogram and heart sounds were amplified via Sanborn amplifiers, stored on magnetic tape and reduced at a later date. At the end of the study, the animals were sacrificed, the position of the arterial catheter and electromagnetic flow probe verified and the flowmeter was calibrated and checked for linearity.

Drugs were administered in amounts sufficient to markedly alter the cardiovascular system and measurements of aortic flow,  $dV/dt$ , arterial pressure,  $dP/dt$ , electrocardiogram, heart sounds, and impedance changes made. The initial drugs were isoproterenol, levophed, methoxamine and pentobarbital. Following this drug sequence, Arfonad was infused to produce hypotension, measurements made, and the prior drug sequence repeated. The drug sequence was varied with each animal. The animals were then bled to death with measurements repeated after removal of successive aliquots of 50 to 100 ml. of blood. Impedance stroke volume was calculated according to the usual formula.

B. Human Studies: In seven healthy volunteers, arterial and superior vena cava catheters were placed percutaneously. Mylar impedance electrodes and electrocardiogram electrodes were placed in the usual manner. Vascular pressures were transduced on appropriate Statham strain gauges, amplified and recorded on either a Visicorder or Grass recorder. Cardiac outputs were measured by the usual indicator dilution technique, using indigo cyanine green with a Gilford densitometer and Gilson recorder. The first derivative of arterial pressure was obtained via electronic differentiation of the arterial pressure pulse. At each measurement point, the electrocardiograph and impedance waveforms were also recorded.

Briefly, the experimental protocol consisted of measuring cardiac output, ECG, Impedance Waveforms, superior vena cava pressure, arterial pressure and  $dP/dt$  during the control period and repeating all measurements at preselected intervals during general anesthesia. Following the control period, the subjects were anesthetized with halothane - nitrous oxide - oxygen and intubated. Respiration was controlled via a Bird 9X ventilator driving an Air-Shields ventimeter which in turn substituted as the breathing bag in the usual anesthetic circle system. Thus, minute volume and respiratory pressures remained constant while the subjects  $P_aCO_2$  was altered by varying the inflow  $P_{CO_2}$ . All measurements were repeated at a  $P_aCO_2$  of 20, 40 and 60 torr during the following end tidal anesthetic levels: 0.3% halothane in 70% nitrous oxide and 30% oxygen, 0.8% halothane in 100%

oxygen, 0.8% halothane in 70% nitrous oxide and 30% oxygen, and occasionally 1.5% halothane in 100% O<sub>2</sub>. Stroke volume, stroke work, minute work, and total peripheral resistance were calculated in the usual manner. Details of the study will be published elsewhere. In both groups, correlation co-efficients were calculated by the method of Pearson and the lines illustrated are the best fit line calculated by the least squares method with assumed linearity.

Results:

A. Dogs: Computer generated scattergrams with best fit lines are shown in figure #1-8 with a summary of correlation co-efficients in Table 1. Correlation co-efficients of the two methods of estimating stroke volume ranged from excellent in #2 and #5 (better than 0.9), to fair in dog #6 (0.748) and dog #4 (0.643) to poor in dog #3 (0.403), to none in dog #1 (0.093). The overall correlation co-efficient was 0.245 when all dogs are included. This rose to 0.682 when dog #1 was eliminated. The correlation between the three derivatives --  $dZ/dt$ ,  $dP/dt$ ,  $dV/dt$  was poor as the correlation co-efficient between  $dZ/dt$  and  $dP/dt$  was 0.411 and the correlation coefficient of  $dZ/dt$  to  $dV/dt$  was 0.381. The range of values of the usual cardiovascular parameters listed in Table 1 demonstrate over a ten fold change in each value.

B. Humans: Again the computer generated scattergrams are presented in figures 9-16 with a summary of correlation

co-efficients in Table 2. In this group the correlation co-efficients ranged from 0.929 in subject #3 to 0.647 in subject #4. Between these extremes in decreasing order were subject #6 (0.904), subject #5 (0.879), subject #7 (0.784), subject #2 (0.694), and subject #1 (0.654). When the absolute values of all stroke volumes were compared, the correlation co-efficient is 0.543. However, this rises to 0.750 when only the relative changes from control are considered.

### Discussion

It should be noted at the outset that the author began this work with the intuitive feeling that the calculated stroke volume impedance would correlate poorly if at all with standard stroke volume measurements. However, the observed correlation co-efficients (with the exception of Dog #1) suggest that the observed trans-thoracic impedance changes are related in some way to stroke volume. Indeed the human data, together with earlier animal data published by Kubicek, suggest that relative changes in stroke volume can be estimated in relatively normal man with fair reliability, particularly if the data from several subjects are pooled. Thus, if circumstances preclude the use of those standard measurements of cardiovascular function which require the insertion of arterial and venous catheters, impedance plethysmography may give an indication of the average direction and relative magnitude of changes in a group of subjects even in its present, poorly understood stage of development.

Having praised the technique (however faintly), I feel it is necessary to identify several limitations and deficiencies. First, the formula used for calculations of stroke volume is empirical and will undoubtedly be replaced as our understanding of the technique improves. Second, the 100 kHz current traverses many vascular structures whose volumes are frequently changing at different rates and in different directions. Therefore the present configuration of electrodes provides data which is difficult to interpret. Third, the scatter of the data preclude its present clinical use because the observer cannot be sure that, in a given individual, an estimated change in stroke volume is real. One cannot even be sure that the direction of change is correct or that a change has, in fact, occurred.

Figure A illustrates some of the problems associated with this technique and an observation which precludes its present use in clinical medicine. Panels A and C illustrate a relatively normal  $dZ/dt$  waveform. In panel B the  $dZ/dt$  falls below zero well before the onset of systole. This invalidates the concept that the impedance change depends solely upon the ejection of blood into the aorta. Panel D is even more disturbing because one observes a relatively normal  $dZ/dt$  waveform in the presence of virtually no blood flow in or change of pressure in the aorta. The author believes that this is a valid observation since subsequent measurements were made on this animal following successful resuscitation. At the present,



no explanation is available for this observation.

Figure B illustrates other interesting observations. In panel A, a biphasic  $dZ/dt$  is seen with a peak  $dZ/dt_{\min}$  occurring during the time corresponding to atrial activity equal to that seen during ventricular activity. In panel B, the systolic  $dZ/dt_{\min}$  peak indicates the reduction in flow during an abnormal ventricular contraction. The infusion of isoproterenol produced panel C in which the atrial  $dZ/dt_{\min}$  peak fuses with the systolic  $dZ/dt_{\min}$  peak so that the ejection time could not be calculated from the waveform. Finally, panel D taken during a period of recovery from cardiac arrest with acetylcholine has a  $dZ/dt_{\min}$  peak occurring during diastole -- a period in which it is difficult to believe that any volume of blood is leaving the chest. These observations strongly suggest that the impedance waveform has complex origins - some of which at present are obscure.

Thus, in its present configuration, the impedance cardiogram is not a suitable clinical tool because the possibility exists that the information obtained at a critical instant might indicate good cardiac function when the cardiovascular system was in a state of collapse or vice versa. However, the overall good to fair correlation between conventional and impedance stroke volume indicates that the impedance cardiogram, even in its present configuration, may be useful in special circumstances; e.g., space flight if proper weight is given to the limitations of the device. Much work, however, remains to be done to transform this fascinating gadget into a reliable medical tool.

TABLE I  
ANIMAL DATA

Stroke Volume Vs. Impedance	#1	#2	#3	#4	#5	#6	All	All - 1	Range
SV IM	0.093	0.910	0.470	0.643	0.918	0.719	0.245	0.682	37-2 ml
MAP	0.030	0.359	0.412	0.368	0.566	0.736	0.379	0.458	179-10 mmHg
HR	0.417	0.133	0.532	0.154	0.062	0.498	0.379	0.325	242-60 beats/min
SYS	0.016	0.467	0.420	0.508	0.670	0.696	0.382	0.497	220-30 mmHg
DIAS	0.058	0.281	0.401	0.289	0.468	0.748	0.366	0.425	152-5 mmHg
Stroke Work	0.024	0.560	0.394	0.674	0.815	0.783	0.307	0.676	3221-67 Gm/m
dP/dt	0.226	0.257	0.146	0.043	0.313	0.058	0.112	0.178	6450-181 mmHg/sec.
dV/dt	0.174	0.358	0.059	0.337	0.550	0.131	0.109	0.189	14200-710 cm/sec <sup>2</sup>
dP/dt- dV/dt	0.115	0.294	0.019	0.241	0.299	0.042	0.060	0.146	
TPR	0.210	0.347	0.005	0.258	0.310	0.571	0.089	0.060	164-12 R.U.
dZ/dt Vs.									
dP/dt	0.109	0.567	0.164	0.120	0.631	0.587	0.343	0.411	
dV/dt	0.176	0.685	0.727	0.706	0.807	0.654	0.314	0.381	
dP/dt - dV/dt	0.146	0.659	0.590	0.556	0.604	0.645	0.348	0.454	
dV/dt Vs.									
dM/dt	0.901	0.496	0.047	0.282	0.446	0.664	0.345	0.252	
Number	28	24	27	14	20	23	136	108	

TABLE II  
HUMAN VOLUNTEERS

S.V. Impedance vs.	#1	#2	#3	#4	#5	#6	#7	All	Range
S.V. Dye	0.654	0.694	0.929	0.647	0.879	0.904	0.784	0.562	125-25 ml.
MAP	0.397	0.409	0.764	0.233	0.480	0.756	0.451	0.311	102-43 mmHg
H.R.	0.190	0.085	0.577	0.010	0.752	0.705	0.396	0.144	102-51 beats/min
Stroke Work	0.550	0.566	0.940	0.461	0.795	0.870	0.703	0.509	12036-1225 Gm/m
dP/dt	0.389	0.509	0.881	0.590	0.860	0.886	0.571	0.433	1315-131 mmHg/sec
TPR	0.399	0.505	0.123	0.337	0.882	0.567	0.438	0.465	2909-700 dynes-cm-sec <sup>-5</sup>
S.V.%	0.654	0.694	0.929	0.647	0.879	0.904	0.784	<u>0.750</u>	
dZ/dt vs. dP/dt	0.403	0.493	0.879	0.690	0.863	0.923	0.704	0.273	
Number	13	16	12	7	9	10	10	77	

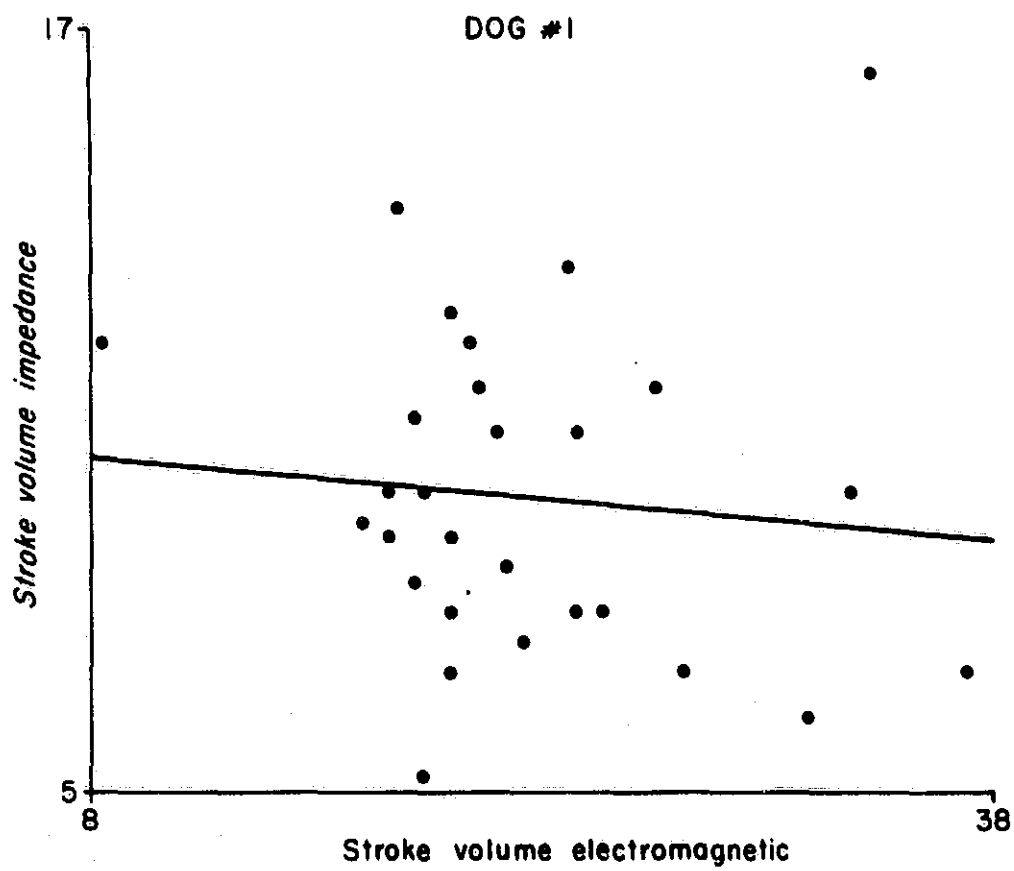

Regression formula,  $Y = 10.5861 + -0.0397X$   
Pearson R = -0.093    Slope = -0.040    Y intercept = 10.586

Figure 1

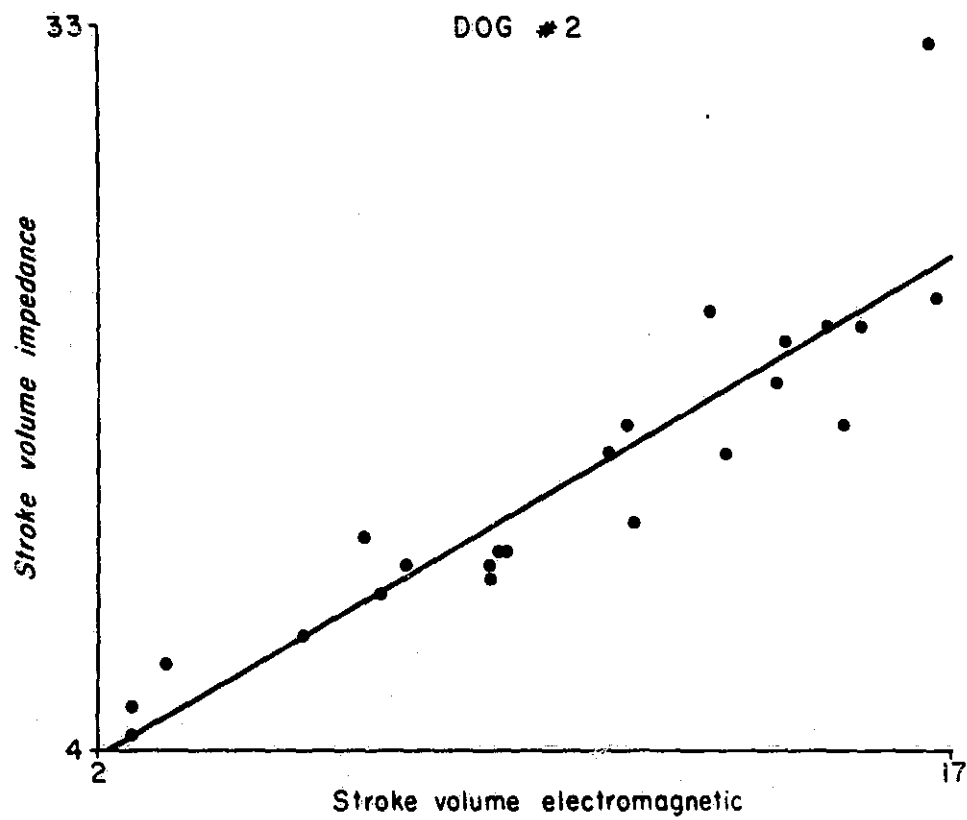

Regression formula,  $Y = 1.1154 + 1.3403 X$   
Pearson R = 0.910    Slope = 1.340    Y intercept = 1.115  
X conf limits    Upper = 12.1417    Lower = 8.6666  
Y conf limits    Upper = 17.6193    Lower = 12.5014

Figure 2

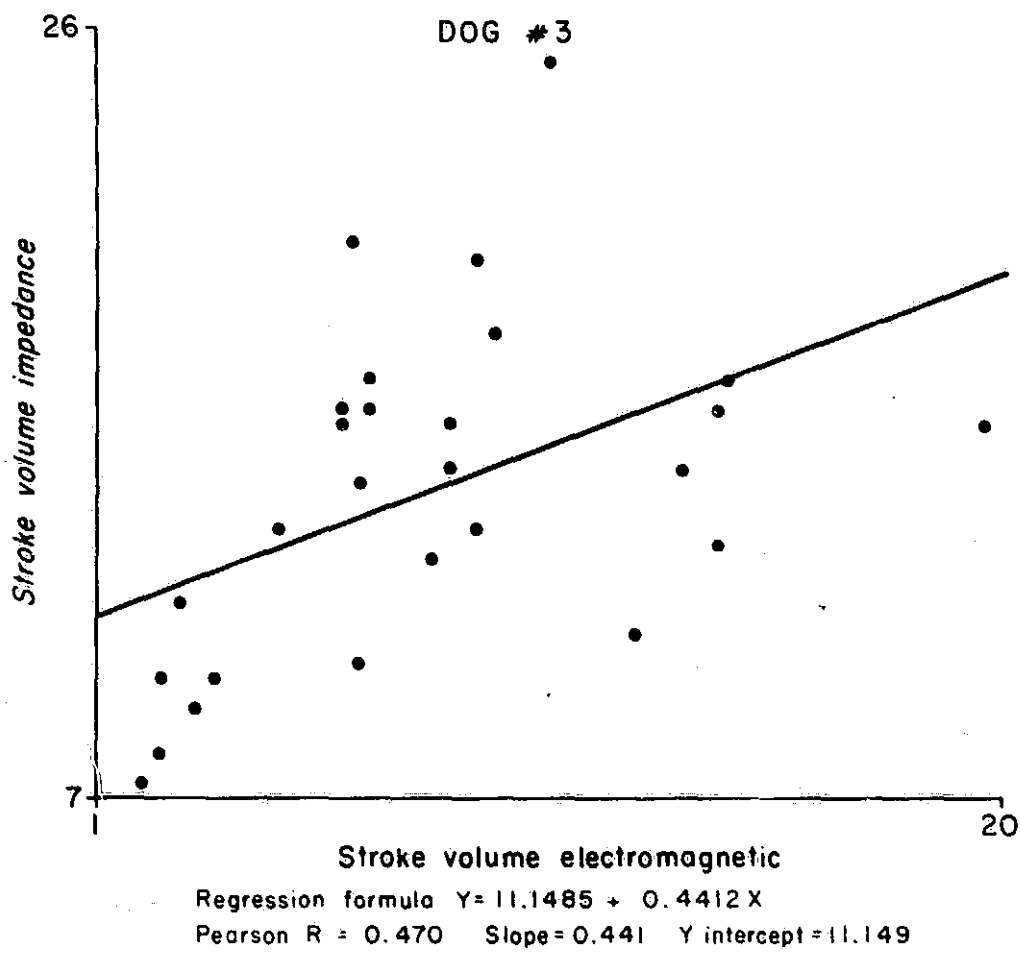

Figure 3

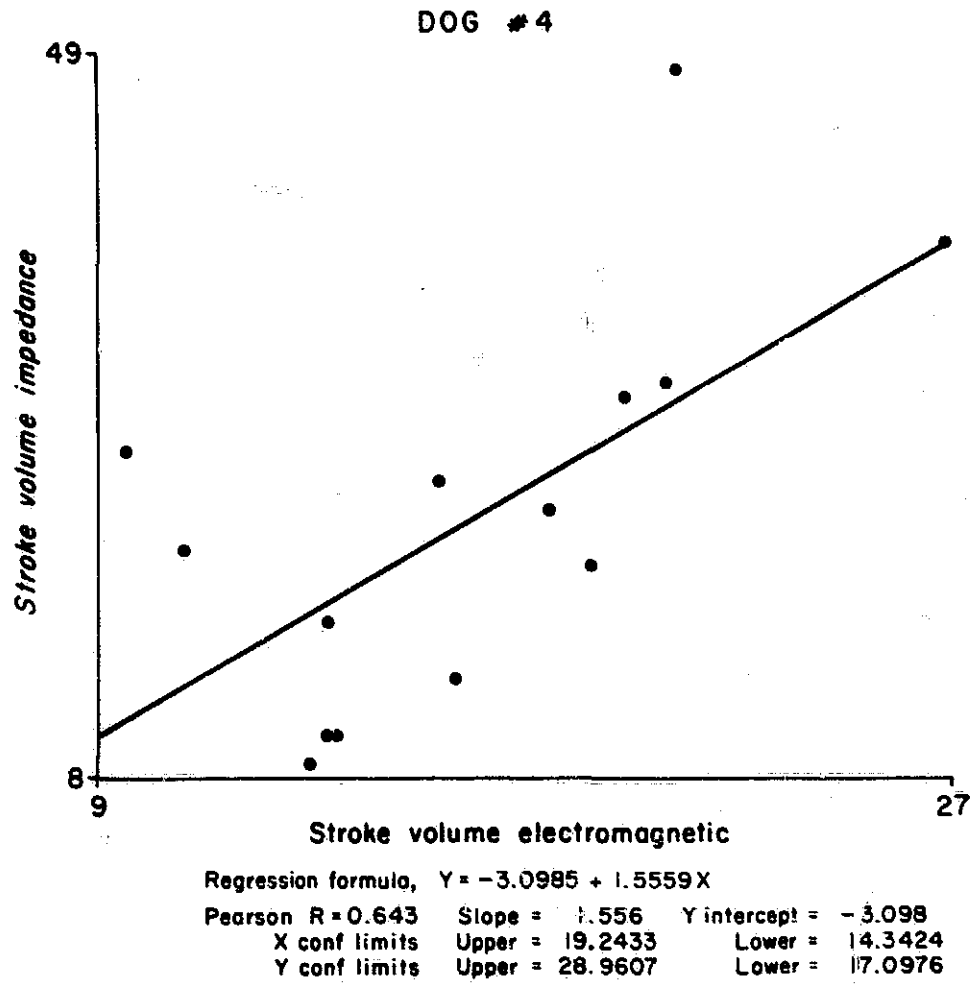

Figure 4

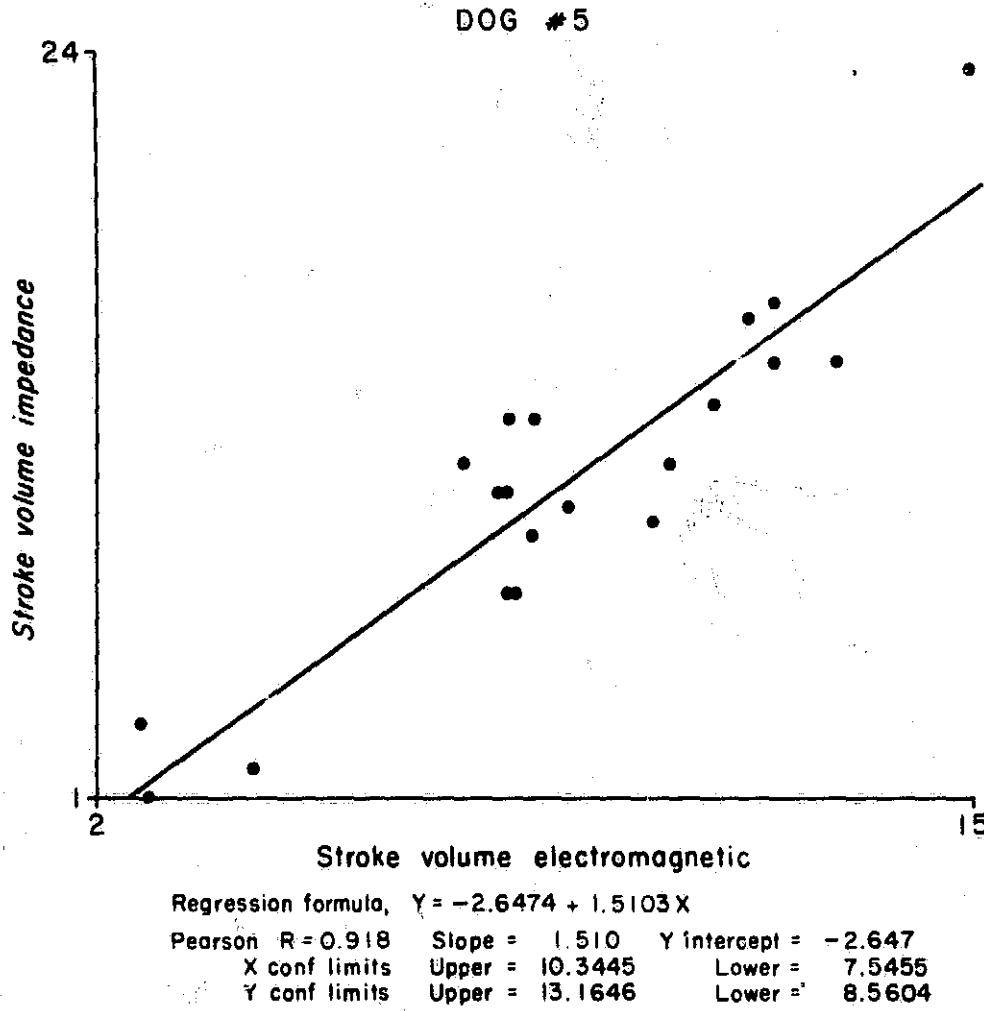

Figure 5



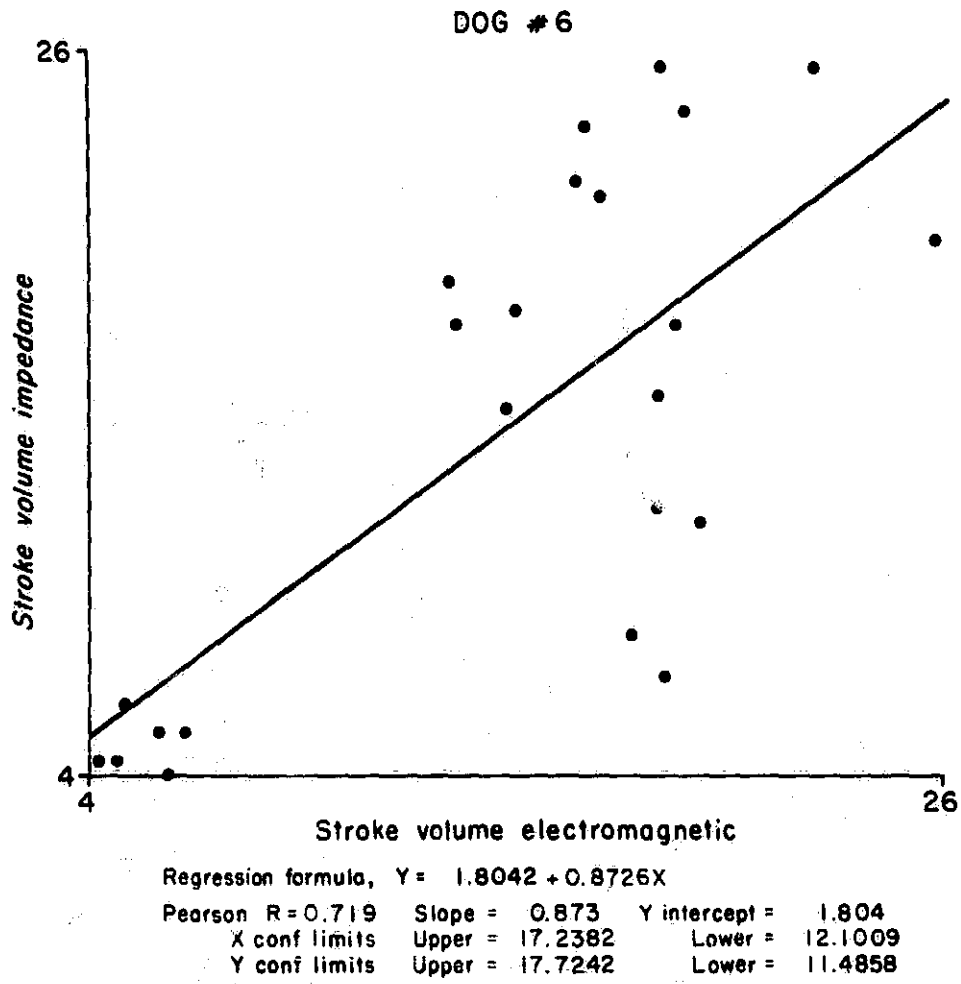

Figure 6

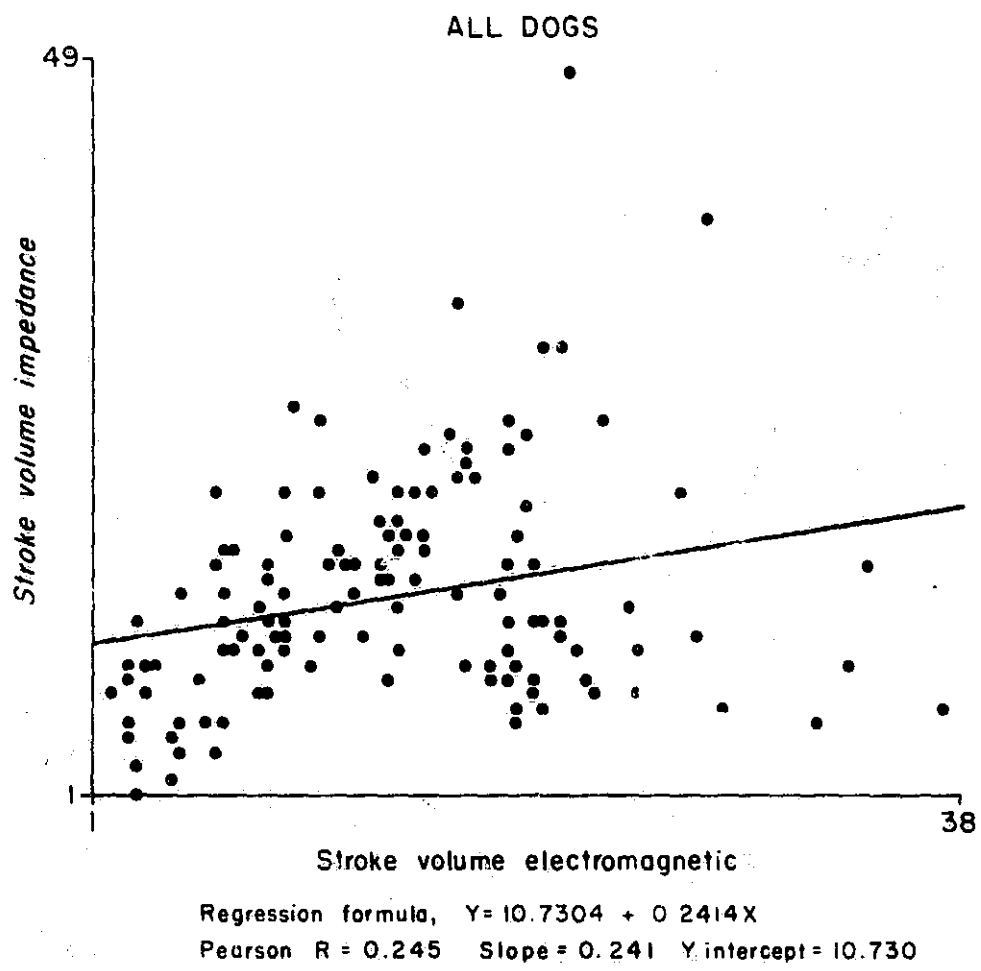

Figure 7

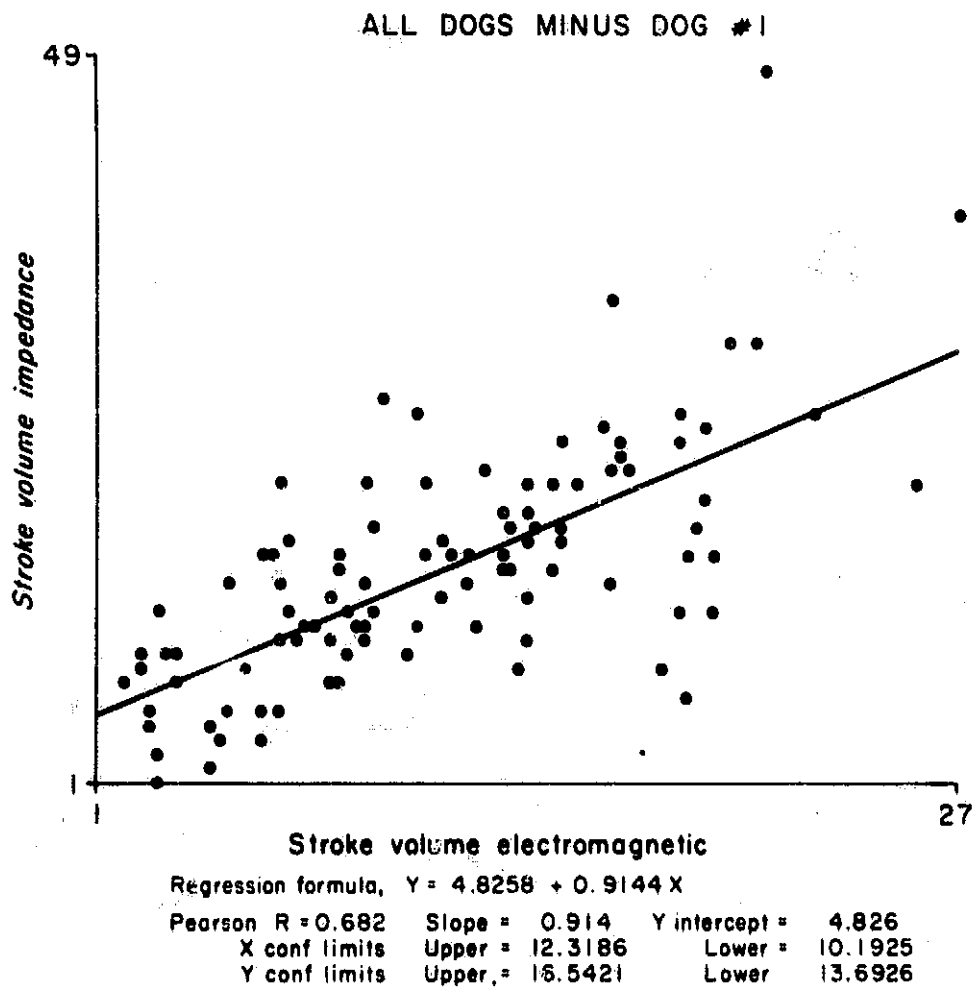

Figure 8

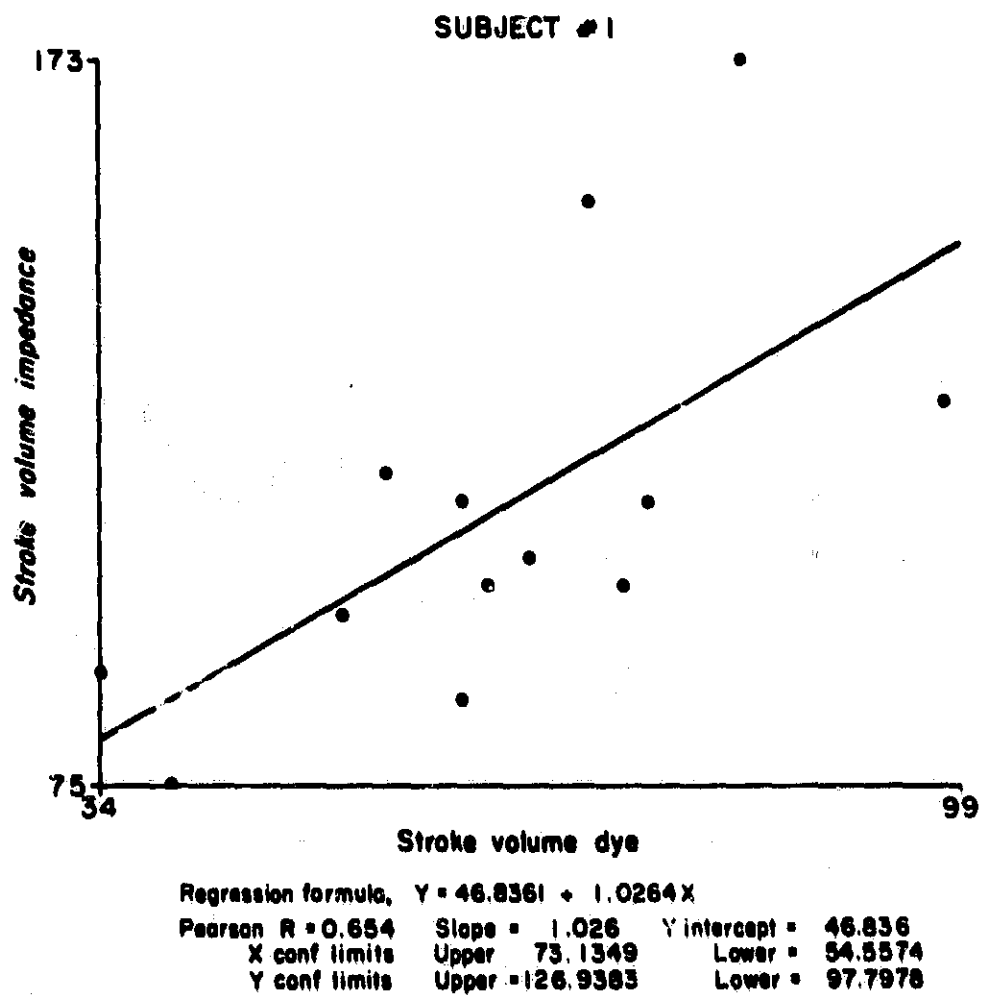

Figure 9

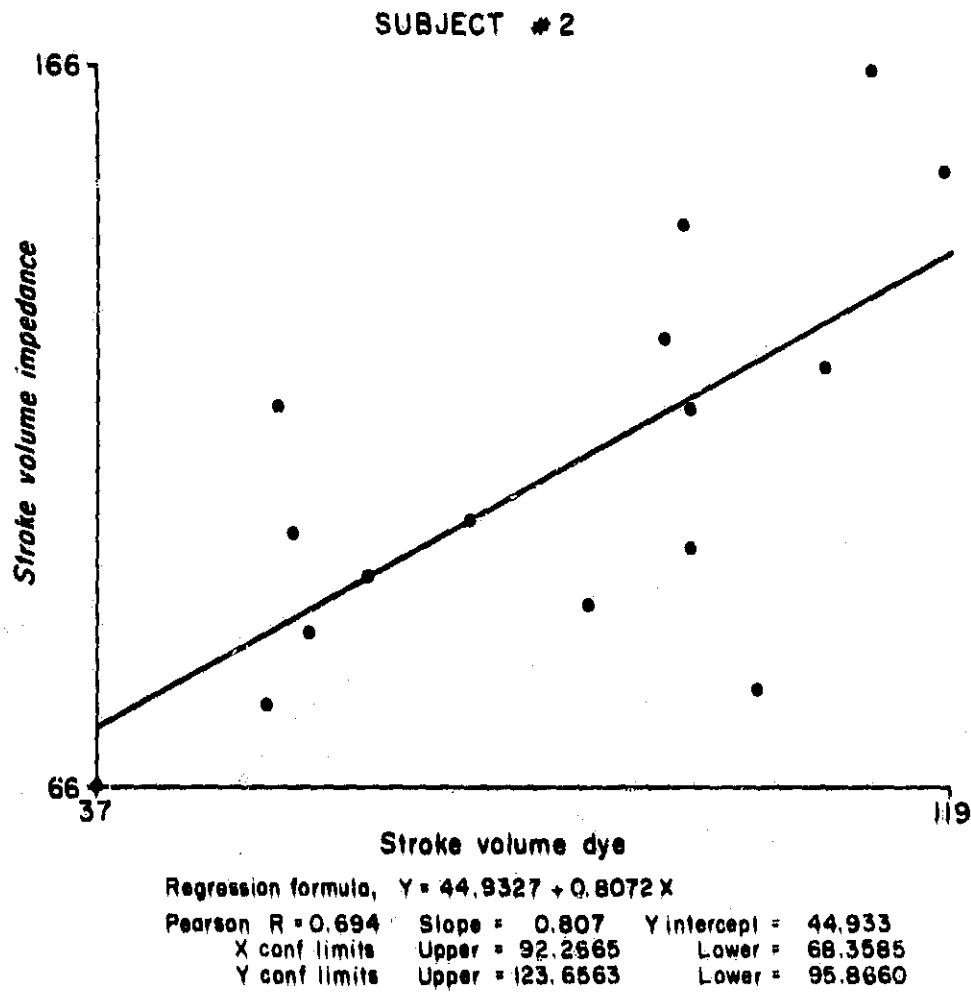

Figure 10

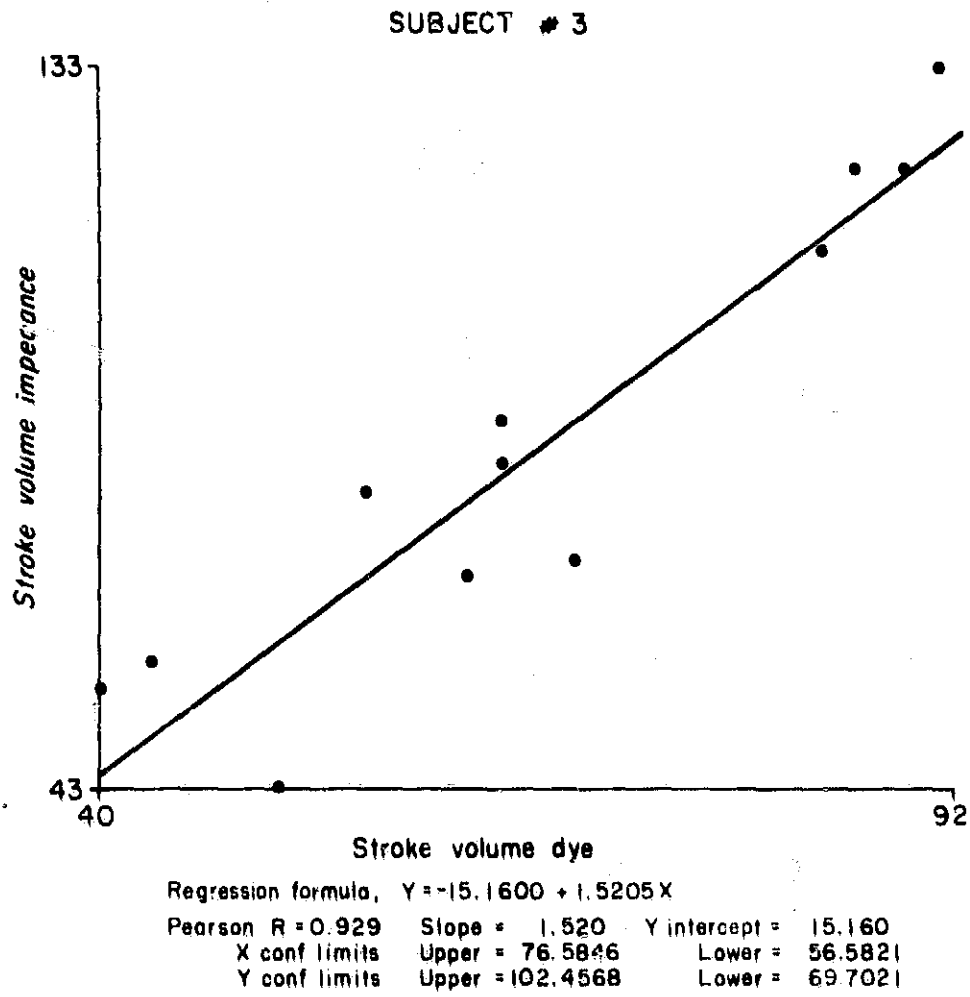

Figure 11

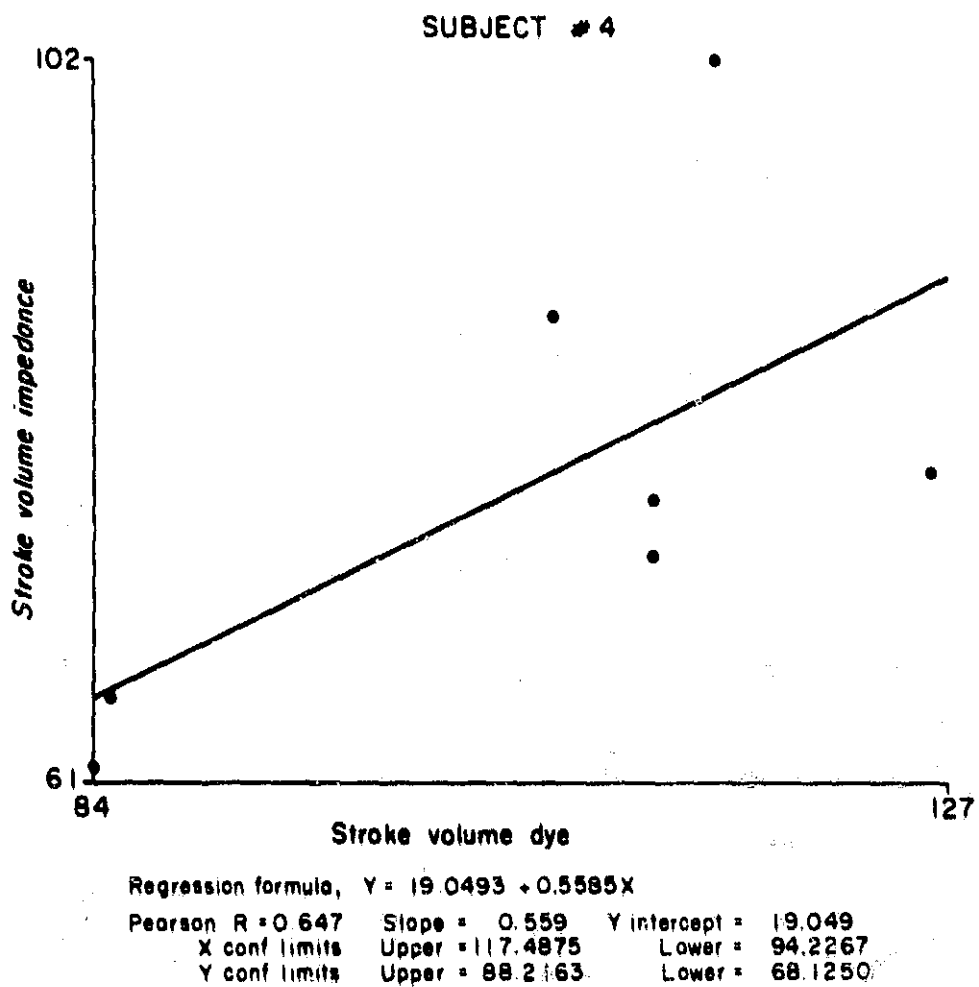
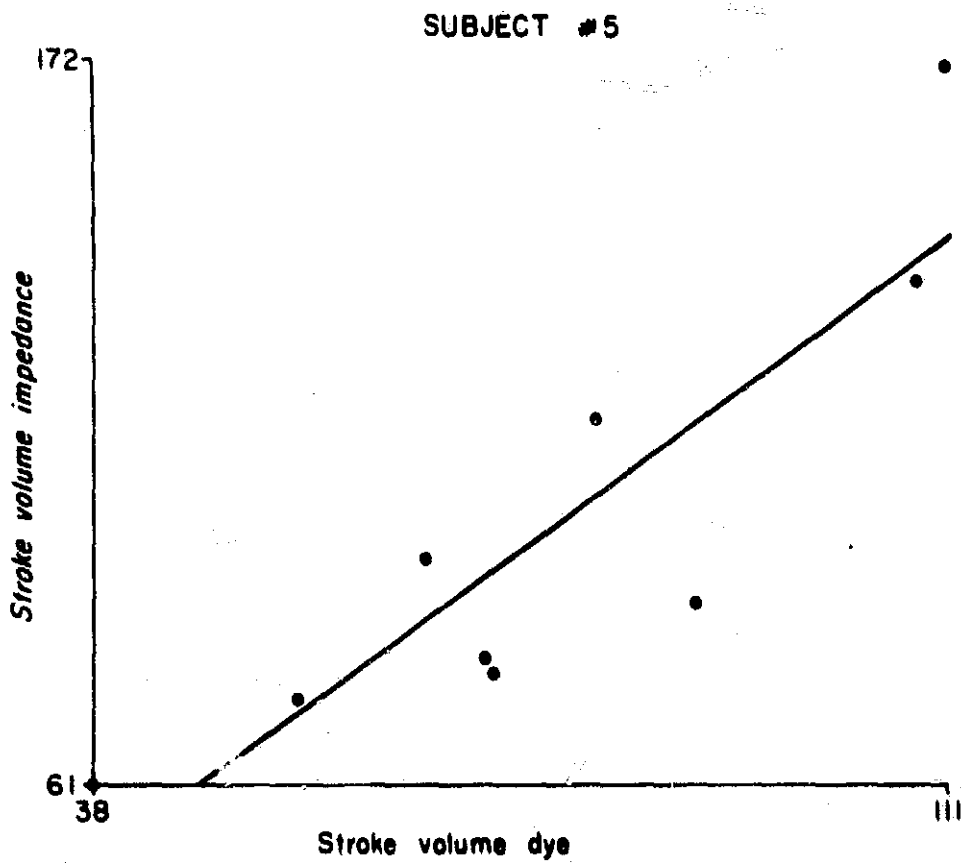

Figure 12



Regression formula,  $Y = -1.0677 + 1.3276X$   
Pearson R = 0.879    Slope = 1.328    Y intercept = -1.068  
X conf limits    Upper = 91.9817    Lower = 61.3516  
Y conf limits    Upper = 123.8551    Lower = 77.5742

Figure 13



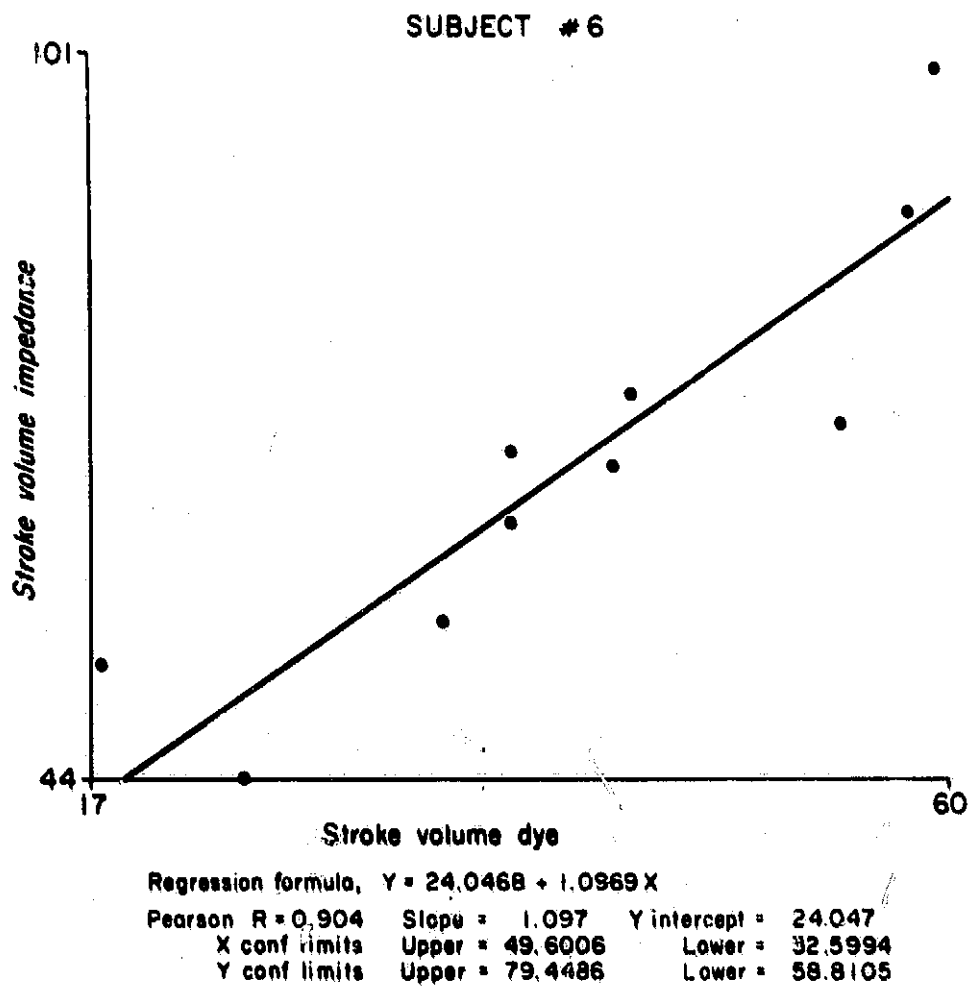

Figure 14

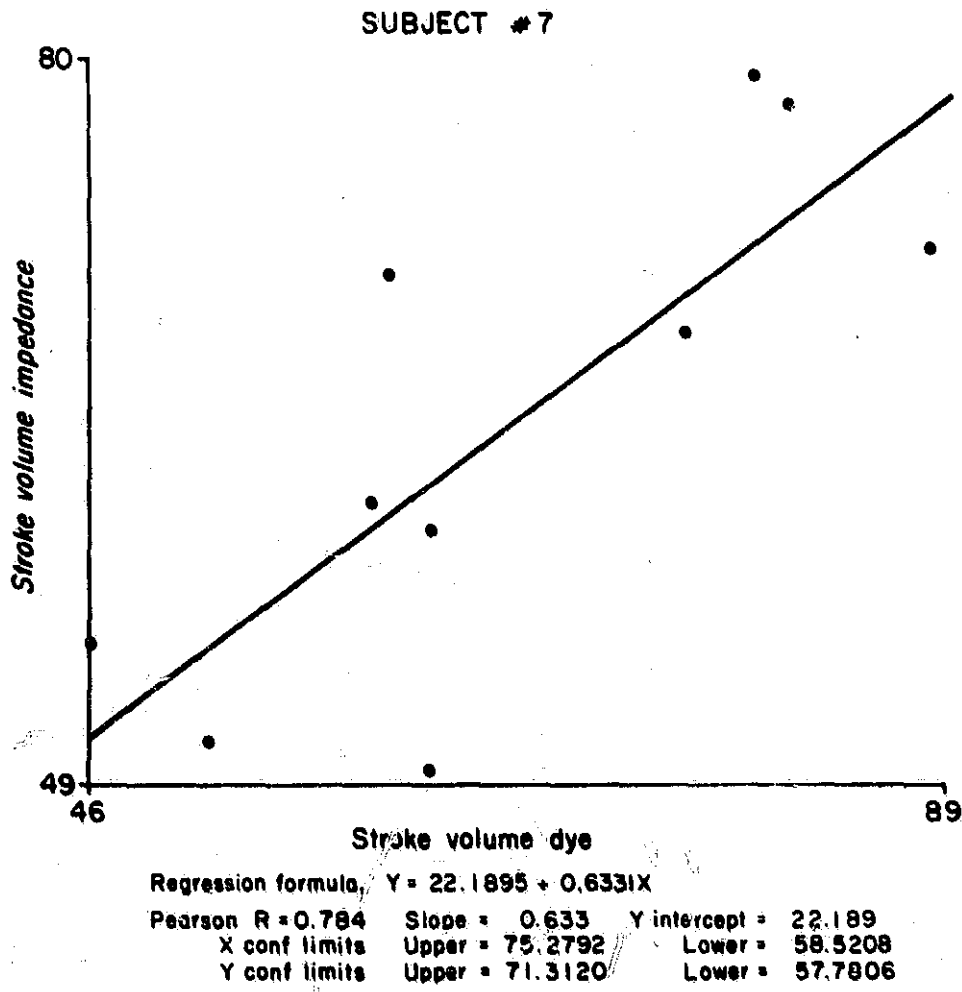

Figure 15

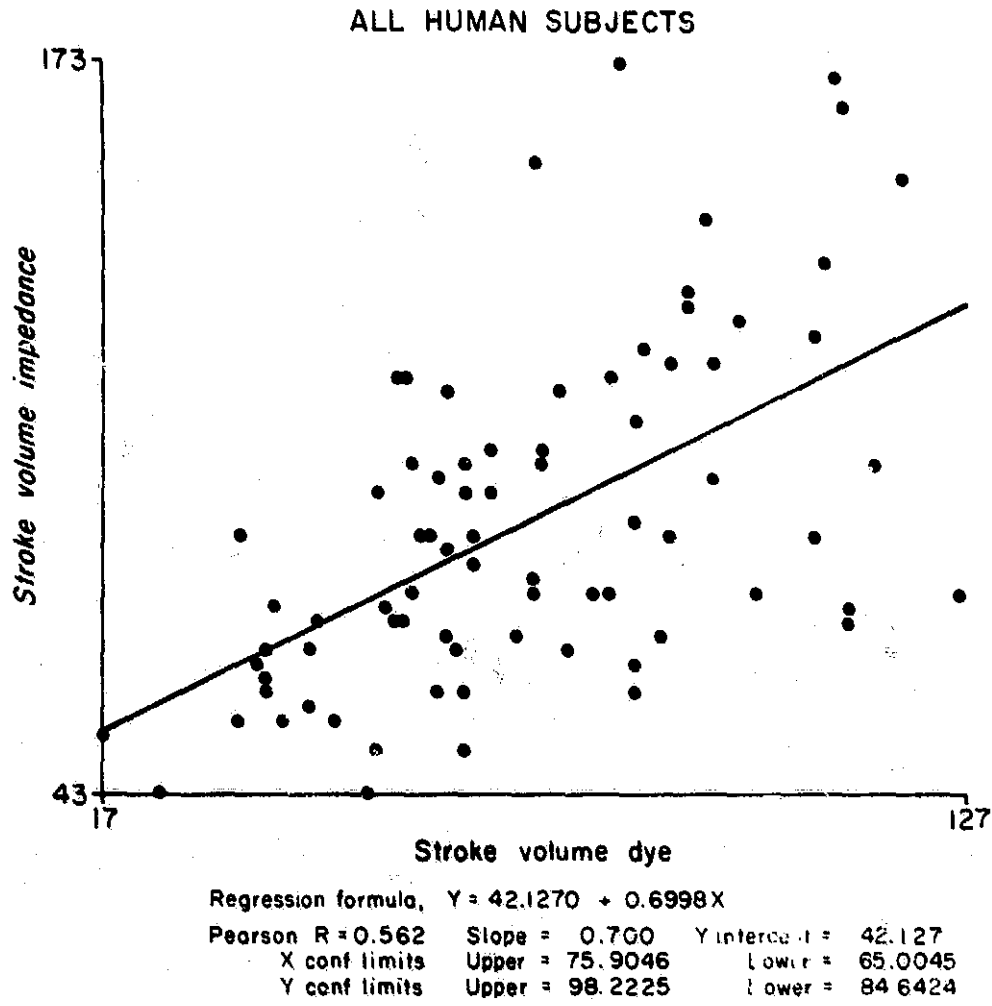

Figure 16

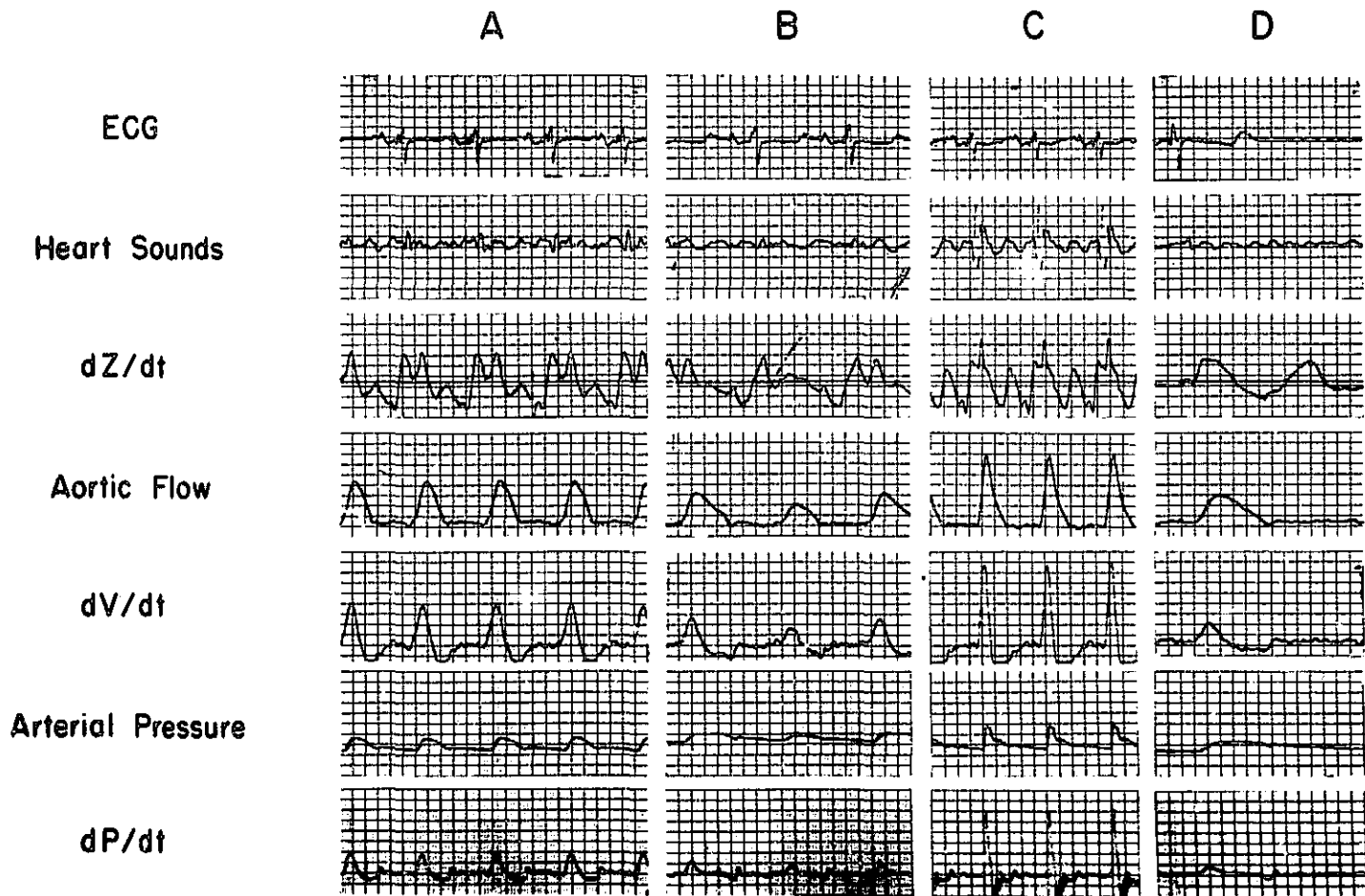

Figure B

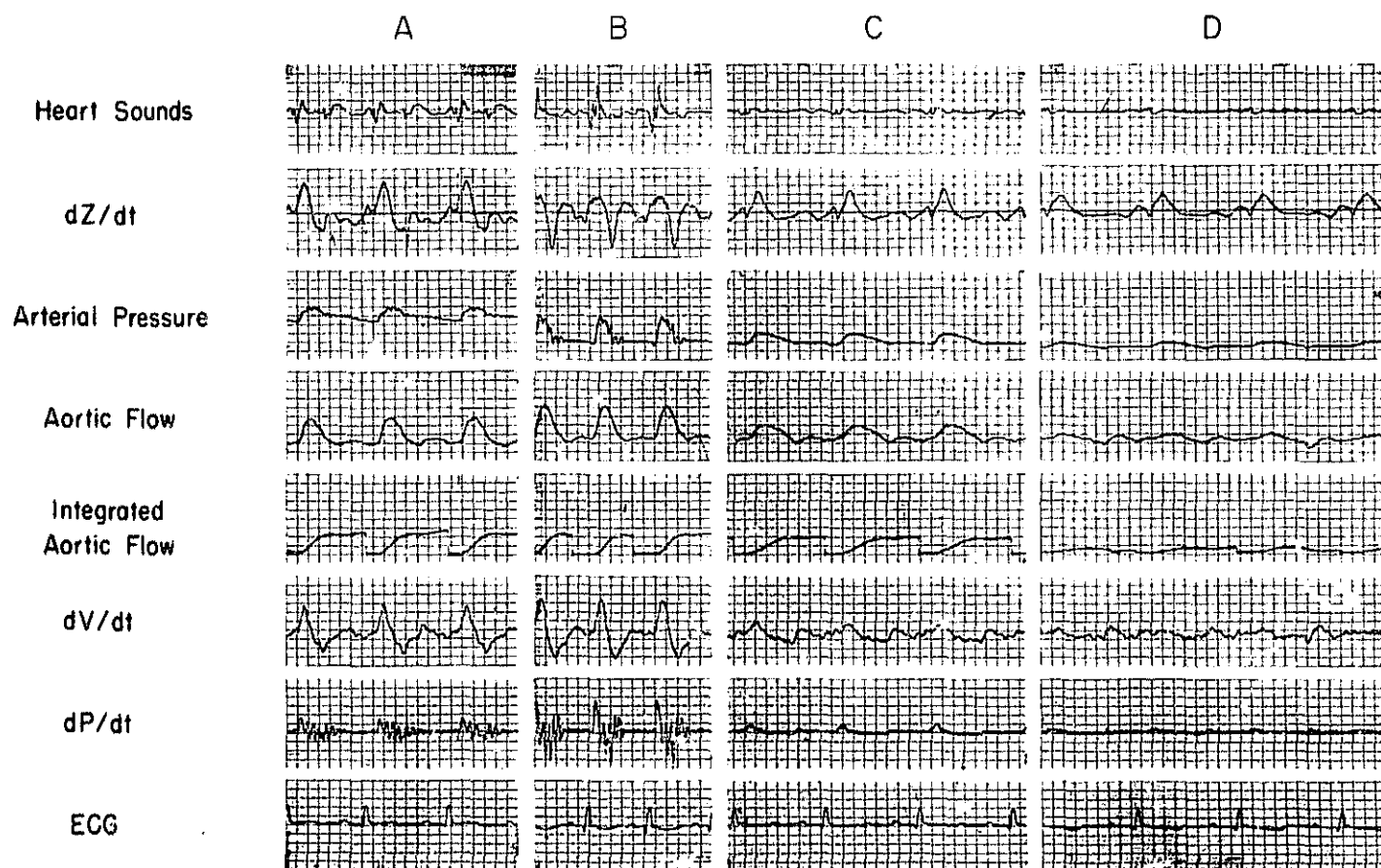

Figure A

CARDIAC OUTPUT FROM TRANSTHORACIC IMPEDANCE VARIATIONS,  
REVIEW OF EXPERIENCE WITH HEART PATIENTS

-----

# N70-10023

E. Kinnen  
College of Engineering and Applied Science  
University of Rochester  
Rochester, New York

It is easily shown that the electrical impedance fluctuations measured across the thorax are related to heart function. As they are readily observed, researchers have questioned whether these changes can be used as the basis of an indirect measure of cardiac output (CO) or stroke volume. The data and results of this paper indicate that it is possible, strictly empirically, to show a close correlation between measures of CO obtained from changes in transthoracic impedance and those obtained by standard procedures involving heart catheterization, for adult heart patients.

Some experimental work has been reported of attempts to make this correlation on man, but the results are ambiguous. The results reported here appear to be significantly better than those previously obtained. As a further consequence of this study, it may be hypothesized that the problem of quantitatively associating thoracic impedance changes to blood flow is partly one of interpretation, possibly more so than one of specific equipment or electrodes. The purpose of this paper is to review what we are doing to interpret the impedance waveforms and the improvement that this has made in our attempts to predict CO in man. A brief description of the plethysmograph for recording the impedance variations and the procedure is appropriate however.

Two pairs of electrodes are placed around the neck and lower thorax, as shown in figure 1. A constant current of about 5 ma. at 100 kHz is passed between the two extreme electrodes and a changing voltage is measured across the inner

pair, thereby reflecting a changing thoracic (basically resistive) impedance (1). Records of the impedance changes are obtained while the subject is lying on his back and during quiescent breathing. Stroke volume is calculated using a double slope extrapolation of the waveform during the systolic interval of each heart cycle. Thus  $\Delta R$ , obtained as shown in figure 2, utilizes the rate of change both during ventricular systole and early diastole. This value of  $\Delta R$  is substituted into the equation

$$SV = \frac{\rho_b l^2}{R^2} \Delta R$$

- where  $\rho_b$  - resistivity of blood (150 ohm cm.),  
 $l$  - separation distance of inner band electrodes,  
 $R$  - average balance resistance,  
 $\Delta R$  - extrapolated change of resistance during the cardiac cycle, figure 2.

Cardiac output is determined from summing individual stroke volumes recorded over one or more complete respiration cycles and converting to units of liters per minute.

The subjects for the study consisted entirely of adult male and female cardiac patients undergoing heart catheterization. Both indicator dye dilution curve (IDC) and Fick procedure determinations of CO were made routinely, to which values from the impedance variations were compared. The patient subjects were unselected except to exclude those with shunts, and represent a variety of heart disease.



This study utilized data from 67 patients. The protocol varied with each patient, but, in general, multiple determinations of CO were made by the IDC technique and usually one Fick determination during a control period. Subsequently, additional IDC measurements were made during patient exercise, pharmacological intervention, the application of a leg tourniquet or a dextran infusion. Thoracic impedance records were made coincident with each CO determination by the IDC or Fick procedure.

If a plot is made of CO per patient as measured by the IDC or Fick procedure versus the value predicted from the trans-thoracic impedance record, the result is a distribution of points throughout the first quadrant not unlike that reported earlier by ourselves and others (1-3). But one can question if the impedance waveforms have characteristics which allow grouping of patients and therefore, strictly empirically, lead to a significantly better correlation. Three observations make this question a reasonable one to ask.

1. We found that when patients had data which did not correlate close, we could not identify these patients with any obvious factors such as diagnosis, sex, thoracic dimensions, balance resistance, etc.
2. We noticed that the thoracic impedance base line change with respiration was highly variable, both for one patient over the course of an experiment and between patients. This phenomenon, however, didn't seem to identify with correlating or non-correlating data.

3. The impedance waveform for a single heart cycle is quite repetitive over a sequence of heart beats. However, for longer periods, from a few minutes to hours, the waveform may change dramatically, apparently as the tone of the patient's cardiovascular system changes. The waveform also changes significantly among the variety of patients we worked with, but again there was no obvious correlation between nominally typical and atypical waveforms in the correlation of cardiac output data.

This third observation is illustrated by the waveforms shown in figures 3 and 4 for comparison to the waveform in figure 2.

A multivariate linear discriminant analysis was used to determine if characteristics of the patient and the impedance waveform could be used to allow or identify patient grouping based on their data correlation. For tests of the discriminant analysis, the patient and the impedance waveform recorded during the control period were scored for the tests or measures shown in Table I. Average test values were used so that each

Table I

PATIENT AND IMPEDANCE WAVEFORM TESTS  
FOR DISCRIMINANT ANALYSIS

- |   |                         |
|---|-------------------------|
| 1. $\Delta R$   | 3. Heart Rate           |
| 2. Systolic Interval  | 4. Electrode Separation |
| 5. Negative Slope (Systolic Interval)                       |                         |
| 6. Positive Slope (Early Diastole)                          |                         |
| 7. Thoracic Balance Resistance                              |                         |
| 8. Maximum to Minimum Change in R<br>during the Heart Cycle |                         |

patient record had a set of 8 scores obtained during the control CO determinations. The linear regression line was found for

the data. The space around it was divided by parallel lines at distances of one standard deviation, thus allowing the patient data to fall within one of four groups. The discriminant analysis was then performed on these patient data groups relative to the waveform test scores to determine a basis for classifying patients with these waveform test scores into the respective groups. After reclassifying all patient waveforms, the data were multiplied by appropriate factors so that each group was centered about a unit slope line through the origin.

It is necessary to recognize two serious problems of a correlative study between any two dissimilar methods of measuring cardiac output in man. First, the generally accepted standard procedures, using an IDC or the Fick procedure, are of unknown accuracy for individual measures. Furthermore, these procedures do not show a completely satisfactory intercorrelation of simultaneous determinations. Any evaluation of a third method must be made recognizing the accuracy or inaccuracy of these standard methods. Second, there is a fundamental problem of data presentation. Simply comparing correlation coefficients or any other single statistical measure of data is only partially descriptive. To this point, we have used a statistical parameter as well as a visual one in discussing our results.

Figure 5 is shown for reference, plotting Fick CO determinations versus IDC values. One item of data appears for each of 25 patients taken during the control period of the catheterization. The center line is drawn at  $45^\circ$ , indicating perfect correlation. The other two lines are drawn for a  $\pm 20\%$

deviations from the 45° line but without preference for a standard. The 20% tolerance lines appear in subsequent figures. The standard correlation coefficient here is 0.95 with 88% of the data falling within or near the 20% tolerance lines (a visual parameter). These data are typical of similar work performed in other labs.

Figure 6 shows the plethysmographic versus IDC data from 67 patients - after the waveforms were tested, a basis for discrimination established, the data reclassified, and CO adjusted as to the results of this reclassification. The correlation coefficient here is 0.84 with 92% of the data within the 20% tolerance lines. 67% is lower than 92% as the class group limits were tighter than the 20% tolerance lines.

If patients are excluded when we have reason to suspect their plethysmographic records as being grossly atypical or problematical, the corresponding results for a new discriminant analysis, a new basis for classification, reclassification, etc. are shown in figure 7.

The question of repeatability of the impedance estimates of cardiac output was considered by examining duplicate values obtained from IDC's and corresponding pairs from the impedance changes. Figure 8 shows data for duplicate determinations from IDC's and figure 9 for the same duplicate determinations from the impedance records.

The information shown in figures 5-9 is summarized in Table II. The comparisons of the plethysmographic values with those determined by the best standard methods available appear

equivalent to the comparisons between the two clinical or standard methods.

Table II

SUMMARY OF CO CORRELATIONS

<u>Correlation</u>	<u>Amount of Data</u>	<u>Correlation Coefficient</u>	<u>Percent Within or Near 20% Lines</u>
Fick/IDC	25	.95	88
EIP/IDC ALL RECORDS	67	.84	92
EIP/IDC EXCL. POOR RECORDS	51	.88	94
DUPL. DETER. EIP	61	.93	97
DUPL. DETER. IDC	56	.87	98

Plotted in figure 10 for both techniques are the normalized differences between the maximum and minimum value of CO output from the multiple determinations made during the control phase of the catheterization. If CO were indeed constant during the control phase and the IDC measurements showed no random variations while the impedance predicted values did, then these data would appear as points distributed along the ordinate. If both techniques were equally accurate and had no random variations, but CO was fluctuating, these data would appear along a straight line in the first quadrant. The scatter of data seen here indicates that in combination with randomness of actual

CO during the control phase, the randomness of the two measurement techniques is about equal. This leads to two important conclusions. First that there is an inherent maximum level of correlation that exists for these data, and second that there is a hazard in attempting to perform correlation studies based on only a few cardiac output measures per patient. This figure shows that a maximum/minimum difference of individual determinations can reasonably be expected to be equal to the average value of a sequence of determinations.

Figure 11 is a plot of results for changes in CO induced during the catheterization procedure. The calculation of the plethysmographic value was the same as that used for the patient during the control phase. Considering these data in the context of the previous shown correlations and the errors in the standard procedure, one could conclude that the correlation is about maximum. Or, alternately, to expect these data to have a tolerance much less than 1 liter/min. by either method would seem hard to justify.

In summary, these results are based on 526 separate determinations of CO from transthoracic impedance changes and a like number by standard methods. They were obtained from 67 cardiac patients representing 12 primary disease states and many more primary/secondary combinations of diseases. We have some evidence to support this number of patients as being statistically significant for the discriminant analysis used. Admittedly, reclassifying the same patients that established the basis of the classification is biased, but only additional data can resolve this point.

It is necessary to note that these results are given specifically for the procedure outlined. One could reasonably ask if they are representative, for example, for other or less waveform tests, healthy subjects, different electronics, alternate electrodes or electrode placement, or a variety of subject positions. The effects of modifying the procedure are unknown, however, and would appear to be verified only by additional statistical significant studies.

Finally, assuming that our sample is statistically significant, we have shown that cardiac output can be predicted for heart patients by a non-interventive electrical impedance plethysmographic technique with an accuracy apparently as good as that of reference procedures. The implications of this are manifold.

---

Acknowledgements: This work has been supported partially by funds from the USAF, ONR, and by a grant from NSF.

The author is indebted to Dr. Paul Yu, Department of Medicine, School of Medicine and Dentistry, University of Rochester, and his staff for making this study possible and for their assistance and counsel.

#### REFERENCES

- (1) E. Kinnen, SAM-TR-65-81, Brooks Air Force Base, Texas.
- (2) E. Kinnen and C. Duff, SAM-TR-68-23, Brooks Air Force Base, Texas.
- (3) A. Harley and J. C. Greenfield, Aerospace Medicine 39:248.

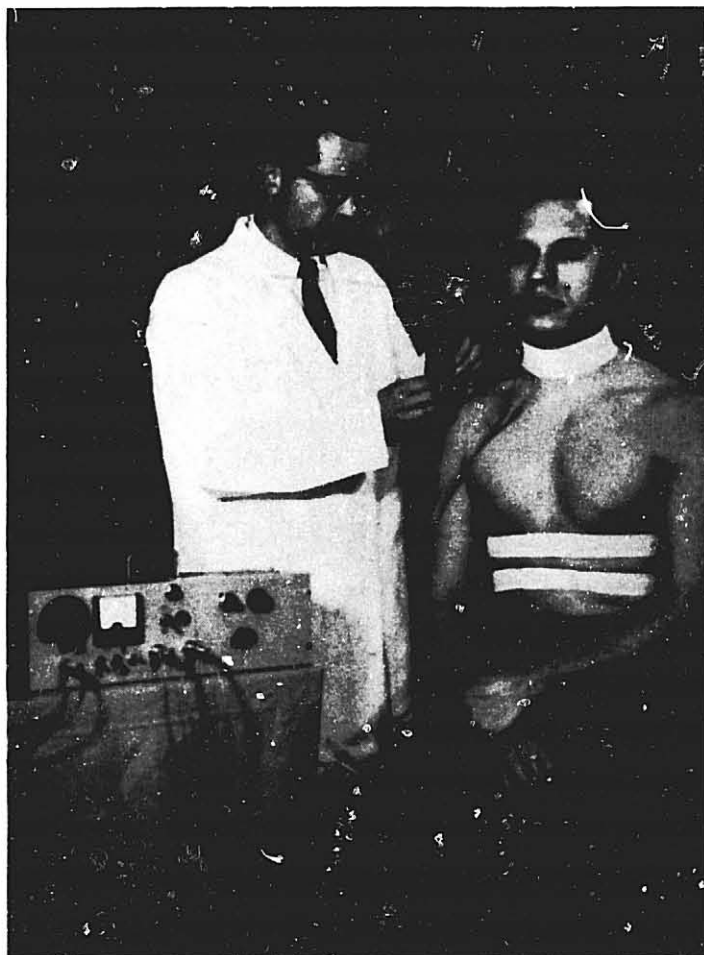

Figure 1 Electrode placement and plethysmograph. The thoracic electrodes are constructed of 2.5 cm. wide metalized Velcro (American Velcro Company sewed to an elastic backing. Stainless steel cloth folded to a width of 1 cm. and sewed to an elastic backing forms each of the neck electrodes. To reduce the electrode-skin impedance, electrode paste (Translyte, Med-tronics, Inc.) is applied to the bands prior to applications.



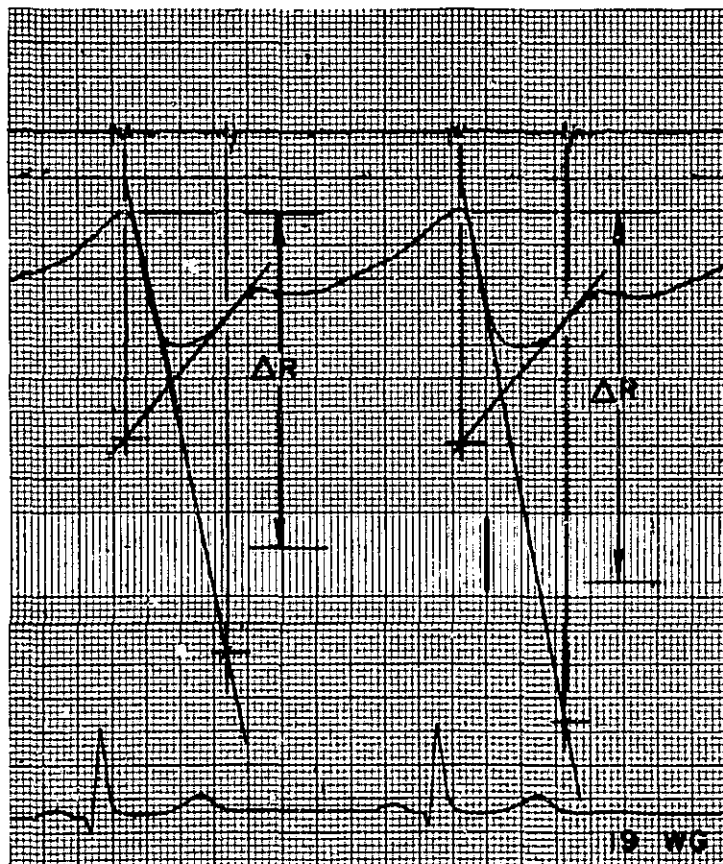

Figure 2 Typical transthoracic impedance change during a heart cycle, indicating the measurement of  $\Delta R$ . The EKG and PCG are also shown. Impedance increasing upward.

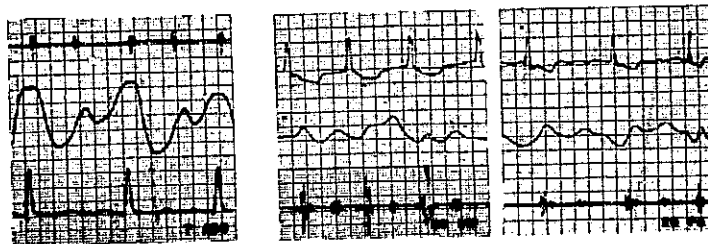

Figure 3 Transthoracic impedance waveform variations obtained from three different female subjects with mitral insufficiency.

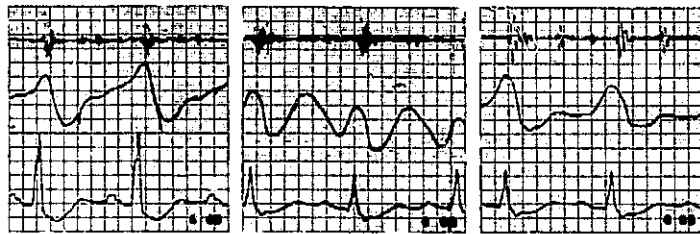

Figure 4 Transthoracic impedance waveform variations obtained from one female subject with aortic insufficiency, separated by 200 minutes and by 12 minutes.

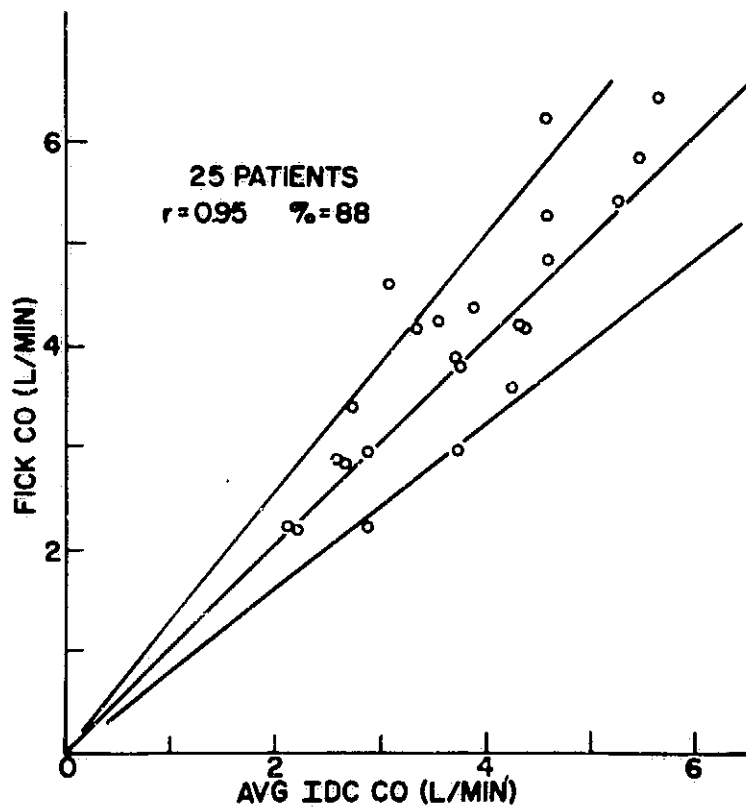

Figure 5 Correlation of CO determined by the Fick procedure and from IDC, obtained during the control phase of the catheterization and generally within a 10 minute period. Two additional points are beyond the edge of the plot, one outside the tolerance line.

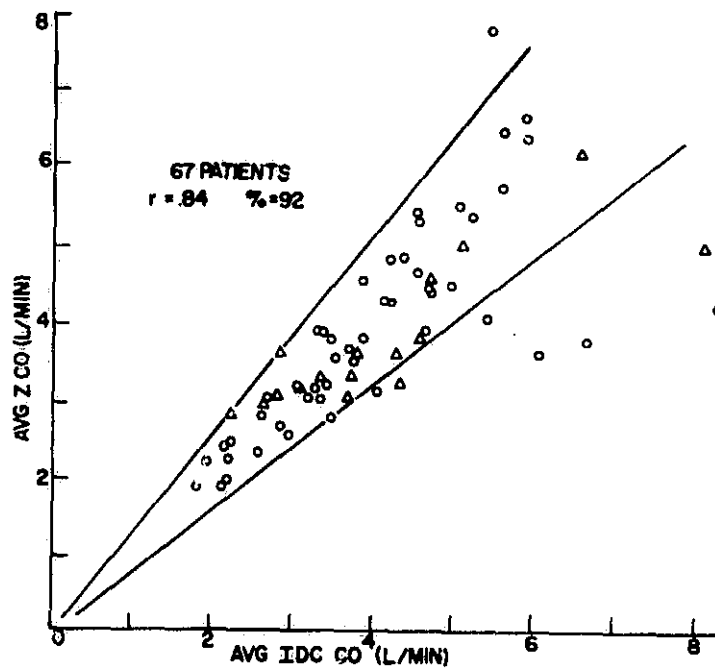

Figure 6 Correlation of CO determined from impedance records and from simultaneously recorded IDC. Values for each axis are the average of at least two repeated determinations during the control period, usually made within 10 minutes. Points indicated by triangles represent experimentally questionable data (see text).

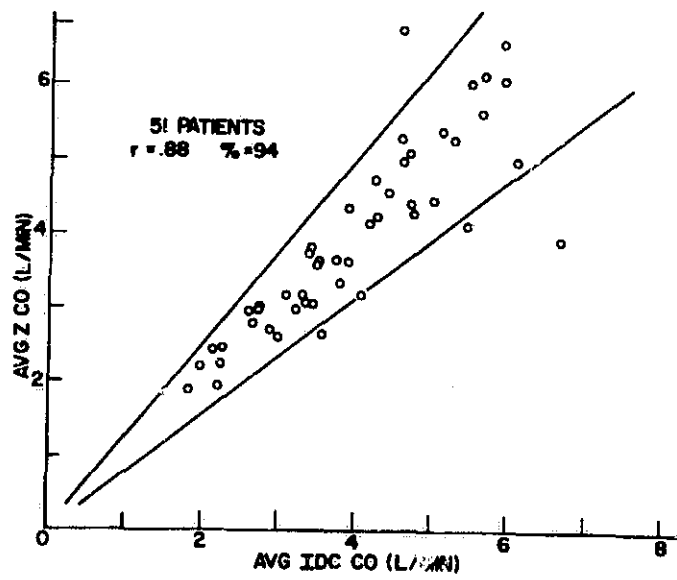

Figure 7 Correlation similar to that shown in figure 6 but excluding subjects with impedance records which could reasonably be suspect as grossly atypical or problematical.

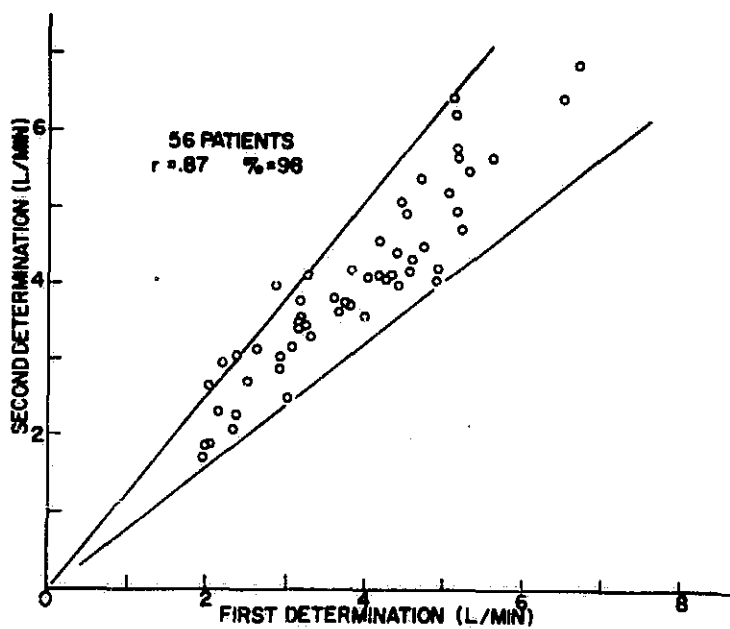

Figure 8 Duplicate values of CO from IDC, taken within 10 minutes during the control phase of the catheterization.

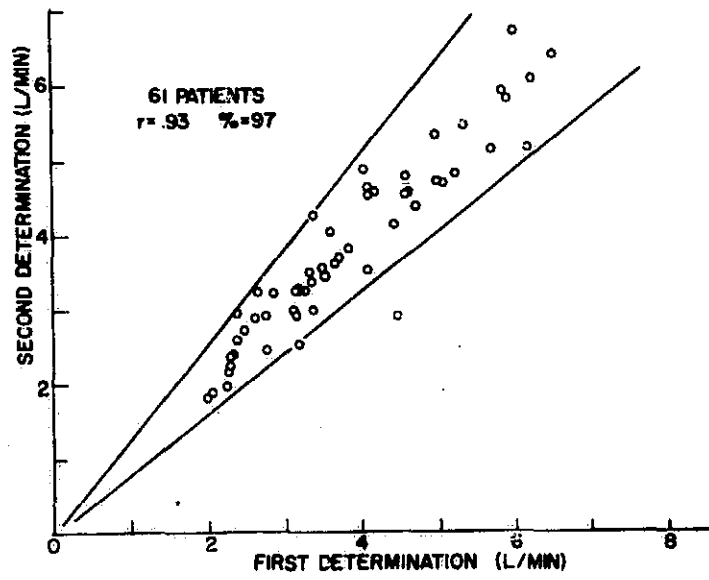

Figure 9 Duplicate values of CO determined from impedance records, taken simultaneously with data plotted in figure 8.

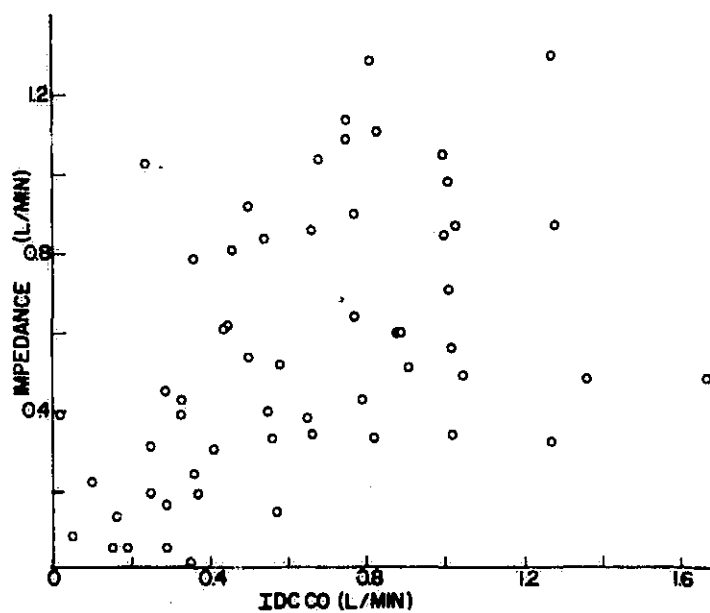

Figure 10 Difference of the maximum/minimum values of CO determined from impedance records plotted versus those from IDC, taken during the control phase of the catheterization.

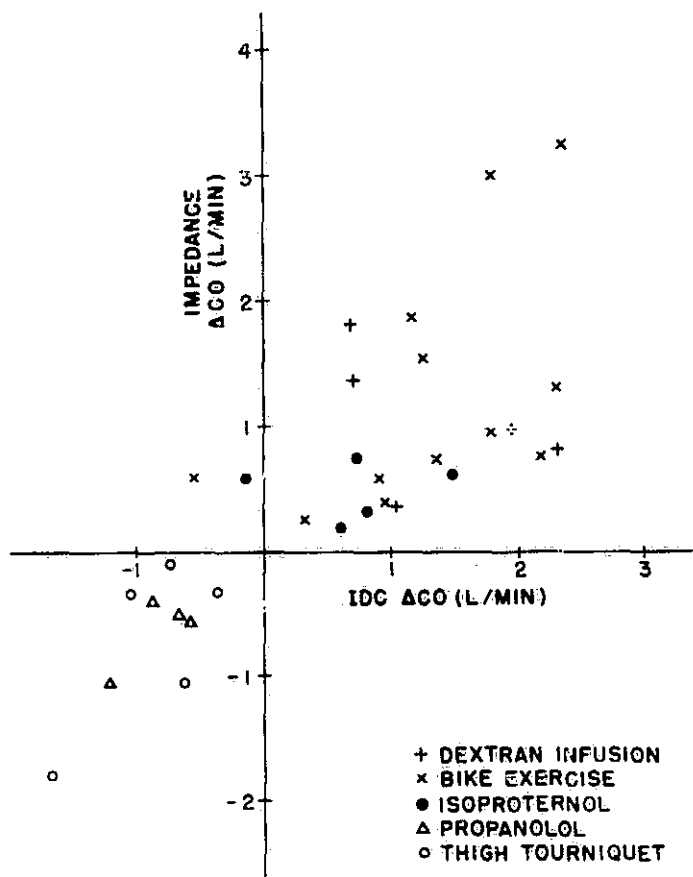

Figure 11 Induced change in CO from the average value measured during the control phase using the methods indicated. CO determined simultaneously from the impedance records and the IDC. Data obtained from 25 patients.



RESISTIVE AND REACTIVE (CAPACITIVE) CARDIAC IMPEDANCE PULSES

by

4 N70-10024

Dr. Richard Namon and Dr. Frank Gollan  
Departments of Neurology & Surgery  
University of Miami School of  
Medicine and  
Veterans Administration Hospital  
Miami, Florida

This investigation was supported in part by Public Health  
Service Grants NB05654-01 and HE-09868

## Introduction

The search for an atraumatic method to measure cardiac stroke volume goes back to Max Cremer who in 1907 recorded the motion of a beating frog heart by electrical capacitance changes between two condenser plates (1). This observation that the beating heart can be monitored without touching a sensor was applied to man by Atzler and Lehmann 25 years later (2). They placed electrodes in front of and behind the chest, and noted that capacitance fell with the emptying and rose with the filling phase of the heart as timed by the electrocardiogram. They were familiar with Cremer's observation and called their method "dielectography." Currents of very high frequency were used by Rosa in 1938 (3) and by Nyboer in 1940 (4); therefore, the term "radio-cardiography" was used. Cardiac impedance pulses were also measured between limb electrodes by Holzer, Polzer and Marko (5), who published a comprehensive monograph under the title of "Rheoelectrocardiography" in 1945. Whitehorn and Pearl (6) recorded capacitive pulses in 1949 and tried to calibrate the method by introducing a known volume of saline between the condenser plates. Preliminary experiments with an alternating current bridge were performed by Mann in cooperation with C. P. Steinmetz as early as 1919, but it was not until the end of the Second World War that improvements in electronics permitted development of an instrument which was sensitive only to changes in capacitance. When this "capacigraph" was connected to electrodes on the thorax, the resulting curves corresponded to the

systolic expulsion of blood. In 1951 Mann concluded that the height of deflection, the rate of rise and the shape of the curve offered a safe, simple and reproducible method of studying cardiac dynamics in clinical practice (7). Provocative recordings of resistive and reactive impedance pulses from electrodes on the limbs and the chest were published by Nyboer in his authoritative book (8). He observed that the reactive component over the limbs was minimal, whereas he found it quite substantial over the chest.

Considering the fact that atraumatic determinations of heart volume started with measurements of capacitance half a century ago and has held sporadic interest since then, it is a sad commentary on the short memory and provinciality of our time that original observations made in non-English speaking countries some years ago, were not re-examined with modern electronic and medical methods.

In this experimental study we have made an initial attempt to fill this gap. This endeavor was greatly facilitated by the detailed and extensive reports to NASA by Kubicek and his co-workers (9,10,11) at the University of Minnesota on the resistive chest impedance changes in health and disease. These indefatigable investigators have, for the first time, correlated such indirect electrical measurements with stroke volume determinations by the green dye dilution technique and thus have made a comparison of various approaches possible.

### Methods

Fourteen greyhound dogs, weighing 25 to 35 kg, were given intramuscular injections of Propiopromazine hydrochloride\* (0.5 mg/kg) and Quinidine (3-4 mg/kg); 30 minutes later the dogs were anesthetized intravenously with sodium pentothal\*\* (30 mg/kg). One common carotid artery and one jugular vein were exposed for catheterization of the left and right ventricle. Total cardiac output, including coronary flow, was determined by injection of indocyanine green dye into the right ventricle and by the dilution curve in the blood withdrawn from the left ventricle. The electrocardiogram recording was used as a cardiac event marker. A large cannula was placed in the vena cava inferior via a femoral vein to allow rapid blood volume changes.

In order to alter stroke volume, rapid hemorrhage and transfusion were performed in 6 experiments, catecholamines were administered in 8 animals, myocardial ischemia was produced in 4 experiments by the intracoronary injection of microbeads and the body temperature of 7 dogs was lowered by ice immersion to about 30°C in order to change stroke volume at a lower heart rate. Because of the uniformity of the results, separate treatment of the data of each procedure will be omitted.

Four aluminum foil electrodes (2.5 x 2.5 cm) having thin wire leads were coated with ECG paste and attached by masking tape to the acetone-cleaned body surface (Fig. 1). To monitor impedance changes in the chest, one current input electrode

---

\*Tranvet, \*\*Diabutal, Diamond Lab., Inc., Des Moines, Iowa.

was placed above the sternal notch (one-third up the neck) and the other below the xiphoid process on the lower abdomen. Two voltage-sensing electrodes were placed midline on the sternum at the estimated level of the apex and base of the heart. The skin over the sternum had a minimum of motion transmitted by the heart. A low, non-stimulating, current of 37k Hz (Hertz now replacing cycles per second) with a constant peak amplitude (2 ma rms) was applied, and the peak voltage produced by that current on the chest was measured. Since impedance has both resistive and reactive components, we measured a voltage related to current. In a model this voltage can be represented by the sum of a resistive and reactive ( $90^\circ$  out of phase) voltage (Fig. 2). When this separation of voltage is done electronically, it is possible to monitor the resistive or reactive electrical impedance.

A simple electronic addition was designed to convert our total impedance change measuring instrument (Physical Instruments Model 450B-1A Rhoencephalograph) to a resistive or reactive impedance monitor. Instead of separating the measured voltage into components, it was added to a resistive or reactive voltage at least 10 times greater than its amplitude. By reading only the peaks of this voltage (as our basic instrument was designed to do) only the component of the measured voltage in phase with the added voltage was measured; the other (or out of phase) voltage was zero while the measured voltage was at its peak. The efficiency of this circuit in isolating resistive and reactive impedance phases was tested with resistive and capacitive pulses. The circuit (Fig. 3) functions as follows: constant

current from the instrument, via the input electrodes, passes through the subject and a series 100 ohm resistor or capacitor (100 ohms at 37 k Hz). The transformer, electrically in parallel with the resistor or capacitor (depending on the mode in use), adds the voltage across the input series load with the voltage across the subject pickup electrodes. These two voltages add together in a vector fashion so that the instrument sees a voltage whose peak value is either mainly resistive or reactive. Therefore, the instrument reflects the resistive or reactive changes across the chest of the subject according to the choice of either resistor or capacitor (switch  $S_1$ ) in series with the input current. This is possible since the subject pickup voltage is less than 10% of the voltage across the series load. There is no appreciable voltage loss across the transformer or across the pickup electrodes using the proper pickup electrode size and transformer load. In order to preserve electronic integrity, the impedance of the transformer from the voltage pickup side and across the subject pickup electrodes should be less than 5% of the measuring instrument input impedance. In our studies this requirement was met; our instrument's voltage input impedance was 30k ohms at 37 k Hz and the impedance directly into the pickup electrodes was less than 600 ohms. The sequence of electrode connections is important since a reversal of either current or voltage pickup electrodes will reverse the phase between the discriminating voltage and the sensed voltage and thereby reverse the polarity of the measured signal. It is therefore necessary to

short-circuit the subject voltage pickup electrodes to determine the direction of decreasing reactance on the recorder.

## RESULTS

Both the resistive and reactive impedances are reduced during systole, but the resistive rheogram has a more complex shape (Fig. 4) and has its maximum change shortly after onset of systole. While the illustrated amplitudes are about equal, the ohm value of the resistive cardiac rheogram is usually three times greater than the reactive rheogram.

The differences between resistive and reactive rheograms become apparent when stroke volume is being changed by hemorrhage and transfusion. In one such experiment the relation between stroke volume and resistive rheometry was poor, while the correlation between stroke volume and reactive rheometry was excellent (Fig. 5). Therefore, only reactive impedance measurements were continued. The time relation between the reactive rheogram, electrocardiogram and pressure tracings corresponded with the emptying and filling of the heart (Fig. 6). The reactive rheogram first decreased between the R and S wave of the electrocardiogram and reached a minimum during the T wave of the electrocardiogram or about the time of peak ventricular pressure. The rheogram preceded the aortic pulse during systole which suggests that it does not originate in the peripheral pulse. The amplitude of the reactive rheogram reflected the induced changes of stroke volume as determined by the green dye dilution technique (Fig. 7) and in the individual experiment

the agreement between these two measurements was satisfactory (Fig. 8).

Then the absolute values of 129 stroke volumes in ml and rheographic amplitudes in mm in 14 experiments of this kind were plotted and a close correlation was found over an extreme range (Fig. 9).

To determine the absolute reproducibility of reactive rheometry from dog to dog, the same data from these 14 dogs was analyzed statistically (Fig. 10). Stroke volume varied from 8.6 to 108 cc, pulse rate from 56 to 227 per min., and cardiac output from 1.0 to 8.4 liters per minutes. The correlation coefficient between stroke volume and rheometry was 0.91 and the standard deviation from a best fit line on a log-log plot was 19%. The slope of the best fit line was 0.53 milliohm per ml. There was a slight inverse relationship between the amplitude of the rheogram with pulse rate which could not be ascribed to the frequency response of the equipment. Over the range of 56 to 227 beats per minute, the amplitude decreased 0.09% per beat. This correction factor was not incorporated into the evaluation since its correlation coefficient was only 0.22 due to an insufficient number of points for the data spread about a perfect line.

#### DISCUSSION

To our knowledge this is the first study of reactive impedance changes and quantitated cardiac stroke volume. The difference in electronic technique between this and other



studies may account to a large extent for the higher correlation observed by us. We have derived empirically a midline placement of electrodes to minimize motion artifacts.

Light tapping of each electrode with a pencil did not produce mechanical artifacts on the reactive impedance pulse. Since midline placement of the electrodes minimized respiratory movements and the transmitted pulse, monitoring of deep impedance changes may have been facilitated. However, there is no evidence that the measured impedance changes are confined to the circulating volume between the voltage sensing electrodes. Helmholtz calculated that "current" and "pickup" electrodes in such a system could be interchanged without altering the measurement (12). We have confirmed this observation with electrodes recording the impedance pulses over the head (13). This demonstrates that volumes common to both pairs of electrodes are monitored with four lead systems.

With the chest electrodes, a slight change of the voltage sensing electrodes up or down the sternum had little effect on the reactive impedance measurement. However, as current and voltage sensing electrodes were placed closer together the electrodes became sensitive to mechanical motion. This indicated that close proximity of the electrodes included the body surface in their field of measurement.

The source of the large reactive impedance pulse over the chest is not yet known and controlled experimental studies are indicated to find its cause. At the same time applied

investigations in man should be conducted to define the optimal size and placement of electrodes for simultaneous resistive and reactive impedance measurements which correlate with stroke volume determinations.

In the past this field has been hampered by a plethora of theoretical calculations, on the one hand, and by clinical empiricism on the other. Impedance pulses of all amplitudes and shapes can be recorded easily and safely, however it will require sustained and disciplined enthusiasm to convert this fascinating biological phenomenon into a reproducible quantitative and predictable method in clinical medicine.

#### SUMMARY

An indirect method to measure cardiac stroke volume using electrical impedance methods with electrodes on the body surface of anesthetized greyhound dogs, was developed. The amplitude of resistive and reactive impedance pulses was compared with the stroke volume calculated from cardiac output determinations using the green dye dilution technique. The reactive impedance pulses reflected the stroke volume changes more accurately and therefore were used in this study. In 14 dogs reactive impedance changes were compared with 129 dye dilution determinations over a wide range of stroke volumes (9 to 107 ml) produced by hemorrhage, transfusion, hypothermia and drugs. The correlation coefficient between the two methods was 0.91: the standard deviation from a best fit line on a log-log plot amounted to 19% and 0.53 milliohm corresponded to one ml of stroke volume.

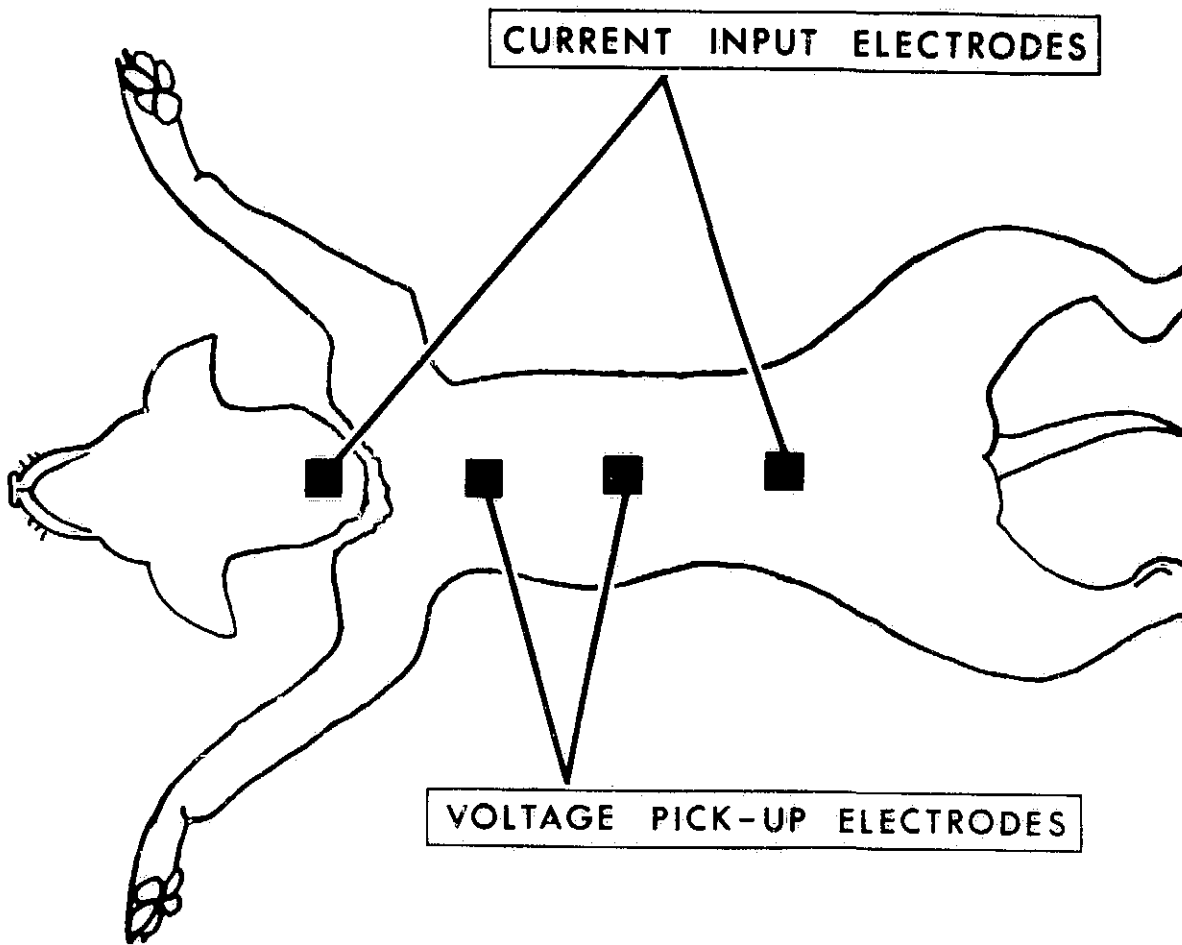

Figure 1 Electrode placement

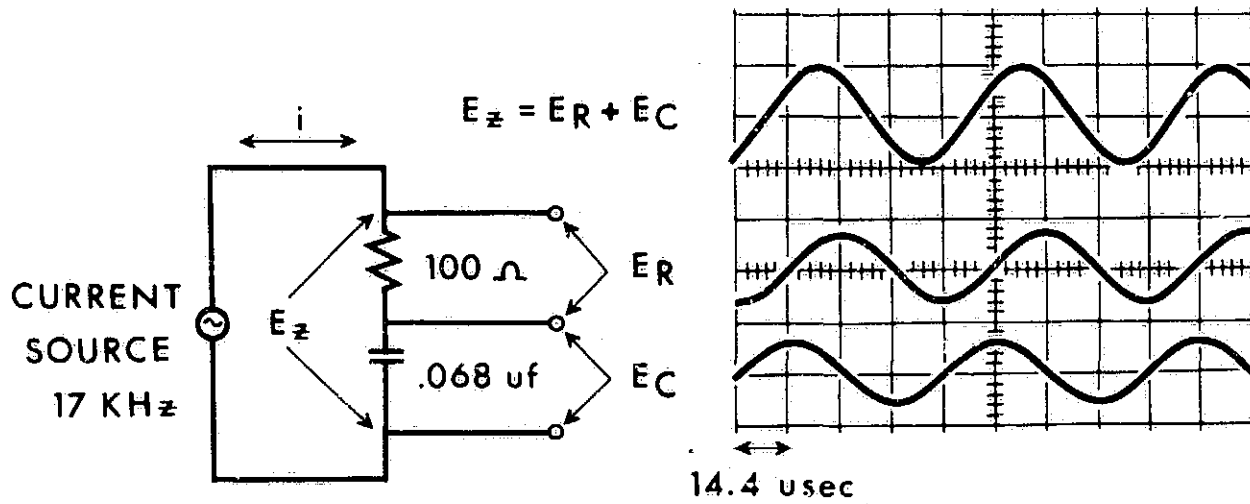

Figure 2 Voltage resulting from the sum of a resistive and a reactive voltage

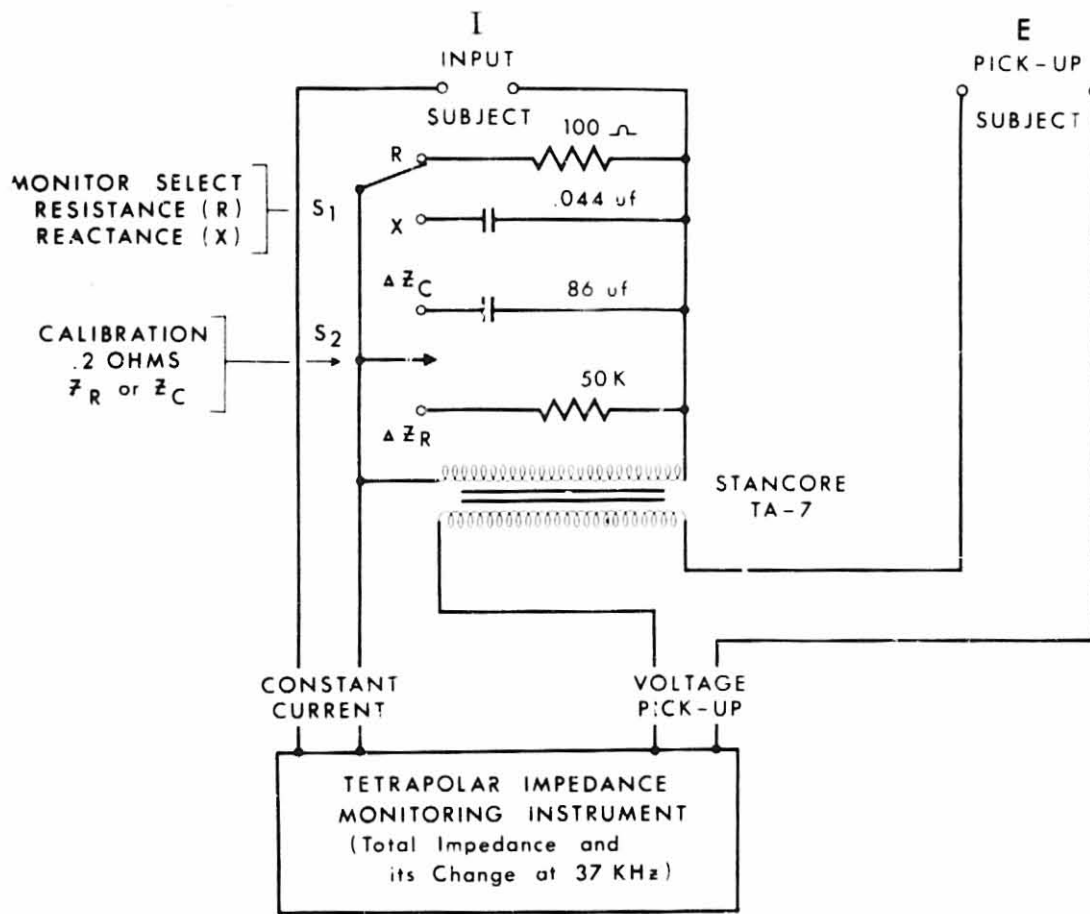
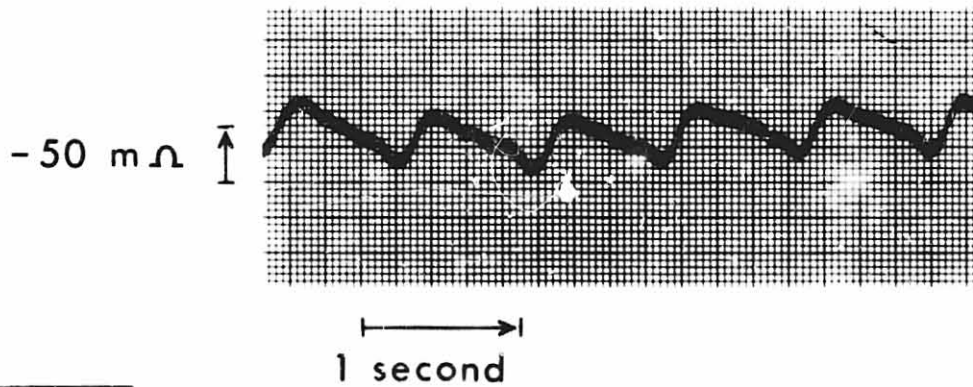

Figure 3 Circuit for monitoring resistive or reactive impedance changes

**REACTIVE**



**RESISTIVE**

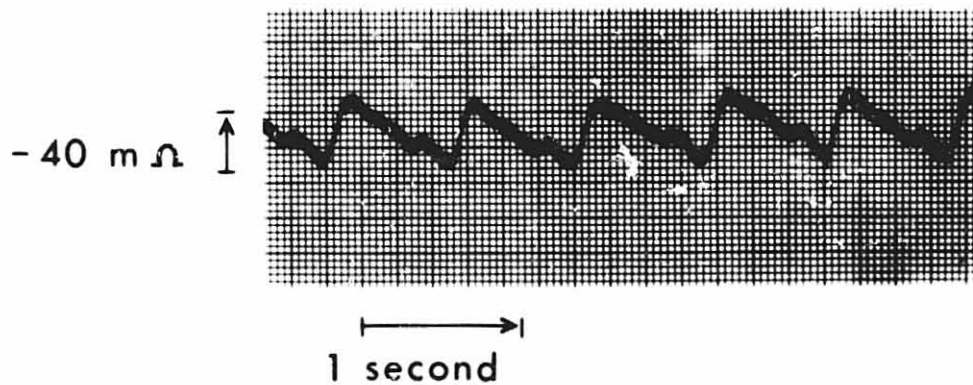

Figure 4 The resistive and reactive cardiac rheogram

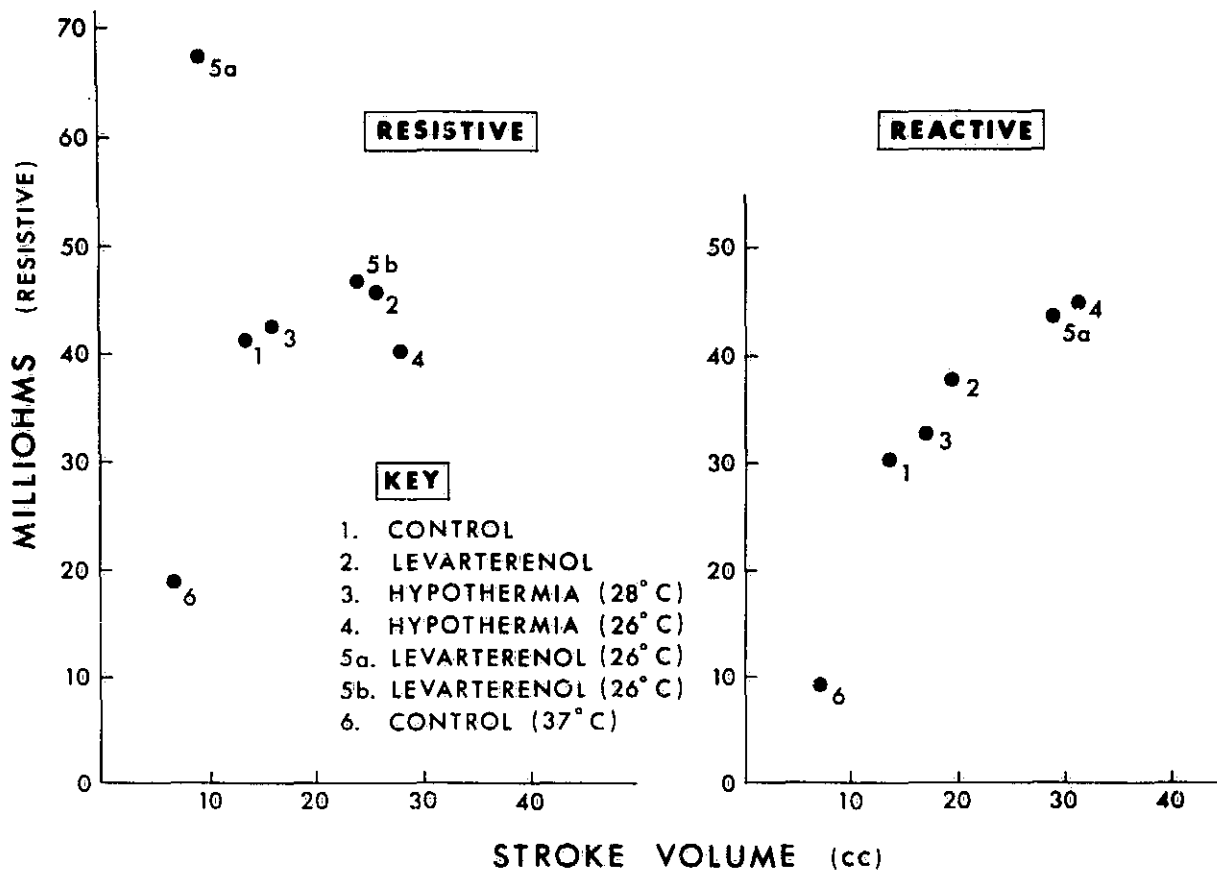

Figure 5 Resistive and reactive cardiac rheometry (alternate measurements)

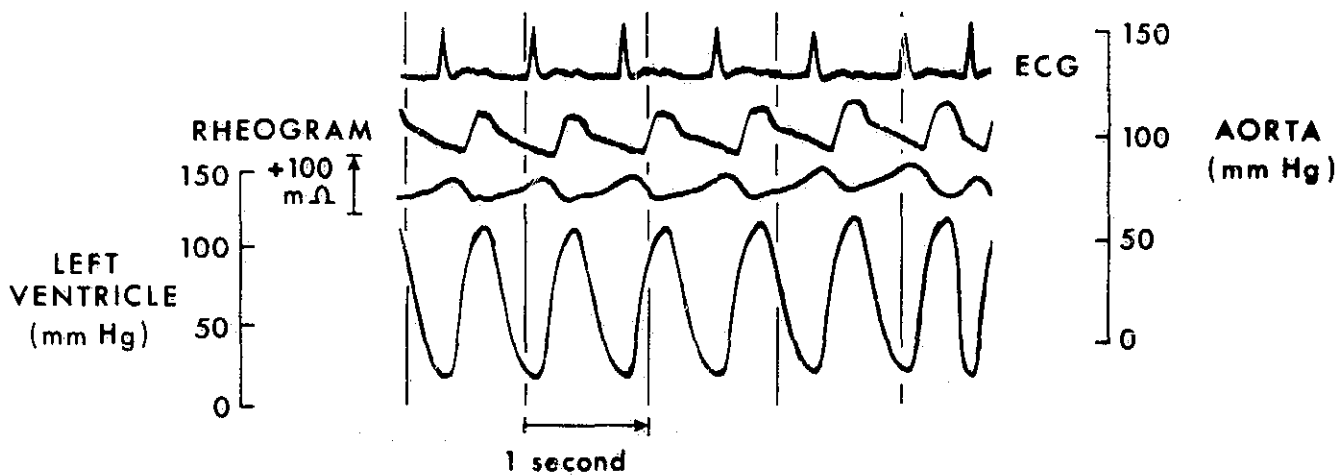

Figure 6 The time relation between the rheogram and the ECG, aortic and left ventricle pressures

### EFFECT OF RAPID BLOOD VOLUME CHANGE ON THE CARDIAC RHEOGRAM

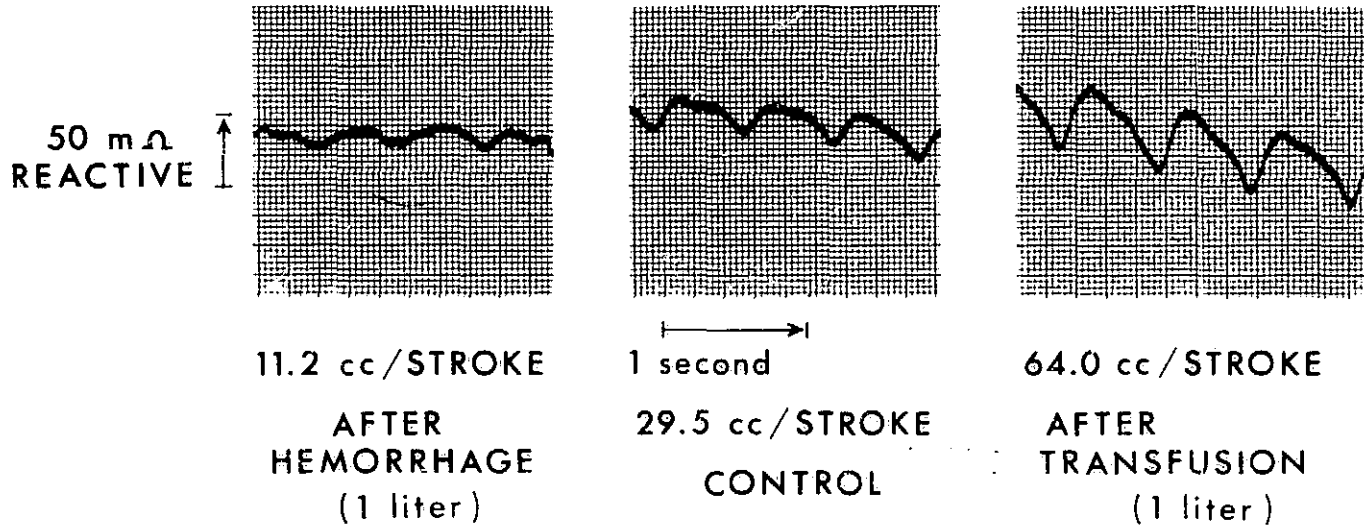

Figure 7 Effect of rapid blood volume change on the cardiac rheogram

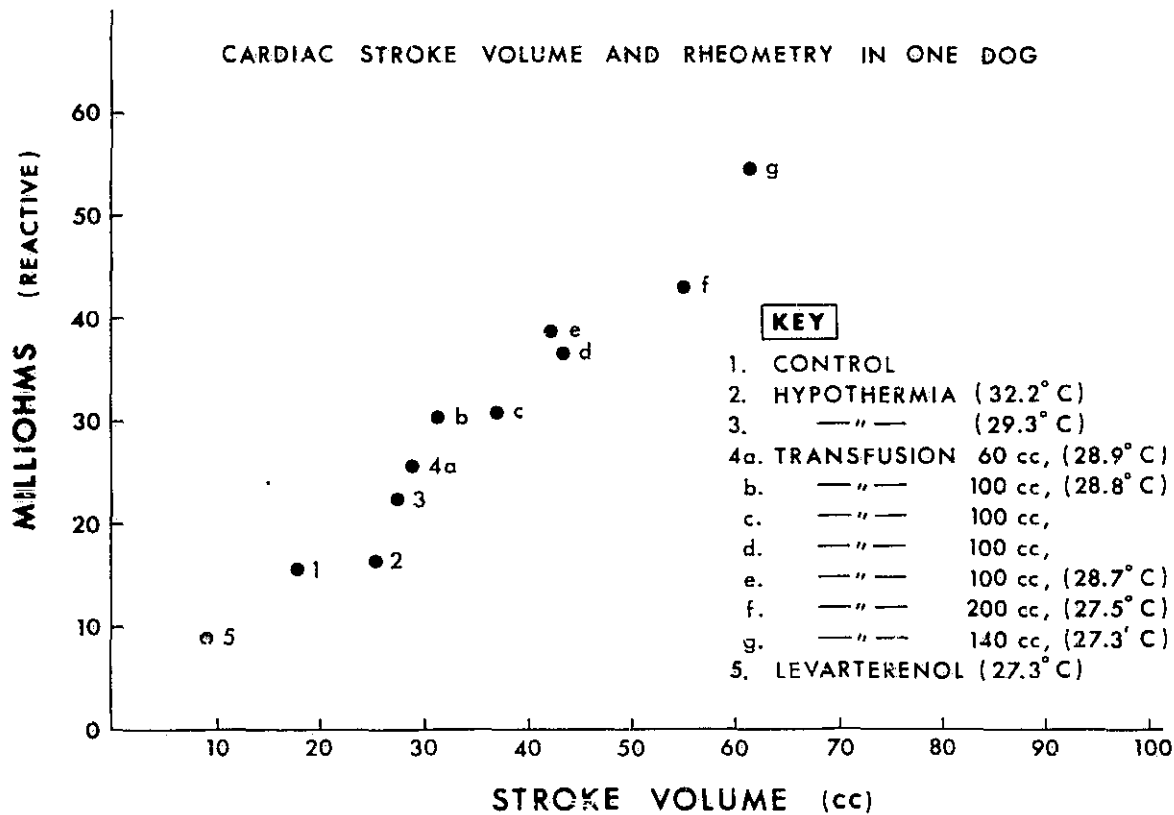

Figure 8 Cardiac stroke volume and rheometry in one dog

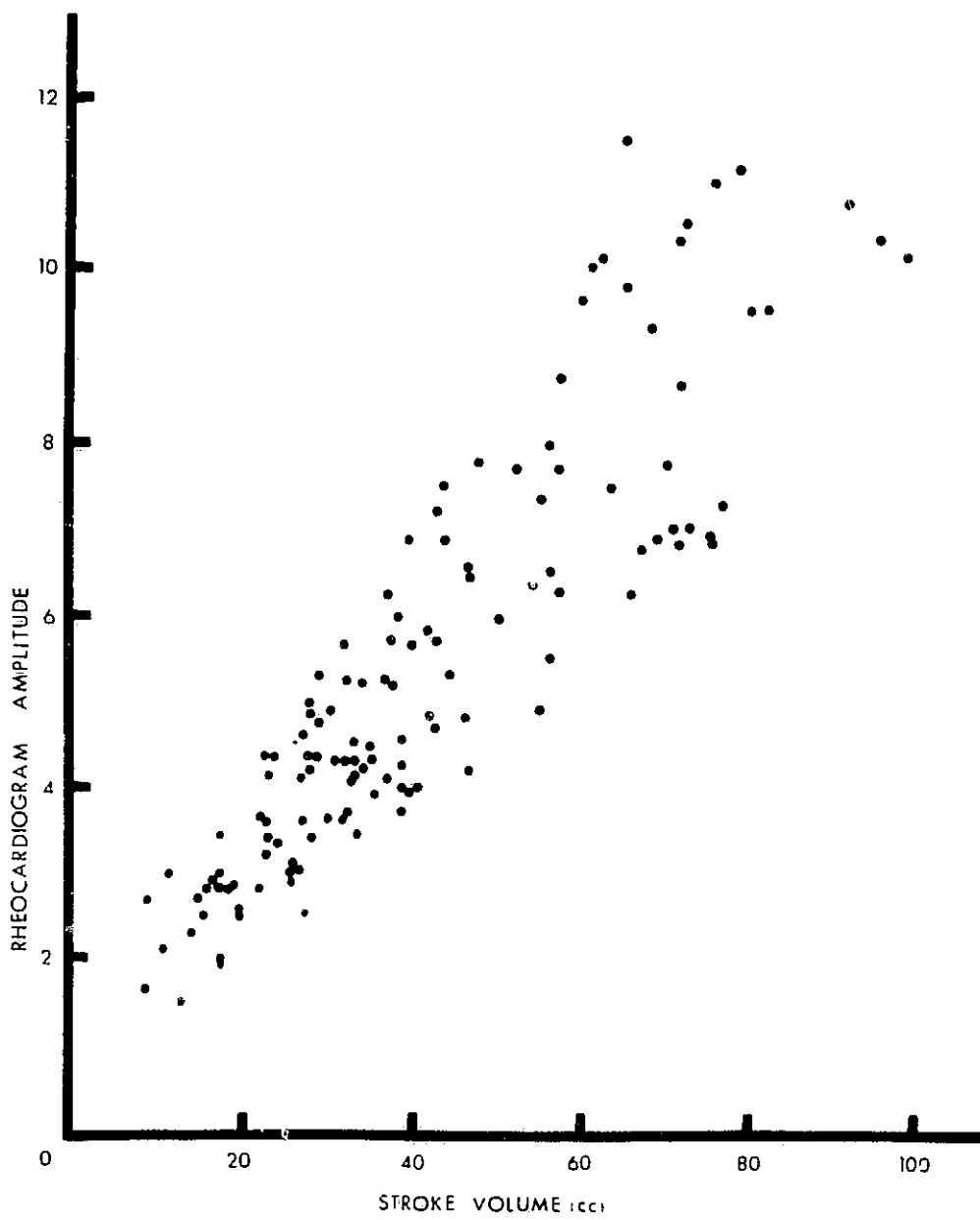

Figure 9 Cardiac stroke volume and rheographic amplitudes for all 14 dogs

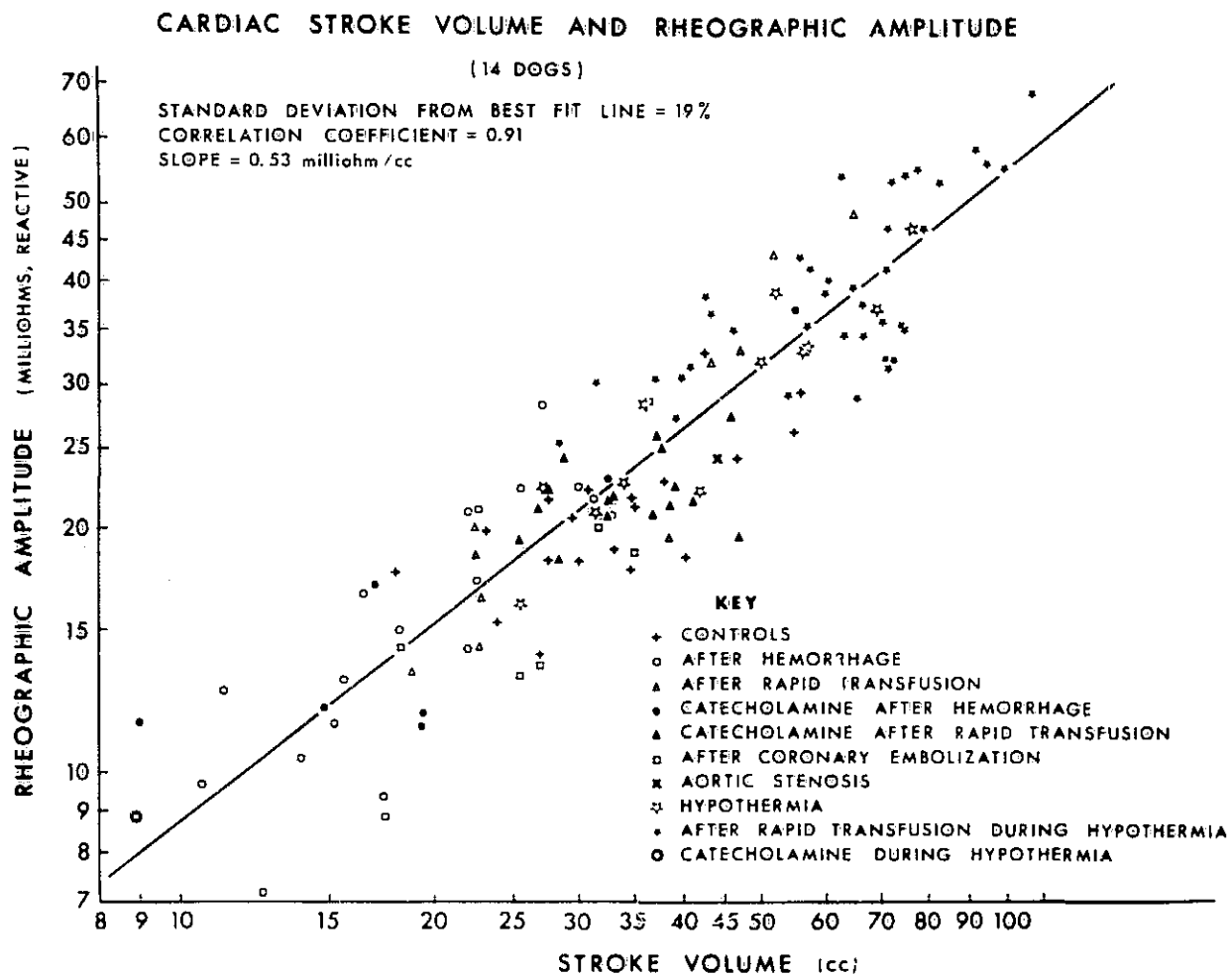

Figure 10 Cardiac stroke volume and rheographic amplitudes for 14 dogs plotted for statistical evaluation with a breakdown of measurement conditions



REFERENCES

1. Cremer, M.: Über die Registrierung mechanischer Vorgänge auf elektrischem Wege, speziell mit Hilfe des Saitengalvanometers und Seitenelektrometers. Münch. Med. Wchenschr. 54: 1629, 1907.
2. Atzler, E., and Lehmann, G.: Über ein neues Verfahren zur Darstellung der Herztätigkeit. Arbeitsphysiologie 5: 636, 1932.
3. Rosa, L.: Nouveaux aspects diagnostiques par les ondes longues et courtes dans les maladies du coeur. Bull. Mem. Soc Radiol. Med. France p. 1, Oct. 1938.
4. Nyboer, J., Bagno, S., Barnett, A., and Halsey, R.H.: Radiocardiograms: Electrical impedance changes of the heart in relation to electrocardiograms and heart sounds. J. Clin. Invest. 19: 693, 1940.
5. Holzer, W., Polzer, K., and Marko, A.: Rheokardiographie. Wilhelm Maudrich, Vienna, 1945.
6. Whitehorn, W., and Perl, E.: The use of change in capacity to record cardiac volume in human subjects. Sci. 109:262, 1949.
7. Mann, H.: The capacigraph. A new instrument for measuring cardiac output. Trans. Amer. Coll. Cardiol. 3:162, 1953.
8. Nyboer, J.: Electrical impedance plethysmography, page 94, Springfield, Ill., 1959, Charles C. Thomas, Publisher.
9. Patterson, R. P., Kubicek, W. G., Kinnen, E., Witsoe, D.A., and Noren, G.: Development of an electrical impedance plethysmography system to monitor cardiac output. 1st Ann. Rocky Mtn. Bioeng. Symp. USAF Acad., Col. Springs Co. Proc.: p. 56, 1964.
10. Kubicek, W. G., Karnegis, J. N., Patterson, R.P., Witsoe, D.A., and Mattson, R. H.: Development and evaluation of an impedance cardiac output system. Aerospace Med. 37: 1208, 1966.
11. Kubicek, W. G., Witsoe, D. A., Patterson, R. P., Mosharrafa, M. A., Karnegis, J. N., and From, A.H.L.: Development and evaluation of an impedance cardiographic system to measure cardiac output. Contract No. NAS 9-4500, Report July 1967.

12. Helmholtz, H. von: Über einige Gesetze der Vertheilung elektrischer Ströme in körperlichen Leitern mit Anwendung auf den thierischen-elektrischen Versuch. Ann. Phys. Chem. 89: 211 and 353, 1853.
13. Namon, R., and Markovich, S.: Monopolar rheoencephalography. Electroenceph. Clin. Neurophysiol. 22: 272, 1967.

N70-10025

THE POTENTIAL ROLE OF IMPEDANCE PLETHYSMOGRAPHY  
IN AEROSPACE MEDICINE\*

Robert D. Allison, Ph. D.  
Director, Vascular Laboratories  
Scott and White Clinic  
Temple, Texas

\* Presented at the First Symposium on Impedance Cardiography,  
NASA Manned Spacecraft Center, Houston, Texas  
June 2, 3, 4, 1969.

THE POTENTIAL ROLE OF IMPEDANCE PLETHYSMOGRAPHY  
IN AEROSPACE MEDICINE\*

Robert D. Allison, Ph. D.  
Director, Vascular Laboratories  
Scott and White Clinic  
Temple, Texas

Introduction

Scientists interested in clinical investigation have been searching for a reliable, physiological, simple-to-use method for measuring quantities of blood volume delivered to biological tissue. The classical approach to measurements of segmental blood flow has involved enclosure of the examined segment in a chamber filled with air or water; thermistors, photoelectric sensors, and oscillometric indications of vascular dynamics. More acute and chronic preparations have involved flow probes positioned around vessels, the injection of radioactive material and contrast dye into the bloodstream and the detection of the decay of radioactivity with externally positioned sensors or the rate of volume dilution in subsequent withdrawn blood samples. All of these methods have advantages and disadvantages. No method has been completely ideal for the clinical investigator or the experimental biologist in a laboratory environment, and few methods are applicable to a wide range of measurements in the space environment. Each of us has evolved a scientific compromise.

-----

\* Presented at the First Symposium on Impedance Cardiography, NASA Manned Spacecraft Center, Houston, Texas, June 2, 3, 4, 1969.

The principles which describe biological volume conduction are  
common to the history and understanding of electrocardiography,<sup>8</sup>  
and the conductive properties of biological segments have been used as  
a technique for indicating vascular dynamics for nearly forty decades in  
this country. From the capacitance bridge designed in Huber Mann's  
laboratory in New York in the early thirties,<sup>9</sup> to the present Minnesota  
impedance cardiograph,<sup>10</sup> we have witnessed the historical development  
of electrical impedance plethysmography with many years of interrupted  
investigative effort interspersed with enthusiasm and further advancement.  
Progress in our form of nondestructive testing has been conditioned by  
individual compromise and the inventiveness and visionary influence of  
bioengineering talent.

The basic principles of biological impedance plethysmography as  
suggested by Dr. Jan Nyboer in the late 1930's have proven to be valid  
and his most recent investigative efforts have certainly provided more  
justification and credence to his pioneering efforts which were designed  
to conceptualize impedance plethysmography as a practical and harmless  
biological measuring system.<sup>11, 12</sup>

During the past twelve years, I have gained historical perspective  
from the early work of Nyboer and others, and we are witnessing the  
results of new approaches to diagnostic medicine, biological science,

and I believe an even wider application of impedance plethysmography to aerospace medicine as exemplified by the work of Geddes, Baker, 13, 14, 15 Kubicek, Kinnen, and many others.

We are presently considering the suitability of biological impedance measuring techniques for studies carried out in the earth-bound laboratory environment and, more directly, the evaluation of biological parameters in the dynamic environment related to human activity on earth and in space.

Impedance plethysmography embraces many facets of biological dynamics, and I would like to review some findings which I have observed in the application of impedance plethysmography and emphasize those areas which I believe have great promise in terms of the dynamic environments consistent with aerospace medicine.

I would like to discuss the applications of four electrode impedance plethysmography in studies related to: 1) cardio-pulmonary dynamics of ventilation, stroke volume and cardiac output; 2) blood volume distributions during weightlessness and changes in body posture; 3) measurements of peripheral pulse volume and blood flow with particular reference to environmental factors influencing these measurements; 4) the effects of age and changes in blood pressure on recorded peripheral blood pulse volumes; 5) measurements of kidney area blood pulse volume; and 6) the concept of silhouette studies using impedance plethysmography in the unconditioned healthy subject and the subject exposed to environmental and pathological stress.

The measurements which I will describe have been obtained with a Bagno four electrode impedance plethysmograph<sup>16</sup> with frequencies of 50 kHz and 120 kHz and electrode voltages and current of 120 mv and .25 mA respectively. The electrodes were 1/4" aluminum strips applied to the skin following sparing amounts of ECG paste.

### Cardiopulmonary Dynamics of

### Ventilation, Stroke Volume and Cardiac Output

Previous studies have indicated a good quantitative correlation between tidal ventilation and four electrode impedance changes with electrodes placed on the neck and posterior lumbar region for signal input ( $I_1 - I_2$ ) and detecting electrodes arranged horizontally at the posterior thorax at the level of the 7th cervical vertebra and 12th vertebra.<sup>17</sup> (Fig. 1, 2, 3)

The superimposed pulsations synchronous with the electrocardiogram have been quantitatively compared with dye dilution techniques for measuring cardiac output in man (Table I)<sup>18, 20, 21</sup> and with Fick dilution methods in dogs (Table II).<sup>19</sup> The correlation is reasonably good, although there is a tendency for the impedance method to overestimate other conventional methods. In a study on human subjects, lead strip markers were positioned on the posterior thorax at the level of the 12th thoracic vertebra. This position conforms to the position of the lower detecting electrode (Fig. 1). The chest was examined radiographically during end expiratory position, maximal inspiratory and maximal expiratory levels. The results indicate

the significance of the position of the diaphragm when impedance changes in the thorax are recorded. <sup>22</sup> (Fig. 4). Obviously, if the diaphragm is in the electrical field during apnea, the measured segmental resistance between detecting electrodes  $E_1 - E_2$  and the pulsatile conductive variations represent changes which are difficult to define in terms of cardiac output as recorded with the four electrode impedance method.

Previous studies before and after exercise using a bicycle ergometer have indicated a reasonable correlation between ventilatory (Wedge spirometer) and impedance spirogram tracings. When the subject held his breath before and following exercise, the amplitude of the impedance blood pulse volumes after exercise increased and suggests this non-destructive method as a <sup>18</sup> means of monitoring exercise studies.

Early animal studies indicated the superimposed blood pulse volume changes recorded from the thorax were synchronous with pulmonary arterial pressure, and I believe the thoracic impedance changes recorded with <sup>23, 24</sup> chest electrodes are characteristic of the pulmonary circulation. Occlusion of the main pulmonary artery results in marked attenuation of the thoracic pulses and the fact that there was not complete absence of pulsations may explain why impedance calculations are often higher than those of other conventional methods. Presumably the pulses recorded from the thorax following occlusion of the main pulmonary artery are related to "thoracic cage" perfusion.



I prefer to speak in terms of pulmonary stroke volume and pulmonary blood pulse volume changes, rather than the more conventional systemic stroke volume and cardiac output. I believe there is more to be gained from a physiological standpoint in the individual interpretation of changes in separately recorded thoracic stroke volume and heart rate changes than information derived from cardiac output alone which may mask either one or the other of these parameters in terms of significant variations.

Correlation with other thoracic dynamics, such as the pneumocardiogram and impedance blood pulse volumes recorded from the thorax, provides additional information concerning mechanisms of central cardiovascular function. (Fig. 5) (Table III).

Position of the aluminum strip electrodes on calf segments and other regions of the body permits simultaneous recording of blood pulse volume changes which may be interpreted quantitatively. (Fig. 6-7).

Comparison of impedance plethysmography with electromagnetic flow meter studies, direct bleedout determinations, water-filled plethysmograph chamber studies, and mercury strain gauge techniques on leg segments in experimental animals and man indicates that the four electrode impedance plethysmograph system correlates within 7 per cent of other conventional measurements with subjects at rest.

Blood Volume Distribution During  
Weightlessness and Changes in Posture

Previous animal studies revealed that as one increases the conductivity of the thorax by introduction of blood or saline, recorded electrical baseline ( $R_0$ ) of the thorax between detecting electrodes changes in proportion to the volume of conductive media introduced into the thorax and therefore suggests that the measured levels of thoracic electrical resistance ( $R_0$ ) will change in association with variation in blood volume displaced into and out of the chest.

The mechanisms for cardiovascular responses to weightlessness and increased gravitational stress have not been adequately explained with particular emphasis on displacements of blood and potential myocardial and vasopressor stress. Electrical impedance thoracic studies were completed on a pilot during weightlessness in a jet aircraft on ten consecutive maneuvers. Detecting electrodes were positioned horizontally at C-7 and T-12 and current input introduced to neck and lumbar electrodes (Fig. 1). The electrodes were fastened under a retaining pad inside a flight suit and leads brought out to a seven channel magnetic  
27, 28  
tape recorder.

Impedance measurements of changes in stroke volume and shifts of blood in and out of the chest were obtained during positive and negative acceleration stress. (Fig. 8).

During a 3G acceleration, conductive volume was forced from the thorax, correlating with a decrease in stroke volume and a compensatory increase in heart rate during this stress. These findings are consistent with other studies carried out in a controlled laboratory environment and designed to identify mechanisms of cardiovascular response to positive and negative pressure breathing maneuvers, particularly during valsalva and Mueller procedures.

In a tilt table study completed this past year on 90 private pilots, measurements of central and peripheral blood pulse volume changes during a standardized 15 minute 65° head up tilt procedure, revealed a decrease in stroke volume of 25 per cent, a decrease of 7 per cent in thoracic conductive volumes associated with an 18 per cent increase in heart rate, a 30 per cent decrease in calf blood pulse volume, and a 6 per cent increase in calf conductive volume (Fig. 9).

When contrasted with a group of 22 patients with diabetes mellitus, who are prone to orthostatic hypotension, the tilt table stress resulted in an average decrease in stroke volume of 42 per cent, a decrease in thoracic conductive volume of 12 per cent associated with an 18 per cent increase in heart rate, a 28 per cent increase in calf pulse volume, and an 11 per cent increase in calf conductive volume. A decrease in conductive volume in the thorax was associated with an increase in conductive volume

of calf segments (Fig. 10). These studies suggest a measurement of cardiovascular competency and circulatory fatigue. Heart rate and blood pressure are the results of changes in central and peripheral effects greatly aids in the explanation of the mechanisms of cardiovascular response to this test procedure.

Syncope has generally been thought to be due to a marked loss of vasomotor tone in the peripheral segments. Simultaneous measurements of central and peripheral vascular changes have not been reported and it was interesting to observe the marked increase in calf conductive volume preceding the subsequent loss of blood volume from the thorax and the decreased stroke volume immediately prior to the syncopal episode in one test subject. (Fig. 11 A-B).

Measurements of Central and Peripheral Blood Pulse Volume  
And Blood Flow With Particular Reference to  
Environmental Factors Influencing These Measurements

Perhaps of most significance in terms of evaluating any biological system is the ability for the measuring system to follow physiological responses to environmental changes.

Hypoxia is associated with a reduction in amplitude of pulmonary blood pulse volumes and the impedance system has become a useful measurement of physiological responses to this stimulus in terms of

hypoxic, emphysematous patients breathing 100 per cent oxygen and  
30  
healthy subjects exposed to hypoxic environments. (Fig. 12). Again,  
emphasis must be given the importance of measuring total and segmental  
thoracic changes and peripheral vascular responses simultaneously.

The impedance system has been useful and reliable as a measurement  
of systolic and diastolic blood pulse volume changes in calf segments during  
increases in environmental temperature, (Fig. 13), decreases in environ-  
mental temperature, (Fig. 14), and changes in posture (Fig. 15). The results  
have been consistent with findings of other conventional measuring systems  
31  
in a more physiological and unmodified manner.

#### The Effects of Age and Blood Pressure

##### On Recorded Peripheral Blood Pulse Volumes

Characteristic pulse contour changes have been identified with progressive  
aging as well as those variations associated with early forms of peripheral  
32  
vascular disease and hypertension. Comparisons have been made between  
electrical and mechanical methods for measuring blood flow in the calf  
segments of healthy subjects in different age groups. (Fig. 16). The results  
of the impedance system using the end systolic slope method for correction  
of venous runoff are acceptable although the range of values between the  
electrical and mechanical methods is variable. It is difficult to ascertain  
which method should be chosen as a standard reference. I believe it is  
important to keep in mind that pilots age and develop peripheral vascular

disease as well as other segments of the population (Fig. 17). In this regard, it is also imperative to assess the peripheral vascular system of cigarette smokers between the ages of 35 and 45 as a means of evaluating early vascular dynamics heralding the onset of more serious vascular complications.

#### Measurements of Kidney Area Blood Pulse Volume

One of the more recent applications of impedance plethysmography has been directed toward identifying variations in renal blood flow related to renal artery stenosis.

An impedance renogram is a record of changes in electrical resistance to high frequency signals which are introduced to electrodes placed on the skin over the renal areas. Variations in the conduction of the signals through these regions are directly related to the cardiac cycle and to the volume of blood distributed to the renal areas during systole. Because the kidneys are highly perfused with blood when compared with the perirenal areas, severe unilateral renal artery stenosis is detected by diminished conduction of the signal and consequential reduction in the recorded amplitude of pulsations over the affected side (Fig. 18).  
33, 34

Typical records from a normotensive individual may be observed and renal artery stenosis is associated with marked reduction (greater than 50%) in amplitude of the pulsations over the affected kidney. (Fig. 19).

In this particular case, the impedance findings were correlated with an aortogram and the renal artery stenosis identified.

### Vascular Silhouette Studies

Because of the applicability of impedance plethysmography to many areas of the body, a new approach for evaluation of the regional vascular system has involved construction of silhouettes based upon the amplitudes of pulsations recorded from many areas of the body. (Fig. 20).<sup>35</sup>

In the healthy subject, the silhouette is characterized by symmetry, unlike the patient with peripheral vascular disease (Fig. 21) often associated with excessive vasoconstriction in specific areas, or severe vascular occlusive lesions in which case the silhouette contour identifies the area of difficulty (Fig. 22 - 23).

I believe we need to emphasize the importance of the impedance plethysmograph, not in an isolated sense measuring one particular area, but rather as a total body volume recorder, perhaps using multisensors in order to sample in a prescribed manner from those areas which are particularly critical for the type of test procedure and environmental conditions under which the subjects are being investigated.

I would not want to leave this discussion without bringing to focus other organisms which may provide useful data under a variety of environmental conditions (Fig. 24).<sup>27</sup>

In a rather panoramic fashion, I have provided you with an outline of some practical clinical applications of impedance plethysmography in areas which I believe deserve further evaluation in terms of the requirements in aerospace medicine. The impedance plethysmograph is not without limitations, particularly in terms of movement artifact, as I believe we all can attest; however, there are many instances in clinical medicine, and I am certain in aerospace medicine, in which movement of the subject is of secondary importance in terms of the measurements which we wish to evaluate, particularly when one considers that in many measurements, we do not require continual measurements but rather samples of magnitude and rate of response in reference to some control level. Applicability of the impedance plethysmograph to subjects in the dynamic environment is an engineering design problem, and I would not suggest that this requirement detracts from the usefulness of the impedance sensing devices, providing we apply a common sense approach and can identify the physiological parameters of greatest importance. At least, that is as I see it.

In summary, I would encourage investigative efforts in the direction of the use of impedance plethysmography as a measurement of stroke volume and cardiac dynamics. The system is useful as a measurement of peripheral blood pulse volume in the controlled laboratory environment and during flight. Measurements of calf blood pulse volume and blood



flow are to be preferred because they are not attended by the same degree of sympathetic activity characteristic of fingers and toes. The complexity of the cardio-pulmonary system serves to encourage development of a multisensor volume detector as a measurement of segmental changes during environmental exposure and, hopefully, one day we may develop a wireless-whole body plethysmograph with selective segmental capabilities. Thomas Jefferson once reflected on the news read in our daily papers -- he said he wished the material could be categorized into probabilities, possibilities, fact, and lies. I have been conservative and I don't believe I have told you any lies, and hope that I have stimulated thoughts that will create additional success from the potential possibilities.

TABLE 1

COMPARISON OF CARDIAC OUTPUT DETERMINATIONS BY DYE DILUTION STUDIES AND IMPEDANCE  
STUDIES DURING CONTROL PERIODS\*

Subject	Age (yrs)	Height (cm)	Weight (kg.)	Chest Circumference (cm)	Cardiogreen Cardiac Output L/Min.		Impedance Cardiac Output (Pulmonary) L/Min.		
AT	24	160	61	83	(1)1.25 (2) 1.6	(1) 1.11 (2) 1.05			
SE	32	173	68	93	(1)1.77 (2) 2.65	(1) 2.8 (2) 2.2			
HE	21	175	75	93	(1)7.8 (2) 7.0	(1) 5.4 (2) 3.7			
BO	22	175	75	94	(1)6.2 (2) 6.9	(1) 6.1 (2) 7.1			
FE	31	179	70	97	(1)1.45 (2) 1.17	(1) 2.4 (2) 2.1			
AM	25	175	75	101	(1)4.4 (2) 5.5	(1) 4.7 (2) 4.6			
CR	28	179	80	109	(1)4.6 (2) 4.5	(1) 3.7 (2) 4.4			
					Mean	3.9	4.2	4.0	3.7
					Std. Dev.	±2.05	±2.44	±1.6	±1.79

\*Subjects horizontal in supine position

TABLE II

COMPARISON OF CARDIAC OUTPUT DETERMINATIONS BY THE FICK PROCEDURE AND  
FOUR ELECTRODE IMPEDANCE STUDIES DURING CONTROL PERIODS (CANINE SUBJECTS)

	<u>Fick</u> <u>Cardiac Output</u>	<u>Impedance</u> <u>Calculated</u> <u>Cardiac Output</u>	<u>%</u> <u>Diff.</u>
1.	3.090 3.750	3.100 3.200	3.2 14.6
2.	1.23 1.064	1.100 1.100	10.6 3.6
3.	2.710 2.778	2.828 2.744	4.2 1.3
4.	2.930 2.984	2.731 2.395	6.8 2.1
5.	3.090 3.750	3.500 3.600	1.2 4.0
6.	.840 1.11	.810 .910	3.6 1.8
7.	2.51 2.60	2.200 2.300	1.24 1.2
8.	2.98 2.78	2.630 2.730	11.7 18.0

TABLE III

COMPARISON OF PNEUMOCARDIOGRAPH RECORDS WITH FOUR ELECTRODE IMPEDANCE PLETHYSMOGRAPH  
 MEASUREMENTS OF THORACIC BLOOD PULSE VOLUME IN A HEALTHY INDIVIDUAL WITH BREATH  
 HELD AT END EXPIRATORY POSITION

<u>Name of Wave</u>	<u>Direction</u>	<u>Phase</u>	<u>ECG</u>	<u>Heart Sounds</u>	<u>Impedance Pulse</u>
a atrial	Neg	Pre-systolic	Between P and Q	atrial vibrations	During diastole
P' Papillary Muscle Contraction	Pos	Closure Tricuspid valve	R-S	first sound	Beginning Systole
V' Ventricular Wave	Neg	Early systole	Between S-T	end first sound	mid systolic upstroke
P'' Peripheral Pulse	Pos	mid-systole	Beginning of T	Between 1st & 2nd	peak of thoracic pulse
V'' Ventricular Wave	Neg	Late Systole	During T	Before 2nd sound	Incisura

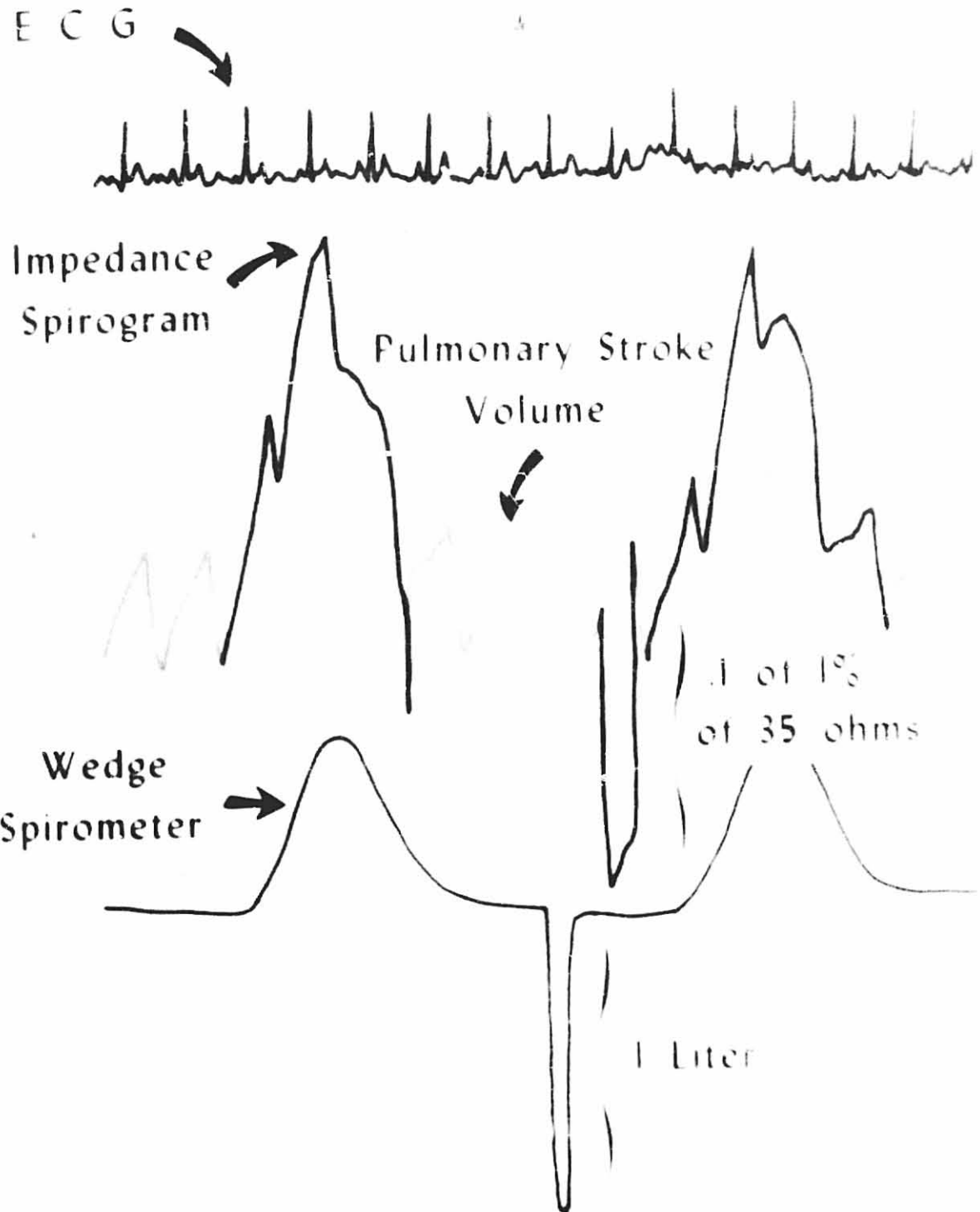
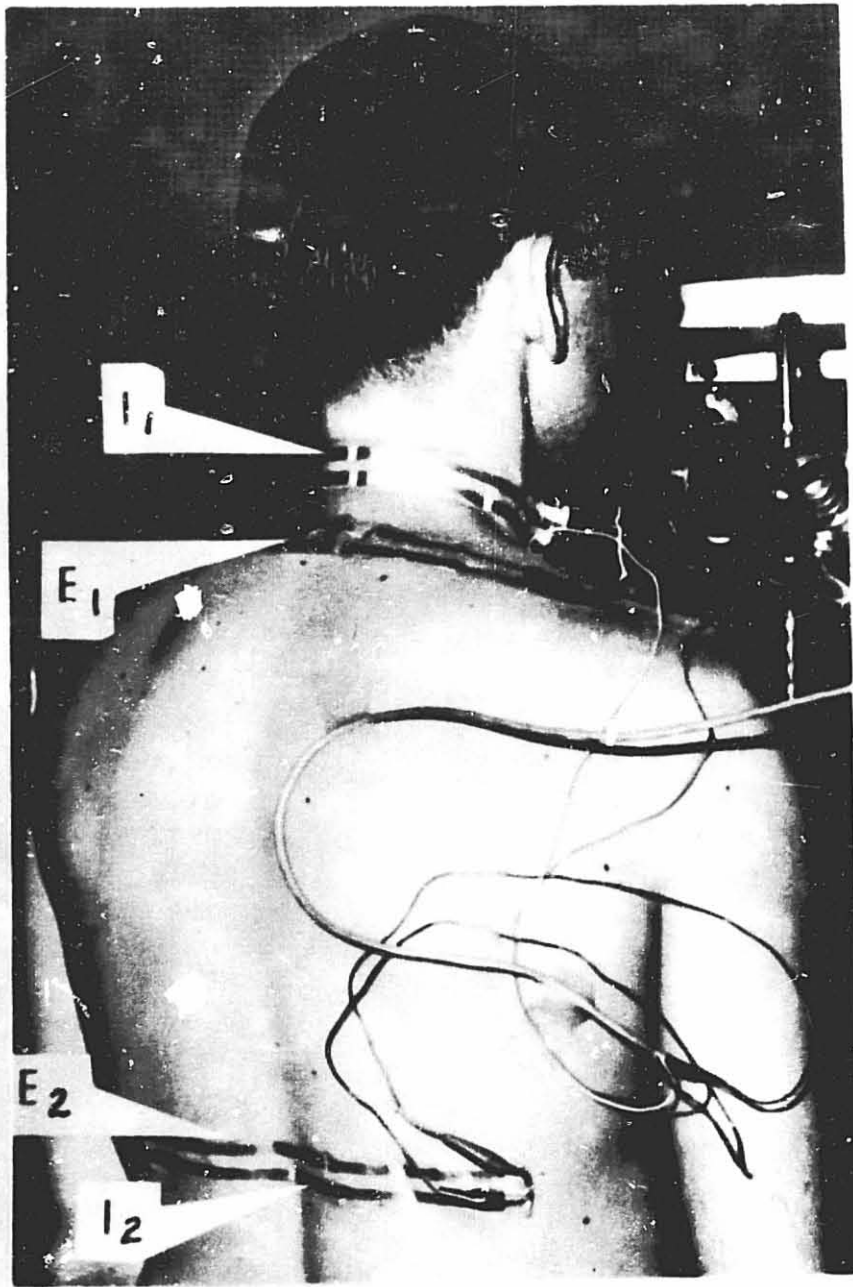
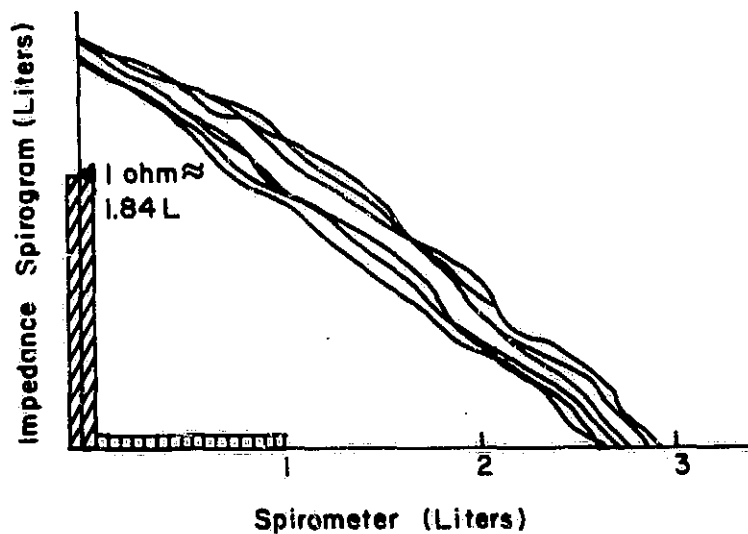

Fig 1 Aluminum strip electrodes are fastened to the neck, the level of the 7th cervical vertebra and the level of the 12th thoracic vertebra. Current is introduced into the outer set of electrodes ( $I_1$ ,  $I_2$ ) and variation in conduction of the current through the thorax is detected between ( $E_1$ ,  $E_2$ ). This system has been useful for recording ventilation and changes in pulmonary blood pulse volume.

Simultaneous X-Y Recording of Pulmonary Air Volumes  
Measured by Conventional Spirometry and Impedance Spirogram



2/II/63 OG WM

Fig 2 Simultaneous X-Y recording of pulmonary air volumes measured by conventional spirometry and impedance spirogram.

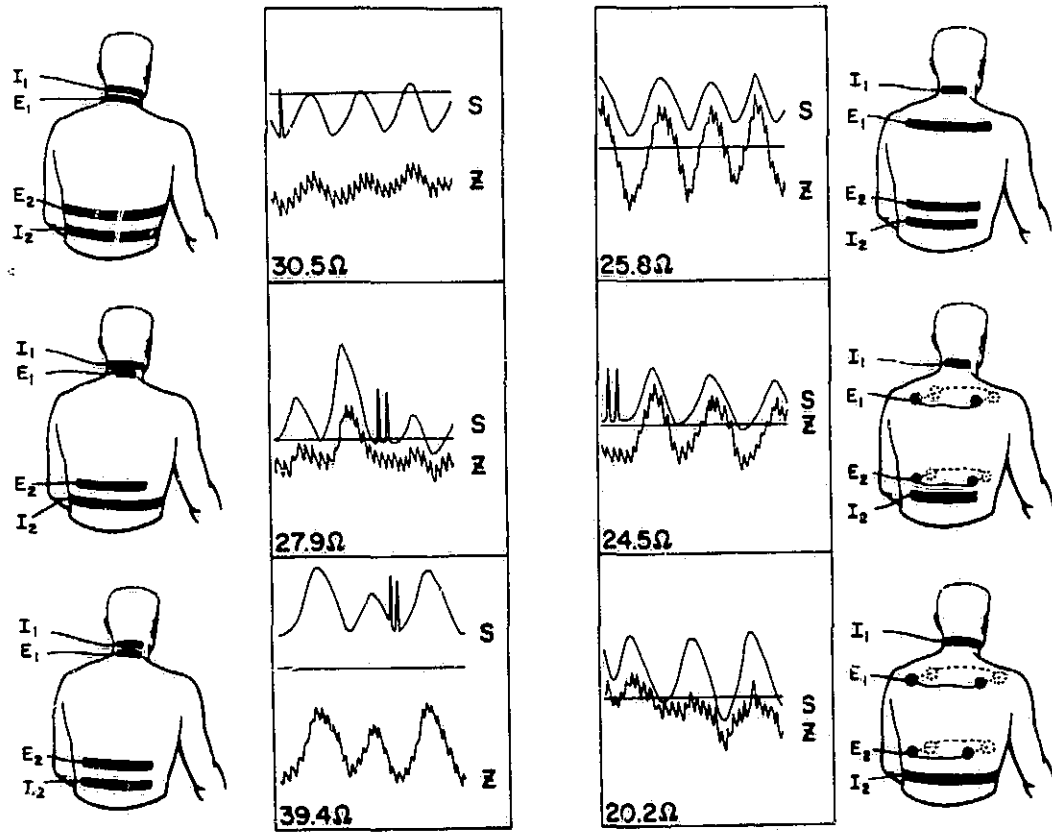

Detecting Length  $E_1 - E_2$   
Spirometer Standard I.IIL

Fig 3 Comparison of electrode placement for recording ventilation and pulmonary blood pulse volume changes.



Fig 4 Comparison of diaphragm position relative to lead markers positioned at the level of the 12th thoracic vertebra during maximal inspiration (left), end expiration (middle), and maximal expiration (right).



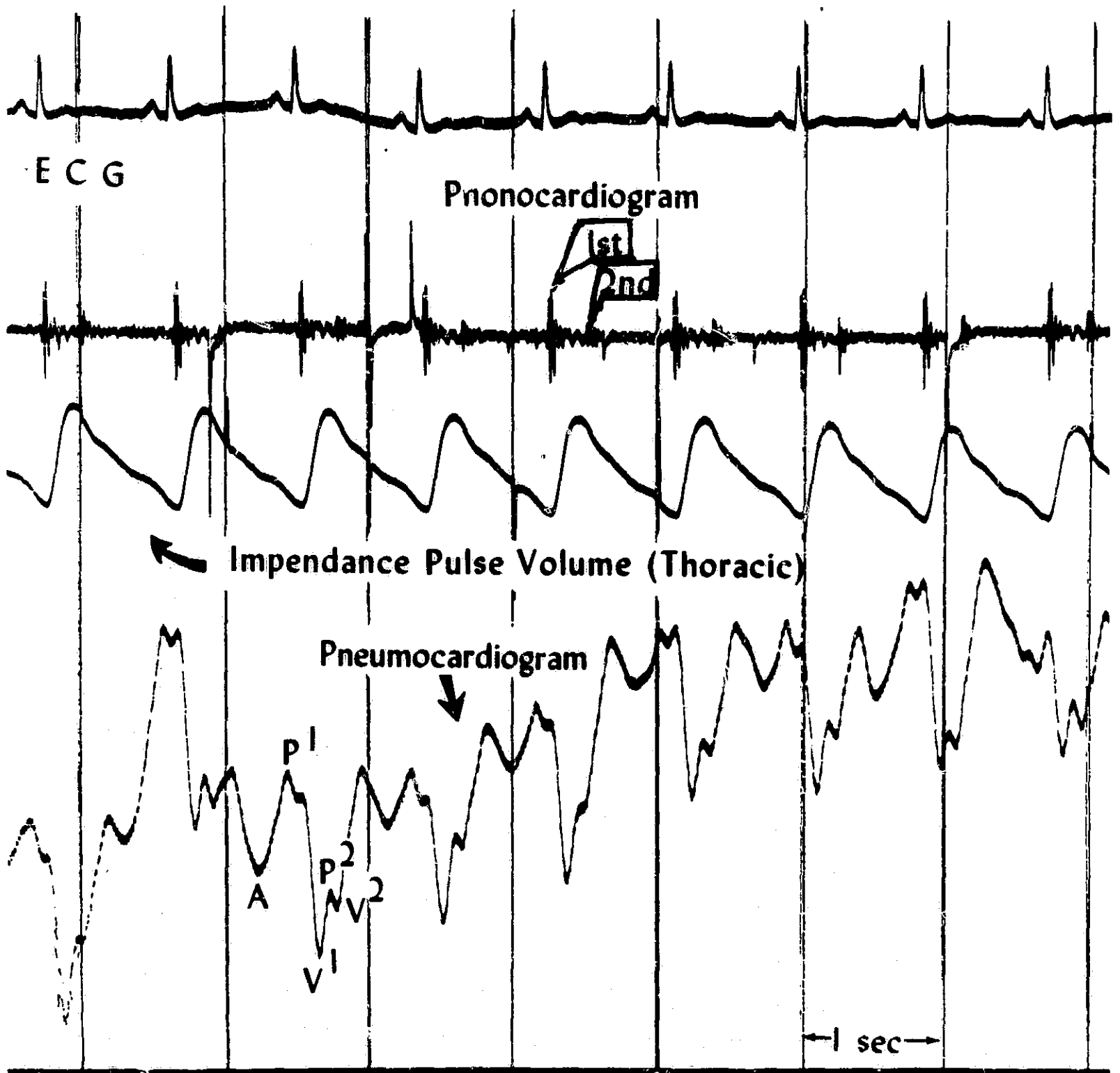

Fig 5 Simultaneous recording of electrocardiogram, phonocardiogram, thoracic blood pulse volume and pneumocardiogram during held respiration in a healthy adult subject.

# DYNAMICS OF IMPEDANCE PLETHYSMOGRAPHY

## Recording

### Pulse Volume Recording

Biological Segment

(Ionic Conductor)

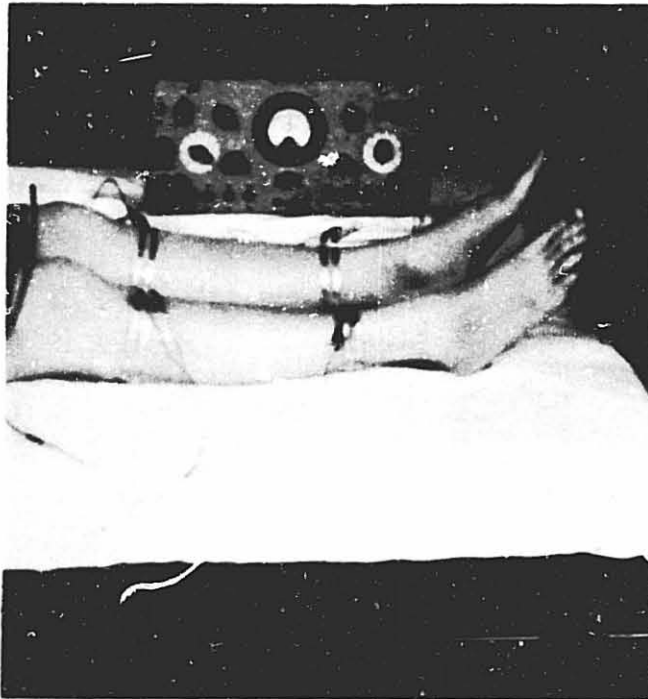

## Calculations

### Calculated Blood Pulse Volume and Blood Flow

Segment between  $E_1 - E_2 = R_0$

New Blood Volume (Systole) =  $R_b$

Change in Resistance =  $\Delta R$

$$\text{Calculated Blood Pulse Volume } (\Delta V) = \frac{\Delta R}{R_0} \times \rho \frac{L^2}{R_0}$$

Calculated Minute Volume ( $\Delta V/\text{min}$ ) =  $\Delta V \times \text{Heart Rate}$

Calculated Perfusion/Tissue Volume =  $\frac{\Delta V/\text{min}}{\text{Segment volume}} \times 100$

( $\Delta V/\text{min}/100 \text{ ml}$   
Tissue)

Segment volume

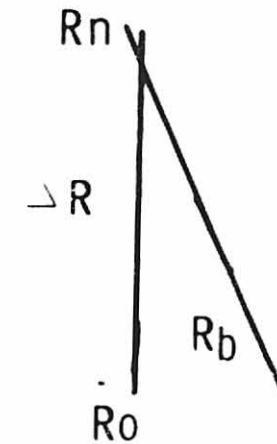
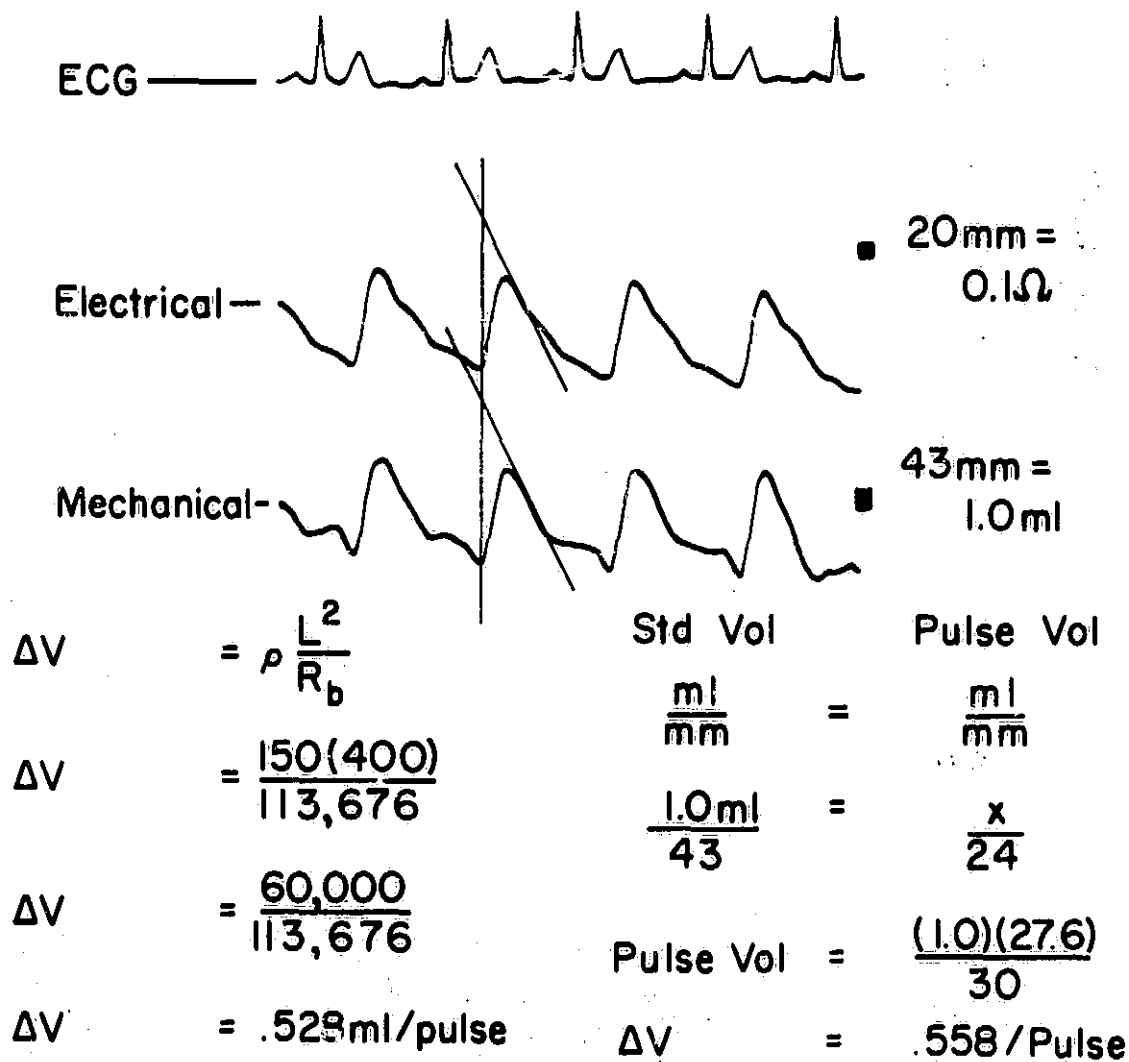

Fig 6 Dynamics of Impedance Plethysmography

Leg Segment (20cm)



$\Delta V/min/100ml = 2.54 ml/min/100ml$  Tissue       $\Delta V/min/100ml = 2.69 ml/min/100ml$  Tissue

Fig 7 Comparison of calculated blood pulse volume and blood flow in calf segments simultaneously with a water-filled plethysmograph chamber (mechanical) and impedance plethysmography (electrical). The end systolic slope method was used to correct for venous runoff in both systems.

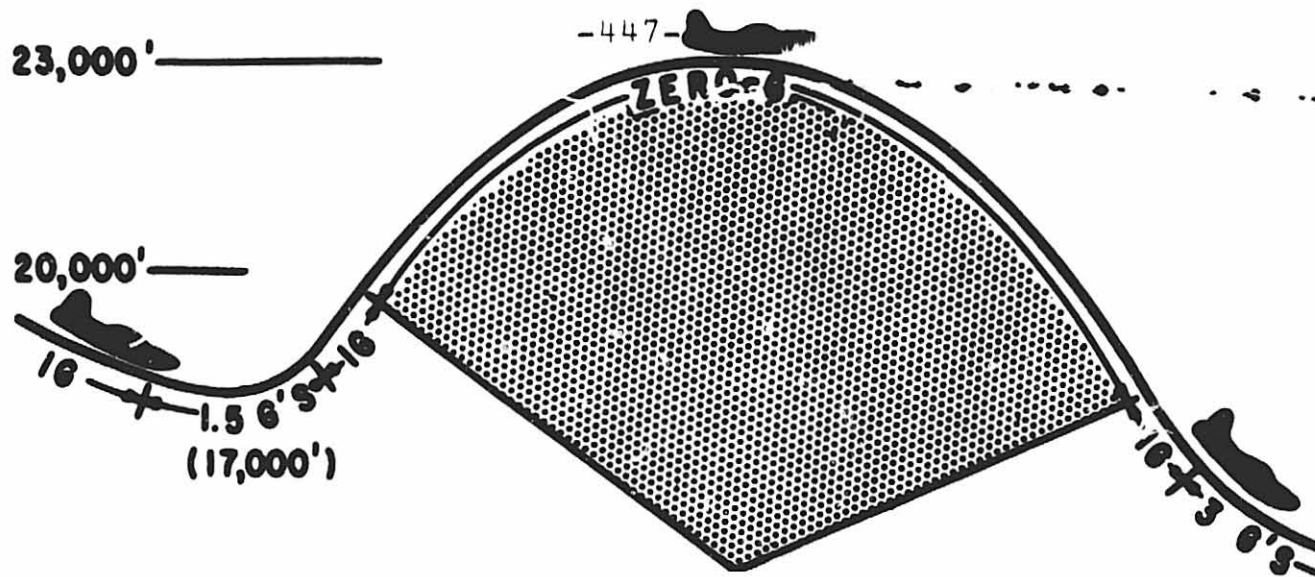

## 17 SECONDS (IN TIME)

Average Changes for Ten Maneuvers  
at Designated (G) Levels

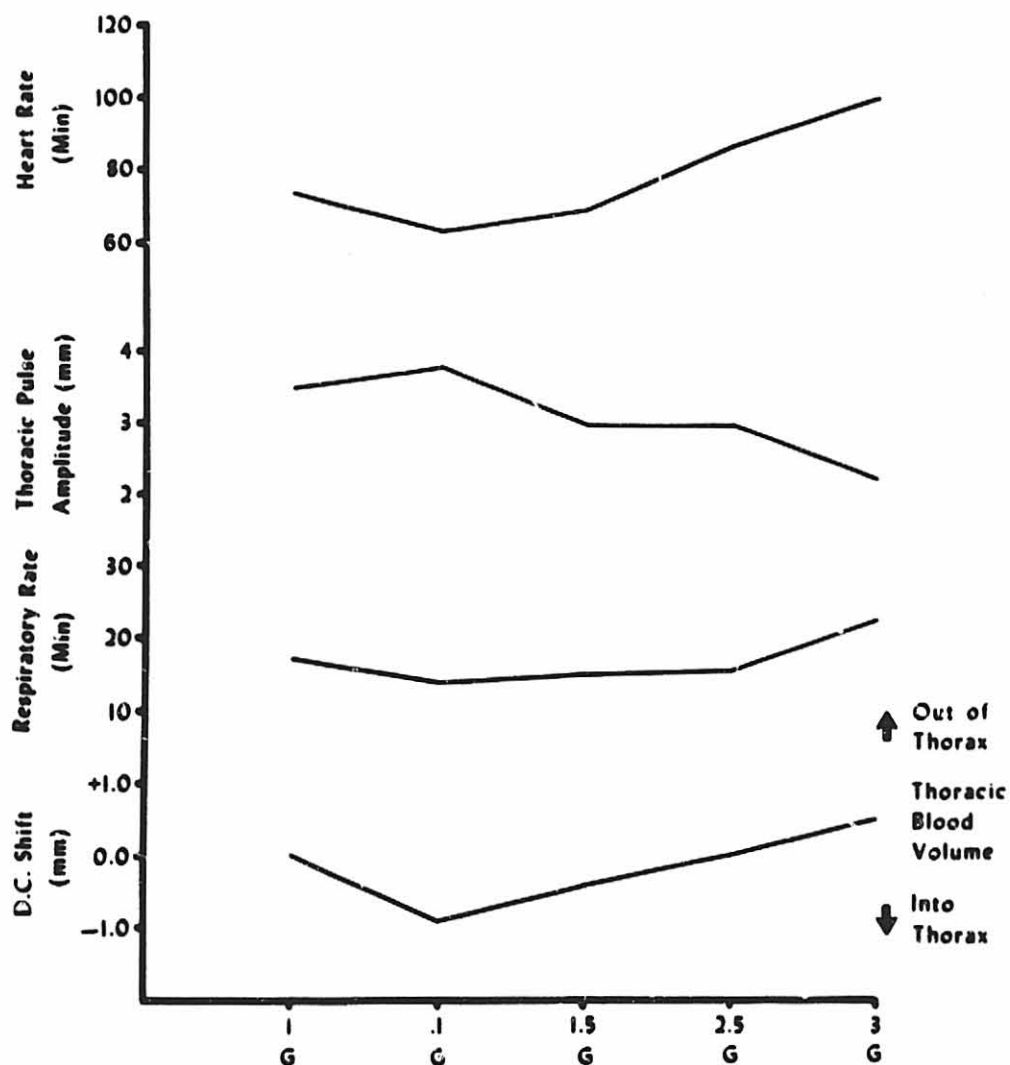

Fig 8 Measurements of heart rate, thoracic pulse amplitude, respiratory rate and changes in electrical resistance of the thorax (D.C. shift) on a pilot during parabolic flight maneuvers. A self balancing four electrode impedance plethysmograph with electrodes placed on the thorax (Fig. 1) was used to obtain these measurements. (28)

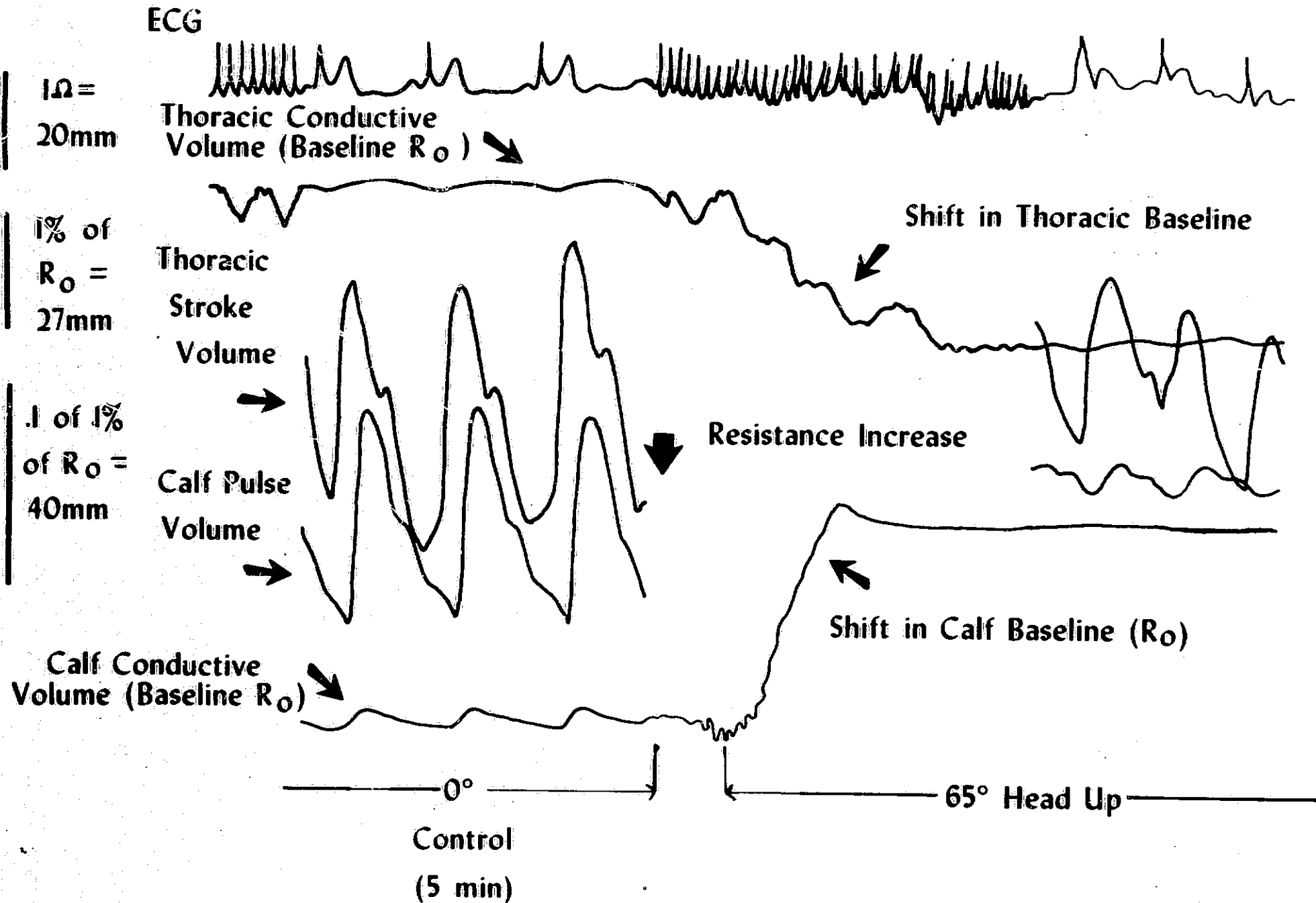

Fig 9 Immediate effects on a healthy subject of 65° head-up attitude on the electrocardiogram and thoracic blood pulse volume. Calf blood pulse volume and changes in electrical conductivity of the thorax and calf segment related to shifts in blood volume. Increases and decreases in resistance are associated with decreased and increased segmental blood volume respectively.

# COMPARATIVE EFFECTS OF TILT TABLE TEST IN HEALTHY SUBJECTS AND PATIENTS WITH DIABETES MELLITUS

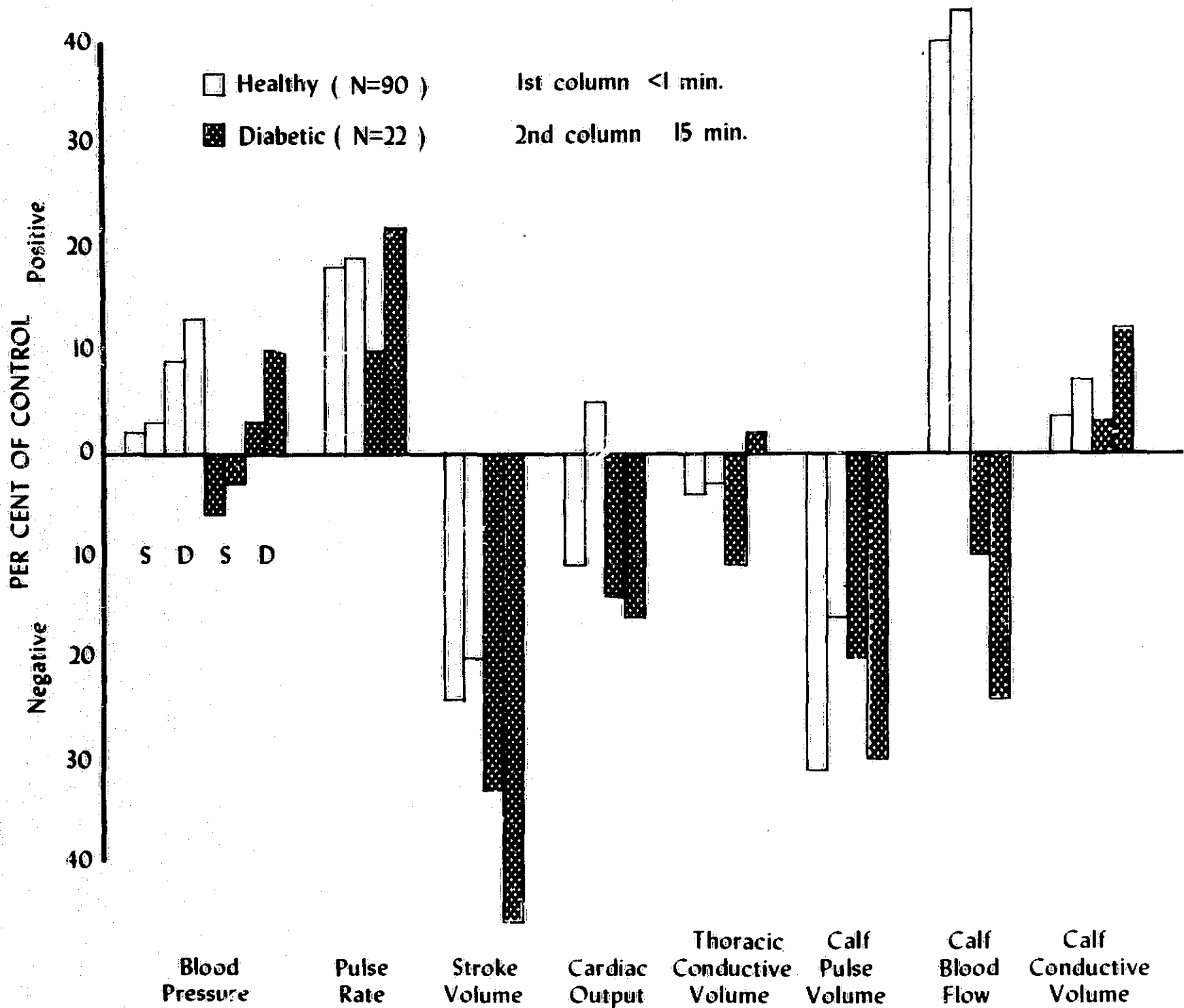

Fig 10 Comparative effects of tilt table test in healthy subjects and patients with diabetes mellitus.

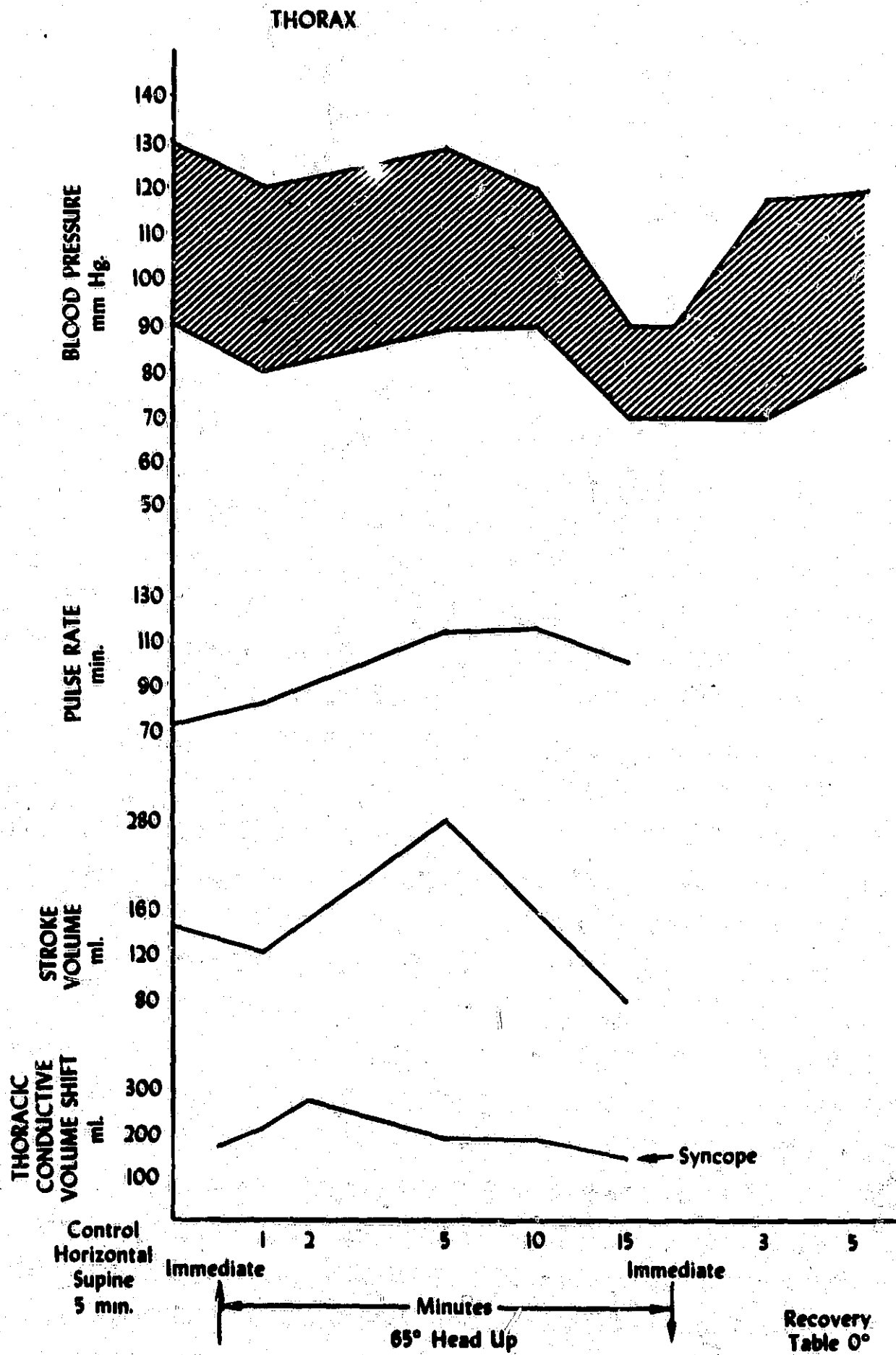

Fig 11A Measurements of central and peripheral vascular effects of 65° head up tilt table stress before and during a syncopal episode.

CALF

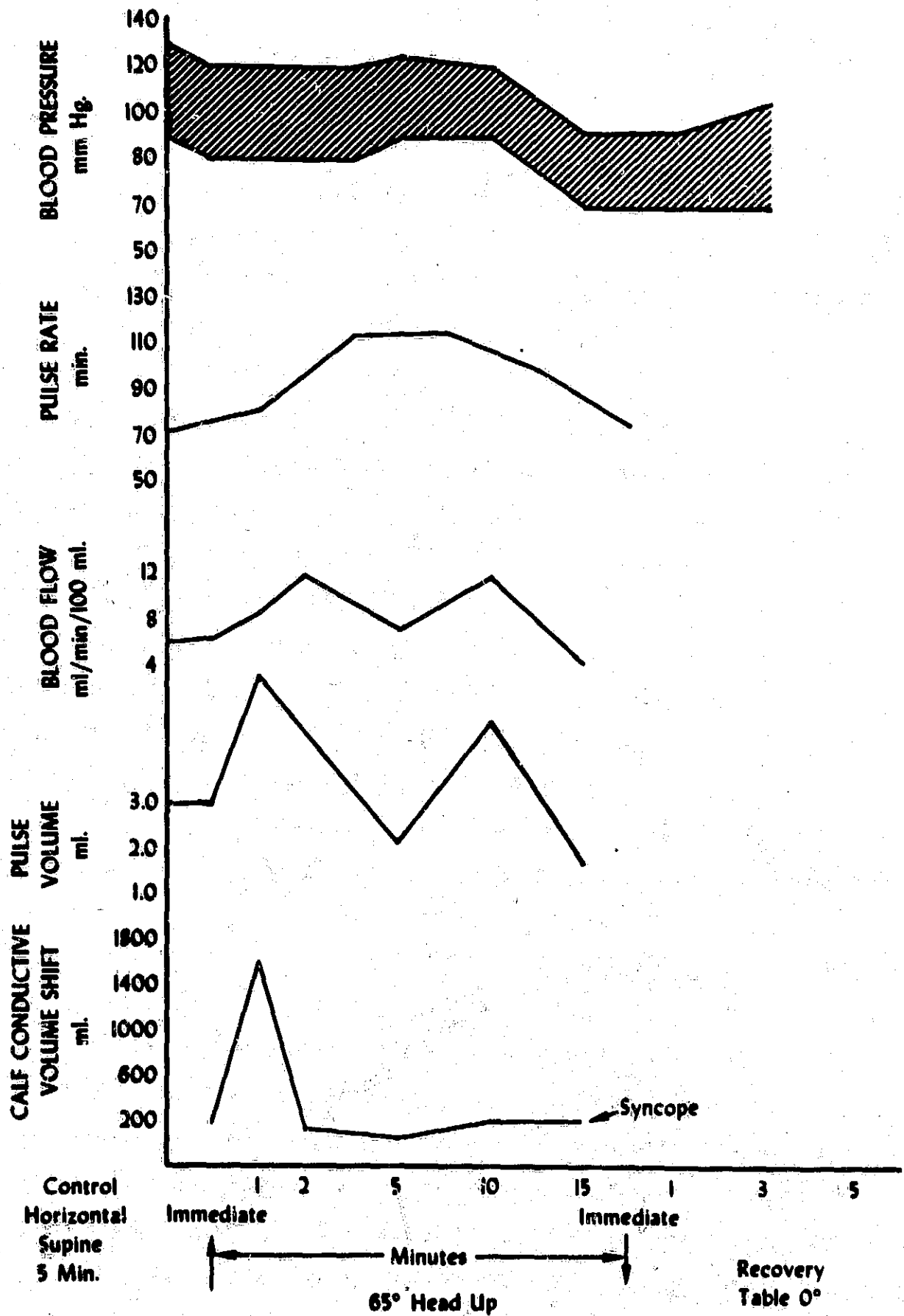
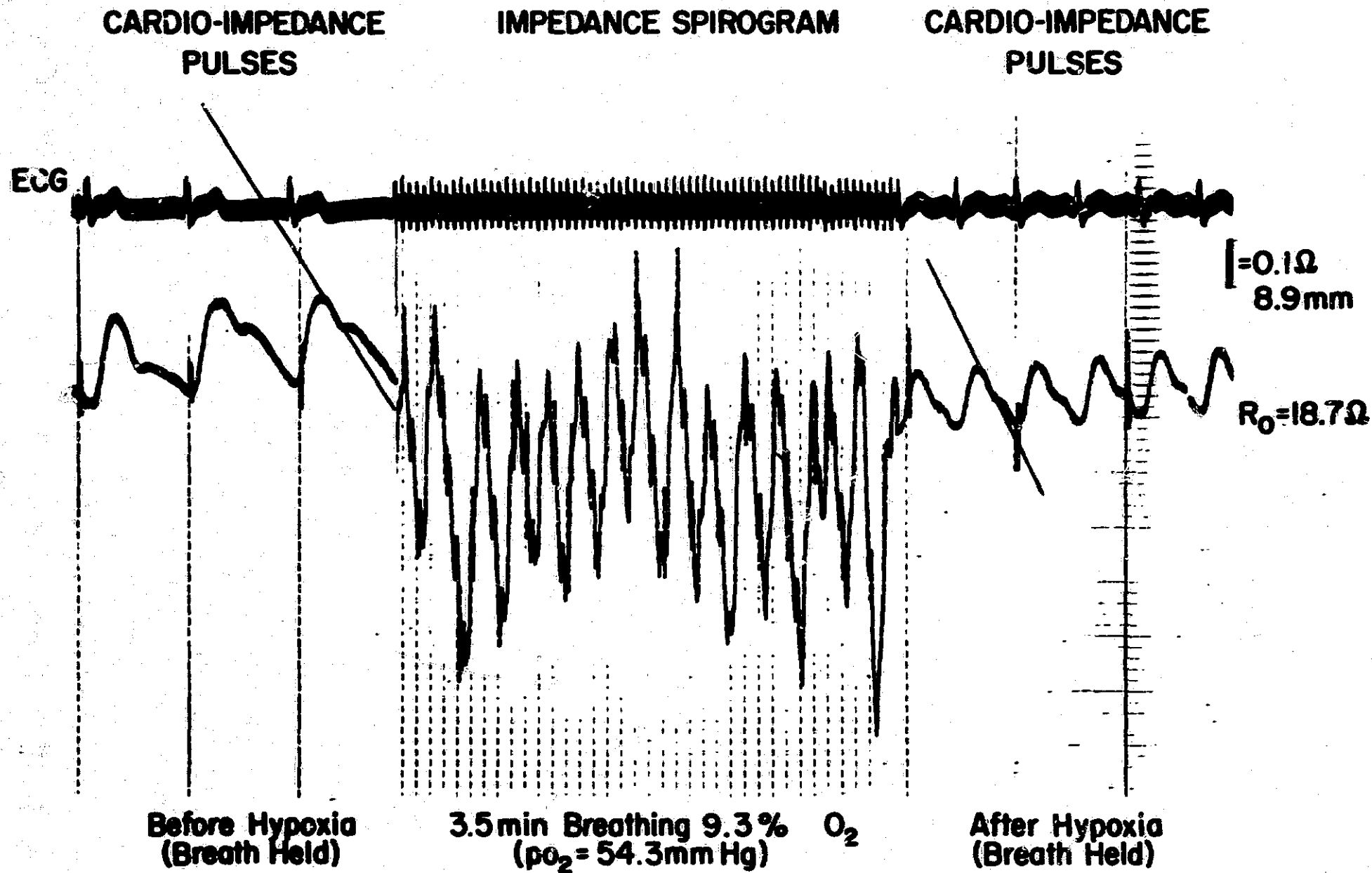

Fig 11B Measurements of central and peripheral vascular effects of 65° head up tilt table stress before and during a syncopal episode.





-452-

4/12/62

Fig 12 Effects of breathing a reduced oxygen mixture (hypoxia) on thoracic blood pulse volume changes. Note the reduced amplitude of pulsations following the exposure to hypoxia.

LEG SEGMENT EXPOSED TO INCREASED TEMPERATURE

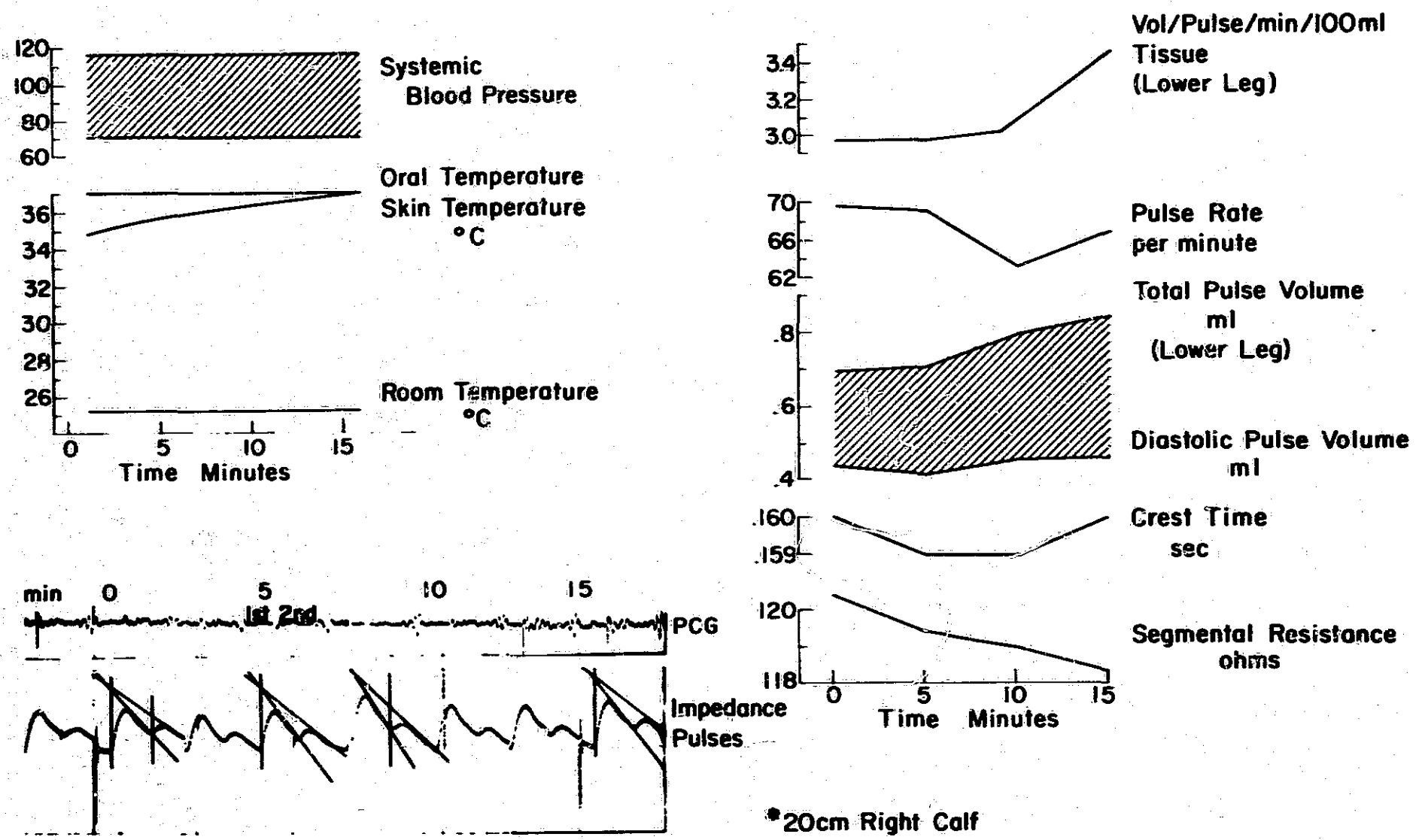

-454-

Fig 13 During exposure to increased temperature, the segmental resistance of calf segments decreases and the crest time increases. There is an increase in systolic and diastolic pulse components.

LEG SEGMENT EXPOSED TO REDUCED TEMPERATURE

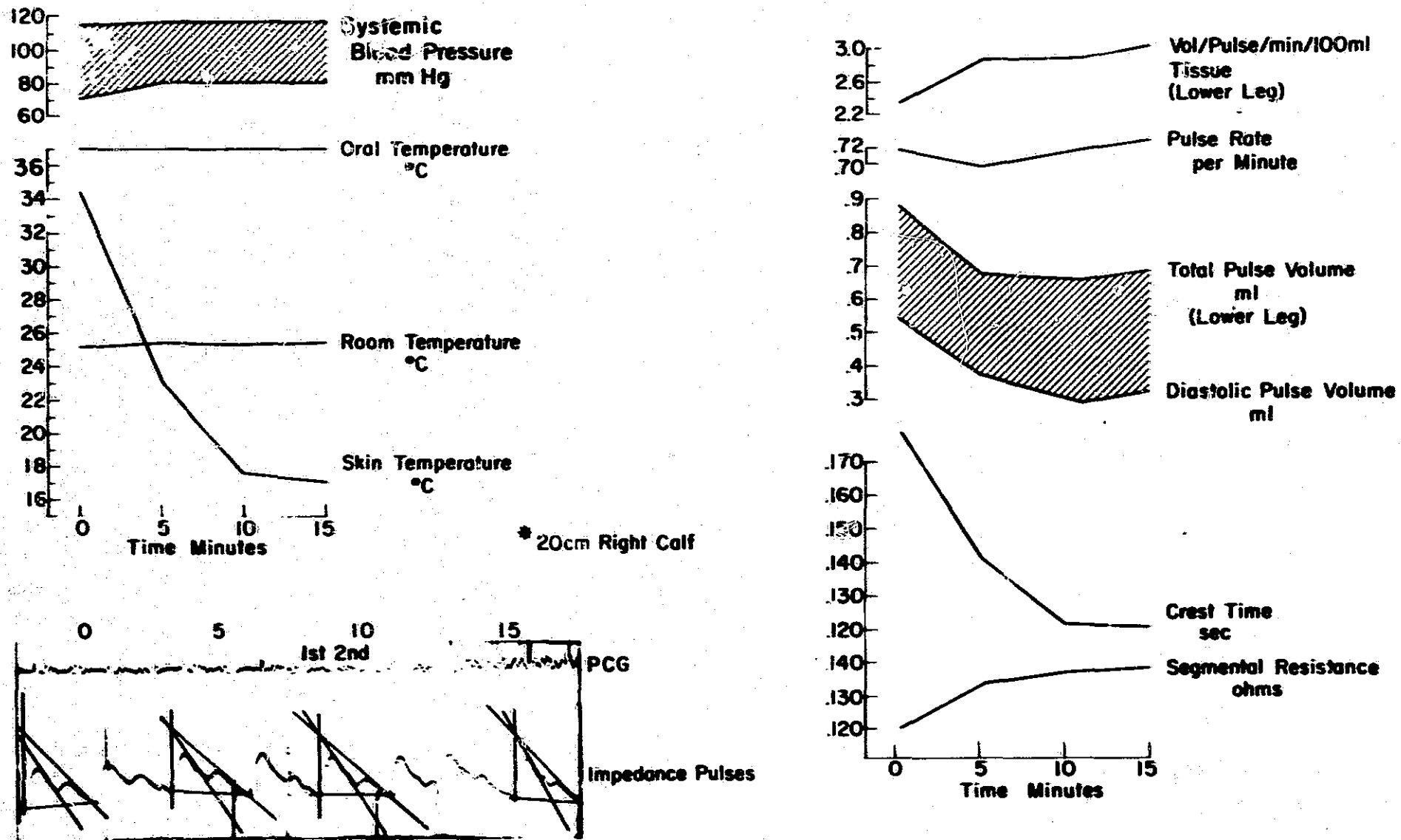

-454-

Fig 14 During exposure to decreased temperature, the segmental resistance increases, crest time decreases, and volume per pulse decreases. There is a reduction in systolic and diastolic pulse components. The diastolic component appears to be affected more than the systolic.

### CHANGE IN BODY POSITION - EFFECT ON LOWER LEG SEGMENT\*

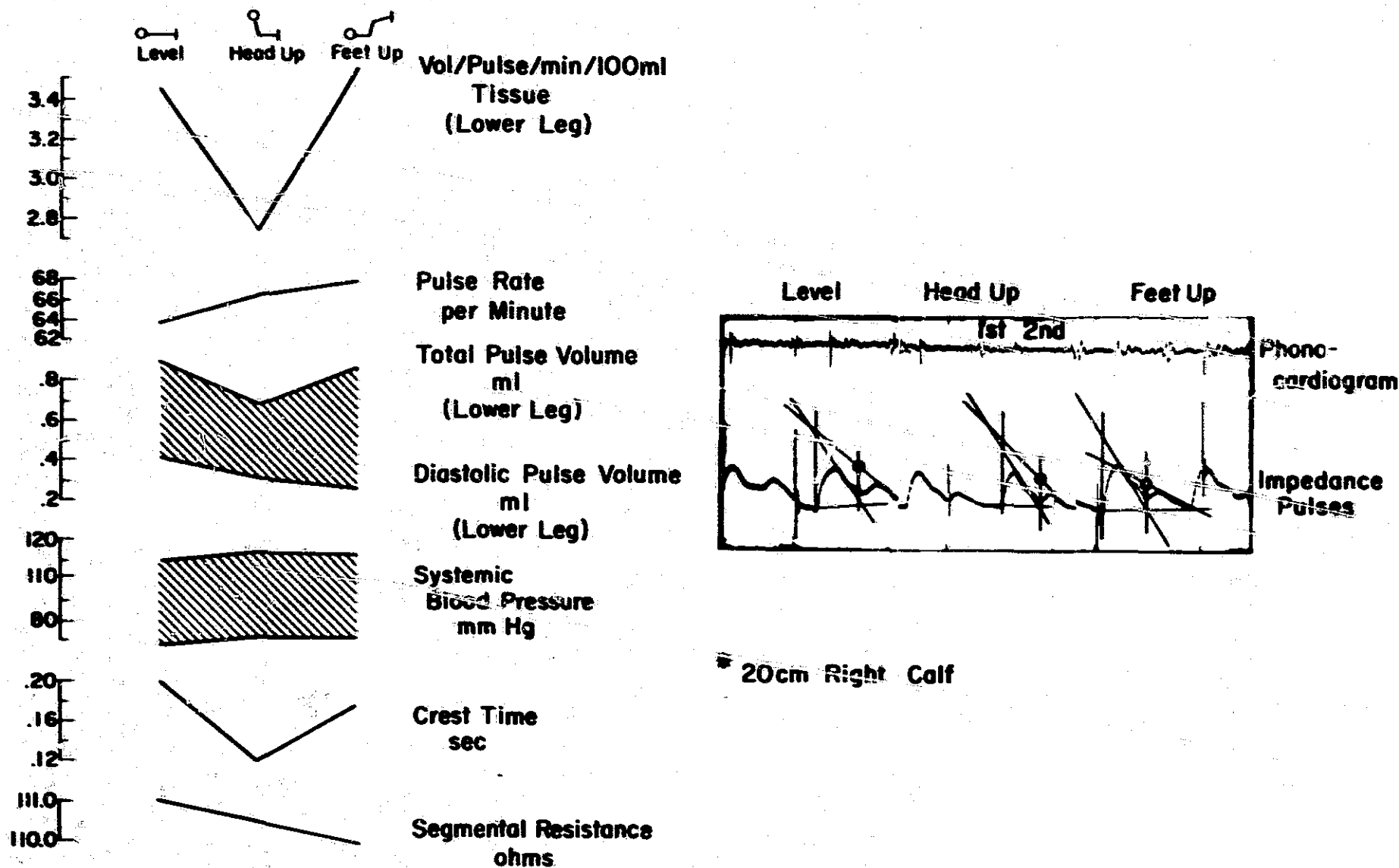

Fig 15 When the calf segment is elevated, the diastolic component of the peripheral pulse becomes less apparent as the result of venous runoff. During dependency, the total amplitude and calculated volume decreases; however, the diastolic component is augmented. Simultaneous changes in segmental resistance and crest time may be observed.

<u>SUBJECT NO.</u>	<u>AGE yrs.</u>	<u>NO. OF STUDIES</u>	<u>LEG VOLUME ml.</u>	<u>BLOOD PRESSURE mm. Hg</u>	<u>ELECTRICAL VOL./MIN. 100 ml. tissue</u>	<u>MECHANICAL VOL./MIN. 100 ml. tissue</u>	<u>% DIFF. % OF MECHANICAL</u>
1 <sub>B</sub>	38	10	1640	146/86	1.798 <sup>±</sup> .513	1.613 <sup>±</sup> .529	-11.5%
2 <sub>I</sub>	40	8	1558	105/74	2.086 <sup>±</sup> .572	2.156 <sup>±</sup> .646	+ 3.2%
3 <sub>Sh</sub>	22	12	1460	124/82	1.009 <sup>±</sup> .243	1.299 <sup>±</sup> .086	+22.3%
4 <sub>M</sub>	37	10	1320	118/83	1.899 <sup>±</sup> .442	2.171 <sup>±</sup> .412	+12.5%
5 <sub>SP</sub>	21	14	1261	123/85	1.105 <sup>±</sup> .132	1.233 <sup>±</sup> .092	+10.4%
6 <sub>RA</sub>	6	10	470	93/60	4.906 <sup>±</sup> .794	5.101 <sup>±</sup> .863	+ 3.8%
7 <sub>EA</sub>	4	4	321	95/60	2.275 <sup>±</sup> .655	2.867 <sup>±</sup> .151	+20.6%
						Average	12%

Group Correlation  $r = .984$ ;  $p = .001$

Group Mean

Electrical 2.154 ml/min/100 ml

Mechanical 2.490 ml/min/100 ml

<sup>±</sup> = SD

Fig 16 Comparison of electrical impedance plethysmography and mercury strain gauge plethysmography (mechanical) in calf segments of various size. The end systolic slope method was used to correct for venous runoff (Fig. 6-7).

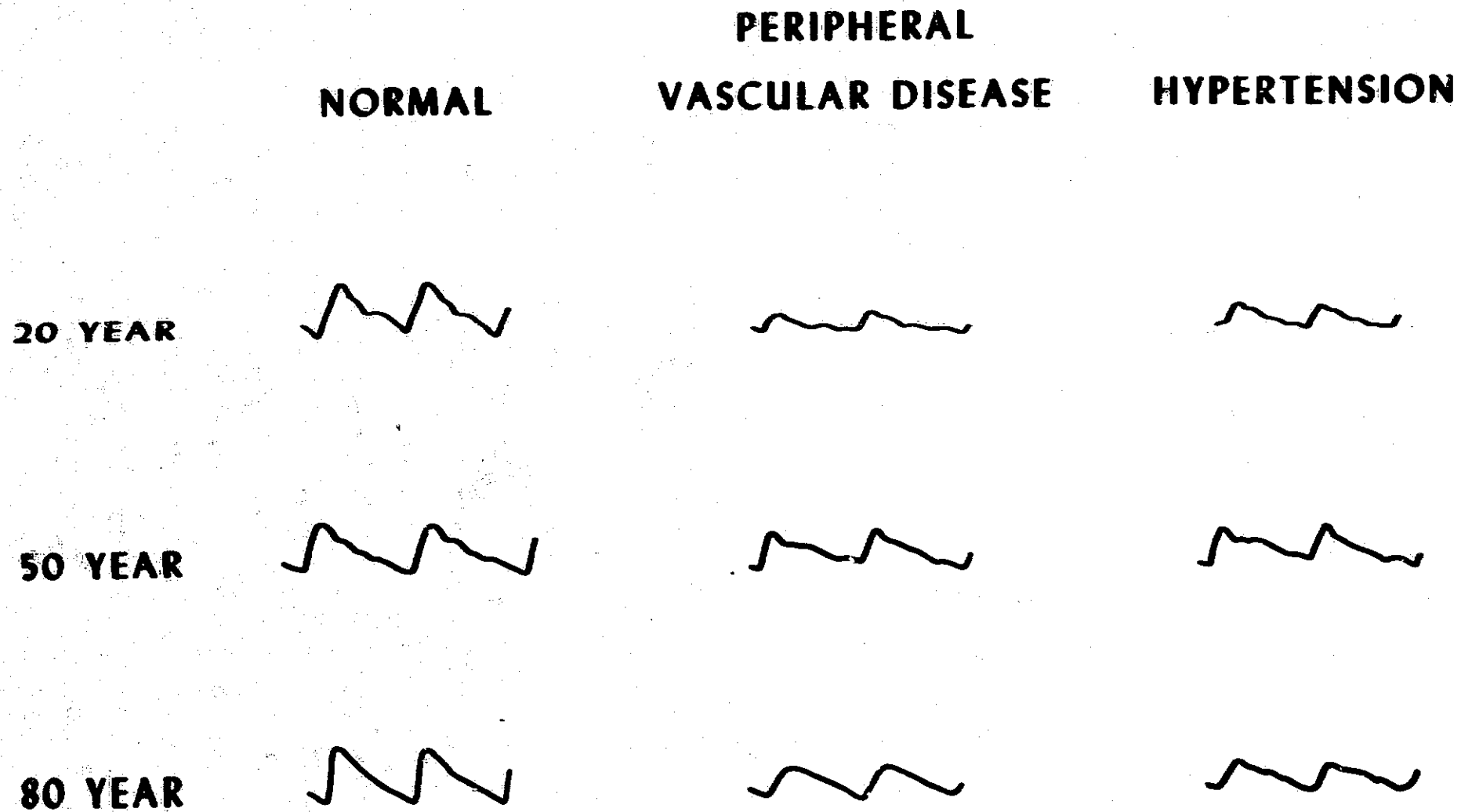

Fig 17 Comparison of pulse curves recorded from calf segments of different age subjects. Peripheral vascular disease is characterized by reduced amplitude, increased crest time and obliteration of the dicrotic notch. Hypertension is characterized by reduced amplitude, moderate increase in crest time and retention of the dicrotic notch.

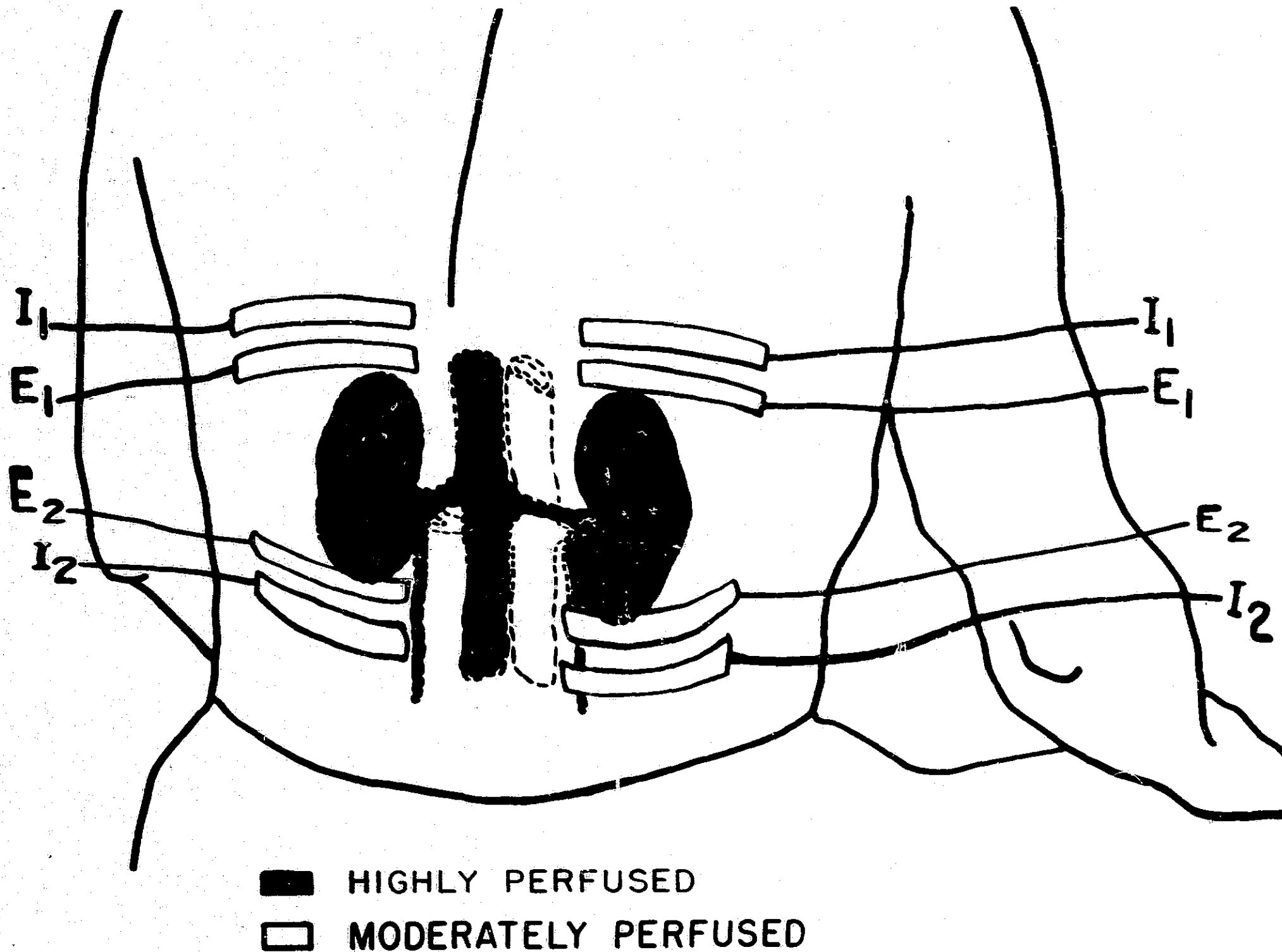

Fig 18 Placement of aluminum strip electrodes on the skin over kidney areas.

# IMPEDANCE RENOGRAM

HEALTHY

RENAL VASCULAR DISEASE

Right Renal Artery Stenosis

Systemic

Blood Pressure 136/82

(mm Hg)

206/110

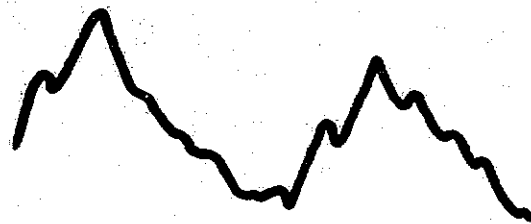

Right Kidney



Left Kidney

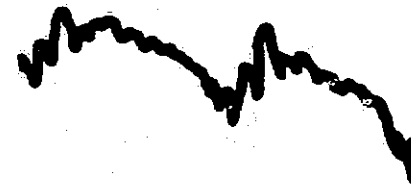

Fig 19 Comparison of impedance renograms in healthy subject and a hypertensive patient with right renal artery stenosis.



SPECIAL  
REGIONS

CEREBRAL

EYE

L VERTEBRAL A

R VERTEBRAL A

L CAROTID

R CAROTID

UPPER  
ABDOMEN

MIDDLE

LOWER

L RENAL

R RENAL

WHOLE  
BODY

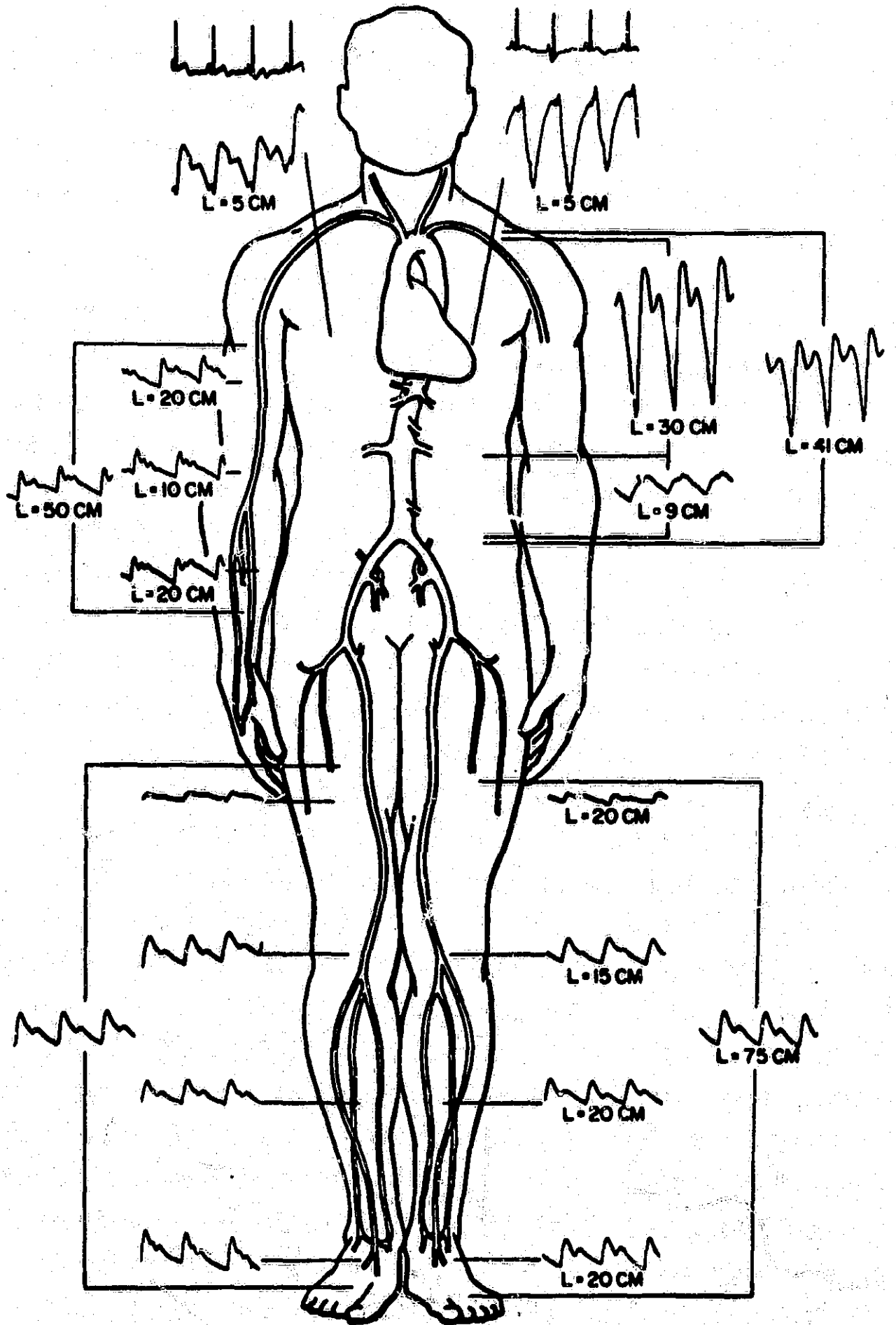

Fig 20 Pulse curves recorded from several regions of the body using a four electrode impedance plethysmograph.

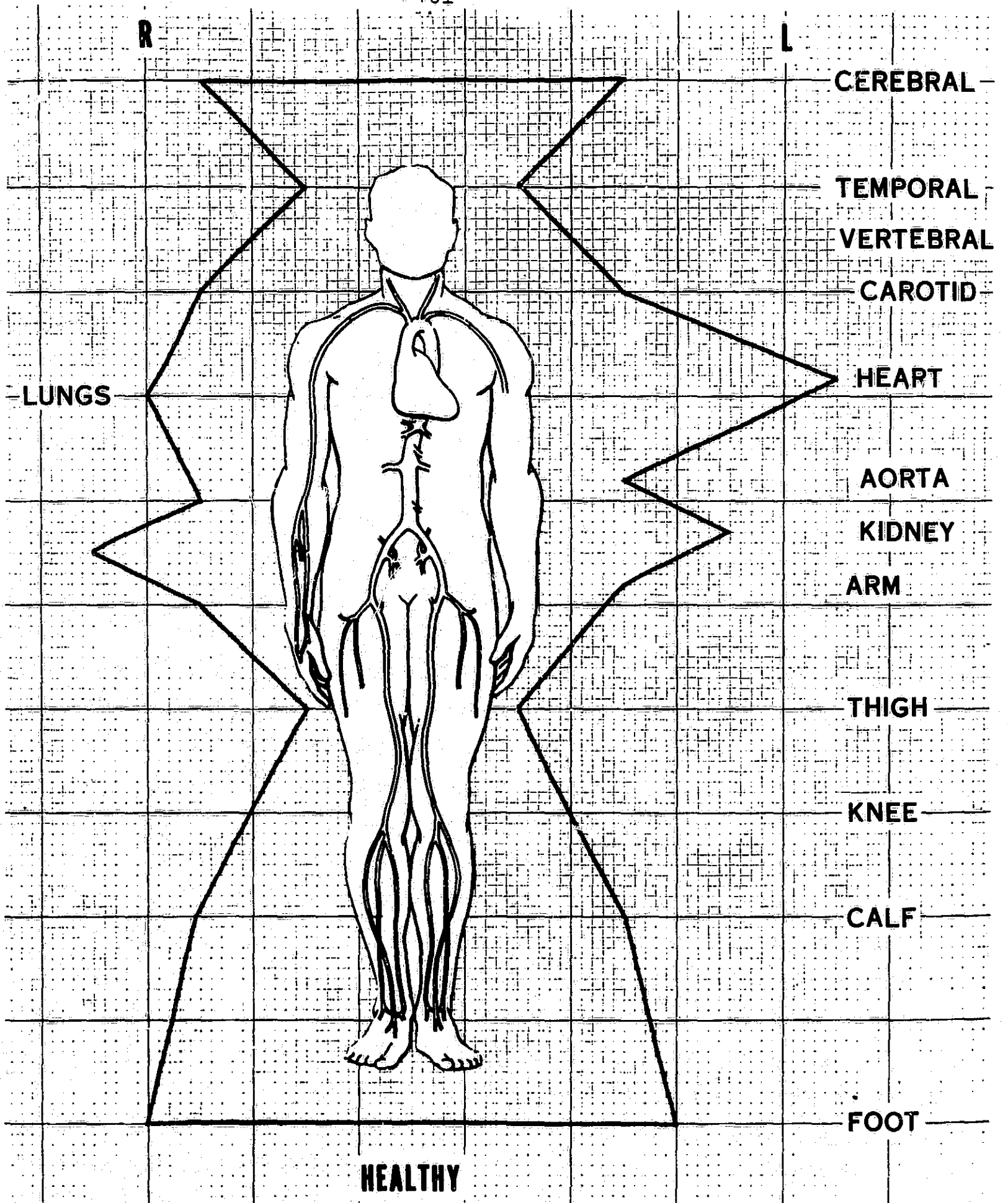

Fig 21 Silhouette constructed from pulse amplitudes recorded from designated areas using the four electrode impedance plethysmograph. The mid-sagittal line was used as a baseline for horizontally plotting pulse amplitudes.

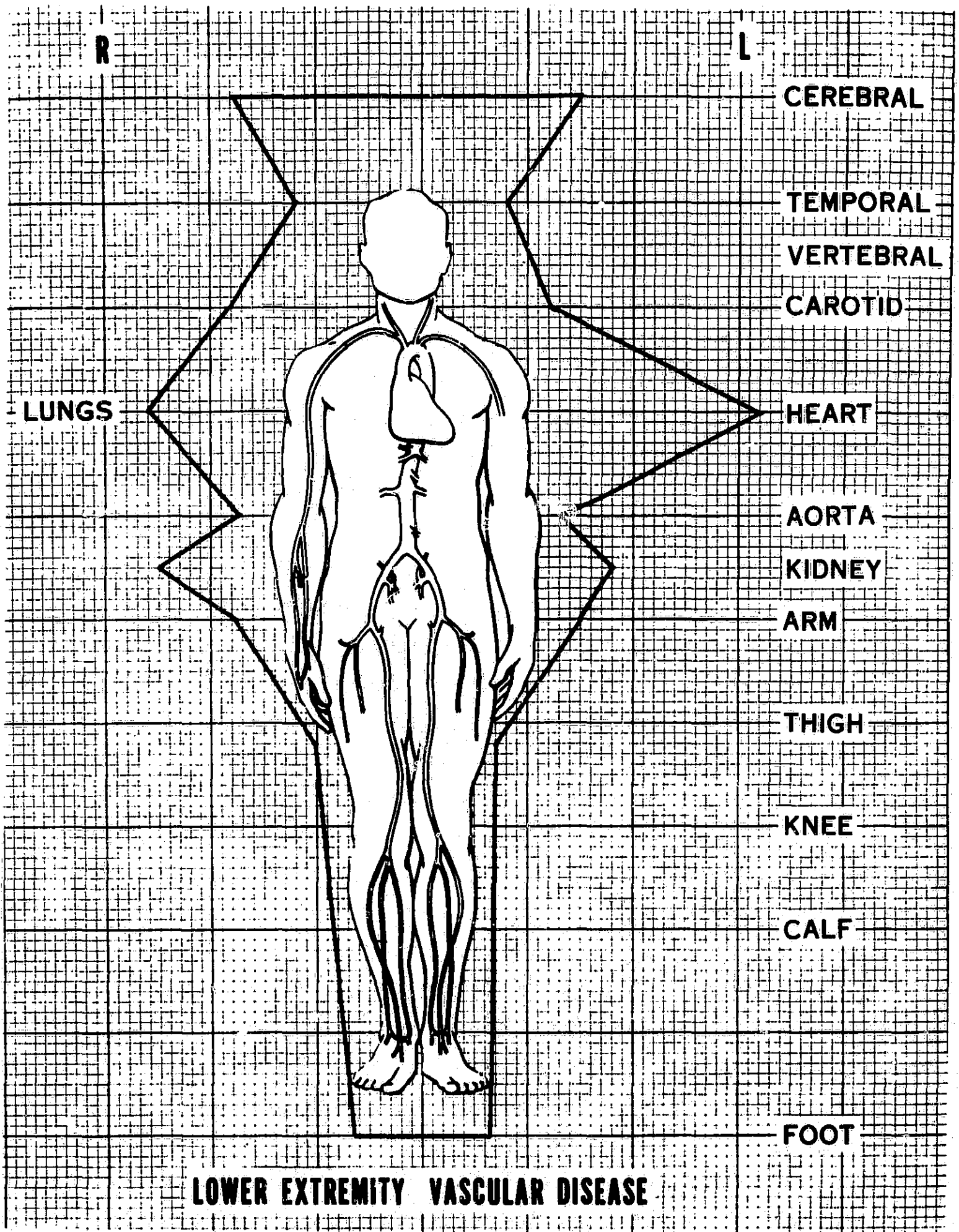

Fig 22 Silhouette vascular profile characteristic of lower extremity vascular disease. Amplitudes of pulses are reduced in the leg regions.

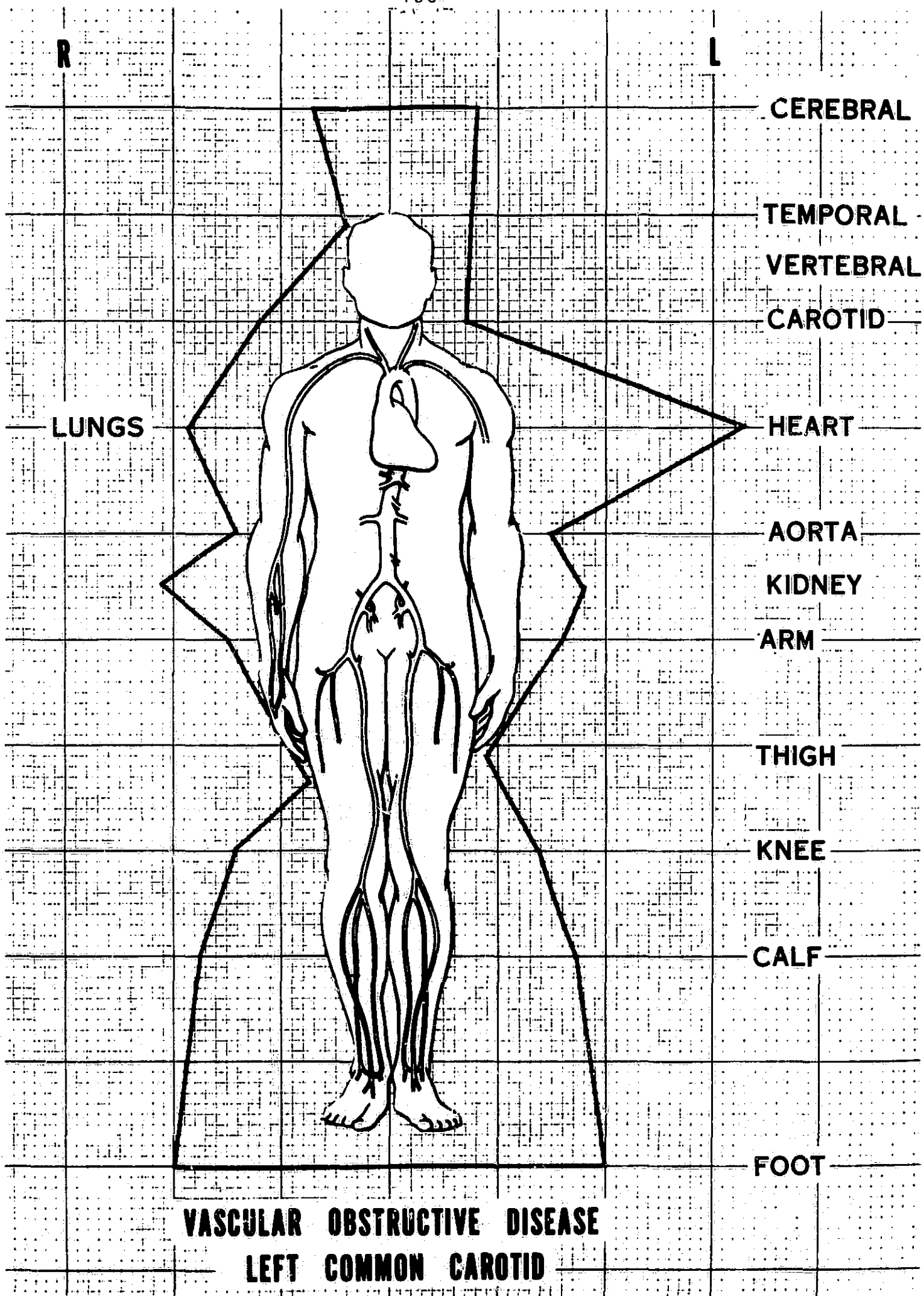

Fig 23 Silhouette vascular profile characteristic of left common carotid obstructive disease.

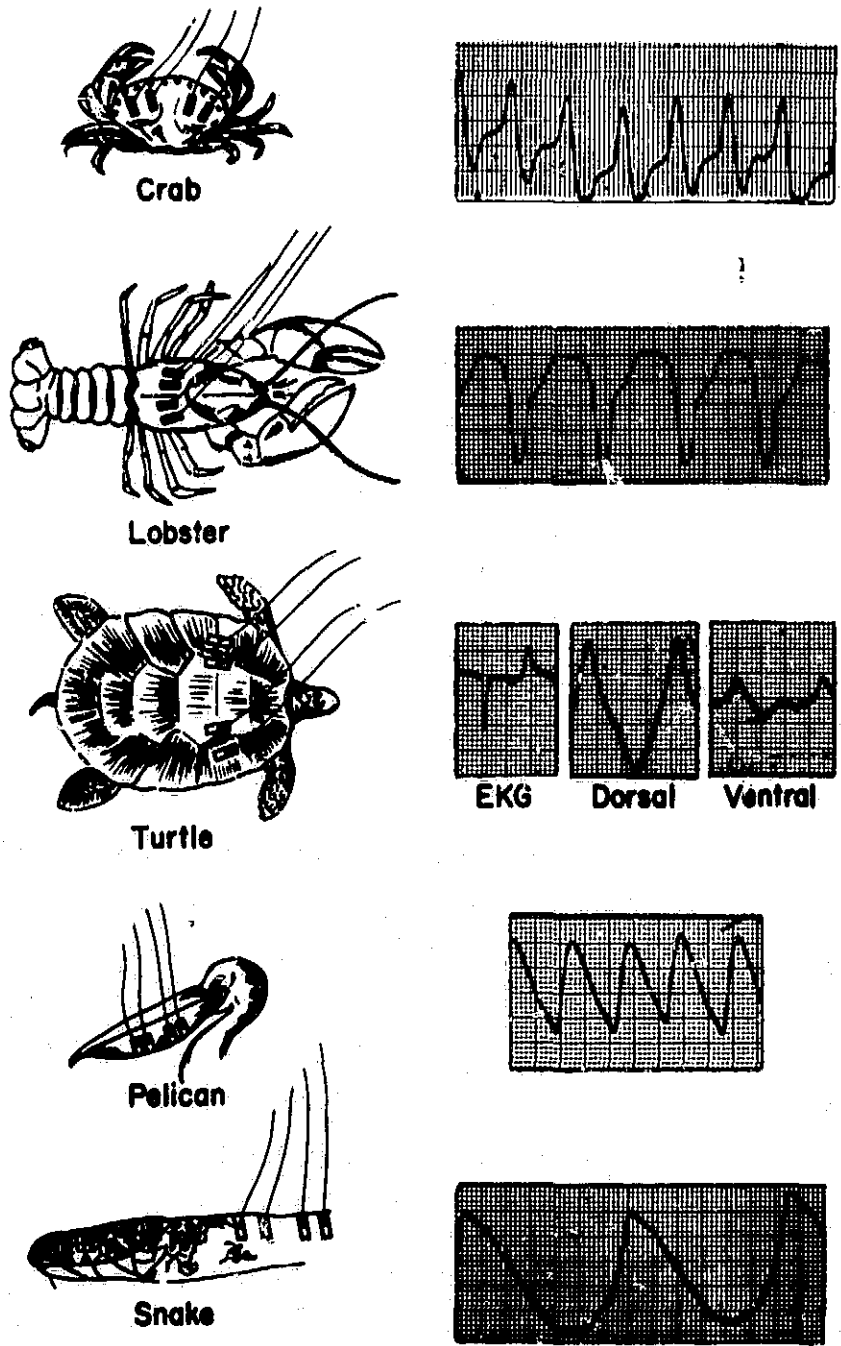

Fig 24 Vascular and ventilatory pulsations recorded from several species.

References

1. Abramson, D. I.: *Vascular Responses in the Extremities of Man in Health and Disease*; Chicago, University of Chicago Press, 1944.
2. Baldes, E. J., Herrick, J. F., Essex, H. E., Mann, F. C.: *Studies on Peripheral Blood Flow*. *Am. J. Physiol.* 128: 743-755, 1940.
3. Hertzman, A. B., and Dillon, J. B.: *Application of Photoelectric Plethysmography in Peripheral Vascular Disease*. *Am. Heart J.* 20: 750-761, 1940.
4. Karpman, H. L., Payne, H. J., Winsor, T.: *A Practical Systematic Laboratory Approach to the Study of the Peripheral Circulation*. *Ann. Int. Med.* 53: 306-318, 1960.
5. Kramer, K., Lochner, W., Wetterer, E.: *Methods of Measuring Blood Flow*; *Handbook of Physiology, Sec. 2: Circulation 2*, p. 1311, 1318, 1963.
6. Allison, R. D.: *Recent Biomedical Applications of Four Electrode Impedance Measuring Techniques*. *Biomedical Sciences Instrumentation* 3: 309, 1967.
7. Kety, S. S.: *Measurement of Regional Circulation by Local Clearance of Radioactive Sodium*. *Am. Heart J.* 38: 321-328, (Sept) 1949.
8. Kaufman, W., Johnson, F. D.: *The Electrical Conductivity of the Tissues Near the Heart and Its Bearing on the Distribution of the Cardiac Action Currents*. *Am. Heart J.* 26: 42-54, 1943.

9. Mann, H. : Study of Peripheral Circulation by Means of an Alternating Current Bridge. Proc. Soc. Biol. & Med. 36: page 670, 1937.
10. Kubicek, W. D., Witsoe, D.A., Patterson, R.P. : Development and Evaluation of an Impedance Cardiographic System to Measure Cardiac Output and Other Cardiac Parameters. Contract NAS9-4500, 1968.
11. Nyboer, J., Bagno, S., Barnett, A., Halsey, R. H. : Radiocardiograms: Electrical Impedance Changes of the Heart in Relation to Electrocardiograms and Heart Sounds. J. Clin. Investigation 19: page 773, 1940.
12. Nyboer, J. : Electrical Impedance Plethysmography. Charles C. Thomas, 1959.
13. Geddes, L. A., Hoff, H. E. : The Measurement of Physiological Events by Electrical Impedance. Amer. J. of Med. Electronics, p. 16-27, Jan-March, 1964.
14. Geddes, L. A., Hoff, H. E., Hickman, D. M., Hines, M., Baker, L. : Recording Respiration and the Electrocardiogram with Common Electrodes. Aerospace Med. 33: 791-793 (July) 1962.
15. Kinnear, E. : Estimation of Pulmonary Blood Flow with an Electrical Impedance Plethysmograph. USAF School of Aerospace Medicine, Report No. TR-65-81 Dec. 1965.
16. Bagno, S., Liebmann, F. M. : Impedance Measurements of Living Tissue. Electronics 62-63 (April 10), 1959.
17. Allison, R.D., Holmes, E.L. Nyboer, J. : Volumetric Dynamics of Respiration as Measured by Electrical Impedance Plethysmography. J. Appl. Physiol. 19: 166-173 Jan. 1964. (Doctoral Dissertation) Aug. 1962.

18. Allison, R.D.: Impedance Plethysmography. Study PR -6-120-NAS4-892. Flight Research Center, Edwards, California 1963.
19. Allison, R.D.: Stroke Volume, Cardiac Output and Impedance Measurements. Proc. Eng. in Med. & Biol. 8: page 53, 1966.
20. Allison, R.D.: Central and Peripheral Vascular Effects During Cigarette Smoking in Healthy Subjects. Archives of Environmental Health - In Press.
21. Schaefer, K. E. Allison, R.D., Dougherty, J.H., Corey, C.R., Walker, R.W., Yost, F., Parker, D.: Pulmonary and Circulatory Adjustments Determining the Limits of Depths in Breathhold Diving. Science 162: 1020-1023 (Nov) 1968.
22. Allison, R.D., Luft, U.C.: Cardio-Pulmonary Dynamics and Electrical Resistance Changes in the Thorax. Fed. Proc. 23: page 116, 1964.
23. Allison, R.D.: Segmental Pulmonary Blood Pulse Volume Changes During Hypoxia as Measured by an Impedance Plethysmograph. Symposium on Biomedical Engineering. Marquette University June 23-25, 1: 378-382, 1966.
24. Allison, R.D.: Flow Determinations Based on the End Systolic Gradient of Pulse Volume Curves Using the Electrical Impedance Plethysmograph. Masters Thesis, Wayne State University College of Medicine, 1960.
25. Allison, R.D.: The Role of Impedance Plethysmography in Biomedical Research and Diagnostic Medicine. Biomed. Eng. 3: 500-503 (Nov) 1968.
26. Allison, R.D.: Comparison of Electrical Impedance Plethysmography with Conventional Blood Flow Measuring Techniques. Fall, 1967, American Physiological Society Meeting. The Physiologist 10: page 108 (Aug) 1967.



27. Allison, R.D.: Impedance Plethysmography in the Dynamic Environment. IEEE Conference Record. Fifth Annual Rocky Mountain Bioengineering Symposium May 6-7, 1968, pp. 55-67.
28. Allison, R.D., Bagnos, S.: A Self Balancing Impedance Plethysmograph for Studies during Weightlessness. An. Conf. Eng. Med. & Biol. 9: page 13.4, 1967.
29. Allison, R.D.: Effects of Tilt Table Studies on Central and Peripheral Vascular Dynamics (An Impedance Plethysmograph Study) Report NAS4-1321 Flight Research Center, Edwards, Calif. Feb. 1968-April 1969.
30. Allison, R.D.: Thoracic Blood Pulse Volume Studies During Emphysema and Hypoxia. Writings and Reports, Scott and White Clinic 4: 129-138, 1967.
31. Allison, R.D.: Arterial-Venous Volume Gradients as Predictive Indices of Vascular Dynamics. Chapter X. Instrumentation Methods for Predictive Medicine. I.S. A. Pub. 1966. p. 127-155.
32. Allison, R.D.: The Effects of Aging, Vascular Disease and Hypertension on Peripheral Blood Pulse Volume. J. of Amer. Geriatrics 16: 39-51, 1968.
33. Allison, R.D., Sanchez, S. A. and Duran, A.: Evaluation of Renal Vascular Hypertension: A Multiple Diagnostic Approach. Tex. Med. 64: 40-44, 1968.
34. Allison, R.D.: Impedance Renograms: A New Screening Test for Renal Vascular Hypertension. Presented IVth International Congress of Nephrology, Stockholm, Sweden, June 22-27, 1969.
35. Allison, R.D.: Vascular Profile Screening Tests: A New Approach to the Detection of Vascular Disease. Am. J. Geriatrics. In Press.