

Final Technical Report on

LOW COST LAUNCH VEHICLE STUDY

23 May 1969

submitted to  
NASA Headquarters  
Director, Transportation Systems  
Code MTV  
Washington, D.C.

in partial fulfillment of Contract No. NASw-1794

Prepared by

J. B. Kendrick

J. B. Kendrick, Assistant Director - LCLV Study

Approved by

P. Dergarabedian

P. Dergarabedian, Director - LCLV Study

TRW SYSTEMS GROUP

One Space Park

Redondo Beach, California

#### ACKNOWLEDGEMENT

The basic inputs for the Low Cost Launch Vehicle Study have been provided by the following TRW personnel, whose useful contributions in the many specialty fields appear in this report. The work of these principal contributors, and many others who have furnished valuable counsel and inputs in various areas, is gratefully acknowledged.

Jack J. Cohen - Vehicle Performance

Harry Frank - Preliminary Design and Costs

Robert W. Ghastin - Ground Support Systems

Abner Kaplan - Structures

Larry R. Maynard - Vehicle Performance

Donald R. Pence - Weights

Larry Raphael - Costs

John A. Vanderlaan - Guidance and Control

TABLE OF CONTENTS

	Page
1.0 Introduction and Summary	1.1
2.0 Launch Vehicle Requirements	2.1
2.1 Mission Estimates for 1973-1985 Period	2.1
2.2 Guidance Errors	2.5
2.3 Description of Baseline LCLV	2.5
3.0 Design Philosophy and Concepts	3.1
3.1 Design and Development Concepts for Minimum Cost	3.1
3.2 Management Concepts for Minimum Cost	3.4
3.3 Configuration Selection for Minimum Cost	3.5
3.4 Payload Versatility for Minimum Cost	3.6
3.5 Effect of Booster Recovery on LV Cost	3.7
3.6 Effect of Payload On Total Mission Cost	3.8
4.0 Review of LV Design Configurations	4.1
4.1 Baseline Configuration	4.2
4.2 Quad Modules of Tanks and Engines	4.8
4.3 Fully Modular Design (7+3+1)	4.8
4.4 Modular Engines and Non-Modular Tanks	4.8
4.5 Low Cost Pump Fed LV	4.11
4.6 Pressure Fed Liquid Booster plus S-IVB Stage	4.12
4.7 Weight and Cost Analysis of Candidate Vehicles	4.15
4.8 Further Comparisons and Tradeoffs	4.24
4.9 Summary of Configuration Studies	4.30
5.0 Design Features	5.1
5.1 TRW Coaxial Injector Engines	5.1
5.2 Pressure-Fed Stages	5.2
5.3 Tank Pressurization	5.7
5.4 Liquid Injection Thrust Vector Control (LITVC)	5.11
5.5 Roll Control and Ullage Control	5.18
5.6 Problem Areas	5.19
5.7 Consideration of LOX-RP vs NTO-UDMH	5.19
5.8 First Stage Nozzle Exhaust Dynamics	5.20
5.9 Propellant Utilization	5.20
6.0 Production and Procurement	6.1
6.1 LV Production in Plant A	6.2
6.2 Alternate Sites for Plant A at KSC	6.2
6.3 Plant A Layout and Work Flow	6.5

## TABLE OF CONTENTS Cont.

	Page	
6.4	Quality Assurance in LCLV Program	6.8
7.0	Ground Support Facilities and Operations	7.1
7.1	Summary of Procedure for Ground Support Studies	7.1
7.2	Objectives	7.2
7.3	Study Approach	7.2
7.4	Guidelines and Constraints	7.5
7.5	Conclusions and Recommendations	7.16
7.6	Requirements and Cost Analysis	7.20
8.0	Guidance and Control Systems and Astrionics Costs	8.1
8.1	Introduction and Summary	8.1
8.2	General Approach to Guidance and Control Systems	8.3
8.3	Guidance Configurations for the LCLV	8.5
8.4	Control System Configuration	8.20
8.5	G C Configuration Tradeoffs	8.32
8.6	Astrionics Costs	8.38
9.0	Cost Analysis and Tradeoffs	9.1
9.1	Non-Recurring Costs	9.4
9.2	Recurring Costs	9.7
9.3	Total Recurring plus Non-Recurring Costs	9.15
9.4	Baseline Configuration Tradeoffs	9.16
9.5	Economics of Modular Units	9.18
9.6	Low Cost Pump-Fed LV	9.20
9.7	PFL Booster plus S-IVB Stage	9.20
9.8	Payload Versatility	9.22
10.0	Development Plan	10.1
10.1	Principal Milestones in Development	10.1
10.2	Effect of Mission Program on Development Plan	10.1
10.3	Sequence of Development of LCLV and lclv	10.6
10.4	Overall Management Policies	10.6
Appendix A	Parametric Weight and Engine Data	A1
Appendix B	Weight, Performance and Structures	B1
Appendix C	Exchange Ratios for LCLV	C1
Appendix D	Summary of Task Completion	D1
Appendix E	Definitions, Equations and Cost Data Sheets for Ground Support Cost Categories	E1
Appendix F	Layout of Baseline LCLV	F1
References		R1

## LIST OF ILLUSTRATIONS

Figure Number	Title	Page
1-1	Low Cost Launch Vehicle Family	1.4
1-2	Domains of Economic Preference for Various LV's	1.5
1-3	Comparison of Design Weights and Costs	1.6
1-4	Total Cost of LCLV Program vs Design Conservatism	1.7
1-5	Effect of Launch Rate on Cost/Launching	1.10
2-1	Estimated Number of Missions through 1985	2.3
2-2	Early Break-Even Point with LCLV	2.4
3-1	Variations in Total Mission Cost	3.10
4-1	Baseline LCLV Configuration (Design No. 1)	4.3
4-2	3-Stage Non-Modular Vehicles - Gross Weight and Cost	4.4
4-3	Effect of Number and Type of Stages on Gross Weight and Cost	4.7
4-4	Modular Variations of Baseline Vehicle	4.9
4-5	Modular vs Non-Modular - Gross Weight and Cost	4.10
4-6	Pressure-Fed Liquid Booster plus S-IVB Stage	4.13
4.8-1	Effect of Number of Stages on Weight and Cost	4.26
4.8-2	Effect of Chamber Pressure and Mixture Ratio on Cost	4.26
4.8-3	Effect of $I_{sp}$ Efficiency and First Stage V on Cost	4.27
4.8-4	Effect of Nozzle Expansion Ratio on Cost	4.27
4.8-5	Effect of Residual Propellant and Material Strength on Cost	4.28
4.8-6	Effect of Velocity Requirements on LCLV Weight and Cost	4.29
5-1	Relative Weight and Cost of First Stage Propellant Tanks	5.4
5-4	Main Tank Injection (MTI) Pressurization System	5.8
5-5	Roll and Ullage Control System	5.18
6-1	Flow Diagram for LCLV	6.1
6-2	Expanded View of LCLV	6.3
6-3	Alternate Locations for Plant A at Kennedy Space Center	6.4
6-4	Plant A Layout	6.6
7.3-1	LCLV Ground Systems Study Approach	7.3
7.4-1	Mobile Launcher/Umbilical Tower	7.7
7.4-2a	Vehicle Assembly Building	7.8
7.4-2b	Vehicle Assembly Building (Phantom View)	7.9
7.4-3	Launch Control Center	7.11
7.4-4	Crawler/Transporter	7.12
7.4-5	Crawlerway (Looking East)	7.13
7.4-6	Mobile Service Structure	7.14

## LIST OF ILLUSTRATIONS CONT.

Figure Number	Title	Page
7.4-7	Launch Pad A (Exploded View)	7.15
7.6-1	LCLV Baseline Configuration for Ground Systems Conceptual Analysis	7.20
7.6-2	Master Flow Diagram Low Cost Launch Vehicle	7.22
7.6-3	Low Cost Launch Vehicle Proposed Plant A and Launch Facility Complex KSC	7.27
7.6-4	Time Based Functional Flow Diagram of LCLV Final Assembly through Launch Operations at KSC-Baseline Concept A	7.28
7.6-5	Conceptual Diagram LCLV Vertical Erection Operation onto Mobile Launcher-Concept A	7.31
7.6-6	Resultant Force to Vertically Erect Completely Assembled LV	7.32
7.6-7	LCLV Structural Interface with Mobile Service Structure and Mobile Launcher	7.35
7.6-8	VAB Plan View	7.38
7.6-9	Time Based Functional Flow Diagram of LCLV Final Assembly through Launch Operations at KSC Baseline Concept B	7.41
7.6-10	Plant A Final Assembly Operations Concept C <sub>1</sub>	7.45
7.6-11	Typical Stage Welding Tool Jig-Concept C <sub>1</sub>	7.46
7.6-12	LCLV Transporter Concept C <sub>1</sub>	7.47
7.6-13	LCLV Cradle Concept C <sub>1</sub>	7.48
7.6-14	LCLV Deep-Pit Launch Site Concept C <sub>1</sub>	7.49
7.6-15	Time Based Functional Flow Diagram of LCLV Final Assembly through Launch Operations at KSC Concept C <sub>1</sub>	7.50
7.6-16	Time Based Functional Flow Diagram of LCLV Assembly through Launch Operations at KSC Concept C <sub>2</sub>	7.58
7.6-17	Conceptual Diagram of LCLV Launch Pad Emplacement Prior to Erection Concept C <sub>2</sub>	7.59
7.6-18a	Alternate Arrangement for LUT Installation and LCLV Erection Concept C <sub>2</sub>	7.60
7.6-18b	Alternate Arrangement for LUT Installation and LCLV Erection Concept C <sub>2</sub>	7.61
8.3-1	Basic Guidance Configurations	8.6
8.3-2	Simplified Strapdown Guidance Schematic	8.10
8.3-3	Low Cost Radio Guidance Block Diagram for Ground Support Equipment	8.14
8.4-1	Functional Schematic of Control System	8.21
8.4-2	Autopilot Electronics	8.22
8.4-3	Actuation Electronics Package with Proportional Injector Operation	8.23
8.4-4	Actuation Electronics Package with On-Off Injector Operation	8.24

## LIST OF ILLUSTRATIONS CONT.

Figure Number	Title	Page
8.4-5	A Typical Polar Controller Functional Schematic	8.25
8.4-6	Primary Control Electronics Configurations	8.27
8.5-1	G & C Cost Penalty - LCLV (Including Effect of $3\sigma$ errors)	8.36
9-1	Basic Cost Relationships	9.2
9-2	Effect of Non-Recurring Cost on Average Unit Cost	9.3
9-3	Development Cost of TRW Engines	9.5
9-4	Estimates of Specific Costs for LCLV Components	9.9
9-5	Low Cost Engine Specific Cost	9.10
9-6	First Stage Engine Cost	9.12
9-7	Effect of Engine Expansion Ratio and Chamber Pressure on Cost	9.13
9-8	Cost Tradeoffs with 90 percent Learning Curve	9.17
9-9	Break-Even Point vs S-IVB Cost	9.21
9-10	Payload Versatility for LEO Missions	9.23
10-1	Development Schedule for 3M lb Thrust Engine	10.2
10-2	Development Schedule for LCLV	10.3
10-3	Overall Development Schedule for Production of LV's	10.4
10-4	Funding Schedule for LCLV Development	10.5
A-1	Booster Engine Thrust/Weight	A5
A-2	Thrust/Weight vs vs Expansion Ratio and Chamber Pressure	A6
A-3	Specific Impulse vs Chamber Pressure (90% $I_{sp}$ Efficiency)	A7
A-4	Specific Impulse vs Chamber Pressure (92% $I_{sp}$ Efficiency)	A8
A-5	Thrust Co-efficient vs Chamber Pressure	A9
A-6	S. L. Specific Impulse vs Expansion Ratio (92% $I_{sp}$ Efficiency)	A10
A-7	Vacuum Specific Impulse vs Expansion Ratio	A11
A-8	Thrust Co-efficient vs Expansion Ratio	A12
A-9	Vacuum Thrust Co-efficient vs Expansion Ratio	A13
A-10	TRW Low Cost Booster Engine Nominal Characteristics	A14
A-11	Booster Engine Dimensions ( $\epsilon=5, P_c=300$ )	A15
A-12	Booster Engine Dimensions ( $\epsilon=6, P_c=300$ )	A16
A-13	Booster Engine Dimensions ( $\epsilon=7, P_c=300$ )	A17
A-14	Booster Engine Dimensions ( $\epsilon=6, P_c=200$ )	A18
A-15	Booster Engine Dimensions ( $\epsilon=6, P_c=400$ )	A19
B-1	Performance of Several Launch Vehicles	B5
B-2	First Stage Trajectory Data	B6
B-3	Buckling Thickness Requirements for Unpressurized Cylinders	B14

LIST OF ILLUSTRATIONS CONT.

Figure Number	Title	Page
B-4	Truss Core Sandwich	B16
B-5	Ring-Stiffened Corrugation	B17
B-6	Optimum Weight of Compressively Loaded Cylindrical Shells	B19
B-7	Weight Densities for Optimized Ring-Stiffened Corrugated Cylinders	B20
B-8	Design Wind Profiles	B22
B-9	LCLV Aerodynamic Coefficients	B23
B-10	Variation of Max $Q\alpha$ with Altitude for 95% Wind Profile	B24
B-11	Limit Equivalent Axial Load $(P + \frac{2M}{R})$	B25
F-1	Layout of Baseline LCLV	F1



## LIST OF TABLES

Table Number	Title	Page
1-I	Family of Low Cost Launch Vehicles	1.3
2-I	Unofficial Estimate for NASA/DOD Missions Planned for Launch from KSC in 1973 to 1985 Time Period	2.2
2-II	Total Mission Program and Cost	2.3
2-III	Typical Guidance Errors and Velocity Cutoff Accuracy	2.5
3-I	Low Non-Recurring Cost for LCLV	3.3
3-II	LCLV Management Concepts	3.5
3-III	LCLV Cost with Booster Recovery	3.7
3-IV	Cost of Current Spacecraft	3.8
4-I	Comparison of Design Philosophy and Basic Data	4.5
4-II	Summary of Low Cost Launch Vehicle Designs	4.6
4-III	Data Summary for Designs No. 1 to 4	4.11
4.7-I	Baseline 3 Stage - Design No. 1B Pressure Fed N <sub>2</sub> O <sub>4</sub> /UDMH Gross Payload = 100,000 lbs. (LEO)	4.16
4.7-II	Configuration 2 - Quad Modules Pressure Fed N <sub>2</sub> O <sub>4</sub> /UDMH Gross Payload = 100,000 lbs. (LEO)	4.17
4.7-III	Configuration 3 - Fully Modular (7+3+1) Pressure Fed N <sub>2</sub> O <sub>4</sub> /UDMH Gross Payload = 100,000 lbs. (LEO)	4.18
4.7-IV	Configuration 4-Modular Engines (9+3+1) Pressure Fed N <sub>2</sub> O <sub>4</sub> /UDMH Gross Payload = 100,000 lbs. (LEO)	4.19
4.7-V	Pump Operating Points	4.20
4.7-VI	Turbine Design Data	4.21
4.7-VII	Turbopump Data	4.21
4.7-VIII	Stage Weights for Pump-Fed Vehicle	4.22
4.7-IX	Cost Estimate	4.22
4.7-X	Weight Estimates for PFL/S-IVB Vehicles	4.23
4.8-I	Comparison of Design Parameters	4.25
4.9-I	Matrix of LV Configurations and Relative Preference	4.30
5-I	Scale-up of TRW Coaxial Injector	5.1
5-II	Strength and Cost of Candidate Structural Materials	5.2
5-III	LCLV Tankage and Structure Material Selection	5.6
5-IV	Characteristics of MII System	5.10

## LIST OF TABLES CONT.

Table Number	Title	Page
5-V	Cost and Weight Estimates	5.14
6-I	Production and Procurement	6.2
6-II	Plant A Layout and Facilities	6.5
7.5-I	Ground Support and Launch Cost Summary	7.17
7.6-I	Comparison of Saturn V/LCLV Dimensions, Weights and Thrust	7.21
7.6-II	Preliminary List of Launch Operations Support (LOS) Functional Requirements for Concepts A, B, and C	7.23
7.6-III	Approximate Manpower Requirements for Low Cost Launch Vehicle Final Assembly through Launch Operation at KSC	7.29
7.6-IV	Included in Appendix E	E22
7.6-V	Summary of $N_2H_4$ /UDMH Properties	7.34
7.6-VI	LCLV Estimated AGE/LF Production and Installation Costs ( $\$X10^3$ ) to Support Various Monthly Launch Rates	7.37
7.6-VII	Approximate Manpower Requirement for Low Cost Launch Vehicle	7.42
7.6-VIII	Included in Appendix E	E48
7.6-IX	LCLV Estimated AGE/LF Production and Installation Costs ( $\$X10^3$ ) to Support Various Monthly Launch Rates	7.43
7.6-X	Approximate Manpower Requirements for Final Assembly through Launch Operations at KSC	7.51
7.6-XI	Included in Appendix E	E73
7.6-XII	LCLV Estimated AGE/LF Production and Installation Costs ( $\$X10^3$ ) to Support Various Monthly Launch Rates	7.52
7.6-XIII	Approximate Manpower Requirements for Low Cost Launch Vehicle Final Assembly through Launch Operations at KSC	7.63
7.6-XIV	Included in Appendix E	E97
7.6-XV	LCLV Estimated AGE/LF Production and Installation Costs ( $\$X10^3$ ) to Support Various Monthly Launch Rates	7.64
7.6-XVI	Comparison of Processing Times and Manpower Requirements for Concepts A, B, $C_1$ and $C_2$ Final Assembly	7.65
7.6-XVII	Comparative Matrix of AGE/LF Total Production and Installation Cost ( $\$X10^3$ ) for Concepts A, B, $C_1$ and $C_2$ to Support Various Monthly Launch Rates	7.66
8.3-I	Preliminary Error Analysis for Simplified Guidance Earth Orbit Injection Mission	8.11
8.3-II	Major Characteristics of Guidance Configurations	8.17
8.3-III	LCLV- 1 Guidance Errors (Gross Estimates for Low Orbits)	8.19
8.3-IV	Attitude Reference Unit, 1 Accuracy Requirements	8.19
8.4-I	Control Electronics, Cost Tradeoff of Primary Configuration	8.31
8.4-II	Estimated Unit Cost of Rate Gyro Packages (in \$)	8.31
8.4-III	Control Electronics Characteristics for Each Guidance Configuration	8.35

## LIST OF TABLES CONT.

Table Number	Title	Page
8.6-I	Astrionics Weight and Cost for Baseline Design	8.39
9-I	Lower Bound for Development	9.4
9-II	Non-Recurring Cost for Baseline Configuration	9.6
9-III	Non-Recurring Costs for Candidate Designs	9.7
9-IV	Low Cost Booster Engine Cost	9.11
9-V	Recurring Cost of Baseline Stage 1 Engine	9.15
9-VI	Recurring Plus Non-Recurring Costs	9.16
9-VII	Development Cost for Modular Engines and Clusters	9.19
9-VIII	Recurring and Non-Recurring Cost for lclv	9.24
B-I	LCLV Weight Breakdown Design No 1B	B2
B-II	LCLV Major Design Criteria	B3
BIII	Weight Breakdown for lclv Design No 1C	B4
B-IV	Candidate Tank Materials	B9
B-V	Propellant Characteristics of Baseline Vehicle	B11
B-VI	Critical Compressive Loads for Propellant Tanks - Unpressurized Ground Condition	B12
B-VII	Interstage Structural Dimensions	B26
C-I	Exchange Ratios for LCLV	C2
C-II	Application of Exchange Ratios	C3
E-I	Baseline List of Ground System Cost Categories	E2
E-II	Preliminary List of LCLV Ground Systems Program Management Functional Elements	E5
E-III	Preliminary List of AGE Functional Elements	E11
E-IV	Preliminary List of LF Functional Elements Vehicle Assembly and Checkout (VAB) Facilities	E14
E-V	Preliminary List of Installation and Checkout Functional Elements	E16
E-VI	Preliminary List of Base Operations Support (BOS) Functional Requirements	E18
7.6-IV	LCLV Ground Systems Estimated AGE/LF RDT E Production and Installation Cost (Concept A)	E22
7.6-VIII	LCLV Ground Systems Estimated AGE/LF RDT E Production and Installation Costs (Concept B)	E48
7.6-XI	LCLV Ground Systems Estimated AGE/LF RDT E Production and Installation Costs (Concept C <sub>1</sub> )	E73
7.6-XIV	LCLV Ground Systems Estimated AGE/LF RDT E Production and Installation Costs (Concept C <sub>2</sub> )	E97

x  
10

NOMENCLATURE

AFRPL - Air Force Rocket Propulsion Laboratory at Edwards AFBase  
 B - Sometimes used to denote billions; i.e. \$B  
 Big LCLV - 3 stage launch vehicle using LCLV 1st and 2nd stages, plus S-IVB final  
 CEI - Contract End Item  
 Class I to IV - Categories of launch vehicles (small to large, see Figure 2-1)  
 CO - Checkout  
 D - Sometimes used to denote development cost  
 DDA - Digital Data Analyzer  
 DDT&E - Design, development, test and engineering  
 ETR - Eastern Test Range  
 f - first unit recurring cost of vehicle or system  
 G&C - Guidance and Control  
 HUGE - Hot Ullage Gas Ejection (roll and ullage control system)  
 IMU - Inertial Measurement Unit  
 I<sub>sp</sub> - specific impulse of propellant, lb sec/lb  
 IU - Instrumentation Unit  
 k - Exponent of unit weight to give cost/lb variation with size  
 K - Sometimes used to denote thousands; i.e. K lb  
 KSC - Kennedy Space Center at Cape Canaveral, Florida  
 LCC - Launch Control Center  
 lclv - Small vehicle using 2nd, 3rd and 4th stages of LCLV  
 LCLV - Low Cost Launch Vehicle (Baseline configuration)  
 LCSC - Low Cost Spacecraft  
 LEO - Low Earth Orbit  
 LITVC - Liquid Injection Thrust Vector Control  
 LMDE - Lunar Module Descent Engine  
 LV - Launch vehicle  
 M - Sometimes used to denote millions; i.e. M lb, \$M  
 MTI - Main Tank Injection (pressurization method)  
 n - Number of modules assembled into a stage, exponent of N for learning curve  
 N - Number of launch vehicles  
 NRC - Non-recurring cost  
 NTO - Nitrogen Tetroxide, N<sub>2</sub>O<sub>4</sub>  
 P<sub>c,t</sub> - pressure in thrust chamber (or tank)  
 PFL - Pressure-fed liquid  
 PFL+S-IVB - 2 stage vehicle with PFL booster and S-IVB upperstage  
 PFL+PFL+S-IVB - 3 stage vehicle with 2 PFL stages and S-IVB upperstage  
 PFRT - Propulsion Flight Rating Test  
 PL - Payload  
 P/U - Propellant Utilization System  
 QA, QC - Quality Assurance, Quality Control  
 RC - Recurring cost  
 SC - Spacecraft  
 S-IVB - Saturn S-IVB stage  
 SRM - Solid Rocket Motor  
 T - Thrust of rocket engine  
 TIIIC(M) - Titan III C (or M) launch vehicle  
 TMC - Total Mission Cost  
 TT&C - Tracking, Telemetry and Command  
 TVC - Thrust Vector Control  
 UDMH - Unsymmetrical Dimethyl Hydrazine  
 UTS - Ultimate Tensile Strength  
 v - velocity of stage or vehicle  
 VAB - Vehicle Assembly Building  
 W<sub>0</sub> - Gross weight of stage or vehicle  
 W<sub>p</sub> - Weight of propellant  
 W<sub>st</sub> - Weight of stage including propellant  
 ε - Expansion ratio of rocket engine, area of exit/area of throat  
 σ - Symbol denoting probability of occurrence, or structure ratio of stage

## 1. INTRODUCTION AND SUMMARY\*

### 1.1 Purpose and Scope

This report is part of the National Space Booster Study, to generate a viable program of NASA/DOD launch vehicle(s) for placing payloads of 40,000 to 100,000 lbs into low earth orbits (LEO), in the 1973 to 1985 period. Other potential missions (with addition of appropriate upper stages) include the 24-hour synchronous orbit, lunar and interplanetary objectives. The Low Cost Launch Vehicle (LCLV) is conceptually designed to attain LEO with minimum cost (recurring plus non-recurring, for assumed launch rates) rather than the previous custom of designing for minimum weight to attain the desired performance. The resulting vehicle is comparable in size to the Saturn V, but much less costly. A summary of this technical report is given in Reference 1.

A mission survey reveals the need for 100 to 150 launch vehicles of the above type, giving an average launch rate of about 1 per month. Such a rate can be maintained with the LCLV as planned, without increasing the budget beyond the current NASA/DOD expenditures for launch vehicles of this type (Section 2).

Recent studies (Reference 2) show that derivatives of existing boosters of the Titan III and Saturn families can be adapted to meet the desired payload range, but the sum of their recurring plus non-recurring cost is several times greater than the desired transportation cost of \$100 to \$150/lb to LEO.

### 1.2 Low Cost Launch Vehicle Thesis

Several technology improvements in recent years, never before combined in a launch vehicle, offer promise of unique simplicity and low cost. These features are: low cost engines such as TRW coaxial injector engine; high strength, low cost steels for pressure-fed stages; hot gas pressurization systems; liquid injection thrust vector control; simple roll and ullage controls; and low cost astronics systems.

Since the launch vehicle design and technology determine not only the cost of hardware but all other areas pertaining to the procurement and operation of the vehicle, the study approach begins with many conceptual designs having novel features affecting the overall cost. Basic costing methodology is used to compare these designs and to determine optimal cost saving features to be incorporated in the preferred design. Some of the variations in these conceptual designs, for which relative costs have been determined, include 2-, 3-, and 4-stage vehicles, modular engines and tanks vs non-modular, pressure-fed vs pump-fed engines, and storable vs high-energy upper stages.

To determine total cost trends, the conceptual designs have been visualized

---

\* See page x for Nomenclature

1.2

through the development and test phase, fabrication, transport, assembly and erection, checkout and launch operations to determine the preferred design having minimum overall cost. By taking a conservative approach to the vehicle design and performance, and by thorough coverage of the simplified modes of development and test, on-site production (in Plant A, near the launch site), and operation of the LCLV, the credibility of this analysis is believed to be enhanced.

1.3 Comparison of Alternate Designs

Five variations are investigated of the original baseline configuration (the 3-stage, pressure-fed, non-modular design). The 3-stage is found to be less costly than the 2-stage vehicle, and no more costly than the 4-stage design; hence, the 3-stage configuration is preferred. Likewise, the non-modular configuration has lower overall cost (for N>50 launchings and the assumptions used) than designs using modular engines and/or tanks. Even with N=25, a saving of only 3 percent is attained by the best of the modular configurations. The modular designs are, therefore, less desirable candidates because of their slightly higher cost and greater complexity. However, further study may indicate the desirability of using modular engines, for reasons other than economy.

While the low cost pump-fed design (which has low-pressure tanks of lighter weight) is found to have lower gross weight and recurring cost than the corresponding pressure-fed vehicle, the probable development cost of the turbo-pump and its increased operating cost will raise the break-even point to N>100 launchings before overall savings will be realized, and at N=200 the saving is less than 4 percent. The pump-fed vehicle is therefore not considered the best candidate LCLV, because of its limited potential savings with a more complex system.

The 2-stage combination of a low cost, pressure-fed booster with a standard S-IVB upper stage has an advantage of lower acquisition cost, but its recurring cost is considerably higher. The break-even point is at N = 24, below which this combination is less costly than the baseline LV. If the S-IVB stage is stripped down to a cost of \$12M, the break-even point increases to N = 31. Since the number of vehicles in the LCLV program is probably greater, this 2-stage combination is not the best candidate, because of its higher cost (20 percent higher at N = 100). However, it does provide a low cost interim LCLV (see Table 1-I).

It is found that for 100 launchings, all of the six original contenders have total costs (including non-recurring cost) within a relatively narrow range of ± 10 percent from a mean value of \$12.9M (plus ground support); hence, any of them would qualify as low cost launch vehicles, in comparison with current LV's. However, the preferred configuration, for reasons of simplicity and low cost, is:

- the baseline design (3-stage to LEO, pressure-fed, non-modular, using hypergolic, storable propellant), which remains the preferred configuration for  $N > 50$ .

Using this basic design, a complete family of related low cost launch vehicles can be generated as shown in Figure 1-1, with characteristics as listed in Table 1-I, using the basic building blocks described in Table 1-II. These vehicles are capable of cost effective operation throughout the entire spectrum of missions.

Table 1-I Family of Low Cost Launch Vehicles

Designation	Gross Wt. (Mlb)	Payload to LEO (Klb)	Av. Cost/Launch (N = 100)(\$M)		\$/lb to LEO (N = 100)	
			Total*	Prod. Only	Total*	Prod. Only
Small lclv	2.3	30	7.5	3.0	250	100
Small PFL+S-IVB	2.1	50	12-14	6.5-7.5	240-280	130-150
Small PFL+S-IVB (Extended)	2.2	62	14.5	8.0	234	129
Large PFL+S-IVB	7.5	100	19.5	10.2	195	102
Large PFL+S-IVB (Extended)	7.6	125	20.2	10.7	160	85
Baseline LCLV	9.3	133	17	6.5	134	49
Baseline LCLV + 4th Stage	9.4	150	18.2	7.0	122	47
Big LCLV (PFL+PFL+S-IVB)	9.3	210	20	12.0	95	57
Big LCLV (S-IVB Extended)	9.4	250	20.7	12.5	83	50

Some of the designs are economically superior when produced in certain quantities, as illustrated in Figure 1-2. For example, in the 100K lb payload range, the large PFL + S-IVB is less costly than the baseline in quantities up to  $N = 25-70$  launchings (the upper bound depending on the cost of the stripped down S-IVB); the baseline vehicle is optimal in the range from  $N = 50$  to 150 units; while the 3-stage pump-fed vehicle has lower cost only for  $N > 100$ .

In other payload ranges, stage combinations related to the above vehicles are worthy of note. For example, the small PFL+S-IVB with 50K lb payload is preferred to Saturn IB or Titan IIIM for  $N > 25$ . Likewise the lclv (30K lb payload) is less costly than TIIM for  $N > 25$  (or less, depending on how the stage development costs are amortized). For larger payloads of  $> 200K$  lb, the Big LCLV is far less costly than Saturn V, and may be expected to replace the latter for launching the largest payloads. See Figure A-2 for plot of LV cost vs payload weight.

#### 1.4 Proposed LCLV and lclv

The proposed Low Cost Launch Vehicle (LCLV) resulting from these investigations, is the first space booster using available technology, which offers promise of credible operation at *less than one-fourth the cost of current LV's*.

\*Total cost includes production, DDT & E and other non-recurring cost, and ground support, including launch cost.

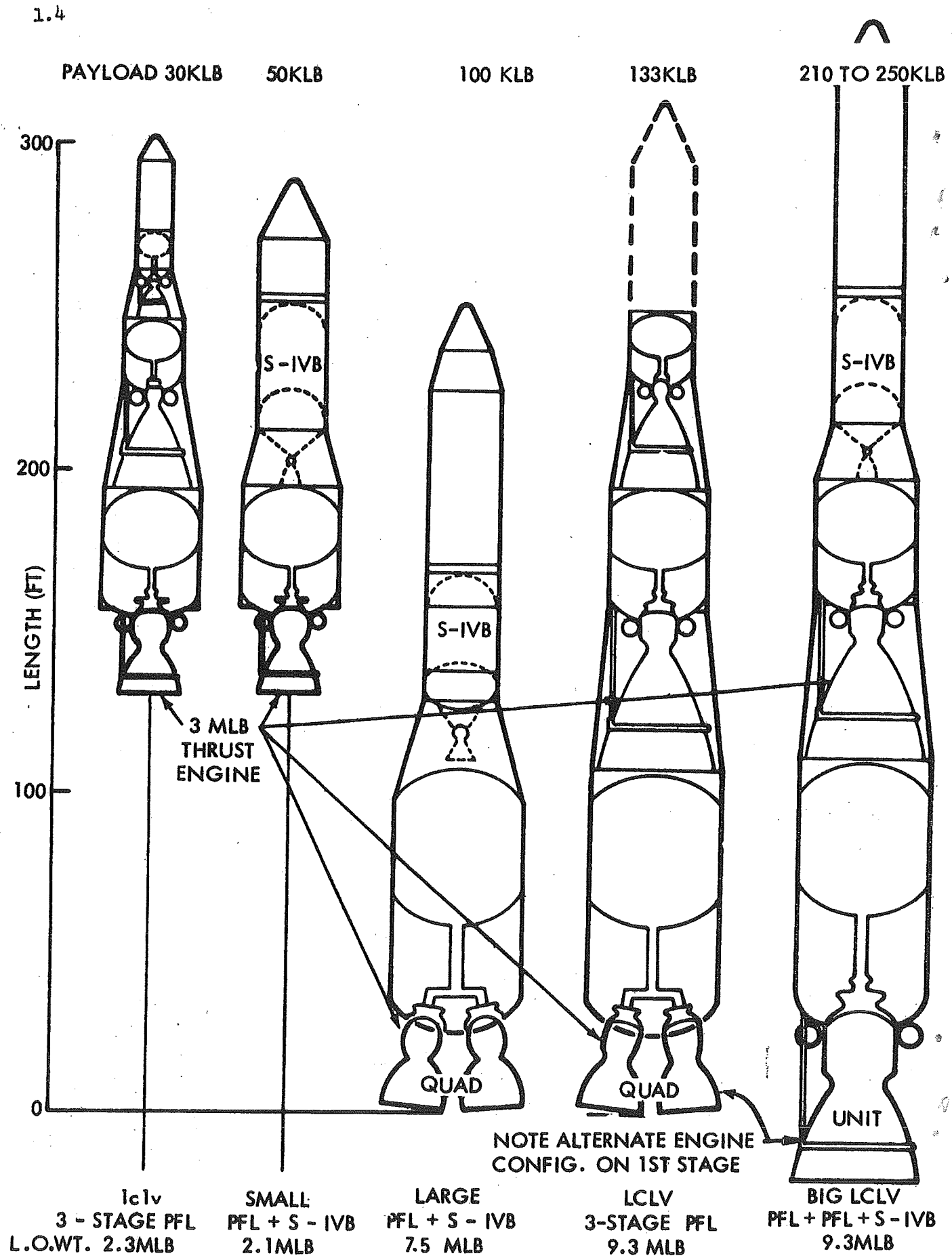
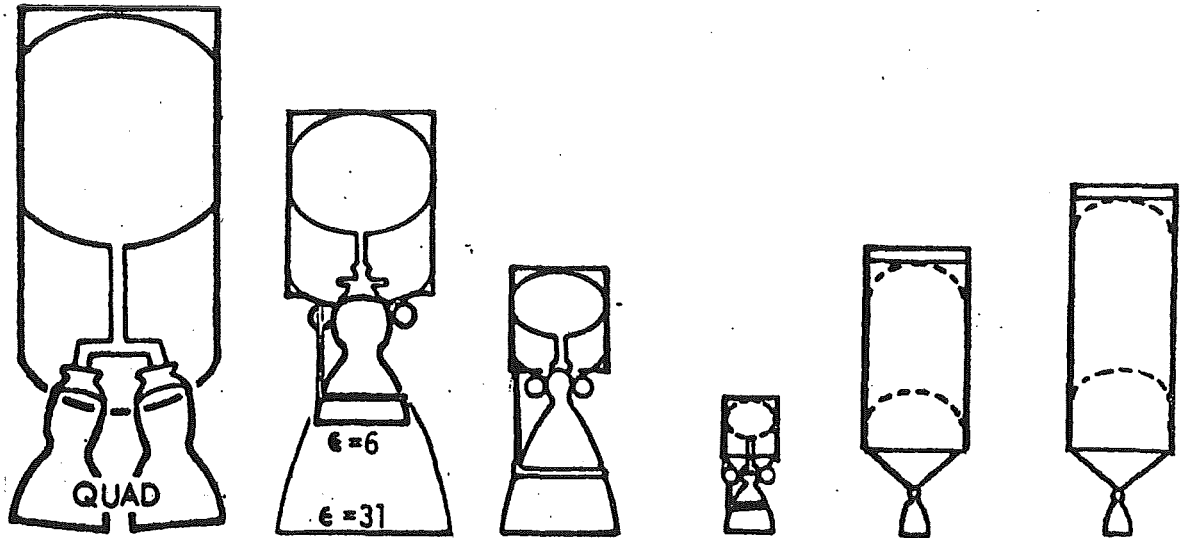

Figure 1-1 Low Cost Launch Vehicle Family



Table 1-II Building Blocks for Low Cost Launch Vehicle Family



	Stage 1	Stage 2	Stage 3	Stage 4	LCS-IVB (Low Cost)	LCS-IVB (Enlarged)
Stage Weight(Klb)	7,099	1,747	356	117	260	350
1st Unit Rec. Cost (\$M)	7.86	3.23	2.09*	.93	12*	12.5*
Non-Rec. Cost (\$M)	164	85	104*	70	100*	150*

\*These upper stages include low cost G & C/IU section

STAGE COMBINATIONS TO ATTAIN VEHICLES SHOWN IN FIGURE 1-1

Baseline LCLV. The 3-stage LCLV is made by assembling Stages 1, 2 and 3, giving a payload of 133K lb to LEO. For missions requiring higher velocity than LEO, Stage 4 is added to launch 20K lb payload to synchronous altitude.

Little lclv. The lclv is assembled from LCLV Stages 2, 3 and 4, the booster stage for the small vehicle having the same 3M lb thrust engine, but without the extended skirt: i.e., epsilon=6 rather than 31. The lclv will launch 30K lb into LEO.

Small PFL+S-IVB. The small PFL+S-IVB combination uses Stage 2 with epsilon=6 and the S-IVB stage, giving 50K lb to LEO.

Large PFL+S-IVB. The large PFL+S-IVB uses Stage 1 plus the S-IVB stage, to give 100K lb to LEO.

Big LCLV. The Big LCLV is assembled from Stages 1 and 2 plus the S-IVB stage, to give 210K lb to LEO. If the S-IVB is enlarged 35 percent, the payload of the Big LCLV increases to 250K lb.

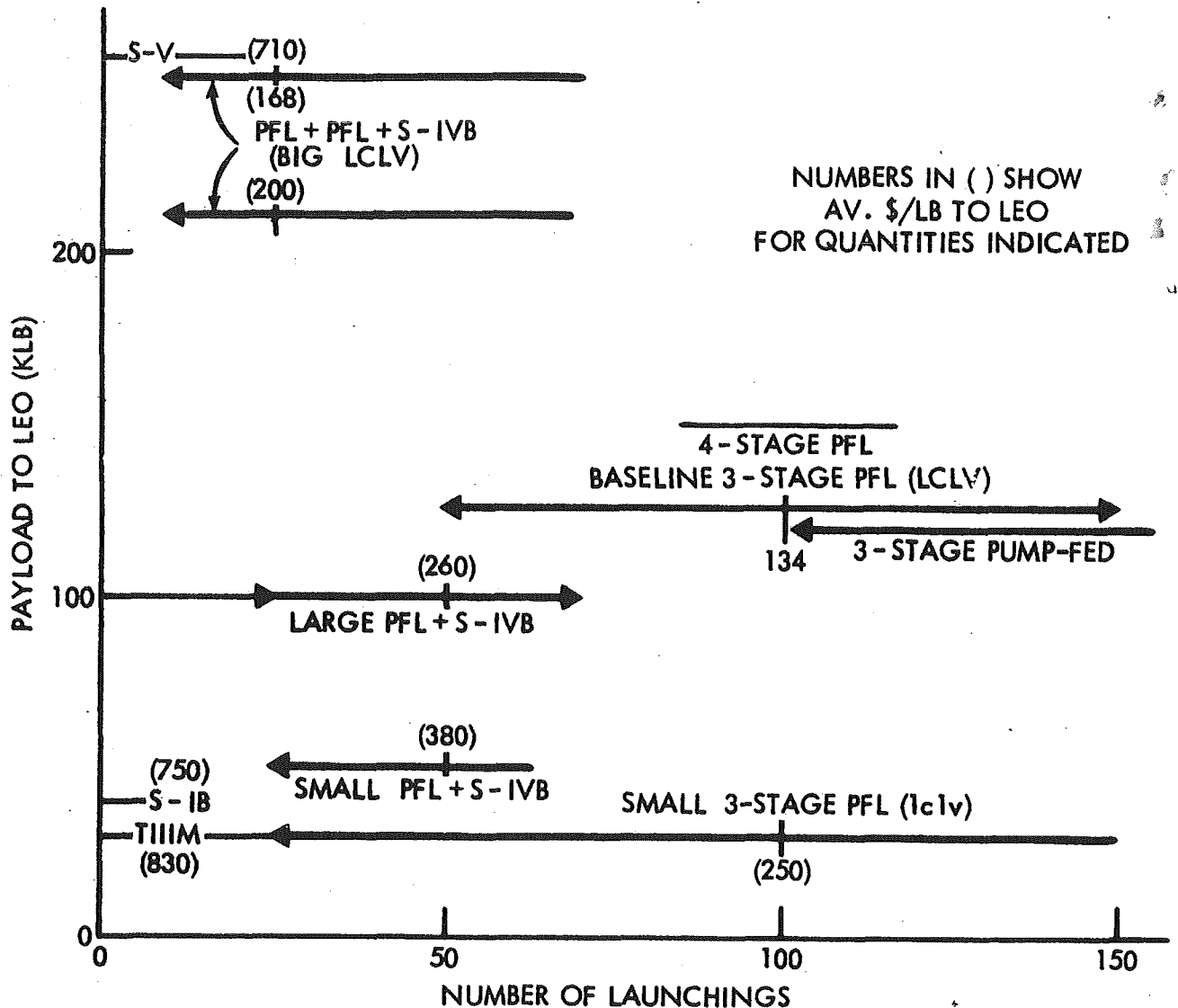

Figure 1-2 Domains of Economic Preference for Various LV's

The LCLV has a transportation cost (including DDT&E and ground support) of \$134/lb to LEO, in quantities of 100, or \$74/lb (excluding DDT&E but including direct cost of launching). This remarkable economy is due to the selection of a simple, pressure-fed vehicle, easy to build and launch with the management techniques proposed, and utilizing many of the existing ground support facilities at KSC.

The average unit cost of the LCLV is sufficiently low that it is even competitive with current launch vehicles having payloads of 10K to 40K lb to LEO. This increases its versatility (measured by the number of units required) by a factor of two or more, with additional savings resulting from the larger quantity production and more standardized launch operations.

Despite the fact that the 3-stage LCLV is cost-competitive for missions in the 10 - 30K lb payload range, an even lower cost configuration is found to be

the lesser 3-stage combination using the 2nd, 3rd and 4th stages of the baseline LCLV. This vehicle, designated lclv, has a payload of approximately 30K lb to LEO, and a cost per launching of about \$7.5M including DT&E and ground support, or \$250/lb in orbit for the smaller vehicle. Since its cost per launching is less than one-half that of the LCLV, it is more cost effective for many of the lesser payload missions.

The gross weight and cost of the baseline configuration vary with payload and design conservatism as shown in Figure 1-3. Conservative and optimistic designs (as defined in Table 4-I), having payloads of 100K lb and 133K lb, are compared in various ways. Lower costs/lb of payload are found to result when the vehicles have greater payload and conservative design margins, the effect of the latter being discussed further in the next section.

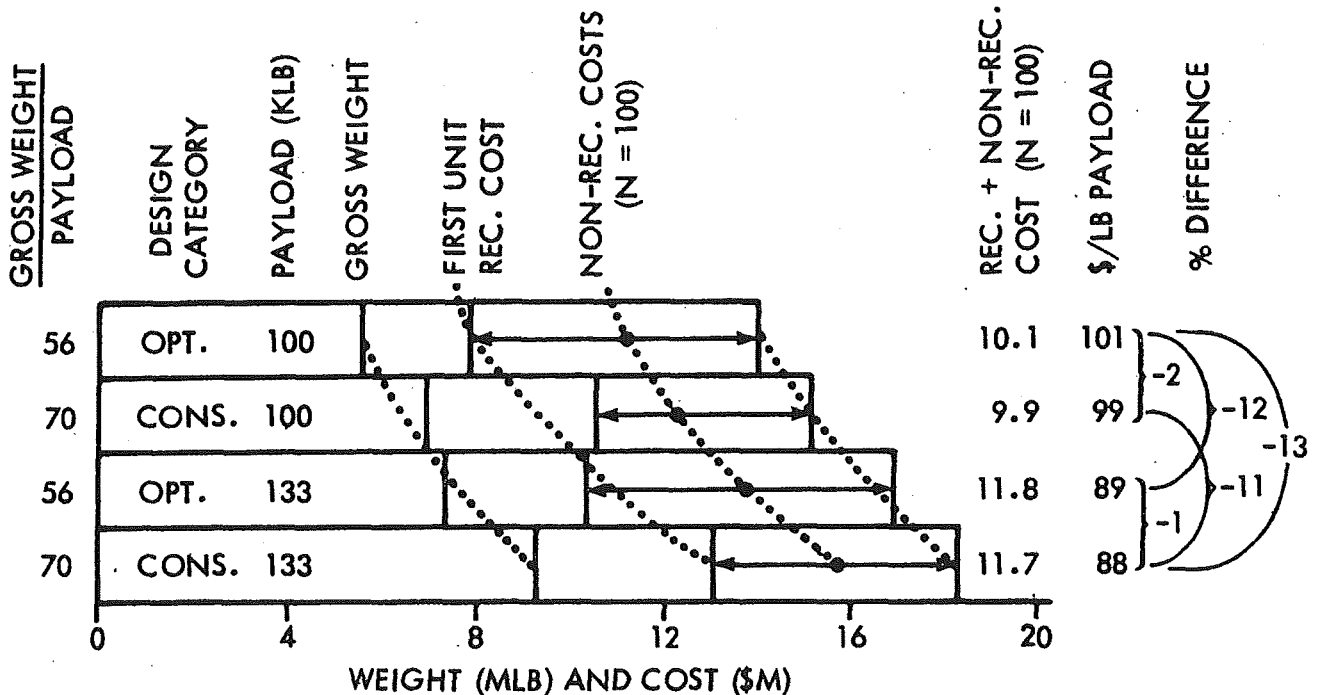

Figure 1-3 Comparison of Design Weights and Costs (Baseline Configuration)

1.5 Effect of Conservatism on Total Cost

One of the most important tradeoffs of this study pertains to the selection of a combination of design margins having the greatest promise of attaining minimum overall cost for developing and producing a specified number of LCLV's. A range of design concepts representing various degrees of conservatism is shown in Table 4-I, resulting in total costs as illustrated in Figure 1-4. That the conservative baseline vehicle, with its LV development cost of \$350M (See Table 9-II), is near optimum can be checked by the following observations.

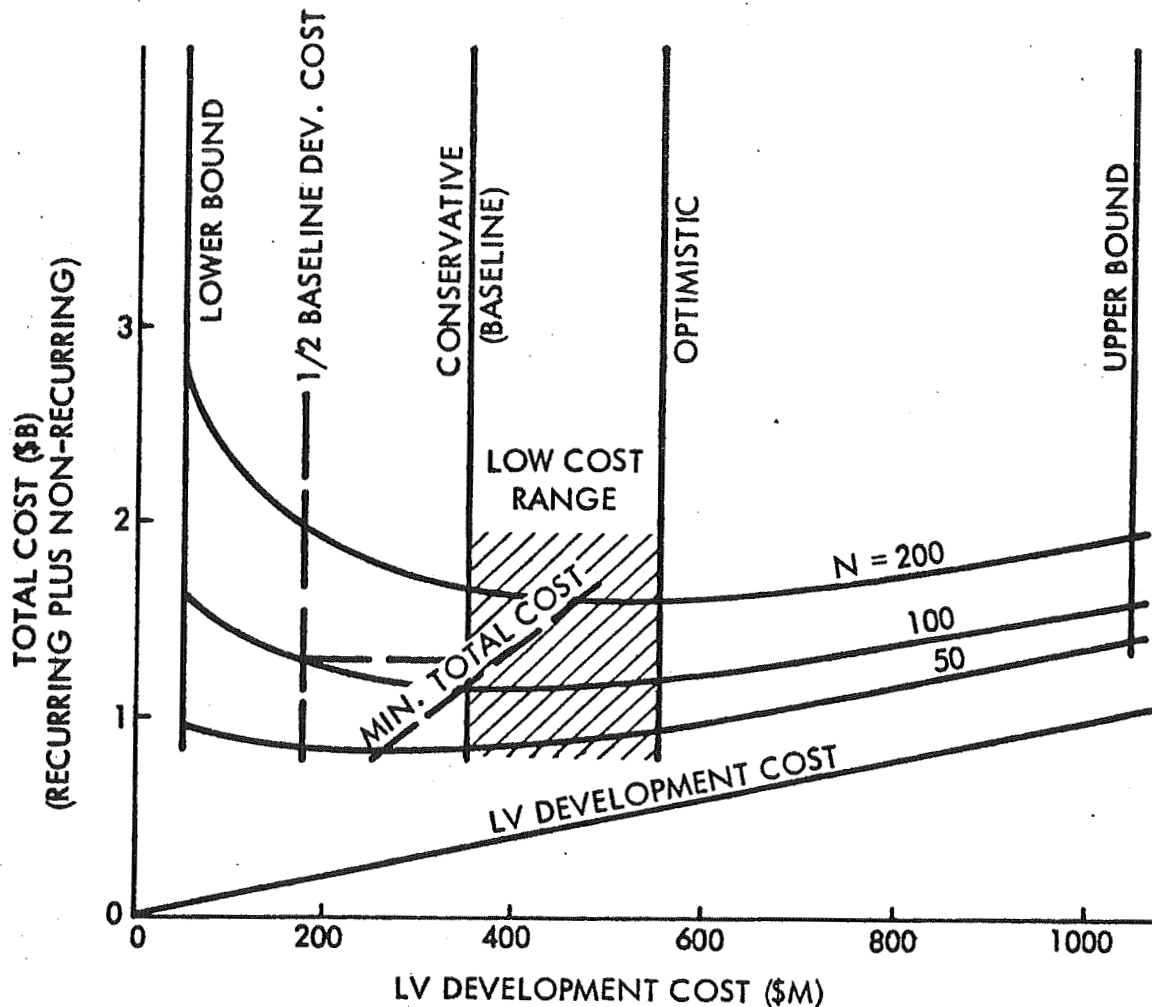

Figure 1-4 Total Cost of LCLV Program vs Design Conservatism

Low Development Cost. The effect of an "Ultra-conservative" set of design margins is shown at the left side of Figure 1-4. This case represents the "Lower Bound" for LV development cost of about \$50M, and the entire development program could hypothetically be carried out with only one set of hardware (as outlined in Table 9-I). However, the vehicle would weigh about twice as much as the baseline, due to its ridiculously high design margins; hence, the cost of producing 100 such units would be excessive. Furthermore, the handling of such a heavy vehicle would require numerous changes to the ground support facilities.

High Development Cost. At the opposite end of the range, the "Super-optimistic" set of design margins, represented by the "Upper Bound" case at the right side of Figure 1-4, would result in a gross weight and unit cost about one-half that of the baseline, but the LV development cost to attain this refinement would be about three times as much; hence, the total cost for developing and producing  $N$  units would be greater than with the baseline.

Optimal Case. Design margins leading to minimum total cost are denoted by the crosshatched region in Figure 1-4. While this range is shown to bracket the desired conditions, more explicit definition of the optimum design margins cannot be stated without further detailed studies of the vehicle designs, engine performance, experimental costs and number of launchings  $N$ . For the present, the "Conservative" design conditions are used as the guideline, because they lead to the following desirable combination of features:

- Minimum-development-cost, within low cost range
- Lowest-development-risk procedure to attain the LCLV
- Maximum-performance-vehicle conveniently handled by present ground support facilities.

Credibility of Estimates. According to Figure 1-4, the development cost of the conservative baseline vehicle, selected by an independent analysis as described in Section 9, results in *minimum total cost for  $N = 100$  units*, showing a proper balance between recurring and non-recurring costs. If the LV development cost were reduced to one-half, as some proponents of low cost vehicles contend, the total cost for  $N = 100$  would increase only 10 percent, and for  $N = 50$ , the increase would be zero. This shows that the baseline development costs are conservative by a factor of approximately 2, thus checking the credibility of the estimates.

### 1.6 Low Cost Payloads

While the principal purpose of this report is to minimize the LV cost of space missions, an equally urgent need is to reduce the cost of space payloads. For minimum total mission cost, the spacecraft and its launch vehicle should be approximately equal in cost (Section 3.6). However, if the LV cost is reduced to one-fourth as proposed, the SC cost should do likewise for proper matching. A new discipline in Low Cost Spacecraft (LCSC) design is needed to match the LCLV, and avoid unnecessary losses in future space budgets.

### 1.7 Scalable Engine

An important test event occurring in recent months is the successful firing of the 250K lb coaxial injector engine at AFRPL, where several short duration runs have been made at rated thrust. These tests help to confirm the thesis of scalability of engines with coaxial injectors to large values of thrust, for this is the third successful scale-up; the first being from 500 lb to 5,000 lb thrust (factor of 10); the second from 5,000 to 10,000 lb; and the third from 10,000 to 250,000 (factor of 25). The next step would be to 3M lb (factor of 12), now under consideration for early development by the Air Force; then to 12M lb

1.10

(factor of 4) for the 2nd and 1st stages of the LCLV, respectively. Alternatively, the latter stage might use quad units of 3M lb, thus precluding the need for the 12M lb engine. From the short tests performed on the 250K lb engine to date, the results are encouraging that full duration runs will be completed without extensive testing, and that additional scale-ups of the engine to thrust values required for the LCLV will be accomplished with equal facility.

1.8 Ground Support

A thorough analysis of LCLV ground support operations and facilities is reported in Section 7. Four concepts for handling the vehicle through assembly, checkout and launch are considered, to attain cost-optimized use of available resources and manpower. The best procedure (Concept B) is to utilize the VAB for stage checkout, assembly and payload integration on the ML, to transport the assembled vehicle to the launch pad with the Crawler/Transporter, and to conduct pre-launch operations with the Mobile Service Structure, in a similar manner to current Saturn V procedures. Some modifications to existing facilities are of course necessary, and these have been costed in the ground support analysis, using functional flow diagrams and time lines for each of the four concepts as the basis for costs and manpower requirements.

Due to the simplicity of the checkout procedures, allowing smaller crews, etc., both the direct and indirect ground support costs are considerably lower than with current large vehicles. The direct labor cost amounts to about \$.54M per launch, or \$4.0/lb to LEO. To obtain the total cost per launching, however, many other services must be included (not necessarily amenable to the reductions brought about by the low cost vehicle philosophy), such as: initial facility modifications and maintenance, mission control and range support for launching, base support costs, etc., bringing the total ground support cost to about \$5.5M per launching at a rate of one vehicle per month.

Throughout the vehicle design, production, checkout and launch operations, prime importance is given to quality assurance and reliability, these items accounting for a higher percentage of the total cost than with current launch vehicles. This principle is believed essential to the ultimate success of the Low Cost Launch Vehicle concept.

1.9 Space Program Economies

- The most significant results of this study are the identification of:
- 1) tremendous cost savings by adopting the LCLV and improved management policies;
  - 2) additional large savings by practicing a new discipline in LCSC design(Sect.3.6).

With the family of vehicles illustrated in Figure 1-1, the entire spectrum of desirable space missions (Figure 2-2) can be accomplished for less than one-fourth the cost of current LV's, the new development cost being amortized in about two years. With this plan, the U.S. Space Program can proceed at a faster pace during the next two decades following the 3-year lclv/LCLV development period.

The foregoing LCLV plans were based on an assumed launch rate of 1/month for a period of 12 years. If a lower launch rate is assumed, the cost/launching increases as shown in Figure 1-5, becoming 37 percent higher for 6/year, and 70 percent higher for 4/year (Sections 7 and 9).

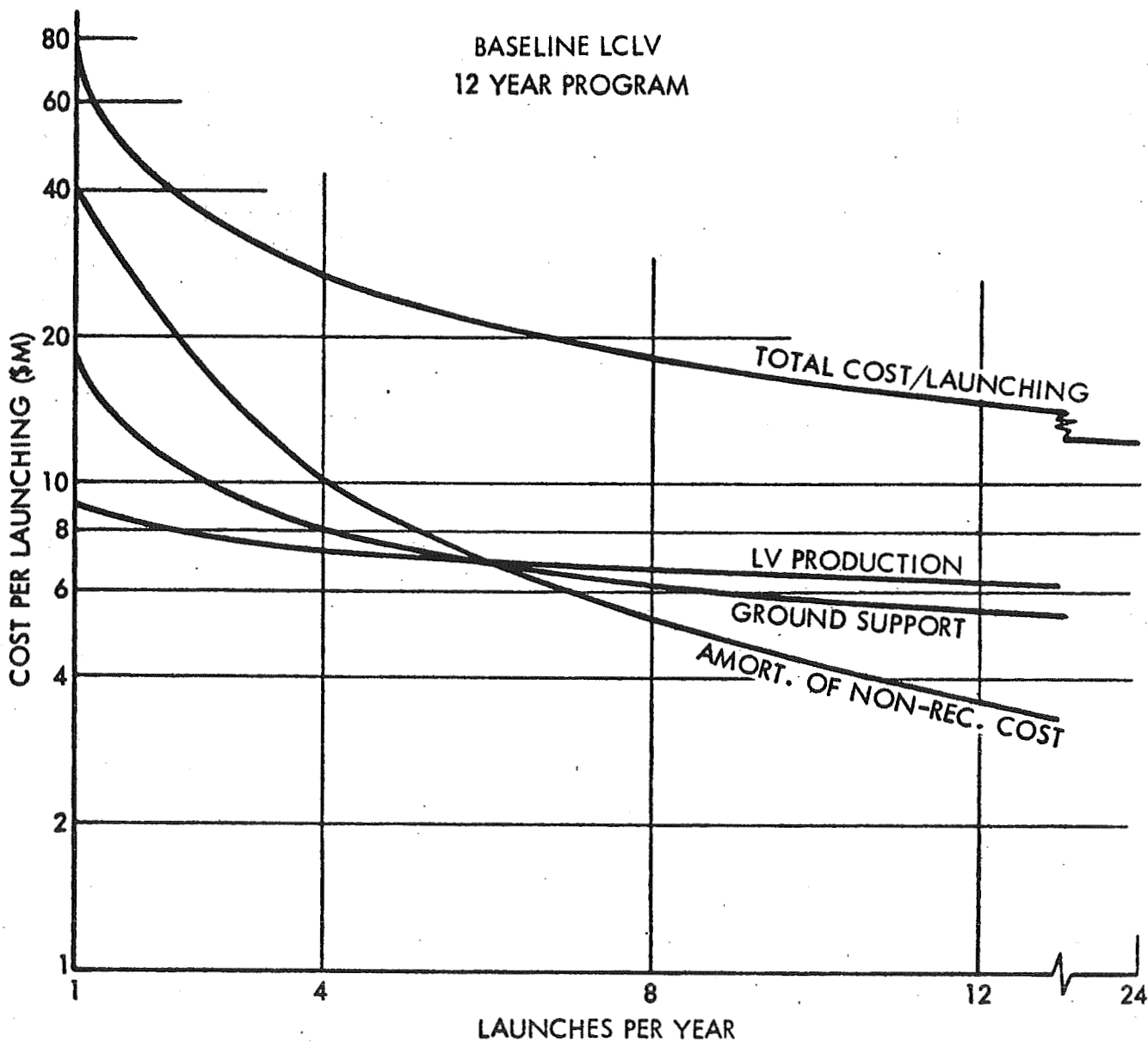

Figure 1-5 Effect of Launch Rate on Cost/Launching (LCLV)

1.12

1.10 Additional Study Areas

Within the relatively limited funding of this study, several areas have received less consideration than would be justified in a broader study. Further consideration is therefore recommended of the following subjects:

- The mission model should be more definitely specified, with estimates of the number of flights to LEO, escape and synchronous (and their payloads); coordinated with the probable LV budgets compatible with the specified number of vehicles (Section 2).
- Low cost payloads should be studied, because of the important interactions with LV capacity, and the huge potential savings through proper PL/LV matching (Section 3.6).
- Pump-fed vehicles should be explored further, to better define the non-recurring costs required in the development of low cost turbo-pumps (especially the turbines).
- Low cost guidance systems have strong interaction with the mission model, to provide adequate accuracy and versatility at minimum cost. Further study of G&C systems for high velocity missions are needed.
- Single vs modular engines deserve further consideration to incorporate the results of current developments such as the 250K lb engine, and proposed developments such as the 3M lb engine, apropos of the ultimate objectives of the low cost launch vehicle program.
- Optimization of LCLV design, including more detailed consideration of the weight and cost of tank and engine materials (T-1 vs HY-140 vs Maraging), safety factors, design margins and subsystems selection; to obtain minimum cost. Include S-IVB upper stage for some applications.
- Standardization of flight planning for similar or duplicate missions. Application of advanced computer techniques for support functions of high frequency launch schedules.
- Further study of ground support operations and facility costs, to determine whether the estimate of 32 percent of the total LCLV cost attributable to these operations is accurate, and how it varies with number of launchings for vehicles of various size. Consider possible interference of LCLV operations, as described, with Saturn V program.
- More detailed study of management policies and development plan, as outlined in Section 10.



## 2. LAUNCH VEHICLE REQUIREMENTS\*

The launch vehicle requirements for space missions in the 1973-1985 period are summarized as follows:

Mission Estimates Guide to Payload-Velocity-Number of LV's Required

Guidance Errors and Velocity Cutoff Accuracy

Operations Compatible with Range Safety Requirements

Tracking-Telemetry and Command Systems

Launch Readiness-As short as economically feasible

Reliability-Equal or better than current vehicles

Other-Engine Throttling-Transfer to Polar Orbits-Etc.

### 2.1 Mission Estimates for 1973-1985 Period

Estimates of the number of space missions to be expected during the 1973-1985 period are, of course, dependent on available budgets and subject to fiscal variations. In recent years, the shrinking budgets have made it increasingly difficult to plan ahead for the number of launchings which seemed to be economically or scientifically justified. This dilemma is alleviated to a large extent by the prospects of greatly reduced cost/launching with the LCLV, making it possible to schedule most of the desirable missions within the curtailed budgets; thus permitting the United States Space Program to progress at a more rapid pace in future.

Mission estimates for intermediate LV's during the 1973-1985 period are shown in Table 2-I. If these missions were all accomplished by the LCLV (in some cases with multiple payloads, see Section 3.4) an average launch rate of 1 per month would be required, and the LV budget for these launchings would be less than \$200M per year, including the non-recurring costs required to initiate the LCLV system. After adding a number of (classified) DOD missions, an unofficial but viable mission plan is suggested, on which to base the design and cost analysis contained in this report.

In graphical form, the above mission estimates appear with other estimates for classes I and IV as in Figure 2-1, subdivided into four classes according to the payload capacity. The complete mission program and approximate costs are then shown in Table 2-II. See Ref. 3 for alternate mission plans.

---

\*See page x for Nomenclature.

Table 2-I Unofficial Estimate of NASA/DOD Missions  
Planned for Launch from KSC in  
1973 to 1985 Time Period

2.2

Missions	Spacecraft	Payload (Klbs)	Launches												
			73	74	75	76	77	78	79	80	81	82	83	84	85
30°-500 NM	Astra	10-30	1		1				1						
Escape	Lunar Logistics	20	2	2	2	2	2	2	2	2	2	2	2	2	2
30°-200 NM	Manned Station	30-60	2	2	2										
Escape	Mariner Follow-on	10	1	1	1	1	1	1	1	1	1	1	1	1	1
200 NM	Logistics Vehicle	30-50	2	2	2	3	3	3	3	3	3	3	3	3	3
* Sync. Eq.	Comsat (Intelsat IV)	2	2	1	1	1	1	1	1	1	1	1	1	1	1
* Sync. Eq.	Direct Broadcast	4			1	1	1	1	1	1	1	1	1	1	1
** Sync. Eq.	Surveillance Satellite	2-2.5	2	2	2										
** Sync. Eq.	Multipurpose Satellite (incl. nuclear detection)	4	1	2	2	2	2	2	2	3	3	3	3	3	3
** Sync. Eq.	Tactical Comsat	2	2	2	2	2	2	2	2	2	2	2	2	2	2
** Sync. Eq.	Data Relay	1.6	2	2	2	2	2	2	2	2	2	2	2	2	2
	Total/yr		17	16	18	14	14	14	15	15	15	15	15	15	15

\* Assume launch rate can be reduced by multiple launches of these two missions.

\*\* Assume launch rate can be reduced by multiple launches of these missions totalling 20 K lb. P.L. weight/launch.

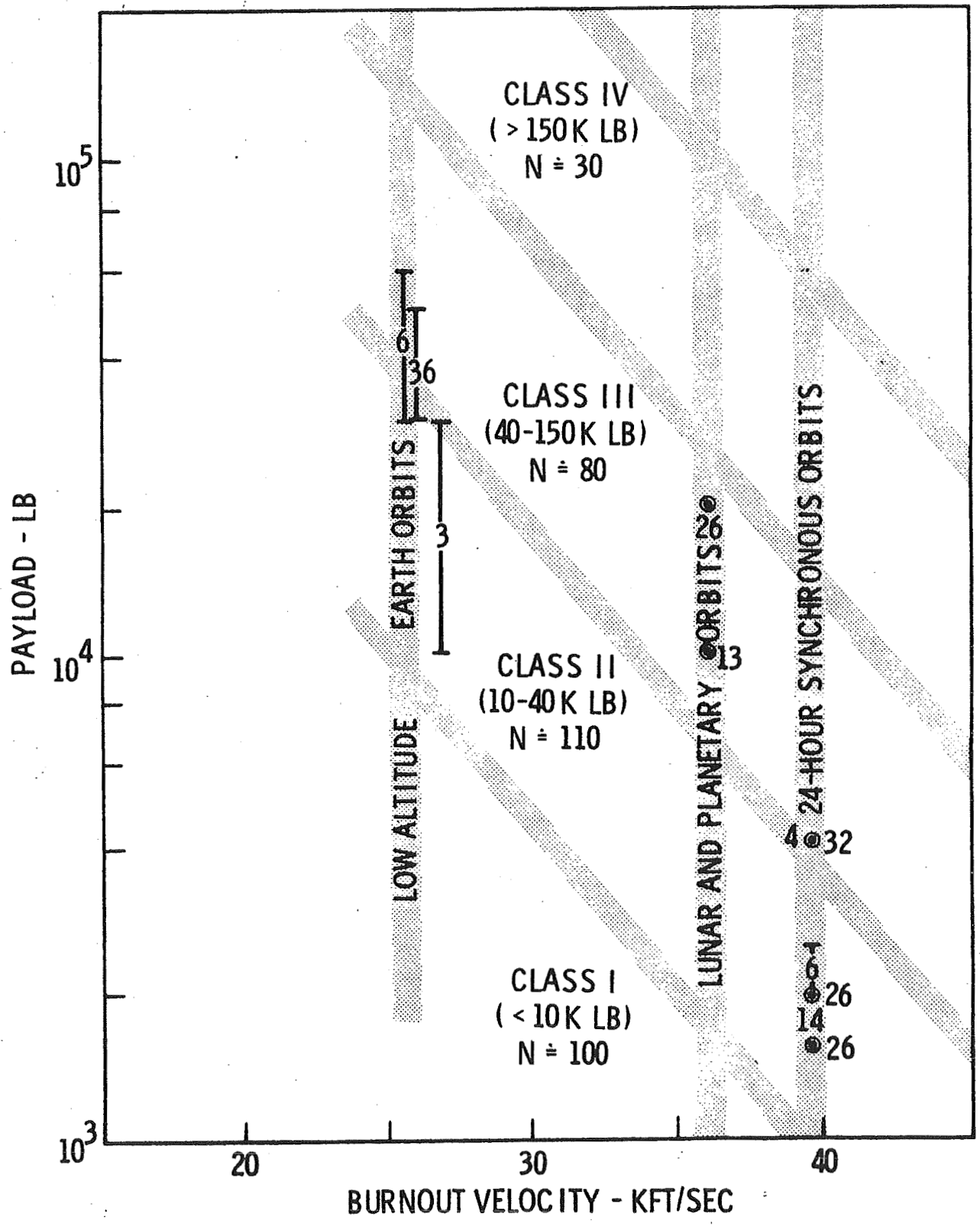

Figure 2-1 Estimated Number of Missions through 1985

Table 2-II Total Mission Program and Costs

LV CLASS	PAYLOAD TO LEO	NO. OF VEHICLE	CURRENT LV's	COST OF CURR. LV's (\$M)	Delta, Sat.V and LCLV (\$M)	Delta, Sat.V LCLV & lclv (\$M)	BIG LCLV LCLV & lclv (\$M)
I	<10K	100	Delta, Atlas-Cent. 50 x 5 50 x 13	900	50x50 } 760 50x102 }	50x50 } 625 50x75 }	Same 625
II	10-30K	111	T-IIIM, Saturn IB 65 x 25 46 x 30	3,000	111x102 1,140	111x75 875	Same 875
III	30-100K	81	66 x 27, 15 x 178	4,500	81x152 1,230	Same 1,230	Same 1,230
IV	>100K	30	Saturn V 30 x 178	5,300	25x152 } 1,270 5x178 }	Same 1,270	25x152 } 650 5x55 }
TOTAL LV COST FOR PROGRAM				\$13,700M	\$4,400M	\$4,000M	\$3,400M

According to this distribution, the above mission program will cost about one-fourth as much with the LCLV family of vehicles, illustrated in Figure 1-1 as with current launch vehicles; or conversely, the LCLV permits four times as many launchings to be made within the limitations of current budgets. The remarkable savings to be attained by use of the LCLV is thus illustrated, savings averaging \$700M/year throughout the 1973-1985 period. Figure 2-2 shows how the LV cost will build up during this period. Amortization of the LCLV development cost will occur during the first year or two, after which the predicted cost savings will accrue.

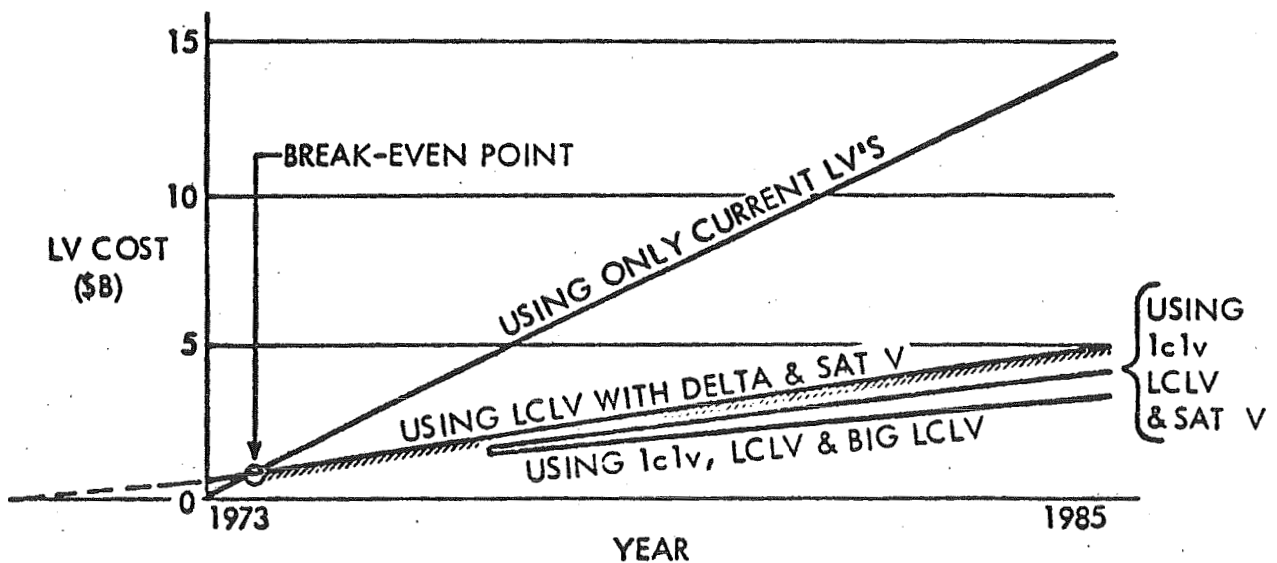

Figure 2-2 Early Break-Even Point with LCLV

## 2.2 Guidance Errors

Since a large number of missions for the LCLV are to low earth orbit, one of the tradeoffs in attaining the minimum cost vehicle for nominal use is to provide a guidance system suitable for operation into LEO but without the added versatility needed to satisfy lunar, interplanetary and synchronous missions as well. These latter refinements are considered to be special mission-oriented requirements justifying added complexity and expense to the payload, rather than to the basic LCLV.

Nominal guidance errors and velocity cutoff errors are shown in Table 2-III, as a basis for determining variations in orbital altitude and eccentricity, and additional propulsion required for correction, to attain a prescribed orbit accuracy or to accomplish orbit rendezvous and docking. Simplified guidance systems are considered in Section 8, for the nominal LEO case, taking advantage of the ability to throttle the engine by 15 percent to maintain a nominal (fly the wire) trajectory.

Table 2-III Typical Guidance Errors and Velocity Cutoff Accuracy

Guidance errors - Orbit plane < 1 mrad	} See Section 8 for tradeoffs
Semi-major axis 2-3 nm	
Orbit period 5-10 sec	
Velocity cutoff - 5-10 ft/sec	
Finer control for docking	

## 2.3 Description of Baseline LCLV

The following description of the baseline LCLV (a 3-stage, non-modular, pressure-fed vehicle, discussed in Section 4) provides a summary of typical requirements pertinent to missions, subsystems, and ground support operations. It is noted that these requirements are only typical, and may be expected to change as a result of further design studies and optimization procedures.

### Missions

- Low Cost Launch Vehicle (LCLV) requirement is for 1973 to 1985 space missions.
- Total payload weight varies from 40K to 150K lb with categories of missions to be launched from KSC as shown in Table 2-I.
- Nominal mission profile is as follows:

2.6

- Stage 1 - propels vehicle to approximately 20 nm altitude at Vbo 6400 ft/sec.
- Stage 2 - propels vehicle to 60 nm altitude at Vbo 16,500 ft/sec.
- Stage 3 - propels vehicle to 100 nm earth orbit at Vbo 25,581 ft/sec.
- Stage 4 - propels 20K lb payload to synchronous equatorial (19,300 nm) at Vbo 40,000 ft/sec.

- LCLV trajectory accuracy requirements are comparable to Intelsat IV for synchronous equatorial missions, to Apollo and MOL for low altitude orbit. Lunar and Mars mission trajectory accuracy requirements are similar to Apollo and Mariner, respectively.
- Post-orbital recovery operations are not to be considered, (although it may be feasible to recover the first stage, as noted in Section 3.5).
- Communication satellites will be available for transmitting LCLV data to earth during its mission, if they reduce overall cost.
- A success-oriented, no-contingency, launch schedule is assumed.
- Three stages will be used to place 40K to 100K lb P.L. in low altitude orbit, and a fourth stage to place 20 lb P.L. in synchronous equatorial orbit.

LCLV Configuration

- A modular building block concept similar to the Saturn program will be considered. For example, instrumentation module will be flyable with third or fourth stage, fourth stage can be flown with second and third stage, etc.
- No LCLV or AGE hardware modifications, other than software, are required to fly the various payloads.
- Dimensions of the LCLV are as follows:

Maximum length of LCLV with 100K payload (less launch escape system) 339'

Maximum length of LCLV with 10K payload 326'

<u>Stage</u>	<u>L (ft.)</u>	<u>D (ft.)</u>
1st	129	40
2nd	84	30
Interstage	50	40/30
3rd	50	19
Interstage	30	30/19
4th	25	12
10K payload	30	12
100K payload	73	19
Launch Escape System (LES)	30	4/2

- LCLV weights less P.L. and LES are approximately 530 tons dry and 4600 tons wet.

#### Propulsion

- All four stages use NTO/UDMH for propulsion. No solid engines or strap-ons are used.
- All stages have a single fixed (non-gimballed) thrust chamber assembly. Oxidizer is injected into the nozzle (downstream of the throat section) for thrust vector control (pitch and yaw).
- During coast periods, pitch and yaw control of upper stages is attained by ejection of hot gas from fuel tank.
- All four stages use hot fuel tank gas ducted to tangential nozzles for roll control.
- Third and fourth stages maintain ullage control during orbital coast period and engine start-up by ejection of hot gas from fuel tank.
- All four stages use auxiliary system for initiating fuel injection into oxidizer tank to start main tank injection (MTI) pressurization system.
- No retro-rockets are used.
- Positive interstage opening is assumed for all stages.
- During all propellant loading and unloading operations, an  $N_2$  blanket pressure is maintained in the LCLV tanks. Total propellant loading and emergency unloading time of all four stages is four hours and one hour, respectively.
- Propellant bleed and drain lines are required.
- Minimum pressure is maintained in oxidizer and fuel tanks of each stage during launch readiness. All MTI systems are initiated before liftoff.
- Prerequisite to missile launch is first stage engine reaches minimum thrust, and upper stage tank pressures reach nominal level.

#### Guidance and Control (G&C)

- Payload G&C is functionally independent of LCLV guidance and control system.
- No hydraulic control system is required since LITVC and hot gas roll control systems are fixed.
- LCLV contains inertial guidance system located in an upper stage instrumentation unit.

- LCLV inertial system is comprised of an inertial measurement unit (IMU), guidance computer and data coupler. Removable, modular construction is used.
  - Computer inputs are: IMU angle and velocity data;  
Trajectory programmed data;  
Ground tracking station telemetry up-link data.
  - Computer outputs are: Direct engine commands;  
Thrust angle commands;  
IMU alignment angles;  
Telemetry data;  
Staging commands.
- Flight control system of all four stages receives guidance commands from the instrumentation unit.
- Roll and attitude control and start-up ullage control for the third and fourth stage during period of unpowered flight is accomplished using hot gas from top of fuel tank.

#### Electrical and Mechanical System

- Separation sequence and ordnance arming is controlled by master sequencer in the instrumentation unit.
- Separation sequence of second and third stages start with shutdown of preceding stage.
- Interstage separation of each stage is initiated following its engine start-up.
- Engine shutdown is initiated upon propellant depletion, or by the guidance computer.
- Emergency detection system is incorporated in each stage for monitoring at the instrumentation unit vehicle abnormal performance.
- 28 VDC batteries are used in each stage for electrical power during flight.
- Umbilicals for each stage are as follows:

<u>Stage</u>	<u>Instrumentation</u>	<u>Propellant Bleed Lines</u>	<u>Fuel Fill and Drain</u>	<u>Oxidizer and Drain</u>	<u>Guidance and Environmental Control</u>
1	1	2	1	1	
2	1		1	1	
3	1		1	1	1 *
4	1		1	1	1

\* Not required when instrumentation unit is flown in fourth stage.

- Single point electrical grounding system is employed.

#### Ordnance

- No retro or ullage rockets are used in the LCLV.



- Explosive charges are used for interstage, stage and payload separation.
- Pressure charge is used to open propellant prevalves and to vent fuel tank for ullage control and burned-out stage separation (if needed).
- Initiators are used for battery activation and in-flight electrical disconnects.
- Prima cords are used for stage destruct.
- S&A devices are used to safe and arm all ordnance.
- Ordnance shorting bars are used until connected to the LCLV electrical system.
- Positive hold-down fittings are used to restrain LCLV motion during launch until released.

### Instrumentation

- All four stages contain an instrumentation and range safety system for monitoring flight performance. System is comprised of:

Measurement sensors  
Telemetry subsystem  
RF subsystems (Range Safety)  
TV monitor systems  
Photographic equipment  
Antennas

- Instrumentation unit (IU) is designed to be housed either in the third or fourth stage. The IU contains the following subsystems:

Inertial guidance and control  
Master timing sequencer  
Measuring and telemetry system  
Radio frequency system (included in second, third, and fourth stages)

Functions IU performs are:

On board LCLV checkout and calibration  
LCLV guidance and control  
Vehicle command and functional sequencing  
Insertion of payload into earth and synchronous orbit  
Stabilization of fourth stage prior to payload synchronous orbit injection  
LCLV emergency conditions  
Measurement of IU performance  
Range safety provisions are essentially as now available at KSC, but simplified by eliminating MISTRAM and Minitrack and including a Unified S - band capability  
Telemetry transmission (PAM/FM/FM, PCM/FM and FM/FM Telemetry)  
LCLV data conditioning, storage and transmission \*  
IU battery power.

\* Assumes payload data handling is independent of LCLV.

2.10

Environmental Control System

- LCLV environmental control will be provided from the ground during prelaunch operations.

Ground Support Systems

- Payload is simulated at LCLV integration and test area.
- The original Concept A, to assemble, integrate and test complete LCLV in Plant A was found to be more costly than to assemble stages in VAB (Concept B) similar to current Saturn V procedures.
- LCLV with payload installed arrives at launch pad in flight ready condition, except ordnance initiators, which are installed at launch pad.
- Launch pad testing and checkout to be a minimum.
- LCLV on-site checkout and launch operations are based on five-day week, one 8-hour shift/day.
- All LCLV modifications are made at factory or integration area. No mods are made at launch site.
- LCLV fault isolation at launch site is to replaceable major sub-assembly, such as C-Band beacon, inertial measurement unit and guidance computer.
- Propellants are loaded aboard LCLV at launch pad prior to terminal count.
- LCLV design will provide for programmed automatic checkout and fault isolation.
- The LCLV instrumentation, range safety and R-F tracking systems are compatible with the ETR, communication satellite and manned and unmanned world-wide ground station network capabilities.

### 3. DESIGN PHILOSOPHY AND CONCEPTS

A review of NASA records for contract end items (CEI) and other costs relating to LV's, reveals the following chief contributors (Reference 2):

- Launch vehicle cost (CEI and CEI Support). . . . . 55%
- Launch and launch support operations . . . . . 40%
- Integration . . . . . 5 - 10%

The hardware cost is found to be only about 25 percent of the total, the remainder being distributed between support activities and integration of the various subsystems, and the final launch cost with its support activities.

In addition to the above LV costs, the overall Space Budget includes the cost of payloads and other mission related activities, which are generally estimated to be equal to the LV costs. A worthwhile objective is to minimize, if possible, the overall Space Budget required to perform the desired missions.

The LCLV concept envisions substantial reductions in all the above categories, to result in LV and total costs less than one-fourth as great as with current systems (see Table 2-II); or conversely, four times as many launchings within the limitations of current space budgets. These economies are due to four principal causes:

- Simpler LV's resulting in lower hardware and launch operation costs, as well as low development cost and simpler ground support facilities.
- Versatile LV's, which can be used economically for missions now employing two or three different LV's.
- Improved efficiency of on-site operations, resulting in fewer personnel involved in integration and support operations.
- Low payload costs resulting from conservative LV performance and allowable payload weight.

Discussion of these cost saving plans are presented in the following sections.

#### 3.1 Design and Development Concepts for Minimum Cost

Launch vehicle design philosophy has heretofore been to conserve weight, and to attain high reliability and maximum performance for a given weight, with cost as a secondary concern. This philosophy has led to extensive testing and frequent schedule delays to attain the performance/weight/reliability specifications, resulting in the escalation of program costs, due to extra testing and extra personnel required to preserve scheduled delivery dates.

The new philosophy of the Low Cost Launch Vehicle is to design for minimum overall cost, by using simplified vehicle concepts, state-of-art techniques, and conservative weight estimates, to find a proper balance between hardware weight/cost, development cost and operations cost. Emphasis is still placed on quality assurance and reliability, but to attain these within the context of simplified vehicles, reduced personnel involvement and more efficient methods of procedure (Refs. 4, 5, 6).

The design approach is to exploit staging to an optimal degree, and to investigate alternate configurations by case studies of novel designs having potential cost savings. The analysis of such designs, with their relative advantages and disadvantages, will lead to the selection of a preferred configuration, to be optimized by further design studies. The principal features of the LCLV thesis are:

Low Cost Engines. One of the basic hypotheses is that engines employing the TRW coaxial injector can be scaled up to large values of thrust without extensive testing. In the past few years, three successful scale-ups have been accomplished, in which high combustion efficiency and stability were demonstrated, leading to confidence that the additional scale-ups for the first two stages of the LCLV will be attained with equal facility. Other cost-saving features of the LCLV engines are ablative (vs regenerative) cooling, storable (vs cryogenic) propellant, and (LITVC) liquid injection thrust vector control (vs gimballed nozzles).

Low Cost Fabrication. Tanks and engines similar to those employed in the LCLV have already been produced of high strength steel by boiler shop/shipyard techniques and personnel. Concepts for LCLV fabrication are based on these proven methods.

Pressure-Fed Stages. The pressurized LCLV has a simplicity reflected throughout all phases of design, development, manufacture and operation, to result in minimum overall cost. High strength steels are employed in the tank construction, and pressurization is accomplished by main tank injection (MTI), or possibly by a hot gas generator (GG) system (Section 5.3).

Low Cost Astrionics. Low cost guidance and control systems, designed primarily for the needs of low earth orbits, rather than for versatility to meet the requirements of high velocity missions as well. Other astrionics costs are reduced by the simplicity of checkout and operation of the pressure-fed LCLV stages (Section 8.6).

Conservative Design. Generous assumptions of weights, costs and specific impulse values, and the selection of proven design concepts are expected to expedite the LCLV development without the need for extensive testing to attain the assumed values of performance and reliability.

Low Cost Development. A low cost development program is expected to prove the performance and reliability of the above features incorporated into the LCLV, as summarized in Table 3-I.

Table 3-I Low Non-Recurring Cost for LCLV

Design for minimum cost rather than weight/performance  
Sufficient performance margin to minimize testing  
Simplified vehicle - Less parts to design/test/QA

Low cost engine development - Means more tests/\$  
Chamber & Ablative nozzle - Coaxial injector

Stage development - Geometrical & operational similarity  
Build small - Test & learn - Build larger

Tests of proven techniques at larger scale - Low DT&E cost  
Engines and LITVC  
MTI pressurization

Utilize existing ground support facilities whenever possible;  
VAB - Mobile Launcher/Crawler - Mobile Service Structure -  
Launch Complex

The "ideal" development program envisions components, subassemblies and systems that function properly the first time, or after minor adjustments. Low development costs will result from the use of conservative design margins to minimize the amount of testing to prove performance and reliability. While the attainment of such an ideal development program is hardly to be expected, there are several factors which tend to simplify the procedure; namely, the simple pressure-fed vehicle concept, the geometrical and operational similarity between stages, the

3.4

testing of smaller stages first, and the scalability of the coaxial injector engine--all tend to increase confidence that the overall development cost will be moderate.

3.2 Management Concepts for Minimum Cost

The wide versatility of usage of the ICLV (see Section 3.4) indicates that it will be produced in large quantities (relative to previous space boosters). An efficient one-plant operation is envisioned for the fabrication, assembly and integration of all stages within a few miles of the launch site. "Plant A" will be managed to maintain a steady flow of work at an optimum production rate for high personnel efficiency. Follow-through of LV checkout personnel to the nearby launch site will avoid excessive overlap of launch support operations and will result in reliability with minimum cost (see Section 6).

Simplified documentation should result from the above management procedures, with fewer contractors involved. Standardized software, generated at the LV source, will result in appreciable savings and reduced probability of error.

These baseline management concepts are consistent with the objective of minimum cost launch vehicles. However, if sufficient justification were shown for broader industrial participation, some modifications to the above concepts can be made.

A summary of the management concepts to be employed in the production and operation of the ICLV is given in Table 3-II.

The baseline ICLV has a combination of simplicity and economy resulting in low cost of fabrication and launch operation. When produced in Plant A adjacent to the launch site (Section 6), the stage integration and subsystems support costs are minimized, and quality assurance is simplified by more direct and efficient procedures, with fewer personnel involved.

Confidence Level in Simplified Approach. The simplified launch vehicles discussed in this report have considerably fewer parts than current LV's, and the conservative design margins permit fewer tests and less stringent monitoring and control in many areas. Nevertheless, careful quality control and reliability assurance are requisite. It is believed that management and engineering will successfully integrate these factors to result in manufacturing, checkout and launch operations to result in minimum overall cost.

Table 3-II LCLV Management Concepts

## Methods of LV manufacture

Systematized boiler ship practice  
 Steel fabrication - Tanks - Engines - Interstage  
 One-Plant fabrication - Assembly - Integration  
 Off-Site checkout before delivery

## Simplified documentation

Reduced coordination paperwork  
 Standardized software  
 Fewer Contractors - block buy without changes

## Reduced on-site and launch operations

Minimum on-site assembly and checkout  
 Reduced personnel requirement

## Optimum production rate - build and store

Incentive contracts for attaining low cost  
 with comparable reliability

## 3.3 Configuration Selection for Minimum Cost

After a comparison of many LV configurations having a variety of cost-saving features, the preferred launch vehicle capable of 100K lb payload to LEO is found (in Sections 4 and 9) to be the baseline configuration (3-stage, pressure-fed, non-modular) which has an average cost per launching of about \$17M in quantities of 100 (including launch operations and non-recurring costs). With a payload of 133K lb to LEO (with zero ft/sec velocity pad), the transportation cost is \$134/lb (\$74/lb including direct cost of launch but not DDT & E, or about 1/10th that of current LV's such as Saturn IB, TIIIC and Saturn V).

For an additional 100 launchings, the average unit recurring cost will be about \$10M/launching (assuming the non-recurring cost is amortized over the first 100 launchings). This low unit cost is then competitive with current launch vehicles capable of about 10K to orbit, as discussed in the next section.

3.6

3.4 Payload Versatility for Minimum Cost

Having sized the LCLV for launching 100K lb (nominal) payloads to LEO, how can it be used most effectively for low cost transportation for other missions in the program plan shown in Figure 2-1? Due to the reduced unit cost for a large number of LV's (all alike), the standard LCLV can be employed economically for many more missions than originally intended (approximately twice as many).

Class III missions. All of the missions designated in the intermediate payload band (30-100K lb) can be accomplished most economically with the conservative LCLV having 100K lb to LEO. It has been proven that the development cost of another smaller LV to accommodate the *lesser* Class III missions (for example, payloads of 30 to 60K lb) is not justified for the number of missions indicated in Figure 2-1.\* Even when the smaller LV is assembled from the same modules used in the larger vehicle, the development cost of the smaller vehicle must be very low to compete with the cost of extra numbers of the larger vehicle.

Class II and Class I Missions. The cost per launching of the above LCLV is sufficiently low that it can even be used economically for most of the Class II missions (involving payloads in the 10K - 30K lb range). Reasoning that the non-recurrent cost of the LCLV is fully justified for and amortized by the Class III missions, its use for lesser missions involves only the recurrent cost of the vehicle (\$10M incl. launch), which is marginally competitive for even the larger Class I missions (payload of 8K - 10K lb, the actual payload boundary to be determined by more detailed cost analysis).

Despite the fact that the 3-stage LCLV is cost-competitive for missions in the 10 - 40K lb payload range, a further saving of 40 percent is found in the lesser 3-stage combination using the 2nd, 3rd and 4th stages of the large LCLV. This vehicle, designated lclv, has a payload of approximately 30K lb to LEO, and a cost per launching of less than \$8M including DT&E and launch operations, or \$250/lb in orbit for the smaller vehicle. The upper stages are identical with those used on the LCLV, while only a few changes are required to adapt the booster stage to low altitude operation.

Multiple Payloads. The above rationale applies to missions having only one payload per launch. The use of multiple payloads offers an important economy in favor of the LCLV with its generous payload capacity. This mode of operation should be compared with the potential savings in payload cost made possible through greater payload capability (see Section 3.6).

\*However, Class II missions are more economically accomplished by a smaller LV.



Class IV Missions. It is assumed that Class IV missions will be accomplished by multiple launches of the LCLV for payloads amenable to assembly in orbit, since this mode of transportation provides lowest cost to LEO. The Saturn V can be used as an alternate (more costly) mode for one-piece payloads up to about 250K lb, or a low cost alternate is provided by the Big LCLV.

Optimal Payload Capacity. Extending the capacity of the LCLV from 100K to 150K lb, for example, raises the question of optimal size for the LCLV. Making the vehicle larger will increase its cost for all the lesser missions, as discussed in the preceding paragraphs. The conservative baseline LCLV\* is believed to be a favorable compromise between the higher payload of 150K lb and the lower Class II missions of 10 - 30K lb payload, satisfied by the more economical lclv combination. Payloads of 150K lb can be launched to LEO with the same LCLV by adding a fourth stage (as required for synchronous orbit), (see Fig. B-1). This simple solution retains the basic advantages of the 100K LCLV for mission versatility.

### 3.5 Effect of Booster Recovery on LV Cost

The sturdy construction of the pressurized tanks of the first stage suggest that parachute recovery might be feasible. With a main parachute area of 16,000 sq ft (similar in size to Apollo but much heavier) a descent velocity of about 250 ft/sec will be obtained. The forward bulkhead might be shaped to permit water entry at such speeds without exceeding the internal tank pressure of 440 psi. Table 3-III shows that savings of 15 to 40 percent might be accomplished in this way.

Table 3-III LCLV Cost With Booster Recovery

Preliminary Estimate of LCLV 1st Unit Cost \$13.1 M (=f)	
90% LC, N = 100, AUC = .5f	\$ 11.7 M (FOB Factory)
Add launch operations cost = \$5M	16.7 M (Launched)
Value of recovered 1st stage	- 3.0 M
Recovery and refurbishment cost	<u>+ 1.0 M</u>
NET COST PER FLIGHT	\$ 14.7 M (Launched)
With N = 100, TRANSPORTATION COST	<u>\$14.7 M = \$111/lb</u> 133K lb
With N = 200, TRANSPORTATION COST	<u>\$12.0 M = \$90/lb</u> 133K lb

The above data suggest that serious consideration be given to recovery of the booster stage, due to its unique structural characteristics and the moderate parachute installation weight required.

\*It is about the largest LV conveniently handled by the present facilities at KSC.

3.8

3.6 Effect of Payload on Total Mission Cost

This study provides design, operation and management concepts to minimize the LV cost for launching space payloads of various weights. However, the total mission cost must include that of the spacecraft, the weight and cost of which have strong interactions with the launch vehicle characteristics. A consideration of these factors is pertinent to the LCLV study, as a guide to the application of the LV for maximum payload versatility. The total mission cost, including launch vehicle and payload, can be minimized by procedures outlined in a proposed Low-Cost Spacecraft Study (Section 3.6.3), representing a cost saving potential comparable to that found in the present LCLV Study.

3.6.1 Current Spacecraft

In support of this thesis, Table 3-IV shows the total development and production costs of several current spacecraft. When divided by the number of units to be flown, the cost of the spacecraft is from 2.4 to 5.7 times as great as that of its launch vehicle. These quantities should be equal to attain minimum total mission cost. Furthermore, if the LV cost is reduced to one-fourth as proposed, the

Table 3-IV Cost of Current Spacecraft

SC Designation ( & Launch Vehicle)	SC Program Cost (\$M)	No. Units Flown	SC Cost (\$M/Unit)	LV Cost (\$M/launch)	\$SC \$LV
Surveyor (Atlas - Centaur)	465	7	66	14	4.7
Lunar Orbiter (Atlas-Agena D)	140	5	28	11	2.5
OA0 (Atlas-Centaur)	320	4	80	14	5.7
OGO (Atlas-Agena D, TAT-Agena)	250	6	42	9	4.6
OSO (Delta)	96	8	12	5	2.4
Apollo (S-V)	6638	15	443	178	2.5

SC cost should do likewise. Evidently the SC should (and can) be made less costly by being more generous with the LV capacity, since a relatively small percentage increase in the permissible SC weight permits a much larger decrease in its cost. This principle serves as a guide to prevent large losses in future space budgets.

The current LCLV study approach has been somewhat influenced by the foregoing principle relative to payload cost. Realizing the importance of proper SC/LV matching, the LV designs are made to have generous payload capacity, to provide the flexibility needed to reduce the payload cost, and thereby the total mission cost.

3.6.2 Guide to Minimum Total Mission Cost

The average launch vehicle cost \$LV, including acquisition expense, varies directly with the weight of payload W according to the equation \$LV = a + bW. . .(1)

However, in the case of the payload cost \$PL, including acquisition expense, it becomes increasingly difficult and more costly to accomplish a given number of functions as the payload weight is decreased; hence, \$PL varies inversely with the payload weight, as for example \$PL = c\_m + d/(W - W\_m). .(2) where c\_m is the minimum cost (regardless of weight) and W\_m the minimum weight (regardless of cost). Since only a few payloads are produced of a given type, the average \$PL may be quite large compared to \$LV. For this reason, it is necessary to determine the optimal combination of these terms to result in minimum total cost.

The total mission cost \$TMC = a + bW + c\_m + d/(W - W\_m). . . . . (3) is then to be minimized. Differentiating with respect to W

d \$TMC / dW = b - d / (W - W\_m)^2 = 0 for minimum cost. . . . . (4)

The optimum value W\_o of payload weight is then determined as a function of optimum \$PL\_o from Equations (2) and (4).

d = b (W\_o - W\_m)^2 = (\$PL\_o - c\_m) (W\_o - W\_m)

or b(W\_o - W\_m) = \$PL\_o - c\_m is the optimization criterion. . . . . (5)

The physical significance of this criterion is seen by inspection of Figure 3-1, for the simple case where W\_m = c\_m = 0. A single curve of \$LV vs W is shown, and a series of \$PL curves of various relative magnitude compared to \$LV. According to Eqs. (1) and (5), the optimum value of W is given by \$LV\_o = bW\_o = \$PL\_o, and \$TMC\_o = \$LV\_o + \$PL\_o = \$2LV\_o, for all values of W\_o resulting from the various combinations of PL and LV curves.

The above result with the simple hyperbolic variation of \$PL vs W (W\_m = c\_m = 0) leads to the well known rule of thumb (that the payload cost is equal to the launch vehicle cost) since the above analysis gives the equation

\$/lb to LEO = Transportation Cost = \$LV\_o / W\_o = \$PL\_o / W\_o

Further study of the above relationships is believed advisable, to better understand the PL/LV matching which will result in minimum total mission cost.

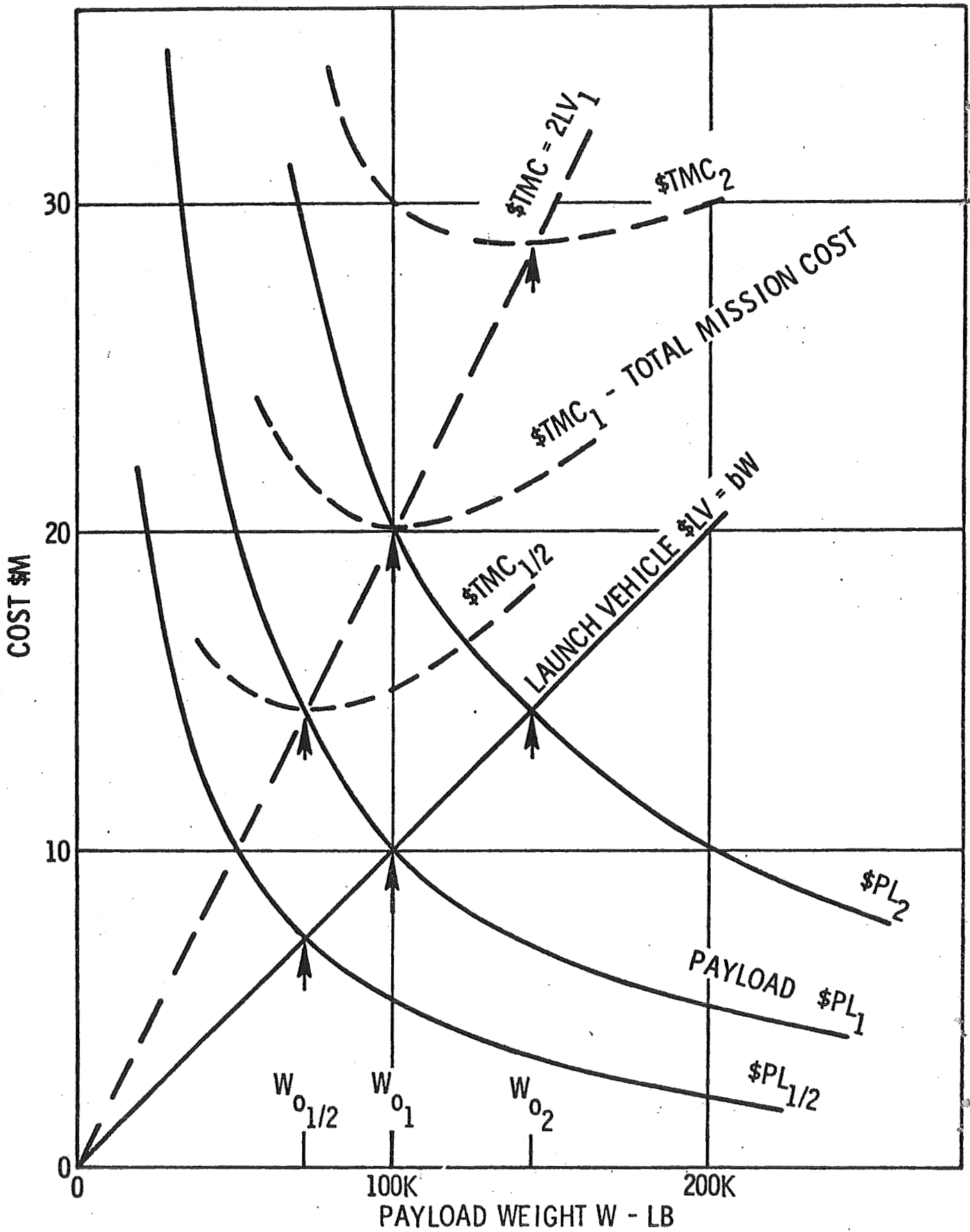

Figure 3-1 Variations in Total Mission Cost

The costs of the LCLV family listed in Table 1-I are plotted together in Figure 3-2, and the envelope curve is labelled "Launch Vehicle Cost." The "Payload Cost" is assumed to vary in the same manner as shown in Figure 3-1. The sum of these values is the "Total Mission Cost" as shown by the upper curve, the minimum occurring at a payload weight of about 230K lb. It is noted that the non-linear curve for launch vehicle cost forces the optimum point to higher payload weight than in the previous example, and the optimum \$PL is then considerably less than \$LV.

If the payload is sized to fit the LCLV capacity of 133K lb, the \$TMC is only 8 percent higher than the minimum (point A). If the payload weighs 100K lb, the \$TMD is 30 percent higher than minimum (point B), using the Large PFL+S-IVB; or 20 percent higher (point C), using the LCLV. As an extreme case with the payload weight reduced to 30K lb, the \$TMC will be 120 percent higher than minimum (point D, off the page). The above examples illustrate the tradeoffs to be considered in LV/PL matching, and the economy to be derived by such practice.

### 3.6.3 Recommended Study of Low Cost Spacecraft (LCSC)

The proposed Low Cost Spacecraft Study is believed to represent a cost saving potential comparable to that of the Low Cost Launch Vehicle Study. It will be an important sequel to the National Space Booster Study, furnishing needed insight and credibility to future planning of the United States Space Program, *whether the launch vehicles are of the current types, or the LCLV family, or more advanced designs.*

Significant changes to the simple model described in the preceding section occur when finite values for  $W_m$  and  $c_m$  are assumed. A study should be made to clarify these effects and to determine the constraints and exchange ratios to be employed for various typical payloads.

Consider the normal procedure in the design and development of a payload for a space project. The spacecraft includes various primary and secondary mission functions, such as: experiments, sensors, personnel accommodations, power supply, environmental control, propulsion, attitude control, guidance and navigation, tracking, telemetry and command, structure, separation mechanism, etc. While the weight and size of many of these items may be specified by available developed components, others may be subject to weight and/or cost savings by further effort in design and test.

The spacecraft design must observe certain obvious constraints imposed by the launch vehicle (i.e., weight, size and launch environment), and accommodate as many of the specified mission functions as possible to give satisfactory

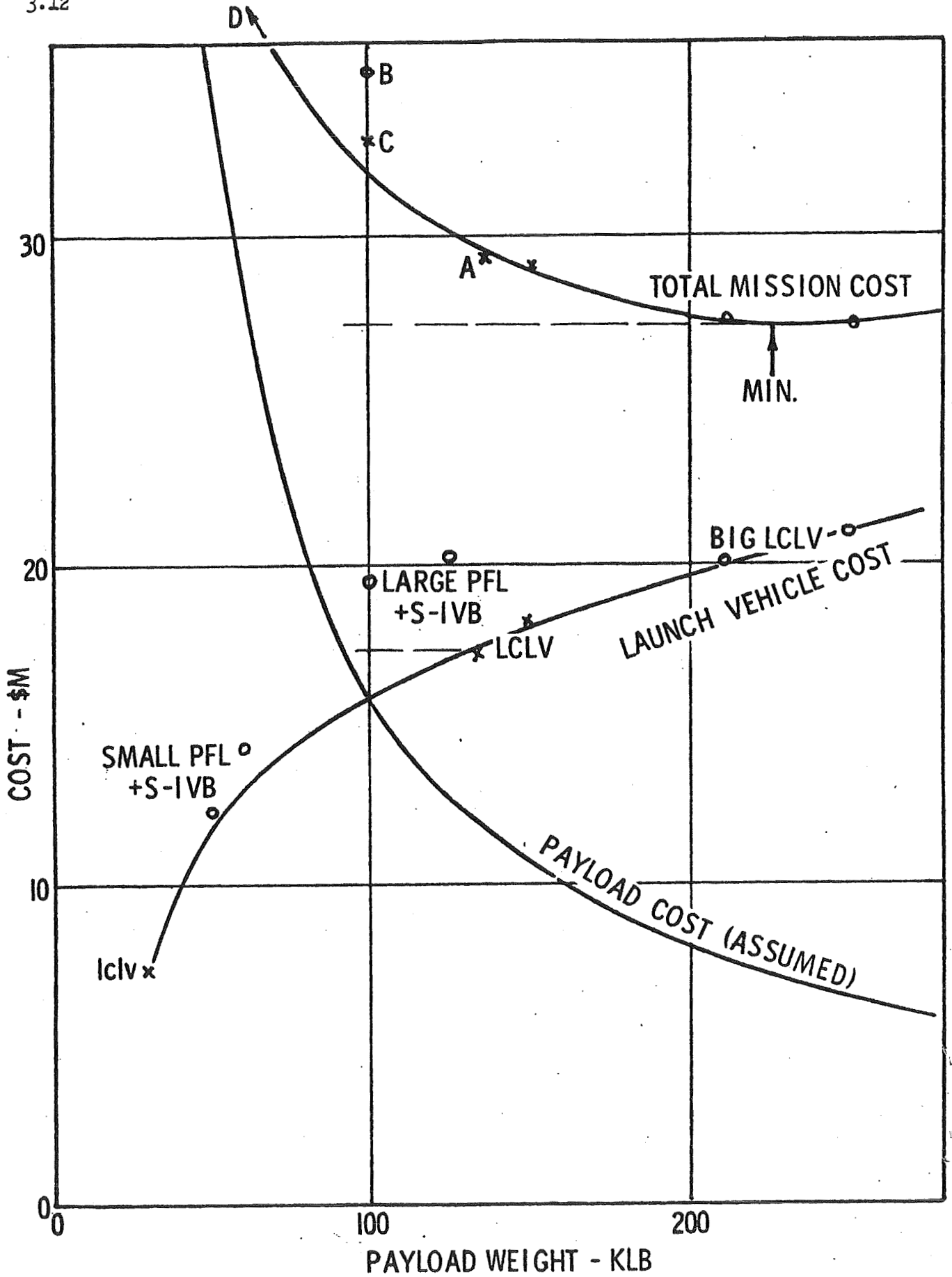

Figure 3-2 Total Mission Cost with LCLV Family

results. In the initial geometrical arrangement of the various items of equipment on a structure compatible with the LV geometry, all of the functions will seldom fit the weight, size and environmental constraints, and several iterations may be required to attain an acceptable design.

Frequently, in attempting to accommodate all of the mission functions to a pre-selected launch vehicle, the spacecraft weight gets out of control, requiring a complete redesign for acceptability, including the use of higher strength materials and more refined subsystems. An appeal may be made to the Program Director to permit the use of up-rated engines on the LV, (sometimes at the expense of reliability), to accommodate the overweight payload without further redesign.

The cumulative costs resulting from such procedures may be appreciably greater than without the weight constraint, as evidenced by the data in Table 3-IV. Both the development cost and the final production cost are escalated because of the weight-saving techniques and special attention required to insure compliance. To avoid such escalation, a credible survey of the spacecraft cost vs weight should be initiated early in the program, permitting a more intelligent selection of the proper launch vehicle, to match the spacecraft program, for minimum total mission cost. The functional relationship between spacecraft weight and cost can be determined as follows:

Determination of Minimum Spacecraft Cost  $c_m$ . The summation of weights of components associated with the primary and secondary functions, using off-the-shelf parts and easy-to-build structures, determines a nominal payload for basic cost evaluations. How can this nominal spacecraft be made less costly? The sensors and experiments may have been designed with certain weight or size limitations, the relaxing of which would permit net savings, beyond the cost of making the changes. The choice of each of the many spacecraft functions should be considered in turn for possible cost savings to be derived by adding weight (intelligently) and noting the results. When making these changes, a uniformly high level of reliability should be preserved by quality assurance methods, redundancy, etc. By plotting the spacecraft cost as a function of the weight additions as determined above, an indication will be obtained of the functional variation of  $\$SC$  with  $W$ , and the probable minimum cost  $c_m$ .

Determination of Minimum Spacecraft Weight  $W_m$ . The opposite procedure leads to more costly spacecraft of lighter weight and smaller size. However, it is a well known fact that performing a function with miniature or sub-miniature parts does not necessarily increase the cost, as evidenced by recent developments in communications and computer systems. But on average, the payload cost varies

3.14

inversely with weight, and this relationship should be sought by use of specific examples wherever they may be found. The spacecraft structure is usually 15 - 25 percent of the payload weight, thus limiting the weight savings in this area, unless drastic changes in the size and weight of other components are made (permitting the structure to be made smaller). In this manner, new data points are added to the \$SC vs W curve, leading to estimates of minimum spacecraft weight  $W_m$ .

Optimum Spacecraft Weight for Minimum Total Mission Cost. By combining the above data on spacecraft cost vs weight, with the corresponding data on launch vehicle cost vs payload weight, as in Figures 3-1 and 3-2, curves of total mission cost are obtained and the proper sizing of SC/LV for minimum cost can then be readily determined.

The above procedure outlines *the new discipline to be practiced in spacecraft design*, to attain reasonable matching of the LCSC and LCLV, and thus to avoid unnecessary drain on future space budgets. This means that the present imbalance in spacecraft cost should be overcome (Table 3-IV), plus an additional factor of 4 due to the lower cost of the LCLV.



#### 4. REVIEW OF LV DESIGN CONFIGURATIONS

During the LCLV investigation, many alternate configurations have been studied to determine their relative costs for launching 100 - 150K lb into low altitude orbit. An important trend resulting from these studies is that the 3-stage vehicle is far lighter and cheaper than the 2-stage (when the same design parameters are used in both cases). Furthermore, the 4-stage vehicle is slightly smaller but no less costly than the 3-stage; hence, the 3-stage vehicle is selected for most of the final contenders. The principal candidates for comparison, covering a wide range of cost saving features, are described as follows:

Design No. 1. Simplest conceivable launch vehicle from the standpoint of fabrication and operation, having 3 stages with only one engine and one set of (pressurized) tanks in each stage. This is called the "non-modular" or "baseline" configuration.

Design No. 2. Quad modules of tanks and engines are used in 1st and 2nd stages. The 2nd and 3rd stage engines and tanks are made the same size. This reduces the size and number of engines and tanks to be developed, and increases the quantity of (smaller) modules to be produced.

Design No. 3. Full use of the modular concept is attempted by assembling 7 modules of tanks and engines in the 1st stage, 3 in the 2nd stage and 1 in the 3rd stage. All of these modules are identical in size, except for the nozzle expansion ratio, which is changed by adding different expansion skirts to the 2nd and 3rd stages.

Design No. 4. Modular engines and non-modular tanks are used. A single engine is developed and used in a cluster of 9 in the 1st stage, 3 in the 2nd stage and 1 in the 3rd stage.

Design No. 5. Low cost pump-fed vehicle, similar in configuration to Design No. 1, for comparison with the pressure-fed vehicles.

Design No. 6. Pressure-fed liquid first stage, with an S-IVB final stage.

Early in the study the costs of the first four designs above were compared by a simplified analysis, leading to the conclusion that Design No. 1 offered the greatest promise for low cost. It is now appropriate to re-examine these designs in greater detail, and compare them with Nos. 5 and 6, to determine which is best for the Low Cost Launch Vehicle of the future. Basic weight scaling laws and propulsion characteristics are given in Appendix A, and costing procedures are presented in Section 9. A summary comparison of the six designs is given in Sections 4.1 to 4.6, using the weight and recurring cost data as presented in Section 4.7.

#### 4.1 Baseline Configuration

Conservative methods for estimating the gross weight and cost of the baseline LCLV (Design No. 1, see Figure 4-1) are presented in Appendix A and Section 9. A detailed weight estimate and performance data for this type vehicle are shown in Appendix B. Values of gross weight vs payload to LEO are illustrated in Figure 4-2 for the LCLV family, showing a range of values from the conservative baseline family to a more optimistic family of vehicles, and to a lower bound representing the approximate weight limits of current state of art for pressurized LV's. See Appendix F for layout of baseline LCLV.

Recurring costs (not including launch operations) are represented by the upper band in Figure 4-2. The differences in design philosophy and basic design values between the conservative and optimistic categories are explained in Table 4-I, and the characteristics of various vehicles are compared in Table 4-II.

For example, the conservative baseline design has a gross weight of 9.3M lb and a first unit recurring cost of \$13.1M\* (Section 4.7.1), to deliver 100K lb to LEO, with a velocity margin of 1800 ft/sec, or 133K lb payload with zero velocity pad, according to the small figure in the lower right hand corner of Figure 4-2. Gross weights and costs for this baseline design and other related (less conservative) vehicles are shown in the table below. Note that the weight and cost of the nominal 100K lb vehicle (with zero velocity pad) are 6.9M lb and \$10.5M, while the corresponding numbers for the optimistic nominal design are 5.4M lb and \$7.7M, respectively. See Sections 1.5 and 9.4 for further discussion of cost tradeoffs relating to conservative vs. optimistic design margins.

Design Category	Margin for 100K lb P.L.(ft/sec)	Gross Weight (M lb)	1st Unit Rec. Cost (\$M)
Conservative (Baseline)	1800	9.3	13.1
"	500	7.4	11.1
" Nominal 100K lb	0	6.9	10.5
Optimistic	1800	7.4	10.2
"	500	5.9	8.3
" Nominal 100K lb	0	5.4	7.7

It is noted that the improvements in gross weight and cost due to weight savings and  $I_{sp}$  increase (Table 4-I) are approximately equal to those due to reduction of the velocity margin.

\* First unit recurring costs quoted in this section do not include launch operations.

PAYLOAD = 30,000 LBS TO LEO

**STAGE 3:**  $W_o = 117,000$  LBS  
 $T_{vac} = 150,000$  LBS  
 $\sigma = .110, \epsilon = 50, I_{sp} = 306$  SEC  
 $V_i = 12,000$  FPS  $P_c = 200$  PSI

**STAGE 2:**  $W_o = 358,675$  LBS.  
 $T_{vac} = 456,000$  LBS.  
 $\sigma = .121, \epsilon = 50, I_{sp} = 306$  SEC  
 $V_i = 9,600$  FPS  $P_c = 200$  PSI

**STAGE 1:**  $W_o = 1,754,891$  LBS.  
 $T_{vac} = 3$  MLBS.  
 $\sigma = .120, \epsilon = 6, I_{sp} = 267$  SEC (VAC)  
 $V_i = 9,100$  FPS  $P_c = 300$  PSI

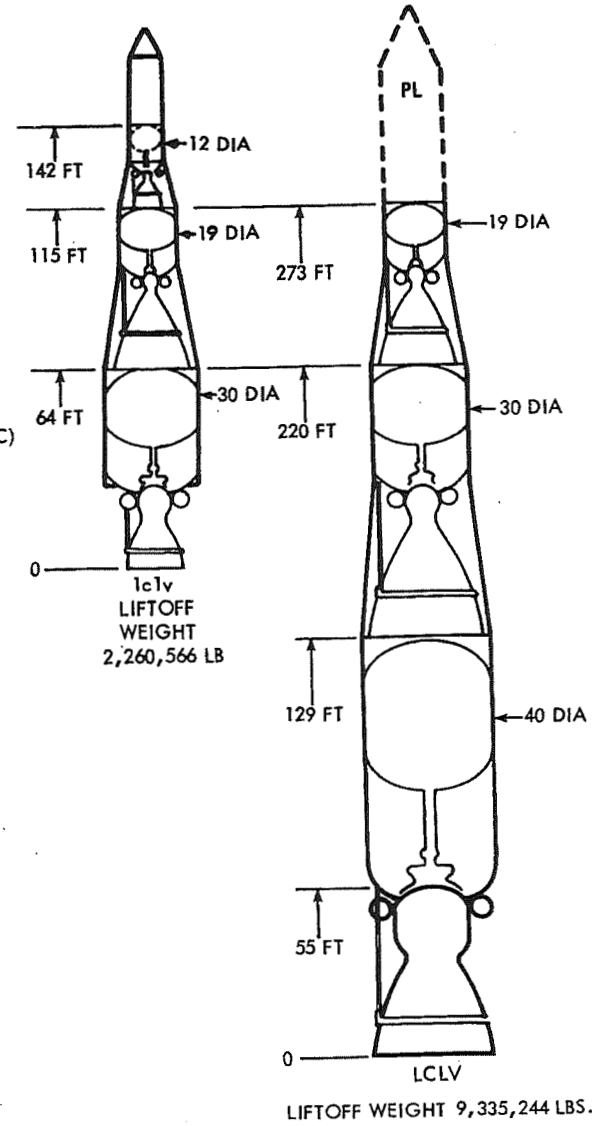

PAYLOAD = 133,000 LBS. TO LEO

**STAGE 3:**  
 $W_o = 355,675$  LBS.  
 $T_{vac} = 456,000$  LBS.  
 JETTISON FRACTION = .121  
 $\epsilon = 50$

$I_{sp} = 306$  SEC.  
 IDEAL V = 11,400 FPS  
 $P_c = 200$  PSIA

**STAGE 2:**  
 $W_o = 1,747,315$  LBS.  
 $T_{vac} = 2,202,000$  LBS.  
 JETTISON FRACTION = .120  
 $\epsilon = 31$

$I_{sp} = 300$  SEC.  
 IDEAL V = 11,400 FPS  
 $P_c = 250$  PSIA

**STAGE 1:**  
 $W_o = 7,099,254$  LBS.  
 $T_{sl} = 11,630,000$  LBS.  
 JETTISON FRACTION = .123  
 $\epsilon = 6$

$I_{sp} = 267$  SEC. (VAC)  
 IDEAL V = 8,900 FPS  
 $P_c = 300$  PSIA

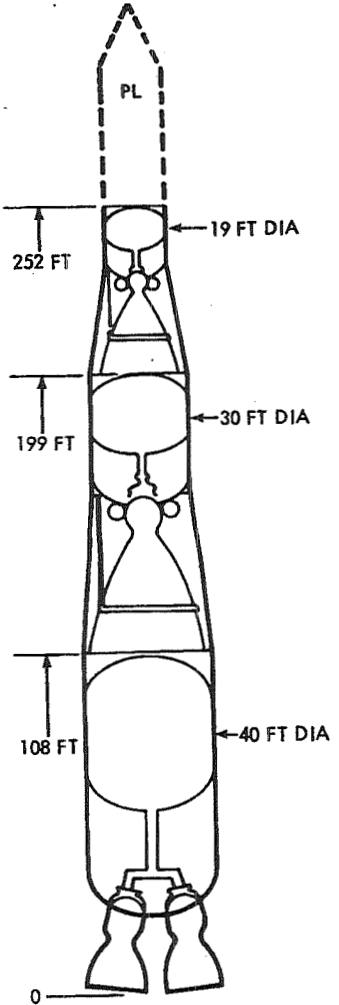

ALTERNATE LCLV  
 USING QUAD ENGINES OF 3MLB THRUST  
 IN FIRST STAGE

Figure 4-1 Configurations of LCLV (Baseline Design No 1) and lclv

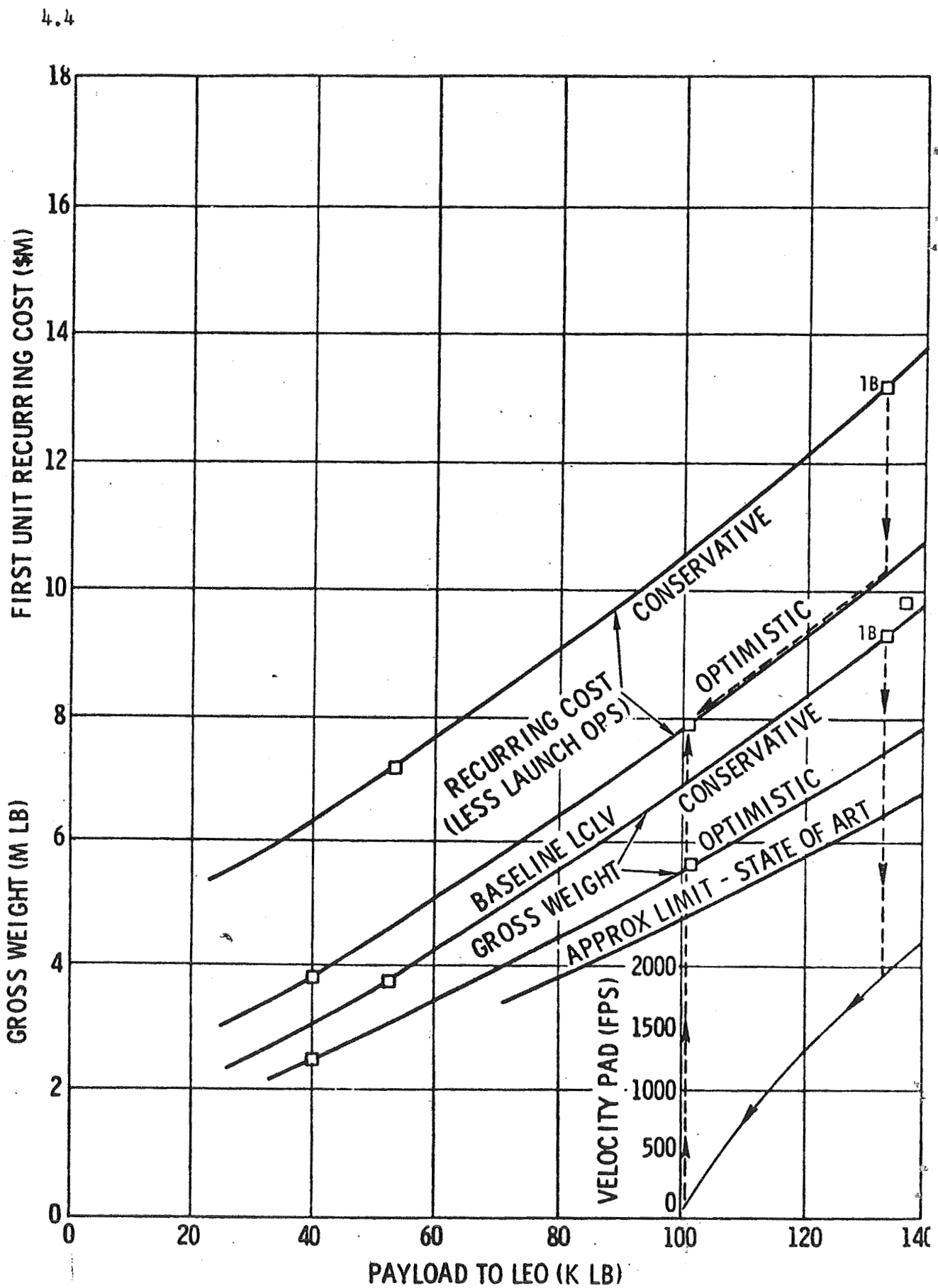

Figure 4-2 3-stage Non-Modular Vehicles - Gross Weight and Cost

Table 4-I Comparison of Design Philosophy and Basic Data  
(See Section 1.5 for further discussion)

Conservative Design

Generous weight and performance margins to minimize total mission cost.  
Vehicle weights and recurring costs to insure credibility of LCLV estimates.  
Non-recurring costs estimated to be about \$520M (Table 9-II).

Optimistic Design

Gross weight about 20% less than baseline design of equal performance.  
Design values well within limits of state of art for pressurized LV's.  
Non-recurring costs considerably higher than conservative design (Section 9.4).

Basic Design Data

<u>Design Category</u>	Ultra-Con- servative	Conser- vative*	Opti- mistic*	Super-Opti- mistic
Safety Factor (based on U.T.S. at 600°F)	3.0	1.5	1.4	1.25
$I_{sp}$ (percent of theoretical)	90	90	92	94
Contingency on inert weight (percent)	10	10	5	0
Ref. Tank Cost (function of wt.) (\$/lb)	3	3	2	2
Guidance & Control Cost (\$M)	1.5	0.35	0.35	0.35

All other design criteria assumed the same.

\*This terminology is used to identify the range of design values and to denote their relative standing only. Further study may reveal that the "optimistic" values above represent a reasonably conservative approach.

Selection of the optimal number of stages is illustrated in Figure 4-3, which shows the cost of the 3-stage vehicle to be definitely lower than the 2-stage design, and approximately equal to that of the 4-stage vehicle. The 3-stage configuration is therefore preferred for the nominal mission of 100K lb payload to LEO.

For higher velocity missions, a 4th stage is added to the conservative baseline vehicle, giving a payload of about 20K lb to synchronous altitude. When the 4-stage vehicle is launched to LEO, a payload of approximately 150K lb is attained (with zero velocity pad), as shown in Appendix B.

A smaller LV, designated the "lclv," can be assembled from the 2nd, 3rd and 4th stages of the baseline design, as shown in the center of Figure 4-1. This vehicle weighs about 2.3M lb and will launch 30K lb to LEO with a first unit recurring cost of less than \$4M; hence it provides a more cost-effective vehicle for Class II and many of the larger Class I missions shown in Figure 2-1.

Table 4-II Summary of Low Cost Launch Vehicle Designs

Design No.	<u>Nominal Payload (K lb)</u>	<u>Design Category</u>	<u>Stage 1 Diam (ft)</u>	<u>Gross Wt. (Mlb)</u>	<u>1st Unit* Cost (\$M)</u>
1.	3-Stage Press. Fed 100	Conservative	40.0	9.3	13.1
		Optimistic	33.4	5.6	8.8
2.	Quad Modules 100	Conservative	--	9.6	15.8
3.	7+3+1 Modules 100	Conservative	--	10.2	18.9
4.	Modular Engines 100	Conservative	40.0	9.9	15.8
5.	3-Stage Pump Fed 100	Conservative	36.4	6.0	11.8
		Optimistic	31.9	4.9	7.7
6.	PFL + S-IV B 100	Optimistic	40.0	6.3	18.0
	4-Stage Press. Fed 100	Conservative	36.4	7.8	13.5
		Optimistic	31.0	5.1	9.1
	2-Stage Press. Fed 40	Conservative	37.8	7.7	10.4
		Optimistic	29.0	3.6	5.5
	2-Stage with S-IV B 40	Conservative	21.7	2.0	15.2
		Optimistic	21.7	1.5	14.5
	3-Stage Press. Fed 40	Conservative	29.3	3.6	7.4
		Optimistic	24.6	2.3	4.7

\*Does not include launch operations or DDT&E cost.

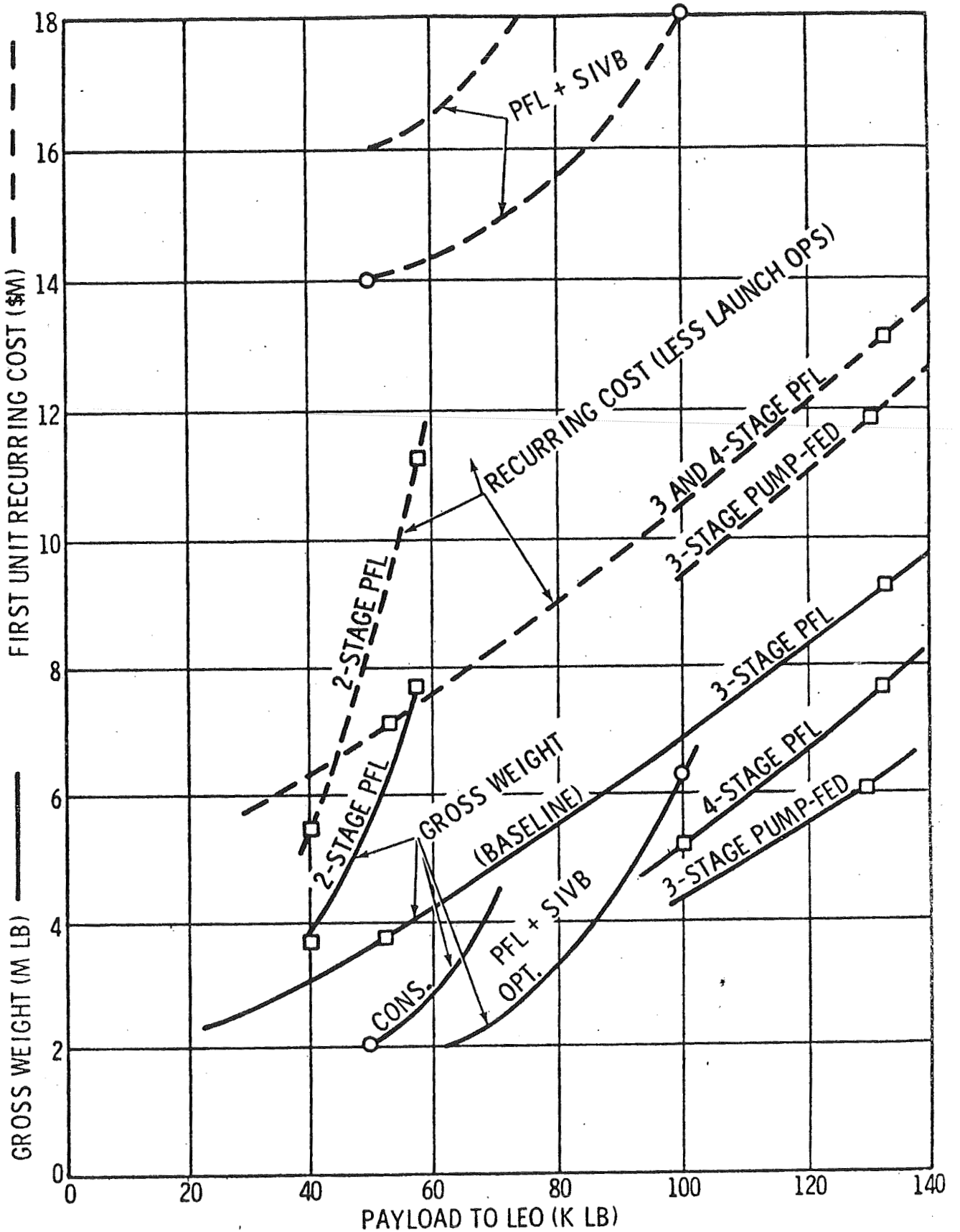

Figure 4-3 Effect of Number and Type of Stages on Gross Weight and Cost

## 4.8

## 4.2 Quad Modules of Tanks and Engines

Using a cluster of four modules of engine/tanks in the first two stages (see Figure 4-4), the LV stage weight and cost are as tabulated in Section 4.7.2. The vehicle gross weight is 9.6M lb and the first unit recurring cost is found to be \$15.8M. See Figure 4-5 and Table 4-II for comparison of weight and cost of the quad module LV with other modular designs, and with the baseline vehicle. Table 4-III gives a summary of data for Designs No. 1 to 4. (Reference 7).

## 4.3 Fully Modular Design (7+3+1)

By developing a single module of engine/tank for the third stage (with a large nozzle extension) and using a cluster of three such modules in the second stage (with smaller nozzle extension) and seven of them in the first stage (without nozzle extension), the amount of development and test is reduced considerably. However, inefficiencies arise due to off-optimum design conditions by use of identical modules; hence it is necessary to make the skin gage different in the various stages. With this provision, the vehicle gross weight is 10.2M lb and the first unit recurring cost \$18.9M, as shown in Section 4.7.3.

## 4.4 Modular Engines and Non-Modular Tanks

A variation from the baseline configuration is to use single tanks in each stage, with modular engines. The engine is sized for stage 3, and used in a cluster of three in stage 2 and nine in stage 1 (with appropriate nozzle extensions in the upper stages). The common engine is somewhat heavier than optimum for the upper stages, to satisfy the design requirements for stage 1. As presented in Section 4.7.4, the gross weight of this vehicle amounts to 9.9M lb and its first unit recurring cost is \$15.8M.

An alternate configuration for modular engines involves the 3M lb engine under consideration by the Air Force. Four of these engines can be employed in the LCLV first stage, and one of them in the second stage (possibly down-rated to give 2.3M lb thrust with a chamber pressure of 250 psi and a larger expansion nozzle). As discussed in Section 9.5, this proposal has no appreciable cost advantage over the single engine per stage, but it does entail a reduction in development risk by eliminating the need for the 12M lb engine.



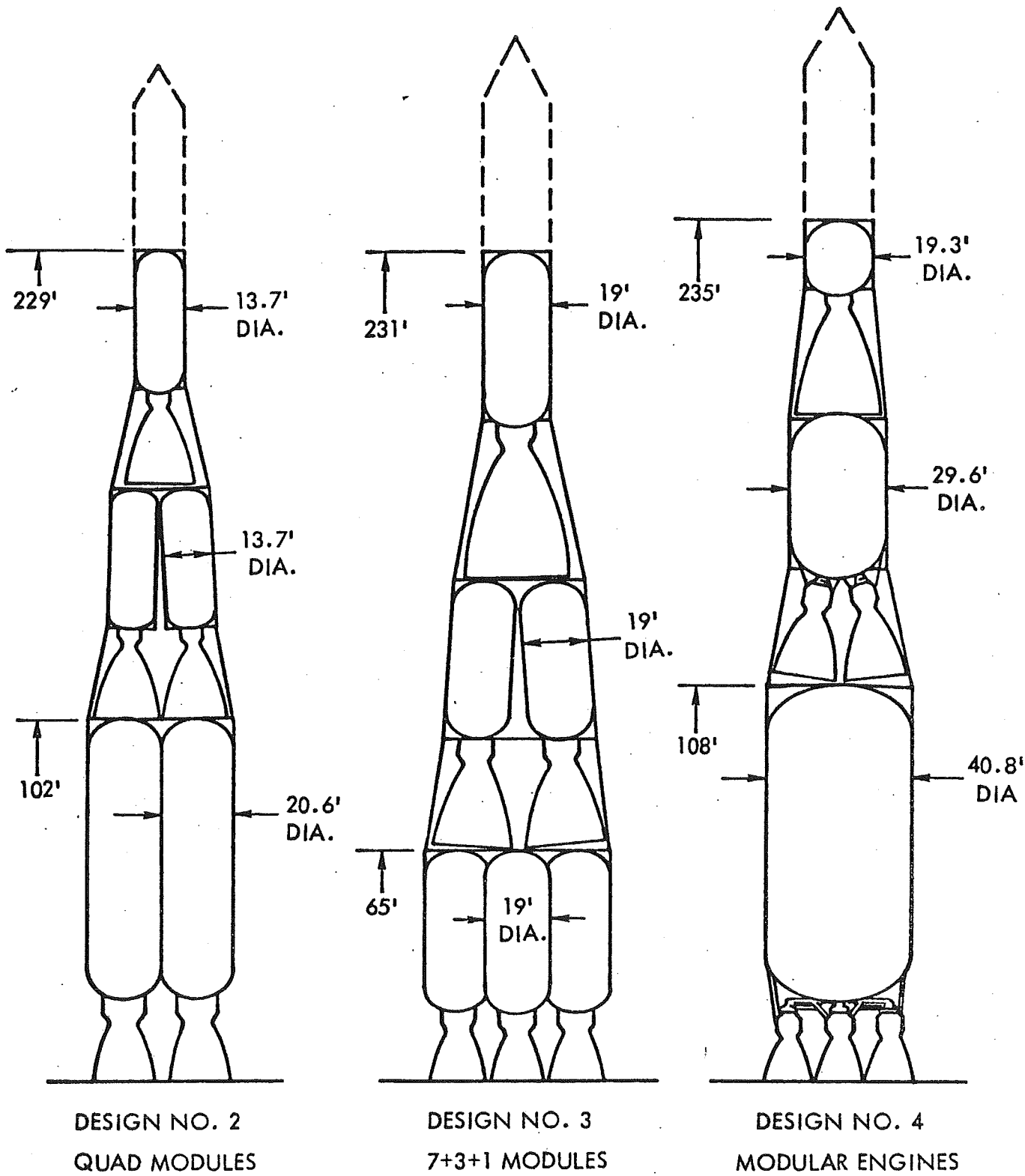

Figure 4-4 Modular Variations of Baseline Vehicle

4.10

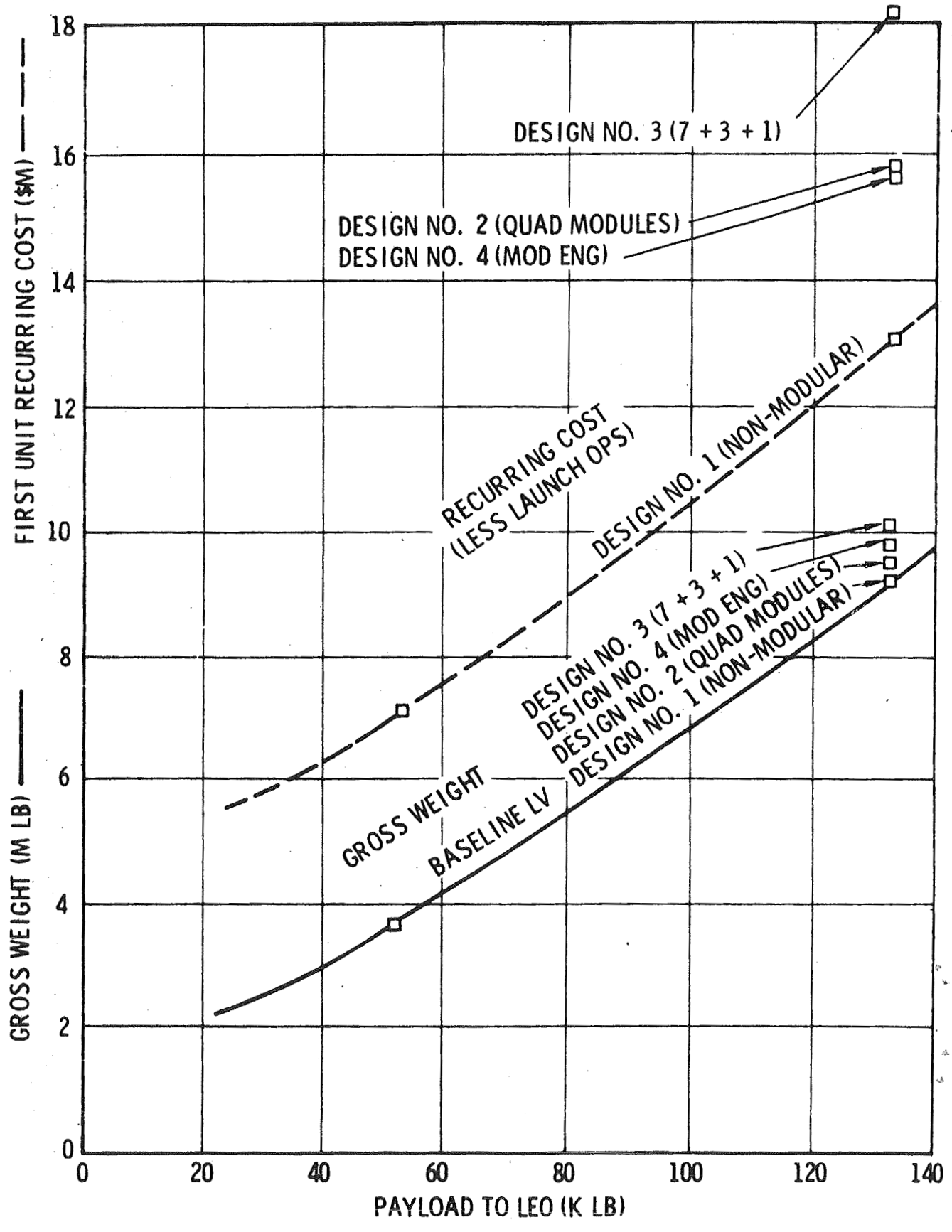

Figure 4-5 Modular vs Non-Modular - Gross Weight and Cost

Table 4-III Data Summary for Designs No 1 to 4

	Configuration			
	1	2	3	4
Gross Weight (incl. P/L), lbs.	9,302,244	9,598,157	10,222,969	9,947,884
Stage 1 Weight	7,099,254	7,472,498	6,458,518	7,625,171
Stage 2 Weight	1,747,315	1,625,461	2,764,207	1,857,615
Stage 3 Weight	355,675	400,198	900,244	365,098
Stage 1 Thrust (SL), lbs.	11,630,000	12,000,000	12,600,000	12,411,000
Stage 2 Thrust (VAC)	2,202,000	2,100,000	3,484,000	2,320,000
Stage 3 Thrust (VAC)	456,000	525,000	1,224,000	465,000
Stage 1 Burnout Fraction*	0.123	0.133	0.145	0.134
Stage 2 Burnout Fraction	0.120	0.119	0.110	0.105
Stage 3 Burnout Fraction	0.121	0.107	0.100	0.117
Stage 1 Chamber Pressure, psia	300	300	300	360
Stage 2 Chamber Pressure	250	200	150	160
Stage 3 Chamber Pressure	200	200	150	100
Stage 1 Isp, sec.	267,220	267,220	267,220	267,227
Stage 2 Isp	300	298	287	287
Stage 3 Isp	306	298	298	300
Stage 1 Expansion Ratio	6	6	6	6
Stage 2 Expansion Ratio	31	30	15	15
Stage 3 Expansion Ratio	50	30	30	35
Maximum Diameter, ft.	40.0	49.5	56.9	40.8
Length (without P/L), ft.	263	229	231	235

\*Does not include interstage.

#### 4.5 Low Cost Pump Fed LV

Further investigations have been conducted (see Section 4.7.5) in the use of modified industrial pumps and low cost turbines for a 3-stage LV employing the same propellant combination, construction materials and design parameters as the pressure-fed LCLV. Commercial pipeline water pumps are employed with inlet pressures of 125, 100, 100 psi in the three stages, respectively. Commercial turbines cannot be used because of excessive weight and modification cost; hence, weight estimates are taken for a low cost two-stage impulse turbine from Aerospace data (Reference 8). A single one design turbo pump

## 4.12

module can be used for all three stages, by proper selection of the number of modules in the various stages.

The results of this investigation indicate that the conservative pump-fed LV will weigh approximately 6M lb and cost about \$11.8M (not including turbo pump development cost), representing a considerable reduction in weight and a small decrease in cost when compared to the corresponding pressure-fed vehicle (see Figure 4-3). Further consideration of the costs are given in Section 9.6.

## 4.6 Pressure Fed Liquid Booster plus S-IVB Stage

A number of studies such as References 7 and 9 have investigated the use of a pressurized storable liquid first stage (similar to those used in Designs No. 1 to 4) with a high energy pump fed upper stage like the S-IVB. A summary of weight estimates for such vehicles is shown in Table 4.7-X. In the first column are listed data from Reference 9, indicating that a payload of 100K lb can be placed in 100 n m orbit with a gross weight of 4.82M lb and an impulse velocity of 28,240 ft/sec (without losses, launched eastward from ETR). Reference 7 indicates a gross weight of 4.6M lb for the same payload and altitude.

TRW estimates are shown in the right hand column of Table 4.7-X. Using the optimistic design assumptions defined in Table 4-I, the gross weight was found to be 6.3M lb to attain LEO with 100K lb payload (zero velocity pad). The increased booster size is due to the need for higher impulse velocity of about 29,700 ft/sec for vehicles of this type (see Sect. 4.8.2). The booster stage is found to be slightly smaller in size to that employed in Design No. 1. Figure 4-6 illustrates the relative size of the above 6.3M lb vehicle with that of Reference 9.

The estimated first unit recurring cost of the TRW booster plus S-IVB stage is \$18M (plus launch operations cost), based on a reduction of the S-IVB cost from the present value of \$20M down to \$12M as a result of current studies by MSFC, McDonnell-Douglas, Boeing, and others.\* The weight and cost of the PFL/S-IVB are plotted in Figure 4-3 for comparison with other vehicles.

It should be noted that the above booster required for 100K lb payload to LEO is "optimistic", as defined in Table 4-I; hence, its development cost will be somewhat higher, as assumed in Table 9-III. The conservative booster was found to be unacceptably large (>20M lb).

---

\*See Section 9.7 for further discussion of costs.

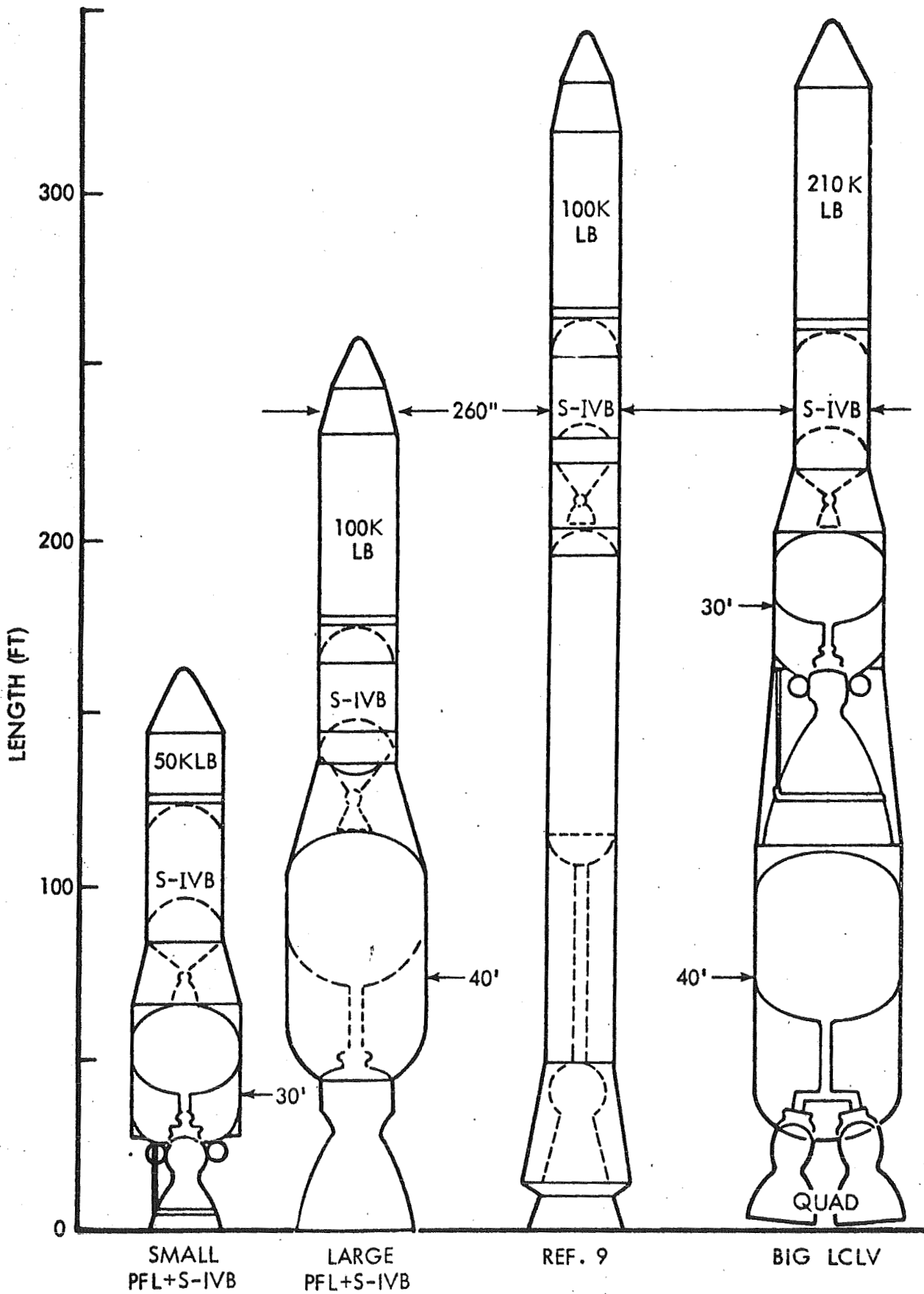

Figure 4-6 Pressure-Fed Liquid Boosters with S-IVB Final Stages

4.14

Using the conservative baseline stage 1 (Table 4.7-I) under the S-IVB stage gives a gross weight of 7.4M lb and a payload of approximately 80K lb to LEO (with zero velocity pad). For this application, the nominal baseline LV booster thrust of 11.6M lb can be reduced to 9.3M lb (thrust/weight ratio of 1.25) by decreasing the chamber pressure from its nominal value to 300 psi to 240 psi. This combination of stages would be considerably enhanced by increasing the propellant capacity of the S-IVB stage (for higher performance and reduced acceleration at burnout of the booster).

The above combination of stages is attractive because it provides an interim low cost intermediate payload vehicle with a first unit recurring cost of about \$28M, without change to the S-IVB, or correspondingly less with a stripped down S-IVB. Furthermore, development funds expended on the booster would be directly applicable to the baseline LCLV, as the ultimate objective of such a program.

Alternate Preferred Approach. Taking advantage of the 3M lb thrust engine under consideration by the Air Force, a more efficient 2-stage combination with PFL booster plus S-IVB can be assembled, weighing about 2.1M lb and capable of 50K lb to LEO (ratio of gross weight/payload of 42). Another advantage of proceeding in this manner is that the small PFL booster is the same size as the second stage of the LCLV.\* Using Stages 1 and 2 with S-IVB final stage gives the Big LCLV, weighing 9.3M lb and capable of 210K lb to LEO (Fig. 4-6). The gross wt/payload ratio is 44, compared to 63 for the large PFL+S-IVB, showing a remarkable improvement in efficiency with the 3-stage design. Furthermore, the latter uses conservative design margins (as defined in Table 4-I), whereas the large PFL+S-IVB requires the optimistic margins (to attain 100K lb to LEO).

If the S-IVB stage is increased in size by adding 35 percent more propellant (at the time of its cost reduction program), the Big LCLV will attain a payload to LEO of 250K lb, (gross weight/payload = 37). With comparable performance, the Big LCLV then provides a low cost replacement for the S-V, with cost savings more than sufficient to justify its development (Table 2-II).\*\*

---

\* Preliminary analysis shows that the 3M lb thrust booster stage can be used interchangeably with the 2nd stage of the LCLV, by adding a nozzle extension and reducing the chamber pressure to give a thrust of 2.5 to 2.8M lb. However, further tradeoffs should be conducted to give best compromise solution for both applications.

\*\* Economic considerations are discussed further in Section 9.7.

## 4.7 Weight and Cost Analysis of Candidate Vehicles

### 4.7.1 Baseline Configuration

Weight and cost analysis for the conservative 3-stage, pressure-fed, non-modular vehicle (baseline design illustrated in Figure 4-1) are shown in Table 4.7-I. This vehicle is represented by the design point labelled 1B on the conservative baseline curve in Figure 4-2. The gross weight of this vehicle is 9.3M lb and the first unit recurring cost is \$13.1M. See Section 9.4 for discussion of cost tradeoffs for baseline configuration.

### 4.7.2 Quad Modules

The weight and first unit recurring cost of the 3-stage vehicle employing quad modules in the 1st and 2nd stages are presented in Table 4.7-II. The first stage is assembled from four identical modules of tanks/engines. Likewise, the second stage is assembled from four smaller modules of tanks/engines. The third stage uses one of the same modules as in stage 2. The gross weight of this vehicle is found to be 9.6M lb and its first unit recurring cost is \$15.8M. See Sections 4.8 and 9.5 for further discussion of cost of modular vs. non-modular vehicles.

### 4.7.3 Fully Modular Design (7 + 3 + 1)

Weights and first unit recurring costs for the 7 + 3 + 1 modular vehicle are given in Table 4.7-III. An attempt was made to use identical modules for all three stages, by assembling 7 of them in stage 1, 3 in stage 2 and one in stage 3. However, it was found that the weight and cost were excessive if identical modules were used in all stages, because the desired chamber pressure for the upper stages is less than that required for stage 1. Hence, the final configuration has modules of the same size, but the skin gages are different for the various stages, and the engines have different expansion ratios. The gross weight of this vehicle is 10.2M lb and its first unit cost is \$18.9M.

### 4.7.4 Modular Engines and Non-Modular Tanks

Weights and first unit recurring costs for this configuration are shown in Table 4.7-IV. A cluster of nine engines is used in the first stage, three in the second stage with nozzle extensions, and one engine in the third stage with a larger nozzle extension. The common engine is somewhat heavier than optimum for the upper stages, hence the gross weight of this vehicle is 9.9M lb and its first unit recurring cost is \$15.8M.

Table 4.7-I Baseline 3 stage - Design No. 1B  
 Pressure Fed  
 N<sub>2</sub>O<sub>4</sub>/UDMH  
 Gross Payload = 100,000 lbs. (LEO)

4.16

	STAGE 1		STAGE 2		STAGE 3	
	Weight (LBS)	Cost (\$)	Weight (LBS)	Cost (\$)	Weight (LBS)	Cost (\$)
Tanks & Skirts	535,550	1,041,514	130,882	400,666	26,113	134,328
Engines & Propellant Valves	101,464	1,476,769	23,413	527,970	6,064	154,342
LITVC System	12,546	343,698	3,106	133,374	635	45,450
Pressurization System	18,819	121,926	3,882	48,424	635	16,786
Roll & Ullage Control System	1,255	23,839	311	10,533	190	7,912
Propellant Utilization System	1,430	78,842	354	30,595	72	10,426
Interstage (Above)	74,153	272,575	13,132	84,289	---	---
Propellant (Total)	6,272,893	1,029,800	1,552,805	254,919	317,346	52,098
Electrical & Instrumentation	2,269	1,053,139	543	472,726	691	613,448
Contingency	78,875	---	18,887	---	3,929	---
Stage Component Assembly	---	620,343	---	258,214	---	134,289
Program Management & Engineering	---	463,190	---	192,800	---	100,269
	7,099,254	\$6,525,635	1,747,315	\$2,414,510	355,675	\$1,269,348

Gross Weight = 9,302,244 lbs.  
 (Incl. Payload)

Sum of Stage Hardware Costs = \$10,209,493  
 Final Assembly & Checkout = 2,041,899  
 Fee = 857,597  
 First Production Unit Cost \$13,108,989\*



Table 4.7-II Configuration 2 - Quad Modules  
 Pressure Fed  
 $N_2O_4$ /UDMH  
 Gross Payload = 100,000 lbs. (LEO)

	STAGE 1 (4 MODULES)		STAGE 2 (4 MODULES)		STAGE 3 (1 MODULE)	
	Weight (LBS)	Cost (\$)	Weight (LBS)	Cost (\$)	Weight (LBS)	Cost (\$)
Tanks & Skirts & Structure	616,700	1,642,260	114,465	515,899	24,462	128,509
Engines and Propellant Valves	100,930	1,867,153	26,722	675,745	6,681	168,936
LITVC System	13,181	555,362	2,904	199,146	725	49,759
Pressurization System	19,771	125,498	2,904	40,861	725	18,151
Roll & Ullage Control System	1,318	24,537	290	10,128	217	8,555
Propellant Utilization System	1,503	127,397	331	45,683	83	11,414
Interstage (Above)	42,962	188,265	9,423	67,305	---	---
Propellant (Total)	6,590,322	1,081,911	1,452,000	238,370	362,704	59,543
Electrical & Instrumentation	2,309	1,063,389	442	422,379	686	609,853
Contingency	83,502	---	15,979	---	3,215	---
Stage Component Assembly	---	973,126	---	350,472	---	134,500
Program Management & Engineering	---	596,851	---	214,956	---	100,526
	7,472,498	\$8,245,749	1,625,461	\$2,780,944	400,198	\$1,289,746

Gross Weight = 9,598,157 lbs.  
 (Incl. Payload)

Sum of Stage Hardware Costs = \$12,316,439  
 Final Assembly & Checkout = 2,463,288  
 Fee = 1,034,581  
 First Production Unit Cost = \$15,814,308

Table 4.7-III Configuration 3 - Fully Modular (7 + 3 + 1)

Pressure Fed

N<sub>2</sub>O<sub>4</sub>/UDMH

Gross Payload = 100,000 lbs. (LEO)

4.18

	STAGE 1 (7 MODULES)		STAGE 2 (3 MODULES)		STAGE 3 (1 MODULE)	
	Weight (LBS)	Cost (\$)	Weight (LBS)	Cost (\$)	Weight (LBS)	Cost (\$)
Tanks & Skirts	565,069	1,865,427	168,282	601,078	45,603	196,034
Engines and Propellant Valves	104,502	2,116,266	56,552	1,117,084	21,269	407,824
LITVC Systems	11,169	594,403	4,936	260,091	1,641	86,558
Pressurization System	16,754	113,912	3,702	47,096	1,231	24,732
Roll & Ullage Control System	1,117	22,272	493	13,813	492	13,794
Propellant Utilization System	1,273	136,352	562	59,663	187	19,855
Interstage (Above)	93,689	319,407	36,321	168,008	---	---
Propellant (Total)	5,584,685	916,819	2,467,903	405,147	820,693	134,730
Electrical & Instrumentation	2,146	1,020,651	696	543,417	897	746,470
Contingency	78,114	---	24,760	---	8,231	---
Stage Component Assembly	---	1,017,915	---	505,019	---	215,600
Program Management & Engineering	---	624,321	---	309,745	---	122,917
	6,458,518	\$8,747,745	2,764,207	\$4,030,161	900,244	\$1,968,044

Gross Weight = 10,222,969  
(Incl. Payload)

Sum of Stage Hardware Costs = \$14,745,950  
 Final Assembly & Checkout = 2,949,190  
 Fee = 1,238,660  
 First Production Unit Cost \$18,933,800

NOTE: Upper stage modules have lower tank wall thickness.

Table 4.7-IV Configuration 4 - Modular Engines (9 + 3 + 1)

Pressure Fed

N<sub>2</sub>O<sub>4</sub>/UDMH

Gross Payload = 100,000 lbs. (LEO)

69

	STAGE 1 (9 ENGINES)		STAGE 2 (3 ENGINES)		STAGE 3 (1 ENGINE)	
	Weight (LBS)	Cost (\$)	Weight (LBS)	Cost (\$)	Weight (LBS)	Cost (\$)
Tanks & Skirts	652,234	1,190,432	106,013	347,322	18,295	105,536
Engines and Propellant Valves	102,201	2,082,754	41,869	800,646	14,964	300,000
ITVC Systems	13,350	727,565	3,333	199,401	652	46,287
Pressurization System	24,040	140,707	2,668	38,887	326	11,368
Roll & Ullage Control System	1,335	24,728	334	10,983	196	8,037
Propellant Utilization System	1,523	82,259	380	32,113	74	10,618
Interstage (Above)	57,989	230,722	17,114	100,867	---	---
Propellant (Total)	6,678,024	1,096,309	1,667,725	273,784	326,005	53,519
Electrical & Instrumentation	2,622	1,141,804	560	485,476	695	616,571
Contingency	91,853	---	17,619	---	3,891	---
Stage Component Assembly	---	778,387	---	290,620	---	150,392
Program Management & Engineering	---	581,196	---	216,794	---	111,465
	7,625,171	\$8,076,863	1,857,615	\$2,796,893	365,098	\$1,413,393

Gross Weight = 9,947,884  
(Incl. Payload)

Sum of Stage Hardware Costs = \$12,287,549  
 Final Assembly & Checkout = 2,457,509  
 Fee = 1,032,154  
 First Production Unit Cost = \$15,777,212

4.20

4.7.5 Low Cost Pump Fed LV

An investigation was conducted of the weight and cost of an LCLV using turbopump fed propellant, to assess the feasibility and problem areas associated with the use of commercial pumps and turbines. A 3-stage vehicle design was analyzed, capable of 100,000 lb payload to low altitude orbit, and utilizing the same storable propellant (N<sub>2</sub>O<sub>4</sub>/UDMH) and design parameters as employed for the pressure-fed LCLV.

A number of industrial pump and turbine companies were contacted; namely, Allis-Chalmers, Baldwin-Lima-Hamilton, De Laval, Ingersoll Rand, Fairbanks-Morse, and Worthington. It was found that available water pumps were adaptable to the LV application, but industrial turbines were too heavy and costly to be acceptable. Consequently, the following analysis uses commercial pump data, but the low cost turbine design is taken from an Aerospace document (Reference 8).

The pump inlet pressures assumed for the three LV stages are 125, 100, 100 psi, respectively. Operating points for the oxidizer and fuel pumps are shown in Table 4.7-V.

Table 4.7-V Pump Operating Points

Stage	No. Pumps	Flow (GPM)	Head (ft H <sub>2</sub> O)	Speed (RPM)
1	5 Ox	105,000	984	3,600
	3 F	70,500	796	3,500
2	1 Ox	20,400	810	3,330
	1 F	13,800	600	2,760
3	1 Ox	5,130	810	2,900
	1 F	3,400	600	2,500

Turbine design data are given in Table 4.7-VI. It is noted that the same turbine module is used for all stages and pump combinations. On Stages 2 and 3, a single wheel is employed for each oxidizer and fuel pump because of the different speed requirements. An improvement in weight could be obtained by trimming the pump impellers to permit a single direct coupled turbine to drive both oxidizer and fuel pumps.

Turbopump design data are presented in Table 4.7-VII. The Worthington 18/24 CPL 18 Pipeline Pump is used for all units. The same turbine wheel is assumed for all stages, with partial admission for lower hp.

Table 4.7-VI Turbine Design Data  
(Same Turbine Used for all Stages and Pump Combinations)

2-Stage Impulse Turbine	300 psia		1760°R		740°R		4800 ft/Sec
	Inlet Pressure	Inlet Temperature	Outlet Temperature	Blade Height	Diameter	Wheel Weight	3.1 In. 51 In. 3500 lbs.
	Stage 1		Stage 2*		Stage 3*		
	Ox	Fuel	Ox	Fuel	Ox	Fuel	
Total HP	32,400	17,700	5,230	2,620	1,310	644	
Total Flow Rate, lb/Sec	128	71.5	22.6	11.8	5.76	3.35	
Speed, RPM	3,600	3,500	3,330	2,760	2,900	2,500	
Tip Speed U, Ft/Sec	800	776	740	612	644	555	
Speed Ratio U/V <sub>e</sub>	.1665	.162	.154	.1275	.134	.1155	
Efficiency %	54	53	52	50	51	43	

\*Notes - Single wheel assumed for each oxidizer and fuel pump because of different speed requirements. Considerable improvement in weight and performance could be obtained by trimming pump impeller and by driving oxidizer and fuel pump with a single wheel direct coupled.

Table 4.7-VII Turbopump Data

	Stage 1	Stage 2	Stage 3
<b>Oxidizer System</b>			
Number of Pumps*	5	1	1
Pump weight - lb	32,500	6,500	6,500
Number of turbines**	2 1/2	1/2	1/2
Turbine power (each) - hp	12,960	5,230	1,310
Turbine weight - lb	8,750	1,750	1,750
<b>Fuel System</b>			
Number of pumps*	3	1	1
Pump Weight - lb	19,500	6,500	6,500
Number of turbines**	1 1/2	1/2	1/2
Turbine power (each) - hp	11,800	2,620	644
Turbine weight - lb	5,250	1,750	1,750
<b>Total System</b>			
Power - hp	50,100	7,850	1,954
Turbine flow rate - lb/sec	200	34.4	9.1
Gas generator inerts - lb	300	59	24
Weight of TP + GG - lb	66,300	16,559	16,524
<b>Turbopump System Cost</b>			
Pump Cost - \$	150,000	40,000	40,000
Turbine cost - \$	100,000	25,000	25,000
Gas generator cost - \$	20,000	10,000	10,000
TP production cost - \$	270,000	75,000	75,000

\*Worthington 18/24 CPL 18 Pipeline Pump used for all units.

\*\* Same turbine wheel used for all units. Partial admission for lower hp.

Stage weights for the pump-fed LV are shown in Table 4.7-VIII.

Table 4.7-VIII Stage Weights for Pump-Fed Vehicle

	<u>Stage 1</u>	<u>Stage 2</u>	<u>Stage 3</u>	<u>Alt. Stage 3</u>
Initial Stage Weight	4,200,000	1,240,000	310,000	310,000
Thrust	7,600,000	1,650,000	410,000	410,000
Engine Weight	47,250	13,950	3,450	3,450
Tanks	117,000	30,500	7,040	7,040
Turbo Pump Weight	66,300	16,559*	16,520*	7,159**
Pressure System	10,100	2,420	380	380
TVC System	9,160	2,720	606	606
Roll Control	1,784	454	71	71
Interstage (above)	10,200	5,710	---	---
Astrionics	2,141	545	467	467
Residual Propellant (1%)	39,360	11,671	2,720	2,815
B.O. Weight (Incl. 10% Contingency)	369,049	103,487	36,834	25,373
Mass Fraction	.0879	.0834	.119	.0818
AV (assuming 100 K lb payload)	9,350	11,500	10,820	11,610

\*Drive oxidizer and fuel pump with one turbine wheel on common shaft.

\*\*Change pump to Worthington 6/10LPL 18.

Cost Estimates for the pump-fed LV are given in Table 4.7-IX.

Table 4.7-IX Cost Estimate

	<u>Stage 1</u>	<u>Stage 2</u>	<u>Stage 3</u>
Turbopumps	270,000	100,500	100,500
Tank and Skirts	455,900	203,380	67,430
Engines	1,496,160	426,400	124,800
LITVC System	371,145	143,452	48,614
Pressurization System	93,686	39,300	12,500
Roll and Ullage Control System	24,584	8,182	5,543
Interstage	227,700	60,890	
Propellant	774,000	231,000	45,600
Astrionics	1,019,596	524,417	531,674
Stage Assembly Labor			
Vehicle Integration	628,592	227,968	235,943
Program Management & Engineering	428,909	157,239	93,808
Subtotal	<u>5,790,272</u>	<u>2,122,728</u>	<u>1,266,412</u>

Above Stage Hardware Cost

9,179,412

Final Assembly and C/O

1,835,882

11,015,294

Fee 7%

771,071

First Unit Hardware Cost

\$11,786,365

## 4.7.6 Pressure Fed Liquid Booster plus S-IVB Stage

Table 4.7-X shows data from Reference 9 for a launch vehicle using a PFL booster with S-IVB upper stage for launching 100 K lb payload to 100 n m orbit (eastward from ETR). The impulse velocity quoted for this vehicle is 28,240 ft/sec. TRW analysis indicates that impulse velocities of about 29,700 ft/sec are needed for vehicles of this type; hence the right hand column reflects the increased vehicle size required. The vehicle configurations are compared in Figure 4-6, and other comments noted in Section 4.6.

Table 4.7-X Weight Estimates for PFL/S-IVB Vehicles

	Ref. 9 Design	TRW Proposal
Payload to 100 n m orbit - EETR	100,000	100,000
1U	4,123	4,123
MS-IVB - Burned Out	24,624	24,624
Residuals	1,673	1,673
Vehicle at 2nd Stage B.O.	130,420	130,420
Thrust Decay Propellant	149	149
Vehicle at 2nd Stage Cutoff	130,569	130,569
Main Propellant	230,596	230,596
Ullage Propellant	183	183
Service Items	127	127
Vehicle at 2nd Stage Liftoff	361,475	361,475
Thrust Buildup Propellant	485	485
Vehicle at 2nd Stage Ignition	361,960	361,960
Interstage	4,730	4,730
Aft Frame Jettisoned	25	25
Retro Rocket Propellant	2,160	2,160
1st Stage at Burnout	455,260	605,000
Vehicle at 1st Stage B.O.	824,135	973,815
Thrust Decay Propellant	-	-
Vehicle at 1st Stage Cutoff	824,135	973,805
Main Propellant	3,960,400	5,263,685
TVC	37,000	49,000
Service Items	2,600	3,500
Vehicle at Liftoff	4,824,135	6,300,000
Impulse velocity - ft/sec	28,240	29,700

#### 4.8 Further Comparisons and Tradeoffs

A comparison of design and cost parameters for the TRW and SRI (Ref. 26) designs for low cost launch vehicles is shown in Table 4.8-I. It is noted that the TRW values are generally more conservative, due to the assumption that such a course leads to low development cost for the various subsystems, and tends to minimize the overall (recurrent plus non-recurrent) cost.

##### 4.8.1 Configuration and Other Design Tradeoffs

The modular configurations are heavier and more costly than the baseline vehicle due to the following factors:

1. Smaller tanks are more expensive per pound of tank weight (Configurations 2 and 3).
2. Smaller engines are more expensive per pound of engine weight or thrust (Configurations 2, 3 and 4).
3. Multiple LITVC systems required by Configurations 2, 3 and 4 are more expensive than a single system.
4. Stage assembly labor and program management and engineering for stages 1 and 2 are higher for multiple modules than for one larger module (Configurations 2, 3 and 4).
5. Structure fractions are higher due to smaller tank units and the structure required to integrate the modules (Configurations 2 and 3).
6. Engine commonality between stages results in nonoptimum engines for upper stages (i.e., engines designed for the higher chamber pressures in lower stages - Configurations 3 and 4).
7. Higher propellant residuals for multiple tanks (Configurations 2 and 3).
8. Third stage module size is nonoptimum if the same module must be used in stage 1 (Configuration 3).

The effect of number of stages on recurring cost and gross weight is shown in Figure 4.8-1. Significant points are that 1) the number of stages has a greater effect on weight than on cost, and 2) the 3- and 4-stage vehicles are about the same cost, considerably less than the 2-stage vehicle.

Figure 4.8-2 shows the effect of chamber pressure and mixture ratio on vehicle recurring cost. The choice of chamber pressure appears to have only a small effect on recurring vehicle cost. Tentative choices of chamber pressures are 300, 250 and 200 psia for Stages 1, 2 and 3, respectively. A mixture ratio of 2.6 appears to yield nearly the minimum cost based on a 90%  $I_{sp}$  efficiency. A mixture ratio of 2.6 is selected since test results indicate that actual engine performance peaks at 2.6 or lower.



Table 4.8-I COMPARISON OF DESIGN PARAMETERS

	TRW	SRI (REF.26)
Structure Ratio of 1st Stage - $\sigma_1$	.123	.089
Structure Ratio of 2nd Stage - $\sigma_2$	.12	--
Specific Impulse - $I_{spl}$ - sec	255 Avg	--
	221 SL	231
	267 VAC	
Specific Impulse - $I_{sp2}$ - sec	300	
Engine Wt/Thrust (Cost/lb wt)	.0087	.01 (\$6.10)
	.0106	
Tank Wt/lb Prop. (\$Cost/lb wt)	.079 (1st, \$2/lb)	.056 $W_p$ (\$2.10)
	( $F_{UTS} = 140K$ )	( $F_{UTS} = 140K$ )
	.075 (3rd, \$5/lb)	
	( $F_{UTS} = 185K$ )	
LITVC Injectant	.01 $W_p$	.011 $W_p$
		( $N_2O_4$ )
LITVC Hardware (\$Cost/lb)	.002 $W_p$ (\$27)	.00076 $W_p$ (\$20)
Pressurization Wt (\$Cost/lb Hdw)	.018 $W_p$ (1st, \$6.50)	.0092 $W_p$ (\$5.60/11)
	.015 $W_p$ (2nd, \$12.50)	
Residual Propellant	.005 $W_p$	.01 $W_p$
Roll Control Propellant	.002 $W_p$	.00064 $W_p$
Propellant Cost/lb	\$.164	\$.22
Propellant Shipping Cost/lb	Incl.	\$.026
Stage Hardware Shipping \$/lb	--	\$.11
Avg Cost/lb Gross Wt - \$/lb	\$1.0 (Prelim)	\$.59
Avg Cost/lb Hdw Wt - \$/lb	\$10.0 (Prelim)	\$5.90

Figure 4.8-3 shows the effect of  $I_{sp}$  efficiency and first stage impulse  $\Delta V$  on vehicle recurring cost. For this study a baseline value of 90%  $I_{sp}$  efficiency has been assumed. An increase to 92% for all stages can reduce the vehicle recurring cost by 9 percent. The first stage impulse  $\Delta V$  for minimum cost is approximately 9000 fps.

The effect of nozzle expansion ratio on vehicle recurring cost is shown in Figure 4.8-4. The strongest sensitivity is noted in Stage 2. Representative values of expansion ratio for the baseline vehicle are 6, 31 and 50 for Stages 1, 2 and 3, respectively.

The effect of residual propellant and material tensile strength on vehicle recurring cost is shown in Figure 4.8-5. Both of these parameters have a strong effect on vehicle cost. A change in residual propellant from 2 to 3 percent of the total propellant weight results in an 8.5 percent increase in vehicle recurring cost. A change in material tensile strength from 140,000 to 220,000 psi results in 21 percent decrease in the vehicle weight. If the change in material cost with increasing tensile strength is known, the desirability of going to higher strength steels can be ascertained from Figure 4.8-5.

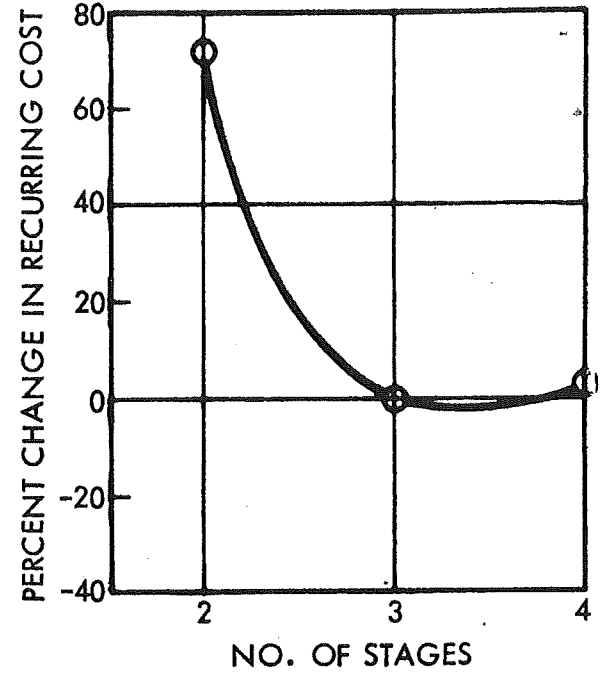
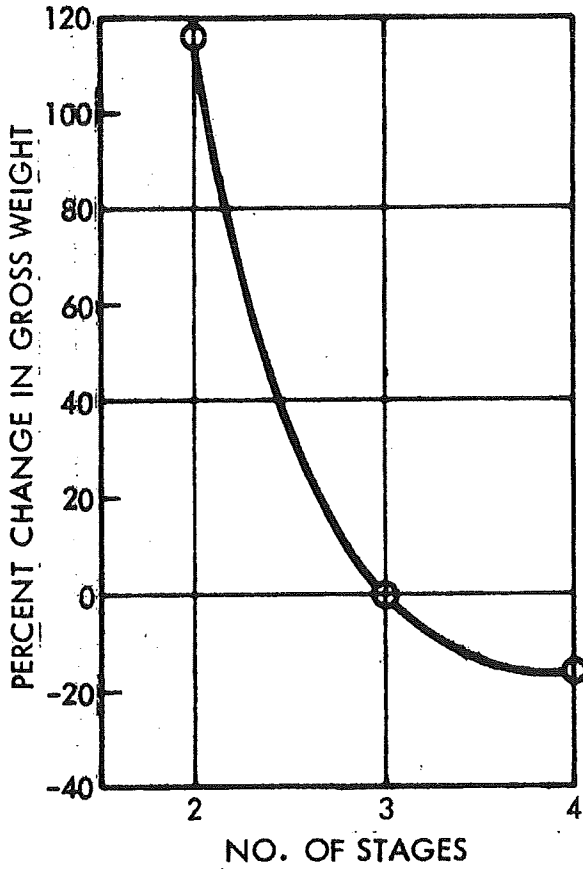

Figure 4.8-1 Effect of Number of Stages on Weight and Cost

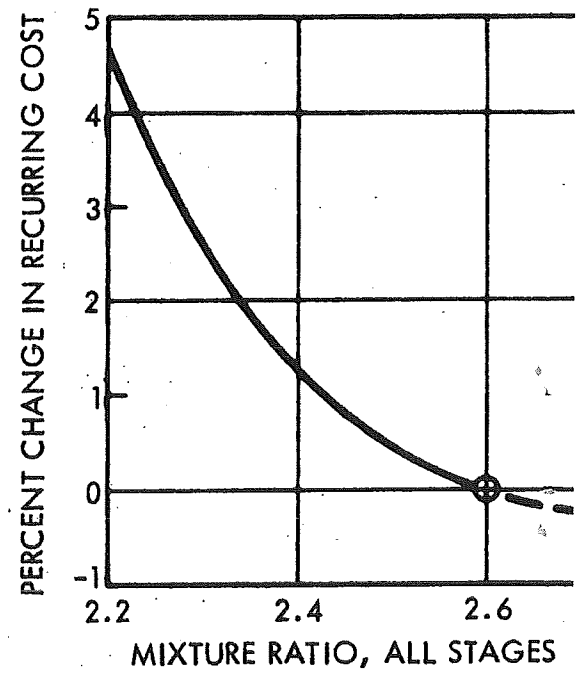
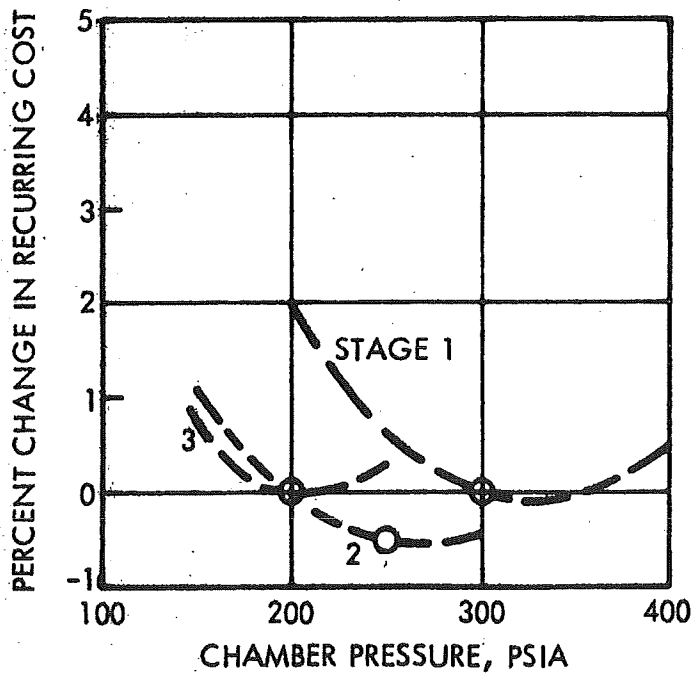

Figure 4.8-2 Effect of Chamber Pressure and Mixture Ratio on Cost

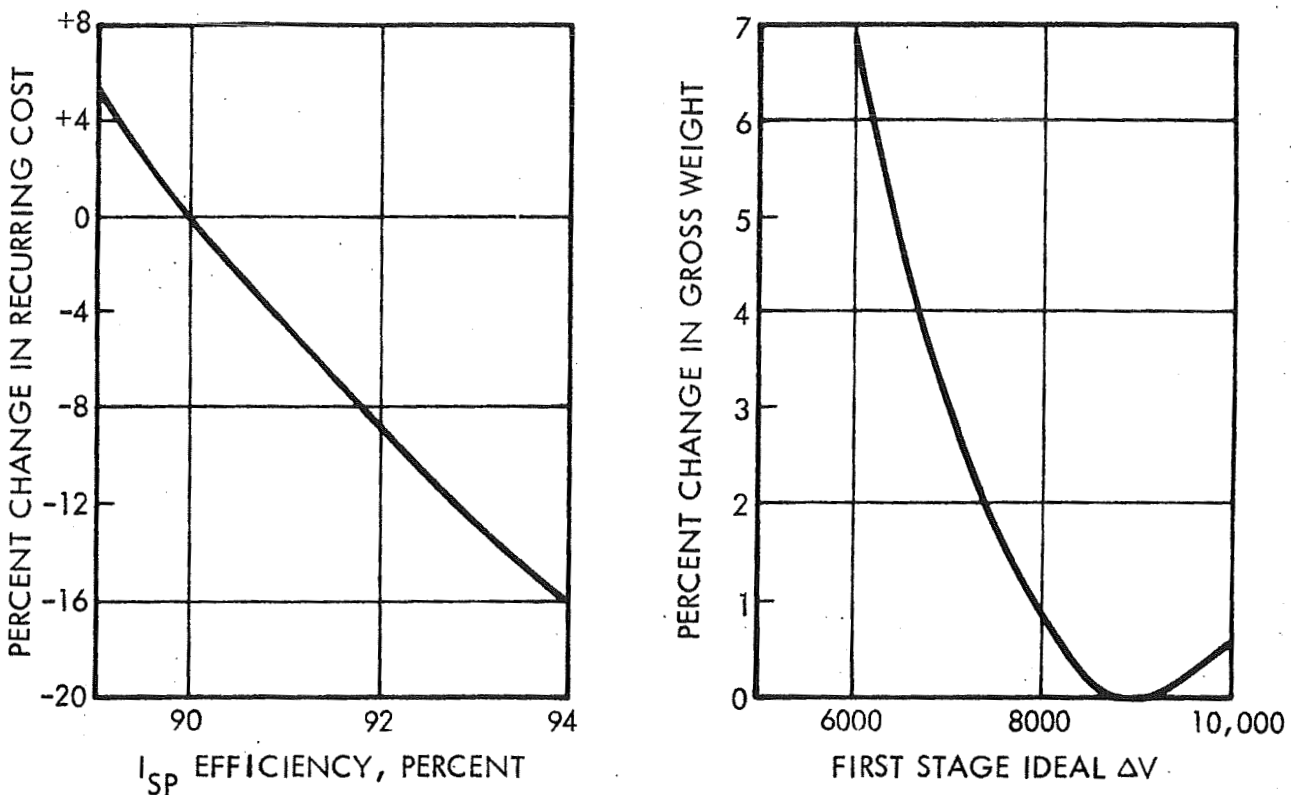

Figure 4.8-3 Effect of I<sub>sp</sub> Efficiency and First Stage V on Cost

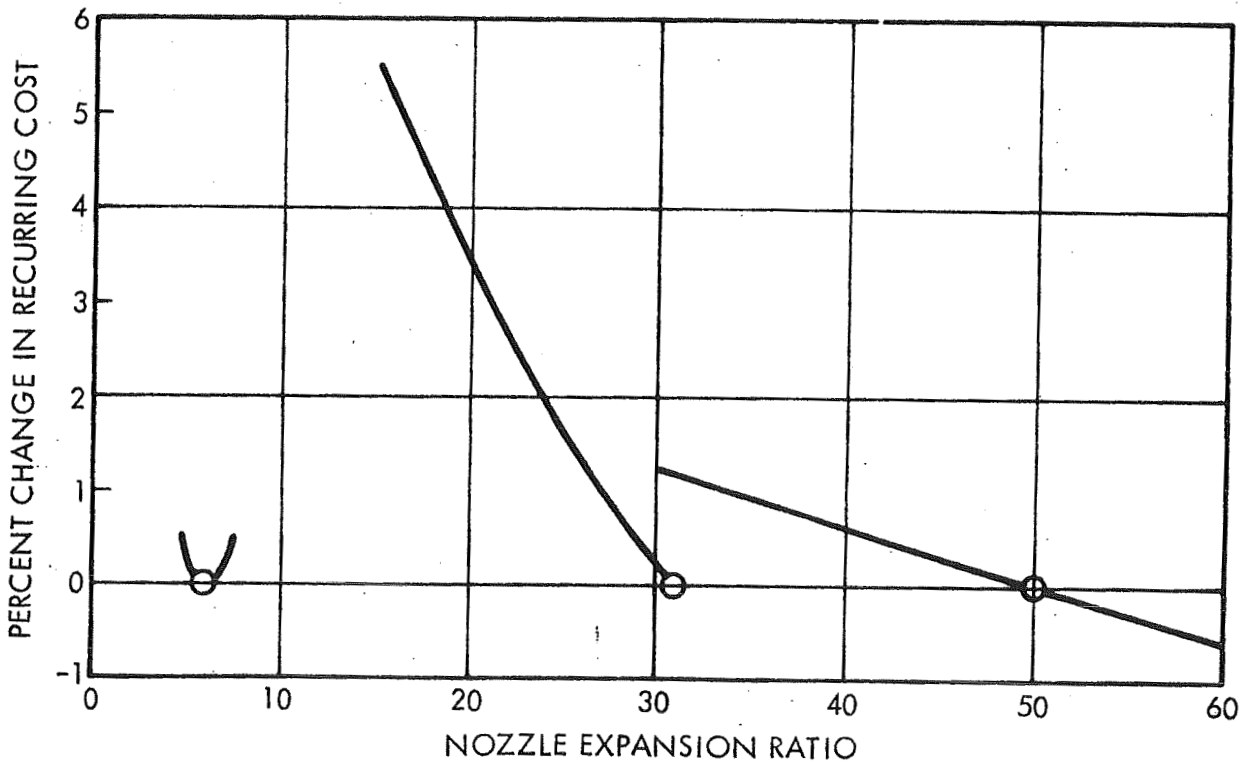

Figure 4.8-4 Effect of Nozzle Expansion Ratio on Cost

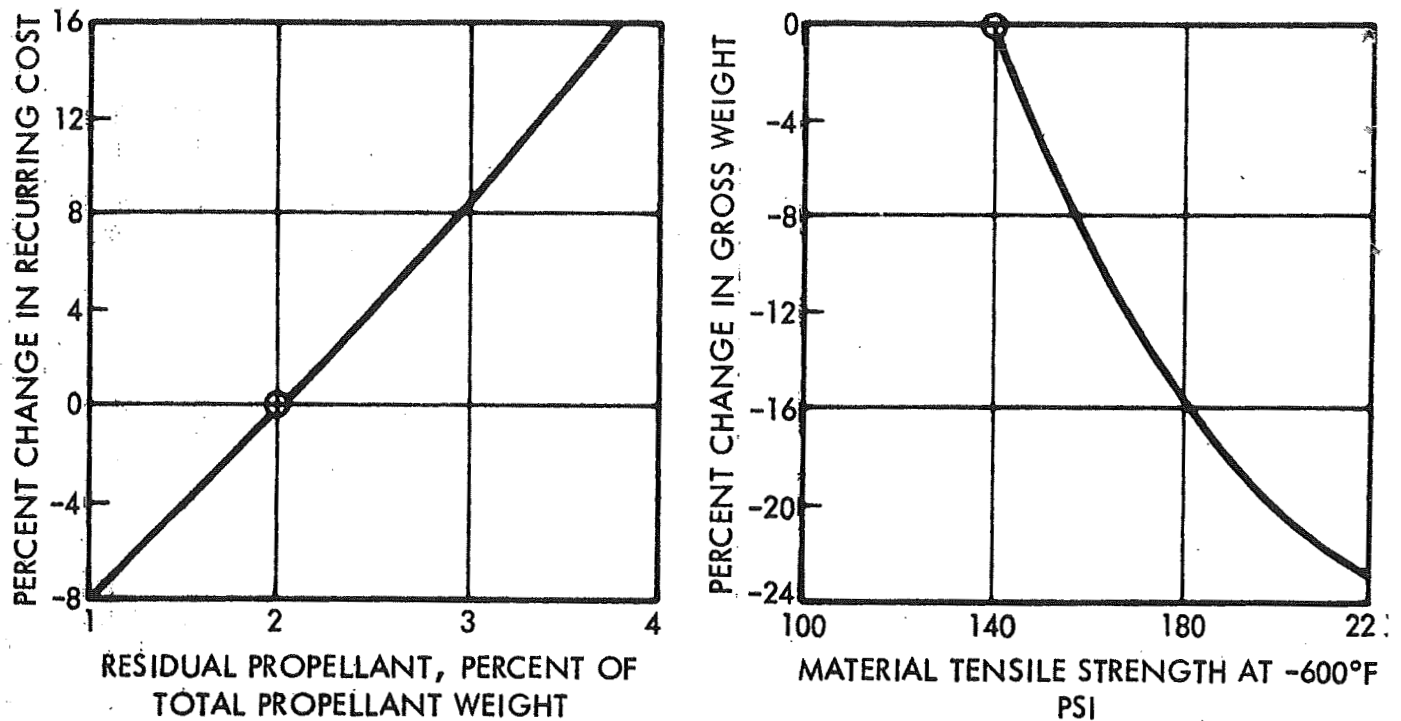

Figure 4.8-5 Effect of Residual Propellant and Material Strength on Cost

#### 4.8.2 Velocity Tradeoffs

The conservative velocity margin (intentionally large to favor low DT&E and payload versatility) deserve reappraisal at this time. The effect of total velocity requirement on the LCLV cost and weight is given in Figure 4.8-6. A reduction of the impulse velocity requirement from 31,700 fps (baseline) to 30,200 fps results in a 19 percent cost reduction and a 24 percent weight reduction. For an eastern launch from ETR, a total impulse velocity requirement of 30,200 fps is required as shown below:

25,580 fps	inertial velocity required for 100 nm orbit
<u>-1,340</u>	effect of earth's rotation at ETR
24,240 fps	booster requirement for eastward launch (no losses)
5,460	total gravity plus drag losses
<u>+ 500</u>	velocity reserve
30,200 fps	total impulse velocity required

These considerations show that a large reduction in vehicle size may be possible, if 100,000 lb payload to LEO is the final requirement. However,

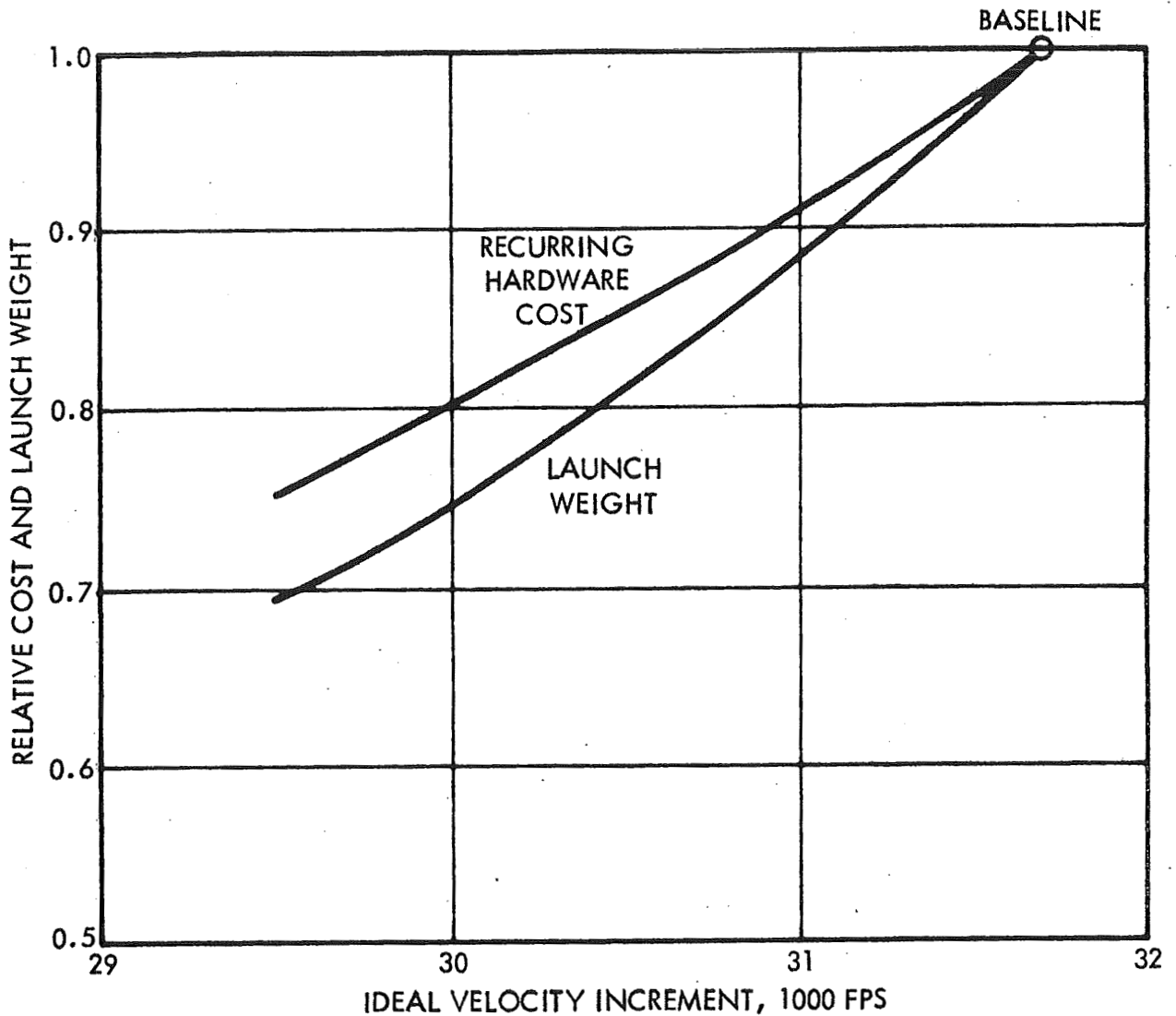

Figure 4.8-6 Effect of Velocity Requirement on ICLV Weight and Cost

if 150,000 lb payload is needed for some (relatively few) missions, the present design weight with a 4th stage as used for high velocity missions should be used (more economical than the Saturn V).

Further consideration of the handling and launch operations costs and the payload versatility are also desirable before trimming the velocity margin and vehicle size as discussed above, because these factors will have important effects on the ultimate effectiveness of the optimal ICLV. See Section 9.8 for discussion of versatility/cost tradeoffs.

4.30

4.9 Summary of Configuration Studies

The many conceivable configurations for the LCLV were reduced by preliminary design studies to the six principal contenders mentioned at the beginning of this section. After a lengthy process of cost analysis, discussed in Section 4.7 and 9.0, all of these designs were found to have a cost spread of only 20 percent; hence, when compared with current LV's, they would all qualify as low cost launch vehicles, by virtue of their being produced and operated in the simplified manner described, rather than by any predominant superiority of configuration.

In comparing the six designs for relative preference, judgment is guided by: 1) the total cost (recurring plus non-recurring) for the estimated number of vehicles to be produced (e.g., N=100); 2) the relative simplicity of the designs, and obvious interactions with reliability; and 3) the development risk.

Using the above criteria, the matrix of LV configurations is shown in Table 4.9-I, with weight and cost numbers resulting from the study analysis, and the relative preference as it appears to the authors. Although the pump-fed vehicle shows a one percent lower total cost than the baseline design for N=100, this difference is believed insufficient to offset its greater complexity and development risk; hence, the baseline vehicle is preferred over the pump-fed. Other configurations are rated according to their relative costs, which progress upward in larger steps.

Table 4.9-I Matrix of LV Configurations and Relative Cost Ratings (100K lb Nom. PL)  
 Sequence of numbers: Gross weight, Mlb (1st unit rec. cost, \$M) [Non-rec. cost, \$M] {RC+NRC, \$M}  
 sources: Section 4.7 Section 4.7 Table 9-III Table 9-VI

Configuration	3-Stage	4-Stage	2-Stage	Rating by Cost for N=100	
				90% LC	95% LC
Pressure-Fed Liquid (PFL)	9.3 (13.1) [520]	7.8 (13.5) [600]	The 2-stage design (without high energy second stage) was found to weigh and cost almost twice as much as the corresponding 3-stage vehicle. For this reason, the 2-stage configuration was eliminated.	{11.7}	{14.6}
PFL-Quad Modules in Stages 1 and 2	9.6 (15.8) [534]	The 4-stage design was somewhat lighter, but slightly more expensive than the corresponding 3-stage vehicle. For this reason the 4-stage vehicle was eliminated.		1	1
PFL-Fully Modular Stages (7+3+1)	10.2 (18.9) [471]			{13.2}	{16.7}
PFL-Modular Engines	9.9 (15.8) [457]			4	4
Pump-Fed Liquid	6.0 (11.8) [577]			{14.2}	{18.3}
			6	5	
			{12.5}	{16.0}	
			3	3	
			{11.6}	{14.3}	
			2	2	
PFL + S-IVB (2-stage only, for 100K lb)	X X X	X X X	6.3(21) [390]	{14.1}	{18.7}
			*	5	6

## 5. DESIGN FEATURES

The principal design features of the LCLV baseline vehicle are

- TRW coaxial injector engines or equivalent
- Simple pressure-fed stage design, utilizing high strength welded steel
- Hot gas pressurization using main tank injection (MTI) or gas generator (GG)
- Liquid injection thrust vector control (LITVC)
- Hot gas roll and ullage control systems

This combination of features is unique in launch vehicle development, representing the simplest means to accomplish the desired results with moderate development cost, for scaling up currently workable systems to the sizes required for the LCLV.

### 5.1 TRW Coaxial Injector Engines

The coaxial injector engine, invented at TRW and developed to four thrust values from 500 lb to 250K lb as outlined in Table 5-I, is perhaps the most important feature of the LCLV thesis. Since the first unit was produced in 1961, three successful scale-ups of this engine have been accomplished, each with

Table 5-I Scale-up of TRW Coaxial Injector

1. First unit - 500 lb thrust - built in 1961
2. Scale-up to 5,000 lb for MIRA - 1962 (factor of 10)
3. Scale-up to 10,000 lb for LMDE - '63 (factor of 2)
4. Scale-up to 250,000 lb for AFRPL (factor of 25)
  - Run 6 times at 50,000 lb at Capistrano ('67)
  - Same hardware run 15 times at 250,000 lb at AFRPL ('68)
  - Short duration runs completed successfully
  - Full duration runs to be scheduled soon
5. Next scale-up to 3M lb for LCLV (factor of 12)
6. Finally to 12M lb for LCLV (factor of 4)

moderate development funds. The 250K lb engine now under test at AFRPL is slightly smaller than the LCLV third stage engine. The success of these programs gives confidence that two additional enlargements of the engine to thrust levels of 3M and 12M lb required for the LCLV second and first stages, respectively, can be accomplished without difficulty. (Ref. 10).

### 5.2 Pressure-fed Stages

Recent developments in the manufacture and fabrication of high strength steels lead to the reconsideration of the simple pressure-fed launch vehicle concept.

Strength and Cost of Materials. The principal material used for the fabrication of tanks and engines for the LCLV is the HY-140 steel (5 Ni-Cr-Mo-V), selected because of its high strength/\$ fabrication cost (see Table 5-II). A

Table 5-II Strength and Cost of Candidate Structural Materials

Material	Ultimate Tensile Stress KSI Temp °F	Tensile Stress KSI		Strength Wt. Ratio (as welded) /ρ x 10 <sup>-5</sup>	Cost-\$/lb.	
		Base Mat'l.	Welds		Material	Fabricated as a Tank
T-1 Steel <sup>(1)</sup>	70	115	109	3.85	0.25	1.10
(ASME SPEC 517)	600	105	100	3.50		
HY-140 Steel <sup>(2)</sup>	70	155	155	5.45	0.43	2
(5 N <sub>1</sub> -C <sub>R</sub> -M <sub>O</sub> -V)	600	140	140	4.93		
Maraging 18 N <sub>1</sub> -200 <sup>(3)</sup>	70	210	200	6.90	1.50	7
	600	190	180	6.20		
Maraging 18 N <sub>1</sub> -250 <sup>(3)</sup>	70	260	246	8.50	1.50	7
	600	234	222	7.70		
2219-T87 <sup>(4)</sup>	70	60	42	4.80	0.75	
Aluminum Alloy	400	40	28	2.80		
2014-T6 <sup>(5)</sup>	70	68	--	6.80	0.68	
Aluminum Alloy	400	44	--	4.40		

- (1) High strength construction steel now in general use.
- (2) High strength steel being developed by the Navy for fabrication of welded deep submergence vehicles without subsequent heat treatment.
- (3) Ultra high strength steel being developed for large solid propellant rockets. Weld strength is obtained by a 900°F aging treatment rather than by a conventional heat treat cycle.
- (4) The most easily welded of the high strength aluminum alloys. Weld strength values are obtained without subsequent heat treatment.
- (5) Candidate for interstage structures where high weld strength is not a factor and buckling is critical. Thermal reduction in strength is very conservative due to extremely short exposure.

series of steels having high yield (HY series) ranging from HY-80 to HY-150 are available. These steels have the characteristics of relatively low material cost (\$.4 - .5/lb), low fabrication cost (~\$2/lb in the quantities used for LCLV), high weld strength without heat treatment after welding, and high strength at elevated temperatures (See Appendix B.3.2).

Higher strength (maraging) steels, with yield strengths of 180 ksi or more, permit some weight savings, but since these materials are considerably more costly to fabricate, and require heat treatment after welding, their use is not justified, except for upper (3rd and 4th) stages.

Interstage structures may be constructed of aluminum alloy for high buckling strength with a moderate amount of internal structure.



Tank Weight. Since the propellant tanks represent the largest single item of weight in the stage design, a brief review of such data is shown below to determine the relative weight of the propellant tanks (See Appendix B.3.1).

The propellant tank weight  $W_t$  is a function of its shape, volume, pressure, safety factor and the strength/weight ratio of its material, formulated as follows:

$$\frac{W_t}{W_p} = K \frac{p\rho}{\delta\sigma} (SF)(1+U)(NOF)$$

where  $W_t$  = weight of propellant of density  $\delta$  (lb/in<sup>3</sup>);  $p$  = tank pressure (lb/in<sup>2</sup>),  $= P_c + \Delta p$ , where  $P_c$  = chamber pressure of the engine and  $\Delta p$  is the pressure drop from tank to engine;  $\sigma/\rho$  = strength/weight ratio of material (lb/in<sup>2</sup> ÷ lb/in<sup>3</sup>); SF = ultimate safety factor ; U = minimum ullage space as a fraction of the tank volume; and NOF = non-optimum factor whose value is determined empirically (see Appendix A).

The shape factor K varies as follows with the ratio of length/diameter (L/D) of the tank:

L/D	1 (sphere)	2	3 . . . . .	(long cylinder)
K	3/2	9/5	15/8 . . . . .	2.0

Steel tank material has a density of  $\rho = .285$  lb/in<sup>3</sup> and an allowable ultimate stress (at an elevated temperature of 600°F) of  $\sigma = 140,000$  lb/in<sup>2</sup> for HY-140 and 185,000 lb/in<sup>2</sup> for maraging steel. The bulk density of N<sub>2</sub>O<sub>4</sub>/UDMH at a mixture ratio of 2.6/1 is  $\delta = .0423$  lb/in<sup>3</sup>.

The safety factor of SF = 1.5 is conservative for a man-rated space booster (1.4 is normally used). The NOF (= 1.15 for 1st stage, 1.25 for 3rd stage) is a design margin to allow for fittings, weldments, off-gage material, which are not included in the simplified weight formula. The ullage space U for filled tanks is assumed as .05 of the tank volume.

The ratio  $W_t/W_p$  will then vary with tank design pressure as follows for tanks having L/D = 2 and the two types of steel:

	p(psi)=	100	200	300	400	500
$\sigma = 140K$ , (1st stage)	$W_t/W_p =$	.0143	.0286	.0430	.0572	.0715
$\sigma = 185K$ , (3rd stage)	$W_t/W_p =$	.0129	.0258	.0387	.0515	.0644

Relative Weight and Cost of First Stage Propellant Tanks. The relative weight of the tank decreases with increasing tensile strength of the tank material, as shown in Figure 5-1, the curve labelled "constant  $\Delta V$ " indicating the relative tank weight to maintain equal performance for all cases.

The fabrication cost per pound of welded steel tanks rises with the yield strength, due to the increased cost of material, the greater effort

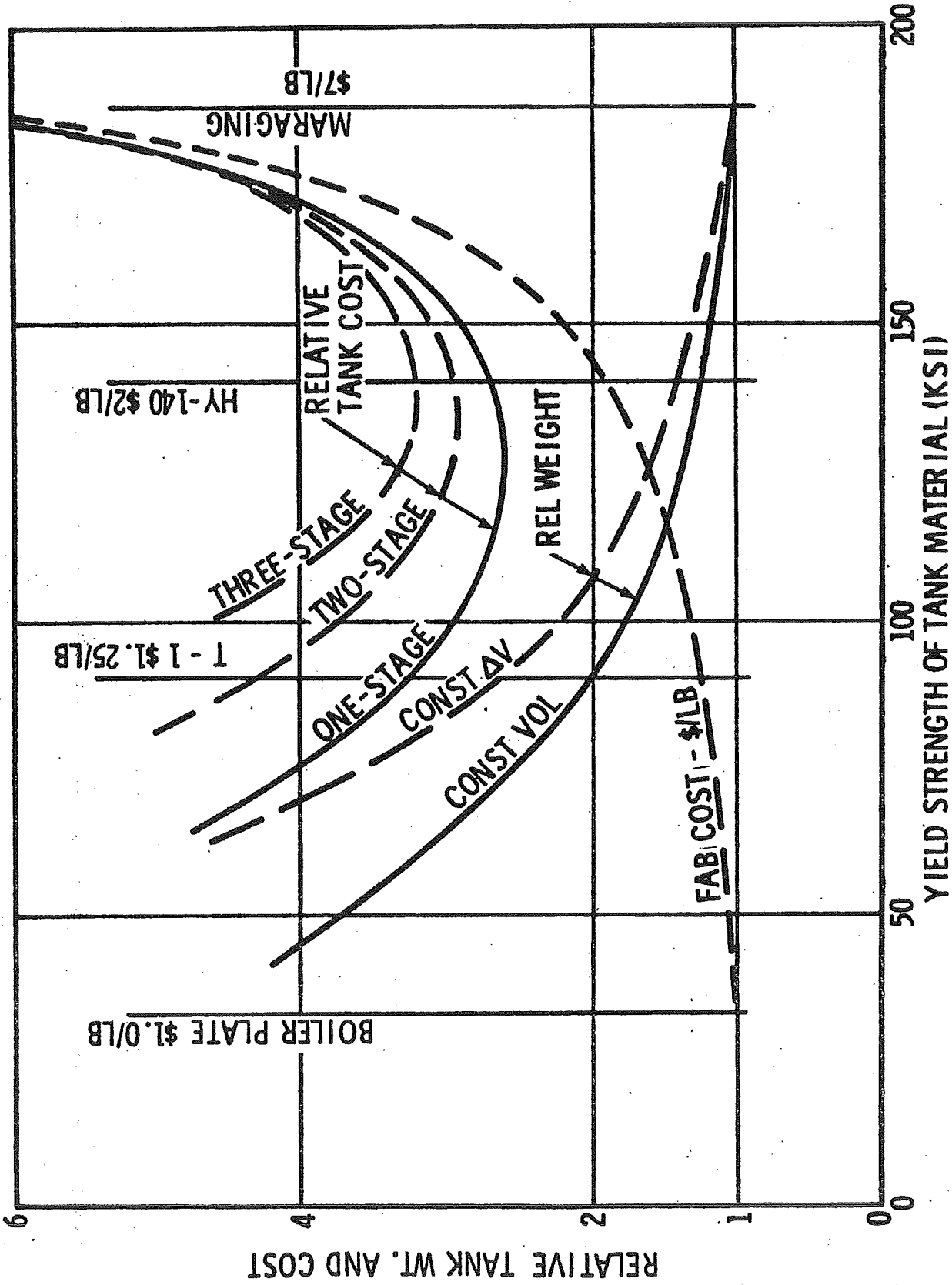

Figure 5-1 Relative Weight and Cost of First Stage Propellant Tanks

required in forming, and the greater care required to weld the material and preserve its high strength. Fabrication costs vary from about \$1/lb for boiler plate to \$7/lb for maraging 200, as shown.

The relative cost of a tank (product of relative tank weight x cost/lb) has a saddle shape as a function of the material yield stress, the minimum occurring midway between the values for T-1 and HY-140 steel as shown in Fig. 5-1. In a multi-stage vehicle such as the LCLV, the minimum moves to the right as stages are added, due to the increased size of the booster stage caused by the extra weight of upper stages (if made of lower strength material). This figure serves to explain why the HY-140 steel is preferred as the basic propellant tank material for the LCLV first stage, since it provides nearly optimum cost effectiveness for the above range of materials. Material selection tradeoffs for boosters and upper stages are discussed further in the following paragraphs.

Comparison of T-1 vs HY-140 as Basic Material. A more detailed study was made to determine the effect of using T-1 steel for the first stage engine and/or the tank structure. Using T-1 instead of HY-140 for the first stage engine injector and shell results in 24% increase in engine weight and a 23% decrease in engine cost. The effect of this substitution on the first stage is to decrease the stage cost by 4.5% (\$288,000) and to increase the stage gross weight by 1.5%. If T-1 is also used for the tankage and structure the stage cost does not decrease further but the stage weight increases by 10%.

From this analysis it is apparent that T-1 may indeed be a cost effective choice for the stage 1 engine material but it confirms the previous conclusion that there is no cost advantage from using a lower strength material for the tank, but a large weight penalty. The specific metal fabrication costs for the engine are: HY-140, \$8/lb; and T-1, \$4.40/lb. It is recognized that these metal fabrication costs are somewhat high for engines; however, they are in keeping with the conservative nature of the previous engine cost estimates.

The above conclusions with respect to stage 1 engine material selection must be tempered by the realization that the relative costs between T-1 and HY-140 are not known with sufficient accuracy to definitely conclude at this time that T-1 is more cost effective.

The results of material selection analysis for the tanks of the 3-stage LCLV are shown in Table 5-III. The fabrication cost of maraging 200 and 250 was assumed to be \$7/lb, compared to \$2/lb for HY-140. The results show

Table 5-III LCLV Tankage and Structure Material Selection

<u>Case</u>	<u>Stage</u>	<u>Material</u>	<u>Jettison Fraction</u>	<u>Relative Liftoff Weight</u>	<u>Relative Recurring Cost</u>
I (Baseline)	3	HY-140	0.127	1.0	1.0
	2	HY-140	0.120		
	1	HY-140	0.122		
II	3	Maraging 200	0.113	0.96	0.98
	2	HY-140	0.120		
	1	HY-140	0.122		
III	3	Maraging 200	0.113	0.89	1.01
	2	Maraging 200	0.106		
	1	HY-140	0.122		
IV	3	Maraging 250	0.104	0.93	0.95
	2	HY-140	0.120		
	1	HY-140	0.122		
V	3	Maraging 250	0.104	0.83	0.94
	2	Maraging 250	0.097		
	1	HY-140	0.122		
VI	3	Maraging 250	0.104	0.77	0.99
	2	Maraging 250	0.097		
	1	Maraging 250	0.099		

Assumed Cost of Maraging 200 and 250 -- Fabricated Cost = 3.5 x HY-140

Note: The values of the baseline configuration jettison fractions given above are slightly higher than the final values because the above represents an earlier design study.

that a 1.7 percent cost reduction would result by the use of maraging 200 in the third stage, but that no cost reduction would result by its use in lower stages. The use of maraging 250 has the following effects:

<u>Used in Stages</u>	<u>Percent Cost Decrease</u>
3 only	4.6
3 and 2	6.0
3, 2, 1	1.0

Although the 6 percent cost reduction for maraging 250 appears significant, HY-140 is recommended for all stages for the following reasons:

1. The "forgiving" nature of HY-140 (i.e., leak before failure, high weld efficiency) makes it a natural choice for low cost construction.
2. The use of the same material in all stages is desirable from the standpoint of simplicity, tooling and fabrication.

However, if vehicle size or weight is found to be a significant parameter in handling and launch operations, the choice would favor maraging steel. As shown in Table 5-III, the weight of the vehicle with maraging 250 in all stages is 77 percent as great as the vehicle constructed of HY-140.

### 5.3 Tank Pressurization

Several methods of pressurizing the propellant tanks are available; as described in the following pages; namely, main tank injection (MTI), hot gas generators (GG) and cold gas supply tanks. The conventional MTI system, employing separate injectant tanks for both oxidizer and fuel, has been assumed in computing the stage weights and costs for the LCLV. However, an alternate system having many attractive features, is described in the next section.

5.3.1 Main Tank Injection (MTI) Pressurization System. Several experimental programs have proven that the injection of hypergolic propellant directly into the main propellant tank is an effective method of pressurization (Refs. 11 to 13). Fuel can be injected into the oxidizer tank, or vice versa, with essentially equivalent results. The quantity of injectant is found to range from 1/4 to 1/2 percent of the main propellant flow rate, and the injector pressure drop is about 80 to 150 psi, giving injectant velocities of 120 to 160 ft/sec. The injector outlet can be at the top of the tank (pointed downward, Refs. 12, 13) or it can be below the liquid level (Ref. 11).

With the injectant flow rate adjusted to pressurize the entire tank in (say) 120 sec, the initial ullage space (nominally 5 percent of the tank volume) will be pressurized in about 6 sec. To avoid excessive overshoot of the initial pressure, the quantity of injectant *in transit* (i.e., between the injector and the propellant level) should be minimized; for example, by placing the injection point below the initial level of propellant; resulting in pressure stabilization at the pressure regulator setting ( $\pm$  a few percent).

The MTI system envisioned for the LCLV (see Figure 5-4), has been devised to utilize the best principles of the previous tests. The main features are as follows:

Oxidizer Tank Pressurization. Pump fuel from the bottom of the fuel tank to the injector (*below* the initial liquid level in the oxidizer tank). The power required to do this in the 1st, 2nd and 3rd stages is 200, 30 and 6 HP, respectively. Each stage will have (for reliability reasons) dual independent motor driven pumps, energized by batteries.

Fuel Tank Pressurization. From the oxidizer standpipe (which extends downward through the fuel tank), inject oxidizer downward into the fuel

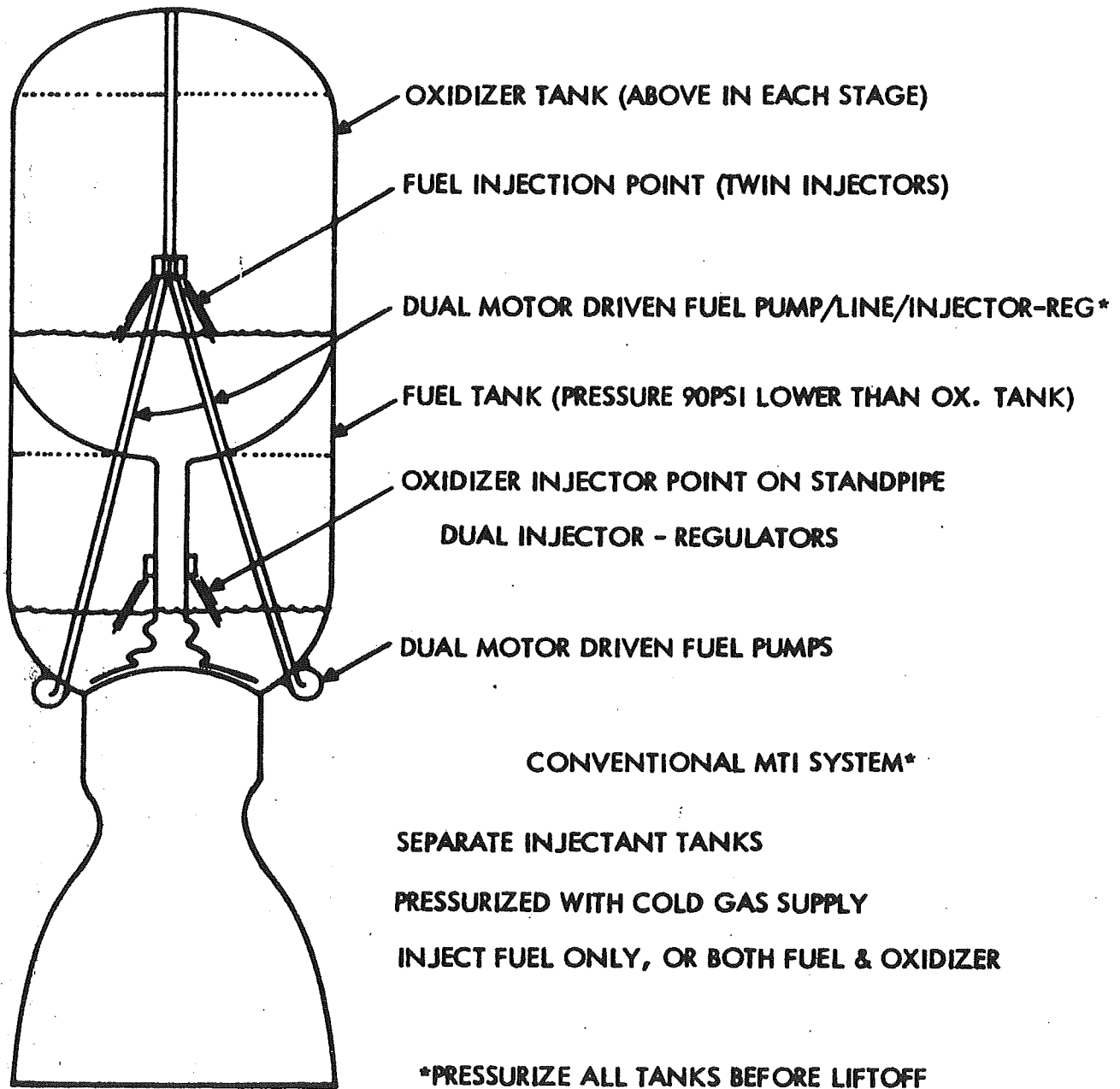

Figure 5-4 Main Tank Injection (MTI) Pressurization System\*\*

\*\* The MTI system as illustrated in figure above is suggested for comparison with the more conventional system using separate injectant tanks.

tank. Since the fuel tank pressure must be approximately 90 psi lower than that of the oxidizer tank (to get proper  $\Delta p$ 's for the main engine injector), this provides adequate MTI injection pressure for the fuel tank.

Initiation and Operation. All stages will be pressurized before liftoff, confirming that the pressurization systems are functioning properly; i.e., the pump/motor/battery/injector systems for all oxidizer tanks, and the injector regulator systems for all fuel tanks. Independent dual systems will be employed for all functions, the capacity of each designed to maintain the required propellant flow to the engine. Thus, in case of malfunction of any system, its mate will be able to accomplish the pressurization function. This combination of dual redundancy and pre-liftoff checkout is expected to result in very high reliability.

Hot Gas in Ullage Space. As propellant is pumped to the engine, the ullage pressure will be maintained by the injectant regulators, and the ullage space will fill with pressurized gas at an elevated temperature, the weight of residual gas being determined by the final pressure and temperature of the vapor. At 600°F, the total weight of residual gas (in both tanks) will be about 1.3 percent of the propellant weight (for the 1st stage, and somewhat less for upper stages).

Gas Temperature Adjustment. To avoid excessive gas temperature, which would cause a reduction in tank material strength, the injectant points will be placed at some intermediate level in the tank, to permit the initial injection to be made below the surface, (for temperature control). As the liquid level in the tank descends, the final injection will then be made above the propellant level for a sufficiently long period of time to bring the ullage gas temperature to a desired maximum value (such as 600°F, to reduce the weight of residual gas). The final temperature should be determined as a weight tradeoff (residual gas weight vs increased tank weight).

Shutdown. Both injectors will be closed during the last few seconds before engine cutoff, to avoid disturbance in the vicinity of the main engine inlets.

The above MTI pressurization system including injectant is computed to weigh less than 1/2 percent of the stage weight. When the residual gas is included, the complete MTI system weighs less than 1.5 percent of the stage weight, which is believed to be the lowest weight attainable in a pressurization system. It is simple, low cost, reliable, easy to install and check out.

There are two ways in which this system differs from those tested in Refs. 11 to 13; namely, 1) the manner of pumping injectant (with motor driven pumps rather than gas-pressurized injectant tanks); and 2) the larger scale of the full size vehicle. The former is believed to be a simple electro-mechanical development, to provide adequate flow and pressure drop to the injector, with due regard to safety and reliability. The scale effect can

be solved by testing successively larger stages, starting with the 3rd stage system, for example, and using the experience gained to simplify the development of the 2nd stage; which will in turn contribute valuable data to the 1st stage system and test program. As in the scale-up of the engine with coaxial injector, there is no fundamental reason why a large system should not work as well as a small system; however, it is necessary to plan and carry out a rational test program to prove the point.

Weight of MTI System. The approximate weight of motors, pumps and batteries required for the MTI system can be determined by a few calculation as follows: The motor input power IHP and energy E required to pump UDMH into the NTO tank at an injectant rate of 0.35 percent of the main oxidizer flow rate  $\dot{W}_0$  ( $= .0035 \dot{W}_0$ , according to Reference 13) is

$$\text{IHP} = \frac{\Delta p \times .0035 \dot{W}_0}{550 \eta_{mp} \rho} = .21 \times 10^{-6} \Delta p \dot{W}_0$$

E = input watts x burning time/input volts

where  $\Delta p = n p_h + \Delta p_i$  = dynamic head plus injector pressure drop ( $\Delta p_i$ ),  $\rho$  = density of UDMH = 49 lb/cu ft, and  $\eta_{mp}$  = motor efficiency times pump efficiency = .60. The main oxidizer flow rate  $\dot{W}_0 = (T/I_{sp})(r/r+1)$ , in terms of the engine thrust T, specific impulse  $I_{sp}$ , and mixture ratio r (= 2.6). Design parameters for the MTI system are then given in Table 5-IV.

Table 5-IV Characteristics of MTI System

	Stage 1	Stage 2	Stage 3
Thrust T (lb)	11.6 M	2.2 M	.46 M
Specific impulse $I_{sp}$ (sec)	255	300	306
Main Oxid. flow rate $\dot{W}_0$ (lb/sec)	32,700	5,300	1,080
Pressure drop $\Delta p$ (lb/ft <sup>2</sup> )	30,000	27,000	26,000
Motor input power (HP)	206	30	6
Motor input (watts)	154,000	22,400	4,500
Burning time (sec)	130	200	240
Battery energy ~28v. (amp sec)	715,000	160,000	39,000
Number of batteries*	30	7	2

\*A battery drain of 200 amps per unit battery for 2 minutes is within current state-of-the-art. Conversely, the number of batteries = battery energy/200x120.

If silver-zinc batteries with an energy density of 40 watt-hours/lb are used the weight of the batteries for the first stage becomes

$$\text{Battery weight} = 154,000 \times \frac{2}{60} \times \frac{1}{40} = 129 \text{ lbs.}$$

To allow for checkout and pre-lift-off system confirmation, generous over-capacity is recommended. This would increase the battery weight to approximately 300 lbs. The estimated weight for the 1st stage injection system is:



Batteries	300 lbs.
D. C. Motor (200 HP at 8 lb/HP)	1,650 lbs.
Pump and Lines	100 lbs.
Controls and Power Conditioning	50 lbs.
Injectant Regulators (2)	<u>30 lbs.</u>
Total	2,130 lbs.

Dual redundant systems are assumed, giving a total weight estimate of 4260 lb, or .0007 times the first stage propellant weight, which is remarkably low for the hardware weight of a pressurization system. The upper stages will have correspondingly low system weights.

Potential problem areas to be considered with this system include:

- a. initial pressure overshoot
- b. control of residual gas pressure and temperature to minimize weight of residual gas
- c. avoidance of excessive gas temperatures
- d. assurance of adequate NPSH to pumps
- e. avoidance of sloshing, vortexing, and drop-out during the last few seconds of engine operation
- f. venting of corrosive or toxic pressurant gases must be carefully controlled.

The above technique for stage pressurization is believed feasible and desirable; however, a series of development tests should be planned to properly evaluate and confirm the operating characteristics of the MII pressurization system. Both steady-state and transient phenomena should be assessed. In addition, pre-flight checkout and operating procedures should be developed to assure safe, reliable operation.

Despite the attractively low weight and cost of the above MII system, and the relatively straight forward development program to prove its effectiveness, an alternate method is suggested as backup. In the weight and cost analysis for all the pressure-fed stages, the more conventional system has been assumed, employing separate injectant tanks for both oxidizer and fuel, with cold gas to drive the injectant into the main propellant tanks.

#### 5.4 Liquid Injection Thrust Vector Control (LITVC) (Reference 14)

Existing technology derived from the 120-inch rocket motor development programs offers compelling reasons for the continued use of LITVC systems. Specific examples cited for reference include the proportional hydraulic servo design used in the Titan III-C system and the proportional electromechanical

design to be used for the Titan III-M vehicle. Extensive operational experience has been acquired. The preponderance of available static and flight test data makes it possible to develop improved versions without incurring large scale expenditure to establish liquid injection design parameters.

For application on liquid boosters, LITVC constitutes an almost ideal approach for vehicle control. Significant weight and cost savings compared to solid motor systems are possible by the elimination of separate propellant tankage and pressurization systems. Provisions for programmed dumping of injectant fluid and compensation for chamber pressure tail-off can be omitted. The overall stage configuration is improved by virtue of the streamlined exterior. However, further improvements to liquid booster TVC systems are within reach.

The purpose of this study was to determine the optimum low cost LITVC design for large thrust liquid booster engines. In so doing, various design approaches were evaluated to establish their impact on system performance, weight, and cost. The use of dual quadrant and polar coordinate firing was considered. Two basic control modes for the injectant valves were investigated: the proportional and digital systems. Within these two control schemes further distinction was made between electrohydraulic and electromechanical valve actuation methods.

The digital approaches studied included two methods of valve modulation plus a discrete "bang-bang" pulse modulation system. The recommended system was then sized for installation on a liquid strap-on booster with performance comparable to that of a Titan III-M 120-inch SRM. Weight and cost comparisons were made for various booster and TVC system combinations.  $N_2O_4$  was used as the injectant on all systems.

The Titan III-M TVC system was characterized by using existing Titan III-C design information (Ref.14) and considering the major design changes being implemented because of the following:

- 1) The Titan III-M system incorporates the most current 120-inch SRM strap-on booster LITVC configuration scheduled for operation.
- 2) The Titan III-M strap-on booster and TVC performance factors can be used to define the liquid strap-on booster and low cost LITVC system design.
- 3) It provides a means of measuring the effects of the existing proportional electromechanical TVC approach on the liquid booster. Conversely, it shows the advantages of the low cost LITVC approach as applied to solid boosters.

No attempt was made to include the Titan III-C proportional hydraulic servo TVC system in the comparison since this approach has been superseded on both the Titan III and Minuteman programs.

Other aspects of the recommended low cost LITVC system were studied. These include checkout and operation sequence, fail safe considerations, control resolution, response and stability, controller design and valve hydraulic design. Two separate studies were performed on the pressure surge evaluation and flight control study aspects of the bang-bang pulse modulation approach. The study culminated in the preliminary design of a low cost LITVC system installed on a  $2.9 \times 10^6$  pound thrust liquid strap-on booster sized for a typical near earth orbit mission. The results of this study program are summarized below.

#### 5.4.1 Recommended TRW Low Cost LITVC System

- Digital electrohydraulic injectant valves operated by polar coordinate firing mode control appear to be the most desirable approach to low cost liquid injection thrust vector control. The TVC system configuration consists of 24 valves equally spaced around the nozzle periphery and normal to the engine thrust line, a polar controller to command simultaneously modulated firing of six valves, propellant tankage lines from the  $N_2O_4$  tank and pressurization features which are common to the liquid booster engine system, and a burst disc for propellant isolation prior to system activation.

- The injectant valve assembly features a hydraulic actuator piston which is integral with the valve pintle, on-off solenoid operated pilot valves, position transducer, and electronics for controlling the on-off operations of the solenoid valves. Pressurized injectant fluid, which in all cases discussed would be engine oxidizer propellant or nitrogen tetroxide ( $N_2O_4$ ), is used for hydraulic actuation.

- Estimates of LITVC systems weight and cost were made. Comparisons were made for four booster/TVC system combinations. These are: (1) an existing 120-inch SRM TVC system (Titan III-M) incorporating proportional electromechanical actuated injectant valves with injectant blowdown from 1100 to 500 psia and featuring dual quadrant firing, (2) the 120-inch SRM with 1100 to 500 psia blowdown operation combined with the digital electrohydraulic injectant valves and employing polar coordinate firing, and (3) a liquid strap-on booster utilizing proportional electromechanical injectant valves coupled with polar coordinate firing. All configurations are referenced to the nominal booster and TVC performance criteria of the Titan III-M system. In all cases TVC duty cycles are assumed to be the same. All systems use  $N_2O_4$  as injectant fluid.

Comparisons were made within each booster category to negate the basic difference in TVC tankage, pressurization, and structure design. In each case, the substitution of the proportional electromechanical dual quadrant design by the digital electrohydraulic polar firing approach resulted in an approximate total system weight savings of 15 to 20 percent, and an average hardware cost savings of 40 percent. The bulk of the weight reduction is attributed to the use of polar coordinate firing which translates into reduced duty cycle injectant fluid, smaller tankage, less pressurization,

and smaller line and manifold volumes. The cost reduction aspect is comprised of two major factors: (1) the predominating influence of the low cost digital electrohydraulic injectant valves, and (2) the lower cost of reduced injectant and pressurization tank structural requirements. Results of the cost and weight estimates are presented in Table 5-V.

Table 5- V Cost and Weight Estimates

Booster Configuration	TVC Configuration	TVC Inert Weight (lb)	TVC Systems Weight (lb)	Hardware Cost*
SRM Strap-On	Proportional E/M Dual quadrant firing	7142	14,642	\$157,500
	Digital E/M Polar firing	5114	11,573	\$ 99,000
Liquid Strap-On	Proportional E/M Dual quadrant	2909	10,407	\$106,130
	Digital E/M Polar firing	2340	8799	\$ 61,460

\*Excludes integration, system tests, and administrative costs.

#### 5.4.1.1 Advantages of Recommended LITVC System

The advantages of the recommended system are presented below:

- A change-over from dual quadrant firing (six valves per quadrant) to polar coordinate TVC firing of six valves, centered around the desired thrust vector angle, results in approximately 15 percent savings of propellants over a typical mission duty cycle. Pinpointing the most probable thrust vector angles by the Monte Carlo random selection technique or direct comparison of previous mission duty cycles is required to obtain more accurate assessment of propellant savings. The combined effects of polar coordinate firing and valve spacing result in a minimum thrust vector angular resolution of  $\pm 2.08$  percent.
- No hydraulic power supply is required. The total actuation requirements for a 150-second mission is estimated to be 3.75 amp-hour at 28 vdc plus 84 pounds of propellant expended as actuation fluid.
- The valve design is relatively unaffected by hydraulic fluid contamination problems that plague conventional hydraulic servo systems.
- The valve slew rates are superior to that of motor actuated valves. Higher response can be obtained by a slight increase in pilot valve flow rate.
- No additional network compensation is required to meet frequency response requirements. On an uncompensated basis dc motors exhibit low response capabilities.
- The actuator design incorporates an inherent fail safe feature causing the valve to remain closed under all passive conditions. An

overriding closing force prevails in the absence of electrical signal during all operating modes. Dual coil solenoids can be provided to enhance the overall reliability.

- Failure modes such as jamming of dc motor ball screw shaft will not occur.
- The design of the digital electrohydraulic injectant valve is amenable to low cost fabrication.

#### 5.4.1.2 Disadvantages of the Recommended LITVC System

The disadvantages of the recommended system are listed below:

- Under normal TVC operations, the pressurized injectant is used as actuation fluid. Exercising of the valves can be accomplished during cold flow tests by the use of inert test fluids. Launch pad validation checks on valve actuation can be made by introducing hydraulic or pneumatic pressure into the injectant manifold through the use of ground support equipment. The injectant burst disc can be designed to withstand the level of downstream pressure necessary to actuate the valves. Thus the main engine oxidizer tank will not be affected. However, because of time consuming operations, it is doubtful that this procedure can be incorporated into the prelaunch countdown schedule. Verification of valve integrity at this stage would be limited to electrical continuity checks of the solenoid valves. While this is sufficient to pinpoint the capability of valve operation, it requires a reorientation in checkout philosophy.

#### 5.4.2 Digital Electromechanical System

The digital electromechanical approach to valve actuation, as represented by stepping motor operations, was considered. In operation it resembles the proportional system with the exception that both input signal and motor output undergo discrete and incremental transmission. Conceptually the approach presents the possibility of a truly digitized open-loop control system. However, the effectiveness of the approach in terms of LITVC application cannot be defined without a comprehensive design investigation covering stepper motor design, electronic control, and flight computer programming. Consequently, in directing the study effort along lines consistent with state-of-the-art development, extensive work on this concept was deferred. Major advantages and disadvantages are listed for future reference.

##### 5.4.2.1 Advantages

- Valve actuation is independent of fluid pressure and can be accomplished during all phases of ground checkout operations.
- Position transducers, digital to analog converters, signal amplifiers, comparison networks, and other associated electronic components can be eliminated by integrating the TVC system with the digital flight computer.
- With the elimination of many of the electronic components, reliability of the system is improved.

5.16

- Good control resolution can be achieved with motors operating at 160 steps per revolution.
- Holding power requirements are reduced to a minimum.
- The system is potentially low in cost.

5.4.2.2 Disadvantages

- Possible problems exist in the availability of a stepping motor which would meet the injectant valve response and power requirements while operating at pulse rates sufficient to yield fine resolution.
- The power-to-weight ratio of stepping motors generally may not be competitive to proportional pancake type dc torque motors.
- The implementation of this concept requires extensive development exceeding the bounds of the present guidance/TVC interface.

5.4.3 On-Off System

The digital on-off system was studied in greater depth than the other candidate LITVC concepts because of questions related to basic system feasibility. As a result of this investigation, it was concluded that the digital on-off system coupled with polar control is potentially the optimum LITVC approach. However, several critical questions remain unanswered which place in doubt whether this concept is suitable for large boosters. Specific conclusions regarding the digital on-off concept are presented in the following paragraphs.

5.4.3.1 Advantages

- Use of on-off valves simplifies the actuation system controller by eliminating the position feedback transducer and associated electronics.
- On-off control logic (number and location of valves and duty cycle) can be included in the guidance computer thus eliminating the need for digital/analog conversion.
- Elimination of closed-loop controller components provides an inherently simple and, therefore, reliable system.
- Elimination of these same components as well as the contoured flow metering pintle results in a minimum cost system. Compared with the digital electrohydraulic modulating valves, the on-off valves can be fabricated at a lower cost.
- The flight control study showed that the on-off system is capable of providing excellent control characteristics during pitch-over maneuvers.
- The pressure surge analysis showed that the on-off system does not create peak pressures greater than 1000 psia for valve response times of 0.050 second and that excellent flow control linearity can be maintained.

5.4.3.2 Disadvantages

- The use of a pulse mode operation may create excessive structural dynamic coupling; additional quantitative analyses are required to make a final evaluation of this potential problem.

- The current Titan III-C maximum slew rate requirement (30 deg/sec) poses a potential problem to the flight control capability of the on-off system because of the necessity of actually slowing down the valve response rate. This results in reducing the effective throttling range and resolution of the system. Whether or not this significantly compromises the flight control capabilities of the system must still be determined.
- The on-off system results in a decreased instantaneous specific impulse because of transient operation. Total propellant consumption is also dependent on control characteristics, however, and a negligible increase in propellant usage is anticipated.

#### 5.4.4 LITVC Design for 2.9M lb Thrust Booster

On the basis of the recommended low cost LITVC approach, the specific preliminary design parameters of a TVC system were established for a  $2.9 \times 10^6$  lb thrust liquid strap-on booster. The 180-inch booster design selected illustrates a typical liquid configuration capable of boosting a 75,000 pound payload into a near-earth orbit. The LITVC system was designed to provide maximum vehicle control during the boost phase of the mission. Data in reference 14 show the essential features and schematic diagrams covering the general liquid booster/LITVC system arrangement. Discussion of the preliminary design considerations leading to the final system selection are also given.

The TVC system performance, weight, and cost features are as follows:

Maximum Side Thrust Deflection (degrees)	5
Maximum Side Thrust (lb)	252,000
Maximum TVC Flowrate (lb/sec)	1260
Total Side Impulse (lb-sec)	$2.72 \times 10^6$ (min.)
System Inert Weight (lb)	3200
Total TVC System Weight	14,506
Estimated Hardware Cost (\$)	100,125

The total weight of the LITVC System constitutes approximately 1.1 percent of the stage lift-off weight. Consistent with the estimated hardware costs applied to other systems described in this report, additional expenditures for system integration test and administration are not included. The performance factors established reflect hardware requirements which are within the range of current development.

5.18

### 5.5 Roll Control and Ullage Control

Roll and ullage control are provided by means of Hot Ullage Gas Ejection (HUGE) from the top of the fuel tank, directly through the tank wall to solenoid controlled nozzles (Figure 5-5). Two pairs of tangential nozzles on each stage provide roll control and four aft-pointing nozzles provide ullage control for the upper stages, as well as pitch and yaw control coasting.

Since the fuel tank pressure is maintained automatically by the MTI pressurization system, the additional hardware is minimal for roll/ullage control. Furthermore, the use of hot ullage gas accomplishes the control functions with a minimal amount of propellant.

The acronym is HUGE but the weight and cost are low. Data on jet thrusts and throat diameters are shown in Figure 5-5.

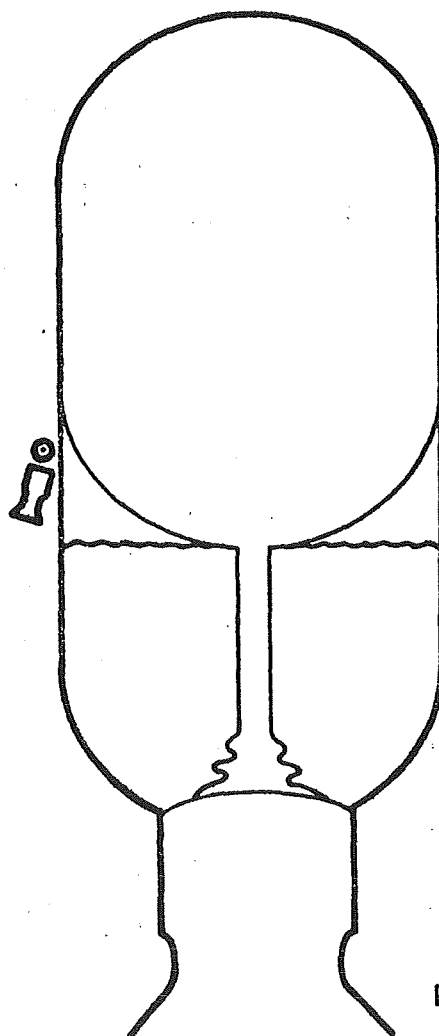

ROLL AND ULLAGE CONTROL - HOT ULLAGE GAS EJECTION (HUGE) FROM FUEL TANK ULLAGE SPACE  
 ROLL JETS - 2 PAIRS USED ON EACH STAGE

JET THRUST/MAIN THRUST = .001 (EACH JET)

STAGE	1	2	3	4
JET THRUST (LB)	12,500	2400	400	100
THROAT DIA (IN)	5	2.5	1.03	.51

ULLAGE JETS - 4 EACH ON 3RD & 4TH STAGES

JET THRUST/STAGE WEIGHT = .001 (TOTAL)

STAGE	3	4
JET THRUST (LB)	4 x 100	4 x 25
THROAT DIA (IN)	.51	.25

SETTLE PROPELLANT 1 FT. IN 8 SEC ( $W_p = .00015 W_{st}$ )  
 10 FT. IN 25 SEC ( $W_p = .00046 W_{st}$ )

INTERMITTENTLY 2/MIN FOR .1 SEC FOR 6 HRS ( $W_p = .00133 W_{st}$ )

Figure 5-5 Roll and Ullage Control System



## 5.6 Problem Areas

The LCLV design concept, leading to the simplest conceivable launch vehicle, is not without many problem areas, such as the following:

- The use of conservative design margins results in a vehicle of about the size of the Saturn V, weighing 9M lb, as the LV of minimum total cost. Handling, transport and erection of this vehicle are believed to be feasible without excessive cost, as described in Section 7.
- The noise level due to an increase in thrust of 50 percent over Saturn V is believed to be permissible for the neighborhood of KSC, and on-board effects can be handled by design techniques.
- Many years experience with Titan II and Atlas have shown that NTO - UDMH is essentially equivalent to LOX-RP from the safety standpoint, and this trend is believed applicable to large vehicles also (see Section 5.7).
- Clearance of the flame deflector of 1.5 to 2 nozzle diameters (60 - 80 ft) can be obtained at the launch pad (Complex 39), and such clearance is expected to avoid excessive ablation of the flame deflector (see Section 5.8).
- The interstage design and separation dynamics are recognized as sizeable development problems, but not fundamentally difficult.

## 5.7 Consideration of LOX-RP vs NTO-UDMH

The coaxial injector, which forms the basis for the LCLV engine designs, was originally conceived to be used with hypergolic propellant combinations, having the advantage that burning will be initiated spontaneously when the oxidizer and fuel come in contact with each other.

The question has been raised whether satisfactory engine operation would result from using a non-hypergolic combination such as LOX-RP, by virtue of the following apparent advantages (independently of propulsion considerations):

- Decrease in bulk propellant cost from 17 to 5¢/lb seems to indicate a saving of about \$1.0M per launching.
- Availability of production and storage facilities for LOX-RP, while such facilities would need to be provided (or enlarged) if NTO-UDMH is used.
- Freedom from atmospheric contamination in case of an oxidizer spill.

However, the question of whether LOX-RP would work with the coaxial injector may be of only academic interest, due to other considerations such as:

1. The difference in bulk propellant cost tends to be equalized when

5.20

the LOX boiloff losses (storage, fill and on-board) are accounted for, plus the additional cost of maintaining the cryogenic facility, plus extra cleanliness and quality control required to maintain reliability.

2. Extra facility costs for NTO-UDMH are relatively unimportant compared to the lower recurrent cost with this propellant combination as used in the LCLV, and lower non-recurring cost for engine development.

3. Several years experience with Titan II vs Atlas has shown that NTO-UDMH is essentially equivalent to LOX-RP from the safety standpoint, and there is no reason why this trend should not hold true for larger vehicles also. Provisions will be made for suppressing fumes (by fog nozzles) in case of a large acid spill, and the liquid will be drained into unvented tanks.

4. LOX-RP is not amenable to the simple, lightweight pressurization system which can be used with hypergolics, and is believed to be best suited to pump-fed designs; but preliminary analysis indicates that the low cost pump-fed vehicle is no less costly than the pressure-fed LCLV, which has a simplicity reflected throughout all phases of design, development, manufacturing and operation, to result in minimum cost; hence, NTO-UDMH is preferable.

5.8 First Stage Nozzle Exhaust Dynamics

A problem in facility design is posed by the large diameter of the first-stage nozzle, which will have an extremely long exhaust plume. The problem is whether the flame deflector, placed 60 to 80 ft below the nozzle exit plane, will be able to withstand the impingement of the exhaust. The Saturn V flame deflector has little or no damage, and can withstand 2 or 3 firings without refurbishment. With the LCLV exit nozzle diameter of 40 ft, the flame deflector will be about 1.5 diameters from the exit plane. It is expected that some erosion of the ablative facing may occur, necessitating that the leading edge be refurbished after each firing. If quad engines were used in the first stage, the above clearance would increase to 3 - 4 diameters, and probably no appreciable erosion would occur. However, the additional cost of quad engines is considerably greater than the refurbishment cost; hence, the single engine is still considered best from the standpoint of minimum cost per launching, unless further study should indicate the desirability of quad engines for reasons other than economy (see Section 4.4).

5.9 Propellant Utilization

Design studies indicate that with care in propellant loading and flow calibration, PU errors of 1.5 to 2.0 percent are likely to be encountered. Since the exchange ratio for residual propellant (Appendix C) is \$682,000/percent, a simple PU system is assumed, capable of reducing the residual propellant to 1/2 percent in each stage, as an economically justifiable addition to the LCLV.

## 6. PRODUCTION AND PROCUREMENT

One reason for the high cost of current launch vehicles is believed to be the large number of widely separated airframe manufacturers involved, with multiple checkout procedures and government inspections required to assure compatibility.

One of the LCLV concepts is based on a single airframe/assembly/integration plant designated "Plant A," located at or near the launch site, where 90 percent of the hardware fabrication and the stage assembly and integration are accomplished, and the fully assembled stages are checked out before delivery (see Figure 6-1).

Raw materials and purchased parts flow into the factory, and the finished stages are transported by railcar or crane to the VAB for LV assembly, payload integration and prelaunch checkout. The LV/ML are then transported to the launch pad by the Crawler/Transporter for final checkout, countdown and launching.

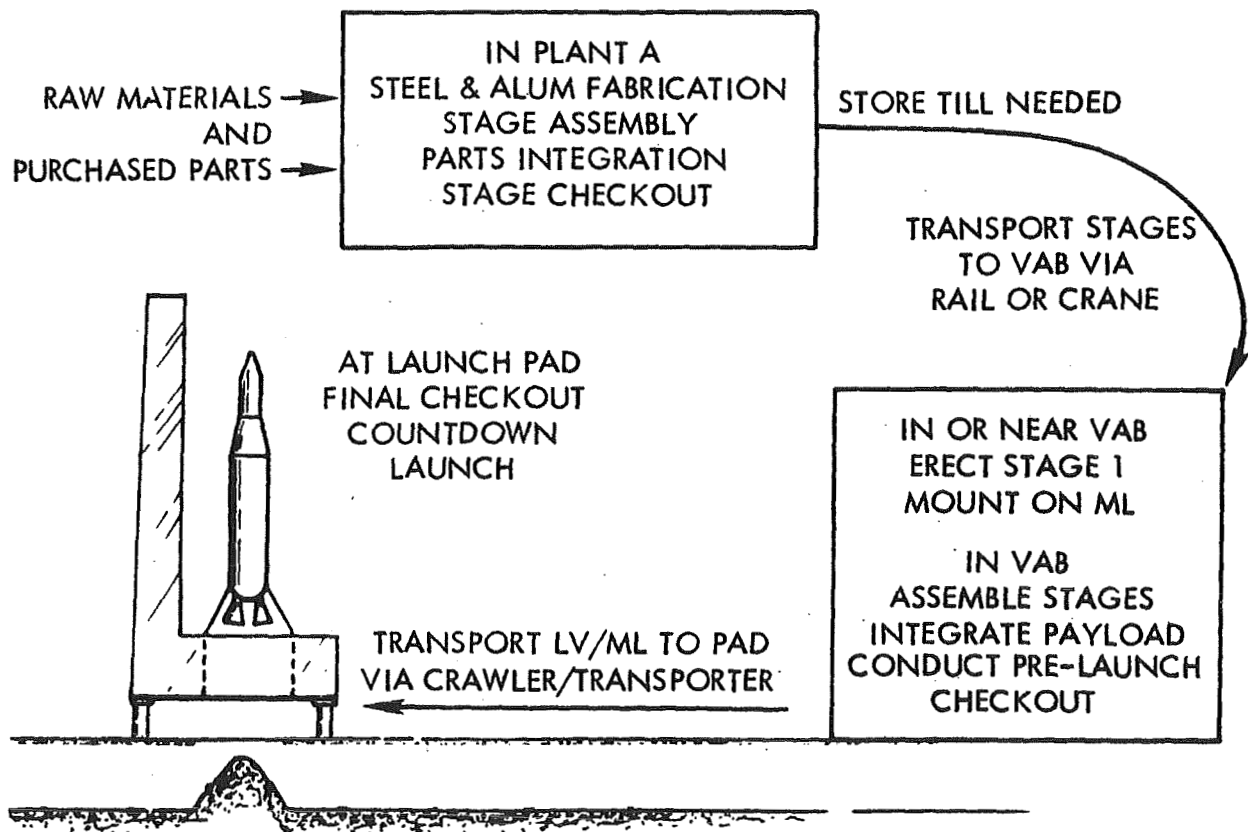

Figure 6-1 Flow Diagram for LCLV

6.2

6.1 LV Production in Plant A

The concept of LV simplicity (Figure 6-2) and conservative design margins leads to a low cost vehicle of about the size of a Saturn V but somewhat heavier. The concept of a factory (Plant A) adjacent to the launch site is consistent with the vehicle characteristics and leads to simplicity in manufacture, transport and launch support operations. The plant is specially designed to facilitate the fabrication of tanks, engines and interstage structures, and the integration of these with purchased parts to complete the launch vehicles.

The concept of management of the factory and launch support activities (Table 6-I) encompasses efficient modes of production/procurement/integration/checkout, with emphasis on quality assurance; and effective customer service, from standardized software to vehicle checkout and launch support.

Table 6-I) Production and Procurement

Plant "A" Located within a Few Miles of Launch Pad

Alternate Locations Available at KSC (See Figure 6-3)

Plant Management

Procurement of Raw Materials and Purchased Parts

Fabrication Techniques - Steel (and Alum) Forming and Welding

Machining of Injectors and Other Parts

Purchased Parts - Components and Small Subsystems

Assembly and Integration of Stages or Complete LV

Quality Assurance of In-House Work and Purchased Parts

Final Checkout of LV - in Factory and at Launch Site

Decision: Government Arsenal vs Chartered Private Industry

Which will Provide Desired Quality at Lowest Cost?

Past Experience Mostly with Private Industry

6.2 Alternate Sites for Plant A at KSC

If Plant A can be located within a few miles of the launch site, rail transport can be used for moving the stages or vehicles to the base, where they are erected in readiness for payload integration and final checkout before launching. If space were unavailable adjacent to the launch site, barge transport would be required, terminated by rail transport from the barge dock to the erection point.

In many respects, the most convenient location for Plant A would be directly adjacent to the VAB, permitting crane transport (rather than rail) of stages

NOTE: FEWER PARTS THAN CURRENT LV'S.  
ALL STAGES GEOMETRICALLY AND  
OPERATIONALLY SIMILAR

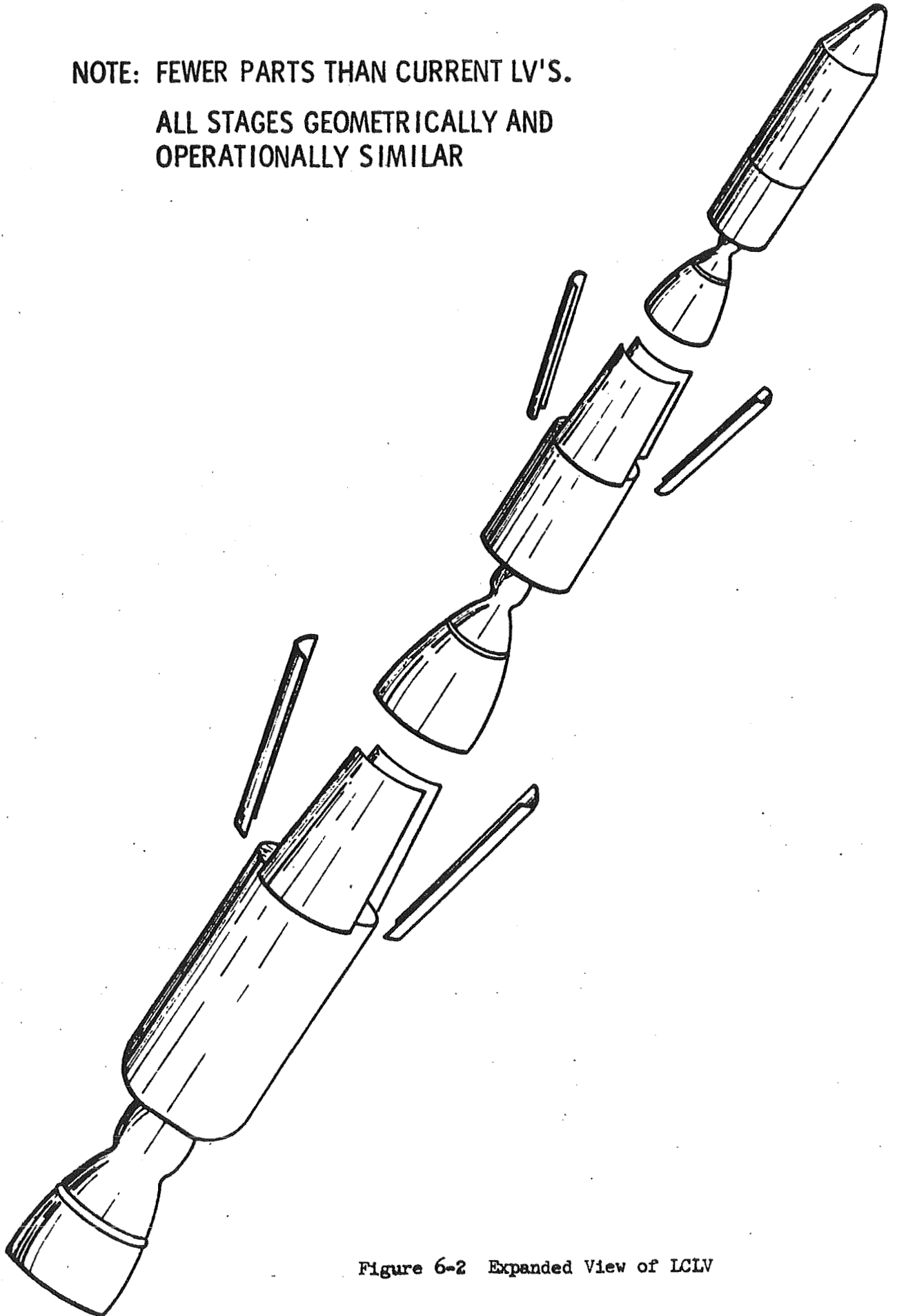

Figure 6-2 Expanded View of LCLV

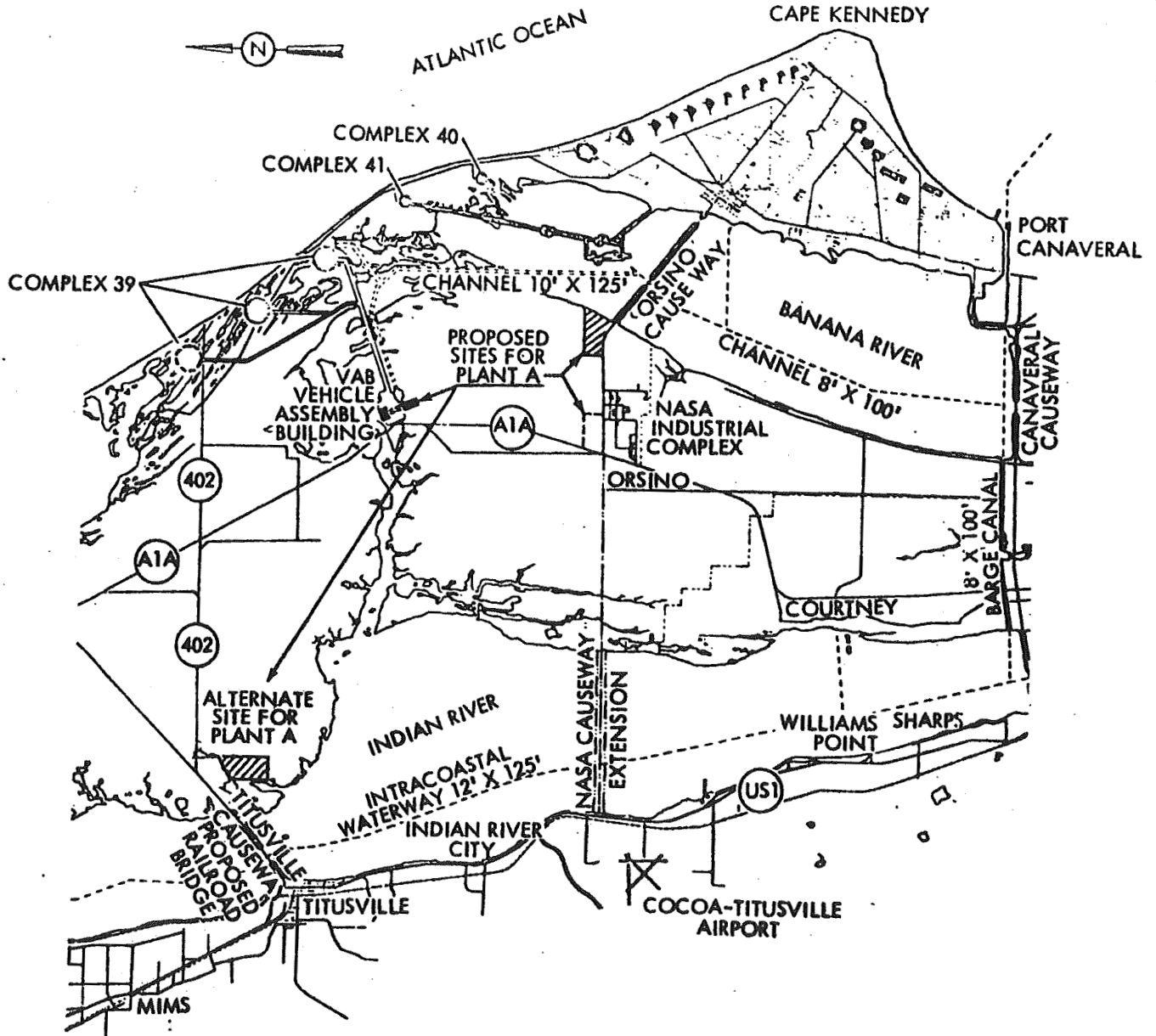

Figure 6-3 Alternate Locations for Plant A at Kennedy Space Center\*

\* The LCLV concepts and costs are based on close cooperation between Plant A and the launch complex, permitting checkout, integration and ground support operations to be accomplished with maximum efficiency of management and personnel. To produce the stages elsewhere would increase the costs considerably, but this case is beyond the scope of the present study.

101

from factory to the vehicle assembly bays, and near the LCC for routine stage checkout. While this location would eliminate preparation of a completely new site, barge dock, rail line, etc., and would simplify the stage transport and checkout operations, possible disadvantages such as pad clearance and interference during the plant construction period should be investigated.

It is fortunate that ample space is available in the vicinity of KSC Launch Complex 39, to accommodate the 30-50 acres needed for Plant A. As shown in Figure 6-3, there is a tract of 10 sq. mi. of vacant land southward from the VAB. Plant A might be located in the southeast corner of this tract, with free access to the Banana River barge channel for the transport of heavy steel plate used in fabrication of the LCLV, and building materials for construction of the factory. This site is spaced 4 miles from the VAB, 5 miles from Launch Pad 39A and about 3 miles from Pad 40, which is believed to provide adequate clearances for safety. Approximately 1.5 miles additional clearance from the launch pads can be attained by moving the factory westward, adjacent to the NASA Industrial Complex, with access to Banana River via a barge canal (dug eastward from the factory site).

Should greater clearance be required from the launch pads, an alternate location for Plant A is about 6 miles west-northwest from the VAB near the Titusville causeway. This location is about 8 miles from Launch Pad 39B, the nearest active launch site. Barge access is available via Indian River.

### 6.3 Plant A Layout and Work Flow

The Plant A layout is designed to provide for convenient handling of raw materials and purchased parts, from the receiving dock through processing and integration into complete launch vehicles, all under one roof. Some of the layout considerations are as follows (Table 6-II and Figure 6-4).

Table 6-II Plant A Layout and Facilities

Barge Dock, Rail Dock and Truck Receiving  
 Materials Handling Equipment (Steel and Alum Plate, Purchased Parts, etc.)  
 Receiving Inspection and Storage  
 Metal Cutting, Forming, Welding, etc.  
 Jigs, Tools and other Facilities  
 Smooth Flow of Work to Assembly Line  
 Stage Buildup and Integration, Checkout  
 Quality Control Inspections throughout Processing and Assembly  
 Rail Transport of Completed Stages and/or Assembled LV's  
 Final Factory Checkout of Stages and/or Assembled LV's  
 Office Space, Restrooms, Restaurant, Recreation Areas  
 Grounds layout-Rail to VAB, Parking Space, Security

**LEGEND**

- 1 REST-ROOM
- 2 OFFICE SPACE
- 3 YARD OFFICE
- 4 INSPECTION LABORATORY
- 5 ACETYLENE-OXYGEN STORAGE
- 6 CUTTING RACKS
- 7 RAW STOCK YARD
- 8 RAILROAD TRACKS
- 9 CRANEWAY RAILS
- 10 CRANE TROLLEY
- 11 TRANSFER DOLLY
- 12 FORMING ROLLS
- 13 FORMING BRAKES
- 14 STORAGE AREA FORMED PANELS 1ST STAGE NOZZLE
- 15 STORAGE AREA FORMED SECTIONS 1ST STAGE TANKS
- 16 FABRICATION AREA 1ST STAGE HEADS
- 17 FABRICATION AREA 1ST STAGE NOZZLE SECTION
- 18 FABRICATION AREA 1ST STAGE TANKS
- 19 STORAGE AREA FORMED PANELS LOWER FAIRING
- 20 FABRICATION AREA LOWER FAIRING
- 21 STORAGE AREA UPPER FAIRING
- 22 FABRICATION AREA UPPER FAIRING
- 23 STORAGE AREA 2ND & 3RD STAGE NOZZLES & TANKS
- 24 STORAGE AREA 2ND & 3RD STAGE HEADS
- 25 FABRICATION AREA 2D STAGE HEADS
- 26 FABRICATION AREA 2D STAGE NOZZLE & TANKS
- 27 FABRICATION AREA 3D STAGE NOZZLE & TANKS
- 28 FABRICATION AREA 3D STAGE HEADS
- 29 CLEANING AREA
- 30 ASSEMBLY & INTEGRATION AREA
- 31 OFFICES, CAFETERIA, FIRST AID, ETC
- 32 PARKING

PLANT LAYOUT

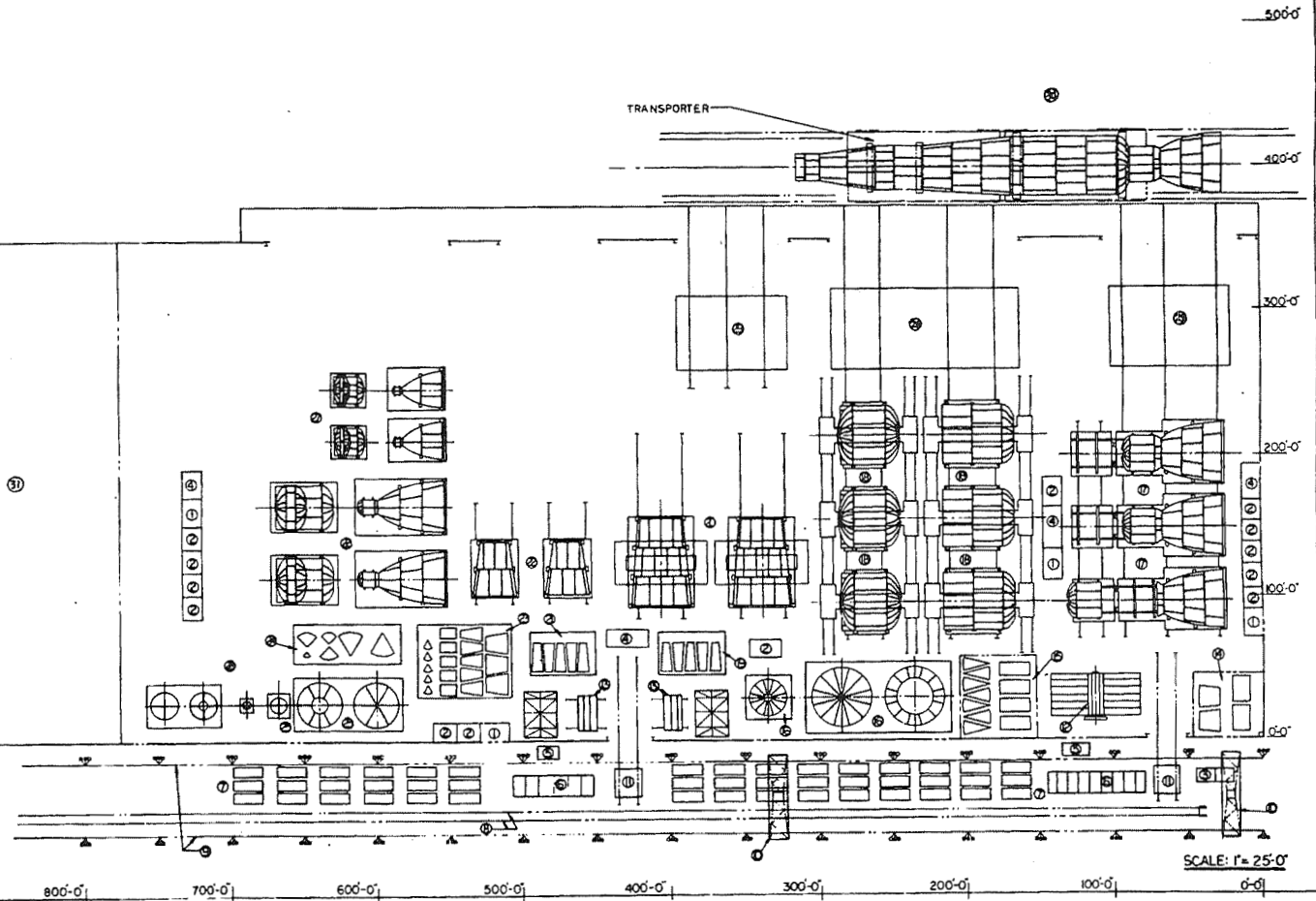

Figure 6-4 Plant A Layout

Figure 6-4 Plant A Layout

102



Work flow will proceed through Plant A according to the following outline:

#### Delivery of Raw Materials and Purchased Parts

Mill runs of steel and aluminum plate - size and thickness

Delivered on palettes by barge, rail or truck

Purchased Parts and Subsystems

Delivered in boxes or crates by rail or truck

#### Receiving Operations

Handling of raw materials - crane, tractor or dolly

Receiving inspection of raw materials and purchased parts

Mark all stock for traceability

Sample and functional tests to prove quality - Acceptance

Storage for convenient access when needed

#### Raw Materials Handling

Remove from storage - clean and inspect before processing

Cutting - shear, torch or saw - template check

Forming plates - brake or roll - check shape

Machined parts - lathe, mill, shape, drill - inspect

#### Welding Assembly

Jig mounted plates and machined parts assure mating

Continuous inspection of welds - repair flaws at once

Clean up and approval of sub-assemblies before mating

#### Sub-assembly Lines Leading to Stage Assembly

Mate and join tanks and engine shell

Add proof test components - hydrostatic proof test (horizontal)\*

Proceed to cleanup or correct leak if necessary

Clean up welded assembly after proof test

Paint or other protective coating

Add components and subsystems to complete stage

Add interstage structure

#### Stage checkout operations

Electrical tie to LCC-automatic checkout procedures

Final inspection - approval for delivery

#### Stage transport to VAB (or storage) in horizontal mode

Stage erection and LV/PL integration as in Section 7.

\*The difference in hydrostatic pressure between the horizontal and vertical modes will be compensated by a few percent increase in proof test pressure (less than the decrease in tank material strength due to elevated temperature at burnout).

6.8:

#### 6.4 Quality Assurance in LCLV Program

The fabrication of tanks and engines for the LCLV can be described as a combination of standardized boiler shop and shipyard practice, for forming and welding the steel tanks and aluminum alloy interstage structures. Many test specimens of small tanks and engines have been produced in this way with simple tooling and at moderate cost. Despite numerous obvious imperfections in these early specimens, they have been found to be considerably stronger than the design values predicted. This experience gives assurance that expensive tooling and uncommon expertise are not required to assure satisfactory quality. Jigs and fixtures for the convenient, efficient handling and holding of work during cutting, forming and welding are of course necessary. Such tooling will be planned and developed in a cost-effective manner, with quality assurance as the guideline.

Advantages of the HY-140 steel are its characteristics of leak-before-failure, high weld strength and toughness, and no heat treatment after welding; all of these properties being admirably suited to the fabrication plan for the LCLV. Proven methods will be used to prevent undue oxidation before welding, and to control weld porosity. Materials and operational specifications will be developed to assure high quality in the final product with systematic sequencing of manufacturing operations and their quality verification.

Provisions for continuous inspection of welds for flaw detection by ultrasonic techniques are assumed, with immediate correction of objectionable defects. Modern continuous x-ray inspection may be used for aluminum welds, but this method is believed to be less effective than ultrasonics for steel. Each tank will be hydrostatic tested for leaks after welding, to a proof pressure well above the normal operating conditions. Engines will be carefully inspected (not hot fired) to prove QA, but proper functioning of valves, gages, etc. will be thoroughly proven during the stage and vehicle checkout sequences.

Standard methods for inspection of raw materials, purchased parts and subsystems will be employed and catalogued in suitable manner for traceability. Appropriate inspection techniques will be used to check such parts during and after integration into stage assemblies. Stages and LV assemblies will be finally checked out in routine manner through the ICC procedures as discussed in the ground support and launch operations section (Section 7).

Configuration management will be accomplished by means of essential but not elaborate specifications and procedures compatible with the low cost vehicle concepts, perhaps best described as a modified AFSCM 375 series. Reference 6 provides a very preliminary example of this simplified approach.

## 7. GROUND SUPPORT FACILITIES AND OPERATIONS

### 7.1 Summary of Procedure for Ground Support Studies

This section contains the results of analysis of several ground system concepts designed to support the model low cost launch vehicle (LCLV) configuration and its possible mission assignments during the 1973 to 1985 time period. Two of the concepts exploit the use of present Saturn V/Apollo facilities, equipment and procedures, appropriately modified to accommodate the LCLV. The others examine the application of completely new facility designs, assembly and checkout operations equally adaptable to other site locations. The latter configurations are investigated for two reasons: one, to explore the relative cost advantages in transporting horizontally the completely assembled LCLV from the factory to the launch pad; and, two, to develop a concept which would preclude scheduling conflicts of the launch facilities of the Saturn V program. Included for each concept is a gross estimate of the facility, equipment, personnel and procedural requirements as well as the non-recurring and recurring costs to process the LCLV from its final assembly phase through launch at KSC and to support the flight mission. In order to provide for an economically acceptable mission program, this information is developed for a range of launch rates of 1, 2, 3 and 4 LCLV's per month.

A review of the objectives of the LCLV Ground Support study will be given, followed by a description of the approach used in accomplishing the task. Study guidelines and constraints are then listed and significant conclusions are identified in summary form. A preferred ground systems concept is recommended.

Contained in the body of the report are: A description of the baseline LCLV configuration and a typical mission program for the proposed ground system concepts; the corresponding ground system functional requirements; preliminary conceptual designs; facilities and equipment performance and personnel requirements with estimated costs; identification and analysis of the system design and operations factors that contribute to either high costs or cost reduction; identification of problem areas; and trade-off analyses recommended for further study. Throughout the investigation, emphasis is placed on minimum cost, flexibility, reliability, safety and use of existing or planned resources.

Presented in Appendix E are definitions and equations for the various ground system cost categories, such as DDT&E, production and operations, developed for use as a standard in estimating the costs of the candidate system. Data sheets for the ground system cost categories are also included in Appendix E.

## 7.2 Objectives

Primary objectives of the ground systems study consisted of:

- o Developing LCLV ground system concepts and modes of operation which are responsive to the criterion of minimum cost rather than maximum performance.
- o Analyzing the cost-effectiveness of the concepts postulated in relation to existing ground system configurations and operations to identify critical constraints and realizable cost reductions.
- o Determining facility and equipment performance and personnel requirements and corresponding costs for the candidate systems.
- o Assessing the advantages in applying advanced technology to the candidate ground system concepts.
- o Identification of a preferred and alternate low cost ground system concepts and areas requiring further technical evaluation.

## 7.3 Study Approach

To accomplish the study objectives, the following essentially sequential procedure was pursued in accordance with Figure 7.3-1: Collecting and assembling pertinent data; defining guidelines and constraints; developing a baseline and alternate ground system concepts for the model LCLV configuration and mission assignments; performing a functional analysis, including time-line flow diagrams for each concept, to determine facility, equipment, personnel and procedural requirements; estimating corresponding costs for multiple launch rates; identifying significant constraints and conducting appropriate cost-reduction, system effectiveness trade-off studies; and establishing a preferred ground systems concept and operating mode based on a comparative and system sensitivity analysis considering such factors as costs, effectiveness, complexity, confidence, maintainability, safety and both acquisition and program schedules. The total ground system cost for program management, RDT&E, production, installation and checkout, and support operations was estimated only for the preferred (baseline) design.

The information and data, much of which is referenced herein, was gathered from a variety of sources, namely: Related studies by various contractors; NASA publications and other governmental agencies; and technical documents available internally. In addition, information was obtained from specialized groups within TRW and from TRW's Florida Operations as well as discussions and meetings with NASA personnel. Where insufficient information was available, assumptions were made as required.

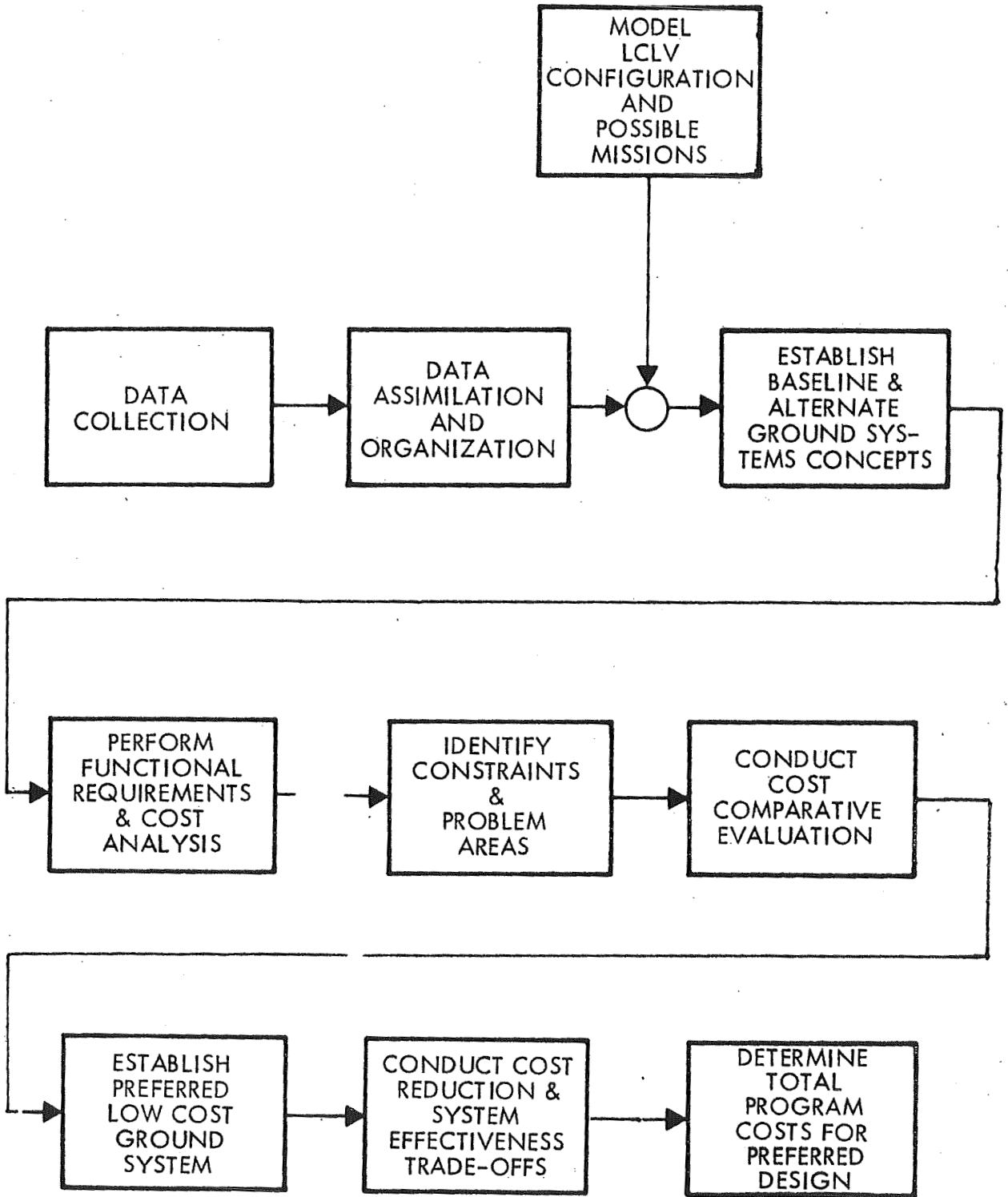

Figure 7.3-1 LCLV Ground Systems Study Approach

Ground subsystem requirements, ICLV processing times and manpower estimates were developed for each of the concepts using functional flow diagrams and time-line analysis sheets. Each of the functions was examined to a level where significant facilities, equipment, personnel and procedures could be costed. The length of time and number of personnel estimated to accomplish the particular functions are based on the complexity of the assembly and checkout tasks and intuitive judgment gained from experience with similar systems. Estimates of the time and manpower for the maintenance functions, except refurbishment, were omitted since a success oriented, no contingency, operational sequence was assumed. Refurbishment time was included because of its effect on launch pad availability. The three concepts which were developed are:

- Concept A (Baseline) - ICLV, less payload, is completely assembled at Plant A and then transported horizontally, erected and emplaced on Mobile Launcher. Payload integration and checkout occurs in VAB.
- Concept B - ICLV stages, guidance system and instrumentation unit are transported separately from Plant A to VAB, where assembly, checkout and payload integration on Mobile Launcher is similar to Saturn V/Apollo.
- Concept C - Assumes Saturn V/Apollo facilities, except LCC, are unavailable. ICLV, less payload, is completely assembled like Concept A at Plant A and then transported horizontally directly to launch pad where it is erected vertically. Payload integration and checkout occur at the pad.

In this concept, two design configurations were considered: One in which the ICLV transporter is an integral and complex design, serving also as an umbilical launch tower when erected at the pad and containing the same electronic checkout equipment, cables and umbilicals used at Plant A during the ICLV final assembly; the other, where the transporter, like that of Concept A, is a simpler design and the launch umbilical tower (LUT) is a fixed installation at the launch pad. The LUT electronics, cables and umbilicals are not the same set used for checkout of the ICLV at the factory.

Cost estimates for production and installation of the ground support AGE and launch facilities were examined for the above concepts, assuming launch rates of 1, 2, 3 or 4 LV's per month.

#### 7.4 Guidelines and Constraints

Additional assumptions and constraints used to provide guidance and direction to the ground systems analysis are as stated below. It is to be noted that the Saturn V/Apollo data were either obtained from the referenced documentation and/or from TRW's Florida operations who gathered the required information from NASA/KSC personnel. References 16-21.

##### LCLV Ground System

- Ground systems requirements are for 1973 to 1985 LCLV space missions.
- Payload is simulated at LCLV integration and test area.
- The original Concept A, to assemble, integrate and test complete LCLV in Plant A was found to be more costly than to assemble stages in VAB, (Concept B) similar to Saturn V procedures.
- LCLV with payload installed arrives at launch pad in flight ready condition, except ordnance initiators, which are installed at launch pad.
- Launch pad testing and checkout to be a minimum.
- LCLV on-site checkout and launch operations are based on five-day week, one 8-hour shift/day.
- All LCLV modifications are made at factory or integration area. No mods are made at launch site.
- LCLV fault isolation at launch site is to replaceable major sub-assembly, such as C-Band beacon, inertial measurement unit or guidance computer.
- Propellants are loaded aboard LCLV at launch pad prior to terminal count.
- LCLV design will provide for programmed automatic checkout and fault isolation.
- The LCLV instrumentation, range safety and R-F tracking systems are compatible with the ETR and manned and unmanned world-wide ground station network capabilities.
- Communication satellites will be available for transmitting LCLV data to earth during its mission.
- LCLV environmental control will be provided from the ground during prelaunch operations.

- A success oriented, no-contingency, launch schedule is assumed.
- Post-orbital recovery operations are not to be considered.
- No LCLV ground system hardware modifications, other than software, are required to fly the various payloads.
- A three-day interval between launches exists where more than one launch per month is scheduled.

#### Saturn V/Apollo Ground System

##### Mobile Launcher (ML) - Figure 7.4-1

- Design of ML is per References 16, 17, 18.
- Gross weight of ML is  $11.5 \times 10^6$  lbs.
- ML support pedestals used at VAB are designed to safely support loads of  $13 \times 10^6$  lbs.
- ML rebound design load is 19,500 KIPS.
- ML holddown design load is 3000 KIPS.
- ML designed primarily for stiffness.
- Construction cost of ML including KSC systems, less AGE, is  $\$28 \times 10^6$ .
- ML AGE production and installation cost is  $\$15 \times 10^6$ .
- There are three ML's constructed and activated.

##### Vehicle Assembly Building - Figure 7.4-2

- Design of VAB is per References 17 and 18.
- Hook height of VAB high bay bridge crane is 462' above ground floor level and can travel to within 50' of high bay doors.
- High bay cell dimensions are 525' high, 150' long and 190' deep.
- Maximum capacity of high bay bridge crane is 250 tons.
- Three high bay cells are activated; fourth cell is not equipped.
- VAB construction cost, less AGE, is approximately  $\$100 \times 10^6$ .
- VAB/AGE production and installation cost is  $\$40 \times 10^6$ .



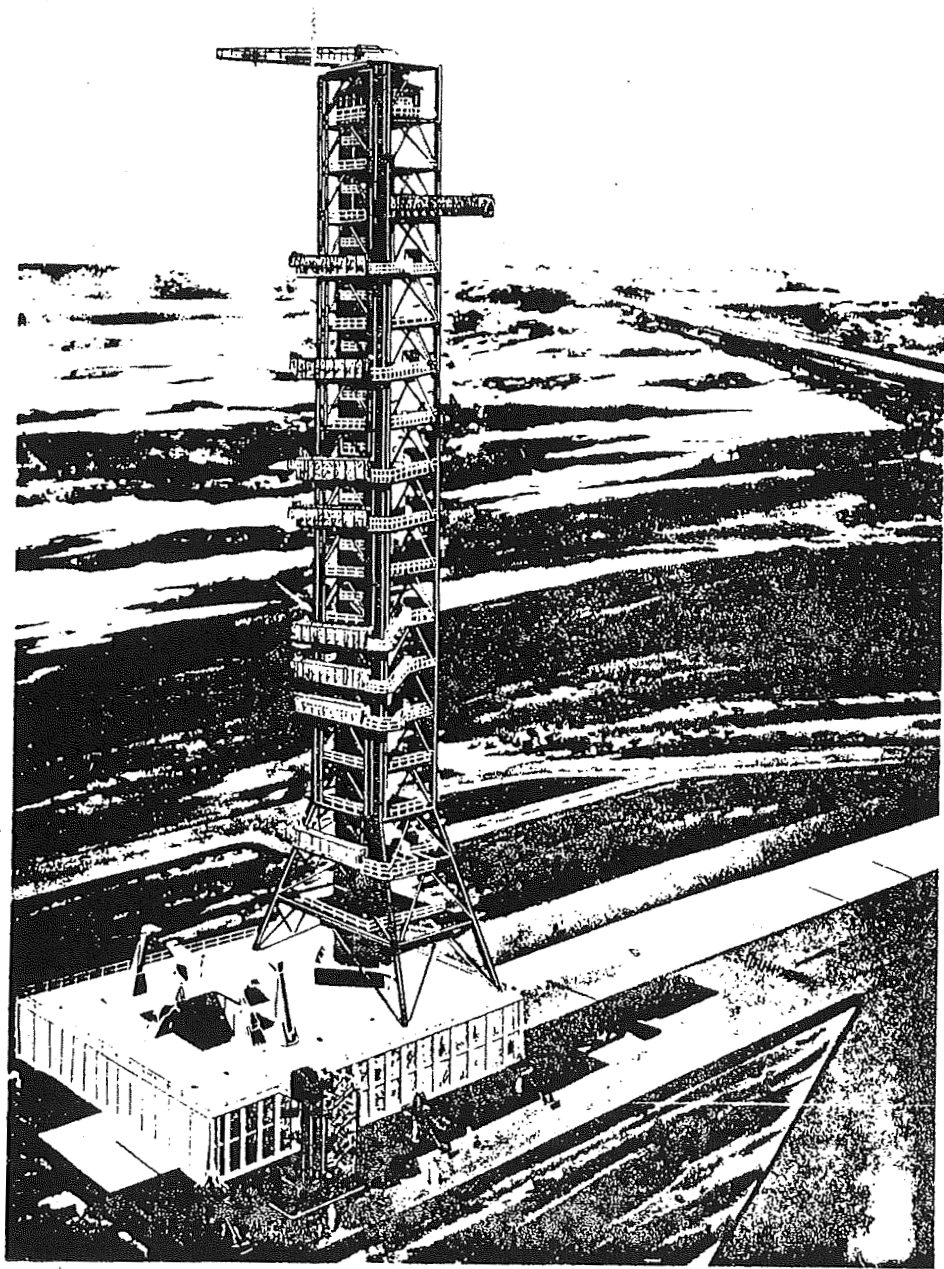
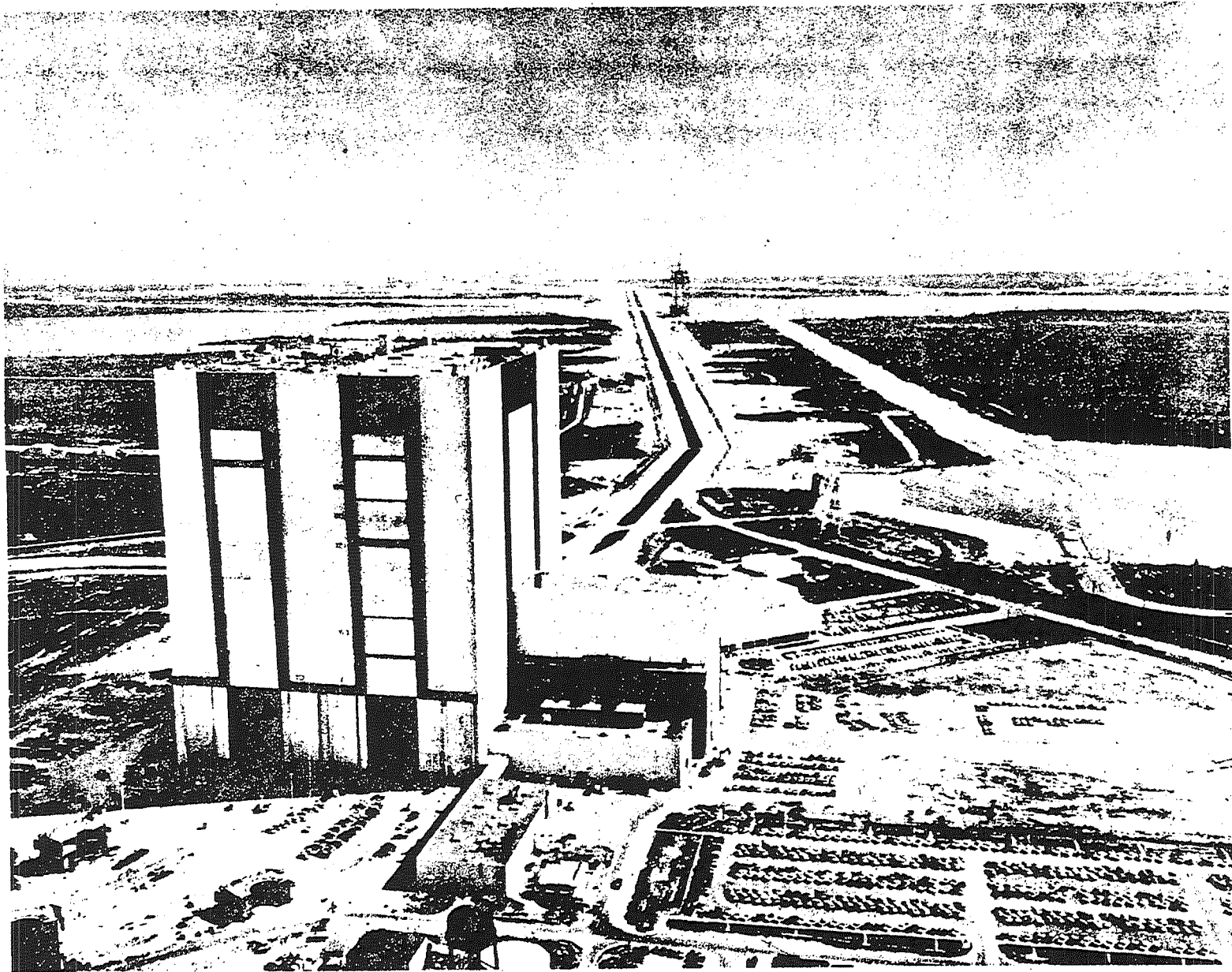

Figure 7.4-1 Mobile Launcher/Umbilical Tower



7.8

Figure 7.4-2a Vehicle Assembly Building

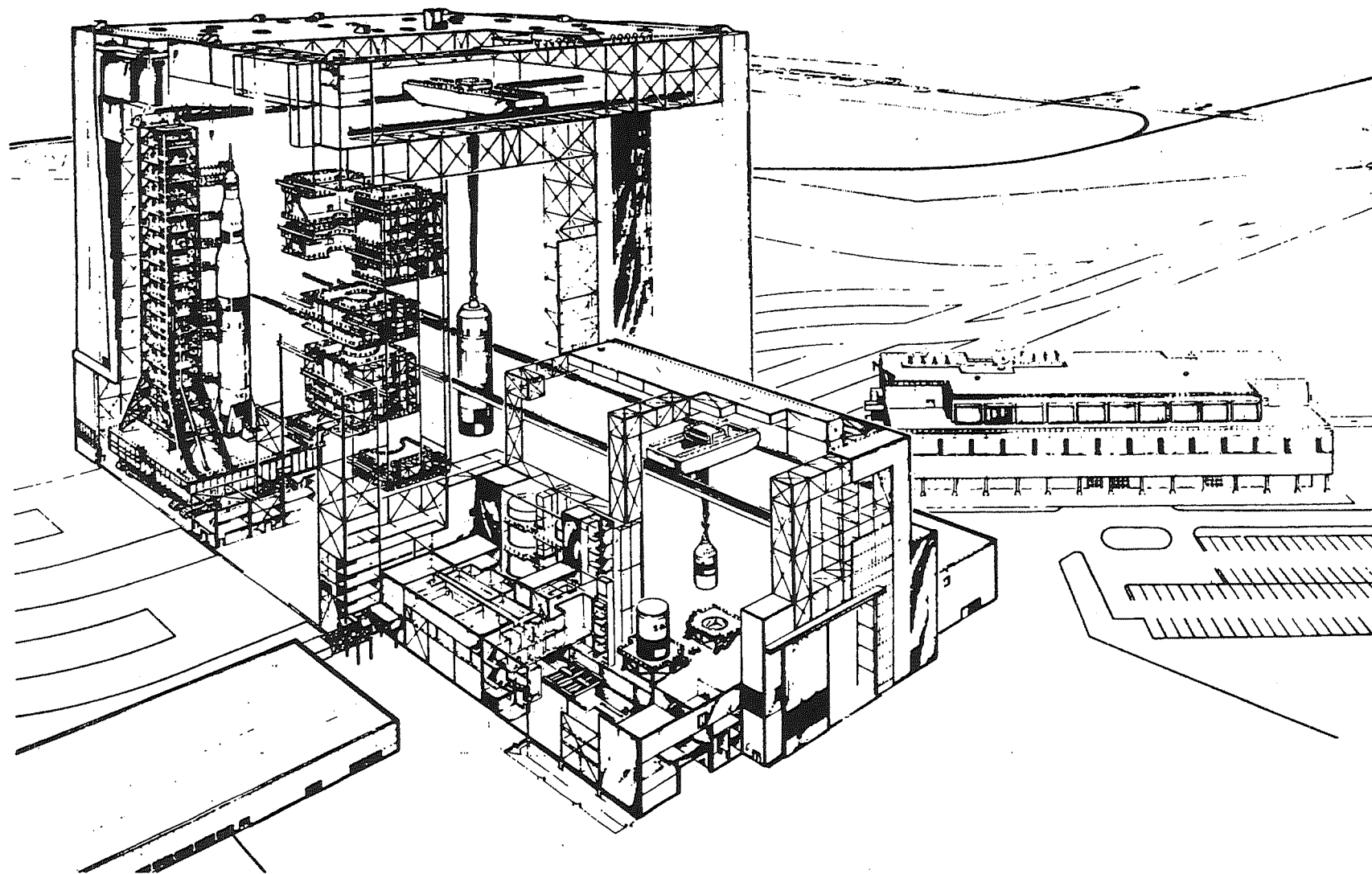

Figure 7.4-2b Vehicle Assembly Building (Phantom View)

Launch Control Center (LCC) - Figure 7.4-3

- o LCC design is per References 17 and 18.
- o Three firing rooms are activated.
- o Cost to equip fourth firing room is estimated at  $\$10 \times 10^6$ .
- o LCC construction cost, less AGE, is approximately  $\$60 \times 10^6$ .
- o Production and installation cost of LCC AGE is  $\$40 \times 10^6$ .

Crawler/Transporter - Figure 7.4-4

- o Crawler transporter design is per References 17 and 18.
- o Gross weight of crawler transporter is  $6 \times 10^6$  lbs.
- o Demonstrated lifting capacity of crawler is  $12.5 \times 10^6$  lbs.
- o Crawler design load for each support corner is  $1 \times 10^6$  lbs dynamic plus  $3 \times 10^6$  lbs static.
- o There are two crawler transporters constructed and activated
- o Construction cost of crawler transporter is  $\$8 \times 10^6$ .

Crawlerway - Figure 7.4-5

- o Crawlerway is designed to safely support  $20 \times 10^6$  lbs.
- o Crawlerway construction cost is  $\$20 \times 10^6$ .

Mobile Service Structure (MSS) - Figure 7.4-6

- o MSS design is per References 17, 18 and 20.
- o Construction cost of MSS including KSC systems, less AGE, is  $\$28 \times 10^6$ .
- o Production and installation cost of MSS/AGE is  $\$18 \times 10^6$ .
- o Construction cost of MSS parking area is  $\$2 \times 10^6$ .

Launch Pad - Figure 7.4-7

- o Launch pad design is per References 17, 18 and 21.
- o Depth of flame trench is 46'.
- o Flame deflector is 48' (base to top of ridge), 55' wide and 85' long mobile unit with removable refractory material. Deflector peaks at 41' above bottom of flame trench.
- o Pad refurbishment requires 2-3 days employing two 8-hour shifts.
- o Launch pad is designed for 3-5 psi overpressure.
- o Construction cost of launch pad including PLPS is  $\$60 \times 10^6$ .

KSC Industrial Area

- o The KSC industrial area and remote facilities are per Reference 15.

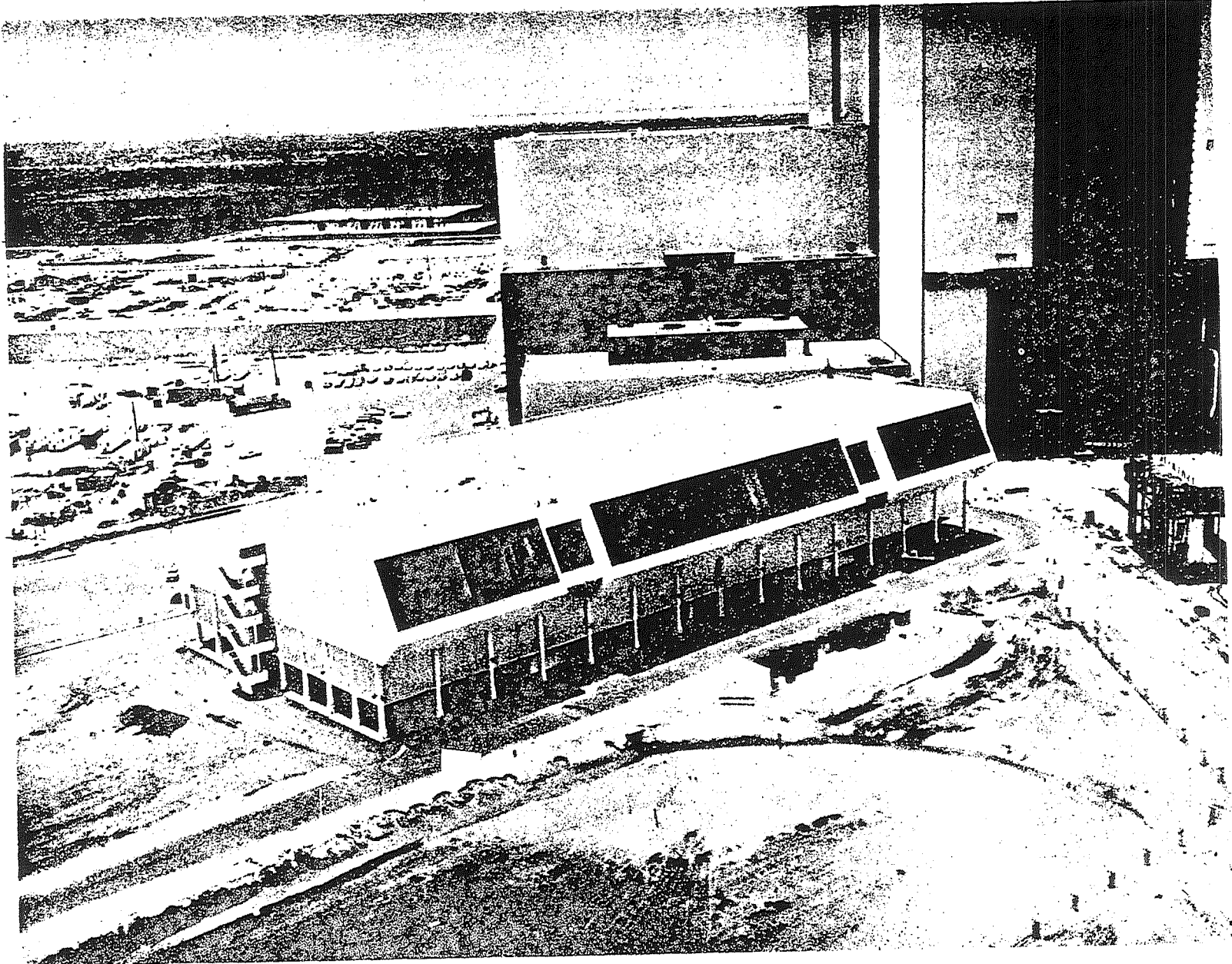

Figure 7.4-3 Launch Control Center

NOT REPRODUCIBLE

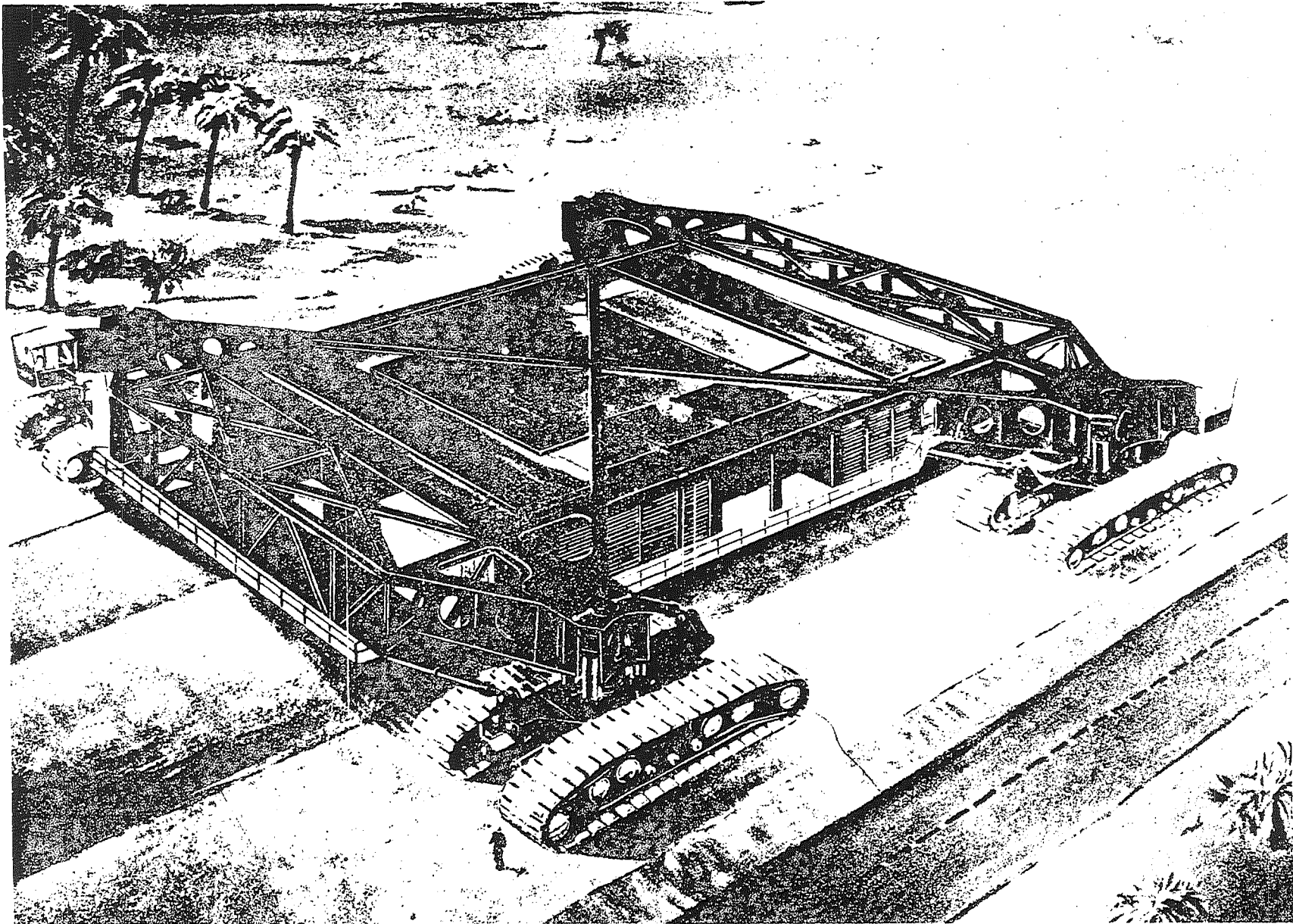
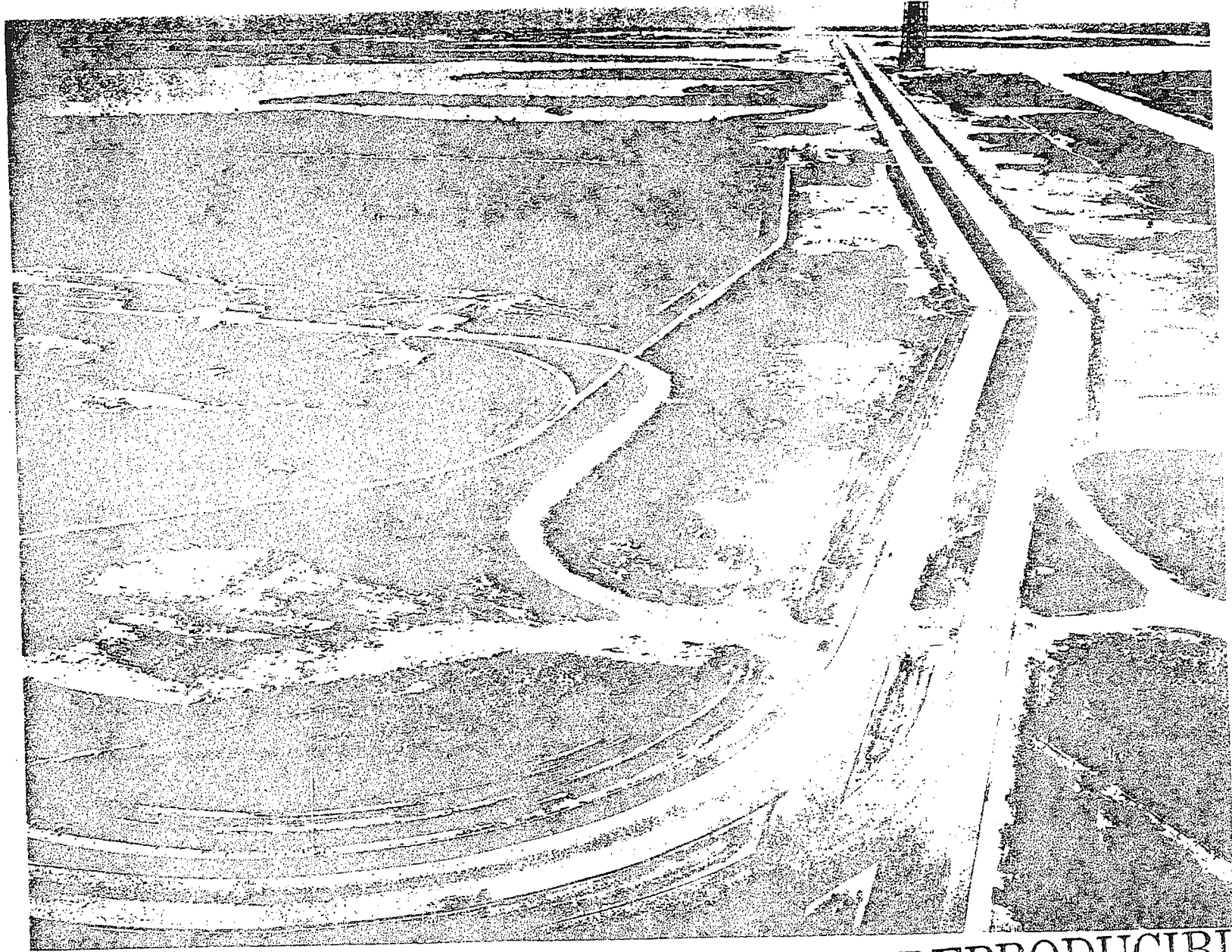

Figure 7.12 Crawler/Transporter

[NOT REPRODUCIBLE



**[NOT REPRODUCIBLE]**

Figure 7.4-5 Crawlerway (Looking East)

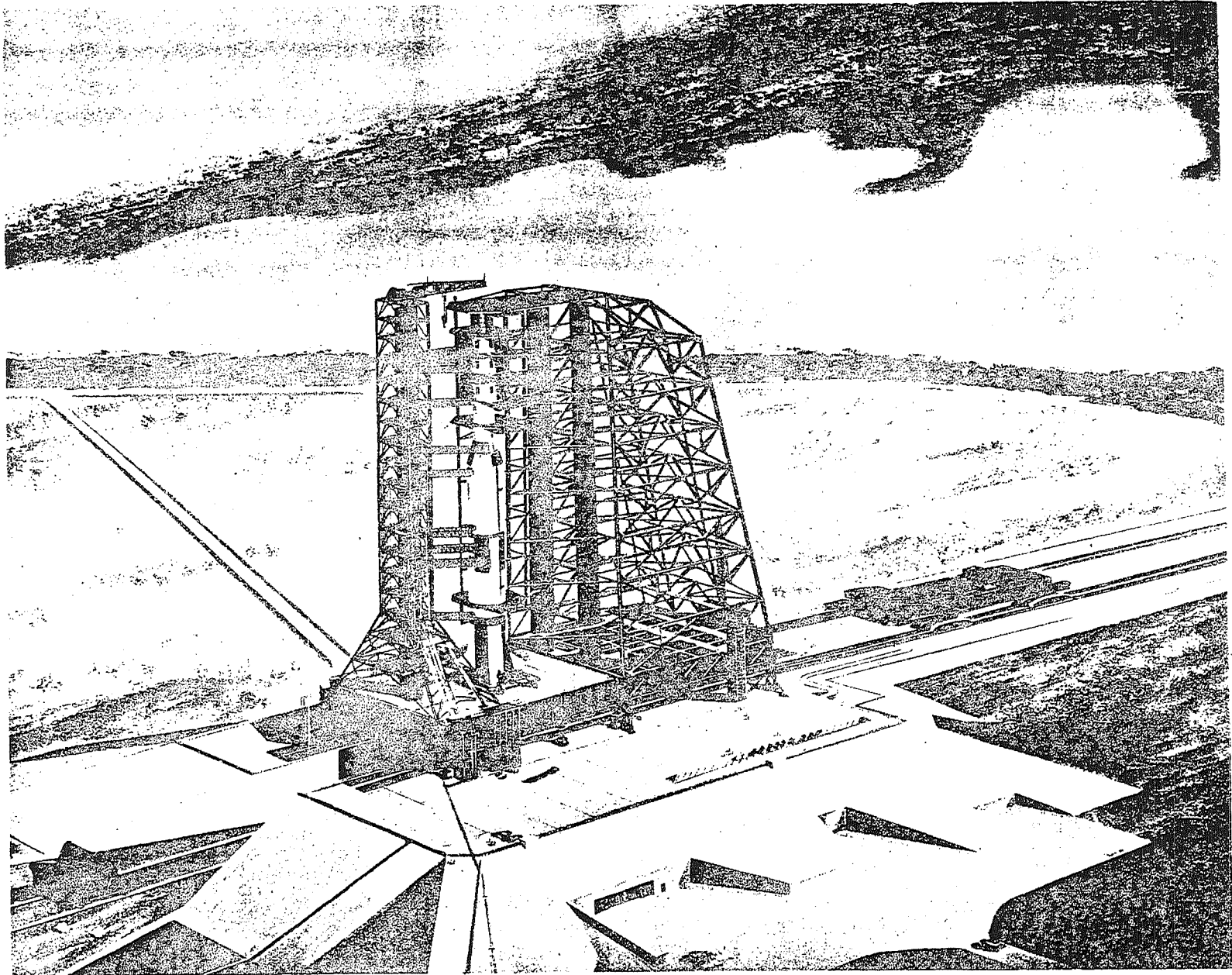

Figure 7.4-6 Mobile Service Structure

NOT REPRODUCIBLE



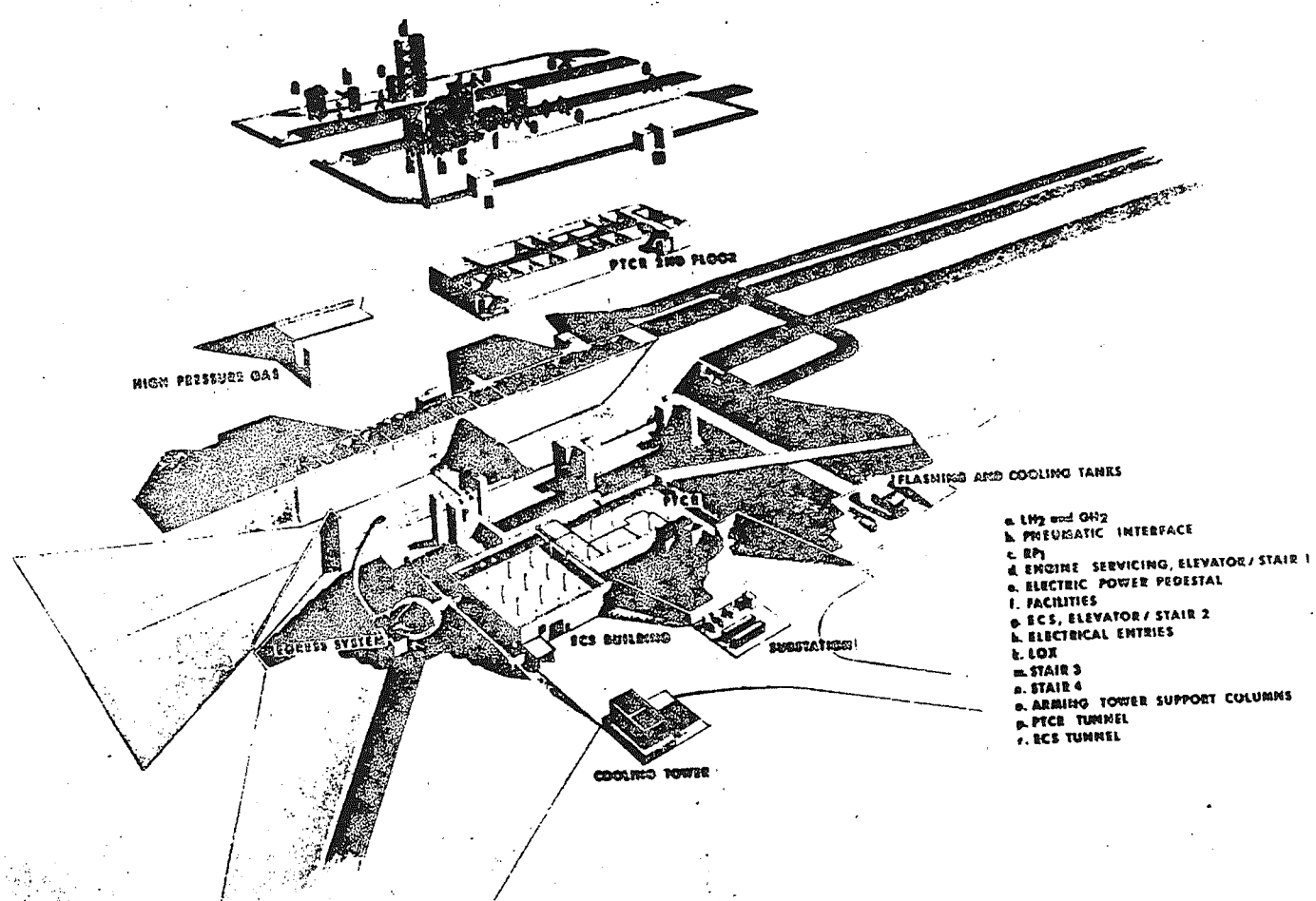

Figure 7.4-7 Launch Pad A (Exploded View)

### 7.5 Conclusions and Recommendations

Four different ground system concepts for the LCLV assembly, checkout and launch operations were developed and evaluated to achieve the study objectives. Based on the results of this requirements and cost-effective analysis, it is concluded that Concept B is the preferred configuration. This concept, to effect minimum cost, exploits the use of Saturn V/Apollo facilities and equipment appropriately modified to accommodate the baseline LCLV configuration. Assembly and checkout operations and procedures are comparable to Saturn V. Summaries of cost data are shown in Tables 7.5-I.

Principle reasons in selecting Concept B are:

- Minimum costs without compromising system performance.
- Minimum total final assembly through launch and refurbishment time (37 days).
- Minimum launch operations support (LOS) man-power requirements (13.4 man-years per LCLV).
- Minimum on-pad time (10 days).
- Maximum use of existing Saturn V/Apollo facilities with minimum modifications, thus more readily permitting support of early 1973 LCLV missions.
- Minimum new hardware requirements and RDT&E and production and installation costs.
- LCLV, payload and ordnance are completely assembled, installed and tested at one location (VAB) before transit to the pad.
- Same checkout equipment, being an integral part of the Mobile Launcher, is used in performing the launch, thereby increasing the confidence level in the space vehicle's flight readiness and correlation of data.
- Flexibility to accommodate other programs and changes in mission requirements.
- System uses proven reliable components.

The total program cost for Concept B to support the 1973-1985 LCLV assumed missions at a launch rate of one/month is estimated at \$794M, or an average cost of \$5.5M per launch for ground support facilities and operations.

If KSC facilities are unavailable, Concept C<sub>2</sub> merits further consideration as an alternate system. A comparison of the four concepts in terms of LCLV processing times, manpower requirements and production and installation costs is contained in Tables 7.6-17 and 7.6-18.

Table 7.5-I

## Ground Support and Launch Cost Summary\*

## Concept B

Direct (Recurring) Cost

Assembly, Checkout and Launch	\$ 536,000
AGE & MGE Equipment, Maintenance	1,072,000
Range Support	200,000
Mission Control Cost Allowance	1,000,000
Base Support	167,000
Management	<u>357,000</u>

Total Direct Cost per Launch \$3,332,000

Amortized Costs (based on 1 launch/month for 12 years)

AGE & MGE Equipment, Facilities Spares, DDT & E and Acquisition	\$ 868,000
Management	<u>104,000</u>

Total Amortized Cost per Launch \$ 972,000

Tracking Net Cost

Missions Beyond LEO	\$1,080,000
Management	<u>130,000</u>

Total Tracking Cost \$1,210,000  
Total Cost per Launch \$5,514,000

\* Based on 144 missions in 12 year period

Other significant conclusions and recommendations in relation to Concept B are summarized below.

#### 7.5-1 Further Conclusions

- Ample space is available in the vicinity of KSC, Launch Complex 39, to accommodate the 30-50 acres needed for Plant A, the proposed LCLV fabrication facility.
- The Vehicle Assembly Building (VAB) provides an excellent base for final assembly of the LCLV, payload integration and final checkout operations.
- A 450-ton capacity overhead bridge crane is required<sup>\*</sup> in the VAB high bay area for LCLV assembly. Also, modification to the VAB cable assemblies, servicing lines and work platforms is required. Use of the low bay cells is not essential.
- Extensive modification to the Mobile Launcher is required, including its 45' X 45' engine flame opening, launch holddown support arms, umbilical tower structure and service arms, AGE and PLPS.
- Considerable modification to the ICC launch vehicle control and monitor equipment is necessary; however, retention of the basic functional equipment arrangement and data handling system is planned.
- No changes to the Crawler/Transporter, Crawlerway and ML support pedestals appear to be required.
- Changes to the Mobile Service Structure are a minimum, involving primarily work platform No. 1 and some of the launch vehicle servicing lines. Location of the MSS line-of-sight aperture for the LCLV inertial system ground alignment may require changes.
- Launch pads 39A and B will be utilized with extensive modifications for hypergolic propellant storage and loading.
- Existing H<sub>2</sub> and N<sub>2</sub> converter/compressors, storage tanks and transfer lines can be used.
- A new flame deflector design is required.
- No change to flame trench design appears necessary.
- Modifications are needed to the Pad Terminal Connection Room (PTCR) and instrumentation lines and equipment.

---

\*Although modification of the high bay hoist is required (250T to 450), use of the VAB for final LCLV assembly and checkout eliminates the need for construction of comparable facilities at Plant A.

- The cost of both mission operations and range support can be reduced significantly by incorporating the proposed simplified LVIC guidance and instrumentation system.
- LCLV assembly, checkout, launch and refurbishment can be accomplished in less than 30 days.

#### 7.5-2 | Recommendations for Additional Study

Detailed studies should be performed on the following:

- Mobile launcher (ML) and launch pad permissible design loads.
- Compatibility of ML, Mobile Service Structure and launch pad materials with  $N_2O_4$ /UDMH propellants.
- Design modifications to ML to incorporate the hypergolic propellant transfer system and the LCLV launch umbilical and service arms. Also, the 45' X 45' flame opening and the ML structure should be studied in relation to the environment produced by LCLV during launch.
- Safety features and explosive and toxic danger envelopes measured from the launch site in relation to propellant spills, explosions and/or "fireball".
- Configuration of the launch pad flame trench. Further analysis may dictate increased dimensions, structural reinforcement and/or refractory lining is required due to  $11 \times 10^6$  lb thrust of LCLV.
- MSS/LCLV structural and electrical interfaces.
- Propellant load cells that can determine accuracy better than 0.5%.
- Ways in which cost reductions can be achieved in existing Saturn V/ Apollo facilities, equipment and procedures in order to optimize LCLV launch operations.
- Confirm validity of parameters used in costing Base Operations Support (BOS) and Mission Operations Support (MOS).
- Structural changes to VAB to accommodate 450 Ton capacity bridge crane vs. erection of Stage 1 outside VAB with special hoist, similar to the concept shown in Fig. 7.6-17, after which the stage, mounted on the ML will be moved inside the VAB for further assembly operations.

## 7.6 Requirements and Cost Analysis

Ground subsystems requirements, LCLV processing times and manpower estimates were developed for each of the concepts mentioned in Section 7.3, using functional flow diagrams and time-line analysis sheets.

### 7.6.1 Baseline LCLV Configuration and Missions

Figure 7.6-1 depicts the baseline LCLV configuration for which the three candidate ground systems were analyzed. The placing of payloads ranging from 40K to 150K lb into low earth orbits (LEO) during the 1973 to 1985 period was assumed the basic LCLV mission. Other possible missions are shown in Table 2-I.

Described below is the LCLV baseline configuration including a fourth stage which would be required for propelling 20K lb payloads into synchronous equatorial orbit. This latter configuration was not analyzed to determine its impact on the ground system concepts but is included for possible future study. Table 7.6-I shows the dimensions, weights and thrusts of Saturn V compared to the baseline LCLV.

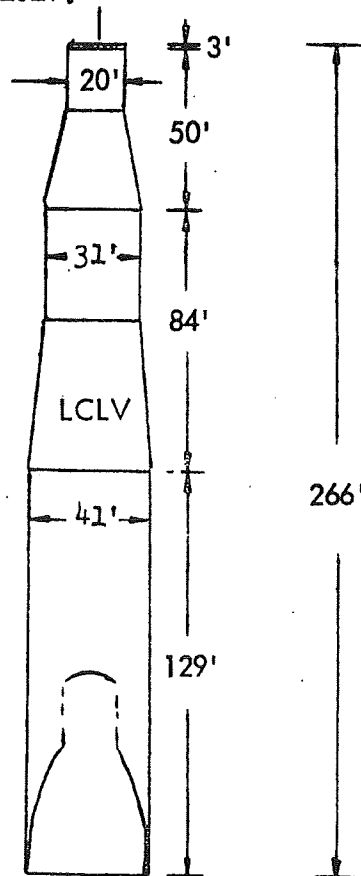

Figure 7.6-1

LCLV Baseline Configuration for Ground Systems Conceptual Analysis

Table 7.6-I

Comparison of Saturn V/LCLV Dimensions, Weights and Thrust

Launch Vehicle	Stage 1	Stage 2	Stage 3	Instrument Unit	Total Length/Weight	
SV	L'	140	80	59	3	282
	D'	*63/33	33	22	22	
	W <sub>D</sub> - lb	287,000	80,000	21,900	3,500	392,400
	W <sub>L</sub> - lb	4,687,000	1,010,000	251,900	3,500	5,952,400
	Thrust - lb	7,500,000	1,000,000	200,000		
LCLV	L'	129	84	50	3	266
	D'	41	41/31	31/20	20	
	W <sub>D</sub> - lb	774,066	191,122	38,381	**2,000	1,005,569
	W <sub>L</sub> - lb	7,011,828	1,767,857	361,478	**2,000	9,143,163
	Thrust - lb	11,523,100	2,224,600	460,570		

\*Fins and fairings included, 48' diameter without fins.

\*\*Assume 2K lb since no data is available.

Further details of the LCLV missions and other vehicle characteristics are given in Section 2.3

### 7.6.2 Master Flow Diagram

Figure 7.6-2 is a master flow diagram of top level functions for the three concepts to process the LCLV from its embryonic assembly phase up through launch at KSC and to perform the flight mission. Functions shown that were further developed are listed in Table 7.6-II. Development of these functions formed the basis for cost-effectiveness trade-off studies and for time line estimates of the manpower, modes of operation and facilities and equipment required to support the model LCLV. The functional diagrams describe the work required at Plant A, the VAB and at the launch pad. The sequence of functions provide for final LCLV assembly either at Plant A or the VAB and horizontal or vertical transportation to the launch pad. Also, the sequence of functions examines either vertically mating the payload to the LCLV at the VAB (Function K9.0) or at the launch site (K32.0).

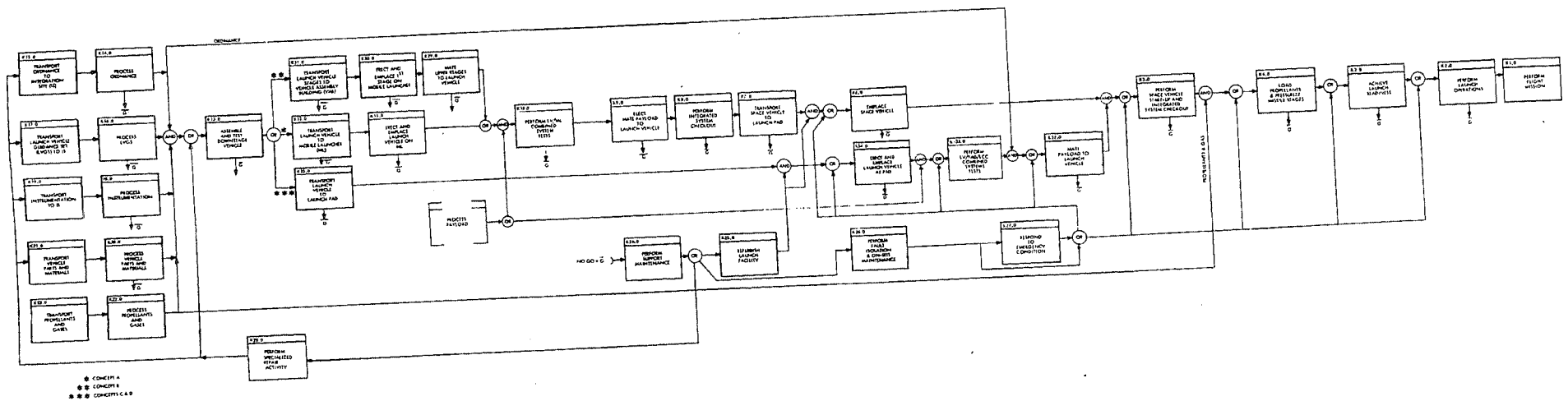

Figure 7.6-2

FLOW TITLE:  
 MASTER FLOW DIAGRAM  
 LOW COST LAUNCH VEHICLE  
 PROGRAM: LCLV STUDY  
 SHEET 1 OF 1  
 FLOW NO. 0.0



129  
Table 7.6-II

Preliminary List of Launch Operations  
Support (LOS) Functional Requirements for  
Concepts A, B and C

<u>Master Flow</u> <u>Functional No.</u>	<u>Function Title</u>	<u>Applicable Concept</u>		
		<u>A</u>	<u>B</u>	<u>C</u>
K2.0	Perform Launch Operations	X	X	X
K3.0	Achieve Launch Readiness	X	X	X
K4.0	Load Propellants and Pressurize	X	X	X
K5.0	Perform Space Vehicle Start-up and Integrated System Checkout	X	X	X
K6.0	Emplace Space Vehicle	X	X	
K7.0	Transport Space Vehicle to Launch Pad	X	X	
K8.0	Perform Integrated System Checkout	X	X	
K9.0	Electrically Mate Payload to Launch Vehicle	X	X	
K10.0	Perform LV/ML Combined System Tests	X	X	
K11.0	Erect and Emplace Launch Vehicle on ML	X		
K12.0	Transport Launch Vehicle to Mobile Launcher (ML)	X		
K13.0	Assemble and Test Downstage Vehicle	X		X
K14.0	Process Ordnance	X	X	X
K16.0	Process LVGS	X	X	X
K18.0	Process Instrumentation	X	X	X
K22.0	Process Propellants and Gases	X	X	X
K29.0	Mate Upper Stages to Launch Vehicle		X	
K30.0	Erect and Emplace 1st Stage on Mobile		X	
K31.0	Transport Launch Vehicle Stages to VAB		X	
K32.0	Electrically Mate Payload to Launch Vehicle			X
K33.0	Perform LV/PAD/LCC Combined Systems Tests			X
K34.0	Erect and Emplace Launch Vehicle at Pad			X
K35.0	Transport Launch Vehicle to Launch Pad			X

7.24

Complementing these in-line operations are the top level maintenance functions, viz., support maintenance (K24.0), refurbishment (K25.0), fault isolation and on-site maintenance (K26.0), specialized repair (K28.0) and requirements to respond to emergency conditions (K27.0).

The following is a brief description of the functional sequences illustrated in Figure 7.6-2 for the various concepts:

For all three concepts, downstage vehicle parts, materials, components and propellants (Functions K15.0, K17.0, K19.0, K21.0 and K23.0) are transported from their source to the integration site (Plant A) where they are processed. It is assumed that Plant A will be located on or close by the launch complex. Although the processing tasks vary depending upon the item, the processing functions (K14.0, K16.0, K18.0, K20.0 and K22.0) will be similar, being comprised of receiving and inspection and storage until requisitioned for vehicle assembly and test (K13.0).

Vehicle assembly at Plant A includes subsystem fabrication and integration of the vehicle's structures, engines, propellant pressurization system, TVC and roll control system, astrionics, and fairing. During assembly, the subsystems are tested at various levels starting from subassembly up through a fully assembled system test.

In Concept A (Baseline), the stages are completely assembled horizontally and checked out in Plant A. The LV is then transported horizontally (K12.0) and erected onto the Mobile Launcher (K11.0). System checkout and payload integration (K10.0-K8.0) are performed in the VAB. Upon completing these tests, the LV/NL is transported vertically on the Crawler Transporter (K7.0) and emplaced on the launch pad (K6.0) where system integration tests (K5.0) are conducted. Propellants are then loaded and the system pressurized (K4.0). Following this, launch readiness is achieved (K3.0) and launch operations performed (K2.0) to effect the flight mission (K1.0). Subsequently, the launch facility is refurbished (K25.0).

Concept B is similar to Concept A, except that the stages are transported separately from Plant A to the VAB (K31.0). The first and upper stages are then assembled (K30.0 and K29.0) on the Mobile Launcher comparable to Saturn V. The remaining functions are the same as Concept A.

With Concept C, as in Concept A, the stages are completely assembled horizontally and checked out (K13.0) at Plant A. However, assuming Saturn V facilities are unavailable, the LV is transported horizontally directly to the launch pad (K35.0), erected and emplaced (K34.0) prior to mating the payload. Combined system and payload integration tests (K33.0 and K32.0) are then conducted. Subsequent functions (K5.0-K1.0), similar to Concepts A and B are then performed.

In the process of performing the above operations, support maintenance (K24.0) or on-site maintenance including fault isolation (K26.0) is initiated as required. When emergency conditions prevail, maintenance is implemented after appropriate emergency procedures have been taken (K27.0). Malfunctioned components are returned either to Plant A or to a specialized activity (K28.0), such as the subcontractor's plant, for repair and recycling into the spares inventory at Plant A.

### 7.6.3 Plant A Alternate Locations at KSC

The TRW concept of the ICLV includes a fabrication facility designated as "Plant A", to be located as near as possible to the launch complex, in order that the fabrication, assembly, integration and checkout of the complete stages can be accomplished under one roof (see Section 6).

If Plant A can be located adjacent to the launch site, rail transport can be used for moving the complete vehicle to the base, where it is erected in readiness for payload integration and final checkout before launching. If space is unavailable adjacent to the launch site, barge transport would be required, terminated by rail transport from the barge dock to the erection point.

It is fortunate that ample space is available in the vicinity of KSC, Launch Complex 39, to accommodate the 30 - 50 acres needed for Plant A. As shown in the map of Figure 7.6-3, there is a tract of 10 sq mi of vacant land southward from the VAB. Plant A might be located in the southeast corner

of this tract, with free access to the Banana River barge channel for the transport of heavy steel plate used in fabrication of the LCLV, and building materials for construction of the factory. This site is spaced 4 miles from the VAB, 5 miles from Launch Pad 39A and about 3 miles from Pad 40, which is believed to provide adequate clearances for safety. Approximately 1.5 miles more clearance from the launch pads can be attained by moving the factory westward, adjacent to the NASA Industrial Complex, with access to Banana River via a barge canal (dug eastward from the factory site).

Should greater clearance be required from the launch pads, an alternate location for Plant A is about 6 miles west-northwest from the VAB near the Titusville causeway. This location is about 8 miles from Launch Pad 39B, the nearest active launch site. Barge access is available via Indian River.

Some of the LCF 39/Saturn V facilities which can be utilized for Concepts A and B in relation to Plant A are identified in Figure 7.6-3.

7.6.4 Concept A (Baseline) LCLV Ground System

The baseline ground system concept, it will be recalled, involves complete LV assembly in Plant A and horizontal transport and erection at the VAB where payload integration and checkout is performed. A time line analysis of the functions comprising this concept is shown in Figure 7.6-4. The functions correspond to those on the master flow diagram but are at the next level of indenture. Some of the findings of this analysis are summarized in Table 7.6-III which shows the time in days and estimated man-hours required to accomplish the in-line LV assembly through launch operations. By definition, these figures do not include base, range and mission support manpower requirements. The number of personnel estimated is based on the complexity of the tasks involved and related experience. Other significant findings are:

- o Total final assembly through launch and refurbishment time: 49 days
- o Time in VAB: 16 days
- o Time on pad: 10 days

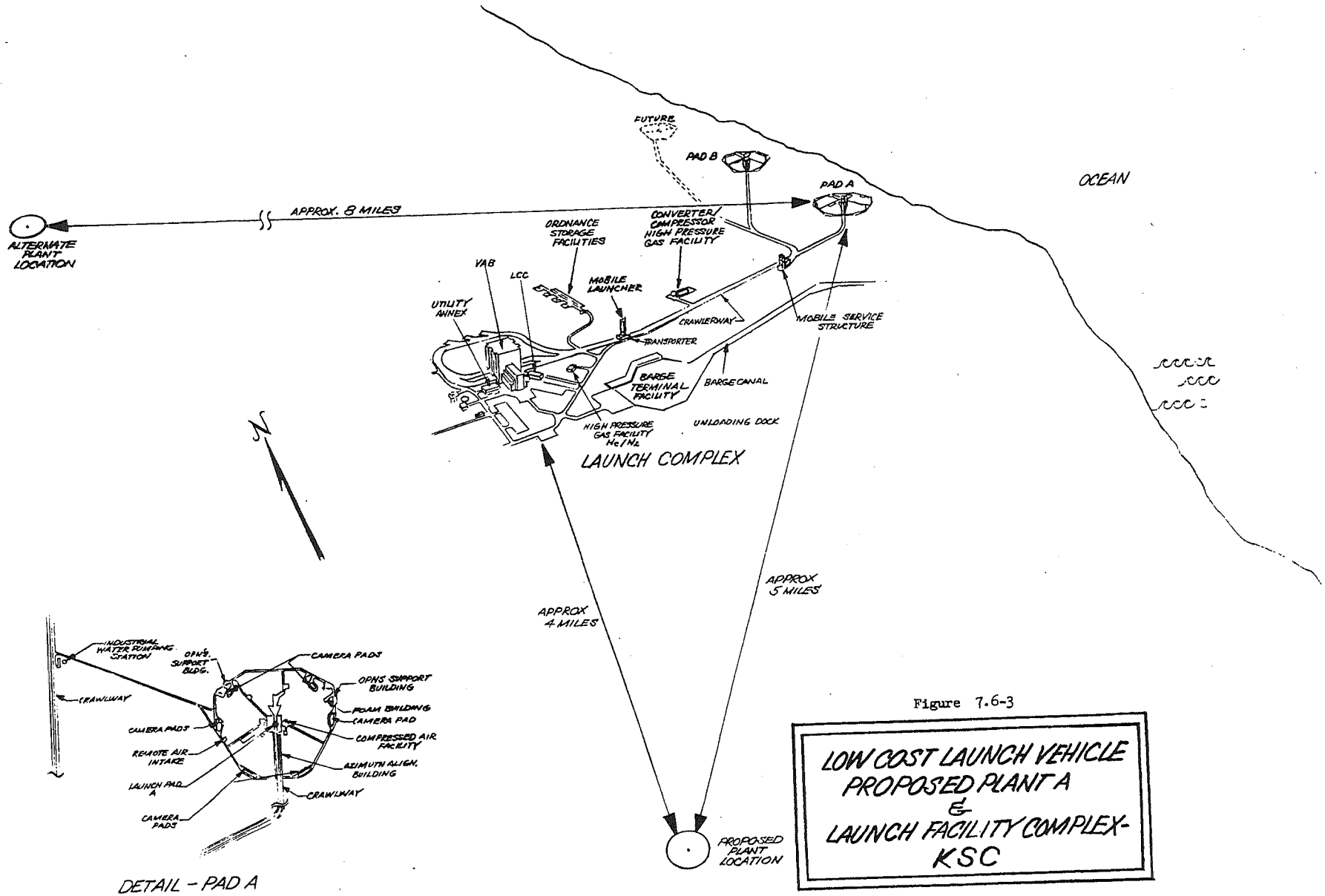

131

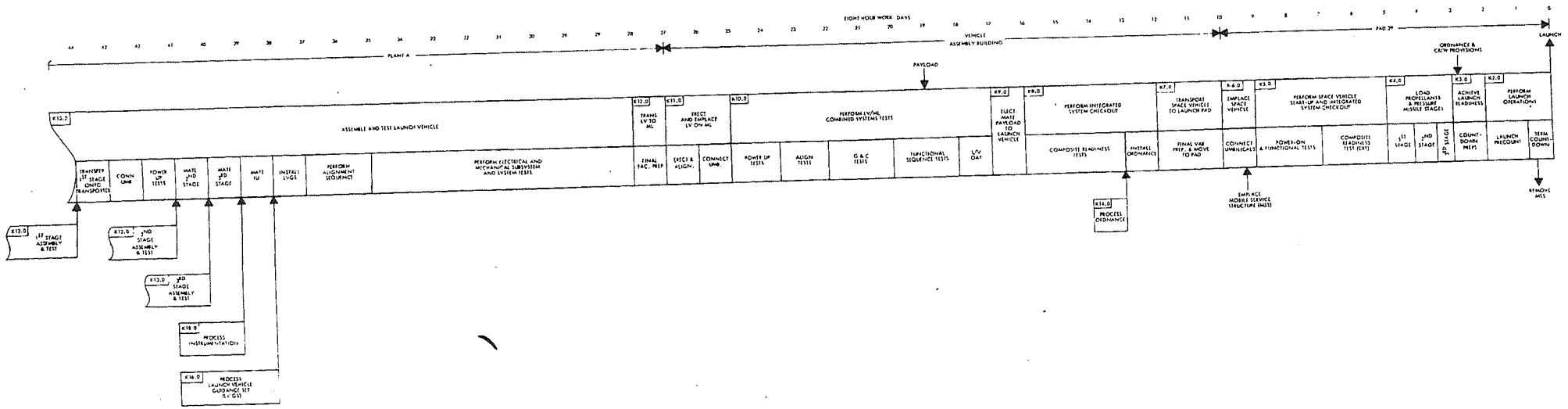

Figure 7.6-4

TIME BASED FUNCTIONAL FLOW DIAGRAM OF LCLV FINAL ASSEMBLY THROUGH LAUNCH OPERATIONS AT KSC-BASELINE CONCEPT A

TABLE 7.6-III

APPROXIMATE MANPOWER REQUIREMENTS  
FOR LOW COST LAUNCH VEHICLE  
FINAL ASSEMBLY THROUGH LAUNCH OPERATIONS AT KSC

-- Baseline Concept A --

<u>Function</u>	<u>Functional Flow No.</u>	<u>Eight Hour* Work Days</u>	<u>Equivalent Hours</u>	<u>Man-Hours</u> *
Process Ordnance	K 14.0	1	8	24
Process LVGS	K 16.0	3	24	96
Process Instrumentation	K 18.0	2	16	80
Assemble and Test Launch Vehicle (LV)	K 13.0	16	128	6400
Transport Launch Vehicle to Mobile Launcher (ML)	K 12.0	1	8	200
Erect and Emplace Launch Vehicle on Mobile Launcher	K 11.0	2	16	960
Perform LV/ML Combined System Tests	K 10.0	8	64	6400
Electrically Mate Payload to Launch Vehicle	K 9.0	1***	8	400
Perform Integrated System Checkout	K 8.0	4	32	4800
Transport Space Vehicle to Launch Pad	K 7.0	2	16	640
Emplace Space Vehicle	K 6.0	1	8	640
Perform Space Vehicle Start-up and Integrated System Checkout	K 5.0	4	32	4800
Load Propellants and Pressurize Missile Stages	K 4.0	2	16	800
Achieve Launch Readiness	K 3.0	1	8	640
Perform Launch Operations	K 2.0	2	16	2400
Refurbish Launch Facility	K 25.0	5	40	1600
			Total Man-Hours .....	30,880
			Total Man-Years Per Vehicle (Assuming 2000 Man-Hours per Man-Year)....	15.4

\* Assumes a success-oriented, no contingency, functional sequence.

\*\* By definition, launch operations manpower requirements do not include base, range and mission support requirements.

\*\*\* Payload checkout times for this activity and subsequent functions are not included.

7.30

Contained in Table 7.6-IV\* is the results of a performance and cost analysis of Concept A which define the sequence of operations in accomplishing each function, new or modified AGE/LF requirements, and estimated RDT&E and unit production and installation costs. The analysis is based on the assumptions and guidelines previously identified and a further expansion of the functional flow diagram shown in Figure 7.6-4. A conceptual drawing of the vertical erection mechanics which employs the Mobile Launcher is illustrated in Figure 7.6-5. The required force to vertically erect the completely assembled LV by cable onto the Mobile Launcher is calculated in Figure 7.6-6 and can be erected in the manner shown without exceeding the flight loads for which the vehicle is designed. It is planned that the erection will take place outside the VAB, using the Umbilical Tower as the leverage point for the hoist with fulcrum supports at the base of the ML, thus permitting the 500T vehicle to be erected with a 300T hoisting load.

After erection, the vehicle launch pedestals on the Mobile Launcher are moved into position to relieve the load on the erection gear, which is then removed. The Crawler/Transporter will then pick up the ML/LV assembly and move it into the VAB for payload integration and final checkout, and afterwards transport the assembly to the launch pad.

In reviewing Table 7.6-IV\* it will be observed that Concept A makes considerable use of existing Saturn V/Apollo facilities modified as indicated to accommodate the LCLV configuration. These facilities include the VAB, Mobile Launcher, Mobile Service Structure, Crawler Transporter, Launch Control Center and Launch Pads A and/or B at Complex 39. Based on the analysis, this approach appears to be effective with minimum cost for Concept A at KSC. However, many technical areas require analyses that are considered beyond the scope of this study before a final conclusion can be made. Several areas requiring detailed study are:

- o Mobile launcher and launch pad permissible design loads. These include LCLV vibration, acoustic, holddown and rebound loads.

\*Because of its bulk (25 pages), Table 7.6-IV is included in Appendix E. By definition, Aerospace Ground Equipment (AGE) is comprised of Operating Ground Equipment (OGE) and Maintenance Ground Equipment (MGE).



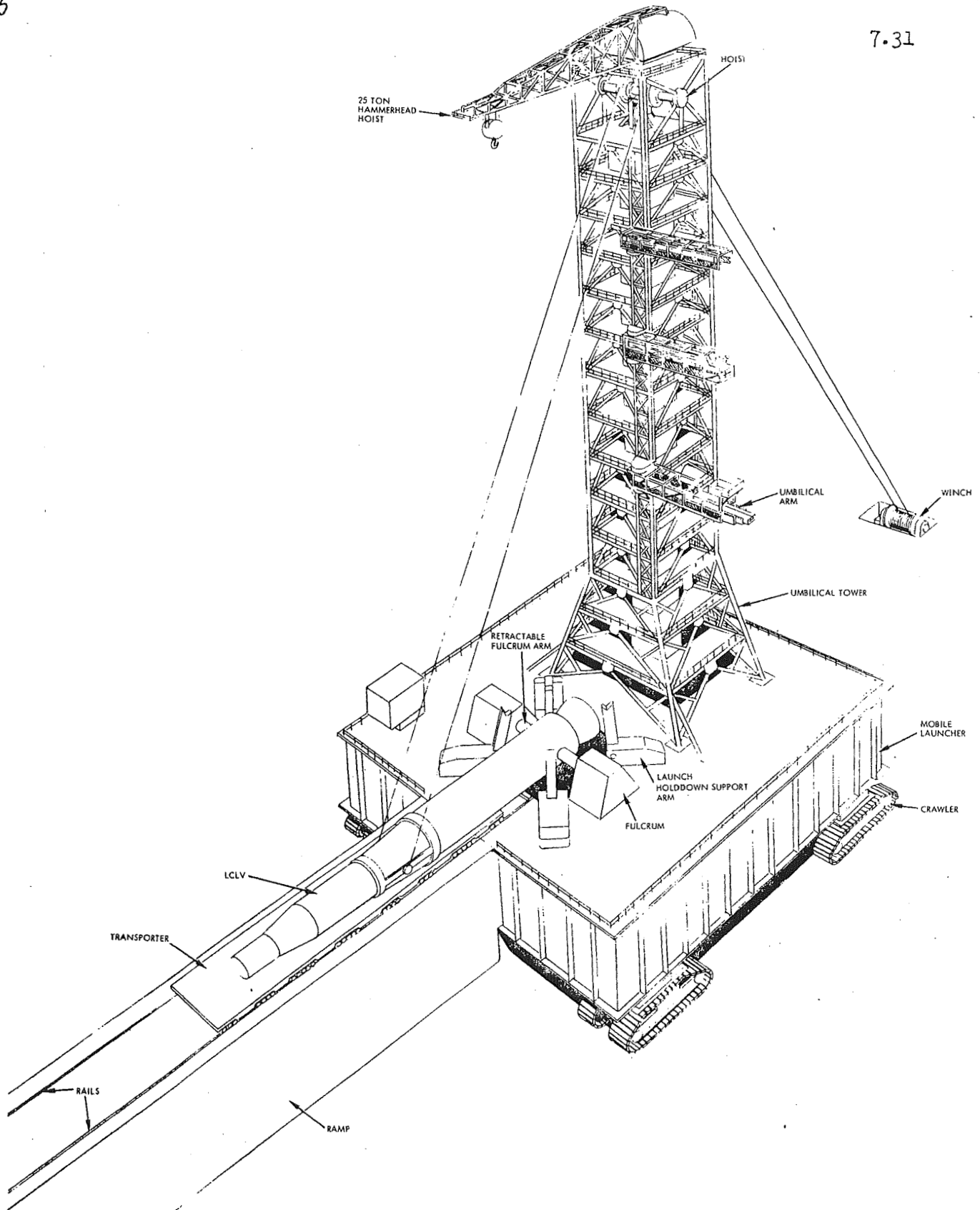
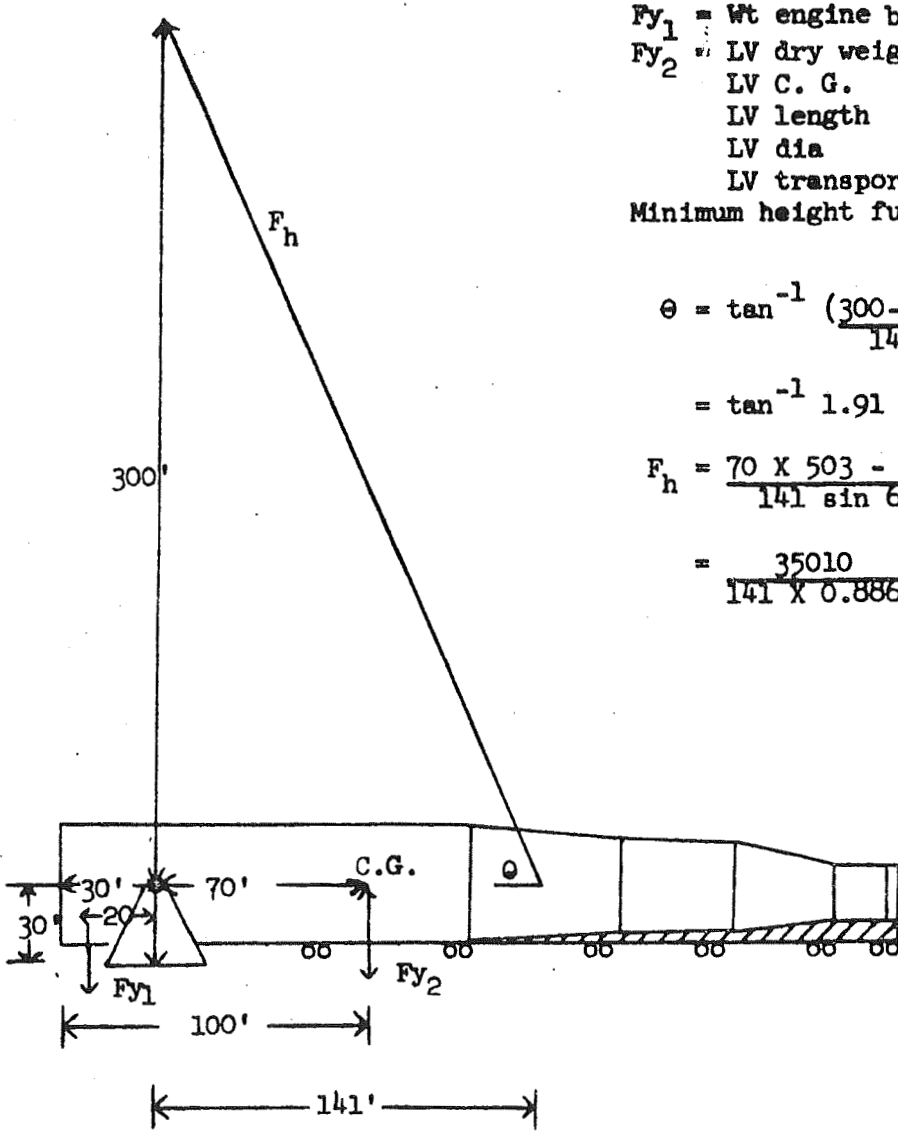

Figure 7.6-5 Conceptual Diagram LCLV  
 Vertical Erection Operation  
 Onto Mobile Launcher-Concept A

\*Structural analysis shows that the bending stresses imposed by erection in this manner will not exceed the flight loads for which the vehicle is designed.



- $F_{y1}$  = Wt engine bell = 10 tons
- $F_{y2}$  = LV dry weight = 503 tons
- LV C. G. = 100' from base
- LV length = 266'
- LV dia = 41'
- LV transport bed = 7' from ground
- Minimum height fulcrum =  $7 + \frac{41}{2} \approx 27.5'$

$$\theta = \tan^{-1} \left( \frac{300-30}{141} \right)^\circ$$

$$= \tan^{-1} 1.91 = 62.3^\circ$$

$$F_h = \frac{70 \times 503 - 10 \times 20}{141 \sin 62.3^\circ}$$

$$= \frac{35010}{141 \times 0.886} = 280 \text{ tons}$$

Figure 7.6-6 Resultant Force to Vertically Erect Completely Assembled LV

- Compatibility of ML, Mobile Service Structure and launch pad materials with  $N_2O_4$ /UDMH. It is recognized that similar propellants are used in the Apollo spacecraft. However, since only a small amount of these propellants are used, the design of the ground equipment may not have stressed compatibility with these liquids.
- Fulcrum design and attendant LCLV loading stresses during erection operations.
- Design modifications to ML launch umbilical tower to accommodate changes in PLPS and launch umbilical and service arms and installation of the LCLV erection hoist. Also, the 45' X 45' flame opening in the base of the ML needs to be investigated further to determine if it can be lined with refractory material or requires enlargement because of LCLV flame plume.
- ML/LCLV retractable support mounts. A completely new design is required.
- Safety features and explosive and toxic danger envelopes measured from the launch site in the event of a spill or explosion and resultant "fire-ball". Table 7.6-V is a summary of some of the more pertinent properties of  $N_2O_4$ /UDMH.
- Total weight of ML when above modifications are incorporated. It may be that the combined weight of the ML/LV exceeds the maximum lifting capacity of the crawler.
- Design of the launch pad flame trench. Further analyses may dictate a greater depth and width is required.
- Minimum modifications to the Mobile Service Structure work platforms to accommodate the larger diameter LCLV appear to be required (See Figure 7.6-7). Confirmation of this requires a more detailed structural interface analysis.
- Design of the LCLV transporter which because of the Plant A complete assembly operations may well require a rather unique configuration with six degrees of freedom.

Table 7.6-V SUMMARY OF  $N_2H_4/O$  /UDMH PROPERTIES

7.34

PROPELLANT	HAZARDS		SAFETY MEASURES	MATERIAL COMPATIBILITY		
	Health	Fire and Explosion		Metals	Nonmetals	Lubricants
$N_2O_4$	$N_2O_4$ in liquid form is corrosive and can cause severe burns of skin and eyes upon contact. The most serious hazard is the inhalation of toxic vapors, the threshold limit value being 2.5 ppm (9 mg/cu m). The main danger from acute poisoning is pulmonary edema in which the lungs fill with fluid.	Liquid $N_2O_4$ , by itself, will not burn but will support combustion. Such nonhypergolic mixtures thus present an explosion hazard, particularly when subjected to elevated temperatures, pressures or impact. If containers leak, $N_2O_4$ vapors can form explosive mixtures with fuel vapors.	Head, face and body protective clothing are required during propellant handling operations. Respiratory equipment is required where $N_2O_4$ fumes exceed threshold limit.	The following metals are suitable for corrosive service when $NO_2$ moisture is 0.1% or less:  Carbon steels Aluminum Stainless steels Nickel Inconel  Under wet conditions stainless steel (300 series) can be used.	The following nonmetals can be used with $NO_2$ :  Ceramic (acid-resistant) Pyrex glass Teflon Kel-F Asbestos (cotton-free) Polyethylene (limited use)	Hydrocarbon lubricants should not be used. The following lubricants, which are inert to strong oxidizers, may be used:  Fluorolube series Nordcoseal -147 and DC 234S Teflon tape
UDMH	Mildly irritating to skin and eyes. Dominant effect is stimulation of the central nervous system, manifested by tremors or convulsions. Threshold limit value is 0.5 ppm (1 mg/cu m).	Flammable in air over a very wide range of concentrations. UDMH vapors greater than 2% in air can be exploded by an electric spark or an open flame. Therefore, all equipment must be grounded to prevent the accumulation of static charges and UDMH, itself, must be stored and handled at all times under an atmosphere of $N_2$ .	Head, face and body protective clothing are required during propellant handling operations. Respiratory equipment is required where UDMH fumes exceed threshold limit.	UDMH is compatible with most common metals. Aluminum is attacked to some extent by dilute aqueous solutions of UDMH. Copper and high copper alloys are prohibited for use in UDMH transfer and storage equipment.	Best materials include Teflon, unplasticized Kel-F, polyethylene and Garlock gasket 900.	Best lubricants are Apiezon L and Reddy Lube 200.

138

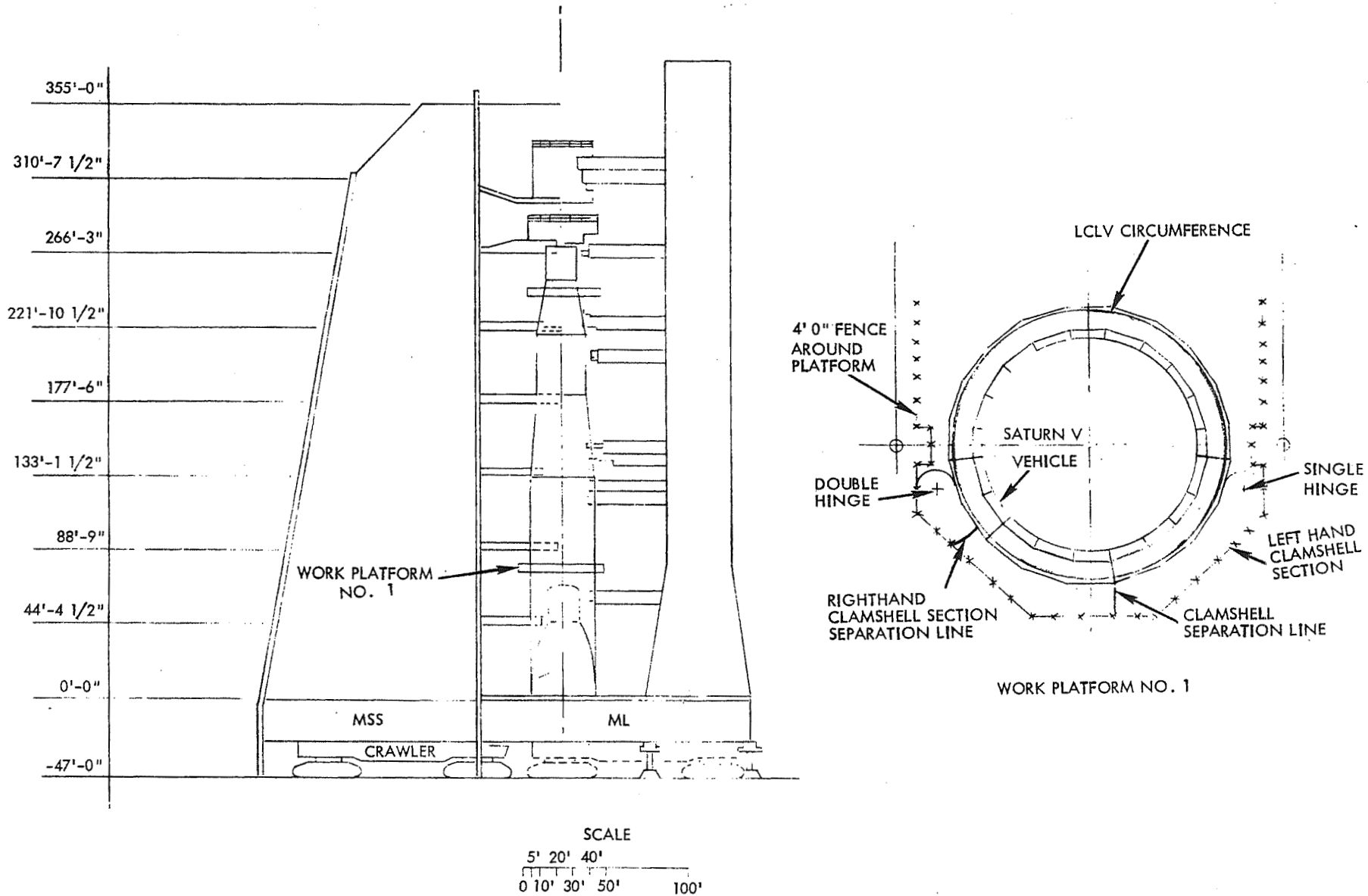

Figure 7.6-7 LCLV Structural Interface with Mobile Service Structure and Mobile Launcher

7.36

Shown in Table 7.6-VI are the production and installation (P&I) costs of the AGE/LF required for Concept A to support a launch rate of 1, 2, 3 or 4 LCLV's per month. These costs were derived using the equations in the appendix, the time line flow diagram and the unit P&I costs. A three-day interval between launches and five-day pad refurbishment cycle are assumed.

7.6.5 Concept B LVLC Ground System

In Concept A, one of the prime reasons for assembling and testing the LCLV at Plant A and then transporting the completely assembled vehicle horizontally to the VAB area for vertical erection onto the ML was to maintain the integrity and confidence level in the LCLV's flight readiness up through launch. As an alternate to this operating mode, Concept B employs the VAB in keeping with its original and present function, i.e., to complete the factory final assembly and compatibility tests of the launch vehicle including its payload with the actual launch support equipment. Thus, for the case where Plant A is directly accessible to the launch complex, each stage is assembled at Plant A and then transported individually to the VAB. At the VAB, the LCLV stages, instrumentation unit and payload are processed similar to the Saturn V/Apollo. The VAB eight low bay cells (Figure 7.6-8) are used, if required, to checkout critical parameters of the second and third stages and instrumentation unit prior to mating them in the high bay. The high bay cells are employed to position the 1st stage on the ML using a 450 ton hoist,\* and to perform individual stage and eventually final space vehicle checkout. Following checkout of the 1st stage, the upper stages are transported from the low bay area into the 95' wide transfer aisle, mechanically mated to their inter-stages, and then transported down the aisle by the 175 ton bridge hoist to the high bay area. At this point, the high bay hoist is used to lift each stage and the payload over the 190' structural wall just like the first stage into the high bay cell for vertical mating and final system testing. Upon completing the space vehicle systems tests, all ordnance except the igniters are installed, and the ML/LV is transported by the crawler to the launch pad. The merits of this concept over that of Concept A are as follows:

\*If the uprating of the present 250 ton crane (and VAB structure) proves to be impractical, the 1st stage can be erected and placed on the ML outside the VAB, then brought inside for integration of other stages and payload. The other alternative (to reduce the size of the LCLV until the 250 ton crane would be adequate) requires a drastic reduction to about 5.6M lb gross weight, which is contrary to the basic design principles of the LCLV as defined in Sections 1, 4 and 9.

Table 7.6-VI LCLV Estimated AGE/LF Production & Installation Costs (\$KX10<sup>3</sup>) to Support Various Monthly Launch Rates

Function No.	CONCEPT A											
	1			2			3			4		
	OGE	MGE	LF	OGE	MGE	LF	OGE	MGE	LF	OGE	MGE	LF
K 22.0			8,000			16,000			24,000			32,000
K 18.0		375			375			375			375	
K 16.0		250			250			250			250	
K 14.0		10			10			10			10	
K 13.0		20,000			35,000			50,000			65,000	
K 12.0	14,000	2,000	16,500	21,000	4,000	22,500	31,000	11,000	50,500	44,000	16,000	78,500
K 11.0		1,000			2,000			3,000			6,000	
K 10.0		100			200			300			300	
K 9.0												
K 8.0												
K 7.0									28,000			36,000
K 6.0	200	50	3,500	400	18,050	34,500	400	36,100	124,000	3,600	54,100	212,000
K 5.0												
K 4.0	100	150		200	300		300	450		400	600	
K 3.0												
K 2.0												
K 1.0												
Totals	14,300	23,935	28,000	21,600	60,185	73,000	31,700	101,485	226,500	48,000	142,635	358,500
Combined AGF/LF Totals	← 66,235 →			← 154,785 →			← 359,685 →			* ← 549,135 →		

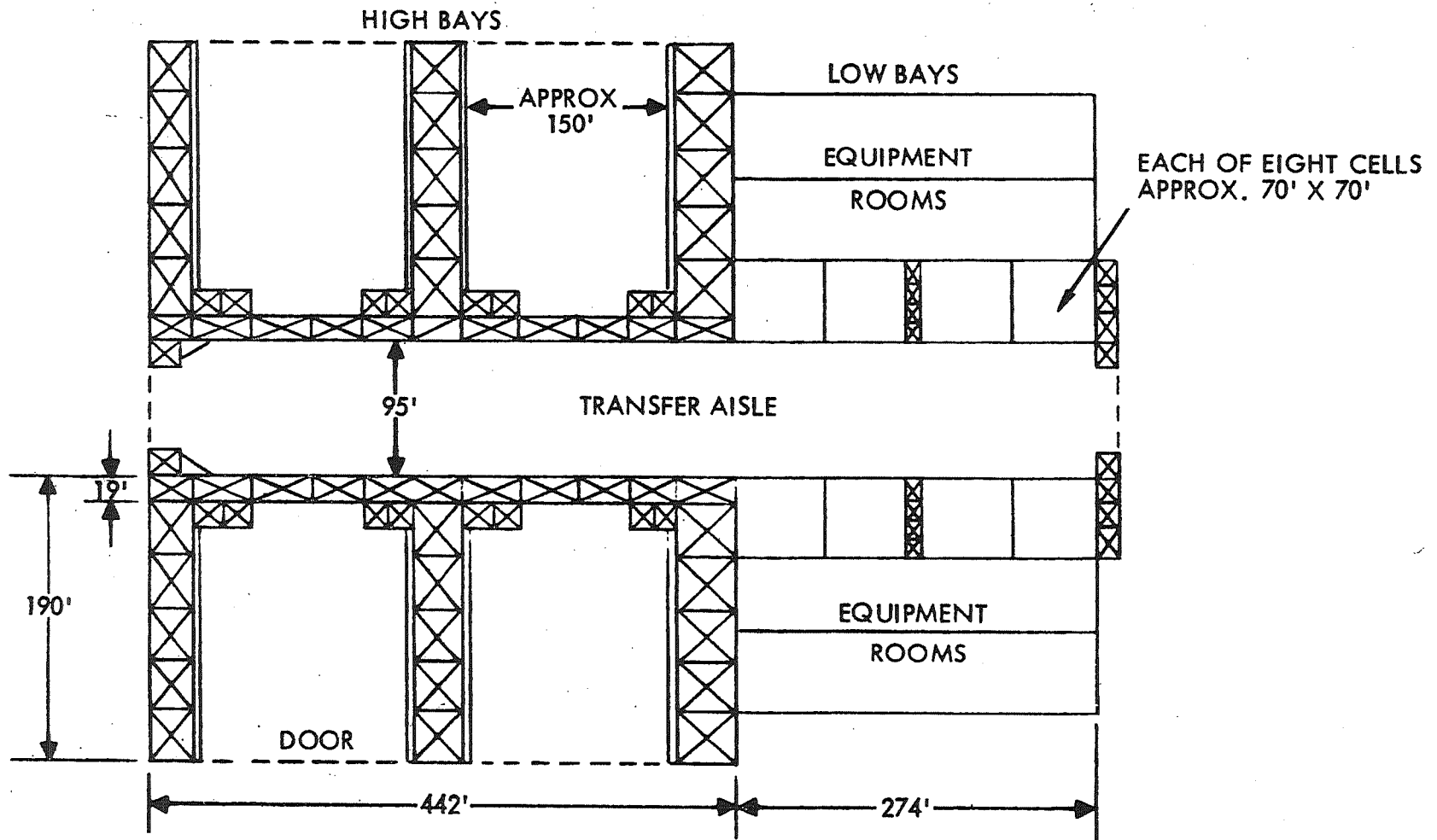

NOTE:  
INTERNAL HEIGHT OF { H.B IS 455' (HOOK HEIGHT)  
L.B IS 210'

Figure 7.6-8 VAB Plan View



- The ML fulcrum and hoist are not required, thus reducing design and modification costs.
- Elimination of fulcrums and hoists and corresponding structural changes, favors weight constraints of ML.
- Eliminates requirement for LCLV transporter to store and transport the fully assembled 500 ton LCLV; stages can be transported and stored individually on more standardized trailers.
- The more complicated railways and ramp are not required for transporting the completely assembled 500 ton LCLV from the factory to the VAB area.
- Although no problem is foreseen, LCLV does not have to be designed for horizontal transportation and vertical erection in completely assembled mode.
- LCLV, payload, launch escape system (if required) and ordnance can be completely assembled, installed, and tested at one location, thus minimizing total checkout time and maximizing confidence level in space vehicle's flight readiness. In this regard, Concept A has the following disadvantages:
  - LCLV is not tested at Plant A with actual launch umbilicals, servicing lines, and launch support equipment since these are an integral part of the Mobile Launcher.
  - Payload and launch escape system are not mated and tested with the LCLV until it is erected at the VAB. Thus, the LCLV, although tested at Plant A, requires further test preparation and checkout using the actual launch support equipment and umbilicals to determine the flight readiness of the entire space vehicle. This additional testing can result in system degradation.
  - Some ordnance will still be installed at the VAB, depending upon the type of ordnance (rockets, retro-rockets, command destruct, etc., which do not compromise the integrity of the LCLV's checkout). However, pyrotechnic squibs for arming ordnance systems are always installed at the launch pad.

7.40

- o Although modification of the high bay hoist is required (250T to 450T), use of the VAB for final LCLV assembly and checkout eliminates the need for construction of comparable facilities at Plant A.
- o VAB verified assembly processes, and procedures, and computerized checkout equipment can be utilized more fully.

A time line analysis of Concept B is presented in Figure 7.6-9. Some of the more significant findings are summarized below and in Table 7.6-VII. It is to be noted that although the "time in VAB" is four days longer than Concept A, the total final assembly through launch time is 12 days shorter:

- o Total final assembly through launch and refurbishment time: 37 days
- o Time in VAB: 20 days
- o Time on pad: 10 days

Table 7.6-VIII\* contains the results of a performance and cost analysis of Concept B. Technical areas requiring further analysis are similar to those identified for Concept A with the exception of the ML fulcrum and LCLV hoist. In addition, modifications to the VAB to install a 450 ton capacity overhead hoist may involve more complications than estimated.

P&I costs for Concept B AGE/LF to support a launch rate of 1, 2, 3 or 4 LCLV's per month are shown in Table 7.6-IX.

7.6.6 Concept C LCLV Ground System

As mentioned earlier, Concept C examined the application of completely new facility designs and assembly and checkout operations, with the exception of the LCC, equally adaptable to other launch sites. The purpose of this investigation was for two reasons: One, to explore the relative cost advantages in transporting horizontally the completely assembled LCLV from the factory to the launch pad; and two, to develop a concept which, by design, avoids potential scheduling conflicts of the existing KSC facilities with other programs. In this concept, two design configurations were analyzed, viz., Concept C<sub>1</sub> and Concept C<sub>2</sub>.

\*Table 7.6-VIII (25 pages) has been transferred to Appendix E.

5

145

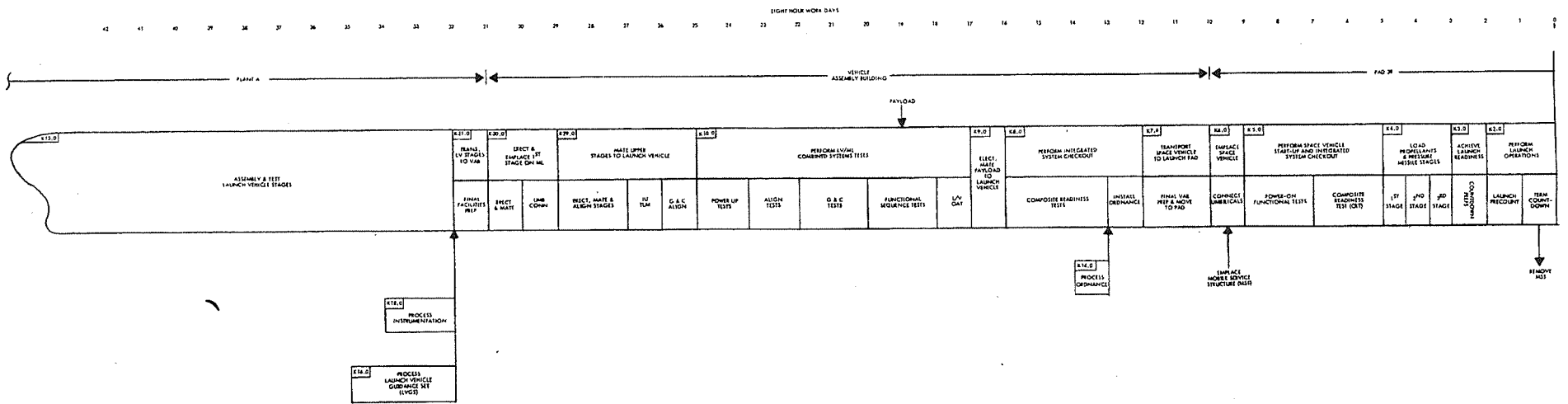

Figure 7.6-9

TIME BASED FUNCTIONAL FLOW DIAGRAM OF LCLV FINAL ASSEMBLY THROUGH LAUNCH OPERATIONS AT KSC-BASELINE CONCEPT B

TABLE 7.6-VII

APPROXIMATE MANPOWER REQUIREMENTS  
FOR LOW COST LAUNCH VEHICLE  
FINAL ASSEMBLY THROUGH LAUNCH OPERATIONS AT KSC

-- Concept B --

<u>Function</u>	<u>Functional Flow No.</u>	<u>Eight Hour* Work Days</u>	<u>Equivalent Hours</u>	<u>** Man-Hours</u>
Process Ordnance	K 14.0	1	8	24
Process Launch Vehicle Guidance Set	K 16.0	3	24	96
Process Instrumentation	K 18.0	2	16	80
Assemble and Test Launch Vehicle (LV)	K 13.0	***		
Transport Launch Vehicle Stages to Vehicle Assembly Building (VAB)	K 31.0	1	8	280
Erect and Emplace First Stage on Mobile Launcher	K 30.0	2	16	800
Mate Upper Stages to Launch Vehicle	K 29.0	4	32	2400
Perform LV/ML Combined System Tests	K 10.0	8	64	6400
Electrically Mate Payload to Launch Vehicle	K 9.0	1****	8	400
Perform Integrated System Checkout	K 8.0	4	32	4800
Transport Space Vehicle to Launch Pad	K 7.0	2	16	640
Emplace Space Vehicle	K 6.0	1	8	640
Perform Space Vehicle Start-up and Integrated System Checkout	K 5.0	4	32	4800
Load Propellants and Pressurize Missile Stages	K 4.0	2	16	800
Achieve Launch Readiness	K 3.0	1	8	640
Perform Launch Operations	K 2.0	2	16	2400
Refurbish Launch Facility	K 25.0	5	40	1600
			Total Man-Hours .....	26,800
			Total Man-Years Per Vehicle (Assuming 2000 Man-Hours per Man-Year)....	13.4

\* Assumes a success-oriented, no contingency, functional sequence.

\*\* By definition, launch operations manpower requirements do not include base, range and mission support requirements.

\*\*\* The time for this function is not included since vehicle final assembly is accomplished at VAB.

\*\*\*\* Payload checkout times for this activity and subsequent functions are not included.

Table 7.6- IX LCLV Estimated AGE/LF Production & Installation Costs (\$X10<sup>3</sup>)  
to Support Various Monthly Launch Rates

Function No.	CONCEPT B											
	1			2			3			4		
	OGE	MGE	LF	OGE	MGE	LF	OGE	MGE	LF	OGE	MGE	LF
K 22.0			8,000			16,000			24,000			32,000
K 18.0		375			375			375			375	
K 16.0		250			250			250			250	
K 14.0		10			10			10			10	
K 13.0												
K 31.0	14,000	8,000	11,000	21,000	15,500	15,000	31,000	28,000	43,000	44,000	38,500	71,000
K 30.0		1,000	2,000		2,000	2,000		3,000	4,000		6,000	4,000
K 29.0		1,500			3,000			4,500			6,000	
K 10.0		100			200			300			300	
K 9.0												
K 8.0												
K 7.0									28,000			36,000
K 6.0	200	.50	3,500	400	18,050	34,500	400	36,000	124,000	3,600	54,100	212,000
K 5.0												
K 4.0	100	150		200	300		300	450		400	600	
K 3.0												
K 2.0												
K 1.0												
Sub Totals	14,300	11,435	24,500	21,600	39,685	67,500	31,700	72,885	223,000	48,000	106,135	355,000
Combined AGE/LF Totals	← 50,235 →		← 128,785 →				← 327,585 →			← 509,135 →		

### 7.6.6.1 Concept C<sub>1</sub>

In this configuration, it was assumed that the LCLV transporter is an integral and complex design, serving also as an umbilical launch tower when erected at the pad. The same electronic checkout equipment, cables and umbilicals used at Plant A during LCLV final assembly, perform the launch preparations.

As shown in Figure 7.6-10, the rail mounted welding jigs for the stages (Figure 7.6-11) move across the plant to the stage assembly area, where the jigs are joined together to form the umbilical tower, cradling the completely assembled launch vehicle.

After LV checkout, the cradle/LV assembly is picked up by the transporter/erector (Figure 7.6-12) mounted on standard rail cars, powered by diesel engines that run on two parallel sets of tracks. After transport to the launch pad the cradle/LV assembly (Figure 7.6-13) is rotated about its center of gravity to the vertical position (Figure 7.6-14).

The LV is picked up by jacks on the launch pedestal. The cradle is then moved a short distance and becomes the umbilical tower. After final countdown, the vehicle is launched from the cruciform pit.

Shown in Figure 7.6-15 is a time line flow diagram of Concept C<sub>1</sub> assembly and checkout operations, which resulted in the following findings:

- Total final assembly through launch and refurbishment time: 68 days
- Time on pad: 22 days

It is to be noted that the total assembly and launch cycle of Concept C<sub>1</sub> is 31 days longer than Concept B and 19 days more than Concept A. The estimated manpower required to perform Concept C<sub>1</sub> final assembly through launch functions is contained in Table 7.6-X. Compared to Concepts A and B, approximately 10,000 and 15,000 additional man-hours, respectively, are required.

The results of a performance and cost analysis of Concept C<sub>1</sub> are included in Table 7.6-XI\*. It will be noted in Table 7.6-XII that the P&I costs for Concept C<sub>1</sub> to support more than one LCLV/month were not determined. This is because of the decision, based on the following findings, to forego further consideration of Concept C<sub>1</sub>:

\*Table 7.6-XI (24 pages) will be found in Appendix E.

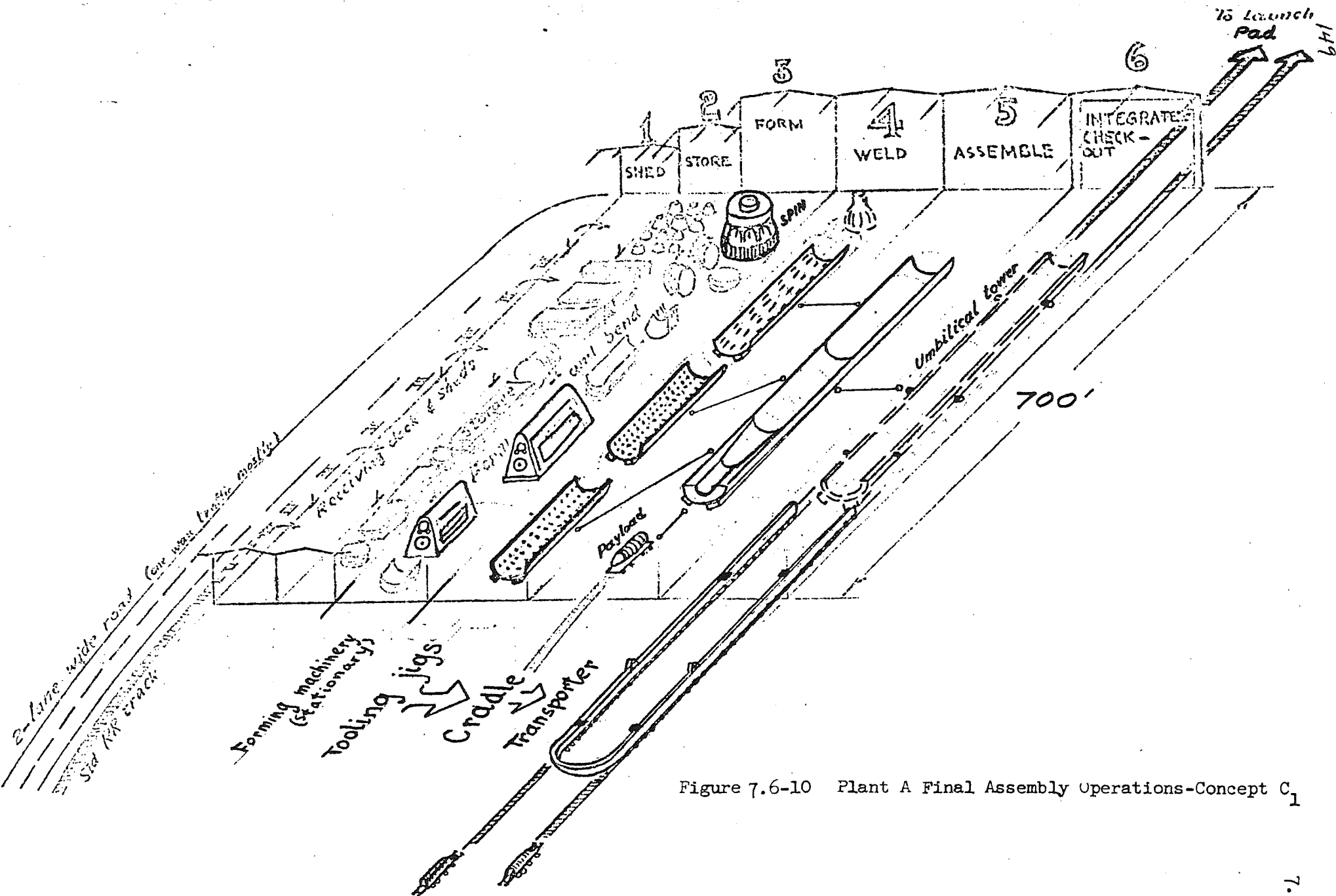

Figure 7.6-10 Plant A Final Assembly Operations-Concept C<sub>1</sub>

4 DL600 Locomotives

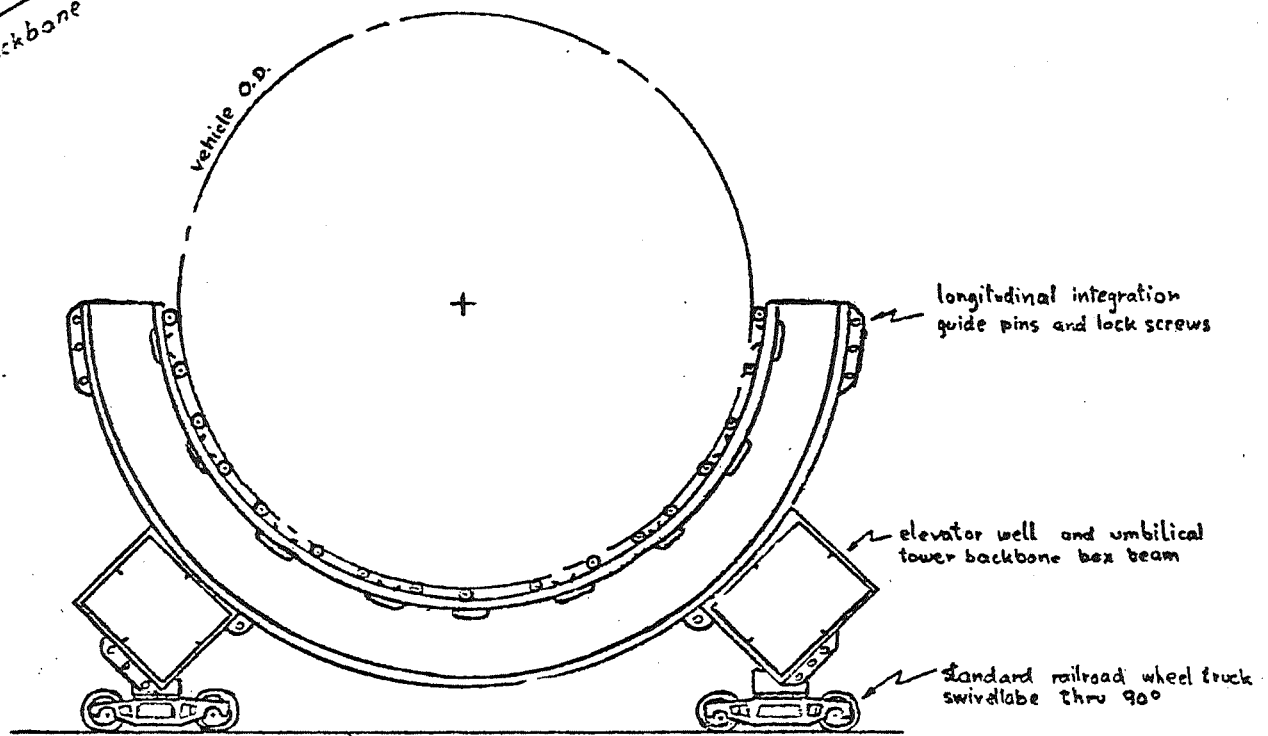
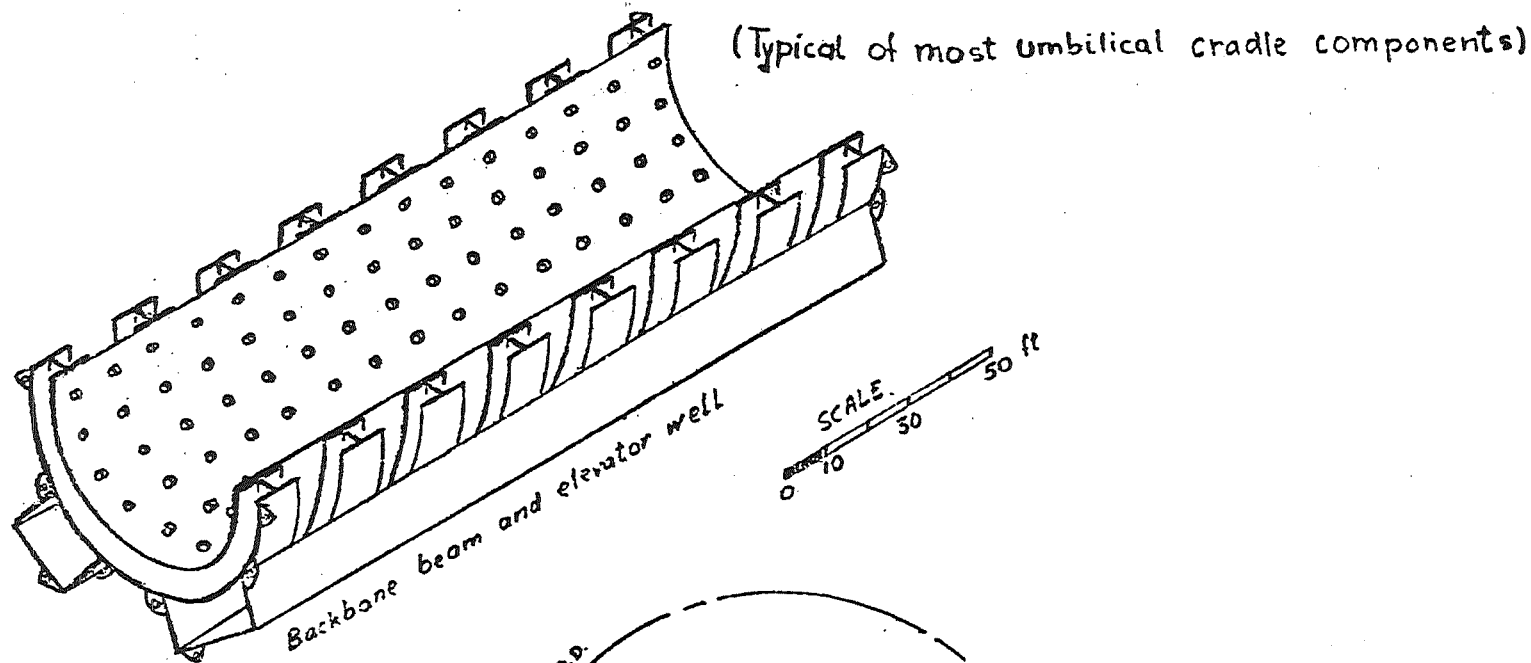

Figure 7.6-11 Typical Stage Welding Tool Jig-Concept C<sub>1</sub>

150  
7.46



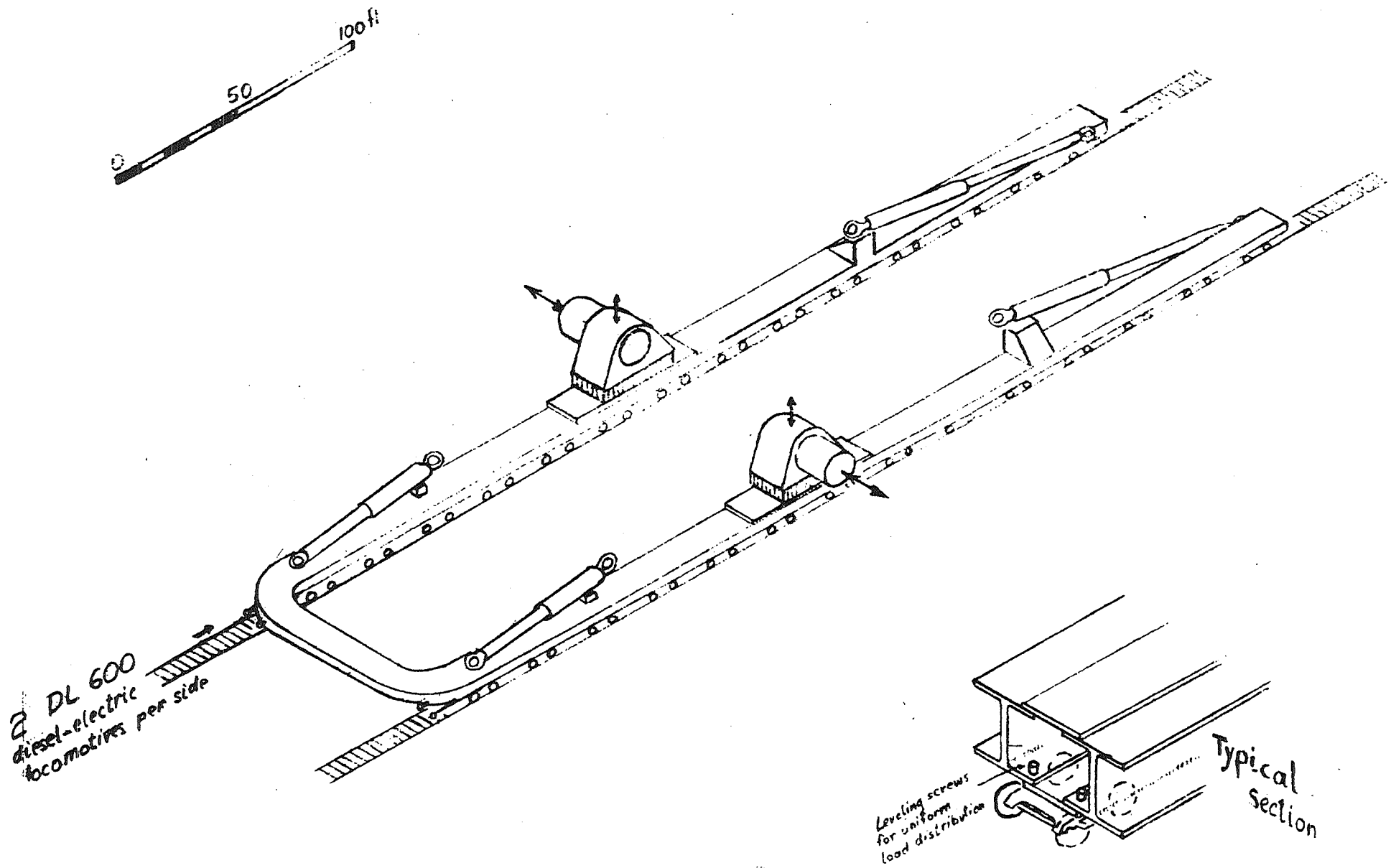

Figure 7.6-12 LCLV Transporter-Concept C<sub>1</sub>

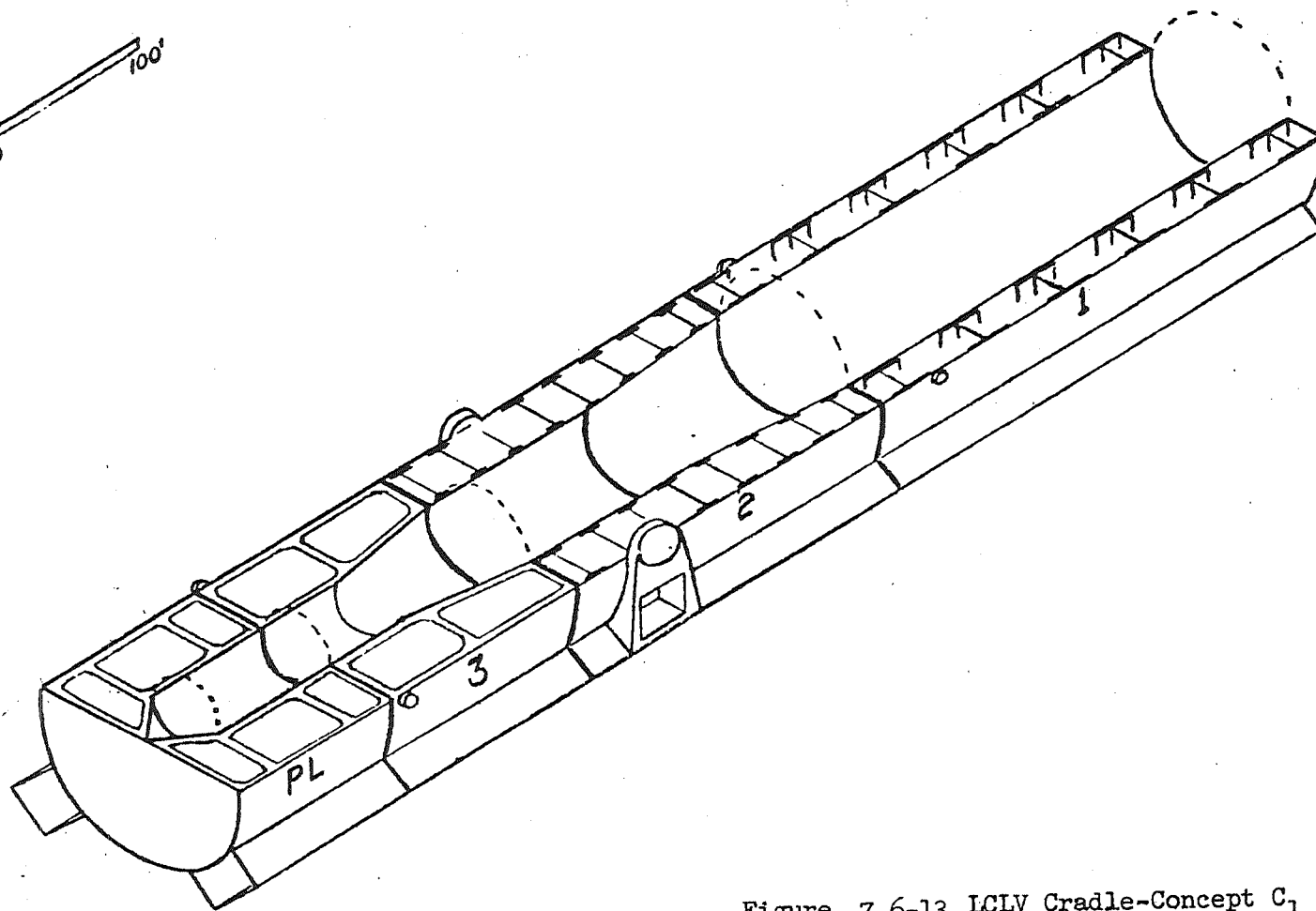
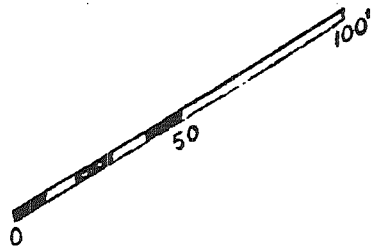

Figure 7.6-13 LCLV Cradle-Concept C<sub>1</sub>

(Umbilical Tower in Horizontal Position)  
Assembled from Welding Tool Jigs

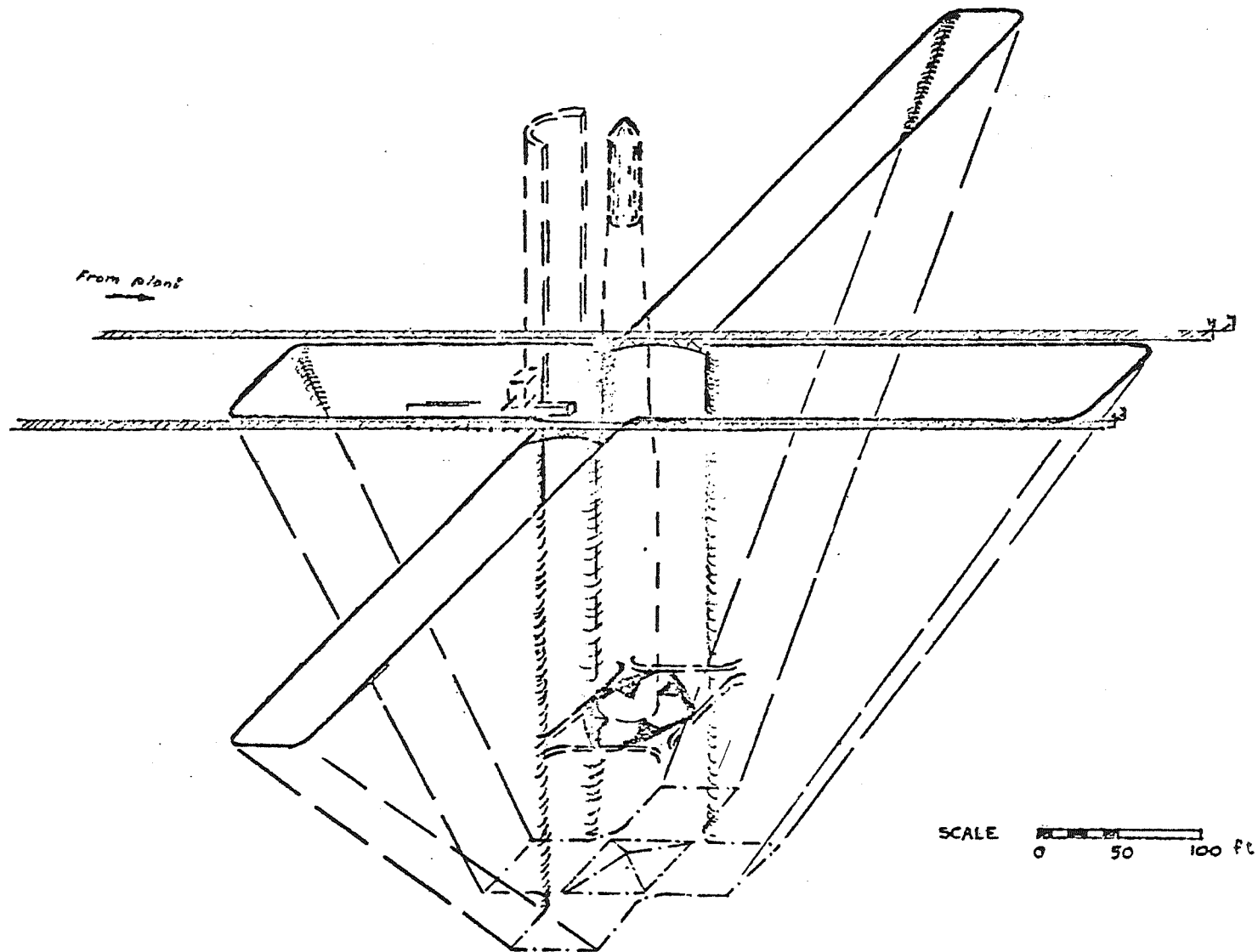

Figure 7.6-14 LCLV Deep-Pit Launch Site-Concept C<sub>1</sub>

153  
7.49

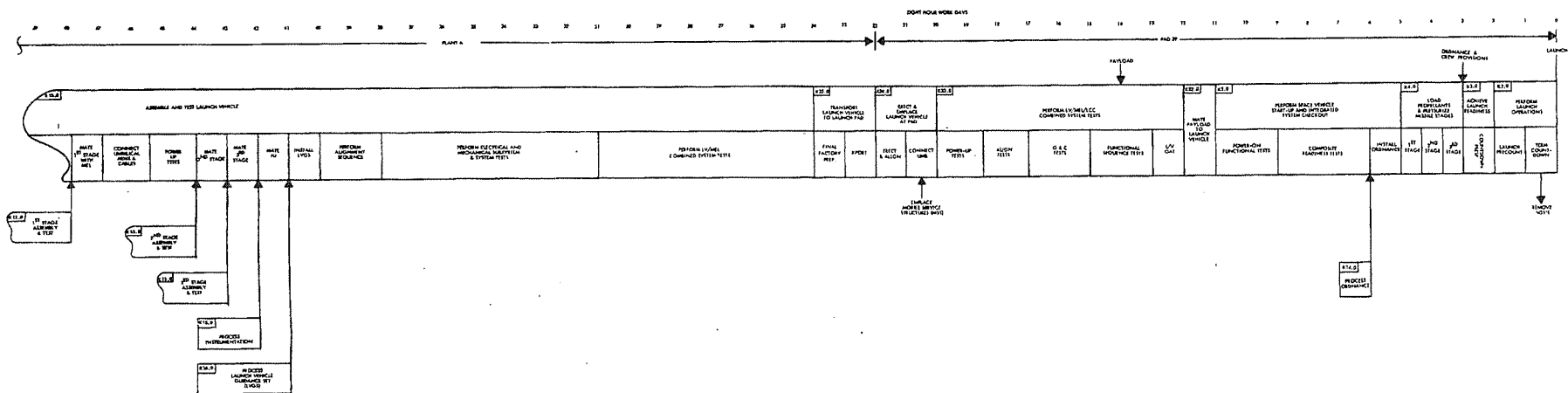

Figure 7.6-15

TIME BASED FUNCTIONAL  
FLOW DIAGRAM OF  
LCLV FINAL ASSEMBLY  
THROUGH LAUNCH  
OPERATIONS AT KSC-  
CONCEPT C<sub>1</sub>

TABLE 7.6-X

APPROXIMATE MANPOWER REQUIREMENTS  
FOR  
FINAL ASSEMBLY THROUGH LAUNCH OPERATIONS AT KSC

-- Concept C1 --

<u>Function</u>	<u>Functional Flow No.</u>	<u>Eight Hour* Work Days</u>	<u>Equivalent Hours</u>	<u>** Man-Hours</u>
Process Ordnance	K 14.0	1	8	24
Process LVGS	K 16.0	3	24	96
Process Instrumentation	K 18.0	2	16	80
Assemble and Test Launch Vehicle	K 13.0	24	192	12480
Transport Launch Vehicle to Launch Pad	K 35.0	2	16	640
Erect and Emplace Launch Vehicle at Pad	K 34.0	2	16	960
Perform LV/MEL/LCC Combined System Tests	K 33.0	8	64	9600
Electrically Mate Payload to Launch Vehicle	K 32.0	1***	8	400
Perform Space Vehicle Start-up and Integrated System Checkout	K 5.0	6	48	7200
Load Propellants and Pressurize Missile Stages	K 4.0	2	16	800
Achieve Launch Readiness	K 3.0	1	8	800
Perform Launch Operations	K 2.0	2	16	2400
Refurbish Launch Facility****	K 25.0	10	80	4800
Total Man-Hours .....				40,280
Total Man-Years Per Vehicle (Assuming 2000 Man-Hours per Man-Year)....				20.1

\* Assumes a success-oriented, no contingency, functional sequence.

\*\* By definition, launch operations manpower requirement do not include, base, range and mission support requirements.

\*\*\* Payload checkout times for this activity and subsequent functions are not included.

\*\*\*\* Does not include refurbishment of MEL which is estimated at 20 days.



As indicated in Table 7.6XII, the AGE/LV production and installation cost for Concept C<sub>1</sub> to launch one LCLV per month at KSC is over  $\$450 \times 10^6$  (approximately 800%) that of either Concepts A or B. The principal reasons for this tremendous difference in cost are as follows:

- With the exception of the LCC at KSC, Concept C<sub>1</sub> requires entirely new launch facilities and AGE, whereas Concepts A and B utilize most of the Saturn V launch facilities with modifications.
- Because of 22 days on-pad time plus the 10 days allocated for launch pad refurbishment, Concept C<sub>1</sub> requires two launch pads to support one launch per month. Both of these pads, estimated at  $\$80 \times 10^6$  each, including AGE, require an entirely new construction due to Concept C<sub>1</sub>'s unique requirements. In addition, because two pads are required, two PLPS transfer systems at  $\$8 \times 10^6$  are needed. In contrast, Concepts A and B require just one launch pad since their LCLV on-pad time plus refurbishment time totals only 15 days. Furthermore, Concepts A and B can utilize either of the two existing Saturn V launch pads with modifications.
- Concept C<sub>1</sub> requires two separate and new mobile service structure designs; one, valued at  $\$32 \times 10^6$  with AGE, to service the stages above ground level; and the other ( $\$18 \times 10^6$ ) to service that portion of the first stage which extends approximately 80' below ground into the flame trench. Also, an MSS parking and maintenance area, valued at  $\$6.0 \times 10^6$ , is required. Concepts A and B utilize the existing MSS with minimum modification as well as its present parking area.
- Concept C<sub>1</sub> requires six launch umbilical towers at an estimated cost of  $\$15 \times 10^6$  each. This is due to an approximate six-month cycle time imposed on the umbilical tower as the result of using it for the LCLV fabrication jigs ( $3\frac{1}{2}$  months) and for final assembly through launch ( $2\frac{1}{4}$  months including refurbishment).

- Three new mobile erector launchers including their OGE, valued at  $\$34 \times 10^6$ , plus a parking and maintenance area ( $\$10 \times 10^6$ ) are required for Concept C<sub>1</sub>. Concepts A and B utilize the existing three Saturn V Mobile Launchers suitably modified.

Also to be added to the above are the costs for spares. It is to be recognized that in addition to the much larger AGE/LV production and installation costs, the cost of Concept C<sub>1</sub> in comparison to A and B for other ground system categories, such as RDT&E, program management, and launch operations, will also be many magnitudes greater. This is due to Concept C<sub>1</sub> not only requiring entirely new LF and AGE designs, but also to the following factors:

- Approximately one month longer, final assembly through launch and refurbishment cycle.
- A 30 to 40% increase in manpower requirements for the final assembly through launch and refurbishment operations.
- Completely new program management involving total system engineering, program control and logistic plans and procedures. The cost for the ground systems program management of Concept C<sub>1</sub> is assumed to be 25% of the total cost for RDT&E, P&I and operating costs. The program management of Concepts A and B, however, requires a minimum of system engineering and makes maximum use of existing procedures which can be optimized. Therefore, it is assumed that the ground systems program management cost of A and B will be only 12% of their RDT&E, P&I and operating costs.
- New RDT&E instrumentation, tooling, facilities, propellants, special test equipment, handbooks and documentation, data reduction and analyses and sustaining engineering. It is estimated that the RDT&E cost of the Concept C<sub>1</sub> ground system, due to its complexity and uniqueness, is approximately 40% of its total P&I costs. The RDT&E costs of Concepts A and B, being far less complex to develop, are considered to be less than 25% of the total P&I costs of new equipment and the necessary modifications.



- Complete retraining of operating personnel for entirely new assembly, checkout, launch and refurbishment operations.

Based on the results of the requirements and cost analysis, Concept C<sub>1</sub> was rejected not necessarily for reasons of costs, but because of its overly complex design. At another site where Saturn V/Apollo type facilities are unavailable, Concept C<sub>1</sub> might prove to be competitive with the costs of producing and installing the ground system for Concepts A or B. However, its design concept involves the solution of many complex technical design problems, some of which it appears require solutions beyond the 1970's state-of-the-art techniques. A few of its design limitations and problems to be solved are as follows:

- Designing LCLV tooling jigs which can be used for the following sequential applications:
  - LCLV welding and individual stage horizontal assembly operations. (The jigs require a means of rotating the stages 360° about their longitudinal axis in the horizontal position.)
  - Transporting the LCLV stages horizontally to the final assembly area (LCLV stages weigh up to 400 tons dry).
  - Final horizontal assembly of the LCLV stages (6 degrees of freedom is required).
  - Forming the launch umbilical tower (LUT) when interconnected and erected vertically (total height of tower required is approximately 300').
  - Supporting up to five umbilical support arms, weighing from 10 to 25 tons, both during horizontal transportation and vertical erection.
  - Transporting entire LCLV horizontally to launch pad when LUT is mounted on transporter.
  - Erecting and lowering the LCLV at the launch pad.
  - Withstanding 60 MPH winds and other KSC climatic conditions at the launch pad and the UDMH/N<sub>2</sub>O<sub>4</sub>, acoustic and vibration environment during launch.

- Complying with RFI requirements.
- Designing a 175-foot deep, cruciform flame trench which provides:
  - Access ramps for MSS and flame deflector emplacement beneath the Stage 1 engine.
  - Protection of the LCLV during engine firing and lift-off (engine protrudes into flame trench approximately 80').
  - Four retractable LCLV holddown support arms which extend from the sides of the flame trench at a location approximately 65' up from the bottom of the trench.
- Designing a mobile erector launcher which can:
  - Support and transport the launch umbilical tower and LCLV horizontally to the launch pad.
  - Incorporate the AGE used both for factory and launch operations.
  - Erect or lower the launch umbilical tower/LCLV at the launch pad.
  - Retract the launch umbilical tower while in its vertical position a distance of 40' from the emplaced LCLV.
- Assuming the launch umbilical and servicing arms are used during the LCLV final assembly and test operations at Plant A, a means is required whereby they can be swung clear of the LCLV while mounted on the jigs. Approximately 40' of additional umbilical cabling and servicing lines are required for each arm to effect this operation. This poses a further design problem at the launch pad where this excess slack of umbilical cables and servicing lines must be retracted so as not to interfere with the LCLV during lift-off.

161

- Because of Plant A's location, the LCC is not used, as it is in Concepts A and B, in the final stage assembly and test operations. Also, since some payloads, such as Apollo are not designed for horizontal transport, final mating with the LCLV must be accomplished at the launch pad. Thus, combined testing with the LCC and payload and the detection of any system anomalies must await emplacement of the LCLV/mobile erector launcher at the launch pad. Also, the upper stage MSS design requires a 100-ton capacity bridge crane for lifting and vertically mating the payload to the LCLV.

#### 7.6.6.2 Concept C<sub>2</sub>

In view of rejecting C<sub>1</sub> from further consideration, one other ground system concept, C<sub>2</sub>, was investigated. The intent of this analysis was to continue examination of the relative cost advantages in transporting horizontally the completely assembled LCLV from Plant A directly to the launch pad and to circumvent some of the design and cost objections of C<sub>1</sub>.

As shown in Figure 7.6-16, the LCLV assembly and checkout functions at Plant A of Concept C<sub>2</sub> are identical to those of A. Completion of these operations is then followed by transporting horizontally the fully assembled LV to the launch pad using the simpler transporter design of Concept A. Erection at the pad is performed similar to Concept A, except that the launch umbilical tower (LUT) is a fixed installation as illustrated in the conceptual drawing of Figures 7.6-17. Figures 7.6-18a and b depict another possible arrangement of the LUT installation at the launch pad which was not pursued because of the advantages of the other approach. The LUT, Mobile Service Structure, launch pad and flame deflector are new designs. Positioning of the MSS is accomplished by rail with diesel locomotives. As in Concept C<sub>1</sub>, payload integration and space vehicle checkout with the LCC is performed at the launch pad. The LUT electronics, cables and umbilicals are not the same set used for checkout of the LCLV at Plant A.

Based on the time line analysis of Figure 7.6-16, it was concluded that Concept C<sub>2</sub> in comparison to Concept C<sub>1</sub> resulted in a reduction of the total final assembly through launch time from 68 days to 45 days.

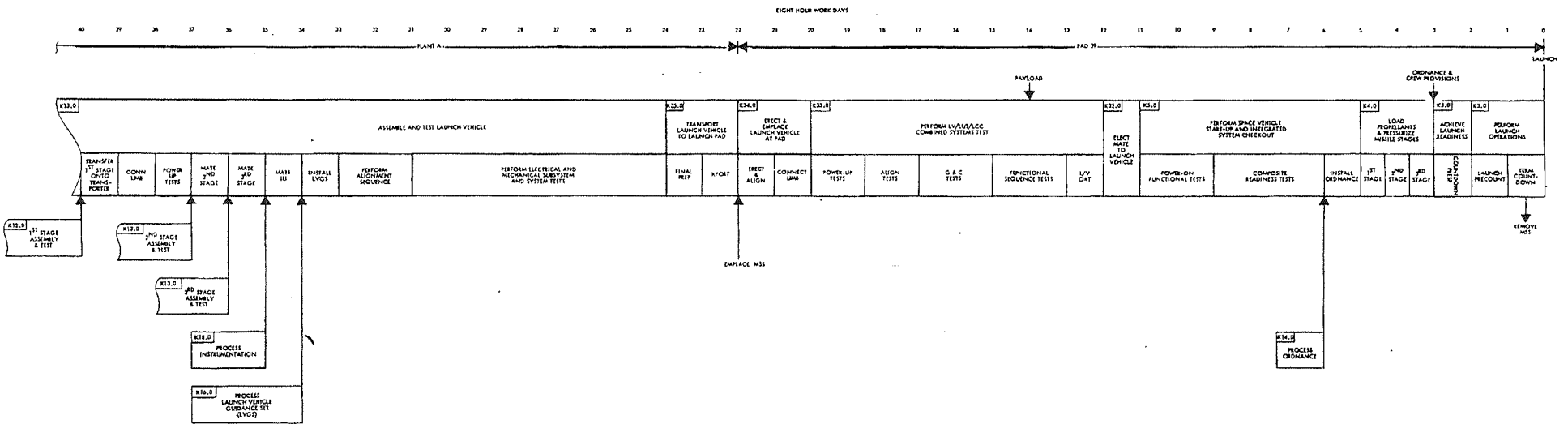

Figure 7.6-16

TIME BASED FUNCTIONAL  
 FLOW DIAGRAM OF  
 LCLV FINAL ASSEMBLY  
 THROUGH LAUNCH  
 OPERATIONS AT KSC-  
 CONCEPT C<sub>2</sub>

102

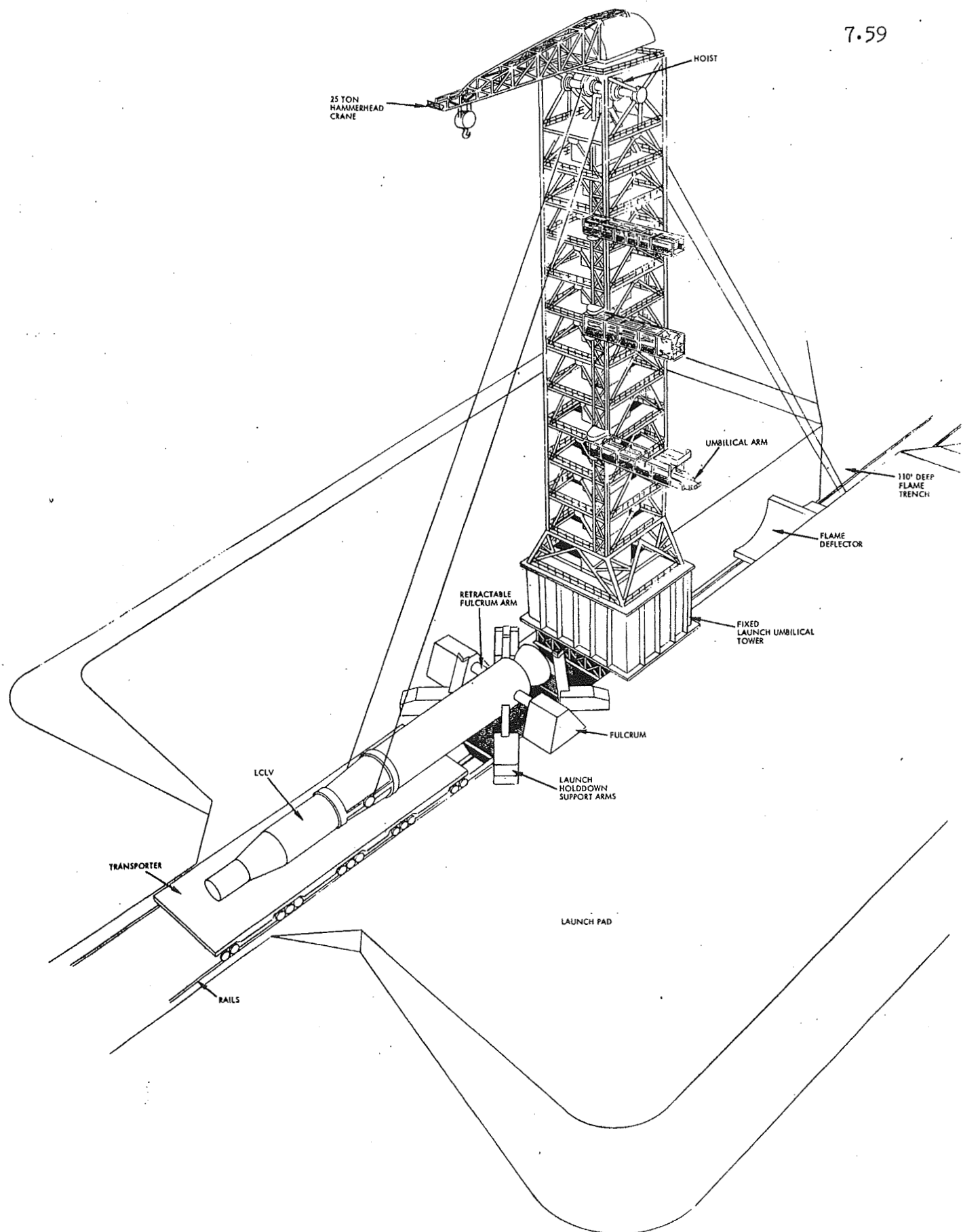

Figure 7.6-17 Conceptual Diagram of LCLV Launch Pad Emplacement Prior to Erection-Concept C<sub>2</sub>

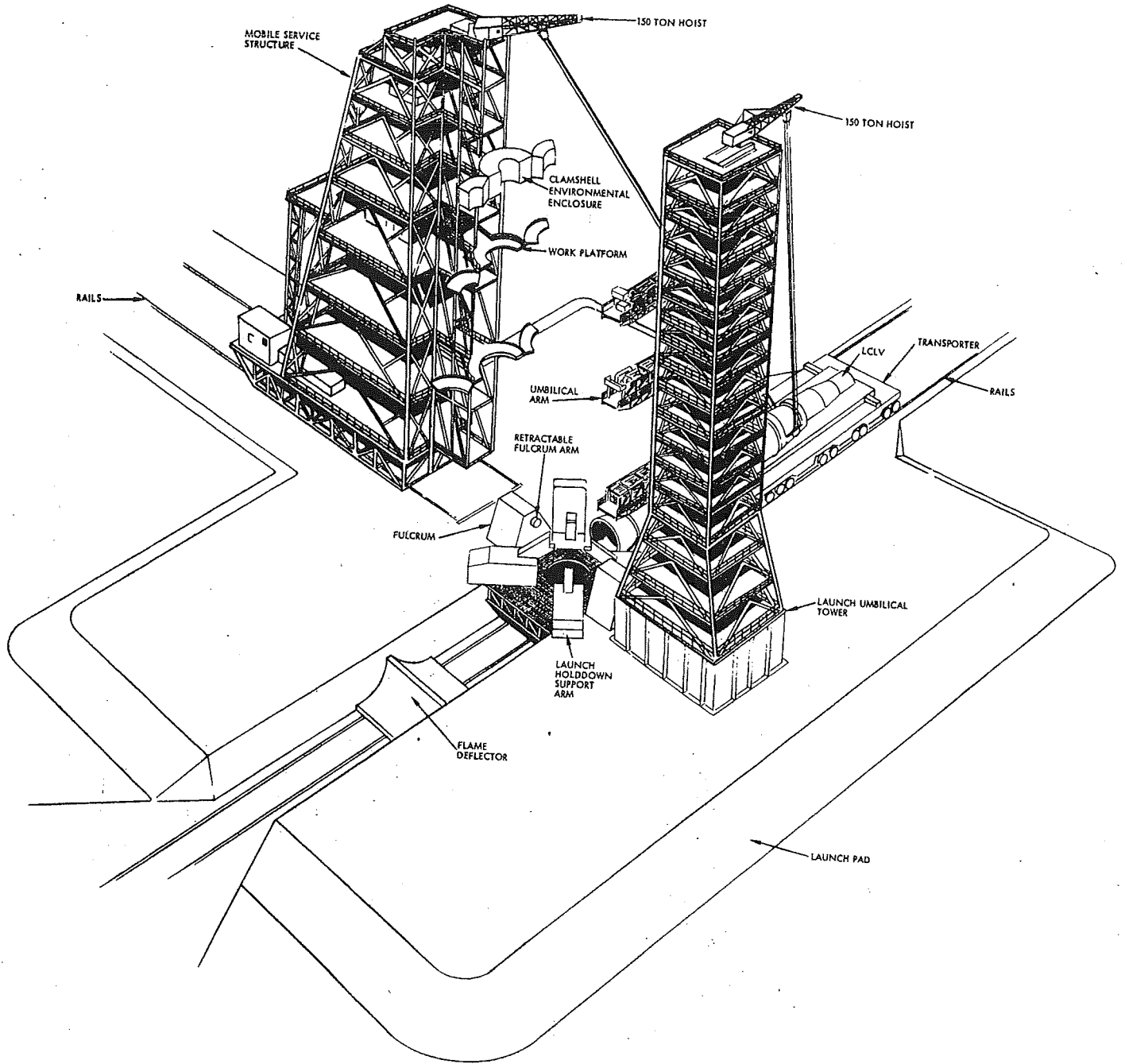

Figure 7.6-18a Alternate Arrangement for  
LUT Installation and LCLV  
Erection-Concept C<sub>2</sub>

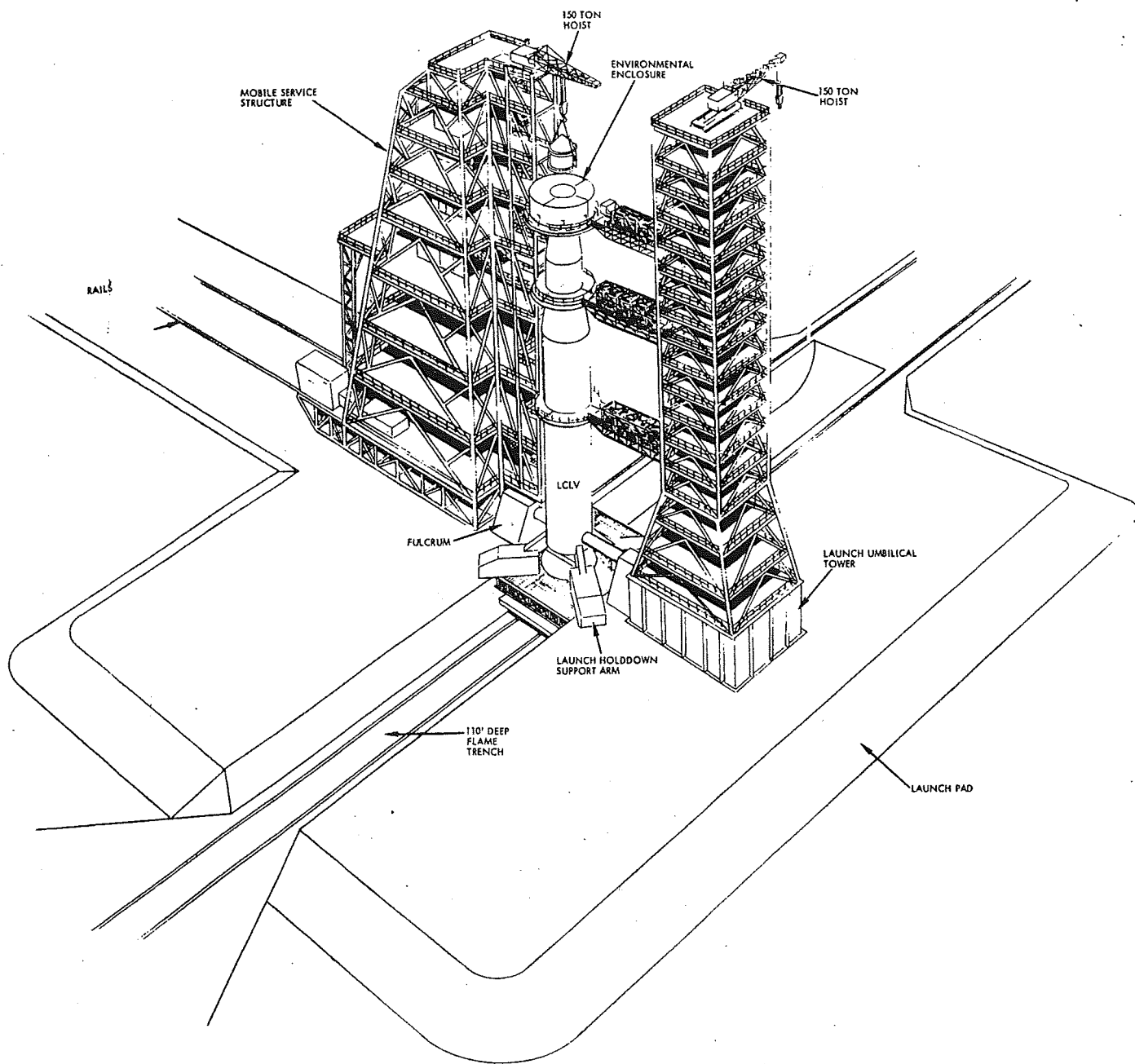

Figure 7.6-18b Alternate Arrangement for  
Lut Installation and LCLV  
Erection-Concept C<sub>2</sub>

The corresponding manpower requirements were also reduced from approximately 40,000 man-hours to 31,000 man-hours as shown in Table 7.6-XIII. Time on pad, however, remained at 22 days. Primary reasons for this reduction in launch operations cost are attributed to simpler Plant A assembly and checkout operations and a less complex facility design.

The AGE and LF performance requirements and related costs are contained in Table 7.6-XIV,\* which summarizes the results of a performance and cost analyses of Concept C<sub>2</sub>. Production and installation AGE/LF costs for Concept C<sub>2</sub> to support a launch rate of 1, 2, 3 or 4 LCLV's/month are presented in Table 7.6-XV. It will be noted that whereas the P&I cost for Concept C<sub>1</sub> to support one launch/month is approximately  $\$520 \times 10^6$ , the corresponding cost for C<sub>2</sub> is reduced to  $\$197 \times 10^6$ . Primary reasons for this cost reduction are:

- A  $\$28 \times 10^6$  saving in the cost of the launch pad due to its simpler constructing, the deep cruciform flame trench among other things being eliminated in preference to a design similar to the Saturn V launch pad. Also, only one launch pad is required since the on-pad plus refurbishment time is less than 30 days.
- Only one MSS is required as opposed to the two for Concept C<sub>1</sub> resulting in a savings of approximately  $\$10 \times 10^6$ .
- The three complicated mobile transporter/erector/launchers of Concept C<sub>1</sub> are eliminated, thus effecting a cost reduction close to  $\$200 \times 10^6$ .

#### 7.6.7 Comparative Evaluation of Ground System Concepts

Contained in Table 7.6-XVI is a comparative listing of some of the more significant findings resulting from the time-line analysis of the candidate ground system concepts. Of particular interest is the total final assembly through launch and refurbishment time which is the least (37 days) for Concept B (final LV assembly at the VAB). Principal reasons for this are attributed to:

- The reduction in checkout time permitted by the use of the Mobile Launcher AGE for final assembly and launching the space vehicle.
- Minimum on-pad time (10 days) afforded by integration and checkout of the payload at the VAB.

\*Table 7.6-XIV (25 pages) will be found in Appendix E.



TABLE 7.6-XIII

APPROXIMATE MANPOWER REQUIREMENTS  
FOR LOW COST LAUNCH VEHICLE  
FINAL ASSEMBLY THROUGH LAUNCH OPERATIONS AT KSC

-- Concept C<sub>2</sub> --

<u>Function</u>	<u>Functional Flow No.</u>	<u>Eight Hour* Work Days</u>	<u>Equivalent Hours</u>	<u>Man-Hours**</u>
Process Ordnance	K 14.0	1	8	24
Process LVGS	K 16.0	3	24	96
Process Instrumentation	K 18.0	2	16	80
Assemble and Test Launch Vehicle	K 13.0	16	128	6400
Transport Launch Vehicle to Launch Pad	K 35.0	2	16	640
Erect and Emplace Launch Vehicle at Pad	K 34.0	2	16	960
Perform LV/LUT/LCC Combined System Tests	K 33.0	8	64	9600
Electrically Mate Payload to Launch Vehicle	K 32.0	1***	8	400
Perform Space Vehicle Start-up and Integrated System Checkout	K 5.0	6	48	7200
Load Propellants and Pressurize Missile Stages	K 4.0	2	16	800
Achieve Launch Readiness	K 3.0	1	8	800
Perform Launch Operations	K 2.0	2	16	2400
Refurbish Launch Facility	K 25.0	5	40	1600
Total Man-Hours .....				31,000
Total Man-Years Per Vehicle (Assuming 2000 Man-Hours per Man-Year)....				15.5

\* Assumes a success-oriented, no contingency, functional sequence.

\*\* By definition, launch operations manpower requirement do not include, base, range and mission support requirements.

\*\*\* Payload checkout times for this activity and subsequent functions are not included.

7.64

TABLE 7.6-XV LCLV Estimated AGE/LF Production & Installation Costs (\$X10<sup>3</sup>)  
to to Support Various Monthly Launch Rates

Function No.	CONCEPT C <sub>2</sub>											
	1			2			3			4		
	OGE	MGE	LF	OGE	MGE	LF	OGE	MGE	LF	OGE	MGE	LF
K 22.0			8,000			16,000			24,000			32,000
K 18.0		375			375			375			375	
K 16.0		250			250			250			250	
K 14.0		10			10			10			10	
K 13.0		20,000			35,000			50,000			65,000	
K 35.0			5,000			6,000			7,500			9,000
K 34.0	25,000	20,550	118,000	50,000	41,100	234,000	75,000	61,150	351,000	100,000	81,200	467,000
K 33.0		30			30			60			60	
K 32.0												
K 5.0												
K 4.0	100	150		200	300		300	450		400	600	
K 3.0												
K 2.0												
K 1.0												
Sub Totals	25,100	41,365	131,000	50,200	77,065	256,000	75,300	112,295	382,500	100,400	147,495	508,000
Combined AGE/LF Totals	← 197,465		→ 383,265			← 570,095			→ 755,895			

Table 7.6-XVI

COMPARISON OF PROCESSING TIMES AND MANPOWER REQUIREMENTS  
FOR CONCEPTS A, B, C<sub>1</sub> AND C<sub>2</sub>  
FINAL ASSEMBLY THROUGH LAUNCH OPERATIONS AT KSC

ITEM	CONCEPT			
	A	B	C <sub>1</sub>	C <sub>2</sub>
● Total final assembly through launch and refurbishment time (Days).	49	37	68	45
● Total final assembly through launch manpower requirements - man years per vehicle.	15.4	13.4	20.1	15.5
● Time in Vehicle Assembly Building (Days).	16	20	*	*
● Time on pad (Days).	10	10	22	22

Above times and manpower requirements are based on eight-hour work day.

\*VAB is not utilized in this concept.

In comparison to the latter, Concept C, which involves payload integration at the launch pad, requires 22 work days. Also significant is the total number of man-years required to process the LCLV, Concept B, again because of its apparently more effective design, requiring the least (13.4 M-Y).

Shown in Table 7.6-XVII, is a comparative matrix of the AGE/LF total production and installation costs for each of the concepts to support a launch rate of 1, 2, 3 or 4 per month. As mentioned earlier, the P&I costs for Concept C<sub>1</sub> to support more than one launch/month were not determined in view of the decision to forego further consideration of its configuration.

#### 7.6.8 Preferred and Alternate LCLV Ground System Concepts

Based on the results of the requirements and cost analysis and subsequent comparative evaluation, Concept B is considered the preferred LCLV ground system configuration. This concept in relation to the other candidates is not only lower in total program costs but also more effective for the following interrelated reasons:

- Minimum total final assembly through launch and refurbishment time (37 days).
- Minimum launch operations support (LOS) man-power requirements (13.4 M-Y/vehicle).

7.66

Table 7.6-XVII

Comparative Matrix of AGE/LF Total  
Production and Installation Costs ( $\$ \times 10^3$ ) for  
Concepts A, B, C<sub>1</sub> and C<sub>2</sub> to Support  
Various Monthly Launch Rates

Concept	LCLV Launches Per Month			
	1	2	3	4
A	66,235	154,785	359,685	549,135
B	50,235	128,785	327,585	509,135
C <sub>1</sub>	520,465	*	*	*
C <sub>2</sub>	197,465	383,265	570,095	755,895

\*P&I costs were not determined in view of decision to forego further consideration of Concept C<sub>1</sub> ground system.

- Minimum on-pad time (10 days).
- Maximum use of Saturn V/Apollo facilities with minimum modifications. Thus, early 1973 LVIC missions are more readily attainable.
- LCLV, payload and ordnance are completely assembled, installed and tested at one location (VAB) before transit to the pad. Malfunctioned subsystems can therefore be replaced more efficiently.
- The same VAB checkout equipment, being an integral part of the ML, is used to conduct the launch, thereby increasing the confidence level in the space vehicle's flight readiness and correlation of data.
- The use of Saturn V facilities and AGE verified assembly processes and procedures and computerized checkout equipment can be exploited and optimized for the LCLV configuration.
- System is flexible to accommodate other programs and changes in mission requirements.
- Available inventories of Saturn V/Apollo facility and AGE spares as well as logistic plans and procedures can be utilized.
- System uses proven reliable components.

In the event Saturn V/Apollo facilities are unavailable, Concept C<sub>2</sub> should be given consideration as an alternate since it might prove to be cost-competitive with that of producing and installing the Concept B ground system at another site. However, compromised system performance can be expected due to the reasons cited earlier.

### 7.6.9 Total Cost of Preferred Ground System

The total program cost of Concept B to support an LCLV launch rate of one/month during 1973-1985 can be estimated from the following equation:

$$C_{GS} = C_{GSPM} + C_{RDT\&E} + C_{P\&I} + C_0 \quad (1)$$

where

$$C_{GS} = \text{Total Cost of Ground System} \quad (2)$$

$$C_{GSPM} = \text{Cost for Ground Systems Program Management} \\ = K_{GSPM} (C_{RDT\&E} + C_{P\&I} + C_0) \quad (3)$$

where

$$K_{GSPM} = \text{Ground Systems Program Management Cost Factor}$$

$$C_{RDT\&E} = \text{Ground Systems Cost for Research, Development, Test and Evaluation}$$

$$C_{P\&I} = \text{Ground Systems Production and Installation Cost} \\ = A_p + F_p + I\&C_{GSIT} + I\&C_{SMT} \quad (4)$$

where

$$A_p = \text{AGE Production + Spares Cost}$$

$$F_p = \text{Facility Production + Spares Cost}$$

$$I\&C_{GSIT} = \text{Ground LF/AGE Subsystem Installation and checkout (I\&C)}$$

$$I\&C_{SMT} = \text{Cost of I \& C Systems Marriage Tests (SMT)}$$

$$C_0 = \text{Ground Systems Operations Cost} \\ = C_{BOS} + C_{LOS} + C_{MOS} \quad (5)$$

where

$$C_{BOS} = \text{Base Operations Support (BOS) Costs}$$

$$= K_B Y_L N_C$$

where

$$K_B = \text{Yearly Base Operations Cost Per LCLV Launch Complex}$$

$$Y_L = \text{Number of Program Years}$$

$$N_C = \text{Number of Launch Complexes}$$

$$C_{LOS} = \text{Launch Operations Support (LOS) Costs} \\ = K_L M_L Y_L \quad (7)$$

where

$$K_L = \text{Average Cost/Man Year}$$

$$M_L = \text{Man Years/Year}$$

$$= N_C M_L (M_o + M_m) \quad (8)$$

7.68

where

$N_c$  = Number of Launch Complexes

$M_1$  = Average Yearly Launch Rate

$M_o$  = Man years to perform launch complex operating functions, such as K2.0, K3.0, etc./LCLV

$M_m$  = Man years to perform individual launch complex maintenance and refurbishment functions, such as K25.0, K26.0, etc./LCLV

$$\begin{aligned}
C_{MOS} &= \text{Mission Operations Support Costs (MOS)} \\
&= C_{MC} + C_{WTN} + C_{RS} \\
&= N (K_{MC} + K_{WTN} T_M + K_{RS} T_L) \tag{9}
\end{aligned}$$

where

$C_{MC}$  = Cost for Mission Control

$C_{WTN}$  = Cost for Worldwide Tracking Network (WTN) Support

$C_{RS}$  = Cost for Range Support (RS)

$N$  = Number of Missions

$K_{MC}$  = Mission Control (MC) Cost Per Mission

$K_{WTN}$  = Worldwide Tracking Network Cost Per Mission Hour

$T_M$  = Average Number of Mission Hours Per Mission

$K_{RS}$  = Range Support Cost Per Initial Launch Phase Hour

$T_L$  = Average Number of Initial Launch Phase Hours Per Mission

To establish the total CGS cost, the following is assumed for the LCLV program less payload.

Note: Credibility of asterisked items needs confirmation.

- $Y_L$  = 1985 - 1973 = 12 Years
- $M_1$  = 12/Year
- $K_{GSPM}$  = 12%
- CRDT&E from Table 7.6-8 = Approximately  $\$10 \times 10^6$
- $A_p + F_p + I\&C_{GSIT}$  from Table 7.6-9 and allowing ~20% of P & I costs +  $\$40 \times 10^6$  for spares for new and existing facilities for the 12-year life cycle = Approximately  $\$100 \times 10^6$

- $I\&C_{SMT} = \text{Approximately } \$15 \times 10^6$
- $K_B = \text{Approximately } \$2 \times 10^6/\text{Year}^*$
- $N_C = 1 \text{ Launch Complex}$
- $K_L = \$40,000/\text{Man-Year}^*$
- $M_O = 13.4 \text{ Man-Years (From Table 7.6-7)}$
- $M_m = 200\% \times 13.4 = 26.8 \text{ Man-Years}$
- $N = 12 \times 12 = 144 \text{ Missions}$
- $K_{MC} = \$1 \times 10^6/\text{Mission}^*$
- $K_{WTN} = \$15 \times 10^3/\text{Hour}^*$
- $T_M = 72 \text{ Hours/Mission}$
- $K_{RS} = \$20 \times 10^3/\text{Hour}^*$
- $T_L = 10 \text{ Hours}$

Based on the above assumptions:

- $C_{P\&I} = \$115 \times 10^6$  From (4)
- $C_{BOS} = \$2 \times 10^6 \times 12 = \$24 \times 10^6$  From (6)
- $C_{LOS} = \$40 \times 10^3 \times 5789 = 231.6 \times 10^6$  From (7)
- $K_{MC} = \$1 \times 10^6/\text{Mission}^*$
- $K_{WTN}^{T_M} = \$15 \times 10^3 \times 72 = 1.08 \times 10^6/\text{Mission}$
- $K_{RS}^{T_L} = 20 \times 10^3 \times 10 = 0.2 \times 10^6/\text{Mission}$
- $C_{MOS} = 144 (\$1 \times 10^6 + \$1.08 \times 10^6 + \$0.2 \times 10^6)$  From (9)  
 $= \$328.3 \times 10^6$
- $C_O = \$24 \times 10^6 + 231.6 \times 10^6 + 328.3 \times 10^6$  From (5)  
 $= \$583.9 \times 10^6$
- $C_{GSPM} = 12\% (\$10 \times 10^6 + \$115 \times 10^6 + \$584 \times 10^6)$  From (3)  
 $= \$85 \times 10^6$

Therefore, the total program cost estimate of the LCLV ground system is:

- $C_{GS} = \$85 \times 10^6 + \$10 \times 10^6 + \$115 \times 10^6 + \$584 \times 10^6$  From (1)  
 $= \$794 \times 10^6, \text{ for } N=144 \text{ missions}$

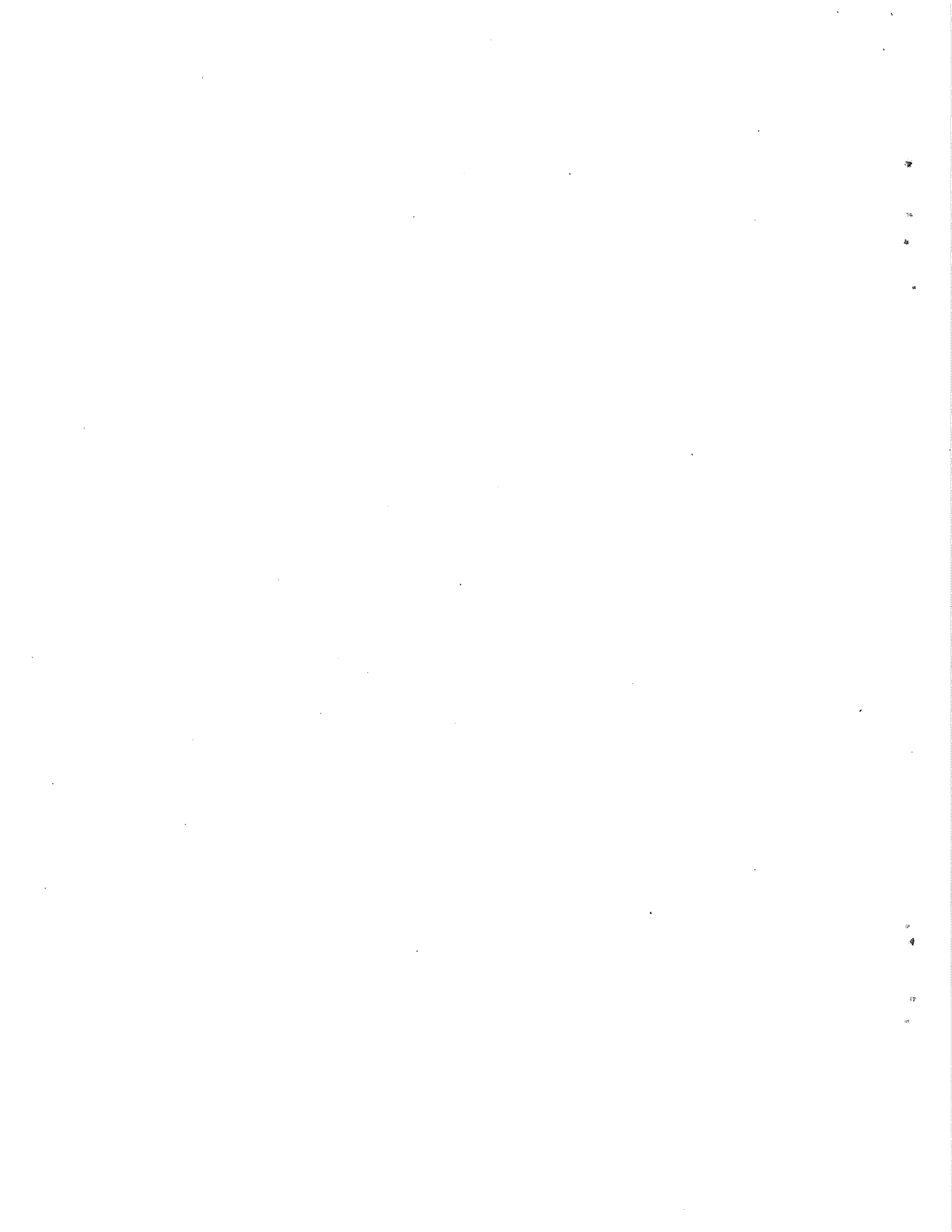



## 8. GUIDANCE AND CONTROL SYSTEMS AND ASTRIONICS COSTS

### 8.1 Introduction and Summary

The purpose of this section of the report is to document a survey of Guidance and Control systems for the LCLV in consonance with the basic principle of attaining high reliability at low cost. The results of this survey are summarized as follows:

Major cost savings in the area of G & C can be obtained by simplification of the functional complexity of the system. For this reason, the G & C system for the LCLV was assumed to be tailored to injection into a low altitude parking orbit, since a large percentage of flights are of this nature. Any subsequent maneuvers or orbital changes such as those required for synchronous, lunar and interplanetary missions are assumed to be executed by G & C functions in the payload itself.

Past experience has shown that the universal modular system approach (use of building blocks which can be assembled in many ways to meet a wide variety of mission and payload requirements) is a non-economical solution; hence, this mode was excluded from consideration in the present survey.

Present state-of-the-art components were considered, and cost savings were effected by the utilization of already qualified subassemblies/components. Highly speculative low cost solutions were excluded in view of the development risk and the uncertainty about performance and reliability.

Three configurations appeared from the tradeoff analysis to be G & C candidates for the LCLV, as follows: simplified inertial guidance, GE Mod III radio guidance, and a low cost radio guidance approach.

A preliminary choice of the G & C system\* for the LCLV consists of:

- Simplified Inertial Guidance Approach, which is essentially a fly-the-wire mode, requiring a 15 percent throttling capability of the main engines.
- A proportional flight control system, with a conventional controller and single autopilot and rate gyro package.
- An analog or DDA type G & C computer, incorporating autopilot and propellant utilization system functions.

---

\*Selection of the final preferred system justifies a more extensive analysis than permitted within the limited funding of the LCLV study. The G & C system for the improved Centaur should also be considered.

- Control electronics with triple redundant circuits, in view of the man rating requirements of the system.
- Utilization of the payload Guidance and Control Capability as a back-up for the LCLV system for manned missions.
- A gimballed or strapdown type inertial measurement unit.
- Prelaunch computations and checkout by means of a launch facility processor.
- Optical alignment facilities for the prelaunch alignment of the inertial measurement unit.

The cost of the airborne G & C equipment using this approach (including software cost) was estimated to be:

recurrent unit cost  $\approx$  \$350K  
nonrecurrent cost  $\approx$  \$ 32M

The system weight is expected to be about 150 lbs. These numbers do not include the downstage cabling or power sources. The system will have a low orbit injection accuracy of  $\approx$  10 fps (1%).

The alternative Radio Guidance approach appeared to be slightly more cost effective, but was not chosen because of possible constraints on trajectory and vehicle maneuvers, and the restriction of launches to ETR. However, this approach should be reconsidered at the time that launch site and missions are better defined. Also, the GE Mod III radio guidance should be considered in a final analysis, in view of its low cost, proven reliability and existing, qualified hardware.

Other alternate systems, using (1) an attitude programmer plus accelerometer, and (2) the recoverable G & C system approach also appeared to be cost effective for a low yearly launch rate of 10 or less. However, the former approach placed a considerable burden on the payload for orbit correction. The latter approach required a rather complex recovery operation and had a considerable risk due to the refurbishment of equipment. For these reasons such approaches were considered to be less attractive and are not recommended for the LCLV at the present time.

Final Comment. The total cost of Astrionics (including G & C, stage instrumentation, power systems, wiring, stage separation ordnance, destruct system, TT & C, etc.) can be reduced to about one-third the cost of present systems, by use of the systems and operational techniques described in this report.

present systems. Similar reductions to stage instrumentation, cabling and checkout procedures are feasible due to inherent simplicity of the pressure-fed stage, as discussed in Section 8.6.

## 8.2 General Approach to Guidance and Control Systems

The first unit cost estimates for the LCLV (less than \$25M) show that the astrionics system, including the G & C system, could become a dominant cost item of the total vehicle system. Present G & C cost for similar type vehicles and missions amount to over \$1M, and would constitute at least 7 percent of the estimated LCLV cost. For this reason, it seemed appropriate to investigate more optimum G & C system approaches in greater detail during this part of the LCLV study, to evaluate the tradeoffs involved, and to establish possible ways for lowering the G & C system cost.

Some of the major contributors to the cost of past G & C systems include features such as high functional complexity, high reliability, man-rating requirements, high accuracy, system weight and volume restrictions, long mission times, operational flexibility, high degree of self-contained operation, and extensive test and qualification requirements. It is TRW's opinion that most of these items can be adapted to the LCLV goals and standards with the benefit of considerable cost savings; provided, however, that certain constraints are placed on the LCLV operation and that full utilization is made of the capabilities contained in the payload. For example, a lower LCLV orbit injection accuracy should be allowed if it proves to be cost effective to make post-injection corrections by means of the payload. Such lower accuracy could substantially reduce the cost of the G & C of the LCLV.

One method by which a wide variety of mission requirements can be met is a universal modular system approach. Such an approach allows the adaptation of the system to the requirements of each specific mission and payload. However, in several occasions in the past (such as the Air Force Standardized Space Guidance System Studies, Reference 22) it became apparent that this approach is not a low cost solution; therefore, it

was not considered further during this study. Instead the approach was taken that the burden of different non-LEO requirements and needs should be placed on the payload itself.

For this purpose the following ground rules were adopted:

- The G & C functions of the LCLV will terminate after injection of the payload in a low altitude (100 to 300 n mi) earth orbit.
- The payload will have a capability of performing post injection orbital and final  $\Delta V$  corrections.
- For man rated systems, the G & C capability of the payload will be utilized as a backup for the primary G & C system of the LCLV.

The ground rules allow an important simplification of the G & C functions and reduce the accuracy requirements for the LV system. Also, the total mission time of the G & C system is drastically reduced, resulting in less stringent requirements on the G & C components. Moreover, the LCLV does not place severe weight and volume constraints on the system and, therefore, it may be feasible to obtain higher reliability in a cost effective manner by the application of subassembly/component redundancy.

In order to lower the G & C system cost, many other cost saving aspects are taken into consideration in the following discussions. Such aspects include:

- Further simplification of G & C functions.
- Application of flight qualified systems, subassemblies and components to the greatest possible extent to reduce the development and qualification cost.
- Greater standardization of mission and trajectories, to reduce software and targeting cost.
- Optimization of integration and test functions, to reduce qualification cost of new or redesigned system items.
- Incorporation of prelaunch computations and checkout in a launch facility processor, to reduce the cost of airborne G & C equipment.

- Limited integration of non-guidance functions in the G & C on-board instrumentation system, to reduce the cost of other airborne systems.

In the following discussion, various guidance and control electronic configurations will be formulated and compared. The tradeoff will be based mainly on the cost effectiveness of the approach, but other factors, such as constraints on mission or vehicle will often be considered.

The flight control electronics configuration selection can be made independently; the benefit of an integrated autopilot will become apparent in the overall G & C system tradeoff.

The mechanization of the configurations was limited to the present state-of-the-art components. The present design and qualification period for a G & C system is about three years. Therefore, the assumed starting point of the LCLV mission (1973) does not allow the development risk associated with highly speculative low cost items.

### 8.3 Guidance Configurations for the LCLV

On the basis of the ground rules adopted in Section 8.2, the LCLV G & C system must perform the following basic task: to guide a payload into a sufficiently precise earth orbit of 100 to 300 n mi altitude. For this task, TRW has selected five basic guidance concepts which will be examined and evaluated mainly on the basis of cost effectiveness. These concepts are presented schematically in Figure 8.3-1 and include the following schemes:

#### Attitude Programmer

A predetermined pitch profile will be executed in an open loop fashion by a highly simplified G & C system. Attitude command and engine disretes are time programmed. The cost of such a system is relatively low; however, the injection errors are large, due to vehicle performance tolerances.

#### Augmented Attitude Programmer

The same scheme as before, with an additional longitudinal accelerometer and integrator to provide engine cutoff disretes. The errors of this approach are smaller than those of the first concept.

8.6

1. ATTITUDE PROGRAMMER

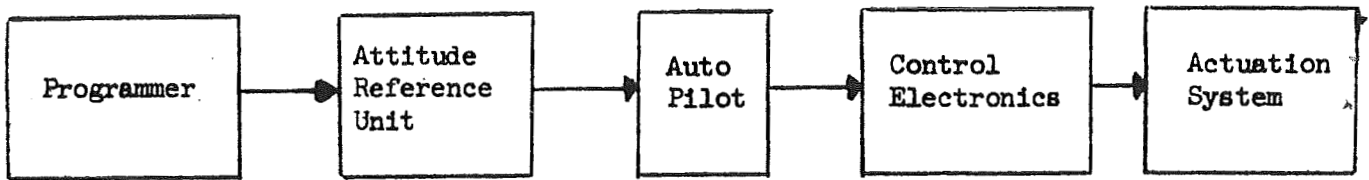

2. AUGMENTED ATTITUDE PROGRAMMER

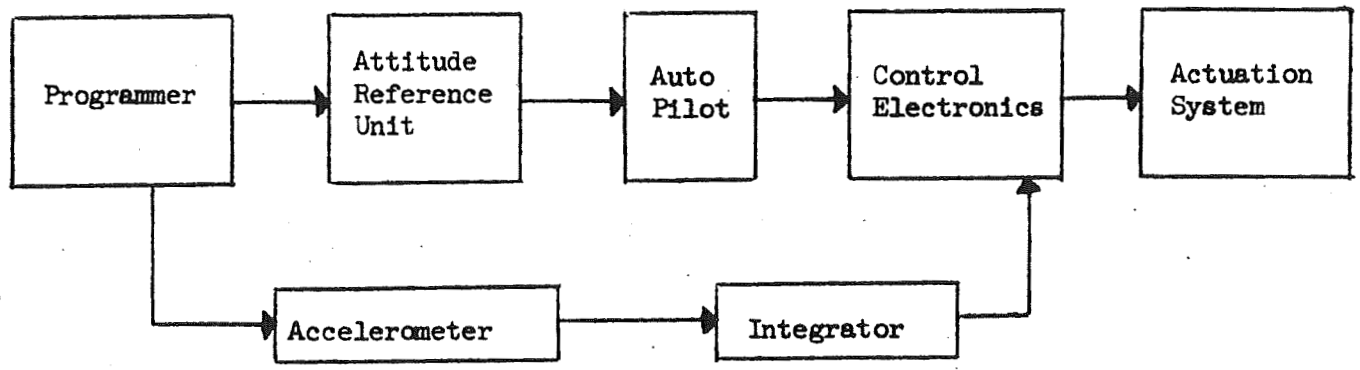

3. SIMPLIFIED INERTIAL GUIDANCE

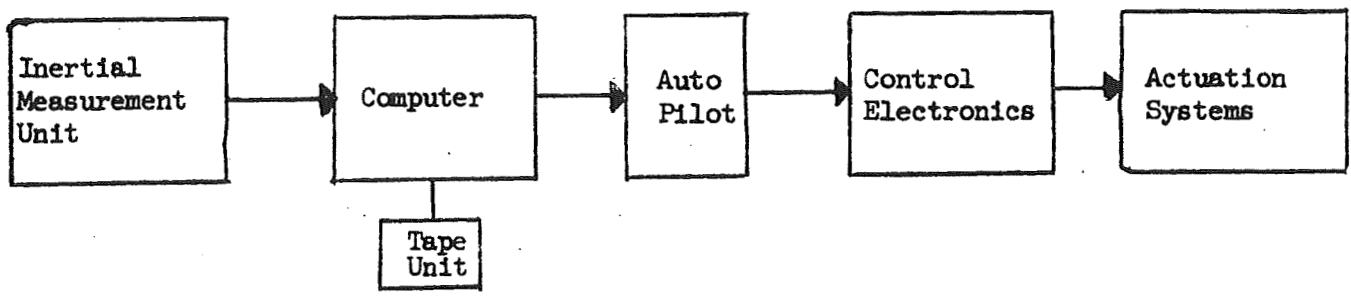

4. RADIO GUIDANCE

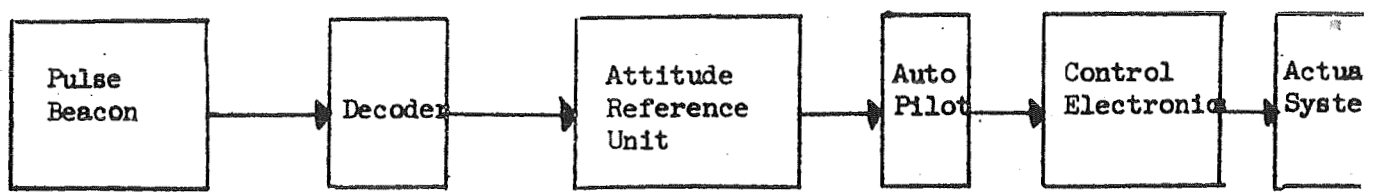

5. RECOVERABLE G & C PLUS INSTRUMENTATION IN STRAP-ON POD

Figure 8.3-1 Basic Guidance Configurations

### Simplified Inertial Guidance

This concept involves a fly-the-wire guidance scheme which reduces the required computational functions and allows the replacement of a digital computer by a simple analog or DDA device. However, an engine throttling capability of about 15 percent is required, which is simple.

### Radio Guidance

This is an accurate guidance scheme, which has the advantage that flight qualified hardware is available. Disadvantages are the high cost of ground station operation and limited flexibility of trajectory and vehicle operations.

### Recoverable G & C System

An existing, qualified G & C system, together with other high cost instrumentation items will be contained in a recoverable strap-on pod. The same equipment can be used for more than one vehicle. The cost effectiveness of this approach depends on the cost of the pod, the recovery operation and equipment refurbishment.

## 8.3.1 Guidance Configuration Description

As will be shown later, the concepts 2, 3 and 4 (Figure 8.3-1) are the most competitive schemes and will therefore be described in greater detail.

### 8.3.1.1 Augmented Attitude Programmer

In this scheme the G & C system controls the vehicle attitude according to a programmed steering sequence and nominally cuts off the third stage engine at a prescribed velocity. It compensates for thrust dispersions during the first three stages through the use of an axial accelerometer. During the first two stages the gain in axial velocity  $\Delta V$  is accumulated, and used before third stage ignition to generate two first order corrections: (1) to the initial pitch command for third stage guidance, and (2) as an addition to the velocity to be gained during third stage burn. The system includes:

- Strapdown 3-axis gyro package employs accelerometers also, including a body mounted thrust x-axis accelerometer.
- An intervalometer that controls mission phase sequencing.
- An attitude programmer which generates steering commands and initialization for each stage of guidance.

The programmer performs the following functions:

- Attitude steering commands are generated by converting intervalometer discretions into binary words in the rate command registers. The register contents are converted to PM in the comparators and filtered into DC gyro torquing signals.
- During first and second stage guidance, the accelerometer output is used to sum the contents of the scale factor register (K) into the velocity-to-go (V) register.
- After second stage separation, the contents of the V-register are transferred to the pitch rate register.

The intervalometer performs the following functions:

- Staging counter is incremented to the next mission phase when the time counter reaches zero.
- The discrete outputs are used to control the other vehicle systems and the programmer.
- The reference for the time counter is supplied by the programmer. During the third stage, it is gated off before velocity cutoff. Staging is then controlled by the V-register.

A further improvement to this type of system can be made by adding engine throttle control to the programmed function, with the loop closed around acceleration by means of the x-accelerometer. Such a system would reduce the effect of thrust variations on cutoff velocity errors.

#### 8.3.1.2 Simplified Inertial Guidance Approach

Simplified guidance is a name given to those guidance schemes which involve "flying the wire" (in other words, following a nominal trajectory). These schemes require an engine throttling capability to null out deviations from the nominal, and accelerometer and gyro packages to measure the deviations. The accelerometers and gyros could be strapdown or a low-cost inertial platform could be used.

The motivation for considering simplified guidance is based on the potential cost reductions inherent in eliminating the digital computer and its associated software development and testing cost. It is also based on the relative ease of providing a shallow throttling capability on all stages (required by simplified guidance) by means of variable pressure drop valves or throttling injectors as already developed at TRW. In summary, the TRW simplified strapdown guidance concept includes:



- Guidance scheme based on flying a nominal trajectory wire by nulling position velocity and attitude deviations from nominal.
- Trajectory will consist, in general, of 3-axis rate or integrated body rate (attitude) time histories, and 3-axis components of sensed acceleration or integrated sensed acceleration (sensed velocity) time histories.
- For a planar trajectory with the nominal sensed acceleration along an accelerometer input axis, only the nominal pitch rate and scalar sensed velocity history need be specified.
- The three attitude integrations and the three velocity integrations may be performed by the inertial sensors if they are of the integrating type. In this case, feedback to the input of the integrators is accomplished by gyro or accelerometer torquing.
- The guidance quantities  $\underline{r}$ ,  $\underline{V}$ ,  $\phi$ ,  $\underline{\omega} - \underline{\omega}_0$  (see Figure 8.3-2 for definition) are input to the autopilot which filters and combines them in order to issue engine throttling and TVC commands.

It has been shown that throttleability of all engines can be achieved at essentially no increase in cost by varying the line pressure drop. This method provides a shallow throttling capability (15 percent) required by the simplified guidance methods developed at TRW. A general block diagram of simplified strapdown guidance is shown in Figure 8.3-2. There are many variations of simplified guidance, all of them involving the use of engine throttling to fly the wire.

The few computations required for the simplified guidance scheme can be mechanized in an analog or DDA type computer. Additional cost for a tape unit to store the nominal trajectory, must be included in the cost evaluation of this approach.

Some time prior to lift-off the simplified guidance system integrators (either analog or DDA) must be initialized. The  $\underline{\Delta r}$  and  $\underline{\Delta V}$  integrators can be initialized with the vehicle deflection (or sway) from the true local vertical coordinate system. This process of determining  $\phi$  is called initial alignment and can be accomplished on board or in a ground based computer. The initial alignment process must be relatively accurate (on the order of arc minutes) as can be seen from Table 8.3-I, which indicates the insertion errors for an initial misalignment of 1 arc minute.

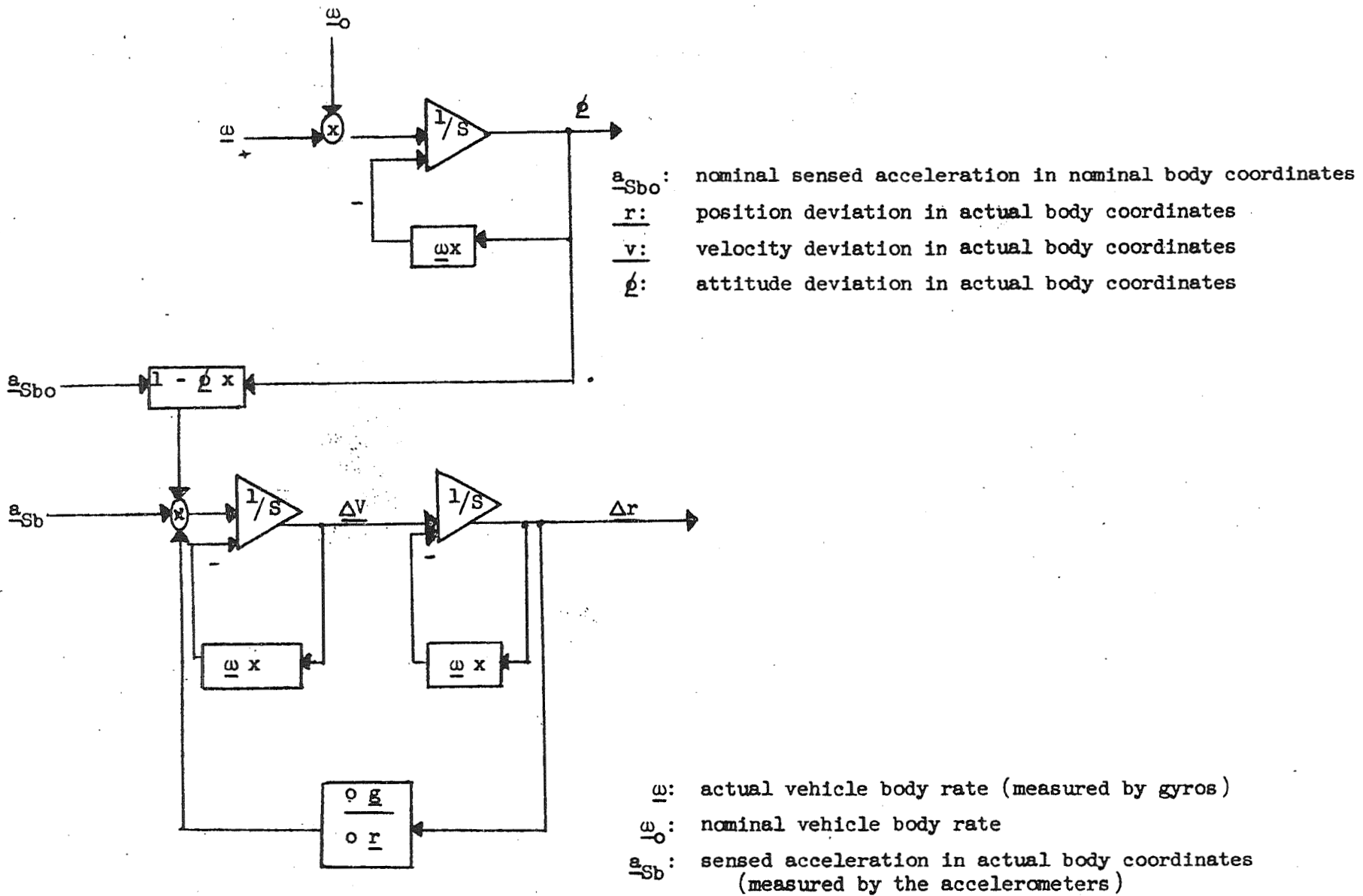

Figure 8.3-2 Simplified Strapdown Guidance Schematic

Table 8.3-I

PRELIMINARY ERROR ANALYSIS FOR SIMPLIFIED  
GUIDANCE EARTH ORBIT INJECTION MISSION

(1 $\sigma$  values)

<u>Error Source</u>		<u>Downrange</u> <u>V<sub>x</sub> ft/sec</u>	<u>Radial</u> <u>V<sub>y</sub> ft/sec</u>	<u>Out-of-plane</u> <u>V<sub>z</sub> ft/sec</u>
Accelerometer Bias 300 $\mu$ g	x <sub>b</sub> -roll	4.0	4.5	0
	y <sub>b</sub> -yaw	1.8	1.6	0
	z <sub>b</sub> -pitch	0	0	3.8
Gyro Bias .2 deg/hr	x <sub>b</sub> -roll	0	0	2.8
	y <sub>b</sub> -yaw	0	0	5.6
	z <sub>b</sub> -pitch	3.5	7.1	0
Initial Misalignment 1 min.	x <sub>b</sub> -roll	0	0	6.4
	y <sub>b</sub> -yaw	0	0	2.0
	z <sub>b</sub> -pitch	3.3	4.5	0

As can be seen from Table 8.3-I, inertial sensor accuracies of a fairly low grade will provide adequate mission accuracy.

#### 8.3.1.3.1 GE Mod III Radio Guidance

One guidance system that has proven itself for the past several years is the GE Mod III System No. 1 (with the Burroughs A-1 Computer) at the Eastern Test Range (ETR) Cape Kennedy, Florida. It has performed 165 consecutive

successful missions. Another is the GERTS GE Mod III/IBM 7094 radio guidance system at the WTR VAFB which has a similar history in launching the RMPB and Series D, E and F Atlas missiles from WTR VAFB. Either of these two radio guidance systems would be a candidate for the LCLV. These ground guidance systems and their related ground and airborne test equipments are GFE. The measured system reliability was .987 for 1966 and .988 for 1967.

GE Radio Guidance has been used successfully on unmanned and manned missions and is therefore flight proven.

The GE Mod III Ground Guidance Systems in TRACK ONLY MODE, as maintained and operated at ETR and WTR under government supervision, are considered good candidates for all considered missions. The ground computers presently in use with these GE Mod III Systems should be replaced with new computers of greater speed, capacity and should be qualified to Mil. Spec. Another possibility is the tie-in to the Central Range Computer system.

A Burroughs D84 M Ground Computer is a Mil Spec (Air Force and Army) qualified unit. It has been designed for greater speed and capacity than the presently installed A-1 Series Computer. The D84 M is designed to Mil. Spec. Field environment for the U.S.A.F. F-111 Checkout System and it is a ground computer for the U.S. Army Pershing Missile Program.

The new missileborne microcircuit Pulse Beacon-Decoder, in one beacon case would be considered for the LCLV. Software Guidance Equations, Programming, Checkout, Design Review and Pre-Flight Certification are required for each GE Mod III Systems series of launches. These software tasks have been generated and supplied to the government by TRW and GD/C.

For ETR a downrange tracking station on Antigua will be required. It is assumed that a presently stored 65-2 Mod III Set with either the A-4 or A-8 Burroughs computer can be utilized.

Several identifiable cost reduction areas can be considered such as:

- o Track only operation. This reduces the GE ground station system maintenance and operation in labor and hardware.
- o The Rate Missileborne transponder is eliminated. Further savings should accrue through elimination of its initial installation costs.

187

- o GE proposes a one unit Microcircuit Pulse Beacon Decoder. Savings here would become an item for further study.
- o The replacement of the Al Burrough Ground Computer with the D84 M ground computer will initially cost about \$430,000 each if two were installed. However, an annual savings in maintenance and operation should be experienced during each operational year.
- o Now that the ETR/WTR GE Mod III Ground Stations are refurbished and brought to the operational state, including all change orders, future refurbishings may be achieved at reduced costs.
- o A GE/Burr/TRW team effort relative to Hardware and Software related tasks could well result in reduced overall maintenance and operational costs. This is an area for study and liaison.

The advantage of the utilization of the GE Radio Guidance equipment is that this system can also be used at WTR in conjunction with the available GERTS system.

#### 8.3.1.3.2 Low Cost Radio Guidance for ETR

TRW has studied some of the aspects of a special low cost Radio Guidance approach for ETR (Reference 23). The low cost is achieved by using tracking facilities already available for each of the NASA launch vehicles and by using existing NASA digital command network. This arrangement was analyzed and was shown to have visibility to Thor/Delta, Atlas/Agena and Atlas/Centaur launches at injection into earth orbit and direct ascent lunar and interplanetary trajectories. A block diagram of the ground support equipment is shown in Figure 8.3-3. The C-band radar tracking data on NASA missions during the ascent phase are presently available in real time. The following tracking data from existing radars may be utilized:

AN/FPQ-6	Patrick AFB	}	Remoted to Cape Kennedy via landline.
AN/TPQ-18	MILA		
AN/TPQ-18	Grand Bahama	}	Remoted to Cape via subcable.
AN/FPQ-6	Antigua		

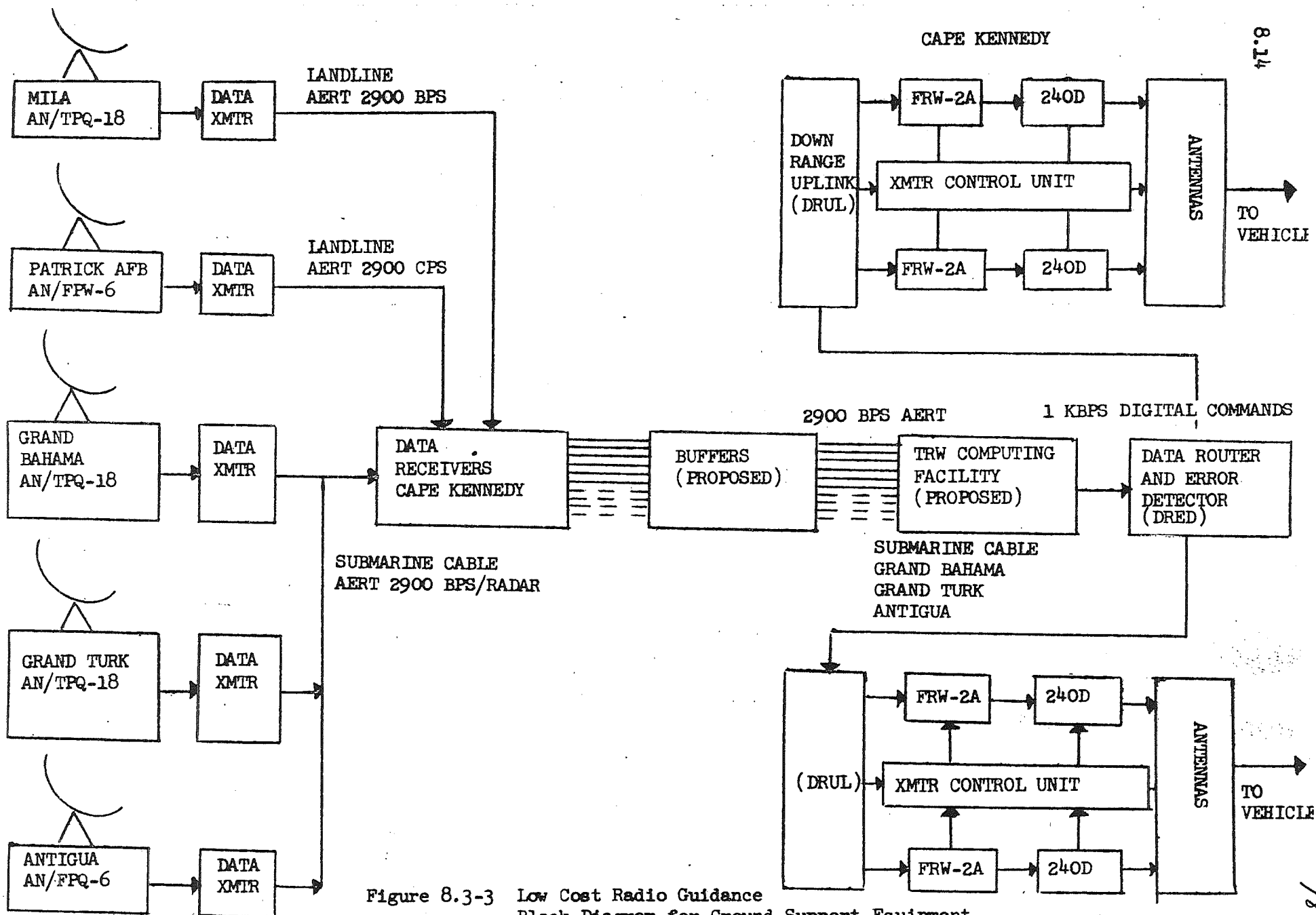

Figure 8.3-3 Low Cost Radio Guidance Block Diagram for Ground Support Equipment

The existing FPS-16 at Bermuda will significantly augment the system for northerly launches. It is not included in the list because data are not presently available at Cape Kennedy.

The system could also utilize S-band tracking data (NASA, unified S-band system of SGLS).

Steering commands, discrete commands and other vehicle required data generated by a previously proposed TRW guidance facility will be remoted to the NASA digital command network (DCN) for transmission to the launch vehicle. The interface with the DCN will be handled at the data routing and error detector (DRED) unit. The guidance program will provide, in addition to the above commands, the routing information as to which of the downrange transmitters is to be used, depending on vehicle position at that time.

The entire ground facility will be completely automatic during launch. The airborne equipment will consist of UHF antenna, receiver, decoder, and vehicle auto pilot system.

The Motorola Apollo CSM up-Date Link Receiver and Decoder has been already flight qualified and could be used for this application.

This guidance scheme requires the addition of a ground computer and buffers to the ground equipment. The non-recurrent cost of this approach is much lower than for the GE Mod III system, due to the assumption that the maintenance and operation cost of the ground support equipment will be absorbed by many other (not LCLV) launch vehicles. This assumption, however, requires a check on the availability of this equipment for LCLV launch, in particular, for the case of high yearly launch rates (up to 40 per year). The cost of airborne equipment and the system accuracy are compatible with GE Mod III system. However, a great disadvantage of this system is that launches would have to be restricted to ETR, since similar ground facilities are not available at WTR.

8.16

8.3.2 Major Characteristics of the Guidance Configurations

Table 8.3-II presents the major characteristics of the different guidance configurations which will be analyzed in a G&C system tradeoff (Section 8.5).

The costs figures are based on TRW hardware surveys of existing systems, and assume the utilization of qualified subassemblies and components to the greatest possible extent. The non-recurrent costs are assumed to be low and will require the implementation of several cost reductions, such as a minimum cost test and integration function. The costs presented include the following items:

Attitude Programmer	Attitude reference unit Programmer Battery and cabling Software
Augmented Attitude Programmer	Attitude reference unit Programmer Accelerometer and integrator Battery and cabling Software
Simplified Inertial Guidance	Inertial measurement unit Computer Battery and cabling Software
Radio Guidance	Attitude reference unit Interface electronics Battery and cabling Pulse beacon and decoder Plumbing and antenna Software
Recoverable System	Guidance and control system Battery and cabling Pod Recovery and refurbishment



TABLE 8.3-II MAJOR CHARACTERISTICS OF  
GUIDANCE CONFIGURATIONS

161

	Cost in \$1)				
	Unit Cost	Nonrecurrent	Weight lbs	Injection velocity accuracy fps	Other tradeoff Considerations
1. Attitude Programmer	50K	4M	30	200	Allows integration of non-guid function and hardware such as PU system
2. Augmented Attitude	60K	4M	33	50	
3. Simplified inertial	202K	31M	78	10	
4. Radio	99K	GE Mod III 26.6M <sup>2</sup> Low cost 6.5M	63	5	Allows integration of range safety function
5. Recoverable	607K <sup>3)</sup>	3M	800 <sup>4)</sup>	5	Allows recovery of other high cost instrumentation

- 1) includes hardware and software
- 2) includes cost of operation and maintenance of ground equipment at ETR over ten years
- 3) Assumes utilization of system for three flights total, includes cost of pod, recovery and refurbishment
- 4) include weight of pod

The non-recurrent cost includes in general an estimate of the engineering, development, qualification and integration cost of hardware and software.

For the GE MOD III radio guidance approach the non-recurrent cost include:

- Refurbishment of MOD III system by GE
- Installation of Burrough computer (downrange and at the Cape)
- Development and checkout of software
- Engineering and start up cost of GE
- Maintenance and operation of ground stations over a 10 year period by GE and Burroughs
- Modification of Pulse Beacon/decoder for extended range
- General engineering, development, qualification and integration cost of hardware.

For the low cost Radio Guidance approach the non-recurrent cost include:

- Lease of extra computer and buffer system
- Operation and maintenance of extra computer facilities
- Tie in to present ground system
- Development and checkout of software
- General engineering, development, qualification and integration cost of hardware

The weight of equipment is listed in Table 8.3-II and is based on similar existing hardware. Table 8.3-III presents a more detailed estimate of performance accuracy of the different configurations. Based on hardware performance requirements contained in Table 8.3-IV, which shows that relatively crude instruments could be utilized, except for a precision inertial system. The alignment requirements, however, require an external azimuth reference for pre-launch alignment, except for the attitude programmer.

The radio guidance configuration (not shown in Table 8.3-III and 8.3-IV) requires a very crude attitude reference. Pre-launch alignment is not very critical for this configuration and does not require an external azimuth reference.

TABLE 8.3-III  
 LCLV -  $1\sigma$  GUIDANCE ERRORS  
 (GROSS ESTIMATES FOR LOW ORBITS)

Guidance Configuration	Injection Error Velocity (fps)	Orbital Errors		
		Period (sec)	Semi-major axis (n mi)	Orbital Plane (mr)
Attitude Programmer	200	120	52	8
Augmented Attitude Programmer	50	30	13	2
Simplified Inertial	10	6	2.6	.4
Radio	5	3	1.3	.2
Recoverable	5	3	1.3	.2

TABLE 8.3-IV  
 ATTITUDE REFERENCE UNIT,  
 $1\sigma$  ACCURACY REQUIREMENTS

Guidance Configuration	Accel. Bias	Gyro Total Drift Rate deg/hr	Align.	
Attitude Programmer	-----	1.0	.1 deg	Align to skin of L.V.
Aug. Att. Prog.	600	.3	2 min	External azimuth
Simpl. Guidance	300	.2	1 min	External azimuth self level
Inertial Guidance (precision)	30	.01	6 sec	Gyro and accel. calibration

8.20

8.4 Control System Configuration

8.4.1 Control Electronics Concepts

A typical functional schematic of a control system, for which the autopilot filters are contained in one package, is shown in Figure 8.4-1. In this design configuration, the gain and filter changes are accomplished within the autopilot electronics package. The routing of commands to the actuation systems of the three stages are also accomplished within this package by the stage select logic which acts upon the staging discretes. The typical limits, gains, and filters contained in the autopilot electronics are shown in Figure 8.4-2. The autopilot parameters which are likely to be changed as a function of flight time are also indicated in this figure.

The functional schematics of the Actuation Electronics Packages for proportional and on-off injector operation are shown in Figures 8.4-3 and 8.4-4. The primary differences are that the proportional control design requires summing amplifiers and servoamplifiers instead of the simpler power switches required for on-off control.

A polar controller is shown in the actuation electronics which is comprised of two sections, a set of logic and computation electronics and a set of decoding electronics. The logic and computation electronics codes the pitch and yaw cartesian commands into a magnitude signal and five logical state signals which specifies the polar firing direction into one of 24 sectors. The magnitude signal would be used for proportional control injector positioning or for on-off control signal level triggering above the desired threshold. The decoding electronics would convert the five logic signals into specification of the appropriate injectors for operation. A typical polar controller schematic is given in Figure 8.4-5.

8.4.1.1 Electronic Packaging Arrangements

Identical actuation electronic packages versus elimination of the autopilot electronics package. The per package cost of the actuation electronics for each of the three stages could be reduced by employing identical packages for these stages. This is possible since the actuation system for each of these stages are of identical configuration.

195

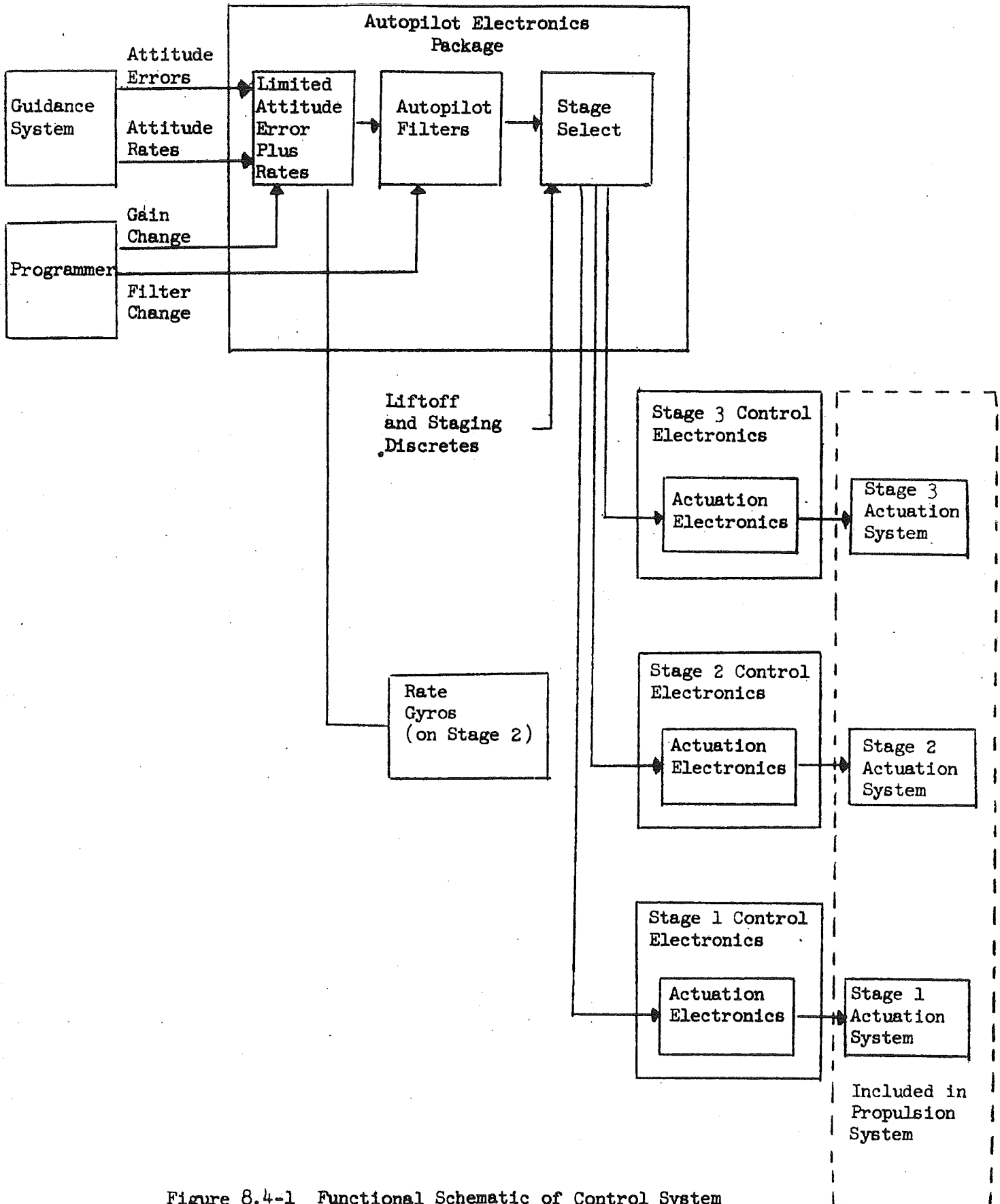
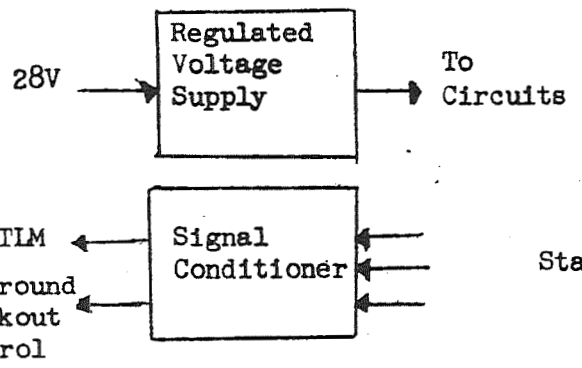
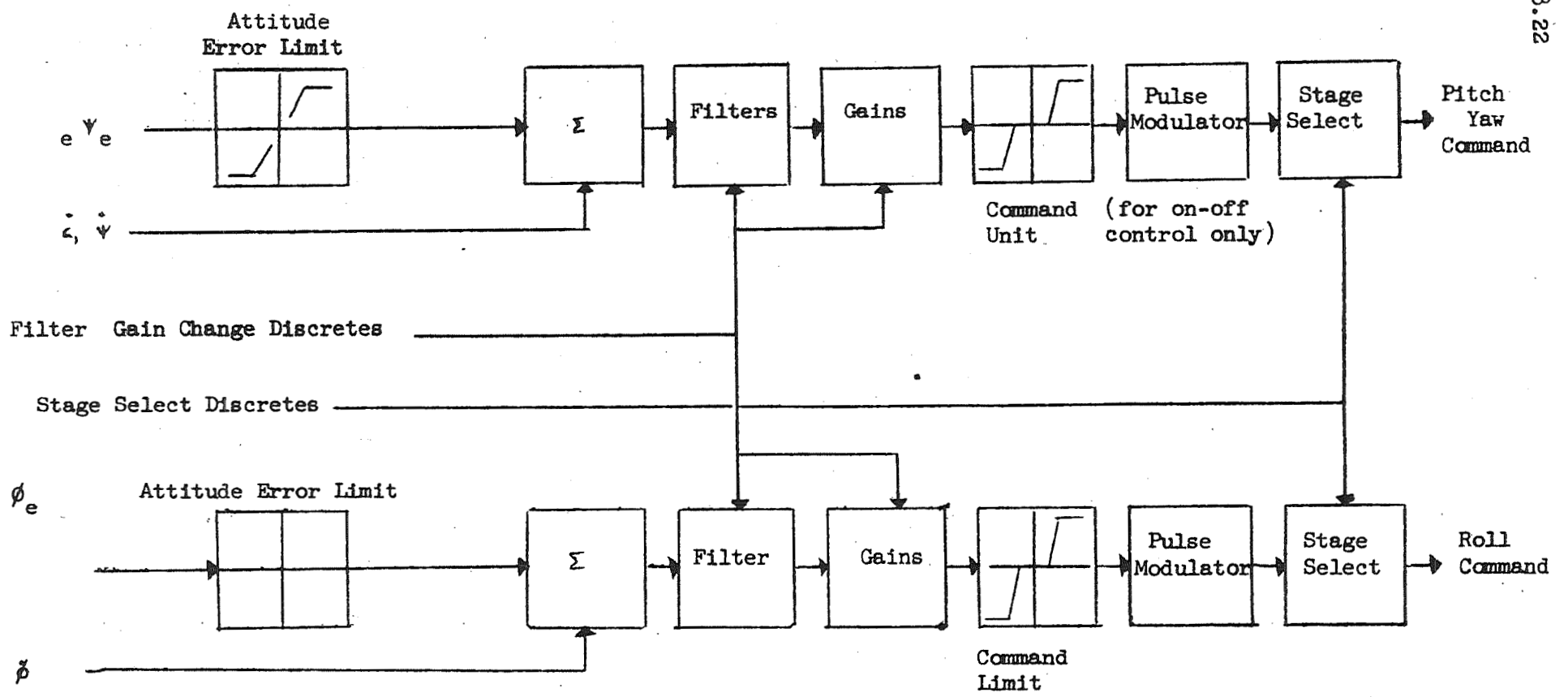

Figure 8.4-1 Functional Schematic of Control System



Stage	Pitch/Yaw			Roll		
	Number of Limits	Number of Filters	Number of Gains	Number of Pulse Modulator Gains	Number of Filters	Number of Gains
1	1	2	2 per axis	1	1	2
2	2	1	2	1	0	2
3	2	1	2	1	0	2

Figure 8.4-2 Autopilot Electronics

196

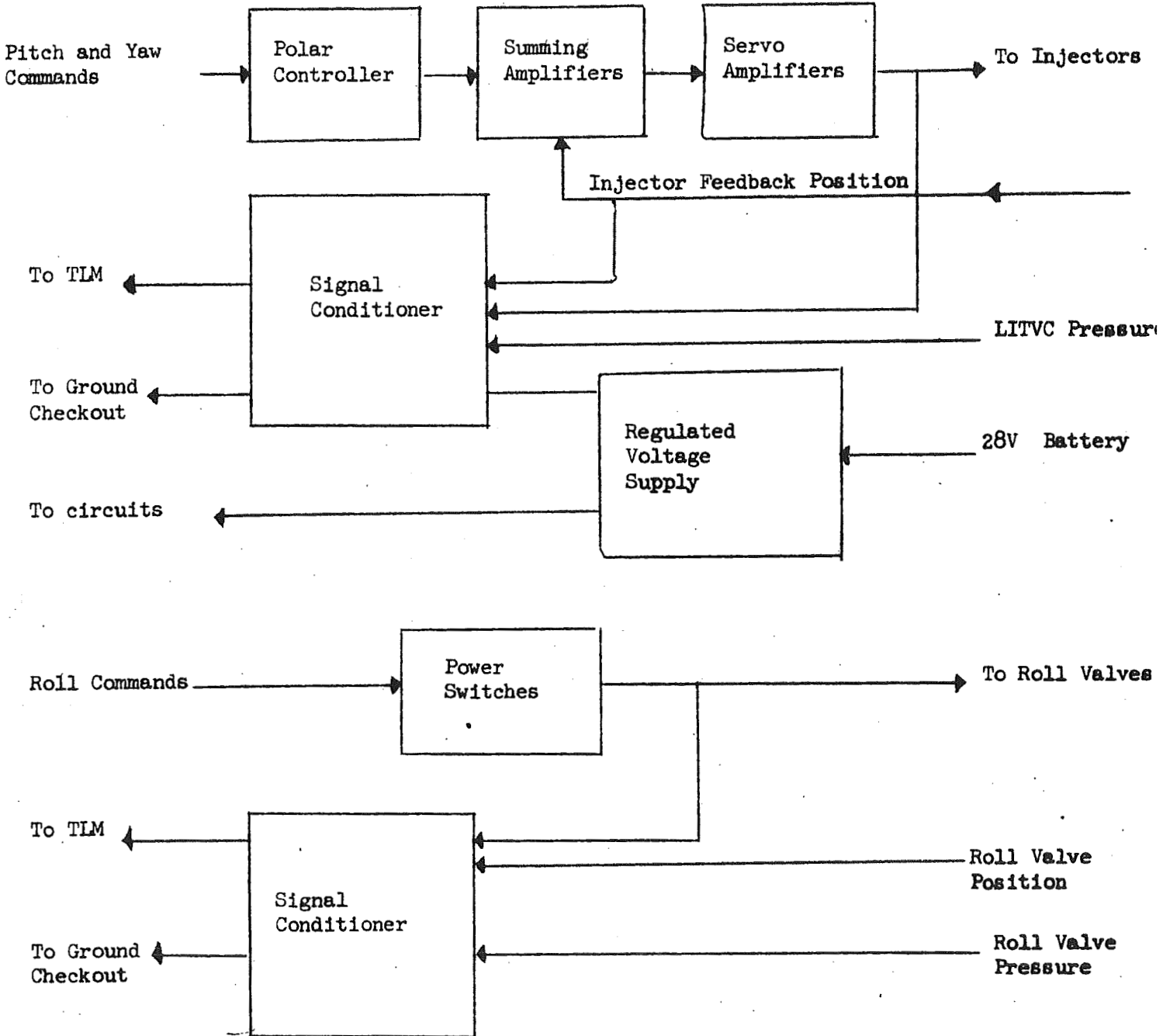

Figure 8.4-3 Actuation Electronics Package with Proportional Injector Operation

8.24

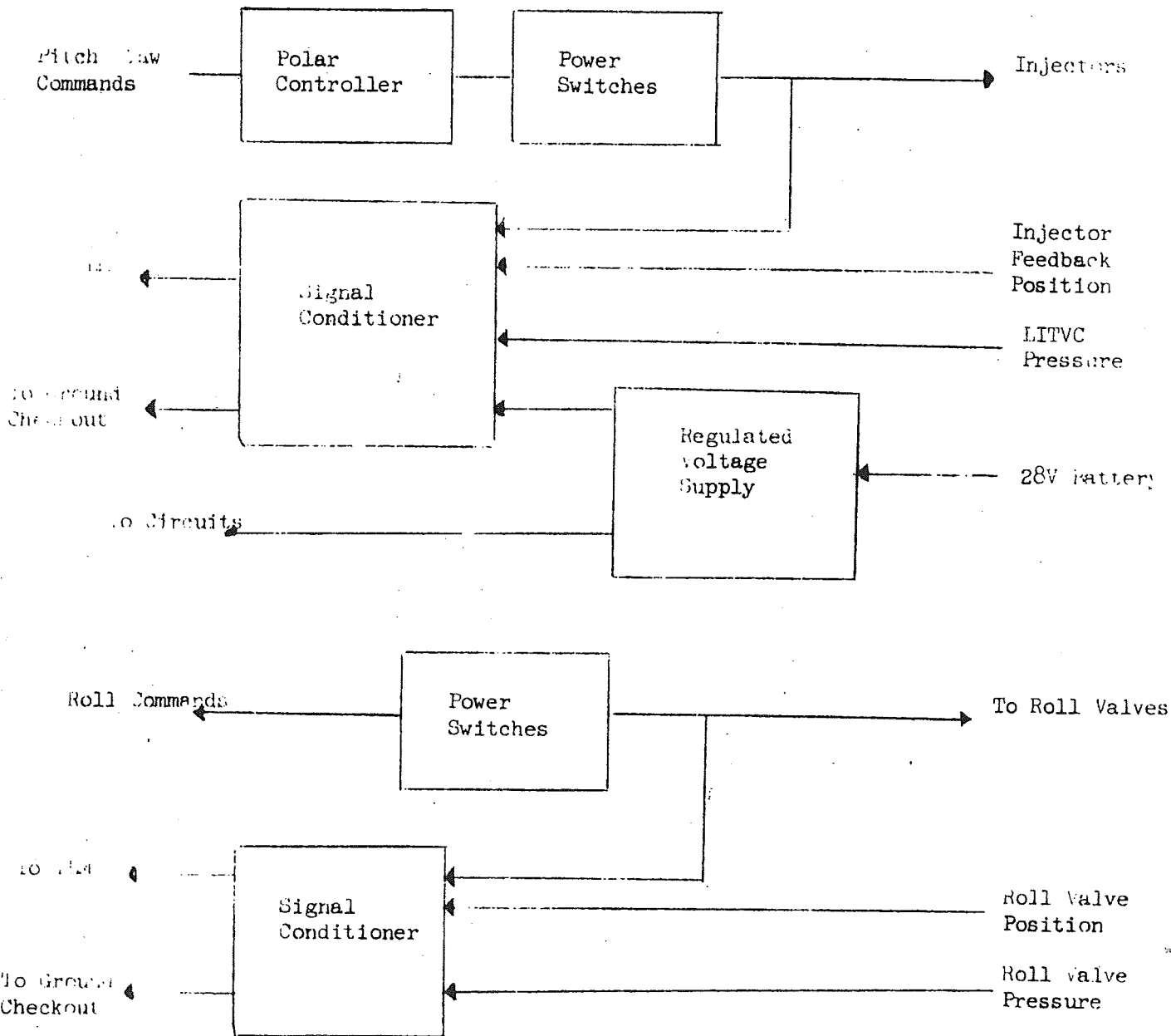

Figure 8.4-4 Actuation Electronics Package with On-Off Injector Operation



Roll and  
2 LITVC  
B Command  
Signals

Autopilot  
Package

5 Logic States  
and Magnitude

24 Injector  
Commands

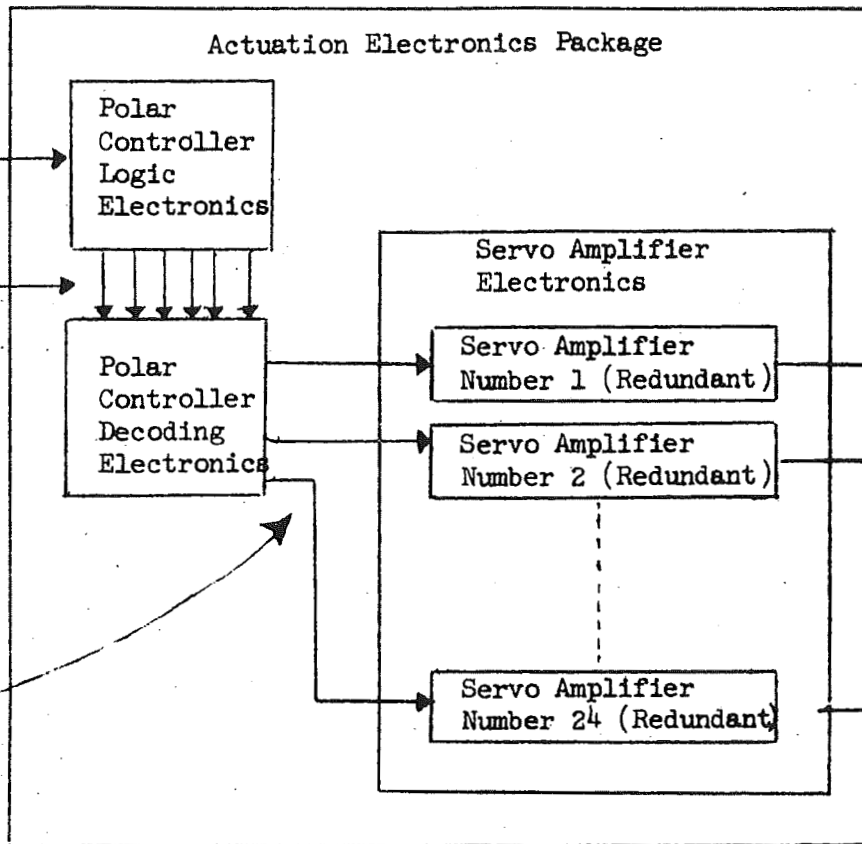

yaw axis

desired  
injection  
direction

desired  
operating  
injectors

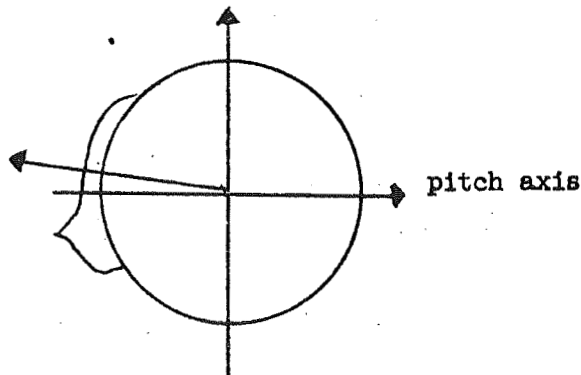

Figure 8.4-5 A Typical Polar Controller  
Functional Schematic

A single autopilot package would be used to accomplish the required stability filtering. On the other hand, the autopilot package could be eliminated by locating the required filtering in each of the down-stage packages; however, with the penalty of requiring separate plug-in units for these packages and the associated costs.

Location of a polar controller within the autopilot versus location within the actuation electronics. One means of reducing the Liquid Injection Thrust Vector Control (LITVC) cost is through reduction in system sizing. This can be accomplished by providing a polar control of the thrust vector in contrast to the conventional cartesian type of pitch and yaw control. The injectant peak flow rates could then be reduced by more than 30 percent. The transformation of the conventional commands into polar commands requires the use of relatively complex electronic circuitry which will be referred to as a polar controller. The location of the polar controller into the single autopilot design versus location within each of the actuation electronics packages will influence the design tradeoffs.

Use of on-off versus proportional injection control. The primary difference between on-off and proportional LITVC control is in the power amplifiers contained in the actuation electronics packages. For proportional control, linear servoamplifiers would be required while for on-off control, simple power switches would suffice. The cost difference would be measurable since 72 injectors are involved with the cost difference increased through the triple redundant circuitry. The use of on-off control may have its drawbacks if the launch vehicle is not sufficiently rigid to withstand the pulsing operation of the on-off control system in that the cost of a more rigid vehicle design would be involved and furthermore the cost of a vehicle re-sizing may be involved. It is pointed out here that with the non-linear on-off control system, a booster rate gyro package may not be required since the bending effects are attenuated by the non-linear system deadzone.

As a result of the previous considerations, the electronic configuration of the autopilot, polar controller logic and decoder, and actuation electronics can take several forms. The five primary system configurations are as follows (see Figure 8.4-6):

LEGEND:

- d = Polar Control Decoder Electronics
- p = Polar Controller Logic Electronics
- a = Autopilot Electronics
- b = Actuation Electronics

Numbers 1, 2, 3 = relate respectively to Stage 1, 2, or 3

System 1 (Conventional Controller, Single Autopilot)

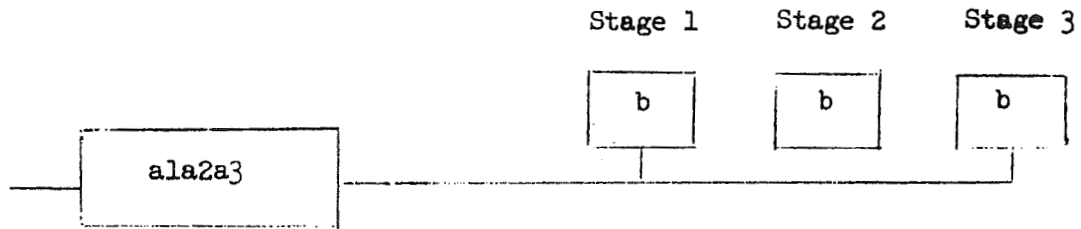

System 2 (Conventional Controller, Integrated Autopilot/Actuation Electronics)

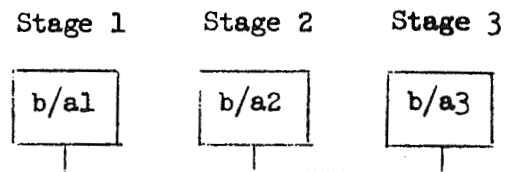

System 3 (Multiple Polar Controller, Single Autopilot)

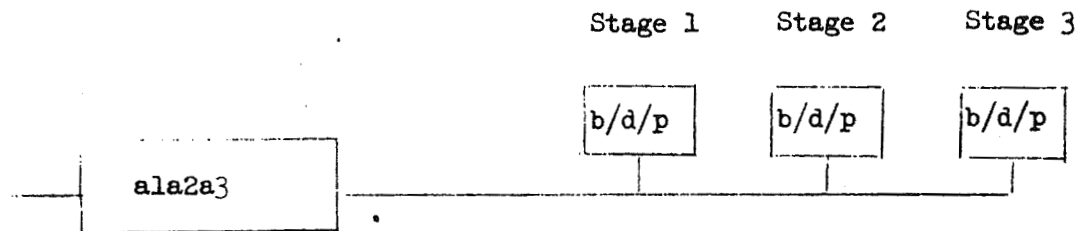

System 4 (Single Polar Controller Logic, Single Autopilot)

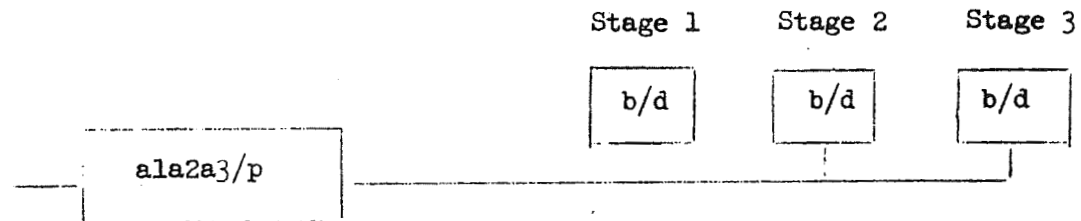

System 5 (Multiple Polar Controller, Integrated Autopilot/Actuation Electronics)

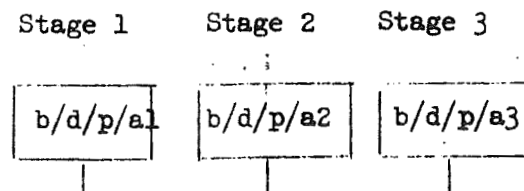

Figure 8.4-6 Primary Control Electronics Configurations

#### 8.4.1.2 Electronic System Configurations

- Conventional controller with single autopilot.
- Conventional controller with integrated autopilot and actuation electronics.
- Multiple polar controller with single autopilot.
- Single polar controller with single autopilot.
- Multiple polar controller with integrated autopilot and actuation electronics.

The first two systems pertain to use of conventional pitch and yaw control while the last three pertain to use of the polar controller. The decoding portion of the polar controller must be kept within the actuation electronics package in order to reduce the number of power routing wires between the autopilot and actuation electronics packages.

The characteristic differences between these primary concepts are:

- 3 versus 4 electronic packages.
- Effect on injector size; the polar controller allows a reduced injector size.
- Difference in injectant requirements, the polar controller requires less injectant. (This may not be significant with the MTI design).
- Cost and weight.

#### 8.4.2 Design Methods to Reduce Costs of the Control Electronics Mechanization

There are several ways in which the basic cost of the flight control system can be reduced, such as:

Filter change through plug-in units. The electronic circuitry for the autopilot filters and gains could be mounted on plug-in cards to facilitate the autopilot design changes that may be required on a per flight basis. In this manner, wiring change to accomplish filter changes could be avoided.

A single set of filters and gains for a selected set of missions. It is possible that changes in plug-in units could be reduced by designing a set of high order filters and gains which are applicable to a selected set

of missions and payloads. Several plug-in units could then be used to cover the entire mission/payload range of interest. The cost of replacing plug-in units and the cost of testing the many different cards could be reduced through this plan.

Use of electro-hydraulic, or electro injectant systems versus electromechanical actuation systems. Although the flight control systems are not considered within this part of the costing study, it is mentioned here to bring attention to the significant cost savings that may be obtained by proper selection of the actuation system design. The electro-injectant system is essentially an electro-hydraulic system that employs the LITVC injectant as the hydraulic fluid. The need for a hydraulic supply system is therefore deleted and this design has been shown to be cost attractive from past preliminary costing studies. The electro-mechanical actuation system was also shown not to be cost attractive. This results primarily from the 2+ electrical motors per stage required to actuate the injectors.

Use of a two-axis rate gyro package. The need for a three-axis rate gyro package is not evident and a reduction in cost can be obtained with a two-axis gyro package. Cost estimates are included for both design configurations for a non-redundant, 3 package redundants, and a triple redundant package designs.

Reduction in redundancy for unmanned flights. It is conceivable that the control electronics cost be reduced for unmanned flights if the triple redundancy is obtained at a package level. For low cost flight, the redundant packages could be removed. This would also be true of redundant rate gyro packages.

Use of developed and qualified electronics modules. The cost of design, development and qualification of control electronics modules such as servoamplifiers and power switches could be deleted through the use of off-the-shelf components.

8.30

#### 8.4.3 Control Electronics System Tradeoff

A preliminary choice of a control electronics configuration will be made primarily on the basis of the cost of the flight control system. However, a final choice should also consider other factors such as:

- Effect on vehicle structure
- Effect on injector and injectant system cost
- Control system performance and stability

These last factors require a more extensive analysis and vehicle simulation, which is beyond the scope of this study. The cost estimates of the different configurations are made under the following ground rules:

- The roll control valves and solenoids are included within the propulsion system cost estimates, and are not included here.
- The LITVC servo injectors and solenoids are included within the propulsion system cost estimate, and are not included here.
- The LITVC system employs electrohydraulic actuators which utilizes the injectant as the hydraulic fluid, hence, auxiliary hydraulic supply systems are not required for costing.
- Twenty-four injector valves and four roll valves are employed on each of the three vehicle stages.
- Triple redundancy and voting logic are required in the electronics packages. Failure detection and launch abort circuitry are not to be included in this design exercise.

The estimated costs of the 5 primary control electronics configurations (Figure 8.4-6) are shown in Table 8.4-I. The cost estimates were obtained by costing the circuit modules of each package. The circuit module costs were based on cost data for similar circuit modules, available at TRW from other launch vehicle programs. The non-recurrent cost, including development analysis, design and all testing are estimated to be approximately \$1.8M.

The proportional control system, includes the cost of a 2-axis, triple redundant rate gyro package (\$14K). Comparative cost of rate gyro packages are shown in Table 8.4-II.

TABLE 8.4-I CONTROL ELECTRONICS, COST TRADEOFF OF PRIMARY CONFIGURATION

<u>Flight Control Electronics Configurations</u>	Unit Cost Per Vehicle in \$	
	<u>On/Off Control</u>	<u>Proportional Control</u>
Conventional controller, single autopilot	140K	226K
Conventional controller, integrated autopilot actuation electronics	237K	323K
Multiple controller, single autopilot	206K	292K
Single polar controller, single autopilot	189K	272K
Multiple polar controller, integrated autopilot/ actuation electronics	303K	389K

TABLE 8.4-II ESTIMATED UNIT COST OF RATE GYRO PACKAGES (in \$)

<u>For 400 Units</u>	<u>2-Axis Package</u>	<u>3-Axis Package</u>
	Non-redundant	5,000
Redundant (3 package)	13,000	17,000
Triple Redundant Package	19,000	26,000
 <u>For 200 Units</u>		
Non-redundant	5,540	7,100
Redundant (3 package)	14,350	18,500
Triple Redundant Package	21,000	28,800

Therefore, for the time being, a proportional control system is recommended for the LCLV. A preliminary choice of the corresponding control electronics can be based on the system cost, consequently, a conventional controller with single autopilot was chosen. Table 4-III provides the resulting cost and weight for each guidance configuration of Section 3.

### 8.5 G & C Configuration Tradeoffs

The tradeoff between the formulated G & C configurations will be based mainly on cost effectiveness. The cost effectiveness will be expressed in a cost penalty per system, which will include:

- Unit production cost per G & C system.
- GSE cost per flight only for GSE in direct support of the flight phase (such as ground tracking for radio guidance).
- Non-recurrent cost per unit, based on 10 to 40 launches per year over a period of 10 years.
- Cost penalty for G & C system weight, based on \$150 per lb in orbit.
- Cost penalty for an error in orbit injection velocity, based on 100,000 lbs payload, Isp of about 300 sec. and cost of \$150 per lb in orbit.
- Cost penalty for injection altitude safety factor for low orbits and large altitude injection error.
- Credit for the incorporation of non-guidance functions in the G & C system, such as propellant utilization or range safety functions.

Not included in the cost comparison are:

- Unit cost variation due to larger or smaller production quantities per year.
- Radio Guidance launches from WTR, utilizing a GE Mod III system.
- Cost of downstage cabling and power.
- Differences in cost of GSE for prelaunch operations.
- Cost differences in transportation, assembly, storage or maintenance.



TABLE 8.4-III CONTROL ELECTRONICS CHARACTERISTICS FOR EACH GUIDANCE CONFIGURATION

207

<u>Guidance Configuration</u>	<u>Control Electronics Cost in \$</u>		<u>Weight lbs.</u>
	<u>Unit Cost</u>	<u>Non-Recurrent</u>	
Attitude Programmer	226K	1.8M	95
Augmented Attitude Programmer	226K	1.8M	95
Simplified* Inertial	152K	1 M	70
Radio	226K	1.8M	95
Recoverable	Already included in Guidance Configuration Estimate Table 8.3-III		

\* Cost weight of integrated autopilot were already included in the Guidance Configuration Table 8.3-II

The characteristics of the G & C configurations derived in Section 8.3 and 8.4 were combined. These characteristics were transferred into equivalent dollars on the basis of the previous stated ground rules. The results are presented in Table 8.5-I showing the total G & C cost per flight as a function of yearly launch rate for a 10 year period. The non-recurrent costs were amortized over the total number of launches.

Figure 8.5-1 includes also the cost curves for a full inertial guidance system, based on the utilization of existing qualified guidance hardware supplemented with a separate control electronics mechanization.

#### 8.5.1 System Comparison

The low cost Radio Guidance approach appears to be the lowest cost configuration for all launch rates. The cost penalty difference with simplified guidance for 20 launches/year amounts to about \$150K (about 30% of total penalty) per flight. The cost of Radio Guidance with the GE Mod III system is somewhat lower than the cost of the simplified inertial system.

The attitude programmer configuration is rather uneconomical due to its large injection velocity error and can be eliminated from further consideration.

The augmented attitude program approach places a relatively large burden on the payload due to its injection velocity inaccuracy ( $3\sigma \approx 150$  fps). Moreover, this only becomes more cost effective than simplified guidance or GE Mod III Radio Guidance approach for low launch rates (10/year or less).

The recoverable system is also only cost-effective for low launch rates. This approach has a considerable risk due to the recovery and refurbishment operation.

In view of these observations, it was decided not to recommend the augmented attitude programmer or recoverable G & C approach for the LCLV study concept.

The low cost radio guidance approach has the disadvantage, that it can only be applied to launches from ETR. The coverage of the ground tracking stations places some constraints on the trajectories for the LCLV. This may be undesirable particularly if all launches are executed from ETR, which may involve dog leg maneuvers.

TABLE 8.5-I G & C COST PENALTIES IN \$

<u>G &amp; C Approach</u>	<u>G &amp; C Cost</u>		<u>G &amp; C Weight Penalty</u>	<u><math>\Delta V</math> Injection Error Penalty</u>	<u>Altitude Error Penalty</u>	<u>Credit for Non-Guid Functions</u>
	<u>Unit</u>	<u>Non-recurrent</u>				
1. Attitude Program	276K	5.8M	11K	900K	90K	None
2. Augmented Attitude Programmer	286K	5.8M	11K	225K	22.5 K	None
3. Simplified Inertial	354K	32 M	16K	45K	negl.	40K
4. Radio	325K	GE Mod III 28.4 Low Cost 8.3*)	16K	22K	negl.	30K
5. Recoverable G. C	607K	3 M	120K	22K	negl.	200K

\*) for 12 launch/year  
will increase to  
app. 9.5M for 40 launches

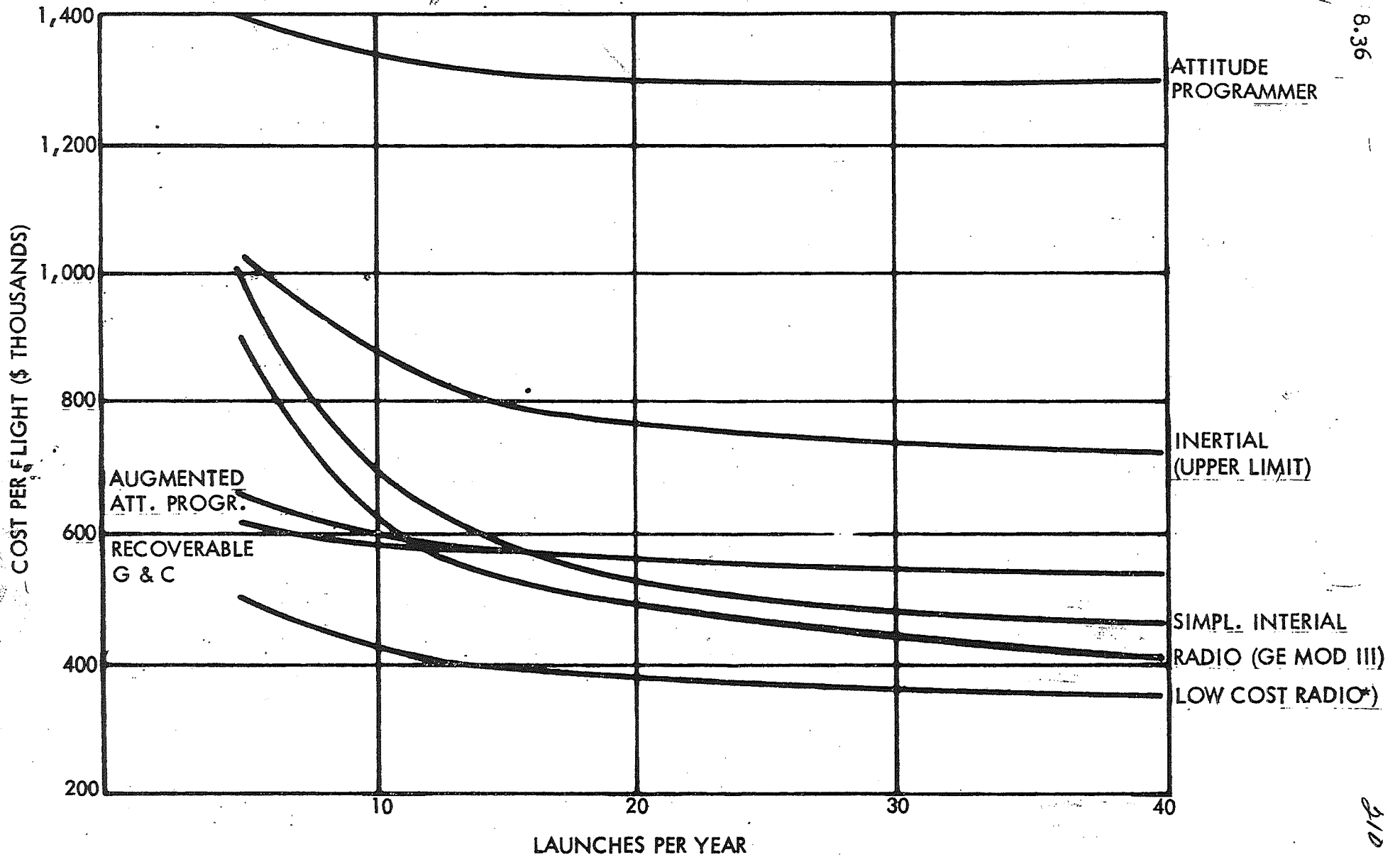

8.36

810

\*) ETR LAUNCHES ONLY

The GE Mod III system has the advantage that the airborne equipment can also be used at WTR in conjunction with the GERTS tracking station. The trajectory constraints are, however, similar to those of the low cost Radio Guidance approach.

The above analysis shows that there are three primary candidate G & C concepts for the LCLV:

- Simplified inertial guidance
- Radio Guidance, GE Mod III
- Low cost radio guidance

It is emphasized that a study in much greater depth is required to do justice to each concept. The evaluation of the radio guidance requires a firm decision on the launch site, and a better definition of the trajectories. Moreover, the tradeoff between the three concepts should take into account many other factors, not considered during the study such as development risk, reliability, availability of trained personnel, and availability of ground support equipment.

The general picture presented by the cost penalty curves of Figure 8.5-1 is that the G & C cost penalty per LCLV flight (for launch rates over 10 per year) will be in the range of approximately \$400K to \$600K. For the LCLV study configuration, a choice of one of the concepts was desirable. For the time being, the Simplified Inertial Guidance was chosen as the baseline system for this study mainly because of the somewhat greater mission flexibility of an inertial system. However, in the future, a more detailed tradeoff among all three concepts is desirable.

#### 8.5.2 Conclusions from Tradeoff Analysis

The conclusions of the previous discussion can be summarized as follows:

- A G & C cost penalty per LCLV flight will be in the range of \$400K to \$600K per flight (launch rate 10 or more per year). Promising concepts are Simplified Inertial Guidance, GE Mod III Radio Guidance and a low cost Radio Guidance approach.
- For the time being, the Simplified Inertial Guidance Configuration is chosen as the G & C baseline approach for the present LCLV study configuration.

- The Low Cost Radio Guidance approach is by far the lowest cost configuration but places some constraints on the trajectory and restricts launches to ETR. This approach should be reconsidered at the time that launch site and missions are better defined.
- The GE Mod III Radio Guidance does provide a small cost improvement over the simplified inertial system but may not have the same mission flexibility. This approach should also be evaluated for a final choice.
- The augmented attitude programmer and recoverable G & C approaches become cost effective only for low launch rates (less than 10 per year) and were eliminated for other reasons (respectively, large  $\Delta V$  correction burden on payload and risk of recovery and refurbishment).
- The attitude programmer was discarded in view of its high cost penalty per flight, caused by the large orbit injection errors.

G & C in Payload. The foregoing considerations have assumed the G & C system to be in the top stage of the launch vehicle, independent of the payload G & C system required for post orbital mission requirements (although the latter may be used as a back-up system for the LV). Time did not permit a tradeoff analysis with the capabilities and cost of the payload system. For example; it may be feasible to incorporate the LCLV guidance functions in a possible G & C system of the payload. This would then require a separate LCLV autopilot and control electronics for each stage. Such a tradeoff was beyond the scope of this study and, moreover, would require a relatively detailed specification of the different payloads, missions and launch frequency of each category. However, such tradeoff should be considered in a final analysis of the LCLV guidance approach.

### 8.6 Astrionics Costs

The total astrionics weights and costs, including G & C, stage instrumentation, power systems, wiring, stage separation ordnance, destruct system, TT & C, etc., have been computed for the baseline vehicle, and summarized in Table 8.6-I.

Table 8.6-I Astrionics Weight and Cost for  
Baseline Design

	<u>1st Stage</u>		<u>2nd Stage</u>		<u>3rd Stage</u>	
	<u>Cost (\$)</u>	<u>Weight (lb)</u>	<u>(Cost (\$))</u>	<u>Weight (lb)</u>	<u>Cost (\$)</u>	<u>Weight (lb)</u>
1. Wiring & Connectors	10,804	126	6,309	73	3,655	42
2. Destruct system and stage separation ordnance	22,000	60	44,000	250	43,000	195
3. Power Selector Switches	135	10	135	10	15,900	55
4. Destruct system electronics	50,000	35	50,000	35	50,000	35
5. Batteries	27,000	185	27,000	185	27,000	185
6. Mounting Hardware	1,500	65	1,000	30	1,000	30
7. Telemetry System					200,000	200
8. Tracking Antennas & Transponders					62,000	47
9. Guidance and Control System					350,000	150
Sub Total	\$111,439	481 lb	\$128,444	583 lb	\$752,555	939 lb
Contin- gency	\$ 18,561	219 lb	\$ 31,556	217 lb	\$376,000	470 lb
TOTALS	\$130,000	700 lb	\$160,000	800 lb	\$1,128,555	1409 lb

Grand Total for 3 stages \$1,418,555 and 2909 lb

Data for these estimates were obtained from a combination of sources including References 24 and 25. The system was laid out in sufficient detail to establish the location of each main subsystem. Based upon the layout, the locations, lengths of wires, number of wires, number of transducers, etc., were established for use in the calculation of the weights. These weights were then used in establishing the cost of the wiring. The assumptions used to determine the sizes and costs of the various components were based on similarities, modified with current known state-of-the-art "off the shelf" improvements, to the Saturn V.

The following assumptions were made in arriving at the cost and weight estimates shown in Table 8.6-I.

1. Procurement costs are based on 100 deliverable boosters.
2. No R & D costs, including R & D instrumentation, are included.
3. Ten high level output pressure transducers will be utilized per stage. The specific pressure measurements are chamber (2), fuel tank (2), oxidizer tank (2), oxidizer gas pressurant tank (1) and fuel gas pressurant tank (1). Six RTT probes per stage, fuel tank (2), ox tank (2), ox gas pressurant tank (1), fuel gas pressurant tank (1).
4. The booster/spacecraft electrical interface is at Station 263.16. (Forward end of 3rd stage).
5. All oxidizer gas pressurant tank transducers will be mounted in the raceways; all other transducers within the interstage areas.
6. All transducers have a common power buss and calibration buss within the raceways with branches to the individual transducers.
7. Destruction of each stage will be accomplished by cutting the main oxidizer feed line through the fuel tank causing mixing and burning of the hypergolic fuels. An explosive charge with a safe and arm device will be used to rupture the oxidizer line. The S & A will be mounted on the skirt with a confined detonating fuse assembly running to the charge on the oxidizer line within the fuel tank. Each stage has its own independent system.
8. All separation charges for each stage will be detonated at one time, utilizing a 2 manifold system and confined detonating fuse assemblies to transmit the detonation. One manifold will connect one end of



215

each charge while the other will connect to the other end of each charge for redundancy.

9. Since the interstage sections are long in relation to their diameters, the engines cannot clear the intact interstages. Interstages will, therefore, be designed to open "petal" fashion. Each interstage will be cut into quarter sections longitudinally as well as circumferentially fore and aft.
10. Structure will be designed so that only tension load member need to be cut at the two separation planes.
11. Interstage structure will be designed so that a single linear shape charge is capable of making each of the longitudinal cuts in the interstage.
12. Vehicle has single pair of command destruct receivers in the forward end of the third stage.
13. No spares or software costs are included in the estimates.
14. Each stage will have three 28 volt power supplies (batteries), one for control functions, one for instrumentation and one for ordnance with switching to permit any one to replace either of the other two in case of a failure.
15. No thrust vector control components and related wiring are included in this estimate, but instrumentation wiring of control systems is included.
16. The vehicle is assumed to be pressure-fed with MTI.
17. One telemetry system is used for the entire missile.
18. One central control system is used for the entire missile.

1  
2  
3  
4

5  
6  
7  
8

## 9. COST ANALYSIS AND TRADEOFFS

The overall cost of the launch vehicle system consists of the sum of costs in the following categories:

- Non-recurring costs, including DDT & E for the LV through its acceptance tests.
- Recurring costs, including fabrication, assembly and checkout of the vehicle, launch operations, and recurring support activities. Some of these costs are subject to improvement on a learning curve, and others are not.
- Refurbishment costs for recoverable LV's or stages, including the cost of recovery.

Methods of analysis of the above costs are described in the following sections.

The nomograph shown in Figure 9-1 provides an excellent overview of the total cost picture, and is found to be useful in making comparisons of the relative cost of systems involving non-recurring, recurring and refurbishment costs. Data on expendable vehicles are shown at the top of the figure and recoverable vehicles at the bottom.

All of the costs are normalized in terms of the first unit recurring cost  $f$ . The average recurring cost per unit then decreases with the number of manufactured units  $N_M$  according to a learning curve  $LC = N_M^n / N_M = N_M^{n-1} \leq 1$ . In the figure, the assumed average learning curve is 90% (for which  $n = .85$ ), showing the effect of a well managed production/assembly/checkout operation. Other recurring costs such as ground support, propellant cost, etc. may be subject to a higher learning curve (between 95 and 100 percent,  $n = .93$  and 1.0, resp.)

Non-recurring costs are represented as multiples of the first unit cost from  $1f$  to  $100f$ , divided by the number of manufactured units  $N_M$ . The average unit cost  $AUC/f$  is then the sum of the learning curve fraction  $LC$  as defined above, plus the non-recurring cost factor, the evaluation of which is discussed in Section 1.5, and further guidelines illustrated in Figure 9-2. Ground support costs are computed in Section 7 and are not included in Figure 9-1.

For recoverable vehicles or stages, the  $AUC/f$  is the non-recurrent cost (divided by recoveries per unit  $N_R$ ) plus the average refurbishment cost  $R/f$ . It is noted that the curves for  $AUC/f$  vs  $N_R$  are the mirror image of those for  $AUC/f$  vs  $N_M$ , when both are based upon the same non-recurrent cost. The break-even point  $N_{RB} = N_{MB}$  is then determined by the criterion  $R/f = 1 - LC/f$ .

The cost nomograph has been used during the preliminary design period as a check against machine runs of specific configurations to resolve such problems as the following:

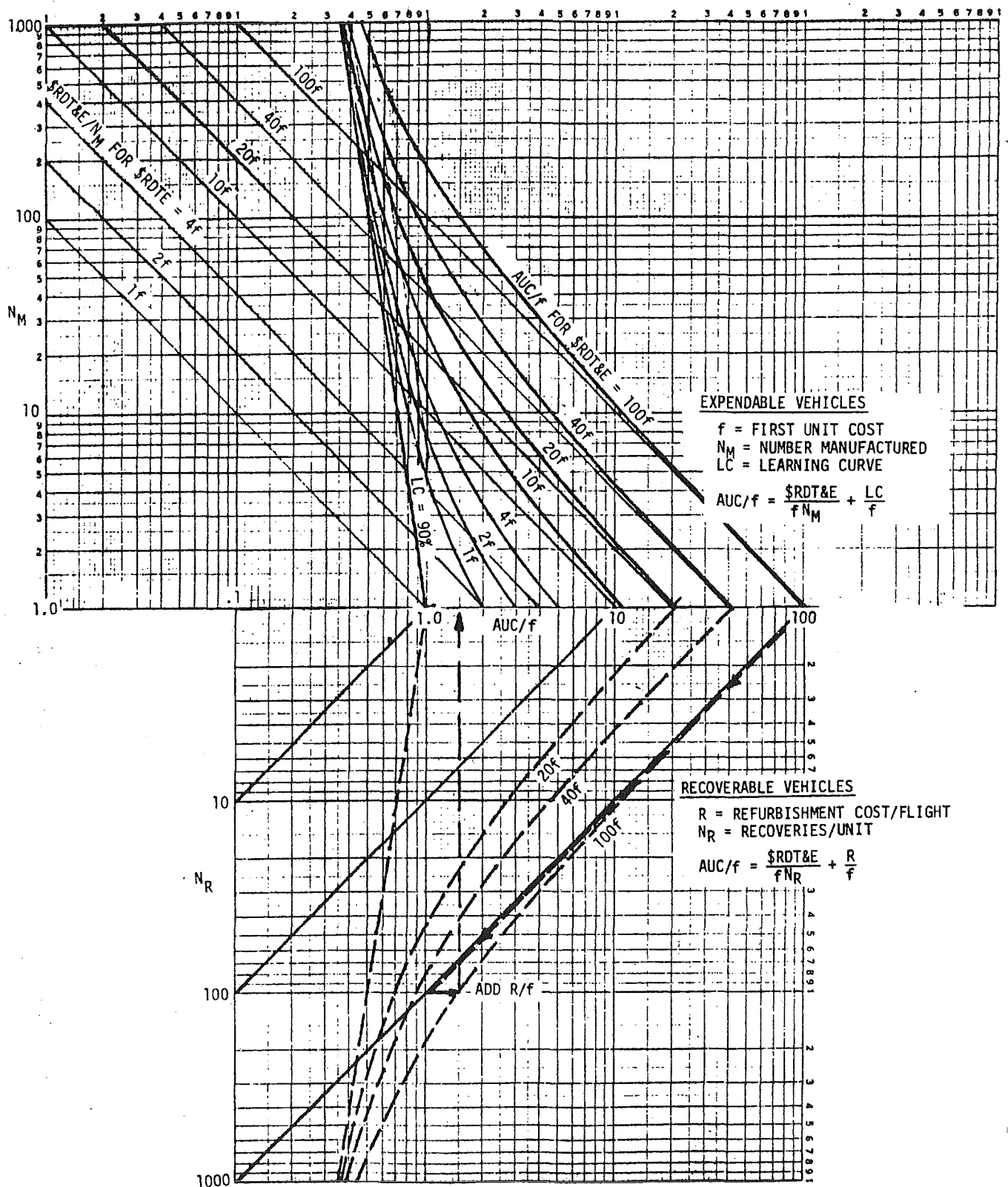

Figure 9-1 Basic Cost Relationships

219

- Relative cost of alternate designs No. 1 through 4
- Whether different sizes (gross weights) of vehicles are desirable in a given class of LV's (see Figure 2-1).
- Cost of stages built up of modular tanks and/or engines
- Optimal use of staging to reduce cost

The optimum development funding for minimum total cost is determined from the general cost equation as follows:

The total cost TC of N missions (including the non-recurring cost  $NRC=Cxf$ ) is

$$TC = NRC + f \times N^{.85} = NRC + NRC \times N^{.85}/C$$

Differentiating with respect to NRC to determine the optimum conditions

$$d(TC)/d(NRC) = 1 + N^{.85}/C = 0, \text{ for minimum total cost}$$

Hence,  $C = NRC/f = N^{.85}$  is the condition for minimum total cost of N vehicles.

When	N = 25	50	100	200
Optimum NRC/f =	15.5	28	50	90

These values are shown plotted in Figure 9-2, and the subject of optimum development cost is discussed further in Section 1.5.

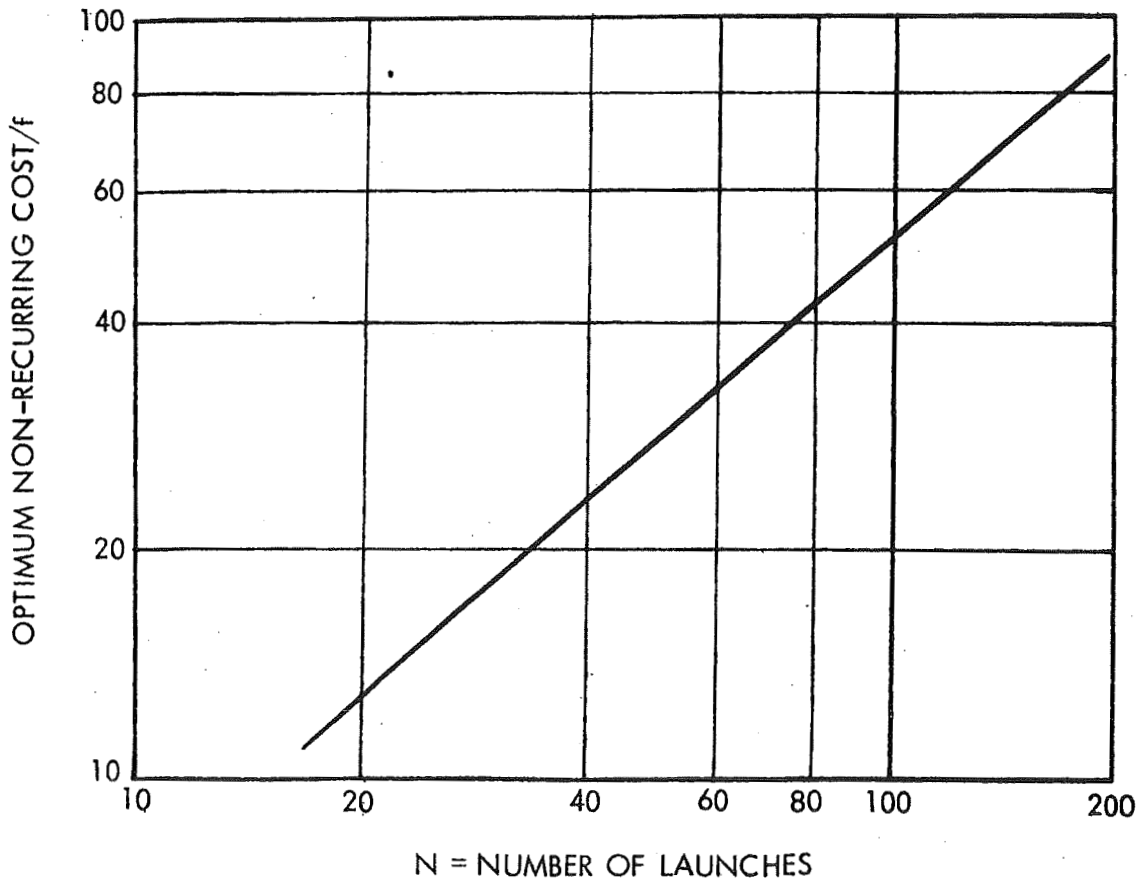

Figure 9-2 Effect of Number of Launches on Optimum Non-Recurring Cost

### 9.1 Non-Recurring Costs

The "ideal" development program envisions components, subassemblies and systems that function properly the first time, or after minor adjustments. Low development costs will result from the use of conservative design margins to minimize the amount of testing to prove performance and reliability. A lower bound for the development cost is outlined in Table 9-I.

Table 9-I Lower Bound for Development Cost

- Build one complete set of hardware
- Run engines on test stand - small engines first
  - Short duration runs - check stability, C\* efficiency
  - Full duration runs - refurbish ablative liner
  - Qualification tests
  - Engines still useable after refurbishment
- Hydrostatic pressure tests of tanks
  - Successively higher pressures to proof load
  - Tanks still okay after pressure tests
- Integrated stage tests - upper stages first
  - Perform functional tests
  - Hot runs of MTI pressurization (with propellant flow)
  - Hot runs of engine and LITVC (with MTI)
- Integrated LV tests
  - Perform functional tests
  - Final checkout - countdown and launch

All with one set of hardware! (of ultra-conservative design)

While the attainment of such an ideal development program is hardly to be expected, there are several factors which move in that direction; namely, the simple pressurized vehicle concept, the geometrical and operational similarity between stages, the testing of smaller stages first, and the scalability of the coaxial injector engine--all tend to increase confidence that the overall development cost will be moderate.

The scaleup of engines using the coaxial injector to LCLV thrust levels is expected to be a routine development, judging by previous experience (outlined in Table 5-1). This experience adds credibility to the estimates of a low cost engine development for the LCLV, as described in Section 9.1.1.

9.1.1 Development Cost of Baseline Engines

Estimated DT & E costs through qualification for TRW low cost engines are shown in Figure 9-3 for the thrust range of interest for this program. The initial facility cost has been estimated at approximately \$20M, independent of engine size. This cost element is included in all cases in Figure 9-3. For multiple engine developments this \$20M cost increment need be assessed only once with additional firing positions costing \$1M each. For the three engine designs applicable to the baseline LCLV the following DT&E cost is then derived:

<u>STAGE</u>	<u>THRUST</u>	<u>DT &amp; E COST</u>
1	11.4 x 10 <sup>6</sup> lbs. (SL)	\$100.3 M
2	2.2 x 10 <sup>6</sup> lbs. (VAC)	52.1 M
3	460 K lbs. (VAC)	37.0 M
		<u>189.4 M</u>
		- 39.0 M (Overpaid facility cost)
	<u>TOTAL</u>	\$151.4 M

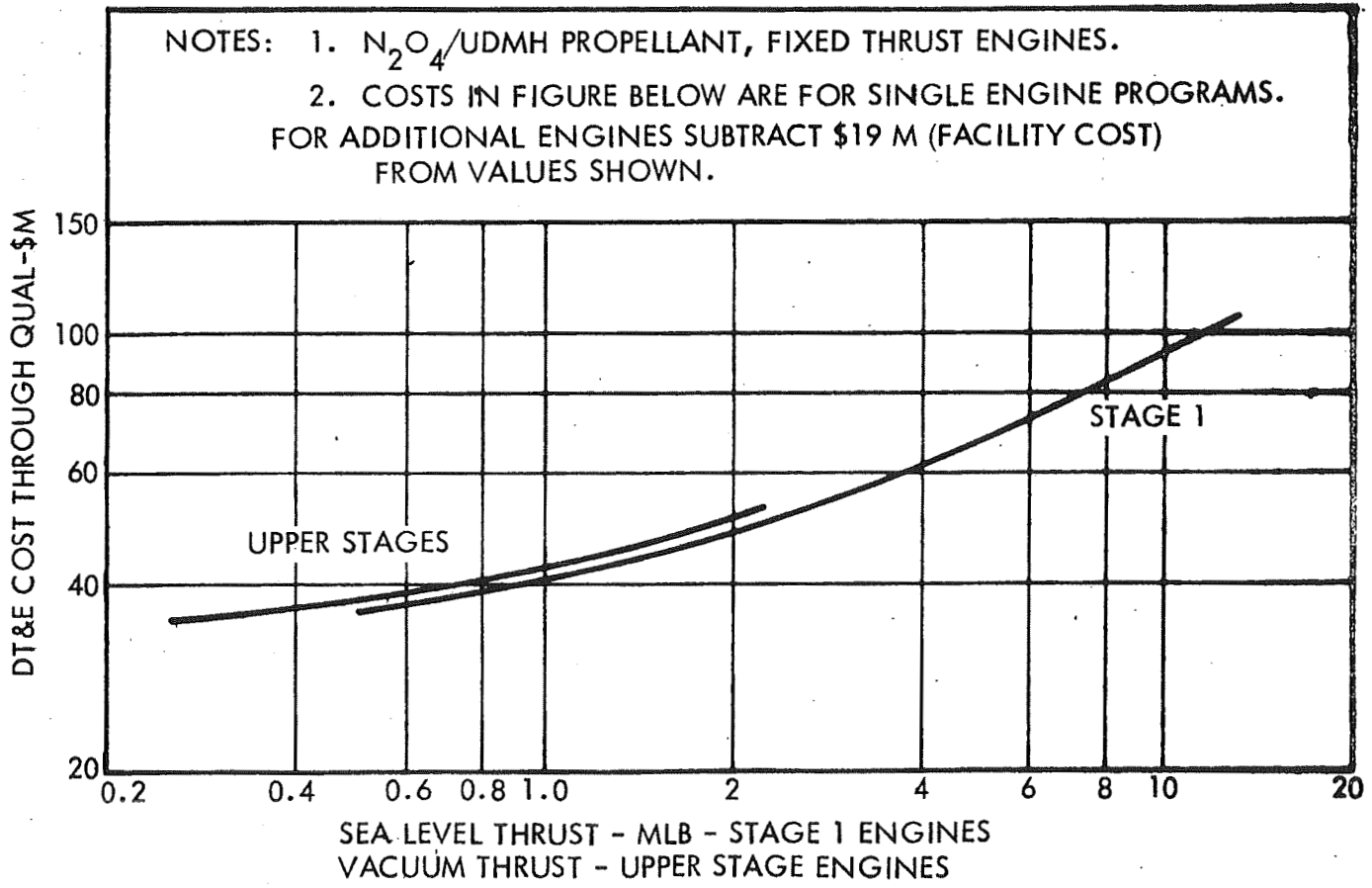

Figure 9-3 Development Cost of TRW Engines

## 9.1.2 Estimate of Non-Recurring Cost

The non-recurring costs of the LCLV can be estimated by the separate analysis of the following systems: propulsion including LITVC; structure including tanks, interstage, pressurization; astronics including G & C, power, instrumentation and cabling; and stage integration, final assembly and check-out. The non-recurring cost NRC of the various systems of the conservative baseline vehicle are shown in Table 9-II, with first unit cost  $f$  of the systems as reference.

Table 9-II Non-Recurring Cost for Baseline Configuration

SYSTEM	STAGE 1		STAGE 2		STAGE 3		TOTAL	
	$f$	NRC	$f$	NRC	$f$	NRC	$f$	NRC
Propulsion	\$2.78M	\$100M	\$ .96M	\$46M	\$ .26M	\$35M	\$ 4.0M	\$181M
Structure	1.40	16	.51	8	.13	4	2.0	28
Astronics	.98	12	.51	6	.55	40	2.0	58
Stage Integration	1.60	16	.80	10	.70	9	3.1	35
Management, fee, etc.	<u>1.10</u>	<u>20</u>	<u>.45</u>	<u>15</u>	<u>.45</u>	<u>16</u>	<u>2.0</u>	<u>51</u>
	\$7.86 M	\$164M	\$3.23 M	\$85M	\$2.09M	\$104M	\$13.1M	\$353M
Vehicle DDT & E						\$353M		
Plant A						25		
Tooling						25		
(Boiler Shop Practice)								
Ground Support Facilities						67 (See Section 7)		
Man Rating						<u>50</u>		
Total Non-Recurring Cost						\$520M (Launch rate, 1/month)		

The judgment of previous investigators of low cost vehicle concepts serves as a guide to the present study. For example, Reference 9 quotes \$433M as the non-recurring cost for the PFL first stage and integration with the S-IVB. The first unit cost of the booster is given as  $f = \$13.5M$ ; hence, the non-recurring cost is 32 times  $f$ . Ref. 26 quotes \$80.5M for the development program (including launch and static test facilities), with a first unit cost of  $f = \$2.67M$ , giving a non-recurring cost of 30 $f$ . It is believed significant that, despite the wide range in dollar values between these two estimates, they are essentially the same when measured as multiples of first unit cost, with a difference of only 7 percent.

From Table 9-II the non-recurring cost of \$520M is 40 times the first unit cost of \$13.1M, representing a margin of 25 to 33 percent over the values given in References 9 and 26. In terms of dollars, the NRC from Table 9-II represents a more conservative estimate than the other two.



### 9.1.3 Non-Recurring Cost of Six Candidate Vehicles

The non-recurring costs of all six candidate designs are summarized in Table 9-III.

Table 9-III Non-Recurring Costs of Candidate Designs  
(Millions of \$)

Design No.	1 Non Modular	2 Quad Modules	3 7+3+1 Modules	4 Modular Engines	5 Pump Fed	6 PFL +S-IVB
Propulsion	181	185	130	126	220	125
Structure	28	32	33	27	25	60
Astrionics	58	59	60	59	59	50
Integration, Assem/CO	35	40	42	38	37	20
Management, Fee, etc.	<u>51</u>	<u>54</u>	<u>45</u>	<u>43</u>	<u>58</u>	<u>45</u>
Vehicle DDT & E	353	370	310	293	399	300
Manuf. Plant	25	22	21	23	28	--
Tooling	25	22	20	23	30	15
Ground Support Equipment	67	70	70	68	70	45
Man Rating	<u>50</u>	<u>50</u>	<u>50</u>	<u>50</u>	<u>50</u>	<u>30</u>
TOTAL NRC	520	534	471	457	577	390

### 9.2 Recurring Costs

For the cost tradeoff studies of the various designs, the following cost categories have been identified, and analyzed as in the following paragraphs. The percentage of total first unit recurring cost is also indicated in each category, for the baseline vehicle.

1) Tanks, skirts and interstages	14.8%
2) Engines and valves	16.5
3) LITVC system	4.0
4) MFI Pressurization System	1.4
5) Roll Control System	0.3
6) P/U System	0.9
7) Propellant	10.2
8) Astrionics	16.3
9) Stage Assembly Labor	7.7
10) Program Management and Engineering	5.8
11) Final Assembly and Checkout	15.6
12) Fee	6.5
	<hr/>
	100.0%

### 9.2.1 Tanks, Skirts and Interstages

Figure 9-4 gives the specific cost based on various industry sources (Boeing, Sun Shipbuilding, Dixie Steel, NASA). The .2 power trend is derived from the low cost engine hardware data shown in Figure 9-5 (Curve A). Different slopes were assumed for other components, based on TRW costing experience, despite Titan IIIC data (Ref. 27) indicating that the same exponent applies to all components of a given vehicle (Curve B of Figure 9-5). The tank scaling law shown in Figure 9-4 is represented by the equation  $C = 136 W^{-.322}$ , including tankage handling and proof testing.

### 9.2.2 Engines and Valves

The assumed engine and valve cost estimating method is illustrated in Table 9-IV and Figure 9-6 for a range of engine thrust from 200K to 2500K ( $P_c = 250$  psia and  $\epsilon = 6$ ). The estimated first stage engine costs are given in Figures 9-6 and 9-7 as a function of thrust, expansion ratio and chamber pressure. The engine and valve costs are given by the following equations:

#### Stage 1

$$\text{Cost (\$)} = 517 \left( \frac{T_{s1}}{1 \times 10^3} \right)^{.85} \left( \frac{\epsilon}{6} \right)^{.256} \left( \frac{300}{P_c} \right)^{.5}$$

#### Upper Stages

$$\text{Cost (\$)} = 710 \left( \frac{T_{vac}}{1304} \right)^{.871} \left( \frac{\epsilon}{15} \right)^{.065} \left( \frac{300}{P_c} \right)^{.5}$$

### 9.2.3 LITVC System

The specific cost given by Figure 9-4 was derived from a TRW preliminary design study.  $\$C = 573 W^{-.322}$

### 9.2.4 Pressurization System

The specific cost given by Figure 9-4 was derived from a TRW preliminary estimate.  $\$C = 368 W^{-.415}$

### 9.2.5 Roll Control System

The roll control system specific cost shown on Figure 9-4 was taken from the recent SRI study of Reference 26.  $\$C = 386 W^{-.415}$

### 9.2.6 P/U System

The P/U System cost is taken as  $573 W^{-.322}$

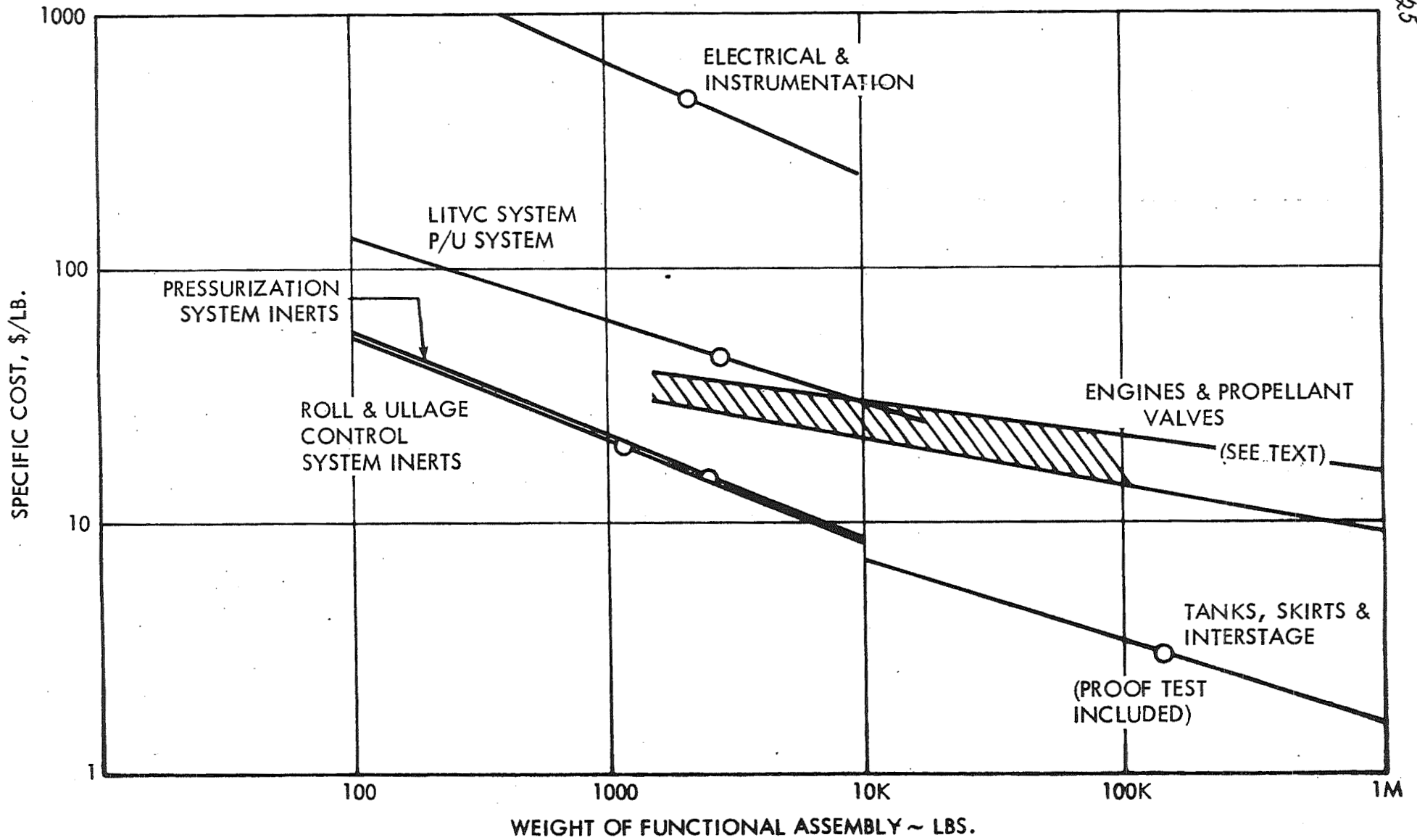
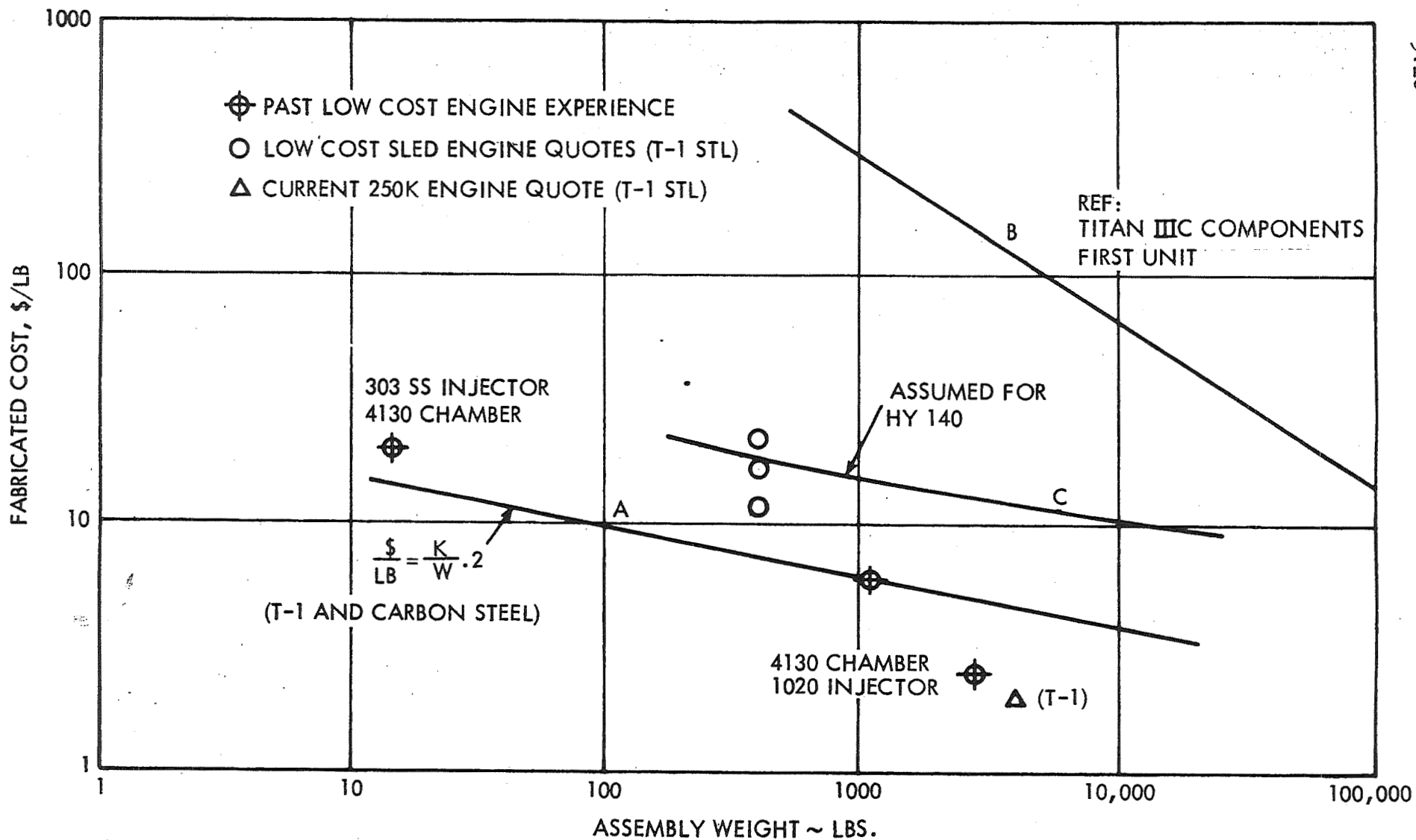

Figure 9-4 Estimates of Specific Costs for LCLV Components

225



9.10

226

Figure 9-5 Low Cost Engine Specific Cost

997

Table 9-IV

Low Cost Booster Engine Costs

( $p_c = 250$  psi,  $\epsilon = 6$ )

MATERIAL	200K			600K			1500K			2000K			2500K		
	W	\$	\$	W	\$	\$	W	\$	\$	W	\$	\$	W	\$	\$
Chamber Shell - HY140	504		(\$15.50/lb)	2050		(\$12.30/lb)	6233		(\$10.80/lb)	8900	125,700	(\$10.20/lb)	11246	152,000	(\$9.90/lb)
Injector - HY140	453	14,810		1205	40,000		1905	88,700		3418			4100		
Liner - DC93-104 \$10/lb. installed	707	7,070		2395	23,950		5600	56,000		6900	69,000		8200	82,000	
Valves -	130	1,750		335	3,500		721	6,200		910	7,300		1100	8,600	
	1794		23,630	5985		67,450	14,539		150,900	20,128		202,000	26,646		242,600
Subcontract 17.5%			4,130			11,800			26,400			35,300			42,500
ASSEMBLY ACCEPTANCE TEST (Vendor)		2000			4000			7200			8600			10,000	
Overhead at 100%		2000			4000			7200			8600			10,000	
			4,000			8,000			14,400			17,200			20,000
SUSTAINING ENGINEERING		1200			1600			2100			2250			2400	
Overhead at 120%		1440			1920			2520			2700			2880	
			2,640			3,520			4,620			4,950			5,280
MISC.			34,400			90,770			196,320			259,450			310,380
			17,200			30,800			51,000			64,900			74,500
			51,600			121,570			247,320			324,350			384,880
G A 10.5%			5,410			12,570			26,000			34,050			40,400
			57,010			134,320			273,320			358,400			425,280
FEE 7%			3,990			94,000			19,100			25,100			29,800
TOTAL COST			\$61,000			\$126,320			\$292,420			\$383,500			\$455,080

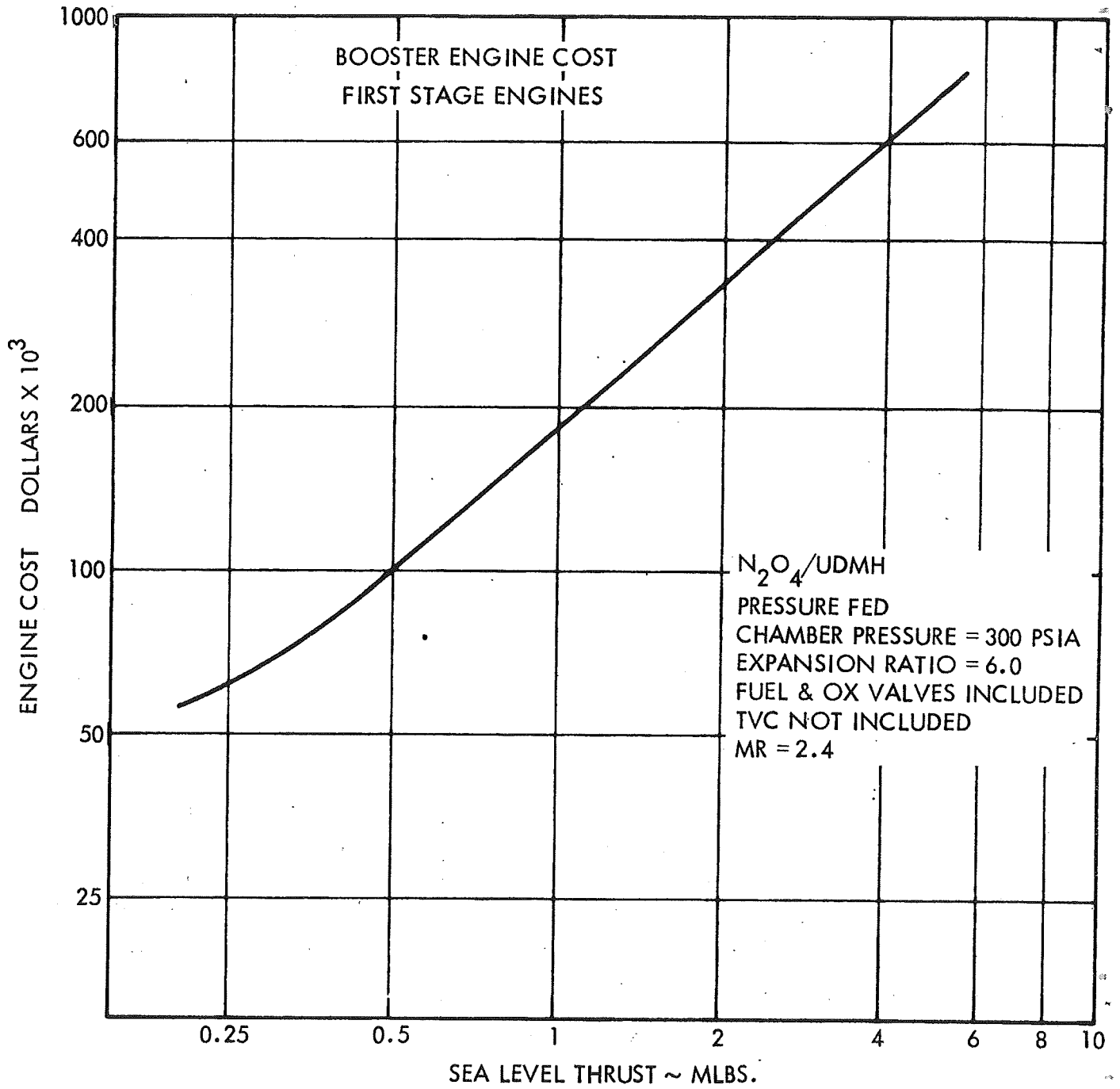

Figure 9-6 First Stage Engine 1st Unit Recurring Cost

229

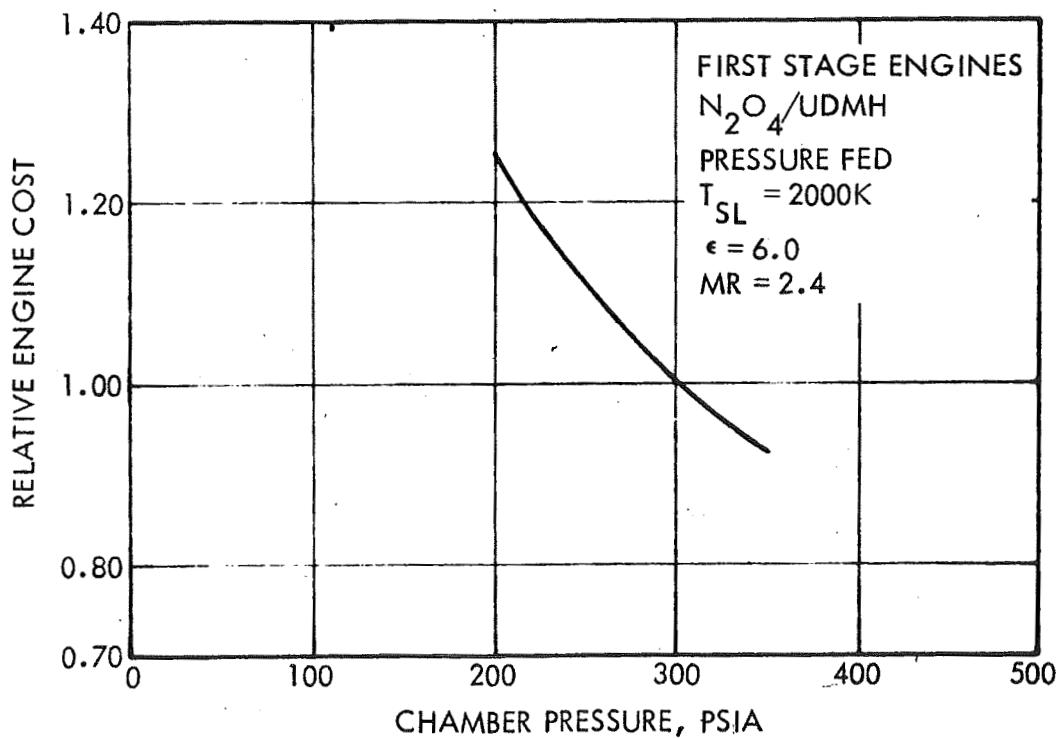
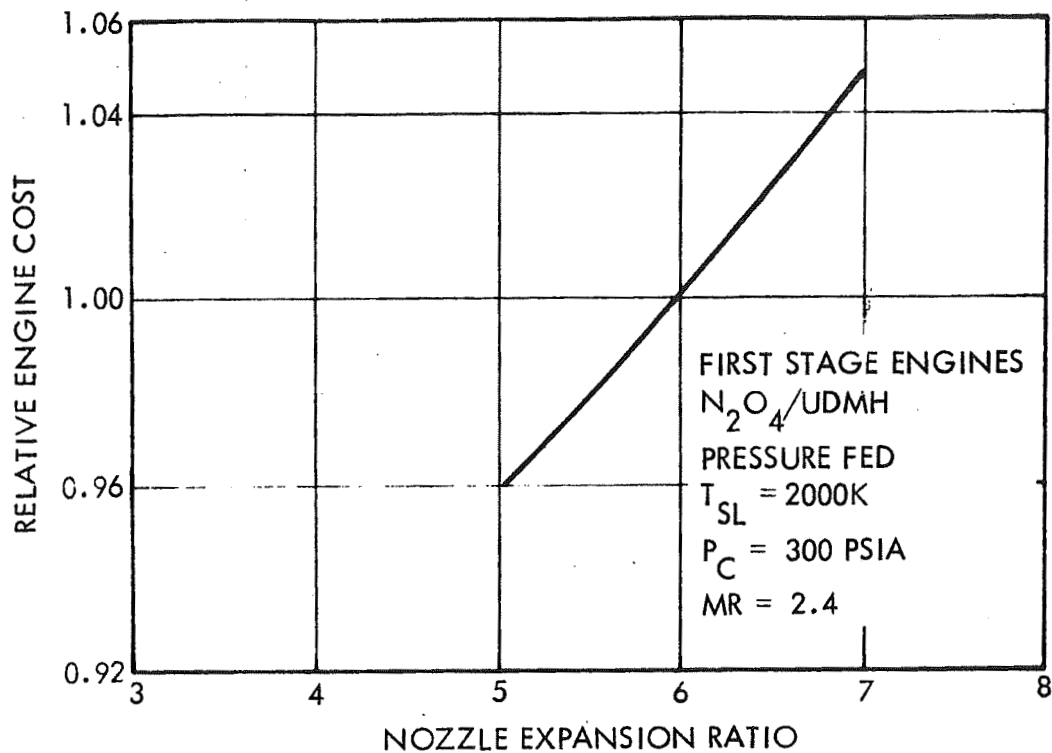

Figure 9-7 Effect of Engine Expansion Ratio and Chamber Pressure on Cost

### 9.2.7 Propellant

The following propellant costs were derived from discussions by PSD personnel with the manufacturers (Hercules and FMC Corp., respectively).

$N_2O_4$  - \$0.065/lb.

UDMH - \$0.35/lb.

Shipment Cost = \$.020/lb.

Current costs are \$.085/lb. and \$.40/lb., respectively. The projected costs were obtained from the manufacturers based on the increased utilization rates projected for the advent of a low cost booster system.

### 9.2.8 Astrionics

The Astrionics cost is estimated as follows:

Astrionics less guidance specific cost = \$13,905  $W^{-.44}$ /lb.

Guidance package cost = \$350,000

Source: Past experience (Saturn, Titan III, Section 8)

### 9.2.9 Stage Assembly Cost

The estimated stage assembly labor cost was calculated as follows:

Conventional stage - 12% of items (1) through (8)

Modular engines - 13% of items (1) through (8)

Modular tanks - 15% of items (1) through (8)

### 9.2.10 Program Management and Engineering Cost

This cost element is estimated to be 8 percent of the sum of items (1) through (9).

### 9.2.11 Final Assembly and Checkout

The estimated final assembly and checkout specific cost is taken as 20% of items (1) through (10).

### 9.2.12 Fee

7 percent of the total of cost items (1) through (11).

### 9.2.13 Recurring Cost of Baseline Engines

A cost breakdown for the baseline stage 1 engine having a thrust of 11.4M lbs. is given in Table 9- V.



Table 9- V Recurring Cost of Baseline Stage 1 Engine

<u>MATERIAL</u>	<u>W</u>	<u>\$</u>	<u>TOTAL \$</u>
Shell @ \$8/lb	59,300	582,000	
Injector	13,400		
Liner @ \$10/lb	23,000	230,000	
Propellant Valves	3,400	22,000	
	99,100 lbs.		\$834,000
Subcontract Management			146,000
ASSY. $\frac{1}{2}$ ACCEPT. TEST OH (100%)		17,000 <u>17,000</u>	
			34,000
SUSTAINING ENGINEERING OH (120%)		3,000 <u>3,600</u>	
			6,600
			<u>\$1,020,600</u>
CONTINGENCY (20%)			204,000
			<u>1,224,600</u>
G $\frac{1}{2}$ A (10.5%)			128,500
			<u>1,353,100</u>
FEE at 7%			94,700
			<u>94,700</u>
		TOTAL	<u>\$1,447,800</u>

The above estimate indicates that the overall recurring cost of the engine will be about \$14/lb of engine weight. The corresponding estimate from Reference 26 is about \$9.6/lb of engine weight.

### 9.3 Total Recurring plus Non-Recurring Costs

A summary of the recurring costs is given in Table 4-II for the six designs, in addition to several other configurations of interest.

The average unit cost (including non-recurring cost but not launch operations) for N launchings is shown in Table 9-VI for the six designs. The unit recurring cost (less launch cost) is computed for various learning curves. Numbers shown in ( ) indicate lower average unit cost than the baseline vehicle, for the same number of launchings. The break-even points for the various designs are discussed further in the following sections.

It is recognized that the assumption of a single learning curve for all the subsystems and other costs is incorrect; hence a range of values is covered in Table 9-VI. It is expected that the average value will be approximately 90 percent, but it is noted that the relative standings of the various designs are the same (with regard to break-even points) with either 90 or 95 percent.

Table 9-VI Recurring Plus Non-Recurring Costs\*

Design No.	Non-Recurr. Cost (\$M)	First Unit Rec. Cost (\$M)	Average Unit Cost (\$M)			
			Recurring plus non-recurring N=25	50	100	200
90 Percent Learning Curve						
1 (Baseline)	520	13.1	28.8	17.7	11.7	8.5
2 (Quad Mods)	534	15.8	31.1	19.5	13.2	9.8
3 (7+3+1)	471	18.9	30.4	20.0	14.2	10.9
4 (Mod. Eng.)	457	15.8	(28.0)	18.0	12.5	9.4
5 (Pump-Fed)	577	11.8	30.4	17.8	(11.6)	(8.2)
6 (PFL/S-IVB)	390	20.6**	(28.4)	19.3	14.1	11.3
95 Percent Learning Curve						
1 (Baseline)	520	13.1	31.3	20.3	14.6	11.7
2 (Quad Mods)	534	15.8	34.0	22.7	16.7	13.5
3 (7+3+1)	471	18.9	34.0	23.8	18.3	15.4
4 (Mod. Eng.)	457	15.8	(30.8)	21.1	16.0	13.2
5 (Pump-Fed)	577	11.8	32.5	20.6	(14.3)	(11.0)
6 (PFL/S-IVB)	390	20.6**	32.0	23.4	18.7	15.9

\* Not including ground support operations.

\*\*Unit cost for performance comparable to that of base line design No. 1 above.

#### 9.4 Baseline Configuration Tradeoffs

The first unit recurring cost of the baseline configuration is \$13.1M (conservative) and \$10.2 M (optimistic), as noted in Section 4.1. The conservative vehicle is estimated to have a non-recurring cost of about \$520M (Table 9-II). How much additional development cost is justified to attain the optimistic design?

The total cost of N units will be  $fN^{.85} + D$ , where f = first unit recurring cost, D = non-recurring (or development) cost, and .85 is the exponent corresponding to the 90 percent learning curve. The total cost of N units of the conservative baseline design will then be  $\$13.1MN^{.85} + \$520M$ , and the optimistic design will be  $\$10.2MN^{.85} + D_{opt}$ . The total cost will be equal when  $\Delta D = D_{opt} - \$520M = (\$13.1M - \$10.2M) N^{.85}$ , where  $\Delta D$  is the additional development cost to attain the optimistic design.

The justifiable increase in development cost  $\Delta D$  to attain the optimistic design is then determined as a function of N, as follows (see Figure 9-8):

Number of Launches N	= 10	50	100	200
Additional Devel. Cost $\Delta D$ (\$M)	= 23	81	145	260

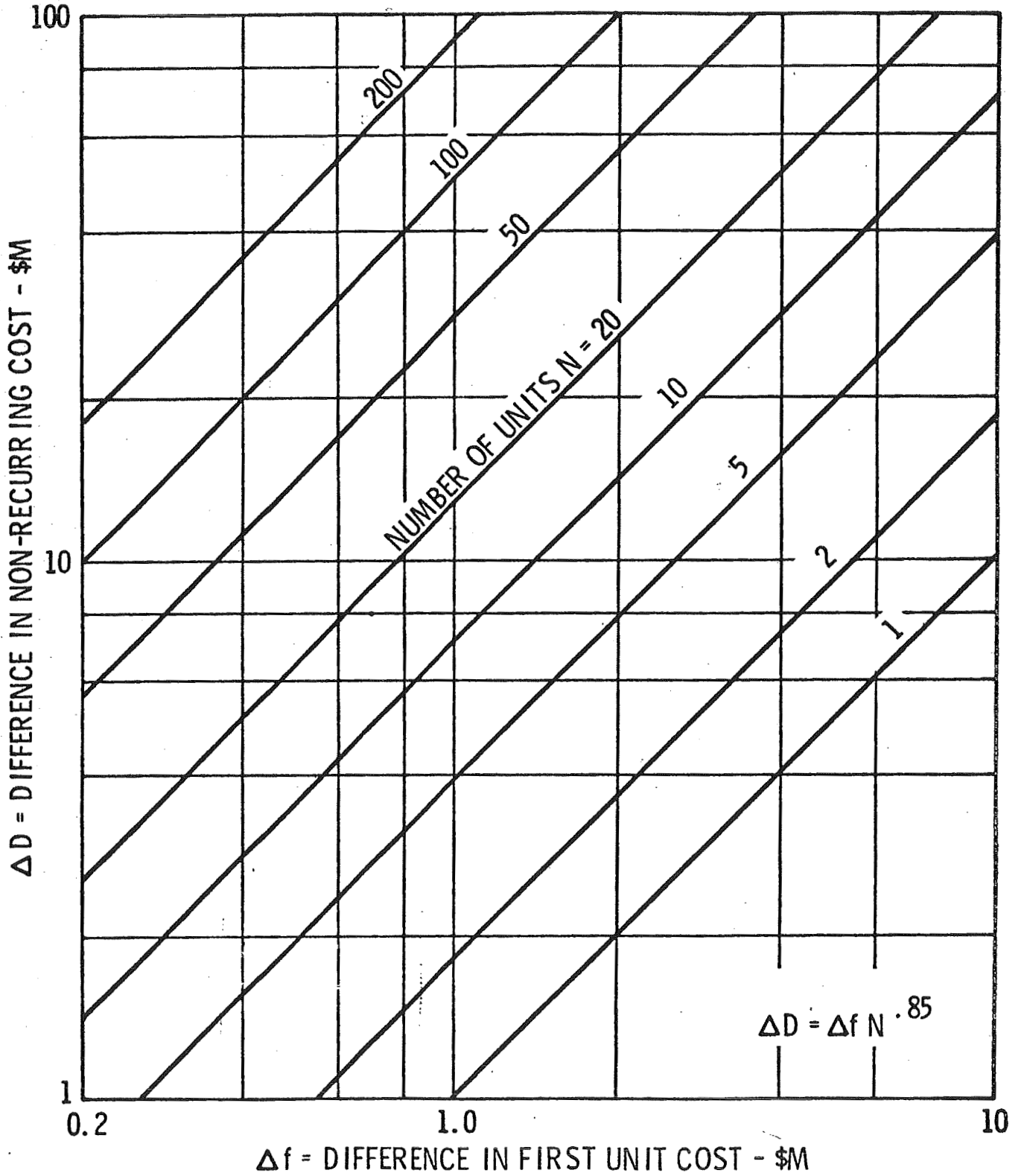

Figure 9-8 Cost Tradeoffs with 90 Percent Learning Curve

The expected number of launches is thus found to be a deciding factor in choosing the economically justifiable improvements to the conservative design. For  $N = 100$  to 200 launches,  $\Delta D$  amounts to \$145M to \$260M respectively. The improvements under consideration (see Table 4-I) are as follows:

- Reduction in Safety Factor from 1.5 to 1.4 in all stages
- Increase in  $I_{sp}$  by 2 percent (approx. 6 sec) in all stages
- Decrease in inert weight of 5 percent in all stages

The estimated DDT&E cost to develop the conservative design in the structures and propulsion categories is \$209M (Table 9-II). The question is whether the above improvements can be attained if the development funding of these categories is approximately doubled. The answer cannot be certain at this time, because further engine testing is needed to determine the confidence level on  $I_{sp}$  efficiency; and detailed analysis of the vehicle structures and subsystem weights are needed, beyond the scope of the present study. For the present, it appears desirable to retain the conservative design and cost numbers as the basis for planning.

#### 9.5 Economics of Modular Units

In Designs No. 2, 3 and 4 (see Figure 4-4), it is proposed to assemble stages and LV's by the use of smaller modules of tanks and/or engines. The relative costs of such assemblies can be compared with those of the baseline configuration (Figure 4-1) by the following procedure.

Recurring Costs. The total cost TC of fabricating  $N$  units, assuming a learning curve of 90 percent, is  $TC_1 = f_1 N^{.85}$  where  $f_1 = W_1 r_1$  = first unit cost,  $W_1$  = weight of the unit and  $r_1$  = cost per pound. Alternatively, if each of the above units is assembled from  $n$  modules, the total cost will be  $TC_n = f_n (nN)^{.85}$ . In the latter case, the first unit cost  $f_n = W_n r_n$ , where  $W_n = W_1/n$  (assuming the total weights to be equal), and  $r_n = r_1 (W_n/W_1)^k$ , where  $k$  ( $= -.2$  to  $-.3$ ) represents the exponential scaling law for cost/lb vs unit weight. The ratio of total cost will then be

$$\begin{aligned} TC_n/TC_1 &= (f_n/f_1)n^{.85} = n^{.85-k-1} \\ TC_n/TC_1 &= n^{.05} \text{ when } k = -.2 \\ &= n^{.15} \text{ when } k = -.3 \end{aligned}$$

For quad units ( $n = 4$ ), the ratio of total cost will then range from 1.07 to 1.23 for  $-.2 > k > -.3$ , showing that the fabrication cost for the assembled quad units will be slightly greater than for the single units. The difference

will actually be somewhat greater than 7 to 23 percent due to the cost of assembling the modules, and the slightly higher structural weight required to join the modules together. Machine runs indicate the increase to be about 21 percent (see Section 4.2).

For the 7+3+1 modular combination ( $n = 11$ ), the ratio of total cost ranges from 1.13 to 1.43 for  $-.2 > k > -.3$ , showing that the modular assembly will be at least 13 to 43 percent greater than for the single unit. Machine runs indicate the increase to be about 45 percent (see Section 4.3).

Non-Recurring Costs. The cost of engine tests through QUAL is almost directly proportional to the engine thrust  $T$ , according to the equation  $C = \$33M + 5.8 T = \$100M, \$46M$  and  $\$35M$  for the three baseline engines, respectively (Figure 9-3). Corresponding costs for quad engines will be  $\$50M$  and  $\$36M$ , respectively, for the 1st and 2nd stages. The engine for the 7-cluster will cost  $\$43M$  to develop. After PFRT, the clustered modules will need to be tested a number of times for stage acceptance, at a cost approximately equal to the PFRT cost of the single module. Hence, the total development cost of the modular engine and cluster will be twice that of the modular engine above. The relative values are approximately as in Table 9-VII (assuming equal thrust for the three modes).

Table 9-VII Development Cost for Modular Engines and Clusters

	Stage 1 \$M	Stage 2 \$M	Stage 3 \$M	Total \$M
Single engine in each stage	100	46	35	181
Quad engines in 1st & 2nd stages 3rd stage engine like 2nd stage (except $\epsilon$ )	100	72	10	182 (Quad saves money on single engine tests, but more expensive for cluster testing)
7 + 3 + 1 Modules Same modules in all stages (except $\epsilon$ )	86	25	10	121 (Fully modular saves enough on single module tests to compensate for cluster testing)
Modular Engines (9+3+1)	82	25	10	117

The above data show that the DDT & E cost for quad engine modules will be approximately the same as for the baseline configuration, while a saving of  $\Delta D = \$60M$  is found for the 7+3+1 combination, and a saving of  $\$64M$  for the modular engines. These savings justify slightly higher first unit recurring costs of  $\$4.0M$  for  $N = 25$ , or  $\$2.2M$  for  $N = 50$  (Figure 9-8). However, as

noted previously in this section, the recurring cost of the 7+3+1 modular LV is about 45 percent higher than the baseline ( $\Delta f \doteq \$4.7M$ ); hence the saving in development cost is quickly absorbed by the increase in production cost, the break-even point occurring at  $N \doteq 13$ . For the modular engines, the break-even point occurs at  $N \doteq 35$ .

The above considerations prove analytically that the various modular concepts represented by Designs No. 2, 3 and 4 fail to show sufficient economic advantage over the simpler baseline configuration to justify their selection for the LCLV. A similar conclusion is reached in Table 9-VI, using machine computed vehicle weights and recurring costs.

#### 9.6 Low Cost Pump-Fed LV

The first unit recurring cost of the pump fed LV is estimated to be \$11.8M, or \$1.3M less than the conservative baseline design. From Figure 9-8, the additional justifiable funding for the turbo pump and associated developments will be  $\Delta D = \$37M$  for  $N = 50$ , and \$65M for  $N = 100$ . Reference 28 provides estimates in the range of \$40M - \$100M for the development of the required low cost turbo pumps. Using the lower value, cost savings will only be attained after producing  $N > 50$  vehicles of this type. A more optimistic analysis shown in Table 9-VI indicates  $N \doteq 100$  to be the break-even point, with only 4 percent saving at  $N = 200$ ; hence, the economic potential of this design is low.

Another adverse effect of the pump fed system (not included in the above analysis) is its increased complexity, which will result in added cost for checkout, countdown and other operational categories. When viewed objectively with the aid of the foregoing analyses of the two systems, it appears that the potential savings by use of the pump fed system do not justify its selection as the preferred candidate for the low cost launch vehicle.

#### 9.7 PFL Booster plus S-IVB Stage

If the S-IVB stage is used without modification, with a large PFL booster stage as described in Section 4.6, the first unit recurring cost of the 2-stage vehicle is \$26M, or  $\Delta f = \$26M - 11M = \$15M$  higher than the corresponding baseline LCLV having 100K lb payload to LEO (Figure 4-3). One advantage of this vehicle lies in the possibility of reduced acquisition cost, since only one new stage is to be developed, at an estimated cost of \$200M (See Section 4.6 and Table 9-II), plus facility changes and man rating (assumed at \$90M), bringing the total

non-recurring cost to \$290M, or a saving of  $\Delta D = \$230M$  compared to the baseline vehicle. The break-even point is then at  $N = 25$ , below which the 2-stage vehicle is less costly. Figure 9-9 shows the BEP vs NRC and S-IVB cost.

If the S-IVB is stripped down to reduce its cost from the original \$20M to \$12M, with an assumed development cost of \$100M (other non-recurring costs as stated above),  $\Delta f$  becomes \$7M and  $\Delta D = \$130M$ . The break-even point then increases to  $N = 32$ , below which the 2-stage vehicle is less costly.

Obviously the PFL/S-IVB combination, by virtue of its lower acquisition cost, is a marginal candidate. However, for a program of 100 launchings, it would be only 20 percent more costly than the baseline vehicle, even if the S-IVB costs \$12M. This conclusion will change if the recurring and non-recurring cost of the Saturn IB are found to be lower\* than the values assumed above, in which case this combination of stages will be more nearly competitive with the baseline vehicle, as indicated by the points at the left side of Figure 9-9.

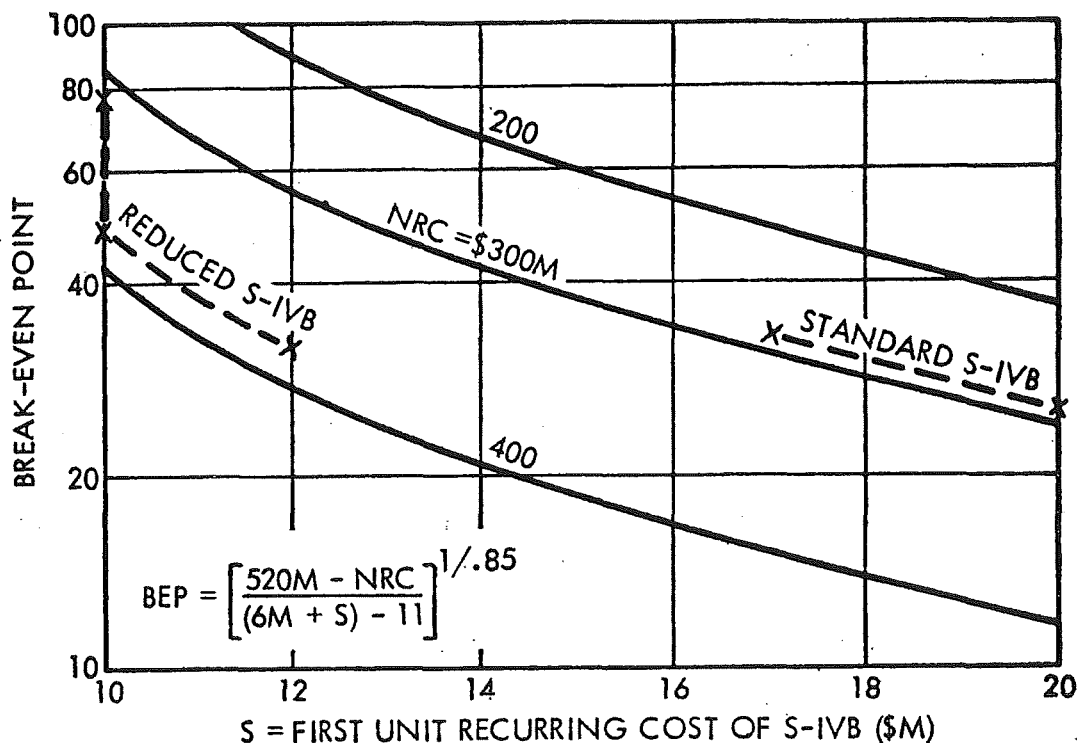

Figure 9-9 Break-Even Points for PFL/S-IVB vs. Baseline ICLV

\*McDonnell-Douglas studies indicate the current S-IVB cost to be about \$17M, which they believe could be reduced to \$10 after a development program costing \$19M. TRW estimates the S-IVB at \$12M, incl. a low cost G & C/IU section. This value should be reduced to approximately \$8M to break even at  $N = 100$ .

9.22

Other LV's with S-IVB Upper Stage. (See Figure 4-6) The small PFL+S-IVB vehicle discussed in Section 4.6 will have a first unit recurring cost of \$13-15M, and a NRC of \$100-200M, depending on how the stage costs are amortized. The average cost per launching for N=100 will range from \$12M to \$14M, including ground support (\$4M/launching) and NRC. This vehicle is therefore less costly than the Saturn IB for payloads in the range below 50K lb.

The Big LCLV, consisting of Stages 1 and 2 with S-IVB upper stage (costing \$12M) will have a first unit cost of approximately \$18M (after producing 100 LCLV's), and a NRC of \$160M (after amortizing the LCLV stage development and facility costs). The average cost per launching will be \$42M for small quantities (N=25) of the Big LCLV, or \$200/lb including NRC and ground support (\$17M/launching). If the enlarged S-IVB (35 percent more propellant) can also be produced for \$12M, the cost/lb decreases to \$168/lb for the 250K lb vehicle. For larger quantities (N=100), the cost drops to \$80/lb, reflecting the broader base for amortizing the NRC.

The saving in total LV cost for the program described in Table 2-II amounts to \$600M, this saving attributable to use of the Big LCLV instead of Saturn V, thus providing a large payoff for the nominal development funds invested.

The characteristics of a complete family of related LCLV's (some with S-IVB upper stages) is shown in Table 1-I.

### 9.8 Payload Versatility

A desirable feature of the LCLV family would be its ability to launch smaller payloads (less than 100K lb to LEO) with corresponding savings in LV cost. For example, a vehicle using quad modules in the first two stages would employ 4 + 4 + 1 modules to give 100K lb to LEO, but only 2 + 2 + 1 modules to give 40,000 lb to LEO, thereby saving about 48 percent of the vehicle gross weight, and about 20 percent in the total cost per launching.

Four LV concepts (Designs No. 1, 2, 3 and 4) are compared in Figure 9-10 from the standpoint of versatility. The 3-stage version of designs No. 1 and 4 do not have much versatility to reduce the cost for smaller payloads, except the rather inefficient combination of Stages 1 + 2 to launch 50K lb to LEO. However, the 4-stage baseline vehicle will give 150K lb to LEO, and the 3-stage lclv (stages 2 + 3 + 4) will give 30K lb to LEO.

Design No. 2 has a range of payload from 10K lb (1 + 1 + 1 modules) to 120K lb (5 + 5 + 1), with appreciable savings in LV cost for the lesser payloads (to be traded-off against the added development cost for proving the various LV's having different numbers of modules).



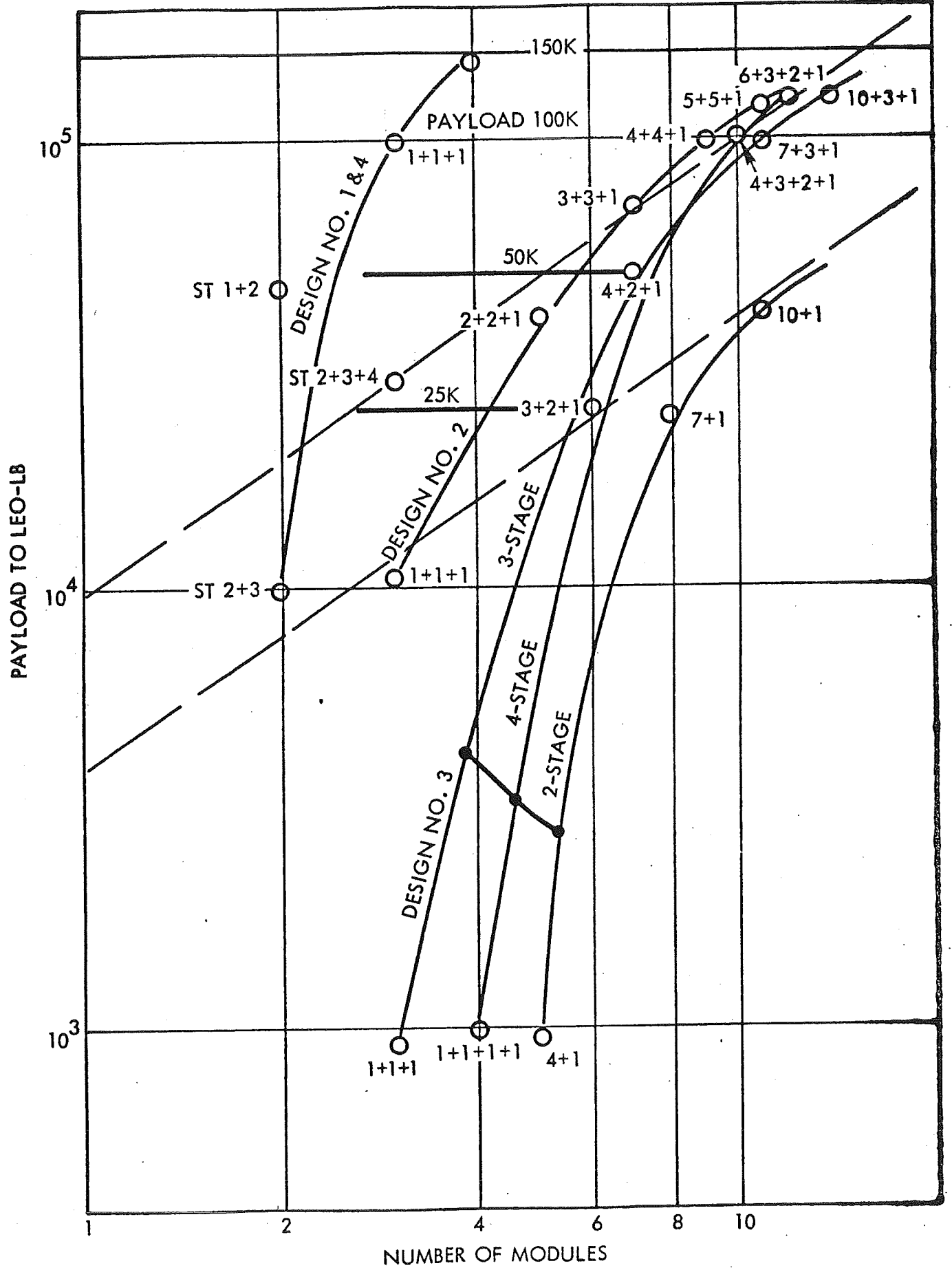

Figure 9-10 Payload Versatility for LEO Missions

Design No. 3 likewise has the capability of adjustment to fit the payload-velocity required. For example, the 7 + 3 + 1 module combination chosen for 100K lb LEO can be reduced to 4 + 2 + 1 for 25K lb LEO with corresponding savings in cost. When used as two-stage LV's, however, the payload of the 10 + 1 combination drops to 40K lb (compared with 100K lb for the 7 + 3 + 1, same number of modules). This again shows that the 3-stage vehicle is far more effective to LEO than the 2-stage vehicle having the same design parameters.

Despite the seeming attractiveness of assembling smaller launch vehicles from the same modules used for the full size LCLV, the total cost of this approach is generally greater than to produce and launch a few more of the full size LCLV's, which is competitive in cost with current launch vehicles, down to payloads of about 10K lb. In general, it is more economical to standardize on the baseline LV for all payloads greater than about 10K lb, for assumed missions and costs.

A notable exception to the above rule is believed to be the small 3-stage version of the baseline LCLV (Stages 2 + 3 + 4), designated lclv (see Figure 4-1). Having conducted acceptance tests on each of the upper stages, the additional DT&E cost to adapt the booster engine and prove out the smaller vehicle is minimal, as are the ground support costs. The first unit recurring cost of the lclv will be about \$6M (Table 9-VIII), and the non-recurring cost about \$153M. With a constant ground support cost of \$3M/launching, the overall cost/launching will then be \$7.5M/unit for N = 100, or \$250/lb to LEO. The lclv is only 45 percent as costly as the LCLV; hence, this vehicle is a desirable addition to the LCLV family for Class I and Class II payloads.

Table 9-VIII Recurring and Non-Recurring Costs for lclv

System	Stage 1		Stage 2		Stage 3		Total	
	f	NRC	f	NRC	f	NRC	f	NRC
Propulsion	\$.96M	\$9M	\$.26M	\$1M	\$.10M	\$34M	\$1.32M	\$44M
Structure	.51	2	.13	1	.06	3	.70	6
Astrionics	.51	1	.20	1	.41	37	1.12	39
Stage Integration	.80	1	.70	1	.25	3	1.75	5
Management, fee, etc.	.45	3	.45	1	.21	15	1.11	19
	\$3.23M	\$16M	\$1.74M	\$5M	\$1.03M	\$92M	\$6.00M	\$113M
							lclv DDT & E	\$113M
							Tooling	5
							Ground Support	10
							Man Rating	25
							Total NRC	\$153M

241

## 10. DEVELOPMENT PLAN AND MANAGEMENT POLICIES

The LCLV has been designed to facilitate a low cost/short time development program. Features have been selected which will be relatively easy to design and develop. Performance margins have been made conservative enough that extensive iterative testing will not be required to attain the level of performance and reliability required. Simplified methods of fabrication permit the construction of experimental hardware with simple tooling and minimum lead time; hence, the test program can get underway soon after go-ahead. Maximum utilization has been assumed of existing facilities at KSC.

### 10.1 Principal Milestones in Development

The development is paced by the engine test program. Fortunately, the 3M lb thrust engine being sponsored by AFRPL is already in the design phase and expected to undergo initial firing tests early in 1970. This engine provides an important building block for the LCLV, since it is required for the 2nd stage (and might be used in quad form for the 1st stage). A typical milestone schedule for the 3M lb engine development is shown in Figure 10-1. A similar schedule might be drawn for the 12M lb engine, if further study reveals the desirability of proceeding with the single unit.

The vehicle development (definition phase) is assumed to start in early 1970, to result in a first LCLV flight in 1973 (Figure 10-2). Five launchings are assumed to be required for man rating qualification. Other milestones in the overall development program are indicated in Table 10-3, to insure the availability of ground support facilities for the first flights, and the commencement of production during '73/'74. These schedules are believed to reflect a similar degree of conservatism as characteristic of other portions of this study. They are keyed to the funding schedule shown in Figure 10.4, as derived in Section 9 for a launch rate of 1 vehicle per month.

### 10.2 Effect of Mission Program on Development Plan

As pointed out in Section 2, the coordination of mission estimates with expected LV budgets provides the essential basis for a development and production plan. This study has been based on unofficial estimates of 100 or more flights for the LCLV, to satisfy an overall program as outlined in Table 2-II, within a budget less than current NASA/DOD expenditures for launch vehicles of this type. The average LV cost (for vehicles of all types) of about \$300M per year for the 12 year period is believed reasonable, and in line with the trend to curtailment of the annual budget for the Space Program.



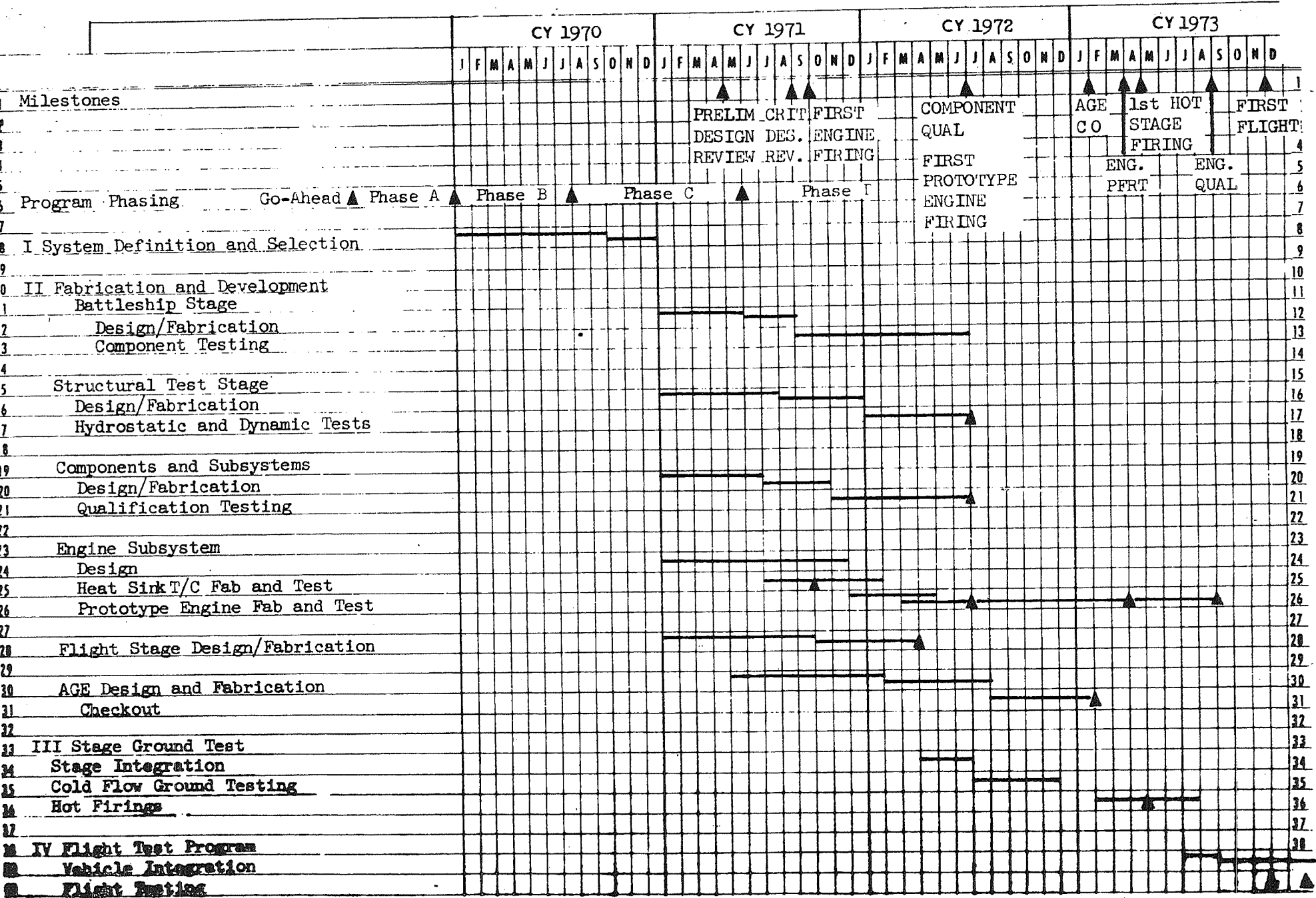

Figure 10-2 Development Schedule for LCV

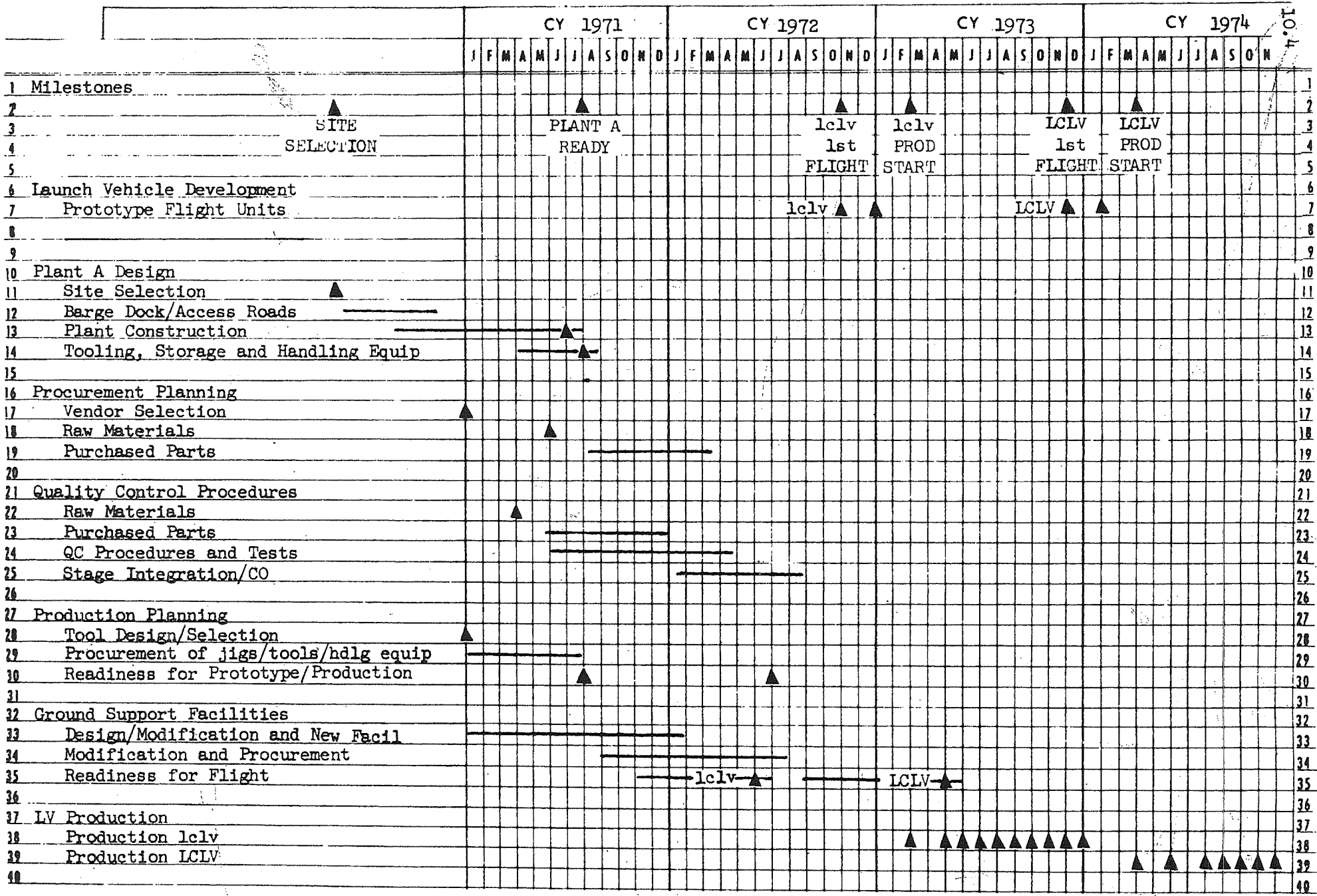

Figure 10-3 Overall Development Schedule for Production of LV's

the

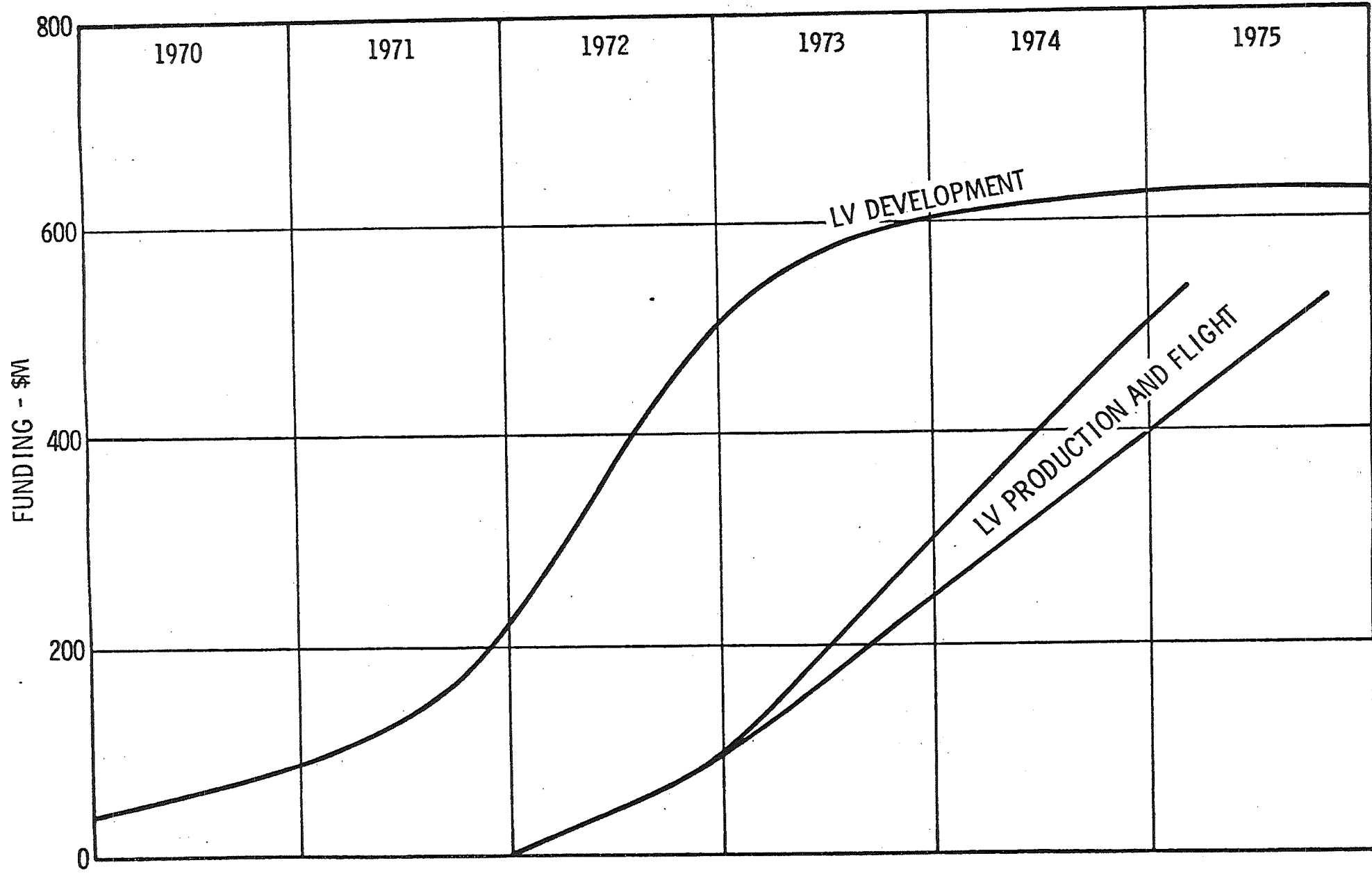

Figure 10-4 Funding Schedule for LCLV/LCLV Development

While the above cost savings are due primarily to the addition of the LCLV to the NASA family, additional savings of \$400M can be attained by adding the lesser lclv to the vehicle mix (for an NRC of \$150M), and a further saving of \$600M by adding the Big LCLV (for an NRC of \$160M). When the official mission plan is made available, the (small or large) PFL+S-IVB may be found to be beneficial from the standpoint of economics and payload versatility. The effect of adding these vehicles to the LCLV program may cause minor extensions of the above schedules.

#### 10. Sequence of Development of lclv and LCLV

Depending on the official mission plan and its LV availability requirements, it may prove desirable to concentrate the early development effort on the lesser lclv for economies in the Class I and Class II mission categories (payload of 5 to 30K lb). This vehicle can be developed approximately one year sooner than the LCLV, with a non-recurring cost less than one-half as great as the larger vehicle. Its availability for 1973 launches will result in the accrual of savings at an earlier date.

Whereas this study was originally chartered to investigate the payload range of 40 to 100K lb, and the lclv was found to be an economical by-product for missions in the 5 to 30K lb range, it now appears desirable for development timing to reverse the emphasis, making the LCLV and Big LCLV logical extensions of the lclv program. This is consistent with the principle of proving the small stages first as an important economy of low cost development.

The alternate development plan with lclv matches properly with that of the LCLV, whose engine will become available after the lclv has been proven in flight, leaving only the large first stage to be proven on the first LCLV flight.

Alternate Programming. Many other sequences of development are possible to assemble the vehicles shown in Figure 1-1 with the building blocks listed in Table 1-II. Such alternate sequencing should be planned with the overall family in mind, to insure that the stage building blocks will match properly when assembled in various ways, as described. For example, note the following sequence ABCD:

A. An interim low cost vehicle with low initial DDT&E cost is the small PFL+S-IVB, giving 50K lb to LEO with an NRC of approximately \$185M. The 3M lb thrust engine is expected to be tested in 1970, forming the basis for the small PFL booster stage, which can later be converted into Stage 2 of the LCLV. While the small booster stage is being developed, the cost reduction program on the S-IVB stage can be accomplished, to culminate in a flyable vehicle during 1972.



B. About one year later, the large PFL+S-IVB vehicle could be made available, using Stage 1 of the LCLV with the low cost S-IVB, to give 100K lb payload to LEO for approximately \$160M additional development funding.

C. The Big LCLV could then be assembled from Stages 1 and 2 plus S-IVB (Stage 2 being converted to this application by adding a nozzle extension to the small booster described in Step A. This vehicle provides a low cost replacement for the Saturn V. To attain equal performance to LEO, the enlarged S-IVB stage can be employed with moderate increase in funding (the stretched version having been planned during the above cost reduction program on the S-IVB).

D. To attain the cost saving features of the lclv/LCLV family, the development of Stages 3 and 4 should be fitted into the above schedule in a manner beneficial to the overall development. Since the PFL stages are geometrically and operationally similar, early (functional) development of the smaller stages will serve like scale models, to reduce the development cost of the larger stages.

#### 10.4 Overall Management Policies

It is essential to the success of the LCLV program that the management policies be wisely selected for compatibility with the ultimate objectives of providing a quality product and smooth operations at minimum cost. Decisions in this regard have important bearing on the formulation of an overall development plan.

Further consideration is needed, for example, in the following areas:

- Optimum vehicle mix to satisfy the (as yet unspecified) official mission program, coordinated with expected budget allocations.
- LCLV development program, by contractor using Government test facilities. Facilities at KSC, MTF, MSFC or RPL. NASA avoid large personnel increase.
- Fabrication and launch operations by single contractor, with full responsibility for on-site manufacture, checkout and launch.
- Fixed price contract (FOB, orbit) with block buy (possible incentives for extra performance and reliability).
- No change philosophy except: Block changes on separate contracts.
- Possibly LCLV contractor takes over Saturn V launch responsibility. How to keep Saturn V alive at moderate cost? or to retire it in favor of the PFL+S-IVB (the Big LCLV) with >200K lb to LEO?
- Means to assure quality with fewer personnel involved.
- Relationship between NASA and prime contractor. Qualification specifications to fit fixed price contract (Modified AFSCM 375)  
Buy-off by NASA after inspection by prime (separate from production)  
Flight operations control. Who says Go?

These and other important management decisions, beyond the scope of the present study, need to be evolved in the coming months, to define a management plan of maximum benefit to the national economy and the success of the space program.

## APPENDIX A

## PARAMETRIC WEIGHT AND ENGINE DATA

This appendix presents the agreed upon (by study team members) LCLV component weight and cost assumptions to be used in the preliminary design phase. Supporting data and the sources for each assumption are also given. (It should be recognized that these assumptions are not final and will undergo modifications as the program progresses).

## 1. WEIGHT SCALING LAWS

## STRUCTURE

Tanks:

1.  $\sqrt{2}$  bulkheads
2. HY-140 steel using 140,000 psi welded ultimate at 600° F
3. FS = 1.5 on ultimate
4. Nonoptimum factor =  $1.842 / (\text{Tank Vol.})^{.0409}$
5.  $P_o = P_c + 140$        $P_{o,f}$  = Oxidizer, or fuel, tank pressure
6.  $P_f = P_c + 50$        $P_c$  = chamber pressure

Interstage and Separation

The interstage weight  $W_i$  is given by:

$$W_i = \pi D L \rho \left[ R \left( \frac{.43 W n}{R^2 E} \right)^{.6} \times \text{NOF} \right]$$

where

D = Interstage diameter, in.

R = Interstage radius, in.

L = Interstage length, in.

$\rho$  = Material density

W = Weight supported

n = Maximum acceleration

E = Modulus of elasticity

NOF = Nonoptimum factor = 3.0 (includes bending moment effect and separation provisions)

Source: experience correlation

Cluster Structure:

10% of stage jettison weight less cluster structure and miscellaneous equipment.

Source: experience correlation

Fairings:

1 lb/in of stage length

Source: experience correlation

Base Heating Provisions:

1 lb/ft<sup>2</sup> of base area (single engine)

2 lb/ft<sup>2</sup> of base area (multiple engines)

Source: experience correlation

## PROPULSION

Engines:Stage 1

$$W = \left( \frac{T_{s1}}{122.5} \right) \left( \frac{T_{s1}}{1 \times 10^6} \right)^{.027} \left( \frac{\epsilon}{6} \right)^{.267} \left( \frac{300}{P_c} \right)$$

Upper Stages

$$W = 8.75 \left( \frac{T_{vac}}{1304} \right)^{1.028} \left( \frac{\epsilon}{.15} \right)^{.096} \left( \frac{300}{P_c} \right)$$

Engine Length: (from top of chamber to end of nozzle)

$$L = 1.465 D_T + .25 \left[ 10\epsilon - 50 \left( \frac{\epsilon}{6} \right)^{1.05} \right] D_T$$

Where

$D_T$  = Throat diameter

$\epsilon$  = Nozzle expansion ratio

Source: PSD preliminary design studies

Propellant Utilization System:

$$W = 2.28 \times 10^{-4} W_p$$

Source: experience correlation

Pressurization System Liquids*		Stage 1 ( $P_c = 300$ )	Upper Stage ( $P_c = 200$ )
$N_2O_4$	In separate tanks	.00131	.00094
	In main tanks	.00811	.00630
$H_e$		.00003	.00003
	$W/W_p =$	.00945	.00727
UDMH	In separate tanks	.00249	.00195
	In main tanks	.00153	.00110
$H_e$		.00005	.00005
	$W/W_p =$	.00407	.00310

Pressurization System Hardware:

Stage 1 ( $P_c = 300$  psia)

$$W = .003 W_p$$

Upper Stages ( $P_c = 200$  psia)

$$W = .002 W_p$$

Source: PSD study

Total MTI Propellant in Separate Tanks:

$$W/W_p = .00388 \text{ (Stage 1)}$$

$$W/W_p = .00298 \text{ (Upper Stages)}$$

Total MTI Propellant in Main Tanks:

$$W/W_p = .00964 \text{ (Stage 1)}$$

$$W/W_p = .00740 \text{ (Upper Stages)}$$

Source: PSD study

CONTROL SYSTEMS

LITVC Hardware

$$W = .002 W_p$$

Source: Average of estimates which vary from .001  $W_p$  to .003  $W_p$

LITVC Propellant ( $N_2O_4$ )

$$W = .01 W_p$$

Source: PSD preliminary design study

\*This system with pressurized injectant tanks, represents an alternate, somewhat heavier, approach than that described in Section 5.

Roll/Ullage/Attitude Propellant (UDMH):Stage 1, 2

$$W = .002 W_p$$

Stage 3, 4

$$W = .006 W_p$$

Source: preliminary design estimate

ASTRIONICS (Navigation and guidance, power and electrical distribution, data acquisition, wiring, installation, range safety and separation.)

Top Stage

$$W = .005 \times (\text{stage jettison weight less astrionics}) + 500$$

Lower Stages

$$W = .003 \times (\text{stage jettison weight less astrionics})$$

Source: Experience correlations

## RESIDUALS

Liquids

$$W = .01 W_p \text{ (without P/U System)} \quad .005 W_p \text{ (with P/U System)}$$

Source: PSD P/U Study

Gases

$$W = .0134 W_p \text{ (} P_c = 300 \text{ psia)}$$

$$W = .0104 W_p \text{ (} P_c = 200 \text{ psia)}$$

Source: PSD study

## CONTINGENCY

$$W = .10 \times (\text{stage jettison weight less contingency})$$

Source: experience correlation

## 11. ENGINE CHARACTERISTICS DATA

Additional engine characteristics data are given in Figures A-1 through A-15.

Engine weight - Figures A-1 and A-2

Engine performance - Figures A-3 through A-9 (The specific impulse given by these figures represents a 92 percent of shifting equilibrium performance level. For this program the specific impulse should be ratioed down to 90 percent).

Engine dimensions - Figures A-10 through A-15

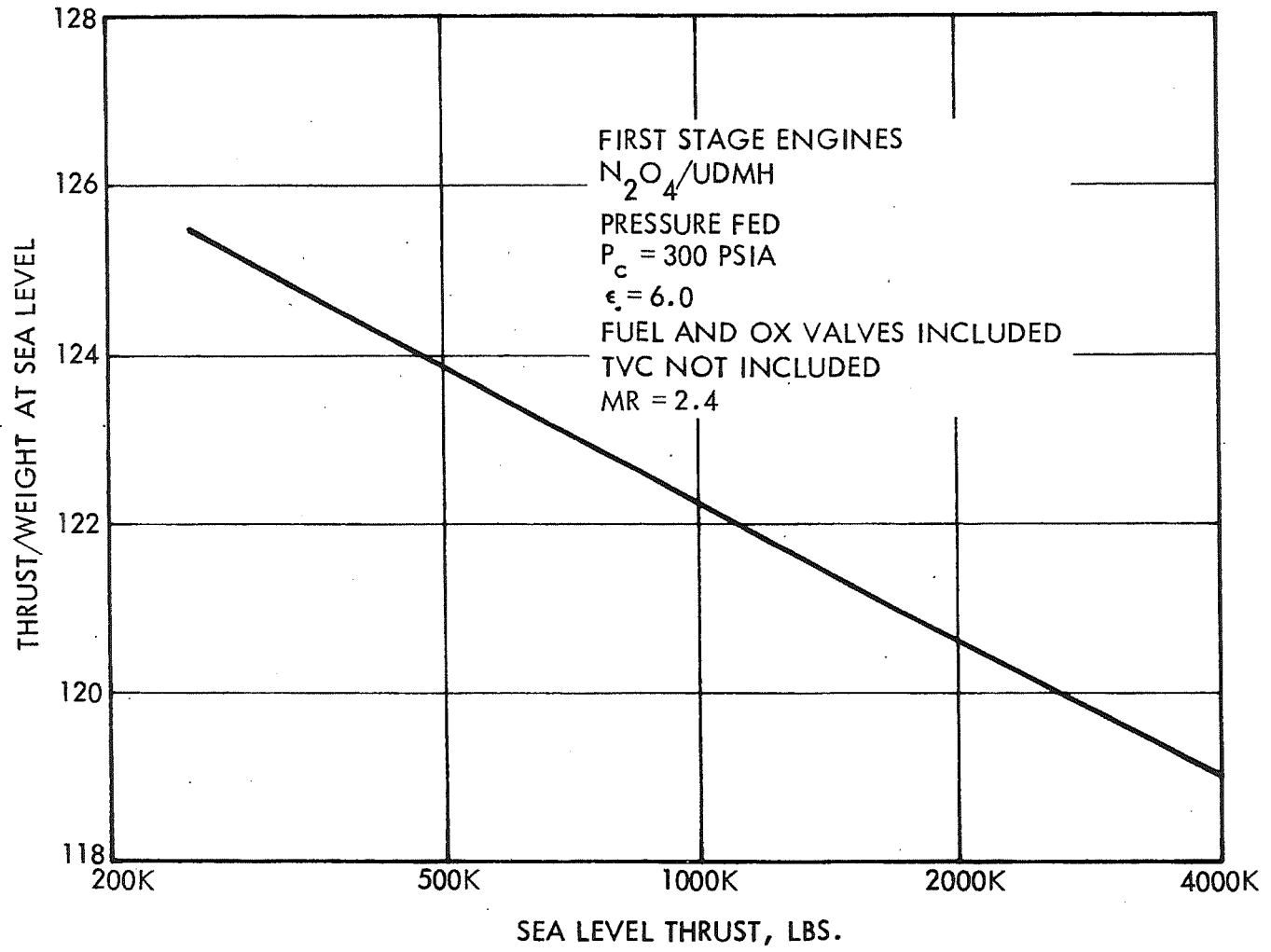

Fig. A-1 Booster Engine Thrust/Weight

EFFECT OF EXPANSION RATIO  
ON ENGINE THRUST/WEIGHT  
FIRST STAGE ENGINES

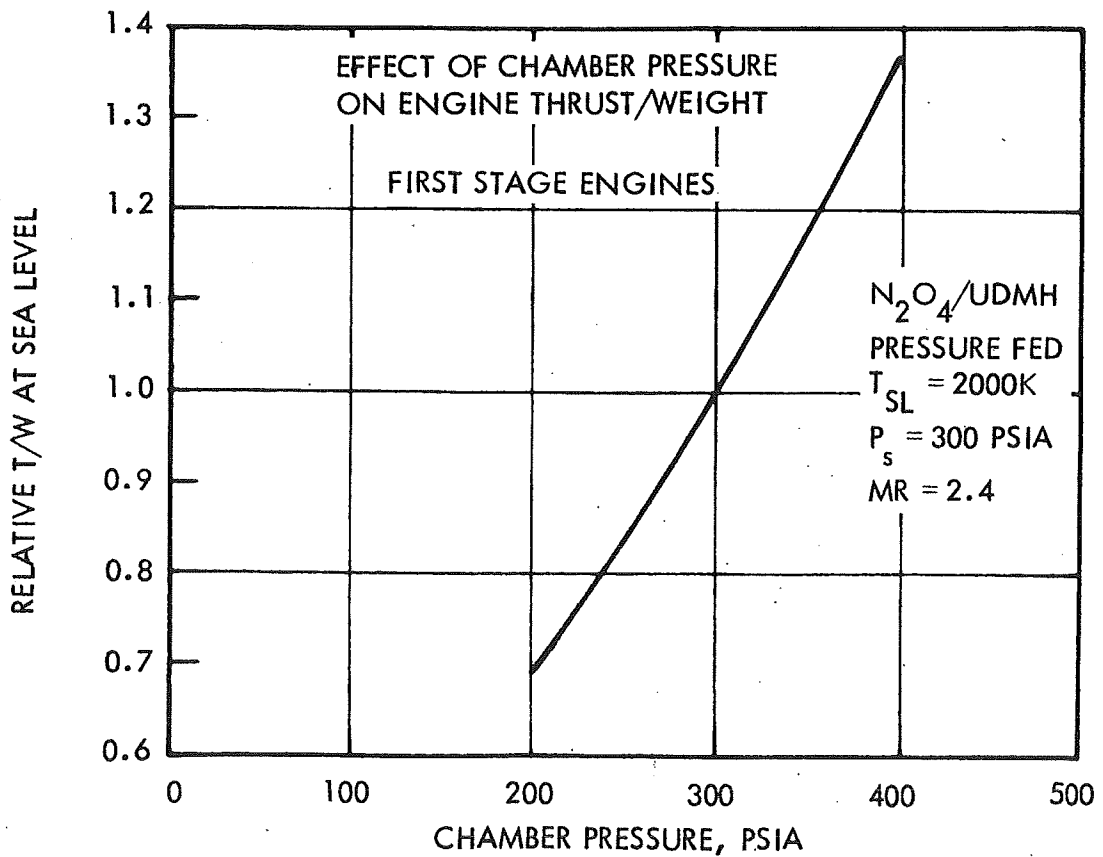
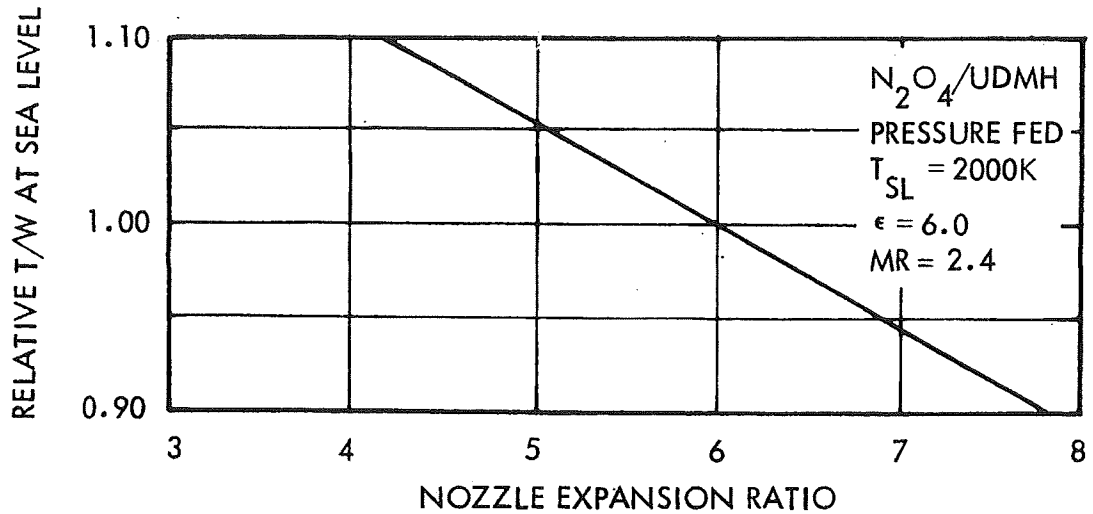

Figure A-2 Engine Thrust/Weight vs Expansion Ratio and Chamber Pressure



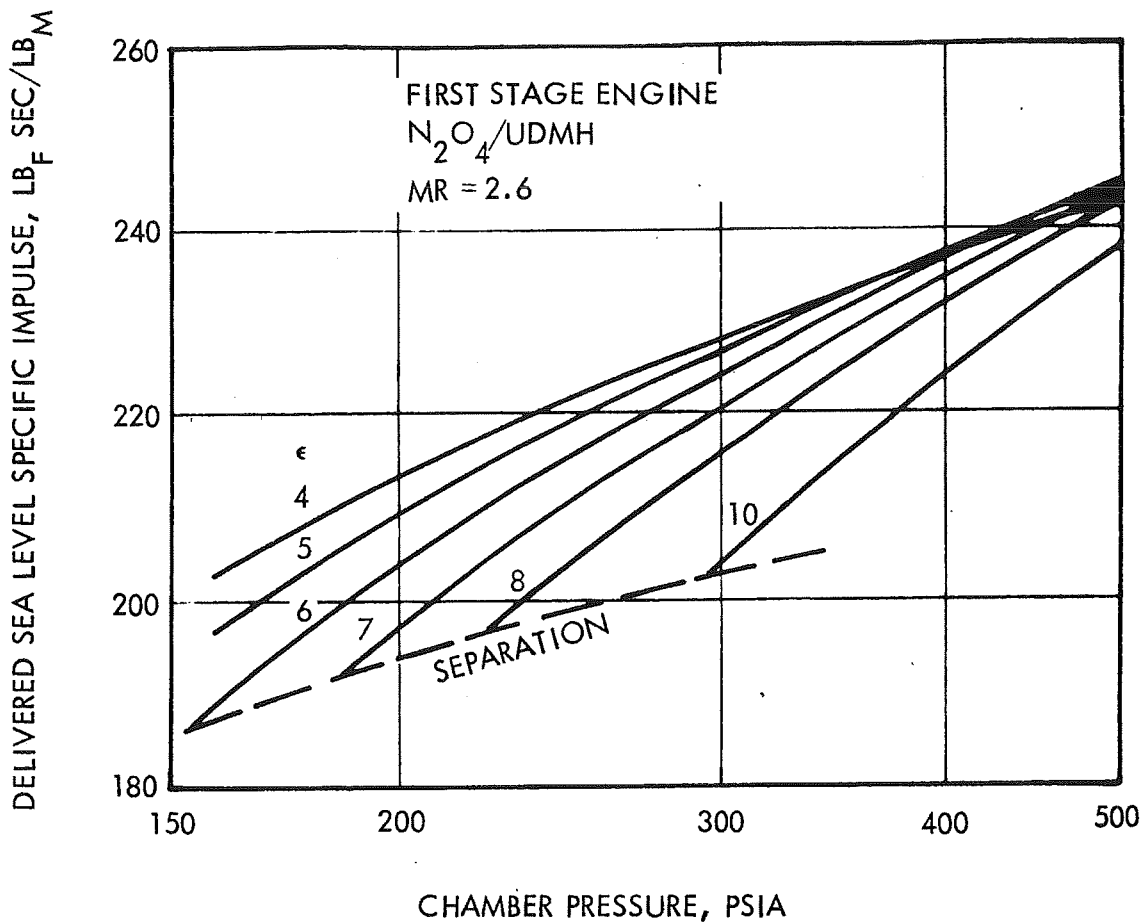

Fig. A-3 Specific Impulse vs Chamber Pressure (90%  $I_{sp}$  Efficiency)

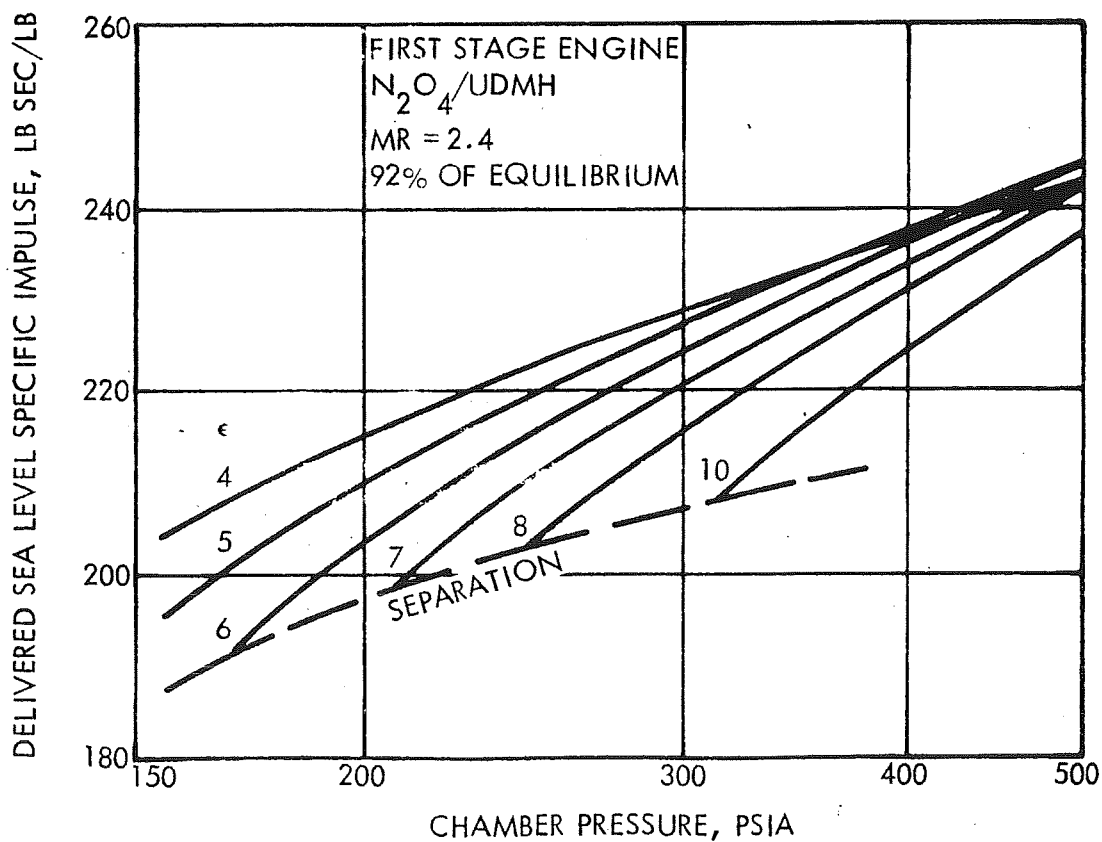

Fig. A-4 Specific Impulse vs Chamber Pressure (92%  $I_{sp}$  Efficiency)

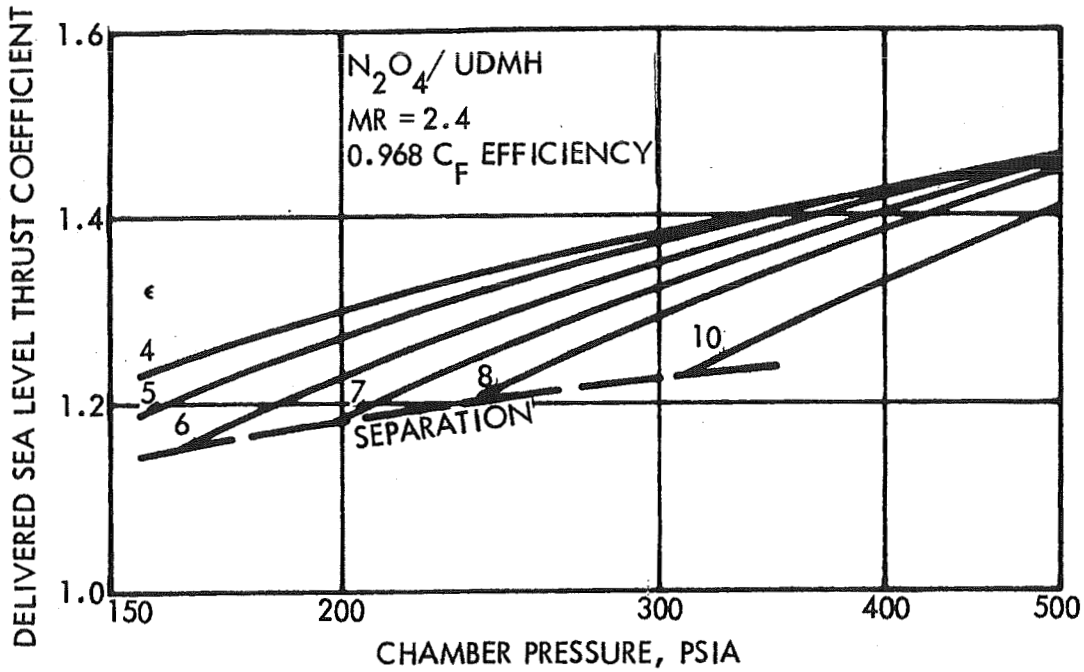

Fig. A-5 Thrust Coefficient vs Chamber Pressure

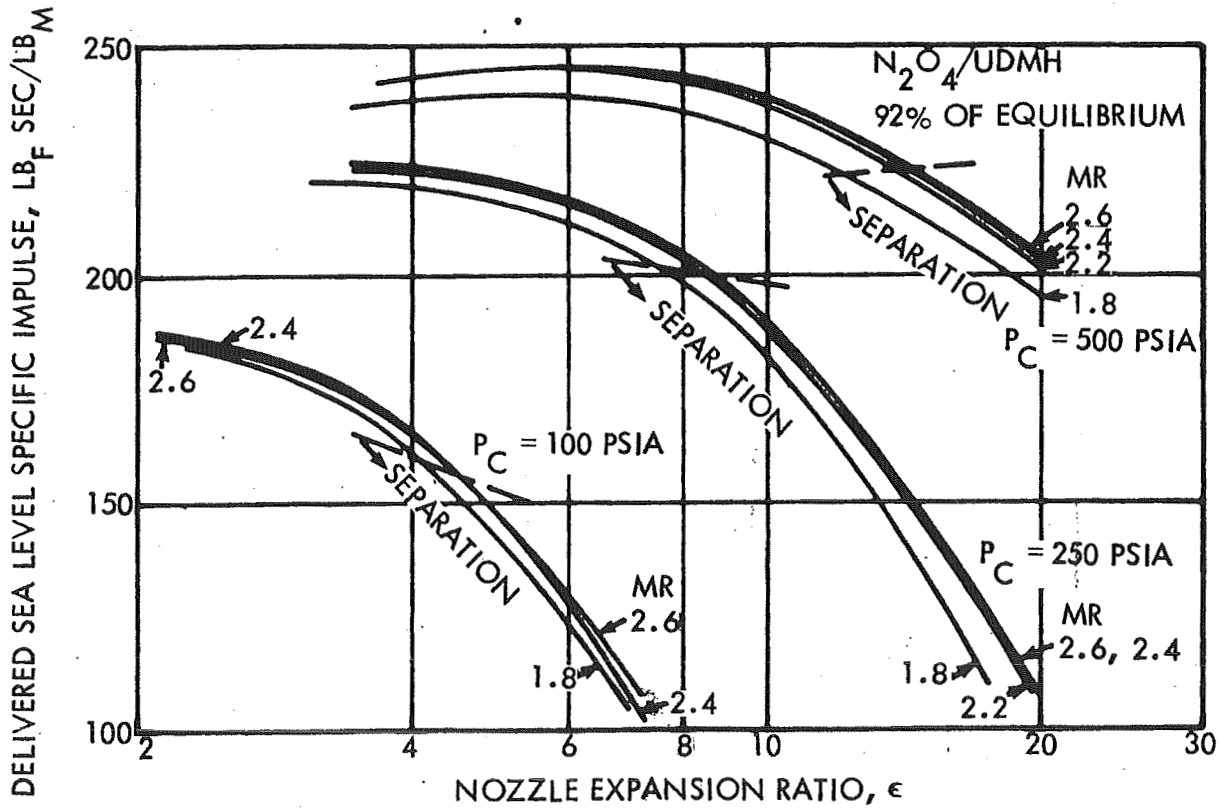

Fig. A-6 S. L. Specific Impulse vs Expansion Ratio (92%  $I_{sp}$  Efficiency)

857

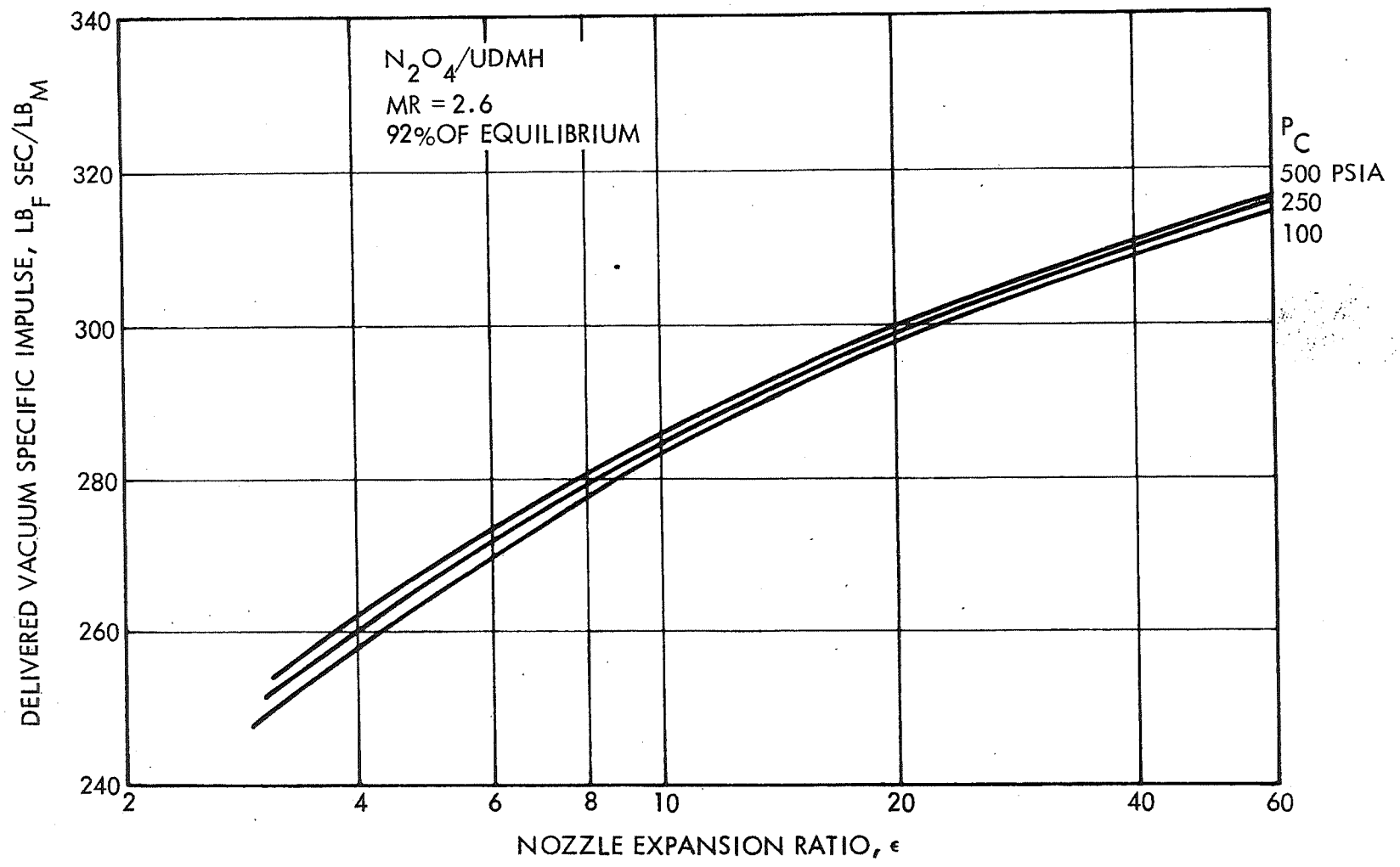

Fig. A-7 Vacuum Specific Impulse vs Expansion Ratio

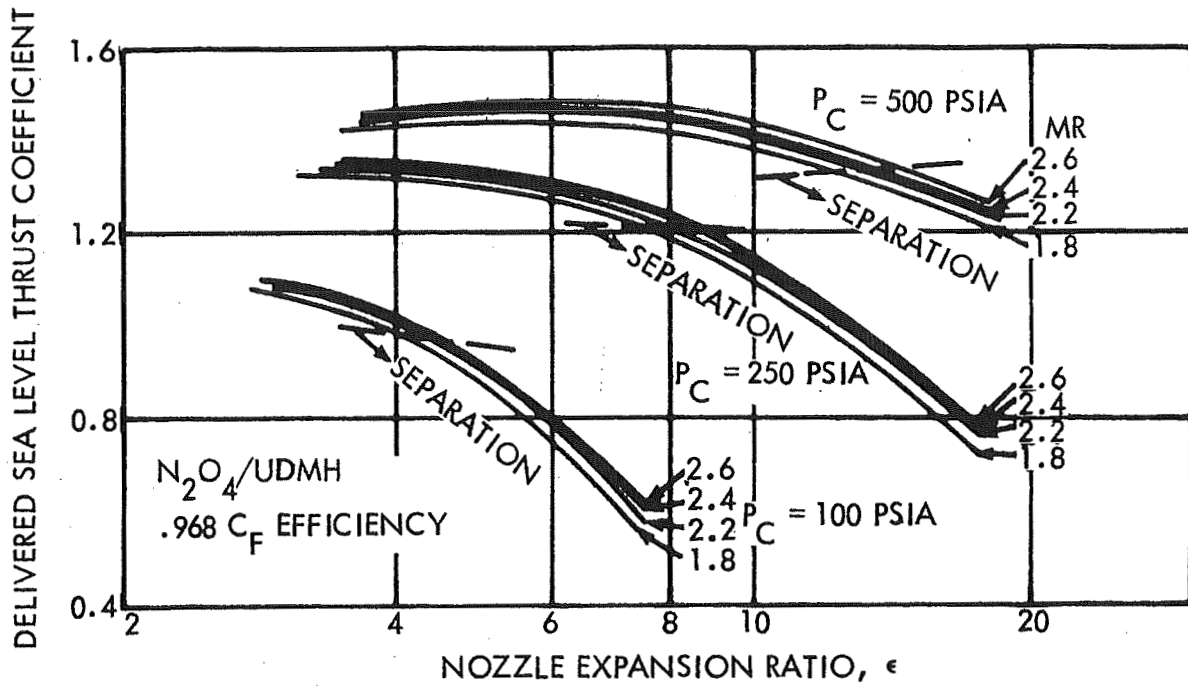

Fig. A-8 Thrust Coefficient vs Expansion Ratio

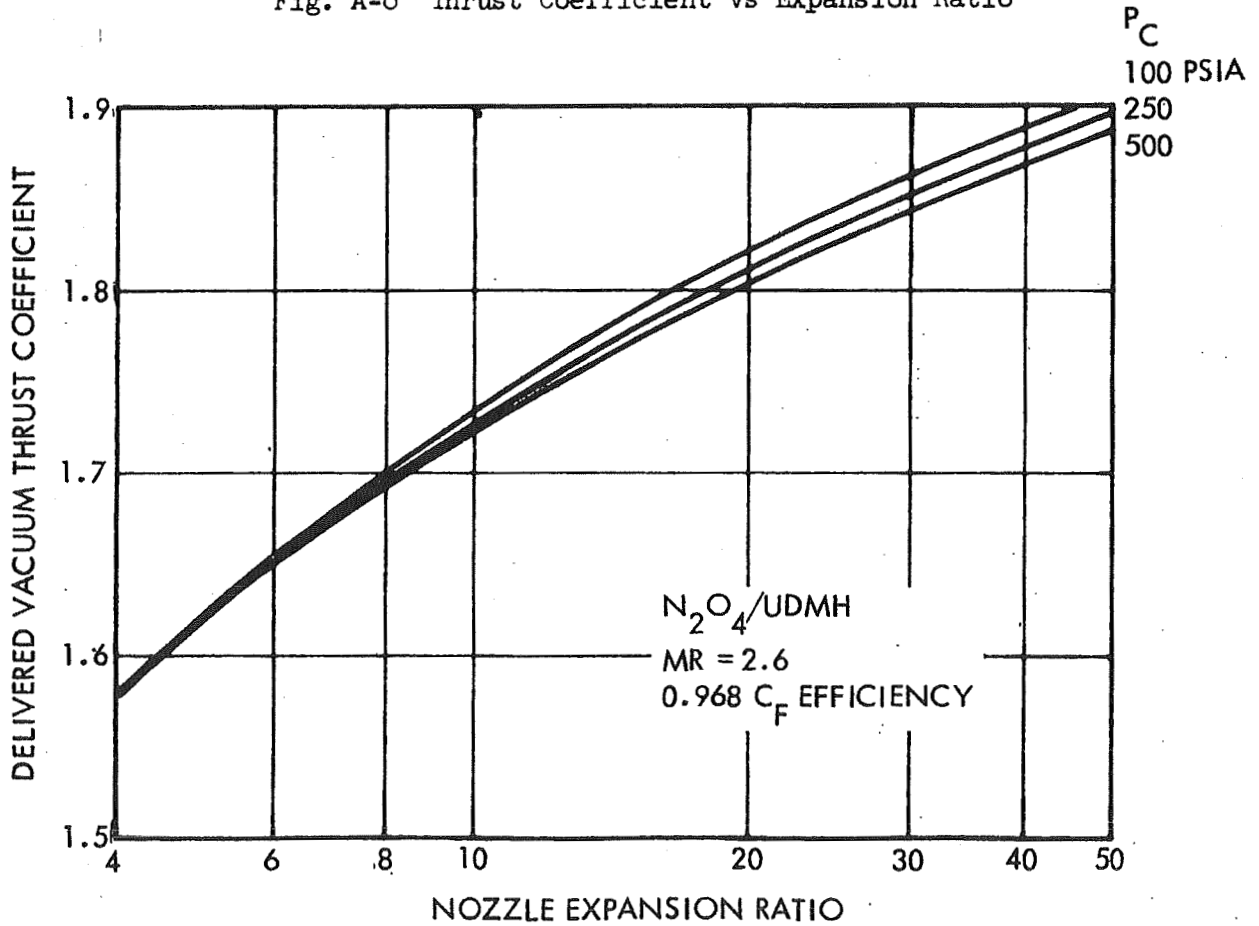

Fig. A-9 Vacuum Thrust Coefficient vs Expansion Ratio

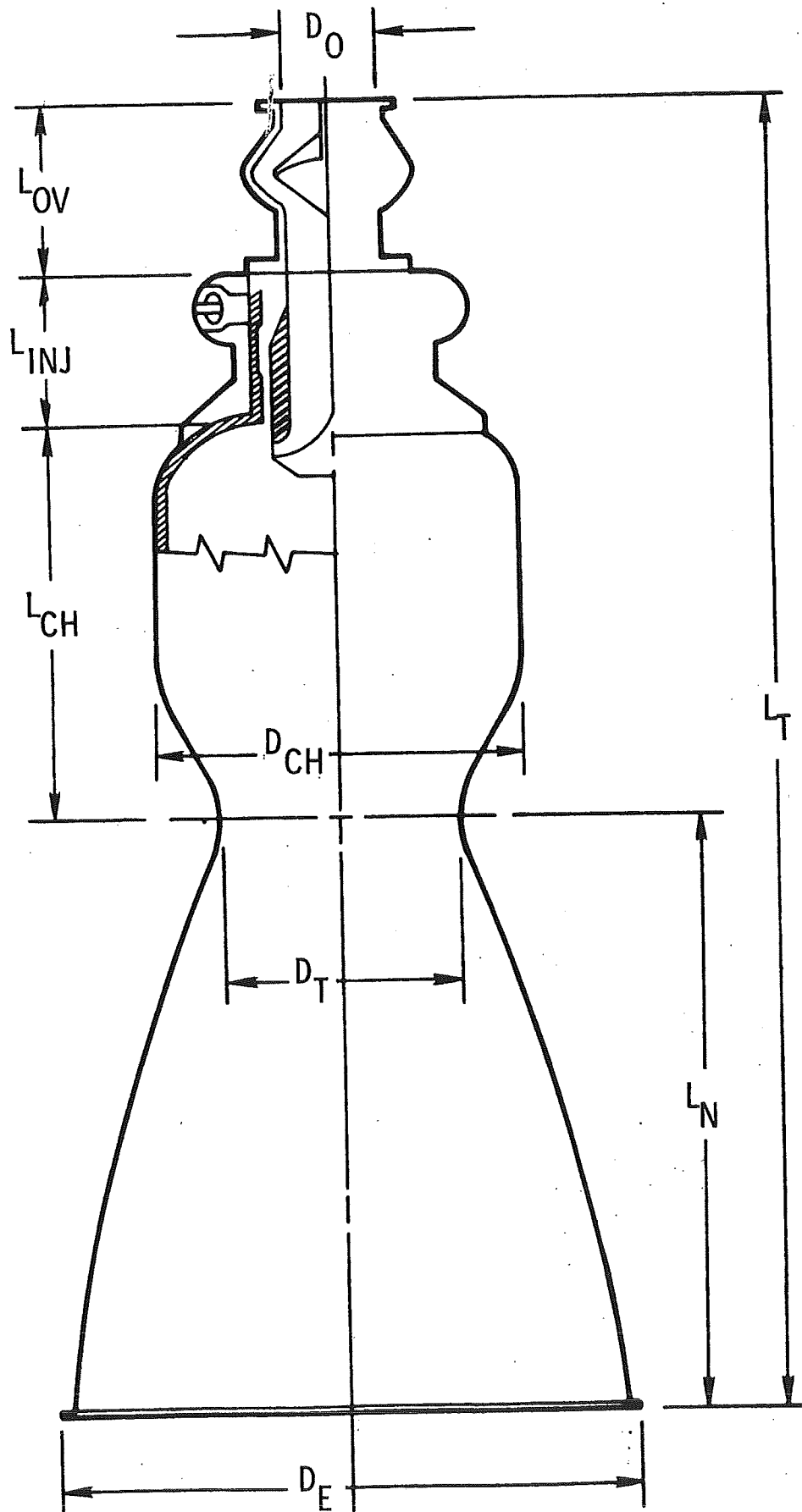

Fig. A-10. TRW Low Cost Booster Engine Nominal Characteristics

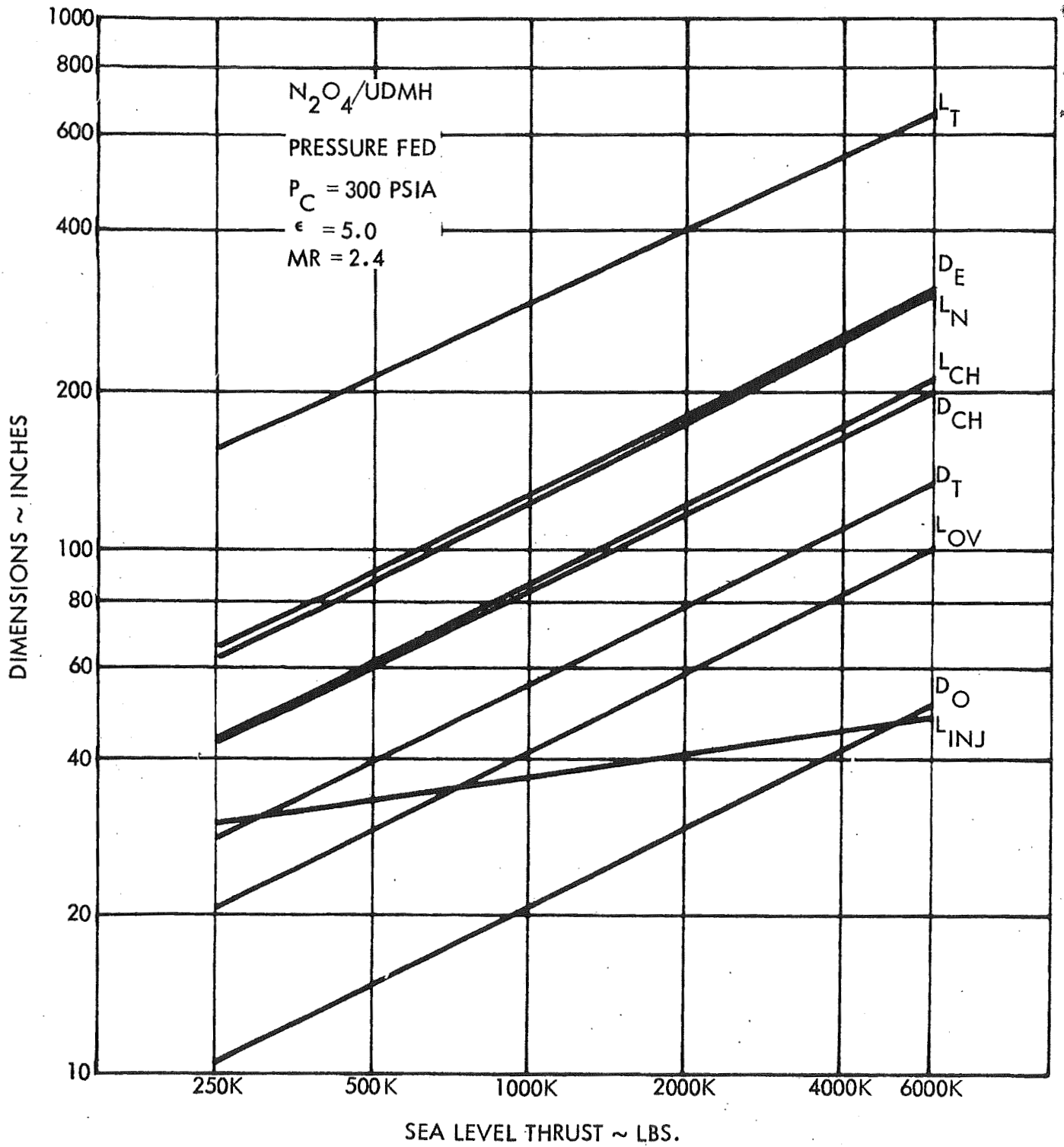

Fig. A-11 Booster Engine Dimensions ( $\epsilon=5, P_c=300$ )

261

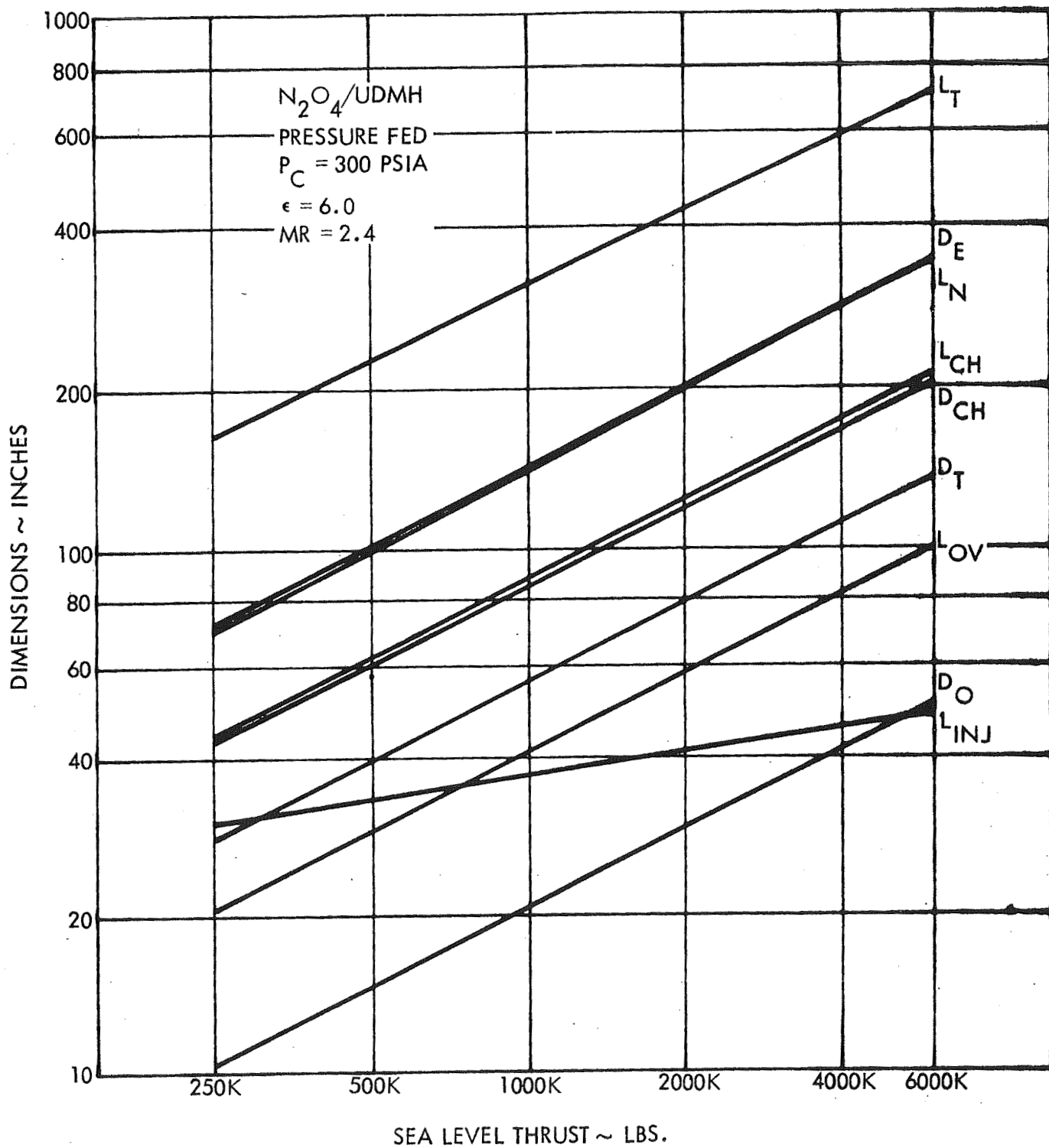

Fig. A-12 Booster Engine Dimensions ( $\epsilon=6, P_c=300$ )

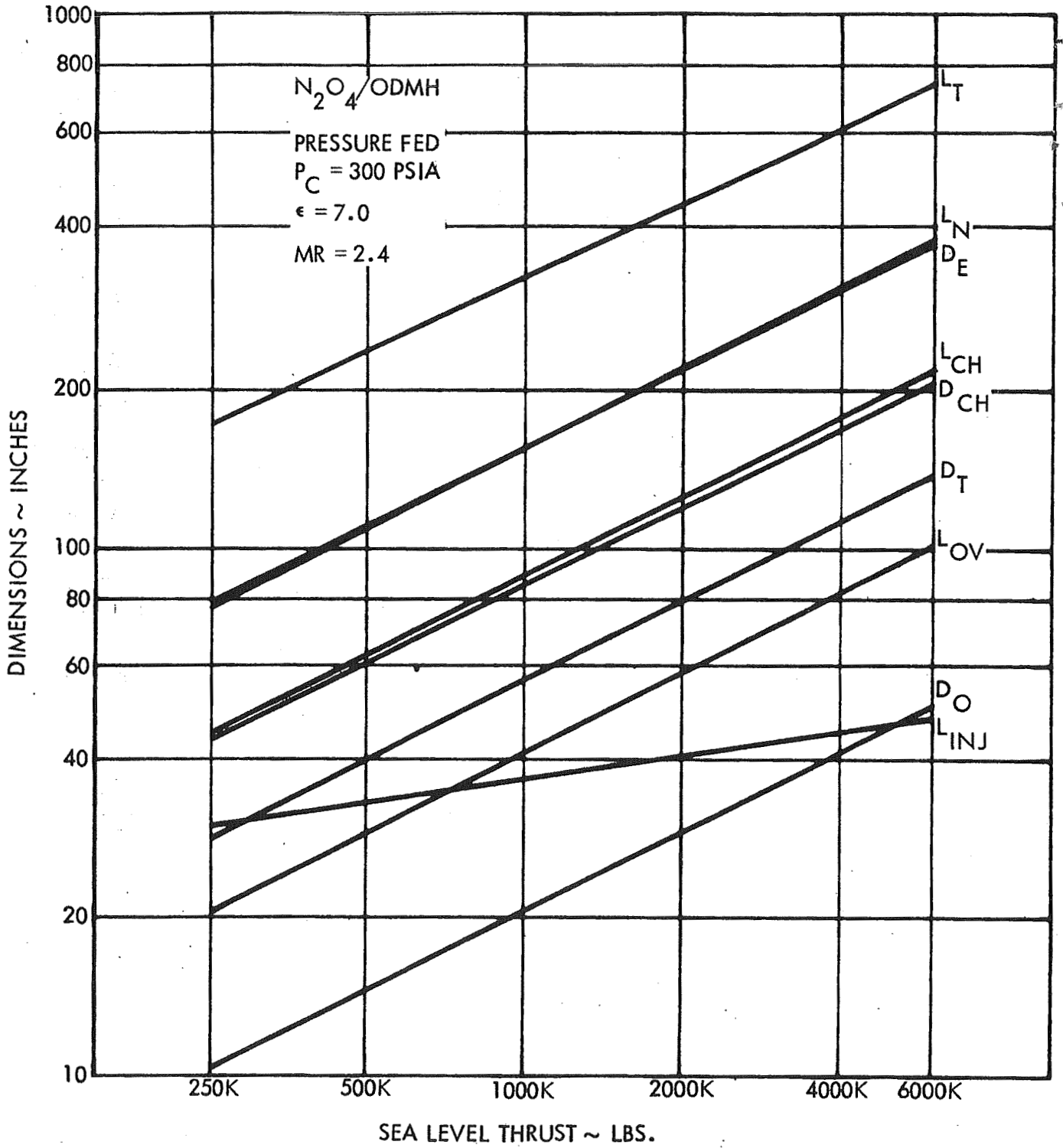
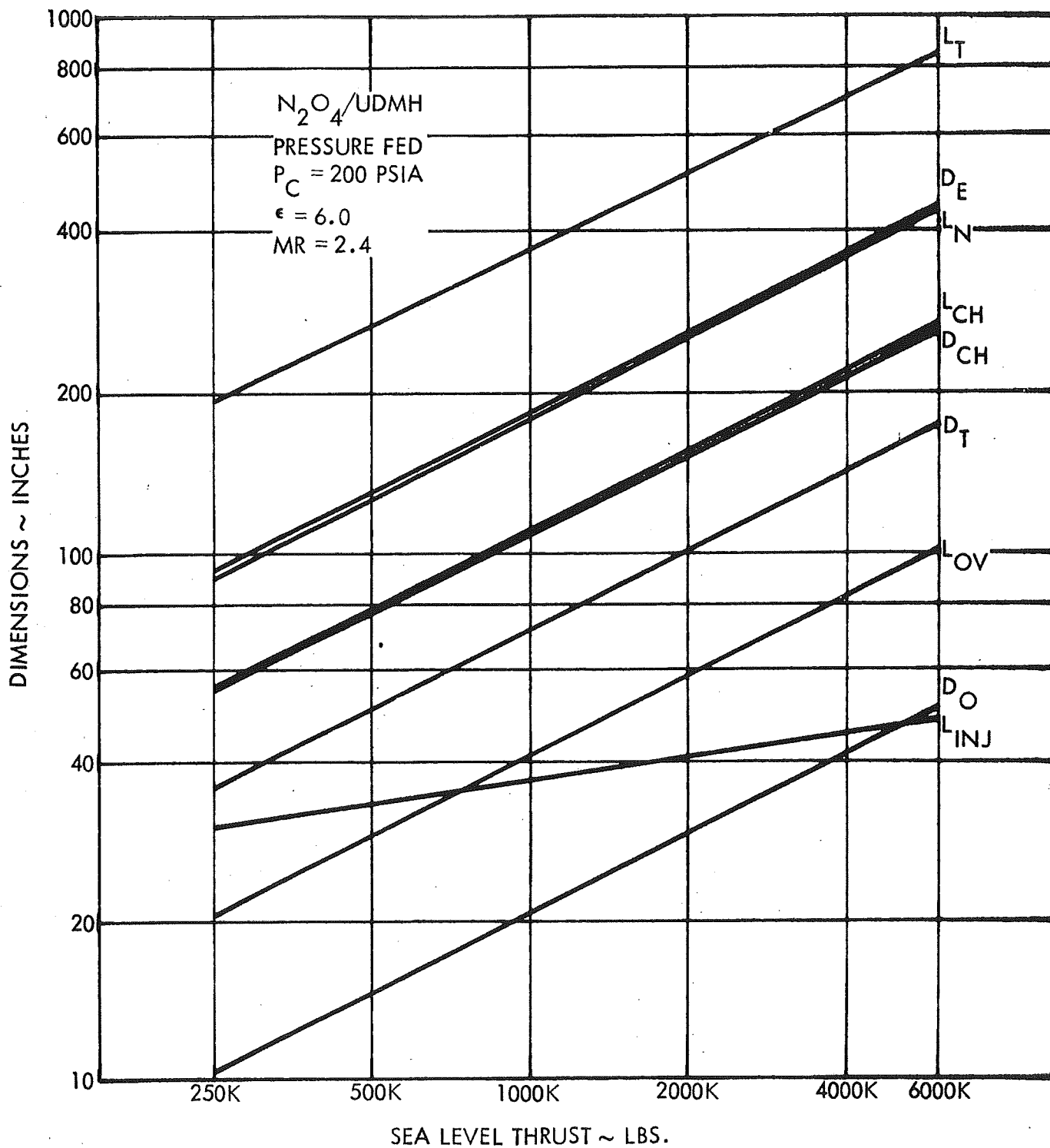

Fig. A-13 Booster Engine Dimensions ( $\epsilon=7, P_C=300$ )



263

Fig. A-14 Booster Engine Dimensions ( $\epsilon=6, P_C=200$ )

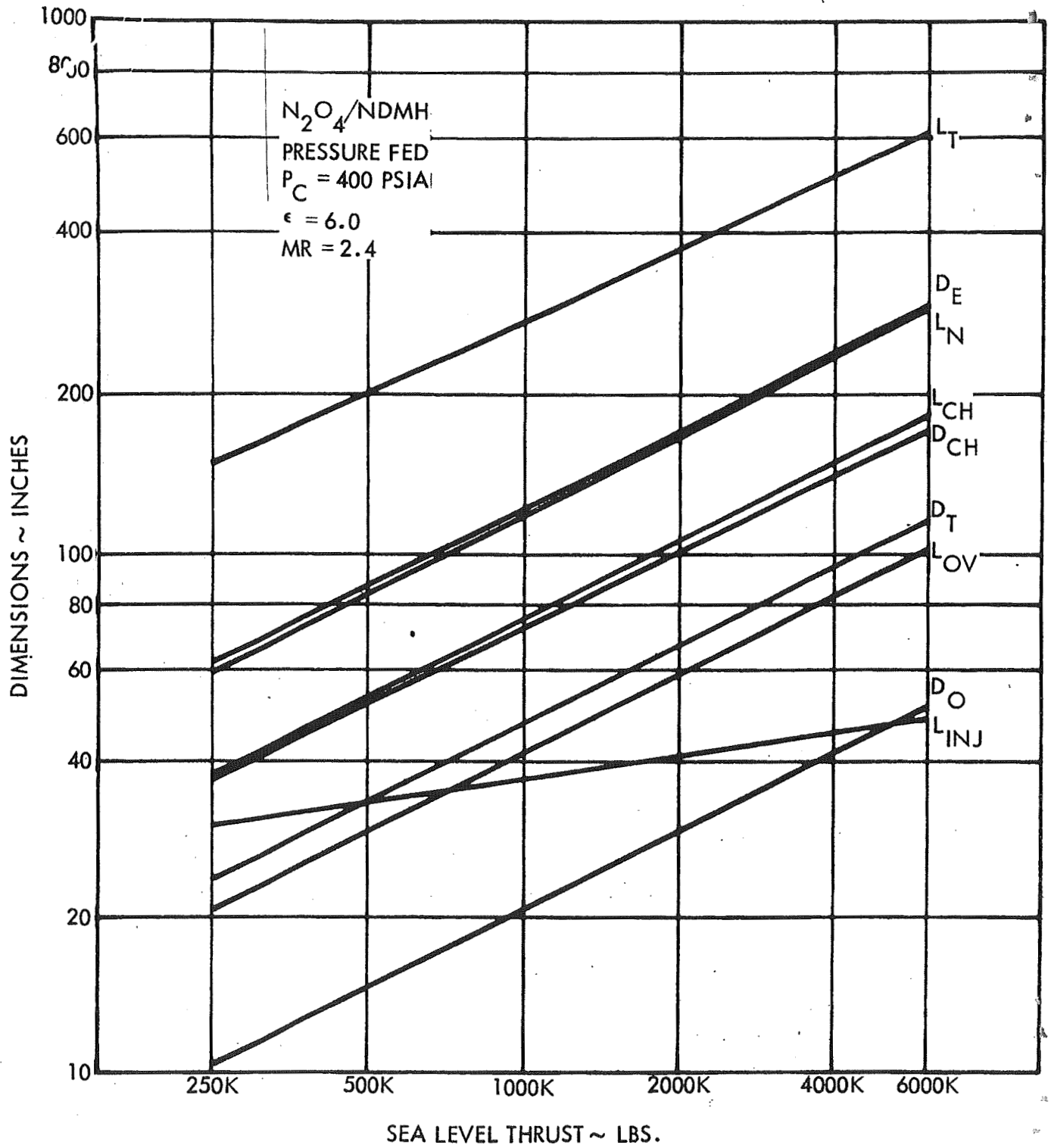

Fig. A-15 Booster Engine Dimensions ( $\epsilon=6, P_c=400$ )

## APPENDIX B

## WEIGHT, PERFORMANCE AND STRUCTURES

## B.1 Detailed Weight Estimates

A three-stage, pressure-fed, common bulkhead, non-modular design, sized to deliver 133,000 lb payload to LEO, has been designated as Design No. 1B. The configuration is illustrated in Figure 4-1, and basic design parameters are listed in Table 4-I in the "conservative" category.

The vehicle is estimated to have a gross weight of approximately 9,202,244 lb (less payload). Stage weight breakdowns and structure ratios are presented in Table B-I. The major design criteria used to estimate weights are shown in Table B-II. Weight breakdown for the small 3-stage vehicle designated lclv is shown in Table B-III.

## B.2 LV Performance

Machine computations of the performance of the foregoing vehicle are shown in Figures B-1 and B-2. The payload to 100 nm circular orbit is 133,000 lb with zero velocity pad (i.e., purposely generous for the nominal mission of 100,000 lb payload to LEO). The summation of impulse velocities for the first three stages is  $V_1 = 29,700$  ft/sec, from which it is found that the losses for vehicles of this type amount to  $\Delta V_L = 5460$  ft/sec for an eastward launch from ETR, with zero velocity margin.

Using a 4th stage ( $I_{sp} = 305$  sec,  $\sigma = .11$ ) to attain synchronous altitude results in a payload of 20,000 lb with a stage weight of 117,000 lb (13,000 lb empty, see Table B-III).

If the 4-stage vehicle is launched to LEO, a payload of 150,000 lb is attained with this combination of stages (with zero velocity pad).

## B.3 Structural Considerations

The aim of the LCLV structural design is to obtain a lightweight, reliable structure which will be simple to design, develop, and fabricate and thus achieve minimum overall costs. This report discusses how this philosophy determines the design configuration of the LCLV propellant tank. The report is divided into 3 parts: the first concerns the geometric configuration, the second the material and pressure capability, and third the flight and ground load capability. The latter includes the equations used for determining the weight of the stiffened pump-fed tanks.

TABLE B-I LCLV WEIGHT BREAKDOWN

Design No. 1

	<u>STAGE 1</u>	<u>STAGE 2</u>	<u>STAGE 3</u>
<u>STRUCTURE</u>	609,703	144,014	26,113
Tanks	495,327	118,918	23,875
Forward & Aft Skirts	40,223	11,964	2,238
Interstage	74,153	13,132	---
<u>PROPULSION</u>	205,774	46,264	10,073
Engine & Propellant Valves	101,464	23,413	6,064
Pressurization System Inerts	18,819	3,882	635
Pressurization Propellants	84,061	18,615	3,302
Propellant Utilization System	1,430	354	72
<u>CONTROLS</u>	13,801	3,417	825
LITVC Inerts	12,546	3,106	635
Roll/Ullage Control Inerts	1,255	311	190
<u>ELECTRICAL &amp; INSTRUMENTATION</u>	2,269	543	691
Power Supply, Wiring, Range Safety, Data Acquisition Telemetry, Guidance & Control, etc.			
<u>RESIDUAL PROPELLANTS (Liquids)</u>	31,360	7,764	1,587
<u>CONTINGENCY</u>	78,875	18,887	3,929
<u>BURNOUT WEIGHT</u>	941,782	220,889	43,218
Main Propellant	6,082,197	1,507,793	307,381
LITVC Propellant	62,729	15,528	3,173 <sup>a</sup>
Roll/Ullage Gases	12,546	3,105	1,903
<u>GROSS WEIGHT</u>	7,099,254	1,747,315	355,675
Burnout Fraction (Incl. Interstage)	0.133	0.126	0.121
(Without Interstage)	0.123	0.120	0.121

Table B-II LCLV Major Design Criteria

<u>Symbol</u>		<u>Units</u>	<u>Stage 1</u>	<u>Stage 2</u>	<u>Stage 3</u>
	Propellants			$N_2O_4$ & UDMH	
M.R.	Mixture Ratio	N.D.	2.6	2.6	2.6
$\rho_o$	Oxidizer Density @ 70°F	Lb/Ft <sup>3</sup>	90	90	90
$\rho_f$	Fuel Density @ 70°F	Lb/Ft <sup>3</sup>	49.3	49.3	49.3
$W_p$	Stage Usable Propellant	Lb	6,082,197	1,507,793	307,381
U	Tank Ullage Factor	N.D.	.05	.05	.05
D	Stage Diameter	Ft	40	30	19
$\beta$	Tank Bulkhead Ellipse Ratio	N.D.	1.415	1.415	1.415
F	Stage Thrust	Lb	11,630,000	2,202,000	456,000
$P_c$	Chamber Pressure	P.S.I.	300	250	200
$\epsilon$	Expansion Ratio	N.D.	6	31	50
$C_f$	Thrust Coefficient	N.D.	1.36	1.85	1.90
$P_o$	Oxidizer Tank Pressure	P.S.I.	440	390	340
$P_f$	Fuel Tank Pressure	P.S.I.	350	300	250
	Structural Material		HY 140	HY 140	HY 140
$F_{tu}$	Material Ultimate @ 600°F	P.S.I.	140,000	140,000	140,000
E	Material Modulus	P.S.I.	$3 \times 10^7$	$3 \times 10^7$	$3 \times 10^7$
F.S.	Tankage Safety Factor	N.D.	1.5	1.5	1.5
NOFT	Tankage Non-Optimum Factor	N.D.	1.15	1.22	1.315
NOFI	Interstage Non-Optimum Factor	N.D.	3.0	3.0	3.0
	Pressurization Scheme		MTI	MTI	MTI
	Control Scheme		LITVC	LITVC	LITVC
	Residual Propellant	%	0.5	0.5	0.5

Table B-III Weight Breakdown for lclv

	<u>STAGE 1</u>	<u>STAGE 2</u>	<u>STAGE 3</u>
<u>STRUCTURE</u>	<u>144,014</u>	<u>29,113</u>	7500
Tanks	118,918	23,875	
Forward & Aft Skirts	11,964	2,238	
Interstage	13,132	3,000	
<u>PROPULSION</u>	<u>53,151</u>	<u>10,073</u>	3200
Engine & Propellant Valves	30,300	6,064	
Pressurization System Inerts	3,882	635	
Pressurization Propellants	18,615	3,302	
Propellant Utilization System	354	72	
<u>CONTROLS</u>	<u>3,417</u>	<u>825</u>	270
LITVC Inerts	3,106	635	
Roll/Ullage Control Inerts	311	190	
<u>ELECTRICAL &amp; INSTRUMENTATION</u>	<u>543</u>	<u>691</u>	350
Power Supply, Wiring, Range Safety, Data Acquisition Telemetry, Guidance & Control, etc.			
<u>RESIDUAL PROPELLANTS (Liquids)</u>	<u>7,764</u>	<u>1,587</u>	520
<u>CONTINGENCY</u>	<u>19,576</u>	<u>3,929</u>	1160
<u>BURNOUT WEIGHT</u>	<u>228,465</u>	<u>41,218</u>	<u>13,000</u>
Main Propellant	1,507,793	310,381	102,340
LITVC Propellant	15,528	3,173	1,040
Roll/Ullage Gases	3,105	1,903	620
<u>GROSS WEIGHT</u>	<u>1,754,891</u>	<u>358,675</u>	<u>117,000</u>
Burnout Fraction (Incl. Interstage)	0.130	0.129	0.11
(Without Interstage)	0.124	0.129	

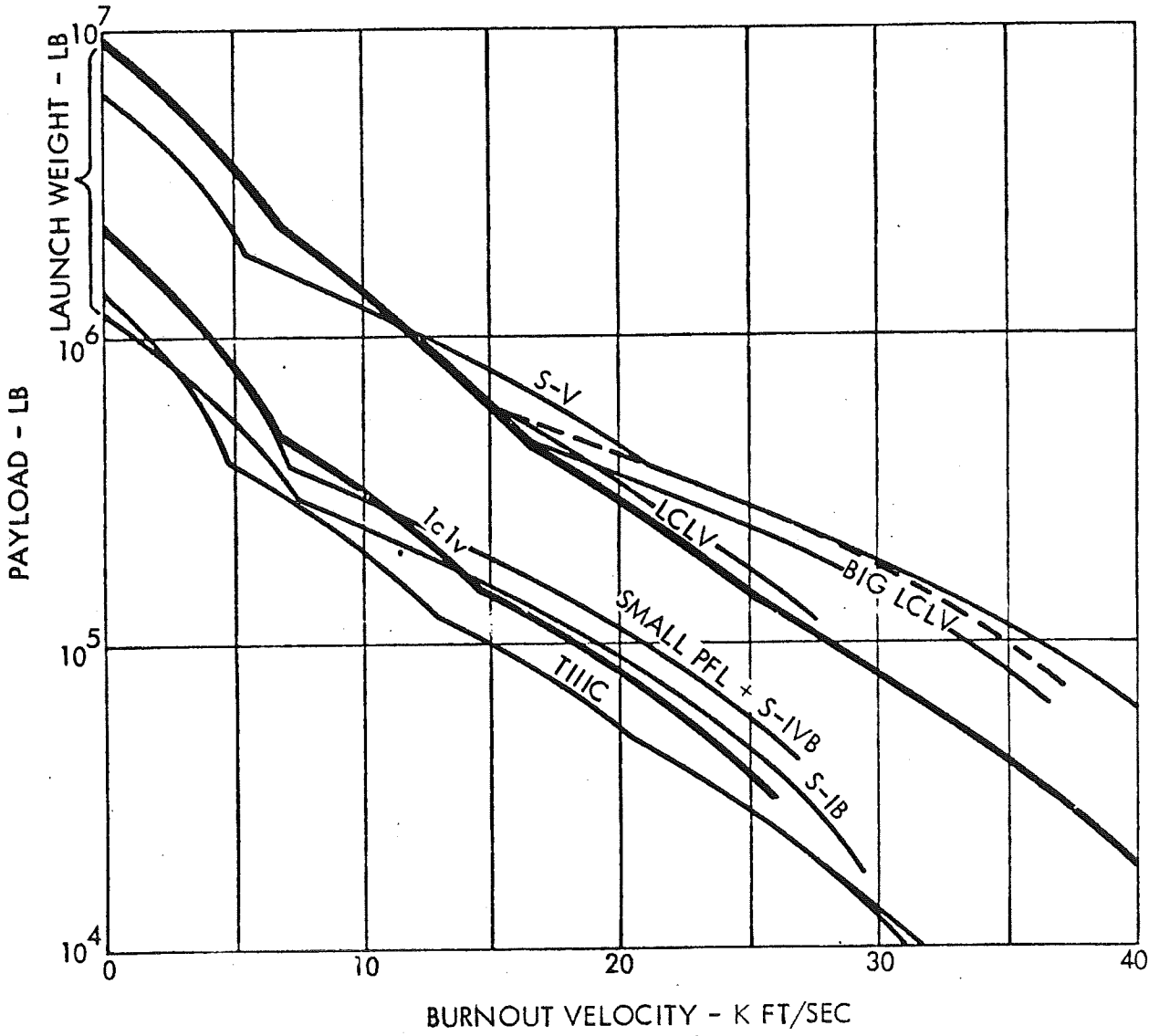

Figure B-1 Performance of Several Launch Vehicles

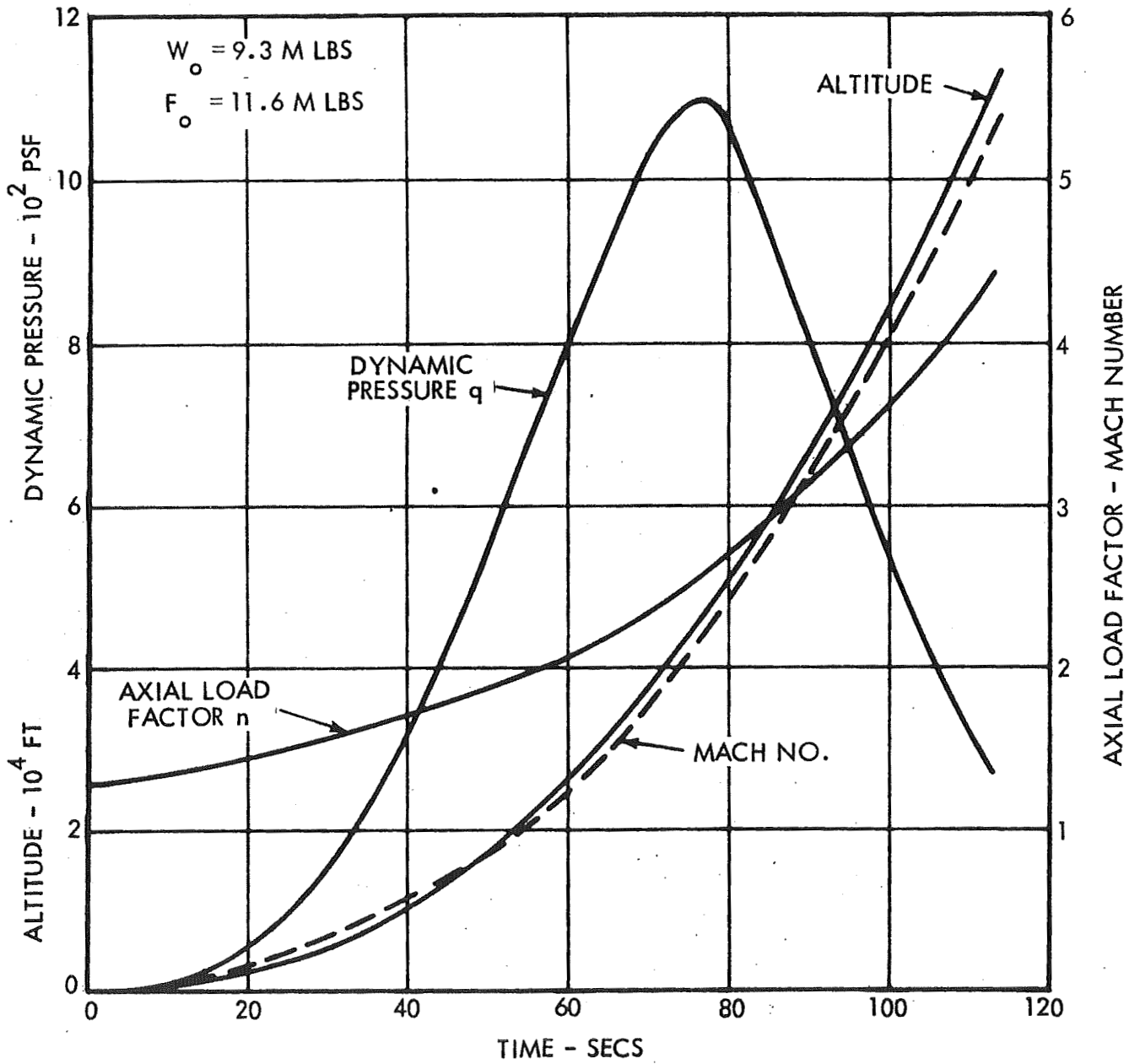
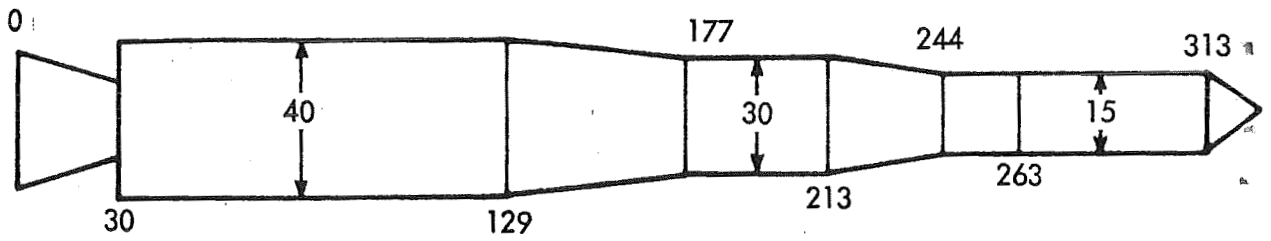

Figure B-2 First Stage Trajectory Data



### B.3.1 Tank Configuration

The three major configuration choices to be made for the propellant tanks are:

- a. Single or separate intermediate bulkheads.
- b. Relative placement of oxidizer and fuel tanks.
- c. Bulkhead shape.

These choices are inter-related since each affects the others.

Separate intermediate bulkheads have been used on the Titan and Thor missiles while single bulkheads have been used on the Atlas, Agena and Centaur, and on the Saturn upper stages. For the Atlas, Agena, and Centaur the intermediate bulkheads are not stiffened and depend on the maintenance of the pressure differences between the tanks to retain their integrity, while the Saturn bulkheads are stiffened to obtain a reverse pressure capability.

The advantages of a single bulkhead are the reduction of weight due to the elimination of one bulkhead and the intertank structure and a significant reduction in overall length. The disadvantages are: the possibilities of leaks, the operational problems of ensuring that the pressure difference is always in the right direction, and the increased thermal stresses which occur with cryogenic propellants. Most of these problems are minimized for the LCLV. Firstly, storable propellants are used so there are no thermal stress problems. Secondly, because of the thick sections the possibility of pin hole leaks is minimized and, even if there was a small leak under pressure, the result would not be catastrophic since the leak would only act as an addition to the MTI pressurization system. Thirdly, due to the large bulkhead thickness ratios required by the high tank pressures and the fact that the buckling pressure increases as rapidly as the square of the thickness ratio, the reverse pressure capability is quite significant. Finally, the possibility of bulkhead pressure reversal is minimized because the MTI pressurization system inherently tries to maintain higher pressure in the oxidizer tank. The oxidizer required to pressurize the fuel tank is forced into the fuel tank by the positive pressure difference between the oxidizer and fuel tanks. If the fuel tank approaches the oxidizer pressure then the flow of oxidizer into the fuel tank will be stopped and the pressure will be stabilized.

Thus for the LCLV the advantages of the single bulkhead considerably outweigh the disadvantages, and therefore the choice was made to use a single, intermediate bulkhead on all the propellant tanks.

The principal advantage of placing the oxidizer tank aft is that this orientation significantly reduces the load which must be sustained by the lower pressure fuel tank, since the oxidizer weight is 2.6 times the fuel weight. However, in flight, with the tanks pressurized, this additional load in the aft tank is easily supported by the internal pressure, and on the ground it is demonstrated in Sect. B.3.3 that for the baseline configuration the fuel tank wall thickness required by the pressure is amply sufficient to sustain the ground load while unpressurized.

The principal advantage of placing the oxidizer tank forward is that since the oxidizer tank pressure is larger than the fuel tank pressure, it is possible to orient the intermediate bulkhead convex downward so that it can support the oxidizer weight by tensile rather than by compressive stresses. This practically eliminates the possibility of the bulkhead buckling on the ground or during the initial launch transient. In addition, the oxidizer feed line through the fuel tank is subjected to a positive internal pressure.

A secondary advantage of placing the oxidizer tank forward is that it moves the vehicle center of gravity forward due to the higher density of the oxidizer. The result is decreased static aerodynamic instability, reduced control force requirements and smaller aerodynamic bending moments. This partly accounts for the fact that for the baseline vehicle (with all oxidizer tanks forward) the critical max  $q\alpha$  loads are less than the burnout loads for both the 1/2 and the 2/3 interstages. Thus the oxidizer tank forward is clearly the preferred orientation.

The optimum bulkhead shape on the basis of weight per unit volume is a hemisphere. A  $\sqrt{2}$  ellipsoidal dome is almost identical in weight, but its enclosed volume is reduced. Therefore, to compare it on an equal volume basis a cylindrical section has to be added. When this is done the ellipsoidal dome is found to be approximately 1/3 heavier than a spherical dome. Despite this penalty  $\sqrt{2}$  ellipsoidal domes were chosen because of their reduced length and the reduced length of interstage structure required between the tangency point and the crown. It is assumed that the bulkhead is tapered in steps corresponding to the welded segments with the edge thickness being 70% of the thickness at the center. This tapering results in a saving of about 15% of the bulkhead weight.

### B.3.2 Material Choice

A number of materials have been considered for the tank material ranging in strength from 100,000 psi to 250,000 psi as listed in Table B-IV.

Table B-IV Candidate Tank Materials

Material	Density lb/in <sup>3</sup>	Modulus E <sub>c</sub> 10 <sup>6</sup> psi	Ultimate Tensile Stress ksi			Strength Weight Ratio (as welded) $\sigma/\rho \times 10^{-5}$	Charpy Impact Energy ft lbs	K <sub>1c</sub> ksi $\sqrt{\text{in}}$
			Temp °F	Base Mat'l.	Welds			
T-1	0.285	30	70 600	115 105	109 100	3.85 3.50	55	130
HY-140	0.285	29.5	70 600	155 140	155 140	5.45 4.90	100	250
Maraging 18 Ni 200	0.293	28	70 600	210 190	200 180	6.83 6.14	33	100
Maraging 18 Ni 250	2.293	28	70 600	260 234	246 222	8.40 7.58	23	85

Aluminum alloys were also considered but because of their poor weld allowables and their reduced strength at the 600°F operating temperature of the MFI pressurization system they are not competitive.

T-1 steel (Ref. 29) is a high strength construction steel which has been developed by U.S. Steel over the last ten years. It is now in general commercial use and has a large background of application to various structures including pressure vessels. It has an ASME boiler code specification. It can be welded with either coated metal electrodes or gas shielded metal electrodes and does not require heat treatment after welding. As indicated by its Charpy impact energy and its fracture mechanics parameter K<sub>1c</sub> it is very tough and resistant to brittle fracture.

HY-140(T) (References 30 to 34) is a high strength alloy presently being developed by the U.S. Navy and U.S. Steel for use on undersea vessels. Because of this requirement it has outstanding toughness and resistance to brittle fracture and crack growth. In most applications a partial thickness crack can be expected to progress through the thickness before growing destructive. Thus a vessel will develop a leak rather than explosively rupture. This resistance to crack growth is indicated by fracture mechanics parameter K<sub>1c</sub> which, as it can be seen by comparison with the other proposed materials, is outstanding. Welding for this material is slightly more difficult than for T-1, but tough, full strength welds can be obtained either with gas shielded or coated metal

B10

electrodes. Only for smaller thicknesses than are to be used in the LCLV does it require the slower gas shielded tungsten electrode method. Work is still being done on the development of this alloy. Depending on its heat treatment and weld practice it is designated HY-130(T) or HY-140(T) with appropriate strengths. Eventually, it is hoped to improve it so that it will become HY-150. For our study we have used the HY-140 strength values.

The Maraging 200 and 250 alloys (Ref. 35) are in a slightly different class than the previous alloys. They have been developed for use on large high strength solid propellant missiles. They require the use of the slower gas shielded tungsten electrode method to obtain the toughest welds and a post welding aging treatment at 900° to obtain full strength. They have good toughness characteristics compared to other alloys in their strength range but are inferior to the two previously mentioned, and cannot be expected to "leak before failure." Thus their use on the LCLV will be considerably more difficult and more expensive on a per pound basis.

In view of the above considerations and the results of the costing studies, it was decided to use HY-140 for the baseline vehicle and all further discussion of the tank design will be concerned with its use.

There are two potentially critical pressure conditions for each tank. Maximum hydrostatic pressure at room temperature, which occurs at launch for the first stage tanks or at first stage burnout for the upper stage tanks, or the burnout empty condition at the MTI design temperature of 600°F. It was found that the high temperature condition was critical for all tanks.

Although it would be possible to save weight by designing the intermediate bulkhead for less than the full oxidizer pressure, it was decided not to do this because, although both tanks are to be pressurized simultaneously, it is conceivable that the oxidizer tank would have considerable pressure before the fuel tank pressure begins to build up. Designing for full pressure also allows the oxidizer tank to be proofed independently of the fuel tank and increases the reverse pressure capability of the bulkhead.

The structural details of the six propellant tanks for the baseline configuration are listed in Table B-V. Included are the unpressurized axial buckling loads,  $P_{cr}$ , of each of the tanks and the buckling pressures,  $p_{cr}$ , of each of the intermediate bulkheads. It is seen that without additional stiffening each of the bulkheads can sustain a reverse pressure which is at least 15% of the design pressure of the tank on its convex side.

### B.3.3 Ground Load Capability

To determine the capability of the vehicle to stand erect while fully

Table B-V Propellant Tank Characteristics of Baseline Vehicle

Tank	Radius (in)	Operating Pressure (psi)	Ultimate Pressure (psi)	Cylinder		Bulkhead	
				Thickness $t_c$ (inch)	$P_{cr}$ ( $10^6$ lbs)	Center Thickness $t_b$ (in)	$P_{cr}$ (psi)
Stage 3							
Oxidizer	114	340	510	0.416*	8.32*	0.294	39.3
Fuel	114	250	375	0.306	3.99	0.216	--
Stage 2							
Oxidizer	180	390	585	0.752	27.2	0.530	51.6
Fuel	180	300	450	0.579	15.5	0.410	--
Stage 1							
Oxidizer	240	440	660	1.131	66.3	0.800	65.6
Fuel	240	350	525	0.900	39.0	0.637	--

\* These are only shown for reference. There is no cylindrical section for this tank.

loaded and unpressurized, a calculation was made of the critical ground loads and these were compared with the unpressurized propellant tank buckling capability for the baseline HY-140 configuration. The results are shown in Table B-VI. The computed bending moments are based on a uniform 60 mph wind, with a drag coefficient of 0.50 and a 1.5 dynamic amplification factor to account for vortex shedding. The results indicate that each tank has more than an ample margin of safety and that the contribution of the aerodynamic bending moment to the total load for each tank is less than 25% except for the Stage 3 oxidizer tank. At the missile base support the equivalent axial load due to the aerodynamic bending moment is only 7% of the total load. Thus resistance to wind loads is not expected to be a problem.

For higher strength tank materials the tank buckling strength is significantly reduced since it is proportional to the square of the thickness. However, even for Maraging 250 each of the tanks would have a positive margin.

For a pump-fed system however, this would not be the case, since the reduction in tank pressure would allow a significant reduction in the tank wall

B12

Table B-VI Critical Compressive Loads for Propellant Tanks -  
Unpressurized Ground Condition

Tank (Station)	Axial Load $P_A$ $10^6$ lbs	Bending Moment $M$ $10^6$ lb ft	$P_M = \frac{2M}{R}$ $10^6$ lbs	$P_T = P_A + P_M$ $10^6$ lbs	$P_{ult} = 1.5P_T$ $10^6$ lbs	Tank Capability $P_{cr}$ $10^6$ lbs	$\bar{P} = \frac{P_{ult}}{\pi R^2}$ psi
Stage 3							
Oxidizer (256)	0.130	0.270	0.057	0.187	0.281	8.320	6.88
Fuel (249)	0.390	0.330	0.070	0.460	0.690	3.990	16.9
Stage 2							
Oxidizer (198)	0.498	1.00	0.133	0.631	0.947	27.200	9.3
Fuel (184)	1.780	1.31	0.175	1.955	2.933	15.500	28.8
Stage 1							
Oxidizer (93)	2.570	4.0	0.400	2.970	4.455	66.300	24.6
Fuel (60)	7.400	5.56	0.556	7.956	11.934	39.000	65.9
Skirt (29)	9.300	6.66	0.666	9.966	14.950		82.6

thickness. Thus it would be expected that these tanks would have to be stiffened in order to sustain the unpressurized ground loads. To support the pump-fed sizing study, equations were developed for the weight of the required stiffening. These equations are based primarily on the results of Ref. 36 for cylinders with rectangular internal longitudinal and ring stiffeners.

$$\frac{t}{R} = \frac{t_s}{R} \left\{ 1 - e^{-\left(1 - \frac{t_m}{t_p}\right)} \right\} + \frac{t_p}{R} \frac{t_s}{t_m} e^{-\left(\frac{t_m}{t_p}\right)} \quad (1)$$

where

$\bar{t}$  = mean cylindrical wall thickness

$t_p$  = cylindrical wall thickness required by pressure

$t_s$  = mean cylindrical wall thickness for an optimized stiffened tank with no thickness requirement for pressure

$$= R \left( \frac{2.27 \bar{P}}{E} \right)^{0.6}$$

$t_m$  = required thickness for a monocoque tank

$$= \left( \frac{0.069 \bar{P}}{E} \right)^{0.6}$$

$$\bar{P} = \frac{P_{eq}}{\pi R^2}$$

$P_{eq}$  = total compressive load including bending

$E$  = elastic modulus of tank walls

Equation (1) is plotted in Figure B-3, in terms of  $t/R$  and  $\frac{\bar{P}}{E}$ .

It is seen that the weight penalty for obtaining small increases in the monocoque buckling capability by stiffening the tank wall is not large. However, the addition of stiffeners would be expected to considerably increase the construction costs. Due to the pressure vessel requirements it is mandatory that wall penetrations be minimized and thus that at least the longitudinal stiffening be integral with the tank wall. This would require that the stiffening either be machined or chem milled from thicker plate, or formed from extrusions. The ring stiffeners could be integral or could be clipped or riveted to the longitudinal stiffeners.

One last important item is the first stage aft skirt which supports the missile on the ground. Ideally, the ground support load would be distributed uniformly over the circumference of the skirt. However, because the first stage nozzle diameter is nearly equal to the skirt diameter, the ground support must retract out of the way before the nozzle passes it. Since it is desirable to minimize the number of simultaneously retracting parts, this will probably mean that the skirt will be supported at four points. It will then be the function of the skirt to distribute the load uniformly into the tank walls. As noted previously (Tab. BVI) the load contribution due to the wind bending moments is small. This means that the critical tensile load occurs during hold down and the critical compressive load occurs on rebound after an engine shutoff. The

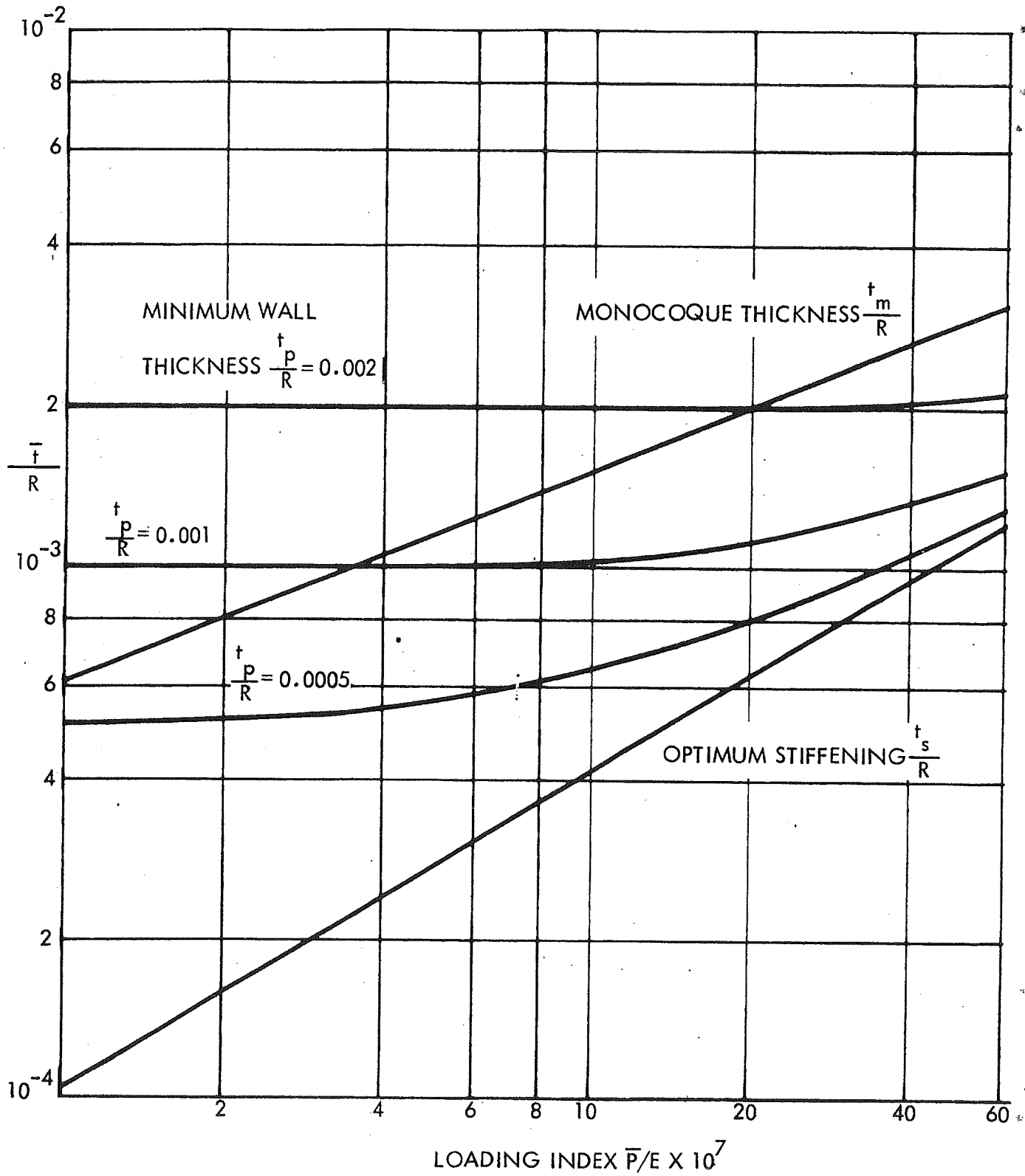

Figure B-3 Buckling Thickness Requirements for Unpressurized Cylinders



hold down load equals  $T - W_0$  or approximately 2.3 million pounds, while the peak rebound load equals approximately  $2 W_0$  or 20 million pounds. If the latter were distributed uniformly into the tank walls it would result in a load of 13,225 lbs/in. This compares with an axial load of 42,000 lbs/in due to the fuel tank pressure and a monocoque buckling load of about 26,000 lbs/in. Thus the skirt will have to distribute the load so that the peak load is less than three times the average load. This is not an unreasonable requirement. An alternate approach which will allow more time for support retraction and may even save weight is to shorten the skirt and reinforce the rear portion of the fuel tank.

#### B.4 Interstage Structures

The preliminary sizing of the LCLV interstage structures was based on optimum weight equations developed on a previous ballistic missile program and the assumption that the critical loading condition occurred at first stage burnout. The objectives of the present investigation were: (a) to determine if the previously developed weight equations were appropriate considering the low cost objective of the LCLV; (b) to determine if the max  $q$  loading condition was more severe than the burnout condition, and (c) to develop a preliminary design for the proposed interstage structure.

It was found that the structural configuration upon which the weight equations were based was not appropriate for the LCLV because of its high construction cost. The most promising low cost type of interstage structure is a ring-stiffened corrugation whose weight, however, is 15% more than that given by the assumed equations. This 15% increase in the theoretical weight will not necessarily result in an increase in the estimated weight because of the generous Non-Optimum Factor which has been assumed. To maintain the weight constant the NOF will have to be reduced from 3.0 to 2.6.

Despite the fact that the maximum dynamic pressure for the LCLV (1050 psf) is fairly high for a liquid propellant launch vehicle, and the ratio of burnout axial acceleration to max  $q$  acceleration is low, the burnout acceleration condition is critical for both interstage. The load contribution due to the aerodynamic bending moments at this condition is very small. Thus the assumed critical loading condition is correct. This also means that the vehicle is insensitive to wind conditions and thus its launch availability should not be wind limited.

Preliminary sizes were computed for steel and aluminum interstages for the baseline configuration. The maximum axial stress for the aluminum inter-

stages is 48,000 psi, allowing the use of 2014-T6 alloy. 7075-T6 alloy could also be used, but it would be slightly heavier. Although the maximum temperature should be in the range of 400°F, the extremely short duration time of heating and loading will minimize the degradation of material properties. The axial compressive stresses for the steel interstages are less than 93,000 psi, so that A-1 steel with a yield stress of 100,000 psi can be used. The steel interstages would be about 50% heavier than the aluminum ones.

#### B.4.1 Weight Equations

The weight equations (App. A) which have been used for the LCLV interstages were developed for use on a booster design for which the prime structural design objective was minimum weight rather than minimum cost. On this basis the selected structural configuration was a truss core sandwich (Fig. B-4). This

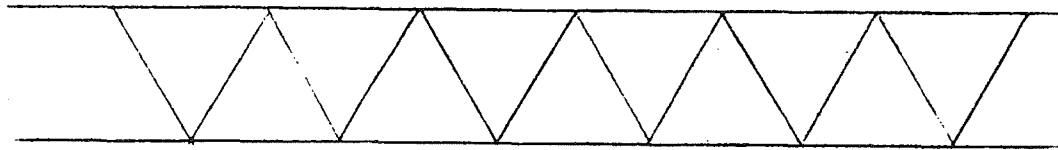

Figure B-4 Truss Core Sandwich

consists of a longitudinally corrugated metal core and inner and outer skins which are welded together along the peaks of the corrugations. This configuration is significantly lighter than a standard skin stringer construction and is slightly more efficient than a bonded honeycomb sandwich. In addition, the use of welding eliminates the reliability problems associated with bonding. Thus, the truss core sandwich is an appropriate type of construction for the original purpose. However, for the LCLV where minimum cost is the objective, it does not appear to be attractive, since the tremendous amount of welding would be expected to be extremely expensive. It was felt necessary to investigate other types of interstage structures even though they might be heavier.

One possibility was the use of a truss-type structure. One of the major problems with a truss interstage, the distribution of the concentrated truss loads into the tank walls, is minimized for the LCLV because of the use of heavy walled tanks required for a pressure fed system. Thus a truss structure would be very efficient for short interstages which would not require intermediate supports. However, for the LCLV with its very large engine exhaust nozzles the interstages are quite long. Therefore the truss columns, to be efficient, would require intermediate rings and shear ties in a similar fashion as for a

shell structure. Thus, it does not appear that a truss or lattice-type structure would be of any particular gain.

A more promising configuration is the ring-stiffened corrugated structure (Fig. B-5), which NASA has studied extensively during the last few years (Refs. 37 to 40). This structural configuration is similar to the previously discussed truss core sandwich, except that the two skins are eliminated and rings are added to supply the missing circumferential stiffness. This type of

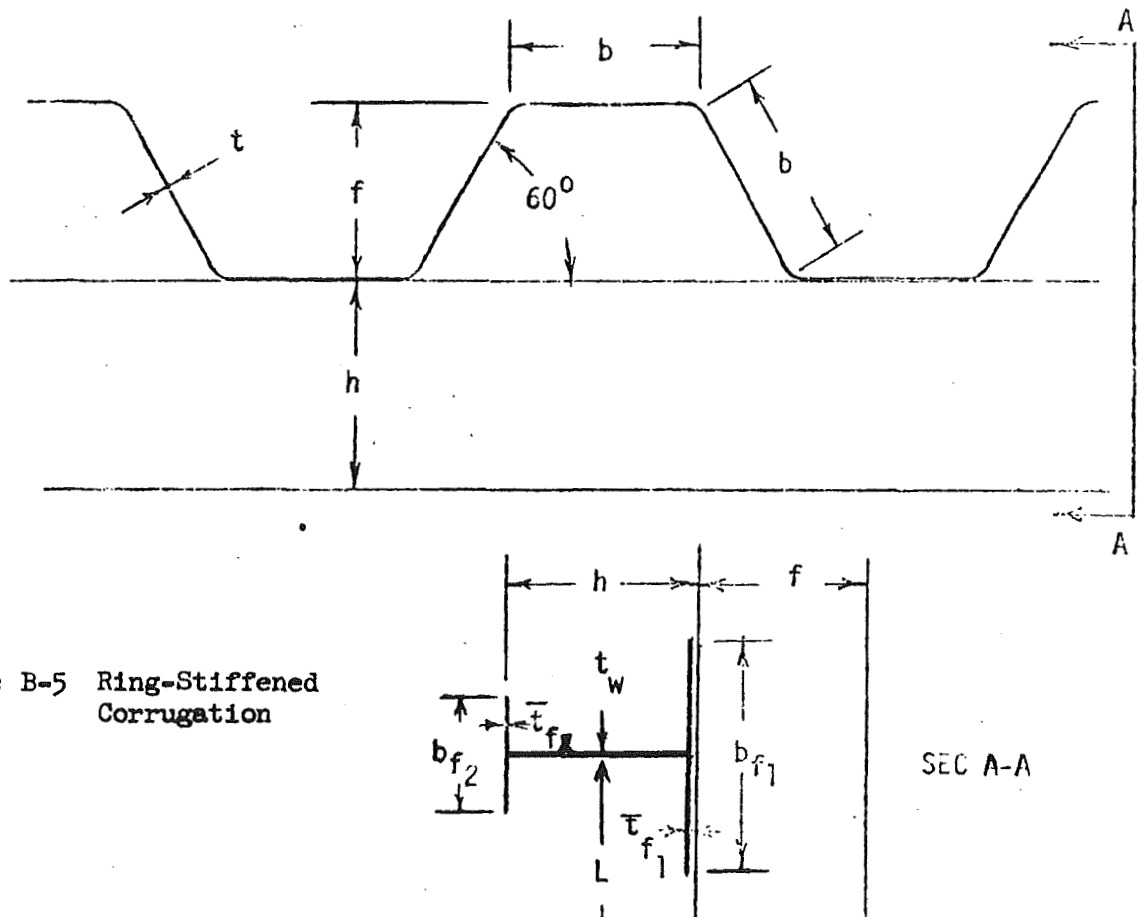

Figure B-5 Ring-Stiffened Corrugation

structure fits in very well with the LCLV concept. The difficult welding of the truss core sandwich is eliminated and the structure can be assembled from large elements by simple riveting or bolting. In addition, the use of a single, fairly thick corrugated skin minimizes the aerodynamic heating and practically eliminates any thermal stress. The basic corrugations can be fabricated very inexpensively in the flat by rolling or braking and bent to the desired curvature on assembly. Both longitudinal and circumferential joints could be made by simply using lap joints. Conical sections would be a little difficult, but could be fabricated by tapering the corrugations to obtain the required change

in diameter. These tapered corrugations could either be brake formed or rolled and subsequently re-formed on a tapered mandrel. Joints between longitudinal sections can be made with close-out channel rings. The only unusual structural requirement would be the end attachments which would have to pick up the individual corrugations and then taper down to meet the flat section of the tank skirts.

In Reference 41 an optimum design study was performed for ring-stiffened corrugated cylinders under axial compression. The results are shown in non-dimensional form in Figure B-6. Also included are the optimized weights for a monocoque structure (Ref. 42), a skin stringer structure with stabilized skin panels (Ref. 41), a waffle structure (Ref. 41), a honeycomb sandwich structure (Ref. 41) and the previously discussed truss core sandwich structure (Ref. 42).

In Figure B-6 the abscissa is  $\frac{P_{eq}}{R^2 E}$  where  $P_{eq}$  is the effective axial load and is obtained by adding  $R/2$  times the applied bending moment to the pure axial load,  $R$  is the section radius and  $E$  the material elastic modulus. The results indicate that the ring-stiffened corrugation with external rings is slightly more efficient than a honeycomb sandwich and about the same efficiency as the truss core sandwich. The ring-stiffened corrugation with internal rings is a little heavier than a honeycomb sandwich, and 15% heavier than the truss core sandwich. Thus, on a weight basis, it is preferable to place the rings externally; however, because of this interference with the airflow and possible excessive aerodynamic heating, they have not been considered for this study. At a later time an external ring with minimum aerodynamic interferences and/or with external insulation might be developed.

The equation for the mean thickness  $\bar{t}$  for the truss core sandwich is

$$\frac{\bar{t}}{R} = \left( \frac{0.43P}{ER^2} \right)^{0.6}$$

For the 15% heavier ring-stiffened corrugation this becomes

$$\frac{\bar{t}}{R} = \left( \frac{.54P}{ER^2} \right)^{0.6} = 1.37 \left( \frac{1}{E} \frac{P}{\pi R^2} \right)^{0.6}$$

this expression multiplied by the material densities is plotted in Figure B-7 to compare the weights for steel and aluminum construction. A value of  $9.6 \times 10^6$  psi is used for the aluminum modulus at the assumed burnout temperature of  $400^\circ F$ . Also shown are the axial compressive stresses in the skin. Since for an optimum design 30% of the weight is in the rings these stresses are higher than they would be for a monocoque structure of equal weight. The actual loads

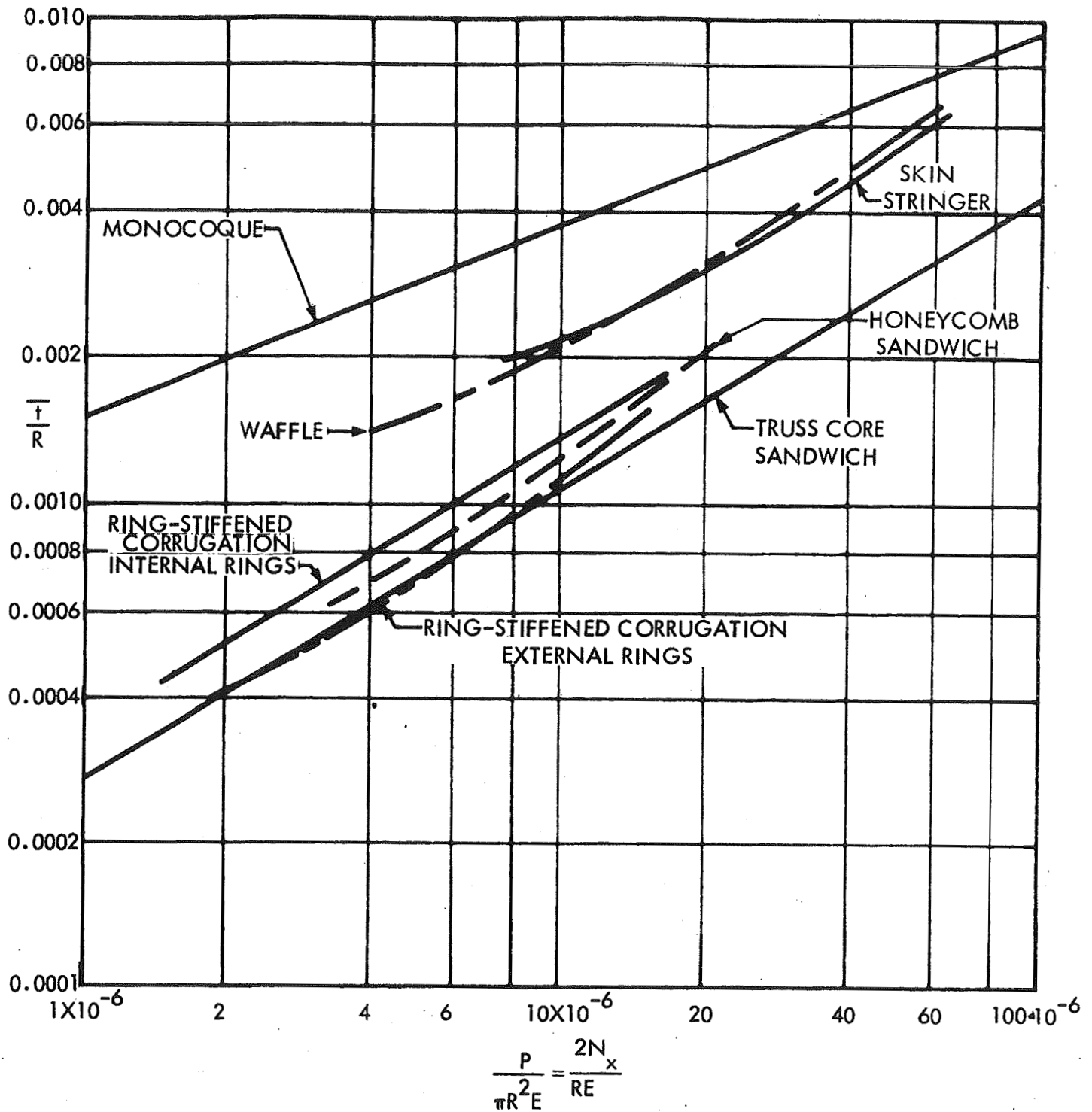

Figure B-6 Optimum Weight of Compressively Loaded Cylindrical Shells

and weights for the baseline interstages are also plotted. It is seen that steel interstages would be approximately 50% heavier than aluminum ones.

#### B.4.2 Calculation of Loads

For the LCLV weight calculations it was assumed that the critical loading

condition was due to the axial acceleration at first stage burnout. This is a reasonable approximation for launch vehicles, although in many cases the combination of axial load and bending moment at maximum dynamic pressure (or more accurately max  $q(\alpha)$ ) may be equal or slightly higher. However, for the LCLV the maximum dynamic pressure is relatively high for a liquid fueled booster and the ratio of burnout acceleration to max  $q$  acceleration is relatively low. Therefore,

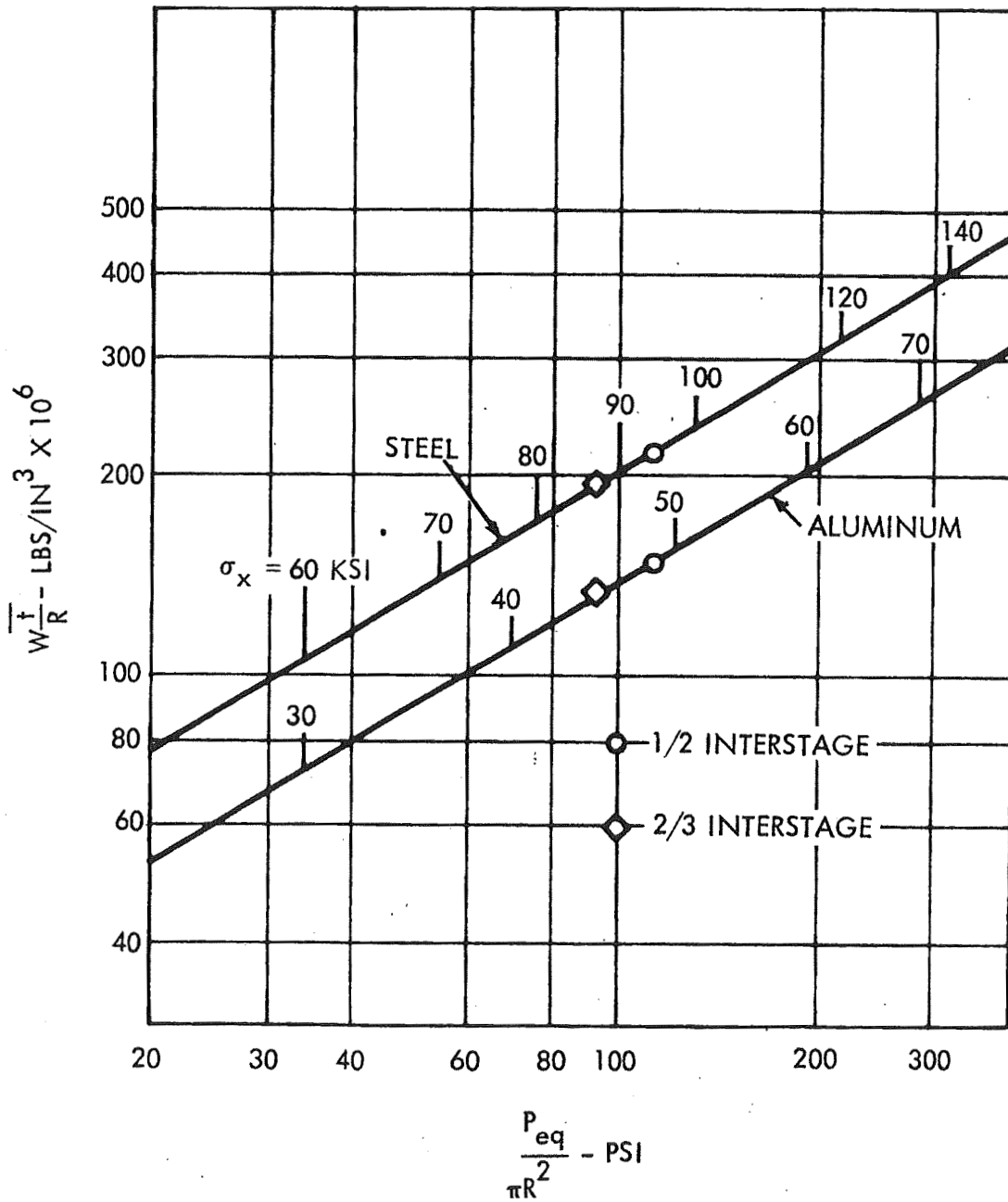

Figure B-7 Weight Densities for Optimized Ring-Stiffened Corrugated Cylinders

there is the possibility that the max q loads might be significantly higher than the burnout loads. To determine if this was the case, an investigation was made of the load history through the latter half of the first stage trajectory (Figure B-2).

To do this, the response of the vehicle to a series of design wind profiles was computed. The maximum velocities of each of these profiles (Fig. B-8) equalled the 95% max wind-altitude envelope for the Eastern Test Range (Ref. 43) but occurred at different altitudes. To obtain the response a computer program which assumed an "ideal" autopilot (i.e., an autopilot which kept the vehicle trimmed at all times with zero pitch acceleration due to the wind) was used. The aerodynamic coefficients were computed and are summarized in Figure B-9. Tail, cross and head wind profiles were assumed with the cross winds being critical. For altitudes above 45,000 feet the peak angle of attack was conservatively obtained by vector addition of the missile velocity and the peak crosswind speed. The results expressed in terms of the peak values of  $\alpha q$  are shown in Figure B-10.

These values were then used to compute the bending moments histories at the midpoint of the interstage structures, Figure B-11. The computed bending moments have been increased by 30% to account for the behavior of a real autopilot and the effects of gusts. The bending moments are presented as the equivalent axial load  $P_{eq} = \frac{2M}{R}$  required to cause the same maximum stress and are added to the axial load (including drag) to obtain the design load history.

The results show that the initial assumption that the burnout load condition is critical is correct. For the 1/2 interstage the max  $q\alpha$  load condition is about 30% lower than the burnout condition, while for the 2/3 interstage it is about 7% lower. It thus appears that the only major structural component which would be designed by the max  $q\alpha$  condition is the payload fairing. Thus the LCLV should have a high launch availability with respect to wind conditions, since its critical structural loads are not a function of the wind velocity.

#### B.4.3 Preliminary Interstage Structural Design

Using the results of Reference 40 a preliminary structural design for the interstage structure has been made. From Figure B-11 the ultimate loading conditions for the two interstages are

Interstage	1/2	2/3
$P_{eq}$	$15.3 \times 10^6$ lbs	$6.6 \times 10^6$ lbs
$\frac{P_{eq}}{\pi R^2}$	110.4 psi	93.4 psi

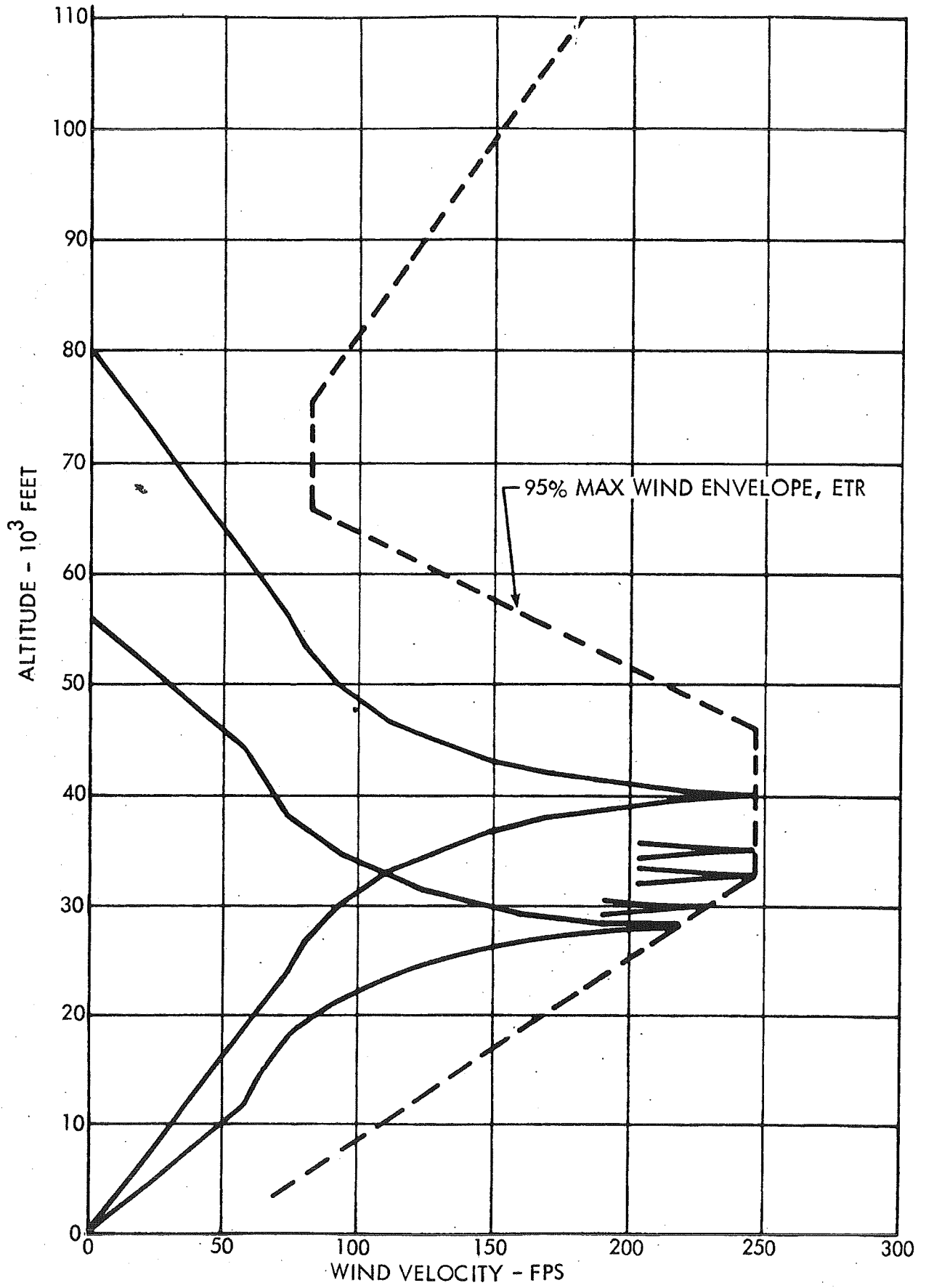

Figure B-8 Design Wind Profiles



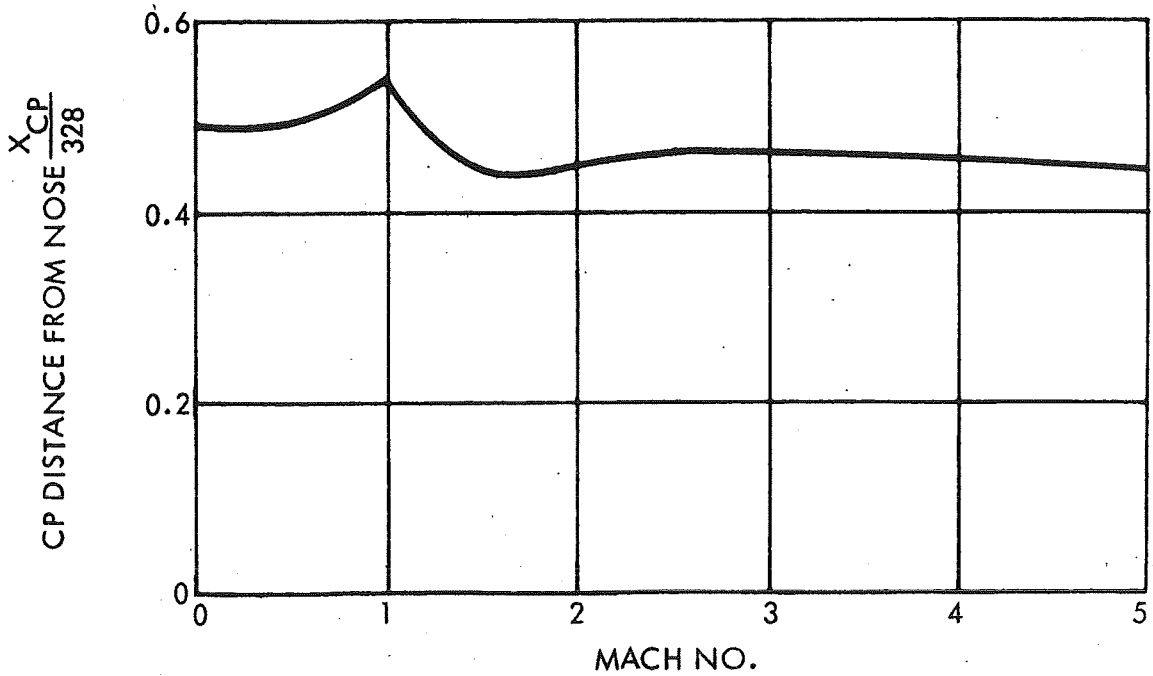
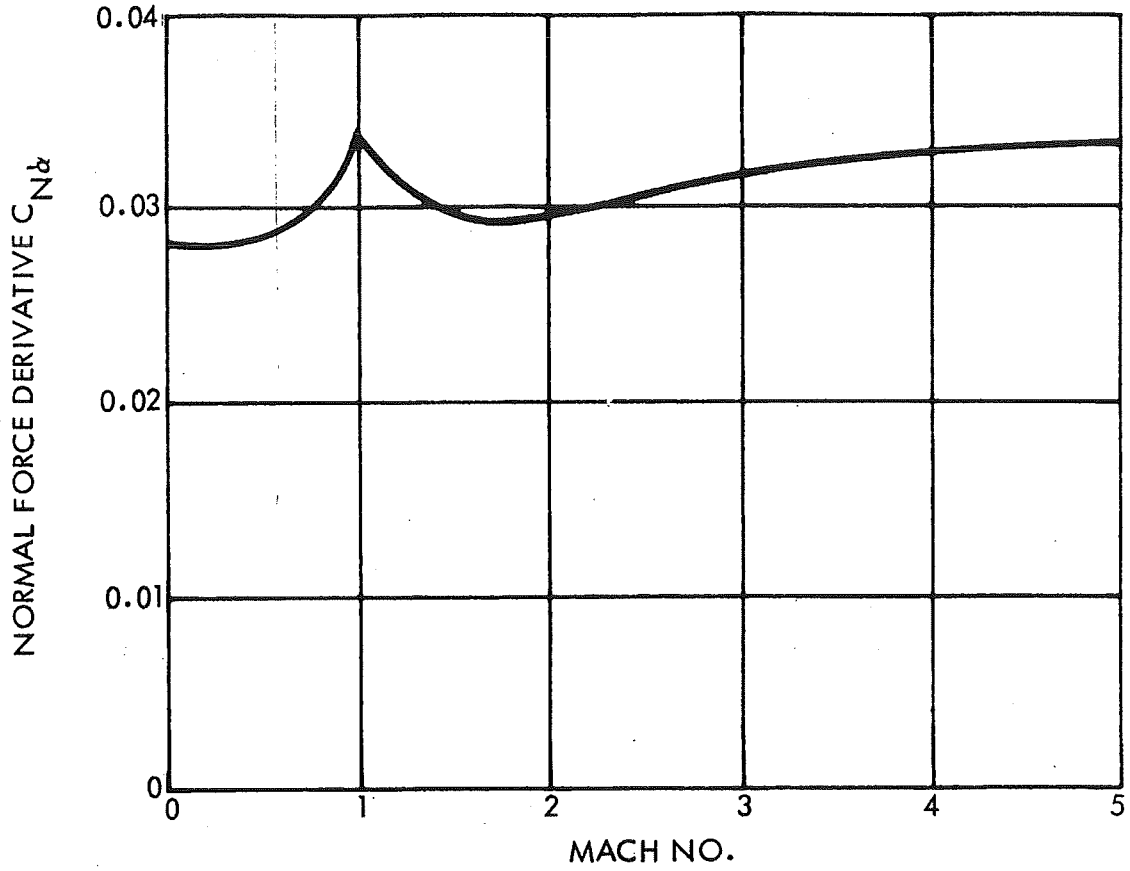

Figure B-9 LCLV Aerodynamic Coefficients

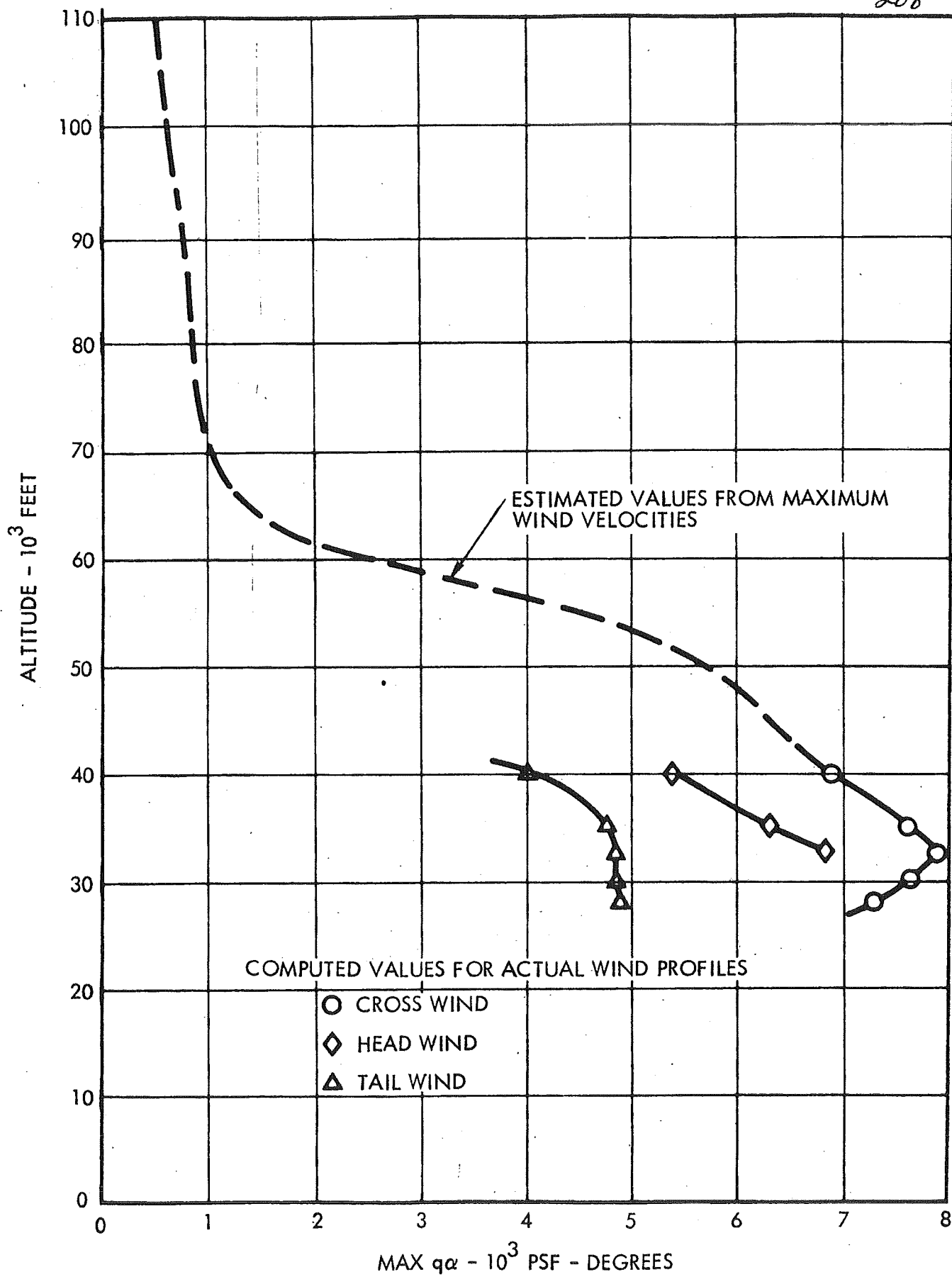

Figure B-10 Variation of Max  $Q\alpha$  with Altitude for 95% Wind Profile

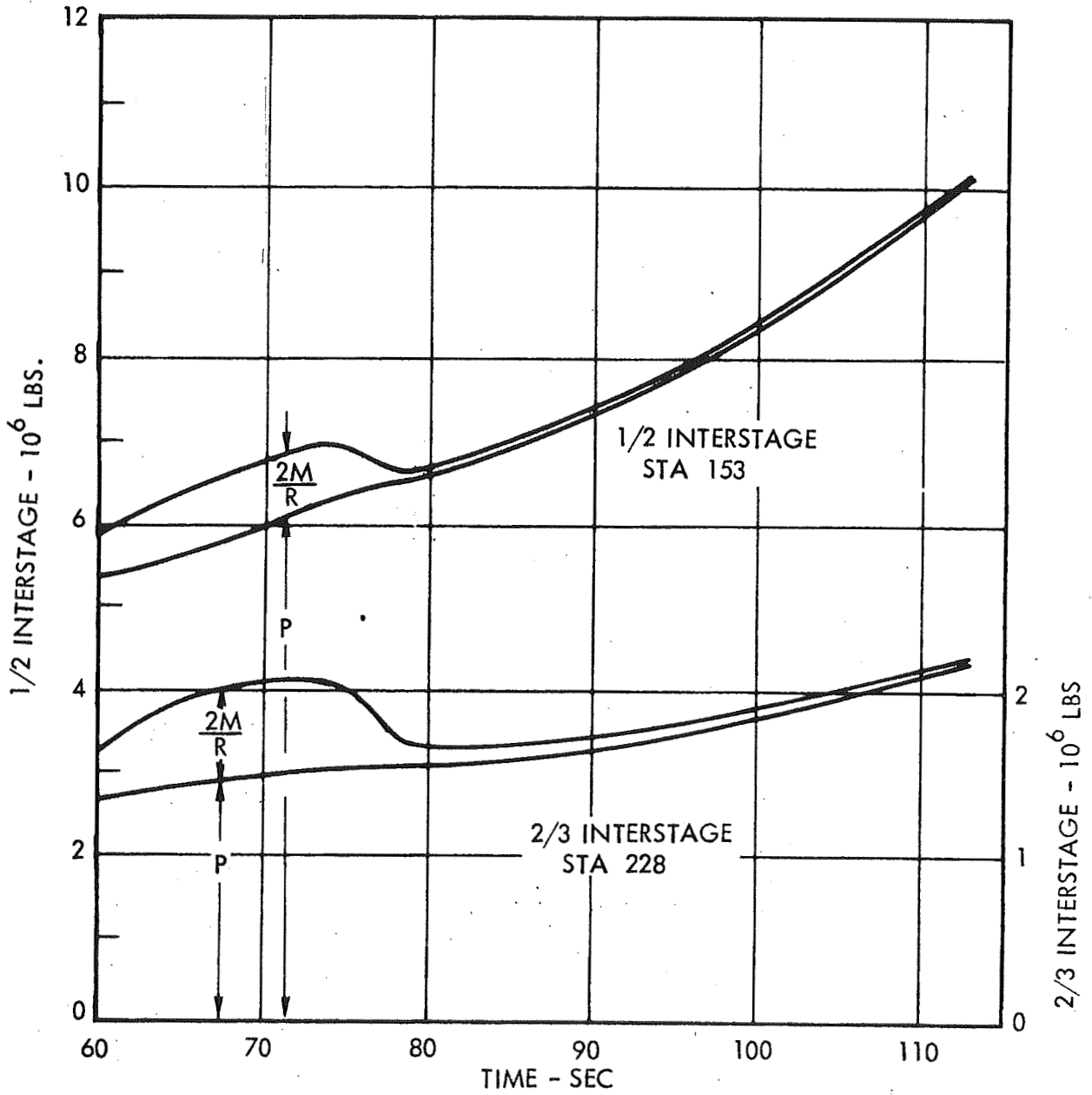

Figure B-11 Limit Equivalent Axial Load  $P + \frac{2M}{R}$

These values are plotted in Figure B-11 to obtain the following average section weights per circumferential inch for steel and aluminum interstages.

	$\frac{1}{2}$	$\frac{2}{3}$
Steel	.0458	.0296 lb/in <sup>2</sup>
Aluminum	.0314	.0203

The complete details for the mid-sections of each of the interstages are described in Figure B-4 and Table B-VII.

For the steel interstages the maximum compressive stress is 92,000 psi and therefore, T-1 steel with a yield stress of 100,000 psi can be used. At the assumed temperature of about 400°F there would be no significant reduction in its allowable stress and elastic modulus.

To account for the assumed burnout temperature of about 400°F the aluminum thicknesses were computed using an elastic modulus of  $9.6 \times 10^6$  equal to 90% of the room temperature value. The resulting ultimate compressive stresses are 48 Ksi for the 1/2 interstage and 45 Ksi for the 2/3 interstage. The 3 standard high strength aluminum alloys available for consideration are:

ALLOY	$E_c - 10^6$ psi		$F_{CY}$ Ksi	
	70°F	400°F	70°F	400°F (1/2 hr duration)
2014-T6	10.7	9.6	66	54
2024-T6	10.7	9.6	49	38
7075-T6	10.5	8.4	66	40

It is seen that 2014-T6 has the best properties at these temperatures and therefore is the material of choice.

Table B-VII Interstage Structural Dimensions

Item	1/2 Interstage		2/3 Interstage	
	Alum.	Steel	Alum.	Steel
Radius R	210" at Sta. 153		150" at Sta. 228	
Mean thickness $\bar{t}$	0.314"	0.163"	0.203"	0.106"
Skin thickness t	0.184	0.094	0.117	0.061
Corrugation plate width b	4.87	3.16	3.25	2.11
Corrugation depth f	4.22	2.74	2.81	1.83
Ring spacing L	76.4	61.7	52.7	42.5
Ring depth h	12.5	8.1	8.32	5.40
Wet thickness $t_w$	0.160	0.104	0.107	0.069
Inner flange width $b_{f1}$	9.2	6.0	6.15	3.98
Inner flange thickness $t_{f1}$	0.307	0.20	0.205	0.133
Outer flange width $b_{f2}$	4.6	3.0	3.08	1.99
Outer flange thickness $t_{f2}$	0.153"	0.10"	0.103"	0.066"
Ultimate axial stress $\sigma$	48 KSI	92 KSI	45 KSI	86.5 KSI

### B.5 Factor of Safety for LCLV

An ultimate factor of safety of 1.5 has been recommended for the LCLV structure because it is felt that the use of a slightly larger factor than is commonly used on space vehicles is consistent with the LCLV design philosophy of minimizing development and fabrication costs at the expense of some increase in weight.

Use of an increased factor of safety should decrease development and fabrication costs for the following reasons:

- a. It minimizes the number and extent of the structural development tests which are required. This is particularly important for the LCLV because of the immense size of the structural components. For instance, with a well thought out program of element and model tests and the proposed factor of 1.5, it should be possible to justify the deletion of full scale interstage tests.
- b. It reduces somewhat the detailed analysis requirements.
- c. It allows a more relaxed attitude toward inspection requirements and the salvage of damaged parts. Again, these are critical problems for the LCLV because of the immense size of the components.

For most current manned space vehicles (Apollo, MOL) an ultimate factor of 1.4 is specified. This factor applies to flight loads and to pressurized integral propellant tanks. For all other pressure vessels, including the manned cabin, the ultimate factor is generally considerably larger.

For all Air Force unmanned ballistic missiles and space vehicles the ultimate factor is 1.25. However, NASA has specified a factor of 1.5 for most of the space vehicles (OGO, Pioneer, OAO, Intelsat) for which they have launch responsibility.

The ultimate factor for all aircraft has been 1.5 for many years.

Thus the proposed factor of 1.5, although slightly higher than the most commonly used factors, is not a radical break with the previous history of structural factors. It is felt that it is a reasonable compromise between the conflicting requirements of minimizing weight and development and fabrication costs.

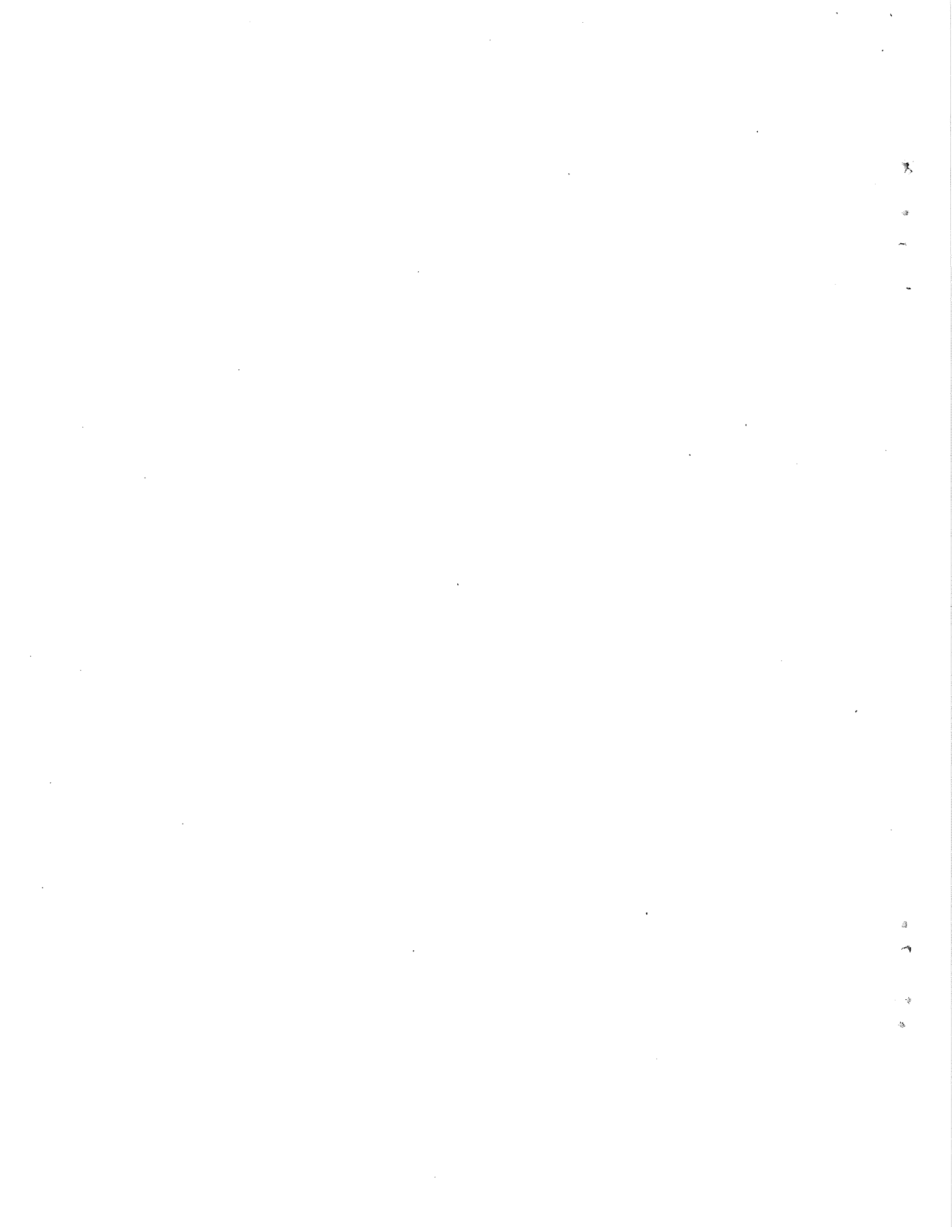

## APPENDIX C

## EXCHANGE RATIOS FOR LCLV

The following exchange ratios are based upon an early version of design No. 1 weighing 10M lbs, costing \$1/lb of vehicle gross weight, and with other characteristics as follows:

Stage Number	1	2	3	(lb) Payload	(lb) Gross
Initial weight $W_o$ , lb	7.60M	2.0M	.3M	.100M	10.0M
Propellant weight $W_p$ , lb	6.61	1.76	.267	---	8.63M
Final weight $W_f$ , lb	.99	.24	.033	---	1.26M
Structure ratio $\sigma$	.13	.12	.11		
Mass ratio $r$	2.95	3.75	3.01		
Specific Impulse $I$ , sec	255	290	295		

Basic exchange ratios for the respective stages are derived as follows, and computed values are shown in Table C-I. Other useful ratios involving weight and cost are shown in Table C-II. Derivations of the Analytic Exchange Ratio equations are presented in Reference 44. Only the equations and important assumptions are presented here. Three different sets of "Ratios" are presented, consisting of:

- 1) Ratios relating perturbations of booster vehicle performance parameters to changes in burnout velocity
- 2) Ratios relating perturbations of booster vehicle performance parameters to payload capability, assuming constant burnout velocity
- 3) Ratios relating perturbations of booster vehicle performance parameters to the amount that stage gross weight must change to maintain a fixed payload capability.

Velocity losses due to gravitational effects are normally estimated from analytic and empirical techniques. However, for LCLV a trajectory was available from which to obtain values of  $\Delta V_g$  for each stage. The equations presented in the following sections were applied to LCLV Design Configuration No. 1 as defined in Figure 4-1, for a 100 nautical mile orbit, and values are summarized in Table C-I.

The definition of symbols used in the derivations are as follows:

$g$	Acceleration due to gravity; $32.174 \text{ ft/sec}^2$
$I_{sp}$	Vacuum specific impulse
$i$ or $n$	Integer corresponding to a particular stage
$N$	Integer corresponding to the total number of stages
$r$	Mass ratio = $W_o/W_{BO}$
$T$	Initial thrust - sea level for the first stage and vacuum for the upper stages
$t_b$	Stage burning time
$W_{BO}$	Burnout weight
$W_o$	Initial gross weight
$W_p$	Propellant weight

Table C-I

EXCHANGE RATIOS FOR LCLV

Values of exchange ratios derived in Appendix B are as follows:

	Stage	1	2	3
VELOCITY EXCHANGE RATIOS	DV/DISP (FPS/SEC)	30.070308	38.333671	34.869963
	DV/DWST (FPS/LB)	-.1675012E-02	-.1236616E-01	-.6000122E-01
	DV/DWP (FPS/LB)	.066782E-02	.1521869E-02	.1074639E-01
	DV/DWPL (FPS/LB)	-.1675012E-02	-.1236616E-01	-.6000122E-01
	DV/DWBO (FPS/LB)	-.2342832E-02	-.1388803E-01	-.07074761
	DV/DT (FPS/%)	12.64	12.158252	1.6441043
	DWPL/DISP (LB/SEC)	501.1613	638.8815	581.15421
PAYLOAD EXCHANGE RATIOS	DWPL/DWST (LB/LB)	-.279163E-01	-.20609854	-1
	DWPL/DWO (LB/LB)	-.0629129E-01	-.2657714E-02	.4707592E-01
	DWPL/DWP (LB/LB)	.1112461E-01	.5325537E-01	.3850494
	DWPL/DWPS (LB/LB)	-.0695871E-01	-.2740376E-02	.5550735E-01
	DWPL/DT (LB/%)	210.66237	202.6334	27.40118
GROSS WEIGHT	DWO/DISP (LB/SEC)	-41043.446	-11337.64	-1495.4546
	DWO/DT (LB/%)	-17252.538	-3595.948	-70.510069



TABLE C-II

APPLICATION OF EXCHANGE RATIOS

$$\frac{dW_o}{d\% \sigma} = \frac{dW_o}{dI_g} \cdot \frac{dV}{d\% \sigma} = \frac{W_o}{I_g} \cdot I_g (\ln r_1 - \ln r_2) = W_o \ln \left( \frac{r_1}{r_2} \right) = W_o \ln \left( \frac{1 + .01}{1 + .01/r_1} \right) = .00667 W_o / \% \sigma$$

$\Delta \sigma$  Stage 1 only:  $.00667 \times 10M = 66,700 \text{ lb}/\% \dots \frac{d\$}{d\% \sigma} = \$66,700/\% \sigma *$

Stage 2 only:  $16,000(1+2.95) = 63,000; .00667 \times 2.4M = 16,000$

Stage 3 only:  $12,700(1+2.95) = 50,000; 2670(1+3.75) = 12,700; .00667 \times .4M = 2670$

$\Delta \sigma$  all 3 Stages:  $179,700 \text{ lb}/\% \sigma \dots \$179,700/\% \sigma *$

$$\frac{dW_o}{d\% I_{SP}} = \frac{dW_o}{dI_{SP}} \cdot \frac{dI_{SP}}{d\% I_{SP}}$$

$\Delta I$  Stage 1 only:  $-41,043 \times 2.55 = -105,000 \text{ lb}/\%; \dots \$105,000/\% *$

Stage 2 only:  $-32,900(1+2.95) = -130,000; -11,338 \times 2.9 = -32,900$

Stage 3 only:  $-21,000(1+2.95) = -82,700; -4410(1+3.75) = -21,000; -1495 \times 2.95 = -4410$

$\Delta I$  all 3 Stages:  $317,700 \text{ lb}/\% \dots \$317,700/\text{lb}\% *$

$$\frac{d\$}{dV} = \frac{d\$}{dW_o} \cdot \frac{dW_o}{dV}$$

$\Delta V$  Stage 1 only:  $\$1/.00667 = \$1500/\text{fps};$

Stage 2 only:  $(1/.00152) (1+2.95) = \$2600/\text{fps};$

Stage 3 only:  $(1/.0107) (1+2.95) (1+3.75) = \$1750/\text{fps}$

$$\frac{d\$}{d\% \text{ Resid.}} = \frac{d\$}{dW_o} \cdot \frac{dW_o}{d\% \sigma} \cdot \frac{d\% \sigma}{d\% \text{ Resid.}} = \$1 \frac{dW_o}{d\% \sigma} \left[ \frac{1+.01(1-\sigma)/\sigma}{1+.01(1-\sigma)r} - 1 \right] \times 100$$

$\Delta$  Resid. Stage 1 only:  $-66,700 \times 3.7 = \$-246,000/\% \text{ Resid.}$

Stage 2 only:  $-63,000 \times 3.2 = -202,000$

Stage 3 only:  $-50,000 \times 4.7 = -234,000$

$\Delta$  Resid. all 3 Stages:  $\$-682,000/\% \text{ Resid.}$

$$\frac{d\$}{d\%(T/W_o)} = \frac{d\$}{dW_o} \cdot \frac{dW_o}{d\% \sigma} \cdot \frac{d\% \sigma}{d\%(T/W_o)} = \$1 \times \frac{dW_o}{d\% \sigma} \times \frac{.01}{\sigma}$$

$\Delta (T/W_o)$  Stage 1 only:  $66,700/13 = \$ 5,100/\%$

Stage 2 only:  $63,000/12 = \$ 5,250$

Stage 3 only:  $50,000/11 = \$ 4,550$

$\Delta (T/W_o)$  all 3 Stages:  $\$14,900/\%$

\*The above exchange ratios are converted to \$ by use of the convenient cost ratio of \$1 per pound of gross weight

$W_{PL}$	Payload weight	
$W_{ST}$	Inert weight	
$\bar{\beta}$	Average flight path angle; $\cos \bar{\beta} = \frac{v}{gt_b}$	
$\lambda$	Ratio of sea level specific impulse to vacuum specific impulse;	$= \frac{I_{spS}}{I_{spV}}$
$\sigma$	Structure ratio	
$\theta$	$\frac{\cos \bar{\beta}}{(I/W_0)}$	
$\Delta V_g$	Velocity losses due to gravitational effects	

### 3.1 Velocity Exchange Ratios

In the following equations it is assumed that the total velocity losses due to atmospheric effects and thrust vector misalignment are not affected by perturbations of vehicle performance parameters. Losses due to gravitational effects are approximated by  $\Delta V_{g_i} = g t_{b_i} \cos \bar{\beta}_i$  where  $t_{b_i}$  is the burn time and  $\bar{\beta}_i$  is the average flight path angle of the  $i$ th stage.

Specific Impulse ( $I_{sp}$ ). A perturbation of specific impulse is assumed to correspond to a change in propellant mass flow rate, effecting a change in burning time.

$$\left( \frac{dV}{dI_{sp}} \right)_n = g \left[ \ln r_n - \frac{\lambda_n \cos \bar{\beta}_n}{(T/W_0)_n} \left( 1 - \frac{1}{r_n} \right) \right]$$

Inert Weight ( $W_{ST}$ ). It is assumed that initial and burnout weight are perturbed equally.

$$\left( \frac{dV}{dW_{ST}} \right)_n = \sum_{i=1}^n \left( \frac{g I_{sp}}{W_0} \right)_i (1 - r_i)$$

Payload Weight ( $W_{PL}$ ). A payload perturbation affects burnout velocity by the same amount as a perturbation in inert weight.

$$\left( \frac{dV}{dW_{PL}} \right)_n = \left( \frac{dV}{dW_{ST}} \right)_n$$

Burnout Weight ( $W_{BO}$ ). It is assumed that initial weight and propellant mass flow rate remain constant, resulting in a change of burning time.

$$\left( \frac{dV}{dW_{BO}} \right)_n = - \left( \frac{g I_{sp}}{W_0} \right)_n \left[ r_n - \frac{\lambda_n \cos \bar{\beta}_n}{(T/W_0)_n} \right]$$

Propellant Weight ( $W_o$ ). Burn time is varied to reflect the change in propellant weight.

$$\left(\frac{dV}{dW_p}\right)_n = \sum_{i=1}^n \left[ \left(\frac{gI_{sp}}{W_o}\right)_i (1 - r_i) \right] + \left(\frac{gI_{sp}}{W_o}\right)_n \left[ r_n - \frac{\lambda_n \cos \bar{\beta}_n}{(T/W_o)_n} \right]$$

Stage Thrust (T). Specific impulse is assumed constant, which results in changing the propellant mass flow rate.

$$\left(\frac{dV}{dT}\right)_n = \frac{\lambda_n g I_{sp_n} \cos \bar{\beta}_n}{100(T/W_o)_n} \left(1 - \frac{1}{r_n}\right)$$

Thrust perturbation,  $dT$ , is expressed as a percentage of nominal thrust.

### 3.2 Payload Exchange Ratios

In the following equations it is assumed that burnout velocity remains constant. A performance parameter perturbation is realized as a change in payload weight. The same assumptions, concerning losses, as made for the Set One equations, apply for Set Two.

Specific Impulse ( $I_{sp}$ ). A change in  $I_{sp}$  is assumed to correspond to a change in propellant mass flow rate.

$$\left(\frac{dW_{PL}}{dI_{sp}}\right)_n = \frac{\ln r_n - \theta_n \left(1 - \frac{1}{r_n}\right)}{\sum_{i=1}^n \left[ \left(\frac{I_{sp}}{W_o}\right)_i (r_i - 1) \right]} \quad \text{where} \quad \theta_n = \frac{\lambda_n \cos \bar{\beta}_n}{(T/W_o)_n}$$

Inert Weight ( $W_{ST}$ ). It is assumed that the  $I_{sp}$  and propellant weight remain constant.

$$\left(\frac{dW_{PL}}{dW_{ST}}\right)_n = - \frac{\sum_{i=1}^n \left[ \left(\frac{I_{sp}}{W_o}\right)_i (r_i - 1) \right]}{\sum_{i=1}^n \left[ \left(\frac{I_{sp}}{W_o}\right)_i (r_i - 1) \right]}$$

For a one stage vehicle this equation reduces to:  $\frac{dW_{PL}}{dW_{ST}} = -1$

Stage Gross Weight ( $W_o$ ). It is assumed that both the propellant and structure weight are perturbed consistent with an amount to accommodate the propellant weight change. The  $I_{sp}$  is assumed to be constant.

$$\left(\frac{dW_{PL}}{dW_o}\right)_n = - \frac{\sum_{i=1}^n \left[ \left(\frac{I_{sp}}{W_o}\right)_i (1 - r_i) \right] + (1 - \sigma_n) \left(\frac{I_{sp}}{W_o}\right)_n (r_n - \theta_n)}{\sum_{i=n+1}^N \left[ \left(\frac{I_{sp}}{W_o}\right)_i (1 - r_i) \right] - (1 - \sigma_n) \left(\frac{I_{sp}}{W_o}\right)_n (r_n - \theta_n)}$$

Propellant Weight ( $W_p$ ). Assumes constant  $I_{sp}$  and structure weight.

$$\left(\frac{dW_{PL}}{dW_p}\right)_n = \frac{\left(\frac{I_{sp}}{W_0}\right)_n (1 - \theta_n) - \sum_{i=1}^{n-1} \left[\left(\frac{I_{sp}}{W_0}\right)_i (r_i - 1)\right]}{\sum_{i=1}^n \left[\left(\frac{I_{sp}}{W_0}\right)_i (r_i - 1)\right]}$$

Propellant Plus Structure Weight ( $W_{PS}$ ). Assumes constant  $I_{sp}$  but differs from Equation 10 by including a variation in structure weight consistent with the change in propellant weight.

$$\left(\frac{dW_{PL}}{dW_{PS}}\right)_n = \frac{\left(\frac{I_{sp}}{W_0}\right)_n (r_n - \theta_n) - \frac{1}{1 - \sigma_n} \sum_{i=1}^n \left[\left(\frac{I_{sp}}{W_0}\right)_i (r_i - 1)\right]}{\sum_{i=1}^n \left[\left(\frac{I_{sp}}{W_0}\right)_i (r_i - 1)\right]}$$

Stage Thrust ( $T$ ). Specific Impulse is assumed constant resulting in a variation of propellant mass flow rate. Structural weight is also assumed constant. Thrust perturbation,  $dT$ , is expressed as a percentage of nominal initial thrust.

$$\left(\frac{dW_{PL}}{dT}\right)_n = \frac{\lambda_n I_{sp_n} \cos \bar{\beta}_n (1 - 1/r_n)}{100 \left(\bar{T}/W_0\right)_n \sum_{i=1}^n \left[\left(\frac{I_{sp}}{W_0}\right)_i (r_i - 1)\right]}$$

### 3.3 Gross Weight Exchange Ratios

The following equations relate perturbations of booster performance parameters to the amount that stage gross weight must be varied in order to maintain a fixed payload capability. Assumptions concerning losses are the same as for Set One. A constant stage structure factor is assumed.

Specific Impulse ( $I_{sp}$ ). Thrust is assumed constant, resulting in a change of propellant mass flow rate. Burn time is assumed to vary in proportion to the change in  $\tau_{sp}$  and stage propellant weight.

$$\left(\frac{dW_0}{dI_{sp}}\right)_n = - \frac{\ln r_n - \theta_n (1 - 1/r_n)}{\frac{I_{sp}}{W_0} [1 - \theta(1 - 1/r_n)]}$$

Thrust ( $T$ ). Specific Impulse and structure factor are assumed constant. Burn time is assumed to vary in proportion to the change in thrust and stage gross weight. Thrust perturbation,  $dT$ , is expressed as a percentage of nominal initial thrust.

$$\left(\frac{dW_0}{dT}\right)_n = - \frac{W_{0n} \theta_n (1 - 1/r_n)}{100 [1 - (1 - 1/r_n) \theta_n]}$$

APPENDIX D  
SUMMARY OF TASK COMPLETION

Statement of Work for Contract No. NASw-1792 is shown below, with references to sections of the report where various subjects are discussed.

The Contractor shall furnish the personnel, facilities, equipment and materials as required to perform an analysis of low cost launch vehicles having payload capability in the 40,000 to 100,000 pound range, suitable for NASA space missions during the 1973 to 1985 time period. The study effort shall include, but not be limited to the following tasks:

1. Collect and review available background information and other data applicable to the study - (Approximately 12% Study Effort)
  - 1.1. Utilize results of previous NASA and Air Force investigations of current and product improved and uprated launch vehicles (when applicable) with particular emphasis on those in the low cost category. Section 3.
  - 1.2. List basic requirements for launch vehicles for future space programs.
    - 1.2.1. Parametric traffic estimates for various ranges of payload versus velocity. Section 2
    - 1.2.2. Requirements for accuracy and operational characteristics such as guidance, cut off velocity, launch readiness, etc. Section 2.
    - 1.2.3. Range of budget allocations to be expected. Section 2.
  - 1.3. Define fundamental extraordinary restraints, such as vehicle assembly building, range facilities and global communications network. Section 7.
2. Investigate cost tradeoffs involving basic design and operational requirements - (Approximately 30% Study Effort)
  - 2.1. Identify critical configurational and programmatic constraints and their cost relationships. Section 3,4,7,9.
  - 2.2. Check the validity of constraints with respect to fundamental mission objectives. Sections 2,3,7,9.
  - 2.3. Indicate where less rigid constraints may be justified while preserving essential objectives. Sections 2,3,6,8.
  - 2.4. Indicate where cost reductions are most likely to be effected in conception, procurement and launch of systems. Sections 3,6,7,9.

2.5. Redraft basic requirements compatible with high standards of safety and effectiveness and more amenable to overall cost economies. Section 2,3,6.

3. Generalized design for minimum overall cost - (Approximately 50% Study Effort)

3.1. Select three launch vehicle sizes suitable for specified missions using new constraints as developed in 2 above. Section 4.

3.2. Choose one of these vehicles as a model for investigating design features in further detail. Conduct preliminary design of this vehicle, and develop methods of scaling results to other sizes. Section 4,9.

3.3. Develop matrix of costs for model vehicle, categorized according to major subsystems, as well as RDT&E, manufacturing and launch operations. Section 4,9.

3.4. Use conservative estimates for costs, and provide rationale to justify potential savings, when compared with cost matrix of current vehicle. Section 1,2,7,9.

4. Determine effectiveness of new launch vehicle family when applied to possible future flight programs - (Approximately 8% Study Effort).

4.1. Use parametric traffic estimates compatible with budget range. Section 2.

4.2. Select vehicle mix to satisfy requirements for payload/velocity/number of launches. Section 1,2,9.

4.3. Compare overall cost of space program using new family with that of current launch vehicles. Section 2.

4.4. Indicate potential expansion of national space program to be attained by applying cost savings to finance additional missions. Section 2.

5. Tasks 1 through 4 will be time phased according to the study plan shown in Attachment 1 to Exhibit A. Additional information, direction, and guidance for the performance of these tasks will be provided to the Contractor by the individual authorized to issue technical direction or his designee in accordance with Article 3, Technical Direction, of the Contract Schedule.

6. The expected results of this study will include, but will not necessarily be limited to, investigation and solution of the following areas:

6.1. Assessment of the impact of mission requirements for earth synchronous, planetary, and other missions on the candidate launch vehicle configuration. Section 4.

6.2. Identification of desired booster performance requirements for the 1973-1985 time period. Section 2,4.

- 6.3. Identification and analysis of the design and operations factors that contribute to high cost operations. Section 3,7.
- 6.4. Identification and analysis of systems and subsystems that will simplify operations and result in cost reductions. Sections 3,4,6,7,9.
- 6.5. Evaluate manufacturing, control, inspection, and test procedures, policies and philosophies from the point of view of simplification and attendant cost reduction.  
Sections 3,6,7.
- 6.6. Develop rationale for an effective progression and transition from development to operational phase. Section 10.
- 6.7. Vehicle configurations will be defined to the conceptual design level. Weight statement, drawings, specification, loads, control, etc. will be provided for each candidate configuration. Section 4,5, Appendix B, F.
- 6.8. Performance will be presented for the missions considered for each configuration. Section 4, Appendix B.
- 6.9. Preparation of schedules for the design, development, testing, and engineering and the projected operational phase. Section 10.
- 6.10. Identification and analysis of the costs and other resources associated with the candidate configurations, production rates, and missions. Sections 1, 2, 7, 9.
- 6.11. Identification and analysis of facilities costs and an estimate of the impact of the schedule on existing programs. Sections 1, 2, 7.
- 6.12. Generate preliminary funding schedules for the development of the candidate vehicles. Section 10.

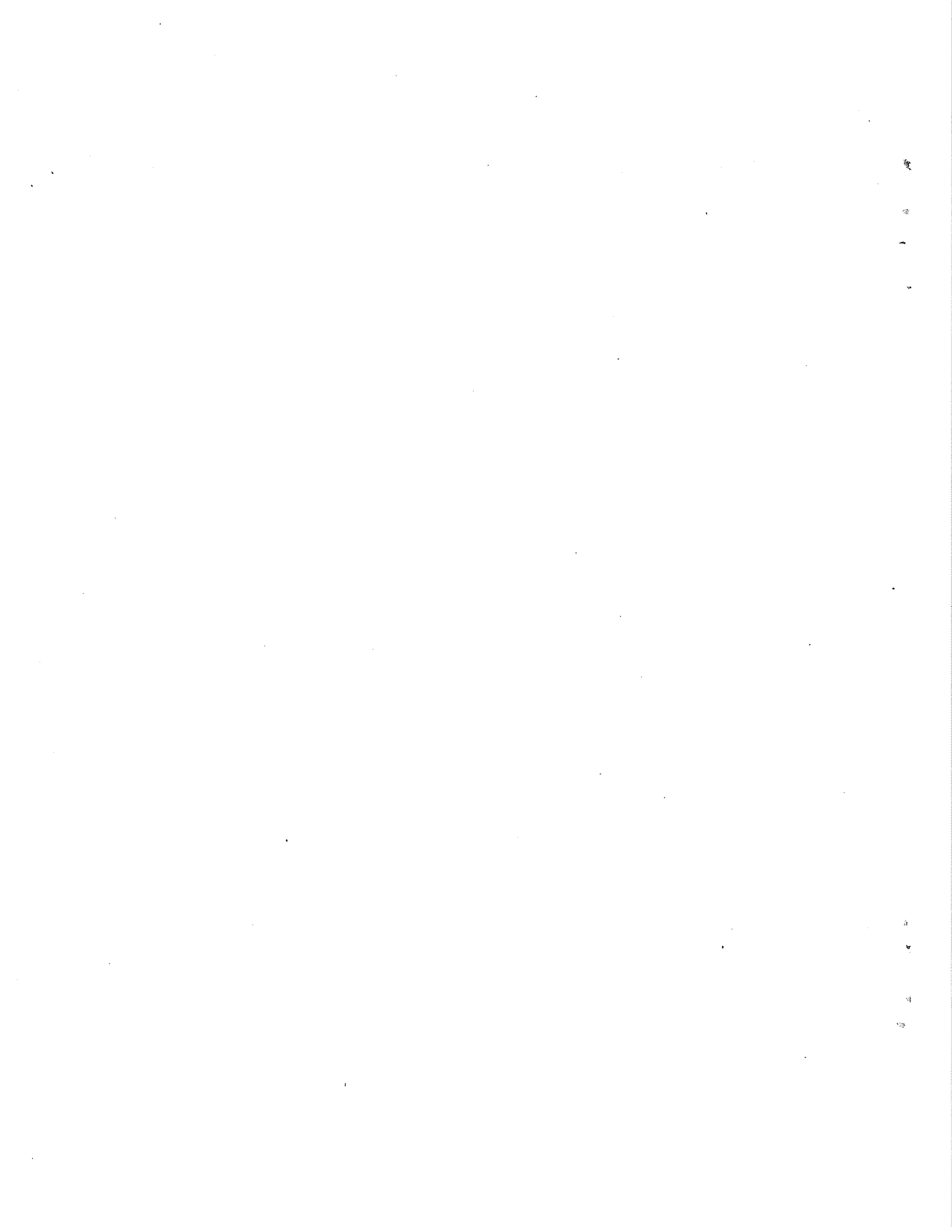



## APPENDIX E\*

DEFINITIONS, EQUATIONS AND COST DATA SHEETS  
FOR GROUND SYSTEM COST CATEGORIES

Presented in Table E-I is a list of ground system cost categories which was developed for use as a baseline in conducting the study. Each of the categories is defined herein in terms of the elements of which they are comprised.

The purpose in developing the list and corresponding definitions was: One, to provide a standard in order to evaluate the various ground systems; and, two, to minimize the semantics problem in classifying and identifying the relationships and meanings of the LCLV ground system cost categories. In particular, it has been noted from previous experience that proposed cost categories, although acceptable in general terms, were open to a matter of interpretation as to what cost elements constituted their detailed definition.

Also included are equations which have been formulated in order to estimate the costs of the candidate LCLV ground system configurations and modes of operation. Equations are developed for each program phase of the LCLV ground system, i.e., RDT & E, production, etc., and constitute a mathematical expression of the functional relationships of the applicable cost elements. The parametric values to be inserted in the equations are a function of such factors as: Operating modes; design and performance criteria; system complexity; launch rates; program duration, number of launch pads; intuitive judgment gained from experience with similar systems; and historical and present cost information on comparable or related systems, e.g., Saturn V.

At the end of this appendix are given cost data sheets for the four concepts, transferred from the main body of text material in Section 7 because of their bulk (100 pages). The table numbers used in Section 7 have been retained.

	*Index To Appendix E1	Page
1.0 Program Management Cost Category		E3
2.0 RDT & E Cost Category		E7
3.0 Aerospace Ground Equipment (AGE) Production Cost Category		E10
4.0 Launch Facilities Production Cost Category		E13
5.0 Site Installation & Checkout (I & C) Cost Category		E15
6.0 Ground Systems Operations Cost Category		E17
Table 7.6-IV Concept A - Estimated AGE/LF etc. Costs		E22
Table 7.6-VIII Concept B - Estimated AGE/LF etc. Costs		E48
Table 7.6-XI Concept C <sub>1</sub> - Estimated AGE/LF etc. Costs		E73
Table 7.6-XIV Concept C <sub>2</sub> - Estimated AGE/LF etc. Costs		E97

Table E-I

Baseline List of Ground System Cost Categories

- Program Management
  - Program Control
  - System Engineering
  - Logistics
  - Product Integrity
  - Management Facilities
- Design, Development, Test & Evaluation
  - DDT&E Management
  - Design and Development
    - Aerospace Ground Equipment (AGE)
    - Launch Facilities (LF)
    - Propellants
    - DED Instrumentation
    - DED Tooling
    - DED Facilities
    - Special Test Equipment
    - Handbooks and Documentation
  - Test and Evaluation (T & E)
    - Facilities
    - Equipment
    - Support
    - Transportation
    - Propellants
  - Sustaining Engineering
  - Data Reduction and Analyses
- Production - AGE and Launch Complex Facilities (LCF)
  - Production Management
  - Subsystems
    - Fabrication
    - Tooling
    - Assembly and Text
    - Integration and Checkout
    - Test Equipment
    - Data Reduction and Analyses
    - Spares
    - Training
    - Packaging and Shipment
    - Production Facilities
- Site Installation and Checkout (AGE & LCF)
  - I&C Management
  - Test Equipment
  - Training
  - I&C Support
  - I&C Operations
  - Data Reduction and Analysis
- Annual Operating Costs
  - Operations Management
  - Launch Operations Support
    - Receiving and Inspection
    - Transportation and Handling
    - Assembly and Test
    - Erection
    - Servicing
    - Checkout
    - Launch
    - Refurbishment
  - Mission Operations Support
    - Mission Control
    - Range Support
    - Manned and Unmanned
    - Tracking Networks
  - Base Operations Support
  - Recovery Operations
  - Maintenance
  - Training

## 1.0 Program Management Cost Category

### 1.1 Definition

The ground systems program management cost category consists of the contractor costs for effecting program control, performing system engineering and integration, providing logistics support and ensuring product integrity. Included are the facilities, equipment, software, and personnel required to implement the overall management of the LCLV program. Corresponding government agencies costs to perform similar LCLV ground system functions are excluded.

More specifically, program control involves the program planning programming, implementation, correlating, integration, reporting, documenting, and financing of the total LCLV ground system. Included are the development and assessment of program schedules, evaluation of contract cost estimates, management of schedules and finances, procurement and coordination of the planning and action of the participants.

System engineering involves the management of the engineering functions and integration of the LCLV ground systems and subsystems. Other significant activities include configuration and data management, performing system requirements analyses and cost-effective trade-off studies through all program phases, developing technical work statements, approving performance specifications, ensuring engineering compliance with system and end-item design requirements and planning, coordinating and managing the ground systems test programs, including installation and checkout and launch and mission operations.

Logistics pertains to the logistics management and support (supply and maintenance) of the LCLV system during its development and throughout its operational phase. This activity involves preparation of maintenance plans, conducting related analyses, maintaining historical records on system reliability and status, and supplying and transporting spares, tools, propellants, etc.

Product integrity involves implementation of a reliability program, assuring the quality of the product by manufacturing control and test procedures, performing system safety engineering to avoid hazardous conditions, conducting value engineering to effect a cost-effective system, and providing manufacturing and material services.

## 1.2 Functional Elements

Contained in Table E-II is a preliminary list of functional elements comprising the LCLV ground systems program management cost category. The cost for implementing these functions can be estimated based on historical data in accordance with the equation defined below.

## 1.3 Ground Systems Program Management Cost Equation

The cost for ground systems program management can be approximated from the following equation:

$$C_{GSPM} = K_{GSPM} (C_{RDT\&E} + C_P + C_{1\&C} + C_O)$$

where

$C_{GSPM}$  = Total cost for ground systems program management

$K_{GSPM}$  = Ground systems program management cost factor

$$= K_{GSPC} + K_{GSE} + K_{GSL} + K_{GSPL} = 31\%$$

where

$K_{GSPC}$  = Ground systems program control cost factor = 7%

$K_{GSE}$  = Ground systems engineering cost factor = 13%

$K_{GSL}$  = Ground systems logistics support cost factor = 3% (assume on site factory operations)

$K_{GSPL}$  = Ground systems product integrity cost factor = 8%

$C_{RDT\&E}$  = Ground systems cost for research development, test and evaluation

$C_P$  = Ground systems production cost

$C_{1\&C}$  = Ground systems installation and checkout cost

$C_O$  = Ground systems operating costs

The above baseline percentages are based on TRW's ballistic missile and space vehicle program management and technical direction experience. Further examination of these percentages as well as the functional elements comprising these cost factors, however, is made during the study.

Table E-II

Preliminary List of LCLV Ground Systems  
Program Management Functional Elements

Program Control

- Program Management
- Program Planning and Analysis
- Program Integration and Coordination
- Funding
- Schedules
- Personnel Training
- Work Breakdown Structure
- Security
- Cost Planning and Control
- Documentation and Progress Reports
- Production Control
- Program Phase Down

System Engineering and Integration

- System Requirement Analysis (SRA)
  - Functional Flow Diagrams and Schematics
  - Performance Requirements
    - Hardware
    - Software
    - Facilities
    - Personnel
    - Procedures
  - Trade-Off Studies
- Specifications
  - Systems
  - Sub-System
  - End-Item
  - Interface
- Documentation and Reporting
  - Engineering Studies
  - Operating Procedures
  - Maintenance Procedures

- Configuration and Data Management
  - Configuration Identification and Control
    - Design Baseline
    - Product Baseline
  - Data Acquisition
    - Contract Data and Reports
    - Technical Publications
    - Engineering Data
- Technical Work Statements
- Test Plans
  - Subsystem and System Development
  - Installation and Checkout
  - Launch and Mission Operations
- System Modifications and Improvements

### Logistics

- Maintenance
  - Integrated Plans and Analyses
  - Maintenance Manuals
  - Spares Requirements and Costs
  - Historical Records
    - Reliability Data
    - Maintainability Data
    - System Status
  - Technical Services
- Supply
  - Subsystems, End-Items and Components
- Transportation
  - Plans and Procedures
  - Spares
  - Tools
  - Test Equipment
  - Propellants
  - Gases

### Product Integrity

- Reliability Assurance
- Quality Assurance
- Safety Engineering
- Value Engineering
- Manufacturing Service Functions

309

## 2.0 RDT&E Cost Category

### 2.1 Definitions & Equations

As shown below, the ground systems RDT&E cost category,  $C_{RDT\&E}$ , is comprised of the AGE and launch facility RDT&E costs. Included in these costs is the cost of propellants used in the test and evaluation of the ground propellant transfer system.

$$\bullet \quad C_{RDT\&E} = K_{A1} A_{RDT\&E} + A_{RDT\&E} + K_{F1} F_{RDT\&E} + F_{RDT\&E}$$

where

$$K_{A1} A_{RDT\&E} = \text{AGE RDT\&E Management Cost}$$

$$A_{RDT\&E} = \text{AGE Research, Development, Test and Evaluation Cost}$$

$$K_{F1} F_{RDT\&E} = \text{Launch Facility RDT\&E Management Cost}$$

$$F_{RDT\&E} = \text{Launch Facilities Research, Development, Test and Evaluation Cost}$$

The AGE and launch facility RDT & E costs are comprised of the following sub-cost categories, the proposed definitions and equations for which are as presented:

#### Design and Development (D&D)

This category is the cost for research, design engineering, development and, where applicable, prototype fabrication of the AGE and launch facility items. Included are the costs for D&D instrumentation, tooling, facilities, special test equipment, handbooks and documentation, such as specifications, drawings and reports. The total cost of this activity can be estimated based on the following equations as a function of the first unit production cost of the AGE and launch facilities:

$$\bullet \quad O_{D\&D} = K_{O_{D\&D}} P_o$$

where

$$O_{D\&D} = \text{Operating AGE Design and Development Cost}$$

$$K_{O_{D\&D}} = \text{Operating AGE D\&D Cost Factor}$$

$$P_o = \text{Operating AGE First Unit Production Cost}$$

$$\bullet \quad M_{D\&D} = K_{m_{D\&D}} P_m$$

where

$$M_{D\&D} = \text{Maintenance AGE Design and Development Cost}$$

$K_{mD\&D}$  = Maintenance AGE D&D Cost Factor

$P_m$  = Maintenance AGE First Unit Production Cost

•  $F_{D\&D} = K_{fD\&D} P_f$

where

$F_{D\&D}$  = Launch Facility Design and Development Cost

$K_{fD\&D}$  = Launch Facility D&D Cost Factor

$P_f$  = Launch Facility First Unit Production Cost

#### Test and Evaluation

Contained in this category are the costs for the facilities, equipment, propellants and personnel required to test and evaluate (T&E), the AGE and launch facility designs. Excluded in this category are the costs of similar requirements to test and evaluate the launch vehicle design.

The ground systems T&E costs are considered a function of the AGE and launch facility D&D costs and can be estimated as follows:

•  $O_{T\&E} = K_{oT\&E} O_{D\&D}$

where

$K_{oT\&E}$  = Operating AGE T&E Cost Factor

•  $M_{T\&E} = K_{mT\&E} M_{D\&D}$

where

$K_{mT\&E}$  = Maintenance AGE T&E Cost Factor

•  $K_{T\&E} = K_{fT\&E} F_{D\&D}$

where

$K_{fT\&E}$  = Launch Facility T&E Cost Factor

#### Sustaining Engineering

Included in the sustaining engineering cost category are the costs incurred in providing additional ground support engineering effort during the production, I&C, and operational phases of the program.



This cost is likewise considered as a function of the AGE and launch facility D&D costs:

- $O_{SE} = K_{OSE} O_{D\&D}$

where

$$K_{OSE} = \text{Operating AGE Sustaining Engineering Cost Factor}$$

- $M_{SE} = K_{mSE} M_{D\&D}$

where

$$K_{mSE} = \text{Maintenance AGE Sustaining Engineering Cost Factor}$$

- $F_{SE} = K_{fSE} F_{D\&D}$

where

$$K_{fSE} = \text{Launch Facility Sustaining Engineering Cost Factor}$$

#### Data Reduction and Analysis

This category covers the cost for the engineering data reduction and analysis required during the development, test and evaluation of the ground systems.

Again, this cost is considered a function of the AGE and launch facility D&D costs:

- $O_{DRA} = K_{ODRA} O_{D\&D}$

where

$$K_{ODRA} = \text{Operating AGE Data Reduction and Analysis Cost Factor}$$

- $M_{DRA} = K_{mDRA} M_{D\&D}$

where

$$K_{mDRA} = \text{Maintenance AGE DRA Cost Factor}$$

- $F_{DRA} = K_{fDRA} F_{D\&D}$

where

$$K_{fDRA} = \text{Launch Facility DRA Cost Factor}$$

### 3.0 Aerospace Ground Equipment (AGE) Production Cost Category

#### 3.1 AGE Definition

Aerospace ground equipment, or commonly called GSE, consists of all equipment required on the ground to install, launch, refurbish, guide, control, track, communicate, direct, inspect, test, adjust, calibrate, measure, assemble, disassemble, handle, transport, safeguard, store, activate, service, repair, overhaul, maintain or operate the system, subsystem, end item or component. AGE can be either a functional part of a system which operates with the vehicle or end item as an essential operating element thereof (operating ground equipment -OGE) or that equipment required to restore a system or end item to operating condition (maintenance ground equipment -MGE).

This definition applies regardless of the method of development, funding or procurement.

#### 3.2 Functional Elements

Contained in Table E-III is a list of AGE functional elements based upon a preliminary requirements analysis from factory assembly and transport of the launch vehicle to the launch site up through launch. Included are maintenance and emergency functions. Costs for each of these functional categories can be determined based on corresponding equipment definition.

#### 3.3 AGE Production Cost Equation

The total AGE production cost is shown below. AGE I&C costs are not considered part of the AGE production cost category.

$$\bullet \quad A_p = P_o + P_m + P_s$$

where

$A_p$  = AGE Production Cost

$P_o$  = Operating AGE Production Cost

$$= N_c (o_{s1} n_{s1} + o_{s2} n_{s2} + \text{etc....})$$

$N_c$  = Number of Complexes

$o_s$  = Operating AGE Subsystem Production Cost

$n_s$  = Subsystem Quantity

$P_m$  = Maintenance AGE Production Cost

$$= n_c (m_{s1} n_{s1} + m_{s2} n_{s2} + \text{etc....})$$

313

Table E-III

Preliminary List of AGE Functional ElementsOperations Functional Elements

- Command and Control
  - Monitor and Control
  - Programming
  - Data and Status Processing and Display
  - Command Processing
  - Decoding
  - Security
- Communications and Tracking
  - Communications Networks
    - Inter-Communications
    - Intra-Communications
  - Unmanned Space Vehicle Tracking
  - Manned Space Vehicle Tracking
- TV and Timing
  - TV Monitoring
  - Time Synchronization
- Power Functions
  - Primary Power
  - Backup Power
  - Emergency Power
- Instrumentation and Destruct
  - Visual and Aural Warning
  - Range Safety
- Cable Assembly and Terminal Distribution
  - Launch Control Cable and Distribution
  - Launcher Cable and Distribution
  - Launch Area Cable and Distribution
- Environmental Control
  - Launch Area Environmental Control
- Alignment Functions
  - Space Vehicle Alignment
  - Guidance Alignment
- Mechanical and Hydraulic
  - Firing Accessories
    - Cable Masts
    - PLPS
    - Water Quench
  - Umbilical Retraction
  - Engine Bleed

Maintenance Functional Elements

- Transportation and Handling
  - Transportation
    - Shipping and Storage
    - Transport
    - Unload
  - Erection
  - Handling
  - Assembly
- Propellant Loading and Pressurization
  - Storage
  - Transfer (Fuel & Oxidizer)
    - Load
    - Unload
  - Measurement
  - Pressurize
  - Disposal
- Hazard Protection
  - Leak Detection
  - Protective Functions
- Checkout and Simulation
  - Simulation
    - Payload
    - Downstage
    - Facility
    - AGE
    - Flight Mission
  - Test and Checkout
    - Downstages
    - Launch Facilities
    - AGE
    - Down Range
    - Manned and Unmanned
    - Space Networks

F12

$m_s$  = Maintenance AGE Subsystem Production cost

$P_s$  = Operating and Maintenance AGE Spares Production Cost

$$= K_{P_4} P_o + K_{P_5} P_m$$

$K_{P_4}$  = Operating AGE Spares Production Cost Factor as a Percentage of Operating AGE Production Cost

$K_{P_5}$  = Maintenance AGE Spares Production Cost Factor as a Percentage of Maintenance AGE Production Cost

315

#### 4.0 Launch Facilities Production Cost Category

##### 4.1 Definition

Launch facilities consist primarily of fixed ground installations, located at the launch complex. This includes launch pads, service structures, cableways, utility installations, roads, canals, airfields, vehicle assembly buildings, launch control center, operations support buildings, propellant servicing and high pressure gas systems.

##### 4.2 Functional Elements

Presented in Table E-IV is a preliminary list of launch facility functional elements suggested for final assembly and transport of the low cost launch vehicle to the launch site and for launch and mission operations. Included are maintenance and storage functions. Costs for each of these functional areas can be determined based on the results of the ground systems requirements analysis.

##### 4.3 Cost Equation

The total LF production cost is shown below. Annual operating costs are not considered part of the LF production cost category.

$$\bullet F_P = N_c (f, n_{f_1} + f_2 n_{f_2} + , \text{etc....}) + F_S$$

where

$N_c$  = Number of Complexes

$f$  = Launch Facility Item Cost

$n_f$  = Number of Launch Facility Items

$F_S$  = LF Spares Production Cost

Table E-IV

Preliminary List of LF Functional ElementsVehicle Assembly and Checkout (VAB) Facilities

- Individual Stage A/C
- Integrated A/C

Transportation Facilities

- Access Roads
- Service Roads
- Crawlways
- Airfield
- Docks
- Slips
- Turning Basin
- Railways

Launch Area Facilities

- Mobile Launcher
- Launch Pad
- Exhaust Deflector
- Hold Downs
- Cableways
- Equipment Rooms
- Pad Terminal Rooms
- Power Distribution
- Water Distribution
- Propellant Distribution
- Firex Distribution
- Pressurization
- Environmental Shelter
- Service Structures
- Camera Sites
- Umbilical Towers

Launch Control Center

- Firing Rooms
- Personnel Rooms

Ordnance Storage

- Storage Structure
- Ordnance Laboratory

Instrumentation Facility

- Equipment Rooms
- Personnel Rooms

Storage and Supply Facility

- R/I Area
- Spares Storage

Propellant Facilities

- Burn Pond
- Converter - Compressor
- Holding Pond
- Disposal Facility
- Tanks and Transfer Lines
- High Pressure Gas System

Operations Support Facility

- Design and Engineering Services
- Calibration Laboratory

Electromagnetic Compatibility Test FacilityUtilities

- Power
- Electrical Distribution
- Sewage
- Water
- Complex Communications

## 5.0 Site Installation & Checkout (I&C) Cost Category

### 5.1 Definition

The ground systems I&C cost category is comprised of the total cost incurred in the installation and checkout of the AGE and launch facilities at the selected launch complexes. Included in this cost category are the costs for I&C management, special tools, test equipment and simulators, I&C support personnel and procedures, test and checkout operations and the required test data reduction and analyses. The end objective of I&C is to assure through integrated checkout with the LCLV that the entire ground and vehicle system and procedures are operationally ready.

In defining this cost category, it should be noted that the I&C costs for a number of the launch facilities are considered part of their production cost. Thus in the case of the VAB, LCC and launch pad where their installation occurs during their fabrication and assembly, the cost of I&C would be included in the total production cost.

### 5.2 Functional Elements

Contained in Table E-V is a preliminary list of functional elements comprising the I&C cost category.

### 5.3 I&C Cost Equation

The ground systems installation and checkout cost,  $C_{I\&C}$ , of the LCLV program can be estimated as follows:

$$C_{I\&C} = I\&C_{GSIT} + I\&C_{SMT}$$

$I\&C_{GSIT}$  = Ground systems integration cost. This is a function of the launch facility and AGE subsystem installation and checkout costs as well as the integrated testing of these subsystems.

$I\&C_{SMT}$  = Cost of systems marriage tests (SMT) between the LCLV and the ground systems. The functional tests comprising the SMT are identified in Table E-V.

Contained in each of the above  $I\&C_{GSIT}$  and  $I\&C_{SMT}$  cost categories are the costs for the special tooling, test equipment, procedures, personnel and data reduction and analysis services required to implement the particular I&C function.

Table E-VPreliminary List of Installation & CheckoutFunctional ElementsGround Systems Integration

- Launch Facility (LF) I&C
  - End Items
  - Subsystem
    - Transportation Subsystem
    - Launch Facility Area Subsystems
      - Camera Sites
      - Propellant Distribution
      - Cableways
      - Power Distribution
      - Etc.
- AGE Installation and Checkout
  - End Items
  - Subsystems
    - Command and Control
    - Communication and Tracking
    - TV and Timing
    - Power
    - Instrumentation
    - Cable Assemblies
    - Etc.
- AGE/LF Integration Tests
  - Launch Control Center
  - Communications Network
  - Launch Pad
  - Instrumentation
  - Servicing Functions
  - Propellant Transfer
  - Etc.

LCLV System Marriage

- LCLV Transportation Systems Tests
- LCLV Emplacement
- Combined Systems Test
  - Launch Readiness
  - Range Support
  - Mission Support
- LCLV Removal Tests



## 6.0 Ground Systems Operations Cost Category

### 6.1 Definition and Equations

Subject cost category is a summation of the costs incurred in the operational phase of the program involving base support at the launch complexes, launch operations support and mission operations support.

$$C_0 = C_{BOS} + C_{LOS} + C_{MOS}$$

where

$C_{BOS}$  = Base Operations Support Costs

$C_{LOS}$  = Launch Operations Support Costs

$C_{MOS}$  = Mission Operations Support Costs

#### 6.1.1 Base Operations Support (BOS) Cost Category

##### 6.1.1.1 Definition

The base operations support cost category consists of these costs charged to the LCLV program for communication services, maintenance of transportation vehicles and facilities, cafeteria service, fire protection, dispensary services, administrative facilities, utilities, sewage disposal, downrange logistic support and other typical base support activities. The total cost of these services is prorated on the magnitude and extent of the LCLV base support requirements.

##### 6.1.1.2 Functional Elements

Presented in Table E-VI is a list of BOS functional elements which are considered basic to the LCLV program.

##### 6.1.1.3 BOS Cost Equation

As shown below, the BOS cost,  $C_{BOS}$ , for the total LCLV program is a function of the program duration in years and number of launch complexes.

$$C_{BOS} = K_B Y_L N_C$$

where

$K_B$  = Yearly base operations cost per LCLV launch complex. The cost is a function of the LCLV demands on the BOS elements listed in Table E-VI.

$Y_L$  = Number of Program Years

$N_C$  = Number of Launch Complexes

Table E-VIPreliminary List of Base OperationsSupport (BOS) Functional RequirementsBase Communications

- Radio
- Voice
- Teletype
- Video

Maintenance

- Facility
- Motor Vehicle
- Communications
- Janitorial and Housekeeping
- Trailers

Range Logistics SupportInstrumentation

- Data Analysis and Display
- Telemetry Reception

SecurityAdministrative Support

- Transportation
- Medical
- Office Space and Supplies
- Personnel
- Food

Fire ProtectionUtilities

- Lighting
- Water
- Heat
- Gas

SafetySewage DisposalPropellant Component Cleaning Functions

## 6.1.2 Launch Operations Support (LOS) Cost Category

### 6.1.2.1 Definition

The launch operations support cost category consists of the manpower costs to receive and inspect, transport and handle, assemble and test, erect, service, checkout, maintain, launch and refurbish the LCLV. Excluded are the costs for mission operations support and for performing similar operations on the payload.

### 6.1.2.2 Functional Elements

LOS elements consist of the personnel requirements to perform the launch complex support operations from final assembly and transport of the LCLV to the launch pad up through launch. Included are maintenance, emergency, and refurbishment functions. Costs for each of these functional requirements can be determined based on time line analyses.

### 6.1.2.3 LOS Cost Equation

As shown below, the LOS cost,  $C_{LOS}$ , for the total program is a function of the program duration in years, average man years required per year and the cost per man year. The man years are a direct function of the various support activities that are performed.

$$\bullet C_{LOS} = K_L M_L Y_L$$

where

$$K_L = \text{Average Cost/Man Year}$$

$$M_L = \text{Man Years/Year}$$

$$Y_L = \text{Total Program Years}$$

Particular parameters that  $M_L$  is a function of are:

$$\bullet M_L = N_c n_1 (M_o + M_m)$$

where

$$N_c = \text{Number of Launch Complexes}$$

$$n_1 = \text{Average Yearly Launch Rate}$$

$$M_o = \text{Man Years to Perform Launch Complex Operating Functions/LCLV}$$

$$= M_{K2.0} + M_{K3.0} + M_{K4.0} + \text{etc.....}$$

$$M_m = \text{Man Years to Perform Individual Launch Complex Maintenance and Refurbishment Functions/LCLV}$$

$$= M_{K25.0} + M_{K26.0} + M_{K27.0} + \text{etc.....}$$

### 6.1.3 Mission Operations Support (MOS) Cost Category

#### 6.1.3.1 MOS Definition

The mission operations support cost category is comprised of the costs charged to the LCLV program for mission control, range support, worldwide tracking and, where required, recovery operations.

Mission control consists of those operations that are performed to command and control (C&C) the LCLV's flight mission. Included are mission scheduling and planning, communications required to handle tracking, telemetry, video, voice, teletype, and C&C data between data acquisition stations and the mission control center, and data processing and analysis.

Range support consists of ETR central control, downrange ships, planes and range tracking stations.

Worldwide tracking networks are comprised of the Deep Space Network (DSN), Manned Space Flight Network, Satellite Control Facility (SCF) and NASA Communications Systems (NASCOM) used in support of the LCLV mission operations.

#### 6.1.3.2 Functional Elements

Presented in Table E-VII is a list of functional elements comprising the MOS cost category. Costs for each of these services can be estimated based on the LCLV subsystem design and missions.

#### 6.1.3.3 MOS Cost Equation

The MOS total program cost,  $C_{MOS}$ , is as shown below, a summation of the costs charged to the LCLV program for mission control, range support and worldwide tracking of the launch vehicle. Costs for mission operations support of the payload are excluded.

$$\begin{aligned} \bullet \quad C_{MOS} &= C_{MC} + C_{WTN} + C_{RS} \\ &= K_{MC}N + K_{WTN}^T M N + K_{RS}^T L N \\ &= N (K_{MC} + K_{WTN}^T M + K_{RS}^T C) \end{aligned}$$

where

$C_{MC}$  = Cost for Mission Control

$C_{WTN}$  = Cost for Worldwide Tracking Network Support

- $C_{RS}$  = Cost for Range Support  
 $N$  = Number of Missions  
 $K_{MC}$  = Mission Control Cost Per Mission  
 $K_{WTN}$  = Worldwide Tracking Network Cost Per Mission Hour  
 $T_M$  = Average Number of Mission Hours Per Mission  
 $K_{RS}$  = Range Support Cost Per Initial Launch Phase Hour  
 $T_L$  = Average Number of Initial Launch Phase Hours Per Mission

Table E-VII

Preliminary List of Mission Operations Support (MOS)

Functional Elements

Mission Control

- Planning and Scheduling
- Data Processing, Display and Analysis
- Data Communications
  - Receive
  - Transmit
  - Record
- Command and Control
  - Command Generation and Verification
  - Command Encoding and Processing

Range Support

- Ground Stations
  - Telemetry Data Acquisition
  - Electronic Tracking
  - Optical Tracking
  - Meteorology
- Ships
  - Instrumentation
- Aircraft
  - Instrumentation

Worldwide Tracking

- Ground Stations
  - Telemetry Data Acquisition
  - Tracking
- Ships
  - Instrumentation
  - Recovery

TABLE 7.6-IV  
 LCLV GROUND SYSTEMS ESTIMATED AGE/LF  
 RDT&E AND PRODUCTION AND INSTALLATION COSTS (CONCEPT A)

Function No.	Function Title & Gross Performance Requirements	Estimated New or Modified (M) AGE/LF Requirements	Estimated RDT&E Cost \$X10 <sup>3</sup>		Estimated Unit Production & Installation Cost \$X10 <sup>3</sup>		
			AGE	LF	OGE	LF	MGE
K 22.0	<p><u>Process Propellants and Gases</u></p> <ul style="list-style-type: none"> <li>• Transfer N<sub>2</sub>O<sub>4</sub> and UDMH into propellant storage areas.</li> <li>• Transfer LN<sub>2</sub> into high pressure gas storage areas.</li> <li>• Transfer H<sub>2</sub> into high pressure gas storage area.</li> </ul>	<p>Two 60,000 ft<sup>3</sup> Storage Tanks                      Transfer Lines, Valves and Feed Pumps                      Control Stations                      Retention and Neutralization Basins                      Toxic Vapor Detection System                      Water Deluge System                      Security Fencing                      Lightning Arrestors                      Lightning                      Meteorological Data System                      Access Roads                      Use existing transfer lines, converter/compressors, and storage banks.                      Waste Propellant Disposal System</p>		2,500		8,000	

TABLE 7.6-IV  
LCIV GROUND SYSTEMS ESTIMATED AGE/LF  
RDT&E AND PRODUCTION AND INSTALLATION COSTS (CONCEPT A)

Function No.	Function Title & Gross Performance Requirements	Estimated New or Modified (M) AGE/LF Requirements	Estimated RDT&E Cost \$X10 <sup>3</sup>		Estimated Unit Production & Installation Cost \$X10 <sup>3</sup>		
			AGE	LF	OGE	LF	MGE
K 18.0	<p><u>Process Instrumentation</u></p> <ul style="list-style-type: none"> <li>● Unload and emplace instrumentation subsystems on support fixtures.</li> <li>● Perform R&amp;I.</li> <li>● Conduct continuity and hazardous current tests.</li> <li>● Perform unit assembly, alignment, calibration and functional sequence tests.</li> <li>● Transport instrumentation unit to storage or vehicle integration area.</li> </ul>	Shipping Containers Slings & Hoisting adapters Support Fixtures Command Destruct subsystem simulator Telemetry & Data Acquisition Test Set RF System Checkout Set Calibration Equipment Alignment Fixtures Data Recording Equipment Battery Test Set Test Cable Assembly Liquid Cooler Assembly & Installation Tools	110				375

325

TABLE 7.6-IV  
 LCLV GROUND SYSTEMS ESTIMATED AGE/LF  
 RDT&E AND PRODUCTION AND INSTALLATION COSTS (CONCEPT A)

E24

Function No.	Function Title & Gross Performance Requirements	Estimated New or Modified (M) AGE/LF Requirements	Estimated RDT&E Cost \$X10 <sup>3</sup>		Estimated Unit Production & Installation Cost \$X10 <sup>3</sup>		
			AGE	LF	OGE	LF	MGE
K 16.0	<u>Process LVGS</u> <ul style="list-style-type: none"> <li>● Unload and emplace on support fixture.</li> <li>● Perform R&amp;I.</li> <li>● Conduct continuity and hazardous current tests.</li> <li>● Perform alignment, calibration and functional tests.</li> <li>● Transport LVGS to storage or vehicle integration area.</li> </ul>	Shipping Container Slings & Hoisting adapters Support Fixture LVGS Test Set Liquid Cooler Calibration Equipment Autocollimator Data Recording Equipment Adapter Cable Assembly	75				250

326



TABLE 7.6-  
 LCLV GROUND SYSTEMS ESTIMATED AGE/LF  
 RDT&E AND PRODUCTION AND INSTALLATION COSTS (CONCEPT A)

Function No.	Function Title & Gross Performance Requirements	Estimated New or Modified (M) AGE/LF Requirements	Estimated RDT&E Cost \$X10 <sup>3</sup>		Estimated Unit Production & Installation Cost \$X10 <sup>3</sup>		
			AGE	LF	OGE	LF	MGE
K 14.0	<u>Process Ordnance</u> <ul style="list-style-type: none"> <li>● Unload and Receive and Inspect (R&amp;I).</li> <li>● Check continuity and isolation and bridge wire resistance.</li> <li>● Transport to storage or launch vehicle integration area.</li> </ul>	Adapter Cables Igniter Test Set (M)	3				10

TABLE 7.6-IV  
 LCLV GROUND SYSTEMS ESTIMATED AGE/LF  
 RDT&E AND PRODUCTION AND INSTALLATION COSTS (CONCEPT A)

Function No.	Function Title & Gross Performance Requirements	Estimated New or Modified (M) AGE/LF Requirements	Estimated RDT&E Cost \$X10 <sup>3</sup>		Estimated Unit Production & Installation Cost \$X10 <sup>3</sup>		
			AGE	LF	OGE	LF	MGE
K 13.0	<u>Assemble and Test Downstage Vehicle (Final Assembly only)</u> <ul style="list-style-type: none"> <li>● Prepare MGE for LV assembly operations.</li> <li>● Prepare S-1 for upper stage mating.</li> <li>● Transport Stage 1 (S-1) to final assembly areas (FAA).</li> <li>● Install work platforms.</li> <li>● Connect S-1 umbilicals &amp; upper stage simulator.</li> <li>● Align S-1 for S-2 mating.</li> <li>● Perform continuity tests.</li> <li>● Apply ground power to S-1.</li> <li>● Perform S-1 electrical &amp; mechanical subsystem tests.</li> <li>● Perform stray voltage and hazardous current tests.</li> <li>● Remove S-1 power.</li> <li>● Install and safe ordnance.</li> <li>● Continue S-1 electrical &amp; mechanical subsystems tests.</li> <li>● Prepare S-2 interstage assembly for mating.</li> </ul>	<u>Transportation, Handling &amp; Assembly</u> Stage transporters. Locomotive Work platforms. Slings. Support rings. Support fixtures. Environmental covers. Assembly stands. Assembly & installation tools. Dolly trucks. Torque wrenches. Theodolite stand. Optical alignment set. Alignment fixtures.	2,000				8,000
		<u>Checkout &amp; Simulation</u> Down stage & upper stage simulators. Igniter testers. Telemetry & data acquisition test set. RF system checkout set. Calibration equipment. Data recording equipment. Liquid coolers. Drain & purge set. LVGS test set. Theodolite. Autocollimator. S&A test set.	4,000				12,000

TABLE 7.6-IV  
 LCLV GROUND SYSTEMS ESTIMATED AGE/LF  
 RDT&E AND PRODUCTION AND INSTALLATION COSTS (CONCEPT A)

Function No.	Function Title & Gross Performance Requirements	Estimated New or Modified (M) AGE/LF Requirements	Estimated RDT&E Cost \$X10 <sup>3</sup>		Estimated Unit Production & Installation Cost \$X10 <sup>3</sup>		
			AGE	LF	OGE	LF	MGE
K 13.0 (Continued)	<ul style="list-style-type: none"> <li>● Transport Stage 2 (S-2) interstage assembly to FAA.</li> <li>● Install work platforms.</li> <li>● Mechanically mate S-2 assembly with S-1.</li> <li>● Connect S-2 umbilicals and service lines and upper stage simulator.</li> <li>● Check mechanical alignment.</li> <li>● Perform continuity tests.</li> <li>● Apply ground power to S-2.</li> <li>● Perform S-2 electrical &amp; mechanical subsystem tests.</li> <li>● Perform stray voltage &amp; hazardous current tests.</li> <li>● Remove all power &amp; install ordnance.</li> <li>● Continue S-2 electrical &amp; mechanical tests.</li> <li>● Prepare Stage 3 (S-3) interstage assembly for mating.</li> <li>● Transport Stage 3 interstage assembly to FAA &amp; perform mating functions similar to S-2.</li> </ul>	S&A test set. Launch facility simulator. Programmer test set. Propulsion test set. Destruct system test set. Cable assemblies. Cable adapters. Control & monitor console. Data processing & display. Antenna RF covers. Standard test equipment. Power supply set & control. Power distribution & control system. Battery test sets.					

TABLE 7.6-IV  
 LCLV GROUND SYSTEMS ESTIMATED AGE/LF  
 RDT&E AND PRODUCTION AND INSTALLATION COSTS (CONCEPT A)

E28

Function No.	Function Title & Gross Performance Requirements	Estimated New or Modified (M) AGE/LF Requirements	Estimated RDT&E Cost \$X10 <sup>3</sup>		Estimated Unit Production & Installation Cost \$X10 <sup>3</sup>		
			AGE	LF	OGE	LF	MGE
K 13.0 (Continued)	<ul style="list-style-type: none"> <li>● Prepare instrumentation unit (IU) for mating.</li> <li>● Transport IU to FAA &amp; perform mating functions similar to S-3 with cooling lines connected.</li> <li>● Prepare LVGS for mating.</li> <li>● Transport LVGS to FAA &amp; perform mating functions similar to IU, with cooling lines connected.</li> <li>● Perform IU telemetry &amp; RF tests.</li> <li>● Perform G&amp;C alignment tests.</li> <li>● Remove upper stage simulators.</li> <li>● Remove all power.</li> <li>● Check all S&amp;A devices &amp; safing pins.</li> <li>● Electrically mate S-1, S-2, S-3, IU and LVGS.</li> <li>● Conduct launch vehicle electrical &amp; mechanical system tests.</li> <li>● Remove power &amp; disconnect AGE.</li> <li>● Prepare launch vehicle for transit to the launcher.</li> </ul>						

330

TABLE 7.6-IV  
 LCLV GROUND SYSTEMS ESTIMATED AGE/LF  
 RDT&E AND PRODUCTION AND INSTALLATION COSTS (CONCEPT A)

Function No.	Function Title & Gross Performance Requirements	Estimated New or Modified (M) AGE/LF Requirements	Estimated RDT&E Cost \$X10 <sup>3</sup>		Estimated Unit Production & Installation Cost \$X10 <sup>3</sup>		
			AGE	LF	OGE	LF	MGE
K 12.0	<u>Transport Launch Vehicle to Mobile Launcher</u>  <ul style="list-style-type: none"> <li>● Using crawler position ML adjacent to ramp in VAB area.</li> <li>● Prepare ML for receipt of LCLV.</li> <li>● Prepare LCLV for transport to ML.</li> <li>● Maintain power on LCLV environmental control system.</li> <li>● Fasten down LCLV to transporter.</li> <li>● Remove work platforms.</li> <li>● Connect diesel locomotives to LC transporter.</li> <li>● Transport LV by rail from Plant A to top of ramp.</li> </ul>	<u>Mobile Launcher (M)*</u>  Modification of hoists, holdarms, service arms, umbilical tower and base structure and AGE within the base housing, such as propellant and pneumatic lines, propellant loading equipment and digital data acquisition system (DDAS). Fulcrums.		2,100		6,000	
		<u>Railroad System</u>  Plant A to VAB area.  Erection area including ramp and winch.		450	3,000	1,500	
		<u>AGE (LCC &amp; ML)</u>  LV simulators. Launch facility simulators. Ground power supplies. Cable assemblies & adapters. Servicing lines. Power distribution & control system. Data Acquisition & display system.	2,500		7,000		2,000

TABLE 7.6-IV  
 LCLV GROUND SYSTEMS ESTIMATED AGE/LF  
 RDT&E AND PRODUCTION AND INSTALLATION COSTS (CONCEPT A)

ESU

Function No.	Function Title & Gross Performance Requirements	Estimated New or Modified (M) AGE/LF Requirements	Estimated RDT&E Cost \$X10 <sup>3</sup>		Estimated Unit Production & Installation Cost \$X10 <sup>3</sup>		
			AGE	LF	OGE	LF	MGE
K 12.0 (Continued)		Instrumentation unit control & monitor console. Data recording equipment. LV cooling system. Drain purge control consoles. LVGS control & monitor console, Propulsion system control & monitor consoles. Pneumatic control & monitor consoles. Standard test equipment.  *Assumes ML material is compatible with propellants.					

332

TABLE 7.6-IV  
 LCLV GROUND SYSTEMS ESTIMATED AGE/LF  
 RDT&E AND PRODUCTION AND INSTALLATION COSTS (CONCEPT A)

333

Function No.	Function Title & Gross Performance Requirements	Estimated New or Modified (M) AGE/LF Requirements	Estimated RDT&E Cost \$X10 <sup>3</sup>		Estimated Unit Production & Installation Cost \$X10 <sup>3</sup>		
			AGE	LF	OGE	LF	MGE
K 11.0	<p><u>Erect and Emplace Launch Vehicle on Mobile Launcher</u></p> <ul style="list-style-type: none"> <li>● Position and prepare transporter for LV erection and emplacement on ML.</li> <li>● Emplace work platforms.</li> <li>● Remove environmental covers.</li> <li>● Connect fulcrum support mounts to LV 1st stage.</li> <li>● Connect hoisting support fixture to LV 2nd stage.</li> <li>● Align LV fulcrum support mounts to ML fulcrum arms.</li> <li>● Extend fulcrum support arms to engage LV fulcrum support mounts.</li> <li>● Prepare ML for LV vertical erection.</li> <li>● Connect ML hoist to LV 2nd stage hoisting fixture.</li> <li>● Using winch erect LV from horizontal to vertical position.</li> <li>● Secure LV in vertical position.</li> <li>● Position and secure holddown arms to LV 1st stage.</li> </ul>	<p><u>Vehicle Assembly Building (M)</u></p> <p>Modification involves VAB cable assemblies, servicing lines, work platforms.</p>		200			1,000

E31

TABLE 7.6-IV  
 LCLV GROUND SYSTEMS ESTIMATED AGE/LF  
 RDT&E AND PRODUCTION AND INSTALLATION COSTS (CONCEPT A)

E32

Function No.	Function Title & Gross Performance Requirements	Estimated New or Modified (M) AGE/LF Requirements	Estimated RDT&E Cost \$X10 <sup>3</sup>		Estimated Unit Production & Installation Cost \$X10 <sup>3</sup>		
			AGE	LF	OGE	LF	MGE
K11.0 (Continued)	<ul style="list-style-type: none"> <li>● Level and align LV by adjusting ML holddown arms.</li> <li>● Return LV transporter to Plant A.</li> <li>● Disconnect and stow winch cabling.</li> <li>● Disconnect hoisting support fixture and stow.</li> <li>● Retract ML fulcrum support arms from LV.</li> <li>● Transport and position ML in VAB high bay area.</li> <li>● Remove crawler transporter from ML.</li> <li>● Connect VAB electrical cables to ML.</li> <li>● Position umbilical support and service arms.</li> <li>● Emplace work platforms.</li> <li>● Connect umbilicals and service lines to LV.</li> </ul>						

334



TABLE 7.6-IV  
 LCIV GROUND SYSTEM ESTIMATED AGE/LF  
 RDT&E AND PRODUCTION AND INSTALLATION COSTS (CONCEPT A)

Function No.	Function Title & Gross Performance Requirements	Estimated New or Modified (M) AGE/LF Requirements	Estimated RDT&E Cost \$X10 <sup>3</sup>		Estimated Unit Production & Installation Cost \$X10 <sup>3</sup>		
			AGE	LF	OGE	LF	MGE
K 10.0	<u>Perform LV/ML Combined Systems Tests</u> <ul style="list-style-type: none"> <li>● Check all S&amp;A devices and safing pins.</li> <li>● Connect spacecraft simulator.</li> <li>● Connect start-up, targeting, and launch countdown and mission simulator ground equipment.</li> <li>● Re-check ML/LV base support level and alignment.</li> <li>● Check theodolite alignment.</li> <li>● Initiate power turn-on sequence to AGE and IU.</li> <li>● Record telemetry data.</li> <li>● Perform LV pre-power on tests.</li> <li>● Conduct digital data acquisition system tests (DDAS).</li> <li>● Perform LV targeting equipment turn-on sequence.</li> <li>● Align inertial measurement unit (IMU).</li> <li>● Perform guidance and control (G&amp;C) tests.</li> <li>● Conduct targeting sequence tests.</li> <li>● Perform RF &amp; telemetry checks.</li> </ul>	Spacecraft simulator. Special purpose test cable assemblies. Launch C/D and mission simulator. Target tape. Simulated flight tape. *LV simulator.	50				100*

\*Does not include cost of LV simulator which is function of PL.

335

E33

TABLE 7.6-IV  
 LCLV GROUND SYSTEMS ESTIMATED AGE/LF  
 RDT&E AND PRODUCTION AND INSTALLATION COSTS (CONCEPT A)

Function No.	Function Title & Gross Performance Requirements	Estimated New or Modified (M) AGE/LF Requirements	Estimated RDT&E Cost \$X10 <sup>3</sup>		Estimated Unit Production & Installation Cost \$X10 <sup>3</sup>		
			AGE	LF	OGE	LF	MGE
K 10.0 (Continued)	<ul style="list-style-type: none"> <li>● Initiate functional sequence &amp; power transfer tests.</li> <li>● Position and prepare payload (PL) in VAB for mating to LV.</li> <li>● Connect ML hoist to PL support adapters.</li> <li>● Mechanically mate PL to IU.</li> <li>● Position PL umbilical support and service arms.</li> <li>● Emplace work platforms.</li> <li>● Connect AGE umbilicals and service lines to PL.</li> <li>● Perform PL ground power-on tests as required.</li> <li>● Perform PL integration tests with LV simulator.</li> <li>● Perform LV overall tests (OAT).</li> <li>● Evaluate telemetry data and ground instrumentation recordings.</li> <li>● Turn off all power.</li> </ul>						

TABLE 7.6-IV  
 LCIV GROUND SYSTEMS ESTIMATED AGE/LF  
 RDT&E AND PRODUCTION AND INSTALLATION COSTS (CONCEPT A)

337

Function No.	Function Title & Cross Performance Requirements	Estimated New or Modified (M) AGE/LF Requirements	Estimated RDT&E Cost \$X10 <sup>3</sup>		Estimated Unit Production & Installation Cost \$X10 <sup>3</sup>		
			AGE	LF	OGE	LF	MGE
K 9.0	<u>Mate Payload to Launch Vehicle</u> <ul style="list-style-type: none"> <li>● Electrically mate PL to LV.</li> <li>● Perform power-on and transfer tests.</li> <li>● Conduct emergency detection system (EDS) and abort system tests as required.</li> <li>● Prepare space vehicle, ML, VAB and LCC for composite readiness tests (CRT).</li> </ul>	No LV AGE/LF new or modified requirements at this level of indenture other than those previously identified.					

TABLE 7.6-IV  
 LCLV GROUND SYSTEMS ESTIMATED AGE/LF  
 RDT&E AND PRODUCTION AND INSTALLATION COSTS (CONCEPT A)

Function No.	Function Title & Gross Performance Requirements	Estimated New or Modified (M) AGE/LF Requirements	Estimated RDT&E Cost \$X10 <sup>3</sup>		Estimated Unit Production & Installation Cost \$X10 <sup>3</sup>		
			AGE	LF	OGE	LF	MGE
K 8.0	<p><u>Perform Integrated System Checkouts</u></p> <ul style="list-style-type: none"> <li>● Connect launch countdown and flight simulators.</li> <li>● Initiate power on sequence.</li> <li>● Turn on IU.</li> <li>● Record telemetry data.</li> <li>● Conduct simulated automatic launch countdown and flight sequence (simulated umbilical ejection, holddown release, liftoff and flight mission.</li> <li>● Evaluate telemetry data and ground instrumentation recordings.</li> <li>● Verify all systems "GO".</li> <li>● Turn off power and remove simulators.</li> <li>● Charge SV batteries as required.</li> <li>● Reconfigure space vehicle for flight.</li> <li>● Performance stray voltage test.</li> <li>● Install final ordnance as required.</li> <li>● Perform final systems test to verify space vehicle and OGE are "GO".</li> <li>● Remove all power.</li> </ul>	No LV new or modified AGE/LF have been identified at this level of indenture other than those previously specified.					

TABLE 7.6-IV  
 LCLV GROUND SYSTEMS ESTIMATED AGE/LF  
 RDT&E AND PRODUCTION AND INSTALLATION COSTS (CONCEPT A)

Function No.	Function Title & Gross Performance Requirements	Estimated New or Modified (M) AGE/LF Requirements	Estimated RDT&E Cost \$X10 <sup>3</sup>		Estimated Unit Production & Installation Cost \$X10 <sup>3</sup>		
			AGE	LF	OGE	LF	MGE
K 7.0	<u>Transport Space Vehicle to Launch Pad</u> <ul style="list-style-type: none"> <li>● Prepare ML/SV for transport from VAB to launch pad.</li> <li>● Maintain power on for SV environmental control.</li> <li>● Retract work platforms.</li> <li>● Disconnect VAB electrical cables to ML.</li> <li>● Open VAB high bay door.</li> <li>● Position crawler transporter beneath ML.</li> <li>● Mate crawler to ML.</li> <li>● Activate crawler's load/leveling system.</li> <li>● Lift ML clear of its base support pedestals using crawler.</li> <li>● Transport ML/SV from VAB to launch pad over crawlerway at approximate speed of 1 mph.</li> </ul>	No LV AGE/LF new or modified requirements at this level of indenture other than those previously specified.					

339

E37

TABLE 7.6-IV  
 LCLV GROUND SYSTEMS ESTIMATED AGE/LF  
 RDT&E AND PRODUCTION AND INSTALLATION COSTS (CONCEPT A)

430

Function No.	Function Title & Gross Performance Requirements	Estimated New or Modified (M) AGE/LF Requirements	Estimated RDT&E Cost \$X10 <sup>3</sup>		Estimated Unit Production & Installation Cost \$X10 <sup>3</sup>		
			AGE	LF	OGE	LF	MGE
K 6.0	<p><u>Emplace Space Vehicle</u></p> <ul style="list-style-type: none"> <li>● Prepare launch pad for receipt of ML/SV and MSS.</li> <li>● Move ML/SV with crawler to top of hardstand.</li> <li>● Position ML/SV with crawler over flame trench and support pedestals.</li> <li>● Retract crawler jacks and lower ML on to support pedestals.</li> <li>● Perform ML leveling and alignment operations by adjusting pedestals.</li> <li>● Secure ML to support pedestals.</li> <li>● Move crawler transporter to Mobile Service Structure (MSS) area.</li> <li>● Install and adjust extensible columns under ML.</li> <li>● Connect electrical cabling, propellant and servicing lines to base of ML.</li> <li>● Prepare ML/SV for receipt of MSS.</li> <li>● Position crawler beneath the MSS.</li> <li>● Connect electrical and service lines between crawler and MSS.</li> </ul>	<p><u>LF</u></p> <p>Modification to:</p> <ul style="list-style-type: none"> <li>● Propellant lines to load and unload N<sub>2</sub>O<sub>4</sub>/UDMH.</li> <li>● Engine Servicing Structure.</li> <li>● MSS #1 work platform, servicing lines and cable assemblies.</li> <li>● Flame deflector.</li> <li>● Toxic vapor detection system.</li> </ul> <p><u>AGE</u></p> <p>ML/MSS/LV simulator. Modification to Pad Terminal Connection Room (PTCR) data transmission link and instrumentation lines and equipment.</p>	15	700		3,500	
			50		200		50

340

TABLE 7.6-IV  
 LCLV GROUND SYSTEMS ESTIMATED AGE/LF  
 RDT&E AND PRODUCTION AND INSTALLATION COSTS (CONCEPT A)

Function No.	Function Title & Gross Performance Requirements	Estimated New or Modified (M) AGE/LF Requirements	Estimated RDT&E Cost \$X10 <sup>3</sup>		Estimated Unit Production & Installation Cost \$X10 <sup>3</sup>		
			AGE	LF	OGE	LF	MGE
K 6.0 (Continued)	<ul style="list-style-type: none"> <li>● Transport MSS to the top of the hardstand.</li> <li>● Position MSS with crawler over flame trench and its support pedestals.</li> <li>● Retract crawler jacks and lower MSS on to support pedestals.</li> <li>● Vertically align MSS by adjusting pedestals.</li> <li>● Secure MSS to support pedestals.</li> <li>● Disconnect MSS/crawler electrical and service lines.</li> <li>● Move crawler to its parking area.</li> <li>● Connect electrical cabling and servicing lines to base of MSS.</li> <li>● Emplace work platforms.</li> <li>● Connect electrical and servicing lines to the SV.</li> <li>● Prepare ML/MSS for SV start-up and integrated system tests.</li> </ul>						

341

E39

TABLE 7.6-IV  
LCLV GROUND SYSTEMS ESTIMATED AGE/LF  
RDT&E AND PRODUCTION AND INSTALLATION COSTS (CONCEPT A)

E40

Function No.	Function Title & Gross Performance Requirements	Estimated New or Modified (M) AGE/LF Requirements	Estimated RDT&E Cost \$X10 <sup>3</sup>		Estimated Unit Production & Installation Cost \$X10 <sup>3</sup>		
			AGE	LF	OGE	LF	MGE
K 5.0	<p><u>Perform Space Vehicle Start-up and Integrated System Checkout</u></p> <ul style="list-style-type: none"> <li>• Verify all S&amp;A devices and safing pins are in "safe" condition.</li> <li>• Connect start-up equipment and launch countdown and flight simulator.</li> <li>• Check alignment of SV and collimator/theodolite.</li> <li>• Verify flight azimuth setting of theodolite.</li> <li>• Initiate power and IU turn-on sequence.</li> <li>• Record telemetry data.</li> <li>• Perform guidance alignment sequence.</li> <li>• Transfer control from launch pad to launch control center.</li> <li>• Verify back-up command, control and communications links to SV.</li> <li>• Initiate SV/launch complex functional and system interface verification checks.</li> <li>• Evaluate test data and verify "GO".</li> </ul>	<p>No LV new or modified AGE/LF have been identified at this level of indenture other than those previously specified.</p>					

342



TABLE 7.6-IV  
 LCLV GROUND SYSTEMS ESTIMATED AGE/LF  
 RDT&E AND PRODUCTION AND INSTALLATION COSTS (CONCEPT A)

343

Function No.	Function Title & Gross Performance Requirements	Estimated New or Modified (M) AGE/LF Requirements	Estimated RDT&E Cost \$X10 <sup>3</sup>		Estimated Unit Production & Installation Cost \$X10 <sup>3</sup>		
			AGE	LF	OGE	LF	MGE
K 5.0 (Continued)	<ul style="list-style-type: none"> <li>● Prepare for Combined Readiness Test (CRT)</li> <li>*● Conduct simulated automatic launch countdown and flight sequence test (simulated umbilical ejection, holddown release, liftoff and flight mission)</li> <li>● Evaluate telemetry data and ground instrumentation recordings.</li> <li>● Verify all systems "GO".</li> <li>● Turn off power and remove simulators.</li> <li>● Charge SV batteries as required.</li> <li>● Reconfigure space vehicle for flight.</li> <li>● Connect ordnance.</li> <li>● Prepare launch facilities and SV for propellant loading.</li> </ul> <p>*This test involves integrated system compatibility tests with ETR and MSC.</p>						

TABLE 7.6-IV  
 LCLV GROUND SYSTEMS ESTIMATED AGE/LF  
 RDT&E AND PRODUCTION AND INSTALLATION COSTS (CONCEPT A)

Function No.	Function Title & Gross Performance Requirements	Estimated New or Modified (M) AGE/LF Requirements	Estimated RDT&E Cost \$X10 <sup>3</sup>		Estimated Unit Production & Installation Cost \$X10 <sup>3</sup>		
			AGE	LF	OGE	LF	MGE
K 4.0	<p><u>Load Propellants and Pressurize Missile Stages</u></p> <ul style="list-style-type: none"> <li>● Perform N<sub>2</sub> leak tests on propellant transfer system and LV propellant system.</li> <li>● Purge and blanket fuel system with N<sub>2</sub>.</li> <li>● Verify weather conditions and vapor disposal system is operating.</li> <li>● Initiate fuel loading sequence.</li> <li>● Load Stages 1, 2 and 3 fuel tanks to prescribed mass of propellant using computer program.</li> <li>● Pressurize Stages 1, 2 and 3 fuel tanks with N<sub>2</sub>.</li> <li>● Drain and purge fuel transfer lines.</li> <li>● Perform fuel leak tests.</li> <li>● Purge and blanket oxidizer system with N<sub>2</sub>.</li> <li>● Initiate oxidizer loading sequence.</li> <li>● Load Stages 1, 2 and 3 oxidizer tanks to prescribed mass of propellant using computer program.</li> </ul>	<p>Load cell with accuracy better than 0.5%. (This approach eliminates need for tank calibration and propellant conditioning equipment.)</p> <p>Leak detection &amp; purge equipment.</p> <p>Computer load programs.</p> <p>Other LV new or modified AGE and LF are as previously identified.</p>	40		100		
			40				150

TABLE 7.6-IV  
 LCLV GROUND SYSTEMS ESTIMATED AGE/LF  
 RDT&E AND PRODUCTION AND INSTALLATION COSTS (CONCEPT A)

Function No.	Function Title & Gross Performance Requirements	Estimated New or Modified (M) AGE/LF Requirements	Estimated RDT&E Cost \$X10 <sup>3</sup>		Estimated Unit Production & Installation Cost \$X10 <sup>3</sup>		
			AGE	LF	OGE	LF	MGE
K 4.0 (Continued)	<ul style="list-style-type: none"> <li>● Pressurize Stages 1, 2 and 3 oxidizer tanks with N<sub>2</sub>.</li> <li>● Drain and purge oxidizer transfer lines.</li> <li>● Perform propellant leak tests.</li> <li>● Monitor LV propellant tank pressures.</li> </ul>						

345

E43

TABLE 7.6-IV  
LCLV GROUND SYSTEMS ESTIMATED AGE/LF  
RDT&E AND PRODUCTION AND INSTALLATION COSTS (CONCEPT A)

E114

Function No.	Function Title & Gross Performance Requirements	Estimated New or Modified (M) AGE/LF Requirements	Estimated RDT&E Cost \$X10 <sup>3</sup>		Estimated Unit Production & Installation Cost \$X10 <sup>3</sup>		
			AGE	LF	OGE	LF	MGE
K 3.0	<p><u>Achieve Launch Readiness</u></p> <ul style="list-style-type: none"> <li>● Monitor propellant pressure.</li> <li>● Install payload provisions.</li> <li>● Wheel launcher flame deflector into pad trench beneath the SV centerline.</li> <li>● Secure flame deflector.</li> <li>● Verify SV and guidance alignment.</li> <li>● Monitor and, if required, charge SV batteries.</li> <li>● Disconnect and retract MSS work platforms and servicing lines from SV.</li> <li>● Remove unnecessary MGE.</li> <li>● Verify ordnance safe.</li> <li>● Remove safing pins from SV and umbilicals.</li> <li>● Install S&amp;A access doors.</li> </ul>	No LV new or modified AGE/LF have been identified at this level of indenture other than that previously specified.					

346

TABLE 7.6-IV  
 LCLV GROUND SYSTEMS ESTIMATED AGE/LF  
 RDT&E AND PRODUCTION AND INSTALLATION COSTS (CONCEPT A)

Function No.	Function Title & Gross Performance Requirements	Estimated New or Modified (M) AGE/LF Requirements	Estimated RDT&E Cost \$X10 <sup>3</sup>		Estimated Unit Production & Installation Cost \$X10 <sup>3</sup>		
			AGE	LF	OGE	LF	MGE
K 2.0	<p><u>Perform Launch Operations:</u></p> <p>A. <u>Launch Precourt</u></p> <ul style="list-style-type: none"> <li>● Confirm range clearances with Range Operations and integrated mission control.</li> <li>● Alert range instrumentation systems of countdown start.</li> <li>● Confirm range support equipment ready.</li> <li>● Confirm reception of visual monitor of launch area.</li> <li>● Confirm capability of aural warning system.</li> <li>● Perform checkout of missile lift-off circuitry to Range Operations.</li> <li>● Perform Range Safety open loop checkout on ground power.</li> <li>● Perform command destruct open loop checkout on ground power.</li> <li>● Perform instrumentation open loop checkout.</li> <li>● Receive launch "GO" from Range Operations and integrated mission control.</li> </ul>	No LV new or modified AGE/LF have been identified at this level of indenture other than that previously identified.					

347

E45

TABLE 7.6-1V  
 LCLV GROUND SYSTEMS ESTIMATED AGE/LF  
 RDT&E AND PRODUCTION AND INSTALLATION COSTS (CONCEPT A)

846

Function No.	Function Title & Gross Performance Requirements	Estimated New or Modified (M) AGE/LF Requirements	Estimated RDT&E Cost \$X10 <sup>3</sup>		Estimated Unit Production & Installation Cost \$X10 <sup>3</sup>		
			AGE	LF	OGE	LF	MGE
K 2.0 (Continued)	<ul style="list-style-type: none"> <li>● Transfer IU to airborne power.</li> <li>● Perform open loop checkout on airborne power.</li> <li>● Prepare for terminal countdown.</li> </ul> <p>B. <u>Terminal Countdown</u></p> <ul style="list-style-type: none"> <li>● Remove MSS with crawler from launch pad area.</li> <li>● Verify launch readiness of S/V and launch control and support equipment.</li> <li>● Receive and verify launch command.</li> <li>● Initiate launch sequence.</li> <li>● Turn-on ground power to SV.</li> <li>● Arm launch circuits.</li> <li>● Start launch sequence.</li> <li>● Perform guidance and control discrettes test.</li> <li>● Confirm flight program entered.</li> <li>● Arm SV ordnance devices.</li> <li>● Activate launch vehicle batteries.</li> </ul>						

348

TABLE 7.6-IV  
 LCLV GROUND SYSTEMS ESTIMATED AGE/LF  
 RDT&E AND PRODUCTION AND INSTALLATION COSTS (CONCEPT A)

Function No.	Function Title & Gross Performance Requirements	Estimated New or Modified (M) AGE/LF Requirements	Estimated RDT&E Cost \$X10 <sup>3</sup>		Estimated Unit Production & Installation Cost \$X10 <sup>3</sup>		
			AGE	LF	OGE	LF	MGE
K 2.0 (Continued)	<ul style="list-style-type: none"> <li>● Open stage prevalves.</li> <li>● Transfer ground to airborne power.</li> <li>● Begin flight computation.</li> <li>● Confirm all systems status "GO".</li> <li>● Disconnect critical leads.</li> <li>● Release umbilicals.</li> <li>● Retract umbilicals.</li> <li>● Ignite first stage.</li> <li>● Confirm reception of SV lift-off signal at LCC, Range Operations and integrated mission control.</li> </ul>						

679

E47

TABLE 7.6-VIII  
 LCLV GROUND SYSTEMS ESTIMATED AGE/LF  
 RDT&E AND PRODUCTION AND INSTALLATION COSTS (CONCEPT B)

E48

Function No.	Function Title & Gross Performance Requirements	Estimated New or Modified (M) AGE/LF Requirements	Estimated RDT&E Cost \$X10 <sup>3</sup>		Estimated Unit Production & Installation Cost \$X10 <sup>3</sup>		
			AGE	LF	OGE	LF	MGE
X 22.0	<p><u>Process Propellants and Gases</u></p> <ul style="list-style-type: none"> <li>• Transfer N<sub>2</sub>O<sub>4</sub> and UDMH into propellant storage areas.</li> <li>• Transfer LN<sub>2</sub> into high pressure gas storage areas.</li> <li>• Transfer H<sub>2</sub> into high pressure gas storage area.</li> </ul>	<p>Two 60,000 ft<sup>3</sup> Storage Tanks            Transfer Lines, Valves and Feed Pumps            Control Stations            Retention and Neutralization Basins            Toxic Vapor Detection System            Water Deluge System            Security Fencing            Lightning Arrestors            Lighting            Meteorological Data System            Access Roads            Use existing transfer lines, converter/compressors, and storage banks.            Waste Propellant Disposal System</p>		2,500		8,000	

358



TABLE 7.6-VIII  
 LCLV GROUND SYSTEMS ESTIMATED AGE/LF  
 RDT&E AND PRODUCTION AND INSTALLATION COSTS (CONCEPT B)

Function No.	Function Title & Gross Performance Requirements	Estimated New or Modified (M) AGE/LF Requirements	Estimated RDT&E Cost \$X10 <sup>3</sup>		Estimated Unit Production & Installation Cost \$X10 <sup>3</sup>		
			AGE	LF	OGE	LF	MGE
K 18.0	<u>Process Instrumentation</u> <ul style="list-style-type: none"> <li>● Unload and emplace instrumentation subsystems on support fixtures.</li> <li>● Perform R&amp;I.</li> <li>● Conduct continuity and hazardous current tests.</li> <li>● Perform unit assembly, alignment, calibration and functional sequence tests.</li> <li>● Transport instrumentation unit to storage or vehicle integration area.</li> </ul>	Shipping Containers Slings & Hoisting adapters Support Fixtures Command Destruct subsystem simulator Telemetry & Data Acquisition Test Set RF System Checkout Set Calibration Equipment Alignment Fixtures Data Recording Equipment Battery Test Set Test Cable Assembly Liquid Cooler Assembly & Installation Tools	110				375

351

TABLE 7.6-VIII  
 LCLV GROUND SYSTEMS ESTIMATED AGE/LF  
 RDT&E AND PRODUCTION AND INSTALLATION COSTS (CONCEPT B)

Function No.	Function Title & Gross Performance Requirements	Estimated New or Modified (M) AGE/LF Requirements	Estimated RDT&E Cost \$X10 <sup>3</sup>		Estimated Unit Production & Installation Cost \$X10 <sup>3</sup>		
			AGE	LF	OGE	LF	MGE
K 16.0	<u>Process LVGS</u> <ul style="list-style-type: none"> <li>● Unload and emplace on support fixture.</li> <li>● Perform R&amp;I.</li> <li>● Conduct continuity and hazardous current tests.</li> <li>● Perform alignment, calibration and functional tests.</li> <li>● Transport LVGS to storage or vehicle integration area.</li> </ul>	Shipping Container Slings & Hoisting adapters Support Fixture LVGS Test Set Liquid Cooler Calibration Equipment Autocollimator Data Recording Equipment Adapter Cable Assembly	75				250

TABLE 7.6-VIII  
 LCLV GROUND SYSTEMS ESTIMATED AGE/LF  
 RDT&E AND PRODUCTION AND INSTALLATION COSTS (CONCEPT B)

353

Function No.	Function Title & Gross Performance Requirements	Estimated New or Modified (M) AGE/LF Requirements	Estimated RDT&E Cost \$X10 <sup>3</sup>		Estimated Unit Production & Installation Cost \$X10 <sup>3</sup>		
			AGE	LF	OGE	LF	MGE
K 14.0	<u>Process Ordnance</u> <ul style="list-style-type: none"> <li>● Unload and Receive and Inspect (R&amp;I).</li> <li>● Check continuity and isolation and bridge wire resistance.</li> <li>● Transport to storage or launch vehicle integration area.</li> </ul>	Adapter Cables Igniter Test Set (M)	3				10

B51

TABLE 7.6-VIII  
 LCLV GROUND SYSTEMS SEPARATED AGE/LF  
 RDT&E AND PRODUCTION AND INSTALLATION COSTS (CONCEPT B)

10

Function No.	Function Title & Gross Performance Requirements	Estimated New or Modified (M) AGE/LF Requirements	Estimated RDT&E Cost \$X10 <sup>3</sup>		Estimated Unit Production & Installation Cost \$X10 <sup>3</sup>		
			AGE	LF	CGE	LF	MGE
7.6.1.0	<u>Transport LV Stages to Vehicle Assembly Building (VAB)</u> <ul style="list-style-type: none"> <li>• Position and prepare Mobile Launcher (ML) in VAB high bay area.</li> <li>• Remove crawler from beneath ML.</li> <li>• Connect locomotives to LV first stage transporter at Plant A.</li> <li>• Transport LV first stage in horizontal position by rail to transfer aisle of VAB.</li> <li>• Position and prepare transporter for LV erection and emplacement on ML.</li> <li>• Repeat above functions for 2nd and 3rd stages.</li> <li>• Transport instrumentation unit and launch vehicle guidance set to VAB high bay from Plant A by truck.</li> </ul>	<u>Transportation Handling &amp; Assembly</u> <p>Stage transporters.            Locomotives.            Work platforms.            Slings.            Support rings.            Support fixtures.            Environmental covers.</p> <p>Railroad system            (Plant A to VAB high bay)</p> <p>Mobile Launcher (M)*</p> <p>Modification of base holddown arms, service arms, umbilical tower structure and AGE within the base housing, such as propellant and pneumatic lines, propellant loading equipment and digital data acquisition system (DDAS).</p> <p>AGE (LCC &amp; ML)</p> <p>LV simulators.            Launch facility simulators.</p>	1,200				6,000
				450		3,000	
				1,200		4,000	
			2,500		7,000		2,000

354

TABLE 7.6-VIII.  
 LCLV GROUND SYSTEMS ESTIMATED AGE/LF  
 RDT&E AND PRODUCTION AND INSTALLATION COSTS (CONCEPT B)

Function No.	Function Title & Gross Performance Requirements	Estimated New or Modified (M) AGE/LF Requirements	Estimated RDT&E Cost \$X10 <sup>3</sup>		Estimated Unit Production & Installation Cost \$X10 <sup>3</sup>		
			AGE	LF	OGE	LF	MGE
K 31.0 (Continued)		Ground power supplies. Cable assemblies and adapters. Servicing lines. Power distribution and control system. Data acquisition and display system. Instrumentation unit control & monitor console. Data recording equipment. LV cooling system. Drain purge control consoles. LVGS control & monitor console. Propulsion system control & monitor consoles. Pneumatic control and monitor consoles. Standard test equipment.					
		*Assumes ML material is compatible with propellants					

355

E53

454

TABLE 7.6-VIII  
 LCLV GROUND SYSTEMS ESTIMATED AGE/LF  
 RDT&E AND PRODUCTION AND INSTALLATION COSTS (CONCEPT B)

Function No.	Function Title & Gross Performance Requirements	Estimated New or Modified (M) AGE/LF Requirements	Estimated RDT&E Cost \$X10 <sup>3</sup>		Estimated Unit Production & Installation Cost \$X10 <sup>3</sup>		
			AGE	LF	OGE	LF	MGE
K 30.0	<u>Erect and Emplace 1st Stage on ML</u> <ul style="list-style-type: none"> <li>● Connect 450-ton hoist to 1st stage support adapter.</li> <li>● Hoist 1st stage over the VAB support truss into high bay area.</li> <li>● Lower 1st stage on to the holddown support arms of the ML.</li> <li>● Position and secure ML holddown arms to 1st stage.</li> <li>● Level and align LV by adjusting ML support arms.</li> <li>● Connect VAB electrical cables to ML.</li> <li>● Position 1st stage umbilical support and service arms.</li> <li>● Emplace 1st stage work platforms.</li> <li>● Connect umbilicals and service lines to 1st stage.</li> </ul>	<u>Vehicle Assembly Building (M)</u>  Replace 250 ton capacity bridge crane with 450 ton unit. Included is modification to VAB structural members to support additional loads.  Modify VAB cable assemblies, service lines and work platforms.	250	400		2,000	1,000

TABLE 7.6-VIII  
 LCLV GROUND SYSTEMS ESTIMATED AGE/LF  
 RDT&E AND PRODUCTION AND INSTALLATION COSTS (CONCEPT B)

357

Function No.	Function Title & Gross Performance Requirements	Estimated New or Modified (M) AGE/LF Requirements	Estimated RDT&E Cost \$X10 <sup>3</sup>		Estimated Unit Production & Installation Cost \$X10 <sup>3</sup>		
			AGE	LF	OGE	LF	MGE
K 29.0	<u>Mate Upper Stages to Launch Vehicle</u> <ul style="list-style-type: none"> <li>● Prepare MGE for LV assembly.</li> <li>● Prepare S-1 for upper stage mating.</li> <li>● Connect upper stage simulator to 1st stage.</li> <li>● Align S-1 for S-2 mating.</li> <li>● Perform continuity tests.</li> <li>● Apply ground power to S-1.</li> <li>● Perform S-1 electrical &amp; mechanical subsystem tests.</li> <li>● Perform stray voltage and hazardous current tests.</li> <li>● Remove S-1 power.</li> <li>● Install &amp; safe ordnance.</li> <li>● Continue S-1 electrical and mechanical subsystem tests.</li> <li>● Prepare S-2 interstage assembly for mating.</li> <li>● Connect 400-ton hoist to 2nd stage support adapter.</li> <li>● Mechanically mate S-2 assembly with S-1.</li> </ul>	<u>Handling &amp; Assembly</u>  Assembly stands. Assembly & installation tools. Torque wrenches. Alignment fixtures.	75				500
		<u>Checkout &amp; Simulation</u>  Down stage & upper stage simulators. Igniter testers. Calibration equipment. S&A test set. Destruct system test set. Cable adapters. Antenna RF covers. Battery test sets.	250				1,000

E55

TABLE 7.6-VIII  
 LCLV GROUND SYSTEMS ESTIMATED AGE/LF  
 RDT&E AND PRODUCTION AND INSTALLATION COSTS (CONCEPT B)

156

Function No.	Function Title & Gross Performance Requirements	Estimated New or Modified (M) AGE/LF Requirements	Estimated RDT&E Cost \$X10 <sup>3</sup>		Estimated Unit Production & Installation Cost \$X10 <sup>3</sup>		
			AGE	LF	OGE	LF	MGE
K 29.0 (Continued)	<ul style="list-style-type: none"> <li>● Position 2nd stage umbilical support and service arms.</li> <li>● Emplace 2nd stage work platforms.</li> <li>● Connect umbilical and service lines to 2nd stage.</li> <li>● Connect upper stage simulator to 2nd stage.</li> <li>● Check mechanical alignment.</li> <li>● Perform continuity tests.</li> <li>● Apply ground power to S-2.</li> <li>● Perform S-2 electrical &amp; mechanical tests.</li> <li>● Perform stray voltage &amp; hazardous current tests.</li> <li>● Remove all power &amp; install ordnance.</li> <li>● Continue S-2 electrical &amp; mechanical tests.</li> <li>● Prepare S-3 interstage assembly for mating.</li> <li>● Perform S-3 mechanical mating and test functions similar to S-2.</li> <li>● Prepare instrumentation unit (IU) for mating.</li> </ul>						

358



TABLE 7.6-VIII  
 LCLV GROUND SYSTEMS ESTIMATED AGE/LF  
 RDT&E AND PRODUCTION AND INSTALLATION COSTS (CONCEPT B)

359

Function No.	Function Title & Gross Performance Requirements	Estimated New or Modified (M) AGE/LF Requirements	Estimated RDT&E Cost \$X10 <sup>3</sup>		Estimated Unit Production & Installation Cost \$X10 <sup>3</sup>		
			AGE	LF	OGE	LF	MGE
K 29.0 (Continued)	<ul style="list-style-type: none"> <li>● Perform IU mechanical mating &amp; test functions similar to S-3 with cooling lines connected.</li> <li>● Prepare LVGS for mating.</li> <li>● Perform LVGS mechanical mating functions similar to IU.</li> <li>● Perform IU telemetry &amp; RF tests.</li> <li>● Perform G&amp;C alignment tests.</li> <li>● Remove upper stage simulators.</li> <li>● Electrically mate S-1, S-2, S-3, IU and LVGS</li> </ul>						

TABLE 7.6-VIII  
 LCV GROUND SYSTEM ESTIMATED AGE/LF  
 RET&E AND PRODUCTION AND INSTALLATION COSTS (CONCEPT B)

ES8

Function No.	Function Title & Gross Performance Requirements	Estimated New or Modified (M) AGE/LF Requirements	Estimated RET&E Cost \$X10 <sup>3</sup>		Estimated Unit Production & Installation Cost \$X10 <sup>3</sup>		
			AGE	LF	OGE	LF	NCE
K 10.0	<u>Perform IV/ML Combined Systems Tests</u> <ul style="list-style-type: none"> <li>● Check all S&amp;A devices and safing pins.</li> <li>● Connect spacecraft simulator.</li> <li>● Connect start-up, targeting, and launch countdown and mission simulator ground equipment.</li> <li>● Re-check ML/LV base support level and alignment.</li> <li>● Check theodolite alignment.</li> <li>● Initiate power turn-on sequence to AGE and IU.</li> <li>● Record telemetry data.</li> <li>● Perform LV pre-power on tests.</li> <li>● Conduct digital data acquisition system tests (DDAS).</li> <li>● Perform LV targeting equipment turn-on sequence.</li> <li>● Align inertial measurement unit (IMU).</li> <li>● Perform guidance and control (G&amp;C) tests.</li> <li>● Conduct targeting sequence tests.</li> <li>● Perform RF &amp; telemetry checks.</li> </ul>	Spacecraft simulator. Special purpose test cable assemblies. Launch C/D and mission simulator. Target tape. Simulated flight tape. *LV simulator.	50				100*

\*Does not include cost of LV simulator which is function of PL.

360

TABLE 7.6-VIII  
 LCLV GROUND SYSTEMS ESTIMATED AGE/LF  
 RDT&E AND PRODUCTION AND INSTALLATION COSTS (CONCEPT B)

361

Function No.	Function Title & Cross Performance Requirements	Estimated New or Modified (M) AGE/LF Requirements	Estimated RDT&E Cost \$x10 <sup>3</sup>		Estimated Unit Production & Installation Cost \$x10 <sup>3</sup>		
			AGE	LF	OGE	LF	MGE
K 10.0 (Continued)	<ul style="list-style-type: none"> <li>● Initiate functional sequence &amp; power transfer tests.</li> <li>● Position and prepare payload (PL) in VAB for mating to LV.</li> <li>● Connect ML hoist to PL support adapters.</li> <li>● Mechanically mate PL to IU.</li> <li>● Position PL umbilical support and service arms.</li> <li>● Emplace work platforms.</li> <li>● Connect AGE umbilicals and service lines to PL.</li> <li>● Perform PL ground power-on tests as required.</li> <li>● Perform PL integration tests with LV simulator.</li> <li>● Perform LV overall tests (OAT).</li> <li>● Evaluate telemetry data and ground instrumentation recordings.</li> <li>● Turn off all power.</li> </ul>						

TABLE 7.6-VIII  
 LCLV GROUND SYSTEMS ESTIMATED AGE/LF  
 RDT&E AND PRODUCTION AND INSTALLATION COSTS (CONCEPT B)

160

Function No.	Function Title & Gross Performance Requirements	Estimated New or Modified (M) AGE/LF Requirements	Estimated RDT&E Cost \$X10 <sup>3</sup>		Estimated Unit Production & Installation Cost \$X10 <sup>3</sup>		
			AGE	LF	OGE	LF	MGE
K 9.3	<u>Mate Payload to Launch Vehicle</u> <ul style="list-style-type: none"> <li>● Electrically mate PL to LV.</li> <li>○ Perform power-on and transfer tests.</li> <li>● Conduct emergency detection system (EDS) and abort system tests as required.</li> <li>● Prepare space vehicle, ML, VAB and LCC for composite readiness tests (CRT).</li> </ul>	No LV AGE/LF new or modified requirements at this level of indenture other than those previously identified.					

362

TABLE 7.6-VIII  
 LCLV GROUND SYSTEMS ESTIMATED AGE/LF  
 RDT&E AND PRODUCTION AND INSTALLATION COSTS (CONCEPT B)

363

Function No.	Function Title & Gross Performance Requirements	Estimated New or Modified (M) AGE/LF Requirements	Estimated RDT&E Cost \$X10 <sup>3</sup>		Estimated Unit Production & Installation Cost \$X10 <sup>3</sup>		
			AGE	LF	OGE	LF	MGE
K 8.0	<u>Perform Integrated System Checkouts</u> <ul style="list-style-type: none"> <li>● Connect launch countdown and flight simulators.</li> <li>● Initiate power on sequence.</li> <li>● Turn on IU.</li> <li>● Record telemetry data.</li> <li>● Conduct simulated automatic launch countdown and flight sequence (simulated umbilical ejection, holddown release, liftoff and flight mission.</li> <li>● Evaluate telemetry data and ground instrumentation recordings.</li> <li>● Verify all systems "GO".</li> <li>● Turn off power and remove simulators.</li> <li>● Charge SV batteries as required.</li> <li>● Reconfigure space vehicle for flight.</li> <li>● Performance stray voltage test.</li> <li>● Install final ordnance as required.</li> <li>● Perform final systems test to verify space vehicle and OGE are "GO".</li> <li>● Remove all power.</li> </ul>	No LV new or modified AGE/LF have been identified at this level of indenture other than those previously specified.					

TABLE 7.6-VIII  
 LCV GROUND SYSTEMS ESTIMATED AGE/LF  
 RDT&E AND PRODUCTION AND INSTALLATION COSTS (CONCEPT B)

Function No.	Function Title & Gross Performance Requirements	Estimated New or Modified (M) AGE/LF Requirements	Estimated RDT&E Cost \$X103		Estimated Unit Production & Installation Cost \$X103		
			AGE	LF	AGE	LF	MGE
K 7.0	<p><u>Transport Space Vehicle to Launch Pad</u></p> <ul style="list-style-type: none"> <li>• Prepare ML/SV for transport from VAB to launch pad.</li> <li>• Maintain power on for SV environmental control.</li> <li>• Retract work platforms.</li> <li>• Disconnect VAB electrical cables to ML.</li> <li>• Open VAB high bay door.</li> <li>• Position crawler transporter beneath ML.</li> <li>• Mate crawler to ML.</li> <li>• Activate crawler's load/leveling system.</li> <li>• Lift ML clear of its base support pedestals using crawler.</li> <li>• Transport ML/SV from VAB to launch pad over crawlerway at approximate speed of 1 mph.</li> </ul>	No LV AGE/LF new or modified requirements at this level of indenture other than those previously specified.					

TABLE 7.6-VIII  
 LCLV GROUND SYSTEMS ESTIMATED AGE/LF  
 RDT&E AND PRODUCTION AND INSTALLATION COSTS (CONCEPT B)

Function No.	Function Title & Gross Performance Requirements	Estimated New or Modified (M) AGE/LF Requirements	Estimated RDT&E Cost \$X10 <sup>3</sup>		Estimated Unit Production & Installation Cost \$X10 <sup>3</sup>		
			AGE	LF	OGE	LF	MGE
K 6.0	<p><u>Emplace Space Vehicle</u></p> <ul style="list-style-type: none"> <li>• Prepare launch pad for receipt of ML/SV and MSS.</li> <li>• Move ML/SV with crawler to top of hardstand.</li> <li>• Position ML/SV with crawler over flame trench and support pedestals.</li> <li>• Retract crawler jacks and lower ML on to support pedestals.</li> <li>• Perform ML leveling and alignment operations by adjusting pedestals.</li> <li>• Secure ML to support pedestals.</li> <li>• Move crawler transporter to Mobile Service Structure (MSS) area.</li> <li>• Install and adjust extensible columns under ML.</li> <li>• Connect electrical cabling, propellant and servicing lines to base of ML.</li> <li>• Prepare ML/SV for receipt of MSS.</li> <li>• Position crawler beneath the MSS.</li> <li>• Connect electrical and service lines between crawler and MSS.</li> </ul>	<p><u>LF</u></p> <p>Modification to:</p> <ul style="list-style-type: none"> <li>• Propellant lines to load and unload N<sub>2</sub>O<sub>4</sub>/UDMH.</li> <li>• Engine Servicing Structure.</li> <li>• MSS #1 work platform, servicing lines and cable assemblies.</li> <li>• Flame deflector.</li> <li>• Toxic vapor detection system.</li> </ul> <p><u>AGE</u></p> <p>ML/MSS/LV simulator. Modification to Pad Terminal Connection Room (PTCR) data transmission link and instrumentation lines and equipment.</p>	15	700	200	3,500	50

TABLE 7.6-VIII  
 LCLV GROUND SYSTEMS ESTIMATED AGE/LF  
 RDT&E AND PRODUCTION AND INSTALLATION COSTS (CONCEPT B)

Function No.	Function Title & Gross Performance Requirements	Estimated New or Modified (M) AGE/LF Requirements	Estimated RDT&E Cost \$X10 <sup>3</sup>		Estimated Unit Production & Installation Cost \$X10 <sup>3</sup>		
			AGE	LF	OGE	LF	MGE
K 6.0 (Continued)	<ul style="list-style-type: none"> <li>● Transport MSS to the top of the hardstand.</li> <li>● Position MSS with crawler over flame trench and its support pedestals.</li> <li>● Retract crawler jacks and lower MSS on to support pedestals.</li> <li>● Vertically align MSS by adjusting pedestals.</li> <li>● Secure MSS to support pedestals.</li> <li>● Disconnect MSS/crawler electrical and service lines.</li> <li>● Move crawler to its parking area.</li> <li>● Connect electrical cabling and servicing lines to base of MSS.</li> <li>● Emplace work platforms.</li> <li>● Connect electrical and servicing lines to the SV.</li> <li>● Prepare ML/MSS for SV start-up and integrated system tests.</li> </ul>						

E64

366



TABLE 7.6-VIII  
 LCLV GROUND SYSTEMS ESTIMATED AGE/LF  
 RDT&E AND PRODUCTION AND INSTALLATION COSTS (CONCEPT B)

367

Function No.	Function Title & Gross Performance Requirements	Estimated New or Modified (M) AGE/LF Requirements	Estimated RDT&E Cost \$X10 <sup>3</sup>		Estimated Unit Production & Installation Cost \$X10 <sup>3</sup>		
			AGE	LF	OGE	LF	MGE
K 5.0	<p><u>Perform Space Vehicle Start-up and Integrated System Checkout</u></p> <ul style="list-style-type: none"> <li>● Verify all S&amp;A devices and safing pins are in "safe" condition.</li> <li>● Connect start-up equipment and launch countdown and flight simulator.</li> <li>● Check alignment of SV and collimator/theodolite.</li> <li>● Verify flight azimuth setting of theodolite.</li> <li>● Initiate power and IU turn-on sequence.</li> <li>● Record telemetry data.</li> <li>● Perform guidance alignment sequence.</li> <li>● Transfer control from launch pad to launch control center.</li> <li>● Verify back-up command, control and communications links to SV.</li> <li>● Initiate SV/launch complex functional and system interface verification checks.</li> <li>● Evaluate test data and verify "GO".</li> </ul>	No LV new or modified AGE/LF have been identified at this level of indenture other than those previously specified.					

TABLE 7.6-VIII  
 LCLV GROUND SYSTEMS ESTIMATED AGE/LF  
 RDT&E AND PRODUCTION AND INSTALLATION COSTS (CONCEPT B)

Function No.	Function Title & Gross Performance Requirements	Estimated New or Modified (M) AGE/LF Requirements	Estimated RDT&E Cost \$X10 <sup>3</sup>		Estimated Unit Production & Installation Cost \$X10 <sup>3</sup>		
			AGE	LF	OGE	LF	MGE
K 5.0 (Continued)	<ul style="list-style-type: none"> <li>● Prepare for Combined Readiness Test (CRT)</li> <li>*● Conduct simulated automatic launch countdown and flight sequence test (simulated umbilical ejection, holddown release, liftoff and flight mission)</li> <li>● Evaluate telemetry data and ground instrumentation recordings.</li> <li>● Verify all systems "GO".</li> <li>● Turn off power and remove simulators.</li> <li>● Charge SV batteries as required.</li> <li>● Reconfigure space vehicle for flight.</li> <li>● Connect ordnance.</li> <li>● Prepare launch facilities and SV for propellant loading.</li> </ul> <p>*This test involves integrated system compatibility tests with ETR and MSC.</p>						

TABLE 7.6-VIII  
 LCLV GROUND SYSTEMS ESTIMATED AGE/LF  
 RDT&E AND PRODUCTION AND INSTALLATION COSTS (CONCEPT B)

Function No.	Function Title & Gross Performance Requirements	Estimated New or Modified (M) AGE/LF Requirements	Estimated RDT&E Cost \$X10 <sup>3</sup>		Estimated Unit Production & Installation Cost \$X10 <sup>3</sup>		
			AGE	LF	OGE	LF	MGE
K 4.0	<u>Load Propellants and Pressurize Missile Stages</u> <ul style="list-style-type: none"> <li>● Perform N<sub>2</sub> leak tests on propellant transfer system and LV propellant system.</li> <li>● Purge and blanket fuel system with N<sub>2</sub>.</li> <li>● Verify weather conditions and vapor disposal system is operating.</li> <li>● Initiate fuel loading sequence.</li> <li>● Load Stages 1, 2 and 3 fuel tanks to prescribed mass of propellant using computer program.</li> <li>● Pressurize Stages 1, 2 and 3 fuel tanks with N<sub>2</sub>.</li> <li>● Drain and purge fuel transfer lines.</li> <li>● Perform fuel leak tests.</li> <li>● Purge and blanket oxidizer system with N<sub>2</sub>.</li> <li>● Initiate oxidizer loading sequence.</li> <li>● Load Stages 1, 2 and 3 oxidizer tanks to prescribed mass of propellant using computer program.</li> </ul>	Load cell with accuracy better than 0.5%. (This approach eliminates need for tank calibration and propellant conditioning equipment.) Leak detection & purge equipment. Computer load programs. Other LV new or modified AGE and LF are as previously identified.	40		100		
			40				150

369

TABLE 7.6-VIII  
 LCLV GROUND SYSTEMS ESTIMATED AGE/LF  
 RDT&E AND PRODUCTION AND INSTALLATION COSTS (CONCEPT B)

EG8

Function No.	Function Title & Gross Performance Requirements	Estimated New or Modified (M) AGE/LF Requirements	Estimated RDT&E Cost \$X10 <sup>3</sup>		Estimated Unit Production & Installation Cost \$X10 <sup>3</sup>		
			AGE	LF	OGE	LF	MGE
K 4.0 (Continued)	<ul style="list-style-type: none"> <li>● Pressurize Stages 1, 2 and 3 oxidizer tanks with N<sub>2</sub>.</li> <li>● Drain and purge oxidizer transfer lines.</li> <li>● Perform propellant leak tests.</li> <li>● Monitor LV propellant tank pressures.</li> </ul>						

370

TABLE 7.6-VIII  
 LCLV GROUND SYSTEMS ESTIMATED AGE/LF  
 RDT&E AND PRODUCTION AND INSTALLATION COSTS (CONCEPT B)

Function No.	Function Title & Gross Performance Requirements	Estimated New or Modified (M) AGE/LF Requirements	Estimated RDT&E Cost \$X10 <sup>3</sup>		Estimated Unit Production & Installation Cost \$X10 <sup>3</sup>		
			AGE	LF	OGE	LF	MGE
K 3.0	<u>Achieve Launch Readiness</u> <ul style="list-style-type: none"> <li>● Monitor propellant pressure.</li> <li>● Install payload provisions.</li> <li>● Wheel launcher flame deflector into pad trench beneath the SV centerline.</li> <li>● Secure flame deflector.</li> <li>● Verify SV and guidance alignment.</li> <li>● Monitor and, if required, charge SV batteries.</li> <li>● Disconnect and retract MSS work platforms and servicing lines from SV.</li> <li>● Remove unnecessary MGE.</li> <li>● Verify ordnance safe.</li> <li>● Remove safing pins from SV and umbilicals.</li> <li>● Install S&amp;A access doors.</li> </ul>	No LV new or modified AGE/LF have been identified at this level of indenture other than that previously specified.					

371

E69

TABLE 7.6-VIII  
 LCLV GROUND SYSTEMS ESTIMATED AGE/LF  
 RDT&E AND PRODUCTION AND INSTALLATION COSTS (CONCEPT B)

E70

Function No.	Function Title & Gross Performance Requirements	Estimated New or Modified (M) AGE/LF Requirements	Estimated RDT&E Cost \$X10 <sup>3</sup>		Estimated Unit Production & Installation Cost \$X10 <sup>3</sup>		
			AGE	LF	OGE	LF	MGE
K 2.0	<p><u>Perform Launch Operations</u></p> <p>A. <u>Launch Precount</u></p> <ul style="list-style-type: none"> <li>● Confirm range clearances with Range Operations and integrated mission control.</li> <li>● Alert range instrumentation systems of countdown start.</li> <li>● Confirm range support equipment ready.</li> <li>● Confirm reception of visual monitor of launch area.</li> <li>● Confirm capability of aural warning system.</li> <li>● Perform checkout of missile lift-off circuitry to Range Operations.</li> <li>● Perform Range Safety open loop checkout on ground power.</li> <li>● Perform command destruct open loop checkout on ground power.</li> <li>● Perform instrumentation open loop checkout.</li> <li>● Receive launch "GO" from Range Operations and integrated mission control.</li> </ul>	No LV new or modified AGE/LF have been identified at this level of indenture other than that previously identified.					

372

TABLE 7.6-VIII  
 LCLV GROUND SYSTEMS ESTIMATED AGE/LF  
 RDT&E AND PRODUCTION AND INSTALLATION COSTS (CONCEPT B)

Function No.	Function Title & Gross Performance Requirements	Estimated New or Modified (M) AGE/LF Requirements	Estimated RDT&E Cost \$X10 <sup>3</sup>		Estimated Unit Production & Installation Cost \$X10 <sup>3</sup>		
			AGE	LF	OGE	LF	MGE
K 2.0 (Continued)	<ul style="list-style-type: none"> <li>● Transfer IU to airborne power.</li> <li>● Perform open loop checkout on airborne power.</li> <li>● Prepare for terminal countdown.</li> </ul> <p>D. <u>Terminal Countdown</u></p> <ul style="list-style-type: none"> <li>● Remove MSS with crawler from launch pad area.</li> <li>● Verify launch readiness of S/V and launch control and support equipment.</li> <li>● Receive and verify launch command.</li> <li>● Initiate launch sequence.</li> <li>● Turn-on ground power to SV.</li> <li>● Arm launch circuits.</li> <li>● Start launch sequence.</li> <li>● Perform guidance and control discretes test.</li> <li>● Confirm flight program entered.</li> <li>● Arm SV ordnance devices.</li> <li>● Activate launch vehicle batteries.</li> </ul>						

TABLE 7.6-VIII  
 ICLV GROUND SYSTEMS ESTIMATED AGE/LF  
 RDT&E AND PRODUCTION AND INSTALLATION COSTS (CONCEPT B)

ET2

Function No.	Function Title & Gross Performance Requirements	Estimated New or Modified (M) AGE/LF Requirements	Estimated RDT&E Cost \$X10 <sup>3</sup>		Estimated Unit Production & Installation Cost \$X10 <sup>3</sup>		
			AGE	LF	OGE	LF	MGE
K 2.0 (Continued)	<ul style="list-style-type: none"> <li>● Open stage prevalves.</li> <li>● Transfer ground to airborne power.</li> <li>● Begin flight computation.</li> <li>● Confirm all systems status "GO".</li> <li>● Disconnect critical leads.</li> <li>● Release umbilicals.</li> <li>● Retract umbilicals.</li> <li>● Ignite first stage.</li> <li>● Confirm reception of SV lift-off signal at LCC, Range Operations and integrated mission control.</li> </ul>						

374



TABLE 7.6-XI  
 LCV GROUND SYSTEMS ESTIMATED AGE/LF  
 RDT&E AND PRODUCTION AND INSTALLATION COSTS (CONCEPT C<sub>1</sub>)

375

Function No.	Function Title & Gross Performance Requirements	Estimated New or Modified (M) AGE/LF Requirements	Estimated RDT&E Cost \$X10 <sup>3</sup>		Estimated Unit Production & Installation Cost \$X10 <sup>3</sup>		
			AGE	LF	OGE	LF	MGE
K 22.0	<u>Process Propellants and Cases</u> <ul style="list-style-type: none"> <li>• Transfer N<sub>2</sub>O<sub>4</sub> and UDMH into propellant storage areas.</li> <li>• Transfer LN<sub>2</sub> into high pressure gas storage areas.</li> <li>• Transfer H<sub>2</sub> into high pressure gas storage area.</li> </ul>	Two 60,000 ft <sup>3</sup> Storage Tanks Transfer Lines, Valves and Feed Pumps Control Stations Retention and Neutralization Basins Toxic Vapor Detection System Water Deluge System Security Fencing Lightning Arrestors Lighting Meteorological Data System Access Roads Use existing transfer lines, converter/compressors, and storage banks. Waste Propellant Disposal System				8,000	

TABLE 7.6-XI  
 LCEV GROUND SYSTEMS ESTIMATED AGE/LF  
 RDT&E AND PRODUCTION AND INSTALLATION COSTS (CONCEPT C<sub>1</sub>)

Function No.	Function Title & Gross Performance Requirements	Estimated New or Modified (M) AGE/LF Requirements	Estimated RDT&E Cost \$X10 <sup>3</sup>		Estimated Unit Production & Installation Cost \$X10 <sup>3</sup>		
			AGE	LF	OGE	LF	MGC
K 18.0	<u>Process Instrumentation</u> <ul style="list-style-type: none"> <li>● Unload and emplace instrumentation subsystems on support fixtures.</li> <li>● Perform R&amp;T.</li> <li>● Conduct continuity and hazardous current tests.</li> <li>● Perform unit assembly, alignment, calibration and functional sequence tests.</li> <li>● Transport instrumentation unit to storage or vehicle integration area.</li> </ul>	Shipping Containers Slings & Hoisting adapters Support Fixtures Command Destruct subsystem simulator Telemetry & Data Acquisition Test Set RF System Checkout Set Calibration Equipment Alignment Fixtures Data Recording Equipment Battery Test Set Test Cable Assembly Liquid Cooler Assembly & Installation Tools					.375

ETL

376

TABLE 7.6-XI  
 LCLV GROUND SYSTEMS ESTIMATED AGE/LF  
 RDT&E AND PRODUCTION AND INSTALLATION COSTS (CONCEPT C<sub>1</sub>)

Function No.	Function Title & Gross Performance Requirements	Estimated New or Modified (M) AGE/LF Requirements	Estimated RDT&E Cost \$X10 <sup>3</sup>		Estimated Unit Production & Installation Cost \$X10 <sup>3</sup>		
			AGE	LF	OGE	LF	MGE
K 16.0	<u>Process LVGS</u> <ul style="list-style-type: none"> <li>● Unload and emplace on support fixture.</li> <li>● Perform R&amp;I.</li> <li>● Conduct continuity and hazardous current tests.</li> <li>● Perform alignment, calibration and functional tests.</li> <li>● Transport LVGS to storage or vehicle integration area.</li> </ul>	Shipping Container Slings & Hoisting adapters Support Fixture LVGS Test Set Liquid Cooler Calibration Equipment Autocollimator Data Recording Equipment Adapter Cable Assembly					250

377

E75

TABLE 7.6-XI  
 LCLV GROUND SYSTEMS ESTIMATED AGE/LF  
 RDT&E AND PRODUCTION AND INSTALLATION COSTS (CONCEPT C<sub>1</sub>)

Function No.	Function Title & Cross Performance Requirements	Estimated New or Modified (M) AGE/LF Requirements	Estimated RDT&E cost \$x10 <sup>3</sup>		Estimated Unit Production & Installation Cost \$x10 <sup>3</sup>		
			AGE	LF	AGE	LF	AGE
K 14.0	<u>Process Ordnance</u> <ul style="list-style-type: none"> <li>• Unload and Receive and Inspect (R&amp;I).</li> <li>• Check continuity and isolation and bridge wire resistance.</li> <li>• Transport to storage or launch vehicle integration area.</li> </ul>	Adapter Cables Igniter Test Set (M)					10

TABLE 7.6-XI  
 LCLV GROUND SYSTEMS ESTIMATED AGE/LF  
 RDT&E AND PRODUCTION AND INSTALLATION COSTS (CONCEPT C<sub>1</sub>)

379

Function No.	Function Title & Gross Performance Requirements	Estimated New or Modified (M) AGE/LF Requirements	Estimated RDT&E Cost \$X10 <sup>3</sup>		Estimated Unit Production & Installation Cost \$X10 <sup>3</sup>		
			AGE	LF	OGE	LF	MGE
K 13.0	<p><u>Assemble and Test Downstage Vehicle (Final Assembly only)</u></p> <ul style="list-style-type: none"> <li>• Prepare MGE and Mobile Erector Launcher (MEL) for LCLV horizontal assembly at Plant A.</li> <li>• Connect electrical cabling and servicing lines between MGE &amp; MEL.</li> <li>• Prepare Stage 1 (S-1) for horizontal mating with MEL.</li> <li>• Transport S-1 to cell.</li> <li>• Align S-1 with MEL for mechanical mating.</li> <li>• Mechanically mate S-1 with MEL.</li> <li>• Install work platforms.</li> <li>• Connect electrical and servicing lines to MEL.</li> <li>• Connect MEL electrical &amp; servicing lines to S-1.</li> <li>• Connect upper stage servicers to S-1.</li> <li>• Align S-1 for S-2 mating.</li> <li>• Verify all S-1 service connections, plus are in safe condition.</li> <li>• Perform continuity tests.</li> <li>• Apply ground power to S-1.</li> <li>• Perform S-1 electrical &amp; mechanical sub-system tests.</li> <li>• Perform stray voltage &amp; hazardous current tests.</li> </ul>	<p><u>Transportation, Handling &amp; Assembly</u></p> <p>Mobile Erector Launcher (MEL)          MEL Parking and Maintenance Area          Transporter Jigs          Locomotives &amp; Rails          Work Platforms          100 Ton Capacity Bridge Crane          Jigs          Support Ramps          Support Platforms          Transportation Service Assembly Stands          Assembly &amp; Installation Tools          Lifting Trucks          Large Hoistches          Transporter Jigs          Control Equipment          Alignment Mechanism</p> <p><u>Mobile Erector Launcher (MEL)</u></p> <p>Data Acquisition &amp; Display System          Ground Power Supplies          Orbis assemblies          Environmental Control System          Servicing Lines          Power Distribution &amp; Control System</p>				35,000	10,000

E77

TABLE 7.6-XI  
 ICLV GROUND SYSTEMS ESTIMATED AGE/LF  
 RDT&E AND PRODUCTION AND INSTALLATION COSTS (CONCEPT 1)

Function No.	Function Title & Gross Performance Requirements	Estimated New or Modified (M) AGE/LF Requirements	Estimated RDT&E Cost \$X10 <sup>3</sup>		Estimated Unit Production & Installation Cost \$X10 <sup>3</sup>		
			AGE	LF	OSE	IF	FGF
13.0 (Continued)	<ul style="list-style-type: none"> <li>• Remove S-1 power.</li> <li>• Install &amp; safe ordnance.</li> <li>• Continue S-1 electrical &amp; mechanical sub-system tests.</li> <li>• Prepare Stage 2 (S-2) interstage assembly for mating.</li> <li>• Transport S-2 interstage assembly to MEL.</li> <li>• Emplace 2nd stage work platforms.</li> <li>• Align S-2 for horizontal mating with S-1.</li> <li>• Mechanically mate S-2.</li> <li>• Connect MEL 2nd stage umbilical support and service arms.</li> <li>• Connect umbilicals and service lines to 2nd stage.</li> <li>• Connect upper stage simulator to 2nd stage.</li> <li>• Check mechanical alignment.</li> <li>• Perform continuity tests.</li> <li>• Apply ground power to S-2.</li> <li>• Perform S-2 electrical &amp; mechanical tests.</li> <li>• Perform stray voltage &amp; hazardous current tests.</li> <li>• Remove all power &amp; install ordnance.</li> <li>• Continue S-2 electrical &amp; mechanical tests.</li> </ul>	Propellant Loading & Pressurization Lines Water Deluge System Instrumentation & Recording Equipment Communication System TV & Timing System Leak Detection System Umbilical Retraction System  MGE Checkout & Test  LV Simulator Upper Stage Simulators Launch Facility Simulator Power Supply Set & Control Cable Assemblies and Adapters Servicing Lines Power Distribution & Control System Telemetry & Data Acquisition Test Set Instrumentation Unit Control & Monitor Console Data Recording Equipment LV Cooling System Drain & Surge Control Consoles LVGS Control & Monitor Console Propulsion System Test Set Pneumatic Control & Monitor Consoles					20,000

TABLE 7.6-XI  
 LCLV GROUND SYSTEMS ESTIMATED AGE/LF  
 RDT&E AND PRODUCTION AND INSTALLATION COSTS (CONCEPT C<sub>1</sub>)

Function No.	Function Title & Gross Performance Requirements	Estimated New or Modified (M) AGE/LF Requirements	Estimated RDT&E Cost \$X10 <sup>3</sup>		Estimated Unit Production & Installation Cost \$X10 <sup>3</sup>		
			AGE	LF	OGE	LF	MGE
K 13.0 (Continued)	<ul style="list-style-type: none"> <li>⊙ Prepare S-3 interstage assembly for mating.</li> <li>⊙ Perform S-3 mechanical mating &amp; test functions similar to S-2.</li> <li>⊙ Prepare instrumentation unit (IU) for mating.</li> <li>⊙ Transport IU to MFL.</li> <li>⊙ Perform IU mechanical mating &amp; test functions similar to S-3 with cooling lines connected.</li> <li>⊙ Prepare launch vehicle guidance set (LVGS) for mating.</li> <li>⊙ Perform LVGS mechanical mating functions similar to IU with cooling lines connected.</li> <li>⊙ Perform IU telemetry &amp; RF tests.</li> <li>⊙ Perform C&amp;C alignment tests.</li> <li>⊙ Remove all power.</li> <li>⊙ Check all S&amp;A devices &amp; safing pins.</li> <li>⊙ Remove upper stage simulators.</li> <li>⊙ Electrically mate S-1, S-2, S-3, IU and LVGS.</li> <li>⊙ Connect spacecraft simulator.</li> <li>⊙ Connect start-up, targeting, and launch countdown &amp; mission simulator ground equipment.</li> <li>⊙ Check LCLV &amp; theodolite alignment.</li> </ul>	Standard Test Equipment Igniter Testers RF System Checkout Set Calibration Equipment Theodolite Anemometer C&C Test Set Programmer Test Set Checkout System Test Car Indicator & Monitor Synthesizer Console External RF Cores Battery Test Sets Time Synchronization System Data Processing & Display Launch Countdown and Mission Simulator Target and Simulated Flight Tape					

TABLE 7.6-XI  
 LCLV GROUND SYSTEMS ESTIMATED AGE/LF  
 RDT&E AND PRODUCTION AND INSTALLATION COSTS (CONCEPT<sub>1</sub>)

Function No.	Function Title & Gross Performance Requirements	Estimated New or Modified (M) AGE/LF Requirements	Estimated RDT&E Cost \$X10 <sup>3</sup>		Estimated Unit Production & Installation Cost \$X10 <sup>3</sup>		
			AGE	LF	OGE	LF	MGE
K 13.0 (Continued)	<ul style="list-style-type: none"> <li>• Initiate power turn-on sequence to MEL, AGE and IU.</li> <li>• Record telemetry data.</li> <li>• Perform pre-power on tests.</li> <li>• Conduct digital data acquisition system tests (DDAS).</li> <li>• Perform IV targeting equipment turn-on sequence.</li> <li>• Align inertial measurement unit (IMU).</li> <li>• Perform guidance and control (GAC) tests.</li> <li>• Conduct targeting sequence tests.</li> <li>• Perform RF &amp; telemetry checks.</li> <li>• Initiate functional sequence &amp; power-transfer tests.</li> <li>• Evaluate telemetry data and instrumentation recordings.</li> <li>• Remove power and disconnect MDE.</li> <li>• Disconnect electrical cabling and servicing lines between MGE and MEL.</li> <li>• Remove work platforms.</li> </ul>						

E80

382



TABLE 7.6-XI  
 LCV GROUND SYSTEMS ESTIMATED AGE/LF  
 RDT&E AND PRODUCTION AND INSTALLATION COSTS (CONCEPT)

383

Function No.	Function Title & Gross Performance Requirements	Estimated New or Modified (M) AGE/LF Requirements	Estimated RDT&E Cost \$X10 <sup>3</sup>		Estimated Unit Production & Installation Cost \$X10 <sup>3</sup>		
			AGE	LF	OGE	LF	MIE
K 35.0	<u>Transport Launch Vehicle to Launch Pad</u> e Prepare MEL/LCV for rail transport from Plant A to launch pad. e Maintain power on LCV environmental control system. e Start up MEL. e Replace environmental covers. e Remove work platforms. e Connect diesel locomotive to MEL. e Transport MEL/LCV by rail from Plant A to launch pad.	Railroad System (Plant A to Launch Pad)					5,000

TABLE 7.6-XI  
 LCLV GROUND SYSTEMS ESTIMATED AGE/LF  
 RDT&E AND PRODUCTION AND INSTALLATION COSTS (CONCEPT C<sub>1</sub>)

Item No.	Function: MEL & Gross Performance Requirements	Estimated Number Modified (M) or New/LF Requirements	Estimated RDT&E Cost \$x10 <sup>3</sup>		Estimated Unit Production & Installation Cost \$x10 <sup>3</sup>		
			AT&E	LF	CGP	F	MOB
34.0	<p><u>Erect and Emplace Launch Vehicle</u></p> <ul style="list-style-type: none"> <li>• Prepare launch pad for receipt of MEL/LV and Mobile Service Structure (MSS).</li> <li>• Move MEL/LV by diesel locomotives to top of hardstand.</li> <li>• Position and secure MEL/LV over flame trench and LV holddown arms.</li> <li>• Emplace MEL work platforms.</li> <li>• Remove LV environmental covers.</li> <li>• Connect ground servicing lines and electrical cables to MEL.</li> <li>• Prepare MEL/LV for vertical erection.</li> <li>• Turn-on MEL electrical and hydraulic power.</li> <li>• Vertically erect LV (1st stage extends approximately 80' from ground level into flame trench).</li> <li>• Level and align LV by adjusting MEL erection mechanism.</li> <li>• Position and secure launch pad holddown arms to LV 1st stage support frame.</li> <li>• Secure LV in vertical position.</li> <li>• Retract MEL umbilical tower and extend umbilical arms.</li> <li>• Emplace LV upper and lower work platforms on MEL.</li> </ul>	<p><u>Launch Facility</u></p> <ul style="list-style-type: none"> <li>• New Launch Pad Complex</li> </ul> <p>Concrete reinforced steel hardstand with approx 175' deep and 70' wide cruciform type flame trench. Exhaust deflector. Holddown arms. Cableways. Electrical equipment rooms. Pad terminal rooms. Power distribution &amp; control. Propellant &amp; pressurization lines. Firex distribution. Environmental control system. Camera pads. Access roads. High pressure gas facilities. Azimuth alignment building. Crawlways. MSS support pedestals. Toxic vapor detection system. Lighting system. Lightning arrestor system. Meteorological data system.</p>				22,000	

88

384

TABLE 7.6-XI  
 ICLV GROUND SYSTEMS ESTIMATED AGE/LF  
 RDT&E AND PRODUCTION AND INSTALLATION COSTS (CONCEPT C<sub>1</sub>)

Function No.	Function Title & Gross Performance Requirements	Estimated New or Modified (M) AGE/LF Requirements	Estimated RDT&E Cost \$X10 <sup>3</sup>		Estimated Unit Production & Installation Cost \$X10 <sup>3</sup>		
			AGE	LF	OGE	LF	MGE
K 34.0 (Continued)	<ul style="list-style-type: none"> <li>• Remove diesel locomotives to MSS parking area.</li> <li>• Prepare MEL/LV for receipt of MSS's.</li> <li>• Connect diesel locomotives to upper stage MSS.</li> <li>• Transport upper stage MSS to top of the hardstand by rail.</li> <li>• Position upper stage MSS over flame trench and its support pedestals.</li> <li>• Adjust support pedestals to vertically align and secure upper stage MSS.</li> <li>• Remove diesel locomotives to parking area.</li> <li>• Connect diesel locomotives stage MSS.</li> <li>• Transport lower stage MSS by rail to bottom of flame trench beneath LV.</li> <li>• Align lower stage MSS with LV and secure MSS.</li> <li>• Remove diesel locomotives to MSS parking area.</li> <li>• Connect electrical cabling and service lines to MSS's.</li> <li>• Emplace work platforms.</li> <li>• Connect electrical and servicing lines to LV.</li> <li>• Prepare MEL/MSS for LV start-up and functional tests.</li> </ul>	Emergency escape system. Pumping stations. Air intake ducts. Work platforms. Upper Stage MSS Approx 300' tower with 120' X 130' base. Four work platforms similar to Saturn V MSS. Tower elevator (passenger freight type). 100-ton capacity hammerhead crane. Base on railroad wheels. Electrical equipment room. Air conditioning. Electrical power and distribution. Fire protection system. Compressed air system. Nitrogen pressurization system. Potable water system. Communications network. Lighting system. Lightning arrestors. Toxic vapor detection system. Sewage disposal.				20,000	

385

E83

TABLE 7.6-XI  
 LCLV GROUND SYSTEMS ESTIMATED AGE/LF  
 RDT&E AND PRODUCTION AND INSTALLATION COSTS (CONCEPT)

Function No.	Function Title & Cross Performance Requirements	Estimated No. or Modified (1) AGE/LF Requirements	Estimated Production Cost \$X10 <sup>3</sup>		Estimated Unit Production & Installation Cost \$X10 <sup>3</sup>			
			AGE	LF	OGE	LF	NGE	
K 34.0 (Continued)		<ul style="list-style-type: none"> <li>• Lower Stage MSS                approx 100' tower with 50' X 100' base. One elevator platform for servicing 1st stage. Base on railroad wheels. Electrical equipment room. Electrical power and distribution. Fire protection system. Compressed air system. Nitrogen pressurization system. Communications network. Lighting &amp; lightning system. Toxic vapor detection system.</li> <li>• MSS Parking Area</li> </ul>				15,000		
			AGE				6,000	
			LF/AGE			10,000		5,000
		<ul style="list-style-type: none"> <li>Data acquisition system.</li> <li>Instrumentation system.</li> <li>TV &amp; timing system.</li> <li>Power generation and control system.</li> <li>Theodolite.</li> <li>Autocollimator.</li> <li>Communication system.</li> </ul>						



TABLE 7.6-XI  
 LCLV GROUND SYSTEMS ESTIMATED AGE/LF  
 RDT&E AND PRODUCTION AND INSTALLATION COSTS (CONCEPT C<sub>1</sub>)

Function No.	Function: MEL & Gross Performance Requirements	Estimated Number Modified (M) or New/LF Requirements	Estimated RDT&E Cost \$x10 <sup>3</sup>		Estimated Unit Production & Installation Cost \$x10 <sup>3</sup>		
			ATB	LF	GGP	F	MCG
34.0	<u>Erect and Emplace Launch Vehicle</u> <ul style="list-style-type: none"> <li>• Prepare launch pad for receipt of MEL/LV and Mobile Service Structure (MSS).</li> <li>• Move MEL/LV by diesel locomotives to top of hardstand.</li> <li>• Position and secure MEL/LV over flame trench and LV holddown arms.</li> <li>• Emplace MEL work platforms.</li> <li>• Remove LV environmental covers.</li> <li>• Connect ground servicing lines and electrical cables to MEL.</li> <li>• Prepare MEL/LV for vertical erection.</li> <li>• Turn-on MEL electrical and hydraulic power.</li> <li>• Vertically erect LV (1st stage extends approximately 80' from ground level into flame trench).</li> <li>• Level and align LV by adjusting MEL erection mechanism.</li> <li>• Position and secure launch pad holddown arms to LV 1st stage support frame.</li> <li>• Secure LV in vertical position.</li> <li>• Retract MEL umbilical tower and extend umbilical arms.</li> <li>• Emplace LV upper and lower work platforms on MEL.</li> </ul>	<u>Launch Facility</u> <ul style="list-style-type: none"> <li>• New Launch Pad Complex               <ul style="list-style-type: none"> <li>Concrete reinforced steel hardstand with approx 175' deep and 70' wide cruciform type flame trench.</li> <li>Exhaust deflector.</li> <li>Holddown arms.</li> <li>Cableways.</li> <li>Electrical equipment rooms.</li> <li>Pad terminal rooms.</li> <li>Power distribution &amp; control.</li> <li>Propellant &amp; pressurization lines.</li> <li>Firex distribution.</li> <li>Environmental control system.</li> <li>Camera pads.</li> <li>Access roads.</li> <li>High pressure gas facilities.</li> <li>Azimuth alignment building.</li> <li>Crawlways.</li> <li>MSS support pedestals.</li> <li>Toxic vapor detection system.</li> <li>Lighting system.</li> <li>Lightning arrestor system.</li> <li>Meteorological data system.</li> </ul> </li> </ul>				22,000	

88

384

TABLE 7.6-XI  
 ICLV GROUND SYSTEMS ESTIMATED AGE/LF  
 RDT&E AND PRODUCTION AND INSTALLATION COSTS (CONCEPT C<sub>1</sub>)

Function No.	Function Title & Gross Performance Requirements	Estimated New or Modified (M) AGE/LF Requirements	Estimated RDT&E Cost \$X10 <sup>3</sup>		Estimated Unit Production & Installation Cost \$X10 <sup>3</sup>		
			AGE	LF	OGE	LF	MGE
K 34.0 (Continued)	<ul style="list-style-type: none"> <li>• Remove diesel locomotives to MSS parking area.</li> <li>• Prepare MEL/LV for receipt of MSS's.</li> <li>• Connect diesel locomotives to upper stage MSS.</li> <li>• Transport upper stage MSS to top of the hardstand by rail.</li> <li>• Position upper stage MSS over flame trench and its support pedestals.</li> <li>• Adjust support pedestals to vertically align and secure upper stage MSS.</li> <li>• Remove diesel locomotives to parking area.</li> <li>• Connect diesel locomotives stage MSS.</li> <li>• Transport lower stage MSS by rail to bottom of flame trench beneath LV.</li> <li>• Align lower stage MSS with LV and secure MSS.</li> <li>• Remove diesel locomotives to MSS parking area.</li> <li>• Connect electrical cabling and service lines to MSS's.</li> <li>• Emplace work platforms.</li> <li>• Connect electrical and servicing lines to LV.</li> <li>• Prepare MEL/MSS for LV start-up and functional tests.</li> </ul>	<p>Emergency escape system.            Pumping stations.            Air intake ducts.            Work platforms.</p> <p>• Upper Stage MSS</p> <p>Approx 300' tower with 120' X 130' base.            Four work platforms similar to Saturn V MSS.            Tower elevator (passenger freight type).            100-ton capacity hammerhead crane.            Base on railroad wheels.            Electrical equipment room.            Air conditioning.            Electrical power and distribution.            Fire protection system.            Compressed air system.            Nitrogen pressurization system.            Potable water system.            Communications network.            Lighting system.            Lightning arrestors.            Toxic vapor detection system.            Sewage disposal.</p>				20,000	

385

E83

TABLE 7.6-XI  
 LCLV GROUND SYSTEMS ESTIMATED AGE/LF  
 RDT&E AND PRODUCTION AND INSTALLATION COSTS (CONCEPT)

Function No.	Function Title & Cross Performance Requirements	Estimated No. or Modified (1) AGE/LF Requirements	Estimated Production Cost \$X10 <sup>3</sup>		Estimated Unit Production & Installation Cost \$X10 <sup>3</sup>			
			AGE	LF	OGE	LF	NGE	
K 34.0 (Continued)		<ul style="list-style-type: none"> <li>• Lower Stage MSS                approx 100' tower with 50' X 100' base. One elevator platform for servicing 1st stage. Base on railroad wheels. Electrical equipment room. Electrical power and distribution. Fire protection system. Compressed air system. Nitrogen pressurization system. Communications network. Lighting &amp; lightning system. Toxic vapor detection system.</li> <li>• MSS Parking Area</li> </ul>				15,000		
							6,000	
						10,000		



TABLE 7.6-XI  
 LCLV GROUND SYSTEMS ESTIMATED AGE/LF  
 COSTS AND PRODUCTION AND INSTALLATION COSTS (CONCEPT<sub>1</sub>)

Function No.	Function Title & General Performance Requirements	Estimated Number of Modifications (M) or LF Requirements	Estimated Production Cost (\$x10 <sup>3</sup> )		Estimated Production Cost (\$x10 <sup>3</sup> )		
			AGE	LF	AGE	LF	MG
7.3.0	<p>Perform MEL/LV Combined tests.</p> <ul style="list-style-type: none"> <li>• Check all S&amp;A devices and safing parts.</li> <li>• Connect spacecraft simulator.</li> <li>• Connect start-up, targeting, and launch countdown and mission simulator ground equipment.</li> <li>• Re-check MEL/LV base support level and alignment.</li> <li>• Check theodolite alignment.</li> <li>• Initiate power turn-on sequence to AGE and IU.</li> <li>• Record telemetry data.</li> <li>• Perform LV pre-power on tests.</li> <li>• Conduct digital data acquisition system tests (DDAS).</li> <li>• Perform LV targeting equipment turn-on sequence.</li> <li>• Align inertial measurement unit (IMU).</li> <li>• Perform guidance and control (G&amp;C) tests.</li> <li>• Conduct targeting sequence tests.</li> <li>• Perform RF and telemetry checks.</li> <li>• Initiate functional sequence and power transfer tests.</li> <li>• Position and prepare payload (PL) for mating to LV.</li> </ul>	*LV Simulator					30
		*Does not include cost of LV simulator which is function of PL.					

TABLE 7.6-XI  
 IOLV GROUND SYSTEMS OPERATED ACE/LF  
 TYPE AND PRODUCTION AND INSTALLATION COSTS (CONCENTC1)

Item No.	Mission Title & Ground System Performance Requirements	Estimated Mission Time (M) or LF Requirements	Estimated Cost (\$)		Estimated Weight (KG)
			ACE	LF	
7.6.3.0	<p>Perform LV MEL/LCC combined tests.</p> <ul style="list-style-type: none"> <li>• Check all S&amp;A devices and safing parts.</li> <li>• Connect spacecraft simulator.</li> <li>• Connect start-up, targeting, and launch countdown and mission simulator ground equipment.</li> <li>• Re-check MEL/LV base support level and alignment.</li> <li>• Check theodolite alignment.</li> <li>• Initiate power turn-on sequence to ACE and IU.</li> <li>• Record telemetry data.</li> <li>• Perform LV pre-power on tests.</li> <li>• Conduct digital data acquisition system tests (DDAS).</li> <li>• Perform LV targeting equipment turn-on sequence.</li> <li>• Align inertial measurement unit (IMU).</li> <li>• Perform guidance and control (G&amp;C) tests.</li> <li>• Conduct targeting sequence tests.</li> <li>• Perform RF and telemetry checks.</li> <li>• Initiate functional sequence and power transfer tests.</li> <li>• Position and prepare payload (PL) for mating to LV.</li> </ul>	*LF Simulator			*30

\*Does not include cost of LV simulator which is function of PL.

TABLE 7.6-XI  
 LCLV GROUND SYSTEMS ESTIMATED AGE/LF  
 RDT&E AND PRODUCTION AND INSTALLATION COSTS (CONCEPT<sub>1</sub>)

Function No.	Function Title & Gross Performance Requirements	Estimated New or Modified (M) AGE/LF Requirements	Estimated RDT&E Cost \$X10 <sup>3</sup>		Estimated Unit Production & Installation Cost \$X10 <sup>3</sup>		
			AGE	LF	OGE	LF	MGE
K 33.0 (Continued)	<ul style="list-style-type: none"> <li>• Connect MSS 100-ton hoist to PL support adapters.</li> <li>• Mechanically mate PL to IU.</li> <li>• Position MEL/PL umbilical support and service arms.</li> <li>• Emplace MSS work platforms.</li> <li>• Connect AGE umbilicals and service lines to PL.</li> <li>• Perform PL ground power-on tests as required.</li> <li>• Perform PL integration tests with LV simulator.</li> <li>• Perform LV overall tests (OAT).</li> <li>• Evaluate telemetry data and ground instrumentation recordings.</li> <li>• Turn off all power.</li> </ul>						

389

TABLE 7.6-XI  
 LCLV GROUND SYSTEMS ESTIMATED AGE/LF  
 RETIRE AND PRODUCTION AND INSTALLATION COSTS (CONCEPT<sub>1</sub>)

Number	Function Title - Cross Performance Requirements	Estimated New or Modified (N) AG/LF Requirements	Estimated Retirement Costs (\$M)		Estimated Production Costs (\$M)		
			AGE	LF	AGE	LF	MIR
8.11.0	Mate Payload to Launch Vehicle • Electrically mate PL to LV • Perform power-on and transfer tests. • Conduct emergency detection system (EDS) and abort system tests as required. • Prepare space vehicle, MEL and LCC for composite readiness tests (CRT).	LCLV AGE/LF new or modified requirements at this level of indenture other than those previously identified.					

TABLE 7.6-XI  
 LCLV GROUND SYSTEMS ESTIMATED AGE/LF  
 RDT&E AND PRODUCTION AND INSTALLATION COSTS (CONCEPT C<sub>1</sub>)

391

Function No.	Function Title & Gross Performance Requirements	Estimated New or Modified (M) AGE/LF Requirements	Estimated RDT&E Cost \$X10 <sup>3</sup>		Estimated Unit Production & Installation Cost \$X10 <sup>3</sup>		
			AGE	LF	OGE	LF	MGE
K 5.0	<p><u>Perform Space Vehicle Start-up and Integrated System Checkout</u></p> <ul style="list-style-type: none"> <li>• Verify all SEA devices and safing pins are in "safe" condition.</li> <li>• Connect start-up equipment and launch countdown and flight simulator.</li> <li>• Check alignment of SV and collimator/theodolite.</li> <li>• Verify flight azimuth setting of theodolite.</li> <li>• Initiate power and IU turn-on sequence.</li> <li>• Record telemetry data.</li> <li>• Perform guidance alignment sequence.</li> <li>• Transfer control from launch pad to launch control center.</li> <li>• Verify back-up command, control and communications links to SV.</li> <li>• Initiate SV/launch complex functional and system interface verification checks.</li> <li>• Evaluate test data and verify "GO".</li> </ul>	No LV new or modified AGE/LF have been identified at this level of indenture other than those previously specified.					

E89

TABLE 7.6-XI  
 LCLV GROUND SYSTEMS ESTIMATED AGE/LF  
 RDT&E AND PRODUCTION AND INSTALLATION COSTS (CONCEPT C<sub>1</sub>)

Function No.	Function Title & Gross Performance Requirements	Estimated New or Modified (M) AGE/LF Requirements	Estimated RDT&E Cost \$X10 <sup>3</sup>		Estimated Unit Production & Installation Cost \$X10 <sup>3</sup>		
			AGE	LF	OGE	LF	MGE
K 5.0 (Continued)	<ul style="list-style-type: none"> <li>• Prepare for Combined Readiness Test (CRT)</li> <li>*• Conduct simulated automatic launch countdown and flight sequence test (simulated umbilical ejection, holddown release, liftoff and flight mission)</li> <li>• Evaluate telemetry data and ground instrumentation recordings.</li> <li>• Verify all systems "GO".</li> <li>• Turn off power and remove simulators.</li> <li>• Charge SV batteries as required.</li> <li>• Reconfigure space vehicle for flight.</li> <li>• Connect ordnance.</li> <li>• Prepare launch facilities and SV for propellant loading.</li> </ul> <p>*This test involves integrated system compatibility tests with ETR and MSC.</p>						

190

392

TABLE 7.6-XI  
 LCLV GROUND SYSTEMS ESTIMATED AGE/LF  
 RDT&E AND PRODUCTION AND INSTALLATION COSTS (CONCEPT C<sub>1</sub>)

393

Function No.	Function Title & Gross Performance Requirements	Estimated New or Modified (M) AGE/LF Requirements	Estimated RDT&E Cost \$X10 <sup>3</sup>		Estimated Unit Production & Installation Cost \$X10 <sup>3</sup>		
			AGE	LF	OGE	LF	MGE
K 4.0	<u>Load Propellants and Pressurize Missile Stages</u> <ul style="list-style-type: none"> <li>• Perform N<sub>2</sub> leak tests on propellant transfer system and LV propellant system.</li> <li>• Purge and blanket fuel system with N<sub>2</sub>.</li> <li>• Verify weather conditions and vapor disposal system is operating.</li> <li>• Initiate fuel loading sequence.</li> <li>• Load Stages 1, 2 and 3 fuel tanks to prescribed mass of propellant using computer program.</li> <li>• Pressurize Stages 1, 2 and 3 fuel tanks with N<sub>2</sub>.</li> <li>• Drain and purge fuel transfer lines.</li> <li>• Perform fuel leak tests.</li> <li>• Purge and blanket oxidizer system with N<sub>2</sub>.</li> <li>• Initiate oxidizer loading sequence.</li> <li>• Load Stages 1, 2 and 3 oxidizer tanks to prescribed mass of propellant using computer program.</li> </ul>	Load cell with accuracy better than 0.5%. (This approach eliminates need for tank calibration and propellant conditioning equipment.) Leak detection & purge equipment. Computer load programs. Other LV new or modified AGE and LF are as previously identified.			100		150

TABLE 7.6-21  
 LCV GROUND SYSTEMS ESTIMATED AGE/LF  
 RDT&E AND PRODUCTION AND INSTALLATION COSTS (CONCEPT<sub>1</sub>)

Function No.	Function Title & Cross Performance Requirements	Estimated New or Modified (M) AGE/LF Requirements	Estimated RDT&E Cost \$X10 <sup>3</sup>		Estimated Unit Production & Installation Cost \$X10 <sup>3</sup>		
			AGE	LF	OGE	LF	MGE
K 4.0 (Continued)	<ul style="list-style-type: none"> <li>• Pressurize Stages 1, 2 and 3 oxidizer tanks with N<sub>2</sub>.</li> <li>• Drain and purge oxidizer transfer lines.</li> <li>• Perform propellant leak tests.</li> <li>• Monitor LV propellant tank pressures.</li> </ul>						



TABLE 7.6-XI  
 LCLV GROUND SYSTEMS ESTIMATED AGE/LF  
 RDT&E AND PRODUCTION AND INSTALLATION COSTS (CONCEPT C1)

395

Function No.	Function Title & Gross Performance Requirements	Estimated New or Modified (M) AGE/LF Requirements	Estimated RDT&E Cost \$X10 <sup>3</sup>		Estimated Unit Production & Installation Cost \$X10 <sup>3</sup>		
			AGE	LF	OGE	LF	MGE
K 3.0	<u>Achieve Launch Readiness</u> • Monitor propellant pressure. • Install-payload provisions. • Wheel launcher flame deflector into pad trench beneath the SV centerline. • Secure flame deflector. • Verify SV and guidance alignment. • Monitor and, if required, charge SV batteries. • Disconnect and retract MSS work platforms and servicing lines from SV. • Remove unnecessary MGE. • Verify ordnance safe. • Remove safing pins from SV and umbilicals. • Install S&A access doors.	No LV new or modified AGE/LF have been identified at this level of indenture other than that previously specified.					

TABLE 7.6-XI  
 LCLV GROUND SYSTEMS ESTIMATED AGE/LF  
 RDT&E AND PRODUCTION AND INSTALLATION COSTS (CONCEPT C<sub>1</sub>)

Function No.	Function Title & Gross Performance Requirements	Estimated New or Modified (M) AGE/LF Requirements	Estimated RDT&E Cost \$X10 <sup>3</sup>		Estimated Unit Production & Installation Cost \$X10 <sup>3</sup>		
			AGE	LF	OGE	LF	MGE
K 2.0 (Continued)	<ul style="list-style-type: none"> <li>• Transfer IU to airborne power.</li> <li>• Perform open loop checkout on airborne power.</li> <li>• Prepare for terminal countdown.</li> </ul> <p>B. <u>Terminal Countdown</u></p> <ul style="list-style-type: none"> <li>• Remove MSS by locomotives from launch pad area.</li> <li>• Verify launch readiness of S/V and launch control and support equipment.</li> <li>• Receive and verify launch command.</li> <li>• Initiate launch sequence.</li> <li>• Turn-on ground power to SV.</li> <li>• Arm launch circuits.</li> <li>• Start launch sequence.</li> <li>• Perform guidance and control disretes test.</li> <li>• Confirm flight program entered.</li> <li>• Arm SV crdnance devices.</li> <li>• Activate launch vehicle batteries.</li> </ul>						

761

396

TABLE 7.6-XI  
 LCLV GROUND SYSTEMS ESTIMATED AGE/LF  
 RDT&E AND PRODUCTION AND INSTALLATION COSTS (CONCEPT C<sub>1</sub>)

347

Function No.	Function Title & Gross Performance Requirements	Estimated New or Modified (M) AGE/LF Requirements	Estimated RDT&E Cost \$X10 <sup>3</sup>		Estimated Unit Production & Installation Cost \$X10 <sup>3</sup>		
			AGE	LF	OGE	LF	MGE
X 2.0	<p><u>Perform Launch Operations</u></p> <p>A. <u>Launch Precount</u></p> <ul style="list-style-type: none"> <li>● Confirm range clearances with Range Operations and integrated mission control.</li> <li>● Alert range instrumentation systems of countdown start.</li> <li>● Confirm range support equipment ready.</li> <li>● Confirm reception of visual monitor of launch area.</li> <li>● Confirm capability of aural warning system.</li> <li>● Perform checkout of missile lift-off circuitry to Range Operations.</li> <li>● Perform Range Safety open loop checkout on ground power.</li> <li>● Perform command destruct open loop checkout on ground power.</li> <li>● Perform instrumentation open loop checkout.</li> <li>● Receive launch "GO" from Range Operations and integrated mission control.</li> </ul>	No LV new or modified AGE/LF have been identified at this level of indenture other than that previously identified.					

TABLE 7.6-XI  
 ICLV GROUND SYSTEMS ESTIMATED AGE/LF  
 RDT&E AND PRODUCTION AND INSTALLATION COSTS (CONCEPT C<sub>1</sub>)

Function No.	Function Title & Gross Performance Requirements	Estimated New or Modified (M) AGE/LF Requirements	Estimated RDT&E Cost \$X10 <sup>3</sup>		Estimated Unit Production & Installation Cost \$X10 <sup>3</sup>		
			AGE	LF	OGC	LF	MGE
K 2.0 (Continued)	<ul style="list-style-type: none"> <li>● Open stage prevalves.</li> <li>● Transfer ground to airborne power.</li> <li>● Begin flight computation.</li> <li>● Confirm all systems status "GO".</li> <li>● Disconnect critical leads.</li> <li>● Release umbilicals.</li> <li>● Retract umbilicals.</li> <li>● Ignite first stage.</li> <li>● Confirm reception of SV lift-off signal at LCC, Range Operations and integrated mission control.</li> </ul>						

B96

398

TABLE 7.6-XIV  
 LCLV GROUND SYSTEMS ESTIMATED AGE/LF  
 RDT&E AND PRODUCTION AND INSTALLATION COSTS (CONCEPT G<sub>2</sub>)

Function No.	Function Title & Gross Performance Requirements	Estimated New or Modified (M) AGE/LF Requirements	Estimated RDT&E Cost \$X10 <sup>3</sup>		Estimated Unit Production & Installation Cost \$X10 <sup>3</sup>		
			AGE	LF	OGE	LF	MGE
K 22.0	<u>Process Propellants and Gases</u> <ul style="list-style-type: none"> <li>• Transfer N<sub>2</sub>O<sub>4</sub> and UDEM into propellant storage areas.</li> <li>• Transfer LN<sub>2</sub> into high pressure gas storage areas.</li> <li>• Transfer He into high pressure gas storage area.</li> </ul>	Two 60,000 ft <sup>3</sup> Storage Tanks Transfer Lines, Valves and Feed Pumps Control Stations Retention and Neutralization Basins Toxic Vapor Detection System Water Deluge System Security Fencing Lightning Arrestors Lighting Meteorological Data System Access Roads Use existing transfer lines, converter/compressors, and storage banks. Waste Propellant Disposal System		2,500		8,000	

349

TABLE 7.6-XIV  
 LCLV GROUND SYSTEMS ESTIMATED AGE/LF  
 RDT&E AND PRODUCTION AND INSTALLATION COSTS (CONCEPT C<sub>2</sub>)

Function No.	Function Title & Gross Performance Requirements	Estimated New or Modified (M) AGE/LF Requirements	Estimated RDT&E Cost \$X10 <sup>3</sup>		Estimated Unit Production & Installation Cost \$X10 <sup>3</sup>		
			AGE	LF	OGE	LF	MSE
K 18.0	<u>Process Instrumentation</u> <ul style="list-style-type: none"> <li>● Unload and emplace instrumentation subsystems on support fixtures.</li> <li>● Perform R&amp;I.</li> <li>● Conduct continuity and hazardous current tests.</li> <li>● Perform unit assembly, alignment, calibration and functional sequence tests.</li> <li>● Transport instrumentation unit to storage or vehicle integration area.</li> </ul>	Shipping Containers Slings & Hoisting adapters Support Fixtures Command Destruct subsystem simulator Telemetry & Data Acquisition Test Set RF System Checkout Set Calibration Equipment Alignment Fixtures Data Recording Equipment Battery Test Set Test Cable Assembly Liquid Cooler Assembly & Installation Tools	110				.375

E98

400

TABLE 7.6-XIV  
 LCLV GROUND SYSTEMS ESTIMATED AGE/LF  
 RDT&E AND PRODUCTION AND INSTALLATION COSTS (CONCEPT C<sub>2</sub>)

Function No.	Function Title & Gross Performance Requirements	Estimated New or Modified (M) AGE/LF Requirements	Estimated RDT&E Cost \$X10 <sup>3</sup>		Estimated Unit Production & Installation Cost \$X10 <sup>3</sup>		
			AGE	LF	OGE	LF	MGE
K 16.0	<u>Process LVGS</u> <ul style="list-style-type: none"> <li>● Unload and emplace on support fixture.</li> <li>● Perform R&amp;I.</li> <li>● Conduct continuity and hazardous current tests.</li> <li>● Perform alignment, calibration and functional tests.</li> <li>● Transport LVGS to storage or vehicle integration area.</li> </ul>	Shipping Container Slings & Hoisting adapters Support Fixture LVGS Test Set Liquid Cooler Calibration Equipment Autocollimator Data Recording Equipment Adapter Cable Assembly	75				250

1401

TABLE 7.6-XIV  
 LCLV GROUND SYSTEMS ESTIMATED AGE/LF  
 RDT&E AND PRODUCTION AND INSTALLATION COSTS (CONCEPT C<sub>2</sub>)

Function No.	Function Title & Gross Performance Requirements	Estimated New or Modified (M) AGE/LF Requirements	Estimated RDT&E Cost \$X10 <sup>3</sup>		Estimated Unit Production & Installation Cost \$X10 <sup>3</sup>		
			AGE	LF	OGI	LF	AGE
K 14.0	<u>Process Ordnance</u> <ul style="list-style-type: none"> <li>• Unload and Receive and Inspect (R&amp;I).</li> <li>• Check continuity and isolation and bridge wire resistance.</li> <li>• Transport to storage or launch vehicle integration area.</li> </ul>	Adapter Cables Igniter Test Set (M)	3				10

407



TABLE 7.6-XIV  
 LCLV GROUND SYSTEMS ESTIMATED AGE/LF  
 RDT&E AND PRODUCTION AND INSTALLATION COSTS (CONCEPT C<sub>2</sub>)

Function No.	Function Title & Gross Performance Requirements	Estimated New or Modified (M) AGE/LF Requirements	Estimated RDT&E Cost \$X10 <sup>3</sup>		Estimated Unit Production & Installation Cost \$X10 <sup>3</sup>		
			AGE	LF	OGE	LF	MGE
K 13.0	<u>Assemble and Test Downstage Vehicle (Final Assembly only)</u> <ul style="list-style-type: none"> <li>● Prepare MGE for LV assembly operations.</li> <li>● Prepare S-1 for upper stage mating.</li> <li>● Transport Stage 1 (S-1) to final assembly areas (FAA).</li> <li>● Install work platforms.</li> <li>● Connect S-1 umbilicals &amp; upper stage simulator.</li> <li>● Align S-1 for S-2 mating.</li> <li>● Perform continuity tests.</li> <li>● Apply ground power to S-1.</li> <li>● Perform S-1 electrical &amp; mechanical subsystem tests.</li> <li>● Perform stray voltage and hazardous current tests.</li> <li>● Remove S-1 power.</li> <li>● Install and safe ordnance.</li> <li>● Continue S-1 electrical &amp; mechanical subsystems tests.</li> <li>● Prepare S-2 interstage assembly for mating.</li> </ul>	<u>Transportation, Handling &amp; Assembly</u> Stage transporters. Locomotive Work platforms. Slings. Support rings. Support fixtures. Environmental covers. Assembly stands. Assembly & installation tools. Dolly trucks. Torque wrenches. Theodolite stand. Optical alignment set. Alignment fixtures.  <u>Checkout &amp; Simulation</u> Down stage & upper stage simulators. Igniter testers. Telemetry & data acquisition test set. RF system checkout set. Calibration equipment. Data recording equipment. Liquid coolers. Drain & purge set. LVGS test set. Theodolite. Autocollimator. S&A test set.	2,000				8,000
			4,000				12,000

TABLE 7.6-XIV  
 LCLV GROUND SYSTEMS ESTIMATED AGE/LF  
 RDT&E AND PRODUCTION AND INSTALLATION COSTS (CONCEPT C<sub>2</sub>)

E102

Function No.	Function Title & Gross Performance Requirements	Estimated New or Modified (M) AGE/LF Requirements	Estimated RDT&E Cost \$X10 <sup>3</sup>		Estimated Unit Production & Installation Cost \$X10 <sup>3</sup>		
			AGE	LF	OGE	LF	MGE
K 13.0 (Continued)	<ul style="list-style-type: none"> <li>● Transport Stage 2 (S-2) interstage assembly to FAA.</li> <li>● Install work platforms.</li> <li>● Mechanically mate S-2 assembly with S-1.</li> <li>● Connect S-2 umbilicals and service lines and upper stage simulator.</li> <li>● Check mechanical alignment.</li> <li>● Perform continuity tests.</li> <li>● Apply ground power to S-2.</li> <li>● Perform S-2 electrical &amp; mechanical subsystem tests.</li> <li>● Perform stray voltage &amp; hazardous current tests.</li> <li>● Remove all power &amp; install ordnance.</li> <li>● Continue S-2 electrical &amp; mechanical tests.</li> <li>● Prepare Stage 3 (S-3) interstage assembly for mating:</li> <li>● Transport Stage 3 interstage assembly to FAA &amp; perform mating functions similar to S-2.</li> </ul>	S&A test set. Launch facility simulator. Programmer test set. Propulsion test set. Destruct system test set. Cable assemblies. Cable adapters. Control & monitor console. Data processing & display. Antenna RF covers. Standard test equipment. Power supply set & control. Power distribution & control system. Battery test sets..					

704

TABLE 7.6-XIV  
 LCLV GROUND SYSTEMS ESTIMATED AGE/LF  
 RDT&E AND PRODUCTION AND INSTALLATION COSTS (CONCEPT C<sub>2</sub>)

405

Function No.	Function Title & Gross Performance Requirements	Estimated New or Modified (M) AGE/LF Requirements	Estimated RDT&E Cost \$X10 <sup>3</sup>		Estimated Unit Production & Installation Cost \$X10 <sup>3</sup>		
			AGE	LF	OGE	LF	MGE
K 13.0 (Continued)	<ul style="list-style-type: none"> <li>● Prepare instrumentation unit (IU) for mating.</li> <li>● Transport IU to FAA &amp; perform mating functions similar to S-3 with cooling lines connected.</li> <li>● Prepare LVGS for mating.</li> <li>● Transport LVGS to FAA &amp; perform mating functions similar to IU, with cooling lines connected.</li> <li>● Perform IU telemetry &amp; RF tests.</li> <li>● Perform G&amp;C alignment tests.</li> <li>● Remove upper stage simulators.</li> <li>● Remove all power.</li> <li>● Check all S&amp;A devices &amp; safing pins.</li> <li>● Electrically mate S-1, S-2, S-3, IU and LVGS.</li> <li>● Conduct launch vehicle electrical &amp; mechanical system tests.</li> <li>● Remove power &amp; disconnect AGE.</li> <li>● Prepare launch vehicle for transit to the launcher.</li> </ul>						

TABLE 7.6-XIV  
 LCLV GROUND SYSTEMS ESTIMATED AGE/LF  
 RDT&E AND PRODUCTION AND INSTALLATION COSTS (CONCEPT C<sub>2</sub>)

Function No.	Function Title & Gross Performance Requirements	Estimated New or Modified (M) AGE/LF Requirements	Estimated RDT&E Cost \$X10 <sup>3</sup>		Estimated Unit Production & Installation Cost \$X10 <sup>3</sup>		
			AGE	LF	OGE	LF	MGE
K35.0	<u>Transport Launch Vehicle to Launch Pad</u> <ul style="list-style-type: none"> <li>● Prepare LCLV for horizontal rail transport from Plant A to launch pad.</li> <li>● Maintain power on LCLV environmental control system.</li> <li>● Fasten down LCLV to transporter.</li> <li>● Emplace environmental covers.</li> <li>● Remove work platforms.</li> <li>● Connect diesel locomotives to LCLV transporter.</li> <li>● Transport LCLV horizontally by rail from Plant A to launch pad.</li> </ul>	Railroad System (Plant A to Launch Pad)	1,000				5,000

FIG 4

406

TABLE 7.6-XIV  
 LCLV GROUND SYSTEMS ESTIMATED AGE/LF  
 RDT&E AND PRODUCTION AND INSTALLATION COSTS (CONCEPT C<sub>2</sub>)

407

Function No.	Function Title & Gross Performance Requirements	Estimated New or Modified (M) AGE/LF Requirements	Estimated RDT&E Cost \$X10 <sup>3</sup>		Estimated Unit Production & Installation Cost \$X10 <sup>3</sup>		
			AGE	LF	OGE	LF	MGE
K 34.0	<u>Erect and Emplace Launch Vehicle</u> <ul style="list-style-type: none"> <li>● Prepare launch pad for receipt of LV transporter.</li> <li>● Prepare Launch Umbilical Tower (LUT) for receipt of LV.</li> <li>● Move LV transporter by diesel locomotives to top of hardstand.</li> <li>● Position and secure LV transporter over flame trench.</li> <li>● Emplace work platform.</li> <li>● Remove environmental covers.</li> <li>● Connect fulcrum support mounts to LV 1st stage.</li> <li>● Connect hoisting support fixture to LV 2nd stage.</li> <li>● Align LV fulcrum support mounts to launch pad fulcrum arms.</li> <li>● Extend fulcrum support arms to engage LV fulcrum support mounts.</li> <li>● Prepare LUT for LV vertical erection.</li> <li>● Connect LUT overhead hoist to 2nd stage hoisting support fixture.</li> </ul>	<u>Launch Facility</u> <ul style="list-style-type: none"> <li>● <u>New Launch Pad Complex</u></li> </ul> Concrete reinforced steel hardstand with approx 110' deep and 80' wide flame trench. Exhaust deflector. Holddown arms. Cableways. Electrical equipment rooms. Pad terminal rooms. Power distribution & control. Propellant & pressurization lines. Firex distribution. Environmental control system. Camera pads. Access roads. High pressure gas facilities. Azimuth alignment building. Crawlways. Fulcrum support pedestals & arms. Toxic vapor detection system. Lighting system.		23,000		65,000	

TABLE 7.6-XIV  
 LCLV GROUND SYSTEMS ESTIMATED AGE/LF  
 RDT&E AND PRODUCTION AND INSTALLATION COSTS (CONCEPT C<sub>2</sub>)

Function No.	Function Title & Gross Performance Requirements	Estimated New or Modified (M) AGE/LF Requirements	Estimated RDT&E Cost \$X10 <sup>3</sup>		Estimated Unit Production & Installation Cost \$X10 <sup>3</sup>		
			AGE	LF	OGE	LF	MGE
X 34.0 (Continued)	<ul style="list-style-type: none"> <li>● Secure LV transporter for LV vertical erection.</li> <li>● Prepare LV for vertical erection.</li> <li>● Erect LV from horizontal to vertical position using winch.</li> <li>● Secure LV in vertical position.</li> <li>● Position and secure launch pad holddown arms to LV 1st stage.</li> <li>● Level and align LV by adjusting launch pad holddown arms.</li> <li>● Remove LV transporter from launch pad.</li> <li>● Retract fulcrum support arms from LV.</li> <li>● Disconnect and stow fulcrum stage support mounts.</li> <li>● Disconnect and stow 2nd stage hoisting support fixture.</li> <li>● Transport Mobile Service Structure (MSS) to launch pad.</li> <li>● Position MSS adjacent to hardstand with diesel locomotives.</li> <li>● Secure MSS to launch pad.</li> <li>● Connect electrical cables and servicing lines to MSS.</li> </ul>	<p>Lightning arrester system.            Meteorological data system.            Sewage disposal system.            Emergency escape system.            Pumping stations.            Air intake ducts.            Work platforms.            300-ton capacity winch and cables.</p> <ul style="list-style-type: none"> <li>● <u>Launch Umbilical Tower</u></li> </ul> <p>Fixed structure approximately 320' high and 100' X 100' base. Tower structure comparable to Saturn V Mobile Launcher.            Overhead hoisting drum for vertical erection of LV.            Passenger elevator.            Umbilicals provide electrical, pneumatic and propellant connections. Base of tower structure contains:                Air Conditioning</p>	4,500	7,500	10,000	25,000	5,000

9016

408

TABLE 7.6-XIV  
 LCLV GROUND SYSTEMS ESTIMATED AGE/LF  
 RDT&E AND PRODUCTION AND INSTALLATION COSTS (CONCEPT C<sub>2</sub>)

Function No.	Function Title & Gross Performance Requirements	Estimated New or Modified (M) AGE/LF Requirements	Estimated RDT&E Cost \$X10 <sup>3</sup>		Estimated Unit Production & Installation Cost \$X10 <sup>3</sup>		
			AGE	LF	OGE	LF	MGE
K 34.0 (Continued)	<ul style="list-style-type: none"> <li>● Emplace MSS work platforms around LV.</li> <li>● Connect MSS service lines to LV.</li> <li>● Position LUT umbilical support and service arms.</li> <li>● Connect LUT umbilicals and service lines to LV.</li> <li>● Prepare LUT/LV/LCC for LV start-up and functional tests.</li> </ul>	<p>Electrical Power &amp; Distribution            Fire Protection Equipment            Instrumentation            Potable Water System            Digital Data Acquisition System            Communications            Lighting System            Toxic Vapor Detection System            Sewage Disposal System</p> <ul style="list-style-type: none"> <li>● <u>MSS Parking Area</u></li> <li>● <u>Mobile Service Structure</u></li> </ul> <p>Approx 360' tower with 120' X 130' base.            Five work platforms similar to Saturn V MSS.            Tower elevator (passenger freight type).            150-ton capacity overhead crane for mating payload.            Base on railroad wheels.            Electrical equipment room.</p>					
				600		3,000	
				7,500		25,000	

404

E107

TABLE 7.6-XIV  
 LCLV GROUND SYSTEMS ESTIMATED AGE/LF  
 RDT&E AND PRODUCTION AND INSTALLATION COSTS (CONCEPT C<sub>2</sub>)

Function No.	Function Title & Gross Performance Requirements	Estimated New or Modified (M) AGE/LF Requirements	Estimated RDT&E Cost \$X10 <sup>3</sup>		Estimated Unit Production & Installation Cost \$X10 <sup>3</sup>		
			AGE	LF	OGE	LF	MGE
K 34.0 (Continued)		<ul style="list-style-type: none"> <li>● <u>MSS/MGE</u></li> </ul> Instrumentation system. TV system. Electrical & hydraulic power system. Communications system. Data transmission system. Environmental control system.	3,000				10,000
		<ul style="list-style-type: none"> <li>● <u>LCC/AGE (Modification)</u></li> </ul> Data acquisition and display system. Ground power supplies. Cable assemblies. Power distribution & control system. Instrumentation unit control, & monitor console. LVGS control & monitor console. PLPS control & monitor console. Control & monitor operators console. Standard test equipment. Time synchronization system.	1,500		5,000		500

E108

440



TABLE 7.6-XIV  
 LCLV GROUND SYSTEMS ESTIMATED AGE/LF  
 RDT&E AND PRODUCTION AND INSTALLATION COSTS (CONCEPT C<sub>2</sub>)

117

Function No.	Function Title & Gross Performance Requirements	Estimated New or Modified (M) AGE/LF Requirements	Estimated RDT&E Cost \$X10 <sup>3</sup>		Estimated Unit Production & Installation Cost \$X10 <sup>3</sup>		
			AGE	LF	OGE	LF	MGE
K 34.0 (Continued)		Air conditioning. Electrical power and distribution. Fire protection system. Compressed air system. Nitrogen pressurization system. Potable water system. Communication network. Lighting system. Lightning arrestors. Toxic vapor detection system. Sewage disposal.  <u>AGE</u> • <u>LF/AGE</u>  Data acquisition system. Instrumentation system. TV & timing system. Power generation and control system. Theodolite. Autocollimator. Communication system. Environmental control system. Cable assemblies.	4,500		10,000		5,000

TABLE 7.6-XIV  
 LCLV GROUND SYSTEMS ESTIMATED AGE/LF  
 RDT&E AND PRODUCTION AND INSTALLATION COSTS (CONCEPT C<sub>2</sub>)

Function No.	Function Title & Gross Performance Requirements	Estimated New or Modified (N) AGE/LF Requirements	Estimated RDT & E Cost \$X10 <sup>3</sup>		Estimated Unit Production & Installation Cost \$X10 <sup>3</sup>		
			AGE	LF	OGE	LF	MGE
K 34.0 (Continued)		• <u>LUT/MSS/LV Simulator</u>	15				50

412

417

TABLE 7.6-XIV  
LCLV GROUND SYSTEMS ESTIMATED AGE/LF  
RDT&E AND PRODUCTION AND INSTALLATION COSTS (CONCEPT C<sub>2</sub>)

Function No.	Function Title & Gross Performance Requirements	Estimated New or Modified (M) AGE/LF Requirements	Estimated RDT&E Cost \$X10 <sup>3</sup>		Estimated Unit Production & Installation Cost \$X10 <sup>3</sup>		
			AGE	LF	OGE	LF	MGE
K 33.0	<p><u>Perform LV/LUT/LCC Combined Systems Tests</u></p> <ul style="list-style-type: none"> <li>● Check all S&amp;A devices and safing pins.</li> <li>● Connect spacecraft simulator.</li> <li>● Connect start-up, targeting, and launch countdown and mission simulator ground equipment.</li> <li>● Re-check LV base support level and alignment.</li> <li>● Check theodolite alignment.</li> <li>● Initiate power turn-on sequence to AGE and IU.</li> <li>● Record telemetry data.</li> <li>● Perform LV pre-power on tests.</li> <li>● Conduct digital data acquisition system tests (DDAS).</li> <li>● Perform LV targeting equipment turn-on sequence.</li> <li>● Align inertial measurement unit (IMU).</li> <li>● Perform guidance and control (G&amp;C) tests.</li> <li>● Conduct targeting sequence tests.</li> </ul>	*LV simulator.	10				30*
		*Does not include cost of LV simulator which is function of PL.					

TABLE 7.6-XIV  
 LCLV GROUND SYSTEMS ESTIMATED AGE/LF  
 RDT&E AND PRODUCTION AND INSTALLATION COSTS (CONCEPT C<sub>2</sub>)

Function No.	Function Title & Gross Performance Requirements	Estimated New or Modified (M) AGE/LF Requirements	Estimated RDT&E Cost \$X10 <sup>3</sup>		Estimated Unit Production & Installation Cost \$X10 <sup>3</sup>		
			AGE	LF	OGE	LF	MGE
K 33.0 (Continued)	<ul style="list-style-type: none"> <li>● Perform RF and telemetry checks.</li> <li>● Initiate functional sequence and power transfer tests.</li> <li>● Position and prepare payload (PL) for mating to LV.</li> <li>● Connect M3S 150-ton hoist to PL support adapters.</li> <li>● Mechanically mate PL to IU.</li> <li>● Position LUT/PL umbilical support and service arms.</li> <li>● Emplace M3S work platforms.</li> <li>● Connect AGE umbilicals and service lines to PL.</li> <li>● Perform PL ground power-on tests as required.</li> <li>● Perform PL integration tests with LV simulator.</li> <li>● Perform LV overall tests (OAT).</li> <li>● Evaluate telemetry data and ground instrumentation recordings.</li> <li>● Turn off all power.</li> </ul>						

2112

717

TABLE 7.6-XIV  
 LCLV GROUND SYSTEMS ESTIMATED AGE/LF  
 RDT&E AND PRODUCTION AND INSTALLATION COSTS (CONCEPT C<sub>2</sub>)

415

Function No.	Function Title & Gross Performance Requirements	Estimated New or Modified (M) AGE/LF Requirements	Estimated RDT&E Cost \$X10 <sup>3</sup>		Estimated Unit Production & Installation Cost \$X10 <sup>3</sup>		
			AGE	LF	OGE	LF	MGE
K 32.0	<u>Mate Payload to Launch Vehicle</u> <ul style="list-style-type: none"> <li>● Electrically mate PL to LV.</li> <li>● Perform power-on and transfer tests.</li> <li>● Conduct emergency detection system (EDS) and abort system tests as required.</li> <li>● Prepare space vehicle, LUT and LCC for composite readiness tests (CRT)</li> </ul>	No LV AGE/LF new or modified requirements at this level of indenture other than those previously identified.					

TABLE 7.6-XIV  
 LCLV GROUND SYSTEMS ESTIMATED AGE/LF  
 RDT&E AND PRODUCTION AND INSTALLATION COSTS (CONCEPT C<sub>2</sub>)

Function No.	Function Title & Gross Performance Requirements	Estimated New or Modified (M) AGE/LF Requirements	Estimated RDT&E Cost \$X10 <sup>3</sup>		Estimated Unit Production & Installation Cost \$X10 <sup>3</sup>		
			AGE	LF	OGE	LF	MGE
K 5.0	<p><u>Perform Space Vehicle Start-up and Integrated System Checkout</u></p> <ul style="list-style-type: none"> <li>● Verify all S&amp;A devices and safing pins are in "safe" condition.</li> <li>● Connect start-up equipment and launch countdown and flight simulator.</li> <li>● Check alignment of SV and collimator/theodolite.</li> <li>● Verify flight azimuth setting of theodolite.</li> <li>● Initiate power and IU turn-on sequence.</li> <li>● Record telemetry data.</li> <li>● Perform guidance alignment sequence.</li> <li>● Transfer control from launch pad to launch control center.</li> <li>● Verify back-up command, control and communications links to SV.</li> <li>● Initiate SV/launch complex functional and system interface verification checks.</li> <li>● Evaluate test data and verify "GO".</li> </ul>	No LV new or modified AGE/LF have been identified at this level of indenture other than those previously specified.					

E114

917

TABLE 7.6-XIV  
 LCLV GROUND SYSTEMS ESTIMATED AGE/LF  
 RDT&E AND PRODUCTION AND INSTALLATION COSTS (CONCEPT C<sub>2</sub>)

LH

Function No.	Function Title & Gross Performance Requirements	Estimated New or Modified (M) AGE/LF Requirements	Estimated RDT&E Cost \$X10 <sup>3</sup>		Estimated Unit Production & Installation Cost \$X10 <sup>3</sup>		
			AGE	LF	OGE	LF	MGE
K 5.0 (Continued)	<ul style="list-style-type: none"> <li>● Prepare for Combined Readiness Test (CRT)</li> <li>*● Conduct simulated automatic launch countdown and flight sequence test (simulated umbilical ejection, holddown release, liftoff and flight mission).</li> <li>● Evaluate telemetry data and ground instrumentation recordings.</li> <li>● Verify all systems "GO".</li> <li>● Turn off power and remove simulators.</li> <li>● Charge SV batteries as required.</li> <li>● Reconfigure space vehicle for flight.</li> <li>● Connect ordnance.</li> <li>● Prepare launch facilities and SV for propellant loading.</li> </ul> <p>*This test involves integrated system compatibility tests with EIR and MSC.</p>						

5115

TABLE 7.6-XIV  
 LCLV GROUND SYSTEMS ESTIMATED AGE/LF  
 RDT&E AND PRODUCTION AND INSTALLATION COSTS (CONCEPT C<sub>2</sub>)

Function No.	Function Title & Gross Performance Requirements	Estimated New or Modified (M) AGE/LF Requirements	Estimated RDT&E Cost \$X10 <sup>3</sup>		Estimated Unit Production & Installation Cost \$X10 <sup>3</sup>		
			AGE	LF	OGE	LF	MGE
K 4.0	<u>Load Propellants and Pressurize Missile Stages</u> <ul style="list-style-type: none"> <li>● Perform N<sub>2</sub> leak tests on propellant transfer system and LV propellant system.</li> <li>● Purge and blanket fuel system with N<sub>2</sub>.</li> <li>● Verify weather conditions and vapor disposal system is operating.</li> <li>● Initiate fuel loading sequence.</li> <li>● Load Stages 1, 2 and 3 fuel tanks to prescribed mass of propellant using computer program.</li> <li>● Pressurize Stages 1, 2 and 3 fuel tanks with N<sub>2</sub>.</li> <li>● Drain and purge fuel transfer lines.</li> <li>● Perform fuel leak tests.</li> <li>● Purge and blanket oxidizer system with N<sub>2</sub>.</li> <li>● Initiate oxidizer loading sequence.</li> <li>● Load Stages 1, 2 and 3 oxidizer tanks to prescribed mass of propellant using computer program.</li> </ul>	Load cell with accuracy better than 0.5%. (This approach eliminates need for tank calibration and propellant conditioning equipment.) Leak detection & purge equipment. Computer load programs. Other LV new or modified AGE and LF are as previously identified.	40		100		
			40				150

GTTT

817



TABLE 7.6-XIV  
 LCLV GROUND SYSTEMS ESTIMATED AGE/LF  
 RDT&E AND PRODUCTION AND INSTALLATION COSTS (CONCEPT C<sub>2</sub>)

Function No.	Function Title & Gross Performance Requirements	Estimated New or Modified (M) AGE/LF Requirements	Estimated RDT&E Cost \$X10 <sup>3</sup>		Estimated Unit Production & Installation Cost \$X10 <sup>3</sup>		
			AGE	LF	OGE	LF	MGE
K 4.0 (Continued)	<ul style="list-style-type: none"> <li>● Pressurize Stages 1, 2 and 3 oxidizer tanks with N<sub>2</sub>.</li> <li>● Drain and purge oxidizer transfer lines.</li> <li>● Perform propellant leak tests.</li> <li>● Monitor LV propellant tank pressures.</li> </ul>						

b17

TABLE 7.6-XIV  
 LCLV GROUND SYSTEMS ESTIMATED AGE/LF  
 RDT&E AND PRODUCTION AND INSTALLATION COSTS (CONCEPT C<sub>2</sub>)

Function No.	Function Title & Gross Performance Requirements	Estimated New or Modified (M) AGE/LF Requirements	Estimated RDT&E Cost \$X10 <sup>3</sup>		Estimated Unit Production & Installation Cost \$X10 <sup>3</sup>		
			AGE	LF	OGE	LF	MGE
K 3.0	<u>Achieve Launch Readiness</u> <ul style="list-style-type: none"> <li>● Monitor propellant pressure.</li> <li>● Install payload provisions.</li> <li>● Wheel launcher flame deflector into pad trench beneath the SV centerline.</li> <li>● Secure flame deflector.</li> <li>● Verify SV and guidance alignment.</li> <li>● Monitor and, if required, charge SV batteries.</li> <li>● Disconnect and retract MSS work platforms and servicing lines from SV.</li> <li>● Remove unnecessary MGE.</li> <li>● Verify ordnance safe.</li> <li>● Remove safing pins from SV and umbilicals.</li> <li>● Install S&amp;A access doors.</li> </ul>	No LV new or modified AGE/LF have been identified at this level of indenture other than that previously specified.					

E118

420

TABLE 7.6-XIV  
 LCLV GROUND SYSTEMS ESTIMATED AGE/LF  
 RDT&E AND PRODUCTION AND INSTALLATION COSTS (CONCEPT C<sub>2</sub>)

Function No.	Function Title & Gross Performance Requirements	Estimated New or Modified (M) AGE/LF Requirements	Estimated RDT&E Cost \$X10 <sup>3</sup>		Estimated Unit Production & Installation Cost \$X10 <sup>3</sup>		
			AGE	LF	OGE	LF	MGE
K 2.0	<p><u>Perform Launch Operations</u></p> <p>A. <u>Launch Precount</u></p> <ul style="list-style-type: none"> <li>● Confirm range clearances with Range Operations and integrated mission control.</li> <li>● Alert range instrumentation systems of countdown start.</li> <li>● Confirm range support equipment ready.</li> <li>● Confirm reception of visual monitor of launch area.</li> <li>● Confirm capability of aural warning system.</li> <li>● Perform checkout of missile lift-off circuitry to Range Operations.</li> <li>● Perform Range Safety open loop checkout on ground power.</li> <li>● Perform command destruct open loop checkout on ground power.</li> <li>● Perform instrumentation open loop checkout.</li> <li>● Receive launch "GO" from Range Operations and integrated mission control.</li> </ul>	No LV new or modified AGE/LF have been identified at this level of indenture other than that previously identified.					

194

TABLE 7.6-XIV  
LCLV GROUND SYSTEMS ESTIMATED AGE/LF  
RDT&E AND PRODUCTION AND INSTALLATION COSTS (CONCEPT C<sub>2</sub>)

Function No.	Function Title & Gross Performance Requirements	Estimated New or Modified (M) AGE/LF Requirements	Estimated RDT&E Cost \$X10 <sup>3</sup>		Estimated Unit Production & Installation Cost \$X10 <sup>3</sup>		
			AGE	LF	OGE	LF	MGE
K 2.0 (Continued)	<ul style="list-style-type: none"> <li>● Transfer IU to airborne power.</li> <li>● Perform open loop checkout on airborne power.</li> <li>● Prepare for terminal countdown.</li> </ul> <p>B. <u>Terminal Countdown</u></p> <ul style="list-style-type: none"> <li>● Remove MSS by locomotives from launch pad area.</li> <li>● Verify launch readiness of S/V and launch control and support equipment.</li> <li>● Receive and verify launch command.</li> <li>● Initiate launch sequence.</li> <li>● Turn-on ground power to SV.</li> <li>● Arm launch circuits.</li> <li>● Start launch sequence.</li> <li>● Perform guidance and control discretes test.</li> <li>● Confirm flight program entered.</li> <li>● Arm SV ordnance devices.</li> <li>● Activate launch vehicle batteries.</li> </ul>						

5120

482

TABLE 7.6-XI  
 LCLV GROUND SYSTEMS ESTIMATED AGE/LF  
 RDT&E AND PRODUCTION AND INSTALLATION COSTS (CONCEPT C<sub>2</sub>)

423

Function No.	Function Title & Gross Performance Requirements	Estimated New or Modified (M) AGE/LF Requirements	Estimated RDT&E Cost \$X10 <sup>3</sup>		Estimated Unit Production & Installation Cost \$X10 <sup>3</sup>		
			AGE	LF	OGE	LF	MGE
K 2.0 (Continued)	<ul style="list-style-type: none"> <li>● Open stage prevalues.</li> <li>● Transfer ground to airborne power.</li> <li>● Begin flight computation.</li> <li>● Confirm all systems status "GO".</li> <li>● Disconnect critical leads.</li> <li>● Release umbilicals.</li> <li>● Retract umbilicals.</li> <li>● Ignite first stage.</li> <li>● Confirm reception of SV lift-off signal at LCC, Range Operations and integrated mission control.</li> </ul>						

\*

## REFERENCES

1. TRW "Low Cost Launch Vehicle Study," Summary Report by J. B. Kendrick et al, TRW Systems Group Report No. 11851-6009-R0-00, 10 April 1969.
2. Chrysler Corp. "National Space Booster Study," Part One, Cost Analysis of Current Launch Systems," Saturn Systems Presentation, AE-PB-68-1, Chrysler Corporation Space Division, 3 October 1968.
3. NAR "Intermediate Payload Vehicle Comparison," North American Rockwell Corp., Space Division Report No. SD-68-325, 24 April 1968.
4. Aerospace "Proposed Minimum Cost Space Launch Program," (U), by A. Schnitt and Col. F. W. Kniss, Aerospace Corp. Report No. TOR-0158(3415-15)-1, 1 July 1968 (C).
5. Aerospace "Minimum Cost Design-Standard Launch Vehicle," Briefing Brochure, Aerospace Corp., 1968 (C).
6. Aerospace Corp. "Fabrication and Acceptance Test Requirements for the Structure of the Space Launch Vehicle (SLV)," February 1969.
7. MSFC "Synopsis of the PFLV Effort: Memorandum Report No. R-P & VE-AV-68-150, 8 November 1968.
8. Aerospace Corp. "Parametric Weight Scaling Relationships for Rocket Engine Turbopumps." by F. G. Ghahremani, Aerospace Corp. Report No. TOR-469(5560-30)-2, 26 July 1965 (C).
9. McDonnell-Douglas "Low Cost Pressure Fed Storable Propellant First Stage Booster," by G. D. Budris, Memorandum No. A 3-830-GDB-1, 12 January 1968.
10. TRW "Advancement of Injector and Thrust Chamber Technology," by G. A. Voorhees, Jr, TRW Systems Group Report No. AFRPL-TR-68-46, Contract No. AF 04(611)-11382, December 1967. (C)
11. JPL "The Pumping of Liquid Rocket Propellant by Injecting Fuel into Oxidizer Tank," by J. B. Kendrick and R. E. Imus, Jet Propulsion Laboratory Report No. 4-19, 14 May 1948.
12. Martin Co. "Development and Demonstration of Main Tank Injection (MTI) Pressurization System," Report No. RTD-TDR-63-1163, The Martin Co., Denver Division, December 1963.
13. Martin Co. "Feasibility Study for the Application of Main Tank Injection Pressurization to Sled Test Vehicles," by R. J. Kenney, D. A. Tobias, M. Smith and P. E. Bingham, The Martin Co., Denver Division, March 1965.
14. TRW "Comparison of Low Cost LITVC Systems," by R. M. Moy, D. F. Reeves and L. B. Dumont, TRW Systems Group Report No. 99900-6572-R000, 5 April 1968.
15. "Apollo/Saturn V Facility Description," Volume I of IV Volumes, K-V-12, KSC Industrial Area and Remote Facilities Description, NASA, John F. Kennedy Space Center, 1 October 1966.

- 425
16. James M. Cunningham "Design of the Saturn V Mobile Launcher," Reynolds, Smith and Hills, Jacksonville, Florida, 17 November 1965.
  17. "Apollo/Saturn V Facility Description," Volume II of IV Volumes, K-V-012, Launch Complex 39 Facility Description, NASA, John F. Kennedy Space Center, 1 October 1966.
  18. "Apollo/Saturn V Facility Description," Volume III of IV Volumes, K-V-012, KSC Provided Saturn V GSE System Description, NASA, John F. Kennedy Space Center, 1 October 1966.
  19. "KSC Apollo/Saturn Top Specification Tree," K-AM-030/1, Revision 3, 8 November 1968.
  20. "Design Data Manual for LC-39 Mobile Service Structure (Arming Tower), Launch Complex 39, John F. Kennedy Space Center, NASA, Merritt Island, Florida," Rust Engineering Company, Birmingham, Alabama, 20 January 1965.
  21. "Apollo Systems Description," Volume III, Office of Manned Space Flight Technical Memorandum X-882, NASA Launch Operations Center, 30 September 1963.
  22. TRW "Standardized Space Guidance System - Phase 1A - Advanced Development Program 698-CG," Air Force Contract No. AF04(695)527, May 1964 (S).
  23. TRW "Low Cost Guidance System for Cape Kennedy," Proposal No. 6408.000 submitted to NASA/Hq, 26 January 1966 (U).
  24. SAMSO "Improved Launch Vehicles for Spacecraft"-Near Term LV Concepts, Volume 2, Technical Report No. SSD-TR-67-18, April 1967.
  25. LMSC "Launch Vehicle Component Cost Study," Volume II Lockheed Missiles and Space Co, Technical Report No. LMSC-895 429, 30 June 1965.
  26. SRI "Comparison of Recurring and System Acquisition Cost for Large Pressure Fed Liquid and Solid Propellant Rocket Motor Booster," Final Presentation Report, Stanford Research Institute, 10 October 1968.
  27. Martin Co. "Design for Minimum Cost Progress Report," The Martin Co., Denver Division, Report No. M-66-49, December 1966.
  28. MSFC "PFLV Presentation Information," Memorandum Report No. R-P & VE-AV-68-110, 2 August 1968.
  29. "T-1 Constructional Alloy Steels," U. S. Manual ADUSS 01-1205, Second Edition, 1966.
  30. "Development of a High Temperature Alloy Plate Steel with a Minimum Yield Strength of 140 ksi," S. J. Manganello, D. S. Dabkowski, L. F. Porter and J. H. Gross, Welding Journal 43(11) Research Supplement 514-S to 520-S, 1964.
  31. "Weldability of a High Toughness Alloy Plate Steel with a Minimum Yield Strength of 140 ksi," A. M. Rathbone, L. P. Connor and H. H. Gross, Welding Journal 43(12) Research Supplement 551-S to 563-S, 1964.

32. "Development of Procedures for Welding HY-130(T) Steel," L. P. Connor A. M. Rathbone and J. H. Gross, Welding Journal 46(7) Research Supplement 309-S to 321-S, 1967.
33. "A Study of Weldments and Pressure Vessels Made of HY-150 Steel Plates," C. F. Tiffany, J. N. Masters and R. E. Regan, NASA CR-72155, January 1967.
34. "Fatigue and Burst Analysis of HY-140 (T) Steel Pressure Vessels," J. M. Barron and S. J. Rolfe, ASME Paper 68-PVP-5, Presented at ASME Petroleum Mech. Engr. Conf., September 1968.
35. "High Strength Steel 18N Maraging," A. M. Hall, R. C. Simon and D. P. Moon, DMIC Processes and Properties Handbook, 1 September 1968.
36. "Structural Optimization of Axially Compressed, Ring-Stringer Stiffened Cylinders," A. B. Burns and B. O. Almroth, Journal of Spacecraft, Volume 3, No. 1, pp. 19-25, January 1966.
37. "The General Instability of Ring-Stiffened Corrugated Cylinders Under Axial Compression," J. W. Dickson and R. H. Broliar, NASA TN D-3089, January 1966.
38. "Bending Tests of Large-Diameter Ring-Stiffened Corrugated Cylinder," J. P. Peterson and J. F. Anderson, NASA TN-D-3336, March 1966.
39. "Bending Tests of Two Large-Diameter Corrugated Cylinders with Eccentric Ring Stiffness," J. K. Anderson, NASA TN D-3702, November 1966.
40. "Structural Efficiency of Ring-Stiffened Corrugated Cylinders in Axial Compression," J. P. Peterson, NASA TN D-4073, August 1967.
41. "Weight-Strength Studies of Structures Representative of Fuselage Construction," J. P. Peterson, NACA TW D-4114, October 1957.
42. "Minimum Weight Potentials for Stiffened Plates and Shells," R. F. Crawford and A. B. Burns, AIAA Journal, Volume 1, No. 4, April 1963.
43. "Terrestrial Environment (Climatic) Criteria Guidelines for Use in Space Vehicle Development, 1966 Revision," G. E. Daniels, J. R. Scoggins and O. E. Smith, NASA TMX-53328, 1 May 1968.
44. "Flight Performance Handbook for Powered Flight Operations," J. F. White, March 1962.



## BIBLIOGRAPHY

427

1. TRW "Launch Vehicle Size and Cost Analysis"  
Phase I Summary, TRW Report No. 9862-2-41, 15 June 1961 (C).  
Phase II Summary (Part I) Recovery, TRW Report No. 8981-0005-RU-000,  
17 November 1961 (U).  
Phase II Summary (Part II) Nuclear Upper Stages, TRW Report No. 8991-  
0006-RC-000, 17 November 1961 (C).  
Phase III (Part I) Reliability, TRW Report No. 8659-6054-RS-000,  
November 1962 (S).  
Phase III (Part III) Cost Analysis, Volume I, Cost Correlation Analysis  
Liquid Propellant Launch Vehicles, TRW Report No. 8659-6055-RU-000,  
1 December 1962 (U).  
Phase III (Part II) Cost Analysis, Volume II, Cost and System Evaluation,  
TRW Report No. 8659-6056-RU-000, 15 December 1962 (U).
2. TRW "Analysis of Medium Class Vehicles," by J. B. Kendrick et al, TRW Report  
No. 8624-0003-RC-000, February 1962 (C).
3. TRW "Launch Vehicle Technology Study," by J. B. Kendrick, et al, TRW Report  
No. 8496-6008-RC-000, 20 March 1964. (C)
4. "Saturn Apollo Applications Program Definition for KSC," Final Report  
Volumes 1 through 5, Program Definition Baselines, NAS 10-3678, TRW Systems,  
January 1967.
5. "Aviation Week and Space Technology," McGraw-Hill Publication, 20 June 1966.
6. "Apollo - A Program Review," SP-257, Society of Automotive Engineers, Inc.,  
October 1964.
7. "Technical Facilities Resume," John F. Kennedy Space Center, Attachment A,  
16 December 1966.
8. "Apollo/Saturn Launch Complex, A Challenge in Design and Construction," NASA.
9. "MSFC Automation Plan," NASA/MSFC, Revision, 1 June 1964.
10. "Saturn Ground Computer System," RCA Aerospace Systems Division, Defense  
Electronic Products, July 1965.
11. "Apollo Applications Program Prelaunch Operations Analysis," Final Report,  
First Summary Report, NAS10-4468, TRW Systems, June 1967.
12. "A Study of Large Sea - Launch Space Vehicle," Design and Cost, Volumes I and II,  
NAS 8-2599, Space Technology Laboratories, Inc./Aerojet General Corporation,  
January 1969.
13. "Range Facilities and Measurement Handbook," Volumes I and II, Document  
8172-001A, General Electric Re-entry Systems Department, Revised January 1965.
14. "Precision S-Band Tracking System Feasibility Study," Final Report, Volumes  
I and II, NAS 10-3158, TRW Systems, 1 March 1966.
15. "Apollo Systems Description (Launch Complex 34, 37 and 39)," Volume III,  
NASA Technical Memorandum X-882, First Issue 1963.
16. "Summary Report, Evaluation of Large Launch Vehicles," Space Technology  
Laboratories, Inc., Report No. 8659-6060-RU-000, April 1963.

17. "Titan III Family Review," Martin Marietta Corporation, January 1968.
18. "Titan III Payload User's Guide," Martin Marietta Corporation," January 1968.
19. "The Handling and Storage of Liquid Propellants," AFM 160-39, Department of the Air Force, 1 April 1964.
20. "Storable Liquid Propellants Nitrogen Tetroxide/Aerozine 50," Report No. LRP198, Second Edition, Aerojet General Corporation, June 1962.
21. "Titan II Storable Propellant Handbook," AFBSD-TR-62-2, Bell Aerosystems Company, March 1962.
22. "Cost of Launch Facilities for Advanced Study Purposes," NASA Advanced Program Office, PFR-2, 14 April 1966.
23. "RCA 110A Control Computer and Display System," RCA, no date.
24. "Multiple Launch Requirements Analysis, NAS 10-2947, TRW Systems, 17 January 1966.