

N 70 12210

NASA CR 107030

Semiannual Report VIII

February 1969 - September 1969

NASA Contract No. NGR-36-003-079

**CASE FILE
COPY**

Solid State Electronics Laboratory

Engineering Design Center

Case Western Reserve University

by

W. H. Ko

E. T. Yon

D. Ramseth

S. Mabrouk

I. Abstract

The major purpose of this project is to design and fabricate miniaturized, portable external heart rate and ECG monitoring systems for prolonged space missions.

The heart rate system has been designed and is being evaluated in breadboard form. All electrical specifications for the system have been met or exceeded in the breadboard model. The amplifier, oscillator and power amplifier of the rate monitoring system are common to the ECG system, therefore, the only major subsystem remaining to be designed and constructed for the ECG monitoring system is the subcarrier oscillator-modulator.

II. Heart Rate System Design

The system proposed is shown in Figure 1. The overall system specifications are as follows.

- A. Input impedance $> 10^7 \Omega$
- B. Microvolt sensitivity
- C. Transmission distance: 10 feet reliability
(RF field strength $> 20 \mu v$)
- D. Volume $< 1/4 \text{ inch}^3$ (not including battery) with
maximum dimension $\leq 2''$
- E. Power consumption less than 75μ watt
- F. Weight - not including battery - 10gms.

At this time, a breadboard system has been designed and is being evaluated. The applicable system specifications have been met or exceeded in this breadboard model. The test results obtained are as follows:

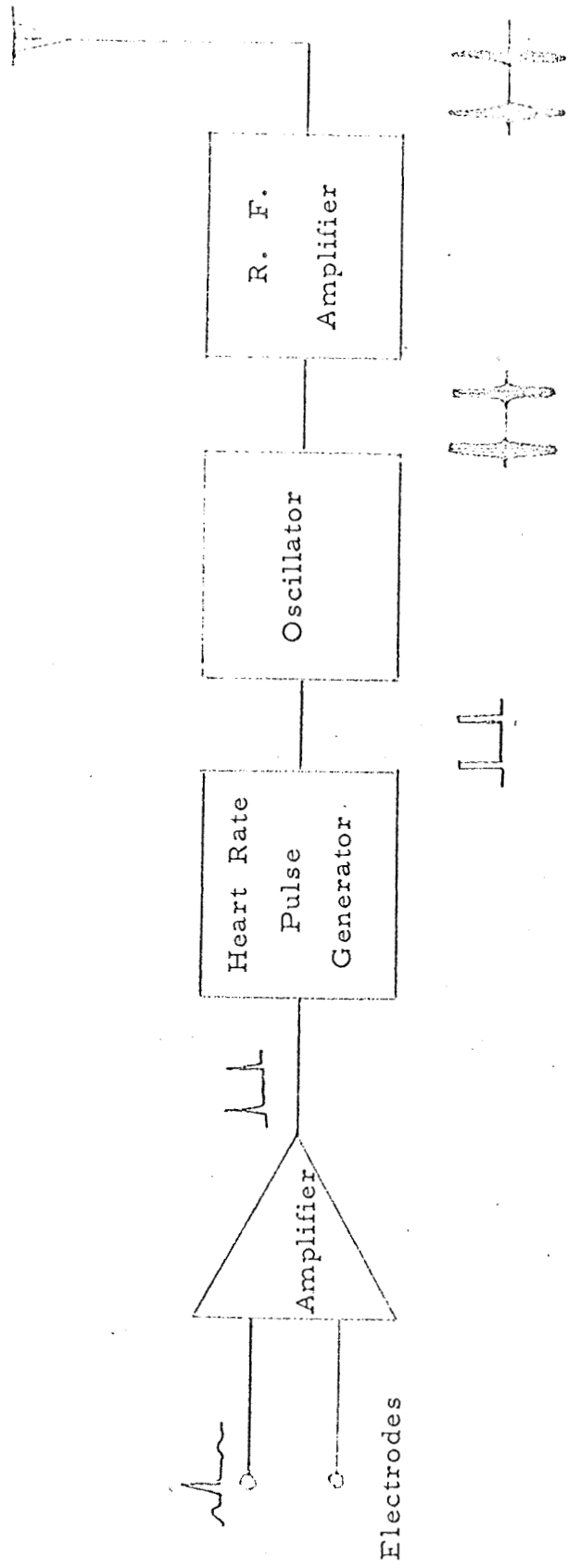

Figure 1. Proposed Heart Rate Monitoring System

- A. Input impedance $2 \times 10^7 \Omega$ to $10^9 \Omega$
- B. Sensitivity $100 \mu v$ - RMS
- C. Transmission distance > 10 feet - (at 10 feet, the field strength is $35 - 50 \mu v$)
- D. Power 40μ watts from a 2.4 - 2.8 volt source.

It is expected that the rest of the system specifications (volume and weight) will be satisfied by the finished prototype.

Detailed circuit and design information will be given in the following sections.

III. Input Amplifier

The input amplifier consists of two differential amplifier stages followed by three single stage amplifiers. The amplifier circuit diagram is shown in Figure 2. Common mode negative feedback is applied between the two differential stages to stabilize the D.C. operating point. The input stage uses junction Field Effect Transistors with low $1/f$ noise characteristics for high input impedance. The operating current level for each transistor is $0.9 \mu A$. The amplifier characteristics are as follows:

Voltage supply	2.4 - 2.8 volts
D.C. current	$6 \mu A$
Voltage gain	5000 (unloaded)
Bandwidth	90Hz
Noise (referred to input)	$10 \mu V$. RMS
Output voltage	2v peak-to-peak maximum

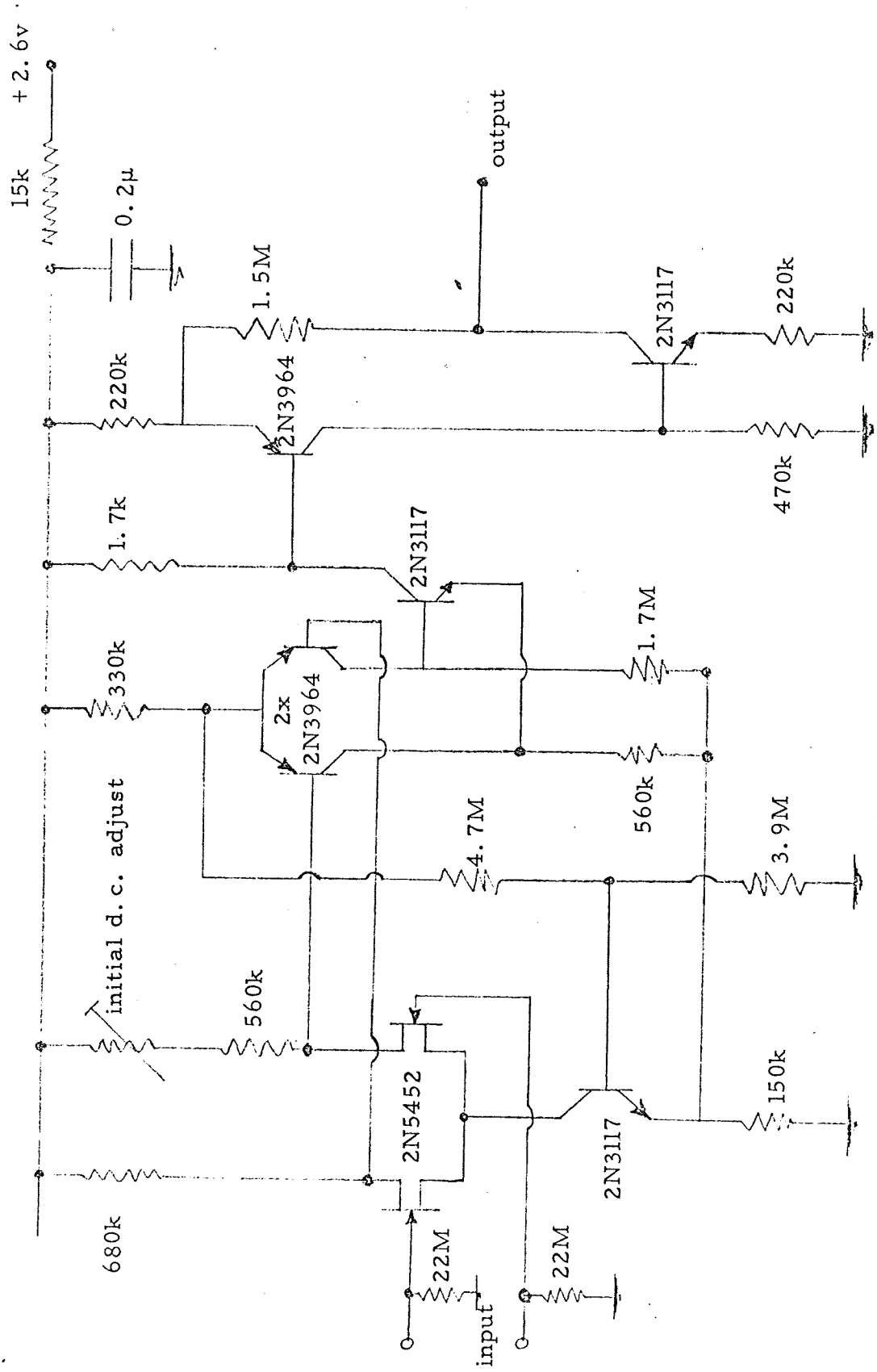

Fig #2. Amplifier

Operating temperature

25 - 50°C

In its present form, the amplifier requires one initial balance adjustment and exhibits some stability problems with variation in supply voltage. This unit is presently being modified using frequency lag compensation techniques to overcome stability problems.

IV. Oscillator and Power Amplifier

The oscillator and power amplifier are shown in Figure 3. The oscillator used is a standard Colpitts oscillator tuned to 67MHz. Attempts will be made to use a crystal controlled oscillator for the prototype unit. The prototype model frequency will depend upon the availability of miniaturized crystals, but will probably be 120MHz.

The power amplifier is a class C tuned doubler. R-C coupling with the oscillator is used in an effort to minimize the final unit volume. The output tank is tuned to 134MHz but will be raised to 240MHz for the prototype. The total power required for the oscillator-amplifier is 10 milliwatts for continuous operation. The unit is operated in pulse mode by the application of a positive triggering potential to the base of the 2N3663 in the oscillator section. For the pulse mode of operation used in this unit, the average power was decreased to 15 microwatts. At this level the field strength, measured at a dipole placed 10 feet from the transmitter, was 35 - 50 μ volts.

V. Pulse Modulator

The modulator used in this system is a monostable multivibrator

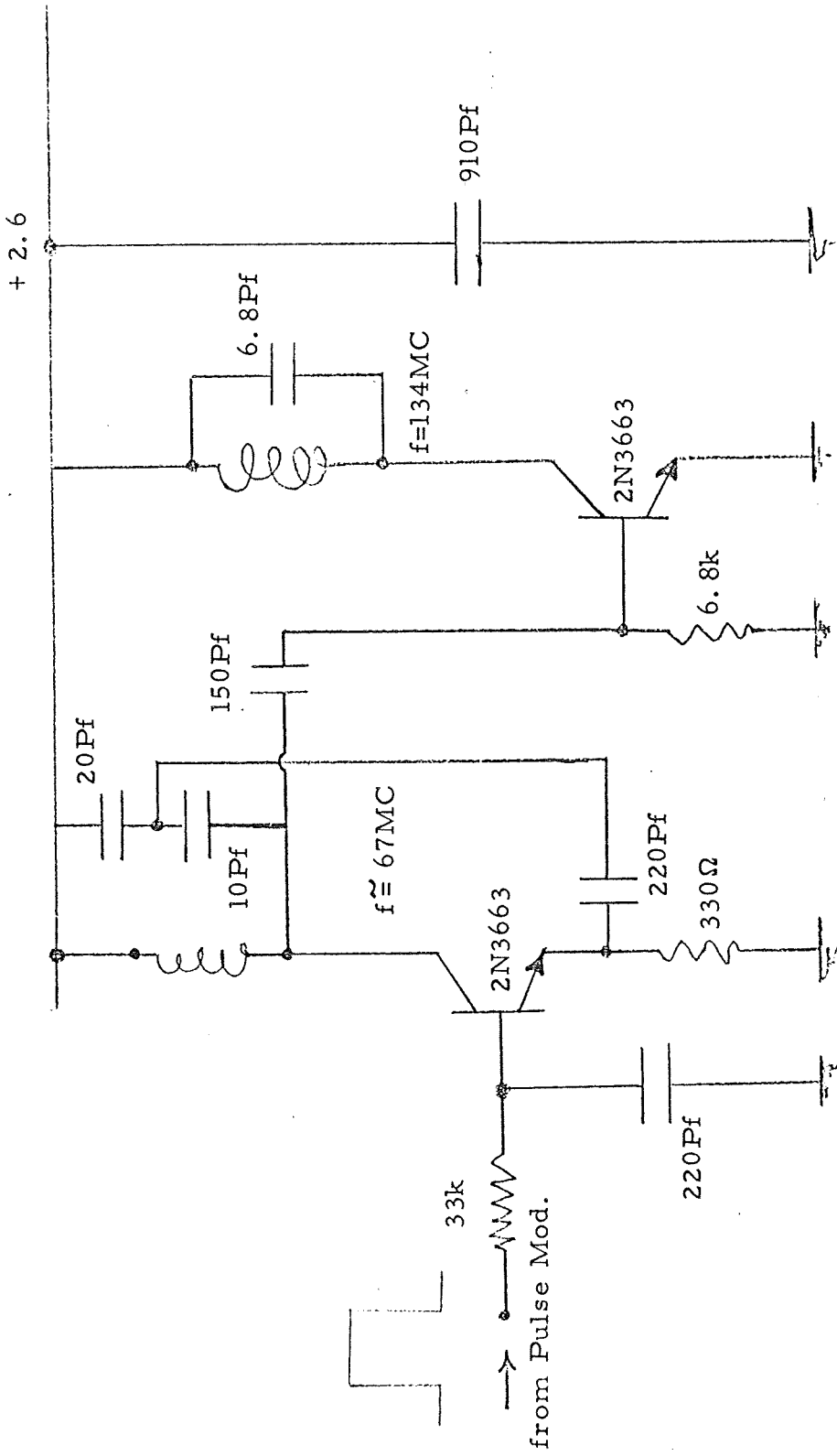

Fig. #3. Oscillator and Amp.

using complementary devices. Triggering of the multivibrator is accomplished by the 2N3117 transistor. Initially all transistors are cut off and stay off until a positive pulse is applied to the base of the 2N3117. When a sufficient pulse is applied, this transistor will conduct for the time the pulse is present. The collector current produces a sufficient drop across the $68K\Omega$ resistor to force the 2N3638 into conduction, which causes the 2N2923 to conduct. At some time, set by the collector-base coupling circuit time constant, the 2N2923 will cease to conduct, allowing the 2N3638 to stop conduction. The pulse width at the output of the multivibrator has been set to be 1.25 milliseconds. This was chosen since it is short enough, considering the normal heart rate, to allow small duty cycle operation yet long enough to allow the oscillator and power amplifier to settle to a steady state operation after being switched on.

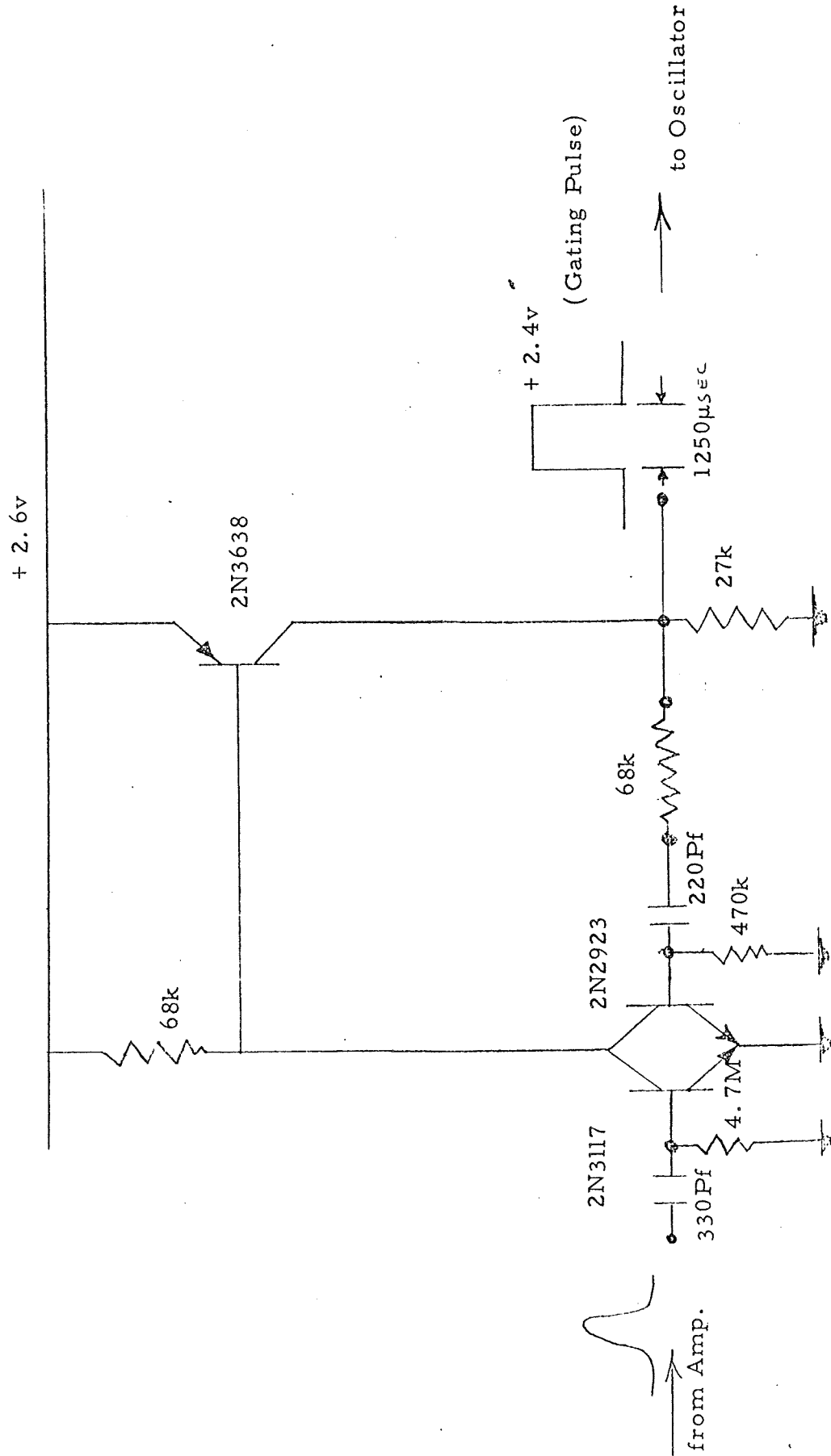

Fig. #4. Pulse Modulator