

General Disclaimer

One or more of the Following Statements may affect this Document

- This document has been reproduced from the best copy furnished by the organizational source. It is being released in the interest of making available as much information as possible.
- This document may contain data, which exceeds the sheet parameters. It was furnished in this condition by the organizational source and is the best copy available.
- This document may contain tone-on-tone or color graphs, charts and/or pictures, which have been reproduced in black and white.
- This document is paginated as submitted by the original source.
- Portions of this document are not fully legible due to the historical nature of some of the material. However, it is the best reproduction available from the original submission.

CR 86279

FOUR CERT VIEWS OF PLANNING R & D PROJECTS*

by

A. Alan B. Pritsker and Ronald A. Enlow
Industrial Engineering Faculty
Arizona State University
Tempe, Arizona

Presented at the
Thirty-Fourth National Meeting of the
Operations Research Society of America

FACILITY FORM 602

N70-15495 (ACCESSION NUMBER)	(THRU)
27 (PAGES)	1 (CODE)
CR-86279 (NASA CR OR TMX OR AD NUMBER)	08 (CATEGORY)

*Sponsored by
Electronics Research Center
National Aeronautics and Space Administration
NASA Contract No. NASA-12-2035

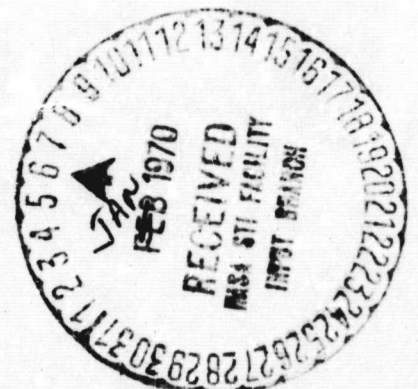

INTRODUCTION

In preparing this talk we ran into three fundamental difficulties: (1) you probably don't know what GERT is; (2) we probably don't agree on a definition of "planning"; and (3) who would dare say what R & D projects are?

The first difficulty we will meet head-on by explaining GERT, and the other two difficulties we will try and maneuver around by presenting examples of the use of GERT for studying the R & D planning process. Basically, we will look at the R & D planning process from four viewpoints: (1) the scientific method or philosophical; (2) idea generation or psychological; (3) administrative control or business orientation; and (4) engineering or technological.

BACKGROUND ON GERT

GRAPHICAL EVALUATION AND REVIEW TECHNIQUE

GERT builds on the work of Eisner (7), who proposed a decision box type of node for PERT networks; Freeman (11), who introduced probabilistic concepts within PERT analysis; and Elmaghraby (8), who defined multi-parameter branches and logical nodes and presented an algebra for dealing with networks of this type. Chart I illustrates the GERT approach to problem solving. Step 1, the conversion of a project, system, or problem into network form, usually involves a hierarchy of networks. The researcher starts with a very simple description in network form of the project.

The network is a graphical model of the project where each possible activity of the project is represented by a branch of the network. Each branch of the network is then expanded to include characteristics which are felt to be important by the researcher. Branches are continually analyzed and broken down into smaller components until the researcher arrives

at a level of detail sufficient to meet his objectives and for performing Step 2 of the GERT procedure which involves collection of the data to describe the branches of the network. Precedence and functional relationships are provided by inserting nodes between the branches. A branch of a network has associated with it a probability that it will be realized and variables which describe the activity in terms of time, cost, profit, etc. The realization of a branch means that the activity would be performed during the actual conduction of the project. Thus all activities included in a network do not have to be performed. This is a major departure from CPM and PERT-type networks and it is this feature that enables one to model the R & D process by inserting alternatives directly in the network structure. When an activity or branch is realized, the characteristics associated with that activity such as time and cost, are then included in the total time and cost associated with the complete network. For a complex network there will be an equivalent function from each source (start) node to each sink (terminal) node.

Steps 3, 4, and 5 deal with the analysis problem once the network has been developed and data collected to describe the branches of the network. In the R & D area, the collection of the data may be the biggest stumbling block to analysis. In this paper, we are concerned mainly with Step 1, which will help us to define what we mean when we talk about research and development projects and planning for such projects.

Chart II presents the node characteristics and symbols for the networks used within the GERT procedure. As can be seen from the chart, each node has an input side and an output side. The input side specifies the logical relationship between the branches incident to the node, while the output side specifies the method for selecting the branches which will be taken when the node is realized. For comparison, the nodes in a PERT network are all of the AND-DETERMINISTIC type. Some clarification as to the difference between the EXCLUSIVE-OR and the INCLUSIVE-OR nodes seems appropriate. The INCLUSIVE-OR node is essentially a minimum operator and the first branch to reach the node causes the node to be realized (the realization of a node causes the branches emanating from a node to be released according to the

output function of the node). If an INCLUSIVE-OR node has been realized, and another branch is realized which is incident to the node, no further action is required. In contrast, the EXCLUSIVE-OR node by definition prohibits two branches on forward paths of the network and incident to the node from being realized. However, feedback branches can be incident to the EXCLUSIVE-OR node and they will cause this node to be realized again. In mathematical terminology, the EXCLUSIVE-OR, PROBABILISTIC node combination performs as a linear operator.

Networks containing only the EXCLUSIVE-OR, PROBABILISTIC node can be analyzed analytically (26,29) and a digital computer program is available for performing the calculations (17,18). In addition in many cases the other node types can be represented in terms of the EXCLUSIVE-OR, PROBABILISTIC node (26).

NETWORK MODEL OF PLANNING R & D PROJECTS

Scientific Method Viewpoint

The GERT approach to planning R & D projects from the scientific method or philosophical viewpoint has been studied by Enlow and Pritsker*. Only the network description and basic elements of the R & D process will be given here. Basically the R & D process is viewed as consisting of the following five milestones: (1) completion of problem definition; (2) completion of research activity; (3) acceptance of a proposed solution; (4) completion of a prototype; and (5) implementation of the solution.

Chart III presents a general network model of the activities involved in achieving the first three milestones. Since a hierarchical network development procedure will be used, the activities are defined in broad terms. The network of Chart III illustrates three attempts at obtaining a solution for a given definition of a problem. If all three solutions are

* A companion paper to this speech is in preparation.

unacceptable then either a re-definition of the problem will be made or a new need will be explored and the researcher will essentially give up on the previous problem. Note that the sink node in Chart III is an EXCLUSIVE-OR node since it is only possible for one of the three branches incident to the node to be realized.

Chart IV presents a GERT representation of the activities involved in problem definition. On the chart is shown a creative thought process following the establishment of the need. As shown, there are four separate efforts involved in attempting to define the problem. On the output side of the node following creative thought, a probabilistic node is used to indicate that the problem is either defined or not defined based on the creative thought efforts. If any one of the efforts results in a problem definition then the node "problem definition proposed" will be reached. Thus an INCLUSIVE-OR node is required at that point. Only if all four of the efforts do not result in a problem definition, will the node "no definition formulated" be realized. Hence, an AND node is required.

The point A on Chart IV represents a possible regeneration point of the problem definition process. If the characteristics of the activities involved in problem definition do not change based on previous attempts at problem definition, then a return to the original start node can be made, and the network need not be repeated as shown on the bottom half of Chart IV. Since learning occurs in the R & D process it is more reasonable to indicate a repeat with new parameters of the activities involved in problem definition. This lack of regeneration points in the R & D process, we believe, has hindered many analysis attempts. On Chart V is shown one possible representation of the research activity for one researcher involved in proposing solutions. Also shown on Chart V is the evaluation procedure modeled in network form for considering both the time and cost considerations involved in the proposed solution.

Chart VI shows the network for generating and evaluating solutions serially. Thus Chart VI includes both milestones 2 and 3. Tying the detailed elements together results in the network shown in Chart VII which illustrates one possible network for representing the scientific method approach to planning R & D projects.

Idea Generation or Psychological Viewpoint

In order to analyze the R & D process from the psychological viewpoint, the concepts of brainstorming will be modeled in network form. The intent is not to present a general model of brainstorming but to clarify our concept of brainstorming and to provide a vehicle by which we can communicate to others what brainstorming means to us. The relationship of brainstorming to R & D projects and to idea generation in particular is assumed.

Again, we will go through the hierarchical method for developing networks. Chart VIII gives two levels of networks describing brainstorming. First brainstorming is divided into three processes -- idea generation, proposal of a concept, and evaluation of a concept. At the next level, each of the above processes is broken down into slightly finer detail illustrating the concepts that an idea can be dropped or picked up, that at some point evaluation of an idea may be sought and that acceptance and rejection of the idea is a possibility (Note in our model of brainstorming that we are including the eventual output of the brainstorming session in our definition of brainstorming. Thus we have communicated this fact through the network model). The next step is to detail each of the processes according to the activities involved.

At this point there are many alternatives which can be modeled. In the idea generation process we can consider stages in which ideas are proposed, elaborated on and either dropped or continued to be elaborated on. Also we can conceive of the idea generation process as being sequential where one participant (researcher) builds on his own or others ideas in a

sequential fashion. Another approach is to consider a simultaneous idea generation process in which the participants are generating ideas and the participant who speaks first has his idea on the floor. An analogy to the processing of signals may clarify the difference between simultaneous and sequential idea generation. In the sequential procedure there is only one signal being processed at a time whereas in the simultaneous idea generation model multiple signals are contained within the system. For the detailed model, the sequential case will be considered with two stages and feedback within each stage and from the second stage to the first stage permitted.

The evaluation will be sought when one of the participants recommends a concept based on the idea process. The network model of the request for evaluation permits the probability of seeking evaluation to be different for each participant and conditioned by who originated the idea. With regard to the evaluation of a concept by the participants, the network model should reflect the decision of each participant based on the proposer of the concept. In addition the rules for accepting or rejecting a concept must be established. Two such rules would be unanimous acceptance by each participant or a majority of the participants accepting. The network model developed will be based on the majority voting principle. The network model with the conditions described above is given in Chart IX.

A program has been written to simulate GERT networks (27,28). The program accepts as input the branches of the network as described by their start and end nodes and the characteristics associated with the branches such as a probability and time to traverse the branch. The logical characteristics of the node are also part of the input to the program.

The GERT Simulation Program was used to analyze the network given in Chart IX. Any branch incident to nodes 2, 3, or 4 is an idea branch and represents the activity "generation of an idea at the first stage of idea generation." The start node is node 43 and the first idea is generated by

researchers 1, 2, and 3 with equal probability. Activities representing second stage idea generation are represented by all branches incident to nodes 19, 20, or 21. The dropping of an idea or a return from the second stage to the first stage is done through nodes 25, 26, or 27. Remaining in stage one is accomplished by passing through nodes 16, 17, or 18 and remaining in stage two through nodes 22, 23, or 24. The suggesting of a concept based on the idea generation stages is given by nodes 5, 6, and 7 for researchers 1, 2, and 3 respectively. Nodes 28, 29, and 30 represent the evaluation by researcher 1 of a concept suggested by researchers 1, 2, and 3 respectively. Nodes 28, 31, and 34 represent the evaluation of a proposed concept by researcher 1 by researchers 1, 2, and 3 respectively. Nodes 37, 39, and 41 represent the acceptance of a concept by researchers 1, 2, and 3 respectively whereas nodes 38, 40, and 42 represent rejection of the concept by researchers 1, 2, and 3 respectively. Since majority voting is required at least two acceptances or two rejections are required to accept or reject a concept. Thus two of the acceptance nodes 37, 39, and 41 must be realized in order for the concept to be accepted. This is shown by the three nodes 8, 9, and 10 and eventually the realization of node 14 if node 8, 9, or 10 is realized. A similar analysis holds for the rejection node 15.

In order to present some quantitative results from the network, several runs were made with the GERT Simulation Program. Since this aspect of the research has just begun, only some preliminary results will be presented without the detailed analysis of the characteristics used to describe the branches of the network. Research is continuing in this area. Chart X is a summary of these preliminary results. A critical researcher is one who does not follow up on other's ideas nor on his own ideas frequently, but causes the idea generation process to continually revert back to the first stage. He also does not suggest a concept as frequently as the other researchers. When he does suggest a concept there is a high probability of it being accepted by him and the other researchers.

To count the number of ideas required before acceptance or rejection, a count is kept on the number of times branches incident to nodes 2, 3, and 4 and 19, 20 and 21 are realized. To obtain the time required to accept or reject a concept, random variables representing the times to generate an idea and the time to evaluate an idea are inserted on the proper branches. The exponentially distributed times employed had a mean time of 30 time units for idea generation and a mean time of 300 time units for evaluation. When normally distributed times were used, the same means were used but a standard deviation of one-tenth the mean values were assumed. Each of the networks as represented by a row in Chart X was simulated 400 times to obtain the network statistics (Note that the difference in the probabilities of acceptance and rejection for a given value of i is due to random sampling since the probabilities associated with the network were not changed.). A sample of the computer output from the GERT Simulation Program is shown for project 20 in Chart XI.

Administrative Control Viewpoint

Mr. A. J. Pearson used GERT for modeling the administrative aspects of R & D projects*. Chart XII is reproduced here with his permission and illustrates the activities required to proceed through the research, development and approval phases of a proposed plan.

Engineering Viewpoint

Analysis of an R & D project using GERT has been presented previously (30). We repeat it here for the convenience of the reader.

Graham (12) analyzes research and development expenditures using the network shown in Chart XIII with definitions of events and activities given in Chart XIV. For each branch of the network, Graham gives the probability that the branch is realized given that the preceding node is realized, and the time and cost (assumed to be constants by Graham) associated with the activity represented

* Personal Communication to A. Alan B. Pritsker, September 16, 1968.

by the branch if the activity is performed. These values are inserted on the GERT network given in Chart XIV by an ordered triple of probability, time (weeks) and cost in \$1000 units, namely, (p, t, c). Time in this example is not a duration but the amount of effort required to perform the activities measured in weeks.

Several changes were made in the construction of the GERT network. First the AC and DC control investigations (Activities B and C) are performed simultaneously and this should be indicated on the network without the aid of a bracket. Second, Nodes I and II do not result in the project being dropped as implied in Chart XIII. Also the decision nodes represent specific events, not either-or types of events. For ease of reference between Charts XIII and XIV, nodes have been labeled with two numbers (2 and 3) and the complements of these numbers ($\bar{2}$ and $\bar{3}$). Thus, Node $2\bar{3}$ represents the event AC control has been found to be suitable and DC control has been found to be unsuitable.

Third, three terminal nodes, U, S and T, have been added. Node U represents the event "project dropped", S represents "project successful", and Node T represents the event "project terminated" whether it was successful or not.

BIBLIOGRAPHY

1. Baker, Norman R., Jack Siegman and Albert H. Rubenstein. "The Effect of Perceived Needs and Means on the Generation of Ideas for Industrial Research and Development Projects." IEEE Transactions on Engineering Management, Vol. EM-14, No. 4, 1967.
2. Catron, Marvin J., Joseph Martino and Lewis Roepcke. "The Selection of R & D Program Content - Survey of Quantitative Methods." IEEE Transactions on Engineering Management, Vol. EM-14, No. 1, 1967.
3. Copi, Irving M. Symbolic Logic, New York, The MacMillan Company, 1960.
4. Compton, J. B. and D. E. Moody. "Flowgraphing Executive Problem." IEEE Transactions on Engineering Management, Vol. EM-12, No. 4, 1965.
5. Dean, Burton V. Operations Research in Research and Development, New York, John Wiley and Sons, Inc., 1963.
6. Drezner, S. M. and A. A. B. Pritsker, Network Analysis of Countdown, The RAND Corporation, RM-4976-NASA, March, 1966.
7. Eisner, Howard, "A Generalized Network Approach to the Planning and Scheduling of Research Program," Journal of Operations Research Society, Vol. 10, No. 1, 1962.
8. Elmaghraby, Salah E., "An Algebra for the Analysis of Generalized Activity Networks," Management Science, Vol. 10, No. 3, April 1964, pp. 494-515.
9. . "On Generalized Activity Networks," Journal of Industrial Engineering, Vol. SVII, No. 11, November 1966, pp. 621-631.
10. Freeman, Paul. The Principles of Scientific Research, New York, Pergoman Press, 1960.
11. Freeman, Raoul I. "R & D Management Research." Paper P-3216, 1965 The RAND Corporation, Santa Monica, California.
12. Graham, P., "Profit Probability Analysis of Research and Development Expenditures," The Journal of Industrial Engineering, Vol. XVI, No. 3, May-June 1965, pp. 186-191.
13. Happ, W. W., "Flowgraph Techniques for Closed Systems," IEEE Transactions, AES, Vol. 2, May 1966, pp. 252-264.
14. Hill, L. S., Management Planning and Control of Research and Technology Projects, Memorandum RM-4921-PR, 1966, The RAND Corporation, Santa Monica, California.

15. _____ "Towards and Improved Basis of Estimating and Controlling R&D Tasks." Paper P-3358, 1966, The RAND Corporation, Santa Monica, California.
16. Hill, T. W. "System Optimization: A Sensitivity Approach Using GERT," unpublished Masters Research Report, Arizona State University, Tempe, Arizona, 1966 (Also in Bulletin #3, Industrial Engineering Research at Arizona State University, 1966).
17. Ishmael, P. C. and A. A. B. Pritsker, User Manual for GERT EXCLUSIVE-OR Program, NASA/ERC, NGR 03-001-034, Arizona State University, July, 1968.
18. _____ . Definitions and Procedures Employed in the GERT EXCLUSIVE-OR Program, NASA/ERC, NGR 03-001-034, Arizona State University, July, 1968.
19. Klein, Burton H. "The Decision-Making Problem in Development." Paper P-1916, 1960, The RAND Corporation, Santa Monica, California.
20. Ledbetter, L. R. "A Study of Computational Aspects of Network Models for Planning and Control," Masters Thesis, Lehigh University, 1967.
21. Marshall, A. W. and W. H. Meckling. "Predictability of the Costs, Time and Success of Development." Paper P-1821, 1959, The RAND Corporation, Santa Monica, California.
22. Moder, Joseph I. and Cecil R. Phillips. Project Management With CPM and PERT, New York, Reinhold Publishing Corp., 1964.
23. Morris, William T. The Analysis of Management Decisions, Homewood, Illinois, Richard D. Irwin, Inc. Revised Edition, 1964.
24. Naltingk, B. E. The Art of Research, New York, Elsevier Publishing Company, 1965.
25. Pardee, Fredrick S. "Technological Projection and Advanced Product Planning." Paper P-3622, 1967. The RAND Corporation, Santa Monica, California.
26. Pritsker, A. Alan B. GERT: Graphical Evaluation and Review Technique, Memorandum RM-4973-NASA, The RAND Corporation, Santa Monica, California, 1966.
27. _____ . User's Manual for GERT Simulation Program, NASA ERC, NGR 03-001-034, Arizona State University, July, 1968.
28. _____ . Definitions and Procedures for GERT Simulation Program, NASA/ERC, NGR 03-001-034, Arizona State University, July, 1968.

29. _____, and W. W. Happ. "GERT: Graphical Evaluation and Review Technique, Part I Fundamentals," The Journal of Industrial Engineering, Vol. XVII, No. 5, pp. 267, May, 1966.
30. _____, and G. E. Whitehouse, "GERT: Graphical Evaluation and Review Technique, Part II - Probabilistic and Industrial Engineering Applications," Journal of Industrial Engineering, Vol XVII, No. 6, June, 1966.
31. _____, and P. J. Kiviat, Simulation Using GASP II: A FORTRAN Based Simulation Language, to be published by Prentice-Hall, Inc. in 1969.
32. Reichner, A. "The inclusion of the Possibility of Unforeseen Occurrences in Decision Analysis." IEEE Transactions on Engineering Management, Vol. EM-14, No. 4, 1967.
33. Rubenstein, Albert H. "A Program of Research on the Research and Development Process." IEEE Transactions on Engineering Management, Vol. EM-11, No. 3, 1964.
34. Schnittger, Jan R. "Dynamics of R & D Activity." IEEE Transactions on Engineering Management, Vol. EM-14, No. 3, 1967.
35. Silverman, Melvin. The Technical Program Manager's Guide to Survival, New York, John Wiley and Sons, Inc., 1967.
36. Smith, R. L. "Stochastic Analysis of Personnel Movement in Formal Organizations," Ph. D. Dissertation, Arizona State University, August 1967.
37. Strasburg, Louis Glen. "Project Design in the Process of Research Management," Ph. D. Dissertation, The Ohio State University, Ann Arbor, Michigan, University Microfilms, Inc., 1962.
38. Villers, Raymond. Research and Development: Planning and Control. New York, Rautenstruch and Villers, 1964.
39. Whitehouse, Gary E. "Extensions, New Developments, and Applications of GERT," Ph. D. Dissertation, Arizona State University, August 1965.
39. _____, and A. A. B. Pritsker, "GERT: Part III, Generating Functions, Conditional Distributions, Counters, Renewal Times, and Correlations," Accepted for Publication, AIIE Transactions, October 1968.
40. Yovits, Marshall Clinton (Editor), and Others. Proceedings of the Conference on Research Program Effectiveness, Washington, D. C., 1965, Gordon & Breach, New York, 1966.

CHART I.





The GERT Approach

GERT is a general procedure for the formulation and evaluation of systems using a graphical approach. The GERT approach to problem solving utilizes the following steps:

1. Convert a qualitative description of a system or problem to a model in stochastic network form.
2. Collect the necessary data to describe the branches of the network.
3. Determine the equivalent function or functions of the network.
4. Convert the equivalent function into performance measures associated with the network. Examples of performance measures are:
 - a. The probability that a specified node is realized;
 - b. The average time to realize the specified node;
 - c. An estimate of standard deviation of the time to realize the specified node;
 - d. The minimum time observed to realize the specified node;
 - e. The maximum time observed to realize the specified node;
 - f. A histogram of the times to realize the specified node.
5. Make inferences concerning the system under study from the information obtained in Item 4 above.

CHART II.

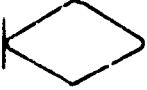
Node Characteristics and Symbols

		Input		
		EXCLUSIVE-OR	INCLUSIVE-OR	AND
Output	DETERMINISTIC			
	PROBABILISTIC			

EXCLUSIVE-OR

The realization of any branch leading into the node causes the node to be realized; by definition one and only one of the branches leading into this node can be realized at a given time. (However, feedback branches can cause the node to be realized again.)

INCLUSIVE-OR

The realization of any branch leading into the node causes the node to be realized. The time of realization is the smallest of the completion times of the activities leading into the INCLUSIVE-OR node.

AND

The node will be realized only if all the branches leading into the node are realized. The time of realization is the largest of the completion times of the activities leading into the AND node.

DETERMINISTIC

All branches emanating from the node are taken if the node is realized; that is, all branches emanating from this node have a p-parameter equal to one.

PROBABILISTIC

At most, one branch emanating from the node is taken if the node is realized.

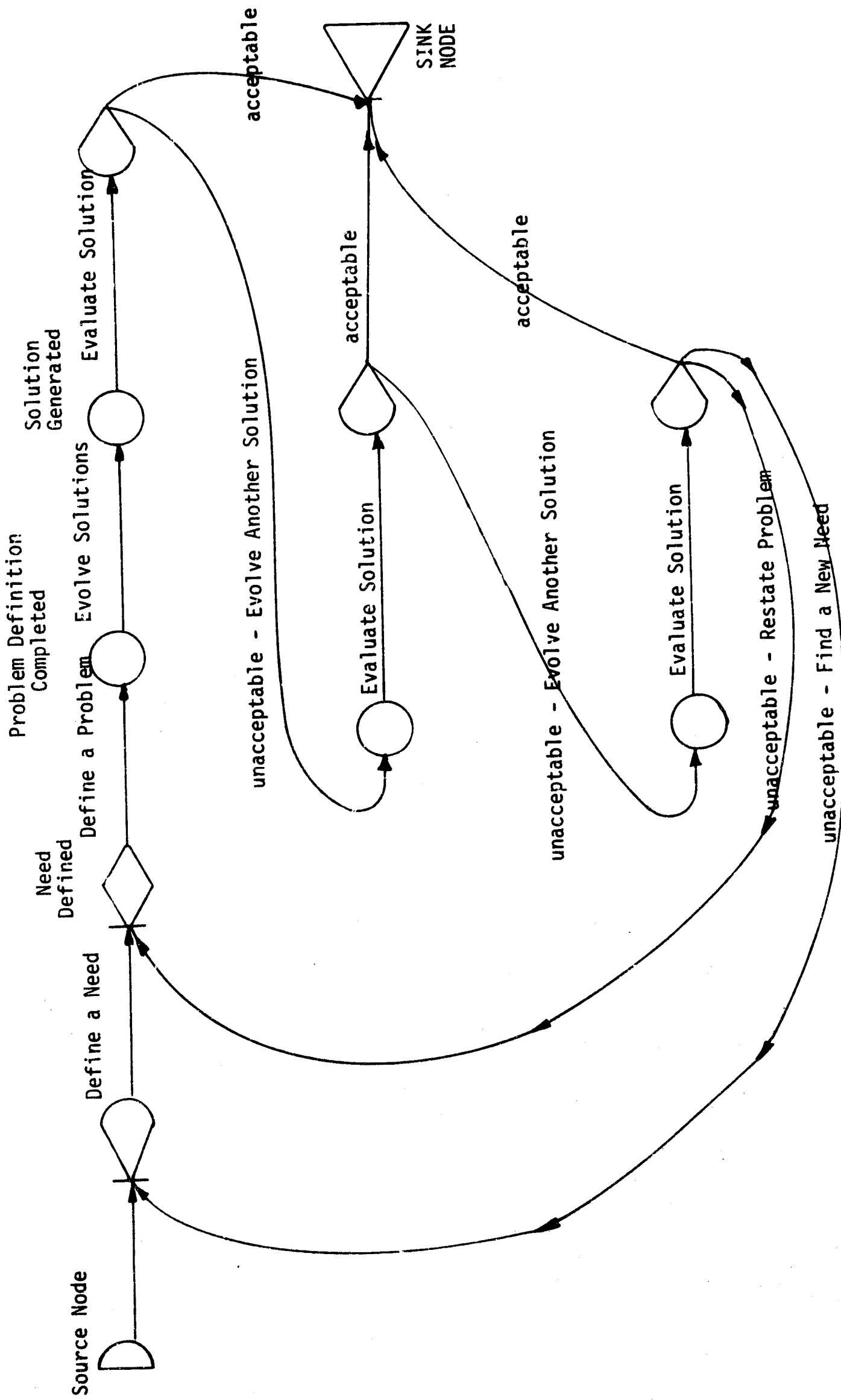

CHART III.

GERT Problem Definition

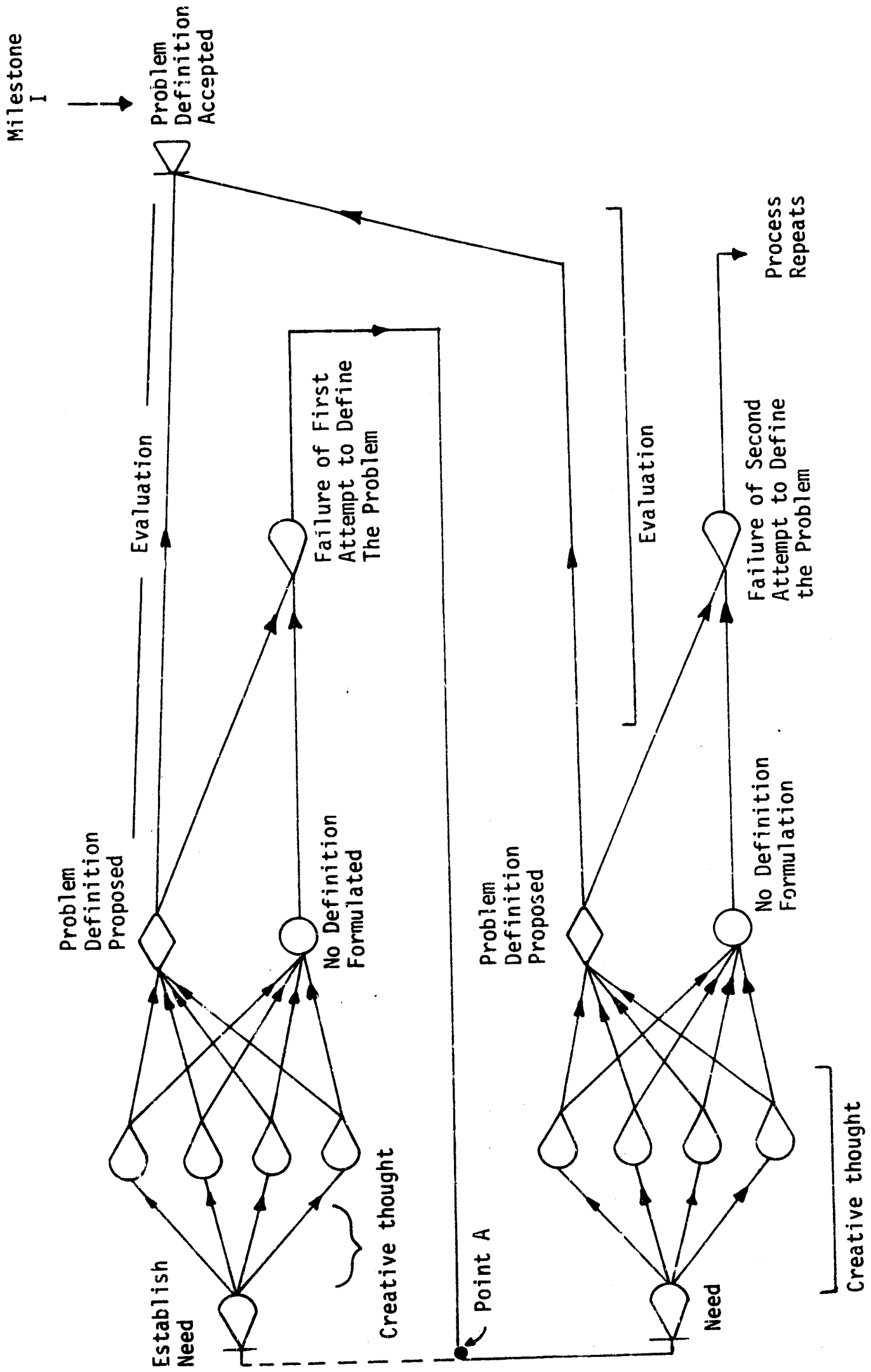
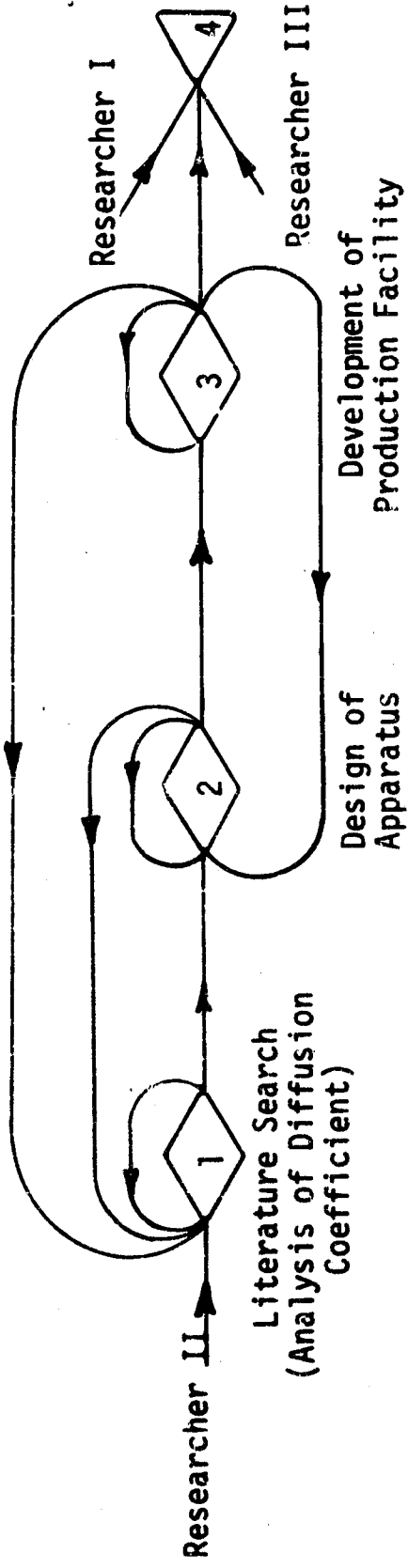

CHART IV.

Network for Generation of Proposed Solutions



First Evaluation of Solution

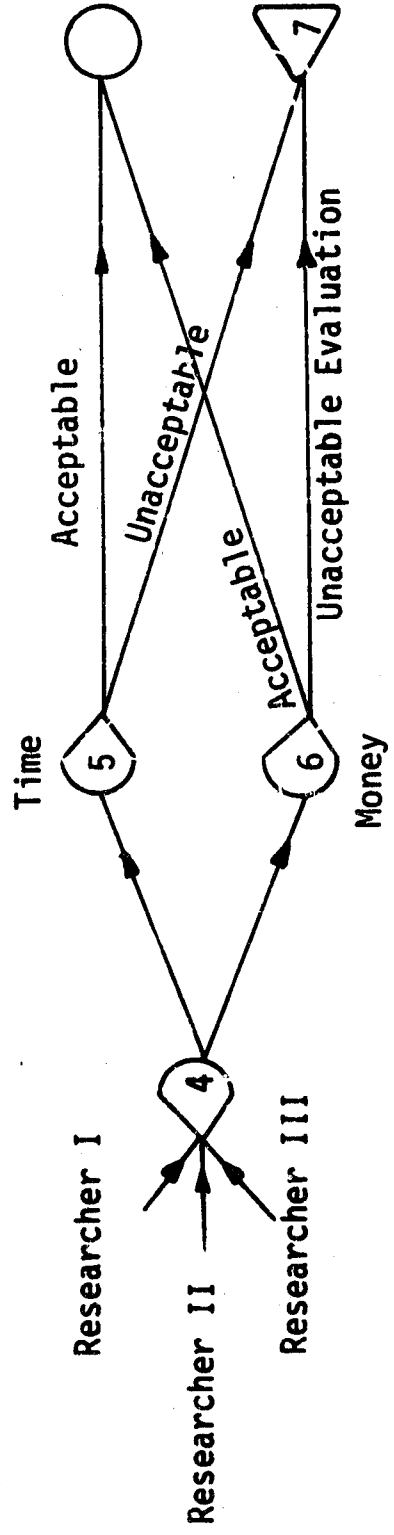

CHART VI.

Series Proposals

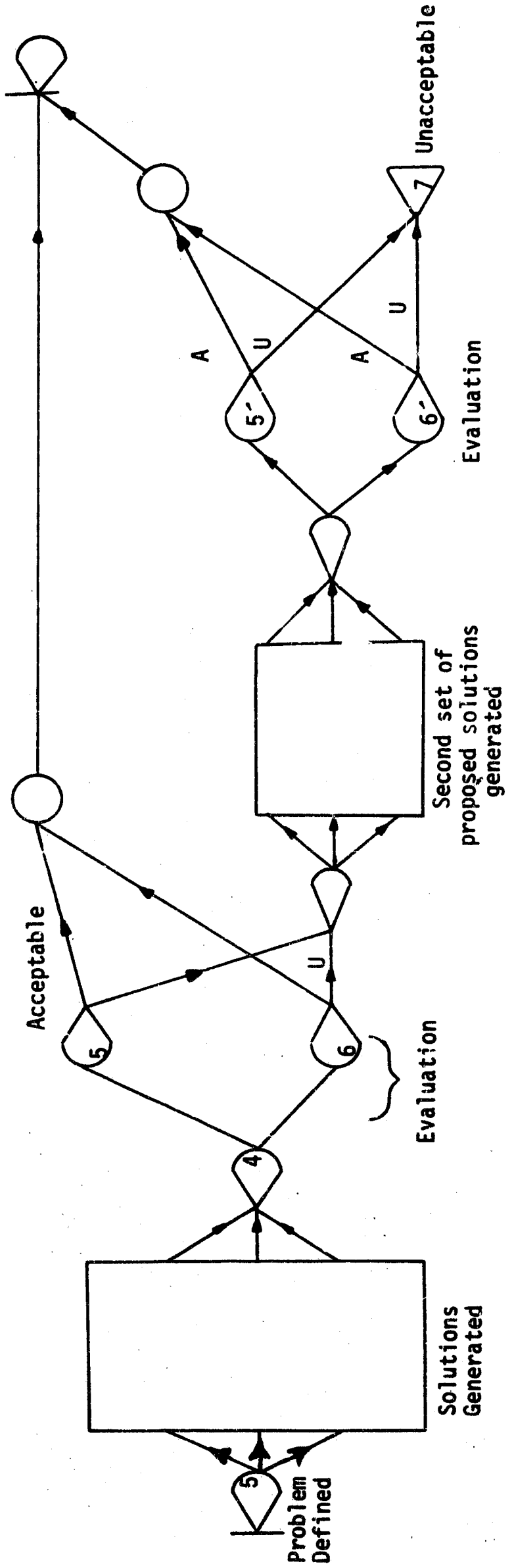
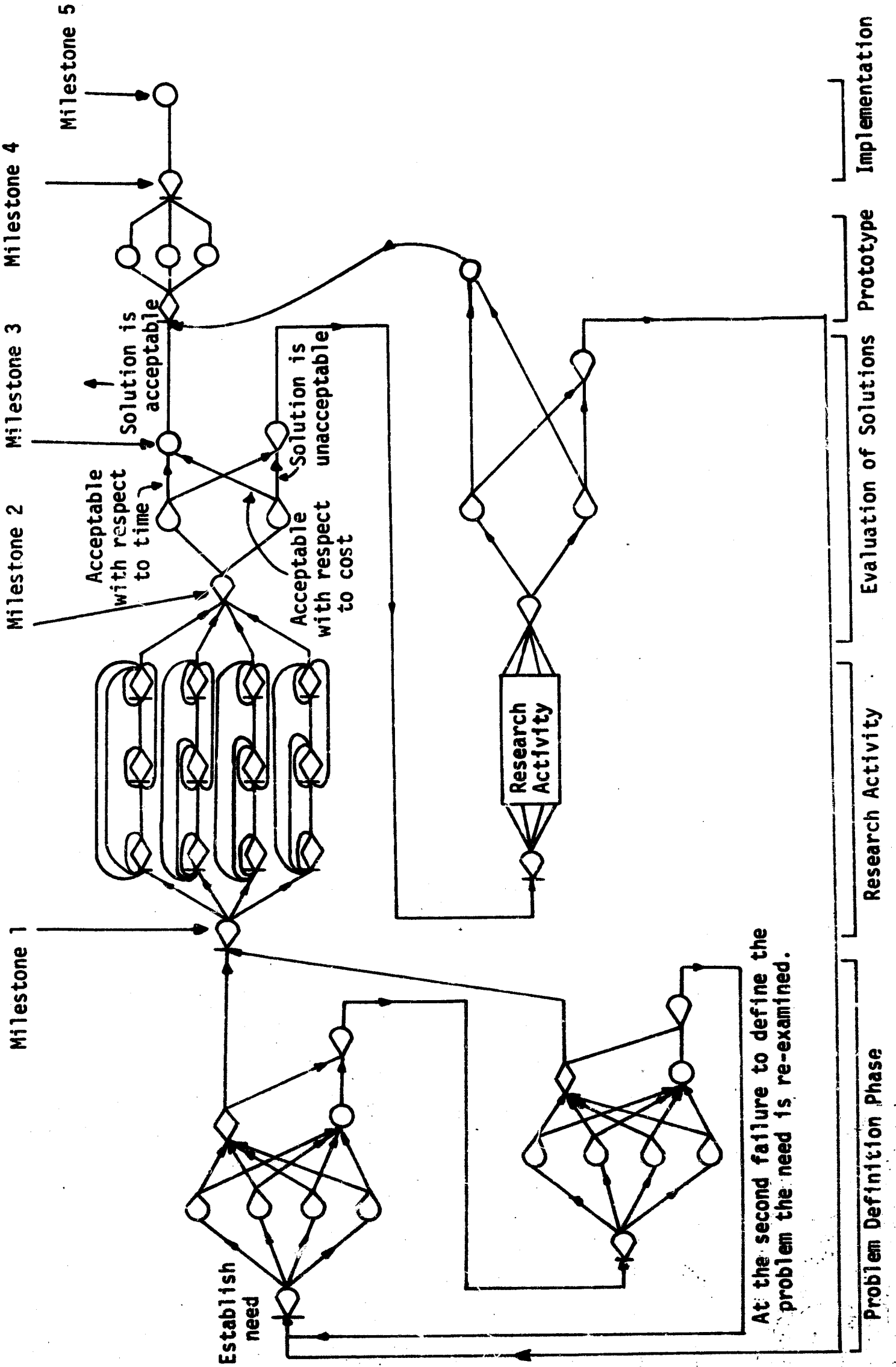
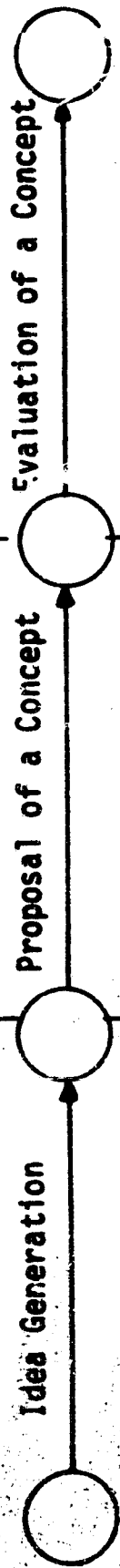

CHART VII.

A GERT Network Representation of an Example R&D Project



Brainstorming



Try Again

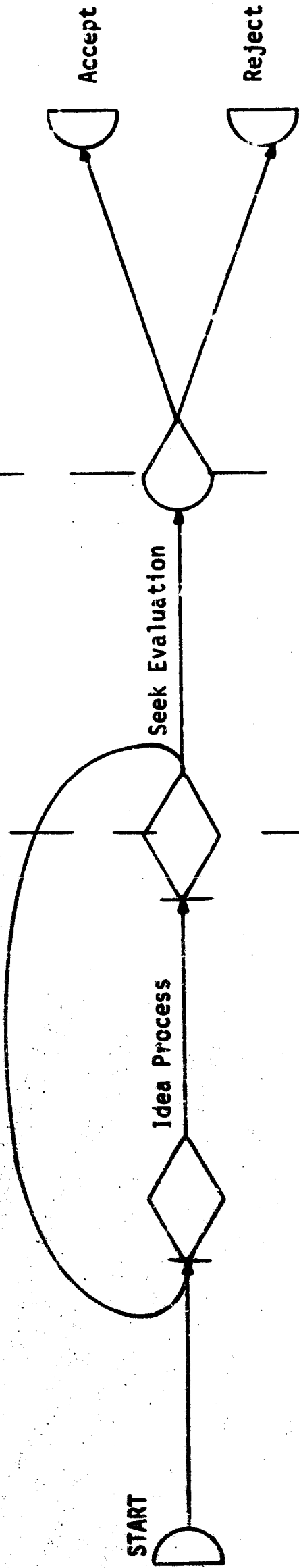

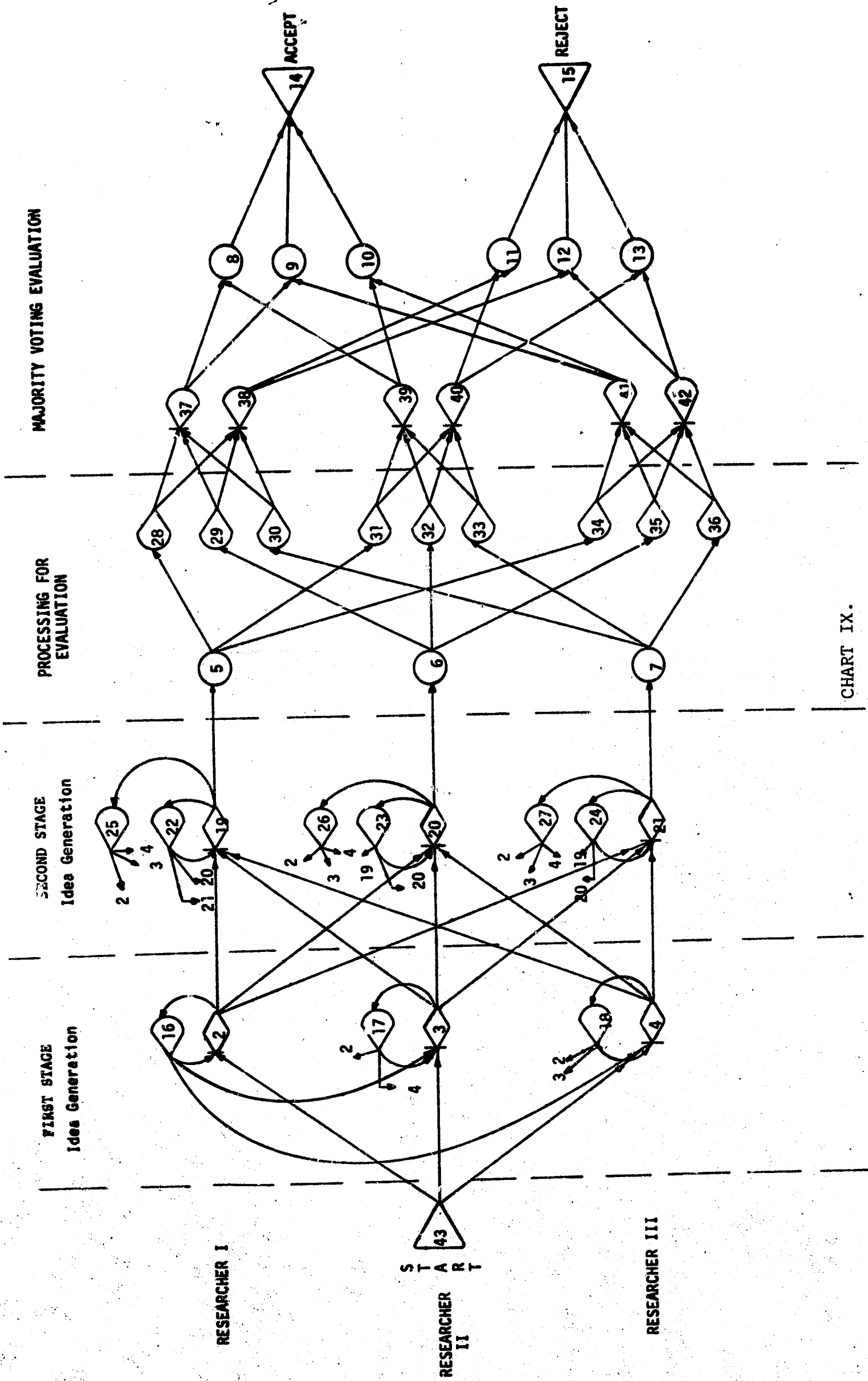

CHART X.

Project Number	Probability		Number of Ideas				Time Required			
	Accept	Reject	Accept		Reject		Accept		Reject	
			μ	σ	μ	σ	μ	σ	μ	σ
10	.495	.505	8.62	6.89	7.89	6.93				
20	.385	.615	12.83	9.77	11.10	9.92				
21	.360	.640					765.	398.	706.	383.
22	.392	.608					632.	266.	648.	325.
30	.403	.597	15.42	13.08	16.45	17.06				
31	.368	.632					880.	562.	824.	511.
32	.370	.630					839.	487.	828.	435.

Code: Project (ij) where if i = 1. Three equal researchers
 2. One critical researcher
 3. Two critical researchers
 j = 0. Count Number of Ideas
 1. Exponentially Distributed Times
 2. Normally Distributed Times

Results Obtained from the GERT Simulation Program

GERT SIMULATION PROJECT 2 BY PRITSKER
DATE 10/ 22/ 1968

FINAL RESULTS FOR 400 SIMULATIONS

NODE	PROB.	MEAN	STD.DEV.	MIN.	MAX.
5	0.2500	10.3100	9.1912	2.0000	54.0000
6	0.4100	12.6341	10.8949	2.0000	72.0000
7	0.3400	11.7941	9.0046	2.0000	46.0000
14	0.3850	12.8312	9.7691	2.0000	45.0000
15	0.0150	11.1016	9.9198	2.0000	72.0000

HISTOGRAMS

NODE	LOWER LIMIT	CELL WIDTH	FREQUENCIES										
5	2.	1.0	0	13	6	12	4	10	8	5	5	1	3
			4	3	3	3	4	3	1	2	2	2	9
6	2.	1.0	0	14	6	17	12	6	10	4	4	6	6
			7	4	6	8	7	2	7	3	3	0	24
7	2.	1.0	0	7	7	17	10	16	5	8	2	6	2
			3	4	2	4	4	11	3	2	3	1	19
14	2.	1.0	0	13	6	19	2	17	9	9	2	2	4
			3	4	3	3	4	9	6	5	5	1	26
15	2.	1.0	0	21	13	27	24	15	14	14	9	11	7
			11	7	8	7	10	8	5	4	3	2	25

CHART XIII.

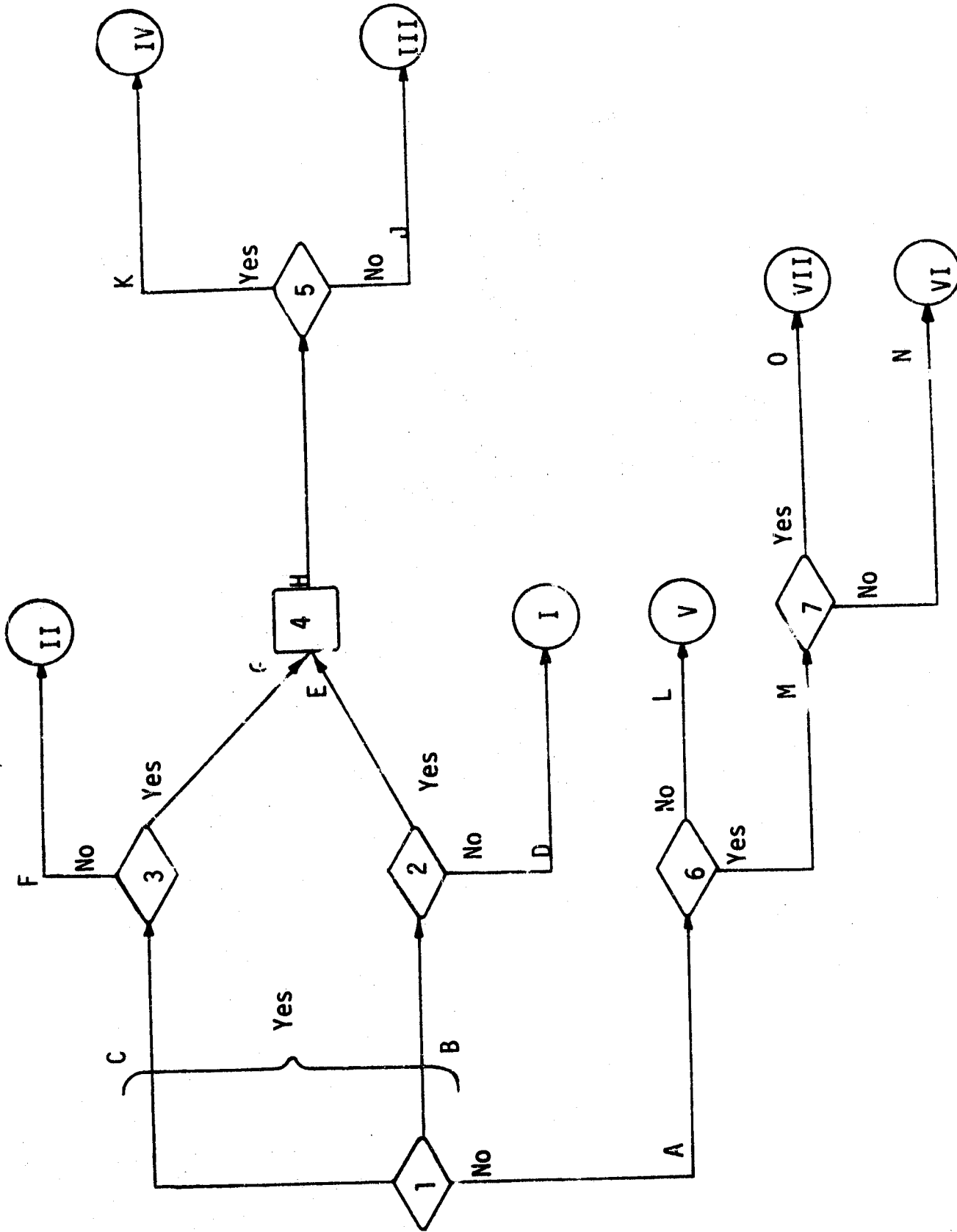

Decision Box Network

CHART XIV.

DESCRIPTION OF PROJECT NETWORK

EVENTS

1. Feasibility study indicates electrical control of high temperature tem is/is not feasible.
2. AC control found suitable/unsuitable.
3. DC control found suitable/unsuitable.
4. Optimum integration of AC/DC circuits achieved.
5. Unit found to be within/outside potential market price.
6. Pneumatic control found to be feasible/unfeasible.
7. Unit found to be within/outside potential market price.

ACTIVITIES

- A. Pneumatic feasibility study.
- B. AC control investigation.
- C. DC control investigation.
- D. Report writing.
- E. Investigation of optimum AC/DC integration.
- F. Report writing.
- G. Investigation of optimum AC/DC integration.
- H. Economic analysis of system.
- J. Report writing.
- K. Report writing.
- L. Report writing.
- M. Economic analysis of system.
- N. Report writing.
- O. Report writing.

OUTCOMES

- I. Project dropped.
- II. Project dropped.
- III. Project dropped.
- IV. Product put into production and marketed.
- V. Project dropped.
- VI. Project dropped.
- VII. Product put into production and marketed.

Third, three terminal nodes, U, S and T, have been added. Node U represents the event "project dropped", S represents "project successful", and Node T represents the event "project terminated" whether it was successful or not.

CHART XV.

