

N70 - 19269

**NASA TECHNICAL  
MEMORANDUM**

NASA TM X-52735

NASA TM X-52735

**CASE FILE  
COPY**

**EXPERIMENTAL INVESTIGATION OF REACTOR-LOOP TRANSIENTS  
DURING SNAP-8 POWER CONVERSION SYSTEM STARTUP**

by Kent S. Jefferies  
Lewis Research Center  
Cleveland, Ohio  
December 16, 1969

EXPERIMENTAL INVESTIGATION OF REACTOR-LOOP  
TRANSIENTS DURING SNAP-8 POWER CONVERSION SYSTEM STARTUP

by Kent S. Jefferies

Lewis Research Center  
Cleveland, Ohio

December 1969

This information is being published in preliminary form in order to expedite its early release

## ABSTRACT

From startup tests of a SNAP-8 power conversion system using a realistic reactor simulator, the following conclusions were drawn: The temperature derivatives of the simulator coolant were considerably less than the reactor's limitations during all of the startups. The peak values of reactor-simulator power and outlet temperature approached the reactor's limitations during a few startups. Increasing mercury-flow-ramp duration from 30 seconds to 100 seconds caused a 30 percent reduction of the maximum temperature derivative. Reactivity coefficients determined from tests of the SNAP-8 reactor caused more severe overshoots of temperature and power than the design coefficients. The overshoots in temperature and power could be diminished by modifying control drum logic during startup.

## EXPERIMENTAL INVESTIGATION OF REACTOR-LOOP

### TRANSIENTS DURING SNAP-8 POWER CONVERSION SYSTEM STARTUP

by Kent S. Jefferies

Lewis Research Center

#### SUMMARY

Startup tests of a SNAP-8 power conversion system using a realistic reactor simulator were recently conducted at Lewis. The primary objective of this study was to determine satisfactory mercury-loop-startup procedures within the constraints of both the SNAP-8 reactor and the power conversion system. This report presents the information obtained from the reactor simulator transients during the startup tests of the power conversion system.

Primary loop transients during a typical power conversion system startup are presented. A comparison is made of transients with reactivity coefficients determined from experimental tests of the SNAP-8 reactor to transients with design reactivity coefficients. Transients with normal control drum action are compared to transients with no control drum action. The trends of maximum coolant temperature derivative and peak reactor simulator power to changes of mercury-flow-ramp duration and of initial reactor simulator power were investigated.

The following conclusions were reached. The coolant temperature derivatives of the reactor simulator were in all startups considerably less than the reactor limitations. The peak values of reactor simulator power and outlet temperature approached the reactor limitations during a few startups. Increasing mercury-flow-ramp duration from 30 seconds to 100 seconds caused a 30-percent reduction of the maximum temperature derivative. Increasing initial reactor power from 40 to 100 kilowatts tends to reduce the power overshoot. Test reactivity coefficients cause more severe overshoots of temperature and power than the design coefficients. The overshoots in temperature and power could be diminished by modifying control drum logic during startup.

#### INTRODUCTION

SNAP-8, a power system being developed for use in space, uses heat from a nuclear reactor to produce electric power. Heat is transferred from the reactor to a mercury boiler by a circulating loop of Nak (eutectic mixture of sodium and potassium). The mercury vapor drives a turbine-alternator to produce electric power. An important aspect of the SNAP-8 system development is the definition of reliable automatic startup procedures to be used in space.

Previous studies of SNAP-8 startup problems are reported in several publications. Birken has made analog computer studies of reactor startup (ref. 1) and of the effects of power conversion system (PCS) startup on the reactor (ref. 2). An experimental study of reactor loop transients during PCS startup (ref. 3) was made at NASA-Lewis with a SNAP-8 simulator system. An important element in this study was an analog-computer-controlled electric heater, which simulated the SNAP-8 reactor (ref. 4).

The NASA experimental facility was later modified to include all the major components of SNAP-8 except the reactor and radiator. With this SNAP-8 test system (ref. 5) an extensive study of the PCS startup was made. Main objectives of this study were to determine a satisfactory combination of mercury-flow-ramp rate (ref. 6), pump bootstrapping frequency (ref. 7), and condenser pressure control. During these tests information was obtained from the reactor simulation regarding the severity of reactor transients during PCS startup. The purpose of this report is to present this reactor information.

The reactor simulator transients for a reference startup are illustrated and discussed. The maximum transient power and maximum NaK coolant temperature derivatives for all the startups are compared to the safety limits of the SNAP-8 development reactor. The effects of mercury-flow-ramp duration and initial reactor simulator power on maximum NaK temperature derivative and maximum reactor simulator power are plotted and discussed. The effects of changes in reactivity coefficients and omission of control drum steps are discussed.

## SNAP-8 TEST SYSTEM AND INSTRUMENTATION

### Test System

A simplified schematic diagram of the SNAP-8 test system is shown in figure 1. The three liquid metal loops shown are: (1) the primary NaK loop which transfers heat energy from the reactor simulator to the boiler; (2) the secondary mercury loop in which mercury vapor generated in the boiler drives a turbine before giving up waste heat in the condenser; and (3) the heat rejection NaK loop which transfers the waste heat from the condenser to the radiator simulator. The auxiliary start heat exchanger is used to cool the reactor simulator and preheat the heat rejection loop during the period before PCS startup. An oil loop which lubricates and cools the rotating components is not shown.

The reactor simulation is conveniently divided into three blocks: control drum logic; reactor nucleonics; and reactor thermodynamics as shown in figure 2. The block for control drum logic simulates a step in reactor control drum position when the outlet temperature is outside deadband limits. The lower deadband limit was  $1280^{\circ}$  F and the upper deadband

limit was 1320° F. The reactor nucleonics block computes reactor power by integrating the effect of simulated control drum position and internal reactor simulator temperature distribution. The reactor thermodynamics block is the determination of outlet temperature and internal temperature distribution based on simulated reactor power, inlet temperature, and NaK flow rate. Control drum logic and reactor nucleonics are simulated on an analog computer. Reactor thermodynamics (except for core temperature) are represented by the electric NaK heater. The electric heater used had a significantly higher heat transfer capability than the SNAP-8 reactor. To compensate for this, a quantity proportional to reactor power was added to heater element temperature to compute core temperature. The reactor simulation is described in more detail in reference 4.

### Instrumentation

The experimental SNAP-8 system was thoroughly instrumented; most of the instrumentation was the same as that described in reference 8. However, only a few instruments were used to obtain the data presented herein. The relative locations of these instruments are indicated on the diagram shown in figure 1. Mercury flow rate was determined by measuring the pressure differential across a calibrated venturi. An electromagnetic flow meter was used to measure primary NaK flow rate. Temperatures were measured using Chromel-Alumel thermocouples referenced to 150° F ovens. NaK heater power was measured by multiplying voltage and current of each phase and totaling the three products. The instrumentation signals were digitized and recorded at a rate of one recording of each variable per 11.4 seconds. Strip chart recordings of key variables were also made. The plots of reactor loop transients during PCS startups were made using the strip chart data. The remaining plots were derived from the digital data.

### TEST PROCEDURES

A typical PCS startup test was accomplished as follows. Before each test, the reactor simulator was brought to a power level of 60 to 120 kilowatts and an outlet temperature near 1300° F. The power was transferred by the auxiliary start heat exchanger to the third loop. The mercury liquid lines were filled between the condenser outlet and the boiler inlet. The pumps were running on auxiliary power at the bootstrap frequency or at design alternator frequency.

Once the above conditions were achieved and the data systems were started, the startup sequence was initiated. Third loop flow through the auxiliary start heat exchanger was stopped. The mercury injection system at the mercury pump inlet was opened. The mercury flow control valve was automatically controlled to provide the desired ramp of mercury liquid flow into the boiler. The boiler transferred heat energy from the primary

loop to boil the mercury. This caused temperature and power transients in the primary loop. Mercury vapor generated in the boiler caused the turbine alternator assembly to accelerate. When the alternator output reached the pump frequency, the pumps were transferred to alternator power. As the alternator output increased to design frequency, the primary pump sped up and the primary NaK flow increased. This increase in primary flow also caused changes in primary loop temperatures.

At the conclusion of the startup transient, mercury flow was at the self-sustaining value, 6600 pounds/hour. The reactor simulator power output was at approximately 290 kilowatts, which was the power required to vaporize the mercury flow and to overcome convection and radiation losses in the primary loop. The reactor simulator outlet temperature was within the deadband limits. The alternator was at design frequency and the primary loop was at rated flow. In a few cases the mercury flow was increased very slowly to 12,000 pounds/hour and the system increased to full-power operation in a quasi-steady manner. Usually, once the system had steadied out at the self-sustaining point, it was shut down in preparation for another startup.

## RESULTS AND DISCUSSION

### Reactor Transients for Reference Startup

The reactor loop transients for a reference PCS startup are shown on figure 3. The mercury flow ramp lasted for the optimum duration, 100 seconds, determined in reference 6; the pump switchover from auxiliary to turbine-alternator power was at 270 hertz, the optimum turbine-pump bootstrapping frequency determined in reference 7. The reactor simulation used the reactivity coefficients determined from experimental tests of the SNAP-8 reactor (test coefficients). The deadband control was simulated except that the first drum step, the drum step at the lower deadband limit, was eliminated.

This PCS startup caused primary loop transients that would be acceptable for actual reactor operation. The maximum rate of change of reactor simulator inlet temperature (determined from digital data for a 11.4-second interval) was 125° F per minute. The maximum heater power reached was 500 kilowatts. The heater outlet temperature's maximum was 1345° F.

### Reactor Constraints

The constraints considered in deciding that the reference PCS startup transients would have been acceptable for actual reactor operation are as follows. The maximum allowable transient NaK outlet temperature is 1450° F. A reactor scram is initiated when the outlet temperature reaches 1400° F. The maximum allowable NaK-temperature time-derivative varied with the duration of the transient. The variation of this constraint from 150° F



per minute for long-term transients to 600<sup>o</sup> F per minute for very brief transients is shown in figure 4. The maximum allowable value of reactor power during a transient is 675 kilowatts. A scram is initiated if reactor power exceeds 750 kilowatts. The constraints mentioned above were used during testing of the S8DR.

These constraints were used to evaluate the various PCS startups made at the Lewis Research Center. These startups included many different combinations of changes to the startup parameters. The number of startups which reached each value of peak outlet temperature is shown in figure 5. This distribution shows that a few of the startups approached the S8DR scram temperature. The number of startups that reached each value of peak power is shown in figure 6. Although most of the runs had peak powers between 500 and 600 kilowatts, three of the runs had NaK heater power limited to 640 kilowatts, the NaK-heater safety limit. If the actual reactor had been used in this testing, the reactor limits may have been exceeded during these three transients.

The maximum NaK temperature derivatives encountered during the PCS startup testing are shown in figures 7 and 8. Figure 7 plots the maximum derivatives during the 11.4-second intervals between successive digital data recordings. Figure 8 plots the maximum derivative during 80-second intervals between digital data recordings. These figures show that there is a wide margin between the temperature derivatives encountered in PCS startup testing and the temperature derivative constraints used in S8DR testing.

Figures 5, 6, 7, and 8 show an approximate Gaussian distribution. This indicates that the variations are probably each due to several factors. Some likely causes of the variations are listed below.

- (1) Mercury flow ramp rate
- (2) Initial NaK heater power
- (3) Reactor simulator reactivity coefficients
- (4) Reactor simulator control drum logic
- (5) Deviations from steady-state operation at the beginning of the transient
- (6) Errors in recording or interpreting the data.

Further analysis of the effects due to the first four factors is made in the following sections of this report.

#### Effect of Mercury Ramp Rate

A mercury flow ramp from zero to self-sustaining flow rate in 100 seconds was about optimum from mercury loop considerations. However, final selection of mercury-flow-ramp rate must also consider what is best for the reactor. Plots of reactor limitations, peak power level and maximum rate of change of NaK temperature, as a function of mercury flow ramp rate were made to determine if there is any correlation.

Peak heater power to mercury-flow-ramp duration for the PCS startups is plotted on figure 9. Mercury-flow-ramp duration, i.e., the time required to ramp the mercury flow from zero to the self-sustaining value, is inversely proportional to mercury-flow-ramp rate. Figure 9 shows practically no correlation of peak power to mercury-flow-ramp duration. Changes to the mercury-ramp duration between 30 and 100 seconds would therefore not be an effective method of reducing the peak power.

Maximum rate of change of heater inlet temperature as a function of mercury-flow-ramp duration for the PCS startups is plotted on figure 10. The temperature derivative used in this plot was the average derivative during an 11.4-second interval between two digital data recordings. There is a definite reduction of temperature derivative as the mercury-flow-ramp duration increases. The startups using a 100-second mercury-flow-ramp (the ramp duration chosen in reference 6) had an average temperature derivative about 30 percent less than the startups using a 30-second ramp. Increase of mercury-ramp duration above 100 seconds would probably reduce the NaK temperature derivative further.

#### Effect of Initial Power

Peak heater power versus initial heater power for the PCS startups is plotted on figure 11. There is a significant trend towards reduced peak heater power with increased initial power. Because previous analytical studies predicted this trend, the auxiliary start heat exchanger was added to the SNAP-8 system.

There are two causes for reduced power overshoots at higher initial power: (1) An inherent feature of reactors is that their sensitivity to reactivity changes is proportional to their power level. With a higher initial power the reactor simulator will respond faster to a change in power demand and will need to overshoot less to compensate for initial sluggishness. (2) Higher initial power is achieved by increasing auxiliary start heat exchanger power demand. The effective disturbance to the reactor simulator, the difference between boiler power demand and auxiliary start heat exchanger power demand, is less at a higher initial power. As the power transient is a response to this disturbance, the power transient is naturally less severe when the effective disturbance is less.

Maximum rate of change of inlet temperature versus initial heater power is plotted on figure 12. In general there is no correlation.

#### Effect of Reactor Coefficients

The temperature coefficients of reactivity are important in controlling reactor power. The SNAP-8 reactor was designed so that thermal expansion tends to reduce reactor power. The magnitude of this tendency is expressed

by three temperature coefficients of reactivity:

- (1) lower grid coefficient
- (2) core coefficient
- (3) upper grid coefficient

As these coefficients were part of the nucleonics portion of the reactor simulator it was convenient to use two sets of reactivity coefficients during the PCS startup testing. The test coefficients were computed from experimental data from the SNAP-8 reactor. The design coefficients were design goals for the SNAP-8 reactor.

	<u>Design</u>	<u>Test</u>
Lower grid (inlet)	$-.07\text{¢}/^{\circ}\text{F}$	$-.10\text{¢}/^{\circ}\text{F}$
Core	$-.10\text{¢}/^{\circ}\text{F}$	$-.10\text{¢}/^{\circ}\text{F}$
Upper grid (outlet)	$-.07\text{¢}/^{\circ}\text{F}$	$-.00\text{¢}/^{\circ}\text{F}$

The test coefficients tend to cause more severe overshoots of power than the design coefficients. Peak power versus mercury-flow-ramp duration (fig. 9) shows the runs using test coefficients represented by circles and the runs using design coefficients by solid dots. Although the 40, 80, 100, 120, and 140-second ramps were done almost entirely with test coefficients, the 30- and 60-second ramps show average peak powers with test coefficients to be about 75 kilowatts higher than with design coefficients.

The difference is more plainly shown in figure 13 by comparing two runs that are similar in all other respects. The power trace shows a lower peak and a less oscillatory response with design coefficients than with test coefficients. The upper grid temperature is a feedback variable in that it increases when power is increased. The lower grid temperature is a feedforward variable in that its value depends on what happens in the boiler and not on power. The test coefficients produce a more oscillatory power response because they provide too much predictive response and not enough feedback.

Another significant difference between the two startup transients is that the outlet temperature has larger excursions with the test coefficients than with the design coefficients. The outlet temperature is almost the same as the upper grid temperature. With the design coefficients, variations of upper grid temperature are opposed by the effect of the upper grid coefficient. This tends to minimize outlet temperature transients. With the test coefficients, the upper grid coefficient is zero and the outlet temperature has larger overshoots.

## Reactor Control Logic

The reactor transients of a run with no control drum steps are compared to those of a run with the normal control action (fig. 14). The control steps tend to make the startup transient more oscillatory. This is not surprising considering that the control drums were designed for steady-state correction of fuel depletion and poison burnout rather than for controlling the startup transient. However, some means is needed during the startup transient to lower the outlet temperature at the end of the transient. One way of doing this is to begin the PCS startup with the outlet temperature below the steady-state operating value. By manually stepping the control drums two or three times and allowing the reactor simulator transients time to settle out, PCS startups were begun with initial outlet temperatures around 1260° F. These startups were similar to the startup with no control drum steps plotted in figure 14, except that the outlet temperature was within the temperature deadband at the end of the transient. Another modification to reactor control logic which was studied was elimination of the first control drum step. An example of this modification is the reference startup shown on figure 3. Eliminating this inward step reduced the value of peak power and lessened the number of outward steps needed to bring the outlet temperature down into the deadband. The three modifications to control drum logic: (1) eliminating all steps, (2) eliminating all steps with the outlet temperature initially below the deadband, and (3) eliminating the first drum step, all reduced excursions of reactor simulator temperature and power.

## CONCLUSIONS

The investigation of a SNAP-8 test system using a reactor simulator has yielded the following information regarding reactor transients during startup of the power conversion system.

- (1) The NaK temperature derivatives of the reactor simulator were in all startups considerably less than the reactor limitations.
- (2) The peak values of reactor simulator power and outlet temperature approached the reactor limitations during a few startups.
- (3) Increasing mercury-flow-ramp duration from 30 seconds to 100 seconds caused a 30 percent reduction of the maximum temperature derivative.
- (4) Increasing initial reactor power from 40 kilowatts to 100 kilowatts by increasing auxiliary start heat exchanger power tends to reduce the power overshoot.
- (5) Reactivity coefficients determined from experimental tests of the SNAP-8 reactor cause more severe overshoots of power and outlet temperature than design coefficients.

(6) Modification of control drum logic for startup tends to reduce reactor simulator overshoots of temperature and power.

Lewis Research Center,  
National Aeronautics and Space Administration,  
Cleveland, Ohio, December 8, 1969.

#### REFERENCES

1. Birken, S.: Response of the SNAP-8 Reactor During Automatic Startup. Rep. NAA-SR-9646, Atomics International Div., North American Aviation, Sept. 24, 1964.
2. Code, C. J., Jr.: Analysis of the Response of the SNAP-8 Nuclear System During Startup of the Power Conversion System. Rep. NAA-SR-9626, Atomics International Div., North American Aviation, June 8, 1964.
3. Thollot, Pierre A.; Block, Henry B.; and Jefferies, Kent S.: Experimental Investigation of Reactor-Loop Transients During Startup of a Simulated SNAP-8 System. NASA TN D-4546, 1968.
4. Jefferies, Kent S.; Packe, Donald R.; and Dittrich, Ralph T.: Design and Performance of a Nuclear Reactor Simulator for Nonnuclear Testing of Space Power Systems. NASA TN D-4095, 1967.
5. Macosko, Robert P.; Hanna, William T.; Gorland, Sol H.; and Jefferies, Kent S.: Performance of an Experimental SNAP-8 Power Conversion System. NASA TM X-1732, 1969.
6. Lottig, Roy A.; and Soeder, Ronald H.: Investigation of Mercury-Flow Ramp Rates for Startup of the SNAP-8 System. NASA TM X-52689, 1969.
7. Soeder, Ronald H.; and Lottig, Roy A.: Investigation of Pump Transfer Frequencies from Auxiliary Power to Alternator Power During Startup of the SNAP-8 System. NASA TM X-52712, 1969.
8. Deyo, James N.; and Wintucky, William T.: Instrumentation of a SNAP-8 Simulator Facility. NASA TM X-1525, 1968.

\*SNAP-8 Components

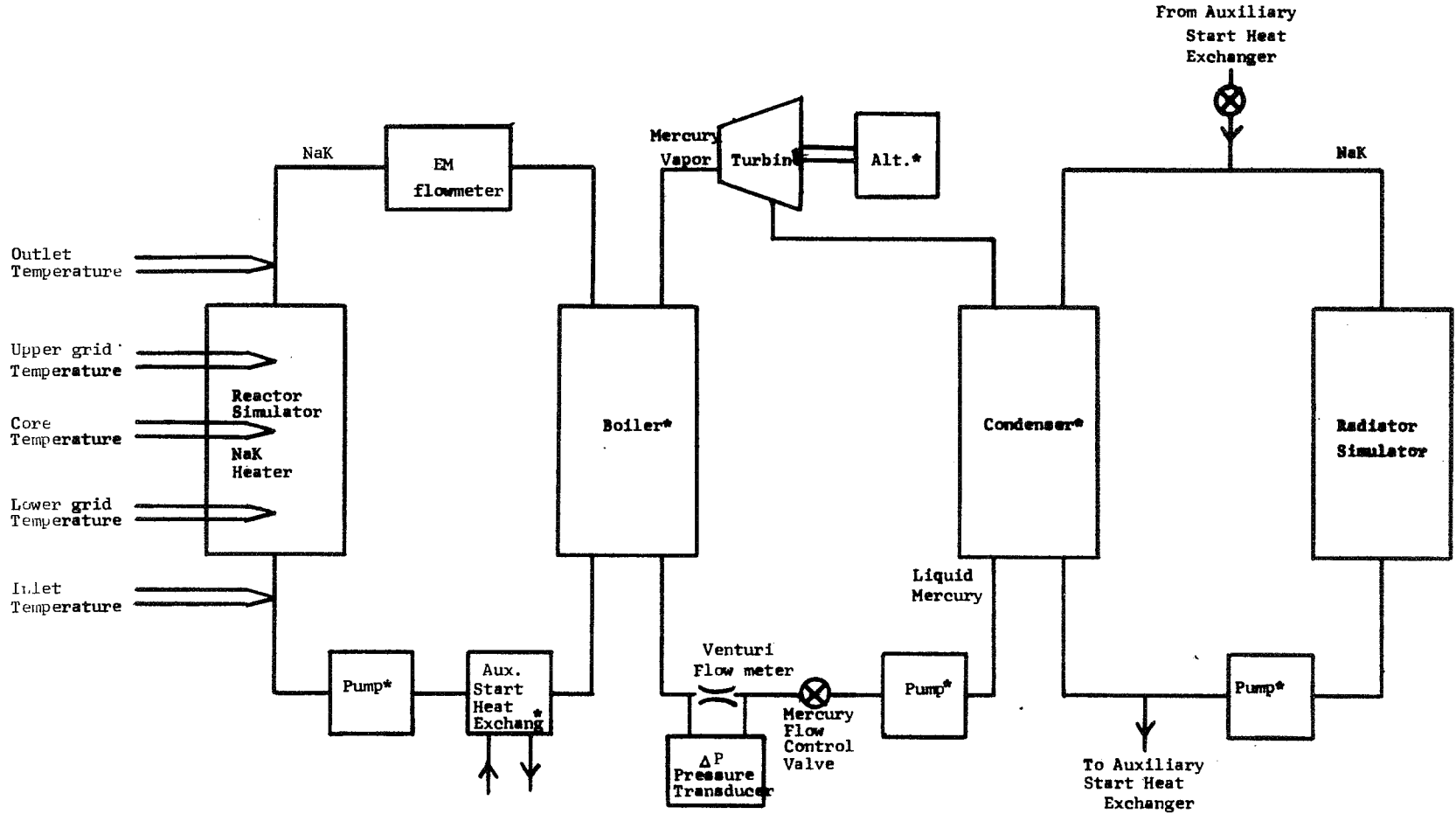

Figure 1. - Simplified Schematic Diagram of SNAP-8 Test System

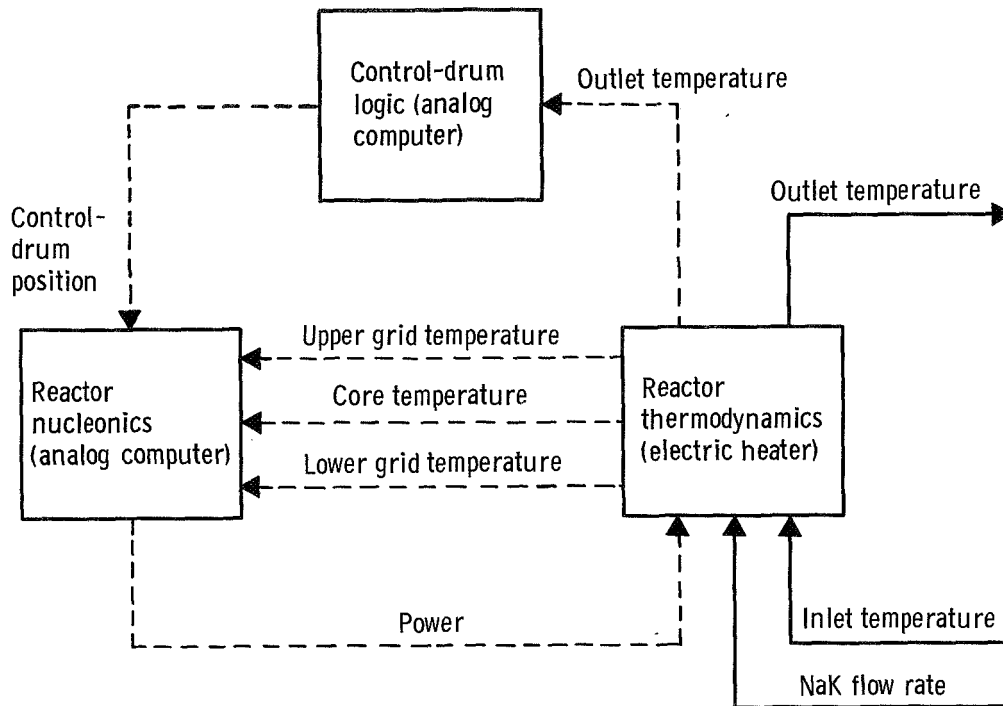

Figure 2. - Block diagram showing basic concept of reactor simulator.

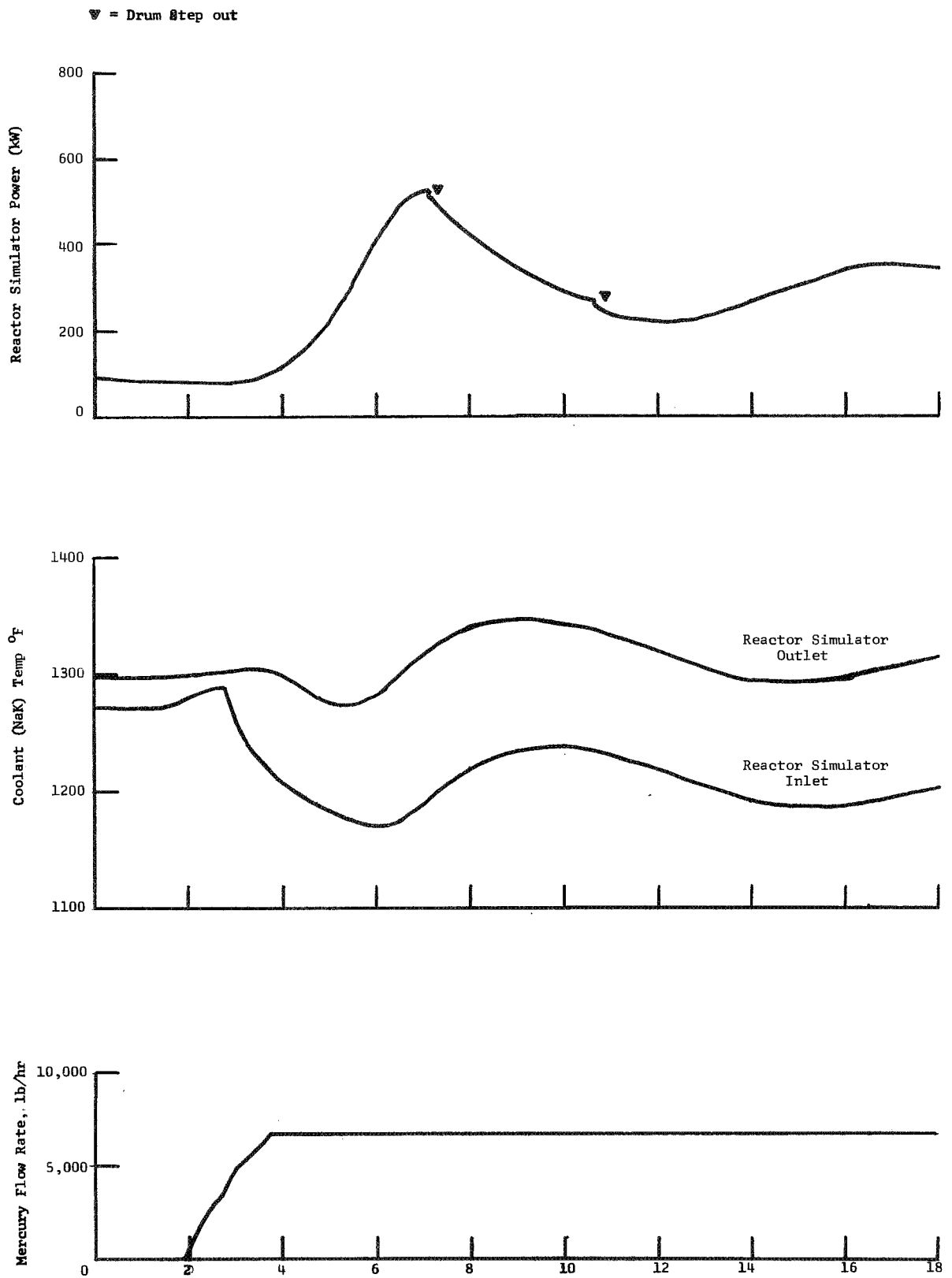

Figure 3 - Reactor Loop Transients for a Reference PCS Startup



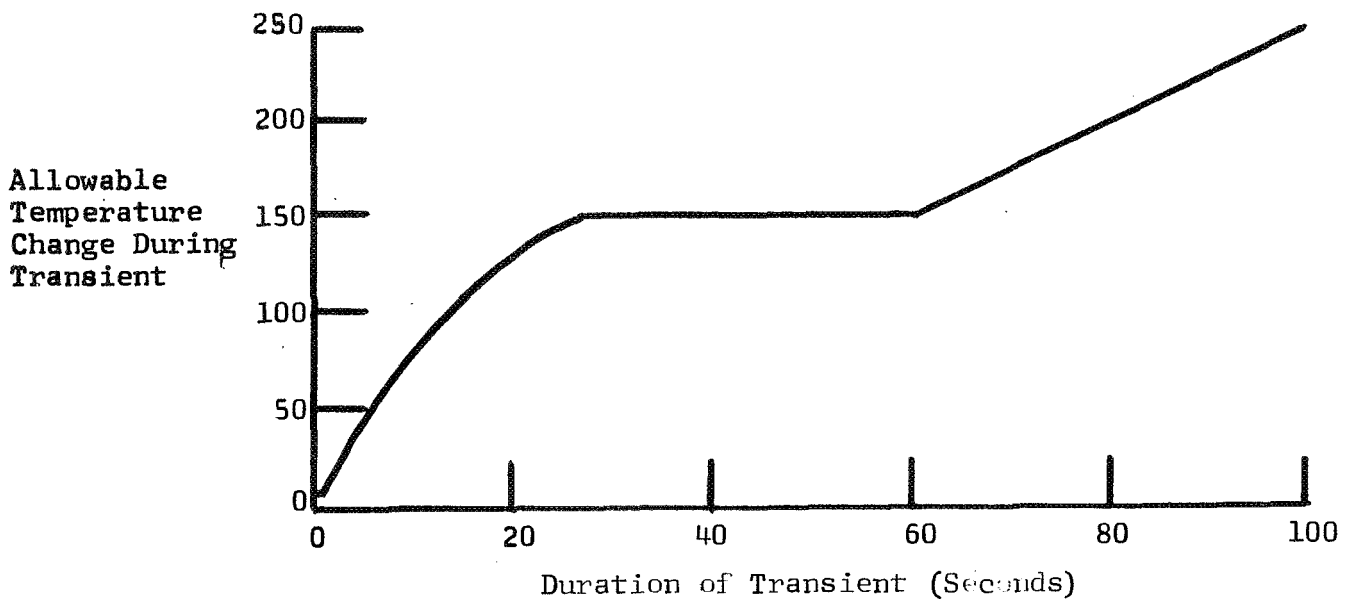
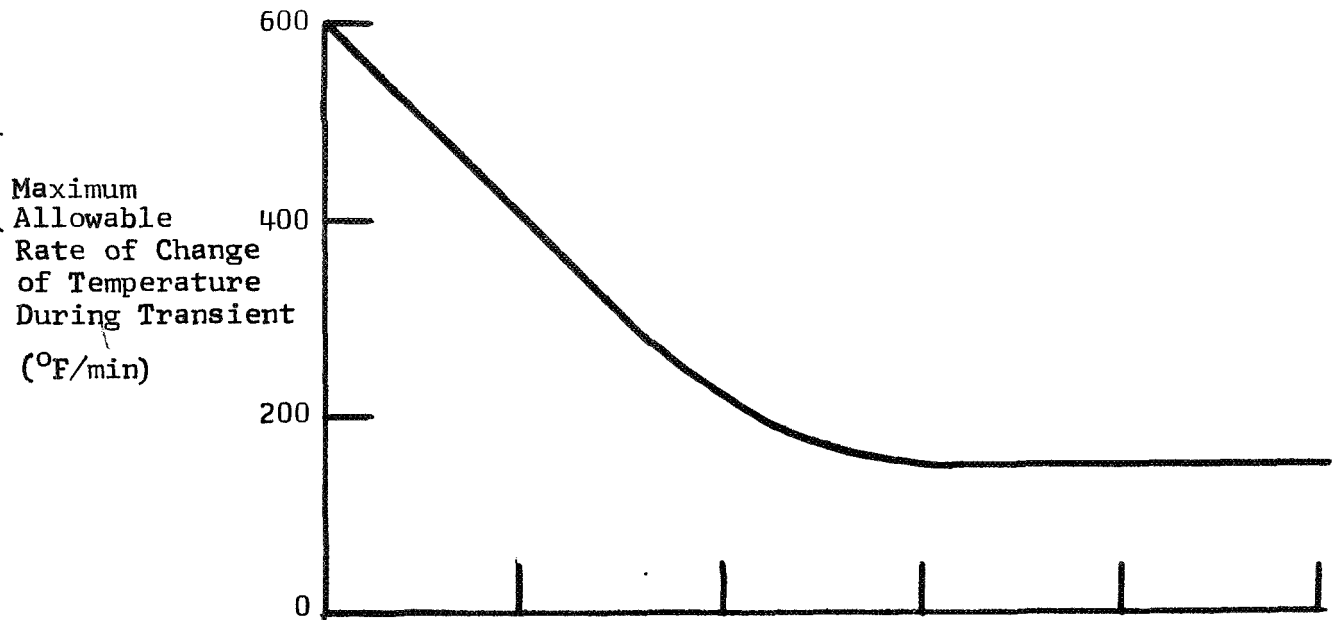

Figure 4 - Allowable Transient Characteristics of Reactor Coolant Temperature Versus Transient Duration

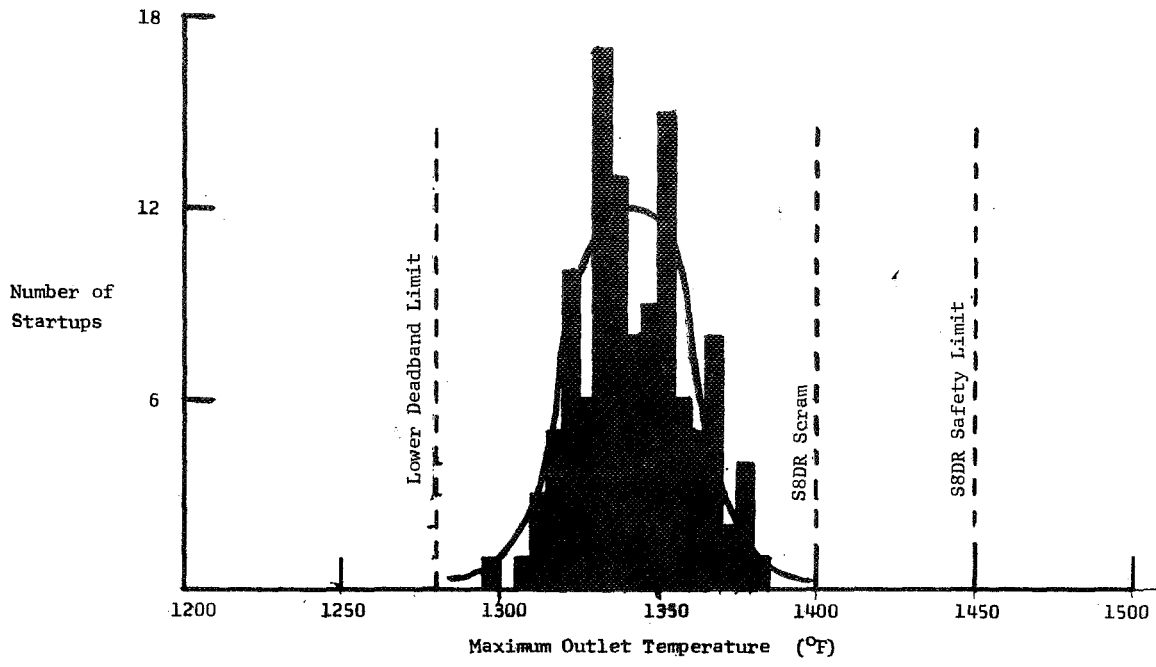

Figure 5 - Number of Startups With The Indicated Reactor Simulator Maximum Outlet Temperature

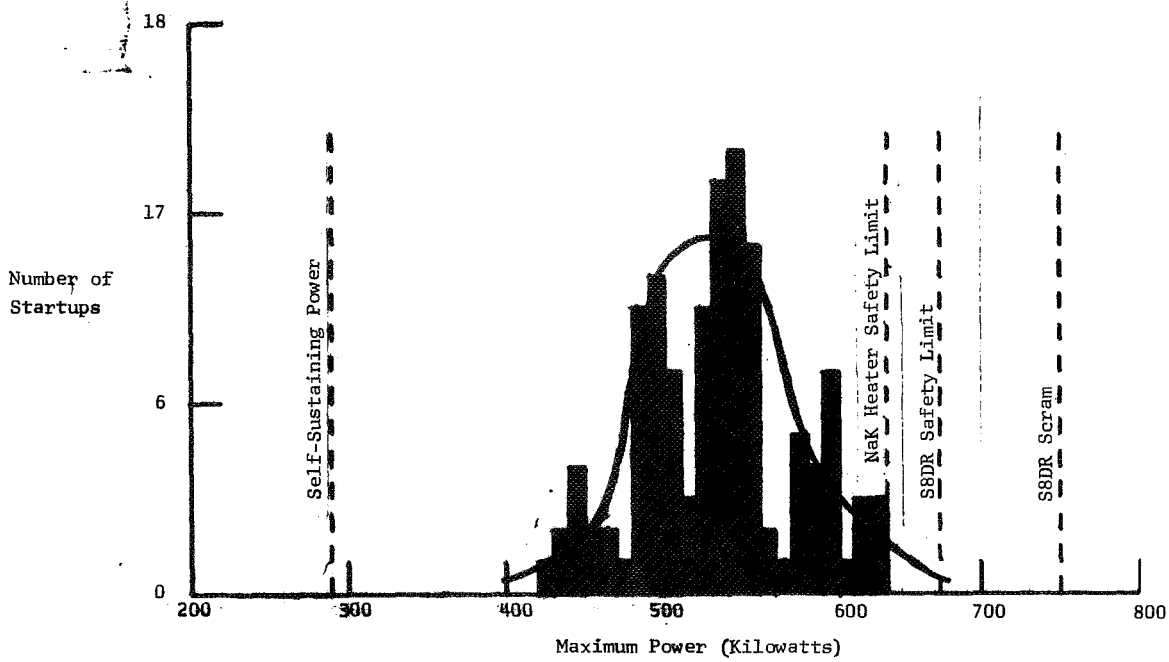

Figure 6 - Number of Startups With The Indicated Maximum Reactor Simulator Power

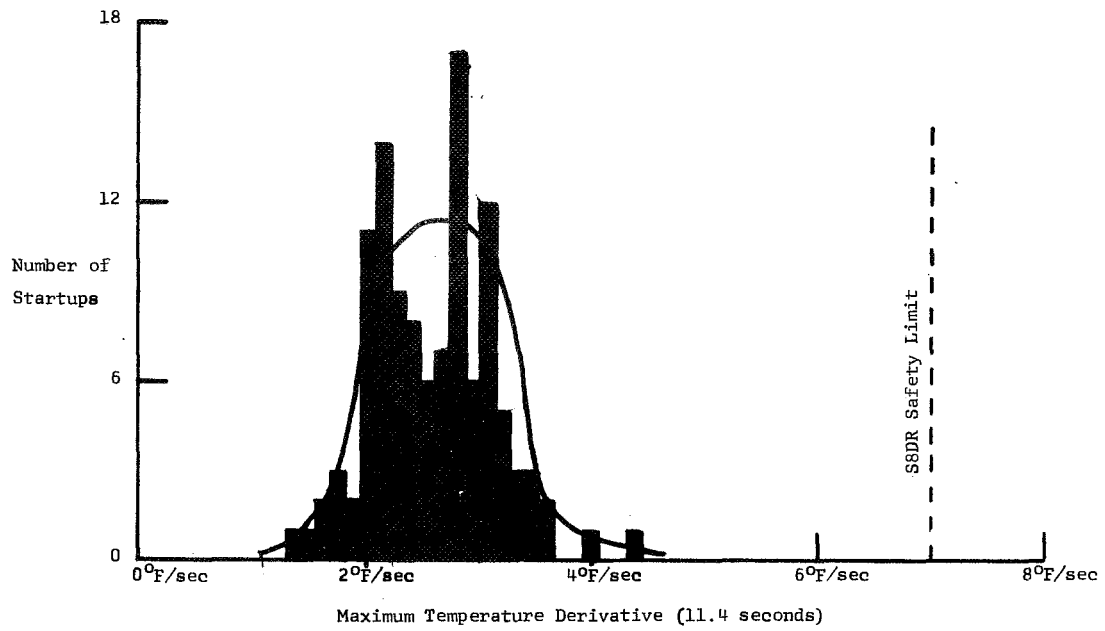

Figure 7 - Number of Startups with the Indicated Maximum NaK Temperature Derivative During an 11.4-Second Time Interval

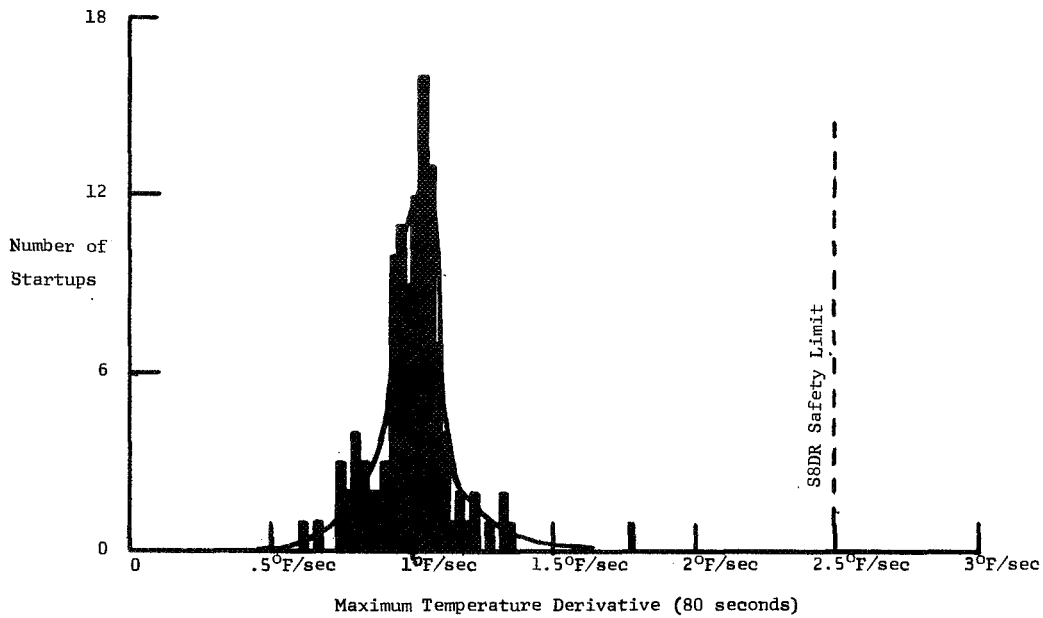

Figure 8 - Number of Startups with the Indicated Maximum NaK Temperature Derivative During an 80-Second Time Interval

SHEET NO. OF .....  
 JOB NO. ....  
 SUBJECT .....  
 DATE .....  
 DATE .....  
 BY .....  
 CHKD. BY .....

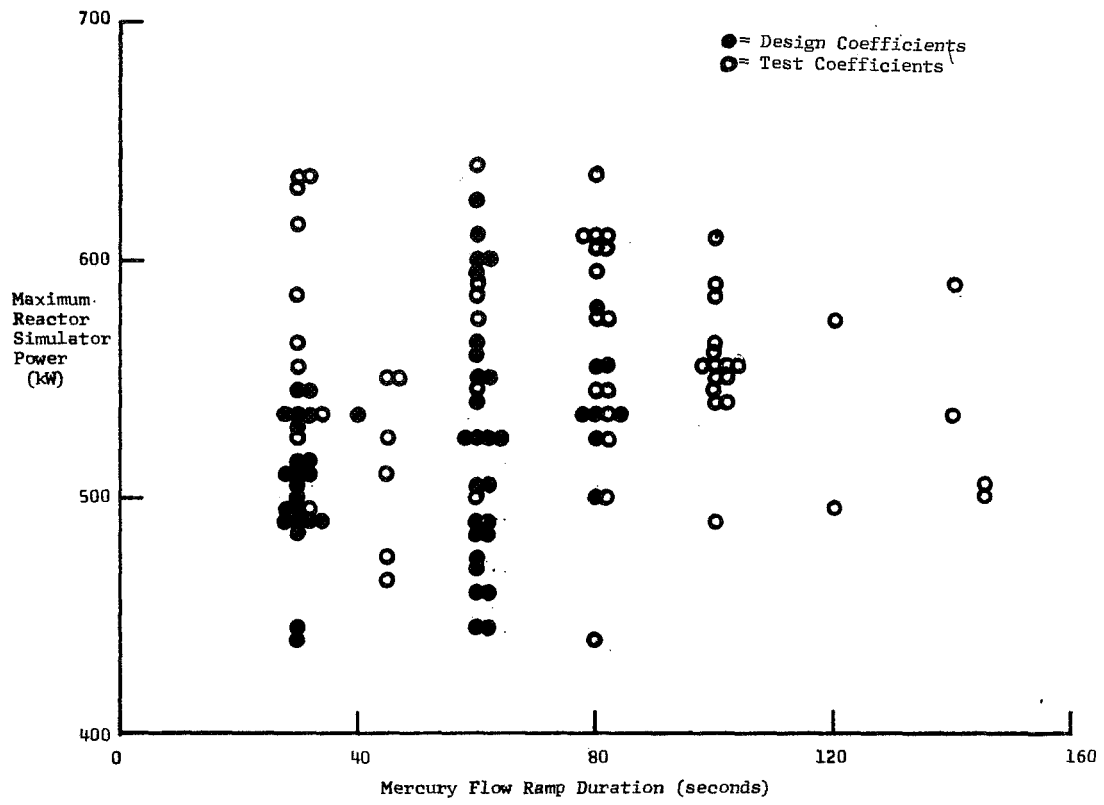

Figure 9 - Effect of Mercury Flow Ramp Duration on Power Peaks

SHEET NO. ....  
 JOB NO. ....  
 SUBJECT .....  
 DATE .....  
 DATE .....  
 BY .....  
 CHKD. BY .....

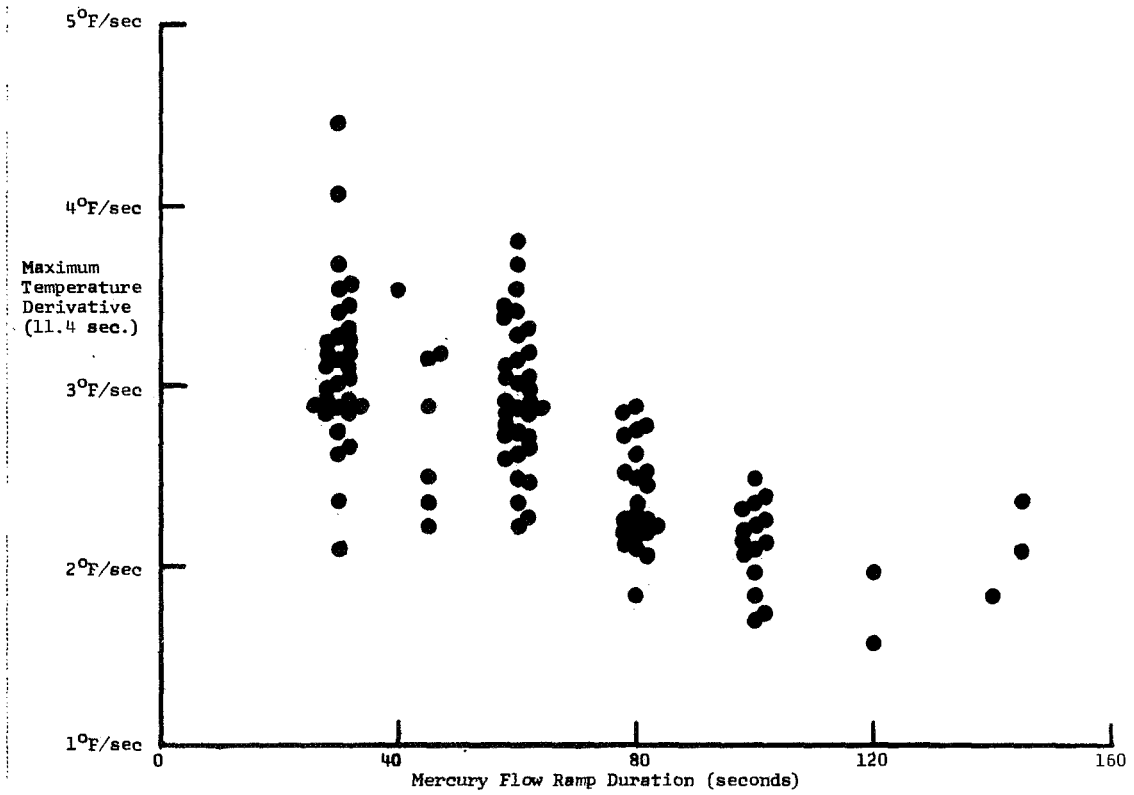

Figure 10 - Effect of Ramp Duration of the Temperature Derivative

BY ..... DATE ..... SUBJECT ..... SHEET NO. OF .....  
 CHKD. BY ..... DATE ..... JOB NO. ....

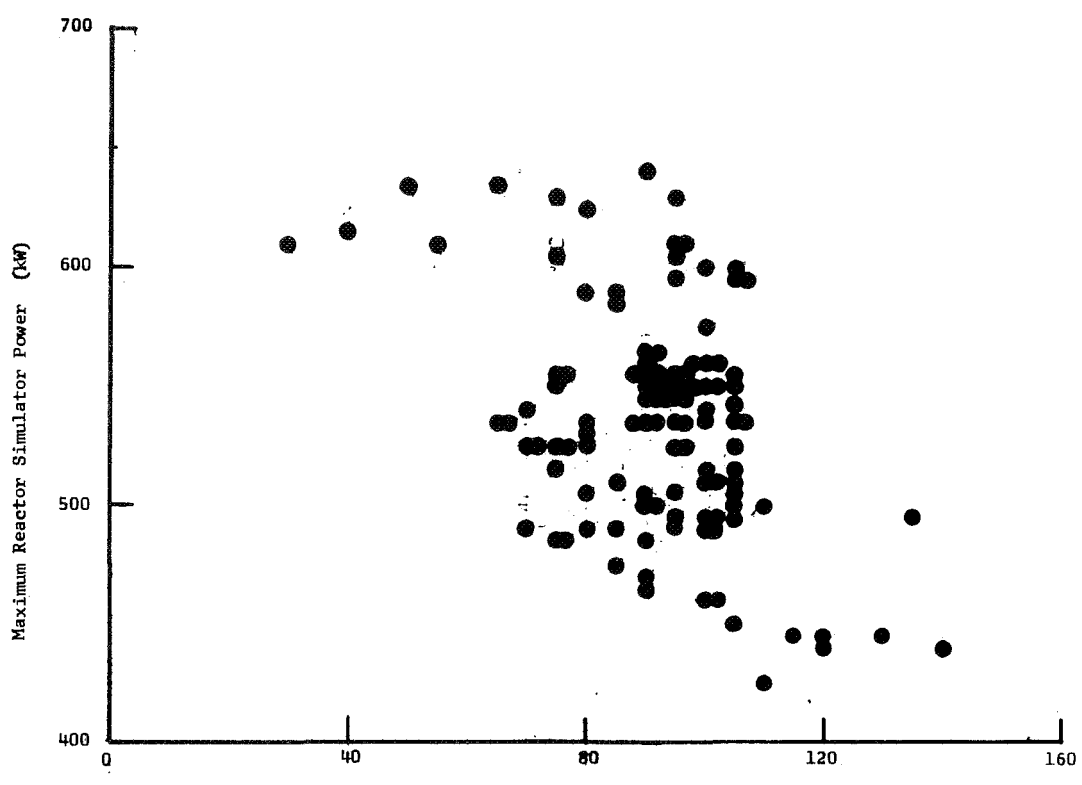

Figure 11 - Effect of Initial Power Level on Peak Power

BY ..... DATE ..... SUBJECT ..... SHEET NO. OF .....  
 CHKD. BY ..... DATE ..... JOB NO. ....

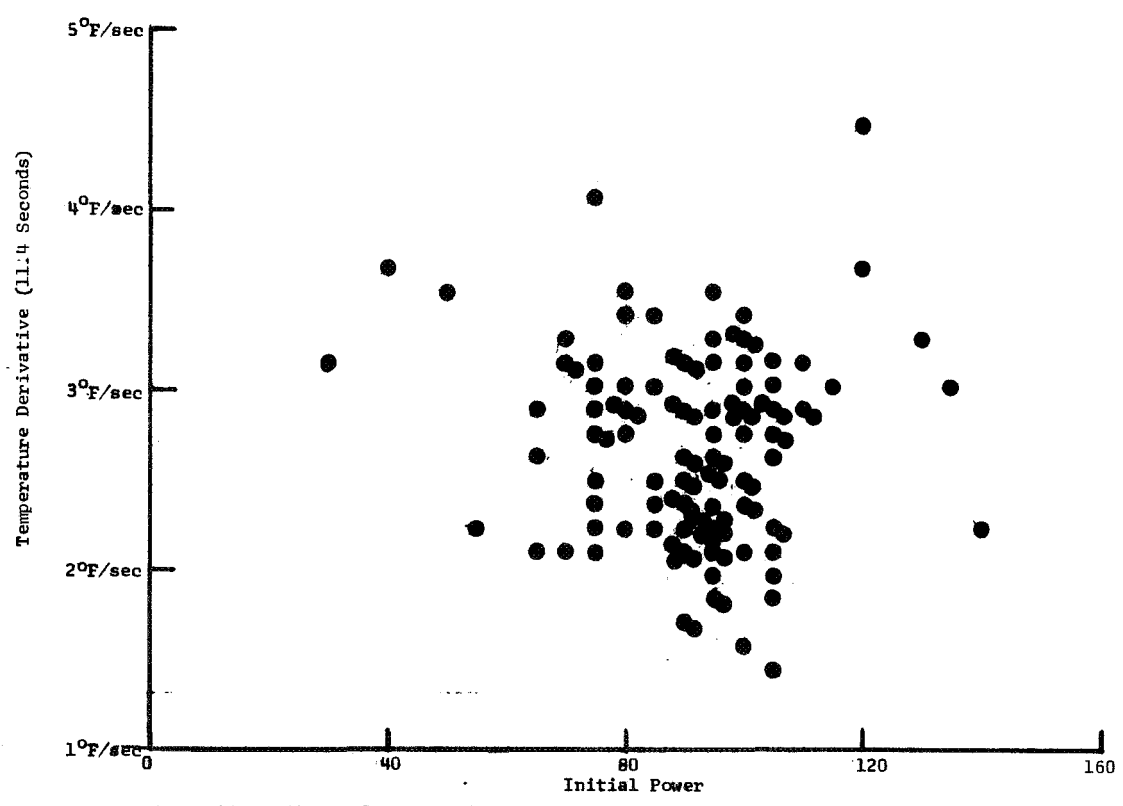

Figure 12 - Effect of Initial Power on Maximum NaK Temperature Derivative (11.4 seconds)

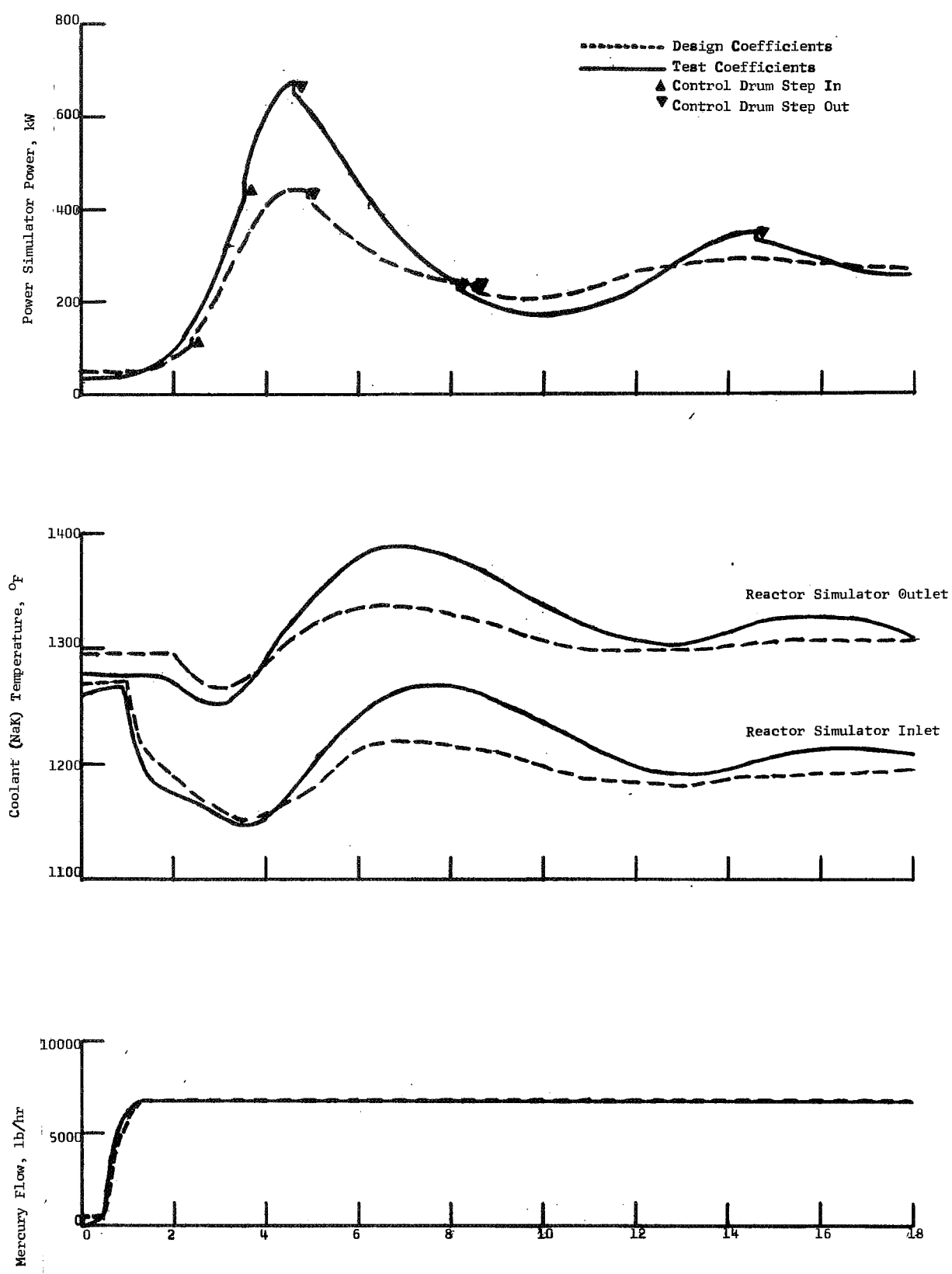

Figure 13 - Reactor Loop Transients for PCS Startups; Comparison of Effect of Design and Test Coefficients

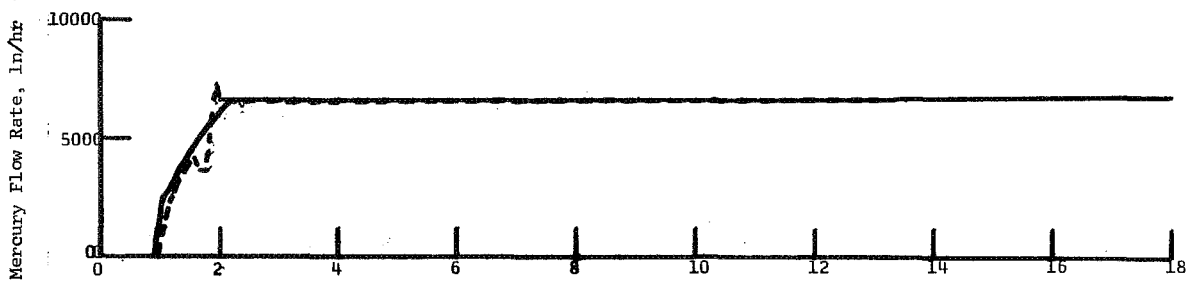
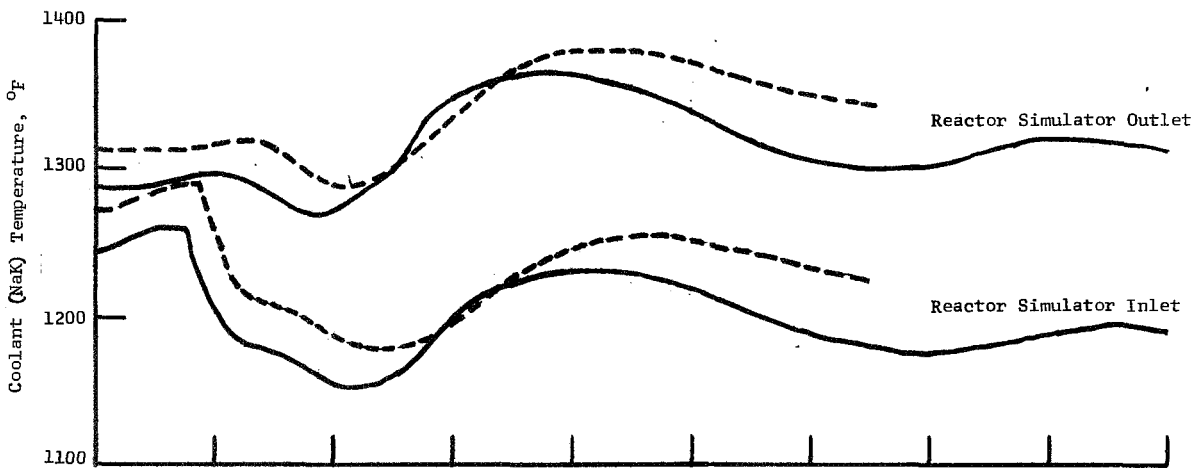
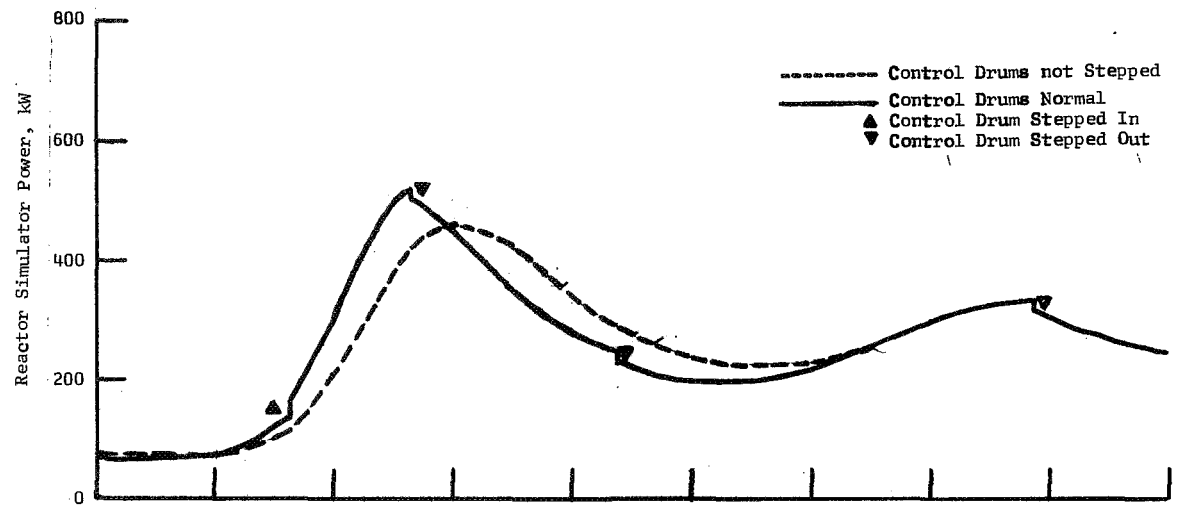

Figure 14 - Reactor Loop Transients for PCS Startups Using Test Reactivity Coefficients. Comparison of Two Transients One With Normal Control The Other With Control Drums Not Stepped.