

NASA TECHNICAL NOTE



NASA TN D-5717

C.1

NASA TN D-5717



LOAN COPY: RETURN TO
AFWL (WLOL)
KIRTLAND AFB, N MEX

OPTICAL STUDY OF SONIC AND SUPERSONIC JET PENETRATION FROM A FLAT PLATE INTO A MACH 2 AIRSTREAM

*by Martin Hersch, Louis A. Povinelli,
and Frederick P. Povinelli*

*Lewis Research Center
Cleveland, Ohio*





0131545

1. Report No. NASA TN D-5717	2. Government Accession No.	3. Recipient's Catalog No.	
4. Title and Subtitle OPTICAL STUDY OF SONIC AND SUPERSONIC JET PENETRATION FROM A FLAT PLATE INTO A MACH 2 AIRSTREAM		5. Report Date March 1970	
		6. Performing Organization Code	
7. Author(s) Martin Hersch, Louis A. Povinelli, and Frederick P. Povinelli		8. Performing Organization Report No. E-5309	
9. Performing Organization Name and Address Lewis Research Center National Aeronautics and Space Administration Cleveland, Ohio 44135		10. Work Unit No. 722-03	
		11. Contract or Grant No.	
12. Sponsoring Agency Name and Address National Aeronautics and Space Administration Washington, D. C. 20546		13. Type of Report and Period Covered Technical Note	
		14. Sponsoring Agency Code	
15. Supplementary Notes			
16. Abstract It is shown that penetration of a helium jet into a supersonic air stream may be accurately measured by densitometer analysis of schlieren photography. The penetration could also be measured, qualitatively, by visual inspection of the photographs. The location of the jet boundary, determined by densitometer analysis of the schlieren photographs, was found to correspond to center plane helium concentrations of approximately 0 to 1 percent by volume. Variables were injection Mach number and injection pressure.			
17. Key Words (Suggested by Author(s)) Injection Photography Jet penetration Schlieren Mixing Supersonic Optical Wind tunnel Penetration		18. Distribution Statement Unclassified - unlimited	
19. Security Classif. (of this report) Unclassified	20. Security Classif. (of this page) Unclassified	21. No. of Pages 14	22. Price* \$3.00

*For sale by the Clearinghouse for Federal Scientific and Technical Information
Springfield, Virginia 22151

OPTICAL STUDY OF SONIC AND SUPERSONIC JET PENETRATION FROM A FLAT PLATE INTO A MACH 2 AIRSTREAM

by Martin Hersch, Louis A. Povinelli, and Frederick P. Povinelli

Lewis Research Center

SUMMARY

Penetration of a helium jet into a Mach 2 airstream was measured by analysis of schlieren photographs. The path of the injected helium appeared as a plume shaped streak in the schlieren photographs. The outer edge of this feature, located by densitometer analysis of the schlieren photographs, corresponded to approximately 0 to 1 percent helium by volume. The results were consistent for a range of injection Mach numbers and injection pressures. It is therefore concluded that jet penetration can be accurately measured from schlieren photographs by densitometer analysis. The jet penetration, when located by visual inspection, was in some cases underestimated by as much as 15 percent. Measurement by visual inspection could perhaps be useful for rapid, qualitative estimates of penetration. A relation between the jet boundary and the location of the first normal shock (Mach disk) across the jet was also investigated.

INTRODUCTION

Supersonic combustion, thrust vector control, and prevention of radio "blackout" from high speed reentry bodies into the terrestrial atmosphere all involve injection of a fluid into a supersonic stream. A critical measurement in studying this flow process is the penetration and mixing of the injectant with the free stream.

The penetration may be measured by injecting a fluid from an appropriate model into a wind tunnel flow stream from which gas samples are collected and analyzed. The injectant penetration and mixing into the free stream is then determined from concentration measurements of the gas samples, as described in references 1 to 5. These concentration measurements were made by gas chromatography, mass spectrometry, and thermal conductivity techniques. Numerous problems treated by Tiné (ref. 6), however, are associated with probing supersonic streams. In addition, elaborate gas analysis equipment, not normally included in wind tunnel instrumentation, is required. The collection and analysis procedures also require long tunnel operation times.

It is advantageous and convenient to employ schlieren techniques to measure jet penetration. Data, in the form of schlieren photographs, may be acquired rapidly. Some examples of schlieren methods for studying jet penetration into a supersonic stream are presented in references 4 and 7. Injectant concentration can not however be determined directly from the photographs. Detailed studies are thus necessary which relate schlieren features to injectant distribution in the flow field.

A distinctive schlieren feature observed in this study with helium injection into a supersonic stream was a plume shaped streak, which suggested the path of the injectant. The outer edge of this feature, once having been correlated with concentration measurements, may then be used to determine jet penetration. A purpose of this study, then, is to correlate concentration measurements to this feature observed on the schlieren photographs for a range of operating conditions.

Helium was injected normal to a Mach 2 airstream from a flat plate. The injection Mach number was varied from 1.0 to 4, and injection pressure from about 48 to 130 psia (3.31×10^5 to 8.96×10^5 N/m²). The injection nozzle throat diameter was held constant. The free-stream total pressure and temperature were 0.92 atmosphere (9.3×10^4 N/m²) and 625° R (347 K), respectively. The jet boundaries, measured from schlieren photographs by microdensitometer analysis and also by visual inspection, were compared with results based on concentration measurements. In addition, the location of the normal shock (Mach disk) in the jet was calculated from the jet boundary data.

APPARATUS AND PROCEDURE

Tunnel

The study was conducted using a 25.4- by 9.75-centimeter Mach 2 wind tunnel. The free-stream total pressure and temperature were 0.92 atmosphere (9.3×10^4 N/m²) and 625° R (347 K), respectively.

Injection System

The helium was injected normal to the free stream from a flat plate which spanned the tunnel walls. The essential features of the plate and its orientation in the tunnel are shown in figure 1. Injection Mach number was varied by using removable nozzle inserts in the flat plate. All nozzles had the same throat diameter ($d^* = 1.9$ mm), but different exit diameters (see fig. 2). The injection Mach numbers were determined by calibration using pitot pressure measurements at the nozzle exits, as opposed to calculation

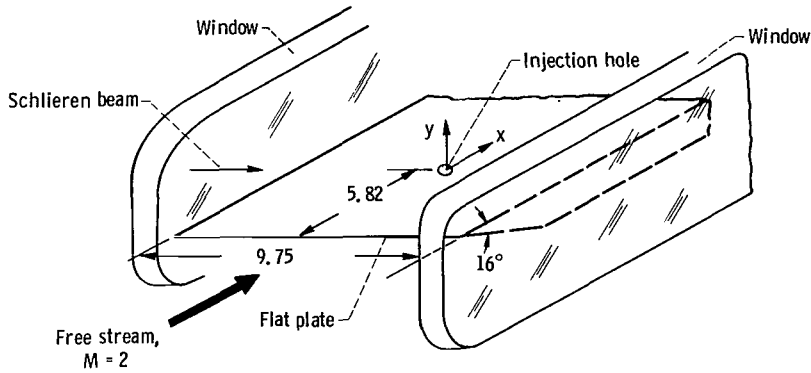

Figure 1. - Flat plate installation in tunnel (dimensions in centimeters).

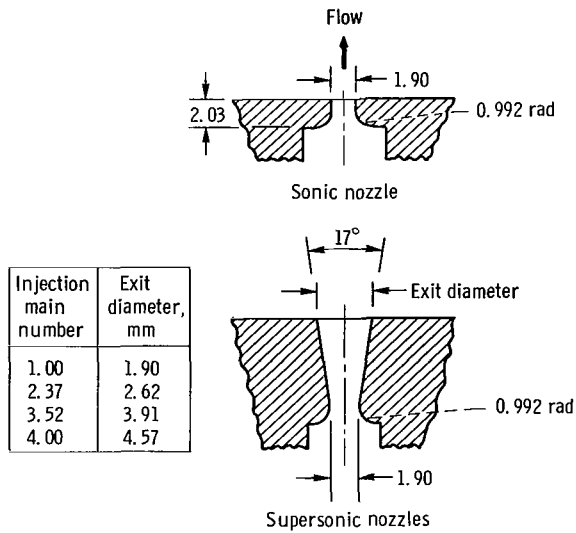

Figure 2. - Injection nozzle dimensions and Mach numbers.

based on area ratio. Injection total pressure was measured immediately upstream of the nozzle throats.

Concentration Measurements

Helium concentration was measured by withdrawing gas from the free stream with a probe and analyzing it with a commercial mass spectrometer helium leak detector. Details of this technique are given in reference 2. The concentration measurements were made on a plane along the centerline of the plate directly downstream of the injection orifice. Concentration profiles on this plane normal to the plate surface, were ob-

tained at approximately 4, 10, and 17 jet throat diameters downstream of the orifice.

Schlieren System

The schlieren system, of single pass standard Z configuration, had a mercury arc light source, 30.5-centimeter diameter main mirrors of 1.82-meter focal length. The knife edge was oriented perpendicular to the free stream. The overall magnification of the system was 0.785.

Photograph Analysis

The photographs were analyzed with an automatic double beam recording micro-densitometer. Measurements by visual inspection of the photographs were also obtained.

RESULTS AND DISCUSSION

Schlieren Photographs

A typical schlieren photograph of helium injection into the Mach 2 airstream is shown in figure 3. One feature is a diffuse plume shaped streak emanating from the injection hole, and extending for a considerable downstream instance.

Previous studies have indicated uncertainty of the physical significance of certain schlieren features observed for jet penetration into a supersonic stream. For example, Zukoski and Spaid (ref. 4), noted a feature which they said "looks like the top or outer boundary of the jet." However, they thought that this feature probably represented a "line of maximum concentration of injectant rather than the jet boundary." Subsequently, Shetz, Hawkins, and Lehman (ref. 7), concluded that the line observed by Zukoski and Spaid (ref. 4), was the outer boundary of the jet shock structure.

The diffuse appearance of the feature associated with the jet observed in this present study suggest that it represented the path of injectant gas. It did not consist of lines characteristic of shock structure. Furthermore, it extended downstream of where jet shock structure should be located.

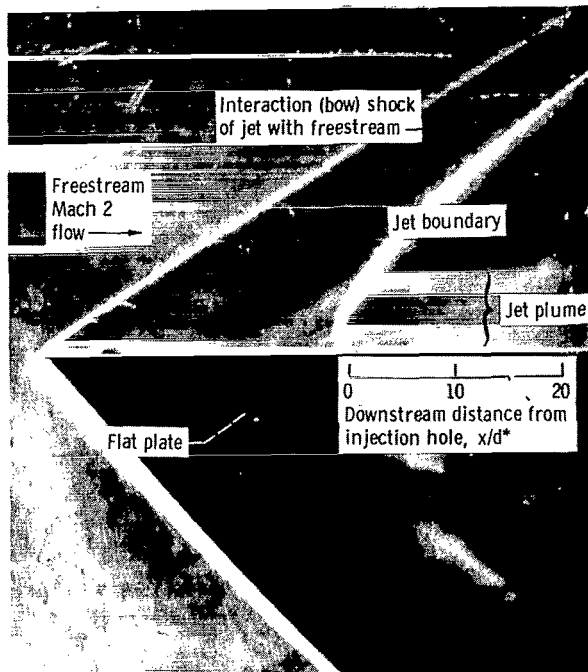

Figure 3. - Typical schlieren photograph (negative). Injection Mach number, 1.0; injection pressure, 100 psia (6.89×10^5 N/M²).

Densitometer Analysis

The densitometer light spot scanned the schlieren negatives in a direction normal to the free stream. Density recordings were obtained from 4 to 20 injection throat diameters d^* downstream of the injection orifice. A typical densitometer recording is shown in figure 4. Relative photographic density is indicated by the abscissa, and nondimensional distance (y/d^*), above the plate by the ordinate. It is estimated that the densitometer light spot location, and resolution of the recordings are known to approximately ± 0.2 millimeters.

The photographic density peak near the flat plate surface corresponds to boundary-layer flow and light diffraction at the plate edge. The upper edge, or outer boundary, of the helium jet is represented in this recording by the density decrease located between 6 to 8 y/d^* units. The interaction (bow) shock of the jet with the free stream is represented by the density increase starting at approximately 13 y/d^* units. The apparent edge of the observed helium plume in the free-stream y_j/d^* is located by the intersec-

tion of the photographic density gradient in the jet boundary with the photographic density corresponding to the helium free region. However, the photographic density of the helium jet approaches gradually that of the helium free region. This intersection is therefore located arbitrarily by extending the linear portion of the helium jet boundary photographic density gradient to the helium free photographic density (as shown in fig. 4). Similarly, due to diffraction effects and boundary layer flow, the edge of the plate is not well defined. The edge of the plate is located by the intersection of the density gradient near the plate edge and the density level of the plate shadow.

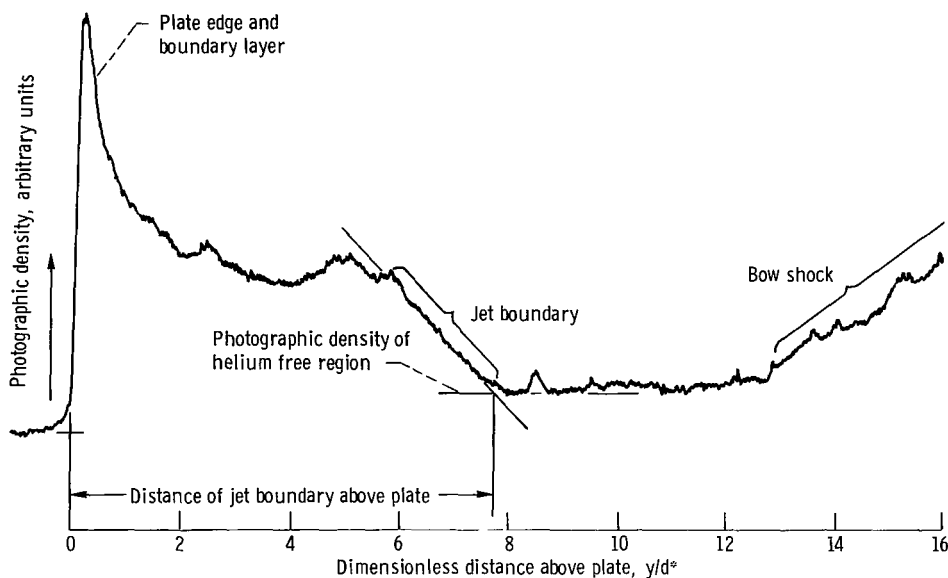

Figure 4. - Typical microdensitometer recording. Injection Mach number, 1.0; injection pressure, 75 psia (5.1×10^5 N/m²); dimensionless downstream distance from injection hole, 12.

Preliminary photographs were made with various photographic emulsion types, exposure times, and schlieren sensitivity settings. It was found that these variables had little effect on the measurement of jet boundary positions.

Comparison of Schlieren to Concentration Results

Measurements of jet boundary locations are shown in figure 5. These measurements were obtained with Panatomic film and 0.1 second exposure time. Two densitometer measurements from a single negative were used to establish each data point. The solid data points represent helium volumetric concentrations of 0 and 1 percent on the center-plane of the plate directly downstream of the injection hole. These points were obtained

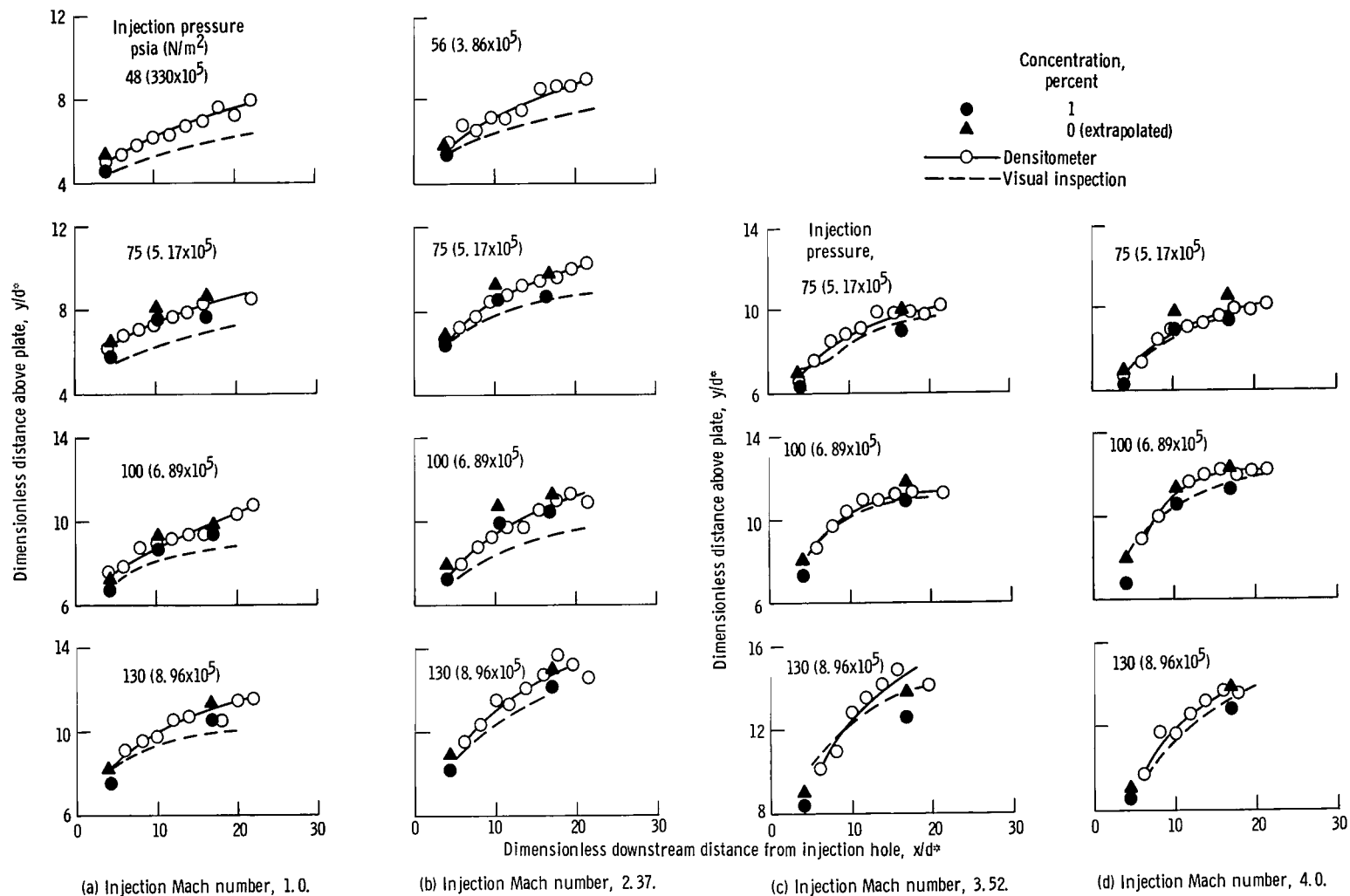

Figure 5. - Helium jet boundary locations. Determined from densitometer and visual inspection measurements of schlieren photographs and comparison with concentration measurements.

from concentration profiles, in turn, obtained by mass spectrometer measurements (see refs. 2 and 3). In most instances, the jet boundary determined from densitometer measurements lies in the region bounded by 0 to 1 percent helium concentration. This indicates that densitometer analysis of schlieren photographs can accurately locate the jet boundary.

Location of Jet Boundary by Visual Inspection

Visual measurements of the apparent jet boundary were also made from the photographs with results shown in figure 5. In some instances the visually located jet boundary agrees quite well with the densitometer and concentration measurements. But in a number of cases, visual measurements underestimated penetration by as much 15 percent. Visual measurements might, however, be acceptable for rapid, qualitative estimates of penetration.

Relative Schlieren Light Intensity as a Function of Helium Concentration

The variation of photographic density near the jet boundary (fig. 4) was related to the corresponding variation in schlieren light intensity. This was accomplished by calibration of the film emulsion using a step wedge filter in the schlieren light beam with no tunnel flow. The resulting relation was then used to determine relative schlieren light intensity variation across the helium jet at a selected x/d^* position from the densitometer recordings. This was then compared with centerplane helium concentration profiles at the same x/d^* positions. Relative light intensities across the jet plume may then be plotted against centerplane helium concentration, as shown in figure 6 at an x/d^* of 10.

Gradients of schlieren light intensity across the plume appear to behave nonlinearly with centerplane helium concentration and are greatest near the jet boundary. In addition, light intensity variation across the plume appears to decrease with increasing injection Mach number. Hence, visualization of the injectant plume may be more difficult at high injection Mach numbers.

These curves suggest that concentration profiles might be determined from schlieren light intensity measurements. However, the light-intensity-concentration profile relation varies with operating conditions, such as injection Mach number and pressure. Extensive calibration would thus be needed to obtain concentration profiles from light intensity measurements.

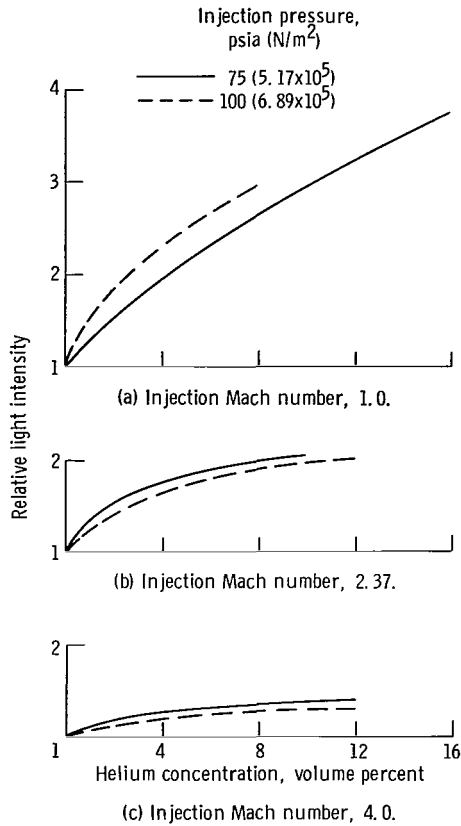

Figure 6. - Effect of centerplane helium concentration on relative transmitted schlieren light intensity. Dimensionless downstream distance from injection hole, 10.

Calculated Mach Disk Position

A significant feature of an underexpanded jet exiting from a nozzle is the first normal shock, often referred to as the Mach disk. This structure, clearly visible in jets expanding into still air, is described in detail by Adamson and Nicholls (ref. 8). Under some conditions the Mach disk or closely related barrel shaped intercepting shocks immediately upstream of and adjoining the Mach disk are the primary features observed for jets flowing into a supersonic stream. A sketch illustrating the jet flow field is shown in figure 7. The normal distance from the injection hole to the top of the Mach disk (ref. 4) or to the center of the Mach disk y_0 , has previously been used as a criterion of jet penetration (refs. 7, 9, and 10). In references 1 to 3 and 5 and in the present study, the outer boundary of the jet y_j where the helium concentration approaches zero, is used as the criterion of jet penetration. As shown in the sketch of figure 7, this is a more complete description of the jet penetration than the Mach disk penetration.

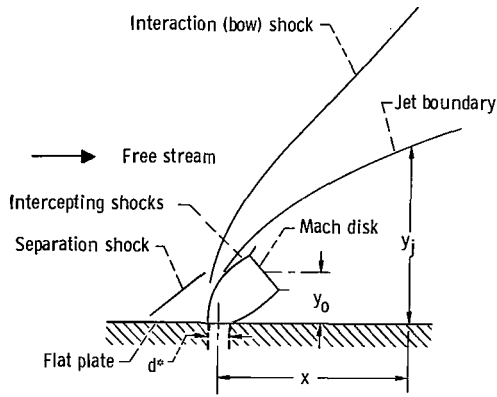

Figure 7. - Diagram of injection flow field.

In the present study some additional schlieren observations were made with nitrogen injection. Jet shock structure was then observed, but the diffuse, plume shaped feature indicating the path of the injectant could not be seen. This is in contrast to helium injection, where no jet shock structure, but only the injectant plume was observed. This observation agrees with Zukoski and Spaid (ref. 4), who also report that shock structure was not observed for helium. They did, however, observe shock structure in nitrogen and argon jets. It would be useful, then, to relate Mach disk position to jet boundary locations for comparison of results using various injectants.

One set of data (Orth and Funk, ref. 10), does provide corresponding jet boundary and Mach disk positions, y_j/d^* and y_0/d^* , respectively. These data were used to calculate the ratio y_j/y_0 . The results, plotted as a function of x/d^* are shown in figure 8.

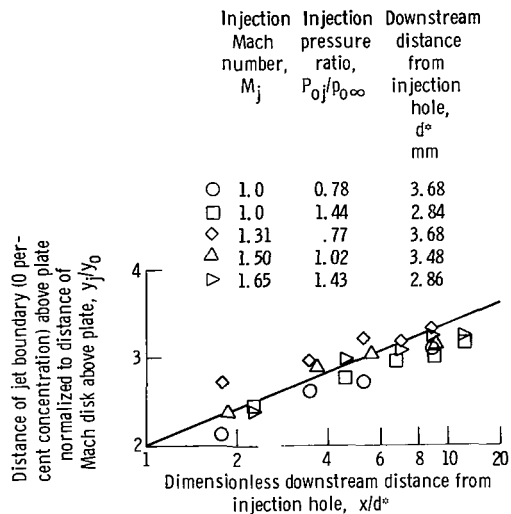

Figure 8. - Ratio of jet boundary to Mach disk location calculated from data of reference 10.

The data included variation of injectant Mach number, injectant to free-stream total-pressure ratio, and injector hole diameter. Considering the limited range of these variables, the points of figure 8 are adequately fitted by a single curve. The Mach disk position, y_o/d^* , corresponding to the jet boundary positions y_j/d^* for the present study, was calculated by the equation

$$\frac{y_o}{d^*} = \frac{\left(\frac{y_j}{d^*}\right)}{\left(\frac{y_j}{y_o}\right)}$$

Here, at a given x/d^* , y_j/y_o is obtained from the curve of figure 8, and y_j/d^* from the densitometer measurements at the same x/d^* from figure 5.

The Mach disk position which is not a function of x/d^* , was calculated using y_j/d^* data at x/d^* positions of 5, 10, 15, and 20. The results were averaged to yield a representative Mach disk position, y_o/d^* for each set of conditions.

The resulting Mach disk positions, as a function of injection pressure and Mach number are shown in figure 9. The jet boundary position at an x/d^* position of 5, which is

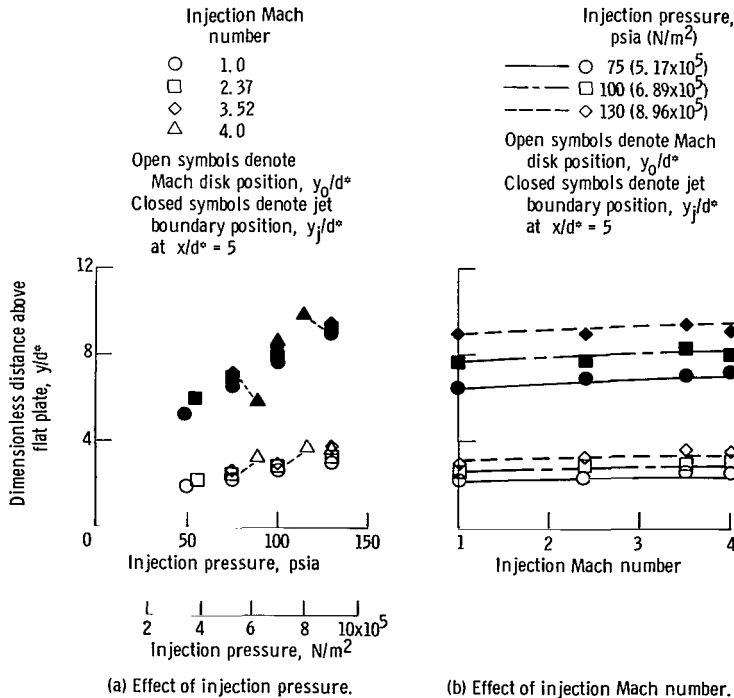

Figure 9. - Comparison of Mach disk position (calculated) and jet boundary position as functions of injection pressure and Mach number.

near the downstream location of the Mach disk, is also shown. The effect of injection pressure is greater than injection Mach number on both jet boundary and Mach disk penetration. The Mach disk penetration is seen to be only a fraction of the jet boundary penetration. These results indicate the advantages of using the jet boundary rather than the Mach disk to study jet penetration.

SUMMARY OF RESULTS

Penetration of a helium jet into a Mach 2 wind tunnel airstream was measured using schlieren photography. The results were compared to concentration measurements obtained by gas sampling and analysis. The advantages of optical techniques are that tunnel operating times can be very short, gas analysis problems are obviated, the overall flow field is observed, and existing schlieren systems with which most wind tunnels are equipped are used.

The helium jet appeared as a plume shaped streak in the schlieren photographs. The outer edge of the streak, detected by microdensitometer analysis of the schlieren photographs was found, by comparison to concentration measurements, to be in the outer 0 to 1 percent helium concentration region. This technique thus gave an accurate measurement of jet penetration.

Visual measurements of the jet boundary underestimated penetration, in some cases, by 15 percent. The relation between the Mach disk and jet boundary positions was also investigated.

Lewis Research Center,
National Aeronautics and Space Administration,
Cleveland, Ohio, December 19, 1969,
722-03.

REFERENCES

1. Torrence, Marvin G. : Concentration Measurements of an Injected Gas in a Supersonic Stream. NASA TN D-3860, 1967.
2. Povinelli, Louis A. ; Povinelli, Frederick P. ; and Hersch, Martin: A Study of Helium Penetration and Spreading in a Mach 2 Airstream Using a Delta Wing Injector. NASA TN D-5322, 1969.

3. Povinelli, Frederick P. ; Povinelli, Louis A. ; and Hersch, Martin: Effect of Angle of Attack and Injection Pressure on Jet Penetration and Spreading from a Delta Wing in Supersonic Flow. NASA TM X-1889, 1969.
4. Zukoski, Edward E. ; and Spaid, Frank W. : Secondary Injection of Gases into a Supersonic Flow. AIAA J. , vol. 2, no. 10, Oct. 1964, pp. 1689-1696.
5. Vranos, A. ; and Nolan, J. J. : Supersonic Mixing of a Light Gas and Air. Presented at the AIAA Propulsion Joint Specialist Conference, Colorado Springs, Colo. , June 14-18, 1965.
6. Tiné, G. : Gas Sampling and Chemical Analysis in Combustion Processes. AGARDograph 47, Pergamon Press, 1961.
7. Schetz, Joseph A. ; Hawkins, Paul F. ; and Lehman, Harry: Structure of Highly Underexpanded Transverse Jets in a Supersonic Stream, AIAA J. , vol. 5, no. 5, May 1967, pp. 882-884.
8. Adamson, T. C. , Jr. ; and Nicholls, J. A. : On the Structure of Jets From Highly Underexpanded Nozzles into Still Air. J. Aero/Space Sci. , vol. 26, no. 1, Jan. 1959, pp. 16-24.
9. Schetz, Joseph A. ; and Billig, Frederick S. : Penetration of Gaseous Jets Injected into a Supersonic Stream. J. Spacecraft Rockets, vol. 3, no. 11, Nov. 1966, pp. 1658-1665.
10. Orth, Richard C. ; and Funk, John A. : An Experimental and Comparative Study of Jet Penetration in Supersonic Flow. J. Spacecraft Rockets, vol. 4, no. 9, Sept. 1967, pp. 1236-1242.
11. Crist, S. ; Sherman, P. M. ; and Glass, D. R. : Study of the Highly Underexpanded Sonic Jet. AIAA J. , vol. 4, no. 1, Jan. 1966, pp. 68-71.

FIRST CLASS MAIL



POSTAGE AND FEES PAID
NATIONAL AERONAUTICS A
SPACE ADMINISTRATION

080 001 37 51 3DS 70058 00903
AIR FORCE WEAPONS LABORATORY /WLOL/
KIRTLAND AFB, NEW MEXICO 87117

ALL R. LOJ BIRKAN, CHIEF, TECH. LIBRARY

POSTMASTER: If Undeliverable (Section 15
Postal Manual) Do Not Ret

"The aeronautical and space activities of the United States shall be conducted so as to contribute . . . to the expansion of human knowledge of phenomena in the atmosphere and space. The Administration shall provide for the widest practicable and appropriate dissemination of information concerning its activities and the results thereof."

— NATIONAL AERONAUTICS AND SPACE ACT OF 1958

NASA SCIENTIFIC AND TECHNICAL PUBLICATIONS

TECHNICAL REPORTS: Scientific and technical information considered important, complete, and a lasting contribution to existing knowledge.

TECHNICAL NOTES: Information less broad in scope but nevertheless of importance as a contribution to existing knowledge.

TECHNICAL MEMORANDUMS: Information receiving limited distribution because of preliminary data, security classification, or other reasons.

CONTRACTOR REPORTS: Scientific and technical information generated under a NASA contract or grant and considered an important contribution to existing knowledge.

TECHNICAL TRANSLATIONS: Information published in a foreign language considered to merit NASA distribution in English.

SPECIAL PUBLICATIONS: Information derived from or of value to NASA activities. Publications include conference proceedings, monographs, data compilations, handbooks, sourcebooks, and special bibliographies.

TECHNOLOGY UTILIZATION PUBLICATIONS: Information on technology used by NASA that may be of particular interest in commercial and other non-aerospace applications. Publications include Tech Briefs, Technology Utilization Reports and Notes, and Technology Surveys.

Details on the availability of these publications may be obtained from:

**SCIENTIFIC AND TECHNICAL INFORMATION DIVISION
NATIONAL AERONAUTICS AND SPACE ADMINISTRATION
Washington, D.C. 20546**