

N 70 28247
NASA CR 102670

MCR-69-410 Copy No. 15

Contract NAS8-21253

**A MECHANICAL FASTENING TECHNIQUE
DEVELOPMENT FOR APPLICATION IN SPACE**

FINAL REPORT

**CASE FILE
COPY**

31 MARCH 1970

**MANUFACTURING ENGINEERING LABORATORY
MECHANICAL & CHEMICAL DEVELOPMENT BRANCH
NATIONAL AERONAUTICS AND SPACE ADMINISTRATION
MARSHALL SPACE FLIGHT CENTER
HUNTSVILLE, ALABAMA**

MARTIN MARIETTA CORPORATION

MCR-69-410

Contract NAS8-21253

A MECHANICAL FASTENING TECHNIQUE DEVELOPMENT
FOR APPLICATION IN SPACE

FINAL REPORT

31 March 1970

Authors

Floyd K. Daisey
Don A. Lewis

Prepared for

NATIONAL AERONAUTICS AND SPACE ADMINISTRATION
MARSHALL SPACE FLIGHT CENTER
HUNTSVILLE, ALABAMA

Approved by

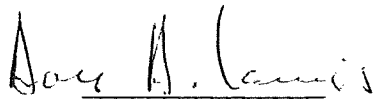

Don A. Lewis
Program Manager

MARTIN MARIETTA CORPORATION
DENVER DIVISION
P.O. Box 179
Denver, Colorado 80201

FOREWORD

This document is submitted in accordance with requirements of exhibit A.B.4 and exhibit B.3 of NASA Contract NAS8-21253 titled "A Mechanical Fastening Technique Development for Application in Space".

This study was begun at Martin Marietta Corporation, Baltimore, Maryland, and completed at Martin Marietta's Denver Division under the direction of Carl M. Wood, Principal Investigator, Manufacturing Engineering Laboratory, NASA-MSFC, Huntsville, Alabama.

Summary

This report describes a study effort to investigate a threaded mechanical fastening technique for use in zero or reduced gravity space environments. The program consisted of four phases of effort:

- 1) State of the Art Survey;
- 2) Selection and Development;
- 3) Evaluation and Testing;
- 4) Definition and Evaluation of Environmental Effects on Joints and Fasteners.

This report details the data gathered and formulated during the various phases of this program.

Martin Marietta Corporation's Space Operations Facilities were used for this study.

CONTENTS

	<u>Page</u>
Foreword	ii
Summary	iii
Contents	iv thru viii
I. Introduction	I-1
II. State-of-the-Art Survey	II-1
A. Future Manned Space Missions	II-1
B. Present Day Fastener Technology	II-6
C. Identification of Fastener Problems	II-14 thru II-15
III. Human Factors Manipulative Test Plans	III-1
A. Introduction	III-1
B. Fastener Selection (Manipulation Tests)	III-2
C. Test Method	III-6
D. Test Procedure	III-9
E. Baseline Tests	III-9 thru III-12
IV. Definition and Evaluation of Environmental Effects	IV-1
A. Space Simulation	IV-1
B. Testing and Analysis	IV-4
C. Mechanical Fastening Technique Development for Application in Space	IV-18
D. Vacuum and High Temperature, Thirty-Day Soak Test	IV-37
E. Vacuum and Cyclic Temperature Test	IV-41
F. Test Results and Conclusions, Cyclic Temperature Torque/Tension Tests	IV-44

G.	Conclusions and Recommendations	IV-68 thru IV-71
V.	List of References	V-1 and V-2

Figure

II-1	Pressure as a Function of Altitude	II-4
II-2	Evaporation Rates for Various Metals in Vacuum, Ambient Pressure: 0.8×10^{-7} to 2.0×10^{-6} millimeter of Mercury	II-10
III-1	Forces Produced by Astronaut in GE Test	III-3
III-2	Fastener Head Configuration for Manipulation Tests	III-5
III-3	Manipulation Test Panel	III-7
III-4	Fastener Manipulation Test Sequence	III-8
III-5	Test Performance Form	III-10
IV-1	Test Cylinder	IV-4
IV-2	Calibration Curves for 6A ℓ -4V Titanium and A-286 Bolts	IV-5
IV-3	Torque vs Induced Load for Test Items 1-24 (Ambient Conditions) A-286	IV-6
IV-4	Torque vs Induced Load (Ambient Conditions) A-286 Six-Wing Bolt Assembly P/N SW1555-4-24 (Moly-Disulfide-Plated Nuts)	IV-7
IV-5	Torque vs Induced Load (Ambient Conditions) Titanium 6A ℓ -4V Six-Wing Bolt Assembly P/N SW2565- 4-24 (306 Type II-Plated Nuts)	IV-8
IV-6	Torque vs Induced Load (Ambient Conditions) A-286 Six-Wing Bolt Assembly P/N SW1555-4-24 (Silver-Plated Nuts)	IV-9
IV-7	Torque vs Induced Load (Ambient Conditions) Titanium 6A ℓ -4V Six-Wing Bolt Assembly P/N SW2565-4-24 (Passivated Nuts)	IV-10
IV-8	Torque vs Induced Load (Ambient Conditions) Titanium Six-Wing Bolt Assembly P/N SW2565-4-24 (VSM 1171-Plated Nuts)	IV-11

IV-9	Vacuum System Environmental Tests	IV-23
IV-10	Evaluation of Test Fixture	IV-24
IV-11	Hi-Temp Vacuum Test Setup	IV-26
IV-12	Hi-Temp Vacuum Test Setup	IV-27
IV-13	Time History of Hi-Temp Chamber Pump Down	IV-29
IV-14	Torque Mechanism Calibration Curve	IV-34
IV-15	Temperature Measurement Block Diagram	IV-36
IV-16	High Temperature Chamber Interior	IV-38
IV-17	Break-Away Torques for Dynamic Test Items	IV-40
IV-18	Break-Away Torques for Static Test Items	IV-40
IV-19	Cyclic Temperature Vacuum Chamber with New Feed-Thru	IV-42
IV-20	Cyclic Temperature Chamber with Cover (Top) Removed	IV-43
IV-21	Test Condition 10^{-9} Torr Vacuum +250°F (Composite)	IV-46
IV-22	Test Condition 10^{-9} Torr Vacuum +250°F (Titanium - VSM 1171)	IV-47
IV-23	Test Condition 10^{-9} Torr Vacuum +250°F (Titanium - Hi-Shear II No. 306)	IV-47
IV-24	Test Condition 10^{-9} Torr Vacuum +250°F (Titanium - Bare Titanium Nut)	IV-47
IV-25	Test Condition 10^{-9} Torr Vacuum +250°F (A-286 - Moly-Disulfide)	IV-48
IV-26	Test Condition 10^{-9} Torr Vacuum +250°F (A-286 - Silver Plate)	IV-48
IV-27	Test Condition 10^{-9} Torr Vacuum +250°F (A-286 - Bare Titanium Nut)	IV-48
IV-28	Ambient vs 10^{-9} Torr Vacuum +250°F Condition	IV-53
IV-29	Vacuum Chamber Interior	IV-55
IV-30	Debris from Titanium Nut Lubricated with VSM 1171	IV-55
IV-31	Debris from A-286 Bolts with Silver-Plated Nuts	IV-56

IV-32	Debris from A-286 Bolt with Moly-Disulfide Lubricated A-286 Nuts	IV-56
IV-33	Vacuum Chamber and Feed-Thru	IV-57
IV-34	Test Arrangement	IV-58
IV-35	Test Cylinder	IV-58
IV-36	Certificates of Conformance	IV-59
IV-37	Proposed Test Fixtures: Vacuum 10^{-6} Torr, Temperature -250° to -317° F	IV-60
IV-38	Torque vs Induced Load (10^{-6} Torr Vacuum -317° F)	IV-61
IV-39	Torque vs Induced Load for A-286 Six-Wing Bolt Assembly P/N SW1555-4-24 Silver-Plated Nut (10^{-6} Torr Vacuum -317° F)	IV-62
IV-40	Torque vs Induced Load for A-286 Six-Wing Bolt Assembly P/N SW1565-4-24 Passivated-Titanium Nut (Ambient and 10^{-6} Torr Vacuum -317° F)	IV-63
IV-41	Torque vs Induced Load for A-286 Six-Wing Bolt Assembly P/N SW1555-4-24 Moly-Disulfide-Plated Nut (Ambient and 10^{-6} Torr Vacuum -317° F)	IV-64
IV-42	Torque vs Induced Load for Titanium 6Al-4V Six-Wing Bolt Assembly P/N SW2565-4-24 Passivated Nut (Ambient and 10^{-6} Torr Vacuum -317° F)	IV-65
IV-43	Torque vs Induced Load for Titanium 6Al-4V Bolt Assembly P/N SW2565-4-24, 306 Type II-Plated Nut (Ambient and 10^{-6} Torr Vacuum -317° F)	IV-66
IV-44	Torque vs Induced Load for Titanium 6Al-4V Bolt Assembly P/N SW2565-4-24, VSM 1362-Plated Nut (Ambient and 10^{-6} Torr Vacuum -317° F)	IV-67
IV-45	Torque vs Induced Load; Ambient vs 10^{-9} Torr Vacuum $+250^{\circ}$ F Conditions and 10^{-6} Torr Vacuum -317° F	IV-70
<u>Table</u>		
II-1	Table of Physical Data for Earth, Moon, Mars and Venus	II-3
IV-1	Torque vs Induced Load (Ambient Conditions) A-286 Six-Wing Bolt Assembly P/N SW1555-4-24 (Unlubricated Combinations)	IV-12

IV-2	Torque vs Induced Load (Ambient Conditions) A-286 Six-Wing Bolt Assembly P/N SW1555-4-24 (Moly-Disulfide-Plated Nuts)	IV-12
IV-3	Torque vs Induced Load (Ambient Conditions) Titanium 6Al-4V Six-Wing Bolt Assembly P/N SW2565-4-24 (306 Type II-Plated Nuts	IV-13
IV-4	Torque vs Induced Load (Ambient Conditions) A-286 Six-Wing Bolt Assembly P/N SW1555-4-24 (Silver-Plated Nuts)	IV-14
IV-5	Torque vs Induced Load (Ambient Conditions) Titanium 6Al-4V Six-Wing Bolt Assembly P/N SW2565-4-24 (Passivated Nut)	IV-15
IV-6	Torque vs Induced Load (Ambient Conditions) Titanium 6Al-4V Six-Wing Bolt Assembly P/N SW2565-4-24 (VSM 1171-Plated Nut)	IV-16
IV-7	Dynamic and Static Test Samples	IV-20
IV-8	Ion Pump Pumping Speeds	IV-30
IV-9	Vacuum-Torque vs Induced Load - Titanium - 1171 Lube	IV-49
IV-10	Vacuum-Torque vs Induced Load - Titanium Hi-Shear Lube	IV-49
IV-11	Vacuum-Torque vs Induced Load - Titanium - No Lube	IV-50
IV-12	Vacuum-Torque vs Induced Load - Titanium A-286 Moly-Disulfide	IV-50
IV-13	Vacuum-Torque vs Induced Load - A-286 Silver- Plated Nut	IV-51
IV-14	Vacuum-Torque vs Induced Load - A-286 - Bare Titanium	IV-51
IV-15	Test Results from Application of Pneumatic Impact Tool	IV-52
IV-16	Torque vs Induced Load for A-286 Six-Wing Bolt Assembly P/N SW1555-4-24 (Silver-Plated Nut)	IV-62
IV-17	Torque vs Induced Load for A-286 Six-Wing Bolt Assembly P/N SW1565-4-24 (Passivated- Titanium Nut)	IV-63

IV-18	Torque vs Induced Load for A-286 Six-Wing Bolt Assembly P/N SW1555-4-24 (Moly-Disulfide-Plated Nut)	IV-64
IV-19	Torque vs Induced Load for Titanium 6Al-4V Six-Wing Bolt Assembly P/N SW2565-4-24 Passivated Nut)	IV-65
IV-20	Torque vs Induced Load for Titanium 6Al-4V Six-Wing Bolt Assembly P/N SW2565-4-24 (306 Type II-Plated Nut)	IV-66
IV-21	Torque vs Induced Load for Titanium 6Al-4V Six-Wing Bolt Assembly P/N SW2565-4-24 (VSM 1362-Plated Nut)	IV-67
IV-22	Summary of Performance	IV-71

I. INTRODUCTION

This document is the result of a NASA Contract with the Martin Marietta Corporation. The Contract was awarded and begun by the Baltimore Division and completed by the Denver Division of the Martin Marietta Corporation. The overall objective of this Contract was to provide information and data relative to presently available threaded fasteners application and performance in manned space missions.

This program was divided into four phases. The first of which was a State-of-the-Art Survey. The area covered in this survey was: (1) space missions involving man and his probable use of threaded fasteners, and (2) threaded fastener configurations and coatings presently available through fastener technology. Probable fastener use and manipulation under reduced gravity conditions, and fastener performance in a hostile space environment, also were considered in the survey.

Phase two consisted of the selection of fasteners to be tested in the ensuing phases of the program, and the development of test procedures and test equipment.

Phase three was to be devoted to the study of problems identified with manipulation of threaded fasteners in space assembly and maintenance operations. Testing to be accomplished in this phase was cancelled at the Government's convenience. The test plans are included in this report to indicate work done only.

Phase four consisted of conducting torque tension performance of several high performance fastener combinations. These tests were conducted at ambient conditions for reference, and were repeated at pressure and temperature extremes of space. Test data was examined, and conclusions and recommendations made.

This report discusses the major parts of the program in the following sequence:

- Chapter II - State-of-the-Art Survey;
- Chapter III - Human Factors Manipulative Tests;
- Chapter IV - Environmental Tests, Discussion, Test Plans, Equipment, Test Results, Conclusions and Recommendations.

II. STATE-OF-THE-ART SURVEY

The State-of-the-Art Survey conducted during this program encompasses three major areas:

- 1) Planned or expected space missions involving man, particularly where threaded fasteners play a part in the accomplishment of maintenance or assembly tasks;
- 2) Today's fastener technology from the practical standpoint of its effect on a joint design, ease of manipulation under the adverse conditions of space environments, and tool interfaces;
- 3) Identification of problems imposed by threaded fasteners and planned approaches for solving these problems.

A. FUTURE MANNED SPACE MISSIONS^{1,2}

Present planning for manned space missions is sketchy and short-ranged compared with the bold visions of the mid-sixties.

Planned missions outlined herein are tentative and constantly changing. The data is as accurate as can be ascertained from government sources, but may be obsolete by the time this report is disseminated.

1. NASA Planned Manned Space Missions

Firm planning information for NASA manned space flights include only the Apollo and Skylab* Programs. Manned flights were begun in mid-1968, and are planned to continue through the 1970s in a stretched-out program. Six additional lunar flights were planned on a contingency basis. The Apollo 13 lunar landing is now scheduled for 11 April 1970, and Apollos 15 and 16 will be launched at six-month intervals in 1971. At present, manned missions to the moon have been slowed to the six-month interval rate.

*New designation for the Apollo Applications Program (AAP).

Equipment required by the astronauts to carry out the scientific experiments on the lunar surface will be mounted on the ALSEP package carried aboard the lunar module. Individual pieces of equipment are mounted to the ALSEP pallet by means of a sophisticated threaded fastener system. The fastening system is designed to withstand the dynamic loads imposed by vehicle launch, but can be easily removed by means of a simple tool and the application of minimum torque. Provisions for maintenance of prime mission equipment which would involve the removal of or reinsertion of threaded fasteners is not presently planned for the Apollo Program.

The Skylab Program is planned to occur in two cycles of five flights each, beginning in 1972. Launch dates are extremely nebulous and contingent upon Apollo Program dates and the availability of remaining usable Apollo hardware. The first cycle of Skylab flights will begin with Skylab-1A, a twelve-to-fourteen-day flight of a Command and Service Module (CSM) and a 5000-pound experiment carrier incorporating earth surface and atmosphere sensors. The carrier is a pressurized truncated cone that will be stowed below the CSM, and to which the CSM will dock in an orbital transposition maneuver. Skylab-1 and Skylab-2 will be the unmanned launch of the Saturn workshop followed within three to five days by a CSM carrying three astronauts. The Saturn workshop will serve as a living and working area providing a shirt-sleeve environment for the astronauts. Most of the experiments will be stowed in the Multiple Docking Adapter for launch, and will be transferred to the workshop area in orbit. Skylab-3 will be launched approximately three to four months after Skylab-1 and -2, carrying a CSM with three-man crew who will return with their data 28 days later. Another three-man crew will go to the workshop approximately three months later, where they will reactivate experiments and remain for as long as 56 days.

The Skylab second cycle will probably begin with a resupply flight to the workshop and Apollo Telescope Mount (ATM) still in orbit from cycle one. The remaining cycle-two flights involve dual CSM-workshop and CSM-ATM missions, similar to cycle-one flights 1-2 and 3-4.

Resumption of the lunar exploration program is anticipated after completion of Skylab late in 1972. Apollos 17 and 18 would be launched in 1973, and Apollo 19 would complete the program in 1974.

2. Future Mission Concepts

Programs such as the extended manned orbital operations are being studied in-house by NASA at the present time; these include:

- 1) Missions lasting from six months to five years in near-earth orbits;
- 2) Extended lunar exploration with gradual extension of lunar surface explorations to 45 days or more;
- 3) Manned planetary flights consisting of fly-by, orbiter and landing missions to Mars.

3. Environments in Space³

The environments of space will be one of the determining factors in the selection of tools, equipment, systems, methods and procedures to be accomplished during extra-terrestrial missions. Available environmental data of the earth's upper atmosphere, the moon and planets, is often contradictory, although provided by eminent astronomers and scientists. For purpose of this study, it was necessary to select from the differing data those hypotheses which were felt to be most accurate, and were recognized by government agencies as being most correct at this time. A table of physical data comparing earth with Mars, Venus, and the moon appears in Table II-1.

CHARACTERISTICS	EARTH	MOON	MARS	VENUS
*Gravity	1	.166	.39	.86
Mean Diameter (in miles)	7918	2165	4200	7600
Surface Atmospheric Pressure	760 mm H _g	**7.6 x 10 ⁻¹² torr	**10 torr	?
Atmospheric Composition	N, O ₂ , A	?	N, A, CO ₂	CO ₂
Distance from Earth				
Minimum Distance (in miles)	--	221,463	35 million	26 million
Maximum Distance (in miles)	--	252,710	247 million	160 million
Minimum Temperature	-90°F	-247°F	-94°F	?
Maximum Temperature	136°F	275°F	86°F	616°F
*Earth referenced. **Estimated. All miles statute miles.				

Table II-1 Table of Physical Data for Earth, Moon, Mars and Venus

Atmospheric pressure and density are greater at the surface of the earth and diminish as altitude decreases. Heavier gases such as nitrogen, oxygen, and argon are concentrated near the surface, while lighter gases such as hydrogen and helium become predominant at the higher altitudes. At earth orbital altitudes of from 100 to 200 miles the atmospheric pressure is in the order of 1×10^{-6} to 1×10^{-8} torr. From 300 miles altitude the pressure drop is more gradual, reaching an estimated 7.6×10^{-12} torr at the lunar surface (as shown in Figure II-1).

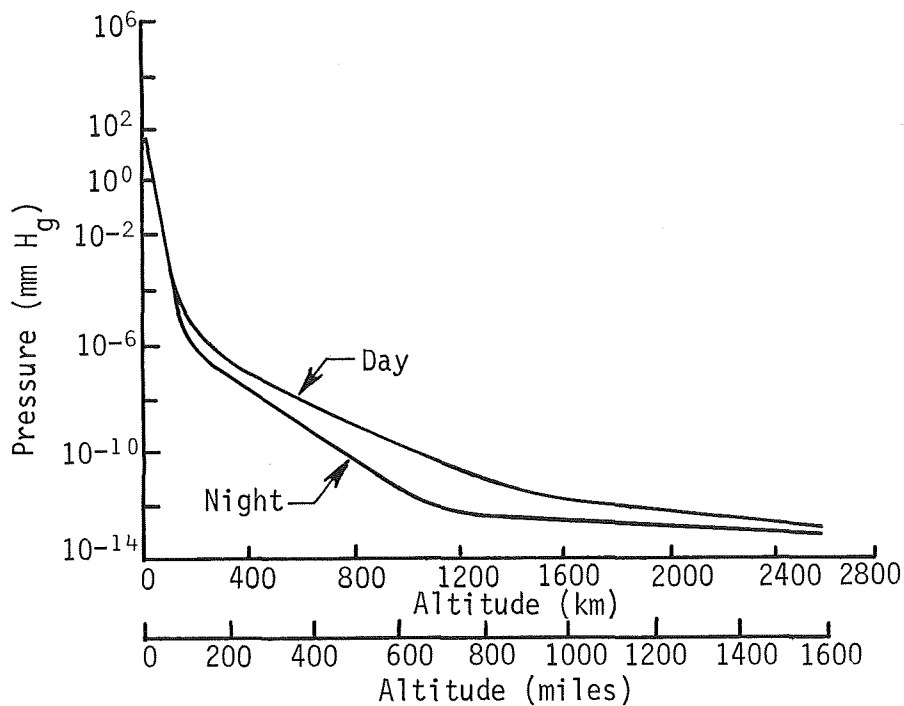

Figure II-1 Pressure as a Function of Altitude⁴

Solar energy reaching the earth's upper atmosphere causes heating of the gases. The heat is distributed through the atmosphere by convection, thus providing some degree of temperature stabilization in the upper troposphere. Some of the solar energy penetrates the atmosphere and strikes the earth's surface. The intensity of the penetrating energy determines to a large extent local temperatures on earth. Objects in the direct sunlight will absorb solar

energy with a consequential temperature rise. The object, however, will not reach the temperature of the solar energy because surrounding air will conduct the heat away from it.

The kinetic temperatures of solar energy reach values on the order of 2000°F and higher at altitudes in the vicinity of 500 to 600 miles. Since there is no atmosphere to conduct the heat away from the object, the surface temperature that an object attains is determined primarily by its ability to reflect solar energy. Above the atmosphere, an object insulated from solar energy will become cold, with its temperature approaching absolute zero. In practical cases, the upper temperature limit that an object will actually attain is controlled by the selection of reflective finishes and the heat flow paths that exist between the surfaces exposed to, and opposite from, the sun. It is generally expected that structures orbiting in space will range in temperature from approximately -150°F to +250°F.

Space vehicles venturing beyond the terrestrial atmosphere are subject to the direct impingement of meteoroid debris, which ranges in size from small dust-like particles to rocks the size of marbles and occasionally larger. This space debris travels at great speeds in unpredictable quantities, and possesses sufficient mass to penetrate an unprotected spacecraft or spacesuit.

Beginning at about 500 miles altitude and extending to 40,000 (at times 60,000) miles away from the earth is the phenomenon known as the Van Allen Radiation Belt. It is thought to be composed of trapped solar protons of ionized hydrogen nuclei and neutrons generated by these protons.

The altitude, intensity and shape of the belt changes considerably from month to month, making precise measurement and predictions difficult. The radiation belt (which does not radiate) is formed perpendicular to the earth's magnetic field.

Solar flares, composed of very high energy ionized hydrogen protons, are randomly emitted from the sun. Their severity and frequency of occurrence tend to follow a cyclic pattern with maximum activity occurring every 11 years. Solar flare activity is now in a maxima period, which began in 1969 and will end in 1971.

A solar flare is sometimes referred to as a tongue of plasma. The flare consists of relatively slow moving charge particles contained within strong magnetic lines of force emanating from the sun. As the tongue of plasma reaches the earth, it provides a direct easy path from the sun for additional heavy concentration of charged solar particles.

The lack of gravity and the necessity to wear cumbersome pressurized spacesuits will, of course, be a hindrance to any task performed by man in space. With respect to fasteners, however, the combination of hard vacuum and elevated temperatures can prove particularly troublesome, resulting in galling, seizing, cold welding and diffusion bonding; all of which are terms describing the same effect. Fastener components made from metals such as stainless steel and titanium have been tested in vacuum furnaces. Test results proved conclusively that these materials must be protectively coated to prevent immediate and severe galling. These coatings are discussed in this report.

4. Mission Impact on Fastener Selection

From the above discussion of future mission plans, it is clear that many different configurations of equipment will exist. Joint and fastener systems will have to be tailored for the specific mission the equipment is intended to perform. For example, some equipment must be threaded-fastener-mounted prior to launch, easily demounted by the pressure-suited astronaut on the lunar surface with no requirement for remounting (ALSEP). Other equipment, such as the Skylab experiment packages, are to be prelaunch mounted and, upon obtaining earth orbit, will be demounted, moved, and remounted by the astronauts. Present Skylab guidelines for orbital operation call for one-handed fastener manipulation, requiring no tools if possible, during the orbital equipment transfer operation. A further requirement, implied by the ATM and Skylab cluster operations, would be fastener-joint configurations, which would be assembled in orbit. These joints and resulting structures would not be subject to the same severe stresses of the launch environment, and therefore could be designed for optimum orbital assembly procedures.

B. PRESENT DAY FASTENER TECHNOLOGY

1. Joint/Fastener System

A joint may be defined as the location in structure where two or more members are to be (or have been) fastened together mechanically by riveting, bolting or specialty fastening, or by brazing or welding⁴. In this report we will deal only with the threaded fastener method of joining. The ability of a joint to

maintain its design performance is based to a large degree on the reliability of its component parts. These parts include the threaded bolt, nut or threaded hole, associated locking devices, and configuration of the faying surfaces. The ideal joint/fastener system for maintenance or assembly would be one in which two or more members could be joined together using one fastener to form a single structure having the characteristics of a homogeneous mass. Make or break of the ideal joint would be accomplished by manipulation of the single fastener with minimal force and simple or no tools. However, design constraints imposed by mission requirements and other practical considerations prevent achievement of the ideal joint/fastener system. Constraining factors include such things as weight, volume, strength of materials, environmental factors, human factors, etc.

In discussing the joint fastener system design problem with engineering personnel in the aerospace field, it becomes readily apparent that there is a divided school of thought between structural design engineers and those oriented to maintainability or human factors. The structural engineer attempts to design to optimum structural integrity but feels he is impeded by the maintainability/human factors requirements. On the other hand, the maintainability/human factors engineers feel equally strong that a maintainable joint could be achieved by the structures engineer with a little more thought, and with little change in design, weight, volume, etc. One reason for the misunderstanding is that while many people have a degree of understanding of the problems relating to maintainability and human factors, few people are familiar with the ground rules which guide the structural engineer in his quest for the optimum joint.

The engineer's choice of fastener size, and the number of fasteners required to secure a given joint, is guided to a large extent by the mechanical requirements of the joint. A sample problem would be defining the proper number and size of fasteners required to secure an aluminum box structure where the fayed surfaces of the joint are formed by extensions of the rear wall of the box to a channel structure. Key factors which would determine fastener selection for this particular problem would be characteristics of the box material, such as thickness, ductility, length and width of the fayed surface, number of mounting strips, and the weight of the box. In addition, forces such as acceleration and vibration must also be known and taken into account. Thin gage materials tend to deform under the compression of large fasteners when the large fasteners are torqued to recommended values. The selected head configurations must distribute the clamp force

properly. For this reason, several small fasteners are generally used to secure this type of joint. If during the tradeoff decision period it is decided that for maintainability reasons a fewer number of large fasteners must be used, it is generally necessary to redesign the joint either by increasing the thickness of the metal or providing load distributing pads between the head of the fastener and the material to be joined. This trade-off enhances maintainability but degrades weight goals.

2. Torque/Tension Relationship

Fasteners generally are torqued to the values recommended in tables supplied by the fastener manufacturers. Torque is used as a means of evaluating the stress induced in a fastener instead of measurement of bolt strain or angular movement of the head or nut, primarily because it lends itself to practical use. Torque tension relationships are highly dependent upon the coefficient of friction existing between the engaged threads and the fayed surfaces of the torqued member of a fastening system. The torque required to produce a given bolt tension can usually be estimated from the following approximate equation:⁵

$$T = KDW$$

where T = Torque (lb-in.)

K = Torque Coefficient (approximately 0.2)

D = Nominal Bolt Size (in.)

W = Bolt Tension (lb)

Although K is generally expressed as being about 0.2, the actual coefficient of friction is dependent upon many things. The more common of these variables are:

- 1) Whether the fastener is or is not plated and, if so, the type of plating;
- 2) Whether it is lubricated and, if so, the type and amount of lubricant used;
- 3) The RMS finish of the contracting surfaces of threads and nut or bolt head fayed surfaces;
- 4) Class of fit (tolerance allowance of threads).

Variables such as these can result in bolt tensions which vary as much as 30% from one another when a similar group of bolts are torqued to the same value. Optimum fatigue characteristics, an important consideration of high performance aerospace fasteners, can be achieved theoretically when a threaded joint is prestressed to or above the yield point of the thinnest material and then slightly loosened.⁶ In so doing, residual stresses are set up at points of greatest stress concentration such as the roots of threads. Tables setting forth recommended values of torque for various size fasteners and used by the engineer community in the design of the joint are developed theoretically wherein the recommended torque value will result in a stress equal to about 80% of the yield point for a given fastener. Maximum overall fastener performance (strength to weight ratio, fatigue life, clamp force, etc.) is best guaranteed when the recommended torque values are adhered to.

3. Materials and Coatings

Threaded fastener joints designed into existing and planned spacecraft are generally made up of materials such as aluminum, titanium, stainless steel or steel alloys. About one-half of the threaded fasteners used by the aerospace industry are fabricated from alloy steels. The remainder of the threaded fasteners are made of titanium. Fasteners made of special materials such as tungsten, boron, beryllium, etc., comprise less than 1% of the total fastener production. The high strength-to-weight ratio of the titanium fastener makes it an ideal candidate for future spacecraft construction.

For years, cadmium plating has been the most popularly specified finish applied to alloy steel fasteners. It provides a finish which improves corrosion resistance and inhibits hydrogen embrittlement.⁴ In addition, the cadmium plating process also acts as a lubricant. Since the plating is applied under very controlled circumstances, the coefficient of friction can be more closely controlled, thereby improving the torque/tension relationships.

Cadmium plating, on the other hand, has one serious disadvantage. When subjected to high vacuum and elevated temperatures, temperatures as low as 400°F, it tends to sublime. As cadmium evaporates from the hot surface it will replate itself on cooler surfaces in the immediate vicinity. Unfortunately, these cooler surfaces include optics, antennas, electrical insulators, etc.

For these reasons, cadmium plated fasteners are no longer allowed to be used in the design of manned spacecraft or the experiments contained thereon (see Figure II-2).

Stainless steel fasteners, by virtue of their metallurgy, offer excellent corrosion resistance. If, however, stainless steel bolts are used in conjunction with stainless steel nuts, particularly lock nuts, serious galling problems occur which result in damage to the threads and unreliable torque/tension characteristics. The nuts are usually silver plated to overcome galling. Silver does not readily sublime and acts as a lubricant and antigalling agent.

Titanium is even more susceptible to galling or seizing than stainless steel, even under atmospheric conditions. Tests conducted by the Hi-Shear Corporation, using the MacMillan wear tester, showed that immediate galling and seizing took place when test loads exceeding 3500 psi were applied to the uncoated titanium test samples.⁷ Titanium test samples treated with Hi-Shear Type II, Code 1000 surface coating, were able to withstand loading of 35,000 psi and 278.5 wear-feet before failure. The addition of a dry film lubricant applied over the coating can improve wear characteristics by a factor of four. The Hi-Shear Corporation also offers a coating designated Type I. This coating is used primarily for identification, and is available in several colors. It offers light load galling relief only.

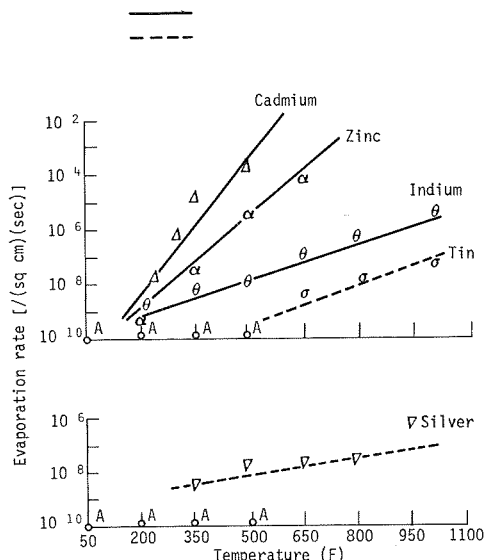

Figure II-2 Evaporation Rates for Various Metals in Vacuum, Ambient Pressure: 0.8×10^{-7} to 2.0×10^{-6} millimeter of Mercury

Voi-Shan Manufacturing has recently developed a new coating material for Titanium fasteners, designated VSM 1171.⁸ Test results published by Voi-Shan indicate that the coating effectively reduces the galling tendency of titanium. Dissimilar metal corrosion does not affect titanium because of its proximity to the noble metals in the galvanic series, but it can simulate sacrificial galvanic corrosion when coupled with the less noble metals, particularly magnesium and aluminum. Published test results of both the Type II and VSM 1171 coatings are effective in reducing sacrificial galvanic corrosion. Information concerning the chemical makeup of the titanium coatings discussed in this report were considered proprietary by the manufacturers.

No tests have been conducted which would indicate how well the coated titanium fasteners would withstand the rigors of installation using production type rotary impact tools. This type of tooling is most commonly used during production assembly and as portable fastener installation tooling, and was utilized in Phase IV testing.

4. Fastener Head Configurations

Proper selection of the head style of the fastener or nut may well be the factor that determines whether an astronaut may or may not be able to perform maintenance or assembly of the joint while in orbit. With respect to the fastener, tool, astronaut interface system, fasteners tend to fall into three categories. The first category includes those head styles which require only torsional forces to remove or install. With the application of torque, the tool is drawn toward the fastener head, therefore requiring no axial force.^{4,9} The high-torque fastener is an example which meets this requirement. The fastener head incorporates a shallow arc-shaped slot. Viewed from the end, the slot walls diverge to form an inverted keystone shape and converge toward the center. The same angles are formed on the driving tool, and therefore develop evenly distributed loading on the driven recessed walls. This type of fastener head will fail in shear rather than cam-out.

The second category of head styles includes hexagon, twelve point (tension-type), and spline head. This type of head requires, in addition to torque, only minimal axial force requirement.

The third category of head style requires both torque and axial forces to remove or install. Head style examples are the Frearson (Reed and Prince), the Phillips, the plain-slotted and the Torq-Set. In addition to the dual force requirement, fairly true axial alignment between the driving tool and the fastener head must be maintained. Failure to maintain true axial alignment or sufficient axial force will result in cam-out and subsequent damage to the fastener head.^{4,9,10} Three major airframe manufacturers are presently proposing a new head style as an aerospace standard. The configuration is called the tri-wing recess; and with the exception of having one less wing, appears to be identical to the torque-set fastener. However, it provides a greater driving surface for the removal of galled or corroded fasteners.

Representatives of fastener manufacturers indicate a high degree of response to customer requirements. Since no customer has placed substantial emphasis on the tool retention capability of the fastener head, little has been done in this area. Due to the extreme competitive nature of the fastener industry, manufacturers are hesitant to risk money or machine time on hardware which has little or no present market. If fastener head styles particularly suited for in-space maintenance and assembly are to be developed, industry and/or government must firmly establish the requirement before the fastener industry will follow through.

5. Tools for Use in Space

For Skylab, ground rules have been established which call for the removal and installation of the mounting hardware for the experiment packages to be accomplished without tools.^{11,12} Special fasteners designed to meet this requirement are being engineered, but by virtue of their size and complexity will have limited future applications. Furthermore, these fasteners will not provide the astronaut with prime mission hardware remove and replacement task experience which will be necessary for the successful accomplishment of interplanetary manned flight. Another example of the tendency to avoid relative maintenance tasks and tools is the Saturn workshop task dome hatch cover problem. The astronaut would have been required to use a power wrenching tool to remove 72 threaded fasteners in order to remove the hatch cover of the dome in its original configuration. Instead, the hatch cover was redesigned to be electrically operated.

Whether the tools required for torquing fasteners should be powered or manually operated will depend to a large extent on the size and number of fasteners involved. Large fasteners requiring high torque values will require power tools. On the other hand, if the large fasteners require minimal torque, such as assembly of orbital structures, a manually-operated wrench will suffice. If many small fasteners must be removed or installed, a small power tool again would be an asset by reducing time, astronaut fatigue, and drain on the life support system. Random maintenance tasks involving fastener sizes up to 5/16ths can probably be handled using manual tools.¹⁰

Regardless of whether power or manually-operated tools are used, it is important that the tool/fastener head interface permit easy mating, and that push-away forces generated between the head and tool can be minimized or eliminated.

Another important consideration is the ability of the tool to retain the fastener during installation and removal. In many instances this can be accomplished by modification of existing fastener head styles or tools. Retention of the fastener by the tool will minimize direct handling by the astronaut, thereby reducing the possibility of losing the hardware.

In addition to the tools used for installation or removal of the bolt, another requirement exists for a simple fastener retention system; minimal direct handling of the fasteners. It could be something as simple as a poly-foam block which would permit the astronaut to deposit the fastener directly from the tool into the block. When ready for installation he would merely re-engage the tool with the fastener head and pluck the fastener from the block.

Some form of restraint will be necessary for the astronaut during the performance of maintenance or assembly tasks. This is particularly true during extra-vehicular activities. The application of forces generated in the removal or assembly of fasteners will cause the astronaut to move about and away from his work position. Requiring him to hold on with one hand while working with the other presents an almost impossible task and degrades work performance. The restraint system is the final consideration in the fastener-tool-man system loop, and the loop can only be as reliable as its weakest component. Tests conducted in Martin Marietta's 5-Degree-of-Freedom Simulator have demonstrated that simple restraint systems consisting of a window washer belt and adhesive attachment points having a holding power of 50 lb proved adequate for most maintenance tasks.¹⁰

C. IDENTIFICATION OF FASTENER PROBLEMS

A review of present-day fastener technology indicates problem areas with regard to in-space use. The problems fall into three general groups:

- 1) Galling, seizing, cold welding, etc;
- 2) Manipulation by a pressure-suited astronaut, such as handling of the fasteners and removal and installation tools;
- 3) Development of fastening systems which would require a minimum use of tools for installation or removal.

1. Galling, Seizing, Cold-Welding^{7,8}

Galling or general seizing of threaded interfaces is caused by the inherent metalurgical characteristics of the components, coupled with the vacuum/thermal environment. Titanium usage is on the increase for the construction of space vehicles because of its high strength-to-weight ratio. Unfortunately, unprotected titanium is extremely susceptible to galling or cold-welding when subjected to even medium loads or elevated temperatures. Fastener manufacturers are continuing to develop and refine solid film anti-galling coatings. To date, no data can be found in the published test reports to prove or disprove the ability of present-day titanium coatings to withstand repeated use under load when subjected to elevated temperatures in a vacuum environment.

Stainless steel fasteners are used in spacecraft applications where fuel compatibility requirements rule out steel or titanium. The galling or seizing tendencies of stainless steel is about the same as titanium. Silver plating offers galling relief, but will not stand up under repeated use. In addition, most stainless steel fasteners lack the strength-to-weight ratio of either A-286 steel or titanium fasteners.

Fasteners made of A-286 steel offer economical, reliable high strength characteristics. Cadmium plating may be applied to A-286 fasteners, thus providing corrosion protection and offering lubricating qualities. Cadmium, however, rapidly sublimates when subjected to vacuum and heat. For this reason, cadmium-plated fasteners are not permitted in the construction of vehicles for manned space use. Various solid film lubricants, such as the molydisulphides, have been applied to A-286 steel.

As part of Phase II and IV of this study, fasteners of various materials (i.e.: A-286 steel, titanium, and stainless steel) were obtained and tested in both standard atmosphere and high vacuum cyclic temperature environments. The titanium fasteners were procured bare and in a variety of available coating configurations. A-286 steel and stainless steel fasteners were tested in combination with silver and molydisulphide lubricants to determine their effectiveness for space use. The fasteners were repeatedly torque tested in a normal atmosphere in order to obtain baseline data. Other fasteners of the same materials were placed in a vacuum chamber and torque tested while subjected to a combination of cyclic temperatures and vacuums.

2. Fastener Manipulation

The general problems of fastener manipulation encountered by pressure-suited astronauts in reduced gravity environments have been described in numerous reports published by various government agencies and leading aerospace manufacturers.^{3,9,10,13} These reports indicate a general agreement that, in the area of fastener manipulation, particular difficulty is encountered while interfacing the tool with the fastener head and attempting to maintain this interface during the tightening or loosening operation. Handling of the actual fasteners during insertion and removal from the threaded hole, and stowage and retrieval, prove to be difficult tasks.

As described earlier, some fastener heads provide a better tool purchase than others. Head styles such as the twelve point, internal and external hexagonal head, Hi-Torque recess, and spline head were procured for manipulation tests to be performed in reduced gravity simulators. However, this phase of the contract was cancelled at the government's convenience.

III. HUMAN FACTORS MANIPULATIVE TEST PLANS

The actual test was canceled at the Government's convenience, but discussion and test plans are presented to indicate the work that was done and to provide information that might be useful.

The test procedures were submitted to S&E-ME-MMP earlier and are included here to reflect the recommendations and comments received from S&E-ME-MMP-41-68 dated 27 September 1968.

It will be necessary to modify the scope of the program somewhat as it progresses, as a result of such things as expanded scope, operational problems during testing, and the limited resources available for the study.

A. INTRODUCTION

Fastening tasks are extremely complex manipulative actions. The skill of the operator, the degree to which the task must be done blind, the encumbrances to the operator, location, and fastening device characteristics are all variables which may be expected to interact. As a result, the nature of the task and the skill of the operator must be delineated before the adequacy of a fastening device can be determined. The current tests are designed to determine the suitability of off-the-shelf fasteners for EVA operations. As such, the test will simulate some of the relevant EVA conditions. One of the EVA conditions, the use of a state-of-the-art pressure suit, would be expected to have further restrictions on the results of these tests. Since a state-of-the-art suit is not available for this type of testing, a Mark IV suit will be utilized as the pressure suit in this series of tests. Blind operations and time-critical operations can be thoroughly tested in the planned series of tests. The goal of the present series of tests is to determine which, if any, currently available fasteners are candidates for EVA operations.

The astronaut's ability to apply forces to fasteners in a zero gravity environment is influenced by the following variables:

- 1) Type of space suit worn and internal suit pressurization;
- 2) Location of the astronaut relative to the working fastener;

- 3) Type of restraint system;
- 4) Force profile required;
- 5) Tooling provided (manual or powered);
- 6) The tool fastener interface.

The objective is to maintain variables 1), 2), and 3) as constant during this series of tests.

The data obtained during execution of NASA contracts NAS8-18117 by General Electric and NAS1-5875 by AiResearch are utilized as sources of information in determining the tether configuration and the pressure-suited astronaut's ability to produce forces.

Figure III-1 indicates the ability of a pressure-suited astronaut to maintain a sustained force using various restraint systems and relative positioning from the work site.

It is desirable to have both hands free so a restraint using the feet and waist has been selected. In Figure III-1, the mean force for a horizontal handle applied in an upward direction 19 in. from the panel is approximately 17 lb. A downward force under the same conditions is approximately the same.

B. FASTENER SELECTION (MANIPULATION TESTS)

Fasteners of fifteen head configurations in three increments of length, and three thread diameters have been selected for inclusion in manipulation tests. These head styles include those which require only torsional forces for removal or installation; the Hi-Torque fastener is an example of a fastener requiring no axial force for installation. Fasteners requiring the addition of a minimal axial force in torquing the fastener include hexagon and twelve-point head styles. Head styles such as Phillips, requiring both torque and axial forces to install, have been included in the manipulation tests.

Figure III-2 illustrates head configurations of those fasteners to be used in the manipulation tests. Each test item will be obtained in No. 10, 1/4 in. and 3/8 in. N.F. thread sizes. The fasteners will conform to appropriate NAS, or MS specifications, and in three increments of fastener length (the minimum length relating to the diameter).

FORCE TYPE SUSTAIN

RECEIVER ANGLE 0°

HANDLE ORIENTATION HORIZONTAL

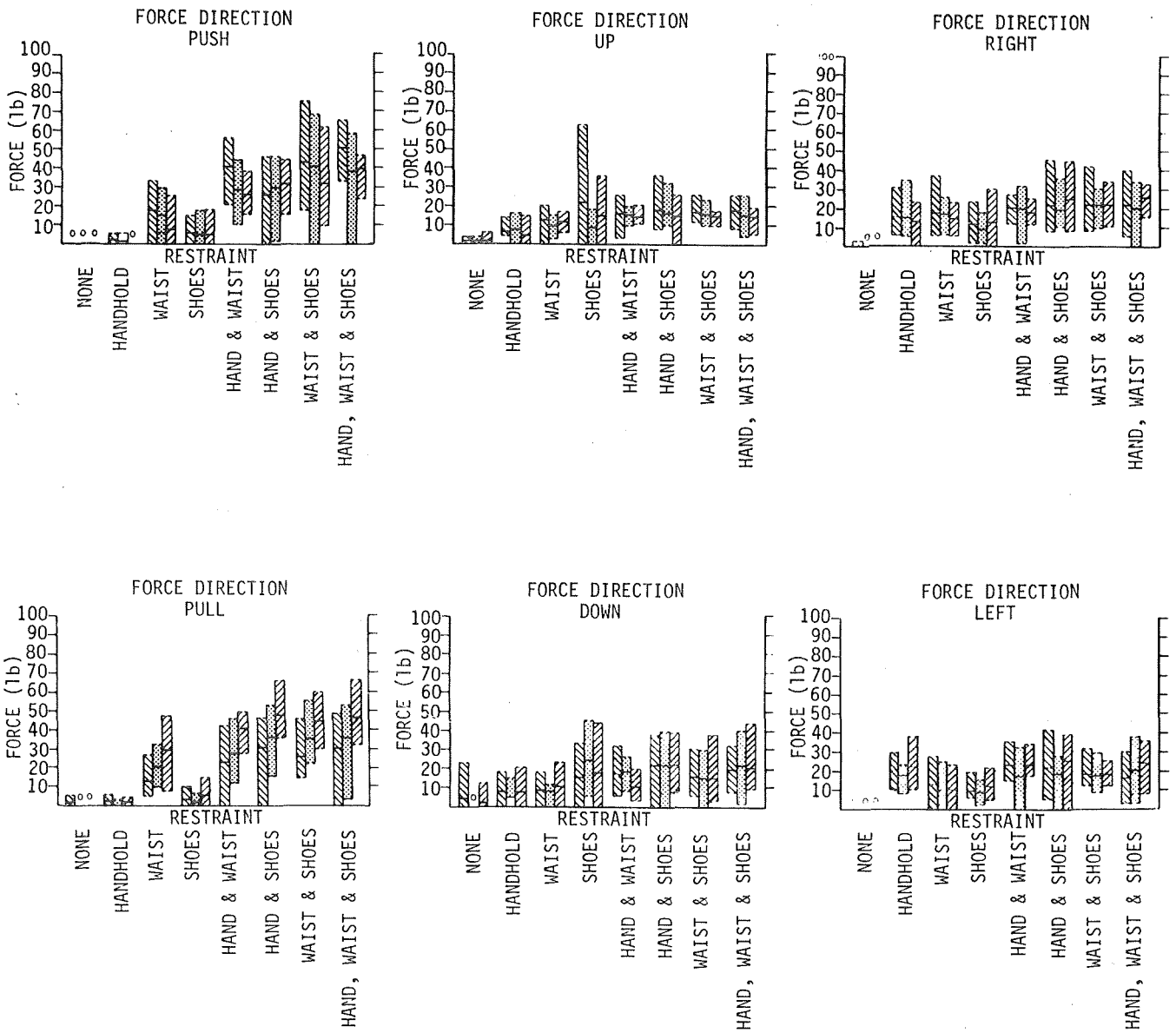

Figure III-1 Forces Produced by Astronaut in GE Test

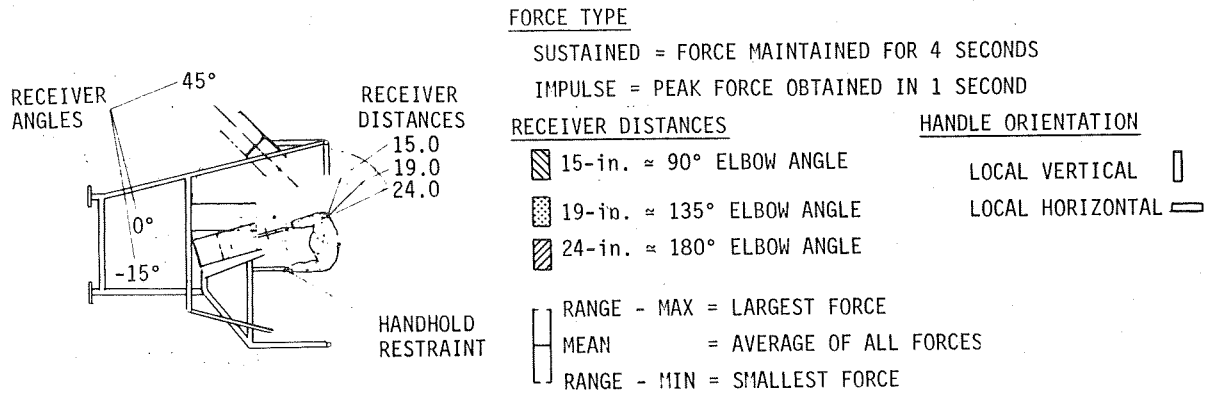

Figure III-1 (Concluded)













Head	Test Item No.	Description	
	1	Driving Recesses	Hex Socket
	2		Phillips
	3		Frearson
	4		Slotted
	5		Pozidriv
	6		Hi-Torq
	7		Torq-Set
	8		Sixces Recess
	9		Tri-Driv
	10		Hex
	11		Six Wing
	12		12 Point
	13		Super Torq
	14		Voi-Shan Split Nut
	15		Calfax

Figure III-2 Fastener Head Configurations for Manipulation Tests

Assuming that the astronaut has to torque a 3/8-in. fastener to 250 in.-lb, he will require a wrench approximately 15 in. long if he is to achieve this torque, $(17 \text{ lb}) \times (15 \text{ in.}) = 255 \text{ in.-lb}$. It is noted that these values are valid using an Apollo suit and assuming that there is not degradation in the coefficient of friction in the fasteners. If a power tool is provided to handle larger forces, the reaction has to be handled via the astronaut through the restraint system. A "zero reaction tool" will further reduce the restraint required.

Reduced mobility of the Mark-IV pressure suit, in relation to the Apollo garment, will be compensated for by utilizing the suit at lower pressure and presenting the task at a desirable position.

Figure III-3 shows the restraint system, the manipulation panel, and the subject's relative position in relation to the work site. It is noted that the relative work position, and astronaut restraints will be maintained in all manipulative tests. The manipulation panel will index each group of three fasteners with common test head configurations to the work position (Fig. III-3). This will allow comparison of fastener operation without having to factor out the variable of fastener location.

C. TEST METHOD

Divers experienced with pressure suits and human factors reporting techniques will be used as test subjects in baseline tests, frictionless simulator, and neutral buoyancy simulations as indicated in Figure III-4. The same subjects will be used in all tests to provide a correlation between the simulations, and to benefit the program with the increased experience and appreciation of the problem being investigated. The test subjects will alternate in the tasks of subject, diver subject, safety diver, and test conductor. The tests will be conducted in stages with detailed test plans revised on the basis of the results of prior tests.

Manipulative characteristics of fasteners in N.F. thread sizes No. 10, 1/4 in., and 3/8 in. in three increments of length will be determined. The fasteners provided will determine the astronaut's ability to manipulate the fasteners during installation, removal, and stowage. These tests will also determine the astronaut's ability to apply proper torques to the fasteners in a 0-g environment.

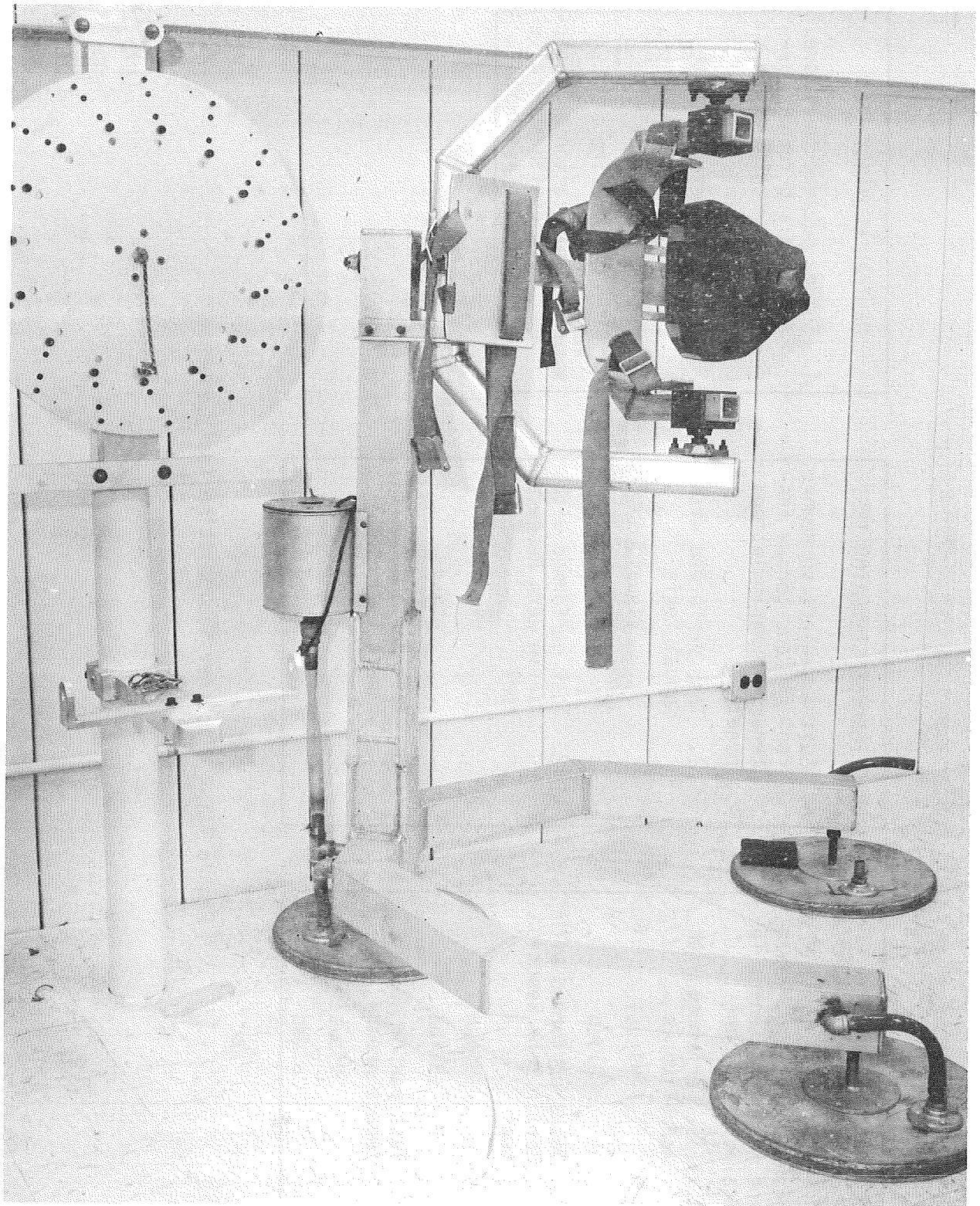

Figure III-3 Manipulation Test Panel

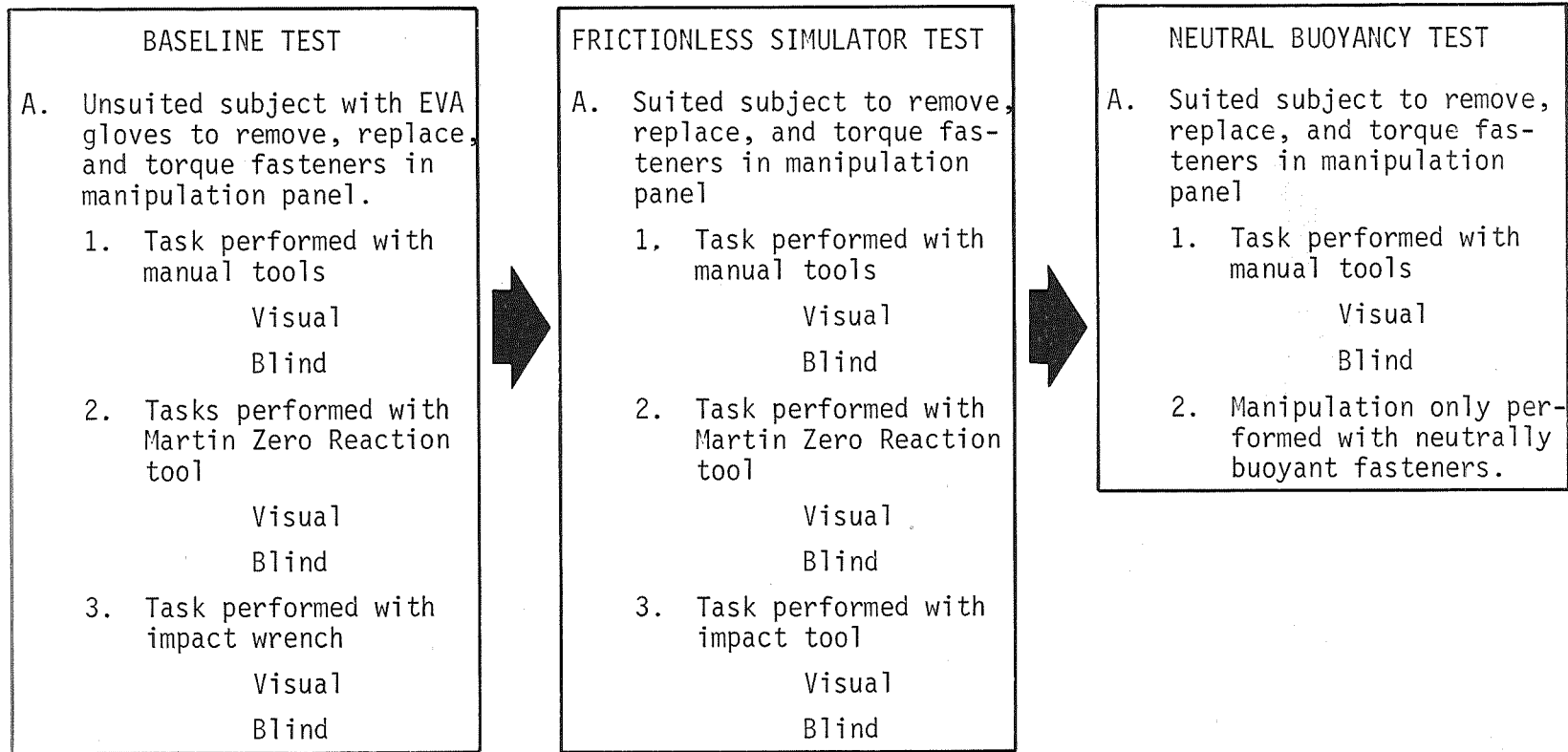

Figure III-4 Fastener Manipulation Test Sequence

The fasteners will be inserted into the fastener manipulation panel and torqued to the following values:

FASTENER TORQUE VALUES	
<u>Bolt Size</u>	<u>Torque (lb-in.)</u>
10-32	30
1/4-28	92
3/8-24	250

D. TEST PROCEDURE

The suited subject will be supplied with the appropriate tools and restraints. He will release, remove, replace and retorque three fasteners of the same head configuration. The panel will then index the next group of three fasteners to the work site, and the task will be repeated. When required, the procedures are to be repeated "blind" with a visual obstruction in place. This is to be repeated through all fifteen head groups. Time (sec) to release and reseal each fastener is to be recorded, along with the astronaut's comments. Errors such as dropping the fastener or misaligning the fastener will be tabulated as indicated in the test form (Fig. III-5).

E. BASELINE TESTS

The BLT tests will be run at 1-g test conditions in the laboratory. This test series will require each subject at ambient or 1-g test conditions to interchange and torque corresponding fasteners contained in the fastener manipulation panel (see Fig. III-4 and III-5). This test will evaluate the ability of the test subject to operate fasteners of different sizes and lengths while equipped with simulated EVA type gloves and interfacing tools. Emphasis is to be on the ability of the subject to remove, transport, store, retrieve, re-engage and torque the fastener with his gloved hand. The subject will remove and interchange and torque the three fasteners in each head configuration. He will perform the tasks both visually and blind until he is familiar with the task. The same series of tasks will then be performed by indexing the next group of bolts to the work site and repeating the sequence.

FASTENER MANIPULATION TEST

TEST FORM						
Bolt Size: 3/8 in. 1/4 in. No. 10 Rank in Order of Preference						
Head	Time to Release and Torque (sec)		Manipulation	Torquing	Comments	Errors
1						
2						
3						
4						
5						
6						
7						
8						
9						
10						
11						
12						
13						
14						
15						

Visual

Blind

Time to Release and Retorque (sec)

Subject _____ Date _____ Time _____

- Test
- Baseline Visual
 - Baseline Blind
 - EVA Gloves Only
 - Mark IV Pressure Suit
 - Suit Pressure _____ psi
 - Six DOF with Impact Wrench
 - Six DOF with Space Tool
 - Six DOF with Manual Torque Wrench
 - Six DOF with Other Tool Note _____
 - Neutral Buoyancy
 - Neutral Buoyancy

Figure III-5 Test Performance Form

The subject's relative position in relation to the manipulation panel will be noted and maintained in the ensuing tests. Notations of fastener improvement and other fastener inclusions or deletions will be noted for incorporation into the frictionless simulation tests.

Frictionless Simulator Tests will be run in Martin Marietta's simulator. The pressure-suited operator will position and tether himself in the same relative position to the manipulation panel as in the baseline tests. He will then perform those tasks indicated in the test forms using the appropriate tools. In this series of tests the Martin zero-reaction space tool and an impact wrench will also be used to torque and remove the fasteners. The times required with these tools will be recorded for comparison with those obtained with manually operated tools. Again, notations about fastener improvement, or their elimination from further testing, will be made.

Neutral Buoyancy Tests will utilize a local swimming pool to conduct a series of tests examining aspects judged to be most significant as a result of the evaluations accomplished in the prior test series. Because the total scope of the program is limited, and the test manpower requirements are significantly higher than for the other methods, it will be necessary to limit this test series. It is planned to conduct the underwater tests in stages, with the detailed test plans revised on the basis of results from the earlier stages to allow maximum use of actual underwater test time.

The subject will be equipped with a Mark-IV pressure suit, a tethering harness, hand tools, and the fastener manipulation test panel. The other two subjects will be equipped with scuba gear and act as safety divers, observers, test conductors, and assistants to the subject. After the subject completes the required task, his comments relating to the task and fastener improvement will be tape recorded. The task will then be executed by the next subject.

To examine the manipulative characteristics in 0-g, neutral buoyancy commercial nylon fasteners will be obtained in the longest length available (approximately 1.5 in. long). If the subject is able to adequately manipulate available fasteners, longer fasteners will be ignored in this test.

The data and comments of the test results are to be examined to identify problems, and propose and evaluate possible solutions.

This effort is to be coordinated with the MSFC NASA Technical Representative to propose possible solutions using either new techniques, hardware, or both.

The tests are to provide a means to note fastener performance and to provide a ranking of preferred fastener types and styles.

IV. DEFINITION AND EVALUATION OF ENVIRONMENTAL EFFECTS

A. INTRODUCTION

1. Space Simulation

The Space Simulation facility utilized in Phase IV was capable of producing a reasonably clean vacuum of the order of 10^{-9} torr. The chamber was equipped with quartz lamps to simulate the thermal-vacuum effects of space, and to thermally clean ("Bake-Out") the test items and chamber interior. A cryogenic cold plate was provided to simulate to some extent the infinite heat sink of outer space. The alternate use of the quartz lamps and the heat sink was to provide temperature cycling to the test samples.

Chamber pumping was accomplished with a getter-ion pump. This arrangement eliminated the possibility of back streaming contamination into the chamber, which could have affected the results of the adhesion and friction characteristics of the test items. Back streamed contaminants are usually fractionated hydrocarbons which would have a lubricating effect if deposited upon the clean metal surfaces of the test items.

Vacuums achieved in the 10^{-9} torr range inhibited the back-reflection of molecules to the test samples. This phenomenon is the result of vaporizing atoms being reflected back to the vaporizing surface by collisions with other atoms or molecules in high ambient pressures. Vapor pressures in the order of 10^{-6} MMHG, in combination with cryogenically cooled condensing surfaces, do not generally suffer inaccuracy from the back-reflection phenomenon; this was an important consideration in this study of the effects of space environment on fastener performance.

Lubrication is strongly influenced by the presence or absence of oxide films on the test sample surfaces. The presence of contaminating films between the faying surfaces of the nut/bolt combinations contribute to the lubrication of the unit. The low pressure of space causes rapid evaporation of ordinary lubricants in space. This, coupled with exposure to radiation flux which influences the stability of the lubricants, can affect the torque

tension relationships of the test samples. The evaporation rates in a vacuum are indicated by the *Langmuir Equation for the rate of evaporation*:

$$G = \frac{P}{17.14} \frac{M}{T}$$

where

G = Rate of vaporization [(g)/(SQCM)(sec)],

P = Vapor pressure (MMHG),

M = Molecular weight,

T = Temperature (°K).

The Vapor-Pressure equation can be written as follows:

$$P = C e^{-L/RT}$$

where

C = Constant,

L = Heat of vaporization,

R = Gas constant.

Note: This equation is based on the assumption that all of the vaporizing atoms are lost and none are back-reflected to the vaporizing surface.

The consequences of the large mean-free-path in space, and a chamber capable of 10^{-9} torr range for space simulation, will allow the investigation of the effects of rapid evaporation and sublimation on fastener performance.

2. Friction and Adhesion

The work of early investigators ascribed the rubbing process and produced friction as resulting from the interlocking of surface irregularities and the energy required in raising one set of surface roughnesses over the other. Generally, the theories of friction and wear have dealt with dry or unlubricated systems. The problem was treated strictly from a mechanical view, neglecting the affects of surface films and the chemistry of the faying surfaces. Also, the fastener environment can have an enormous effect on friction and wear. Under torquing, the interfaces may emit a gas by frictional heat, or a solid could be formed in the contact zone from a liquid or a gas.

Adhesion theory may be summarized as the result of the following factors acting on the interface of the junction surfaces:

- 1) The area of actual contact between the faying surfaces can be quite small in comparison to apparent contact area;
- 2) The loading of the fasteners to 70 to 80% of their yield for preloading and fastener efficiency can enhance the tendency to cold weld.

Evans ¹⁵, in his surface welding in vacuum study, indicates that at temperatures normally found in spacecraft components (below 150°C), and at stresses 50% of the yield point, there is little difference in the metal-to-metal tendency between like or unlike pairs. In the work of Winslow and McIntyre ¹⁶, only when rotation under load between the specimens was introduced were consistent indications of adhesion obtained.

B. TESTING AND ANALYSIS

1. Ambient Torque/Tension Tests and Results

The following torque vs. induced load tests were run using two test specimen holders, one of stainless steel and one of titanium. A GSE Inc. fastener-force-transducers model (FT-250) was used to measure the clamping force developed by the bolt. Specimen test cylinders are 0.750 in. in diameter and 1.500 in. long, and their internal diameter is 0.255 in. The squareness of the internal bore to the bearing surfaces was ± 10 minutes, and the surfaces were machined to a 32-rms finish.

Fasteners were installed as shown in Figure IV-1, and the bolt was retained against rotation by the bolt head. Tensioning of the test samples was in all cases accomplished by applying torque to the lubricated nut. After the test items were removed, all granulated lubricant was removed and the bearing surface under the nut was cleaned to remove any residual lubricant prior to installation of the next test item.

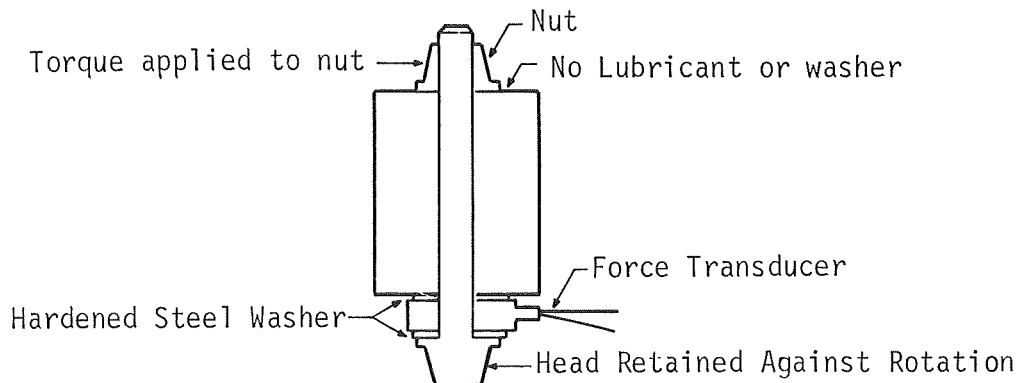

Figure IV-1 Test Cylinder

Elongation of the bolts was measured and recorded as a function of the induced load indicated by the force transducer. This was done since calculation of bolt elongation was not sufficiently accurate enough due to variables of threadlocking, necking of bolt cross section, etc. The bolt elongation calibration curve (Figure IV-2) was developed to provide a means of determining the induced load of test samples in vacuum chamber runs by measuring bolt elongation. Measurements with a micrometer accurate to 0.0001 in. were recorded in an environment having constant humidity and temperature.

All bolts were cleaned with acetone and rinsed with alcohol prior to installation of the nuts. This was done to duplicate cleaning procedures of those items installed in the vacuum chamber.

The test items were torqued with a calibrated torque wrench in increments of 25 in.-lb, from 50 to 175 in.-lb. Exceptions to this were those fasteners which exhibited yielding in upper torque ranges. When the test item exhibited yielding, higher torques were not applied. This was done to prevent any excessive distortion to the test items which might affect the results of repeat applications needed to determine the effects of wear on the test item.

Results of torque vs. induced load are contained in Tables IV-1 to IV-6, and Figures IV-3 to IV-8. As anticipated, non-lubricated combinations of A-286 nuts and bolts galled and siezed before the nuts could be chased down far enough to create any tension in the bolt (see Table IV-1). This combination was not given serious consideration for fastener application.

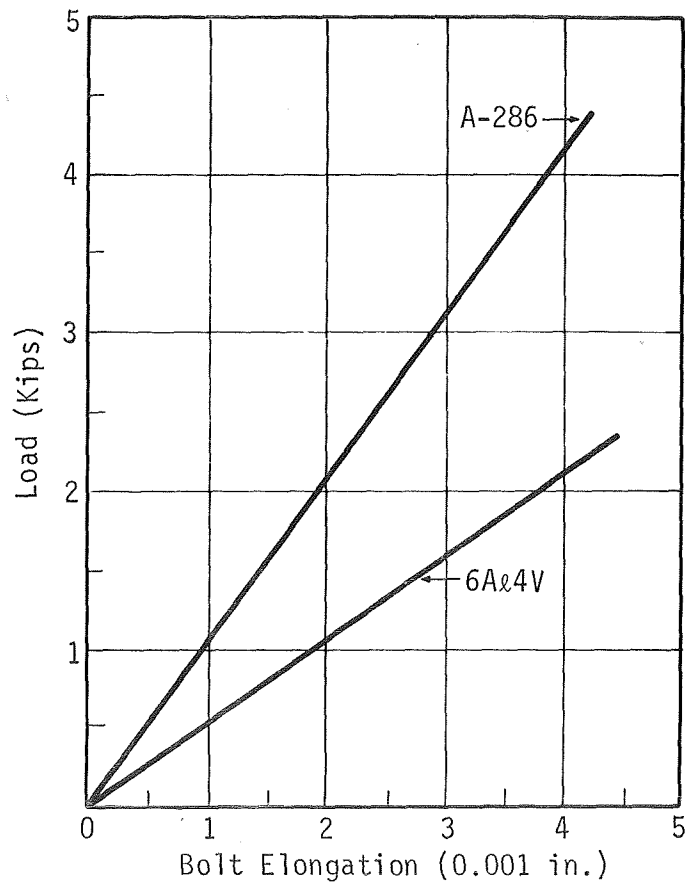
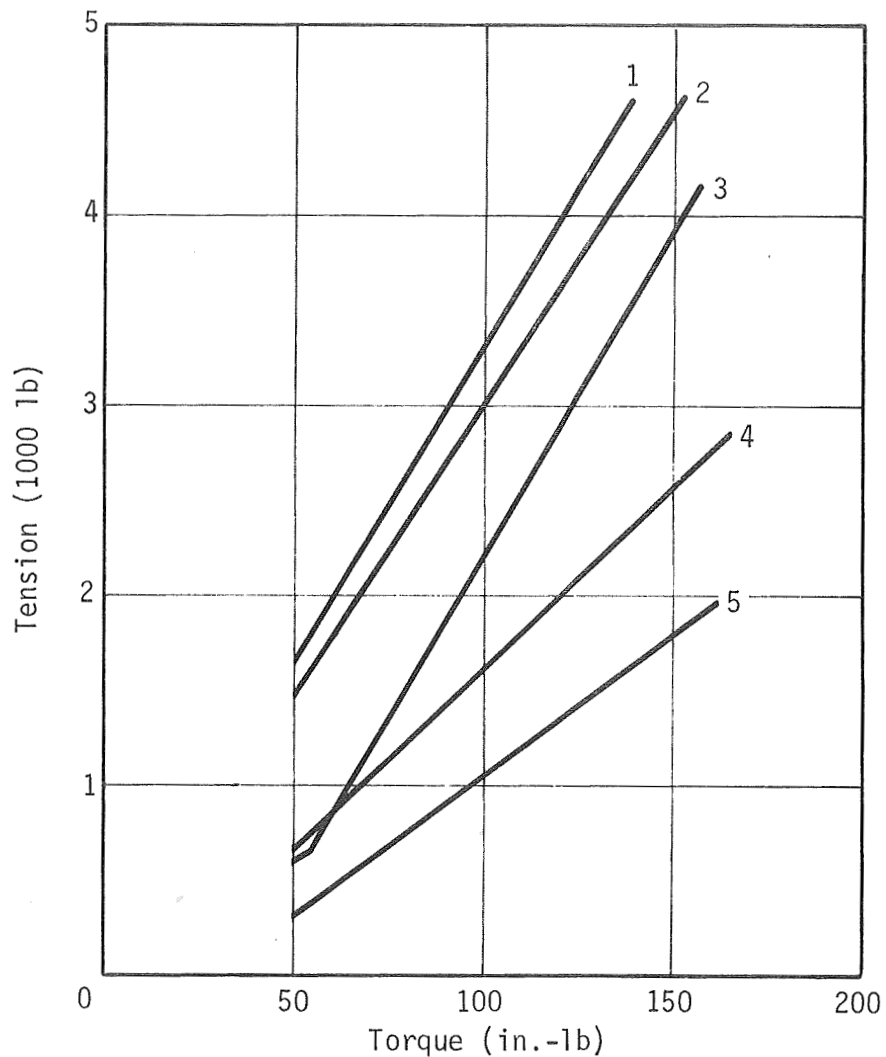

Figure IV-2 Calibration Curves for 6Al4V Titanium and A-286 Bolts



- 1) A-286 Six-Wing Bolt Assembly P/N SW1555-4-24 (Moly-Disulfide-Plated Nuts)
- 2) A-286 Six-Wing Bolt Assembly P/N SW1555-4-24 (Silver-Plated Nuts)
- 3) Titanium 6Al-4V Six-Wing Bolt Assembly P/N SW2565-4-24 (306 Type II-Plated Nuts)
- 4) Titanium 6Al-4V Six-Wing Bolt Assembly P/N SW2565-4-24 (VSM 1171-Plated Nuts)
- 5) Titanium 6Al-4V Six-Wing Bolt Assembly P/N SW2565-4-24 (Passivated Nuts)

All Bolts 0.250 Nom Dia x 1.5 in. Grip x 28 TPI

Figure IV-3 Torque vs Induced Load for Test Items 1-24 (Ambient Conditions)

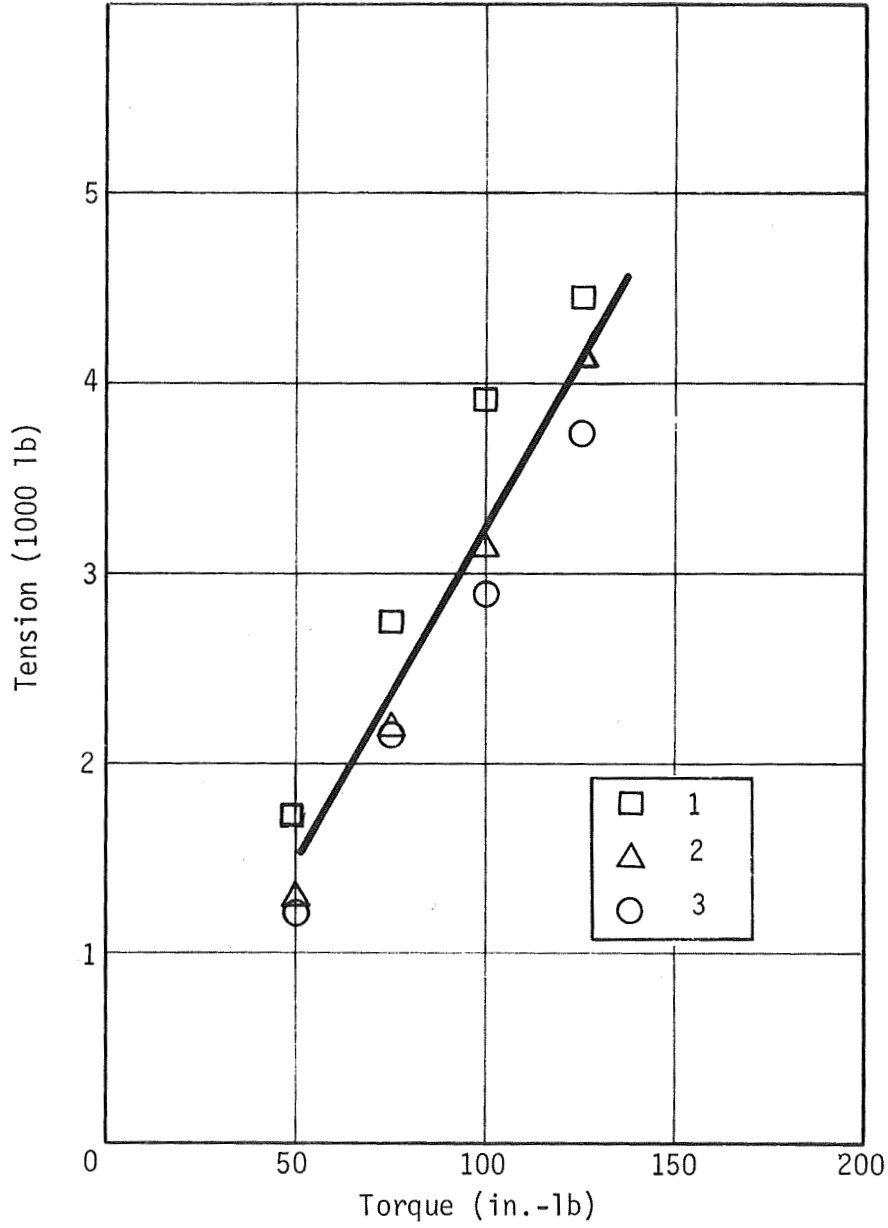

Figure IV-4 Torque vs Induced Load (Ambient Conditions)
A-286 Six-Wing Bolt Assembly P/N SW1555-4-24
(Moly-Disulfide-Plated Nuts)

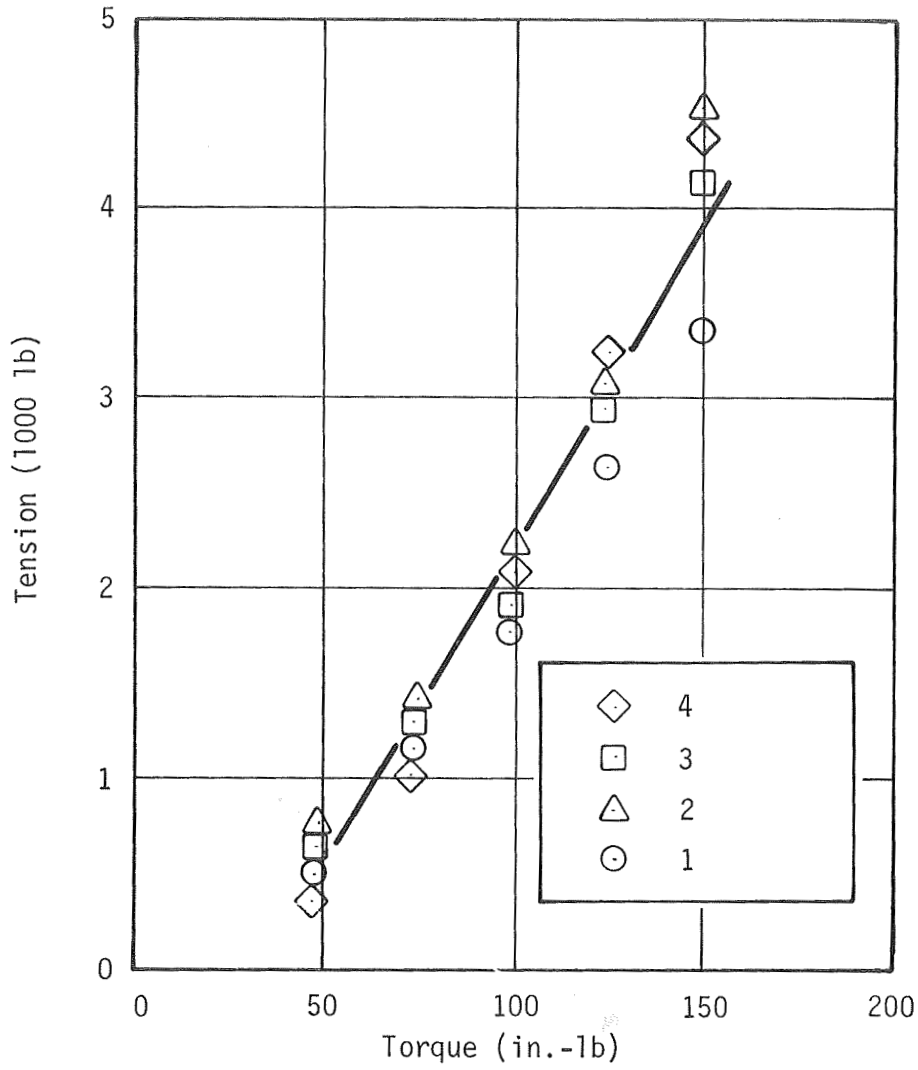

Figure IV-5 Torque vs Induced Load (Ambient Conditions)
 Titanium 6Al-4V Six-Wing Bolt Assembly
 P/N SW2565-4-24 (306 Type II-Plated Nuts)

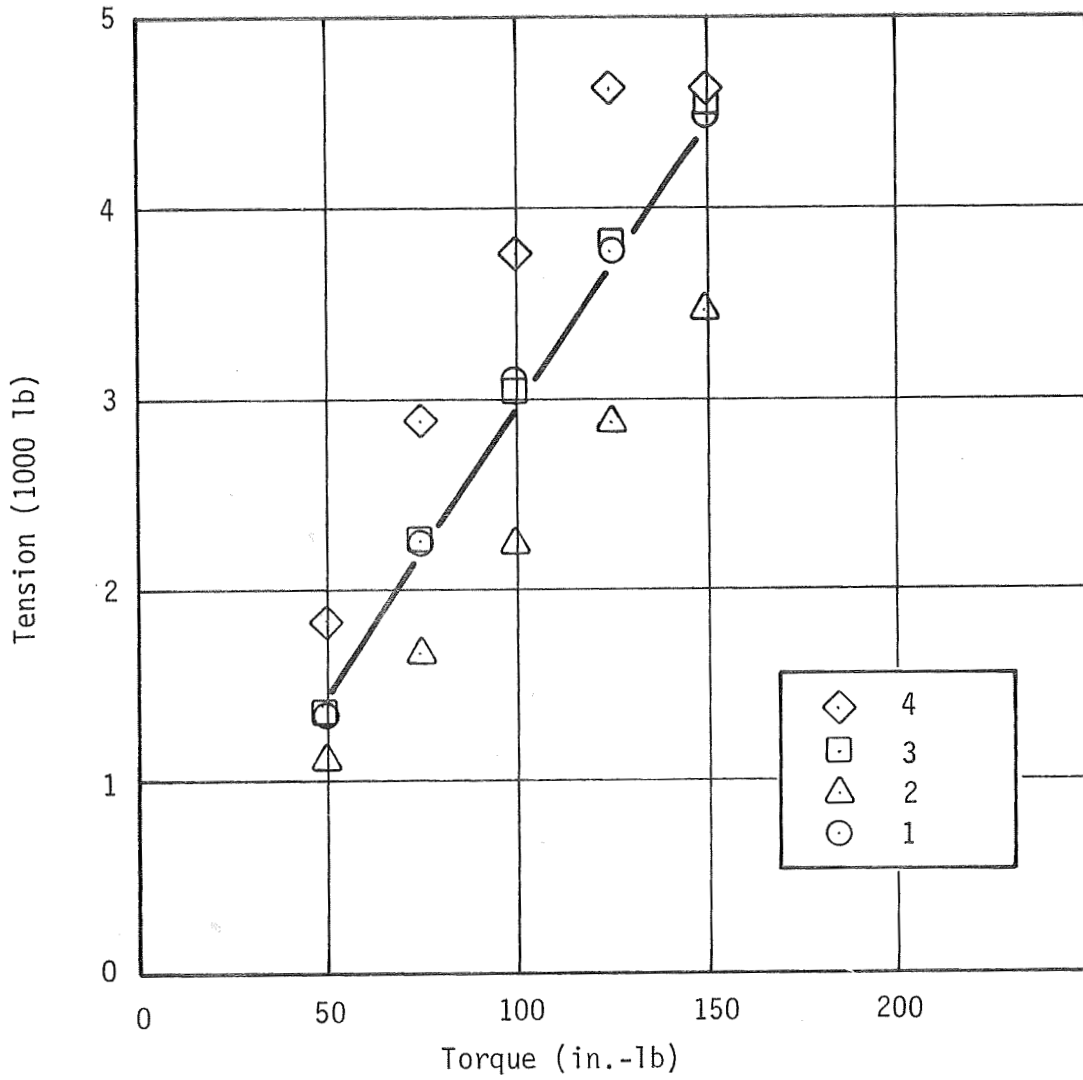

Figure IV-6 Torque vs Induced Load (Ambient Conditions)
A-286 Six-Wing Bolt Assembly P/N SW1555-4-24
(Silver Plated Nuts - AMS 5737)

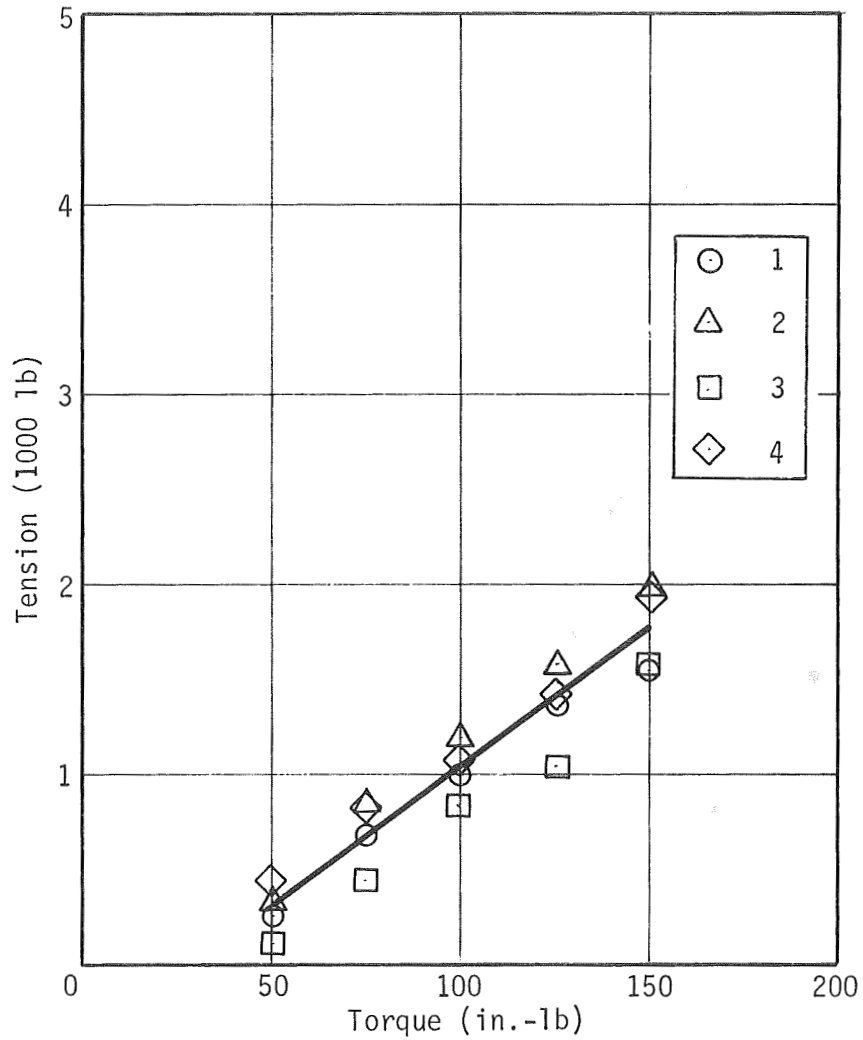

Figure IV-7 Torque vs Induced Load (Ambient Conditions)
Titanium 6Al-4V Six-Wing Bolt Assembly
P/N SW2565-4-24 (Passivated Nuts)

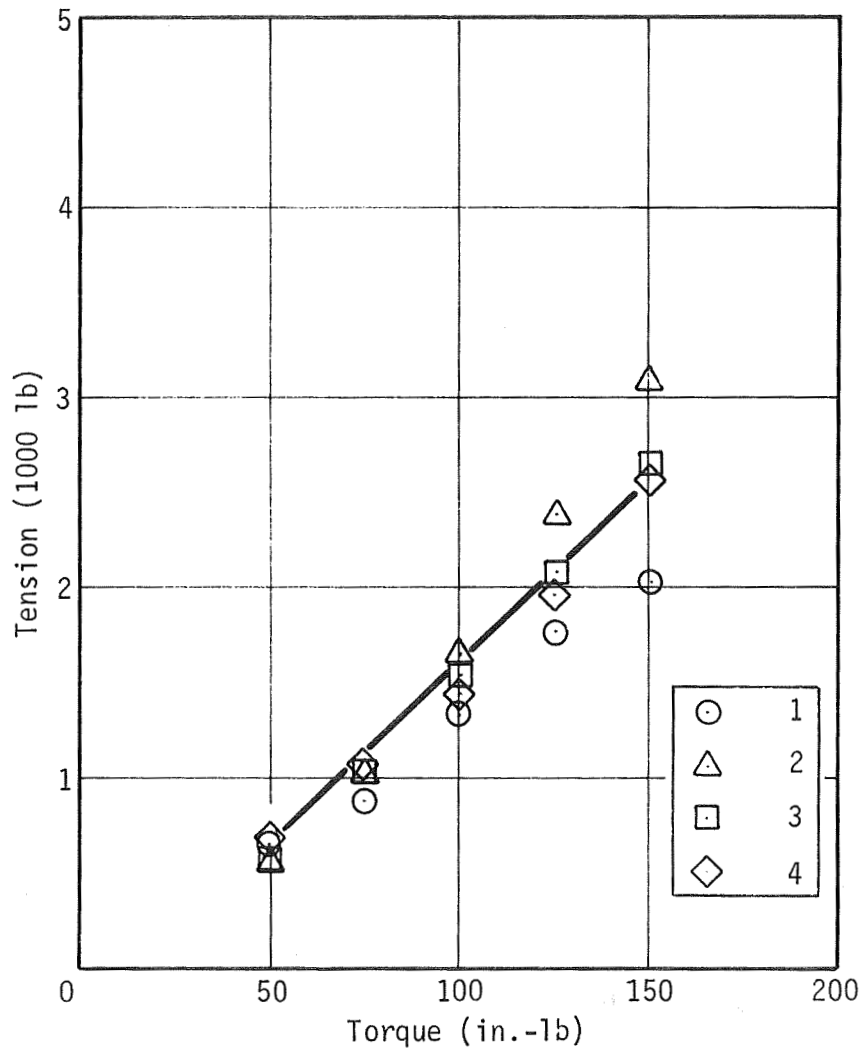

Figure IV-8 Torque vs Induced Load (Ambient Conditions)
Titanium 6Al-4V Six-Wing Bolt Assembly
P/N SW2565-4-24 (VSM 1171-Plated Nuts)

Table IV-1 Torque vs Induced Load (Ambient Conditions)
A-286 Six-Wing Bolt Assembly P/N SW1555-4-24
(Unlubricated Combinations)

TORQUE (in.-lbs)	LOAD (LB)			
	BOLT AND NUT ASSEMBLY NUMBER			
	1	2	3	4
50	0	0	0	0
<p><u>Note:</u> No nuts were run down far enough on the bolt to apply tension to the bolt. All test items galled and seized and bolts broke at approximately 250 in.-lb of torque.</p>				

Table IV-2 Torque vs Induced Load (Ambient Conditions) A-286
Six-Wing Bolt Assembly P/N SW1555-4-24 (Moly-Disulfied-Plated Nuts)

TORQUE (in.-lbs)	LOAD (LB)					
	BOLT AND NUT ASSEMBLY NUMBER					
	1		2		3	
50	1250		1370		1875	
	1250		1250		1875	
	1250		1250		1625	
	1205(M)	1250	1274(M)	1250	1725(M)	1500
	100(S)	1025	53(S)	1250	162(S)	1750
75	2750		2050		3000	
	2250		2250		2750	
	2125		2125		2625	
	2150(M)	1875	2163(M)	2200	2775(M)	2500
	380(S)	1750	77(S)	2190	223(S)	3000
100	3625		3125		4230	
	3000		3250		4000	
	2875		3125		3750	
	2900(M)	2625	3145(M)	3125	3921(M)	3625
	470(S)	2375	59(S)	3100	237(S)	4000
125	4375*†		4200		4200††	
	3950		4250			
	3750		4125			
	3740(m)	3500	4115(m)	4000	4475(m)	4625
	469(s)	3125	114(s)	4000	238(s)	4600
<p><u>Note:</u> 1. Bolt not torqued over 125 in.-lb to prevent yielding. 2. No allowance was made for prevailing torque.</p>						
<p>* Bolt yielding (M) Mean † Break away torque 90 in.-lb (S) Standard Deviation †† Bolt yielding at 110 in.-lb</p>						

Table IV-3 Torque vs Induced Load (Ambient Conditions)
 Titanium 6Al-4V Six-Wing Bolt Assembly P/N SW2565-4-24
 (306 Type II-Plated Nuts)

TORQUE (in.-lb)	LOAD (LB)							
	BOLT AND NUT ASSEMBLY NUMBER							
	1		2		3		4	
50	750		875		690		200	
	750		865		625			
	625		625		625			
	650(M)	625	725(M)	630	663(M)	625	413(M)	
	209(S)	500	132(S)	630	56(S)	750	300(S)	625
75	1625		1875		1500		1025	
	1375		1500		1375			
	1250		1190		1250			
	1260 (M)	1110	1413(M)	1250	1325(M)	1250	1138(M)	
	(144)(S)	937	284(S)	1250	112(S)	1250	159(S)	1250
100	2500		3063		2180		2375	
	2125		2375		2120			
	1870		1880		1500			
	1899 (M)	1500	2238(M)	2000	1951(M)	2080	2123(M)	
	(428)(S)	1500	504(S)	1870	277(S)	1875	356(S)	1870
125	3500		4250		3000		3500	
	3000		3375		2750		3500	
	2375		2750		3125			
	2605 (M)	2125	3100(M)	2625	2965(M)	3000	3225(M)	
	(762)(S)	2125	724(S)	2500	136(S)	2950	389(S)	2950
150	4500*		4500*		3950		4615	
	3810		4250		4200			
	2950		3750		4375			
	3377 (M)	2875	3800(M)	3375	4128(M)	4000	4370(M)	
	(748)(S)	2750	576(S)	3125	171(S)	4125	109(S)	4125
175	4500*		4500*		Yielding*			
*Release Torque 140 in.-lb								
(M) Mean								
(S) Standard Deviation								

Table IV-4 Torque vs Induced Load (Ambient Conditions) A-286
 Six-Wing Bolt Assembly P/N SW1555-4-24 (Silver-Plated Nuts)

TORQUE (in.-lb)	LOAD (LB)			
	BOLT AND NUT ASSEMBLY NUMBER			
	1	2	3	4
50	1500	*1250	1530	1750
	1340	1250	1500	2000
	1335(M) 1250	1100(M) 1025	1383(M) 1250	1844(M) 1875
	118(S) 1250	130(S) 1025	153(S) 1250	119(S) 1750
75	2375	1875	2375	3000
	2250	1750	2375	2875
	2250(M) 1250	1641(M) 1600	2251(M) 2130	2844(M) 2875
	124(S) 2125	230(S) 1340	143(S) 2125	157(S) 2625
100	3125	2500	3250	2875
	3050	2250	3125	3875
	3013(M) 2875	2234(M) 2060	3031(M) 3000	3781(M) 3750
	105(S) 3000	194(S) 2125	213(S) 2750	119(S) 3625
125	3875	3125	4050	4625
	3822	3000	3875	4625
	3768(M) 2635	2888(M) 2800	3825(M) 3750	4625(M) 4625
	108(M) 3750	212(S) 2625	181(S) 3625	0(S) 4625
150	4500	4130	4625	4625
	4500	3625	4600	4600
	4469(M) 4375	3470(M) 3500	4586(M) 4620	4612(M) ---
	62(S) 4500	620(S) 2625	185(S) 4500	17(S) ---
*Meter stuck at 1250. (M) Mean (S) Standard Deviation				

Table IV-5 Torque vs Induced Load (Ambient Conditions) Titanium
6Al-4V Six-Wing Bolt Assembly P/N SW2565-4-24
(Passivated Nut)

TORQUE (in.-lb)	LOAD (LB)							
	BOLT AND NUT ASSEMBLY NUMBER							
	1		2		3		4	
50	0		0		0		0	
	250		310		125		650	
	250		325		150		500	
	250(M)	250	321(M)	325	104(M)	70	456(M)	375
	0(S)	250	7(S)	325	40(S)	60	152(S)	300
75	750		900		375		900	
	650		875		500		750	
	750		875		550		650	
	705(M)	750	829(M)	720	475(M)	500	710(M)	625
	62(S)	625	82(S)	750	66(S)	500	118(S)	625
100	1025		1375		900		1375	
	1025		1250		875		1025	
	1025		1240		875		900	
	1000(M)	1025	1183(M)	1025	849(M)	750	1045(M)	1025
	55(S)	900	153(S)	1025	62(S)	800	195(S)	900
125	1500		1725		1250		1875*	
	1500		1625		1250		1500	
	1350(M)	1250	1520		1025		1375	
	132(S)	1250	1569(M)	1500	1115(M)	1025	1375(M)	1375
	1250		119(S)	1450	123(S)	1025	102(S)	1250
150	1875		2125		1875		2250	
	1875		2100		1600		1875	
	1375		2000		1750		1875	
	1525(M)	1250	1995(M)	1875	1670(M)	1625	1949(M)	1870
	322(S)	1250	119(S)	1875	145(S)	1500	168(S)	1875
*Break Away Torque 125 in.-lb (Torque to Reverse Fastener)								
(M) Mean								
(S) Standard Deviation								

Table IV-6 Torque Induced Load (Ambient Conditions) Titanium
 6A α -4V Six-Wing Bolt Assembly P/N SW2565-4-24
 (VSM 1171-Plated Nut)

TORQUE (in.-lb)	LOAD (LB)			
	BOLT AND NUT ASSEMBLY NUMBER			
	1	2	3	4
50	625	575	600	825
	675	650	625	650
	550	625	550	600
	620 (M) 625	560 (M) 450	580 (M) 500	615 (M) 500
	45 (S) 625	84 (S) 500	54 (S) 625	112 (S) 500
75	440	1185	1175	1275
	1125	1225	1075	1075
	975	1025	1000	925
	868 (M) 925	1087 (M) 1000	1005 (M) 750	1015 (M) 900
	259 (S) 875	147 (S) 1000	145 (S) 1025	154 (S) 900
100	1275	1950	1825	1850
	1550	1810	1725	1500
	1300	1440	1450	1375
	1335 (M) 1300	1670 (M) 1625	1540 (M) 1250	1480 (M) 1300
	122 (S) 1250	208 (S) 1525	205 (S) 1450	217 (S) 1375
125	1700	2700	2245	2375
	1900	2425	2300	2000
	1780 (M) 1750	2375	2000	1850
	1825	2385 (M) 2300	2097 (M) 1800	1975 (M) 1775
	66 (S) 1725	209 (S) 2125	183 (S) 1950	238 (S) 1875
150	2050	3310	2775	3075
	2450	3100	3000	2575
	2250	3125	2650	2350
	2019 (M) 2125	3067 (M) 3050	2680 (M) 2475	2550 (M) 2375
	152 (S) 2075	177 (S) 2700	215 (S) 2500	252 (S) 2375

2. Statistical Analysis

When analyzing data obtained from several trials of an experiment, the two most important statistics one can calculate are the sample mean and sample variance. If the results of the experiment are N numbers denoted X_1, X_2, \dots, X_n then the sample mean and the sample variance are given by the equations

$$\bar{X} = \frac{1}{N} \sum_{i=1}^N X_i \quad (\text{Sample mean})$$

$$S^2 = \frac{1}{N-1} \sum_{i=1}^N (X_i - \bar{X})^2 \quad (\text{Sample variance})$$

\bar{X} and S^2 are the unbiased estimates of the mean and variance respectively. They are also sufficient estimators since neither estimate contains either the true mean or variance. Note that it is possible to estimate the mean without estimating the variance, but that the sample variance contains the sample mean. An interpretation of the sample mean and variance follows.

The sample mean is the most likely value to expect from the experiment and, as such, is the average of the trials already observed. The sample variance and its square root, the standard deviation, are measures of dispersion about the sample mean. The sample variance is always a positive number being the sum of squares of N real numbers. The deviation is a measure of data variability. A large standard deviation is an indication of a large dispersion or variability in the data.

Ideally, an experiment as described in Subsection 1, which is essentially the torquing of a nut to a specified level and measuring the load on the bolt, should yield similar results when repeated. The confidence one associates with any one of these numbers is directly related to the sample standard deviation.

The sample mean and standard deviation associated with each experiment was displayed in Tables IV-2 thru IV-6. The test results are grouped in columns of four or five numbers, and the numbers to the left of the test results are the sample mean and variance. For example, referring to Table IV-2, the numbers to the left of the first column, 1205 and 100, are respectively the sample mean and standard deviation.

C. MECHANICAL FASTENING TECHNIQUE DEVELOPMENT FOR APPLICATION IN SPACE

Interfacial bonding or cold welding of metal surfaces subjected to the ultra-high vacuum and temperature extremes of deep space will affect fastener operation. The removal and replacement of fasteners used in space operations will depend on the fastener-joint combination's ability to prevent cold welding and seizing.

The ability of metallic surfaces to adhere across the interface when brought into intimate-clean-contact has been well established in the results of adhesion welding experiments on engineering metals. These experiments have provided the mechanisms to disrupt surface oxides to ensure metallic contact to induce the adhesion of the contacting surfaces. The test conditions can be duplicated in fastener operation in space.

The removal or emplacement of the nut on the bolt can provide the abrasion and heat necessary for removal of surface oxides and lubricants to induce adhesion when the assembly is tightened. This condition could prove to be catastrophic in the event the fastener required removal or emplacement, or precise tensioning to prevent bolt fatigue.

To investigate specific performance of fastener-joint combinations in a space environment, it is desirable to select commercially available fasteners and operate them in the anticipated environment. This required subjecting the fastener to the cyclic temperature extremes of +250°F to -250°F, the ultra-high vacuum of 10^{-9} torr, and to provide a means of fastener operation and detecting its response. This will be accomplished by mounting the fastener in a vacuum chamber fixture with mechanical feed-thrust for torquing, and measuring devices to detect the fastener's response. The complexity and expense of the test system requires the careful screening of test items to eliminate possible combinations that will fail. It is the intent of this test to select fastener combinations that are likely to succeed, and to reduce the number of uncontrolled variables that are likely to mask fastener performance. An ideal candidate is titanium, which forms a brittle and tenacious surface oxide and resists plastic yielding that would tend to fracture the oxide coating. The labyrinth formed by the nut on the thread further reduces the loss of the surface oxides. Abrasion will produce relatively clean surfaces for brass, silver-tin alloys with less tenacious oxides and lower oxygen absorption energies

than the more reactive metals (steel and titanium). The greater difficulty in removing surface oxides from the more reactive metals will be used in the fastener joint combinations to maintain low adhesion efficiencies.

1. Methods

The test samples are to be mounted on a disc which can be indexed about its axis in a vacuum of 10^{-9} torr. Samples to be dynamically tested by actually applying tightening and loosening torques while in the chamber will be mounted on the outer diameter of the disc; while the long term static test samples, which will have been pretorqued and will be tested for breakaway torque at ambient temperature and pressure, will be located on the inner diameter. A thermal control system will provide the temperature extremes of $+250^{\circ}\text{F}$ to approximately -250°F as required during the test. The indexing fixture will be rotated by remote control in increments to align each fastener to be torqued with the remotely controlled wrenching mechanism contained within the vacuum chamber. Calibration curves on the system will be developed prior to test runs to assure accurate data. Direct measurement of the torque forces required to loosen or tighten a given fastener will be made with calibrated torque wrenches and/or strain gauge instrumented force bars, or calibrated weights, to establish calibration points for the fixture and the ambient baseline data for the torque/tension relationships. Test sample temperatures will be varied, and the baseline established over a range of temperatures, to ensure that unknown deflections of the fixture do not degrade the data. These tests are not designed to evaluate absolute values of fastener tensile strength, but are intended to provide relative and repeatable torque/tension conditions approximating the values expected for a given size of fastener so that the relative effects of the environment on various fasteners can be noted.

A 30-day test will be made, using new fasteners, which will expose the fastener-joint combinations to a vacuum of 10^{-9} torr and a temperature of $+250^{\circ}\text{F}$. Torque-tension recordings will be made at sample temperatures of $+250^{\circ}\text{F}$ on each dynamic sample at equal time increments during the test. At the end of 30 days the test will be terminated and the fasteners examined, and the data will be analyzed to determine fastener performance.

A final determination of those fastener-joint combinations to be included in the final vacuum cyclic temperature test will be made.

The long-term exposure soak utilizing new fasteners will be of 30 days duration at 10^{-9} torr vacuum and a constant temperature of +250°F. Torque tension readings will be made at equal time increments during the test.

The fastener-joint, lubrication combinations shown in Table IV-7 will be mounted in the vacuum test fixture in the following test sample combinations.

Table IV-7 Dynamic and Static Test Samples

DYNAMIC TEST ITEM	SIZE	BOLT MATERIAL	JOINT MATERIAL	NUT MATERIAL	LUBE
1 2 3 4	¼-28	Titanium 6Al-4V Per AMS 4928 Six-Wing Bolt P/N SW25-4-24	Titanium 6Al-4V Per AMS 4928	Titanium 6Al-4V Per AMS 4928 Six-Wing Nut P/N SW65-4	Anti-Galling per Hi-Shear Spec 306 Type II Film Lube per Electrofilm Spec 4396
5 6 7 8	↓	↓	↓	↓	VSM 1171 Solid Film Lubricant Voi-Shan Mfg. Co.
9 10 11 12	↓	↓	↓	↓	None Nuts (Passivated)
13 14 15 16	↓	A-286 CRS per AMS 5735F Six-Wing Bolt P/N SW15-4-24	A-286 CRS per AMS 5735F	A-286 CRS AMS 5735F Six-Wing Nut P/N SW55-4	Silver Plate Nut per AMS 2410C
17 18 19 20	↓	↓	↓	↓	None
21 22 23 24	↓	↓	↓	↓	Molybdenum Disulfide

Table IV-7 (concl)

STATIC TEST ITEM	SIZE	BOLT MATERIAL	JOINT MATERIAL	NUT MATERIAL	LUBE
25 26 27 28	1/4-28	A-286 P/N NAS 1004-12A	Stainless 303	A-286 CRS P/N MS9360-10	Silver Plate Nut per AMS 2410C
29 30 31 32	1/2-20	A-286 P/N NAS 1008-8	↓	P/N MS9357	↓
33 34 35 36	1/4-28	Multiphase (SPS) P/N SPS 69040-41	4130 Steel	Silver Plate A-286 MS9360-10	SPS K-3
37 38 39 40	1/2-20	P/N SPS 69040-81 This Item Not Available for Testing	Stainless 303	Silver Plate A-286 MS9357-14	↓
41 42 43 44	1/2-20	A-286 P/N NAS1004-24A	Stainless 303 Not Tested	A-286 Moly- Disulfied MS9357-14	Moly-Disulfied
45 46 47 48	1/2-20	Multiphase (SPS) P/N SPS 69040-81 Not Available or Testing	4130 Steel	Silver Plate A-286 MS9357-14	SPS K-3
49 50 51 52	1/2-20	A-286 P/N NAS1004-24A	Stainless 303	A-286 MS9357-14 Bare	No Lubricant
53 54 55 56	1/4-28	Multiphase (SPS) P/N SPS 69040-41	4130 Steel	Silver Plate A-286 P/N MS9360-10	

2. Fastener Installation

The test items are to be inserted and torqued to provide tension loads of approximately 70-80% of the fastener yield strength. The joint insert is to provide the fastener with a mounting surface consistent with the service rating of the fastener. The joint inserts will maintain dimensional and modulus of elasticity characteristics to avoid any detrimental plastic deformation of the joint in the area of the fastener. The fasteners will be retightened to insure that "seating" of the fastener has not caused a relaxation of the joint due to the compression of surface irregularities.

Fasteners will be installed with appropriate head washers, and the bolt retained against rotation by the bolt head. Tensioning of the test samples will in all cases be accomplished by applying torque to the nut.

3. Test Equipment (Environment Test)

The test apparatus consists of a fixture for holding twenty-four dynamic test items, and a series of blocks containing static test samples mounted to the flat surface of the revolving test disk (Figure IV-9 and IV-10). The chamber will provide a vacuum to 10^{-9} torr obtained with Ion pumping.

The dynamic test items are mounted in carefully machined specimen holders indexed to a test station. A sliding-socket is raised to engage the test item's head from below, and a torque wrench extends into the chamber and grips the nut for application of torque through a magnetic feed-thru mounted to the fixture-base-plate. After torque is applied, the test item is rotated to engage a caliper to detect fastener elongation.

The revolving test disk contains a torus cavity to which LN_2 will be circulated to produce test item temperatures of -250°F (see Figures IV-9 and IV-10). Temperatures of $+250^\circ\text{F}$ will be produced either by applying direct current to the disk or circulating hot gas or liquid in the cavity to produce the desired test item temperature (Figure IV-9).

The rotary magnetic feed-thru mounted to the base plate of the vacuum fixture is utilized to manually revolve the test disk, and to provide torque to the test item. An indicator on the feed-thru body will display the positions of the various test items in the chamber. A view port in the vacuum chamber will provide visual access to the test items.

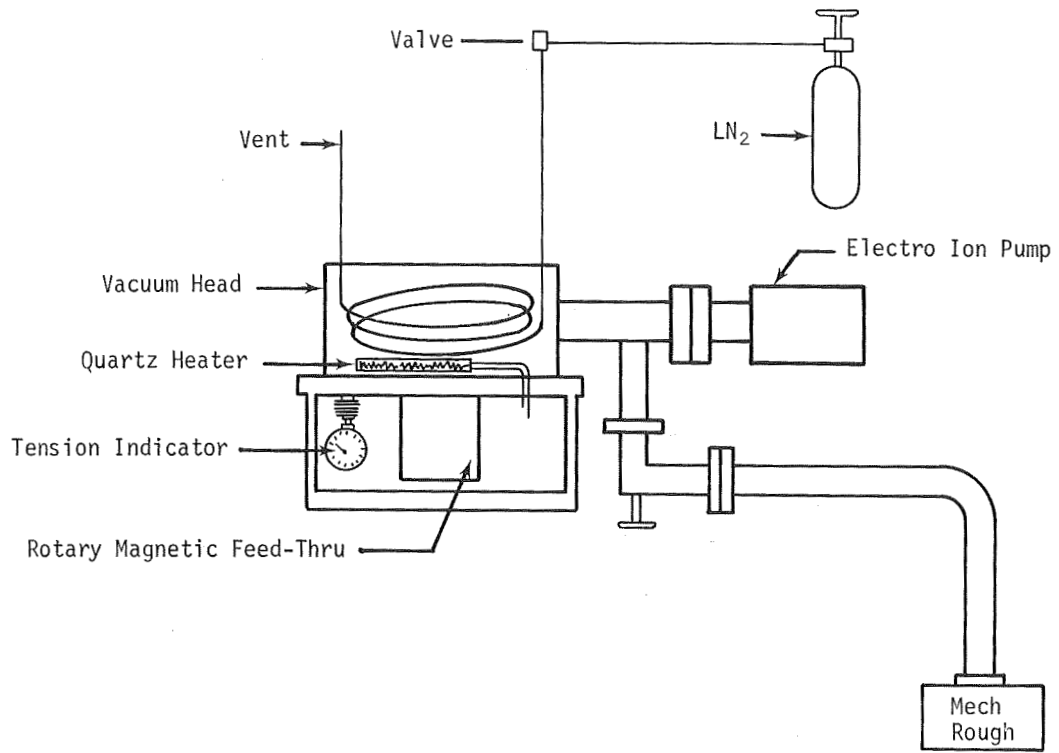

Figure IV-9 Vacuum System Environmental Tests

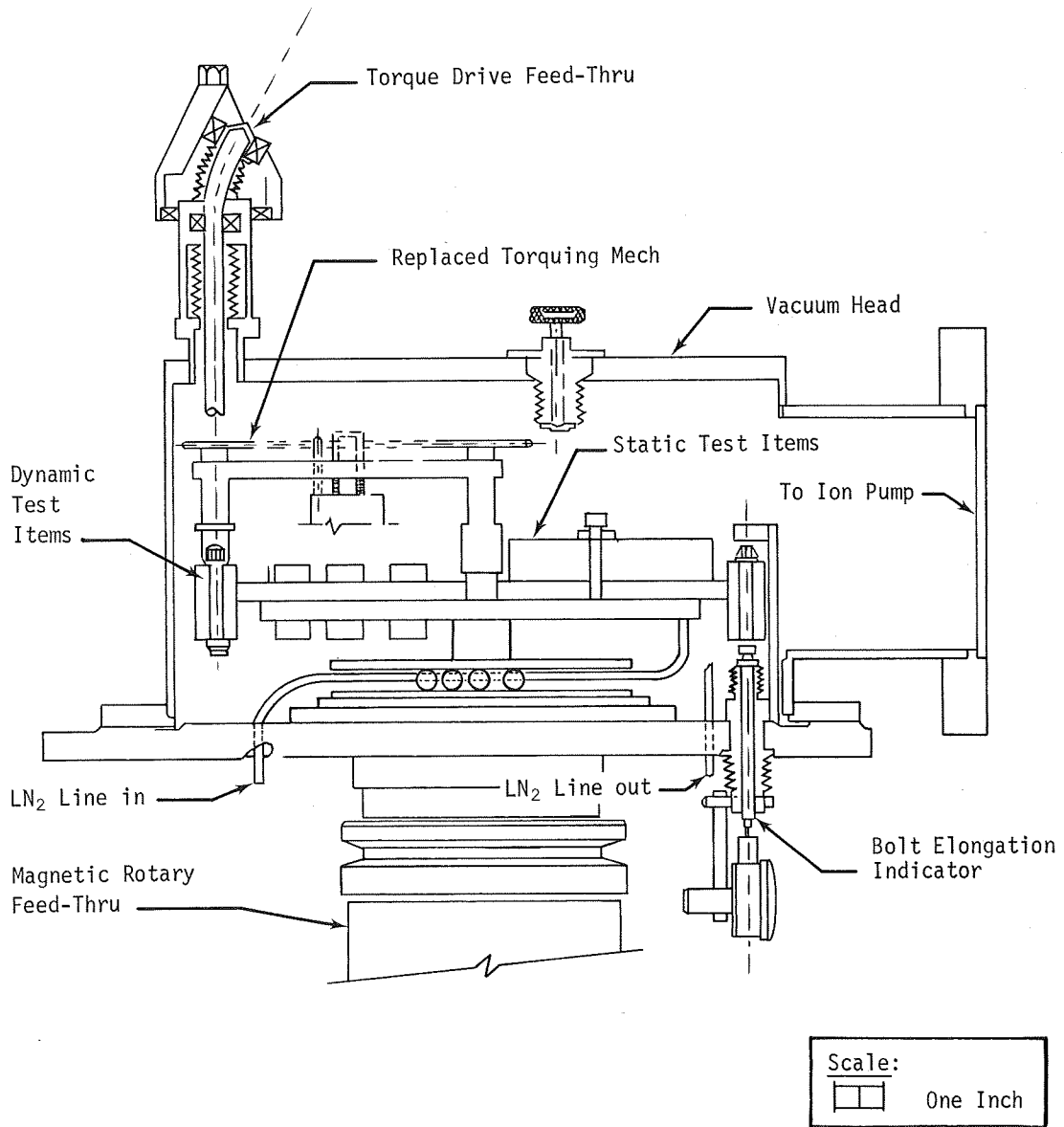

Figure IV-10 Elevation of Test Fixture

4. Variables Effecting Bolt Tension

The object of this series of tests is to detect the effects of environment on the fasteners performance. Ideally data indicating a change in the friction between the faying surfaces of the nut and the bolt is wanted. However, the following variables have the capability of masking fastener performance and producing a low confidence level in the test results.

Friction Ratcheting caused by repeated load application will attempt to be controlled by providing specimen holders with the same coefficient of expansion as the test item. However, an uneven heat exchange between the holder and the test items caused by thermal excursions will be hard to control. If the preload of the test item is cycled by thermal reaction the loosening rotation of "ratcheting" could be induced during the loading phase.

Yielding of the faying surfaces between the bolt head, the nut, and the specimen holder will be minimized by grinding the bearing surfaces of the specimen holders. Also, the stress relaxation, due to small localized yielding caused by smoothing of the thread, due to dilation and wear will also contribute to the loss of tension in the fastener.

The results of a preliminary test exposing nine 1/4-28 x 3/4-. in. bolts to a hard vacuum for 30 days with four heat cycles up to 550°F, resulted in a release torque 60 to 70% below the initial torque.*

Loosening by isolated thread yielding during cycling of the fasteners will be impossible to control, resulting in the tension changes indicated above.

5. Test Apparatus

The Phase-IV high temperature test was conducted with the Test Apparatus shown in Figure IV-11 and IV-12. The vacuum chamber was constructed of stainless steel, and is approximately 12 in. in diameter and 6.5 in. high. A Granville-Phillips 6 in. 1600 liter/sec Electro Ion Pump was flange mounted to the chamber proper. Figure IV-13 is a time history of required chamber pump down and heating cycle. The flange mount contained valving for inter-connecting a liquid-nitrogen trapped mechanical force-pump and an air-admittance valve (not shown in figure). The pump power supply and controller are shown placed at the left of the chamber.

*Additional information (as presented in MB-2560, 6 October 1967) can be obtained from Mr. George Armstrong, /PR-SS Purchasing Officer, MSFC.

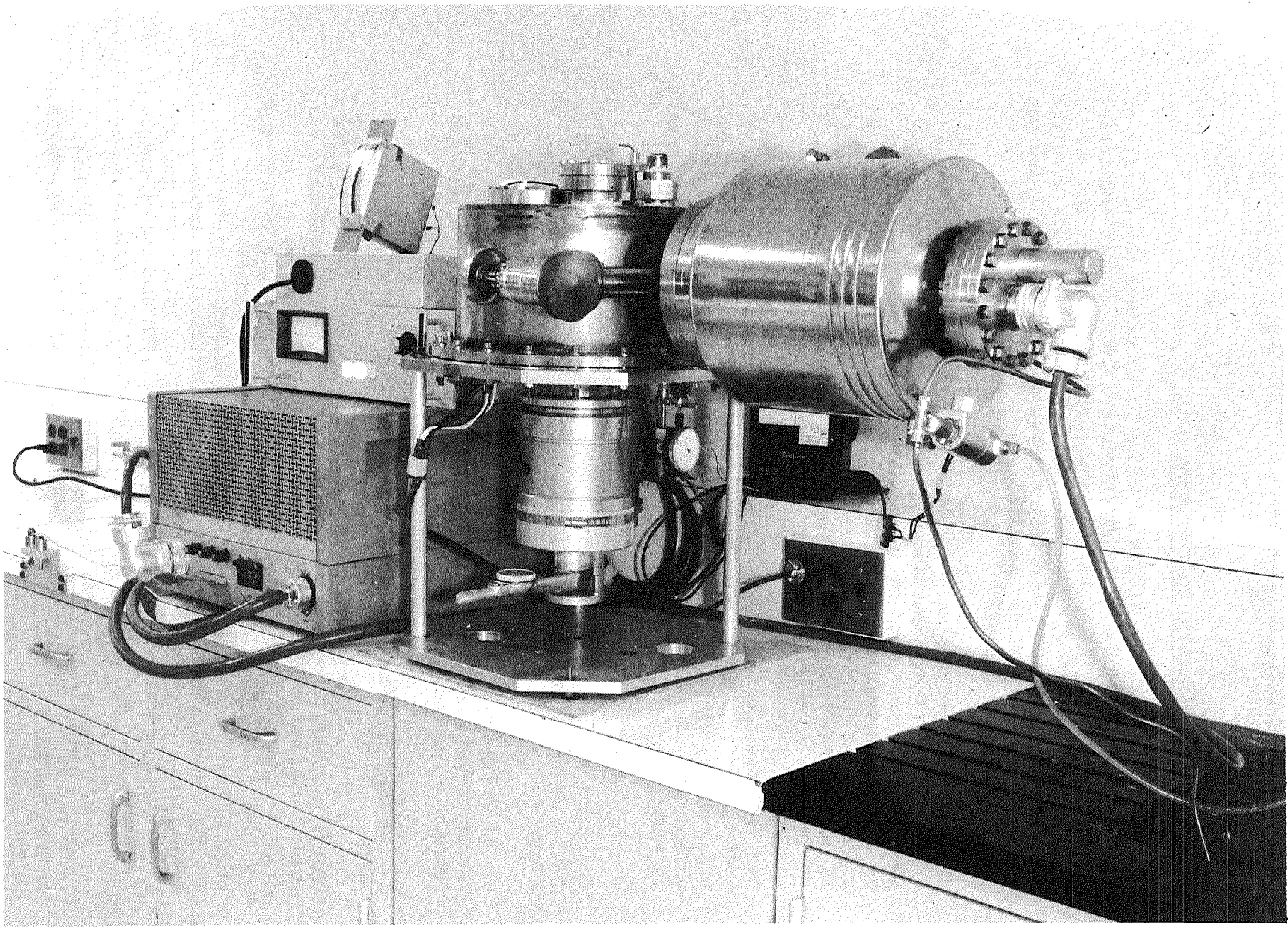

Figure IV-11 Hi-Temp Vacuum Test Setup

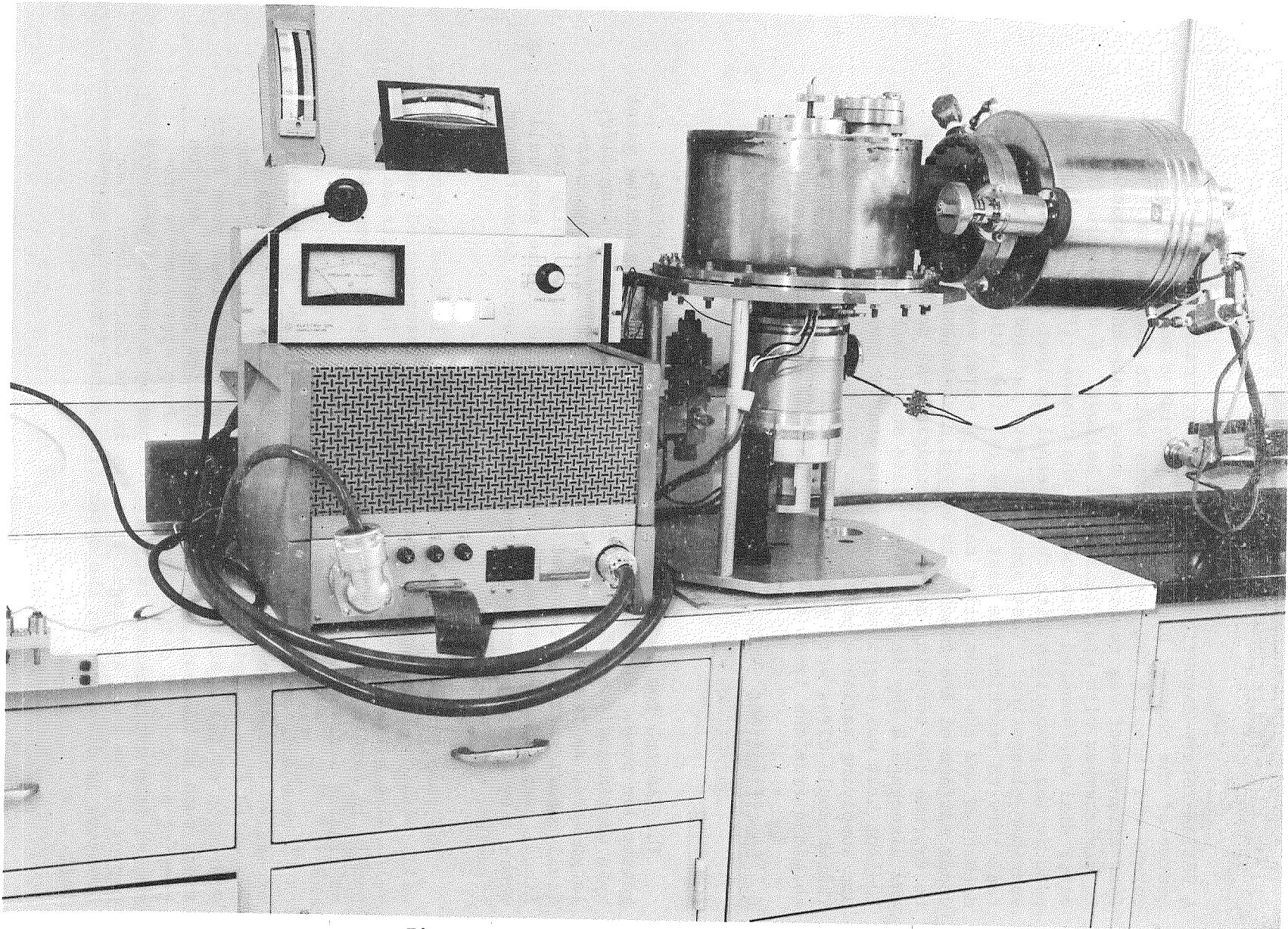

Figure IV-12 Hi-Temp Vacuum Test Setup

A Varian-rotary-magnetic-feed-thru was vertically mounted to the center of the chamber base plate to provide a means of supplying torque and indexing the test specimens within the chamber. A caliper arrangement was mounted to the base plate and interconnected to the chamber with stainless steel bellows. A 0.0001-in. indicator dial was mounted external to the chamber (Figure IV-11) and used in the connection with the internal caliper to measure test specimen elongation. Test specimens were indexed by rotating the feed-thru to position the test items in line with the torquing mechanism and the elongation caliper. A screw was mounted to the upper surface of the chamber to extend a stainless steel bellows to depress the torquing mechanism engaging the nut to be torqued and disengage a key in the index plate shown in Figure IV-10. Radiant heat was supplied by mounting quartz lamps in the chamber and supplying variable power through base mounted pin connectors. Thermocouple wires were mounted to internal chamber structure shielded from the lamps to indicate chamber temperature.

6. Specifications

Ion Pump

The Electro Ion is an electrostatic, multicelled, triode, getter-ion pump. Pumping is achieved by (1) gettering active gases by a continuously deposited titanium film provided by a long-life, large-area, resistance-heated sublimator; and (2) ionizing chemically inert gases by means of a cloud of electrostatically confined, energetic electrons, and burying the ions in the pump wall where they are permanently trapped by the continuous deposition of titanium.

The pump consists of an electrode assembly located concentrically within a cylindrical, stainless-steel, water-cooled housing, which also serves as the cathode of the pump. The electrode assembly is mounted on a removable bakeable flange, and contains a sublimator surrounded by four ionizer cells.

A removable optical baffle prevents the escape of titanium or excessive thermal energy from the pump. Ions and electrons are prevented from escaping by electrostatic fields within the pump. Operation of the Electro-Ion is automatic. All normal pump functions such as bakeout, starting, sublimation pumping, and ion pumping are carried out automatically. Pump operation is protected from overpressure and malfunctions by a special pressure sensor in the pump and logic circuits in the Controller. Pump pressure is displayed on the meter from about 1 torr to 5×10^{-9} torr.

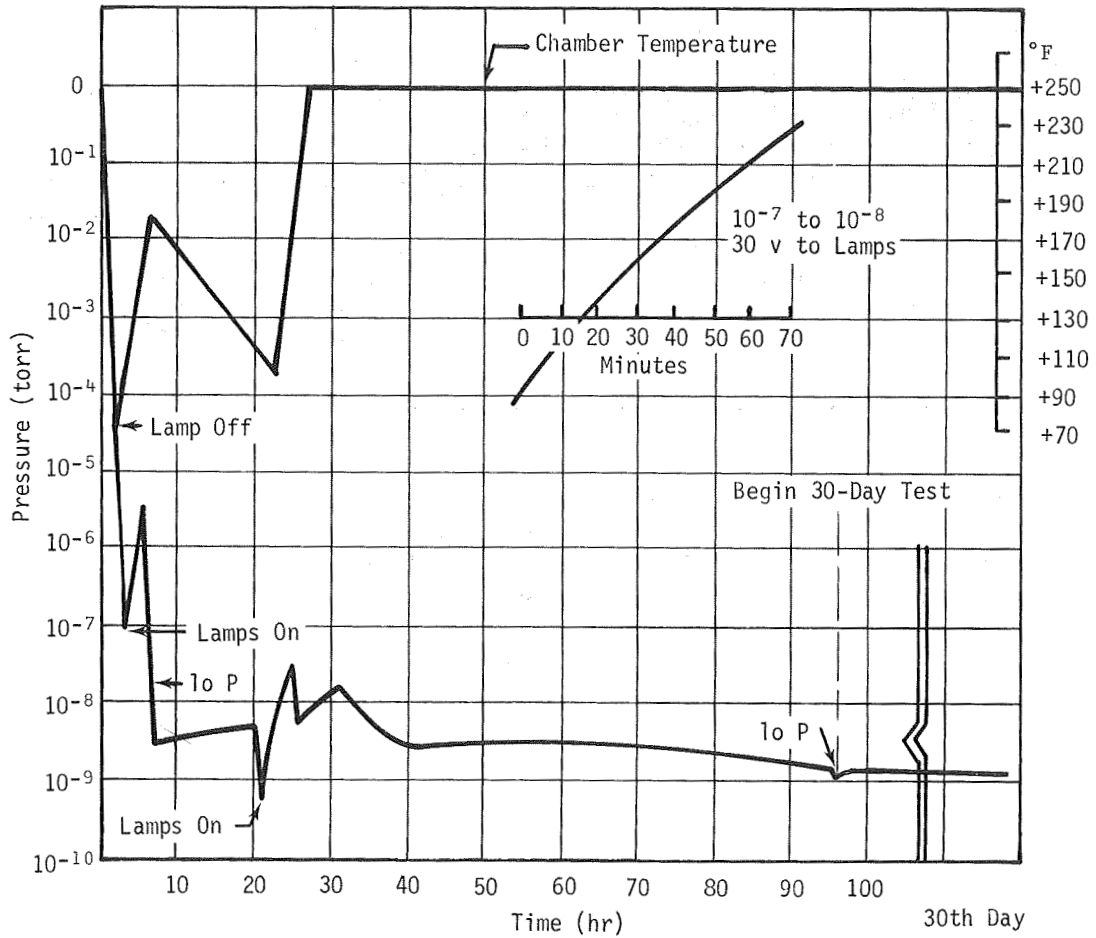
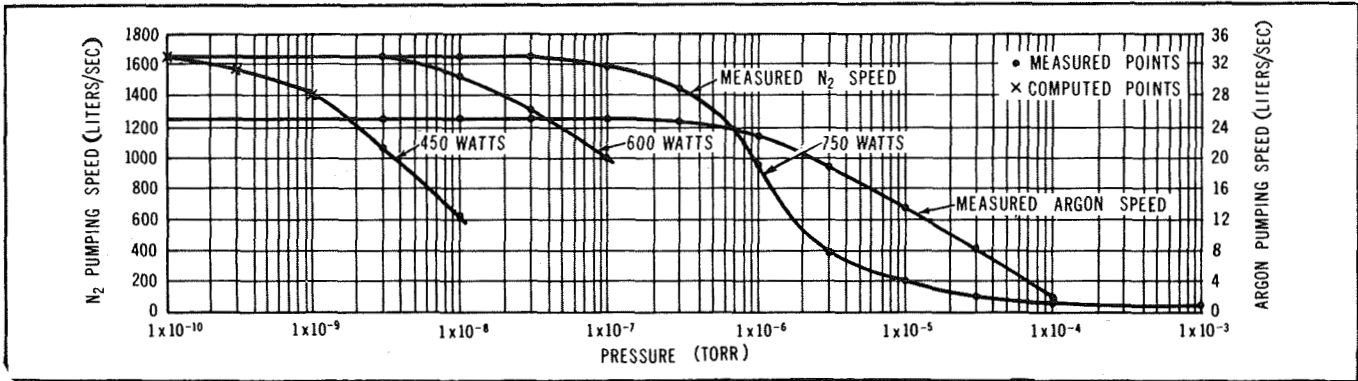

Figure IV-13 Time History of Hi-Temp Chamber Pump Down

The pumping speeds for a fully baffled pump for various gases at 10^{-7} torr are given in Table IV-8.

Table IV-8 Ion Pump Pumping Speeds



Nitrogen	1600 l/sec	Carbon Monoxide . . .	1600 l/sec
Hydrogen	4800 l/sec	Argon	24 l/sec
Oxygen	1500 l/sec	Helium	2.5 l/sec
Carbon Dioxide	1300 l/sec		

Ion Pump

Controller

Inputs

From Power Supply

Outputs

Pressure indication on taut band, 5 in. panel meter from 1 torr to 5×10^{-9} Torr on 7 meter ranges. 0.5A relay contact to operate the cooling water supply valve. 0.5A relay contact for control of a mechanical forepump, if used. 0.5A relay contact for control of a solenoid actuated foreline valve. Low voltage dc status signals which appear after each Controller switching logic function is completed.

Temperature Limit

50°C maximum ambient without forced cooling.

Construction

All solid state, computer style, replaceable, circuit boards.

Mounting

Standard Rack Mounting

Net Weight

10 lb 5 kg

Shipping Weight

17 lb 8 kg

Power Supply

Input Power

115 v, 60 cps, 16A single phase.

High Voltage

4000 vdc

Duty Cycle

Continuous

Temperature Limits

50°C maximum ambient without forced cooling.

Ion Pump

Pump

Baffled Speed for N₂

1600 liters/sec

Temperature Limits

300°C maximum external bakeout temperature with cable removed. Internally self baking to 300°C during operating cycle.

Magnetic Field

None used. An externally applied magnetic field of 100 gauss parallel to the pump axis causes less than 1% decrease in the ion pumping speed and does not affect the getter pumping speed.

Current Flux @ 1×10^{-8} torr from port of fully baffled pump

 $i - 6 \times 10^{-11} \text{A}$ $i + 1 \times 10^{-10} \text{A}$

Radiant Flux

Approximately 19 w of thermal energy is radiated through the inlet port.

Cooling Water

1 liter/min (approximately 0.25 gpm)

Materials

Housing: All Type 304 stainless steel.

Electrodes: Very low vapor pressure metals, vacuum fired at 1000°C, and alumina ceramic insulators.

Sublimator: Titanium, refractory metals, other very low vapor pressure metals, plus beryllia and alumina ceramics.

Internal Volume

14 liters

Bolt Load Cell

The force transducer used to obtain data for the Ambient Torque/Tension Tests was Government furnished equipment. The transducer was a GSE Inc. Model FT-250 with the following:

- 1) Construction: Steel Flexure, Aluminum Cover;
- 2) Sensor: 120 to 350 Ohm, Full Bridge Bonded Strain Gages;
- 3) Output: Nominal 1.5 mv/v at Full Scale;
- 4) Accuracy: $\pm 1\%$ of Rated Load;
- 5) Excitation: 12 vdc or ac (maximum);
- 6) Temperature Compensation: Zero Drift Less than 1%;
- 7) Shunt Calibration Resistor: Furnished;
- 8) Stiffness: $1\text{b/in.} \times 10.5 \times 10^{-6}$.

The force transducer used in the phase low temperature runs was a GSE Model FT-250-B, which had better performance than the standard unit with a calibrated-modulus compensating-resistor inside the transducer case.

Torque Mechanism

The torquing mechanism was constructed of 304 stainless with copper plated sprockets and ladder chain. The sprockets were journalled with needle bearings, with a 3:1 torque output when engaged with the magnetic feed-thru. Figure IV-14 is a calibration curve developed for the fixture.

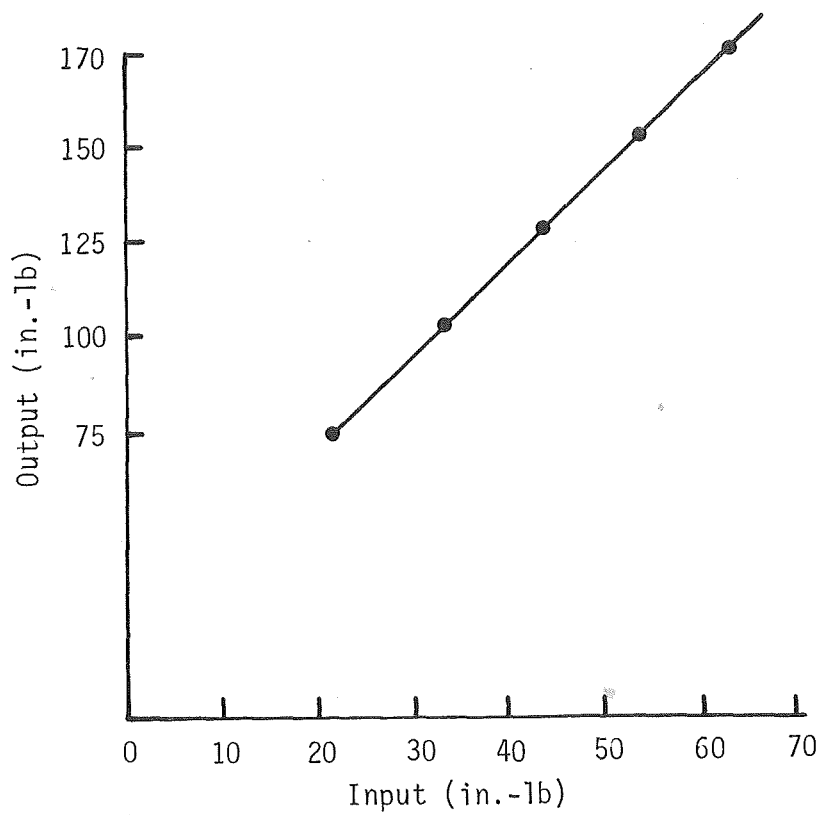

Figure IV-14 Torque Mechanism Calibration Curve

Rotary Motion Feed-Thru Varian Model 954-5039

The varian-rotary-motion feed-thru is designed to transmit rotary motion into ultra-high vacuum systems. Torque is transmitted through magnetic lines of force, eliminating sliding vacuum seals and their lubrication.

The feed-thru delivers 6 ft-lb of torque to the output shaft, and with the magnet removed is bakeable to 400°C. The stray magnetic field strength along the axis of the feed-thru is 4 gauss at the flange, 1 gauss 2 in. from the flange, and 0.5 gauss 4 in. from the flange.

The lubricant is dry molybdenum disulfide (Molykote Type Z), which has a low vapor pressure and will withstand high-temperature bakeout without gassing or breaking down.

7. Temperature Measurement

The experiment required measuring temperature at three locations:

- 1) Stainless steel bolt cylinder;
- 2) Titanium bolt cylinder;
- 3) Ambient radiant energy at center of vacuum chamber.

Copper-constantan thermocouples (TCs) were selected as a transducer for the problem, and a simple electronic readout using room temperature as a reference-temperature was constructed. The completed system had a measurement error of less than $\pm 5^{\circ}\text{F}$ (approaching $\pm 2^{\circ}\text{F}$), and appeared to be compatible in all ways with experiment requirements.

A block diagram of the temperature measurement system is shown in Figure IV-15.

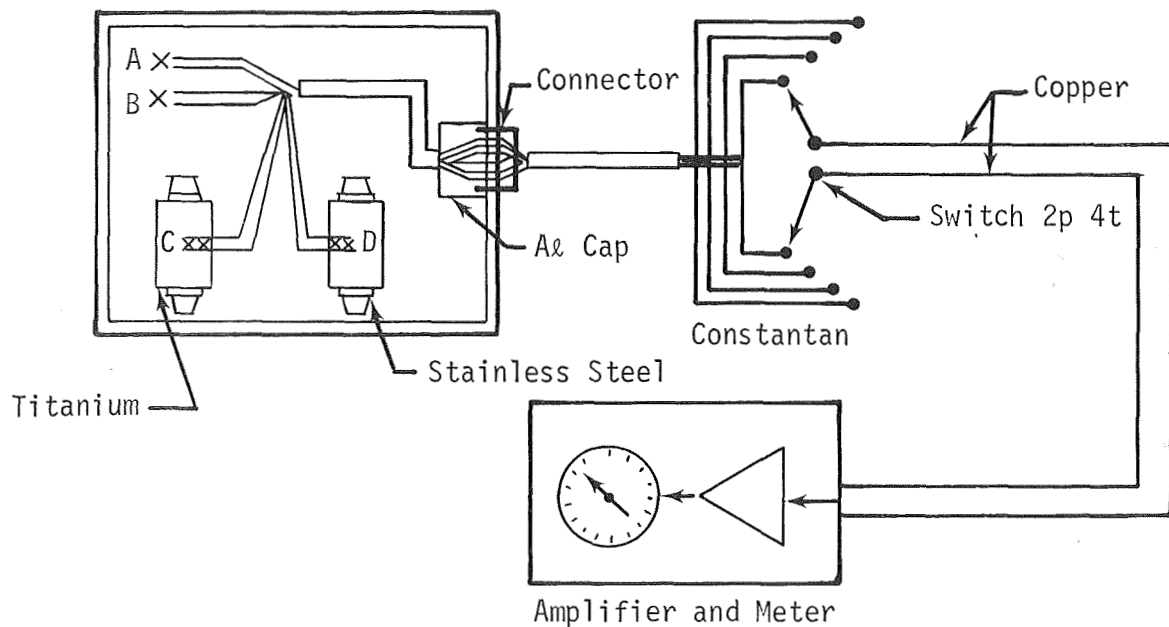

Figure IV-15 Temperature Measurement Block Diagram

TCs C and D were welded directly to the belt cylinders. TCs A and B were flattened at the active junction to a thickness of 0.005 in. and exposed to ambient radiation. Electrical connection through the chamber was made with gold-plated copper pins. TCs were continuous CU-CON on both sides of the connector. An aluminum cap was placed over the connector on the inside of the chamber as a radiation shield. Polyurethane insulation was placed over the connector on the outside of the chamber as a heat conduction insulator. Heat insulation at the connector held the temperature gradient across the pins to a negligible value. Any gradient at this point of TC discontinuity will create temperature readout errors. The electrical switch was a 2-pole 4-position switch with silver-plated contacts. Copper lead wire was used from switch to amplifier/meter, hence the TC reference junction was at the switch. A Burr-Brown operational amplifier and a simple meter movement was used for readout. Appropriate nulling and balance potentiometers were used in the amplifier to assure adequate sensitivity and accuracy. TCs were made of AWG No. 30 size wire to minimize the time-constant and heat-conduction problems. Teflon insulation was used where appropriate; ceramic TC tubing was used where necessary.

D. VACUUM, AND HIGH TEMPERATURE, THIRTY-DAY SOAK TEST

This test was conducted at pressure levels of 10^{-9} torr and a constant temperature of $+250^{\circ}\text{F}$. Three days of bake-out and pump-down were required before chamber and test sample out-gassing were diminished to levels to maintain a chamber pressure in the 10^{-9} torr range. (Figure IV-13, page IV-29, indicated a profile of time vs pressure and temperature during chamber pump-down.) Test items contained in the chamber are shown in Figure IV-16. The dynamic test samples' free-lengths and the nuts torque to an initial load of 75 in.-lb. Seventy-five in.-lb was selected as the installation torque to overcome the self-locking feature of the nuts to insure the seating of the test item in the test cylinder. The torquing mechanism was calibrated at ambient temperature prior to closing the chamber. (The torquing mechanism calibration curve was shown in Figure IV-14, page IV-34). The static test sample items were pretorqued to 175 in.-lb, and items 29 thru 32 were torqued to 700 in.-lb prior to installation in the chamber.

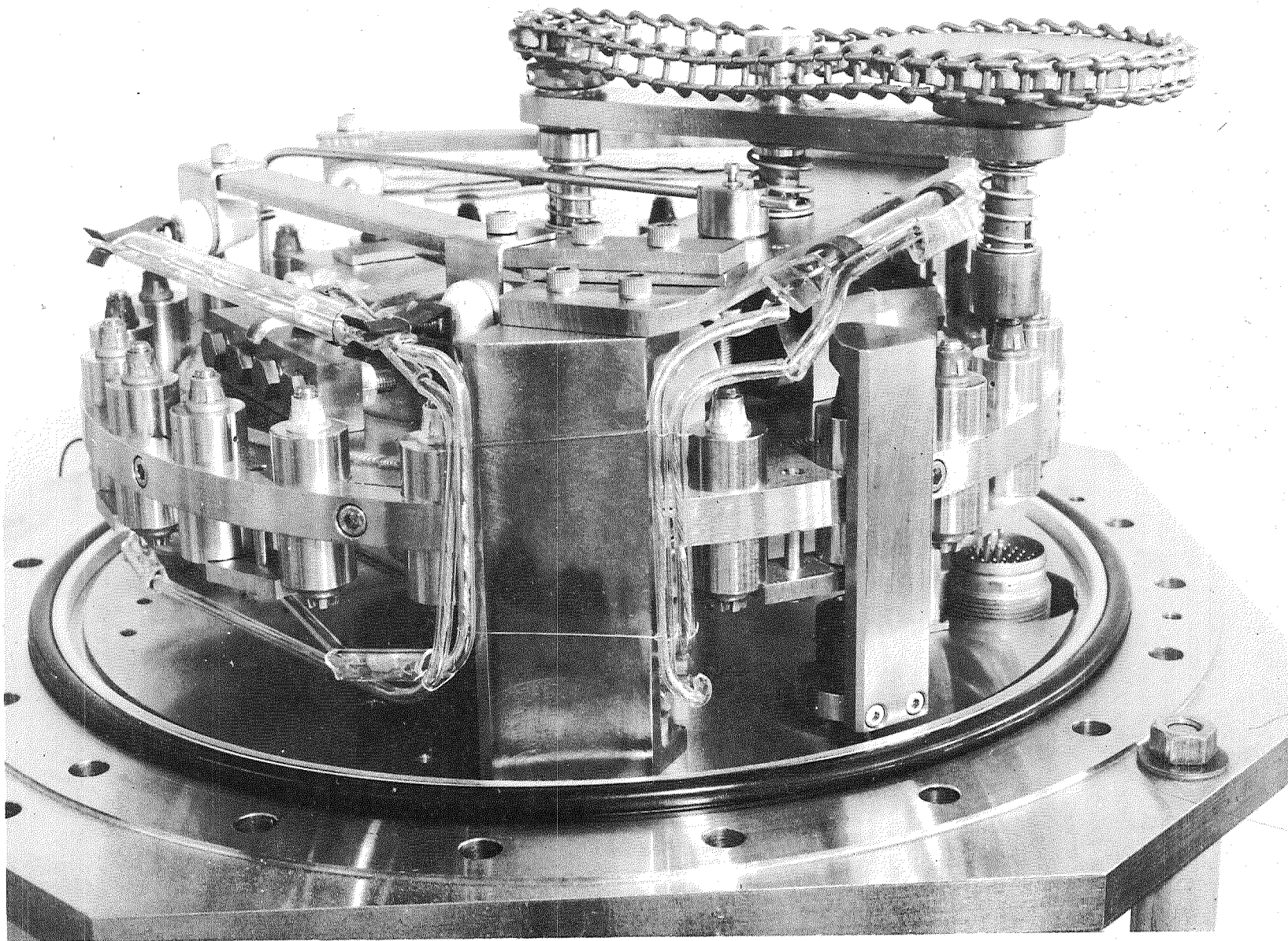

Figure IV-16 High Temperature Chamber Interior

One week into the test, torquing of the bolts to 100 in.-lb began. After torquing and measuring several bolts, the caliper arrangement used to measure bolt elongation jammed. It was noted that some of the torqued nuts exhibited sheared portions of the drive wings. It was assumed that chips from the drive lugs could have dropped into the sliding interfaces of the caliper to cause the jammed condition. It was decided to continue the test to determine if gross adhesion would occur later in the test, because lead time would be required to obtain a new set of bellows to fabricate a new caliper.

Test items 17 thru 24 were cycled four times in quick succession to the magnetic feed-thru breakout point, approximately 175 to 185 in.-lb of torque (Figure IV-14). The nut was chased through several pitches as quickly as possible to develop heat and abrasion at the faying surface between the nut and the bolt. The three-to-one reduction in the torquing mechanism prevented the nut from being rotated at speed comparable to chasing down a nut with a simple one-to-one ratio of a wrench or ratchet.

It was noted that of those test items cycled as described above, only test item 24, which seized upon the initial application of torque, failed to respond. This test item was a combination of an unlubricated stainless nut and bolt. Adhesion of similar unlubricated combinations occurred in ambient baseline conditions, and no significance was attached to the seizing of the test item. Unfortunately, because of the caliper failure, tension in the bolts as a function of the torque application could not be monitored in this test.

During bolt cycling, a sliding key used to disengage the index plate with the torque mechanism froze, rendering the mechanism inoperative. This was the result of attempting to run the mechanism dry to prevent the possibility of lubricant backstreaming from the torque mechanism to the test samples. Originally, a torque mechanism capable of delivering the required torque levels at a one-to-one ratio was considered. The torque levels required were far in excess of the capability of standard vacuum feed-thrus. Long delivery time required for the development of a special feed-thru precluded its use within the scope of the original time span. Upon the failure of the chamber feed-thru, an extension to the contract was requested and obtained to secure a replacement. The new feed-thru was ordered for use in the follow-on cyclic environmental tests, and the high temperature test was continued to give a total running time of 30 days at +250°F and a 10^{-9} torr vacuum level.

Fastener release torques were noted immediately after the chamber was opened. However, the time span from chamber opening to bolt release was not short enough to prevent reoxidation of those surfaces exposed to atmosphere. Figures IV-17 and IV-18 indicate break-away torque required to release dynamic and static test items.

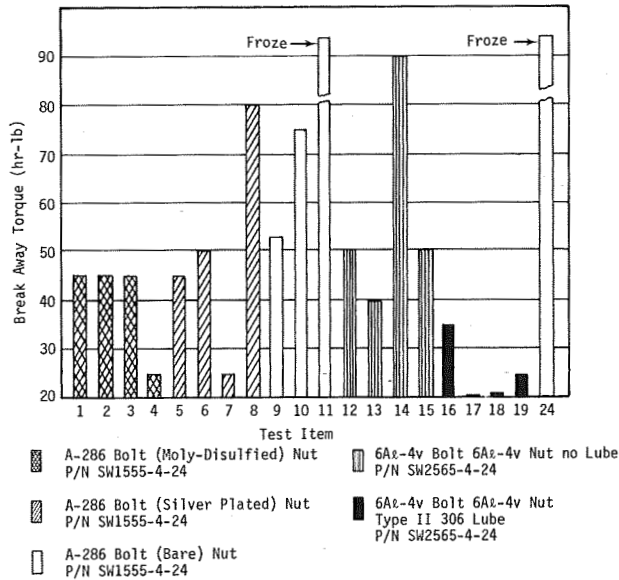

Figure IV-17 Break-Away Torques for Dynamic Test Items

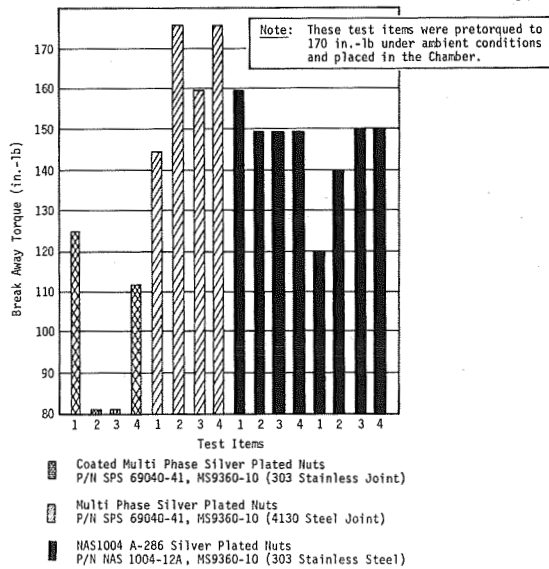

Figure IV-18 Break-Away Torques for Static Test Items

E. VACUUM AND CYCLIC TEMPERATURE TEST

The chamber was modified to accept the new feed-thru designed and fabricated to overcome the difficulties with the initial torque drive. Figure IV-19 shows the feed-thru mounted in working position. The test fixture was modified as shown in Figure IV-20. Quadrants in the fixture spider were removed, and the bottom surface was lapped to insure contact with the copper heat sink. The heat sink is visible through the spokes of the spider. Originally it was planned to run LN₂ through a cavity in the spider-visible in the spoke radiating toward the caliper measuring device. However, this concept proved impractical because of flexible bellows squirm, and the inability of the magnetic feed-thru to provide the additional torque required to uncoil or coil tubing required to run the coolant from the base plate to the index plate.

The non-rotating heat sink shown consisted of a solid copper plate with LN₂ passages machined into its interior. The mating surface was lapped and the plate-spring loaded to maintain sliding contact with the rotating spider.

New test items were installed as shown in Figure IV-20. It is noted that the nuts were just barely engaged to expose the threads to the vacuum environment. Both ends of the test bolt were carefully center drilled to accept the ball ends of the micrometer. The quartz lamps are shown mounted to close proximity to the test items. Removal of quadrants in the rotating spider were made to decrease its mass to aid in temperature response and to provide a radiant path from the lamps to heat the plate.

The chamber was closed and pumped down, and LN₂ was passed through the heat sink in an attempt at cool down. The results were disappointing and the chamber was broken open and insulation was applied to the chamber interior and modifications were made to instrumentation. The stainless, titanium and copper used in the chamber are poor black bodies and not a good choice for rapid and wide excursions of temperature response. However, the materials were selected to produce a hard clean vacuum which was considered of primary importance. The alternative of painting the interior with black vacuum chamber paint to enhance temperature response was not considered wise. Previous experience with this type of fix indicated that a probable degradation in the vacuum levels would result requiring higher power levels

introducing a higher radiant flux thru the pump inlet port into the chamber. Larger chambers available with cryopanel and the required cooling capacity did not have the 10^{-9} vacuum capability. Because of this problem, it was decided that hard vacuums in the 10^{-9} torr and $+250^{\circ}\text{F}$ temperatures would be more conducive to adhesion than the application of low temperature, and that it would be more effective to run torque tension data at 10^{-9} torr and $+250^{\circ}\text{F}$. Cool-down would be accomplished after the data was obtained by turning off the Ion Pump and applying LN_2 . Torque tension readings would then be made at the lowest temperatures attainable, and vacuum levels below 10^{-6} torr.

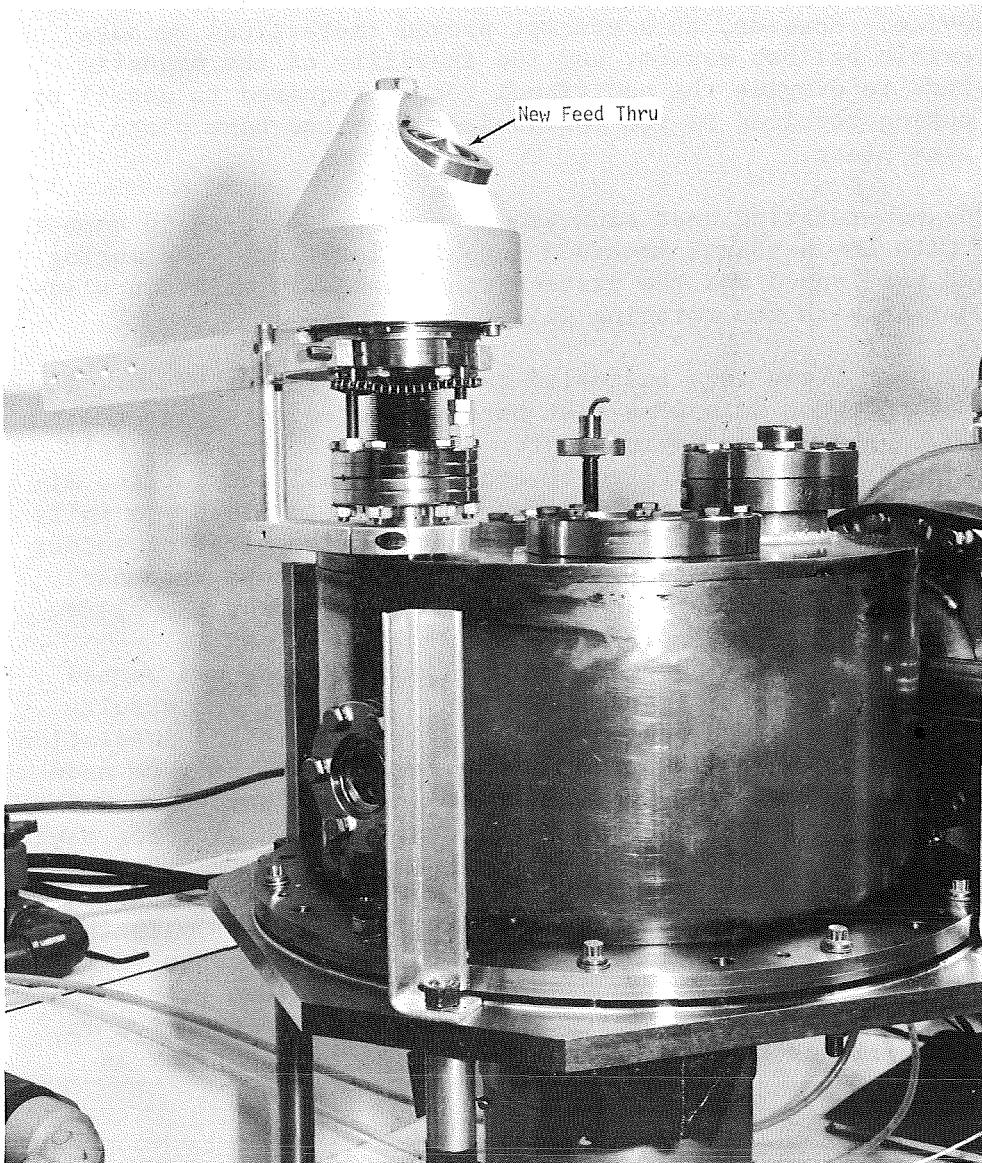

Figure IV-19 Cyclic Temperature Vacuum Chamber
with New Feed-Thru

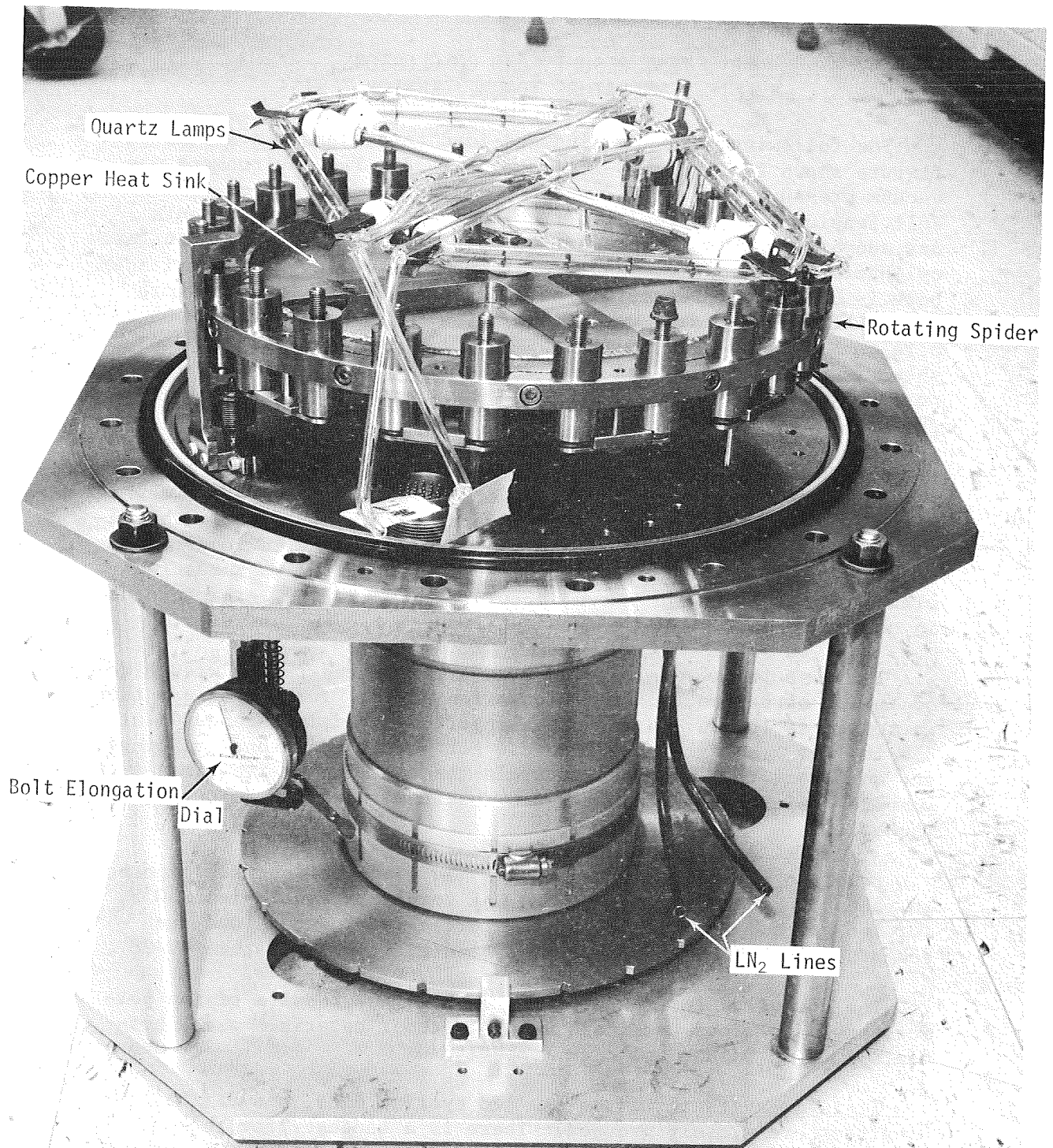

Figure IV-20 Cyclic Temperature Chamber with Cover (Top) Removed

F. TEST RESULTS AND CONCLUSIONS, CYCLIC TEMPERATURE TORQUE/TENSION TESTS

The following torque vs induced-load tests were run in the fixture shown in Figure IV-16 on page IV-38. The environment was vacuum pressure of 5×10^{-9} and a constant temperature of $+250^{\circ}\text{F}$. Bolt tension was interpolated from bolt elongation measurements and converting this measurement to bolt tension. The specimen test cylinders are 0.750 in. in diameter and 1.5 in. long. The cylinder bore is 0.255 in. diameter. The squareness of the internal bore to the bearing surfaces was ± 10 minutes. The bearing surfaces were machined to a 32 RMS finish. The fastener was installed as shown in Figure IV-16 with the bolt retained and vertically supported by the bolt head. The nuts were assembled to the bolt as shown in the foreground.

Torque was applied to the nut through the feed-thru shown in Figure IV-19. Torque was applied with a calibrated torque wrench and pneumatic impact tool. The bolt threads were cleaned with acetone and rinsed with alcohol and the nuts were handled in a manner intended to prevent contamination. Bolt elongation was measured with the dial indicator shown, accurate to 0.0001 in., and recorded in an environment having a constant temperature and humidity.

The test items were torqued with a calibrated torque wrench to 50 in.-lb of torque, and the elongation noted. The torque was then increased to 100 in.-lb and the elongation noted, and repeated at 150 in.-lb. The available time did not permit additional readings and an impact tool was used to cycle the test items five times and compare "before and after" torques required to chase the nut down the bolt.

Prior to cycling, the test items had been continuously exposed to vacuum in the 10^{-9} torr range, and temperatures of plus 250°F , for 168 hours. The results of the torque vs. induced load are contained in Tables IV-9 thru IV-15 and Figures IV-21 thru IV-28.

The composite in Figure IV-21 compares the results of the performance of various combinations of fastener materials and lubricants in hard vacuum and high temperature.

It is noted that for the limited cycling done, the various combinations are closely grouped. There is a tendency for those combinations involving the A-286 bolt to exhibit a little more efficiency in the vacuum when compared to the performance of Titanium articles. When compared to the data obtained from ambient torque tension data, the vacuum environment exhibits a tendency to degrade the fasteners performance as the torque levels are increased.

Of course, the vacuum environment will also affect the efficiency of the feed-thru as well as fastener performance. Calibration of the feed-thru at ambient conditions obtained before chamber pump-down is subject to degradation imposed by the vacuum environment. A loss of efficiency during exposure to the vacuum during the test will go undetected, and exposure to atmosphere for recalibration will not give a true indication of the mechanism performance in the vacuum. Also, it is anticipated that the application of the impact tool on the feed-thru bearings could produce a masking effect in trying to determine the effect of the feed-thru on the initial fastener performance in the chamber.

Under the circumstances, it seems proper to attribute the loss of fastener efficiency to the effects of the vacuum rather than the performance of the feed-thru. However, to assign a number to the effect of vacuum on fastener performance with the data obtained would be presumptuous. Tests limiting the number of variables and equipment capable of more discreet measurements would be required for definitive results. However, no instances of gross adhesion occurred in the combination tested in a vacuum environment, with the exception of bare stainless or stainless.

A pneumatic impact wrench was used to investigate its effect on fastener performance in a vacuum. The wrench was used to rotate the nut up and down the threaded portion of the bolt. Torque readings were made of the torque required to rotate the nut up and down the thread before and after the impact wrench was used. These values are recorded in Table IV-15. The torque values recorded are those forces required to overcome the resistance afforded by the self-locking feature of the nuts when chased up and down the bolt thread.

The significant fact of the test was that no gross adhesion or cold welding occurred as a result of vibration and heat.

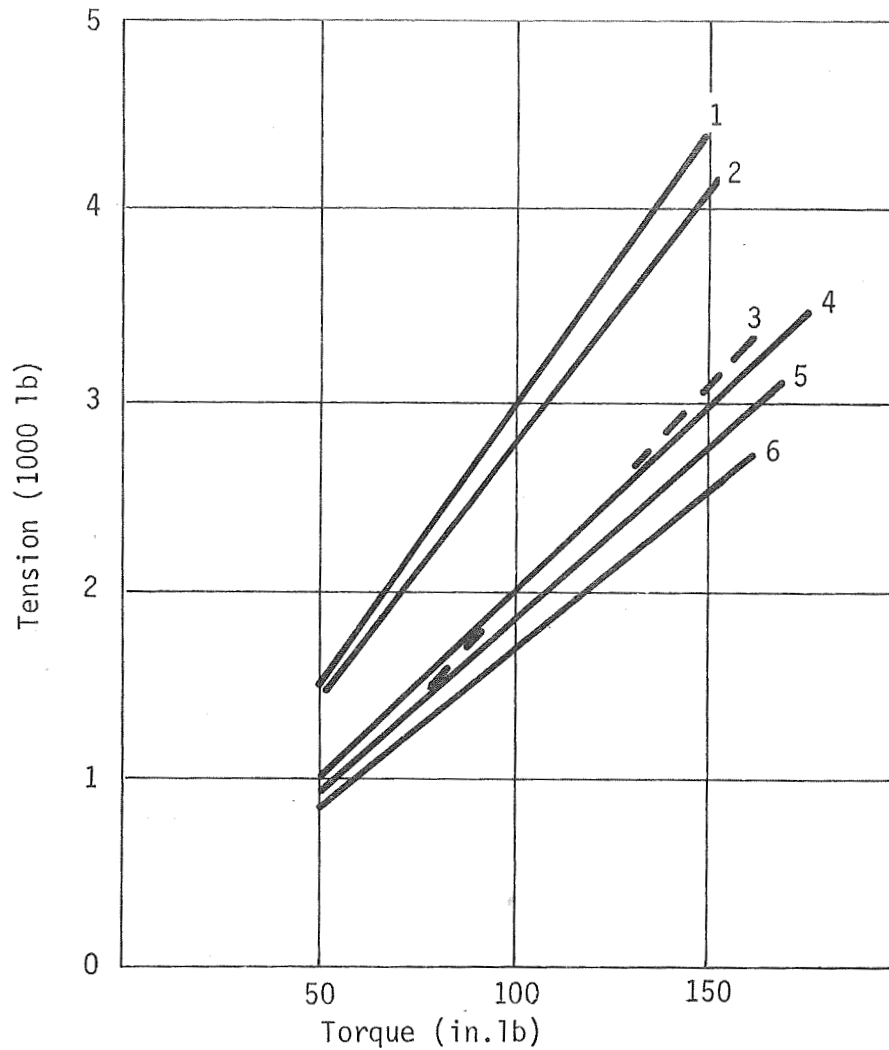

- 1) A-286 Six-Wing Bolt Assembly P/N SW1565-4-24 (Passivated-Titanium Nut)
- 2) A-286 Six-Wing Bolt Assembly P/N SW1555-4-24 (Silver-Plated Nuts)
- 3) A-286 Six-Wing Bolt Assembly P/N SW1555-4-24 (Moly-Disulfide-Plated Nuts)
- 4) Titanium 6Al-4V Six-Wing Bolt Assembly P/N SW2565-4-24 (Passivated Nut)
- 5) Titanium 6Al-4V Six-Wing Bolt Assembly P/N SW2565-4-24 (306 Type II-Plated Nut)
- 6) Titanium 6Al-4V Six Wing Bolt Assembly P/N SW2565-4-24 (VSM 1171-Plated Nut)

All Bolts 0.0250 Nom Dia x 1.5 in. Grip x 28 TPI

Figure IV-21 Test Condition 10^{-9} Torr Vacuum +250°F (Composite)

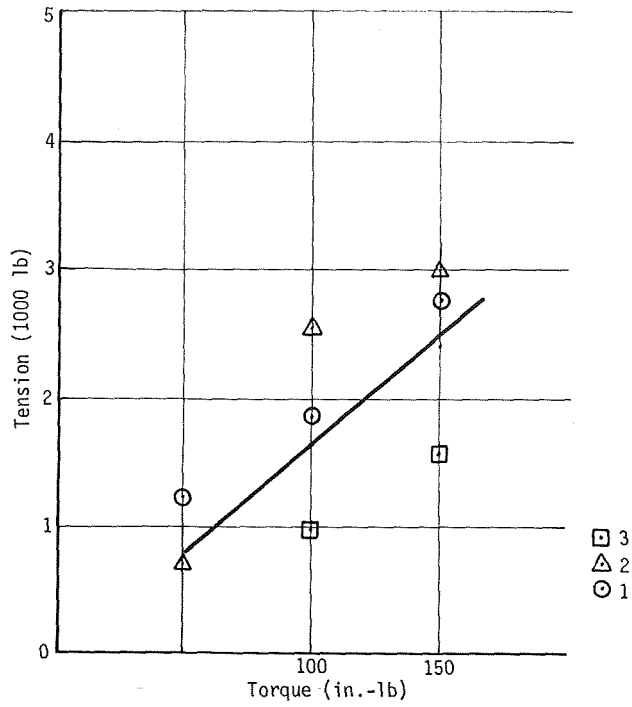

Induced load for Titanium 6Al-4V Six-Wing bolt assembly P/N SW 2565-4-24, 0.250 nom dia 1.5 in. grip. Nut lubricated with VSM 1171.

Figure IV-22 Test Conditions 10^{-9} Torr Vacuum +250°F (Titanium - VSM 1171)

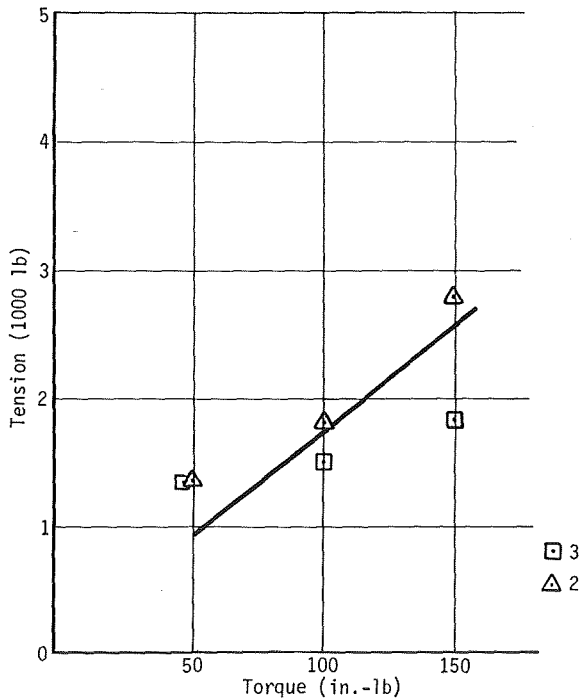

Torque vs induced load for Titanium 6Al-4V Six-Wing bolt assembly P/N SW2565-4-24, 0.250 nom dia x 1.5 in. Grip. Nut lubricated with Hi-shear Type II No. 306.

Figure IV-23 Test Conditions 10^{-9} Torr Vacuum +250°F (Titanium - Hi-Shear II No. 306)

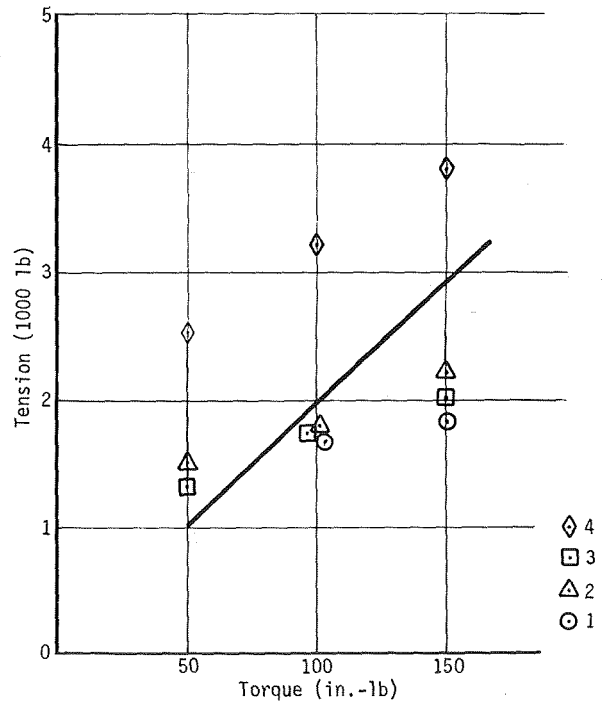

Torque vs induced load for Titanium 6Al-4V Six-Wing bolt assembly. P/N SW2565-4-24, 0.250 nom dia x 1.5 Grip. Bare passivated Titanium nut.

Figure IV-24 Test Conditions 10^{-9} Torr Vacuum + 250°F (Titanium - Bare Titanium Nut)

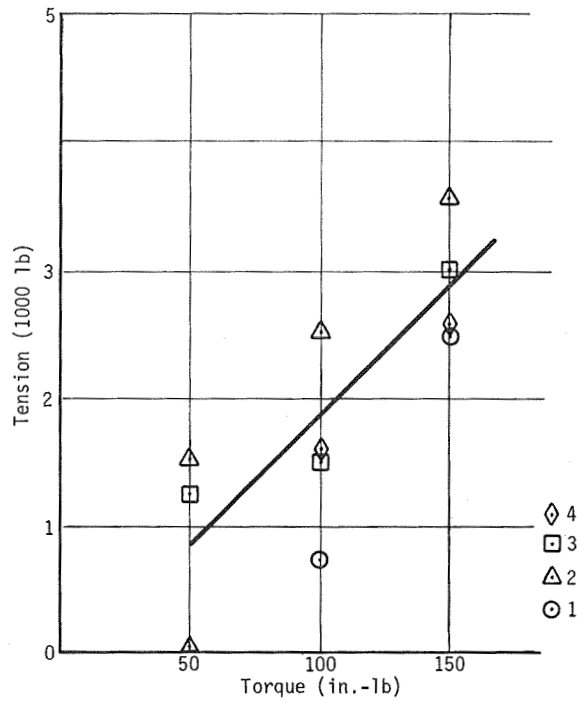

Torque vs induced load for A-286 Six-Wing bolt assembly
P/N SW1555-4-24 nut lubricated with Moly-Disulfide.

Figure IV-25 Test Conditions 10^{-9} Torr Vacuum + 250°F
(A-286 - Moly-Disulfide)

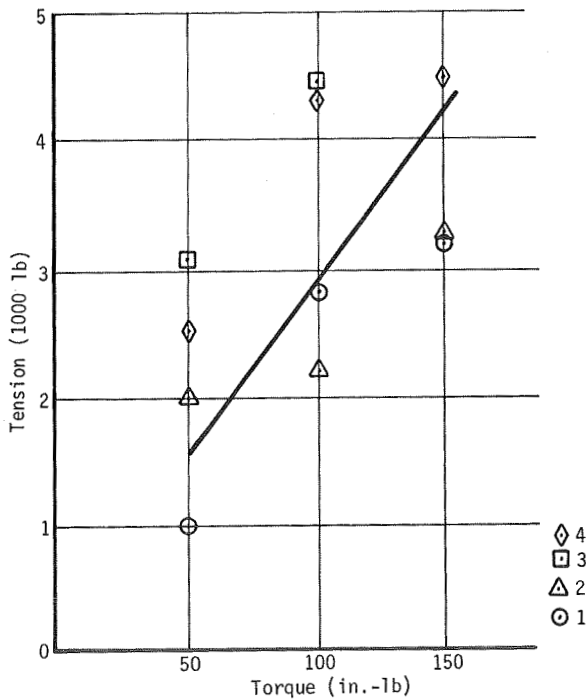

Torque vs induced load for A-286 Six-Wing bolt assembly.
P/N SW1555-4-24 Nut lubricated with Silver Plate.

Figure IV-26 Test Conditions 10^{-9} Torr Vacuum +250 F
(A-286 - Silver Plate)

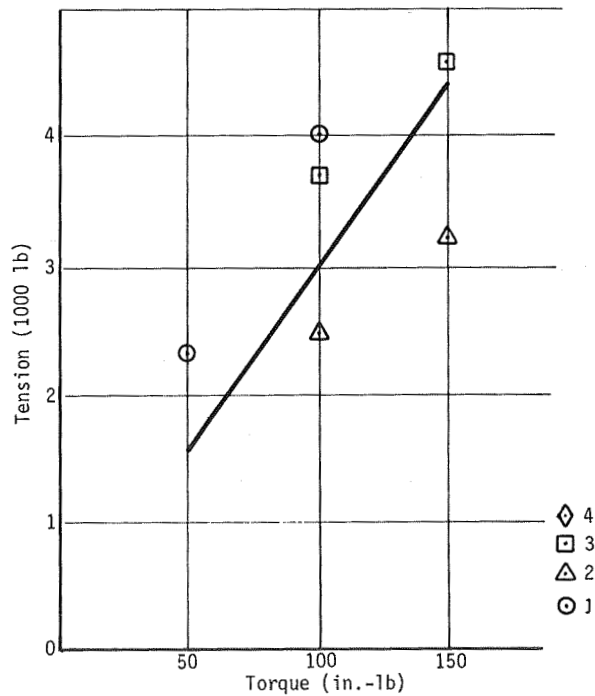

Torque vs induced load for A-286 Six-Wing assembly.
P/N SW1555-4-24 passivated Six-Wing unlubricated 6Al-4V
Titanium nuts. 0.250 nom dia x 1.5 in. grip.

Figure IV-27 Test Condition 10^{-9} Torr Vacuum +250°F
(A-286 - Bare Titanium Nut)

Table IV-9 Vacuum-Torque vs Induced Load - Titanium -
1171 Lube

Test Conditions 10^{-9} Torr Vacuum +250°F

TORQUE (in.-lb)	LOAD (lb)			
	BOLT AND NUT ASSEMBLY NUMBER			
	1	2	3	4
50	1200	900	0000	Bolt Turns in Fixture, Could Not Torque
100	1800	2500	900	
150	2700	3000	1500	
Break Away Torque	150 in.-lb	150 in.-lb	150 in.-lb	

Torque vs. induced load for Titanium 6Al-4V Six-Wing Bolt Assembly P/N SW 2565 4-24, 0.250 nom dia x 1.5 in. grip. Nut lubricated with VSM 1171.

Table IV-10 Vacuum-Torque vs Induced Load - Titanium -
Hi-Shear Lube

Test Conditions 10^{-9} Torr Vacuum +250°F

TORQUE (in.-lb)	LOAD (lb)			
	BOLT AND NUT ASSEMBLY NUMBER			
	1	2	3	4
50	Bolt Turns	1300	1400	Bolt Turns
100		1800	1500	
150		2800	1850	
Break Away Torque		125 in.-lb	100 in.-lb	

Torque vs. induced load for Titanium 6Al-4V Six-Wing Bolt Assembly. P/N SW 2565-4-24, 0.250 nom. dia. x 1.5 in. grip. Nut lubricated with Hi-Shear Type II 306.

Table IV-11 Vacuum-Torque vs Induced Load - Titanium - No Lube
 Test Condition: 10^{-9} Torr Vacuum +250°F

TORQUE (in.-lb)	LOAD (lb)			
	BOLT AND NUT ASSEMBLY			
	1	2	3	4
50	0000	1500	1300	2600
100	1700	1700	1700	3200
150	1800	2200	2000	3800
Break Away Torque	125 in.-lb	125 in.-lb	125 in.-lb	100 in.-lb
Torque vs induced load for Titanium 6Al-4V Six-Wing Bolt Assembly. P/N SW2565-4-24, 0.250 nom dia x 1.5 in. grip. Bare passivated Titanium nut.				

Table IV-12 Vacuum-Torque vs Induced Load - A-286 Moly-Disulfide
 Test Condition: 10^{-9} Torr Vacuum +250°F

TORQUE (in.-lb)	LOAD (lb)			
	BOLT AND NUT ASSEMBLY			
	1	2	3	4
50	0000	1500	1200	0000
100	700	2500	1500	1500
150	2500	3600	3000	2500
Break Away Torque	100 in.-lb	125 in.-lb	100 in.-lb	100 in.-lb
Torque vs induced load for A-286 Six-Wing Bolt Assembly P/N SW1515-4-24. Nut lubricated with Moly-Disulfide, 0.250 nom dia x 1.5 in. grip.				

Table IV-13 Vacuum-Torque vs Induced Load - A-286 - Silver Plated Nut

Test Condition: 10^{-9} Torr Vacuum +250°F

TORQUE (in.-lb)	LOAD (lb)			
	BOLT AND NUT ASSEMBLY NUMBER			
	1	2	3	4
50	1000	2000	3100	2500
100	2800	2200	4500	4300
150	3200	3200	6000	4500
Break Away Torque	150 in.-lb	150 in.-lb	125 in.-lb	100 in.-lb
Torque vs induced load for A-286 Six-Wing Assembly P/N SW1555-4-24. Nut lubricated with Silver Plate.				

Table IV-14 Vacuum-Torque vs Induced Load - A-286 - Bare Titanium

Test Condition: 10^{-9} Torr Vacuum +250°F

TORQUE (in.-lb)	LOAD (lb)			
	BOLT AND NUT ASSEMBLY NUMBER			
	1	2	3	4
50	2300	2000	0000	---
100	4000	2500	3700	---
150	6000	3200	4600	---
Break Away Torque	125 in.-lb	125 in.-lb	125 in.-lb	
Torque vs induced load for A-286 Six-Wing Bolt P/N SW1565-4-24 with Passivated Six-Wing Unlubricated 6Al-4V Titanium Nut. 0.250 Nom Dia x 1.5 in. Grip.				

Table IV-15 Test Results from Application of Pneumatic Impact Tool

TEST ITEM NO.	TORQUE REQUIRED TO ROTATE NUT ON BOLT (in.-lb)		
		Before	After
1	1	7	8
2	[2 3 4	Bolt Turns 9	Nuts Chased Up and Down Bolt with 11
3	[5	5	Pneumatic Bolt Turned
	[6	5	Impact Wrench 8
	[7	2	4
	[8	5	Cycle Repeated 4
1	[9	5	(5) Times 5
	[10	12	10
	[11	8.5	10
	12	Open	
	13	Open	
4	[14	3	4
	[15	4	3
	[16	5	4
	[17	7	7
5	[18	10	10
	[19	10	10
	[20	10	20 *
6	[21	4	5
	[22	8	25 *
	[23	4.5	5
	[24	4	6
*Only evidence of galling			
Key 1) Titanium 6Al-4V Six-Wing Bolt Assembly P/N SW2565-4-24 (Passivated Nut)			
2) Titanium 6Al-4V Six-Wing Bolt Assembly P/N SW2565-4-24 (306 Type II-Plated Nut)			
3) Titanium 6Al-4V Six-Wing Bolt Assembly P/N SW2565-4-24 (VSM 1171-Plated Nut)			
4) A-286 Six-Wing Bolt Assembly P/N SW1555-4-24 (Silver-Plated Nuts)			
5) A-286 Six-Wing Bolt Assembly P/N SW1565-4-24 (Passivated-Titanium Nut)			
6) A-286 Six-Wing Bolt Assembly P/N SW1555-4-24 (Moly-Disulfide-Plated Nut)			

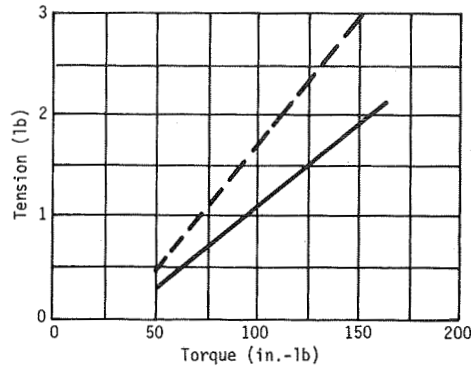

Titanium 6Al-4V Six-Wing Bolt Assembly
P/N SW2565-4-24 (Passivated Nut)

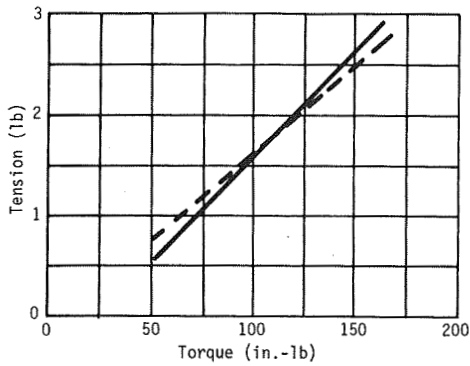

Titanium 6Al-4V Six-Wing Bolt Assembly
P/N SW2565-4-24 (VSM 1171-Plated Nut)

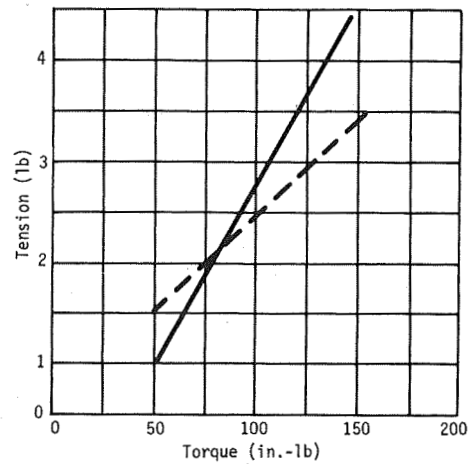

Titanium 6Al-4V Six-Wing Bolt Assembly
P/N SW2565-4-24 (306 Type II-Plated Nut)

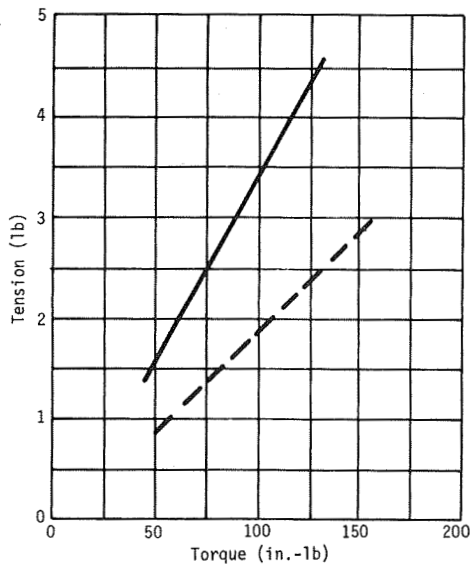

A-286 Six-Wing Bolt Assembly P/N SW1555-4-24
(Moly-Disulfided-Plated Nut)

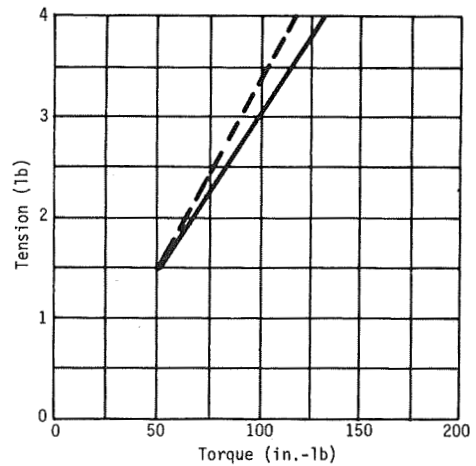

A-286 Six-Wing Bolt Assembly P/N SW1555-4-24
(Silver-Plated Nut)

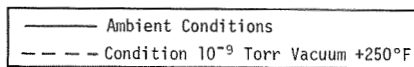

Figure IV-28 Ambient vs 10^{-9} Torr Vacuum +250°F Conditions

Figure IV-29 indicates the condition of the vacuum chamber interior after the completion of this series of tests. The debris flaked from the fasteners during the testing is evident on the surface of the spider in the foreground. Also, lubricant from the static bolt samples contained in the blocks on the heat sink condensed on the heat sink surface. The shadow under the heads of the bolts in the block in the foreground is actually lubricant that evaporated from the bolts and condensed on the cold heat sink. This occurrence is undesirable, especially if the condensing surface happens to be an optical lense or other critical part. The lubricant on the static test samples during this series of tests was SPS K-3 supplied by Standard Pressed Steel.

Figure IV-30 shows in detail debris that accumulated during the torque/tension and impact wrench tests in the area of Item 8. This test sample (center of Figure IV-30) consisted of a titanium bolt and a titanium nut lubricated with VSM 1171 lubricant.

Figure IV-31 shows debris on the fixture from test items 14, 15, and 16. These test items were combinations of A-286 bolts with Silver Plated A-286 nuts.

Figure IV-32 shows combinations of A-286 bolts with Moly-Disulfide coated A-286 nuts.

It is apparent in the above figures that fasteners subjected to vacuum, high temperature, and driving tool impact will produce debris when operated. This production of debris by cycled fasteners should be taken into account in the placement and use of the fastener.

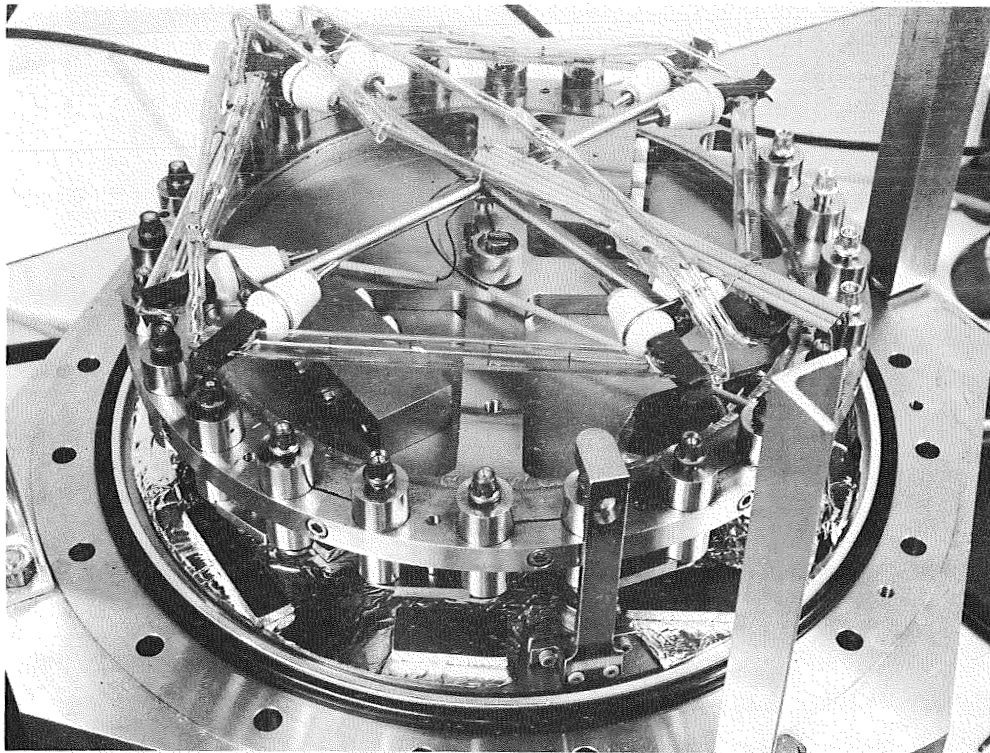

Figure IV-29 Vacuum Chamber Interior

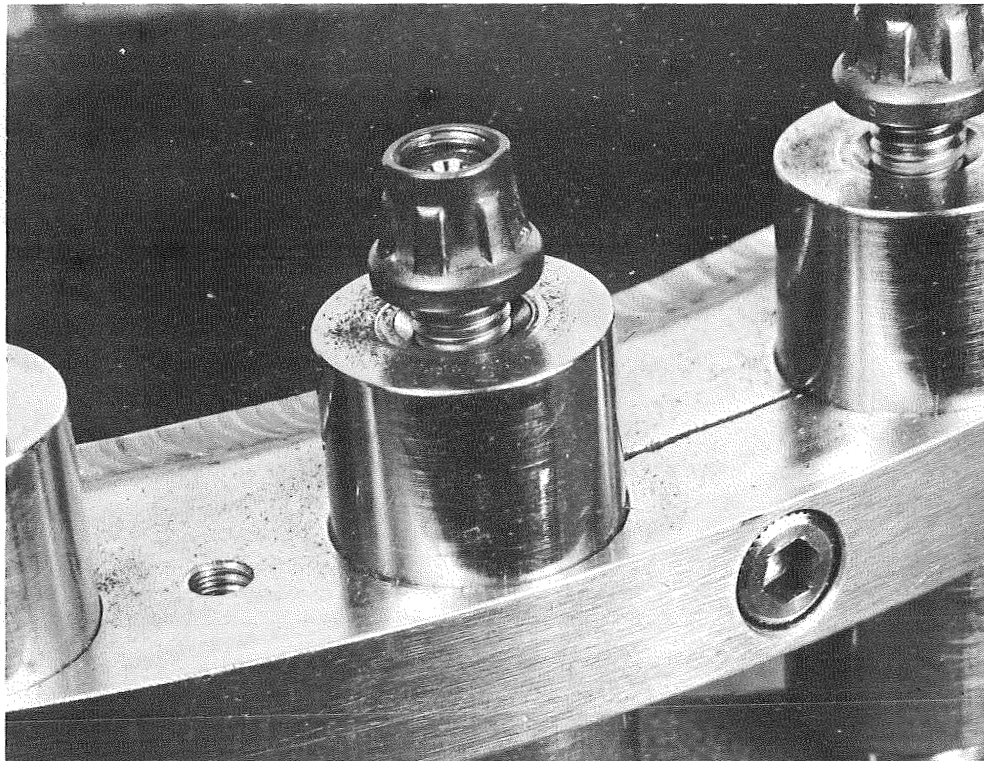

Figure IV-30 Debris from Titanium Nut Lubricated with VSM 1171

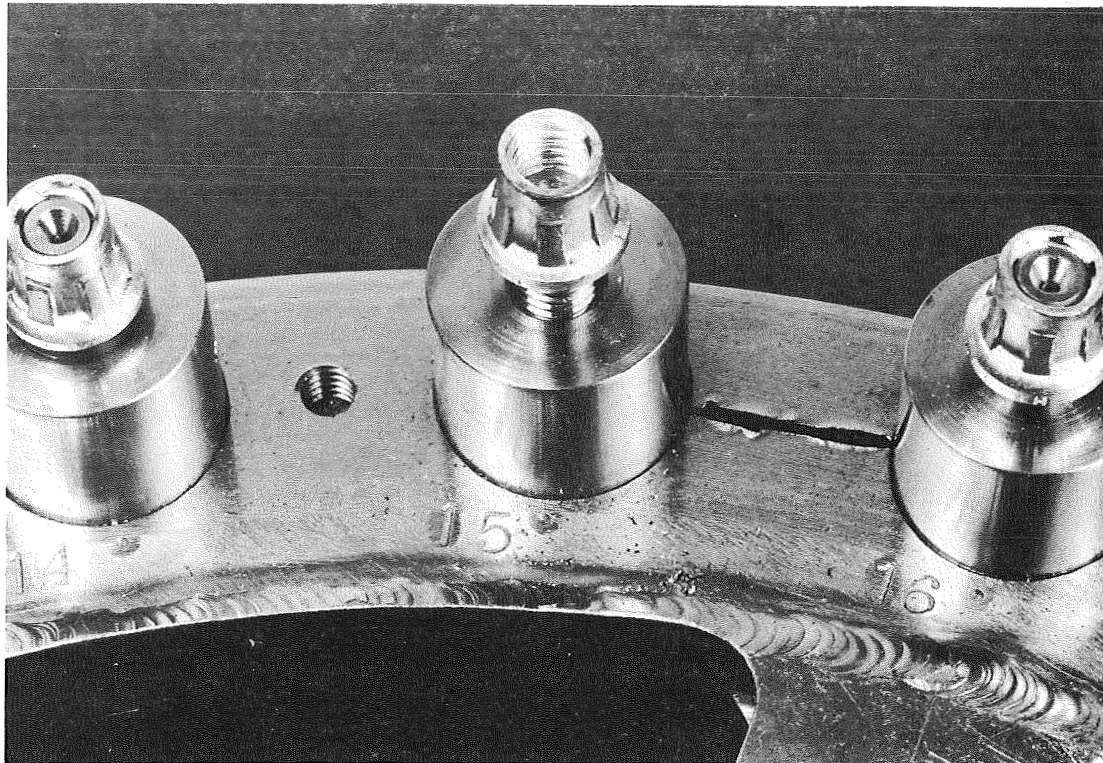

Figure IV-31 Debris from A-286 Bolts with Silver Plated Nuts

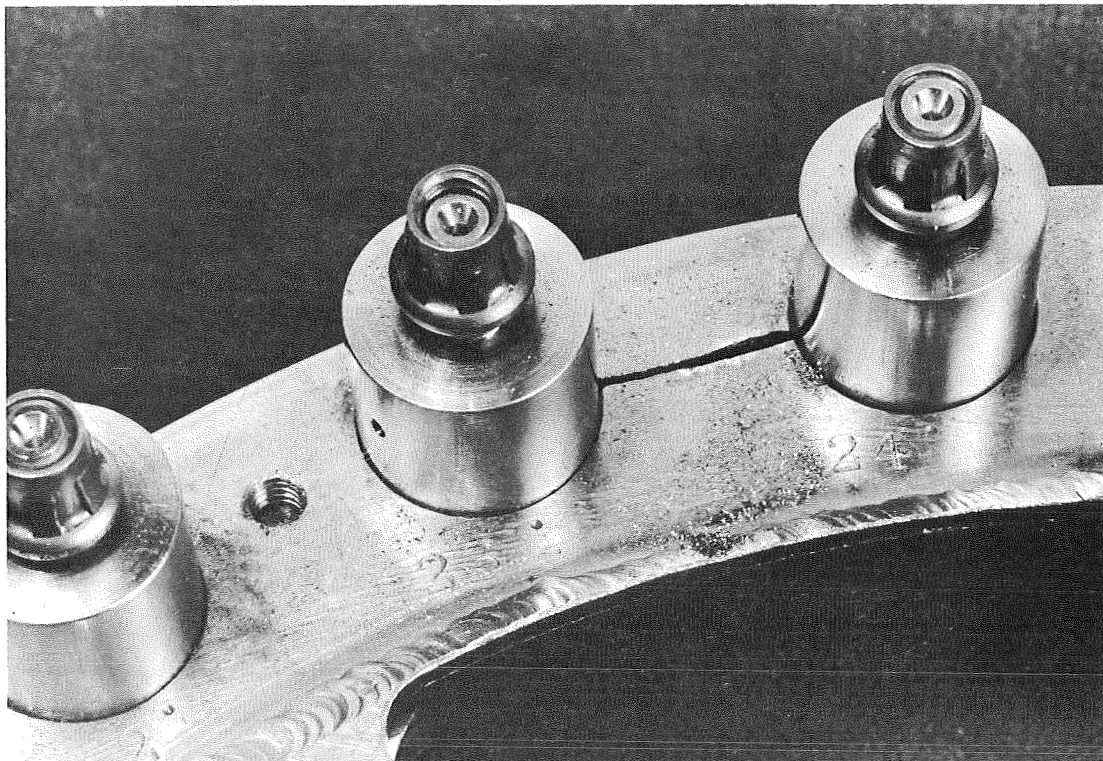

Figure IV-32 Debris from A-286 Bolt with Moly-Disulfide Lubricated A-286 Nuts

1. Low-Temperature Torque-Tension Tests

Difficulty in cooling the chamber environment from ambient to -250°F with the cold plate resulted in the fabrication of the test fixture shown in Figures IV-33, IV-34, and IV-35. Test samples were individually loaded in the fixture as shown in Figures IV-33 and IV-34, and the chamber evacuated and immersed in LN_2 . Prior to immersing the fixture in LN_2 , and during evacuation of the chamber, ambient torque-tension data was obtained.

The test item was given a pre-torque to snug-up the bolt, load cell, specimen holder, nut, and drive socket to cool these items. After the cool-down period, the pre-torque was released and the bolt torqued to increments of 50, 100, and 150 in.-lb and the tension in the bolt recorded.

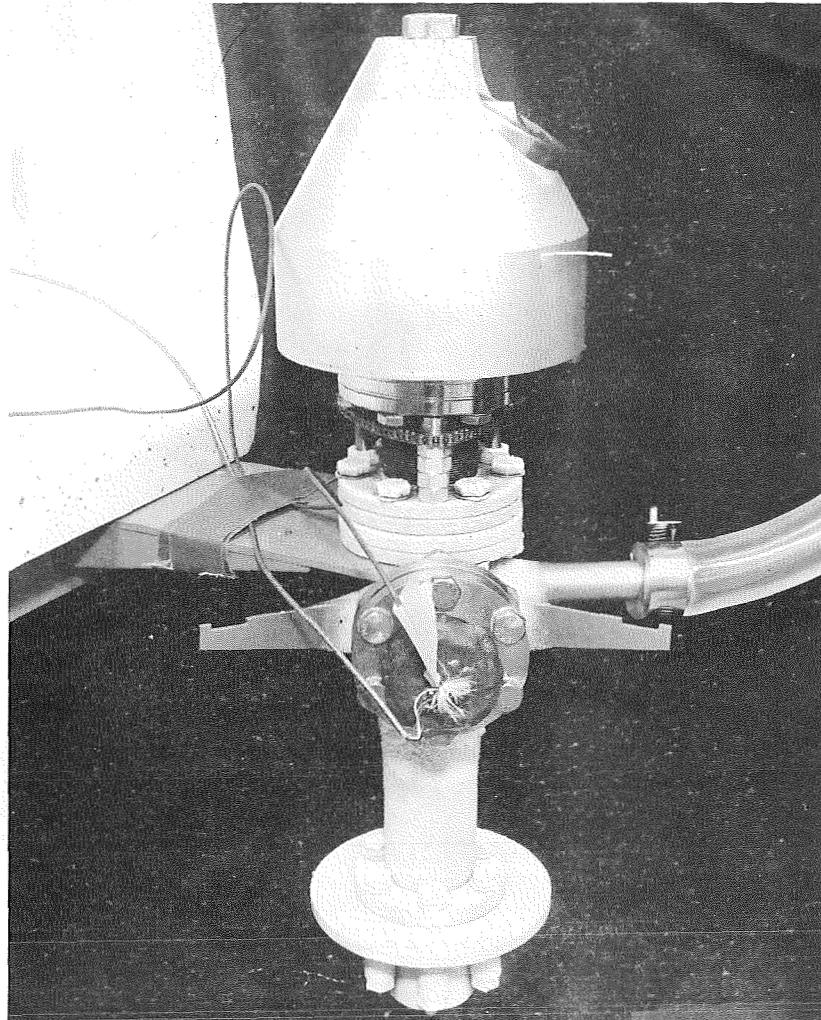

Figure IV-33 Vacuum Chamber and Feed-Thru

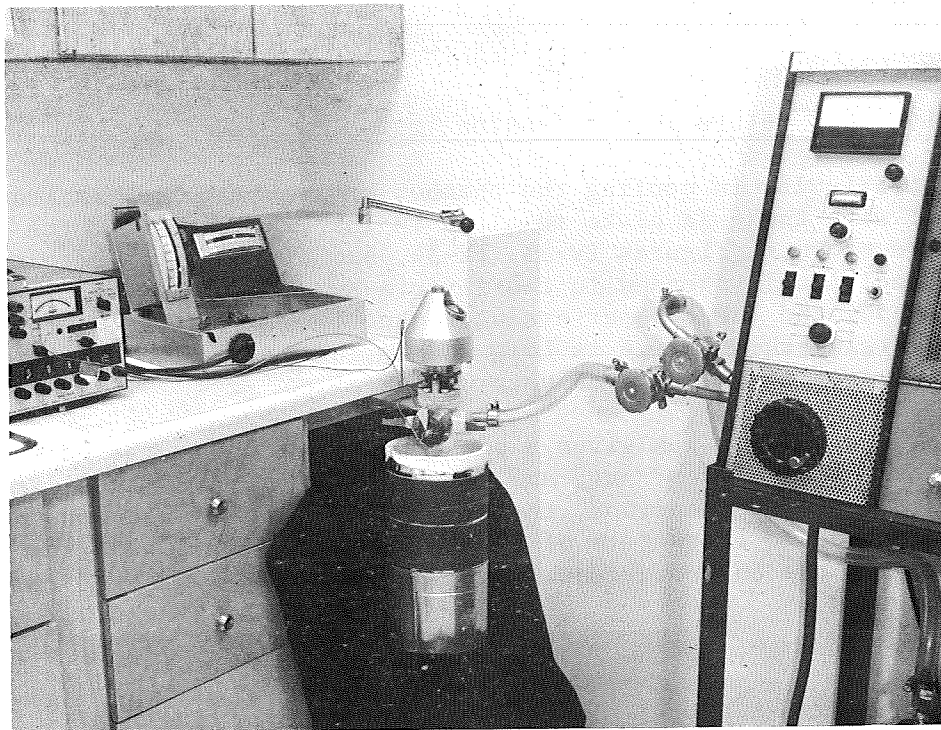

Figure IV-34 Test Arrangement

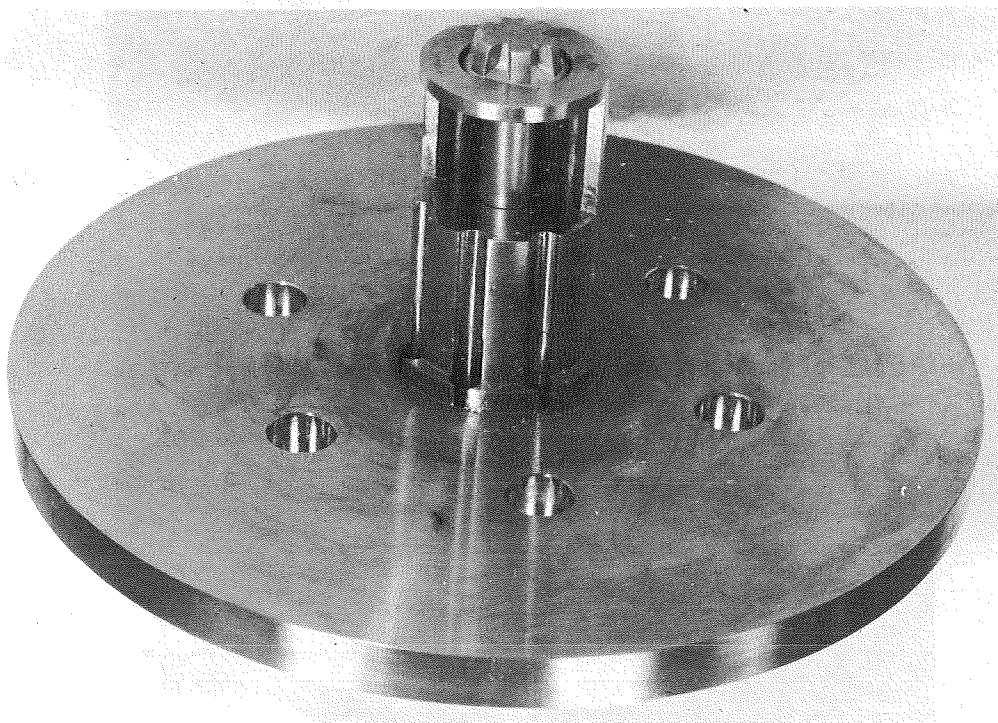

Figure IV-35 Test Cylinder

Duplicate fastener combinations tested in the earlier test at +250°F were obtained for testing at -250°F. These fasteners included four test samples of each of the following combinations (see Certificates of Conformance, Figure IV-36):

- 1) A-286 Six-Wing Bolt Assembly P/N SW1565-4-24 (Passivated-Titanium Nut)
- 2) A-286 Six-Wing Bolt Assembly P/N SW1555-4-24 (Silver-Plated Nut)
- 3) A-286 Six-Wing Bolt Assembly P/N SW1555-4-24 (Moly-Disulfide-Plated Nut)
- 4) Titanium 6Al-4V Six-Wing Bolt Assembly P/N SW2565-4-24 (Passivated Nut)
- 5) Titanium 6Al-4V Six-Wing Bolt Assembly P/N SW2565-4-24 (306 Type II-Plated Nut)
- 6) Titanium 6Al-4V Six-Wing Bolt Assembly P/N SW2565-4-24 (VSM 1171-Plated Nut)

All bolts 0.250 Nom Dia x 1.5 in. Grip x 28 TPI

The VSM 1171 lubricant for Item 6 had been discontinued and was replaced with Voi-Shan's Lubricant, VSM 1362.

One day was devoted to chamber pump down and the following day the fixture immersed in LN₂ and torque-tension data was obtained after cool down at the end of the day.



bh



To: Bob White
 Hi-Shear Corp
 9942 Edgecliff Circle
 Dallas, Texas 75238

To: Bob White
 Hi-Shear Corporation
 9942 Edgecliff Circle
 Dallas, Texas 75238

Purchase Order # RC9-584231

Purchase Order # RC-584231

Packing Sheet # 60814

Packing Sheet # 60815

Date Shipped: 11/21/69

Date Shipped: 11-21-69

Quantity and Description:

- 1. 18 pcs. SW65-4 Six Wing Nut
- 2. 18 pcs. SW15-4-24 "
- 3. 6 pcs. SW55-4 Six Wing Nut
- 4. 6 pcs. SW55-4 "
- 5. 18 pcs. SW25-4-24 Six Wing Bolt

Quantity and Description:

- 6. 6 pcs SW65-4 Six Wing Nut
- 7. 1 pcs

CERTIFICATE OF CONFORMANCE

This is to certify that all items above have been manufactured, processed, inspected and tested in complete accord with all requirements of this purchase order. Records indicating conformance are on file and subject to examination. Magnetic particle and fluorescent penetrant inspections as required have been performed by certified personnel.

Subscribed and sworn to before me this 20 day of Nov. 19 69.

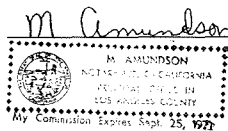

Signature of M. Amundson and text: Inspection-Authorized Personnel

Form 8-215 Rev. 5-68

CERTIFICATE OF CONFORMANCE

This is to certify that all items above have been manufactured, processed, inspected and tested in complete accord with all requirements of this purchase order. Records indicating conformance are on file and subject to examination. Magnetic particle and fluorescent penetrant inspections as required have been performed by certified personnel.

Subscribed and sworn to before me this 21st day of Nov 19 69.



Signature of M. Amundson and text: Inspection-Authorized Personnel

Form 8-215 Rev. 5-68

Figure IV-36 Certificates of Conformance

2. Test Apparatus

The fixture shown in Figures IV-33 and IV-37 consisted of the feed-thru flange mounted to a tubular stainless steel vacuum chamber. A drive socket was attached to the drive end of the rotary feed-thru via an insulating coupling. The function of this insulator between the rotary drive and the socket was to allow the socket to contact the nut during cool down without providing a heat path through the mass of the feed-thru. This arrangement prevented a warm driving socket from contacting a chilled nut, which would warm the test sample during torquing operations.

The test cylinder (Figure IV-35) provided the mounting surfaces for the test item, a cavity for the force transducer under the head of the bolt, and the geometry for preventing rotation of the bolt during application of torque to the nut. The test cylinders were made of A-286 and 6Al-4V Titanium for use with bolts of like material. Flanges on the test cylinders provided a large surface area with the LN₂ for good cool down of the test cylinder. Passages were drilled in the test cylinder to allow evacuation of the end cap, and to providing the interconnection of instrumentation leads. The removable end cap contained a bolt heat sink, which was attached to the cap with a stainless bellows. Contact was maintained between the ground surfaces on the bolt head and the heat sink by the flexibility of the bellows and the pressure differential across them. Contact of the heat sink via the head of the bolt and its extension into the LN₂ provided a heat path for cool down of the test item (Figure IV-37).

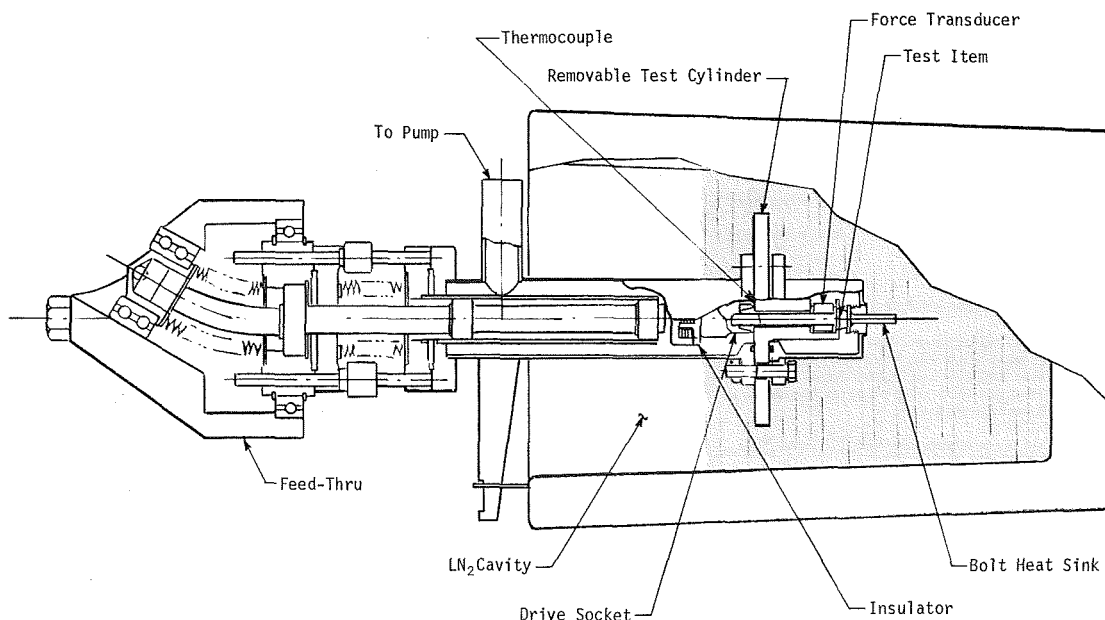

Figure IV-37 Proposed Test Fixture; Vacuum 10^{-6} Torr,
Temperature -250° to -350° F

3. Calibration

A fixture calibration check consisted of instrumenting a bolt with thermocouples attached to the end of the threaded portion of the bolt. The bolt, nut, and load cell were loosely assembled and placed in the fixture, and the feed-thru was lowered to engage the driving socket with the nut. The thermocouples from the bolt were run through a hole in the drive socket to an external DVM. An additional thermocouple was welded to the top surface of the specimen holder in the vicinity of the nut.

The fixture was closed and evacuated to the 10^{-6} torr range, and was immersed in LN_2 . It was found that by maintaining a liquid level $3/4$ in. above the specimen cylinder flange for 4 hr, the bolt temperature in the area of the thread stabilized at -250°F (\pm a couple of degrees). This cool down procedure was repeated with the test items; however, the bolt thermocouple was removed to allow torquing the test items, and the specimen holder thermocouple was used to indicate temperature. Test cylinder temperatures stabilized at -317°F during calibration runs and actual tests.

Load cell calibration curves were developed for -317°F by immersing the load cell in LN_2 and applying known loads with a tension testing machine. These curves were used to interpolate the data contained in Tables IV-16 thru IV-21 and Figures IV-38 thru IV-44. The load cell was checked after testing was completed to insure calibration data was consistent throughout the test.

- 1) A-286 Six-Wing Bolt Assembly P/N SW1555-4-24 (Silver Plated Nut)
 - 2) A-286 Six-Wing Bolt Assembly P/N SW1565-4-24 (Passivated-Titanium Nut)
 - 3) A-286 Six-Wing Bolt Assembly P/N SW1555-4-24 (Moly-Disulfide-Plated Nut)
 - 4) Titanium 6Al-4V Six-Wing Bolt Assembly P/N SW2565-4-24 (Passivated Nut)
 - 5) Titanium 6Al-4V Six-Wing Bolt Assembly P/N SW2565-4-24 (306 Type II-Plated Nut)
 - 6) Titanium 6Al-4V Six-Wing Bolt Assembly P/N SW2565-4-24 (VSM 1362-Plated Nut)
- All Bolts 0.250 Nom Dia x 1.5 in. Grip x 28 TPI*

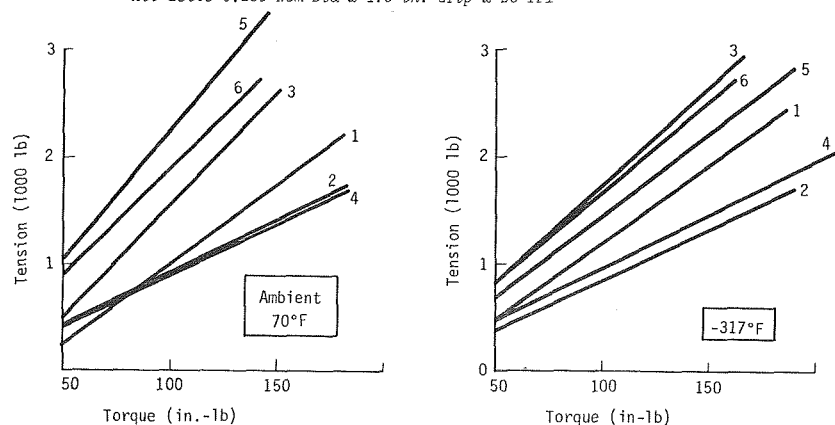

Figure IV-38 Torque vs Induced Load (10^{-6} Torr Vacuum -317°F)

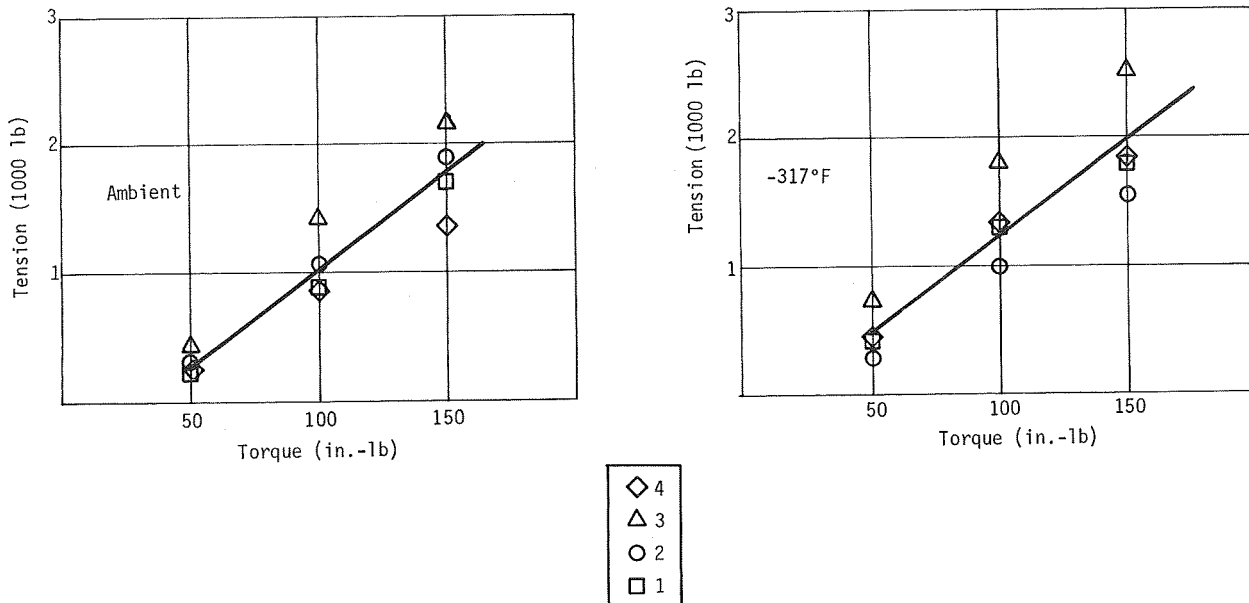

Figure IV-39 Torque vs Induced Load for A-286 Six-Wing Bolt Assembly P/N SW1555-4-24 Silver-Plated Nut (Ambient and 10^{-6} Torr Vacuum -317°F)

Table IV-16 Torque vs Induced Load for A-286 Six-Wing Bolt Assembly P/N SW1555-4-24 (Silver-Plated Nut)

TEST CONDITIONS (AMBIENT)

TORQUE (in.-lb)	BOLT AND NUT ASSEMBLY NO. LOAD (lb)			
	1	2	3	4
50	200	300	400	235
100	900	1050	1400	900
150	1700	1900	6150	1350

TEST CONDITIONS 10^{-6} TORR VACUUM -317°F

TORQUE (in.-lb)	BOLT AND NUT ASSEMBLY NO. LOAD (lb)			
	1	2	3	4
50	410	310	770	410
100	1330	1025	1850	1330
150	1840	1590	2570	1890

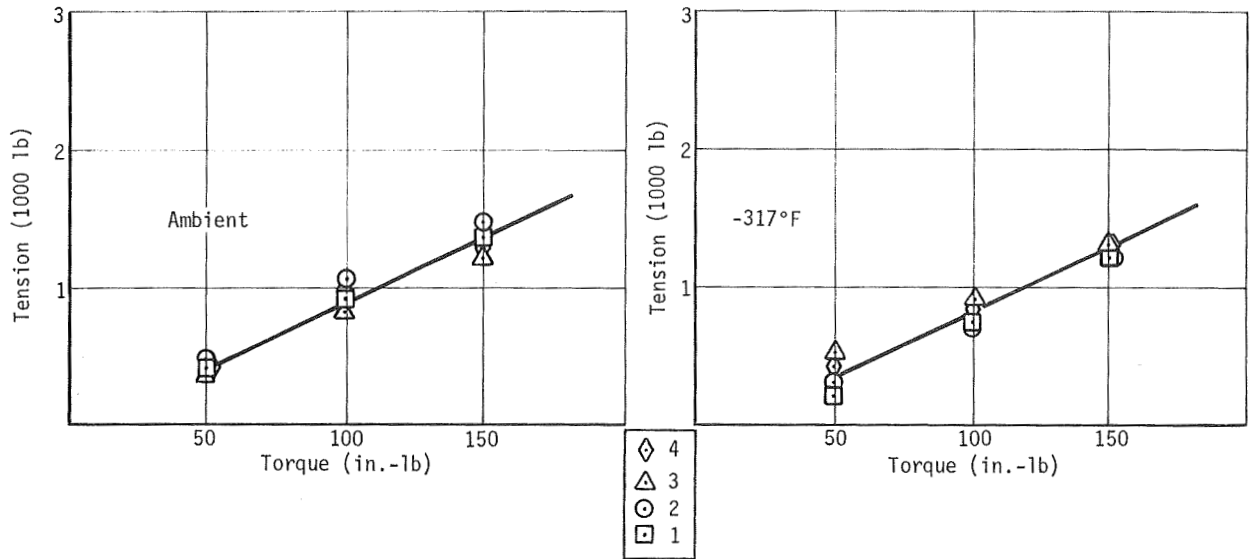

Figure IV-40 Torque vs Induced Load for A-286 Six-Wing Bolt Assembly P/N SW1565-4-24 Passivated-Titanium Nut (Ambient and 10^{-6} Torr Vacuum -317°F)

Figure IV-17 Torque vs Induced Load for A-286 Six-Wing Bolt Assembly P/N SW1565-4-24 (Passivated-Titanium Nut)

TEST CONDITIONS (AMBIENT)				
TORQUE (in.-lb)	BOLT AND NUT ASSEMBLY NO.			
	LOAD (lb)			
	1	2	3	4
50	400	475	395	400
100	400	1025	800	935
150	1350	1450	1200	1300

TEST CONDITIONS 10^{-6} TORR VACUUM -317°F				
TORQUE (in.-lb)	BOLT AND NUT ASSEMBLY NO.			
	LOAD (lb)			
	1	2	3	4
50	200	310	510	410
100	760	715	920	870
150	1230	1330	1330	1280

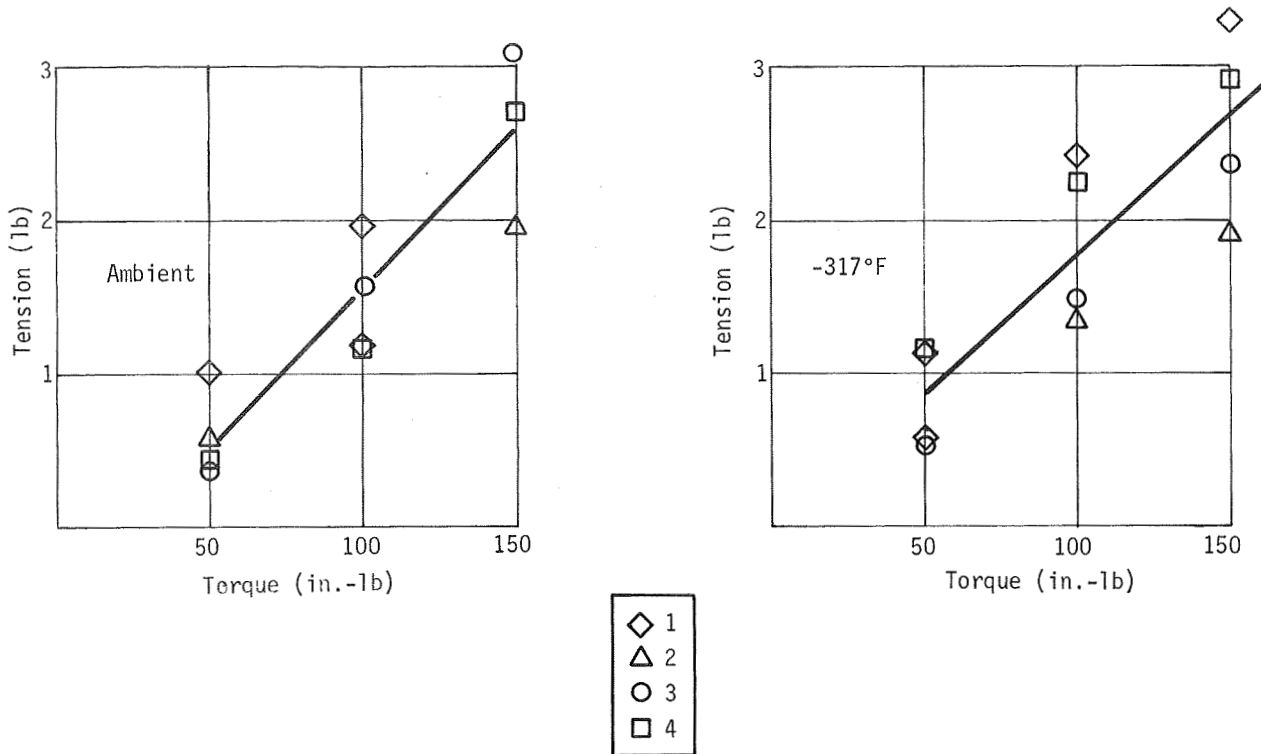

Figure IV-41 Torque vs Induced Load for A-286 Six-Wing Bolt Assembly P/N SW1555-4-24 Moly-Disulfide-Plated Nut (Ambient and 10⁻⁶ Torr Vacuum -317°F)

Table IV-18 Torque vs Induced Load for A-286 Six-Wing Bolt Assembly P/N SW1555-4-24 (Moly-Disulfied-Plated Nut)

TEST CONDITIONS (AMBIENT)

TORQUE (in.-lb)	BOLT AND NUT ASSEMBLY NO.			
	LOAD (lb)			
	1	2	3	4
50	450	375	595	1000
100	1150	1600	1175	1975
150	2775	3075	1960	3150

TEST CONDITIONS 10⁻⁶ TORR VACUUM -317°F

TORQUE (in.-lb)	BOLT AND NUT ASSEMBLY NO.			
	LOAD (lb)			
	1	2	3	4
50	1180	510	560	1100
100	2300	1530	1410	2460
150	2970	2410	1950	3380

Note: The Moly-Disulfide tends to flake and turn to dust in the chamber

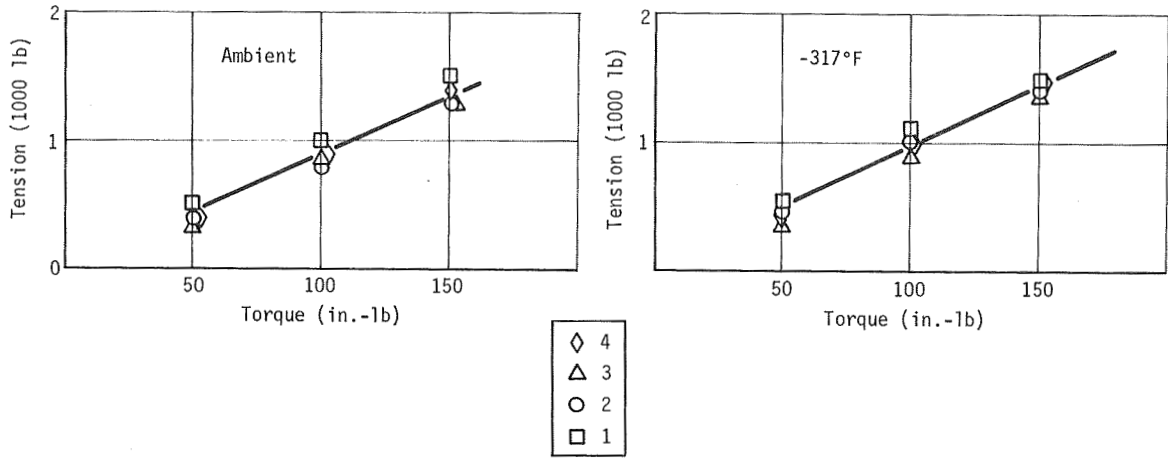

Figure IV-42 Torque vs Induced Load for Titanium 6Al-4V Six-Wing Bolt Assembly P/N SW2565-4-24 Passivated Nut (Ambient and 10⁻⁶ Torr Vacuum -317°F)

Table IV-19 Torque vs Induced Load for Titanium 6Al-4V Six-Wing Bolt Assembly P/N SW2565-4-24 (Passivated Nut)

TEST CONDITIONS (AMBIENT)				
TORQUE (in.-lb)	BOLT AND NUT ASSEMBLY NO.			
	LOAD (lb)			
	1	2	3	4
50	500	400	375	400
100	1000	800	850	900
150	1500	1300	1300	1400

TEST CONDITIONS 10 ⁻⁶ TORR VACUUM -317°F				
TORQUE (in.-lb)	BOLT AND NUT ASSEMBLY NO.			
	LOAD (lb)			
	1	2	3	4
50	540	485	360	410
100	1120	1025	920	1025
150	1540	1435	1435	1537

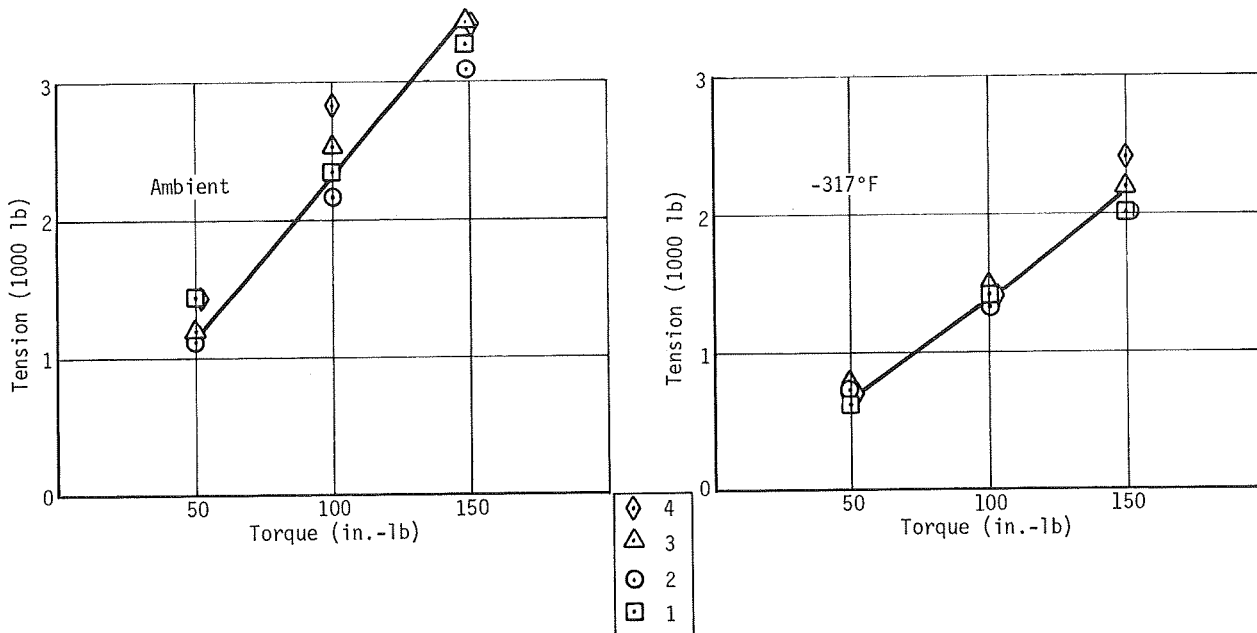

Figure IV-43 Torque vs Induced Load for Titanium 6Al-4V Six-Wing Bolt Assembly P/N SW2565-4-24 306 Type II-Plated Nut (Ambient and 10⁻⁶ Torr Vacuum -317°F)

Table IV-20 Torque vs Induced Load for Titanium 6Al-4V Six-Wing Bolt Assembly P/N SW2565-4-24 (306 Type II-Plated Nut)

TEST CONDITIONS (AMBIENT)				
TORQUE (in.-lb)	BOLT AND NUT ASSEMBLY NO. LOAD (lb)			
	1	2	3	4
50	1450	1100	1200	1375
100	2300	2150	2500	2825
150	3350	3100	3550	3550

TEST CONDITIONS 10 ⁻⁶ TORR VACUUM -317°F				
TORQUE (in.-lb)	BOLT AND NUT ASSEMBLY NO. LOAD (lb)			
	1	2	3	4
50	670	770	770	750
100	1430	1330	1490	1500
150	2050	2050	2260	2425

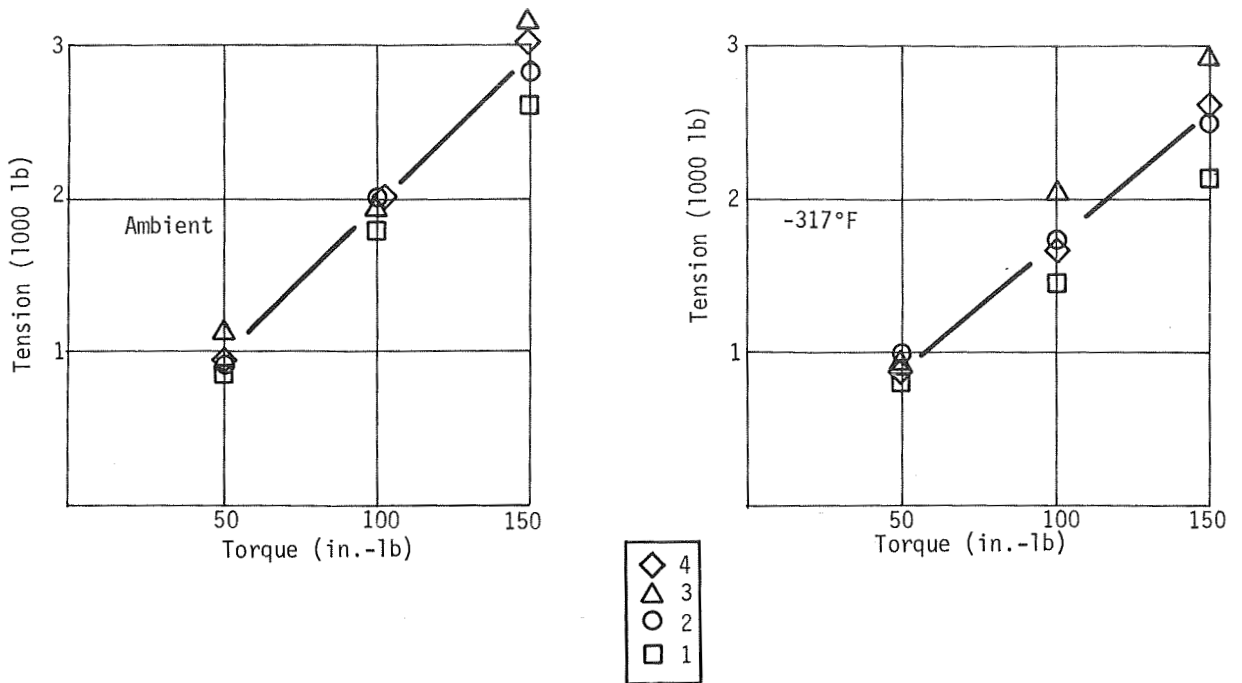

Figure IV-44 Torque vs Induced Load for Titanium 6Al-4V Six-Wing Bolt Assembly P/N SW2565-4-24 VSM 1362-Plated Nut (Ambient and 10⁻⁶ Torr Vacuum -317°F)

Table IV-21 Torque vs Induced Load for Titanium 6Al-4V Six-Wing Bolt Assembly P/N SW2565-4-24 (VSM 1362-Plated Nut)

TEST CONDITIONS (AMBIENT)					TEST CONDITIONS 10 ⁻⁶ TORR VACUUM -317°F				
TORQUE (in.-lb)	BOLT AND NUT ASSEMBLY NO.				TORQUE (in.-lb)	BOLT AND NUT ASSEMBLY NO.			
	LOAD (lb)					LOAD (lb)			
	1	2	3	4		1	2	3	4
50	850	875	1100	900	50	750	975	950	850
100	1800	2000	1950	2000	100	1450	1750	2025	1650
150	2600	2850	3200	3050	150	2150	2500	2925	2650

Note: The VSM 1362 tends to flake and turn to dust in the chamber

G. CONCLUSIONS AND RECOMMENDATIONS

1. Conclusions

Planned and expected space missions are difficult to define with any degree of certainty. Available data is presented in the test and implies that each of the missions will involve the manipulation of threaded fasteners by astronauts. However, there does not seem to be any way to arrange the diverse requirements into meaningful groups.

A conflict between structures engineers and human factors designers exists in the majority of places using threaded fasteners. The structures engineer generally requires a multiplicity of fasteners to minimize weight and point loads while the human factors man would like to have no fasteners or one. No single solution can apply to all cases. The only conclusion is that for each and every case where space maintenance or repair might be involved, both structural and human factors must be factored into the design as a system.

The major problems imposed by threaded fasteners, and planned approaches for solving them, are listed below:

<u>Problem</u>	<u>Solution</u>
Galling, seizing, cold welding;	Material selection, proper lubricants.
Manipulation and handling of fasteners;	Astronaut education, tool design, and bolt head design (very little done to date, more could be done).
Development of fastening systems using minimum number of tools;	Design specifications, engineering education; test specifications requiring both engineering and human engineering participation.

At ambient test conditions, combinations of A-286 bolts with A-286 Moly-Disulfide lubricated nuts, and A-286 bolts with A-286 silver plated nuts initially were more efficient than the Titanium combinations tested.

At ambient test conditions, the use of 306 type II and VSM 1171 coatings increased the efficiency of nut and bolt combinations of 6Al-4V Titanium.

At ambient conditions, the combination of an A-286 bolt with a Moly-Disulfide nut can produce yielding in a quarter inch bolt at torque levels as low as 125 in.-lb.

At ambient and vacuum conditions, unlubricated combinations of A-286 should be avoided. Test items galled and seized before the nuts could be chased down the bolt to seat the nut.

Vacuum levels of 10^{-9} torr at temperatures of 250°F tend to lower the efficiency* of various combinations of fasteners when compared to torque tension data obtained at ambient conditions.

No combinations tested in the vacuum above, except bare A-286 bolts and nuts, exhibited a gross tendency to adhere or seize. This was with thread exposure to vacuum of both the nut and bolt prior to torquing the nut on the bolt, and the application of impact to cycle the items five times.

The use of impact tools to chase the nuts up and down on various fastener combinations in the vacuum does not exhibit a tendency to cause adhesion in the fastener operation. However, the application of impact to the fastener in the high temperature vacuum environment resulted in the generation of large amounts of debris. This debris consisted of granulated lubricant flailed from the test item nuts.

At least one lubricant (SPS K3) tested during the high temperature 10^{-9} torr vacuum evaporated and redeposited on the cold plate when it was cooled with LN₂.

Exposure to low temperature -250°F and vacuum had a small adverse effect on torque vs induced load on the test items. However, the low temperature contributed to granulation and loss of the Moly-Disulfide or VSM 1362 lubricants from the test items.

The use of fasteners in space applications should consider possible debris generated when cycling the fastener, and possible condensation of the lubricant on super-cooled surfaces.

* Efficiency is defined as the ratio of the bolt tension produced to the ideal bolt tension which is 2π (applied torque) (threads per in.).

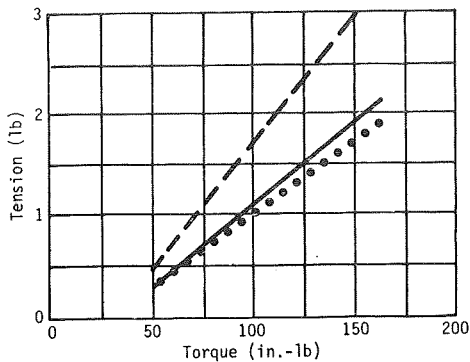

Titanium 6Al-4V Six-Wing Bolt Assembly
P/N SW2565-4-24 (Passivated Nut)

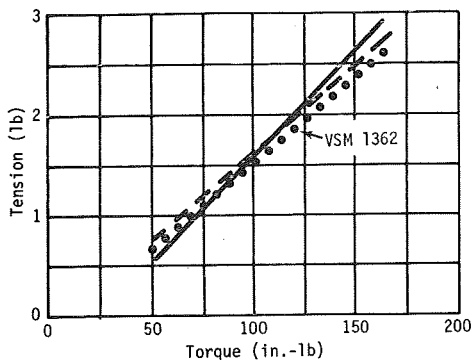

Titanium 6Al-4V Six-Wing Bolt Assembly
P/N SW2565-4-24 (VSM 1171-Plated Nut)

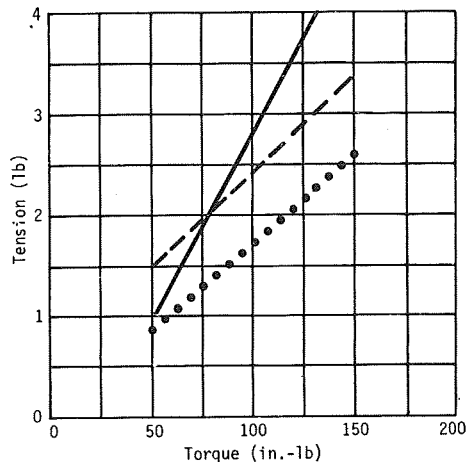

Titanium 6Al-4V Six-Wing Bolt Assembly
P/N SW2565-4-24 (306 Type II-Plated Nut)

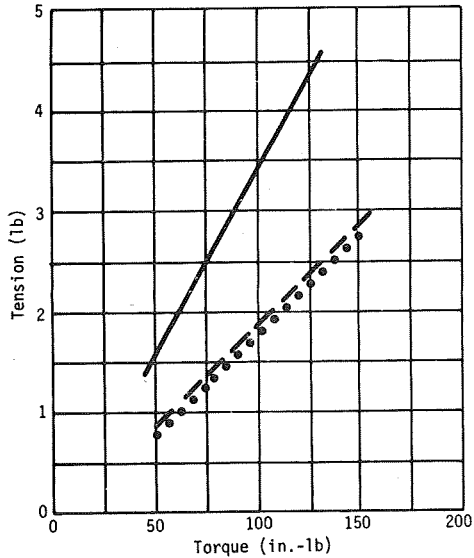

A-286 Six-Wing Bolt Assembly P/N SW1555-4-24
(Moly-Disulfide-Plated Nut)

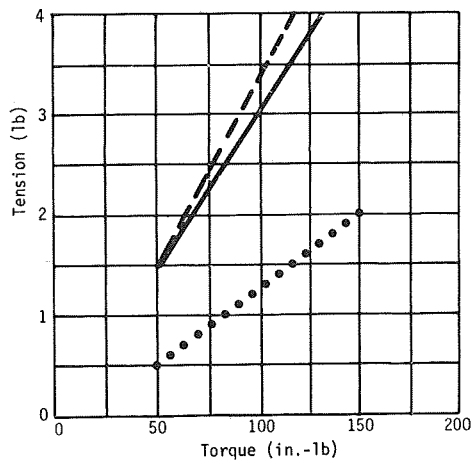

A-286 Six-Wing Bolt Assembly P/N SW1555-4-24
(Silver-Plated Nut)

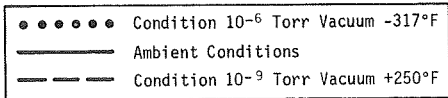

Figure IV-45 Torque vs Induced Load; Ambient vs 10^{-9} Torr Vacuum $+250^{\circ}\text{F}$ Conditions and 10^{-6} Torr Vacuum -317°F

In summary, no analysis, test, or data review of this study indicated that threaded fasteners could not be used in space. Rather, threaded fasteners will prove as useful and versatile in space as they do here on earth if proper design practices are developed and used. (See Table IV-22)

Table IV-22 Summary of Performance

MATERIAL	COMMENTS
A-286	At ambient and vacuum environments unlubricated combinations of A-286 galled and the nuts seized.
Titanium 6Al-4V	None of the combinations of Titanium nuts and bolts tested at ambient, +250 and -250°F vacuum environments, exhibited a tendency to gall.
LUBRICANTS	COMMENTS
Silver Plate	Performed well as a lubricant in combinations with A-286 in ambient and vacuum environments. However, produced debris in form of flaked silver plating when used in combination with an impact wrench and 10^{-9} torr vacuum and +250°F.
Moly-Disulfide	Performed well as a lubricant in combination with A-286 in ambient and vacuum environments. However, produced debris when an impact wrench was utilized at 10^{-9} torr vacuum and +250°F. It turned to dust at 10^{-6} torr vacuum and -250°F.
306 Type II	Performed as lubricant in combinations of Titanium 6Al-4V Titanium nuts and bolts in ambient and vacuum environments. However, produced debris when an impact wrench was utilized at 10^{-9} torr vacuum and +250°F.
VSM 1172	The manufacture of this lubricant was discontinued during the test period. However, its use as a lubricant in combination with 6Al-4V Titanium produced debris at 10^{-9} torr and +250 F when an impact wrench was used.
VSM 1362	A replacement for VSM 1172 was utilized at 10^{-6} torr and -250°F as a lubricant for the 6Al-4V Titanium combinations, the VSM 1362 tended to flake and turn to dust in the chamber.

2. Recommendations

Although no gross indications of adhesions were noted during the tests, except as noted with bare A-286 combinations, a tendency of the vacuum to cause a loss of efficiency in various fastener combinations was noted. This fact, coupled with the limitations of the space simulations and the possible critical application of fasteners and related mechanisms in space, suggests an attempt should be made to provide a means of duplicating these tests in the actual space environment. A test with equipment to provide discrete data relating to the fastener's efficiency in the actual environment should be attempted.

Some form of load determining bolt should be used to insure correct loading of critical fasteners in the space environment. This is a result of the loss of efficiency observed in fasteners exposed to the vacuum when compared to the performance of fasteners in ambient conditions. The load determining feature would provide an indication when the desired bolt tension was achieved.

V. LIST OF REFERENCES

1. *Space/Aeronautics*. January, 1968.
2. *Aerospace Technology*. November 1967 thru April 1968.
3. *A Service and Support Summary for Manned Space Programs*. ALR-2440-1, Martin Marietta Corporation.
4. *Handbook of Aerospace Fastener Technology*. Voi-Shan Manufacturing Company.
5. W. C. Stewart: *Torque for Bolts and Nuts*. Industrial Fasteners Institute.
6. *Kent's Mechanical Engineering Handbook*. John Wiley & Sons, 12th Edition.
7. D. Reid: *Titanium Surface Coating*. Hi-Shear Corporation.
8. *VSM Solid Film Lubricant Performance*. Test Report No. 386, Voi-Shan Manufacturing Company.
9. J. F. Costick: *The Necessity for Development and Use of Fastening Devices with Special Characteristics for Space Use*. Technical Paper, Martin Marietta Corporation.
10. A. E. Holmes: *Space Tool Kit Survey, Development and Evaluation Program*. ER 13942, Martin Marietta Corporation.
11. S. A. White: MEL Technical Report, SE-54-68. Hayes International Corporation.
12. *Apollo Applications Program Payload Integration Technical Study and Analysis*. ED-2002-12 Rev. A, Martin Marietta Corporation, 15 June 1967.
13. F. K. Daisey: *Minimum Reaction Space Power Tool for Experimentation on Gemini*. Final Report ER 14114, Martin Marietta Corporation.
14. Robert Jastrow: *Lunar and Terrestrial Atmospheres*. Advances in Aeronautical Science, Vol 5, Plenum Press, Inc., 1960, pp 338-345.

15. R. M. Evans and R. E. Monroe: *Surface Welding in the Space Environment*. DMIC Memorandum 214, Defense Metals Information Center, 9 June 1966.
16. P. M. Winslow and C. V. McIntyre: Final Report No. P65-94, NASA Contract NAS8-11066, Hughes Aircraft Company, 20 August 1965.