

N70-13387
CR-102557

REPORT NO. GDC-DCB69-046
CONTRACT NAS 9-9207

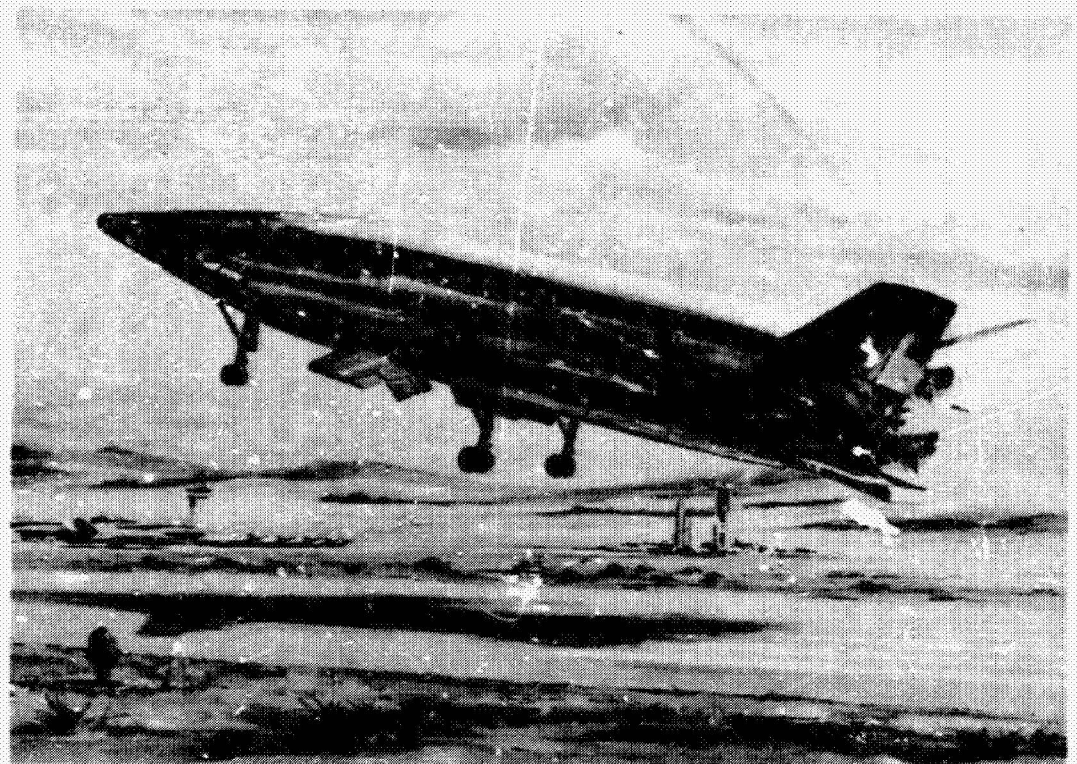

SPACE SHUTTLE FINAL TECHNICAL REPORT

VOLUME X • PROGRAM DEVELOPMENT, COST ANALYSIS,
AND TECHNOLOGY REQUIREMENTS

FACILITY FORM 602

N70-31545 (ACCESSION NUMBER)	_____	(THRU)
247 (PAGES)	_____	1 (CODE)
CR-102557 (NASA CR OR TMX OR AD NUMBER)	_____	31 (CATEGORY)

GENERAL DYNAMICS
Convair Division

REPORT NO. GDC-DCB69-046

**SPACE SHUTTLE
FINAL TECHNICAL REPORT**

VOLUME X ♦ PROGRAM DEVELOPMENT, COST ANALYSIS,
AND TECHNOLOGY REQUIREMENTS

31 October 1969

Prepared by
CONVAIR DIVISION OF GENERAL DYNAMICS
San Diego, California

FOREWORD

This volume of Convair Report No. GDC-DCB 69-046 constitutes a portion of the final report for the "Study of Integral Launch and Reentry Vehicles." The study was conducted by Convair, a division of General Dynamics Corporation, for National Aeronautics and Space Administration George C. Marshall Space Flight Center under Contract NAS 9-9207 Modification 2.

The final report is published in ten volumes:

Volume I	Condensed Summary
Volume II	Final Vehicle Configurations
Volume III	Initial Vehicle Spectrum and Parametric Excursions
Volume IV	Technical Analysis and Performance
Volume V	Subsystems and Weight Analysis
Volume VI	Propulsion Analysis and Tradeoffs
Volume VII	Integrated Electronics
Volume VIII	Mission/Payload and Safety/Abort Analyses
Volume IX	Ground Turnaround Operations and Facility Requirements
Volume X	Program Development, Cost Analysis, and Technology Requirements

Convair gratefully acknowledges the cooperation of the many agencies and companies that provided technical assistance during this study:

NASA-MSFC	Aerojet-General Corporation
NASA-MSC	Rocketdyne
NASA-EF 7	Pratt and Whitney
NASA-LaRC	Pan American World Airways

The study was managed and supervised by Glenn Karel, Study Manager, C. P. Plummer, Principal Configuration Designer, and Carl E. Crone, Principal Program Analyst (all of Convair) under the direction of Charles M. Akridge and Alfred J. Finzel, NASA study co-managers.

ABSTRACT

A study was made to obtain a conceptual definition of reusable space shuttle systems having multimission capability. The systems as defined can deliver 50,000-pound payloads having a diameter of 15 feet and a length of 60 feet to a 55-degree inclined orbit at an altitude of 270 n.mi. The following types of missions can be accommodated by the space shuttle system: logistics; propellant delivery; propulsive stage delivery; satellite delivery, retrieval, and maintenance; short-duration missions, and rescue missions.

Two types of reusable space shuttle systems were defined: a two-element system consisting of a boost and an orbital element and a three-element system consisting of two boost elements and an orbital element. The vehicles lift off vertically using high pressure oxygen/hydrogen rocket engines, land horizontally on conventional runways, and are fully reusable. The boost elements, after staging, perform an aerodynamic entry and fly back to the launch site using conventional airbreathing engines. Radiative thermal protection systems were defined to provide for reusability. Development programs, technology programs, schedules, and costs have been defined for planning purposes.

During the study, special emphasis was given to the following areas: System Development Approaches, Ground Turnaround Operations, Mission Interfaces and Cargo Accommodations/Handling, Propulsion System Parameters, and Integrated Electronics Systems.

PRECEDING PAGE BLANK NOT FILMED.

TABLE OF CONTENTS

<u>Section</u>		<u>Page</u>
1	INTRODUCTION	1-1
2	DEVELOPMENT PROGRAM	2-1
	2.1 DEVELOPMENT CONSIDERATIONS	2-1
	2.2 BASELINE DEVELOPMENT PROGRAM PLAN	2-3
	2.2.1 Program Summary	2-7
	2.2.2 Design and Engineering	2-8
	2.2.3 Major Procurement	2-9
	2.2.4 Tooling	2-9
	2.2.5 Manufacturing	2-16
	2.2.6 Testing	2-17
	2.2.7 Test Facilities	2-45
	2.3 ALTERNATIVE DEVELOPMENT APPROACHES	2-52
	2.3.1 Flight Test Program	2-56
	2.3.2 Ground Test Considerations	2-57
	2.4 FR-3 DEVELOPMENT PROGRAM	2-58
	2.4.1 Program Summary	2-58
	2.4.2 Design, Engineering, and Procurement	2-62
	2.4.3 Tooling and Manufacturing	2-63
	2.4.4 Test Program	2-63
	2.4.5 Test Facilities	2-65
3	COST ANALYSIS	3-1
	3.1 COST METHODOLOGY	3-1
	3.1.1 Ground Rules and Assumptions	3-1
	3.1.2 Unit Hardware Cost	3-3
	3.1.3 Development Program Cost	3-4
	3.1.4 Investment Cost	3-9
	3.1.5 Operations Cost	3-9
	3.2 COST SENSITIVITY ANALYSIS	3-11
	3.3 COMPARISON OF FR-3 AND FR-4	3-13
	3.4 DETAILED PROGRAM COSTS	3-20
	3.4.1 Approach	3-20
	3.4.2 FR-3 Program	3-23
	3.4.3 FR-4 Program	3-50
	3.5 REFERENCES	3-77

TABLE OF CONTENTS, Contd

<u>Section</u>		<u>Page</u>
4	TECHNOLOGY REQUIREMENTS	4-1
4.1	TECHNOLOGIES	4-1
4.2	AERODYNAMICS AND CONFIGURATION	4-4
4.2.1	Hypersonic Flow Field Analysis (Category I)	4-4
4.2.2	Aerodynamic Environment During Launch (Category I)	4-5
4.2.3	Jet Engine Propulsion Effects (Category I)	4-6
4.2.4	Subsonic Aerodynamic Handling Criteria (Category I)	4-7
4.2.5	Space Shuttle Synthesis Computer Programs (Category II)	4-8
4.2.6	Trajectory Optimization for Space Shuttle (Category II)	4-9
4.3	AEROTHERMODYNAMICS	4-10
4.3.1	Definition of Flow Field Thermodynamic Properties (Category I)	4-10
4.3.2	Transitional and Turbulent Boundary Layer Aerodynamic Heat Transfer (Category I)	4-11
4.3.3	Aerodynamic Heating in Shock Interaction Regions (Category I)	4-13
4.3.4	Thermal Protection System (TPS) Surface Roughness and Discontinuities (Category I)	4-15
4.3.5	Heat Transfer in Regions of Flow Reattachment (Category I)	4-16
4.3.6	Aerodynamic Heat Transfer Flight Test (Category I)	4-17
4.3.7	Heat Barriers for Radiation-Cooled Entry Vehicles (Category I)	4-18
4.3.8	Base Heating (Category II)	4-20
4.3.9	Plume Impingement Heating (Category II)	4-21
4.4	STRUCTURES DESIGN AND MATERIALS	4-22
4.4.1	Composite Material Applications to Space Shuttle Structures (Category I)	4-22
4.4.2	Structural Design Criteria Tradeoff Studies (Category I)	4-24
4.4.3	Synthesis of Structural Components (Category I)	4-25
4.4.4	Hot Structures (Category I)	4-27
4.4.5	High Temperature Control Surfaces (Category I)	4-28

TABLE OF CONTENTS, Contd

<u>Section</u>	<u>Page</u>
4.4.6 Joining High Temperature Materials for Space Shuttle Application (Category I)	4-29
4.4.7 Materials Properties Determination (Category I)	4-31
4.5 THERMAL PROTECTION SYSTEM DESIGN AND MATERIALS	4-33
4.5.1 Metallic Radiative Thermal Protection Systems (Category I)	4-33
4.5.2 Ablative Thermal Protection Systems (ATPS) (Category)	4-35
4.5.3 Nonmetallic, Nonreceding Radiative Thermal Protection Subsystem (RTPS)(Category I)	4-37
4.5.4 Thermal Protection Subsystem (TPS) Analysis and Performance Improvement (Category I)	4-39
4.5.5 High Temperature Nose Cap and Leading Edges (Category I)	4-41
4.5.6 High-Temperature Insulation Development (Category I)	4-43
4.5.7 Nondestructive Test (NDT) Development (Category I)	4-44
4.5.8 Improved Ductibility of Radiative Thermal Protection Subsystems (RTPS) Materials (Category I)	4-46
4.5.9 Fabrication Development of Thoria Dispersed Nickel Chromium (TDNiCr) Materials (Category I)	4-47
4.5.10 Fabrication Development of Refractory Materials (Category I)	4-49
4.5.11 Fabrication (Forming, Joining, and Machining) of Ceramic Nose Caps and Leading Edges (Category I)	4-50
4.5.12 Mechanical/Thermal Interface Attachments for Thermal Protection Systems (Category I)	4-52
4.6 MATERIALS	4-53
4.6.1 Reusable Cryogenic Propellant Duct Insulation (Category I)	4-53
4.6.2 Cryogenic Propellant Tank Insulation (Category I)	4-54

TABLE OF CONTENTS, Contd

<u>Section</u>	<u>Page</u>
4.6.3 Bearings and Lubricants Subjected to Space and Operational Environment (Category II)	4-56
4.7 PROPULSION	4-57
4.7.1 Oxygen-Hydrogen Attitude Control Propulsion System (Category I)	4-57
4.7.2 Airbreathing Engine Propulsion (Category I)	4-58
4.7.3 Main Rocket Engine Propulsion (Category I)	4-60
4.7.4 Main Propulsion Propellant System (Category I)	4-61
4.7.5 Orbiter Cryogenic Technology (Category II)	4-62
4.8 AEROELASTICS AND DYNAMICS	
4.8.1 Structural Mode Stability and Loads Analysis (Category I)	4-64
4.8.2 Pre-Entry Control Requirements (Category I)	4-65
4.8.3 Boost Phase Control Requirements (Category I)	4-66
4.8.4 Transonic Acoustic Loading on Clustered Vehicles (Category I)	4-68
4.8.5 Vibration and Fatigue Specifications and Testing (Category I)	4-69
4.8.6 Flutter and Buffet Model Testing Throughout the Speed Regime (Category II)	4-70
4.9 INTEGRATED ELECTRONICS	4-71
4.9.1 Space Shuttle System Autonomy (Category II)	4-71
4.9.2 Strapdown Inertial Guidance (Category II)	4-73
4.9.3 Display Formats of Integrated Electronic Subsystems (Category II)	4-74
4.9.4 Multiple Redundancy of Integrated Electronic Subsystems (Category II)	4-75
4.9.5 Onboard Computer Architecture (Category II)	4-76
4.9.6 Multiplex Data System Interfaces (Category II)	4-77
4.9.7 Software Language (Category II)	4-78
4.10 HUMAN FACTORS	4-79
4.10.1 Human Factors of Display Characteristics and Formats (Category II)	4-79
4.10.2 Human Factors of Electronic Controls (Category II)	4-80

TABLE OF CONTENTS, Contd

<u>Section</u>		<u>Page</u>
4.10.3	Human Factors of Crew and Passenger Visibility (Category II)	4-81
4.10.4	Crew and Passenger Restraint Systems (Category II)	4-82
4.11	SUBSYSTEMS	4-83
4.11.1	Remote Controlled Solid-State Circuit Breaker Development (Category II)	4-83
4.11.2	H ₂ -O ₂ Auxiliary Power Engine Development (Category II)	4-85
4.11.3	LH ₂ Utilization for Subsystem Heat Sink (Category II)	4-86

LIST OF ILLUSTRATIONS

<u>Figure</u>		<u>Page</u>
2-1	Sources of Requirements	2-2
2-2	Integrated Development Plan	2-2
2-3	FR-4 Vehicle Configurations	2-5
2-4	Summary Development Program Plan Baseline Vehicle Configuration (FR-4)	2-6
2-5	Manufacturing Breakdown Structure	2-10
2-6	Hot Form Die	2-13
2-7	Hot Forming Die Techniques	2-13
2-8	Press Form Die Classifications	2-14
2-9	Automatic Sinusoidal Welder	2-14
2-10	FR-4 Orbiter Body and Fixture	2-15
2-11	FR-4 Wing Primary Assembly Fixture	2-15
2-12	TSTS FR-4 Orbiter Element	2-18
2-13	Booster Production Sequence	2-19
2-14	Major Element and Total Vehicle Assembly Span	2-20
2-15	Summary Flight Test Program	2-38
2-16	Structural Fatigue and Cycling Test	2-47
2-17	Acoustic Test Facility Supporting Dynamic Structural Tests	2-48
2-18	Skeleton "Iron Horse" for Flight Control Systems Test	2-50
2-19	SIC Test Stand, MTF, Modification Required to Accept FR-4 Booster	2-51
2-20	Environmental Control Systems Test	2-52
2-21	Turnaround Phases and Location	2-53
2-22	Turnaround Phases and Location as Applicable to Complex 39, ETR	2-54

LIST OF ILLUSTRATIONS, Contd

<u>Figure</u>		<u>Page</u>
2-23	Alternative Development Program Plan FR-4 Configuration	2-55
2-24	FR-3 Vehicle Configuration	2-59
2-25	FR-3 Space Vehicle Superimposed on Saturn V LUT	2-67
3-1	FR-3 Total Program Cost Versus Traffic Rate	3-3
3-2	FR-4 Total Program Cost Versus Traffic Rate	3-4
3-3	Operational Program Manning Levels	3-11
3-4	FR-3 Program Cost Sensitivity to Inert Weight	3-12
3-5	FR-3 Program Cost Sensitivity to Weight Contingency	3-12
3-6	FR-3 Program Cost Sensitivity to Volumetric Efficiency	3-12
3-7	FR-3 Program Cost Sensitivity to Payload Weight	3-13
3-8	FR-3 Program Cost Sensitivity to Maneuver Δ Velocity Requirements	3-13
3-9	FR-3 Program Cost Sensitivity to Staging Velocity	3-14
3-10	FR-3 Program Cost Sensitivity to Change in I_{sp}	3-14
3-11	FR-3 Program Cost Sensitivity to Change in Flyback L/D	3-14
3-12	FR-4 Program Cost Sensitivity to Inert Weight	3-15
3-13	FR-4 Program Cost Sensitivity to Weight Contingency	3-15
3-14	FR-4 Program Cost Sensitivity to Volumetric Efficiency	3-15
3-15	FR-4 Program Cost Sensitivity to Payload Weight	3-16
3-16	FR-4 Program Cost Sensitivity to Maneuver Δ Velocity Requirements	3-16
3-17	FR-4 Program Cost Sensitivity to Staging Velocity	3-16
3-18	FR-4 Program Cost Sensitivity to Change in I_{sp}	3-17
3-19	FR-4 Program Cost Sensitivity to Change in Flyback L/D	3-17

LIST OF ILLUSTRATIONS, Contd

<u>Figure</u>		<u>Page</u>
3-20	FR-3 and FR-4 Vehicle Total Program Cost Comparison	3-17
3-21	Recurring Cost Per Launch, 25 to 100 Launches Per Year	3-18
3-22	FR-3 Versus FR-4 Program Cost Comparison	3-19
3-23	FR-3 Program Funding Schedule	3-23
3-24	FR-3 Configuration Development and Production Plan Schedule	3-46
3-25	FR-4 Program Funding Schedule	3-50
3-26	FR-4 Configuration Development and Production Plan Schedule	3-73
4-1	Summary of Technology Programs, Schedule, and Costs	4-3

LIST OF TABLES

<u>Table</u>		
2-1	Ground Test Program (FR-4 Baseline Vehicle Configuration)	2-24
2-2	FR-4 Booster Major Test Hardware Summary	2-32
2-3	FR-4 Orbiter Major Ground Test Hardware Summary	2-33
2-4	Flight Test Article, Initial Configuration	2-34
2-5	Flight Test Program Summary Test Objectives	2-35
2-6	Horizontal Flight Tests — Low-Subsonic	2-36
2-7	Horizontal Flight Tests — High-Subsonic	2-37
2-8	Vertical Launch Tests — Single Element	2-41
2-9	Vertical Launch Tests — Separation and Abort	2-43
2-10	Vertical Launch Tests — Earth Orbital	2-44
2-11	Comparison of Orbiter Characteristics	2-60
2-12	Comparison of Booster Characteristics	2-61

LIST OF TABLES, Contd

<u>Table</u>		<u>Page</u>
2-13	Trajectory Data Comparison	2-62
2-14	Test Facility Requirements for FR-3 and FR-4 Space Shuttle Vehicle	2-68
3-1	FR-3 Configuration -- Total Program Cost	3-2
3-2	FR-4 Configuration -- Total Program Cost	3-2
3-3	First Unit Cost Estimating Relationships	3-5
3-4	Development Cost Estimating Relationships	3-7
3-5	Investment Cost Estimating Relationships	3-9
3-6	Operations Cost Estimating Relationships	3-10
3-7	Development Program Cost Comparison	3-18
3-8	Comparison of Operations Cost Per Launch at 50 Launches Per Year	3-19
3-9	Map of First Article Costs into NASA WBS and Convair Investment Categories	3-21
3-10	Detailed FR-3 Costs (\$ Million) in Convair Format	3-24
3-11	Detailed FR-3 Costs (\$ Million) in NASA WBS Format	3-30
3-12	Technical Characteristics Data for the FR-3 Configuration	3-36
3-13	Detailed FR-4 Costs (\$ Million) in Convair Format	3-51
3-14	Detailed FR-4 Costs (\$ Million) in NASA WBS Format	3-56
3-15	Technical Characteristics Data for the FR-4 Configuration	3-62

SUMMARY

The baseline development program described in Section 2 is considered representative of either the FR-3 or the FR-4 Space Shuttle configuration. NASA Study Phase C and Development Phase D are assumed concurrent insofar as required by long-lead development activities. The combined C/D Phases are assumed to begin by the second quarter of 1971 and continue for 66 months to a first operational flight prior to the fourth quarter of 1976. The first horizontal flight of an element will occur in 43 months from go-ahead; the first single-element vertical launch occurs in 53 months; the first all-up launch configuration in 61 months; and the final R&D flight in 65 months. The FR-3 requires 12 and the FR-4 requires 13 major test articles to complete the development phase; six are used in the flight test program for the FR-3 concept, and seven for the FR-4.

Total program costs, which are presented in Section 3, are estimated at \$6.84 billion for the FR-3 vehicle and \$6.91 billion for the FR-4 with the following breakdown:

	FR-3	FR-4
Development	\$5.20	\$4.83
Investment	.49	.69
Operations	1.15	1.39
	\$6.84 billion	\$6.91 billion

These costs are based on a 10-year operational program at a traffic rate of 50 launches per year. The FR-3 and FR-4 total program costs are not significantly different between 20 and 50 launches per year. At traffic rates above this range, the FR-4 program becomes increasingly more expensive than the FR-3 program.

The operations cost per flight (including launch operations, refurbishment, and support) is \$2.30 million for the FR-3 and \$2.77 million for the FR-4. This results in a recurring operations cost of \$46/pound and \$55/pound of payload delivered to orbit for the FR-3 and FR-4 respectively.

Technology programs, with their schedules and costs, required to support the development of the space shuttle are described in Section 4. It is intended that these programs will be conducted in parallel with the development programs associated with Phases B, C, and D, but would be supported as separate and distinct technology studies. The programs presented here are directed to the solution of basic technology problems in the fields of aerodynamics, aerothermodynamics, structures, thermal protection systems, materials, propulsion systems, aeroelastics and dynamics, integrated electronics, and

human factors. The programs include analysis studies, such as the Structural Design Criteria Tradeoff Studies; wind tunnel programs such as Transitional and Turbulent Boundary Layer Heat Transfer; and experimental flight test programs such as Aerodynamic Heat Transfer Flight Tests. Technological breakthroughs are not required for the successful completion of these programs, as the programs are considered to be state-of-the-art either currently or within the time period of their projected application.

SECTION 1
INTRODUCTION

Section 2 of this volume discusses the development program considerations for the space shuttle vehicle. The primary function of the development program is to build, test, and demonstrate the capability of the space shuttle design to satisfactorily perform a variety of missions; and to attain this capability within a reasonably targeted time span. The two vehicle concepts discussed are the FR-3, a two-element configuration, and the FR-4 a three-element configuration. The basic designs of both vehicle concepts are described in Volume II; however, the major differences affecting their respective development programs are noted in Section 2 of Volume X.

The baseline development program presented in Section 2.2 refers primarily to the FR-4 configuration as a reference vehicle; however, it also reflects the FR-3 development as both programs are very similar in total time and typical development activities, including major test phases. Specific variations to this baseline program due to the FR-3 configuration are discussed in Section 2.4. Alternate approaches to the baseline program are covered in Section 2.3.

Section 3 contains a description of the methodology used in generating cost estimates for the FR-3 and FR-4 vehicle development, investments, and operations programs. The methodology includes a listing of study ground rules and assumptions, and cost estimating relationships. A discussion of the basis for cost estimates is also included. The results of cost sensitivity analyses and cost comparisons between the FR-3 and FR-4 vehicles are shown. Detailed cost breakdowns for the final vehicle configurations are provided in both Convair and NASA cost reporting formats.

Section 4 discusses the technology programs required to complement Phases B, C, and D development programs for the space shuttle vehicles. It is intended that the technology programs be conducted in parallel with the development programs, but supported as separate studies. Their primary purpose is to support major design and systems decisions encountered during Phase B and C, thus reducing the development risk to a minimum and increasing the confidence of a successful development at the beginning of Phase D and an early operational capability.

The technology programs fall into two categories. Category I includes those programs that support the space shuttle configuration development and selection. It is mandatory that these programs be initiated immediately to minimize the development risk. Category II programs are only slightly less important in that they do not necessarily support configuration definition; they are required to support milestone decisions.

SECTION 2

DEVELOPMENT PROGRAM

2.1 DEVELOPMENT CONSIDERATIONS

The primary function of the development program is to build, test, and demonstrate the capability of a selected space shuttle vehicle design to perform all selected missions satisfactorily and to attain this capability within a reasonably targeted time span. The two vehicle concepts pursued were the FR-4 (a three-element version) and the FR-3 (a two-element version). The basic design approaches followed are described in more detail in Volume II, whereas the probable missions are discussed in Volume III.

The development program discussions in this section refer to the FR-4 vehicle concept, which is considered representative of the FR-3 concept with specific exceptions noted in Section 2.4.

Program considerations that constrained the baseline development program include:

- a. Firm target date (at least as established for this study) for the initial operational mission in mid-1976.
- b. Strong emphasis on minimizing the total number of R&D vehicles because of their relatively high production costs (when compared to existing comparable launch vehicles) and on maximizing the number of these R&D vehicles converted for operational use.
- c. Expendable hardware must be held to an absolute minimum.

The development approach followed, as implied in Figures 2-1 and 2-2, is one of satisfying alternative and sometimes conflicting requirements from various sources. In meeting the imposed mission requirements, the triple functional or operational requirements of a space shuttle that is a launch vehicle, entry spacecraft, and aircraft must be considered. Applications of current capabilities or state of the art must be used wherever feasible to ensure timely availability. For the FR-4 configuration, such areas would include folding wings, LO₂/LH₂ main rocket propellants, modified existing types of turbofans as flyback engines, etc. For a fully reusable space shuttle, however, new developments will also be required where existing capability is not adequate. In some areas, new technologies must be explored in time to implement adequate design decisions in support of an orderly planned program aimed at a specific operational target goal. These areas would include such items as the thermal protection system (TPS), integrated electronics, high-pressure rocket engine, attitude control propulsion system, reusable cryogenic tank and duct insulation, composite

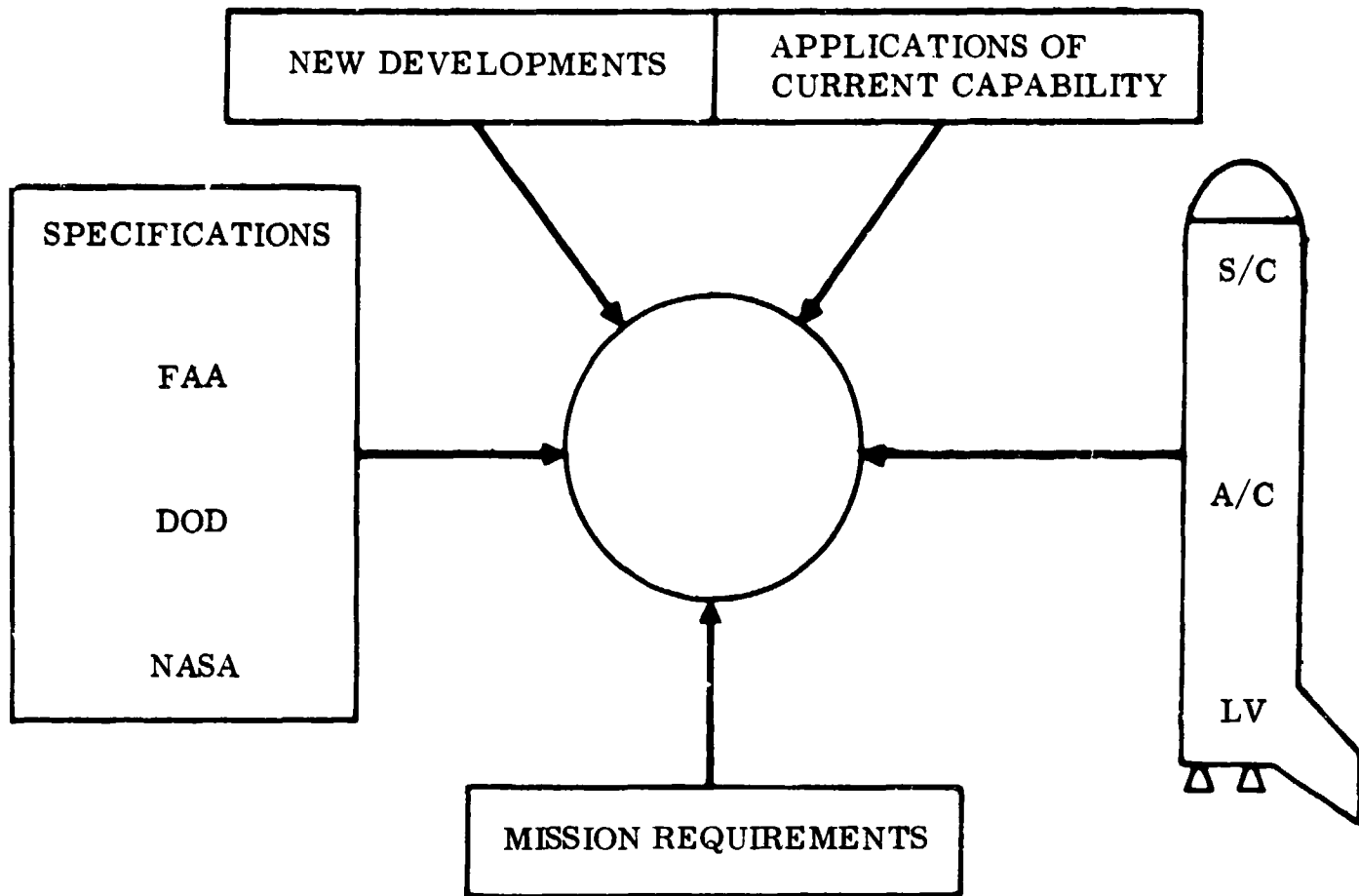

Figure 2-1. Sources of Requirements

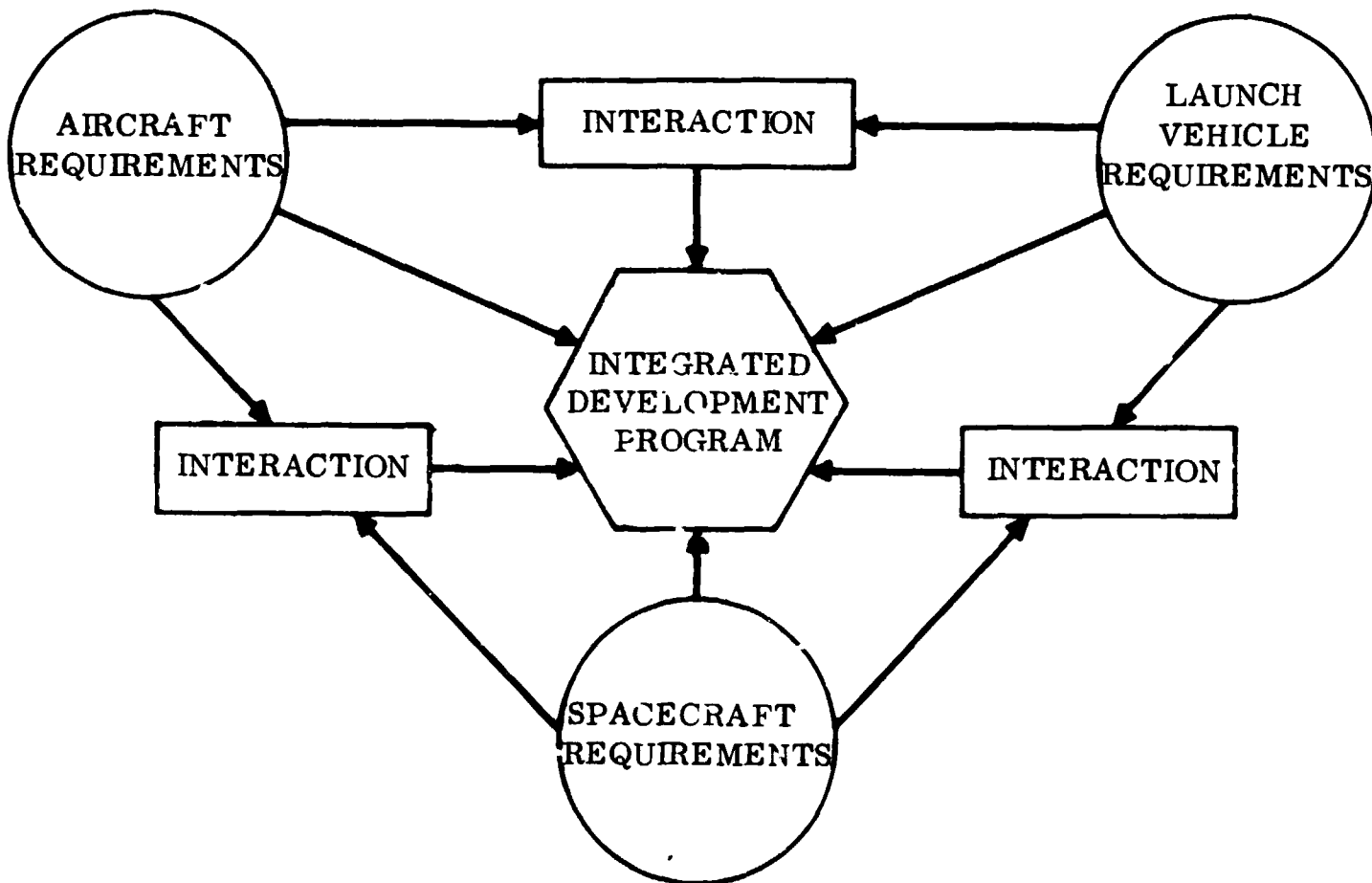

Figure 2-2. Integrated Development Plan

materials application to spacecraft structures, and high-temperature insulation development. Selected key FAA and/or DOD and NASA specifications will probably have to be satisfied for the peculiar aspects of the space shuttle operational mission.

These considerations meld into the baseline approach to be used. In defining the total integrated development requirements, all three aspects of the vehicle configuration need to be satisfied (Figure 2-2). The aircraft-type flight requirements are analyzed in light of both the launch vehicle and spacecraft requirements. These requirements are merged wherever feasible into a single development or test verification requirement satisfying two (all three, if possible) of the facets of the multi-functional vehicle. Such tests as static firings, propellant tanking and flow, and launch tests are principally launch vehicle tests; docking, attitude control simulations, and space environmental tests are indicative of spacecraft tests; taxiing, takeoff, landing, and horizontal flying and handling qualities are typical of the aircraft-type tests. Even though these tests are predominately oriented toward only one of the three facets considered, they have some effect or influence on testing relative to the other two facets. In other areas, there is a strong interdependency between types of tests; i.e., structural tests must be established to satisfy the critical loading conditions found in each vehicle facet (aircraft, launch vehicle, and spacecraft). These will not always be satisfied by taking only the more stringent flight phase for testing. Where feasible, however, the three facets were combined into integrated tests to minimize total test article requirements as well as test facility requirements and the test operation. Another consideration (discussed in Sections 2.2.6 and 2.2.7) concerns utilization of existing development facilities as much as possible, particularly for large test articles approaching a complete element size. Development of new test facilities is restricted to test-type fixtures for the smaller ground test articles and vehicle subassemblies.

2.2 BASELINE DEVELOPMENT PROGRAM PLAN

The baseline development program reflects the FR-4 space shuttle configuration; possible variations relating to the two-element FR-3 vehicle configuration are discussed in Section 2.4. Since both vehicle concepts include booster and orbiter elements that are similar, their overall development plans are very similar in context and schedule, especially when considering the same targeted initial operational flight.

Alternative approaches to the baseline program discussed in Section 2.3 are relative to the FR-4 vehicle configuration only. In general these approaches discussed for the FR-4 are also appropriate for the FR-3.

Several assumptions have a direct affect on the course and content of this baseline development program. The degree of design differences between the booster and orbiter elements of the FR-4, as compared to the FR-1 configuration is a good example. The FR-4 boosters differ structurally from the orbiters, even though their external aerodynamic configurations are similar. This alone has a great effect on

the total development program plan, impacting design, tooling, manufacturing, and ground and flight testing as well as indirectly affecting most other development related areas. The specific design comparisons of the orbiter and booster are described in detail in Volume II. To more clearly visualize the impact of subsequent discussion relative to tooling, manufacturing, and testing, the basic differences between the booster and orbiter airframe configurations are shown in Figure 2-3. Some basic vehicle subsystems are also different; for those that are considered similar, the orbiter subsystems reflect the more complex configurations. It is the major differences between these elements, however, that cause the significant increases in tool and test article quantities when compared with the FR-1 concept of basically common elements. A single contractor approach to development is also implied in this program plan.

As shown in Figure 2-4, the development program reflects a combined Phase C/D effort, with a contract award date assumed for the beginning of the second quarter of CY 1971. A 1976 initial operational launch date was considered as a firm target milestone; some overlap of engineering and testing activities is required to support this date. In spite of the lack of commonality between the orbiter and booster elements, a concentrated effort was expended to minimize the quantity of expendable test hardware and support facility requirements. Where the orbiter test configuration was considered representative of both elements, a booster article would not be provided. Consequently, as discussed in a later section on testing, one test article/test stand is sometimes used to satisfy the test requirements for both the booster and orbiter elements. In addition, major test facilities for the larger ground test articles were not considered as new facility hardware if suitable existing facilities could be modified for the task (e.g., static firing test facility, Section 2.2.7).

Development of the jet (cruise) engines and the main rocket propulsion engines is assumed initiated prior to the start of Phase C/D go-ahead by six months or more. Engine selection is assumed made prior to the preliminary design review (PDR) indicated in Figure 2-4. The overall space shuttle development time reflects a nominal state of the art advance for that period, especially in the tooling, manufacturing, and testing areas. The state of the art achieved should be that estimated attainable by CY 1972.

Some specific areas of design, however, must be supported by timely pursuance of technology items, notably:

- a. Radiative-type thermal protection material as well as fabrication and joining techniques.
- b. An expanded-capability attitude control propulsion system.
- c. Entry cooling requirements.
- d. Reusable propellant (cryogenic) duct and tank insulation.

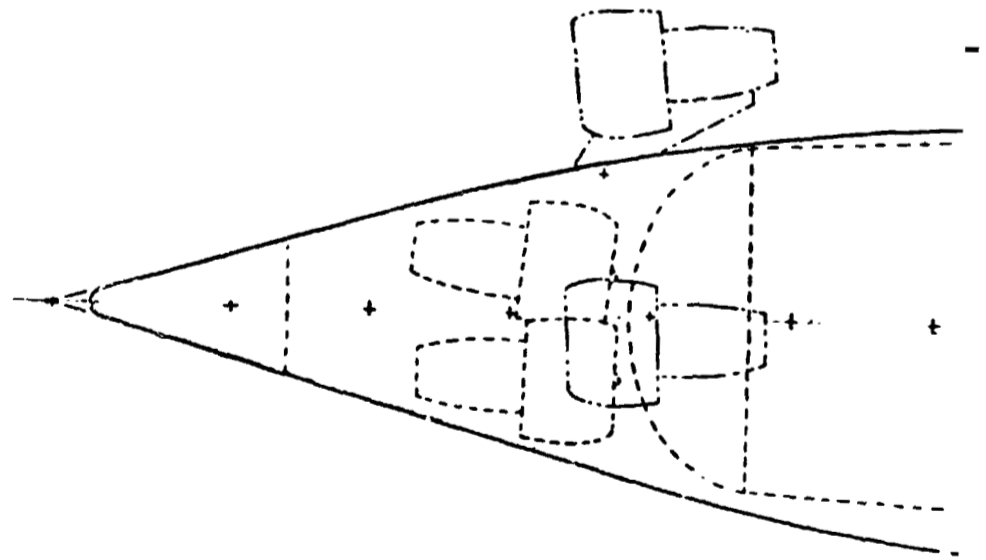
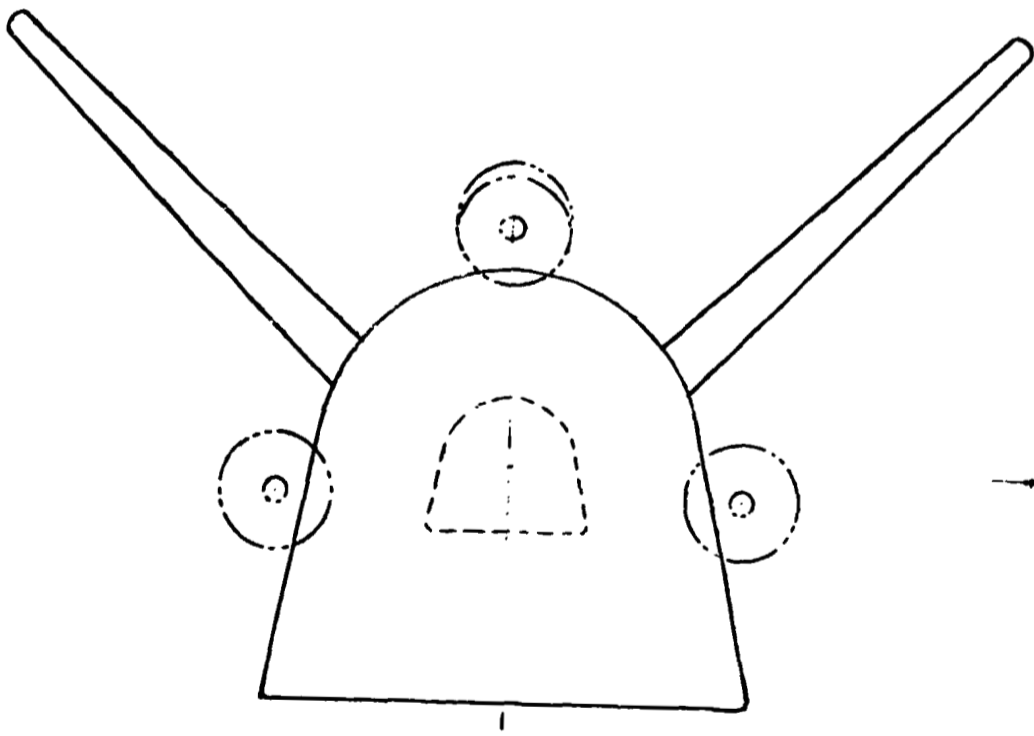
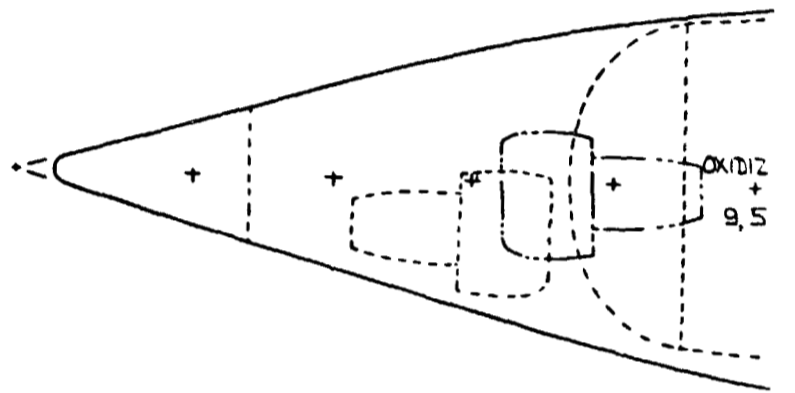

FOLDOUT FRAME — (

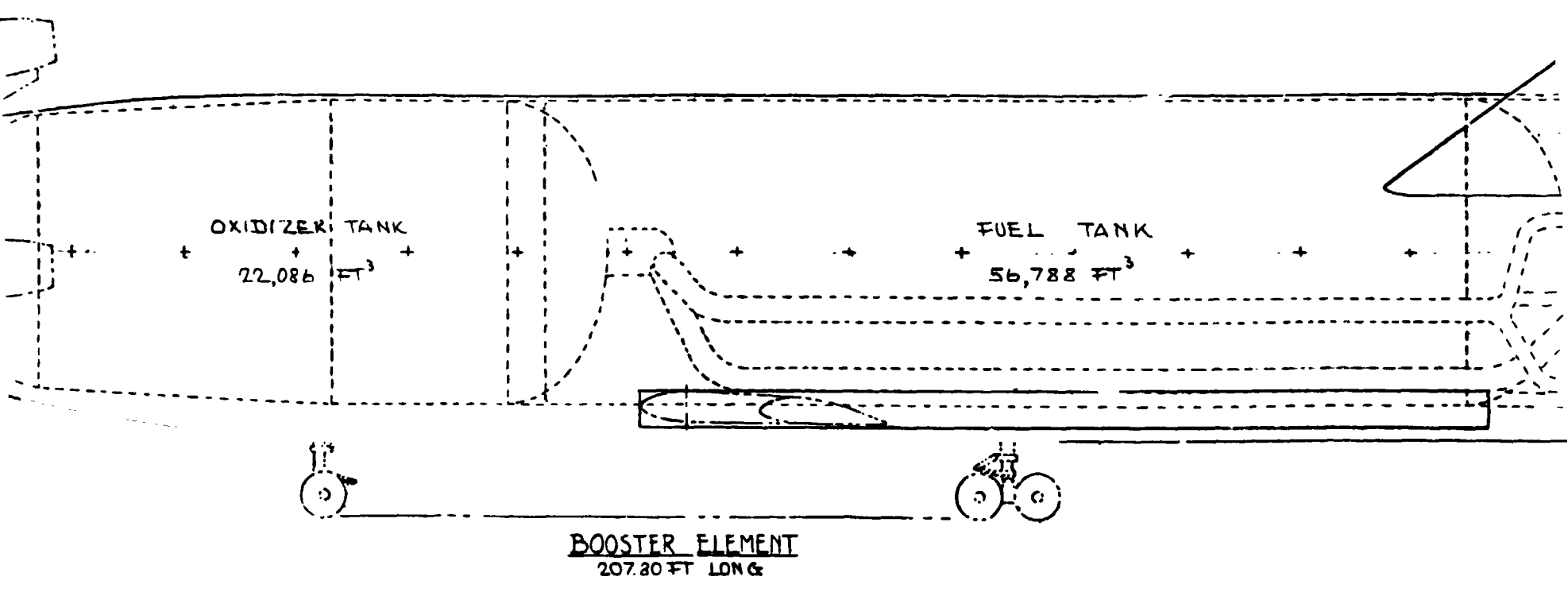
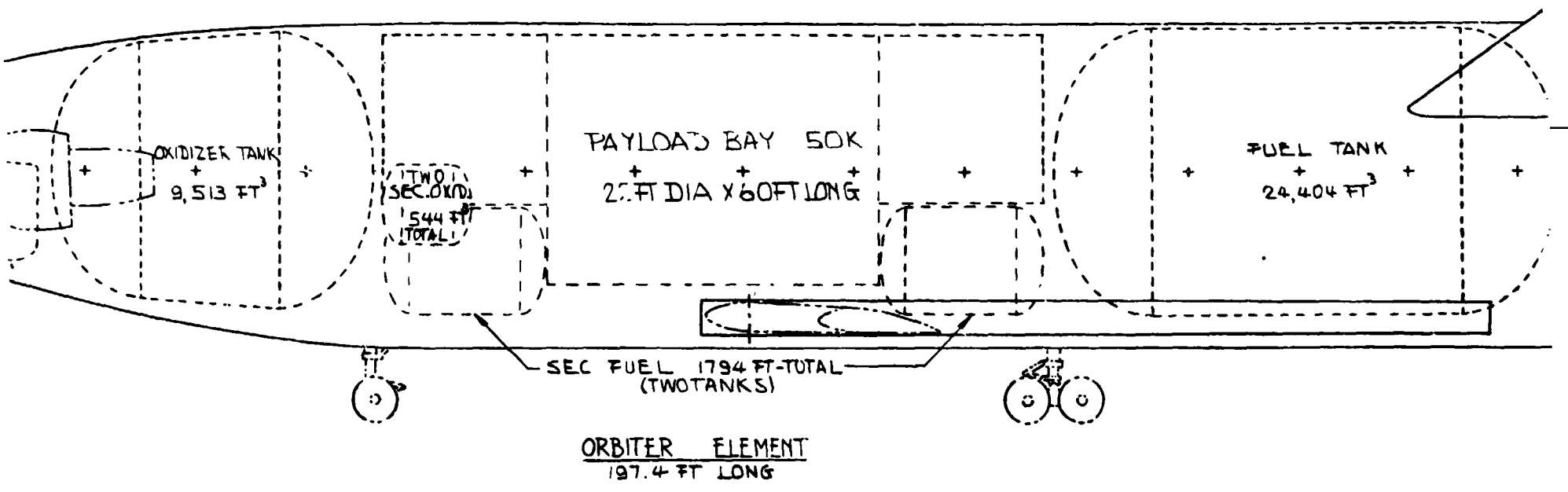

FOLDOUT FRAME - 2

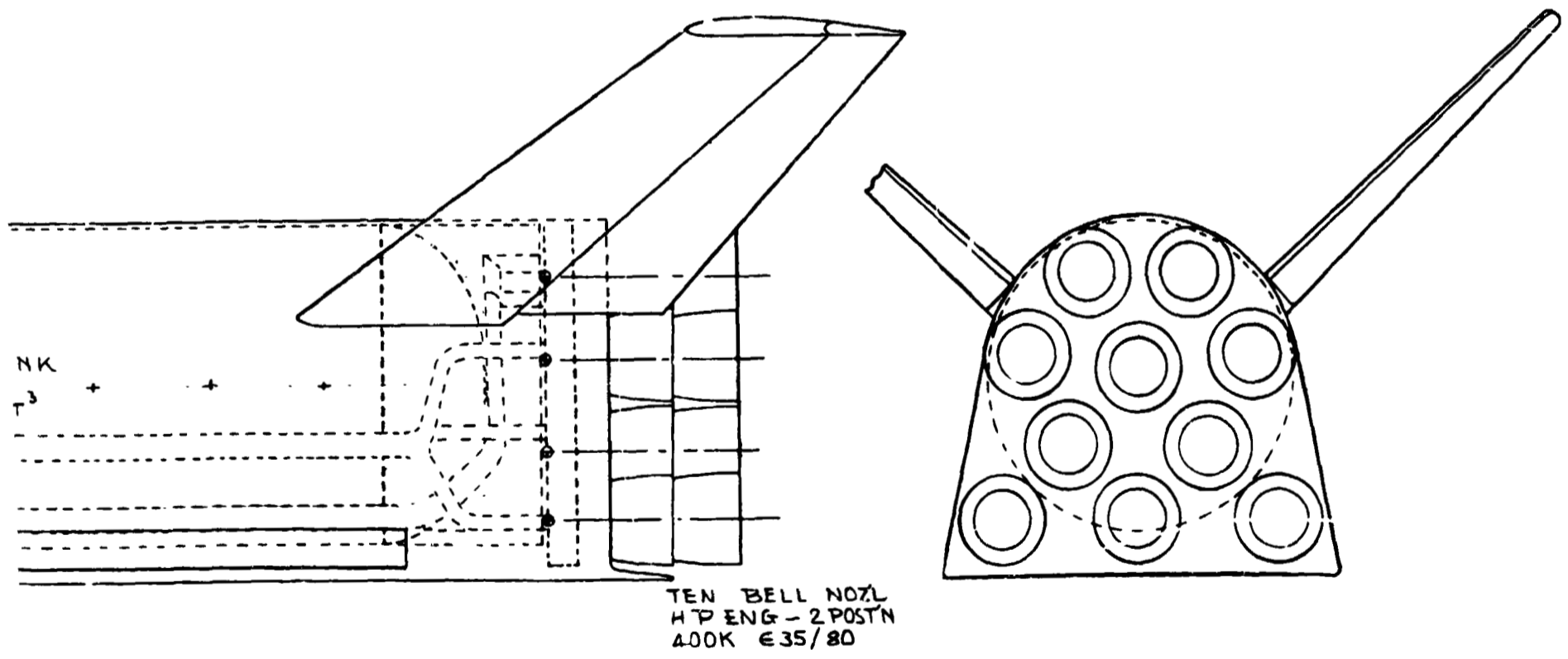
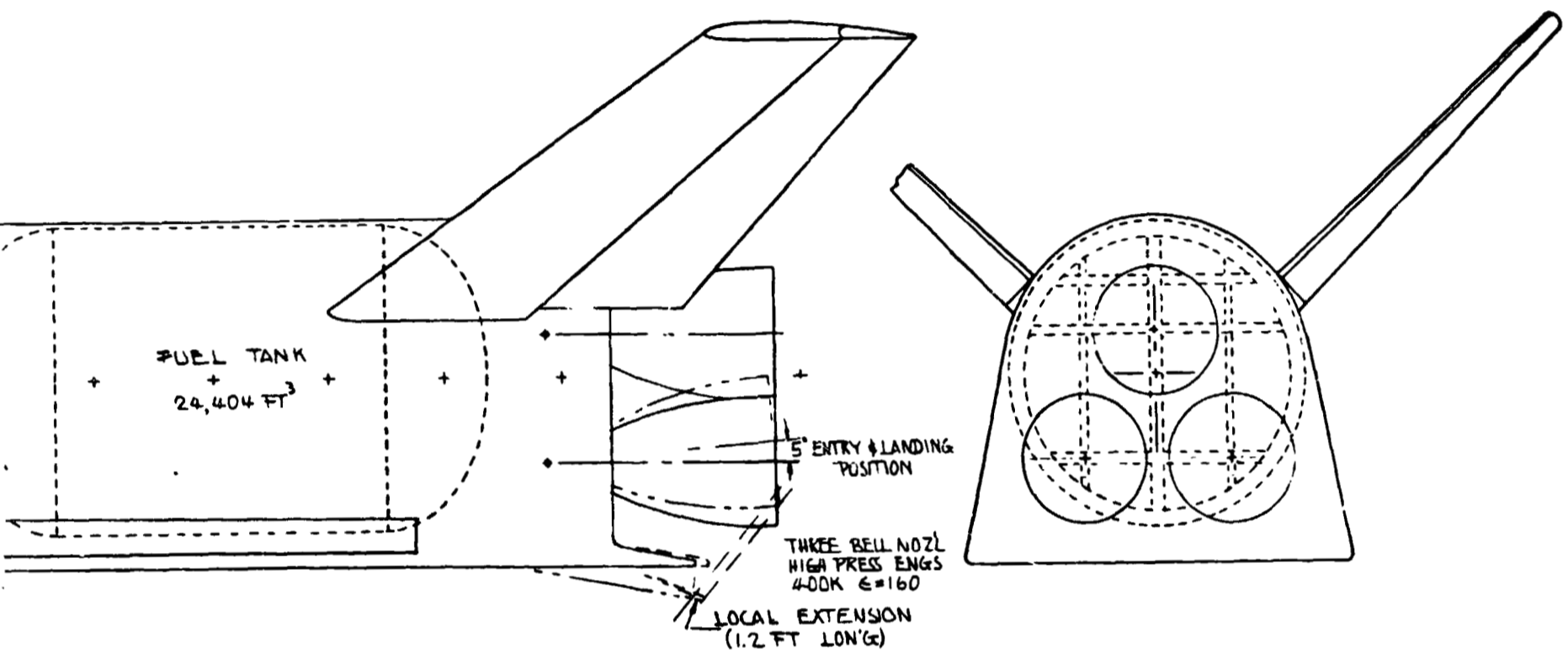
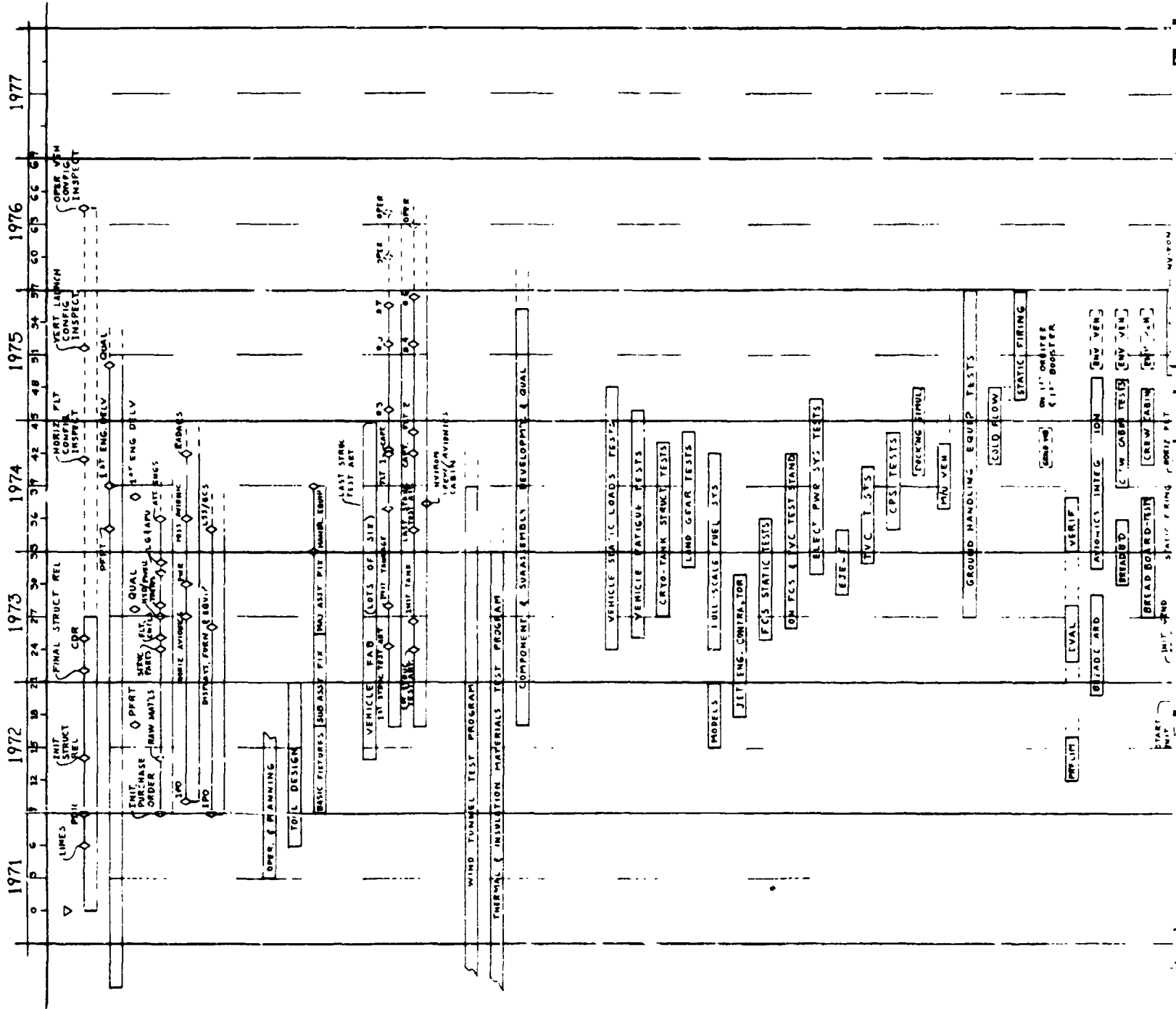

Figure 2-3. FR-4 Vehicle Configurations

2-5

EOLDOUT FRAME -3



- PHASE C/D CURRENT MAJOR
- DESIGN REVIEW & REVISIONS
- ROCKET ENGINE DEVELOPMENT PROGRAM
- JET ENGINE DEVELOPMENT PROGRAM
- MAJOR PROCUREMENT PROGRAM
- CONSTRUCTION & MECHANICAL DRAWINGS
- ELECTRICAL & ELECTRONIC SUB-ASSEMBLIES
- CREW SUPPORT EQUIPMENT
- TOOLS
- TOOL OPERATIONS & PLANNING
- TOOL DESIGN
- TOOL FABRICATION
- MANUFACTURING
- DETAILED FABRICATION
- DOORER ELEMENTS ASSEMBLY & CHECK OUT OPERATIONS
- ORBITER ELEMENTS ASSEMBLY & CHECK OUT OPERATIONS
- GROUND TEST PROGRAM
- WIND TUNNEL TEST PROGRAM
- THERMAL & INSULATION MATERIALS TEST PROGRAM
- COMPONENT & SUBASSEMBLY DEVELOPMENT & QUAL
- VEHICLE SEAT LOADS TESTS
- VEHICLE FATIGUE TESTS
- VEHICLE TANK STRUCT. TESTS
- VEHICLE GEAR TESTS
- VEHICLE FUEL SYS
- VEHICLE STATIC TESTS
- VEHICLE VIBRATION TESTS
- VEHICLE FLAME TESTS
- VEHICLE FIRE TESTS
- VEHICLE CRASH TESTS
- VEHICLE BURST TESTS
- VEHICLE COLLISION TESTS
- VEHICLE IMPACT TESTS
- VEHICLE THERMAL TESTS
- VEHICLE HUMIDITY TESTS
- VEHICLE CORROSION TESTS
- VEHICLE WEAR TESTS
- VEHICLE FATIGUE TESTS
- VEHICLE STATIC TESTS
- VEHICLE VIBRATION TESTS
- VEHICLE FLAME TESTS
- VEHICLE FIRE TESTS
- VEHICLE CRASH TESTS
- VEHICLE BURST TESTS
- VEHICLE COLLISION TESTS
- VEHICLE IMPACT TESTS
- VEHICLE THERMAL TESTS
- VEHICLE HUMIDITY TESTS
- VEHICLE CORROSION TESTS
- VEHICLE WEAR TESTS

FOLDOUT FRAME

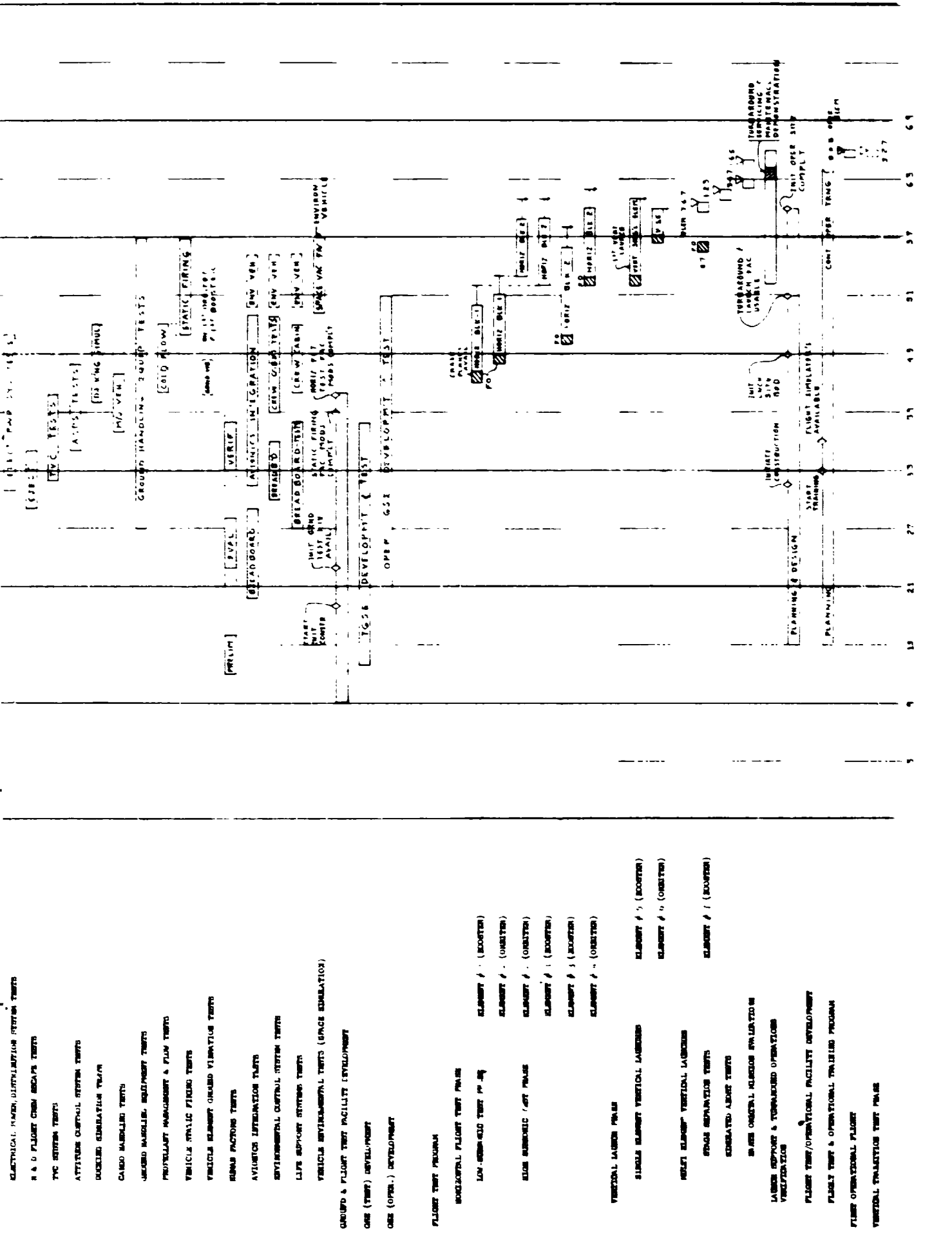

Figure 2-4. Summary Development Program Plan
Baseline Vehicle Configuration (FR-4)

e. High-temperature insulation development.

Section 4 includes the key technology requirements directly supporting Phases B, C, and D. The more important technologies, including the Category I items, are discussed in Section 4. Their activity schedules are also included, and relate to some of the key development program milestones.

A comprehensive wind tunnel test program and TPS material development program should also be initiated prior to vehicle development go-ahead.

2.2.1 PROGRAM SUMMARY. The combined Phase C/D development program for the space shuttle is initiated in April 1971 and continues for 66 months to the first operational launch in October 1976. This reflects the earliest attainable operational launch date; a more nominal approach, which would greatly reduce the risk, would probably extend the first operational launch into CY 1977 or early 1978. The current baseline is attainable under a degree of development risk and increased costs, especially in tooling, manufacturing, and testing.

The key milestones reflected by the baseline schedule of Figure 2-4 are:

- 17 months to start of major vehicle subassembly.
- 43 months to first horizontal flight.
- 47 months to start of vehicle static-firing tests.
- 54 months to first single-element vertical launch.
- 60 months to first three-element vertical launch.
- 63 months to first earth-orbital flight.

Delivery dates of the seven flight-test elements and the major ground test hardware subassemblies are reflected in the manufacturing schedule also shown in Figure 2-4. (See Sections 2.2.6.2 and 2.2.6.3 for a discussion and description of each major test article and flight vehicle.)

The major ground test program, excluding the wind tunnel and component and materials development and qualification programs, begins in the second quarter of CY 1973 and ends in the fourth quarter of CY 1975 (33 months). The development activities on the master program schedule concern primarily the airborne equipment development tests; testing of ground support and handling equipment is covered summarily to reflect appropriate time interfaces. The basic ground test program is structured in a sequential fashion that tends toward progressive support of the more severe or complex test conditions, including appropriate and timely support to the various phases of the flight test program.

The flight test program begins 42 months after go-ahead and spans about 23 months. The two basic flight test phases (horizontal and vertical) overlap by seven to eight months; however, the vertical launch phase does not begin until the design limit loads for horizontal flight have been demonstrated adequately. Horizontal flight tests would be conducted at an existing test site such as the Edwards Air Force Test Site. Vertical launches would be performed at a site designated for the initial operational launches.

Development and availability of ground test facilities in support of both the ground flight test programs (Section 2.2.7) are shown in the master schedule, giving the key milestones or interface timing requirements. These include the launch complex and turnaround facilities necessary to meet the operational program requirements. To satisfy the continuous standby requirement for emergency rescue operations during the operational phase, two launch pads must be available by the 1976 operational date even though only one pad would be required for the R&D flight test phase.

2.2.2 DESIGN AND ENGINEERING. Considering a combined Phase C/D development program beginning in second quarter 1971, a preliminary design review (PDR) of the selected vehicle configuration would be attained in nine months (by 1972). The critical (final) design review (CDR), which constrains assembly of the flight test vehicles, occurs some 16 months later (second quarter of 1973). Inspection of the first horizontal flight element configuration occurs 41 months from go-ahead (third quarter 1974), and inspection of the first vertical launch configuration occurs 11 months later (third quarter 1975). The final operational configuration inspection would be performed in the third quarter of 1976, prior to releasing the vehicle for the first operational flight.

The combined C/D phase is preceded by a vehicle definition and predesign phase, where one configuration would have been selected and soft mockups for this configuration established. Six months after the start of Phase C/D, sufficient configuration design data should be available to establish the basic vehicle lines, permitting initiation of the tooling operations.

An initial major structural design release by mid-1972 would allow completion of some basic fixtures and tools. Final structural release by early 1973 allows all tools to be completed, enabling manufacturing to proceed with assembly of the major ground and flight test vehicles.

The CDR would approve the basic build-to specifications and would be supported by data from the research, development, and design support tests (e.g., wind tunnel, materials, and component development).

The horizontal flight configuration inspection or design review would serve to evaluate the first flight article against the final design and the results of applicable ground test phases (those in support of the horizontal flight mode). The vertical flight configuration inspection would likewise evaluate the first vertical launch element against its design

requirements and applicable ground test results. The operational configuration inspection would ascertain that the component elements making up the first operational flight vehicle do, in fact, reflect all design changes or modifications determined necessary from the ground test program and the flight test program. The R&D flight test elements or vehicles being transferred to the operational program must also reflect these modifications.

2.2.3 MAJOR PROCUREMENT. The main rocket propulsion engines and the turbofan jet (cruise) engines are prime procurement items, although both are considered to be under separate-but-parallel development contracts. The main rocket engine, whether it is of the bell or aerospike configuration, would have to begin development in CY 1970 to support the baseline vehicle development program. The rocket engine preliminary flight rating tests (PFRT), an engine development milestone, should be accomplished by the first quarter of 1974.

Initial engine delivery to the vehicle contractor would be in second quarter 1974 to support vehicle/propulsion system integration testing. Engines qualified for flight would be used on flight test vehicles No. 5, 6, and 7 and would be retrofitted on vehicle No. 1 through 4 during one of their scheduled modifications between flight phases. The turbofan jet engine development milestones are also indicated in Figure 2-4. This program reflects a comprehensive modification of existing type engines. The primary candidates include the CF 6-B1, RB 211-22, TF 39-1, and JT 9D-7. Of these, the RB 211-22 appears to be a likely choice for the FR-4 vehicles. At this time, availability of these engines in time to support the ground and flight test program needs is not considered a pacing problem.

Other major hardware procurement milestones are also reflected on the schedule and are based on the initial purchase orders being placed by the beginning of CY 1972, at PDR or immediately thereafter. The longer lead items in this schedule would include the rendezvous radars, attitude control engines, certain mission-required avionics, and the environmental control and life support systems hardware.

The ground test program uses some prototype hardware for initial testing as well as preproduction and production hardware elements. The flight test program will require all production-type hardware or at least components that have been previously qualified for flight by the vendors. No procurement problems have been identified as yet.

2.2.4 TOOLING. The approach to tooling as applied to a baseline space shuttle concept such as the FR-4 design is governed by the manufacturing breakdown structure (MBS) shown in Figure 2-5.

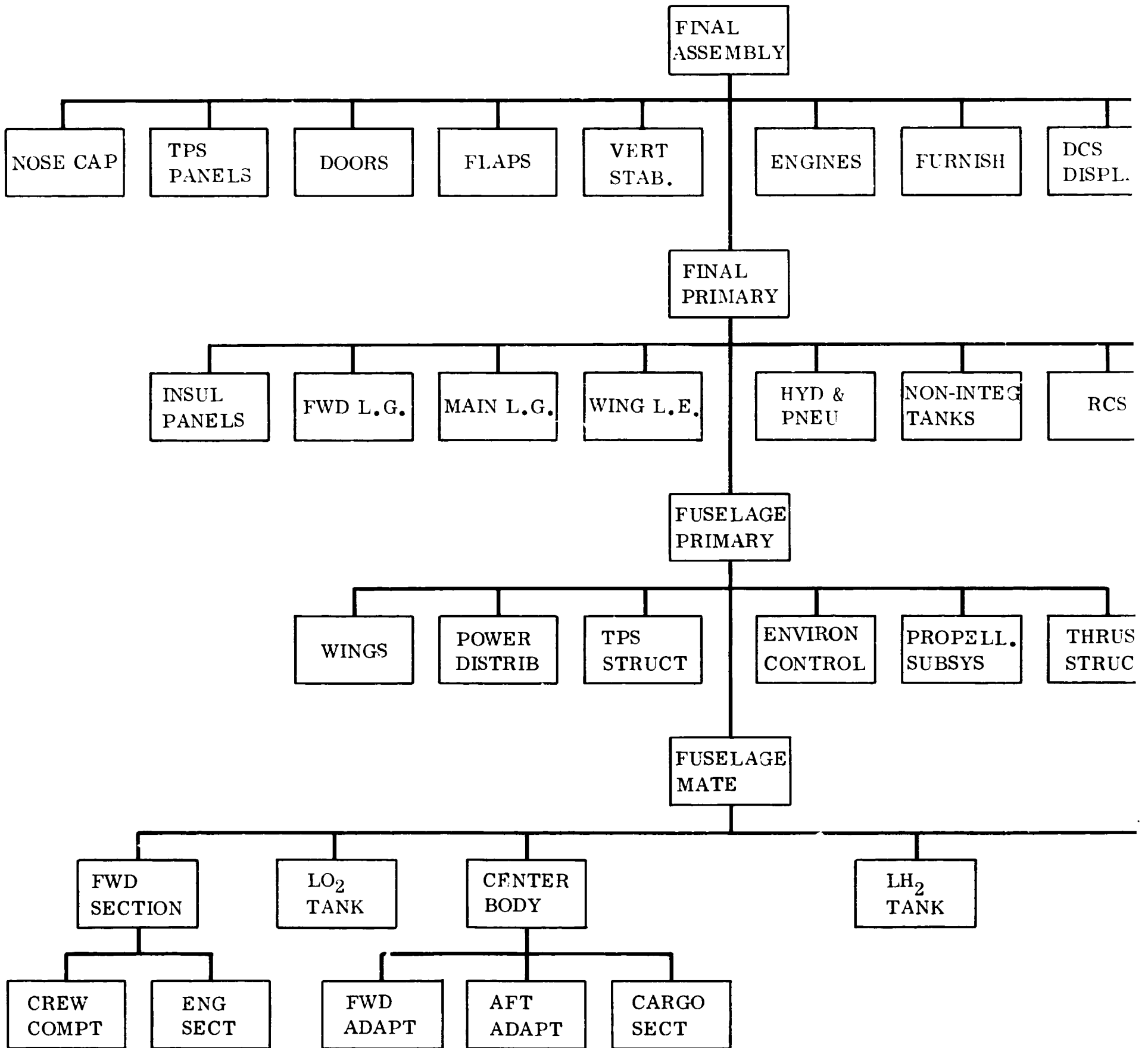
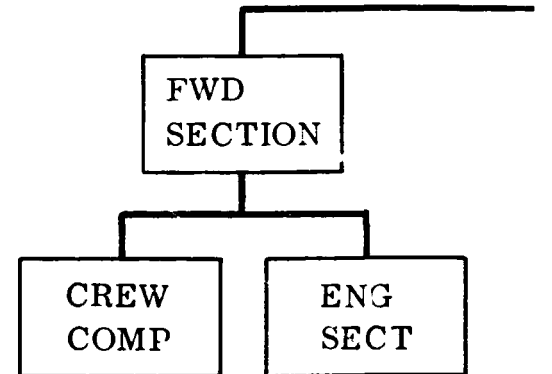
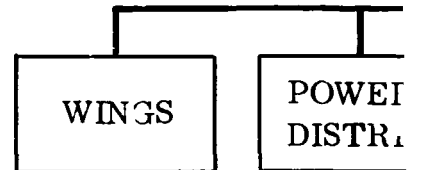
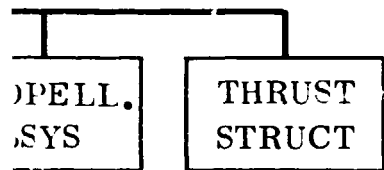
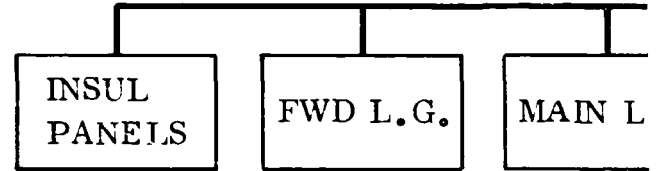
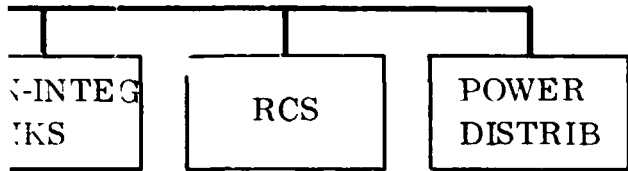
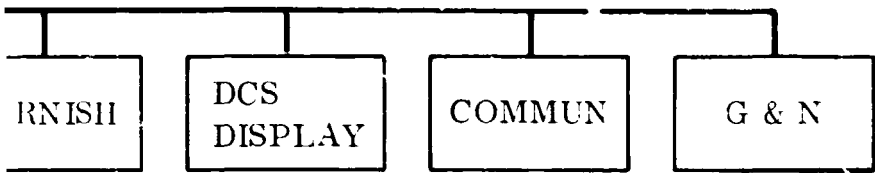
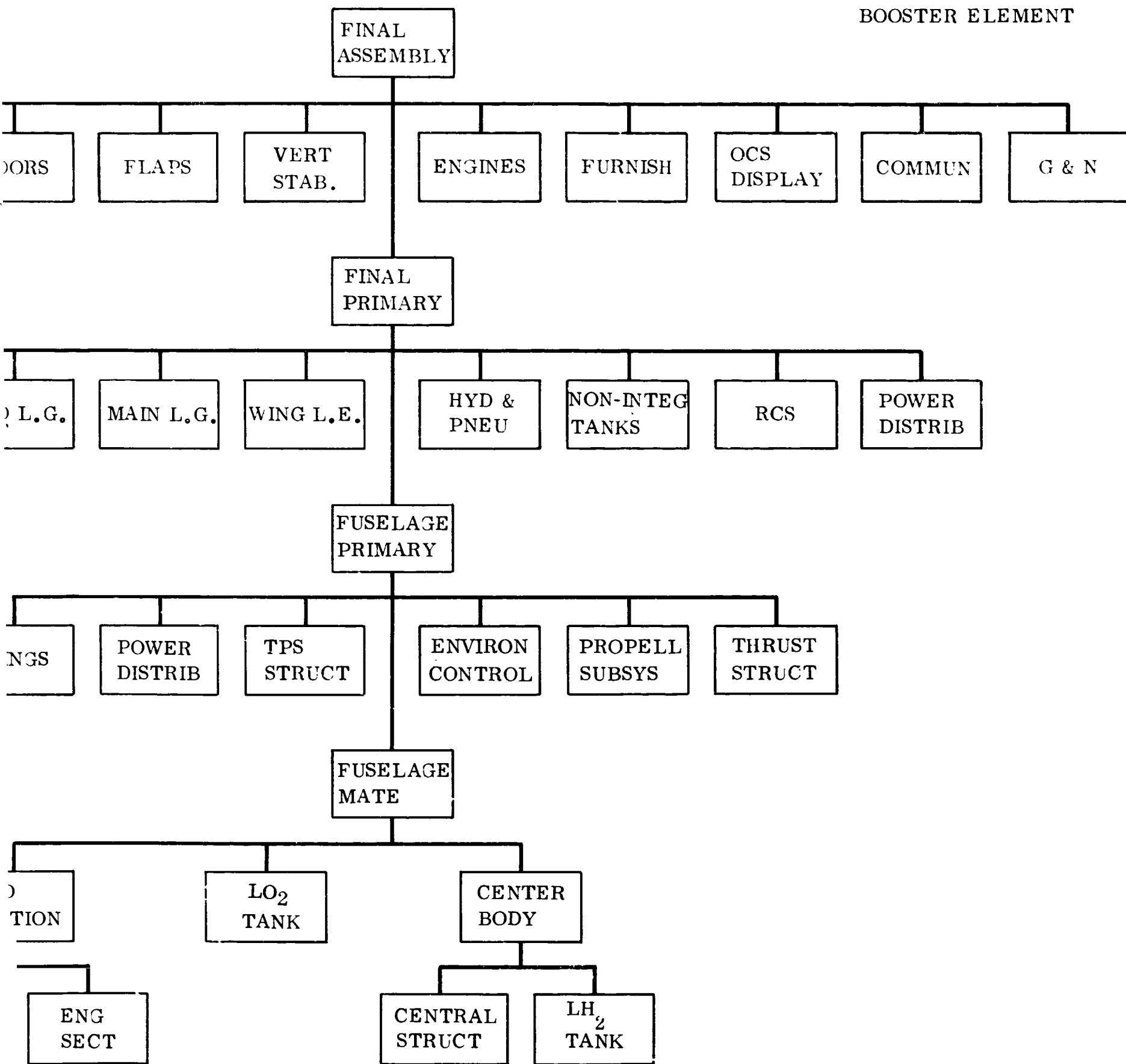

Figure 2-5. Manufacturing Breakdown Structure

ORIBTER ELEMENT



BOOSTER ELEMENT



The design and application of tooling will be heavily influenced by physical size of the airframe. The largest influences however, are the advanced manufacturing techniques in the realm of materials, facilities, and equipment as applied to:

Fabrication

Hot Form Dies
Stretch Forms
Form Rolls
Form Dies

Joining

Roll Fusion Tools
Welding Fixtures
Weld Manipulators
Fusion Dies
Fastener Drill Tools

Dimensional Control

Master Gages
Coordination Plates
Inspection Gages
Protective Tools
Laser Devices
Interface Tooling
Environment

Metal Removal

Plank Mill Fixtures
Numerical Control Tapes
Ring Turning Fixtures
Special Cutting Tools
Chem-milling

Assembly

Air Bearing Devices
Modular Assembly Fixtures
Laser/Optics Equipment
Mobile Fixtures

Processing

Handling Tools
Conveyance Adaptations
Maskant Aids

Development & Test

Mockups
Harness Fixtures
Test Fixtures
Production Samples

The make or buy analysis will identify the subcontract items and related tools to be provided by the respective vendors. Control tools in the form of "masters" would be maintained in sufficient quantities to coordinate the numerous interfaces and interchangeability and replaceability requirements. With the variable environments considered for these vehicles, extensive tool families are expected for spares and maintenance service. Experience data on such items as erosion of thermal-coated panels; leading edge life; door seal, hinge, and latch performance; fusion-bonded composite adhesion; etc., is required.

Fabrication tools should have longer production lives than current tooling; thus, material selection is of primary interest in the sense of hot-forming dies, bonding fixtures, and machine tools. For economy, expendable materials would also be considered; e.g., cerro-matrix, glass die pads, urethane and wax fillers, vermiculite insulation, mylar blankets, etc.

Certain aspects of hot-forming titanium details are exemplified in Figures 2-6 and 2-7. Typical press form dies are illustrated in Figure 2-8. An example of development tooling and/or facility expected to support a particular form of welding is the automatic sinusoidal welder pictured in Figure 2-9 (E/B or GTA).

The TPS fabrication requires the only true mass-production tooling concept used in the space shuttle development. A tooling philosophy comparable to that of a landing mat production line is expected. Within this flow, a means of bead-forming of strip material is conceived, with perhaps a continuous or interrupted spur diffusion bonding. Assembly may resort to high-temperature brazing for further development. TPS shingle quantities approach 4,000 units per month on average vehicle production rates.

A more or less conventional fixture approach will be applied on major FR-4 component tools to properly align the part while operations such as drilling, riveting, or welding are performed by moving the cutting head or welder. Major tank assembly fixtures would be of a vertical buildup concept comparable to the Saturn production practice. Design of fixtures would be sensitive to stage length.

As shown in Figure 2-10, major fixtures take on the appearance of shipyard dry docks. The unique forms of laser alignment and total parts positioning are omitted for clarity.

Wing buildup of the primary structure would also resort to the more conventional tooling with particular attention applied to the wing pivot fitting. Wing and empennage fixtures would resemble Figure 2-11 in left- and right-hand sets.

Preliminary calculations show the centerbody section buildup to be the pacing item of both booster and orbiter elements. On the basis of this component rate (see Figure 2-14, next section), the following tooling sets are required for typical total element inventories and production rates.

Two-Year Inventory

Total Elements	5 Boosters	3 Orbiters
Tool Sets	2 sets tooling	1 set tooling
Production Rate	2-2-1	1-1-1
Total Elements	7 Boosters	6 Orbiters
Tool Sets	3 sets tooling	2 sets tooling
Production Rate	3-3-1	2-2-2

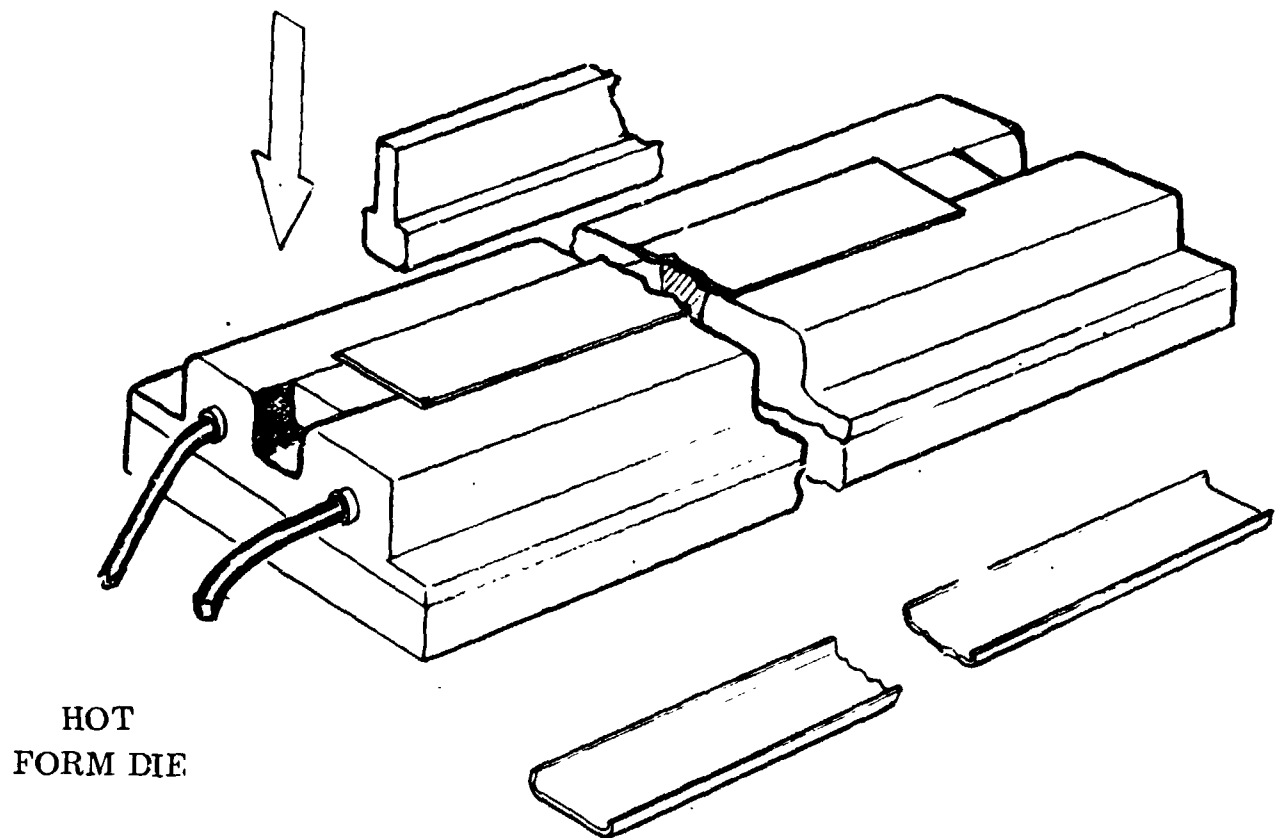

Figure 2-6. Hot Form Die

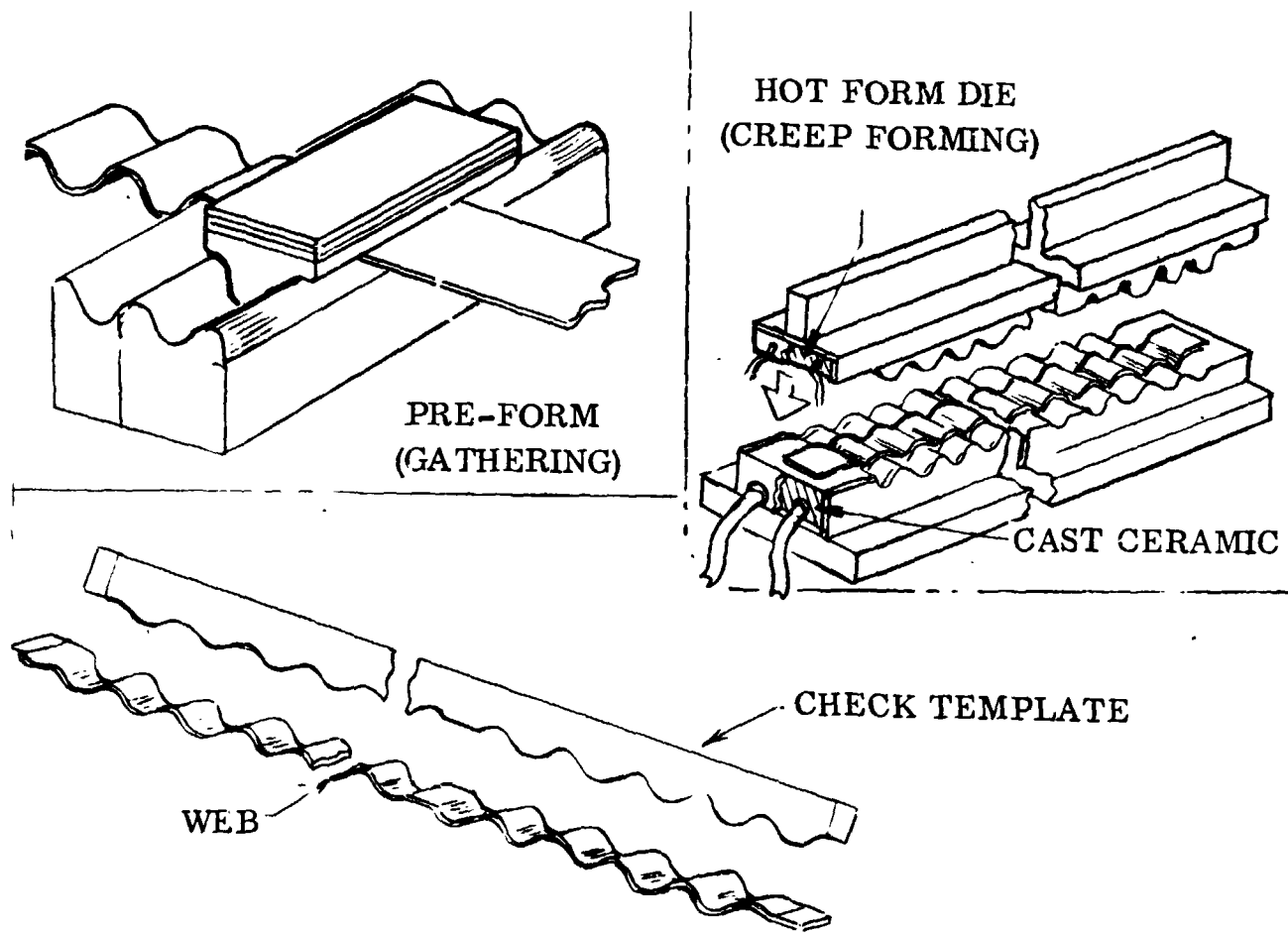

Figure 2-7. Hot Forming Die Techniques

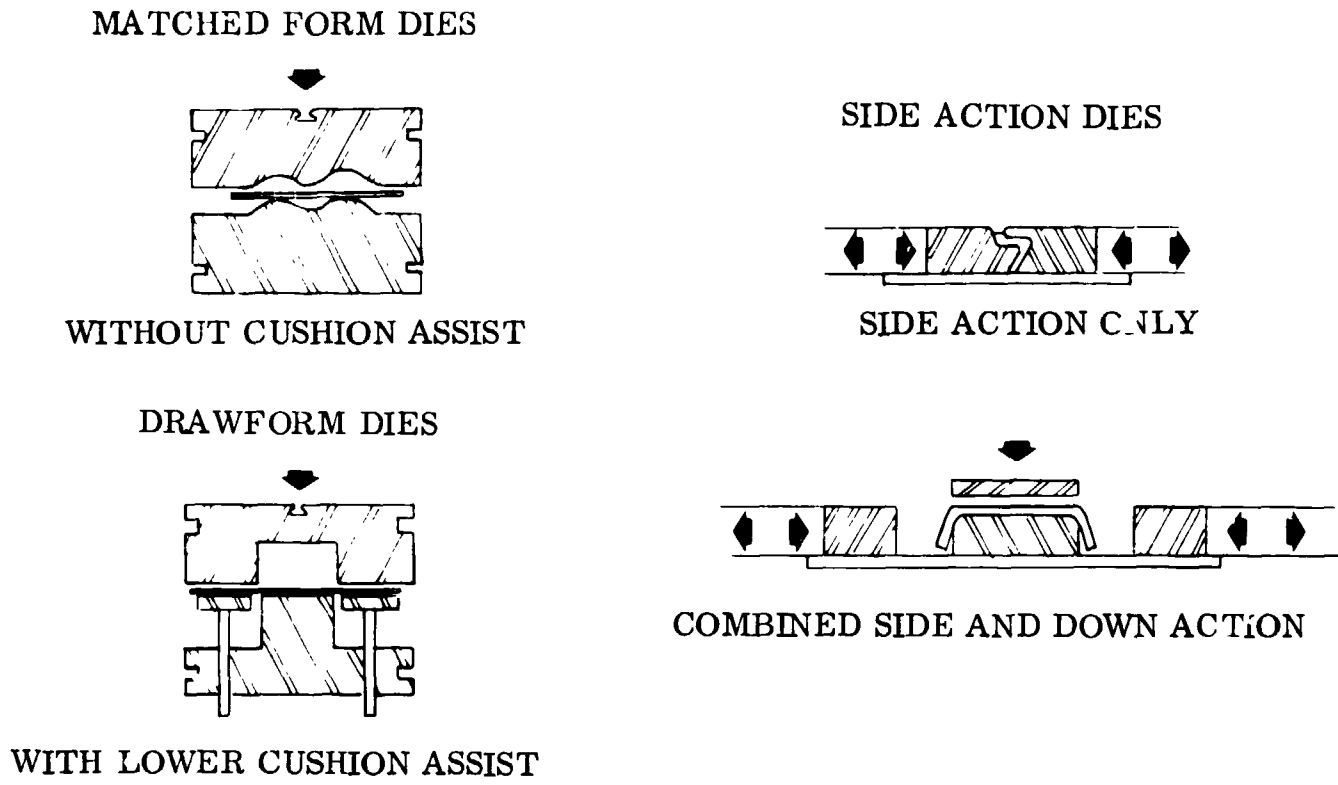

Figure 2-8. Press Form Die Classifications

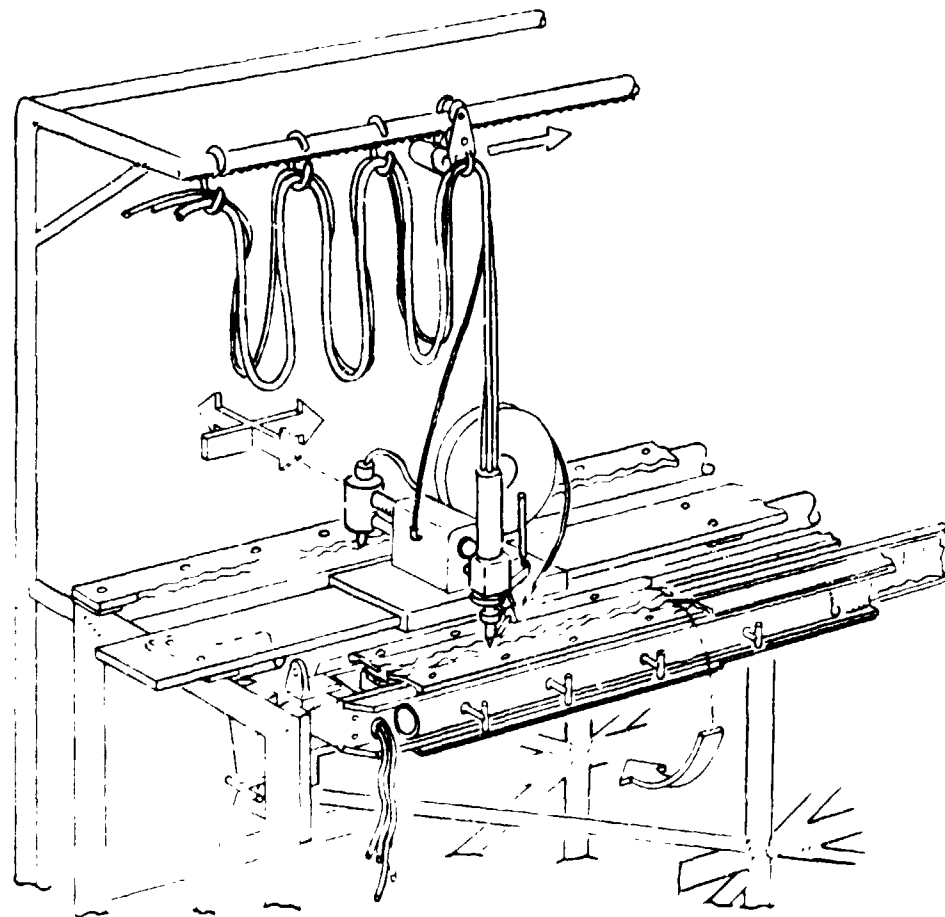

Figure 2-9. Automatic Sinusoidal Welder

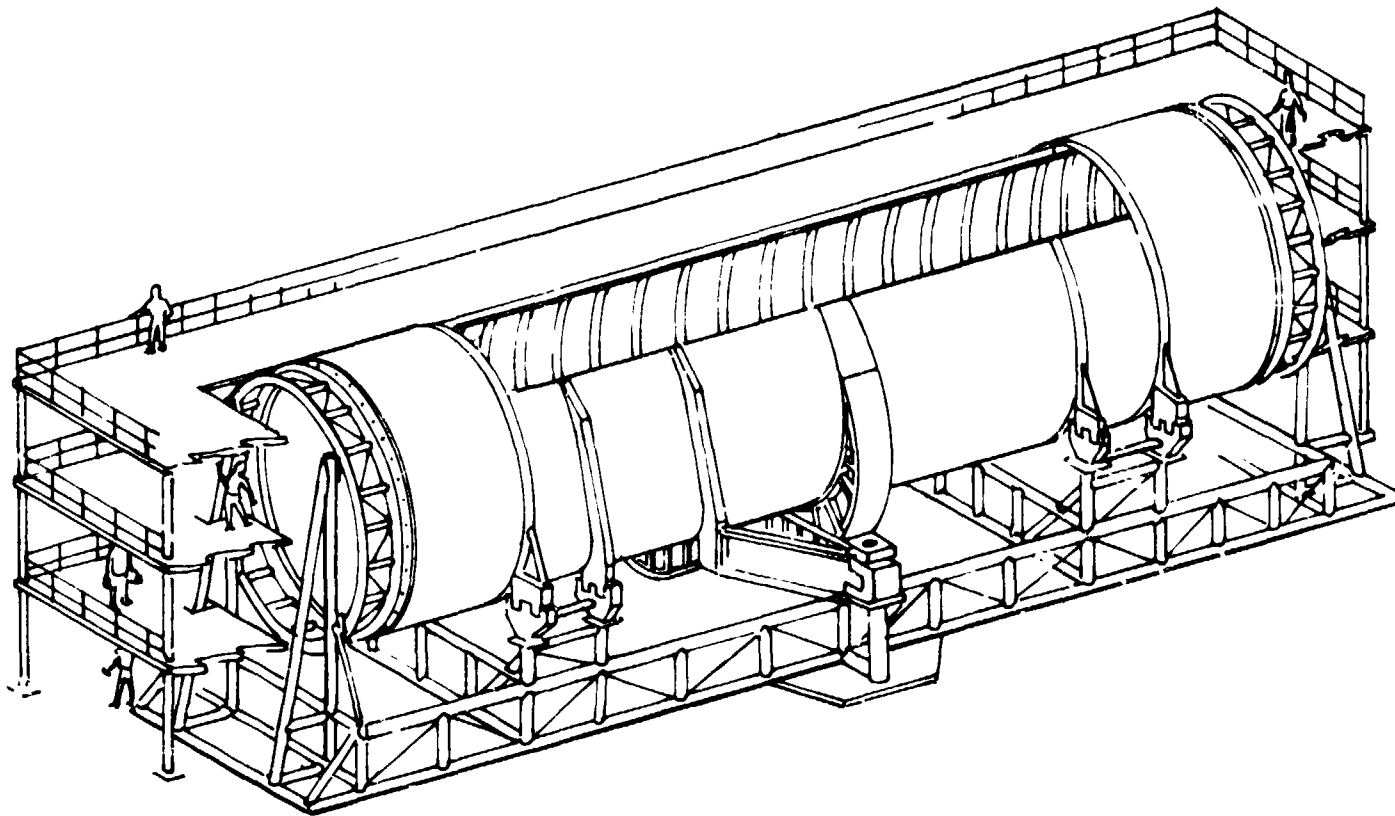

Figure 2-10. FR-4 Orbiter Body and Fixture

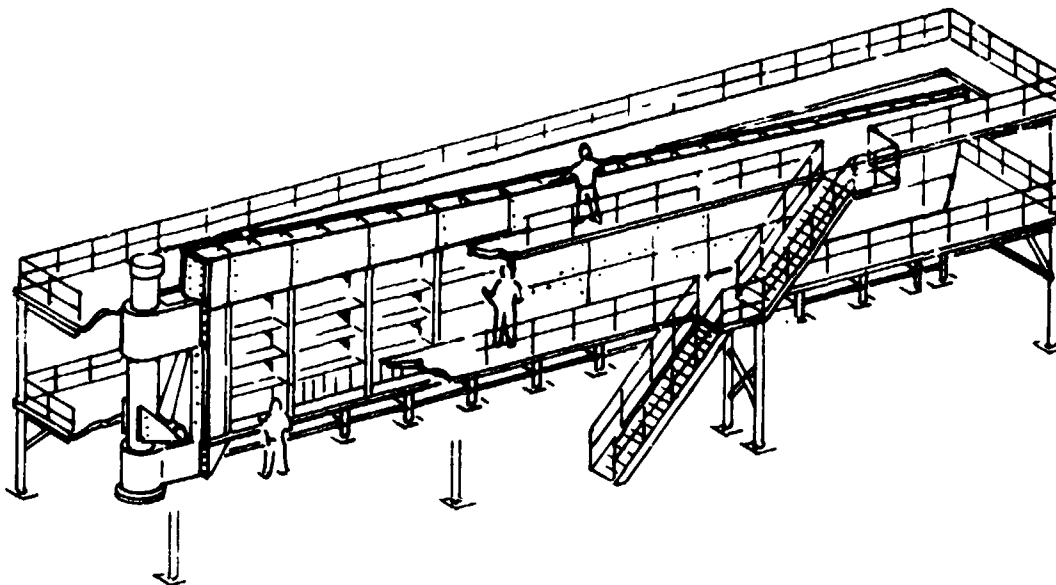

Figure 2-11. FR-4 Wing Primary Assembly Fixture

Three-Year Inventory

Total Elements	11 Boosters	6 Orbiters
Tool Sets	3 sets tooling	2 sets tooling
Production Rate	3-3-3-2	2-2-2
Total Elements	21 Boosters	11 Orbiters
Tool Sets	4 sets tooling	3 sets tooling
Production Rate	4-4-4-4-5	3-3-3-2

2.2.5 MANUFACTURING. Technologies involved in production of reusable space transports are of greater expanse over the industry than ever before encountered. Raw material suppliers must provide extensive shapes and sizes (i. e., integral panels, rails, rings, forgings, and castings) in substantially increased volumes of the higher level metal alloys. Heat-resistant and high strength/weight composite materials are also imperative. Suppliers throughout the industry will have extensive demands made upon them to permit the airframe builders to concentrate on fabrication and assembly operations.

Considerations of the modes and routes of transporting materials and components are a chief concern of the aerospace industry. Manufacturing planning is contemplated in terms of national location of suppliers, subcontractors, in-plant logistics, and ultimate flight tests. Since space shuttle design trends are becoming composites of aircraft, spacecraft, and launch vehicles, manufacturing facilities should be capable of producing these multi-functional vehicles. An airframe design such as the FR-4 has some commonality within its subsystems equipment; structurally, however, there is little similarity.

Fabrication facilities are confronted with three metals: basic aluminum alloys, intermediate titaniums, and superalloys of Rene 41, Columbium, and TD nickel. Composite materials such as aluminum-boron and graphites essentially represent a fourth group.

Categorically, the production methods as applied to the aluminum parts of integrally stiffened panels, structural bulkheads and frames, and crew-compartment structure and associated details will almost be totally machined of sized plates, extrusion, and forgings. Metal removal would be rapid via multispindle machines, while forming operations are essentially conventional. Adjoining facilities would be appropriate to accomplish aluminum-boron fabrication and to laminate bonding of caps to structural parts. Development techniques acquired on F-111 aircraft test parts is rapidly becoming state-of-the-art. Tape-laying machines, roll corrugation, and compression forms need advancement to further effect autoclave bonding processes.

Gains are being attained with the hot-forming of titanium alloys. Titanium work, properly tooled, and formed gradually as with cushion presses or staged rolls and subsequently heat-treated, is rapidly becoming a competitive material application. Cost reduction in tooling and equipment is becoming a continuous trend in areas of heated platen dies, heated stretch forms, multistaged forms, etc. to new areas of ceramics, vacuum forming and heated draw die forming material. Suppliers can provide valuable assistance in the cost reduction areas.

Inconel 718, indicated for use in the FR-4 booster, is a usable alloy. Considerable manufacturing knowledge has been attained at Convair from the production of a 20-foot-long Siamese Li_2 tank under Contract AF33(615)-2048. No outstanding problems are foreseen in the forming, welding, machining, or heat-treating of sheet metal parts for the space shuttle elements.

A concentration of effort is needed in the area of the TPS panel fabrication. High-rate production is represented in this area of materials difficult to form and join while retaining a quality finish. Considerable research is in order to accomplish strip roll form (bead) and to perform a laminate fusion or brazed joining of inner/outer skins.

Covering of these articles entails weld-joining integrally stiffened skin panels, adding a protective insulation, and attaching the TPS. Large numbers of TPS panels are needed to support the ultimate production; hence, some manufacturing development is necessary to acquire high production rates of quality titanium and superalloy shingles. A production savings may be available in the substitution of aluminum alloy parts from common tools and installed for limited horizontal flights.

Primary structural frames, rings, or bulkheads would incur some extensive numerical-controlled machining approaches. Mill heads travelling about the part with proper spindle spacing would apply to the more symmetrical rings, while multi-spindled three- to five-axial profilers continue to provide gross metal removing operations.

Final assembly production lines do not contain sufficient dimensional commonality between the booster and orbiter elements to warrant a two-track line or end-to-end conveyance. Parts stock would not be inhibited by the items of similarity, but would tend to congest flow into dual production lines. Figures 2-12 and 2-13 present a typical production sequence for the orbiter and booster elements, respectively. Figure 2-14 is symbolic of the relative fabrication spans of the major element assemblies and total vehicle assembly.

2.2.6 TESTING

2.2.6.1 Test Program Summary. Testing in support of the FR-4 vehicle development actually begins well in advance of the combined Phase C/D program with design-information-type tests; e.g., wind tunnel analysis of specific configurations under varying environment and effects on critical maneuvers. Also, advanced testing would develop special material handling techniques and applicability to the specific space shuttle missions. Individual component design support or evaluation testing and vehicle subsystem or subassembly testing would begin after PDR of the combined C/D Phase, and then only after completion of sufficient design, tooling, and fabrication to support such tests. This later test phase, identified as major ground tests, closely supports the horizontal and vertical flight test phases.

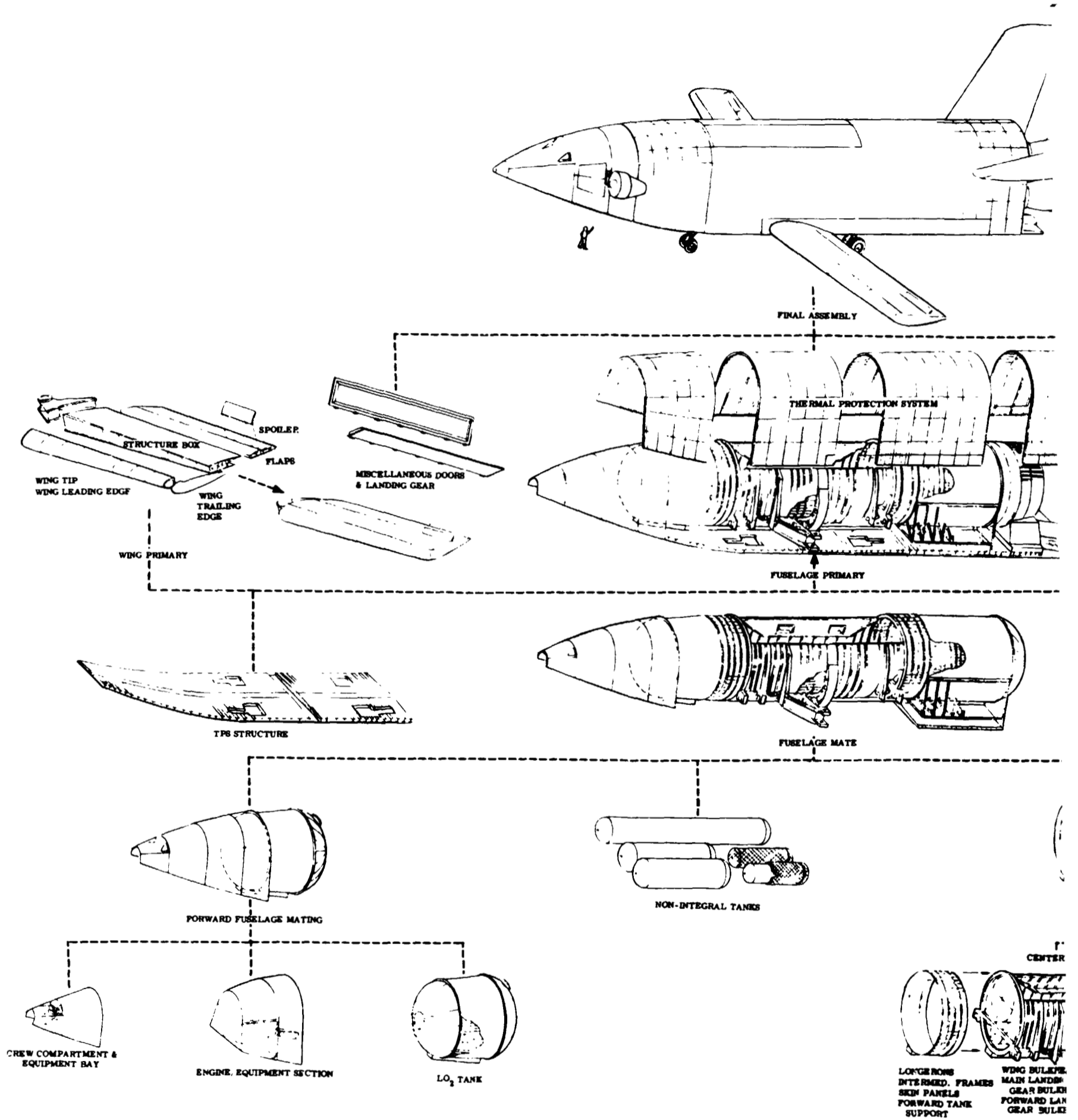
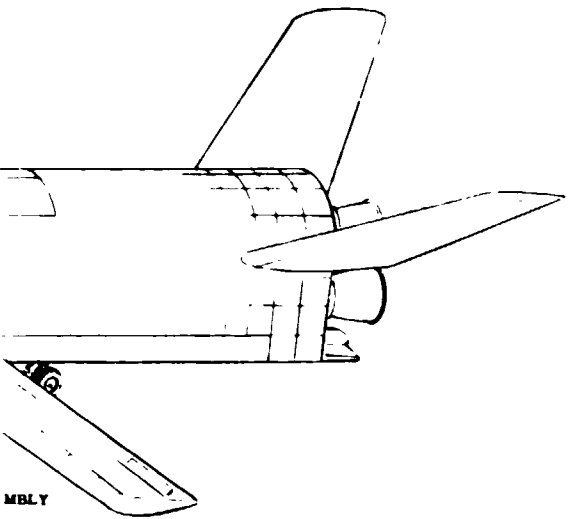
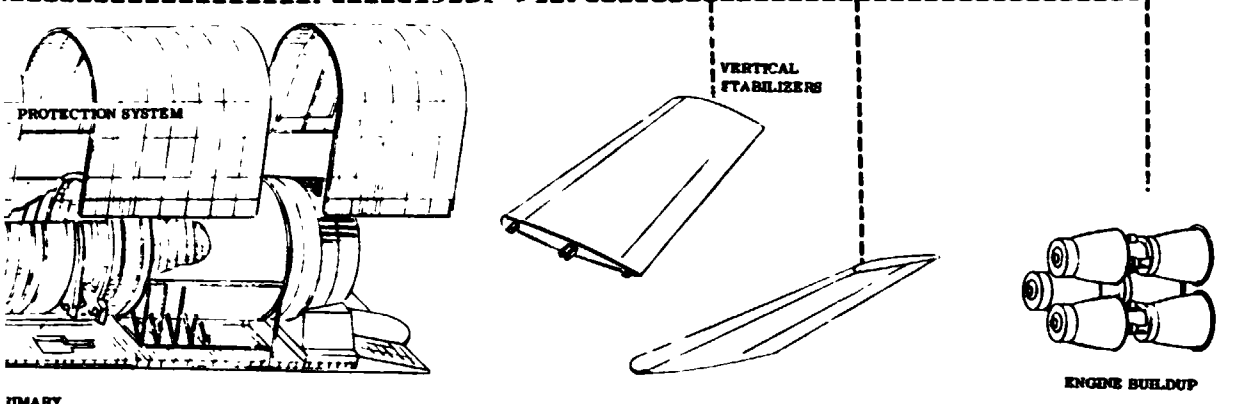

Figure 2-12. TSTS FR-4 Orbiter Element



MBLY



IMARY

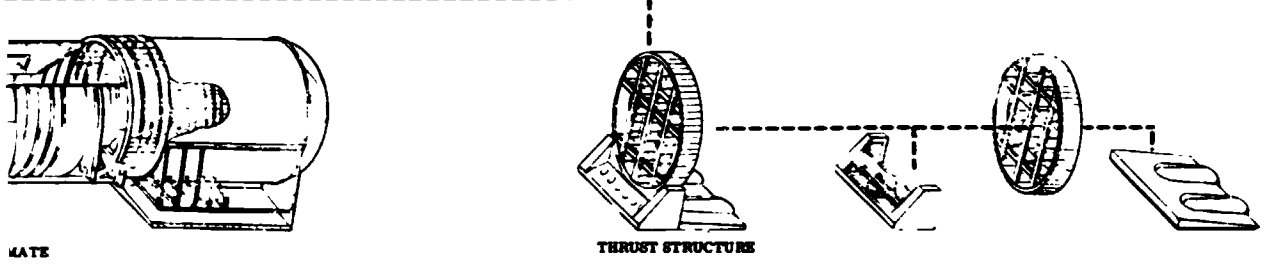

MATE

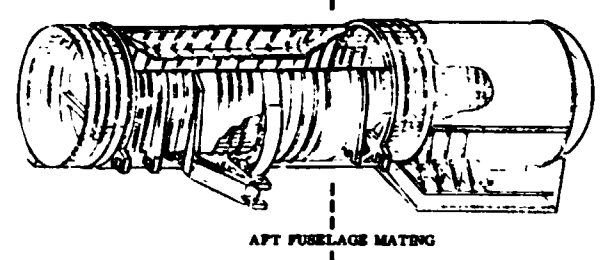

AFT FUSELAGE MATE

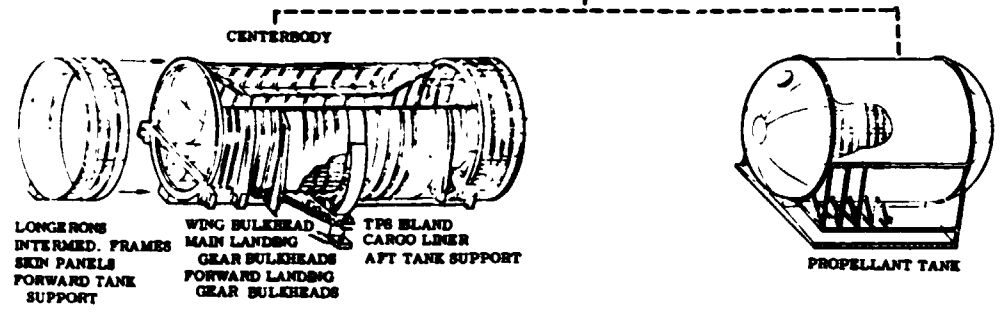

CENTERBODY

PROPELLANT TANK

- LONGERONS
- INTERMED. FRAMES
- SKIN PANELS
- FORWARD TANK SUPPORT
- WING BULKHEAD
- MAIN LANDING GEAR BULKHEADS
- FORWARD LANDING GEAR BULKHEADS
- TPS ISLAND
- CARGO LINER
- AFT TANK SUPPORT

EOLDOUT FRAME - 2

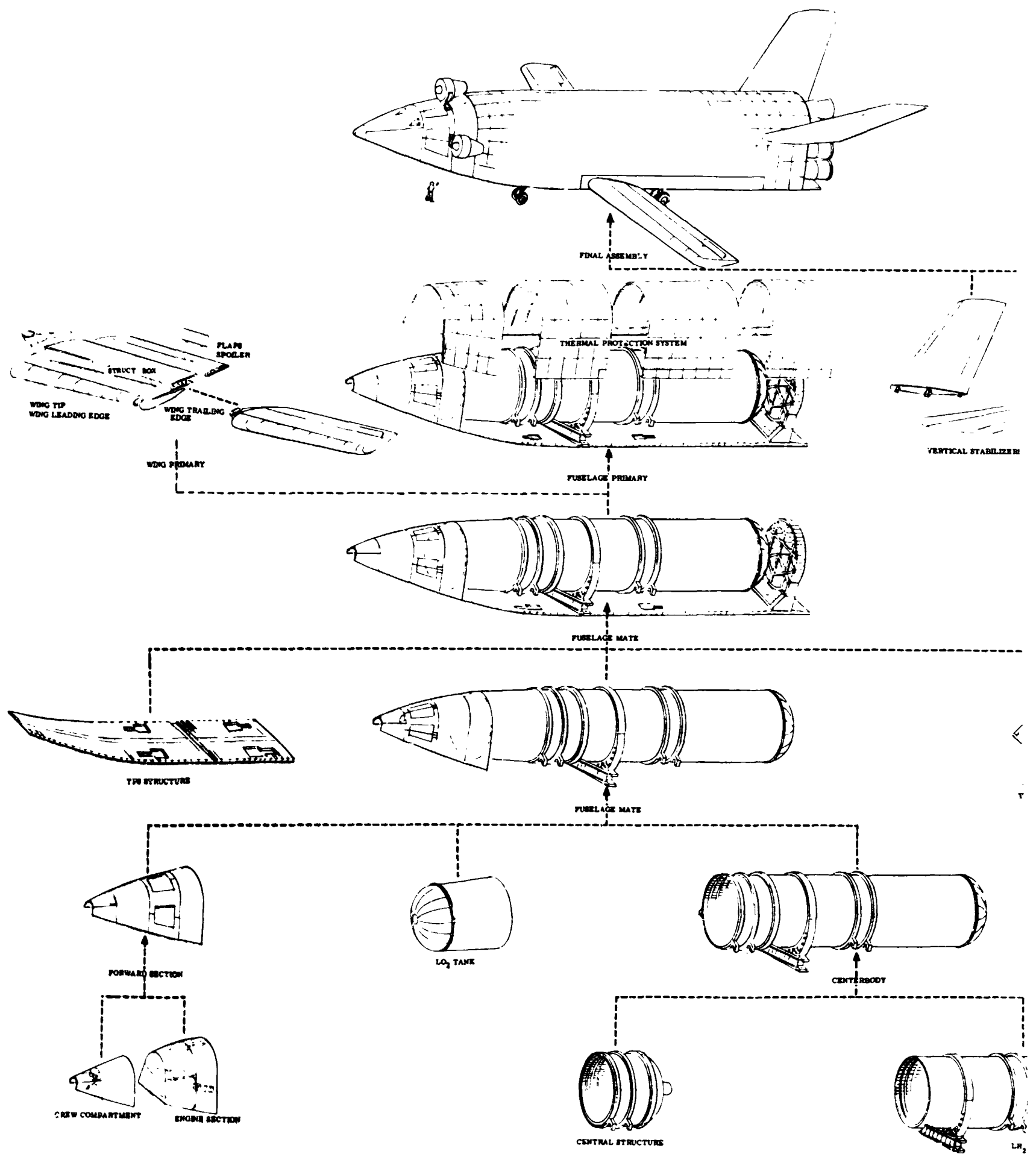

FOLDOUT FRAME -1

Figure 2-13. Booster Production Sequence

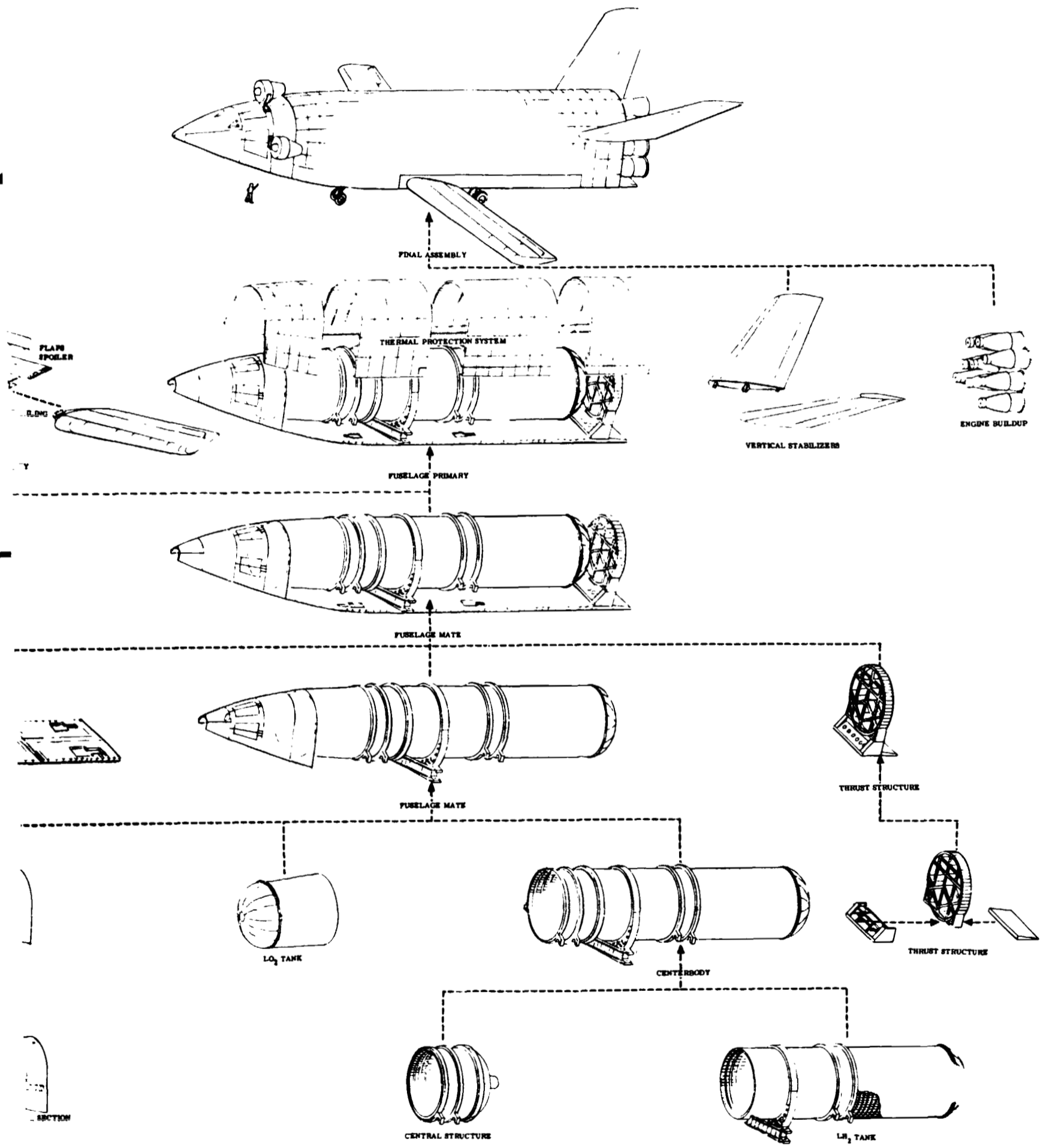

JT FRAME -1

Figure 2-13. Booster Production Sequence

FOLDOUT FRAME -2

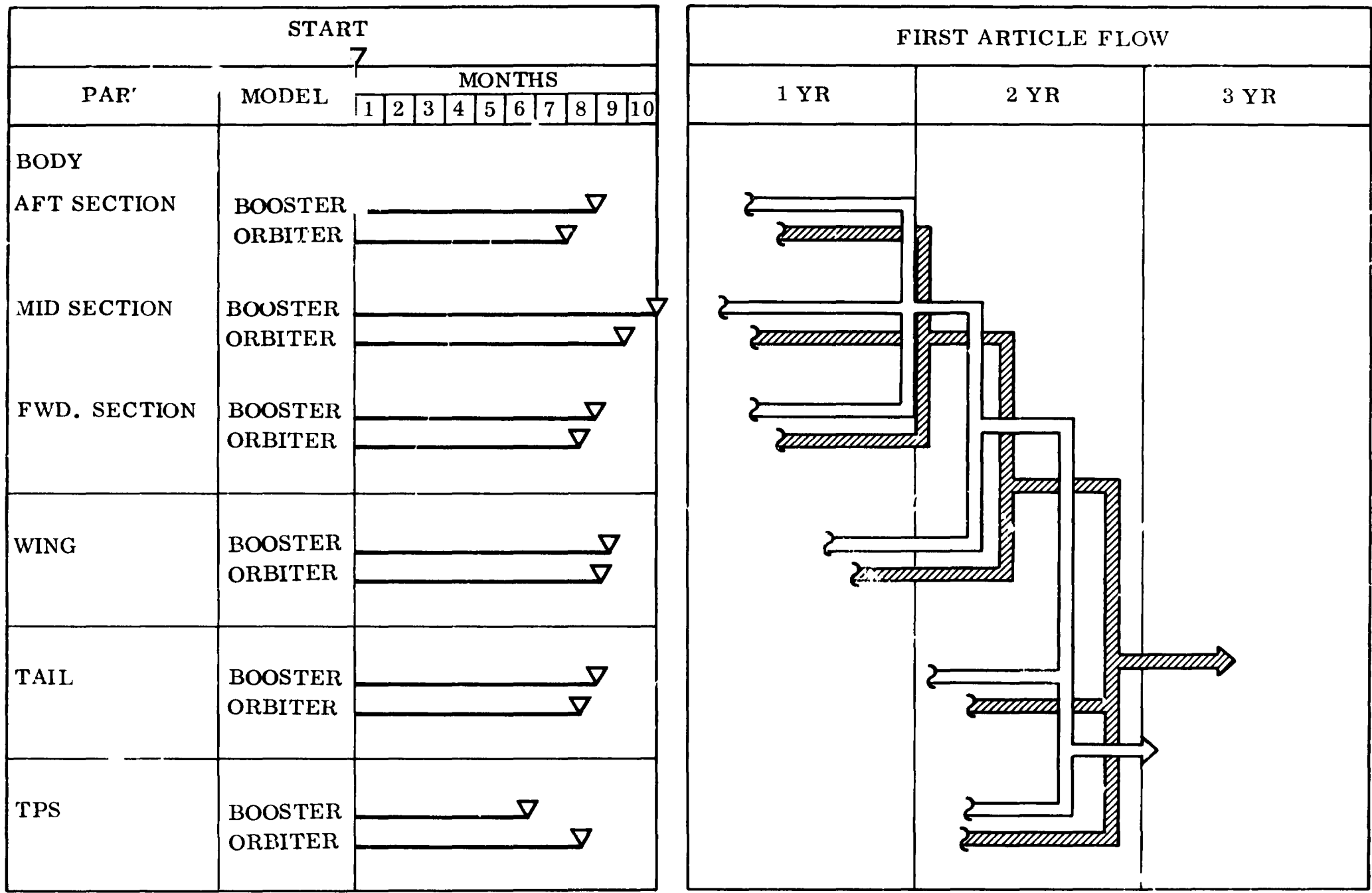

Figure 2-14. Major Element and Total Vehicle Assembly Span

The combined ground and flight test programs span about 41 months, with a 15-month overlap. Ground and flight tests are scheduled to support succeeding tests requiring more severe test conditions. Specific milestones must be met in the ground test program before the horizontal flight tests are begun. Specific milestones must also be attained in the horizontal flights before the vertical launches may begin.

Manufacturing fabrication and assembly of the required test articles must be geared to deliver these test articles to support the test program. Sequencing of test hardware in the subassembly areas has a direct bearing on initial flight article availabilities and must be considered in establishing the desired test article delivery requirements.

Facility and ground support equipment planning, design, construction, test, and/or checkout are scheduled for proper integration with the airborne hardware test program. Specific availability and need dates are indicated in the program development schedule, Figure 2-4. The ground and flight test facility approaches used reflect intended utilization of existing government facilities wherever feasible, especially for large ground test articles and for the complete flight test program. Test phases and facility requirements are discussed further in the following sections.

2.2.6.2 Ground Test Program. The baseline-vehicle ground test program was based on two considerations:

- a. The need to determine all structural and subsystem critical performance parameters, in so far as possible, prior to their flight phase verification or demonstration. This is considered essential in establishing the required confidence level for the initial vertical flight tests, all of which are manned.
- b. The need to maintain the ground test program costs within reasonably budgetary constraints.

The latter goal is approached through conservation of test hardware and ground test facilities. Composite test articles and single test fixtures are designed to satisfy two or more test phases (except when tests would have to be run concurrently).

In the FR-4 vehicle configuration, the booster and orbiter elements are different structurally (even though they are very similar in their aerodynamic configurations) but are similar in most of their subsystems. Thus, dual test articles (one orbiter and one booster configuration) are required to fulfill the requirements of most of the major ground tests identified herein, particularly in the areas of major structural, thrust vector control, cold flow and static-firing tests, flight and attitude control systems. For other limited tests, the test article requirements were tailored to support the more extensive orbiter subsystem design, then modified to test the booster subsystems.

Because the principal ground test articles are large, existing industrial or government facilities are the best approach where modifications to these facilities to accommodate the specific space shuttle configuration are feasible.

The ground test program shown in the baseline vehicle development program schedule (Figure 2-4) reflects three major subdivisions for convenience of handling: 1) wind tunnel test program, 2) materials and component development, evaluation, and qualification test program, and 3) major ground test phase. This latter phase is also a development, evaluation, and partial qualification test program; the only difference is the size and extent of assembly of the required test articles and supporting test hardware and test stands. Major ground tests are identified and discussed in this section.

Table 2-1 lists the ground test phases and major ground tests shown on the master program schedule and states the primary objective of each test. The basic test article configuration and hardware are also obtained and any special test or facility considerations implied by the tests are discussed. Tables 2-2 and 2-3 summarize the ground test hardware configurations for these major ground tests.

The ground test program outlined requires 33 calendar months to complete, beginning in early CY 1973 and terminating around the fourth quarter of CY 1975 (excluding the wind tunnel or component development test phases, which essentially parallel the entire vehicle development phase). The higher risk or potential problem area reflected in this ground test program is the capability of testing sufficiently large sections of thermally protected skin surfaces or TPS panel assemblies at or near the temperatures expected during vehicle entry. Such tests are currently assumed limited to small sections of the body and vertical tail leading edges and to test specimens of the TD NiCr or other TPS materials representing the booster and orbiter elements.

2.2.6.3 Flight Test Program. The FR-4 flight test program begins 43 months after the combined Phase C/D go-ahead and spans about 23 months to the first operational flight. The program is divided into two basic test phases: horizontal and vertical flight tests. Flights in both phases are manned and flight test vehicles are recoverable and reusable, as in the operational program. This over-all test approach is more aligned with an aircraft approach to testing than with the launch vehicle approach, as discussed under the alternative development approaches in Section 2.3.

Seven flight test elements, (four-booster and three-orbiter) are used to fulfill the flight test program requirements. Four are required to fully satisfy the horizontal flight test phase and all seven are used in the vertical launch phase. The first two elements delivered (a booster and an orbiter) would satisfy the basic flying requirements within a restricted, low-subsonic flight envelope. Both elements would be modified or updated as required and would join the third and fourth elements in extending the flight tests into a high-subsonic flight regime. These test phases are described later in this discussion.

The fifth vehicle element, a modified booster, is introduced at the start of the vertical flight test phase for single-element launches. Two more elements (one each) are required to support the multi-element launches. When the four elements used in the horizontal tests complete their program, they will be modified as required and retrofitted for a vertical launch capability in the multi-element launch phase. Initial delivery of these four elements does not include vertical launch capability. This is to provide a reasonable horizontal flight test lead time over the vertical launches.

Table 2-4 shows the initial configuration for each of the seven elements. The vertical flight test phase will verify and demonstrate the launch vehicle and spacecraft capabilities of the FR-4 and its design mission compatibility. This test phase is also described in detail later in this discussion. Figure 2-15 is a composite flight program schedule showing the time phasing of both the horizontal and vertical flight test phases. The principal flight test objectives and their applicability to each type test within the horizontal and vertical flight phases are summarized in Table 2-5.

The seven flight-test articles used in the R&D program would eventually be refurbished and used to support the operational program. It may be advantageous, however, to hold back one complete three-element vehicle for extended test evaluations and analyses of potential flight problems. The elements held back for this continuing flight backup test phase, should be those produced early in the program and those that are heavily instrumented for limit-load testing; these types of vehicles are the least suited for immediate operational status.

The all-manned flight test approach in this program may help reduce total R&D costs by conserving high-cost test vehicles, but some element of risk is involved. One potential problem area is the transition phasing from horizontal test flights to vertical launch tests. The entry attitude control subsystem, the orbiter TPS, and the post-entry wing and engine deployment subsystem must be demonstrated to be adequate prior to their first full-requirement flight (which is manned under this baseline approach). These areas need further investigation before an optimum test solution can be devised. Possible solutions reflected in the alternative development approaches of Section 2.3 include: unmanned expendable launch vehicles with scaled-down simulations of space shuttle and critical subsystems and a launch vehicle approach to development, at least for the vertical flight tests prior to manned launch tests.

The baseline development program requires ample supporting data from extensive, repetitive ground testing of critical subsystems; e. g., wing and engine deployment cycles under various simulated flight conditions, attitude control subsystem functional reliability, TPS evaluation through wind tunnel and materials testing. The baseline program is also strongly dependent on a thorough technology program in several areas. These tests must be completed early in the development program so design decisions can be made in time to support the high altitude vertical launches.

Table 2-1. Ground Test Program (FR-4 Baseline Vehicle Configuration)

<p>A. WIND TUNNEL TESTS</p> <ol style="list-style-type: none"> 1. Objectives — Investigate and provide data support to final design decisions re: <ol style="list-style-type: none"> a. Subsonic through supersonic stability and control. b. Afterbody effect and lift-to-drag ratios. c. Aerodynamic force and moments. d. Flow field and heat transfer data. e. Surface roughness and discontinuity effect. f. Flutter and aeroelastic stability. g. Staging dynamics. h. Jet engine exhaust flow effects. 2. Test Article Configuration — Approximately 18 scale models, powered and unpowered, full and semi-span; some with cold gas plume simulation. 3. Special Test Considerations — This test program is a continuation of the wind tunnel tests begun during Study Phase B and will be accomplished through a series of test phases using models sized to the specific facility identified for the test. 4. Special Test Facility Considerations <ol style="list-style-type: none"> a. High and low speed wind tunnels. b. Plasmic-arc thermal tunnel. c. Hypersonic shock tunnels. 	<ol style="list-style-type: none"> 3. Special Testing Considerations — Material properties in high temperature ranges would be determined. Cyclic environmental exposure tests would be performed under varying stresses and pressure. Tests would also include various contour and joint designs for advanced materials.
<p>B. THERMO-MATERIAL DEVELOPMENT AND QUALIFICATION</p> <ol style="list-style-type: none"> 1. Objectives — Develop, evaluate, or validate design concepts for: <ol style="list-style-type: none"> a. Composite materials applicability to the ILRV vehicle. b. Newly developed superalloys, refractory metal alloys, and oxidation protection coatings in high-temperature environments. c. Joining TD NiCr parts and other materials for applicable TPS use. 2. Test Article Configuration — Many coupon-type test specimens of various types of thermal and thermo-structural materials, including one fourth of a complete set of dissimilar TPS panels for both the orbiter and booster elements. 	<p>C. COMPONENT DEVELOPMENT AND QUALIFICATION</p> <ol style="list-style-type: none"> 1. Objective — Provide design evaluation of engineering prototypes to validate design approaches and specification attainability, and later to qualify the resulting pre-production and production hardware to design specifications. 2. Test Article Configuration — The test specimens will consist of various quantities of each new design or critical component of both the booster and orbiter elements, where different. These quantities would be determined after a more detailed analysis of the specific tests to be performed, but will probably equate to two or three equivalent ship-sets of components (exclusive of major structure).
	<p>D. VEHICLE STRUCTURAL STATIC LOADS TESTS</p> <ol style="list-style-type: none"> 1. Objective — Verify and qualify the basic vehicle structure (booster and orbiter elements) for critical ground and flight conditions (to ultimate loads). 2. Test Article Configuration — The following structural subassemblies are used rather than a completely assembled vehicle element. <ol style="list-style-type: none"> a. Booster Element: <ol style="list-style-type: none"> (1) Jet engine equipment bay. (2) Main rocket engine thrust structure, including vertical stabilizers (Empennage section). (3) One wing and wing pivot support structure. (4) Complete set of unlike major doors and hatches (i.e., wing, engine, access, etc.).

Table 2-1. Ground Test Program (FR-4 Baseline Vehicle Configuration), Contd

<ul style="list-style-type: none"> (5) Selected sections of TPS panels and support structure. (6) Stage separation gear. <p>b. Orbiter Element:</p> <ul style="list-style-type: none"> (1) A structural centerbody section. (2) Jet engine equipment bay. (3) Rocket engine thrust structure, including vertical stabilizers (Empennage section). (4) One wing and wing pivot support structure. (5) Complete set of all unlike doors (i.e., wing, payload, engine, access, etc.). (6) Selected sections of TPS panels and support structure. (7) Stage separation provisions. 	<p>b. Orbiter Element:</p> <ul style="list-style-type: none"> (1) Crew compartment and integrated electronics compartment. (2) Empennage section (including thrust structure, vertical stabilizers, and section of afterbody with TPS panels). (3) Two sets of main propellant tanks; full LO₂ tanks and stub LH₂ tanks. (4) Two sets of unlike payload bay propellant tanks (two each of the three different size tanks in a stub configuration). (5) One wing and wing pivot support structure. (6) One main landing gear and one nose gear set with supporting structure.
<p>c. Special Test Considerations — Static testing of each major structural assembly will simulate loading conditions of:</p> <ul style="list-style-type: none"> a. Rolling pull-out and negative maneuvers. b. Positive symmetric low and high angle of attack conditions. c. Maximum bending and torsion effects (wings/tail/fuselage). d. Controls proof tests. e. Positive symmetric and unsymmetric and gust loading conditions. 	<p>3. Special Test Considerations — Structural fatigue tests on these assemblies would include:</p> <ul style="list-style-type: none"> a. Structural integrity of tanks at cryogenic temperatures, including fatigue cycling. b. Qualification of cryogenic tank insulations. c. Repeated loads simulating two service lives and then to failure. d. Crew and avionics compartment leak and cyclic fatigue. e. Simulated acoustic environment as induced by main rocket engines on the crew and avionics area. f. Landing gear qualification and service drop tests and cyclic operation.
<p>E. VEHICLE STRUCTURAL FATIGUE TESTING</p> <ul style="list-style-type: none"> 1. Objective — Structurally qualify the vehicle elements for repeated loads and design service life and establish the acquired margins of safety. 2. Test Article Configuration — Basic structural assemblies required for this test program are: 	
<ul style="list-style-type: none"> a. Booster Element: <ul style="list-style-type: none"> (1) Crew compartment and integrated electronics compartment. (2) Empennage section (including thrust structure, vertical stabilizers, and section of afterbody with TPS panels). (3) Two LO₂/LH₂ integral structural tanks, (LH₂ section a stub tank configuration). (4) One wing and pivot support structure. 	<p>F. JET FUEL SYSTEM TESTS</p> <ul style="list-style-type: none"> 1. Objectives <ul style="list-style-type: none"> a. Demonstrate full-scale fuel system operation and design performance. b. Verify analytical predictions of engine fuel supply, vent, and pressurization characteristics of the system. c. Verify fuel system flow characteristics at various simulated altitudes and conditions of fuel icing, hot fuel, and expected fuel flow demands.

Table 2-1. Ground Test Program (FR-4 Baseline Vehicle Configuration). Contd

<p>2. Test Article Configuration</p> <p>a. Test of the jet fuel systems for booster and orbiter configurations, using production components and plumbing in a similar geometric layout.</p> <p>b. See-through model(s) of the above for early design verification.</p> <p>3. Special Test Considerations</p> <p>a. Scale model tests will precede the full-scale test phase.</p> <p>b. Laboratory heat exchangers will be used for hot fuel tests and icing tests.</p> <p>c. Prime movers used for fuel pump drives.</p> <p>d. Tank calibrations will be run on the No. 1 and 2 flight elements.</p>	<p>3. Special Test Considerations — Tests would obtain data on response times, gaps, breakout forces, hysteresis, control force gradients, and positioning accuracy.</p> <p>The hydraulic actuation system would be tested for back pressures, flow rates, temperature, and surges under no loads and simulated flight loads.</p> <p>Tests would also obtain data on the AFCS electrical parameters, stability, positioning accuracy, dynamic response and limits, etc.</p>
<p>G. JET ENGINE SYSTEM INTEGRATION</p> <p>1. Objective — Verify compatibility of the jet engines with the jet fuel management systems.</p> <p>2. Test Article Configuration — Production plumbing and control elements of the jet fuel management system (Booster and Orbiter).</p> <p>3. Special Test Considerations — Fuel system components would be integrated with the jet engines at the engine contractors' test site.</p>	<p>1. HYDRAULIC SYSTEM TESTS</p> <p>1. Objective — Verify and qualify the structural and functional adequacy of the various hydraulic subsystems and components.</p> <p>2. Test Article Configuration — All booster/orbiter hydraulic subsystem hardware not already included with the flight control system hardware, except for the main rocket thrust vector control system. The flight controls system "iron horse" test stands would be used.</p> <p>3. Special Test Considerations -- This test would be an extension of the flight controls system tests to determine fill and bleed procedures, flow rates, pressure drops, temperatures, etc. for the hydraulic subsystem hardware associated with engines, doors, and landing gear.</p>
<p>H. FLIGHT CONTROLS SYSTEM TESTS</p> <p>1. Objective — Verify the design and structural adequacy of flight controls and actuation system and verify the design and compatibility of the automatic flight control system (AFCS) with the flight control and hydraulic system.</p> <p>2. Test Article Configuration — Two "iron horse" test stands (one for the booster and one for the orbiter) consisting of structure simulating the wings and fuselage with a flight configuration empennage and aft fuselage section. All control surfaces would be simulated, but using production actuators and linkage. The cockpits would include all related controls required to fly a simulated mission. The automatic flight control systems and hybrid computers would be used with these setups.</p>	<p>J. ELECTRICAL SYSTEM TESTS</p> <p>1. Objectives</p> <p>a. Verify and demonstrate adequacy of the electrical systems for normal mission and emergency operations.</p> <p>b. Determine proper system operation and establish system integrity under conditions of operational loads.</p> <p>2. Test Article Configuration</p> <p>a. A complete orbiter production electrical system including racks, panels, wiring harnesses, and power generator systems complete with hydraulic drives.</p> <p>b. Any booster electrical equipment that differs from the orbiter configuration.</p>

Table 2-1. Ground Test Program (FR-4 Baseline Vehicle Configuration), Contd

<p>c. Laboratory equipment (i.e., prime movers, gear boxes, load banks, batteries, and recording equipment) would be required.</p> <p>3. Special Test Considerations — Testing would demonstrate ability of the electrical system to satisfy specification requirements. The a-c and d-c loads would be simulated and voltage and frequency regulation, harmonic distortion, synchronization, IR drops, feeder current, generators and converter temperatures, etc., would be monitored.</p> <p>The system would be evaluated under normal, emergency, excess capacity, and failure conditions.</p>	<p>c. Aft thrust structure and engine mounts (uses one of the structural test articles).</p> <p>d. TVC-associated hydraulic subsystem hardware.</p>
<p>K. R&D FLIGHT CREW ESCAPE TESTS</p> <p>1. Objective — Verify and demonstrate functional adequacy of a crew eject system for the R&D horizontal flight phase only.</p> <p>2. Test Article Configuration — A static crew compartment mockup (for either the booster or orbiter) with test crew specially designed ejection seats. Crew-area clearances will be simulated and special design eject or breakaway hatches will be installed in the mockup structure.</p> <p>3. Special Test Considerations — Testing would be limited to static eject tests, with emphasis on escape hatch operation and crew/seat stability and clearances during the escape maneuver.</p>	<p>M. ATTITUDE CONTROL SUBSYSTEM (ACS) TESTS</p> <p>1. Objectives</p> <p>a. Verify attitude control system propellant management and utilization system performance.</p> <p>b. Determine reaction engine thrust rise and decay rates.</p> <p>c. Verify ACS operational sequencing and dynamic and time-response characteristics.</p> <p>d. Demonstrate integration and compatibility of all ACS hardware and total system control effectiveness and reliability.</p> <p>2. Test Article Configuration</p> <p>a. Orbiter:</p> <p>(1) Static test fixture simulation of the orbiter airframe for proper positioning of reaction engines and propellant system hardware elements.</p> <p>(2) Complete set of orbiter reaction control engines and structural support hardware.</p> <p>(3) ACS propellant storage and management system hardware.</p> <p>(4) System control elements and associated electronic hardware.</p> <p>b. Booster:</p> <p>(1) Static test fixture simulating the nose structure and yaw-control rocket engine positions.</p> <p>(2) The four yaw-control engines, control elements, propellant storage, and management system hardware.</p>
<p>L. THRUST VECTOR CONTROL (TVC) SUBSYSTEM TESTS</p> <p>1. Objectives</p> <p>a. Verify TVC system structural response and adequacy.</p> <p>b. Verify response characteristics of the TVC hydraulic support subsystem.</p> <p>c. Determine load distribution through aft thrust structure during simulated engine gimbaling.</p> <p>2. Test Article Configuration (one each for Booster and Orbiter)</p> <p>a. One set of dummy rocket engines.</p> <p>b. Thrust vector controls and actuators.</p>	<p>N. DOCKING SIMULATION TESTS</p> <p>1. Objectives</p> <p>a. Evaluate docking maneuvers, sequence, and procedures.</p>

Table 2-1. Ground Test Program (FR-4 Baseline Vehicle Configuration), Contd

<ul style="list-style-type: none"> b. Determine adequacy of docking system hardware elements. c. Provide test and operational crew training support. <p>2. Test Article Configuration</p> <ul style="list-style-type: none"> a. Docking simulator at MSC, Houston, modified for the space shuttle configuration. b. Prototype and production components representing any docking interface systems hardware. <p>3. Special Test Facility Requirements — Apollo docking simulator at Manned Space Center (MSC) Houston.</p>	<ul style="list-style-type: none"> 2. Test Article Configuration — One set of specialized ground support equipment including cargo ground handling, booster/orbiter erector gear, transport dollies, tow-bars, maintenance lift jacks, etc. 3. Special Test Considerations — Majority of this equipment to be refurbished, if necessary, after tests for use in the ground and flight test programs.
<p>O. CARGO HANDLING TESTS</p> <p>1. Objectives</p> <ul style="list-style-type: none"> a. Verify structural and functional adequacy of the orbiter cargo-handling equipment under a full gravity environment. b. Demonstrate cargo ground loading and in-orbit deployment operations procedures, and envelope clearance. c. Verify compatibility of the orbiter equipment, payload/cargo pallets, and associated ground support equipment. <p>2. Test Article Configuration</p> <ul style="list-style-type: none"> a. Soft mockup of the orbiter cargo compartment, simulating the fuselage structure and cargo bay doors. b. Payload/cargo pallet mockups. c. Fuselage-cargo securing, alignment, and deployment mechanisms hardware. d. Supporting external ground handling equipment will be required. <p>3. Special Test Facility Requirements — Counterbalancing system for simulating test conditions during cargo deployment tests.</p>	<p>Q. PROPELLANT MANAGEMENT AND FLOW TESTS</p> <p>1. Objectives</p> <ul style="list-style-type: none"> a. Verify main propellant system flight worthiness and subsystem compatibility and interfaces. b. Demonstrate the propellant management system integration, including chilldown, tanking, detanking, flow, pressurization, venting, purging, etc. c. Demonstrate design adequacy of internal and external cryogenic tank insulation. d. Develop and validate test and operational procedures for static firing tests and prelaunch operations. <p>2. Test Article Configurations — These tests use the Booster and Orbiter static-firing test articles and test facility.</p>
<p>P. GROUND HANDLING EQUIPMENT TESTS</p> <p>1. Objective — Verify structural integrity, functional performance, and compatibility of specialized ground support and vehicle handling equipment.</p>	<p>R. VEHICLE STATIC FIRING TESTS</p> <p>1. Objectives</p> <ul style="list-style-type: none"> a. Demonstrate satisfactory integration of the main propulsion system with the airframe interfaces and other associated systems. b. Demonstrate propulsion system flight readiness capability. c. Verify system test and prelaunch checkout procedures. d. Monitor acoustic levels and environmental temperatures in and around critical vehicle areas for design evaluation. e. Demonstrate and verify adequacy of launch support equipment.

Table 2-1. Ground Test Program (FR-4 Baseline Vehicle Configuration), Contd

<p>2. Test Article Configurations</p> <p>a. Booster:</p> <ol style="list-style-type: none"> (1) An assembled booster element structure including: <ol style="list-style-type: none"> (a) Main integral propellant tank structure. (b) Internal and external cryogenic tank insulation as applicable. (c) Main propulsion system engines and vehicle thrust structure. (2) The TVC system and necessary hydraulic support hardware. (3) Propellant management and control system. (4) Simulated vertical stabilizer for engine-exhaust radiation tests. (5) Simulated wings, jet engines, and associated doors. (6) Selected areas of TPS material and support structure. <p>b. Orbiter:</p> <ol style="list-style-type: none"> (1) An assembled orbiter element structure including: <ol style="list-style-type: none"> (a) Forward and aft integral tank structures. (b) Centerbody structure with included payload bay propellant tanks. (c) Cryogenic tank insulation as applicable. (d) Main propulsion system engines and vehicle thrust structure. (2) The TVC system and necessary hydraulic support hardware. (3) Propellant management and control system. (4) Simulated vertical stabilizers for engine exhaust radiation tests. (5) Simulated wings, jet engines, and associated doors. (6) Some selected areas of the TPS panels and support structure. 	<p>Static firing tests will be preceded by main propellant system cold-flow tests and progress from initial short-duration shakedown firings through longer and finally full-duration static firings on test articles.</p> <p>4. Special Facility Considerations — Static firing test stand(s) and support facilities similar to that used for the Saturn launch vehicles would be required. Use of existing facilities is a primary consideration for this test series.</p> <p>S. BOOSTER/ORBITER ELEMENT DYNAMIC AND GROUND VIBRATION TESTS</p> <ol style="list-style-type: none"> 1. Objective — Determine the longitudinal and torsional dynamics and the lateral bending mode frequencies, shapes, and damping ratios of the booster and orbiter elements. 2. Test Article Configuration — Horizontal flight test vehicle configuration with appropriate mass/cg simulations for missing vertical launch hardware. The initial horizontal flight elements of both the booster and the orbiter would be used prior to delivery to the flight test site. 3. Special Test Considerations — Both element configurations would be tested under conditions simulating individual element flight under various conditions (i.e., landing gear up and down, flaps versus no flaps, deflected versus non-deflected surfaces, maximum gross weight, landing gross weight, etc.). <p>T. HUMAN FACTORS TESTS</p> <ol style="list-style-type: none"> 1. Objective — Develop and demonstrate man/vehicle physical and functional interfaces (i.e., crew compartment furnishings and locations, controls and displays, avionics and other serviceable equipment, hardware accessibility, visibility, ingress and egress under normal and emergency conditions). 2. Test Article Configurations (Booster and Orbiter) <ol style="list-style-type: none"> a. Soft mockup of the avionics and crew compartment areas. b. Simulated or prototype crew furnishings, displays, and controls.
<p>3. Special Test Considerations — The static test articles will test both the booster and orbiter tanking configurations. Throttleable engine tests will simulate the orbiter flight configuration and firing sequence.</p>	

Table 2-1. Ground Test Program (FR-4 Baseline Vehicle Configuration), Contd

<ul style="list-style-type: none"> c. Simulated avionics and other serviceable equipment. d. Simulated access and egress hatches. <p>3. Special Test Considerations — Human factors testing will also be associated with other test articles for evaluation of critical handling, loading, maintenance operations.</p>	<p>avionics, and cargo compartments, as applicable, under simulated conditions of equipment operation and heat loads.</p> <ul style="list-style-type: none"> c. Demonstration of adequate performance of the windshield rain repellent and washing system under simulated rain and airflow across the windshield area will be conducted on this test article.
<p>U. AVIONICS INTEGRATION TESTS</p>	
<ul style="list-style-type: none"> 1. Objectives <ul style="list-style-type: none"> a. Verify the individual and integrated performance adequacy of the navigation and guidance, communications, automatic landing system, data processing, flight control, rendezvous, and other related avionics equipment and subsystems under simulated mission environments. b. Demonstration of avionic subsystems compatibility under various combinations of operation, simulating expected or emergency operating conditions. 2. Test Article Configuration <ul style="list-style-type: none"> a. Complete set of the orbiter avionics equipment and supporting subsystems. b. Additional booster avionics that are uncommon to the orbiter. 	<ul style="list-style-type: none"> 2. Test Article Configurations (Booster and Orbiter) <ul style="list-style-type: none"> a. Mockup of crew area, avionics, and cargo compartments. b. Flight-type ducting. c. Simulated avionics and crew heat loads. 3. Special Test Considerations <ul style="list-style-type: none"> a. The initial test phase consists of breadboard-type tests for design verification and/or support. b. Subsequent tests use the above mockup for production equipment evaluation in the operational vehicle configuration. c. Final tests use the environmental test vehicle for verification of production hardware under simulated solar vacuum conditions.
<ul style="list-style-type: none"> 3. Special Test Considerations — Initial testing to support design and engineering decisions may use prototype equipment and breadboard-type layout (bench tests). <p>Later testing will use production hardware in a bench-test-type layout simulating the operational configuration electrically.</p> <p>The final test phase will make use of the environmental test vehicle when undergoing testing in a solar vacuum chamber (orbiter element only).</p>	<p>W. LIFE SUPPORT SYSTEM (LSS) TESTS</p> <ul style="list-style-type: none"> 1. Objectives <ul style="list-style-type: none"> a. Verification and demonstration of the crew cabin pressurization, atmospheric conditioning, and oxygen supply system under various operational and mission conditions. b. Demonstrate adequacy of the food, water, and waste management subsystems. c. Demonstrate satisfactory operation or functional capability of life support subsystems and hardware including combined operation compatibility.
<p>V. ENVIRONMENTAL CONTROL SYSTEM TESTS</p>	
<ul style="list-style-type: none"> 1. Objectives <ul style="list-style-type: none"> a. Verification of the environmental control system design for both the booster and orbiter. b. Demonstrate proper cabin air distribution between crew compartment, 	<ul style="list-style-type: none"> 2. Test Article Configuration <ul style="list-style-type: none"> a. Booster: <ul style="list-style-type: none"> (1) The crew/avionic compartment mockup as established for the booster-element ECS tests will be used for this test on a time-sharing basis.

Table 2-1. Ground Test Program (FR-4 Baseline Vehicle Configuration), Contd

<p>(2) The mockup will be complete with life support and cabin environmental subsystems.</p> <p>b. Orbiter:</p> <p>(1) The orbiter test phase will use the environmental vehicle test article before and during its simulated mission testing in a vacuum chamber.</p> <p>(2) The above test article will include lift support and cabin environmental subsystems.</p> <p>3. Special Test Considerations</p> <p>a. Initial testing includes breadboard-type tests for design support and verification.</p> <p>b. The second phase covers evaluation of the life support subsystem (LSS) and crew/avionics compartment under an earth-atmospheric environment (including qualification tests).</p> <p>c. The third phase concludes the ground demonstration of the LSS and ECS in the simulated vacuum environment.</p>	<p>with all included subsystems in a simulated vacuum environment.</p> <p>b. Demonstrate satisfactory cabin leak rates and thermal balance capability.</p> <p>c. Demonstrate continued subsystems performance under simulated space missions.</p> <p>2. Test Article Configuration</p> <p>a. A production crew and avionics compartment and forward nose section with thermal insulation systems included is required.</p> <p>b. Production subsystems and hardware to be included in the test article are the LSS, ECS, crew simulators and furnishings, displays and controls, lighting and electrical equipment, set of mission avionics for the orbiter, access hatches and seals, and mechanical support systems.</p> <p>3. Special Test Facility Considerations</p> <p>a. A 35-foot-diameter thermal vacuum chamber with cold-wall capability is required for this test phase. There are existing vacuum chambers of this size, capable of simulating the near-earth thermal space environment (see Figure 2-20).</p>
<p>X. VEHICLE ENVIRONMENTAL TESTS (ECS) (ORBITER ONLY)</p> <p>1. Objectives</p> <p>a. Demonstrate the compatibility of a production crew/avionics compartment</p>	

Table 2-2. FR-4 Booster Major Test Hardware Summary

Test Identificatic	Crew/Avionics Compartment	Jet Engine Compartment	LH ₂ /LO ₂ integ. Tank	Wings and Support Pivots	Empennage	Rocket Engine Thrust Structure	Vertical Stabilizers	Major Doors and Hatches	Stage Separation Hardware	Thermal Protection Subsystem	Landing Gear	Jet Engines	Main Rocket Engines	Propellant Plumbing	Jet Tankage and Distribution Subsystem	Hydraulic and Pneumatic Subsystems	Flight Control System	Yaw-Control-Rocket Engine Subsystem	Electrical Subsystem Hardware	Horizontal-Flight Avionic Subsystem	Suborbital/Entry Avionics Subsystem	Crew Furnishing Controls and Displays	Environmental Control and Displays	Life Support Subsystem
Structural Static Loads Test		●		●	●	●	●	●	●	●														
Structural Fatigue Tests	●			1						2			S											
Jet Fuel Subsystem Tests			3	1																				
Hydraulic and Flight Controls Subsystem Tests	S			S	S		S				S	S												
Thrust Vector Control Tests						4							S							2				
Attitude Control Subsystem Tests																								
Electrical Subsystem Tests																								
Cold Flow and Static-Fairing Tests			●	S	●	●	S			2	S		●	●										
Human Factors Testing	S																							
Avionics Integration Tests																								
Environmental Control Subsystem Tests	S																		S	S	S	S	●	●
Lift Support Subsystem Tests	S																		S	S	S	●	●	2

- Test/Hardware Applicability
- S Simulated Hardware Configuration
- 1 Only one Wing and Pivot Required
- 2 Partial Subsystems or Hardware

- 3 Two Tanks with Stub LH₂ Section
- 4 Uses Static or Fatigue Test Article
- 5 Uses ECS Crew Area Mockup

Table 2-3. FR-4 Orbiter Major Ground Test Hardware Summary

Test Identification	Crew/Avionics Compartment	Jet Engine Compartment	Integral LO ₂ Tank	Integral LH ₂ Tank	Centerbody Structural Section	Payload Bay Propellant Tanks	Wings, Pivots, & Support Structure	Empennage	Rocket Engine Thrust Structure	Vertical Stabilizers	Major Doors & Hatches	Stage Separation Hardware	Thermal Protection Subsystem	Landing Gear	Jet Engines	Main Rocket Engines	Propellant Plumbing	Jet Fuel Tanks & Distrib. Subsystem	Hydraulic & Pneumatic Subsystem	Flight Control Subsystem	Attitude Control Propulsion Subsystem	Electrical System Hardware	Orbiter Docking Equipment	Cargo Deployment Equipment	Horizontal Flight Avionics Subsystem	Orbital Mission Avionics Subsystem	Crew Furnishings, Controls & Displays	Environmental Control Subsystem	Life Support Subsystem
Structural Static Loads Tests		●			●		●	●	●	●	●	●																	
Structural Fatigue Tests	●		●	●		●	●	●	●	●		●		●		5													
Jet Fuel Subsystem Tests			●	●			●	●	●	●								●											
Hydraulic and Flight Control Subsystem Tests	5						5	5		5				5	5				●	●					●				
Thrust Vector Control Subsystem Tests									4							5			●	●									
Attitude Control Subsystem Tests																					●								
Docking Simulation Tests																						●							
Cargo Handling Tests																			●				●						
Electrical Subsystem Tests																			●										
Cold-Flow and Static-Firing Tests			●	●	●	●	5	●	●	5	●		●	5	●	●		●	●										
Human Factors Testing	5																									●		5	
Avionics Integration Tests																													
Environmental Control Subsystem Tests	●	5																							●	5	●	●	●
Life Support Subsystem Tests	●	5																								●	●	●	●
Crew/Avionics Cabin Mission Environmental Tests	●																					●			●	●	●	●	●

- Test/Hardware Applicability
- 5 Simulated Hardware Configuration
- 1 Only One Wing and Pivot Structure Required
- 2 Partial Subsystems or Hardware
- 3 Two Sets of Propellant Tanks
- 4 Uses Static or Fatigue Test Article
- 5 Uses Mission Environmental Test Vehicle

Table 2-4. Flight Test Article, Initial Configuration

Flight Tests & Test Articles	Booster/Orbiter Element Configuration											
	Basic Airframe	Thermal Protection Subsystem	Jet Engines	Rocket Engines	Propellant Plumbing	External Tank Insulation	Attitude Control Propulsion Subsystem	Horizontal Flight Avionics	Mission Avionics	Docking and Cargo Support Hardware	Stage Separation Hardware	Life Support and Environmental Control
HORIZONTAL FLIGHT PHASE												
Low-Subsonic Flight Tests												
Element No. 1 - Booster	●	S	3	S	S			●				P
Element No. 2 - Orbiter	●	S	2	S	S			●				P
High-Subsonic Flight Tests												
Element No. 3 - Booster	●	●	3	S	S	●		●				P
Element No. 4 - Orbiter	●	●	2	S	S	●		●	S			P
VERTICAL LAUNCH PHASE												
Single-Element Launches												
Element No. 5 - Booster	●	●	3	9	●	●	●	●	P			●
Element No. 6 - Orbiter	●	●	2	3	●	●	●	●	P	S		●
Multi-Element Launches												
Booster Element No. 1, 3, 5, & 7	●	●	3	9	●	●	●	●	●		●	●
Orbiter Elements No. 2, 4, & 6	●	●	2	3	●	●	●	●	●	●	●	●

Table 2-5. Flight Test Program Summary Test Objectives

Test Objectives	Horizontal Flight Phase				Vertical Launch Phase		
	Low Subsonic		High Subsonic		Single Elem. Launch	3-Elem. Launch	
	Booster	Orbiter	Booster	Orbiter		Sep.	Abort
Demonstrate ground handling equipment and procedures.	•	•	•	•	•	•	•
Verify vehicle erection and mating operations.					•	•	•
Verify vehicle/launch complex compatibility.					•	•	•
Verify pre-launch ground purging operation.					•	•	•
Verify vehicle turnaround facilities compatibility.					•	•	•
Verify adequacy of cargo loading equipment.							•
Demonstrate horizontal takeoff for landing.	•	•	•	•	•	•	•
Verify airframe structural integrity.			•	•	•	•	•
Demonstrate adequacy of TPS.					•	•	•
Demonstrate satisfactory horizontal-flight characteristics.	•	•	•	•	•	•	•
Demonstrate satisfactory hypersonic through transonic flight characteristics.					•	•	•
Verify satisfactory jet engine performance.	•	•	•	•	•	•	•
Demonstrate satisfactory performance of the rocket propulsion system.					•	•	•
Demonstrate adequacy of the ACPS/mission compatibility.					•	•	•
Demonstrate vehicle subsystem compatibility.			•	•	•	•	•
Demonstrate postentry horizontal flight configuration attainment.					•	•	•
Demonstrate satisfactory horizontal flight engine deployment.					•	•	•
Demonstrate horizontal flight cruise and ferry capability.			•	•			
Demonstrate preflight tanking and launch operations.					•	•	•
Demonstrate satisfactory subsystem performance.			•	•	•	•	•
Demonstrate satisfactory vertical flight characteristics.					•	•	•
Demonstrate satisfactory booster staging sequence.						•	•
Demonstrate adequacy of the boost phase abort maneuver.						•	
Demonstrate vehicle/mission performance capability.						•	•
Verify adequacy of on-orbit cargo handling.							•
Verify adequacy of the rendezvous and docking maneuvers.							•
Demonstrate vehicle postflight serviceability and maintainability.					•	•	•
Obtain data on vehicle components/hardware reusability.					•	•	•
Verify adequacy of ECS and LCS in mission environment.					•	•	•
Demonstrate satisfactory performance of the automatic landing subsystem.			•	•	•	•	•
Demonstrate guidance and control subsystem accuracy.						•	•
Verify adequacy of cryogenic tank insulation.					•	•	•

Table 2-6. Horizontal Flight Tests — Low-Subsonic

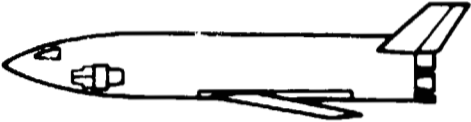
<p>PHASE I — LOW SUBSONIC FLIGHT TESTS</p> 	<p>BOOSTERS: 1 ORBITERS: 1</p> <hr/> <p>FLIGHT TEST SITE: Horizontal Flight Test Site</p> <hr/> <p>TOTAL VEHICLE TEST MONTHS: Approximately 15</p>
<p><u>OBJECTIVES:</u></p> <ul style="list-style-type: none"> Establish basic flight safety Demonstrate basic vehicle subsonic flying qualities. Determine flight vehicle dynamic response characteristics. Evaluate initial subsystem performance. Demonstrate normal landing and takeoff capability and general jet engine system performance. 	<p><u>TEST VEHICLE CONFIGURATION:</u></p> <ul style="list-style-type: none"> Booster and orbiter horizontal flight configuration. Hardware, equipment, and/or subsystems required only for the launch, orbital or entry configuration may be simulated to maintain external aerodynamic shape and cg location. (See Table 2-4.)

TEST APPROACH:

This test phase encompasses the basic flying qualities of the flight vehicle and subsystem performance tests that can be conducted within a restricted operational envelope which is, at that time, limited primarily on the basis of sound engineering knowledge and that will be expanded as appropriate ground testing permits. The intent is to examine as many areas as possible within the restricted operational envelope so that maximum time for solution and retesting is available.

Table 2-7. Horizontal Flight Tests — High-Subsonic

<p>PHASE II — HIGH SUBSONIC FLIGHT TESTS</p> 	<p>BOOSTERS: 2 ORBITERS: 2</p> <hr/> <p>FLIGHT TEST SITE: Horizontal Flight Test Site</p> <hr/> <p>TOTAL VEHICLE TEST MONTHS: Approximately 30</p>
<p><u>OBJECTIVES:</u></p> <p>Extend jet engine/fuel system performance and integration.</p> <p>Extend dynamic and structural load tests to design limits (including conditions of flutter, vibration, and buffet).</p> <p>Investigate stability and control in the extended speed/altitude envelope.</p> <p>Continue evaluation, integration, and demonstration of the horizontal-flight avionic equipment and other vehicle subsystems.</p> <p>Verify increased gross weight and ferry capability.</p>	<p><u>TEST VEHICLE CONFIGURATION:</u></p> <p>Booster and orbiter horizontal flight test configuration.</p> <p>Hardware, equipment, and/or subsystems required only for the launch, orbital, or entry mission phases may be simulated to maintain the external aerodynamic shape and horizontal flight characteristics. (See Table 2-4.)</p>

TEST APPROACH:

This test phase is intended to extend evaluation, verification, and qualification of the vehicle (horizontal flight configuration) and necessary subsystems as the flight envelope is gradually increased to design limits. Demonstration and verification of all horizontal-flight subsystem performance and integration are an essential part of this test phase, with special emphasis on avionics (including automatic landing system and on-board checkout) and airborne crew support systems.

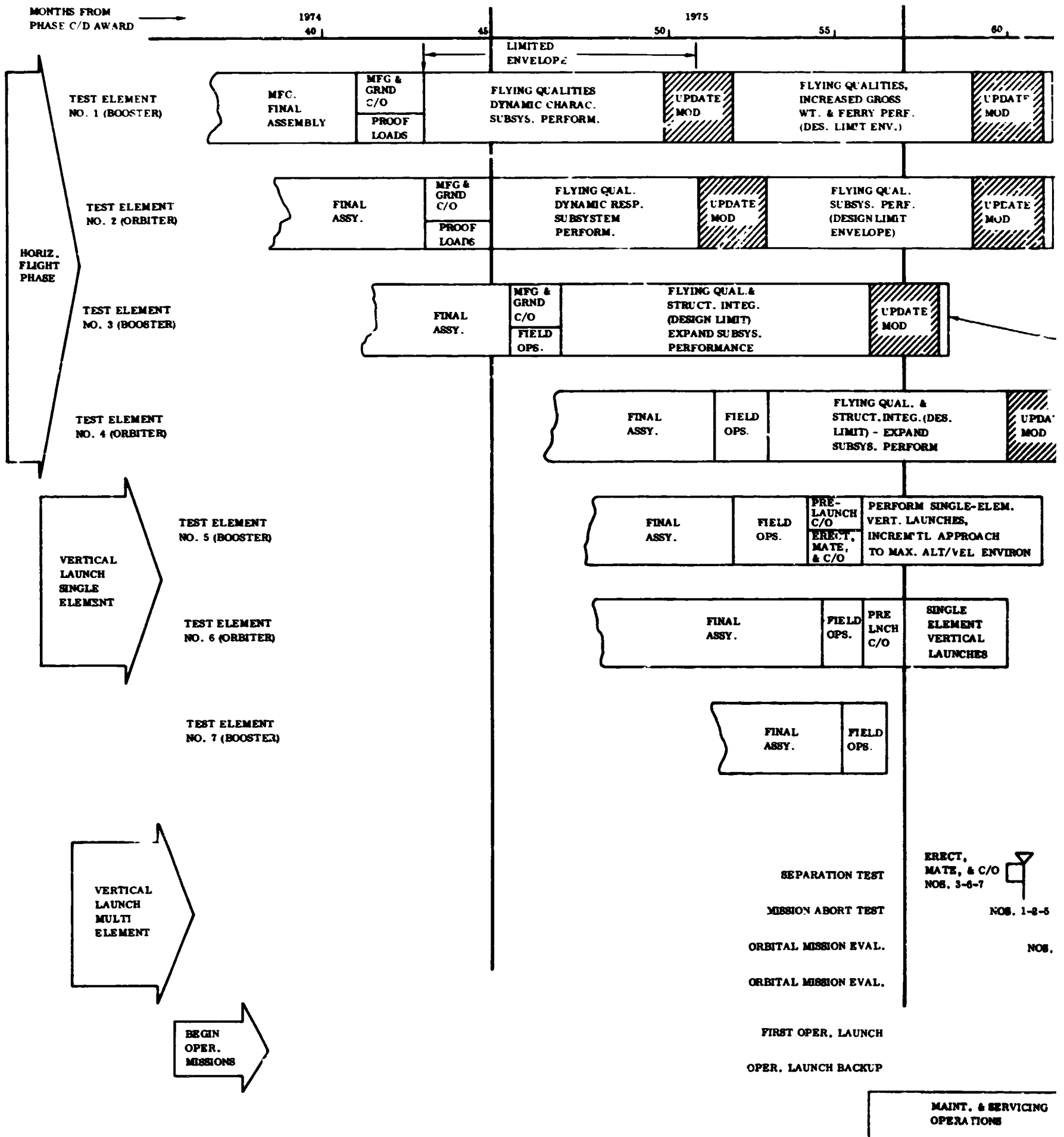
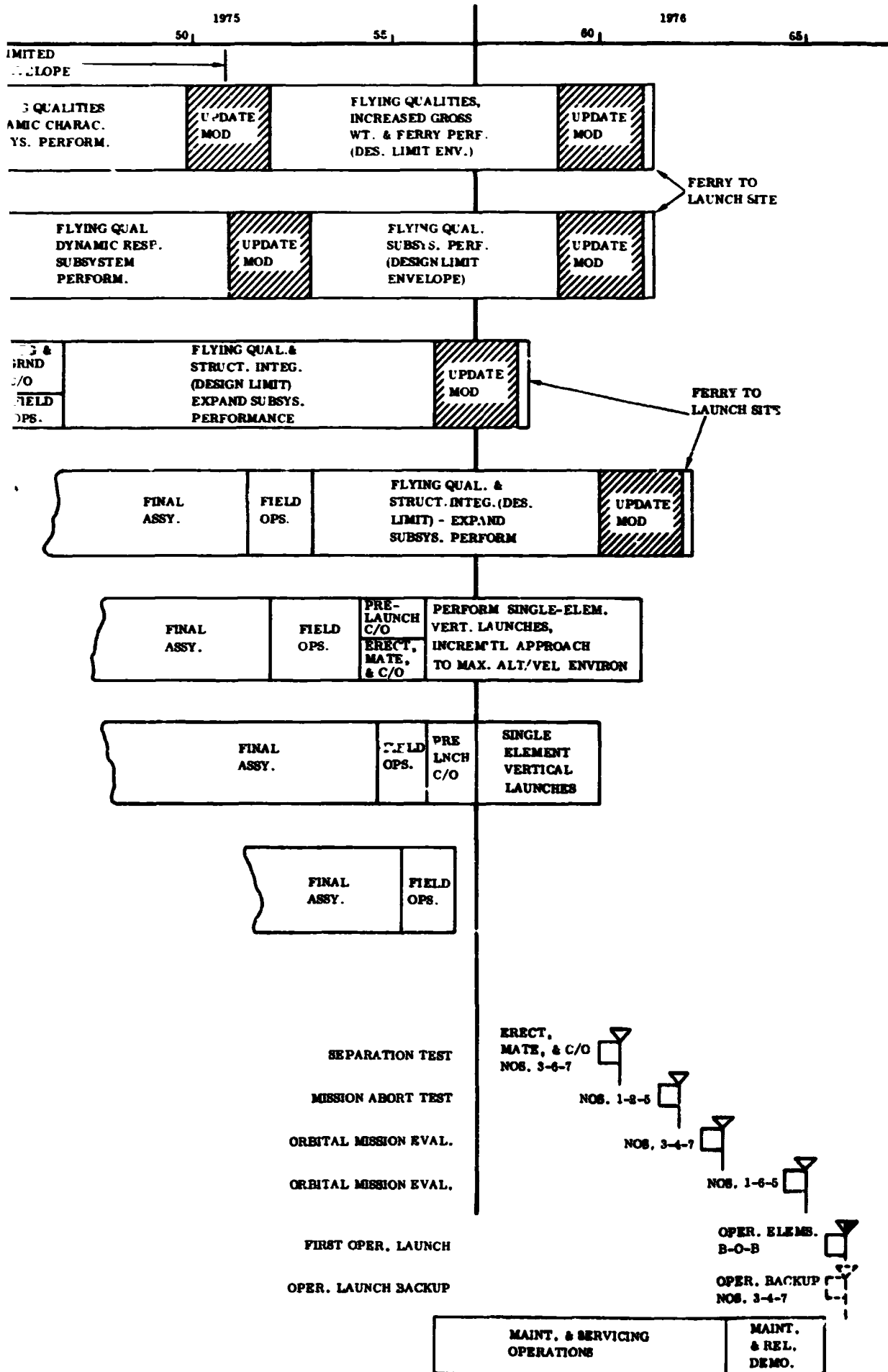

Figure 2-15. Summary Flight Test Program

Volume X



st Program

FOLDOUT FRAME -2

FOLDOUT FRAME -1

Horizontal Flight Test Phase. Space shuttle horizontal flight test may be considered as a subsystem test relative to the final mission for the shuttle vehicles. Therefore, the basic approach is to use horizontal flight tests to supplement, or in some cases replace, ground laboratory tests where advantages can be realized in environment, reduced complexity, and/or costs. Specific objectives to be realized are:

- a. Evaluation of vehicle hardware characteristics and operational procedures that cannot be adequately evaluated by laboratory testing.
- b. Collection of inflight quantitative data that will allow correlation of flight environment with laboratory test data.
- c. Extended flight verification and qualification of vehicle subsystems prior to vertical launch, including man as an active element in the subsystem.
- d. Crew training in vehicle horizontal flight and handling characteristics.

Horizontal flight tests can parallel ground laboratory tests in many cases, thereby realizing a schedule advantage and reducing program cost. This departure from normal series-type testing requires that the early test vehicles be ballasted and equipped with dummy and/or mockup external aerodynamic shape simulating the vertical launch vehicle element configurations, e. g. ; dummy rocket nozzles and alternative TPS covering. Horizontal flight tests are planned to provide a safe and progressive expansion of the space shuttle design-speed/altitude/normal-load-factor envelope. This testing can generally be divided into two phases, based on the level of engineering confidence. The first encompasses those flight tests that can be conducted within a restricted operational envelope based on sound engineering knowledge (low-subsonic regime). The second phase involves conducting tests for gradual and progressive collection of quantitative data necessary to permit evaluation, verification, and qualification of the vehicle and to expand the systems flight envelope to design limits (high-subsonic regime). Test objectives, vehicle configuration, test approach, and other data for the low-subsonic horizontal flight tests are contained in Table 2-6 and for the high-subsonic flight tests, in Table 2-7. The time-dependency of both phases and their relation to the vertical (launch) flight tests are shown in Figure 2-15. The test philosophy used for the horizontal flight phase is for rapid examination of as many areas as possible while restricted to each operational envelope, thereby uncovering problems early so as to provide maximum time for solution and retest. Control subsystems, life support and vehicle subsystems, freedom from flutter, structural vibration, and buffet are the major items that can be evaluated by horizontal flight test. Horizontal flight test provides an early opportunity to verify and qualify the onboard checkout equipment, along with other elements of electronics including real-time discrete-function monitoring.

As noted in Tables 2-6 and 2-7 and Figure 2-15, the horizontal flight test phase contains about 45 vehicle-flight-test months, including the field operations and checkout phase for each test vehicle. The high-subsonic phase is minimum even at twice the

time allowed for the low-subsonic phase; however, both phases are shortened so the test vehicles can be refurbished for vertical launch tests during third quarter 1976. Four test vehicles (two orbiters and two boosters) are required for the horizontal flights since the booster and orbiter are considered to be primarily different vehicles.

Vertical-Launch Flight Test Phase. This phase extends testing to the launch vehicle configuration and ultimately to the spacecraft mission capability demonstrations. These tests are conducted in single and multi-element launch configurations.

The first subphase involves the single-element, vertical-launch configuration for initial verification of vertical flight performance of the single element and its recoverability to the horizontal subsonic flight configuration. These single-element launches are planned to explore the higher velocity/altitude recovery environments progressively, approaching the orbiter entry conditions as closely as possible. These tests present a minimum-hazard approach to evaluation of TPS for manned flights.

The second subphase verifies the three-element launch configuration for the first time. Since all flight tests in this baseline program approach are manned, each successive flight and test phase must be approached with a high level of confidence based on positive results of each prior flight test and extensive ground backup tests. Each test would then be designed to prepare the test article configuration adequately for its next test phase. The three-element test flights extend the test program from the vehicle staging demonstration to the final mission capability demonstration.

- a. Single Element Vertical Launches (Table 2-8). These tests will be conducted initially on a booster element. A prime test consideration is to test the TPS incrementally under simulated entry conditions in as far as attainable with the single-element launches. The booster includes an additional propellant capability and slightly greater thrust-to-weight ratio than the orbiter. Preliminary investigation indicates that a velocity of around 19,000 ft/sec at a 260,000-foot altitude could be attained by the booster, with some reduction considered for flyback jet fuel. The orbiter capability is about 4000 ft/sec less than booster capability at the same altitudes. Specific trajectory paths must be explored for maximum attainable simulation of orbiter entry conditions and possibly to reduce the fuel flyback requirements, although the velocity penalty for the latter may be too restrictive.

The test article designated for this test phase would spend one to two months in normal field checkout operations prior to initial vertical launch tests. The vertical launch tests would begin only after the horizontal flight test phase (high-subsonic regime) had demonstrated the vehicle's structural capability to limiting loads for that flight mode.

Table 2-8. Vertical Launch Tests — Single Element

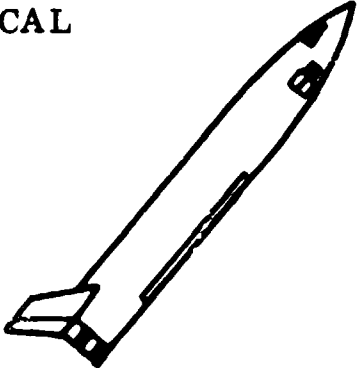
<p>PHASE III — VERTICAL LAUNCH - SINGLE ELEMENT TESTS</p> 	<p>BOOSTERS: 1 ORBITERS: 1</p> <hr/> <p>FLIGHT TEST SITE: Operational Launch Site</p> <hr/> <p>TOTAL VEHICLE TEST MONTHS: Approximately 14</p>
<p><u>OBJECTIVES:</u></p> <p>Ground handling, erection, and launch support compatibility.</p> <p>Vertical launch and boost-phase flight capability.</p> <p>Post-boost phase recovery and transition to horizontal subsonic flight configuration.</p> <p>Extend TPS evaluation to approximate orbiter entry conditions as far as feasible.</p> <p>Extend vehicle/subsystem performance and integration.</p> <p>Initial evaluation of post-recovery turnaround operation and facilities.</p>	<p><u>TEST VEHICLE CONFIGURATION:</u></p> <p>Complete booster and orbiter element vertical launch configuration.</p> <p>The booster/orbiter separation system and launch interconnects may be omitted, as they are not required for this test phase.</p> <p>The orbiter includes additional flyback fuel tanks in the payload bay.</p> <p>The orbiter is essentially complete, ready for the multi-element launches.</p>

TEST APPROACH:

This test phase will primarily use a single booster element in the vertical launch mode. Extensive use of this vehicle will be made in initial evaluations of ground handling and launch support equipment and for the operational site vehicle turnaround operations and facilities. The vertical flight phase will be explored in increasing velocity increments to the limit attainable by a single booster and/or orbiter element. The velocity steps will be controlled by offloading launch ballast on each succeeding flight until the maximum test conditions are reached. Other flight trajectories will be tailored for simulating maximum heating conditions.

The initial vertical launches would be short-duration boost-phase flights with ballasting to replace the offloaded propellants (so the required launch conditions will be maintained). Ten vertical launches are assumed, with each extending the severity of the flight regime explored. The postflight vehicle turnaround operations for these flight tests will provide initial assessment of the ground recovery, maintenance, and servicing operations and facilities.

The last test orbiter may be launched in the single-element configuration prior to its use in a multi-element launch to demonstrate its capability of postboost recovery to a horizontal flight configuration and its pre-entry attitude control system performance as well as that of the main rocket propulsion system. To attain a reasonable thrust-to-weight ratio for these flights, the booster engine exhaust nozzles may be used on the orbiter engines and the total propellant quantities reduced. This would limit the velocity/altitude envelope, but should be sufficient for the demonstrations even with the necessary flyback fuel added.

- b. Multi-Element Vertical Launches (Tables 2-9 and 2-10). These flight tests require the all-up launch configuration to extend the flight environment envelope beyond the single-element flight capability and to demonstrate the operational launch configuration and stage separation techniques.

The first three-element launch verifies the launch complex facilities and support-equipment compatibility with the space shuttle vehicle. The first two launches (Table 2-9) will demonstrate the vehicle staging maneuver and the horizontal-flight-mode recovery and cruise flyback (to launch site) for the two booster elements. The orbiters will circle the earth once and return to the launch site or a designated alternate. The second launch will simulate a boost-phase abort condition to evaluate the staging and recovery maneuvers under abort conditions. The recovery maneuvers for the booster and orbiter elements are similar for both flights. Post-flight turnaround operations will continue verification and validation of the turnaround facilities, support equipment, and procedures and will provide data essential to maintenance and service analyses.

The third and fourth vertical launches extend exploration of the orbiter's flight environment and vehicle performance to operational mission simulations in orbit (Table 2-10). On both flights the orbiter will perform orbital-transfer and target-rendezvous maneuvers, docking operations as applicable, and simulated cargo/crew transfer or payload deployment and retrieval operations applicable to the orbiter element. Two tests are considered sufficient to demonstrate capability and repeatable performance, retest any minor subsystem modifications required, verify basic mission capabilities, and demonstrate orbiter adequacy for maximum mission duration (seven days).

Table 2-9. Vertical Launch Tests — Separation and Abort

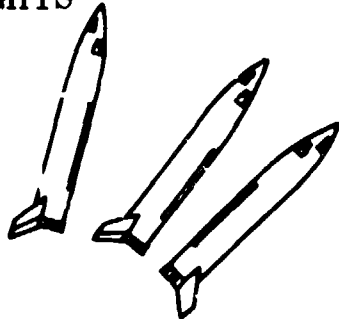
<p>PHASE III — VERTICAL LAUNCH - MULTI-ELEMENT, SEPARATION AND ABORT TEST FLIGHTS</p> 	<p>BOOSTERS: 2/Launch ORBITERS: 1/Launch</p> <hr/> <p>FLIGHT TEST SITE: Operational Launch Site</p> <hr/> <p>TOTAL VEHICLE TESTS: Two Vertical Test Flights</p>
<p><u>OBJECTIVES:</u></p> <p>Demonstrate multi-element erection and mating plus facility integration and checkout.</p> <p>Demonstrate capability of three-element launch configuration through the launch and boost phases of flight.</p> <p>Demonstrate satisfactory staging, recovery and entry maneuvers and attainment of the horizontal subsonic cruise configuration.</p> <p>Demonstrate boost-phase abort and recovery sequence and performance.</p>	<p><u>TEST VEHICLE CONFIGURATION:</u></p> <p>Complete operational configuration for booster elements.</p> <p>Complete operational configuration for orbiter element. Rendezvous, docking, cargo deployment, and other on-orbit mission support hardware need not be operative on these tests.</p>

TEST APPROACH:

Two vertical flights are programmed for this test phase. The first will demonstrate adequacy of the stage-separation maneuver, including the booster-element recovery maneuver, entry, and subsonic flyback to the launch site, and the orbiter once-around return to the launch site or an alternate. The second launch will demonstrate a simulated boost-phase abort operation and maneuver sequence that closely follows the same recovery techniques as the first launch.

Table 2-10. Vertical Launch Tests - Earth Orbital

<p>PHASE III - VERTICAL LAUNCH - MULTI-ELEMENT, EARTH-ORBITAL MISSION EVALUATION FLIGHTS</p> 	<p>BOOSTERS: 2/Launch ORBITERS: 1/Launch</p> <hr/> <p>FLIGHT TEST SITE: Operational Launch Site</p> <hr/> <p>TOTAL VEHICLE TESTS: Two Orbital Test Flights</p>
<p><u>OBJECTIVE:</u></p> <p>Demonstrate orbital transfer, rendezvous, and docking maneuvers and simulated cargo handling and transfer operations.</p> <p>Demonstrate adequacy of orbiter and mission-related subsystems during extended (7 days) on-orbit operations.</p> <p>Validate operational turnaround and servicing procedures.</p> <p>Demonstrate the maintainability and serviceability of booster and orbiter elements.</p>	<p><u>TEST VEHICLE CONFIGURATION:</u></p> <p>Complete orbiter- and booster-element operational configurations with all mission systems operational.</p>

TEST APPROACH:

Two orbital flights are considered sufficient for demonstrating adequacy and repeatability of orbital operations and maneuvers. Modifications to mission equipment determined during the initial flight will be accomplished and verified on the second flight. The turnaround operation for the space shuttle will be thoroughly validated for operational mission support. Reliability and maintainability demonstrations will also be a major milestone during this flight test phase.

Ground turnaround operations between these flights will be geared to booster turnaround spans that would be required to support the second orbital test flight. At this phase in the flight program, the turnaround span should not exceed one month, but may be considerably less. Early in the operational flight program, this turnaround time per three-element vehicle will be reduced to something less than two weeks. (See Volume IX.)

Following the final two R&D flight test vehicle recoveries, the three shuttle elements will serve during their turnaround sequence to:

- a. Demonstrate the booster/orbiter maintainability and serviceability.
- b. Demonstrate capability to support the initial operational flights adequately.
- c. Indicate the level of confidence of the reusability of each shuttle element.

The vertical launch phases are conducted from one pad at an initial operational launch complex; the second pad will be used to erect a standby vehicle as necessary for emergency or mission backup. The vehicle to be erected on this backup pad would be one of the R&D flight test vehicles. The operational site layout, facilities, and operations are covered in Section 2.2.7.2.

2.2.7 TEST FACILITIES. Test facilities outlined in this section have been identified as necessary to support the ground test program described in Section 2.2.6.2 and the flight test program described in Section 2.2.6.3. Existing government test facilities have been examined; those that could be used to support the program have been identified.

Where modification is required, only gross requirements have been identified. Refinement of these requirements can be made only after completion of detailed vehicle design.

The impact of the planned use of government facilities on other current or projected test programs has not been resolved, but should be considered in future studies.

2.2.7.1 Ground Test Facilities

- a. **Wind Tunnel Tests.** High and low speed wind tunnels, plasma arc tunnels, and hypersonic shock tunnels. All test models will be sized to suit existing facilities. Since this program will probably require use of several major facilities concurrently, full usage of the best facilities available (AGDC, MSFC, NASA Langley and Ames, and other industrial facilities) is foreseen.
- b. **Thermo Material Development and Qualification.** Test laboratories capable of performing these tests are common throughout government and industry, so no special emphasis is placed on this facility.

- c. Component Development and Qualification. Test laboratories are common, no special emphasis.
- d. Vehicle Structural Static Loads Tests. Static load testing could be performed at either the contractor's facilities or the MSFC Static Load Test Annex. No apparent modification is required for the MSFC facility. Test articles identified for these tests (except for the wing and wing pivot support structure) could all be tested within this facility. Wing testing could best be accomplished in the hangar-type facility common to the aircraft industry.
- e. Vehicle Structural Fatigue Testing. Several separate facilities are required to perform tests in this category, including:
 1. Fatigue cycling of tanks at cryogenic temperatures.
 2. Crew compartment leak and cyclic fatigue.
 3. Acoustic environment of rocket engines on avionics and crew.
 4. Empennage structure (including thrust structure) fatigue tests.

Fatigue cycling of tanks requires an enclosed tower-type support structure (Figure 2-16) capable of receiving a full-scale integral LH₂/LO₂ booster tank. The LH₂ tank would be a stub tank to hold the overall length to approximately 80 feet. An additional tower structure will be required to support the independent (orbiter) LO₂ tank and an independent LH₂ stub tank.

The test stands will require cryogenic storage facilities consisting of about 400,000 gallons of LH₂ and 140,000 gallons of LN₂. Pumping systems to duplicate the flow rates for operational systems will be required (20,000 gpm). Calibration and heat flow measuring devices, together with recording instrumentation for insulation testing, should be located in an area or separate building adjacent to the test stand.

Crew compartment leak and cyclic fatigue could be accomplished in the MSFC Static Load Test Facility. No apparent modification is required.

Acoustic environmental testing of the crew/passenger compartment could be accomplished at MSC Houston in the Spacecraft Acoustic Laboratory. No modification to the structure is envisioned. Two acoustic shrouds tailored to the configuration of the crew module and the passenger module will be required, and the sound production capability must be increased from 170 to 180 db. A schematic representation of this facility is shown in Figure 2-17.

Fatigue testing of the empennage and thrust structure can be accomplished at the contractor's site or in the MSFC Static Load Test Facility. The latter facility cannot accept the full empennage and thrust structure unless a portion of the tail structure is cropped.

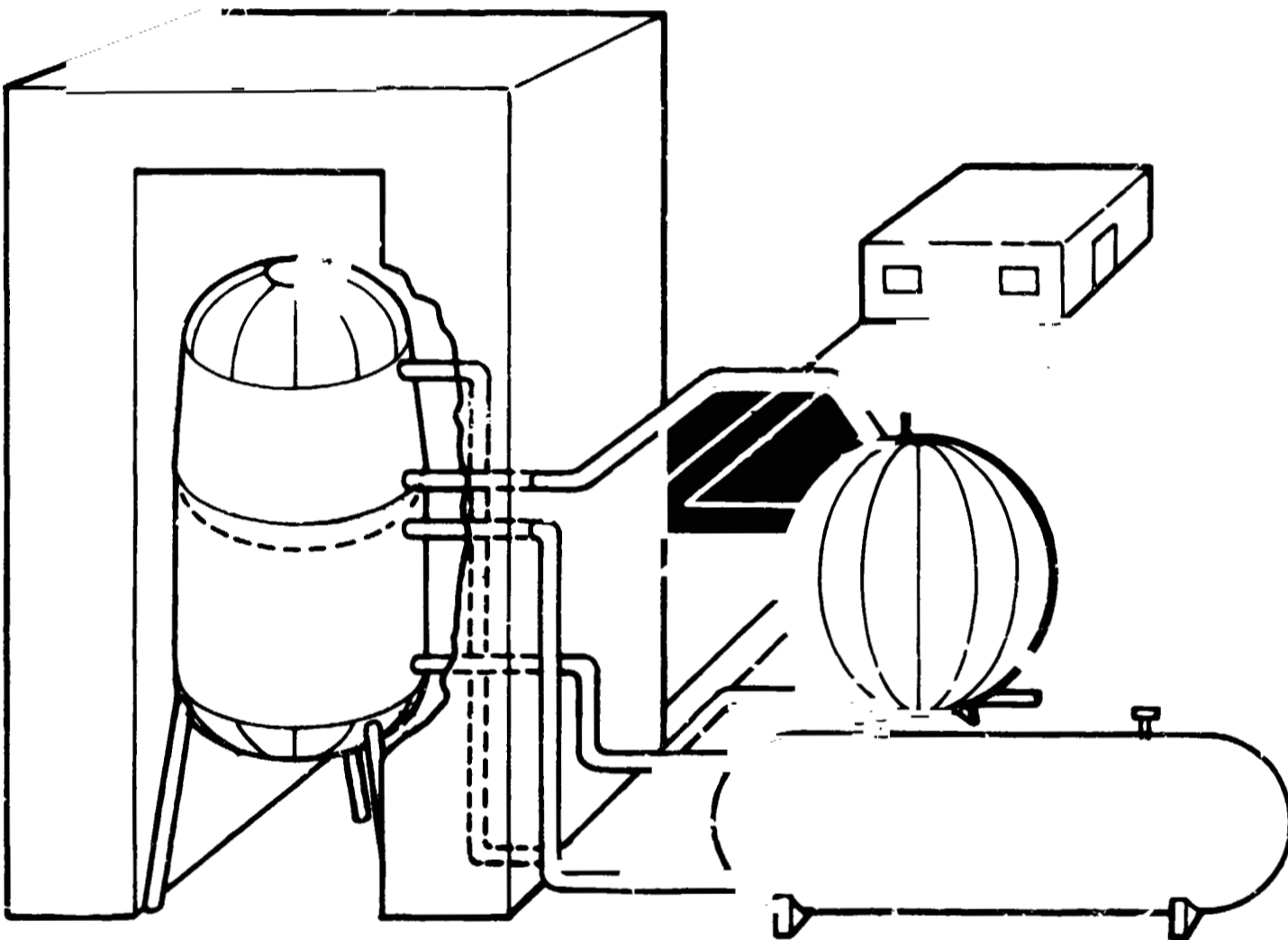

STRUCTURAL TESTS:
FATIGUE TEST AT CRYOGENIC TEMPERATURES
CYCLING TESTS
INSULATION TESTS

TEST ARTICLES
LO₂/TANK WITH LH₂ STUB TANK (BOOSTER
ELEMENT ILLUSTRATED, ORBITER ELEMENT SIMILAR)
TWO SETS OF UNLIKE PA (LOAD BAY PROPELLANT TANKS

Figure 2-16. Structural Fatigue and Cycling Test

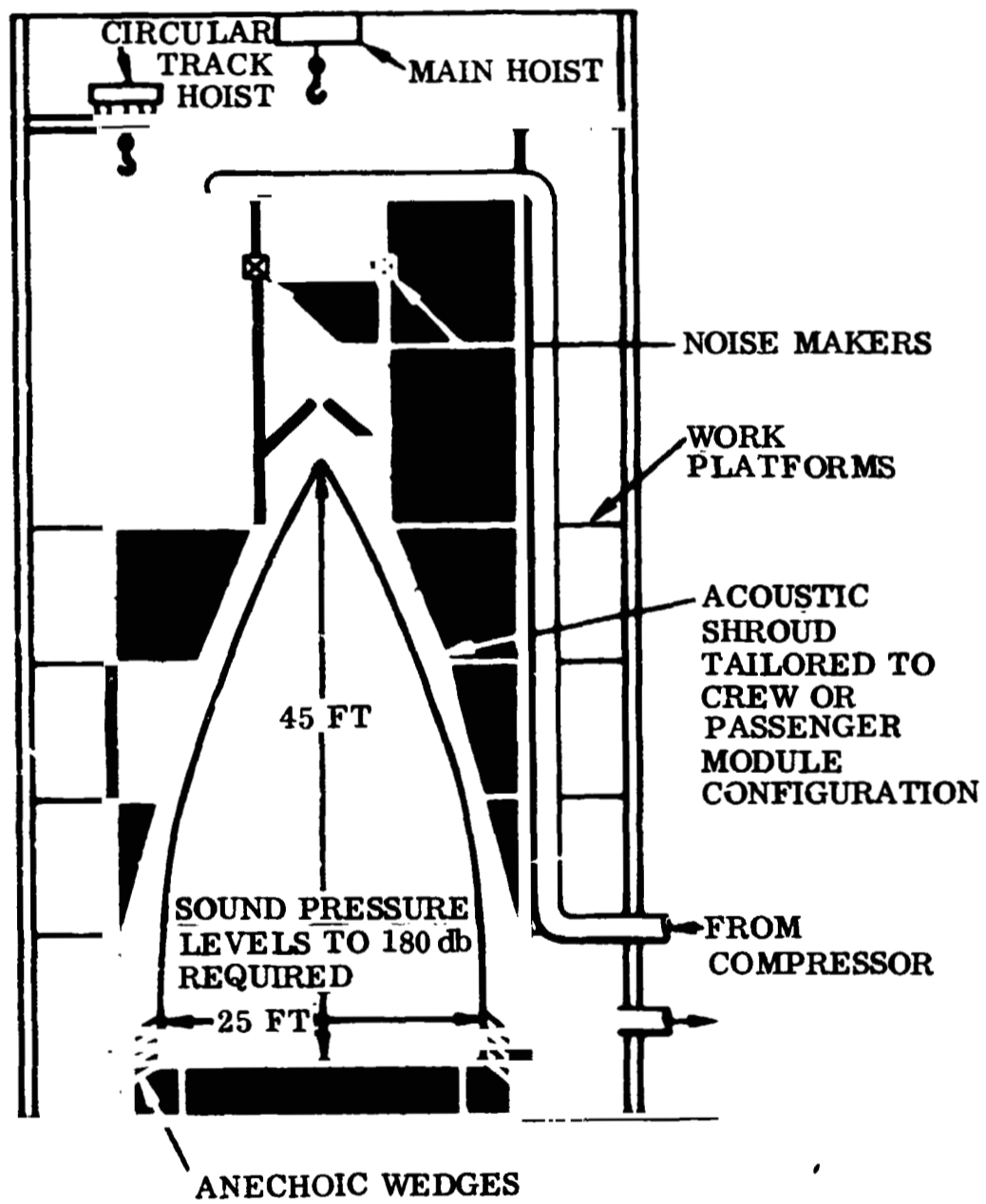

Figure 2-1 Acoustic Test Facility Supporting Dynamic Structural Tests

Landing gear and nose wheel testing will be accomplished in contractor-owned facilities.

- f. Jet Fuel Subsystem Tests. Will be accomplished at engine contractor's facilities.
- g. Flight Control Subsystem Tests. The "iron horse" test stand referred to in Table 2-1 is illustrated in Figure 2-18. Facility requirements other than housing are for a source of hydraulic power, electrical power, and connections to a hybrid computer. In addition to the flight controls subsystem, system hydraulic subsystems will be tested on this stand.
- h. Electrical Subsystem Tests. No special facility is required to perform these tests.
- i. Flight Crew Escape Tests. These tests would be performed at the contractors facility. No special equipment is involved.
- j. Thrust Vector Control Subsystem Tests. Testing of the thrust vector control subsystems could be accomplished at the contractor's facility or at MSFC Static Test Facility. No modification is assumed required.
- k. Attitude Control Subsystem Tests. This test will require a hangar-type building large enough to accept simulated airframe segments of both booster and orbiter. Since hot-firing tests will be conducted, the building should be fireproof and equipped with power-operated ventilation systems to remove heat buildup from combustion products. Storage tanks containing approximately 5000 gallons of LO₂ and 13,000 gallons of LH₂, a fuel-transfer system, recorders, and instrumentation will be necessary to support the tests.

Typical of the facilities capable of supporting these tests are the MSFC Rocket Propulsion Test Stands (4583) and (4570). Other facilities available, include KSC, MSC, and MSC/White Sands.

- l. Docking Simulation Test. The Simulation Laboratory at MSC Houston is proposed for this test. Because the space vehicles are so large, only hardware pertaining to docking systems will be used. Vehicle masses and moments of inertia will be simulated. Alternatively, scaled models would be used to obtain the required test information.
- m. Cargo and Ground Handling Tests. A major portion of the cargo and ground handling equipment tests can be performed at MSFC GSE Test Facility (4646). No facility modifications are indicated, although certain special tools may have to be built. For example, a counterbalancing system to assist operations during cargo deployment is required. No design has yet been formulated, but equipment designed to counterbalance a 15-foot-diameter, 60-foot-long payload may be fairly large and complex.

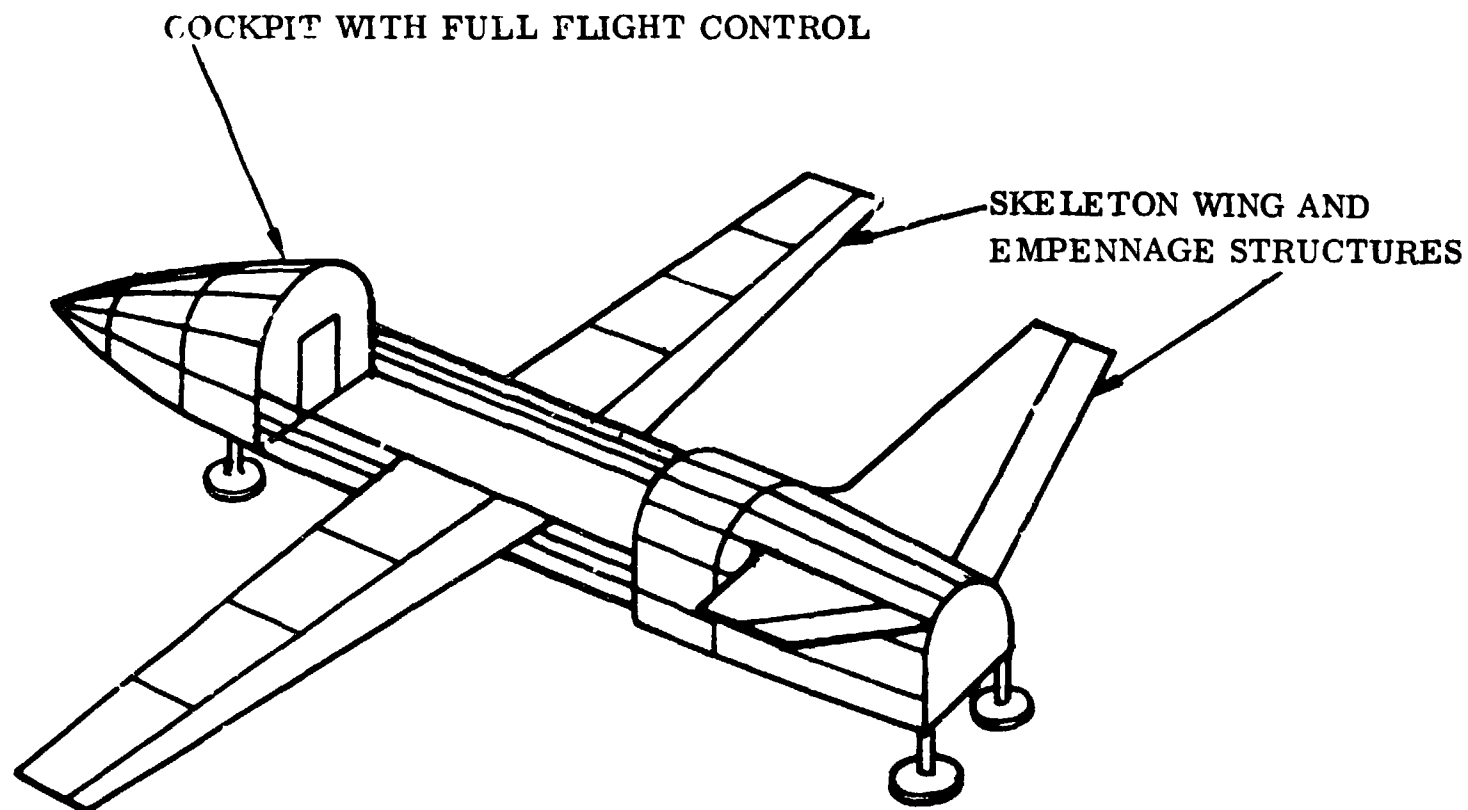

Figure 2-18. Skeleton 'Iron Horse' for Flight Control Systems Test

- n. Propellant Flow and Management Tests and Vehicle Static Firing Tests. The existing Mississippi Test Facility (MTF) S-IC test stand is proposed for both of these tests. The stand will require modification, as shown in outline in Figure 2-19. The proposed modification does not exceed the planned design growth for this facility.

For cold-flow testing and static firing, augmented pumping capability to equal operational flow rate requirements and a complete LH₂ storage and transfer system containing approximately 400,000 gallons are required. Existing LO₂ storage capacity is adequate. If desirable, the extension of both firing cells on this stand would allow installation of the FR-4 booster and orbiter at the same time.

- o. Booster/Orbiter Element Ground Vibration Tests. No special facility is required to support these tests; test equipment is common through industry.
- p. Human Factors Tests. No special facility is required to support these tests.
- q. Avionics Integration Tests. Support facilities at MSC Houston (such as the Electronic Systems Compatibility Lab and the Guidance and Control Electronics Lab) could be used for these tests, although ample industry capability is available. No facility modification is envisioned. Vehicle-peculiar equipment would be required.

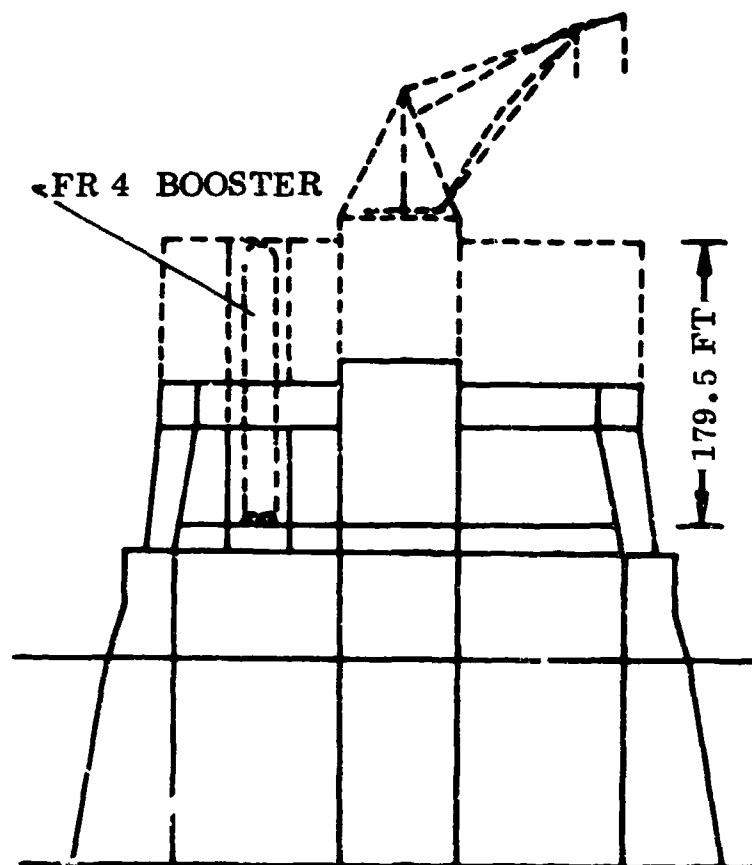
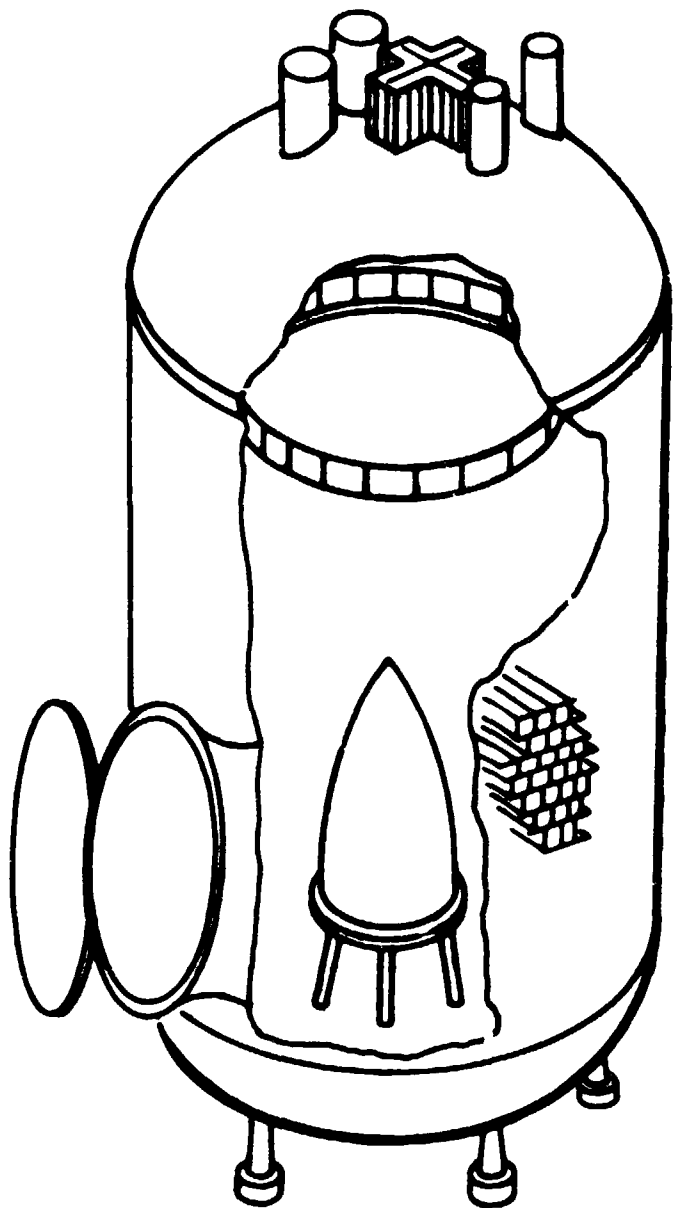

Figure 2-19. SIC Test Stand. MTF. Modification Required to Accept FR-4 Booster

- r. Environmental Control Systems Test. These tests would be performed jointly with contractor facilities and the MSC Houston Environmental Test and Evaluation Laboratories. The MSC Space Environmental Simulation Chamber A is proposed for verification of production (orbiter) hardware under simulated solar vacuum conditions (Figure 2-20).

2.2.7.2 Flight Test Facilities

- a. Horizontal Flight Testing. Several DOD bases within the continental United States have facilities for horizontal flight testing. The recommended facility is Edwards Air Force Base, California, which has been used many times for experimental aircraft. In general, all necessary ground support equipment is available (except specialized tow bars). Examination of available hangar space is desirable and hangar clearances will require checking, especially in the empennage area (which has an envelope about 75 feet wide by 55 feet high).



REQUIREMENTS:
 ACCEPT 20-FT DIA x 27-FT-LONG CREW CAPSULE
 VERT & HORIZONTAL MODE
 LN₂ COLD WALL,
 1 x 10⁻⁶ PUMPING CAPABILITY
 SOLAR RADIATION SIMULATION
 FROM TOP AND SIDE OF CHAMBER.

Figure 2-20. Environmental Control Systems Test

- b. Vertical Launch Tests. Vertical launch testing will be accomplished at an operational launch facility. For this facility, either the conceptual new facility shown in Figure 2-21 or the modified KSC Complex 39 shown in Figure 2-22 will be used. The facility construction/modification schedule should be formulated to meet the scheduled requirements of the test program. (See Figure 2-4.) Other than scheduled need, the test requirements impose no constraints on facility design. In effect, partial construction completion of the launch facility will allow implementation of the early portions of the vertical-launch test program.

2.3 ALTERNATIVE DEVELOPMENT APPROACHES

In examining alternatives for development of the space shuttle system, certain constraints used to scope the baseline development program were compromised to define alternatives that would reduce development risk or improve development timing. More specifically, the mid-1976 initial operational capability (IOC) date was not considered a hard date and was permitted to extend to a time commensurate with achieving a higher level of operational confidence at the conclusion of the development program. Alternatives with the most merit for consideration are discussed in the following sections.

2-53

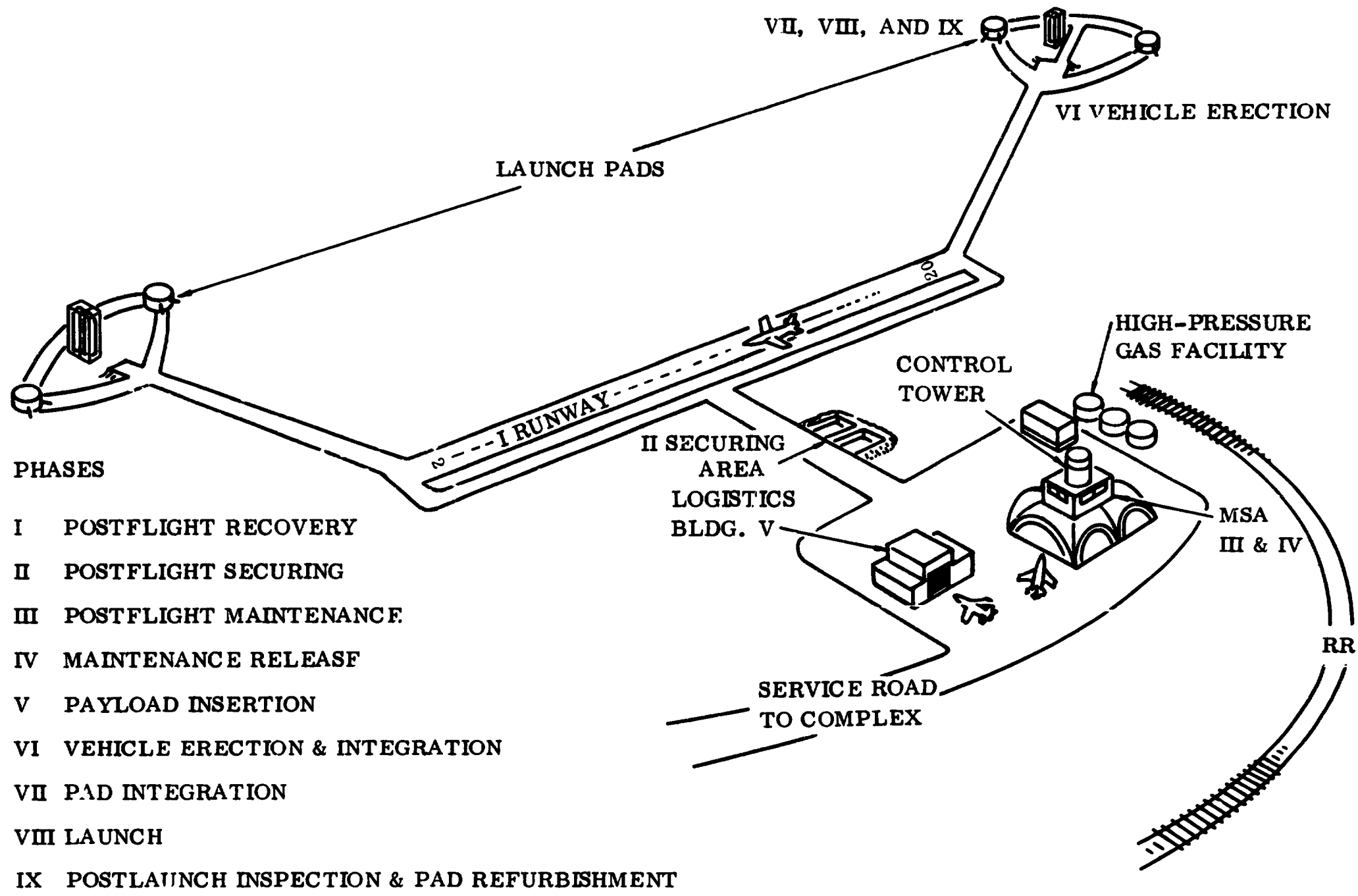

Figure 2-21. Turnaround Phases and Location

Volume X

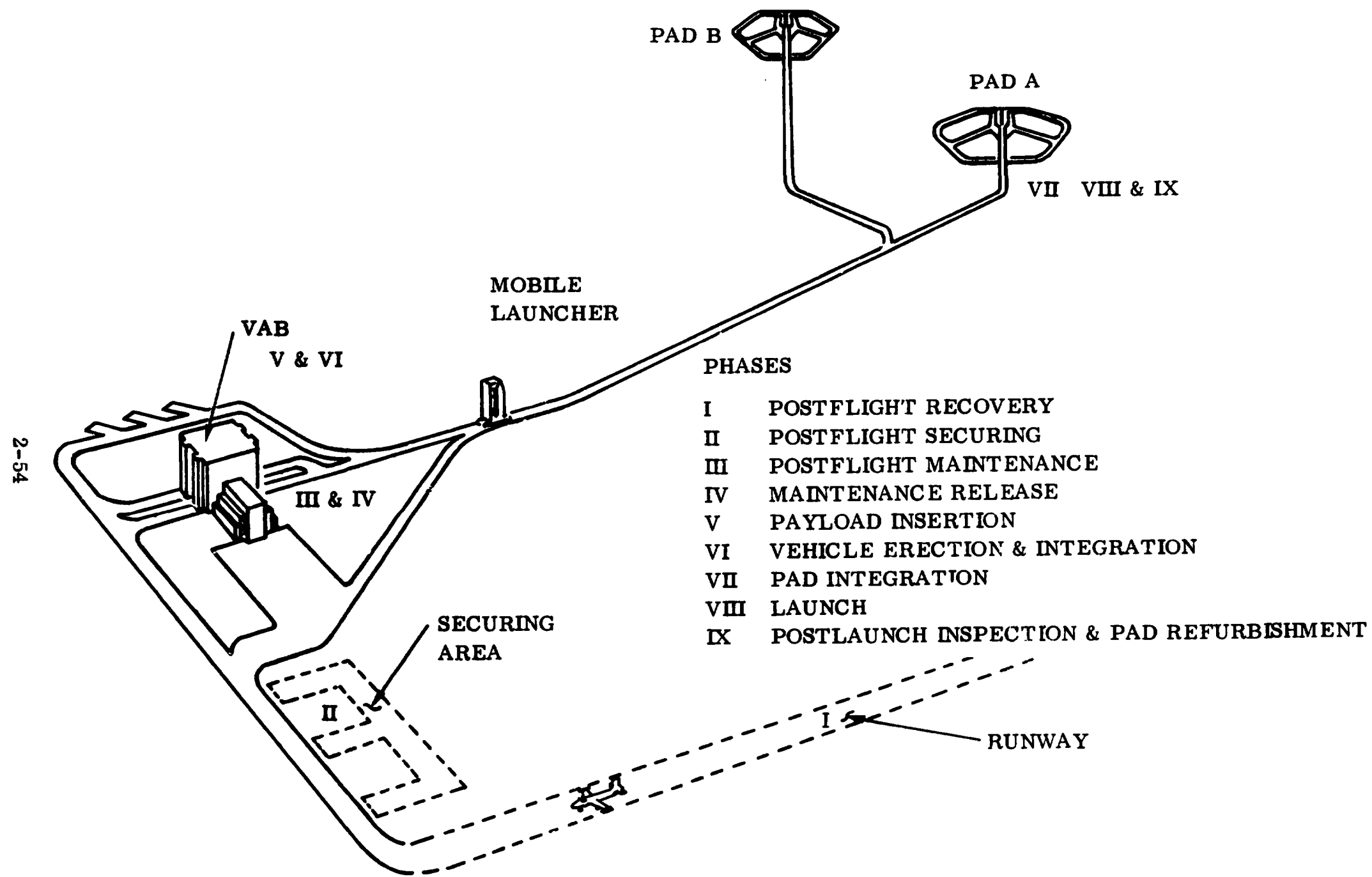
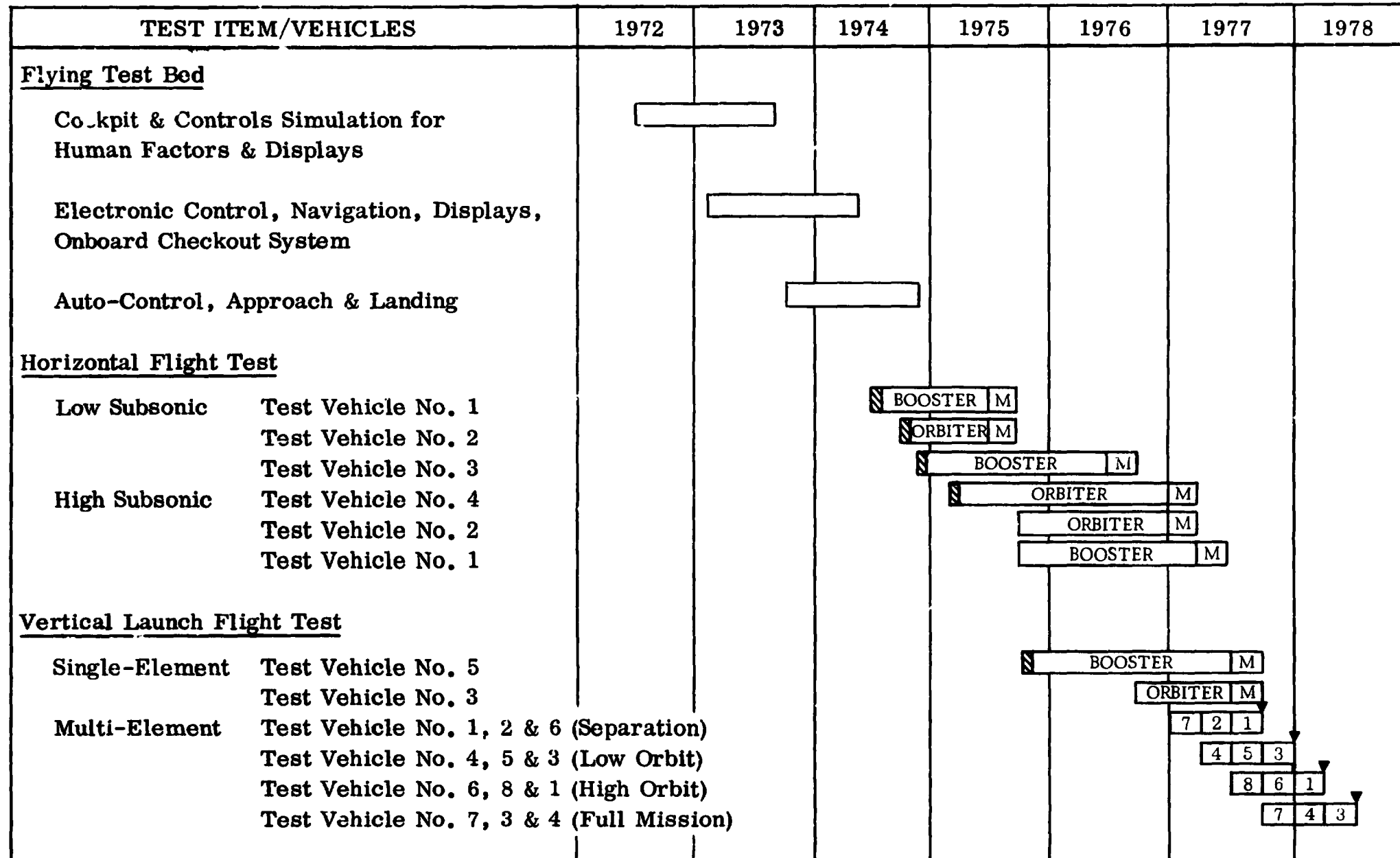

Figure 2-22. Turnaround Phases and Location as Applicable to Complex 39, ETR



M = MODIFICATION

Figure 2-23. Alternative Development Program Plan FR-4 Configuration

2.3.1 FLIGHT TEST PROGRAM. The baseline development program depicted in Figure 2-4 shows IOC achieved in the third quarter of 1976. Analysis of the design, tooling, manufacturing, and ground test programs against other large aircraft, large launch vehicles, and spacecraft programs indicates that time spans for these activities compare favorably. Therefore, availability dates for flight-test articles are considered somewhat invariable. However, achieving a very high level of confidence in operational capability after a limited 24 month horizontal and vertical flight test program is not substantiated by other program data.

The alternative to this baseline program is shown in Figure 2-23, where the IOC date is extended to mid-1978 to accumulate about 49 horizontal-flight test months on the booster element and 45 flight-test months on the orbiter element. Also, a more balanced flight test program is achieved because the low subsonic tests are accomplished on two booster elements and only one orbiter, whereas the high subsonic tests are accomplished on two orbiters and one booster.

The single-element vertical test program could be flown using booster elements only, eliminating the need for extensive flight test modifications and innovations required to fly the orbiter as a single element. With this approach, however, the orbiter will never have flown in the vertical environment until the first multi-element launch, and may require a more extensive ground test and analysis program to achieve the same level of confidence as currently generated for other large launch vehicle (booster) programs.

Another alternative in the flight test development program is to develop the integrated avionics subsystem (including, but not limited to, cockpit controls and displays, control and navigation, and approach and landing subsystems) in a flying test bed (possibly a NASA 990 aircraft). This development program could be run concurrently with the laboratory test and development programs to provide a higher level of confidence for the first booster horizontal flights. This approach has added effect in that it will permit the shuttle vehicles to expend more time evaluating the high speed/temperature regime and flying qualities rather than developing the integrated avionics.

Another major departure from the baseline program could be to conduct unmanned flight tests for early evaluation of aerodynamic heating effects and the orbiter TPS under entry conditions. Such a test program would augment the baseline test approach of all manned flights, and the orbiter TPS configuration could be thoroughly evaluated before man would be exposed to the entry environment. Predicting aerodynamic heat transfer to a spacecraft is complicated. The lower surface of the orbiter element would experience the most severe aerodynamic environment during entry and hence is the controlling factor in the design and operation. Therefore, a flight test program designed to obtain data in the true aerodynamic environment would provide a definite plus factor for future manned flight safety.

For this test approach, an existing launch vehicle such as Atlas or Titan would be fitted with a shroud or model representative of the space shuttle's lower surface. This shroud or model should be at least 60 feet long and flown on trajectories representative of the L/D and C_L maximum capabilities of the orbiter. The resulting data should support TPS final design decisions early enough in the vehicle development phase to be useful on the initial vertical launch tests. A typical program would require at least two separate launch tests and would span 24 to 26 months. The full value of this approach should be explored further, as it may be constrained by the size of the test vehicles usable with the Atlas or Titan vehicles and launch facilities. An alternative approach is to consider use of available Saturn IB launch vehicles for these tests.

2.3.2 GROUND TEST CONSIDERATIONS. A few alternative approaches to the baseline ground test program and their likely effect on the overall schedule are briefly outlined in this section. For instance, the major vehicle structural tests (static load and fatigue) may be accomplished better on complete structural vehicles than on major subassemblies such as used in the baseline program. The total vehicle concept is the more normal approach and has some definite test advantages; however, it does impact the manufacturing schedule because it takes longer to produce the fully assembled structural test vehicles. Test facilities and support functions are also impacted by the much larger size of the completed test articles. Tooling and manufacturing efforts must be significantly increased to support the baseline schedule as it now stands.

Another approach to testing could be considered if time is critical: various phases of the test program, such as qualification tests of components and subsystems, could be accelerated. For the major ground test phase, this would require duplicate test articles and test facilities in some cases and a definite reduction in the amount of combined, non-simultaneous testing for a single test article (such as was considered in the baseline program). The degree of parallel testing, as permitted by duplicate test articles, would be limited to those tests that do not have to be performed sequentially. Such an accelerated program would cause cost increases in tooling, manufacturing, testing, and facilities, but could improve scheduled availability of operational flights; the degree of risk involved would need to be better understood.

Another consideration would be to optimize multiple use of major test articles. This approach was followed to some degree in the baseline program, as reflected by the environmental test vehicle (crew/avionic cabin) being used to evaluate portions of the avionics system, the life support system, and the environmental control system in both a sequential and parallel test operation.

Another approach to vehicle dynamic testing would be to provide a limited-configuration booster and orbiter element for testing in the Saturn V dynamic test stand at MSFC. It is assumed that this stand could be modified to accept either the booster or orbiter element individually, but some other method of simulation would be required

for the three-element vehicle configuration. If the two elements were to be provided, their level of assembly would be sufficient to permit cryogenic tanking and cold-flow operations as well. Still another approach would be to route the initial vertical launch test articles through this facility for verification prior to delivery to the test site. In either case, the overall program schedule would probably be delayed by the necessity for additional test articles and/or test time that constrains vertical launches.

2.4 FR-3 DEVELOPMENT PROGRAM

In general, the development programs for the FR-3 and FR-4 space shuttle concepts are very similar, especially since both programs are constrained by an IOC target date of mid-1976 and since there is about the same degree of difference between the booster and orbiter elements of either vehicle configuration. Figure 2-3 showed the basic booster and orbiter configurations for the FR-4 vehicle; Figure 2-24 displays the general vehicle configurations for the FR-3 concept. The orbiter elements have essentially the same structure, general configuration, and subsystems, with the FR-3 being slightly smaller than the FR-4. Table 2-11 compares some basic physical characteristics of the FR-3 and FR-4 orbiter elements.

The booster elements display the greater differences, with the FR-3 booster outsizing its FR-4 counterpart. Even the aerodynamic configurations vary considerably in the nose, crew, and jet-engine compartment areas. As shown in Figure 2-24 the FR-3 booster nose is more blunt and the crew area is on top of the jet engine compartment rather than in front of it. The FR-3 body consists primarily of two separate integral tank structures, whereas the FR-4 is a single tank with an intermediate bulkhead. The 33-foot-diameter tank of the FR-3 is about 10 feet longer than the FR-4. The FR-3 vehicle cross-section is 41 feet across the bottom and 37 feet high, not including the seven-foot landing gear or the vertical tail heights. The total height of the vertical tail when in the taxiing configuration is 68 feet with an 84-foot span between vertical tail tips. The thrust structure is more complex because it supports 15 rocket engines instead of 9 engines on the FR-4. Table 2-12 compares the basic booster characteristics.

In the total vehicle or multi-element launch configuration, the FR-3 has one booster element and the FR-4 has two. The differences in the vehicle launch configuration cause some differences in their respective flight trajectories. As noted in Table 2-13, these differences reflect slightly different flight test conditions between the vehicles, but not enough to alter the type or number of R&D vehicle launches significantly.

2.4.1 PROGRAM SUMMARY. The total development program span for the FR-3 configuration, based on the same ground rules as considered for the FR-4, is the same as shown in Figure 2-4; i.e., 65 months from the start of a combined Phase C/D effort. The earliest probable operational flight, based on these same ground rules, would be about 66 months from go-ahead. Such a program reflects a relatively

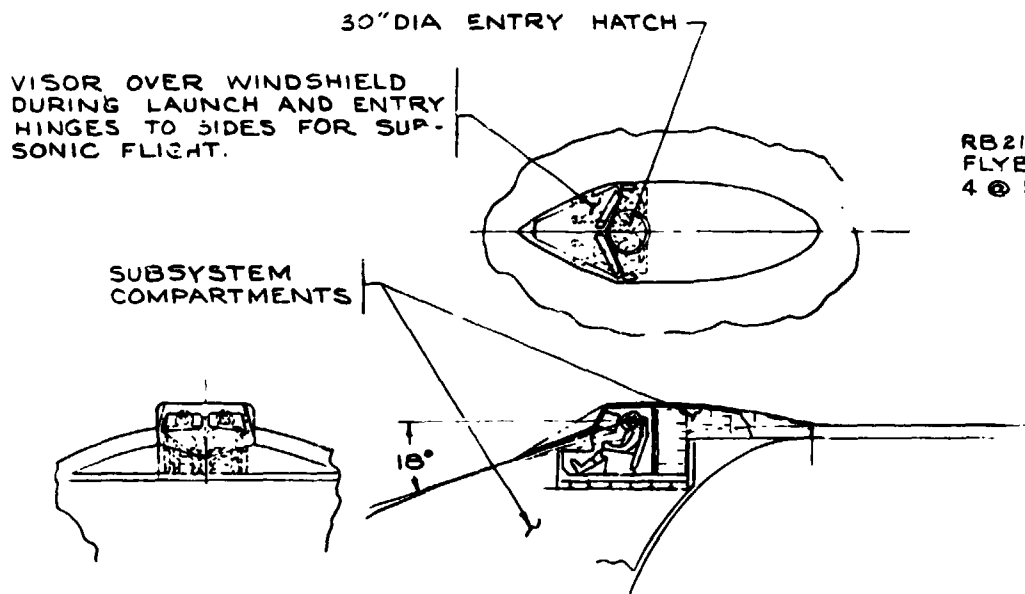

RB211-56 OR EQUIV.
FLYBACK ENGINES
4 @ 52,500 LB SLS THRUST

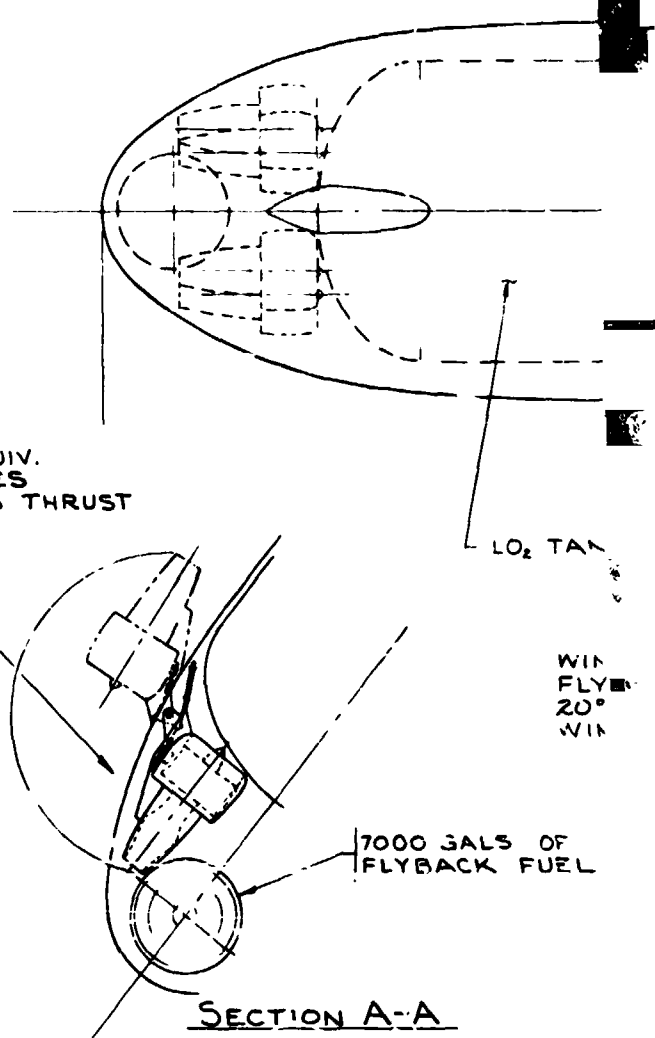

PILOT'S COMPARTMENT
1/30 SCALE

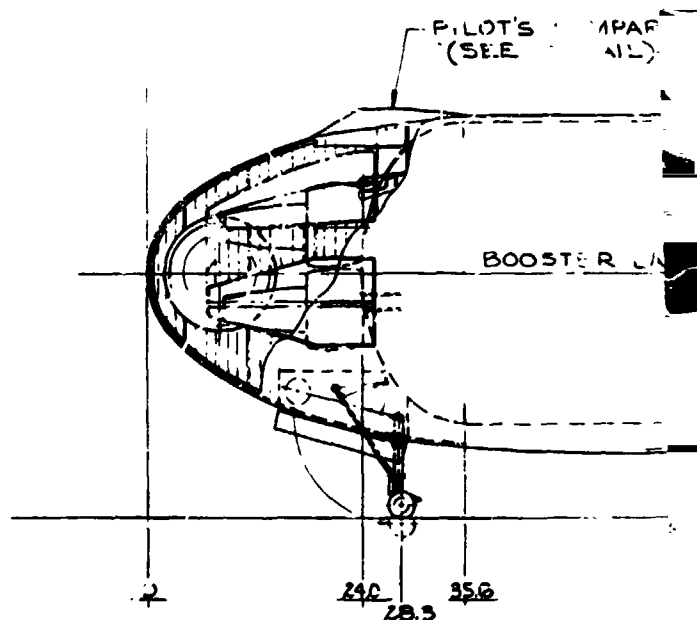
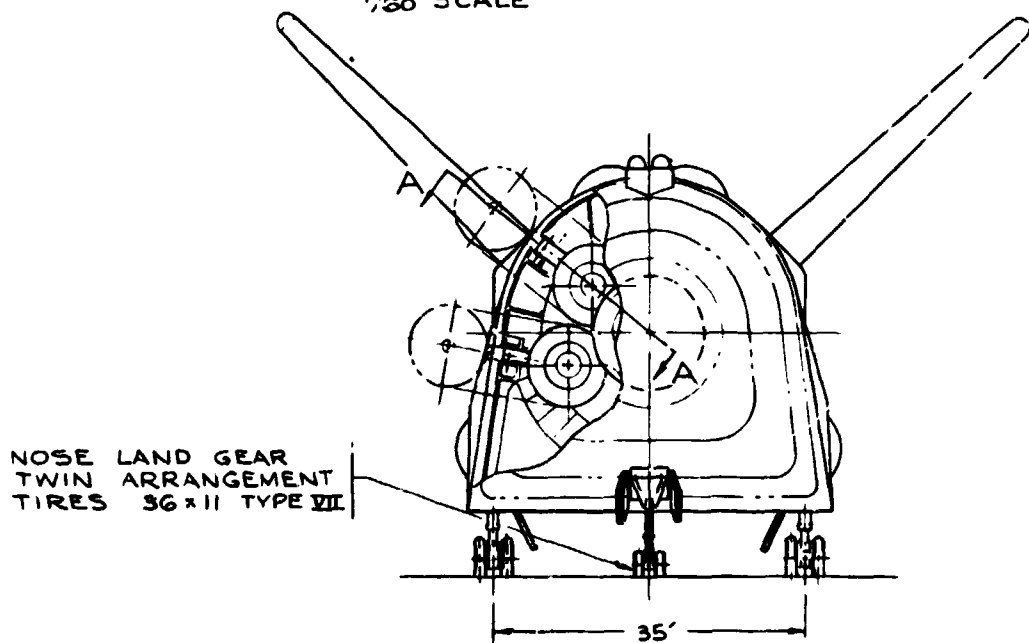

FOLDOUT FRAME |

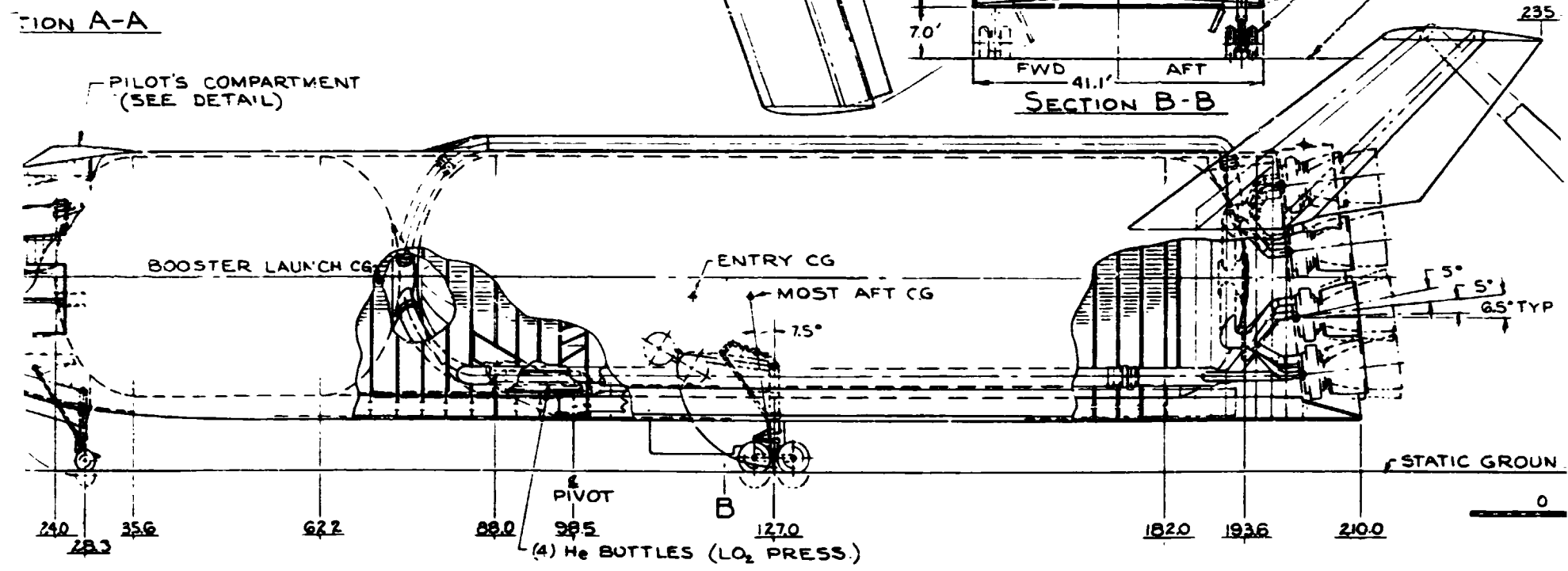
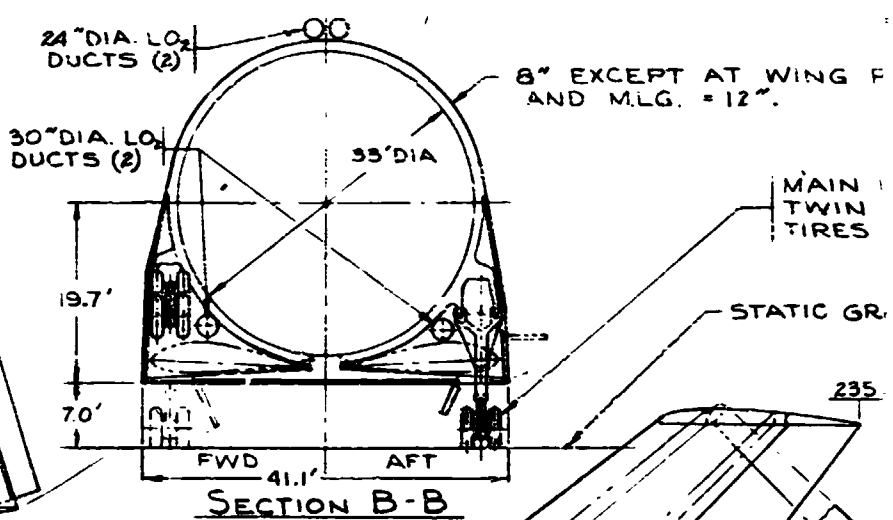
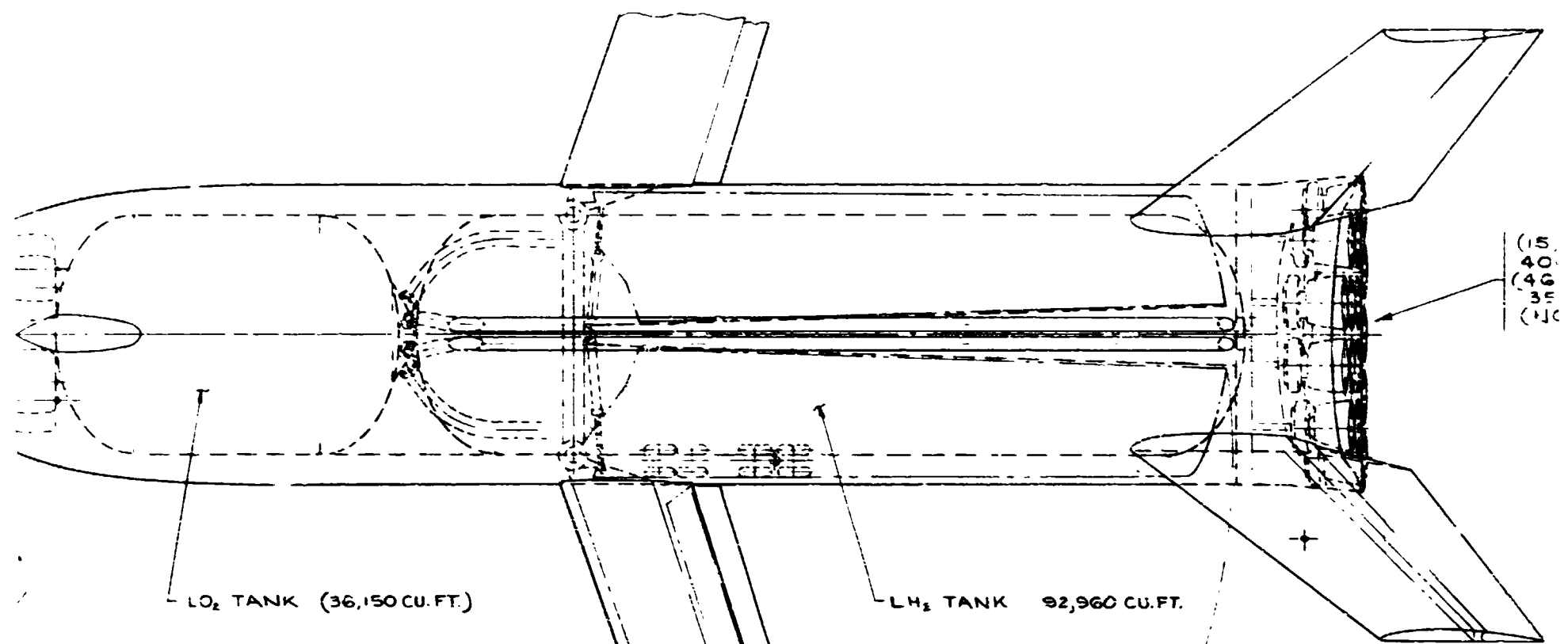

FOLDOUT FRAME 2

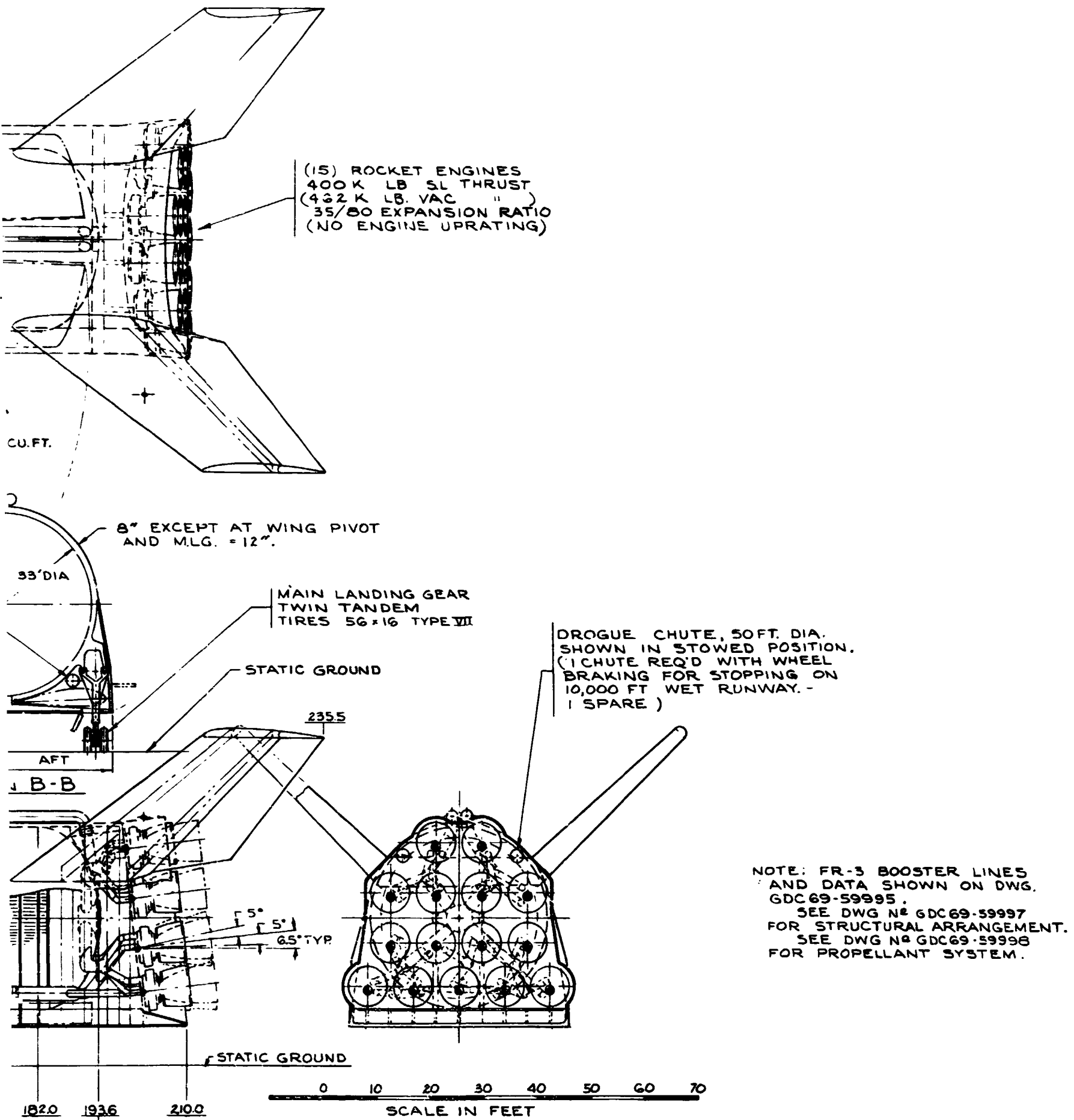

Figure 2-24. FR-3 Vehicle Configuration

Table 2-11. Comparison of Orbiter Characteristics

	FR-4	FR-3	FR-3
	ORBITER	ORBITER	DIFF E
Weight (pounds)			
Propellant	825,500	628,600	-196,900
Flyback Fuel	3,200	2,900	-300
Structure	246,900	213,000	-33,900
Total*	1,161,100	925,600	-235,500
Landing	322,400	286,600	-35,800
Volume (ft ³)			
Fuel	19,100	15,000	-4,100
Oxidizer	10,000	7,600	-2,400
Propellant	29,100	22,600	-6,500
Total*	107,500	88,900	-18,600
Geometry			
Length (ft)	191	179	-12
Body Wetted Area (ft ²)	16,900	14,900	-2,000
Body Planform Area (ft ²)	5,560	4,900	-660
Propulsion			
T/W	1.22	1.53	+0.31
Number of Engines	3	3	0
Total Vacuum Thrust (pounds)	1,414,800	1,414,800	0

*Totals include other breakdowns besides those included in this table.

Table 2-12. Comparison of Booster Characteristics

	FR-4 Booster	FR-3 Booster	FR-3 Difference
Weight (pounds)			
Propellant	1,507,500	2,809,600	+1,302,100
Flyback Fuel	30,700	46,900	+ 16,200
Structure	294,800	469,700	+ 174,500
Total*	1,877,500	3,399,800	+1,522,300
Landing	324,600	517,300	+ 192,700
Volume (ft³)			
Fuel	49,800	92,900	+ 43,100
Oxidizer	19,400	36,100	+ 16,700
Propellant	69,200	129,000	+ 59,800
Total*	122,400	235,800	+ 113,400
Geometry			
Length (ft)	199	210	+ 10
Body Wetted Area (ft ²)	18,400	26,600	+ 8,200
Body Planform Area (ft ²)	6,070	8,170	+ 2,100
Propulsion			
T/W (Vehicle Launch)	1.46	1.39	- 0.07
T/W (Single Element)	1.9	1.77	- 0.13
No. of Main Engines	9	15	+ 6
No. of Jet Engines	3	4	+ 1

*Totals include other items not listed in this table

Table 2-13. Trajectory Data Comparison

	FR-4 Vehicle	FR-3 Vehicle	FR-3 Difference
Trajectory Data			
Max. αq (lb/ft ²)	658	670	+ 12
Staging Dynamic Press (lb/ft ²)	50	50	0
Relative Staging Velocity (ft/sec)	9,400	10,900	+ 1500
Staging Altitude (ft)	179,300	187,500	+ 8200
Relative Staging Flight Path Angle (deg)	5.8	2.2	- 3.6
Inertial Injection Velocity (lb/sec)	25,900	25,900	0
Injection Altitude (ft)	260,000	260,000	0

high-risk approach when compared to a nominal approach where reasonable manufacturing and test activities are allowed to pace the program. When considering sufficient time for a proper evaluation in the horizontal flight test phase, the initial operational flight data could slip into late 1977 or early 1978, as mentioned with respect to the baseline program of Section 2.2.

In general, the tooling, manufacturing, and testing phases will not change appreciably from the baseline program. Tooling sizes will differ, but the same basic approach is considered. Separate manufacturing production lines will still be required, although the specific test articles sizes and configurations may differ from those defined for the FR-4. The same number of booster and orbiter test articles will be required, except for the flight test program where the FR-3 has one less than the FR-4. However, the size of some FR-3 major ground test articles causes variations in their respective test facilities and locations.

The same high risk or potential problem areas identified for FR-4 apply to the FR-3 development program.

2.4.2 DESIGN, ENGINEERING, AND PROCUREMENT. Specific design and engineering activities are somewhat different for the FR-3, but the design and engineering milestones in the baseline schedules (Figure 2-4) are basically valid. Typical procurement milestones reflecting initial availability of subsystem hardware for test operations is also about the same, at least until specific subsystems are further defined, such as in Phase B and C.

The rocket engine development milestones would not be altered unless affected by the larger number required by the vehicle contractor for ground and flight testing. (FR-3 requires six additional rocket engines.) The fanjet engine requirements would also slightly increase because the booster requires four as opposed to three for the FR-4. However, this increase is considered to be of little significance to the engine development program.

2.4.3 TOOLING AND MANUFACTURING. The tooling and manufacturing approach is basically the same as described for the baseline (FR-4) approach in Section 2.2. Separate tooling is required for the orbiter and booster under both vehicle concepts, although tool sizes are necessarily increased to support the FR-3 booster subassembly and assembly requirements. The FR-3 orbiter is only slightly smaller than the FR-4 orbiter.

Separate assembly lines are also used in producing the booster and orbiter test and operational elements. However, due to the larger vehicle cross-section (41 feet wide by 37 feet high) and larger booster tank diameter (33 feet), the availability of adequate clearance assembly facilities may be limited. Adequate vertical clearances for the primary assembly operation could dictate the methods to be employed in this operation. A high-bay assembly area (probably a modification of existing contractor facilities) will be required for the vertical stabilizer installations. Because of size and complexity, the FR-3 booster will probably require a slightly longer production span than the FR-4 booster, but, this will not significantly alter the test hardware availability shown in Figure 2-4.

2.4.4 TEST PROGRAM. The FR-3 development test program is very similar to the content and scheduling of the baseline FR-4 concept (Figure 2-4). Specific deviations from the baseline schedule for the ground and flight test phases are discussed in this section. This program like that for the FR-4, will make maximum use of available test facilities within government and industry, especially for large ground-test facilities and for the flight-test sites. This becomes even more demanding because of the larger dimensions of this booster, but also constrains the current capability of some of the existing facilities. The capability of adequate modification to these facilities must be re-assessed when a specific Phase B configuration is explored.

2.4.4.1 Ground Test Program. The FR-3 will require dual test articles for most major ground tests; i. e. , static and fatigue tests, thrust vector control, attitude control, flight controls, propellant management or cold-flow tests, static-firing tests. A slight increase in test activity spans and manpower requirements may be expected, primarily due to the increased size of the booster, but this effect is insignificant. Sharing of test facilities between the booster and orbiter will be limited to the subsystem test areas because of the relatively large difference in sizes of the booster and orbiter element and because parallel testing is required to support a tight target date for operational flights.

There is even greater emphasis on subassembly testing of the static structural and fatigue test articles as opposed to total vehicle tests. The nature of the tests and the large size of the elements lean more toward the subassembly approach when considering the capability of existing test facilities and the advantage gained in simultaneous testing capability to meet the early operational date. Tank fatigue tests will require simultaneous test stand capability to meet the early operational date. Tank fatigue tests will require simultaneous test stand capability for the orbiter and booster tanks. The primary difference over the FR-4 test requirements is that the booster now has two individual propellant tanks (which are larger in diameter) instead of one integrated LO₂/LH₂ tank. The aft tanks in either element would be a stub-tank configuration. Either four test stands would be needed for simultaneous testing of all four tanks (two in booster and two in orbiter) or sequential testing must be performed in two stands, extending the total tank test spans. The extension would not impact the total structural test span as shown in Figure 2-4, however.

FR-3 fuel, flight controls, hydraulic, and orbiter subsystem testing will require somewhat larger test articles, but the activities displayed in the baseline schedule are basically valid. The impact of booster size on major ground test facilities is summarized in Section 2.4.5.

The level of detail reflected in Figure 2-4 for the wind tunnel, materials development, and component development and qualification programs would not show the differences involved when considering the specific designs of the FR-3 vehicle elements.

2.4.4.2 Flight Test Program. The total flight test program span will remain the same as shown in Figures 2-4 and 2-15 because the availability of the flight test elements should not differ significantly from the baseline and because of the tight operational target date and the need for the same type of test flights. Since the FR-3 concept has structurally different orbiter and booster elements, both must be evaluated and demonstrated in flight; thus, the same horizontal and vertical flight phases are required. Four horizontal flight test articles (two orbiter and two booster) would be required for much the same reasons given for the FR-4 vehicle. A total of six elements (three booster and three orbiter) are necessary for the total flight test program, with at least two boosters and two orbiters used in the operational program at conclusion of the R&D phase. Since only one booster is required for the multi-element (total vehicle) configuration, only two elements need be held back to provide a launch capability for operational phase backup testing. Then, as for the baseline program, this vehicle would later be outfitted as an operational vehicle. Again, all flights are manned and all vehicles fully reusable.

- a. **Horizontal Flight Phase.** The four test articles required reflect the same reasoning as used for FR-4; i. e., at least two of each basic type of flight article is required, and the booster and orbiter fall in this category. If anything, the horizontal flight test phase for the FR-3 should be longer than that planned for the FR-4 because of the greater relative differences between the boosters

and orbiters. Even the baseline horizontal flight phase is considered tight relative to the aircraft flight-test months attainable. That program was shortened to a bare minimum so as to fall within the constraining elements of the operational target date and the production availability of test articles, and yet maintain a reasonable number of total R&D test vehicles. The FR-3 booster has a larger volume and an increase of at least 50 percent in landing weight over the FR-4 (Table 2-12).

- b. Vertical Flight Phase. The vertical launch test flights outlined under the FR-4 test program are equally applicable to the FR-3 program, even though vehicle geometry is rather different. The flight maneuvers beyond separation or staging are essentially the same. Using only two elements instead of three for each vehicle launch will impact the number of booster/orbiter elements to be in the postflight turnaround cycle at any one time, but its immediate effect on maintenance and servicing facilities is not fully apparent without also considering the required launch rates.

Single-element vertical launches are also used with this configuration for incrementally exploring the flight envelope from the high subsonic regime to the full mission maneuver. For the FR-3, however, it seems advisable to use an orbiter element rather than a booster for this phase for the following reasons.

1. To fit orbiter TPS panels to a larger booster would create excessive new designs and tools not otherwise warranted.
2. The orbiter thrust-to-weight ratio is high enough when excluding the payload; the booster would require excessive ballast to approach its thrust-to-weight ratio when in the total vehicle configuration.

Even so, the orbiter must be fitted with the booster engine exhaust nozzles for sea-level launch, and extra flyback fuel tanks must be added. This area will need to be explored further prior to and during the Phase B activities, but it seems reasonable that enough of the desired flight envelope can be obtained to make the approach worthwhile.

The booster element would at least be checked out in this flight mode initially, prior to the first multi-element launch.

The multi-element launches will remain the same as for the FR-4 program except, of course, for the launch vehicle configuration. Table 2-13 compares the differences between the flight trajectory parameters for the two- and three-element launch vehicles. Maximum q is slightly increased for the FR-3 concept, but staging q remains at 50 psf. Staging velocity and altitude are only slightly increased over those for the FR-4 configuration. In general, these differences should not vary the type or number of flight tests shown.

2.4.5 TEST FACILITIES. Test facilities required for the FR-3 vehicle will not differ appreciably from those described for the FR-4. Exceptions are:

- a. Static firing of the FR-3 booster cannot be accomplished within the MTF S-1C Test Stand because of the 41-foot envelope required for the fuselage. The MSFC S-1C stand may be usable if it can be extended vertically to accept a 186-foot-long vehicle.
- b. A 60-percent increase in the volume of fuel required for firing tests will be necessary. Similar increases will be required for structural tank testing (cryogenic cycling).
- c. Vertical launch tests will have a much smaller impact on launch facility construction schedules if Complex 39 is used, because much of the existing facility requires little or no modification. (Figure 2-25). Volume IX describes the launch facilities required for the FR-3 vehicle.

Table 2-14 reflects the general test facility requirements and probable existing capability for both the FR-3 and FR-4 vehicle concepts.

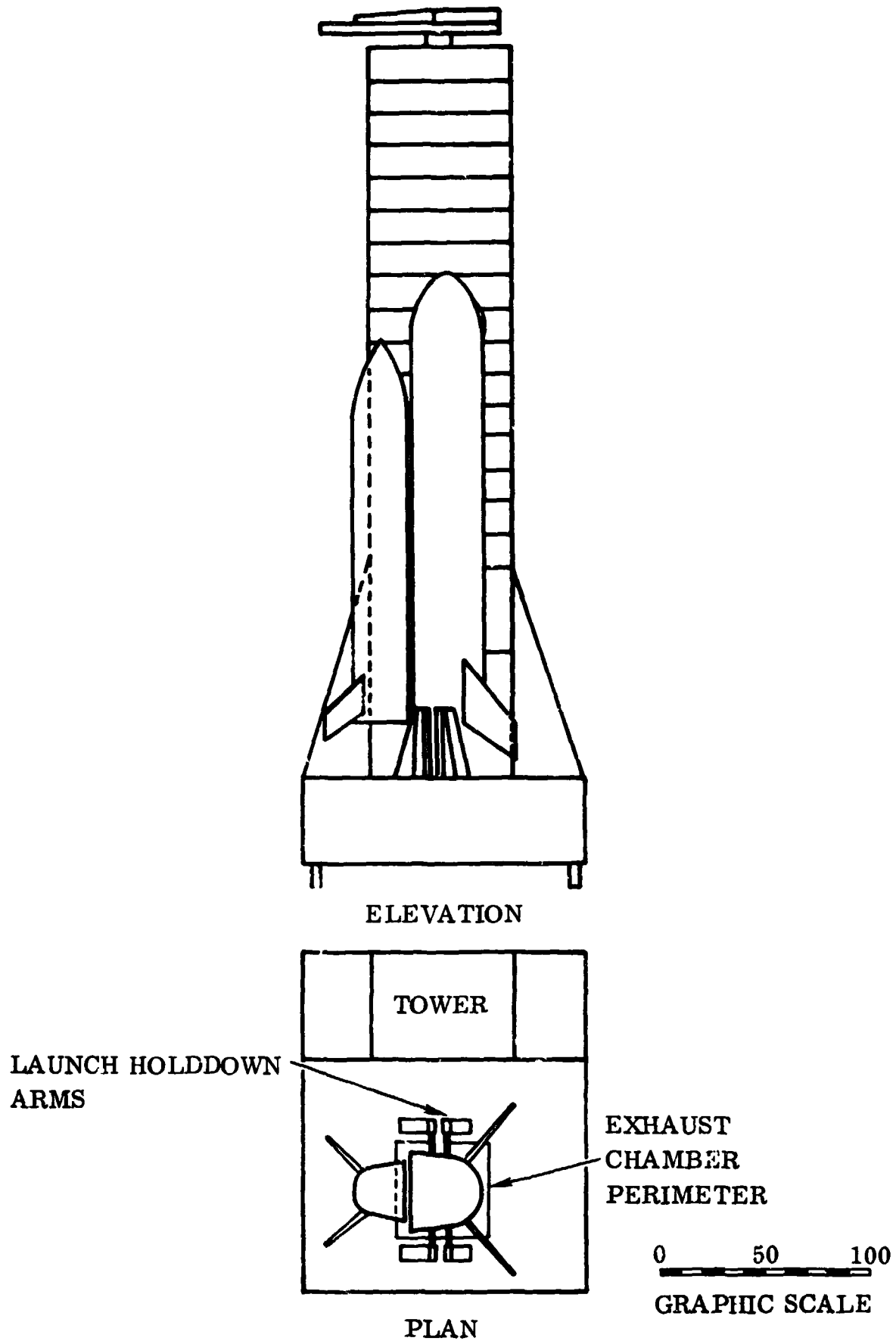

Figure 2-25. FR-3 Space Vehicle Superimposed on Saturn V LUT

Table 2-14. Test Facility Requirements for FR-3 and FR-4 Space Shuttle Vehicle

Test	Type of Facility Required	Location
Wind Tunnel	High and low speed tunnels	Contractor facility
	Plasma Arc tunnel	MSFC
	Hypersonic shock tunnel	
Material development	Environmental test lab	Contractor facility
Component development	Component test lab	Contractor facility
Structural static load test	Test tower and hangar	MSFC static load test facility (Contractor hangar for wing test)
Structural fatigue test		
Cryogenic cycling	Test Tower	None suitable existing
Acoustic	Cryogenic propellant Loading equipment 180ds acoustic chamber	Contractor/or MSFC Houston MSC, acoustic test facility
Jet fuel system tests	Jet engine test facility	Contractor facility
Flight control subsystem test	Vehicle skeleton mockup	Contractor facility
Electrical subsystem test	Electrical test equipment	Contractor facility
R&D crew escape test	Compartment mockup	Contractor facility
Thrust vector control test	Test stand	Contractor MSFC Static test facility
Attitude control subsystem test	Hangar building	Contractor facility
Docking simulation tests	Docking simulator	MSC simulation laboratory
Cargo & Ground Handling test	GSE test facility	MSFC GSE test facility
Propellant flow & vehicle static firing	Large static firing test facility	MTF S-IC test stand*
Ground vibration tests	Hangar	Contractor facility
Human factors test	Life science support facility	Contractor facility
Avionics integration tests	Electronics lab	MSC Houston
Environmental control tests	Space vacuum chamber	MSC chamber A
Horizontal flight tests	Aircraft test facility	Edwards AFB, Calif.
Vertical launch tests	Launch complex	ETR, Florida

*FR-3 booster cannot be accommodated at MTF S-IC stand. It can be tested at MSFC S-IC stand if stand is modified.

SECTION 3 COST ANALYSIS

In conjunction with design, development, and operations studies of the space shuttle, an analysis was performed to determine the cost of developing, procuring, and operating the candidate systems. The costs were generated using Convair-developed cost estimating relationships (CERs) and methodology. This section presents the cost analysis results for the final FR-3 and FR-4 configurations and a discussion of Convair CERs and methodology. Tables 3-1 and 3-2 present summary total program costs for the FR-3 and FR-4 configurations. The relationship of program costs to variations in annual traffic rates is shown in Figures 3-1 and 3-2. These costs represent total cost to the government for development, production, and ten years of operation (excluding mission-associated costs such as range operations, and payload costs). In addition to the baseline vehicle cost analyses, the sensitivity of program cost to variations in vehicle design characteristics for both the FR-3 and FR-4 vehicle configurations was investigated.

3.1 COST METHODOLOGY

System costs were synthesized using parametric CERs and point estimates. Parametric CERs were generated for hardware cost elements and subsystem development tasks by collection and analysis of cost data from various hardware and study contracts and proposals, together with CERs developed by research institutes, other contractors, and government agencies. Some cost estimates (test operations, facilities, operational personnel, etc.) were generated from direct estimates of the requirements (number of personnel, etc.) for the system under consideration.

Convair's Advanced Vehicle Systems Evaluation Model (AVSEM) cost model, Reference 3-1, was modified for use in analyzing reusable space transportation system costs. The model generates costs in three major categories: development, investment, and operations. The model uses vehicle configuration data (e.g., weights, engine thrust, number of engines), program plan data (number of equivalent test articles, number of production units, etc.) and operational requirements (manpower, recycle times, etc.) to generate detailed total program costs.

3.1.1 GROUND RULES AND ASSUMPTIONS. The following are the ground rules and assumptions for the cost study.

- a. Costs are expressed in constant 1969 dollars and include contractor overhead, burdens, and fee.

Table 3-1. FR-3 Configuration — Total Program Cost

COST ITEM*	ANNUAL LAUNCH RATE		
	25	50	100
Development	5231	5231	5231
Investment	378	435	878
Operations	697	1151	2084
Total	6306	6867	8193

*Costs in millions of dollars

Table 3-2. FR-4 Configuration — Total Program Cost

COST ITEM*	ANNUAL LAUNCH RATE		
	25	50	100
Development	4883	4883	4883
Investment	584	694	1141
Operations	830	1387	2535
Total	6297	6964	8559

*Costs in millions of dollars

- b. No NASA headquarters or centers costs are included in program costs.
- c. One airframe contractor was assumed to develop both the booster and orbiter elements.
- d. The airframe contractor is the system prime contractor; however, rocket and jet engine development and hardware are government direct purchased items.
- e. Development facilities, tooling, etc. are the minimum required to demonstrate operational capability, but will be suitable for operational program use.
- f. The cost of flight test vehicle hardware and GSE that is acquired and used during development and later transferred to the operational program is included in the development costs.

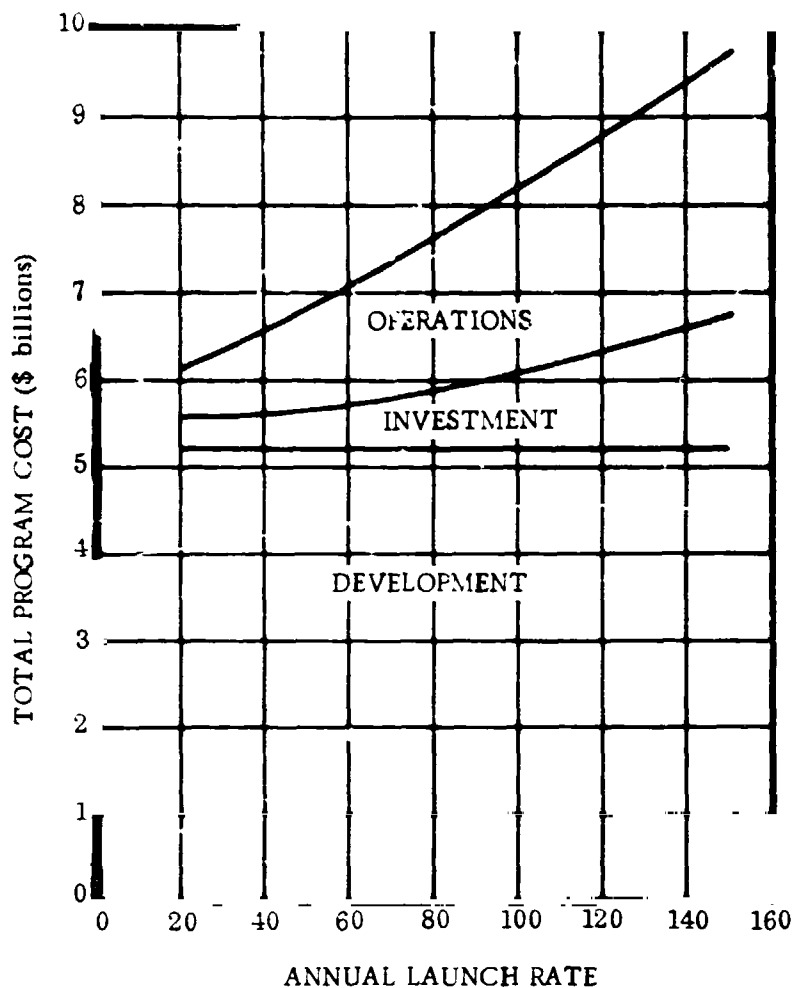

Figure 3-1. FR-3 Total Program Cost Versus Traffic Rate

- g. Two flight-test orbiter elements and two booster elements will be transferred to the operational program from the FR-4 development program. Two boosters and two orbiters will be transferred to the operational program from the FR-3 development program.
- h. Rocket engines are without idle mode capability and use different nozzle extension configurations for booster and orbiter application.
- i. Manufacturing facilities are assumed to be available.
- j. Operational program costs are based on 10 years of steady-state operations at 25, 50, and 100 launches per year.
- k. All launch rates assume two pads operational (one pad with a standby vehicle).

- l. Operational vehicle inventories are sized according to turnaround time spans, orbital stay times, and standby vehicle requirements.
- m. The seven-day mission was used to determine orbiter inventory.
- n. Unlimited vehicle life is assumed for determination of vehicle inventory.
- o. Operations manning for the FR-3 is assuming to be 80% of the FR-4 manning.

3.1.2 UNIT HARDWARE COST. In generating cost estimates for the FR-3 and FR-4 systems, primary attention was given to the theoretical first unit (TFU) hardware cost. As subsystems were defined, their characteristics were reviewed to determine if cost data were available on analogous systems, to appraise the validity of existing CERs, and (if necessary) to request vendor cost estimates.

Because of the size of the thermal protection system, its cost was of special interest. The materials used represent an advancement in the state-of-the-art of both development and fabrication techniques. Radiative TPS cost analyses have been undertaken by McDonnell Douglas (References 3-2, 3-3, and 3-4), Martin (Reference 3-5), and Convair (Reference 3-6). While costs are not in specific agreement, two things are apparent: costs are generally stated in terms of area rather than weight, and efficiencies of scale appear to be sensitive to panel size rather than the total TPS area.

The thermal protection system used on the FR-3 and FR-4 vehicles is estimated to cost approximately \$480/ft² for fabrication cover panels plus \$200/ft² for installation. The vehicle insulation is estimated to cost \$50/ft² for installation. Although booster and orbiter cover panels are of different materials, the material cost differences do not appreciably affect the average cost per square foot.

The first article cost CERs that were developed or adopted for use on FR-3 and FR-4 vehicles are shown in Table 3-3.

3.1.3 DEVELOPMENT PROGRAM COST.

An investigation was made of development costs at the subsystem level. The level at which engineering design and development costs were generated is:

- Basic Vehicle
- Thermal Protection
- Landing Gear
- Electrical
- Reaction Control
- Crew Systems
- Environmental Controls & Life support
- Guidance and Navigation
- Communication
- Onboard Checkout and Instrumentation
- Rocket Engines
- Jet Engines

These categories include engineering personnel and laboratory test hardware but do not include vehicle ground test and flight test hardware.

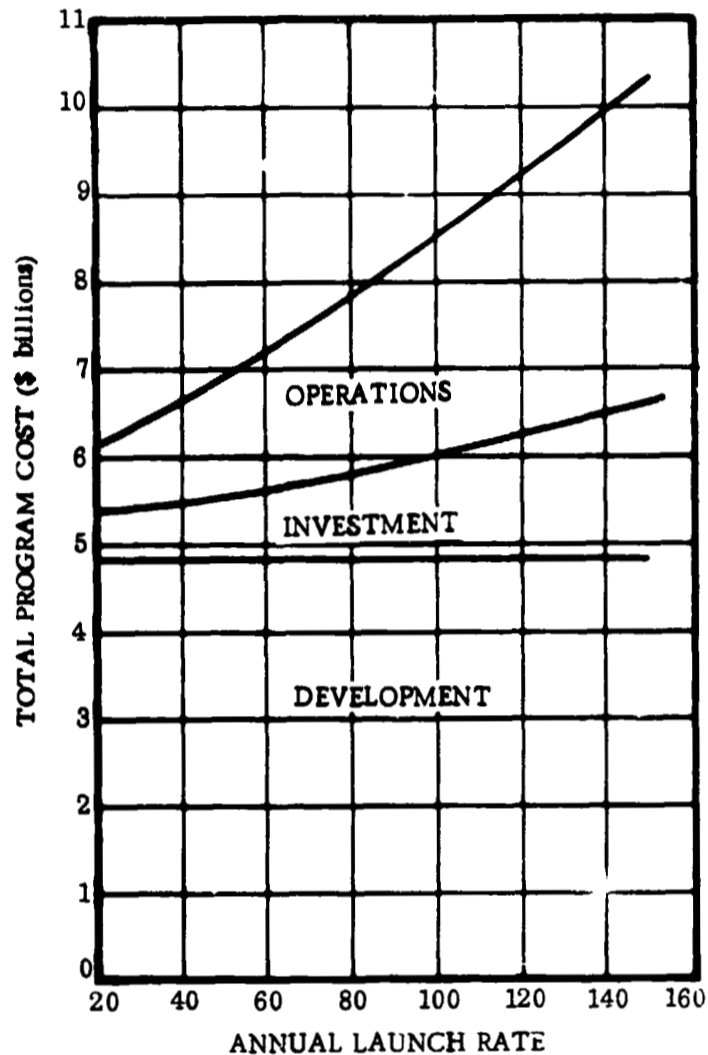

Figure 3-2. FR-4 Total Program Cost Versus Traffic Rate

Table 3-3. First Unit Cost Estimating Relationships

CATEGORIES	CERs (for costs in millions)
Wings	$0.00782 W^{0.7}$
Vertical Surfaces	$0.00782 W^{0.7}$
Horizontal Surfaces	$0.00782 W^{0.7}$
Fairings	$0.00782 W^{0.7}$
Integral Fuel Tanks	$0.00252 W^{0.7}$
Integral Oxidizer Tanks	$0.00252 W^{0.7}$
Basic Body Structure	$0.00782 W^{0.7}$
Thrust Structure	$0.00923 W^{0.7}$
Secondary Structure	$0.000175 W$
Radiative Cover Panels	$0.000682 A$
Vehicle Insulation	$0.000065 A$
Landing Gear	$0.00094 W^{0.8}$
Docking Structure	$0.0005 W$
Rocket Engines	$0.0037 \left(F_{vac} \right)^{0.527}$
Nonintegral Fuel Tanks	$0.00252 W^{0.7}$
Nonintegral Oxidizer Tanks	$0.00252 W^{0.7}$
Secondary Fuel Tanks	$0.00252 W^{0.7}$
Secondary Oxidizer Tanks	$0.00252 W^{0.7}$
Propellant Insulation	$0.000903 W^{0.668}$
Fuel System	$0.0076 W^{0.7}$
Oxidizer System	$0.0076 W^{0.7}$
Pressurization and Purge	$0.0076 W^{0.7}$
Airbreathing Engines	$0.000243 \left(F_{SL} \right)^{0.8737}$
Airbreathing Fuel System and Tankage	$0.00176 W^{0.7}$
Separation and Staging	$0.0091 W^{0.555}$
ACS System	$0.0318 W^{0.645}$

Table 3-3. First Unit Cost Estimating Relationships (continued)

CATEGORIES	CERs (for costs in millions)
ACS Tankage and Systems	$0.0348 W^{0.512}$
Power Sources, Tankage, and Electrical Power Conversion	$0.0703 W^{0.493}$
Hydraulic Power Conversion and Distribution	$0.0156 W^{0.555}$
Aerodynamic Control	$0.0162 W^{0.555}$
Guidance and Navigation	$0.3041 W^{0.485}$
Onboard Checkout and Instrumentation	$0.016062 W^{0.5956}$
Communication	$0.1032 W^{0.5743}$
Environmental Controls and Life Support	$0.00855 W^{0.84}$
Personnel Provisions	$0.0002 W$
Crew Station Controls and Panels	$0.0015 W$
Final Assembly and Checkout	14.5% of Subsystems TFU Less Engines & Avionics

$W = \text{weight in pounds, } F = \text{thrust in pounds, } A = \text{area in ft}^2.$

Convair's propulsion costs are based on the assumption that the engine contractors will be funded directly by the contracting agency, and that the airframe contractor would add no cost overrides to the propulsion costs. Therefore, the rocket and jet engine development and hardware cost includes only engine contractor burdens, fee, and overhead.

The basic vehicle category includes all structure and subsystems that are not specifically identified by another category. All of the above engineering design and development costs were generated using parametric CERs. Table 3-4 shows the specific CER used for each of these categories.

The development cost of booster subsystems that are similar to those in the orbiter element are reduced by a commonality factor (C) as shown below:

$$\text{Net booster subsystem cost} = (1 - C) \times \text{gross booster subsystem cost}$$

$$\text{where } C = \frac{\text{weight of subsystem common pieces}}{\text{total subsystem weight}}$$

Program costs that were not estimated parametrically (e.g., system ground tests and flight tests) are dependent on a development program plan. Point estimates were made of test hardware requirements, test manning, etc., and costs were estimated based on these figures.

Table 3-4. Development Cost Estimating Relationships

CATEGORY	CERs (for costs in millions)
Contract Definition - Contractor Segment	2 contractors, 390 men, 11 months @ \$0.0035/manonth
Systems Engineering and Integration	$0.01534 (W_{\text{dry}})^{0.7544*}$
Engineering Design and Development	
Basic Vehicle	$64.0 (\text{Airframe TFU})^{0.308}$
Landing Gear	$0.001643 W^{0.8}$
Thermal Protection System	$0.0506 W^{0.675}$
Electrical Power	Booster: $(1-C) \times 0.0716 W^{0.765}$ Orbiter: $1.022 W^{0.48}$
Attitude Control	$1.423 W^{0.5}$
Crew Systems Furnishings, Controls & Displays	$0.3473 W^{0.525}$
Env. Control and Life Support	$0.8567 W^{0.48756}$
Guidance and Navigation, Incl. Autopilot	$(1-C) \times 3.797 W^{0.4084}$
Communication	$(1-C) \times 1.720 W^{0.412}$
Onboard C/O and Instrumentation	$0.644 W^{0.365}$
Rocket Engines	$0.1215 (F_{\text{vac}})^{0.65}$
Jet Engines	Input cost determined outside model
Systems and Ground Tests	
Operations	Man months \times \$0.0025/man month

* W_{dry} = element dry weight

Table 3-4. Development Cost Estimating Relationships (continued)

CATEGORY	CERs (for costs in millions)
Hardware	No. of equivalent elements × TFU of element
Propellants & Gases	$\$0.15 \times 10^{-6}$ /pound
Tooling	6.96 (Airframe TFU) ^{0.52}
AGE Design & Development	0.2 (total airframe engineering design & development)
AGE Cost Per Stage	3.00 (Stage TFU) ^{0.288}
Flight Tests	
Operations	Man months × \$0.0025/man month
Mission Control	1.25 years × \$3M/yr
Hardware	No. of equivalent elements × TFU element
Propellants & Gases	$\$0.15 \times 10^{-6}$ /pound
Facilities	
Ground Test	Direct input determined outside model
Flight Test Complex	Direct input determined outside model
Training	
Trainers	0.2 (element TFU)
Simulators	Direct input determined outside model
Training Program Development	1.0 (simulators and trainers cost)

For the FR-3 configuration, 3.5 equivalent booster elements and 4.4 equivalent orbiter elements are required for the ground test program test hardware. For the FR-4, 3.65 equivalent booster elements and 4.4 orbiter elements are required. In the flight test program, the FR-3 requires 4.56 equivalent booster elements and 6.03 equivalent orbiter elements for flight test hardware and spares. The FR-4 requires 4.2 equivalent booster elements and 4.2 equivalent orbiter elements. Both the FR-3 and FR-4 require three sets of AGE with associated spares.

3.1.4 INVESTMENT COST. The estimation of investment costs requires application of appropriate cost improvement (learning) curves to the TFUs for the hardware quantities required for the operational program. The log-linear unit cost improvement curves assumed are presented in Table 3-5 together with the relationships used to derive the cost of spares and GSE.

Table 3-5. Investment Cost Estimating Relationships

CATEGORY	COST BASIS
Flight Hardware (by major category)	TFU of category with the following cost improvement applied. 0.90 for structure 0.90 for subsystems 0.95 for rocket engines 0.90 for jet engines 0.95 for avionics
Spares	Fraction of investment flight hardware: 0.1 Airframe Structure 0.1 Airframe Subsystems 0.3 Rocket Engines 0.3 Jet Engines 0.1 Avionics
GSE	2 additional operational sets for each stage, 0.95 learning

The development tooling, which is sufficient for production of test hardware, is also adequate for the production of the operational vehicle fleet.

3.1.5 OPERATIONS COST. The operations cost CERs are shown in Table 3-6. The manning estimates shown are based upon the analysis performed by Pan American World Airways (Reference 3-7). This analysis covered the manpower levels required by a three-element vehicle (FR-4) for an annual traffic rate of 100 launches per year. Figure 3-3 shows the manning levels used for other launch rates. As can be seen, certain minimum crew sizes were estimated for the different functions. Based on the relative difference in size and number of elements it was assumed that the manning level for the FR-3 vehicle configuration is 80% of that required for the FR-4.

Table 3-6. Operations Cost Estimating Relationships

CATEGORY	COST BASIS	
Launch Operations Personnel	FR-3	(FR-4)
25 launches per year	10 yrs. \times \$0.03/M-Y \times 59 men	(73 men)
50 launches per year	10 yrs. \times \$0.03/M-Y \times 59 men	(73 men)
100 launches per year	10 yrs. \times \$0.03/M-Y \times 59 men	(73 men)
Maintenance (Refurbishment) Personnel		
25 launches per year	10 yrs. \times \$0.03/M-Y \times 128 men	(160 men)
50 launches per year	10 yrs. \times \$0.03/M-Y \times 128 men	(160 men)
100 launches per year	10 yrs. \times \$0.03/M-Y \times 216 men	(270 men)
Operations Support Personnel		
25 launches per year	10 yrs. \times \$0.03/M-Y \times 252 men	(315 men)
50 launches per year	10 yrs. \times \$0.03/M-Y \times 268 men	(335 men)
100 launches per year	10 yrs. \times \$0.03/M-Y \times 300 men	(375 men)
Refurbishment Materials & Operational Spares (per flight)		
Structure	0.00035 TFU structure	
TPS Cover Panels	Booster: 0.02 TFU cover panels Orbiter: 0.0222 TFU cover panels	
TPS Insulation	0.02 TFU insulation	
Airframe Subsystems	0.005 TFU subsystems	
Rocket Engines	0.25 TFU rocket (per 100 flights)	
Jet Engines	0.005 TFU jet	
Avionics	0.005 TFU avionics	
Propellants and Gases	Vehicle load @ 0.15×10^{-6} /pound	
GSE Maintenance	5% of operational GSE cost per year	
Facility Maintenance	5% of operational facilities cost per year	

All Costs in \$ Millions
M-Y = Manyear

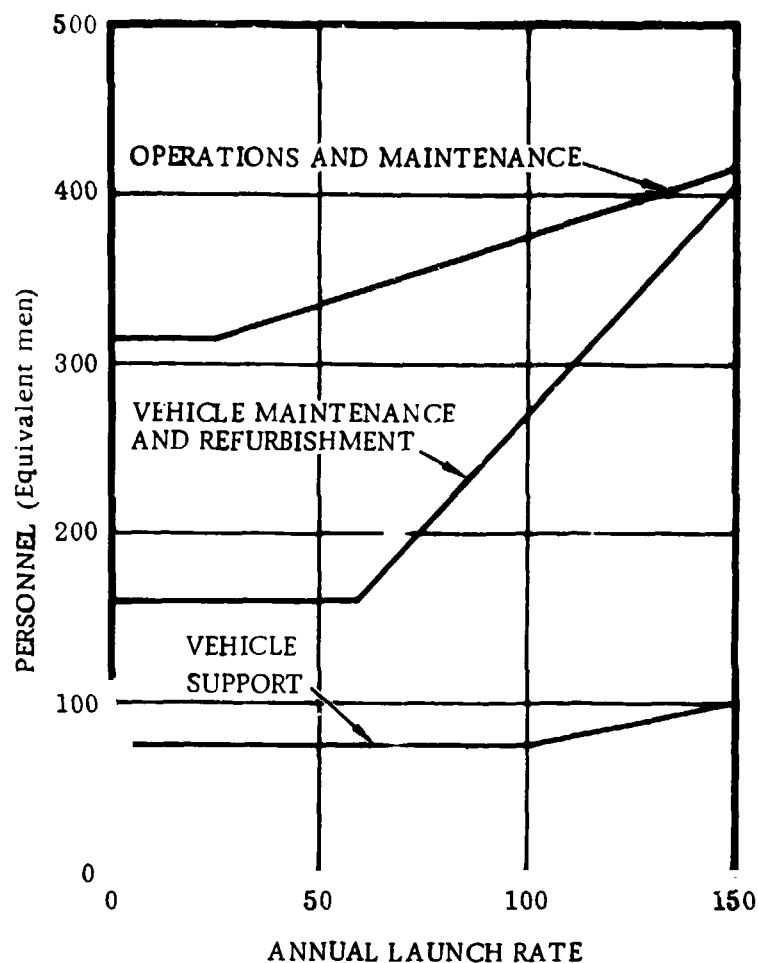

Figure 3-3. Operational Program Manning Levels

change in total program cost plotted against the change in the cost-sensitive parameter. In all cases the 0 cost point represents the baseline vehicle configuration.

The cost sensitivities associated with the FR-3 vehicle configuration appear in Figures 3-4 through 3-11. Figure 3-4 shows the cost impact of changes in inert weight of both the booster and orbiter. The much higher sensitivity of program cost to orbiter inert weight is a result of the cascading effect of stage weight growth on the stage below it.

Figure 3-5 shows the cost reduction that is associated with reducing the booster and orbiter contingency from the baseline 10% value to 0%. The cascading effect, once again, results in a greater orbiter sensitivity. The results shown in this figure must be tempered with the realization that the cost reductions shown could only be achieved if the vehicles were built without any weight growth and do not reflect the cost associated with expensive weight control programs that would probably be required if a vehicle were designed without an adequate allowance for weight increases.

The program cost sensitivity to variations in the unusable vehicle volume are shown in Figure 3-6. More unusable volume results in a larger, heavier vehicle and hence higher program costs. It can be seen that the orbiter is more sensitive than the booster to packing efficiency.

The refurbishment materials and operational spares factors were determined from estimates of wearout, replacement, and failure rates. This cost category was dominated by the allowance of an entire TPS replacement after 50 flights. In this manner, 1/50 of the TPS cost is charged to each flight. The orbiter was charged an additional 0.22% of the TFU per flight to account for the small areas of limited life materials.

3.2 COST SENSITIVITY ANALYSIS

The sensitivity of cost to changes in various vehicle design characteristics was analyzed for an annual traffic rate of 50 launches per year. The total program cost associated with variations in design characteristics was determined by costing out several synthesized vehicle configurations and comparing them to the baseline vehicle. The results of this analysis are shown as parametric sensitivity curves of the

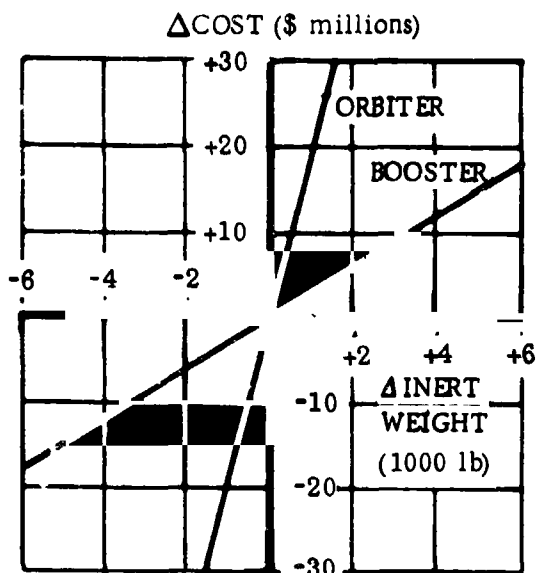

Figure 3-4. FR-3 Program Cost Sensitivity to Inert Weight

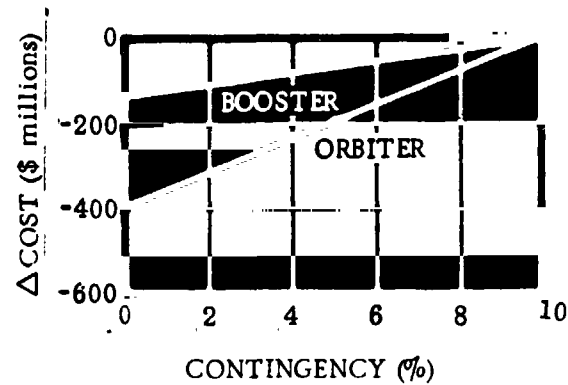

Figure 3-5. FR-3 Program Cost Sensitivity to Weight Contingency

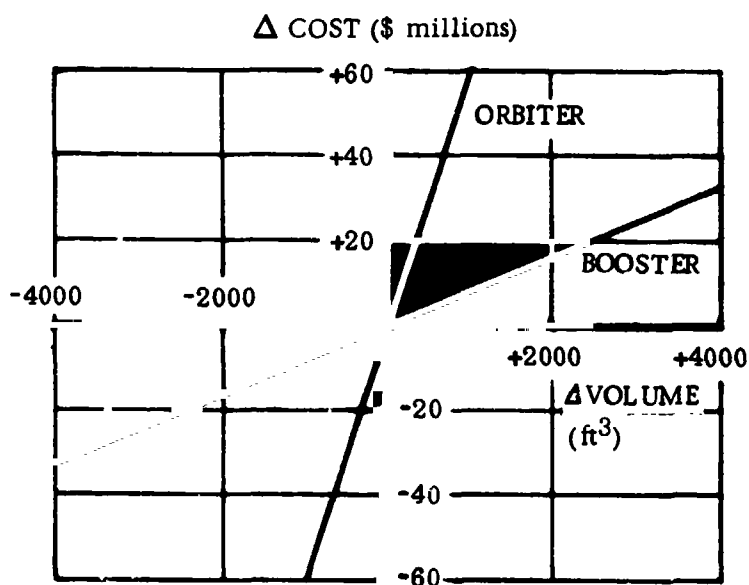

Figure 3-6. FR-3 Program Cost Sensitivity to Volumetric Efficiency

Figure 3-7 portrays the change in program cost with variations in payload weight. It should be noted that program costs are presented for 50 launches per year, and therefore, different payload weights represent different values of payloads to orbit per year.

Figure 3-8 shows the change in total program cost associated with varying the on-orbit ΔV requirement. The marginal cost of one fps of ΔV requirement about the baseline is approximately \$382,000 for the FR-3 configuration.

The sensitivity of cost to variations in staging velocity about the baseline system value is shown in Figure 3-9. This indicates that total program cost exhibits a decreasing trend as staging velocity is increased within the area of interest.

Figure 3-10 depicts the change in total program cost of the FR-3 configuration when the I_{sp} of the booster and orbiter are allowed to vary about the baseline value. As can be seen from the plot, a greater cost impact is associated with a given change in orbiter I_{sp} than in booster I_{sp} . This is due to the cascading effect of orbiter growth on booster size. When orbiter I_{sp} is varied the size of both the orbiter and booster are affected to a greater extent than when booster I_{sp} is altered.

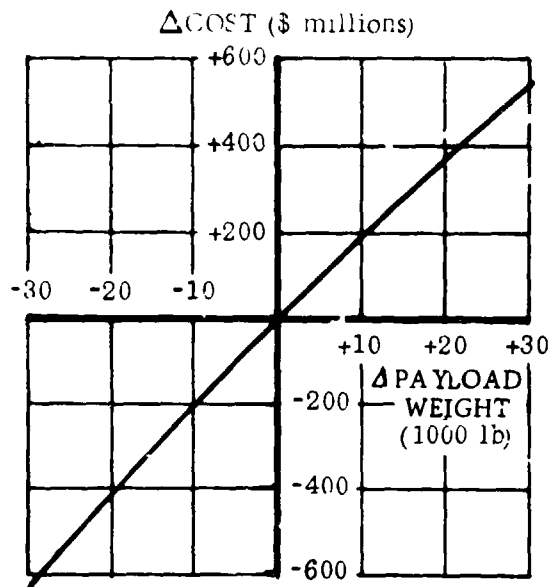

Figure 3-7. FR-3 Program Cost Sensitivity to Payload Weight

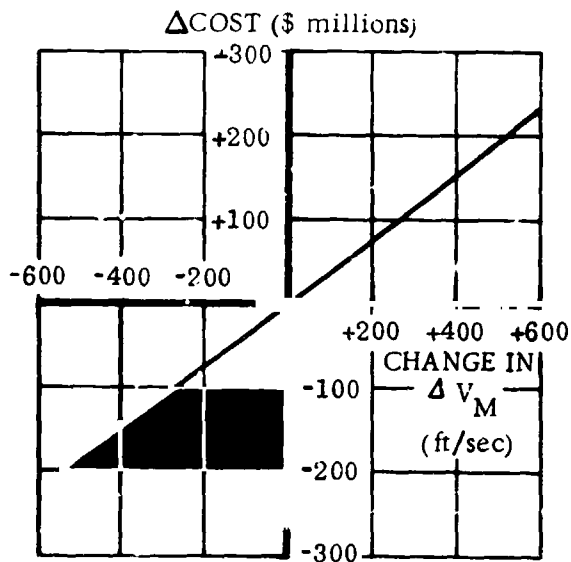

Figure 3-8. FR-3 Program Cost Sensitivity to Maneuver Δ Velocity Requirements

hand, the development cost of the FR-3 is higher than that of the FR-4. This is because although the FR-3 and FR-4 orbiters are quite similar in size, a smaller booster is developed in the case of the FR-4 since the boost function has been broken down into two identical hardware elements rather than one large one. (A detailed development cost comparison was tabulated and appears in Table 3-7.) Both the operations and investment costs are larger for the FR-4. This is the result of a larger total vehicle at liftoff, since the volumetric efficiency of two boost elements is not as good as for one element.

Figure 3-11 illustrates the change in total program cost associated with changes in vehicle flyback L/D. From this it can be seen that program costs are relatively insensitive to excursions in flyback L/D.

The same cost sensitivity analysis described above was also conducted on the FR-4 vehicle configuration. The results of this study are shown in Figures 3-12 through 3-19. The general comments for the FR-3 vehicle cost sensitivities also apply to the FR-4 with the exception of the ΔV requirement sensitivity, which exhibits a marginal cost of approximately \$400,000 per ft/sec of ΔV for the FR-4 vehicle.

In addition to the cost sensitivities presented in graphical form, an alternate payload size was also analyzed. The baseline vehicles were sized for a 15 foot diameter payload. If the vehicle were sized for a 22 foot diameter payload the impact on total program cost would amount to an increase of approximately \$240 million for the FR-3 vehicle and \$282 million for the FR-4 vehicle.

3.3 COMPARISON OF FR-3 AND FR-4

The total program costs (at 50 launches/year) for the FR-3 and FR-4 are compared in Figure 3-20. It can be seen that at this launch rate the FR-4 has a slightly higher total cost. On the other

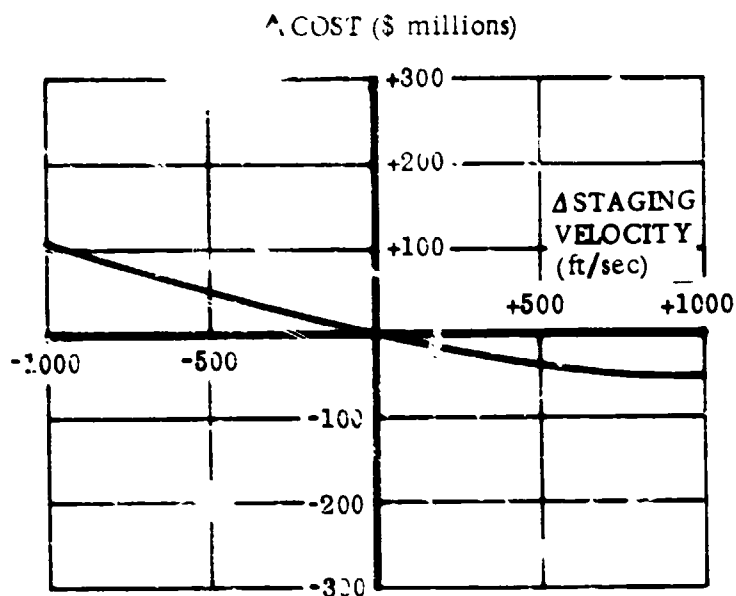

Figure 3-9. FR-3 Program Cost Sensitivity to Staging Velocity

The operations cost per launch for the two vehicles were also compared over a range of launch rates from 25 to 100 per year. This comparison appears in Figure 3-21. The greater volumetric and operational efficiency of one boost element rather than two results in lower per launch costs at all launch rates for the FR-3. A more detailed comparison of the recurring costs per launch for the two vehicles appears in Table 3-8.

Since a comparison of FR-3 versus FR-4 on a total program basis is dependent on the launch rate assumed, total program costs for the two systems have been plotted versus launch rate.

This comparison appears in Figure 3-22.

From this plot, it can be seen that at low launch rates (25 per year) the FR-3 and FR-4 have approximately the same total program cost. However, as the traffic rate is increased the higher recurring costs of the FR-4 begin to dominate and the FR-4 total program costs become progressively higher than those of the FR-3 configuration.

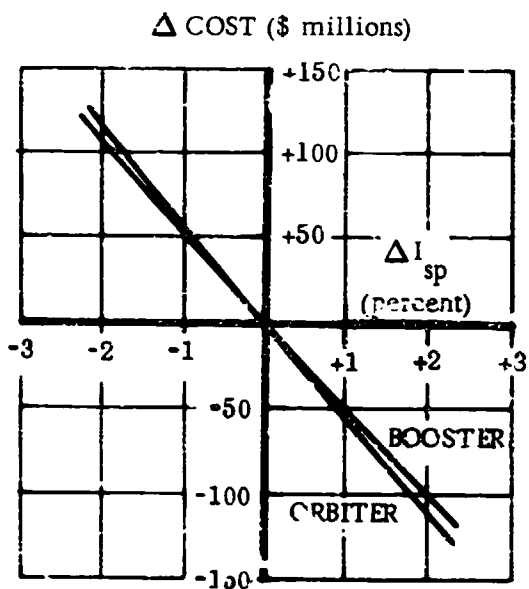

Figure 3-10. FR-3 Program Cost Sensitivity to Change in I_{sp}

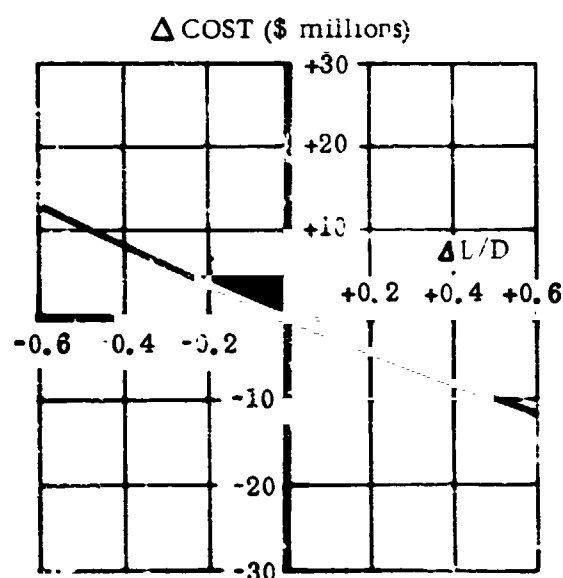

Figure 3-11. FR-3 Program Cost Sensitivity to Change in Flyback L/D

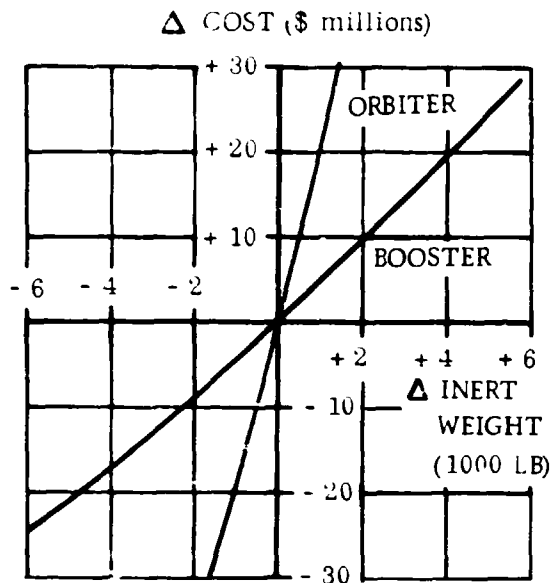

Figure 3-12. FR-4 Program Cost Sensitivity to Inert Weight

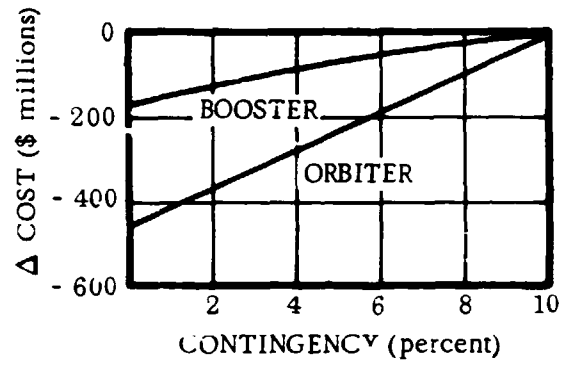

Figure 3-13. FR-4 Program Cost Sensitivity to Weight Contingency

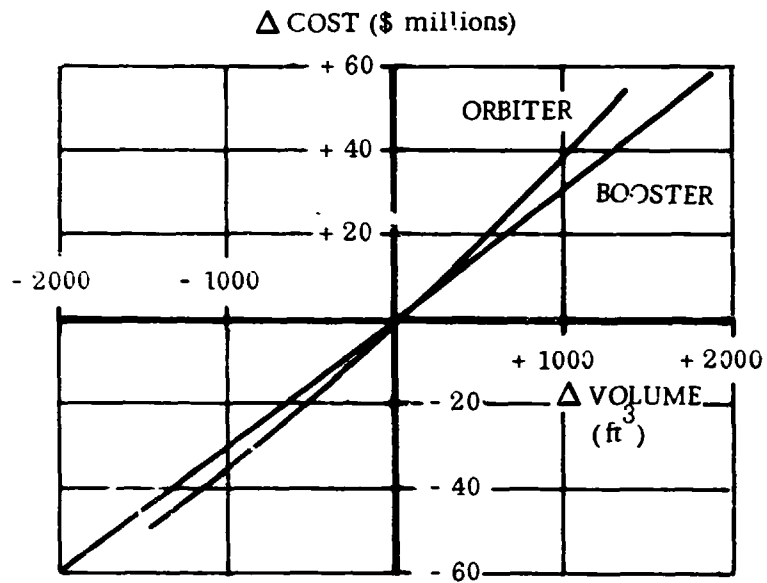

Figure 3-14. FR-4 Program Cost Sensitivity to Volumetric Efficiency

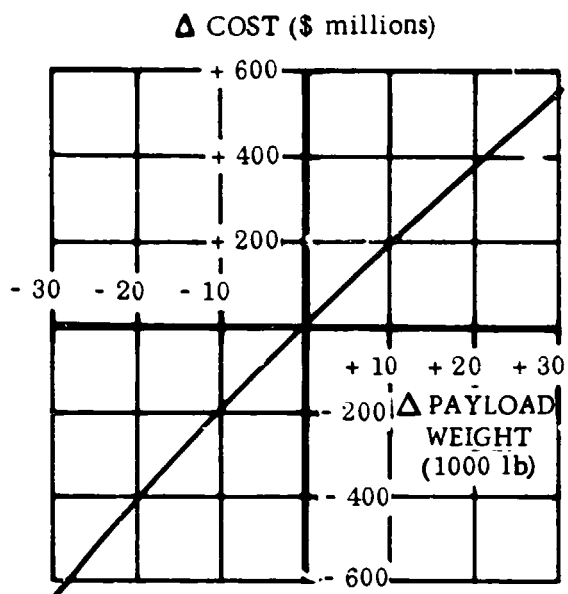

Figure 3-15. FR-4 Program Cost Sensitivity to Payload Weight

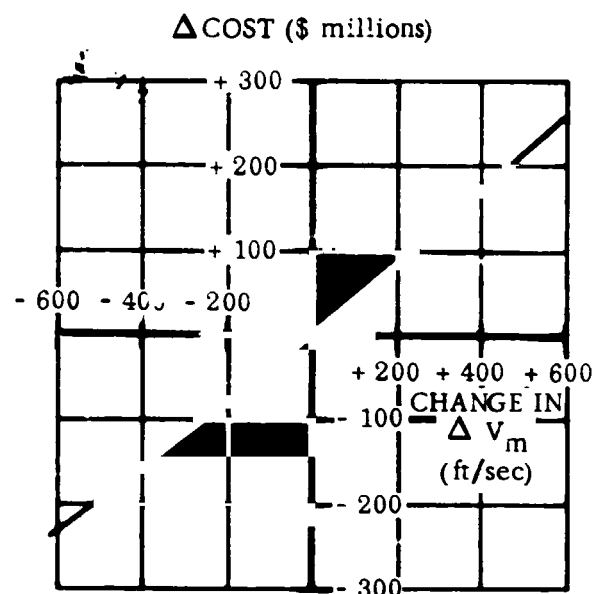

Figure 3-16. FR-4 Program Cost Sensitivity to Maneuver Δ Velocity Requirements

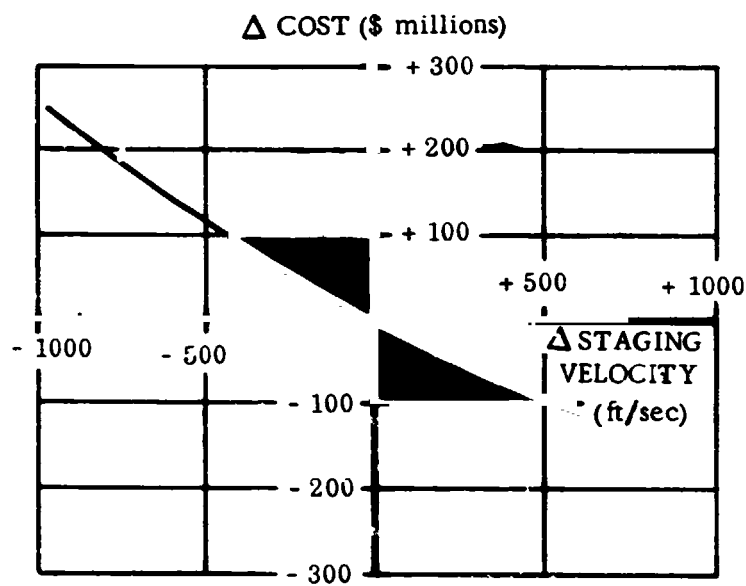

Figure 3-17. FR-4 Program Cost Sensitivity to Staging Velocity

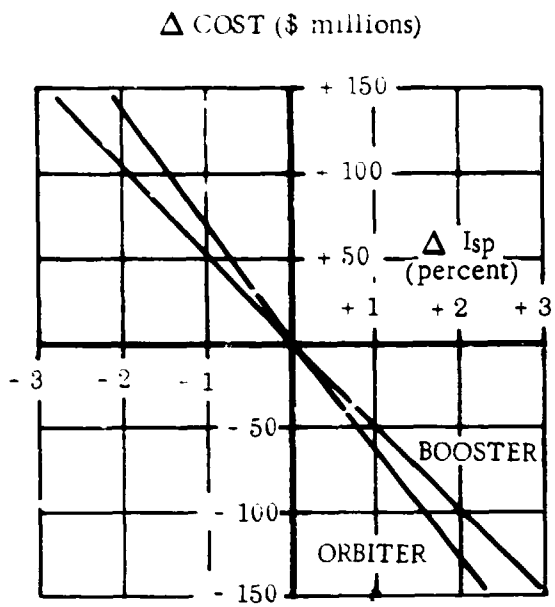

Figure 3-18. FR-4 Program Cost Sensitivity to Change in I_{sp}

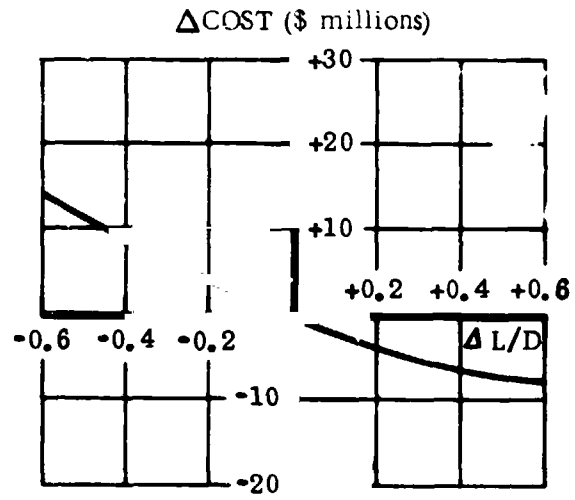

Figure 3-19. FR-4 Program Cost Sensitivity to Change in Flyback L/D

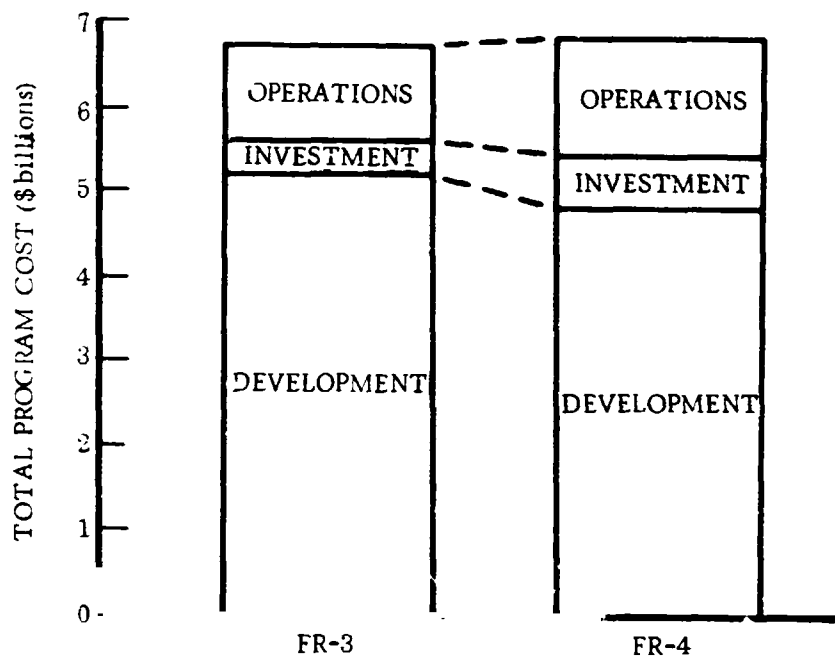

Figure 3-20. FR-3 and FR-4 Vehicle Total Program Cost Comparison (50 launches/year)

Table 3-7. Development Program Cost Comparison

DEVELOPMENT	FR-3	FR-4
Airframe	984*	952
Propulsion	557	527
Avionics	79	79
AGE	254	243
Ground Test	1267	1098
Flight Test	1384	1331
Facilities	224	248
SE&I	452	385
Total	5201	4853

*All costs are in millions of dollars

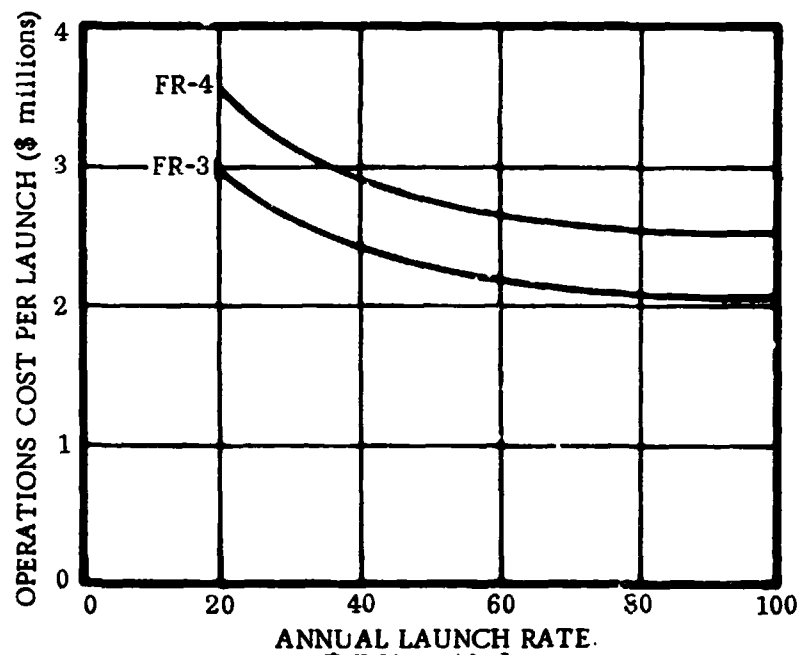

Figure 3-21. Recurring Cost Per Launch, 25 to 100 Launches Per Year

Table 3-8. Comparison of Operations Cost Per Launch at 50 Launches Per Year

ITEM	FR-3	FR-4
Personnel	0.273*	0.341
Materials		
Booster	0.805	1.121
Orbiter	0.477	0.511
Propellants & Gases	0.513	0.573
GSE Maintenance	0.108	0.102
Facilities Maintenance	0.126	0.126
	2.302	2.774
Recurring Cost/Launch	2.302	2.774

*All costs are in millions of dollars

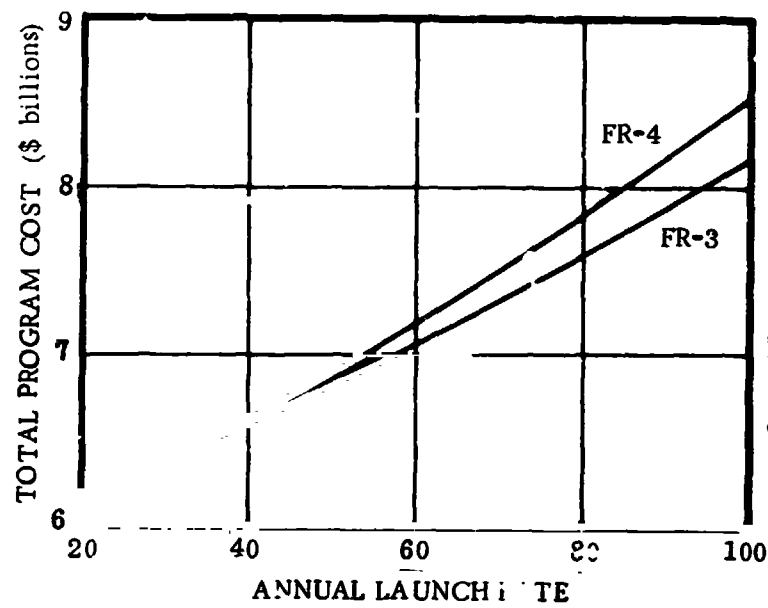

Figure 3-22. FR-3 Versus FR-4 Program Cost Comparison

3.4 DETAILED PROGRAM COSTS

This section presents the detailed FR-3 and FR-4 total program costs. Costs for each vehicle system are shown in Convair and NASA Work Breakdown Structure (WBS) formats. Completed Cost Estimate Data Forms and Technical Characteristics Data Forms are included. Also included are funding schedules for the FR-3 and FR-4 programs. Development and production plan schedules in the NASA format are presented.

3.4.1 APPROACH. The current configuration of the Convair cost model does not output costs in the NASA WBS format. Consequently, it was necessary to manually rearrange the FR-3 and FR-4 costs into a format consistent with NASA WBS requirements. The Convair model's first unit and development cost output formats are in close agreement with the NASA categories down to the WBS level 5. However, subsequent operations internal to the computer model result in significantly less format agreement in the investment and operations outputs. For example, investment costs are calculated by aggregating the various first unit subsystem costs into the categories of airframe structure, airframe subsystems, rocket propulsion, jet propulsion, and avionics. Table 3-9 shows the various first article subsystem costs, the corresponding categories (structure, subsystems, propulsion, avionics) they are aggregated into, and the equivalent NASA WBS identification numbers. Appropriate factors for quantity, learning rate, and spares are applied at these higher level categories. This type of a computation results in significant masking of the equivalent NASA level 5 categories for recurring costs.

The data shown in the NASA Cost Estimate Data Forms were generated based on the following ground rules and assumptions:

- a. The WBS Identification, ID Numbers, and WBS level are based on the terminology and definitions of Reference 3-8.
- b. All costs appearing in the Cost Estimate Data Forms are for a launch rate of 50 per year and include fee.
- c. The number of units indicated for each line item are based on the total units (less spares) of each investment category (A/F Structure, A/F Subsystems, Propulsion, Avionics).
- d. "Expected Cost" values are the first unit cost of an item increased by the applicable spares percentage.
- e. Spares percentages used were 10% for A/F structure, A/F subsystems, and avionic items, and 30% for rocket and jet propulsion items.
- f. The cost improvement percentages (learning) for each line item represent the learning applied to the corresponding Convair investment categories (90% for A/F structures, A/F subsystems and jet propulsion, and 95% for rocket propulsion and avionics).

Table 3-9. Map of First Article Costs Into NASA WBS and Convairst Investment Categories

CONVAIR FIRST ARTICLE COST CATEGORY	EQUIVALENT NASA WBS ID NUMBER	CONVAIR INVESTMENT CATEGORY
Wing & Wing Mounted Control Surfaces	xxx-xx -01-00	Airframe Structure
Vertical Surfaces	-01-00	Airframe Structure
Horizontal Surfaces	-01-00	Airframe Structure
Fairings, Shrouds, & Assoc. Structures	-01-00	Airframe Structure
Structural Fuel Containers	-01-00	Airframe Structure
Structural Oxidizer Containers	-01-00	Airframe Structure
Basic Body Structure	-01-00	Airframe Structure
Thrust Structure	-01-00	Airframe Structure
Cover Panels, Nonstructural	-19-00	Airframe Structure
Vehicle Insulation	-19-00	Airframe Structure
Landing Gear	-15-00	Airframe Subsystems
Primary Engines and Accessories	-03-01	Propulsion Rocket
Fuel Containers and Supports (Tank)	-01-00	Airframe Structure
Secondary Fuel Containers & Supports	-01-00	Airframe Subsystems
Secondary Oxygen Containers & Supports	-01-00	Airframe Subsystems
Propellant Insulation	-01-00	Airframe Structure
Fuel System	-03-08	Airframe Subsystems
Oxidizer System	-03-09	Airframe Subsystems
Pressurization & Purge System	-17-00	Airframe Subsystems
Air-Breathing Engines	-03-04	Propulsion Jet
Fuel & Tankage System, Jet	-03-08	Airframe Subsystems
Separation and Staging	-04-00	Airframe Subsystems
Spatial Attitude Control System	-04-00	Airframe Subsystems
Control Propellant Tankage & System	-04-00	Airframe Subsystems
Electrical Power	-05-00	Airframe Subsystems
Hydraulic/Pneumatic	-08-00	Airframe Subsystems
Aerodynamic Control	-08-00	Airframe Subsystems
Guidance and Navigation	-10-00	Avionics
Onboard Checkout & Instrumentation	-13-00	Avionics
Communication	-07-00	Avionics
Environ. Control & Life Support	-06-00	Airframe Subsystems
Personnel Provisions	-16-00	Airframe Subsystems
Crew Station Controls & Panels	-08-00	Airframe Subsystems
Final Assembly and Checkout	xxx-xx -02-00	Airframe Subsystems

- g. Propulsion values are shown at the NASA WBS level 6 to distinguish between rocket engines, jet engines, and their respective propellant feed systems.
- h. Subsystem installation nonrecurring costs are not identified separately, but are included in the test hardware item at level 5 (3xx-0x-97).
- i. Launch escape system costs are not applicable to either configuration.
- j. Ordnance subsystems costs were included in the basic structure.
- k. Thermal protection system costs were identified as a new level 5 item (3xx-0x-19).
- l. The Test Hardware (3xx-0x-97) category included stage-associated nonrecurring costs for systems and ground test hardware, initial tooling, initial sets of ground test and launch site AGE, and flight test hardware.
- m. Ground and Flight Test Operations and Services costs are shown at the vehicle level (WBS level 4) under ID number 300-98-000 and include ground and flight test operations, ground and flight test propellants and gases, and flight test mission control.
- n. GSE design and development costs and GSE procurement costs for operational sets (sets in addition to those carried over from the development program) are shown at the vehicle level (WBS level 4) under ID number 300-18-00.
- o. Facilities costs are shown at the vehicle level under ID number 300-95-00 and include ground and flight test facilities cost, training program equipment costs, and operational launch facility costs.
- p. Recurring launch operations and services costs are shown at a WBS level 3 under ID number 500-00-00. Included are the operational program costs associated with launch personnel, maintenance personnel and materials, operations support personnel, propellants and gases, GSE maintenance, and facility maintenance.
- q. The values shown for "highest cost" and "lowest cost" in Tables 3-11 and 3-14 allow for uncertainties in the cost estimating relationships, advancement in the level of technology required, and differences between the existing design definition and the article actually produced. Uncertainties associated with commonality assumptions are also reflected in these figures.
- r. A rectangular spreading function was selected as the cost distribution curve most applicable to several FR-3 and FR-4 program cost items. This function is designated by index number 6.

3.4.2 FR-3 PROGRAM. Detailed FR-3 program costs are presented in the Convair format in Table 3-10. The FR-3 Program Funding Schedule is shown in Figure 3-23. Detailed FR-3 program costs are shown in the NASA WBS format in Table 3-11. Technical characteristics data for the FR-3 configuration are presented in Table 3-12. The FR-3 Development and Production Plan Schedule generated from Table 3-11 data appears as Figure 3-24.

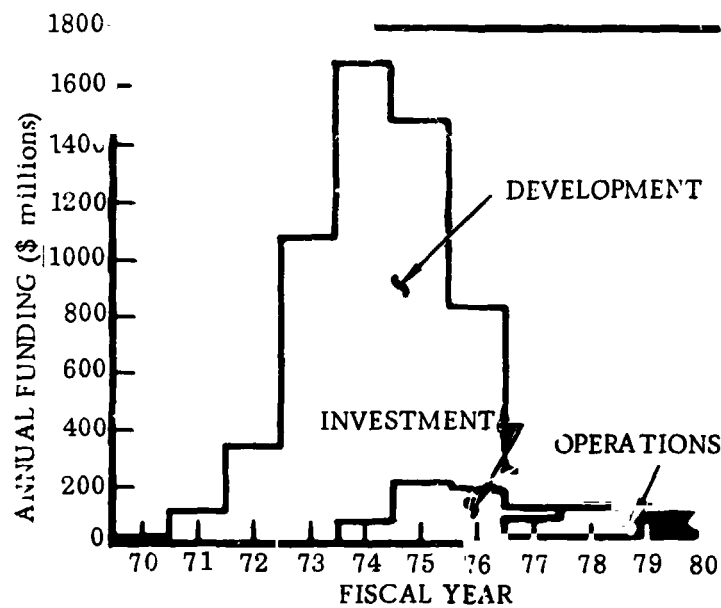

Figure 3-23. FR-3 Program Funding Schedule

Table 3-10. Detailed FR-3 Costs (\$ Million) in Convair Format

FIRST ARTICLE COST, FR-3 CONFIGURATION			
		Booster	Orbiter
First-Article Cost Total		193.500	102.519
Aerodynamic Surfaces		24.615	18.692
Wing and Wing Mounted Control Surfaces	15.427		8.945
Vertical Surfaces	9.188		7.284
Horizontal Surfaces	0.000		1.336
Fairings, Shrouds and Assoc. Structure	0.000		1.126
Body Structure		42.304	19.652
Structural Fuel Containers	3.305		1.393
Structural Oxidizer Containers	2.022		1.240
Basic Body Structure	22.338		12.860
Thrust Structure	14.638		4.159
Thermal Protection		19.880	17.134
Cover Panels, Non-Structural	18.150		10.165
Vehicle Insulation	1.730		.969
Launch Recovery Docking		3.084	1.909
Landing Gear	3.084		1.809
Docking Structure	0.000		.100
Main Propulsion		80.657	20.804
Primary Engines and Accessories	53.658		10.850
Fuel Containers and Supports (Tank)	0.000		.710
Secondary Fuel Containers and Supports	0.000		.347
Secondary Oxidizer Containers+Supports	0.000		.221
Propellant Insulation	.374		.296
Fuel System	3.670		1.067
Oxidizer System	7.601		2.053
Pressurization and Purge Systems	1.883		.817
Air Breathing Engines	12.932		4.356
Fuel and Tankage System, Air Breathing	.540		.087
Orientation, Sep. and Ullage Control		2.307	8.389
Separation and Staging	.803		.331
Spatial Attitude Control System	1.046		6.802
Control Propellant Tankage and Systems	.453		1.256
Electrical Power		2.891	3.186
Hydraulic Power		3.840	2.652
Hydraulic/Pneumatic	1.353		.934
Aerodynamic Control	2.487		1.718
Guidance and Navigation	4.874		5.980
Onboard Checkout and Instrumentation	.480		.544
Communication	1.937		1.937
Environmental Controls and Life Support		2.048	3.529
Personnel Provisions		.054	.112
Crew Station Controls and Panels		.420	.420
Final Assembly and Checkout		4.109	3.580

Table 3-10. Detailed FR-3 Costs (\$ Million) in Convair Format (Cont'd)

DEVELOPMENT PROGRAM, FR-3 CONFIGURATION

	<u>Booster</u>	<u>Orbiter</u>	<u>Vehicle</u>	<u>Total</u>
Development	2422.701	1755.557	1023.620	5230.878
Definition Phase	0.000	0.000	30.030	30.030
Development Phase				
Systems Engineering and Integration	291.584	160.615	0.000	452.199
Engineering Design and Development	426.612	544.966	497.290	1468.863
Airframe	384.350	448.646	0.000	
Basic Vehicle	251.533	208.370	0.000	
Thermal Protection	67.966	56.418	0.000	
Landing Gear	5.391	3.162	0.000	
Electrical	5.145	41.886	0.000	
Reaction Control	27.556	102.619	0.000	
Crew Systems	6.360	7.938	0.000	
Environmental Controls and Life Support	20.599	28.253	0.000	
Avionics	12.262	66.320	0.000	
Guidance and Navigation	5.688	46.648	0.000	
Communication	1.410	14.097	0.000	
Onboard Checkout and Instrumentation	5.165	5.75	0.000	
Propulsion	30.000	30.000	497.290	
Rocket Engines	0.000	0.000	497.290	
Jet Engines	30.000	30.000	0.000	
Systems and Ground Tests	686.581	449.899	130.500	1266.980
Operations	0.000	0.000	130.500	
Hardware	678.110	448.115	0.000	
Propellants and Gases	8.471	1.785	0.000	

3-25

Volume X

Table 3-10. Detailed FR-3 Costs (\$ Million) in Convair Format (Cont'd)

DEVELOPMENT PROGRAM, FR-3 CONFIGURATION (CONT'D)

	Booster	Orbiter	Vehicle	Total
Tooling-Airframe	83.765	67.445	0.000	151.211
Ground Support Equipment	47.562	39.611	166.599	253.772
Design and Development	0.000	0.000	166.599	
Ground Test Site GSE	15.854	13.204	0.000	
Launch Site GSE	31.708	26.407	0.000	
Flight Tests	886.596	431.027	66.201	1383.824
Launch Operations	0.000	0.000	60.400	
Mission Control	0.000	0.000	3.750	
Hardware	882.360	430.581	0.000	
Propellants and Gases	4.236	.446	2.051	
Facilities	0.000	0.000	162.000	162.000
Ground Test	0.000	0.000	7.000	
Launch	0.000	0.000	155.000	
Trainers	0.900	61.994	0.000	61.994

3-26

Volume X

Table 3-10. Detailed FR-3 Costs (\$ Million) in Convair Format (Cont'd)

INVESTMENT, FR-3 CONFIGURATION — 15 LAUNCHES PER YEAR

	Booster	Orbiter	Vehicle	Total
Total Investment Cost	242.372	136.039	0.000	378.410
Flight Hardware	185.233	100.812	0.000	286.045
Airframe Structure	87.173	50.583	0.000	
Airframe Subsystems	32.446	28.269	0.000	
Primary Engines	46.550	9.413	0.000	
Air Breathing Engines	11.773	4.086	0.000	
Avionics	7.291	8.461	0.000	
Spares	30.188	12.781	0.000	42.969
Airframe Structure	8.717	5.058	0.000	
Airframe Subsystems	3.245	2.827	0.000	
Rocket Engines	13.965	2.824	0.000	
Jet Engines	3.532	1.226	0.000	
Avionics	.729	.846	0.000	
Ground Support Equipment	26.951	22.445	0.000	49.396

INVESTMENT, FR-3 CONFIGURATION — 50 LAUNCHES PER YEAR

Total Investment Cost	241.726	243.409	0.000	485.135
Flight Hardware	184.736	196.114	0.000	380.850
Airframe Structure	87.173	98.302	0.000	
Airframe Subsystems	32.446	54.938	0.000	
Primary Engines	46.053	18.625	0.000	
Air Breathing Engines	11.773	7.563	0.000	
Avionics	7.291	16.685	0.000	
Spares	30.039	24.849	0.000	54.888
Airframe Structure	8.717	9.830	0.000	
Airframe Subsystems	3.245	5.494	0.000	
Rocket Engines	13.816	5.588	0.000	
Jet Engines	3.532	2.269	0.000	
Avionics	.729	1.669	0.000	
Ground Support Equipment	26.951	22.445	0.000	49.396

3-27

Volume X

Table 3-10. Detailed FR-3 Costs (\$ Million) in Convair Format (Cont'd)

INVESTMENT, FR-3 CONFIGURATION -- 100 LAUNCHES PER YEAR

	<u>Booster</u>	<u>Orbiter</u>	<u>Vehicle</u>	<u>Total</u>
Total Investment Cost	440.622	437.911	0.000	878.533
Flight Hardware	356.184	368.735	0.000	724.920
Airframe Structure	169.411	184.197	0.000	
Airframe Subsystems	63.056	102.943	0.000	
Primary Engines	87.684	35.462	0.000	
Air Breathing Engines	21.655	13.822	0.000	
Avionics	14.378	32.311	0.000	
Spares	57.486	46.730	0.000	104.217
Airframe Structure	18.941	18.420	0.000	
Airframe Subsystems	6.306	10.294	0.000	
Rocket Engines	26.305	16.839	0.000	
Jet Engines	6.497	4.147	0.000	
Avionics	1.438	3.231	0.000	
Ground Support Equipment	26.951	22.445	0.000	49.396

Table 3-10. Detailed FR-3 Costs (\$ Million) in Convair Format (Cont'd)

Launches Per Year	OPERATIONS, FR-3 CONFIGURATION					
	25		50		100	
	Total	Per Launch	Total	Per Launch	Total	Per Launch
Total 10 Years Operations	697.266	2.789	1150.875	2.302	2084.495	2.084
Personnel	131.700	.527	136.500	.273	172.500	.172
Operations and Maintenance	17.700		17.700		17.700	
Vehicle Support	38.400		38.400		64.800	
Vehicle Maintenance & Refurbishment	75.600		80.400		90.000	
Materials	320.614	1.282	641.228	1.282	1282.455	1.282
Booster	201.263		402.526		805.053	
Airframe Structure	107.026		214.052		428.105	
Airframe Subsystems	35.421		70.843		141.686	
Rocket Engines	33.536		67.073		134.145	
Jet Engines	16.165		32.330		64.661	
Avionics	9.114		18.228		36.457	
Orbiter	119.351		238.701		477.402	
Airframe Structure	65.686		131.372		262.745	
Airframe Subsystems	30.862		61.723		123.446	
Rocket Engines	6.782		13.563		27.126	
Jet Engines	5.445		10.889		21.778	
Avionics	10.577		21.154		42.307	
Propellants and Gases	128.196	.513	256.392	.513	512.784	.513
AGE/GSE Maintenance	53.756	.215	53.756	.108	53.756	.054
Facility Maintenance	63.000	.252	63.000	.126	63.000	.063

3-29

Volume X

Table 3-11. Detailed FR-3 Costs (\$ Million) in NASA WBS Format

X Design and Development (Nonrecurring)
 ___ Production and Operations (Recurring)

Identification Number a	WBS Identification b	WBS Level c	No. Units d	Expect. Cost e	Highest Cost f	Lowest Cost g	Confid. Rating h	T _d i	T _s j	Spred. Funct. k	Learn Index l
000-00-00	Program Nonrecurring	3	NA	5230.878	NA	NA	NA	NA	NA	NA	NA
300-01-00	Booster Stage	4		2907.284	See Details		2	NA	NA	NA	
300-02-00	Orbiter Stage	4		1691.333	See Details		2	NA	NA	NA	
300-18-00	Vehicle GSE	4		166.599	280	68	2	45	54	3	
300-95-00	Facilities	4		223.994	249	199	2	36	51	5	
300-98-00	Test Operations & Services	4		211.639	775	156	2	50	51	5	
--	CDP Studies	NA	NA	30.030	45	15	2	12	78	6	NA

3-30

Volume X

X Design and Development (Nonrecurring)
 ___ Production and Operations (Recurring)

Identification Number a	WBS Identification b	WBS Level c	No. Units d	Expect. Cost e	Highest Cost f	Lowest Cost g	Confid. Rating h	T _d i	T _s j	Spred. Funct. k	Learn Index l
300-01-00	Booster Stage	4	NA	2907.284	NA	NA	NA	NA	NA	NA	NA
300-01-(*)	Basic Vehicle	5	↑	251.333	420	140	2	61	66	1	↑
300-01-03**	Propulsion (Rocket)	↑	↑	497.290	720	270	↑	57	73	3	↑
300-01-03	Propulsion (Jet)	↑	↑	30.000	47	20	↑	34	73	5	↑
300-01-04	Reaction Control	↑	↑	27.556	180	22	↑	57	66	3	↑
300-01-05	Electrical Power	↑	↑	5.145	42	4	↑	62	↑	3	↑
300-01-06	Environ. Ctrl. & L.S.	↑	↑	20.599	41	15	↑	63	↑	6	↑
300-01-07	Communication	↑	↑	1.410	15	0.5	↑	↑	↑	3	↑
300-01-10	Guidance & Navigation	↑	↑	5.688	44	2.0	↑	↓	↑	↑	↑
300-01-13	Instrumentation	↑	↑	5.165	14	3.4	↑	63	↑	3	↑
300-01-15	Landing & Recovery	↓	↓	5.391	19	2	↑	51	↓	5	↑
300-01-16	Crew Systems	5	NA	6.360	40	2	↑	55	66	3	↑
300-01-18	Ground Support Equipment	(See Vehicle Level.)			NA	NA	↑	NA	NA	NA	↑
300-01-19	Thermal Protection Sys.	5	NA	67.966	143	40	↑	63	66	1	↑
300-01-92	Systems Support	↓	↑	291.584	520	170	↓	66	66	6	↓
300-01-97***	Test Hardware	5	NA	1691.797	NA	NA	2	42	52	3	NA

3-31

Volume X

*Includes -01, -08, -14, -17
 **Covers rocket engine R&D for both stages due to common design.
 ***Includes -02

X Design and Development (Nonrecurring)
 ___ Production and Operations (Recurring)

3-32

Identification Number a	WBS Identification b	WBS Level c	No. Units d	Expect. Cost e	Highest Cost f	Lowest Cost g	Confid. Rating h	T _d i	T _s j	Spred. Funct. k	Learn Index l
300-02-00	Orbiter Stage	4	NA	1691.333	NA	NA	NA	NA	NA	NA	NA
300-02-(*)	Basic Vehicle	5	NA	208.370	360	110	2	61	66	1	↑
300-02-03**	Propulsion (Rocket)	5	NA	--	NA	NA	3	57	73	3	↑
300-02-03	Propulsion (Jet)	5	NA	30.000	47	20	3	34	73	5	↑
300-02-04	Reaction Control	5	NA	102.619	180	82	2	57	66	3	↑
300-02-05	Electrical Power	5	NA	41.886	76	38	2	62	↑	3	↑
300-02-06	Environ. Ctrl. & L.S.	5	NA	28.253	54	21	2	63	↑	6	↑
300-02-07	Communication	5	NA	14.097	40	8	2	↑	↑	3	↑
300-02-10	Guidance & Navigation	5	NA	46.648	85	40	2	↑	↑	↑	↑
300-02-13	Instrumentation	5	NA	5.575	14	3.7	2	63	↑	3	↑
300-02-15	Landing & Recovery	5	NA	3.162	19	2	2	51	↓	5	↑
300-02-16	Crew Systems	5	NA	7.938	60	2.5	2	55	66	3	↑
300-02-18	Ground Support Equipment	(See Vehicle Level.)			NA	NA	2	NA	NA	NA	↑
300-02-19	Thermal Protection Sys.	5	NA	56.418	119	40	2	63	66	1	↑
300-02-92	Systems Support	5	NA	160.615	340	100	2	66	66	6	↑
300-02-97***	Test Hardware	5	NA	985.752	NA	NA	2	42	52	3	NA

Volume X

* Includes -01, -08, -14, -17
 ** Covers rocket engine R&D for both stages due to common design.
 *** Includes -02

___ Design and Development (Nonrecurring)
 X Production and Operations (Recurring)

Identification Number a	WBS Identification b	WBS Level c	No. Units d	Expect. Cost e	Highest Cost f	Lowest Cost g	Confid. Rating h	T _d i	T _s j	Spred. Fu t. k	Learn Index l
300-01-00	Booster Stage	4	NA	215.421	NA	NA	NA	NA	NA	NA	NA
300-01-01	Structure	5	1	72.921	160	40	2	14	25	6	90
300-01-02	Subsystem Installation	5	1	4.520	43	3.1	2	13	20	6	90
300-01-03-01	Rocket Engine	6	15	4.650	6.1	3.4	3	24	38	6	95
300-01-03-04	Jet Engine	6	4	4.203	4.2	2.1	3	12	26	6	90
300-01-03-08	Fuel Delivery System	6	1	4.631	7.5	2.1	2	15	35	6	90
300-01-03-09	Oxidizer Delivery System	6	1	8.361	15	4.3	2	15	35	6	90
300-01-04	Reaction Control	5	1	2.934	5.8	1.5	2	15	35	6	90
300-01-05	Electrical Power	5	1	3.180	5.4	2.1	2	15	35	6	90
300-01-06	Environment Control	5	1	2.253	6	1.6	2	15	35	6	90
300-01-07	Communication	5	1	2.131	2.3	0.9	2	18	38	6	95
300-01-08	Stabilization & Control	5	1	4.686	9.4	3.3	2	15	35	6	90
300-01-10	Guidance & Navigation	5	1	5.361	6.5	3.5	2	18	38	6	95
300-01-13	Instrumentation	5	1	0.528	0.8	0.4	2	15	35	6	95
300-01-15	Landing & Recovery	5	1	3.392	12	2.3	2	15	35	6	90
300-01-16	Crew Systems	5	1	0.059	0.12	0.02	2	15	35	6	90
300-01-17	Pressurization	5	1	2.071	3.5	1.0	2	15	35	6	90
300-01-19	Thermal Protection	5	1	21.868	33	19	2	15	35	6	90

3-34

Volume X

Design and Development (Nonrecurring)
 Production and Operations (Recurring)

Identification Number a	WBS Identification b	WBS Level c	No. Units d	Expect. Cost e	Highest Cost f	Lowest Cost g	Confid. Rating h	T _d i	T _s j	Spred. Funct. k	Learn Index l
300-02-00	Orbiter Stage	4	NA	220.964	NA	NA	NA	NA	NA	NA	NA
300-02-01	Structure	5	2	43.909	95	24	2	22	25	6	90
300-02-02	Subsystem Installation	5	2	3.938	22.7	2.7	2	16	14	6	90
300-02-03-01	Rocket Engine	6	6	4.650	6.1	3.4	3	12	22	6	95
300-02-03-04	Jet Engine	6	6	1.888	4.2	0.9	3	14	28	6	90
300-02-03-08	Fuel Delivery System	6	2	3.471	6.5	1.8	2	18	35	6	90
300-02-03-09	Oxidizer Delivery System	6	2	2.258	4.2	1.2	2	18	35	6	90
300-02-04	Reaction Control	5	2	9.228	18.5	4.6	2	18	35	6	90
300-02-05	Electrical Power	5	2	3.505	5.7	2.4	2	18	35	6	90
300-02-06	Environment Control	5	2	3.882	10	2.8	2	18	35	6	90
300-02-07	Communication	5	2	2.131	2.3	1.5	2	20	38	6	95
300-02-08	Stabilization & Control	5	2	3.379	6.8	2.7	2	18	35	6	90
300-02-10	Guidance & Control	5	2	6.578	12	4.2	2	20	38	6	95
300-02-13	Instrumentation	5	2	0.598	0.9	0.5	2	18	35	6	95
300-02-15	Landing & Recovery	5	2	1.990	10.7	1.4	2	18	35	6	90
300-02-16	Crew Systems	5	2	0.123	0.2	0.1	2	18	35	6	90
300-02-17	Pressurization	5	2	0.899	1.7	0.5	2	18	35	6	90
300-02-19	Thermal Protection	5	2	12.247	25.5	10.5	2	18	35	6	90

3-35

Volume X

Table 3-12. Technical Characteristics Data for the FR-3 Configuration

IDENTIFICATION NUMBER	WBS IDENTIFICATION	WBS LEVEL	QUANTITY OR VALUE		UNITS OF MEASURE	CHARACTERISTICS	NOTES
			CURRENT	NEW			
300-01-00-00	Booster	3		3.402	M Pounds	Gross Weight	
				0.517	M Pounds	Dry Weight	
				210	Feet	Length	
				41	Feet	Width	
				37	Feet	Height	
300-02-00-00	Orbiter	3		0.927	M Pounds	Gross Weight	
				0.234	M Pounds	Dry Weight	
				179	Feet	Length	
				31	Feet	Width	
				26	Feet	Height	
300-01-01-00	Structure	5		6	g	Ultimate Loading	
				4	g	Limit Loading	
300-02-01-00	Structure	5		6	g	Ultimate Loading	
				4	g	Limit Loading	
300-01-03-00	Propulsion (Rocket)	5		400,000	Pounds	Thrust	
				See Vol. VI	Seconds	ISF Actual	
				See Vol. VI	Seconds	ISP Theoretical	
				See Vol. VI	Lb-Sec	Total Impulse	
				10,912	Ft-Sec	ΔV Requirement	
				100	--	Number of Burns	
				463,868	Pounds	Inert Weight	
				190	Seconds	Max Burn Time	

Table 3-12. Technical Characteristics Data for the FR-3 Configuration (Cont'd)

IDENTIFICATION NUMBER	WBS IDENTIFICATION	WBS LEVEL	QUANTITY OR VALUE		UNITS OF MEASURE	CHARACTERISTICS	NOTES
			CURRENT	NEW			
				10	Hours	Operating Life	
				10	--	Throttling Ratio	
				80	--	Expansion Ratio	
				LH ₂ /LO ₂	--	Propellants	
300-02-03-00	Propulsion (Rocket)	5		400,000	Pounds	Thrust	
				See Vol. VI	Seconds	ISP Actual	
				See Vol. VI	Seconds	ISP Theoretical	
				See Vol. VI	Lb-Sec	Total Impulse	
				14,000	Ft/Sec	ΔV Requirement	
				5	--	Number of Burns/Mission	
				213,150	Pounds	Inert Weight	
				300	Seconds	Max Burn Time/Mission	
				10	Hours	Operating Life	
				10	--	Throttling Ratio	
				160	--	Expansion Ratio	
				LH ₂ /LO ₂	--	Propellants	
300-01-03-00	Propulsion (Jet)	5		4	Number	No. of Engines	
				52,500	Pounds	Max S. L. S. T/Engine	
				39,600	Pounds	Total Engine Weight	
				46,916	Pounds	Fuel Weight	
300-02-03-00	Propulsion (Jet)	5		3	Number	No. of Engines	
				21,000	Pounds	Max S. L. S. T/Engine	

37

Volume X

Table 3-12. Technical Characteristics Data for the FR-3 Configuration (Cont'd)

IDENTIFICATION NUMBER	WBS IDENTIFICATION	WBS LEVEL	QUANTITY OR VALUE		UNITS OF MEASURE	CHARACTERISTICS	NOTES
			CURRENT	NEW			
				16,100	Pounds	Total Engine Weight	
				2,868	Pounds	Fuel Weight	
300-01-04-00	Reaction Control	5		2,500	Pounds	Thrust	
				16	--	Number	
				400	Seconds	ISP Actual	
				450	Seconds	ISP Ideal	
				0.4	M Lb-Sec	Total Impulse	
				1,000	Pounds	Wt. of Propellant	
				250	Lb-Sec	Min Impulse Bit	
				1,300	Pounds	Inert Weight	
				500	Seconds	Burn Time	
				2.5	Deg/Sec ²	Acceleration	
				1	Lb/Sec	Compressor Flow Rate	GH ₂
				10	Hours	Operating Life	
				5	Lb/Sec	Compressor Flow Rate	GO ₂
300-02-04-00	Reaction Control	5		2,500	Pounds	Thrust	
				48	--	Number	
				400	Seconds	ISP Actual	
				450	Seconds	ISP Ideal	
				2.4	M Lb-Sec	Total Impulse	
				6,300	Pounds	Wt. of Propellant	
				250	Lb-Sec	Min Impulse Bit	

Table 3-12. Technical Characteristics Data for the FR-3 Configuration (Cont'd)

IDENTIFICATION NUMBER	WBS IDENTIFICATION	WBS LEVEL	QUANTITY OR VALUE		UNITS OF MEASURE	CHARACTERISTICS	NOTES
			CURRENT	NEW			
				5,200	Pounds	Inert Weight	
				1,300	Seconds	Burn Time	
				2.5	Deg/Sec ²	Acceleration	
				0.03	g	Acceleration	
				1	Lb/Sec	Compressor Flow Rate	GH ₂
				10	Hours	Operating Life	
				5	Lb/Sec	Compressor Flow Rate	CO ₂
300-01-05-00	Electrical Power	5		9,000	Watts	Total Power	Fuel Cells
				3,700	Watts	Average Power	
				3,046	Pounds	Weight	
300-02-05-00	Electrical Power	5		600	W-Hr	Total Power	Batteries
				1,313	Watts	Average Power	
				646	Pounds	Weight	
300-01-06-00	Environmental Control	5		344	Ft ³	Press. Module Vol.	
				26	Pounds	Wt. of Atmos. Gas	
				1	A. U.	Min. Dist. from Sun	
				1	A. U.	Max. Dist. from Sun	
				0	N. Mi.	Min. Dist. from Earth	
				30	N. Mi.	Max. Dist. from Earth	
				118	Pounds	Weight	
				100	Ft ³ /Min	Max. Gas Flow Rate	
300-02-06-00	Environmental Control	5		344	Ft ³	Press. Module Vol.	

3-39

Volume X

Table 3-12. Technical Characteristics Data for the FR-3 Configuration (Cont'd)

IDENTIFICATION NUMBER	WBS IDENTIFICATION	WBS LEVEL	QUANTITY OR VALUE		UNITS OF MEASURE	CHARACTERISTICS	NOTES
			CURRENT	NEW			
				138	Pounds	Wt. of Atmos. Gas	
				1	A. U.	Min. Dist. from Sun	
				1	A. U.	Max. Dist. from Sun	
				0	N. MI.	Min. Dist. from Earth	
				270	N. Mi.	Max. Dist. from Earth	
				1,507	Pounds	Weight	
				300	Ft ³ /Min	Max. Gas Flow Rate	
300-01-07-00	Communication	5					
	UHF Transceiver			15	Pounds	Weight	
				30	Watts	Output	
				3	Number	Units	
	Crash Beacon			9	Pounds	Weight	
				15	Watts	Output	
				1	Number	Units	
	Radar Beacon			10	Pounds	Weight	
				15	Watts	Output	
				1	Number	Units	
	Intercom			3	Pounds	Weight	
				12	Watts	Output	
				6	Number	Units	
	Matrix SW			8	Pounds	Weight	Solid State Audio
				1	Number	Units	Mechanical RF

3-40

Volume X

Table 3-12. Technical Characteristics Data for the FR-3 Configuration (Cont'd)

IDENTIFICATION NUMBER	WBS IDENTIFICATION	WBS LEVEL	QUANTITY OR VALUE		UNITS OF MEASURE	CHARACTERISTICS	NOTES
			CURRENT	NEW			
300-02-07-00	Communications	5					
	UHF Transceiver			15	Pounds	Weight	
				30	Watts	Output	
				3	Number	Units	
	S-Band Transceiver			30	Pounds	Weight	
				30	Watts	Output	
				3	Number	Units	
	S-Band Amplifier			30	Pounds	Weight	
				180	Watts	Output	
				2	Number	Units	
	Crash Beacon			9	Pounds	Weight	
				15	Watts	Output	
				1	Number	Units	
	Radar Beacon			10	Pounds	Weight	
				15	Watts	Output	
				1	Number	Units	
	Intercom			3	Pounds	Weight	
				12	Watts	Output	
				8	Number	Units	
	Matrix SW			8	Pounds	Weight	Solid State Audio
				1	Number	Units	Mechanical RF
	Antenna Parabolic			50	Pounds	Weight	

Table 3-12. Technical Characteristics Data for the FR-3 Configuration (Cont'd)

IDENTIFICATION NUMBER	WBS IDENTIFICATION	WBS LEVEL	QUANTITY OR VALUE		UNITS OF MEASURE	CHARACTERISTICS	NOTES
			CURRENT	NEW			
				1	Number	Units	
300-01-07-00	Stabilization & Control	5		0.01	Deg/Sec	Min. Attitude Change Rate	
						Permissible	
						Angular Errors	
				0.1	Degrees	Roll	
				0.1	Degrees	Pitch	
				0.1	Degrees	Yaw	
				400	N. Mi.	Max. Dist. from Reference	
				10	--	No. of Major Maneuvers	
300-02-08-00	Stabilization & Control	5		0.001	Deg/Sec	Min. Attitude Change Rate	
						Permissible	
						Angular Errors	
				0.01	Degrees	Roll	
				0.01	Degrees	Pitch	
				0.01	Degrees	Yaw	
				3,00	N. Mi.	Max. Dist. from Reference	
				100	--	No. of Major Maneuvers	
300-01-10-00	Guidance & Navigation	5					
	Inertial Meas. Unit			85	Pounds	Weight	
	Accelerometer			40	PPM	3 σ Bias	
				40	PPM	3 σ Scale Factor	
	Gyro			0.15	Deg/Hr	3 σ CT	

3-42

Volume X

Table 3-12. Technical Characteristics Data for the FR-3 Configuration (Cont'd)

IDENTIFICATION NUMBER	WBS IDENTIFICATION	WBS LEVEL	QUANTITY OR VALUE		UNITS OF MEASURE	CHARACTERISTICS	NOTES
			CURRENT	NEW			
				0.2	Deg/Hr/g	3 σ MUIA	
				0.3	Deg/Hr/g	3 σ MUSA	
				3	Number	Units	
	Instrument Land System			2	Number	Units	
				5	Pounds	Weight	
	Radar Altimeter			3	Number	Units	
				5000	Feet	Range	
				53	Pounds	Weight	
	Distance Meas. Equip.			2	Number	Units	
				20	Pounds	Weight	
	Weather Radar			1	Number	Units	
				18	Inches	Antenna Size	
				180	N. Mi.	Range	
				37	Pounds	Weight	
300-02-10-00	Guidance & Navigation	5					
	Inertial Meas. Unit			85	Pounds	Weight	
	Accelerometer			40	PPM	3 σ Bias	
				40	PPM	3 σ Scale Factor	
	Gyro			0.15	Deg/Hr	3 σ CT	
				0.2	Deg/Hr/g	3 σ MUIA	
				0.3	Deg/Hr/g	3 σ MUSA	
				3	Number	Units	

Table 3-12. Technical Characteristics Data for the FR-3 Configuration (Cont'd)

IDENTIFICATION NUMBER	WBS IDENTIFICATION	WBS LEVEL	QUANTITY OR VALUE		UNITS OF MEASURE	CHARACTERISTICS	NOTES
			CURRENT	NEW			
	Instrument Land System			2	Number	Units	
				5	Pounds	Weight	
	Radar Altimeter			3	Number	Units	
				300	Feet	Range	
				80	Pounds	Weight	
	Distance Meas. Equip.			2	Number	Units	
				20	Pounds	Weight	
	Weather Radar			1	Number	Units	
				18	Inches	Antenna Size	
				180	N. Mi.	Range	
				37	Pounds	Weight	
300-02-10-00	Horizon Scanner	5		1	Number	Units	
				50	Pounds	Weight	
	Rendezvous Laser Radar			3	Number	Units	
				46	Pounds	Weight	
300-01-15-00	Landing and Recovery	5		517,286	Pounds	Landing Weight	
				12	Ft/Sec	Term. Sink Speed	
				2.5	Degrees	Term. Glide Slope	
				25,000	Pounds	Subsystem Weight	
				0.0765	Lb/Ft ³	Term. Atmos. Density	Sea Level, 59°F
300-02-15-00	Landing and Recovery	5		286,655	Pounds	Landing Weight	
				12	Ft/Sec	Term. Sink Speed	

3-44

Volume X

Table 3-12. Technical Characteristics Data for the FR-3 Configuration (Cont'd)

IDENTIFICATION NUMBER	WBS IDENTIFICATION	WBS LEVEL	QUANTITY OR VALUE		UNITS OF MEASURE	CHARACTERISTICS	NOTES
			CURRENT	NEW			
				2.5	Degrees	Term. Glide Slope	
				13,000	Pounds	Subsystem Weight	
				0.0765	Lb/Ft ³	Term. Atmos. Density	Sea Level @59°F
300-01-16-00	Crew Systems	5		2	Number	No. Crew Stations	
				344	Ft ³	Press. Volume	
300-02-16-00	Crew Systems	5		2	Number	No. Crew Stations	
				344	Ft ³	Press. Volume	
300-01-17-00	Pressurization	5		30,000	Pounds	Gas	
				2,000	Pounds	Hardware	
300-02-17-00	Pressurization	5		7,000	Pounds	Gas	
				500	Pounds	Hardware	
300-01-19-00	Thermal Protection Sys.		NA	RTPS	Specify	Type	
				26,610	Ft ²	Surface Area	Body Area
				1.54	Lb/Ft ²	Unit Weight	
				1,700	Degree F	Temperature	Mean Lower Surf.
				30	Ft ²	Panel Size	Avg. for Vehicle
			NA	50	Number	Reusability	No. of Flights
300-02-19-00	Thermal Protection Sys.		NA	RTPS	Specify	Type	
				14,900	Ft ²	Surface Area	Body Area
				2.07	Lb/Ft ²	Unit Weight	
				1,850	Degree F	Temperature	Mean Lower Surf.
				30	Ft ²	Panel Size	Avg. for Vehicle
			NA	50	Number	Reusability	No. of Flights

3-45

Volume X

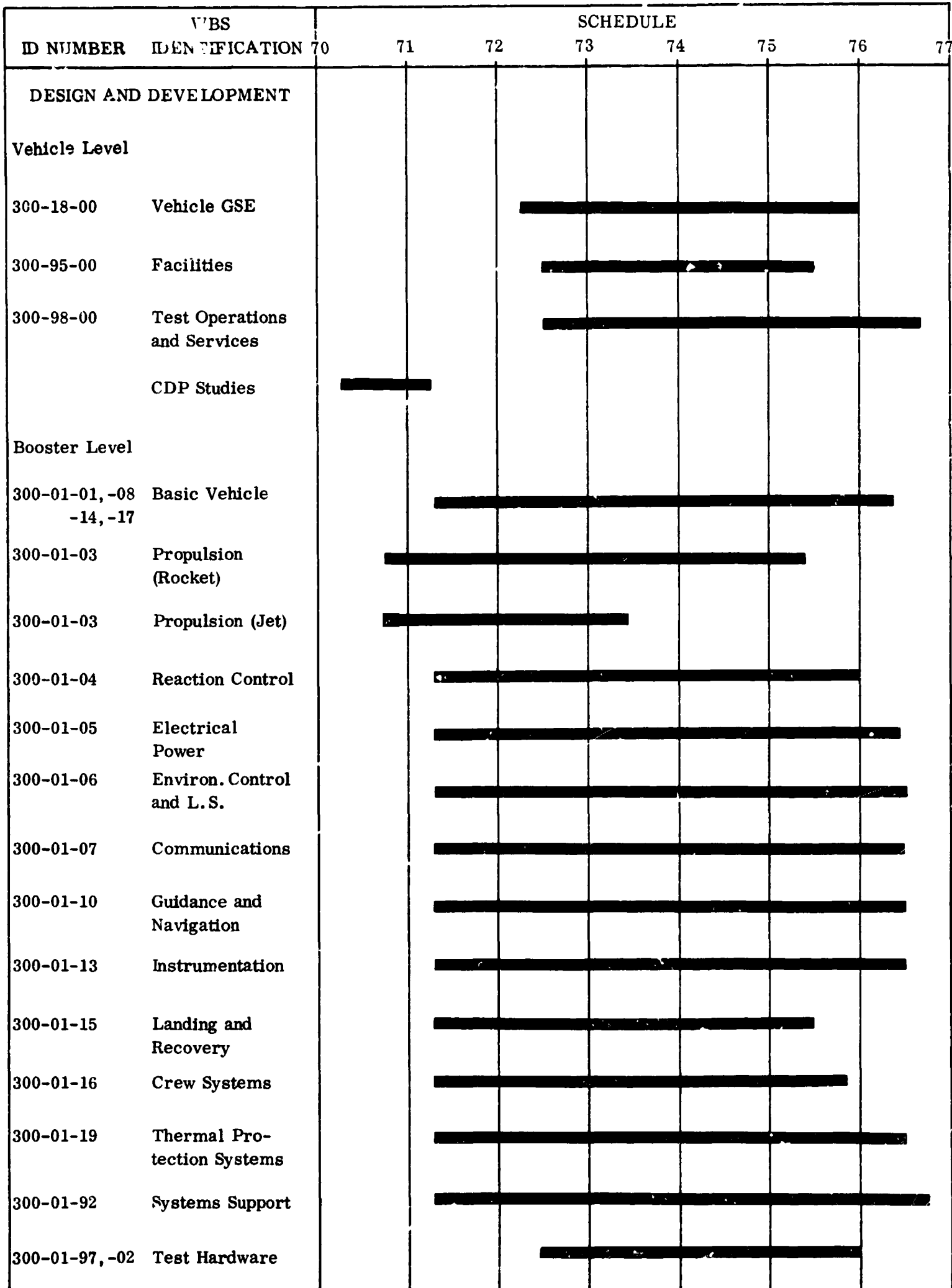

Figure 3-24. FR-3 Configuration Development and Production Plan Schedule

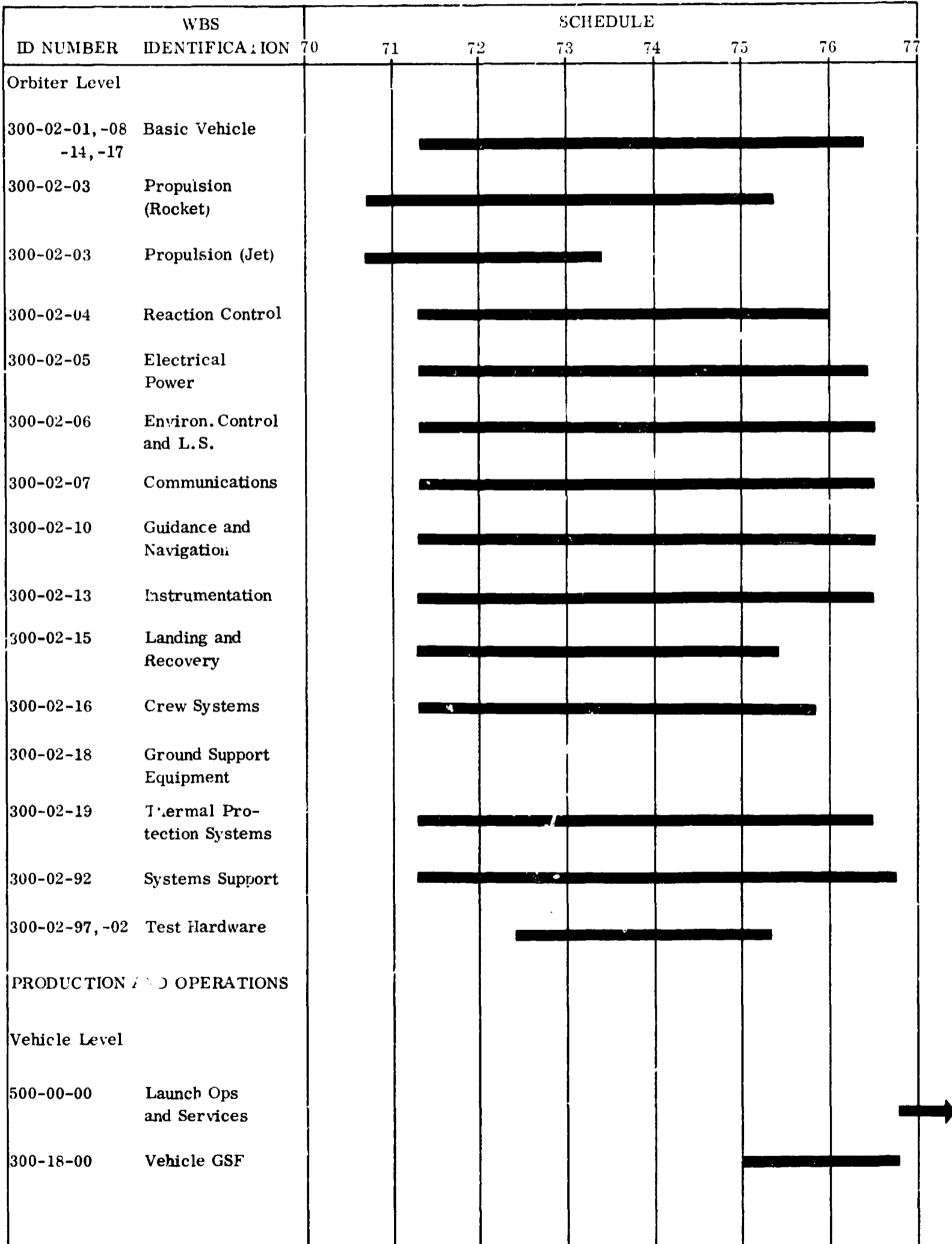

Figure 3-24. FR-3 Configuration Development and Production Plan Schedule (Cont'd)

ID NUMBER	WBS IDENTIFICATION	SCHEDULE							
		70	71	72	73	74	75	76	77
Booster Level									
300-01-01	Structures							██████████	██████████
300-01-02	Subsystem Installation							██████████	██████████
300-01-03-01	Rocket Engine					██████████	██████████	██████████	
300-01-03-04	Jet Engine							██████████	██████████
300-01-03-08	Fuel Delivery System						██████████	██████████	
300-01-03-09	Oxidizer Delivery System						██████████	██████████	
300-01-04	Reaction Control						██████████	██████████	
300-01-05	Electrical Power						██████████	██████████	
300-01-06	Environ. Control						██████████	██████████	
300-01-07	Communications					██████████	██████████	██████████	
	Stabilization and Control							██████████	██████████
	Guidance and Navigation						██████████	██████████	
	Instrumentation						██████████	██████████	
	Landing and Recovery						██████████	██████████	
300-01-16	Crew Systems						██████████	██████████	
300-01-17	Pressurization						██████████	██████████	
300-01-19	Thermal Protection						██████████	██████████	
Orbiter Level									
300-02-01	Structures							██████████	██████████
300-02-02	Subsystem Installation								██████████

Figure 3-24. FR-3 Configuration Development and Production Plan Schedule (Cont'd)

ID NUMBER	WBS IDENTIFICATION	SCHEDULE								
		70	71	72	73	74	75	76	77	
Orbiter Level (Cont.)										
300-02-03-01	Rocket Engine									
300-02-03-04	Jet Engine									
300-02-03-08	Fuel Delivery System									
300-02-03-09	Oxidizer Delivery System									
300-02-04	Reaction Control									
300-02-05	Electrical Power									
300-02-06	Environmental Control									
300-02-07	Communication									
300-02-08	Stabilization and Control									
300-02-10	Guidance and Control									
300-02-13	Instrumentation									
300-02-15	Landing and Recovery									
300-02-16	Crew Systems									
300-02-17	Pressurization									
300-02-19	Thermal Protection									

Figure 3-24. FR-3 Configuration Development and Production Plan Schedule (Cont'd)

3.4.3 FR-4 PROGRAM. Detailed FR-4 program costs are presented in the Convair format in Table 3-13. The program funding schedule for FR-4 is shown in Figure 3-25. The corresponding detailed FR-4 program costs in the NASA WBS format appear as Table 3-14. The FR-4 configuration technical characteristics data are presented in Table 3-15. Figure 3-26 shows the FR-4 Development and Production Plan Schedule.

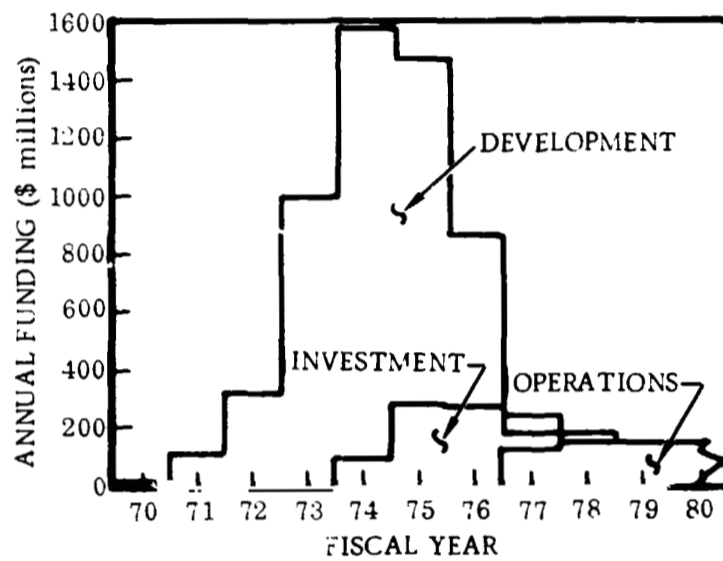

Figure 3-25. FR-4 Program Funding Schedule

Table 3-13. Detailed FR-4 Costs (\$ Million) in Convair Format

FIRST ARTICLE COST, FR-4 CONFIGURATION			
	Booster	Orbiter	
First-Article Cost Total		133.262	107.505
Aerodynamic Surfaces		20.089	20.409
Wing and Wing Mounted Control Surfaces	9.820		9.820
Vertical Surfaces	7.493		7.90
Horizontal Surfaces	1.471		1.21
Fairings, Shrouds and Assoc. Structure	1.306		1.21
Body Structure		27.218	27.279
Structural Fuel Containers	3.140		1.648
Structural Oxidizer Containers	1.870		1.508
Basic Body Structure	13.369		13.967
Thrust Structure	8.838		4.157
Thermal Protection		13.767	12.617
Cover Panels, Non-Structural	12.569		11.519
Vehicle Insulation	1.198		1.098
Landing Gear		1.994	1.924
Main Propulsion		49.539	22.198
Primary Engines and Accessories	32.180		10.846
Fuel Containers and Supports (Tank)	0.000		1.060
Secondary Fuel Containers and Supports	0.000		.378
Secondary Oxidizer Containers + Supports	0.000		.239
Propellant Insulation	.286		.308
Fuel System	2.494		1.078
Oxidizer System	5.210		2.065
Pressurization and Purge Systems	1.218		.966
Air Breathing Engines	7.748		5.165
Fuel and Tankage System, Air Breathing	.403		.094
Orientation, Sep. and Ullage Control		2.256	6.943
Separation and Staging	.758		.375
Spatial Attitude Control System	1.046		5.232
Control Propellant Tankage and Systems	.453		1.337
Electrical Power		2.536	3.244
Hydraulic Power		2.924	2.837
Hydraulic/Pneumatic	.999		.999
Aerodynamic Control	1.925		1.838
Avionics		7.291	8.461
Guidance and Navigation	4.874		5.980
Onboard Checkout and Instrumentation	.480		.544
Communication	1.937		1.937
Environmental Controls and Life Support		2.048	5.520
Personnel Provisions		.054	.112
Crew Station Controls and Panels		.420	.420
Final Assembly and Checkout		3.126	3.465

Table 3-13. Detailed FR-4 Costs (\$ Million) in Convair Format (Cont'd)

DEVELOPMENT PROGRAM, FR-4 CONFIGURATION

	Booster	Orbiter	Vehicle	Total
Development	1980.029	1804.797	1047.500	4883.326
Definition Phase	0.000	0.000	30.030	30.030
Development Phase				
Systems Engineering and Integration	205.163	179.444	0.600	384.607
Engineering Design and Development	356.490	524.664	527.015	1408.170
Airframe	344.228	458.344	0.000	
Basic Vehicle	225.481	213.852	0.000	
Thermal Protection	56.548	72.505	0.000	
Landing Gear	3.485	3.485	0.000	
Electrical	4.199	42.625	0.000	
Reaction Control	27.556	89.687	0.000	
Crew Systems	6.360	7.938	0.000	
Environmental Controls and Life Support	20.599	28.253	0.000	
Avionics	12.262	66.320	0.000	
Guidance and Navigation	5.688	46.648	0.000	
Communication	1.410	14.097	0.000	
Onboard Checkout and Instrumentation	5.165	5.575	0.000	
Propulsion	0.000	0.000	527.015	
Rocket Engines	0.000	0.000	497.015	
Jet Engines	0.000	0.000	30.000	
Systems and Ground Tests	492.573	475.136	130.500	1098.209
Operations	0.000	0.000	130.500	
Hardware	488.027	472.776	0.000	
Propellants and Gases	4.546	2.360	0.000	
Tooling - Airframe	70.577	69.283	0.000	139.860
Ground Support Equipment	42.719	40.156	160.514	243.389
Design and Development	0.000	0.000	160.514	
Ground Test Site CSE	14.240	13.385	0.000	
Launch Site CSE	28.479	26.771	0.000	

3-52

Volume X

Table 3-13. Detailed FR-4 Costs (\$ Million) in Convair Format (Cont'd)

DEVELOPMENT PROGRAM, FR-4 CONFIGURATION (CONT'D)

	Booster	Orbiter	Vehicle	Total
Flight Tests	812.508	452.124	66.440	1331.072
Launch Operations	0.000	0.000	60.400	
Mission Control	0.000	0.000	3.750	
Hardware	810.235	451.534	0.000	
Propellants and Gases	2.273	.590	2.290	
Facilities	0.000	0.000	184.000	184.000
Manufacturing	0.000	0.000	0.000	
Ground Test	0.000	0.000	7.000	
Launch	0.000	0.000	177.000	
Recovery	0.000	0.000	0.000	
Refurbishment	0.000	0.000	0.000	
Mission Control	0.000	0.000	0.000	
Trainers	0.000	63.989	0.000	63.989

3-53

Volume X

Table 3-13. Detailed FR-4 Costs (\$ Million) in Convair Format (Cont'd)

INVESTMENT, FR-4 CONFIGURATION — 25 LAUNCHES PER YEAR			
	Booster	Orbiter	Total
Total Investment Cost	443.194	140.592	583.786
Flight Hardware	362.814	104.721	467.535
Airframe Structure	172.692	55.673	
Airframe Subsystems	69.468	27.363	
Primary Engines	80.800	9.077	
Air Breathing Engines	18.660	4.147	
Avionics	21.195	8.461	
Spares	56.173	13.117	69.290
Airframe Structure	17.269	5.567	
Airframe Subsystems	6.947	2.736	
Rocket Engines	24.240	2.723	
Jet Engines	5.598	1.244	
Avionics	2.119	.846	
Ground Support Equipment	24.206	22.754	46.961
INVESTMENT, FR-4 CONFIGURATION — 50 LAUNCHES PER YEAR			
Total Investment Cost	441.939	252.597	694.536
Flight Hardware	361.849	204.195	566.044
Airframe Structure	172.692	108.195	
Airframe Subsystems	69.468	53.176	
Primary Engines	80.253	18.032	
Air Breathing Engines	18.240	8.107	
Avionics	21.195	16.685	
Spares	55.884	25.647	81.531
Airframe Structure	17.269	10.820	
Airframe Subsystems	6.947	5.318	
Rocket Engines	24.076	5.410	
Jet Engines	5.472	2.432	
Avionics	2.119	1.669	
Ground Support Equipment	24.206	22.754	46.961
INVESTMENT, FR-4 CONFIGURATION — 100 LAUNCHES PER YEAR			
Total Investment Cost	685.665	455.443	1141.109
Flight Hardware	572.842	384.328	957.170
Airframe Structure	272.280	202.735	
Airframe Subsystems	109.529	99.641	
Primary Engines	128.603	34.674	
Air Breathing Engines	28.063	14.967	
Avionics	34.367	32.311	
Spares	88.617	48.361	136.978
Airframe Structure	27.228	20.273	
Airframe Subsystems	10.953	9.964	
Rocket Engines	38.581	10.402	
Jet Engines	8.419	4.490	
Avionics	3.437	3.231	
Ground Support Equipment	24.206	22.574	46.961

Table 3-13. Detailed FR-4 Costs (\$ Million) in Convair Format (Cont'd)

OPERATIONS, FR-4 CONFIGURATION						
Launches Per Year	25		50		100	
	Total	Per Launch	Total	Per Launch	Total	Per Launch
Total 10 Years Operations Cost	829.756	3.319	1387.008	2.774	2534.510	2.535
Personnel	164.400	.658	170.400	.341	215.400	.215
Operations and Maintenance	21.900		21.900		21.900	
Vehicle Support	48.000		48.000		81.000	
Vehicle Maintenance & Refurbishment	94.500		100.500		112.500	
Materials	408.103	1.632	816.205	1.632	1632.411	1.632
Booster	280.127		560.254		1120.508	
Airframe Structure	143.410		296.821		593.641	
Airframe Subsystems	53.893		107.786		215.571	
Rocket Engines	40.225		80.450		160.900	
Jet Engines	19.370		38.741		77.481	
Avionics	18.228		36.457		72.913	
Orbiter	127.976		255.952		511.903	
Airframe Structure	74.292		148.584		297.168	
Airframe Subsystems	29.872		59.744		119.487	
Rocket Engines	6.778		13.557		27.114	
Jet Engines	6.457		12.914		25.827	
Avionics	10.577		21.154		42.307	
Propellants and Gases	143.148	.573	286.297	.573	572.594	.573
AGE/GSE Maintenance	51.105	.204	51.105	.102	51.105	.051
Facility Maintenance	63.000	.252	63.000	.126	63.000	.063

3-55

Volume X

X Design and Development (Nonrecurring)
 ___ Production and Operations (Recurring)

Identification Number a	WBS Identification b	WBS Level c	No. Units d	Expect. Cost e	Highest Cost f	Lowest Cost g	Confid. Rating h	T _d i	T _s j	Spred. Funct. k	Learn Index l
300-01-00	Booster Stage	4	NA	2500.227	NA	NA	NA	NA	NA	NA	NA
300-01-(*)	Basic Vehicle	5	↑	225.481	395	120	2	61	66	1	↑
300-01-03 **	Propulsion	↑	↑	527.015	765	287	↑	57	73	3	↑
300-01-04	Reaction Control	↑	↑	27.556	180	22	↑	57	66	5	↑
300-01-05	Electrical Power	↑	↑	4.199	42	4	↑	62	↑	3	↑
300-01-06	Environ. Ctrl & L.S.	↑	↑	20.599	41	15	↑	63	↑	6	↑
300-01-07	Communication	↑	↑	1.410	15	0.5	↑	↑	↑	3	↑
300-01-10	Guidance & Nav.	↑	↑	5.688	44	2	↑	↑	↑	3	↑
300-01-13	Instrumentation	↑	↑	5.165	14	3.4	↑	63	↑	3	↑
300-01-15	Landing & Recovery	↓	↓	3.485	19	2	↑	51	↓	5	↓
300-01-16	Crew Systems	5	NA	6.300	40	4.5	↑	55	66	3	↓
300-01-18	Ground Support Equip.	(See Vehicle Level)					↑	NA	NA	NA	↓
300-01-19	Thermal Protection Sys.	5	NA	56.548	119	40	↑	63	66	1	↓
300-01-92	Systems Support	↑	↑	205.163	460	152	↓	66	66	6	↓
300-01-97 ***	Test Hardware	5	NA	1411.558	See Unit	Costs	2	42	52	3	NA

3-57

Volume X

* Includes -01, -08, -14, -17.
 ** Covers rocket & jet engine R&D for both stages.
 *** Includes -02.

Table 3-14. Detailed FR-4 Costs (\$ Million) in NASA WBS Format (Cont'd)

X Design and Development (Nonrecurring)
 ___ Production and Operations (Recurring)

Identification Number a	WBS Identification b	WBS Level c	No. Units d	Expect. Cost e	Highest Cost f	Lowest Cost g	Confid. Rating h	T _d i	T _s j	Spred. Funct. k	Learn Index l
300-02-00	Orbiter Stage	4	NA	1737.858	NA	NA	NA	NA	NA	NA	NA
300-02-(*)	Basic Vehicle	5	↑	213.852	370	115	2	61	66	1	↑
300-02-03**	Propulsion	↑	↑	—	NA	NA	↑	57	73	3	↑
300-02-04	Reaction Control	↑	↑	89.687	180	82	↑	57	66	1	↑
300-02-05	Electrical Power	↑	↑	42.625	76	38	↑	62		3	↑
300-02-06	Environ. Ctrl & L.S.	↑	↑	28.253	54	21	↑	63		6	↑
300-02-07	Communication	↑	↑	14.097	40	8	↑	↑		3	↑
300-02-10	Guidance & Nav.	↑	↑	46.648	85	40	↑	↓		↑	↑
300-02-13	Instrumentation	↑	↑	5.575	14	3.7	↑	63		3	↑
300-02-15	Landing & Recovery	↓	↓	3.485	19	2	↑	5i		5	↑
300-02-16	Crew Systems	5	NA	7.938	60	6.0	↑	55	66	3	↑
300-02-18	Ground Support Equip.	(See Vehicle Level)					↑	NA	NA	NA	↑
300-02-19	Thermal Protection Sys.	5	NA	72.505	153	40	↑	63	66	1	↑
300-02-92	Systems Support	↑	↑	179.444	312	169	↓	66	66	6	↓
300-01-97***	Test Hardware	5	NA	1033.749	See Unit Costs		2	42	52	3	NA

3-58

* Includes -01, -08, -14, -17.
 ** Covered in booster stage.
 *** Includes -02.

— Design and Development (Nonrecurring)
 X Production and Operations (Recurring)

Identification Number a	WBS Identification b	WBS Level c	No. Units d	Expect. Cost e	Highest Cost f	Lowest Cost g	Confid. Rating h	T _d i	T _s j	Spred. Funct. k	Learn Index l
300-01-00	Booster Stage	4	NA	417.733	NA	NA	NA	NA	NA	NA	NA
300-01-01	Structure	5	3	52.352	115	29	2	23	25	6	90
300-01-02	Subsystem Installation	5	3	3.439	84	2.4	↑	22	20	↑	90
300-01-03-01	Rocket Engine	6	27	4.650	6.1	3.4	↑	33	40	↑	95
300-01-03-04	Jet Engine	↑	9	3.357	3.4	1.6	↑	14	28	↑	90
300-01-03-08	Fuel Delivery System	↓	3	3.187	6.0	1.7	↑	18	35	↑	↑
300-01-03-09	Oxidizer Delivery System	6	↑	5.731	10	3	↑	↑	↑	↑	↑
300-01-04	Reaction Control	5	↑	2.483	5	1.2	↑	↑	↑	↑	↓
300-01-05	Electrical Power	↑	↑	2.790	5	1.7	↑	↓	↓	↑	↓
300-01-06	Environmental Control	↑	↑	2.253	6	1.6	↑	18	35	↑	90
300-01-07	Communication	↑	↑	2.131	2.3	1.5	↑	20	38	↑	95
300-01-08	Stabilization & Control	↑	↑	3.675	7.3	2.6	↑	18	35	↑	90
300-01-10	Guidance & Nav.	↑	↑	5.361	6.5	3.5	↑	20	38	↑	95
300-01-13	Instrumentation	↑	↑	0.528	0.8	0.4	↑	18	35	↑	95
300-01-15	Landing & Recovery	↑	↑	2.193	7.8	1.5	↑	18	35	↑	90
300-01-16	Crew Systems	↑	↑	0.059	1.2	0.03	↑	18	35	↑	90
300-01-17	Pressurization	↓	↓	1.340	2.4	0.7	↓	10	35	↓	90
300-01-19	Thermal Protection	5	3	15.144	26	12.9	2	18	35	6	90

3-60

Volume X

-- Design and Development (Nonrecurring)
 X Production and Operations (Recurring)

Identification Number a	WBS Identification b	WBS Level c	No. Units d	Expect. Cost e	Highest Cost f	Lowest Cost g	Confid. Rating h	T _d i	T _s j	Spred. Funct. k	Learn Index l
300-02-00	Orbiter Stage	4	NA	229.843	NA	NA	NA	NA	NA	NA	NA
300-02-01	Structure	5	2	48.041	105	26	2	22	25	6	90
300-02-02	Subsystem Installation	5	2	3.811	23.4	2.6	2	16	14	↑	90
300-02-63-01	Rocket Engine	6	6	4.645	6.1	3.4	3	12	22	↑	95
300-02-03-04	Jet Engine		4	3.357	3.4	1.7	3	14	28		90
300-02-03-08	Fuel Delivery System		2	1.289	2.4	.7	2	18	35		↑
300-02-03-09	Oxidizer Delivery System	6	↑	2.272	4.2	1.2	↑	↑	↑		↑
300-02-04	Reaction Control	5	↑	7.638	15.2	3.8	↑	↓	↓		↓
300-02-05	Electrical Power	↑		3.568	5.8	1.5		↓	↓		↓
300-02-06	Environmental Control			3.882	10	2.8		18	35		90
300-02-07	Communication			2.131	2.3	0.9		20	38		95
300-02-08	Stabilization & Control			3.583	7.1	2.6		18	35		90
300-02-10	Guidance & Nav.			6.578	12	4.2		20	38		95
300-02-13	Instrumentation			.598	0.9	0.5		18	35		95
300-02-15	Landing & Recovery			2.138	7.8	1.5		↑	↑		90
300-02-16	Crew Systems			0.123	0.25	0.06		↑	↑		↑
300-02-17	Pressurization	↓	↓	1.096	2	0.6	↓	↓	↓	↓	↓
300-02-19	Thermal Protection	5	2	13.879	35	11.8	2	18	35	6	90

3-61

Volume X

Table 3-15. Technical Characteristics Data for the FR-4 Configuration

IDENTIFICATION NUMBER	WBS IDENTIFICATION	WBS LEVFL	QUANTITY OR VALUE		UNITS OF MEASURE	CHARACTERISTICS	NOTES
			CURRENT	NEW			
300-01-10-00	Booster	3		1,879	M Pounds	Gross Weight	
				1,540	M Pounds	Dry Weight	
				199	Feet	Length	
				34	Feet	Width	
				29	Feet	Height	
300-02-10-00	Orbiter	3		1,161	M Pounds	Gross Weight	
				0,829	M Pounds	Dry Weight	
				191	Feet	Length	
				33	Feet	Width	
				28	Feet	Height	
300-01-01-00	Structure	5		6	g	Ultimate Loading	
				4	g	Limit Loading	
300-02-01-00	Structure	5		6	g	Ultimate Loading	
				4	g	Limit Loading	
300-01-03-00	Propulsion (Rocket)	5		400,000	Pounds	Thrust	
				See Vol.VI	Seconds	ISP Actual	
				See Vol.VI	Seconds	ISP Theoretical	
				See Vol.VI	Lb/Sec	Total Impulse	
				9,400	Ft/Sec	ΔV Requirement	
				100	-	Number of Burns	
				355,767	Pounds	Inert Weight	
				190	Seconds	Maximum Burn Time	

3-62

Volume X

Table 3-15. Technical Characteristics Data for the FR-4 Configuration, (Cont'd)

IDENTIFICATION NUMBER	WBS IDENTIFICATION	WBS LEVEL	QUANTITY OR VALUE		UNITS OF MEASURE	CHARACTERISTICS	NOTES
			CURRENT	NEW			
				10	Hours	Operating Life	
				10	--	Throttling Ratio	
				80	--	Expansion Ratio	
				LH ₂ /LO ₂	--	Propellants	
300-02-03-00	Propulsion (Rocket)	5		400,000	Pounds	Thrust	
				See Vol. VI	Seconds	ISP Actual	
				See Vol. VI	Seconds	ISP Theoretical	
				See Vol. VI	Lb/Sec	Total Impulse	
				15,600	Ft/Sec	ΔV Requirement	
				5	--	Number of Burns	
				327,176	Pounds	Inert Weight	
				300	Seconds	Maximum Burn Time	
				10	Hours	Operating Life	
				10	--	Throttling Ratio	
				160	--	Expansion Ratio	
				LH ₂ /LO ₂	--	Propellants	
300-01-03-00	Propulsion (Jet)	5		3	Number	Number of Engines	
				40,600	Pounds	Max. SLST/Engine	
				22,930	Pounds	Total Engine Weight	
				30,711	Pounds	Fuel Weight	

Table 3-15. Technical Characteristics Data for the FR-4 Configuration (Cont'd)

IDENTIFICATION NUMBER	WBS IDENTIFICATION	WBS LEVEL	QUANTITY OR VALUE		UNITS OF MEASURE	CHARACTERISTICS	NOTES
			CURRENT	NEW			
300-02-03-00	Propulsion (Jet)	5		2	Number	Number Engines	
				40,600	Pounds	Max. SLST/Engine	
				15,292	Pounds	Total Engine Weight	
				3,225	Pounds	Fuel Weight	
300-01-04-00	Reaction Control	5		3,500	Pounds	Thrust	
				16	—	Number	
				400	Seconds	ISP Actual	
				450	Seconds	ISP Ideal	
				0.4	M Lb-Sec	Total Impulse	
				1000	Pounds	Weight of Propellant	
				250	Lb-Sec	Minimum Impulse Bit	
				1300	Pounds	Inert Weight	
				500	Seconds	Burn Time	
				2.5	Deg/Sec ²	Acceleration	
				1	Lb/Sec	Compressor Flow Rate	GH ₂
				10	Hours	Operating Life	
300-02-04-00	Reaction Control	5		3500	Pounds	Thrust	
				48	—	Number	
				400	Seconds	ISP Actual	
				450	Seconds	ISP Ideal	
				2.4	M Lb-Sec	Total Impulse	

Table 3-15. Technical Characteristics Data for the FR-4 Configuration (Cont'd)

IDENTIFICATION NUMBER	WBS IDENTIFICATION	WBS LEVEL	QUANTITY OR VALUE		UNITS OF MEASURE	CHARACTERISTICS	NOTES
			CURRENT	NEW			
				6000	Pounds	Weight of Propellant	
				250	Lb-Sec	Minimum Impulse Bit	
				5200	Pounds	Inert Weight	
				1300	Seconds	Burn Time	
				2.5	Deg/Sec ²	Acceleration	
				0.03	g	Acceleration	
				1	Lb/Sec	Compressor Flow Rate	GH ₂
				10	Hours	Operating Life	
				5	Lb/Sec	Compressor Flow Rate	GO ₂
300-01-05-00	Electrical Power	5		9000	Watts	Total Power	Fuel Cells
				3700	Watts	Average Power	
				3046	Pounds	Weight	
300-02-05-00	Electrical Power	5		600	W-Hr	Total Power	Batteries
				1313	Watts	Average Power	
				646	Pounds	Weight	
300-01-06-00	Environmental Control	5		344	Ft ³	Press. Module Volume	
				26	Pounds	Weight of Atmos. Gas	
				1	A.U.	Min. Distance from Sun	
				1	A.U.	Max. Distance from Sun	
				0	N.Mi.	Min. Distance from Earth	
				30	N.Mi.	Max. Distance from Earth	
				118	Pounds	Weight	

3-65

Volume X

Table 3-15. Technical Characteristics Data for the FR-4 Configuration (Cont'd)

IDENTIFICATION NUMBER	WBS IDENTIFICATION	WBS LEVEL	QUANTITY OR VALUE		UNITS OF MEASURE	CHARACTERISTICS	NOTES
			CURRENT	NEW			
				100	Ft ³ /Min.	Max. Gas Flow Rate	
300-02-06-00	Environmental Control	5		344	Ft ³	Press. Module Volume	
				138	Pounds	Weight of Atmos. Gas	
				1	A.U.	Min. Distance from Sun	
				1	A.U.	Max. Distance from Sun	
				0	N.Mi.	Min. Distance from Earth	
				270	N.Mi.	Max. Distance from Earth	
				1507	Pounds	Weight	
				300	Ft ³ /Min	Max. Gas Flow Rate	
300-01-07-00	Communications	5					
	UHF Transceiver			15	Pounds	Weight	
				30	Watts	Output	
				3	Number	Units	
	Crash Beacon			9	Pounds	Weight	
				15	Watts	Output	
				1	Number	Units	
	Radar Beacon			10	Pounds	Weight	
				15	Watts	Output	
				1	Number	Units	
	Inercom			3	Pounds	Weight	
				12	Watts	Output	
				6	Number	Units	

3-66

Volume X

Table 3-15. Technical Characteristics Data for the FR-4 Configuration (Cont'd)

IDENTIFICATION NUMBER	WBS IDENTIFICATION	WBS LEVEL	QUANTITY OR VALUE		UNITS OF MEASURE	CHARACTERISTICS	NOTES
			CURRENT	NEW			
	Matrix Switch			8	Pounds	Weight	Solid State Audio
				1	Number	Units	Mechanical RF
300-02-07-00	Communications	5					
	UHF Transceiver			15	Pounds	Weight	
				30	Watts	Output	
				3	Number	Units	
	S-Band Transceiver			30	Pounds	Weight	
				30	Watts	Output	
				3	Number	Units	
	S-Band Amplifier			30	Pounds	Weight	
				180	Watts	Output	
				2	Number	Units	
	Crash Beacon			9	Pounds	Weight	
				15	Watts	Output	
				1	Number	Units	
	Radar Beacon			10	Pounds	Weight	
				15	Watts	Units	
				1	Number	Units	
	Intercom			3	Pounds	Weight	
				12	Watts	Output	
				8	Number	Units	

57

Table 3-15. Technical Characteristics Data for the FR-4 Configuration (Cont'd)

IDENTIFICATION NUMBER	WBS IDENTIFICATION	WBS LEVEL	QUANTITY OR VALUE		UNITS OF MEASURE	CHARACTERISTICS	NOTES
			CURRENT	NEW			
	Matrix Switch			8	Pounds	Weight	Solid State Audio
				1	Number	Units	Mechanical RF
	Antenna Parabolic			50	Pounds	Weight	
				1	Number	Units	
300-01-07-00	Stabilization & Control	5		0.01	Deg/Sec	Minimum Attitude	
						Change Rate	
						Permissible	
						Angular Errors	
				0.1	Degree	Roll	
				0.1	Degree	Pitch	
				0.1	Degree	Yaw	
				400	N.Mi.	Max. Distance from Reference	
				10	Number	Number of Major Maneuvers	
300-02-08-00	Stabilization & Control	5		0.001	Deg/Sec	Min. Attitude Change Rate	
						Permissible Angular Errors	
				0.01	Degree	Roll	
				0.01	Degree	Pitch	
				0.01	Degree	Yaw	
				3000	N.Mi.	Max. Distance from Reference	
				100	Number	Number of Major Maneuvers	
300-01-10-00	Guidance & Navigation	5					
	Inertial Measuring Unit			85	Pounds	Weight	

Table 3-15. Technical Characteristics Data for the FR-4 Configuration (Cont'd)

IDENTIFICATION NUMBER	WBS IDENTIFICATION	WBS LEVEL	QUANTITY OR VALUE		UNITS OF MEASURE	CHARACTERISTICS	NOTES
			CURRENT	NEW			
	Accelerometer			40	PPM	3 σ Bias	
				40	PPM	3 σ Scale Factor	
	Gyro			0.15	Deg/Hr	3 σ CT	
				0.2	Deg/Hr/g	3 σ MUIA	
				0.3	Deg/Hr/g	3 σ MUSA	
				3	Number	Units	
	Instrument Land System			2	Number	Units	
				5	Pounds	Weight	
	Radar Altimeter			3	Number	Units	
				5000	Feet	Range	
				53	Pounds	Weight	
	Distance Meas. Equip.			2	Number	Units	
				20	Pounds	Weight	
	Weather Radar			1	Number	Units	
				18	Inches	Antenna Size	
				180	N.Mi.	Range	
				37	Pounds	Weight	
300-02-10-00	Guidance & Navigation	5					
	Inertial Meas. Unit			85	Pounds	Weight	
	Accelerometer			40	PPM	3 σ Bias	
				40	PPM	3 σ Scale Factor	
	Gyro			0.15	Deg/Hr	3 σ CT	

3-69

Volume X

Table 3-15. Technical Characteristics Data for the FR-4 Configuration (Cont'd)

IDENTIFICATION NUMBER	WBS IDENTIFICATION	WBS LEVEL	QUANTITY OR VALUE		UNITS OF MEASURE	CHARACTERISTICS	NOTES
			CURRENT	NEW			
				0.2	Deg/Hr/g	3 σ MUIA	
				0.3	Deg/Hr/g	3 σ MUSA	
				3	Number	Units	
	Instrument Land System			2	Number	Units	
				5	Pounds	Weight	
	Radar Altimeter			3	Number	Units	
				300	Feet	Range	
				80	Pounds	Weight	
	Distance Meas. Equip.			2	Number	Units	
				20	Pounds	Weight	
	Weather Radar			1	Number	Units	
				18	Inches	Antenna Size	
				180	N. Mi.	Range	
				37	Pounds	Weight	
300-02-10-00	Horizon Scanner	5		1	Number	Units	
				50	Pounds	Weight	
	Rendezvous Laser Radar			3	Number	Units	
				46	Pounds	Weight	
300-01-15-00	Landing & Recovery	5		324,789	Pounds	Landing Weight	
				12	Ft/Sec	Terminal Sink Speed	
				0	Degrees	Terminal Glide Slope	
				13,000	Pounds	Subsystem Weight	

3-70

Volume X

Table 3-15. Technical Characteristics Data for the FR-4 Configuration (Cont'd)

IDENTIFICATION NUMBER	WBS IDENTIFICATION	WBS LEVEL	QUANTITY OR VALUE		UNITS OF MEASURE	CHARACTERISTICS	NOTES
			CURRENT	NEW			
				0.0765	Lb/Ft ³	Terminal Atmos. Density	Sea Level at 59° F
300-02-15-00	Landing & Recovery	5		322,475	Pounds	Landing Weight	
				12	Ft/Sec	Terminal Sink Speed	
				0	Degrees	Terminal Glide Slope	
				13,000	Pounds	Subsystem Weight	
				0.0765	Lb/Ft ³	Terminal Atmos. Density	Sea Level at 59° F
300-01-16-00	Crew Systems	5		2	Number	Number Crew Stations	
				344	Ft ³	Pressure Volume	
300-02-16-00	Crew Systems	5		2	Number	Number Crew Stations	
				344	Ft ³	Pressure Volume	
300-01-17-00	Pressurization	5		19000	Pounds	Gas	
				2000	Pounds	Hardware	
300-02-17-00	Pressurization	5		9000	Pounds	Gas	
				500	Pounds	Hardware	
300-01-19-00	Thermal Protection Sys.			RTPS	Specify	Type	
				18,420	Ft ²	Surface Area	Body Area
				1.61	Lb/Ft ²	Unit Weight	
				1400	°F	Temperature	Mean Lower Surf.

3-71

Volume X

Table 3-15. Technical Characteristics Data for the FR-4 Configuration (Cont'd)

IDENTIFICATION NUMBER	WBS IDENTIFICATION	WBS LEVEL	QUANTITY OR VALUE		UNITS OF MEASURE	CHARACTERISTICS	NOTES
			CURRENT	NEW			
				30	Ft ²	Panel Size	Average for Vehicle
				50	Number	Reusability	No. of Flights
300-02-19-00	Thermal Protection Sys.			RTPS	Specify	Type	
				16,890	Ft ²	Surface Area	Body Area
				2.34	Lb/Ft ²	Unit Weight	
				1850	°F	Temperature	Mean Lower Surf.
				30	Ft ²	Panel Size	Average for Vehicle
				50	Number	Reusability	No. of Flights

3-72

Volume X

ID NUMBER	WBS IDENTIFICATION	SCHEDULE							
		70	71	72	73	74	75	76	77
DFSK	DEVELOPMENT								
Vehicle Level									
300-18-00	Vehicle CSE								
300-95-00	Facilities								
300-98-00	Test Operations and Services								
	CDP Studies								
Booster Level									
300-01-01, -08 -14, -17	Basic Vehicle								
300-01-03	Propulsion (Rocket)								
300-01-03	Propulsion (Jet)								
300-01-04	Reaction Control								
300-01-05	Electrical Power								
300-01-06	Environ. Control and L.S.								
300-01-07	Communications								
300-01-10	Guidance and Navigation								
300-01-13	Instrumentation								
300-01-15	Landing and Recovery								
300-01-16	Crew Systems								
300-01-19	Thermal Protection Systems								
300-01-92	Systems Support								
300-01-97, -02	Test Hardware								

Figure 3-26. FR-4 Configuration Development and Production Plan Schedule

WBS ID NUMBER	WBS IDENTIFICATION	SCHEDULE							
		70	71	72	73	74	75	76	77
Booster Level									
300-01-01	Structure								
300-01-02	Subsystem Installation								
300-01-03-01	Rocket Engine								
300-01-03-04	Jet Engine								
300-01-03-08	Fuel Delivery System								
300-01-03-09	Oxidizer Delivery System								
300-01-04	Reaction Control								
300-01-05	Electrical Power								
300-01-06	Environmental Control								
300-01-07	Communications								
300-01-08	Stabilization and Control								
300-01-10	Guidance and Navigation								
300-01-13	Instrumentation								
300-01-15	Landing and Recovery								
300-01-16	Crew Systems								
300-01-17	Pressurization								
300-01-19	Thermal Protection								
Orbiter Level									
300-02-01	Structure								

Figure 3-26. FR-4 Configuration Development and Production Plan Schedule (Cont'd)

ID NUMBER	WBS IDENTIFICATION	SCHEDULE							
		70	71	72	73	74	75	76	77
Orbiter Level (Cont.)									
300-02-02	Subsystem Installation								██████████
300-02-03-01	Rocket Engine							██████████	
300-02-03-04	Jet Engine						██████████		
300-02-03-08	Fuel Delivery System					██████████	██████████		
300-02-03-09	Oxidizer Delivery System					██████████	██████████		
300-02-04	Reaction Control					██████████	██████████		
300-02-05	Electrical Power					██████████	██████████		
300-02-06	Environmental Control					██████████	██████████		
300-02-07	Communication					██████████	██████████		
300-02-08	Stabilization and Control					██████████	██████████		
300-02-10	Guidance and Control					██████████	██████████		
300-02-13	Instrumentation					██████████	██████████		
300-02-15	Landing and Recovery					██████████	██████████		
300-02-16	Crew Systems					██████████	██████████		
300-02-17	Pressurization					██████████	██████████		
300-02-19	Thermal Protection					██████████	██████████		

Figure 3-26. FR-4 Configuration Development and Production Plan Schedule (Cont'd)

3.5 REFERENCES

- 3-1 C. R. Bernick, et al., Advanced Vehicle System Evaluation Model (AVSEM), Convair division of General Dynamics, GDC-ERR-AN-1140, October 1968.
- 3-2 Optimized Cost/Performance Design Methodology, Volume II Book 5, McDonnell Douglas Astronautics Company, Eastern Division, Report No. G975, 15 April 1969.
- 3-3 R. Johnson, Jr., Dispersion-Strengthened Metal Structural Development, McDonnell Douglas Astronautics Company, Western Division, DAC-62433, November 1968.
- 3-4 Multipurpose Reusable Spacecraft Preliminary Design Effort (Category A), Volume V Book 1, Cost Analysis, (U), Confidential, Douglas Aircraft Company MSSD, Report DAC-58072, November 1967.
- 3-5 J. W. McCown and R. M. Davis, Comparison of Radiative Versus Ablative Heat Shield Concepts for Manned Lifting Entry Vehicles with L/D's of 1.4 and 2.7, Martin Company, Baltimore, Md.
- 3-6 William F. Black, Radiative Thermal Protection Systems Development for Maneuverable Re-Entry Spacecraft, Convair division of General Dynamics, GDC-ERR-1272, February 1969.
- 3-7 Airline Methods Applied to Space Shuttle System Turnaround Plan and Cost Analysis, Pan American World Airways, Inc., 6 October 1969.
- 3-8 Specification for the Presentation of Cost and Schedule Plans for New Space Projects, NASA, Office of Advanced Manned Missions, 30 January 1969.

SECTION 4

TECHNOLOGY REQUIREMENTS

4.1 TECHNOLOGIES

The programs briefly described in this section identify those technologies required to permit orderly and expedient development of the manned reusable space shuttle system that would be operational in the year 1976. Results of these technology studies are intended to support Phase B and C decisions regarding technical approaches to major design and systems problems, thus minimizing development risk and increasing confidence at the outset of the Phase D development program and an early operational capability. Figure 4-1 shows the relationship of these technology programs with each other and with the space shuttle phased development program.

Technologies described here are independent of any specific space shuttle configuration and do not include those studies that are normally conducted as part of the Phase B, C, and D development programs. Configuration-oriented development programs and those that are normally conducted within the Phase B, C, and D studies are included in the development plans of Section 2 of this volume. The technology programs listed here are intended to be conducted in parallel with the Phase B, C, and D programs, with each scheduled to support a specific milestone in the total development plan. Costs of individual technology programs are based on their being conducted by a contractor to NASA and do not include program administration costs by NASA. Costs of those technology programs conducted "in-house" by NASA may also vary somewhat from those shown here.

The technology programs presented here fall into two categories. Category I contains those programs that support the space shuttle configuration development and selection. It is mandatory that these programs be initiated immediately in order to minimize development risk. Category II programs are slightly less important since they do not necessarily support configuration definition. While the start of these programs is not as urgent as those in Category I, they are required to support milestone decisions within the development program plan.

It is important to note that although a number of technology programs must be started and completed as soon as possible to support the development of the space shuttle, none of these involve critical technologies. This means that all of the programs associated with development of the space shuttle can be accomplished by application of existing and demonstrated technology methods and techniques, and that no technological breakthroughs are required.

4.3.5	I	Heat Transfer in Regions of Flow Reattachment		195
4.3.6	I	Aero Heat Transfer Flight Test		9,950
4.3.7	I	Heat Barriers for Radiation Cooled Entry Vehicle		240
4.3.8	II	Base Heating		380
4.3.9	II	Plume Impingement Heating		255
4.4		Structure Design and Materials		(12,315)
4.4.1	I	Composite Materials Application to Space Shuttle		4,600
4.4.2	I	Structural Design Criteria Tradeoff Studies		175
4.4.3	I	Synthesis of Structural Components		330
4.4.4	I	Hot Structures		330
4.4.5	I	High Temperature Control Surfaces		380
4.4.6	I	Joining High Temperature Materials		840
4.4.7	I	Material Properties Determination		380
4.5		Thermal Protection Design and Materials		(7,035)
4.5.1	I	Metallic Radiative Thermal Protection Systems		289
4.5.2	I	Ablative Thermal Protection Systems		670
4.5.3	I	Nonmetallic, Nonreceding Radiative TPS		380
4.5.4	I	TPS Analysis and Performance Improvement		515
4.5.5	I	High Temperature Nosecap and Leading Edges		640
4.5.6	I	High Temperature Insulation Development		140
4.5.7	I	Nondestructive Test Development		410
4.5.8	I	Improved Ductility of Radiative TPS Materials		470
4.5.9	I	Fabrication Development of TD NiCr Materials		630
4.5.10	I	Fabrication Development of Refractory Materials		480
4.5.11	I	Fabrication of Ceramic Nosecaps and Leading Edges		710
4.5.12	I	Mechanical/Thermal Interface Attachments for TPS		310
4.6		Materials		(5,644)
4.6.1	I	Reusable Cryogenic Propellant Duct Insulation		1,645
4.6.2	I	Reusable Cryogenic Propellant Tank Insulation		5,875
4.6.3	II	Bearings and Lubricants Subjected to Space and Operational Environments		400
4.7		Propulsion		(7,920)
4.7.1	I	Attitude Control Propulsion - LO ₂ /LH ₂		22,000
4.7.2	I	Air Breathing Engine Propulsion		14,300
4.7.3	I	Main Rocket Engine Propulsion		18,500
4.7.4	I	Main Propulsion System		7,500
4.7.5	II	Orbiter Cryogenic Propellant System		540
4.8		Aeroelastics and Dynamics		(62,840)
4.8.1	I	Structural Modes Stability and Loads Analysis		340
4.8.2	I	Pre-Entry Control Requirements		120
4.8.3	I	Boost Phase Control Requirements		100
4.8.4	I	Transonic Acoustic Loading on Cluster d		330

FOLDOUT FRAME 2

4.6.1	I	Reusable Cryogenic Propellant Duct Insulation		1,645
4.6.2	I	Reusable Cryogenic Propellant Tank Isolation		5,875
4.6.3	II	Bearings and Lubricants Subject to and Operational Environments		400
4.7		Propulsion		(7,920)
4.7.1	I	Attitude Control Propulsion - LO ₂ /LH ₂		22,000
4.7.2	I	Air Breathing Engine Propulsion		14,300
4.7.3	I	Main Rocket Engine Propulsion		18,500
4.7.4	I	Main Propulsion System		7,500
4.7.5	II	Orbiter Cryogenic Propellant System		540
4.8		Aeroelastics and Dynamics		(62,840)
4.8.1	I	Structural Modes Stability and Loads Analysis		340
4.8.2	I	Pre-Entry Control Requirements		120
4.8.3	I	Boost Phase Control Requirements		100
4.8.4	I	Transonic Acoustic Loading on Clustered Vehicles		330
4.8.5	I	Vibration and Fatigue Specifications		240
4.8.6	II	Flutter and Buffet Model Testing Throughout Speed Regime		645
4.9	II	Integrated Electronics		(1,775)
4.9.1	II	Space Shuttle System Autonomy		592
4.9.2	II	Strapdown Inertial Guidance		700
4.9.3	II	Display Formats of Integrated Electronics		364
4.9.4	I	Multiple Redundancy of Integrated Electronics		296
4.9.5	II	Onboard Computer Architecture		1,008
4.9.6	II	Multiplex Data System Interfaces		608
4.9.7	II	Software Language		232
4.10		Human Factors		(3,800)
4.10.1	II	Human Factors of Display Characteristics and Formats		650
4.10.2	II	Human Factors of Electronic Controls		625
4.10.3	II	Human Factors of Crew and Passenger Visibility		210
4.10.4	II	Crew and Passenger Restraint Systems		210
4.11		Subsystems		(1,695)
4.11.1	II	Remote Controlled Solid-State Circuit Breaker Development		450
4.11.2	II	H ₂ -O ₂ Auxiliary Power Engine Development		1,350
4.11.3	II	LH ₂ Utilization for Subsystem Heat Sink		810
				109,676

Figure 4-1. Summary of Technology Programs, Schedule, and Costs

FOLDOUT FRAME

4.2 AERODYNAMICS AND CONFIGURATION

4.2.1 HYPERSONIC FLOW FIELD ANALYSIS (CATEGORY I)

OBJECTIVE: Develop a procedure to properly evaluate the environment at the surface of the vehicle in hypersonic flow.

PROBLEM: Accurate description of the hypersonic flow field about the vehicle is required to properly evaluate conditions at the vehicle surface. Aerodynamic design loads can be adequately handled with less sophisticated descriptions of the flow field; but moments, shear and heat transfer coefficients require a better understanding of the flow field. The three-dimensional nature of the flow field with a varying entropy gradient from the surface to the curved bow shock complicates the problem. Upper surface conditions are further complicated by vortical flow and separation.

TECHNICAL APPROACH & TASK DESCRIPTION: Develop and adapt a finite-difference numerical solution of the supersonic inviscid three-dimensional flow field about an arbitrary lifting body. Develop boundary layer techniques for laminar, transitional and turbulent flows with arbitrary boundary conditions and real gas effects. Establish procedures for coupling inviscid and viscous flows, such as an effective body shape caused by a displacement thickness, and evaluate coupled solutions to establish complete flow field properties. Conduct detailed flow field surveys, along with surface pressure and heat transfer distribution measurements, through wind tunnel tests. Correlate experimental data with the analytic approach to validate the analytic model for the "cold" gas wind tunnel environment; then analytically evaluate the real gas full-scale conditions.

Tasks	1970												1971				Cost (\$K)	
	J	F	M	A	M	J	J	A	S	O	N	D	J	F	M	A		
Develop Inviscid Solution	████████████████████																	30
Develop Viscous Solution	████████████████████																	80
Develop Couple Flow Solution																		50
Design and Fabricate Models																		50
Conduct Wind Tunnel Tests																		150
Analyze Test Results																		20
Correlate Data and Analysis																		20
Apply Analysis to Flight Conditions																		5
Total Cost																405		

4.2.2 AERODYNAMIC ENVIRONMENT DURING LAUNCH (CATEGORY I)

OBJECTIVE: Establish structural design criteria and acoustic loading on crew/passenger compartment during launch.

PROBLEM: In the launch phase, acoustic environment, fluctuating pressures, venting and local flow field data are required for structural design concepts, crew and passenger protection concepts, and panel flutter characteristics. A clustered launch system such as the space shuttle represents an unusual configuration posing a great deal of uncertainty as to the acoustic loading potentially imposed on the crew compartment and structure. This loading is primarily due to shock wave-boundary layer interactions which, on this multiple body arrangement, occur in an extremely complex flow field. This program would define shock wave impingement patterns, separated regions, resulting acoustic load intensities and venting requirements to establish design criteria affecting configuration concept.

TECHNICAL APPROACH & TASK DESCRIPTION: Conduct a combined analytic and experimental approach on related clustered-vehicle configurations. Use methods such as Van Dyke's second-order slender body approach at supersonic speeds and empirical techniques such as developed at USAF-FDL for hypersonic interference effect in the analytic interference study. This phase is not expected to give quantitative results, but will evaluate flight regimes which may prove critical, allowing the experimental phase to be concentrated on those regimes. Implement venting analysis methods.

The wind tunnel test phase will consist of pretest planning, model design and fabrication, testing, and data analysis and correlation. Build wind tunnel models as large as practicable since size of dynamic pressure transducers is directly related to boundary layer displacement thickness. Small models, with thin boundary layers, require very small transducers (which have low sensitivity) and instrumentation systems with very high frequency capability. For example, if frequencies up to 10 KHz for a full-size vehicle are of interest, use of a 1/40-scale model would require frequency capability of about 400 KHz.

Data to be collected during wind tunnel tests includes as a minimum the following:

- a. Shock location (using static pressure probes and Schlieren coverage).
- b. Boundary layer and shock interaction pressures (using flush-mounted pressure transducers).
- c. Boundary layer pressure cross-correlation data (using flush-mounted pressure transducers).

Tasks	1970												1971				Cost (\$K)	
	J	I	M	A	M	J	J	A	S	O	N	D	J	F	M	A		
Analyze Venting			■	■	■	■	■	■	■	■	■	■	■	■				40
Design & Fabricate Model			■	■	■	■	■	■	■	■	■	■	■	■				55
Conduct Wind Tunnel Test								■	■									60
Analyze Data								■	■	■	■	■	■					40
Define Design Criteria											■	■	■	■	■			12
Total Cost																	207	

4.2.3 JET ENGINE PROPULSION EFFECTS (CATEGORY I)

OBJECTIVE: Define the effects of jet engine operation on the aerodynamic characteristics of the subsonic configuration.

PROBLEM: Powered approach and landing will add jet engine effects on the vehicle stability and control. With forward-mounted jet engines on the body, the wake will affect most of the body and verticals as well as inboard wing sections. Effects of jet engine flow on the aerodynamic characteristics must be evaluated to establish potential problem areas in vehicle stability and control, particularly as the subsonic behavior influences vertical tail size and wing location.

TECHNICAL APPROACH & TASK DESCRIPTION: Design and fabricate a low-speed wind tunnel model including operating jet engines capable of simulating proper exhaust flow. A matched inlet-exhaust flow simulation is not expected to add much more to engine effects than exhaust flow simulation since the engines are located so far forward. Conduct a subsonic wind tunnel test on this configuration with and without jet engines operating, including the condition of asymmetric thrust due to an engine failure. Analyze resulting data to determine effects of jet exhaust and what configuration modifications are required to eliminate any adverse effects.

Tasks	1970												1971				Cost (\$K)	
	J	F	M	A	M	J	J	A	S	O	N	D	J	F	M	A		
Design & Fabricate Model	█																	50
Conduct Wind Tunnel Tests						█												40
Analyze Data							█	█	█	█	█	█						30
Total Cost																120		

4.2.4 SUBSONIC AERODYNAMIC HANDLING CRITERIA (CATEGORY I)

OBJECTIVE: Establish the subsonic design criteria of a reusable cruise and landing geometry space shuttle.

PROBLEM: The subsonic flight regime will impose design requirements affecting the inert weight of booster and orbiter vehicles, thus having a significant influence on launch vehicle weight. Vertical tail sizing will be defined by subsonic handling qualities criteria. The hypersonic case will have increased directional stability due to deflecting the vertical tail surfaces for pitch trim or through use of an attitude control system. Jet engine size and exhaust effects on aerodynamic characteristics are also dictated by subsonic cruise, takeoff, and landing approach go-around capability. Landing loads define structural weight of the landing gear subsystem. The importance of proper subsonic design criteria for such items is indicated by the roughly 30:1 increase in launch weight for each pound added to the orbiter inert (return) weight.

TECHNICAL APPROACH & TASK DESCRIPTION: Design, fabricate and flight test a subsonic model of a reusable launch vehicle element. Model scale should be evaluated against cost of achieving technology objectives, and range from a full-scale vehicle where mass properties and resulting behavior are fully simulated to sub-scale vehicles requiring onboard flight simulators to duplicate handling qualities. Design vehicle to state-of-the-art aluminum structure. Use available jet engines to get proper thrust-to-weight simulation. High-bypass-ratio engines are not considered necessary to simulate exhaust effects since complete mixing of exhaust with adjacent flow occurs within eight to ten engine diameters downstream, well ahead of the wing. Conduct flight testing to evaluate handling qualities and establish control power requirements, takeoff and landing characteristics, unusual aerodynamic behavior such as unsymmetrical periodic body vortex shedding, landing loads, and jet engine effects.

Tasks	1970												1971				Cost (\$K)	
	J	F	M	A	M	J	J	A	S	O	N	D	J	F	M	A		
Determine Design Requirements			█	█	█	█	█	█										500
Prepare Engineering Drawings						█	█	█	█	█	█	█						300
Fabricate Soft Tooling									█	█	█	█						500
Fabricate Model									█	█	█	█	█					1000
Check Out Model														█				200
Conduct Flight Testing																█	█	500
																	Total Cost	3000

4.2.5 SPACE SHUTTLE SYNTHESIS COMPUTER PROGRAMS (CATEGORY II)

OBJECTIVE: Develop space shuttle synthesis computer programs with required mission and vehicle flexibility, including adequate models for propulsion system simulation. Include ascent and return trajectory simulation capability in the synthesis programs, with realistic feedback of ascent and return trajectory parameters (e.g., aerodynamic heating and loads) to the weight/sizing process. Provide weight/sizing and trajectory computations with sufficient accuracy and modeling realism to obtain meaningful configuration and performance sensitivities.

PROBLEM: Synthesis programs are an indispensable tool in space shuttle performance, sizing, and trade-off analyses. When trajectory and weight/sizing computations are performed separately, it is difficult to obtain genuine vehicle and trajectory sensitivities to configuration and mission parameters. To maximize the synthesis tool utility, it must be kept current with the configuration, propulsion systems, missions, etc., being studied. Realism and detail must be added to system and subsystem weight/sizing laws as configurations evolve and improved data becomes available. Near-optimum but computationally rapid trajectory control laws must be developed and used in the synthesis.

TECHNICAL APPROACH AND TASK DESCRIPTION: Establish a general synthesis program framework for anticipated space shuttle missions and configurations. Provide for flight profile flexibility, including simulation of the return flight path. Develop synthesis models for various space shuttle propulsion systems, such as tandem and parallel firing sequence, rocket vs. air-breathing engines, throttleable engines, and attitude control systems. Add representative aerodynamic heating equations to synthesis. Improve the weight/sizing laws to add detail and accuracy to evolving configurations, particularly the effects of trajectory parameters (entry loads and temperatures, maximum dynamic pressure and αq) on structures and thermal protection systems. Develop synthesis program options for developing and presenting tradeoff data in terms of fixed payload and variable liftoff weight, or fixed liftoff weight and variable payload. Provide for simulating both fixed engine (fixed thrust) and fixed thrust-to-weight ratio cases. Develop trajectory control laws (pitch, yaw and roll) that are rapid to compute, but near-optimum for performance, and which adequately approximate control laws amenable to potential guidance schemes.

Tasks	1970												1971				Cost (\$K)	
	J	F	M	A	M	J	J	A	S	O	N	D	J	F	M	A		
Establish General Framework			█	█	█	█	█	█	█									40
Develop Synthesis Models						█	█	█	█	█	█	█						50
Develop trajectory simulation and control laws					█	█	█	█	█	█	█	█	█	█	█			60
Total Cost																150		

4.2.6 TRAJECTORY OPTIMIZATION FOR SPACE SHUTTLE (CATEGORY II)

OBJECTIVE: Formulate a technique for optimizing the ascent trajectory, booster return flight path, orbiter entry trajectory, and aerodynamic orbital maneuvers. Develop an implementing computer program. Determine feasibility of an appropriate, more rapid predesign version of the optimizing technique and implement, if feasible. Investigate unified trajectory control methods applicable to all flight phases and to abort.

PROBLEM: Trajectory optimization for the space shuttle presents practical problems not solved in previous launch vehicle trajectory analyses. First, the lifting characteristics of space shuttle configurations provide a means of controlling and altering trajectories. Aerodynamic effects should therefore be considered in any optimal control scheme, for both boost and entry trajectories. Second, the necessity for efficiently and safely recovering the booster influences the desired shape of the ascent trajectory. Third, the required option for on-board, manual decision-making and control in abort situations, and the necessity for maximizing safety, puts a premium on trajectory guidance schemes employing simple and reliable techniques in both software and hardware. Such schemes must be applicable for large dispersions from nominal conditions (due, for example, to engine failures or off-nominal retro). Aerodynamic heating and loads constraints must be observed. A trajectory optimization technique of the calculus-of-variations type, with proper handling of these constraints and with payoff flexibility for alternate missions, must be developed for use in guidance system studies, abort studies and vehicle synthesis and performance analysis.

TECHNICAL APPROACH & TASK DESCRIPTION; Establish a detailed mathematical formulation to optimize trajectories with initial and final conditions and constraints. Both powered and coasting flight must be considered. The most likely candidate formulation is the calculus of variations. Code appropriate formulation into a digital computer program and run adequate test cases to verify its workability and to establish "baseline" data.

Study the feasibility of using a unified optimization method for all flight phases (powered ascent, booster return, orbiter entry and return), as well as the applicability of the method to in-flight abort situations and to nonabortive equipment failures resulting in control changes. Make tradeoffs among alternative optimal control methods applicable to separate flight phases, and to abort trajectories.

Investigate the feasibility of more rapid predesign approximations to the detailed formulations. If any of these approximations appear to be workable and useful, develop a computer program to provide an economical, easy-to-use trajectory optimization tool for predesign sensitivity and tradeoff studies. Verify the rapid technique by use of the more detailed method and its computer program.

Tasks	1970												1971				Cost (\$K)
	J	F	M	A	M	J	J	A	S	O	N	D	J	F	M	A	
Formulate Detailed Approach			■	■	■	■	■	■									50
Develop Detailed Program							■	■	■	■	■	■	■	■	■		50
Develop Tradeoff Data							■	■	■	■	■	■					10
Investigate Rapid Approaches								■	■	■	■	■	■	■			25
Investigate Flight Abort Concepts							■	■	■	■	■						10
Develop Predesign Program													■	■	■	■	25
Verify Predesign Method																■	10
	Total Cost															160	

4.3 AEROTHERMODYNAMICS

4.3.1 DEFINITION OF FLOW FIELD THERMODYNAMIC PROPERTIES (CATEGORY I)

OBJECTIVE: Provide an accurate description of the flow field surrounding a lifting entry vehicle during descent into the atmosphere. This description will enable better prediction of the heat transfer to the vehicle.

PROBLEM: The aerodynamic heat transfer to space shuttle vehicles is dependent upon the accurate description of the thermodynamic properties of the flow field in which the boundary layer develops. Vehicle geometry and angle of attack cause significant variations in the flow field thermodynamic properties. These variations can alter the turbulent heat transfer rate by as much as 100 percent, as well as influence the onset of boundary layer transition.

Lower surface flow-field thermodynamic properties are controlled by the nose and leading edge bluntness. A large nose and low angle of attack will produce high entropy thermodynamic air properties, which will control the heat transfer rate for many nose diameters downstream. This high entropy air will contain the boundary layer until the mass flow in the boundary layer equals the free stream mass flow, which passes through the strong shock associated with the nose. When the mass flow in the boundary layer greatly exceeds the high entropy mass flow, the heat transfer is controlled by the weaker shock wave (lower entropy) thermodynamic properties of the flow field. Evaluation of upper surface flow-field thermodynamic property is complicated by flow from the high-pressure, lower-surface shock layer. The results are "hot" streaks. At low angles of attack, the upper surface flow and side flow are affected by flow separation, vortex formation, and subsequent flow reattachment.

TECHNICAL APPROACH AND TASK DESCRIPTION: Perform a coordinated analytical and experimental program. Develop flow field computer programs and conduct experimental programs that measure flow field properties which can be compared to the computer program values. This comparison process would start with simple shapes and finish with a comparison on a representative space shuttle spacecraft. Starting with simple shapes provides the base to assemble the more complex analysis required to evaluate the space shuttle spacecraft configuration.

Tasks	1970	1971	1972	1973	Cost (\$K)
Phase B					
Phase C/D					
Define Flow-Field Properties	█				10
Predict Flow-Field Values	█				35
Prepare Test Plans	█				10
Design & Fabricate Models	█				40
Conduct Test Program		█	█		170
Correlate Analytical & Test Data		█			20
				Total Cost	285

4.3.2 TRANSITIONAL AND TURBULENT BOUNDARY LAYER AERODYNAMIC HEAT TRANSFER (CATEGORY I)

OBJECTIVE: Improve accuracy of aerodynamic heating prediction in regions of transitional and turbulent boundary layers. Increased analytical capability requires better understanding of the turbulent boundary layer phenomena.

PROBLEM:

Turbulent Boundary Layer Heat Transfer: A number of semi-empirical methods for prediction of turbulent heat transfer have been developed in recent years. Each is based on some body of data, and each method has strong advocates. Unfortunately, when extrapolated to entry flight conditions, the predicted heat-transfer levels vary drastically with prediction method. As a result, the confidence of a) thermal protection system material selection, and b) permissible entry maneuver selection, is low. The resulting influence on lifting entry spacecraft is large from both the entry mass, entry maneuvers, and crossrange standpoint.

Transitional Boundary Layer Heat Transfer: The gradual transition from a laminar boundary layer to a turbulent boundary layer can have a significant influence on the peak heat-transfer rate during entry. Peak heat-transfer rate reductions associated with gradual transition can influence thermal protection system material selection. These also affect entry maneuvers, which in turn can significantly alter crossrange capability.

TECHNOLOGY APPROACH AND TASK DESCRIPTION: Perform analytical and experimental studies to establish a) boundary layer transition criteria; b) transitional boundary layer growth and heat-transfer rates; and c) turbulent heat-transfer rate levels and distribution following the transitional boundary layer. Establish boundary layer transition criteria to predict the onset of the transitional heat transfer. (There may be common variables influencing the onset of transition and the development of the transitional boundary layer.) Test for transitional and turbulent heat transfer rates to obtain data on boundary-layer transition criteria.

Transitional Boundary Layer: Perform tests in AEDC tunnels C and F on three basic shapes over a range of Mach number, Reynolds number and angle of attack. Make flow-field and boundary-layer measurements to obtain basic flow data to support correlation of measured heat transfer rates. The basic shapes recommended are: a) wedge, b) cone, and c) delta wing. Investigate nose bluntness and delta wing sweep.

Desired results are:

- a. Verification of transitional boundary layer heating as a function of flow and geometry parameters.
- b. Transitional boundary layer heating correlation verified by experimental data.

Turbulent Boundary Layer: Perform turbulent boundary-layer wedge testing over a range of boundary-layer edge properties. Measure the heat-transfer rates and the flow-field properties. Support flow-field property measurements with calculations of the measured flow-field properties. The turbulent boundary layer should not be artificially tripped, but should occur naturally. Tunnels C and F should be used with Cornell Aeronautical Laboratories 96-inch hypersonic leg as a possible alternative.

Desired results are:

- a. Turbulent heat transfer rates supported by sufficient flow data to describe the properties of the boundary layer and shock layer.
- b. Development of a correlation procedure that can be successfully applied to other ground data and flight data.

The above studies should be coordinated with the proposed aerothermodynamic flight test program.

Tasks	1970	1971	1972	1973	Cost (\$K)
Phase B					
Phase C/D					
Perform Analytical Studies					100
Prepare Test Plans					20
Design & Fabricate Models					100
Conduct Wind Tunnel Tests					215
Perform Test Analysis					40
				Total Cost	475

4.3.3 AERODYNAMIC HEATING IN SHOCK INTERACTION REGIONS (CATEGORY I)

OBJECTIVE: Develop improved analytical methods for predicting the location of shock interaction regions and the attendant increased heat transfer rates in such locations.

PROBLEM: Space shuttle vehicles are being designed to achieve orbital velocities and altitudes, followed by maneuverable entry, cruise, and subsequent landing on conventional type runways. Control surfaces (fins) and lifting surfaces (fixed and/or retractable wings) will be required. Shock waves, generated by such body protuberances, interact with boundary layers on adjacent body surfaces, causing locally high increases in aerodynamic heating. Similar effects can result, during the launch phase, from an intersection of nose-tip-generated shock waves with adjacent vehicle surfaces, as would occur on any multibody-type configuration. The location and magnitude of such peak heat transfer rates must be defined for each space shuttle design under consideration.

TECHNICAL APPROACH AND TASK DESCRIPTION: A two-phase experimental approach should be pursued. These phases differ in the methods of obtaining data:

- a. Temperature sensitive coatings/oil flow visualization.
- b. Pressure/heat transfer measurements.

Initially conduct temperature-sensitive coating (paint) and oil-flow visualization tests, employing all variations of the basic configuration. Design model sections, including fin-body junctions, as interchangeable plates; this allows the desired geometric variations to be accomplished at minimal cost. Locate areas of high heating and flow separation. Conduct pressure and heat transfer measurements in these critical areas.

Coat all sections of the temperature-sensitive coating models with a thick layer of silicone rubber, contoured to the desired vehicle configuration. The rubber insulates the model interior against heat flux, providing a model temperature response amenable to simple analytical data reduction. "Tempilaq phase-change coating" is one example of a temperature sensitive coating.

Incorporate interchangeable sections near fin-body junctions on the pressure models. Obtain Schlieren and shadowgraph pictures during the pressure tests to assist in defining the overall flow field.

Incorporate the interchangeable-section concept in heat-transfer models. Use a thin-skinned model in conjunction with the "transient temperature technique." This technique consists of injecting a model with a cool, uniform initial temperature into the tunnel air stream and recording the surface temperature versus time. Temperature sensors will be thermocouples mounted on the inside surface of the model skin.

Correlate analytical models of the shock interaction region with the test data to improve the prediction of heat transfer in such areas. Extrapolation of prediction to environments more severe than those provided by wind tunnels will require accurate analytical or semi-empirical methods based on a sound experimental program.

Tasks	1970	1971	1972	1973	Cost (\$K)
Phase B					
Phase C/D					
Develop Prediction Methods					50
Plan Wind Tunnel Tests					10
Design & Fabricate Models					40
Conduct Wind Tunnel Tests					110
Correlate Test Data					35
Total Cost					245

4.3.4 THERMAL PROTECTION SYSTEM (TPS) SURFACE ROUGHNESS AND DISCONTINUITIES (CATEGORY I)

OBJECTIVE: Develop improved analytical techniques for predicting aerodynamic heat transfer in areas of surface roughness and discontinuity. Develop design criteria for acceptable surface imperfection.

PROBLEM: The predicted aerodynamic heat transfer rates and temperatures are obtained by assuming that the spacecraft has a smooth surface, free from roughness and discontinuities. Surface roughness of the thermal protection system comes from thermal distortion and fabrication techniques. Thermal distortion can cause ripples or bumps which may or may not be permanent, in the cover panels (heat shield). If these project sufficiently into the boundary layer, local separation can occur, resulting in local increases in temperatures over that predicted using a smooth surface. This increase may be sufficient to cause failure of the cover panel. Discontinuities due to design and fabrication can be limited if aerothermodynamic analysis provides design criteria for acceptable discontinuity levels.

TECHNICAL APPROACH AND TASK DESCRIPTION: Perform experimental investigations on representative surface roughness and discontinuity models. Develop an empirical method to be used for thermal protection system design.

Tasks	1970	1971	1972	1973	Cost (\$K)
Phase B					
Phase C/D					
Develop Analytical Models					45
Prepare Test Plan					10
Design & Fabricate Models					75
Conduct Wind Tunnel Tests					120
Analyze Data					20
Develop Design Prediction Methods					20
	Total Cost				290

4.3.5 HEAT TRANSFER IN REGIONS OF FLOW REATTACHMENT (CATEGORY I)

OBJECTIVE: Improve prediction of the separated/reattachment flow field and the heat transfer distribution throughout the reattachment region.

PROBLEM: Space shuttle vehicles are being designed to achieve orbital velocities and altitudes, followed by maneuverable entry, cruise, and landing. Such high-speed flight through the atmosphere results in the formation of a high temperature viscous layer on the vehicle surface. Under certain circumstances, this high-temperature boundary layer separates from the vehicle surface; its subsequent reattachment to alternate surfaces can cause substantial increases in heat transfer rates. An understanding of the reattachment flow field, and its relation to aerodynamic heating, is essential for the proper design of space shuttle vehicles.

Regions of increased reattachment heat transfer, as might be experienced on various space shuttle configurations, include:

- a. Flow separation ahead of, and subsequent reattachment to, vehicle elevon surfaces placed at positive angles of attack to the oncoming flow.
- b. Flow separation at the vehicle trailing edge and its subsequent reattachment to some portion of the propulsion equipment located in the vehicle base region.
- c. Flow separation from the vehicle's lower (lifting) surface, resulting from a high angle of attack, and its subsequent reattachment to the side panel surfaces.

TECHNICAL APPROACH & TASK DESCRIPTION: Conduct a combination analytic/experimental program, involving several basic separation-reattachment flow geometries, with the following objectives:

- a. To define the separated and reattachment flow field (e.g., length of separated region, reattachment point location, and reattachment pressure distribution).
- b. To define the associated reattachment heat transfer distribution and its relation to the reattachment point location and pressure gradient.
- c. To obtain experimental data corresponding to a. and b. above, and compare such data to the theoretical predictions using straightforward empirical correlations of the pressure and heat transfer data.

Tasks	1970	1971	1972	1973	Cost (\$K)
Phase B	CONFIG SELECT				
Phase C/D		PDR		CDR	
Analyze Reattachment Flow Heating	██████████	██████████			30
Develop Test Plans	██████████				10
Design & Fabricate Models	██████████				30
Conduct Wind Tunnel Tests		██████████			95
Correlate Test Data		██████████	██████████		30
			Total Cost		195

4.3.6 AERODYNAMIC HEAT TRANSFER FLIGHT TEST (CATEGORY 1)

OBJECTIVE: Obtain aerodynamic heating data from actual entry under flight conditions similar to those expected during entry by reusable lifting spacecraft.

PROBLEM: The prediction of the aerodynamic heat transfer to a space shuttle spacecraft configuration is complicated. Proper heat transfer rates and the resulting temperatures can be obtained only with accurate flow-field thermodynamic property determination, transition Reynolds number prediction, transitional heat-transfer prediction, and turbulent heat-transfer prediction. The lower surface of the spacecraft experiences the most severe aerothermodynamic environment and hence is the controlling factor in the spacecraft design and operation.

TECHNICAL APPROACH AND TASK DESCRIPTION: Conduct a flight test program to obtain data in the true aerothermodynamic environment. Specific technology areas will be flow field thermodynamics property definition, transition Reynolds number, transitional heat transfer, turbulent heat transfer, and scaling of experimental ground test data to flight conditions. Modify a launch vehicle such as Atlas or Titan with a 60-foot-long shroud representative of a space shuttle lower surface. Fly trajectories representative of the L/D and C_L maximum capabilities of the representative space shuttle. Using the resulting data, make thermal protection system material selections no later than early Phase D.

Tasks	1970	1971	1972	1973	Cost (\$K)	
Phase E						
Phase C/D						
Develop Flight Trajectories					500	
Prepare Test Plan					50	
Design & Fabricate Booster Mods					2,400	
Modify Launch Facilities					1,000	
Modify Booster					4,000	
Check out Booster & Launch Site					1,500	
Conduct Flight Tests						
Analyze Data					300	
Finalize TPS Design Criteria					200	
Total Cost					9,950	

4.3.7 HEAT BARRIERS FOR RADIATION-COOLED ENTRY VEHICLES (CATEGORY I)

OBJECTIVE: Develop various heat barrier concepts for use in conjunction with the low density insulation behind radiation cover panels. These concepts are to be compared as to relative effectiveness, complexity, development required, weight, size, and cost. Such tradeoff studies will aid in selection of a system to minimize thermal protection system requirements and remove stored energy from the thermal protection system at landing.







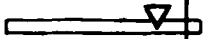
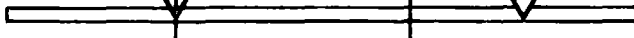

PROBLEM: Radiation-cooled lifting entry vehicles currently provide structural thermal protection through heat insulation and heat-sink characteristics of available insulating materials, i.e., Dyna-Flex and Micro-quartz. The insulation thickness required is primarily a function of the vehicle's maximum allowable internal structural temperature (about 200°F), the maximum allowable outer skin temperature (about 2000°F), and the time of flight.

Preliminary calculations indicate that the heat flow to the vehicle inner structure is less than one Btu/minute per square foot of surface. Very low heat flow to the inner structure suggests that a relatively small heat sink at the inner insulation face would provide an additional and effective heat barrier. This added barrier (heat sink) would prevent heating the inner structure above a maximum allowable level for all flight and ground conditions. Extending this concept further, the insulation thickness could be reduced and a somewhat larger heat sink could be used to protect the inner structure.

TECHNICAL APPROACH AND TASK DESCRIPTION: Heat Barrier Concepts. One heat sink concept consists of low density sheets of wicking material encased within thin metal or plastic sheets. Water is retained by the wicking material until absorbed thermal energy vaporizes part of the available water to steam. Steam is exhausted through small, porous wall collection tubes by a hydrophobic (water repellent) treatment of the porous walls. Three general variations in the wicking material are possible: a) the wick density may be varied; b) the wick thickness may be increased such that the total water supply for a flight is contained within the wick; c) the wick may be relatively thin, and make-up water is supplied continuously by small tubes.

A second heat sink concept employs a continuously circulated coolant in small, thin wall tubes, which may be bonded to a thin metal sheet for improved efficiency. The coolant is then circulated through a heat exchanger, where thermal energy is transferred to a sacrificial coolant. Some coolant candidates are water, water-glycol mixtures, gaseous helium, and gaseous hydrogen.

Task Description. Perform analytical studies to provide a basis for concept selection. Analyze selected concepts, then design and build test specimens. Define final design criteria based on test results.

Tasks	1970	1971	1972	1973	Cost (\$K)
Phase B					
Phase C/D					
Analyze Heat-Barrier Concepts					10
Perform Concept Comparison					15
Select Concepts					10
Analyze Selected Concepts					25
Design & Fabricate Test Specimens					50
Conduct Radiative Panel Tests					120
Define Design Criteria					10
			Total Cost		240

4.3.8 BASE HEATING (CATEGORY II)

OBJECTIVE: Define the base heating during launch and entry phases to ensure adequate thermal protection in this area.

PROBLEM: The heat transfer rates to the base of the space shuttle must be defined for both the launch and entry phases.

TECHNICAL APPROACH AND TASK DESCRIPTION: Launch Phase. Define the engine plume geometry and properties using accepted calculation techniques. Use this information to develop analytical models of base recirculation. Predict radiation heat transfer to the base using the plume geometry and properties. Verify analytical predictions with scale model hot rocket tests in an altitude chamber.

Entry Phase. Study the aerodynamic heating on the base region due to the backward-facing step, using experimental techniques (basically wind tunnel models). Use this data in conjunction with the PRIME and ASSET base heating data to generate analytical models.

Tasks	1970	1971	1972	1973	Cost (\$K)
Phase B					
Phase C/D					
Develop Base Heating Prediction					25
Prepare Test Plan					10
Analyze Entry Base Heating					25
Design & Fabricate Models					80
Conduct Test Program					220
Correlate Analytical Test Data					*20
Define Design Criteria					10
Total Cost					380

4.3.9 PLUME IMPINGEMENT HEATING (CATEGORY II)

OBJECTIVE: Evaluate the extent and severity of rocket exhaust plume impingement heating of vehicle elements.

PROBLEM: During the stage separation of multibody boost and orbital vehicles, the rocket exhaust plume from the orbiter will impinge on the boost vehicle(s). The amount of impingement is a function of the engine characteristics, flight altitude and velocity, and separation sequence. Severe heating can occur in areas of significant interaction between the vehicle and the plume.

Additional plume impingement can occur on the tail surfaces and base regions of the vehicles during boost, and on vehicle surfaces during ACS firing.

TECHNICAL APPROACH AND TASK DESCRIPTION: Define the exhaust plume properties as functions of time of flight. Using this data, analyze the anticipated maximum heat transfer to the affected vehicle surfaces for separation concepts being considered. Select the least-hazardous staging concepts for verification by experimental tests. Conduct plume impingement tests to confirm analytical studies.

Analytically determine heat transfer to fin and base regions of the vehicles using plume properties. Evaluate heating from ACS firing for use in determining local thermal protection requirements. Verify these heat transfer predictions by model tests.

Tasks	1970	1971	1972	1973	Cost (\$K)
Phase B					
Phase C/D					
Define Plume Properties					10
Predict Vehicle Heating					30
Prepare Test Plans					10
Design and Fabricate Models					60
Conduct Test Program					120
Correlate Analytical Test Data					25
	Total Cost				255

4.4 STRUCTURES DESIGN AND MATERIALS

4.4.1 COMPOSITE MATERIAL APPLICATIONS TO SPACE SHUTTLE STRUCTURES (CATEGORY I)

OBJECTIVE: Validate design concepts for the application of composite materials to reusable launch vehicles. Potential applications include the engine thrust structure, vehicle interconnect structure, empennage, wing, major bulkheads, payload door longerons, and main cryogenic tanks.

PROBLEM: Advanced composite materials can offer as much as a 30% overall structural weight saving to the recoverable booster. Existing material systems and design concepts in composites have been tailored to supersonic aircraft, however, and must be extended to account for the unusual environments and design requirements of the recoverable booster.

TECHNICAL APPROACH AND TASK DESCRIPTION: Perform an initial systems application study to identify the most promising and potentially cost-effective component applications and composite material systems. Prepare a preliminary design of each selected component. Characterize candidate materials, in terms of mechanical and physical properties, for the booster environment. Perform design allowable testing for appropriate materials and joining methods. Design, fabricate, and test a series of increasingly sophisticated structural components to verify composite applicability.

In addition, perform the following tasks.

- a. Perform design, performance, and cost analyses to determine most promising areas of composite material application.
- b. Perform material and process studies to characterize material properties, joining methods, and tooling and fabrication concepts.
- c. Perform design allowables testing on selected composite systems and joining methods.
- d. Perform structural element tests (plates, shapes, tubes) to verify analytical methods and provide optimization data.
- e. Select and design typical structural components from areas such as the engine thrust structure, empennage box beam, payload bay longerons, and cryogenic tanks.
- f. Fabricate specimens of each of the designs to verify fabrication techniques and provide test specimens.
- g. Test the structural members to verify design concepts, allowable loads, deflections, fatigue resistance, and other applicable properties or environmental requirements.

Tasks	1970	1971	1972	1973	Cost (\$K)
Phase B					
Phase C/D					
First Structure Release					.
Study Systems Application					400
Study Material & Process					1,400
Define Design Allowables					300
Conduct Basic Element Tests					200
Design Full-Scale Test Articles					400
Fabricate Full-Scale Test Articles					1,200
Conduct Environmental Tests					600
Evaluate Tests					100
				Total Cost	4,600

4.4.2 STRUCTURAL DESIGN CRITERIA TRADEOFF STUDIES (CATEGORY I)

OBJECTIVE: Determine sensitivity of structural weight of various components to changes in design criteria.

PROBLEM: Due to the criticality of the structural mass fraction and cost of space shuttle vehicles, establishing adequate design criteria is important. Design criteria is ultimately reflected in the choice of materials, concept, and manufacturing technology; which in turn lead to interdependent weights and costs. Sensitivity studies are required to identify design criteria having a marked effect on structural weight and to establish trends.

TECHNICAL APPROACH AND TASK DESCRIPTION: Establish nominal design criteria for a current space shuttle configuration and break it down into specific design criteria for each major structural component such as wing, body, tanks, payload bay area, thrust structure, fin and TPS. Determine critical design condition(s) for each component. Perturbate criteria that affect the critical design conditions, and determine the associated weight changes for each component. Investigate perturbations in design criteria such as ground wind intensities, T/W ratio at liftoff, maximum αq values, maximum axial acceleration during boost, noise and vibration environments, abort trajectories, shock overpressures, dispersions in exit and entry trajectories, wind shear profiles, subsonic gust velocities, propellant tank proof and maximum pressures, safety factors, flutter margins, design life, design temperatures, material allowables and fracture toughness sensitivity, reliability goals for orbiter and booster structures, fail-safe philosophy, landing sink speed, manufacturing technology, and fabrication control and tolerances. Tasks are:

- a. Select vehicle configuration and trajectories as a basis for study.
- b. Establish specific design criteria (nominal) for each component.
- c. Determine critical load/temperature/time design conditions for each component.
- d. Perturbate nominal design criteria and find effect on critical design condition.
- e. Translate the changes in critical design conditions into weight increments or decrements for each component.
- f. Integrate the results of component sensitivities into overall vehicle sensitivities.
- g. Determine the effects of overall vehicle sensitivities on total liftoff weight, payload, lateral range, and orbital maneuvering ΔV .

Tasks	1970												1971				Cost (\$K)	
	J	F	M	A	M	J	J	A	S	O	N	D	J	F	M	A		
Select Vehicle Configuration	█																	5
Establish Nominal Design Criteria	█																	10
Determine Critical Design Conditions		█																10
Perturbate Nominal Design Criteria			█	█	█	█	█	█	█	█								50
Determine Component Weight Changes				█	█	█	█	█	█	█								50
Determine Vehicle Weight Sensitivities										█	█							20
Determine Effects on Liftoff Weight, Payload, Etc.											█	█						20
Document Results												█						10
Total Cost																175		

4.4.3 SYNTHESIS OF STRUCTURAL COMPONENTS (CATEGORY I)

OBJECTIVE: Develop computerized sizing procedures for structural components such as wings, bodies, cryogenic propellant tanks, intertank adapters, fins and elevons.

PROBLEM: The evaluation of alternate design concepts for main structural components is presently done by means of inherently slow procedures which do not lend themselves to the quick response times typical of present and future contractual requirements. Systematic computerized procedures are needed to determine gages, sizes and weights of alternate designs, and to provide adequate data for meaningful engineering decisions. Expeditious structural sizing programs are needed to enable: a) quick and consistent evaluation of alternate designs; b) selection of effective weight/cost structures for specific projects; c) generation of detailed design and weight data; and d) short response times. The use of computerized sizing procedures can provide an answer to these problems.

TECHNICAL APPROACH AND TASK DESCRIPTION: Develop sizing procedures for main structural components using both multiple station and matrix analysis approaches. Incorporate capability to handle multiple loading conditions, including thermal loads. Use weight as the merit criterion. Develop means of incorporating load, strength, aeroelastic and manufacturing considerations within the automated procedures. Investigate the use of special techniques for search optimization. Computerize the developed procedures to obtain a main sizing program for each component.

Also perform the following specific tasks.

- a. Select structural and aeroelastic (where applicable) analysis procedures for each component.
 1. Establish design criteria and load/temperature conditions.
 2. Define component configuration.
 3. Select structural concepts, materials and failure modes.
 4. Define design variables, constraints and linking schemes.
 5. Write stress and aeroelastic analysis subroutines.
- b. Define objective function (weight) for each component.
- c. Write input/output subroutines for each component.
- d. Incorporate subroutines into a general-purpose optimization program, compile a main sizing program for each component.
- e. Demonstrate sizing programs using typical components of space shuttle vehicles.
- f. Document each program with example cases.

4.4.4 HOT STRUCTURES (CATEGORY I)

OBJECTIVE: Develop and validate design concepts for use of uninsulated or partially insulated hot structure to reduce cost and weight and improve reliability, sealing, and insulation effectiveness. Promising areas of application are the fins and top and sides of the vehicle.

PROBLEM: Large scale hot load carrying structures are desirable for space shuttle vehicles where temperatures do not exceed 1200°F. Candidate designs should be examined and tested to determine ultimate design allowables. Areas of critical stress concentration should be defined. Fabrication of titanium and super-alloys will necessitate the design of tooling for joining (welding, brazing, or diffusion bonding). Structures of this size and complexity should be completely fabricated to minimize potential problem areas.

TECHNICAL APPROACH AND TASK DESCRIPTION: Develop and analyze design concepts for each potential area of application. Design and conduct environmental and functional tests on critical elements. Design, analyze, and fabricate full-scale components. Subject components to simulate environment and functional tests including loads, temperature vs. time profiles, and thermal gradients. Tasks are:

- a. Develop and analyze design concepts for each potential application of hot structure.
- b. Select the most promising concepts.
- c. Design and conduct functional and environmental tests on elements.
- d. Design, analyze, and fabricate full-scale components.
- e. Conduct simulated environmental and functional tests on full-scale components.
- f. Integrate test results into the design.

Tasks	1970	1971	1972	1973	Cost (\$K)
Phase B					
Phase C/D					
Design & Analyze Hot-Structure Components					80
Design & Conduct Element Tests					40
Fabricate Full-Scale Components					130
Conduct Environmental Tests					45
Analyze Test Results					8
Define Design Modifications & Recommendations					12
Document Results					15
			Total Cost		330

4.4.5 HIGH TEMPERATURE CONTROL SURFACES (CATEGORY I)

OBJECTIVE: Validate the design concepts developed for each of the identifiable critical areas of the high temperature control surfaces. Such areas are the leading edge, transition between hot leading edge and cooler upper and lower surfaces, heat shielding, insulation, heat shield supports through the insulation, load-carrying hot structure inside the insulation, hinges, seals between fixed and movable surfaces, actuating system, and damping system for the nonaerodynamically balanced movable surfaces.

PROBLEM. High temperatures and heating rates are developed in localized areas of control surfaces. Realistic testing must be done to verify flow theory associated with leading edge gaps and leeward surface flow separation. Flow restricting devices such as wiper seals and end plates should be examined and perfected to reduce hot gas leakage. Actuating devices should be investigated and tested to determine the resistance to high temperatures and fatigue.

TECHNICAL APPROACH AND TASK DESCRIPTION: Define and select a basic approach integrating the structure, insulation system, and actuation system for the high-temperature control surfaces. Perform analyses and generate designs for each of the problem areas with attention to the interfaces with adjacent problem areas. Select from candidate designs considering reliability, life, weight, and cost. Validate selected concepts by environmental and functional tests. Fabricate large-scale components and subject to a simulated hypersonic entry environment in a test facility such as the 50-megawatt plasma arc at USAF RTD. Such a facility would closely approximate the flow composition, enthalpy, pressure, shear, and time/temperature/pressure relationships of the hypersonic environment. Tasks are:

- a. Identify and perform analyses and detailed design studies of the critical areas of the high-temperature control surfaces.
- b. Design, fabricate, and test full-scale elements to establish fabrication techniques and verify design allowables.
- c. Design and fabricate sub-scale components of the elevon and rudder/fin: one selected elevon and well design and one selected rudder/fin design.
- d. Subject the selected components to hypersonic entry environmental tests in a facility such as the USAF RTD 50-megawatt plasma arc; perform cyclic entry thermal environmental tests, acoustic and mechanical vibration tests, and static load tests.

Tasks	1970	1971	1972	1973	Cost (\$K)
Phase B	▽ CONFIG SELECT				
Phase C/D	▽ PDR				
	▽ CDR				
Design & Analyze Control-Surface Components	██████████				110
Design & Conduct Element Tests	██████████				50
Fabricate Full-Scale Components		██████████			120
Conduct Environmental Tests		██████████			50
Analyze Test Results			██████████		15
Apply Results to Design Modifications			██████████		20
Document Results			██████████		15
	4-28				
	Total Cost				380

4.4.6 JOINING HIGH TEMPERATURE MATERIALS FOR SPACE SHUTTLE APPLICATION (CATEGORY I)

OBJECTIVE: Develop joining methods which produce useful structures of refractory, dispersion strengthened, and titanium alloys.

PROBLEM: In order to satisfactorily join refractory and dispersion strengthened (D/S) alloys for elevated temperature applications, a number of hazards must be avoided, or the joint will have no useful strength. These hazards are:

- a. The grain size in refractory systems must be maintained below one fourth of the minimum sheet thickness. This prevents through-crack growth in the transverse direction.
- b. Joints in refractory systems must be post-join coatable to maintain high temperature oxidation resistance.
- c. Lap joints in refractory systems must develop contiguous fillets and be post-join coatable. This is to maintain both coating and joint integrity.
- d. Joints in both refractory and D/S systems must have elevated temperature toughness as well as strength.
- e. Joints in both refractory and D/S systems must be inspectable to ensure joint integrity.
- f. Rejected joints should be repairable without requiring large components to be scrapped. This saves money and time, and eliminates acceptance of poor-quality joints.
- g. Joints in D/S systems must not agglomerate the dispersion. If the dispersion is agglomerated, the elevated temperature strength and oxidation resistance are greatly reduced.
- h. Joining systems for D/S materials must not cause alloying elements to vaporize or harmful intermetallic compounds to form on the surface. This would seriously weaken the material surfaces and lead to premature failures.
- i. Refractory-to-D/S joining systems must have all of the above properties. Brittle interstitial compounds must not form at the joint interface.
- j. The joining systems must not adversely affect the materials away from the joints.

TECHNICAL APPROACH AND TASK DESCRIPTION. All the basic joining methods: fusion and resistance welding, brazing, diffusion bonding, and mechanical fastening will be evaluated individually and in combinations. Basic evaluation of each joining method and its applicability to each alloy in question will facilitate the initial screening and selection of the most promising methods for each joint system under consideration.

The initial screening will be based not only on resultant mechanical and physical properties, but also on applicability, ease of fabrication and the interaction between the joining system and the total structure. The effect of joining processes on coatings and of coatings on joining processes will be of specific concern.

Re-use and the realities of all joining systems require development of joint repair methods. Removal of damaged areas, rework, coating removal and replacement, and basic joint repair technology will be evaluated in initial selection of joining repair methods. The repair methods selected will be evaluated in the same manner as initial joints. This data may require a change in the recommended joining method because of repairability difficulties. The following tasks comprise this program.

- a. Develop and evaluate Gas Tungsten Arc (GTA) and Electron Beam (EB) welding of C129Y columbium and T222 tantalum and titanium alloys. Develop and evaluate butt, lap, fillet and toe joint repair welding of the above welding methods which prove successful.
- b. Develop and evaluate resistance spot and seam welding of titanium to C129Y, T222 and TDNiCr alloys. This joining method is not feasible for refractory joining because of the inability to coat the faying surfaces, nor feasible for TDNiCr because the Thoria agglomerates and reduces joint properties. Develop repair procedures and evaluate for all successfully resistance-welded systems.

- c. Develop and evaluate diffusion bonding techniques for C129Y and T222. Diffusion bonding is not practical for TDNiCr because of the severe distortion that occurs in fabricated parts at bonding temperatures.
- d. Evaluate TD6 braze alloy for TDNiCr over full range of usefulness. Evaluate the effects of interactions between refractory brazing alloys and refractory protective coating systems over full range of coating usefulness.
- e. Develop and evaluate diffusion spot bonding, spot brazing, and braze/diffusion bonding methods for various alloy combinations. Evaluate spot brazing, using localized heat and pressure, for titanium to C129Y, T222 and TDNiCr. Evaluate braze/diffusion bonding (the use of "extra-thin" braze foils for refractory joining so that after furnace heating all of the braze alloy diffuses into the base metal).
- f. Evaluate mechanical fastener systems for all alloy combinations previously listed. Perform an in-depth evaluation of mechanical fastener repair techniques.
- g. Select the most promising joining methods and evaluate in depth. Perform creep, fatigue, stress-rupture, oxidation, and vibration testing. Perform physical, mechanical, and metallurgical tests to evaluate reproducibility and reliability of these joining methods.
- h. Evaluate, as described in Task g, the most promising repair joining methods for rework in fabrication damage, flight damage, and coatability.

Tasks	1970	1971	1972	1973	Cost (\$K)
Phase B	CONFIG SELECT ▽				
Phase C/D		PDR ▽			
Initial Structure Release		▽			
<u>Screen & Evaluate:</u>					
Gas Tungsten Arc Welding	██████████				50
Electron Beam Welding	██████████				50
Resistance Spot Welding	██████████				30
Seam Welding	██████████				30
Diffusion Bonding	██████████				60
Brazing & Braze Coating	██████████				100
Diffusion Spot Bonding	██████████				40
Spot Brazing	██████████				40
Braze/Diffusion Bonding	██████████				50
Mechanical Fasteners	██████████				100
<u>Test & Evaluate in Depth:</u>					
Original Joints	██████████	██████████			170
Repaired Joints	██████████	██████████			120
Total Cost					840

4.4.7 MATERIALS PROPERTIES DETERMINATION (CATEGORY I)

OBJECTIVE: Evaluate, in elevated temperature environments, newly-developed superalloys, refractory metal alloys and oxidation protection coatings. Provide design data as well as other data for the comparative evaluations necessary in materials selection for elevated temperature applications.

PROBLEM: For successful fabrication of structures subject to extended periods at extreme temperatures, it is not possible to design to elevated temperature using mechanical property data based on short-time measurements. Test data must be obtained over periods comparable to those expected during actual vehicle performance. Creep and cyclic environmental exposure test data is required, including effects of temperature, stress and oxygen partial pressure. Good creep data is meager for temperatures over 2000°F.

TECHNICAL APPROACH AND TASK DESCRIPTION: The two most promising methods of measuring creep and strain are by optical instruments. One requires the attachment of an extensometer or some type of measuring scale or marks to the specimen. At higher temperatures, compatibility problems, damage to the coating, or loss of identifying marks can occur. The optical method proposed for this program uses tabs machined on the specimen as targets for strain measurements. Other areas which require attention are effect of environmental exposure on superalloy and coated refractory alloy joints (welds, diffusion bonds, spotwelds, etc.); thermal expansion and conductivity measurements; compatibility of the various vehicle materials directly exposed to the high temperatures of entry, e.g., silicide coated columbium and tantalum alloys; and the reaction products of the ablation process. Tasks are:

- a. Develop technique for measurement of true creep in the 2000 to 3100°F range using
 1. Radiation heating.
 2. Optical temperature measurement.
 3. Optical strain measurement.
- b. Obtain creep data for silicide coated columbium and tantalum alloys in 2000 to 3100°F range, and for TD nickel chromium up to 2300°F.
- c. Design and build equipment suitable for cyclic environmental exposure testing to 3100°F with capabilities of varying stress and pressure.
- d. Perform cyclic environmental testing of coated columbium and tantalum alloys, TD nickel chromium, and nickel and cobalt base superalloys.
- e. Prepare ductile coated refractory alloy joint specimens and uncoated superalloy joint specimens. Ductile coated columbium alloy weld joints will require a post weld heat treatment study.
- f. Perform cyclic environmental testing of joint specimens.
- g. Perform thermal expansion and conductivity measurements.

Tasks	1970	1971	1972	1973	Cost (\$K)
Phase B					
Phase C/D					
Obtain materials	██████████				30
Prepare & coat specimens	██████████				
Design & fabricate test equipment	██████████				
Develop test techniques	██████████				30
Conduct creep tests		██████████			30
Conduct environmental exposure tests		██████████			60
Perform thermal measurements	██████████				20
Perform compatibility tests		██████████			20
Analyze results & publish report		██████████			40
				Total Cost	380

4.5 THERMAL PROTECTION SYSTEM DESIGN AND MATERIALS

4.5.1 METALLIC RADIATIVE THERMAL PROTECTION SYSTEMS (CATEGORY I)

OBJECTIVE. Develop and validate by tests heat shield concepts applicable to identifiable problem areas of space transportation system vehicles such as large cover panels, door, hatches and access panels.

PROBLEM: Heat shields and support structures have generally been restricted to sizes under two feet square. With the advent of large vehicles such as the proposed space shuttles, large panels will be required to minimize assembly problems and reduce hot gas ingestion into the insulation system. These panels will require scaling-up forming and joining techniques applicable to high-temperature metals such as TD NiCr, columbium, and tantalum. Simulated environmental testing is necessary to man-rate the system for its design life and determine ultimate loading factors.

TECHNICAL APPROACH AND TASK DESCRIPTION: Conduct a cost-effectiveness study to determine the optimum heat shield structural configuration for STS loading conditions. Select a basic heat shield/insulation system with specific emphasis on large panels that will minimize the number of required fasteners and will reduce hot gas ingestion through expansion joints. Apply insulation optimization techniques to packaged insulation configurations, thereby reducing the effect of insulation movement while maintaining minimum system thickness. Generate designs and perform analysis for the resolution of identified problem areas. Full-scale components of the selected design will be fabricated and subjected to simulated environmental flight tests. Tasks are:

- a. Identify and conduct detailed design studies and analysis of critical problem areas.
- b. Conduct tradeoff studies, i.e., structural efficiency, structural reliability, and relative costs of candidate heat shield and support designs.
- c. Design and fabricate full-scale RTPS test components to establish fabrication techniques.
- d. Subject full-scale heat shields to ultimate load testing to verify design allowables. Loading conditions will occur during cyclic thermal exposure and include pressure loads and vibration.
- e. Design and fabricate one upper surface RTPS for a typical vehicle location that includes at least one access hatch or door.
- f. Design and fabricate one lower surface RTPS that includes one door, such as a nose landing gear door.
- g. Subject the components described as items c, e, and f to hypersonic entry environmental testing in a facility such as the AFFDL 50-megawatt Electro-Gas Dynamic Facility, which would simulate the thermal profile of entry. Conduct additional specimen tests in a radiant heat lamp chamber in which simultaneous thermal cycling, pressure differential and vibration are programmed. Conduct supplemental acoustic tests.
- h. Study the effects of micrometeoroid impact on radiative heat shields to determine structural damage to brittle materials such as TD NiCr and coated refractory metals. Typical small scale RTPS specimens will be fabricated from applicable alloys and subjected to hypervelocity impact tests.

Tasks	1970	1971	1972	1973	Cost (\$K)
Phase B					
Phase C/D					
Conduct heat shield tradeoff studies					18
Design & analyze RTPS Components:					
Modular system					20
Upper surface with access door					16
Lower surface with door					18
Purchase materials					
Fabricate:					
Modular system					30
Upper surface panel					35
Lower surface panel					35
Conduct Tests:					
Ultimate load					18
Environmental					30
Micrometeoroid					18
Nondestructive					15
Perform Post-Test Analysis					8
Design modification & recommendations					13
Document Results					15
				Total Cost	289

4.5.2 ABLATIVE THERMAL PROTECTION SYSTEMS (ATPS) (CATEGORY I)

OBJECTIVE: Develop and validate heat shield concepts applicable to reusable space transportation system vehicles. In particular, investigate identifiable problem areas such as access panels, hatches, leading edge gaps, transition joints between high and low density ablators and large modular panels in the lower surface ATPS.

PROBLEM: The use of ablative thermal protection systems on some types of entry vehicles is definitely within the state of the art. However, the ablative TPS technology as used on the Gemini and Apollo capsules is not directly transferable to space shuttle applications because of the following reasons:

- a. The heat shields used for Gemini and Apollo were of relatively small size and consisted of one continuous structural and ablative surface with no joints or splices.
- b. No cutouts, access ports, doors, or hatches were required in those heat shields.
- c. No discontinuities or edge joining were required with other ablative panels, high density nose caps or leading edges, or radiative panels in areas of relatively high flow and heating conditions.
- d. Relatively high density ablators (40-60 lb/ft³) were used on Apollo and Gemini.
- e. Higher heating rates for much longer periods than in previous flights will be experienced on the space shuttle.
- f. Fabrication techniques used for Apollo, Gemini and Prime ablative TPS were time consuming and costly.
- g. Very costly nondestructive testing and inspection techniques have been used in the past to ensure the quality of the ablative TPS.

TECHNICAL APPROACH AND TASK DESCRIPTION: Design, analyze, fabricate and test heat shield concepts that stress minimum weight and minimum heat transfer to the primary structure. Select candidate designs that stress low cost, adaptability, easy refurbishment and fail-safe reliability. Investigate and verify feasible manufacturing processes. Fabricate full-scale components of selected designs and subject them to simulated environmental flight tests and other design verification tests. Stress interchangeability of hardware with a radiative system such that either system can be used. Use the ATPS as a backup or primary flight system as circumstances require. The following tasks comprise this program:

- a. Identify and enumerate problem areas to be analyzed such as:
 1. Large modular ablative panels.
 2. Insulative systems, support structure, and attachment techniques.
 3. Nose caps.
 4. Leading edges (or edge members in general).
 5. Cutouts and access ports (to include such items as service hatches and landing gear doors as well as sealing techniques to be used with such doors).
 6. Ablative panel interface concepts with other ablative panels, with leading edges and with radiative panels.
- b. Perform thermal analyses to define typical heating rates and total integrated heat to be used for design requirements for each problem area.
- c. Define total design parameters to be imposed on each problem area. Design parameters should include typical static and dynamic (including acoustic, vibration and acceleration) loads as well as any design interfaces required.
- d. Select ablative materials to be used in designs.
- e. Perform thermal (plasma arc), mechanical, and thermochemical and thermophysical tests to completely characterize the materials to be used.

- f. Design concepts to solve defined problem areas. Several concepts for each problem should be investigated and the best selected for further evaluation and test.
- g. Perform thermal and structural analysis of all concepts.
- h. Perform cost analysis of selected concepts to develop cost predictions.
- i. Select best designs on the basis of functional performance, and thermal, structural, and cost analysis to fabricate full-scale test specimens.
- j. Use normal inspection as well as nondestructive test techniques to verify quality of material and fabrication techniques.
- k. Perform thermal, static loads, acoustic vibration and acceleration tests on full-scale specimens to validate designs.
- l. Reduce test data and evaluate results.
- m. Submit final report and engineering data.

Tasks	1970	1971	1972	1973	Cost (\$K)
Phase B	▽ CONFIG SELECT				
Phase C/D		▽ PDR			
		▽ CDR			
Perform Thermal & Dynamic Loads Analysis	■				15
Define Design & Material Criteria	■				15
Determine Material Properties	■				30
Define Insulation Subsystem & Structure	■				30
Design Ablative Subsystem Specimens	■				50
Perform Design & Cost Analysis	■				40
Select Best Concepts	■				
Design Full-Scale Components		■			40
Perform Thermal & Stress Analysis		■			20
Develop Full-Scale Test Plan		■			10
Fabricate Full-Scale Test Articles		■			180
Conduct Full-Scale Environmental Tests		■			120
Evaluate Data & Document Results		■			20
		4-36	Total Cost		670

4.5.3 NONMETALLIC, NONRECEDING RADIATIVE THERMAL PROTECTION SUBSYSTEM (RTPS) (CATEGORY I)

OBJECTIVE: Develop and validate design concepts employing semi-rigid insulating materials as heat shields.

PROBLEM: A possible alternative solution to problems inherent in an ablative or radiative TPS is non-metallic, nonreceding radiative TPS. This system could be lighter than an ablative TPS and could accept higher equilibrium temperatures than a refractory metal radiative TPS with a comparable basic weight. It can be much more tolerant of local hot spots than a metal radiative TPS. Materials such as low-density ceramics, bonded silica fiber matrix systems, and carbon-faced radiative systems have been studied, but no extensive investigation, fabrication, or testing has been done.

Basic development must be performed to define a workable TPS and final design, analysis, and verification testing must be accomplished to validate this type of TPS for flight use.

TECHNICAL APPROACH AND TASK DESCRIPTION: Develop design concepts employing these heat shields and associated components to provide such desirable characteristics as low unit weight, compatible thermal expansion, good reusability, good insulative properties, large panel capability, and low unit cost. Tasks required to design, analyze, fabricate and subject full-scale components to simulated environmental tests are:

1. Evaluate and select materials for a nonreceding radiative TPS. Develop basic material characteristics to provide good basis for comparison.
2. Check compatibility of materials, particularly thermal expansion characteristics, with vehicle basic structural design concept and materials.
3. Develop material mechanical properties and allowables for design.
4. Design, fabricate, and test typical heat shield panel to verify basic design performance.
5. Design typical large modular panels.
6. Develop interface concepts for joining with nose caps, leading edges, or other edge members.
7. Design cutouts and access ports.
8. Perform thermal and structural analysis of all concepts.
9. Perform cost analysis of selected concepts to develop cost predictions.
10. Select best designs on the basis of functional performance and thermal, structural, and cost analysis.
11. Fabricate full-scale test specimens.
12. Use normal inspection and NDT techniques to verify material quality and fabrication techniques.
13. Perform thermal, static loads, acoustic vibration, and acceleration tests on full-scale specimens to validate designs.
14. Reduce test data and evaluate results.

Tasks	1970	1971	1972	1973	Cost (\$K)
Phase B					
Phase C/D					
Review & Select Candidate Materials					15
Define Material/Structure Compatibility					5
Determine Material Properties					20
Perform Thermodynamic Loads Analysis					15
Define Design Parameters					15
Define Insulation System & Support Structure					20
Design & Fabricate Subscale Panels					25
Test Subscale Panels					15
Design Access Cutouts & Joining Concepts					30
Analyze Selected Concepts					30
Select Best Concepts					5
Design & Analyze Full-Scale Panels					20
Develop Full-Scale Test Plan					5
Fabricate Full-Scale Test Articles					40
Conduct Full-Scale Environmental Tests					100
Evaluate and Document Results					20
Total Cost					380

4.5.4 THERMAL PROTECTION SUBSYSTEM (TPS) ANALYSIS AND PERFORMANCE IMPROVEMENT (CATEGORY I)

OBJECTIVE: Increase the accuracy and confidence level of TPS analytical techniques so TPS performance will be improved by enabling further refinement of concepts and designs.

PROBLEM: Current analysis techniques can be used to determine safe TPS thickness requirements, but they are not accurate enough to define an optimum design. Sizing of low-density insulation (4.5 to 8.25 lb/ft³) is based on steady-state thermal conductivity measurements, neglecting the coupled radiation conduction energy transport characteristic of the fibrous insulation materials. Sizing of ablator materials is also inaccurate: predictions by only one of seven competent technical groups approximated measured flight data on Apollo. The ablator sizing problem is further complicated by using experimental data derived from testing that was not truly representative of the flight environment as empirical parameters to computer programs; these TPS designs and test facilities must also be improved.

TECHNICAL APPROACH AND TASK DESCRIPTION: Improve existing TPS analysis and experimental techniques of the insulation (radiative) type TPS by:

- a. Investigating coupled radiation conduction energy transport through the low-density insulation material.
- b. Investigating boundary-layer leakage into the insulation and flow to lower pressure areas of the entry spacecraft.
- c. Investigating the cover panel (heat shield) support analysis to minimize hot spots on the basic structure.
- d. Defining methods to remove the energy stored in the TPS at landing.
- e. Developing test facilities to provide representative flight-environment flow over the insulation TPS test specimen.

Improve specific ablator TPS analysis and experimental techniques by:

- a. Developing rapid and accurate ablator sizing analysis.
- b. Controlling surface melting and roughness.
- c. Developing variable-density composite systems.
- d. Devising methods to increase transpiration cooling of the ablator material.
- e. Developing test facilities to provide representative flight-environment flow over ablator TPS test specimens.

Tasks	1970	1971	1972	1973	Cost (\$K)	
Phase B						
Phase C/D						
Extend Prediction Techniques					80	
Correlate Techniques/Test Data					80	
Develop Ablator Sizing Method					40	
Develop Ablator Joint Analysis					25	
Develop Insulation Conductivity Analysis					30	
Analyze Boundary Leaks to Insulation					40	
Improve Cover Panel Analysis					50	
Evaluate Real Simulation Approach					15	
Develop Test Plans for TPS					15	
Conduct TPS Environmental Tests					100	
Define Design Criteria					40	
Total Cost					515	

4.5.5 HIGH TEMPERATURE NOSE CAP AND LEADING EDGES (CATEGORY I)

OBJECTIVE: Develop and validate design concepts using high temperature ceramic-radiator materials of the diboride series.

PROBLEM: Nose cap materials such as the modified diborides have been developed but have not been scaled up to full-size hardware configurations. Forming is generally done by powder metallurgy techniques, which require high temperatures and pressures. Local inclusions or voids must be eliminated to obtain a satisfactory structure capable of sustaining the thermal environments.

A major problem with the diboride ceramics is that of machining. Hot pressing is unsatisfactory because of the intricate shapes required for nose caps and leading edges. Thus final shapes and the details for attachment to the base structure must be machined from the bulk hot pressed part, preferably by diamond machining methods or by electrolytically assisted machining processes. The compatibility of the diboride materials in an entry environment with the adjoining thermal protection system is also a potential problem areas.

TECHNICAL APPROACH AND TASK DESCRIPTION: Generate designs and analyze concepts that stress maximum reusability and minimize heat transfer to the primary structure. Scale up and develop feasible manufacturing processes. Since diamond machining, ECM, and EDM are the most attractive processes to remove ceramic material, investigate these for low-cost optimization. Since hot-forming and forging the diborides are extremely attractive processes for some designs, scale these up for feasibility. Investigate emittance-improving coatings and examine joining techniques such as diffusion bonding and welding. Tasks are:

- a. Identify and conduct detailed design studies and analysis of critical problem areas.
- b. Design full-scale nose cap and leading edge components.
- c. Conduct a fabrication feasibility study to determine the most desirable forming, machining, and joining processes.
- d. Conduct elemental tests to determine design allowables.
- e. Fabricate full-scale nose cap and leading edge components for representative space shuttle vehicle.
- f. Subject the components to hypersonic entry environmental testing in a facility such as the AFFDL 50 megawatt Electro-Gas Dynamic Facility. Subject the components to vibration, acoustic, mechanical, loads, acceleration, and impact tests.

Tasks	1970	1971	1972	1973	Cost (\$K)
Phase B					
Phase C/D					
Design & Analyze Nose Cap & Leading Edge					100
Conduct Element & Subelement Tests					60
Perform Fabrication Study					50
Fabricate Full-Scale Components					320
Conduct Environmental Tests					80
Analyze Test Results					10
Apply Results to Design Modifications					15
Document Results					15
Total Cost					640

4.5.6 HIGH-TEMPERATURE INSULATION DEVELOPMENT (CATEGORY I)

OBJECTIVE: Develop an insulation system for temperatures in excess of 2700° F capable of providing the most efficient and compatible thermal barrier between external heat shields and primary structure.

PROBLEM: Proven capability of insulations for use on hypersonic flight hardware where temperatures exceed 2700° F is nonexistent. Several potential materials are available on a laboratory pilot scale and should be tested for shrinkage, sintering, compatibility, and resistance to pulverizing under vibration. Normal thermo-physical property data through the applicable temperature regime must be determined in order to optimize the insulation system.

TECHNICAL APPROACH & TASK DESCRIPTIONS: Determine the available or easily modified fibrous materials that offer the greatest potential as probable constituents for a high-temperature insulation system. Select the most promising materials on the basis of dimensional stability, chemical stability, radiation attenuation, resistance to sonic fatigue, compatibility with other TPS materials, low conductivity-density product, and satisfactory cost. Conduct thermal cycling tests to determine heat transfer ratio. Investigate the effect of heat shield composites such as foils, flakes, and particulates on the most promising candidates. Tasks are:

- a. Survey insulation systems capable of sustaining the required thermal profiles and analytically determine their capability.
- b. Prepare subscale specimens and subject to thermal profiles at reduced pressures to determine the relative heat transfer rates. Evaluate various densities and bulk volumes to optimize the desirable characteristics of the composite system.

Tasks	1970	1971	1972	1973	Cost (\$K)
Phase B					
Phase C/D					
Analyze High-Temperature Materials					20
Develop & Fabricate Insulation Specimens					40
Conduct Physical Property Tests					30
Conduct Elemental Specimen Tests					30
Analyze Test Results					10
Document Results					10
Total Costs					140

4.5.7 NONDESTRUCTIVE TEST (NDT) DEVELOPMENT (CATEGORY I)

OBJECTIVE: Develop NDT methods and instrumentation to evaluate radiative and ablative thermal shield materials.

TECHNICAL APPROACH AND TASK DESCRIPTION: Coating Preflight Evaluation (Process Control): Investigate reliability and cost of existing NDT techniques (thermoelectric testing, eddy current, radiography, etc.) for predicting satisfactory coating performance. Investigate inherent radiation emission properties to be developed into the coating system (see postflight evaluation) for determining the thickness and uniformity of the coating. Develop suitable instrumentation to scan the shield following application of the coating.

Refractory Metal Preflight Evaluation: Investigate techniques for performing NDT of refractory alloys, emphasizing adaptation of existing NDT techniques to complex geometries and accessibility problems. Establish criteria for determining serviceability of both coated and uncoated refractories.

Ablative Material Preflight Evaluation: Investigate various NDT methods for evaluating ablative materials prior to use. Employ microwave reflectometry during the early development stages of low-density ablatives to detect voids and possible separation (disbond) in laminated material.

Joining Methods Preflight Evaluation: Define standards for controlling NDT application in evaluating joining processes. Develop standards and criteria for practical NDT evaluation of critical joint areas.

Coated Refractory Postflight Evaluation: Investigate radiochemistry techniques for seeding the coatings with relatively long-lived beta-emitting isotopes to measure coating thickness and diffusion into the refractory substrate. Use solid-stage surface barrier detectors or scintillation detectors to scan selected areas of the shield. Develop suitable instrumentation and techniques that may be economically and meaningfully applied to this inspection.

Ablative Material Postflight Evaluation: Develop techniques for monitoring ablation rate of ablative materials in flight. Design and implant sensors within the ablative to be depleted by exposure to heat and atmosphere. Develop suitable instrumentation for feedback to the control station regarding recession of ablative material.

Ceramic Material Postflight Evaluation: Since density and electrical conductivity of the oxide layer varies significantly from that of the nonoxidized state, investigate eddy current and ultrasonic techniques for measuring thickness of the conversion layer. Investigate infrared methods for detecting abnormal recession of the ceramic in flight.

Thermal Insulation Postflight Evaluation: Accomplish NDT evaluation of the thermal insulator material by implanting thermocouples within the insulation or support posts. During postflight inspection, determine temperature profile near the support post for a small heat flux and compare profiles with those established for critical insulation areas prior to flight. Use heat dissipation rate and temperature gradients to determine condition of insulation. Investigate ultrasonic and/or microwave techniques for detecting disbond between propellant storage tank insulation and fuel tank wall.

TDNiCr Postflight Evaluation: Since ductility of TDNiCr is critically reduced by diffusion and vaporization at extreme temperatures, investigate eddy current techniques for detecting losses that reduce ductility in the alloy.

Phase I -- Investigation of Techniques:

1. Determine the reliability of current state-of-the-art techniques for determining thickness and composition of thermal coatings.
2. Determine the effect of abrupt change in coating thickness, segregation of elements, cracks, porosity, etc. under simulated load and thermal conditions. Establish NDT criteria for acceptable coating(s).

- Demonstrate feasibility for new instrumentation and techniques for NDT of coatings, radiative ceramic, and insulative material.

Phase E — Development of Technique: Optimize techniques found suitable during Phase I for application to hardware. Develop coupling mediums, positioning devices, and coils as required. Based on Phase I findings, develop a suitable technique for preparing a radioactive coating for application to a refractory substrate; establish handling, safety requirements, etc. Develop detector and establish technique to measure coating thickness. Establish meaningful NDT criteria for predicting satisfactory shield performance.

Tasks	1970	1971	1972	1973	Cost (\$K)
Phase B	CONFIC SELECT ▽				
Phase C/D	PDF ▽				
	CDR ▽				
Investigate Techniques	██				30
Develop Preliminary Criteria	██	██			40
Define Access Restrictions		██	██		40
Define Ablative Measurement Techniques	██				20
Develop Joining & Fabrication NDT Standards		██	██		20
Develop Isotope Seeding Coatings	██	██			80
Develop Counter & Scan Requirements	██	██			20
Develop NDT Techniques for Other Materials	██	██	██		50
Demonstrate NDT - Full Scale			██		20
Complete NDT Master Plan			██	██	20
Design & Fabricate Instrumentation		██	██		40
Implement Techniques			██		30
				Total Cost	410

4.5.8 IMPROVED DUCTIBILITY OF RADIATIVE THERMAL PROTECTION SUBSYSTEMS (RTPS) MATERIALS (CATEGORY I)

OBJECTIVES. Increase ductility of: coated columbium and tantalum alloys, columbium alloy welds after silicide coating, and TD nickel-chromium.

TECHNICAL APPROACH & TASK DESCRIPTION: Columbium and tantalum alloys have been developed to produce an optimum combination of strength, fabricability, and weldability. Further development does not appear desirable, but ductility can be increased by improved thermo-mechanical treatments. Improving coated alloy ductility is more difficult. Normal silicide coatings are brittle. A two-step slurry-sinter technique works, but needs additional development. Ductility of silicide-coated columbium alloy welds can be improved by suitable post-weld overaging heat treatment before coating. TD nickel-chromium ductility is being improved by the producer. Additional improvement in fabricability seems possible by thermo-mechanical treatments. Tasks are:

- a. Investigate effect of temperature, strain rate, and deformation on fabricability of columbium and tantalum alloys. Include influence of various annealing treatments.
- b. Continue to develop ductile oxidation resistant coatings for columbium and tantalum alloys. Include improved techniques for applying silicide coatings.
- c. To solve the coated columbium weld embrittlement problem, characterize the aging behavior of each alloy of interest. Overaging heat treatments can then be selected.
- d. Investigate effect of temperature, strain rate, and deformation on fabricability of TD nickel-chromium. Include influence of various annealing treatments.

Tasks	1970	1971	1972	1973	Cost (\$K)
Phase B					
Phase C/D					
Obtain Material & Prepare Specimens					30
Conduct Thermomechanical Tests					50
Conduct Program to Develop Ductile Oxidation-Resistant Coating					300
Perform Aging Studies					60
Analyze Results					15
Document Results					15
Total Costs					470

4.5.9 FABRICATION DEVELOPMENT OF THORIA DISPERSED NICKEL CHROMIUM (TDNiCr) MATERIALS (CATEGORY I)

OBJECTIVE: Develop TDNiCr heat shield panels for test evaluation of radiative thermal protective systems in the space shuttle program.

TECHNICAL APPROACH AND TASK DESCRIPTION. Investigate TDNiCr to establish formability limits and effect of forming processes on mechanical properties of end product.

Initially, examine TDNiCr material with and without recrystallization after rolling for formability and mechanical properties. Material without recrystallization has elongation in the range of 30% in 1 inch at 1200-1300F, but recrystallized material has a maximum elongation of about 17% at ambient temperature. Ductility decreasing with increasing temperature rules out elevated temperature for improved formability. Determine cost effectiveness and function of heat shields of each material condition by trade studies. Evaluate selected condition in detail considering a) maximum uniform % elongation with and without stress relieving between forming stages, b) effect of various percentages of strain and stress relieving on mechanical properties, and c) effect of strain rates on uniform elongation to evaluate relative merits of slow and rapid forming. The following tasks are:

1. Select TDNiCr material condition from trade studies for customer approval.
2. Procure material for test panels.
3. Conduct strain tests to establish maximum uniform % elongation for forming operations with and without stress relieving between forming stages.
4. Test for tensile and compression mechanical properties in material with various percentages of strain and stress relieving treatments.
5. Evaluate effect of forming rate on formability, using various types of equipment including high-energy forming velocities.
6. Examine material structure metallographically after various percentages of strain and stress relieving treatments.
7. Design and manufacture tooling to fabricate typical heat shield panels.
8. Using optimum processes, fabricate typical heat shield panels.

Tasks	1970	1971	1972	1973	Cost (\$K)
Phase B					
Phase C/D					
Select Material Condition					10
Select Materials					40
Conduct Strain Tests					20
Perform Material Properties Tests					20
Evaluate Forming Properties					20
Design & Fabricate Test Component Tooling					100
Fabricate Test Articles					210
Conduct Nondestructive Tests					10
Conduct Life-Cycle Tests					200
				Total Cost	630

4.5.10 FABRICATION DEVELOPMENT OF REFRACTORY MATERIALS (CATEGORY I)

OBJECTIVE: Develop columbium and tantalum heat shield panels for evaluations of radiative thermal protective systems in the space shuttle program.

TECHNICAL APPROACH AND TASK DESCRIPTION: Investigate a selected columbium and tantalum alloy to establish formability limits and effect of forming processes on mechanical properties of end product. Produce panels in each material for environmental testing. Include parameters such as (a) maximum uniform ϵ_u elongation with and without stress relieving between forming stages, (b) effect of various percentages of strain and stress relieving treatments on mechanical properties, and (c) effect of strain rates on uniform elongation to evaluate relative merits of slow and rapid forming. Tasks are:

1. Select a columbium and tantalum alloy for customer approval and procure material.
2. Conduct strain tests to establish maximum uniform ϵ_u elongation for forming operations with and without stress relieving between forming stages.
3. Perform tensile and compression mechanical property tests in material with various percentages of strain and stress relieving treatments.
4. Evaluate effect of forming rate on formability, using various types of equipment including high-energy forming velocities.
5. Test metallographically material structure after various percentages of strain and stress relieving treatments.
6. Design and manufacture tooling to fabricate typical heat shield panels.
7. Fabricate panel details for three assemblies from columbium and tantalum materials.
8. Assemble details by suitable joining processes (3 columbium assemblies and 3 tantalum assemblies).
9. Coat panels for oxidation protection.
10. Test nondestructively detail parts and assembled components before and after coating.
11. Conduct environmental life-cycle tests.

Tasks	1970	1971	1972	1973	Cost (\$K)
Phase B					
Phase C/D					
Select materials					100
Establish formability					30
Perform mechanical property tests					30
Conduct metallographic analysis					10
Design & fabricate test tooling					90
Fabricate test components					200
Conduct nondestructive tests					20
Conduct life-cycle tests					200
Total Cost					580

4.5.11 FABRICATION (FORMING, JOINING, AND MACHINING) OF CERAMIC NOSE CAPS AND LEADING EDGES (CATEGORY I)

OBJECTIVE: Develop methods for fabricating large ceramic structures for the space shuttle.

PROBLEM: The desirable characteristics of ceramics for nose cones and leading edges make ceramic materials difficult to fabricate. Ceramics cannot be reformed once an initial shape is achieved. Machining ceramics, due to the hard and brittle nature of the materials, is extremely expensive and slow, and the brittle nature of ceramics makes fastening of ceramic to itself or to another material a difficult problem.

TECHNICAL APPROACH AND TASK DESCRIPTION: Investigate improvements in basic forming to extend the complexity and types of configuration. Develop improved tooling and processing to enlarge ceramic parts and reduce number of pieces that must be assembled. Improve casting and powder metallurgy procedures to attain closer dimension and thickness tolerances, and reduce weight and the machining costs.

Joining: Investigate metal fasteners for joining ceramics. Fasteners should have a thermal expansion coefficient close to the ceramic material and should be thermally protected to function in a usable temperature range. Threaded fasteners should be attached to the ceramic by means of metal inserts since direct threading is not reliable. Joining methods other than mechanical attachment are feasible with ceramic, particularly if the ceramic is mixed with metal to form a cermet. With metal present, processes such as welding, brazing, and diffusion bonding are possible. For brazing and diffusion bonding, an additional aid to joining would be the metal spraying or plating of the surface prior to the joining operation.

Machining: Heavy machining operations are usually required because of the difficulty of casting ceramic to shape and maintaining close tolerances. Machining represents the greatest cost in using ceramics for space shuttle. Several machining methods work with ceramics, particularly if the ceramic is metal filled and conductive. These methods fall into two general categories: a) machining with diamonds, and b) the use of electrical eroding processes. An evaluation of the relative efficiency of each process will be conducted and will include electrodischarge machining, electrochemical machining, diamond tool processes, ultrasonic and abrasive jet machining. Tasks are:

1. Select specimen configuration and material, and purchase materials.
2. Evaluate current manufacturing procedures for producing ceramic shapes.
3. Improve and further develop processing of ceramic shapes.
4. Produce tooling and manufacture ceramic specimens.
5. Evaluate dimensionally and determine quality of ceramic specimens.
6. Conduct a joining program on ceramics to include mechanical fasteners, welding, diffusion bonding, and brazing. Investigate plating or metal spraying of ceramic surface prior to joining operation.
7. Evaluate joint efficiencies through physical and mechanical property tests.
8. Investigate machining methods relative to specific removal rates, cost, scaleup, tolerance, reproducibility finish, and tooling requirements.
9. Produce and assemble typical nose cone hardware.
10. Nondestructively test quality of assembly.

Tasks	1970	1971	1972	1973	Cost (\$K)
Phase B					
Phase C					
Initial Structure Release		▽			
Select materials					50
Evaluate manufacturing methods					50
Develop selected method					150
Fabricate specimens					60
Evaluate quality					30
Conduct joining program					80
Evaluate joints					30
Investigate machining methods					50
Fabricate & assemble hardware					160
Test hardware					50
Total Cost					710

4.5.12 MECHANICAL/THERMAL INTERFACE ATTACHMENTS FOR THERMAL PROTECTION SYSTEMS (CATEGORY I)

OBJECTIVE: Develop interface attachments which will impede heat flow across interfaces and be accessible for inspection and refurbishment.

PROBLEM: During entry, the kinetic energy transmitted into a vehicle produces vast heat. Temperatures should be limited to 200° F to 300° F.

TECHNICAL APPROACH AND TASK DESCRIPTION: Screen candidate thermal obstruction materials: coated refractory metals, diboride ceramics, oxides and carbides, specialized carbons and graphites, and thermal insulations. Candidate thermal obstructing methods will include a) high temperature insulators, b) radiation barriers, c) closed loop cooling, d) prestressed ceramics, e) heat sinks, f) low conductivity paths, g) oriented thermal path material, h) heat block fasteners.

Define attachment concepts generated by the screening and by materials considerations. Fabricate and test the most promising interface attachments at thermal profiles found at selected vehicle interfaces.

Tasks are:

- a. Identify and analyze thermally critical areas.
- b. Conduct tradeoff studies of candidate thermal obstruction methods and candidate materials systems.
- c. Fabricate one or more subscale test articles to establish attachment fabrication techniques and to validate design considerations.
- d. Subject subscale test articles to various qualification tests.
- e. Fabricate one or more full scale interface attachments.
- f. Test full scale attachments under simulated entry conditions. Include typical thermal profiles, thermal cycle vibration, and acoustical and mechanical load cycles.
- g. Evaluate full-scale test results and prepare final report.

Tasks	1970	1971	1972	1973	Cost (\$K)
Phase B					
Phase C/D					
Initial Struct. Release		▽			
Perform Thermal Analysis	█				20
Perform Tradeoff Studies	█				20
Design & Fabricate Subscale	█				40
Test Subscale Articles	█				60
Evaluate Tests	█				20
Design & Fabricate Full Scale	█				60
Test Full-scale Attachments		█			50
Evaluate Test Results		█			40
Total Cost					310

4.6 MATERIALS

4.6.1 REUSABLE CRYOGENIC PROPELLANT DUCT INSULATION (CATEGORY I)

OBJECTIVE: Develop reusable lightweight duct insulation.

PROBLEM: Cryogenic propellant lines require insulation to prevent cryopumping air and moisture and to minimize heat leaks. It must be reusable for up to 100 flights.

TECHNICAL APPROACH & TASK DESCRIPTION: Develop structural liners inside the ducts. Moderate-density foams which can be installed inside duct sections are candidate materials.

Dry nitrogen purge will prevent significant frost buildup around the ducts. Insulation, even with low thermal efficiency, inside the ducts is preferable because of the reduced susceptibility to damage. External bonded and sealed insulation is recommended only where other techniques are not acceptable. Double-wall propellant ducts have been considered to increase the propulsion system reliability. They should contain a flexible foam spacer rather than utilize a vacuum.

Tasks	1970	1971	1972	1973	Cost (\$K)
Phase B					
Phase C/D					
Conduct Analysis & Design					80
Conduc. Materials Evaluation					230
Develop Components					465
Design, Fabricate, & Test Full-Scale Components					870
Total Cost					1645

4.6.2 CRYOGENIC PROPELLANT TANK INSULATION (CATEGORY I)

OBJECTIVE: Develop cryogenic propellant tank insulation for reusable space transportation vehicles.

PROBLEM: Reusable space vehicle cryogenic propellant tanks require insulation and purge provisions to prevent cryopumping of oxygen, and moisture during ground operations and launch. Select and optimize cryogenic insulation on orbital maneuvering propellant tanks for weight and thermal efficiency during orbital storage and during ground hold, launch, space, and entry for up to 100 flights.

Make insulation structurally compatible with propellant tank design and integrate it into structural environment including structural bending, flexing, buckling, and thermal stresses plus the launch and vibration loads.

Design structure so that insulation is accessible for inspection and maintenance during normal turnaround and maintenance period.

TECHNICAL APPROACH AND TASK DESCRIPTION: The main propellant tanks require insulation during ground hold and launch. Candidate internal insulations are 1) an open-cell system using a stagnant layer of propellant gas as an insulation, or 2) the sealed 3D foam system installed internally on Saturn SIVB hydrogen tank. Internal insulation has distinct advantages. It is accessible without disassembling the external reentry heat shield. Tank structure and wall/insulation bond line do not get low-temperature thermal stress because the internal insulation keeps them warm.

Candidate external insulations are 1) helium-purged fiber blankets, or 2) porous, nitrogen-purged system that permits some nitrogen cryopumping and frost buildup. An external insulation system cannot fail and cause an abort due to ingestion in the fuel system. Purged materials not directly bonded to a tank can serve as part of the overall high-temperature thermal protection system, but helium is scarce, and its use eventually will become prohibitively expensive.

Orbital maneuvering cryogenic propellant tanks require some high-performance insulation for thermal protection to prevent boil-off losses over several days in orbit.

The open-cell concept utilizes small cells bonded to the inner tank wall at one end and open to the liquid on the other end. Surface tension prevents liquid entry into cells and develops an insulating gas layer.

Internal 3D polyurethane foam has been subjected to numerous cryogenic tanking cycles during static ground test of the S-IVB vehicle, but it must be demonstrated to be reusable by cyclic life testing under structural load, vibration, and thermal environments.

The nitrogen-purged system permits nitrogen frost to build up in a porous material similar to a water frost buildup. Select such that porous material through pore size and/or orientation liquid forming and flowing is minimized. The nitrogen-purged insulation concept is compatible with the inert dry-nitrogen environmental purge contemplated for the space shuttle. Tasks are:

- a. Preliminary Design and Analysis.
 1. Investigate integral and nonintegral tankage.
 2. Compare and evaluate internal and external insulations.
 3. Determine installation, inspection and maintenance requirements associated with the insulation configurations.
 4. Specify environmental criteria - pressures, temperatures, type atmosphere (gases/vacuum) versus time.
- b. Evaluate Insulation Concepts
 1. Purged porous materials.
 2. Sealed internal systems.

- 3. Open cell - honeycomb/tubing.
- c. Select Materials -- Insulations, adhesives and liners which are compatible with cryogenic temperatures, the environmental cycles, and the fluids LH₂, LO₂, moisture, etc.
- d. Flight Configuration Design.
 - 1. Design full scale flight configuration insulation installations.
 - 2. Evaluate detail design problems around structural reinforcements, penetrations, propellant lines, etc.
- e. Small Scale Component Tests. Evaluate:
 - 1. Thermal performance/efficiency.
 - 2. Environmental cycles.
 - 3. Thermal stress, launch loads, vibration.
- f. Large Scale Test -- Flight Configuration.
 - 1. Test article should include propellant lines and attached heat shield.
 - 2. Evaluate insulation/structure compatibility, insulation thermal performance, and reliability.

Tasks	1970	1971	1972	1973	Cost (\$K)
Phase B					
Phase C/D					
Perform Predesign & Analysis					75
Conduct Material Evaluation Tests					215
Design Flight Configuration Article					55
Conduct Small-Scale Article Tests					520
Conduct Centrifuge & Loads Tests					560
Select Final Insulation Configuration		▼			2,650
Conduct Large-Scale Article Tests					
Design & Fabricate Flight Article					1,200
Conduct Cryogenic Test-Flight Article				▼	
Total Cost					5,875

4.6.3 BEARINGS AND LUBRICANTS SUBJECTED TO SPACE AND OPERATIONAL ENVIRONMENT (CATEGORY II)

OBJECTIVE: Qualify bearing materials and lubricants to the space shuttle requirements of complete reusability under operational conditions and space environment.

PROBLEM: Bearing materials and lubricants currently being used in space programs have not been qualified to the operational and environmental requirements for complete reusability for the space shuttle booster and booster vehicles. Qualify these materials for space shuttle application.

TECHNICAL APPROACH & TASK DESCRIPTION: Conduct evaluation tests of candidate lubricant materials and bearing alloys under simulated operational conditions of high temperatures due to solar radiation, aerodynamic heating, rocket plume, and low space temperatures; atmospheric pressure; applied dynamic and vibrational loads; and time. Conduct tests in vacuum chambers at 1×10^{-11} torr and large enough to accommodate dynamic and thermal test equipment that would be used to apply required loads and to perform such measurements as bearing friction. Investigate rolling, sliding, sweeping, and point-contact motion. Also, evaluate each lubricant for toxicity to humans and for compatibility with fuels and oxidizers under zero gravity and vacuum conditions. Evaluate potential application of candidate lubricants and bearing alloys for such space shuttle components as control linkages, hydraulic and pneumatic actuators, electric motors, latches, pivots, hinges, gears, and clutches. Tasks are:

- a. Conduct lubricant and bearing alloy screening and material property tests, including 1) compatibility with other potential contact materials, 2) toxicity to humans, 3) reusability, and 4) physical properties under vacuum, temperature extremes, and applied loads.
- b. Select candidate alloys for all bearings and bushings for further environmental testing.
- c. Select candidate lubricants including both liquidomorphous and solid films, metallic combinations, and metal pretreatment penetrants for further environmental testing.
- d. Fabricate components such as linkages, pivots, hinges, and shafts for environmental testing of the bearings and lubricants.
- e. Conduct environmental cyclic life tests at 1×10^{-11} torr and combined thermal vibration, and structural loads tests for real-time conditions.

Tasks	1970	1971	1972	1973	Cost (\$K)
Phase B					
Phase C/D					
Initial Struct. Release			▽		
Vehicle Subassembly Start			▽		
Screen Lubricants					80
Select Bearing Alloys					80
Select Bearing & Lube Material					
Fabricate Test Components					70
Conduct Environmental Cyclic Tests					170
	4-56		Total Cost		400

4.7 PROPULSION

4.7.1 OXYGEN-HYDROGEN ATTITUDE CONTROL PROPULSION SYSTEM (CATEGORY I)

OBJECTIVE: Identify and establish the attitude control propulsion systems requirements. Demonstrate thrust chambers and propellant systems to increase confidence and identify unknowns.

PROBLEM: The characteristics of the oxygen-hydrogen attitude control propulsion system have not been sufficiently defined to initiate hardware fabrication and demonstration. Attitude control thrusters with thrusts of 1,000 to 4,000 pounds operating at chamber pressures of 10 to 20 psia or higher have not been demonstrated. Propellant systems have not been demonstrated that are capable of a) using residual oxygen-hydrogen gases and liquids with boiloff, and b) providing relatively consistent inlet conditions to the thrusters.

TECHNICAL APPROACH AND TASK DESCRIPTION: The required technology program should have five phases. Tasks are:

Phase 1: Conduct studies to a) identify requirements; b) define candidate systems; c) develop characteristics of the system and its effect on the space shuttle, e.g., cost; d) identify the current technology base; e) identify preferred systems; and f) prepare specifications for the preferred system.

Phase 2: Develop thrust chambers for the preferred systems. Investigate low pressure spark ignition, high pressure spark ignition, and high pressure catalyst ignition. As an integral part of each program, investigate cooling, injector, valve, combustor, mounting, and insulation. Thrust levels of 1,000 to 4,000 pounds and chamber pressures of 10 to 20 for the low pressure and 100 to 500 for the high pressure appear to be typical requirements.

Phase 3: Develop propulsion systems. Because of the great number of candidate systems and the possible high cost of some, it is not possible to identify at this time likely candidates; however, at least two approaches will be pursued.

Phase 4: Demonstrate the total attitude control propulsion system including thrust chambers in a ground facility.

Phase 5: Demonstrate the system by flight testing to verify its ability to operate in a zero-g environment. (This may be part of a space shuttle test article.)

Consider using the subsystems to augment or eliminate components in the airbreathing propellant supply, auxiliary power unit, electrical power supply, residual return system, and life support system.

Tasks	1970	1971	1972	1973	Cost (\$K)
Phase B	CONFIG SELECT				
Phase C/D		PDR			
				CDR	
Phase 1: Identify ACPS requirements	[Bar]				1,000
Phase 2: Develop thrusters	[Bar]				6,000
Phase 3: Develop propulsion	[Bar]				2,000
Phase 4: Demonstrate system			[Bar]		5,000
Phase 5: Perform flight tests				[Bar]	8,000
			Total Cost		22,000

4.7.2 AIRBREATHING ENGINE PROPULSION (CATEGORY I)

OBJECTIVE: Identify the airbreathing engine requirements and evaluate potential problems. Demonstrate the critical subsystem elements and the subsystem.

PROBLEM: Airbreathing engines using hydrogen are planned for the space shuttle. Before engine, propellant system, and space shuttle development can proceed, however, the following questions must be evaluated:

- a. Determine whether airbreathing engines can be incorporated in the orbiter considering the large weights and volumes required.
- b. Determine whether the engines can use propellant scavenged from the residual gases and liquids or if extra propellants must be carried.
- c. Determine the best method of supplying hydrogen to the engines.
- d. Determine whether the airbreathing engines can be used during boost considering their added thrust and lower propellant consumption per pound of thrust.
- e. Determine type and quantity of engines and their characteristics, such as bypass ratio.
- f. Determine modifications such as encapsulation and flex mounting to permit use of "existing" engines to accommodate hydrogen and the anticipated environments.
- g. Determine whether windmill start will be satisfactory, or if auxiliary starting systems must be provided.
- h. Determine level of emergency ratings and how it might be provided, such as over temperature or water injection.
- i. Determine the task schedule and cost to develop the airbreathing engine and the associated propellant systems for the candidate airbreathing systems.

After answering these questions, critical component demonstrations may be needed. Confidence may be still low unless a system demonstration is performed both on the ground and in flight.

TECHNICAL APPROACH AND TASK DESCRIPTION: The total effort will consist of several phases. The first phase will comprise seven tasks.

Task 1: Identify airbreathing engine requirements, including environments, based on space shuttle characteristics.

Task 2: Describe candidate systems by schematic and design layouts.

Task 3: Define the sensitivities of space shuttle cost, weight, size, and development time to airbreathing engine characteristics; e.g., number of engines, fuel-supply quality (gas, mixed phase, or liquid), propellant feed mechanism, and bypass ratio.

Task 4: Identify the existing technology applicable to candidate system.

Task 5: Define cost and schedule for the candidate system. At the end of the first five tasks, identify a preferred system or systems.

Task 6: Prepare specifications for the preferred systems.

Task 7: Define technologies to support the space shuttle development.

During Phase 2, demonstrate effectiveness of subsystems such as small gas compressors to supply hydrogen to the airbreathing engines, leak-proof propellant lines, encapsulation systems, mounting systems, improved bearings, and seals. Perform these tasks for the propellant and engine system.

During Phase 3, demonstrate the engine and propellant system during a static ground test program.

In Phase 4, demonstrate system confidence by a flight demonstration.

Tasks	1970	1971	1972	1973	Cost (\$K)
Phase B					
Phase C/D					
Phase 1					
Task 1: Define requirements					
Task 2: Define candidates					
Task 3: Define sensitivities					
Task 4: Define technology base					
Task 5: Define cost & schedule					
Select system(s)					
Task 6: Prepare specifications					
Task 7: Define technology					300
Phase 2					
Demonstrate propellant system					1,000
Demonstrate engine					2,000
Phase 3					
Demonstrate system					3,000
Phase 4					
Conduct flight demonstration					8,000
Total Cost					14,300

4.7.3 MAIN ROCKET ENGINE PROPULSION (CATEGORY I)

OBJECTIVE: Identify engine characteristics and demonstrate engine critical features.

PROBLEM: The characteristics of the 400,000-lb engine are vaguely defined at this time. The following unknowns must be defined:

- a. Helium requirements for engine operation.
- b. Need for LO₂ pump inducers.
- c. Idle mode requirement.
- d. Vehicle flexline requirement.
- e. Engine weight based on airloads, heating, and acceleration.
- f. Pressurization-gas flow rates, pressures, and temperatures.

Critical engine features require demonstration, e.g., seals and valves which do not require helium, long-life flexlines, idle mode injectors and controls, hyper-thin preburners, insulated pumps for minimum chill-down, insulation to prevent air liquification.

TECHNICAL APPROACH AND TASK DESCRIPTION. Perform studies to resolve problems identified above. These studies will be made by engine and airframe contractors working together under NASA direction.

As part of the Phase B engine definition and design tasks, demonstrate components that may have a significant effect on engine cost and schedule. The most significant technology program is the Air Force ADP Project 2 - High Pressure Engine Technology - XLR 129. This program has provided and will continue to provide much significant data. Cooling system, injectors, and pumps for higher chamber pressures will be demonstrated because of the potential system advantages associated with compact engines. Tasks are:

Demonstrate idle mode injectors. Demonstrate pump mode operation with mixed phase propellants to minimize chilldown propellants. Test insulated pumps to determine their cooldown flow and pressure requirements. Evaluate reusable insulation for prevention of air liquification. Conduct tests to demonstrate the engine nozzles' ability to sustain the anticipated loads, such as air and heating.

Tasks	1970	1971	1972	1973	Cost (\$K)
Phase B					
Phase C/D					
Main Rocket Engine					
Perform Study					
Demonstrate Engine:					
XLR-129					22,000
Higher Pc					13,000
Cooling					
Pumps					
Injector					
Idle mode					6,000
Mixed phase pumping					2,000
Insulated pumps					3,000
Insulation					1,000
Nozzle verification					1,000
Bearing & seals					1,000
Advanced injectors					1,000
		4-60	Total Cost		18,500

4.7.4 MAIN PROPULSION PROPELLANT SYSTEM (CATEGORY I)

OBJECTIVE: Identify and characterize a preferred propellant system. Demonstrate the system to increase confidence.

PROBLEM: The propellant system characteristics for the main engines are not firmly resolved. The following criteria will require resolution:

- a. Whether a single duct with branch lines to each engine should be used, or whether individual lines should supply each engine.
- b. Location of the oxygen tank.
- c. The use of integral or separated tanks.
- d. The tank materials required considering the importance of low weight.
- e. Tank pressure and temperature histories.
- f. The type of pressurant considering attitude control propulsion system, power supply system, life support system and airbreathing engine usage of residual propellant.
- g. Propellant tank purging required prior to entry.
- h. Propellant velocities, pressure variations, and duct diameters that characterize the propellant system.
- i. Type of insulation, such as vacuum jacketing, helium purged, for the propellant lines and the tanks.
- j. Types of seals, bellows, joints, and lines based on the reuse requirements.

TECHNICAL APPROACH AND TASK DESCRIPTION: Conduct a study to define the system criteria described above. Demonstrate solution of these criteria to provide data on their characteristics, increase confidence in the system, and identify unknowns.

Tasks	1970	1971	1972	1973	Cost (\$K)
Phase B					
Phase C/D					
Main Propellant System Perform Study					500
Demonstrate:					
Ducts					1,000
Insulation					
Bellows					
Seals					
Joints					
Tankage					3,000
Insulation					
Fatigue					
Baffles					
Pressurization					2,000
Gas Requirements					
Diffuser					
Insulation Effects					
Controls					
Purge					
Propellant Utilization					1,000
Total Cost					7,500

4.7.5. ORBITER CRYOGENIC TECHNOLOGY (CATEGORY II)

OBJECTIVE: Develop optimum systems for propellant feed of a cryogenic vehicle requiring restart in space and for tank pressure control of cryogenics during coast where reusability, long life, and ease of maintenance are prime requirements.

PROBLEM: Vehicle mass requirements for supplying engine propellants during start-up under low-gravity conditions can be considerable. These mass requirements or weight penalties are due to auxiliary fuel required to a) settle the main propellants to assure liquid at the engine feed lines and b) replenish chilldown losses associated with conditioning feed lines and pumps for proper engine start-up. Weight penalties may evolve from loss of liquid trapped in propellant lines following engine shutdown. Times and accelerations needed to settle propellants are a significant unknown at present.

Control of propellant tank pressure of a vehicle operating in space must be accomplished with a minimum loss of propellant. This is particularly difficult with a cryogenic vehicle such as a space shuttle operating under low gravity conditions. Conventional systems allow direct venting of liquid with an intolerable weight penalty, since the orientation of liquid and vapor within the propellant tank may be unknown.

TECHNICAL APPROACH AND TASK DESCRIPTION: Develop techniques to analyze propellant conditions and temperature histories in transfer lines and pumps during transient chilldown. Modify existing computer programs to consider internal and external insulation, internal coatings, distributed line masses and flow rate. Analyze various engine chilldown and preconditioning schemes to determine the optimum approach for the space shuttle. These include maintaining wet lines or recovering line propellants back into the tank following engine shutdown. Tasks are:

- a. Develop techniques to determine required settling times and accelerations to provide liquid at the propellant system inlet.
- b. Analyze various propellant control schemes to determine the optimum design for providing liquid at the space shuttle engine feed inlet. The primary candidates are linear acceleration and surface tension or capillary liquid containment systems.
- c. Perform predesign studies of the following three candidate pressure control methods for application to the space shuttle mission:
 1. Bulk or compact heat exchanger system which can efficiently vent vapor when surrounded by either liquid or vapor. This system utilizes a mixer to flow bulk fluid through the exchanger and promote energy exchange in the tank.
 2. A wall heat exchanger operating on the same principle as the bulk unit, except that the exchanger is distributed around the inside and/or outside of the propellant tank, and a mixer is not used. Such a system depends on natural perturbations for mixing.
 3. Nonvent storage where the tank is designed to withstand pressure buildup. In this system, it is anticipated that propellant mixing will be required to maintain a homogeneous tank fluid.
- d. Select optimum systems on the basis of weight, reliability, and cost.
- e. Perform detail design and development testing of selected feed systems.
- f. Perform detail design and development testing of the selected pressure control system.

Tasks	1970	1971	1972	1973	Cost (\$K)
Phase B					
Phase C/D					
Analyze chilldown and pre-conditioning					30
Analyze propellant settling					10
Analyze propellant control methods					30
Analyze and pre-design pressure control systems					55
Select optimum systems					20
Feed system:					
Design and procure					120
Test and evaluate					100
Pressure control:					
Design and procure					100
Test and evaluate					70
				Total Cost	540

4.8 AEROELASTICS AND DYNAMICS

4.8.1 STRUCTURAL MODE STABILITY AND LOADS ANALYSIS (CATEGORY I)

OBJECTIVES:

1. Determine structural modes of clustered/winged space shuttle vehicles.
2. Determine effects of structural modes on vehicle loading.
3. Determine need for load-alleviation devices.
4. Determine sensitivity of overall closed-loop stability of clustered/winged vehicle to structural modes.
5. Determine nonlinear structural response characteristics.

PROBLEM: Vehicle bending modes couple into the control subsystem through the body rate and attitude sensors, which are a part of the stability and control subsystem. These modes are complex for the clustered/winged vehicles, necessitating three-dimensional modal analysis. Body modes are excited in the vehicle by gusts and winds as the vehicle follows its prescribed flight profile. The modes can cause increased loading due to increased local deflections and also due to limitations they place on gain and bandwidth of the attitude control system. If the low gain and bandwidth lead to large overshoots in response to gusts, large loads can occur. A load-alleviation system, if warranted, would relieve these loads.

TECHNICAL APPROACH AND TASK DESCRIPTION: From a structural description of a typical clustered/winged vehicle, determine structural modes by using a three-dimensional modal analysis program. Using modal properties, determine dynamic response of the vehicle to gusts and winds. If resulting steady and dynamic loads result in increased structural weight, conduct study to determine a load-alleviation control system technique, sensor locations, and overall control subsystem characteristics. Also investigate coupling of structural modes and rigid-body modes through the control subsystems. Conventional root locus techniques will be used for this analysis.

Tasks	1970	1971	1972	1973	Cost (\$K)
Phase B					
Phase C/D					
Initial Structural Release					
Determine three-dimensional modes					200
Determine mode effects on landing					40
Define load alleviation requirements					20
Determine mode effects on control					80
Total Cost					340

4.8.2 PRE-ENTRY CONTROL REQUIREMENTS (CATEGORY I)

OBJECTIVE: Determine angular acceleration criteria applicable to large entry vehicles such as the space shuttle.

PROBLEM: Angular acceleration criteria used to determine thrust requirements for entry vehicle reaction control subsystems have been Cornell Specification TC-1332-F-1, Handling Requirements for Hyper-Velocity Aircraft. Previous vehicles (X-15, for example) have required RCS engine thrust levels between 50 and 300 pounds. Versions of the space shuttle require thrust levels from 1200 to 5000 pounds or higher to meet these criteria.

TECHNICAL APPROACH AND TASK DESCRIPTION: Conduct a dynamic study, including a six-degree-of-freedom simulation, to determine if angular accelerations imposed by the Cornell specification should be retained or different criteria established for large entry vehicles. Establish minimum attitude control accelerations that are adequate for control just prior to atmospheric entry. These accelerations can be directly converted into attitude control thrust requirements with knowledge of the attitude control engine arrangement and the mass moments of inertia of the space shuttle configurations. As part of the study, determine minimum velocity increment required, required reproducibility of thrust pulses, and duty cycles to be expected for contemplated missions.

Tasks	1970	1971	1972	1973	Cost (\$K)
Phase B					
Phase C/D					
Perform simulation studies	■				80
Develop acceleration requirements		■			20
Develop RCS motor requirements		■			20
	Total Costs				120

4.8.3 BOOST PHASE CONTROL REQUIREMENTS (CATEGORY I)

OBJECTIVE: Determine the most cost-effective control concept for boost phase of flight.

PROBLEM: Control force during launch phase can be provided by engine gimbaling, thrust deflections by gas or liquid injection into the nozzle, aerodynamic surfaces, thrust modulation, reaction thrusters, or combinations. Determination of control method can have significant influence on engine and vehicle design. Use of gimbals vs gas or liquid injection will have significant impact on engine design. Use of thrust modulation for control can determine response and magnitude requirements for modulation. Use of aerodynamic surfaces for launch phase would reduce gimbal or injection requirements. Reduction in gimbal requirements eases the flexible (movable) propellant feed line design. Also, reduced gimbal requirements will reduce space requirements dictated by possible engine bell motions in event of a malfunction. Choice of control concept must consider performance, reliability, and cost relationships on entire space shuttle system. Previous launch vehicle systems using liquid-fueled engines have employed gimbaled systems; however, configuration and lifetime requirements peculiar to a reusable system could lead to a system other than gimbal. A decision on control concept should be reached prior to final engine design requirements.

TECHNICAL APPROACH AND TASK DESCRIPTION: Examine one or two typical configurations and establish control force requirements as a function of flight time. Most significant times would be liftoff, max q, staging, orbit, and orbit change. Translate force requirements into gimbal angles, thrust modulation, gas or liquid injectant, aerodynamic surface size and angle, and reaction control jets (primarily for orbital stage). Use these requirements to establish design and design variations within concepts. Typical considerations are:

a. Gimbal Engine

1. Use flexible (movable) low-pressure propellant feed lines for gimbal pump and nozzle.
2. Use flexible high-pressure propellant lines for gimbal between pump and engine.
3. Use aerodynamic surfaces during high dynamic pressure to reduce engine deflection requirements.
4. Examine benefits of thrust modulation to reduce engine deflection requirements, particularly the cg offset contribution.

b. Injection System

1. Provide duty-cycle requirements to propulsion contractors for design evaluation of gas and liquid injection systems.
2. Evaluate performance effects of injection systems.
3. Use aerodynamic surfaces during high dynamic pressure to reduce injection requirements.
4. Examine using thrust modulation to reduce injection requirements.

c. Aerodynamic Surfaces

1. Evaluate aerodynamic surfaces in combination with gimbal and injection systems.
2. Evaluate reaction subsystem as an auxiliary to aerodynamic surfaces for periods of low dynamic pressure.

Primary consideration during these design studies is reliability, cost, and performance.

Tasks	1970	1971	1972	1973	Cost (\$K)	
Phase B						
Phase C/D						
Define Control-Force Requirements					40	
Define TVC Subsystem Requirements					20	
Define Injection Subsystem Requirements					10	
Define Aero Control Requirements					10	
Define Controls Subsystem					20	
Total Cost					100	

4.8.4 TRANSONIC ACOUSTIC LOADING ON CLUSTERED VEHICLES (CATEGORY I)

OBJECTIVE: Determine acoustic load intensities in critical vehicle areas and define the shock wave impingement patterns by analytical studies and wind-tunnel tests on related clustered/winged vehicle configurations.

PROBLEM: With a clustered/winged launch vehicle system such as some versions of the space shuttle, there is uncertainty as to where the shock wave pattern will form as the vehicles pass through Mach 1. Acoustic loading on a vehicle flying transonically is fairly severe in the vicinity of the shock wave. This loading is due to shock wave boundary layer interaction.

TECHNICAL APPROACH AND TASK DESCRIPTION: Perform analysis and test models in wind tunnel. Wind tunnel models are to be as large as practicable since the size of dynamic pressure transducers is directly related to boundary layer displacement thickness. Make three types of measurements in the wind tunnel:

- Shock location (by means of static pressure probes).
- Boundary layer and shock interaction pressures (by means of flush mounted pressure transducers).
- Boundary layer pressure cross-correlation data (by means of flush transducers).

Tasks	1970	1971	1972	1973	Cost (\$K)
Phase B					
Phase C/D					
Plan Wind Tunnel Tests	■				15
Design & Fabricate Model	■				100
Conduct Wind Tunnel Test		■			125
Reduce Data		■			30
Cross-Correlate Data		■			30
Define Load Intensities		■			30
			Total Cost		330

4.8.5 VIBRATION AND FATIGUE SPECIFICATIONS AND TESTING (CATEGORY I)

OBJECTIVE: Develop vibration and fatigue specifications for the space shuttle that are realistic for the missions proposed. These will be significantly modified and combined versions of both space launch vehicle and aircraft specifications.

PROBLEM: Previous launch vehicle testing has been high level, short duration, and aircraft testing has been low level, long duration. For launch vehicles the load and vibration environment will be of about the same magnitude, but the duration, because of reuse, will be 100 times greater. For aircraft, duration will be much shorter than typical aircraft usage, and levels for the flyback phase will be comparable to previous aircraft load and vibration levels. Space shuttle specifications must be developed to ensure adequate testing of structure and components, but they must be realistic to eliminate over-design (added cost and weight) of the overall system.

TECHNICAL APPROACH AND TASK DESCRIPTION: Local Structure and Component Vibration. Predict external environment for a typical mission profile for logical vehicle zones, based on aerodynamic pressure and engine thrust. Include level, frequency, and duration. Use to predict vibration test levels by applying scaling factors to vibration data and specifications of vehicles of similar type structures and components. This will give a set of vibration test levels and durations for each vehicle zone.

In deriving the tests for each zone, consider testing capability and costs. Establish an upper limit on test level by laboratory equipment capability and an upper limit on test duration by laboratory operations costs.

Develop a final, detailed specification when the space shuttle has been sized and typical structure and components identified by modification of test levels defined in this effort. The test philosophy and preliminary predicted levels will provide sufficient information for preliminary component specifications.

Vehicle Structure Fatigue: Determine a rational maneuver spectrum. Consider the maneuver capability inherent to this class of vehicle and the most probable maneuvers that will be commanded by the guidance and navigation system. Also consider determining rational landing sink speed and taxi load spectra.

Determine gust fatigue loads and spectra by the conventional techniques used in present aircraft designs.

Tasks	1970	1971	1972	1973	Cost (\$K)
Phase B					
Phase C/D					
Define External Environment					40
Define Initial Vibration Data					40
Develop Final Vibration Test Specs					80
Develop Fatigue Maneuver Spectrum					30
Develop Fatigue Gust Spectrums					50
			Total Cost		240

4.8.6 FLUTTER AND BUFFET MODEL TESTING THROUGHOUT THE SPEED REGIME (CATEGORY II)

OBJECTIVE: Due to uncertainties in flutter and buffeting analysis of the wings, fins, and horizontal tails, wind-tunnel buffeting and flutter model testing is needed to establish buffet and flutter boundaries. In particular, techniques in analytically determining unsteady aerodynamics at transonic speeds are unsatisfactory and require substantiation by wind tunnel tests. Conduct studies and tests to determine flutter boundaries for various configurations and to establish effects of structural trends such as stiffness and mass distributions.

TECHNICAL APPROACH AND TASK DESCRIPTION: Perform analyses followed by wind tunnel testing. Write test plan prior to beginning of tests. Design wind tunnel model to structurally and inertially simulate the selected design concept. (Model capable of structural and inertia variations). Divide wings and fins into sections and change section bending and torsional stiffness along with the mass properties.

Conduct test at various points in the flight envelope of the selected design concept. Determine flutter boundaries to establish compliance with MIL Specification 8870.

Tasks	1970	1971	1972	1973	Cost (\$K)
Phase B					
Phase C					
Design & Fabricate Trend Model	█				75
Conduct Wind Tunnel Tests	█				20
Analyze Buffet Data		█			30
Design & Fabricate Structural Model		█			250
Conduct Wind Tunnel Tests			█		220
Analyze Flutter Data			█		50
Total Cost					645

4.9 INTEGRATED ELECTRONICS

4.9.1 SPACE SHUTTLE SYSTEM AUTONOMY (CATEGORY II)

OBJECTIVE: Specify the degree of autonomy practical for the space shuttle.

PROBLEM: It is desired to have the space shuttle completely autonomous. Complete autonomy could add extra sensors, computing capability, and storage units thereby increasing overall weight and reducing the payload.

TECHNICAL APPROACH AND TASK DESCRIPTION: The space shuttle will have to make the mission-oriented decisions onboard rather than depend upon a mission control center. The approach requires an examination of all the tasks that must be performed aboard space shuttle to determine sensors, computing support, storage capacity. The examination should include at least the following tasks, which have been handled by a mission control center. Tasks are:

- a. Develop the following for maneuver planning:
 1. Methods for internal inertial alignments.
 2. Rendezvous techniques for emergency rescue.
 3. Methods for automatic approach and docking.
 4. Entry energy management methods.
 5. Automatic landing methods.
- b. Develop the following for orbit optimization:
 1. Launch guidance equations.
 2. Rendezvous guidance equations.
 3. Guidance equations for entry energy management.
 4. Guidance equations for automatic landing.
- c. Investigate avoidance of collisions with space debris.
- d. Develop mission management and scheduling.
- e. Determine status of weather in the landing area.
- f. Predict solar flare activity.

Tasks	1970												1971				Cost (\$K)	
	J	F	M	A	M	J	J	A	S	O	N	D	J	F	M	A		
Computer Manufacture Start											▽							
Computer Software Start											▽							
Examine Tasks:																		
Plan Maneuvers	████████████████████																	120
Optimize Orbit	████████████████████																	256
Ways of Avoiding Space Debris	██████████																	32
Mission Management and Scheduling	████████████████████																80	
Predict Weather in Landing Area	████████████████████																	64
Predict Solar Flares					██████████													40
Total Cost																592		

4.9.4 MULTIPLE REDUNDANCY OF INTEGRATED ELECTRONIC SUBSYSTEMS (CATEGORY 7)

OBJECTIVE: Establish system design guidelines for implementing multiple redundancy.

PROBLEM: The requirement for multiple redundancy — fail operational, fail operational, fail safe — can only be met by careful planning and design of the complete electronic subsystems and their associated software.

TECHNICAL APPROACH AND TASK DESCRIPTION: Some work has already been started by the Air Force and the Army to have fail operational, fail operational, fail safe modes of redundancy. The present requirement for commercial airline category III blind landing systems is fail operational - fail safe.

Perform studies to develop design guidelines for fail operational, fail operational, fail safe. Define sensor redundancy requirements on board the space shuttle. Tasks are:

- a. Examine multiple redundancy methods of Air Force and Army.
- b. Enumerate multiple redundancy techniques with advantages and disadvantages of each.
- c. Create new multiple redundancy techniques.
- d. Establish design guidelines for multiple redundancy.
- e. Define sensor redundancy requirements.

Tasks	1970												1971				Cost (\$K)
	J	F	M	A	M	J	J	A	S	O	N	D	J	F	M	A	
Computer Manufacturer Starts											▽						
Computer Software Starts											▽						
Examine Air Force & Army methods	■	■															16
Determine advantages & disadvantages of existing methods	■	■															24
Create new redundancy techniques		■	■	■	■	■	■	■	■								112
Establish design guidelines							■	■	■	■							34
Define sensor redundancy requirements						■	■	■	■								80
Total Co																296	

4.9.6 MULTIPLEX DATA SYSTEM INTERFACES (CATEGORY II)

OBJECTIVE. To create an early definition of the multiplex data system so that development schedule dates can be met.

PROBLEM: To get early attention to the details of the multiplex data system interfaces so that subsystem designs can proceed independently.

TECHNICAL APPROACH AND TASK DESCRIPTION: The multiplexed data system interfaces with all subsystems, including the computer. The proper multiplexing concepts can be selected only after considering the expected noise levels, required data rate, desired error rate, compatibility with multiple redundancy and computer input/output characteristics.

Perform study, using simulation and laboratory testing, to select the best system. Completely define its characteristics so that the multiplex digital interfaces may be incorporated into all the electronic subsystems. Determine:

- a. Expected noise levels.
- b. Required data rate.
- c. Desired error rate.
- d. Compatibility with multiple redundancy.
- e. Compatibility with computer input/output.

Tasks	1970												1971				Cost (\$K)	
	J	F	M	A	M	J	J	A	S	O	N	D	J	F	M	A		
Computer Manufacture Start											▽							
Computer Software Start											▽							
Determine expected noise levels	■	■																16
Determine required data rate	■	■	■															24
Determine desired error rate	■	■																16
Determine compatibility with multiple redundancy	■	■	■															24
Determine compatibility with computer input/output	■	■	■															24
Conduct simulation			■	■	■	■	■	■	■									168
Conduct laboratory testing		■	■	■	■	■	■	■	■	■								246
Define interface							■	■	■	■	■							90
Total Cost																608		

4.9.7 SOFTWARE LANGUAGE (CATEGORY II)

OBJECTIVE: Early development of high-level language that can be used uniformly in factory and subcontractor checkout, systems integration checkout, operational programs, flight test programs and trainers.

PROBLEM: The problem is to derive a software language that has a command structure compatible with the mathematics appearing in the networks, schedules, trajectories, statistical estimation processes, etc., that are known to exist for the space shuttle project.

TECHNICAL APPROACH AND TASK DESCRIPTION: Since the computational system must perform a large integration task to meet all of the mission requirements, it is important to develop a high-order language for the computer, to allow an orderly sequence of design and test.

Develop a software language that includes the capabilities of the recently developed space programming language (SPL) of the Air Force (or its NASA subset known as CLASP), together with a checkout and test language like ATOLL (automatic test operations launch language).

Tasks	1970												1971				Cost (\$K)	
	J	F	M	A	M	J	J	A	S	O	N	D	J	F	M	A		
Computer Manufacture Start																		
Computer Software Start																		
Investigate SPL, ATOLL	█	█																16
Define mathematics, logic, etc.	█	█	█															24
Derive high level language			█	█	█	█	█	█	█	█	█	█						192
Total Cost																232		

4.10 HUMAN FACTORS

4.10.1 HUMAN FACTORS OF DISPLAY CHARACTERISTICS AND FORMATS (CATEGORY II)

OBJECTIVE: Determine display characteristics and human factors requirements; develop optimum formats for presenting status, flight management, decision making, and other required information to the flight crew.

PROBLEM: What information should be presented to the crew and how it should be presented during each phase of the space shuttle mission is a problem in even comparatively simple systems having electronic displays. Display formats for the space shuttle vehicle will require a concerted effort due to the wide variance in the information which must be presented on the same displays during the different segments of the mission; e.g., display formats for landing will be entirely different from those needed for launch and orbital operations.

TECHNICAL APPROACH AND TASK DESCRIPTION: System analysis, research studies, design, display simulation, and performance testing techniques will be used to develop display formats including characters, symbols, lines, conics, etc., which will present information to the crew in the most useful manner during each mission segment, i.e., preflight/inflight checkout, launch, transfer, rendezvous, docking, on-orbit, entry, landing, and postflight.

System analysis efforts:

- a. Perform an analysis to determine function allocations. Perform a task analysis to determine time-lines for normal, degraded, and contingency operating modes for preflight, launch, on-orbit, return, and postflight phases.
- b. Determine, flow, and analyze the information required for the operator(s) to perform each allocated function and task to ascertain data quantities, rates, response times, and processing requirements.

Research studies:

- a. Determine state-of-the-art display characteristics and formats which will be available by mid-FY 1972.
- b. Determine display formats and characteristics which should be tested.

Design efforts: Design the displays to be tested and the simulation equipment.

Simulation and testing efforts:

- a. Fabricate the display simulator.
- b. Test subjects to determine the most adequate display characteristics and formats.

Tasks	1970	1971	1972	1973	Cost (\$K)
Phase B					
Phase C/D					
Avionics Integ. Test Start					
Conduct system analysis & research					150
Design & fabricate simulator					200
Perform simulate & test					300
			Total Cost		650

4.10.2 HUMAN FACTORS OF ELECTRONIC CONTROLS (CATEGORY II)

OBJECTIVE: Determine human factors requirements: optimum types and characteristics of controls to be used on orbital space shuttle vehicles including monofunction and multifunction switches, cursors, and key-sets.

PROBLEM: Integrated controls for aircraft or spacecraft which meet orbital space shuttle vehicle requirements have not been developed. Space shuttle vehicles must have truly integrated controls, i.e., completely functionally arranged, identical switches and arrangements for all subsystems, etc. The normal practice of leaving switch selection, location, etc., to subcontractors for major subsystems such as communications, guidance and navigation, etc., will not suffice for space shuttle vehicles.

TECHNICAL APPROACH AND TASK DESCRIPTION: System analysis, research studies, design, simulation and performance testing techniques will be used to develop/select controls which meet space shuttle and human factors requirements.

System analysis efforts:

- a. Perform an analysis to determine function allocations. Perform a task analysis to determine time-lines for normal, degraded, and contingency operating modes for preflight, launch, on-orbit, return, and postflight phases.
- b. Determine, flow, and analyze the control actions required for the crew to implement their functions and tasks to ascertain vision and reach envelopes, reaction times, etc.

Research studies:

- a. Determine state-of-the-art and technology baseline for controls by mid-FY 1972.
- b. Determine types and characteristics of controls to be tested. For example, several types and sizes of cursor controls including lightpens, joysticks, and track balls work very well in a stable ground environment. Determine which of these, if any, will work in the flight environments and stress to be encountered during space shuttle missions.

Design effort:

- a. Design the control test setups and the simulation equipment.

Simulation and testing efforts:

- a. Build the control simulator(s).
- b. Test subjects to determine the most adequate control types and characteristics.

Tasks	1970	1971	1972	1973	Cost (\$K)
Phase B					
Phase C/D					
Avionics integ. Tests Start				▽	
Conduct system analysis & research	████████████████████				150
Design & fabricate electronic controls		████████████████████			200
Conduct simulation & test			████████████████████		275
			Total Cost		625

4.10.3 HUMAN FACTORS OF CREW AND PASSENGER VISIBILITY (CATEGORY II)

OBJECTIVE: Establish human factors criteria for crew and passenger visibility in orbital space shuttle vehicles.

PROBLEM: External visibility requirements for the flight crew to perform rendezvous, docking, and landing maneuvers have not been adequately defined.

External visibility requirements for passengers have not been called out, to date, and no specific human factors criteria exist in this area. However, disorientation, air sickness, and various stress problems are known to exist in current aircraft with crew positions that do not have external reference positions. It is conceivable that these same problems will exist in orbital space shuttle vehicles unless external reference is provided.

TECHNICAL APPROACH AND TASK DESCRIPTION: Apply human factors research, simulation, and testing techniques to establish design criteria for crew visibility and human factors criteria for passenger visibility.

During initial human factors efforts, produce air crew vision design criteria for space shuttle vehicles (orbiter and booster) similar to those specified in MIL-STD-850 for military aircraft. Document vision plots for rendezvous, docking, landing and ground handling, and rationale for same.

Define human factors criteria for passenger visibility. Research all available information in this area. If external vision is necessary or desirable, perform studies, simulation, and tests to establish the relative merits of all means of providing same, e.g., windows, TV, IR, optical devices, etc.

Tasks	1970	1971	1972	1973	Cost (\$K)
Phase B					
Phase C/D					
Avionics Integ. Tests Start					
Determine crew vision criteria	██████████				30
Determine passenger vision criteria	██████████				40
Design & fabricate mockup		██████████			80
Conduct visibility criteria verification tests		██████████			60
	Total Cost				210

4.10.4 CREW AND PASSENGER RESTRAINT SYSTEMS (CATEGORY II)

OBJECTIVE: Develop optimal crew and passenger restraint systems for space shuttle vehicles.

PROBLEM: Current aircraft and spacecraft restraint systems are unsatisfactory for space shuttle applications since they do not provide for:

- a. Selective positioning of passengers/patients relative to the acceleration vectors of entry, aerodynamic flight and recovery to maximize the g tolerance of seriously debilitated individuals due to either illness and/or protracted exposure to zero g.
- b. Rapid (nominally one minute) safe egress following major malfunctions prior to liftoff and subsequent to landing emergencies.
- c. Positioning for work, rest, and recreation.

TECHNICAL APPROACH AND TASK DESCRIPTION: During the first six months of the proposed study, a) define the detailed technical requirements of the restraint systems and b) evaluate and test the design concepts of all candidate couch-restraint and acceleration attenuation systems. Estimate realistic g tolerance envelopes for return-shuttle passengers/patients, based on ground-based clinical and zero-g analogue studies and on projections from exposures to true weightlessness. The incompatibility of these tolerance envelopes with the nominal and off-nominal mission g loading profiles will determine the technical requirements of the protection and restraint systems. Subsequent soft mockup, engineering, and structural loading studies will provide data required to translate the technical requirements into preferred design layouts.

Following tentative design acceptance, fabricate prototype systems and perform human comfort and mobility tests, including dynamic test with instrumented couch and anthropomorphic dummies, to establish conformance with technical and structural requirements.

Tasks	1970	1971	1972	1973	Cost (\$K)
Phase B					
Phase C/D					
Conduct system analysis & research	■				50
Design mockup		■			50
Fabricate mockup		■			60
Conduct mobility tests		■			50
			Total cost		210

4.11 SUBSYSTEMS

4.11.1 REMOTE CONTROLLED SOLID-STATE CIRCUIT BREAKER DEVELOPMENT (CATEGORY II)

OBJECTIVE: Develop a family of circuit protection devices, using semiconductors, to protect distribution wiring from thermal overloads and short circuits and operate as the power switching element for each piece of utilization equipment.

PROBLEM: A device is needed that will interface with the data lines and respond (open or close) to a coded signal. This will permit the power switching device to be located in areas remote from the command center and permit rapid, automatic, and manual programming of all electrical loads for any mode of operation. Semiconductor switching holds the promise for greater reliability over existing electromechanical contactors and circuit breakers. The solid-state switching problem areas are: EMI, RFI, heat sinking, efficiency, demonstrated reliability, weight, forward voltage drop, leakage current, and high power capability.

TECHNICAL APPROACH AND TASK DESCRIPTION: A development program for solid-state switching has been in operation for nearly six years. Building on this technology, devices need to be developed for a range of currents for 28 vdc, 280 vdc, 115 vac single phase and 200 vac three phase 400 Hz applications. Features required are: low forward voltage drop, zero crossover switching (ZCS), current limiting, pulse mode operation (dc), operation from digital information, status signal. Tasks are:

Prepare specifications that describe the various requirements. Evaluate availability of semiconductor devices that will satisfy these requirements. Determine compromises, penalties, and limitations that will affect subsystem design. This program should be paralleled with a development effort for a hybrid device that would use a combination of semiconductors and electromechanical techniques to meet the same performance requirements, but perhaps in the larger ratings.

Tasks	1970	1971	1972	1973	Cost (\$K)
Phase B					
Phase C/D					
Review current technology	█				30
Evaluation/test of available devices	█				20
Define solid-state range and electromechanical range of ratings	█				10
Define data bus interface	█				5
Prepare specifications	█				30
Evaluate candidate suppliers		█			
Supplier proposal period		█			
Evaluate proposals		█			20
Dual awards			▽		
Design subsystem		█	█		100
Evaluate engineering prototype			█		20
Perform qualification test			█	█	50
Perform reliability test			█	█	100
Review test report				█	5
Perform system integration test (CV)				█	60
			Total Cost		450

4.11.2 H₂ - O₂ AUXILIARY POWER ENGINE DEVELOPMENT (CATEGORY II)

OBJECTIVE: Develop an H₂-O₂ engine using gases at cryogenic temperature to provide shaft power output in the 50 to 300 horsepower range. Engine could be of reciprocating or turbine type depending on further study.

PROBLEM: An auxiliary power unit capable of using H₂ and O₂ from the main propulsion tanks of the shuttle vehicle will provide a lightweight energy source. Gas conditioning, mixture control, and thermal control are the principal characteristics to be defined.

TECHNICAL APPROACH & TASK DESCRIPTION: Prototype H₂-O₂ engines have been developed, but operational units have not yet been required. Tasks are:

- a. Determine effect of propellant supply conditions on configuration.
- b. Determine applicability of system for the various shuttle missions.
- c. Define preliminary propellant conditioning components, power controls, starting system, and electrical system.
- d. Select materials.
- e. Perform reliability analysis.

Accomplish detail design and fabricate one or more test articles. Following component and prototype test evaluation, prepare engine specifications to which flight qualified engines can be procured and qualification tests accomplished.

Tasks	1970	1971	1972	1973	Cost (\$K)
Phase B					
Phase C/D					
Evaluate propellant supply conditions	█				10
Conduct mission studies	█				15
Conduct feasibility tests on components & subsystems	█				40
Select material	█				20
Perform reliability analysis		█			40
Design & build prototype		█			150
Test & modify prototype		█			250
Prepare specifications			█		25
Design & build flight-type unit			█		300
Conduct qualification tests				█	500
				Total Cost	1,350

4.11.3 LH₂ UTILIZATION FOR SUBSYSTEM HEAT SINK (CATEGORY II)

OBJECTIVE: The use of residual H₂ from the main propulsion tank offers a potential heat sink for vehicle subsystems. New heat exchanger designs, including controls to prevent freeze-up, should be developed to provide a convenient method to use the thermal capacity of this source.

PROBLEM: Problems in the design of suitable heat transfer equipment include:

- a. Materials selection compatible with an operational temperature range of 40°R to 500°R.
- b. Development of modulating controls to prevent freeze-up of the cooled fluid.

TECHNICAL APPROACH AND TASK DESCRIPTION: Determine typical subsystem heat rejection requirements to establish the temperature ranges for transferring heat from the subsystems. Examine the use of or requirement for intermediate heat transfer fluids to interface with the cryogen. Analyze subsystem fluids, and develop candidate configurations. Develop a predesign based on the most promising concepts. Perform feasibility testing and evaluate materials and controls. Develop heat transfer and friction parameters over a range of surface configurations to provide parametric data for future design. Develop final configuration from this data consisting of a complete composite heat transfer system. Perform evaluation tests, followed by full qualification tests, to provide the hardware necessary to meet this need.

Tasks	1970	1971	1972	1973	Cost (\$K)
Phase B					
Phase C/D					
Establish typical subsystem heat rejection requirements	█				10
Develop heat transfer system concepts for feasibility testing	█				40
Accomplish component and controls evaluation testing		█			85
Design and fabricate prototype heat transfer system and accomplish parametric evaluation testing		█			200
Design and fabricate flight-type system			█		125
Complete qualification and reliability testing			█		350
				Total Cost	810