

2  
mix

226

Goodwin

JUL 19 1968

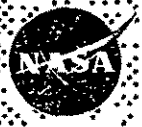

NATIONAL AERONAUTICS AND SPACE ADMINISTRATION

MSC INTERNAL NOTE NO. 68-FM-160

July 3, 1968

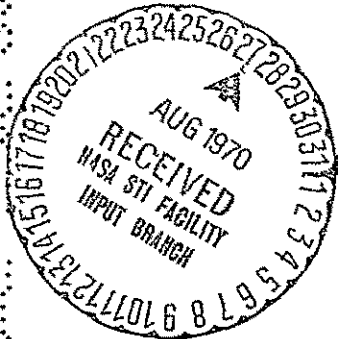

# SLA PANEL JETTISON SEPARATION AND RECONTACT ANALYSIS

By Marland L. Williamson  
and  
Charles W. Fraley,  
Flight Analysis Branch

FACILITY FORM 602	<u>170-35869</u>	(THRU)
	<u>62</u>	(CODE)
	<u>TMX-65092</u>	<u>31</u>
	(NASA CR OR TMX OR AD NUMBER)	(CATEGORY)

MISSION PLANNING AND ANALYSIS DIVISION



MANNED SPACECRAFT CENTER  
HOUSTON, TEXAS

MSC INTERNAL NOTE NO. 68-FM-160

---

PROJECT APOLLO

SLA PANEL JETTISON SEPARATION AND RECONTACT ANALYSIS

By Marland L. Williamson and Charles W. Fraley  
Flight Analysis Branch

---

July 3, 1968

MISSION PLANNING AND ANALYSIS DIVISION  
NATIONAL AERONAUTICS AND SPACE ADMINISTRATION  
MANNED SPACECRAFT CENTER  
HOUSTON, TEXAS

Approved:

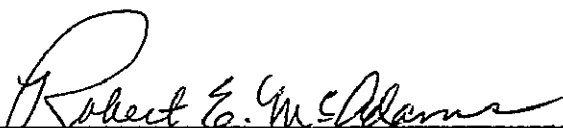
  
for Claiborne R. Hicks, Jr., Chief  
Flight Analysis Branch

Approved:

  
John P. Mayer, Chief  
Mission Planning and Analysis Division

CONTENTS

Section	Page
1. SUMMARY . . . . .	1
2. INTRODUCTION . . . . .	2
3. DESIGN REQUIREMENTS AND PARAMETRIC CONSIDERATIONS . . . . .	3
3.1 SLA Panel Jettison Design Requirements . . . . .	3
3.2 Parametric Considerations . . . . .	3
4. COORDINATE SYSTEMS . . . . .	4
4.1 S-IVB and Panel Jettison Attitudes . . . . .	4
4.2 Panel Identification . . . . .	4
4.3 Relative Motion Coordinates . . . . .	4
5. ABORTS . . . . .	5
5.1 Mode II Aborts . . . . .	5
5.2 Mode III Aborts . . . . .	9
5.2.1 Relative motions of panels 1 and 2 . . . . .	9
5.2.2 Relative motions of panels 3 and 4 . . . . .	10
5.2.3 Conclusions . . . . .	10
5.3 Mode IV Aborts . . . . .	15
5.4 Orbital Aborts . . . . .	19
6. APOLLO D MISSION . . . . .	22
7. APOLLO E MISSION . . . . .	22
8. APOLLO F AND G MISSIONS . . . . .	24
9. CONCLUSIONS . . . . .	24
10. REFERENCES . . . . .	58

TABLES

Table		Page
I	INITIAL CONDITIONS AT PANEL JETTISON OCCURRING AT THE BEGINNING OF MODE II . . . . .	6
II	INITIAL CONDITIONS AT PANEL JETTISON OCCURRING AT THE MIDDLE OF MODE II . . . . .	7
III	INITIAL CONDITIONS AT PANEL JETTISON OCCURRING AT THE END OF MODE II . . . . .	8
IV	INITIAL CONDITIONS AT PANEL JETTISON OCCURRING AT THE BEGINNING OF MODE III . . . . .	12
V	INITIAL CONDITIONS AT PANEL JETTISON OCCURRING AT THE MIDDLE OF MODE III . . . . .	13
VI	INITIAL CONDITIONS AT PANEL JETTISON OCCURRING AT THE END OF MODE III . . . . .	14
VII	INITIAL CONDITIONS AT PANEL JETTISON OCCURRING AT THE BEGINNING OF MODE IV . . . . .	16
VIII	INITIAL CONDITIONS AT PANEL JETTISON OCCURRING AT THE MIDDLE OF MODE IV . . . . .	17
IX	INITIAL CONDITIONS AT PANEL JETTISON OCCURRING AT THE END OF MODE IV . . . . .	18
X	ORBITAL AND NOMINAL D MISSION INITIAL CONDITIONS AT PANEL JETTISON . . . . .	21
XI	NOMINAL E MISSION INITIAL CONDITIONS AT PANEL JETTISON . . . . .	23

FIGURES

Figure		Page
1	S-IVB and SLA panel attitude identification.	
	(a) Pitched panels (X-Z plane) . . . . .	26
	(b) Yawed panels (X-Y plane) . . . . .	26
	(c) Front view (Y-Z plane) . . . . .	27
2	Mode II aborts relative motion of the SLA panels, $\Delta V = 8$ fps.	
	(a) Pitched panels for the beginning of Mode II .	28
	(b) Pitched panels for the middle of Mode II . . .	29
	(c) Pitched panels for the end of Mode II . . . .	30
	(d) Yawed panels for the beginning of Mode II . .	31
	(e) Yawed panels for the middle of Mode II . . . .	32
	(f) Yawed panels for the end of Mode II . . . . .	33
3	Mode III aborts relative motion of the SLA panels for $\Delta V$ 's of 8 and 15 fps.	
	(a) Pitched panels for the beginning of Mode III ( $\Delta V = 8$ fps) . . . . .	34
	(b) Pitched panels for the middle of Mode III ( $\Delta V = 8$ fps) . . . . .	35
	(c) Pitched panels for the end of Mode III ( $\Delta V = 8$ fps) . . . . .	36
	(d) Pitched panels for the beginning of Mode III ( $\Delta V = 15$ fps) . . . . .	37
	(e) Pitched panels for the middle of Mode III ( $\Delta V = 15$ fps) . . . . .	38
	(f) Pitched panels for the end of Mode III ( $\Delta V = 15$ fps) . . . . .	39
	(g) Yawed panels for the beginning of Mode III ( $\Delta V = 8$ fps) . . . . .	40
	(h) Yawed panels for the middle of Mode III ( $\Delta V = 8$ fps) . . . . .	41
	(i) Yawed panels for the end of Mode III ( $\Delta V = 8$ fps) . . . . .	42
	(j) Yawed panels for the beginning of Mode III ( $\Delta V = 15$ fps) . . . . .	43
	(k) Yawed panels for the middle of Mode III ( $\Delta V = 15$ fps) . . . . .	44
	(l) Yawed panels for the end of Mode III ( $\Delta V = 15$ fps) . . . . .	45

Figure		Page
4	Mode IV aborts relative motion of the SLA panels, $\Delta V = 8$ fps.	
	(a) Pitched panels for the beginning of Mode IV . .	46
	(b) Pitched panels for the middle of Mode IV . . .	47
	(c) Pitched panels for the end of Mode IV . . . . .	48
	(d) Yawed panels for the beginning of Mode IV . . .	49
	(e) Yawed panels for the middle of Mode IV . . . .	50
	(f) Yawed panels for the end of Mode IV . . . . .	51
5	Orbital aborts relative motion of the SLA panels for $\Delta V = 8$ fps.	
	(a) Pitched panels (X-Z plane) . . . . .	52
	(b) Yawed panels (X-Y plane) . . . . .	53
	(c) Yawed panels (X-Z plane) . . . . .	54
6	Nominal Mission D relative motion of the SLA panels for $\Delta V$ 's of 5, 8, and 15 fps.	
	(a) Pitched panels ( $\Delta V = 5$ fps) . . . . .	55
	(b) Pitched panels ( $\Delta V = 8$ fps) . . . . .	56
	(c) Pitched panels ( $\Delta V = 15$ fps) . . . . .	57

## SLA PANEL JETTISON SEPARATION AND RECONTACT ANALYSIS

By Marland L. Williamson and Charles W. Fraley

### 1. SUMMARY

This analysis was conducted to determine if the jettison of the four spacecraft - LM adapter (SLA) panels, to prevent the service module reaction control system plumes from reflecting onto the LM, would create eventual recontact problems.

Jettisoning the SLA panels has been proposed for Apollo Missions D (CSM-103/LM-3), E (CSM-104/LM-4), F (CSM-106/LM-5), and G (CSM-107/LM-6). The SLA panels will be jettisoned at CSM/S-IVB separation immediately following panel deployment, therefore, nominal separation for each of the above missions is considered in this analysis. The nominal and abort analyses performed in this study assume that CSM separation and panel jettison occur under stable and controlled S-IVB conditions.

The results of this analysis indicate that jettisoning the four SLA panels at 8 fps at an attitude of  $110 \pm 20^\circ$  with respect to the S-IVB +X-axis assures adequate separation clearances for the nominal D, E, F, and G missions and the orbital, mode II, and mode IV aborts for these missions. Additional analysis is required to determine if potential mode III abort recontact possibilities will impose operational constraints on the jettison of the SLA panels.

Separation ranges of the four jettisoned panels were found to be more than adequate to preclude recontact with spacecraft except in the mode III abort region. As expected, the in-plane retrograde SPS deorbit maneuver performed about 2 minutes after a mode III abort is initiated, results in the spacecraft flying near or between the four jettisoned panels.

The orbital abort sequence analyzed also incorporates an in-plane retrograde SPS deorbit maneuver, but it is not performed until 20 minutes after panel jettison, thereby, allowing adequate panel displacement to be generated such that when the spacecraft flies between them, sufficient clearance is available (minimum of 6000 feet).

## 2. INTRODUCTION

The primary purpose of this analysis is to determine the feasibility of jettisoning the four spacecraft - LM adapter (SLA) panels with respect to eventual recontact with the spacecraft. In addition, this report identifies the potential recontact regions and notes the additional analysis currently in progress to determine any operational constraints that may be required to alleviate possible recontact.

The objective of jettisoning the four SLA panels is to prevent the service module reaction control system (SM RCS) plumes from reflecting onto the LM. The reflection from the opened SLA panels during the CSM docking creates an excessive heat input to the LM. This problem may be eliminated by either jettisoning the SLA panels or providing additional LM insulation. To insure that the former method does not result in any high probability of recontact, this analysis was performed.

The technique of jettisoning the SLA panels has been proposed for Apollo missions D (CSM-103/LM-3), E (CSM-104/LM-4), F (CSM-106/LM-5), and G (CSM-107/LM-6) (ref. 1). SLA panel jettison will occur at CSM/S-IVB separation immediately following panel deployment, therefore, nominal separation for each of the above missions is considered in this analysis. The nominal and abort analysis performed in this study assumes that CSM separation and panel jettison occur under stable and controlled S-IVB conditions. A tumbling S-IVB at panel jettison would considerably alter the relative motions of the SLA panels with respect to the spacecraft as these motions are primarily dependent on the panel jettison attitude with respect to the inertial velocity vector ( $V_1$ ) of the S-IVB.

Analysis not included in this report and presently in progress where potential recontact areas may exist includes aborts occurring during the translunar injection (TLI)-phase of Apollo missions E, F, and G, midcourse corrections or maneuvering effects upon panel relative motion during Apollo missions F and G, and the post lunar orbit insertion (LOI) maneuver effects upon panel relative motion for Apollo E mission. These studies will be published as completed in later reports



### 3. DESIGN REQUIREMENTS AND PARAMETRIC CONSIDERATIONS

#### 3.1 SLA Panel Jettison Design Requirements

To determine what requirements North American-Rockwell was employing in designing the SLA panel spring jettison system and also what analysis they were planning to meet these requirements, a meeting was held with Mr. G. Pape, NR, on April 23, 1968.

The SLA panel jettison and recontact analysis in this report was based on these design requirements as specified in reference 2 and summarized below.

- a. The SLA panels shall deploy with a minimum rotation rate of 33.5 deg/sec.
- b. Hinges shall release the panels at an angle of from  $45^{\circ}$  to  $60^{\circ}$  measured from the S-IVB +X axis to the SLA panel center line.
- c. Spring thruster assemblies (two per panel) shall provide positive separation of each panel through its center of gravity (c.g.).
- d. Springs having a preload of approximately 450 lb and a constant of 50 lb/in. shall be used.
- e. Total resultant jettison velocity from panel rotation and spring thrusters shall be a minimum of 8 fps at an attitude of  $110 \pm 20^{\circ}$  with respect to the S-IVB x-axis.
- f. Panel jettison velocity and direction of travel shall minimize the possibility of recontact with the spacecraft.

#### 3.2 Parametric Considerations

Utilizing the above requirements as a guide, the SLA panel jettison analysis of this report considered the following parametric variations and inputs for the SLA panels.

- a. SLA panel jettison attitudes of  $90^{\circ}$  and  $130^{\circ}$  measured from the S-IVB +x-axis to the panel center line.
- b. Total resultant jettison velocities from panel rotation and spring ejection thrusters (two per panel) of 5, 8, and 15 fps.
- c. The S-IVB attitude with respect to the inertial velocity vector for each case.

d. An average panel weight of 593 lb (includes an estimated net growth increase of 20 lb per panel to accommodate the spring thruster assembly, (ref. 2).

e. A projected panel reference area of 239 sq ft (ref. 2) and a tumbling drag coefficient of 1.7 (ref. 3).

#### 4. COORDINATE SYSTEMS

##### 4.1 S-IVB and Panel Jettison Attitudes

The primary factor affecting the relative motion of the SLA panels is the direction in which they are jettisoned with respect to the inertial velocity vector of the S-IVB at the time of jettison. This direction is determined by the jettison attitude ( $\theta$ ) of the panels and the attitude of the S-IVB ( $\phi$ ) with respect to  $V_i$ . Jettison attitudes are measured in the S-IVB pitch plane for the upper and lower panels (fig. 1a) and in the S-IVB yaw plane for the two lateral panels (fig. 1b).

##### 4.2 Panel Identification

For identification and simplification the four SLA panels are referred to as Panel 1, 2, 3, or 4 throughout this report. The pitched up (+Z) and pitched down (-Z) panels are numbered 1 and 2, respectively (figure 1a). The yawed right (+Y) and yawed left (-Y) panels are numbered 3 and 4, respectively (fig. 1b). A front view of all four panels is presented in figure 1c.

##### 4.3 Relative Motion Coordinates

The relative motion figures presented in this report were generated in the inertial azimuth coordinate system. The origin of this system is located at the origin of the body coordinate system of the reference vehicle. In this report, the spacecraft is always the reference vehicle and, therefore, is located at the origin with the figures indicating the relative motion of the panels about the spacecraft. Down range distance, X, coincides with and is positive in the direction of the spacecraft  $V_i$  (fig. 1a). Radial distance is indicated as either Y or Z displacement. Lateral displacement, Y, is measured in the local horizontal plane normal to X and positive to the right (fig. 1b). Vertical displacement, Z, lies in the orbital plane normal to X and is positive up (fig. 1a).

## 5. ABORTS

The launch phase and orbital aborts were all initially analyzed utilizing a jettison velocity of 8 fps at panel attitudes of  $\theta = 90^\circ$  and  $130^\circ$ . Three cases (beginning, middle, and end) were evaluated for each of the mode II, III, and IV aborts. Mode I aborts are tower jettisons with the CM separating from the SM, therefore, no panel deployment or jettison occurs.

### 5.1 Mode II Aborts

The mode II abort region begins at launch escape tower (LET) jettison (end of mode I) and ends when the CM full-lift landing point reaches the Atlantic Discrete Recovery Area (ADRA). Upon initiation of a mode II abort, the CSM separates from the S-IVB, (CSM separation  $\Delta V$ 's are presented in tables I, II, and III) and following CM/SM separation and entry preparation, flies a full-lift entry into the Atlantic Continuous Recovery Area (ACRA). No CSM SPS burns are incorporated in a mode II abort.

Analysis for Mode II aborts indicate that the jettisoned SLA panels will not result in any eventual recontact problems. Relative motions of the pitched panels (panels 1 and 2) and the yawed panels (panels 3 and 4) reveal that they will remain well behind the spacecraft and continue to increase in range for any mode II abort.

For aborts initiated at the beginning, middle, and end of mode II the relative motions of panels 1 and 2 for  $\theta = 90^\circ$  and  $130^\circ$  are presented in figures 2a, 2b, and 2c, respectively. At a CM altitude of 200 000 ft, the minimum ranges for panels 1 and 2 vary from approximately 15 000 ft for an abort initiated at the beginning of the mode II region to 178 000 ft for aborts at the end of mode II. Separation ranges continue to increase until CM landing. Since panels 1 and 2 are jettisoned in the orbital plane, less than 100 ft of lateral displacement is generated

Relative motions of panels 3 and 4 for  $\theta = 90^\circ$  and  $130^\circ$  for aborts initiated at the beginning, middle, and end of mode II are presented in figures 2d, 2e, and 2f, respectively. At a CM altitude of 200 000 ft, the minimum ranges for panels 3 and 4 vary from 15 500 for a beginning mode II abort to 198 500 for aborts at the end of mode II. The vertical displacement, Z, ranges from approximately 3500 to 6000 ft at the same CM altitude indicating that the panels are above as well as behind the spacecraft. This vertical displacement and the total range continue to increase until CM landing.

The initialization conditions at SLA panel jettison (CSM/S-IVB separation) for the beginning, middle, and end of the mode II abort region are presented in tables I, II, and III (ref 4).

TABLE I.- INITIAL CONDITIONS AT PANEL JETTISON  
OCCURRING AT THE BEGINNING OF MODE II

g.e.t , sec . . . . .	186.857
inertial velocity ( $V_1$ ), fps . . . . .	9394.27
flight path angle ( $\gamma_i$ ), deg . . . . .	16.3791
azimuth, inertial ( $\psi_1$ ), deg . . . . .	75.4807
latitude, geodetic ( $\phi_d$ ), deg . . . . .	29.0676
longitude ( $\lambda$ ), deg . . . . .	-79.0302
altitude (h), ft . . . . .	316974.0
total weight (wt), lb . . . . .	1324704.0
CSM separation velocity (CSM sep $\Delta V$ ), fps .	10 321
S-IVB attitude with respect to $V_1$	
Pitch ( $\phi$ ), deg . . . . .	12.5
Yaw, deg . . . . .	0 1
Roll, deg . . . . .	0.0

TABLE II - INITIAL CONDITIONS AT PANEL JETTISON OCCURRING  
AT THE MIDDLE OF MODE II

g.e.t., sec . . . . .	360.00
$V_1$ , fps . . . . .	14351.51
$\gamma_1$ , deg . . . . .	2.7575
$\psi_1$ , deg . . . . .	77.5437
$\theta_d$ , deg . . . . .	30.3123
$\lambda$ , deg . . . . .	-73.8364
h, ft . . . . .	594272.0
wt, lb . . . . .	851872.0
CSM Sep AV, fps . . . . .	15 947
S-IVB attitude with respect to $V_2$	
Pitch ( $\phi$ ), deg . . . . .	13.9
Yaw, deg . . . . .	-0.2
Roll, deg . . . . .	0.0

TABLE III.- INITIAL CONDITIONS AT PANEL JETTISON  
OCCURRING AT THE END OF MODE II

g.e.t., sec . . . . .	600.00
$V_1$ , fps . . . . .	23881.55
$\gamma_1$ , deg . . . . .	-0.3029
$\psi_1$ , deg . . . . .	84.5438
$\phi_d$ , deg . . . . .	32.3131
$\lambda$ , deg . . . . .	-60 2968
h, ft . . . . .	634494.0
wt, lb . . . . .	321417.6
CSM sep $\Delta V$ , fps . . . . .	8 294

S-IVB attitudes with respect to  $V_1$

Pitch ( $\phi$ ), deg . . . . .	8.0
Yaw, deg . . . . .	0.9
Roll, deg . . . . .	-0.6

## 5.2 Mode III Aborts

The mode III abort procedure consists of performing an SPS fixed inertial attitude, retrograde burn and CM half-lift entry in order to land in the ADRA. (CSM/S-IVB separation and SPS burn  $\Delta V$ 's are presented in Tables IV, V, and VI.) Launch aborts occurring late in the mode III region require large SPS retrograde burns to effect a safe water landing in the ADRA. This is not a desirable situation as the spacecraft landing point moves westward across Africa, and a premature SPS shutdown could result in a land landing. Therefore, the mode III abort is not a prime operating procedure, and a mode IV contingency orbit insertion (COI) will be utilized when possible.

The mode III abort discussions are divided into three sections. The first section is concerned with the relative motions of the pitched-up (panel 1) and pitched-down (panel 2) panels, the second with the two lateral panels (3 and 4), and the third section presents the conclusions.

5 2.1 Relative motions of panels 1 and 2.- Mode III abort analysis establishes a potential recontact situation due to the retrograde SPS maneuver performed to deorbit the CSM and the motion of the lower or pitched-down panel (panel 2). As the deorbit  $\Delta V$  increases from the beginning to the end of the mode III region, panel 2 passes from above to below the CSM. For a jettison  $\Delta V$  of 8 fps at an attitude of  $130^\circ$ , panel 2 passes approximately 375 ft above the CSM during the deorbit maneuver for an abort initiated at the beginning of mode III region (fig. 3a). For aborts at the middle and end of mode III, this same panel, however, passes below the CSM by approximately 150 and 250 ft, respectively (fig. 3b and 3c). Changing the jettison attitude from  $130^\circ$  to  $90^\circ$  considerably improves the relative motion of the pitched-down panel. For the beginning of mode III, panel 2 passes below instead of above the CSM by 850 ft (fig. 3a), and for the middle and end of Mode III aborts, the distance below increases by an additional 50 and 100 ft, respectively (fig. 3b and 3c). Relative motion of the pitched up panel (panel 1) for either the  $90^\circ$  or  $130^\circ$  jettison attitude indicates adequate separation clearance for any mode III abort. The minimum clearance for panel 1 as it passes above the CSM is approximately 1800 ft.

The mode III abort region was also analyzed for an increased jettison velocity of 15 fps. At an attitude of  $130^\circ$ , panel 2 at the beginning of a mode III still passes above the CSM, but clearance is reduced from 375 ft to less than 50 feet (figure 3d). For the middle and end of the mode III region, this panel passes below by approximately 700 and 800 ft, respectively (fig. 3e and 3f), considerably better than the 150 and 250 ft distances of the 8 fps case. Increasing the jettison velocity to 15 fps, therefore, does not alleviate the potential recontact situation created by panel 2 passing from above to below the spacecraft.

Changing the jettison attitude from  $130^\circ$  to  $90^\circ$  considerably improves the relative motion of panel 2 for the 15 fps case also. For the beginning, middle and end of mode III, panel 2 at  $90^\circ$  consistently passes below instead of above by approximately 2000 feet (figure 3d, 3e, and 3f).

The pitched-up panel (panel 1) relative motion jettison at 15 fps for either  $\theta = 90^\circ$  or  $130^\circ$  indicates adequate separation with a minimum clearance above the CSM of approximately 3000 ft (fig. 3d, 3e, and 3f).

Relative motion for all mode III abort figures was terminated at a CM attitude of 400 000 ft. Separation ranges at this altitude for panels 1 and 2 vary from 45 000 to 470 000 feet above and ahead of the CSM for the 8 fps case, and from 38 000 to 273 000 ft above and ahead of the CSM for the 15 fps case. This indicates that separation range at a CSM altitude of 400 000 ft actually decreases when panel jettison velocity is increased from 8 fps to 15 fps. The above separation ranges will continue to increase until CM landing. Since panels 1 and 2 are jettisoned in the orbital plane during a mode III abort, less than 100 ft of lateral displacement is generated for either the 8 fps or 15 fps case.

5.2.2 Relative motions of panels 3 and 4.- Relative motions of the yawed panels (3 and 4) during a mode III abort indicates that lateral displacement is sufficient to preclude any recontact.

The minimum separation clearance for panels 3 and 4 jettisoned during a mode III abort at 8 fps is approximately 800 feet (figure 3g, 3h, 3i) and at 15 fps is approximately 1550 ft (figure 3j, 3k, 3l). If the vertical displacement (Z) is included, then the actual separation ranges are approximately 1150 and 1800 ft for the 8 fps and 15 fps cases, respectively. The above minimum separation clearances reflect the relative motions of panels 3 and 4 jettisoned at  $\theta = 130^\circ$ . As the jettison attitude is decreased to  $\theta = 90^\circ$ , the minimum clearances will increase (figure 3g through 3l).

Separation ranges for panels 3 and 4 at a CM attitude of 400 000 feet vary from 47 000 to 470 000 ft for the 8 fps case and 41 000 to 271 000 for the 15 fps case. These ranges continue to increase until CM landing.

5.2.3 Conclusions.- The primary conclusion which can be drawn from the mode III data is that panel 2 at a pitched-down attitude of  $130^\circ$  will pass from above to below the CSM during its deorbit maneuver for the mode III aborts for any jettison  $\Delta V$  from 8 fps to 15 fps. This means that there exists a specific set of conditions during a mode III abort where panel 2 recontact with the CSM will occur. However, this same panel at a pitched-down attitude of  $90^\circ$  will consistently pass below the CSM for any mode III abort and  $\Delta V$  range of 8 fps to 15 fps. Therefore, there also exists a range of jettison attitudes between  $90^\circ$  and  $130^\circ$  which



will provide adequate separation distance for panel 2.

Relative motions of the other three panels (1, 3 and 4) indicate that they will adequately clear the CSM and continue to increase in separation range until CM landing.

The initialization conditions at SLA panel jettisoning (CSM/S-IVB separation) for beginning, middle, and end of the mode III region are presented in Tables IV, V, and VI (ref. 4)

TABLE IV.- INITIAL CONDITIONS AT PANEL JETTISON  
OCCURRING AT THE BEGINNING OF MODE III

g e.t., sec . . . . .	620.00
$V_1$ , fps . . . . .	24351.01
$\gamma_1$ , deg . . . . .	-0.2999
$\psi_1$ , deg . . . . .	85.334
$\phi_d$ , deg . . . . .	32.427
$\lambda$ , deg . . . . .	-58 870
h, ft . . . . .	632038.0
wt, lb . . . . .	310526.0
CSM sep $\Delta V$ , fps . . . . .	4.6
S-IVB attitude with respect to $V_1$	
Pitch ( $\phi$ ), deg . . . . .	8.4
Yaw, deg . . . . .	0 8
Roll, deg . . . . .	-0.4
SPS deorbit burn	
g.e.t., sec . . . . .	745.00
Attitude with respect to LH	
Pitch ( $\phi$ ), deg . . . . .	-134.84
Yaw, deg . . . . .	0.0
Roll, deg . . . . .	0.0

TABLE V - INITIAL CONDITIONS AT PANEL JETTISON  
OCCURRING AT THE MIDDLE OF MODE III

g.e.t., sec . . . . .	640.00
$V_1$ , fps . . . . .	24836.5
$\gamma_1$ , deg . . . . .	-0.2379
$\psi_1$ , deg . . . . .	86.1437
$\phi_d$ , deg . . . . .	32.524
$\lambda$ , deg . . . . .	-57.410
h, ft . . . . .	629792.0
wt., lb . . . . .	299636.9
CSM sep $\Delta V$ , fps . . . . .	4.6
S-IVB attitudes with respect to $V_1$	
Pitch ( $\phi$ ), deg . . . . .	9.1
Yaw, deg . . . . .	0.8
Roll, deg . . . . .	0.5
SPS deorbit burn	
g.e.t., sec . . . . .	765.00
$\Delta V$ , fps . . . . .	802.0
Attitude with respect to LH	
Pitch ( $\phi$ ), deg . . . . .	-134.74
Yaw, deg . . . . .	0.0
Roll, deg . . . . .	0.0

TABLE VI.- INITIAL CONDITIONS AT PANEL JETTISON  
OCCURRING AT THE END OF MODE III

g.e.t., sec . . . . .	669.00
$V_1$ , fps . . . . .	25565.0
$\gamma_1$ , deg . . . . .	-0.0006
$\psi_1$ , deg . . . . .	87.3538
$\phi d$ , deg . . . . .	32.635
$\lambda$ , deg . . . . .	-55.231
h, ft . . . . .	628214.0
wt, lb . . . . .	283910.0
CSM, fps . . . . .	4.6
S-IVB attitudes with respect to $V_1$	
Pitch ( $\phi$ ), deg . . . . .	11.0
Yaw, deg . . . . .	0.8
Roll, deg . . . . .	-0.5
SPS deorbit burn	
g.e.t., sec . . . . .	794.0
$\Delta V$ , fps . . . . .	2166.0
Attitude with respect to LH	
Pitch ( $\phi$ ), deg . . . . .	-134.48
Yaw, deg . . . . .	0.0
Roll, deg . . . . .	0.0

### 5.3 Mode IV Aborts

The mode IV abort procedure incorporates a posigrade SM SPS burn to establish a safe orbit condition defined as a CSM perigee altitude equal to or greater than 75 nautical miles. (CSM/S-IVB separation and SPS burn  $\Delta V$ 's are presented in tables VII, VIII, and IX). The mode IV abort region overlaps the mode II and III abort boundaries, and will be utilized as the prime operating mode whenever the capability exists to achieve a contingency orbit insertion (COI).

Adequate separation ranges are achieved by the SLA panels for any mode IV abort where the panels are jettisoned at 8 fps between the attitudes of  $90^\circ$  and  $130^\circ$ , inclusive.

Relative motions indicate that the pitched panels (1 and 2) and the yawed panels (3 and 4) will separate behind and below the CSM with ranges continuing to increase until CM landing. At a CM altitude of 400 000 feet, minimum separation distances vary from 150 000 to 220 000 ft for panels 1 and 2 (figure 4a, 4b, 4c) and from 204 000 to 222 000 ft for panels 3 and 4 (figure 4d, 4e, 4f).

The initialization conditions at SLA panel jettisoning (CSM/S-IVB separation) for the beginning, middle, and end of the mode IV region are presented in tables VII, VIII, and IX (ref. 4).

TABLE VII.- INITIAL CONDITIONS AT PANEL JETTISON  
OCCURRING AT THE BEGINNING OF MODE IV

g.e.t., sec . . . . .	580.00
$V_1$ , fps . . . . .	23427.6117
$\gamma_1$ , deg . . . . .	0.2381
$\Psi_1$ , deg . . . . .	83.7733
$\phi_d$ , deg . . . . .	32.1846
$\lambda$ , deg . . . . .	-61.6905
h, ft . . . . .	636630.0
wt, lb . . . . .	332298.4
CSM sep $\Delta V$ , fps . . . . .	4 6
S-IVB attitude with respect to $V_1$	
Pitch ( $\phi$ ), deg . . . . .	7.4
Yaw, deg . . . . .	0.8
Roll, deg . . . . .	-0.4
SPS deorbit burn	
g.e.t., sec . . . . .	705.00
$\Delta V$ , fps . . . . .	2450.0
Attitude with respect to LH	
Pitch ( $\phi$ ), deg . . . . .	18.51
Yaw, deg . . . . .	0.0
Roll, deg . . . . .	0.0

TABLE VIII.- INITIAL CONDITIONS AT PANEL JETTISON  
OCCURRING AT THE MIDDLE OF MODE IV

g.e.t., sec . . . . .	600.00
$V_1$ , fps . . . . .	23881.55
$\gamma_1$ , deg . . . . .	-0.3029
$\psi_1$ , deg . . . . .	84.5438
$\phi_d$ , deg . . . . .	32.3131
h, ft . . . . .	634494.0
wt, lb . . . . .	321417.6
CSM sep $\Delta V$ , fps . . . . .	4.6
S-IVB attitude with respect to $V_1$	
Pitch ( $\phi$ ), deg . . . . .	8.0
Yaw, deg . . . . .	0.9
Roll, deg . . . . .	-0.6
SPS deorbit burn	
g.e.t., sec . . . . .	725 000
$\Delta V$ , fps . . . . .	1835.3
Attitude with respect to LH	
Pitch ( $\phi$ ), deg . . . . .	18.303
Yaw, deg . . . . .	0.0
Roll, deg . . . . .	0 0

TABLE IX.- INITIAL CONDITIONS AT PANEL JETTISON  
OCCURRING AT THE END OF MODE IV

g.e.t., sec . . . . .	640.00
$V_i$ , fps . . . . .	24836.5
$\gamma_i$ , deg . . . . .	-0.2379
$\psi_i$ , deg . . . . .	86.1437
$\phi_d$ , deg . . . . .	32.524
$\lambda$ , deg . . . . .	-57.410
h, ft . . . . .	629792.0
wt, lb . . . . .	299636.9
CSM sep $\Delta V$ , fps . . . . .	4.6
S-IVB attitude with respect to $V_i$	
Pitch ( $\phi$ ), deg . . . . .	9.1
Yaw, deg . . . . .	0.8
Roll, deg . . . . .	-0 5
SPS deorbit burn	
g.e.t , sec . . . . .	765.00
$\Delta V$ , fps . . . . .	721.22
Attitude with respect to LH	
Pitch ( $\phi$ ), deg . . . . .	18.141
Yaw, deg . . . . .	0.0
Roll, deg . . . . .	0 0



## 5.4 Orbital Aborts

Orbital aborts were analyzed based on the following contingency sequence (ref. 5)

	Event	Time from abort initiation (min sec)
I	a. initiate abort	
	b. CSM/S-IVB separation	
	c. begin +X translation	00:00
II	a. end +X translation	
	b. begin coast	00 10
III	a. end coast	
	b. begin +X translation	
	retrograde, horizon monitor	
	attitude	00:40
IV	a. end +X translation	
	b. begin coast	01 10
V	begin SPS deorbit	20.00

This sequence employs a SPS retrograde deorbit maneuver, but unlike mode III aborts, it delays the maneuver for 20 minutes and incorporates +X translation of the CSM during this period to maximize separation clearances. Such tactics are not possible during a mode III abort, as time from abort initiate to entry interface (300 000 ft) is considerably less than necessary to perform the delayed SPS burn sequence.

The jettison of the SLA panels at 8 fps for any attitude between  $90^\circ$  and  $130^\circ$  for the above orbital abort sequence presents no recontact problems. Relative motion for panels 1 and 2 jettisoned between  $90^\circ$  and  $130^\circ$  is presented in figure 5a and indicates that the CSM will pass between them with adequate clearance during its deorbit burn. Panel 2 will pass the nearest, below and in front of the CSM by a minimum of 6000 and 7000 feet, respectively, while panel 1 separates above and behind the CSM, and its closest approach during the deorbit burn is over 20 000 ft (fig. 5a).

Sufficient radial displacement is generated by the yawed panels (3 and 4) to preclude any recontact. Relative motions presented in the horizontal (x-y, fig 5b) and the orbital planes (x-z, fig 5c) indicate that panels 3 and 4 will pass almost directly above the CSM by over 100 000 ft, and will remain above and behind the CSM with separation ranges continuing to increase until CM landing.

The initialization conditions at SLA panel jettison for the orbital abort analyzed are presented in Table X (ref. 6), and are the same as the nominal D mission conditions at CSM/S-IVB separation.

TABLE X.- ORBITAL ABORT AND NOMINAL D MISSION

## INITIAL CONDITIONS AT PANEL JETTISON

g.e.t., hr.min sec . . . . .	2:43.12
$V_1$ , fps . . . . .	25581.4
$\gamma_1$ , deg . . . . .	0.00289
$\psi_1$ , deg . . . . .	57.91
$\phi_d$ , deg . . . . .	-7.05
$\lambda$ , deg . . . . .	169.84
h, ft . . . . .	611582.3
wt, lb . . . . .	281441.0
Apogee altitude, n. mi. . . . .	104
Perigee altitude, n. mi. . . . .	103
CSM sep $\Delta V$ (Orbital Abort), fps . . . . .	2.2
CSM sep $\Delta V$ (D nominal), fps . . . . .	1.0
S-IVB attitude with respect to $V_1$	
Pitch ( $\phi$ ), deg . . . . .	1.6
Yaw, deg . . . . .	0.0
Roll, deg . . . . .	0.0

## 6. APOLLO D MISSION

Results of the D mission analysis indicate that for panels jettisoned at nominal separation, no recontact problems exist for jettison attitudes between  $90^\circ$  and  $130^\circ$  and velocities of 5, 8 and 15 fps. The four SLA panels are expected to decay and impact within 2.5 hours after jettison therefore, no long term panel recontact possibilities exist. Separation ranges continue to increase after jettison, with all four panels remaining below and in front of the CSM until entry. The minimum separation clearance is generated by panel 1, jettisoned at 5 fps at an attitude of  $130^\circ$ . It passes approximately 3500 ft behind the CSM (fig. 6a). For the designed jettison velocity of 8 fps, Panel 1 clearance increases to approximately 6000 feet, and to over 10 000 ft for the 15 fps case (fig. 6b and 6c).

Initialization conditions at SLA panel jettison on the Apollo D mission are presented in Table X (ref. 6).

## 7. APOLLO E MISSION

Jettison of the SLA panels on the Apollo E mission at nominal CSM/S-IVB separation does not result in any eventual recontact situations. The relative motions and separation ranges of the four panels were generated for three revolutions. This data indicates that panels 1 and 2 which are jettisoned in the orbital plane will achieve greater separation ranges than will panels 3 and 4, which are jettisoned laterally, out-of-plane. For panels 1 and 2, minimum separation ranges vary from 53 000 to 400 000 ft, and for panels 3 and 4 from 6500 to 155 000 ft. The minimum separation range of 6500 feet is generated by panel 3 jettisoned at  $90^\circ$  with a velocity of 5 fps. Increasing the jettison velocity to the nominal of 8 fps generates a minimum range of approximately 10 500 ft.

These separation ranges are influenced by the first SPS burn on the Apollo E mission, which raises the spacecraft perigee from 107 n. mi. to approximately 133 n. mi., and places it in a higher orbit than any of the jettisoned panels, therefore no recontact is possible until later in the mission when the CSM apogee is lowered by the LOI burn. Further investigation is in progress beyond the SPS LOI burn phase to determine if potential recontact areas exist.

Initialization conditions at SLA panel jettison on the Apollo E mission are presented in Table XI (ref. 7).

TABLE XI.- NOMINAL E MISSION INITIAL CONDITIONS

## AT PANEL JETTISON

g.e.t., hr·min sec . . . . .	3.43 40
$V_1$ , fps . . . . .	22560.53
$\gamma_1$ , deg . . . . .	19 9161
$\psi_1$ , deg . . . . .	115.14
$\phi d$ , deg . . . . .	-21.5175
$\lambda$ , deg . . . . .	23.3738
h, ft . . . . .	9288308.5
wt, lb . . . . .	206160 3
Apogee altitude, n. mi. . . . .	3956
Perigee altitude, n. mi. . . . .	107
CSM sep $\Delta V$ , fps . . . . .	1 0
S-IVB attitude with respect to $V_1$	
Pitch ( $\phi$ ), deg . . . . .	-79.3
Yaw, deg . . . . .	0.0
Roll, deg . . . . .	1.8

## 8. APOLLO F AND G MISSIONS

The results of the preliminary analysis for Apollo F and G missions (ref. 8) conclude that eventual recontact will not be a problem based on the assumption that the CSM/LM will require no midcourse corrections or maneuvering. This assumption definitely limits the applicability of the results, therefore a more sophisticated analysis is now being instigated to determine what effects midcourse corrections will have on SLA panel separation clearances.

The preliminary study determines that there will be no recontact problems with any of the SLA panels jettisoned at  $110^\circ \pm 20^\circ$  (measured from the panel center line to the S-IVB X axis) with a resultant velocity from 5 to 15 fps. The minimum separation ranges are generated by the panels jettisoned normal to the orbital plane (right and left panels) with ranges increasing gradually to approximately 40 n. mi. at pericyynthion. These distances could substantially change if midcourse corrections were applied. Also, close-in recontact situations may develop during midcourse maneuvering as the separation clearance for the bottom panel jettisoned at  $130^\circ$  with a  $\Delta V = 5$  fps is approximately 1500 ft as it passes in front of the CSM/LM

Therefore, this study primarily indicates that a more sophisticated analysis evaluating the effects of midcourse corrections upon the relative motions of the four SLA panels is required for the close-in and eventual recontact regimes.

## 9. CONCLUSIONS

Based on the analysis performed in this report the following conclusions can be drawn.

1. The jettisoning of the four SLA panels at resultant velocities between 5 and 15 fps at an attitude of  $\theta = 110^\circ \pm 20^\circ$  with respect to the S-IVB +X-axis will result in adequate separation displacement from the spacecraft for the nominal Apollo missions D, E, F and G. Further analysis is in progress to determine if potential recontact areas exist after the simulated LOI burn in the Apollo E mission, and near mid-course corrections or maneuvering on Apollo F and G missions.

2. Should an aborted mission be initiated, no potential panel recontact possibilities exist unless the abort sequence includes an in-plane retrograde SPS burn. This analysis determines that panels jettisoned during the mode II and IV region will not recontact the spacecraft.

If the abort does include an inplane retrograde SPS burn then the spacecraft will pass near or between the jettisoned panels. This was found to occur during a mode III or an orbital abort, each of which incorporates an inplane retrograde SPS burn.

In the orbital abort sequence, however, the retrograde SPS burn is not initiated until 20 minutes after the panels are jettisoned. This delay allows the four panels sufficient time to disperse, such that when the spacecraft passes between them during its deorbit burn, adequate separation clearance is maintained. For the cases analyzed, the spacecraft passes above and behind panel 2 by a minimum of 6000 and 7000 ft, respectively (figure 5a).

The Mode III abort sequence retrograde SPS burn is performed 125 seconds after the panels are jettisoned. If the abort is initiated early in the mode III region, the spacecraft passes below panel 2. For aborts occurring at the midpoint or later of the mode III region, the greater  $\Delta V$  of the retrograde burn (Tables IV, V and VI) results in the spacecraft flying above panel 2. Therefore, there does exist a specific set of conditions which will cause the spacecraft to recontact panel 2 during a mode III abort, where panel 2 is jettisoned at 8 fps at an attitude of 130 deg. Further analysis is underway to determine if operational constraints can be placed on the present mode III abort sequence or on the SLA jettison technique to alleviate this recontact situation.

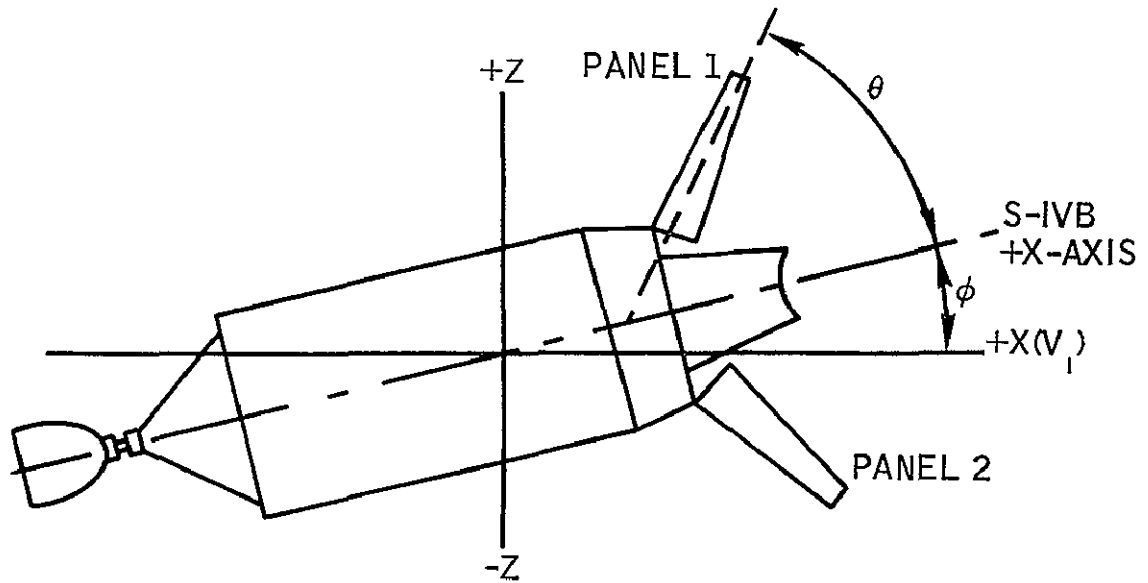

$X(V_1)$  DOWNRANGE DISPLACEMENT (INERTIAL VELOCITY VECTOR)

$\phi$  S-IVB ATTITUDE WITH RESPECT TO  $V_1$

$\theta$  PANEL JETTISON ATTITUDE (PITCH)

Z VERTICAL DISPLACEMENT

(a) Pitched panels (X-Z plane).

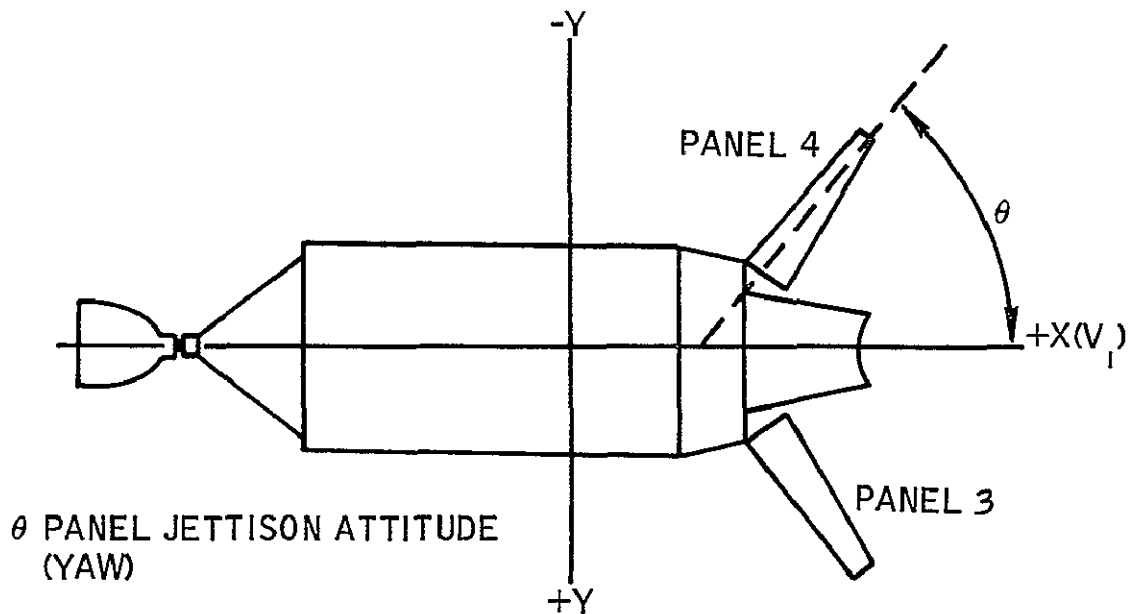

$X(V_1)$  DOWNRANGE DISPLACEMENT (INERTIAL VELOCITY VECTOR)

Y LATERAL DISPLACEMENT

(b) Yawed panels (X-Y plane).

Figure 1.- S-IVB and SLA panel attitude identification.



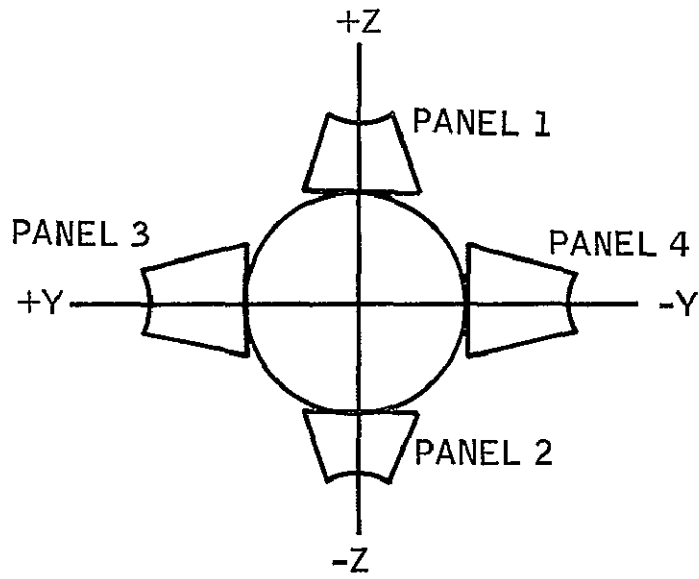

(c) Front view (Y-Z plane).

Figure 1.- Concluded.

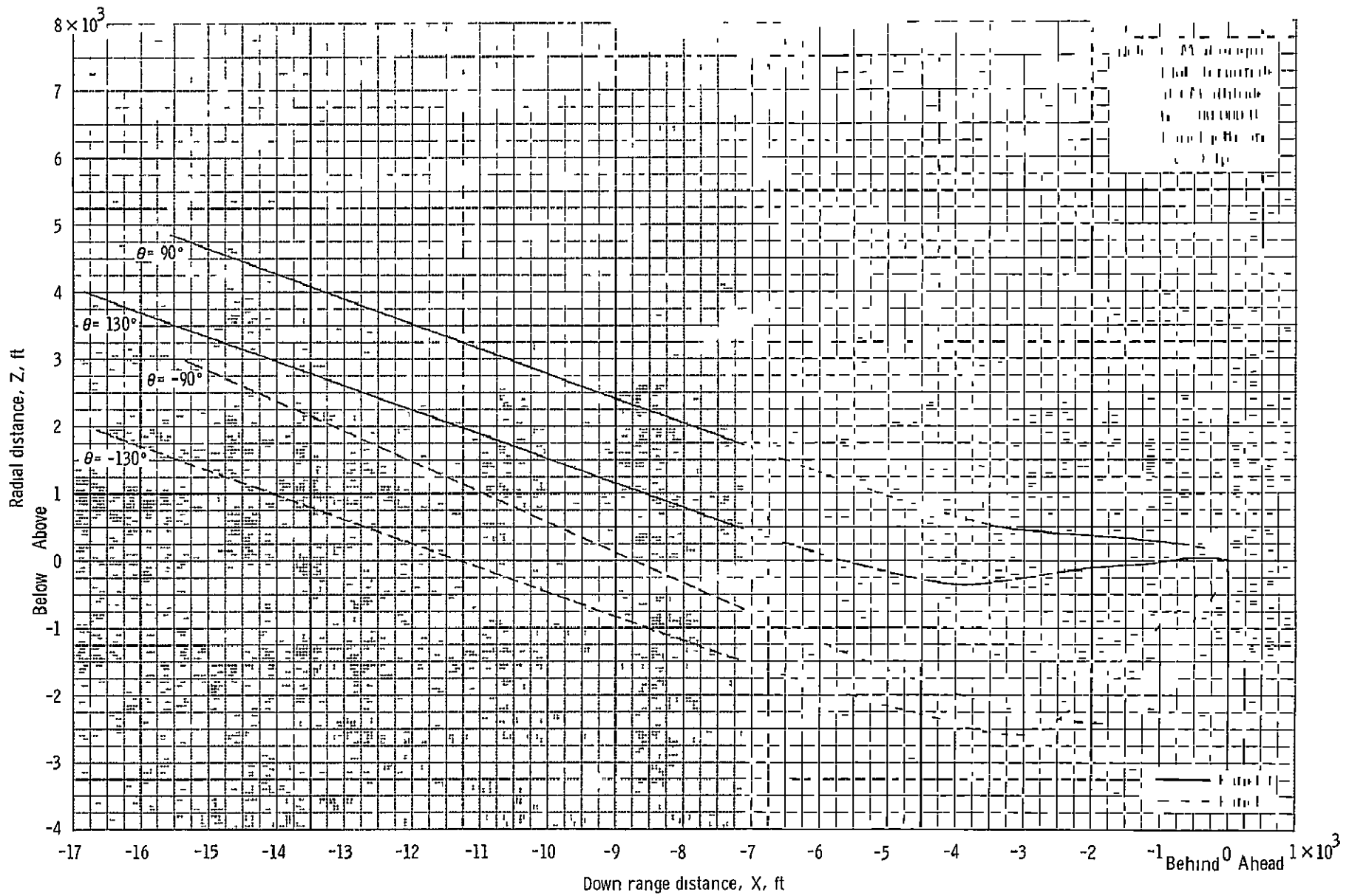

(a) Pitched panels for the beginning of Mode II

Figure 2 - Mode II aborts relative motion of the SLA panels,  $\Delta V = 8$  fps

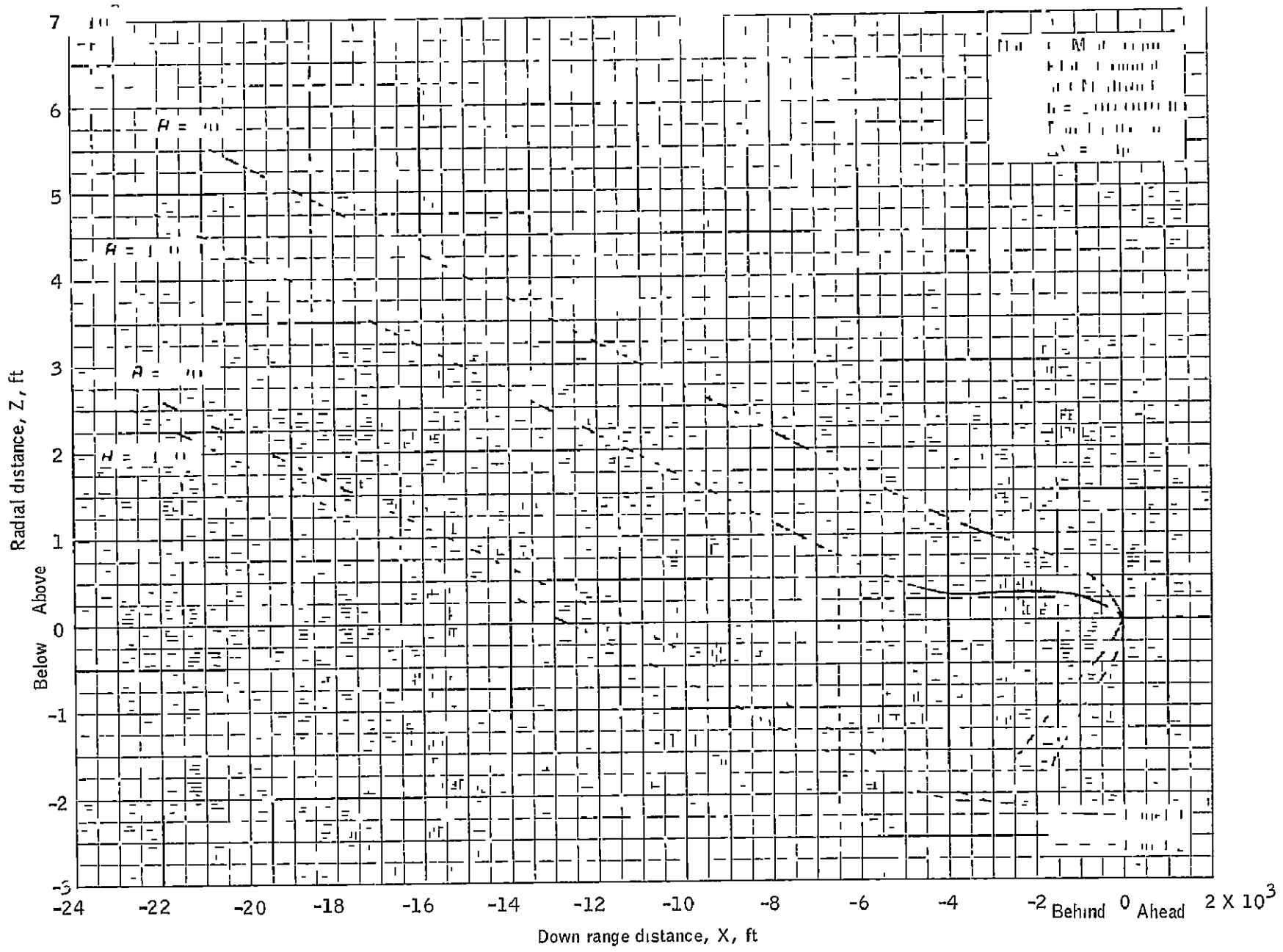

(b) Pitched panels for the middle of Mode II.

Figure 2. - Continued

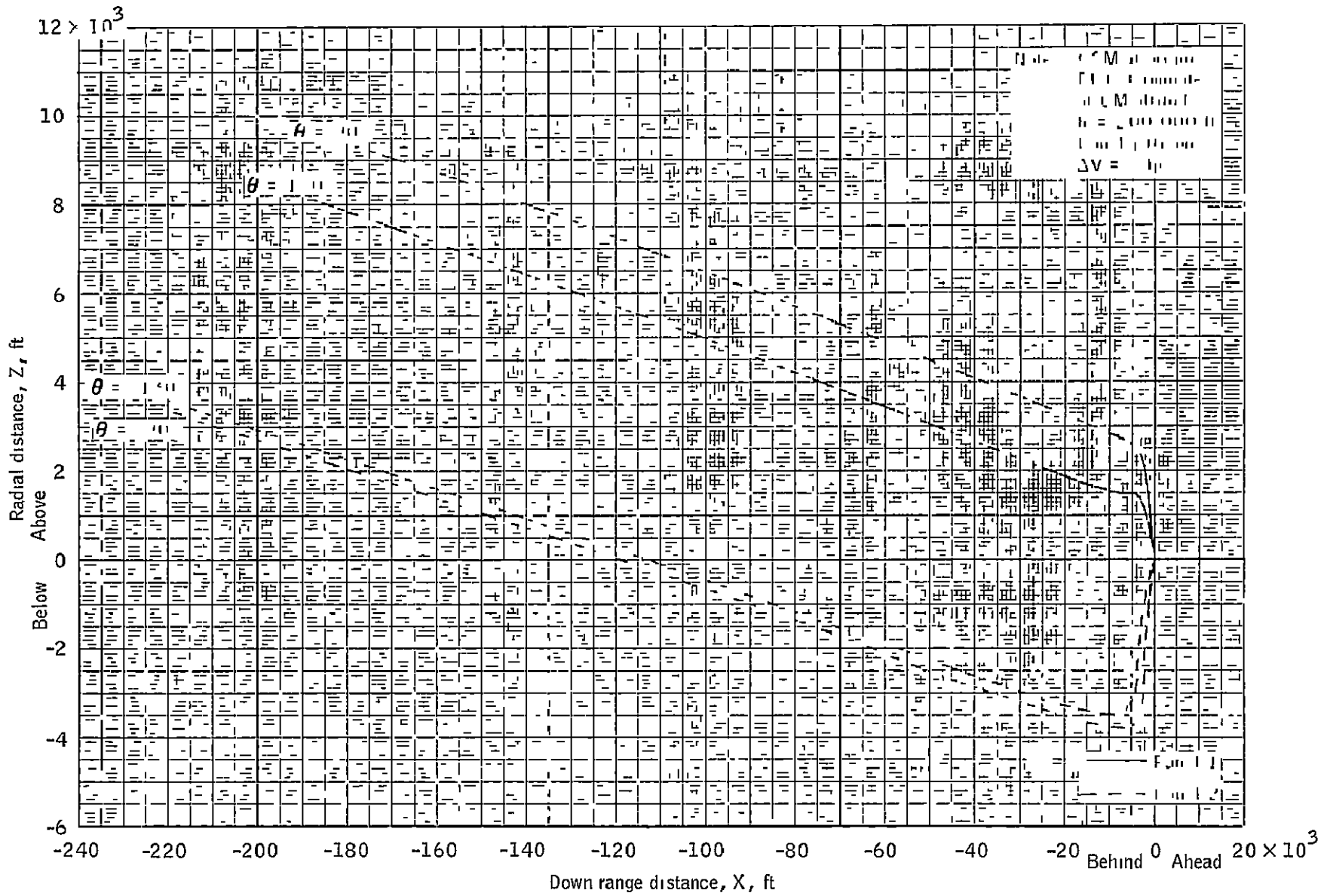

(c) Pitched panels for the end of Mode II.

Figure 2 - Continued

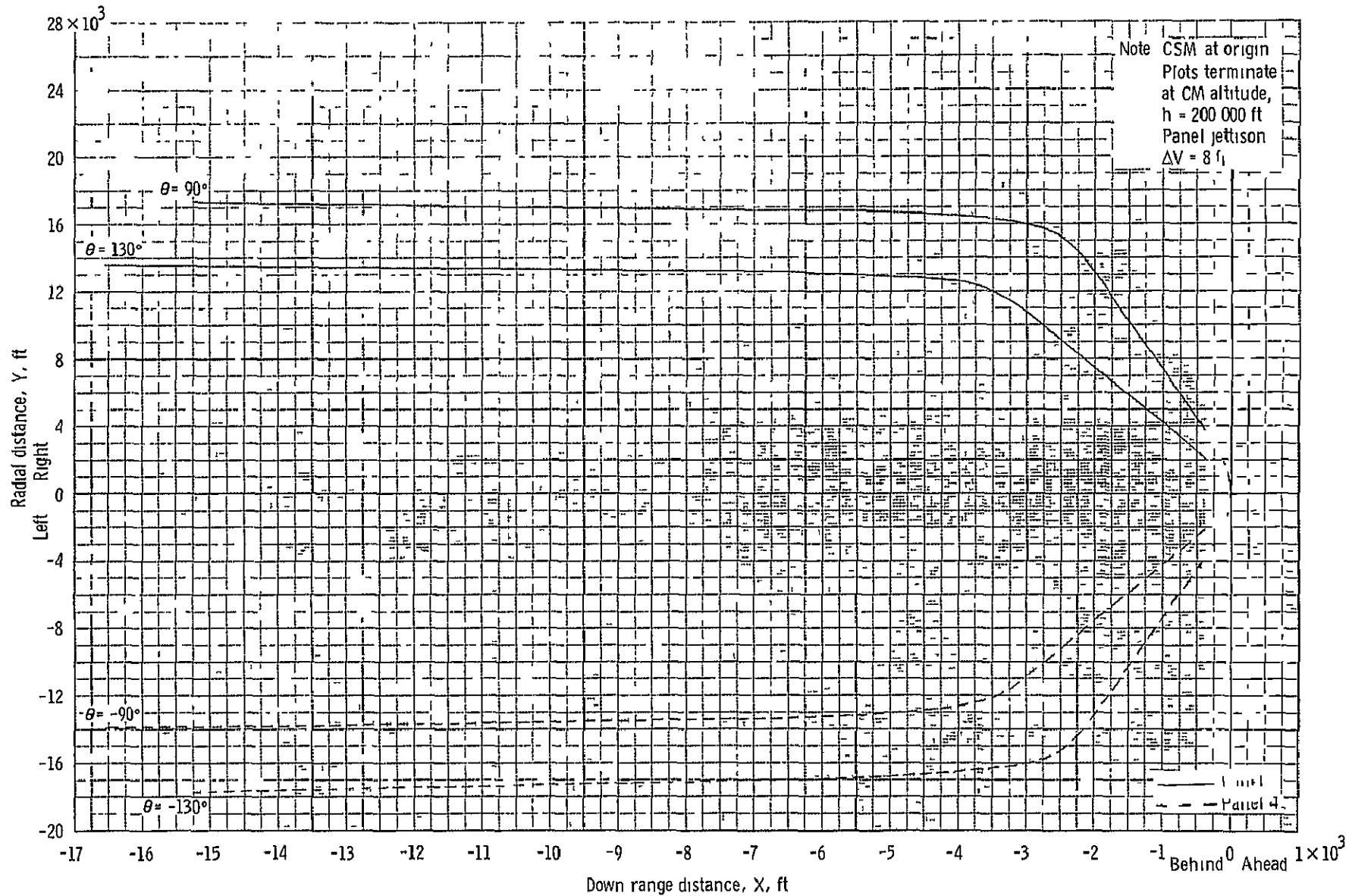

(d) Yawed panels for the beginning of Mode II

Figure 2 - Continued

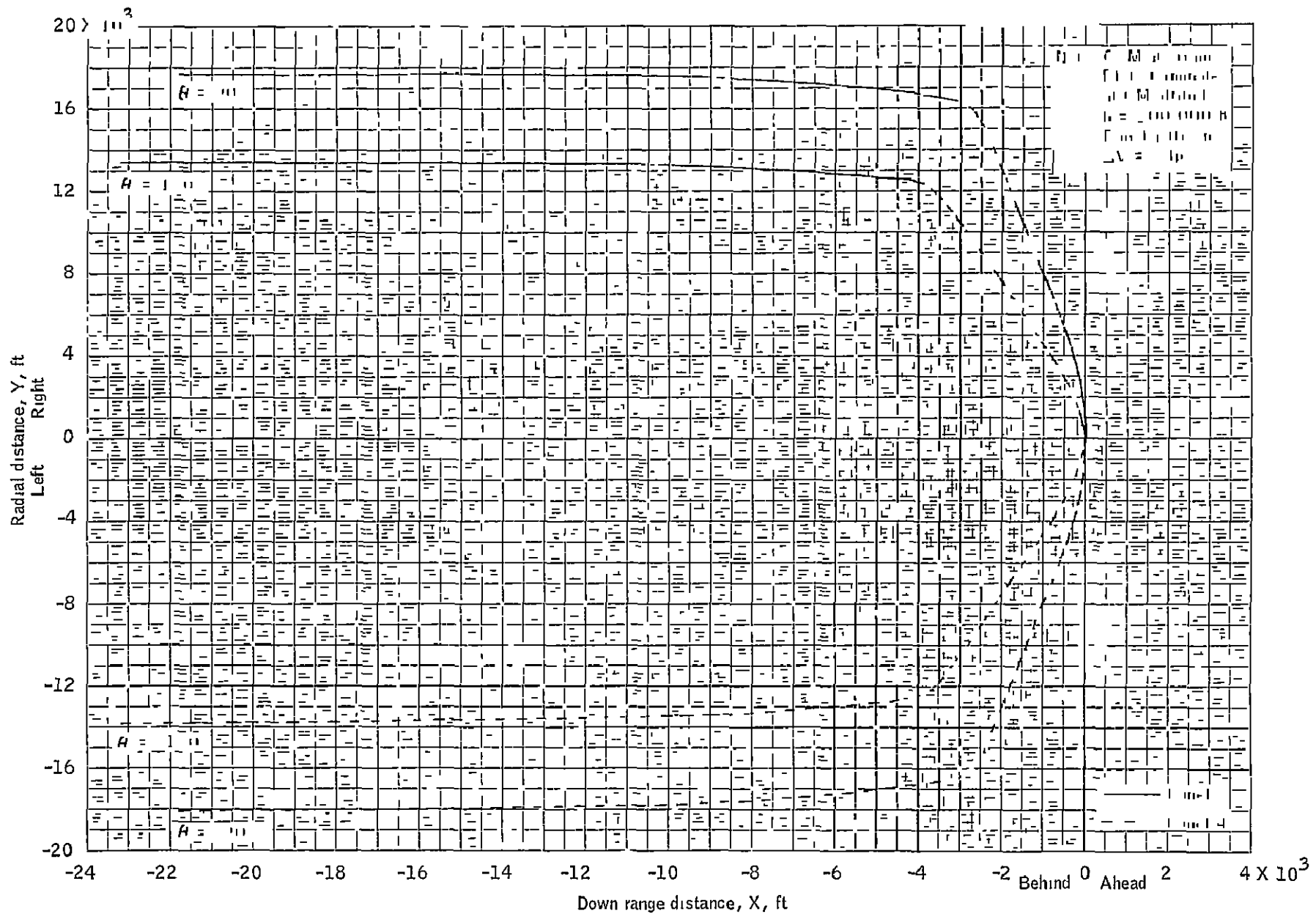

(e) Yawed panels for the middle of Mode II.

Figure 2 - Continued

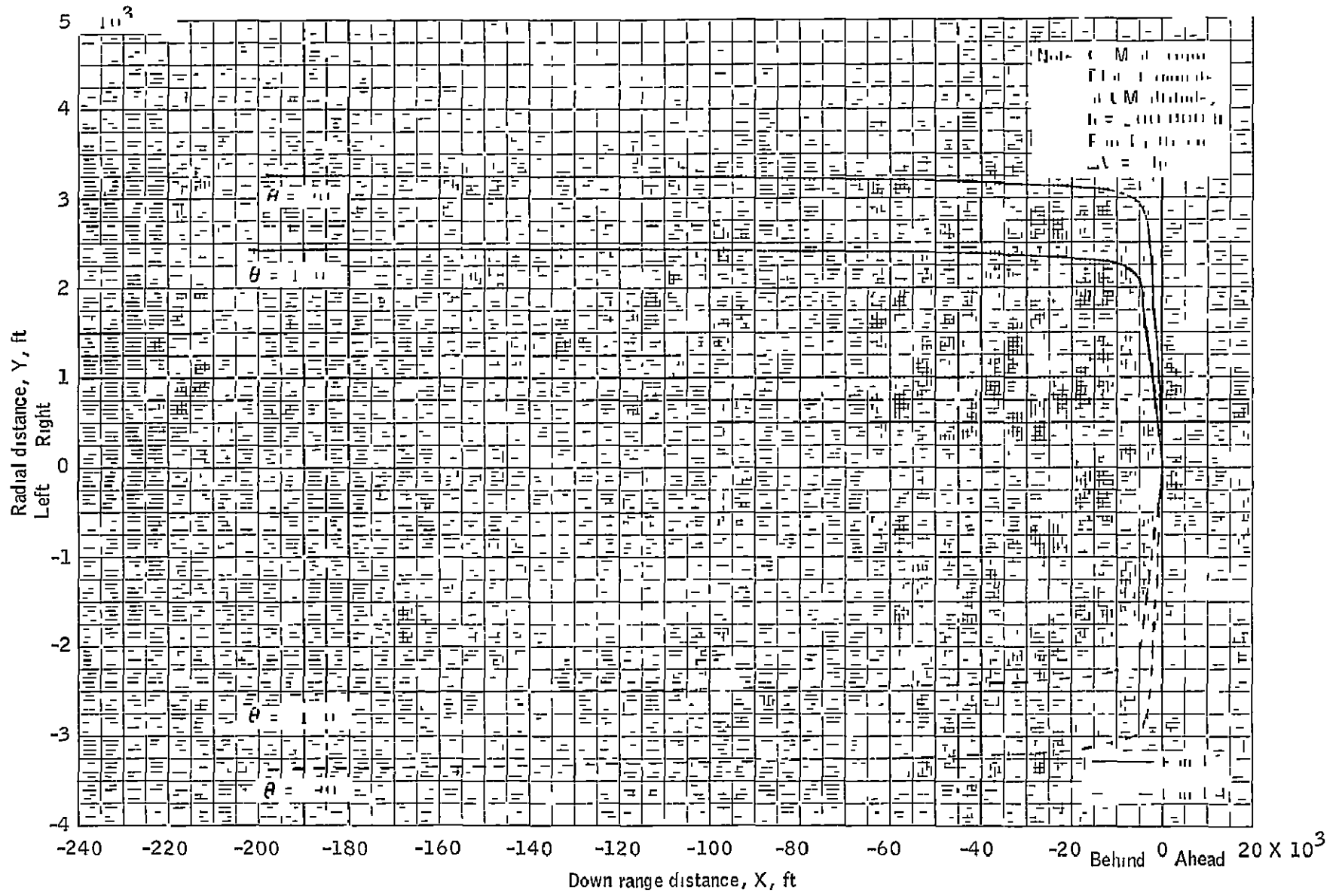

(f) Yawed panels for the end of Mode II.

Figure 2 - Concluded

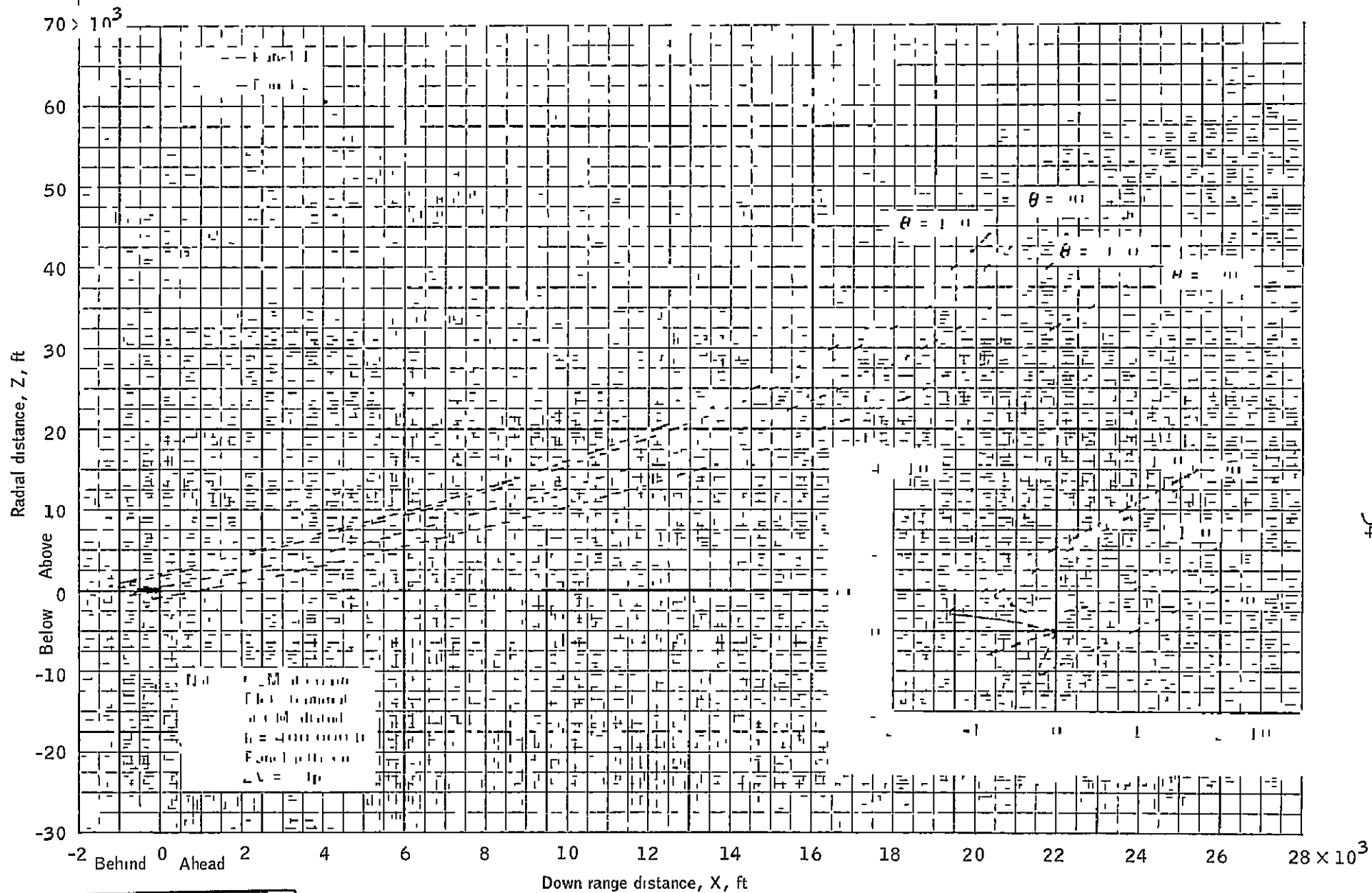

(a) Pitched panels for the beginning of Mode III ( $\Delta V = 8$  fps)

Figure 3 - Mode III aborts relative motion of the SLA panels for  $\Delta V$ 's of 8 and 15 fps.

NASA/MSC/FOD  
MISSION PLANNING AND ANALYSIS DIVISION  
BRANCH FAB DATE 5/21/68  
BY MLH/CWF PLOT NO 18228



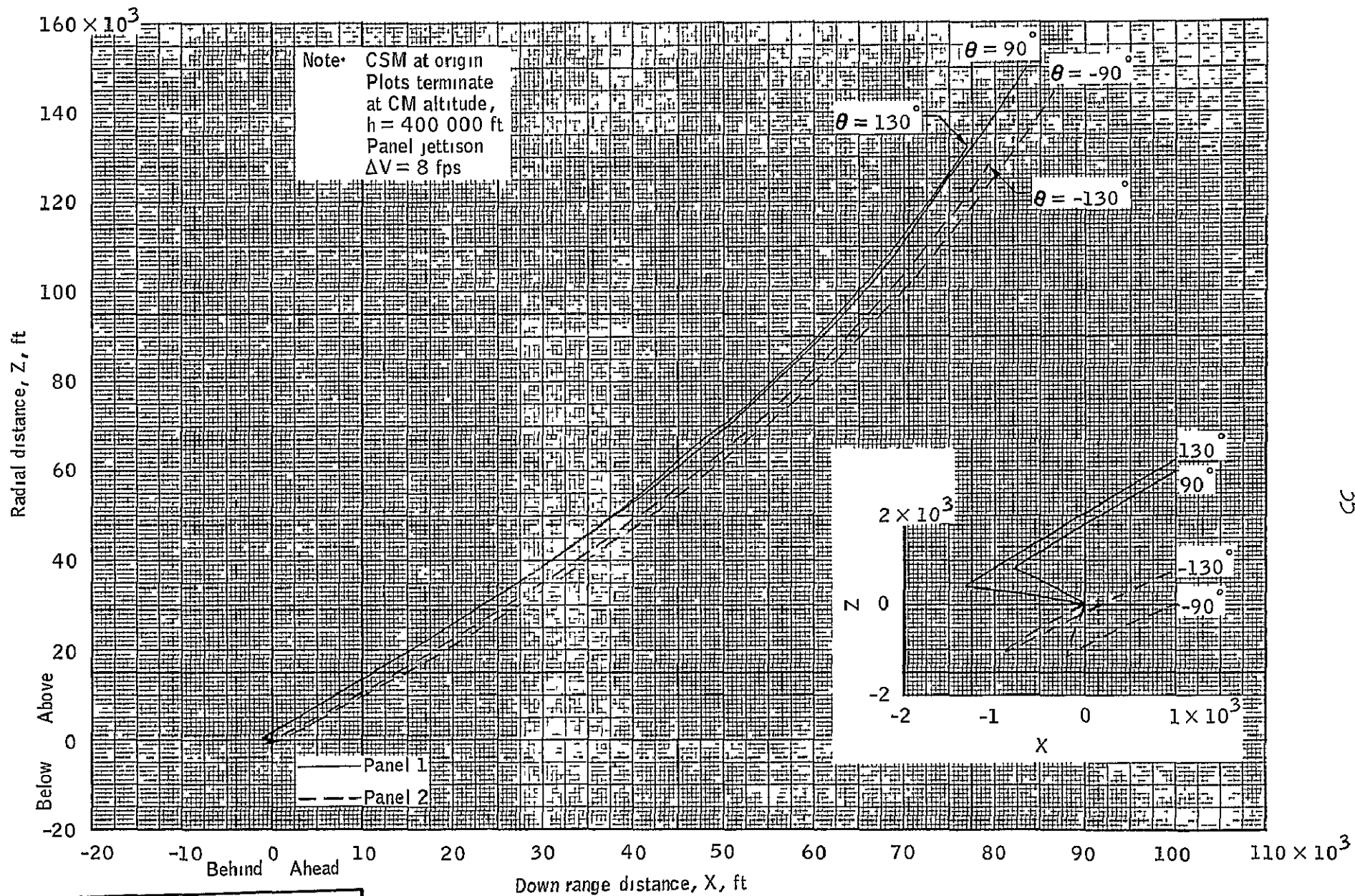

35

NASA/MSC/FOD  
MISSION PLANNING AND ANALYSIS DIVISION  
BRANCH FAB DATE 5/21/68  
BY MTW/CWP PLOT NO 18229

(b) Pitched panels for the middle of Mode III ( $\Delta V = 8$  fps).

Figure 3.- Continued.

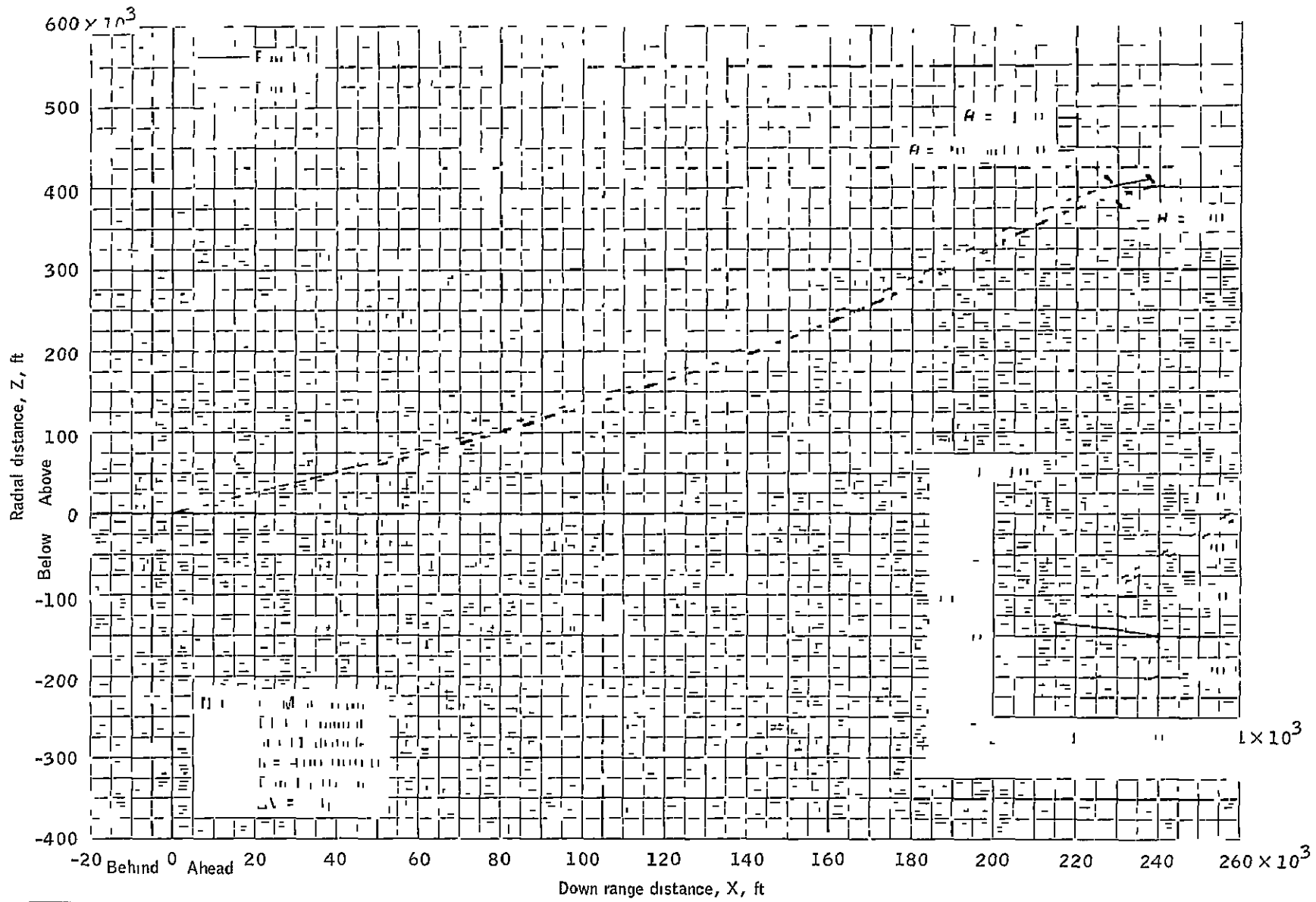

NASA/MSC/FOD  
 MISSION PLANNING AND ANALYSIS DIVISION  
 BRANCH FAB DATE 5/21/68  
 BY MTW/CWP PLOT NO 18230

(c) Pitched panels for the end of Mode III ( $\Delta V = 8$  fps)

Figure 3 - Continued

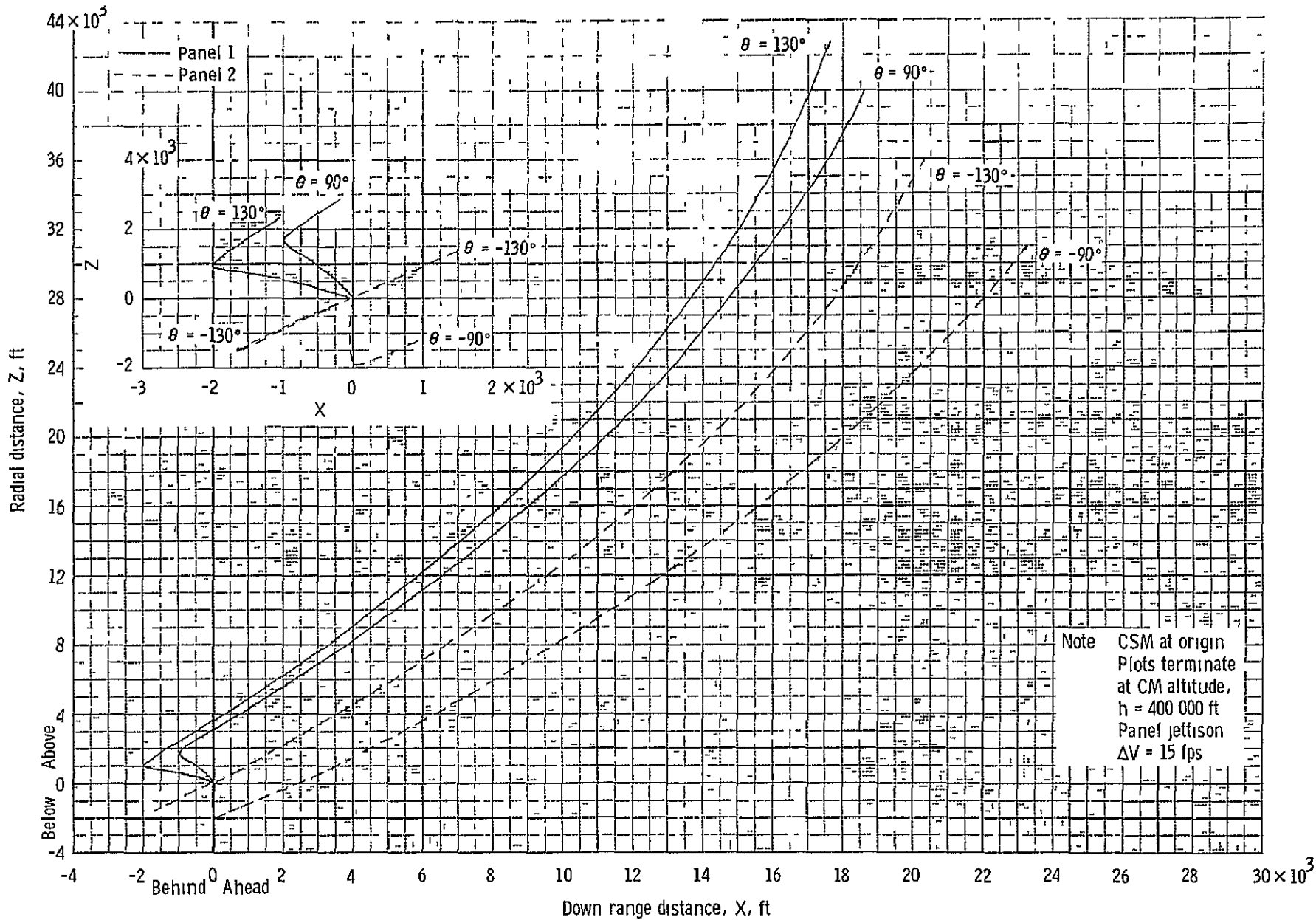

NASA/MSC/FOD  
MISSION PLANNING AND ANALYSIS DIVISION  
BRANCH FAB DATE 5/21/68  
BY M.J./G/P PLOT NO 18231

(d) Pitched panels for the beginning of Mode III ( $\Delta V = 15$  fps)

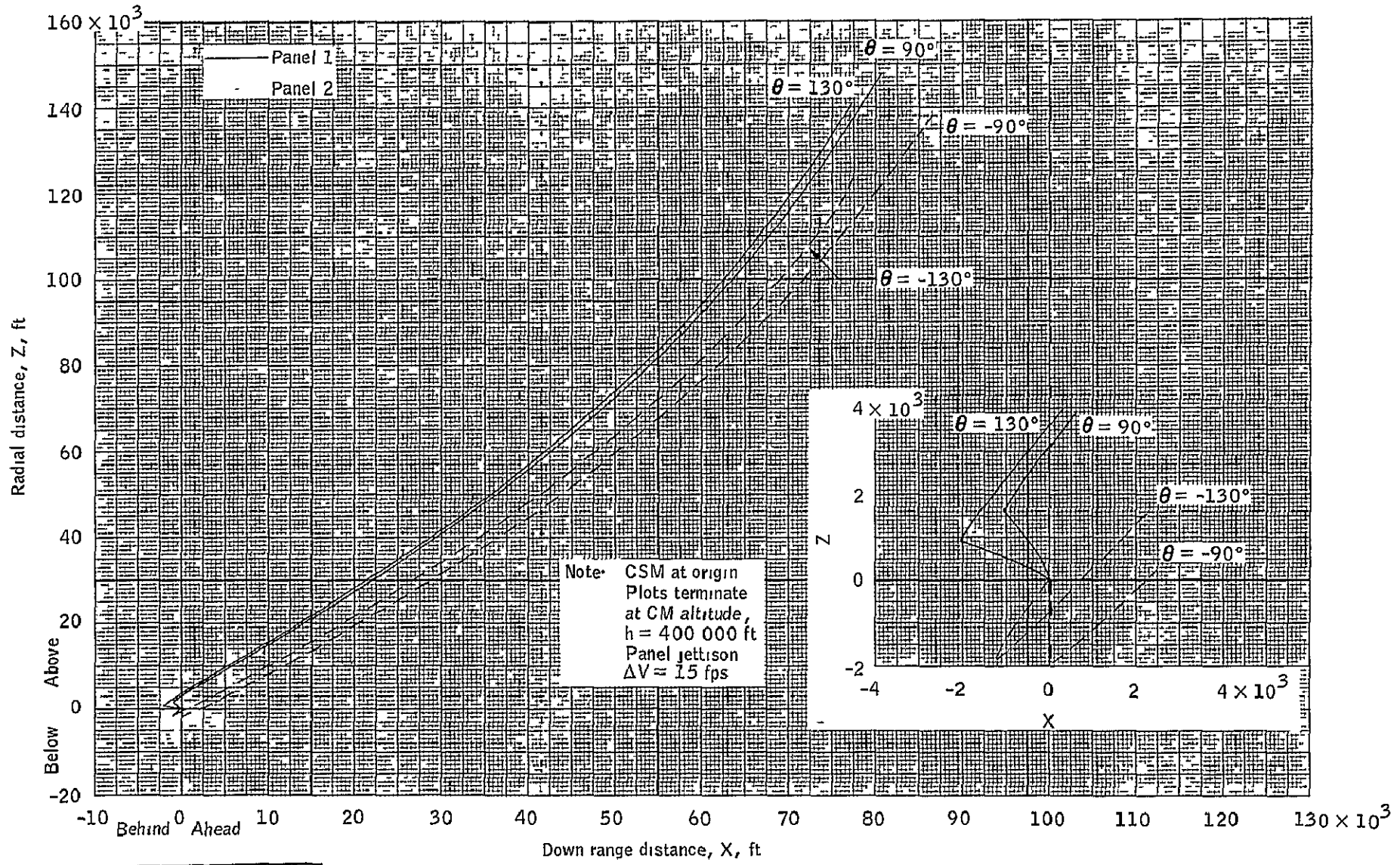

NASA/MSC/FOD  
MISSION PLANNING AND ANALYSIS DIVISION  
BRANCH FAB DATE 5/21/68  
BY MTW/CWF PLOT NO 18232

(e) Pitched panels for the middle of Mode III ( $\Delta V = 15$  fps).

Figure 3 - Continued

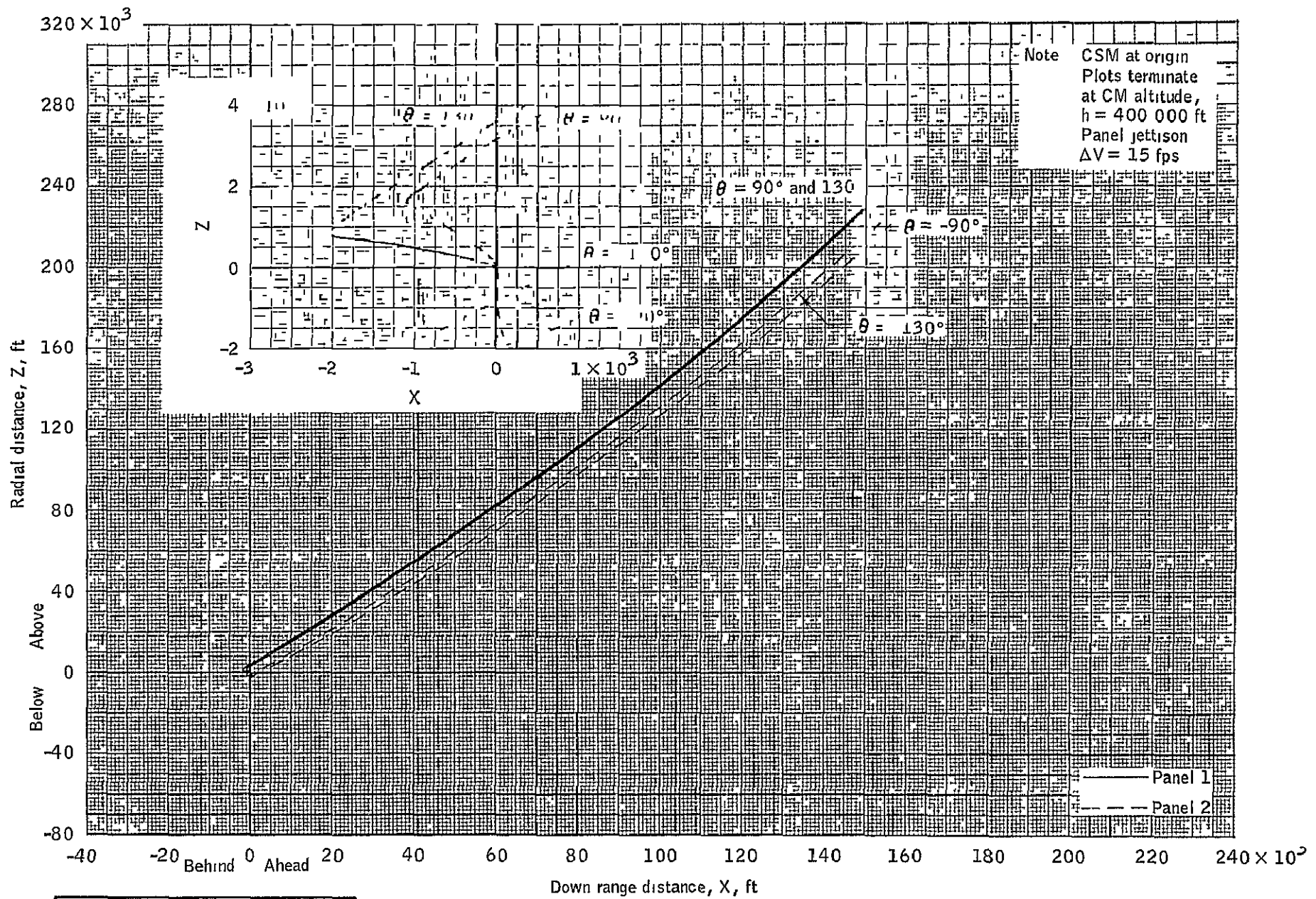

NASA/MSC/FOD  
 MISSION PLANNING AND ANALYSIS DIVISION  
 BRANCH DAB DATE 5/21/68  
 BY MLW/CWP PLOT NO 18233

(f) Pitched panels for the end of Mode III ( $\Delta V = 15$  fps).

Figure 3 - Continued.

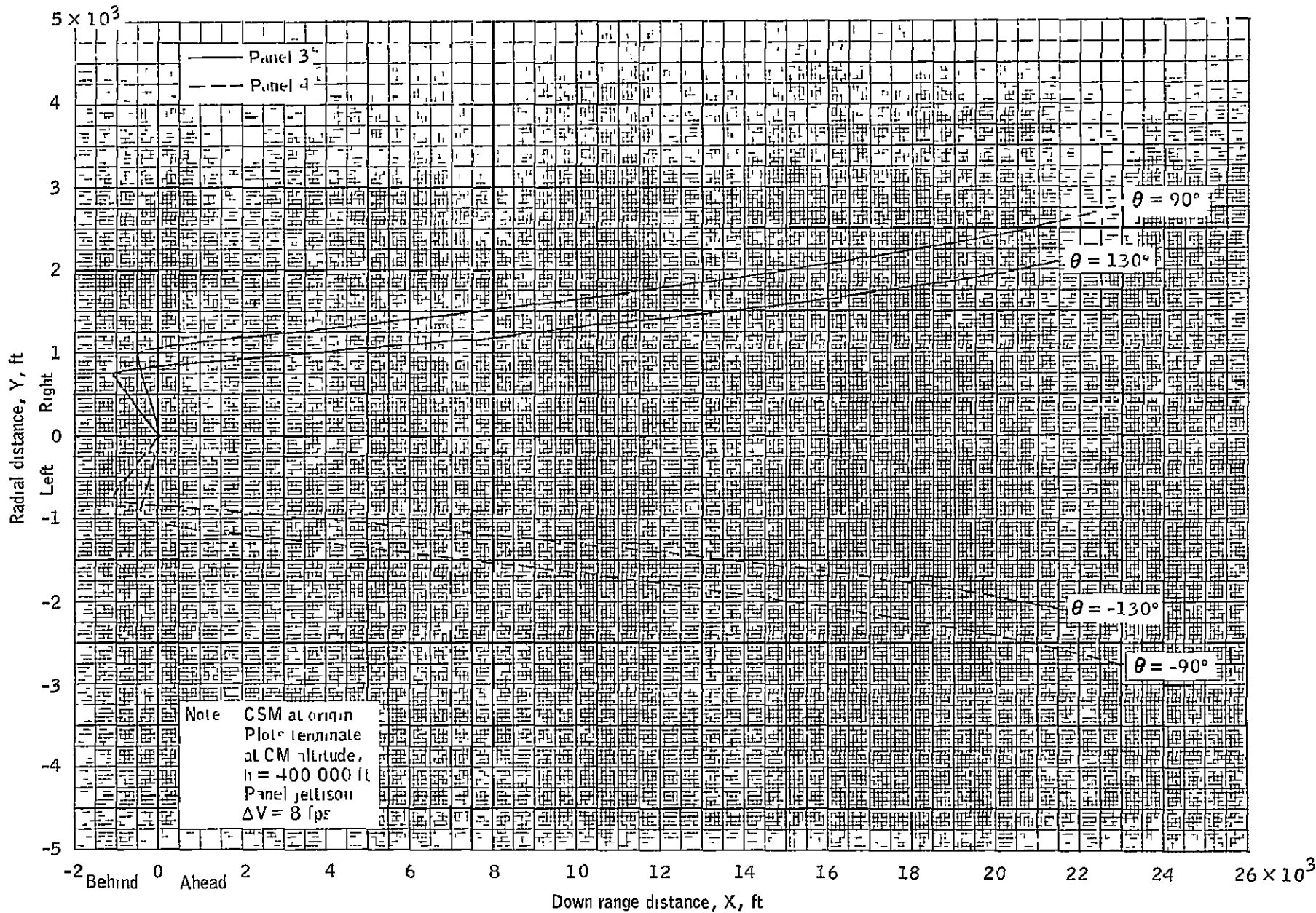

(g) Yawed panels for the beginning of Mode III ( $\Delta V = 8$  fps)

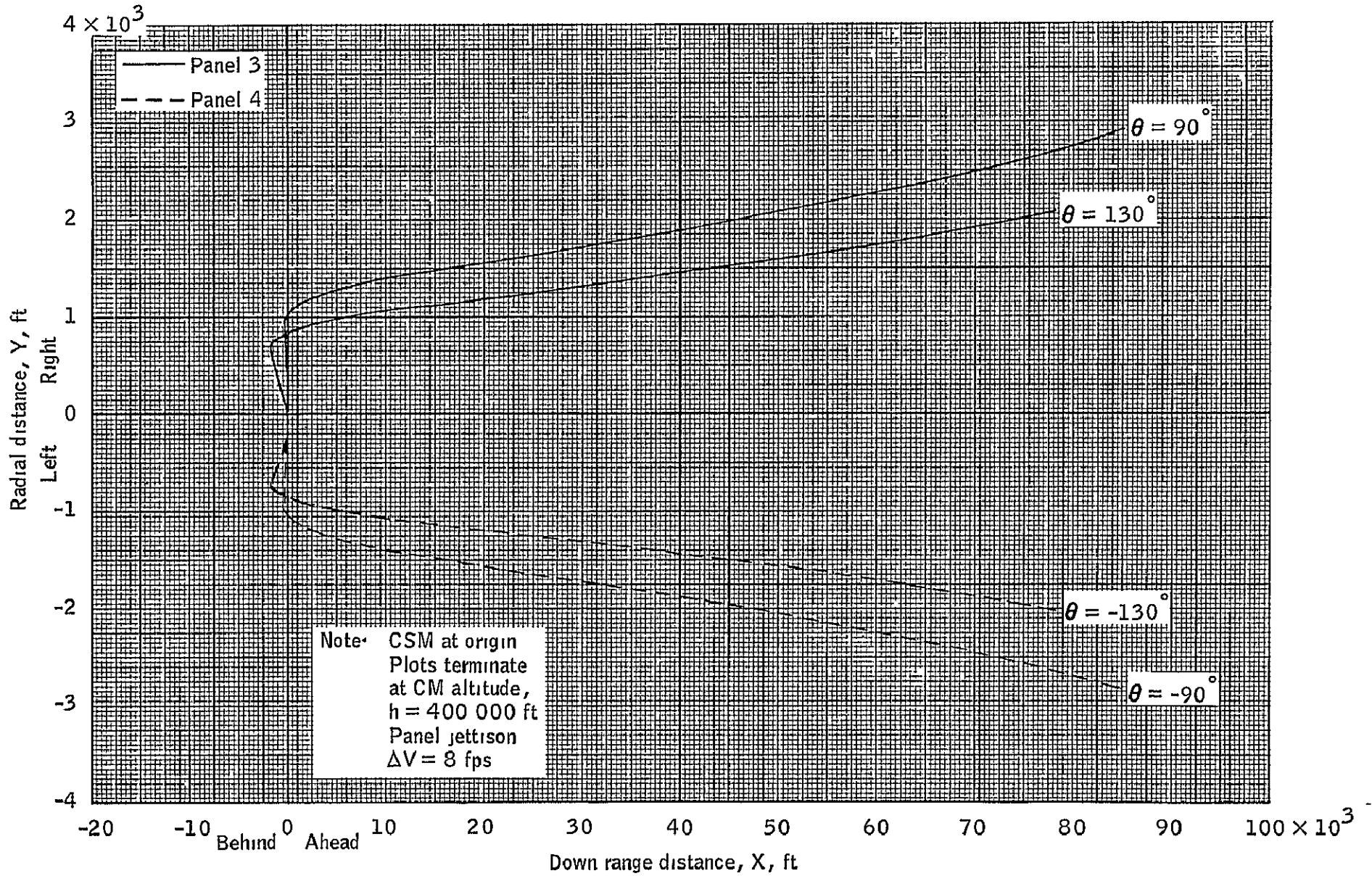

17

(h) Yawed panels for the middle of Mode III ( $\Delta V = 8$  fps).

Figure 3. - Continued.

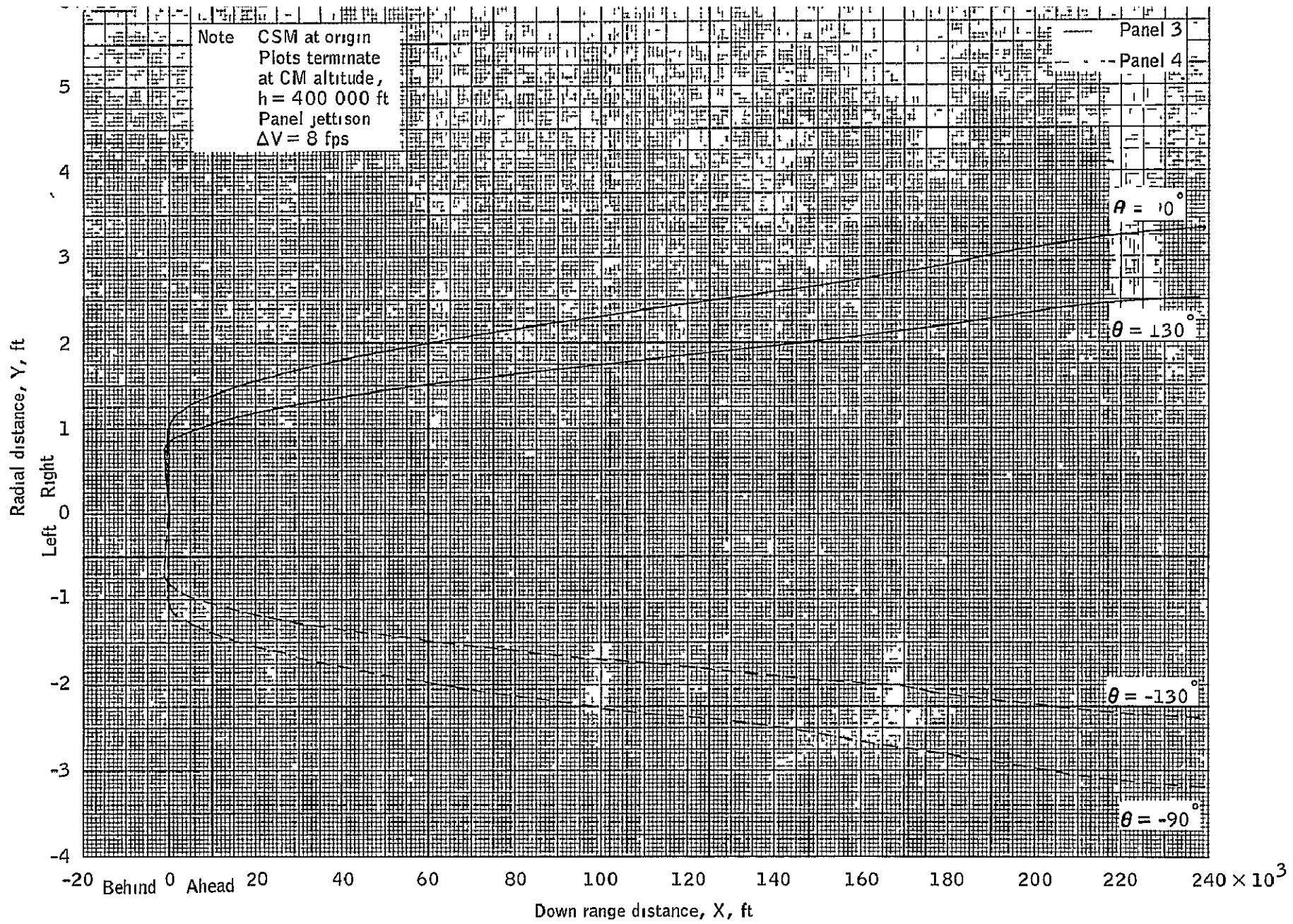

(i) Yawed panels for the end of Mode III ( $\Delta V = 8$  fps).

Figure 3 - Continued.



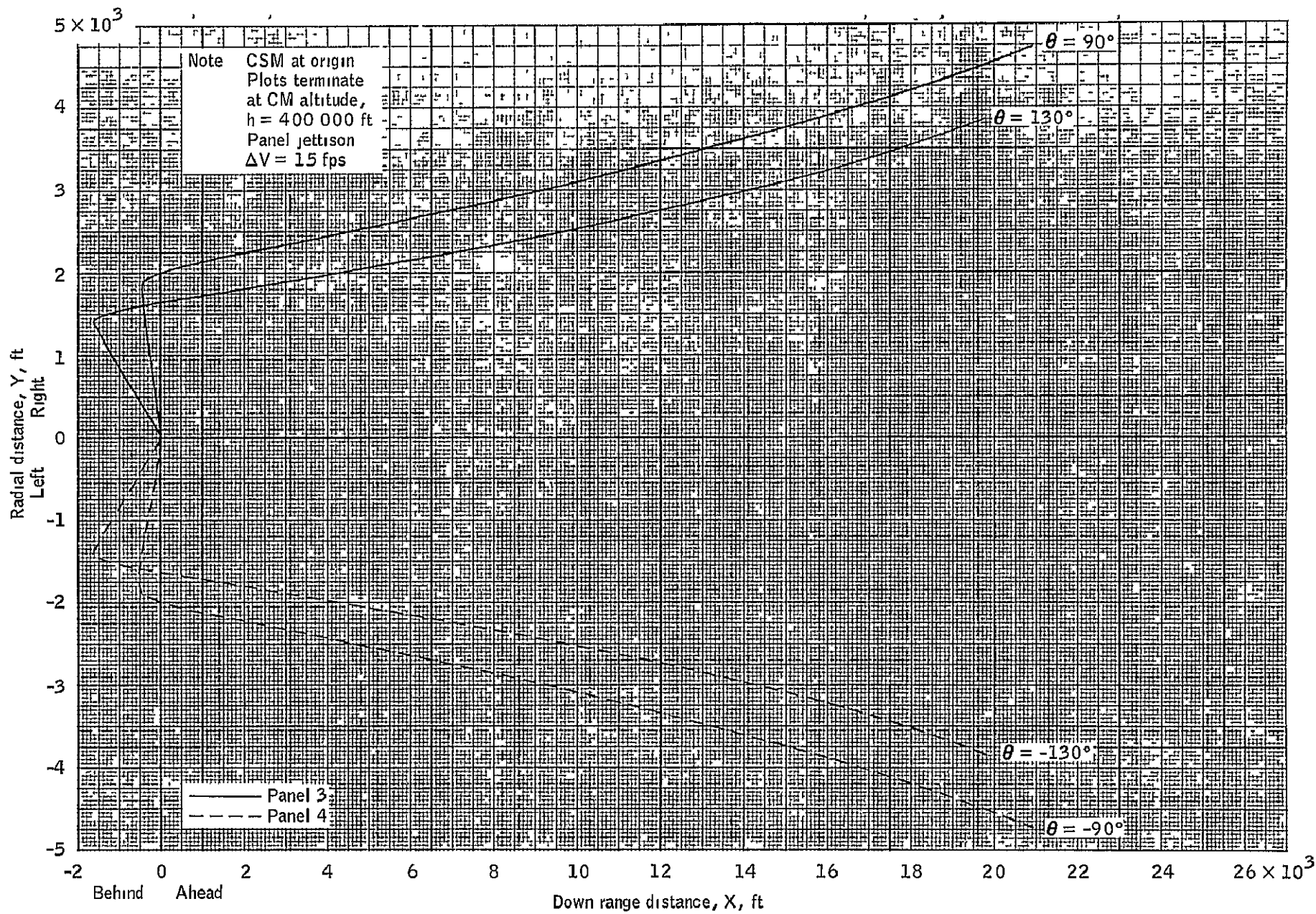

43

(j) Yawed panels for the beginning of Mode III ( $\Delta V = 15$  fps)

Figure 3.- Continued

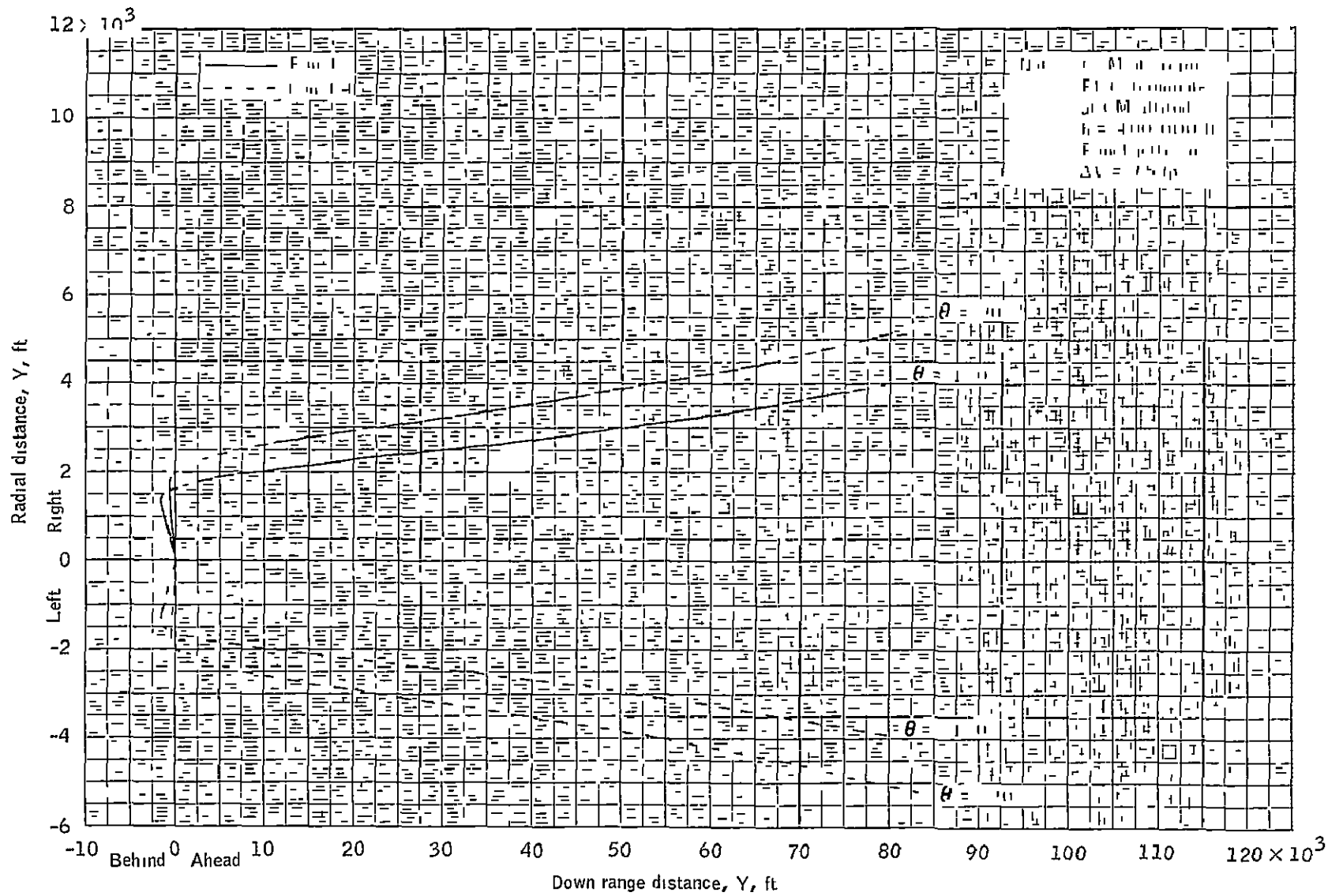

(k) Yawed panels for the middle of Mode III ( $\Delta V = 15$  fps).

Figure 3 - Continued.

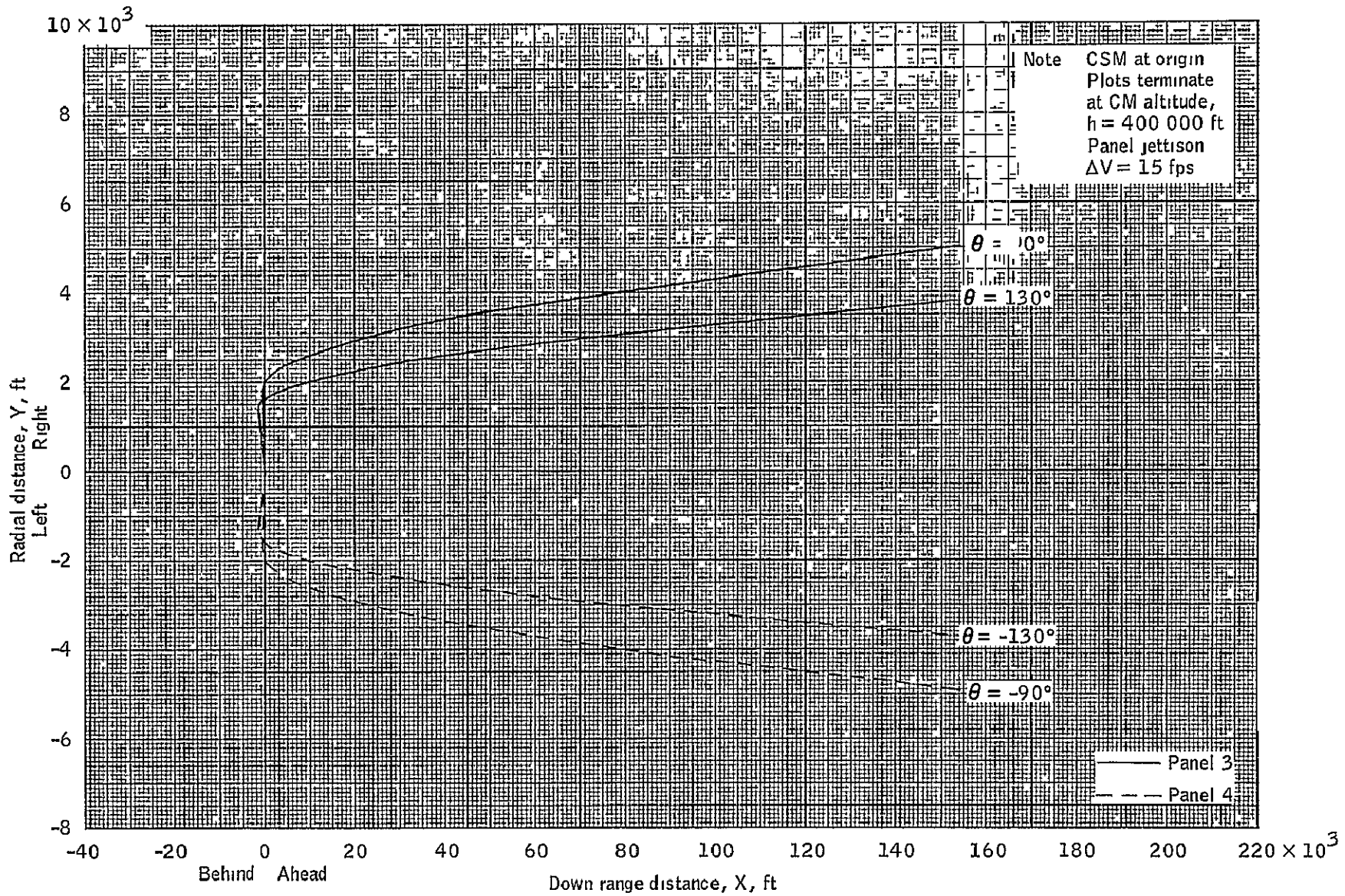

57

(1) Yawed panels for the end of Mode III ( $\Delta V = 15$  fps).

Figure 3. - Concluded.

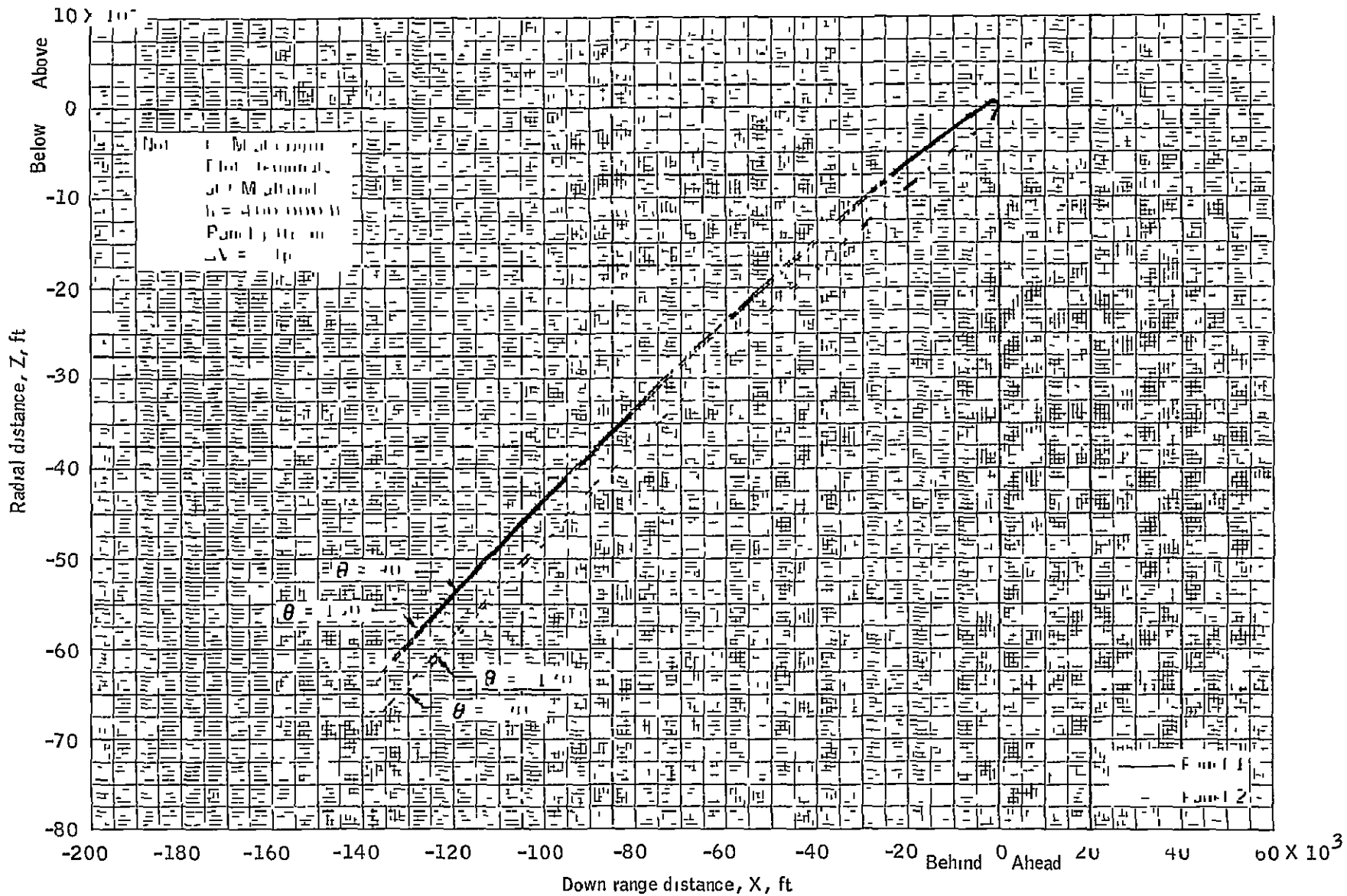

(a) Pitched panels for the beginning of Mode IV.

Figure 4 - Mode IV aborts relative motion of the SLA panel's,  $\Delta V = 8$  fps.

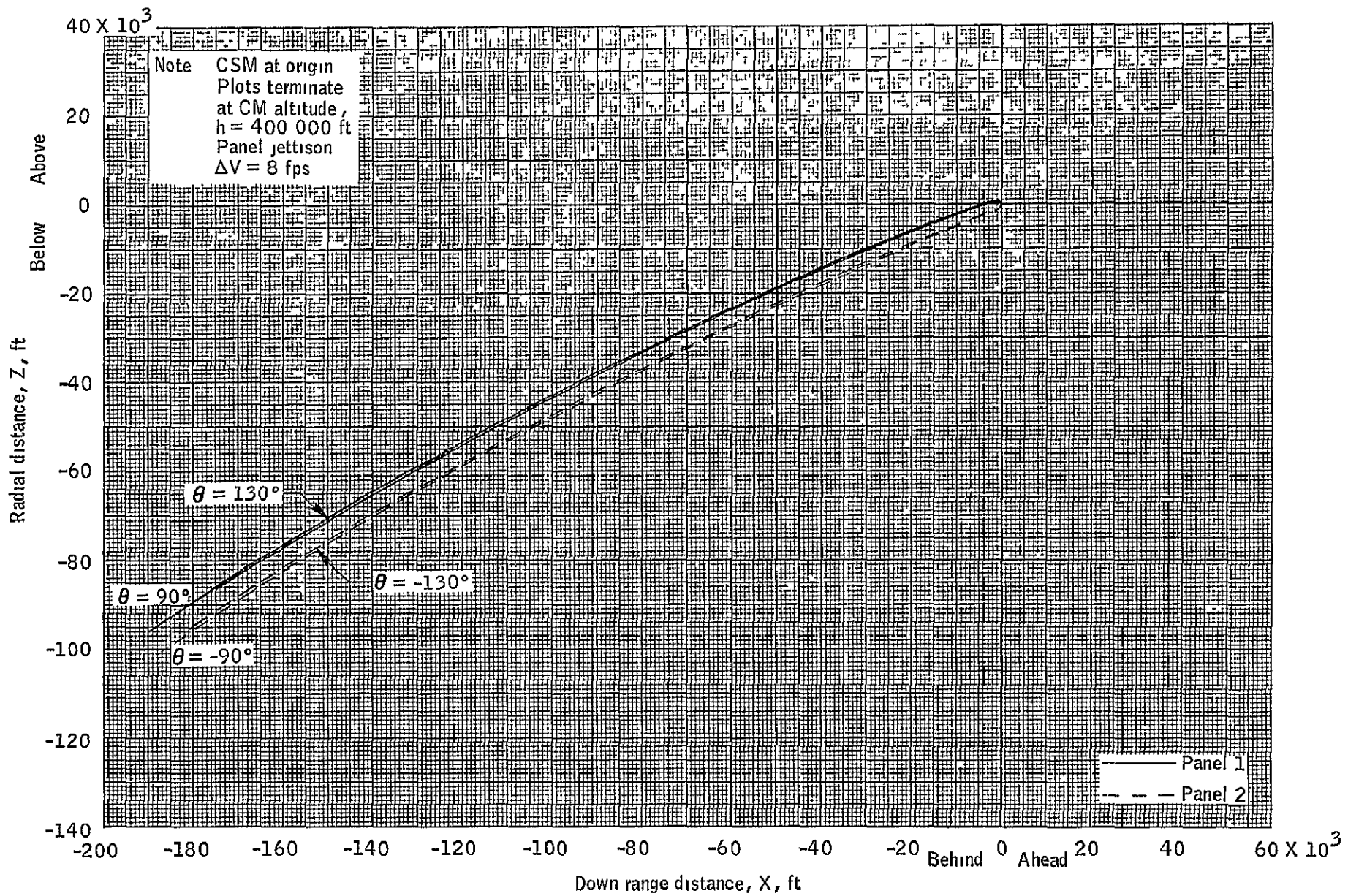

(b) Pitched panels for the middle of Mode IV.

Figure 4 - Continued.

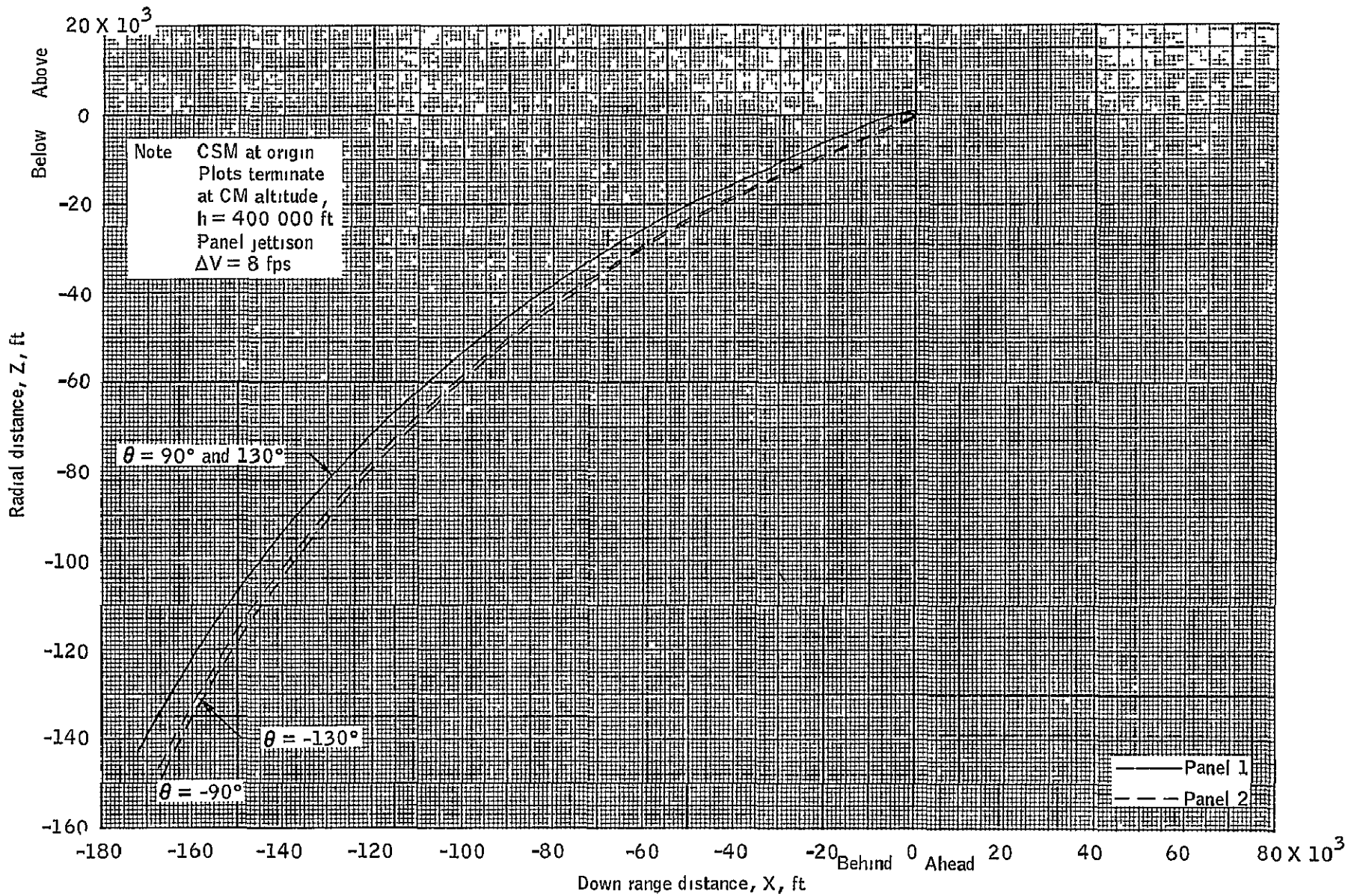

(c) Pitched panels for the end of Mode IV.

Figure 4.- Continued.

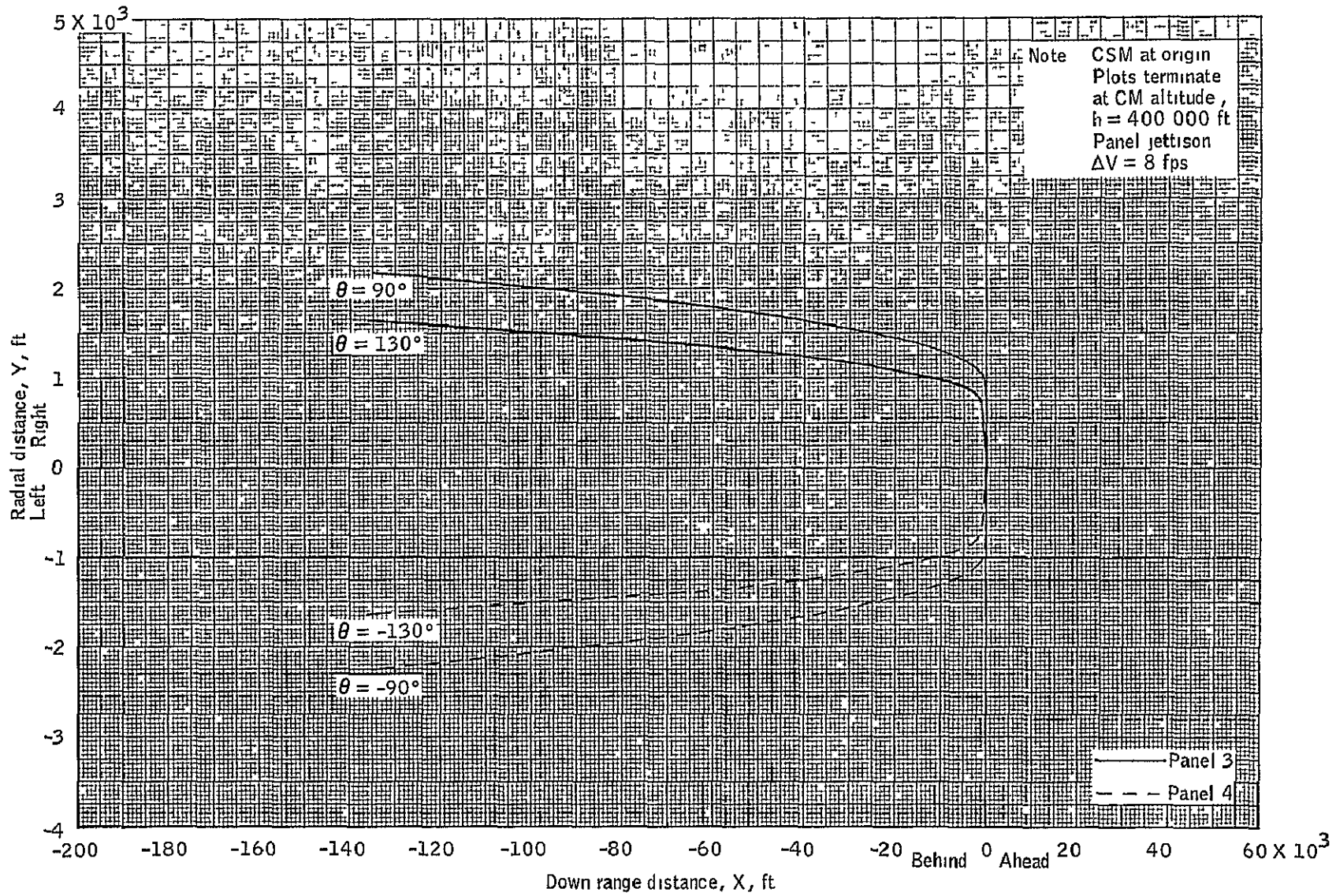

(d) Yawed panels for the beginning of Mode IV.

Figure 4.- Continued

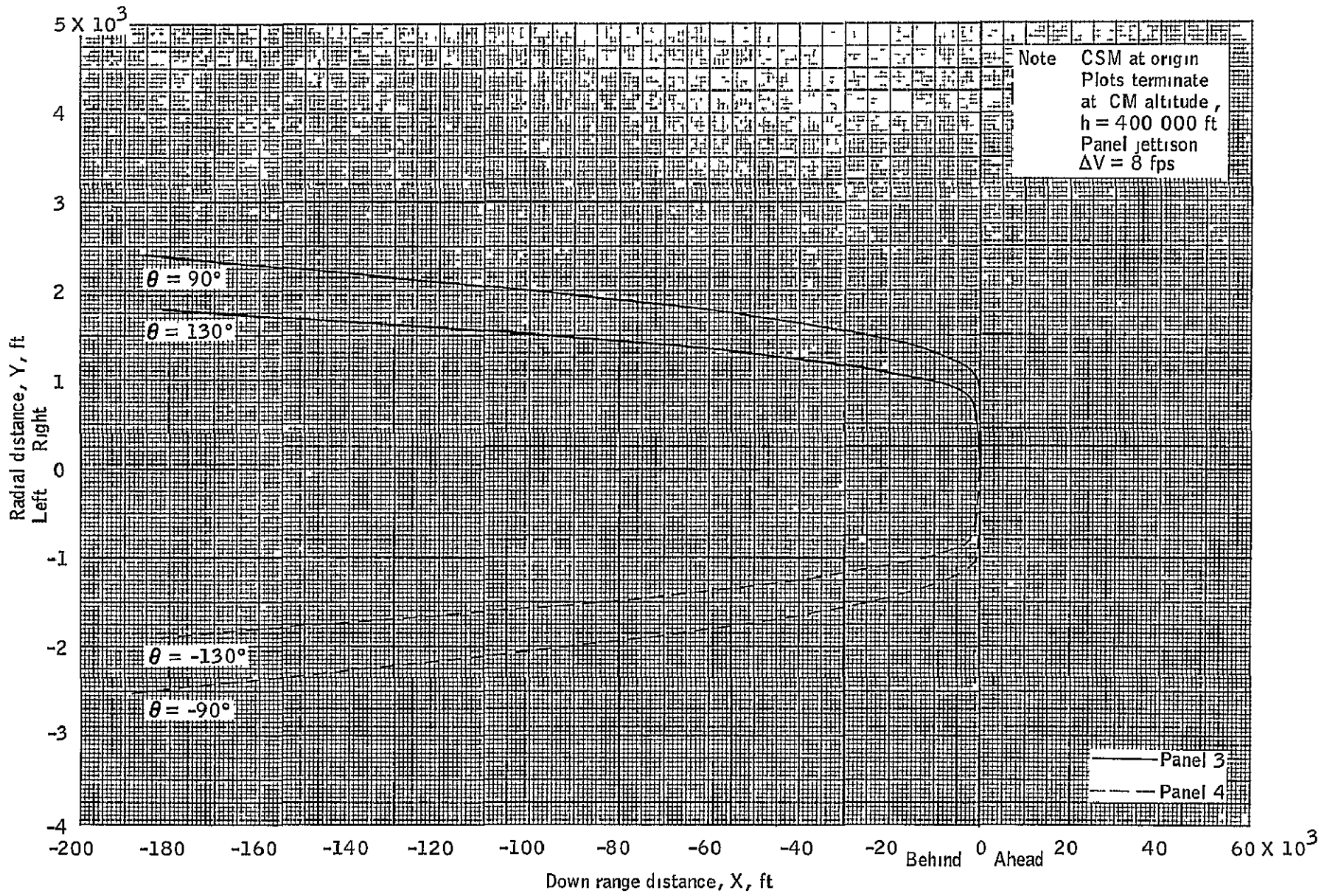

(e) Yawed panels for the middle of Mode IV.

Figure 4, - Continued.



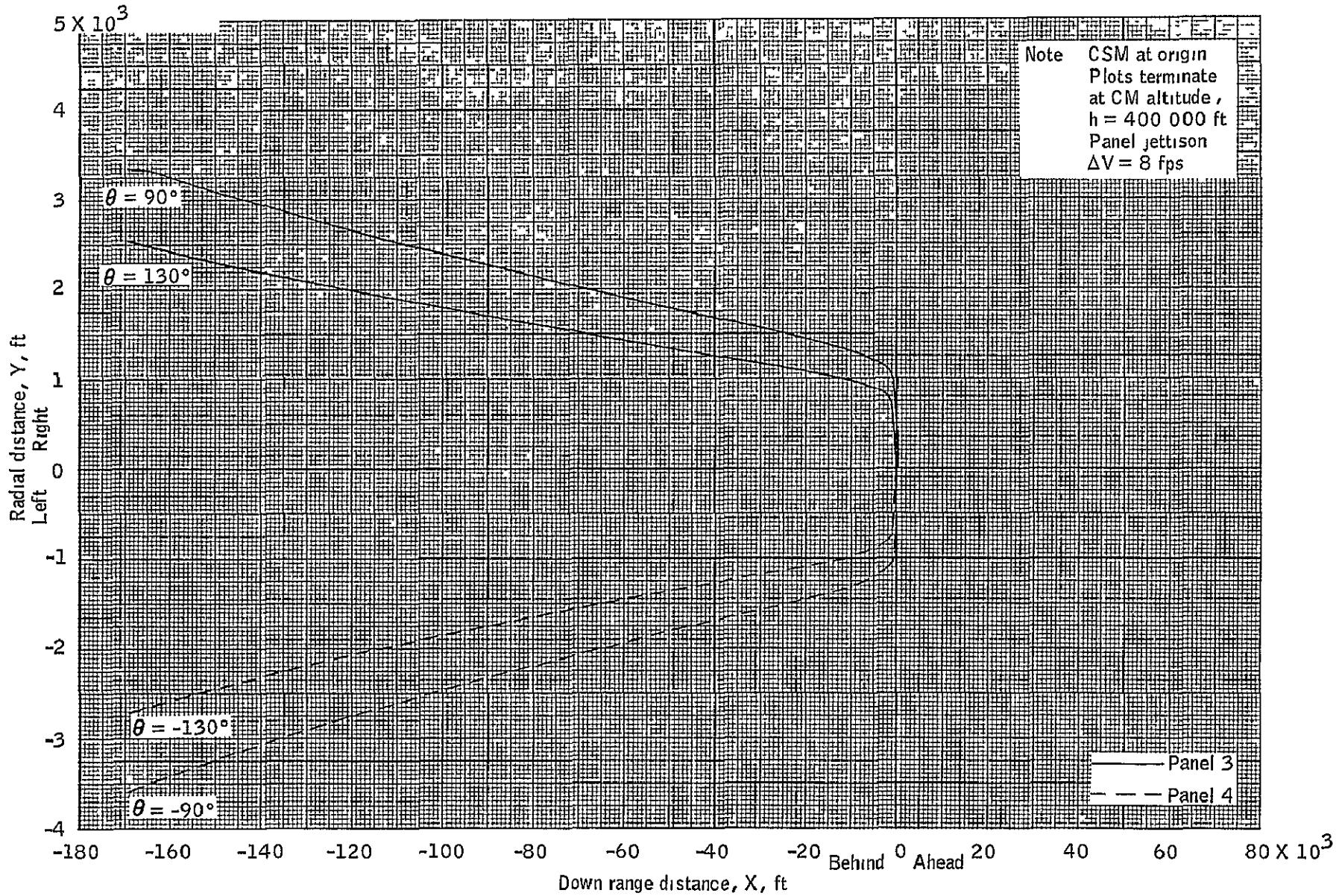

(f) Yawed panels for the end of Mode IV.

Figure 4.- Concluded.

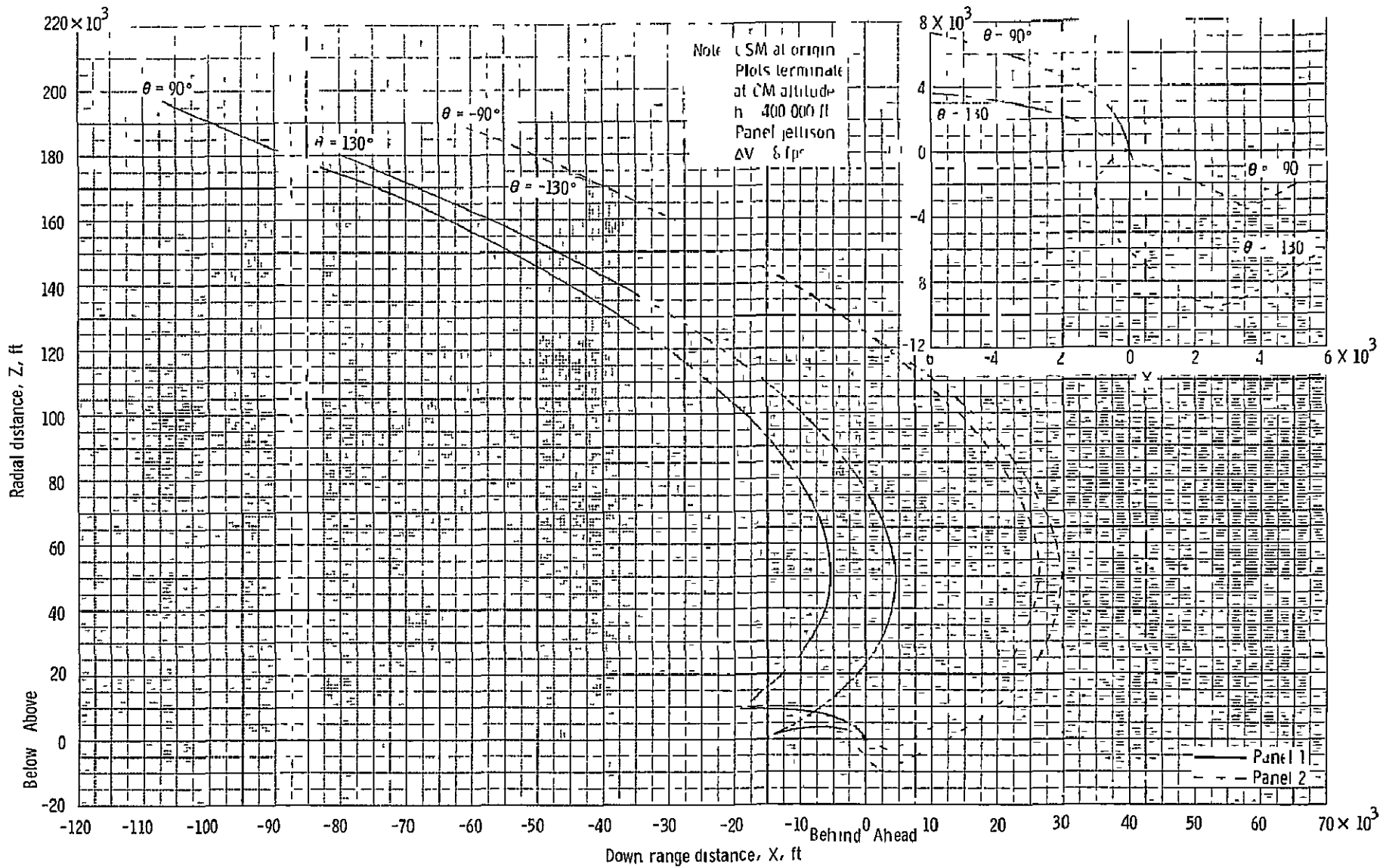

(a) Pitched panels (X-Z plane)

Figure 5 - Orbital aborts relative motion of the SLA panels for  $\Delta V = 8$  fps

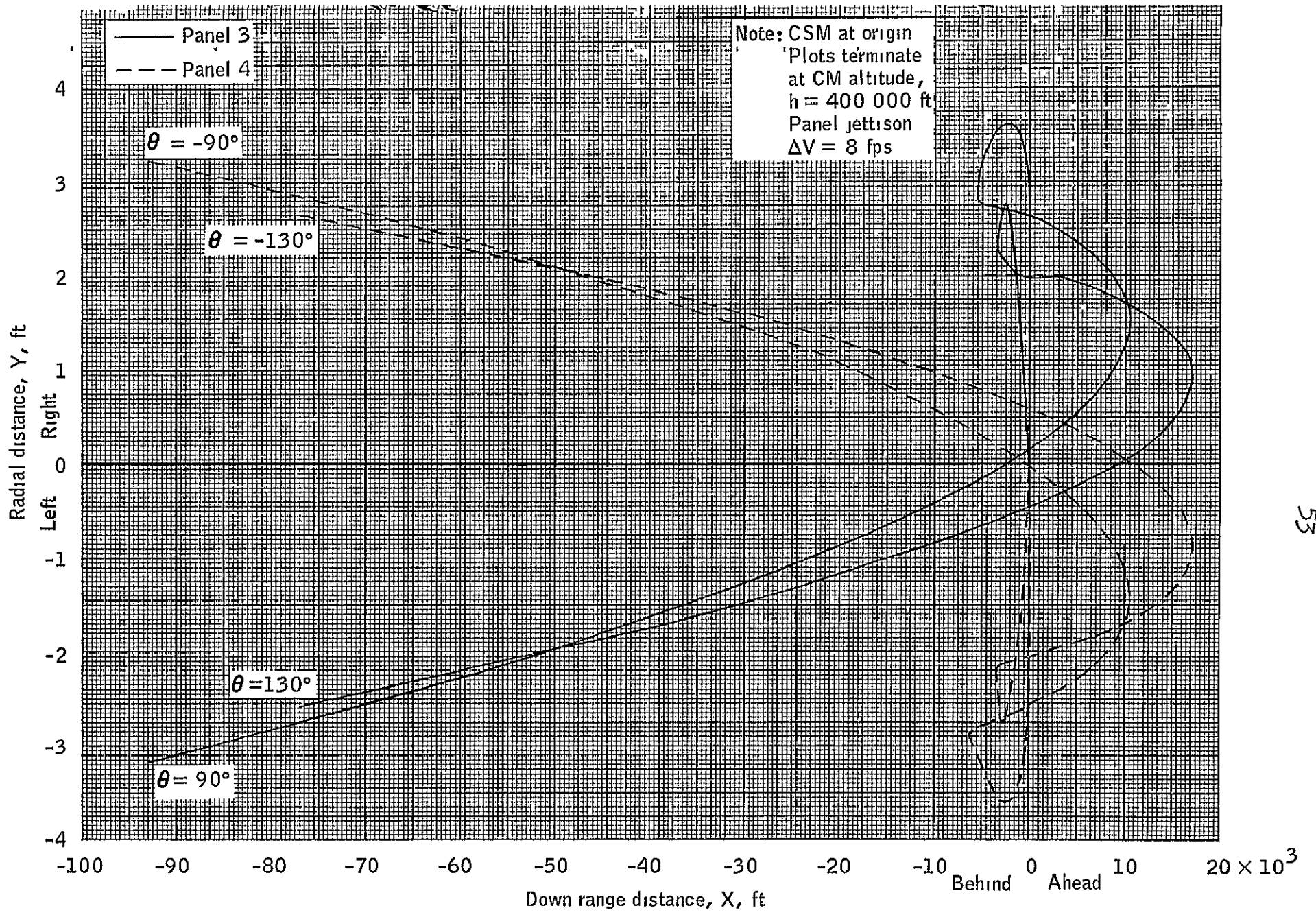

53

(b) Yawed panels (X-Y plane).

Figure 5.- Continued

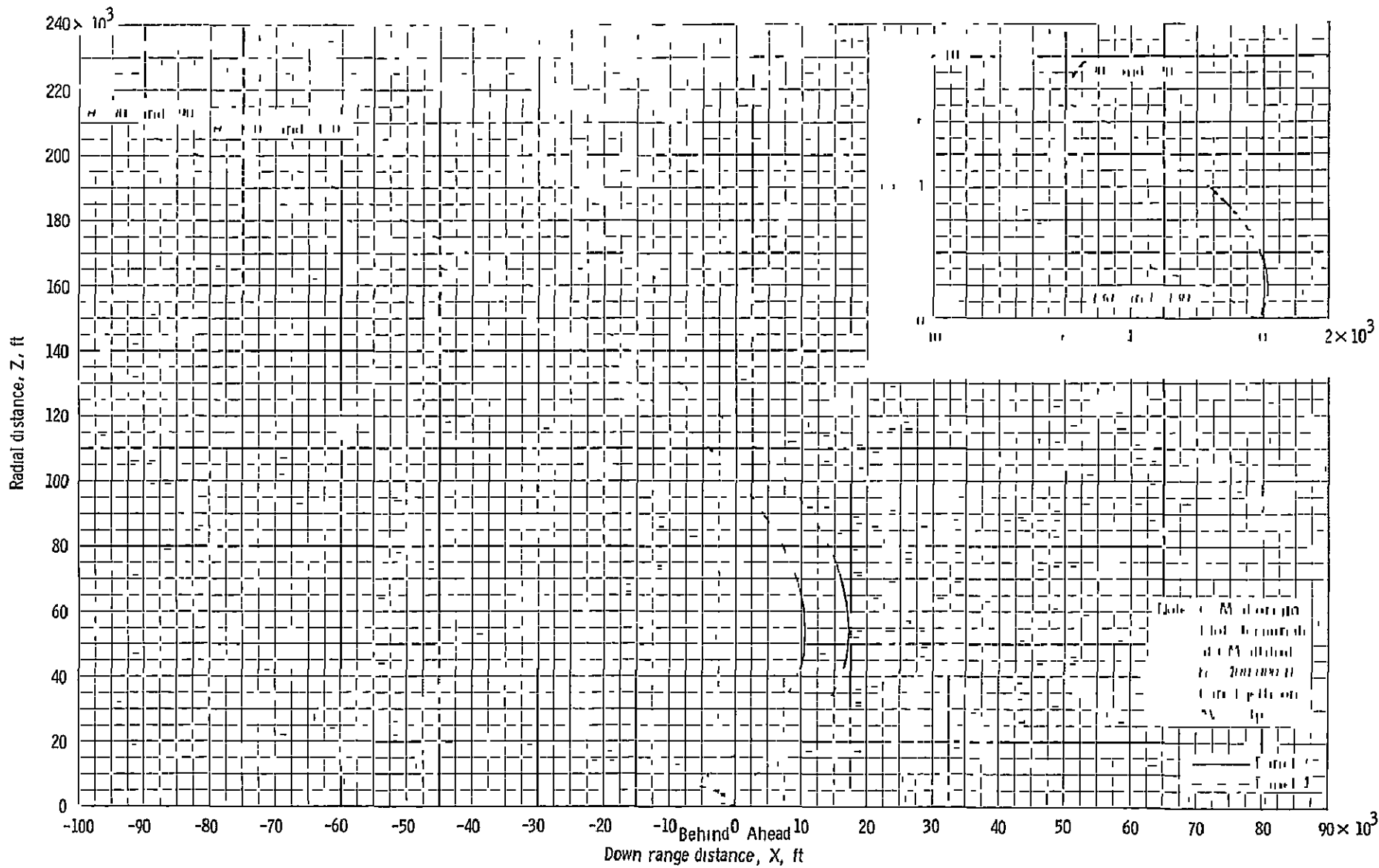

54

(c) Yawed panels (X-Z plane)

Figure 5 - Concluded

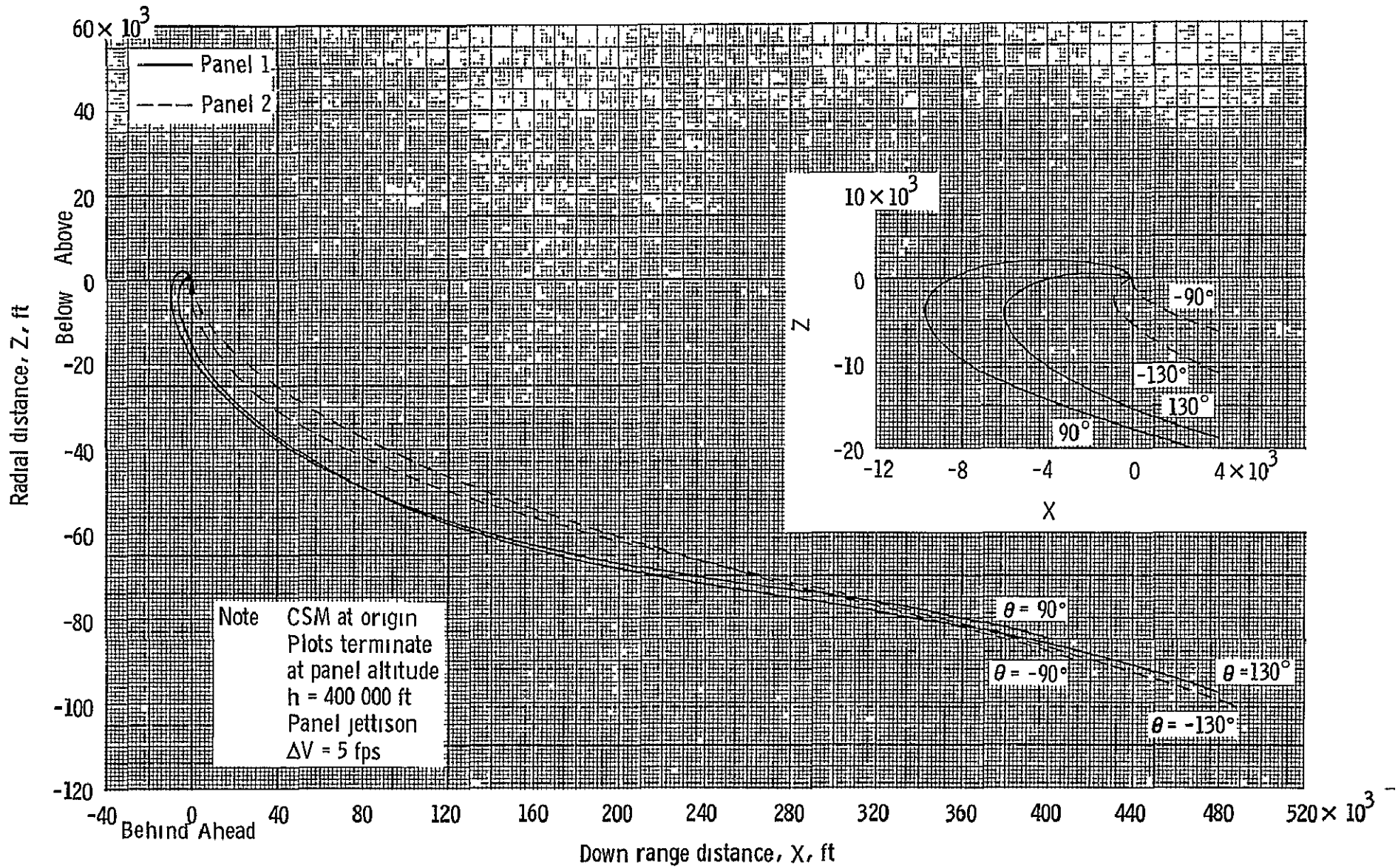

(a) Pitched panels ( $\Delta V = 5$  fps)

Figure 6.- Nominal Mission D relative motion of the SLA panels for  $\Delta V$ 's of 5, 8, and 15 fps.

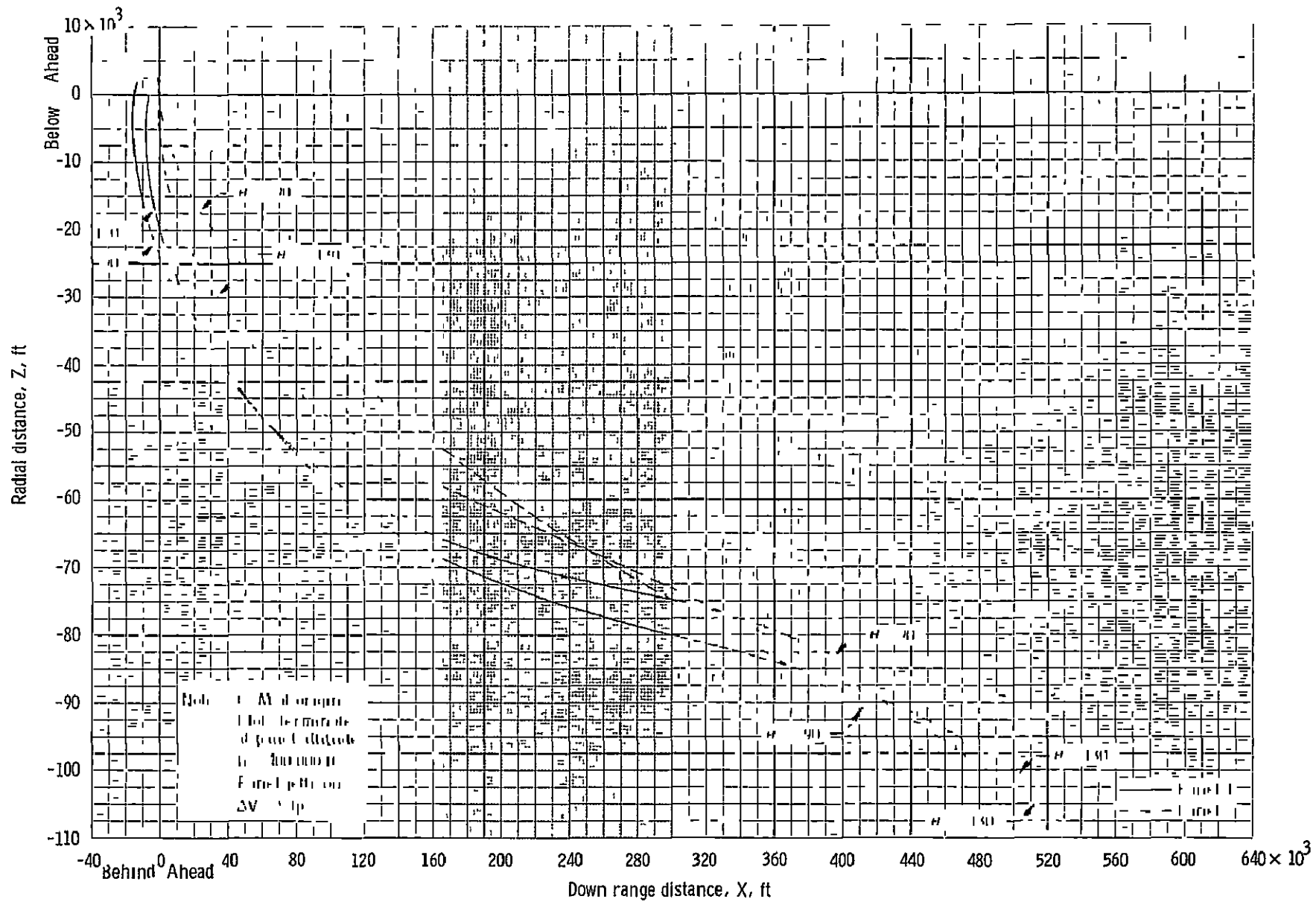

(b) Pitched panels ( $\Delta V = 8$  fps)

Figure 6 - Continued

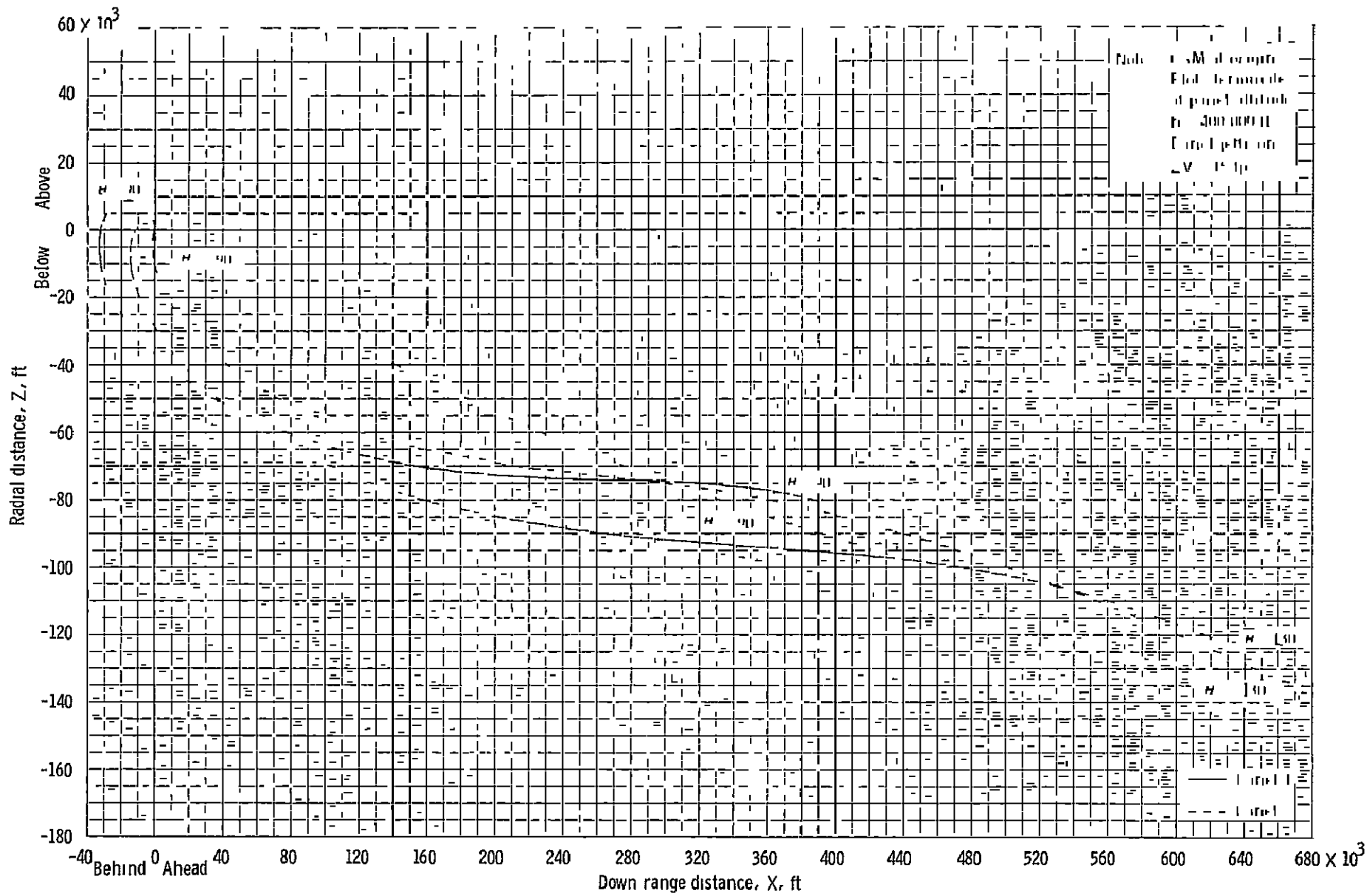

(c) Pitched panels ( $\Delta V = 15$  fps)

Figure 6 - Continued

## REFERENCES

1. Johnson, C. C.: SLA Panels Jettison. MSC Memo, April 12, 1968.
2. Williamson, Marland L.; Gott, Charles J.: SLA Panel Jettison Meeting. MSC Memo 68-FM37-223, May 7, 1968.
3. Graham, R. E.: Low Density SLA Panel Drag Coefficients. MSC Memo, April 10, 1968.
4. Henderson, E. M.: Preliminary Launch Abort Study For Apollo Mission D/CSM-103. MSC IN to be published.
5. Flight Control Division: Apollo 7 (C/CSM-101) Mission Rules. Rule number 4-22. To be published.
6. Conway, H. L. Apollo Mission D (AS-503/CSM-103/LM-3) Spacecraft Reference Trajectory, Volume II - Trajectory Listing. MSC IN 68-FM-94, April 15, 1968.
7. De Atkine, David D., Hill, Oliver Apollo Mission E (AS-504/CSM-104/LM-4) Spacecraft Reference Trajectory, Volume II - Trajectory Listing. MSC IN 68-FM-71, March 18, 1968.
8. Williamson, M. L.: SLA Panel Jettison Separation Analysis For Apollo Missions F/CSM 106/LM-5 and G/CSM 107/LM-6. MSC Memo 68-FM37-268, June 14, 1968.