

NASA CONTRACTOR
REPORT

NASA CR-61334

**CASE FILE
COPY**

PROCESSES FOR SPACE MANUFACTURING
Definition of Criteria for Process Feasibility and Effectiveness

By Dr. W. H. Steurer and D. J. Gorham

General Dynamics, Convair Division
San Diego, California 92111

June 1970

Final Report

Prepared for

NASA-GEORGE C. MARSHALL SPACE FLIGHT CENTER
Marshall Space Flight Center, Alabama 35812

TECHNICAL REPORT STANDARD TITLE PAGE

1. REPORT NO. NASA CR-61334	2. GOVERNMENT ACCESSION NO.	3. RECIPIENT'S CATALOG NO.	
4. TITLE AND SUBTITLE PROCESSES FOR SPACE MANUFACTURING Definition of Criteria for Process Feasibility and Effectiveness		5. REPORT DATE June 1970	
		6. PERFORMING ORGANIZATION CODE	
7. AUTHOR(S) Dr. W. H. Steurer and D. J. Gorham		8. PERFORMING ORGANIZATION REPORT # GDC-DBG 70-001	
9. PERFORMING ORGANIZATION NAME AND ADDRESS General Dynamics, Convair Division San Diego, Calif. 92111		10. WORK UNIT NO.	
		11. CONTRACT OR GRANT NO. NAS 8-24979	
12. SPONSORING AGENCY NAME AND ADDRESS NASA-George C. Marshall Space Flight Center Marshall Space Flight Center, Alabama 35812		13. TYPE OF REPORT & PERIOD COVERED Final Contractor Report	
		14. SPONSORING AGENCY CODE	
15. SUPPLEMENTARY NOTES Work performed for Manufacturing Engineering Laboratory, Science and Engineering George C. Marshall Space Flight Center			
16. ABSTRACT This document is the final report of an evaluation study on "Processes for Space Manufacturing". The report defines the scientific and engineering criteria used in determining the feasibility and effectiveness of space manufacturing processes and defines an R&D program for initial space manufacturing experiments. A total of 24 processes for space manufacturing are evaluated. The evaluation of each process analyzes the fundamental and technological criteria, defines the expected process and product capabilities, and outlines anticipated tooling requirements. The potentials, limitations, and priorities of each process are discussed in detail, and substantiating quantitative and qualitative data is included.			
17. KEY WORDS Materials Science Manufacturing in Space		18. DISTRIBUTION STATEMENT STAR ANNOUNCEMENT <i>A. C. Yates, Jr.</i>	
19. SECURITY CLASSIF. (of this report) U	20. SECURITY CLASSIF. (of this page) U	21. NO. OF PAGES 268	22. PRICE

FOREWORD

This report summarizes the investigations on Space Manufacturing carried out under contract NAS8-24979 for the Manufacturing Engineering Laboratory, Marshall Space Flight Center. The program was administered and monitored by I. C. Yates, Jr., (S&E-ME-A) supported by E. C. McKannan (S&E-ASTN-MM) and G. M. Arnett (S&E-SSL-TR). Basic technical guidelines were established by H. F. Wuenschel (S&E-ME-DIR).

The work was carried out by the Space Manufacturing team of the Convair division of General Dynamics, headed by Dr. W. H. Steurer and D. J. Gorham who served as program coordinator. Major contributions were made by the following team members: G. B. Wood (Liquid Mechanics and Experimentation); G. L. O'Barr (Fundamental Physics); Dr. S. Kaye (Physical Chemistry); M. L. Lanfranco (Fluid Mechanics); Dr. M. Miller (Metallurgy); S. Goodman (Materials Processing) and J. A. Pardubski (Facilities). Numerous helpful suggestions were made by Dr. Jan Raat (Theoretical Physics) and E. W. Schwartz (Thermodynamics). The efforts were closely coordinated with the Experiment Module Concepts Study (contract NAS8-25051).

Acting as program consultants, Prof. Dr. W. A. Tiller of Stanford University and Dr. J. Glasser of Chemical and Metallurgical Research, Inc., provided valuable advice in materials sciences and process applications.

The authors are further indebted to Dr. J. H. Bredt and Dr. R. R. Nash of NASA Headquarters, as well as Ken Taylor of MSFC for program reviews and recommendations.

CONTENTS

Paragraph		Page
	PART 1	
	FUNDAMENTALS	
1.1	THE NEAR SPACE ENVIRONMENT	1-1
	1.1.1 The Gravity-Gradient Field	1-1
	1.1.2 Atmospheric Pressure and Density	1-2
1.2	NATURE AND EFFECTS OF THE ORBITAL G ENVIRONMENT	1-5
	1.2.1 Definition of "G"	1-5
	1.2.2 Orbital G-Levels	1-6
	1.2.3 Drift of a Free Floating Object Within a Space Station	1-6
1.3	PHYSICS OF THE LIQUID STATE	2-4
	1.3.1 Definition of Solid, Liquid, and Gaseous States	1-7
	1.3.2 Intrinsic Pressure	1-8
	1.3.3 Surface Tension of Liquids	1-11
	1.3.4 Data on Surface Tension and Viscosity	1-18
	1.3.5 Solid-Liquid-Gas Interfaces	1-21
	1.3.6 Spreading of Liquids on Solid Surfaces	1-21
	1.3.7 Surface Tension-Induced Convection and Motion	1-23
	1.3.8 Stability of Liquid Membranes	1-25
1.4	ZERO-G LIQUID MECHANICS	1-28
	1.4.1 Intrinsic Formation of a Liquid Sphere	1-28
	1.4.2 Liquid Sphere Oscillations	1-36
	1.4.3 Deformation of a Sphere by a Uniform Force Field	1-42
	1.4.4 Deformation of a Liquid Sphere by Spinning	1-42
	1.4.5 Deformation of a Liquid Sphere Caused by a Positioning Force	1-45
	1.4.6 Distortion of Liquid Spheres Due to the Gravity- Gradient	1-45
	1.4.7 Drag Forces on Fibers and Bubbles	1-46
	1.4.8 Time to Zero-Motion for a Whisker in a Liquid	1-48
	1.4.9 Moving Liquids in Circular Pipes	1-50
	1.5 THERMODYNAMICS	1-53
	1.5.1 Heating Requirements	1-53
	1.5.2 Cooling	1-53
	1.5.3 Surface Evaporation (or Sublimation)	1-56
	1.5.4 Vaporization Rates	1-57

CONTENTS (Contd)

Part		Page
1.6	SOLIDIFICATION AND CRYSTALLIZATION	1-61
	1.6.1 Factors Affecting Nucleation	1-61
	1.6.2 Factors Affecting Crystal Growth	1-66
	1.6.3 Factors Affecting Reaction Kinetics	1-70
	1.6.4 The Effect of Gravity on the Solidification Process	1-74

PART 2 PROCESSES

2.1	BASIC PROCESSING PHENOMENA AND TECHNIQUES	2-1
	2.1.1 Absence of Buoyancy	2-1
	2.1.2 Absence of Convection	2-3
	2.1.3 Intermolecular Forces	2-4
	2.1.4 Application of Low-G Phenomena in Processes	2-5
2.2	SELECTION OF PROCESSES FOR EVALUATION	2-5
2.3	EVALUATION OF INDIVIDUAL PROCESSES	2-8
	2.3.1 Process 1: Production of Spheres	2-9
	2.3.1b Process 1b: Liquid Forming	2-18
	2.3.2 Process 2: Adhesion Casting	2-21
	2.3.3a Process 3a: Thin-Wall Hollow Spheres	2-23
	2.3.3b Process 3b: Thick-Wall Hollow Spheres	2-25
	2.3.3c Process 3c: Blow Molding	2-32
	2.3.4a Process 4a: Flat Membranes	2-34
	2.3.5 Metallic Foams	2-41
	2.3.5a Process 5a: Pressure-Stiffened and Composite Foams	2-50
	2.3.6 Composite Casting	2-52
	2.3.7 Growing of Single Crystals	2-57
	2.3.7a Single Crystal Growth From Solution	2-66
	2.3.7b Single Crystal Growth by Zone Melting	2-68
	2.3.7c Pulling of Single Crystals from the Melt	2-70
	2.3.8 Growing of Whiskers	2-73
	2.3.9 Amorphous Materials (Glasses)	2-75
	2.3.10 Dispersed Particle Castings	2-79
	2.3.11 Process 11: Thermosetting Alloys	2-81

CONTENTS (Contd)

Paragraph		Page
	2.3.12 Supercooling	2-83
	2.3.13 Supersaturated Alloys	2-83
	2.3.14 Purification	2-90
	2.3.15 Unit Separation Processes	2-92
	2.3.16 Containerless Melting of High-Temperature Alloys	2-93
	2.3.17 Superconductors	2-94

PART 3 EXPERIMENTS

3.1	OBJECTIVES AND APPROACH	3-1
3.2	EVALUATION OF PROCESS AND EXPERIMENT EFFECTIVENESS	3-2
	3.2.1 Evaluation Methods	3-2
	3.2.2 Evaluation 1. Numerical Matrix	3-4
	3.2.3 Evaluation 2. Qualitative Matrix	3-6
	3.2.4 Preliminary Definition of Experiment Priorities	3-13
	3.2.5 Summary of Effectiveness Evaluation	3-14
3.3	EXPERIMENT REQUIREMENTS AND FACILITIES	3-15
	3.3.1 Commonality Evaluation	3-15
	3.3.2 Specification of Basic Facilities	3-20
	3.3.3 Special Facilities	3-22
3.4	CONCEPTUAL DESIGN OF BASIC FACILITIES	3-24
	3.4.1 Mold Casting Chamber a, A	3-24
	3.4.2 Free Processing Chamber b, B	3-26
	3.4.3 High-Melt Free-Processing Chamber c, C	3-29
3.5	EXTRAVEHICULAR OPERATIONS AND FACILITIES	3-31
	3.5.1 Extravehicular Radiator	3-31
	3.5.2 Extravehicular Experiment Performance-Attached Mode	3-32
	3.5.3 Serpentuator-Based Experiment Performance	3-33
	3.5.4 Detached Module-Based Experiments	3-35

CONTENTS (Contd)

Paragraph		Page
3.6	DEFINITION OF AN EXPERIMENT PROGRAM	3-35
	3.6.1 Correlation of Experiment Priorities & Facilities	3-35
	3.6.2 Final Experiment Program	3-39
3.7	RESEARCH AND DEVELOPMENT REQUIREMENTS	3-42
	3.7.1 Identification of Topics and Priority Evaluation	3-42
	3.7.2 Definition	3-61
	3.7.3 Free-Fall Experiments for R&D Support	3-67
	3.7.4 Facility Development	3-68

APPENDIXES

1	TERMS AND SYMBOLS
2	REFERENCES
3	INDIVIDUALS AND ORGANIZATIONS ENGAGED IN SPACE MANUFACTURING R&D
4	GEOMETRIC SHAPES FORMED BY LIQUIDS AROUND ORIFICES UNDER CONDITIONS OF ZERO GRAVITY
5	NUMERICAL PROCESS/EXPERIMENTAL EVALUATION MATRIX

ILLUSTRATIONS

Figure		Page
1-1	Acceleration Due to Gravity g as a Function of Geometric Altitude	1-2
1-2	G-Level of Gravity Gradient versus Altitude	1-3
1-3	Pressure as a Function of Geometric Altitude	1-4
1-4	Density as a Function of Geometric Altitude	1-4
1-5	Definition of g	1-5
1-6	Force Field Plot	1-9
1-7	Vertical Molecular Forces for an Imagined Material A	1-15
1-8	Horizontal Molecular Forces for an Imagined Material A	1-16
1-9	Surface Tension	1-22
1-10	Surface Tension-Induced Convection and Motion in the Presence of a Thermal Gradient	1-24
1-11	Stability of Membranes	1-26
1-12	Liquid Movement in Membranes	1-27
1-13	Fluid Model	1-28
1-14	Correlation of Analytical Zero-g Deformation Time with NASA Drop-Test Data, Ethyl Alcohol (Ref. 1-6)	1-33
1-15	Variation of Forces and Deformation Velocity for the Transformation of a Liquid Cylinder into a Sphere	1-35
1-16	Decaying Oscillation of a Molten Copper Sphere Ten cm Diameter	1-40
1-17	Scaling of (Lightly Damped) Liquid Oscillations	1-41
1-18	Qualitative Variation of Forces and Deformation Velocity with Time for the Deformation of a Sphere of Liquid into a Non-Spherical Shape	1-43
1-19	External Force F_m Modulated Such That, at Time T , is Just Equal to the Surface Tension Force	1-44
1-20	Distortion of a Liquid Sphere by Spinning	1-44
1-21	Distortion of a Liquid Drop by Gravity-Gradient Forces	1-46
1-22	Whisker Moving in a Liquid	1-48
1-23	Variation of C_D with R_e	1-49
1-24	Flow of a Liquid in a Circular Pipe	1-51
1-25	Radiation Cooling 10-CM Diameter Sphere in Free Space	1-55
1-26	Metal Evaporation Rates in Vacuum (Mass Rate)	1-59
1-27	Metal Evaporation Rates in Vacuum (Rate of Surface Loss)	1-60
1-28	Interrelationship of Nucleation Criteria	1-62
1-29	Interrelationship of Growth Criteria	1-67
1-30	Interrelationship of Solidification Rate Criteria	

ILLUSTRATIONS (Contd)

Figure		Page
2-1	Internal Pressures Resulting from Surface Tension	2-10
2-2	Sphere Oscillations in Terms of Potential and Kinetic Energy	2-11
2-3	Damping of Sphere Oscillations	2-12
2-4	Failure Density as a Function of Ball Latitude (for 211 Failures and 10 Materials)	2-13
2-5	Processing of Liquid Spheres	2-15
2-6	Sphere Deployment Nozzles	2-16
2-7	Electrical Conductivity of Material versus Temperature	2-20
2-8	Pressures and Dimensional Characteristics of Thick-Wall Hollow Spheres	2-26
2-9	Inflation of Hollow Sphere (4kg of Copper)	2-28
2-10	Dual-Nozzle Deployment System for Thick-Wall Hollow Spheres	2-29
2-11	Techniques for Bubble Centering	2-31
2-12	Formation of Flat Membranes from Hollow Spheres	2-35
2-13	Drawing of Membranes	2-36
2-14	Identification of Variables for the Mechanical Drawing of Membranes	2-38
2-15	Conceptual Electric Tooling for Drawing of Filaments from a Liquid Sphere	2-40
2-16	Foaming by Gas Injection (Quiescent Chamber)	2-43
2-17	Foaming by Gas Injection (with Agitation)	2-44
2-18	Nucleate Foaming	2-45
2-19	Pressure in a Bubble Containing a Fixed Mass of Gas (Assuming Zero External Pressure)	2-46
2-20	Ultrasonic Foaming	2-47
2-21	Self Expansion of Pressurized Microfoam	2-51
2-22	Highest Attainable Fiber Contents for Random Orientation	2-53
2-23	Microstructure of Modified Cast Composites	2-53
2-24	Strength of Cast Composites in Comparison with Conventional Materials	2-55
2-25	Interrelationship Between Criteria for Single Crystal Growth	2-62
2-26	Interrelationship Between Criteria for Single Crystal Growth	2-65
2-27	Single Crystal Growth from a Solution	2-66
2-28	Zone Remelting Method of Zero-g Single Crystal Manufacturing	2-69
2-29	Non-Contact Melt Control for Growing Crystals	2-71
2-30	Comparison of Volume Expansion of Crystals and Amorphous Materials	2-76

ILLUSTRATIONS (Contd)

Figure		Page
2-31	Classification of Phase Diagrams with Regard to Intermetallics	2-84
2-32	Non-Contact Stirring for Mixing Gas Disposal	2-91
3-1	Overview of Evaluation Procedure (Part 3)	3-3
3-2	Process and Experiment Evaluation Matrix	3-5
3-3	Mold-Casting Chamber a	3-25
3-4	Free-Processing Chamber b	3-26
3-5	Free-Processing Chamber B	3-28
3-6	Electromagnetic Tooling	3-28
3-7	Electrostatic Positioning and Melting Chamber C	3-30
3-8	Space Manufacturing Experiments, Method B	3-32
3-9	Attached Mode, Extravehicular Experiment	3-33
3-10	Space Manufacturing Operations	3-34
3-11	Materials Science and Processing Experiment Module	3-36
3-12	Typical Chamber Components	3-69

INTRODUCTION

OBJECTIVES AND SCOPE

This document represents the final report of an evaluation study on "Processes for Space Manufacturing," carried out under contract NAS8-24979. The objective of this study was to define the scientific and engineering criteria which determine the feasibility and effectiveness of processes and, on the basis of these criteria, to formulate a program for the establishment of initial space manufacturing capabilities.

This report contains primarily the results of the investigation, while discussions are limited to those subjects whose inclusion were deemed necessary for the substantiation of the conclusions and at the same time, provide pertinent information for ensuing development efforts. The unprecedented nature of space manufacturing necessitated a broad interdisciplinary approach, including many subjects which eventually proved to be of secondary significance and which were, therefore, omitted from this report. Likewise, numerous laboratory experiments, carried out in support of the studies, remain unreported. A selected number of these experiments were documented in form of a motion picture entitled "Liquids in Zero-g".

DEFINITION OF SPACE MANUFACTURING

Space manufacturing may be defined as the manufacture of materials or finished products in orbital operations, employing unique orbital environments for the achievement of product characteristics superior to, or not attainable in, terrestrial operations. It represents a new area of space utilization. While other fields of space utilization, such as astronomy, meteorology, communications or earth resources survey consist essentially in services, space manufacturing is aimed at products and has, therefore, a considerable growth potential.

At present, and specifically in this report, space manufacturing is limited to near-earth orbital operations, even though it may eventually be extended to other orbital regimes or to operations on the moon surface. The apparent reason for this temporary limitation is the logistics requirement for the shipment of materials to, and the return of products from, orbital operations.

The technological concept of space manufacturing has been well established during the past years and may be summarized as follows:

- a. Space manufacturing is exclusively based on the utilization of the zero- or low-g condition encountered in orbital operations, since it is the only truly unique environment. This environment can be reproduced on earth only as a transient effect, too short for practical utilization.

Other components of the space environment, such as high vacua, low temperatures, solar heat, high energy radiation and the perfect black-body characteristics of deep space are not unique, as they may be reproduced - even though less conveniently - on earth. Such environments are confined to secondary applications, wherever beneficial, in conjunction with zero- or low-g processes.

- b. Space manufacturing represents processing of materials in the liquid, or more generally speaking, the fluid state of matter, in view of its high response to variations in g. The primary zero-g phenomena in liquids, which are employed in individual processes in a variety of combinations, are
 - 1. The absence of buoyancy
 - 2. The absence of thermal convection
 - 3. The unrestrained effectiveness of intermolecular forces
- c. The absence of mass acceleration, commonly referred to as weightlessness, eliminates the need for support of liquid or solid matter and is employed in contact-free processing techniques.

Space manufacturing is sometimes referred to as "space materials processing" or "space materials sciences." In an accurate interpretation of terms, they have to be considered as partial fields or developmental phases of space manufacturing in which they find their ultimate application.

POTENTIAL OF SPACE MANUFACTURING

The reasons for the expected high technical and, eventually, commercial potential of space manufacturing may be summarized as follows:

- a. The processing of matter in the liquid state under the unique environmental conditions of space offers opportunities for new products and otherwise unattainable product capabilities.
- b. The undisturbed or "clean" environmental condition can be precisely defined. The behavior and control of matter in such environments, which forms the basis of space manufacturing, can, therefore, be accurately predicted. This represents a high assurance of success.
- c. Unique products generate demand and profit opportunities. This assures a rapid growth, in the variety of processes and product types, as well as in production quantity.
- d. While presently primarily directed at structural and electronic materials or components, space manufacturing offers equally attractive applications in other disciplines and production sectors, such as chemistry, pharmaceuticals or nuclear materials.

- e. The new fundamental knowledge and technological capabilities generated in space manufacturing activities will undoubtedly enhance the advancement of science and technology for purely terrestrial applications.

From an evolutionary point of view, the most powerful assurance of a high potential of space manufacturing lies in the effective utilization of space for life on earth, as it is the ultimate purpose of space endeavors.

OUTLINE OF APPROACH AND REPORT ARRANGEMENT

In view of the newness of the subject and the absence of any experience or data, the conventional method of analysis, which starts with the assessment of existing information, had to be preceded by a number of conceptual studies with the objective of establishing a basis for the systematic evaluation.

The first task was the identification of the pertinent scientific or fundamental subjects. This was accomplished by means of a preliminary study and evaluation of all proposed or conceivable processes. In the course of this preliminary evaluation, many process concepts were eliminated because of an apparent lack of feasibility - fundamental or technological - or lack of "uniqueness" as to the employment of orbital environments.

The identified fundamental subjects were then studied in depth and the criteria, relationships, and data defined which were considered essential for the assessment of process effectiveness as well as the development of specific processes. The fundamental subjects may be divided into three types: (1) the nature of space environment and its effect upon matter; (2) subjects of significance to the application of zero-g phenomena in processing techniques, and (3) subjects not related to zero-g, yet essential to the proper functioning of processes. The selected fundamental subjects are discussed in Part I of this report.

On the basis of the established fundamental criteria and enhanced judgement, a second and more detailed evaluation of selected processes was carried out. A total of 24 processes were analyzed, some of which included a number of variations as to processing methods, material type, or product. Preference was given in the selection to processes with high potential and uniqueness, however, the primary consideration was a fairly complete and unbiased representation of typical concepts. The evaluation of each process consisted in the analysis of fundamental and technological criteria, the definition of expected process and product capabilities and the investigation of tooling requirements, in many cases supported by laboratory experiments. This evaluation is documented in Part 2 of this report.

The established information and criteria of processes and related fundamentals permitted a more systematic approach in the definition of promising space experiments and of a program for the development of initial space manufacturing capabilities. This analysis, documented in Part 3 of this report, proceeded in the following order:

- a. Definition of relative process effectiveness
- b. Definition of relative experiment effectiveness and preliminary experiment priorities
- c. Definition of experiment facility and operational requirements
- d. Definition of final experiment priorities on the basis of requirement commonalities
- e. Definition and conceptual design of basic experiment facilities
- f. Integration of experiment priorities and basic facilities in an experiment program
- g. Definition of supporting R&D requirements
- h. Formulation of an R&D program adapted to the established experiment program

A number of subordinate, yet pertinent subjects are documented in form of Appendixes.

PART 1

FUNDAMENTALS

ELEMENTS OF SPACE MANUFACTURING

The discussion of fundamentals is limited to those subjects which are of direct significance to space manufacturing. The purpose of this compilation of selected fundamental subjects is threefold:

- a. To define the nature of g and its effect upon matter, as a basis for its proper and effective application in processes
- b. To analyse specific problems encountered in process applications and operations, particularly those which are typical to all or to groups of processing concepts, and
- c. To provide a convenient reference for significant processing criteria and requirements, including those which are not directly affected by the g environment, yet are important for the proper functioning of the process.

The discussion of fundamentals is divided into six sections as follows:

- a. Definition of the near-earth space environment.
- b. Nature and effects of g , low- g and zero- g .
- c. Nature and fundamentals of the liquid state and the related properties of liquids.
- d. Pertinent problems of "liquid mechanics" as a special case of fluid mechanics.
- e. Thermodynamics and typical thermal requirements, including vaporization.
- f. Criteria of solidification and the liquid-solid interphase.

The frequently used terms, symbols, and dimensions are defined in Appendix 2.

1.1 THE NEAR SPACE ENVIRONMENT

1.1.1 THE GRAVITY-GRADIENT FIELD. The earth's gravitational field is actually not uniform but follows Newton's gravitational law; i. e., the gravitational force decreases inversely proportional to the square of the distance from the center of the earth. One consequence of this gradient is the distortion of liquid spheres in a space workshop experiment. Figure 1-2 shows the magnitude of the vertical gravity gradient - centrifugal gradient difference, in terms of G -level, as a function of the orbital radius. The

magnitude of the horizontal gravity gradient - centrifugal gradient force field is only one third that of the vertical field (Reference 1-1).

The variation of the acceleration due to gravity for the altitude regime of near-earth orbital operations is shown in Figure 1-1.

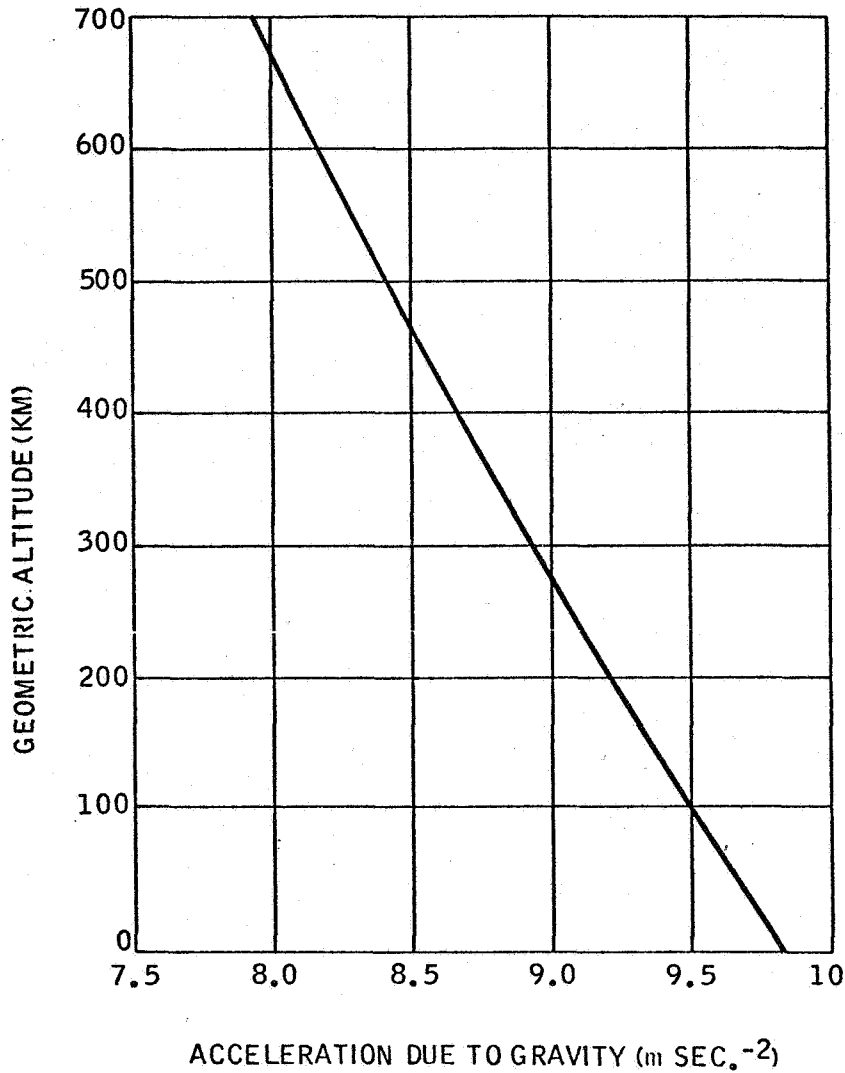

Figure 1-1. Acceleration Due to Gravity g as a Function of Geometric Altitude

1.1.2 ATMOSPHERIC PRESSURE AND DENSITY. The variation of pressure and density with altitude in the atmosphere may be found in Reference 1-2. Graphical representations of these variations are given in Figure 1-3 and 1-4.

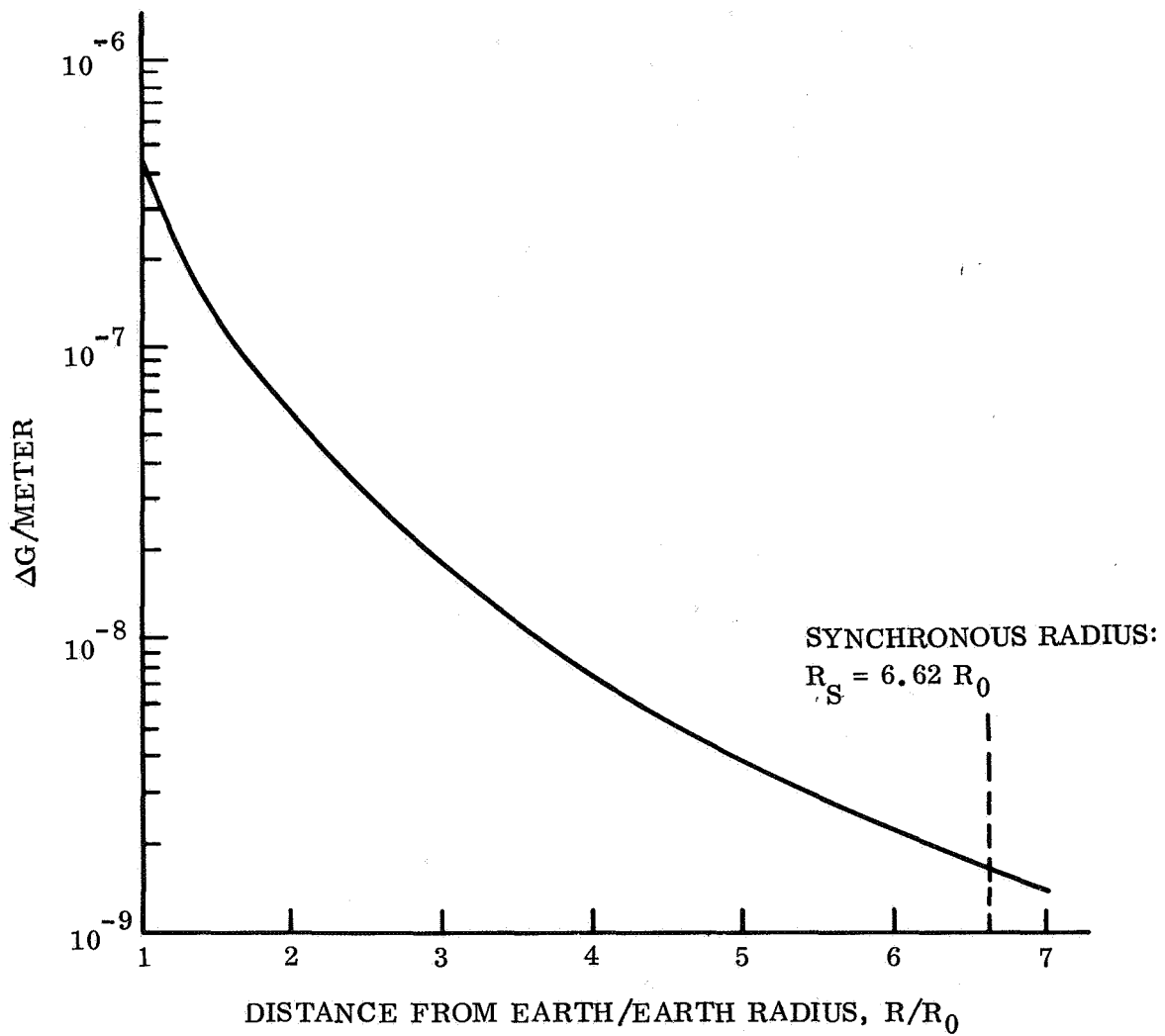

Figure 1-2. G-Level of Vertical Gravity Gradient - Centrifugal Gradient Difference versus Radius Function

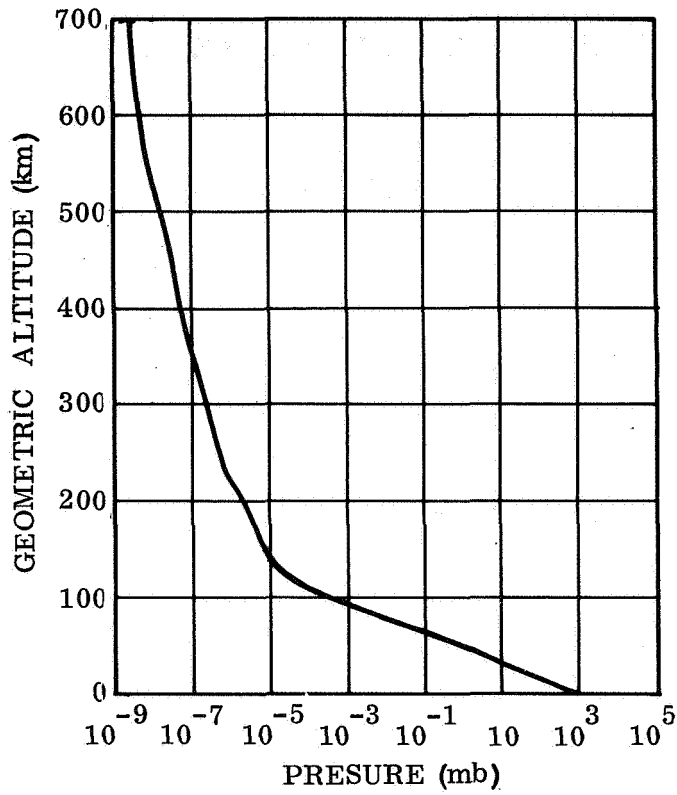

Figure 1-3. Pressure as a Function of Geometric Altitude

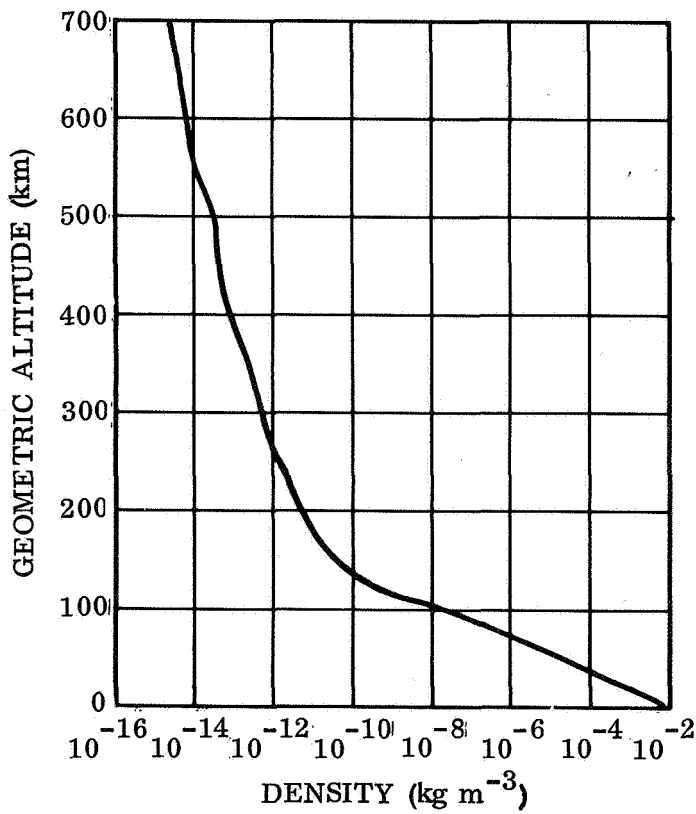

Figure 1-4. Density as a Function of Geometric Altitude

1.2 NATURE AND EFFECTS OF THE ORBITAL G ENVIRONMENT

1.2.1 DEFINITION OF "G". Even though the term "zero-g manufacturing" is often used in this report, it is apparent that absolute zero-g exists only under very rare conditions and that in most cases we deal with certain low-g levels, depending on the orbital characteristics of the vehicle and the specific position of manufacturing operations with regard to the vehicle.

The term "g" as used in this report should be clearly distinguished from the g representing acceleration due to earth gravity, which for the purpose of this clarification is defined as g_E . The g used in such expressions as "zero-g" or "low-g" defines a g-level as it is commonly used in dynamics and aerodynamics. By relating g to g_E it becomes a dimensionless value.

For a more accurate definition of the dimensionless g-level, we may consider a particle P of mass m in the gravitational field. The particle is acted upon by the gravitational force \bar{F}_{g_E} and by applied forces ΣF_{ip} , with a resultant inertial acceleration \bar{a}_p , as identified in Figure 1-5. The g-level or g, as used in the discussion, is then defined by

$$g = \frac{\Sigma F_{ip}}{mg_E} \quad (1)$$

as the sum of forces applied to P divided by m to make it an acceleration and by g_E to make it dimensionless (Ref. 1-3).

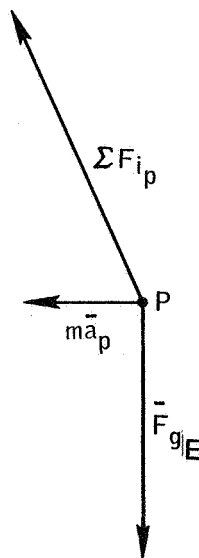

Figure 1-5. Definition of g

1.2.2 ORBITAL G-LEVELS. At the mass center of a vehicle orbiting at a given altitude, the downward gravitational force is balanced by the centrifugal force, except for the rather minute effect of vehicle drag. At this point the g-level, as defined previously, is for all practical purposes zero. For any other point of the vehicle it can be shown that the g-level in radial direction is given by

$$g = \frac{\Delta F}{m} = -3 \omega^2 \cdot \Delta r / g_E \quad (2)$$

where ω is the orbital rate and Δr the radial distance from the mass center (Ref. 1-3). Above the mass center, the distances Δr at which certain g-levels are encountered, are as follows:

<u>Distance Δr (ft)</u>	<u>g-level</u>
0.87	10^{-7}
8.7	10^{-6}
87	10^{-5}
870	10^{-4}
8,700	10^{-3}
87,000	10^{-2}

1.2.3 DRIFT OF A FREE FLOATING OBJECT WITHIN A SPACE STATION. An object in an orbiting space station whose mass center does not lie on the orbital path will describe its own trajectory within the space station. Rheinfurth (Ref. 1-1) presents the following relation for the average distance which such an object drifts in the direction of the orbital path during one orbit:

$$d = -12\pi \Delta r = -37.7 \Delta r \quad (3)$$

where Δr is the initial displacement from the orbital path. The object started from rest. The minus sign indicates that, for positions above the orbital path, the object is drifting backwards; for positions below the orbital path the object is drifting forward within the space station. It should also be noticed that the average drift distance per orbit is independent of the orbital altitude.

Approximate drift distances above the orbital path for one orbit and for a 1/2 hour experiment (max. sensitive liquid processing cycle) in a 2-hour orbit as related to the original displacement are as follows:

<u>Initial Displacement Δr (ft)</u>	<u>Drift/Orbit d_O (ft)</u>	<u>Drift/Experiment d_X (ft) approx.</u>
1	-37.7	-9.5
5	-188.5	-47
10	-377	-95
20	-754	-190
50	-1885	-470

1.3 PHYSICS OF THE LIQUID STATE

1.3.1 DEFINITION OF SOLID, LIQUID, AND GASEOUS STATES. There are many properties and/or energy relationships that can be used to differentiate between these three states of matter. These may be such functions as density, rigidity, form, elasticity, viscosity, compressibility, etc., which are normally different for each state. However, some of these relationships are only relative and exceptions often occur. Also, the solid state itself has various forms, and properties for one form are not always true for the other forms. Therefore, definitions are not usually absolute and must be accepted with caution. Probably the most meaningful relationships must deal with the intermolecular force fields between these molecules. Even here one must keep in mind that these force fields are not constant but are subject to the random motions of the molecules. Therefore, almost all relationships must be considered as the average or mean relationship for a large number of interactions. Also, these large number of interactions may be restrictive as to time or spacial extent, or to both.

The intermolecular force fields for a solid are such that the relative positions of the molecules are normally stable even under normal thermal agitations. This means that it normally takes an external force to change their relative positions. Usually the force fields are sufficiently stable that large restoring forces can be developed to return these positional changes back to their original positions. For these solids, rigidity and form elasticity, with elastic limits, etc., are important properties. For those solids in which the stability is weak or actually approaches a neutral equilibrium condition for some of the agitations existing, relative changes would be expected to occur in a random fashion. Over a long period of time, these changes could eventually add up to a fluid type flow.

For a liquid, the force fields that are developed around the molecules are not as rigid as for the solid and allow (for partial periods of time and more often than for solids) changes in relative positions of individual molecules. For a liquid, the energy of motion associated with these changes in relative positions is normally less than the total energy of attraction between the molecules.

For a gas, essentially complete freedom of movement exists, and the energy of the motion that exists between changes in relative position is normally greater than the normal energy of attraction that exists between the molecules.

In all condensed matter (solids and liquids) the cohesive (attractive) forces have balanced the natural dispersive forces due to random thermal motion. It is the nature of this balance that determines whether or not the condensed phase is a solid or a liquid. In a solid the normal molecules are under a stable force field (stable equilibrium balance) in all three dimensional directions (and usually in the rotational mode also) for all normal thermally agitated positions. In a liquid, the molecules have at least one direction (possibly randomly orientated) where a neutral or unstable

equilibrium force balance exists under the normal thermally agitated positions that occur. In at least one direction at the surface, the cohesive forces must balance the dispersive forces for the normal molecule. In a gas, no balance between the cohesive forces and the dispersive forces can be achieved in any direction.

1.3.2 INTRINSIC PRESSURE. The molecular force between a pair of molecules can often be described with the Lennard-Jones potential. This potential results in a force which is a function of the distance between the pair of molecules; a very strong, large gradient, repulsive force at close distances and a weaker, smaller gradient, attractive force at larger distances. These forces are "short range" forces in that they essentially go to zero at finite distances.

To see how these forces result in intrinsic pressures, the following simplification is appropriate. A line of imaginary atoms will be formed, and the forces between these atoms will be calculated for an assumed force field relationship. As the number of atoms increases, the repulsive force between adjacent atoms near the middle of the line will be seen to approach a constant value. This repulsive force between adjacent atoms on a one dimensional line is synonymous with intrinsic pressures in a three dimensional liquid.

The following simple force field, which entails all essential features of a force field derived from a Lennard-Jones potential is assumed:

a. $F = 400 - 100 X$
for $0 \leq X \leq \approx 4.1'$

b. $F = X - 14$
for $\approx 4.1' \leq X \leq 14'$

c. $F = 0$
for $14' \leq X < \infty'$

A plot of these force equations is made in Figure 1-6. Arbitrary units were chosen for discussion purposes only, with F in units of lb and X in feet.

If two atoms having the force field as described by the force equations were placed less than 14 feet apart on a line with zero static friction and kinetic damping, they would eventually position themselves exactly 4 feet apart. At this distance, no unbalanced forces would exist between them. The 4-foot spacing is the natural, "non-stress" condition for this force field. If a third atom were placed on this line, within 14 feet of any one of the original pair, a new balance would be achieved. This new balance would be with a distance of approximately 3.94 feet between each pair of adjacent atoms. This resulting compression, reducing the distance between adjacent atoms from the natural 4-foot spacing to an unnatural 3.94 foot spacing, results in a repulsive force existing between adjacent atoms. This repulsive force, according to

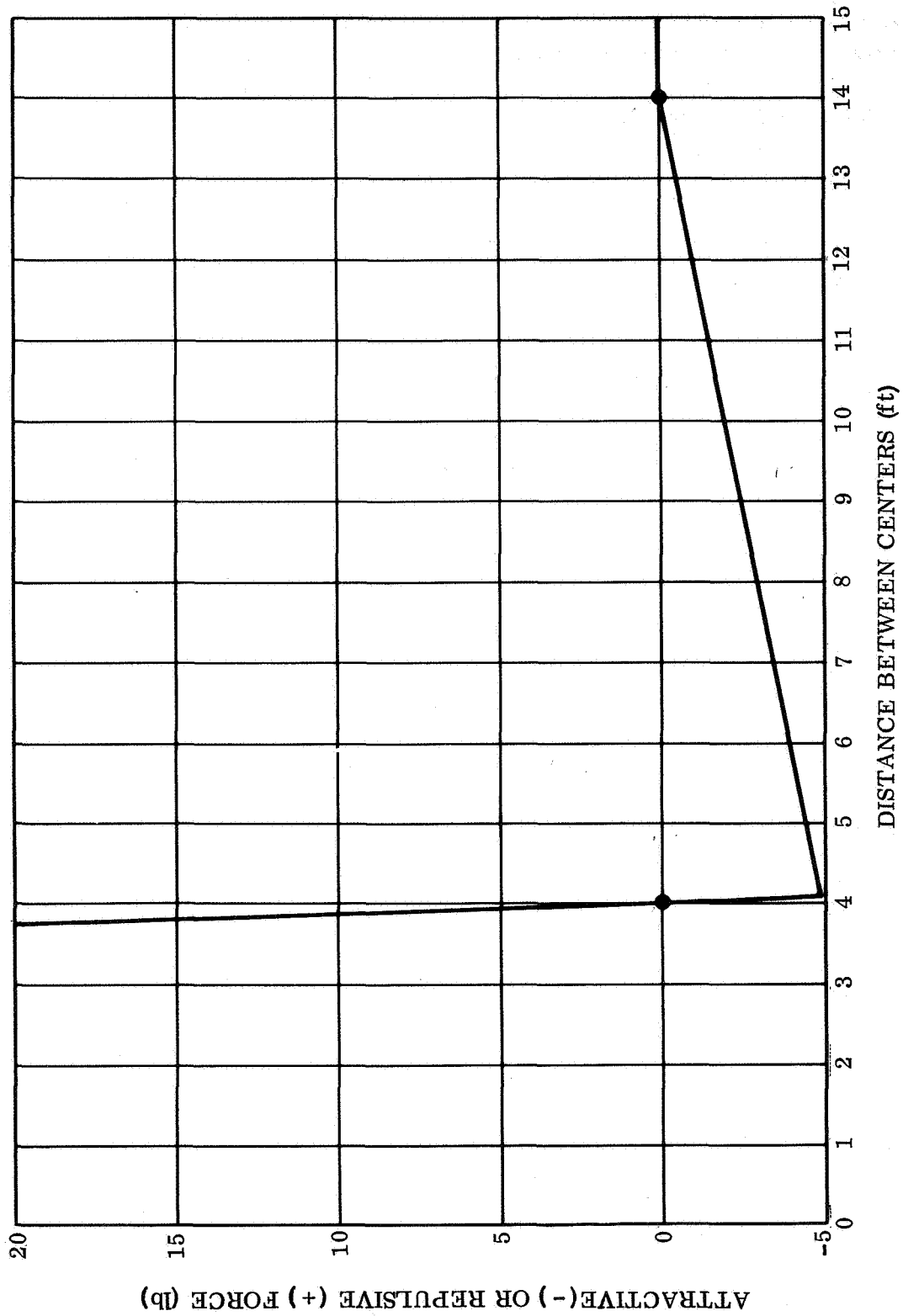
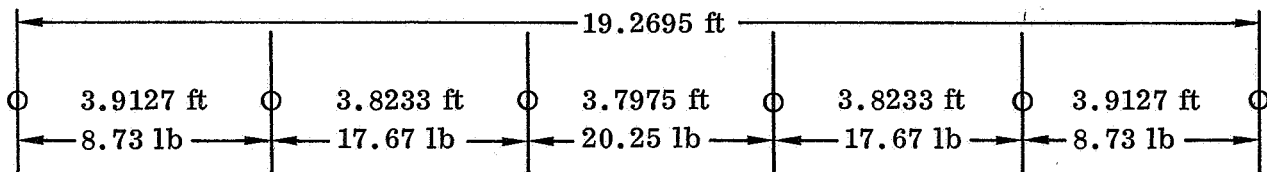

Figure 1-6. Force Field Plot

the equations given, would be approximately 6.12 lb, and is the intrinsic pressure. Between the two end atoms which are separated by the center atom, an attractive "cohesion" force of approximately 6.12 lb exists. It is this attractive "cohesion" force that has caused the compression which in turn has caused the intrinsic pressure force to be generated. Both of these forces exist at the same time, since the one exists as a result of the other.

If four of these atoms were placed on line, the center two would position themselves approximately 3.85 feet apart, and the spacing between atoms on the ends would be approximately 3.91 feet. The pressure forces would be approximately 14.8 and 8.57 lb, respectively, for these two spacings.

For five atoms, spacings and forces would be approximately 3.83 feet and 3.91 feet or 17.46 lb and 8.69 lb, respectively. For six atoms, the positions and forces would be:



If an infinite number of atoms were arranged on this line, and the spacing between each atom were observed beginning at one end, the following would be seen:

		<u>Total Distance</u> <u>from Number 1</u>
between 1 and 2	3.9127 ft = 8.7334 lb	3.9127
2 and 3	3.8230 ft = 17.7034 lb	7.7357
3 and 4	3.7953 ft = 20.4685 lb	11.5310
4 and 5	3.7935 ft = 20.6518 lb	15.3245
5 and 6	3.7931 ft = 20.6874 lb	19.1176
6 and 7	3.7931 ft = 20.6896 lb	22.9107
	etc.	

The maximum intrinsic pressure force within an infinite line of atoms with the force field given would be 20.68965 ± 5 lb. As can be seen, this maximum value is closely approached with only six atoms on a line, and with an infinite number of atoms, the 7th atom "deep" is essentially identical to the maximum possible pressure condition.

In analyzing the results of what has been done, the following important points should be noted:

First, maximum attraction does not exist between closest adjacent atoms as is normally supposed. An actual, real, repulsive force must exist between adjacent atoms

in any real, bulk assembly of atoms or molecules. Therefore, investigators who attempt to infer that all or even a majority of cohesion forces exist in the closest adjacent atoms are absolutely in error. Many investigators fail to even note the existence of intrinsic pressures, and even those that mention it do not always understand or appreciate its importance.

Second, the range of surface tension effects essentially extends as far as there are changes occurring in the intrinsic pressure force i. e., there is a finite intrinsic pressure gradient. In our particular example this range would definitely be over 20 feet. (Theoretically, the maximum intrinsic pressure is never reached with a finite number of atoms.) Many investigators infer that the range of surface tension effects are limited to the range of the Lennard-Jones potential. In this case, this would have been only 14 feet. Surface tension effects extend as far as approximately one-half of the thickness of neutrally stable films that can be formed out of the liquid involved, and for some liquids this is an order of magnitude beyond the Lennard-Jones potential.

Another important point can also be noted. Even though a net balance exists on every atom at every point, the nature of that balance is different. Near the middle of a large line of atoms, the pressure force acting against one atom in one direction only would be over 20 lb, while the net cohesive force acting on that one atom in one direction is only 9 lb. Thus, if any of the middle atoms become slightly displaced or out of line, the forces that would be developed by this action would act to increase the displacement and cause the line to collapse. Thus, knowledge of the nature of the balance is important in understanding the stability or tendencies of any particular molecular arrangement.

1.3.3 SURFACE TENSION OF LIQUIDS. The following important points relate to the study of surface tension:

- a. Intermolecular forces are short range forces. A common description (for non-polar molecules) is the Lennard-Jones potential:

$$V(r) = 4\epsilon \left(\left(\frac{\sigma}{r} \right)^{12} - \left(\frac{\sigma}{r} \right)^6 \right) \quad (4)$$

(Values of σ range from approximately 2.5 to 8 Å.)

- b. Surface tension is reported to be a maximum at 0°K and falls to zero at the critical temperature (or $\approx 6^\circ$ before T_c).
- c. One of the most basic fluid laws requires the pressure at any point in a fluid to be equal in all directions at that point.

According to the Lennard-Jones potential, two molecules allowed to move to their equilibrium point would no longer have forces acting between them. This is especially clear at 0°K. Even at finite temperatures where movement or vibrations occur, there may be no unbalanced forces over any reasonable time average. As long as forces are zero, there can be no surface tension. Also, if the surface were truly in tension in a direction parallel to the surface, and yet atmospheric or external pressures were maintained across its thickness, a law of physics would be disobeyed. None of these facts were mentioned in the literature survey.* In fact, all explanations of surface tension were found to be based on unacceptable assumptions (except for some of the energy concept approaches, which are valid but lead to little understanding of the mechanisms involved).

The key to understanding of surface tension depends upon the following concepts:

- a. We begin at 0°K (where surface tension is reported to be a maximum) and where vibration motion (ignoring zero point energies) ceases.
- b. At 0°K, any two molecules would tend to go to their equilibrium point, at which point no net forces would exist. If other molecules were added, they would each tend to take positions at which they were each at equilibrium distances apart. However, as more molecules are added (e. g. when the total becomes greater than 4), it physically (geometrically) becomes impossible for each molecule to be the same distance apart from every other molecule. It is at this point where net forces begin to appear. Those molecules "forced" to be too far away will cause other molecules to be too close together. These forces eventually result in the nearest neighbor molecules repelling rather than attracting.
- c. The most important point of item b. above is the fact that at 0°K, attractive forces can not exist between nearest neighbor molecules. (No investigator showed appreciation for this fact. In fact, attractive forces were usually indicated as a maximum for the nearest neighbor molecules.) However, for surface tension to exist, attractive forces do have to be present.
- d. In consideration of item c. above, attractive forces must appear beyond the nearest neighbor molecules and extend at least to the next nearest molecule.
- e. A separation between attractive forces and repulsive forces is important. The repulsive forces are "pressure" producing forces and pressure can be "redirected" in other directions. Attractive forces are very directional and can not be "redirected." (Only one investigator - Bakker - had some appreciation for this relationship.)

*A fair survey was conducted, but by no means exhaustive.

- f. There are many other important points relating to free or non-free surfaces, spreading coefficients, adhesive pressures, interfacial boundaries, etc., but most of these points will be covered in the following examples of surface tension.

Using the following gross concept, surface tension can be explained as follows:

At 0°K, we can assume that molecules are small square blocks, 10^{-8} cm cubes; A line of molecules, $10^{-8} \times 10^{-8} \times 1$ cm, is placed next to a semi-infinite assembly of blocks as shown in Figure 1-7. The perpendicular forces (in dynes) between the 1 cm line of molecules with each of the infinite lines of molecules in the assembly are arbitrarily assigned. (We are probably safe in doing this since surface tension exists for a large number of different materials in which these forces would certainly vary. However, some care was taken to consider symmetry, relatively short range, and the effect of angle. This is shown in that symmetry between the left and right in Figure 1-7 is maintained, the range of forces are limited to three or four layers, and lines of molecules located to the side or at large angles to the vertical are shown with zero vertical force components. Also, points b and c (page 1-12) are considered in that the nearest neighbor line of molecules is shown with a negative attraction or repulsive force. Thus, even though the forces are arbitrarily chosen, the choices were made in accordance with some reasonable guide lines.)

Once these individual forces are assigned, the total force acting on the 1 cm line of molecules can be summed. (The total attractive force would be balanced by the repulsive force, X_1 , and thus the value of " X_1 " would be determined by this same summation.) The changes in the total attractive force can also be considered if any particular line or groups of lines were removed or changed in their positions. In fact, by moving the 1 cm line to various positions within the assembly (somewhat like using a unit mass to plot a force field), the forces and pressures within the assembly can be determined at every point.

We shall now use this process to determine the pressures that exist within a liquid at each level. We will assume that the surface pressure is zero. At the top layer each 1 cm line of molecules is being acted upon by a net attractive force down equal to 32 dynes (the summation of all the individual forces shown in Figure 1-7). This force is balanced by the repulsive (pressure) force of the line of molecules immediately below. Thus, the pressure force (the force established by a pressure being exercised over a 10^{-8} cm \times 1 cm area) is 32 dynes and is shown tabulated in Column A of Figure 1-7. The average pressure - or as tabulated, the average force pressure - within the first layer is assumed to be the average between the upper and lower surface of the layer, which is 16 dynes, and is tabulated in Column B of Figure 1-7. At the bottom surface of the second layer, the pressure force will be equal to the pressure force at the top layer, plus the net attractive force acting on the second layer. The net attractive force acting on the second layer is found in Figure 1-7 by placing one layer of molecules above the 1 cm line of molecules, assigning to that layer corresponding values found in the layer at the corresponding position

below the 1 cm line of molecules, and then calculating the net forces acting on the 1 cm line. Since in this case, the layer being added has no attractive force components, the net attractive force acting is again 32 dynes and the resulting pressure force at the bottom of this layer would be 64. The average between 64 and 32 is 48 dynes and this value is shown in Column B. Placing two layers of molecules above the 1 cm line of molecules does introduce attractive forces that will now cancel some of the attractive forces below the 1 cm line of molecules, and the net force acting on the third layer is only 4 dynes, and Columns A and B are adjusted accordingly. The addition of other layers causes no other net forces (the attractive forces above the 1 cm line cancels out all of the attractive forces below the line) and therefore no further changes in pressure occurs. The final maximum pressure in this case is 68×10^8 dynes/cm². This is a tremendous pressure and is referred to in some literature as the intrinsic pressure of a liquid.

In calculating the pressure forces, we were concerned only with the force components in a direction perpendicular to the surface. These vertical forces are in themselves of no real consequences since at each and every point they are exactly balanced by a pressure force. However, considering the basic fluid law mentioned previously, the pressure acting vertically at any point is also acting equally in the horizontal directions at that point.

It now becomes important to consider the attractive force components that are acting in the horizontal direction. We can again use Figure 1-7, but now up and down becomes left and right. However, to ensure that no confusion result, Figure 1-8 is presented as a working aid. The net attractive force acting to the right of AA in the top layer would be the net forces acting on each of the 1 cm line of molecules located on the left of AA in the top layer. For the first line, a, closest to AA, the force components are as shown in Figure 1-8 and they add up to 22 dynes. The second 1 cm line from AA in the top layer, a', would also see a force to the right and would be equivalent to the sum of forces to the right of A'A', again equal to 22 dynes. The third 1 cm line, a'', would see a net force of 3 dynes (sum of all force components on the right of A''A''), and all farther 1 cm lines of atoms would experience no attractions at all to the right due to molecules located to the right of boundary AA. The total of these forces adds to 47 dynes, and is tabulated in Column C of Figure 1-7 as the cohesive force exhibited within the top layer.

The net attractive forces acting to the right of AA in the second layer is determined exactly in the same manner, except a layer of atoms is added above the surface to the right of AA with force components equal to the corresponding force components in the layer below of the same relative position. The total force in the second layer is $31 + 31 + 4 = 66$ dynes. The third layer comes to a total of 68 dynes, and all following layers show this same value. It is a mathematical equality that the maximum intrinsic pressure force and the maximum cohesive force are equal when symmetry exists as has been assumed in the preceding relationships. However, near the surface, even with perfect symmetries, these forces are not equal. It is this

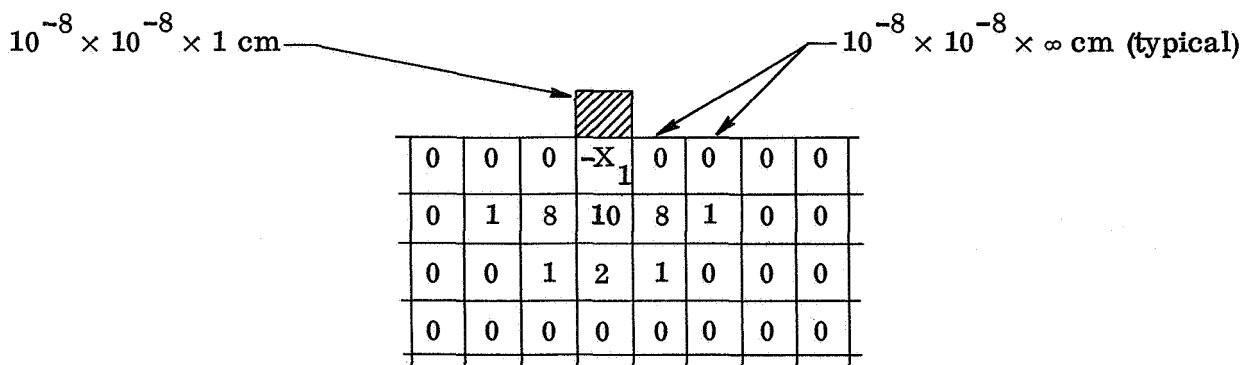

Value within each square represents the net vertical component attractive force between that line of molecules with the 1 cm line of molecules (in dynes)

A	B	C	D
Force Over $10^{-8} \times 1 \text{ cm}$ Area Between Layers	Average Pressure, Force in Each Layer	Cohesive Force	Surface Tension
Top surface = 0			
1st layer deep = 32	1st layer = 16	47	31
2nd layer deep = 64	2nd layer = 48	66	18
3rd layer deep = 68	3rd layer = 66	68	2
4th layer deep = 68	4th layer = 68	68	0
5th layer deep = 68	5th layer = 68	68	0
6th layer deep = 68	6th layer = 68	68	0
			51 dynes/cm

$$\text{Max. Intrinsic Pressure} = 68/10^{-8} \text{ cm} \times 1 \text{ cm} = 68 \times 10^8 \text{ dynes/cm}^2$$

$$\text{Max. Cohesive Strength} = 68/10^{-8} \text{ cm} \times 1 \text{ cm} = 68 \times 10^8 \text{ dynes/cm}^2$$

Figure 1-7. Vertical Molecular Forces for an Imagined Material A

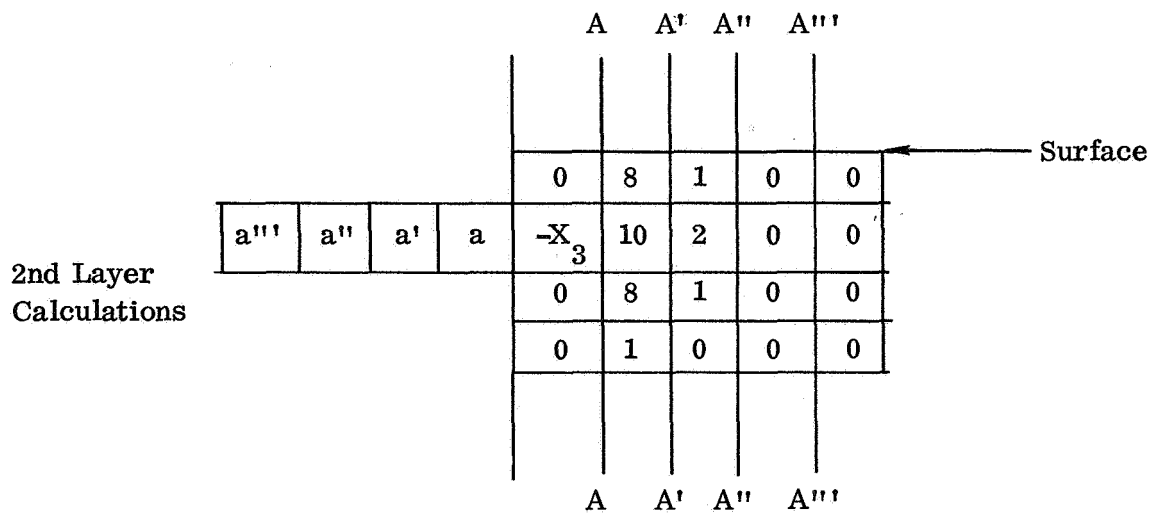
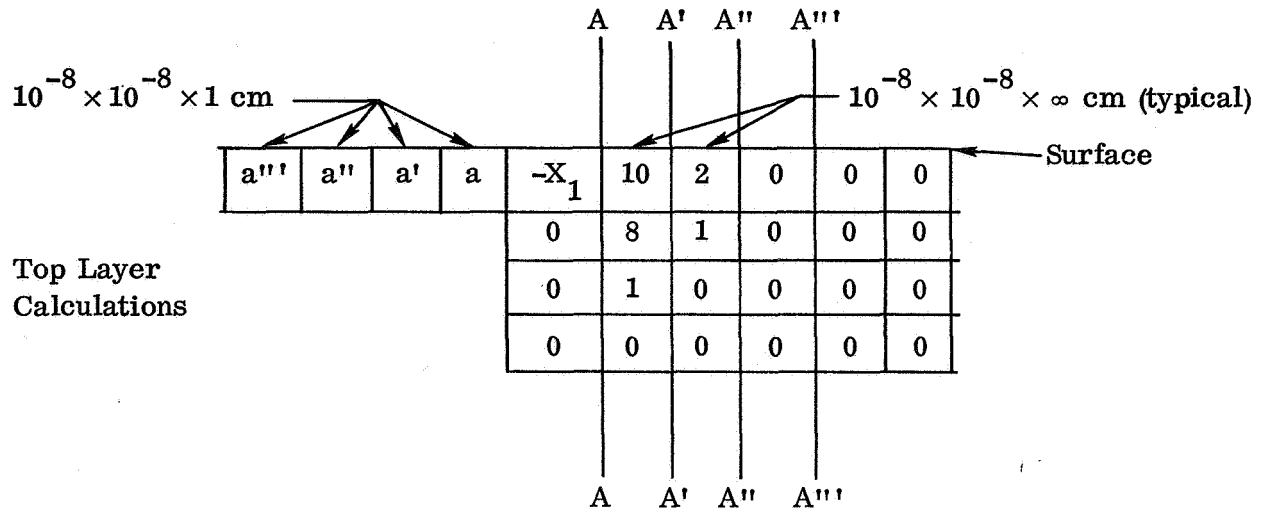

Figure 1-8. Horizontal Molecular Forces for An Imagined Material A

difference that gives rise to the phenomenon known as surface tension. The differences layer by layer, and their total values, are shown in Figure 1-7.

The following points should be noted:

- a. To the degree that the word "tension" is associated with a stress or strain resulting from external lateral forces which pull particles away from some neutral equilibrium position, surface tension is certainly a misnomer. The molecules that make up a surface, if anything, are actually under pressure, and "tensional" stresses exist only because the molecules, due to their own "physical size", prevent themselves from coming together as close as they would like even with the acting compressive pressures.
- b. The relationships established up to this point were under the assumed condition of 0°K . The introduction of finite temperature certainly would modify these relationships, but would not change any of the basic principles. With high enough temperatures, it is conceivable that even nearest neighbor molecules would be so far apart that the net effect would be an attractive force relationship. This of course does essentially happen with expanding gases. Whether a liquid could remain a liquid under these conditions is thought provoking. Possibly this is what does occur approximately 6° before critical temperatures (when surface tension goes to zero). It is true that surface tension is not a requirement for a liquid. In fact, a liquid could theoretically have a negative surface tension. The main effect of temperature is an introduction of a dispersive (repulsive type) force which in essence weakens cohesive forces, reduces intrinsic pressures, and lowers surface tensions.
- c. Intrinsic pressures are real and should play a very important roll with respect to nucleation points.

To review the essences of the previous concepts; if an imaginary plane were positioned through the surface of a liquid without disturbing any of the molecules of the liquid, two types of forces would appear acting through this plane:

- a. Attractive cohesive forces between a molecule on one side of the plane for a molecule on the other side.
- b. Pressure forces - repulsive forces - due to molecules across the plane being too close together.

Since these are the only major forces acting through this plane, then an understanding of these forces must result in an understanding of surface tension.

The gross approach used showed that the surface tension is really a difference between internal or intrinsic pressure forces and the cohesive forces. This difference

exists only near the surface. The cohesive forces are actually weaker at the surface than they are in the bulk. Intrinsic pressures are very great and would prevent formation of small vapor bubbles and explains the need for nucleation points within a liquid. A size, shape, and surface energy relationship for nucleation sites must exist. Also, at non-free surfaces, intrinsic pressure differences can result in accelerated mechanical and/or chemical degradation of these non-free surfaces.

1.3.4 DATA ON SURFACE TENSION AND VISCOSITY. Typical or "technical" data of surface tension and viscosity for materials of potential interest are compiled in Table 1-1. At the end of the table, a few other liquids are listed merely for comparison. It is emphasized that all values are approximate, as they vary with specific conditions. Surface tension is extensively dependent upon the environmental gas and pressure; both, surface tension and viscosity further vary with temperature.

The variation of viscosity with temperature for (most) metals is represented by the relationship

$$\mu = \frac{1}{C_1 (T - T_m) + C_2} \quad (5)$$

in which T_m is the melting temperature (absolute) and C_1 and C_2 constants. For most liquids, viscosity decreases with temperature as evidenced by the following data:

Liquid	Temperature °C	Viscosity dyne-sec/cm ²
Water	0	0.0179
	30	0.0080
	60	0.0047
	100	0.0028
Bismuth	285	0.0161 ⁺
	304	0.0166 [*]
	365	0.0146 ⁺
	451	0.0128 [*]
	600	0.0100 [*]
Antimony	645	0.0155
	700	0.0126
	800	0.0108
	850	0.0105

(+* = Different References)

Table 1-1. Surface Tension and Viscosity of Liquids

Material (Liquid)	Environment Gas	Temp. °C	Surface Tension σ dyne/cm	Viscosity μ dyne-sec/cm ²
Mercury	Air	15	487	0.016
Tin	H ₂	255	526	0.020
Lead	H ₂	350	453	0.028
Magnesium	Air	670	542	0.011
Aluminum	Air	700	840	0.029
Silver	Air	960	1,140	0.039
Copper	H ₂	1,130	1,100	0.034
Copper	?	1,130	1,280	0.034
Nickel	?	1,400	1,750	0.05
Iron	?	1,420	1,500	0.040
Titanium	?	1,850	1,510	--
Silica	Air	1,600	~300	5,000
Alumina	Air	2,050	690	
Water	Air	18	73	0.011
Engine Oil	Air	20	15-30	10-20
Glycerine	Air	20	(20)	15

The effect of temperature upon surface tension is somewhat more complex. It has generally been found that the surface tension is a maximum at zero degrees absolute and falls off to zero near the critical temperature. Partington (Reference 1-4), gives the following relationship:

$$\sigma_T = \frac{K}{(MV)^{2/3}} (T_c - T - d) \quad (6)$$

where

$$\sigma_T = \text{surface tension at temperature "T"}$$

$K = \text{constant}$

$M = \text{molecular weight}$

$V = \text{specific volume}$

$T_c = \text{critical temperature}$

$T = \text{temperature}$

$d = \text{constant} \approx 6 \text{ if } T \text{ and } T_c \text{ in } ^\circ\text{C}$

Also, the same reference gives ratios for some materials as follows:

$$\frac{\sigma_o}{\sigma_b} = 3.5 \quad (7)$$

and

$$\frac{\sigma_b}{\sigma_m} = 0.578 \quad (8)$$

where

$\sigma_o = \text{surface tension at absolute zero}$

$\sigma_m = \text{surface tension at melting point}$

$\sigma_b = \text{surface tension at boiling point}$

The surface tensions of liquids generally decreases with increasing temperature, the only exceptions apart from liquid crystals, are the metals cadmium, iron, and copper,

Note: Goldberg's rule $T_c = 3/2 T_b$

The effect of temperature upon the surface tension of metals is illustrated by the following examples:

Material	Temperature °C	Surface Tension dynes/cm
Liquid Bismuth and Hydrogen	300	388
	583	354
Liquid Lead and Hydrogen	350	453
	750	423
Liquid Tin and Hydrogen	253	526
	878	508
Sodium and Vacuum	100	206.4
	250	199.5
Mercury and Vacuum	0	480.3
	60	467.1

1.3.5 SOLID-LIQUID-GAS INTERFACES. Figure 1-9 shows the force balance at the all-important contact point where solid, liquid, and gas meet. Here σ represents surface tension or surface energy. For an energy vector the force balance is readily apparent. For steady conditions, the upper equation presents the situation when the contact angle β is finite. Such a situation does not necessarily exist for all gas/liquid/solid combinations. β may be zero with the liquid spreading out under the gas. The resulting inequality may then be algebraically resolved by adding to the right side of the equation a "Spreading Coefficient" which is a measure of the enthusiasm or activity of the spreading. A similar analysis may of course be made for the contact point between two immiscible liquids and a solid.

Considering a small puddle of liquid on a plate, it is readily apparent that reducing the surface tension on one side of the puddle (as by heating or contaminating it) will cause the puddle to move away, drawn by the higher surface tension at the other side. Similarly, but opposite, a gas bubble in liquid will swim toward the heat, for its surface is drawn to the cold high σ side, and so to speak, paddles the bubble through the relatively dense and viscous liquid.

1.3.6 SPREADING OF LIQUIDS ON SOLID SURFACES

1.3.6.1 In zero g on a flat surface of infinite extent, and with

$$S_f = \sigma_{SV} - \sigma_{SL} - \sigma_{LV} \text{ spreading will occur as follows:} \quad (9)$$

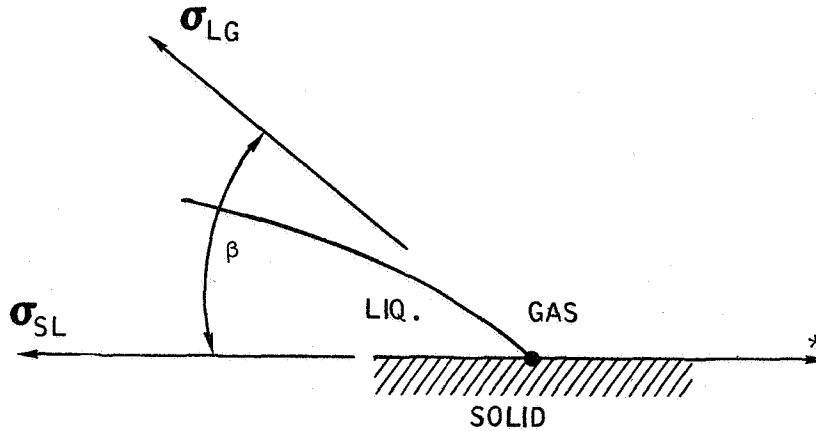

$$* \longrightarrow \sigma_{SG} = \sigma_{SL} + \sigma_{LG} \cos \beta$$

OR, FOR $\beta = 0$ $\sigma_{SG} \geq \sigma_{SL} + \sigma_{LG}$

Figure 1-9. Surface Tension

If S_f is negative, the liquid will assume the shape of a spherical segment of one base (the one base being a portion of the flat surface). The angle of contact between the spherical zone and the flat surface is defined as θ ,

where

$$\theta = \cos^{-1} \left(\frac{\sigma_{SV} - \sigma_{SL}}{\sigma_{LV}} \right) \quad (10)$$

If the area of contact is A , then:

$$A = \pi^{1/3} \frac{\sin^2 \theta V^{2/3}}{(1 - \cos \theta)^{4/3} \left(\frac{2 - \cos \theta}{3} \right)^{2/3}} \quad (11)$$

where

V = volume of the liquid.

Thus, it is seen that the area over which the liquid will spread is limited and is a function of the volume of liquid and the contact angle only.

If $S_f = 0$ or is positive (and the surface is infinite in extent), the liquid will continue to spread until it is as thin as a monolayer in thickness.

1.3.6.2 Spreading. In zero g within a spherical shell with an inside radius of R_0 :
If S_f is negative:

For very small liquid volumes compared to the inside volume of the shell, equation (11) is essentially valid. However, as the liquid volume is increased, the shape of the volume of liquid changes from an approximate one base spherical segment to two back-to-back one base spherical segments, to an inverted one base spherical segment (where the inside shell surface forms the spherical boundary of the spherical segment and the free surface of the liquid forms a flat base), to a complete sphere. All of these shapes can, of course, be described as the volume between two intersecting spheres where the radius of one remains constant, R_0 , and the other radius goes from zero to infinity back to zero, with the locus of the center going from entrance port to $-\infty$, reappears at $+\infty$ and goes to point opposite of entrance.

If S_f is positive:

The liquid will be contained in the volume between two spheres, one sphere inside the other, the outer sphere being the inside surface of the shell of radius, R_0 , and the inner sphere being the liquid-vapor interface. The radius of the inside sphere, r , would be:

$$r = \left(R_0^3 - \frac{3V}{4\pi} \right)^{1/3} \quad (12)$$

V = volume of liquid

However, the center for this radius may be located anywhere within the distance $\approx R_0 - r$ of the center of the spherical shell. (Or more exactly, $R_0 - r - a$, where a is the range of surface tension effects.)

It should be noted that in none of these cases does a constant thickness automatically result except where $R_0 - r \leq a$ or monolayer thicknesses would be approached.

In an enclosed sphere where S_f was positive, a constant thickness could be maintained if means were available to detect and locate the inside liquid surfaces and means were available to control the liquid mass. If the shape was anything other than spherical, even this could not be done unless very special force fields were present.

1.3.7 SURFACE TENSION-INDUCED CONVECTION AND MOTION. It has been shown that surface tension decreases with temperature (section 1.3.4). Any thermal gradient along the surface is therefore associated with a surface-tension gradient. This causes surface material to move from the region of higher temperature and lower surface tension to the colder region of higher surface temperature ("Marangoni Effect", Ref. 1-5). In a liquid body, such as a sphere, an internal convection effect

when

$$M \begin{cases} \ll 1 & \text{the Marangoni effect is small} \\ \gg 1 & \text{the Marangoni effect is large} \end{cases}$$

Surface tension gradients also give rise to cellular convection patterns within a liquid sphere. The gradient sets up interface motion which, in turn, augments the heat transfer within the sphere.

While the possibility of surface-tension induced convection has to be considered in all types of liquid state processing, it is of particular importance for processes which are based on the low-g phenomenon of uninterrupted convection.

1.3.8 STABILITY OF LIQUID MEMBRANES. Nothing has been found in the literature which discusses the mechanical stability of thin films or membranes. Some information has been found on the disruptive forces, however, unless it is known what these disruptive forces are acting against, only qualitative comparisons can be made. A theoretical investigation has been made into the mechanical stability of thin films. For a normal (nonpolar) material, the following points have been established:

A neutral stability range for thin films does exist. This neutral stability range occurs at a thickness of approximately $2a$ to $1a$, where "a" represents the effective depth of surface tension forces (Figure 1-11). In this range, the film will be of equal theoretical strength for any thickness and yet internal pressure gradient - cohesive force gradient differences - exist to maintain a uniform thickness.

When a thickness below "a" is reached, the film becomes very weak and can be pulled apart by the thicker sections. Above "2a", the strength remains the same, but the thickness equalization mechanism is no longer effective.

This neutral stability of thin films involves a relationship between intrinsic pressures and cohesive forces, and the fact that these two functions are affected differently by changes in thickness. As thickness is reduced, the intrinsic pressures fall off quicker than the cohesive forces, sufficiently to maintain a constant strength. This is a most remarkable relationship.

In the same process in which the strength of the film is maintained, the differences between the intrinsic pressure gradients and the cohesive gradients (Figure 1-12) will cause mass flow from thicker to thinner sections of a film. When a film is near "2a" in thickness, this action is not very strong, but as a thickness of "a" is approached, the forces can be very large.

It must be noted that the stabilization is a neutral stabilization and any stress gradients would eventually predominate for all normal materials.

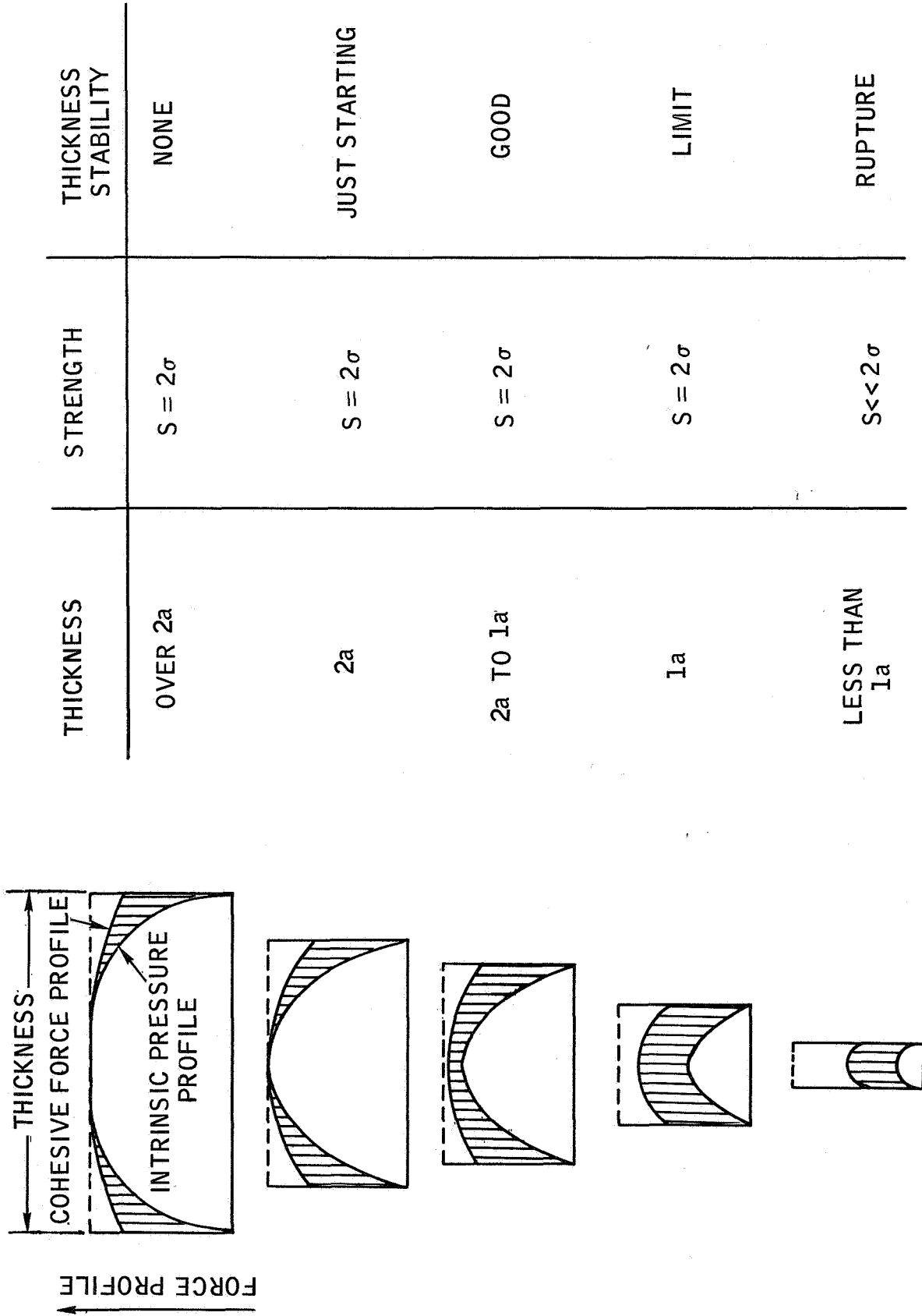

Figure 1-11. Stability of Membranes

For a mixture, or liquid with foreign atoms present, the pressure gradient and adhesive gradient effects may vary differently for the foreign atoms than for the host atoms. These effects can and do cause concentration gradients and concentration, in turn, affects surface tension. Also, depending upon the degree of concentration obtained and the relative relationships between the two types of atoms, essentially a negative surface tension can be generated over portions of the surface. These effects, among others, can increase the stability of thin films under appropriate circumstances. Probably the most important effect with a mixture is the extension of the effective reach of the surface tension forces. This is the natural result of the concentration gradient. The thicker the neutral stability zone becomes, the longer a film can exist and be the least affected by the many disruptive factors that may be present.

The mathematics for these relationships were developed for a noncompressible material at absolute zero degree temperature. It is not expected that compressibility or temperature will greatly modify the basic relationships which have been established.

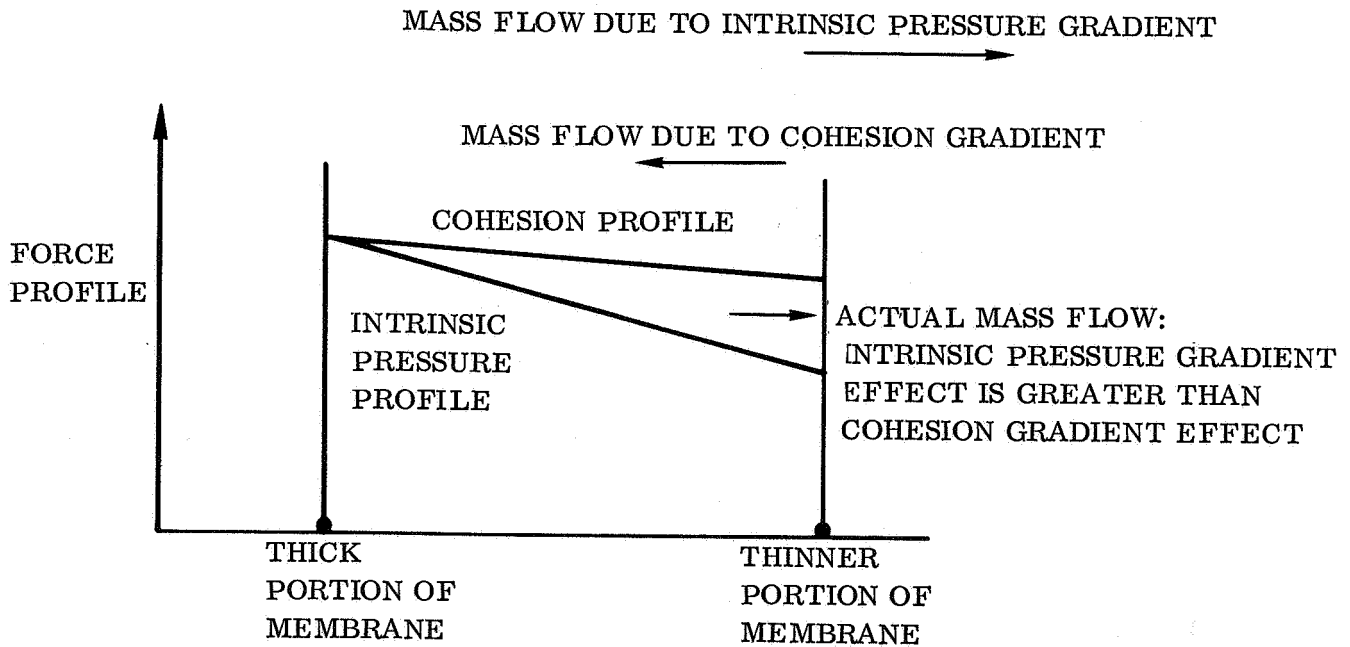

Figure 1-12. Liquid Movement in Membranes

1.4 ZERO-G LIQUID MECHANICS

1.4.1 INTRINSIC FORMATION OF A LIQUID SPHERE. For the analysis of the criteria involved in the formation of a sphere by intrinsic forces, the initial non-spherical shape is represented by a liquid cylinder.

The fluid model for the problem is shown in Figure 1-13 where the dimensions of the cylinder are of the order of the sphere radius.

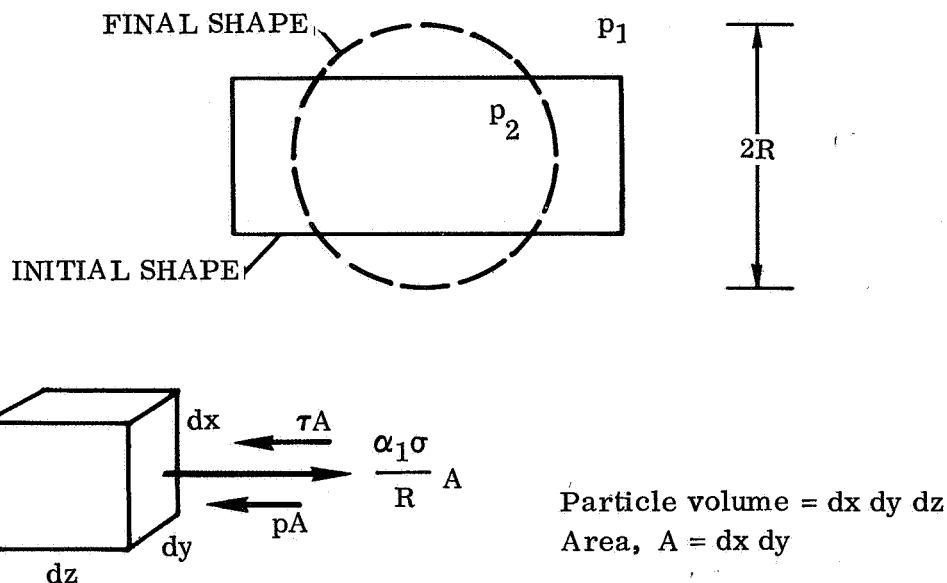

Figure 1-13. Fluid Model

Newton's law for a fluid particle of dimensions dx , dy , dz located on the cylinder at time $t = 0$

$$\Sigma F = Ma \tag{14}$$

The forces acting on the fluid particle are:

a. Surface tension force, the deforming force:

$$\frac{\partial \left(\frac{\alpha, \sigma}{R} \right)}{\partial z} dz dx dy$$

where

σ is the surface tension, $\frac{F}{R}$

α_1 is a constant, 0(1), which is related to the shape

R is the radius of the sphere

b. Pressure force, resisting deformation

$$\frac{\partial p}{\partial z} dz dx dy$$

where

p is the pressure, $\frac{F}{2R}$

c. A typical viscous force, resisting deformation

$$\frac{\partial \tau}{\partial x} dx dy dz = \mu \frac{\partial^2 V}{\partial x^2} dx dy dz$$

where

μ is the coefficient of viscosity, $\frac{Ft}{R^2}$

τ is the shear stress = $\mu \frac{\partial V}{\partial x}$, $\frac{F}{R}$

V is the velocity of the particle, $\frac{R}{t}$

d. A typical inertia force, resisting deformation

$$\rho V \frac{\partial V}{\partial z} dz dx dy$$

where

ρ is the density, $\frac{Ft^2}{R^4}$

Substituting the forces into equation (1-14) yields

$$\alpha_1 \frac{\partial \left(\frac{\sigma}{R} \right)}{\partial z} dx dy dz - \frac{\partial p}{\partial z} dx dy dz - \mu \frac{\partial^2 V}{\partial x^2} dx dy dz = \rho V \frac{\partial V}{\partial z} dx dy dz \quad (15)$$

Performing an order-of-magnitude estimate on the terms in equation (15), after dividing through by the volume $dx dy dz$:

$$V = \alpha_2 \frac{R}{t} \text{ where } \alpha_2 = 0(1) \text{ and is set equal to unity}$$

x and z are $0(R)$ and are set equal to R

Substituting into (15)

$$\alpha_1 \frac{\sigma}{R} \frac{1}{R} - \frac{\Delta p}{R} - \mu \frac{R}{t} \frac{1}{R^2} \approx \rho \frac{R^2}{t^2} \frac{1}{R}$$

or, multiplying by R

$$\alpha_1 \frac{\sigma}{R} - \Delta p - \frac{\mu}{t} - \rho \frac{R^2}{t^2} \approx 0 \quad (16)$$

Solving for t in equation (16) yields the time of deformation

$$t \approx \frac{\mu \pm \sqrt{\mu^2 + 4 \left(\alpha_1 \frac{\sigma}{R} - \Delta p \right) \rho R^2}}{2 \left(\alpha_1 \frac{\sigma}{R} - \Delta p \right)} \quad (17)$$

In equation (17) Δp (equal to $p_2 - p_1$ from Figure 1-13) may be expressed as

$$\Delta p = \alpha_3 \frac{\sigma}{R}$$

where

α_3 is a shape dependent constant, $0(1)$.

Substituting into equation (17) the term in parentheses becomes

$$\left(\alpha_1 \frac{\sigma}{R} - \alpha_3 \frac{\sigma}{R}\right) = (\alpha_1 - \alpha_3) \frac{\sigma}{R}$$

Since α_1 and α_3 are both $0(1)$, it follows that $\alpha_1 - \alpha_3 = 0(1)$ and can be set equal to α_4 which is also $0(1)$ and, for the order of magnitude estimate, can be set equal to 1. Thus equation (17) becomes

$$t \approx \frac{\mu \pm \sqrt{\mu^2 + 4 \sigma \rho R}}{2 \frac{\sigma}{R}} \quad (18)$$

Rewriting (18) and taking the plus sign

$$t \approx \frac{1 + \sqrt{1 + \frac{4 \sigma \rho R}{\mu^2}}}{2 \frac{\sigma}{R\mu}} \quad (19)$$

One could also introduce the Reynolds number and Weber number into equation (19) as follows:

$$R_e = \frac{\text{inertia force}}{\text{viscous force}} = \frac{\rho VR}{\mu}$$

$$W = \frac{\text{inertia force}}{\text{surface tension force}} = \frac{\rho RV^2}{\sigma}$$

Now substituting $\frac{R_e^2}{W} = \frac{\sigma \rho R}{\mu^2}$ into equation (19) yields

$$t \approx \frac{1 + \sqrt{1 + 4 \frac{R_e^2}{W}}}{2 \frac{\sigma}{R\mu}} \quad (20)$$

Examples of values for the deformation time t for different liquids using equation (19) with $R = 10$ cm and 1 cm are as follows:

Liquid	Temp °C	σ Dyn/cm	μ Dyn-sec/cm ²	$\frac{\rho}{\text{cm}^4}$ Dyn-sec ²	$4 \frac{R_e^2}{W}$	t sec (R=10)	t sec (R=1)
Water	18	73	0.011	1	2.41×10^7	3.7	0.117
Copper	1, 131	1, 103	0.038	8.91	2.72×10^8	2.84	0.09

Since $4 \frac{R_e^2}{W} \gg 1$ for the above liquids, equation (19) reduces to

$$t \approx \left(\frac{\rho}{\sigma} \right)^{1/2} R^{3/2} \quad (21)$$

thus arriving at the important conclusion that relative to the inertia and surface tension forces, the viscous force is negligible for these liquids. Note that equation (21) is exactly equation (17) given by Paynter in Reference 1-6. Paynter's derivation consists of equating the change in free surface energy to the change in kinetic energy of the liquid contained in a sphere of radius $\approx 0(R)$ and neglecting viscosity. A correlation using a relationship having the form given by equation (21), of some drop test data for ethyl alcohol is presented in Figure 1-14 taken from Reference 1-6.

The present derivation gives expressions for the separate forces and their relative magnitudes and demonstrates that the viscous force is negligible. With regard to viscosity, Paynter goes on to state, p. 1630 in Reference 1-6, that "viscous energy, neglected in this analysis, explains the variation in H (a correlation coefficient which is a function of R) at the smaller container sizes ($R < 1.0$ ft) where liquid shear becomes significant." Table 1-2 shows that, at least for water and copper, even though the viscous force increases by a factor of about 30 as R decreases from 10 cm to 1 cm, the viscous force is still negligible when compared to the surface tension force and even the inertia force. Hence, including viscous energy will not explain the variation in H at the small container sizes.

Expressions for the separate forces per unit area are given below

$$\text{Surface tension: } F_{ST}/A \approx \frac{\alpha_1 \sigma}{R} \quad (22)$$

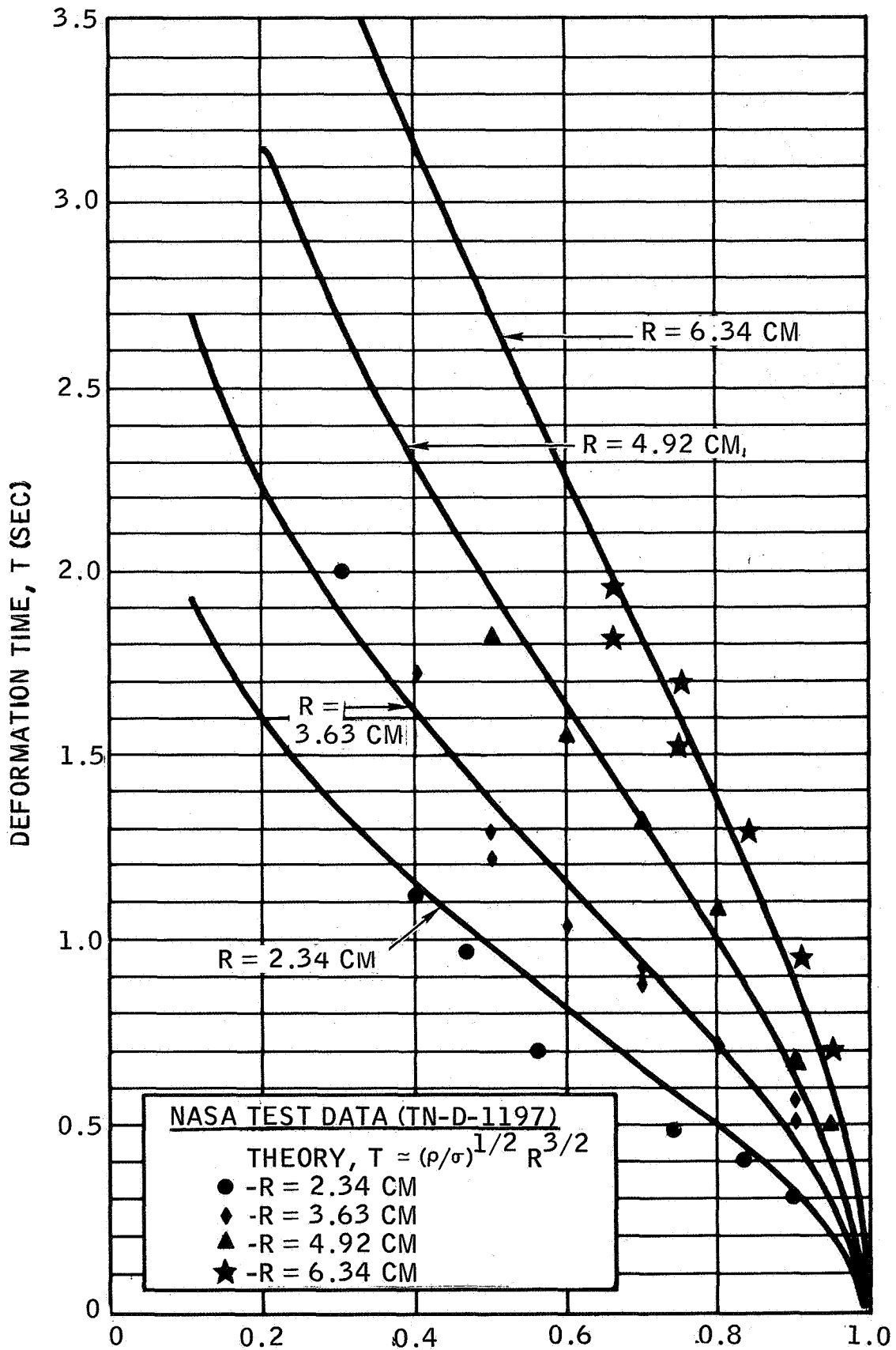

Figure 1-14. Correlation of Analytical Zero-g Deformation Time With NASA Drop-Test Data, Ethyl Alcohol (Ref. 1-6)

Pressure: $F_P/A \approx F_{ST}/A$ (23)

Inertia: $F_I/A \approx \rho \frac{R^2}{t^2}$ (24)

Viscous: $F_V/A \approx \frac{\mu}{t} \approx \mu \frac{V}{R}$ (25)

The variations with time of the two dominating forces, F_I and F_{ST} , are presented qualitatively in Figure 1-15 along with the deformation velocity. Numerical examples for spheres ($R = 10$ cm and 1 cm) of water and liquid copper are given in Table 1-2 to illustrate the relative magnitudes of the forces.

Table 1-2. Relative Magnitudes of the Forces/Unit Area

	Liquid			
	Water	Water	Copper	Copper
R (cm)	10	1	10	1
t (sec)	3.7	0.117	2.84	0.09
σ (dyn/cm)	73	73	1103	1103
$\frac{\mu}{\text{cm}^2}$ (dyn-sec)	0.011	0.011	0.038	0.038
ρ (dyn-sec ² /cm ⁴)	1.0	1.0	8.91	8.91
F_{ST}/A (dyn/cm ²)($\alpha_1=2$)	14.6	146	220	2200
F_V/A (dyn/cm ²)	0.003	0.094	0.013	0.422
F_I/A (dyn/cm ²)	7.3	73	110	1100

F_I = INERTIA FORCE

F_{st} = SURFACE TENSION FORCE

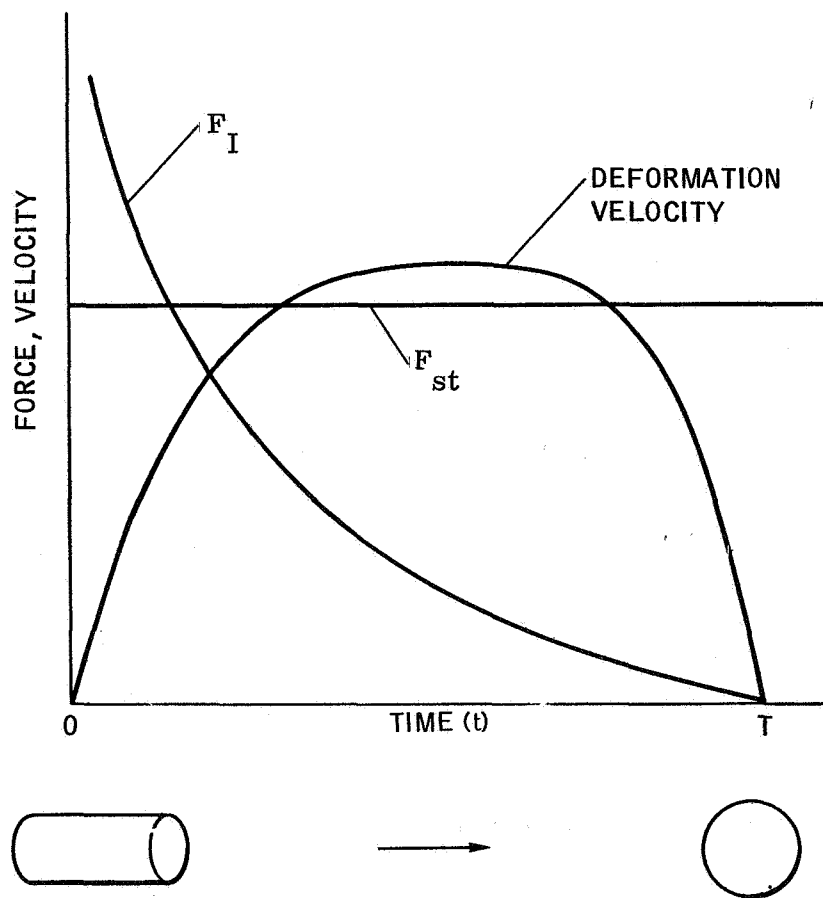

Figure 1-15. Variation of Forces and Deformation Velocity for the Transformation of a Liquid Cylinder into a Sphere

1.4.2 LIQUID SPHERE OSCILLATIONS. The response of a physical system to a disturbance can take many forms. One of the most useful approximations is to represent the situation by a second order linear differential equation with constant coefficients, solutions of which are commonly available in graphical form in terms of the coefficients. The equation is shown below for convenience in such form as to represent the manner in which a mechanical system having mass (M), stiffness (K), and damping (C) responds to a transient disturbance.

$$M \ddot{x} + C \dot{x} + Kx = 0 \quad (26)$$

The equality to zero indicates that the disturbing force has been removed. Then, if the response is a lightly damped oscillation such as will be characteristic of liquid metals constrained by their surface tension, it may be conveniently expressed by the relation:

$$x = e^{-\frac{t}{\tau}} \bar{X} \cos (2\pi ft + \epsilon) \quad (27)$$

x = amplitude of the response.

t = elapsed time.

τ = time required for the response to decay to 1/e of its initial amplitude.

\bar{X} = maximum amplitude of the response.

f = frequency of the response.

ϵ = phase lag of the response.

Relating these to the differential equation, it should also be noted that:

$$2\pi f = \sqrt{K/M}, \text{ and}$$

$$\tau = 2M/C, \text{ sometimes known as the "modulus of decay".}$$

It should also be noted that the above relations apply with mathematical exactitude to the oscillatory response of real systems, but only when $f\tau \gg 1$, i.e. for lightly damped systems. For more heavily damped systems, the relations are rather more complex, and the response time expression is of the form of Equation (18) in Section 1.4.1. This will be picked up again below.

Turning to the fluid mechanics, Sir Horace Lamb (Reference 1-7) gives expressions for the oscillatory period (Paragraph 275) and decay modulus (Paragraph 355) of

fluid masses constrained by nearly spherical surfaces of uniform tension. His expressions are paraphrased below for a spherical globe of liquid in vacuo or in another fluid of negligible density and viscosity, and for a bubble surrounded by a liquid of (effectively) infinite extent and inflated with a fluid of negligible density and viscosity. Then defining $S = f\tau$ as the number of swings required for the oscillation to decay to $1/e$,

For the sphere:

$$f_g = H_{fg} \sqrt{\frac{\sigma}{\rho}} \cdot D^{-3/2} \quad (26a)$$

$$\tau_g = H_{\tau g} \frac{\rho}{\mu} \cdot D^2 \quad (26b)$$

$$S_g = H_{sg} \frac{\sqrt{\rho\sigma}}{\mu} \cdot D^{1/2}, \text{ and} \quad (26c)$$

For the bubble:

$$f_b = H_{fb} \sqrt{\frac{\sigma}{\rho}} \cdot D^{-3/2} \quad (27a)$$

$$\tau_b = H_{\tau b} \frac{\rho}{\mu} \cdot D^2 \quad (27b)$$

$$S_b = H_{sb} \frac{\sqrt{\rho\sigma}}{\mu} \cdot D^{1/2} \quad (27c)$$

Where

σ = surface tension

ρ = density

μ = viscosity

D = diameter

H = a constant depending on the situation and on the harmonic order (n) of the oscillation as tabulated in Table 1-3. ($n = 2$ for the simplest oscillatory response.)

Table 1-3. Values for Oscillation Constant H

		n =				
		2	3	4	5	6
H_{fg}	$\frac{\sqrt{2n(n-1)(n+2)}}{\pi}$	1.273	2.466	3.820	5.326	6.974
$H_{\tau g}$	$\frac{1}{4(n-1)(2n+1)}$	0.0500	0.01786	0.00926	0.00568	0.00385
H_{sg}	$\frac{\sqrt{2n(n-1)(n+2)}}{4\pi(n-1)(2n+1)}$	0.0636	0.0440	0.0354	0.0303	0.0268
H_{fb}	$\frac{\sqrt{2(n+1)(n-1)(n+2)}}{\pi}$	1.559	2.847	4.271	5.835	7.533
$H_{\tau b}$	$\frac{1}{4(n+2)(2n+1)}$	0.01250	0.00714	0.00463	0.00325	0.00240
H_{sb}	$\frac{\sqrt{2(n+1)(n-1)(n+2)}}{4\pi(n+2)(2n+1)}$	0.0195	0.0203	0.0198	0.0189	0.0181

The approximate characteristics of a few interesting liquids are tabulated in Table 1-4.

Table 1-4. Materials Data for Computation of Oscillation Characteristics

Liquid	Temp °K	ρ (g/cm ³)	σ (dy/cm)	$\frac{\mu}{\text{dy sec}}^2$ cm ²	$\sqrt{\frac{\sigma}{\rho}} \times \frac{\rho}{\mu} = \frac{\sqrt{\rho\sigma}}{\mu}$
Water	293	1.00	73	0.010	$8.5 \times 100 = 850$
Mercury	293	13.5	470	0.016	$5.9 \times 840 = 5000$
Tin	530	7.0	530	0.020	$8.7 \times 350 = 3000$
Aluminum	970	2.4	840	0.029	$5.9 \times 83 = 490$
Copper	1400	8.1	1100	0.038	$11.6 \times 213 = 2500$
Iron	1700	6.9	1400	0.040	$14.3 \times 173 = 2500$

Comparing the data in the two tables above indicates that liquid metal globes one centimeter in diameter will oscillate a hundred or more times before the amplitude has decayed to the $1/e$ level. The "light damping" postulation is justified, at least for the simpler modes of vibration. The decreasing nature of H_{sg} as n becomes large indicates that small ripples on even a large globe of metal will be more heavily damped, just as would the basic oscillations of a very small globe.

A sample plot is shown as Figure 1-16 for a copper globe ten centimeters in diameter. Let us assume that such a globe is momentarily exposed to a disturbance so configured that the first few harmonics are excited at the same level, say five millimeters. Two hours later, the remnant response will according to theory be a $5 \mu\text{m}$ oscillation at 0.47 Hz ($n = 2$) plus a 20 pm oscillation at 0.9 Hz ($n = 3$) with the higher harmonics having dropped out of sight some time before. (For reference, the wavelength of green light is $0.5 \mu\text{m}$). From this we may infer that the lack of mathematical rigor in treating the short wavelength, high order oscillations is of little practical significance.

The effect of size on the oscillations appears quite explicitly in the equations and is graphed in Figure 1-17 to provide a little more feel for the situation. The effect of size on the damping time (τ) shows its importance. Globes or bubbles a few meters in diameter could take a year or more to settle down after a disturbance.

Considering the decay of the lower order oscillation, a reasonable limit may be set to the region of interest by comparing the remnant amplitude with the static deflection of the globe under the influence of the gravity and centrifugal gradients existing at the orbital factory. In this connection, the correspondence between equation (2-5) of TN-70-AE-03 and the equation appearing here for the response frequency of a liquid globe is quite striking. Combining these equations gives the result:

$$\epsilon/R \doteq 3(f_o/f_g)^2 \quad (28)$$

where

ϵ = radial static deflection

R = undeflected radius

f_o = orbital frequency

Considering then a 92 minute orbit, the static gradient radial deflection of the 10 cm molten copper sphere will be about 20 pm. Extrapolating the $n = 2$ line of Figure 1-16 indicates that the original 5 mm perturbation will have decayed to the static deflection about 3 hours and 40 minutes after the start.

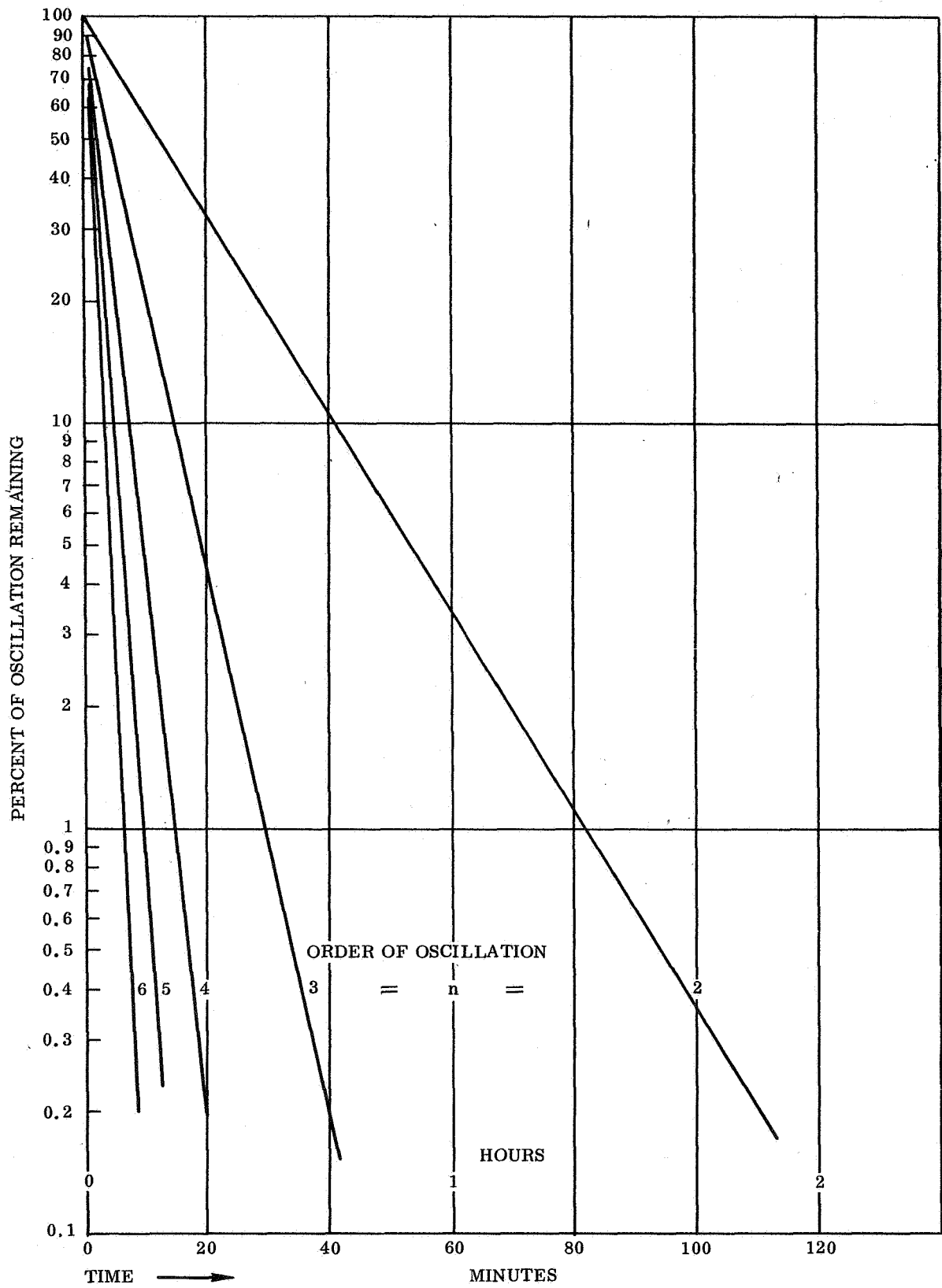

Figure 1-16. Decaying Oscillation of a Molten Copper Sphere Ten cm Diameter

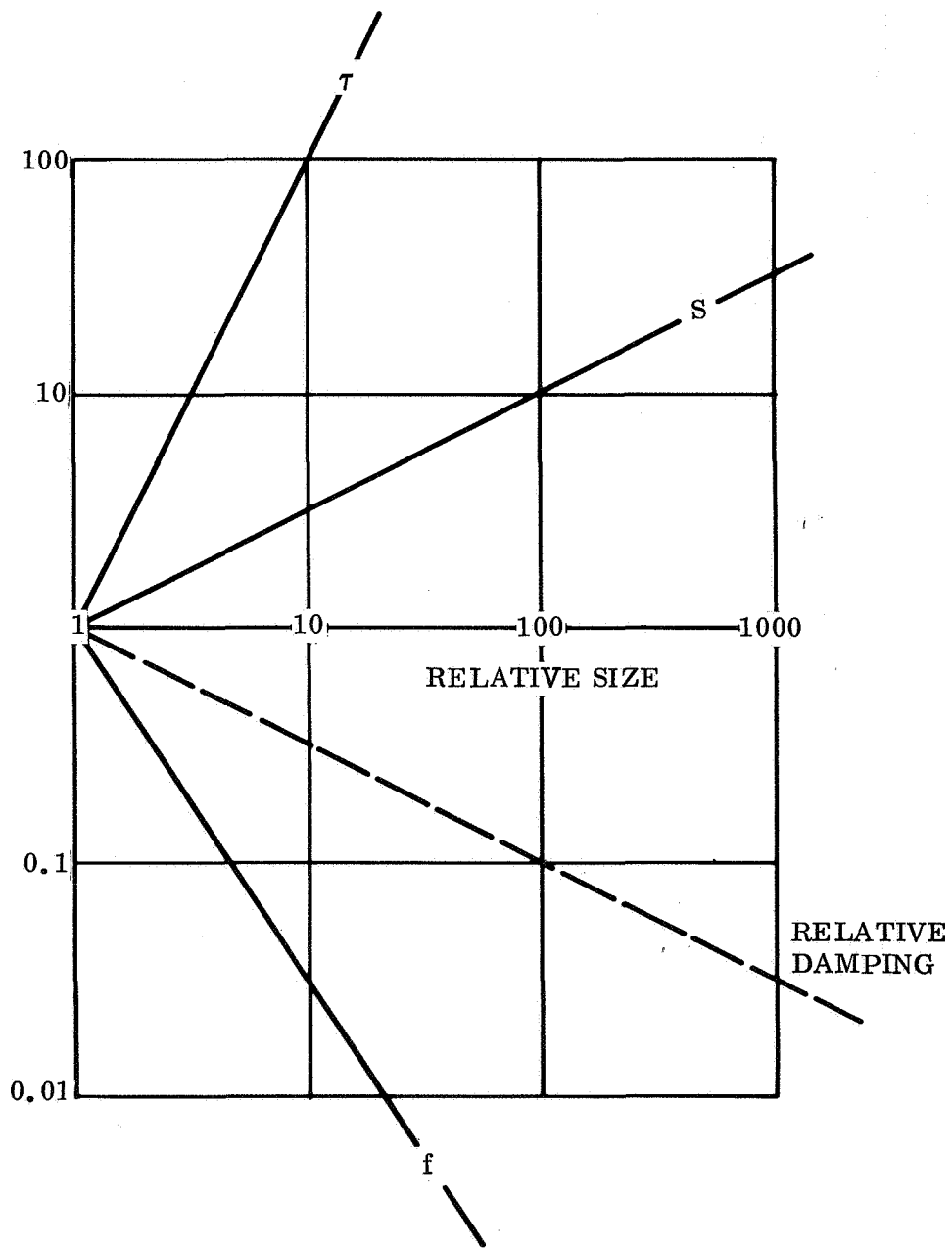

Figure 1-17. Scaling of (Lightly Damped) Liquid Oscillations

1.4.3 DEFORMATION OF A SPHERE BY A UNIFORM FORCE FIELD. Forming a non-spherical shape from an initially spherical shape is the reverse of the problem in Section 1.4.1 and thus requires a force having the magnitude

$$F > F_{ST} - F_P + F_V + F_I \quad (29)$$

applied externally. The forces on the right hand side of equation (29) are given by equations (22) to (25).

Since F_V can be neglected, we have

$$F > F_{ST} - F_P + F_I \quad (30)$$

To hold the non-spherical full shape, while the liquid solidifies, requires an externally applied force equal to the surface tension force minus the pressure force, since the deformation velocity is zero (deformation time = ∞). Therefore

$$F = F_{ST} - F_P \simeq \frac{\sigma}{R} A \quad (31)$$

since F_P is of the same order of magnitude as F_{ST} , equation (23).

The curves in Figures 1-18 and 1-19 show qualitatively the forces and deformation velocity as functions of time for three types of externally applied forces. In Figure 1-18(a) the applied force F_c is a constant for all time, greater than $F_{ST} - F_P + F_I$, and results in an ever increasing deformation velocity. In Figure 1-18(b) the applied force F_v varies with time and results in deformation velocity that increases faster than in Figure 1-18(a). The externally applied force must be modulated in such a fashion as to be equal to the surface tension force minus the pressure force when the desired shape is achieved (deformation velocity zero) as shown in Figure 1-19.

1.4.4 DEFORMATION OF A LIQUID SPHERE BY SPINNING. Centrifugal forces created by spinning a liquid sphere about an axis will cause a distortion δ , Figure 1-20.

Rheinfurth (Ref. 1-1) presents the following equation for the amount of distortion δ

$$\delta = \frac{1}{8} \omega^2 \left(\frac{\rho}{\sigma} \right) a^4 \quad (32)$$

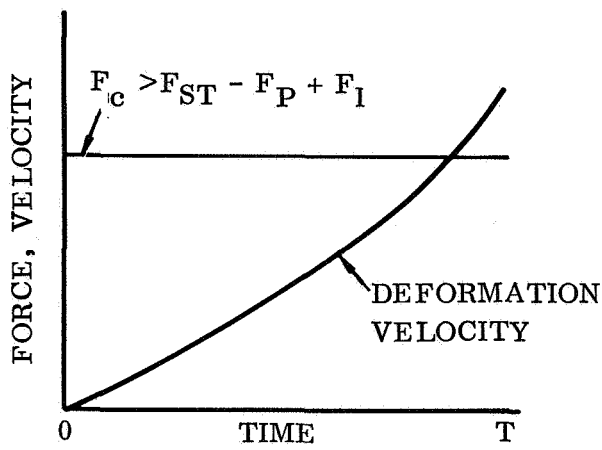

(a) Constant external force, F_c

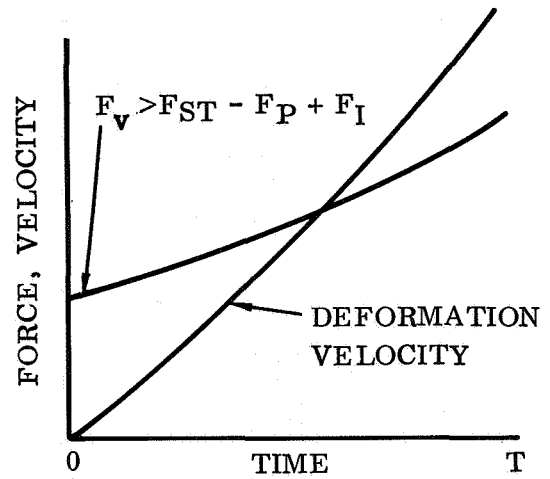

(b) Variable external force, F_v

Figure 1-18. Qualitative Variation of Forces and Deformation Velocity with Time for the Deformation of a Sphere of Liquid into a Non-Spherical Shape

where

ω = spin rate

a = radius of the sphere

ρ = liquid density

σ = liquid surface tension

Solving equation (32) for the spin rate yields

$$\omega = \frac{\left[8 \left(\frac{\sigma}{\rho} \right) \delta \right]^{1/2}}{a^2} \quad (33)$$

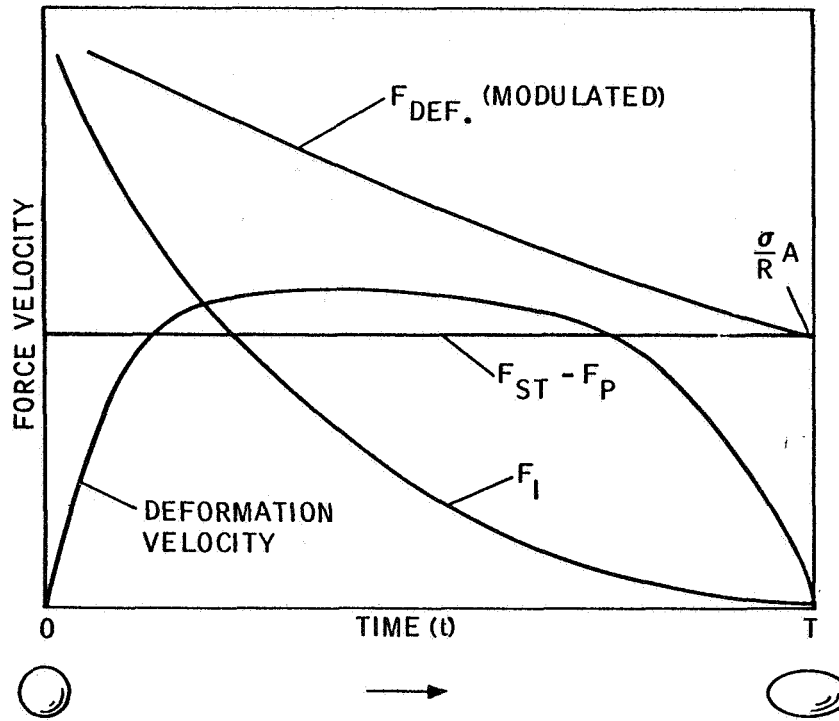

Figure 1-19. External Force F_m Modulated Such That, at Time T, is Just Equal to the Surface Tension Force

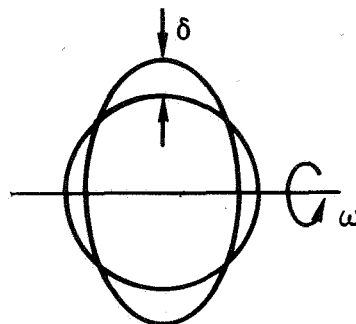

Figure 1-20. Distortion of a Liquid Sphere by Spinning

An example for the spin rate required to deform an aluminum sphere by an amount δ equal to half a radius is as follows:

Spin Rate to Deform a Sphere of Aluminum

Material	σ dyne/cm	$\frac{\rho}{\text{cm}^4}$ dyne-sec ²	a cm	δ cm	ω rad/sec
Aluminum	900	2.36	10	5	1.235 (~12 rpm)

1.4.5 DEFORMATION OF A LIQUID SPHERE CAUSED BY A POSITIONING FORCE. If it is desired to hold a liquid sphere stationary in an orbiting space station, the magnitude of the holding force is equal to the net gravitational force minus the centrifugal force. Since the surface tension force is exactly balanced by the internal pressure force of the sphere, this holding force will cause a deviation from a perfect sphere in addition to the deviation caused by gravity gradient effects. In order to determine the holding force deviation, it is necessary that the nature of the holding force be known, i. e., the distribution of the force field in space must be ascertained. In addition, the interaction of the force field with the liquid sphere must be determined. Both these problems require analysis quite beyond the scope of this analysis.

1.4.6 DISTORTION OF LIQUID SPHERES DUE TO THE GRAVITY-GRADIENT. Objects such as liquid spheres within an orbiting space station will be subject to gravity gradient forces. Rheinforth has studied the distortion of liquid drops under the influence of gravity gradient forces in Reference 1-1. His results are summarized here.

Referring to Figure 1-21 the deviation ϵ from a perfect sphere of radius r is given by

$$\epsilon \approx \frac{3}{8} \omega_o^2 \left(\frac{\rho}{\sigma} \right) r^4 \tag{34}$$

where

ω = orbital rate

ρ = density

σ = surface tension

r = radius of the sphere

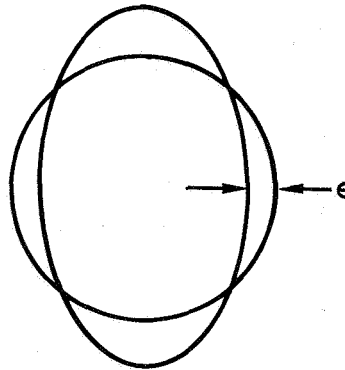

Figure 1-21. Distortion of a Liquid Drop by Gravity-Gradient Forces

An example of the magnitude of ϵ for an aluminum drop in a 200 nautical mile circular orbit is given below:

Material	r cm	$\frac{\rho}{\text{cm}^4}$ dyne-sec ²	σ dyne/cm	ω_0 sec ⁻¹	ϵ cm
Aluminum	1.0	2.36	900	1.14×10^{-3}	$\approx 10^{-9}$

This distortion is reduced as the orbital altitude is increased since ω_0 goes down. It is to be noted that the distortion increases as the sphere radius to the fourth power.

1.4.7 DRAG FORCES ON FIBERS AND BUBBLES. The motion of a body through a fluid is retarded by a drag force.

For a detached bubble of gas moving through a liquid, the viscous drag force F_D for a $R_e \approx 0(1)$ is assumed to be

$$F_D \Big|_{\text{bubble}} = 6\beta\pi\mu_l R_{\text{max}} V \quad (35)$$

where

$$\beta = 1 \text{ for very small bubbles (Stokes flow)}$$

$$\beta < 1 \text{ for large bubbles}$$

μ_l = viscosity of the liquid

R_{\max} = maximum bubble radius

V = bubble velocity

R_e = Reynold's Number = $2\rho \frac{VR}{\mu_l}$

ρ = liquid density

For a solid circular cylinder of fiber moving through a liquid, the maximum viscous drag force occurs when the flow is perpendicular to the longitudinal axis h

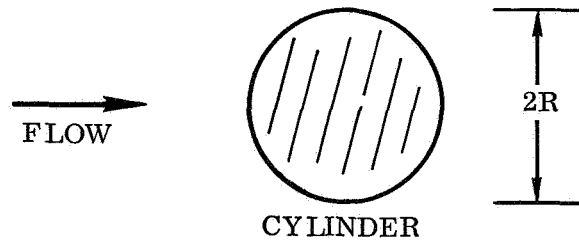

and is given by Reference 1-8:

$$F_D \Big|_{\text{cyl}} = \left(\frac{10.9/R_e}{0.87 - \log R_e} \right) \rho V^2 R h \quad (36)$$

where

R_e is the Reynold number $\frac{2\rho VR}{\mu}$ which lies in the range $.01 < R_e < 1$

μ is the viscosity of the liquid

ρ is the density of the liquid

V is the velocity of the cylinder

The term in parenthesis is the drag coefficient C_D and varies from about 300 at $R_e \approx 0.01$ to 10 at $R_e \approx 1$.

1.4.8 TIME TO ZERO-MOTION FOR A WHISKER IN A LIQUID. Consider a cylindrical whisker moving under the influence of an external force at some velocity in a liquid medium, Figure 1-22.

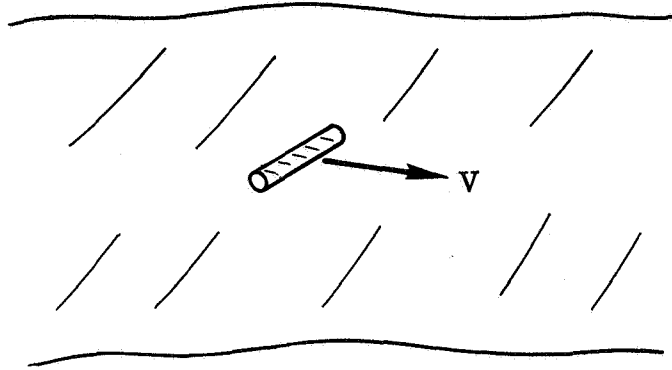

Figure 1-22. Whisker Moving in a Liquid

An estimate for the time required for the whisker to come to rest is found by writing Newton's Law

$$(m_l + m_w)a = F_D \quad (37)$$

or

$$(k\rho_l + \rho_w) (\pi r^2 h) \frac{DV}{Dt} = C_D \rho_l V^2 rh \quad (38)$$

where

F_D = drag force acting on the whisker

V = velocity of the whisker

a = acceleration of the whisker

r = radius of the whisker

h = length of the whisker

m = mass

ρ_w = density of the whisker

C_D = drag coefficient of the whisker

ρ_l = density of the liquid

k = shape dependent constant, equal to 1 for a cylinder

t = time

$\frac{D()}{Dt}$ = denotes the substantial derivative and is

$$\text{given by } \frac{\partial()}{\partial t} + u \frac{\partial()}{\partial x} + v \frac{\partial()}{\partial y} + w \frac{\partial()}{\partial z}$$

u, v, w = velocity components in x, y, z directions

The term $k\rho_l\pi r^2 h$ in equation (38) is known as the virtual mass of the cylinder (Reference 1-9) and accounts for the displacement of the liquid as the whisker passes. The drag coefficient is a function of the Reynolds number $2\rho_l Vr/\mu_l$, where μ is the dynamic viscosity of the liquid. For a cylinder, C_D varies logarithmically as shown in Figure 1-23.

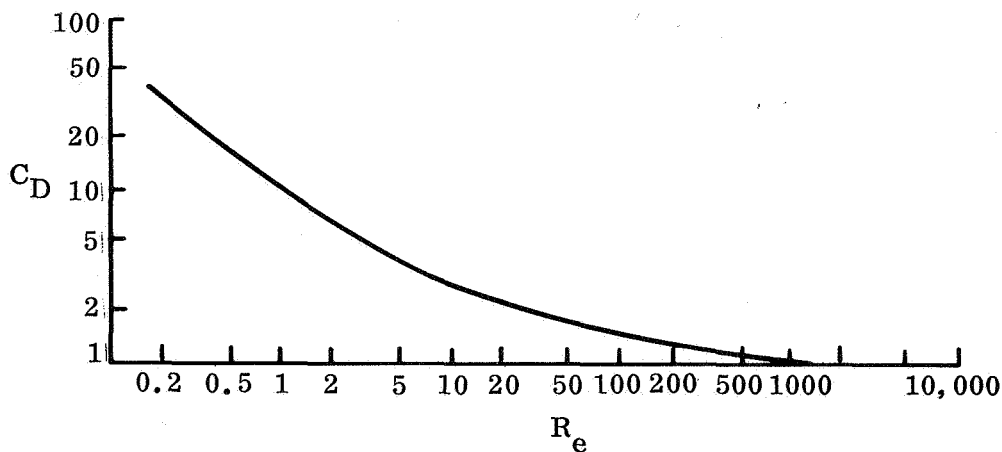

Figure 1-23. Variation of C_D with R_e

Performing an order-of-magnitude estimate on the terms in equation (38) yields

$$(k\rho_l + \rho_w) (\pi r^2 h) \frac{V}{t} \simeq C_D \rho_l V^2 r h \quad (39)$$

Solving for the time to zero motion yields

$$t_{zm} \simeq \frac{\pi(k\rho_l + \rho_w)r}{C_D V \rho_l} \quad (40)$$

where V is the velocity when the external force is removed.

An example for t_{zm} for cylindrical ($k=1$) sapphire whiskers in aluminum and the drag force F_D for a whisker 0.1 centimeter long is as follows:

Material	$\frac{\rho_l}{\text{cm}^4}$ dyne-sec ²	$\frac{\rho_w}{\text{sec}^4}$ dyne-sec ²	r cm	$\frac{\mu_l}{\text{cm}^2}$ dyne-sec	
Aluminum with Sapphire Whiskers	2.36	3.97	0.001	0.029	
Material	V cm/sec	Re	C_D	F_D dyne	t_{zm} sec
Aluminum with Sapphire Whiskers	2.0	0.326	20	0.019	0.21×10^{-3}

Equation (40) will be used in determining criteria for mixing and mixture stability.

1.4.9 MOVING LIQUIDS IN CIRCULAR PIPES. The adiabatic isothermal steady flow of a liquid through a circular pipe, Figure 1-24, is impeded by friction. The pressure (Reference 1-8) required to overcome friction is given by

$$\Delta p = p_1 - p_2 = f \frac{l}{D} \frac{\rho V^2}{2} \quad (41)$$

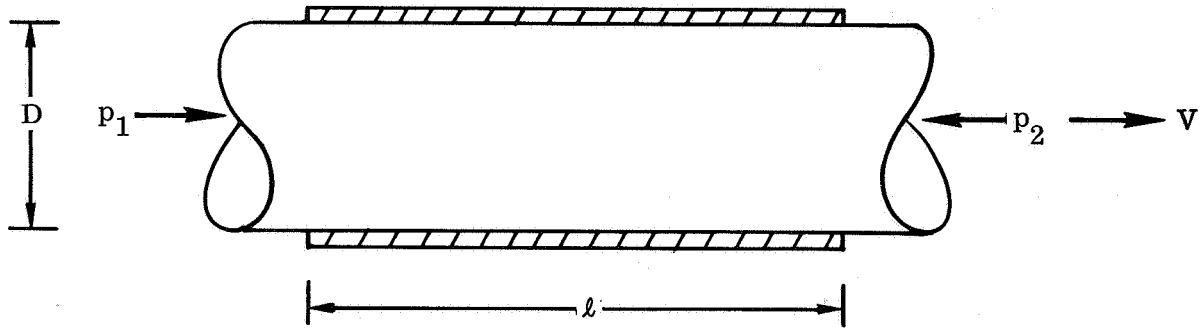

Figure 1-24. Flow of a Liquid in a Circular Pipe

where

l = pipe length

D = pipe diameter

ρ = liquid density

V = liquid velocity

f = friction coefficient

The friction coefficient is a function of the pipe surface and temperature except in the special case of laminar flow. For laminar flow, where the Reynolds number $R_e = \rho VD/\mu$ is less than 2000, f is independent of the pipe surface and is given by

$$f = \frac{64}{R_e} \quad (42)$$

Substituting in equation (41) yields

$$\Delta p = \frac{32\mu l V}{D^2} \quad (43)$$

Having Δp independent of the pipe surface means, among other things, that pipe of any material may be used and that corrosion of the pipe will not increase the friction and hence Δp .

An example of the pressure required to move liquid aluminum in a circular pipe (Δp for laminar flow) is given in the table below. Also shown is the mass flow

$$Q = \dot{\rho} \frac{\pi D^2}{4} V \quad (44)$$

Material	$\frac{\mu}{\text{cm}^2}$ dyne-sec	$\frac{\rho}{\text{cm}^4}$ dyne-sec ²	D cm	V cm/sec
Aluminum	0.029	2.36	5.0	5.0
Material	R_e	l cm	Δp dyne/cm ²	Q g/sec
Aluminum	~2000	10	1.86	232

1.5 THERMODYNAMICS

This section is confined to the generally applicable thermal problems of heating, cooling, and vaporization. Thermodynamic aspects of solidification are included in Section 1.6 and the thermal requirements of processes are discussed in the evaluation of individual processes.

1.5.1 HEATING REQUIREMENTS. The heat required to bring the material from shirt sleeve temperature to processing temperature (through melting) ranges from 150 to 600 Btu/lb. The amount of material varies over a wide range from a few grams for hollow spheres to 8 lb for spheres or various types of castings. As an example, the heat required for spheres of several diameters and materials is as follows:

<u>Sphere Diameter:</u>	<u>1 cm</u>	<u>4 cm</u>	<u>10 cm</u>
		<u>Btu</u>	
Aluminum	0.75	48	750
Nickel	4.1	262	4100
Copper	2.8	178	2800
Alumina	5.6	356	5580

However, the prime consumer of heat, particularly for small samples, is the chamber and, if applicable, the supply system, as their inner liners necessarily have to be at processing temperature. While the liners can be thin in view of the weightless situation, a considerable amount of heat is absorbed in the passive insulation or an active cooling system. Since the amount of heat required depends extensively on the equipment design and tooling requirements, it can be defined in the form of typical values. Based on a number of point-designs, the heat requirements for a medium-size chamber, as envisioned for workshop experiments are presented in Table 1-5. The data is based on a one-hour heating and cooling cycle. For longer processing times, after initial heating, the combined heat input is considerably less as it only has to balance the losses.

1.5.2 COOLING. The amount of heat absorbed during the cooling period is essentially equal to the total heat input less the losses incurred during processing, which are rather small. Of prime interest is, however, the cooling rate of the experiment material, as this rate may induce thermal gradients and affect the microstructure of the solidified material. In mold-type experiments, this cooling rate can be readily controlled by the coolant flow rate. For a contact-free material which has to rely entirely on cooling by radiation, the cooling rates and times are a matter of material emissivity, chamber wall absorptivity, and the degree of active chamber wall cooling. It, consequently, varies extensively, depending on equipment, material amount, and thermal properties of the material. However the basic radiation-cooling condition, namely the radiation into deep space, can be defined rather accurately. For example,

Table 1-5. Typical Heat Input Requirements of Experiments in a Medium-Size Chamber (Chamber "B" - 24 in Diameter)

Heat Consumer	Btu			Btu/Hr Mean ~
	Min. *	Max. *	Mean	
<u>Single Experiment - 1 Hr</u> <u>(Melting in Chamber)</u>				
Material	10	600	200	
Chamber	10,000	20,000	12,000	
Losses/System Cooling	3,000	6,000	4,000	
Total	13,010	26,600	16,200	16,000
Extended Processing Time				8,000
<u>Multiple Experiment with</u> <u>Supply System - 3 Cycles</u> <u>(Including Losses)</u>				
Material	600	1,800	900	
Chamber, 1st Hour	10,000	20,000	12,000	
Chamber, 2 Additional Hours	12,000	24,000	16,000	
Supply System, 1st Hour	2,500	4,600	3,000	
Supply System, 2 Additional Hours	3,500	7,000	5,000	
Total	28,600	57,400	36,900	
Continuing Operation				10,500
*Combined consideration of material amount and temperature level.				

the cooling characteristics of a 10 cm diameter sphere of various materials are presented in Figure 1-25 in terms of temperature over time. This data takes into account the thermal effects and the reduction of surface area due to vaporization, if applicable.

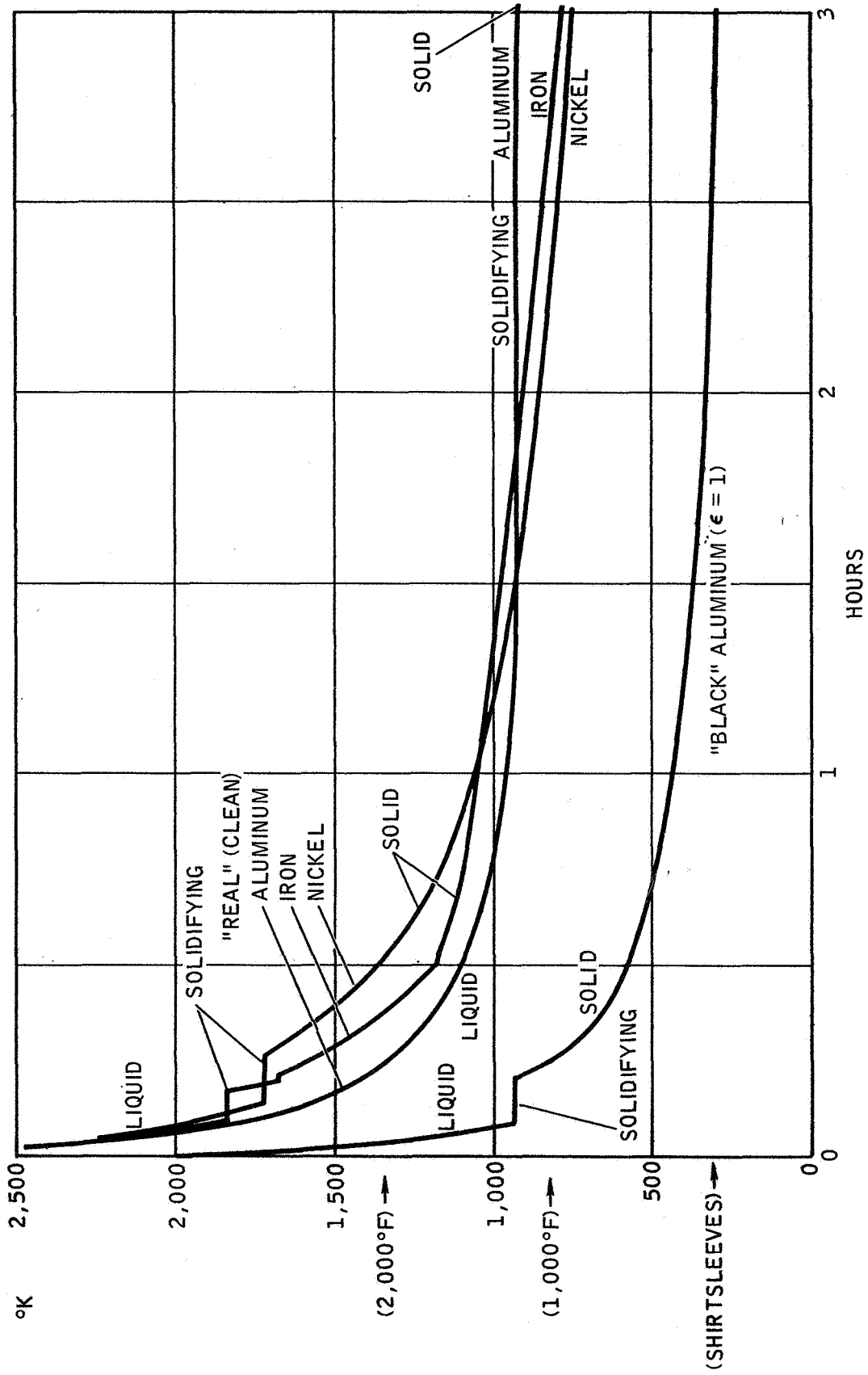

Figure 1-25. Radiation Cooling 10-CM Diameter Sphere in Free Space

1.5.3 SURFACE EVAPORATION (OR SUBLIMATION). Whether or not a solid material body is losing or gaining mass due to evaporation-condensation exchange at its surface is entirely dependent upon the partial pressure gradient of the gaseous material at the surface. Under steady state conditions (steady partial pressures and gradients) and where the partial pressure gradient is zero, no mass rate loss or gain occurs, but a negative partial pressure gradient will result in a mass loss and a positive gradient will result in a mass gain (positive spatial direction being outward at the surface).

The direction of the partial pressure gradient is determined by the vapor pressure conditions (thickness and type of substrate, temperature, curvature, etc.) of the surrounding boundary (which may be open space) compared to the vapor pressure conditions at the material surface. Whichever has the highest absolute vapor pressure - assuming there are no other intervening force fields or energy gradients, etc. - will lose mass to the lower vapor pressure region. The rate of that loss, however, will depend on other factors in addition to the difference in values of the vapor pressures.

The following point should be made clear: the partial pressure that exists at a surface is the vapor pressure determined by the conditions of the surface and not the surrounding environment. The partial pressure existing at the melted surface of a ball of iron in deep space is the same as that which would exist in a closed test chamber on earth. However, the partial pressure gradient at the surface would differ tremendously. It is this gradient and not the magnitude that determines whether or not mass is lost or gained.

The amount of mass lost or gained is dependent upon the magnitude of the partial pressure gradient and upon the mass rate of flow required to maintain this gradient. (A steady state condition presupposes that the internal heat energy exchange is sufficient to balance the heat required for the evaporation or condensation rate). The determination of the mass rate of flow for a particular pressure gradient involves the type and size of gas molecules present, temperature, energy distribution, densities, mean molecular velocities, mean free paths, scattering and diffusion functions, interacting potential functions, convection or flow conditions, cohesive or binding energies, geometry, etc.

These factors are basically used to determine the flow resistance or mass transport characteristics or the mass diffusion coefficient (proportional to the viscosity) of the gas material in the total gas atmosphere present and/or the mass momentum rate of change that occurs. Although this function can often be easily approximated by several theoretical relationships, the assessment of all of these factors for even the simplest cases are usually sufficiently difficult that most data is experimentally derived. The data derived, of course, is only valid for that particular condition to include the state of the material as well as its total environment.

Table 1-6 presents the theoretical relationships used to determine rate of evaporation.

Table 1-6. Theoretical Relationships for Evaporation

Basic Constants	Density	Velocity and Mean Free Path	Related Common Equations
$D_{12} = \frac{1}{2} \alpha_1$	*	$\bar{V}_1 \lambda_{12}$	$\dot{m}/A = -D \left(\frac{\Delta \rho}{\Delta x} \right)$
$\eta = \frac{1}{2} \beta$	* ρ	$\bar{V} \lambda$	$\frac{F}{A} = -\eta \left(\frac{\Delta V}{\Delta x} \right)$
$K = \frac{1}{2} \gamma$	* ρC_V	$\bar{V} \lambda$	$\dot{q}/A = -K \left(\frac{\Delta T}{\Delta x} \right)$

Where D_{12} = mass diffusion coefficient for gas 1 in gas 2 mixture.

η = viscosity

K = thermal conductivity

α, β and γ are constants, often close to unit value

and

ρ = density

C_V = specific heat at constant volume

\bar{V} = mean velocity

λ = mean free path

1.5.4 VAPORIZATION RATES. Vaporization may be used to advantage for two purposes:

- a. Material purification, i. e., removal of undesirable material constituents which vaporize within the liquid temperature range of the base material. Due to the absence of g , this requires an induced convection.
- b. Mass adjustment, by initial deliberate over-sizing of the mass and reduction to accurate size by vaporization in a precisely programmed over-heating cycle.

Of prime concern, however, is the negative aspect of vaporization in the form of material loss. For practical applications, the vaporization rate \dot{m} for a vacuum environment is commonly determined by the Langmuir equation:

$$\dot{m} = P_v \sqrt{\frac{M}{2\pi RT}} \text{ g/cm}^2\text{-sec}$$

$$P_v = \text{Vapor pressure - dynes/cm}^2$$

$$M = \text{Gram-molecular weight}$$

$$R = \text{Gas constant}$$

$$T = \text{Temperature - } ^\circ\text{K}$$

The calculated loss rates of several metals of interest are plotted in Figure 1-26 over temperature. In Figure 1-27 the loss is expressed in terms of surface ablation (recession) in mil/hr. It is interesting to note that the melting point has no effect upon vaporization, i. e., vaporization is independent of the state of aggregation.

In many processes, the material requires, for chemical or other reasons, a gas environment of a finite pressure. This raises the question of the effect of environmental pressures and specific gases upon vaporization rate. No substantiated relationships nor any experimental data could be found, except one specific case of a tungsten filament at 2,870°K (Reference 1-10). The effect of environmental pressure was as follows:

Pressure (mm Hg)	Evaporation Rate \dot{m} (gm/cm ² - sec)
0	2.3×10^{-7}
10	0.575×10^{-7}
50	0.235×10^{-7}
100	0.205×10^{-7}
250	0.103×10^{-7}
500	0.054×10^{-7}
700	0.042×10^{-7}
1650	0.020×10^{-7}

As is to be expected, the vaporization rate decreases substantially with increasing environmental pressures, in this case to 1% of the vacuum-value at a pressure of 2 psia. The reduction of material loss due to vaporization by means of pressurized gas envelopes represents an important tool of liquid-state processing. This implies the necessity of establishing reliable relationships and data in theoretical and experimental investigations.

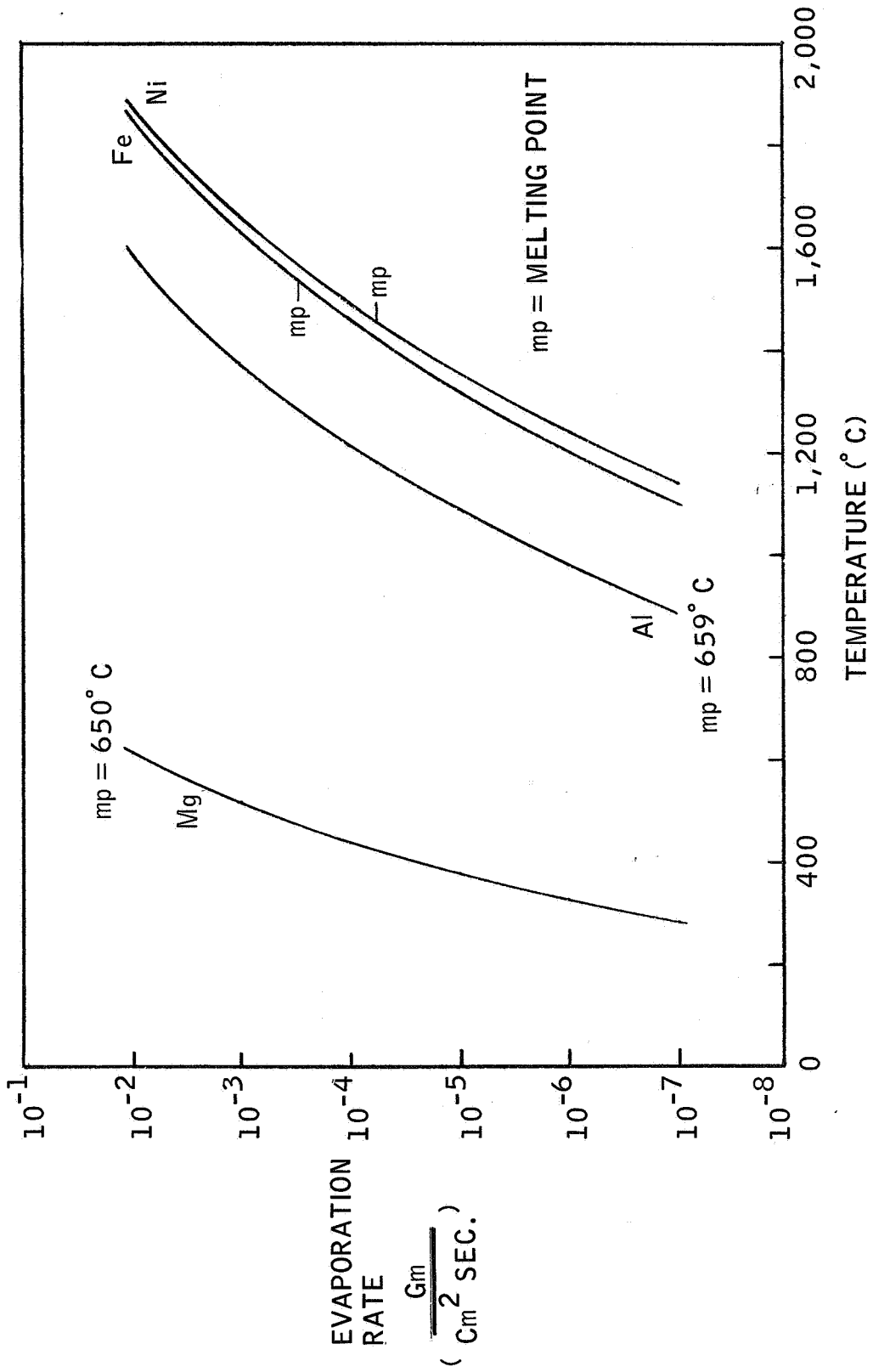

Figure 1-26. Metal Evaporation Rates in Vacuum (Mass Rate)

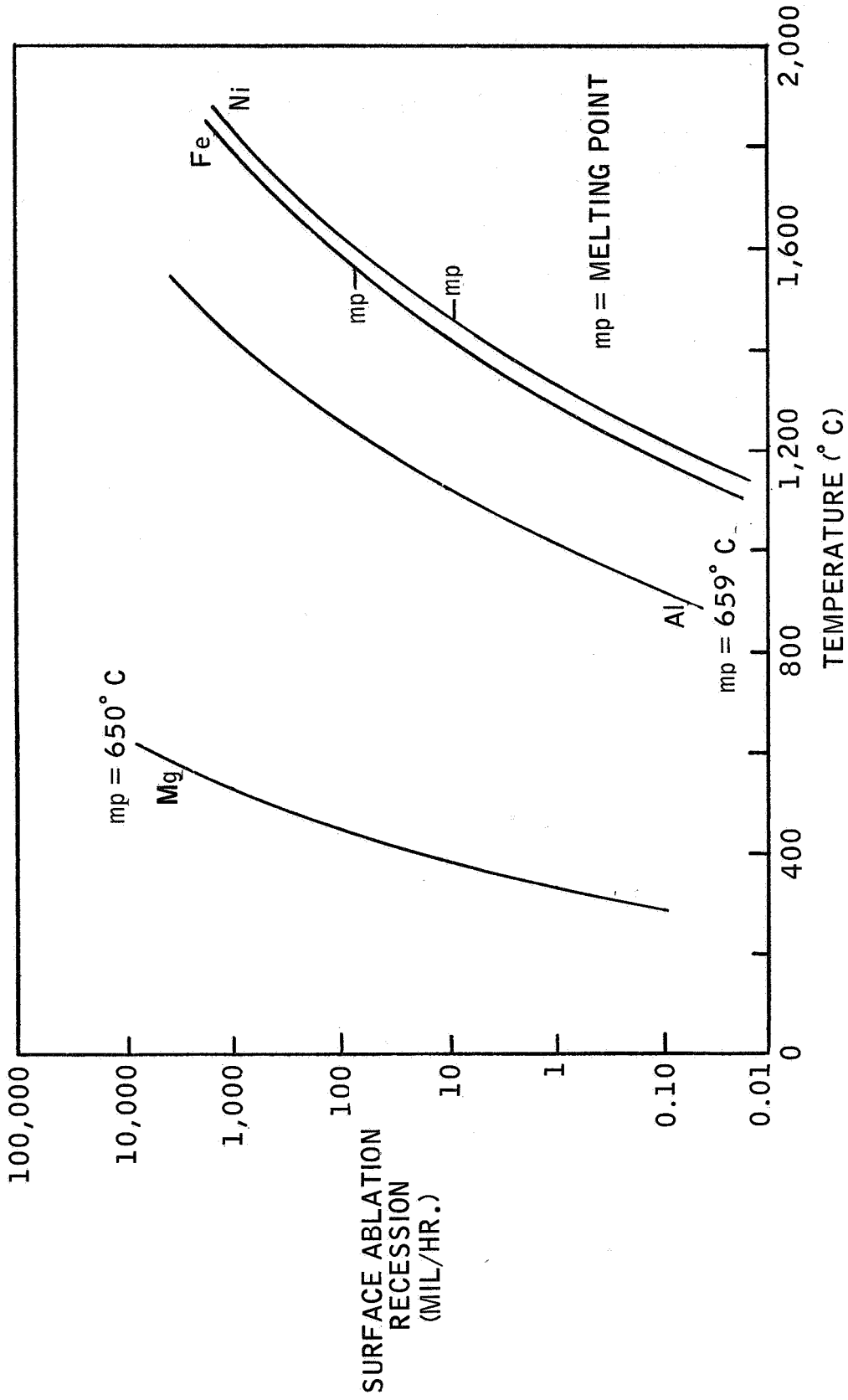

Figure 1-27. Metal Evaporation Rates in Vacuum (Rate of Surface Loss)

1.6 SOLIDIFICATION AND CRYSTALLIZATION

The three major categories of solidification-nucleation, growth, and reaction-kinetics are presented, along with those factors (extracted from theory or experimental observations) which determine when and how the various processes occur.

1.6.1 FACTORS AFFECTING NUCLEATION. There are several factors which effect the nucleation of liquid materials. The major criteria is listed in Table 1-7 along with the direction of their effect; the inter-relationships are shown diagrammatically in Figure 1-28.

Table 1-7. Factors Affecting Nucleation

Factor	Direction to Increase Nucleation
Thermodynamic Driving Force	
Embryo Size	Max. Size ~200 atoms
Embryo Shape	Flatter (increase r)
Bulk Free Energy	More negative
Surface Free Energy	Less positive
Undercooling (ΔT)	Greater ΔT
Volume of Material	Greater volume
Foreign Particles	More particles
Liquid Motion	Increase motion
Composition	
Supersaturation	Greater supersaturation
Gas Content	-
Radiation	-

1.6.1.1 Thermodynamic Driving Force. Those elements comprising the driving force are important to the formulation of a nucleus of critical size. These elements are defined in the following paragraphs.

- a. Embryo Shape and Size. An embryo is more likely to grow if it has a large radius of curvature (that is, nucleation becomes more likely as the embryo becomes flatter). For most metals, nucleation will occur without any "external help" (homogeneous nucleation) when the embryo reaches a size of about 200 atoms.
- b. Bulk Free Energy (ΔG_v). When the bath temperature falls below the equilibrium temperature (for a solid and liquid), the bulk free energy becomes negative, and consequently the free energy of the system is lowered upon nucleation (by a

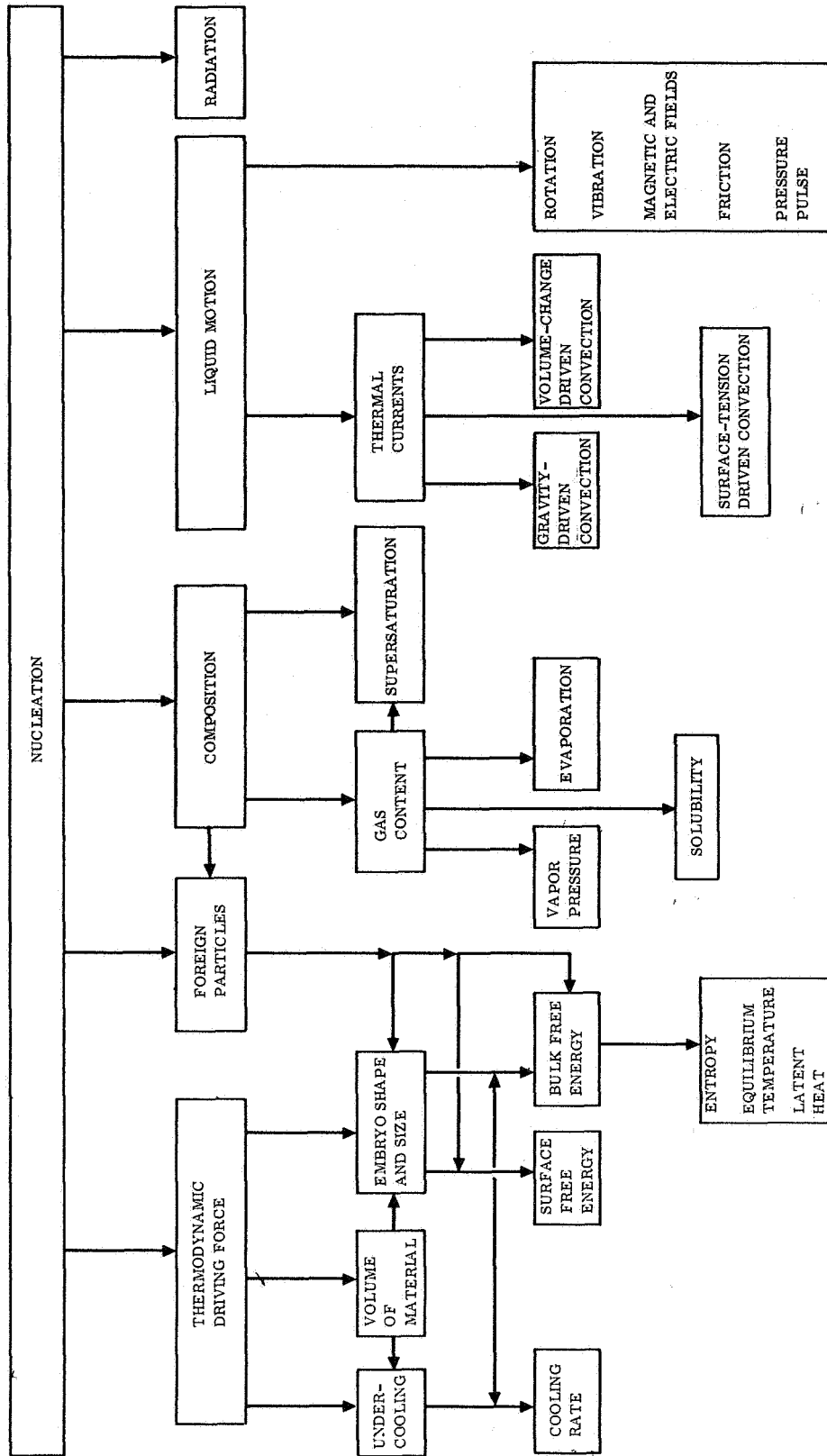

Figure 1-28. Interrelationship of Nucleation Criteria

factor of ΔG_V^2). This factor is dependent on the entropy of the solid and liquid phases (higher entropy of the liquid with respect to the solid aids nucleation), and on the degree of undercooling. The latent heat of fusion of a material can also influence the bulk free energy of the system. The lower the latent heat, the greater the probability of nucleation. (The heat given off (L_M) tends to raise the bath temperature of the liquid back towards the equilibrium temperature, thus decreasing the negative value of ΔG_V , and hence causing a decrease in the free energy for the entire system.)

- c. Surface Free Energy (ΔG_S). The formation of a new surface (solid in a liquid bath) causes an increase in the free energy of the system by a factor of $(\Delta G_S)^3$. The greater this excess surface free energy, the more difficult nucleation becomes. Any factor that causes a lowering of the surface free energy aids nucleation.
- d. Undercooling (ΔT). The greater the undercooling (temperature below the equilibrium temperature T_E), the more driving force there is for the formation of embryos of critical size. In most metal systems, the maximum undercooling is about $0.2 T_E$ (in $^{\circ}\text{C}$); below this temperature, homogeneous nucleation occurs. The faster the cooling rate, the more likely it will be to reach this undercooling; however, for most metal systems, it is virtually impossible to go below this value without nucleating regardless of cooling rate, unless one reaches rates of $10^{-5}^{\circ}\text{C}/\text{sec}$.
- e. Volume of Material. Because nucleation can be considered to occur when the probability of forming a cluster of atoms of a critical size, i , reaches a certain value, nucleation can be retarded by decreasing the volume. This decreases the probability of reaching the critical size (there is less chance of finding an embryo of critical size in a smaller volume). Additionally, smaller volumes can be cooled more rapidly, and in some cases, by-pass nucleation.

1.6.1.2 Foreign Particles. Any foreign particle (solid) present in the liquid will tend to aid nucleation, because part of the excess surface free energy (caused by a solid-liquid interface) will be supplied by the foreign surface. Based on the assumption that the surface tension may be equated with surface free energy, the "wettability" of various systems is a guide to increased nucleation. This is reflected in the contact angle θ . The effectiveness of these foreign particles is also dependent on the rate of nucleation in the system. The distribution of these nuclei may also play an important role. If there are great differences in density between the solid particles and the liquid, there may be a segregation in the crystal structure. Any increase in liquid motion would decrease this segregation. Any point of contact between the liquid and a foreign surface will tend to increase nucleation.

1.6.1.3 Liquid Motion. Any form of liquid motion will tend to increase the number of nuclei. This is done by two separate mechanisms: actual nucleation caused by vibrations, pressure pulses, or friction in the liquid, and crystal multiplication (of already existing nuclei) caused by any form of liquid motion.

1.6.1.4 Composition. Depending on the type of material, a certain degree of undercooling can be obtained prior to nucleation. Addition of alloying elements (as opposed to foreign particles) will change the characteristics of the liquid.

- a. **Supersaturation.** This criteria generally applies to aqueous solutions where it is possible to form a supersaturated liquid. The greater the supersaturation, the more unstable the solution becomes, and thus, the more readily nucleation will occur. This is because increased supersaturation decreases the critical size (radius) of an embryo required for nucleation.
- b. **Gas Content.** The gas content of the liquid and the surrounding atmosphere can both play important roles in nucleation. When the vapor pressure over the system is greater than the equilibrium vapor pressure, nucleation is enhanced because of a smaller embryo size required. A difference in solubility of gases in liquids and solids will also aid in nucleation (either of the solid phase or possibly of a gas-solid-such as a metal-oxide-phase). In a vacuum, there will be some evaporation of the liquid. This may cause a cooling effect on the system, and subsequently greater nucleation.

1.6.1.5 Radiation. Currently, there is little information available on the effects of radiation on nucleation. Since high intensity radiation is capable of causing defects in solid materials, it seems plausible that it would have a similar effect on the liquid-solid structure. The radiation could conceivably cause an increase in nucleation, and possibly cause defects in the freshly nucleated embryos.

1.6.1.6 Gravity Effects on Nucleation. Several of the factors governing nucleation are affected by the elimination of gravity. In most cases, greater control over the forces causing nucleation can be achieved in a zero-G environment (Table 1-8).

Table 1-8. Effect of Gravity on Nucleation Criteria

Criteria	Importance	Zero-g Control
Driving Force	High	None
Foreign Particles	High	High
Liquid Motion	High	High
Composition	Medium	High
Radiation	Unknown	Space Effect
Conclusion: Zero or near zero-g environment permits control of nucleation.		

- a. **Foreign Particles-Important Effect in Zero-g.** Foreign particles are used as nucleating aids (heterogeneous nucleation). In the absence of gravity, nucleants

of varying density can be distributed to all sections of a liquid pool, giving more effective nucleation. Thus a zero-g advantage.

- b. Liquid Motion - High Control in Zero-g. Several of the causes of liquid motion can be controlled to varying degrees in the absence of gravity.
- c. Vibration. The body (liquid) may be separated from any mechanical contact with the ground (ship), thus eliminating any uncontrolled vibrations due to engine operation, astronaut motion, life support systems, etc. Thus a zero-g advantage.
- d. Convection (Thermal Current). The absence of gravity means that gravity induced convection will not exist (or will be very small). Control of growth rate will reduce the effect of volume-change induced convection. Surface tension convection may be eliminated by allowing the liquid to come to equilibrium. This means that when necessary, all convection forces can be eliminated. It also means that when desired, a certain amount of convective motion may be introduced into the system. Thus a zero-g advantage.
- e. Other Liquid Motion. Other factors (friction, rotation, pressure pulse) are equally amenable to control on earth or in space. Because of the additional control of convection and vibration in space, control of these other modes of motion become more meaningful. Thus a zero-g advantage.
- f. Electric and Magnetic Fields. When the proper frequency from an alternating electric field is introduced to many liquids, the material begins to move. This motion causes crystal multiplication. On earth, these fields are optional. In zero-G environments, containerless molding requires some sort of disturbing field. These will set the fluid into motion. This effect may or may not be desirable. Thus zero-g affected.
- g. Composition - High Zero-g Control. The purity of materials is important from both a quality standpoint and one of nucleation control.
- h. Impurities. By using containerless melting and solidification, impurities can be better controlled, and possibly eliminated. Thus a zero-g advantage.
- i. Gas Content. Any gas that comes out of solution during solidification will tend to remain in the melt, rather than rise to the surface. This can cause increased porosity (void formation and nucleation); however, it may be possible to eliminate this through application of convective currents. Thus a zero-g effect.
- j. Radiation. The material may be subjected to high intensity radiation (for example, due to solar flare-ups) which would probably cause increased nucleation and

frequency of defects. This effect could be controlled to some extent by the same radiation shielding used to protect astronauts. Radiation contamination is not zero-g affected.

- k. Other Factors. Those factors governing nucleation that are not discussed above are believed to be zero-g insensitive.

1.6.2 FACTORS AFFECTING CRYSTAL GROWTH. The major criteria relating to the growth of crystals is shown in Table 1-9 and their interrelationships are indicated in Figure 1-29.

Table 1-9. Factors Affecting Growth

Factor	Direction to Increase Growth
Thermodynamic Driving Force	
Available Sites	More sites
Latent Heat of Fusion (L_M)	Lower L_M
Diffusion	Faster
Surface Free Energy (ΔG_S)	Higher ΔG_S
Undercooling (ΔT)	Larger ΔT
Liquid Motion	
Thermal Gradients	-
Viscosity	-
Composition	-
Imperfections	More imperfections

1.6.2.1 Thermodynamic Driving Force. Several of the growth criteria discussed in following paragraphs may be considered factors effecting the driving force for growth.

- a. Interface Reactions. Depending upon the system (materials used), the interface will either be smooth or rough. A smooth surface has very few available sites for growth unless an imperfection such as a dislocation is present, whereas, a rough surface grows with little difficulty.
- b. Available Sites. The probability of growth increases as the number of sites (available to a liquid atom at the solid interface) increases. This is in part determined by the shape of the growing crystal, and in part, the size. An interior curve is a more likely site because of the stronger (more numerous) bonds available to hold the atom. The larger the size of the growing crystal, the more available sites there will be, and thus the greater the ease of growth.

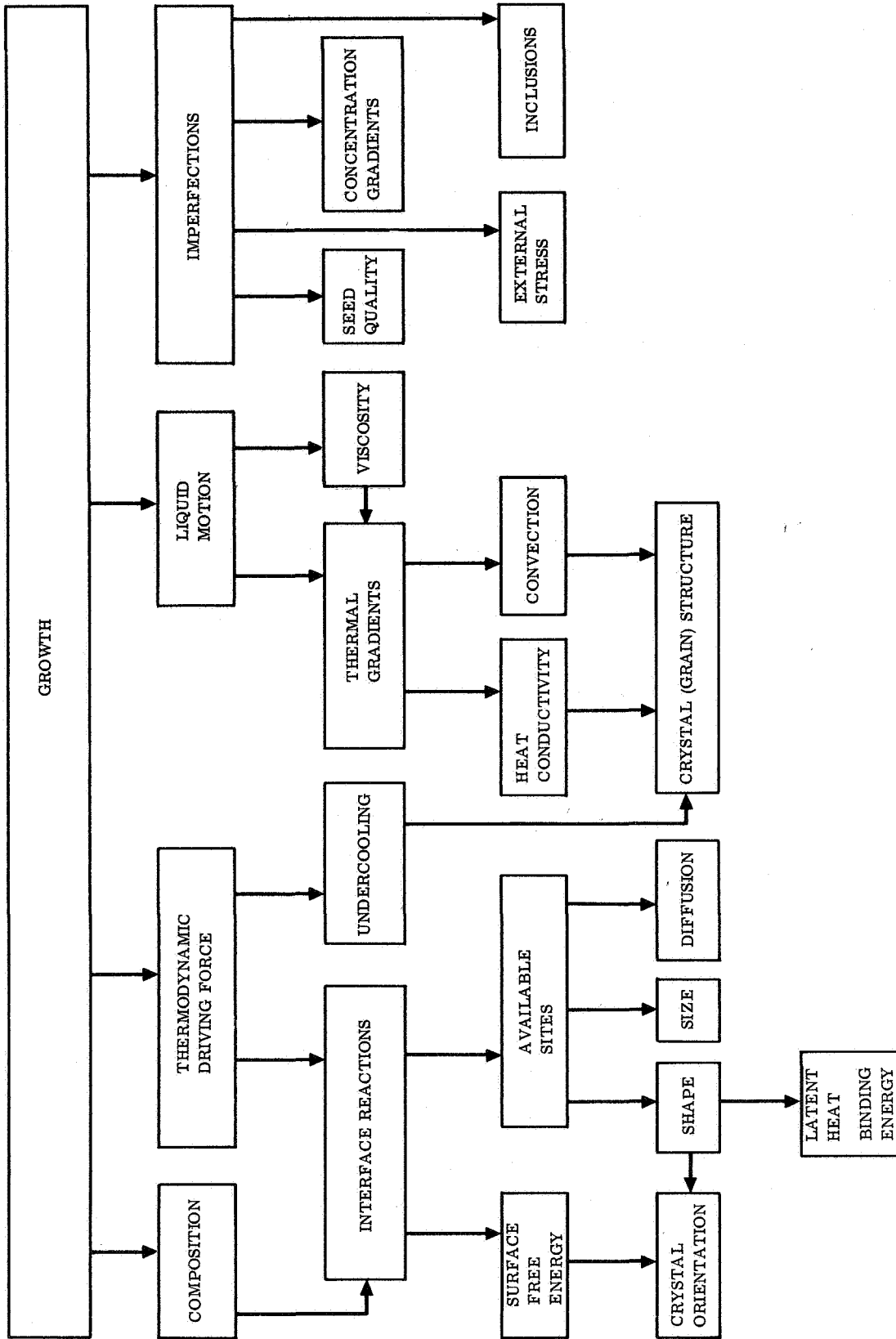

Figure 1-29. Interrelationship of Growth Criteria

- c. Latent Heat of Fusion. The greater the heat of fusion, the smoother the interface, and thus the more difficult growth becomes. The binding energy of the atom to the crystal is also dependent on the latent heat (L_M /total number of bonds).
- d. Diffusion. In many cases, diffusion plays an important role in the growth of crystals. An atom impinging on the surface of a crystal migrates to a favorable site where it becomes permanently attached to the surface.
- e. Surface Free Energy. The surface free energy of a crystal is different from that of a liquid or embryo; it is dependent upon crystallographic orientation. Thus, the equilibrium shape of a solidified crystal is not a sphere as in liquids. The more loosely packed planes have the highest free energy and grow with the greatest ease. This means that these planes grow themselves out of existence, and thus lower the overall surface free energy of the crystal. A two or three-dimensional Wulff plot is required to determine the actual relationship between orientation and surface energy.
- f. Undercooling. The greater the degree of undercooling, the greater the driving force for growth.

1.6.2.2 Liquid Motion. The degree of motion of the liquid can affect the growth of crystals. If the motion is violent, physical damage can occur to the growing crystals. The degree of liquid motion can also affect the distribution of solutes at the solid-liquid interface.

- a. Thermal Gradients. It is necessary to have thermal gradients to facilitate growth. These gradients set up convective motion in the liquid which can affect the type and rate of growth.
- b. Viscosities. The viscosity of the liquid materially affects the motion of the liquid. The greater the viscosity, the less important factors such as thermal gradients become (that is, there is less liquid motion). This difference in the ability of the liquids to flow will result in a variety of possible crystal morphologies.

1.6.2.3 Composition. Composition is an important factor in determining the type of crystal that grows. In binary alloys, solute rejection may set up a compositional barrier preventing certain atoms from reaching the interface. The different concentrations at intervals away from the interface mean that the effective liquidus temperature varies setting up the possibility of constitutional supercooling and the attendant cellular or dendritic growth.

1.6.2.4 Imperfections. On smooth interfaces, dislocations or other irregularities can aid growth by increasing the possible number of available sites. The growth of imperfect crystals is dependent upon the following:

- a. Quality of seed (in single crystal growth)
- b. External stresses
- c. Concentration gradients
- d. Thermal gradients
- e. Inclusions.

The predominant form of imperfection present in the crystal is the dislocation. Dislocation-free growth is difficult, and might have to be done using techniques similar to those incorporated in growing whiskers.

1.6.2.5 Gravity Affects on Growth. Several of the growth criteria are amenable to better control in a zero-g environment, Table 1-10. These growth criteria are discussed in the following paragraphs.

Table 1-10. Effect of Gravity on Growth Criteria

Criteria	Importance	Zero-g Control
Driving Force	High	None
Liquid Motion	High	High
Composition	Low	High
Imperfections	Medium	Moderate
Conclusion: Zero or near zero-g environment permits control of growth.		

- a. Liquid Motion - High Control in Zero-g. The control of liquid motion in a low gravity environment was discussed in Section 1.6.1.6. Thus a zero-g advantage.
- b. Heat Extraction. In a zero-g environment, judicious placement of heating elements (and possibly heat sinks) may permit more precise heat control with less chance of liquid motion. Thus a possible zero-g advantage.
- c. Composition - High Control in Zero-g. The control of composition and impurities in a zero-g environment was discussed in Section 1.6.1.6. Thus a zero-g advantage.
- d. Imperfections - Moderate Zero-g Control. Imperfections may be either desirable (increasing growth rate in planer interface systems) or harmful (effect on mechanical and physical properties). Imperfections due to contamination or thermal

shock from mold walls can be controlled and eliminated with the containerless melting in zero-g environments. Thus a zero-g advantage.

- e. Other Factors. Those factors governing growth that are not discussed above are believed to be zero-g insensitive.

1.6.3 FACTORS AFFECTING REACTION KINETICS. The solidification rates, of necessity, incorporate many of the same criteria enumerated in nucleation and growth. The reaction kinetics are comprised of growth rates, nucleation rates, and the interrelationships between these. The major factors affecting solidification rates and the direction of individual criteria which enhances solidification are summarized in Table 1-11. These interrelationships are shown graphically in Figure 1-30.

Table 1-11. Factors Affecting Solidification Rates

Factor	Direction to Increase Solidification Rates
Nucleation Rate Number of Nuclei Formed Rate Atoms Strike Embryo Surface Area of Embryo	More nuclei Greater rate Larger surface
Mobility	Increase mobility
Driving Force Undercooling (ΔT) Latent Heat (L_M)	Increase ΔT Less L_M
Foreign Particles	More particles
Relationship of G_R/N_R Curves	-
Cooling Rate Liquid Motion	-
Composition Supersaturation	Increase saturation

1.6.3.1 Nucleation Rate. Nucleation is of prime importance to solidification. Without nuclei, there can be no growth of crystals.

- a. Number of Nuclei Formed (n^*). The rate of nucleation depends upon the number of embryos present. The factors which effect the nuclei formation were discussed in Section 1.6.1.

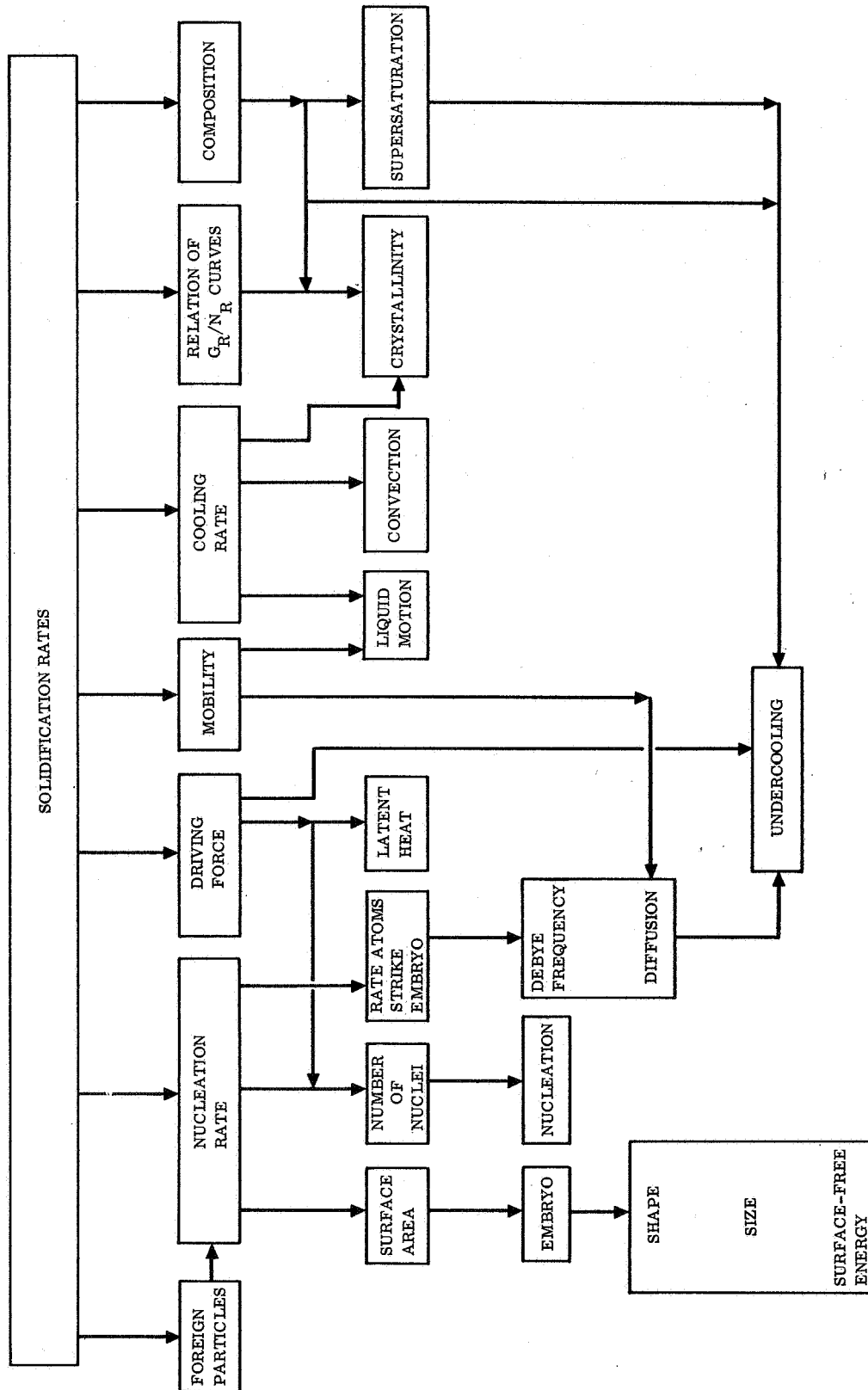

Figure 1-30. Interrelationship of Solidification Rate Criteria

- b. **Rate Atoms Strike Embryo (z).** The more frequently the atoms strike the embryo, the greater the probability of embryonic growth. This rate is a function of the Debye Frequency $\nu = kT/h \sim 10^{13}$ cycles/sec., a characteristic of each material, and the rate of diffusion of atoms towards the embryo. There is an activation energy ΔG_A , which must be overcome before an atom can reach an embryo. This particular factor becomes greater at higher temperatures, and is, in a sense, opposed to all other factors which operate more effectively at lower temperatures.
- c. **Surface Area of Embryos (s*).** As the total surface area of the embryos increases, there is a greater probability of attracting and capturing additional atoms. The shape, number, and surface free energy of the embryos are all important in determining the amount of surface available. A decrease in temperature will cause an increase in the total surface area of the embryo.

1.6.3.2 **Mobility.** The mobility of atoms in the melt greatly affects the solidification rate. The higher the mobility, the more likely it is for atoms to converge and form crystals. This process is essentially a diffusion controlled process, but is at least in part, dependent upon liquid motion.

1.6.3.3 **Driving Force.** The driving force is a measure of the free energy difference between the equilibrium structure (solid in our case), and the actual structure (liquid in our case). Several of the factors associated with the driving force have already been discussed. Discussion of undercooling and latent heat factors follow.

- a. **Undercooling.** The greater the undercooling, the greater the difference between the two free energies, and thus the greater the driving force for solidification. The nucleation rate is sensitive to the temperature of the system. At a specific amount of undercooling (depending upon the material), nucleation begins. As the temperature is lowered further, the rate of nucleation increases; however, if the rate of cooling were sufficiently rapid (say 10^5 °C/sec); it would be possible to bypass all nucleation and form an amorphous material. The growth rate curve has the same general form as the nucleation rate curve. The growth rate curve, however, generally begins to increase at a lower undercooling than the nucleation rate curve.
- b. **Latent Heat (L_M).** As a crystal grows, the latent heat of fusion is released to the system. This heat raises the temperature of the surrounding liquid and tends to slow down growth until an equilibrium point is reached wherein the heat evolved is matched by the heat extracted from the system.

1.6.3.4 **Foreign Particles.** In general, impurities decrease the effective surface energy of the system, thus allowing nucleation to occur with less difficulty. With all other factors remaining constant, the addition of impurities should increase the solidification rate.

1.6.3.5 Relation of G_R/N_R Curves. The relative positions of the nucleation and growth rate curves will, when coupled with the cooling rate, determine the type of grain (crystal) structure obtained (fine-grained, coarse-grained, amorphous). These curves are inherent properties of the materials used.

1.6.3.6 Cooling Rate. The rate at which a material cools will determine the type of final structure present (crystalline or amorphous). At low cooling rates, the full extent of crystallization can occur (in non-glass materials). At extremely rapid cooling rates, it is possible to transform some normally crystalline materials into glass.

a. Liquid Motion. The thermal gradients introduced during solidification induce convection in the liquid. The transfer of heat through the liquid is greater when convection occurs. This is because the rate of heat flow by conduction through a liquid is $1/2$ to $2/3$ that of solids. Thus, the rate of heat extraction from the liquid, and hence the cooling efficiency, is affected by liquid motion.

1.6.3.7 Composition. In systems in which there is more than one component, rejection of solute atoms is likely to occur. The liquid near the interface will then have a concentration different than that of the bulk of the liquid. This means the degree of undercooling is different, and depending upon the type of growth encountered, the rate of growth will change. (The type of Crystal structure-columnar, dendritic, etc. - is in part dependent upon the composition of the liquid.)

a. Supersaturation. In systems where the liquid plays a passive role (as in aqueous solutions), the higher the supersaturation, the greater the tendency for nucleation and thus the greater the solidification rate. Generally, there is a critical amount of supersaturation below which nucleation is quite slow. With just slightly more supersaturation, solidification occurs catastrophically (assuming all other parameters remain constant).

1.6.3.8 Gravity Affects on Solidification Rates. Those factors affecting solidification rates that are sensitive to control in a zero-g environment are discussed in following paragraphs, and tabulated in Table 1-12.

a. Nucleation Rate - High Zero-g Effect. The nucleation rate is essentially dependent upon those factors that govern the formation of nuclei. These criteria have been discussed in relation to zero-g environments in section 1.6.1.6. Thus a zero-g advantage.

b. Mobility - Medium Zero-g Control. The reaction kinetics for solidification are dependent upon both mobility and the driving force. Mass and heat transport are portions of the mobility, and are, to some degree, dependent upon liquid motion. To the degree that liquid motion plays a part in the transport, the transport can be more effectively controlled in a zero-g environment. Thus a moderate zero-g effect.

- c. **Foreign Particles - High Zero-g Control.** Because of the decreased surface energy required, foreign particles cause an increase in the nucleation rate. The benefits in a zero-g environment were mentioned in section 1.6.1. Thus a zero-g effect.
- d. **Cooling Rate - Minor Zero-g Control.** To the extent that convection (liquid motion) affects the cooling rate, there is some degree of control over cooling. In general, however, there is a limit to the maximum cooling rate obtainable (in containerless operations) because of the dependency on radiation cooling. Thus a minor zero-g effect.
- e. **Composition - High Zero-g Control.** Impurities can affect the quality of the growing crystal. As discussed before, containerless melting will allow greater control of impurity content. Further, because liquid motion due to density differences can be controlled, there will be better distribution control of the impurities. Thus a zero-g effect.
- f. **Other Factors.** Those factors not listed above are not affected by the absence of gravity.

Table 1-12. Effect of Gravity on Solidification Rates

Criteria	Importance	Zero-g Control
Nucleation Rate	High	High
Mobility (mass + Heat Transport)	High	Moderate
Driving Force	High	None
Foreign Particles	Moderate	High
Relation of G/N Curves	Moderate	None
Cooling Rate	Moderate	Minor
Composition	Moderate	High
Conclusion: Zero or near zero-g permits improved solidification control.		

1.6.4 THE EFFECT OF GRAVITY ON THE SOLIDIFICATION PROCESS. From the discussion in the preceding sections, it can be seen that there are many opportunities to control the solidification process in a zero-g environment. Specifically, the

control of various criteria will permit selection of the type of solid desired - polycrystalline, single-crystal, or an amorphous material.

1.6.4.1 Polycrystalline Materials. Polycrystalline materials are those solids that are grain-refined. The advantage of grain-refined materials is an increase in desirable mechanical properties. Because of the solidification controls available in a zero-g environment, it should be possible to produce the fine-grained structure in a single-step casting process rather than the multi-step operations required on earth.

Those solidification criteria of primary importance in the formation of polycrystalline materials are mixture stability of foreign particles and liquid motion. The foreign particles act as sites for heterogeneous nucleation, and in a zero-g environment, they can be dispersed throughout the liquid to give increased nucleation. The control of the type, intensity, and duration of liquid motion in a zero-g environment will also assist in creating additional nucleation sites. The control of composition is of secondary importance; the purity of the material can be more easily controlled in the containerless operations available on a zero-g environment. The effects of various criteria on polycrystalline-solidification are summarized in Table 1-13.

1.6.4.2 Single Crystals. The utility of single crystals in the electronics industry has been discussed in great length. The introduction of laser technology has brought new interest into the optical properties of single crystals, such as rubies. A less definite, though highly promising area, is the field of structural single crystals.

Control of composition is of primary importance. In zero-g, this is facilitated by containerless operations. Additionally, the control of imperfections (easier in a zero-g environment) is critical. The elimination of imperfections and contamination will mean greater payoffs in physical and mechanical properties. In single crystal growth, it is important to prevent extraneous nucleation; therefore, the advantages in control of foreign particles and liquid motion in a zero-g environment will be important. These effects are summarized in Table 1-13.

1.6.4.3 Amorphous Materials. Glasses, or non-crystalline materials, have found widespread use in optical applications. They are also used in structural applications, and are beginning to make inroads into the electronics industry.

One of the primary advantages to glass-forming in a zero-g environment is the ability to cast without a container. Containerless operations permit strict control of contamination and limit the production of surface defects, which means higher quality and strength. Controlled cooling rates are important to prevent unnecessary residual tensile stresses from occurring during the cooling operations. These considerations are summarized in Table 1-13.

Thus, there are two main areas of solidification in which the absence of gravity plays an important role. These two areas are: 1) chemical and physical purity, and

2) liquid motion. These factors are important criteria for nucleation, growth, and the solidification rate. The greatest benefit occurs in the area of nucleation. Fluid motion effects nucleation by means of crystal-multiplication, and impurities aid nucleation by providing foreign surfaces that decrease the overall surface energy. Cast structures of varied grain size can readily be produced. Because of the increased control of grain size in zero-gravity, not only can fine-grain materials be produced, but by keeping nucleation to a minimum, single crystal and glass growth may be facilitated.

Therefore, there is an advantage available in zero-g solidification. This advantage will be of considerable interest in controlling the mechanical properties, quality (purity), and structure of polycrystalline, single crystal, and amorphous materials.

Table 1-13. Control of Solid Formation

	Foreign Particles	Liquid Motion	Composition	Imperfections	Mobility	Cooling Rates
Polycrystalline Materials	4	4	3	1	2	2
Single-Crystal Materials	3	3	4	4	1	2
Amorphous Materials	3	2	4	4	1	3
<p>Rating: 1 - Little or no importance 2 - Minor importance 3 - Secondary importance 4 - Major importance</p> <p>Summary: Polycrystalline Average = 2.7 Single-Crystal Average = 2.8 Amorphous Average = 2.8</p>						

PART 2

PROCESSES

EVALUATION AND DEFINITION OF METHODS, PRODUCTS, AND CRITERIA

The evaluation of individual processes is preceded by a discussion and definition of the basic "zero-g phenomena," which represent the major technical effects of the complex interaction of the g-environment and liquid matter, discussed in detail in Part 1. The purpose of this definition is twofold:

- a. To permit identification of these phenomena in the process discussion by a simple "call-out" without repetitious explanation, and
- b. To identify the predominant applications of zero-g in terms of basic processing techniques; this facilitates the introduction of such techniques from the outset of the process evaluation and eliminates the need for referring the reader to the specific process in which the techniques are discussed in detail.

The definition of zero-g phenomena is followed by discussion of criteria used in the selection of processes for evaluation. This is followed by a detailed evaluation of each process which identifies and defines the criteria and requirements used as the basis for assessing the effectiveness of each process.

2.1 BASIC PROCESSING PHENOMENA AND TECHNIQUES

Application of the peculiar effects of the g-environment to basic liquid-state processing techniques is defined by three "basic processing phenomena." The absence of buoyancy, the minimized convection, and the unrestrained interaction of intrinsic energies or intermolecular forces. In most processes, these phenomena are applied in various combinations - in the following sections, they are defined individually.

2.1.1 ABSENCE OF BUOYANCY. The most obvious application of the absence of buoyancy and the resulting stability of mixtures is the liquid-matrix processing of materials of different density. These mixtures comprise liquid-solid, liquid-gas, and liquid-liquid mixtures. A survey of all potential mixtures between solids, liquids, and gases in various forms is presented in Table 2-1.

Liquid-solid mixtures find primary application in the casting of composites, particularly metal-matrix composites. Under terrestrial conditions, the liquid-matrix preparation of composites is limited to liquids of high viscosity, such as polymers. Metal-matrix composites are exclusively produced in the solid state because of the extremely low viscosity of molten metals. Solid-state processes have serious limitations with regard to matrix continuity, reinforcement integrity, and the resulting material properties.

Table 2-1. Potential Combinations of Matter in Various States of Aggregation

Elementary Components	Continuous Surfaces		Particles		
	Solid	Liquid	Solid Particles	Liquid Micro-spheres	Gas Micro-spheres
Liquid Continuum	Adhesion Capillary Action		Composites	Materials From Liquid Mixtures	Foams
Gas Continuum	Adhesion Mass Attraction		Material From Monolithic Cloud		
Liquid Mist in Gas Continuum			Materials From Heterogeneous Cloud		

Further, solid-state processes are limited to shapes dictated by the necessary uni-directional reinforcement orientation. Preparation in the liquid-matrix state — possible only under low-gravity conditions — eliminates all these constraints and the costly secondary fabrication, since composite preparation and casting of a complex end-product can be carried out in one single operation.

While composite castings primarily involve fibrous reinforcement, there are several applications for mixtures of liquids with fine particles; one being the casting of dispersion-stabilized alloys either as end-products or as ingots for secondary (terrestrial) fabrication. Evenly distributed fine particles may also be used as nucleation sites during solidification, resulting in fine-grain castings with superior mechanical properties.

With proper temperature and pressure control of the liquid, finely dispersed particles may act as nucleation sites for vaporization and the formation of gas bubbles or foams. Metal particles in a low-melting dissimilar metal matrix may also permit an extension of alloy formation by amalgamation, or the preparation of alloys at moderate temperatures. These applications will be further discussed in connection with related processes.

The application of liquid-liquid mixture stability has so-far been limited to multiphase metals and alloys. In alloying, it prevents or reduces segregation between elements of different density and permits the preparation of supersaturated alloys. Unique alloy systems for specific applications may further be obtained from metal combinations which exhibit liquid-phase immiscibility. The application of liquid-liquid mixture stability in chemistry, even though of considerable potential, has not yet been evaluated.

Liquid-gas mixtures comprise two types — liquid continuum and gas continuum. So-far, only the liquid-continuum variety, consisting of a liquid matrix such as a molten metal and finely distributed gas bubbles has been investigated. The stability of this mixture requires temperature homogeneity. The objective are materials of reduced or variable density. In the gas-continuum variety the liquid is finely distributed in the form of microspheres, much like a fog, and unique homogenous or heterogenous materials may be obtained by condensation or deposition of single or multiple-phase mist on a permanent or disposable substrate.

2.1.2 ABSENCE OF CONVECTION. The term "absence of convection" as used here refers to internal motion resulting from the combined effect of gravity and density differences produced by thermal gradients. While there are other sources of convection, such as variable surface tension (defined in Section 1.3.7) or non-uniform thermal expansion, the gravity-induced convection is of substantially greater magnitude, so that under zero-g or low-g conditions, internal motion is reduced to a minimum. Internal motion is of prime concern in the process of solidification for two reasons:

- a. Motion enhances nucleation and is, therefore, undesirable in all processes of crystallization control, such as the growth of single crystals or whiskers, directional solidification, or suppressed crystallization.
- b. Convective currents may induce imperfections during crystal growth, such as dislocations, and impair the properties of the end product.

Consequently, the absence of gravity-induced convection permits a control of crystal formation and material perfection not attainable under terrestrial conditions.

There are, however, cases where convection is desirable, particularly for the removal of gases evolving internally from a molten material. In the absence of gravity the movement of such gases to the surface may be accomplished by localized surface-tension induced convection. The advantage of such an induced process is its accurate controllability. In other words, in the gravity-free environment, such processes can be applied wherever and whenever necessary. In contrast, the gravity-environment cannot be turned off.

2.1.3 INTERMOLECULAR FORCES. The most pronounced characteristic of liquids in a gravity-free environment is the undisturbed action and interaction of molecular forces.

In the continuum or bulk liquid, the intermolecular forces, — i.e., the attractive and repulsive forces — are balanced. There is no free energy which could act upon the material or be acted upon by induced forces. Momentary unbalances occur only by induced relative motion. The total effect of these unbalances is sensible as "internal friction" or viscosity.

Viscosity of molten metals is extremely low, while it is higher in liquid nonmetallic inorganics, such as oxides. Consequently, oxides are less sensitive to motion during crystallization, so that nucleation can be completely suppressed even at slow cooling rates (formation of glasses).

As we approach the surface, the intermolecular balance of forces is disturbed in one direction with a considerable increase of free energy. The total free energy of the surface region is referred to as interfacial tension, or, in the case of the liquid-gas interface, as "surface tension."

Surface tension produces pressure in the bulk, whose magnitude is inversely proportional to the radius of surface curvature according to the relationship

$$p = \frac{2\sigma}{r} \quad (49)$$

A liquid will always assume the geometry of minimum free energy, which, under dimensional constraints, represents a finite curvature and bulk pressure. In zero-g, the undisturbed liquid will assume perfect spherical shape.

If due to some induced disturbance the curvature is non-spherical, two orthogonal radii must be introduced, and the relationship in equation (49) is modified to

$$\Delta p = \sigma \left(\frac{1}{r_1} + \frac{1}{r_2} \right) \quad (50)$$

Surface tension σ , as used here and later in this discussion is more accurately the interfacial tension between the liquid and gas phase, identified by σ_{LG} . There are, likewise, interfacial tensions σ_{LS} and σ_{SG} for liquid-solid and solid-gas contact. The force balance of the contact point, where liquid, solid, and gas meet is defined in Figure 1-9 (Section 1.3.5) and represented by the relationship

$$\sigma_{SG} = \sigma_{LS} + \sigma_{LG} \cdot \cos\beta \quad (51)$$

For a finite contact angle β , the liquid will only spread-out until a uniform curvature has been attained. If β is zero, equation (51) is modified to

$$\sigma_{SG} \geq \sigma_{LS} + \sigma_{LG} \quad (52)$$

and spreading is essentially unlimited; theoretically, the rate of spreading is determined by the difference between the two sides of the equation. In reality, the rate of spreading is affected by a number of secondary factors, such as shear forces on a solid-surface roughness, which may be combined into a "spreading factor," best determined experimentally.

2.1.4 APPLICATION OF LOW-G PHENOMENA IN PROCESSES. Specific effects of the basic zero-g phenomena discussed in preceding sections are achieved by the introduction of certain controls. These controlled effects are the basis of all zero-g manufacturing processes.

The basic means of control and the resulting basic process concepts or products are identified in Table 2-2 for each of the three zero-g phenomena. The table is arranged in two sections. The first comprises all techniques of processing in the liquid state; the resulting products may be either solids or liquids. In the second group, the prime zero-g effect occurs in the liquid-solid interphase, i.e., during solidification; all products are, consequently, solids.

The purpose of Table 2-2 is to give a first-order overview of the primary application of the low-gravity environment in various processes and products. While it identifies the methods of control only in generic terms, there are various modifications and combined applications for specific processes and products. Likewise, the zero-g phenomena may be applied in various highly effective combinations. The contact-free formation of a sphere, for instance, as a basic process employs only the intrinsic intermolecular forces without any controls. The mechanical properties may, however, be improved by the addition of strengthening fibers, involving the phenomenon of mixture stability. The microstructure of the composite sphere matrix may further be improved or customized for specific applications by various methods of solidification control.

2.2 SELECTION OF PROCESSES FOR EVALUATION

A considerable number of processes and products have been suggested over the past few years (see Appendixes 2 and 3). Many of these represent only modifications of basic processes, while others are rather vague in the definition of capabilities and effective use of zero-g effects. To include all these processes in the evaluation would have been wasteful and would have increased the complexity of the evaluation by the introduction of additional criteria of secondary significance. It was therefore attempted to reduce the number of processes to a limited yet complete spectrum on the basis of the following general criteria:

Table 2-2. Application of Zero-g Phenomena in Basic Processing Techniques

STATE	MEANS OF CONTROL	PRIMARY ZERO-G PHENOMENA		
		MIXTURE STABILITY	REDUCED CONVECTION	INTERMOL. FORCES
Liquid	None	Supersaturated Liquid/ Liquid Mixtures		Contact-Free Formation of Spheres, Container- less Melting
	Induced Forces	Variable Density Mixtures	Unit Separation	Contact-Free Forming Formation of Membranes
	Mechanical Forces	Liquid Continuum-Bubble Mixtures		Formation of Hollow Spheres, Foaming
	Gas Injection			
	Thermal Gradient	Liquid-Matrix Composites	Controlled Liquid/Motion	Controlled Vaporization (Nucleate Foaming)
	Solid Particles			Adhesion/Deposition, Spreading
Liquid-Solid Interphase (Solidification)	Solid Interface			
	None	Supersaturated Alloys Metal/Metal Composites	Reduced Nucleation	Containerless Solidification
	Thermal Gradient		Single - Crystal Growth	Growth of High-Purity Single Crystals
	Solid Particles	Induced Nucleation Formation of Intermetallics		

- a. Typical - representing typical processing concepts either individually or in various combinations.
- b. Potential - in terms of process uniqueness, product capabilities and/or product applications.
- c. Assurance of Success - in general as well as with regard to initial space experiments.

Not all selected processes meet all three requirements. A number of processes which are very questionable as to requirements b. and c. were retained, since they represent a concept not covered in other processes, such as adhesion casting or blow molding. It would have been presumptuous to eliminate these processes on the basis of our present judgement and knowledge, as the increasing experience may well give these processes a new impetus.

The selection was based on iteration of effectiveness evaluations, using various approaches and rating systems. It would serve no purpose to include these preliminary evaluations, particularly in view of the detailed process effectiveness evaluation contained in Part 3.

The processes finally selected for this evaluation are listed in Table 2-3. To avoid confusion in reference to earlier process discussions, not included in this report, previously used identification codes have been retained. The identification by single numbers or added letters have, therefore, no technical meaning.

The processes are listed in Table 2-3 in the sequence of identification numbers. With regard to the use of zero-g phenomena, they may be categorized into four groups as follows:

- a. 1 through 5 - processes primarily based on intermolecular forces, particularly of the liquid-gas interface.
- b. 6, 10, 11, 13 - process primarily based on mixture stability or zero buoyancy.
- c. 7, 8, 9, 12, 17 - processes primarily based on crystallization control, including nucleation, crystal growth, and solidification.
- d. 14, 15, 16 - processes employing other or combined zero-g effects.

The term "primarily" used in all definitions implies the additional use of other zero-g effects in various combinations, discussed in the following evaluation of individual processes.

Table 2-3. Processes Selected for Evaluation

Processes or Products	
1	Production of Spheres
1a	Liquid Forming
2	Adhesion Casting
3a	Thin-Wall Hollow Spheres
3b	Thick-Wall Hollow Spheres
3c	Blow Molding
4a	Flat Membranes
4b	Drawing of Filaments
5	Metallic Foams
5a	Pressure Stiffened and Composite Foams
6	Composite Casting
7a	Single Crystal Growth From Solution
7b	Single Crystal Growth by Zone Melting
7c	Pulling of Single Crystals From the Melt
8	Growing of Whiskers
9	Amorphous Materials (Glasses)
10	Dispersed Particle Castings
11	Thermosetting Alloys
12	Supercooling
13	Supersaturated Alloys
14	Purification
15	Unit Separation Processes
16	Containerless Melting of High-Temp Alloys
17	Superconductors

2.3 EVALUATION OF INDIVIDUAL PROCESSES

The prime objective of the following evaluation of individual processes is to identify and define the significant criteria and requirements which, in turn, provide the basis for the assessment of relative process effectiveness and experiment priorities in Part 3. Consequently, prime emphasis is placed on criteria and requirements with a minimum of discussion. It is assumed that most readers are familiar with the process concepts; otherwise, detailed information can be obtained from recent publications.

The scope and arrangement of the individual discussions, as well as the wording of the subtitles are adapted to the nature and objectives of each process and are, therefore, not uniform. However, each discussion is concluded with a summary of the defined criteria and requirements.

2.3.1 PROCESS 1: PRODUCTION OF SPHERES. Since the sphere represents the minimum free-energy state of a given mass of material, any liquid under zero-g will assume perfect spherical shape. The sphere may be considered the basic shape of the gravitation-free environment and is, therefore, discussed in detail.

CRITERIA OF SPHERE FORMATION. The accurate spherical shape is generated in the liquid state by interface energy only. The equilibrium between internal pressure, environmental pressure and surface tension has been defined in equation (49) in Section 2.1.3 as

$$\Delta p = \frac{2\sigma}{r}$$

In numerical dimensions (dyne; cm; kg) this is equal to

$$\Delta p = \frac{4\sigma \cdot 10^{-6}}{D} \text{ (kg/cm}^2\text{)} \quad (53)$$

The internal pressures generated by surface tension are consequently inversely proportional to the sphere diameter as illustrated in Figure 2-1 (external pressure = 0).

In the process of forming the sphere from a non-spherical shape, forces resisting deformation are inertia and viscosity. However, in comparison with surface tension and inertia, viscosity can be neglected as indicated by the following data calculated for the transformation from a liquid cylinder to a 10 cm diameter sphere:

<u>Forces/Area (dyne/cm²)</u>	<u>Water</u>	<u>Copper</u>
Surface Tension	14.6	220
Viscosity	0.003	0.013
Inertia	7.3	110

As illustrated in Figure 1-15 (Section 1.4.1), the inertia force is highest at the beginning of the forming process and becomes zero at its conclusion, while the surface tension force is essentially constant. The time required for the transformation has been defined by equation (20) in Section 1.4.1, which for most liquids may be simplified to

$$t \approx \left(\frac{\rho}{\sigma}\right)^{1/2} R^{3/2} \quad (54)$$

The formation time is, therefore, in close approximation defined by density, surface tension, and sphere size. The transformation is extremely fast, as evidenced by the following data:

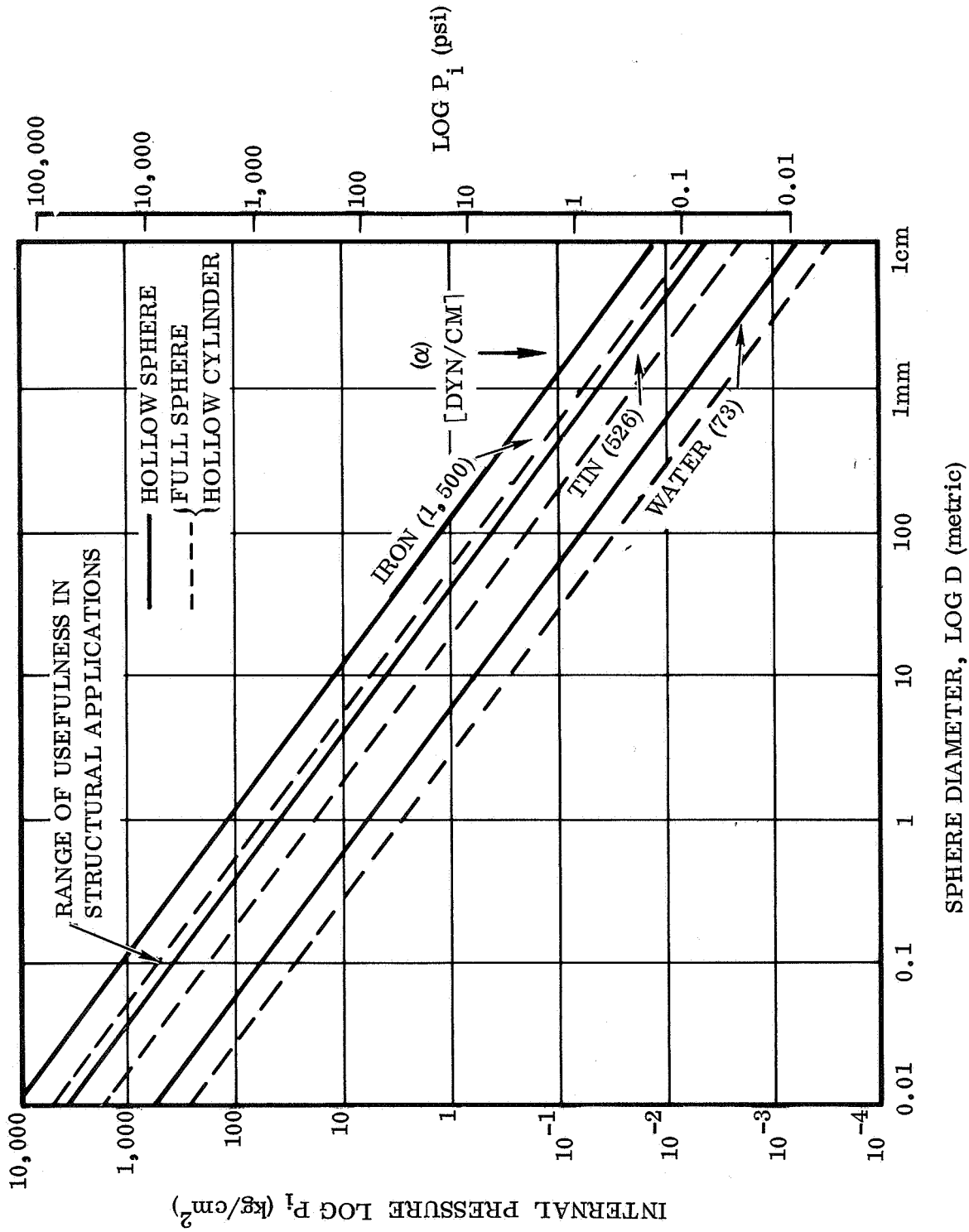

Figure 2-1. Internal Pressures Resulting from Surface Tension

<u>Liquid</u>	<u>Time in Seconds</u>	
	D = 10 cm	D = 1 cm
Water	3.7	0.117
Copper	2.84	0.09

It is apparent that the accelerated mass does not come to a stop after these times, but rather continues to oscillate around the spherical shape. Since the initial non-spherical shape before release represents a potential energy, these oscillations may be regarded as a continuing alternation between the potential and kinetic energy state, as illustrated in Figure 2-2.

The frequency, f , of these oscillations and the time, t , required for the initial amplitude to decay to $1/e$ are represented by equation (26) in Section 1.4.2. For the simplest and most common oscillatory mode, the constants H are approximately

$$H_f = 1.273$$

$$H_\tau = 0.05$$

and for most applications, the terms f and τ may be defined by

$$f = 1.273 \sqrt{\frac{\sigma}{\rho}} \cdot D^{-3/2} \quad (55)$$

$$\tau = 0.05 \frac{\rho}{\mu} \cdot D^2 \quad (56)$$

It can be seen from these relationships that, with regard to active intrinsic material properties, the frequency is determined by surface tension only, and the damping time by viscosity.

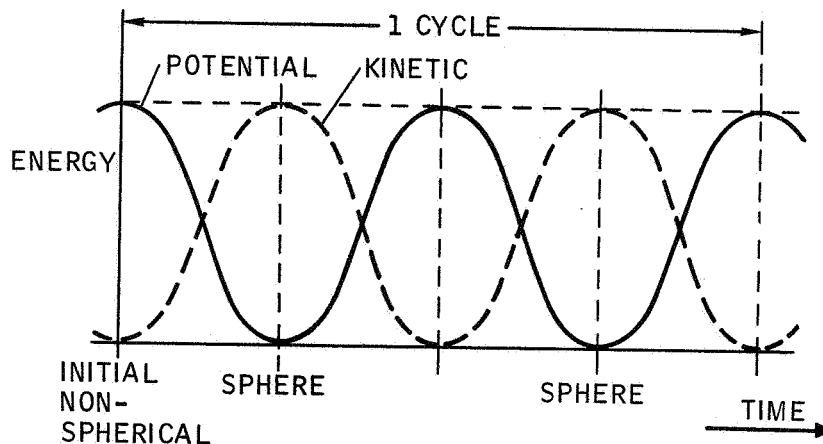

Figure 2-2. Sphere Oscillations in Terms of Potential and Kinetic Energy

The high dependency of oscillation damping time upon sphere diameter is illustrated in Figure 2-3, in which the time to dampen to 10% and 1% of the initial amplitude is plotted over sphere diameter for water and for two metals of low and high surface tension. The damping time to 1% for a 10 cm diameter iron sphere is in the order of 1 hour, in contrast to 10 seconds for a sphere diameter of 0.5 cm.

PRODUCT DEFINITION. Spheres generated in the liquid state by intrinsic forces comprise four application categories:

- a. Solidified spheres as end products.
- b. Solidified spheres as ingots for secondary (terrestrial) fabrication.
- c. Liquid spheres as initial form for further liquid-state forming.
- d. Microspheres and mist as components for special materials.

PRODUCT CRITERIA. The primary pay-off criterion of the sphere as end product is high spherical shape perfection in terms of maximum deviation from the absolute spherical shape. Tolerances of spheres currently produced under terrestrial conditions are in the order of 10^{-5} inches achieved at high cost. Consequently, the tolerances of space-manufactured spheres have to be in the order of 10^{-6} inches or less.

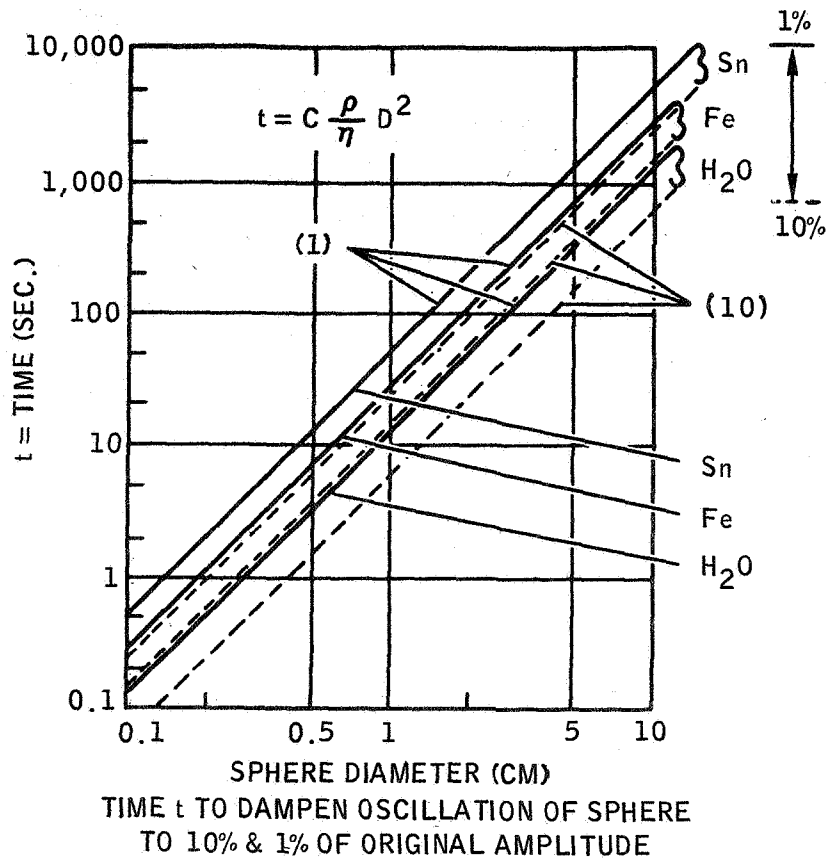

Figure 2-3. Damping of Sphere Oscillations

The accuracy attainable in liquid formation is determined by the damping of oscillations resulting from the detachment of the liquid sphere from deployment tools. Since, the magnitude of these oscillations is a function of sphere diameter and time, any desired accuracy for a given diameter can, therefore, be achieved by the waiting time from deployment to solidification. Due to the gravity gradient across the sphere in the direction to the earth mass center, the oscillations will ultimately level off at a finite distortion. The magnitude of this deviation from the perfect spherical shape, according to equation (34) in Section 1.4.6, is proportional to the fourth power of the diameter. It is 10^{-9} cm at 1 cm sphere diameter and exceeds conventionally attainable accuracies by several orders of magnitude.

The second pay-off is the absence of any preferred microstructural orientation after solidification. Conventional spheres, such as ball bearings, are machined from mill stock, retaining its microstructural orientation. As illustrated in Figure 2-4 this produces two sphere areas of high failure (crack) sensitivity. The zero-g manufactured sphere is completely homogenous; the grain size can further be refined by induced fine-grain solidification, discussed in Process 10.

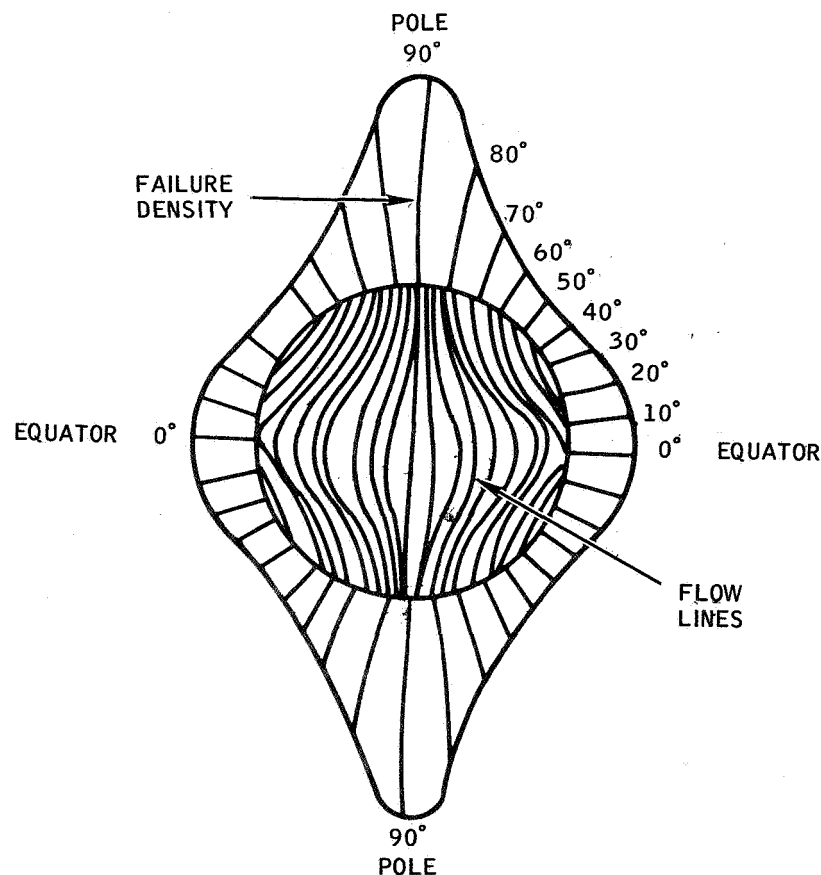

Figure 2-4. Failure Density as a Function of Ball Latitude
(for 211 Failures and 10 Materials)

For the sphere as ingot, as applicable to the containerless melting and alloying of extreme-temperature metals (Process 16) or to the production of glass blanks (Process 9), there is no particular accuracy requirement and solidification can be induced immediately upon sphere formation.

Since the self-formation is, in contrast to machining, completely free of vibrations, an almost perfect surface finish can be expected, never achievable in conventional fabrication. In the liquid state, the surface is perfect; imperfections of extremely small magnitude can only occur during the solidification process.

The prime objective of spherical ingots is the elimination of any negative effects of tooling contact; in addition, it has again the benefit of a homogenous microstructure.

If the liquid sphere is produced for further free-forming in the liquid state, as applicable to processes 1a, 9, and 16, damping of oscillations to a finite level will be required. The degree will depend on the method and extent of subsequent forming operations, as discussed in Process 1a. This adjustment presents no problems.

The use of spheres in the form of microspheres or super-microspheric "mist" for the fabrication of special materials, such as heterogenous materials or metal-non metal composites is not sufficiently defined to permit the identification of criteria. While the accuracy is very likely of no importance, the high internal pressure generated by surface tension may be used to advantage. In some cases a uniform microsphere size requirement may present problems of measuring and diameter control.

PROCESS CRITERIA AND REQUIREMENTS. Liquid spheres may be produced by two methods:

- a. Melting of near-spherical ingots.
- b. Deployment from a nozzle.

For the re-melting method, a near-spherical solid ingot is prepared in terrestrial production by either casting or powder metallurgy. The ingot is suspended in the melting chamber and in the center of a position-control system by means of a string or wires of the sphere material. Position control is activated during the heating cycle, taking-over after melting of the suspension wires as illustrated in Figure 2-5 (Position B). The advantage of this method is low initial oscillations and, consequently, shortened time to shape perfection. Disadvantages are extended processing periods, requiring complete cooling and reheating of the entire chamber, and the preclusion of in-space variation of sphere size or adjustment of material composition.

The primary method of sphere production is nozzle-deployment of liquid material supplied from a melting chamber (Figure 2-5, Position A). The proper sphere formation at the nozzle is determined primarily by:

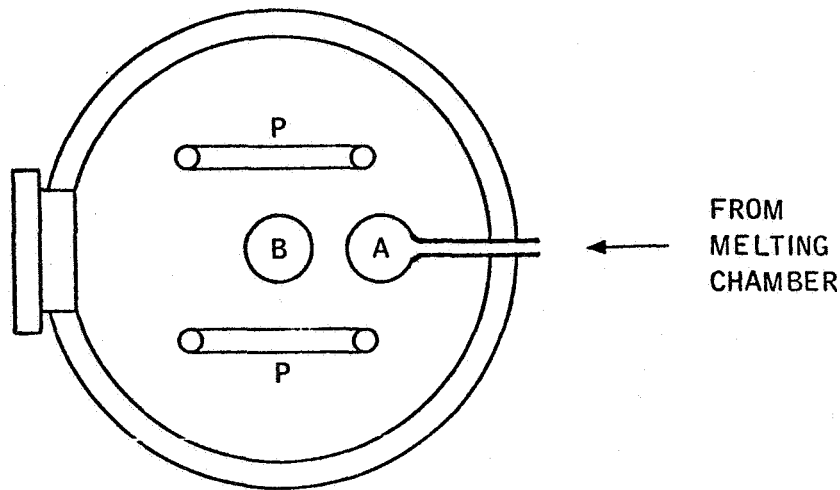

Figure 2-5. Processing of Liquid Spheres

- a. Nozzle configuration.
- b. Nozzle wetting characteristics.
- c. Pressure differential between melting and production chambers.

The clean formation and growth of the liquid sphere requires an optimum combination of orifice configuration and wetting characteristics, i.e., arrangement of wetting and non-wetting surfaces. This represents a delicate problem of interfaces which is discussed in detail in Appendix 4. Theoretical tooling studies require extensive experimental support — much can be learned on this subject from equal-density model experiments, particularly with regard to nozzle configuration and detachment techniques. The final combination of nozzle configuration with wetting surface arrangement can only be checked-out under near zero-g conditions, as they are obtained in drop-tower and aerial free-fall experiments (Section 3.7.3). A number of conceptual nozzle designs and wetting arrangements are shown in Figure 2-6 (A,B,C). The purpose of these figures is only the identification of requirements, rather than the definition of functional designs.

The adjustment of final sphere size requires an accurate control of the pressure differential between supply material (melting chamber) and production chamber. The involved pressure differentials are of extremely small magnitude, particularly if the sphere is formed in a vacuum environment. For approximate size, as for manufacture of spherical ingots, manned control may be adequate. For accurate size control, an automatic control system consisting of an optical sensing device which monitors the pressure control systems, may be required.

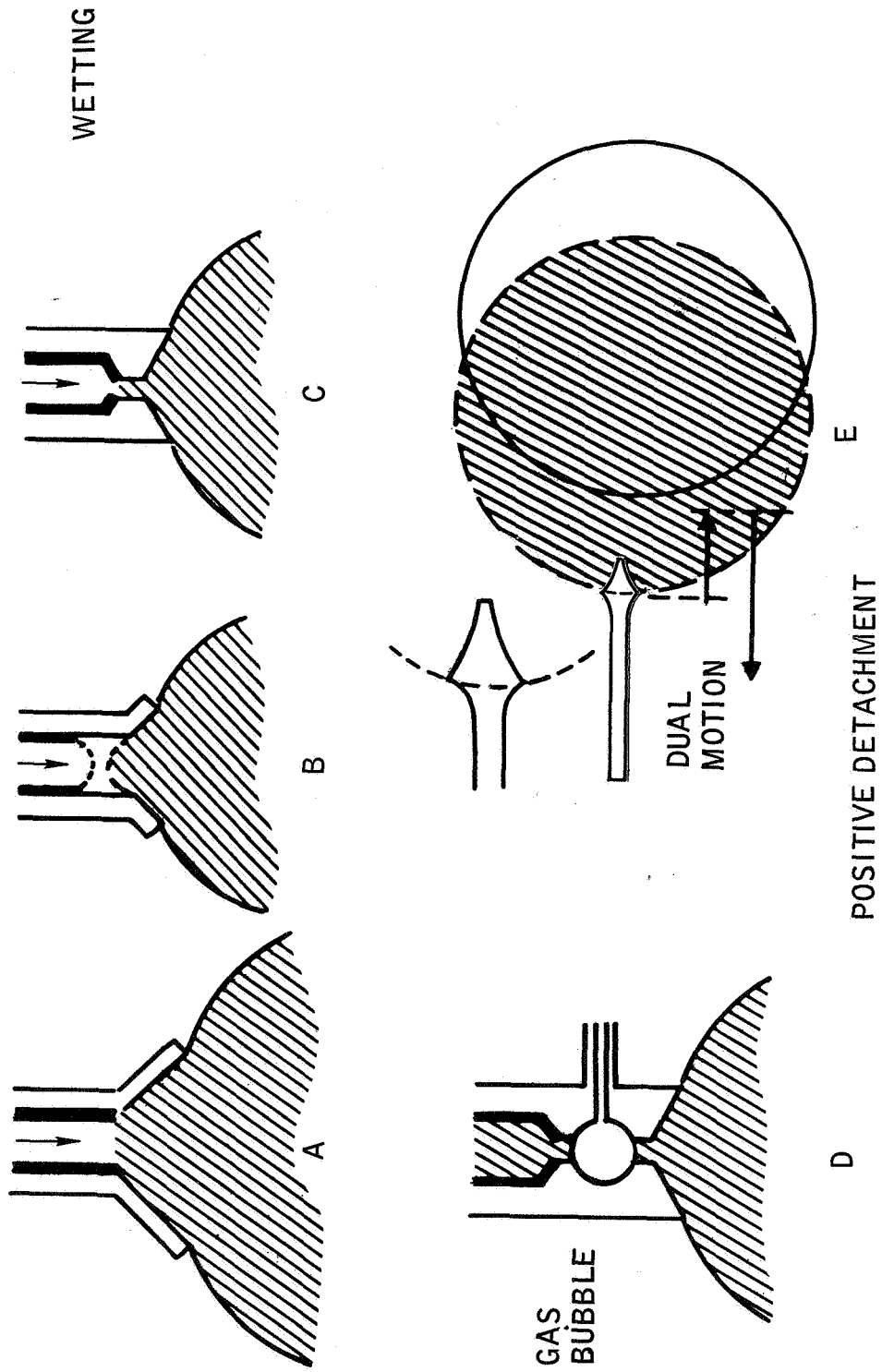

Figure 2-6. Sphere Deployment Nozzles

Once the proper size has been obtained, the sphere has to be detached from the nozzle and deployed in the central area of the position control system (Position B in Figure 2-5), where it is held in place for the period of oscillation damping and solidification. Preliminary concepts of sphere detachment are as follows:

- a. Separation from the nozzle by means of a gas bubble grown in a properly shaped section of the nozzle assembly close to the orifice (Figure 2-6-D). The disadvantage of this method is that it imparts motion to the sphere which has to be stopped by the position control system, requiring considerable field strength.
- b. Dual-motion detachment. A slow forward motion of the nozzle and a fast retraction ("injabbing") are dimensioned so that there is no resultant motion of the sphere. This method, which has been checked-out in equal-density liquid insulation experiments, requires a specific nozzle configuration (Figure 2-6-E). The disadvantage of this method are comparatively high initial sphere oscillations.
- c. Ultrasonic detachment by ultrasonic nozzle vibration. This method, even though not experimentally proven, appears promising since it does not generate any additional sphere oscillations. A known disadvantage is the relatively high weight of the excitation unit.

SUMMARY OF CRITERIA AND REQUIREMENTS

- a. Functional
 1. Sphere formation: Surface tension
Viscosity
Internal pressure
 2. Nozzle deployment: Nozzle configuration
Interfacial tensions
Viscosity of material
- b. Fundamental
 1. G-level at various vehicle positions
 2. Damping of deployment oscillations
 3. Terminal distortions due to earth-gravity gradient
 4. Effect of variations in surface tension
 5. Sources of convection
 6. Thermal gradients during cooling
 7. Vaporization rates
 8. Radiation cooling rates from MP + 300°F to RT

c. Technological

1. Material supply (melting and feeding) system
2. Material deployment tooling: Deployment nozzle design
Detachment techniques and devices
3. Position control system: Size control and measuring devices
Disposal of evolving gases
Methods to prevent void formation
Heating and cooling methods and devices

d. Data

For metals in the temperature range from the melting point to $MP + 300^{\circ}F$:

Surface tension and viscosity
Interfacial tension data
Vapor pressures
Emissivity

2.3.1b PROCESS 1b: LIQUID FORMING. The objective of this process is the forming of liquid bodies without contact tooling. The absence of contact tooling precludes material contamination and reduces the probability of nucleation. This process further promises highest surface finish due to the absence of tool-induced vibration and friction. The process is of particular importance for forming optical blanks (Process 9), where any contact would introduce crystallization and defy the objective of producing new types of glasses.

The process is an extension of Process 1, as it uses the liquid sphere as original form. Deformation of the sphere may be accomplished in two ways:

- a. By controlled electromagnetic fields.
- b. By inertia-motion.

The required forces can be derived from the relationships established in Sections 1.4.3 and 1.4.4. As pointed out, there, the forces are primarily determined by surface tension — viscosity and inertia can, for all practical purposes, be neglected.

Liquid forming is carried out at extremely low deformation rates to permit accurate shape control, avoid "overshooting" of the end-shape, and to minimize oscillations. The forming force is highest at the beginning of the process to overcome inertia, and is modulated so that it equals the shape-integrated surface tension force upon achieving final configuration.

The holding force which is required to maintain the final product shape to the time of complete solidification is, according to Section 1.4.3, defined with sufficient accuracy by

$$F_{\text{Hold}} = \frac{\sigma}{R} A \quad (57)$$

in which A may in first approximation be represented by the cross section normal to the applied force. The basic forming program, in terms of forces and deformation rate, is illustrated in Figure 1-19 (Section 1.4.3).

For forming with electromagnetic fields, the response of the material and, consequently the required field strength, can be represented by electrical conductivity as shown in Figure 2-7. The high conductivity of metals is slightly affected by temperature and the required forces are rather low. While the conductivity of nonmetals, such as oxides, increases substantially with temperature, it is even at the liquid-state temperature 4 to 6 orders of magnitudes lower than in metals. Most nonmetals require, therefore, extremely high field forces and special facilities. It may then be more efficient to use electromagnetic methods for inducing spinning motion. It has been shown in Section 1.4.4 that the required spinning rates are extremely low, for most shapes in the order of 5 to 30 rpm.

SUMMARY OF CRITERIA AND REQUIREMENTS

a. Functional

Deformation of liquid spheres resulting from the interaction of surface tension, inertia, and induced forces

b. Fundamental

Fluid Mechanics

1. Liquid deformation mechanism
2. Relationships for the determination of induced forces required for deformation
3. Response of metallic and nonmetallic materials to electromagnetic fields

c. Technological

1. Multicoil system for position control and deformation of high-conductivity materials
2. System for position control and formation of induced forces in the nonmetallic materials
3. Shape sensing system

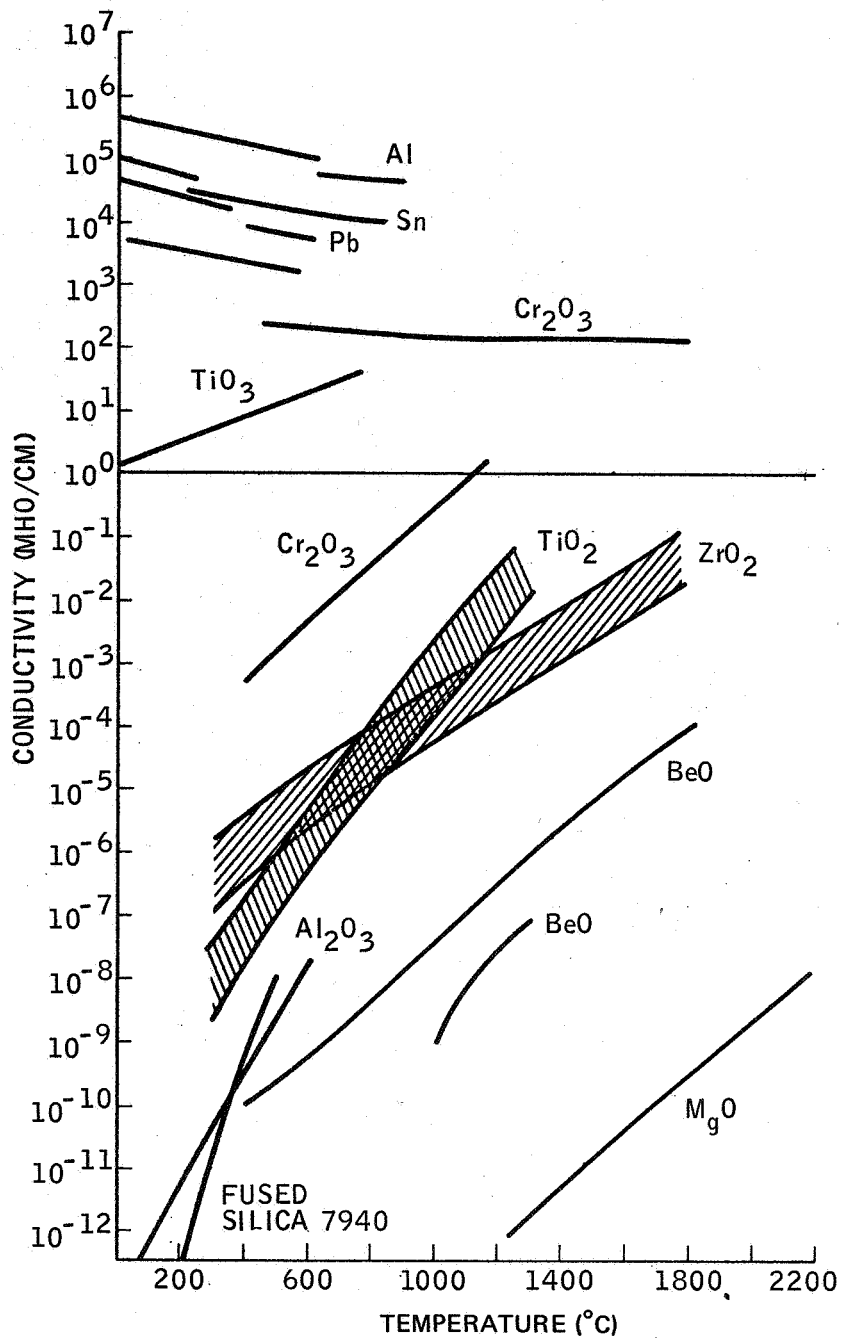

Figure 2-7. Electrical Conductivity of Material Versus Temperature

d. Data

1. Surface tension of metallic and nonmetallic materials in the liquid state in the temperature range close to the melting point
2. Electrical conductivity of nonmetallic materials in the same temperature range

2.3.2 PROCESS 2: ADHESION CASTING. The principle of this process is deployment of liquid material at one spot of a closed mold which, under adhesion forces and the absence of gravity, is expected to spread over the entire mold surface. After solidification a formed casting is obtained whose wall thickness is determined by the mass of deployed material. Repeated deployment further offers the potential of a laminated product of dissimilar materials.

To assess the potential of this process, the mechanism of spreading has to be analyzed in further detail. If liquid material is deployed on a flat plate under terrestrial conditions, the spreading will be primarily determined by two inertia:

- a. The relative wettability, i.e., the solid-liquid-gas interface conditions,
- b. The hydrostatic pressure, and
- c. The position of the place with regard to g; the surface tension of the liquid is only effective in the edge configuration of the spreading material.

While in a zero-g environment the position or shape of the substrate becomes immaterial, the hydrostatic force is missing; under these conditions, and assuming a positive wetting angle, two types of spreading have to be distinguished:

- a. Upon deployment, a thin layer will immediately spread over the entire surface due to the interface forces; there is no data available to predict the thickness of this film which is in the order of molecular spacings. With the completion of this layer the interface driving force has been absorbed and the remaining bulk material will remain at the place of deployment in a shape determined by its surface tension. In other words; the situation has changed from the original triple interface to a dual liquid-gas interface.
- b. Due to the absence of the surface driving force, further spreading of the bulk material can only be generated by either surface tension (i.e., the remaining liquid-gas interface) or in conjunction with an artificially induced mass acceleration. The intrinsic bulk spreading under the pressure generated by surface tension will slow down quickly, or may stop completely, since with the flattening of the surface the internal pressures become extremely small and approach the magnitude of internal deformation resistance (viscosity). Even though data for prediction of the intrinsic spreading rate do not exist, it can be safely assumed, that the time to obtain even an approximate uniformity of wall thickness exceeds

reasonable process times by orders of magnitude. The fundamental criteria and relationships for intrinsic bulk spreading are discussed in Section 1.3.6.

Bulk spreading by induced mass acceleration, however, appears entirely feasible. The mass acceleration plays the same role as the hydrostatic pressure in terrestrial spreading. The mass motion may be induced by deployment of the material with a certain velocity ("impact spreading") or by continuous feeding of material. The principal problem is the achievement of a uniform wall thickness; even in a spherical mold, the wall thickness may develop unevenly and present the same problem as the centering of the bubble of a thick-wall hollow sphere. In irregularly shaped molds, the wall thickness or concentration of material will depend on the degree of shape discontinuity and be governed by surface tension.

The initial thin-film spreading is a well known phenomenon, referred to in physics as "spreading"; as the driving force exceeds the gravitational force, it is not unique to zero-g environment, yet may proceed at a much higher rate and under low interface driving forces.

The induced bulk spreading merits further investigation. At this time, the potential is judged low, particularly since equivalent castings can be obtained by other methods.

SUMMARY OF CRITERIA AND REQUIREMENTS

a. Functional:

1. Film spreading: solid-liquid-gas interface forces only
2. Induced bulk spreading:
 - a. Initial spreading - Induced mass acceleration and surface tension
 - b. Material concentration at concavities, depletion at convexities, formation of minimum free-energy radii

b. Fundamental:

1. Spreading effect and spreading rate at liquid-solid-gas interfaces
2. Rate of material movement under surface-tension induced pressures
3. Adhesion or liquid-solid interface tension

c. Technological:

1. Methods of material deployment
 - a. Continuous feeding
 - b. Impact deployment

2. Definition of mold shape complexity limitations
3. Material supply (melting and feeding) system

d. Data:

Interfacial tension data: Liquid/gas (surface tension) and liquid/solid/gas for various material combinations.

2.3.3a PROCESS 3a: THIN-WALL HOLLOW SPHERES

PROCESS/PRODUCT DEFINITION. Thin-wall hollow spheres are produced by blowing, similar to the blowing of a soap "bubble." The spherical shape and the stability of the product is maintained by the equilibrium between internal gas pressure and the free energy of the two interfaces or the two surfaces—tension "shells." During the blowing process the interface energy at the two growing surfaces is maintained by continuous supply of molecules from the bulk material. The wall of the thin-wall hollow sphere may be considered as an endless membrane.

EXPERIMENT OBJECTIVES AND CRITERIA. Thin-wall hollow spheres have little practical applications, except in microsize for assembly into low density materials (microsphere composites). These spheres are, however, the first step necessary to the development of thick-wall spheres (Process 3b), membranes (Process 4) and foams (Process 5), and also serve as perfect test samples in the exploration of the fundamental nature of liquids and liquid-gas interfaces.

The equilibrium condition for the thin-wall H/S is represented by the relationship

$$D = \frac{8\sigma \cdot 10^{-6}}{P} \text{ (cm)} \quad (58)$$

i.e., the size is determined by surface tension and pressure differential between the internal and the environmental pressure. The relationship of internal gas pressure and diameter is illustrated in Figure 2-1 (Section 2.3.1).

The use of a single diameter term in equation (58) implies — that the wall thickness can be neglected. At the same time, the full representation of the free energy at both interfaces by 2σ implies a substantial wall thickness. While this may appear to be a paradox, it raises the fundamental question as to whether there is a change in surface tension as soon as the wall thickness is reduced to a point where the interface-affected surface zones meet. Since the experimental reproduction of this effect in pure liquids is impossible in the g-environment, all our theories of the nature of liquid matter is based on assumptions and "models." The knowledge obtained from experiments with thin-wall hollow spheres will not only form the basis for unique membranes (Process 4), but bridge a significant gap in our knowledge of the basic nature of matter.

Another basic question is the degree of wall thickness uniformity of membranes. From fundamental studies, discussed in Section 1.3.8 it was concluded that the intrinsic pressure equilibrium postulates an automatic adjustment of any transient difference in wall thickness.

The third problem to be resolved by thin-wall hollow sphere (H/S) experiments is the necessity of "surface stabilization," of importance to membranes and foams. Theoretically a membrane, even of a single material, should be stable under zero-g. However, this has been questioned and it is quite possible, particularly at higher g-levels, that the surface has to be stabilized with an appropriate additive which performs the same function as the soap in a soap bubble. A conclusive answer to this problem can only be obtained from space experiments, since the short zero-g periods of free-fall tests do not provide sufficient time for the movement of all additive-molecules to, and proper arrangement at, the surface.

EXPERIMENT REQUIREMENTS. These experiments require two types of deployment techniques and tools:

- a. Generation of a small hollow sphere, to be blown to a large size without any further material supply; this requires a blow nozzle with a finite amount of material.
- b. Controllable addition of material during the blowing process; this requires a blow nozzle with controllable material feeding.

In either case, the material is contained in the nozzle assembly in solid condition. The nozzle is inserted in the experiment chamber and the material melted by heating of the entire chamber. Nozzles may be refilled in the workshop. Detachment and position control is accomplished with the methods and devices defined for process 1.

SUMMARY OF CRITERIA AND REQUIREMENTS

- a. Functional:
Interrelation of surface tension, diameter, and pressure differential
- b. Fundamental:
 1. Interface energy conditions in ultra-thin membranes
 2. Stability criteria for membranes of pure liquids
 3. Bulk material movement in membranes, effect on wall thickness homogeneity
 4. Effect of environmental gases and pressures upon surface tension
 5. Surface stabilization and related additives
 6. Damping of H/S oscillations; minimum oscillation level versus diameter

c. Technological:

1. Blow nozzle design; configuration, wetting characteristics, and material positioning
2. Pressure control
3. Detachment techniques and devices
4. Position control system
5. H/S size sensing and size (pressure) control

d. Data:

1. Surface tension versus temperature
2. Vaporization rates versus temperature

2.3.3b PROCESS 3b: THICK-WALL HOLLOW SPHERES

PROCESS AND PRODUCT DEFINITION. Thick-wall hollow spheres may be considered as a combination of the sphere and a bubble, in which the ratio of bubble and sphere diameters d/D is >0.5 . Both outside and inside diameters are controlled by the bubble pressurization. The principal pay-off is seamlessness, as seamless hollow spheres cannot be produced by terrestrial methods. Secondary product characteristics are microstructure homogeneity, spherical accuracy, and high surface finish. High mechanical properties may also be obtained by induced fine-grain solidification (Process 10) or fiber reinforcement (Process 6).

PROCESS CRITERIA. The generation of a thick-wall hollow sphere starts with the deployment of a (full) sphere, in which a bubble is grown by injection of an appropriate pressurized gas. The size of the gas bubble at any point of the growing process is exactly determined by the curvature-pressure relationship (equation 49), in which the radius is determined by the pressure differential between gas and surrounding liquid, whose pressure, in turn is related to the outside diameter and the environmental pressure. As illustrated in Figure 2-8, the equilibrium condition at any point of the growing process is defined by three pressures and two diameters. The only constant value is the volume of the liquid material which is pre-measured accurately for a desired final wall thickness and outside diameter.

The relationships between size, volume, and pressure in a sphere of metal are based on the geometry and on the outside-to-inside pressure difference created by the surface tension. The basic relations, quite simply, are $P = 4\sigma/D$, and $V = \pi D^3/6$, but combining these to show explicitly the outside diameter of a hollow sphere as a function of the volume of metal, bubble pressure, and surface tension produces a sixth power equation which can be solved only by approximation. Assuming the globe is being

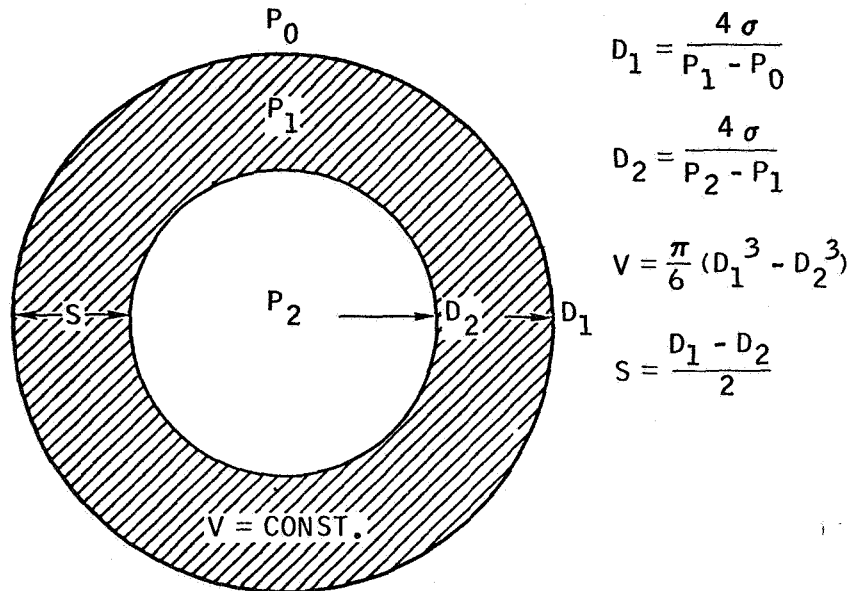

Figure 2-8. Pressures and Dimensional Characteristics of Thick-Wall Hollow Spheres

blown in vacuo, and working from the basic relations, the implicit equation is shown below:

$$V = \frac{\pi}{6} \left[D^3 - \left(\frac{4\sigma D}{PD - 4\sigma} \right)^3 \right] \quad (59)$$

where:

V = total volume of liquid

D = outside diameter

σ = surface tension

P = pressure in the bubble

For practical applications, the situation can be worked out quite readily from*:

$$P_L = 4\sigma/D_1, P_2 = P_L + 4\sigma/D_2, D_1^3 - D_2^3 = \frac{6}{\pi} V_L, \quad (60)$$

and the approximate statement of the gas laws,

*Assume V_L and D_2 ; compute D_1, P_L, P_2 and m in that order.

$$m = \frac{\text{Mol. Wt. of Gas}}{83} \cdot \frac{PV}{T} \quad (61)$$

where

P = pressure	dynes/cm ²
D = diameter	cm
σ = surface tension	dynes/cm
V = volume	cm ³
m = mass of gas	micrograms
T = temperature	°Kelvin

Subscripts

- 1 = sphere (OD)
- 2 = bubble (ID)
- L = liquid (metal)

Considering the process of inflating a hollow sphere, it will be apparent that for any given outside diameter, the mean wall thickness (or inside diameter) is uniquely determined by the mass of metal in the globe. It is also apparent that the pressure in the bubble will decrease as it becomes larger, leading to some question of the stability of the situation. To examine this, a typical example is shown in Figure 2-9 for a 4kg mass of molten copper inflated with helium. ($\rho = 8.3 \text{ g/cc}$, $\sigma = 1100 \text{ dy/cm}$, $T = 1356^\circ\text{K}$, Mol. Wt. of He = 4.) The solid curves show the principal vital statistics of the hollow sphere plotted against the mass of helium in the bubble, and their monotonically changing character indicates that the diameters can be stably controlled by controlling the mass of gas in the bubble. The dotted curve shows the total mass of helium, including the bubble and an assumed feed pipe having one milliliter of dead volume intimately connected to the bubble. The double rising character of this curve indicates that the dead volume produces an instability when the bubble is small. Some sophistication of the feed system will be required for smooth starting of the inflation process.

METHODS AND TOOLING. The manufacture of thick-wall H/S comprises six steps:

- a. Deployment of a (full) sphere
- b. Blowing of the bubble
- c. Detachment
- d. Damping of oscillations

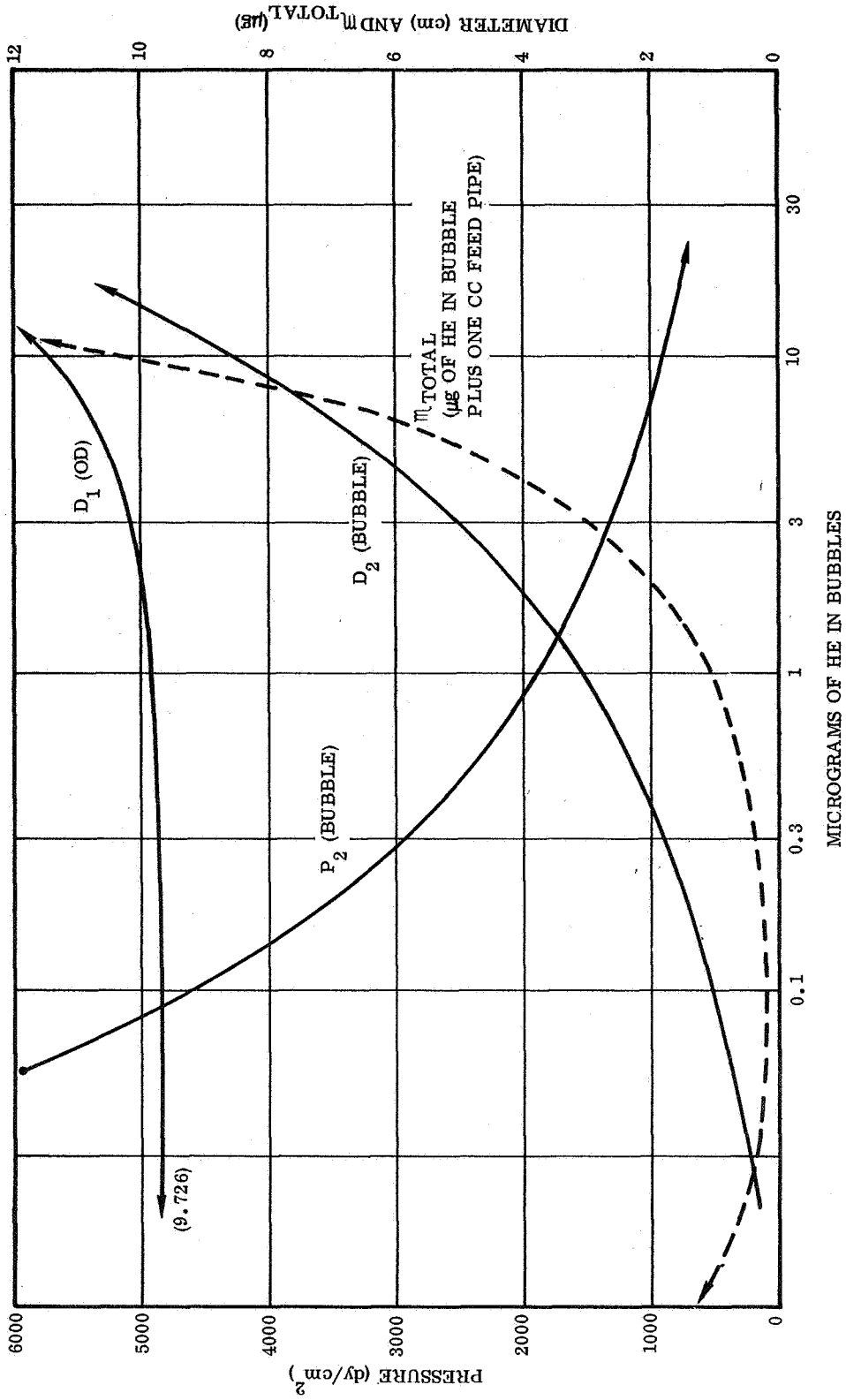

Figure 2-9. Inflation of Hollow Sphere (4kg of Copper)

- e. Bubble centering
- f. Solidification

The deployment of the initial sphere follows the procedures for Process 1. The generation of the bubble and the blowing to the desired inside and outside diameters with an appropriate gas requires a second (inner) nozzle system (Figure 2-10). Two concepts of bubble deployment have been defined:

- a. The inner nozzle is inserted in the sphere at a depth equal to the final wall thickness; the bubble is blown while the inner nozzle remains in fixed position.
- b. The inner nozzle is inserted to the exact sphere center; as the bubble and the outside diameter grow simultaneously, the pressurizing nozzle is slowly retracted so that the bubble is always centered. This motion is controlled by the bubble pressure according to the pressure-diameters relationship.

In both methods, the pressure is held constant as soon as the desired H/S size has been attained and the inner nozzle is pulled-out at high velocity.

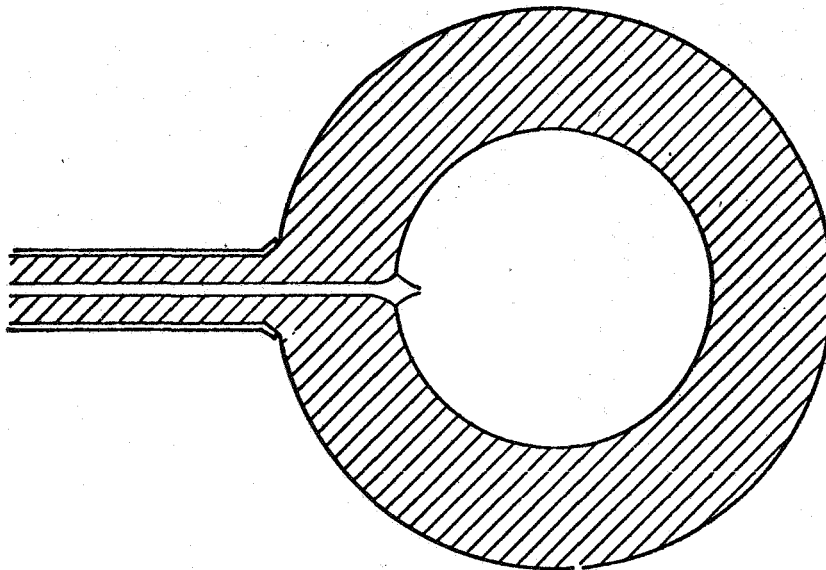

Figure 2-10. Dual-Nozzle Deployment System for Thick-Wall Hollow Spheres

For detachment, any of the methods defined in Process 1 may be applied. The H/S is then held in place by the position control system at constant temperature until oscillations have dampened to the desired wall dimensional accuracy. During this period, the bubble may shift its position and a method for bubble centering, representing uniform wall thickness, has to be devised. A number of concepts have been proposed, all of which require evaluation in zero-g experiments. One method of bubble centering consists of applying heat to the heaviest part of the sphere, causing the bubble to move toward the heat source, and simultaneously the material shifts away from the heat source, due to the variation of surface tension as shown in Figure 2-11(a). This method requires the sensing of the bubble position, which poses difficult problems and requires considerable equipment. This requirement does not exist in methods of self-centering by multiple-mode rotation. The most positive of these methods is illustrated in Figure 2-11(b). A comparatively fast rotation is induced around Axis A with simultaneous braking action at the polar sections, tending to form two toroidal circulation patterns.

Any method of bubble-centering will very likely have to be maintained during the period of cooling to complete solidification.

SUMMARY OF CRITERIA AND REQUIREMENTS

a. Functional:

Relationship between bubble pressure, environmental pressure, inside diameter, outside diameter, and surface tension.

b. Fundamental:

1. Interfacial tension - specific application to nozzle orifice, adhesion, and detachment
2. Damping of oscillations
3. Terminal distortion due to earth-gravity gradient
4. G-levels at various vehicle positions
5. Sources of non-gravity convection
6. Movement of bubbles and surface material by induced thermal gradients
7. Criteria for centering of a bubble in a liquid sphere
8. Vaporization rates
9. Induced fine-grain solidification (Process 10)
10. Strength of fiber-reinforced castings

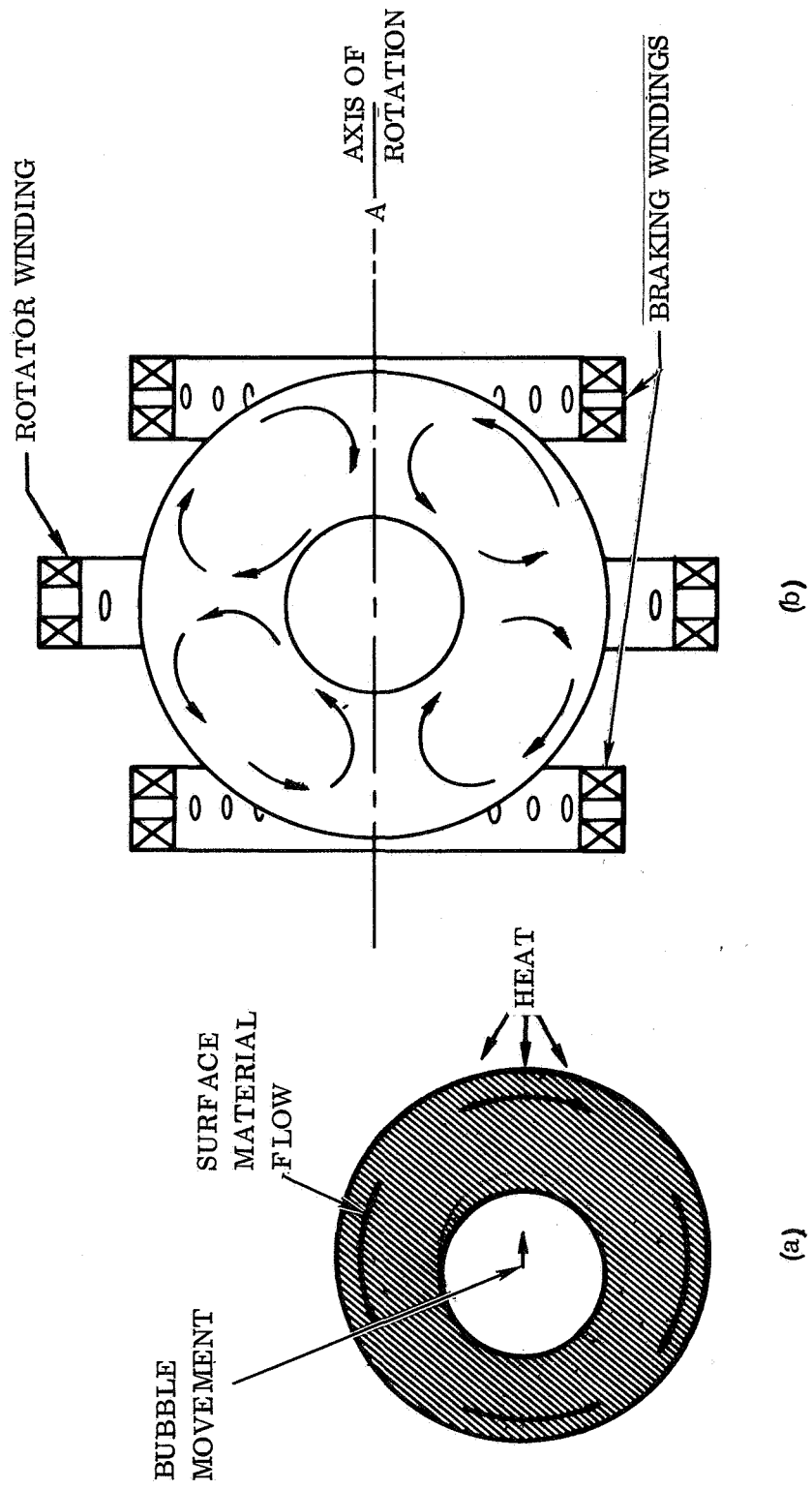

Figure 2-11. Techniques for Bubble Centering

c. Technological:

1. Material supply (melting and feeding) system
2. Mixing system for composite H/S
3. Material deployment tooling:
 - Dual-nozzle system for sphere deployment and controlled bubble generation
 - Detachment techniques and devices
4. Position control system
5. Bubble centering techniques and devices:
 - Controlled local heating
 - Multiple-mode rotation devices
 - Bubble position sensing technique
6. Mixing system for composite H/S

d. Data:

1. In the temperature range from the melting point to MP + 300°F:
 - Surface tension and viscosity
 - Interfacial tension data
 - Thermal properties
2. Vaporization rates versus temperature

2.3.3c PROCESS 3c: BLOW MOLDING. The production of a thin-wall casting by expanding a hollow sphere against the inner surface of a mold is known as blow molding. The attractive features of this process consist of:

- a. Seamlessness of the product,
- b. Elimination of a core, and
- c. Low cost.

This process is practiced in terrestrial manufacturing, but is limited by the apparent gravity effects to materials of high viscosity and/or rapid cooling.

Under low-g conditions these limitations appear to be minimized if not eliminated. This, however, applies only to near-spherical molds and shapes without severe discontinuities, such as edges and corners, since surface tension causes a concentration of the liquid at concavities and a depletion at convexities. The rate of material movement after deployment increases with the ratio σ/μ of surface tension to viscosity —

it is high for metals due to their high fluidity and surface tension, and requires immediate solidification.

Since material deployment starts with the formation and expansion of a hollow sphere, the criteria of thick-wall or thin-wall hollow spheres (Processes 3a and 3b) and the related tooling apply. The principal difference is the absence of an environmental pressure, since the mold has to be under the highest possible vacuum to assure complete contact of the liquid with the wall. After deployment at the mold wall, the conditions are similar to those encountered in adhesion casting (Process 2).

Improved products may be obtained by the application of induced fine-grain solidification techniques (Process 10) and/or by the use of composite materials (Process 6).

While blow molding has a definite potential, particularly for thin-wall shapes, it represents only an improvement of existing (terrestrial) capabilities. In view of this lack of uniqueness and the high return-volume of the finished products, its hardware evaluation should be deferred in favor of more effective processes.

SUMMARY OF CRITERIA AND REQUIREMENTS

a. Functional:

1. Relationship between bubble pressure, surface tension and inside/outside diameters as applicable to the formation of hollow spheres
2. Adhesion to the mold surface
3. Shifting of material as related to surface tension and mold configuration

b. Fundamental:

1. Interfacial tension:

Specific application to nozzle orifices

2. Correlation of adhesion and solid/liquid interface energies
3. Vaporization rates in high vacuo
4. Induced fine-grain solidification
5. Strength of fiber-reinforced castings

c. Technological: Requirements

1. Material supply (melting and feeding) system
2. Dual-nozzle system for sphere deployment and wall thickness control
3. Bubble centering techniques and devices

4. Processing techniques and devices for fine-grain and composite products
5. Definition of mold shape complexity limitations

d. Data:

Interfacial tension data - with emphasis of the liquid-solid interface.

2.3.4a PROCESS 4a: FLAT MEMBRANES

PROCESS DEFINITION. This process consists of formation of flat membranes from metallic or nonmetallic materials without tooling contact, except for the membrane edges. Prime objectives of this process are absolute flatness, freedom from contamination, and extremely low wall thickness, including thicknesses in the order of a limited number of molecular spacings.

PROCESS DISCUSSION. The terrestrial manufacture of thin films and membranes is severely limited by gravity effects, during initial manufacture, because a perfectly plain surface is required for support of the liquid material or deposit, as well as during the lift-off process in which gravity causes the solidified film to deform or fracture. Under zero-g conditions these problems do not exist since there is no need for support.

A thin film may be produced by drawing, similar to the thin-wall hollow sphere process. In fact, a thin-wall hollow sphere is essentially an endless membrane. While in the hollow sphere the tension for the drawing of the wall is produced by internal pressurization, in flat membranes it may be generated by mechanical means.

EXPENDABLE HOLLOW SPHERE METHOD. One proposed process is the conversion of a thin-wall hollow sphere into a flat membrane. It can be carried out in a sphere-production chamber without significant additional tooling and consists of the following three operations (Figure 2-12):

- a. Blowing of a membrane-sphere to desired wall thickness,
- b. Deposition on a frame of the desired membrane-edge configuration, and
- c. Removal of the unused section of the sphere by "blowing-up"; the membrane remaining at the frame is under a homogeneous pressure environment and, consequently, absolutely flat.

Back-flow of material from the sphere after blow-up can be prevented by proper wetting characteristics of the frame.

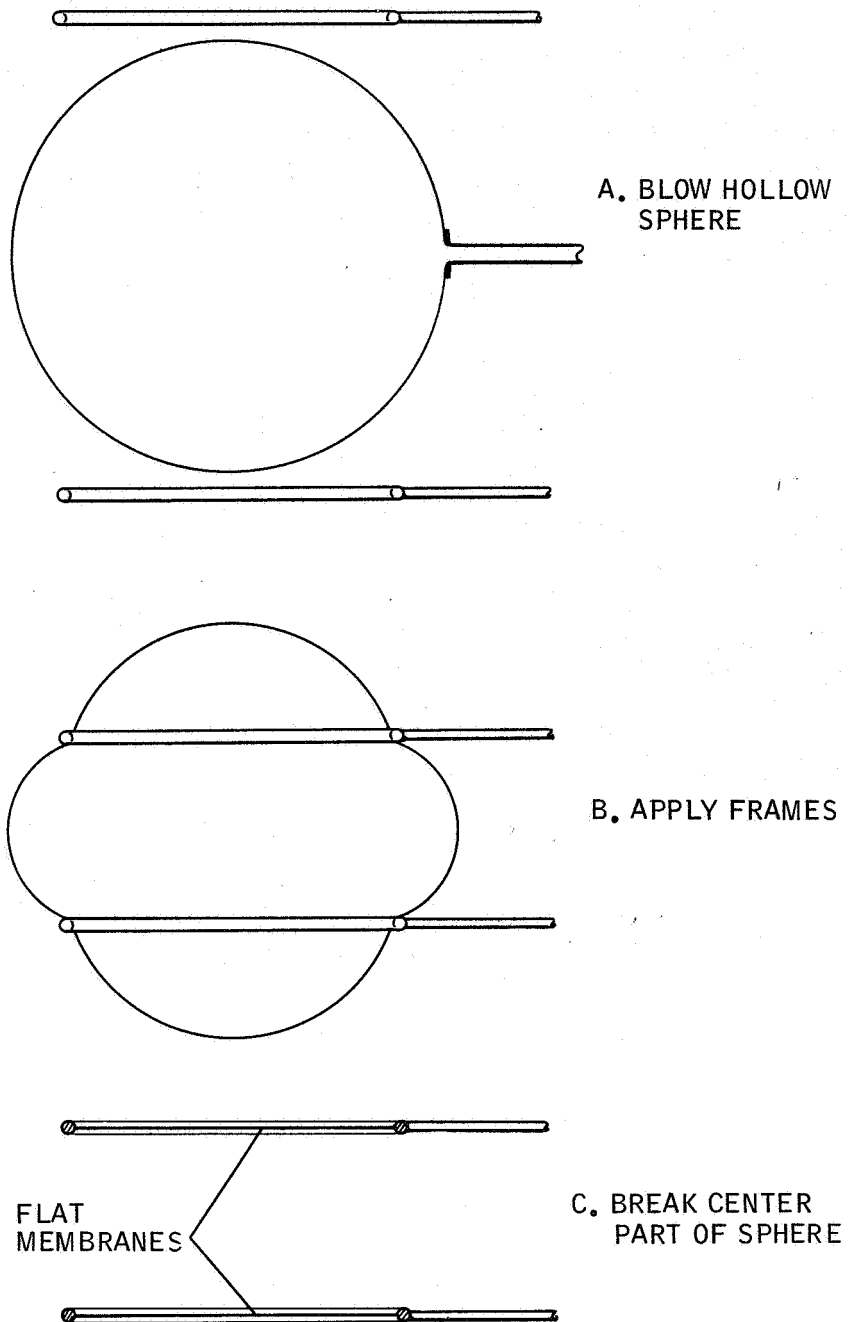

Figure 2-12. Formation of Flat Membranes from Hollow Spheres

MECHANICAL DRAWING METHODS. One concept of a mechanical drawing method is shown in Figure 2-13. The tooling illustrated on the right of the figure consists of two stationary and two movable leading edges. As indicated in the cross-section of the movable tool at the lower left of the figure, the liquid material flows from two supply tubes to the tip where the two films converge. The process is started by bringing the two tips in contact; as they are pulled apart (upper left of the figure), a membrane forms which is held at the stationary tools by means of a high-adhesion edge. This method may be modified into a continuous process, in which the material is supplied from one side only and the membrane gradually solidifies in approaching a revolving drawing drum, followed by a take-up drum. Coiled membrane tapes may be produced by drawing liquid material from a spherical supply over a fork-shaped tool onto a revolving drum, where it is solidified and transferred to a take-up coil.

PROCESS CRITERIA. The decisive criterion for production of membranes - as well as for thin-wall hollow spheres - is their stability. The fundamental criteria for the stability of membranes, were defined in Section 1.3.8.

On the basis of theoretical considerations it is expected that in zero-g even pure materials of low viscosity, such as metals, will form stable membranes. Whether this holds true in practical applications, or whether a surface-stabilizing additive will be needed, can only be answered by experiments under sustained zero-g.

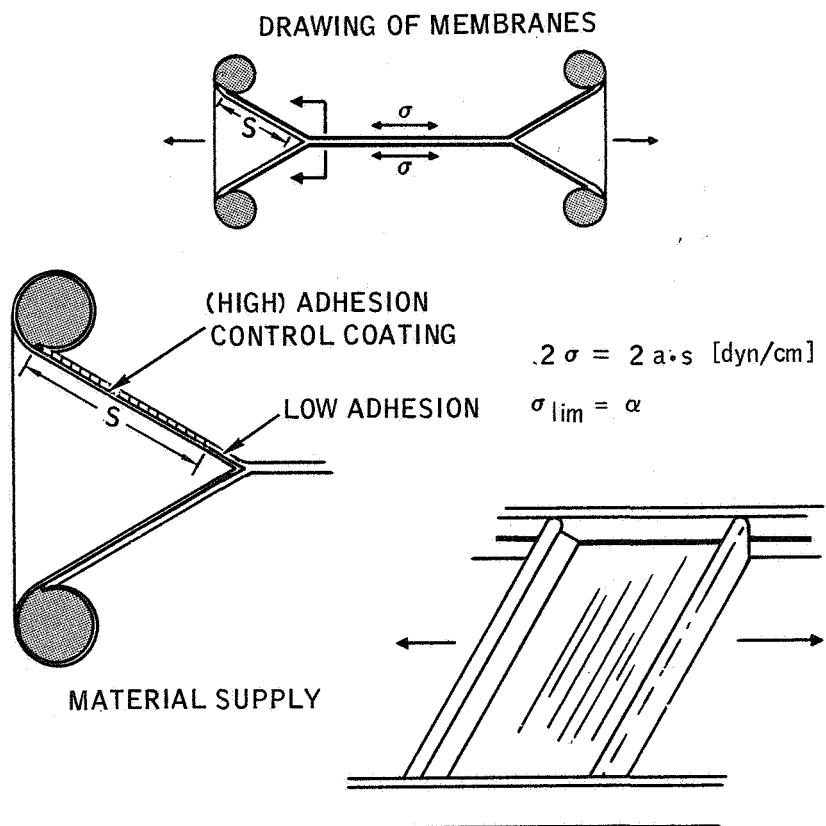

Figure 2-13. Drawing of Membranes

Assuming the stability of liquid membranes, the criteria for the formation by the expendable hollow-sphere method are a combination of those discussed for the thin-wall hollow sphere (Process 3a) and controlled wettability of the edge members (frame). For the mechanical drawing methods, the interaction of intrinsic and extrusion forces and properties is more complex. It is discussed in some detail in the following section for the method illustrated in Figure 2-13.

FUNDAMENTAL CRITERIA FOR THE DRAWING METHOD. The complete separation of a liquid from a solid takes work or energy. The work or energy necessary to accomplish separation per original unit area of contact is:

$$W_{LS} = \sigma_{SV} + \sigma_{LV} - \sigma_{LS} \quad (62)$$

The force required to separate the liquid from the solid could vary with the shape of the contact and the direction in which the separation occurs. However, any change in geometry that reduces the force required would also increase the distance over which that force must operate, so that the total energy required per unit area remains the same.

Those actions which reduce the surface tension (temperature increases, etc.) would, of course, reduce the total energy required for separation.

The drawing of a membrane takes work or energy. If the drawing of the membrane is at a fixed velocity rate, the force, F , required per transverse unit length of membrane is:

$$F = 2\sigma$$

where

$$\sigma = \text{surface tension}$$

The energy or work would therefore be

$$F \cdot V \cdot t$$

where

$$V = \text{velocity}$$

$$t = \text{time}$$

$$V \cdot t = \text{distance over which the membrane is pulled}$$

The forces acting at a "continuous flow" nozzle would include a friction loss to the degree that relative motion existed between the liquid and the nozzle, but work of adhesion does not play a direct part in the interaction as long as the wetted area of contact between the liquid and the nozzle remains a constant (which is the normal situation).

Therefore, the drawing force can be divided into the following components:

a. $F_{f_m} = K_1 L_1 V$ (63)

Friction force developed between membrane and medium through which it is being drawn — for pure space $K_1 \rightarrow 0$. K_1 = Engineering Constant, L_1 = longitudinal length, V = velocity.

b. $F_m = \rho t V^2$ (64)

Mass acceleration term function of mass density, thickness and velocity (assuming initial mass velocity = 0).

c. $F_{f_n} = K_2 L_2 V$ (65)

Friction force developed between liquid flow and nozzle, L_2 dimensional factor of nozzle, V = effective velocity between liquid and nozzle.

The nozzle may also support a pressure differential force and a surface tension force — both functions of surface tension with separate functions of contact angles and radius of curvatures. All of these forces will vary with different kinds of nozzles.

For the method and tooling concept illustrated in Figure 2-13, the equilibrium of forces is as follows (Identification of Symbols Figure 2-14):

$$F = 2\sigma$$

$$2\sigma = 2\sigma \cos \theta_1 + K_1 L_1 V$$

$$2\sigma \cos \theta_1 = \rho t V^2 + K_2 L_2 V + 2\sigma \cos \theta_2$$

$$K_2 L_2 V \approx \frac{2\mu (2V)(L_2)}{(t/2)} \approx \frac{8\mu V L_2}{t} \quad (66)$$

Potential temperature and pressure gradients were ignored.

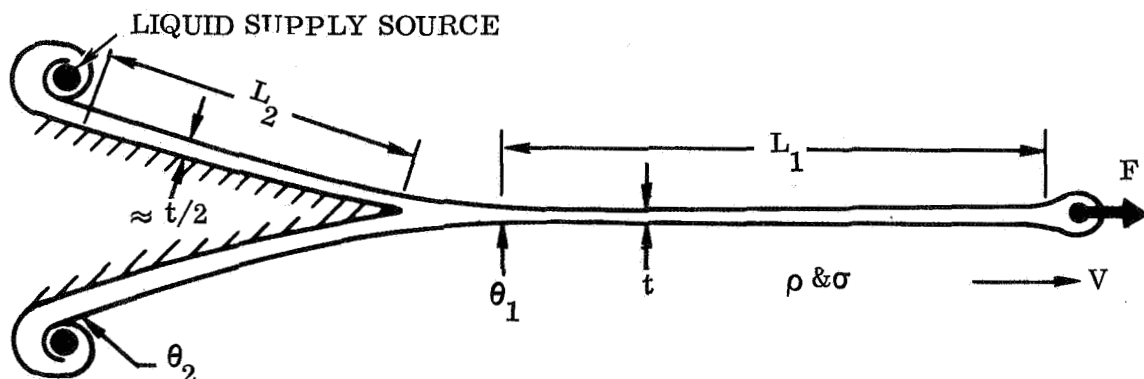

Figure 2-14. Identification of Variables for the Mechanical Drawing of Membranes

PRODUCTS. Membranes have a considerable number of potential applications in electronics, chemistry, and for advanced structural materials (laminated materials). The properties can be varied in accordance with specific application requirements. Fibers or whiskers, which orient themselves during the drawing process, may be added to increase strength and for assembly into high strength laminates. By appropriate solidification control, unidirectional orientation of the microstructure may be obtained. Heterogeneous membranes or laminates of extremely thin membranes of dissimilar materials may have semi-permeable characteristics of interest in the processing of chemicals, such as sea water conversion. Membranes of electronic materials, presently deposited as films on substrates, may exhibit unique properties and degree of perfection due to the contact-free production.

Many of the potential applications can be pre-evaluated with spherical membranes to obtain the data and experience required for design of more sophisticated methods and tools.

SUMMARY OF CRITERIA AND REQUIREMENTS

a. Functional:

1. Interrelation of surface tension, diameter, and pressure differential (expandable hollow-sphere method)
2. Relationship between membrane tension and tooling friction, interface energies (mechanical drawing method)

b. Fundamental:

1. Friction forces resulting from liquids moving on solid surfaces
2. Solid-liquid interface phenomena and interfacial tension
3. Stability of membranes and potential stabilizing additives
4. Effect of environmental gases and pressures upon surface tension
5. Bulk material movement in membranes, effect on wall thickness homogeneity
6. Interface energy conditions in ultra-thin membranes
7. Potential of membrane formation from heterogeneous (immiscible multiphase) liquids

c. Technological:

1. Blow nozzle design and pressure control for thin-wall hollow spheres
2. Edge member tooling development (configuration, arrangement of wetting and non-wetting surfaces)

3. Materials analysis - definition of membrane materials for structural, chemical, and electronic applications

d. Data:

1. Interfacial tension data, particularly for solid-liquid interfaces
2. Vaporization rates

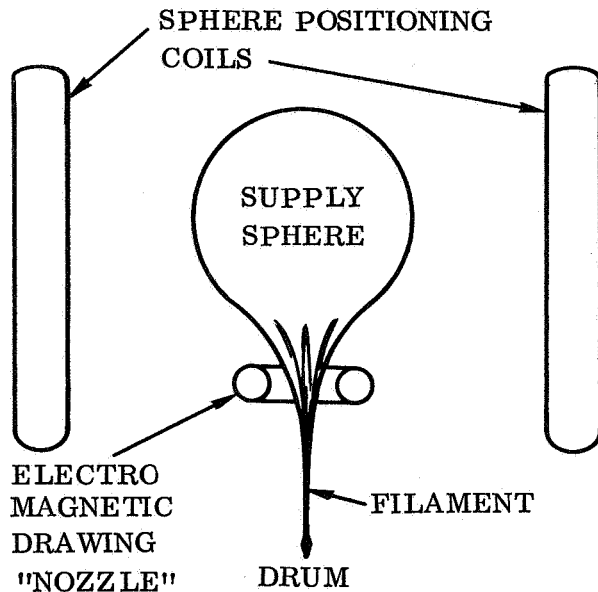

2.3.4b PROCESS 4b: DRAWING OF FILAMENTS. Filaments are effectively produced by a variety of terrestrial methods. For this reason, methods which represent only improvement of terrestrial techniques and products are not considered at this time - the discussion is limited to one unique application of the low-g environment which consists of the drawing of a filament from liquid material supply sphere, held in place by a position control system. The material is drawn without tooling contact; the conventional nozzle is replaced by an electric field ("electric tooling") which controls the liquid curvature between sphere and filament (Figure 2-15). The mechanical drawing force is produced by the take-up coil.

Figure 2-15. Conceptual Electric Tooling for Drawing of Filaments from a Liquid Sphere

In this basic form, the principal gain of this process is the absence of contamination by tooling, which may be significant for specific materials and specific applications. The process may be further extended to include controlled directional solidification.

A prerequisite of the contact-free filament drawing process is the perfection of position control systems and electric tooling techniques.

SUMMARY OF CRITERIA AND REQUIREMENTS

a. Functional:

Interface shape control of a moving liquid by electromagnetic forces

b. Fundamental:

1. Deformation of liquids by induced forces
2. Internal pressure and liquid/gas interface energy relationship
3. Criteria and methods of directional solidification

c. Technological:

1. Position control systems
2. Electromagnetic coil system for compression of liquids

d. Data:

Solid-gas interfacial tension data

2.3.5 METALLIC FOAMS. Foaming is a typical liquid-state process consisting of the formation and dispersion of gas bubbles in, or from, a liquid continuum. To obtain a solid foam, the bubbles and their distribution have to remain stable in the liquid state to the point of solidification. In the gravity environment, this requirements is only met by materials of high viscosity, such as polymers. The formation of solid foams from liquids of low viscosity, such as molten metals, is not feasible. Under zero-g, liquid foams are expected to be more stable, regardless of viscosity which permits the production of metallic foams. In view of their uniqueness to zero-g and their potential applications, this discussion concerns itself only with metallic foams.

GENERAL CONSIDERATIONS AND CRITERIA. Metallic foams offer the structural advantage of combining high specific strength and stiffness with low density. The production of such material involves the creation, dispersion, and maintenance of bubbles in liquid metal — it is believed that the low gravity environment offers unique advantages for such production.

Considering first the foam maintenance, it is necessary that the bubbles be the right size, remain the right size in the right place, and that they do not coalesce into each other. Bubbles in a pure low viscosity liquid such as water or molten metal coalesce when pushed together. This is expected to occur as soon as the bubbles come into spherical or geometric contact, although some flattening of the surfaces is occasionally observed.

Remarkably stable foams are commonplace in every household, but so far as is known stable foams have not been produced in liquid metal. Soap molecules migrate preferentially to a water surface. These molecules are polarized and align themselves, so to speak, head first toward the gas, the result being that if two gas bubbles in soapy water are brought near together they are repelled from each other by the like charges surrounding the tails of the soap molecules. As a result, the bubbles can be flattened against each other for long periods without coalescing. The strong repulsive forces which keep the surfaces separated are probably not available in liquid metal, but it is hoped that some surface stabilization can be achieved.

In the low-g environment, the situation is much more favorable, even though for low density foams, some geometric crowding will probably occur or be desired. It appears that at least a modicum of surface stabilization will be needed to ensure the integrity of the bubbles.

For actual methods of foam production, once more the bubble maintenance might appear to pose difficulties, but of a different kind from that mentioned previously. With the melt exposed to the vacuum of space (or to some higher pressure) the density of the foam would decrease as the bubbles expand, increase as they cool, and contract in a manner difficult to control. Some consideration, however, indicates that the density of the finished product can be exactly controlled by controlling the mass of metal employed and the final volume. The various foaming methods outlined in following sections therefore feature a closed container which establishes the volume and density of the finished foam.

The creation of a foam essentially consists of the formation of many small bubbles in the liquid metal. This process, in contradistinction to the dispersion and maintenance of the foam, is not particularly sensitive to gravity, but it does pose certain problems. Therefore, the production methods outlined utilize basically different systems to produce the bubbles.

The foaming methods are labeled Gas Injection, Nucleate, and Ultrasonic Foaming. Gas Injection foaming is theoretically simple and straightforward but may lead to some mechanical complications. The opposite is true of nucleate foaming and of Ultrasonic Foaming. The Ultrasonic Foaming method has some of the features of the other two methods.

In the production of metallic foams, the base metal may be relatively pure or it may be an alloy. The alloy may have the advantage because the foaming process may be conducted below or only slightly above the temperature at which the metal becomes a pure liquid. The pasty or slushy nature of a partially melted alloy can help maintain the integrity and positional arrangement of the bubbles.

STRENGTH OF FOAMS. The possible geometry of foam can provide a guide to the overall density and mechanical properties which should be reasonably available. The most compact arrangement of equal diameter spheres appears to be the pattern existing in a pyramidal pile of balls. Whether the base be square or triangular*, for a very large number of spheres the ratio of their volume to the total volume of the pile turns out to be $\pi/\sqrt{18}$. This means that without flattening the spheres they can occupy 74% of the total volume. The 26% metal represents a density which may not be readily achievable in practice, but which on the other hand may possibly be exceeded either by flattening the bubbles or by providing smaller ones which can fit between the big ones. The number is believed to be valuable, however, as a guide to design and as a criterion against which the results of experiments may be judged or rated.

*Careful consideration of these pyramids indicates that their internal structures are the same, but oriented differently.

The tensile or shear strength of a foam may be assessed on a "weakest link" basis by cutting through the pyramid in a plane containing the centers of those bubbles which are in a triangular array. The bubbles occupy $\pi/\sqrt{12}$ or 90.7% of the area, leaving 9.3% for the metal. The specific strength (per gram/cm) would thus be down from 100% (basic metal) to $9.3/26 = 36\%$ (foam). Some of this loss can be recovered by adding smaller bubbles between the large ones. This could reduce the foam density to less than 20% of the base metal without further strength reduction.

The cell walls, because of their thinness, will probably have better mechanical properties than would heavy sections of the same metal. This will provide some "free" strengthening of the "weak link." This strengthening may be considerable, and of particular importance, for stabilized foams where the cell walls would be thin over an appreciable area. Such foams could be extremely low density and the "free" strengthening would then apply to an appreciable fraction of the structure.

PROCESS DESCRIPTION

GAS INJECTION FOAMING. For this method of foam generation the gas would be added to the metal at one or more discrete and predetermined points and distributed by moving the molten metal past those points. A possible execution is shown schematically in Figure 2-16, where the molten metal would be driven past a gas injection

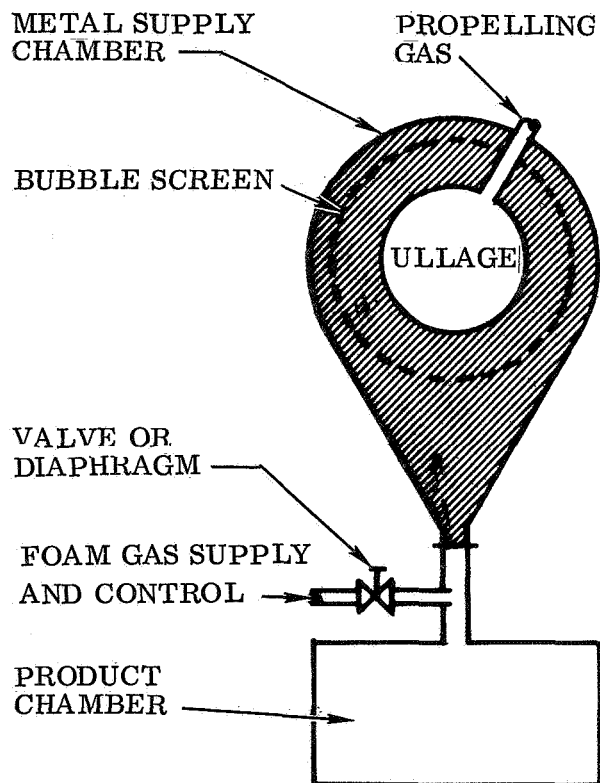

Figure 2-16. Foaming by Gas Injection (Quiescent Chamber)

point into an initially evacuated product chamber. For this system, the mass flow rate of gas and metal would be kept in essentially constant ratio throughout the material transfer process. This gas-to-metal ratio is anticipated to be a controlling factor in the quality of the finished product. Furthermore, it appears that with the mass flow ratio constant, the volume flow ratio will vary during the process. As the pressure in the product chamber builds up, the liquid foam first delivered at a high volume ratio will subsequently be compressed to more nearly match the later denser foam.

The "agitated" method of Figure 2-17 at first sight might hold promise of stirring the foam to uniformity either during or after the time the foam gas is being injected. The stirring, however, would have to be done very gently and adroitly to avoid separating the gas from the liquid by acceleration induced flotation.

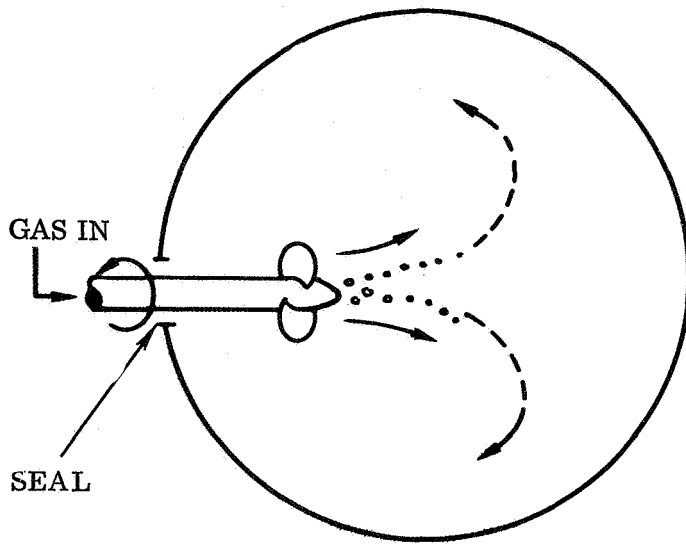

Figure 2-17. Foaming by Gas Injection (with Agitation)

The configuration shown, for example, would collect bubbles in a toroidal ring.

The production of a foam by Gas Injection does not, from a truly basic view point, involve the creation or birth of bubbles. Rather, the small bubbles break or pinch off from a gaseous cylinder which is being fed into the liquid metal, and it is anticipated that the bubble diameters available will range upward from about equal to the feed pipe diameter. Quiescent or slow moving liquid will allow the bubbles to grow large. High velocity will tear them loose while they are small. Once a bubble is formed, however, the mass of gas in it is essentially determined. It is, so to speak, born fully grown.

NUCLEATE FOAMING. This process, as mentioned previously is mechanically simple but conceptually sophisticated. A homely analog is the sudden opening of a warm carbonated beverage. High speed movies of the sudden depressurization of such a solution of carbon dioxide in water have shown that a dense uniform foam is produced in less than a quarter of a second. The planned nucleate foaming process is similar, and some consideration has been given to the microscopic details of the beginning of this process. Surface tension forces cause the pressure in a one-millimeter bubble in water to be about one-third atmosphere higher than in the surrounding liquid. In molten copper the higher surface tension increases this difference to over four atmospheres. For smaller bubbles these pressures are proportionately higher. In the general case this leads to the conclusion that a bubble-free liquid can support negative pressure. This has been experimentally verified for various pure liquids at tension levels up to hundreds of atmospheres. At least two mechanisms are, however, available to start the bubble formation without the negative pressure. Gas solubility in liquid decreases with increasing temperature, and accordingly, if a liquid is saturated with gas at a given temperature and is then heated, considerable pressure can be made available to create bubbles. Pressure changes can work similarly (except that the solubility increases with pressure) plus the practical point that the pressure can be abruptly increased or decreased. In addition, nucleation points can be provided. Nucleation points are small cavities or crevices on the surface of a solid immersed in the liquid, which retain small gas bubbles by reason of their reentrant configuration. Such discontinuities are normally present in a typical household container — in gently boiling water the steam can be seen to arise in a train of bubbles from each nucleation point.

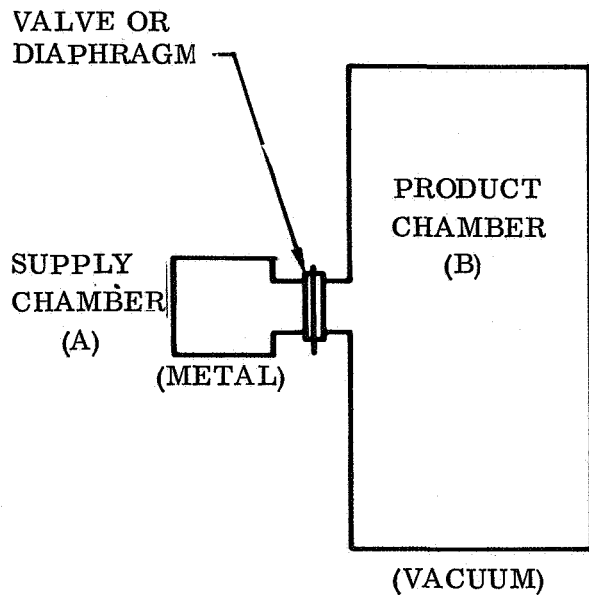

Figure 2-18. Nucleate Foaming

The planned Nucleate Foaming process is illustrated schematically in Figure 2-18. The molten metal will, before foaming, be retained in a small, strong supply chamber which will be completely or very nearly full. The liquid will contain a considerable amount of dissolved gas at high pressure, and the foaming will be initiated by the sudden opening of the passage between the supply and product chambers. It is anticipated that this will be accomplished by electrically fusing a highly stressed diaphragm. The sudden pressure release will allow the dissolved gas to come out of solution, propelling the foam as it forms into the product chamber where it will be retained to solidify. The finished foam density will be controlled

by the mass of metal and the chamber volume. The uniformity of the foam and the mean size of the bubbles will be controlled by the basics of the foaming process and are expected to be good.

When the diaphragm bursts, the pressure on the liquid metal will drop almost instantly and quite considerably. A considerable number of minute bubbles will be formed very quickly, and then slowly grow to their final volume. The instantaneous stability of the bubble diameter may be verified by considering that the gas pressure within a bubble (for a given mass of gas) varies as $1/D^3$ whereas the restraining pressure (surface tension) varies as $1/D$. This is shown graphically in Figure 2-19. It will be seen that the equilibrium bubble diameter is stable because if the bubble gets larger the internal gas pressure decreases more than the restraining surface pressure, and vice versa. The bubble will grow as more gas is added to it, but this growth rate is limited by the diffusion of the gas through the surrounding liquid, which is a relatively slow process.

The final diameters of bubbles depend on the rate of diffusion of the gas through the surrounding liquid. If we start with a uniform concentration of dissolved gas, this concentration will be reduced in the neighborhood of any bubble as soon as the bubble is formed or immediately thereafter. This not only retards the bubble growth rate, but also inhibits the birth of another bubble in the immediate vicinity. A "concentration map" of the situation just after several bubbles have formed should show a generally level surface with a dent at each bubble. A large bubble will make a large dent, and having lower gas concentration available, it will grow more slowly than the smaller ones. The dimpled nature of the gas concentration map will promote the production of many small bubbles. This tendency should respond positively to deepening the dimples, as by having a high vapor pressure of dissolved gas at the start and by reducing the static pressure on the liquid very rapidly.

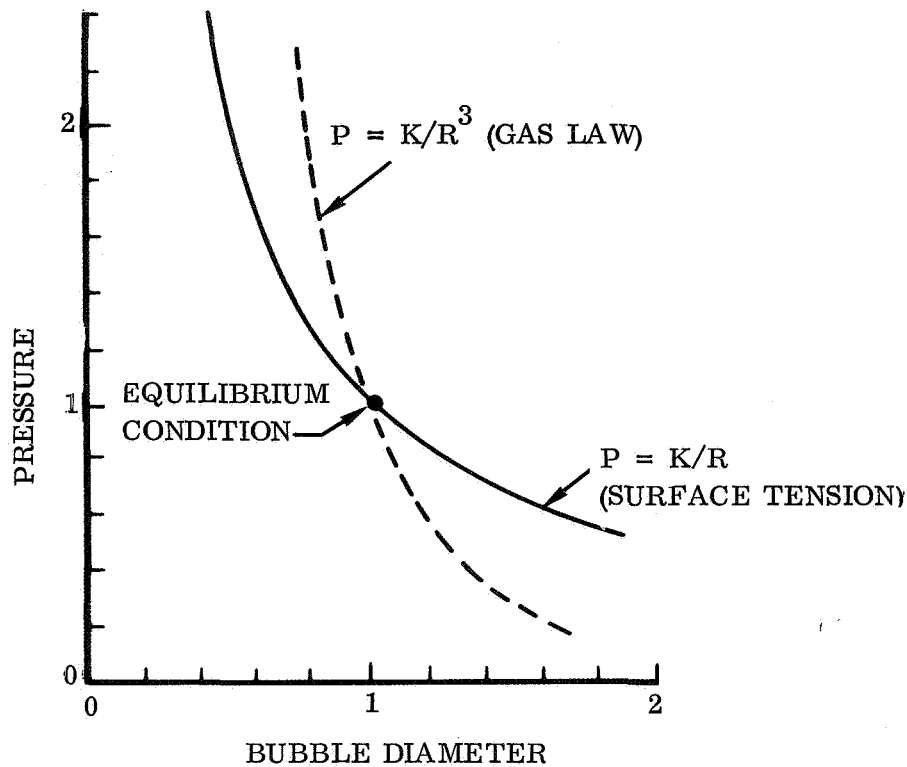

Figure 2-19. Pressure in a Bubble Containing a Fixed Mass of Gas
(Assuming Zero External Pressure)

Quantitative assurance that the concentration gradient effects described in preceding paragraphs will produce a suitably fine foam is not presently available. If such assurance can not be provided, it is planned that nucleation points be distributed throughout the molten metal. The nucleation points would be very small irregular solid particles made of a material which is not readily wet by the liquid metal so that they can retain microscopic gas bubbles from which the small bubbles can grow. It is also conceived that the nucleation points, rather than being trapped on solid particles foreign to the melt, may simply be microscopic bubbles formed and trapped in the base metal on earth by vigorous agitation of the metal before and during solidification. The small size of either the solid or gaseous nucleation points will allow them to follow the metal motion and resist acceleration separation during such a process.

With or without the nucleation points, the rate of bubble growth is expected to be slow enough so that the entire volume of liquid will be at essentially the same pressure. It is anticipated that, with a reasonably large port between the supply and product chambers, the overall foam growth rate will not be so high as to produce acceleration induced bubble flotation effects during or after the transfer.

Fibrous reinforcement material added to, or included in, the base metal before foaming produce multiple beneficial effects. In addition to strengthening the bulk foam, the fibers will strengthen the cell walls while the metal is still liquid and thus provide some level of assurance of bubble integrity. Furthermore, it is quite possible that the fibers or their multitude points of contact with each other can also serve as nucleation points.

ULTRASONIC FOAMING. This process combines some of the features of the Gas Injection and Nucleate foaming methods, with the molten metal being moved past a transducer head where the gas will be driven out of solution. Referring to Figure 2-20(a), the single chamber will be made of a material in which the molten metal will wet enthusiastically (positive spreading coefficient). The chamber will be charged with a predetermined quantity of metal and gas, sealed, and heated to melt the metal. The surface tension of the molten metal will cause it to spread around the inside of the container, including the face of the ultrasonic transducer, until the ullage reaches a spherical shape. During or after the melting process, the ultrasonic oscillator will be turned on at such a level as to form bubbles at the face of the transducer and propel the resulting foam gently across the chamber. The foaming process will be continued as long as required to achieve the desired uniformity of the foam.

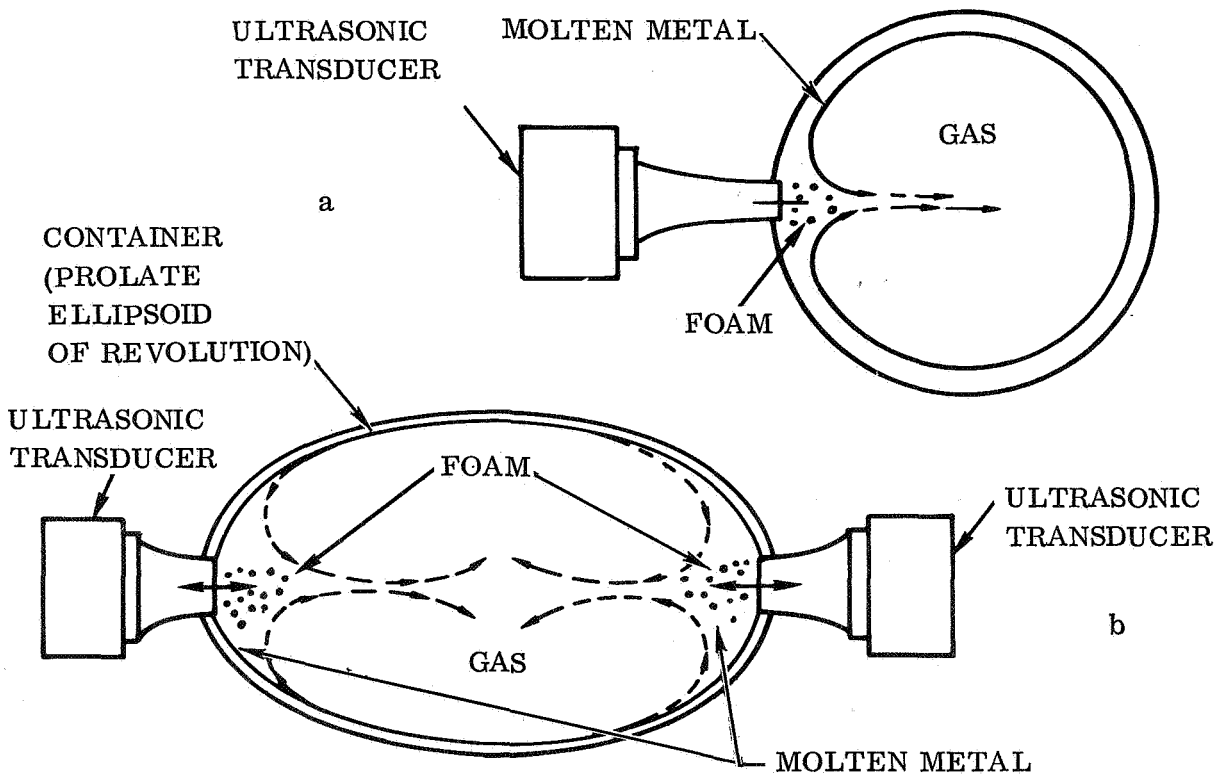

Figure 2-20. Ultrasonic Foaming

In an alternate and preferred configuration, Figure 2-20(b), the surface tension induced feed of the liquid metal to the transducer face would be promoted by shaping the chamber as a prolate ellipsoid of revolution with a transducer at each end. The foaming procedure would be the same as that discussed in the preceding paragraph.

SUMMARY OF CRITERIA AND REQUIREMENTS

a. Functional:

1. Mixture stability and mobility
2. Surface tension-pressure-diameter relationship of bubbles
3. Gas evolution control by nucleation sites and by vibration

b. Fundamental:

1. Definition of surface stabilization mechanisms for liquid metal
2. Analytical model of bubble growth rate and gas concentration gradients
3. Effect of bubble spacing and size variation on structural quality of foams
4. Strength of thin metallic membranes
5. Mechanisms of ultrasonic bubble formation
6. Pattern of bubble break-off from injection nozzle

c. Technological:

1. General:

Control of foam density by metal mass and product container volume

Liquid material supply system

Mold casting techniques

Heating requirements and temperature control of the melt

Gas and metal injection flow control

2. Gas Injection:

Bubble formation by break-off of injected gas stream (liquid velocity, surface tension)

Bubble dispersion by foam circulation*.

*Indicates that this process function would be destroyed or inhibited by earth's normal gravity.

3. Nucleate Foaming:

Bubble formation/creation by pressure release.

Bubble distribution control by initial mixture uniformity*.

Nucleation source characteristics: capability and maintainability.

4. Ultrasonic Forming:

Bubble formation/creation by ultrasonic pressure reduction.

Bubble dispersion by ultrasonically induced foam circulation*.

d. Data:

1. Solubility of gases in liquid metals.

2. Diffusion rate of gas through liquid metals.

3. Effective vapor over-pressure required to form bubbles in liquid metals

2.3.5a PROCESS 5a: PRESSURE-STIFFENED AND COMPOSITE FOAMS

For high performance structural applications, the stiffness and strength of metallic foams may be improved by internal foam pressurization and by reinforcement with fibers or whiskers.

PRESSURE-STIFFENED FOAMS. Of particular interest for aerospace and deep-sea applications is the potential of producing pressurized or pressure-stiffened foams. The pressure in each microsphere may be generated by intrinsic forces only, or by additional extrinsic pressurization.

In general, the internal pressure in a bulk foam is approximately equal to the pressure in a single foam bubble of medium size, as it is generated by surface tension.

From the pressure-size relationship in Figure 2-1 (full sphere data), it can be seen, that in the micro-size regime the pressures in metallic foams are of the order of thousands of psi. While such pressures may be adequate for deep-sea applications, the stiffening effect required for aerospace materials call for pressures between 10,000 and 50,000 psi. The required sub-micron size foam or composite may be difficult to produce; however, high pressures in coarser foams may be achieved by processing in a high-pressure enclosure. This does not affect the foaming technique and the related tooling, as its function is only determined by a pressure differential.

The stiffening effect may be further enhanced by transforming the individual spheres into ellipsoids, thus producing a preferred orientation. This may be accomplished by the process illustrated in Figure 2-21. The solidified microsphere material is placed in an enclosure, permitting expansion only in one direction (A); upon heating the entire pack to a temperature of reduced deformation resistance of the foam material, the internal pressure causes the foam to expand (B) and its structure is changed as indicated in (C). Such directionally pressure-stiffened light-weight materials are of high interest in aircraft engineering, since many structural components are stiffness- and compression-critical.

COMPOSITE FOAMS. Although all foams exhibit high stiffness, their strength, determined by the total cross-section of solid material, is moderate. This can be offset by the production of composite foams. The reinforcement fibers have to exhibit a positive wetting coefficient and are mixed with the molten metal prior to foaming. In the formation of the cell walls, the liquid flow and the surface pressure will orient fibers or whiskers in the wall plane. The resulting material will have a combination of stiffness, strength, and density, which exceeds present capabilities by almost an order of magnitude.

Whisker-reinforced foams provide unique core materials for high stiffness and strength-critical components, such as aerodynamic lift surface panels (Detailed discussion of metal-whisker composites is contained in process 6).

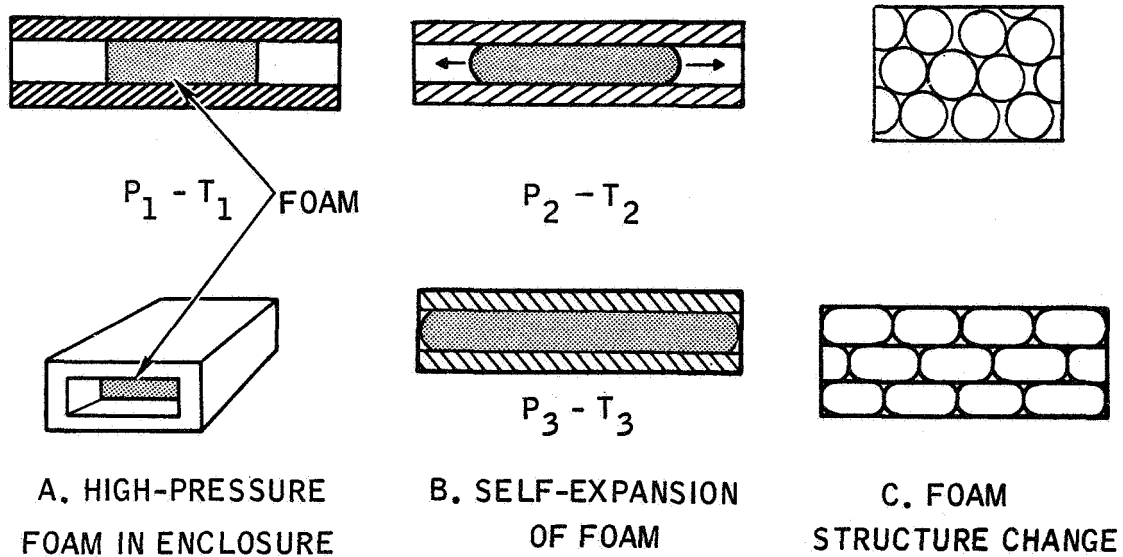

Figure 2-21. Self Expansion of Pressurized Microfoam

SUMMARY OF CRITERIA AND REQUIREMENTS (in addition to Summary 2.3.5)

a. Functional:

1. Pressures in bubbles as related to size and surface tension
2. Mixture stability

b. Fundamental:

1. Effect of pressurization of spherical and non-spherical cells upon stiffness of bulk foams
2. Liquid mechanics of liquid-fiber mixtures
3. Generation of foam (process 5a)

c. Technological

1. Methods and tooling for foaming under high environmental pressures
2. Strength of whisker composites
3. Fiber coating techniques
4. Mixing techniques
5. Liquid supply and feeding system

d. Data:

1. Viscosity and surface tension of molten metals
2. Properties of whiskers

2.3.6 COMPOSITE CASTING

The most direct application of the absence of buoyancy is the casting of composites from a mixture of a liquid matrix and solid reinforcements. Casting of metal-base composites is not feasible under terrestrial conditions.

Composite casting is of particular interest for the demonstration of space manufacturing capabilities in early experiments, since it permits the application of basic zero-g processing concepts in a variety of effective combinations, and has a high assurance of experiment success.

PROCESS AND PRODUCT DEFINITION. Composite casting is a typical mold-process which may be carried out in two ways:

- a. The two materials are precast in a mold on earth and then remelted, mixed, and solidified in space — this process may be used for initial experiments, and
- b. Complete manufacture in space in a special facility consisting of a melting chamber, a feeding and mixing system, and exchangeable molds.

In large-scale production, extravehicular operation of the facility is preferable, in view of the high amounts of heat involved and the advantage of cooling by radiation in deep space.

The objective of the basic process of composite casting is to produce high-strength materials and components consisting of a metal matrix and random-oriented reinforcements of various materials, forms, and packing densities.

The maximum attainable fiber reinforcement contents have been determined by tests with equal-density models. It is primarily dependent upon the length-to-diameter ratio (L/D) of the whiskers. As shown in Figure 2-22, the maximum density for random-oriented fibers of high L/D, which are of prime interest, is in the order of 35%. It may be increased by vibrations. However, it is expected that, in view of the complex strengthening mechanism, highest fiber contents may not even be desirable and that an optimum condition is achieved at a specific content for each system.

The uniform mixture distribution attainable under zero-g, together with the high fluidity of molten metals, permits the movement of individual fibers with small induced forces. Both variable fiber distribution (fiber concentration) and controlled fiber orientation (alignment) are most effectively achieved by the combined action of vibrations and a directional force. The objective of vibrations, generated either mechanically or by an alternating electromagnetic field is to free the fibers from their interlocked position and to ensure high mobility. The directional force is provided by either an electromagnetic or an electrostatic field. Both are applied simultaneously after casting prior to solidification. The effect of various modes can be well demonstrated and evaluated with equal-density models.

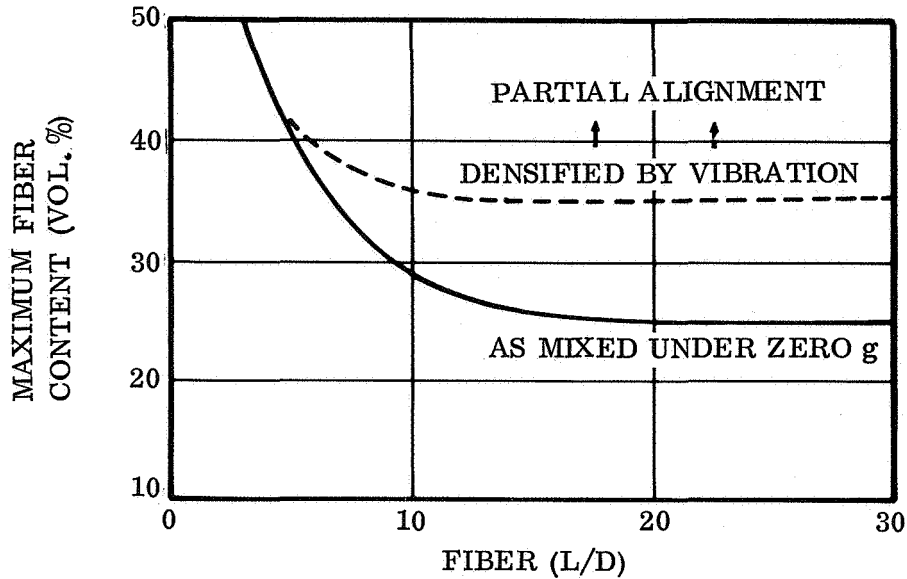

Figure 2-22. Highest Attainable Fiber Contents for Random Orientation

By combination of the basic process with zero-g methods of nucleation and crystallization control, products may be achieved that exhibit not only superior strength and stiffness, but also high ductility. Improved ductility may already be obtained in the basic process, as the individual whiskers will undoubtedly generate grain segmentation during solidification or act as nucleation sites. The resulting grain size will be substantially smaller than obtainable in conventional casting (Figure 2-23 A).

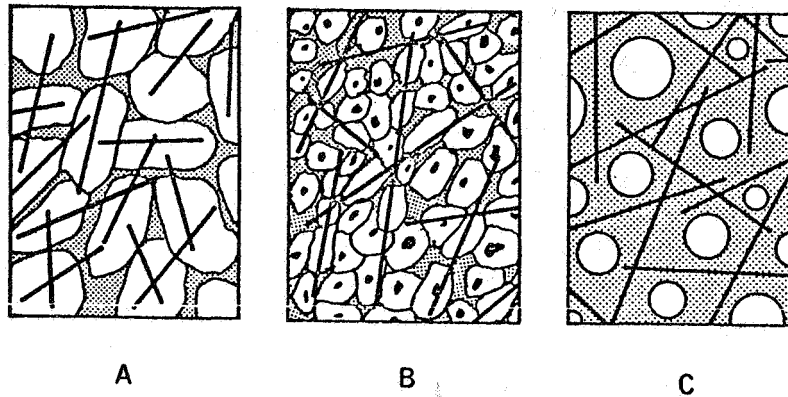

Figure 2-23. Microstructure of Modified Cast Composites

A considerably higher degree of grain refinement and, consequently, ductility may be achieved by the generation of a high number of nucleation sites in the form of finely dispersed microparticles whose uniform distribution is assured by the zero-g phenomenon of mixture stability (Figure 2-23 B).

The third modification of the basic process consists of the injection of an inert gas into the liquid matrix to form a foamed low-density composite as illustrated in Figure 2-23 C. The gas may be introduced during mixing or, preferably, by continuous dispersing shortly before entrance into the mold.

On the basis of equal weight, foaming will increase stiffness, while the strength remains unchanged. The low-density composite will, therefore, find application primarily in stiffness-critical structures. A foamed nickel-base composite may serve as an effective core material for lifting surface panels operating at high temperatures.

MATERIALS. In view of the absence of terrestrial limitations to composite fabrication, composite casting offers a wide spectrum of potential matrix and reinforcement combinations.

Metal matrix-whisker composites are, however, most attractive. The strength and stiffness of whiskers surpass conventional materials by almost an order of magnitude, as evidenced by the selected whisker data in Table 2-4. In spite of their unique properties and long availability, whiskers have never been used in composites, since they are incompatible with composite fabrication in the solid state, dictated by the gravity environment. The liquid-state fabrication, by composite casting offers the following product capabilities:

- a. Extremely high strengthening and stiffening effect
- b. Random orientation, i. e. , anisotropic mechanical properties
- c. No product-shape limitations
- d. Preservation of whisker integrity, consequently full effectiveness
- e. Production of complex high-performance components in one single operation.

The evaluation of various feasible matrix and reinforcement combinations indicated the best overall experiment effectiveness for the following material systems:

- a. Aluminum matrix, reinforced with sapphire whiskers or mixed whiskers of sapphire and aluminum nitride
- b. Nickel matrix, reinforced with silicon carbide whiskers

The two selected systems are representative of two major material groups, so that the data and processing experience gained in experiments will be useful for a wide spectrum of composite casting applications.

The aluminum system is typical of light-metal matrices aimed at high strength and stiffness-to-weight ratio. Processing temperatures are moderate and the cooling rates by radiation to space environment rather low. The nickel system is primarily

Table 2-4. Properties of Potential Reinforcements

Material	Melting Temp. (° F)	Density (G/CM ³)	Diameter (Microns)	Length (Microns)	Strength (10 ⁶ psi)	Elastic Modulus (10 ⁶ psi)	Cost (\$/lb)
Whiskers							
Al ₂ O ₃ -α (Sapphire)	3780	3.97	1-30	50-2000	0.5-3.5	60-150	9000
Al ₂ O ₃ -α/Al N	4000	3.6	3-30	30-600	0.5-2.0	50-100	900
SiC	4200	3.21	1-10	20-400	2-6	80-150	3000-11,000
SiC/Al ₂ O ₃ -α	4000	3.6	2-30	20-1000	2-6	60-150	900
Si ₃ N ₄	3450	3.1	1-10		0.7-2	55	
BeO	4650	2.78			1.8	50	
Graphite	6700	2.22	0.5	1 CM	2.8	~100	Millions
Others							
Graphite Fibers	6700	2.22	7	Any	0.5	~100	350
Boron Filament	4200	2.3	100	Any	0.3-1.5	60	300
Be Chopped Wire	2340	1.82	100	Any	0.18	40	2000

aimed at superior high-temperature components with high creep strength and oxidation resistance. It serves as a model for a wide variety of nickel, cobalt, and ferrous alloys as matrix materials. Its high processing temperatures require a modified line of tooling. Heating requirements in terms of Btu/lb are essentially the same for both systems; on the basis of equal volume (which may be more meaningful for casting of components), they differ by a factor of 2.5.

The expected capabilities of the two selected whisker-composites are illustrated in Figure 2-24 in terms of strength-to-weight ratio. In the calculation of data, allowance for uncertainties has been made by the use of a composite effectiveness factor of 0.5, which should ensure reasonable reliability. The figure demonstrates that, even at lower whisker contents, the capabilities of cast composites substantially surpasses any present high-strength structural alloy.

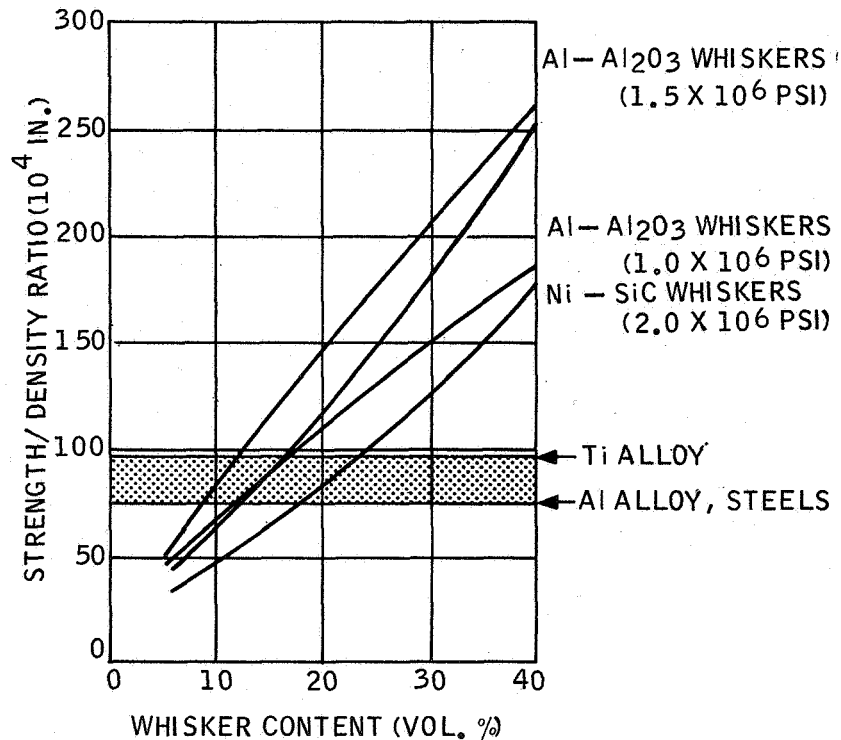

Figure 2-24. Strength of Cast Composites in Comparison with Conventional Materials

PRODUCT APPLICATIONS. The primary applications of metal-base composite castings are all types of high performance structural components presently produced by forging and machining. In addition to the superior capabilities, space-produced composite components show also cost advantages in spite of the high cost of transportation to and from orbit. The average cost of forged and machined steel and titanium components for high-performance aircraft is 200 \$/lb. This figure can be matched by

space-produced composite castings using expendable launch vehicles. With the availability of the shuttle, the cost of space-produced components drops to 110 \$/lb, including space vehicle or module write-off and indirect operations cost.

SUMMARY OF CRITERIA AND REQUIREMENTS

a. Functional:

Mixture stability

b. Fundamental:

1. Liquid mechanics of mixtures

Drag forces in liquid-fiber mixtures

Time to zero motion ("Stilling").

2. Liquid-solid interface characteristics

3. Particle-induced nucleation and crystallization

4. Generation of foams (process 5a)

c. Technological:

1. Mixing techniques

2. Liquid supply and feeding systems

3. Mold casting techniques

4. Fiber coating techniques (for control of wetting characteristics).

5. Strength of whisker composites

d. Data:

1. Viscosity of molten metals

2. Properties and dimensional characteristics of whiskers

2.3.7 GROWING OF SINGLE CRYSTALS

The primary criteria for the formation of a single crystal are of a metallurgical nature and have to be observed regardless of whether it is carried out on earth or in space. The growing of single crystals in space introduces, therefore no new process, but rather an improvement of the conditions and controllability of existing processes with the objective of improved products and new material types. While this may, at first glance, appear not too exciting, one must realize that in the field of single crystals even marginal gains in capabilities may open up entirely new fields of application with considerable technological and commercial potential.

Single crystals are produced by three basic types of processes: growth from solution, growth from the melt, and growth from the vapor.

In order to obtain an overview of the significance of all conceivable process parameters, a systematic evaluation was performed and the results displayed in a single chart. This display, Table 2-5, identifies, in form of a first-order assessment, the following:

- a. Applicability of parameters to each individual process and technique
- b. Degree of significance of each parameter
- c. Potential effect of zero-g upon each parameter

This preliminary evaluation indicated that, for initial experiments, preference should be given to the first two basic methods — the growth from solution and from the melt.

PRODUCT CRITERIA. The predominant characteristics of single crystals which may be improved through growth in a zero-g environment are purity and integrity (perfection). Certain materials (such as those that are highly reactive and have high melting points) are difficult to produce on earth because of the contamination due to container material. Growing the crystal by a containerless method in a suitable atmosphere (or vacuum) will greatly enhance the control over contamination.

For semiconductor applications, a critical amount of doping may be required, but an excess (or any contaminant) is detrimental to its performance capabilities.

The three causes of crystal imperfection that can be controlled to some extent in a zero-g environment are as follows:

- a. Compositional Fluctuations. In addition to chemical inhomogeneity per se, uncontrolled fluctuations can cause improper crystal growth (development of a celled or dendritic structure).

- b. Irregular Nucleation. In some instances, physical limitations on earth dictate imperfect heating arrangements which can cause irregular nucleation along low index planes. This situation may be minimized by wider choice of heating arrangements possible in space.
- c. Temperature Fluctuations. Another important criterion is the control of temperature fluctuations. These fluctuations can cause convection or supercooling (depending on whether the temperature gradient is high or low) and may give rise to stresses and imperfections (due to thermal shock, changes in interface geometry, and differences in growth rate, causing banding and high dislocation densities.) In most cases these factors can be more easily controlled in space. In addition many problems (such as vibration) that are so common on earth will either be eliminated or minimized.

PROCESS CRITERIA. The principal criteria which represent the basic parameters of individual processes are controlled nucleation, temperature control, environment control, and control of the interface between the solid and liquid phases.

NUCLEATION CONTROL. Nucleation is primarily determined by the seed crystal, as it causes nucleation in the desired orientation; in addition, control of undesirable random nucleation is necessary.

The critical characteristics of the seed are the crystallographic orientation, crystallographic perfection, and chemical purity. The most important of these factors is the orientation, including the dependency of crystallographic orientation on growth rates. Choosing a less favorable crystallographic orientation would favor polycrystalline growth. The freedom from defects or perfection of seed structure is of next importance since structural defects propagate into the newly solidified material. They may be reduced in some processes by such techniques as necking-down the crystal or permitting vacancy condensation in dislocation loops that are then permitted to climb to surfaces where they dissipate. Chemical purity of the seed is of lesser importance and is determined by seed preparation techniques. Since the seed preparation will be conducted on earth, it is of no significance in the present analysis.

The control of random nucleation depends on three factors: the chemical contamination by the container, the physical effect of potential nucleation sites at the container wall, and the supersaturation required to permit and facilitate crystal growth in all methods except the solidification from the melt. Another factor, though of lesser importance, is the concentration of impurities in the liquid phase, as it can be dealt with in preliminary purification processes. The interrelation of the criteria for nucleation control, their relative significance and their sensitivity to g are illustrated in Figure 2-25 (a).

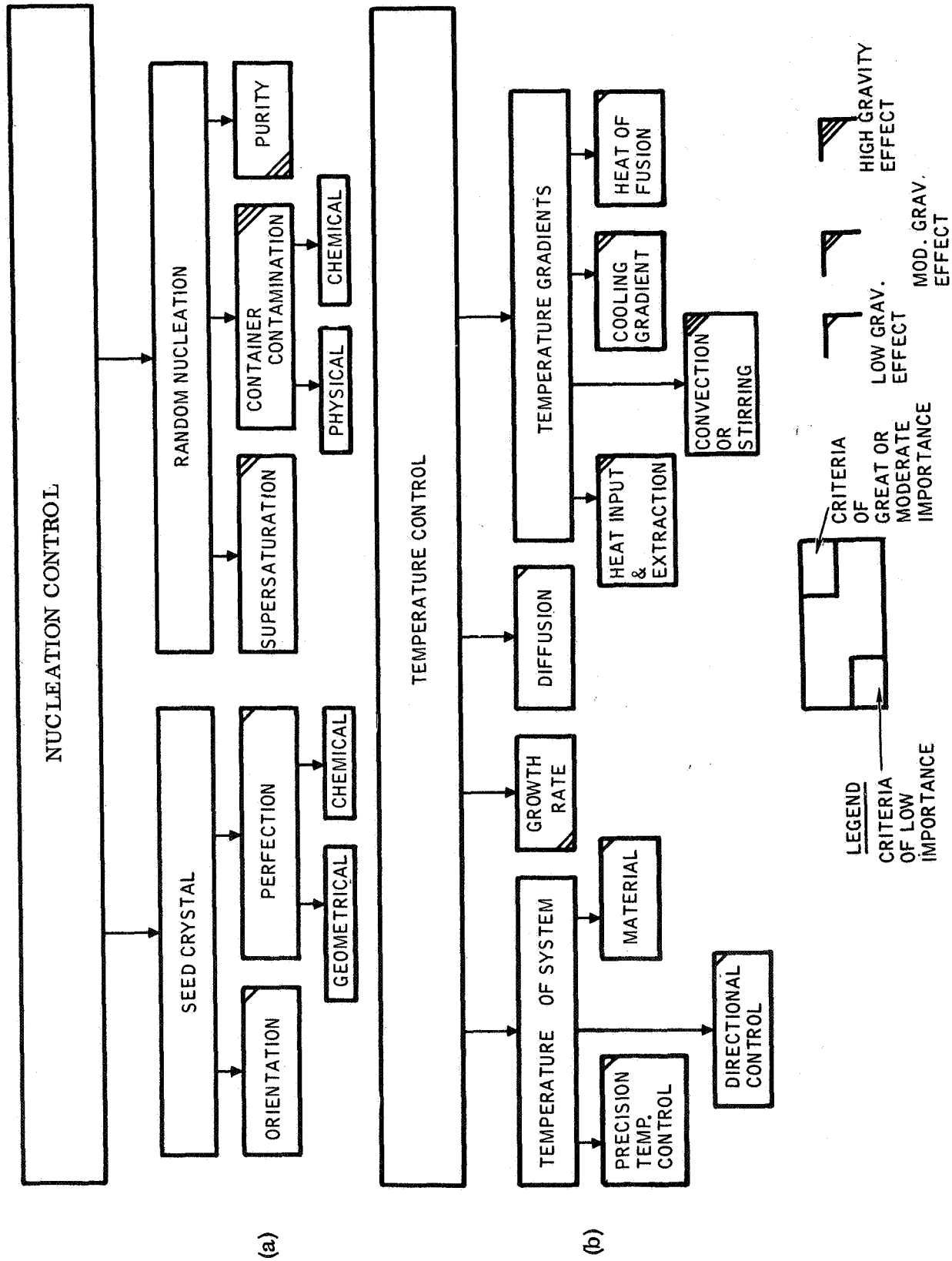

Figure 2-25. Interrelationship Between Criteria for Single Crystal Growth

TEMPERATURE CONTROL. The precision of temperature control is important since relatively small fluctuations can cause perturbations in the process and could result in polycrystalline, rather than single crystal, growth. The temperature level and the temperature precision required is determined by the material identity. All of these factors are of high importance but are not significantly influenced by zero-g.

Thermal gradients are encountered at the solidification front and at container walls. Both are, under terrestrial conditions, necessarily associated with thermal current which are often very violent. Such motion induces residual stresses in the crystal, irregularities in the crystal structure and dislocations in the atomic lattice. In some materials it even precludes the formation of a single crystal, as motion basically enhances nucleation and, consequently polycrystalline solidification. All these negative effects are minimized in a low-g environment due to the absence of thermal convection. Motion in the liquid can, however, not be eliminated entirely, since there are other sources of convection. Of particular concern is the liquid motion induced by variable surface tension at the liquid-solid interface as well as at the environmental interface (surface). Such other types of convection are, however, of a substantially smaller magnitude than thermal convection, so that in zero- or low-g, a considerable improvement of crystal perfection can be expected. As pointed out initially, even moderate gains in the related properties may represent significant gains in electronic, optical, and mechanical applications.

Crystal perfection is further affected by the rate of growth. It is generally accepted that reduction of growth rate has a favorable effect upon dislocation density. Even though unaffected by g, growth rates will have to be carefully selected and controlled in space experiments.

The significance of temperature control criteria is illustrated in Figure 2-25 (b).

ENVIRONMENTAL CONTROL. Environmental control is the third of the major criterion of single crystal growth. In case of high temperatures and/or vacuum exposure, vapor pressure must be considered. Low vapor pressure materials will give higher product yields and reduce the problem of condensation of vapor on equipment and specimens.

Mechanical factors include materials handling, vibration, and perturbation control. While not usually considered mechanical factors, electrical and magnetic fields used for shape and position control should be considered since perturbation, as well as position control problems, can be generated by them.

Chemical reaction with the environments is controlled by the proper selection of environmental gases, pressures, and container materials. This may be significantly enhanced by the elimination of the container in some growing methods from solution or melt.

INTERFACE CONTROL. Interface control refers primarily to the maintenance of a planar interface for optimum crystal growth. Convection interferes with planar growth and may cause cellular growth or other undesirable interfaces. It has been postulated that the equilibrium form in zero-g will be a hemispherical interface. The influence of such an interface on crystal growth has not been determined experimentally, however, excessive seed wetting may result. Control of interface form and stability may be achieved through temperature and heat input manipulation. With the reduction of gravity, surface tension effect will become more pronounced.

The relationships and gravitational effects of environment and interface control criteria are summarized in Figure 2-26.

2.3.7a SINGLE CRYSTAL GROWTH FROM SOLUTION

PROCESS DESCRIPTION. There are several different types of solution growth, depending on the type of solvent (salt, glass, water, or other suitable molten material), the temperature, and the pressure of the system. Basically, a seed crystal is introduced into a supersaturated solution. Conditions are such that heterogeneous nucleation is a minimum. When the seed is introduced, it presents a preferred site for crystal growth. An example of this type of crystal growing is shown in Figure 2-27 where six seed crystals are supported by a spider arm.

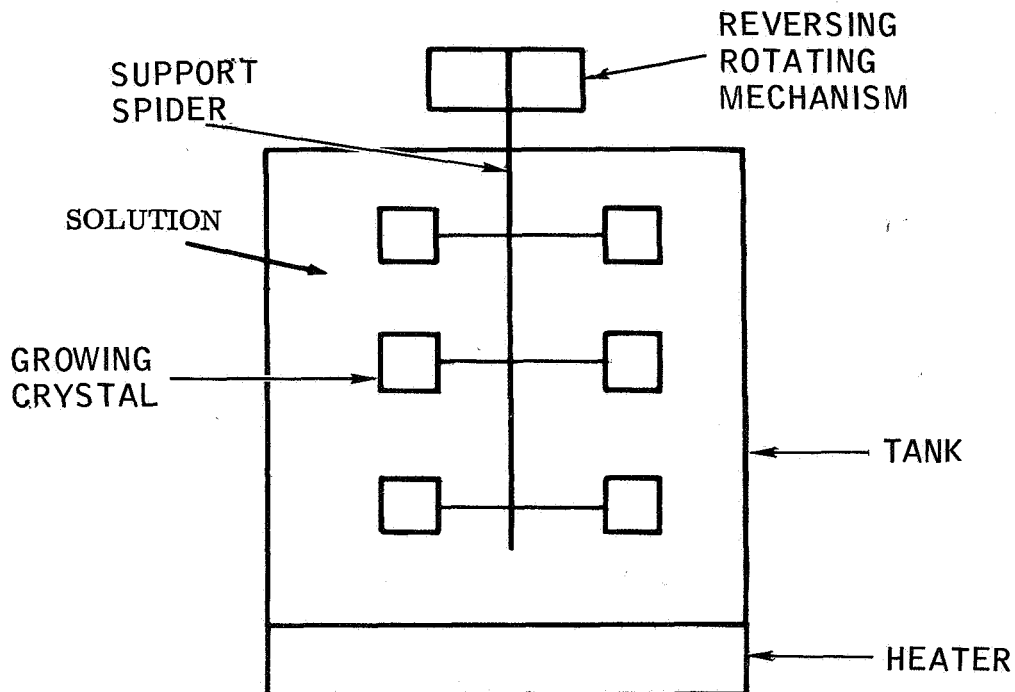

Figure 2-27. Single Crystal Growth From a Solution

PRODUCT/PROCESS CRITERIA. The principal goal of this technique is to produce a single crystal that has no growth defects and is free from contamination. Almost any type of crystal can be grown because of the wide choice of solvents. Thermal stresses are usually lowest in this type process.

In the growing process from a solution, low-g offers the following advantages:

- a. The stability of supersaturated mixtures, as discussed in process 13, and
- b. The potential elimination of the container and mechanical seed support, which may introduce contamination and thermal disturbances in the solution, as well as stresses in the crystal.

The process and the equipment are relatively simple and will require little monitoring. One experiment, the growing of Gallium Arsenide single crystals from solution, is already in preparation for the first orbital workshop.

SUMMARY OF CRITERIA AND REQUIREMENTS

a. Functional:

Seed — induced crystal formation from a supersaturated solution.

b. Fundamental:

1. Homogeneity of supersaturated solutions in zero-g
2. Optimum growth rates at temperatures and pressures required for various solvents
3. Sources of convection, their magnitude, and effect on growth
 - Surface tension-induced convection
 - Volume change-induced convection
4. Solid-liquid interface relationships
5. Nucleation and growth control (orientation control)
6. Diffusion (mass transport from solution to crystal)
7. Thermal gradients

c. Technological:

1. Proper heat source, location, and temperature control
2. Non-support positioning in liquid media
3. Solvent interference with growth (substitution and inclusion of solvent atoms)
4. Heat extraction
5. Process automation

d. Data:

Solubility of crystal material in various media as related to temperature and pressure.

2.3.7b SINGLE CRYSTAL GROWTH BY ZONE MELTING

Conventional single crystal growth by zone melting consists of progressive re-melting of a polycrystalline specimen whose end tapers down into a small spike. The re-melting starts at the spike which serves as seed; as it progresses, the crystal orientation of the seed is extended over the entire specimen, converting it into a single crystal. The attainable crystal perfection is limited by the gravity-induced phenomena.

PROCESS DESCRIPTION. For space experiments - and manufacturing - it appears prudent to use a conventional (imperfect) single crystal, prepared on earth, in place of a polycrystalline material which is converted in the low-g environment into a single crystal of high perfection.

One possible experiment arrangement is shown in Figure 2-28. The specimen would be prepared on earth in a Bridgeman type crucible. At one end, the specimen would be tapered into a short spike which serves as seed. The other end would be attached to a support which would position and hold the specimen. Melting would be started at the spike-specimen junction and the molten zone moved toward the opposite end at a preset progression rate converting the entire rod into a single crystal. The process could further be combined with a zone refining effect. The single crystal produced in this manner would be of high perfection, be more chemically pure, and could be larger than those obtainable in terrestrial production.

PRODUCT/PROCESS CRITERIA. The principal goal of this technique is to produce crystals of larger size (diameter) and increased integrity. Equipment and process are relatively simple and will require little monitoring.

Low-g will allow the maintenance of larger molten zones and consequently larger specimens can be grown. In addition, the crystals can be grown faster, and with a closer control of thermal gradients, resulting in lower dislocation densities. The effect of surface tension will have to be closely examined to determine the optimum molten zone width and configuration. This will have to be correlated with the interface shape, which in zero-g may tend to be hemispherical rather than planar.

SUMMARY OF CRITERIA AND REQUIREMENTS

a. Functional:

1. Crystal formation from a seed by progressive zone re-melting
2. Inherent zone refining effect (chemical)

b. Fundamental:

1. Basic single crystal growth criteria (Section 2.3.7)
2. Sources of convection, their magnitude and effects upon crystal orientation and growth rates

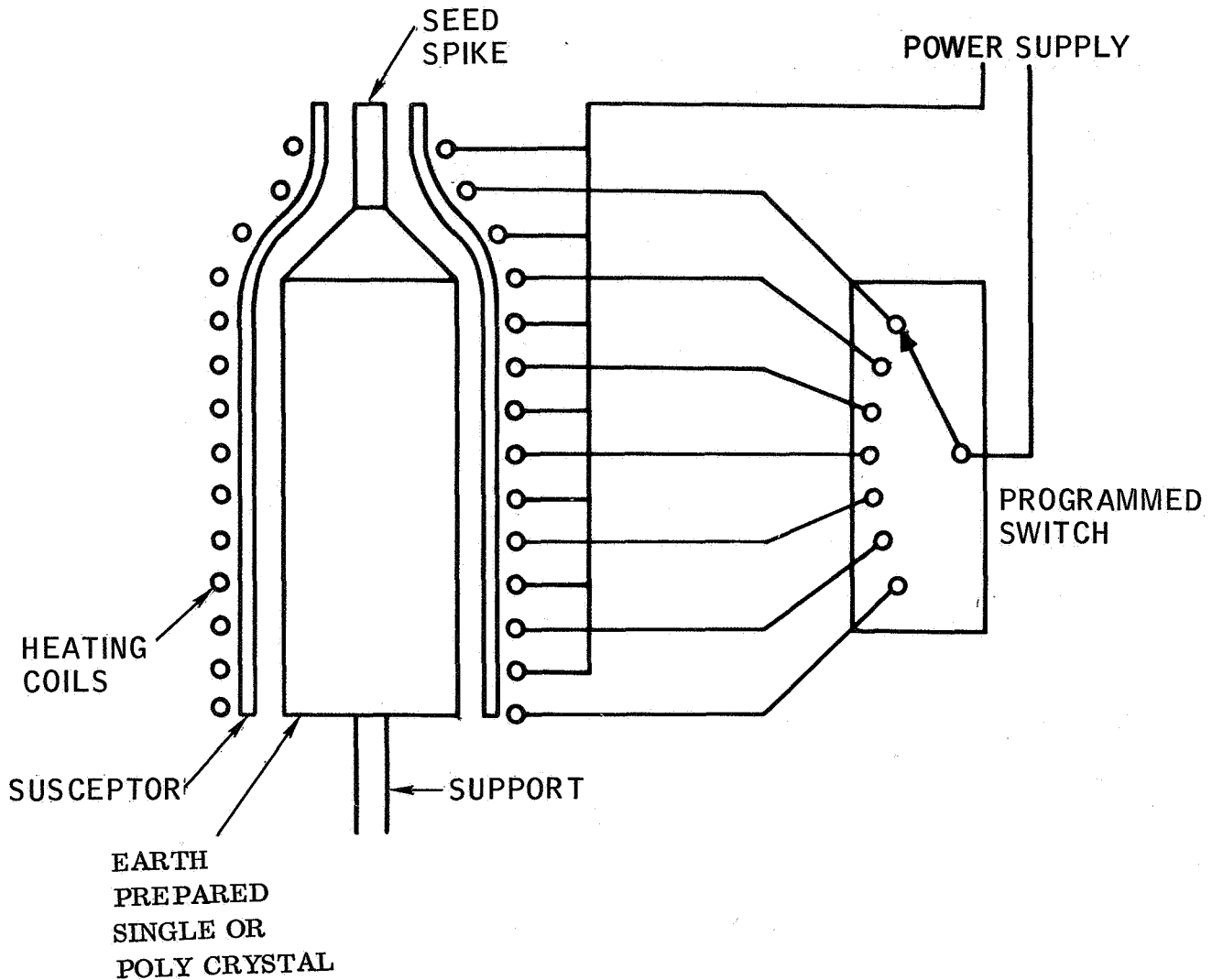

Figure 2-28. Zone Remelting Method of Zero-g Single Crystal Manufacturing

c. Technological:

1. Terrestrial preparation of specimen
2. Proper selection of materials
3. Proper heat source and temperature control
4. Definition and control of optimum crystal growth rates
5. Control of convection currents
6. Control of thermal gradients across the molten zone

d. Data:

Viscosity and surface tension of materials.

2.3.7c PULLING OF SINGLE CRYSTALS FROM THE MELT

The second type of crystal growth from the melt is the "pulling" or Czochralski method. The terrestrial techniques exhibit the typical limitations of the gravity environment: the necessity of a container, a flat liquid surface, weight of the lifted liquid, and disturbed intermolecular forces in the solid-liquid interphase and interfaces. The absence of all these constraints in zero-g permits a complete re-design of the process with the result of continuous production of single crystal rods or shapes of highest perfection. It consists in the drawing of crystals from a suitably controlled molten pool without allowing the melt to contact any solid materials other than solid components of the same material. In addition, the pool is not stirred or disturbed by extraneous dynamic forces.

PROCESS DESCRIPTION. The attempt to adopt the conventional Czochralski method to zero-g simply by replacing the melt container with a free positioned liquid sphere is not feasible, since the liquid will spread along the seed rod. This led to an entirely new concept in which the molten pool will be maintained by its own surface tension, the surface forces being applied between the pool and three solid rods of the same material. Figure 2-29 shows the general arrangement of the apparatus. Two of the locating rods will be of any convenient crystalline structure and will be fed into the pool as they melt. The third will be the product crystal which will be drawn outward from the pool as it solidifies. The heat required to melt the material will be provided by electrical resistance heating, the current being carried by the two feed rods. The process control will involve control of this current, the rate at which the crystal is withdrawn, the rate at which the two feed rods are moved into the melt, and an accurate motion of the feed rods to control the location of the molten pool.

It is anticipated that this process could be operated on a batch or continuous basis. For continuous operation the crystal could, in zero-g, be allowed to grow as long as desired, and be broken or cut off into suitable lengths. The feed rods would have new pieces resistance-welded to their outer ends without interfering with the conditions in the processing pool.

The stability of position of the molten pool can be maintained in zero-g by adjusting the position of the feed rods even though these two rods and the growing crystal are all of different diameters. The process and process controls could be tested on earth on a small scale. The size of free molten pool would be limited, but by using two weld rods as source material and a single crystal as seed material, the basic concepts of the experiment could be verified. There would be no problem with atmosphere since a vacuum or inert atmosphere furnace could be used. Vibration isolation of the furnace from its supports can be provided if necessary.

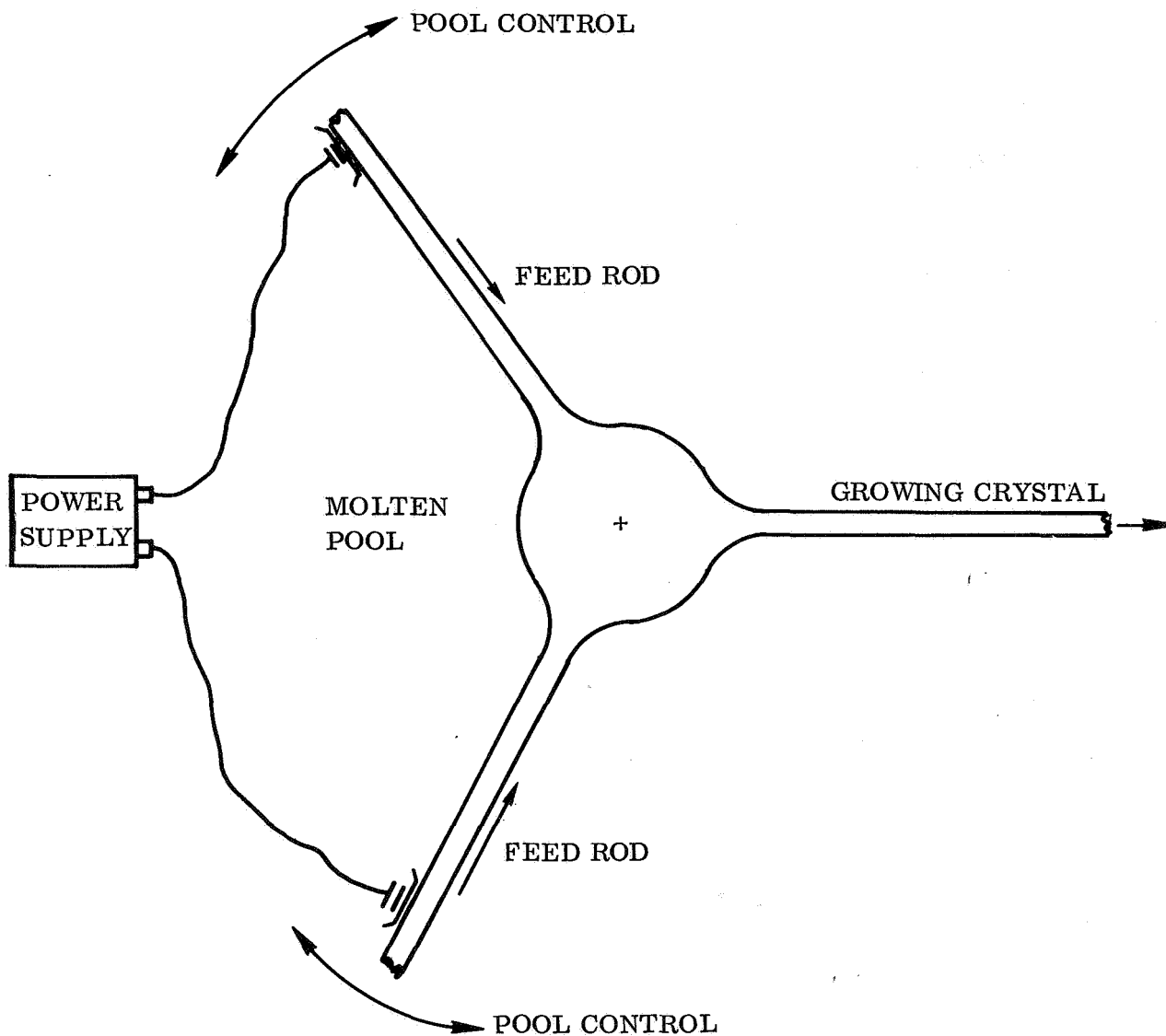

Figure 2-29. Non-Contact Melt Control for Growing Crystals

PRODUCT CRITERIA. The described facility would permit the production of single crystals of cylindrical or other simple geometrical shapes with no basic limitations as to size. The orientation of the seed crystal will cause no problems. Since the entire operation will be performed in a containerless manner, there will be no danger of chemical or physical contamination. It is anticipated that single crystals of extreme lengths can be grown by this method. With proper position control of the two source rods and the pulling single crystal, the maintenance of large molten pools should be possible.

SUMMARY OF CRITERIA AND REQUIREMENTS

a. Functional:

1. Crystal growth from the melt
2. Maintenance of containerless melt by surface tension — shape control

b. Fundamental:

1. Liquid form control by surface tension
2. Solid liquid interface phenomena and relationships
3. Sources of convection
 - Surface tension-induced convection
 - Motion in molten pool due to movement of crystal
4. Nucleation and growth control (Section 2.3.7)
5. Crystal growth rates and their relation to crystal geometry

c. Technological:

1. Positioning of source material, crystal, and molten pool
2. Process automation
3. Temperature control
4. Convection control

d. Data:

Viscosity and surface tension of liquid materials.

2.3.8 GROWING OF WHISKERS

Whiskers are extremely perfect single crystals of high aspect ratio (L/D).

PROCESS/PRODUCT DEFINITION. Whiskers can be produced from either the solid, liquid, or gaseous phase. The very nature of space manufacturing precludes any advantages in the solid state production. However, the absence of thermal convection in zero-g greatly enhances the process effectiveness in the liquid and, particularly, the gaseous state.

The limitations of terrestrial production from the vapor phase are threefold:

- a. Thermal currents, which are often extremely violent
- b. The combination of thermal gradients and gravity may generate segregation in gaseous mixtures, and
- c. On arriving at a certain length, gravity causes the whiskers to bend and/or to break; the broken whiskers fall to the container surface and are difficult to collect without creating additional damage.

PROCESS/PRODUCT POTENTIAL. The most attractive characteristics of whiskers is their great strength - in the order of millions of psi. It would be desirable to produce these fibers in larger quantities, and it has been suggested that longer, thinner, and stronger crystals could be grown in a zero-g environment. Even the possibility of producing continuous whiskers exists.

At the present time there is no commercial use for whiskers because there is no suitable rapid production method available for obtaining good quality whiskers in suitable lengths at reasonable costs. If commercial methods ever become available, whiskers would find immediate use as high strength reinforcements for composite materials.

Space-produced whiskers could be directly used in other processes without prior return to earth, particularly in composite casting (process 6) and, to lesser degree, in processes 1 to 5.

SUMMARY OF CRITERIA AND REQUIREMENTS

- a. Functional:
 1. Single crystal growth criteria (Section 2.3.7)
 2. Absence of thermal convection

b. Fundamental:

1. Nucleation and growth control
2. Sources and effects of convection
3. Potential segregation in gas mixtures
4. Solid-gas interface reactions
5. Diffusion
6. Exothermic effects of solidification

b. Technological:

1. Gas pressures and concentrations
2. Convection control
3. Whisker positioning and support
4. Heat extraction
5. Process automation
6. Definition of optimum growth rates
7. Heat sources

c. Data:

Viscosity of gases

2.3.9 AMORPHOUS MATERIALS (GLASSES)

The capability of contact-free suspension of liquids in zero- or low-g and the minimized convection eliminate two significant sources of nucleation and, consequently, offer the potential of producing otherwise crystalline materials in the amorphous state. Amorphous materials are considered to be materials with no long-range crystallographic order. They are found in both metals and non-metals.

PRODUCT DEFINITION. While metals have been produced in the amorphous state, there are two reasons why they have no promise in space manufacturing:

- a. The molten metal must be quenched at rates of 10^5 °C/sec to 10^7 °C/sec, and
- b. There is a maximum size of 30-50 Å thickness that can be achieved.

The former eliminates the factor of gravity and the latter precludes a commercially useful product.

As evidenced by the common silicate, borate and phosphate glasses, nonmetallic inorganics are more adaptable to amorphous solidification. Processes are, therefore, limited to nonmetallic inorganics (oxides) and the amorphous products referred to as "glasses".

Glasses are essentially supercooled liquids, and as such have essentially no plastic properties. X-ray diffraction patterns of crystalline materials show distinct patterns indicating long-range order of atoms; glass x-ray patterns, however, show only diffuse reflections that cannot be accurately measured. These patterns are almost identical with those obtained with liquids and are indicative of short-range order.

PROCESS CRITERIA. The production of glass can only be accomplished by the suppression of growth. This can be achieved in either of two ways:

- a. High cooling rate, or
- b. High viscosity of the liquid.

In Figure 2-30, the volume expansion is plotted against temperature. For a crystalline solid, there is a definite point, T_E , where the liquid transforms to solid. In glasses, the transition is much more gradual. For simplicity, the glass temperature, T_G , is taken as the temperature where the glass reaches a viscosity of 10^{13} poise. Any liquid that can be made extremely viscous has a chance of becoming a glass. A typical molten glass has a viscosity of 10^7 poise. Water, which has a viscosity close to that of liquid metals, is only 10^{-2} poise. In order for water to solidify as a glass, it must be cooled approximately 10^9 times as fast as a regular glass material.

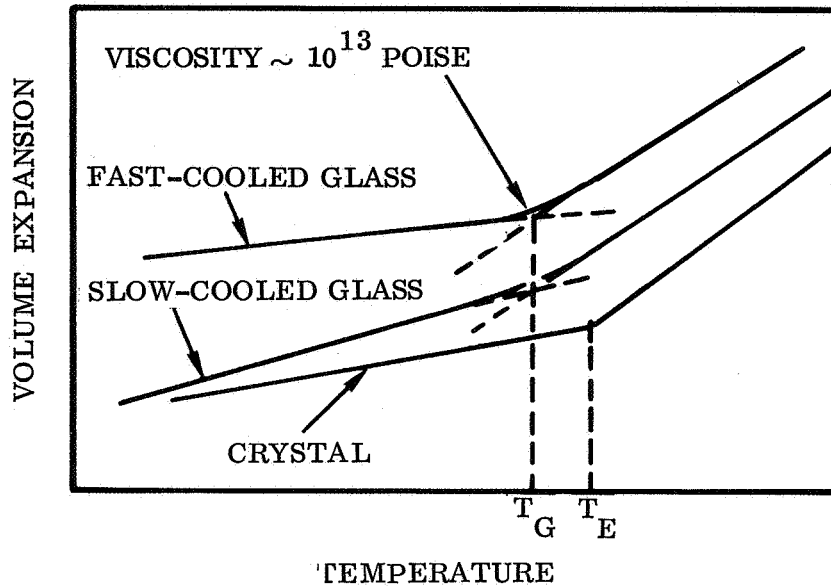

Figure 2-30. Comparison of Volume Expansion of Crystals and Amorphous Materials

Critical factors, for amorphous solidification are, therefore, the cooling rate, viscosity of the liquid, and external forces such as convection or sites for heterogeneous nucleation.

Manufacturing in space permits containerless melting, eliminating the most powerful source of nucleation sites and chemical contamination. The absence of thermal convection eliminates a source for striations and varying index of refraction. Controlled radiation cooling will minimize the development of thermal stresses. Internally evolving gases may be removed by surface-tension induced convection, as described in process 14.

TOOLING REQUIREMENTS. In the envisioned in-space production, pre-shaped crystalline oxide ingots are deployed in an electrostatic positioning system. Several methods of contact-free heating to the required high temperatures (3000 to 4500° F) have been proposed, such as:

- a. Initial radiation heating with additional induction heating in the upper temperature regime of increasing conductivity,
- b. Arc-image furnace,
- c. Solar furnace, and
- d. Dielectric heating.

In the liquid state, an oxide-rich gas envelope will be required. Cooling is achieved exclusively by radiation to the cooled chamber wall. The employment of liquid forming techniques (process 2) may further permit manufacture of finished optical shapes with surface finishes not attainable in terrestrial grinding and polishing processes.

PRODUCT CAPABILITIES AND APPLICATIONS. With the proper processing facilities, essentially all oxides can be produced as glasses. Such new glasses would exhibit optical properties not attainable in conventional silicate, borate and phosphate glasses. The potential in advanced optical systems is apparent. The higher purity of space-produced glasses will increase their light transmitting capability, i.e., reduce absorption. In conventional glasses, iron impurities range from 1/10 ppm to 1/2% Fe, and higher purity is mandatory. Infrared transmitting glasses require extremely low oxygen contents. The life of laser materials can be significantly increased by reduced impurity content.

For color control, an impurity alloy is introduced into the glass. The fine dispersion available in the absence of gravity will increase the uniformity and quality for colored glasses.

Several glasses can be made semi-conducting by the addition of transition metal oxides (especially those of Fe, V, Mn). A change in the ionic state (valence) of the metal ion causes a charge interchange (for example, $\text{Fe}^{++} \rightarrow \text{Fe}^{+++} + 1e^{-}$).

The advantage of glass over conventional semiconductors is ease of production and low cost. The higher purity of space-produced glasses will significantly increase their application as semiconductors.

Another useful property of glasses is their high strength: the theoretical tensile strength of glass is on the order of 1 to 2×10^7 psi. However, tensile properties are greatly reduced by tooling contact, which introduces surface defects. It is expected that contact-free production will yield strengths close to the theoretical limit.

Finally the possibility exists of producing high quality glass ceramics. These are materials that are formed in the glassy state and then devitrified (or crystallized) for increased strength or toughness. This crystallization is induced by selected additives, whose uniform dispersion is assured by the phenomenon of mixture stability.

SUMMARY OF CRITERIA AND REQUIREMENTS

a. Functional:

1. Contact-free melting and processing
2. Materials of high viscosity and gradual liquid/solid transition

b. Fundamental:

1. Nucleation

Heterogeneous

Homogeneous

Dynamic

2. Effect of cooling rates upon crystal growth

3. Sources and magnitude of convection

4. Prediction of optical properties of amorphous oxides

5. Thermal gradients

6. Miscibility of oxides with various additives

c. Technological:

1. Deployment techniques

2. Contact-free positioning system for dielectrics

3. Techniques of contact-free heating to 4500° F

4. Gas evolution and removal

d. Data:

1. Viscosity of oxides in the liquid and semi-solid state

2. Electrical conductivity of oxides

3. "Softening" temperatures of oxides

2.3.10 DISPERSED PARTICLE CASTINGS

The processes employing dispersed micro-particles are based on the phenomenon of liquid-solid mixture stability and are carried out exclusively by casting in or into a mold. For sub-micron size particles, random distribution is maintained even in a gravity environment due to Brownian motion. The particles required for the proposed casting processes are of micron size or larger and segregation can only be prevented by a low-g environment. Three processes or products have been defined as follows:

- a. Casting of metals with extremely fine grain size and the associated improved mechanical properties (strength and ductility).
- b. Castings of dispersion strengthened metals, and
- c. Combination of a. and b.

FINE-GRAIN CASTING. In the fine-grain casting process, the particles act as seeds for nucleation and crystallization during solidification. The grain size can, therefore, be controlled by the degree of dispersion or the mean particle spacing. By sufficiently high dispersion, the resulting microstructure may be comparable to mill-products, so that structural components of mill product quality can be obtained in one operation directly from the melt. Therefore, the numerous operational steps of conventional fabrication, such as material refinement, forming and/or machining of component elements, and their assembly in a final component by various joining methods can be bypassed. The one-step fabrication offers perfect anisotropic mechanical properties, lower cost, and increased reliability due to the substantial reduction of the number of processing variables.

DISPERSION STRENGTHENED ALLOYS. The effect of dispersed particles, such as oxides, for the stabilization of strengthened microstructures of metals is well established. There are two methods of particle dispersion — precipitation from solution at a discreet temperature, and mixing. In the gravity environment, the problem of mixture segregation confines both methods to the solid state, such as powder metal-lurgy techniques. The low-g environment permits the production of dispersion-stabilized alloys from the melt, either in the form of ingots for secondary terrestrial processing, or in the form of end-shape components.

The product may further be improved by the combination of both applications, i. e. the simultaneous dispersion of two dissimilar particle types and sizes, resulting in a fine-grain dispersion-strengthened casting of high and well controllable mechanical properties.

TOOLING AND PRODUCTS. As typical mold processes, experiments may be carried out in the same manner and the same equipment described in process 6. The primary applications are structural materials, in the form of finished components or in the form of mill shapes, fabricated on earth from space-produced ingots.

SUMMARY OF CRITERIA AND REQUIREMENTS

a. **Functional:**

Mixture stability

b. **Fundamental:**

1. Induced nucleation and crystal growth
2. Definition of effective seed materials for specific metals and alloys
3. Effect of dispersed oxides upon mechanical properties of metals and alloys
4. Time to zero-motion of an agitated mixture

c. **Technological:**

1. Mixing techniques
2. Material supply and feeding system
3. Mold casting techniques
4. Particles coating techniques to obtain certain wetting characteristics

d. **Data:**

1. Wetting coefficient of liquid metals in contact with solid metals and oxides
2. Viscosity of molten metals

2.3.11 PROCESS 11: THERMOSETTING ALLOYS

Thermosetting alloys are intermetallics produced at room temperature, or at slightly elevated temperatures from a mixture of a low-melting liquid metal and fine particles of one or several high-melting metals. The requirement of high mixture stability makes the production of such alloys unique to zero-g.

PROCESS DISCUSSION. The phase diagrams of metallic systems contain an abundance of intermetallics which are either formed during solidification from the melt, or during solid-state cooling due to the varying solubility of component elements. For systems in which one element has a low melting point, such intermetallics may be formed from a mixture of liquidized low-melting element with solid particles of the other constituents. While processing temperature is near the low melting temperature of the liquid phase, the resulting solid intermetallic is stable to its much higher melting temperature, as defined by the phase diagram. This principle has been applied for half a century in the dental restoration field where an intermetallic is formed from a mixture of solid silver and liquid mercury at room temperature, known as "amalgam." Since we deal with a liquid-solid mixture, the mixture stability of low-g offers the potential of producing high temperature-resistant intermetallic materials at moderate temperatures.

PROCESS AND PRODUCT CRITERIA. The process of formation of intermetallics is one of solution, in which the liquid acts as solute and the solid as solvent. The criteria for favorable liquid metals are, therefore

- a. Low melting temperature, and
- b. High solubility in other metals

Requirement b. excludes sodium, potassium and lead, as their solubility is low in all metals of technical usefulness. Promising candidates and their melting points are:

<u>Metal</u>	<u>Melting Temperature ° F</u>
Mercury	-37
Gallium	84
Lithium	356
Tin	450

The process of complete solution may be enhanced and the setting time reduced by "curing" at elevated temperature. The intermetallics produced in this manner have, therefore, been designated as "thermosetting alloys."

Candidate compositions have been defined from phase diagrams and solubility calculations.

With regard to the type and usefulness of intermetallics, the phase diagrams may be classified as illustrated in Figure 2-31. Type (a) exhibits an intermetallic at a temperature between the melting points of the two components. In Types (b) and (c) the temperature capability of the intermetallic is close to that of the high-melting component (solvent); however, the intermetallic (b) is limited to a very discreet composition in contrast to (c), which allows a certain latitude in composition. Most desirable are types (d) and (e) in which the temperature capability of the intermetallic is higher than that of either component. Again, the high temperature capability of the intermetallic (d) is limited to a discreet composition, which drops significantly at minute deviations. Type (e) represents the ideal case, as it combines the high temperature capability with a range of compositions between two intermetallics.

An analysis of all existing phase diagrams produced a considerable number of promising intermetallics. These are listed in Table 2-6 together with the pertinent compositions and the expected temperature stability after low-temperature solidification.

For practical applications, a limited excess of the solid phase does not appear to be critical; while it reduces the high-temperature capability, the presence of unalloyed pure metal may have a favorable effect upon specific properties, such as ductility. Intermetallics are notorious for their brittleness, even though there is no reason for this to be a rule. It is expected that some compositions behave exactly as an alloy produced by conventional solidification from the high-temperature melt. Above and beyond the use of an excess solid-phase, the addition of other metals or even fibers to the low-temperature mixture may permit a control of end-product properties not obtainable in conventional alloy production.

POTENTIAL. The process is extremely sensitive to mixture distribution homogeneity, attainable only in a gravitation-free environment. Initial space experiments can be carried out without any particular facilities. Eventually, it may be possible to produce intermetallic components in one operation with almost negligible heating requirements.

It is too early to assess the full potential of the concept of thermosetting alloys. Its prime attractiveness is the fact that it represents the first departure from conventional alloying methods, all based on the complete melting of all constituents.

SUMMARY OF CRITERIA AND REQUIREMENTS

a. Functional:

Liquid-solid mixture stability

b. Fundamental:

1. Solubility and/or diffusion of low-temperature liquid metals in solid metals

2. Process of the formation of intermetallics
3. Definition of promising compositions by studies and laboratory experiments

c. Technological:

1. Preparation of pure (oxide-free) metallic powders
2. Mixing techniques
3. Definition of optimum setting temperatures and times
4. Evaluation of temperature stability of the product

d. Data:

Wetting characteristics of various solid and liquid metals

2.3.12 SUPERCOOLING

Supercooling of materials from the liquid state is essentially equivalent to amorphous solidification. The application to inorganic nonmetallics is discussed in detail in process 9 (glasses). As stated in Section 2.3.9, the potential of supercooling of metals from the liquid state is limited to conditions which have little practical applications potential. Supercooling of metals is, therefore not pursued any further at this time.

The term "supercooling" is often also applied to suppressed phase changes in the solid state. As the solid state is not affected by gravity, this type of supercooling has no place in space manufacturing.

2.3.13 SUPERSATURATED ALLOYS

Supersaturated solutions are stable above a certain temperature; below this temperature, the excess phase solidifies in the form of crystals. The exact temperature at which crystallization sets in depends on the undercooling capability of the solution, liquid motion, and the presence of favorable nucleation sites. This effect is applied in the growth of single crystals from solution (process 7a).

The formation of a stable supersaturated mixture at high temperatures is also encountered in metals which, at lower temperatures, are immiscible or exhibit a miscibility gap. The temperature dependency of the miscibility implies that it is the result of the increased thermal agitation. Below this temperature, miscibility can no longer be maintained, and - in the case of a binary system - two discreet liquid phases appear, one in the form of a liquid continuum, and one in form of dispersed liquid microspheres. The dispersed phase is characterized by higher surface tension.

PROCESS CRITERIA. In the gravity environment this condition cannot be obtained since the formation of the immiscible phases is associated with immediate segregation. The zero-g phenomenon of mixture stability permits maintenance of the dispersed sys-

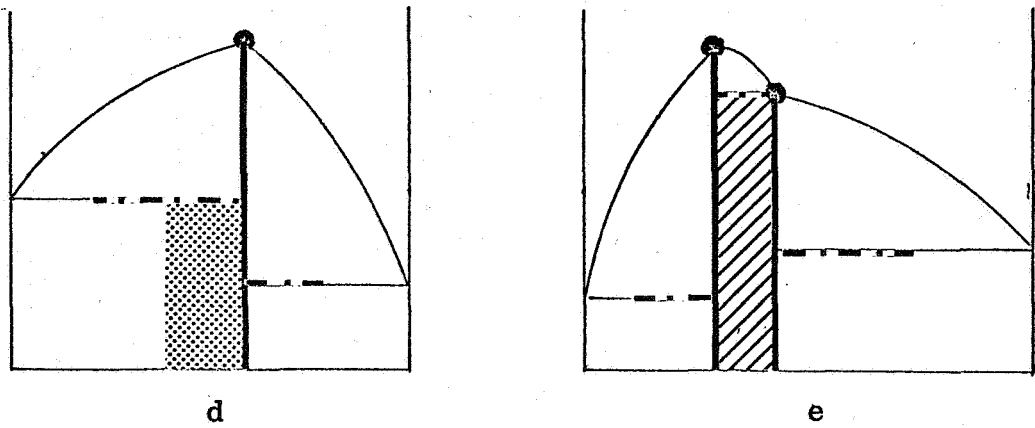
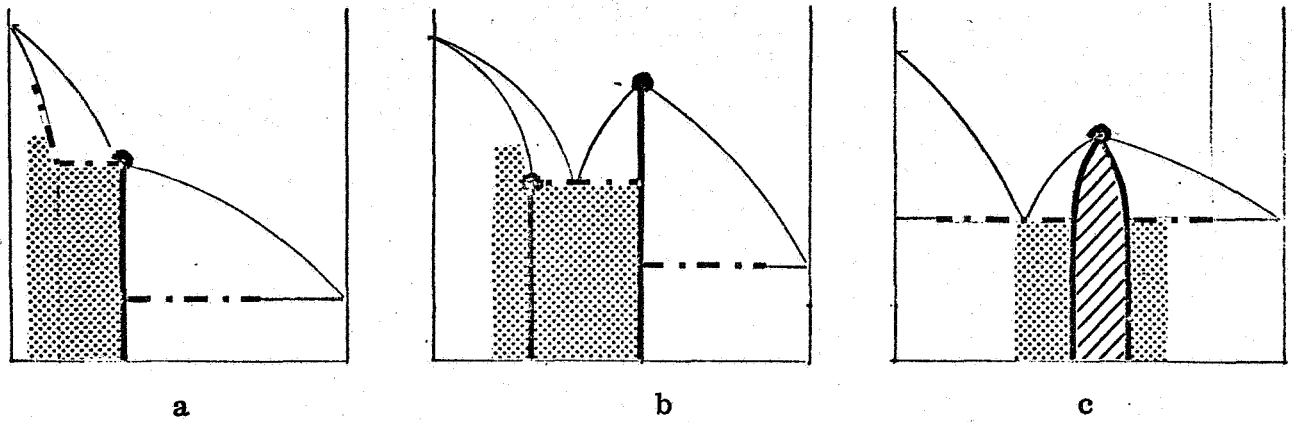

- Intermetallics
- - - - - Temperature Limit Outside Intermetallic Composition
- ////// Intermetallic Composition Range
- Useful Composition Range (Part Intermetallic)

Figure 2-31. Classification of Phase Diagrams with Regard to Intermetallics

Table 2-6. Candidate Compositions for Thermosetting Alloys

a. GALLIUM BASE

Min. Working Temperature = 80°F

Liquid Ga %	Alloying Element %	Intermetallics	Temp. Stability °F max.	Solidification Time Hrs at RT.	Tentative Rating
46	Mg 54	Mg ₅ Ga ₂	840		1
56.4	Al 43.6	Al ₂ Ga	830		1
34 (32.8)	Cu 66	Cu ₉ Ga ₄	1650	4	1
13	Ag 87		1100		2
36.4	Sb 63.6	Sb Ga			2
27	Te 73	Ga ₂ Te ₃	1450		1
36	64	Ga Te	1450		1
18	Au 82	Au ₃ Ga (+Au)	840	5	1
22-27	73-78	Au ₃ Ga	790		1
34 (28-40)	66	Au Ga ₂ + Au Ga	900(+)	8	2
91	Li 9	Ga Li	(low)		3
32	44 Cu - 24 Sn		1200	24	1
32	50 Cu - 18 Sn		1290	24	1
33	44 Cu - 33 Au		1200	8	2

Table 2-6. Candidate Compositions for Thermosetting Alloys (Contd)

b. MERCURY - BASE

Min. Working Temperature = 50°F

Liquid Hg %	Alloying Element %	Intermetallics	Temp. Stability °F max.	Tentative Rating
30	Ag 70	$\text{Ag}_3 \text{Hg}_4$ (+ Ag)	1100	1
50	50	$\text{Ag}_3 \text{Hg}_4$ (+ Ag)	530	1
60	40	$\text{Ag}_3 \text{Hg}_4$	530	1
70	30	$\text{Ag}_5 \text{Hg}_8$	265	2
22-27	Au 78-73	$\text{Au}_2 \text{Hg}$	750	1
30-60	70-40	$\text{Au}_2 \text{Hg} + \text{Au}_2 \text{Hg}_3$	265	3
68	Cu 32	$\text{Cu}_3 \text{Hg}_2$	(low)	4
95	Li 5	Hg Li_2	710	2
96.66	3.34	Hg Li	1100	2
77	Mg 23	$\text{HgMg}_2 + \text{HgMg}_3$	950	2
85	15	$\text{Hg Mg} + \text{Hg Mg}_2$	1030	2

Table 2-6. Candidate Compositions for Thermosetting Alloys (Contd)

c. LITHIUM - BASE

Min. Working Temperature = 360°F

Liquid Li %	Alloying Element %	Intermetallics	Temp. Stability °F max.	Tentative Rating
12.5	Mg 87.5	Li Mg ₂	1100	1
21	Al 79	Al Li	1250	1
23	Pb 77	Li ₇ Pb ₂	1200	2
8-9	Bi 91-92	Bi Li + Bi Li ₃	780(+)	2
9.06	90.94	Bi Li ₃	2180	2
18-19	Sn 81-82	Li ₄ Sn + Li ₇ Sn ₂	1380	1
6.6	Zn 93.4	Li ₂ Zn ₃	970	2
6	Ag 94	Ag Li	1750	2
16	84	Ag Li ₃	840	3

Table 2-6. Candidate Compositions for Thermosetting Alloys (Contd)

d. TIN - BASE

Min. Working Temperature = 450°F

Liquid Sn %	Alloying Element %	Intermetallics	Temp. Stability °F max.	Tentative Rating
14.5	Ag 85.5	Ag ₃ Sn	1330	1
8	Au 92		(1000)	2
37	63	Au Sn	540	2
51	Co 49	Co ₂ Sn	1700 (-2100)	3
37.5	Cu 62.5	Cu ₃ Sn	1230	1
20-30	80-70	Cu ₃₁ Sn ₈ (+Cu)	1350	1
18-50	Fe 82-50	Fe Sn (+Fe)	1650	4
55-67	45-33	Fe ₂ Sn + Fe Sn	1470	4
40-70	Mg 60-30	Mg ₂ Sn (+ Mg)	1040	1
71	29	Mg ₂ Sn	(1400)	1
40	Ni 60	Ni ₃ Sn	2135	1
20-40	80-60	Ni ₃ Sn (+ Ni)	2080	2
40-53	60-47	Ni ₃ Sn + Ni ₃ Sn ₂	2135	3
57	43	Ni ₃ Sn ₂	2290	3
(30-) 35	Sb (70-)65	Sb Sn (+ Sb)	790	1
20 (-30)	Sr 80 (-70)	Sn ₃ Sr (+ Sn Sr)	1080	4

tem through solidification. At a coarse dispersion, the resulting solid may be classified as a metal-metal composite. With increasing fineness of dispersion, the solid may have the characteristics of an alloy. The feasibility of producing such "supersaturated alloys" hinges on appropriate techniques to prevent coalescing of the dispersed phase and to generate an extremely fine dispersion or homogenization.

PRODUCT POTENTIAL. Homogenized immiscible systems represent a new family of alloys not attainable under terrestrial conditions. They comprise a wide variety of binary and ternary systems. Prime interest is in their application as semi-conductor materials, such as Gallium-Bismuth or improved Lead-Tin-Telluride.

Unique characteristics may be achieved by directional solidification, induced by a controlled thermal gradient. The resulting material may exhibit a fibrous structure with the associated directionality of properties.

Metal-metal composites, obtained from a coarse liquid dispersion, may have attractive structural or bearing-material applications.

Since this process comprises metallic alloys, metal-oxide mixtures are omitted. They pertain either to composite casting (process 6) or dispersed particle alloys (process 10).

SUMMARY OF CRITERIA AND REQUIREMENTS

a. Functional:

Liquid-liquid mixture stability

b. Fundamental

1. Characteristics of liquid-liquid mixtures - criteria for continuum and dispersed phases
2. Solidification of immiscible metallic mixtures
3. Definition of miscibility-temperature relationship
4. Definition of promising supersaturated alloy compositions and the applicable transformation temperatures

c. Technological:

1. Techniques for homogenized dispersion of immiscible liquid metals
2. Mold casting techniques and tooling
3. Temperature control

d. Data:

1. Metal phase diagrams
2. Liquid-liquid interphase tension

2.3.14 PURIFICATION

One of the early concepts of space application to materials was the utilization of the unlimited vacuum environment for high-purity vacuum melting and the preparation of metal standards. In the meantime it is agreed that, even though the unlimited "pumping capacity" of space is advantageous in vacuum processes, the concept is not unique, as extremely high vacua can be produced on earth. Vacuum processes, such as vacuum melting of alloys, may be used in connection with zero-g processes, but not as a primary, independent process.

Likewise, purification of materials is not a process by itself, but a prerequisite of a number of primary processes which deal with delicate materials or with phenomena sensitive to impurities, such as the drawing of membranes and the production of single crystals, whiskers, glasses, thermosetting alloys or vaccines. It is limited to the final purification cycle, since all conventional purification will be part of the material preparation on earth; it is apparent that the removal of macro-impurities can be better accomplished in the gravity environment. Purification in space is, consequently, confined to two types:

- a. Final ultra-high purification, and
- b. Disposal of impurities coagulating during processing, particularly evolving gases which may create voids or otherwise impair the product integrity.

In the zero-g environment and the absence of buoyancy or thermal convection, intrinsic movement of impurities or gases to the surface by diffusion may be feasible for thin membranes and fibers. For larger masses, movement has to be induced. Directional movement by electrophoresis is discussed in Section 2.3.15. In conductive liquids, convection can be generated by appropriately controlled electromagnetic fields, as indicated in Figure 2-32-a.

Another method, applicable to conductive as well as nonconductive liquids, is surface tension — induced convection (see Section 1.3.7). The surface tension gradient is generated by means of a radiant heat beam, normal to the surface for opaque materials and tangentially for transparent materials, as illustrated in Figure 2-32-b.

In both methods, the impurities will eventually be carried to the surface. Gases will dissipate, while the disposition of immiscible liquid impurities or solids has to be adapted to the particular process and materials. The merits of these methods are:

- a. Contact-free operation, precluding additional contamination
- b. Full control over timing, duration, and intensity of the induced convection (as opposed to the ever-present gravity on earth).

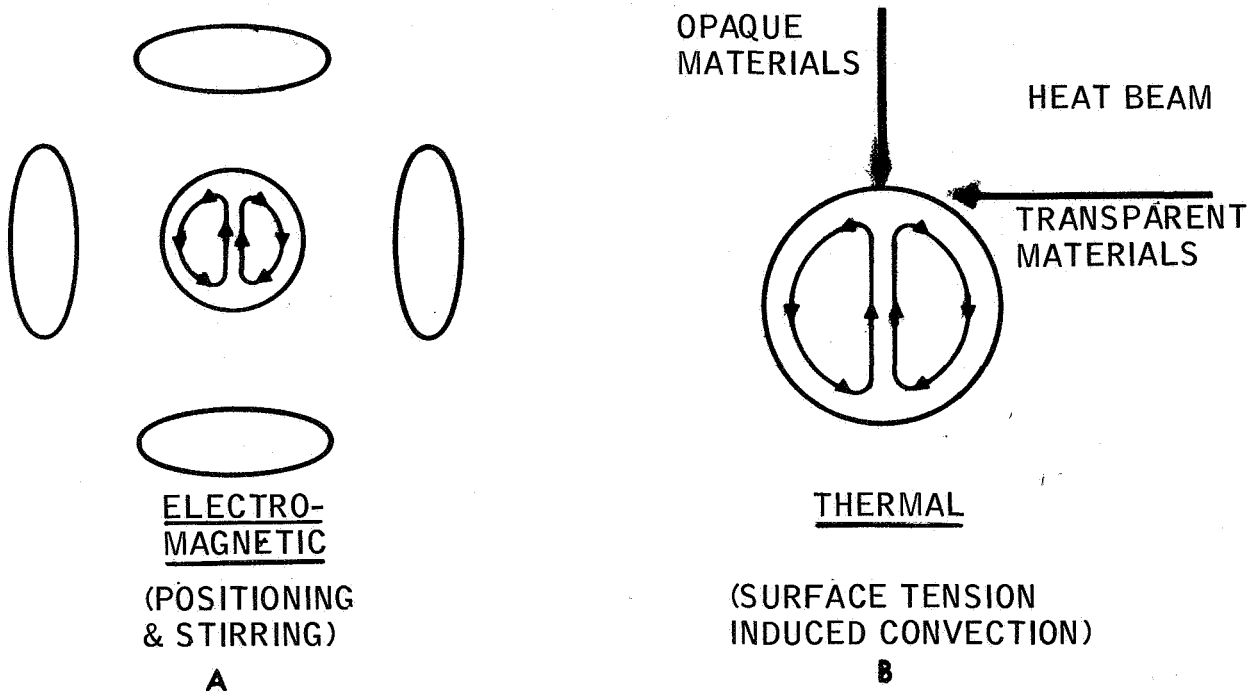

Figure 2-32. Non-Contact Stirring for Mixing Gas Disposal

Purification, as an integral part of other processes, finally, includes the removal of oxides or other surface contaminants from solids. To preclude any new contamination, the final "cleaning" directly precedes the main processing cycle, as it is, for instance, imperative in the case of thermosetting alloy formation.

SUMMARY OF CRITERIA AND REQUIREMENTS

- a. Functional:
 1. Dissipation of impurities by boil-off in a high vacuum environment
 2. Contamination-free operation due to the absence of tooling contact
 3. Induced convection
- b. Fundamental:
 1. Gas evolution and coalescence as related to pressure and temperature
 2. Diffusion in liquid metals and nonmetallic inorganics
 3. Effects of surface tension gradients

c. Technological:

1. Contact-free positioning system
2. Techniques for surface tension control and induced convection
3. Methods for surface cleaning of solids and solid particles in high vacuum

d. Data:

1. Vapor pressure vs temperature for metals and nonmetallic inorganics
2. Surface tension (liquid/gas) and viscosity of liquids

2.3.15 UNIT SEPARATION PROCESSES

For the separation and/or purification of species of minute difference in molecular weight in liquid suspension, such as microorganisms or isotopes, two methods are commonly used:

- a. Ultracentrifugal separation
- b. Electrophoresis

Since both methods are highly sensitive to convective currents, the minimized convection of the low-g environment is expected to significantly reduce, if not entirely remove, the capability limitations of terrestrial production. The primary gains are higher resolution and higher yield, as well as shorter processing time.

PROCESS CRITERIA. The gain in the operation of an ultra-centrifuge in a low gravity environment is primarily derived from the absence of a rotor support, which induces thermal gradients and vibrations. The resulting freedom from extraneous liquid motion increases the resolution. However, even by positioning in the axis of the orbital path, the gravity gradient across the rotor and batch may cause substantial interference. The process requires extensive specialized equipment and extravehicular operations. For these reasons, consideration of ultracentrifugal experiments should be deferred.

In contrast, the equipment for the electrophoretic method, even though also specialized and extremely delicate, is rather small and needs little monitoring. The expected high resolution is derived from the absence of sedimentation and thermal convection. There is no question as to the absence of sedimentation; to what extent sources of liquid motion (other than thermal convection) such as thermal expansion or variable interfacial tension effects, affect the effectiveness of the process, and to what extent they can be minimized, can only be resolved by further theoretical studies and laboratory investigations. The process is, however, promising enough to be considered for a space experiment. In addition to the specific objective, the space experiment will generate generally applicable data on electrophoretic methods and intrinsic sources of liquid motion.

PRODUCTS. Prime interest in high-resolution separation processes is in the fields of vaccines (microorganisms) and isotopes, products of extremely high value in \$/lb. For vaccines, the preparation of the culture (fermentation) preceding separation may be included in the space experiment, as biosatellite experiments indicate a favorable effect of low-g levels upon growth rate and density. Other space environments, such as low temperatures, ultraviolet radiation, and vacuum may also be used to advantage for product sterilization and preservation.

SUMMARY OF CRITERIA AND REQUIREMENTS

a. Functional:

Increase of resolution due to minimized convection

b. Fundamental:

1. Sources and magnitude of various types of convection, intrinsic liquid motion
2. Effect of thermohomogeneity and liquid motion upon resolution in unit separation
3. Effect of electric fields upon migration rate of macromolecular ions or colloidal particles

c. Technological:

1. Electrophoretic processing methods and apparatus design
2. Thermal control
3. Vibration-free apparatus suspension

d. Data:

1. Viscosity of liquids
2. Thermal conductivity of liquids

2.3.16 CONTAINERLESS MELTING OF HIGH-TEMPERATURE ALLOYS

The alloying of metals with extremely high melting temperatures encounters extreme difficulties and limitations in terrestrial production due to reaction with, and contamination by, the necessary crucible. These shortcomings are completely eliminated by containerless melting in a low gravity environment. A preshaped ingot, compressed on earth from granules of the component elements, is deployed in a position control system, which at the same time may serve for induction heating. After melting, it assumes spherical shape and the various processing methods for liquid spheres and purification may be employed such as induced convection for gas removal and mixture homogeneity. Solidification cooling is achieved by radiation to the cooled chamber wall.

Since the product is merely an ingot, it has no particular shape accuracy requirements and the problems are confined to the tooling for the extreme temperatures involved. For this reason, experiments should be deferred until tooling experience has been accrued from experiments at lower temperatures.

The applications of refractory metal alloys are well known. Once production status has been achieved, ingots may be produced in shapes more adaptable to terrestrial secondary fabrication by means of contact-free liquid forming techniques (process 1a).

SUMMARY OF CRITERIA AND REQUIREMENTS

a. Functional:

Contact-free processing of liquids

b. Fundamental:

1. Criteria for sphere formation (Section 2.3.1)
2. Criteria for liquid forming (Section 2.3.1a)

c. Technological:

1. Position control system for metals
2. Deployment techniques
3. Induction and radiation heating to 4500° F

d. Data:

Electrical conductivity of metals at high temperatures (3000 - 4500° F)

2.3.17 SUPERCONDUCTORS

Superconductors are materials that can, under specific conditions, conduct electricity with almost no loss of current due to resistance.

PROCESS/PRODUCT DEFINITION. There is an increasing interest in superconductor applications in the electric and electronics industry, and it is envisioned that in the future they will find applications in long-distance power transmission cables, noise-free amplifiers, frictional bearings, and in the form of electromagnets. One of the draw-backs of superconductors is their performance limitation to extremely low temperatures. A Nb-Al-Ge alloy (transition point 20.1° K) is the only alloy discovered so far that is superconducting beyond 19° F. The BCS (Bardeen-Cooper-Schrieffer) theory predicts the maximum attainable transition temperature will be around 40° F.

A proposed method for improving the properties of certain superconductors involves directional solidification of ternary eutectic alloys that allow a range of compositions in a specified temperature-pressure system.

PROCESS/PRODUCT CRITERIA. The process of directional solidification will be dependent upon proper control of several factors. Most important are the nucleation and growth criteria discussed in detail in Section 1.6. Both temperature and compositional fluctuations will have to be carefully monitored; temperature fluctuations can cause convection, and compositional fluctuations can cause a break-down in desired eutectic growth patterns (see Appendix 2, Ref. 2-19). Many of the considerations related to single crystal growth (Section 2.3.7) must also be taken into account. The number of promising systems is limited (it is required that at least two eutectic phases be superconductive), and extensive preliminary alloy development will be required.

SUMMARY OF CRITERIA AND REQUIREMENTS

a. Functional:

Directional solidification of ternary eutectic alloys

b. Fundamental:

1. Solid-liquid interface
2. Effects of compositional fluctuations and contamination
3. Source and effects of convection
4. Nucleation and growth control

c. Technological:

1. Alloy development
2. Temperature control
3. Convection control
4. Composition control
5. Process automation
6. Support or positioning system

d. Data:

1. Conductivity and magnetic characteristics of alloys
2. Electronic transition temperatures
3. Equilibrium phase diagrams
4. Crystal growth rates

PART 3

EXPERIMENTS

SPACE EXPERIMENT PRIORITIES, FACILITIES, AND PROGRAMS

3.1 OBJECTIVES AND APPROACH

The development of space manufacturing capabilities in terms of processes, tooling, and products will necessarily comprise the following phases:

- a. Verification of the conceptually and theoretically predicted capabilities.
- b. Refinement and optimization of methods, tooling, and products.
- c. Scale-up of tooling and products with regard to size and production quantity.
- d. Manufacturing of specific products for specific applications and checkout of such applications as the first step toward utilization and commercial operations.

Although, on a laboratory scale, the verification of some effects and the development of some tooling details can be carried out in equal-density simulation and in free-fall tests on earth, the demonstration and optimization of the complete processes can only be accomplished under the sustained low-gravity environment of space experiments.

The term "experiment" has been generally accepted for in-space investigations in various disciplines, such as astronomy, radiation research, biochemistry, and others. It is therefore retained, even though space manufacturing "experiments" represent the development of an entirely new field of technology, from initial demonstration tests to a full-scale production capability.

The question as to how and when we can expect to achieve this capability may then be rephrased more accurately as:

- a. Which experiments should be carried out first or what is the most effective experiment program.
- b. What are the required experiment facilities, and
- c. What fundamental and technological R&D is necessary to ensure successful experiments with regard to experiment objectives as well as reliable functioning of experiment facilities.

The definition of an effective experiment program is approached in five steps:

- (1) Assessment of relative processes effectiveness on the processes' own merits, regardless of initial experiment constraints and facility requirements.
- (2) Time-phasing of processes on the basis of step (1) by the additional consideration of experiment constraints and the leadtimes for research and tooling development.
- (3) Assessment of facility requirement commonalities and definition of basic experiment facilities.
- (4) Integration of steps (1), (2), and (3) in an effective minimum-effort experiment program.
- (5) Definition of an R&D program necessary for direct support of the initial experiment phases defined in step (4).

This final evaluation is the subject of Part 3 of this report. An overview of the evaluation procedure is presented in form of a flow chart in Figure 3-1. It is based on the information contained in the individual process discussions of Part 2, particularly the "summary of criteria and requirements" at the end of each discussion.

The numerous individual process criteria, requirements, and their interrelations are integrated in a limited number of evaluation criteria and expressions for their relative significance. Discussions are confined to the definition of procedures, the reasons for their choice, and the necessary explanation of criteria. Extensive use is made of symbols and numerical representations for the identification of subjects, the rating of criteria, and the definition of the type of space experiments.

3.2 EVALUATION OF PROCESS AND EXPERIMENT EFFECTIVENESS

Even for new terrestrial processes, the assessment of effectiveness prior to hardware tests is quite complex and entails numerous intricate tradeoffs, whose numerical representation is difficult. For space processes, this task is necessarily more complex and more difficult in view of the complete absence of any precedent and the unconventional operational conditions.

Since the definition of experiment effectiveness represents the prime objective of this study and the key to experiment facilities and program formulations, a number of evaluations with different matrices and number of individual criteria were carried out. It is significant, that all these evaluations produced the same result, with surprisingly little variations. In the following two sections, the evaluation is demonstrated by means of two selected systems representing a numerical and a qualitative approach. They comprise evaluation steps (1) and (2), as identified in Section 3.1.

3.2.1 EVALUATION METHODS. The prime feature of the numerical system is the identification, correlation, and weighing of all significant criteria, from conceptual

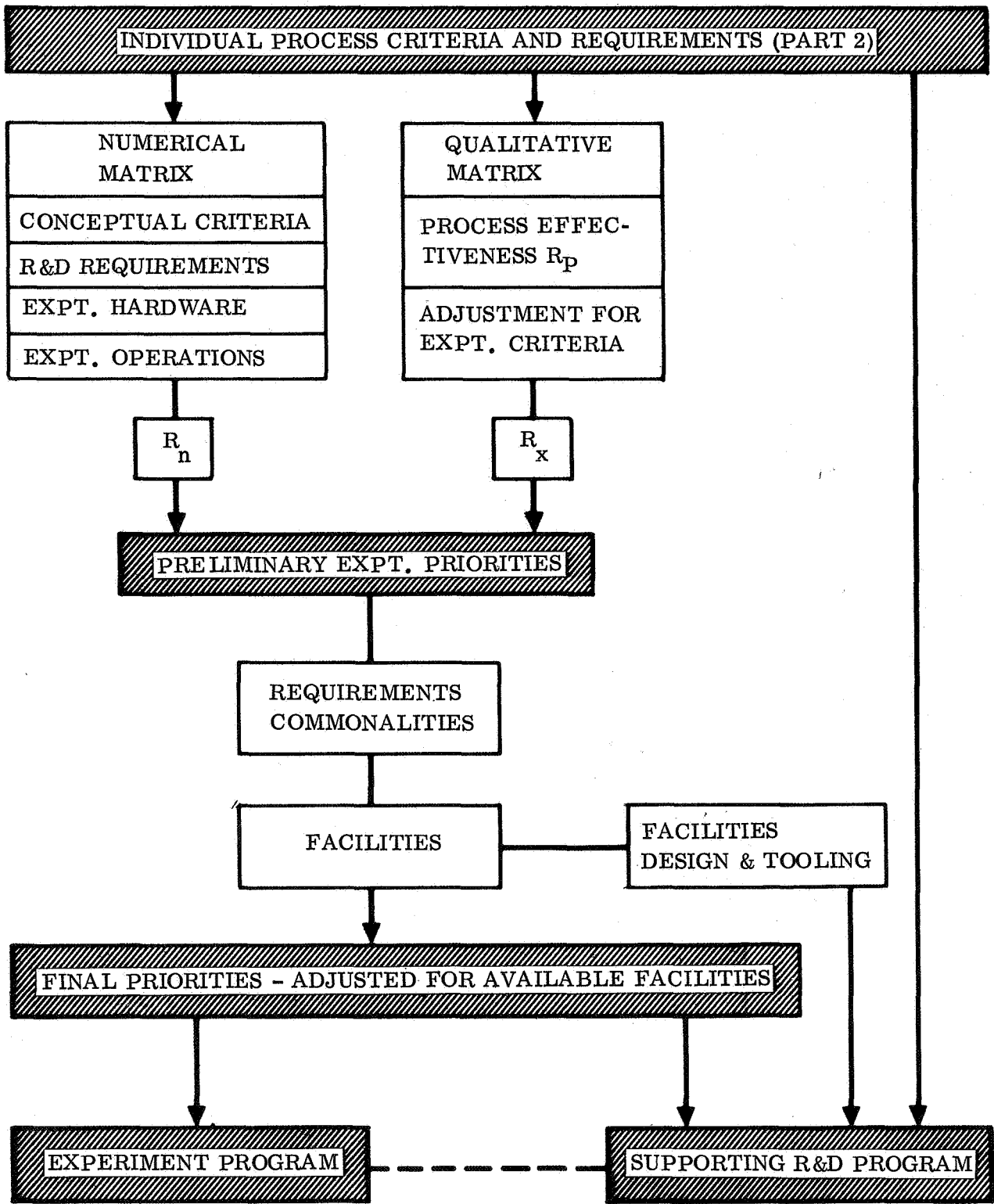

Figure 3-1. Overview of Evaluation Procedure (Part 3)

fundamentals to space experiment operations. Once complete numerical data are established, the effect of variations in any single criterion upon experiment effectiveness can be readily obtained, preferably by programming for computer evaluation. The method has, however, a number of shortcomings: The diversified nature and dimensions of the criteria are not adaptable to direct comparison and computation; this necessitates their measuring by an arbitrary rating scale. Furthermore, in many instances the judgment can only be regarded as tentative in view of the newness of the subject, the lack of data, the fluctuations in the space program and other uncertainties or unpredictables.

For these reasons, an alternate evaluation with a simplified matrix is introduced. It integrates the multitude of second-order criteria in a limited number of readily conceivable criteria whose significance is determined by subjective judgment. It has the advantage of conveying, at any point of the evaluation, a complete picture of the logic of deduction and the significance of criteria.

The parallel performance of two independent evaluations, representing a detailed and a simplified approach, was expected to enhance the confidence in the results. As will be shown later, the results are practically identical. They were further verified by a number of other evaluations which are not formally documented.

3.2.2 EVALUATION 1: NUMERICAL MATRIX. An overview of the numerical evaluation system and its major criteria is presented in Figure 3-2. It consists of the following four major blocks, representative of developmental phases:

- I. "Conceptual" criteria, comprising functional, fundamental, and technological criteria for the determination of process feasibility and potential.
- II. Requirements and leadtimes of the necessary fundamental research, process development, and equipment engineering.
- III. Experiment hardware requirements, primarily representing equipment limitations (complexity, weight, cost) and vehicle integration constraints.
- IV. Operational requirements and limitations, such as power requirements, astronaut involvement, interference with other operations, potential vehicle contamination and logistics.

The detailed evaluation matrix is presented in Appendix 5. It consists of:

- a. Identification of first-, second- and third-order criteria.
- b. Rating criteria and rating values for the third-order criteria, and
- c. Relationships for computation of higher-order criteria and total effectiveness.

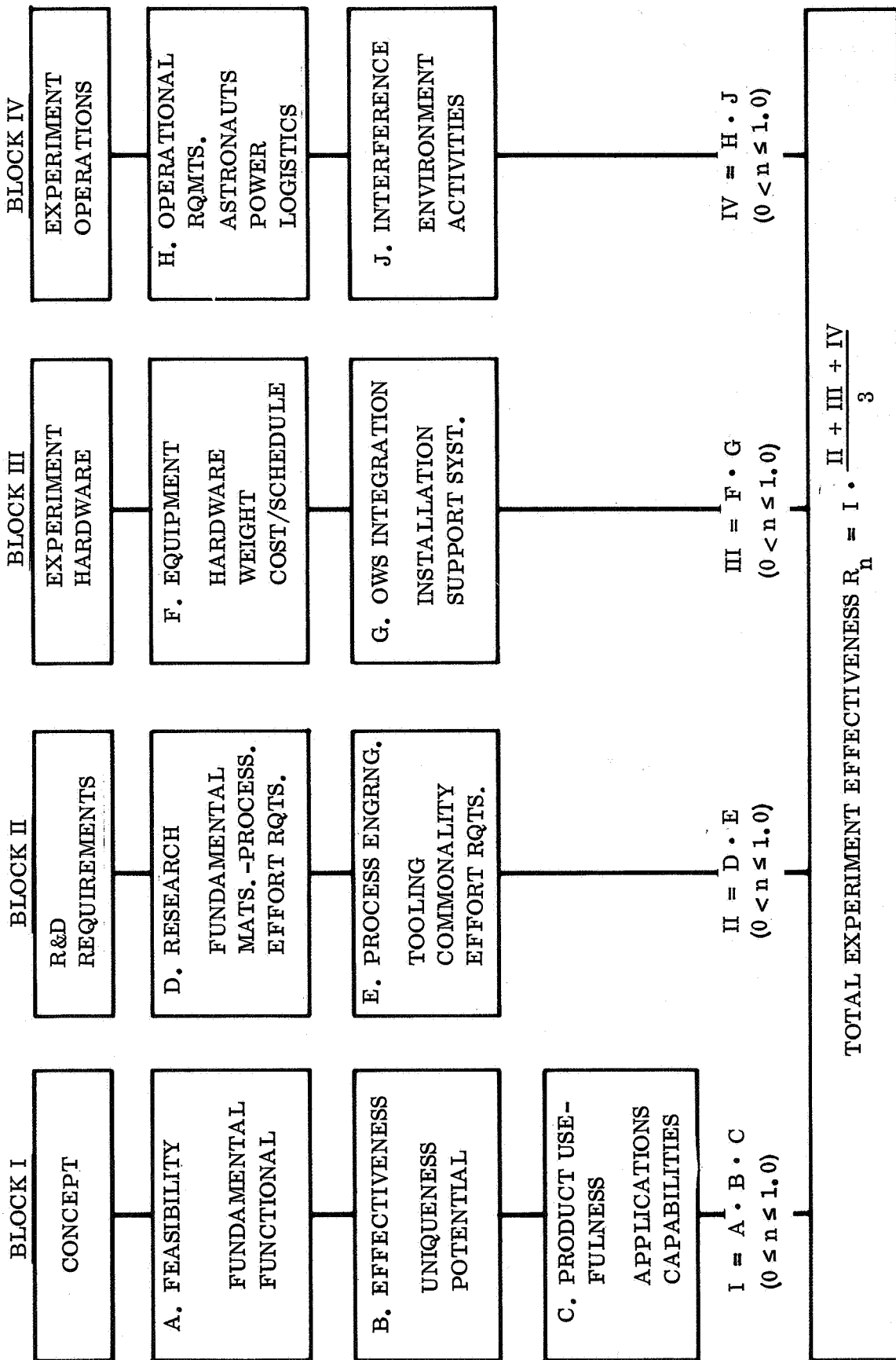

Figure 3-2. Process and Experiment Evaluation Matrix

Rating values are assigned to the third-order criteria by judgment. While the rating criteria (step b. above) serve as guide for this judgment, it has to include the consideration of a variety of contributing factors and trade-offs. This diversification necessitates the adoption of an arbitrary rating scale, ranging from 0 to 1.0. Once the third-order values are defined, the second- and first-order criteria ratings, as well as the total effectiveness rating are computed by means of the relationships (step c. above) which account for the relative significance and interdependence of criteria. The resulting values likewise range from 0 to 1.0 which facilitates their expression in percent.

The rating data for the 24 selected processes are compiled in Table 3-1. In view of their primary importance (at this time), the data for the first group (Block I) include the third-order values. For the remaining groups, only the computed values for the second- and first-order criteria are listed. The shaded columns of Table 3-1 represent the ratings for the first-order criteria and for the total process effectiveness. Final process/experiment effectiveness ranges from a low of 0 to a high of 0.86.

3.2.3 EVALUATION 2: QUALITATIVE MATRIX. As indicated in Figure 3-1, the alternate ("simplified") evaluation method consists of two major steps: the definition of process effectiveness, and conversion into experiment effectiveness by the introduction of experiment criteria.

3.2.3.1 Process Effectiveness: The first step appraises the effectiveness of the process on its own merits, unaffected by experimental constraints. The effectiveness assessment is based on three primary criteria: fundamental soundness, technological feasibility, and product potential. The detailed matrix of criteria and their definitions are as follows:

1. Fundamental Effectiveness
 - a. Fundamental feasibility, soundness and effectiveness.
 - b. Uniqueness of process and/or products, particularly with regard to the utilization of the zero-g environment.
2. Technological Effectiveness
 - a. Functional feasibility and effectiveness; feasibility of transfer from conceptual state to the hardware state.
 - b. Growth potential; potential of increased process capabilities and/or evolution into new processes and products.
3. Product Effectiveness
 - a. Product capabilities, including material properties and component capabilities; superiority over conventional capabilities and/or cost effectiveness.

Table 3-1. Numerical Experiment Effectiveness Evaluation (R_n)

Processes	Block I Process Concept												Block II R&D Requirements				Block III Expt. Hardware			Block IV Expt. Operations			Experiment Effectiveness
	Matrix Elements												I	D	E	F	G	H	J	IV	R_n		
	a	b	A	a	b	B	a	b	C	I	D	E										F	
1	1.0	1.0	1.0	1.0	1.0	1.0	1.0	0.92	0.92	1.0	1.0	1.0	1.0	1.0	0.95	1.0	0.95	0.9	0.9	0.9	0.95	0.86	
1a	0.9	0.8	0.72	1.0	1.0	1.0	1.0	0.65	0.9	0.9	0.9	0.9	0.9	0.9	0.9	1.0	0.9	0.9	0.9	0.9	0.9	0.9	0.51
2	0.8	0	0	0	0	0	0	0	0	0	0	0	0	0	0	0	0	0	0	0	0	0	0
3a	1.0	0.9	0.9	1.0	0.9	0.95	0.8	0.91	0.9	0.9	1.0	1.0	0.95	1.0	1.0	1.0	1.0	1.0	1.0	1.0	1.0	1.0	0.90
3b	1.0	0.9	0.9	1.0	1.0	1.0	1.0	0.85	0.95	0.9	1.0	1.0	0.81	0.95	1.0	0.95	0.9	0.9	0.9	0.9	0.9	0.9	0.76
3c	0.8	0	0	0	0	0	0	0	0	0	0	0	0	0	0	0	0	0	0	0	0	0	0
4a	1.0	0.9	0.9	0.9	1.0	0.95	0.85	0.92	0.92	1.0	1.0	1.0	0.78	0.95	0.95	1.0	0.95	1.0	1.0	1.0	1.0	1.0	0.74
4b	1.0	0.9	0.9	0.8	0.8	0.8	1.0	0.65	0.9	0.8	1.0	1.0	0.81	0.9	0.9	1.0	0.9	0.9	1.0	1.0	0.95	0.95	0.57
5	1.0	0.9	0.9	1.0	1.0	1.0	1.0	0.9	1.0	1.0	1.0	1.0	0.9	0.95	1.0	0.95	0.9	0.9	1.0	1.0	0.9	0.9	0.81
5a	1.0	0.9	0.9	1.0	1.0	1.0	1.0	0.9	1.0	1.0	1.0	1.0	0.9	0.95	1.0	0.95	0.9	0.9	1.0	1.0	0.9	0.9	0.81
6	1.0	1.0	1.0	1.0	1.0	1.0	1.0	1.0	1.0	1.0	1.0	1.0	0.95	0.95	1.0	0.95	0.9	0.81	0.8	1.0	0.8	1.0	0.80
7a	1.0	1.0	1.0	0.8	0.9	0.85	1.0	0.77	1.0	0.9	1.0	1.0	1.0	1.0	1.0	1.0	1.0	1.0	1.0	1.0	1.0	1.0	0.77
7b	1.0	0.9	0.9	0.6	0.9	0.75	1.0	0.57	0.85	0.7	1.0	1.0	0.85	1.0	1.0	1.0	1.0	0.95	0.9	1.0	0.95	0.95	0.50
7c	1.0	0.9	0.9	0.9	1.0	0.95	1.0	0.81	0.95	0.9	1.0	1.0	0.85	0.9	0.77	0.9	0.9	0.9	0.9	0.95	0.9	0.95	0.70
8	0.8	0.9	0.72	0.7	0.9	0.8	1.0	0.83	0.95	0.9	1.0	1.0	0.81	0.86	0.70	0.9	0.9	0.95	1.0	0.95	1.0	0.95	0.47
9	1.0	0.9	0.9	1.0	1.0	1.0	1.0	0.9	1.0	1.0	1.0	1.0	0.81	0.9	0.9	0.95	1.0	0.95	0.9	0.95	0.9	0.95	0.80
10	1.0	0.95	0.95	0.8	0.9	0.85	1.0	0.73	1.0	0.8	1.0	1.0	1.0	1.0	1.0	0.9	0.9	0.8	1.0	1.0	0.8	1.0	0.64
11	1.0	0.9	0.9	0.8	0.9	0.85	0.9	0.70	0.92	0.95	0.9	1.0	0.9	1.0	1.0	1.0	1.0	1.0	1.0	1.0	1.0	1.0	0.88
12	0.5	0	0	0	0	0	0	0	0	0	0	0	0	0	0	0	0	0	0	0	0	0	0
13	1.0	0.9	0.9	0.9	1.0	0.95	1.0	0.85	0.95	0.9	1.0	1.0	0.81	0.9	0.9	0.95	1.0	0.95	1.0	1.0	1.0	1.0	0.73
14	0.9	0.9	0.81	0.8	0.9	0.85	1.0	0.65	0.95	0.9	1.0	1.0	0.95	0.95	0.9	1.0	1.0	1.0	1.0	0.92	0.96	0.96	0.83
15	0.95	0.9	0.86	0.9	1.0	0.95	1.0	0.79	0.97	0.95	1.0	1.0	0.81	0.85	0.69	1.0	1.0	1.0	1.0	1.0	1.0	1.0	0.71
16	1.0	1.0	1.0	0.7	0.9	0.8	1.0	0.72	0.9	0.8	1.0	1.0	0.8	1.0	0.8	0.87	1.0	0.87	0.7	1.0	1.0	0.83	0.80
17	0.8	0.9	0.72	0.9	0.8	0.85	1.0	0.58	0.95	0.9	1.0	1.0	0.73	0.9	0.8	0.8	0.8	0.9	0.9	1.0	1.0	0.9	0.60

- b. Product potential, with regard to defined applications and generation of new applications or even new fields of technology; consideration of potential production rates and attractiveness to private enterprise.

The individual factors to be considered and weighed against each other in each criterion vary with the nature of the process. While this leaves a considerable latitude to judgment, it provides a high adaptability to the specific characteristics and requirements of each process.

The significance of criteria and the effectiveness are expressed in numerical unit terms. The rating scale is as follows:

Second-order Criteria (1. and 2. above)

- 0 = unfeasible or none
- 1 = low
- 2 = intermediate
- 3 = high

Primary Criteria (1. 2. 3. above)

Arithmetic mean of a. and b., likewise ranging from 0 to 3.

Resulting Process Effectiveness " R_p ":

Sum of primary criteria (1 + 2 + 3), ranging from 0 to 9.

The rating scale is designed to permit a convenient comparison between the major elements of any new process — fundamental soundness, technological effectiveness and product usefulness. At the same time, the criteria which affect the process effectiveness most — positively or negatively — can be readily identified.

The evaluation of the 24 selected processes is performed in columns 1 to 10 in Table 3-2. Examination of the effectiveness ratings R_p shows a good differentiation, ranging from a low of 2 to a high of 8.

3.2.3.2 Experiment Effectiveness. The second major step of the simplified evaluation procedure is the definition of the expected effectiveness of each process in initial experiments. It introduces the following additional criteria:

- a. Probability of success, as expected in initial experiments.
- b. Leadtime of required fundamental and technological R&D.
- c. Tooling aspects — problems as well as positive characteristics.

Table 3-2. Process and Experiment Effectiveness Evaluation

Processes	Process Effectiveness Evaluation (Qualitative Matrix)										Adjustment for Initial Exptmt.			Expt. Effectiveness			Prelim. Phasing		
	Feas.	Uniq.	r ₁	Func.	Pot.	r ₂	Cap.	Appl.	r ₃	R _p	Prob. of Success		R _x	P _x	P _n	I	II	III	
											R&D Leadt.	Tooling Probl.							
1	3	3	3	3	1	2	2	2	2	7	+1	+1	9	0.86	I	●			
1a	2	3	2.5	1	2	1.5	1	2	1.5	5.5	-1	-1	3.5	0.51	III			●	
2	1	1	1	1	0	0.5	1	1	1	2.5	-1	-1	1.5	0	-	-	-	-	
3a	3	3	3	3	1	2	2	2	2	7		+1	8	0.80	I	●			
3b	2	3	2.5	2	3	2.5	3	2	2.5	7.5			7.5	0.76	I	●			
3c	1	1	1	1	0	0.5	1	1	1	2.5	-1	-1	1.5	0	-	-	-	-	
4a	2	3	2.5	2	3	2.5	3	2	2.5	7.5			7.5	0.76	I	●			
4b	3	1	2	2	1	1.5	1	3	2	5.5		-1	4.5	0.57	III			●	
5	2	3	2.5	2	3	2.5	2	3	2.5	7.5			7.5	0.81	I	●			
5a	2	3	2.5	2	3	2.5	3	3	3	8			8	0.81	I	●			
6	3	3	3	3	2	2.5	2	3	2.5	8	+1	+1	9	0.86	I	●			
7a	3	2	2.5	2	2	2	1	3	2	6.5	+1	+1	7.5	0.77	I	●			
7b	2	1	1.5	2	1	1.5	1	2	1.5	4.5			4.5	0.56	III			●	
7c	3	2	2.5	2	3	2.5	2	3	2.5	7.5		-1	6.5	0.70	II			●	
8	1	1	1	2	3	2.5	1	3	2	5.5	-1	-1	4.5	0.47	III			●	
9	3	3	3	2	2	2	3	3	3	8	+1	+1	7	0.80	I	○		●	
10	3	1	2	3	1	2	1	2	1.5	5.5			5.5	0.64	II			●	
11	2	2	2	1	2	1.5	2	2	2	5.5		+1	6.5	0.68	II	○		●	
12	0	1	0.5	0	1	0.5	1	1	1	2	-1	-1	1	0	-	-	-	-	
13	3	2	2.5	2	2	2	2	3	2.5	7	+1	+1	7	0.78	I	●			
14	3	1	2	2	1	1.5	1	3	2	5.5			5.5	0.68	II			●	
15	2	2	2	1	3	2	2	3	2.5	6.5			6.5	0.71	II			●	
16	3	1	2	3	1	2	1	3	2	6	+1	+1	5	0.60	III			●	
17	2	1	1.5	1	2	1.5	2	3	2.5	5.5	-1	-1	3.5	0.46	III			●	

Explanations:

Col. 1-9	0, 1, 2, 3 = None, low, intermediate, high
1	Feasibility = Fundamental soundness
2	Uniqueness = Works only or better in space
4	Functional = Reducibility to practice (tooling)
5	Potential = Growth potential of process
7	Capabilities = Superiority over conventional capabilities (properties, integrity, cost effectiveness)
8	Applications = Identifiable uses and users
10	Process effectiveness $R_p = r_1 + r_2 + r_3$
11	Probability of success of first experiment
12	R&D leadtime (-above, + below average)
13	Tooling problems (- considerable leadtime; + high simplicity or typicality)
14	$R_x = R_p$ adjusted for experiment adaptability
16	P_x = Preliminary experiment priority without consideration of joint facility usage
15, 17	R_n, P_n = Ratings and priorities of numerical evaluation, for comparison
18-20	o = Exploratory or demonstration experiments ● = Capability (product) development experiments

It is apparent that these criteria have already been included — directly or indirectly — in the basic process evaluation. Consequently, the experiment effectiveness rating R_x is obtained by an adjustment of the process rating R_p , limited to those instances where the transfer into experiment hardware and operations introduces significant deviations. Negative adjustments represent low probability of success, serious problems, or long development and tooling leadtimes. Positive adjustments represent high assurance of success or the generation of experience and data of high value to space manufacturing in general or to science.

The adjustment — for simplicity in unit values — and the resulting experiment effectiveness ratings R_x are listed in columns 11 to 14 of Table 3-2.

3.2.4 PRELIMINARY DEFINITION OF EXPERIMENT PRIORITIES. The experiment ratings R_x and R_n , obtained independently by the two discussed evaluation methods, are listed next to each other in columns 14 and 15 of Table 3-2. An examination shows a high degree of agreement; except for the lowest values, the differences do not exceed 10%.

On the basis of these two sets of ratings — supported by other not-reported evaluations — the processes were grouped into three experiment priorities. Even though not rigidly applied, the demarcation lines between these preliminary priorities are as follows:

Priority P_x, P_n	R_x	R_n
I	7.0 and over	> 0.75
II	5.5 to 6.5	0.60 - 0.75
III	3.0 to 5.0	0.30 - 0.60
Deferred or Deleted	< 3.0	< 0.30

The assigned priorities are listed in columns 16 and 17 of Table 3-2. They represent the "preliminary priority" (P_x), as they will be adjusted once more in subsequent evaluation steps for tooling commonality.

Assuming that the "preliminary priorities" P_x determine the scheduling of experiments, the processes are arranged in columns 18 to 20 in three preliminary experiment phases. In a few cases (membranes, glasses, thermosetting alloys) the experiment in the assigned phase is of an exploratory nature in view of uncertainties or severe tooling requirements. For example, glasses (process 9, priority I) call for extremely high temperatures and a contact-free positioning system for materials of low electrical conductivity. The perfection of these requirements (as indicated by "-2" in column 13) represents considerable effort and leadtime. Phase I experiments will, therefore, be carried out either with makeshift tooling or miniaturized equipment. Once extreme-temperature facilities are perfected in Phase II, other extreme-temperature experiments of a lesser priority (such as containerless melting, process 16, priority III) present no difficulties.

3.2.5 SUMMARY OF EFFECTIVENESS EVALUATION. In Table 3-3A the processes are listed in the order of decreasing effectiveness. The sequence is based on the final rating, R (col. 4), which represents an average of the ratings R_x and R_n obtained in the two evaluation methods employed. For convenience, it is expressed in percent; the perfect process would represent 100% and would be equivalent to the rating numbers 1.0 and 10 of the numerical and qualitative evaluation matrices, respectively. The priority classification (column 5) is based on the definition of ranges on page 3-10 and the results of the priority evaluation of Table 3-2 (columns 16-20).

Table 3-3A. Processes in the Order of Effectiveness

1	2	3	4	5
Order of Effectiveness	Processes		Rating* R %	Preliminary** Priority P_G
1	1	Production of Spheres	88	I
2	6	Composite Casting	88	I
3	5a	Pressure Stiffened and Composite Foams	80	I
4	3a	Thin-Wall Hollow Spheres	80	I
5	5	Metallic Foams	78	I
6	7a	Single Crystal Growth from Solution	76	I
7	9	Amorphous Materials (Glasses)	75	I
8	3b	Thick-Wall Hollow Spheres	75	I
9	4a	Flat Membranes	75	I
10	13	Supersaturated Alloys	72	I
11	15	Unit Separation Processes	68	II
12	7c	Pulling of Single Crystals from Melt	67	II
13	11	Thermosetting Alloys	66	II
14	10	Dispersed Particle Castings	66	II
15	14	Purification	59	II
16	16	Containerless Melting of High Temp Alloy	55	III
17	4b	Drawing of Filaments	51	III
18	7b	Single Crystals - Zone Melting	50	III
19	8	Growing of Whiskers	46	III
20	1a	Liquid Forming	43	III
21	17	Superconductors	40	III
22	2	Adhesion Casting	8	-
23	3c	Blow Molding	8	-
24	12	Supercooling of Metals	5	-

* Col. 4 Rating R = Average of R_x and R_n (Table 3-2, columns 14, 15) expressed in %.

** Col. 5 Preliminary Priority (not yet considering tooling commonalities) as defined in Table 3-2 (col. 16, 17).

3.3 EXPERIMENT REQUIREMENTS AND FACILITIES

The identified phases could serve as an experiment program, if each experiment would be carried out in a separate facility. This is, however, impractical and unnecessary, as extensive commonalities in tooling requirements indicate the potential combination of several experiments into a limited number of multipurpose facilities.

In the following section, the required facilities and their process applications are defined on the basis of an evaluation of commonalities in process and experiment requirements.

3.3.1 COMMONALITY EVALUATION. For space experiments, attempts should be made to carry-out as many processes as possible in one single facility or to combine experiments with common processing and tooling requirement in a limited number of basic facilities. An assessment of the commonality of those requirements which represent a major hardware development effort is shown out in Table 3-3. The three first-order criteria for the design of any space processing facility are 1) the processing temperature regime, 2) the method of liquid material management during the processing cycle, consisting of melting, processing and solidification, and 3) the method of material deployment.

3.3.1.1 Basic Requirements and Facilities. The first-order requirements of each process, listed in columns 1 through 6 of Table 3-3, represent the basic requirements for the primary facility or experiment "chamber". These requirements are identified by various signs to enhance distinction and to convey a visual overview of existing commonalities. A more accurate specification of these criteria is as follows:

a. Processing Temperature Regime

1. Below 3000°F (column 1)
2. 3000 — 4500 (-5000) °F. (column 2)

b. Liquid Material Management or "Suspension"

1. Contact management, either by casting into a mold or the processing in a container with no particular shape requirement. This type is depicted as mold casting. This permits a wide latitude in the method of heating and cooling, primarily by conduction (column 3).
2. Contact-free management during processing and cooling through solidification, and, in some cases, also during melting and liquid pre-processing (column 4).

c. Material Deployment

1. Single batch, melted and deployed in the processing chamber (column 5).

Table 3-3. Commonality Evaluation of Facilities

Processes	1		2		3		4		5		6		7			8		9		10		11		12		13		14		15		16		17		18					
	Temp. °F		Suspension		Deployment		Mold		Contact-Free		Special Facil.		Positioning		Mat. Supply		Mech. Tool.		Mat. Mix.		Mat. Press.		Gas Env.		Vac.																
	3000	4500	Cont.	Free	Single	Multipl.	3000	4500	3000	4500			Met.	Nonmet.	Mat. Supply																										
1	○	○	■	■	---	---	3000	3000	■	■			M		S					(X)																					
1a	○	●	■	■	---	---		■	■	---	---	■	M	N	S					(X)																					
2	○	○	□	□	---	---	■	■	---	---					S					(X)																					
3a	○	○	■	■	---	---		■	■	---	---	M									X																				
3b	○	○	■	■	---	---		■	■	---	---	M			S					(X)	X																				
3c	○	○	□	□	---	---	■	■	---	---	■				S					(X)	X																				
4a	○	○	■	■	---	---		■	■	---	---																														
4b	○	●	■	■	---	---		■	■	---	---																														
5	○	○	□	□	---	---	■	■	---	---					S						X																				
5a	○	○	□	□	---	---	■	■	---	---					S						X																				
6	○	○	□	□	---	---	■	■	---	---					S						X																				
7a																																									
7b																																									
7c	○	○	■	■	---	---		■	■	---	---																														
8																																									
9		●	■	■	---	---		■	■	---	---																														
10	○	○	□	□	---	---	■	■	---	---					S																										
11	○	○	□	□	---	---	■	■	---	---																															
13	○	○	□	□	---	---	■	■	---	---																															
14	○	●	■	■	---	---		■	■	---	---																														
15																																									
16	○	●	■	■	---	---		■	■	---	---																														
17																																									

Explanations:

Col. 1,2	Material processing temperature
3,7	Container liquids (Contact Management)
4, 8,9	Contact-free liquid management (Position Control)
5	Single material batch (1 product)
6	Several experiments and product from same melt
11	Contact-free position control system for metals
12	Contact-free position control system for non-metallic inorganics (oxides, glasses)
14-18	See text

Symbols:

Col. 1-6	○ □ ■ X signs for visual distinction only
A	Mold casting facility
B	Free processing chamber - 3000°F
C	Free processing chamber - 4500°F
P	Special Experiment Packages
M	Metals
N	Nonmetallic Inorganics
S	Liquid Material Supply System

2. Melting in a separate chamber and deployment in the processing chamber by a feeding system, permitting continuous supply or processing of several batches from the same melt (in the metal-producing industry referred to as "heat") (column 6).

The commonality assessment indicates three repetitive requirement combinations which are more clearly identified in columns 7, 8, and 9. They represent three basic facility types, designated as A, B, and C. A limited number of processes, identified in column 10, exhibit no commonalities and will, therefore, be carried out in customized facilities or experiment packages, designated "P". At this point of the commonality evaluation, the following basic facility types have been identified:

- Type A — Mold Casting Chamber — 3000°F
- Type B — Free Processing Chamber — 3000°F
- Type C — Free Processing Chamber — 4500°F
- Type P — Five Special Experiment "Packages".

3.3.1.2 Subsystems and Tooling. For a more accurate specification of the basic facilities, the commonality of major subsystems requirements are identified in columns 11 to 13 of Table 3-3.

The contact-free liquid management is accomplished with a "position control" subsystem. The temperature capability of this subsystem has already been defined in columns 8 and 9, calling for two capability regimes ("room" temperature to 3000 and 4500°F). In view of the potential use of electromagnetic or electrostatic fields for position control, an additional distinction has to be made with regard to the electrical properties of the liquid materials. The applicability of the system to metals (M) or non-metallic inorganic materials, such as oxides (N) is identified in columns 11 and 12. It indicates, that facility type B deals almost exclusively with metals, while non-metals are primarily associated with facility "C".

Returning to the basic methods of material deployment in columns 5 and 6, a considerable number of processes call for multiple experiments from a central melt supply. The requirement of a special subsystem for the melting and feeding of the material is identified in column 13 by "S". Correlation with the basic facilities (columns 7 to 10) indicates application of this subsystem to chambers "A" and "B".

Finally, all identifiable major tooling details were evaluated for repetitive applicability to various processes. The tooling requirements which proved to exhibit a high degree of commonality are the following:

- a. Mechanical and electrical devices for servomechanisms, structural support, and for controls.

- b. Mixing devices for liquid/solid and liquid/liquid mixtures.
- c. Material pressurization systems, such as gas injection for foaming.
- d. Gas supply systems for liquids which call for processing in a specific gas and pressure environment.
- e. Vacuum or access to the extravehicular pressure.

The applicability of these tooling requirements to processes and basic facilities is indicated in columns 14 to 18 of Table 3-3.

Excluded from this evaluation are heating and cooling devices, as they are an integral part of either the chamber or the position control system and do not represent separate subsystems. The required type of heating and cooling is however, defined by the mode of material management. Contact management (chamber A, supply subsystem S) permits conductive heat transfer with a wide choice of techniques. In contact-free management (chambers B and C), cooling is exclusively accomplished by radiation to the cooled chamber wall. The heating method depends on the type of material and the shape sensitivity of the product. The most effective methods are as follows:

<u>Material Type</u>	<u>Shape Sensitivity</u>	<u>Melting and Pre-processing</u>	<u>Processing</u>
Metals	Low	Induction, E.B.	Induction
	High	Induction, E.B.	Radiation
Non-Metals	Low	(1) Dielectric	
		(2) Radiation + Induction	Induction
	High	(3) Arc-Image	Arc-image
		(1) Dielectric	Radiation
	(2) Arc-Image	Radiation	

Nonmetallic inorganics (oxides) whose electrical conductivity increases substantially with temperature, may be heated by radiation in the low-conductivity regime, followed by induction in the regime of higher conductivity. If the conductivity remains low at high temperatures, dielectric heating appears most effective. Heating by an arc-image system is limited to small material masses. The use of a solar furnace is considered beyond the scope of the present experiment program.

3.3.2 SPECIFICATION OF BASIC FACILITIES. The established commonalities of major tooling requirements indicate that, with few exceptions, all processes as well

as additional ones which may evolve from further studies or space experiments, can be carried out in three basic facilities or "processing chambers" as follows:

a. Mold casting chamber with a temperature capability up to 2700° F (resistance heating) and the optional use of a material supply system, for the following processes (listed in the order of tentative experiment priority):

1. Composite casting (process 6)
2. Foams (process 5)
3. Composite foams (process 5a)
4. Supersaturated alloys (process 13)
5. Thermosetting alloys (process 11)
6. Dispersed particle castings (process 10)
7. Adhesion casting (process 2)
8. Blow molding (process 3c)

Since a separate material supply system is optional, it may not be included in the facility for initial experiments — it is to be added later; however, in view of the difficulty of in-space equipment modification, the chamber may from the outset include a material supply system, to be used optionally. Consequently, two versions of the mold casting chamber are indicated:

1. Mold casting chamber "a" without material supply system and/or
2. Mold casting chamber "A" with material supply system.

b. Chamber for contact-free liquid management during the processing and cooling cycles and with a temperature limitation of 3000° F for the following processes/products:

1. Spheres as end-products and spherical ingots (process 1)
2. Thin-wall hollow spheres (process 3a)
3. Thick-wall hollow spheres (process 3b)
4. Membranes (process 4a)
5. Single crystals from melt (process 7c)
6. Purification (process 14)
7. Containerless melting (process 16)
8. Filaments (process 4b)
9. Liquid forming (process 1a)

For the optional material supply system, the considerations of (a) apply equally, leading to two chamber versions as follows:

1. Free processing chamber "b" with small material supply system and/or
 2. Free processing chamber "B" with large material supply system.
- c. Chamber for contact-free material management during all processing cycles (melting, processing, cooling) and with temperature capabilities to approximately 4500°F, covering the following processes/products:
1. Amorphous oxides (glasses) (process 9)
 2. Purification (process 14)
 3. High-melting alloys (process 16)
 4. Filaments (process 4b)

This chamber does not require a material supply system, as in all cases the material is deployed in the form of a solid ingot in the position control system, where it is held in place during all processing cycles. However, in view of the complex tooling, particularly for the contact-free heating to extreme temperatures, the full-capability chamber may be preceded by a smaller experimental version to be used for process verification and the establishment of data for tooling optimization. This indicates two chamber versions as follows:

1. Small free hi-melt processing chamber "c" with limited capabilities and/or
2. Large free hi-melt processing chamber "C" with all capability requirements, particularly with regard to maximum temperature and the related method of heating.

The specifications of the basic facilities or "experiment chambers" are summarized in Table 3-4.

3.3.3 SPECIAL FACILITIES. The evaluation of Table 3-3 identifies two processes of higher priority which call for very specialized equipment, not adaptable to the three basic chambers, as follows:

- a. Single crystal growth from solution (process 7a)
- b. Unit separation (process 15)

These processes are preferably carried out in independent facilities, designated as experiment "packages". In the initial experiment phase, small packages "p" are proposed to be replaced later, pending success of the initial experiments, by larger special facilities "P", integrating any indicated modifications in methods and tooling.

Table 3-4. Definition of Basic Facilities (Typical Characteristics)

Major Units	Characteristics and Capabilities	Type "A"		Type "B"		Type "C"	
		a	A	b	B	c	C
Chamber	Configuration	Cylind.	Cylind.	Spheric.	Spheric.	Spheric.	Spheric.
	Approx. Size (in)	24 x 15 dia	30 x 20 dia	20 dia	30 dia	15 dia	30 dia
	Mat. Support Melting	Contact	Contact	Contact	Contact	Free	Free
	Mat. Support Processing	Mold	Mold	Free	Free	Free	Free
	Mat. Support Solidific.	Mold	Mold	Free	Free	Free	Free
	Max. Temp. °F	2700	2700	3000	3000	4500	4500
	Heating	Conduct.	Conduct.	Induction Radiation	Induction Radiation	Radiation Dielectric	Radiation Dielectric
Material	Cooling	Conduct.	Conduct.	Rad.	Rad.	Rad.	Rad.
	Peak Power kw	1	3	2	4	2	5
	Type	Metals	Metals	Metals	Metals	Non-Met. Inorgan. Hi-Melt-Metals	Non-Met. Inorgan. Hi-Melt-Metals
	Max. Weight lb	2	10	1	10	100 gr	10
	Max. Product Vol. in ³	20	150	30	200	2	100
	Positioning	-	-	Electromagnetic	Electromagnetic	Electrostatic or Gas	Electrostatic or Gas
	Mat. Supply System	-	Yes	Small	Large	-	-
Sub-systems	Heat Exchanger	Internal	External	Internal	External	Internal	External
	Mixing Unit	Yes	Yes	Yes	Yes	-	-
	Vibration Unit	-	Optional	Optional	Yes	-	-
	Mat. Pressurization	Yes	Yes	Yes	Yes	-	-
	Gas Envelope	-	-	Optional	Optional	O ₂	O ₂
	Vacuum	Yes	Yes	Optional	Optional	Optional	Optional
	Optional Sub-systems						

Processes of a lesser priority, to be initiated at a later date, which likewise call for special packages are:

- a. Single crystal growth by zone melting (process 7b)
- b. Superconductors by directional solidification (process 17)
- c. Whisker growth (process 8)

It may further be desirable to provide special equipment at a later phase of the program for several processes initially carried out in one of the basic facilities, primarily because the scale-up exceeds the dimension of the basic chambers. This applies primarily to:

- a. Foams (processes 5, 5a)
- b. Membranes (large flat) (process 4a)
- c. Single crystals from melt (process 7c)
- d. Thermosetting alloys (process 11)

It is apparent, that any successful process will eventually require a separate tailor-made facility, particularly if it moves toward the production stage. This is, however, of no concern at this time and is left to later program definitions.

3.4 CONCEPTUAL DESIGN OF BASIC FACILITIES

The following chamber descriptions represent conceptual "point designs" primarily for the purpose of identifying the major elements and to provide a basis for the assessment of the required development and hardware efforts.

3.4.1 MOLD CASTING CHAMBER a, A. An initial, minimum-effort mold casting facility Type "a" is shown in Figure 3-3. It consists basically of a resistance-heated and water-cooled mold assembly, a heat-shielding chamber with access and viewing ports, and a power and control unit. The material is supplied in a thin mold of standard configuration which is simply inserted in the mold assembly for processing. The chamber has provisions for mold evacuation, if necessary. Attachments for optional use, such as a foaming or a mixing unit, are attached to the rear port and connected with the mold assembly by means of a multiple-attachment head.

An optional subsystem is a material supply system, which will be attached to the rear port. This permits the filling of several empty (vacuum-vented) molds from the same heat. It will further generate experience and design data for supply units of larger chambers (A, B).

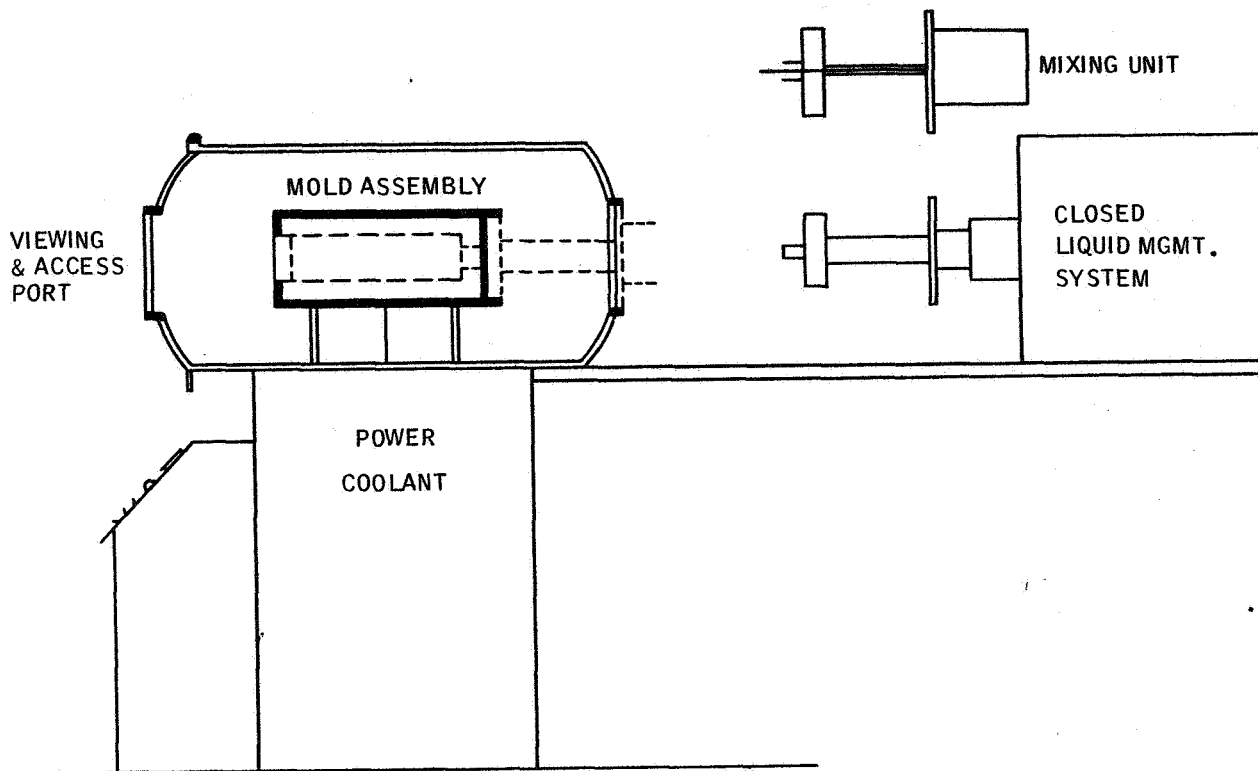

Figure 3-3. Mold-Casting Chamber a

The advanced and larger chamber "A" follows the same design concept, except it has an integrated material supply system, including mixing and gas injection units. The mold assembly further is adaptable to various mold-insert shapes. The entire chamber is centrally controlled.

The maximum temperature capability of both versions is 2700°F which is adequate for all envisioned experiments.

There are three options for chamber deployment:

- a. Chamber "a" without supply system, followed by Chamber "A", or
- b. Chamber "a" with a small supply system, followed by Chamber "A", or
- c. Full-size Chamber "A" only, with full-size supply system.

The major elements and capabilities of Chambers "a" and "A" are summarized in Table 3-4.

3.4.2 FREE PROCESSING CHAMBER b, B. Both chambers "b" and "B" for the free processing of metals or metal-matrix composites are similar in design. Both require an integrated material supply system and a heat-radiating spherical chamber with adequate insulation to the shirt-sleeve environment. They differ primarily in size, total heat input, and in the sophistication of the free-suspension system.

A conceptual design of the smaller Chamber "b" is shown in Figure 3-4. The three major subassemblies are the material supply system, the processing chamber, and the power supply with central controls.

The material supply system consists of the resistance- or induction-heated melting chamber, feeding system, permanently integrated mixing and shaking units, and a multiple attachment head for a variety of attachments in accordance with individual process and product requirements. The feeding system includes gas supply, pressurization control, and a cut-off device at the multiple attachment head. For some experiments, the supply system is not used and the test material is deployed in the solid state and melted within the processing chamber or at the nozzle orifice (thin-wall hollow spheres).

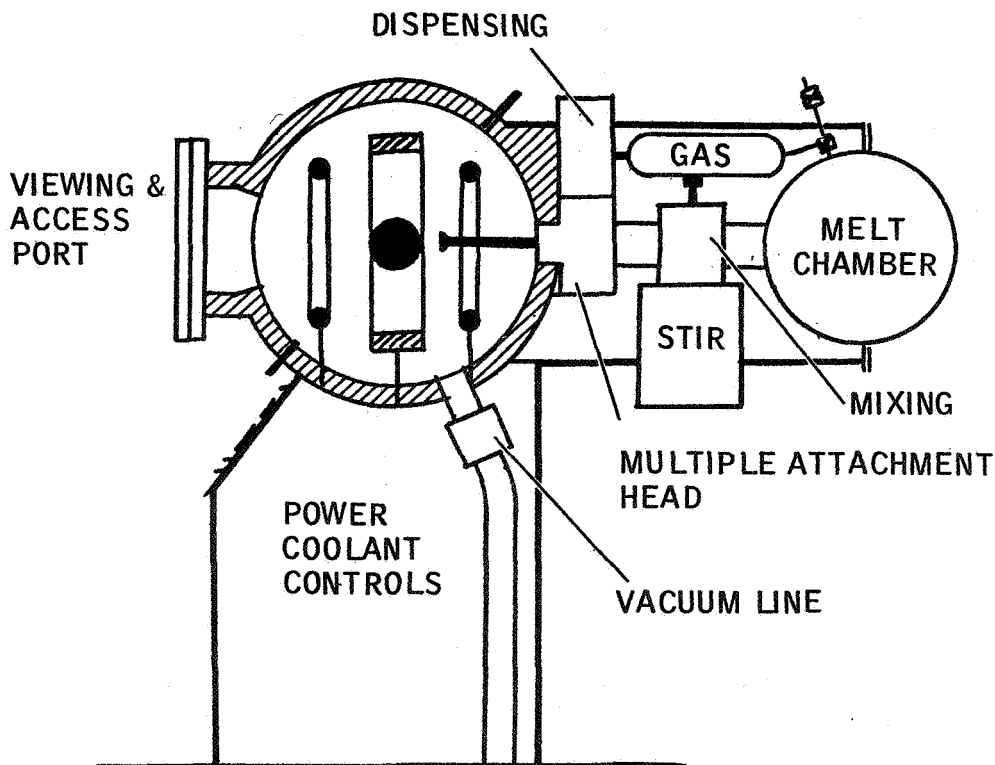

Figure 3-4. Free-Processing Chamber b

The spherical envelope of the processing chamber has three functions: 1) maintaining material temperature by means of radiant heating; 2) cooling of the product through solidification by switching from a hot to a cooled inner wall; and 3) heat-protection of the shirt-sleeve environment by insulation and active cooling. The cooling of the inner surface and the outer shield requires two separate coolant passage systems. For some experiments, radiation heating remains inactive, if adequate heating can be achieved by induction and the associated deformation of the liquid is acceptable. Depending on the process and the type of experiment, either of the following heating methods may be used:

- a. Melting in the material supply system, temperature-hold by radiation (maximum temperature 2700°F).
- b. Melting in the processing chamber by induction, temperature-hold by radiation (maximum temperature 3000°F).
- c. Local melting (e.g., at nozzle) by resistance heating, temperature-hold by radiation (small batches) (maximum temperature 2700°F).
- d. Melting and temperature-hold by radiation (maximum temperature 3000°F).

The most important component of the processing chamber is the position-control subsystem. For the initial Chamber "b" a water-cooled two-coil system is proposed, whose effectiveness for positioning (holding in center) has been verified in laboratory experiments. An additional coil assembly for product rotation is exchangeable for optional use. Likewise optional is the use of two separate induction heating coils, not shown in Figure 3-4.

The material deployment devices (nozzles, stings, etc.) are attached at the multiple-attachment head. The chamber further provides for pressurization with appropriate gases and for vacuum access. The viewing and access port, as well as the control are arranged at one side of the chamber.

The advanced Chamber B exhibits the same basic design, except for larger size and a 6-coil position control system capable of performing the following functions:

- a. Heating
- b. Positioning
- c. Rotating around one or two axes
- d. Induced convection
- e. Controlled deformation

The Chamber "B" with the six-coil system is illustrated in Figure 3-5. The material supply system is omitted in this figure, as it is identical to the one shown in Figure 3-4. The functional capabilities of the six-coil system are illustrated in Figure 3-6.

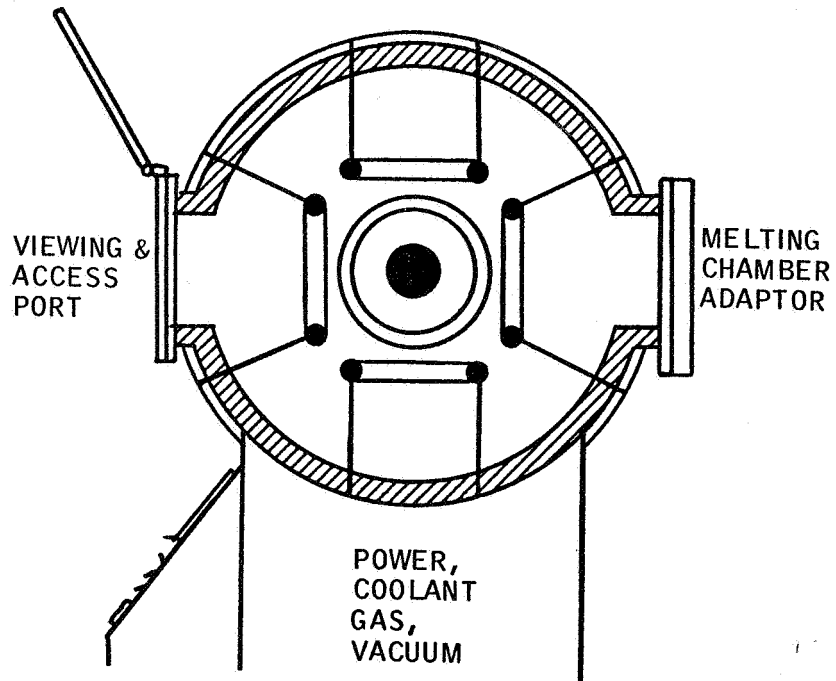

Figure 3-5. Free-Processing Chamber B

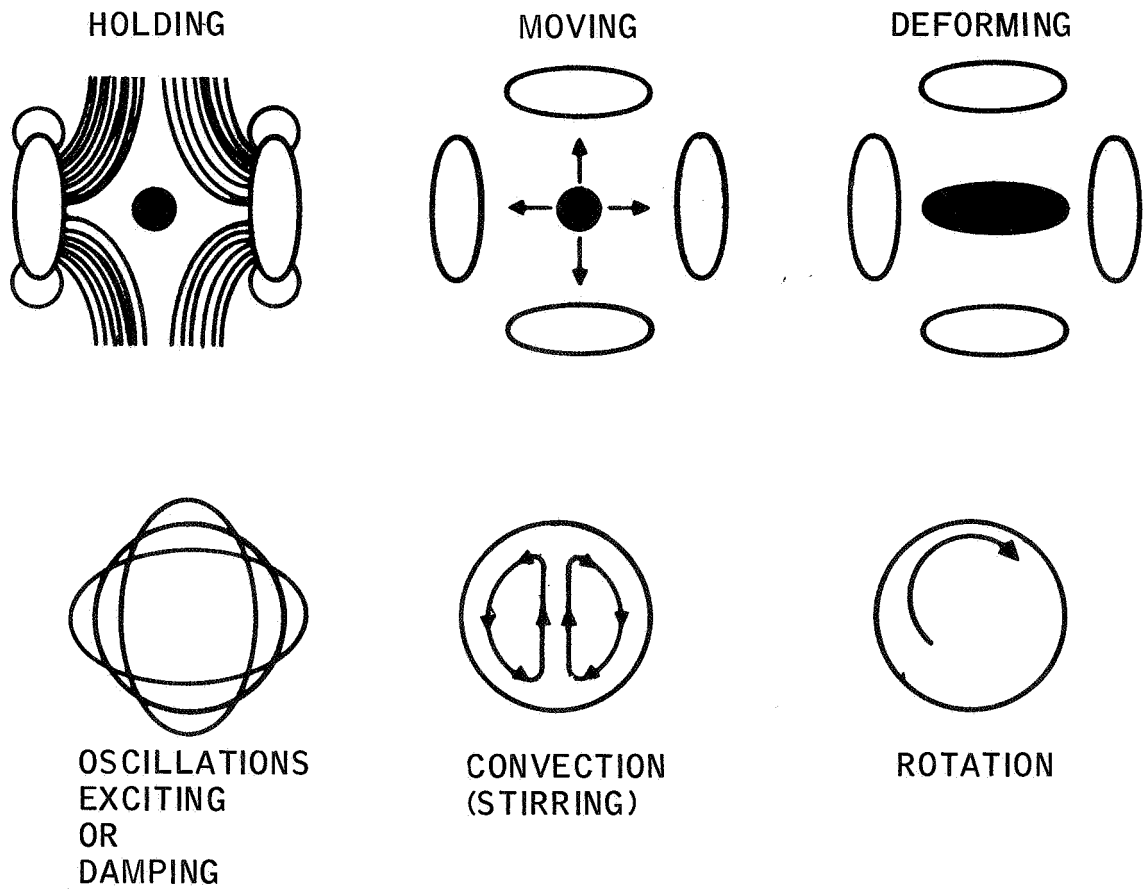

Figure 3-6. Electromagnetic Tooling

Development and deployment options for the free-processing chamber are as follows:

- a. Chamber "b" with 2-coil system, followed by Chamber "B" with 6-coil system at a later date, or
- b. Chamber "B" only, with interchangeable coil systems.

The components and capabilities of Chambers "b" and "B" are summarized in Table 3-4.

3.4.3 HI-MELT FREE-PROCESSING CHAMBER c, C. In contrast or addition to Chamber "B", the "hi-melt free-processing Chamber C" requires the following capabilities:

- a. No tooling contact during the entire processing cycle (solid-liquid-solid).
- b. Processing of metallic and nonmetallic materials.
- c. Temperature capability up to 4500°F.

Requirement a. excludes a material supply system and the material is exclusively deployed in the center of the processing chamber in form of a solid ingot. Since the chamber has to be adaptable to high-melting metals (processes 14, 16) and non-metals (processes 11, 14), it requires two interchangeable heating systems. Metals may be heated by induction or electron beams. Non-metals, such as oxides, may be heated by radiation or dielectric heating. The most effective radiation heating is the solar furnace; this is, however, excluded at this time in view of the extensive equipment and vehicle adaptation requirements. The other alternative of pure radiation heating is an arc-image system which, in the vehicle constraint, appears only feasible for smaller material masses. For some non-metals, the radiation heating requirements can be reduced by additional induction heating (provided by the water-cooled coil system needed for position control). As shown in Figure 2-7 (page 2-20), the response of nonmetallics to induction heating, measured by electrical conductivity (MHO/cm), increases with temperature, so that it becomes increasingly effective in the temperature range of highest heat input. However, even at high temperatures the conductivity of non-metals still differs from metals by several orders of magnitude. While it is adequate for position control, its effectiveness for induction heating is relatively low.

An attractive possibility of simultaneous heating and position control of non-metals is an electrostatic system, illustrated in Figure 3-7. The material is heated by dielectric heating between six water-cooled plates. The position is controlled by alternate charging and discharging of the material with an electron and an ion beam, generating potentials between material and plates which cause the material to move.

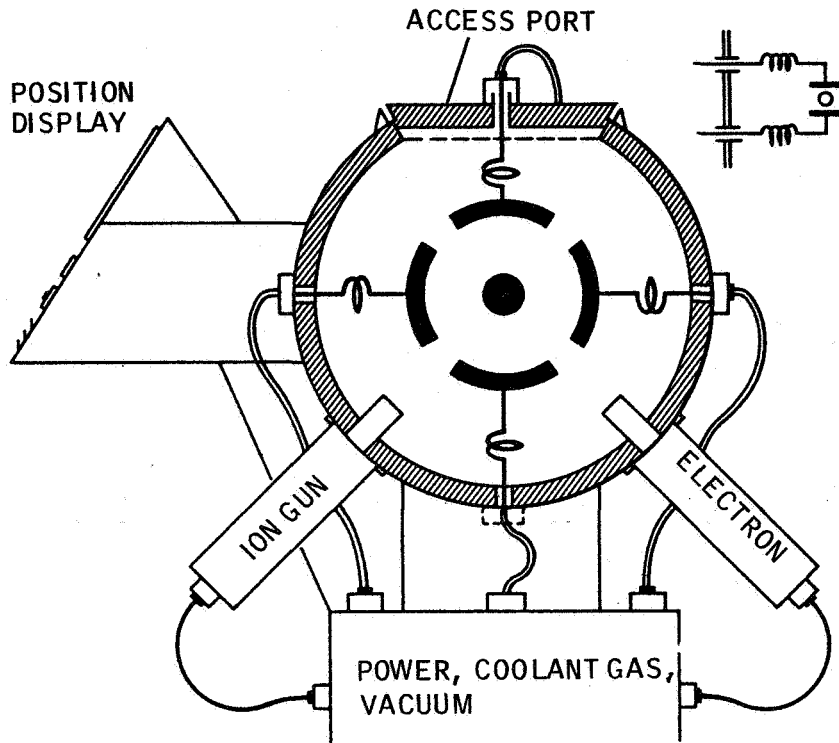

Figure 3-7. Electrostatic Positioning and Melting Chamber C

Since oxides require an oxygen-rich gas envelope, it may also be considered to use the controlled circulation of the hot gases for position control, independent of the heating system. Positioning with a gas flow is an early concept of space manufacturing.

In either method of heating, this chamber requires extensive cooling of the heating and position control elements, as well as of the chamber wall, which calls for an external heat exchanger (radiator).

In view of the complexity of any facility design and the high heat inputs, it is proposed to consider at this time only a smaller chamber (Type "c") with full temperature (4500°F) capabilities, and capable of handling material mass to 100 grams; for most materials, this represents spheres in the range from 2 to 4 cm diameter. This is sufficient for the evaluation of the produced material, including the preparation of prisms for the determination of the optical properties of glasses. The construction of a larger facility "C" should be deferred pending experiences obtained with the smaller chamber and advanced capabilities of orbital operations.

The major components and capabilities of Chamber "c" and "C" are summarized in Table 3-4.

3.5 EXTRAVEHICULAR OPERATIONS AND FACILITIES

Even though the need for any extravehicular operations and facilities was minimized, at least in the initial experiment phase, their potential merits will be defined in view of the leadtime for integration in vehicle designs and programs. Potential extravehicular operations are connected with three functional requirements:

- a. Dissipation of heat
- b. Achievement of minimum g-levels and deformation-free position control, and
- c. Use of environmental vacua.

3.5.1 EXTRAVEHICULAR RADIATOR. Many initial experiments will be carried out with small amounts of material whose heat emission during processing and cooling can be absorbed within the vehicle. However, provision for extravehicular heat exchange have to be made from the outset for the following reasons:

- a. Eventually, most processes will involve larger amount of material.
- b. Many processes are meaningful only with a substantial mass of material, particularly all mold-casting processes.
- c. Even if small amounts are involved, the major portion of the heat is stored in the chamber wall and/or the material supply system.

The amounts of heat involved would place an unacceptable load on the vehicle temperature control system and a separate regenerative cooling system with an external heat exchanger has to be provided which can be connected with each processing chamber. The size of this radiator depends not only on the maximum total heat — in the order of 5000 to 25,000 BTU — but also on the amount of coolant, i.e., heat storage capacity. The external heat dissipation system will require the following major components:

- a. Radiator
- b. Sun-pointing shadow shield
- c. Earth-pointing shadow shield
- d. Support structure
- e. Coolant lines and vehicle wall feed-through.

It should be mentioned that the pointing shadow shields present no major problem, as the related technology is well established.

3.5.2 EXTRAVEHICULAR EXPERIMENT PERFORMANCE — ATTACHED MODE.

The problem of heat input ("rejection") into the vehicle is completely eliminated, if the experiment is carried-out in extravehicular operation. For stationary, i.e., attached mode, this requires a facility which permits the internal performance of all pre- and post-experiment functions, and the transfer of the entire chamber to an extravehicular position for experiment performance. One conceptual design of such a facility and the sequence of operations are illustrated schematically in Figure 3-8.

Apparatus preparation, charging with material, and setting controls are carried out in Position 1 inside the vehicle, with full 360-degree access. For deployment, the apparatus is moved into a vehicle-attached tube by means of telescoping rails (Position 2). After the inside hatch is sealed and the external hatch is opened, the apparatus is moved into Position 3, at least 20 feet from the vehicle, followed by the deployment of the shadow shields. Experiment performance is monitored by the astronaut via the control unit attached to the inside hatch. After cooling of the entire unit, it is retracted into the vehicle in a reversed sequence of deployment steps.

In the fully deployed Position 3 the apparatus may be removed from the guide rails by a serpentuator and carried into a more favorable processing position as described in Section 3.5.3.

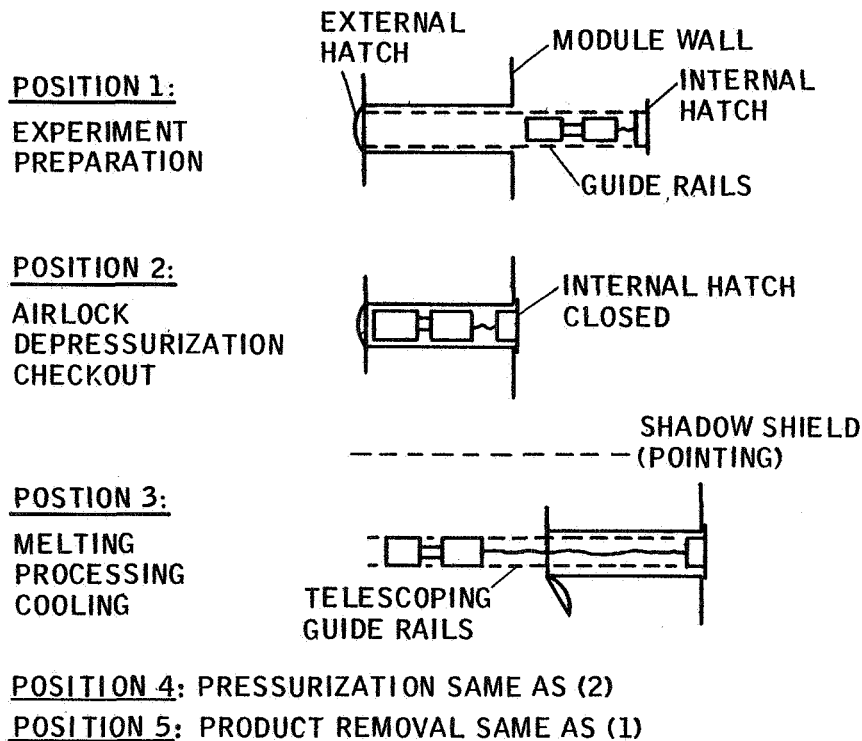

Figure 3-8. Space Manufacturing Experiments, Method B

Figure 3-9 shows a close-up of the facility carrying a mold-casting chamber. To permit cooling by radiation into space, the mold heating assembly consists of two halves attached to swing-away arms. As for the radiator, effective cooling requires a sun-pointing and an earth-pointing shadow shield.

3.5.3 SERPENTUATOR-BASED EXPERIMENT PERFORMANCE. The facility of Figure 3-9 can be designed so that the entire chamber can be detached from the guide rails and picked-up by a manned or remote-controlled serpentuator. The serpentuator-based experiment performance offers three unique capabilities:

- a. The unit can be moved further away from the vehicle, essentially eliminating heat exchange between experiment and vehicle wall. The shadow shields may further be stationary, and the entire unit is turned in pointing position.
- b. For processes in which highest vacua are desirable, the experiment can be moved into the vacuum wake of the vehicle, where vacuum reaches a level of 10^{-14} mm Hg.
- c. The most attractive potential of the serpentuator is the achievement of a "free-flying" mode, in which almost absolute zero-g is obtained (Section 1.2.3), except

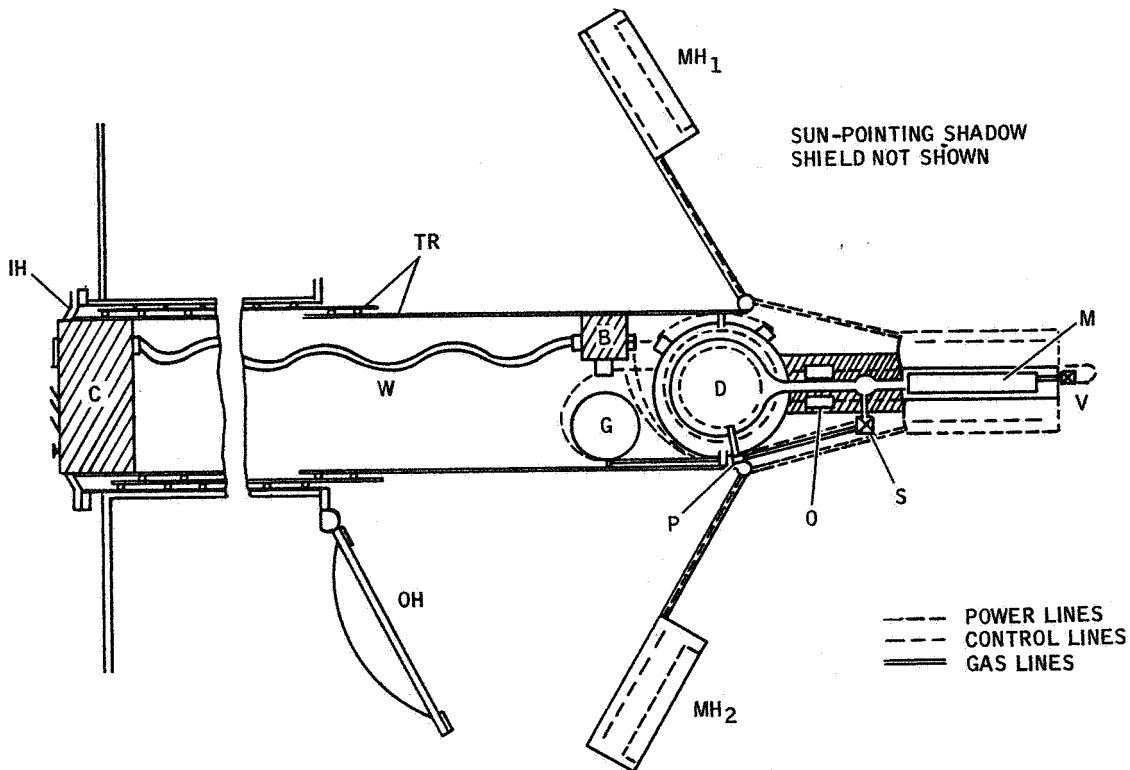

Figure 3-9. Attached Mode, Extravehicular Experiment

for the always-present earth-gravity gradient across the liquid mass (Section 1.4.6). In the attached mode, the position control force, which prevents the material from free drifting on its own trajectory, exerts an often undesirable g-level. The elimination of this force is particularly desirable in fundamental experiments calling for the "cleanest" environmental conditions.

One means of achieving a free-drifting condition is through the use of a detached vehicle whose attitude is controlled by the movement of the test material. Since for most experiments the drifting distance after initial positioning is well within the movement capabilities of the serpentuator, the same effect can be achieved at a substantially lower effort by monitoring the serpentuator position by the drifting test material so that it remains in the center of the chamber. The use of the serpentuator for this semi-detached mode is illustrated in Figure 3-10. The procedure is as follows:

- a. Deployment of the chamber to extravehicular position as discussed in Section 3.5.2.
- b. Activation of position control system.
- c. Pick-up by the serpentuator.
- d. Material deployment.

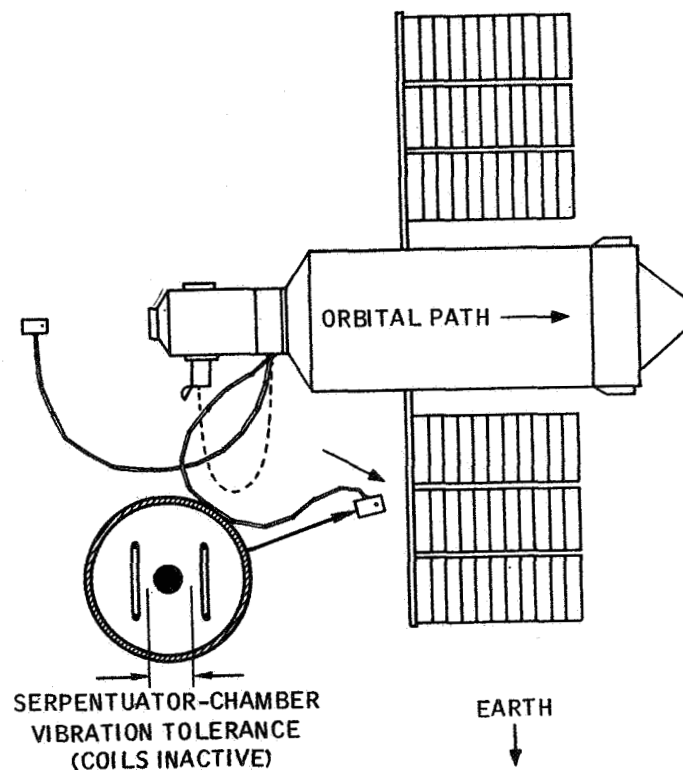

Figure 3-10. Space Manufacturing Operations

- e. Simultaneous de-activation of position control and activation of serpentuator attitude control.
- f. Processing through solidification.
- g. Change-over from serpentuator attitude control to position control.
- h. Return of chamber to deployment apparatus and retraction into vehicle.

Position control of the serpentuator may be continuous if serpentuator vibrations can be fully attenuated by a closed-loop servo system. If vibrations cannot be eliminated, position adjustment is carried out in increments, consisting of momentary position sensing, followed by a period of serpentuator movement and vibration damping. Vibrations during this period have no effect upon the material. The maximum permissible vibration amplitude as measured in the processing chamber is indicated in the insert of Figure 3-10.

3.5.4 DETACHED MODULE-BASED EXPERIMENTS. If the free-drifting condition should be maintained over long time periods, during which the displacements with regard to the base vehicle are large (Section 1.2.3), a detached module, whose position is controlled by the experiment material, becomes necessary. A potential design for a manufacturing module with detachable section, as it has been proposed for the space station, is shown in Figure 3-11. It consists of a larger section which remains attached to the base vehicle. After preparation of the experiment, the smaller section is detached and the experiment is monitored by remote control. This type of operation is beyond the scope of this study and is included only for completeness.

3.6 DEFINITION OF AN EXPERIMENT PROGRAM

At this point of the evaluation of process priorities and their integration into space experiments, the following conclusions have been generated:

- a. Tentative experiment priorities and program phases, defined in Sections 3.2.4 and 3.2.5, and in the last column of Tables 3-2 and 3-3A.
- b. Specification of the most effective lines of experiment facilities, defined in Sections 3.3.2 and 3.3.3, and in Table 3-4.

The final step of the experiment program development is the correlation of a. and b. above, leading to a final adjustment and refinement of experiment priorities on the basis of available facilities. It represents a trade-off between desirable experiment priorities and the necessarily gradual advancement of facility capabilities.

3.6.1 CORRELATION OF EXPERIMENT PRIORITIES AND FACILITIES. The framework for the correlation is identified by the horizontal and vertical column headings of Table 3-5, representing inputs a. and b., as listed under Section 3.6. The

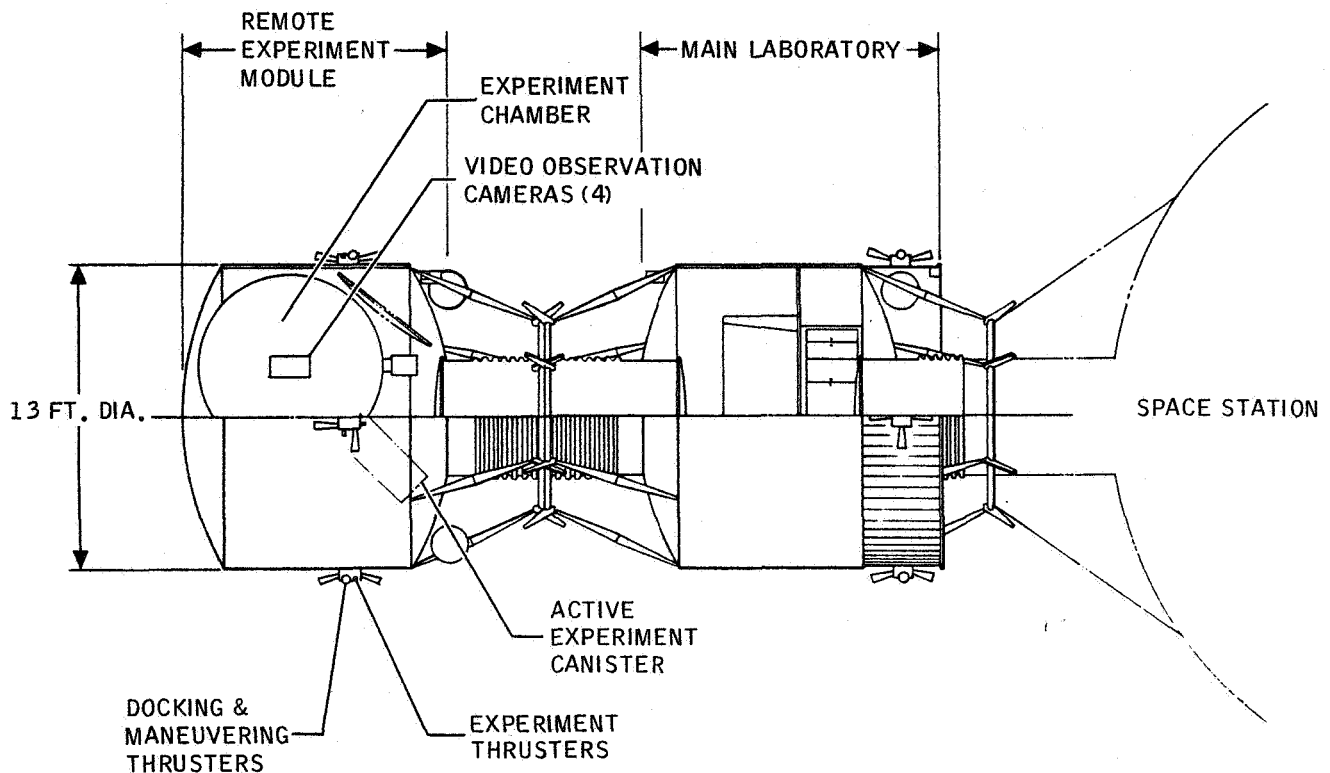

Figure 3-11. Materials Science and Processing Experiment Module

tentative experiment priorities, defined in Section 3.2.4, are listed in columns 1 and 2, distinguishing between exploratory and capability-development experiments. The proposed facilities, specified in Section 3.3.2, are arranged in three phases as follows:

- Phase I: Initial smaller facilities, a, b, c, and p.
- Phase II: Full-size experiment chambers A, B, C, and P.
- Phase III: Continued use of Phase II facilities (A, B, C, P) and the optional introduction of prototype production facilities (M) and extravehicular operations.

Even though the phases imply a developmental sequence, they do not necessarily represent a firm time schedule; the decisions as to schedules rest ultimately with the responsible NASA agencies and are beyond the scope of this study. In support of program planning, a number of facility development options have been proposed in Section 3.4. It may, for instance, be preferable and less expensive to delete one of the smaller facilities (a, b, c) and use one full-size chamber from the outset, covering Phase I and II. Such facility schedule modification will, however, not affect the experiment sequence.

Table 3-5. Phasing of Experiments and Facilities

Processes/Products	Tentative Phasing (Table 3-2)		Phase I			Phase II			Phase III						
	o	●	a	b	c	p's	A	B	C	P	A, B, C	P	M	Att.	EVA
	1	2	3	4	5	6	7	8	9	10	11	12	13	14	15
1		I	●												
1a		III													
2															
3a		I	●												
3b		I	●												
3c															
4a	I	II	o												
4b		III													
5		I	●												
5a		I	●												
6		I	●												
7a															
7b		III													
7c		II	o												
8		III													
9	I	II													
10		II													
11	I	II													
13		I	●												
14		II	o												
15		II													
16		III													
17		III													

Explanations:

Col. 1, 2 Preliminary priorities as defined in Table 3-2

Col. 3-15 Priorities adjusted for equipment commonality

A, B, C, P Facilities as defined in Tables 3-3 and 3-4

M Potential introduction of separate experimental production facility for specific products

Eva. -Att. Extravehicular operation desirable, attached mode

Eva. -Det. Detached or semi-detached (serpentuator) extravehicular operation desirable

o = Exploratory or demonstration experiments

● = Capability development experiments

⊙ = Full-scale operations experiments

Symbols

This sequence or distribution over the three phases evolves without further evaluation from the earlier defined priorities and facility capabilities. Minor phasing adjustments are only made with regard to:

- a. Advancement of experiment start to an earlier phase in view of adaptability to existing facilities.
- b. Finer distinction between exploratory (verification, demonstration) and capability development experiments.
- c. Projection to full-scale or production experiments, primarily aimed at specific high pay-off products.
- d. Potential introduction of extravehicular operations.

The experiment types, defined in b. and c. above, and the phasing adjustment are identified in Table 3-5. The shading denotes the phases of full capability development experiments.

3.6.2 FINAL EXPERIMENT PROGRAM. The evaluation of Table 3-5 produces the following experiment program (using the term "phase" as qualified in Section 3.6.1):

a. Phase I

- Exploratory and tooling development experiments:
 - Formation of membranes (process 4a)
 - Single crystal growth from the melt (process 7c)
 - Purification of metals (process 14)
- Verification and demonstration experiments:
 - Production of new glasses (process 9)
 - Thermosetting alloys (process 11)
- Capability development experiments:
 - Production of spheres (process 1)
 - Hollow thin-wall spheres (process 3a)
 - Hollow thick-wall spheres (process 3b)
 - Foams and composite foams (process 5)
 - Composite casting (process 6)
 - Single crystals from solutions (process 7a)
 - Supersaturated alloys (process 13)

b. Phase II

- **Research and methods development experiments:**
 - Liquid forming of metals (process 1a)
 - Production of filaments (process 4b)
 - Purification of glasses (process 14)
 - Unit separation (process 15)
 - Containerless melting of metals (process 16)
- **Advance from exploratory to capability development status:**
 - Production of membranes (process 4a)
 - Single crystals from melt (process 7c)
 - Production of glasses (process 9)
 - Thermosetting alloys (process 11)
 - Purification of metals (process 14)
- **New capability development experiments:**
 - Dispersed particle castings (process 10)
- **Continued Phase I capability development experiments:**
 - Production of spheres (process 1)
 - Hollow thin- and thick-wall spheres (processes 3a, 3b)
 - Foams and composite foams (process 5)
 - Composite casting (process 6)
 - Single crystals from solution (process 7a)
 - Supersaturated alloys (process 13)

c. Phase III

- **Exploratory and research experiments:**
 - Adhesion casting (process 2)
 - Blow molding (process 3c)
- **Advance from exploratory to capability development status**
 - Liquid forming (process 1a)
 - Production of filaments (process 4b)

- Purification of glasses (process 14)
- Unit separation (process 15)
- Containerless melting of metals (process 16)
- New capability development experiments:
 - Single crystals by zone melting (process 7b)
 - Growing of whiskers (process 8)
 - Superconductors (process 17)
- Continued Phase II capability development experiments:
 - Hollow thin-wall spheres (process 3a)
 - Foams and composite foams (process 5)
- Prototype production experiments:
 - Production of spheres (process 1)
 - Thick-wall hollow spheres (process 3b)
 - Production of membranes (process 4a)
 - Production of foams (process 5)
 - Composite casting (process 6)
 - Single crystals from solution (process 7a)
 - Single crystals from melt (process 7c)
 - Production of glasses (process 9)
 - Dispersed particle castings (process 10)
 - Thermosetting alloys (process 11)
 - Supersaturated alloys (process 13)
- Extravehicular experiments, attached mode:
 - Production of spheres (process 1)
 - Composite casting (process 6)
 - Production of glasses (process 9)
 - Dispersed particle castings (process 10)
 - Containerless melting of metals (process 16)

- Extravehicular experiments, detached mode:
 - Production of spheres (process 1)
 - Liquid forming (process 1a)
 - Hollow spheres (processes 3a, 3b)
 - Formation of membranes (process 4a)
 - Unit separation (process 15)

The program is summarized in Table 3-6, identifying the experiment schedule for each basic facility type.

3.7 RESEARCH AND DEVELOPMENT REQUIREMENTS

The development of space manufacturing processes and experiments comprises four major areas of supporting R&D:

- a. Fundamental and applied research.
- b. Technological research and development.
- c. Terrestrial zero-g experiments.
- d. Facilities design and hardware development.

The following definition of requirements is based on the foregoing conclusions as to experiment priorities and basic facilities. It is limited to those topics which represent either new areas of endeavor, or topics where the present state of knowledge is inadequate; requirements which are within the present state of art are deliberately excluded. The R&D support for the facility development is included in a., b., and c., while d. consists only in the identification of the required major hardware components.

3.7.1 IDENTIFICATION OF TOPICS AND PRIORITY EVALUATION. The definition of requirements was extracted from the discussion of processes in Section 2.3 and, in particular from the topical "Summary of Criteria and Requirements" listed, primarily for this purpose, at the end of each discussion. From a statistical compilation of all requirements, first all those which were considered to be either of minor significance or within the state of art were deleted. The remaining list was then further reduced by combining, wherever possible, individual requirements related to the same subject into a limited number of topical statements, representative of potential R&D projects. The topics were arranged in eight groups or disciplinary areas as follows:

- a. Basic and Applied Liquid-State Physics (PH)
- b. Applied Fluid Mechanics (FM)
- c. Applied Orbital Mechanics (OM)
- d. Solidification and Crystallization (SC)

Table 3-6. Space Experiment and Development Capability

Basic Facility	Processes/Products	Space Experiments Schedule		
		I	II	III
Mold Casting Facility "A" (or a + A)	6 - Composite Casting			
	5 - Foams - All Types			
	13 - Supersatur. Alloys			
	10 - Fine-Grain Castings			
	11 - Thermoset. Alloys			
	2 - Adhesion Casting			
	3c - Blow Molding			
Free Processing Facility "B" (or b + B)	1 - Spheres			
	3a - Thin Hollow Spheres			
	3b - Thick Hollow Spheres			
	4a - Membranes			
	7c - Single Crystals Pulling/Melt			
	14 - Purification/Metals			
	1a - Liq. Forming - Metals			
Free Hi-Temp. Facility "C" (or c + C)	4b - Filaments			
	9 - Glasses			
	14 - Purification/Hi-Melt			
	16 - Hi-Melt Alloys			
Individual Packages "P" (or p + P)	1a - Liq. Forming - Glasses			
	7a - Single Cry. from Solution			
	15 - Unit Separation			
	11 - Thermoset. Alloys			
	4a - Membranes/Special			
	7b - Single Cry. Zone Melting			
8 - Whiskers				
17 - Superconductors				

Explanations: In each facility group, sequence in order of experiment start

- Demonstration, verification, or research experiments
- Capability (process, tooling, products) development experiments
- ▭ Full-scale production development experiments
- ▨ Potential extravehicular operation

- e. Thermodynamics (TH)
- f. Materials (MA)
- g. Tooling and Methods (TM)
- h. Required Data (DA)

The defined research topics in each disciplinary area and the evaluation of their priorities are presented in Tables 3-7 through 3-14. The applicable processes are identified in Columns 4 to 7 by means of the process numbers introduced in Part 2. The four columns distinguish between the earliest R&D target times in terms of the experiment phases defined in Section 3.6.2 and Table 3-5:

- "I" (Column 4): Capability development experiments to start in Phase I.
- "I - II" (Column 5): Phase I exploratory experiments advancing to the capability development status in Phase II.
- "II - III" (Column 6): Capability development experiments starting in Phase II and exploratory experiments for Phase III.
- "III" (Column 7): Experiments to be started in Phase III.

Below each process number, the functional importance of the R&D topic for that specific process is indicated by the following underscores:

- Double Underscore (=): Of primary importance for the functioning of the basic concept of the process.
- Single Underscore (-): Of secondary functional importance or applying only to certain process modifications.
- No Underscore: Applying and beneficial to the process, yet not absolutely necessary.

The degree of need was determined by the combined consideration of the earliest time of need, the number of processes involved in each target group and their functional significance. It is defined in Column 8 by a rating number, based on a numerical evaluation formula. Elaboration of this formula is omitted, as comparative qualitative assessments by judgment led to the same result.

The relative rating was further adjusted for two criteria representative of the required effort (Columns 9 and 10).

- a. The significance of the problem to space manufacturing in general and the degree of effort required for its solution (increase of rating).
- b. The existing state of art and available data (decrease of rating).

Table 3-7. Major R&D Topics and Priorities -- Basic and Applied
Liquid State Physics (PM)

Subjects	Materials		Processes and Experiment Start Phase				Priority Evaluation				
	M	NM	I	I - II	II - III	III	Need ⁺	Probl. ⁺	SOA	Ratg.	Priori
Description of the Liquid State: Intermolecular Forces	M	NM		← Generally Applicable →			2	2	1	3	III
Interface Theory: Interfacial Tensions, Relationships	M	NM		← Generally Applicable →			5	3	2	6	I
Applied Liquid-Gas and Liquid-Solid Interface Effects	M	NM	<u>1 3a 3b 5 13</u>	<u>4a 7c 9</u>	<u>1a 4b 16</u>	<u>2 3c 7b 8</u>	5	3	2	6	I
Spreading of Liquids on Solid Surfaces Shape Effects	M	NM	7a	<u>7c</u>		<u>2 3c 7b</u>	2	2	1	3	III
Interface Effects on Orifices, Tooling: Design Criteria	M	NM	<u>1 3a 3b 5</u>	<u>4a 7c</u>	<u>1a</u>	<u>3c 17</u>	5	3	1	7	I
Effect of Surface Tension on Shape of Liquid Bodies	M	NM	<u>1 3a 3b 5</u>	<u>7c 9</u>	<u>1a</u>	<u>2 3c</u>	4	3	1	6	I
Liquid Membranes: Intermolecular Forces, Stability	M	NM	<u>3a 5</u>	<u>4a</u>			4	2	0	6	I
Interface Mechanics of Liquid-Solid Mixtures	M	NM	<u>5a 6 7a 13</u>	<u>11</u>	<u>10</u>		4	2	1	5	II
Interface Criteria for Immiscible Liquid Mixtures	M	NM	<u>7a 13</u>	<u>4a</u>	<u>15</u>		4	2	2	4	III
Mechanism of Ultrasonic Bubble Formation	M	NM	<u>5</u>	<u>14</u>			4	1	1	4	II
Diffusion of Gases in Liquid Metals	M	NM	<u>5</u>	<u>9 14</u>			4	1	2	3	III
Unit Separation: Effect of Liquid Motion and Thermohomogeneity	M	NM			<u>15</u>		2	2	0	4	II
Response of Liquids to Electromagnetic and Electrostatic Forces	M	NM	<u>1 3b</u>	<u>7c 9 14</u>	<u>1a 16</u>		4	3	1	6	I
Electrophoresis: Migration Rate of Ions and Colloidal Particles	M	NM			<u>15</u>		2	3	1	4	II

PMO-p/10/1 #

EXPLANATIONS

Col. 2 and 3 M = Metals, NM = Nonmetallic Materials
Col. 4 to 7 I = Phase I Capability Development Experiments
I, II = Phase I Exploratory Advancing to Capability Development in Phase II
II, III = (a) Capability Development Starting in Phase II
(b) Exploratory Experiments for Phase III
III = Experiments Starting in Phase III

Numbers: Processes Code Numbers — correspond to the following:

<u>Code Numbers</u>	<u>Processes</u>
1	Production of Spheres
1a	Liquid Forming
2	Adhesion Casting
3a	Thin-Wall Hollow Spheres
3b	Thick-Wall Hollow Spheres
3c	Blow Molding
4a	Flat Membranes
4b	Drawing of Filaments
5	Metallic Foams
5a	Pressure Stiffened and Composite Foams
6	Composite Casting
7a	Single Crystal Growth from Solution
7b	Single Crystal Growth by Zone Melting
7c	Pulling of Single Crystals from the Melt
8	Growing of Whiskers
9	Amorphous Materials (Glasses)
10	Dispersed Particle Castings
11	Thermosetting Alloys
12	Supercooling
13	Supersaturated Alloys
14	Purification
15	Unit Separation Process
16	Containerless Melting of High-Temp Alloy
17	Superconductors

Underscoring:

(=) = Primary importance
(-) = Secondary importance or limited application
(no underscoring) = Applicable and beneficial but not mandatory

Col. 8 to 11 (Relative Ratings)

"Need" — (Functional significance, number of applications, target time)

"Problem" — Basic significance, effort for solution

"SOA" — State of art

*Fold out
#2*

Table 3-8. Major R&D Topics and Priorities -- Applied Fluid Mechanics (FM)

1 Subjects	2 M	3 Materials	4 Processes and Experiment Start Phase			5 Priority Evaluation			7 III	8 + Need	9 + Probl.	10 SOA	11 Ratg.	12 Priority
			1 I	2 I - II	3 II - III	4 I - II	5 II - III	6 SOA						
Sphere Formation: Criteria, Oscillations, Ultimate Accuracies	M	NM	1 3b	7c 9 14	1a 4b 16				5	3	2	6	I	
Free Forming of Liquids: Mechanism, Generation of Forces	M	NM		7c 9	1a 4b 16	2 3c		2	2	2	0	4	II	
Thick-Wall Hollow Sphere: Relationships, Bubble in Liq. Contin.	M		3b 6			3c		4	4	3	1	6	I	
Thin-Wall Hollow Spheres: Relationships, Membrane Effects	M		3a 5					4	4	3	1	6	I	
Sources and Magnitudes of Convection; Effect of Variable Surface Tension	M		1 3b 5a 6 7a	11	1a 10	2 3c		4	4	3	1	6	I	
Mixture Stability; Time to Zero Motion: Liquid-Solid Mixtures	M		1 3b 5a 6 7a	11	1a 10	2 3c		4	4	3	1	6	I	
Mixture Stability; Time to Zero Motion: Liquid-Gas Mixtures	M		5 6					4	4	3	1	6	I	
Mixture Stability; Time to Zero Motion: Liquid-Liquid Mixtures	M		7a 13	4a	15 16			4	4	2	1	5	II	
Liquid-Fiber Mixtures: Drag Forces, Flow, Alignment	M		3a 3b 5a 6			2 3c		3	3	1	1	3	III	
Liquid Flow on Solid Surfaces, in Pipes, Effect of Discontinuities	M		1 3b 5 6		10	2 3c		3	3	2	2	3	III	
Movement of Bubbles in Liq. Continuum: Mechanics, Control	M	NM	3b 5	14		3c		4	4	1	1	5	II	
Mechanics and Means of Bubble Dispersion in Foams	M		5 5a 6					4	4	1	1	5	II	

Table 3-9. Major R&D Topics and Priorities -- Applied Orbital Mechanics (OM)

1 Subjects	2 M	3 Materials	4 Processes and Experiment Start Phase			5 Priority Evaluation			7 III	8 + Need	9 + Probl.	10 SOA	11 Ratg.	12 Priority
			1 I	2 I - II	3 II - III	4 I - II	5 II - III	6 SOA						
Orbital G-Levels: Altitude, Position of Experiment				Generally Applicable										
Trajectories, Displacement Off Mass Center - Holding Forces			1 3b	4a 7c 9	1a 4b 16			4	4	3	2	6	I	
Deformation of Liquids Due to Gravity Gradient			1 3a 3b	4a	1a 16			4	4	3	2	5	II	

SEE "EXPLANATIONS" ON FACING PAGE

Table 3-10. Major R&D Topics and Priorities --
Solidification and Crystallization (SC)

1	2	3	4	5	6	7	8	9	10	11	
											Processes and Experiment Start Phase
Subjects	Materials		I	I - II	II - III	III	+ Need	+ Probl.	SOA	Ratg.	Pri
	M	NM									
Nucleation, Crystal Growth from Melt: Mechanism, Rates, Control	M			7c	10	7b 17	3	3	2	4	
Nucleation, Crystal Growth from Solution: Mechanism, Rates, Control	M	7a					5	3	2	6	
Nucleation, Crystal Growth from Vapor: Mechanism, Rates, Control	M	NM				8	1	3	2	2	
Effect of Liquid Motion (Convection) Upon Crystal Growth, Perfection	M	NM	7a	7c		7b 8	4	3	0	7	
Nucleation and Crystal Growth Criteria - Molten Oxides		NM		9			3	3	0	6	
Control of Crystal Orientation and Geometry	M		7a	7c		7b 8 17	3	2	1	4	
Induced Nucleation and Crystallization: Seed Materials, Dispersion	M		1 3b 5 6		1a 10	2 3c	3	2	1	4	
Criteria and Methods for Directional Solidification	M			4a	4b	8 17	2	3	2	3	
Solvents for Crystal Growth from Solution - Diffusion Rates	M		7a				4	3	2	5	
Solidification of Immiscible Metals - Dispersion, Alloys	M		13				4	3	1	6	
Criteria for Formation of Intermetallics from Liquid-Solid Mixtures	M			11			3	2	1	4	

Talk #1
from plot

Table 3-12. Major R&D Topics and Priorities -- Materials (MA)

1 Subjects	2		3		4		5			6			7			8			9			10			11		
	Materials		Processes and Experiment Start Phase		Priority Evaluation		Priority Evaluation			Priority Evaluation			Priority Evaluation			Priority Evaluation			Priority Evaluation			Priority Evaluation					
	M	NM	I	I - II	II - III	III	Need	Probl.	SOA	Ratg.	Prio.																
Whisker Composites: Properties versus Content, Orientation	M	NM	1 3b 5a 6 2 6	11	1a	2 3c	5	2	1	6	I																
Materials for Single Crystals and Whiskers	M	NM	7a 6	7c	8 7b	5	3	2	6	I																	
Membrane Materials: Structural, Chemical, Electronic	M	NM	3a 5	4a		3	2	1	4	I																	
Feasibility of Heterogeneous Materials for Membranes	M	NM	3a	4a		2	2	1	3	I																	
Additives to Oxides for Specif. Properties; Miscibility		NM		9		3	3	2	4	I																	
Effect of Oxide Particle Dispersions in Metals		NM	1 3b 3c 6		10 1a	3	2	2	3	I																	
Particle Materials for Induced Crystallization (Seeds)	M	NM	3 3b 3c 5 6		10 1a	4	2	1	5	I																	
Coatings of Metals, Non-Metals for Wettability Control	M	NM	5a 6	11	10	5	2	2	5	I																	
Solutions for Single Crystal Growth			7a			4	3	1	6	I																	
Gases for Whisker Growth from Vapor					8	1	2	1	2	I																	
Promising Compositions for Supersaturated Alloys	M		13			4	3	1	6	I																	
Promising Compositions for Thermosetting Alloys	M			11		3	3	1	5	I																	
Properties of Foams, Reinforced and Pressurized Foams	M		5 5a 6			4	2	0	6	I																	

EXPLANATIONS

- Col. 2 and 3 M = Metals, NM = Nonmetallic Materials
Col. 4 to 7 I = Phase I Capability Development Experiments
I,II = Phase I Exploratory Advancing to Capability Development in Phase II
II,III = (a) Capability Development Starting in Phase II
(b) Exploratory Experiments for Phase III
III = Experiments Starting in Phase III

Numbers: Processes Code Numbers — correspond to the following:

<u>Code Numbers</u>	<u>Processes</u>
1	Production of Spheres
1a	Liquid Forming
2	Adhesion Casting
3a	Thin-Wall Hollow Spheres
3b	Thick-Wall Hollow Spheres
3c	Blow Molding
4a	Flat Membranes
4b	Drawing of Filaments
5	Metallic Foams
5a	Pressure Stiffened and Composite Foams
6	Composite Casting
7a	Single Crystal Growth from Solution
7b	Single Crystal Growth by Zone Melting
7c	Pulling of Single Crystals from the Melt
8	Growing of Whiskers
9	Amorphous Materials (Glasses)
10	Dispersed Particle Castings
11	Thermosetting Alloys
12	Supercooling
13	Supersaturated Alloys
14	Purification
15	Unit Separation Process
16	Containerless Melting of High-Temp Alloy
17	Superconductors

Underscoring:

- (=) = Primary importance
(-) = Secondary importance or limited application
(no underscoring) = Applicable and beneficial but not mandatory

- Col. 8 to 11 (Relative Ratings)
"Need" — (Functional significance, number of applications, target time)
"Problem" — Basic significance, effort for solution
"SOA" — State of art

Table 3-13. Major R&D Topics and Priorities -- Tooling and Method (TMM)

1 Subjects	2 Materials		3 Processes and Experiment Start Phase				4 Priority Evaluation				
	M	NM	I	I - II	II - III	III	Need	Prod.	SOA	Ratg.	Priority
Liquid Deployment and Detachment: Nozzle Design, Methods	M	NM	1 3a 3b 5	4a		2 3c	5	3	0	8	I
Solid Deployment: Tooling and Methods	M	NM	1	7c 9 14	1a 16		3	2	0	5	II
Tooling for Hollow Sphere Bubble Centering	M		3b			3c	4	3	0	7	I
Liquid Feeding: Techniques, Tooling, Control Elements	M		1 3b 5 6 13		10	2 3c	5	2	1	6	I
Mixing Techniques: Liquid/Solid, Liquid, Gas	M		1 3b 5 5a 6 13	9 11	1a 10 16	2 3c	5	3	1	7	I
Membrane Drawing Techniques and Tools	M	NM		4a 4b			2	3	0	5	II
Mold Casting Techniques: Methods and Tooling	M		5 5a 6 13	11	10		5	1	2	4	II
Foaming Techniques: Gas Injection Systems	M		5 5a 6				5	3	2	6	I
Tooling for Contact-Suspension of Molten Pools	M			7c	16	7b	2	3	1	4	II
Contact Free Electromagnetic Position Control System	M		1 3a 3b	7c 14	4b 16	17	5	3	1	7	I
Contact-Free Electromagnetic Manipulation System	M		1 3b	14	1a 16		4	3	1	6	I
Contact-Free Positioning Systems for Non-Conductors		NM		9	4b		2	3	0	5	II
Liquid Metal Melting and Supply Systems	M		1 3b 5 6		1a 10	2 3c	5	3	0	8	I
Contact-Free Heating Systems for Metals	M		1 3a 3b	4a 14	1a 4b 16		5	3	2	6	I
Contact-Free Heating Systems for Non-Metals		NM		9 14	1a		2	3	0	5	II
Contact-Free Cooling Systems	M	NM	1 3a 3b	4a 9 14	1a 4b 16		5	2	1	6	I
Methods to Prevent Void Formation During Cooling	M	NM					3	2	2	3	III
Methods and Contact-Free Tooling for Induced Convection	M	NM	1 3b	14	16		4	2	1	5	II
Cleaning Methods for Particles and Fibers	M	NM	5a 6	11	10		4	1	2	3	III
Bubble Sensing Methods and Tooling for Opaque Materials	M		3b			3c	3	3	1	5	II
Electromagnetic Tooling for Contact-Free Shape Control	M	NM		7c	1a 4b	17	1	3	1	3	III
Electrophoretic Methods and Tooling		NM			15		2	3	1	4	II

Generally Applicable

SEE "EXPLANATIONS" ON FACING PAGE

Table 3-14. Major R&D Topics and Priorities -- Data (DA)

Subjects	Materials			Processes and Experiment Start Phase			Priority Evaluation					
	M	NM		I	I - II	II - III	III	Need	Probl.	SOA	Ratg.	Priorit
	2	3	4	5	6	7	8	9	10	11	12	
Liquid State: Surface Tension, Viscosity versus Temperature	M	NM	1 3a 3b 5 6	4a 7c 9 14	1a 4b 16	2 3c	5	3	1	7	I	
Fundamental Interfacial Tension Data	M	NM	1 3a 3b 5	4a 7c 9 14	1a 4b 16	2 3c 7b	5	3	1	7	I	
Vapor Pressures of Liquids	M	NM	↓	← Generally Applicable →			5	3	2	6	I	
Emissivity - Solid and Liquid State	M	NM	1 3a 3b	4a 7c 9 14	1a 4b 16	17	4	2	2	4	II	
Thermal Conductivity - Liquid State	M	NM	↓	← Generally Applicable →			4	2	2	4	II	
Electrical Conductivity - Liquid State	M	NM	1 3a 3b	7c 9 14	1a 4b 16	17	5	2	1	6	I	
Technical "Wetting" Data - Liquid versus Solid	M	NM	↓	← Generally Applicable →			5	2	1	6	I	
Solubility of Gases in Liquid Metals	M		5 5a	11 14			3	2	2	3	III	
Solubility of Metals in Other Metals and Solvents	M		7a 13	11			4	2	2	4	II	
Expected Optical Properties of Oxides		NM		9			2	2	1	3	II	
"Softening" Temperature of Oxides		NM		9	4b		2	2	2	2	III	
Mechanical Properties of Whiskers	M	NM	1 3b 5a 6	4a 11	1a	2 3c 8	5	2	2	5	II	

EXPLANATIONS

Col. 2 and 3 M = Metals, NM = Nonmetallic Materials
Col. 4 to 7 I = Phase I Capability Development Experiments
I, II = Phase I Exploratory Advancing to Capability Development in Phase II
II, III = (a) Capability Development Starting in Phase II
(b) Exploratory Experiments for Phase III
III = Experiments Starting in Phase III

Numbers: Processes Code Numbers — correspond to the following:

<u>Code Numbers</u>	<u>Processes</u>
1	Production of Spheres
1a	Liquid Forming
2	Adhesion Casting
3a	Thin-Wall Hollow Spheres
3b	Thick-Wall Hollow Spheres
3c	Blow Molding
4a	Flat Membranes
4b	Drawing of Filaments
5	Metallic Foams
5a	Pressure Stiffened and Composite Foams
6	Composite Casting
7a	Single Crystal Growth from Solution
7b	Single Crystal Growth by Zone Melting
7c	Pulling of Single Crystals from the Melt
8	Growing of Whiskers
9	Amorphous Materials (Glasses)
10	Dispersed Particle Castings
11	Thermosetting Alloys
12	Supercooling
13	Supersaturated Alloys
14	Purification
15	Unit Separation Process
16	Containerless Melting of High-Temp Alloy
17	Superconductors

Underscoring:

(=) = Primary importance
(-) = Secondary importance or limited application
(no underscoring) = Applicable and beneficial but not mandatory

Col. 8 to 11 (Relative Ratings)
"Need" — (Functional significance, number of applications, target time)
"Problem" — Basic significance, effort for solution
"SOA" — State of art

The resulting final rating in Column 11 served as guide to the assignment of priorities in Column 12. They are distinguished as follows:

- Priority I: R&D efforts which should be started immediately, even in case of modifications in the experiment program. They represent problems of basic significance to space manufacturing.
- Priority II: R&D efforts which are likewise desirable for immediate activation, yet may be limited to studies and an effort level commensurate with available funds.
- Priority III: R&D efforts which will have to be initiated eventually, yet may be deferred at this time.

If funding limitations call for a finer distinction within each priority group, the relative rating numbers in Column 11 may serve as a guide for the identification of preferred topics.

3.7.2 DEFINITION OF AN R&D PROGRAM. On the basis of the foregoing identification and priority evaluation of supporting R&D requirements, the following program of R&D projects has been formulated. It is arranged in the order of the three defined priority levels. Within each disciplinary area, the projects are listed in the order of importance. The project statements for Priority I are somewhat more detailed; for Priorities II and III they are in the form of a topical listing.

3.7.2.1 Priority I R&D Projects

- Scope: R&D problems whose solution is imperative for the successful performance of any initial space experiment program.
- Type of R&D: Theoretical studies, engineering studies including conceptual designs, supported by laboratory investigations and free-fall experiments.
- Start Time: Immediate initiation desirable and necessary for the program defined in Section 3.6.

PH — Applied Liquid-State Physics

- (1) Theory of interfaces. Intermolecular forces, interfacial tension, relationships. Definition of the terms "surface tension" and "adhesion" of liquids.
- (2) Applied interface theory. Surface tension of liquids and its effect on bulk material and surface shape. Liquid-solid interface effects, such as "wetting" characteristics, adhesion and friction.
- (3) Interface effects applied to orifices and other tooling elements. Definition of design criteria.

- (4) Liquid membranes; intermolecular theory; stability, thickness limitations and intrinsic material flow. Expected properties of membranes after solidification.
- (5) Response of metallic and nonmetallic liquids to electromagnetic and electrostatic forces.

FM — Applied Fluid Mechanics

- (1) Sources and magnitude of intrinsic liquid motion (convection). Emphasis on the effect of variable surface tension.
- (2) Formation of the liquid sphere by intrinsic forces. Mechanism, relationships, criteria; oscillations and damping time; ultimately attainable dimensional accuracies for various g-conditions and sphere sizes.
- (3) Formation of thick-wall hollow spheres; criteria and relationships. Bubble behavior and its control.
- (4) Criteria in the formation of thin-wall hollow spheres by pressurization. Correlation with membrane theories, PH-4.
- (5) Liquid-solid and liquid-gas mixtures. Mixture stability; time to zero motion of activated mixtures; dispersion, coagulation and their control.

OM — Applied Orbital Mechanics

- (1) Definition of orbital g-levels as related to altitude, orbit characteristics, position of experiment.

SC — Solidification and Crystallization

- (1) Crystal growth from solution. Nucleation, crystal growth rates, crystal orientation, controls.
- (2) Effect of liquid motion upon crystal growth, orientation and perfection. Correlated with Project FM-1.
- (3) Solidification of immiscible liquids (supersaturated alloys). Effect of dispersion; correlation with FM-5.
- (4) Criteria for nucleation and crystal growth in molten nonmetallic inorganics (oxides).

TH — Thermodynamics

- (1) Heating requirements for various materials and experiment facilities in BTU and BTU/hr for single and continued experiments.

- (2) Cooling rates for various materials, masses and shapes by conductive and radiative heat transfer.
- (3) Contact-free heating and cooling methods for metals; comparison of effectiveness.
- (4) Contact-free heating methods for nonmetallic materials to temperatures up to 4500°F.
- (5) Vaporization rates of metallic and nonmetallic materials under various gas and pressure environments. Potential internal gas evolution.

MA — Materials

- (1) Whisker composite castings. Predicted properties in relation to materials, whisker content and orientation.
- (2) Theoretical prediction of the mechanical properties of foams, as related to cell size, wall thickness and dispersion; properties of reinforced and pressure-stiffened foams.
- (3) Definition of effective materials for single crystals and whiskers.
- (4) Definition of solutions for single crystal growth experiments from solution.
- (5) Promising compositions for supersaturated alloys; prediction of properties and definition of applications; correlation with SC-3.

TM — Tooling and Methods

- (1) Development of methods and tooling for the deployment and detachment of liquids; deployment nozzles for single small batch and continuous feeding; nozzle systems for the deployment of hollow spheres.
- (2) Methods and tooling for bubble-centering of thick-wall hollow spheres.
- (3) Design of elements for the feeding of liquid metals, including pressure and flow controls, cut-off devices.
- (4) Mixing techniques for liquid-solid, liquid-liquid and liquid-gas mixtures. Conceptual design of mixing devices.
- (5) Design and experimental demonstration of a contact-free electromagnetic positioning system operating at temperatures up to 3000°F. (Correlation with PH-5.)
- (6) Design and experimental demonstration of a contact-free electromagnetic system for positioning, moving, rotation of, and convection in, liquid metal spheres at temperatures up to 3000°F. (Correlation with PH-5.)
- (7) Design and laboratory demonstration of a liquid metal supply system, capable of melting and feeding, including pertinent control mechanisms.

- (8) Design of contact-free heating systems for metals and a maximum temperature of 3000° F. (Correlated with Project TH-3.)
- (9) Design of contact-free cooling systems for controllable cooling from 3000° F to 1000° F. (Correlated with Project TH-3.)
- (10) Techniques and tooling for foaming of metals by gas injection; control of cell size, dispersion.

DA — Data

- (1) Surface tension and viscosity of liquid metals and nonmetallic inorganics in a 500° F temperature range above the melting (softening) point; surface tension for vacuum and various gas environments.
- (2) Fundamental data on interfacial tensions; establishment of relationships for engineering solution of interface problems.
- (3) Vapor pressures of metals and nonmetals.
- (4) Electrical conductivity of metals and nonmetallic inorganics versus temperature to 500° F above melting (softening) points.
- (5) Technical "wetting" data for metallic and nonmetallic liquids in contact with various solids.

3.7.2.2 Priority II R&D Projects. The projects assigned to the second priority consist primarily of studies. From the technical viewpoint, their initiation concurrent with Priority I projects is desirable. However, a low rate of effort or deferment due to funding limitations will not impair the initial experiment program.

PH — Basic and Applied Liquid-State Physics

- (6) Interface mechanics of liquid-solid mixtures.
- (7) Interface criteria for immiscible liquid-liquid mixtures.
- (8) Effect of liquid motion and thermohomeogeneity upon resolution in unit separation processes.
- (9) Mechanism of ultrasonic bubble formation.
- (10) Electrophoresis. Migration rate of ions and colloidal particles.

FM — Applied Fluid Mechanics

- (6) Stability of immiscible liquid-liquid mixtures.
- (7) Movement of bubbles in liquid continuum; control.
- (8) Mechanics and means of bubble dispersion in foams; resulting foam cell geometry.

- (9) Mechanics of free-forming of liquids by induced forces.

OM — Orbital Mechanics

- (2) Trajectories and displacement of masses off vehicle mass center; resulting "holding" forces.
- (3) Deformation of liquids due to gravity gradient.

SC — Solidification and Crystallization

- (5) Solvents for crystal growth from solution.
- (6) Nucleation, crystal growth from melt; mechanism, variables, rates, control.
- (7) Control of crystal orientation and geometry.
- (8) Induced nucleation and crystallization; seed materials, dispersion, resulting microstructures.
- (9) Criteria for the formation of intermetallics from liquid-solid metal mixtures.

TH — Thermodynamics

- (6) Thermal gradients during cooling of liquid bodies and at liquid-solid interfaces.
- (7) Effect of vibrations upon internal gas evolution (bubble nucleation).
- (8) Thermal gradients encountered in unit separation processes.

MA — Materials

- (6). Particle materials (seeds) for induced nucleation and crystallization.
- (7) Coatings for wettability control of metals and nonmetals.
- (8) Promising compositions for thermosetting alloys.
- (9) Definition of membrane materials for structural, chemical and electronic applications.
- (10) Additives to oxides for control of optical and electronic properties; assessment of miscibility.

TM — Tooling and Methods

- (11) Contact-free positioning system for nonconductors. (Correlation with PH-5.)
- (12) Contact-free heating systems for nonmetallic materials. (Correlation with PH-5.)
- (13) Bubble sensing methods and devices for opaque materials.

- (14) Mold casting techniques; design of experiment mold assemblies.
- (15) Methods and tooling for contact-free induced convection.
- (16) Deployment of solid masses. Methods and tooling.
- (17) Tooling for suspension and shape control of molten pools by point-contacts.
- (18) Electrophoretic methods and tooling. (Correlation with PH-10.)
- (19) Membrane drawing techniques and tools.

DA — Data

- (6) Mechanical, physical and surface properties of whiskers.
- (7) Thermal conductivity of metals and nonmetals in the liquid state.
- (8) Emmissivity of metals and nonmetals in the solid and liquid state.
- (9) Solubility of metals in other metals and in solvents.

3.7.2.3 Priority III R&D Projects. The R&D requirements assigned to Priority III are either of lesser importance or permit a later activation date.

PH — Basic and Applied Liquid-State Physics

- (11) Fundamental definition of the liquid state; intermolecular forces in the continuum and in the surface region.
- (12) Spreading of liquids on solid surfaces. Interface relationships and effects. Liquid shapes at substrate discontinuities.
- (13) Diffusion of gases in liquid metals.

FM — Applied Fluid Mechanics

- (10) Liquid metal-fiber mixtures. Flow, drag forces, orientation and coagulation.
- (11) Flow of liquid metals in pipes; effect of discontinuities; flow control.

SC — Solidification and Crystallization

- (10) Criteria and methods for directional solidification.
- (11) Nucleation and crystal growth from the vapor phase; mechanism, growth rates, controls.

TH — Thermodynamics

- (9) Exothermic effects of solidification, particularly in single-crystal and whisker formation.

MA — Materials

- (11) Effect of oxide particle dispersions in metals.
- (12) Feasibility of membrane formation from heterogeneous materials; definition of materials and applications.
- (13) Definition of gas compositions for whisker growth from the vapor phase.

TM — Tooling and Methods

- (20) Methods and tooling for contact-free shape control. (Correlated with FM-9.)
- (21) Methods to prevent void formation during cooling and solidification. (Correlation with TH-5.)
- (22) Methods for cleaning of particles and fibers (prior to experiment).

DA — Data

- (10) Solubility of gases in liquid metals.
- (11) Expected optical and electronic properties of amorphous oxides (glasses).
- (12) "Softening" temperatures of oxides.

3.7.3 FREE-FALL EXPERIMENTS FOR R&D SUPPORT. In the performance of most R&D tasks, the primary difficulty is the almost complete absence of data on the behavior of matter under zero-g. Some qualitative information, primarily applicable to liquid-liquid and liquid-solid interaction may be derived from neutral-buoyancy experiments; liquid-gas interface phenomena, however, can only be simulated with two liquids. Data obtained by extrapolation from high g-levels in a centrifuge have only very limited usefulness and reliability.

Accurate data, which can be related to the specific properties of materials, can only be obtained under true zero-g conditions. Two methods can be used to generate zero- or low-g conditions in the terrestrial environment: vertical free-fall with a maximum practical time of five seconds, and aerial free-fall (Keplerian trajectory), either in an aircraft or in an aircraft-launched vehicle with a maximum time of 35 seconds. The vertical free-fall is preferred for the following reasons:

1. For the majority of problems, adequate data can be obtained within the limited time of the vertical free-fall.
2. Experimental conditions can be selected and defined precisely with a high degree of reproducibility.

3. Free-fall experiments are relatively simple and inexpensive to perform.
4. A number of directly applicable free-fall facilities are in existence within NASA.

An overview of the effectiveness of free-fall experiments for the investigation of typical R&D requirements is presented in Table 3-7 (p. 3-57). It shows, that free-fall experiments can provide all essential data on liquids and interface problems, as well as on the behavior of liquids, the related processing techniques, and on tooling details. Even on subjects which require longer times, such as the deceleration rate of mixtures or solidification effects, useful data can be obtained, either by measuring variations within the available time period, or by the use of very small material masses.

A suggested free-fall experiment program is outlined in Table 3-8 (p. 3-58). The classification of priorities is based on the following considerations:

1. Need of data, with regard to unavailability or their significance in first-priority processes and related R&D.
2. Experiment and equipment complexity. The program provides for a gradual increase of complexity and a maximum re-use of experiment units.
3. Existing installations in the 300-ft drop tower at MFSC.

The early initiation of a free-fall experiment program will not only enhance the confidence in the functional integrity of process concepts, but will substantially reduce the R&D cost by the elimination of extensive theoretical studies and unsuccessful approaches.

3.7.4 FACILITY DEVELOPMENT. The procedures for the planning, development, construction and check-out of space hardware are well established and require no further elaboration. The discussion of facility development requirements is, therefore, confined to (1) the identification of major components, (2) the correlation with research projects, (3) unconventional testing requirements and (4) a proposed hardware schedule.

3.7.4.1 Major Facility Components. The typical major components of a space manufacturing facility and the pattern of assembly are identified in Figure 3-12.

The processing chamber consists of an integrated assembly of the following components.

- (1) Chamber structure with access and viewing ports
- (2) Heating and cooling system
- (3) Pressurization and vacuum system
- (4) "Multiple Attachment Head" for subsystems and optional units
- (5) Power system
- (6) Control system and control panel.

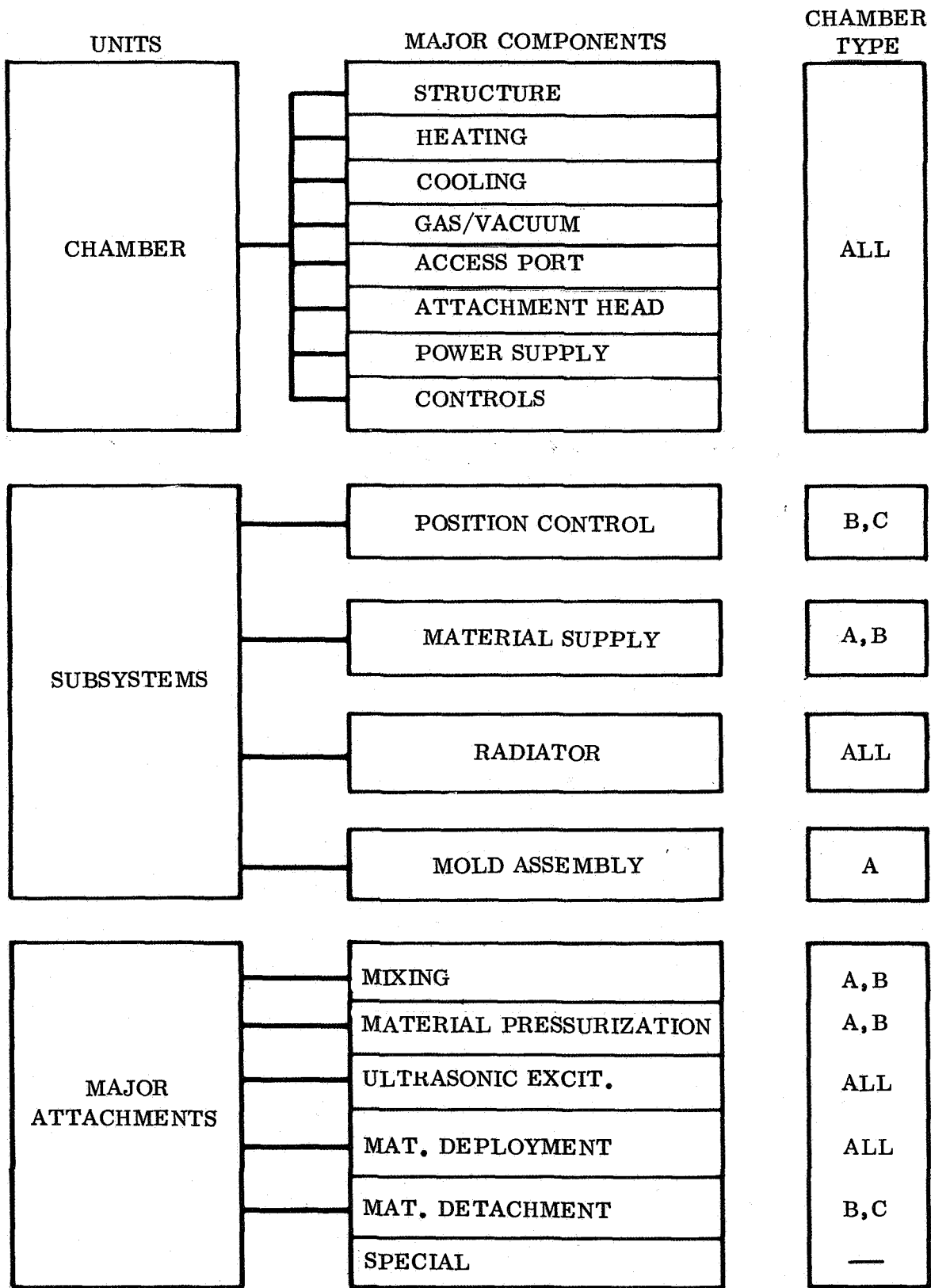

Figure 3-12. Typical Chamber Components

Typical major subsystems, either for temporary use or permanent assembly with the processing chamber are:

- (1) Contact-free position control systems
 - (a) Electromagnetic system for position control only
 - (b) Electromagnetic system for position control, heating and material activation
 - (c) Position control system for non metallic materials
- (2) Liquid material supply system, consisting of
 - (a) Melting chamber
 - (b) Feeding system
- (3) Heat exchanger for cooling cycle
 - (a) Internal - for heat storage and slow dissipation
 - (b) External radiator
- (4) Mold assembly for facilities Type "A".

Attachments, representing self-contained units for optional use:

- (1) Mixing unit
- (2) Ultrasonic excitation unit
- (3) Gas injection unit
- (4) Device for induced convection
- (5) Material deployment (nozzles) and detachment tools
- (6) Other attachments for specific processes or products

The relevancy of subsystems and attachments to the basic facility types is defined in the facility descriptions, Section 3.4 and indicated in Figure 3-12.

3.7.4.2 Development Requirements. The supporting research for tooling and facilities has been incorporated in the R&D program, Section 3.7.2. The most desirable correlation between R&D and facility development phases is as follows:

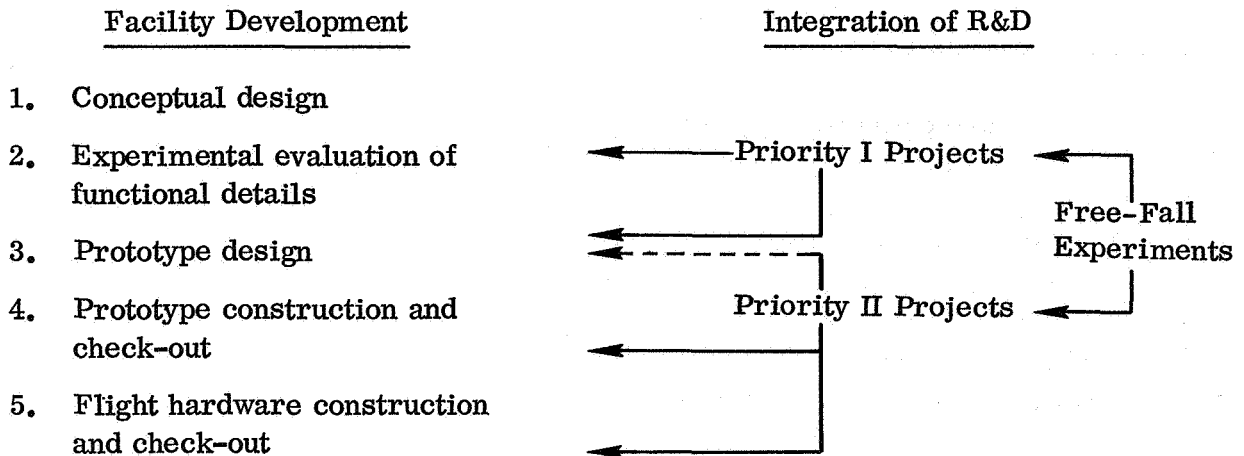

It will be the primary monitoring task to assure an effective cross-fertilization between R&D and facility development, integrating R&D results in the facility design, as well as adapting the R&D objectives to the increasing specificness of facility requirements.

While most of the involved laboratory investigations and tests are of a conventional nature, the proper functional and check-out of systems or individual tooling under zero-g calls for exceptional testing techniques and facilities. Numerous zero-g effects and tooling details can be effectively evaluated in equal-density model experiments. The final verification and the generation of accurate data can, however, only be obtained under actual zero- or low-g conditions. Free-fall experiments in drop towers or in aerial keplerian trajectories (Section 3.7.3, p. 3-51) will be an indispensable facility development tool.

3.7.4.3 Proposed Facility Program. A number of facility options have been defined in Section 3.4. Under the present conditions, the following facility development schedule appears to be most effective:

- I. First generation, to be developed concurrently:
 - (1) Full-size mold casting facility type "A" (2700° F)
 - (2) Medium-sized free-processing chamber type "b" with electromagnetic 2-coil position control system (3000° F)
 - (3) Small-size material supply system, to be used alternately with facility (1) and (2), or permanently attached to each facility
 - (4) Development of a sophisticated electromagnetic 6-coil position control, material activation and induction heating system, to be integrated in chamber "B" in II, below.
 - (5) Small, laboratory type facility "c" for the preparation of small glass samples (radiation heating - 4500° F)

Table 3-7 Effectiveness of Free-Fall Experiments

EXPERIMENT OBJECTIVE		EFFECTIVENESS		
		1	2	3
BEHAVIOR OF LIQUID	Formation of Liquid Bodies	X		
	Oscillations, Damping	X		
	Interfaces and Surface Stabilization	X		
	Variable Surface Tension	X		
	Absence of Convection		X	
	Behavior of Bubbles in Liquid Continuum	X		
	Spreading on Solid Surfaces		X	
	Formation of Monolayers	X		
	Formation of Multilayers			X
TECHNIQUES AND TOOLING	Liquid Management, Systems	X		
	Liquid Deployment, Tooling	X		
	Blowing of Hollow Bodies	X		
	Formation of Membranes		X	
	Foaming, Foam Stability	X		
	Mixing and Mixture Stability			X
	Induced Deformation		X	
	Positive Control		X	
SOLIDIFICATION	Crystallization - Polycrystalline			X
	Formation of Single Crystals			X
	Supersaturated Alloys			X
	Free Melting and Solidification			X
	Formation of Amorphous Oxides			X

Effectiveness Definition:

- 1 Useful quantitative data can be obtained within 2 to 4 seconds; material mass representative of full-scale behavior.
- 2 Verification of effects and/or qualitative data.
- 3 Experiments limited to either very small masses or only partial observation of a long-time process.

II. Second generation:

- (1) Large-size free processing chamber "B" (3000° F) with integrated position control, material activation and heating system I-4, above
- (2) Second-generation mold-casting facility with integrated large-capacity material supply system.
- (3) Medium-size free-processing chamber type "C" with dielectric heating and position control
- (4) Either external radiator serving all facilities, or apparatus for attached extravehicular operation of all large facilities and for facility transfer to a serpentuator

In view of their individual nature and purpose, single-process experiment packages type "P" are omitted. Concurrent development and deployment should present no difficulties, as they represent self-contained units.

Table 3-8 Proposed Free-Fall Experiment Program

1	2	3	4	5	6	7
Experiment Series	Experiments	Complexity	Priority			
			I	II	III	
A-1	Sphere Formation	Demonstration	X	1, 2		3
		Effect of Interface Tension	X	1, 2		3
A-2	Sphere Deployment	From Nozzle - Attached	X	1, 2		
		Inertia Detachment	XX	1, 2		
		Scale-up	XX		1, 2	
		Ultrasonic Detachment	XXX			1, 2
A-3	Sphere Oscillations	Attached to Nozzle	X	1, 2		
		Detached - Free Floating	XX		1, 2	
		Scale-up	XX		1, 2	
		Position Control	XXX			2, 3
A-4	Sphere Deformation	Inertia - Motion	XX		1, 2	
		Electromagnetic	XXX			2, 3
A-5	Convection	Relation to G-Levels	X	1		
		Induced Sphere Convection	XX	1		
		Induced Bubble Motion	X	1		
B-1	Blowing Techniques	Nozzle Configurations	X	1		
		Scale-up	X		1	3

Table 3-8 Proposed Free-Fall Experiment Program, Contd

1	2	3	4	5	6	7
Experiment Series	Experiments	Complexity	Priority			
			I	II	III	
B-2	Hollow Spheres	Thin (Membrane) Wall	X	1	3	
		Thick Wall	XX		1	3
B-3	Flat Membranes	Hollow Sphere Method	X	1	3	
		Roving Tool Method	XX		1,2	3
		Drawing	XXX			1,3
C-1	Membrane Stability	Bubbles in Liquid Continuum	X	1		
		Contacting Hollow Spheres	X	1	3	
C-2	Mechanical Foaming	Gas Injection	XX	1		3
		Continuous Mixing	XX		1	3
		Stirring - Ultrasonic	XXX			1,3
C-3	Nucleate Foaming	Nucleation Grid	X	1		
		Dispersed Nuclei	X	1		
		Scale-up	X	1		3
C-4	Reinforced Foam	Optimum Method C-2 or C-3	XX	1		3
D-1	Intrinsic Spreading	Flat Solid Surface	X		1,2	3
		Closed Mold	X		1,2	3
D-2	Induced Spreading	Continuous	XX		1,2	3
		Impact	XX		1,2	3
D-3	Thin Film Spreading	Monolayers	X		1,2	3
		Multilayers	XXX		1	3
E-1	Liquid Mgt. System	Chamber Configurations	X	1		
		Tubes	X	1		
		Valves	XX	1		
		Scale-up Complete System	XX		1	3
E-2	Position Control	Solid Sphere	XXX		0	
		Liquid Sphere	XXX		2	3
		Sphere Rotation	XXX		2	3
E-3	Mixing (Liquid-Solid)	Low Frequency Excitation	X	1		
		Continuous Mixing	XX		1	
		Ultrasonic Excitation	XXX			1

Table 3-8 Proposed Free-Fall Experiment Program, Contd

1	2	3	4	5	6	7
Experiment Series		Experiments	Complexity	Priority		
				I	II	III
F-1	Crystallization	From Solution	XX	1		3
		Single Crystal Growth	XXX			
G-1	Supersaturation	Homogenization	XX		1	3
		Supersaturated Alloys	XXX			
H-1	Containerless Melting	Metals	XXX			3
		Oxides (Glasses)	XXX			

EXPLANATIONS

Col. 4 Number of "X" denote degree of complexity (most "X" indicate highest complexity)

Col. 5 to 7 Priorities:

- I Quantitative data
- II Qualitative data or verification of Zero-g effects
- III Limited data or small material masses

Numbers in columns denote material class as follows:

- 0 Solid
- 1 Transparent room-temperature liquids
- 2 Room-temperature liquid metals (Hg, Ga)
- 3 Materials requiring melting

APPENDIX 1

TERMS AND SYMBOLS

DEFINITION OF UNCOMMON TERMS

In order to enhance exchange of information and to minimize repetitious explanations, it is necessary to agree on a number of terms and designations as applied to space manufacturing. The following terminology has proven to be most convenient in past studies and is recommended for future use:

Sphere	Full sphere, consisting of a spherical liquid or solid continuum and one single spherical interface with gas or vacuum
Bubble	Gas sphere in a liquid or solid continuum with one single interface
Hollow Sphere (Abbrev. H/S)	Self-explanatory, it may be considered as a combination of a sphere and bubble and has two interfaces. (Should no longer be referred to as bubble).
Thin-wall H/S	Hollow sphere consisting of a spherical membrane. (Like a soap "bubble" in past terminology)
Thick-wall H/S	Hollow sphere whose wall thickness is less than 0.5 OD. Wall thicknesses of more than 0.5 OD are considered a bubble-containing sphere.
Membrane	Unsupported liquid or solid film with interfaces so close that liquid bulk properties (viscosity) become insignificant and characteristics are solely determined by interface energies
Film	Liquid on a substrate (one liquid-gas and one liquid-solid interface)
Foam	Close-packed bubbles in a liquid continuum.
Cellular Foam	Foam without liquid continuum, consisting of membranes only

Casting	Forming in liquid state followed by solidification
Mold Casting	Forming in liquid state followed by solidification in mold
Free Casting	Forming in liquid state followed by solidification without mold
Blowing	Forming by pressurized gas
Blow Molding	Forming by pressurized gas against substrate (mold)
Liquid Management	Control of liquids (position, flow)
Closed System	Mechanical containing of materials from melting to solidification
Position Control	Counteracting drift due to low-g levels

FREQUENTLY USED SYMBOLS

a	Acceleration, cm/sec^2
A	Area, cm^2
C_D	Drag coefficient, $F_D / (\frac{1}{2} \rho V^2 A)$
F	Force, dyne
F_D	Drag force, dyne
F_I	Inertia force, dyne
F_P	Pressure force, dyne
F_{ST}	Surface tension force, dyne
F_V	Viscous force, dyne
h	length of cylinder longitudinal axis, cm
M	Mass, $\text{dyn}\cdot\text{sec}^2/\text{cm}$
p	Pressure, dyne/cm^2
R	Radius, cm
Re	Reynolds number, $\rho VR/\mu$
t	Time, sec

FREQUENTLY USED SYMBOLS (Contd)

V	Velocity, cm/sec
W	Weber number, $\rho R V^2 / \sigma$
x, y, z	Coordinate system

Greek Letters

α_1	Surface tension shape constant
μ	Dynamic viscosity, dyne-sec/cm ²
π	3.14159
ρ	Density, dyne-sec ² /cm ⁴
σ	Surface tension, dyne/cm
τ	Shear stress, dyne/cm ²

v

Subscripts

l	Liquid
max, min	Maximum, minimum

Notation

O()	Denotes quantity is "of the order of ()"
------	---

APPENDIX 2

REFERENCES

1. Specific References (Referred to in Part 1)

- 1-1. Rheinfurth, M. H., "Low Gravity Gradient Mechanics," Presentation made at meeting on Manufacturing Technology Unique to Zero Gravity Environment, Marshall Space Flight Center, November 1968.
- 1-2. Anonymous — U.S. Standard Atmosphere, 1962, NASA, Washington, D.C.
- 1-3. Eggleston, D. M., "Relative Orbital Motion and Stationkeeping," Convair Report GDC-ERR-1440, January 1970.
- 1-4. Partington, J. R., "An Advanced Treatise of Physical Chemistry, : Vol. II, "The Properties of Liquids," Longmans, Green and Co., Publishers, 1955.
- 1-5. Scriven, L. E. and Sternling, C. V., "The Marangoni Effects," Nature, Vol. 187, 1960, pp 186-188.
- 1-6. Paynter, H. L., "Time for a Totally Wetting Liquid to Deform from a Gravity-Dominated to a Nulled-Gravity Equilibrium State," AIAA Journal, Vol. 2, No. 9, September 1964, pp 1624-1630.
- 1-7. Lamb, Horace, Hydrodynamics 6th Edition 1932 or 1st American Edition 1945, New York Dover Publications, pages 475, 640, 641.
- 1-8. Hoerner, S. F., "Fluid Dynamic Drag," Published by the author, New Jersey, 1965.
- 1-9. Dryden, H. L., et.al., "Hydrodynamics," page 97, Dover Publications, Inc., 1956.
- 1-10. Dushman, S. and Lafferty, J. M., "Scientific Foundations of Vacuum Technique," Wiley & Sons, New York, 1962, pp 70-72.

2. Publications on Space Manufacturing (in Chronological Order)

- 2-1. Wuenscher, H. F., Serpenuator Patent, NASA Case 5344, 28 June 1965.
- 2-2. Wuenscher, H. F., Method of Making Homogeneous Material in a Zero Gravity, Patent, NASA Case 9902, 20 July 1966.

- 2-3. Wuenscher, H. F., Space Foundry Machine Patent, NASA Case MSF-20410, 20 July 1966.
- 2-4. Deutsch, George, Background Materials for Discussion of Processing Materials in Space, NASA Headquarters, 27 July 1967.
- 2-5. Wuenscher, H. F., "Low and Zero-g Manufacturing in Orbit," AIAA Paper 67-842, AIAA 4th Annual Meeting and Technical Display, 23 October 1967.
- 2-6. Steurer, W. H., "Orbital Manufacturing," report to NASA Research and Technology Advisory Subcommittee on Materials, 25 October 1967.
- 2-7. McCreight, L. R., Frost, R. T., and Steg, Leo, Proposal to Study the Preparation of Materials in Space, General Electric GE-N-10951, 24 April 1968.
- 2-8. "Zero-g Manufacturing — Products and Methods Development for Orbital Experiments," Convair proposal GDC-PIN 68-310, 24 May 1968.
- 2-9. Enzer, S., Shepphird, F. H., and Wahl, B. W., Considerations Affecting Opportunities for Space Manufacturing, Douglas Report DAC-58149, July 1968.
- 2-10. Steurer, W.H., and Roye, C. E., "Zero-g Manufacturing Process Concepts," Convair Report, July 1968.
- 2-11. Wuenscher, H.F., Conceptual Hermetically Sealed Elbow Actuator, NASA Tech. Brief 68-10300, August 1968.
- 2-12. Steurer, W.H., Requirements for Zero "g" Manufacturing Experiments, General Dynamics Proposal, 30 September 1968.
- 2-13. "Manufacturing Technology Unique to Zero Gravity Environment," Proceedings of Conference at NASA-MSFC, 1 November 1968.
- 2-14. Wahl, B. W., "Analysis of Selected Opportunities for Manufacturing in Space," Douglas Paper 10119, February 1969. Presented to the Sixth Space Congress 17-19 March 1969, Cocoa Beach, Florida.
- 2-15. "Experiment Module Concepts Study," Convair GDC PIN 69-092, May 1969.
- 2-16. Wuenscher, H. F., "Space Manufacturing Unique to Zero-g Gravity Environment," Marshall Space Flight Center Report No. S&D-ME-IN-69-4, May 1969.

- 2-17. McCreight, R. R., "Materials Processing in Space," Society of Aerospace Materials and Process Engineers, National Symposium on "Materials and Processes for the 1970's," 1 May 1969, pp 1131-1139.
- 2-18. Steurer, W. H., "Processing of Materials in Space," *ibid* pp 1109-1129.
- 2-19. "Space Processing and Manufacturing," Proceedings of Conference at NASA-MSFC, 21 October 1969.

3. Directly Applicable Bibliography

- 3-1. Larson, D.B., "The Structure of the Physical Universe," North Pacific Publishers, Portland, Oregon, 1960.
- 3-2. Ruzic, N. P., "The Case for Going to the Moon," A. P. Putnam's Sons, New York, 1965.
- 3-3. Hughel, T. J., "Liquids — Structure, Properties, Solid Interaction," (General Motors Conference, Warren Michigan, 1963), Elsevier Publishers, Amsterdam and New York, 1965.
- 3-4. Partington, J. R., "An Advanced Treatise of Physical Chemistry," "The Properties of Liquids," Longmans, Green and Co., Publishers, 1955.
- 3-5. "Chemistry and Physics of Interface," Proceedings of Symposium at Washington, D. C., 1964 (published by American Chemical Society 1965).
- 3-6. Burke, J. J., Reed, N. L., and Weiss, V., "Surfaces and Interfaces I — Chemical and Physical Characteristics," Proceedings of the 13th Sagamore Army Materials Research Conference, August 1966, Sagamore University Press, 1967.
- 3-7. Semenchko, V. K., "Surface Phenomena in Metals and Alloys," Pergamon Press, New York, 1961.
- 3-8. Weiss, P., "Adhesion and Cohesion," Elsevier Publishing Co., New York, 1962.
- 3-9. "Surface Energy Measurements," Conference, Institute of Metals, London, January 1968, (report in Metals and Materials, May 1968).
- 3-10. Boys, C. V., "Soap Bubbles and the Forces Which Mould Them," Lectures, London 1890; first published 1902; reprint Doubleday & Co., New York, 1959.

- 3-11. Cogan, H. and Rogers, M., "Fluid Mechanics and Heat Transfer Under Low Gravity," Symposium Proceedings, 24-25 June 1965.
- 3-12. Van Wazer, J. R., et al., "Viscosity and Flow Measurement," Interscience Publishers, 1963.
- 3-13. Chalmers, B., "Principles of Solidification," John Wiley and Sons, New York, 1964.

APPENDIX 3

INDIVIDUALS AND ORGANIZATIONS ENGAGED IN SPACE MANUFACTURING R&D

The publications listed in the last column refer to the identifications in Appendix 2.

Subjects	Individuals	Organizations	Publications
1. SURVEYS AND PLANNING STUDIES			
Processes and Experiments	Wuenschner Steurer	MSFC General Dynamics	2-5, 13, 16, 19, 20 2-6, 10, 13, 18, 20
Experiment Planning	Armstrong Bredt	Off. Manned Space Flight Off. Manned Space Flight	2-19
R&D Planning	Deutsch Nash	OART OART	2-4
2. THEORETICAL STUDIES			
Solidification	McKannan Fabiniak, R. T. Bannister Grodzka Roy Miller Tiller	MSFC Cornell MSFC Lockheed University of Alabama General Dynamics Stanford University	2-19 2-19 2-19 2-19 2-19
Process Fundamentals	Wahl Kober Shaw	McDonnell-Douglas Martin Carnegie-Mellon	2-9, 14 2-20
Fluid Mechanics	Steurer-Lanfranco	General Dynamics	2-20
Gas Management	Bauer	Georgia Tech.	2-19
Chemistry Applications	Fogarty Libby	Grumman UCLA	2-19 2-19
Orbital Mechanics	Rheinfurth Eggleston	MSFC General Dynamics	1-1 (2-13) 1-3
Fluid State Physics	O'Barr	General Dynamics	

Subjects	Individuals	Organizations	Publications
3. INDIVIDUAL PROCESSES AND PRODUCTS			
Spheres, Hollow Spheres	Frost Wechsler Buzzard	General Electric A. D. Little USAF	2-19, 20 2-19 2-13
Foams	Wuenschler Steurer-Wood	MSFC General Dynamics	2-5, 13, 16, 19, 20 2-10, 13, 18, 19, 20
Composite Casting	Steurer Wechsler	General Dynamics A. D. Little	2-13, 18, 19, 20 2-19
Containerless Melting	Frost Hoppe	General Electric MSFC	2-19, 20 2-19
Particle Composites	Mondolfo	Revere Copper & Brass	2-19
Filaments	Witt, Kloepper	Grumman	2-19
Single Crystal Growth	Utech Mazelski Arnett Kulshreshtha Mookherji Housley Henry Roy	Bureau of Standards Westinghouse MSFC MSFC Brown Engineering NAR General Electric University of Alabama	2-13 2-19 2-19 2-19 2-19 2-19 2-19 2-19
Whisker Growth	Utech Davis	Bureau of Standards Univ. of Alabama	2-13 2-19
Amorphous Oxides (Glasses)	Olsen Happe Deeg	NAR NAR American Optical	2-13 2-19 2-19
Sintering	McKannan Fabiniak, R. T.	MSFC Cornell	2-19 2-19
Supersaturated Alloys	Wuenschler Reger	MSFC TRW	2-13, 19, 20 2-19
Thermosetting Alloys	Steurer-Kaye Glasser	General Dynamics Chem. & Met. Res. Inc.	2-20 r
Superconductors	Pollock, Wald	Tyco Labs.	2-19
Unit Separation	McCreight Jordan Taylor	General Electric Martin Intern. Res. & Tech'y.	2-17, 19 2-19 2-19

Subjects	Individuals	Organizations	Publications
4. EXPERIMENT FACILITIES AND TOOLING			
Space Experiment Chambers and Tooling	Wuenschel-Yates Steurer-Gorham Parks Orr	MSFC General Dynamics MSFC MSFC	2-3, 5, 13, 19, 20 2-13, 19, 20 2-19 2-13
Position Control	Frost Wood	General Electric General Dynamics	2-19, 20
Heating and Melting	Hoppe Rasquin	MSFC MSFC	2-19 2-19
Serpentuator	Wuenschel Berge	MSFC MSFC	2-1, 5, 11, 13, 19 2-20
Free-Fall Experiments	Yates-Yost Steurer-Wood	MSFC General Dynamics	2-8

APPENDIX 4
GEOMETRIC SHAPES FORMED BY LIQUIDS AROUND
ORIFICES UNDER CONDITIONS OF ZERO GRAVITY

Assumptions:

1. Zero-g conditions (no gravity or acceleration effects).
2. No external force fields (partially includes 1).
3. No thermal gradients.
4. Equilibrium between:
 - a. Vapor-liquid exchange
 - b. Vapor-solid surface exchange
5. σ_{SV} , σ_{LS} and σ_{LV} known and assumed to be constants.
6. Pure elements and simple surfaces, i.e. no mixtures, concentrations, etc.

Under these conditions, the following equations are applicable:

1. $S_i = \sigma_S - \sigma_{SL} - \sigma_{LV}$
 $S_f = \sigma_{SV} - \sigma_{SL} - \sigma_{LV}$
 $\pi = \sigma_S - \sigma_{SV}$
 if $S \leq 0$, $\sigma_{SV} = \sigma_{SL} + \sigma_{LV} \cos \theta_e$
 $\therefore S = \sigma_{LV} (\cos \theta_e - 1)$
2. $\Delta P_{\text{(free surface)}} = \sigma_{LV} \left(\frac{1}{R} + \frac{1}{R} \right)$
3. $P_{V_R - V_\infty} \approx \left(\frac{\rho_V}{\rho_L - \rho_V} \right) \sigma_{LV} \left(\frac{1}{R} + \frac{1}{R} \right)$
 $P \rightarrow 0$

4. Various adsorption isotherms

$$1. \quad \ln \frac{P}{P_o} = \frac{-K}{n S}, \quad n = \frac{V}{V_m}, \quad S \approx 3$$

$$2. \quad \frac{V}{V_m} = \frac{CX}{(1-X)(1-X+CX)}, \quad X = \frac{P}{P_o}$$

Definition of Terms

S_i	= initial spreading coefficient
S_f	= final spreading coefficient
π	= spreading pressure
π_e	= equilibrium spreading pressure
σ_S	= surface tension for solid (no vapor present, etc)
σ_{SV}	= surface tension for solid and vapor interface
σ_{SL}	= surface tension for solid and liquid interface
ΔP	= change in pressure which occurs across a free surface interface. This change due to "surface tension".
$\Delta P_{V_R - V_\infty}$	= difference in equilibrium vapor pressure above a surface with a finite radius of curvature "R" compared to a flat surface ($R = \infty$).
C, S, K	= constants
V_m	= volume or number of monolayers

Equilibrium conditions will always result in the following:

1. All exposed vapor interfaces will have the same vapor-pressure balance.
2. All common bulk liquids will have equal internal pressures.

No. 2 requirement will result in the free surfaces of any common bulk liquid having the same curvature. (The particular curvature will be fixed by geometry, contact angles and volume of liquid involved, etc).

No. 1 requirement will mainly determine thicknesses of films on various exposed surfaces and give transport capability to the liquid. Also, non-connecting free surfaces will also have same curvature due to No. 1 requirement.

Special Points:

1. Thermal equilibrium will not be easy to maintain: evaporation from one point and condensation at another can cause violent shifts in temperature and overt effort will have to be taken (or long time periods) if true equilibrium is going to be reached.
2. Several different shapes or positions can often result - especially if the geometry is complicated. Normally, the condition or position which results in the lowest energy will predominate unless the approach to this position requires overcoming of energy barriers, etc.
3. External walls will always eventually predominate unless they are of different materials or kept at a different temperature, etc.

Case #1

FOR GEOMETRY SHOWN (FLAT FACE ORIFICE) AND WITH "S" POSITIVE (NO SURROUNDING SURFACES)

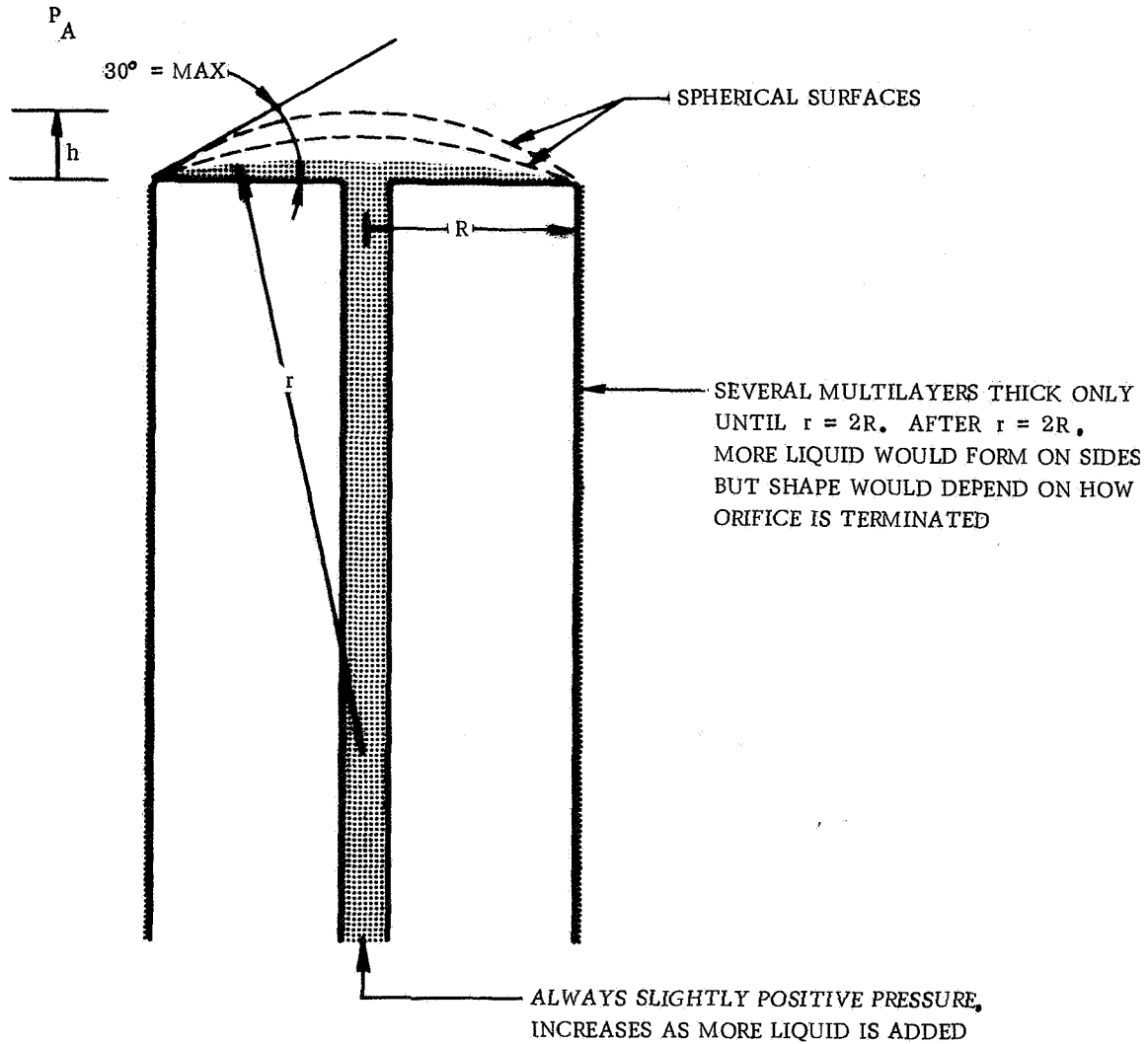

$$\left\{ \begin{array}{l} V_L = 2\pi h^2 \left(r - \frac{h}{3} \right) \\ h = r - \sqrt{r^2 - R^2} \end{array} \right.$$

$$\Delta P = \frac{2\sigma}{r}$$

$$P = \frac{2\sigma}{r} + P_A$$

Case #2

SAME GEOMETRY AS FOR 1 BUT S = NEGATIVE

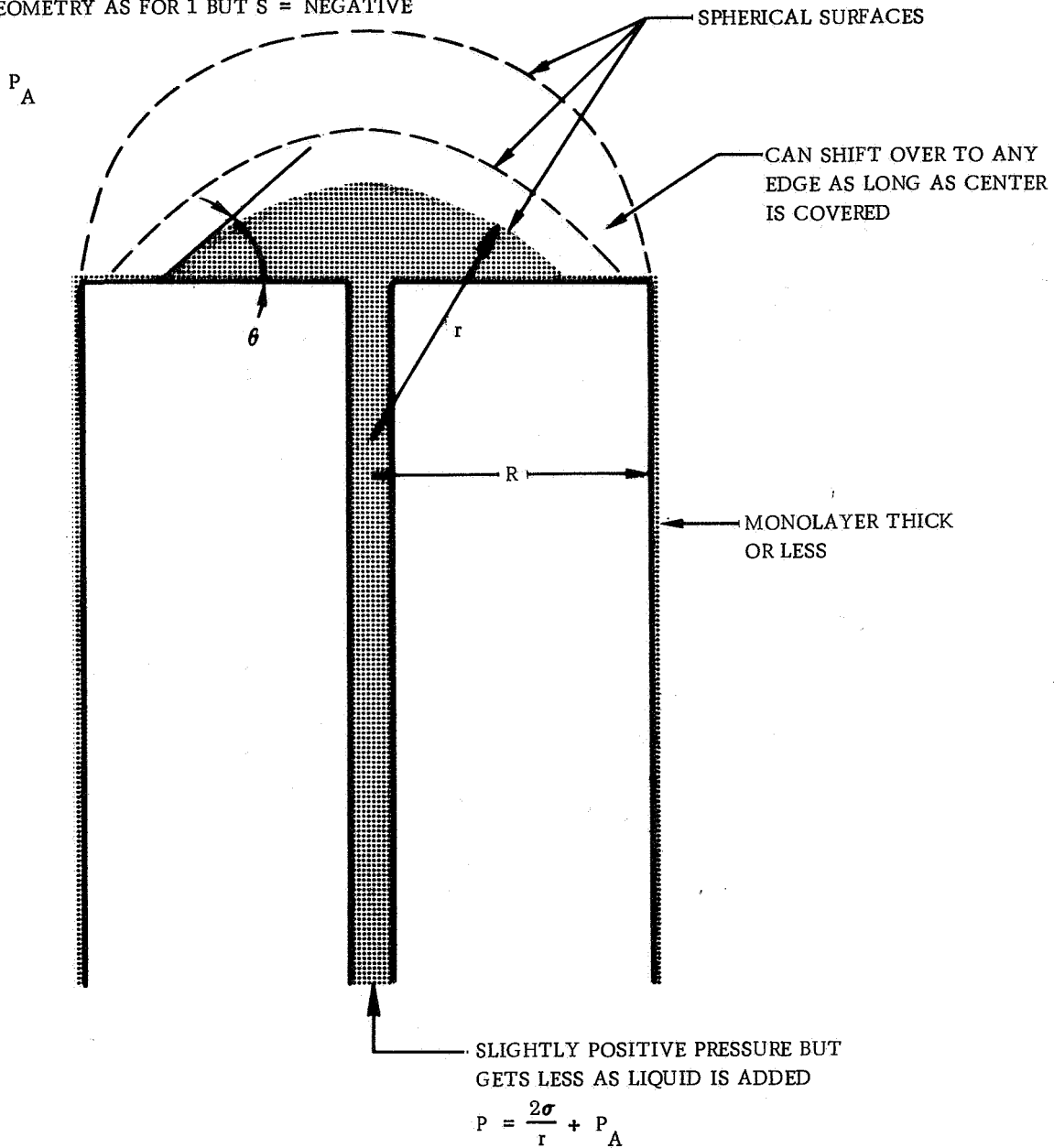

NON-STEADY STATE MAY EXIST WHILE r IS SMALL. EXACTLY WHERE STEADY STATE IS REACHED WOULD DEPEND ON SURROUNDING PRESSURE ISOTHERMS AND GEOMETRY, ETC.

θ IS CONSTANT UNTIL CORNERS ARE REACHED.

$$\cos \theta = \frac{\gamma_{SV} - \gamma_{SL}}{\gamma_{LV}}$$

AT CORNER: $\sin \theta_{\max} = \gamma_{SV} / \gamma_{LV}$

Case #3

FOR GEOMETRY SHOWN (CURVED ORIFICE) AND
WITH "S" POSITIVE (NO SURROUNDING SURFACES)

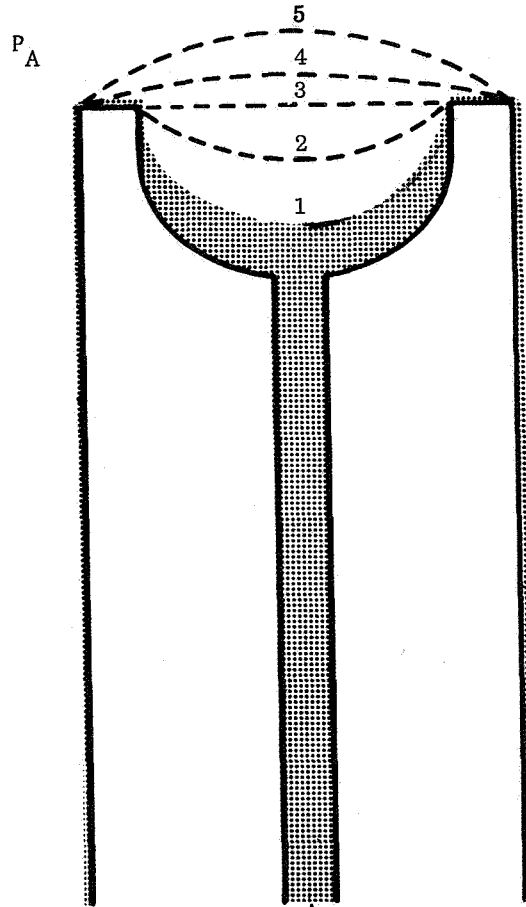

PRESSURE LESS THAN VAPOR PRESSURE, P_A , UNTIL
LINE 3 IS REACHED, THEN SAME AS CASE 1.

AFTER LINE 3 IS REACHED, GEOMETRY IS
THE SAME AS FOR CASE 1)

Case #4

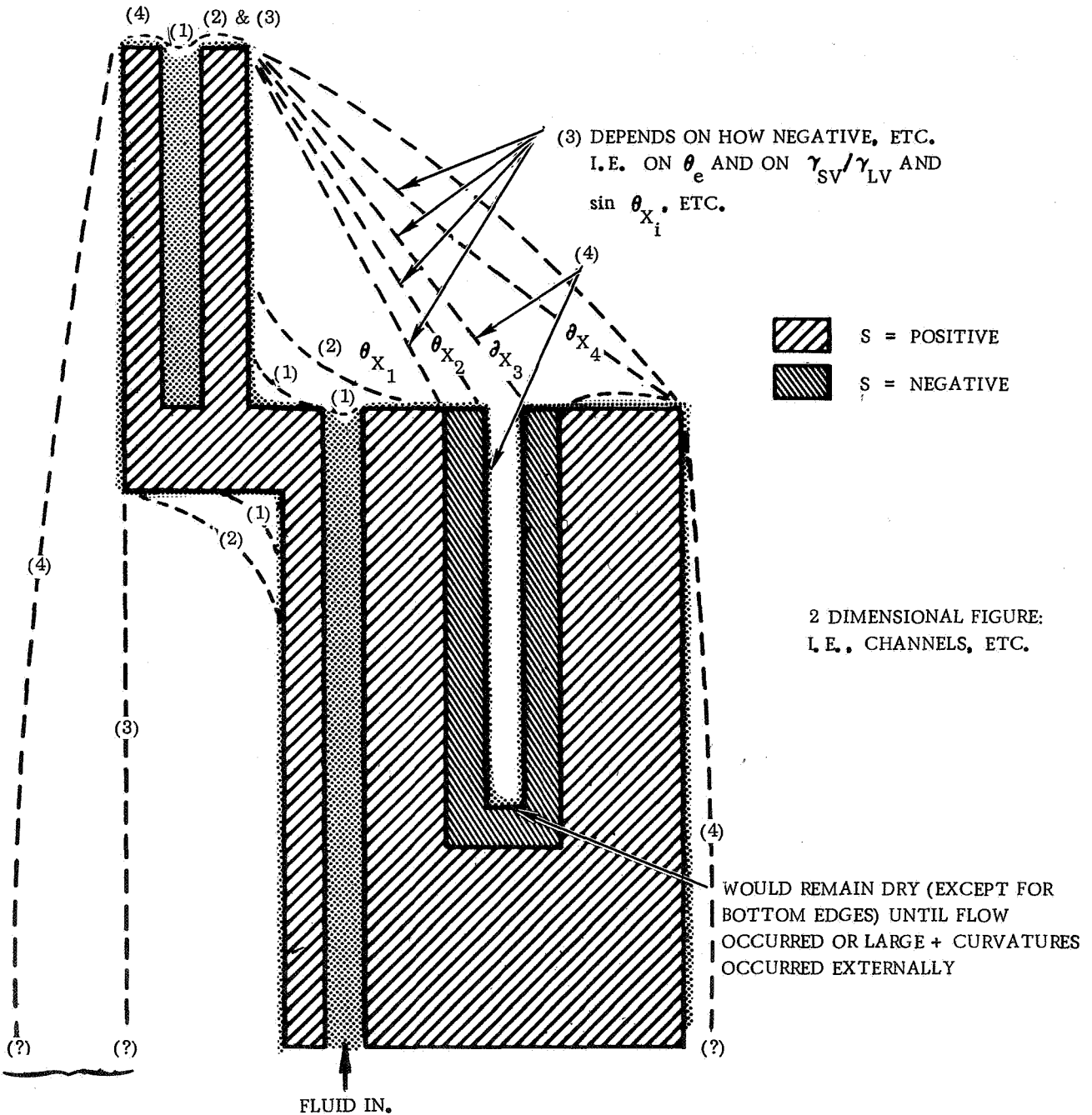

DEPENDS ON HOW
ORIFICE IS
TERMINATED

LEGEND: 1 AND 2 CONCAVE SURFACE
3 FLAT SURFACE
4 CONVEX SURFACE

References:

1. An Advanced Treatise on Physical Chemistry: Volume II.
2. ASTM Symposium on Properties of Surfaces (1963).
3. Fluid Behavior in Zero Gravity, I.A.C. 1962.

APPENDIX 5

NUMERICAL PROCESS/EXPERIMENTAL EVALUATION MATRIX

Process/Experiment Evaluation Chart

PHASE	MAJOR CRITERIA	CRITERIA	n	COMPUT.	n	COMPUT.	n
CONCEPT	A FEASIBILITY	a. FUNDAMENTAL		A = a·b		I CONCEPT	
		b. FUNCTIONAL					
	B EFFECTIVENESS	a. UNIQUENESS		$B = \frac{a+b}{2}$			
		b. POTENTIAL					
	C PRODUCTS	a. APPLICATIONS		$C = \frac{a+b}{2}$			
		b. CAPABILITIES					
DEVELOPMENT REQUIREMENTS	D RESEARCH	a. FUNDAMENTAL		$D = c \cdot \frac{a+b}{2}$		II DEVELOPM. REQUIREMTS.	
		b. MATS.-PROC.					
		c. EFFORT					
	E ENGINEERING	a. TOOLING		$E = c \cdot \frac{a+b}{2}$			
		b. COMMONALITY					
		c. EFFORT					
EXPT. INTEGRATION	F EQUIPMENT	a. HARDWARE		$F = \frac{a+b+c}{3}$		III EXPT. INTEGRATION	
		b. WEIGHT					
		c. COST/SCHEDULE					
	G OWS INTEGRA- TION	a. INSTALLATION		G = a·b			
		b. SUPPORT SYS.					
EXPT. OPERATION	H OPERATIONAL REQUIREMENTS	a. ASTRONAUTS		$H = \frac{a+b+c}{3}$		IV EXPT. OPERATION	
		b. POWER					
		c. LOGISTICS					
	J INTERFERENCE	a. ENVIRONMENT		$J = \frac{a+b}{2}$			
		b. ACTIVITIES					
V. TOTAL PROCESS/EXPERIMENT RATING				$R_n = I \cdot \frac{II+III+IV}{3}$			

I. CONCEPT EVALUATION

$$I = A \cdot B \cdot C$$

(Validity of process concept as basis for acceptance;
Rating of expected effectiveness.)

A. CONCEPT FEASIBILITY

$$A = a \cdot b$$

a. Fundamental

Fundamentally feasible — 100% sound	1.0
High probability	0.9
Questioned by some	0.8
Doubtful	0 (no-go)

b. <u>Functional</u>		
No problems foreseen — will work		1.0
Problems — approach to solution defined		0.9
Approach to solution undefined		0.8
Problems not yet defined		0.8
Functioning questionable		0 (no-go)
B. <u>CONCEPT EFFECTIVENESS</u>		$B = \frac{a + b}{2}$
a. <u>Uniqueness</u>		
Works only in space		1.0
Works better in space		0.9 - 0.6
Works also in space		0.5
b. <u>Potential</u>		
High potential — defined		1.0
High potential — undefined		0.9
Growth expected		0.9
Process ok, growth unexplored		0.8
Potential not established		0
C. <u>(CONCEPTUAL) PROCESS USEFULNESS</u>		$C = \frac{a + b}{2}$
a. <u>Product Identification</u>		
Products and Users defined		1.0
Products defined		0.9
Process capabilities will create products		0.8
Products not yet defined		0.6
b. <u>Product Capabilities</u>		
Capabilities can never be achieved in terrestrial production		1.0
Capabilities and cost effectiveness superior to present level		0.9
Capabilities <u>or</u> cost effectiveness superior		0.8
Equal to present capabilities, yet more growth potential		0.6 - 0.7
Equal to present capabilities		0.5

II. DEVELOPMENT REQUIREMENTS

$$\Pi = D \times E$$

(Minimum development required to achieve experiment-process capabilities.)

D. R&D REQUIREMENTS

$$D = c \left(\frac{a + b}{2} \right)$$

a. Fundamental

1.0

Within state of art

1.0

Application studies required

0.95

Problems which have to be solved

0.9

Some problems can not be clearly defined yet

0.8

Extensive R&D necessary

0.6

b. Methods and Materials

Defined; no applications problems

1.0

Some details have to be verified

0.95

Some problems have to be solved

0.9

Some details are not yet defined

0.8

Extensive R&D required

0.5

c. Effort Requirements

Experiment schedule can be met

1.0

Reasonable efforts required to meet schedule

0.9

High rate of effort required to meet schedule

0.8

Completion of tooling on time not assured

0

E. MANUFACTURING ENGINEERING

$$E = c \left(\frac{a + b}{2} \right)$$

a. Tooling Development

Within state of art

1.0

Special tooling required, no problems expected

0.95

Tooling problems — no conceptual solution yet

0.9

Complete new tooling to be developed

0.85

b. Tooling Commonality

Tooling applicable to other processes

1.0

Tooling partially applicable to other processes

0.95

Some tooling details potentially applicable

0.9

otherwise

Exclusive new tooling

0.8

c. Effort Requirements

Experiment schedule can be met	1.0
Reasonable efforts required to meet schedule	0.95
High rate of effort required to meet schedule	0.8
Completion of tooling on time not assured	0

III. EXPERIMENT INTEGRATION

$$III = F \times G$$

(Requirements for the transfer from development to OWS-integrated hardware.)

F. EXPERIMENT EQUIPMENT

$$F = \frac{a + b + c}{3}$$

a. Hardware Availability

Complete experiment apparatus for scheduled and future experiments can be built and checked-out within schedule	1.0
Complete apparatus for initial experiments available on time	0.95
Simplified apparatus available on time, to be augmented later	0.9
High effort rate required to meet initial experiment schedule	0.8
Availability on time possible, yet not assured	0.6

b. Weights (Complete Unit)

Below 200 lbs	1.0
200 — 500 lbs	0.95
500 — 2000 lbs	0.9
Over 2000 lbs	0.8

c. Cost

Below 250K	1.0
250 — 1000K	0.9
Over 1000K	0.8

G. OWS INTEGRATION

$$G = a \times b$$

a. Installation

No OWS modifications required	1.0
Minor modifications — no interference	0.9
Adaptable major modifications	0.8
Major modifications in OWS structure	0.6

b. Support Systems

Presently planned OWS systems adequate	1.0
Minor additions/modifications required	0.9
Major additions, capability increase or new systems required	0.7

IV. EXPERIMENT OPERATIONS

$$IV = H \times J$$

H. OPERATIONAL REQUIREMENTS

$$H = \frac{a + b + c}{3}$$

(Compatibility with presently planned OWS capabilities and operations.)

a. Astronaut Assistance

1 - 2 men, less than 100 mhrs/month	1.0
1 - 2 men, 100 - 250 mhrs/month	0.95
More men and/or mhrs/month required	0.8
No astronaut participation	0

b. Power

< 5 kwh -- 1.0 kw maximum	1.0
< 5 kwh -- 2.0 kw maximum	0.9
<10 kwh -- 3.0 kw maximum	0.8
Higher requirements	0.7

c. Logistics (Earth -- OWS/Per Year)

< 100 lbs supply, 50 lbs return	1.0
100 - 500 lb supply, 50 - 200 lb return	0.95
500 - 2000 lb supply, 200 - 500 lb return	0.9
Higher requirements	0.7

J. INTERFERENCES

$$J = \frac{a + b}{2}$$

a. OWS Environment (Contaminants, Heat)

None	1.0
Minute -- no special provisions required	0.95
Low -- minor provisions required	0.9
Substantial -- absorbing system required	0.7
High -- extensive provisions necessary	0.5

b. Operations

Independent operations, no interference	1.0
Requires careful scheduling to prevent interference	0.9
Interference — no other concurrent experiments possible	0.8

V. TOTAL EXPERIMENT RATING

$$R_n = I \times \left(\frac{II + III + IV}{3} \right)$$