

**NASA TECHNICAL
MEMORANDUM**

NASA TM X-52876
Volume IV

NASA TM X-52876
Volume IV

N.A.S.A. HISTORICAL ARCHIVES
NO.

SPACE TRANSPORTATION SYSTEM TECHNOLOGY SYMPOSIUM

IV - Propulsion

NASA Lewis Research Center
Cleveland, Ohio
July 15-17, 1970

1. Report No. TM X-52876 - Volume IV	2. Government Accession No.	3. Recipient's Catalog No.	
4. Title and Subtitle SPACE TRANSPORTATION SYSTEM TECHNOLOGY SYMPOSIUM IV - Propulsion		5. Report Date July 1970	6. Performing Organization Code
		8. Performing Organization Report No. E-5866	10. Work Unit No.
7. Author(s)		11. Contract or Grant No.	
		13. Type of Report and Period Covered Technical Memorandum	
9. Performing Organization Name and Address		14. Sponsoring Agency Code	
		12. Sponsoring Agency Name and Address National Aeronautics and Space Administration Washington, D. C. 20546	
15. Supplementary Notes Held at the NASA-Lewis Research Center, July 15-17, 1970			
16. Abstract The Symposium encompassed seven technical areas, each published in a separate volume of NASA Technical Memorandum X-52876: Volume I - Aerothermodynamics and Configurations (includes aerodynamics; atmospheric operations; and aerodynamic heating) II - Dynamics and Aeroelasticity (includes dynamic loads and response; aeroelasticity; and flight dynamics and environment) III - Structures and Materials (includes structural design technology; thermal protection systems; and materials technology) IV - Propulsion (includes main propulsion; auxiliary propulsion; and airbreathing propulsion) V - Operations, Maintenance, and Safety (Including Cryogenic Systems) (includes general and cryogenics) VI - Integrated Electronics (Including Electric Power) (includes system integration; data management, systems monitoring, and checkout; navigation, guidance, and control; communication, instrumentation, and display; and power subsystems) VII - Biotechnology			
17. Key Words (Suggested by Author(s))		18. Distribution Statement Unclassified - unlimited	
19. Security Classif. (of this report) Unclassified	20. Security Classif. (of this page) Unclassified	21. No. of Pages 378	22. Price* \$3.00

*For sale by the Clearinghouse for Federal Scientific and Technical Information
Springfield, Virginia 22151; also as microfiche
at \$.65 per copy.

FOREWORD

The prospect of undertaking a reusable launch vehicle development led the NASA Office of Manned Space Flight (OMSF) to request the Office of Advanced Research and Technology (OART) to organize and direct a program to develop the technology that would aid in selecting the best system alternatives and that would support the ultimate development of an earth-to-orbit shuttle. Such a Space Transportation System Technology Program has been initiated. OART, OMSF, and NASA Flight and Research Centers with the considerable inputs of Department of Defense personnel have generated the program through the efforts of several Technology Working Groups and a Technology Steering Group. Funding and management of the recommended efforts is being accomplished through the normal OART and OMSF line management channels. The work is being done in government laboratories and under contract with industry and universities. Foreign nations have been invited to participate in this work as well. Substantial funding, from both OART and OMSF, was applied during the second half of fiscal year 1970.

The Space Transportation System Technology Symposium held at the NASA Lewis Research Center, Cleveland, Ohio, July 15-17, 1970, was the first public report on that program. The Symposium goals were to consider the technology problems, their status, and the prospective program outlook for the benefit of the industry, government, university, and foreign participants considered to be contributors to the program. In addition, it offered an opportunity to identify the responsible individuals already engaged in the program. The Symposium sessions were intended to confront each presenter with his technical peers as listeners, and this, I believe, was substantially accomplished.

Because of the high interest in the material presented, and also because the people who could edit the output are already deeply involved in other important tasks, we have elected to publish the material essentially as it was presented, utilizing mainly the illustrations used by the presenters along with brief words of explanation. Those who heard the presentations, and those who are technically astute in specialty areas, can probably put this story together again. We hope that more will be gained by compiling the information in this form now than by spending the time and effort to publish a more finished compendium later.

A. O. Tischler
Chairman,
Space Transportation System
Technology Steering Group

CONTENTS

	Page
FOREWORD	iii
<u>MAIN PROPULSION</u>	
OVERVIEW AND OBJECTIVE	
H. G. Paul, NASA-Marshall Space Flight Center	vi
TECHNOLOGY CONSIDERATIONS FOR MAIN ENGINE SPECIFIC IMPULSE	
D. L. Kors, Aerojet Liquid Rocket Company	27
TECHNOLOGY FOR SPACE SHUTTLE MAIN ENGINE CONTROL, CHECKOUT AND DIAGNOSIS (GP 70-232)	
L. D. Emerson and B. C. Miller, Pratt & Whitney Aircraft	57
REGENERATIVE COOLING OF THE SPACE SHUTTLE ENGINE	
Henry C. Wieseneck, North American Rockwell, Rocketdyne Division.	90
TECHNOLOGY ISSUES FOR SHUTTLE MAIN ENGINE - STAGE INTEGRATION	
A. L. Worlund, T. W. Winstead, and W. B. McAnelly, NASA-Marshall Space Flight Center	122
<u>AUXILIARY PROPULSION</u>	
SPACE SHUTTLE REACTION CONTROL SYSTEM REQUIREMENTS	
Henry O. Pohl, NASA Manned Spacecraft Center	145
LOW PRESSURE OXYGEN-HYDROGEN AUXILIARY PROPULSION SUBSYSTEMS	
Lloyd F. Kohrs, McDonnell Douglas Corporation	163
SPACE SHUTTLE HIGH PRESSURE AUXILIARY PROPULSION SYSTEM	
H. L. Burge and J. Cuffe, TRW Systems Group, and A. Shaffer, Airesearch Manufacturing Company	189
TECHNOLOGY FOR THE DEVELOPMENT OF A GASEOUS HYDROGEN - GASEOUS OXYGEN APS ENGINE FOR THE SPACE SHUTTLE	
Albert Seidel, Messerschmitt-Bölkow-Blohm, Germany	225
SPACE SHUTTLE AUXILIARY PROPULSION TECHNOLOGY REQUIREMENTS	
Keith D. Coates, NASA-Marshall Space Flight Center	251
SPACE SHUTTLE AUXILIARY PROPULSION TECHNOLOGY PLANS	
Donald L. Nored, NASA-Lewis Research Center	265
<u>AIR BREATHING PROPULSION</u>	
ENGINE DESIGN AND TECHNOLOGY REQUIREMENTS	
Warner L. Stewart, NASA-Lewis Research Center, William R. Collier, General Electric Company, Lindsay G. Dawson, Rolls-Royce, England, and Charles L. Joslin, Pratt & Whitney Aircraft	291

OVERVIEW AND OBJECTIVE

H. G. Paul

NASA-Marshall Space Flight Center
Huntsville, Alabama

Propellant massfractions of projected Space Shuttle stages are around 0.8 for the shuttle booster and 0.7 or less for the orbiter; in comparison the Saturn-V first stage has a propellant massfraction of 0.94.

IA

For a given vehicle velocity increase ΔV , propellant massfraction and specific impulse are related in FIG 1. High massfractions permit lower specific impulse; but low propellant massfraction must be compensated by high specific impulse. (Items needed for reuse and aircraft-type operational flexibility, and adding inert weight are marked by open circles.)

SPECIFIC IMPULSE VERSUS MASS FRACTION

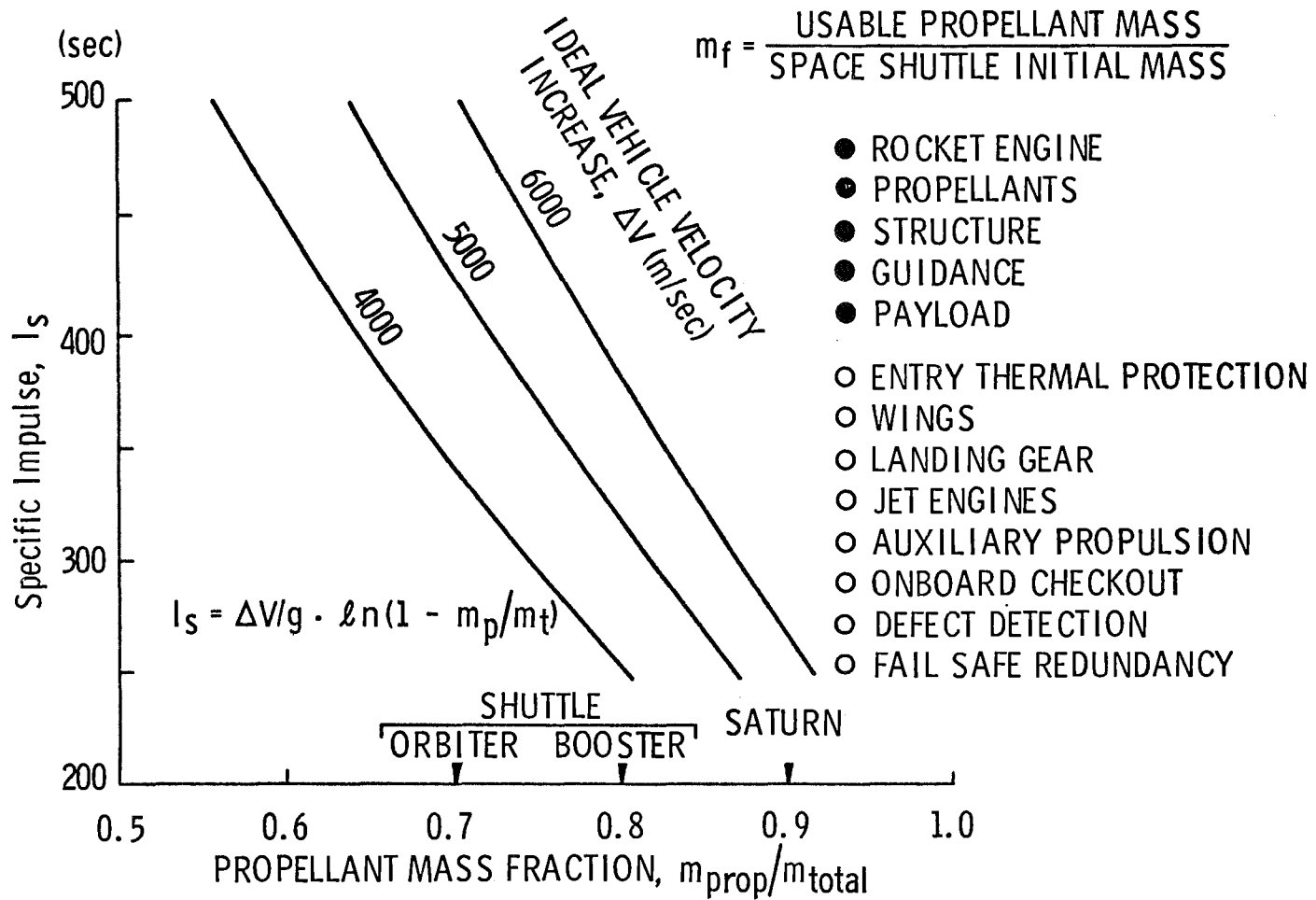

A high energy propellant combination, like $\text{LH}_2 - \text{LO}_2$, provides high specific impulse. Improvements in spec. impulse can be obtained from increased nozzle exit to throat area ratios as shown in FIG 2. At large area ratios, however, small increases in spec. impulse require relatively large increases in nozzle exit area if chamber pressures are kept constant, and impose undesirable envelope and weight penalties.

SPECIFIC IMPULSE VERSUS NOZZLE AREA RATIO

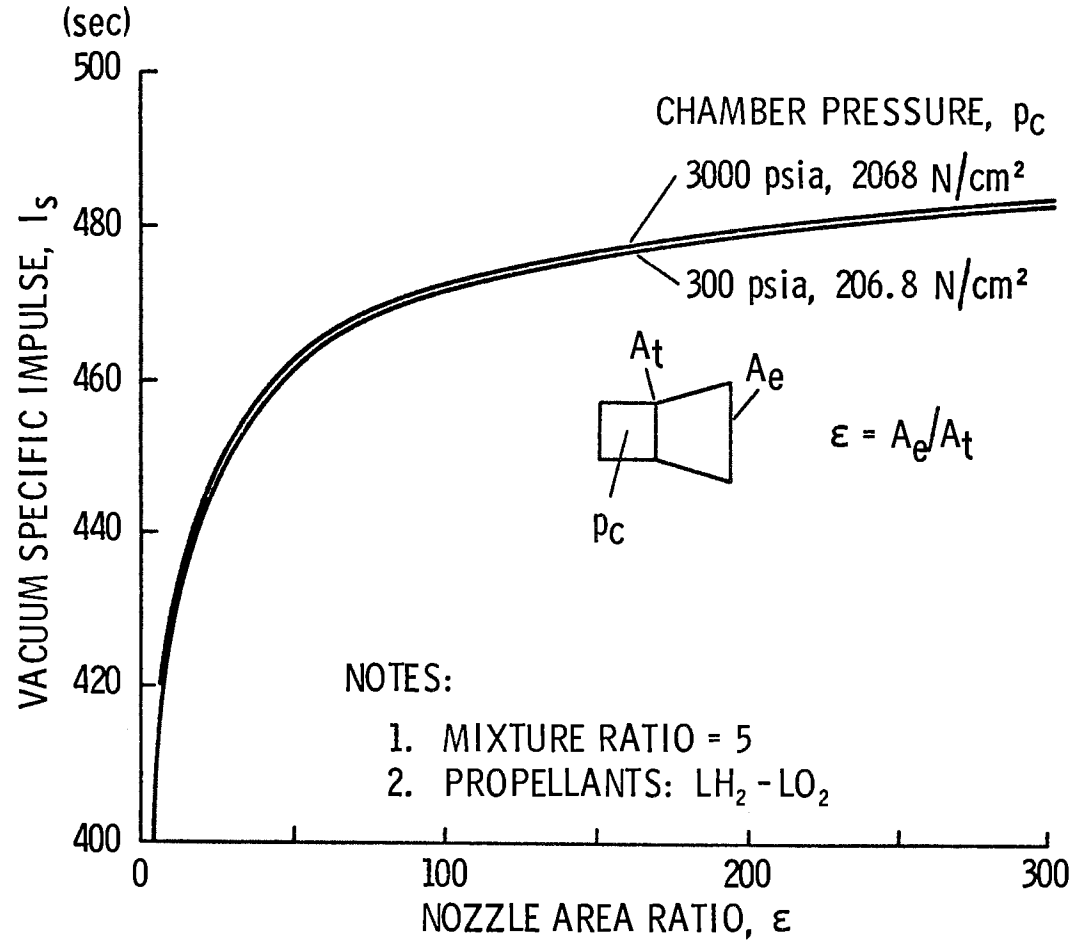

To obtain high spec. impulse from large area ratios while minimizing nozzle exit area, chamber pressure must be high. Increasing the chamber pressure from 1000 to 3000 psi as shown in FIG 3. reduces the exit area by almost two-thirds.

EXIT AREA TO THRUST RATIO OVER CHAMBER PRESSURE

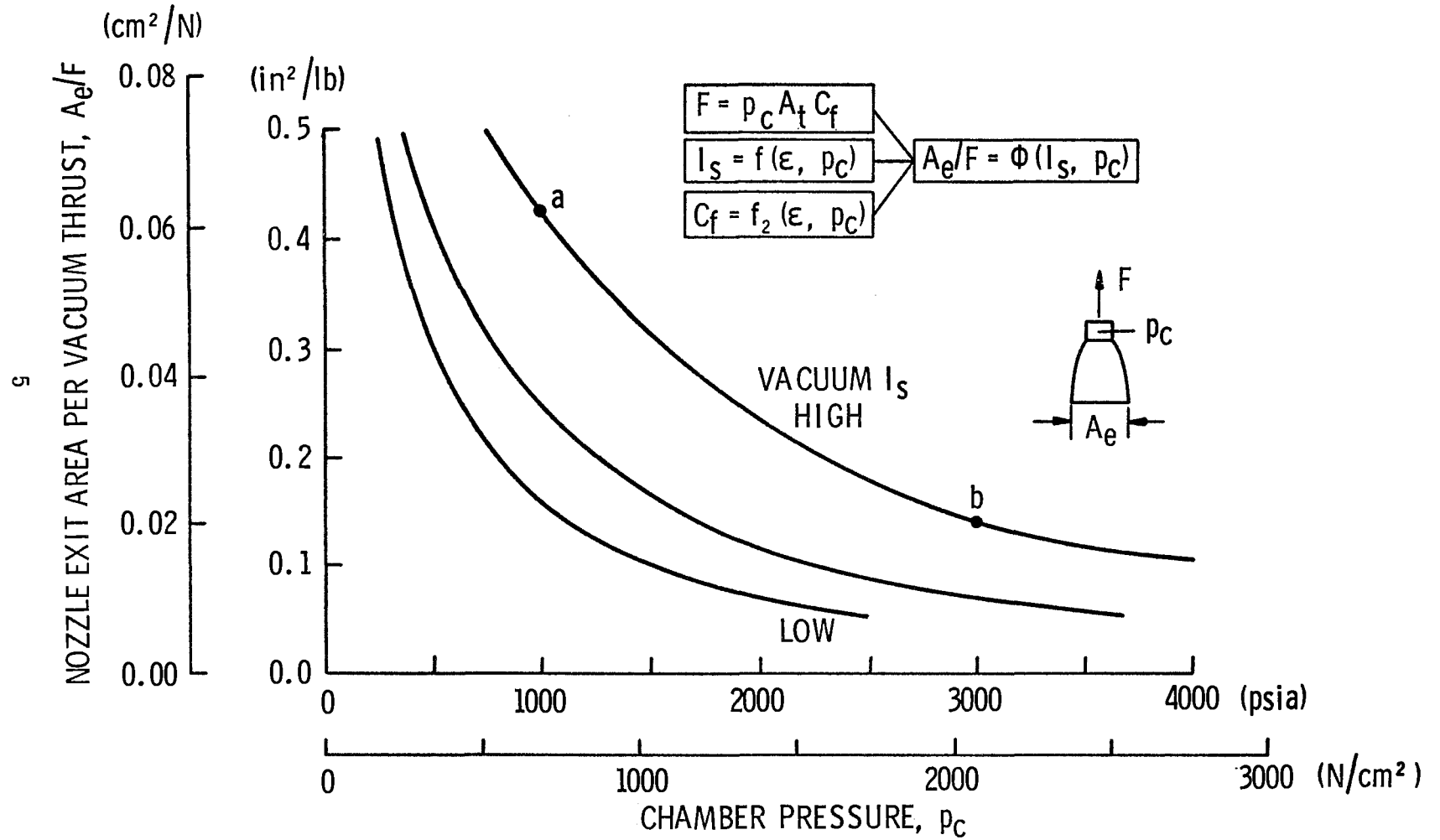

The ratio of dry engine weight to vacuum thrust over the ratio of nozzle exit area to vacuum thrust is plotted in FIG 4. for several H₂ - O₂ rocket engines. A trend of decreasing engine weight for decreasing nozzle exit area can be seen. The square indicates target values for the Space Shuttle main engine.

LH₂-LO₂ ENGINE WEIGHT VERSUS NOZZLE EXIT AREA

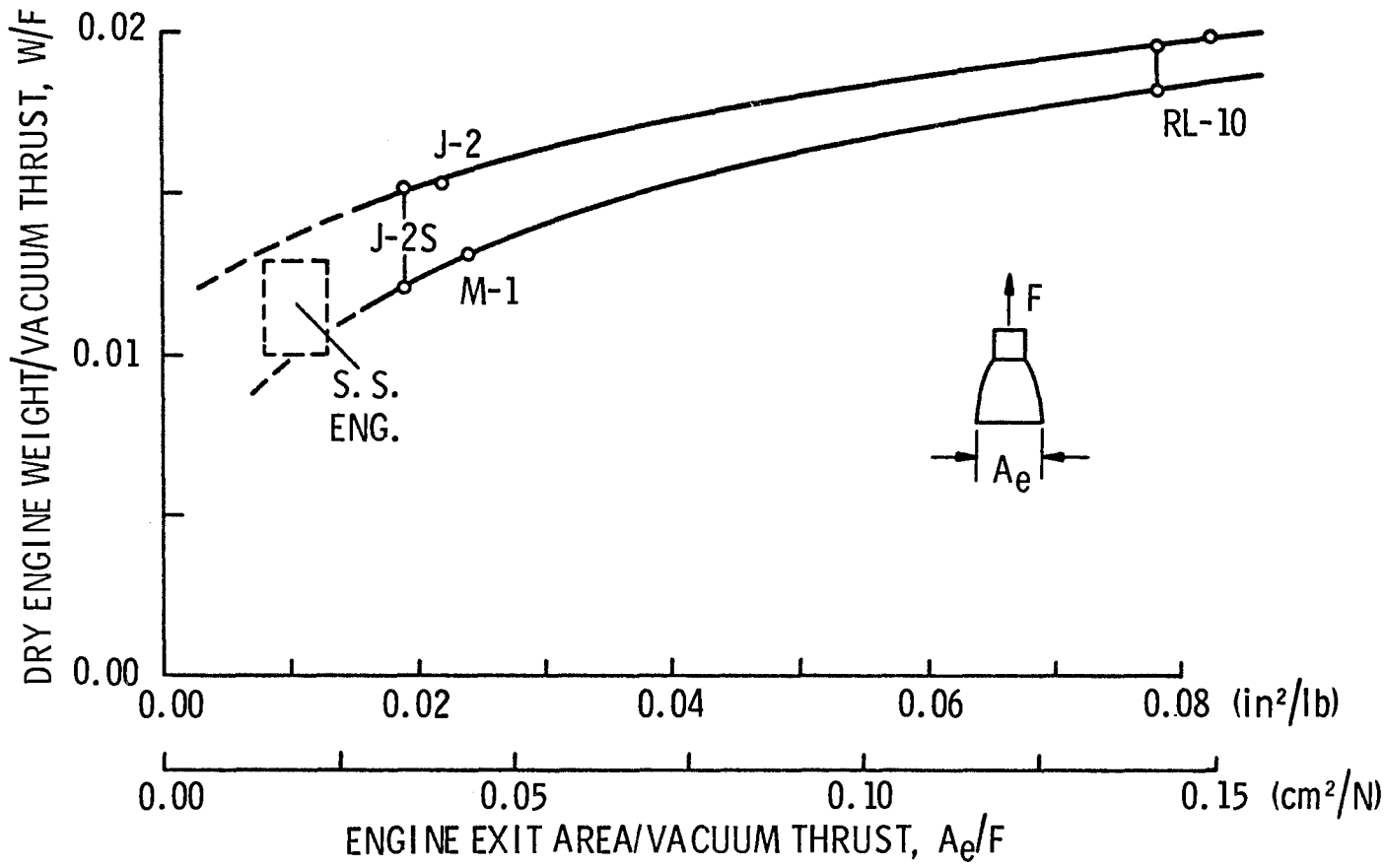

4

∞

For constant values of vacuum specific impulse FIG 5. relates chamber pressure, nozzle exit area for unit vacuum thrust, and engine dry weight for unit vacuum thrust.

It is shown that nozzle compactness, low engine dry weight, and high specific impulse result from increased chamber pressures.

RELATION OF DRY WEIGHT , SPECIFIC IMPULSE, AND CHAMBER PRESSURE

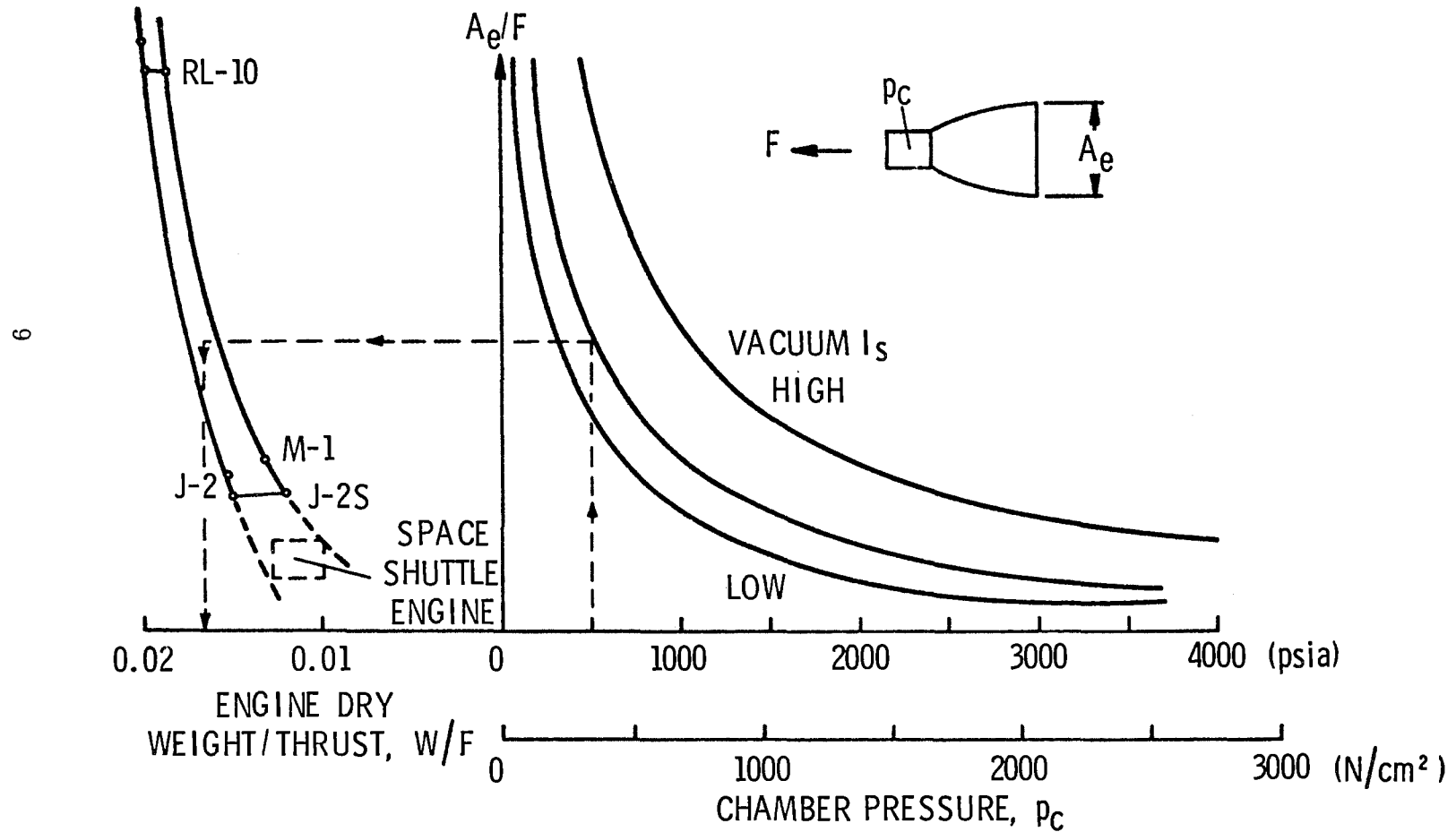

High chamber pressures require increased turbine power (~ 100,000 kw for 500 k lb thrust at Pc 3000 psi) for propellant pump feeding and a turbine power generation scheme with minimum or no losses.

The fuel-rich turbine working fluid flows separately and parallel to the main propellants in the gas generator cycle and in series from the turbine combined into the propellant total through the main combustion chamber in the preburner cycle as illustrated in FIG 6.

GAS GENERATOR AND PREBURNER SYSTEMS (SIMPLIFIED)

11

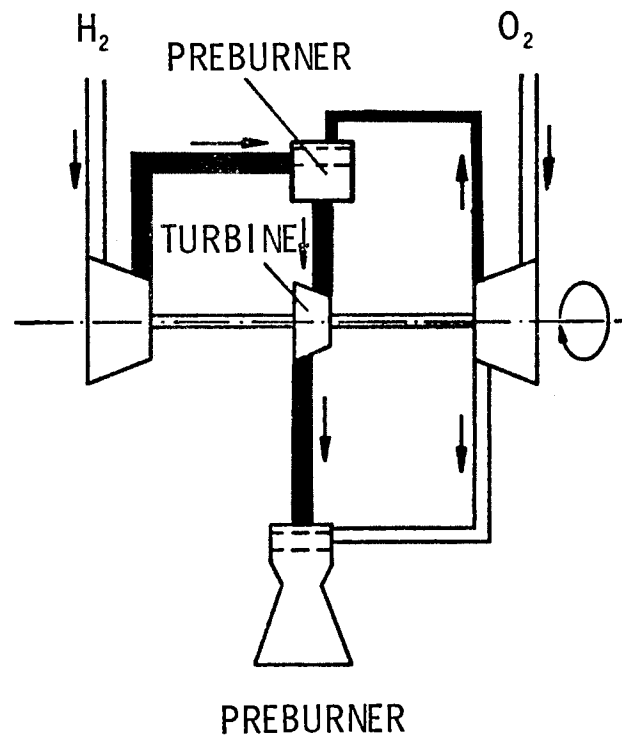
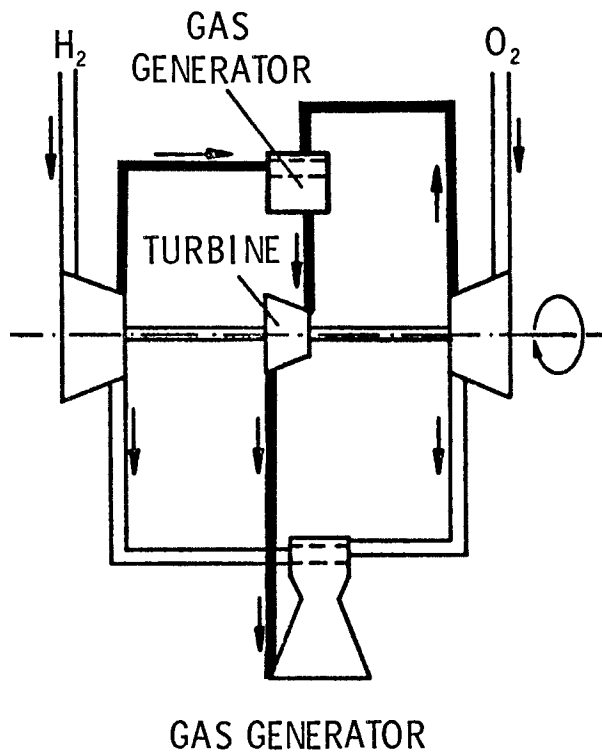

The preburner cycle (see FIG 7.) offers higher specific impulse than the G. G. cycle, but requires pump discharge pressures about twice the chamber pressure (at 3000 psi) for providing pressure drop across the turbine and shaft power.

SPECIFIC IMPULSE AND PUMP DISCHARGE PRESSURES

18

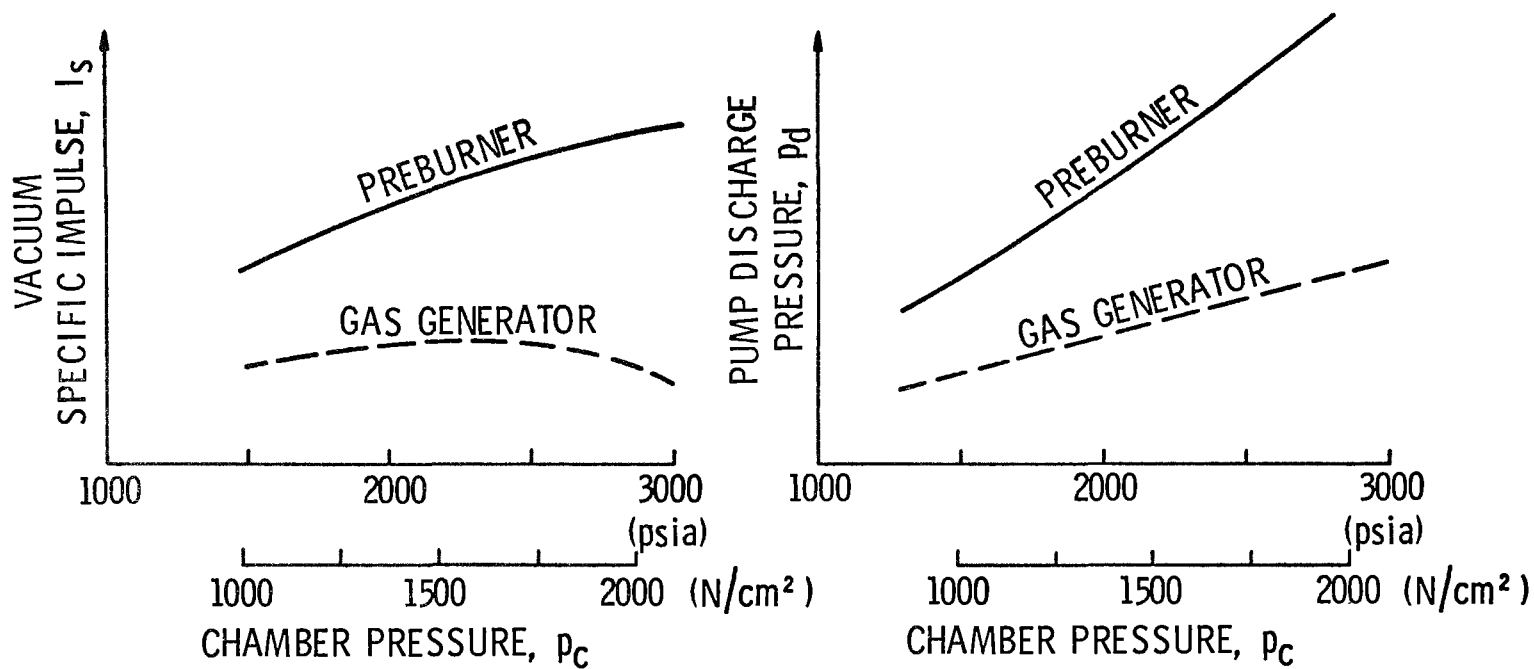

High pump discharge pressures call for increased head rises from the individual pump stages and for increased impeller tip speeds to minimize number of pump stages and pump weight.

Tip speed trends for LH₂ pumps are given in FIG 8; trends for bearing dn-values and shaft seals are similar.

TIP SPEED TREND

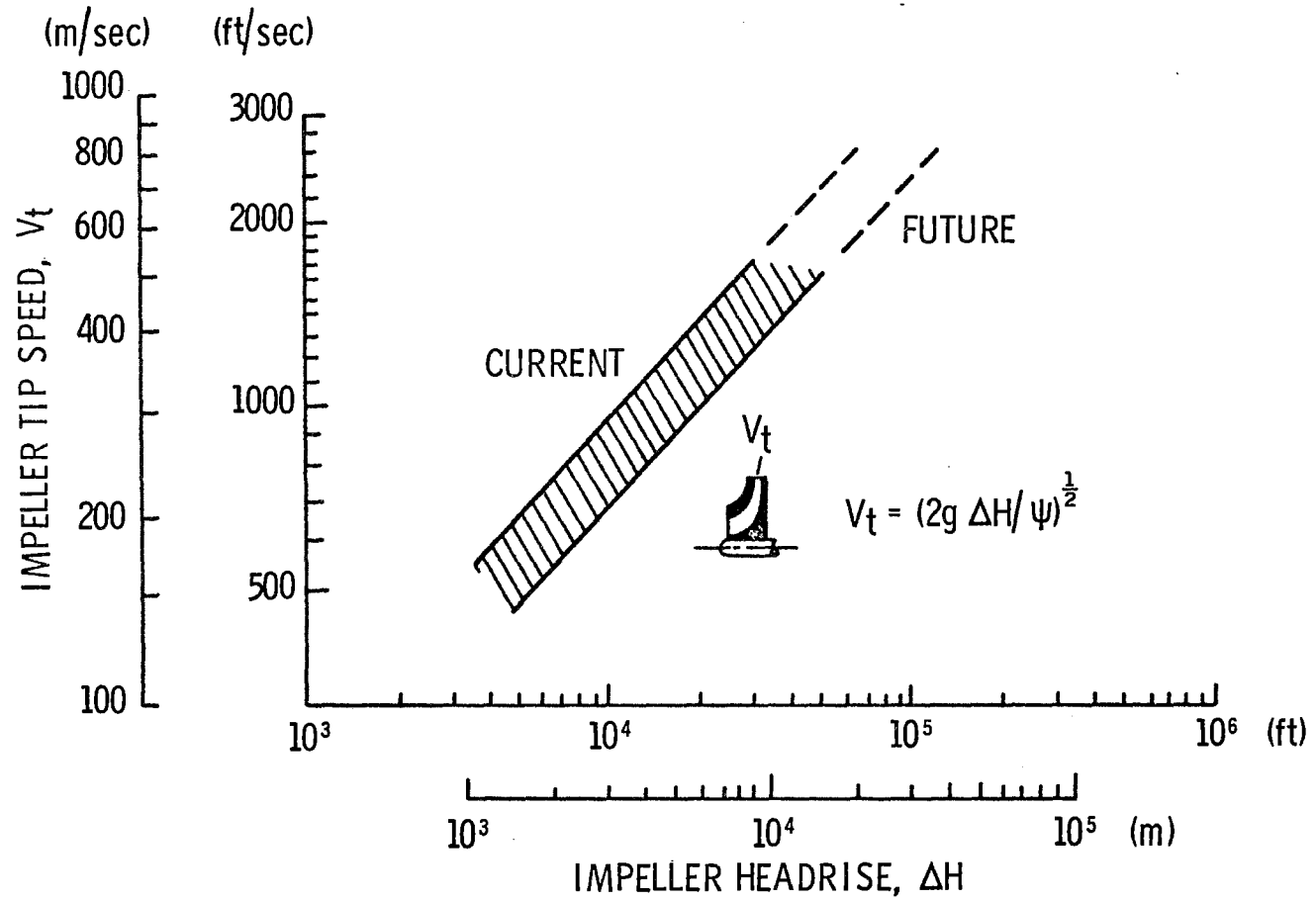

A two-stage LH₂ pump for 350 K (lb) thrust, operating at tip speeds of around 2500 (ft/s) and 6000 psi discharge pressures is shown on FIG 9. Several such LH₂ and LO₂ pumps have been built and successfully run.

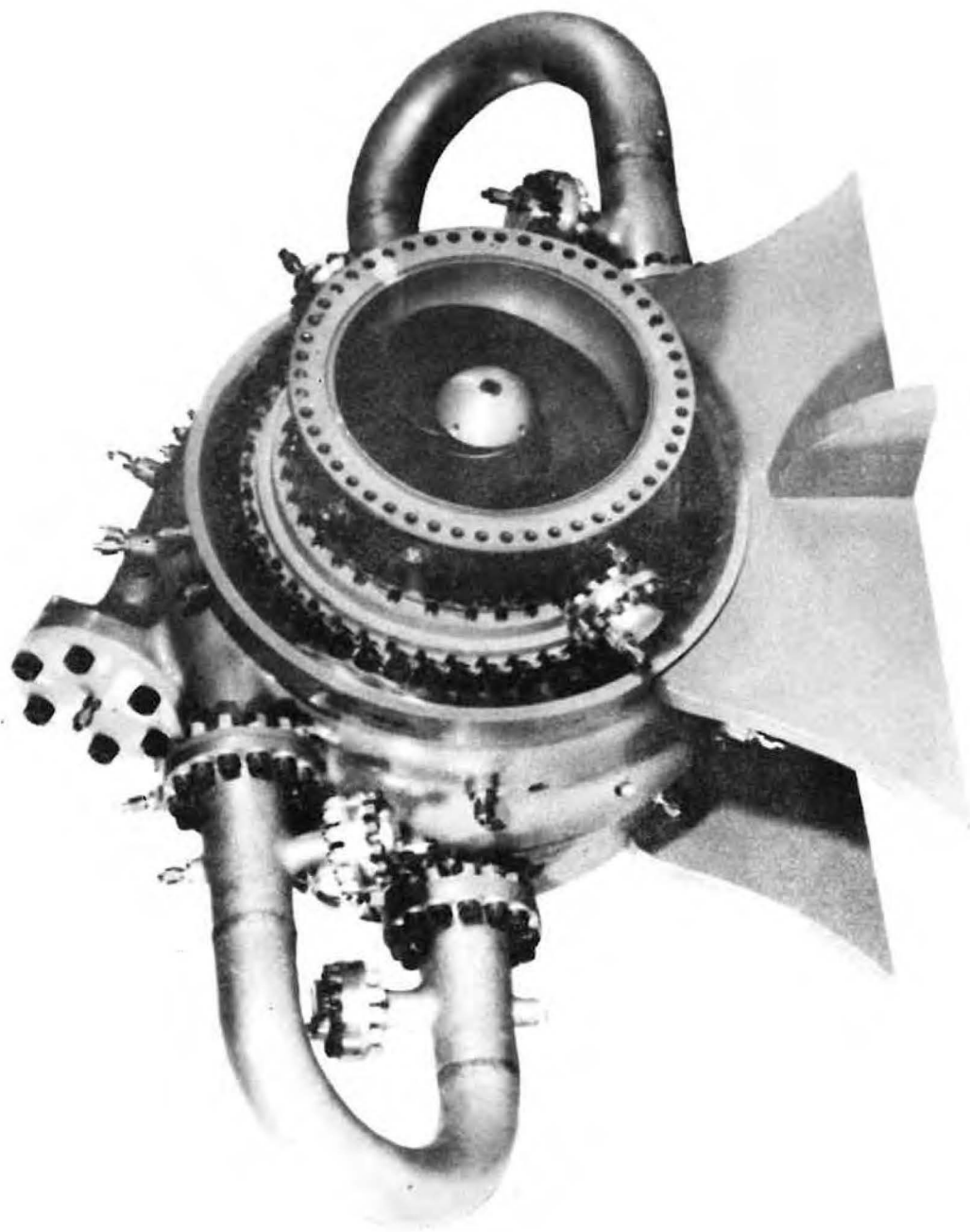

HIGH PRESSURE LIQUID HYDROGEN PUMP

High chamber pressures increase gas side heat transfer and likewise throat heat flux rates which are estimated in FIG 10 for chamber pressures of interest.

Regeneratively cooled thrust chambers were successfully fired at very high chamber pressures.

THROAT HEAT FLUX TREND

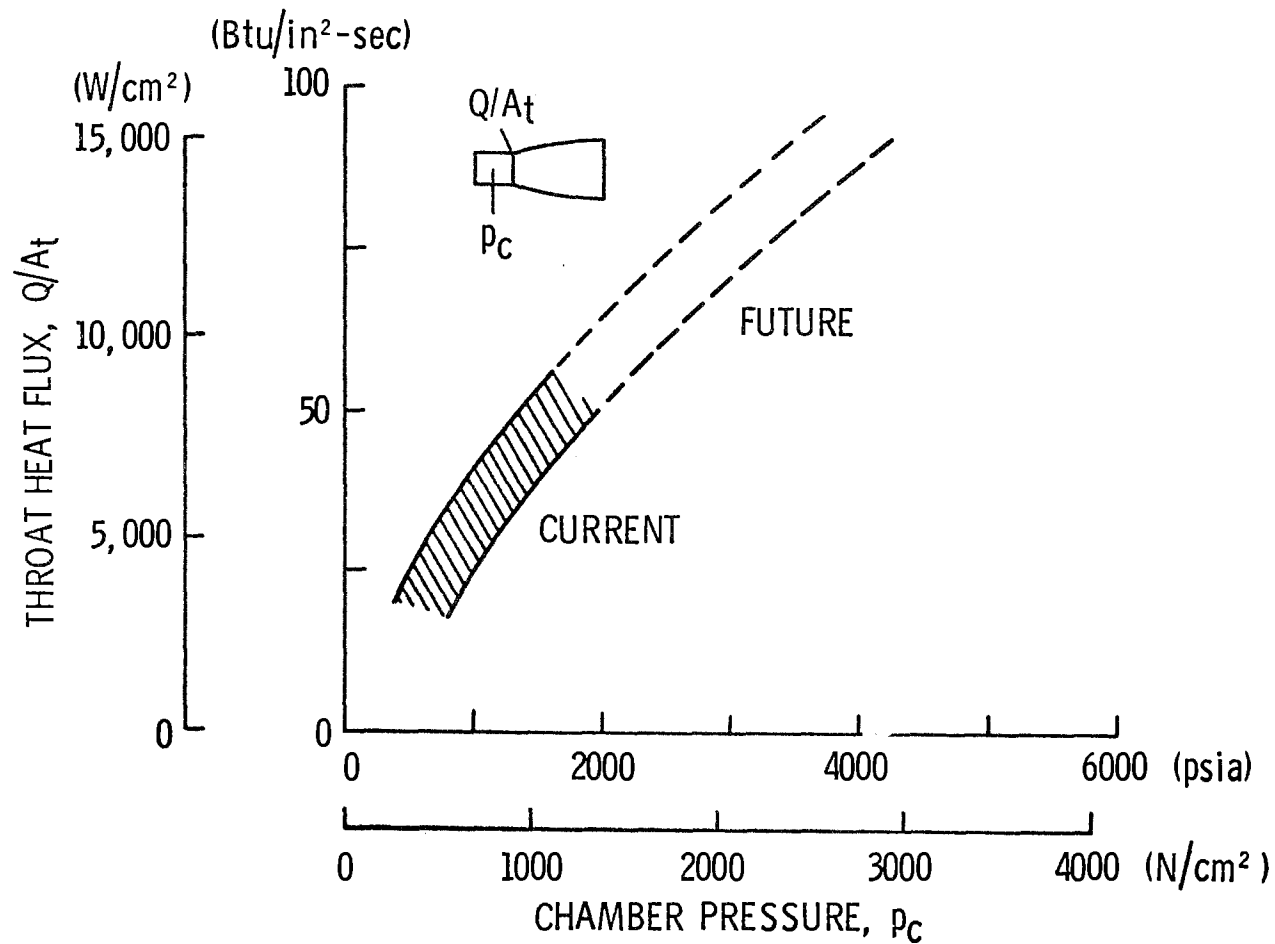

SHUTTLE MAIN ENGINE
CLOSED LOOP CONTROLLER

PREBURNER CYCLE ENGINE COMPONENTS OPERATE NEAR FUNCTIONAL LIMITS

CLOSED LOOP CONTROLLER:

- Regulates Turbine Inlet Temperature
Main Chamber Wall Temperature
Pump NPSH
Pump RPM
- Prevents Overloads During: Transients
Emergency Power Level (EPL)
- Protects for Long Service Life
- Optimizes Mixture Ratio

- Evaluates Engine Performance
- Checks Out Engine System
- Diagnosis Engine Condition
- Isolates Engine Malfunctions

SHUTTLE MAIN ENGINE/STAGE INTEGRATION

Main Engine and Shuttle Stage Must Be Functionally Compatible. Main Engine/Stage Integration Involves Technology Areas Such As:

Feed System/Engine Propellant Therm. Conditioning

- Geysers Elimination (Orbiter Start)
- Propellant Quality Control
- Engine Start M. R. Control
- Saturated Propellant Pumping

Engine/Stage Dynamic Interactions

- Engine Start
- POGO Prevention
 - Flow Perturbation Control
 - Pump Cavitation Model

Stage Base/Engine Heating

- Base Heating Data Limited
- Update, Advance Math. Models

SPACE SHUTTLE MAIN PROPULSION SYSTEM

OBJECTIVES:

- High Spec. Impulse
- Low Weight
- Small Envelope
- Long Service Life, Reuse
- Safe Operation
- Simple Maintenance
- Optimum Engine/Stage Integration

SPACE SHUTTLE PROPULSION
REQUIREMENTS

<u>MAIN ENGINE:</u>	<u>BOOSTER</u>		<u>ORBITER</u>	
	<u>S.L.</u>	<u>VAC.</u>	<u>S.L.</u>	<u>VAC.</u>
● THRUST (1000 lb) \pm 3%				
EMERGENCY EPL	469.3	531.3	+)	552
NORMAL NPL	400	462	+)	480
MINIMUM MPL	++)	231	+)	240
● SPEC. IMPULSE (sec); AREA RATIO: 53			EXT. SKIRT:	200 (150)
MIN. AT EPL	383	442	+)	459
M.R. = 6.0 NPL	383	442	+)	459
MPL	++)	437	+)	453
● PROPELLANTS		H ₂ /O ₂		
● MIXTURE RATIO RANGE (NPL & MPL)		5.5 -6.5		
● NPSH (ft) NPL		O ₂ =16; H ₂ =60		
● THROTTLING RANGE		2:1		
● GIMBAL ANGLE (°)		\pm 7		
● BURN TIME (sec)		~ 250-600		
● ENGINE RELIABILITY:		0.99		
● PROBABLE CATASTROPHIC FAILURE:		1 x 10 ⁻⁴		
● TIME TO OVERHAUL (hrs)		10 or 100 Starts		
● CLOSED LOOP CONTROLLER				
● ENGINE-INTEGRATED FLEX JOINTS AND T.V.C.				
● ONBOARD AUTOMATIC CHECKOUT; CONDITION DIAGNOSIS				

ENGINE MUST RUN AT S.L. W/O ALTITUDE FACILITY AT ANY POWER LEVEL FROM EPL TO MPL WITH: +) ORBITER NOZZLE ++) BOOSTER NOZZLE.

H₂ - O₂ ENGINE COMPARISON

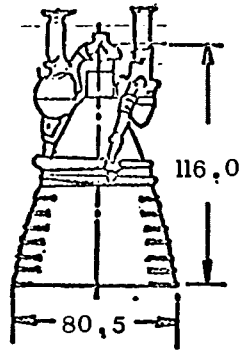

J-2
ENGINE

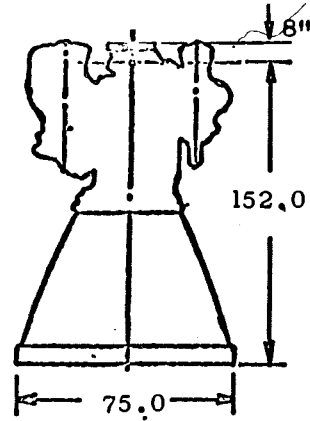

BOOSTER
ENGINE

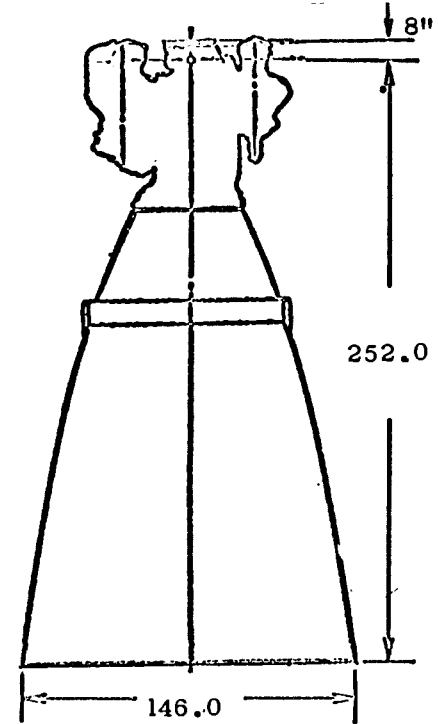

ORBITER
ENGINE

24

ENGINE	J-2	BOOSTER	ORBITER
THRUST VAC	230K	462K	480K
M.R.	5.5	6	6
P _c (psia)	778	3000	3000
MIN I _s VAC (sec)	421	442	459
AREA RATIO	27.5	53	200
WEIGHT MAX (lb) (complete)	3500	5200	7000

SPACE SHUTTLE MAIN ENGINE DEVELOPMENT

PHASE B: 11 Months Duration

- Define Requirements
- Design Prototype Engine in Detail
- Show Design Feasibility by Analysis & Test
- Show Schedule Feasibility
- Give Data for Selecting Config. to be Developed
- Prepare Development Plans

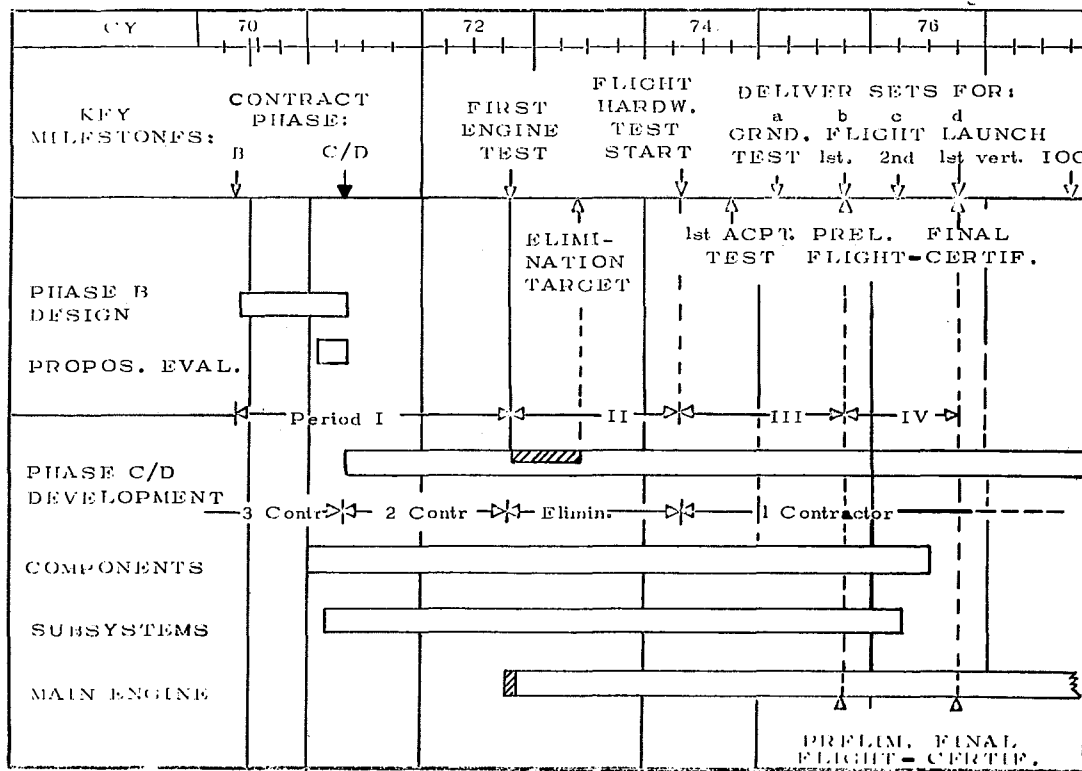

**SPACE SHUTTLE
MAIN ENGINE SYSTEM**

CONCLUDING REMARKS:

**Useful Results From Previous Technology Work
Combined With Complementary Efforts Justify The
Confidence That The Shuttle Main Engine System
Can Be Successfully Developed.**

TECHNOLOGY CONSIDERATIONS FOR MAIN ENGINE SPECIFIC IMPULSE

D. L. Kors

Aerojet Liquid Rocket Company
Sacramento, California

TOPICS TO BE DISCUSSED

- . IMPORTANCE OF SPECIFIC IMPULSE
- . SPECIFIC IMPULSE CONSIDERATIONS IN CYCLE SELECTION
- . SOURCES OF SPECIFIC IMPULSE INEFFICIENCY
- . COMBUSTION PROCESS
- . THRUST CHAMBER COOLING PROCESS
- . NOZZLE EXPANSION PROCESS
- . SPECIFIC IMPULSE PREDICTION TECHNOLOGY STATUS

TECHNOLOGY CONSIDERATIONS FOR MAIN ENGINE SPECIFIC IMPULSE

INTRODUCTION

The space shuttle vehicle is being designed for requirements not considered on previous man-rated rocket launch systems. Criteria such as airline-type checkout, maintenance, and turn around operations for a fully recoverable vehicle impose stringent performance requirements on the propulsion system. The specific impulse value required for mission success has resulted in selection of a high chamber pressure, staged combustion cycle and a high energy cryogenic propellant combination. Even with these favorable decisions from a performance standpoint, the NASA Phase B Work Statement¹ specifies a minimum delivered specific impulse which is in excess of 96% of theoretical at the 3000 psia chamber pressure design point. Consequently, the highest possible specific impulse efficiency must be realized from each engine component.

Another factor which makes specific impulse an extremely important design parameter is the sensitivity of payload to a reduction in delivered specific impulse. This effect is illustrated quantitatively by the data presented in Figure 3, which is based on mission analysis data for a typical space shuttle vehicle. It shows almost a 3% reduction in allowable payload for each second loss in specific impulse. Some vehicle studies show an even larger effect of specific impulse on mission payload. Although these data are preliminary at this state of development, the trend suffices to point out the extreme importance of achieving the specific impulse requirement.

¹ Space Shuttle Main Engine, Statement of Work - Phase B, George C. Marshall Space Flight Center, NASA, Feb. 16, 1970

EFFECT OF SPECIFIC IMPULSE ON MISSION PAYLOAD

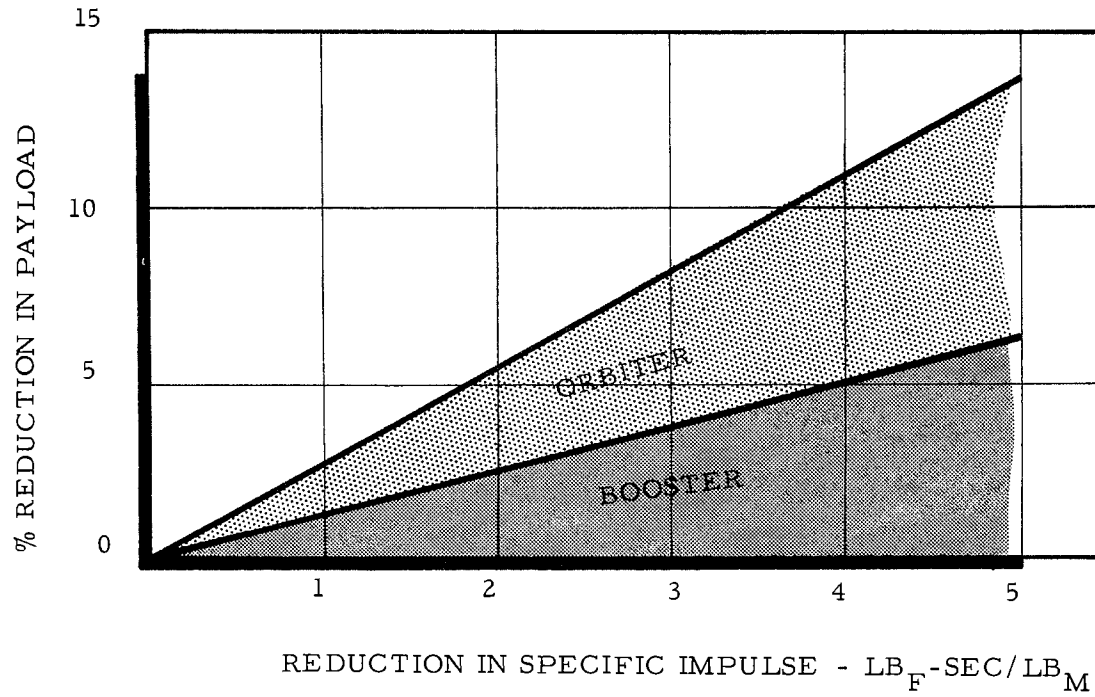

THRUST CHAMBER SPECIFIC IMPULSE LOSSES

Specific impulse losses for a staged combustion cycle are primarily related to the thrust chamber. These losses can be identified using the convention adopted by the ICRPG Performance Standardization Working Group in their Liquid Propellant Thrust Chamber Performance Evaluation Manual ². Sources of inefficiency are listed as the abscissa on Figure 4 and defined in detail in the ICRPG Manual ³. In addition to those losses defined by the ICRPG, Figure 4 contains two other specific impulse losses. One is cooling loss, which the ICRPG excluded from their analysis since the scope of their initial effort was limited. The other loss is a 3 sigma instrumentation allowance which is not a specific impulse loss per se, but must be included as part of the margin between theoretical specific impulse and minimum delivered specific impulse. It accounts for the uncertainty of the acceptance test measurements and performance extrapolations to assure that the delivered specific impulse of all engines is not less than the value required.

The comparative magnitude of the specific impulse losses are noted in Figure 4, where they are expressed as a percentage of the difference between the theoretical specific impulse and the minimum value specified in the NASA C. E. I. (Contract End Item) document. A maximum and minimum value is listed for each loss, which define the estimated limits to account for different design concepts, technology state-of-the-art uncertainty and the difference between booster and orbiter configurations.

The 3 sigma instrumentation decrement reflects measurement state-of-the-art, which is another area of technology and will not be included in the present discussion. The remaining losses can be grouped into three categories; inefficiency in the combustion process, cooling process and gas expansion process (nozzle). This paper will concentrate on these three technology areas and the specific impulse prediction techniques associated with each source of inefficiency.

² Pieper, J. L., ICRPG Liquid Propellant Thrust Chamber Performance Evaluation Manual, Rept. 178, Sept. 1968, Chemical Propulsion Information Agency

³ *ibid.*

THRUST CHAMBER SPECIFIC IMPULSE LOSSES

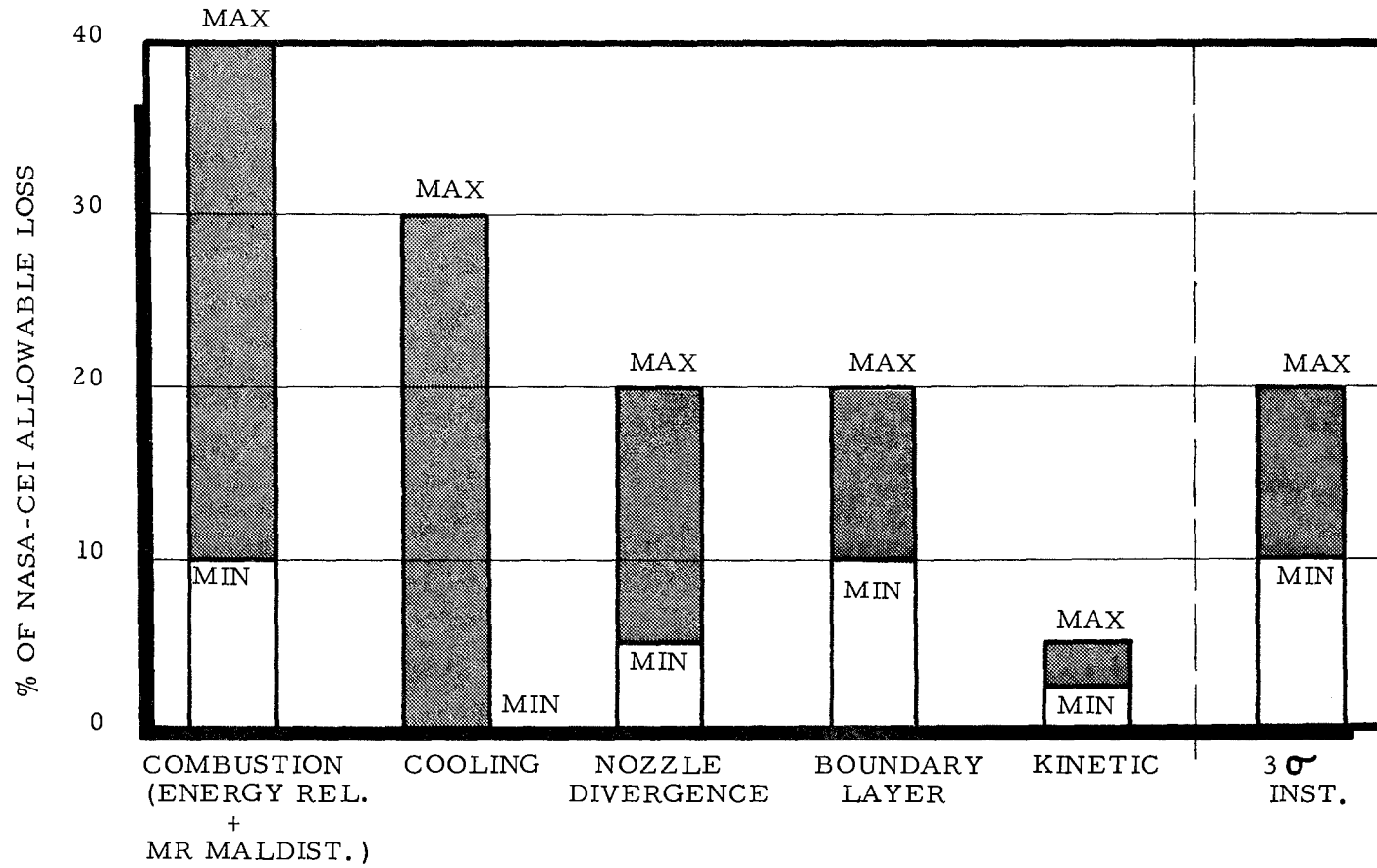

CRITERIA FOR HIGH COMBUSTION EFFICIENCY

Five design criteria must be satisfied to assure attainment of high combustion efficiency on the space shuttle main engine. These are listed on Figure 5 along with a schematic drawing indicating the location where each criterion must be satisfied.

Preburner gas homogeneity must be satisfied prior to injection into the thrust chamber. In addition to possibly different mixture ratio preburner gases, significant quantities of coolant and/or bypass flows of hydrogen at various energy levels are introduced into the fuel-rich gaseous propellant stream. This flow must be mixed prior to injection into the thrust chamber in order to prevent mixture ratio maldistribution performance effects. Next, both propellants must be uniformly distributed across the injector face so that mass and mixture ratio gradients are not significant. Then the liquid oxygen must complete the supercritical vaporization process within the chamber. Also propellant mixing must be completed on a fine basis so that the chemical reaction process can go to completion on a molecular scale within the chamber.

CRITERIA FOR HIGH COMBUSTION EFFICIENCY

1. PREBURNER GAS HOMOGENEITY
2. BOTH PROPELLANTS UNIFORMLY DISTRIBUTED
3. COMPLETE LIQUID OXIDIZER VAPORIZATION
4. COMPLETE PROPELLANT MIXING
5. COMPLETE CHEMICAL REACTION

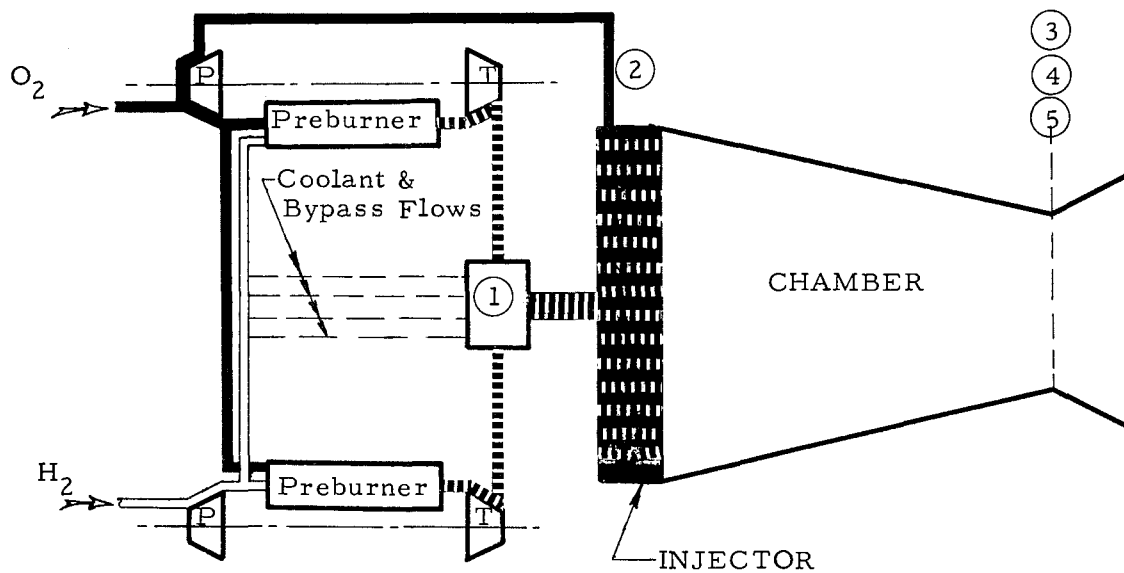

TECHNIQUES FOR ACHIEVING HIGH COMBUSTION EFFICIENCY

Although the combustion criteria represent difficult design requirements for the engine designer, there are both analytical and experimental techniques available which will permit him to accomplish this task. Some of the primary techniques are tabulated on Figure 6 for each combustion criterion.

Analysis of the combustion process must still depend to some extent on empirical techniques. As noted on Figure 6, those criteria which are rate limiting can be characterized by cold flow experimental techniques. These techniques use simulated propellants which are non-reactive and permit mixing and flow distribution processes to be directly measured. Cold flow testing has been demonstrated on numerous engine development programs and provides an economical method for verifying that important design criteria have been met early in the development program. Proper utilization of this experimental technique will greatly assist in the achievement of high combustion efficiency on the space shuttle main engines.

TECHNIQUES FOR ACHIEVING HIGH COMBUSTION
EFFICIENCY

<u>CRITERIA</u>	<u>ANALYTIC TECHNIQUE</u>	<u>EXPERIMENTAL TECHNIQUE</u>
PREBURNER GAS HOMOGENEITY	GEOMETRIC & FLOW SIMILITUDE	GAS-GAS COLD FLOW TESTING
UNIFORM PROPELLANT DISTRIBUTION	MANIFOLD FLOW DISTRIBUTION ANALYSIS	GAS/LIQUID COLD FLOW TESTING
PROPELLANT MIXING	1. TURBULENT MIXING MODEL 2. SPRAY CORRELATIONS	GAS/LIQUID COLD FLOW TESTING
*OXIDIZER VAPORIZATION	SUPERCRITICAL DROPLET VAPORIZATION MODEL	HOT FIRE TESTING
*CHEMICAL REACTION	TURB. MIXING AND REACTION MODEL	HOT FIRE TESTING

* PROBABLY NOT RATE LIMITING ON THE MAIN ENGINE

GAS COLD FLOW TEST INSTALLATION

An example of the type of cold flow installation for testing the preburner gas flow distribution is shown in Figure 7. This particular installation was used on the ARES Program⁴ to assure that the preburner gases were uniformly distributed immediately downstream of the vane type thrust chamber injector. The ARES was a high pressure, staged combustion cycle, transpiration-cooled engine developed by Aerojet for the Air Force. Since only one fluid was involved in the cold flow experiment, pressure profile instrumentation was sufficient to determine mass distribution.

A test to determine preburner gas homogeneity would of course, require measurements which can be related to mixture ratio distribution. To accomplish this an additional parameter such as temperature distribution can be used to infer the uniformity of the mixture; or more directly, the mixture ratio distribution can be measured with a mass spectrometer using two cold gas simulants of varying composition. In setting up this type of experiment, care must be exercised to maintain similitude with the actual engine geometry, flow rate ratio and static-to-dynamic pressure relationships.

⁴ Beichel, R., Gibb, J. A., Hankins, R. A., Advanced Rocket Engine-Storable, Phase 1 Final Report, Supplement 1, Report 10830-F-1, Phase 1, Supplement 1, Aerojet General Corporation, AFRPL-TR-68-70, May 1968 (Confidential)

GAS COLD FLOW TEST INSTALLATION

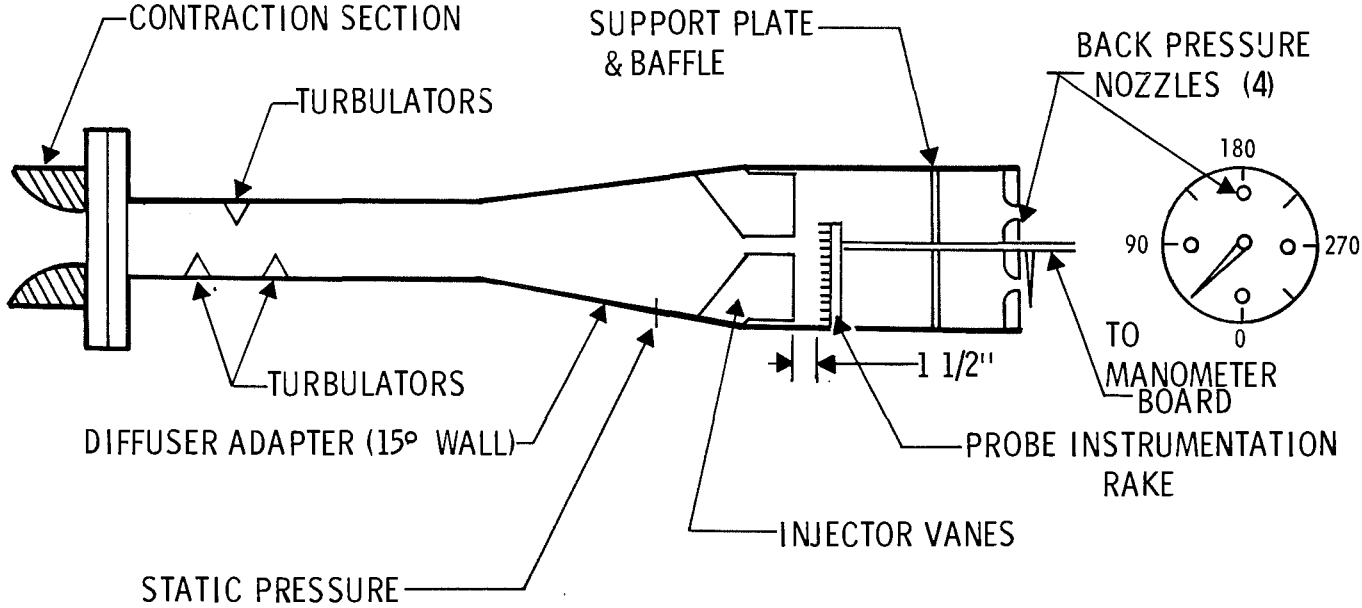

GAS COLD FLOW EXPERIMENTAL RESULTS

The test installation shown in Figure 7 was used to measure the preburner gas distribution downstream of the ARES vane injector. Figure 8, at the top, shows a typical test flow distribution which resulted from the original configuration. The flow parameter, (Gas Flow/Unit Area) x Radius, permits the variation of flow area with radial distance to be included in the data. The flow distribution deviated from the uniform profile to the extent that design modifications were required to prevent a significant mixture ratio distribution specific impulse loss. The bottom portion of Figure 8 shows the flow distribution plate and additional turbulators which were incorporated into the revised design. An example of the flow distribution determined from subsequent cold flow testing is also shown on Figure 8, which indicates that the design modification was successful in achieving uniform preburner gas flow distribution.

The other propellant, which was liquid and injected through the vaned injector, was also cold flow tested to verify that its mass distribution was uniform immediately downstream of the injection plane. For this ARES configuration both propellants were uniformly distributed and subsequent hot fire testing demonstrated high combustion performance which resulted in a specific impulse value that exceeded the contract requirement.

GAS COLD FLOW EXPERIMENTAL RESULTS

39

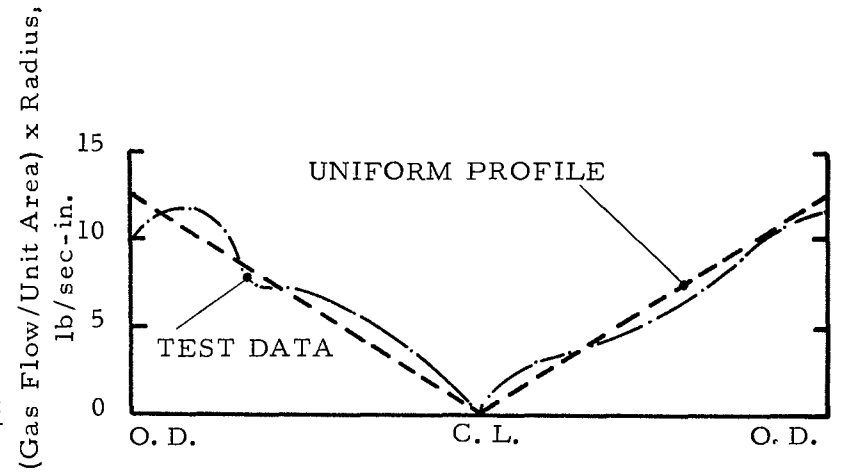
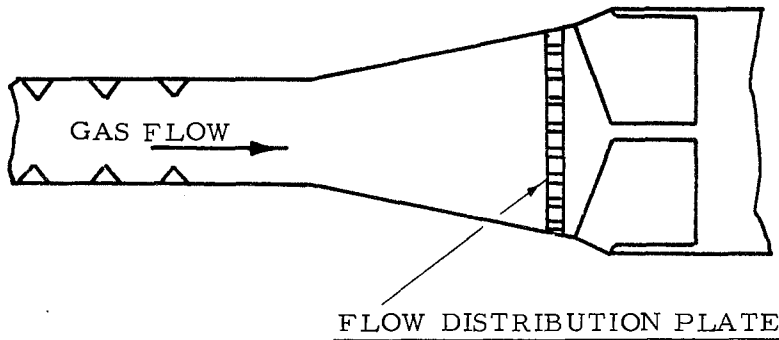
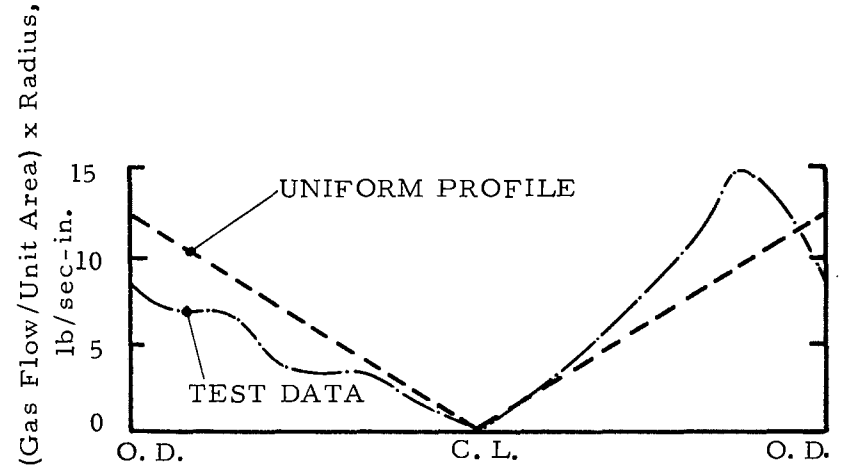
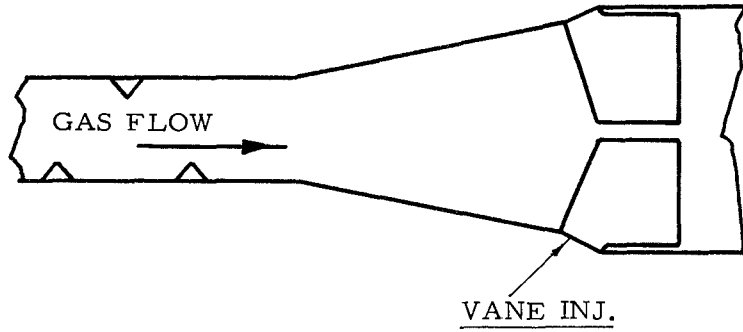

LIQUID COLD FLOW APPARATUS

Figure 9 is a drawing of a cold flow apparatus which can be employed to determine liquid mass distribution from a gas/liquid injector such as proposed for the space shuttle main engines. The injector is positioned face down on the top platform and the simulated cold flow propellant is collected a few inches downstream with a matrix-type collection head which has several hundred individual probes. Each probe is plumbed to a separate tube at the bottom of the fixture with flexible tubing. After each test an automatic liquid-level scanning device records the quantity of simulated propellant in each tube and feeds it into a computer program which prints out the mass distribution across the injector face.

LIQUID COLD FLOW APPARATUS

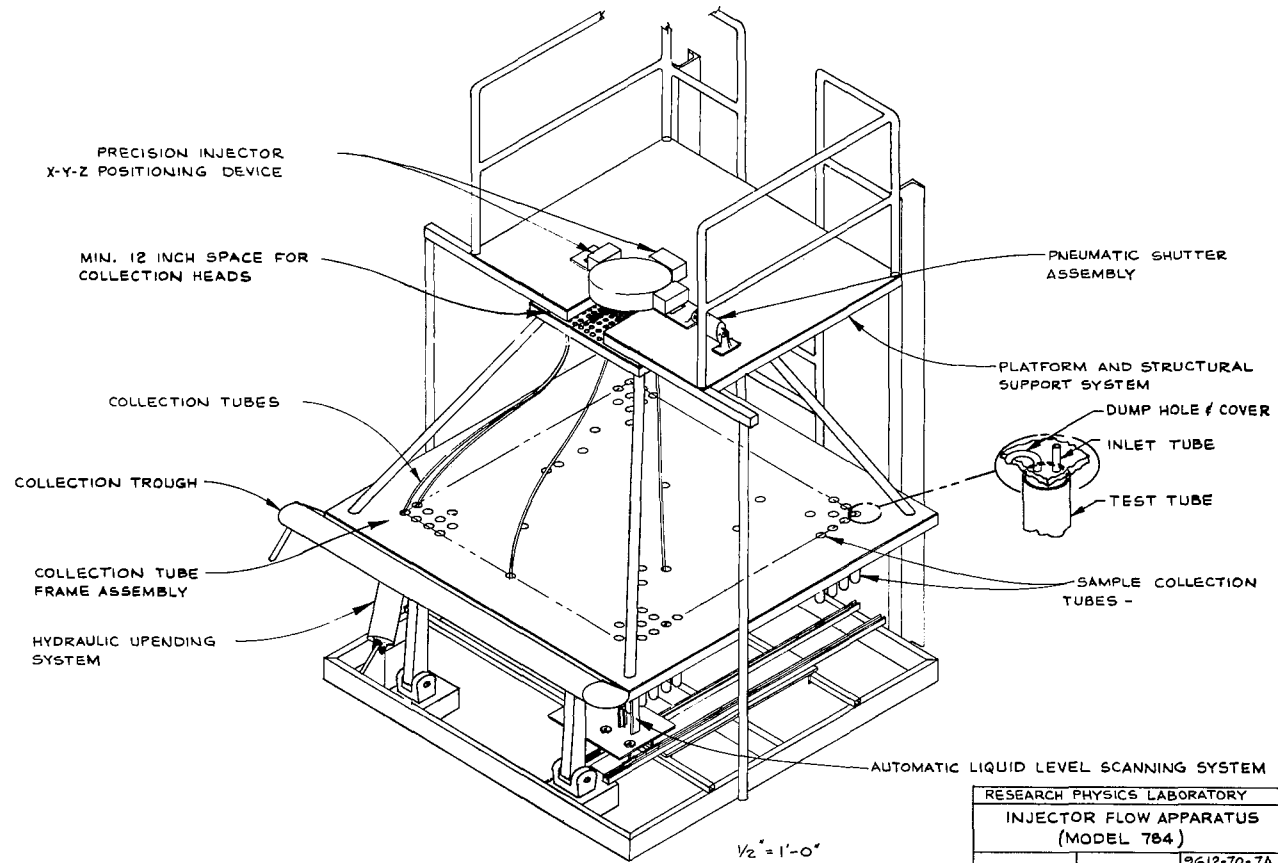

RESEARCH PHYSICS LABORATORY	
INJECTOR FLOW APPARATUS	
(MODEL 784)	
	9612-70-7A

THRUST CHAMBER COOLING TECHNOLOGY

The second area of technology relating to specific impulse is the thrust chamber cooling concept. Two basic types are proposed for the main engine; both concepts use hydrogen as the coolant. One is the regenerative design which introduces the coolant into the preburner gases upstream of injection into the thrust chamber, thus eliminating a propellant mixing process within the thrust chamber.

The other concept is a transpiration coolant design which introduces the coolant flow through discrete apertures into the combustion chamber walls. The coolant flow carries away heat transferred to the wall from the combustion gases and subsequently mixes with the boundary flow to produce a lower energy wall barrier. This cooling concept causes a specific impulse loss due to (1) mixture ratio maldistribution and (2) reduced expansion of that portion of the coolant flow injected downstream of the throat. The loss due to reduced expansion appears to be quite minor based on calculations using the main engine design and operating parameters. Consequently, transpiration coolant specific impulse loss primarily results from mixture ratio maldistribution caused by incomplete mixing of the hydrogen coolant with the primary combustion gases.

THRUST CHAMBER COOLING TECHNOLOGY

DESIGN
CONCEPT:

REGENERATIVE

TRANSPIRATION

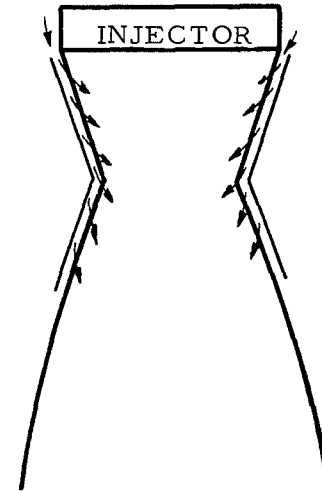
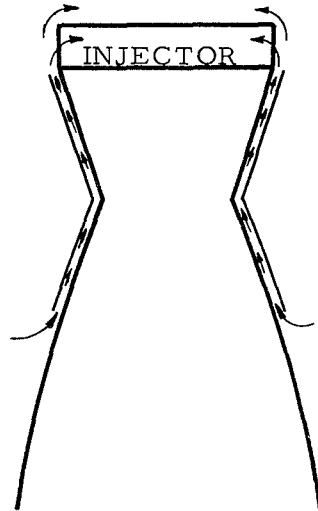

TYPE OF
MIXING
PROCESS:

COOLING FLOW MIXED
WITH FUEL RICH GASES
PRIOR TO INJECTION

COOLING FLOW MIXED
WITH COMB. GASES IN
CHAMBER

PERFORMANCE
EFFECT:

NO DIRECT PERFORMANCE LOSS

PERFORMANCE LOSS DUE TO MIXTURE
RATIO MALDISTRIBUTION AND
REDUCED EXPANSION

TRANSPIRATION COOLANT PERFORMANCE LOSS

Since the specific impulse loss due to transpiration coolant is primarily due to mixture ratio maldistribution, it is a function of two parameters. One is the quantity of coolant injected and the other is the effectiveness of the subsequent mixing process with the injector flow. The specific impulse loss for the main engine as a function of these two parameters is parametrically plotted on Figure 11. The "% Inj. Flow Mixing" parameter is the fraction of the total injector flow that is assumed to have mixed with the coolant. The specific impulse effect was then calculated for the two stream tubes - (1) mixed coolant and fraction of injector flow and (2) remaining injector flow - and compared to the specific impulse for a completely mixed gas composition.

A "probable operating zone" is also included in Figure 11. The upper and lower boundaries are based on a range of estimated coolant quantity, \dot{W}_c / \dot{W}_t , which is expected to be required to maintain the chamber wall temperature at a low enough temperature to permit the long-life design for the space shuttle. The left boundary (2% injector Flow Mixing) represents an estimated value of mixing for the space shuttle engine design based on analysis of test data conducted by Aerojet on various transpiration coolant designs. The right boundary (5% Inj. Flow Mixing) represents a value which makes allowance for possible measurement tolerances in the test data and variations due to injector flow composition at the chamber wall.

TRANSPIRATION COOLANT PERFORMANCE LOSS

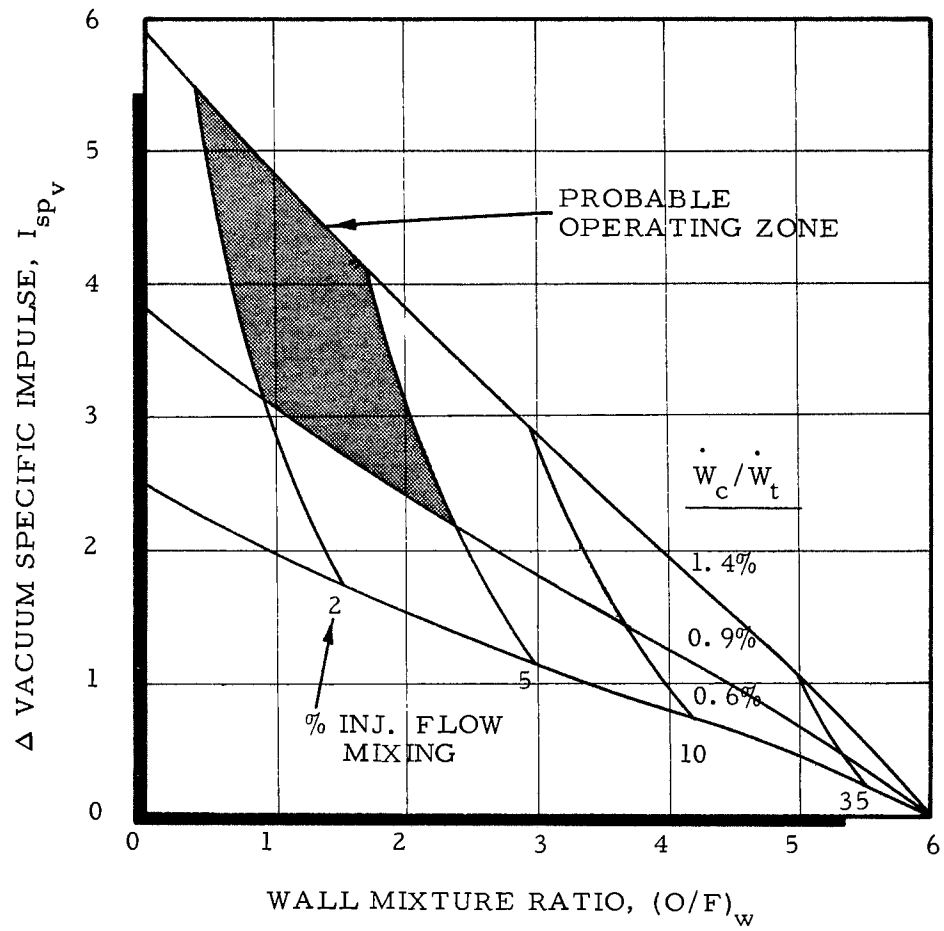

TECHNIQUES FOR MINIMIZATION OF COOLANT PERFORMANCE LOSS

No performance loss occurs for the regenerative coolant flow if it is mixed with the preburner gases prior to injection into the thrust chamber (Combustion Criterion No. 1 on Figure 5). Preliminary analysis indicates that this can be accomplished without a significant penalty for mixer weight and/or pressure drop.

Various modeling techniques are available for the transpiration coolant process.⁵ Due to the extremely complex flow mechanisms involved, these models are largely supported by empirical correlations which are somewhat configuration sensitive. They have been successfully applied to provide initial design values including the coolant flow rate required. However, specific impulse loss for the transpiration design can be reduced primarily by experimental techniques which establish a gas side wall temperature vs. coolant flow rate relationship. Flow rate can thereby be lowered to a value that will result in a gas side wall temperature which represents the maximum value consistent with the long life requirements of the space shuttle main engines.

⁵ *ibid.*

TECHNIQUES FOR MINIMIZATION OF COOLANT PERFORMANCE LOSS

REGENERATIVE DESIGN

NO PERFORMANCE LOSS IF COOLANT FLOW IS MIXED
WITH PREBURNER GASES (COMBUSTION EFFICIENCY
CRITERION)

TRANSPIRATION DESIGN

TEMPERATURE - FLOW RATE TEST DATA CORRELATIONS
EMPLOYED TO MINIMIZE COOLANT FLOW

TECHNIQUES FOR NOZZLE PERFORMANCE OPTIMIZATIONS











The third area of technology which affects the main engine specific impulse is the nozzle flow expansion process. The nozzle design parameters which influence specific impulse are listed at the center-top of Figure 13. The component performance effects are listed in the left column, and applicable JANNAF computer program (s) available for evaluating each performance effect are listed in the corresponding row of the right hand column. A large dot has been placed under each nozzle design parameter if it influences the corresponding performance effect.

Except for limitations which will be discussed later, the nozzle design parameters can be adequately optimized using the applicable JANNAF^{*} Computer Programs listed on Figure 13, except for the vehicle specific impulse trade-off effects for weight and envelope. Since 3 out of the 4 nozzle design parameters identified on Figure 13 are influenced by vehicle trade-off factors, it is apparent that accurate values must be available to the engine designer if the highest effective specific impulse is to result.

* Rocket engine contractors have other state-of-the-art nozzle analysis programs which may be equally applicable to this type of analysis. However, use of other programs sacrifices commonality and requires government agencies to assess the relative merit of the analysis as well as the design when comparing 2 or more engine concepts.

TECHNIQUES FOR NOZZLE PERFORMANCE OPTIMIZATIONS

49

PERFORMANCE EFFECT	NOZZLE DESIGN PARAMETER				JANNAF COMPUTER PROGRAMS
	AREA RATIO	LENGTH	CONTOUR (INITIAL DIV.)	WEIGHT PER IN ²	
POTENTIAL THERMO-CHEMICAL PERFORMANCE					ONE DIMENSIONAL EQUILIBRIUM
DIVERGENCE LOSS					TWO DIMENSIONAL KINETIC TWO DIMENSIONAL EQUILIBRIUM
BOUNDARY LAYER LOSS					TURBULENT BOUNDARY LAYER, TBL
KINETIC LOSS					ONE DIMENSIONAL KINETIC TWO DIMENSIONAL KINETIC
VEHICLE TRADE-OFFS					(VEHICLE OPTIMIZATION ANALYSIS)

JANNAF PERFORMANCE PREDICTION TECHNIQUES

Applicability of the JANNAF Performance Methodology for analyzing the space shuttle main engine was the subject of a joint NASA-JANNAF Liquid Rocket Performance Committee meeting earlier this year . All three main engine contractors presented their evaluation of the JANNAF methodology when applied to space shuttle main engine analysis. The information tabulated on Figure 14 was primarily synthesized from information presented at that meeting and documented in the minutes.⁶ It should be emphasized that Figure 14 is applicable to JANNAF methodology only and the "ADDITIONAL DEVELOPMENT" column does not necessarily account for more highly developed performance prediction techniques which may be in the possession of one or more of the rocket engine contractors.

The performance effects which are not adequately modeled by the JANNAF methodology are noted in the right hand column of Figure 14. Some work is presently being conducted to provide initial modeling of the energy release loss and the transpiration/film cooling loss. However, major efforts could be profitably utilized to improve these techniques even though a completely generalized performance model based exclusively on engine design and operating parameters could not be synthesized within the time-table presently envisioned for the space shuttle.

The mixture ratio maldistribution model listed on Figure 14 is a stream tube model without any provision for mass, momentum or energy transport between stream tubes. This assumption is probably not valid under conditions where significant velocity gradients exist between stream tubes. The other major development area listed in Figure 14 is nozzle flow separation, which may become a performance influence for the main engines when they are operated at a back pressure exceeding the nozzle exit pressure. Nozzle flow separation mechanisms are not well understood and represent a technology area which needs additional effort before the engine designer can quantitatively evaluate this effort on his design.

⁶ Liquid Rocket Performance Committee, 2nd Meeting Minutes, JANNAF Performance Standardization Working Group, NASA Lewis Research Center, April 30, May 1, 1970

JANNAF PERFORMANCE PREDICTION TECHNIQUES

<u>SSE PERFORMANCE EFFECT</u>	<u>APPLICABLE JANNAF PROGRAM</u>	<u>ADDITIONAL DEV. REC. FOR SSE</u>
THEORETICAL PERFORMANCE	ONE DIMENSIONAL EQUILIBRIUM	NO
ENERGY RELEASE LOSS	(NOT AVAILABLE)	MAJOR DEV.
MIXTURE RATIO MALDISTRIBUTION	STREAM TUBE MODEL	MAJOR DEV.
51 COOLING LOSS (TRANSPARATION/ FILM)	(NOT AVAILABLE)	MAJOR DEV.
DIVERGENCE LOSS	TWO DIMENSIONAL KINETIC TWO DIMENSIONAL EQUILIBRIUM	NO
BOUNDARY LAYER LOSS	TURBULENT BOUNDARY LAYER	MINOR DEV.
KINETIC LOSS	ONE DIMENSIONAL KINETIC TWO DIMENSIONAL KINETIC	NO MINOR DEV.
SEPARATION CRITERIA	(NOT AVAILABLE)	MAJOR DEV.

SUMMARY AND CONCLUSIONS

Four major technology areas which influence main engine specific impulse were discussed. This included a description of the techniques which are available for achieving success in each of these areas and some of the limitations of the techniques. A brief summary for each of these areas is given below.

Combustion Process

High combustion performance can be achieved by using interrelating analytical and experimental techniques to satisfy five combustion criteria. The experimental data can be, to a large extent, obtained from cold flow testing using models or subscale hardware. This will permit the initial designs to be evaluated early in the program and revisions incorporated without the time loss associated with full scale hot firing testing.

Cooling Process

The regenerative design will not result in a specific impulse penalty if the coolant flow is mixed with the preburner gases prior to injection into the thrust chamber. The specific impulse loss for a transpiration coolant design is dependent on the coolant flow rate and the effectiveness of the downstream mixing process. The primary technique for reducing the loss due to transpiration cooling is to conduct tests in which thermal data and local coolant flow rate data can be obtained. This will permit correlations to be developed which will assure minimum coolant quantity (and specific impulse loss) consistent with wall temperatures required for long chamber life.

Nozzle Process

Optimization analysis can be conducted using JANNAF Computer Programs to determine the effect of nozzle design parameters on engine delivered specific impulse. In order to assure that a nozzle is designed for maximum effective specific impulse, it is imperative that accurate vehicle trade-off data be available to the nozzle designer.

SUMMARY

HIGH COMBUSTION PERFORMANCE

- . INTERRELATED ANALYTICAL
- . AND EXPERIMENTAL TECHNIQUES

MIN. COOLING PERFORMANCE LOSS

- . REGENERATIVE DESIGN
(NO LOSS)
- . TRANSPIRATION DESIGN
DESIGN/TEST ITERATION

HIGH NOZZLE PERFORMANCE

- . JANNAF COMPUTER PROGRAMS
- . ACCURATE TRADE-OFF FACTORS

JANNAF PREDICTION TECHNIQUES

- . ACCURATE + 1% (REGEN) WITH
COLD OR HOT FLOW COMBUSTION
DATA
- . COMBUSTION AND TRANSPIRA-
TION COOLING MODELS INADE-
QUATE

Summary and Conclusions (cont.)

JANNAF Prediction Techniques

Although a rigorous error analysis has not been conducted, it is estimated that specific impulse predictions using the JANNAF methodology with cold or hot flow combustion data should be within + 1% of subsequent test data values. The performance losses which at present cannot be analyzed with adequate JANNAF models are the combustion and transpiration cooling losses. Some limited development efforts are progressing in these areas but additional effort will be required to develop models which will be adequate to evaluate main engine specific impulse potential without extensive experimental data input.

RECOMMENDATION FOR ADDITIONAL PERFORMANCE
TECHNOLOGY EFFORTS

Most of the technology effort required to assure the space shuttle main engines will achieve their specific impulse potential has been identified and appropriate development effort is being conducted. However, it is recommended that JANNAF prediction techniques be further developed particularly in the areas of the combustion process, transpiration cooling process and the nozzle separation process. In addition, it is recommended that the techniques used for cold flow testing be standardized, so that the government agencies can be assured of consistent data from each rocket contractor. This is a task for which the JANNAF Liquid Rocket Performance Committee could also assume cognizance.

Each of these items have an impact on delivered specific impulse, and models should be available to the engine designer and government agency monitor at the earliest possible data. Although the schedule for completing these models may not be compatible with Phase B, they would be valuable in the subsequent development phase to help interpret test data and assure that specific impulse will not limit mission success for the space shuttle.

INVESTIGATION OF NOZZLE FLOW SEPARATION PHENOMENON

JANNAF COMBUSTION PERFORMANCE MODEL

JANNAF TRANSPIRATION/FILM COOLING PERFORMANCE
MODEL

STANDARDIZATION OF COLD FLOW PERFORMANCE EXTRAPOLATIONS

TECHNOLOGY FOR SPACE SHUTTLE MAIN ENGINE CONTROL,
CHECKOUT AND DIAGNOSIS (GP 70-232)

L. D. Emerson and B. C. Miller

Pratt & Whitney Aircraft
West Palm Beach, Florida

ABSTRACT

The Space Shuttle Main Engine (SSME) performance and weight requirements are best met by a staged combustion cycle. Because a high performance light weight engine must operate close to component physical limits, control of critical engine parameters must be maintained during steady-state and transient conditions. A control system is therefore required to provide both engine protection and overall thrust and mixture ratio precision.

Based on considerations of precision, environment, and compatibility with vehicle interface commands, an electronic engine control unit appears to be best suited to the SSME design. Use of an electronic control makes available many functions that logically provide the information required for engine system checkout and diagnosis.

The performance, reliability and maintainability goals, established for the SSME, place demanding requirements on the engine sensor elements. To assure confidence that these sensor elements will perform accurately and reliably in the SSME environment, further technological development and thorough environmental testing is required.

INTRODUCTION

In the past, fixed thrust rocket engines have been generally controlled in a straight-forward manner, employing time-sequenced valves for control of the engine start and shutdown transients, and trimmable orifices for control of steady-state set points. Operational checks generally included preflight engine firing and component tests and required considerable ground test equipment. Monitoring sensors were added to the engine for flight performance assessment.

The advent of the Space Shuttle with its requirements for high specific impulse, long life and low cost have dictated a staged combustion cycle and a closed loop control system to allow the engine components to run close to operating limits. These performance requirements combined with the necessity for low operational costs have placed new demands on rocket engine control, system checkout, and diagnosis technology.

I. VALUE OF SPECIFIC IMPULSE TO THE SPACE SHUTTLE

The importance of specific impulse to the Space Shuttle is typically illustrated by a Lockheed study that showed the propellants for the Space Shuttle to represent approximately 80% of the launch weight. For a tanked 3.75-million-pound vehicle, propellants will amount to over 3 million pounds.

The Space Shuttle requires approximately 60 pounds of propellant per pound of payload, while a conventional cargo aircraft requires approximately 1 pound of propellant per pound of payload. Because of the high propellant-to-payload ratio, small specific impulse changes can have large effects on the space shuttle payload capability.

As indicated by Mr. Stewart and Mr. Wetherington during the AAS annual meeting in June, one second of impulse has been calculated by some authorities to be worth approximately \$25,000,000, and 1500 and 2000 pounds of payload. The loss of one second of specific impulse is then worth 4% of the total payload for a 50,000 pound payload vehicle. With a 5.4% loss in specific impulse (25 seconds), the Space Shuttle would have no payload capability at all.

In figure 1 the demonstrated impulse capabilities of some existing engine cycles are compared to the Space Shuttle. It can be seen that in the development of the SSME, high performance is a prime criterion.

ENGINE CYCLE SELECTION

The engine cycle options are narrowed by the performance requirements and vehicle constraints on envelope and weight. The design goals for the SSME are outlined in table 1.

TABLE 1
SPACE SHUTTLE
MAIN ENGINE REQUIREMENTS

Thrust Lbs. (SL)	400K ± 3%
Propellants	O ₂ /H ₂
ISP, Min. (Sec.)	
- Booster (SL/VAC) = 55.1	382/442
- Orbiter (VAC) = 220:1	459
Mixture Ratio	6.0
Throttling Range	2:1
PU Range	±0.5 ± 2%
Gimbal Angle - Degrees	±7.0
NPSH (Ft.)	
- Oxidizer	16
- Fuel	60
Burn Time (Sec.)	250
Time to Overhaul	10 Hrs. or 100 starts

The candidates considered included the bootstrap, gas generator, staged combustion and tapoff cycles. These cycles are shown schematically in figure 2.

The boot-strap cycle obtains the drive horsepower by heat transfer through the chamber wall to the fuel, which then expands through a turbine to drive the pumps. It is not within the state of the art to transfer sufficient horsepower to obtain the 3,000 psia main chamber pressure required for the SSME. The gas generator and tapoff cycles can obtain the horsepower but suffer impulse loss because of less than optimum expansion of the turbine exhaust gases. The staged-combustion cycle avoids these constraints by using a pre-combustor to supply the turbine drive gas and then passes all the propellants through the main combustion chamber. This paper will simply state, without further discussion, that the selected staged combustion cycle can deliver a higher specific impulse than the other candidates.

ENGINE LIMITS

The staged combustion cycle shown in figure 3 has several critical performance parameters that must be controlled to obtain the desired specific impulse with a minimum engine weight. Each of these parameters has an established limit that must not be exceeded. Repeated minor violations of these limits can reduce engine life; major violations of these limits, even for short time periods as in an engine transient, can produce component failures. The engine operational boundaries are shown in figure 4.

The critical engine performance parameters include turbine inlet temperature, main chamber wall temperature, turbopump speed and turbopump NPSH margin. If the engine is designed for wide margins between the operational boundaries and the established physical limits, this will result in additional weight for a given engine performance. A low turbine inlet temperature requires a higher preburner chamber pressure with additional turbopump and chamber weight. A lower chamber wall temperature requires additional coolant, which can reduce specific impulse by distorting the main chamber exit temperature profile. To restore specific impulse, a higher main chamber pressure and chamber weight is required. Additional main turbopump NPSH margin results in either: larger low speed inducers to provide additional main turbopump inlet pressure, or a reduction in speed of the main turbopumps. For the same discharge pressures the turbopump impeller diameters and turbopump weight will increase. Efficient engine design, therefore, dictates that the engine operate close to the performance parameter limits.

An engine designed to operate close to limits is sensitive to changes in inlet conditions or degradations in component performance. The engine will be exposed to variations in inlet pressure and temperature, which will affect turbopump NPSH margin and, unless accounted for, will affect such critical engine parameters as turbine inlet temperature and main chamber temperature. Gradual degradations in component performance may be encountered for a long-life engine, or minor component malfunctions may produce step changes in performance. Unless wide steady state operating margins are provided to account for these changes and the weight penalty accepted, a closed loop control is required. A closed loop control that senses selected engine parameters not only protects the engine from steady state environmental change and degradations in component performance, but can also provide protection during transient operation.

Open loop influence factors will differ slightly for each staged combustion engine arrangement but typically, turbine temperature will change approximately 35°R for a 1.0°R change in fuel temperature and 50°R for 100 psi change in oxidizer supply pressure. This is significant if the engine is running at the maximum thrust and maximum allowable turbine temperature where it is life limited by turbine creep. If the engine is operated at this power point with a 25°R over-temperature it will last approximately one-half of its design life.

II. APPROACH TO CONTROL SYSTEM DEVELOPMENT

A. Selection of Valve Locations

To determine the best control arrangement for a given engine, the valves are first identified as power controls or load controls. Power controls modulate power delivered by the turbines and load controls modulate the power required to drive the pumps. Power controls can be further subdivided into variable area turbines and turbine throttles. For each general category the best valve location is selected primarily by its effect on specific impulse. Then a minimum number of valves is added until the combination can modulate the engine over the desired thrust and mixture ratio range. A fairly complete steady-state thermodynamic model of the engine is required in this analysis for the results to be meaningful in terms of engine performance. For the case studied here, the model required 225,000 bytes of core storage in an IBM-360 computer.

Figure 5 shows the best combination identified in each category and figure 6 shows the typical performance trade-offs that must be considered in the selection of category. The choice here is the load controls combination based on minimum impulse penalty if the pump speed and turbine temperature boundaries are acceptable.

B. Dynamic Analysis

A parallel study must also be conducted to evaluate the dynamic requirements the control system must satisfy. As shown in figure 7, the steady-state performance studies and the dynamic analysis both influence the engine design and arrangement. Application of the three dynamic modeling methods will be necessary to properly assess the control performance. An analog model, a digital dynamic model and finally a hybrid model will be required. The importance of dynamic evaluation can be visualized by considering figure 8, which shows the typical response characteristics of the engine to a thrust command (2.8 cps). For a valve to reasonably control any loop within the engine, its response should be approximately 5 times as fast or 14 cps. For a control to track and modulate this valve position, its response should be approximately 5 times as fast as the valve, or 70 cps. The basic engine thrust

response appears slow, primarily because of propellant compressibility in the heat exchangers; however, inner loops of the engine are extremely fast. In comparison, a turbojet engine with similar control requirements, has approximately 15 times the SSME rotor inertia and only 40% of the steady-state turbine power, and is, therefore, slower in response and easier to control.

In formulating the engine dynamic simulations each component must be described in sufficient mathematical detail to define its time-dependent character in terms of hydrodynamic and thermodynamic performance, and its time-dependent relation to adjacent components. This constitutes the digital dynamic model used for accurate analysis. A simpler analog model is also constructed, which represents components with non-linear partial derivatives, and is used for initial control system evaluation. With these tools available, a preliminary selection of the control elements (sensors, actuators and control computer logic) is made and a dynamic model is constructed. This control simulation is married to the appropriate engine model and evaluation of control modes can begin. Because the primary function of the control system is to protect the engine components, the system is evolved until adequate engine protection is afforded under all steady-state and transient conditions.

Typical problems and solutions are evaluated as shown in figure 9 where speed overshoot and a cooling margin deficiency are identified in the open-loop "gross mode" of control and are corrected by addition of the feedback loops.

C. Logic Mode

A potential logic mode for the SSME control consists of a basic open loop scheduled system, with supervisory trim for precision and overrides for failure protection. The basic open loop system runs the engine through its normal operating range with an absolute minimum dependence on measurements. The propellant modulating elements of the engine are moved in response to vehicle requests in accordance with a predetermined schedule of effective flow area as a function of the requested power or mixture ratio. Dynamic compensation is accomplished in this system by directly relating flow area change with time (rate control). Information to establish these schedules and rate limits is obtained from prior analysis and confirmed by engine and valve test data. The schedules are stored in the digital control permanent memory. A typical basic schedule control loop is shown in figure 10.

A secondary mode of control is the supervisory, or limited authority trim function that employs some process measurements for its operation. This mode improves thrust and mixture ratio precision by sensing engine parameters such as total flow or flow ratio and trimming the basic control to within the allowable error limits. A typical supervisory trim control loop is shown in figure 11.

While the primary function of the control system is to protect the engine during steady-state and transient operation, an important secondary function is to protect the engine against the effects of deterioration of any component part of the engine or control system. Critical engine parameters must be monitored to keep the engine within its design operating limits even though an unanticipated environmental change or a component malfunction has changed the basic engine characteristics so that the predetermined schedules are no longer valid. A limit override system senses the critical engine parameters and functions only when an established limit has been exceeded. A typical limit override system is shown in figure 12.

Redundancy in sensing elements with voting logic to select the sensor which is functioning properly can reduce the effect of sensor malfunction. Typical redundant sensor inputs are shown in figure 13.

Safety and reliability must be considered in the control system arrangement. The basic control mode should permit safe engine operation with reduced accuracy after loss of the supervisory trim system. The supervisory trim system should provide protection from the effects of performance degradation of engine components which alter the desired predetermined valve schedules. In addition, the redundant sensors and electronic control logic, employing self test techniques, can assure the required reliability levels and confidence.

Computer Configuration

Hydromechanical and electronic configurations were considered for the Space Shuttle Engine Control Unit (ECU). Hydromechanical control has been adequate on turbojet engines and on a development model of the P&WA RL10 throttling rocket engine but the requirement for improved engine performance and the acceptance of "fly-by-wire" vehicle controls has accelerated the introduction of electronic controls. Fortunately, major advances in solid state electronic equipment have made the change possible at this time. P&WA is

currently applying engine-mounted electronic controls to gas turbine engines under development; many thousands of hours of operational experience will be accumulated in these programs. Solutions to the environmental problems obtained in these programs will be available to supplement the SSME control design and later development. Hydromechanical control applications for the SSME are handicapped by the lack of a suitable working fluid; the engine propellants are compressible and their properties vary over the engine operating range, introducing inaccuracy in a hydromechanical computer. The addition of a third fluid as a working medium necessitates careful conditioning to maintain properties and prevent freezing during engine tanking and hold operations. Environmental conditioning can be accomplished for electronic controls and the desired computation precision can be attained. The electronic control interfaces readily with the vehicle and connects easily with remotely located valve actuators. Based on these considerations for precision, environment, and compatibility with interface commands, an electronic engine command unit is best suited for the SSME.

Engine-mounting the engine command unit not only simplifies the engine/vehicle interface but provides a special-purpose computer dedicated solely to engine protection. This is an important safety consideration for manned systems as outlined in a paper by Operations Research Incorporated. Seven safety principles were outlined and seem appropriate:

- Separate vital functions
- Isolate vital equipment
- Employ fail-safe bias
- Design for serial independence
- Employ positive sequences
- Design for consistent behavior
- Design for physical strength

These considerations should be applied in the concepts for design, production and operation of the SSME control system.

III. ENGINE CHECKOUT AND DIAGNOSIS

A prime goal in the space shuttle is economy. The airlines have found that this requires high utilization of a small fleet through efficient checkout and maintenance. Automated on-board checkout and recording systems minimize the need for ground based special-test equipment and their associated maintenance and reliability problems. An operational readiness signal will indicate that the engine can start and accelerate to any thrust level. The engine inlet conditions will be measured and compared to limits stored in the control.

The vehicle operational readiness checks will include self test of the control. If all systems are within the limits, a signal will be provided to the vehicle. If any parameter is out of limits, it can be identified to the vehicle. These checks will be made prior to start.

Parameters presently included in the operational readiness check are:

1. Electrical Power
2. Control Operation (Self Test Program)
3. Helium System Pressure
4. Propellant Inlet Conditions
5. Main Turbopump Housing Temperature

The sensors and control logic required for engine control and protection also provides most, if not all the information which should be monitored for engine performance assessment, check-out, diagnosis and malfunction isolation. The availability of this information is evident in figure 14 which shows one of the control loops in block diagram form. Uncorrected error signals which persist after a normal transient are indicative of a system fault. An uncorrected trim error signal indicates that the engine component characteristics have degraded beyond the capacity of the limited authority trim loop. An uncorrected valve position error indicates a malfunction in the valve or actuator. An active override signal denotes that a major change in component characteristics has occurred. Signals are also available from the sensor and voting logic networks.

Since it is not desirable to hot fire the SSME for ground checks, inflight data recording and telemetry of available parameters is most important to expedite the maintenance turnaround. Interrogation and multiplexing procedures

for the monitored parameters must be coordinated with the vehicle to assure that adequate vehicle computer memory capacity is available and that fault indications are properly assessed by the vehicle for corrective action.

Malfunctions may be classified as to effect on engine and vehicle operation.

<u>Failure Type</u>	<u>Effect on Engine</u>	<u>Vehicle Action Required</u>
Failure of a component which has a redundant backup	None	Identify for ground maintenance
Failure of a component requiring a switch to a backup control mode	Reduced engine precision and reliability	Assess effects on mission
Degradation of a subsystem requiring override trim	Reduced engine thrust	Assess effects on mission. Minor trim compensation in thrust
Failure of a subsystem requiring advance to shutdown	Engine shutdown	Assess effects on mission. Major trim compensation in thrust and possibly gimbal angle

The following signals are being considered for monitoring and recording in the vehicle.

1. Uncorrected Valve Position Error Signals
2. Uncorrected Flow or Chamber Pressure Error
3. Uncorrected Mixture Ratio Error
4. Operation of backup control modes
5. Control system override signals
 - a. Turbopump speeds
 - b. Turbopump vibration
 - c. Turbopump NPSP
 - d. Turbine discharge temperatures
 - e. Nozzle coolant flow

Engine monitoring during preflight and flight operation can provide the data necessary to identify failed Line Replaceable Units and schedule maintenance activity.

IV. SENSOR TECHNOLOGY

Although basic schedules for the SSME control components will be pre-determined and scheduled as open loop, supervisory trim systems for precise thrust and mixture ratio control, and overrides for engine protection are planned and sensors are used in these control loops. The supervisory trim loops will require propellant flow or chamber pressure measurement; override loops utilize turbine exit temperature, turbopump speeds and some engine pressure measurements. Sensor accuracy will be confirmed by calibrations compared to the reference standards. The precision and accuracy of the reference standards, the engine trim procedure for thrust and mixture ratio and the precision of remaining system components will define a precision band for engine mounted sensor elements. In addition, these sensors should not introduce biases which are a function of the operating environment and result in an output shift. The sensor elements should be stable with ambient temperature changes, vibration, acoustic noise, varying ambient pressure, G loads, and changes in attitude.

Propellant flow measurement must be made on a mass basis to account for range in propellant inlet conditions encountered on the SSME. In lieu of a pure mass flow measurement system, density must be calculated from additional pressure and temperature measurements. Successful development of a pure mass flow measurement device for the SSME would result in an overall system improvement. Some of the problems encountered with typical flow measurement devices are illustrated in figure 15 where the effects of installation on sensor output are shown.

Pressure sensors for the SSME control will probably be of the diffused strain gage or deposited strain gage type. These devices are precise when used in a reasonable environment. Acceptable steady-state temperature compensation methods are available but we have found that a change in output will be experienced for substantial time after an ambient temperature change. Typical test results are shown in figure 16. The calibration results are shown as percent deviation in output signal from the signal obtained in a standard setup. A controlled environment for the strain gage can be added but it would be better if a thermally insensitive instrument could be developed.

Turbine temperature is an excellent parameter to use for engine protection and diagnosis. Chromel Alumel thermocouples will probably be used for this application but we are continually searching for more precise and reliable devices. One candidate is the infrared sensor which is now being tested for application to gas turbine engine blade temperature measurement. However, this sensor requires control of the environment, and a window access through the high pressure burner will be difficult to produce. Another candidate is the acoustic thermometer which measures temperature with a sonar technique. Some cyclic endurance test results are shown in figure 17 that indicate a repeatability problem in the unit tested, and a drift in output with time. Post-test inspection of the sample revealed evidence of oxidation which may have caused the drift, perhaps this characteristic can be used to assess turbine life.

The performance, reliability and maintenance goals for the Space Shuttle Main Engine place demanding performance requirements on the engine sensors. To assure that these sensors will perform accurately and reliably in the SSME environment, further technological development and thorough environmental testing are required.

V. CONCLUSION

The technology for successful development of the SSME control system, checkout and diagnosis systems is presently available in most areas. Existing techniques for development of control system logic modes through dynamic analysis have been proved effective. The engine control system design will require thorough dynamic evaluation for application to the SSME. Extensive coordination between the engine, vehicle, and operational personnel will be required to formulate effective engine checkout and diagnosis procedures. Advances in technology for process sensors are needed to improve reliability, reduce sensitivity to environmental changes, and provide the confidence levels necessary for space shuttle applications.

VI. REFERENCES

1. Cornell, Merrill E., Implementation of Safety Provisions in Manned Systems, AIAA Paper Number 67-937, October 23, 1967, Operations Research Incorporated.
2. Hill, L. J., K. Urbach, Implications of an Integrated Electronics System in Space Shuttle Operations, AIAA Paper Number 70-257, February 4, 1970, Lockheed Missiles and Space Company.
3. Kirchnir, Englebert, Checkout After Apollo, Space/Aeronautics, April, 1970.
4. McCall, J. C., F. Hudson, Integrated Electronics System for Space Shuttle, AIAA Paper Number 70-261, February 4, 1970, International Business Machines Corporation.
5. Przybylko, S. J., Criteria for a Turbine Engine Control System Development Model, Technical Memorandum APTA-TM-69-13, June 1969, Turbine Engine Division-Air Force Aero Propulsion Laboratory-Air Force Systems Command.
6. Stewart, F. M., R. L. Wetherington, Space Shuttle Main Propulsion, AAS Paper No. 70-044, June 7, 1970. Marshall Space Flight Center.
7. Warwick, T. R., Helicopter Engine Dynamic Analysis, American Helicopter Society Paper No. 332, May 14, 1969, Pratt & Whitney Aircraft.

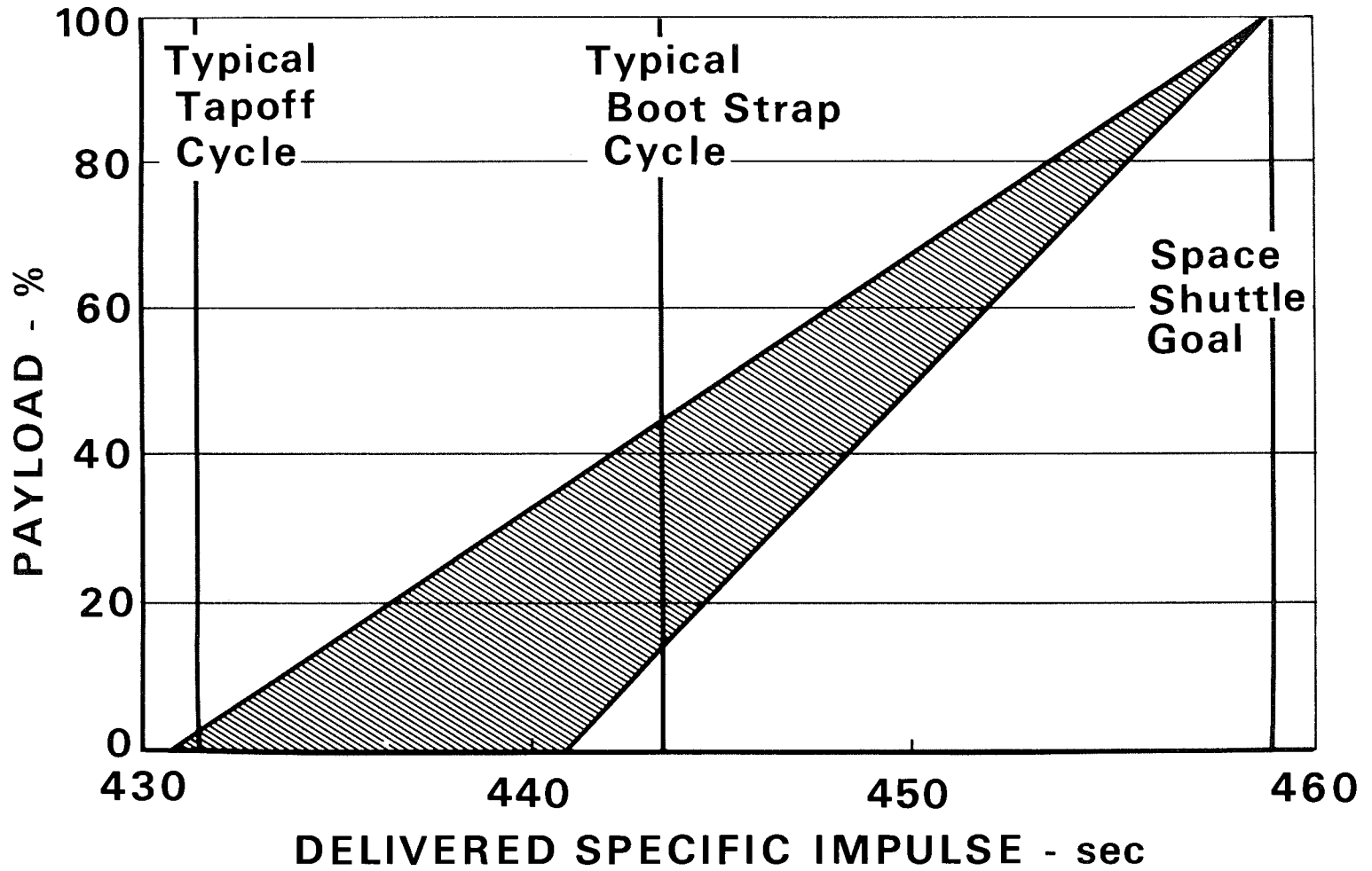

Figure 1. Shuttle Payload is very Sensitive to Specific Impulse

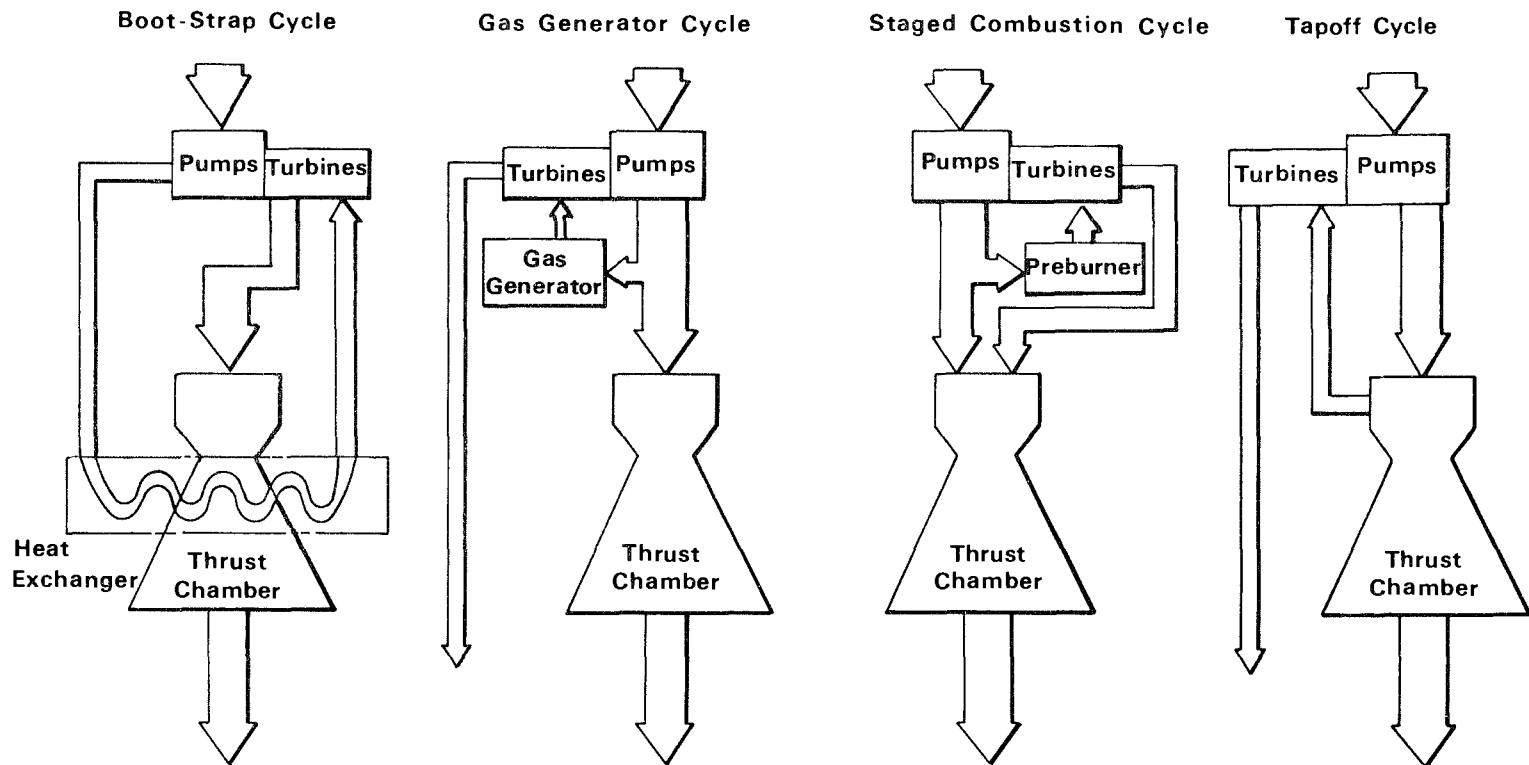

Figure 2. Candidate Engine Cycles

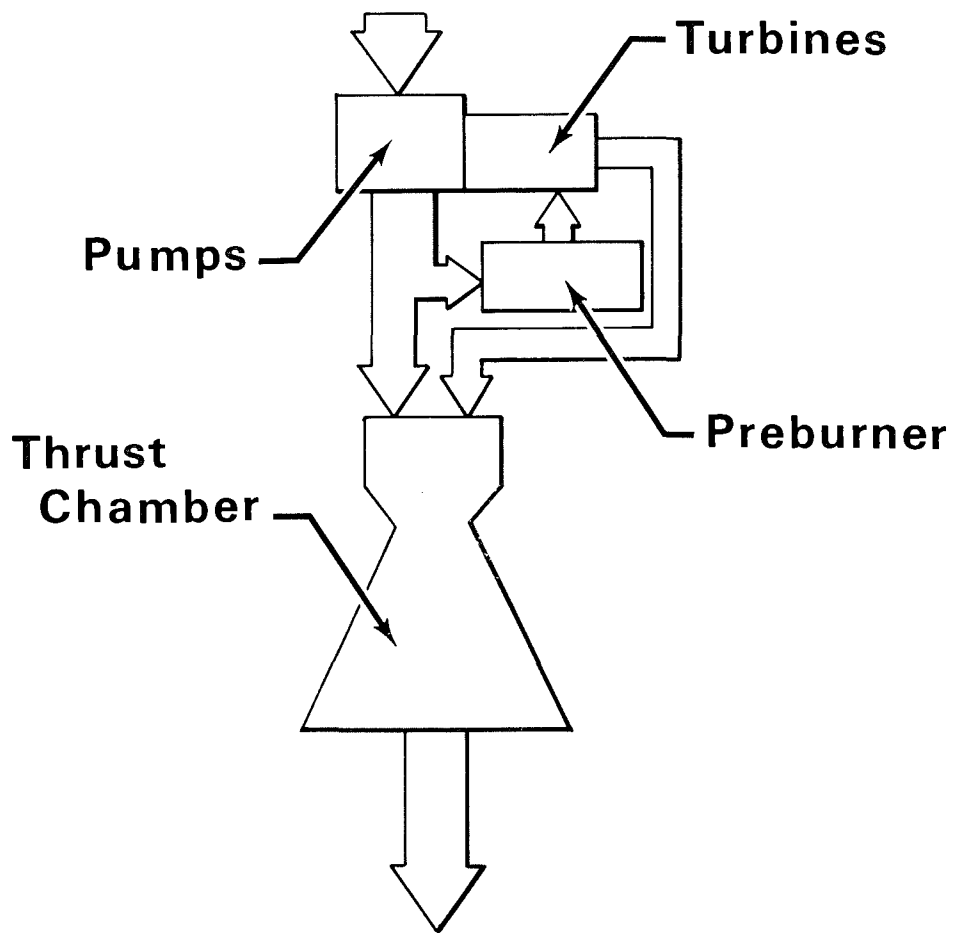

Figure 3. Staged-Combustion Cycle

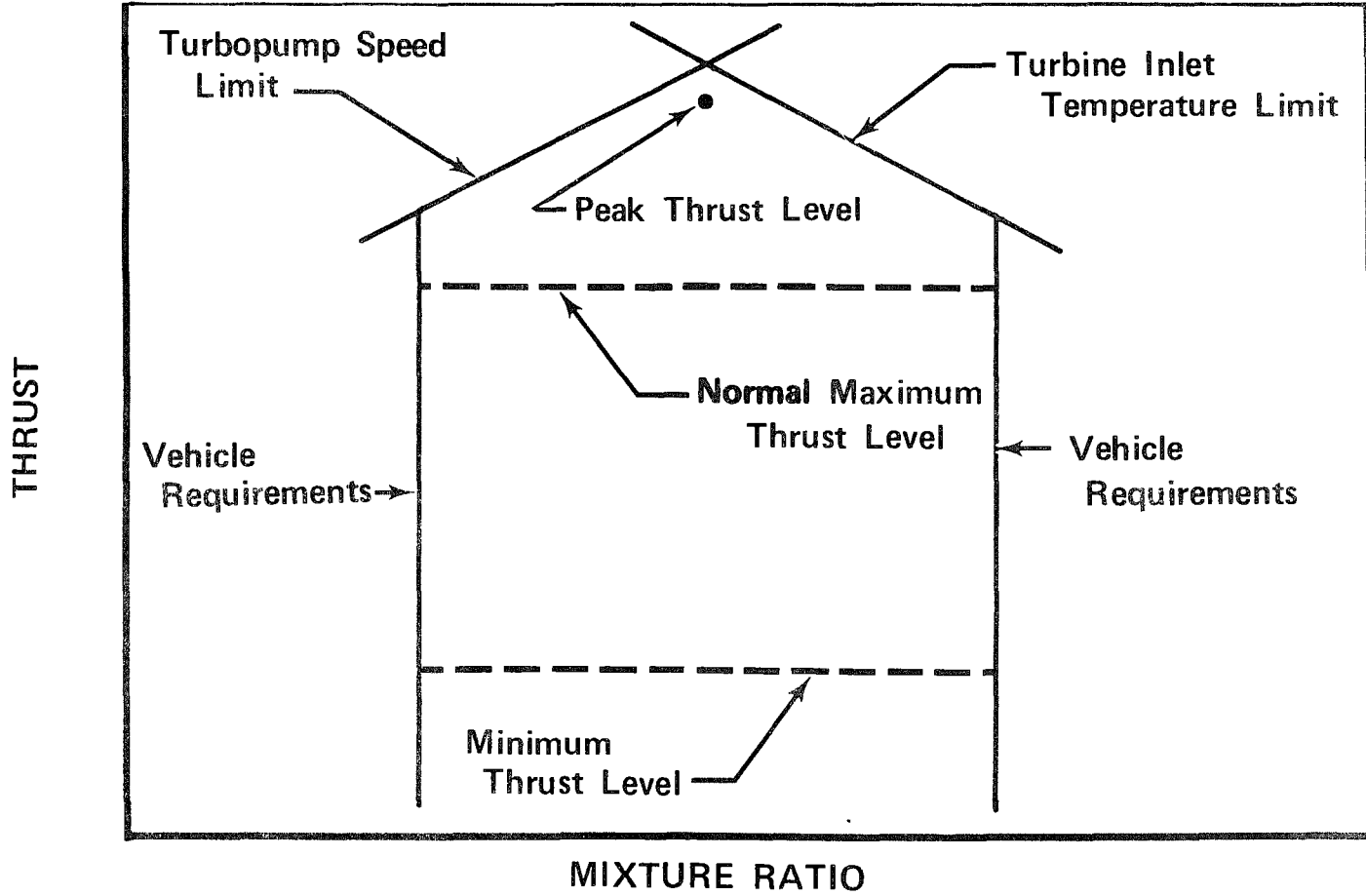

Figure 4. Engine Operating Limits

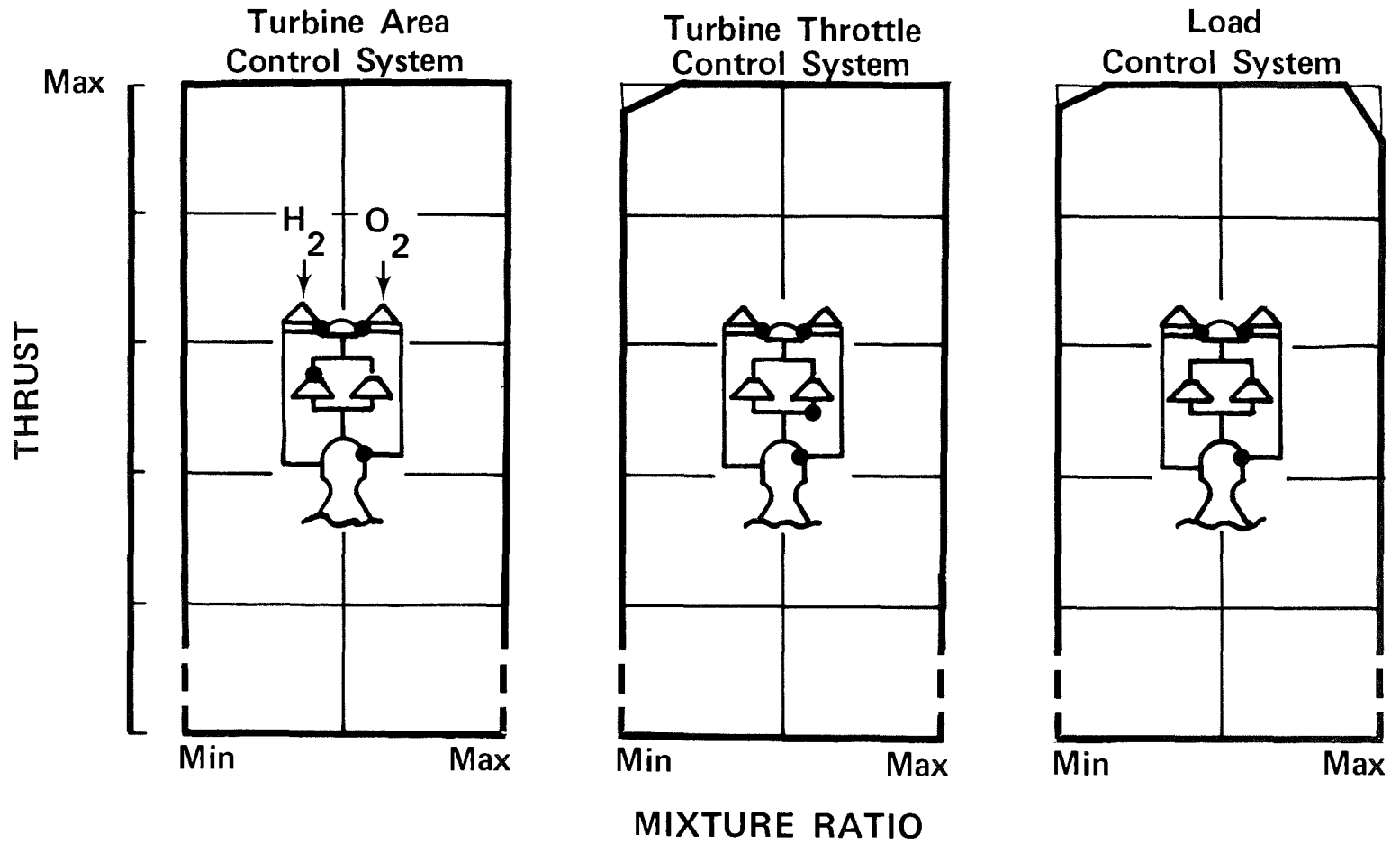

Figure 5. Comparison of Control Systems Operating Regions

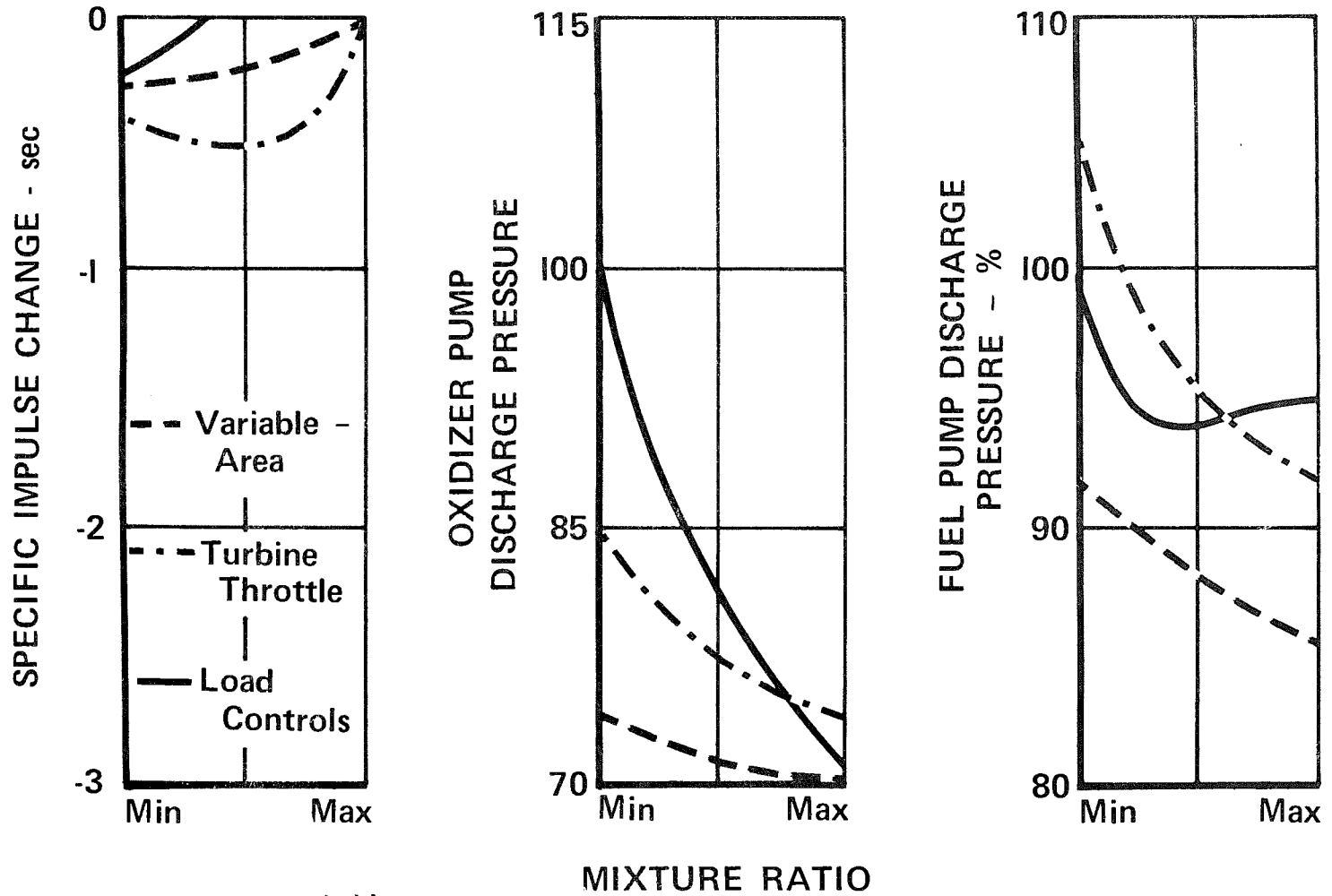

Figure 6. Control System Study - Engine Characteristics

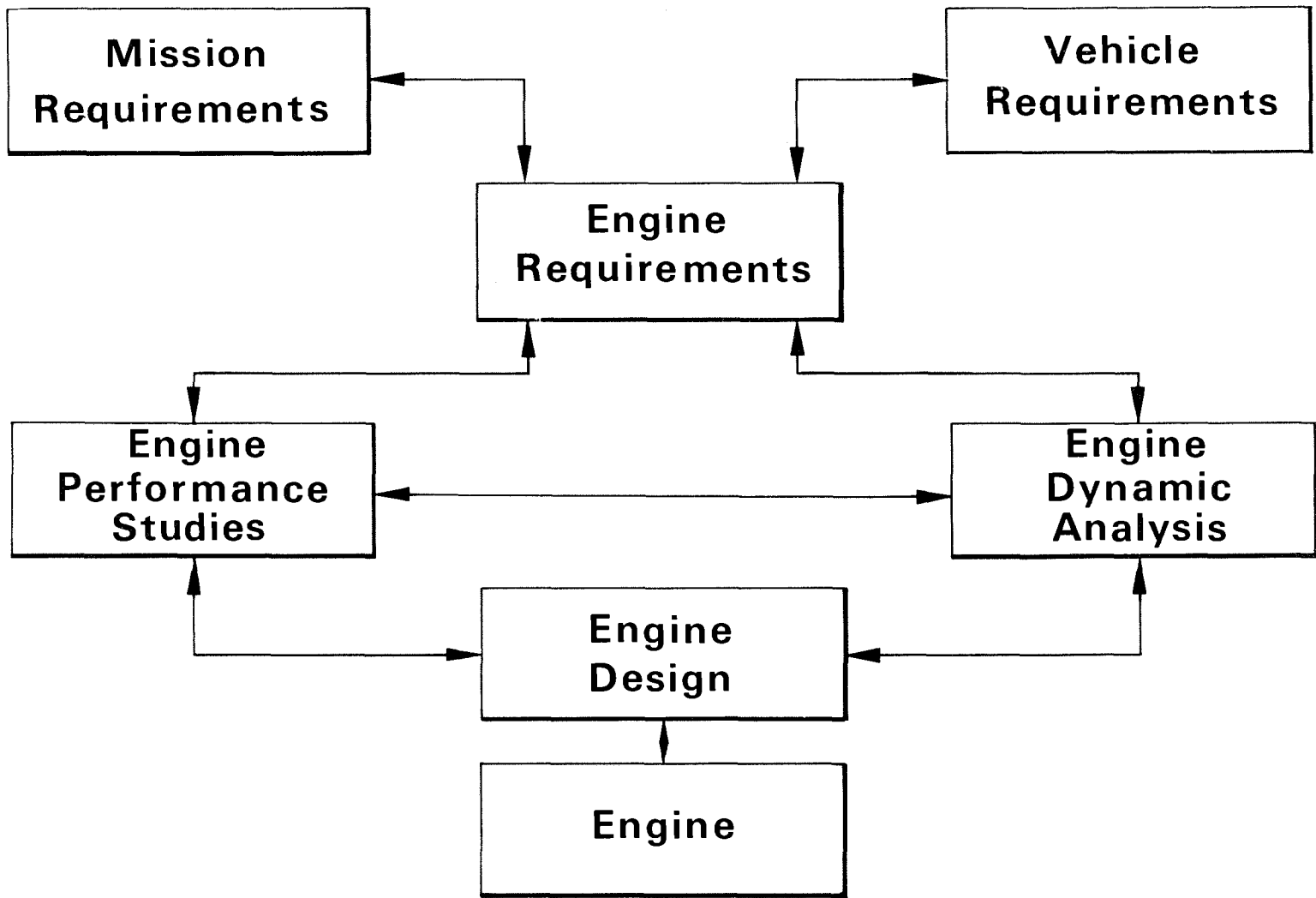

Figure 7. Engine Dynamic Analysis is an Integral Part of System Analysis

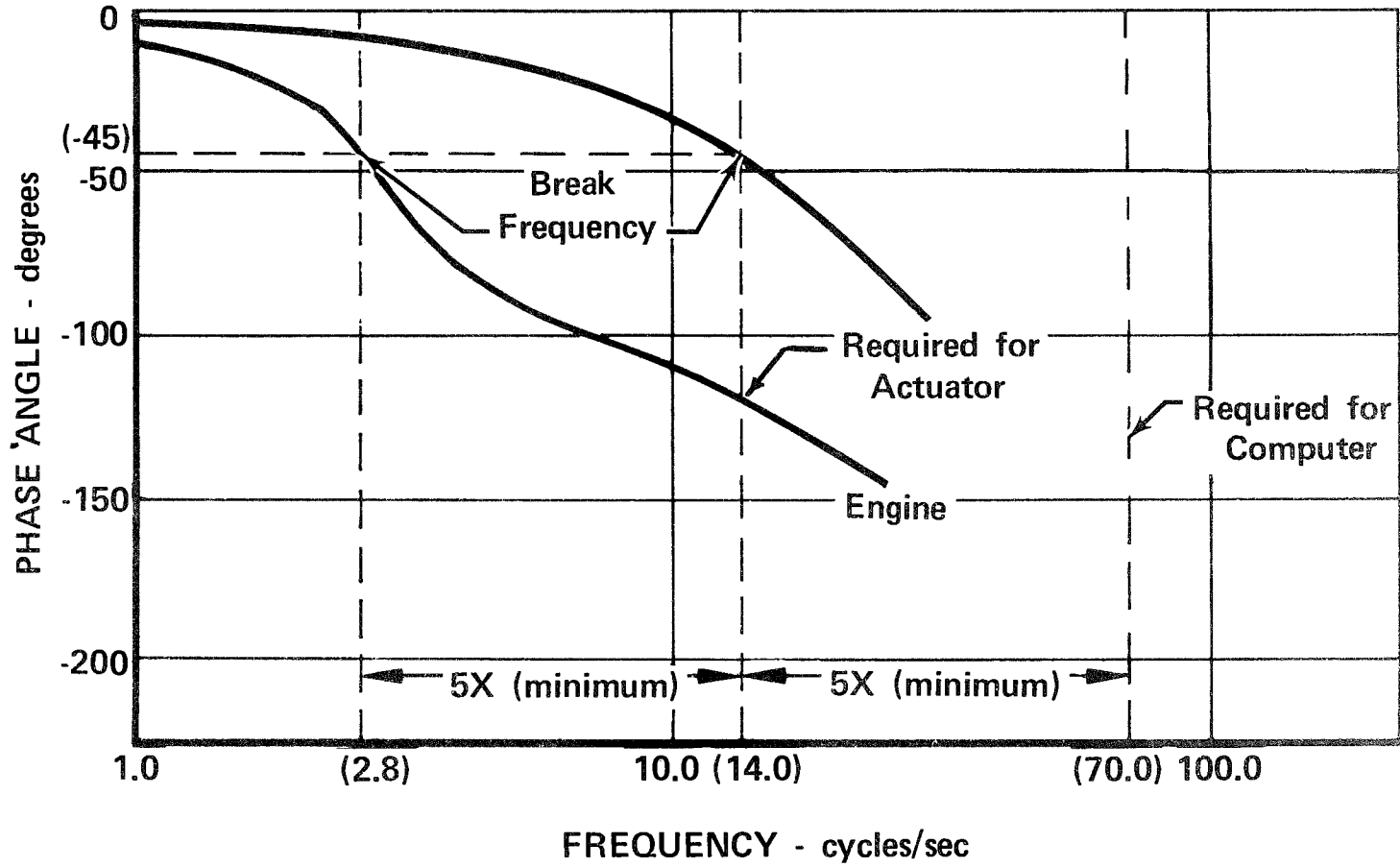

Figure 8. Engine Dynamics Dictate Normal Control Response

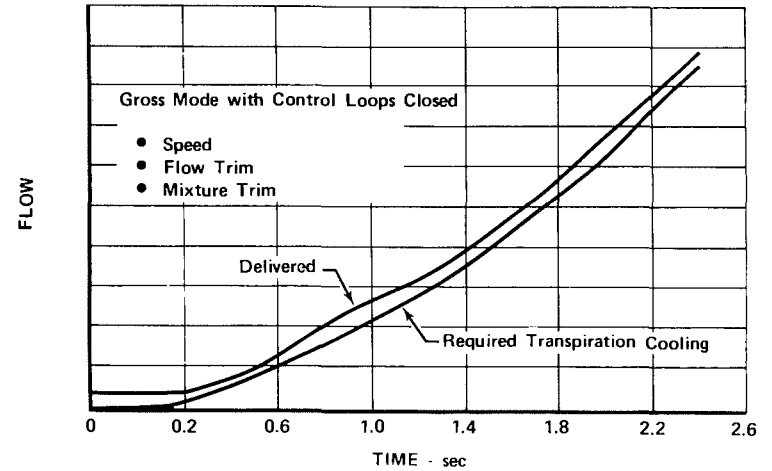
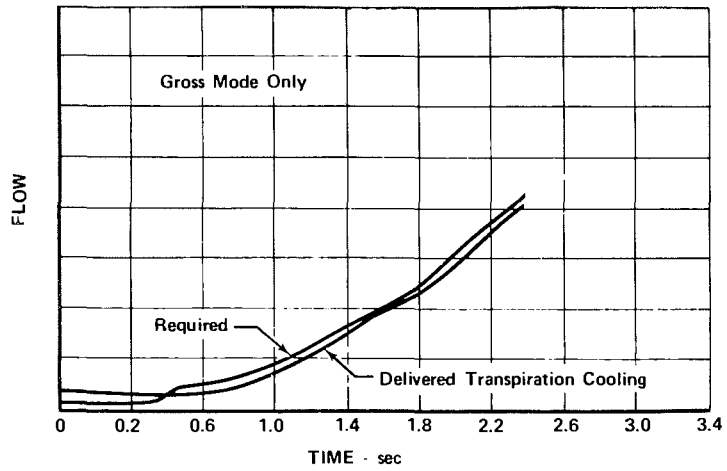
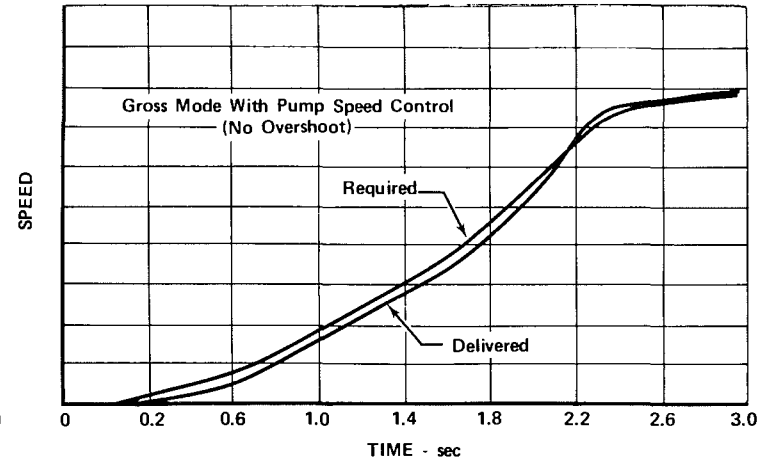
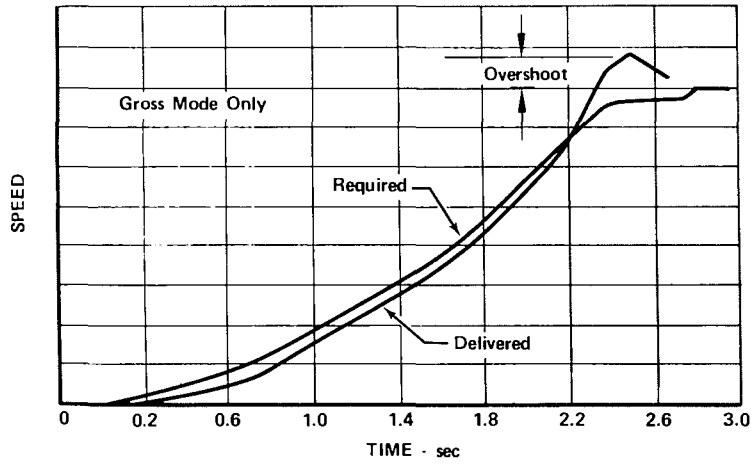

Figure 9. Acceleration

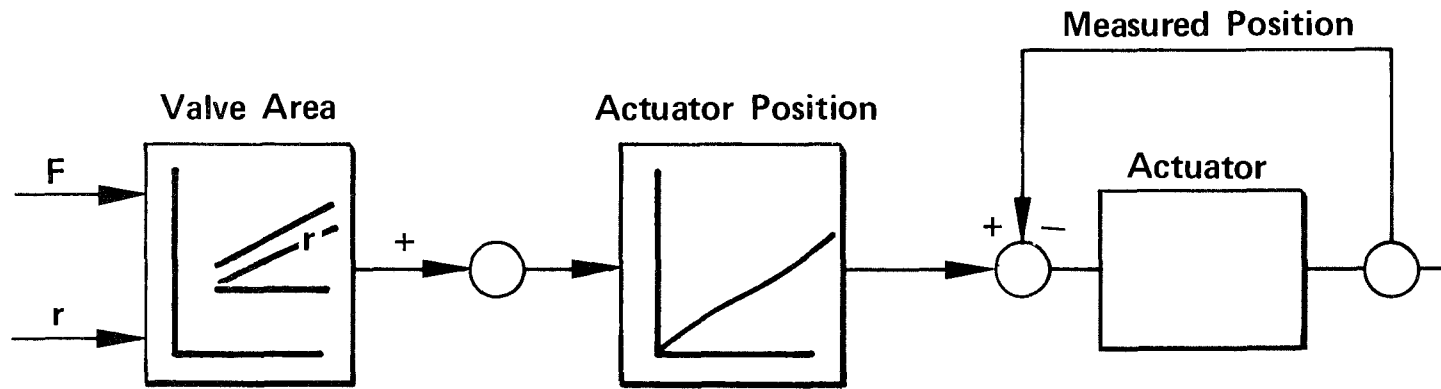

Figure 10. Basic Schedule

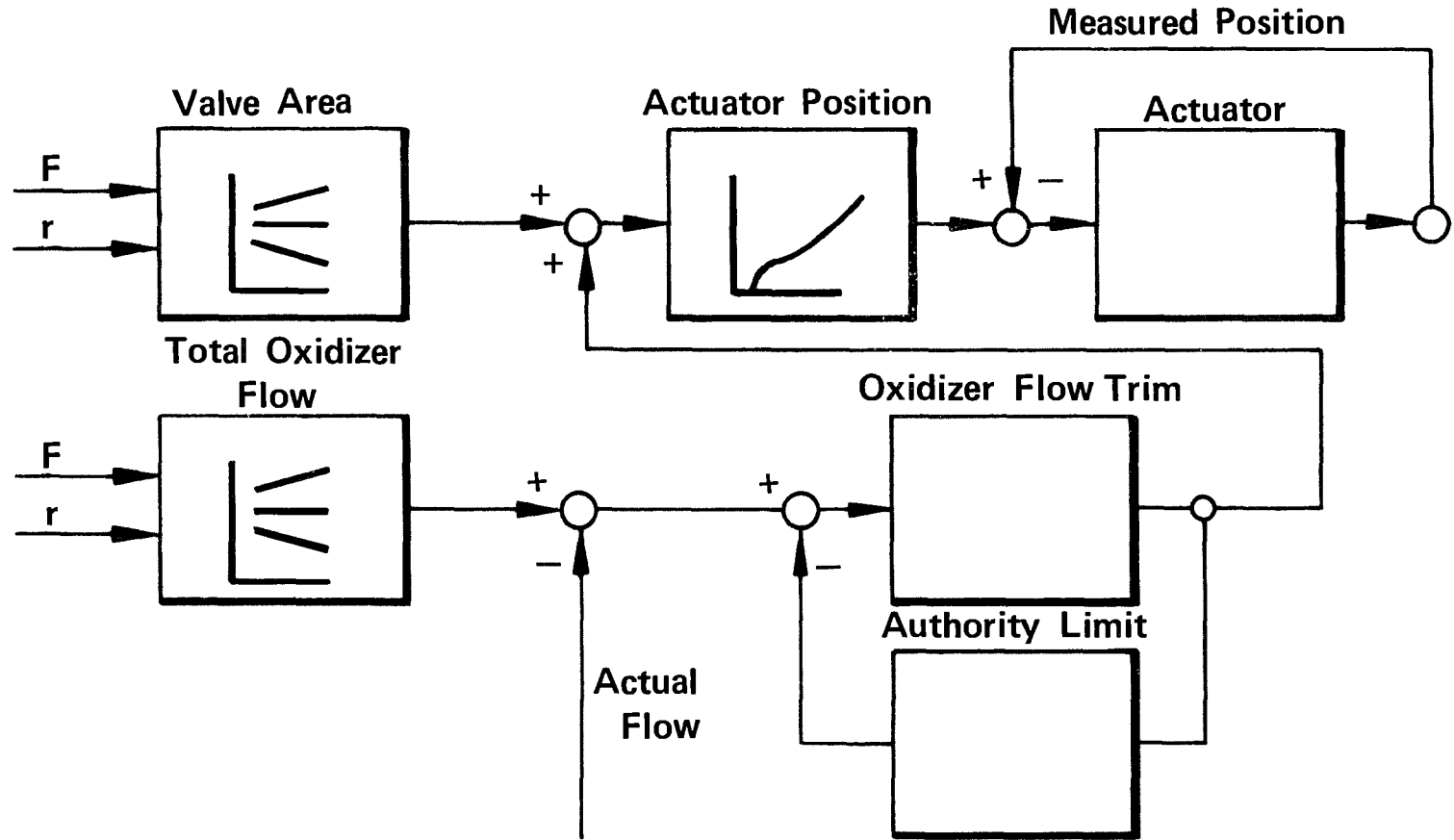

Figure 11. Supervisory Trim

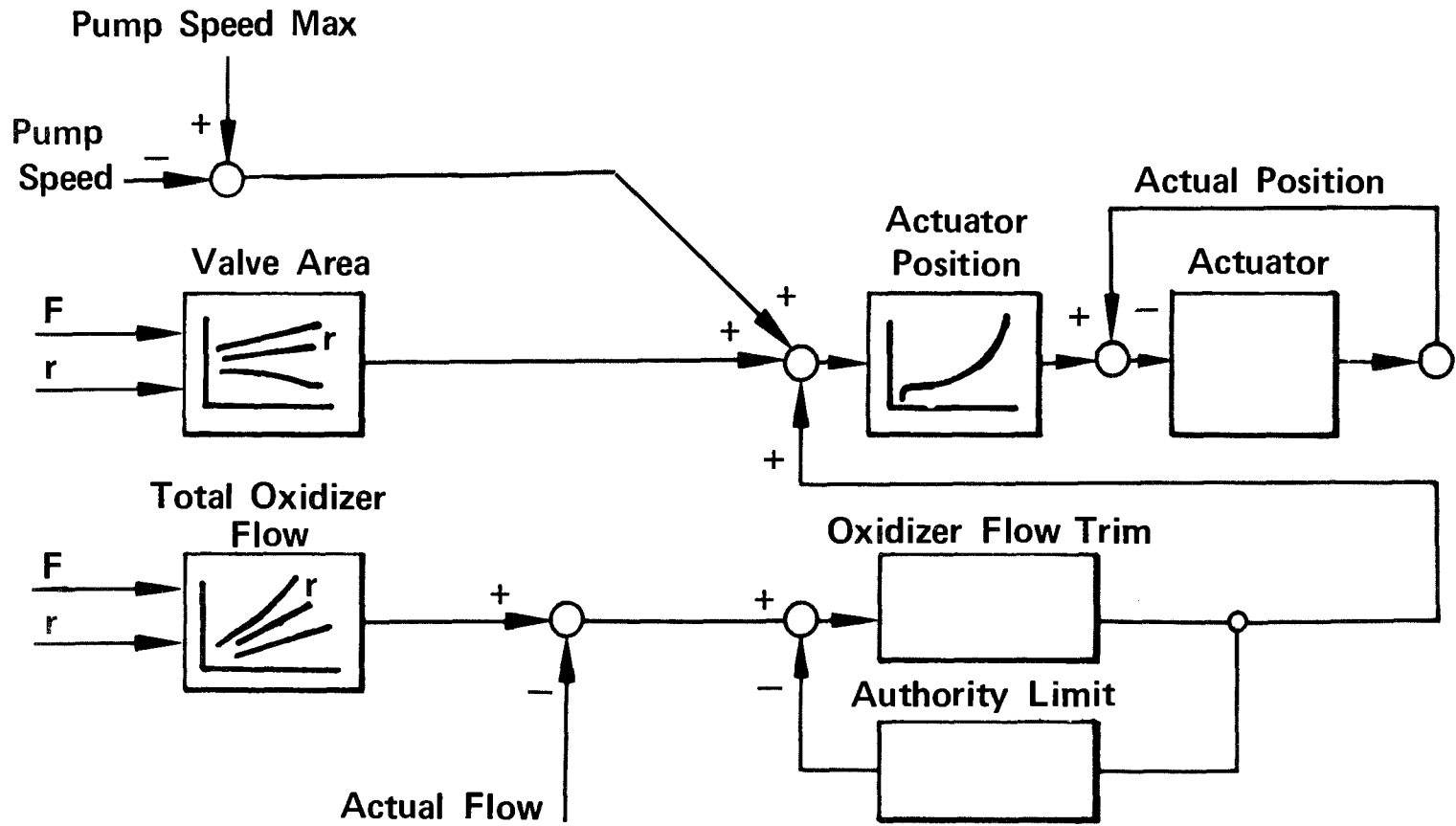

Figure 12. Limit Override

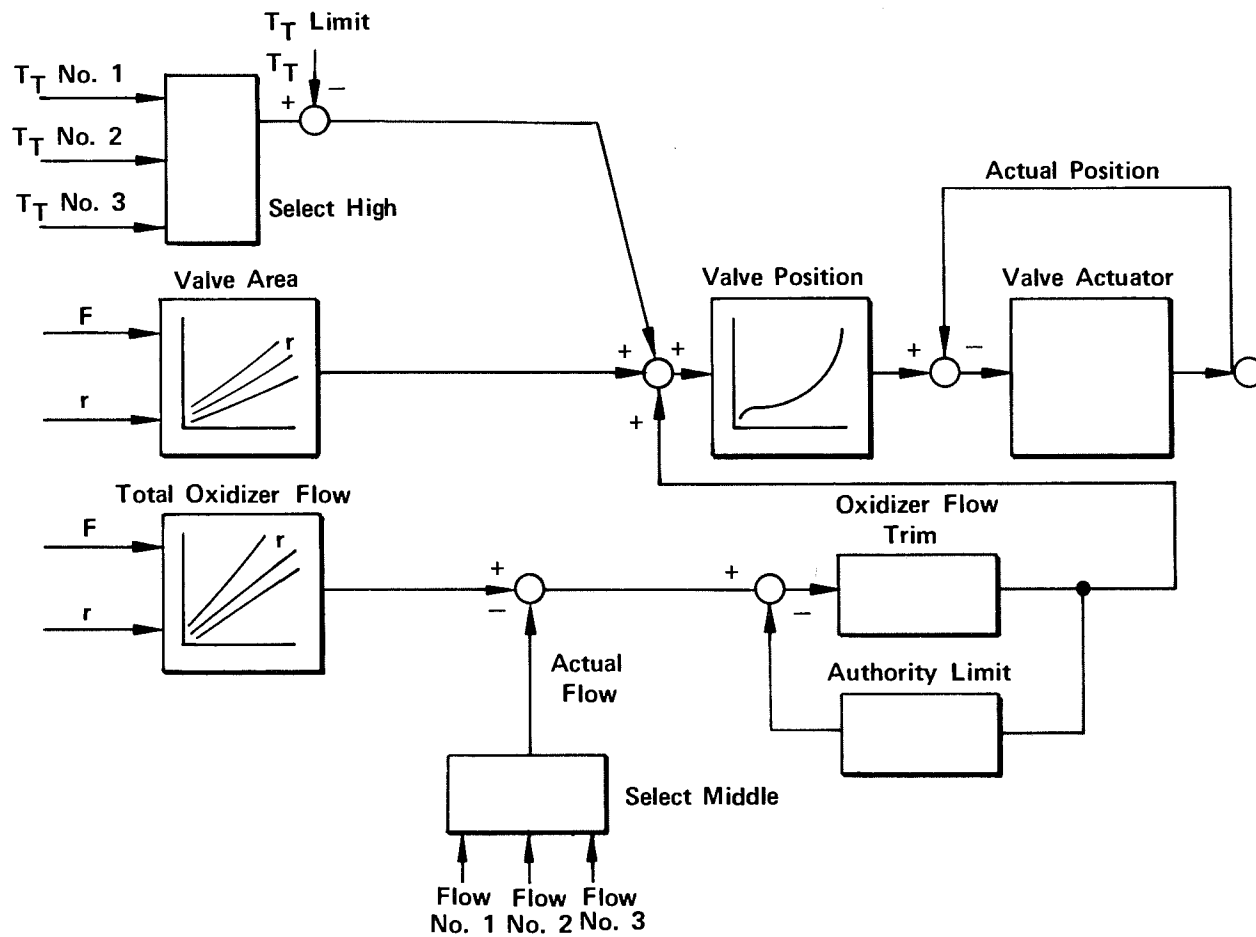

Figure 13. Redundant Sensors

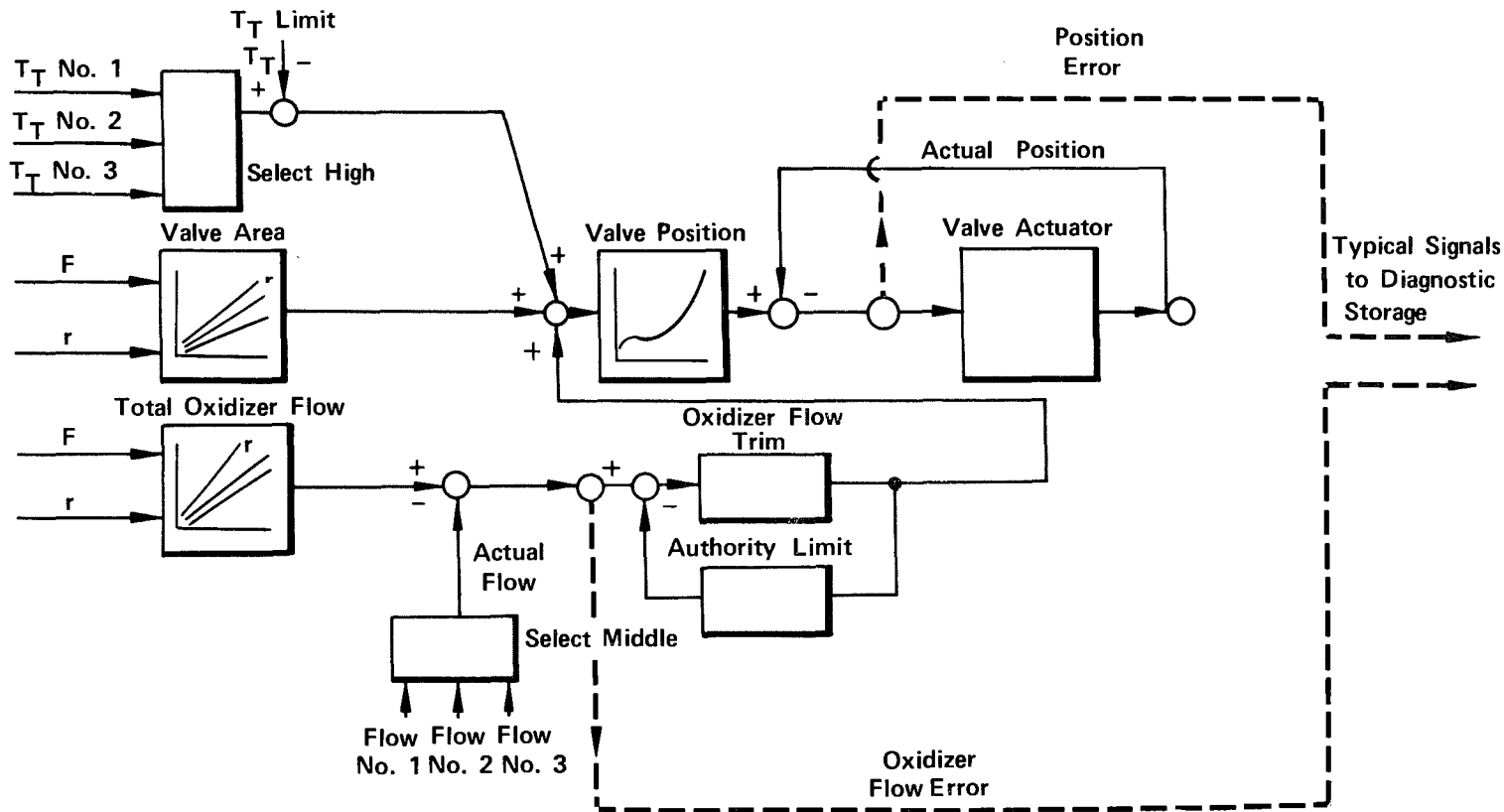

Figure 14. Diagnostic Signals are Available

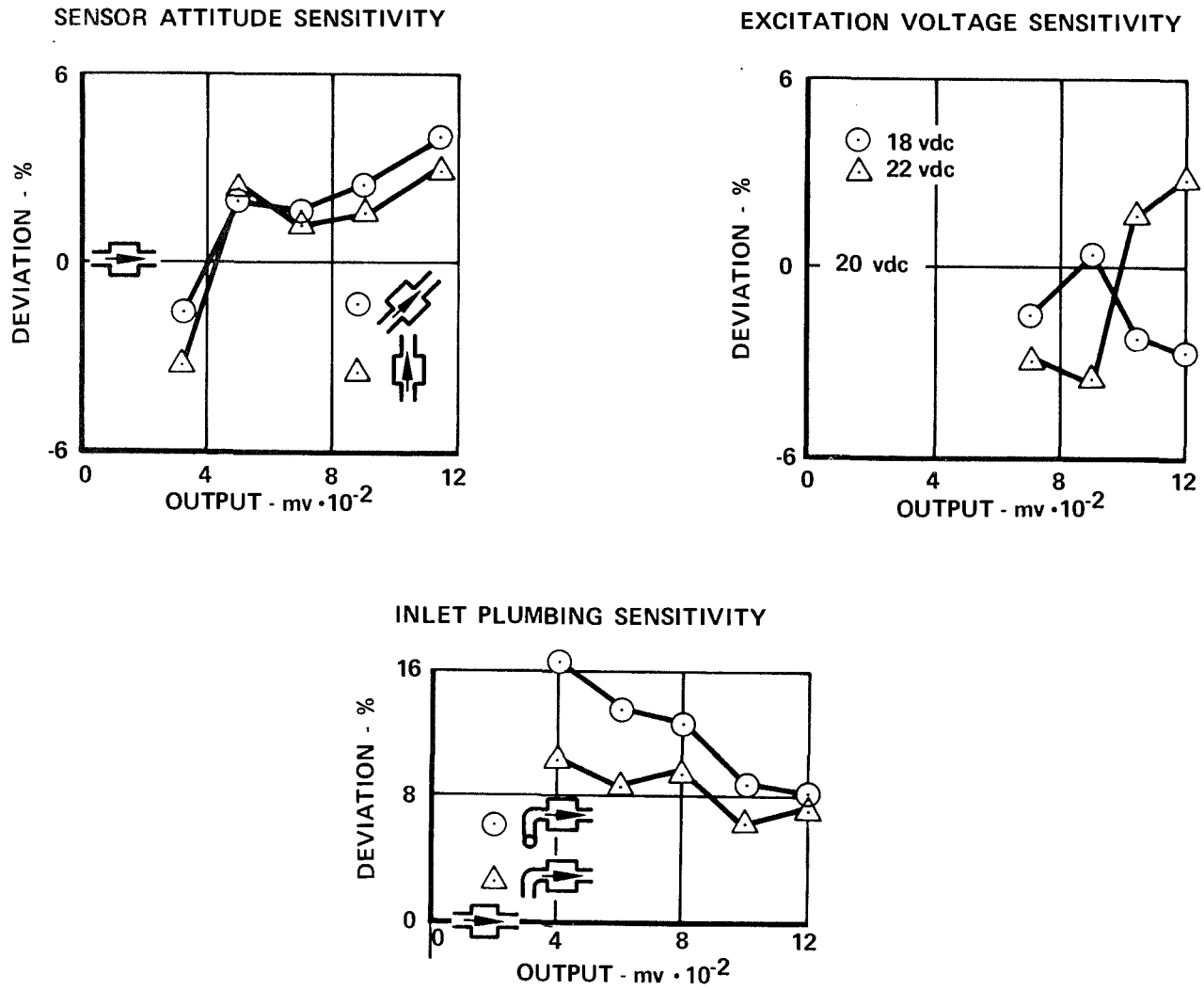
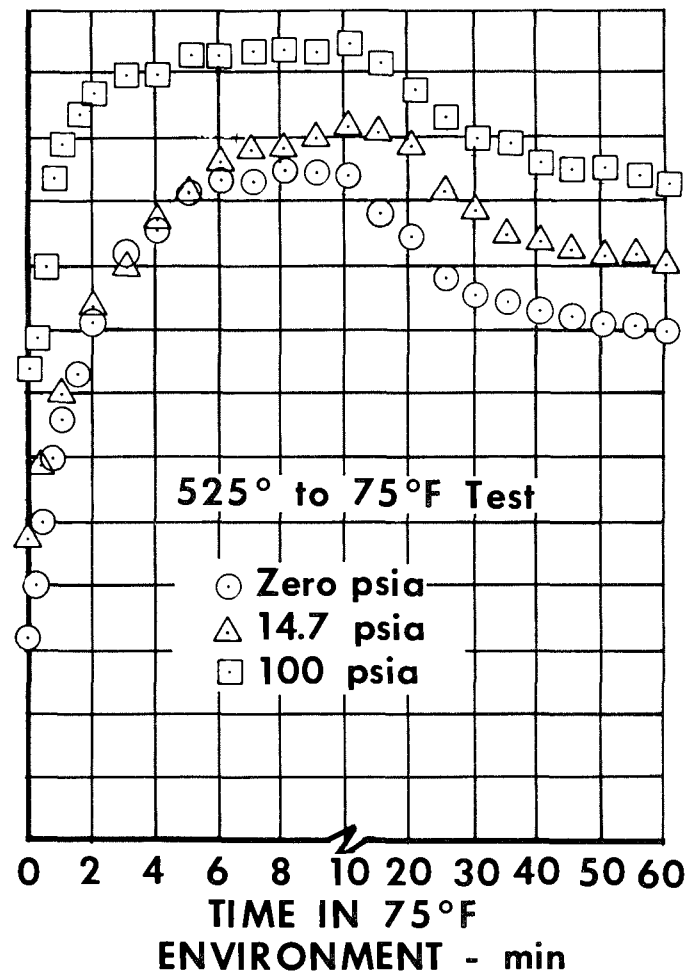
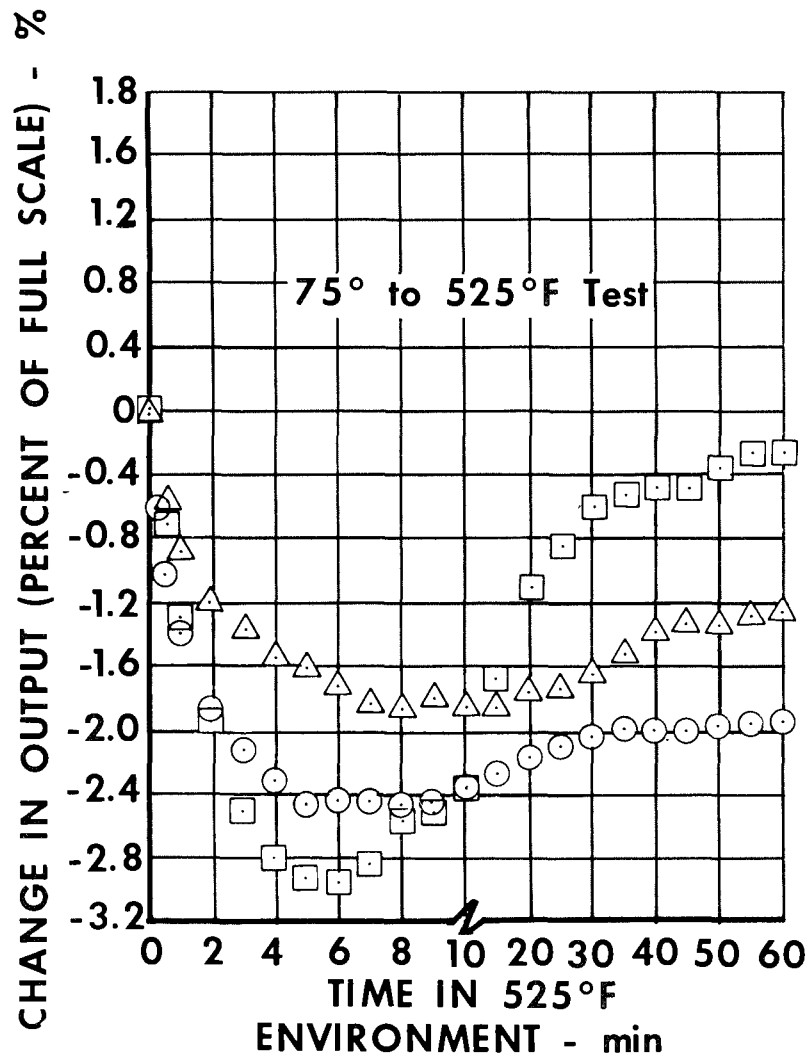

Figure 15. Flow Sensor Calibrations



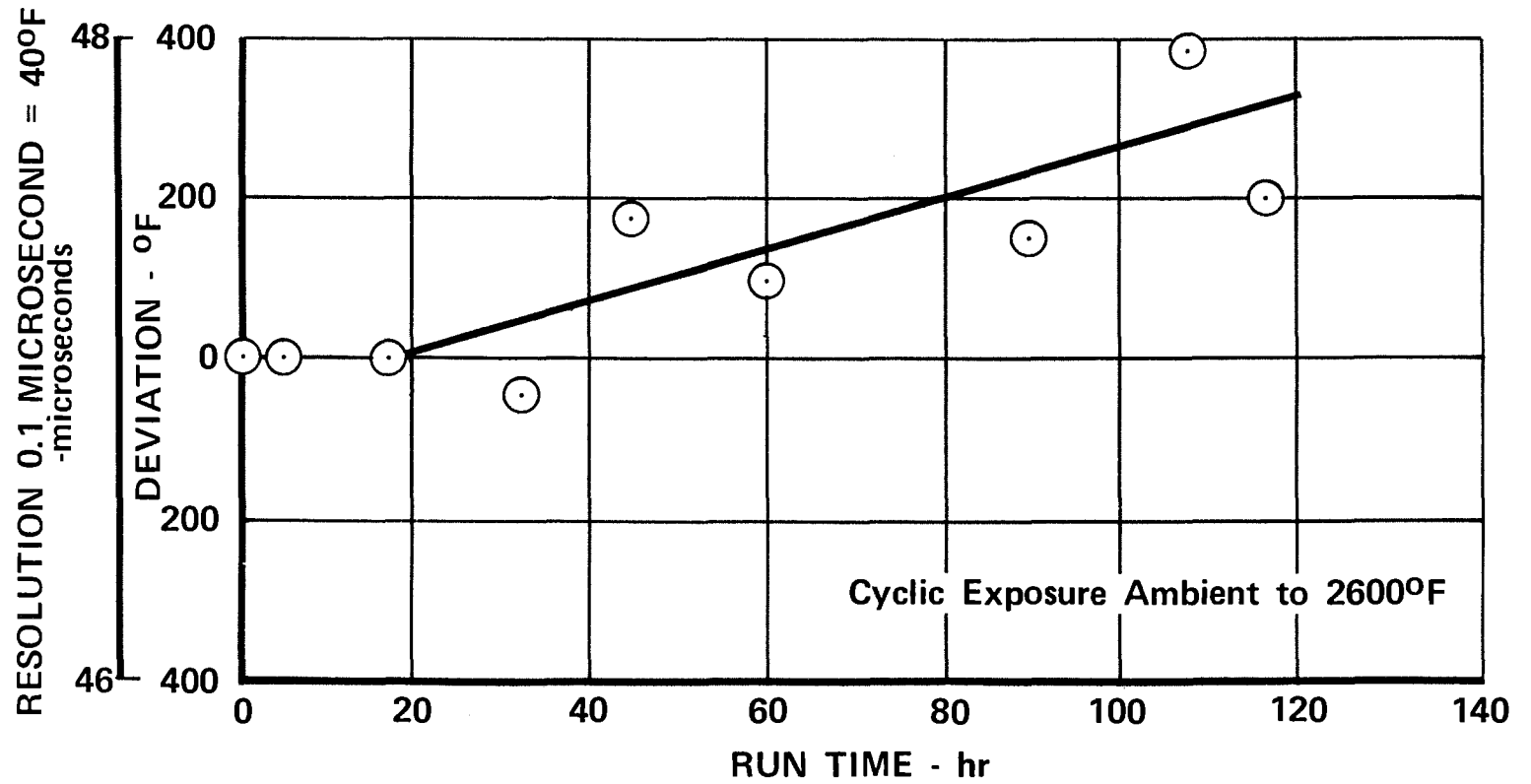

Figure 17. Signal Output Drift. Acoustic Thermometer; Iridium Wire Sensor.

REGENERATIVE COOLING OF THE SPACE SHUTTLE ENGINE

Henry C. Wieseneck

North American Rockwell, Rocketdyne Division
Canoga Park, California

INTRODUCTION

The high temperature associated with the efficient combustion of rocket propellants necessitates the selection of a cooling technique which reliably maintains safe operating temperatures on all critical components. For all liquid booster propulsion units, such as the J-2 engine (Fig. 1), this task is accomplished by regenerative cooling. The prime assets of regenerative cooling are reliability, durability, and high performance.

The Space Shuttle Engine imposes requirements on regenerative cooling well beyond those associated with current engine systems. This presentation will compare those requirements to capabilities and available technology of regenerative cooling.

J-2 ENGINE FIRING

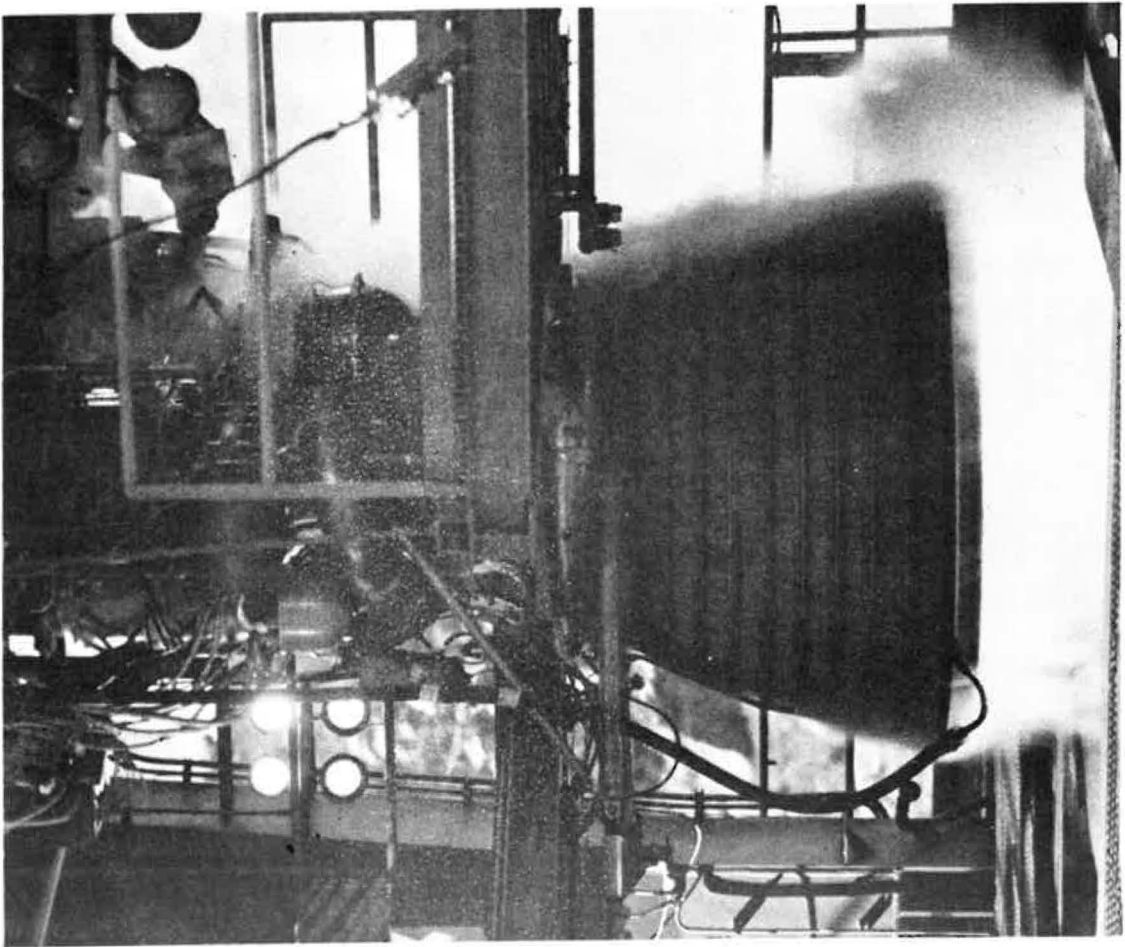

REGENERATIVELY COOLED THRUST CHAMBER

The principal of regenerative cooling is to maintain a cool wall by utilizing one of the propellants within the rocket engine to absorb heat that is transmitted to the thrust chamber from the combustion products. The selected coolant absorbs heat as it travels through the coolant passages and then returns this heat (regenerates) to the combustion process when it is injected into the combustion chamber.

92

Many types of coolants have been utilized in regeneratively cooled thrust chambers. Both oxidizers and fuels have been applied; cryogenics and storable propellants have each demonstrated the capability to cool regeneratively.

The techniques for constructing the coolant passages have also varied. The thrust chambers used for the early V-2 and Redstone rockets utilized a simple double wall construction. Later chambers utilized tubular construction. Current engines rely on both tubes and channel wall constructions. The latter is a modification of the earlier double wall technique.

REGENERATIVELY COOLED THRUST CHAMBER

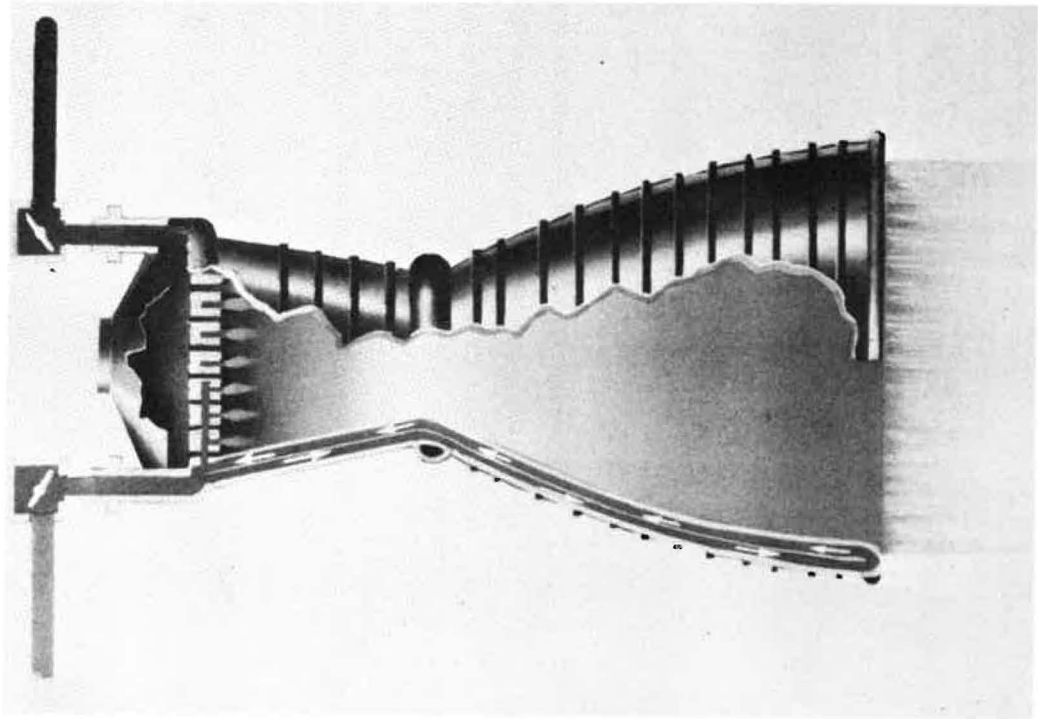

ENGINE LAUNCHES

The reliability of regenerative cooling is impressive. Figure 3 indicates space boosters and ballistic missiles which utilize regeneratively cooled engines. The number of flights for each of the propulsion systems is indicated and the number of regeneratively cooled engines associated with each vehicle is also shown. This chart represents over 4000 applications of regeneratively cooled engines. On all of these flights, regenerative cooling has had a failure-free operation.

ENGINE LAUNCHES

NUMBER OF REGENERATIVELY COOLED ENGINES	1	1	3	5-7	3	9-14	11
NUMBER OF FLIGHTS	75	46	404	386	54*	15	8

* DOES NOT INCLUDE BALLISTIC MISSILE FLIGHTS

95

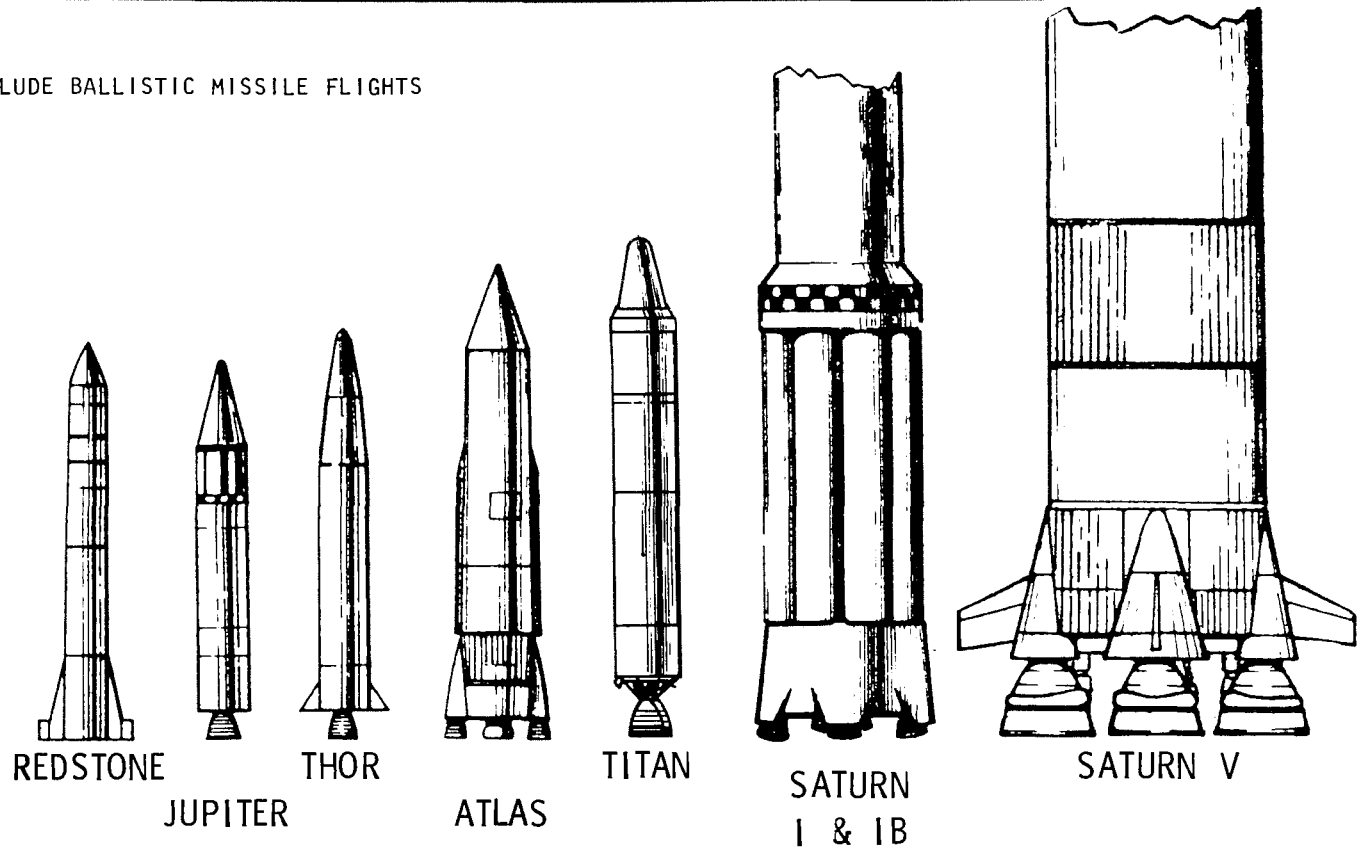

THERMAL CHARACTERISTICS OF PROPULSION SYSTEMS

The thermal environment within a rocket engine is substantially more severe than those experienced within other propulsion systems. Figure 4 indicates relative temperatures and heat fluxes that are experienced in rocket engines and air breathing propulsion systems. The severity of the thermal conditions is directly related to the stagnation temperature, the properties of the combustion gases, and the Mach number.

96

For air breathing systems combustion temperatures frequently exceed the allowable temperatures of most metals; but rarely approach the stagnation temperatures of from 6,000 to 8,000 degrees that are obtained within rocket engines. The heat fluxes experienced within oxygen-hydrogen rocket engines are substantially more severe than those encountered in air breathing propulsion. In the rocket engine the high stagnation temperature is combined with sonic hot gas conditions at the throat of the thrust chamber. Current oxygen-hydrogen rocket engines, such as the J-2, J-2S, and M-1, experience heat fluxes ranging from 17 to 35 Btu/in²-sec. At the Space Shuttle Engine design point the maximum heat flux is 72 Btu/in²-sec. Regenerative cooling provides the only means for handling these severe heat fluxes without encountering appreciable performance losses.

THERMAL CHARACTERISTICS OF PROPULSION SYSTEMS

96

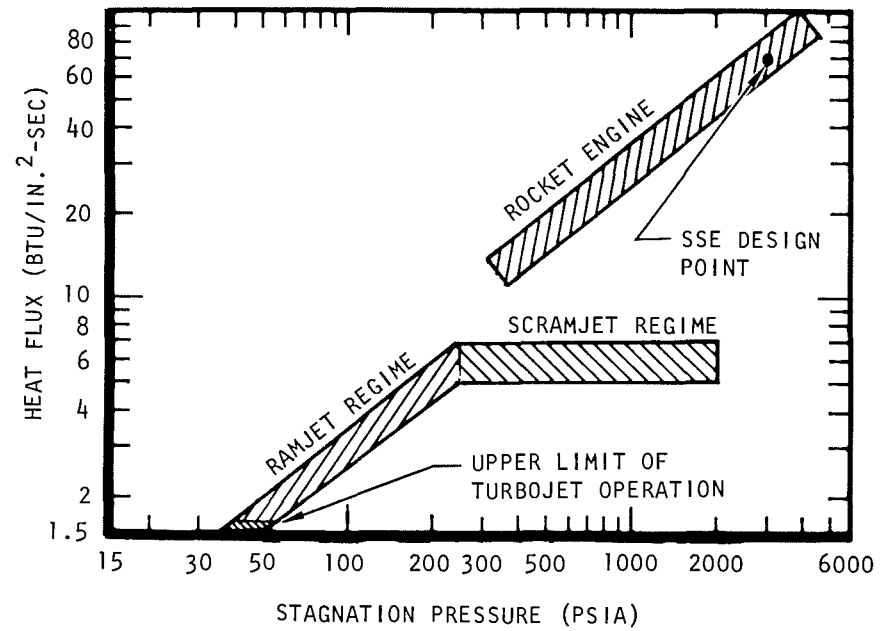
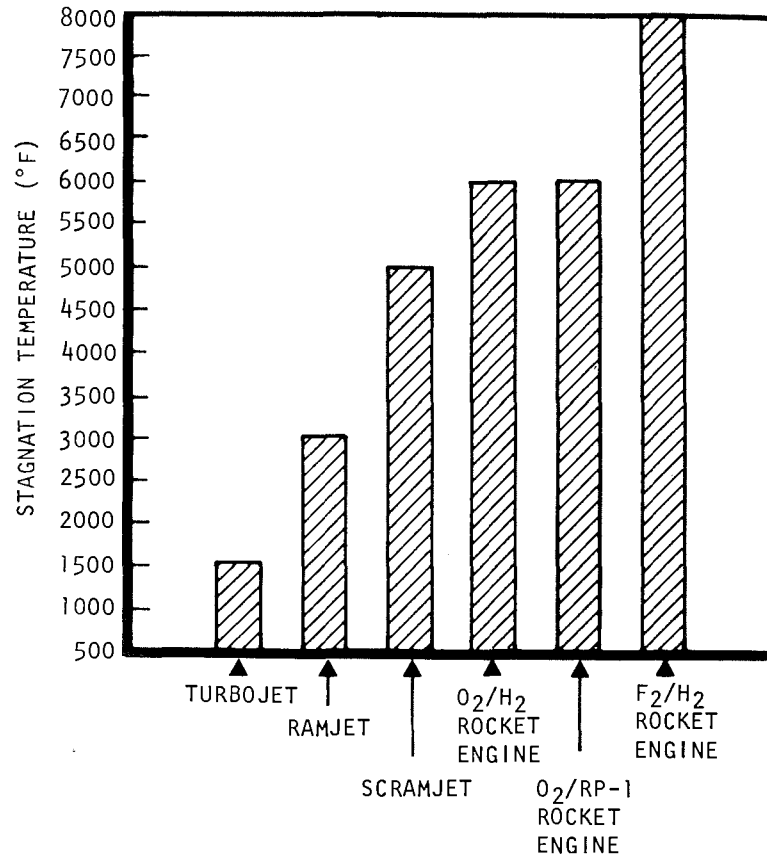

PERFORMANCE OF REGENERATIVE COOLING

The performance advantage of a regenerative cooling can be illustrated by comparing regenerative and non-regenerative cooling to an ideal combustion process. For a given set of propellant inlet conditions an ideal (adiabatic and nonviscous) combustion and expansion process is illustrated by the center bar; mixing is uniform, combustion is perfect and there are boundary layer losses. However, in a real thrust chamber potential performance detriments must be evaluated. For non-regenerative cooling, the boundary layer loss, which is largely a function of a wall temperature, is substantially unrecoverable. In addition, non-regenerative cooling methods may require mixture ratio maldistribution, injector bias and/or mass addition downstream of the throat. These factors incur additional performance losses. This loss generally ranges from a few seconds to several percent and is a function of the cooling technique. The extent of this loss is minimized by careful design and extensive testing.

Regeneratively cooled chambers are normally designed for low wall temperatures, thus the energy lost in the boundary layer is usually larger than that associated with non-regenerative methods. However, the majority of the enthalpy is recovered by the coolant and returned to the combustion process. This recovery of enthalpy provides a regenerative cooling performance gain.

The performance gain associated with regenerative cooling, plus the losses associated with non-regenerative cooling techniques form the difference between regenerative and non-regenerative cooling methods.

PERFORMANCE OF REGENERATIVE COOLING

66

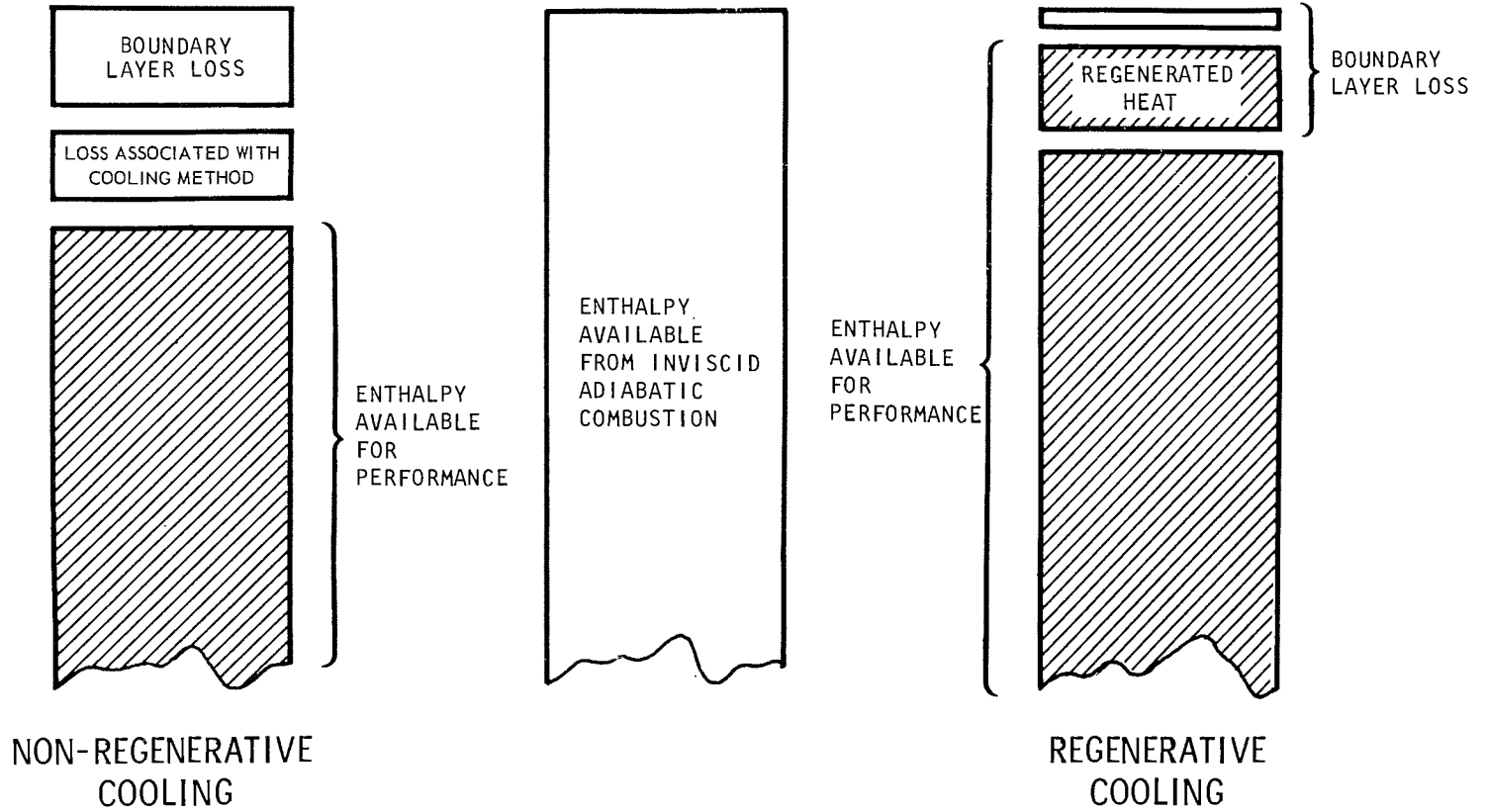

PERFORMANCE GAIN FROM REGENERATION

The performance gain of regenerative cooling can also be illustrated by using an enthalpy-entropy diagram for the equilibrium exhaust products of a reaction (neglecting divergency and kinetics). Pressure lines diverge on an h-s plot with increasing enthalpy or entropy; thus when heat is added to the propellants prior to combustion the enthalpy available from the expansion process is increased significantly.

Figure 6 illustrates the favorable effect of preheating propellants. In a regeneratively cooled chamber this heat is removed from the combusted propellants. If the heat is all removed at chamber pressure no gain is noted.

The maximum performance occurs when all the heat is removed at the nozzle exit. In a real engine, the heat is removed continuously so that the performance gain falls between these two extremes. For the Space Shuttle Engine the gain associated with the regenerative cycle is nearly one percent.

PERFORMANCE GAIN FROM REGENERATION

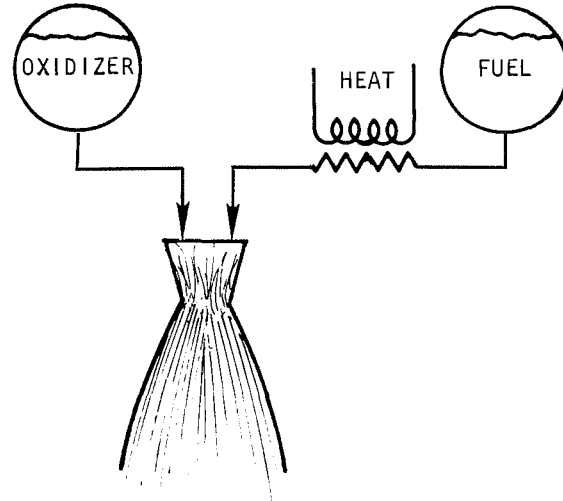
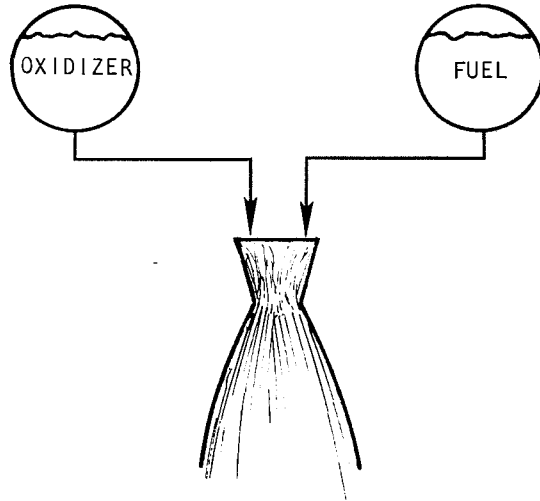

101

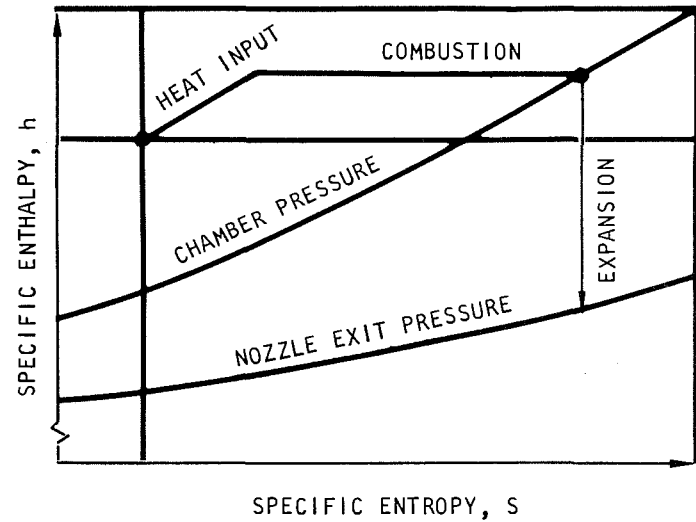
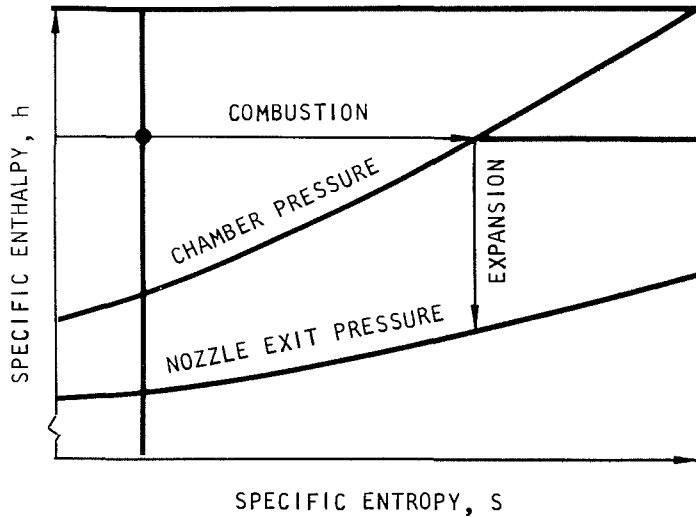

SPACE SHUTTLE ENGINE

The previous charts have discussed some of the features of regenerative cooling. It is now appropriate to explore the requirements and limitations associated with this cooling technique. The Space Shuttle Engine is designed to achieve a high thrust and high performance within a compact envelope. To accomplish these objectives, the engine operates at a chamber pressure of 3000 psi and produces heat flux four times as high as those experienced in the current J-2 engine. To understand the feasibility of regeneratively cooling the Space Shuttle Engine, it is necessary to compare the capabilities of coolant and thrust chamber materials with the engine requirements.

SPACE SHUTTLE ENGINE

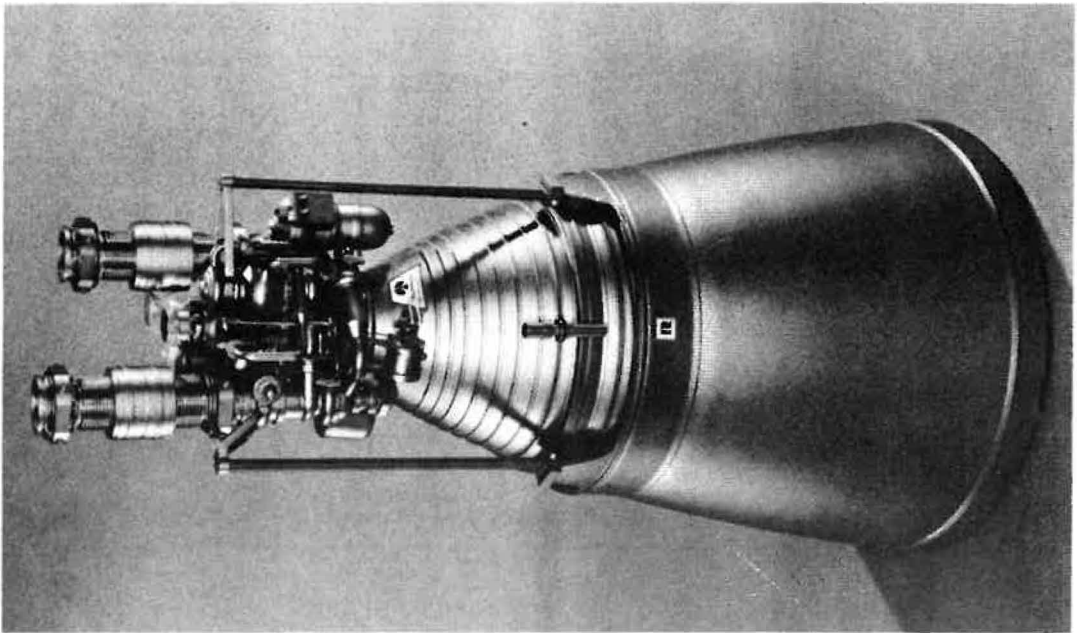

PROPERTIES AND PERFORMANCE OF COOLANTS

The characteristics of several coolants are compared in Fig. 8. The high coolant specific heat of the hydrogen minimizes the bulk temperature throughout the cooling circuit. Hydrogen easily ranks as the best coolant in terms of minimizing bulk temperature rise ($1/\Delta P_b$).

Another measure of cooling ability is the dynamic pressure required to cool a given heat flux. The pressure drop in the cooling system is a direct function of this parameter. Again hydrogen is far superior to other coolants which require from two to six times the amount of pressure drop to cool a given heat flux.

The availability of hydrogen within the Space Shuttle Engine is a prime factor in the ability to cool regeneratively.

PROPERTIES AND PERFORMANCE OF COOLANTS

COOLANT	DENSITY (LB _M / FT ³)	SPECIFIC HEAT (BTU/LB _M ⁻⁰ R)	COOL. TEMP. RISE RATING RELATIVE TO H ₂ (%)	PRESSURE DROP RATING RELATIVE TO H ₂ (%)
H ₂	2.2	3.50	100	100
H ₂ O	62.4	1.00	29	42
N ₂ H ₄ -UDMH (50-50%)	55.5	0.70	20	38
RP-1	52.0	0.44	13	34
CH ₄	27.8	0.80	23	61
O ₂	20.0	0.32	9	17

ALLOWABLE REGENERATIVE COOLING REGIMES

The effect of the material properties on the allowable regenerative cooling operating regimes is indicated in this figure. Four thrust chamber materials are analyzed in terms of the conduction and stress requirements. The conduction limit represents the maximum wall thickness, which if exceeded will result in excessive wall temperature and/or high coolant pressure drops. Conduction limits are based on a 400°F coolant side wall temperature (typical of the SSF throat). A maximum gas side wall temperature of 1000°F was used for the two copper materials, and 1400°F was used for nickel and stainless steel. The stress limit line represents the minimum wall thickness, which is necessary for structural integrity. Stress limits are based on conservatively designed channel thrust chambers. Yield strengths utilized are consistent with the previous chart.

The figure clearly indicates that stainless steel and nickel are unacceptable candidates for high chamber pressure operation. OFHC copper and copper alloys are the appropriate materials for high chamber pressure operation. Annealed OFHC copper can achieve chamber pressures approaching 4000 psi. Higher pressures can be obtained by strength improvements to the copper. Because of its high strength and high thermal conductivity the copper alloy (NARloy) can be operated at extremely high chamber pressures.

ALLOWABLE REGENERATIVE COOLING REGIMES

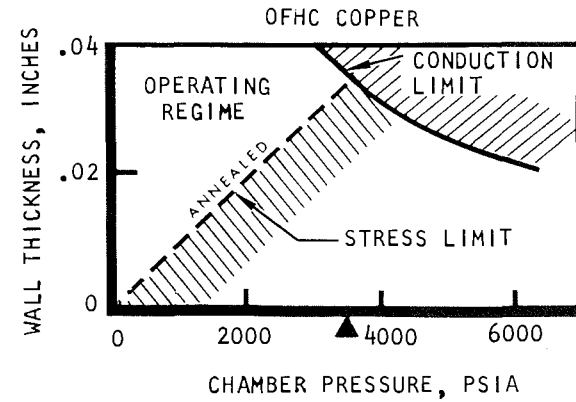
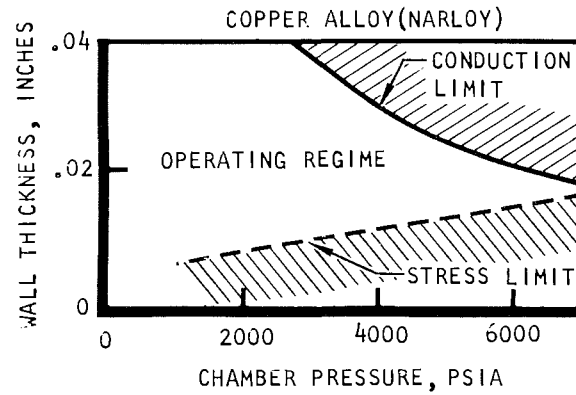
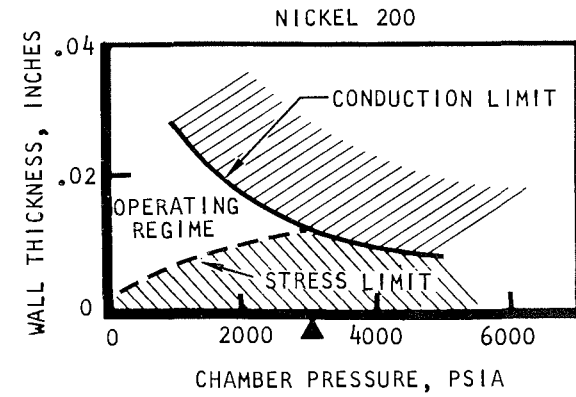
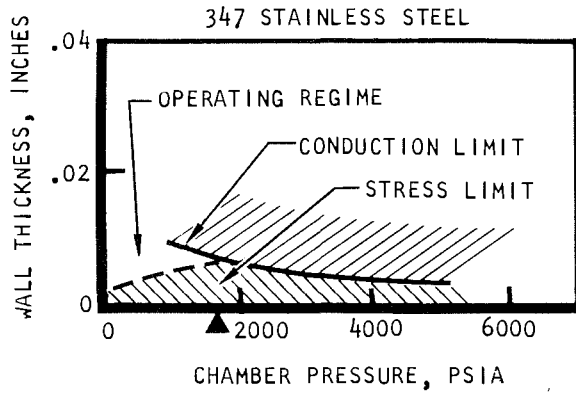

O₂/H₂ REGENERATIVE COOLING FEASIBILITY LIMITS

The combined potential of the hydrogen coolant and the copper alloy (NARloy) material is illustrated in this figure. It is evident that the Space Shuttle Engine design point is well within the capabilities of regenerative cooling. In general, regenerative cooling becomes easier as the thrust level increases. At high thrust the difference between the wall conduction limit, which represents an ultimate limit, and the pressure drop limit, which represents a practical constraint becomes minimal. The pressure drop limit line represents a coolant pressure drop equal to one-tenth of the chamber pressure.

O₂/H₂ REGENERATIVE COOLING FEASIBILITY LIMITS

COPPER ALLOY (NARloy)
T_{wg} = 1000 F

109

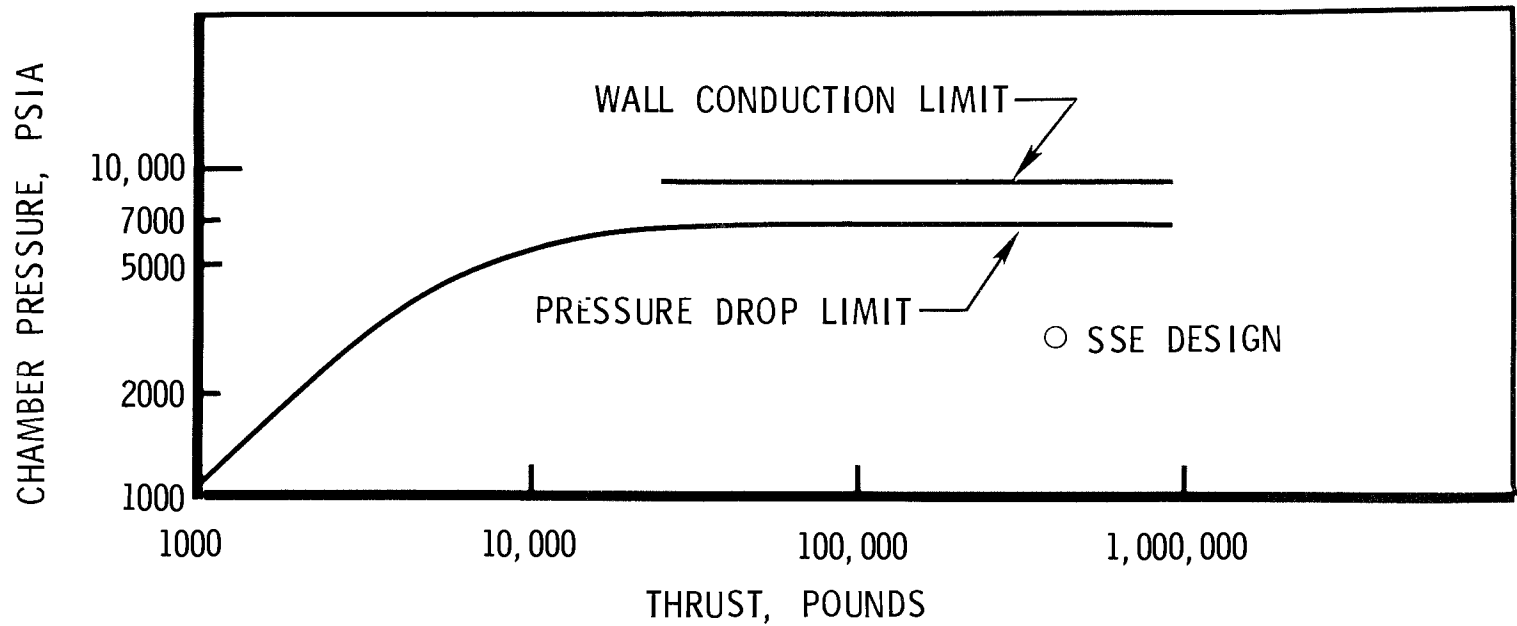

CONSTRUCTION METHODS

Durable and economical fabrication methods are necessary for a suitable Space Shuttle Engine design.

Although tubular thrust chamber designs are feasible, tubular construction does not take full advantage of high conductivity materials. Tubular construction has been used almost exclusively for nickel and stainless steel chambers.

A far more preferential technique is channel construction. In the channel construction method the coolant passages are formed by channels fabricated on the outer periphery of a chamber liner. The channel construction offers the advantages of having a smooth hot gas wall thereby reducing the heat load and since the channels themselves are machined, the flow areas can be closely controlled. The structure is rugged and durable. One of the chief advantages is the fact that channel construction takes full advantage of the high conductivity of the thrust chamber wall material. Flow or area variations in any single channel are negated by conduction of heat to the adjacent channels.

CONSTRUCTION METHODS

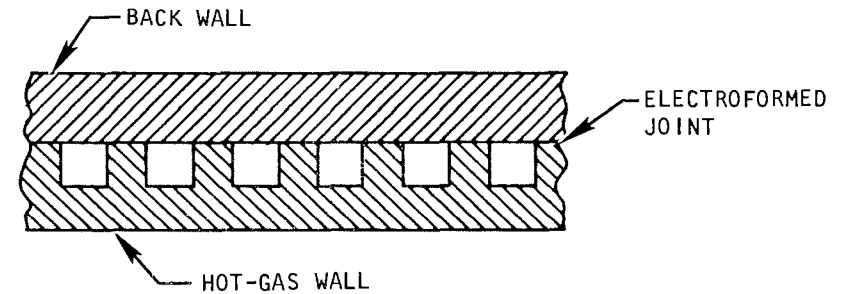
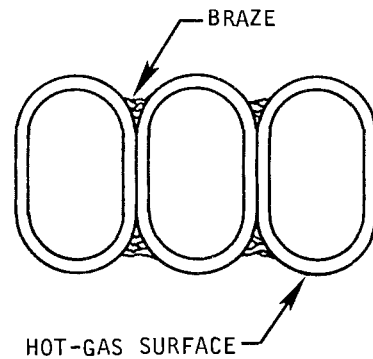

111

TUBULAR CONSTRUCTION

- LIGHT-WEIGHT
- EXTENSIVE FABRICATION EXPERIENCE
- LITTLE CONDUCTION BETWEEN TUBES

CHANNEL CONSTRUCTION

- SMOOTH HOT-GAS WALL (REDUCED HEAT LOAD)
- CONDUCTION BETWEEN CHANNELS
 - TOLERANCE TO FLOW VARIATION
 - TOLERANCE TO FABRICATION VARIATIONS
- CHANNEL FLOW AREA CAN BE CLOSELY CONTROLLED

RECENT ROCKETDYNE REGENERATIVE COOLING CONTRACTS

The application of regenerative cooling to the Space Shuttle Engine is based on the results of numerous NASA and Air Force studies which have advanced the regenerative cooling technology. The attached figure lists recent contracts associated with regenerative cooling that have been conducted at Rocketdyne. Additional studies have been conducted at other companies and within the NASA and Air Force centers. The documentation is quite extensive, however the security classification of these studies varies.

The results of these studies have demonstrated the capability of regenerative cooling over a wide range of chamber pressures. The advanced construction techniques have been demonstrated and the capability of hydrogen as an exceptional coolant has been verified. Extensive data have also been gathered on the ability of regenerative cooled chambers to achieve a large number of re-used cycles. The following charts present some of these data.

RECENT ROCKETDYNE REGENERATIVE COOLING CONTRACTS

ENGINE APPLICATIONS	TECHNOLOGY
NAS8-19541	NAS8-20349
NAS8-5604	NAS3-11191
NAS8-19	NAS7-65
NAS8-26187	NAS7-715
AF04(611)-11617	NAS8-4011
AF04(611)-11399	AF04(694)-110
AF04(611)-9721	AF04(611)-10916
AF04(645)-2	AF04(611)-67C-0093
DA-04-495-ORD-53	AF04(611)-68C-0061
DA-04-495-ORD-803	AF04(647)-171

COOLANT ENHANCEMENT FACTORS

During the technology studies several factors have been isolated which enhance the hydrogen coolant capabilities. These factors are wall roughness and coolant passage curvature. The roughness enhancement is a function of surface roughness, passage dimensions, and Reynolds number. The roughness enhancement has been demonstrated experimentally and is shown on the adjoining chart for three values of coolant mass velocity.

Curvature enhancement occurs wherever a bend in the coolant passage exists. Enhancement is highest at the outside of the curve and lowest on the inside surface. This enhancement has been experimentally verified in both tubular and channel passages. The enhancement is primarily a function of the turning angle.

By proper use of these enhancement factors, the cooling capability of hydrogen can be more than doubled in the high heat flux regions of the chamber and coolant pressure drop requirements can be minimized. This advanced technology has been incorporated into the design of the Space Shuttle rocket engine.

COOLANT ENHANCEMENT FACTORS

115

ROUGHNESS

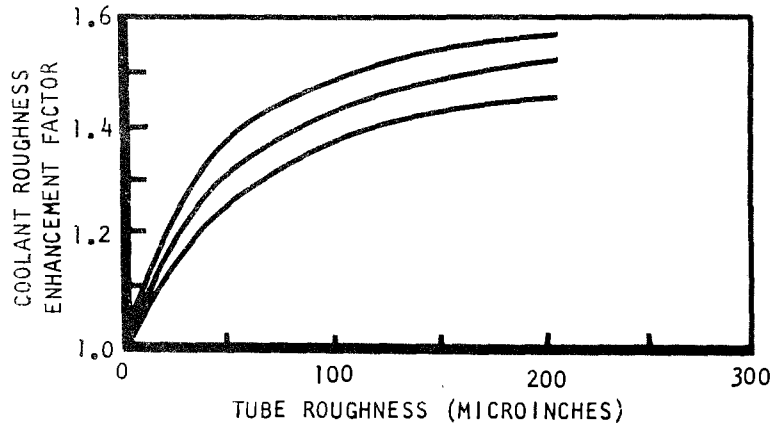

CURVATURE

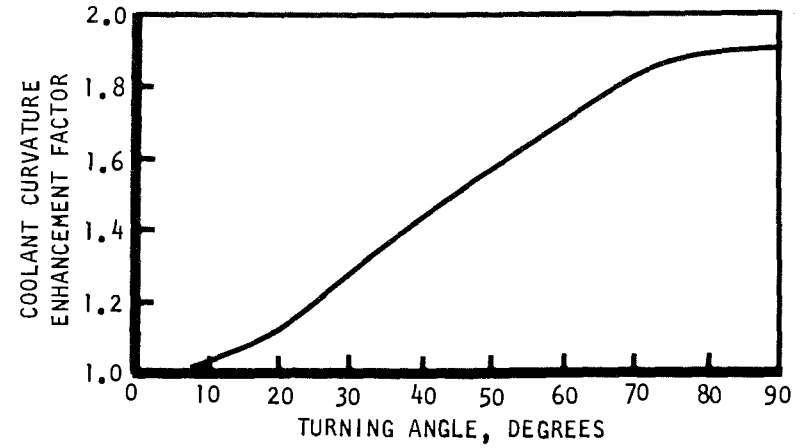

THRUST CHAMBER CONSTRUCTION

New fabrication techniques and materials have been developed for thrust chambers which offer simplification in fabrication and improved regenerative cooling capabilities. Experimental programs have proven these designs in hot-firing test series.

The sequence for fabrication is first to fabricate the thrust chamber liner and form grooves on the outside of the liner. These grooves are then filled, the chamber is coated with a striking agent, and a closeout wall (generally electroforming) is applied to cover the entire liner. The final step in the formation of the coolant passages is to melt the filler out.

Thrust chambers have been constructed in this manner using liners fabricated from powdered metallurgy, metal spinning, machined from billets, completely electroformed and castings. (In the cast designs, the grooves are cast integral with the basic liner eliminating the need for machining the grooves). Hot firing tests on these chambers have demonstrated the feasibility of these fabrication methods, and their regenerative cooling capability.

THRUST CHAMBER CONSTRUCTION NON TUBULAR WALL

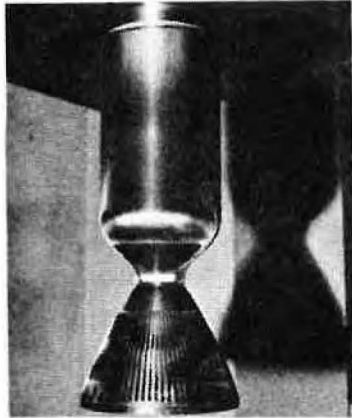

Cu, MILLED CHANNEL WALL
ELECTROFORMED CLOSEOUT

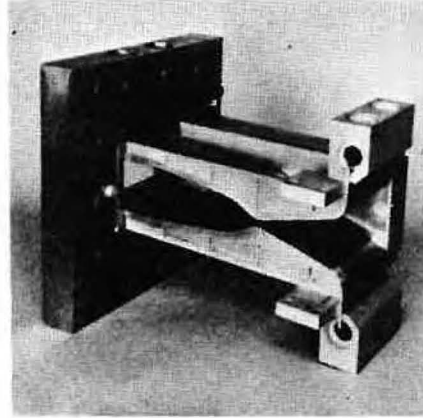

Cu, MILLED CHANNEL WALL
BRAZED CLOSEOUT



Ni, CAST CHANNEL WALL
ELECTROFORM CLOSEOUT



NICKEL, MILLED CHANNEL WALL
ELECTROFORMED CLOSEOUT



NICKEL, MILLED CHANNEL WALL
ELECTROFORM CLOSEOUT (CHAMBER/NOZZLE)

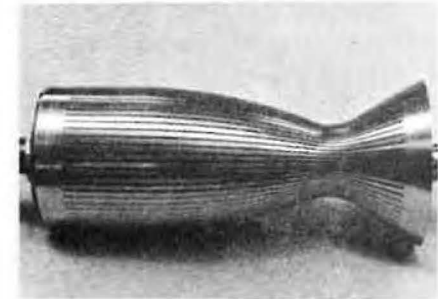

INCO 625 SPUN LINER
MILLED CHANNEL WALL
ELECTROFORM CLOSEOUT

EXTENDED LIFE DEMONSTRATION

Extended life testing to demonstrate the long-life characteristics of regeneratively cooled channel wall thrust chambers has been conducted. Test results have verified the durability of these designs. A regeneratively-cooled chamber was fabricated using copper alloy wall material and electroformed nickel. Five hundred and sixteen hot-firing tests were conducted on this combustor with no hardware damage. The propellants used were oxygen-hydrogen; combustion gas temperature was over 6100^oF. Regenerative cooling was used to control the hot gas wall temperature to a maximum of 1000^oF.

During each test in the series, the thrust chamber was subjected to a complete thermal cycle. The temperature of the thrust chamber wall varied from the inlet temperature of the hydrogen coolant, to the hot gas design wall temperature (1000^oF).

Throughout the test series the combustor remained in excellent condition. The combustor is capable of continued testing.

EXTENDED LIFE DEMONSTRATION NON TUBULAR WALL THRUST CHAMBER

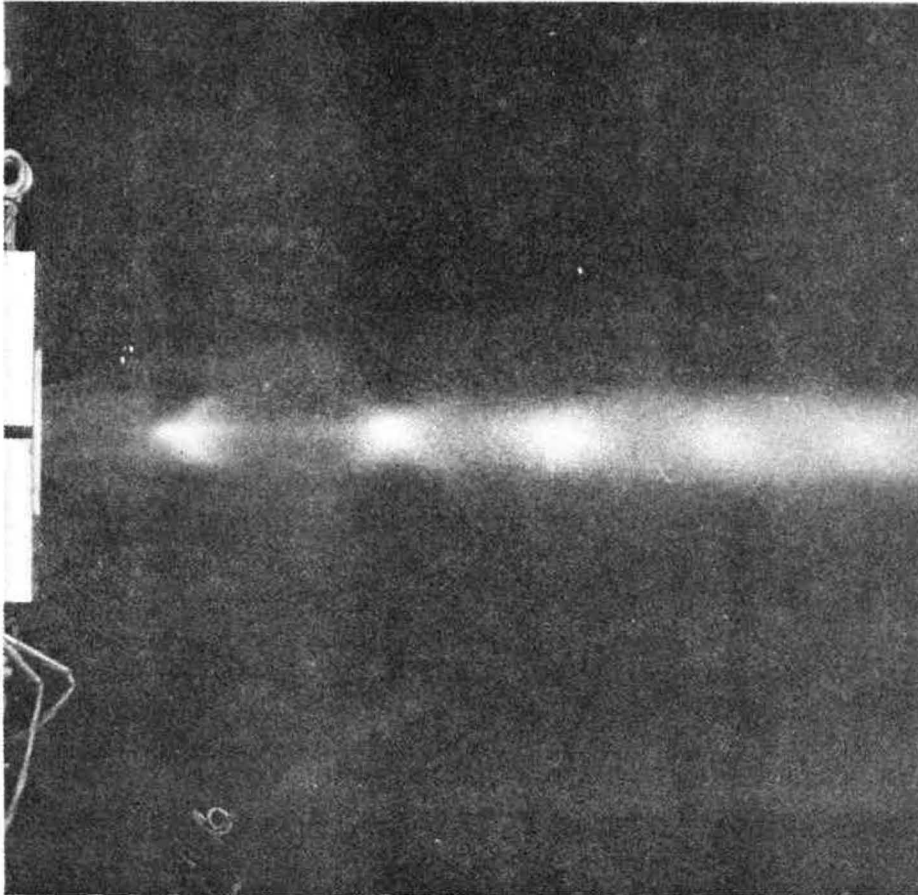

119

DESIGN

- O_2/H_2 PROPELLANTS AT MR: 6.0:1
- H_2 REGENERATIVE COOLING
- COPPER ALLOY MATERIAL (NAR10y)
- HOT GAS WALL TEMPERATURE: 1000°F (MAX)

TESTING

- 516 TESTS COMPLETED
- THERMAL CYCLE - H_2 COOLANT INLET TEMPERATURE TO DESIGN HOT GAS WALL TEMP.

SPACE SHUTTLE REQUIREMENTS

In conclusion, the Space Shuttle Engine must provide high performance in a compact configuration. It must be capable of long life operation. Regenerative cooling enhances the ability of the Space Shuttle Engine to meet these requirements.

SPACE SHUTTLE REQUIREMENTS

- PERFORMANCE
- HIGH PRESSURE
- LIFE

TECHNOLOGY ISSUES FOR SHUTTLE MAIN ENGINE - STAGE INTEGRATION

A. L. Worlund, T. W. Winstead, and W. B. McAnelly

NASA Marshall Space Flight Center
Huntsville, Alabama

Introduction

The development goal of the Space Shuttle vehicle is to provide a flexible, high utility, low cost space transportation system. Achievement of the goal depends on early consideration of engine-stage capabilities in the imposed environments. Disciplines involved in integration considerations include structural design, thermal protection, materials, cryogenics, aerodynamics, launch support, maintenance and reliability. Discussions on propellant thermal conditioning, engine-stage dynamics and response, and base thermal environment will present an assessment of the existing technology base, illustrate potential problems and suggest technology tasks and approaches that may enhance the development of a main propulsion system.

- Propellant Thermal Conditioning
- Engine-Stage Dynamics And Response
- Base Thermal Environment

Propellant Thermal Conditioning

Feedline geyser suppression and propellant quality control are considerations critical to the engine-stage integration. A geyser results from the formation of a Taylor bubble in a line filled with boiling liquid. When the Taylor bubble fills a majority of the cross section of the line, it reduces the pressure on the fluid below, which feeds the Taylor bubble by flash boiling and "burps" fluid from the line. Geyser suppression is essential since the hydraulic forces produced during refill of long vertical LOX feedlines can greatly exceed the design loads. For example, S-IC LOX feedline geysers resulted in pump inlet pressures approaching 1400 psi.

Orbiter main-engine start requirements for propellant thermal conditioning are primarily to prevent vapor from forming in feed systems. The loss of accelerationhead pressure at booster cutoff will cause propellant "flashing" if the feed system propellants are superheated at tank pressures. Vapors would then have to be ingested by the engine pumps during the engine start. The more severe thermal conditioning requirements of the orbiter may dictate booster feedline designs due to the common engine concept.

The mechanics of geysering and the controlling geometric and environmental parameters have been established.¹ The geyser-nongeyser region correlation, presented on chart 3, can be used as preliminary design criteria for prelaunch conditioning of propellant feedlines. The existing geyser-nongeyser region correlation was developed for vertical feedlines, and modifications to the correlation may be required to establish utility for line configurations with significant horizontal runs or multiple branches. Propellant thermal conditioning systems used to suppress feedline geysers and control propellant quality are summarized on chart 4. These approaches may be applicable to the Shuttle vehicle if complex sequence schemes and single point failure modes are avoided.

¹Murphy, D. W., "Mechanics of Geysering of Cryogenics," Final Report NAS8-5418, June 1964.

Propellant Thermal Conditioning

- Requirement
 - Feedline Geyser Suppression - Prelaunch
 - Propellant Quality Control - Ignition

- Technology Status
 - Geyser-Nongeyser Criteria Established
 - Systems Available To Provide Subcooled Propellants

GEYSER-NONGEYSER CORRELATION

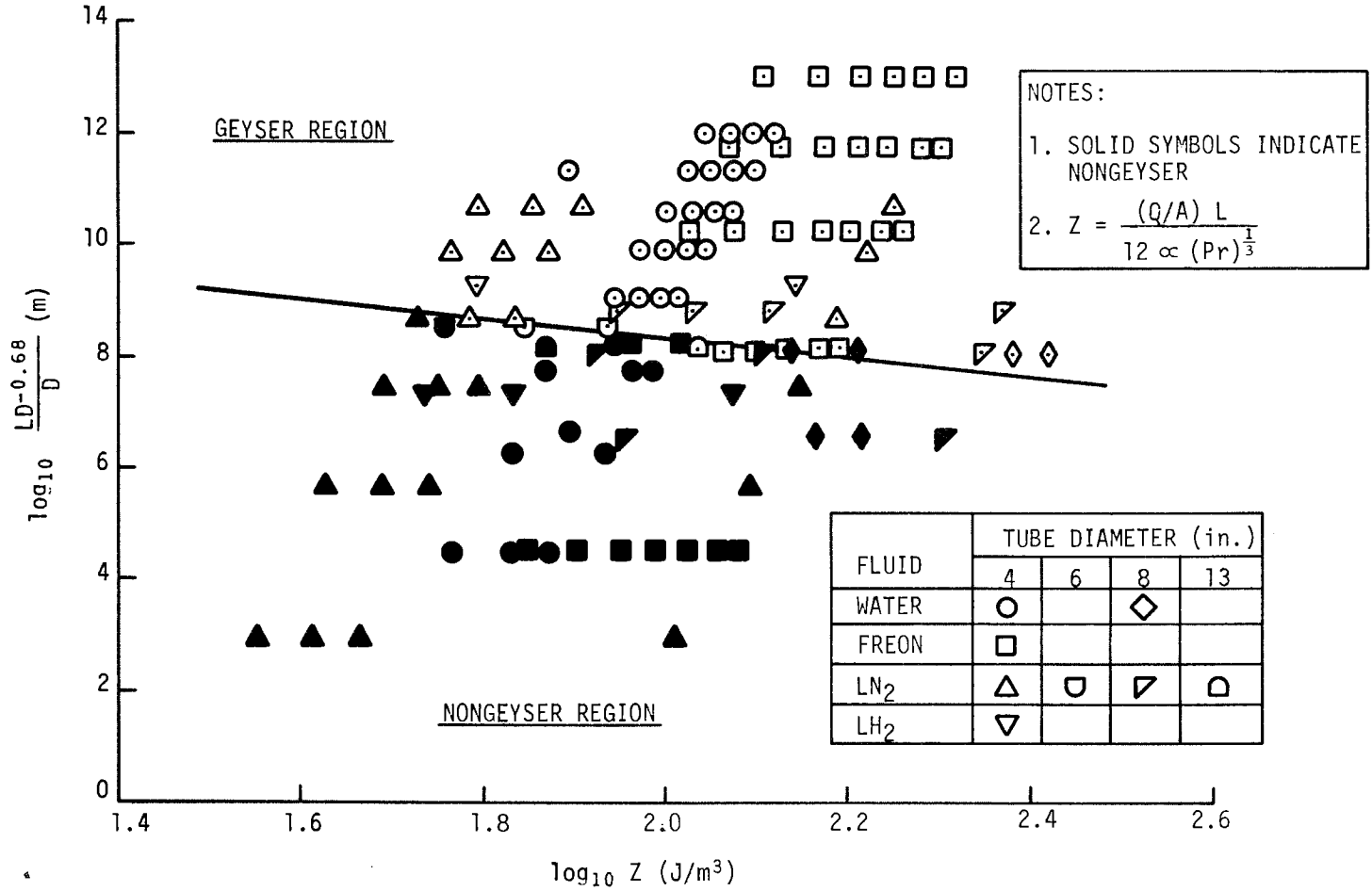

Propellant Thermal Conditioning

- Technology Application

Method	Geyser Suppression	Quality Control	Shuttle Application
Subcool Replenish		Atlas (LO ₂)	Constraint - Load/Facility
Recirculation			
- Natural	S-1C (LO ₂)	S-II (LO ₂) Atlas (LO ₂)	Booster/Orbiter
- Forced		S-IVB (LO ₂ /LH ₂) S-II (LH ₂) Centaur	Orbiter
Evaporative Cooling	S-1B (LO ₂)	S-IV (LO ₂)	Limited Utility
Overboard Dump		S-IV (LH ₂) Centaur	Impact - Payload/Abort

- Additional Geyser Suppression Schemes Are Being Investigated (NAS10-7258)

Propellant Thermal Conditioning

The Saturn S-II stage recirculation systems are typical. The thermal conditioning of the LO₂ feed system is accomplished by natural recirculation. Forced recirculation of the LH₂ feed system is provided by an electric motor driven pump. LH₂ flows through the pre valve by-pass line, feedline, pump, pump discharge line, and the tank return line. A few seconds prior to engine ignition, the LH₂ pre valve is open to flush any vapor trapped upstream of the pre valve into the tank.

PROPELLANT FEED SYSTEM

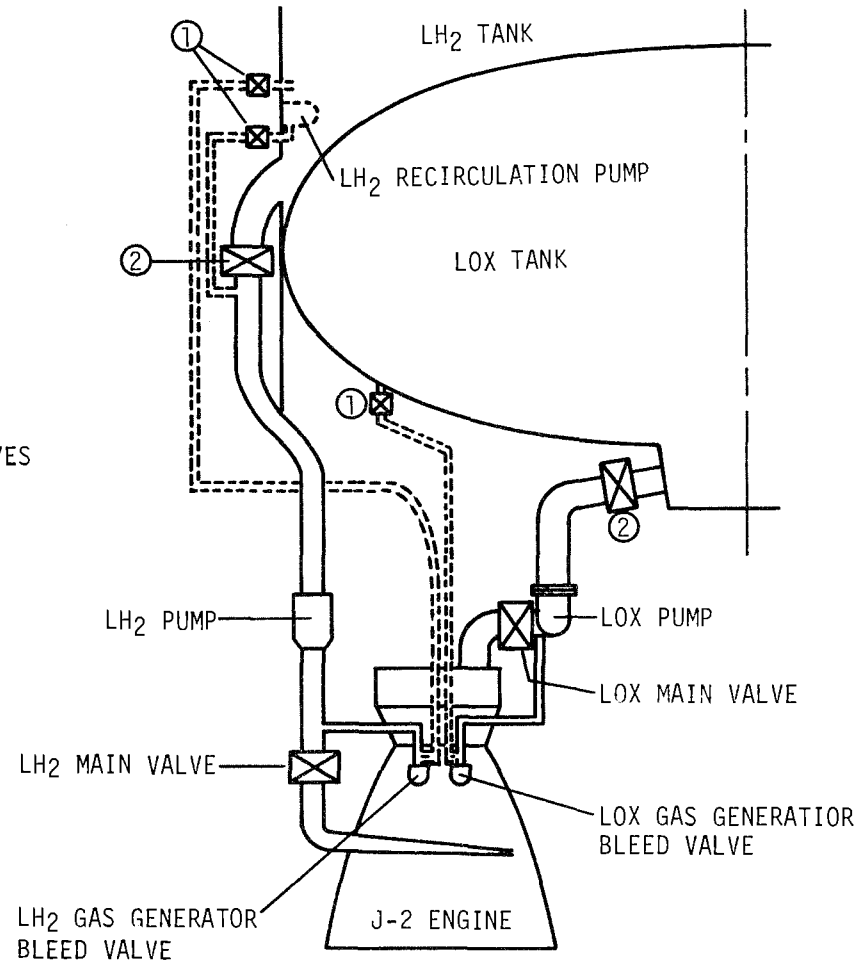

- ① RECIRCULATION VALVES
- ② PREVALVES

Propellant Thermal Conditioning

Propellant thermal conditioning considerations of engine-stage integration can impact the main engine technology program. Without propellant quality control, the propellant densities can vary over an order of magnitude. The technology required to develop mixture ratio control capability for these possibilities must be weighed against the degradation in vehicle reliability or maintainability resulting from implementing an optimum thermal conditioning system. "Flight-development" with the attendant failure risks may be required since the booster cutoff transient and the zero g environment cannot be simulated. Also, commonality of booster and orbiter engines must be maintained. Past programs avoided these technology tasks and flight development risk by accepting the additional interfaces required to circulate bulk propellants through the feed system and back into the propellant tanks to effect continuous thermal conditioning.

Propellant Thermal Conditioning Technology Issue

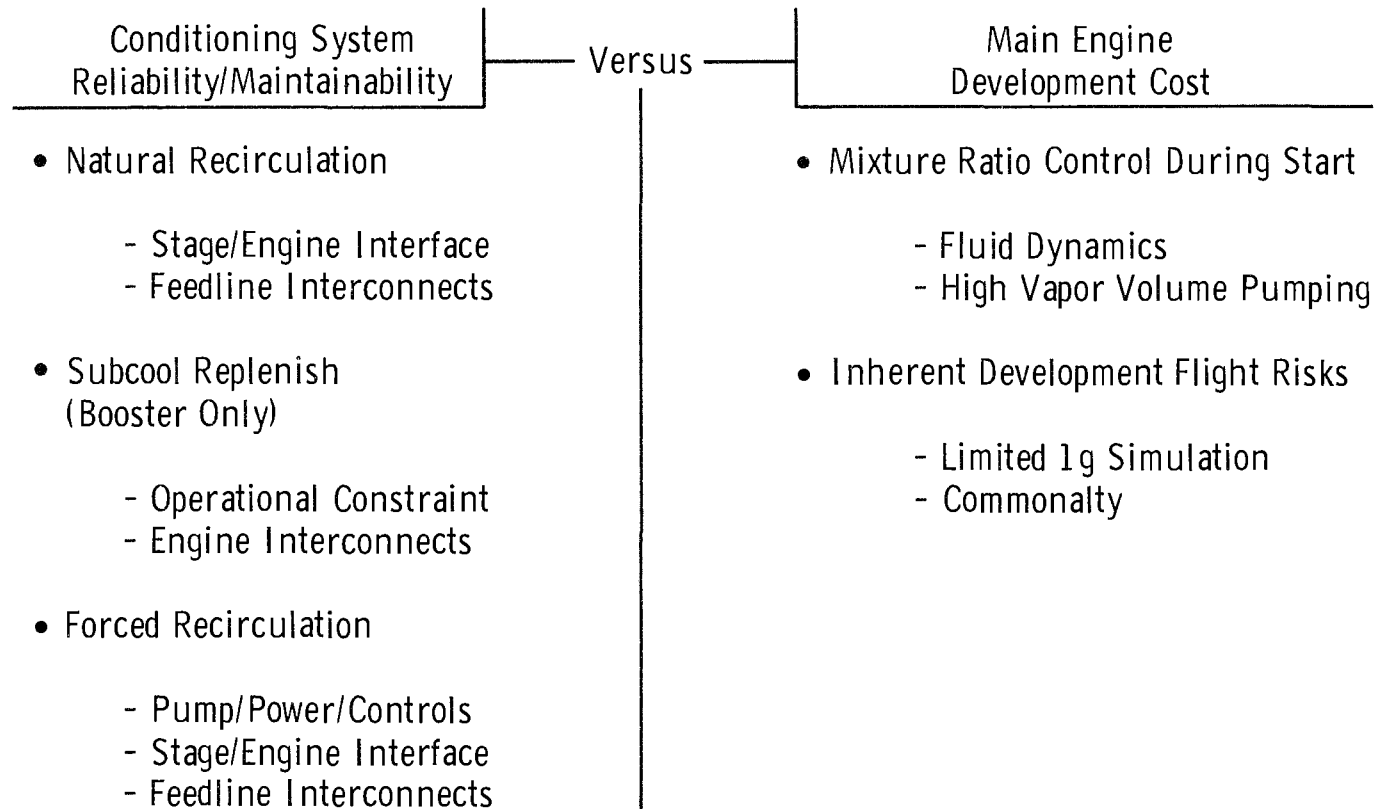

Engine-Stage Dynamics and Response

Engine-stage integration studies to evaluate the dynamics and response characteristics of the propulsion system in the advanced development phase may preclude incompatibility of engine and stage designs and minimize potential for vehicle instability. A major redesign of the Saturn V booster (S-IC stage) resulted from the development of an engine control system that preceded and neglected stage considerations. The belated engine-stage integration analysis, indicated that the NPSH requirements would not be satisfied during the start transients. A portion of the LOX feedline was increased from 17 to 20 inches in diameter to successfully integrate the F-1 engine into the S-IC stage.

The POGO phenomena, a longitudinal vehicle stability problem induced and sustained by interaction of the structure, feedline and engine during flight, has been encountered on most liquid propellant launch vehicles. The Atlas, Titan and Saturn V (S-IC) oscillation amplitudes in the primary vehicle modes exceeded design limits for either payloads or crew. Saturn V (S-II stage) oscillations were experienced in stage modes that impacted performance and local structure. Multiple engine configurations, large range of operating parameters, and wide variations in payloads increase the potential for POGO. Therefore, the evaluation of the response characteristics of propulsion system should be a prime consideration in technology and advanced development planning.

Mathematical modeling techniques applicable to the physical elements of the propulsion system are adequate. A transient model of the propulsion system derived from engine and stage design data then updated and validated with component and sub-system data will support early engine-stage integration studies. These early studies will establish the sensitivity of mixture ratio control parameters to stage configurations and isolate engine control system concepts applicable to both booster and orbiter stages.

A comprehensive summary evaluation of vehicle stability technology, suggested stability criteria and recommended practices to achieve stability has been compiled.²

²Rubin, S., "Suppression of Structure-Propulsion Instability (POGO)," NASA Space Vehicle Design Criteria Program in Structure Contract NAS1-6024, May 1970.

Engine-Stage Dynamics And Response

- Requirement
 - Engine/Stage Compatibility - Start, Cutoff, Throttling
 - Longitudinal Stability (POGO)
- Technology Status
 - Dynamic Modeling Techniques Available
 - POGO Stability Analytical Techniques And Criteria Established

Engine-Stage Dynamics and Response

The POGO block diagram represents the important elements of the linear closed loop stability model and the source of essential input data. The structural model, developed from mass distribution and stiffness data, is validated by results from a dynamic test vehicle (DTV). The feedline and engine models are developed from component design or performance data. The pump inlet cavitation compliance dominates the feedline frequency but cannot be analytically described. Therefore, numerical evaluation of the pump compliance is accomplished by flow perturbation tests (pulsing) on engine or pump facilities that duplicate or dynamically simulate the stage feedlines.

POGO Block Diagram

135

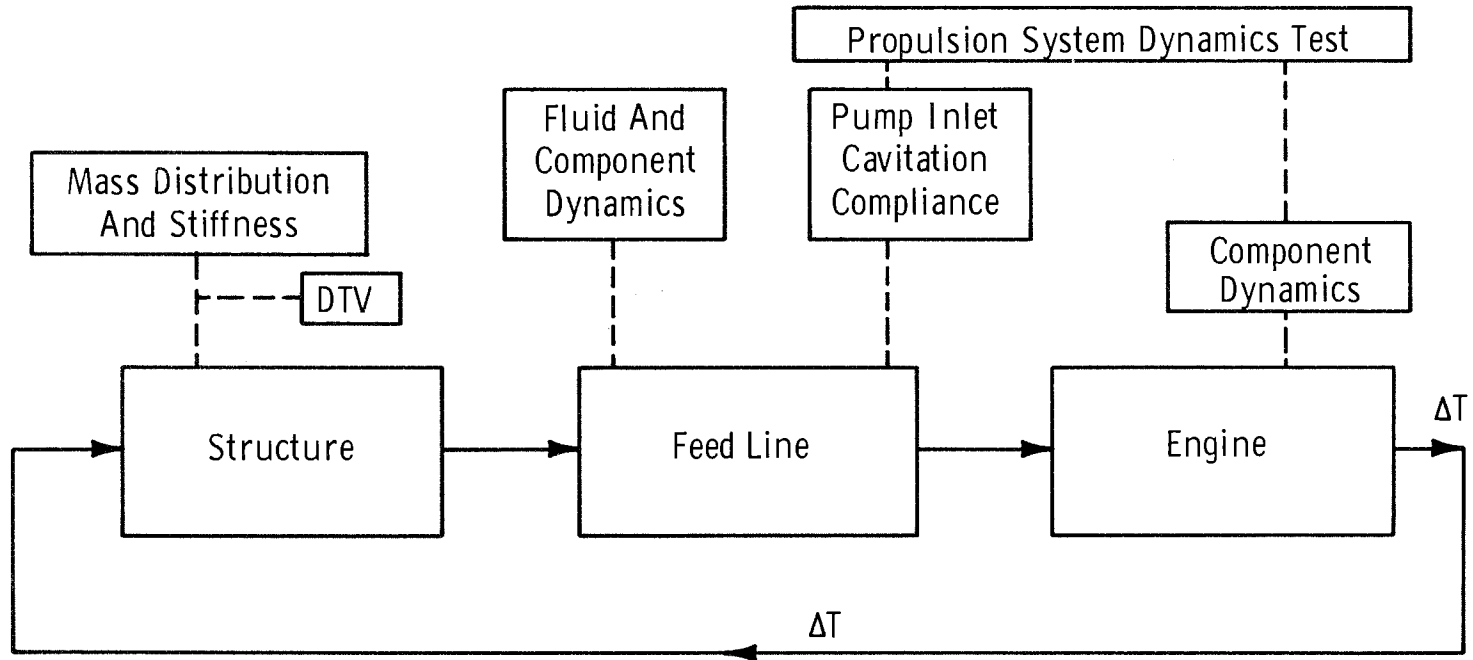

Engine-Stage Dynamics and Response

Engine-stage integration studies initiated in the technology or advanced development programs should define engine characteristics applicable to booster and orbiter configurations. Engine development facilities that dynamically simulate stage feedlines could minimize previous integration problems.

Stability analyses conducted in the development phase will be supported by immature data. However, judicious application of the present technology base can indicate stability trends in the primary vehicle modes and the capability of engine and stage components to suppress oscillations. Since analytical evaluation of pump cavitation compliance for a new pump is not presently possible, Saturn data is being used to develop analytical or semi-empirical relationships between component and fluid parameters and the cavitation compliance (NAS8-26266). Also, an alternate approach to flow perturbation (pulsing tests) to experimentally define the response characteristics of a new propulsion system can be applied. This alternate approach utilizes the low level random oscillations from engine development test to isolate the system characteristics. A comparison of the feedline frequencies obtained from pump inlet measurements on non-pulsing and pulsing tests for Saturn propulsion systems is presented in chart 10. Characteristics adequate for preliminary engine/stage integration studies may be obtained from Shuttle main engine development tests by close-coupled instrumentation and accurate data acquisition and reduction.

Engine technology programs should include feasibility studies of active controllers that cancel or suppress flow perturbations within the engine system. The prime advantages of a wide range active controller is to negate the requirement for early isolation of the unstable vehicle mode. A secondary advantage is simultaneous development with the engine, thus, benefiting from extensive engine testing. The disadvantage is that the amplitude of an instability must increase to a finite level in order for the controller to function.

Stage technology programs should provide for accumulators in the feedline. The accumulators should be located near the pump inlet, lower the feedline resonant frequency below the significant structural modes and not degrade engine performance.

It is improbable that active controllers or feedline accumulators can preclude all oscillations. Therefore, the allowable amplitude/frequency relationship for the Shuttle crew and passengers must be established.

Engine-Stage Dynamics And Response Development Approach

- Early Engine-Stage Integration
 - Define Engine Controls And Common Usage
 - Dynamically Simulate Vehicle At Engine Development Facility
- Pump Cavitation Modeling
 - Develop Correlation Based On Previous Data (NAS8-26266)
 - Evaluate Dynamic Response From Development Tests
- Engine Dynamic Flow Controller (Feasibility Studies)
- Baseline Provisions For Stage Accumulator
- Establish Oscillation Limits For Crew/Passengers

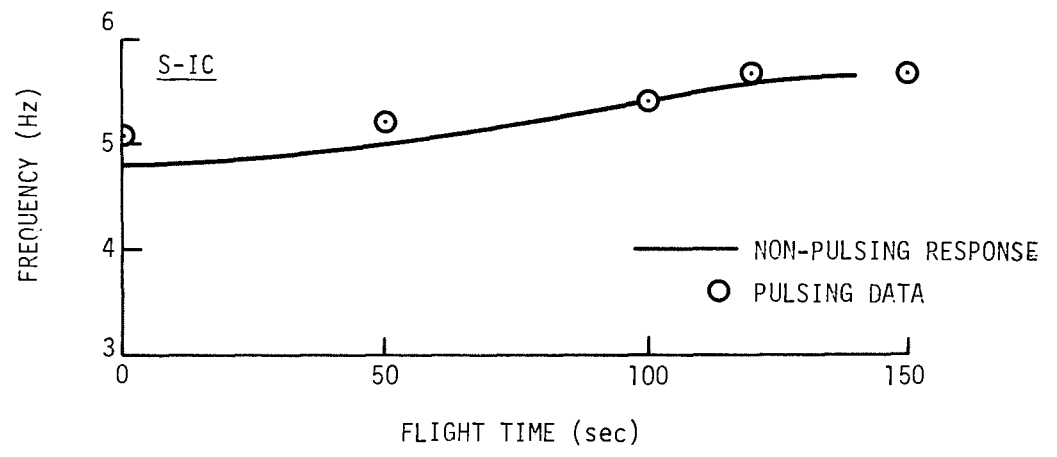
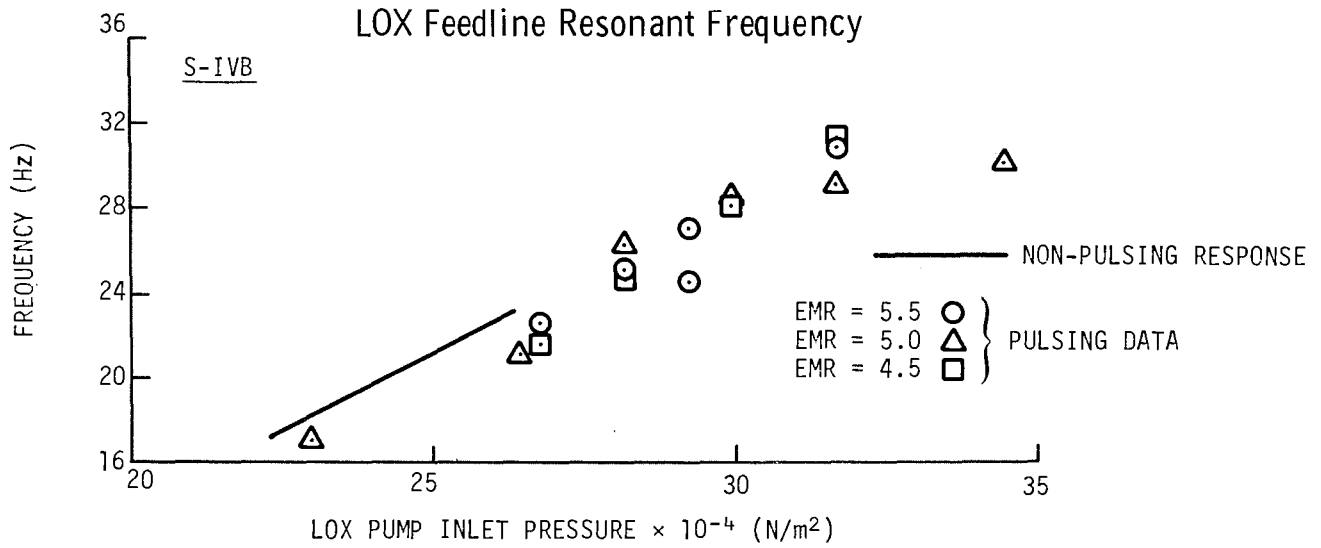

Base Thermal Environment

The base thermal environment is dictated by vehicle configuration, engine arrangement, engine gimbaling characteristics and booster-orbit attachment. The major areas impacted by base heating or vehicle-plume interaction are presented on chart 12. The booster thermal design criteria for components and the reusable base thermal protection system will be dictated by ascent convective heating. Impingement heating of stage surfaces during separation, one consideration in selection of a vehicle thermal protection concept, will not be discussed in detail. Aerodynamic heating of the orbiter base region during reentry will be significant.

The prime considerations for the Shuttle base thermal protection system are reusability, maintainability and minimum weight. However, the present technology is based on the concept of low utility. The operation/reliability of control surfaces subsequent to repeated impingement heating, accessibility to protected components and unsymmetrical heating due to canted heat shield are unique Shuttle considerations not emphasized in previous programs.

The base thermal environment cannot be accurately defined by analytical techniques. Therefore, empirical extrapolation of pertinent data from previous programs is used to develop models that establish preliminary heating profiles. The estimates of the relative temperature of the base region presented on chart 13 were derived from Saturn flight data. The maximum booster environment occurs during ascent with equilibrium temperatures approximately 80% of the Saturn S-IC level. The orbiter ascent levels are equivalent to the Saturn S-II level, however, reentry heating is a more severe condition due to the extended exposure period.

Analytical and experimental studies are necessary to provide an accurate model of the base thermal environment. The assessment of the base region flow fields, engine arrangement and vehicle aerodynamics should provide design criteria for the engine or vehicle components. Well conceived and carefully conducted model test programs are required to complement the analytical studies. An alternative to developing an accurate model of the base thermal environment is to use over-conservative designs and upgrade the design criteria with flight development tests.

Base Thermal Environment

- Requirements
 - Identify Areas Impacted By Exhaust Plume/Vehicle Interactions
 - Establish Thermal Environment For Engine And Vehicle Components
 - Define Criteria For Reusable Base Thermal Protection System

- Technology Status
 - Analytical Technology Inadequate
 - Preliminary Heating Environment Established
 - Some Problem Areas And Design Interactions Identified

- Development Approach
 - Improve Analytical Models
 - Define Criteria For Base And Engine Components
 - Conduct Model And Component Tests

Vehicle-Plume Interaction Areas

141

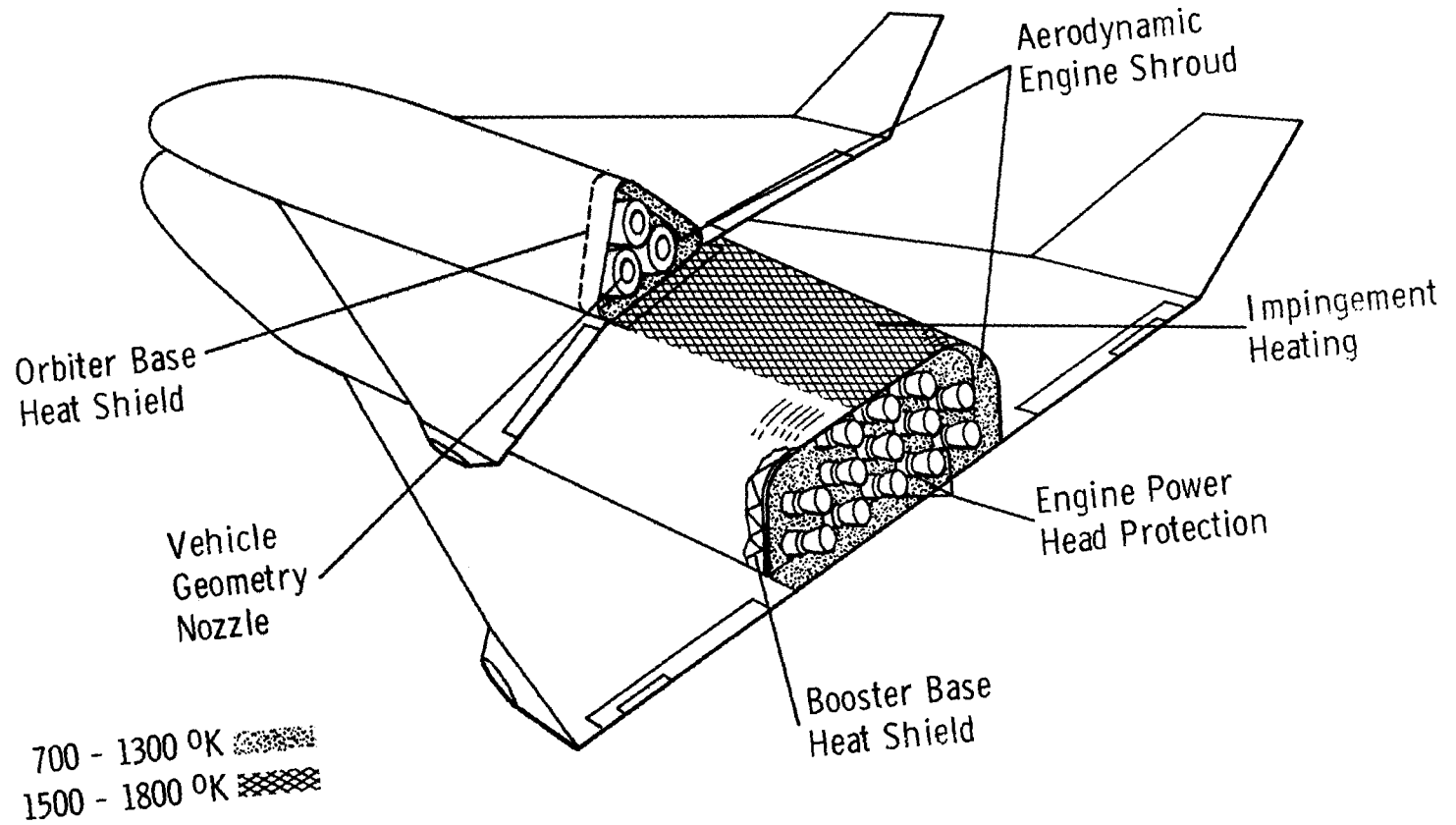

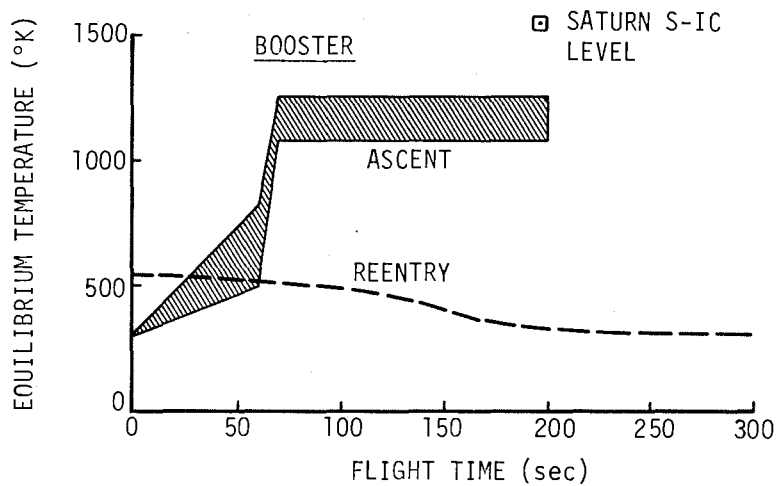
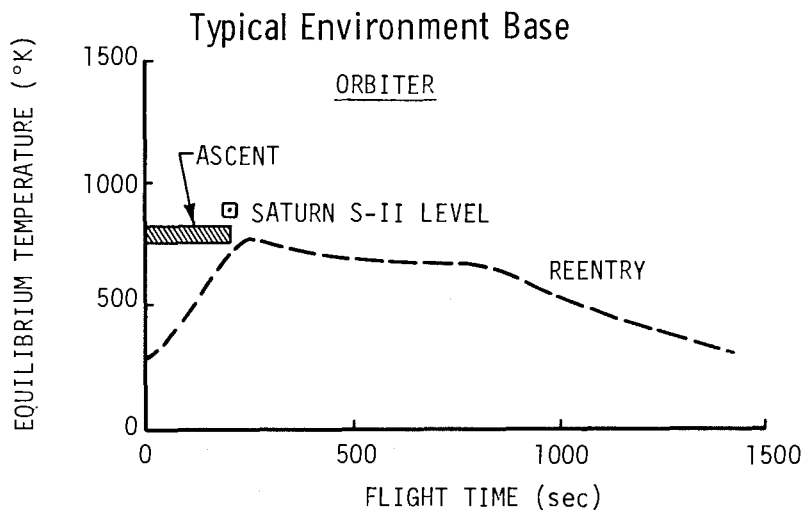

SUMMARY

The high performance objectives and cost effective development goals of the Shuttle main engine are enhanced by early consideration of engine-stage integration requirements. The propellant thermal conditioning required to suppress feedline geysers can also provide orbiter propellant quality control at booster-orbiter staging. This capability could reduce engine development cost. Early analytical and experimental consideration of the engine-feedline transient response will preclude incompatibility of the engine control system and the vehicle feedlines and will minimize the potential for longitudinal vehicle instability (POGO). The application of existing base heating data to the Shuttle is limited. Therefore, technology tasks are required to develop adequate models of the base thermal environment and to establish design criteria for engine and stage components.

SPACE SHUTTLE REACTION CONTROL SYSTEM REQUIREMENTS

Henry O. Pohl

NASA Manned Spacecraft Center
Houston, Texas

ABSTRACT

THE OPTIMUM REACTION CONTROL SYSTEM IS THE ONE WHICH WILL PROVIDE ADEQUATE OVERALL PERFORMANCE AND SIMULTANEOUSLY RESULT IN THE MAXIMUM VEHICLE PAYLOAD CAPABILITY. THIS REQUIREMENT IS IN MOST CASES SATISFIED BY THE SUBSYSTEMS CONCEPTS (INJECTION PROPULSION, ORBIT MANEUVERING PROPULSION, RCS, ETC.) WHICH COLLECTIVELY RESULT IN THE LOWEST TOTAL VEHICLE WEIGHT. THIS PAPER NOT ONLY DEALS WITH THE TANGIBLE SHUTTLE VEHICLE RCS REQUIREMENTS WHICH HAVE ALREADY BEEN IDENTIFIED OVER THE PAST YEAR (SUCH AS ACCELERATIONS, TOTAL IMPULSE, THRUST LEVELS, ETC.), BUT ADDRESSES ITSELF, AS WELL, TO THE ADVANTAGES OF SOMEWHAT INTANGIBLE REQUIREMENTS WHICH ARE NOT READILY APPARENT TO THE UNINITIATED OBSERVER.

GENERAL REQUIREMENTS

THE ONLY REAL TANGIBLE REQUIREMENT THAT CAN BE GENERALLY SPECIFIED FOR THE RCS OF AN EARTH TO ORBIT SPACE SHUTTLE CRAFT IS THAT IT BE DESIGNED SO AS TO PROVIDE ADEQUATE VEHICLE CONTROL IN ALL 3 AXES, BOTH ROTATIONAL AND TRANSLATIONAL. THE DESIGN SHOULD BE SUCH THAT IT WILL TEND TO MAXIMIZE THE PAYLOAD CAPABILITY FOR A WIDE RANGE OF AS YET UNIDENTIFIED MISSIONS, AT A REASONABLE COST, YET BE SIMPLE AND HIGHLY RELIABLE.

THE OVERALL GOAL, RELATIVE TO THE SPACE SHUTTLE RCS, IS TO PROVIDE A SYSTEM WHICH POSSESSES ADEQUATE OVERALL PERFORMANCE AND RESULTS IN MAXIMUM PAYLOAD CAPABILITY AND MISSION FLEXIBILITY FOR ANY SELECTED VEHICLE CONFIGURATION. THESE GOALS, OF COURSE, MUST BE ACCOMPLISHED WITHIN THE CONSTRAINTS OF A SAFE CREW RETURN AND MINIMUM COST. THE KEY REQUIREMENT, FOR ALL SHUTTLE SUBSYSTEMS, WILL BE TO PROVIDE MAXIMUM MISSION FLEXIBILITY. THIS WILL BE REQUIRED IN ORDER TO FLY A BROAD RANGE OF MISSION PROFILES AND ACHIEVE MAXIMUM COST EFFECTIVENESS FOR THE SPACE SHUTTLE PROGRAM. IN CONTRAST, IN THE APOLLO PROGRAM, THE RCS REQUIREMENTS ALSO INCLUDED FLEXIBILITY TO OPERATE OVER A RANGE OF CONDITIONS (i.e., DUTY CYCLES, PRESSURES, TEMPERATURES, ETC.); HOWEVER, THE DESIGN REFERENCE MISSION WAS FIXED AND REMAINED FIXED FOR ALL LUNAR LANDING MISSIONS. THIS RESULTS IN A VEHICLE WHICH CAN REQUIRE MAJOR HARDWARE MODIFICATIONS IN ORDER TO PERFORM OTHER MISSION PROFILES. THIS BECOMES EVIDENT, IF ONE EXAMINES THE EXTENSIVE MODIFICATIONS REQUIRED TO THE APOLLO COMMAND MODULE AND SERVICE MODULE IN ORDER TO BE COMPATIBLE WITH THE RELATIVELY SIMPLE MISSION PROFILES TO BE FLOWN ON THE SKYLAB PROGRAM.

THE SHUTTLE VEHICLE MUST BE A WORKHORSE OF THE SPACE PROGRAM, CAPABLE OF PERFORMING A MULTITUDE OF MISSIONS AND MUST BE ORIGINALLY DESIGNED FOR INHERENT FLEXIBILITY AND MUST NOT REQUIRE MODIFICATION FOR EACH MISSION CATEGORY.

GENERAL REQUIREMENTS

SELECT RCS CONCEPT WHICH POSSESSES ADEQUATE OVERALL PERFORMANCE THAT WILL PROVIDE MAXIMUM PAYLOAD CAPABILITY AND MISSION FLEXIBILITY WHILE MEETING THE RELIABILITY REQUIREMENTS FOR CREW SAFETY AT A REASONABLE OVERALL COST.

OPERATING CHARACTERISTICS

ONE OF THE MOST SIGNIFICANT CHALLENGES IN THE SHUTTLE RCS AREA WILL BE THE DESIGN OF A TOTAL SYSTEM WHICH WILL BE ABLE TO SAFELY OPERATE OVER AN EXTREMELY WIDE RANGE OF INPUT AND OPERATIONAL PARAMETERS. THE RCS MUST BE CAPABLE OF RESPONDING TO ANY DUTY CYCLE FROM MULTIPLE-MINIMUM-IMPULSE-BITS TO STEADY-STATE FIRINGS OF EXTENDED DURATION WHICH CAN BE RECEIVED FROM THE GUIDANCE SYSTEM. IT MUST BE CAPABLE OF OPERATING OVER A WIDE RANGE OF TEMPERATURES AND PRESSURES. FOR EXAMPLE, THE DENSITY OF THE PROPELLANTS, JUST DUE TO THE EFFECTS OF TEMPERATURE, WILL VARY IN EXCESS OF 100 % . SIMILAR EFFECT ON PRESSURE CAN BE EXPECTED DUE TO MULTIPLE ENGINE FIRINGS AND THE INERTIA OF THE FLOW CONTROL EQUIPMENT. OXYGEN TO FUEL RATIOS, THRUST LEVELS AND COOLING MARGINS CAN ALSO BE EXPECTED TO VARY ACCORDINGLY.

THESE REQUIREMENTS, TYPICAL FOR ALL ATTITUDE CONTROL SYSTEMS, CAN RESULT IN SIGNIFICANT CONCESSIONS IN TERMS OF STEADY-STATE AND PULSE MODE PERFORMANCE IN ORDER TO ACHIEVE SATISFACTORY ATTITUDE CONTROL CHARACTERISTICS, HIGH RELIABILITY, AND LONG LIFE. AS AN EXAMPLE THE SERVICE MODULE AND LUNAR MODULE RCS ENGINES WOULD BE CAPABLE OF EXCEEDING 95 % C* EFFICIENCY IF THEY WERE DESIGNED TO ONLY OPERATE STEADY-STATE; HOWEVER, IN ORDER TO MEET PULSE MODE AND DUTY CYCLE CONSTRAINTS WITH SUFFICIENT MARGIN TO MAINTAIN HIGH RELIABILITY THE ENGINES ARE OPERATED AT A C* EFFICIENCY OF ONLY 85 % .

ALSO, SINCE THE RCS IS A CREW SAFETY SYSTEM, IT MUST BE CAPABLE OF OPERATING SAFELY AFTER INCURRING FAILURES. REDUNDANCY FOR THE PURPOSE OF CREW SAFETY IS NECESSARY; HOWEVER, THE PHILOSOPHY OF REDUNDANCY FOR THE PURPOSE OF MISSION SUCCESS MUST BE CAREFULLY CONSIDERED BEFORE INDISCRIMINATELY GROUNDING MULTIPLE COMPONENTS. AS AN EXAMPLE, IT WOULD BE RIDICULOUS TO REDUCE THE PAYLOAD CAPABILITY OF THE SHUTTLE, BY SEVERAL THOUSAND POUNDS, FOR ITS 100 MISSION LIFE IN ORDER TO SUSTAIN AN OPERATIONAL FAILURE, IF THE PROBABILITY OF IT OCCURRING IS VERY REMOTE.

OPERATING CHARACTERISTICS

- o RCS MUST BE CAPABLE OF RESPONDING TO ANY INPUT FROM GUIDANCE SYSTEM.
- o RCS IS A CREW SAFETY SYSTEM; THEREFORE, IT MUST BE CAPABLE OF OPERATING SAFELY AFTER INCURRING FAILURES. JUDGEMENT MUST BE APPLIED TO PHILOSOPHY RELATIVE TO REDUNDANCY.
- o RCS MUST BE CAPABLE OF OPERATING SAFELY OVER TOTAL RANGE OF PRESSURES AND TEMPERATURES.

CONTROL REQUIREMENTS

THE VEHICLE MANEUVERING REQUIREMENTS FOR LINEAR AND ANGULAR ACCELERATIONS ARE NOT TOTALLY AGREED UPON AT THIS TIME AND DEPENDS TO A LARGE EXTENT ON VEHICLE CONFIGURATION; HOWEVER, IT IS APPARENT THAT ANGULAR ACCELERATIONS COMPARABLE TO THOSE USED ON PREVIOUS MANNED SPACECRAFT WILL NOT BE POSSIBLE. INSTEAD, IT IS PROBABLY THAT THE SHUTTLE MANEUVERING RATES WILL BE DETERMINED BY THE MINIMUM ALLOWABLE RATES, IN TERMS OF HARDWARE SENSING LIMITATIONS, RATHER THAN PILOT PREFERENCE BASED ON "FEEL" AS HAS BEEN DONE IN THE PAST.

THE MINIMUM ALLOWABLES FOR NOMINAL ANGULAR ACCELERATIONS, FOR ENTRY, HAVE SETTLED AT APPROXIMATELY $2 \text{ } \circ/\text{sec}^2$ FOR THE PRIMARY MANEUVERING AXIS (YAW) AND $1 \text{ } \circ/\text{sec}^2$ FOR PITCH AND ROLL. THE MINIMUM ALLOWABLE LINEAR ACCELERATION, FOR TERMINAL RENDEZVOUS, ARE APPROXIMATELY $0.5 \text{ ft}/\text{sec}^2$ FOR THE +X DIRECTION AND 0.2 FOR LATERAL AND VERTICAL TRANSLATION. EMERGENCY LEVELS ARE CONSIDERED TO BE SOMEWHERE BELOW THE ABOVE LEVELS, BUT CANNOT BE ACCURATELY DETERMINED WITHOUT CONSIDERABLE SIMULATION STUDIES.

OTHER RCS REQUIREMENTS CONSIDERING THRUST LEVELS, ENGINE LOCATIONS, NUMBER OF ENGINES, TOTAL IMPULSE, AND MINIMUM IMPULSE BITS, ARE EXTREMELY SENSITIVE TO CHANGES IN VEHICLE CONFIGURATION AND REFERENCE MISSION. ONE FACTOR TO REMEMBER; HOWEVER, IS THAT THRUST LEVELS, NUMBER AND LOCATION OF ENGINES HAVE TO BE CONSIDERED CONCURRENTLY IN ORDER TO SATISFY REDUNDANCY, SAFETY AND SATISFACTORY MANEUVERING RATES WHILE MINIMIZING SYSTEM WEIGHT BY REDUCING THE NUMBER AND THRUST LEVEL OF ENGINES TO THE ABSOLUTE MINIMUM. THE LOCATION, SIZE AND NUMBER OF ENGINES IS EXTREMELY IMPORTANT WHEN CONSIDERING EFFICIENT UTILIZATION OF PROPELLANTS FOR MANEUVERING AND ATTITUDE CONTROL. THE TOTAL IMPULSE WILL BE IN THE 1.5 MILLION LB-SEC RANGE WITH THRUST LEVELS FROM 500 TO 2000 LBS DEPENDING ON VEHICLE CONFIGURATION, REDUNDANCY REQUIREMENTS AND SCIENTIFIC NEEDS.

A FEW WORDS SHOULD ALSO BE MENTIONED ABOUT THE PURPOSE OF THE SHUTTLE. MOST EFFORT IS DIRECTED TOWARD THE "DESIGN REFERENCE MISSION" FOR SPACE STATION RESUPPLY. THIS IS USEFUL FOR FEASIBILITY STUDIES AND CLOSELY COMPARING THE CAPABILITIES OF VARIOUS SUBSYSTEMS; HOWEVER, IT SHOULD BE REMEMBERED THAT THE SPACE STATION RESUPPLY MISSION IS ONLY ONE OF A WIDE VARIETY OF INTENDED SPACE RELATED MISSIONS. FOR THIS REASON, THE CHOSEN SYSTEMS SHOULD POSSESS THE HIGHEST DEGREE OF INHERENT MISSION FLEXIBILITY WITHOUT LOSS OF PAYLOAD OR INCREASED COMPLEXITY. IN MOST INSTANCES THE INTEGRATION OF SUBSYSTEMS NOT ONLY RESULTS IN INCREASED MISSION FLEXIBILITY BUT IN OVERALL WEIGHT SAVINGS AS WELL.

CONTROL REQUIREMENTS

- o ACCELERATION REQUIREMENTS
 - o ROLL 1 $^{\circ}/\text{sec}^2$
 - o PITCH 1 $^{\circ}/\text{sec}^2$
 - o YAW 2 $^{\circ}/\text{sec}^2$
 - o \pm X .5 ft/sec²
 - o \pm Y .2 ft/sec²
 - o \pm Z .2 ft/sec²

- o THE FOLLOWING REQUIREMENTS ARE VEHICLE CONFIGURATION AND INTEGRATION SENSITIVE
 - o THRUST LEVEL - 500 - 2000 lbs.
 - o ENGINE LOCATIONS
 - o NO. OF ENGINES
 - o TOTAL IMPULSE - 1.5 MILLION lb-sec
 - o MINIMUM IMPULSE BIT
 - o NOMINAL - .05 \pm .01 $^{\circ}/\text{sec}$
 - o SCIENTIFIC - .01 - .05 $^{\circ}/\text{sec}$

SYSTEM LIFE REQUIREMENTS

THE SHUTTLE DESIGN GOAL OF 100 MISSIONS OVER A SEVERAL YEAR PERIOD, IS A SIGNIFICANT DIVERGENCE IN DESIGN PHILOSOPHY FROM PREVIOUS MANNED SPACEFLIGHT PROGRAMS AND REPRESENTS A MAJOR CHALLENGE TO SYSTEM AND COMPONENT DESIGNS. FOR EXAMPLE, THE RCS ENGINES MAY BE REQUIRED TO START UP TO 10,000 TIMES PER MISSION. IF THE SAME ENGINES WERE TO BE USED FOR 100 MISSIONS, A USEFUL CYCLE LIFE OF ONE MILLION STARTS WOULD BE REQUIRED. THIS PRESENTS A SIGNIFICANT FATIGUE PROBLEM FOR LIGHTWEIGHT COMPONENTS ESPECIALLY IF ONE CONSIDERS THERMAL EFFECTS FROM EXTREME TEMPERATURES, AND PRESENTLY UNKNOWN EFFECTS OF HIGH TEMPERATURE HYDROGEN EXPOSURE TO MATERIALS USED FOR CONSTRUCTION. THE EFFECTS OF SIGNIFICANT PRESSURE AND THERMAL CYCLING OF HIGHLY STRESSED COMPONENTS (ACCUMULATORS, DISTRIBUTION LINES, TURBINES, HEAT EXCHANGERS, ETC.) EXPOSED TO ABOVE AMBIENT TEMPERATURE HYDROGEN ARE ESSENTIALLY UNKNOWN AND UNPREDICTABLE AT THIS TIME. IT IS KNOWN; HOWEVER, THAT FEW HIGH STRENGTH MATERIALS ARE UNAFFECTED BY HYDROGEN EXPOSURE AT PRESSURES AND TEMPERATURES ABOVE AMBIENT. FOR THIS REASON, SYSTEMS REQUIRING ULTRA-HIGH CYCLE-LIFE AND HOT HYDROGEN EXPOSURE HAVE INHERENTLY FEWER "BUILT-IN" HYDROGEN COMPATIBILITY PROBLEMS WHEN OPERATING AT LOW PRESSURES AND LOW COMBUSTION TEMPERATURES, THAN SYSTEMS OPERATING AT HIGH PRESSURES AND HIGH COMBUSTION TEMPERATURES. THEREFORE, IT MAY BE DESIRABLE TO DESIGN A SYSTEM TO OPERATE AT O/F RATIOS AND PRESSURES THAT WOULD APPEAR TO BE LESS THAN OPTIMUM WHEN VIEWED FROM ENGINE PERFORMANCE OR CONSUMABLES REQUIRED TO MEET A PREDETERMINED TOTAL IMPULSE. IN FACT THE DECREASE IN COMPLEXITY COULD EASILY RESULT IN AN INCREASE IN PAYLOAD.

LIFE REQUIREMENTS

- o RCS MUST BE CAPABLE OF OPERATING FOR 100 MISSIONS OVER
A SEVERAL-YEAR PERIOD, WITH MINIMUM REFURBISHMENT

- o RCS ENGINES CYCLE REQUIREMENT
10,000 TIMES PER MISSION (NO REFURBISHMENT)
1,000,000 TIMES TOTAL (MINOR REFURBISHMENT)

- o THERMAL CYCLES

- o COMPONENT LIFE

- o OPERATING

- o NONOPERATING

MISSION FLEXIBILITY

THE DESIGN REFERENCE MISSION FOR SPACE STATION RESUPPLY IS BUT ONE OF A LARGE VARIETY OF INTENDED MISSIONS AND IS PRESENTLY BEING USED AS THE BASELINE FOR THE PHASE "B" SPACE SHUTTLE VEHICLE STUDIES. THE IMPORTANCE OF SUCH A REFERENCE MISSION IS NOT QUESTIONED AS A NECESSARY TOOL FOR COMPARISON OF VEHICLES AND SUBSYSTEMS, BUT VEHICLE REQUIREMENTS SHOULD NOT BE MOLDED AROUND A RIGID MISSION PROFILE AT THIS PHASE OF THE SPACE SHUTTLE STUDY. IT SHOULD BE EMPHASIZED THAT THE SPACE SHUTTLE SHOULD BE THE WORKHORSE OF THE FUTURE SPACE PROGRAM AND THAT MISSION FLEXIBILITY WILL DETERMINE THE OVERALL USEFULNESS AND COST EFFECTIVENESS OF THE SPACE SHUTTLE.

154

IT IS ANTICIPATED THAT THE SHUTTLE WILL REGULARLY DEPLOY, SERVICE IN ORBIT, AND RECOVER VARIOUS TYPES OF WEATHER, COMMUNICATIONS, SURVEILLANCE, AND EARTH RESOURCE TYPE SATELLITE SYSTEMS. THE SHUTTLE MAY BE REQUIRED TO FLY LONG DURATION MISSIONS, BECOMING A MINATURE SPACE STATION ITSELF FOR SEVERAL CREW MEMBERS. FOR THIS TYPE OF MISSION, VERY LITTLE ΔV MAY BE NECESSARY; WHEREAS EXTREMELY LARGE QUANTITIES OF HYDROGEN AND OXYGEN MAY BE REQUIRED FOR LONG DURATION ATTITUDE CONTROL, SIGNIFICANT ENVIRONMENTAL CONTROL AND POWER GENERATING CAPABILITY. THE TYPE MISSION DESCRIBED ABOVE COULD NOT BE CARRIED OUT BY A SHUTTLE WHICH HAD INDEPENDENT CRYOGENIC STORAGE FOR INDIVIDUAL SUBSYSTEMS SIZED FOR THE SPACE STATION RESUPPLY MISSION. ON THE OTHER HAND, THE ABOVE MISSION COULD EASILY BE FLOWN BY A SHUTTLE, SIZED FOR THE SPACE STATION RESUPPLY MISSION, WITH AN INTEGRATED PROPELLANT SUPPLY. THE ABILITY TO EFFICIENTLY PERFORM SUCH A WIDE VARIATION OF MISSION PROFILES IS POTENTIALLY ONE OF THE MAJOR ADVANTAGES OF THE SHUTTLE OVER PREVIOUS BOOST/SPACECRAFT COMBINATIONS.

MISSION FLEXIBILITY

- o DESIGN MISSION IS SPACE STATION RESUPPLY
- o MUST ALSO BE CAPABLE OF FLYING OTHER MISSIONS WITHIN LIMITATIONS OF CONSUMABLES
- o INTEGRATION OF PROPELLANT STORAGE SYSTEMS
- o OPTIMUM OVERALL PROPELLANT UTILIZATION

SHUTTLE DESIGN ALTERNATIVES WHICH INCREASE
MISSION FLEXIBILITY AND/OR PAYLOAD

IN ORDER TO ACHIEVE MAXIMUM MISSION FLEXIBILITY AND PAYLOAD CAPABILITY, SYSTEM TRADEOFFS MUST BE PERFORMED TO OPTIMIZE THE INTEGRATED VEHICLE. SYSTEM INTEGRATION, POTENTIALLY OF ALL CRYOGENICS INTO A COMMON TANKAGE SYSTEM, MINIMIZES PROPELLANT RESIDUALS, PROVIDING FOR THE UTMOST USAGE OF AVAILABLE PROPELLANTS. IT ALSO MINIMIZES PROPELLANT LOADING REQUIREMENTS AND MAKES IT POSSIBLE TO VARY THE AMOUNT OF PROPELLANT USED BY THE OMS, RCS AND APU'S FROM MISSION TO MISSION.

SYSTEM INTEGRATION, PARTICULARLY BETWEEN THE RCS AND THE INJECTION TANKS, MAKES AVAILABLE TO THE RCS THE INJECTION SYSTEM RESIDUALS WHICH OTHERWISE WOULD WARM AND VENT TO SPACE. THESE RESIDUALS COULD AMOUNT TO A SIZABLE QUANTITY OF "FREE" PROPELLANT. USAGE OF THE ORBITER INJECTION TANKS AS A LARGE GASEOUS ACCUMULATOR COULD GREATLY SIMPLIFY THE RCS. IT WOULD PROVIDE, AT NO COST TO THE SYSTEM, AN EXISTING ACCUMULATOR, AN ITEM OF SIGNIFICANT WEIGHT SAVINGS. IT WOULD PROVIDE A RESERVOIR WHERE OMS BOILOFF AND OMS ENGINE SHUTDOWN RESIDUALS COULD BE STORED FOR FUTURE RCS USE. UNCONTROLLED BOILOFF OF THESE GASES WILL OTHERWISE RESULT IN AN INCREASED RCS PROPELLANT REQUIREMENT. INTEGRATION OF SEVERAL SUBSYSTEMS COULD BE MADE ON A COMMON FUNCTIONAL BASIS. REDUNDANT LINE RUNS COULD BE MERGED FOR SEVERAL SYSTEMS BY INCREASING A SINGLE RUN'S CARRYING CAPACITY AND HENCE SAVE ADDITIONAL LINE WEIGHT. INTEGRATION OF SYSTEMS OFFERS MANY POTENTIAL OPTIMIZATIONS FOR GREATER MISSION FLEXIBILITY AND GREATER PAYLOAD CAPABILITY.

SHUTTLE DESIGN ALTERNATIVES WHICH INCREASE
MISSION FLEXIBILITY AND/OR INCREASE PAYLOAD

- o INTEGRATION OF CRYO STORAGE SYSTEM
- o UTILIZE INJECTION SYSTEM RESIDUALS
- o UTILIZE OMS BOILOFF AND RESIDUALS (BOILOFF VENTING RESULTS
IN INCREASED RCS REQUIREMENTS UNLESS CAREFULLY CONTROLLED)
- o COLLECTIVE PROPELLANT UTILIZATION
- o UTILIZE MAJOR COMPONENTS FOR MULTI-SUBSYSTEM FUNCTION

COST EFFECTIVENESS

TO A LARGE EXTENT, THE COST EFFECTIVENESS OF THE SHUTTLE WILL BE DETERMINED BY THE VERSATILITY INHERENT IN THE SHUTTLE SUBSYSTEMS AND THE RANGE OF SPACE MISSIONS THAT CAN BE EFFICIENTLY PERFORMED WITHOUT MAJOR MODIFICATIONS. IN ADDITION TO THE ABOVE, THE COST EFFECTIVENESS OF THE SHUTTLE CAN BE ENHANCED BY SELECTION OF SUBSYSTEMS WHICH OFFER INHERENT SIMPLICITY OF OPERATION AND THE MINIMUM NUMBER OF ACTIVE COMPONENTS. NOT ONLY WILL THIS PHILOSOPHY REDUCE THE TECHNOLOGY, DEVELOPMENT, AND END ITEM COSTS; BUT, WILL ALSO MINIMIZE THE REFURBISHMENT COSTS. VERY CLOSE CONSIDERATION MUST BE GIVEN WHEN MAKING SYSTEM SELECTIONS TO INSURE THAT SELECTION OF COMPLEX SUBSYSTEMS, WHEN SIMPLER ALTERNATIVES EXIST, RESULT IN A CORRESPONDING INCREASE IN PAYLOAD CAPABILITY TO JUSTIFY THE ADDED COMPLEXITY AND ASSOCIATED INCREASE IN COST.

ANOTHER AREA OF POTENTIAL COST REDUCTION IS AVAILABLE IN THE AREA OF COMMON TECHNOLOGY AND COMMON USAGE OF COMPONENTS. AN EXAMPLE OF COMMON USAGE, ON THE APOLLO PROGRAM, IS THE SERVICE MODULE AND LUNAR MODULE RCS ENGINE, CERTAIN COMPONENTS AND GROUND SERVICING EQUIPMENT. THIS PHILOSOPHY UNDOUBTEDLY SAVED MILLIONS OF DOLLARS ON THE APOLLO PROGRAM. THE SAVINGS CAN BE EVEN MORE DRAMATIC ON THE SHUTTLE PROGRAM, SINCE MULTIPLE MISSIONS ARE INVOLVED AND ACTUAL REPAIR OF COMPONENTS WILL BE REQUIRED. THE FEWER THE NUMBER OF DIFFERENT TYPES OF COMPONENTS TO BE SERVICED AND REPAIRED, THE FEWER THE NUMBER OF TRAINED PERSONNEL WILL BE REQUIRED TO DO THIS JOB. COMMONALITY MUST HOWEVER BE WEIGHED AGAINST A POTENTIAL PAYLOAD GAIN THAT MAY BE ACHIEVED BY USING DIFFERENT COMPONENTS. FOR EXAMPLE, THE COST, IN TERMS OF PAYLOAD, FOR USING THE SAME ENGINE IN ALL LOCATIONS ON THE ORBITER AND BETWEEN THE ORBITER AND BOOSTER, MUST BE EVALUATED.

COST EFFECTIVENESS

- o UTILIZE SIMPLEST SUBSYSTEM CONCEPTS (BE SURE THAT INCREASED COMPLEXITY RESULTS IN CORRESPONDING INCREASE IN PAYLOAD CAPABILITY TO WARRANT THE ADDITIONAL COST AND COMPLEXITY)
- o UTILIZE COMMON COMPONENTS AND COMMON TECHNOLOGY BETWEEN SUBSYSTEMS TO REDUCE COST AND INCREASE RELIABILITY
- o UTILIZE SUBSYSTEM CONCEPTS WITH MINIMUM COMPONENTS AND CONTROLS

MANAGEMENT REQUIREMENTS

160

MOST OF THE EMPHASIS TO DATE HAS BEEN AIMED AT ACHIEVING A DESIGN THAT WOULD SATISFY THE REQUIREMENTS OF A "DESIGN REFERENCE MISSION" AND STILL BE COST EFFECTIVE. TO ACHIEVE THIS GOAL THE TOTAL VEHICLE DESIGN MUST BE HIGHLY EFFICIENT. THE PRIMARY EMPHASIS IS THEREFORE TO MAXIMIZE THE PAYLOAD POTENTIAL FROM EACH OF THE VARIOUS SYSTEMS OR SUBSYSTEMS. THIS APPROACH, TO REALIZE THE ULTIMATE, DICTATES THE USE OF INTEGRATED SYSTEMS. IF ALL THE PROPELLANT COULD BE PLACED IN ONE TANK AND ALL THE USERS OF THAT PROPELLANT SHARE THE WEIGHT OF THE PRESSURIZATION AND DISTRIBUTION SYSTEMS A SIGNIFICANT WEIGHT SAVINGS COULD BE REALIZED. TO ACCOMPLISH THIS WILL REQUIRE A TOTALLY DIFFERENT DESIGN AND MANAGEMENT PHILOSOPHY THAN THAT USED ON THE PREVIOUS MANNED SPACE PROGRAM. FIRST THE DESIGNERS AND ENGINEERS MUST BE CONDITIONED TO THINK NOT ONLY IN TERMS OF WHAT IS BEST FOR THEIR RESPECTIVE SYSTEM BUT ALSO WHAT IS BEST FOR THE PROGRAM. IT WILL NO LONGER BE POSSIBLE TO OPTIMIZE OR DESIGN THE BEST SUBSYSTEM, BUT RATHER DESIGN THE BEST COMBINATION OF SUBSYSTEMS. IN FACT EXTREMELY LOW PERFORMANCE OF THE APU OR RCS COMBINED WITH A HIGH PERFORMING OMS OR BOOST ENGINE YET SHARING COMMON COMPONENTS OR TANKS MIGHT WELL RESULT IN GREATER PAYLOAD CAPABILITY THAN THAT OBTAINED FROM OPTIMIZING ALL 3 SYSTEMS INDEPENDENTLY.

INTEGRATION OF SUBSYSTEMS POSES ANOTHER PROBLEM OF PERHAPS EVEN GREATER MAGNITUDE. THAT IS MANAGEMENT. THE CHANCES OF SOMETHING BEING OVERLOOKED IS SIGNIFICANTLY INCREASED. FOR EXAMPLE, DR. GEORGE LOW STATED IN A PAPER ENTITLED "APOLLO SPACECRAFT" PRESENTED AT THE AIAA 6TH ANNUAL MEETING AND TECHNICAL DISPLAY, THAT AN IMPORTANT DESIGN RULE IS TO "MINIMIZE FUNCTION INTERFACES BETWEEN COMPLEX PIECES OF HARDWARE. IN THIS WAY, TWO ORGANIZATIONS CAN WORK ON THEIR OWN HARDWARE RELATIVELY INDEPENDENTLY OF EACH OTHER." WE WILL PROBABLY NOT BE ABLE TO FOLLOW THIS DESIGN RULE IN THE SHUTTLE VEHICLE BECAUSE OF THE FLEXIBILITY REQUIRED. THEREFORE, BOTH THE GOVERNMENT AND INDUSTRY PERSONNEL WILL BE REQUIRED TO CONTINUALLY INSURE THAT THE MANY INTERFACES ARE COMPATIBLE AND THAT SYSTEM INTERACTIONS ARE TOLERABLE. IN ADDITION TO THE MANY INTERFACE PROBLEMS, A SIGNIFICANT INCREASE IN DEVELOPMENT COST CAN BE EXPECTED BECAUSE OF THE COMPLEX TEST PROGRAMS REQUIRED TO VERIFY THE INTEGRITY OF THE TOTAL SYSTEM.

MANAGEMENT REQUIREMENTS

- o APOLLO UTILIZED INDEPENDENT SUBSYSTEMS
 - o MINIMIZED FUNCTIONAL INTERFACES
 - o ALLOWED INDEPENDENT SUBSYSTEM DEVELOPMENT
- o SHUTTLE MUST UTILIZE INTEGRATED SUBSYSTEM TO MAXIMIZE PAYLOAD AND PROVIDE REQUIRED MISSION FLEXIBILITY
 - o RESULTS IN MANY COMPLICATED SYSTEMS INTERFACES AS WELL AS MANAGEMENT INTERFACES
 - o GOVERNMENT AND INDUSTRY MUST CONTINUALLY STRIVE TO INSURE INTERFACE COMPATIBILITY

LOW PRESSURE OXYGEN-HYDROGEN AUXILIARY PROPULSION SUBSYSTEMS

Lloyd F. Kohrs

McDonnell Douglas Corporation
St. Louis, Missouri

INTRODUCTION

A PRIME CANDIDATE FOR THE AUXILIARY PROPULSION SUBSYSTEM OF THE SPACE SHUTTLE VEHICLE IS THE LOW PRESSURE CONCEPT WHICH TAKES ADVANTAGE OF THE MAIN BOOST TANK AS AN ACCUMULATOR, A HEAT EXCHANGER, AND A SOURCE OF PROPELLANT. DEFINITION OF THE LOW PRESSURE SYSTEM SUITABLE FOR THE ORBITER AND BOOSTER IS THE SUBJECT OF CONTRACTED EFFORT BY MSC AND MSFC WITH MDAC-EAST AND TRW. IN ADDITION, THIS APS CONCEPT WILL BE CONSIDERED AS A TASK IN THE PHASE B VEHICLE DEFINITION PROGRAM.

PRESENTED ARE THE RESULTS OF ANALYSIS THAT HAVE BEEN CONDUCTED ON THE SUBSYSTEM DISCUSSING ALTERNATIVE METHODS OF OPERATION AND THE TECHNOLOGY REQUIREMENTS FOR SOME OF THE COMPONENTS AND ASSEMBLIES WHICH MAKE UP THE SUBSYSTEM.

THE BASIC LOW PRESSURE SYSTEM CONCEPT IS SHOWN IN THE ACCOMPANYING FIGURE. THE MAIN ENGINE TANK-AGE IS THE CENTRAL ELEMENT SERVING AS AN ACCUMULATOR, HEAT EXCHANGER, AND SOURCE OF PROPELLANT. THE ADDITIONAL PROPELLANT IS SEPARATELY STORED. AS A FUNCTION OF THE APPLICATION OR MISSION THIS ADDITIONAL PROPELLANT MAY REQUIRE CONDITIONING TO THE PRESSURE AND TEMPERATURE LEVELS REQUIRED BY THE THRUSTER. THE THRUSTERS FEED DIRECTLY FROM THE MAIN ENGINE TANK.

THIS DISCUSSION DEALS PRIMARILY WITH THE CONDITIONING ASSEMBLY AND THE BEHAVIOR OF THE MAIN ENGINE TANKAGE AND THE THRUSTER. FIRST THE THRUSTER.

BASIC LOW PRESSURE APS CONCEPT

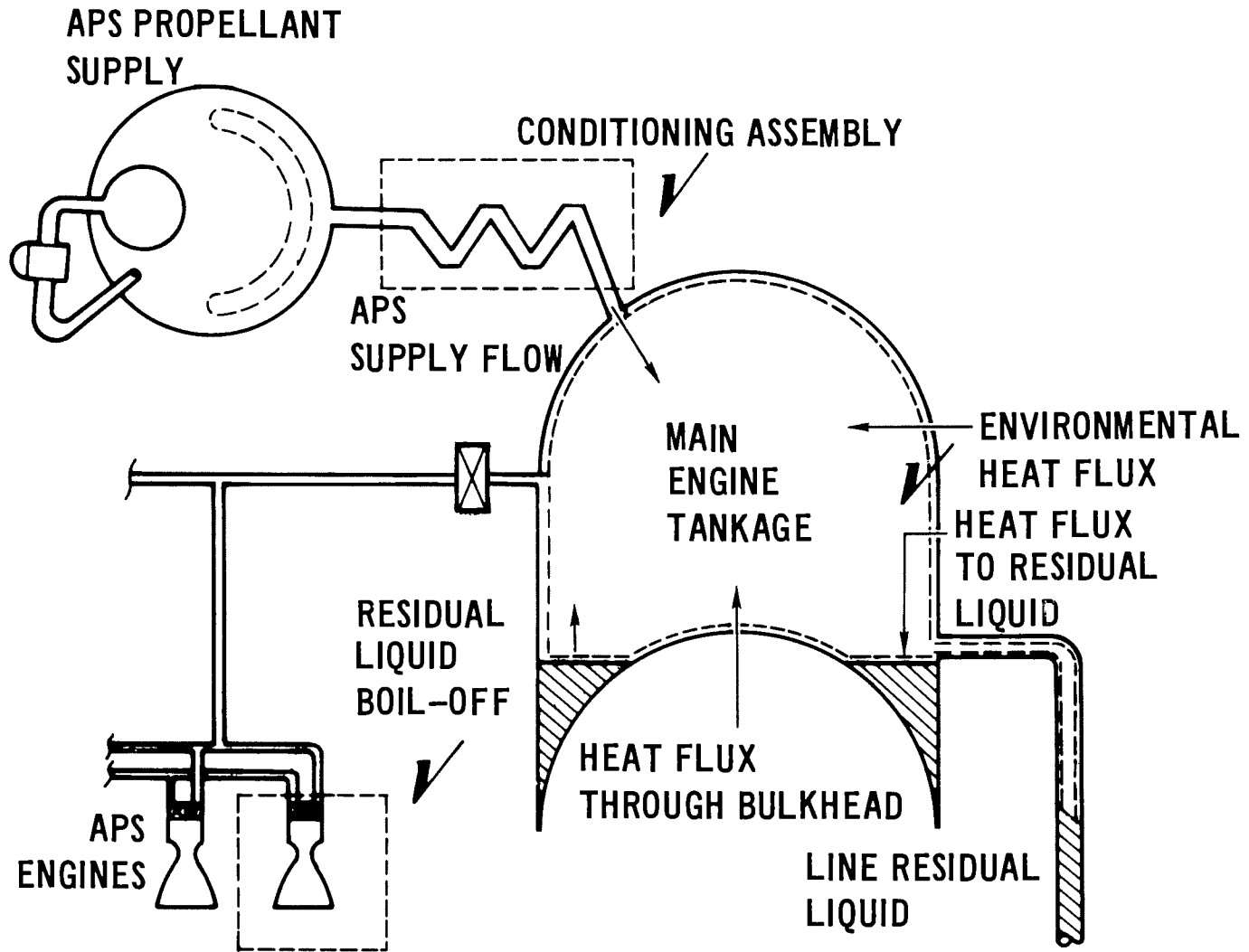

THE THRUSTER REQUIREMENTS ARE OF COURSE DEPENDENT ON THE VEHICLE CONFIGURATION, THE MISSION AND THE HANDLING QUALITIES REQUIRED BY AND DESIRED OF THE VEHICLE. TYPICAL THRUSTER REQUIREMENTS ARE SHOWN IN THE ACCOMPANYING FIGURE. THESE REQUIREMENTS ARE IN GENERAL AGREEMENT WITH THE LOW PRESSURE THRUSTER TECHNOLOGY PROGRAMS BEING FUNDED BY LeRC AND WERE USED THROUGHOUT THIS STUDY.

WHAT THIS THRUSTER DESIGN MEANS TO OVERALL SYSTEM IN TERMS OF SYSTEM REQUIREMENTS IS SHOWN BY THE NEXT FIGURE.

TYPICAL THRUSTER OPERATING REQUIREMENTS

- THRUST LEVEL_____1500 LB
- CHAMBER PRESSURE_____20 psia
- MIXTURE RATIO_____3:1 O/F
- INLET PRESSURE_____25 – 30 psia
- INLET TEMPERATURE_____300 – 600 °R
- THRUSTER INLET LINE SIZE_____~3 IN DIA O₂ & H₂
- THRUSTER MAIN SUPPLY LINE SIZE_____~6 IN DIA O₂ & H₂
- MAIN ASCENT TANK PRESSURE_____35 – 45 psia

THE CHARACTERISTICS OF THE GAS-GAS THRUSTER WHEN COUPLED TO THE FEED SYSTEM HAVE BEEN ANALYZED. THESE DATA SHOW THAT THE MOST SIGNIFICANT EFFECT OF CHANGES IN INLET CONDITIONS IS IN THE MIXTURE RATIO SHIFT CAUSED BY VARIATIONS IN INLET PRESSURE AND TEMPERATURE. AS SHOWN, THE EFFECT OF INLET PRESSURE IS EXTREME, AN OPPOSING VARIATION OF 1 PSI IN OXIDIZER AND FUEL CAUSING 1 UNIT SHIFT IN MIXTURE RATIO. SHIFTS OF THIS NATURE HAVE LARGE IMPLICATIONS IN THRUSTER DESIGN. HOWEVER, EVEN IF THE THRUSTER COULD ACCOMMODATE THESE SHIFTS WITHOUT PERFORMANCE PENALTIES, THE PENALTIES ASSOCIATED WITH TANKING FOR THE MR UNCERTAINTY WOULD BE APPRECIABLE. THE SLOPE OF THE CURVE INDICATES CONTROL OF PRESSURE AS A REQUIREMENT. THE CURVE ALSO SUGGESTS THAT A CONTROL METHOD WHICH CONSTRAIN VARIATIONS IN INLET PRESSURE TO BE LIKE VARIATIONS WOULD BE DESIRABLE.

AS SHOWN IN THE FIGURE, THOUGH THE TREND WITH TEMPERATURE IS SIMILAR TO PRESSURE, THE CONSEQUENCE OF OPPOSING VARIATIONS IS SIGNIFICANTLY REDUCED. IT IS ANTICIPATED THAT THE TEMPERATURE VARIATION EXPERIENCED WILL APPROACH LIKE VARIATIONS DUE TO THE SIMILARITY OF THE BOOST TANK ENVIRONMENT. THE ABOVE STATEMENT ASSUMES THE CONDITIONING SYSTEM KEEPS BOTH PROPELLANTS AT THE SAME TEMPERATURE, 500°F, IN THE ILLUSTRATION. ANY VARIATIONS IN CONDITIONING SYSTEM PERFORMANCE WOULD BE REFLECTED AS AN OPPOSING VARIATION. THE SLOPE OF THE CURVE SUGGESTS A $\pm 50^{\circ}\text{R}$ CONDITIONING SYSTEM TOLERANCE WOULD BE ACCEPTABLE.

RATHER PRECISE CONTROL OF THE OXIDIZER AND FUEL PRESSURES OR THE DIFFERENCE BETWEEN THEM IS REQUIRED. CONSIDERATION HAS BEEN GIVEN TO DOWNSTREAM REGULATION AND REGULATION BY MASS ADDITION.

THRUSTER MIXTURE RATIO SENSITIVITY

-AEROJET LIQUID ROCKET CO. DATA-

- THRUST - 1500 lb
- CHAMBER PRESSURE - 20 psia
- MIXTURE RATIO - 3:1 O/F

169

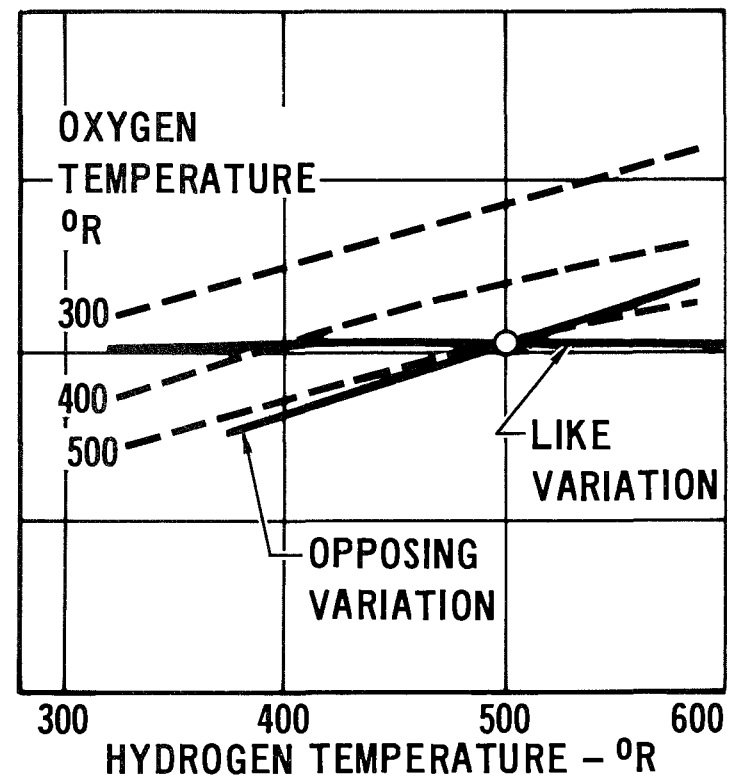
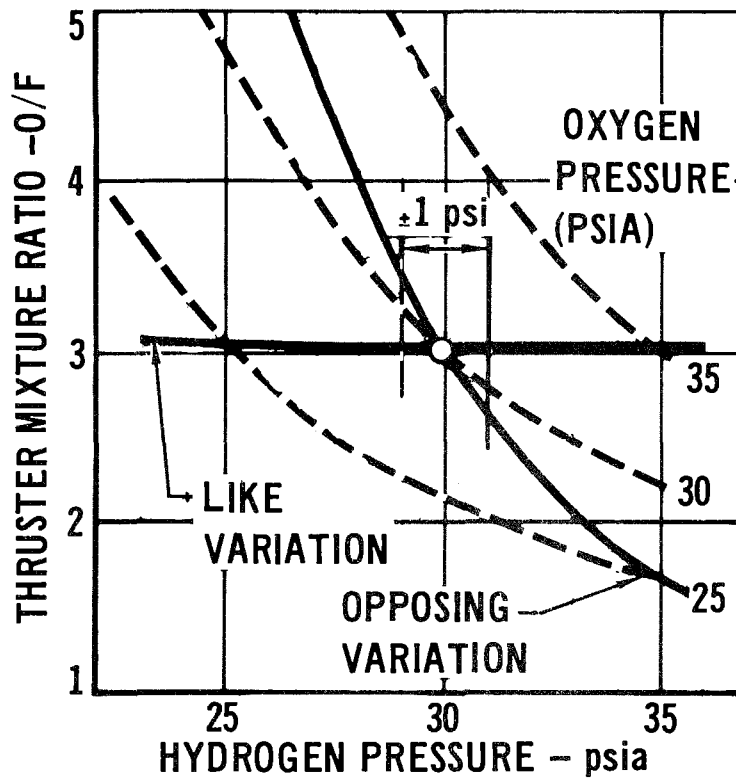

IN ALL CASES PRESSURE IN THE TANK IS CONTROLLED BY ADDING PROPELLANT TO THE TANK. THRUSTER INLET PRESSURE CAN THEN BE CONTROLLED EITHER BY REGULATION OF TANK PRESSURE WITHIN THE TIGHT BAND REQUIRED FOR MIXTURE RATIO CONTROL OR THE TANK PRESSURE BAND CAN BE WIDENED AND COMMON OR INDIVIDUAL THRUSTER REGULATORS ADDED DOWNSTREAM FOR CONTROL OF MIXTURE RATIO.

EACH CONCEPT HAS THE CHARACTERISTICS NOTED IN THE FIGURE AND EACH CONCEPT HAS LIMITATIONS AND PENALTIES ASSOCIATED WITH THOSE LIMITATIONS.

INJECTOR INLET PRESSURE CONTROL

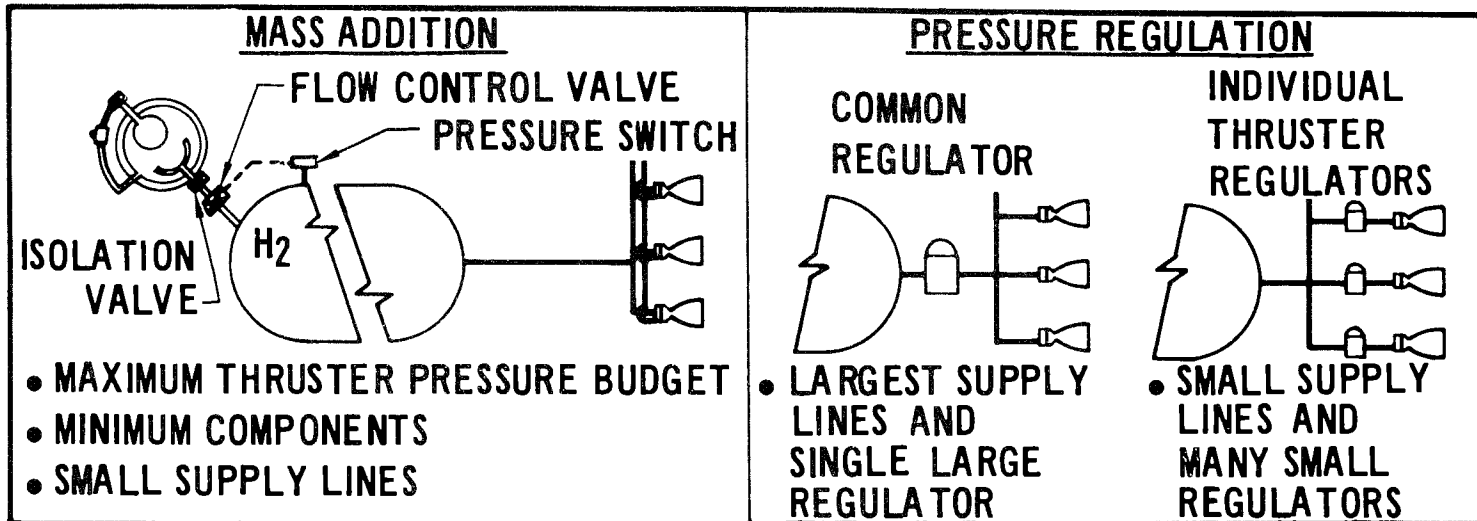

171

TIGHT PRESSURE BAND

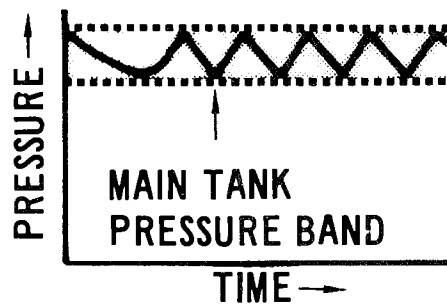

LARGE PRESSURE BAND

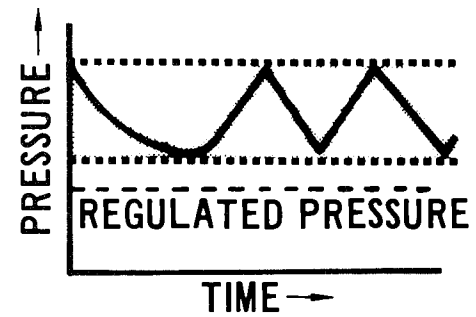

THE ADDITION OF PROPELLANT WITHOUT CONDITIONING, USING DOWNSTREAM REGULATION FOR CONTROL OF THRUSTER INLET PRESSURE AND MIXTURE RATIO, HAS THE INHERENT ADVANTAGE OF SYSTEM SIMPLICITY. HOWEVER, THIS SIMPLICITY IS GAINED AT THE COST OF LIMITING THE SINGLE BURN IMPULSE CAPABILITY OF THE SYSTEM. AS SHOWN IN THE FIGURE, INJECTING PROPELLANT AT SATURATION (HYDROGEN IN THE ILLUSTRATION) THE MAXIMUM SINGLE BURN IMPULSE THAT COULD BE OBTAINED IS 6000 LB THRUST OPERATING ABOUT 40 SECONDS, CORRESPONDING TO A ΔV OF APPROXIMATELY 30 FT/SEC FOR A TYPICAL ORBITER. THE DESIGN GOAL IS ABOUT 60 FT/SEC. THE MAXIMUM SINGLE BURN IMPULSE COULD BE EXTENDED TO THE LIMITS SHOWN ON THE CURVE BY PRECONDITIONING PROPELLANT.

PRACTICALLY THE LIMITATION ON SINGLE BURN IMPULSE IS SOMEWHAT SMALLER THAN QUOTED ABOVE. AT THE DESIGN POINT OF 30 PSIA MINIMUM THRUSTER INLET PRESSURE, THE LIMITATION WOULD BE EQUIVALENT TO A ΔV OF APPROXIMATELY 20 FT/SEC.

THE COST OF EXTENDING THE ΔV BY REDUCING THE NOMINAL THRUSTER CHAMBER PRESSURE OR INCREASING THE TANK PRESSURE TO ALLOW FOR A LARGER CHANGE IN TANK PRESSURE IS SHOWN ON THE NEXT FIGURE.

PRESSURE PROFILES WITH MASS ADDITION

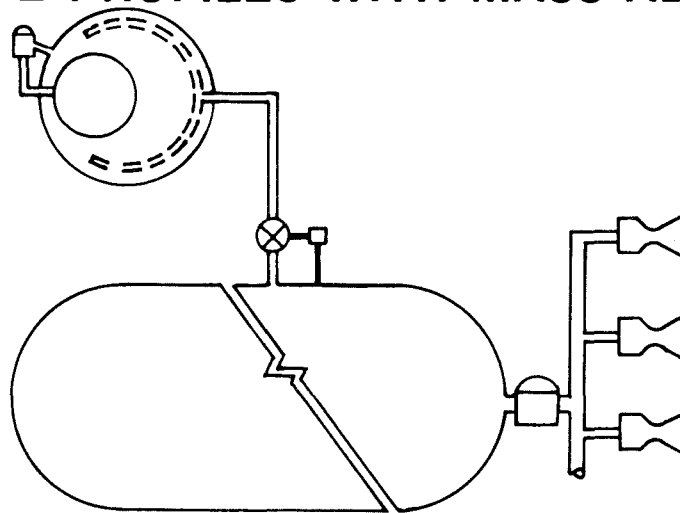

$T_0 = 350^{\circ}\text{R}$
 $Q/A = 0.5 \text{ BTU/HR-FT}^2$
 $F = 6000 \text{ LB}_f$

$\Delta V = 30 \text{ FT/SEC}$

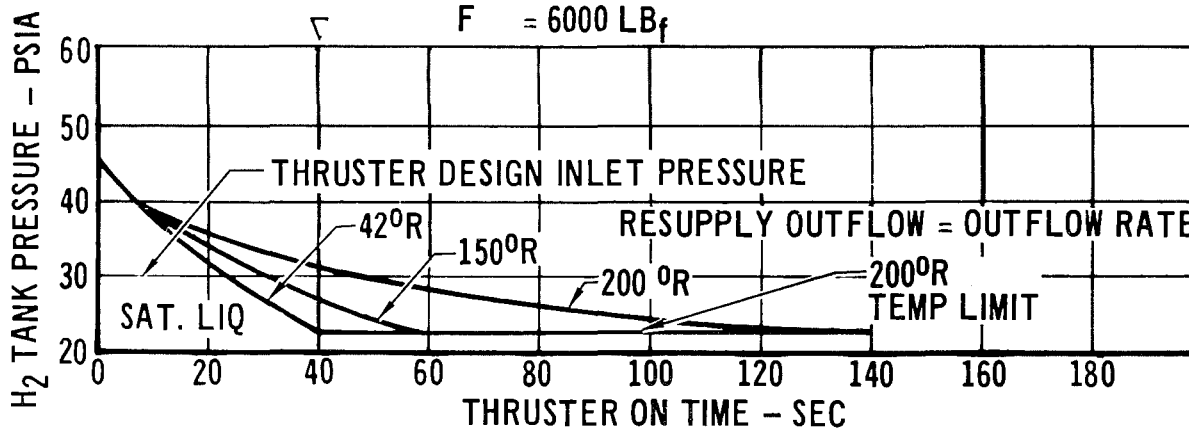

ILLUSTRATED IS THE WEIGHT PENALTY RESULTING FROM INCREASING THE ALLOWABLE PRESSURE DROP BUDGETED FOR TANK PRESSURE CHANGE PLUS REGULATOR PRESSURE DROP FOR A TYPICAL ORBITER. FROM THE DESIGN POINT DISCUSSED ON THE PREVIOUS CHART, THE SINGLE BURN ΔV COULD BE INCREASED FROM 20 FT/SEC TO 30 FT/SEC BY INCREASING THE TANK AND REGULATOR PRESSURE DROP FROM 15 PSI TO 22 PSI. THE WEIGHT PENALTY ASSOCIATED WITH THIS CHANGE WOULD BE 400-700 LBS INERT WEIGHT DEPENDING ON THE METHOD.

BASED ON THE MISSION TIME LINE OF THE VEHICLE DESCRIPTION DOCUMENT BEING USED FOR THE APS DEFINITION CONTRACTS, THE LOW PRESSURE APS WITHOUT CONDITIONING COULD ACCOMPLISH ALL OF THE ATTITUDE CONTROL AND STATION KEEPING FUNCTIONS FROM LAUNCH UNTIL REENTRY AT THE EXPENSE OF A MODERATE INCREASE IN SYSTEM INERT WEIGHT AND THE NECESSITY OF DEVELOPING PRECISE PRESSURE REGULATORS WITH LIFE CAPABILITIES EQUAL TO THE LIFE CAPABILITIES OF THE THRUSTER.

HOWEVER, FOR THE REENTRY PORTION OF THE MISSION, CURRENTLY STATED AS A ΔV OF 60 FT/SEC PRECONDITIONING OF THE PROPELLANT PRIOR TO INJECTION INTO THE ASCENT TANKS IS REQUIRED.

HARDWARE WEIGHT PENALTIES FOR REGULATION

-COMMON REGULATOR CONCEPT-

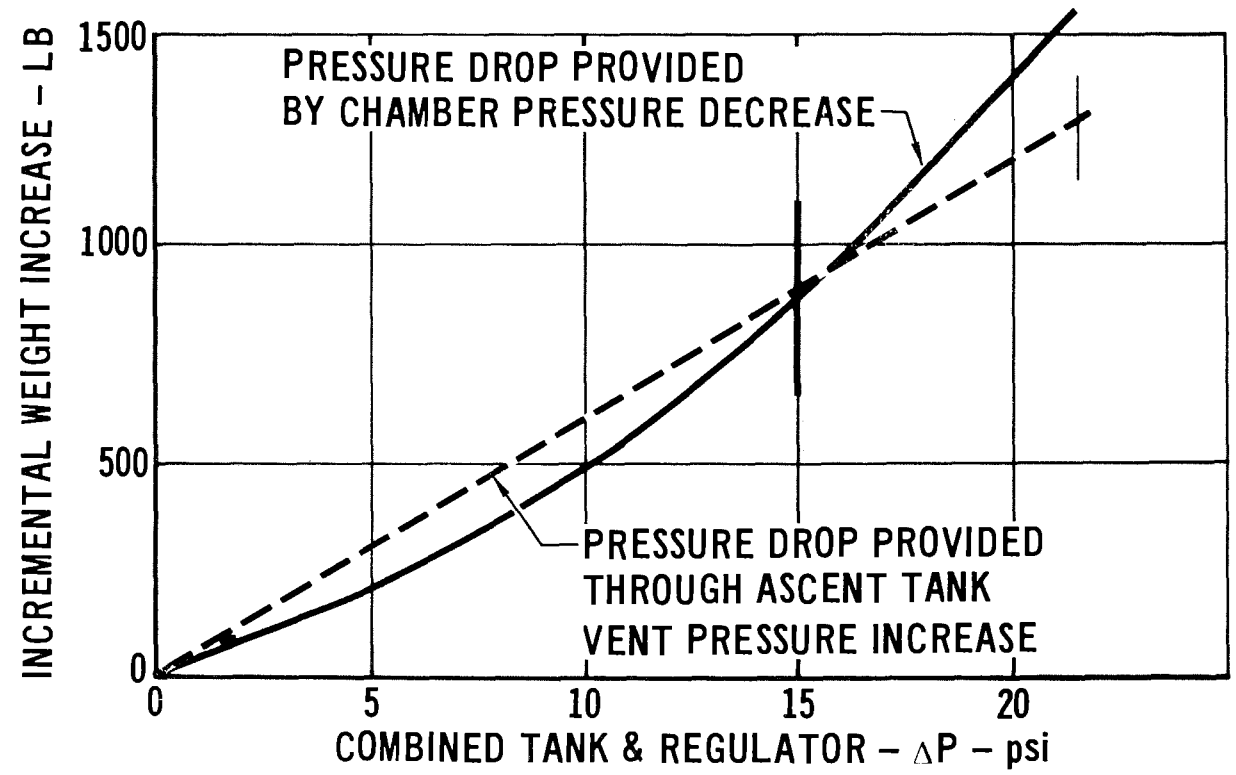

PASSIVE AND ACTIVE CONDITIONING ASSEMBLY CONCEPTS ARE BEING ANALYZED. PASSIVE SYSTEMS INCLUDE SURFACE HEAT EXCHANGERS USING SOLAR ENERGY AND HEAT SINK TYPE HEAT EXCHANGERS USING THE VEHICLE STRUCTURE INCLUDING THE ASCENT TANK AS AN ENERGY SOURCE.

ACTIVE SYSTEMS BEING CONSIDERED ARE SHOWN IN THE UPPER HALF OF THE CHART. THEY RANGE FROM THE HIGHLY INTEGRATED REGENERATIVE SYSTEM WHERE THE ENGINES FOR +X AXIS MANEUVERS ARE USED AS HEAT EXCHANGERS TO PRECONDITION THE PROPELLANT FOR STORAGE IN THE MAIN TANK TO THE RELATIVELY STRAIGHT FORWARD SYSTEM WHERE A SEPARATE LOW PRESSURE GAS GENERATOR CONDITIONS THE PROPELLANT BEFORE STORAGE IN THE MAIN TANK.

CONDITIONING ASSEMBLY CONCEPTS

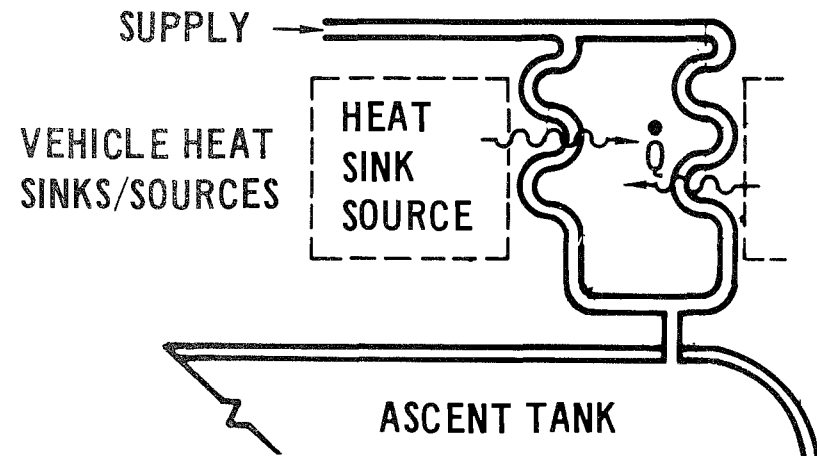
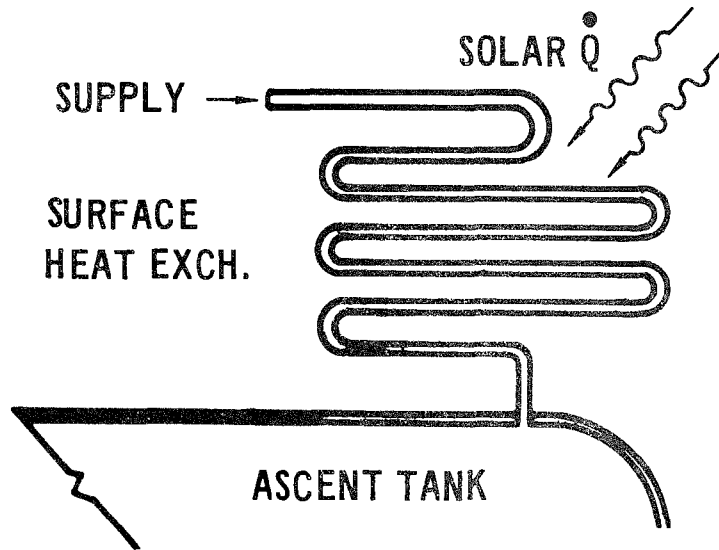
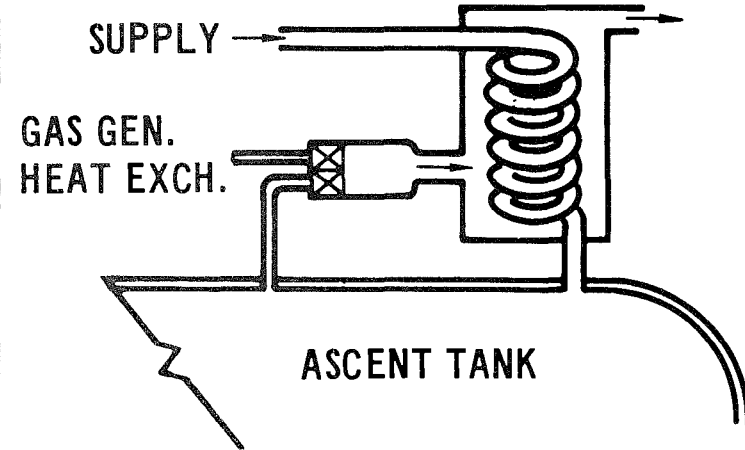
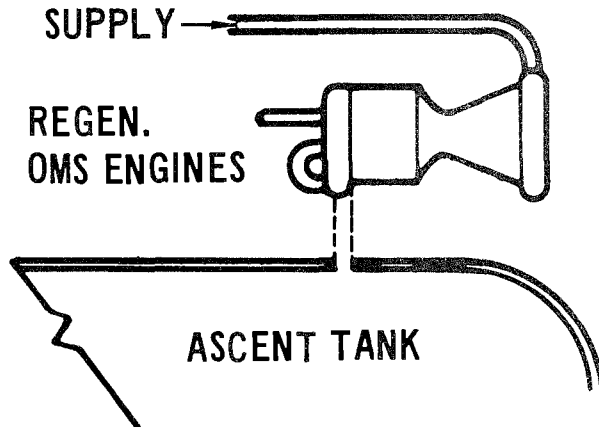

WHAT THE CONDITIONING SYSTEM IS REQUIRED TO DO IS TO EXTEND THE SINGLE BURN IMPULSE CAPABILITY OF THE SYSTEM. THIS CAN BE ACCOMPLISHED BY PARTIALLY CONDITIONING THE PROPELLANT ALONG THE 150°R AND 200°R LINES SHOWN ON THE FIGURE. HOWEVER, IN THIS CASE, AS PREVIOUSLY DISCUSSED, A DOWNSTREAM REGULATOR IS REQUIRED FOR MR CONTROL AND THE RESULTING SUBSYSTEM HAS THE COMPLICATIONS OF BOTH GAS PRESSURE REGULATION AND CONDITIONING.

AN ALTERNATIVE IS TO CONDITION THE PROPELLANT WITHIN THE PRESSURE LIMITS REQUIRED FOR MIXTURE RATIO CONTROL WITHOUT DOWNSTREAM REGULATORS.

APPROACHES TO THIS ALTERNATIVE ARE DISCUSSED ON THE FOLLOWING TWO CHARTS.

PRESSURE PROFILES WITH MASS ADDITION ^{L7}

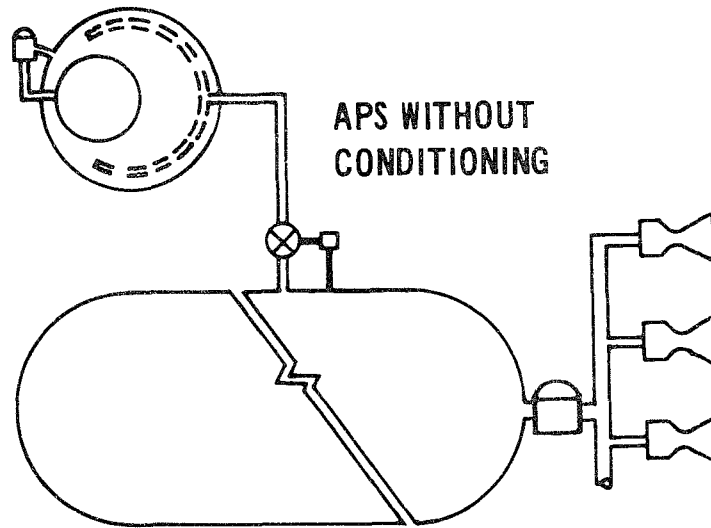

APS WITHOUT
CONDITIONING

$T_0 = 350^{\circ}\text{R}$
 $Q/A = 0.5 \text{ BTU/HR-FT}^2$
 $F = 6000 \text{ LB}_f$

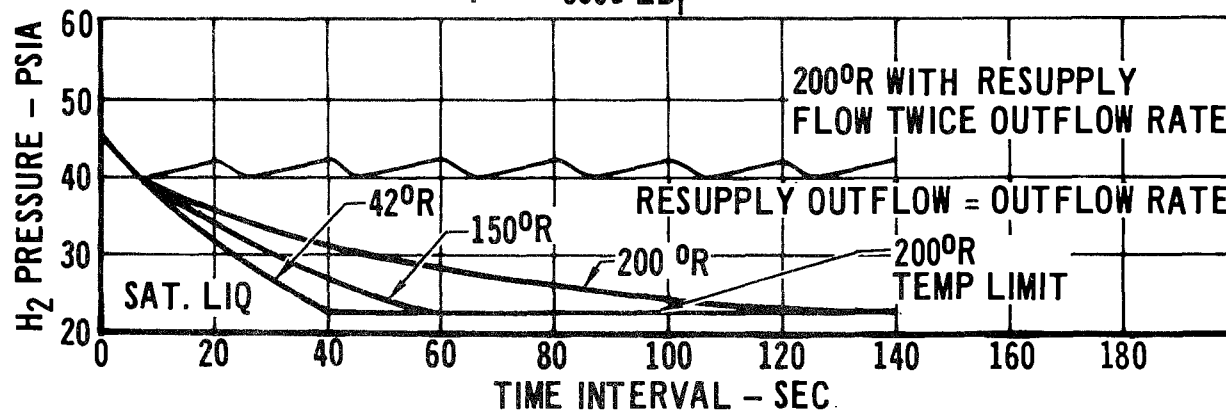

THE RESUPPLY CAN BE AT A RATE EQUAL TO THE OUTFLOW AND THE TEMPERATURE ADJUSTED TO MAINTAIN PRESSURE WITHIN THE PRESCRIBED LIMITS OR, AT A FIXED CONDITIONING TEMPERATURE, THE RESUPPLY FLOW RATE CAN BE ADJUSTED TO MAINTAIN TANK PRESSURE. THE ALTERNATIVES ARE SHOWN IN THE CURVES OF THE CHART.

FOR THE CASE OF RESUPPLY FLOW EQUAL TO OUTFLOW, A CONDITIONING TEMPERATURE OF APPROXIMATELY 460°R IS REQUIRED TO MAINTAIN TANK PRESSURE WITHIN THE CONTROL DEAD BAND. LOWER TEMPERATURES CAUSE PRESSURE DECAYS AS A RESULT OF REDUCING GAS TEMPERATURE. HIGHER TEMPERATURE CAUSES REPEATED CYCLING OF THE CONDITIONING SYSTEM.

FOR EVERY TEMPERATURE LINE THERE IS A RATIO OF INFLOW/OUTFLOW THAT CAN BE USED TO MAINTAIN TANK PRESSURE WITHIN THE REQUIRED LIMITS. FOR THE CASE OF 235°R RESUPPLY TEMPERATURE, THE INFLOW IS TWO TIMES THE OUTFLOW. THE PENALTY OF THIS SYSTEM WOULD BE VENTING OF EXCESS PROPELLANT DURING WARM-UP FOLLOWING SHUTDOWN.

THE TRADE BETWEEN VENT PROPELLANT AND CONDITIONING PROPELLANT REQUIRED IS SHOWN IN THE NEXT FIGURE.

EFFECT OF RESUPPLY CONDITIONS ON OPERATION

ASCENT SYSTEM O₂ TANK

181

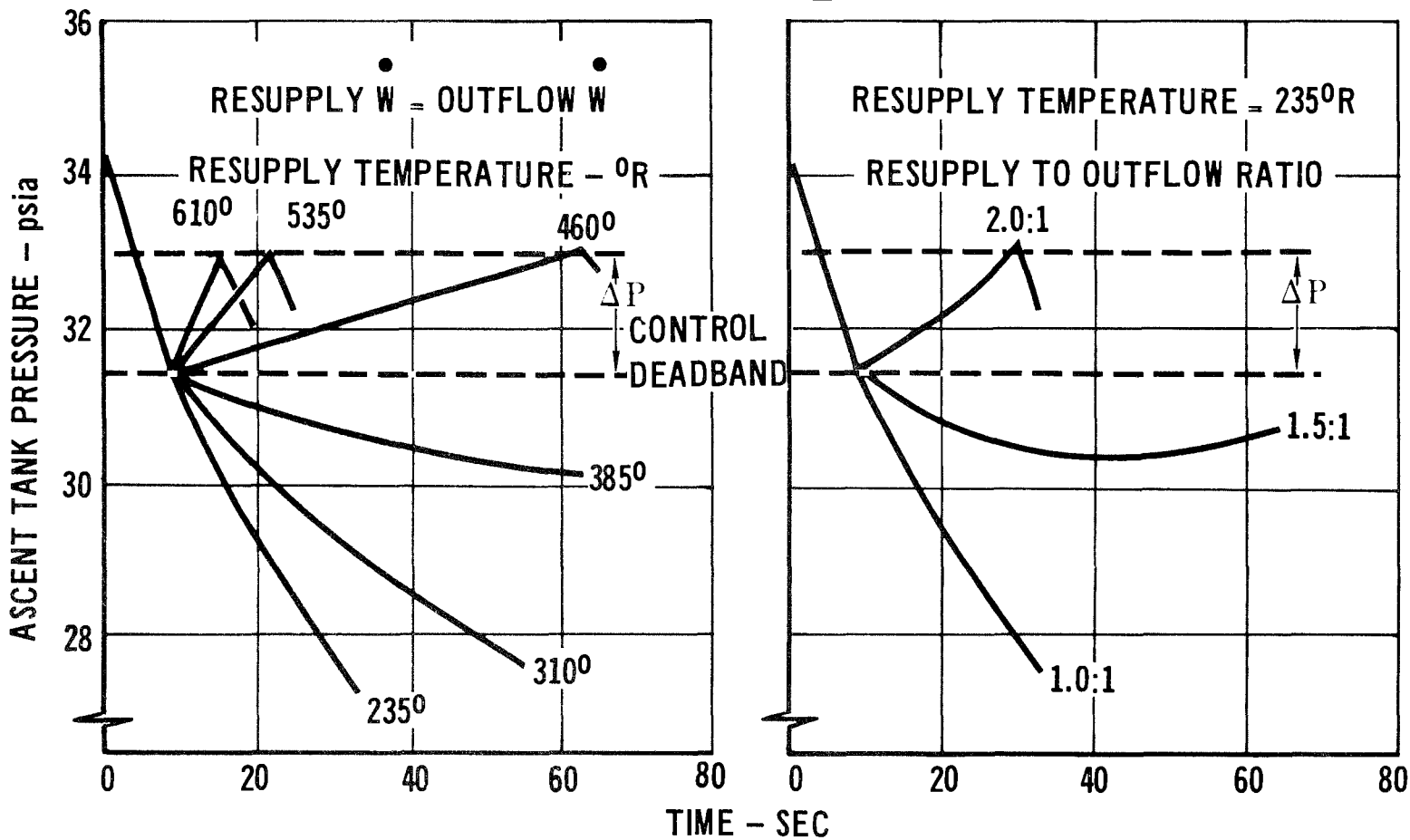

THE TRADE OF PROPELLANT REQUIRED FOR CONDITIONING OF THE IMPULSIVE PROPELLANT VS THE VENT LOSSES AND INCREASED GAS RESIDUALS LEADS TO THE CONCLUSION THAT FOR MANEUVERS APPROACHING 50 FT/SEC A CONDITIONING TEMPERATURE APPROACHING AMBIENT TEMPERATURE IS MOST DESIRABLE. THIS TREND IS ILLUSTRATED BY THE CURVE OF CHART. THE POINT AT 500°R IS AN ARBITRARY REFERENCE POINT.

EFFECT OF CONDITIONING TEMPERATURES ON RESUPPLY

-ORBITER - ≤ 50 FPS MANEUVERS-

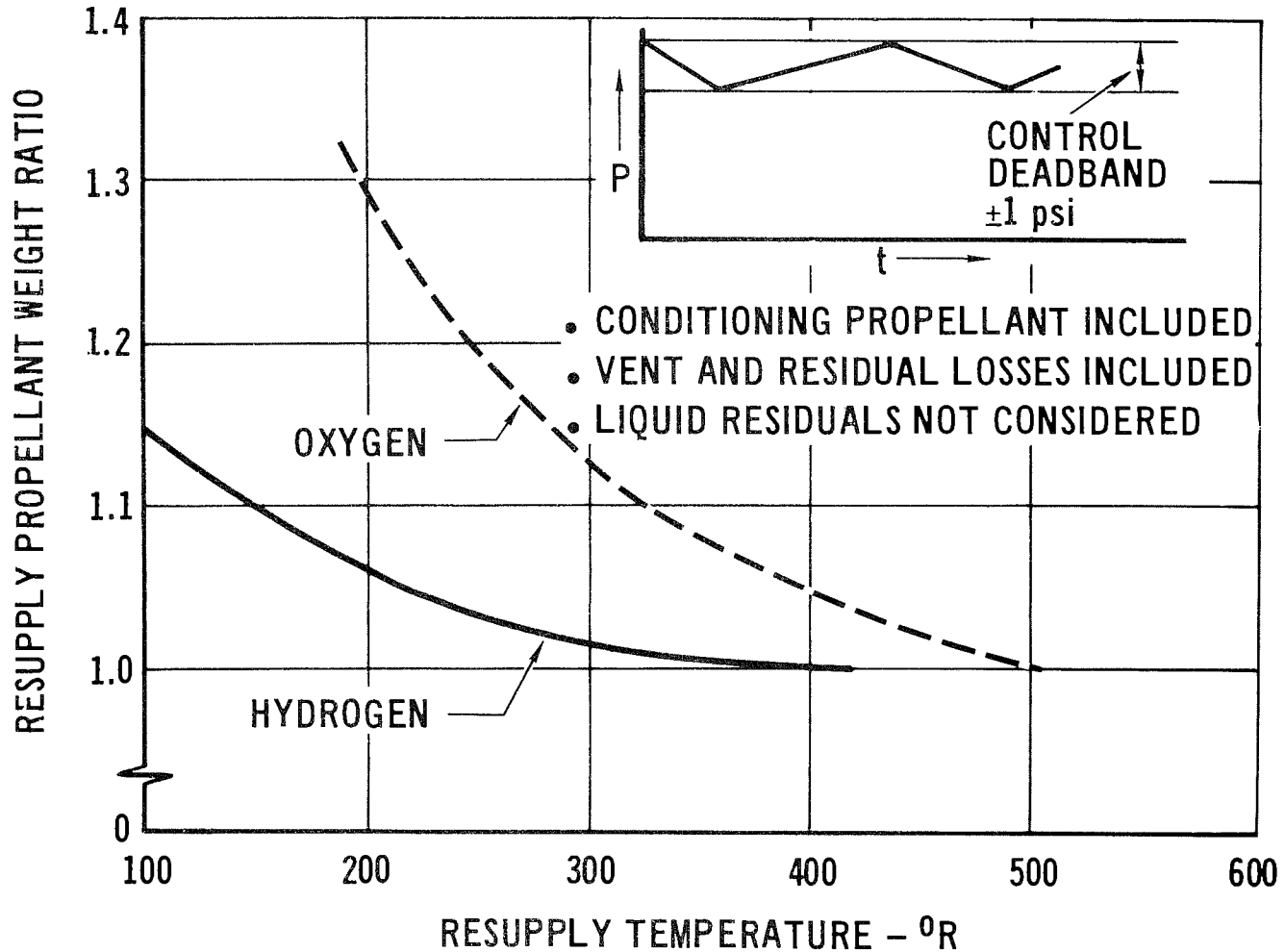

THE EFFECT OF ASCENT TANK HEATING RATE ON SYSTEM PERFORMANCE HAS BEEN EXAMINED TO DETERMINE THE EFFECT ON SYSTEM OPERATION AND PERFORMANCE. AS ILLUSTRATED BY THE CURVES, DURING THE THRUSTER FIRING AN ORDER OF MAGNITUDE CHANGE IN HEAT FLUX HAS LITTLE IMPACT ON THE AMOUNT OF TOTAL IMPULSE AVAILABLE WITHOUT PROPELLANT CONDITIONING.

DURING NONUSE HOWEVER, AN ORDER OF MAGNITUDE CHANGE IN HEAT FLUX WOULD EFFECT THE TIME TO VENT BY AN ORDER OF MAGNITUDE. IN THE PRACTICAL SENSE THE PROPELLANT IN THE TANK WILL COME TO EQUILIBRIUM WITH THE ENVIRONMENT THUS THE VENT LOSSES WILL ALWAYS OCCUR IF THE PROPELLANT IS CONDITIONED TO A TEMPERATURE LESS THAN THE TEMPERATURE OF THE ENVIRONMENT.

EFFECT OF ASCENT TANK HEATING RATE

DURING THRUSTER FIRING

- HYDROGEN TANK
- NO THERMAL CONDITIONING
- LIQUID RESUPPLY

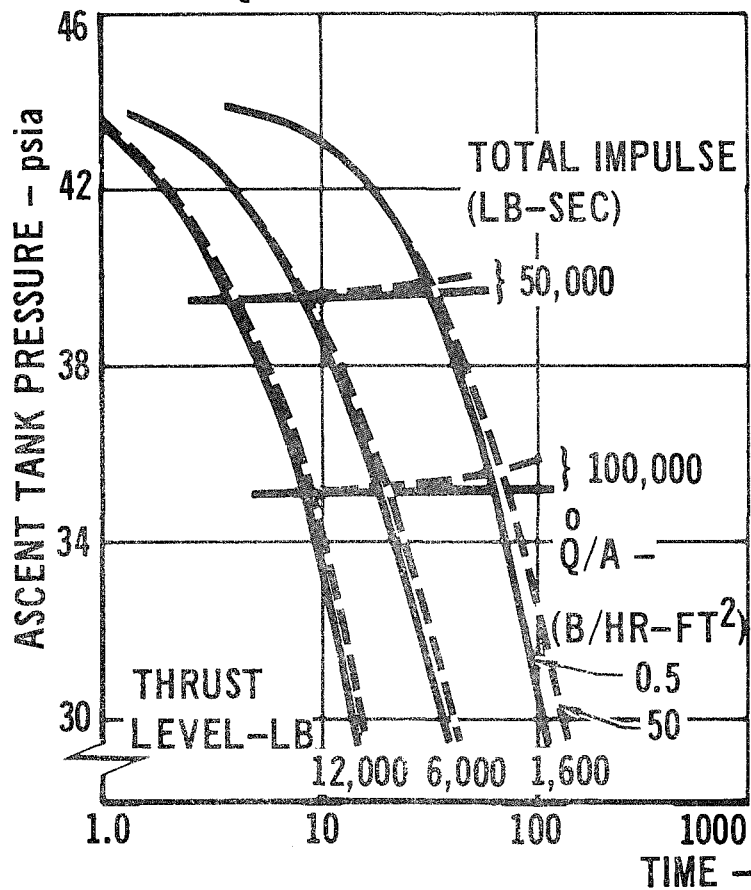

DURING NON-USE PERIODS

$$\dot{Q}/A \text{ (B/HR-FT}^2\text{)}$$

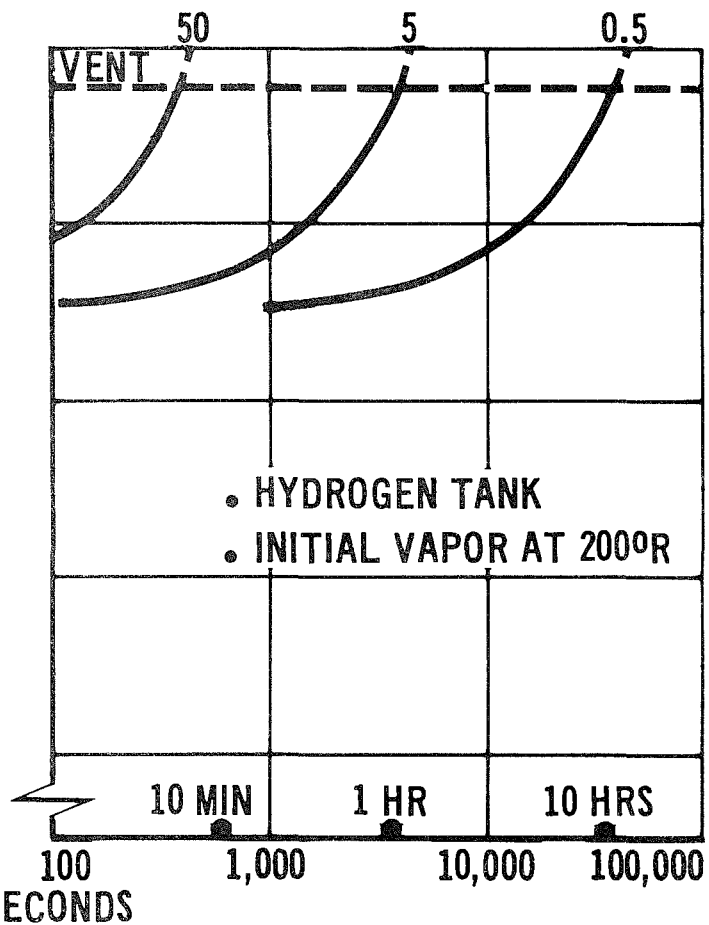

A CRITICAL ELEMENT IS THE REGULATION ASSEMBLY. THE PERFORMANCE REQUIREMENTS ARE GIVEN IN THE FIGURE. CRITICAL AND BEYOND THE STATE OF THE ART ARE THE ACCURACIES AND CYCLE LIFE REQUIREMENTS. THE ACCURACY REQUIREMENTS GIVEN ARE REQUIRED TO ATTAIN ABOUT A 2% PROPELLANT OUTAGE DUE TO MR UNCERTAINTIES. THE REQUIREMENTS ON LIFE VARY WITH THE SYSTEM CONCEPT. THE PROMISE OF LOWER CYCLE LIFE AND LINE SIZE ON THE LIQUID RESUPPLY REGULATION SYSTEM IS ATTRACTIVE. HOWEVER A PROPELLANT CONDITIONING SYSTEM WILL PROBABLY BE REQUIRED WITH THIS SYSTEM TO MINIMIZE VENT LOSSES AND, AS A FUNCTION OF THE APPLICATION, TO ATTAIN SUITABLE SINGLE BURN TOTAL IMPULSE CAPABILITY.

CONDITIONING SYSTEM REQUIREMENTS ARE GIVEN. SIGNIFICANT EXPERIMENTAL WORK WITH LOW PRESSURE HEAT EXCHANGERS OF THE REQUIRED CAPACITY HAS NOT BEEN ACCOMPLISHED.

PRESSURE CONTROL - CONDITIONING ASSEMBLY SUMMARY -LOW PRESSURE APS-

PRESSURE CONTROL REQUIREMENTS	SINGLE REGULATOR	THRUSTER REGULATORS	RESUPPLY REGULATOR
OPERATING PRESSURE	30-45 PSI		
CONTROL ACCURACY	± 0.5 PSI		
FLOW RATE - OXYGEN	12 LB/SEC	3 LB/SEC	12 LB/SEC
- HYDROGEN	4 LB/SEC	1 LB/SEC	3 LB/SEC
TYPICAL LINE SIZE	6" DIA	3" DIA	1-2" DIA
*CYCLE LIFE	4	1	1/100
*RESPONSE	10-15 MS	10-15 MS	200-500 MS
CONDITIONING ASSEMBLY REQUIREMENTS			
FLOW RATE - OXYGEN	12 LB/SEC		
- HYDROGEN	4 LB/SEC		
OPERATING PRESSURE	30-45 PSI		
OPERATING TEMPERATURES	300-600 °R		
*CYCLE LIFE	1/100		

*REFERENCED TO THRUSTER LIFE REQUIREMENT AND THRUSTER VALVE RESPONSE OF 10-15 MS.

CONCLUSIONS

1. REGARDLESS OF THE APPLICATION PRESSURE REGULATION IS REQUIRED.
2. THE PRESSURE REGULATION CONCEPT SHOULD CONSTRAIN OXIDIZER AND FUEL PRESSURE TO VARY IN SAME DIRECTION FOR BEST CONTROL OF OUTAGE.
3. CONDITIONING IS REQUIRED FOR MANEUVERS GREATER THAN 30 FT/SEC.
4. CONDITIONING TO AMBIENT TEMPERATURE MINIMIZES THE VEHICLE – SUBSYSTEM PERFORMANCE INTERFACE AND RESULTS IN MINIMUM SYSTEM WEIGHT.

SPACE SHUTTLE HIGH PRESSURE AUXILIARY PROPULSION SYSTEM

H. L. Burge and J. Cuffe
TRW Systems Group
Redondo Beach, California

and A. Shaffer
Airesearch Manufacturing Company
Los Angeles, California

ABSTRACT

THE REQUIREMENTS FOR A HIGH PRESSURE SSAPS ARE REVIEWED. FOR A DEFINED VEHICLE AND MISSION, THESE ARE DETERMINED BY THE PRIMARY PROPULSION SYSTEM CAPABILITY. SOME OF THE FUNDAMENTAL SYSTEM PROBLEMS ARE DISCUSSED AND THE INFLUENCE OF APS ΔV REQUIREMENTS UPON THE SYSTEM PERFORMANCE SENSITIVITY IS DETERMINED. THE MAIN ELEMENTS OF A HIGH PRESSURE APS ARE DEFINED. TECHNOLOGY EFFORTS ARE DIVIDED INTO THREE OVERLAPPING AND INTERACTING ACTIVITIES, NAMELY FUNDAMENTAL LIMITS, APPLICATION LIMITS AND PREDEVELOPMENT ACTIVITIES. TO ILLUSTRATE SOME OF THE PROBLEMS DISCUSSED IN THIS PAPER, A CANDIDATE HIGH PRESSURE APS FOR HIGH ΔV APPLICATIONS IS PRESENTED AND DISCUSSED.

GENERAL REQUIREMENTS

THE AUXILIARY PROPULSION SYSTEM (APS) WILL BE REQUIRED TO FUNCTION FOR A MINIMUM SERVICE LIFE OF 100 MISSION CYCLES OVER EIGHT (8) YEARS PRIOR TO MAJOR OVERHAUL/REFURBISHMENT AND WITH ONLY MINOR SERVICING ALLOWED BETWEEN EACH MISSION. DESIGN REQUIREMENTS FOR THE APS INCLUDE LONG LIFE, HIGH RELIABILITY, REUSABILITY, MINIMAL AND EASY SYSTEM MAINTENANCE AND REFURBISHMENT, ONBOARD SYSTEMS STATUS/CHECKOUT/FAILURE DETECTION AND ISOLATION SYSTEM, HIGH PERFORMANCE, MINIMUM COMPLEXITY, AND MINIMUM WEIGHT. IN ADDITION, THE SYSTEM MUST HAVE THE CAPABILITY TO REMAIN OPERATIONAL WITH A SINGLE FAILURE AND WITH A SECOND FAILURE TO ASSUME A FAIL-SAFE CONDITION FOR CREW SURVIVAL.

FURTHERMORE, THE APS MUST HAVE THE FLEXIBILITY NECESSARY TO BE ABLE TO ACCOMMODATE MISSION CHANGES AND IT IS DESIRABLE THAT IT SHOULD REQUIRE A MINIMUM OF NEW TECHNOLOGY.

GENERAL REQUIREMENTS

HIGH DELIVERED PERFORMANCE

RELIABILITY

MAINTAINABILITY

LONG LIFE

SAFETY

MISSION FLEXIBILITY

MINIMIZE CRITICAL TECHNOLOGY

APS ELEMENTS

THE AUXILIARY PROPULSION SYSTEM WILL UTILIZE THE SAME TYPE PROPELLANTS AS THE VEHICLE MAIN PROPULSION; I.E., OXYGEN AND HYDROGEN, TO TAKE ADVANTAGE IN INHERENT HIGH PERFORMANCE, NON-TOXIC AND NON-CORROSIVE PROPERTIES, CLEAN EXHAUST PRODUCTS AND SIMPLIFIED VEHICLE PROPELLANT LOGISTICS. BECAUSE OF THE DIFFICULTY OF DELIVERING THE CRYOGENIC LIQUIDS OVER LONG DISTANCES, THE APS THRUSTORS WILL OPERATE WITH GASEOUS OXYGEN AND HYDROGEN. THE PROPELLANTS HOWEVER, MAY BE STORED IN GASEOUS OR LIQUID FORM, AND THE APS PROPELLANT STORAGE MAY BE INDEPENDENT OF THE MAIN VEHICLE PROPULSION TANKAGE, OR PARTIALLY OR WHOLLY INTEGRATED WITH IT. POTENTIAL BENEFITS MAY BE REALIZED FROM UTILIZING VEHICLE MAIN PROPULSION TANK RESIDUALS IN THE APS.

THE APS CONSISTS OF THE FOLLOWING ASSEMBLIES:

- PROPELLANT STORAGE ASSEMBLY
- PROPELLANT DISTRIBUTION ASSEMBLY
- PROPELLANT CONDITIONING ASSEMBLY
- THRUSTORS

APS ELEMENTS

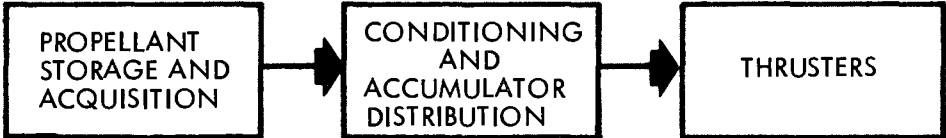

ACQUISITION/ORIENTATION

TURBOMACHINERY (PUMPS/COMPRESSORS)

TANKAGE

HEAT EXCHANGERS

CONTROLS

STATUS INSTRUMENTATION

GAS GENERATORS

THRUSTERS

VALVES

CONTROLS

INSTRUMENTATION

DISTRIBUTION NETWORK

VEHICLE INFLUENCED APS CHARACTERISTICS

BOOSTER

THE BOOSTER APS HAS TO CONTROL THE EMPTY STAGE FROM SEPARATION UNTIL REENTRY INTO THE ATMOSPHERE, WHERE THE AERODYNAMIC CONTROLS BECOME EFFECTIVE. THE ACTUAL SEPARATION MANEUVER OF THE BOOSTER AND ORBITER IS NOT CARRIED OUT BY THE APS. THE APS DUTY CYCLE IS OF SHORT DURATION (UP TO 6 MINUTES), LOW TOTAL IMPULSE, AND ESSENTIALLY THE SAME ON EACH MISSION. THE PROPELLANT REQUIRED BY THE APS REPRESENTS ONLY SOME 10 PERCENT OF MAIN TANK RESIDUALS. THE PERFORMANCE SENSITIVITY OF THE BOOSTER APS IS LOW, SO HIGH SPECIFIC IMPULSE IS NOT OF PRIME IMPORTANCE.

ORBITER

THE ORBITER MUST HAVE THE CAPABILITY TO ACCOMMODATE A VARIETY OF MISSIONS WITH POSSIBLE EXTENDED ON-ORBIT STAY TIME. SYSTEM FLEXIBILITY IS THEREFORE OF PRIME IMPORTANCE, AND ON EXTENDED MISSIONS, THESE SYSTEMS MUST BE CAPABLE OF UTILIZING PROPELLANTS CARRIED IN THE VEHICLE'S PAYLOAD BYA. THE ON-ORBIT ΔV REQUIREMENTS FOR THE APS ARE NOT PRESENTLY DEFINED AND THIS PARAMETER STRONGLY INFLUENCES THE REQUIRED CHARACTERISTICS OF THE APS.

VEHICLE INFLUENCED APS CHARACTERISTICS

BOOSTER

LOW TOTAL IMPULSE
LOW PERFORMANCE SENSITIVITY
SHORT TIME OF OPERATION
LARGER QUANTITY OF RESIDUALS
LOW PEAK FLOW RATES
(SEPARATION MANEUVER EXCEPTED)

ORBITER

INCREASING DELTA-V REQUIREMENTS

INCREASE IN TOTAL IMPULSE
INCREASE IN PERFORMANCE SENSITIVITY
INCREASE IN RANGE OF THRUSTER T. I. REQUIREMENT
STATIONKEEPING (M.I.B.)
EXTENDED TIME OF OPERATION
REDUCTION OF PERCENT OF RESIDUALS

PAYLOAD/APS SPECIFIC IMPULSE SENSITIVITY

THESE VEHICLES ARE TYPICAL OF THE DESIGNS BEING CONSIDERED IN THE PHASE B STUDIES. VEHICLE A IS OF LOW CROSS-RANGE CONFIGURATION, VEHICLE B OF HIGH. FOR VEHICLE A, THE PAYLOAD IS ASSUMED TO HAVE BEEN LEFT IN ORBIT, WHEREAS FOR VEHICLE B, A CONSTANT PAYLOAD UP AND DOWN HAS BEEN ASSUMED.

NOTE THAT WHEREAS FOR AN APS ΔV REQUIREMENT OF 150 TO 200 FT/SEC, $\frac{\partial \text{PAYLOAD}}{\partial I_{SP}}$ COEFFICIENT IS LOW, APPROXIMATELY 10 LB/SEC OR LESS, FOR AN APS WITH A ΔV REQUIREMENT OF 2000 TO 2200 FT/SEC, THIS COEFFICIENT IS INCREASED BY AN ORDER OF MAGNITUDE. IN THIS CASE, OVERALL APS PERFORMANCE IS OF GREAT IMPORTANCE.

APS ΔV REQUIREMENTS

THE ΔV REQUIREMENTS FOR THE ORBITER APS, FOR A GIVEN MISSION, ARE LARGELY DETERMINED BY THE MAIN ENGINE CHARACTERISTICS, WHICH ARE NOT PRESENTLY DEFINED, AND UPON WHETHER AN ON-ORBIT MANEUVERING PROPULSION SYSTEM IS USED OR NOT. HENCE, THERE ARE BASICALLY THREE DIFFERENT RANGES OF APS ΔV REQUIREMENTS TO BE CONSIDERED FOR THE SPACE STATION RESUPPLY DESIGN MISSION.

ALL MANEUVERS ON ALL AXES
(HIGH DELTA-V)

MAIN ENGINE WITH NO RESTART CAPABILITY
(DESIGN CASE)

ALL MANEUVERS ON ALL AXES
EXCEPT + X AXES OF >50 FT/
SEC (INTERMEDIATE DELTA-V)

RESTARTABLE MAIN ENGINE, THROTTLED IN
PUMP FED MODE OR SEPARATE ON ORBIT PRO-
PULSION SYSTEM

ALL MANEUVERING ON ALL AXES
EXCEPT + X AXIS OF >10 FT/
SEC (LOW DELTA-V)

RESTARTABLE MAIN ENGINE, WHICH CAN OPERATE
IN THROTTLED AND PRESSURE FED IDLE MODES,
OR A SEPARATE VARIABLE THRUST ON ORBIT PRO-
PULSION SYSTEM

PERFORMANCE CRITICALITY HAS BEEN SHOWN TO BE A FUNCTION OF THE ΔV REQUIREMENT AND IS VERY IMPORTANT ON THE HIGH ΔV SYSTEM. PROPELLANT CONDITIONING PENALTIES ARE PARTICULARLY IMPORTANT HERE. AN INDICATION OF THE MAGNITUDE OF THESE PENALTIES IS SHOWN.

APS ΔV REQUIREMENTS

APS

ALL MANEUVERS

ALL MANEUVERS EXCEPT
+ X AXIS > 50 FT/SEC

ALL MANEUVERS EXCEPT
+ X AXIS > 10 FT/SEC

PRIMARY PROPULSION

NO RESTART

THROTTLED AND RESTART
OR O.M.S.

IDLE MODE, THROTTLED, MULTIPLE
RESTART OR THROTTLED O.M.S.

APS ΔV FT/SEC

~ 2000 - 2200

~ 400 - 600

~ 150 - 200

198

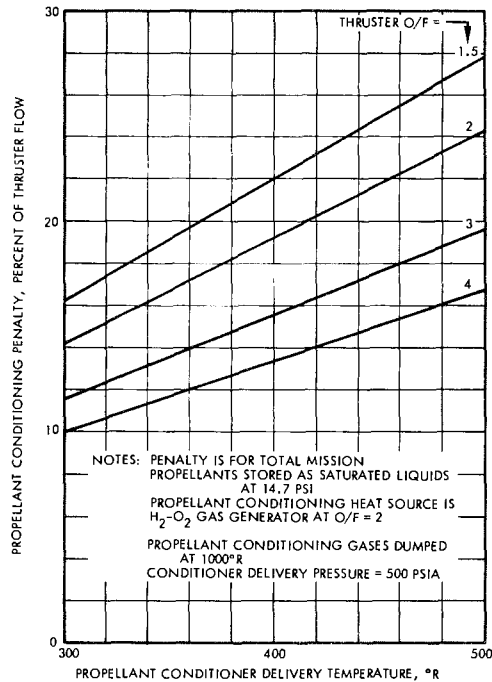

ORBITER

THRUSTER ISP = 420 SEC

$$1800 \text{ FT/SEC} \frac{\delta P.L.}{\delta I_{SP}} = 72 \text{ LB/SEC } I_{SP}$$

$$\text{AT 20\% LOSS} \quad \Delta P.L. = 420 \times \frac{20}{100} \times 72$$

$$= 6000 \text{ LB}$$

BOOSTER EFFECT. \approx - 5 LB BOOSTER P. L. / SEC I_{SP}

APS PROPELLANT REQUIREMENTS

THESE VEHICLES ARE TYPICAL OF THE DESIGNS BEING CONSIDERED IN THE PHASE B STUDIES. VEHICLE A IS OF LOW CROSS-RANGE CONFIGURATION, VEHICLE B OF HIGH. FOR VEHICLE A, THE PAYLOAD IS ASSUMED TO HAVE BEEN LEFT IN ORBIT, WHEREAS FOR VEHICLE B, A CONSTANT PAYLOAD UP AND DOWN HAS BEEN ASSUMED.

ORBITER

NOTE THAT FOR AN ORBIT ΔV 'S FOR 2000 - 2200 FT/SEC, THE APS PROPELLANT REQUIRED APPROACHES THAT OF THE PAYLOAD MASS. HENCE, ASSUMING NO IN ORBIT REFUELING; THEN, EVEN WITH NO PAYLOAD, IT IS DOUBTFUL IF THE 5000 FT/SEC ΔV REQUIREMENT FOR THE 800 N.M. ORBIT CAN BE MET.

BOOSTER

THE APS ΔV REQUIREMENT, ASSUMING NO SEPARATION MANEUVER, IS <30 FT/SEC. THE PROPELLANT REQUIRED, EVEN WITH A SYSTEM OF LOW I_{sp} , IS LESS THAN ONE-THIRD PERCENT OF THE EMPTY VEHICLE MASS AT STAGING.

DESIGN WEIGHING FACTORS

BOOSTER

WITH ITS LOW PERFORMANCE SENSITIVITY AND MISSION FLEXIBILITY REQUIREMENTS, THE DESIGN EMPHASIS IS FOR A SIMPLE AND RELIABLE SYSTEM, AT MINIMUM COST AND UTILIZING A MINIMUM OF NEW TECHNOLOGY.

ORBITER

THE PERFORMANCE WEIGHING FACTOR (SYSTEM WEIGHT, WHICH IS A COMBINATION OF INERT AND PROPELLANT WEIGHTS) IS STRONGLY DEPENDENT UPON THE ΔV REQUIREMENT. WHEREAS RELIABILITY AND FLEXIBILITY CANNOT BE COMPRISED, HIGH PERFORMANCE FOR THE HIGH ΔV APPLICATIONS HAS TO BE OBTAINED, EVEN IF THIS RESULTS IN A MORE COMPLICATED SYSTEM REQUIRING THE APPLICATION OF NEW TECHNOLOGY.

DESIGN WEIGHTING FACTOR CONSIDERATIONS

201

	BOOSTER		ORBITER	
	LO ΔV	LO ΔV	INTER ΔV	HIGH ΔV
	~ 25 - 30 FPS	~ 150 - 200 FPS	~ 400 - 600 FPS	~ 2000 - 2200 FPS
SYSTEM WEIGHT	LOW	INTER.	INTER.	HIGH
RELIABILITY	HIGH	HIGH	HIGH	HIGH
FLEXIBILITY	LOW	HIGH	HIGH	HIGH
SIMPLICITY	HIGH	HIGH	INTER.	LOW
MIN. NEW TECHNOLOGY	HIGH	INTER.	INTER.	LOW
COST	HIGH	INTER.	INTER.	INTER.

CANDIDATE CYCLES

THREE GENERAL CLASSES OF SYSTEMS MAY BE CONSIDERED:

1. GASES STORED AT HIGH PRESSURE AND AT TEMPERATURES ACCEPTABLE TO THE THRUSTER INLET REQUIREMENTS. HIGH PRESSURE GAS STORAGE SYSTEMS ARE SIMPLE, BUT THEY MAY NOT BE SELECTED, EVEN FOR USE IN THE BOOSTER, BECAUSE OF THEIR EXCESSIVE WEIGHT PENALTY.
2. LIQUIDS STORED AT HIGH PRESSURE HEATED TO ACCEPTABLE THRUSTER INLET CONDITIONS. HIGH PRESSURE SUPERCRITICAL STORAGE ARRANGEMENTS REQUIRE SEPARATE APS STORAGE AND COULD POTENTIALLY ELIMINATE THE USE OF ACCUMULATORS; THIS WOULD PROBABLY NOT BE TRUE IN PRACTICE BECAUSE OF THRUSTER RESPONSE REQUIREMENTS AND THE SIZABLE LINE LENGTHS REQUIRED IN SHUTTLE. THE CONCEPT OFFERS HIGH SYSTEM RELIABILITY, LOW DEVELOPMENT COST, AND CAN SUPPLY PROPELLANT INDEPENDENT OF THE GRAVITY FIELD OR VEHICLE ATTITUDE.
3. LIQUID OR GAS AT LOW TEMPERATURE AND PRESSURE COMPRESSED (PUMPED) AND HEATED TO ACCEPTABLE THRUSTER INLET CONDITIONS.

CANDIDATE CYCLES

THREE GENERAL CLASSES

I STORED HIGH PRESSURE GAS

- o SEPARATE TANKAGE - HIGH WEIGHT PENALTY

II LIQUIDS STORED AT HIGH PRESSURE

- o SUPER CRITICAL STORAGE
- o REQUIRE SEPARATE STORAGE
- o CONTROLLED HEAT INPUT
- o POSSIBLE MAKEUP REQUIREMENT
- o GAS GENERATOR/ VENTING
- o HEAT EXCHANGER OPERATION

III LOW PRESSURE STORED GAS/LIQUID

PUMPED/HEATED

COMPRESSED

- o REQUIRES HIGH TEMPERATURE ACCUMULATORS FOR TIME CONSTANTS
- o PROPELLANT ACQUISITION
- o GAS GENERATOR/VENTING
- o HEAT EXCHANGER OPERATION
- o TEMPERATURE ? POWER FOR GAS

TURBOCOMPRESSOR CONCEPT

CYCLES USING TURBOCOMPRESSORS POTENTIALLY PERMIT BOOST TANK RESIDUAL VAPOR TO BE USED AT NO PENALTY TO THE APS. COMPRESSOR PRESSURE RATIOS ATTAINABLE WITH REASONABLE MACHINERY LEAD TO RELATIVELY LOW GAS ACCUMULATOR PRESSURES AND THUS BULKY AND HEAVY ACCUMULATORS. COMPRESSOR POWER AND ACCUMULATOR WEIGHTS ARE PARTICULARLY SENSITIVE TO INLET GAS TEMPERATURE AND BECOME EXCESSIVE AS THESE APPROACH ROOM TEMPERATURE.

TURBOPUMP CONCEPT

TURBOPUMPING CYCLES OFFER HIGH PERFORMANCE AND HIGH FLOW CAPABILITIES AND THUS WILL RECEIVE HEAVY EMPHASIS IN THE PROPOSED STUDY. THEY UTILIZE PROPELLANTS STORED AS LOW PRESSURE LIQUIDS AND THUS PERMIT LOW STORAGE PENALTIES. HOWEVER, FOR SPACE SHUTTLE APS APPLICATIONS, THE FEED SYSTEMS HAVE TO BE ABLE TO SUPPLY LIQUID TO THE PUMP UNDER ZERO G CONDITIONS OR WITH AN ACCELERATION VECTOR IN ANY DIRECTION. HIGH DELIVERY PRESSURES ARE RELATIVELY EASILY ACCOMPLISHED, PERMITTING THE USE OF COMPACT ACCUMULATORS TO HANDLE TRANSIENT DEMANDS.

"CONDITIONER" = PRESSURE CONDITIONING AND TEMPERATURE CONDITIONING

SOME CANDIDATE PRESSURE CONDITIONING METHODS

205

	<u>POTENTIAL APPLICATIONS</u>			
	<u>BOOSTER</u>	<u>HI DELTA-V</u>	<u>INTER. DELTA-V</u>	<u>LO DELTA-V</u>
HIGH PRESSURE STORED GAS				
o MONOPROPELLANT	X			
o BIPROPELLANT	X			
HIGH PRESSURE CRYOGENIC				
o PRE-CHARGED	X		X	X
o TAP FROM TURBOPUMP ENGINE	X		X	X
TURBO COMPRESSOR	X			
PUMP				
o HIGH TEMPERATURE, HIGH PRESSURE TURBINE		X	X	X
o LOW TEMPERATURE, LOW PRESSURE TURBINE		X	X	X
o ELECTRICAL		X	X	X

CANDIDATE SUPERCRITICAL STORAGE CYCLE

THE CHART SHOWS A BASIC HIGH PRESSURE, HIGH DENSITY STORAGE SYSTEM WHICH PROVIDES FOR PROPELLANT PRESSURIZATION WITHOUT TURBOMACHINERY OR PROPELLANT ACQUISITION PROVISIONS. HERE THE PROPELLANTS ARE STORED AT CRYOGENIC TEMPERATURES AND PRESSURES HIGHER THAN CRITICAL AND HIGHER THAN THRUSTER REQUIREMENTS. AS PROPELLANTS ARE WITHDRAWN FROM STORAGE, HEAT IS ADDED TO MAINTAIN STORAGE TANK PRESSURE; ADDITIONAL ENERGY IS ADDED TO EACH PROPELLANT BEFORE DELIVERY TO THE THRUSTERS. THE HIGH PRESSURE CRYOGENIC STORAGE CONCEPT OFFERS SYSTEM SIMPLICITY AND A SOLUTION TO ZERO G SUPPLY PROBLEMS AT THE EXPENSE OF INCREASED STORAGE TANK WEIGHTS AND A POTENTIALLY HIGH PROPELLANT CONDITIONING PENALTY (RELATIVE TO THE TURBO-MACHINERY CONCEPT). IT IS THUS MOST APPLICABLE IN CASES WHERE APS EFFICIENCY IS NOT CRITICAL. AS IN THE TURBOPUMP CYCLE, A CLOSED HELIUM LOOP IS USED FOR TANK PRESSURIZATION AND FLUID HEATING; THE CYCLE HEAT SOURCE IS A GAS GENERATOR OPERATING ON A PORTION OF THE PROPELLANTS. OXYGEN TANK PRESSURIZATION IS ACHIEVED BY PASSING THE HEATED HELIUM THROUGH A HEAT EXCHANGER LOCATED IN THE TANK. A FAN IS LOCATED IN THE TANK TO PROVIDE CIRCULATION AND A HIGH HEAT TRANSFER COEFFICIENT. HYDROGEN TANK PRESSURIZATION IS ACCOMPLISHED INDIRECTLY; HERE FLUID IS WITHDRAWN FROM THE TANK, COMPRESSED, HEATED BY HELIUM, AND READMITTED TO THE TANK.

CANDIDATE SUPERCRITICAL STORAGE CYCLE

207

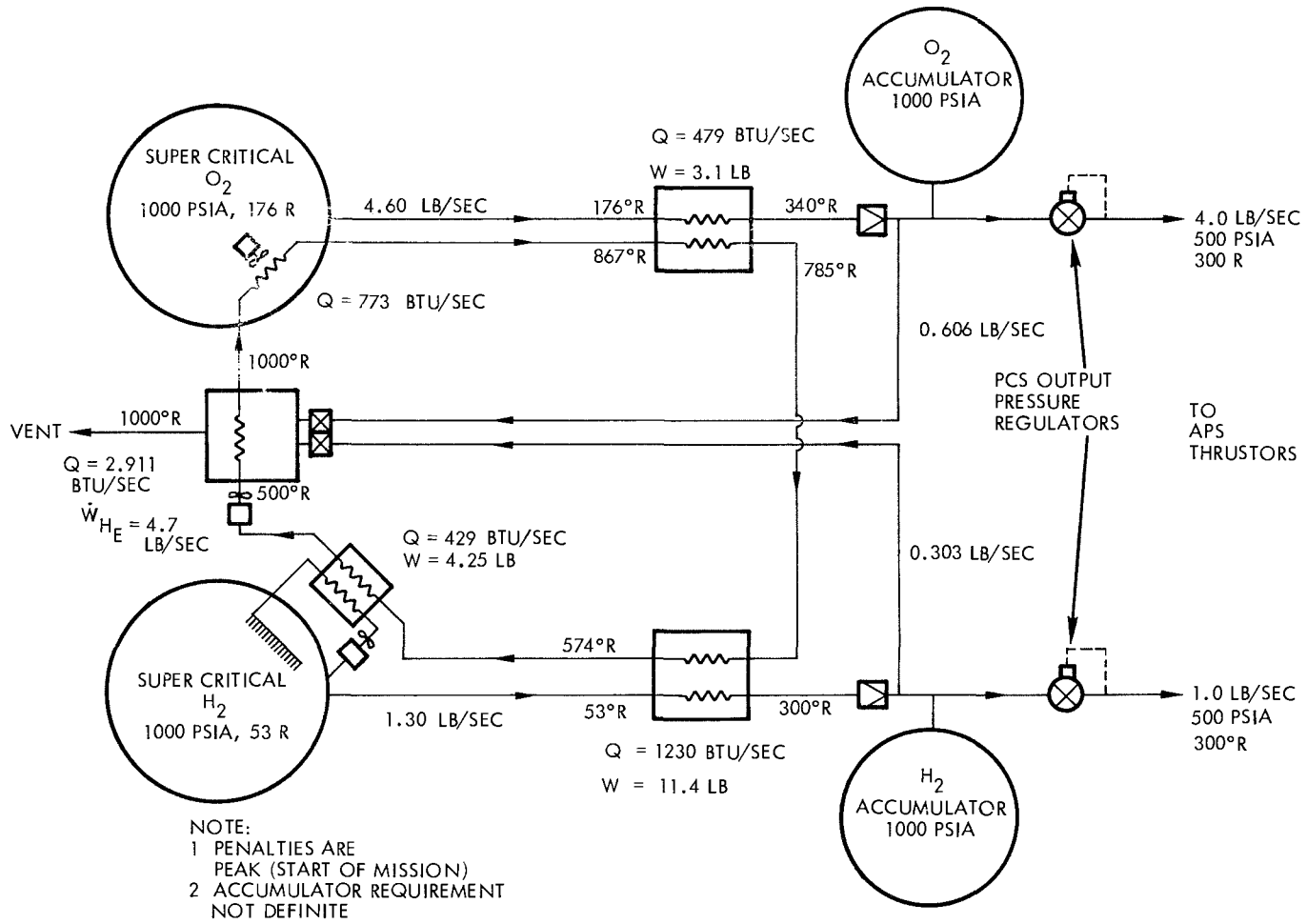

CANDIDATE TURBOPUMP CYCLE

THE CHART IS A SIMPLIFIED SCHEMATIC OF A TURBOPUMP CYCLE SHOWING MAJOR SYSTEM COMPONENTS AND STEADY-STATE OPERATING CONDITIONS FOR A THRUSTER HYDROGEN FLOW OF 1 LB/SEC, A THRUST O/F OF 4, A PCS DELIVERY PRESSURE OF 1500 PSIA AND A DELIVERY TEMPERATURE OF 300°R. A CENTRAL GAS GENERATOR BURNING HYDROGEN AND OXYGEN PROVIDES HOT GAS FOR THE TURBOPUMP TURBINES AND THERMAL ENERGY (THROUGH A CLOSED HELIUM LOOP) FOR HEATING THE PROPELLANTS TO STORAGE ACCUMULATOR TEMPERATURES.

CANDIDATE TURBOPUMP CYCLE

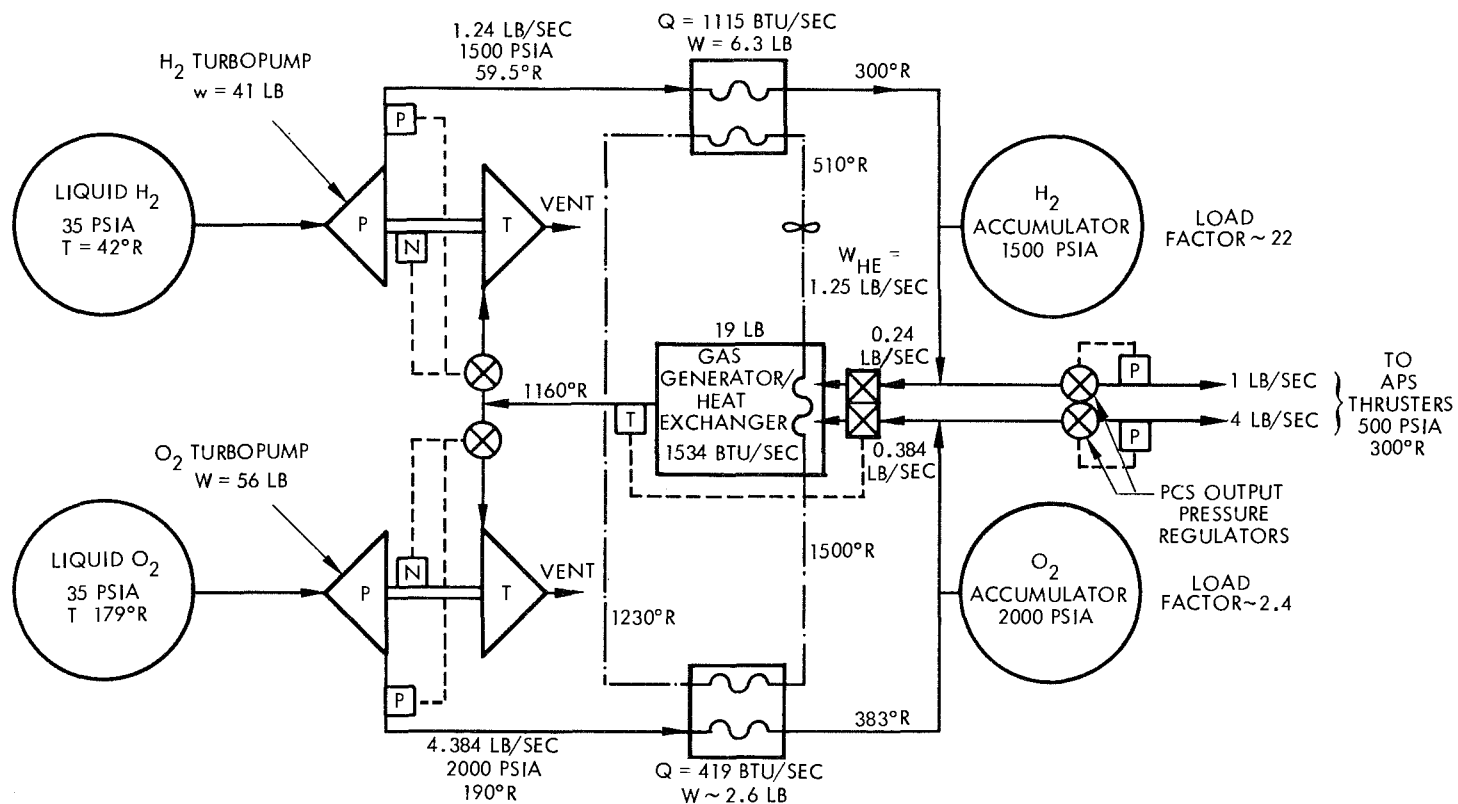

TURBOPROP PROPELLANT CONDITIONING PENALTY

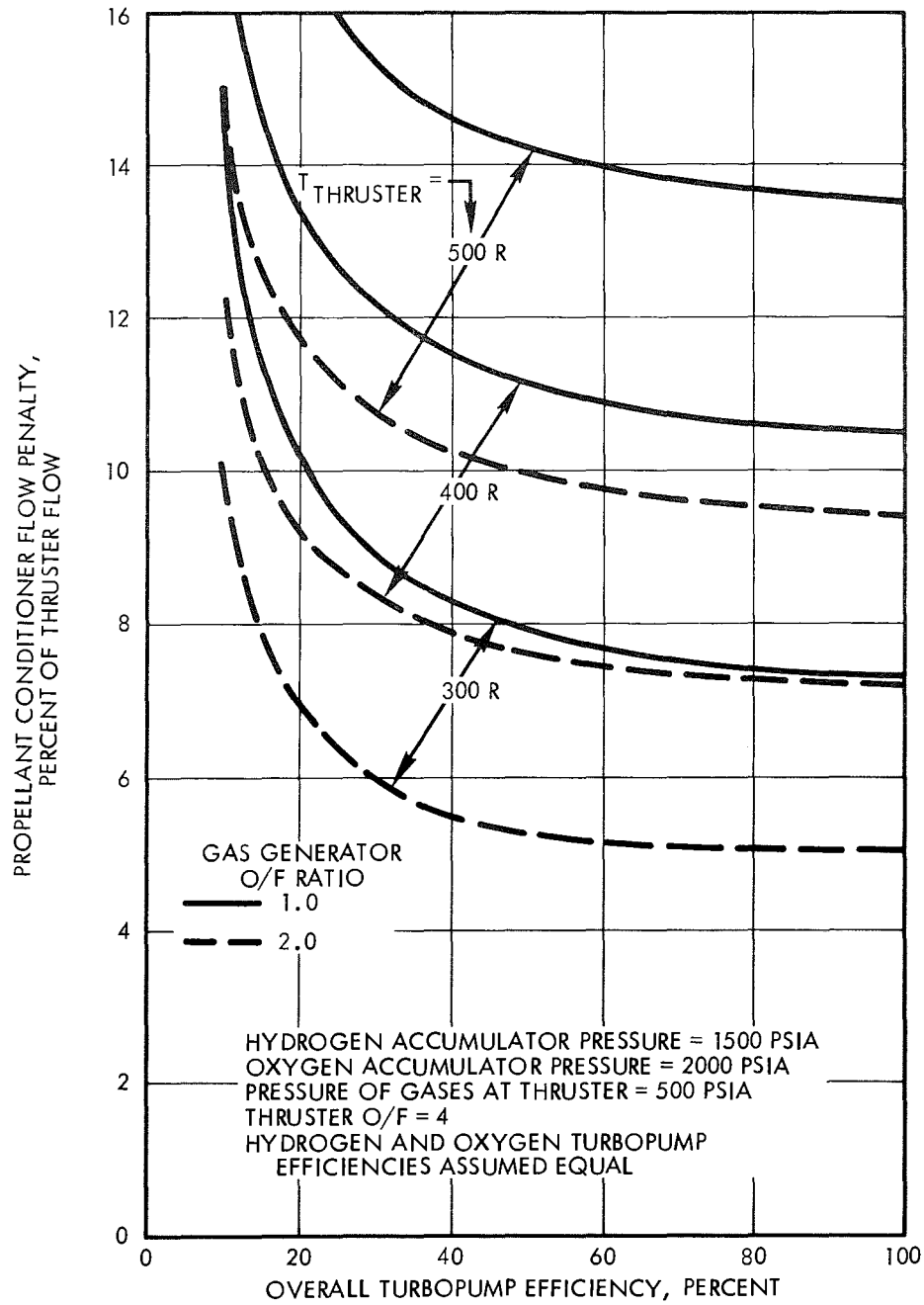

TURBOPUMP CONDITIONER WEIGHT FACTORS

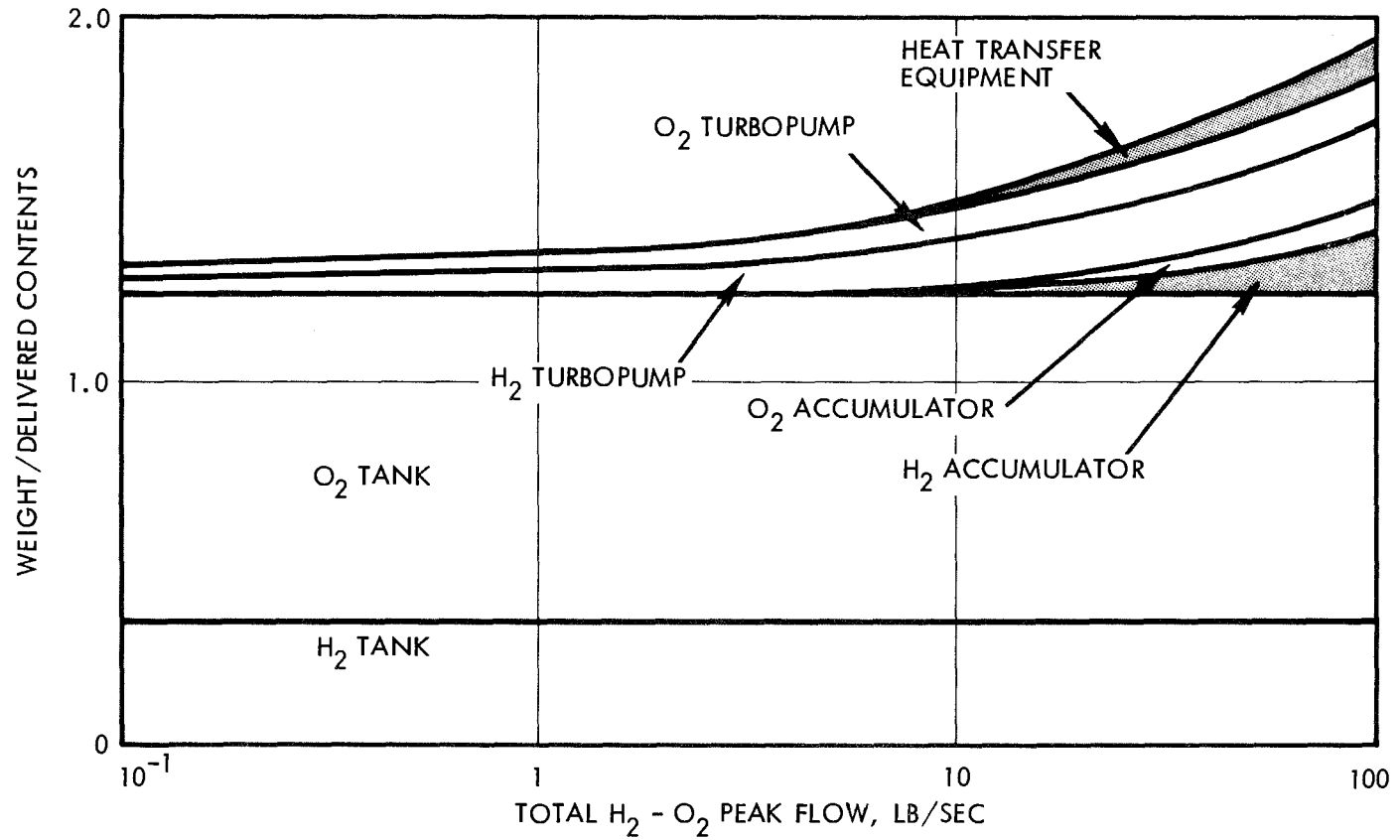

HEAT EXCHANGER WEIGHTS AND VOLUMES

IN THE POWER CONDITIONING CYCLES CONSIDERED, THE HIGH FLUID DENSITIES AND HIGH TEMPERATURE DIFFERENCES AVAILABLE FOR HEAT TRANSFER LEAD TO MODEST HEAT EXCHANGER WEIGHTS AND VOLUMES EVEN AT THE HIGH OPERATING PRESSURES. AT A THRUSTER O/F OF 4, THE HELIUM-TO-HYDROGEN HEAT EXCHANGER, FOR EXAMPLE, WILL WEIGH LESS THAN 10 POUNDS AT A HYDROGEN FLOW OF 1 POUND PER SECOND. AT A FLOW RATE OF 10 LB/SEC AND A THRUSTER INLET TEMPERATURE OF 300°R, THIS HEAT EXCHANGER WILL WEIGH BETWEEN 20 AND 40 POUNDS FOR PRESSURES UP TO 3000 PSIA. THESE WEIGHTS WILL BE APPROXIMATELY TRIPLED FOR A THRUSTER INLET TEMPERATURE OF 500°R. THE HELIUM-TO-OXYGEN HEAT EXCHANGERS HAVE MUCH LOWER REQUIREMENTS AND HAVE ESTIMATED WEIGHTS ONE-HALF TO ONE-THIRD THOSE OF THE HYDROGEN HEAT EXCHANGERS. IF THE PROPELLANTS WERE TO BE HEATED DIRECTLY BY COMBUSTION PRODUCTS, THESE WEIGHTS WOULD BE CONSIDERABLY GREATER BECAUSE OF THE PROVISIONS REQUIRED TO MINIMIZE THE FREEZING PROBLEM. THIS IS PARTICULARLY TRUE FOR THE OXYGEN HEAT EXCHANGER.

HEAT EXCHANGERS

HEAT EXCHANGERS INTEGRAL PART OF ALL SYSTEMS UNDER CONSIDERATION

BASIC SYSTEMS: INERT GAS THERMAL TRANSFER LOOP
 DIRECT G G EXCHANGE
 ENVIRONMENT CONDUCTION/CONVECTION

PROBLEM: WIDELY VARYING PROPERTIES
 ZERO LEAKAGE ALLOWABLE
 MINIMUM WEIGHT, ΔP

H₂ TO He - HIGH h, P ⇒ TUBULAR ALL PRIME SURFACE

O₂ TO He - LOWER h ⇒ MAY NEED EXTENDED SURFACE

COMBUSTION TO He - REQUIRES THERMAL CONTROL

WEIGHTS - MODEST WEIGHTS/VOLUMES

EX - He/H₂ \dot{W} (O/F = 4) = 1 LB/SEC, W < 10 LB
 W = 10 LB/SEC, W ~ 40 LB
 T = 300°F

DISTRIBUTION

RELATIVELY LARGE DISTRIBUTION LOOP WITH LARGE MOMENT ARMS

- o IMPOSES REQUIREMENT FOR CLOSE P, T CONTROL

CONSIDERATIONS

- o DUCT SIZING
- o LOOP CHOICE, T OR CIRCULATORY
- o ACCUMULATOR SIZING/ PLACEMENT
- o THERMAL/STRUCTURAL
- o ACCESSIBILITY/MAINTAINABILITY
- o LEAKAGE/DETECTION
- o FLOW RATE/MIXTURE RATIO

SPACE SHUTTLE APS- RANDOM ENGINE FIRING

PROPELLANT LINES = 1.0 IN. DIA., 100 FT. LONG
ACCUMULATORS: FUEL = 10 FT³; OX = 10 FT³

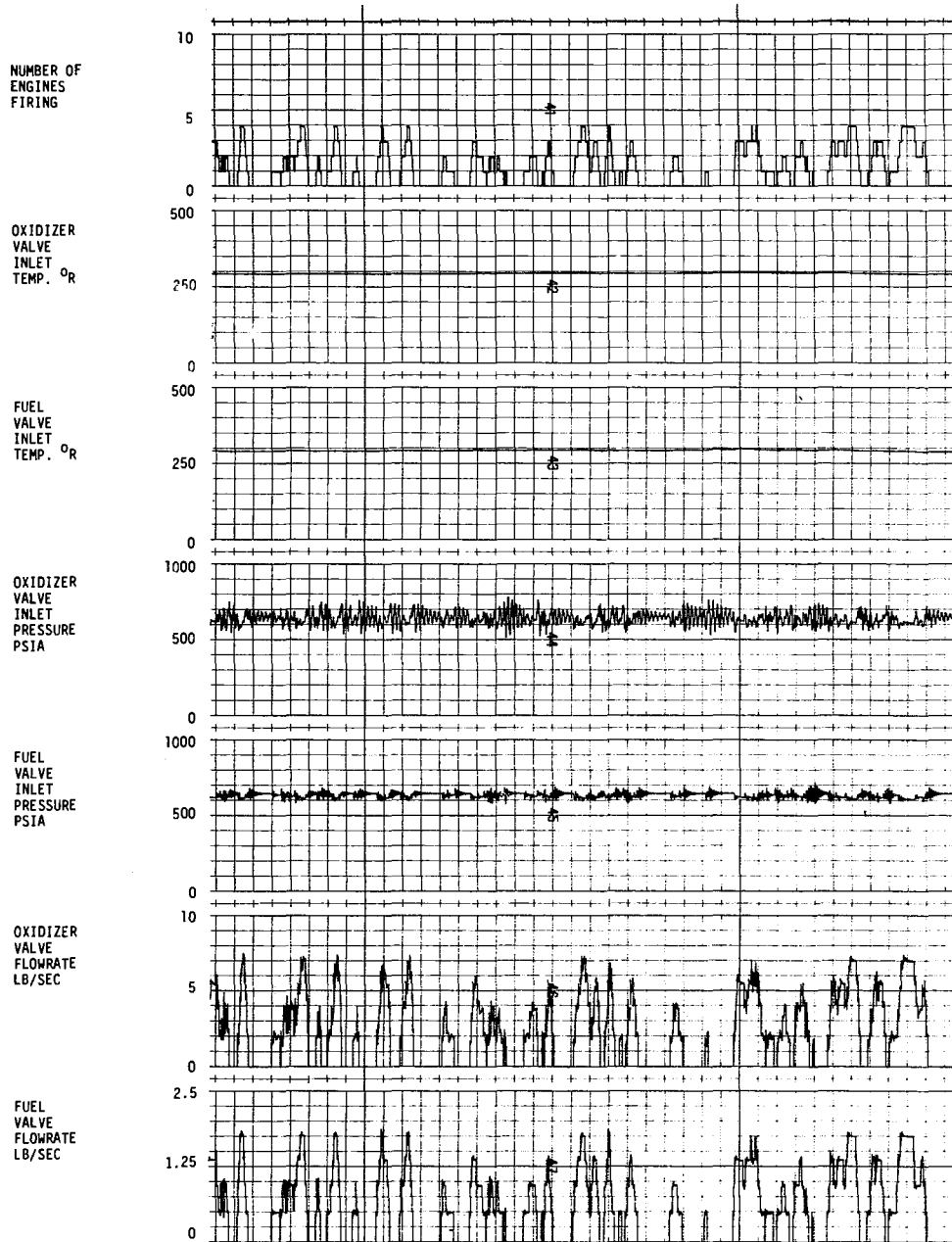

SPACE SHUTTLE APS - RANDOM ENGINE FIRING

PROPELLANT LINES = 2½ IN. DIA., 100 FT. LONG
ACCUMULATORS: FUEL = 50 FT³; OX = 12.5 FT³

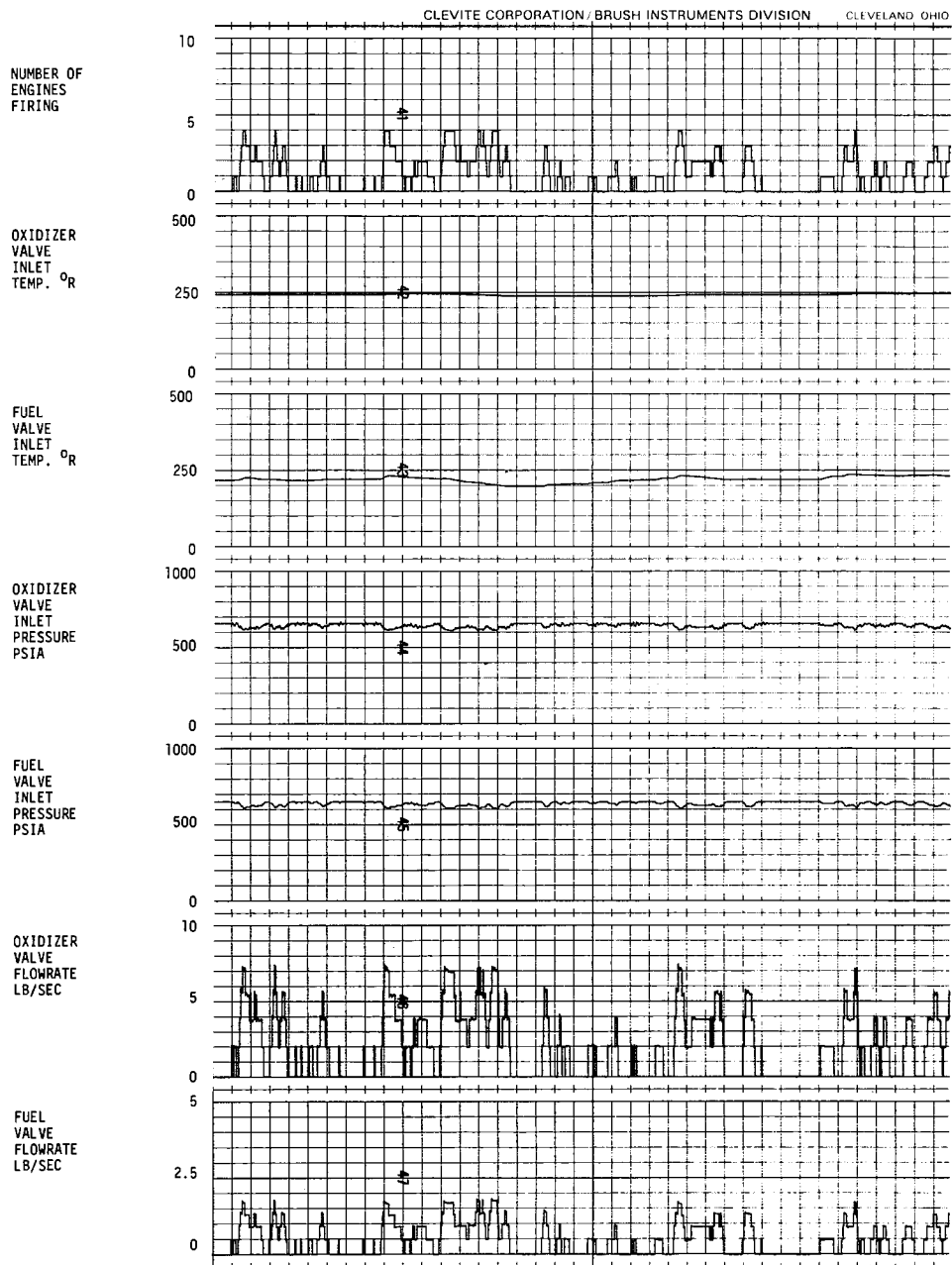

THRUSTERS

REQUIREMENTS

-

WIDE RANGE OF TOTAL IMPULSE
INSTALLATION (BURIED, RE-ENTRY)
HIGH PERFORMANCE, PULSE/S. S.
LIFE (500,000 - 1,000,000 CYCLES)
CHECKOUT STATUS
OPERATIONAL INSENSITIVITY
MINIMIZE INSTALLED WEIGHT
RELIABILITY/MAINTAINABILITY

THERMODYNAMIC EFFECTS AT THRUSTER

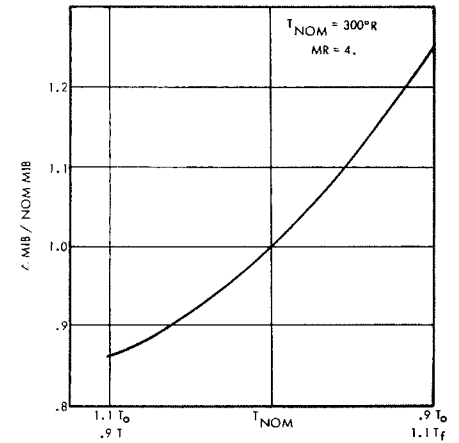
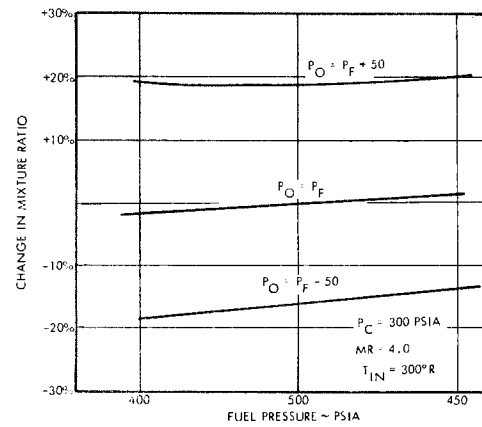
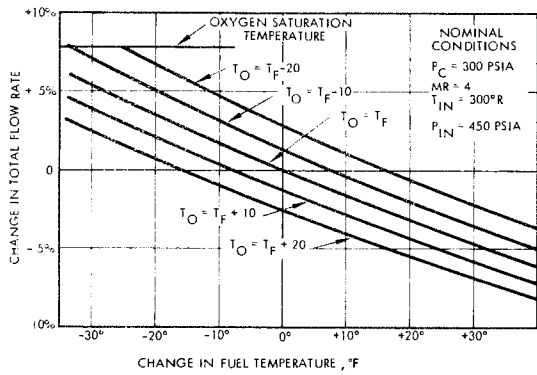

OVERALL APS PERFORMANCE OPTIMIZATION

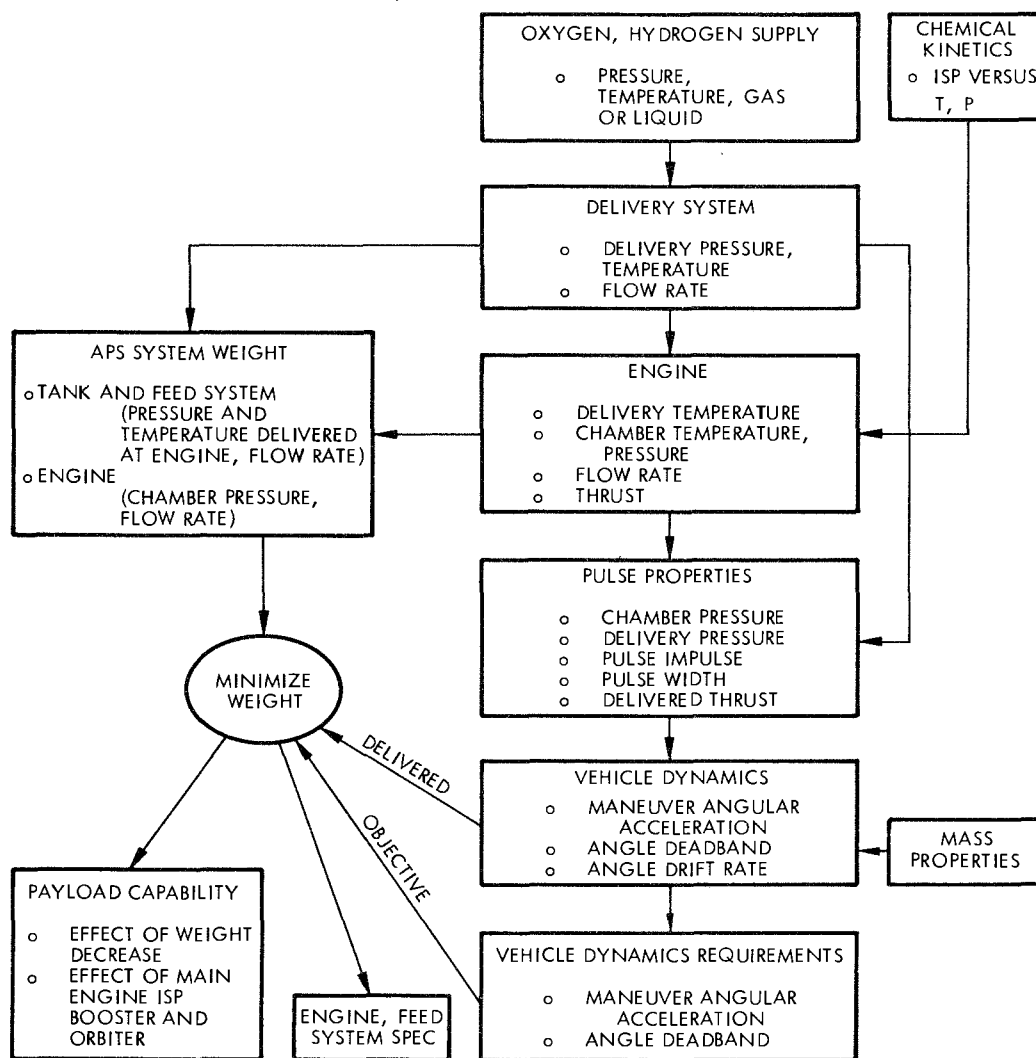

PARTIAL SYSTEM RELIABILITY ASSESSMENT

<u>Subassembly</u>	<u>Percent of All Failures</u>	<u>No. in System</u>	<u>Share of Failures for Each Unit, %</u>
Igniter valve	26.4	48	0.55
Igniter	20.1	48	0.42
Bipropellant valve	18.0	24	0.75
Control valve	8.1	24	0.34
Distribution lines	6.8	32	0.21
Line valve	5.8	24	0.24
Thrust chamber	4.5	24	0.19
Relief valve	4.4	40	0.11
Regulator	2.7	16	0.17
Propellant line	2.4	16	0.15
Accumulator	0.6	20	0.03

APS PROBLEM AREAS

SAFETY

CONTROL AND INSTRUMENTATION

LIFE AND RELIABILITY

MATERIALS

221

ASSEMBLY	PROPELLANT ACQUISITION AND STORAGE	CONDITIONER	DISTRIBUTION	THRUSTER
ASSEMBLY PROBLEM AREAS	PHASE SEPARATION ACCELERATION	DEMAND RANGE RANGE OF INPUT CONDITIONS FREEZING	TEMPERATURE RANGE INSTALLATION	VALVE INSTALLATION DEMAND RANGE

APS TECHNOLOGY PHASING

THE TECHNOLOGY EFFORTS MAY BE DIVIDED INTO THREE OVERLAPPING AND INTERACTING PHASES.

1. FUNDAMENTAL LIMITS. FUNDAMENTAL LIMITS INFORMATION REQUIRED TO ENABLE SYSTEM SELECTION TO BE MADE PRIOR TO THE START OF PHASE C. THIS EFFORT MIGHT INCLUDE:

PHASE SEPARATION, MATERIALS, IGNITION DEVICES, SYSTEM SAFETY, INSTRUMENTATION, LONG LIFE CRYOGENIC TURBOPUMPS, GG/TURBOMACHINERY CONTROLS, COMBUSTION GAS FREEZING, VALVES AND SEALS, BEARINGS AND FILTERS.
2. APPLICATION LIMITS. QUANTITATIVE INFORMATION, REQUIRED FOR SYSTEM DEFINITION. THIS EFFORT MIGHT INCLUDE: MATERIALS, PROPELLANT TRANSFER, VALVES, SEALS, SYSTEM HEALTH DIAGNOSIS, CONNECTER FABRICATION AND CRYOGENIC TURBOMACHINERY.
3. PREDEVELOPMENT. INVESTIGATE SUBSYSTEM INTEGRATION AND INTERACTION EFFECTS. CARRY OUT COMPONENT SELECTION.

APS TECHNOLOGY PHASING

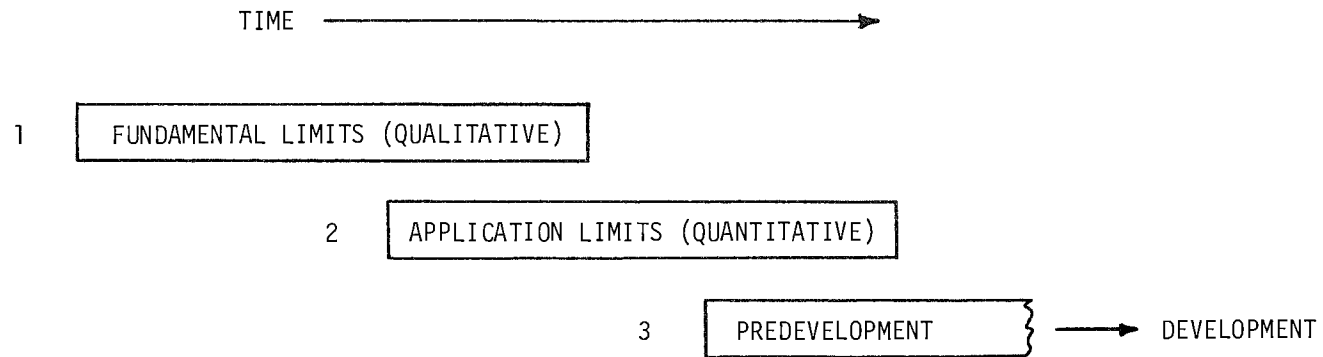

223

1. INFORMATION REQUIRED PRIOR TO SYSTEM SELECTION
2. INFORMATION REQUIRED TO DEFINE SYSTEM REQUIREMENTS.
3. SUBSYSTEM INTEGRATION AND INTERACTION INFORMATION. COMPONENT SELECTION.

TECHNOLOGY FOR THE DEVELOPMENT OF A GASEOUS HYDROGEN - GASEOUS OXYGEN
APS ENGINE FOR THE SPACE SHUTTLE

Albert Seidel

Messerschmitt-Bölkow-Blohm
Munchen-Ottobrunn, Germany

1. Abstract

The Messerschmitt-Bölkow-Blohm Company (MBB) has sufficient technical background for the development of a GH_2/GO_2 -APS-engine for the Space-Shuttle program.

MBB has been conducting rocket engine development work with cryogenic propellants since 1959. Since that time essentially the following rocket engines have been developed and/or tested:

- 66-lb sea-level-thrust GH_2/LF_2 experimental thrust chambers for establishment of fluorine technology,
- 1,100-lb vacuum-thrust LH_2/LF_2 engine (under development since 1968),
- 66-lb vacuum-thrust LH_2/LO_2 engine (flight prototype) with restart capability and an effective vacuum specific impulse of 415 sec,
- 30,000-lb sea level thrust LH_2/LO_2 extreme high pressure experimental engine (tested at Rocketdyne's Reno facility).

As a result of this work, MBB has the experience and technological capability to produce thrust chambers of various designs, injector heads and engine valves and the capability to test them. This experience can be utilized by MBB for the development of a Space Shuttle APS engine.

The above mentioned 1,100-lb engine falls into the presently discussed performance category for a high pressure Space

Shuttle APS engine. Using the same chamber geometry of the 1,100-lb engine, running it with GH_2/GO_2 at a chamber pressure of 150 psia and at a mixture ratio of 4, it would produce a vacuum thrust of 1,500 lbs with an area-ratio-30 nozzle. With constant engine geometry and varying chamber pressure it can also be adjusted to other thrust levels within a wide range. Currently a sea-level demonstration engine of this type is under development in order to demonstrate its ability of safe ignition, regenerative cooling and high performance. Engine valves shall also be developed. Testing will be done at MBB's Ottobrunn facilities.

2. Introduction

The Messerschmitt-Bölkow-Blohm Company (MBB) has sufficient technical background for the development of a GH_2/GO_2 -APS-engine for the Space Shuttle program. MBB has been conducting rocket engine development work with cryogenic propellants since 1959. Since that time, LOX/Kerosene, H_2/F_2 and H_2/O_2 engines as well as storable propellant engines have been developed and/or tested.

The following discussion will deal to a minor extent with the H_2/F_2 -engine work but mainly the H_2/O_2 -engine work will be discussed.

3. Test and Propellant Facilities

At first a few words should be said about MBB's test and propellant facilities for cryogenic propellants that were constructed in the early 60's. The first slide (1) shows the complete complex of these facilities at MBB's Ottobrunn plant near Munich. It comprises a double test stand in the foreground with a small scrubbing tower for toxic gases, and a small altitude simulation chamber, a fluorine storage and liquefaction plant in the left background, and a hydrogen liquefaction plant in the right background. The test stands are designed for handling thrusts up to 10,000 lbs. The propellant feed systems presently installed are designed for testing engines up to 2,000 lbs.

All engine test sequences are automatically controlled by a separate control center.

Data recording is done by analog multi-channel oscillographs and by digital data processing equipment.

4. Small H₂/F₂-Experimental Engines

In the mid 60's, MBB conducted some experimental work with small GH₂/LF₂-engines with a nominal sea-level thrust of 66 lbs. The engines were heat sink and water cooled chambers of different chamber lengths and were run with chamber pressures up to 150 psia and mixture ratios ranging from 5 to 14. On the one hand, this experimental program was aimed to gain the full experience of the safe handling of gaseous and liquid fluorine on rocket test stands.

On the other hand, the program was aimed to give practical experience with the measurement problems in a fluorine system, with the performance behavior of the H₂/F₂-propellant system, and of different propellant injection processes.

Slides 2 and 3 show respectively, a test run of a water cooled GH_2/LF_2 -experimental engine, and the coaxial-jet type injector as an example of the injectors tested. The tested injector types were the coaxial-jet injector, a pentad configuration and an unlike impinging jet configuration.

5. The 1,100-lb LH_2/LF_2 -Engine

Due to the experience with the small experimental H_2/F_2 -engines and with the other cryogenic engines to be described later, MBB was awarded a contract for the development of a LH_2/LF_2 engine with a vacuum thrust of 1,100 lbs. This engine under development since 1968, has a nominal chamber pressure of 107 psia and a nominal mixture ratio of 10.

In the beginning of the development of this engine, sea level tests with heat-sink and water-cooled chambers and with three different types of injectors were performed.

Both chamber types were installed with numerous thermocouples in order to gain the actual values of the combustion gasside film coefficient for the proper design of the regeneratively cooled chamber. The testing of the three different injector configurations with some modifications on each of them and with different chamber lengths, chamber pressures and mixture ratios, was aimed to find the most optimum injector design with respect to performance and chamber wall heat load.

Slides 4 and 5 show respectively, a segmented heat-sink chamber and the water cooled chamber with 7 individual water jackets. Slides 6 through 8 show some test runs of the heat-sink chambers.

The three injectors tested, a coaxial-jet type with solid and porous face plate, a pentad type, and a splash-plate type are shown on slides 9 through 12, respectively.

The best c^* -efficiency, being 98 % compared with the equilibrium- c^* at design point, was achieved with the coaxial-jet injector at a characteristic chamber length of 0,85 m (33.5 in).

The development of the 1,100-lb H_2/F_2 -engine also includes the development of its main propellant valves. As an example of this development work slide 13 shows a test version of the pneumatically operated liquid fluorine valve, whereas slide 14 shows its electromagnetic pilot valve, which needs only a short current-impulse for both opening and closing.

6. The 66-lb LH_2/LO_2 -Flight Prototype Engine

The most intensive development work of MBB in the field of cryogenic engines in the 60's was done with H_2/O_2 -propellants, both, with very small and relatively large engines.

In the years from 1962 to 1966, MRB under a contract from the German Federal Ministry for Science and Education, developed a flight-prototype LH_2/LO_2 -engine with a nominal vacuum thrust of 66 lbs, a nominal chamber pressure of 70 psia, and a nominal mixture ratio of 5.5.

The development program of this engine was, on the one hand, aimed at the establishment of the technologies needed for the handling of liquid hydrogen in rocket test facilities and at learning to overcome the measurement problems of relatively small liquid hydrogen mass flows. On the other hand, the program was also aimed at the demonstration, that even such small LH_2/LO_2 -engines can be realized with at least partial regenerative cooling, with a safe and reliable ignition, and with reasonable high performance in terms of specific impulse within a certain operating range.

At the start of the development of this engine, practically no concrete experience for the design of such small engines existed. Therefore, testing began with watercooled aluminum chambers of very long chamber lengths and with radial injection of the propellants. With development time proceeding, the chamber length could be made shorter and shorter and propellant injection was accomplished with a star-shaped splash-plate injector. Regenerative cooling was first introduced into the program with copper chambers and was later done with stainless steel chambers. Slide 15 shows the progress from the first sea-level aluminum chamber to the final prototype engine with a vacuum nozzle extension.

The final engine in an all-welded version is shown by slide 16. The engine used regenerative cooling up to an area ratio of 16. The rest of the nozzle was radiation cooled. Since no specification of the number of required restarts existed, ignition was done chemically by injection of a small amount of triethylaluminum (TEA). The TEA was stored in a small capsule, the volume of it being sufficient for a total of four ignitions. Slide 17 shows a cross section of the engine and slide 18 essentially shows the previously mentioned star shaped splash-plate injector.

Slide 19 shows a sea-level flame pattern of this engine.

The final engine version had the following performance data:

vacuum thrust	66 lbs
chamber pressure	71 psia
mixture ratio	5.5
nozzle area ratio	57
characteristic chamber length	15.8 inches
effective vacuum specific impulse	415 sec
chamber pressure range	57 + 114 psia

mixture ratio range	3.5 + 6.5
number of possible starts	4
total burning time	20 min

The final testing of the engine was done in an altitude simulation chamber, with simulated altitudes ranging up to 130,000 feet.

The development of the main propellant valves of the engine, their electrical pilot valves, and the igniter capsule was also required. Both propellant valves were pneumatically operated 3-way valves with the third position of the valves utilized for propellant line and valve precooling. Slides 20 through 23 show such a 3-way valve and the igniter capsule, respectively.

A 20-minutes sound film, synchronized in English, may show some more details of the development of this engine.

7. The 30,000-lb LH₂/LO₂-High Pressure Engine

In the late 50's and early 60's MBB developed a new thrust chamber cooling technique allowing the realization of high chamber pressures with full regenerative cooling. After this technique was first successfully demonstrated in a high pressure LOX/RP1-engine, MBB in cooperation with the Rocketdyne Division of NAR, succeeded in obtaining the interest of the US Air Force and the German DOD in this new chamber technology. As a result, a joint Air Force/German DOD program was established which was aimed at the demonstration of the extreme high pressure regenerative cooling capability of the milled-copper-chamber concept. In this program, MBB designed and fabricated such milled copper chambers with

matching injectors for LH₂ and LO₂ propellants. The testing and evaluation of this engine was done at Rocketdyne's Reno facilities.

This LH₂/LO₂-engine had the following design data:

sea level thrust	30,000 lbs
chamber pressure	≈ 3,000 psia
mixture ratio	≈ 6

During engine testing it was successfully demonstrated that the milled copper chamber concept is capable of handling the extreme high heat fluxes experienced at such high chamber pressures. With this engine, the highest chamber pressure ever known up to that time in the free world was achieved. It was shown that considerably less hydrogen was needed for cooling the chamber than was injected into it. In a severe cycling test, the engine experienced no deviation from its normal performance.

Slides 24 through 26 show this high pressure chamber, a total view of Rocketdyne's test stand, and a test run of the engine, respectively.

A short silent film shows the cycling test of the engine.

8. Engine Fabrication Technology

Recently, MBB has developed some modern thrust chamber fabrication techniques, fully or partly based on the application of electroforming. Intensive use of these fabrication techniques has been made on the just described LH₂/LO₂-high pressure engine. Other engines, like the above mentioned 1,100-lb LH₂/LF₂ engine, and small, high-pressure engines for storable propellants, also make use of them, because cooling channels

of varying cross sections and thicknesses can be produced with relative ease.

Slides 27 and 28 show examples of such fully electroformed thrust chambers having cooling channels similar to a tubular chamber.

Slide 29 shows a complete small high-pressure chamber for a thrust level of 2,200 lbs and pressures in the range of 3,000psia, which is used for testing the regenerative cooling capability of such chambers with storables. The coolant inlets and outlets are fitted to the chamber and sealed by local electroforming.

9. Possibility of the Development of a Space-Shuttle

APS-Engine

Using its experience with small low-pressure and large high-pressure H_2/O_2 -engines and using its technological potential, MBB is able to develop, fabricate and test a H_2/O_2 -APS-engine for the Space Shuttle program.

The above mentioned 1,100-lb LH_2/LF_2 -engine currently under development at MBB falls into the presently discussed thrust category for a high pressure Space Shuttle APS-engine. The engine can be run with H_2/O_2 instead of H_2/F_2 with nearly the same cooling channel geometry but using another chamber material, e. g. copper. The coaxial-jet type injector of the engine can also be used for H_2/O_2 by only changing the sizes of the injector holes and providing for the installation of an igniter.

Using the same inner geometry of the combustion chamber of the 1,100-lb H_2/F_2 engine and running it with GH_2/GO_2 at a chamber pressure of 150 psia and a mixture ratio of 4, it would deliver a vacuum thrust of 1,500 lbs with an area-

ratio-30 nozzle. With the same engine geometry and varying chamber pressure, it could also be adjusted to other thrust levels within a wide range, if needed.

Since the design of the thrust chamber is well underway, MBB under a contract of the German Ministry of Science and Education, is currently preparing the demonstration of a sea level GH_2/GO_2 -engine in order to show its ability of safe ignition, regenerative cooling and high performance. The testing of such an engine can be done on MBB's Ottobrunn facilities with only minor adjustments for producing the cold H_2 - and O_2 -gases with which the Space Shuttle APS-engine shall be fed.

In addition a parallel development of main propellant valves for pulse mode operation shall be initiated. These are the reasons, why MBB thinks, that it can contribute well to the development of a Space Shuttle APS-engine.

10. Conclusions

In the preceding discussion it was shown that MBB has a lot of experience in the development of H_2/O_2 -engines and a broad technological background for fabricating such engines.

The 1,100-lb H_2/F_2 -engine presently under development at MBB can be run with H_2/O_2 propellants with only minor modifications. This is the reason, MBB feels it can contribute to the development of a H_2/O_2 -APS-engine for the Space Shuttle.

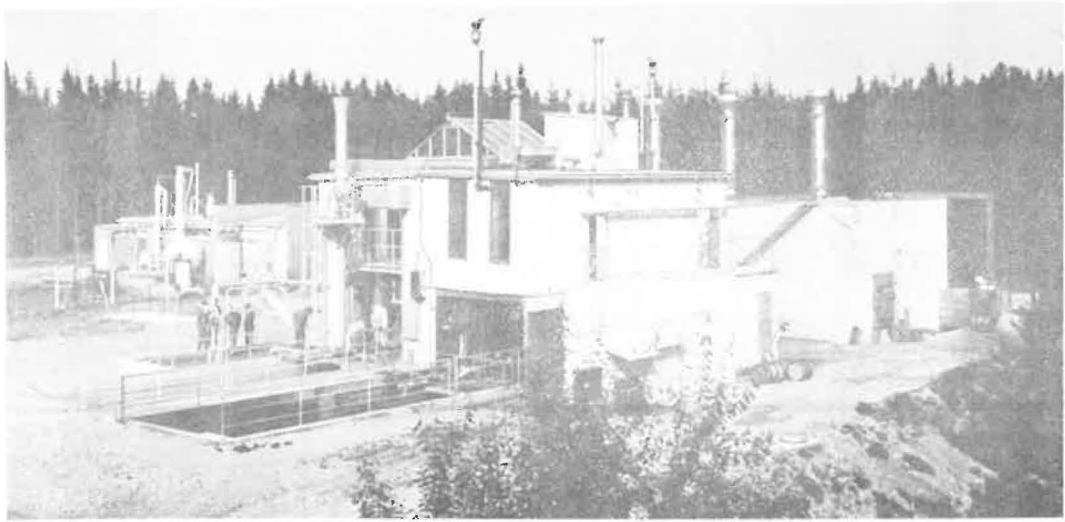

Fig. 1 MBB's test facilities for engines using cryogenic propellants.

Double test stand in the foreground,
fluorine liquefaction and storage plant in left
background,
hydrogen liquefaction plant in right background.

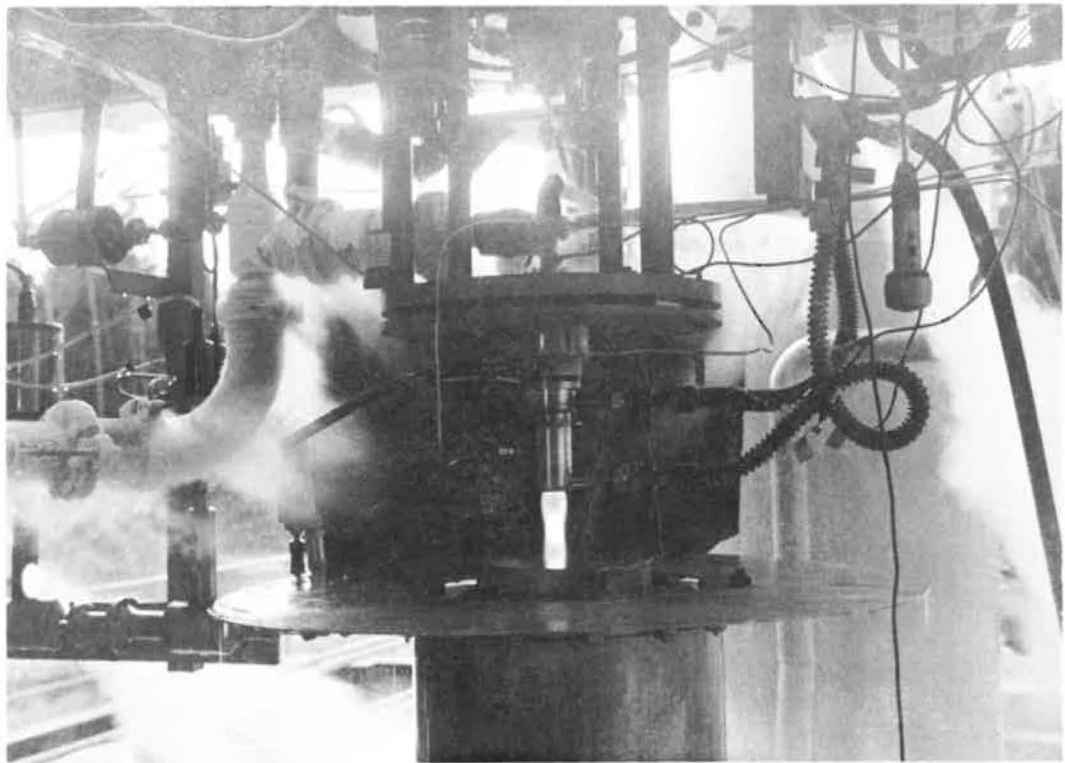

Fig. 2 Test run of a watercooled 66-lb GH_2/LF_2 experimental engine

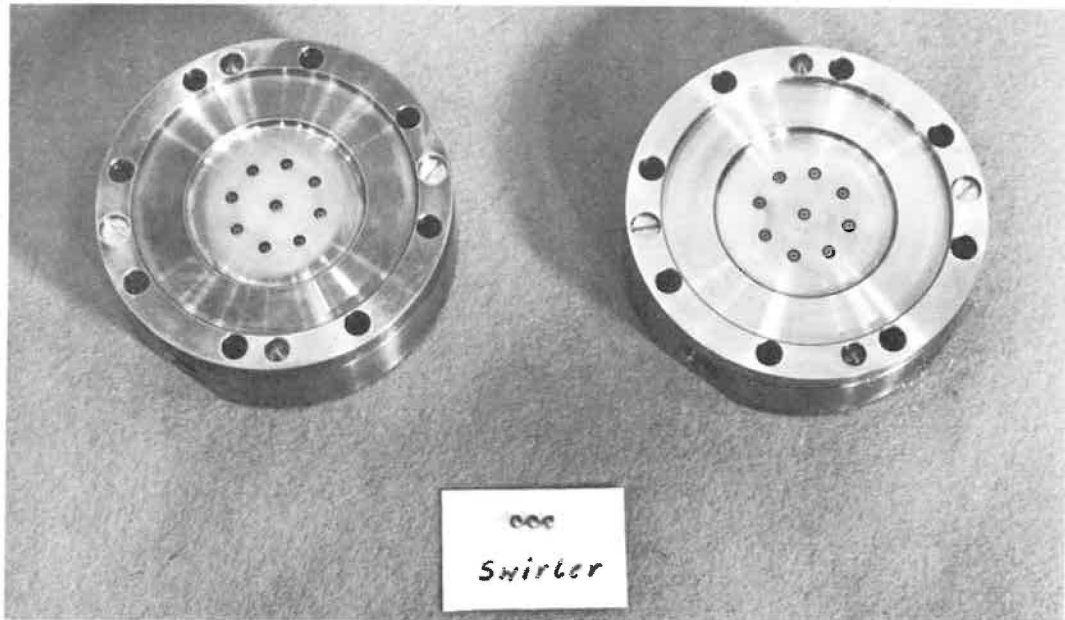

Fig. 3 Coaxial-jet type injector for GH_2/LF_2 experimental engine with copper face plate, left, and nickel-chromium alloy face plate, right



Fig. 4 Segmented heat sink 1,100-lb H_2/F_2 experimental engine for sea level testing, with thermocouples installed

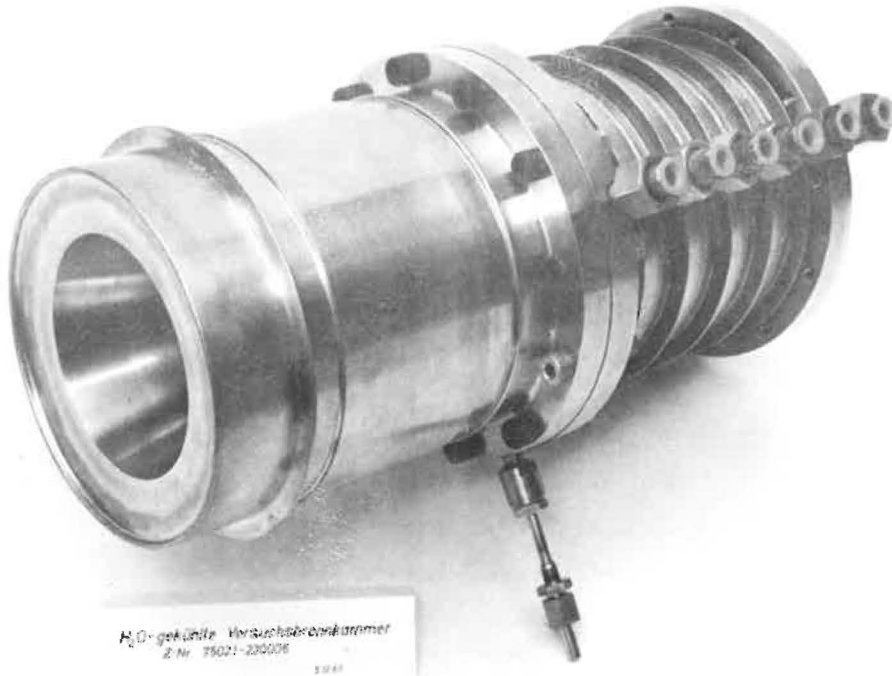

Fig. 5 Watercooled 1,100-lb H_2/F_2 experimental engine for sea level testing with 7 individual water jacket

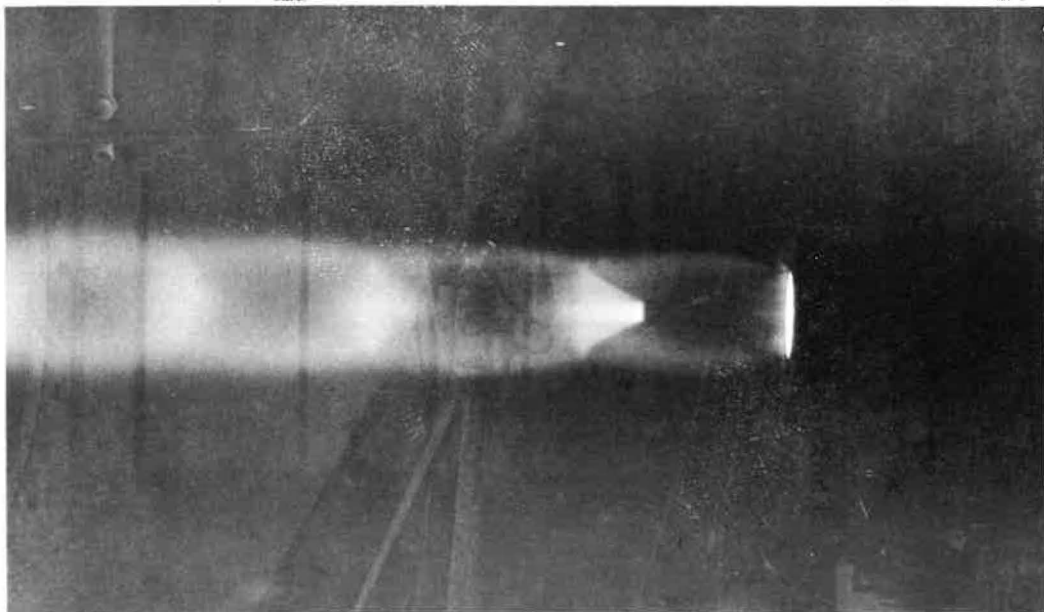

Fig. 6 Sea level flame pattern of the 1,100-lb H_2/F_2 -engine; unsegmented heat sink chamber

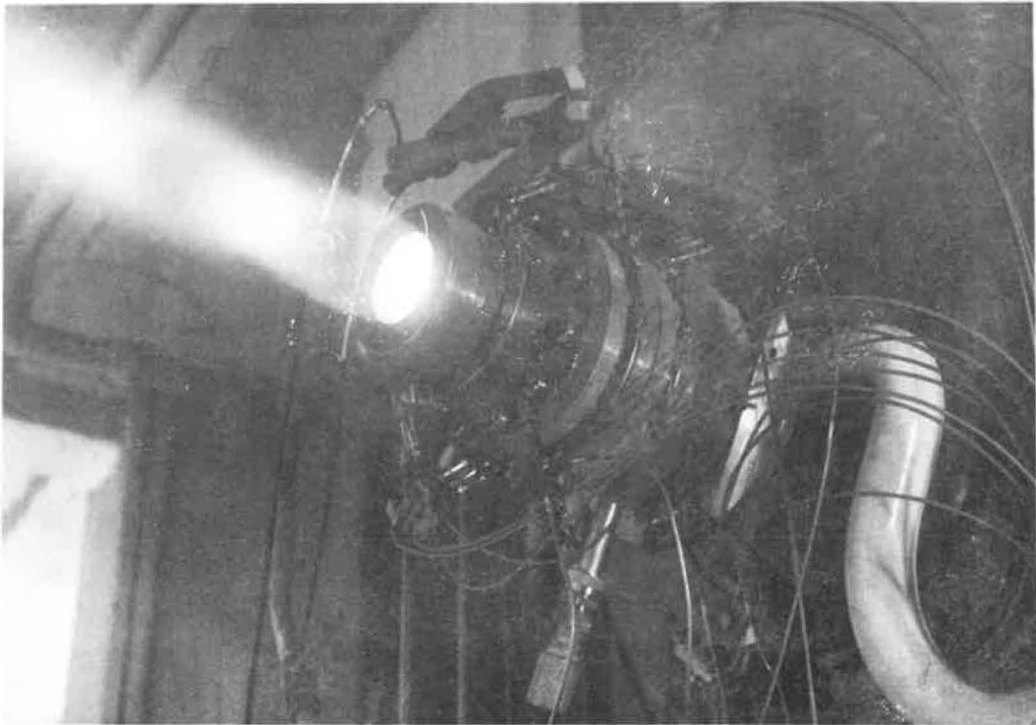

Fig. 7 Sea level flame pattern of the 1,100-lb H₂/F₂-engine;
segmented heat sink chamber

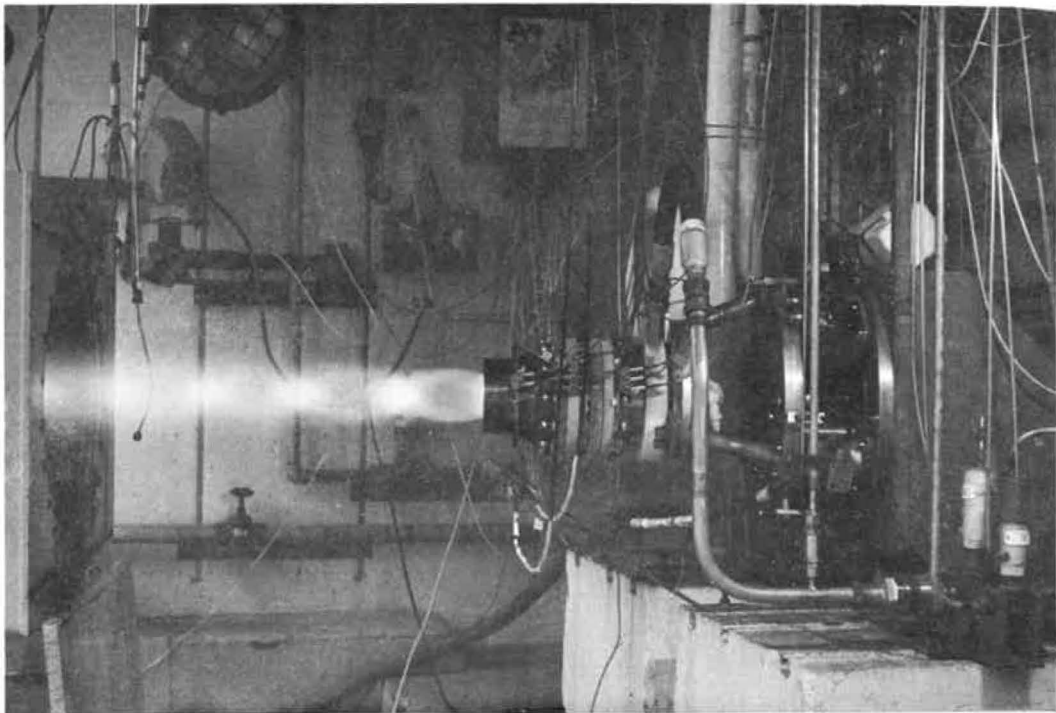

Fig. 8 Sea level flame pattern of the 1,100-lb H₂/F₂-engine;
segmented heat sink chamber; details of test stand

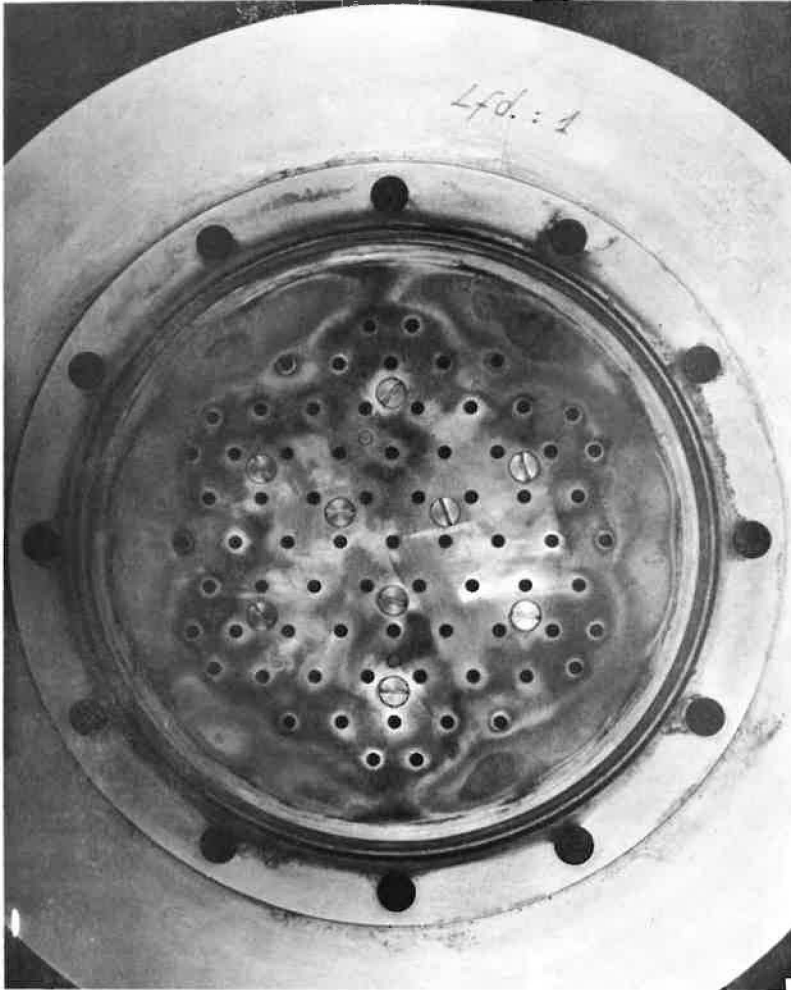

Fig. 9 Coaxial-jet injector with solid faceplate for the 1,100-lb H_2/F_2 -engine

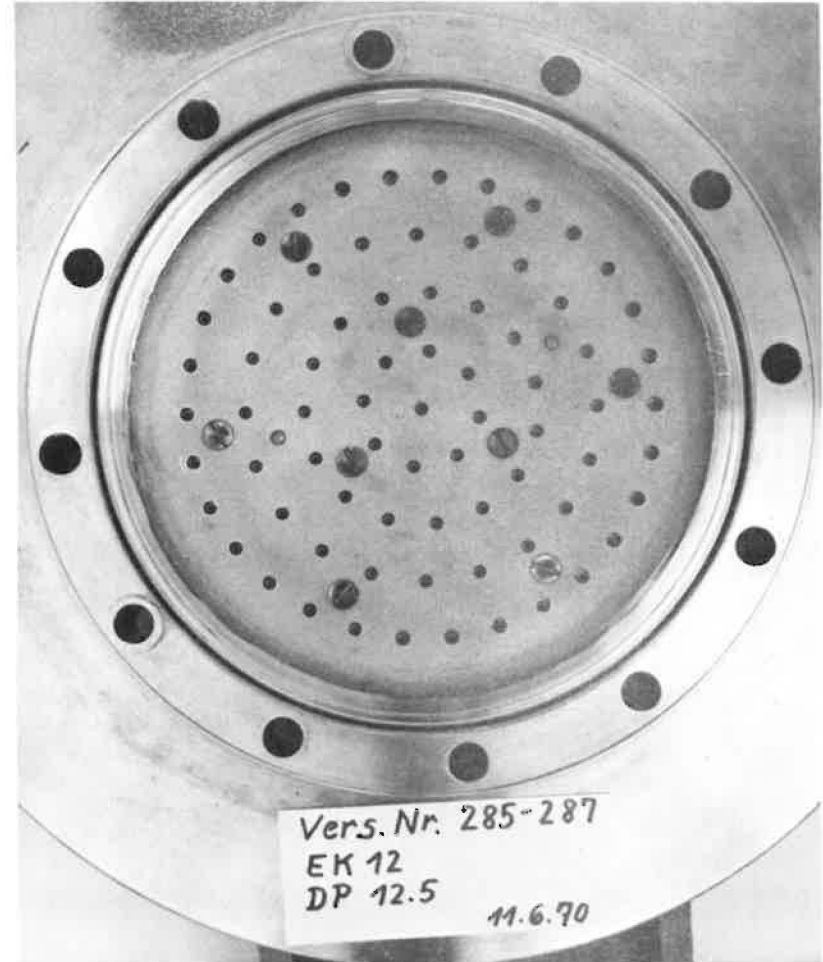

Fig. 10 Coaxial-jet injector with porous faceplate for the 1,100-lb H_2/F_2 -engine

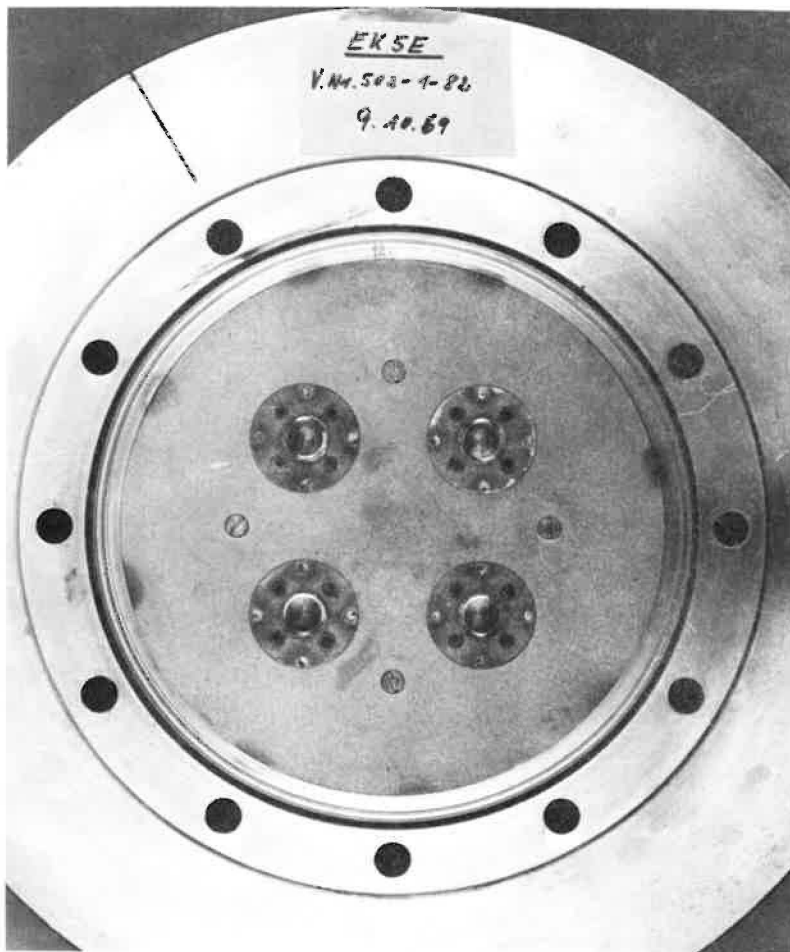

Fig. 11 Pentad injector for the 1,100-lb H_2/F_2 -engine

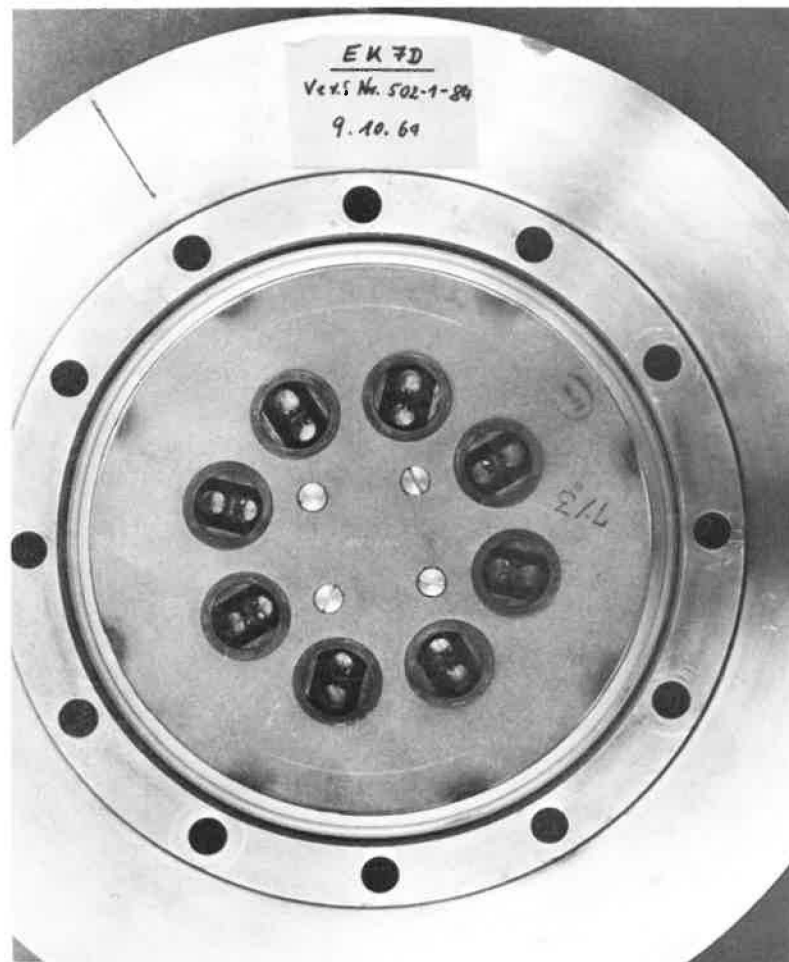

Fig. 12 Splashplate injector for the 1,100-lb H_2/F_2 -engine

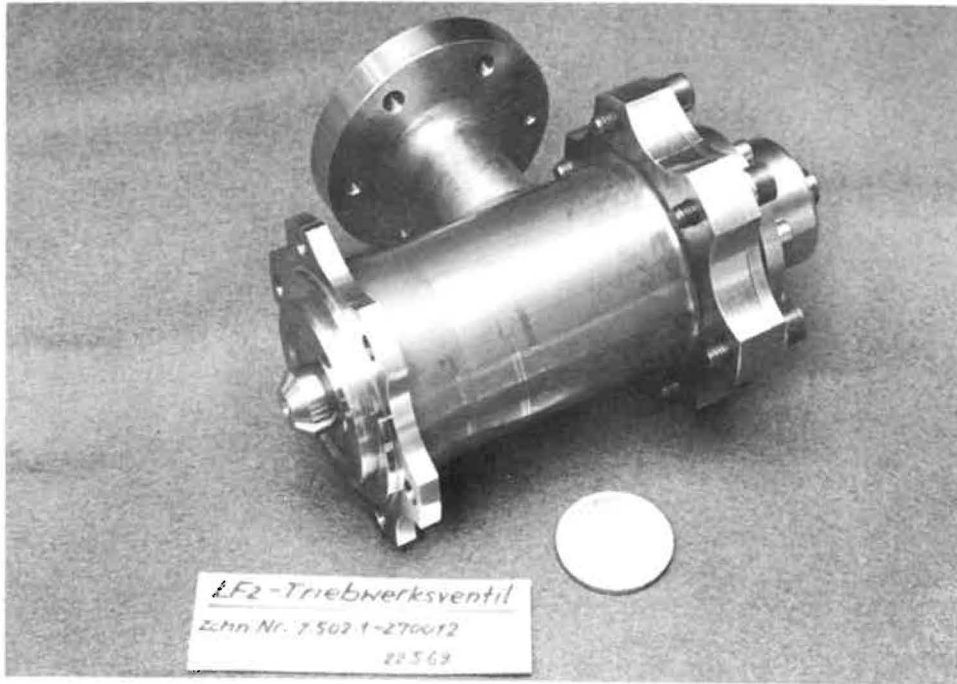

Fig. 13 Test version of a LF₂-main-shutoff valve



Fig. 14 Electromagnetic pilot valve for the LF₂-main-shutoff valve



Fig. 15 Development history of the 66-lb LH_2/LO_2 -engine



Fig. 16 Final version of the 66-lb LH_2/LO_2 -engine with its main propellant valves on top of the chamber and the igniter capsule left of the chamber

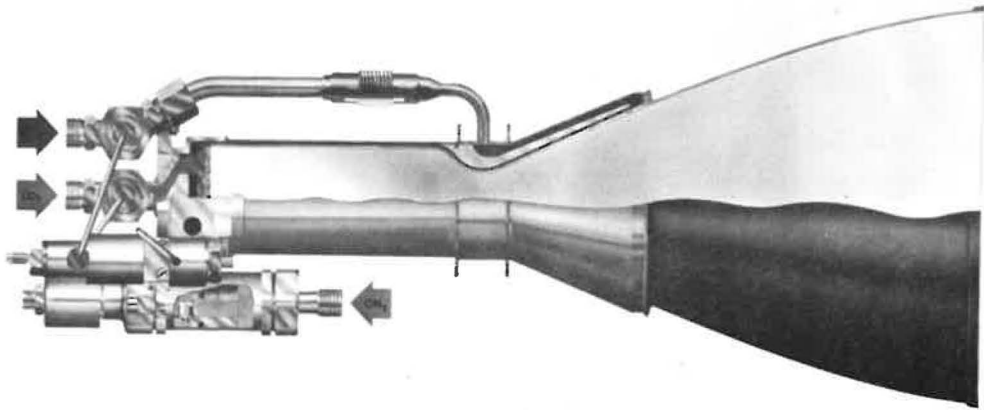

**FUNKTIONSDARSTELLUNG
DES 30kp-LH₂/LO₂-TRIEBWERKES**

Fig. 17 Function schematic of the 66-lb LH₂/LO₂-engine

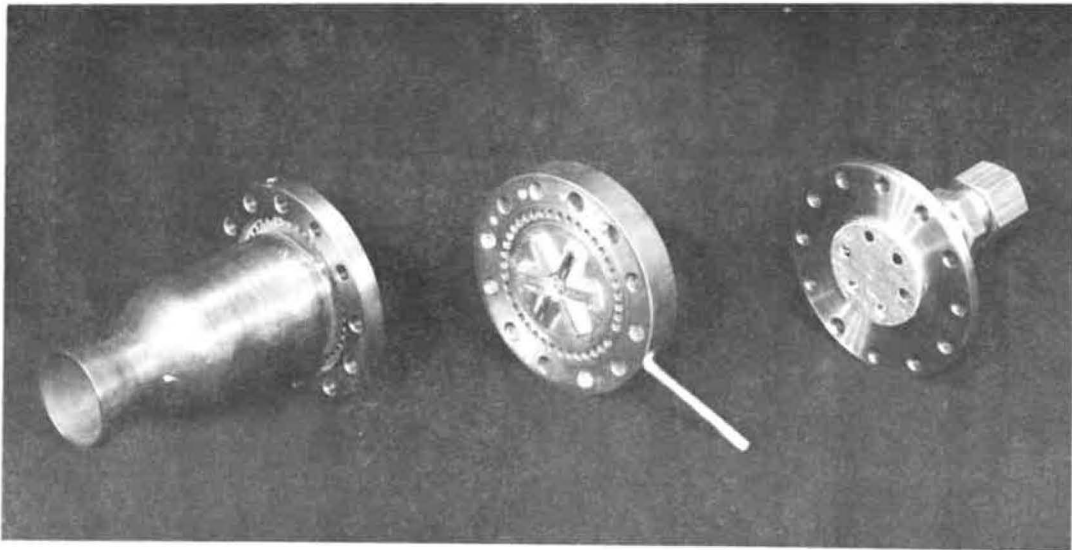

Fig. 18 Star shaped splashplate injector of the 66-lb
LH₂/LO₂-engine

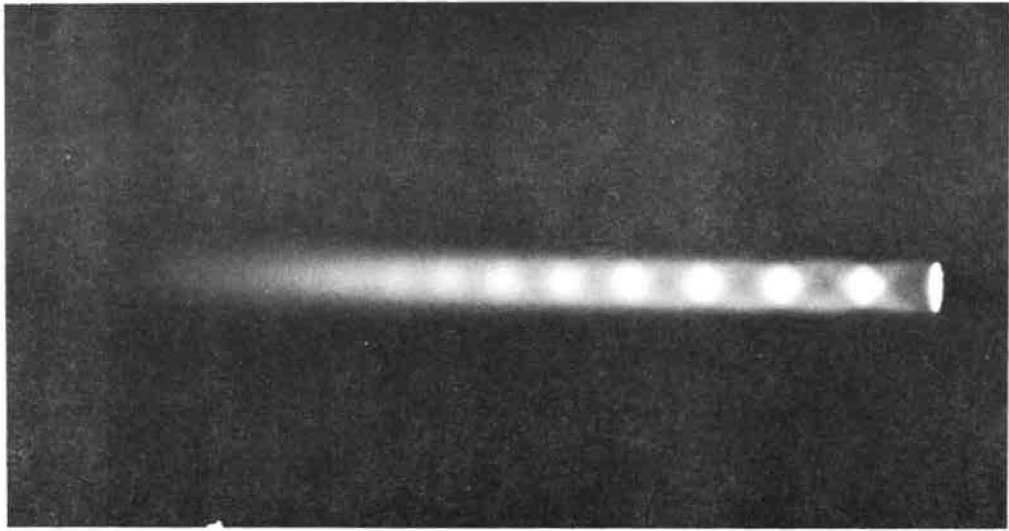

Fig. 19 Sea level flame pattern of the 66-lb LH₂/LO₂-engine

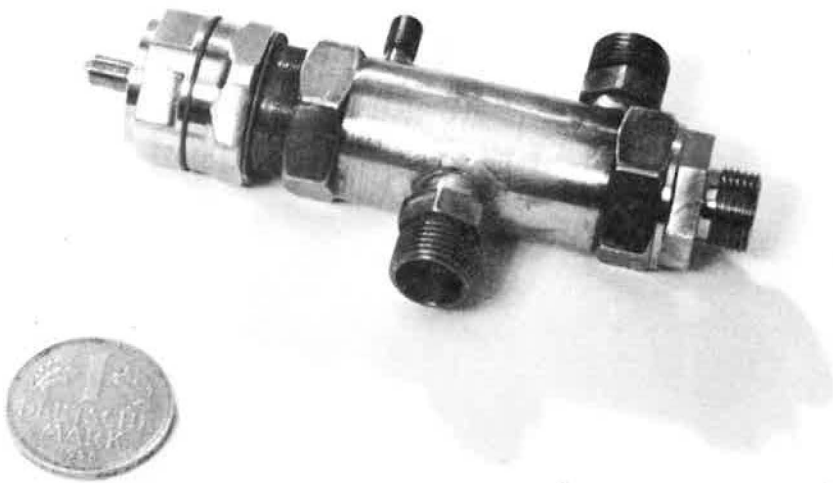

Fig. 20 3-way main propellant valve for the 66-lb LH₂/LO₂-engine

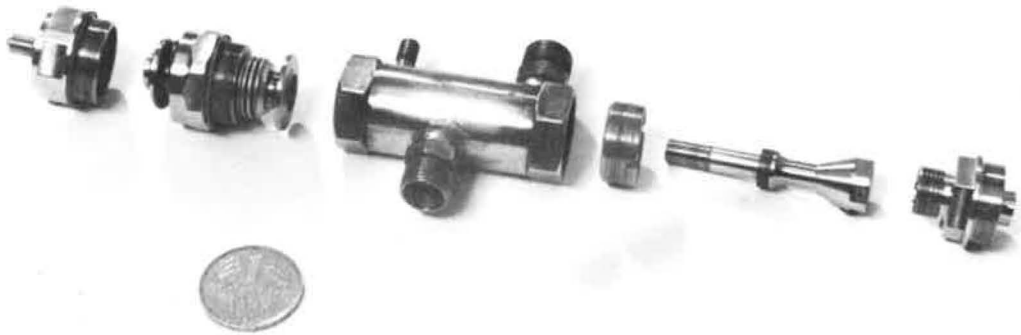

Fig. 21

3-way main propellant valve;
exploded view

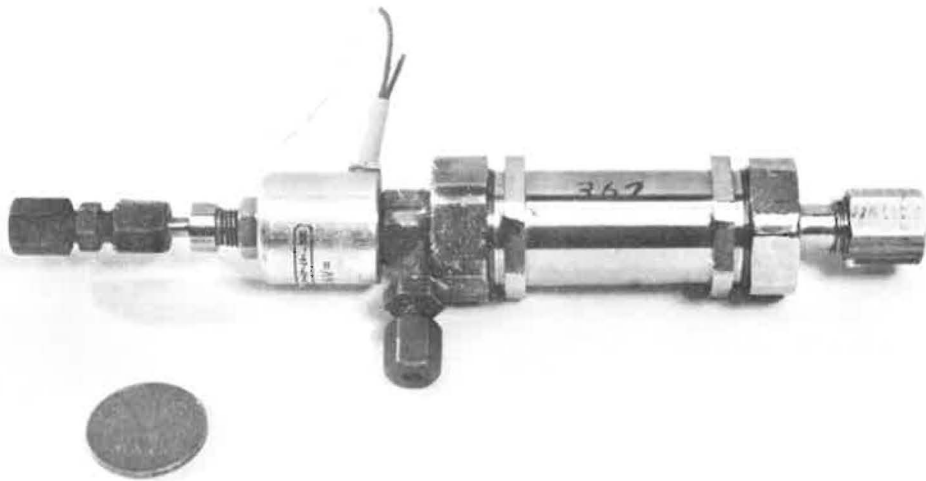

Fig. 22

Igniter capsule for the 66-lb LH_2/LO_2 -engine



Fig. 23 Igniter capsule; exploded view



Fig. 24 30,000-lb high pressure LH₂/LO₂-thrust chamber

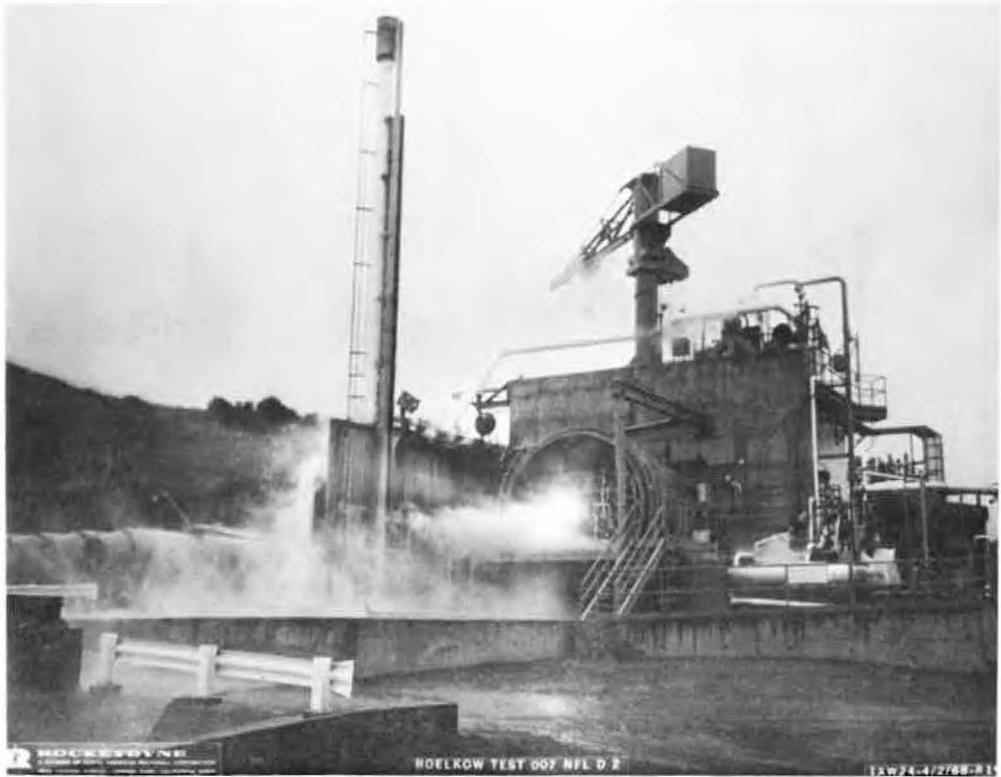

Fig. 25 Total view of the teststand with the 30,000-lb high pressure LH_2/LO_2 -engine running

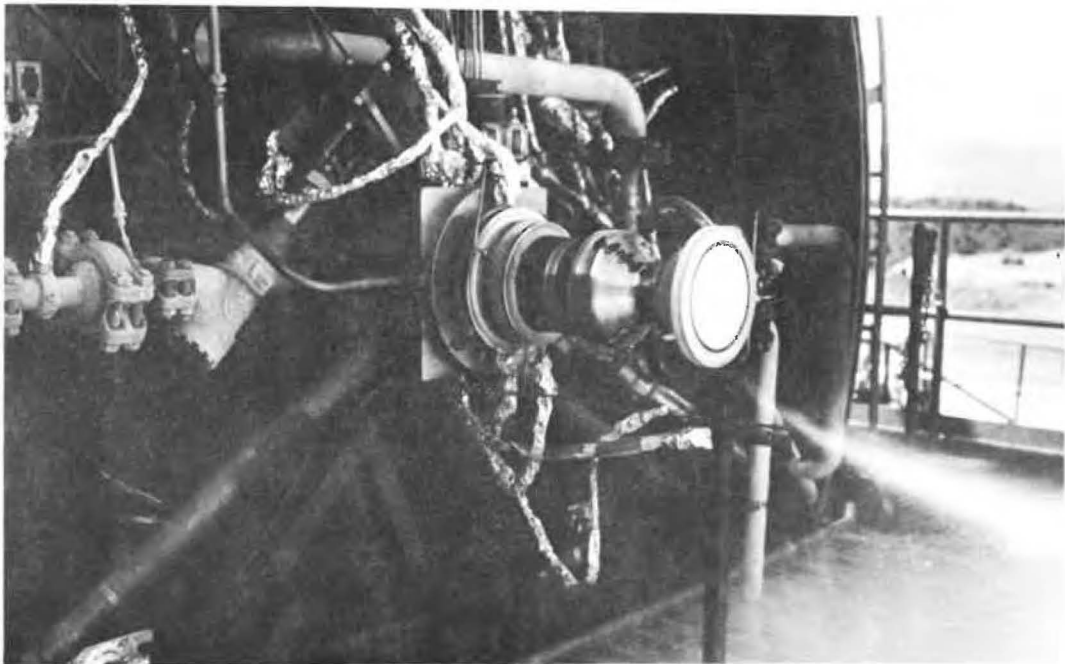

Fig. 26 Test run of the 30,000-lb high pressure LH_2/LO_2 -engine



Fig. 27

Completely electroformed copper thrust chamber



Fig. 28

Completely electroformed nickel thrust chamber



Fig. 29

Completely electroformed 2,200-lb high pressure copper thrust chamber with coolant inlets and outlets

SPACE SHUTTLE AUXILIARY PROPULSION TECHNOLOGY REQUIREMENTS

Keith D. Coates

NASA Marshall Space Flight Center
Huntsville, Alabama

The presentation will cover a definition of two basic terms used in this presentation, a discussion of characteristics of typical system candidates, a comparison of propulsion systems utilizing oxygen and hydrogen as propellants with the Space Shuttle Auxiliary Propulsion System (APS) requirements, a discussion of the areas of greatest technological concern, and a summary.

INTRODUCTION

In order for everyone to more properly understand the objective of this paper, a definition of two major terms is required. "Technology" is a term which enjoys wide usage but implies different things to different people. This presentation will use the term as "systematic knowledge" in a review of several areas of a Space Shuttle APS. The term "auxiliary propulsion" is used at the Marshall Space Flight Center to include propulsion systems other than the vehicle primary (main engine) propulsion system. However, technology requirements for air-breathing engines will not be covered since it will be discussed in another part of the session.

Two types of O_2/H_2 propulsion systems have been proposed for the shuttle application. Basically, the candidates are systems that utilize either high chamber pressure (> 100 psia) engines or low chamber pressure (< 100 psia) engines. Each type of system has several alternatives that must be evaluated against the necessary criteria before a meaningful system choice can be made. Likewise each type system has its advantages and disadvantages. No attempt will be made to choose one type system over the other but an effort will be made to note those areas of each which seem to be most critical insofar as the requirement for more "systematic knowledge" is concerned.

INTRODUCTION

● DEFINITIONS

- TECHNOLOGY - (1) INDUSTRIAL SCIENCE; SYSTEMATIC KNOWLEDGE OF THE INDUSTRIAL ARTS.
(2) TERMINOLOGY USED IN ARTS, SCIENCES OR THE LIKE.
(3) APPLIED SCIENCE.
- AUXILIARY PROPULSION - PROPULSION SYSTEMS OTHER THAN PRIMARY.
(DOES NOT INCLUDE AIR BREATHING ENGINE FOR THIS PRESENTATION)

● SYSTEM CANDIDATES

- HIGH PRESSURE - ACS, OMS, OTHER
- LOW PRESSURE - ACS, OTHER (OMS?)

SYSTEM CANDIDATES

Both the high and low pressure systems perform essentially the same functions, i.e. store propellant, condition it to the proper state, distribute it to the thruster inlets while maintaining the proper state, and accelerate the fluids by the combustion process through the thrusters. The means by which these functions can be accomplished determine the best system to meet the mission requirements.

Thus the hardware required to fulfill the functions is the problem at hand. The uniqueness of the Space Shuttle Vehicle (i.e. reusability, long life, reliability, low cost) imposes a different type of APS hardware requirements than those associated with rocket propulsion of the past. Active use of system conditioning measurements (i.e. temperature, pressure) for closed loop control of the subsystems is an example of an area which has not been fully addressed by rocket propulsion personnel in the past. Controls will cause a much larger impact in future auxiliary propulsion systems design. Integration of the functions of the OWS, APS, APU, and other potential O₂/H₂ users offers the potential of significant advantages in overall vehicle reliability, weight, cost (common components), and development testing.

O₂/H₂ PROPULSION EXPERIENCE

256

A summary of some general characteristics of propulsion systems that are state of art and other experience that has some applicability is shown in the Chart. It is noted that all flight propulsion systems have utilized liquid cryogenic propellant pumped to a high pressure before being burned in the thrust chamber. Space Shuttle requirements which are apparently significantly different from past requirements are: (1) the number of starts, (2) operational run life, (3) state of the propellant (gas/liquid) at the thruster inlet, and (4) maintainability. Even though the experience gained by the NASA and aerospace industry in cryogenic propulsion systems is extensive for the flight systems, the items of difference represent design requirements which are very difficult to fulfill in many instances. It should be noted that the operating pressure column gives the end to end pressure for the system (i.e. storage tank/thrust chamber pressure).

The S-IVB Helium Heater is actually a heat exchanger/gas generator pressurization device and not a propulsion system. However, the experience gained in areas such as ignition, cooling, and heat transfer should be useful. The Cryogenic Auxiliary Propulsion System (CAPS) experience at Rocketdyne and TRW represents the extent of NASA contracted gas/gas thruster work. Industry has performed several studies and conducted some tests during the past five years in an attempt to define an O₂/H₂ APS. However, the efforts have been too small to provide any significant advancements.

O₂/H₂ PROPULSION SYSTEM EXPERIENCE

SYSTEM	PROPELLANT CONDITION	OPERATION RUN LIFE	INFLIGHT STARTS	OPERATING PRESS (PSIA)	TURBO PUMP	IMPULSE/ MISSION (#-SEC)	THRUST/ ENGINE (Lbf)	MAIN- TAINA. LIFE
CENTAUR	LIQUID	HOURS	2	15/300	YES	10 ⁷	15,000	NO
S-IV	LIQUID	MINUTES	1	15/300	YES	4.5 x 10 ⁷	15,000	NO
S-IV ^B STAGE	LIQUID	HOURS	2	27/780	YES	10 ⁸	200,000	NO
He HTR	LIQUID	HOURS	4,000(QUAL)	25	NO	—	25	NO
S-II	LIQUID	MINUTES	1	27/780	YES	4 x 10 ⁸	200,000	NO
NAR CAPS	GAS	—	MULTIPLE	10	—	—	20	NO
TRW	GAS	—	MULTIPLE	10	—	—	20	NO
INDUSTRY	MATERIALS, INSULATION, ENGINES, PROPELLANT CONTROL, ETC.							
STUDIES	CENTAUR APS, S-IV ^B APS, ETC.							
SHUTTLE APS	GAS	MONTHS	10 ⁶	15/1000	NO/YES	1.5 x 10 ⁷	500/5,000	YES

IDENTIFICATION OF CRITICAL TECHNOLOGIES

After reviewing "what is the job?" and "what has been done previously?", areas which require that more "systematic knowledge" be made available can be identified. The object of any hardware is to provide a required function. To select hardware, certain criteria must be assessed in terms of relative importance. Some criteria will govern the design of one component more than another. The ultimate criteria which seems to always be the hardest to define is cost and cannot be disassociated from any of the other criteria.

After assessing the importance of the criteria, one must determine the alternatives to meeting those requirements. Long life may be met by redundant components, replaceable or repairable components. If weight or other criteria does not allow this, a new development program may be required. The state of the Space Shuttle APS presently is such that the criteria and alternative have not been thoroughly defined nor evaluated. Preliminary requirements indicate some areas that are deficient in their capability to meet the Space Shuttle objectives.

IDENTIFICATION OF CRITICAL TECHNOLOGIES

259

● CRITERIA

- OPERATIONAL RUN LIFE
- ENVIRONMENT
- NO. OF STARTS
- SUB-SYSTEM INTEGRATION
- VEHICLE INTERFACE - STRUCTURAL, THERMAL, ELECTRICAL
- WEIGHT (PERFORMANCE)
- GROUND OPERATIONS
- DEVELOPMENT STATUS

● ALTERNATIVES

- SYSTEM DESIGN - ASSIGN FUNCTION TO OTHER COMPONENT
- MULTIPLE COMPONENTS
- REPLACEABLE COMPONENTS
- REPAIRABLE COMPONENTS
- NEW DEVELOPMENT

IDENTIFICATION OF CRITICAL TECHNOLOGIES (CONT'D)

The Space Shuttle Vehicle may require up to 30 engines or more to meet basic mission needs. Requirements for many starts and low leakage dictate that new valves must be developed. O_2/H_2 engines capable of providing low impulse bits (≈ 50 lb-sec) require fast response from the large gaseous propellant valves.

Reliable ignition of gaseous O_2/H_2 many times causes concern. An item such as a spark plug igniter might be an excellent candidate for periodic replacement such as practiced in automobiles.

High performance and low weight are almost synonymous with high combustion temperatures. The temperatures in conjunction with quick response creates a cooling problem which must be evaluated.

Uncontrolled slosh or any movement of propellant masses within the propellant tanks will result in usage of attitude control propellant due to the induced disturbances. The location of the propellant within the propellant tanks and the resultant heat transfer impact due to the propellant being in contact or not being in contact with the tank walls in a zero "g" environment will impose a bigger requirement on the system which depends on utilization of primary vehicle residual boost or solar heat input as a source of energy. The acquisition of liquid propellant for turbopump operation is of concern primarily if many starts are required of the turbopump. The inability to create a zero "g" environment for long periods of time causes a lack of confidence in the proving of many designs until they are flown.

IDENTIFICATION OF CRITICAL TECHNOLOGIES (CONT' D)

261

<u>POTENTIAL CRITICAL AREAS</u>	<u>LP</u>	<u>HP</u>
● <u>ENGINES</u>	✓	✓
● <u>VALVES</u> CAPABILITY TO MEET NO. OF STARTS WITHOUT LEAKAGE OR FAILURE TO OPERATE WITH QUICK RESPONSE	X	X
● <u>IGNITION</u> CONCEPT FOR MANY STARTS	X	X
● <u>COOLING</u> TECHNIQUE FOR HIGH PERFORMANCE ENGINE CAPABLE OF QUICK RESPONSE	X	X
● <u>PROPELLANT CONTROL</u>	✓	✓
● <u>SLOSH</u> EFFECT ON VEHICLE CONTROL DYNAMICS	X	X
● <u>LOCATION</u> OF PROPELLANT IN TANK IN ZERO "G" (EFFECT ON HEAT TRANSFER)	X	
● <u>ACQUISITION</u> OF LIQUID PROPELLANT FOR TURBOPUMP OPERATION		X
● <u>DEMONSTRATION</u> OF ZERO "G" EFFECTS IN TEST PROGRAM	X	X

IDENTIFICATION OF CRITICAL TECHNOLOGIES (CONT'D)

Separate from the problem of being able to control heat transfer in a zero "g" environment is the problem of favorably (i.e. use environment advantageously) isolating the propulsion system. Tanks, lines, heat exchangers and other parts of the system should be capable of operating in the expected thermal and vacuum environment which requires the use of high performance insulating (HPI). Susceptibility of HPI to physical damage, moisture, and contamination warrants it to be a major concern.

The heat exchanger sizes dictated by requirements of cycle life, response, and efficiency do not exist in the O₂/H₂ stable of components. The magnitude of the requirements indicates that significant knowledge must be gained before a suitable heat exchanger will be available.

The area of turbopumps/turbocompressors is of concern especially in the system in which the pump or compressor must undergo many starts. The run life of these components is nearly the same if a high pressure OWS is assumed with a low pressure ACS. Thus the problem of bearing life, seal life, etc. would exist for either concept. The power required to operate either a turbopump or compressor represents an inefficient use of propellant and is a candidate for improvement in efficiency.

Other areas of concern are system interactions (i.e. effect of operation of one component on another), subsystems integration, (i.e. different requirements of propellant conditions, etc.) and closed loop controls.

IDENTIFICATION OF CRITICAL TECHNOLOGIES (CONT'D)

263

<u>POTENTIAL CRITICAL AREAS</u>	<u>LP</u>	<u>HP</u>
● <u>THERMAL CONTROL</u>	✓	
● <u>INSULATION SUSCEPTIBILITY TO PHYSICAL DAMAGE, MOISTURE, CONTAMINATION</u>	X	
● <u>HEAT EXCHANGER CYCLE LIFE, RESPONSE, AND EFFICIENCY</u>	X	X
● <u>TURBOPUMPS/TURBOCOMPRESSORS</u>		✓
● <u>RUN LIFE OF BEARINGS, TURBINE BLADES, ETC.</u>	X(OMS)	X
● <u>START TRANSIENT EFFECTS ASSOCIATED WITH MANY STARTS</u>		X
● <u>POWER REQUIRED FOR OPERATION</u>		X
● <u>OTHER</u>	✓	✓
● SYSTEM INTERACTIONS	X	X
● SUBSYSTEMS INTEGRATION	X	X
● CONTROLS	X	X

SUMMATION

After a review of the anticipated most critical areas required for design of an APS for the Space Shuttle, the conclusion is that existing technology is not adequate. Also, it can be stated that new technology is required regardless of the choice of a high or low pressure APS. However, with the O_2/H_2 propulsion systems base existing within the NASA and industry and with the required time and funds made available, the areas of concern only represent interesting engineering problems and not impossible dreams.

SPACE SHUTTLE AUXILIARY PROPULSION TECHNOLOGY PLANS

Donald L. Nored

NASA-Lewis Research Center
Cleveland, Ohio

INTRODUCTION

Auxiliary propulsion for the Space Shuttle has been identified as a critical technology area. Requirements for long system life, reusability, minimal checkout and maintenance, and high performance are unique and critical to the Space Shuttle concept. The technology base for auxiliary propulsion systems utilizing gaseous hydrogen and gaseous oxygen, the selected propellants, is very limited, however, and a major extension to current state-of-the-art will be needed to meet such requirements. In addition, consideration of translational propulsion (e.g., orbital maneuvering) will impose an added complexity. To insure that decision milestones can be met in a timely manner, thus leading to an acceptable Space Shuttle development schedule, NASA has initiated an in-depth component and system technology program in this area.

APS Technology Plan

Five general objectives have been outlined for the technology work in the auxiliary propulsion system (APS) area. A continuing effort is devoted to identification of technology needs, as related to the most current operational requirements, and to assessment of technology status relative to the needs. Screening of components and subsystems, to define the most attractive systems, is required in order to provide a reasonable limitation to the work in this area. For those items not previously evaluated, fundamental limits as well as operational limits must be established if overall feasibility is to be demonstrated. The largest efforts, however, will be devoted to generation of extensive engineering data. Such data will provide an in-depth understanding of system and component design and operation, and they will also be useful in establishing realistic performance and design characteristics. This technology level is required if shuttle vehicle study efforts, both current and future, are to be meaningful, and if risk is to be minimized in the development stage. Finally, during the development program itself, it is expected that technology efforts may be required to provide support or to explore attractive alternate approaches, possibly approaches offering improvements in system performance.

The approach to meeting these objectives is primarily as outlined. System concepts will be defined, and associated components and subsystems identified. Analytical screening will reduce the number to a workable level, and then experimental evaluation of the critical items will be conducted. This establishes performance characteristics necessary for final system design. Ultimately, complete system evaluation—both analytically and experimentally—will be required to obtain an understanding of component and subsystem interactions.

AUXILIARY PROPULSION SYSTEM TECHNOLOGY PLAN

OBJECTIVES

- IDENTIFY TECHNOLOGY STATUS & NEEDS
- DEFINE ATTRACTIVE SYSTEMS, SUBSYSTEMS, & COMPONENTS
- DEMONSTRATE FEASIBILITY
- GENERATE COMPREHENSIVE TECHNOLOGY BASE TO:
 PROVIDE INPUT TO VEHICLE TRADEOFF STUDIES & DESIGNS
 PROVIDE BASIS FOR INITIATION OF LOW TECHNICAL RISK
 DEVELOPMENT
- SUPPORT DEVELOPMENT EFFORTS

APPROACH

- CONCEPTUAL DEFINITION
- SCREENING
- INVESTIGATION OF CRITICAL COMPONENTS/SUBSYSTEMS
- SYSTEM EVALUATION

CS-54894

Auxiliary Propulsion System

Technology Plan - Responsibilities

To conduct this technology program on the APS, three centers - Lewis Research Center, Marshall Space Flight Center, and the Manned Spacecraft Center - have been assigned certain general responsibilities. Definition of system requirements will be a prime responsibility of MSFC and MSC due to their close relationships to the current vehicle studies. Associated feed system technology efforts, and in particular the feed system-vehicle integration, will also be primarily conducted by these centers. The thruster technology program, which includes efforts on thrust chamber cooling, combustion, ignition, and control valves, will be the responsibility of Lewis. Obviously, close coordination between all three centers and their associated contractors is required if duplication or unnecessary efforts are to be avoided, and its results are to be utilized in a timely manner.

AUXILIARY PROPULSION SYSTEM TECHNOLOGY PLAN

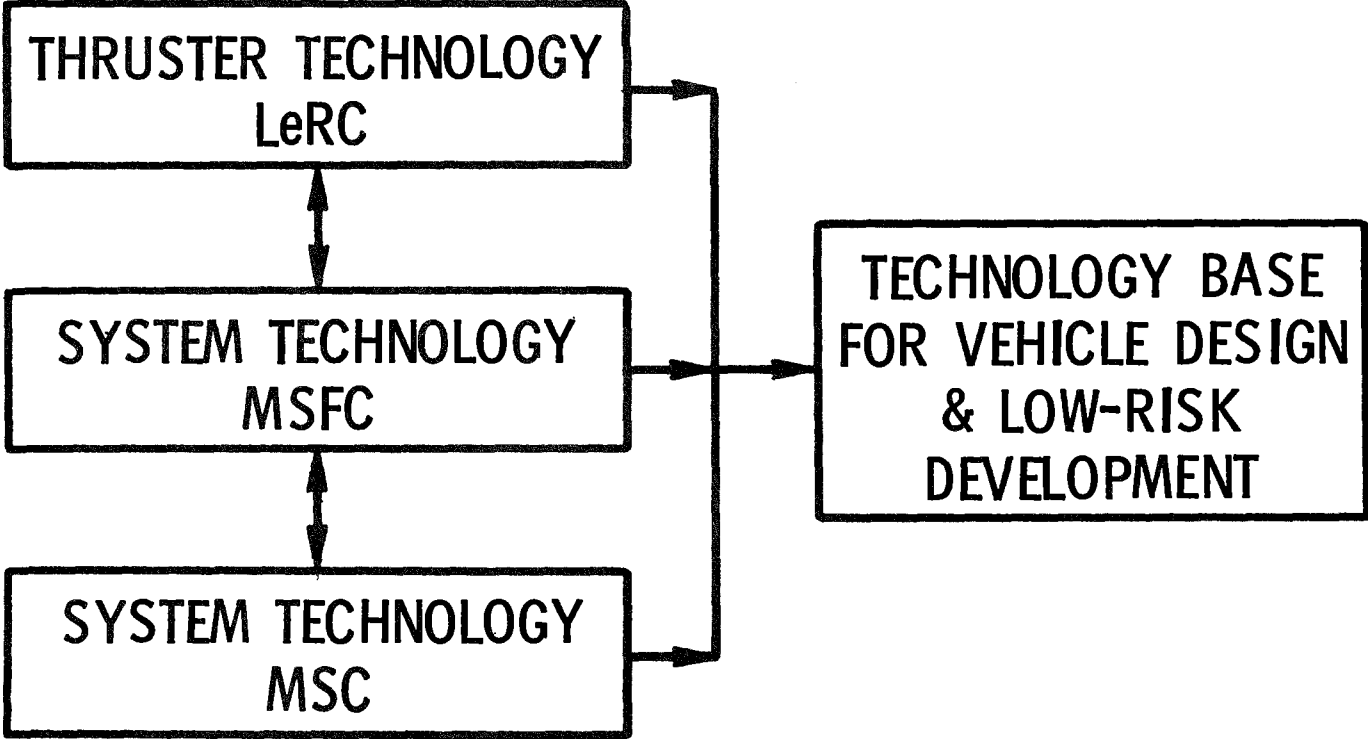

269

APS Definition Study

Basic to all the effort in the auxiliary propulsion area are the APS Definition Study contracts recently awarded. These studies will generate information and data for use in the overall shuttle vehicle study efforts as well as for the technology programs. The studies are broad in scope in order to identify attractive concepts, to define ranges of application, to define any limitations on performance or design, to identify critical technology areas, and to establish development or technology priorities.

To be realistic, the studies are centered around two different vehicle designs representative of the ones currently under consideration. For these vehicles, trade-off studies will be conducted for a variety of system concepts, and following a screening and selection process, preliminary design studies and trades will be performed in detail. To be included in the study are guidance and control analysis; effects of vehicle configuration on thrust level, number of engines, and location of engines; determination of total impulse and impulse bit requirements; definition of vehicle interior environments; and, finally, design of the feed system based on these and various other inputs from the study.

A key factor in these studies is that the results must have sufficient scope and flexibility to be pertinent to other shuttle vehicle designs as they evolve. Another important consideration is that systems for attitude control, with varying requirements for translational maneuvers, are to be evaluated and optimized. This evaluation will be of importance in establishing preliminary requirements for the Orbiter Maneuvering System (OMS).

Follow-on activities in the definition area may be necessary to evaluate integration of the auxiliary propulsion feed system with other cryogenic storage and feed systems of the Space Shuttle. The desirability of such integration is presently being evaluated. More in-depth study is required, however, to fully establish the impact of such integration on the APS requirements.

AUXILIARY PROPULSION SYSTEM DEFINITION STUDY

OBJECTIVES

- GENERATE DATA FOR VEHICLE STUDY & DESIGN EFFORTS
- IDENTIFY ATTRACTIVE CONCEPTS
- DEFINE RANGES OF APPLICATION & LIMITATIONS
- IDENTIFY CRITICAL TECHNOLOGY AREAS & DEVELOPMENT PRIORITIES

APPROACH

- SPECIFIC VEHICLES SELECTED
- TRADE-OFF STUDY OF ALTERNATE SYSTEM CONCEPTS
- PRELIMINARY DESIGN OF SELECTED SYSTEM(S)

CONSIDERATIONS

- INFORMATION PERTINENT TO OTHER VEHICLES
- BOTH ATTITUDE CONTROL & TRANSLATION MANEUVERS

CS-54912

APS Definition Study - Responsibilities

This definition study is to be performed by two different contractors, reporting to MSFC and MSC as shown. The work is divided into low pressure studies and high pressure studies, reflecting the general types of feed systems to be separately evaluated. Low pressure feed systems utilize the main engine ascent tankage in some manner, and the APS thrusters operate in the range of 10-20 psia. High pressure APS thrusters have chamber pressures in the order of 100-500 psia, and the associated feed system may use turbo pumps, as one example.

AUXILIARY PROPULSION SYSTEM DEFINITION STUDY

NASA CENTER	CONTRACTORS	
	LOW PRESSURE STUDY	HIGH PRESSURE STUDY
MSC	MCDONNELL DOUGLAS ¹ (NAS 9-11012)	TRW SYSTEMS ² (NAS 9-11013)
MSFC	TRW SYSTEMS ² (NAS 8-26249)	MCDONNELL DOUGLAS ² (NAS 8-26248)

¹ASSISTED BY AEROJET LIQUID ROCKET CO.

²ASSISTED BY AIRESEARCH, & PRATT & WHITNEY AIRCRAFT.

CS-54908

Attitude Control Propulsion System

Technology Plan

The Attitude Control Propulsion System (ACPS) is required to satisfy all the attitude control functions as well as some amount of translational maneuvering. The overall plan for technology efforts in this area begins with the APS Definition Studies. These studies will establish detailed requirements for both ACPS engine and feed system components. However, based on preliminary knowledge of these requirements, component evaluation will start prior to completion of the definition studies. Hopefully, component data will be available in time to factor into the definition studies. As rapidly as possible, work on breadboard systems will be initiated to gather information on component interactions. Marriage of the engine and feed system into a complete integrated package will be the final step in the technology program.

Identification of technology requirements will be a continuing process throughout the course of the technology efforts. Such identification can come from many different sources (such as the Phase B Vehicle Studies), and the technology efforts will be modified, as necessary, to reflect the latest requirement.

ATTITUDE CONTROL PROPULSION SYSTEM TECHNOLOGY PLAN

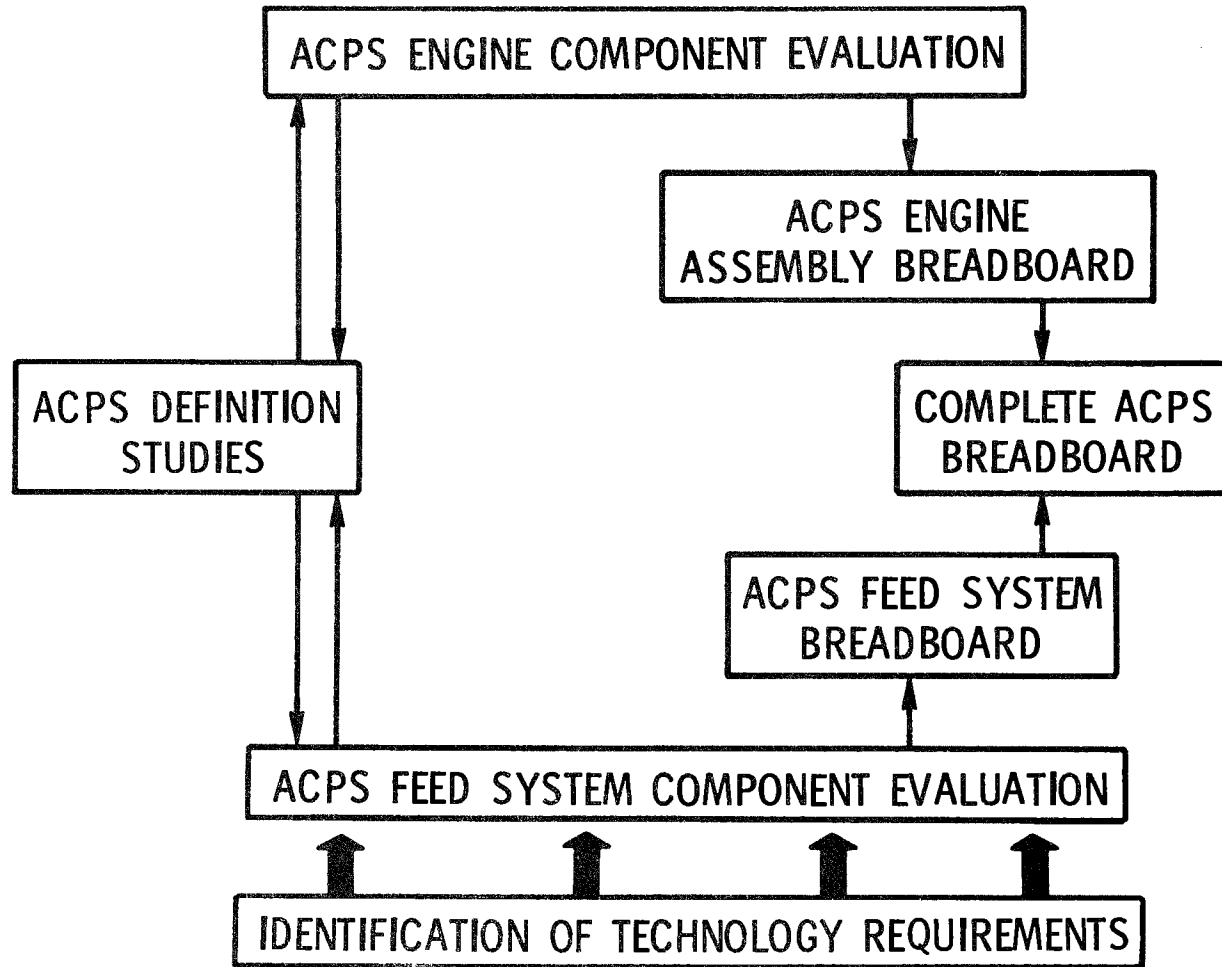

275

ACS Engine Technology Program

In the engine technology area, the general objective is again to establish a comprehensive technology base. The general approach has been to break the effort down into four key items: (1) injection techniques for gaseous propellants, (2) chamber cooling designs for long life, (3) reliable ignition concepts for hydrogen-oxygen in a manner consistent with attitude control requirements, and (4) design of valves for fast operation and high cycle life. In all these areas, the operational limits, life expectancy, response, and performance must be established on the component level. Next, integration and evaluation of interactions must be accomplished. Forthcoming from this effort will be the design data necessary for initiation of low-risk development.

Considerations unique to the shuttle vehicle concept will guide the efforts in all of the technology areas. One hundred missions (as a goal) with multiple uses on each flight constitute severe requirements. To do this with a minimum of inspection and servicing is particularly demanding. Finally, since mission requirements are not well established, and, indeed, since they may never be, the auxiliary propulsion system must be capable of widely varying operating ranges. These considerations have a major impact on engine design, and the entire engine technology program is devoted to obtaining an understanding of how these requirements can best be met, and to what degree.

ACS Engine Technology Areas

Considerations to be investigated for each component area are listed. Work on injectors will be conducted jointly with the cooling analysis of the thrust chambers. Since performance of the attitude control thrusters is not as important a consideration as durability and life, injector efforts will primarily be devoted to achieving a cool, uniform boundary layer. Streaking must be minimized, and the wall temperatures must be kept to a very low value, if thermal fatigue problems are to be avoided. Establishment of operational limits - such as propellant temperature and pressure ranges - will also be an important part of this investigation. Their effects on mixture ratio and thrust level will be evaluated, and control techniques determined.

In the ignition area, three approaches are being pursued. Electrical ignition - which includes spark plugs and plasma devices - constitutes the main stream effort. Operating limits and design variables will be evaluated for these units. Investigation of the problems associated with high tension electrical leads, and the possible electromagnetic interference (EMI) from spark plugs, will be included. Catalytic ignition has been under investigation by LeRC for a number of years. Many design variables and operating limits are already known. For the Space Shuttle, design criteria will be extended, durability and life of the catalyst bed will be more firmly established, and improvements in the design - such as heating of the catalyst bed to promote more rapid ignition at low propellant temperatures - will be made. A third approach which is being investigated, although to a more limited amount than for electrical or catalytic devices, is the use of auto-ignition. This concept uses the so-called "resonance tube" ignition principle. Hydrogen gas flows from a nozzle and impinges on the open end of a tube (closed at the other end). Shock waves in the tube cause an increase in gas temperature. Oxygen gas, admitted from the closed end, will then ignite with the hot hydrogen gas. This concept has been the subject of research programs at several labs (e.g. LeRC and Ohio State University), but there are still many design variables, operating limits, and other unknowns which must be resolved.

The area of valves represents a major problem area, and one in which the Shuttle requirements - as presently known - are well beyond current state-of-the-art. To achieve low leakage values, for the large number of required cycles, will necessitate major advances in sealing closure design. Our program will screen valve concepts and experimentally evaluate design criteria for many different sealing closures (e.g. poppet, ball, butterfly, blade, etc.) Both metal-on-metal and metal-on-plastic seat combinations will be included. For the low pressure APS, weight and response of the valves will be a major problem to overcome. Line sizes, hence the valves, will be very large (6-9 inches diameter). New valving concepts may be required for this system.

Following the above component efforts, a complete engine package will be assembled and tested to determine interaction effects, pulsing performance, and life.

ACS ENGINE TECHNOLOGY AREAS

THRUST CHAMBER/INJECTOR

INJECTION DESIGN CRITERIA
COOLING CONCEPT SCREENING
DURABILITY & LIFE
PERFORMANCE & RESPONSE
PROPELLANT TEMP/PRESSURE SENSITIVITY
FABRICATION

IGNITION

ELECTRICAL, CATALYTIC, AUTOIGNITION
DESIGN VARIABLE EFFECTS
OPERATING LIMITS
RESPONSE
DURABILITY & LIFE
VEHICLE INTERACTIONS

VALVES

DESIGN CONCEPT SCREENING
SEALING CLOSURE INV
LEAKAGE
CYCLIC LIFE
ACTUATOR INV
RESPONSE
WEIGHT
VEHICLE INTERACTIONS

THRUST CHAMBER ASSEMBLY

INTEGRATION (INTERACTION EFFECTS)
PULSED PERFORMANCE & RESPONSE
DURABILITY & LIFE

ACPS Engine Program Schedule

The schedule for the engine program is shown on the attached figure. Parallel and multiple contracts on thrusters, ignition, and valves will extend from July, 1970 to July, 1971. New programs under consideration for this fiscal year (FY 1971) include efforts on pressure regulators and gas/gas combustion. Pressure regulation will be critical for engine mixture ratio control, and reliable components in this area are a necessity. Since our understanding of gas/gas combustion and combustion instability is limited, efforts in this area are also necessary. Following completion of the component work, complete engine breadboard systems will be assembled and tested, using optimum and flightweight (or at least flight type) components. NASA in-house activities will be maintained throughout the technology time period to support the contract efforts. These activities consist of evaluation of alternate component and system concepts, as well as integration of components from several different contractors. Close coordination will be maintained with the system definition studies and with the Phase B Vehicle Studies.

ATTITUDE CONTROL PROPULSION SYSTEM

ENGINE PROGRAM SCHEDULE

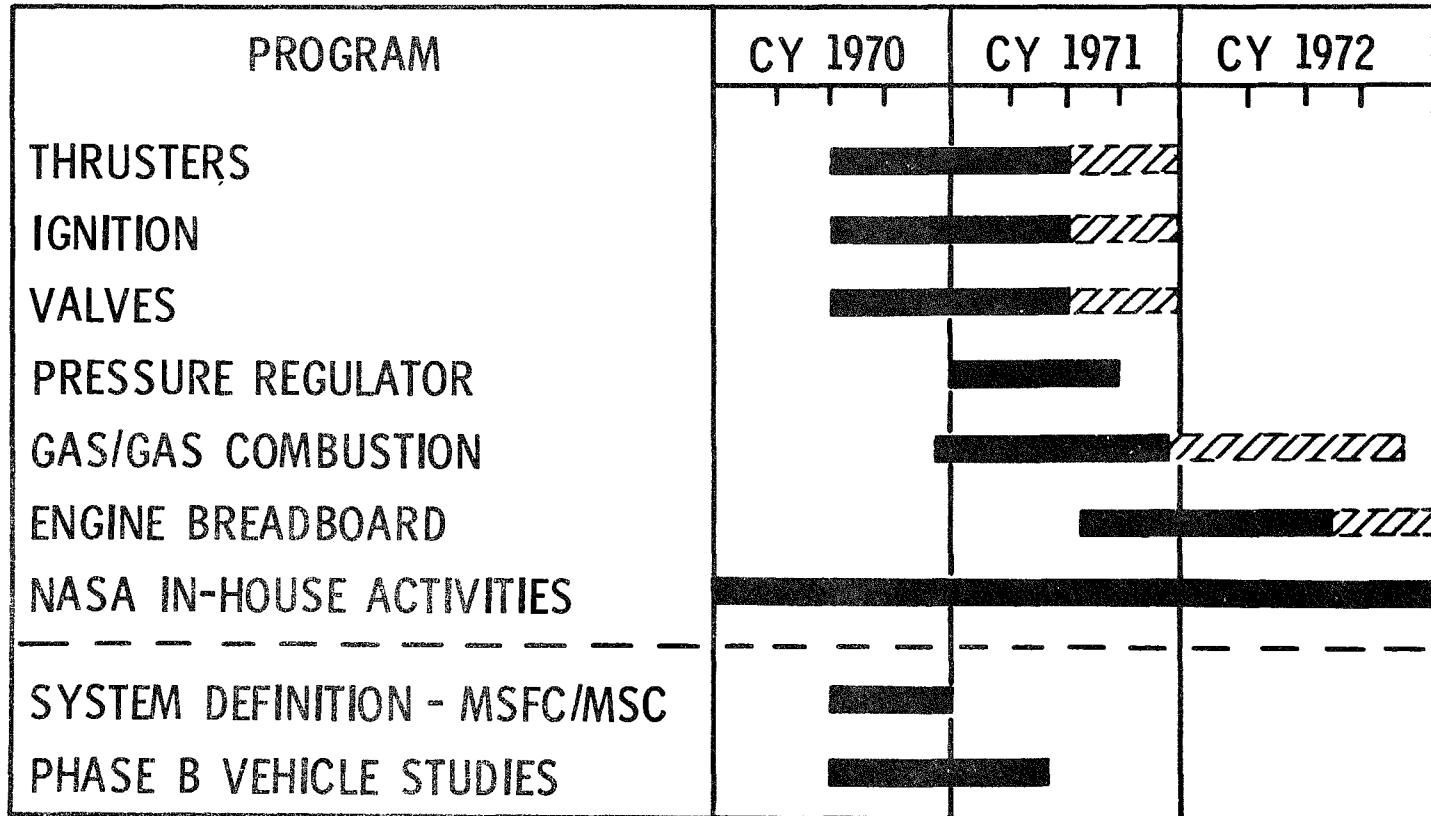

281

CS-54906

Attitude Control Propulsion System

Feed System Program

This program will be based upon identification of attractive feed system approaches during the APS Definition Studies. Components of such systems will be investigated, and, ultimately, system breadboards will be evaluated. Some previously identified critical components and their design considerations are listed. Liquid acquisition devices are particularly critical, being basic to many different types of feed systems. Such devices probably constitute the area of greatest unknown and will require intensive investigation to establish feasibility and to determine design parameters.

ATTITUDE CONTROL PROPULSION SYSTEM FEED SYSTEM PROGRAM

OBJECTIVES

- GENERATE COMPONENT TECHNOLOGY
- DEFINE:
 - SYSTEM DYNAMICS & INTERACTIONS
 - OPERATIONAL LIMITS
 - EXTENT OF REUSE, REFURBISHMENT, & ONBOARD CHECKOUT

CRITICAL ITEMS

- HEAT EXCHANGERS - THERMAL FATIGUE, CONTROL
- GAS GENERATORS - THERMAL FATIGUE, CONTROL, IGNITION
- VALVES - LOW LEAKAGE, HIGH CYCLIC LIFE
- PRESSURE REGULATION - LONG LIFE
- PUMPS OR TURBOCOMPRESSORS - TWO PHASE FLOW, MULTIPLE START, LOW FLOW
- STORAGE TANKS & ACCUMULATORS - THERMAL CONTROL, WEIGHT, CYCLIC LIFE
- LIQUID ACQUISITION OR PHASE SEPARATION DEVICES - RELIABLE, ACCELERATION INSENSITIVE
- SYSTEM CONTROL - INTERACTIONS

CS-54907

Attitude Control Propulsion System

Feed System Program Schedule

As previously indicated, efforts will start on critical components as rapidly as possible. As components become available, feed system breadboards will be fabricated and tested. Several component and system areas have previously been identified, and efforts are already underway as shown. Gaseous feed system flow dynamics will be an effort under the cognizance of MSC for FY 1971. Effects of vibration and cycling on bellows design is being evaluated under a LeRC contract with Bell Aerosystems, Inc. In support of the NASA program, the Air Force is conducting work on propellant orientation and gaging. Close coordination will be maintained with the system definition studies, engine component and breadboard evaluations, and the Phase B vehicle studies.

Orbiter Maneuvering System (OMS) Engine

Large translational maneuvers will place a premium on high performance. The need for high specific impulse, along with thrust requirements of 8,000 to 15,000 lbs. may require another engine system in addition to the attitude control propulsion system. This engine will have requirements (actually goals at the present time) and implied design considerations as shown. The use of helium pressurization or autogeneous pressurization for multiple restarts will require careful evaluation. Use of autogeneous pressurization might provide a lighter weight system, but would require a pressure-fed idle mode for engine start, along with quick chilldown capability. Reusability (for 100 missions) implies an engine that is easily inspected and maintained. Reliability requirements will place a premium on conservative safety margins and design. Flexibility in the engine is desirable to provide propellant utilization control (by capability for operation over a broad mixture ratio range). Integration to the largest possible extent with the ACPS is also desirable to provide minimum weight and maximum reliability for the total auxiliary propulsion system.

ORBITER MANEUVERING SYSTEM (OMS) ENGINE

- FUNCTION: PERFORM HIGH ΔV TRANSLATIONS (≈ 1500 FPS TOTAL)
- THRUST: 8 000-15 000 LB

REQUIREMENTS (GOALS)

10 RESTARTS/MISSION

MAINTAINABLE & REUSABLE
(100 MISSION LIFE)

RELIABLE

FLEXIBLE

DESIGN CONSIDERATIONS

AUTOGENEOUS PRESSURIZATION;
PRESSURE-FED IDLE MODE; QUICK
CHILLDOWN

ACCESSIBLE & EASILY REPLACED
COMPONENTS; SELF-CONTAINED
CHECKOUT

CONSERVATIVE STRESS VALUES; HIGH
MARGINS ON COOLING; CONTROLS
REDUNDANCY, DYNAMICALLY STABLE

BROAD O/F OPERATING RANGE; HIGH
MARGINS ON POWER; INTEGRATION
WITH ACS; HIGH ISP; LOW WT

OMS Engine Program

Several programs in this area are planned for FY 1971. MSC will conduct an OMS/Vehicle Trade-Off Study to establish system requirements, desirable degree of integration with the ACPS, and attractive feed system designs. LeRC will conduct an engine characterization program, concentrating on turbopump drive cycle screening and selection, followed by preliminary engine design. As indicated, this characterization would also include dynamic modeling and control system evaluation. This program would be similar to recent programs conducted by LeRC for characterization of a FLOX Methane Engine (NAS3-12010 and NAS3-12024). Further efforts on evaluation of fiberglass composite feed lines is also planned. Such lines may provide a quick chilldown capability, desirable for both the OMS engine and the main engines of the Space Shuttle.

OMS ENGINE PROGRAM

FY 1971

OMS/VEHICLE TRADE-OFF STUDY - MSC

- DEFINE SYSTEM REQUIREMENTS & VEHICLE INTEGRATION EXTENT
- ESTABLISH PRELIMINARY SYSTEM DESIGN
- IDENTIFY TECHNOLOGY NEEDS
- MAJOR CONSIDERATION - EVALUATE OMS ENGINE INTEGRATION WITH ACPS

ENGINE CHARACTERIZATION - LeRC

- EVALUATE
 - COOLING TECHNIQUES
 - TURBOPUMP DRIVE CYCLES
 - CONTROL SYSTEMS
- PERFORM
 - COMPONENT DESIGN
 - ENGINE PRELIMINARY DESIGN
 - DYNAMIC MODELING
- INVESTIGATE
 - INTEGRATION WITH ACPS
 - CHILLDOWN & STARTUP
 - SELF-CONTAINED CHECKOUT INSTRUMENTATION

THERMAL CONDITIONING - LeRC

- COMPOSITE FEED LINES

ENGINE DESIGN AND TECHNOLOGY REQUIREMENTS
(Panel Discussion)

Warner L. Stewart, NASA Lewis Research Center, Cleveland, Ohio; William R. Collier, General Electric Company, Evandale, Ohio; Lindsay G. Dawson, Rolls-Royce, Derby, England; and Charles L. Joslin, Pratt & Whitney Aircraft, West Palm Beach, Florida

INTRODUCTION

Warner L. Stewart

The shuttle concept as currently envisioned includes vehicle reuse for cost effectiveness and a semi-airline operating mode. Such characteristics result in the requirement for a third propulsion system (in addition to main and auxiliary) to provide for vehicle return and recovery. The airbreathing gas turbine engines thus employed would provide three principal functions (a) return cruise and landing glide-path control, (b) emergency go-around, and (c) vehicle ferrying.

Unique requirements for the shuttle mission result in non-conventional features for the airbreathing engines. The sensitivity of payload to inert weights has resulted in the consideration of hydrogen as the fuel and a desire for reduction in engine weight. Further, deviations from conventional engine internal design will be required to accommodate the new operating environments. This presentation will review some of the engine features and problem areas and then discuss those areas that are of greatest concern.

TYPICAL BOOSTER AIRBREATHING FLIGHT PROFILE

After staging, the booster reenters the atmosphere about 350 to 450 nautical miles away from its liftoff (and landing) site. The airbreathing engines are started at an altitude of about 35,000 feet, and the vehicle cruises back at an altitude of about 20,000 feet and a Mach number of .4 to .5. The engines are sized to meet the cruise requirement and this gives them enough thrust to provide go-around as well as self-ferry capability. The length of the flight time, which approaches two hours, makes the fuel consumption a major consideration for engine selection.

TYPICAL BOOSTER AIRBREATHING FLIGHT PROFILE

ENTRY AFTER STAGING

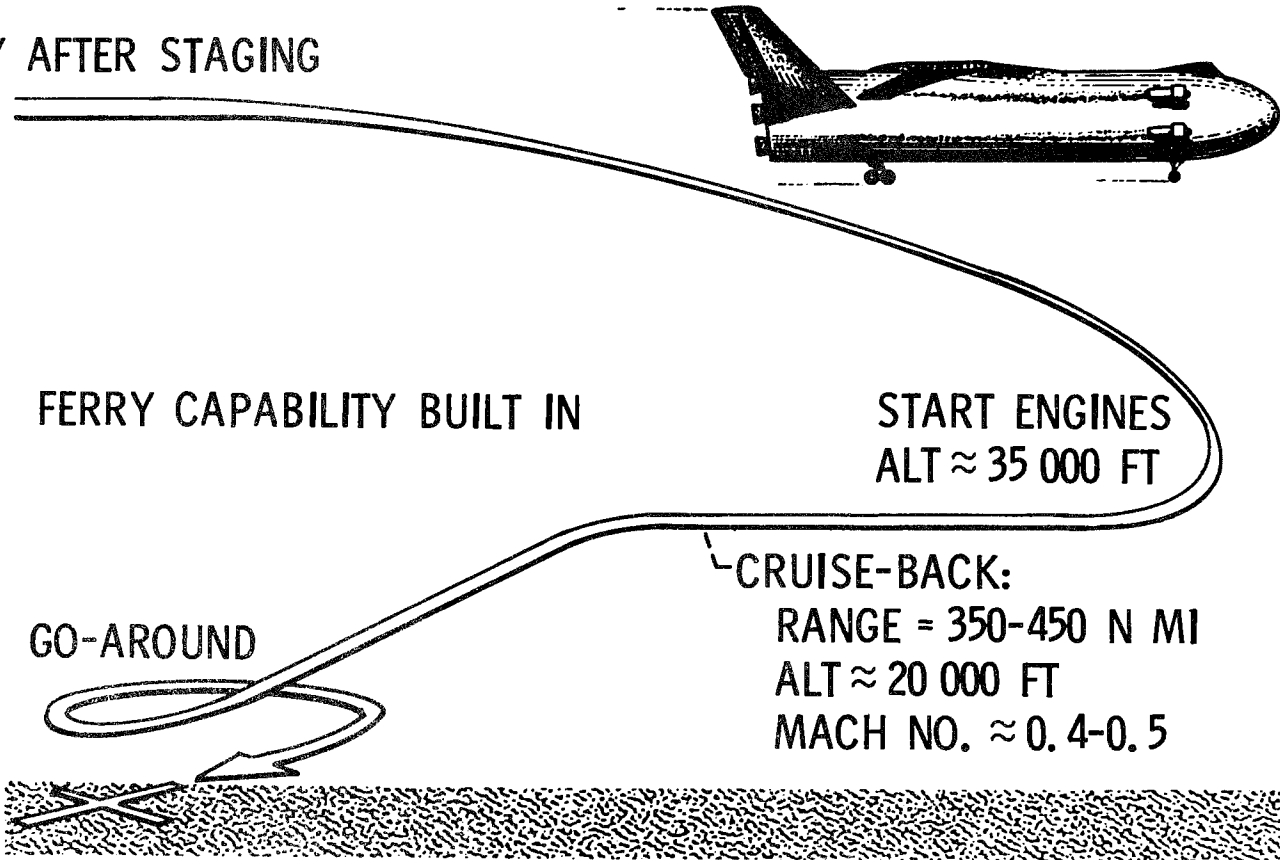

293

CS-54839

TYPICAL ORBITER AIRBREATHING FLIGHT PROFILE

After de-orbiting, the orbiter vehicle descends unpowered towards its landing site. The airbreathing engines are started at an altitude of about 20,000 feet, and the vehicle makes a power-assisted descent and landing. At present, go-around and self-ferry capability are required, and it is these requirements that size the engine. Since the engine operating time is very short, about 15 minutes, it is the engine weight that is a major consideration for engine selection.

If self-ferry and go-around requirements can be deleted, which is a current consideration, a significant weight reduction may result from the accompanying reduction in thrust requirement or possible elimination of the engines. However, any payload gain must be carefully weighed against mission safety considerations.

TYPICAL ORBITER AIRBREATHING FLIGHT PROFILE

ENTRY
FROM
ORBIT



FERRY CAPABILITY?

START ENGINES
ALT \approx 20 000 FT

POWER ASSISTED
DESCENT

GO-AROUND?



CS-54838

ENGINE REQUIREMENTS

Except for the common use of hydrogen fuel, the engines for the booster and the orbiter vehicles have significantly different requirements. The booster engines must provide higher total thrust and longer life than the orbiter engines, but the weight of the booster engines does not affect payload as critically as does the weight of the orbiter engines. These differences in requirements together with the previously shown differences in mission imply that optimum engine cycles for the booster and the orbiter would be different. In addition, the orbiter engine requires protection against extended space vacuum and temperature exposure while the booster engine does not.

ENGINE REQUIREMENTS

	BOOSTER	ORBITER
FUEL	HYDROGEN	HYDROGEN
LOW WEIGHT - ENGINE/PAYLOAD WEIGHT SENSITIVITY	5/1	1/1
TOTAL INSTALLED THRUST (SLS), LB	140-200 000	60-80 000
LIFE, HR	500	50
SPACE EXPOSURE	MINUTES	≤ 30 DAYS

297

CS-54844

EXAMPLE EFFECTS OF FUEL TYPE AND ENGINE WEIGHT

For a typical booster mission, the amount of hydrogen required would be about 40,000 pounds less than the amount of JP fuel. This difference in fuel weight reflects a payload gain of about 8,000 pounds when using hydrogen. For the orbiter mission with its much shorter operating time, the approximately 2,000 pound savings in fuel directly corresponds to a 2,000 pound payload gain. Thus, the use of hydrogen as the fuel, while yielding payload gains for both vehicles, is especially attractive for the booster.

If the thrust-to-weight ratio of the orbiter engine could be doubled, then even with a doubling of the fuel consumption, there could result a payload gain of about 5000 pounds. For the booster, it can be seen that such a trade would yield a larger increase in fuel weight than would be the decrease in engine weight. Such a thrust-to-weight ratio improvement could possibly be achieved with advanced turbojet engines currently being studied for VTOL application. However, this type of engine in the size range required for the shuttle is not under development at present.

EXAMPLE EFFECTS OF FUEL TYPE AND ENGINE WEIGHT

299

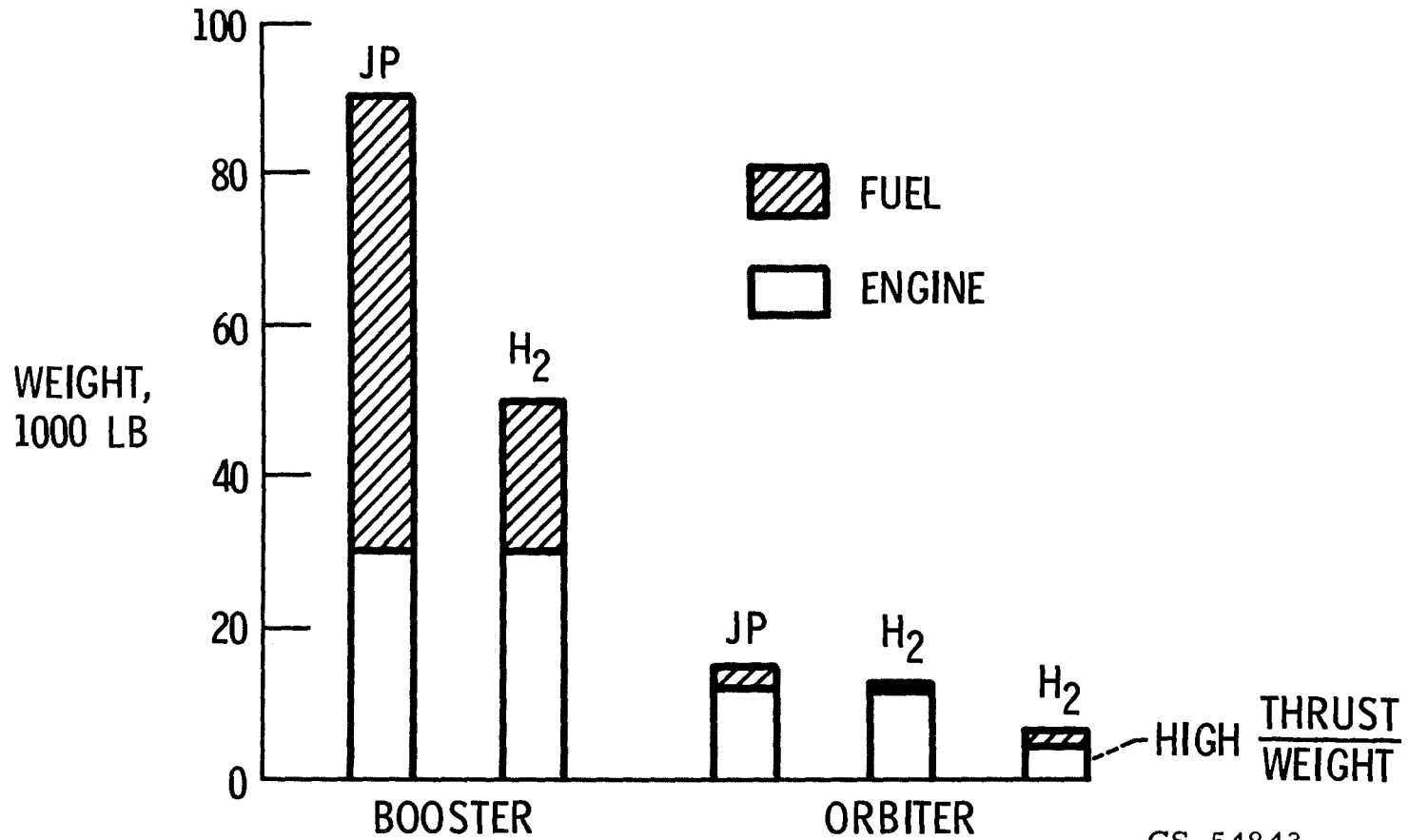

CS-54843

CONSIDERATION OF ENGINE COMMONALITY

It was stated previously that optimum engine cycles would probably differ for the booster and the orbiter. For the booster, turbofan engines of high bypass ratio would yield the desired low fuel consumption. However, other considerations, such as frontal area, extend downward the range of bypass ratios to be considered. For the orbiter, high thrust-to-weight ratio engines such as turbojets or low bypass ratio turbofans are considered.

As indicated in the figure, there is some overlap in the bypass ratio ranges being considered for each mission. Thus, the bypass ratio range of about .5 to 2 would be the area of interest for a common engine for both vehicles. While a common engine probably would not be optimum for either mission, the performance penalty might not be too severe and the monetary savings would be quite significant. As seen from the indicated thrust requirements, the use of a common engine would result in the booster requiring at least twice the number of engines as the orbiter.

CONSIDERATION OF ENGINE COMMONALITY

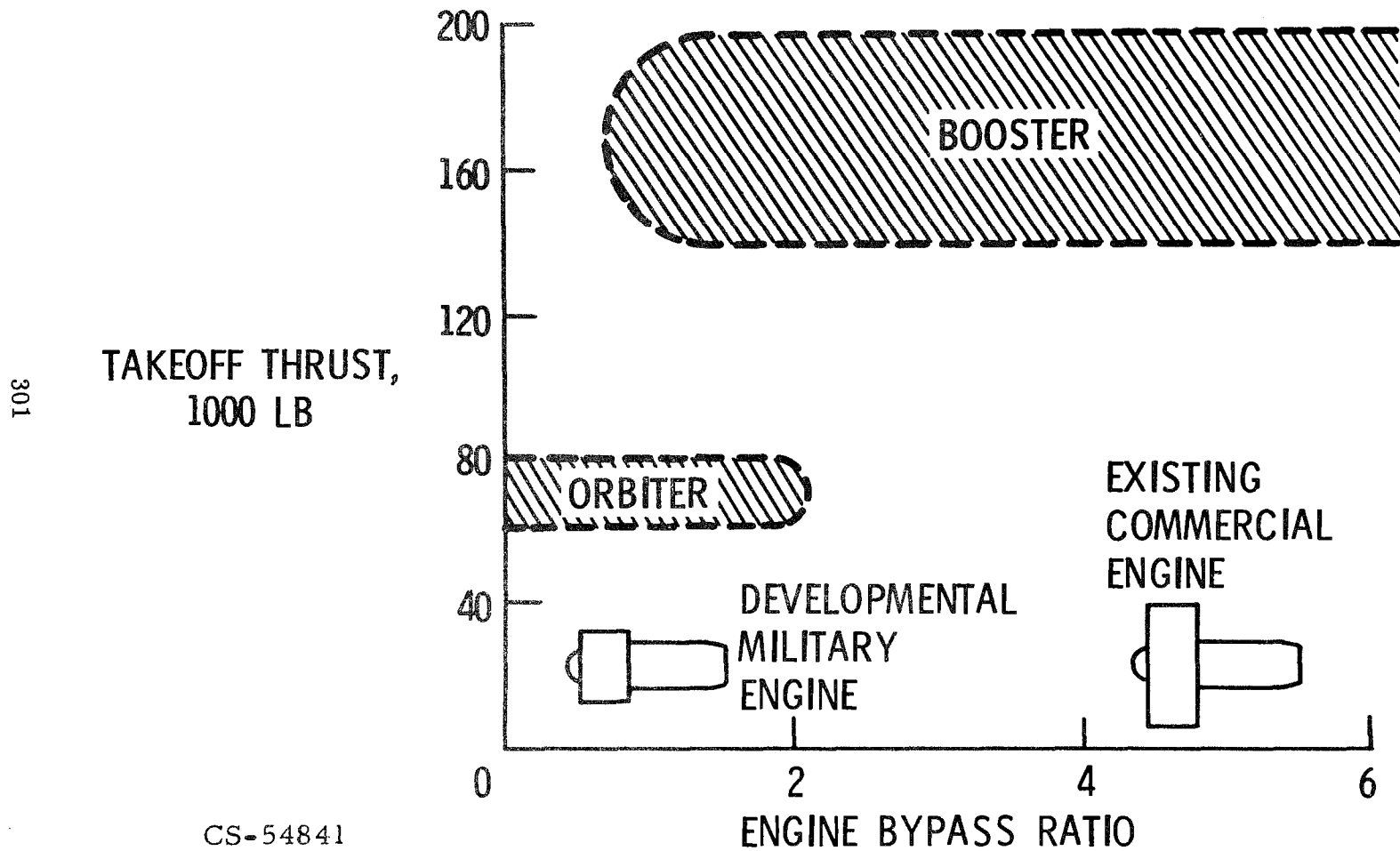

TECHNOLOGY AREAS

In considering the shuttle mission and engine requirements, we find that there are several new technology areas that must be explored before a firm design can be established. Experience with hydrogen fuel systems for jet engines has been very limited. With rocket engines, for which there is considerably more experience, the operating time is only a matter of minutes as compared to the several hundred hours required for the shuttle. The payload gain associated with engine weight reduction leads to the desire to explore lightweight-engine techniques and materials. The launch loads and vibration and the space vacuum and temperature environments require that examination be made of associated problems with materials, structures, bearings, and lubrication system.

TECHNOLOGY AREAS

HYDROGEN FUEL
SYSTEM
PUMP

LIGHTWEIGHT ENGINES

LAUNCH & SPACE ENVIRONMENT
STRUCTURES & MATERIALS
BEARINGS & LUBE SYSTEM

AIRCRAFT WITH PUMP-FED LIQUID HYDROGEN FUEL SYSTEM

Jet engines have been run on a test basis using hydrogen fuel. This figure shows a B-57 airplane that was used for such a purpose at Lewis Research Center in the mid 1950s. Modifications were made such that the engine could be run on hydrogen fuel during altitude flight. Successful operation was achieved.

AIRCRAFT WITH PUMP-FED LIQUID-HYDROGEN FUEL SYSTEM

305

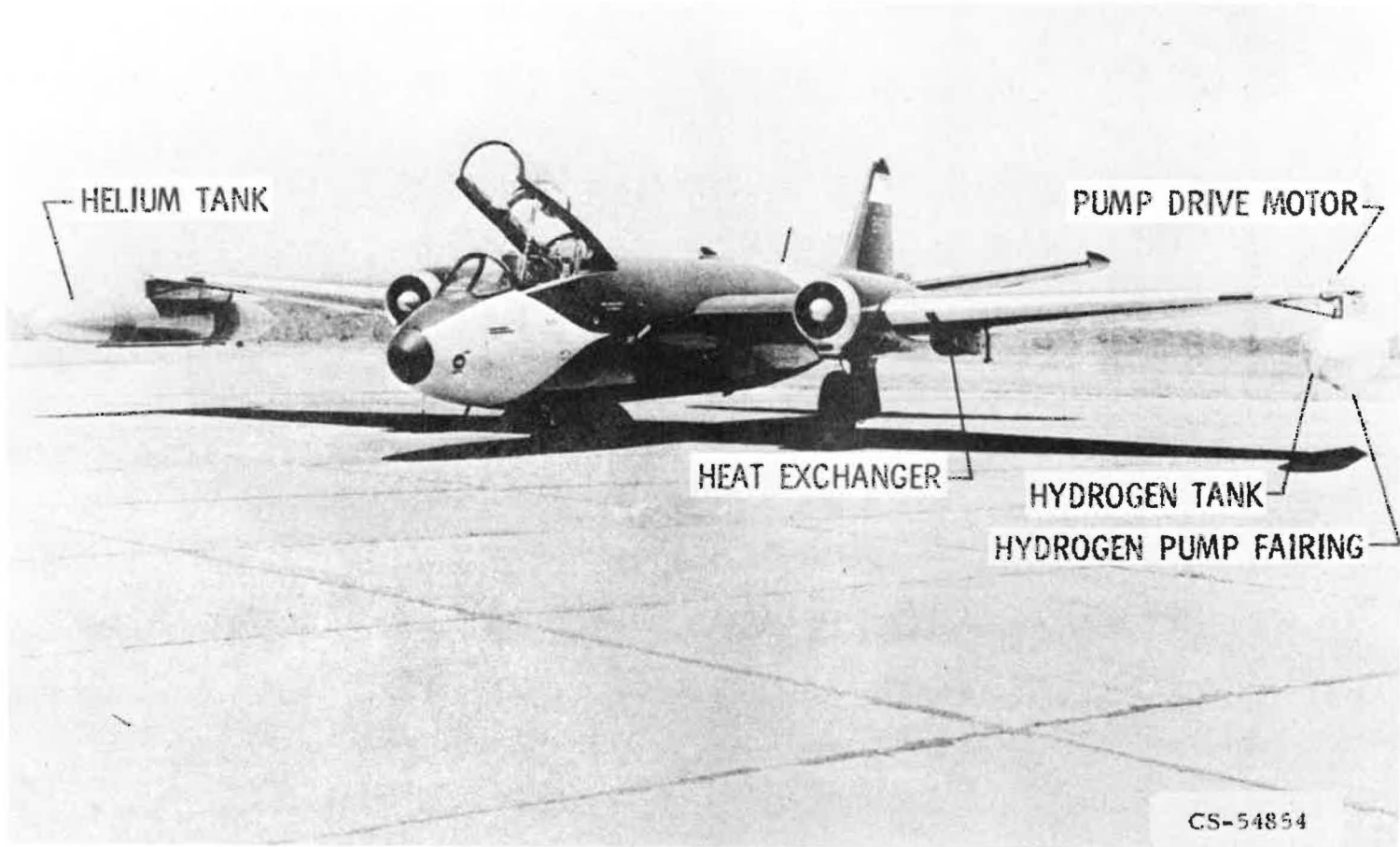

Charles L. Joslin

Experience with hydrogen at Pratt & Whitney Aircraft began in 1956. In 1957 the J-57 engine was converted to hydrogen fuel. The facing photograph shows the converted engine at the top compared with the standard JP fueled J-57. The shorter length of the modified version is due entirely to the afterburner being shortened to take advantage of the better burning characteristics of hydrogen.

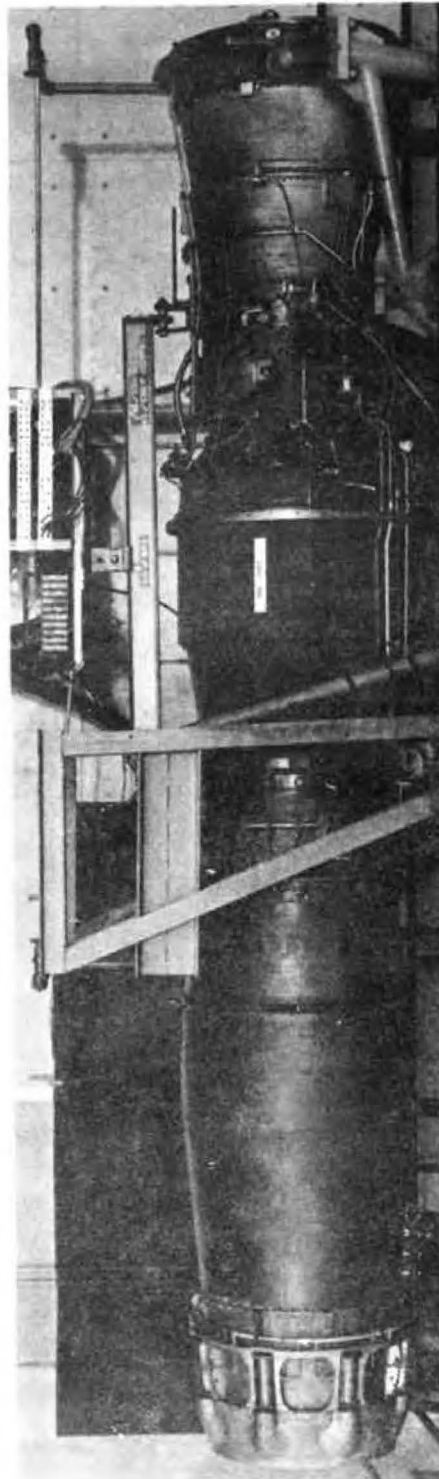
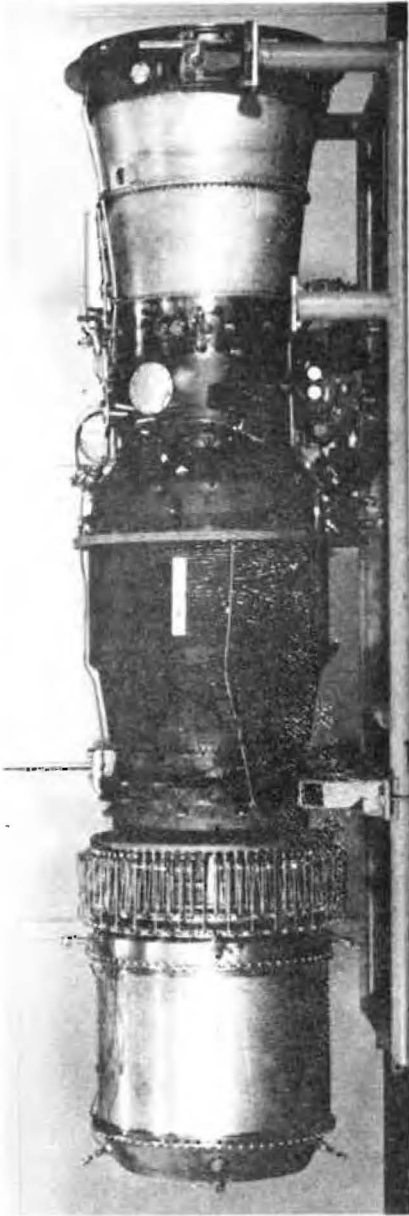

Comparison of J-57 Engine With H₂ Regeneratively Cooled Afterburner and With Standard Afterburner

This photograph shows the tailpipe of the converted J-57 engine operating on hydrogen fuel at full afterburning thrust. Although the afterburner gas temperature is approximately 4150°R, the afterburner case is cold since it is regeneratively cooled with hydrogen.

HYDROGEN-FUELED AFTERBURNER IN OPERATION

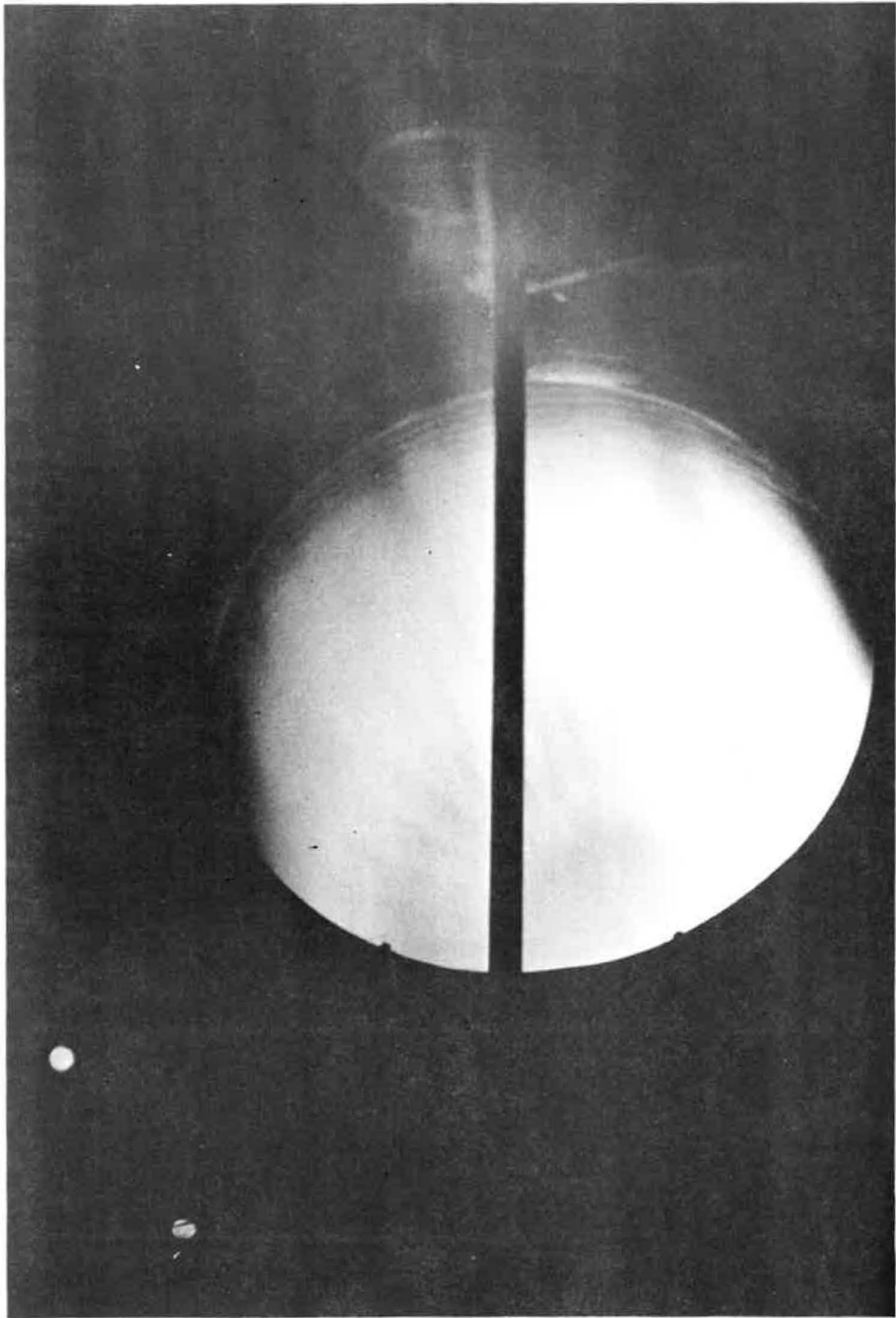

Relatively small increases in turbine inlet temperature can significantly improve engine performance. This figure illustrates the magnitude of this effect on a typical mixed flow turbofan engine. The higher temperature improves engine thrust-to-weight ratio. If the engine is augmented, increased turbine temperature also improves specific fuel consumption. If the engine is non-augmented, the specific fuel consumption increases slightly.

TYPICAL EFFECT OF TURBINE INLET TEMPERATURE ON ENGINE PERFORMANCE

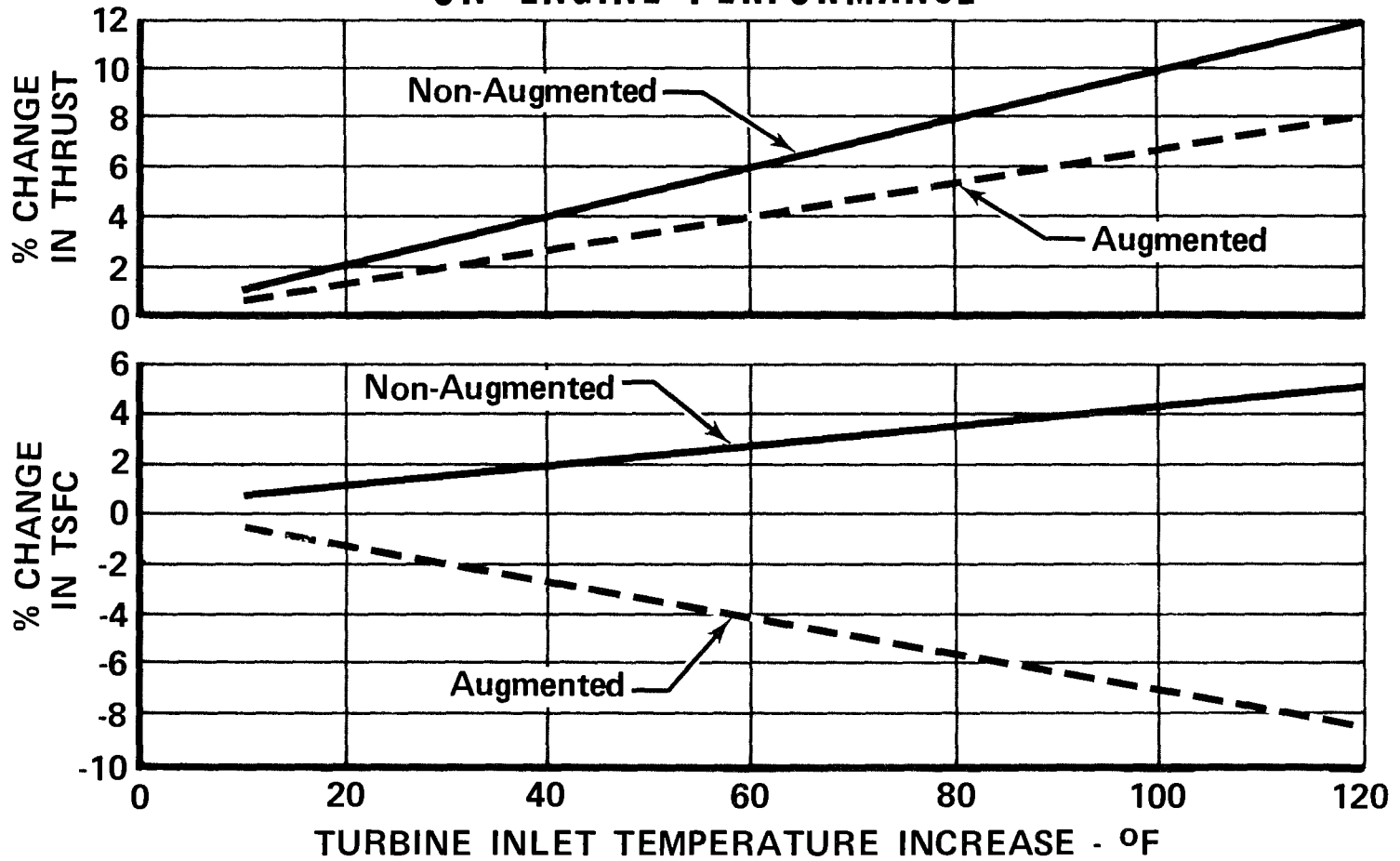

The Space Shuttle requires considerably less engine service life than a conventional aircraft. Reduced life, in turn, permits increased turbine operating temperature. This chart shows the approximate magnitude of this effect for a typical mixed-flow turbofan engine, based on representative duty cycles for the Space Shuttle booster and orbiter.

TURBINE TEMPERATURE CAN BE RAISED TO MATCH REDUCED LIFE REQUIREMENTS

TURBINE INLET TEMPERATURE INCREASE - °F

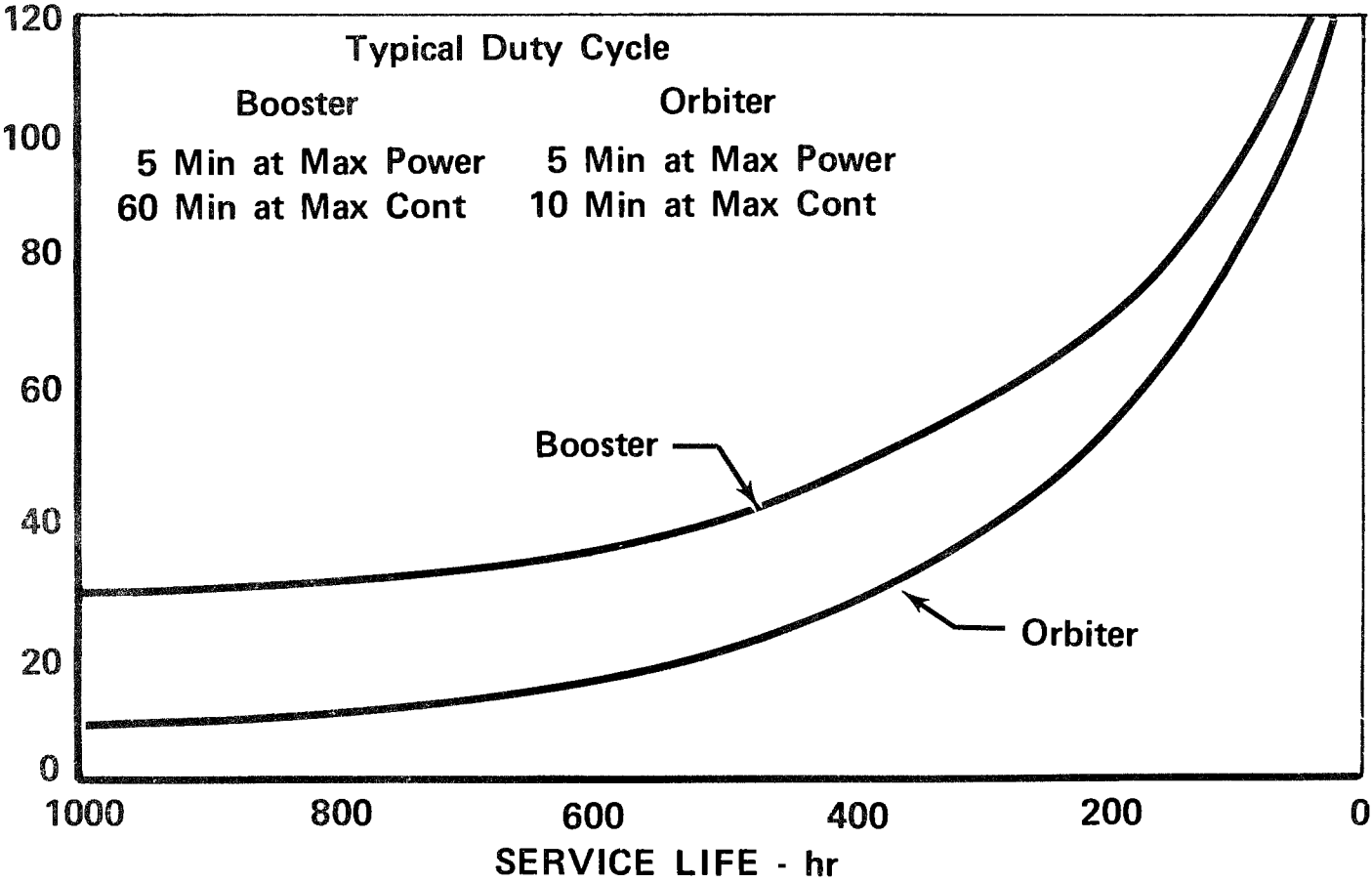

The use of hydrogen fuel introduces the possibility of raising the turbine inlet temperature by cooling the turbine cooling air. The facing chart illustrates the trade-offs associated with this technique.

Reducing the amount of cooling air improves specific fuel consumption while increasing turbine temperature raises thrust-to-weight ratio. Both of these effects reduce engine-plus-fuel weight, but a heat exchanger is required and this increases weight. The proper trade-off should produce a net gain for the mission.

CHANGE OF ENGINE-PLUS-FUEL-WEIGHT WITH TURBINE INLET TEMPERATURE AND TURBINE COOLING AIR

315

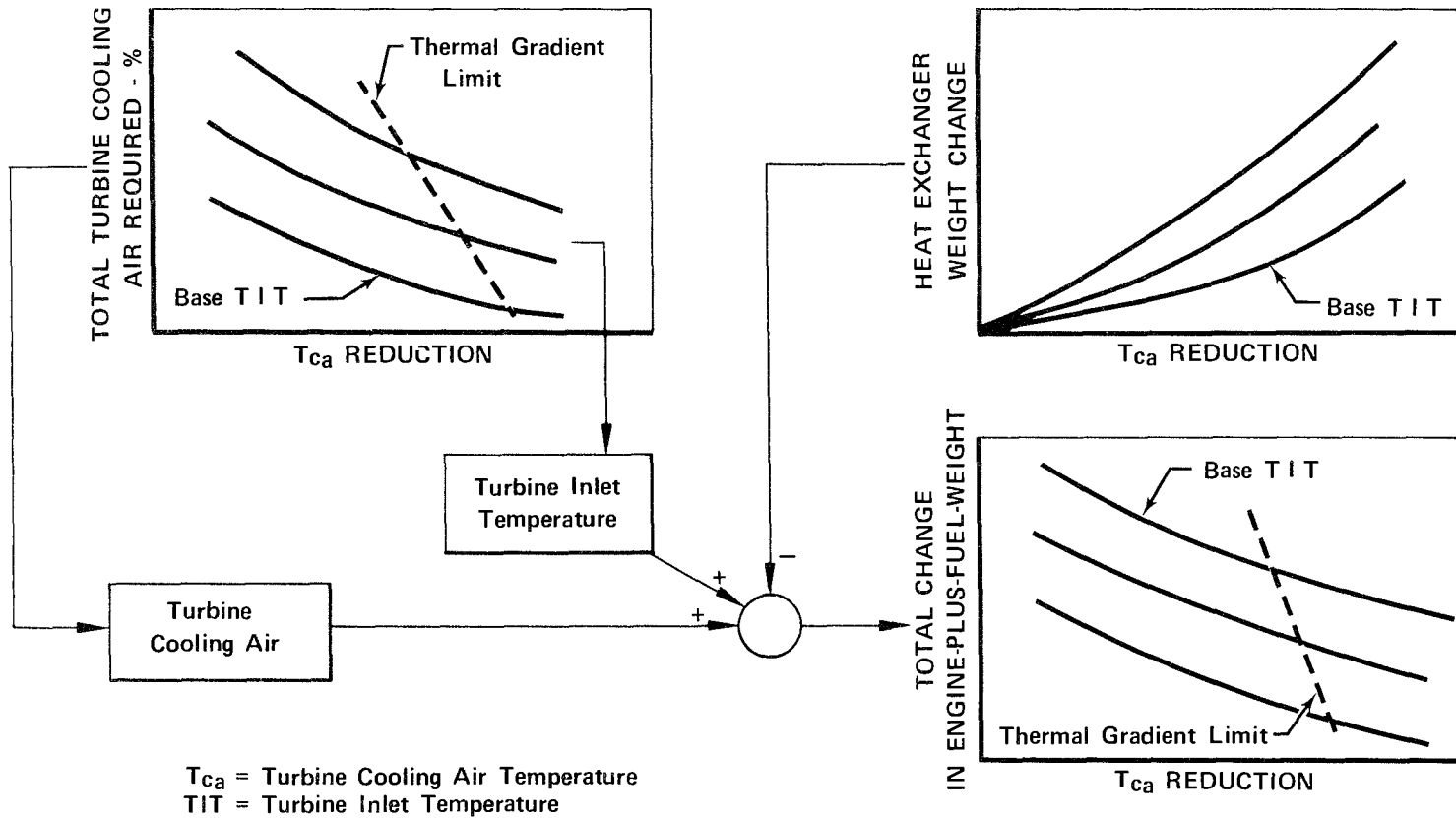

HYDROGEN FUEL SYSTEM

William R. Collier

The major modification necessary to adapt airbreathing engines to the Space Shuttle requirements is the conversion to cryogenic hydrogen fuel. NASA has a technology program to design and evaluate a hydrogen fuel system which will culminate in operation of a J85 engine on hydrogen fuel in 1971. The program will encompass the key development areas of pumping, regulation and metering of flow levels, and transient investigations.

While the actual combustion of hydrogen fuel is expected to be a routine development, a number of problems exist in supplying, metering and delivering the fuel in the proper state and quantity for combustion. The fuel is assumed to be supplied from the tank in the liquid phase, and at sufficient pressure at the main pump inlet to prevent cavitation.

The characteristic low starting fuel flow of a turbojet or turbofan engine necessitates a high pump turndown ratio, 40:1. This requirement coupled with a fast response places a stringent demand on the fuel supply system. A vane pump with variable speed drive is capable of delivering higher pressure in the low flow range than the more conventional centrifugal pumps. It is, however, recognized that little or no experience exists on vane pumps-pumping cryogenic fuels, and thus other types of pumps are also being studied.

HYDROGEN FUEL SYSTEM

- NASA / LEWIS TECHNOLOGY PROGRAM TO EVALUATE FUEL SYSTEM AND COMPONENTS BY ENGINE TESTING IN 1971
- DIRECTED TOWARD INVESTIGATION OF SUCH ITEMS AS
 - PUMPING
 - TEMPERATURE CONTROL
 - PRESSURE REGULATION
 - TRANSIENT CHARACTERISTICS
 - METERING
 - SAFETY

Control main fuel pump discharge is obtained by enclosing the pump in a closed servo-loop, with pump shaft speed regulated to maintain the discharge pressure at the constant reference level.

The heat exchanger is planned to provide sufficient heat addition to the fuel to assure that it will be gaseous as it enters the metering valve and will be designed for supercritical pressures to achieve a more predictable heat transfer coefficient.

The metering valve is designed for precise flow control and for accurate flow measurement. Area is varied as a function of the position of a fixed area plug which is positioned along the axis of the valve. The plug, or pintle, is controlled electro-hydraulically with the position measured and fed back by a linear variable differential transformer, (LVDT). The gas flow is then calculated from measured gas temperatures and pressures by the electronic computer and employed as a feedback signal in the fuel flow control loop. The metering valve area is thus controlled to maintain engine core speed during steady-state and transient operation.

FUEL SUPPLY SYSTEM

LH2 FUELED TURBOFAN

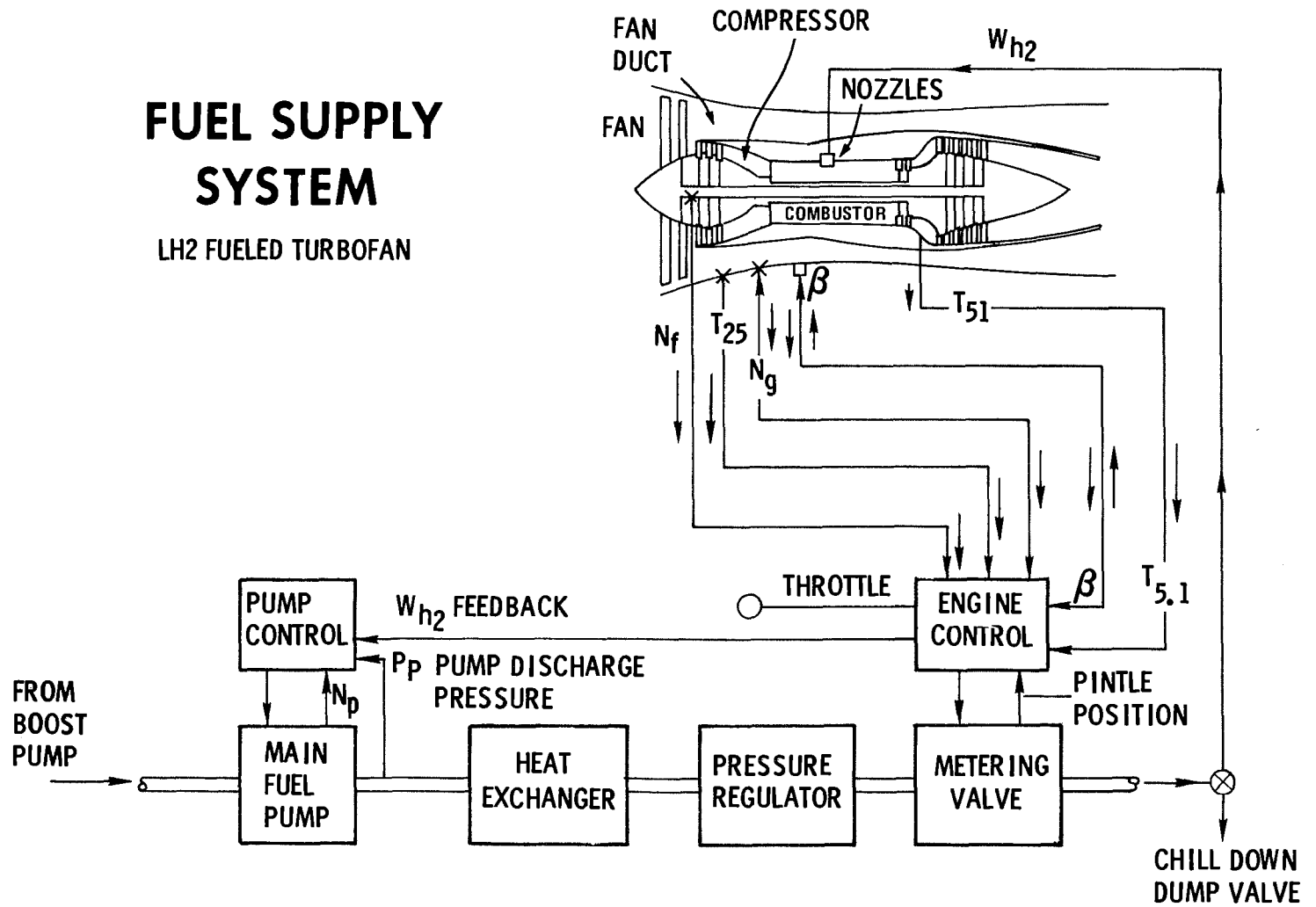

The need for the space shuttle to operate on cryogenic hydrogen fuel places a new set of requirements on the engine combustion system. No major problems are foreseen in burning hydrogen. Combustor sector testing and full scale testing of the J85 engine on gaseous hydrogen, as low as -244°F , have indicated smooth starts and stable operation. Slide 3 is a photograph of a hydrogen fuel injector used in the J85 engine test for 2 hours and 45 minutes.

The high reactivity of the fuel will in general improve light-off and stability limits, but it will also necessitate modification of the combustor liner to introduce more cooling air in the primary combustion zone. The reduced luminosity of the hydrogen flame will reduce radiation to the combustor liner so that some reduction in metal temperatures may be expected, improving part life.

J85 HYDROGEN FUEL NOZZLE

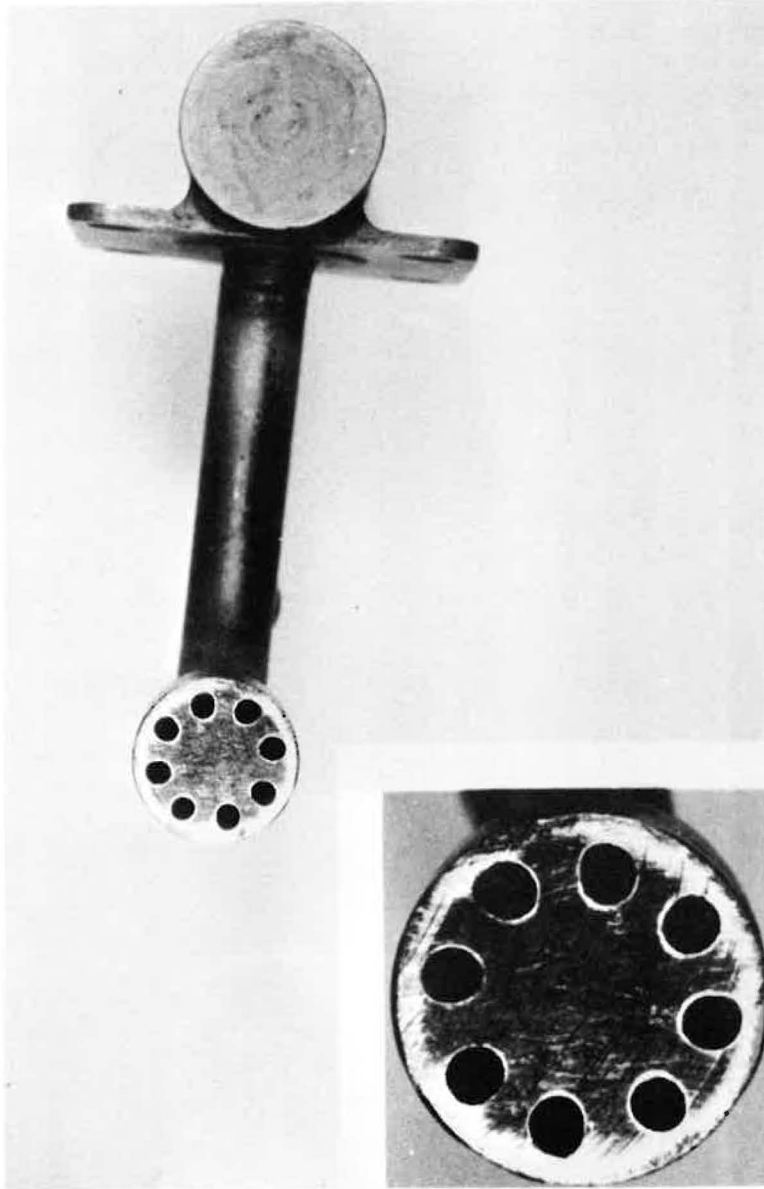

Charles L. Joslin

The marriage of the engine to the Space Shuttle vehicle introduces a variety of interface considerations. Of major importance to the vehicle manufacturer, is the positive suction pressure that must be provided at the inlet to the engine fuel pump. As can be seen in this chart, the RL10 rocket engine hydrogen fuel pump has been successfully operated with zero suction head when liquid was provided at the pump inlet.

RL10A-3-7 FUEL PUMP PERFORMANCE

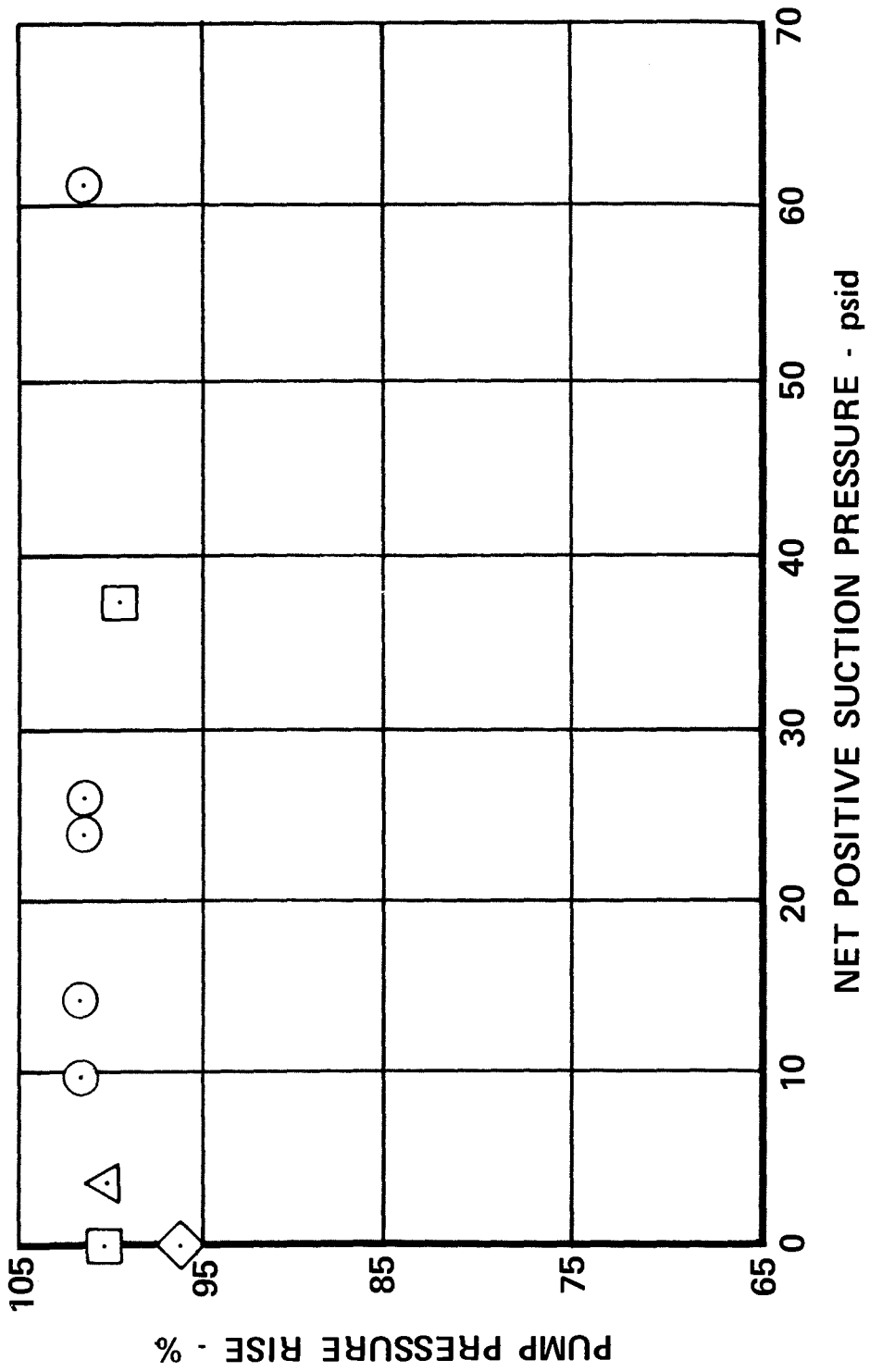

Another important interface requirement is the cooldown flow that must be provided to the engine. As can be seen in this figure, an increase in net positive suction pressure (possibly in conjunction with other techniques) can minimize cooldown time. There appears to be a trade-off between boost pump weight and cooldown propellant losses.

RL10 CRYOGENIC COOLDOWN EXPERIENCE

325

Time Period	Oxidizer Pump		Fuel Pump	
	Inlet Pressure, psia	Cooldown Required, sec	Inlet Pressure, psia	Cooldown Required, sec
1960 - 1964 Early Centaur Flights	110	20	45	20
1964 - 1965 Saturn Flights	45	10	35	40
1964 - 1965 Experimental RL10	45	0	55	0*

*KEL-F Internally Insulated Pump

This figure shows the Baljé plot. In it, Baljé has correlated the best of the various types of pumps in terms of specific speed and specific diameter. The circle shows the region which appears to apply to the space shuttle airbreathing engine. As can be seen, both the vane type positive displacement pump and the centrifugal pump may be candidates.

SELECTION OF MOST SUITABLE PUMP REQUIRES EXPERIMENTAL AND ANALYTICAL INVESTIGATIONS

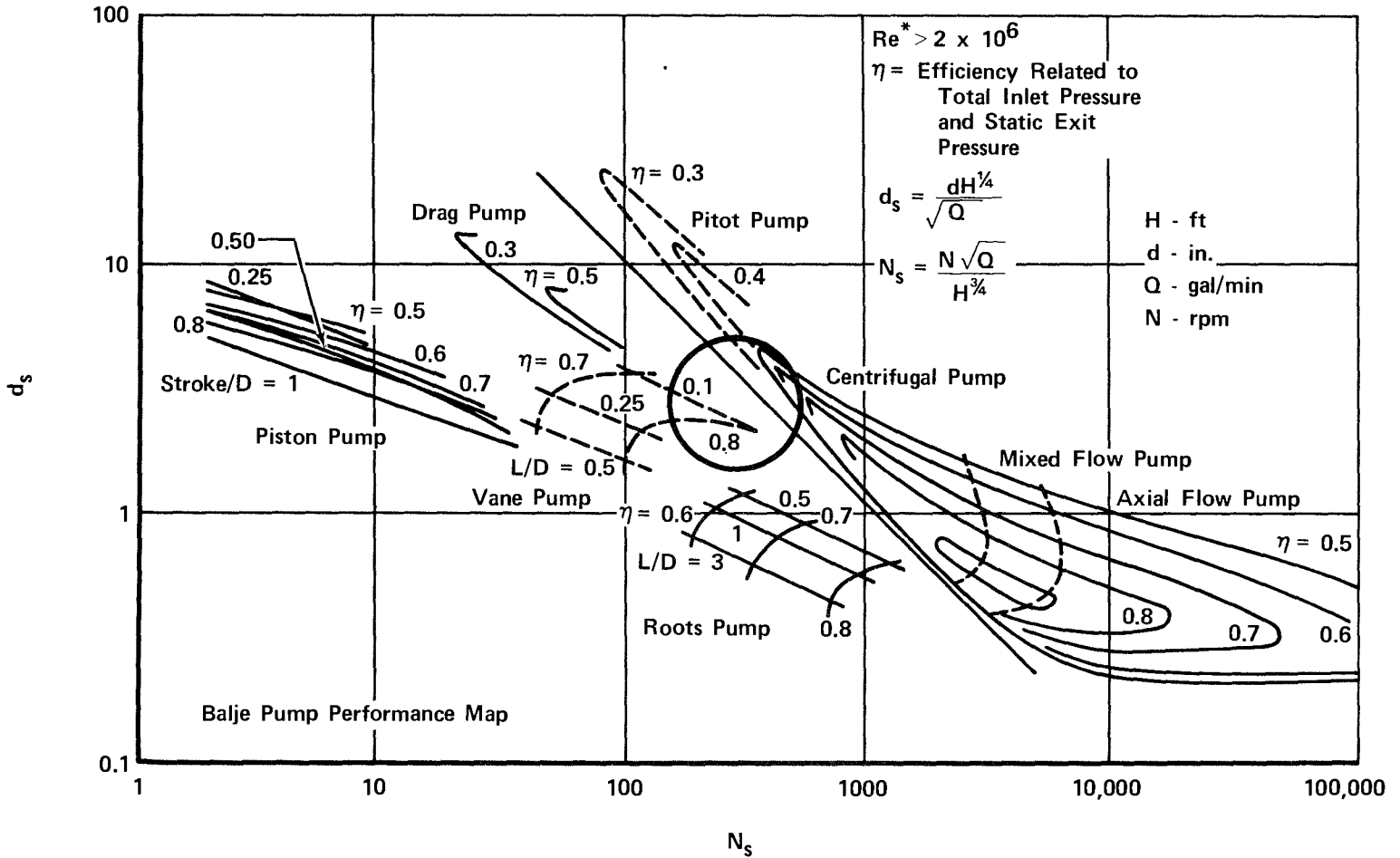

327

This figure shows schematics of representative positive displacement pumps. The positive displacement pump has some characteristics that are attractive for Space Shuttle application. However, no flight type cryogenic positive displacement pump has ever been developed.

POSITIVE DISPLACEMENT PUMP TYPES

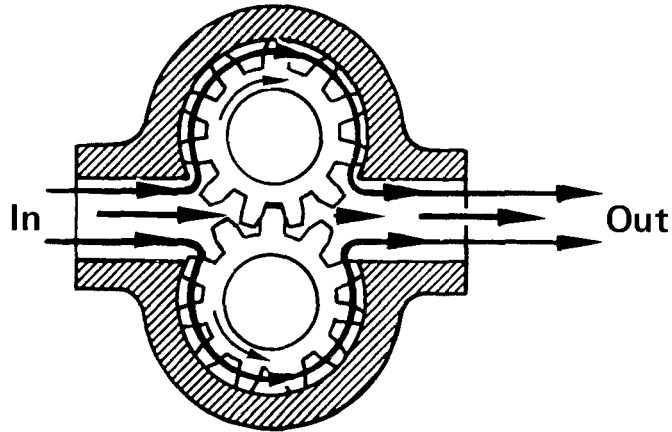

a. Gear Pump-External

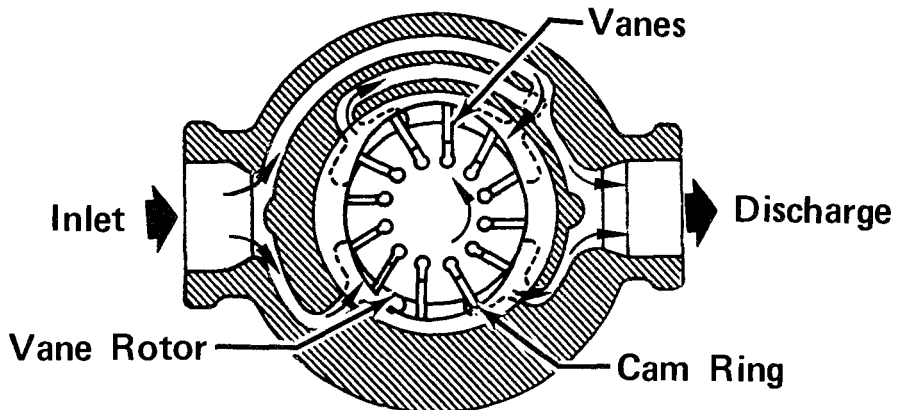

b. Balanced Rotor Vane Pump

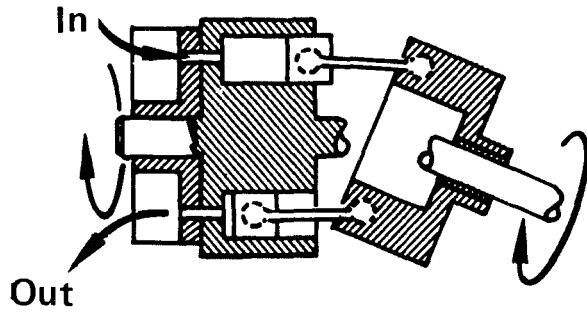

c. Bent Axis Piston

This figure is a schematic of a typical modern cryogenic centrifugal pump. The experience that has been gained with centrifugal hydrogen pumps provides a sound base for the Space Shuttle engine fuel system.

CENTRIFUGAL TURBOPUMP

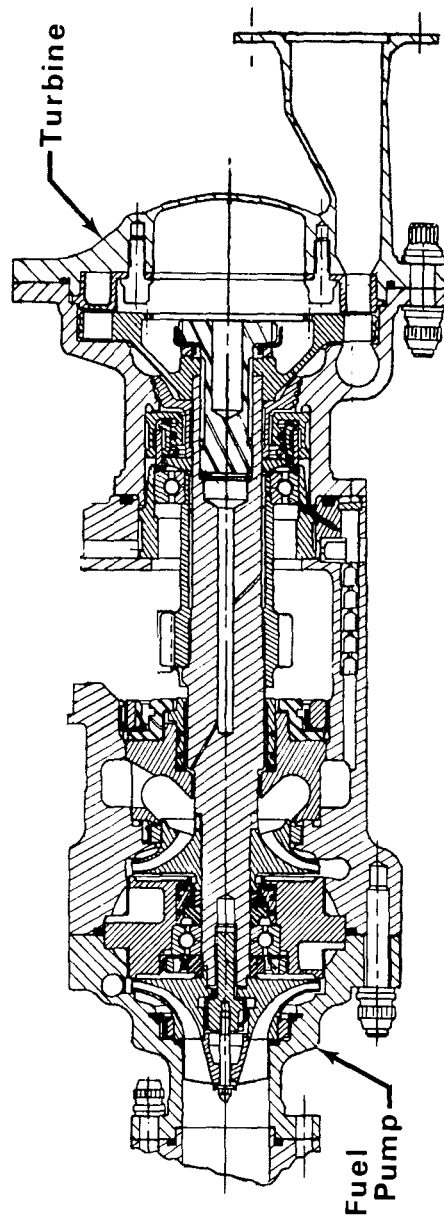

In this chart the fuel flow requirements of the JT9D turbofan engine are plotted against typical centrifugal pump characteristics. Because of the wide flow range required, the pump may be operating in or near stall at the high altitude-low fuel flow conditions.

TYPICAL HYDROGEN PUMP WITH JT9D FUEL PRESSURE AND FLOW REQUIREMENTS

333

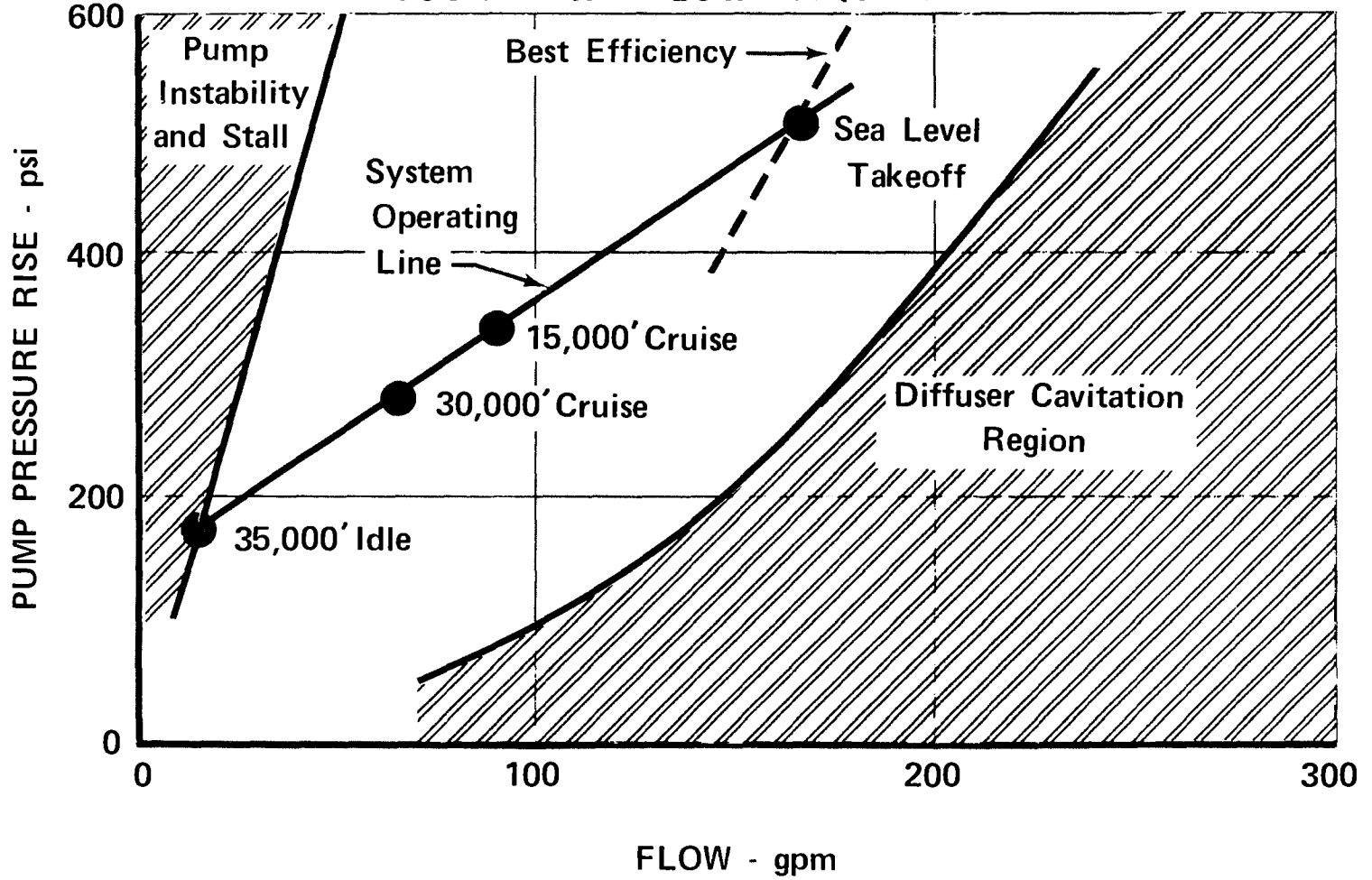

Previous hydrogen pumps have been developed for rocket engines with very low life requirements compared to an airbreathing engine. Although the service life of the Space Shuttle airbreathing engines has not been specified yet, a 250 to 500 hour life requirement for the engine may mean that the fuel pump should have a life of 500 to 1000 hours. This introduces a new area of hydrogen bearing technology, as can be seen in the facing table.

HYDROGEN COOLED BEARING TECHNOLOGY

Demonstrated Life

Time, hr

80 mm (Ball) 4 Million DN	0.2
200 mm (Ball) 3 Million DN	1.2
35-40 mm (Ball) 1.2 Million DN	50
35-40 mm Roller 0.8 Million DN	50

Required Life

25-40 mm (Ball) 1.4 Million DN	500-1000
20 mm (Roller) 0.2 Million DN	500-1000

HOLLOWED BALL BEARINGS

Warner L. Stewart

Several advanced bearing concepts for operation in a cryogenic environment are being studied at Lewis Research Center. These bearing concepts have potential application for both the main rocket engine pumps and the airbreathing engine fuel pump. Being studied are a self-lubricating concept using lead-coated retainers and a concept using hollow (drilled) balls as shown in this figure. This type of bearing with oil lubrication has been run at 3 million DN for a period of 4 hours. Testing is being continued.

HOLLOWED BALL BEARING



C-69-1256
CS-54845

Airbreathing Engines for Shuttle Vehicles (VML 42793)

Lindsay G. Dawson

The facing diagram indicates the value of applying lift engine technology to the Orbiter vehicle gas turbine engines.

A saving of up to 50% in installed engine and fuel weight would appear possible as compared with advanced military and civil engine technology.

In the case of the Orbiter this saving is directly recoverable as payload.

In the case of the Booster low specific consumption civil engine technology results in a lower total engine and fuel weight due to the longer duration of the Booster cruise mission.

Further improvements to the installed weight can be expected by the application of short life engine technology to these engines.

AIRBREATHING ENGINES FOR SHUTTLE VEHICLES

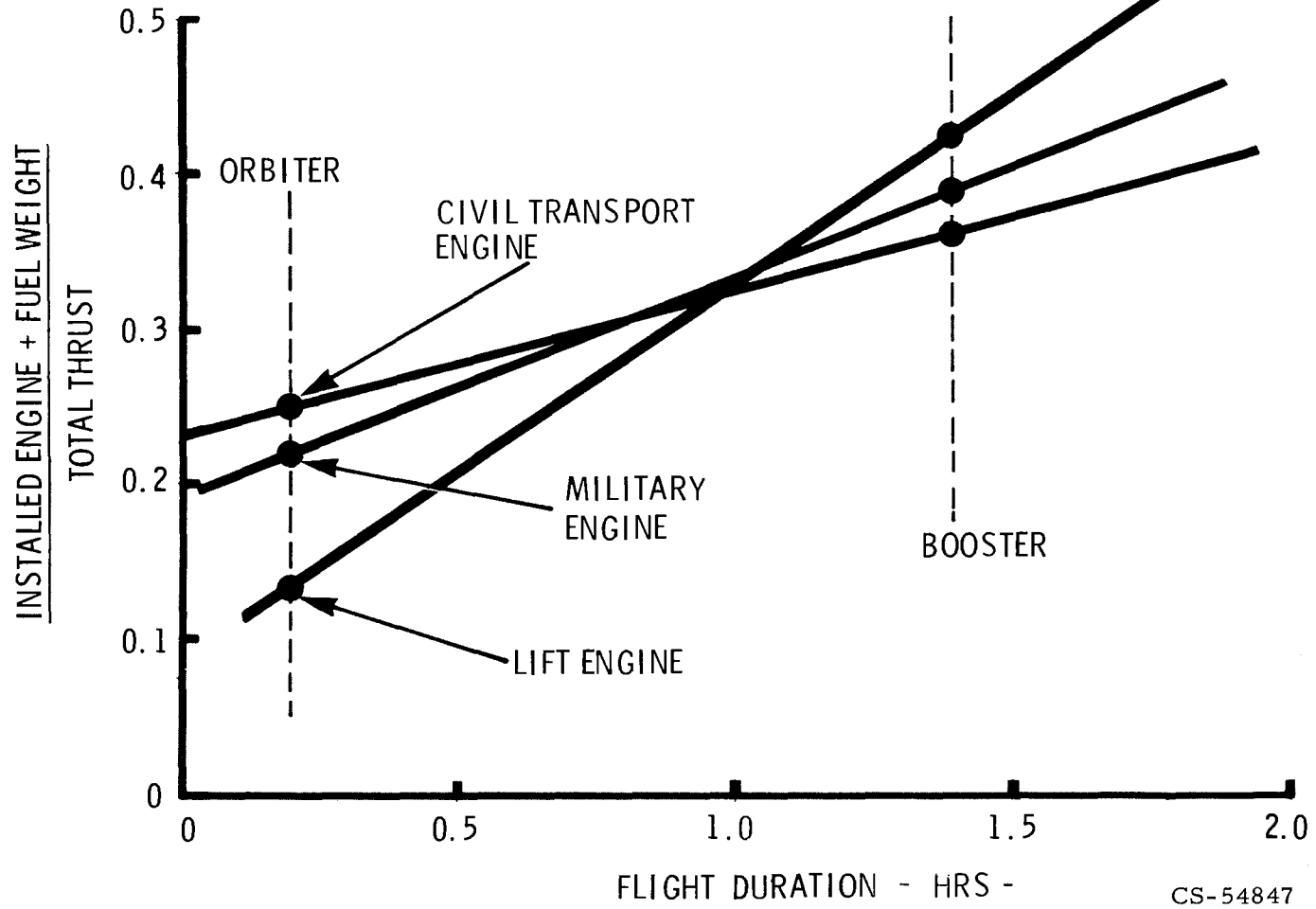

339

CS-54847

RB.162 - Components in Composite Material (Dec 1969 4513)

This picture shows the extensive use of fibre glass composite material in the RB.162 lift engine. Compressor blading, stator casings, front bearing housing, intake fairing, inlet guide vanes and front bearing housing oil reservoir, are all constructed of composite material. The stator case is in two halves joined by a renewable glass fibre bandage.

RB.162 – Components in composite material

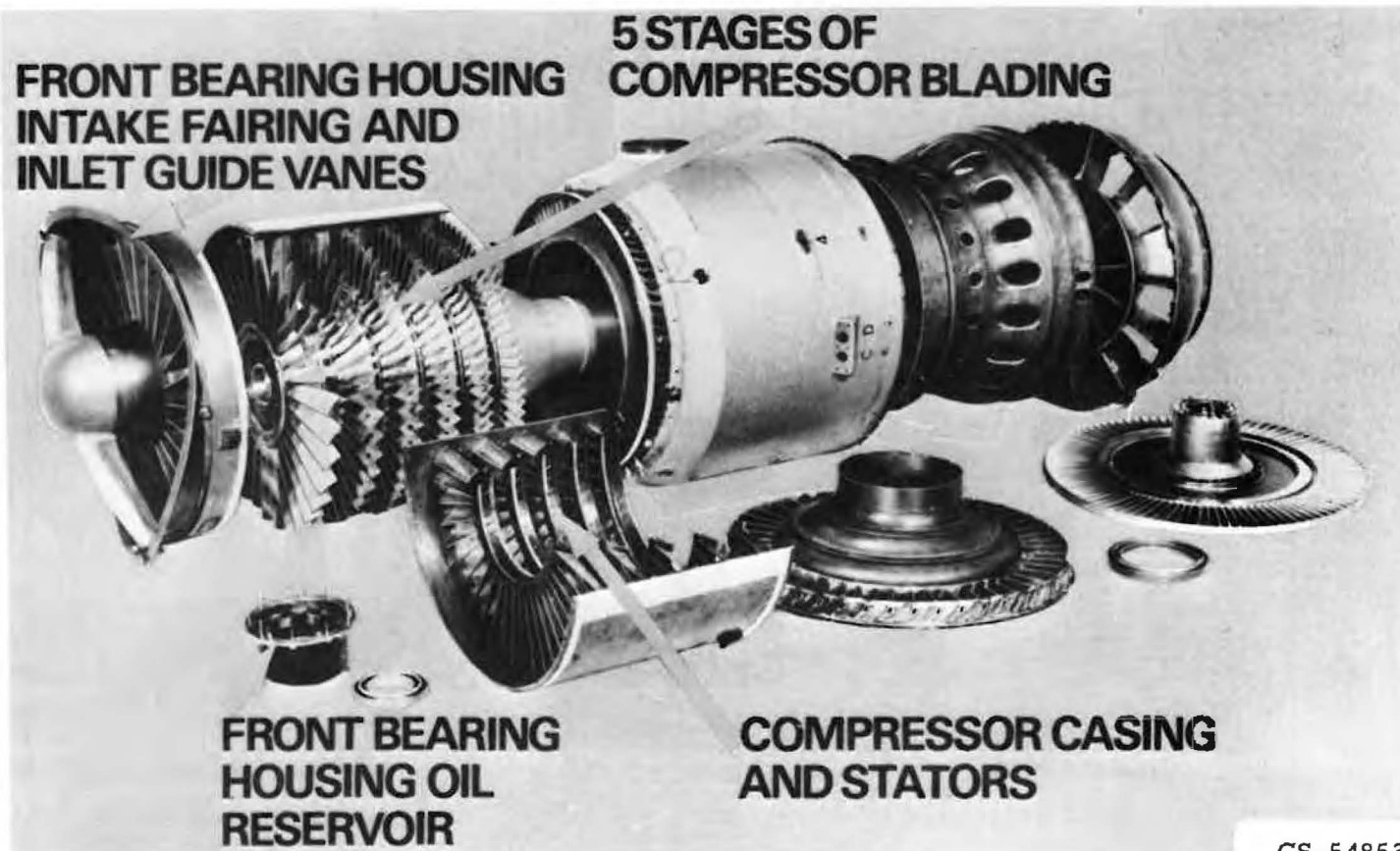

341

CS-54853

Potential Weight Saving for Space Shuttle Application (WLL #2814)

The chart illustrates the potential weight reduction obtained by deleting those features of a commercial fanjet which may not be required for Space Shuttle operation.

The first bar indicates the basic engine weight (less installation features) for initial airline supply and includes titanium fan blades.

The second bar is our datum for Space Shuttle application and is the eventual airline basic engine standard with Myfil fan blades. From this datum we illustrate a progressive weight reduction by eliminating such features as, full blade containment, design for long life commercial operation, aircraft accessory drives, fuel systems, modular construction, cabin off-takes etc.

POTENTIAL WEIGHT SAVING FOR SPACE SHUTTLE APPLICATION
BASED ON RB 211 ENGINE

343

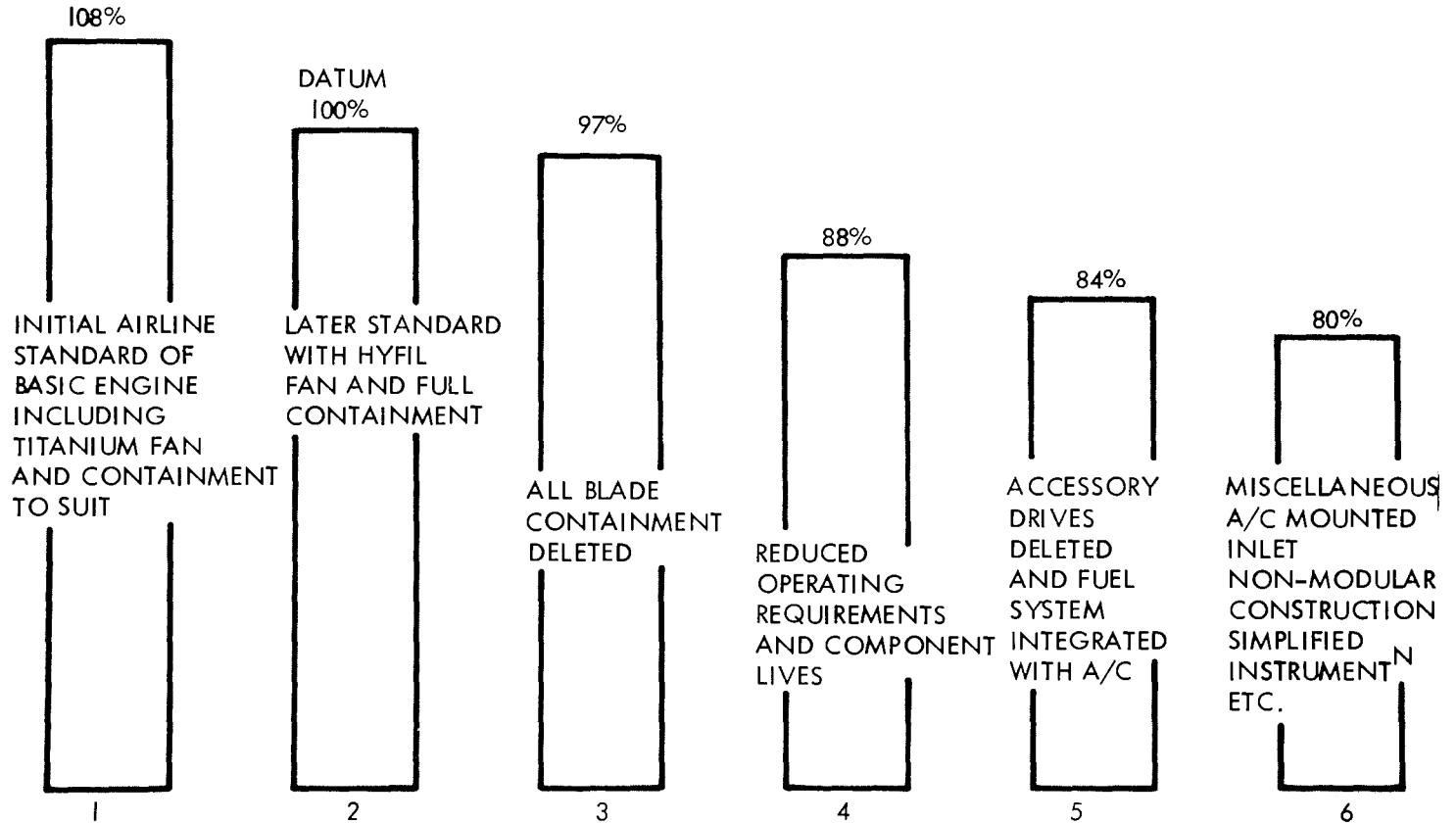

Hyfil Fan Blade (2024)

The Hyfil RB.211 fan blade has an aerofoil span of approximately 30 in. and weighs 10.6 lb.

The aerofoil has a metal foil reinforced leading edge because of hard object and bird ingestion, and the blade flanks are erosion coated.

The aerofoil is carried on a single curved dovetail root.

RB. 211 Hyfil fan blade

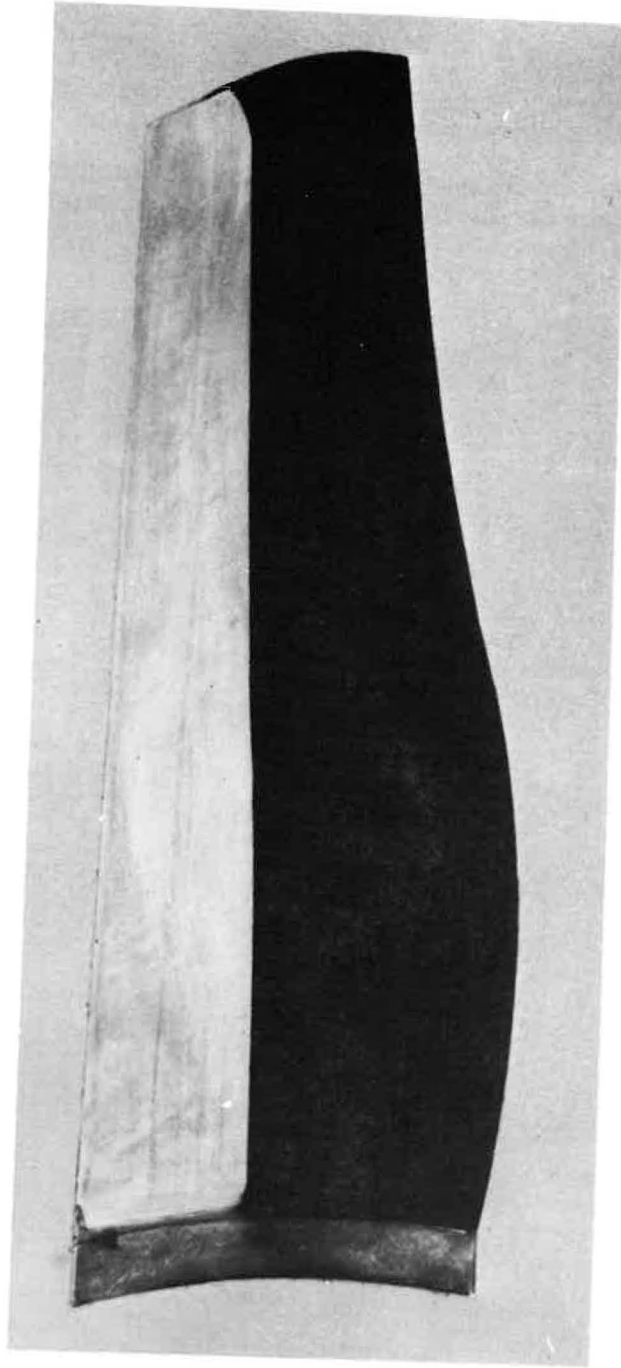

CS-54850

Typical Layup (14070/1)

The Hyfil blade is built up from shaped laminates stamped out of Hyfil sheet material. Most of the laminates have the carbon fibres running in the spanwise direction, though some have the carbon fibres angled.

The pack of laminates (including the metal foil) is die moulded to produce the finished aerofoil blade shape.

TYPICAL LAY-UP OF COMPOSITE ROTOR BLADE

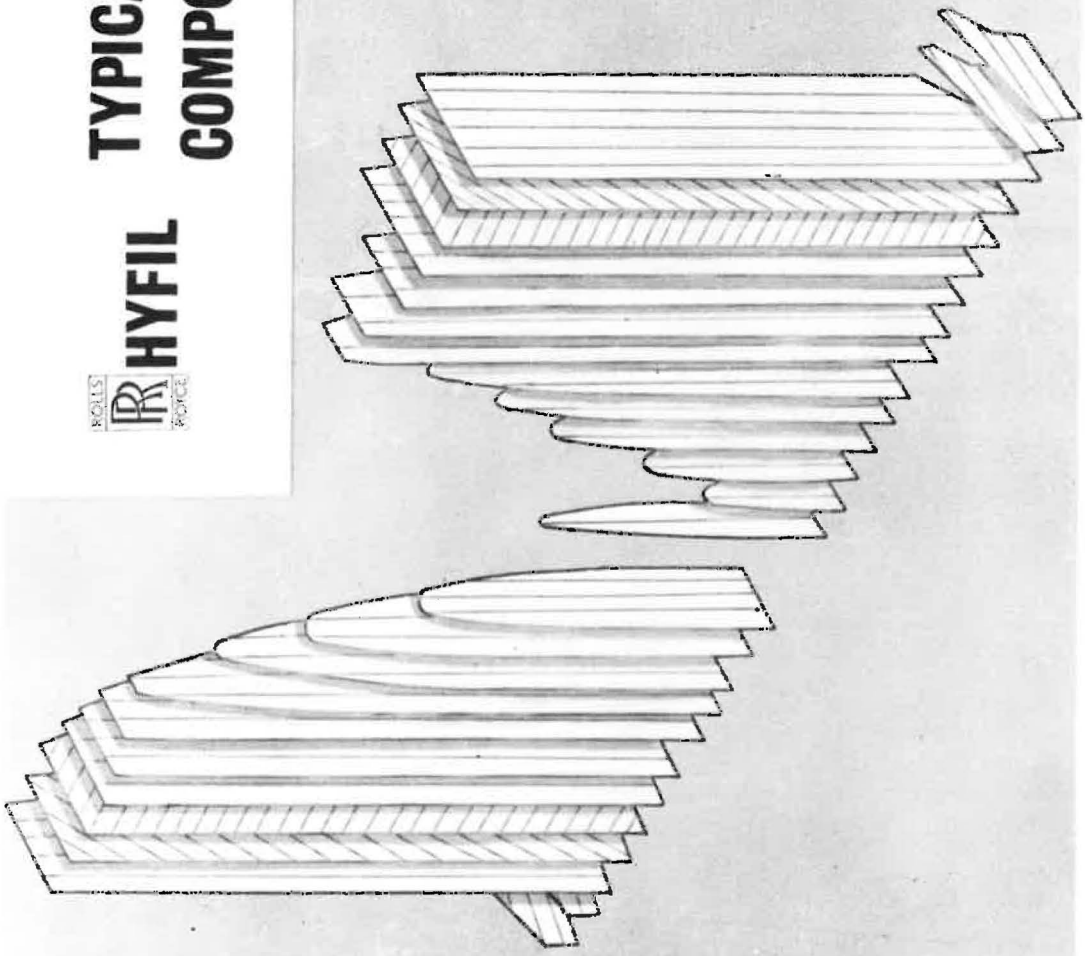

CS-54852



Root Sections - Diagrammatic (VML 42435)

The Hyfil laminates comprising the blade aerofoil fit into the blade root, where they are interspersed with glass reinforced composite to make up the dovetail root fixing.

Currently, blades for the engine development programme are being made with the "interleaved" root, which rig and engine testing has shown to have adequate overspeed capability.

The "split wedge" root is an alternative construction which is being looked at, as it has a number of manufacturing advantages.

RB 211 HYFIL FAN BLADE
ROOT SECTIONS - DIAGRAMMATIC

HYFIL 
GLASS
COMPOSITE 

349

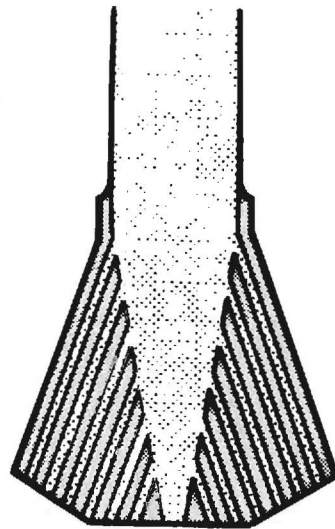

INTERLEAVED ROOT

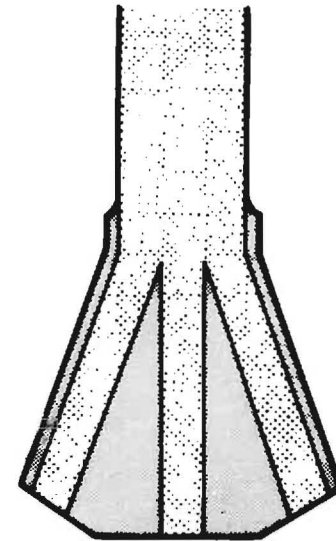

SPLIT-WEDGE ROOT

Blade Root Section (SMP 89237)

The picture opposite shows the actual cross section of an "interleaved" Hyfil fan blade root.

All blade roots are subject to N.D.T. (Non Destructive Testing) including X-ray and ultrasonic checks.

Blade root development includes static tensile testing of test pieces and of full size fan blades as well as blade spinning.



CS-54851

NEW ENVIRONMENTS FOR ENGINES

Warner L. Stewart

The airbreathing engines for the shuttle will be subjected to environments never before faced by jet engines in commercial or military service. The engine structures and materials must survive the launch loads and vibration, the reentry heating temperatures, and the space soak temperatures. Lubrication fluids have to be protected against evaporation during vacuum exposure. Outgassing of non-metallics must be considered. Space radiation may affect certain materials and fluids. The engine must start reliably in flight after exposure to the new environments. Some of these items are covered in the discussion to follow.

NEW ENVIRONMENTS FOR ENGINES

LAUNCH LOADS & VIBRATION

REENTRY HEATING TEMPERATURES

SPACE SOAK TEMPERATURES

HARD VACUUM

SPACE RADIATION

CS-54842

LUBE SYSTEM

William R. Collier

The space shuttle environment introduces two major problems in the area of the lubrication system. These are associated with the space environment and use of cryogenic fuel.

A potential problem is cold-welding of metal parts which are in intimate contact at very low pressures. Although this phenomenon may not be a serious concern based on available spacecraft experience, it warrants further investigation in certain key areas such as ball or roller bearings. Special coatings or dry film lubricants may be required to inhibit cold-welding of these parts. In the case of the orbiter, the main shaft bearings should be fully unloaded and vibration levels are expected to be low, thus it is unlikely that sufficient unit loading will occur to cause trouble.

Another point of concern is the danger of brinnelling the bearings during the launch phase. Experience has indicated that brinnelling problems can occur during engine shipment, when subjected to vibratory and impact loading with the rotor stationary. Since the time during launch when the engines will be exposed to high vibration levels is relatively short, this problem may be insignificant. If it does occur, the engines could be motored slowly during the launch to continuously reseal the bearings.

ENGINE LUBRICATION SYSTEM

CURRENT ACTIVITY DIRECTED TOWARD MODIFICATION OF THE ENGINE LUBE SYSTEM IN CONSIDERATION OF:

- ENVIRONMENT
 - POTENTIAL HIGH VACUUM
 - TEMPERATURE
 - ISOLATION
- COOLING DURING ENGINE OPERATION
 - OIL TO AIR HEAT EXCHANGER
- BEARING LIFE & RELIABILITY
 - BRINNELLING
 - "COLD WELDING"

Current engine technology employs a dry-sump lubrication system with the bulk of the oil stored in an external tank. Oil is supplied to all bearings and gears by an engine driven gear-type main oil pump, and scavenged from the sumps and gearboxes by multiple element scavenge pumps. It is then deaerated, cooled, and returned to the tank.

The vacuum environment, particularly for the orbiter, will expose the engine to pressures as low as 10^{-7} in. Hg. This could cause evaporation or outgassing of residual fluids through the shaft seals and engine vent, with possible deposition on critical surfaces of the vehicle. This problem can be controlled by isolating the oil in the tank by shutoff valves or diaphragms until the engine is readied for use. The temperature environment of the oil tank must also be such as to prevent freezing of the oil, or a heating element may be required. Alternate oils such as silicone types will also be considered from the standpoint of improved thermal characteristics.

The fact that the booster vehicle will be subsonic in its flight application permits the use of ram air for cooling the oil. Air/oil coolers could be mounted in the inlet ducts of the engines. This type of cooler would be highly desirable from a system reliability and safety standpoint, but would be generally heavier than its fuel/oil counterpart. The technology for such a heat exchanger is in-hand, and it has the advantage of keeping the lube system for each engine entirely self-contained, minimizing the number of interfaces with the vehicle.

LUBE SYSTEM SCHEMATIC

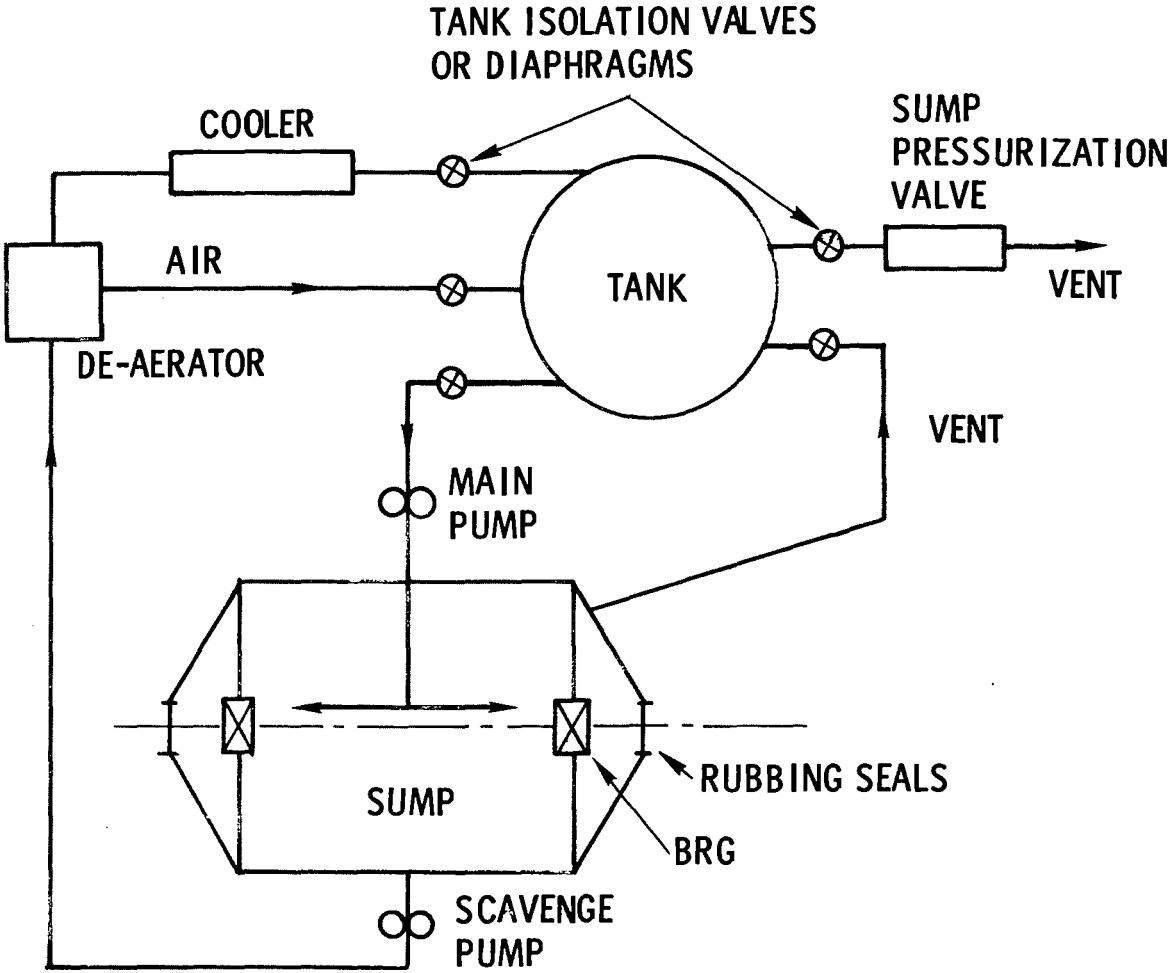

ENGINE MATERIALS & STRUCTURES

The use of current airbreathing aircraft engine technology in the space shuttle vehicles requires that the materials used in the engines be carefully reviewed in light of the pressures and temperatures to be encountered in the space environment. These conditions will be considerably more severe in the orbiter which must withstand up to 30 days in orbit than in the booster. This slide presents a typical list of the materials currently used in engines.

It is expected that the metallic materials will be unaffected by the orbiter environment, however, the non-metallic organic materials can suffer varying degrees of damage due to the low pressure (10^{-5} to 10^{-7} Torr) and temperature variations (-200 to + 300 F is possible, depending on the installation). Fortunately, the Viton A elastomer commonly used for the O-ring seals and the Teflon used for fuel and lubricant hoses, are among the better elastomers tested for spacecraft use. Most spacecraft evaluations, however, have not covered the entire possible temperature range for the orbital soak condition. The structural stability of various plastics and potting compounds used in electrical components must also be investigated. All lubricants and hydraulic system fluids will require careful study to determine if material as well as system changes must be made.

ENGINE MATERIALS & STRUCTURES

METALLICS	NON-METALLICS
FAN & COMPRESSOR SECTION <ul style="list-style-type: none">● TITANIUM ALLOYS● NICKEL BASE ALLOYS	SEALS <ul style="list-style-type: none">● ELASTOMERICS● VITON A
COMBUSTOR & TURBINE SECTION <ul style="list-style-type: none">● NICKEL BASE ALLOYS	OIL HOSES <ul style="list-style-type: none">● TEFLON
SHAFTING, GEARS & BEARINGS <ul style="list-style-type: none">● HIGH STRENGTH STEELS<ul style="list-style-type: none">- MARAGED- 9310 AND M-50	DUCT CASINGS <ul style="list-style-type: none">● POLYIMIDE
GEARBOX <ul style="list-style-type: none">● ALUMINUM OR MAGNESIUM ALLOYS	

A potential problem common to both booster and orbiter engines arises from the use of hydrogen as fuel. Considerable effort was expended by General Electric in 1957-1965 period investigating the effects of hydrogen combustion products on the high temperature alloys used for turbine hot parts. Reductions in fatigue and stress-rupture strengths were noted for several alloys when tested in hydrogen combustion products instead of air. While these tests were generally conducted with fuel-rich combustion, there is evidence that the high water vapor content of the hot gas was at least partly responsible for about 10% loss in fatigue and rupture strength. Degradation of the 1800°F fatigue strength of Rene'41 is shown in Slide 8.

FATIGUE BEHAVIOR OF RENÉ 41

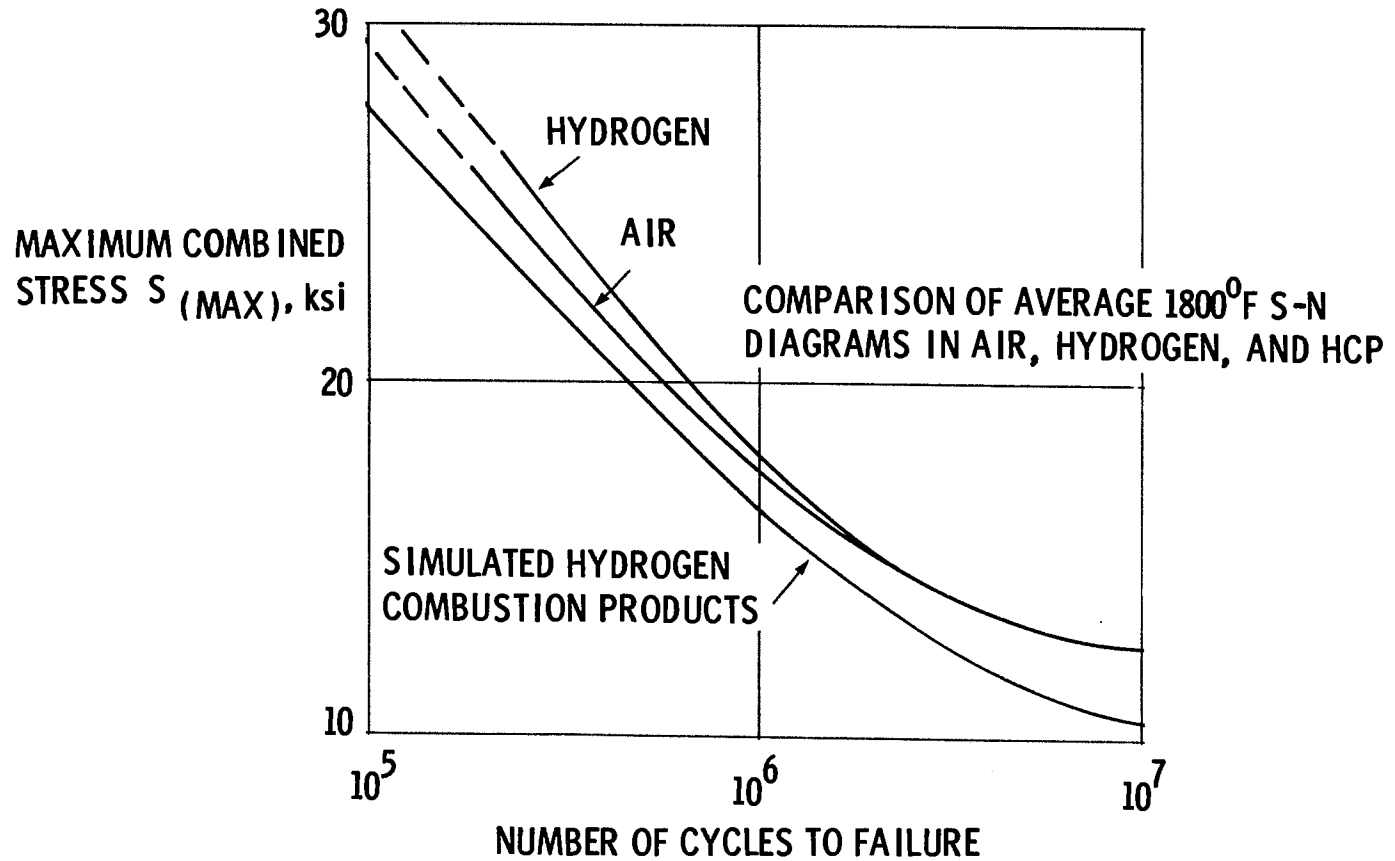

Slide 9 shows the effect on stress-rupture strength of this alloy. An assessment will be made of whether these effects will influence life or reliability of materials used in the selected engine.

In addition to the effects of hydrogen combustion products on hot parts, materials used in the fuel delivery system to the combustor must be carefully selected to assure that their mechanical properties are not harmfully degraded by liquid or gaseous hydrogen.

RENÉ 41 MASTER RUPTURE CURVES

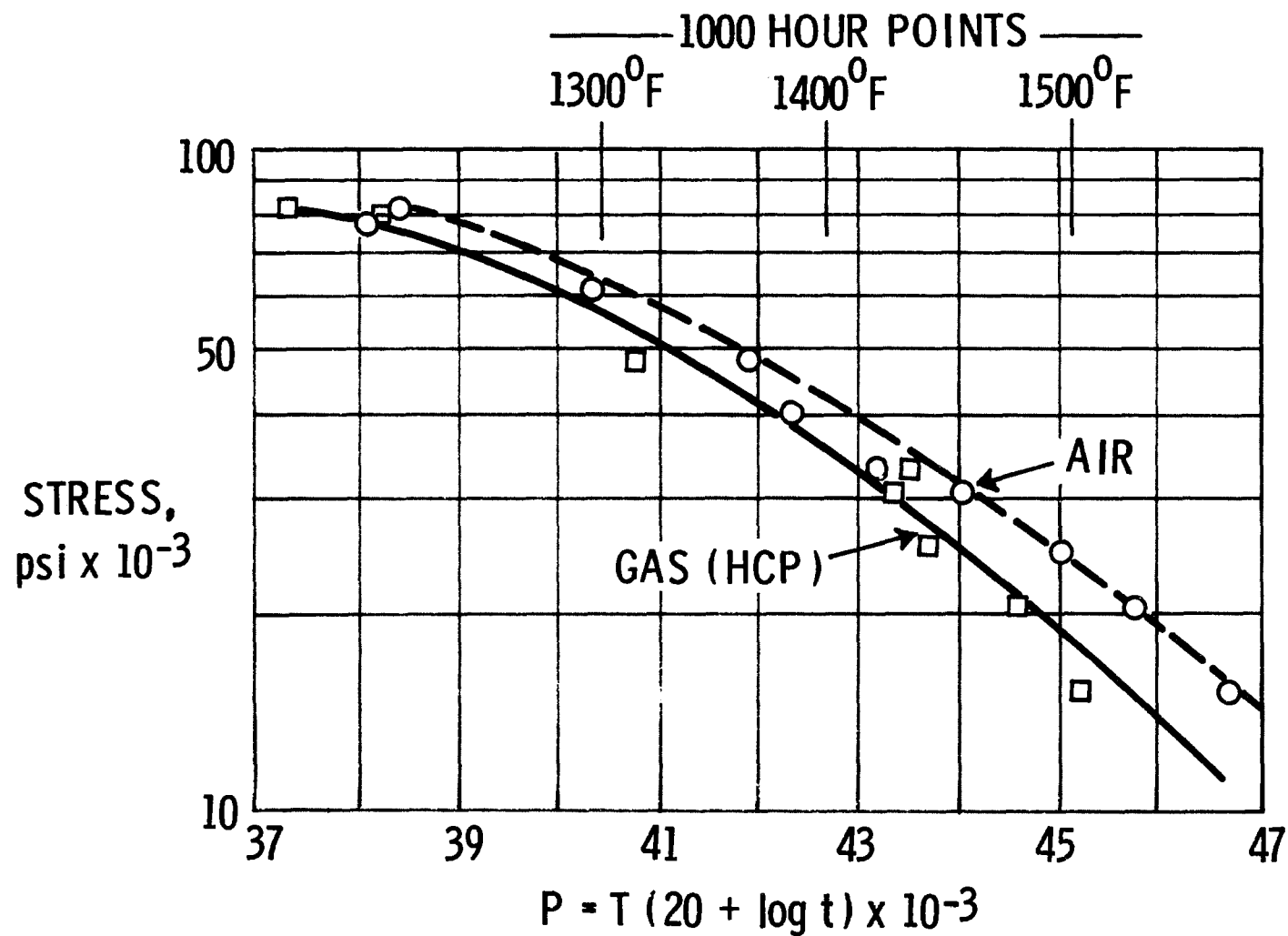

363

Charles L. Joslin

The airbreathing engines in the Space Shuttle must provide an absolutely reliable inflight starting capability, and the time available for the start sequence will be limited. This figure illustrates that in regions of low Mach number and high altitude, some on-board starting system may be required to assist in getting the engine up to self sustaining speed. At higher speeds and/or lower altitudes, ram air will windmill the engine for the start.

ENGINE RAM-AIR AND STARTER-ASSIST ENVELOPE

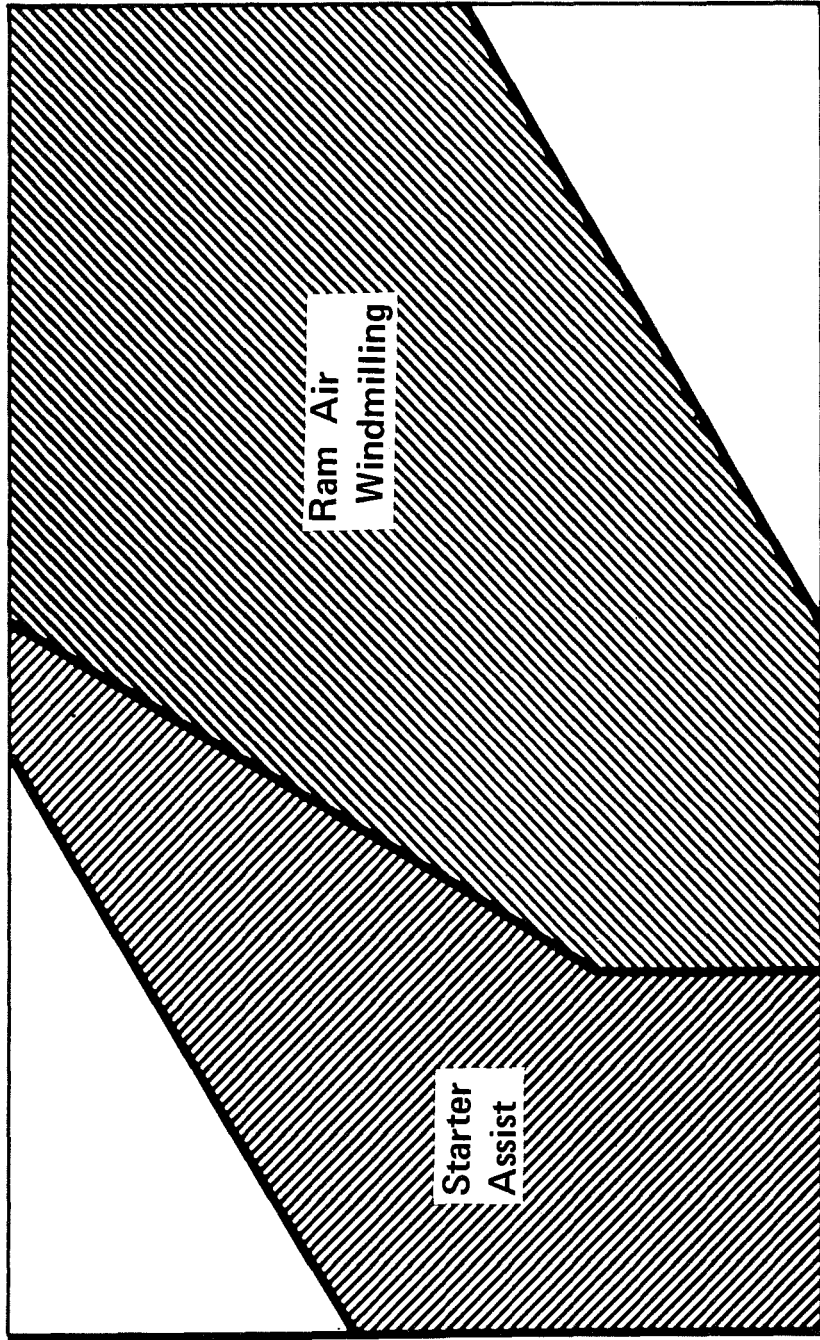

ALTITUDE

MACH NO.

This sketch is intended to show what is perhaps the most important consideration in locating the airbreathing engines on the Space Shuttle. Although engine operation will be at subsonic flight speeds, the high angles of attack and rapid rate of descent of the Shuttle may produce areas of very irregular airflow. The engines must be located with some care to provide sufficiently undistorted inlet airflow for reliable starting.

INFLIGHT STARTING REQUIRES AIR TO THE ENGINE

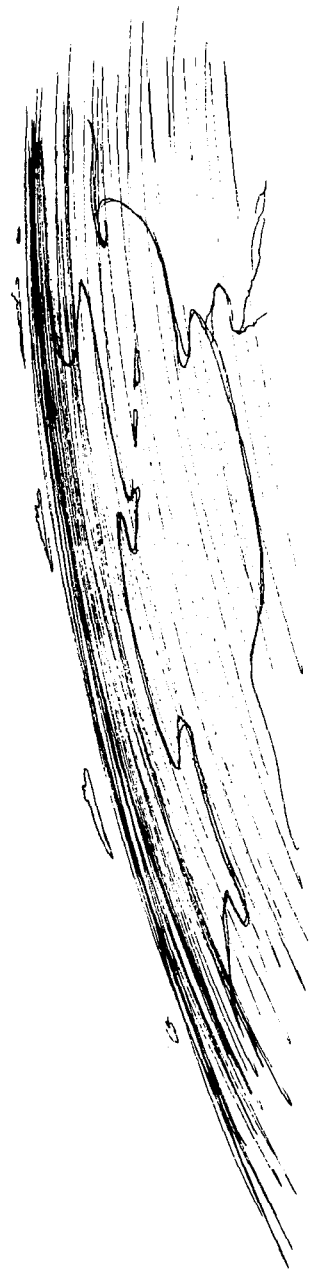
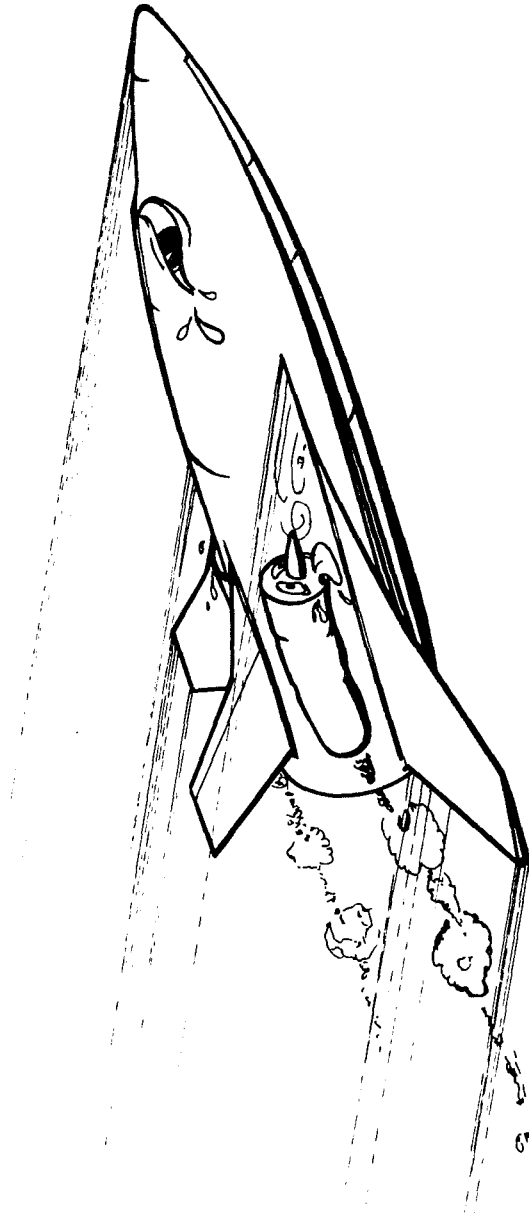

AIRBREATHING ENGINE QUALIFICATION/CERTIFICATION

The major elements of the development cycle of an airbreathing engine include the development testing, qualification requirements, and schedule. Current experience is based on engine development programs conducted for USAF weapons systems and for commercial aircraft applications requiring FAA certification. Specific and unique space shuttle requirements have not yet been fully identified. Engine development and qualification or certification is a time and dollar consuming task which grows more difficult and expensive as specialized proof testing requirements are added.

This slide shows the interrelationship between a typical new engine development schedule and the NASA Space Shuttle schedule as currently planned. Good agreement is seen providing a go-ahead on the engine development occurs early in the Space Shuttle vehicle program.

ENGINE DEVELOPMENT CYCLE

ENGINE DEVELOPMENT PATH

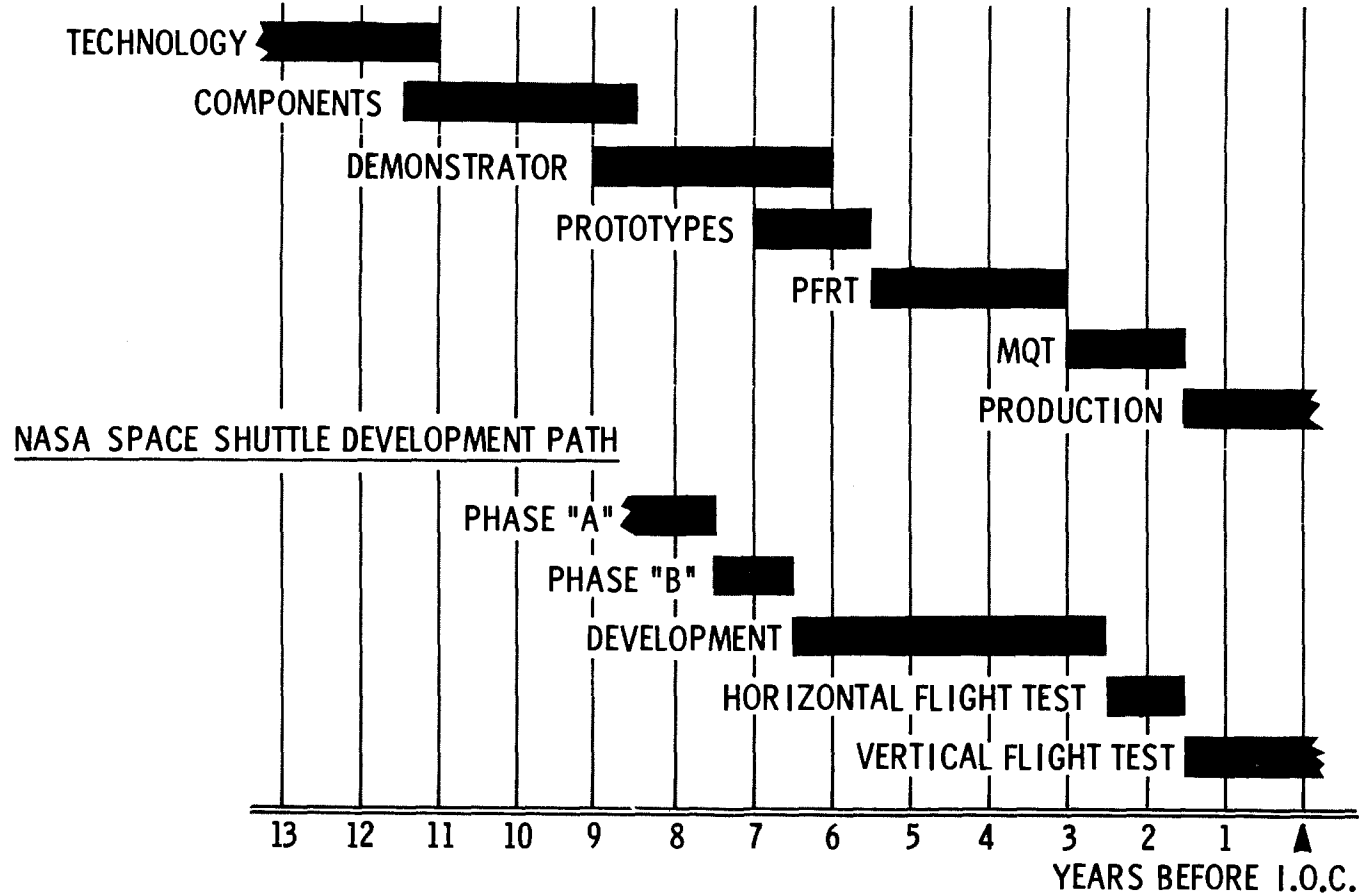

The types of engine tests required for a typical airbreathing engine qualification/certification program are shown on this slide. These tests are intended to demonstrate that all engine design requirements have been met prior to acceptance of production engines by the customer. Many of the requirements have evolved to meet military needs, and are not pertinent to the Space Shuttle. For example, infrared signature (IRS), and exhaust smoke measurement may not be of interest.

In the event that a partially developed or qualified engine is selected and modified for Space Shuttle, many of the specific tests will have already been completed reducing the extent of the required program.

The actual PFRT and QT test schedules have been devised to demonstrate engine performance and durability in aircraft service. Extensive endurance and cyclic operation are included, representative of aircraft duty cycles. The relatively brief Space Shuttle mission will require shorter life capability, but will place extreme emphasis on starting reliability. Hence, a new qualification concept with revised proof testing schedules would seem appropriate.

TYPICAL AIRBREATHING ENGINE

(QUALIFICATION REQUIREMENTS)

ENGINE TESTING

- SYSTEMS AND PERFORMANCE
- ENDURANCE - MECHANICAL INTEGRITY
- COMPATIBILITY - AIRCRAFT INTEGRATION
- ALTITUDE PERFORMANCE AND OPERATION
- ENVIRONMENTAL - HOT & COLD STARTING, INGESTION, ICING, ETC.
- SERVICE LIFE - MISSION ENDURANCE
- MISCELLANEOUS - OVERSPEED, OVERTEMPERATURE, NOISE, SMOKE, IRS, ETC.
- OFFICIAL PFRT
- OFFICIAL MQT

In addition to the engine testing requirements outlined in the previous slide, much of the required proof testing is completed by rig and bench testing. Major engine components such as the fan and compressor are run in test rigs, where greater operating flexibility is available for performance mapping. More extensive instrumentation is also possible, permitting thorough strain gage, and thermocouple surveys.

Controls and accessory components as well as built up subsystems are bench tested under simulated operating conditions. These tests are used to demonstrate that the many environmental and safety design requirements have been met. Bench testing ordinarily exceeds the total number of engine test hours, although the testing is far less costly.

TYPICAL AIRBREATHING ENGINE

(QUALIFICATION REQUIREMENTS)

MAJOR COMPONENT TESTING

- PERFORMANCE & COMPATIBILITY
- ENDURANCE - LIFE, STRESS, FATIGUE, ETC.
- SAFETY - OVERSPEED & OVERTEMPERATURE

CONTROLS & ACCESSORY - COMPONENT & SUBSYSTEM TESTS

- FUEL SUPPLY & CONTROL SYSTEM
- LUBE & HYDRAULIC SYSTEM
- ELECTRICAL SYSTEM
- ENVIRONMENTAL - EMI, SALT CORROSION, FUNGUS, ETC.
- SAFETY - FIREPROOF, EXPLOSION PROOF, ETC.
- CRITICAL COMPONENT QUALIFICATION

This slide illustrates typical buildup of engine test hours in support of a qualification or certification program. The upper curve is typical of a military aircraft engine qualification. By eliminating the test elements not essential to the needs of Space Shuttle, it is anticipated that the total engine running hours can be considerably reduced. In addition, a further reduction is possible if the selected Space Shuttle engine is based on a developed aircraft engine with necessary modifications to the fuel system and lubrication system.

The experimental flight test program is ordinarily started shortly after completion of the Preliminary Flight Rating Test. Unrestricted flight operation is contingent upon acceptance of the Qualification Test.

ENGINE TEST REQUIREMENTS

(APPROXIMATE TEST HOURS)

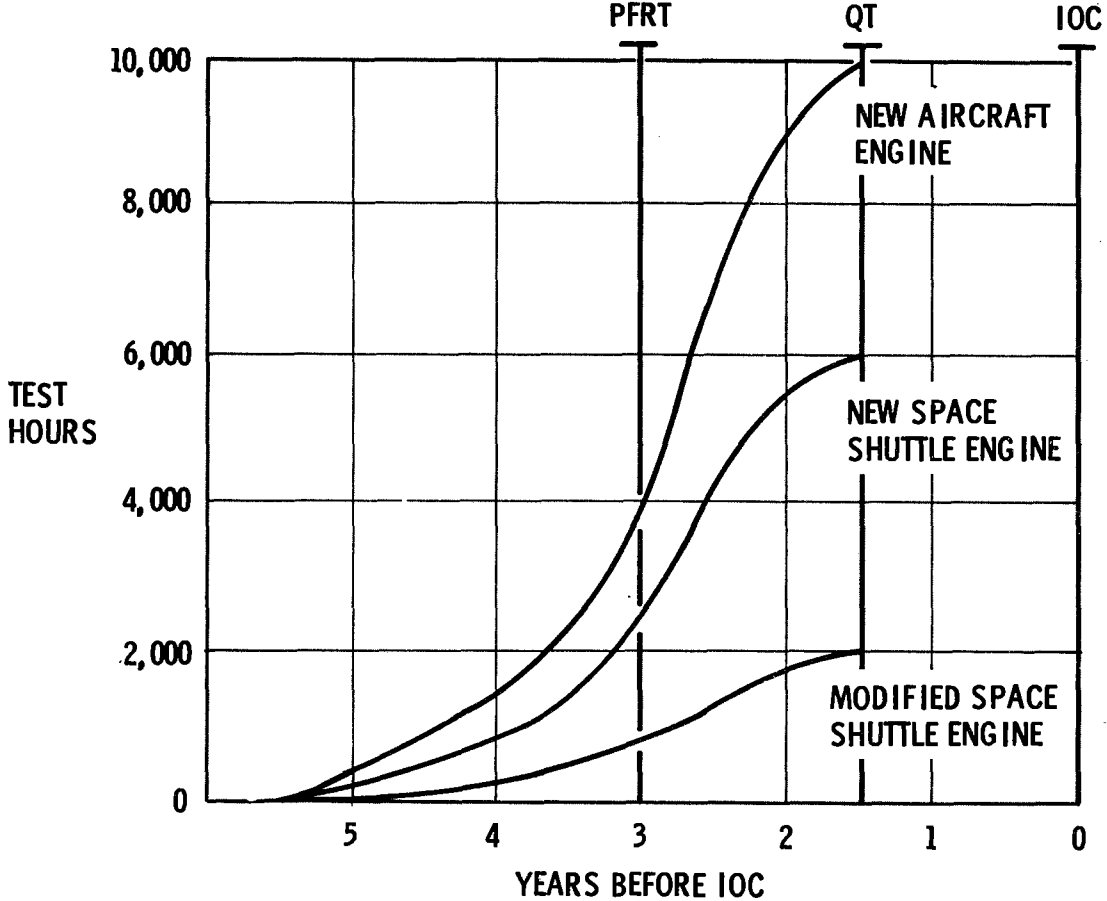

375

The approximate number of test hours necessary to complete the qualification program for an airbreathing engine are shown on this slide. The left column is typical of current aircraft engine programs. Because of the restricted operating envelope, lack of a combat environment, and reduced life requirements, the Space Shuttle engines can require less testing as indicated in the center column. Furthermore, if a developed or qualified engine is modified for Space Shuttle use, further savings can be made in the engine and major component test requirements.

Although the total number of test hours can be reduced by about half, compared to current aircraft standards, it is important that the modified engine approach achieves large reductions in the more expensive engine and major component test requirements. Therefore, the reduction in overall program cost will be greater than indicated by the total test hours.

ENGINE TEST REQUIREMENTS

(APPROXIMATE TEST HOURS)

377

	TYPICAL AIRCRAFT ENGINE	NEW ENGINE SPACE SHUTTLE	MODIFIED ENGINE SPACE SHUTTLE
ENGINE TESTING	10,000	6,000	2,000
MAJOR COMPONENT TESTING	50,000	40,000	5,000
C&A COMP & SYSTEM TESTS	150,000	100,000	100,000
TOTAL	210,000	146,000	107,000

CONCLUDING REMARKS

Warner L. Stewart

This discussion has reviewed some of the mission and environmental requirements facing the airbreathing engines for the space shuttle. Many of these requirements are new for gas turbine engines. These include the hydrogen fuel system and exposure to the launch, reentry, and space environments. Technology studies in these areas have been initiated by NASA.

Engine design studies being conducted by two contractors have the primary purpose of determining engine features and modifications required for the shuttle mission. Engines typical of those being considered for the shuttle vehicles will be selected for these design studies. The steady-state and transient operation of a hydrogen fuel system will be studied by analyzing, fabricating and testing such a system using an existing engine as a test bed. Studies associated with other components and systems will be conducted as required. The purpose of the technology studies is to provide a sound basis for the development of the airbreathing propulsion system for the shuttle.