

**NASA TECHNICAL
MEMORANDUM**

NASA TM X- 52951

NASA TM X- 52951

CASSELL
COPY

**CONCEPTS FOR COST REDUCTION ON TURBINE
ENGINES FOR GENERAL AVIATION**

by Robert L. Cummings and Harold Gold
Lewis Research Center
Cleveland, Ohio

TECHNICAL PAPER proposed for presentation at
Western Metal and Tool Exposition Conference sponsored by the Society of
Manufacturing Engineers and the American Society for Nondestructive Testing
Los Angeles, California, March 8-11, 1971

CONCEPTS FOR COST REDUCTION ON TURBINE ENGINES FOR GENERAL AVIATION

ABSTRACT

Current results of a NASA study of methods for achieving drastic cost reduction on gas turbine engines for General Aviation aircraft are presented. Performance trade-offs for engine simplicity are discussed. Results of fabrication studies on simplified axial stage constructions are presented.

INTRODUCTION

Gas turbine engines have now almost completely taken over the field of large aircraft propulsion. Their small size and weight would also make them very attractive for light aircraft. There is a major obstacle to their use, however, which is not technical but economic. The very high cost of current gas turbine engines substantially restricts their use. This problem of cost is shown in Figure 1.

There we have tabulated the current prices of some aircraft engines: First, the turbocharged reciprocating engine and its propeller and, second, aircraft gas turbine engines. In evaluating this table it should be kept in mind that the "general aviation" light plane must be suitable for a retail sales price of around \$30,000 for a single engine aircraft and \$45,000 for a light twin. We can then see several things: First, the turbocharged piston engines are themselves quite costly. For the high flight speeds, which we will consider, the 425 hp engine would be required, but the price of over \$17,000 is already too high. Next: the currently available turbojet, turboshaft, and fanjet engines are much too costly, with prices ranging from \$22,000 to over \$65,000.

Looking at these prices, we should now picture the competitive impact of a really low cost gas turbine engine of 1000 lbs. SLS thrust, having a total manufacturing price of \$5000, or \$5 per lb. of thrust. Such an engine would provide important performance gains for light aircraft and also have a very important price advantage, compared to either current piston engines or current jet engines. In order to sell at 1/3 to 1/4 the price per lb. of thrust of current jet engines, however, this engine would require really major design simplifications and manufacturing cost reduction.

The purpose of this paper is to discuss the major results of a program which is concerned with such low cost engines. This has been a small NASA Lewis Research Center in-house program, with only limited assistance from contractors. It has been exploratory in nature, covering a number of problem areas, as shown in Figure 2. The main areas covered in this paper are: (1) Engine cycle analysis and airplane performance studies relating to the cost-performance trade-off question, (2) engine configurations which are being emphasized and their fabrication and joining techniques,

(3) the results from a fabrication development program intended to establish some possible new compressor and turbine construction methods, and results from spin tests, (4) construction methods of experimental models, and test results on a low cost annular combustor, (5) results on a new type of hydromechanical fuel control and discussion of its production feasibility, and (6) discussion of work on low cost accessories. Finally, we will say a few words about current NASA plans for construction and test of complete turbojet and fanjet engines.

ENGINE DESIGN DISCUSSION

Well, now how can low cost be achieved on a device as complex and critical as a gas turbine engine? Obviously a most critical factor is to find low cost manufacturing methods, and this will be the main subject of this paper. However, we also would find it necessary to start out with designs having inherent economy. A basic observation which has, therefore, been made is that if lower cost gas turbine engines are to be obtained, we must be willing to give up some performance; limit the design temperature to a level low enough to obtain reliable machinery, requiring only low cost materials; limit the pressure ratio to reduce the tip speeds, the stress levels, and the number of expensive stages. The decisions as to just how far to go with this approach are a matter of judgment involving a tradeoff of engine performance against its initial cost.

The performance tradeoffs on fuel consumption and thrust are shown in Figures 3 and 4, where we have the specific fuel consumption and specific thrust of turbojet and fanjet engines plotted against pressure ratio. These results are for a flight speed of 450 mph at 25,000 feet, which are being used as a typical advanced general aviation aircraft design point, and for a turbine inlet temperature of 1300°F. This choice of a low turbine temperature was made to promote economy and reliability in the design.

From Figure 3 we can see that choice of a low pressure ratio of 4.0 does indeed cause about 25% higher fuel consumption than if 12.0 were chosen. The pressure ratio of 4.0 can be achieved with about 1/2 of the number of stages required for a pressure ratio 12.0, however, and this is the type of tradeoff we must make if we are to achieve low cost. For the turbojet, it is our expectation that the main application would be for missile and drone engines. The design point for the turbojet has therefore been chosen, as shown on the figure, at the lowest pressure ratio consistent with moderate performance.

The fanjet engine design point takes advantage of the added fan stage to operate at a higher overall pressure ratio. The fan stage also provides additional propulsive mass flow. Both of these factors improve the engine performance. Note in Figure 4 that the fanjet design point uses a moderate bypass ratio of 2.5 and a fan pressure ratio of 1.3 and thereby achieves a significant performance improvement, compared to a simple turbojet. At the design point a specific fuel consumption of only .90 lbs/hr. per lb. of thrust is achieved with only a single additional stage. The fanjet engine, thus, has moderately good fuel consumption and should be the most attractive for aircraft propulsion.

For both the turbojet and the fanjet engines we see in Figure 4 that we get a very useful specific thrust level, in the range of from 45 to 55 lbs. per lb./sec of core engine airflow. Here the core engine airflow is considered as the relevant parameter, since the core engine contains the expensive components. This specific thrust level means that 1000 lbs. SLS thrust can be obtained with either a turbojet or a fanjet engine with an inlet diameter of less than 10 inches. The gas turbine engine is, thus, much smaller than the piston-type engine it would replace. A further factor, which should be noticed on Figure 4 is the specific thrust advantage of the fanjet. For the same thrust level, the fanjet has a size advantage which would tend to offset the cost penalty due to added complexity of the fan stage.

With design points chosen, as shown, the performance obtained for both the turbojet and the turbofan is substantially lower than most modern jet engines currently being manufactured. The critical question, however, is: Are these performance levels good enough to provide useful range and operating cost for a light aircraft? This question is the subject of Figure 5.

Here are given the performance figures for a light twin engine airplane, designed to cruise at 450 mph at 25,000 feet. It has a typical fuel-to-gross-weight ratio and fuel reserve, and a wing loading low enough to provide the low takeoff and landing speed of 80 mph. For this airplane the two 1000 lb. takeoff thrust engines are capable of achieving a low takeoff distance of only 1050 feet. The very useful range of over 1000 miles is also obtained at an operating fuel cost level less than piston engines of equivalent thrust horsepower. These cost estimates, of course, take into account the lower cost of jet fuel, compared to aviation gasoline.

This airplane must be stressed to operate at flight speeds at least twice as great as current light planes and be capable of cabin pressurization. To achieve these qualities at reasonable cost, work will be necessary on how to manufacture a low-cost, high performance airplane. For the present, however, the discussion will be limited to the engine.

During the course of this program, numerous turbojet and fanjet designs have been considered. Both axial flow and radial flow type compressor designs were evaluated and compared. The engine design using a radial compressor which was most thoroughly studied is shown in Figure 6. The design uses a single stage axial flow, transonic, compressor to super-charge and therefore reduce the size of a radial compressor. The overall pressure ratio of this engine was 4.0, matching the turbojet engine design point, previously shown. The combustion chamber is an annular can, and the turbine is a single stage. Investment cast construction was featured on all rotor components. Both front and rear struts and the compressor housing were also fabricated by casting. For a 1000 lb. thrust level, this engine was found to be about two feet in diameter by five feet in length. This engine was completely detailed and cost estimates were obtained on all the parts. The cost aspect will be discussed later in this paper. From an overall comparability standpoint, it was soon established, however, that an axial flow compressor type engine could be manufactured about as economically and would be substantially smaller and lighter. The fabrication development work and all recent engine design work on this project has been

concentrated on the axial type compressor and the remainder of this paper will be devoted to discussion of that type engine.

For application to light aircraft, the improved range and the lower noise levels of the fanjet caused major interest to be centered on this type engine. The objective of the fanjet design study was to obtain the economy of its smaller size core engine without adding costs because of an undue amount of complexity.

The configuration which has been most extensively studied for the fan engine is shown in Figure 7. This figure shows a geared fanjet engine design, which provides a low noise, low tip speed fan, while still retaining a single shaft, two bearing design, for the core engine. The 1000 lb. thrust engine uses a 15" diameter fan, a 10" diameter 5 stage compressor, and a two stage axial turbine. It also uses a 650 hp gear box of about a 2 to 1 speed reduction ratio. This gear box allows the turbine stages to operate at high speed and to share the work and, therefore, minimizes the diameter and the number of stages required.

The design of this gear box has been studied by the Allison Division of General Motors under a NASA contract, and their results indicate that a conservative, 650 hp, co-axial gearing system can be produced at a total cost of approximately \$600. The design of this gear box is shown in Figure 8. It uses 3 parallel, two mesh, speed reduction gear shafts which reduce all bearing loads to levels suitable for standard bearings and the gear crushing and bending stresses to levels which are low compared to aircraft practice and suitable for hobbed (or shaped) and shaved gears. Using such a gear box, we can avoid the complexity of co-axial shafting with its additional high DN bearing and seals. The compressor and turbine shown in the figure use sheet metal construction, which will be further described later. This geared fan engine configuration has a number of advantages. However, other fan engine designs are adaptable to the low cost fabrication techniques and are also still under consideration.

In addition to general aviation applications, Lewis Research Center has been working in cooperation with the U. S. Navy to determine the applicability of the low cost designs and fabrication techniques to engines for missiles and drones. Such expendable engines are referred to as ordnance engines. A typical current requirement for such an engine is given in Figure 9, and the resulting 4 stage compressor, engine design is shown in Figure 10.

The requirement is for 350 lbs. of thrust as the design point of $M = .8$ at 20,000 feet, and 650 lbs. thrust at sea level. The weight limit is 100 lbs., the diameter limit is 12 inches, and the specific fuel consumption must be below 1.8. Both windmill start, under ram conditions, and impingement start at sea level are required. The design flight duration is only 15 minutes.

The turbojet engine designed to meet these conditions uses a 4 stage axial flow compressor and a single stage turbine. This drawing, of Figure 10, also shows the simple shaft and bearing design. This engine is only $11\frac{1}{2}$ inches outside diameter, and it is estimated to weigh 80 lbs. and to have a specific fuel consumption of 1.3. With these size and performance

figures, it will provide overall range and payload much better than can be achieved by a rocket engine. It is also attractive in its promise for low production cost.

FABRICATION DEVELOPMENT DISCUSSION

The principal fabrication methods that will be employed in this design are as follows: The compressor rotor is an investment casting of 17-4 PH stainless steel. Each compressor rotor stage is cast separately, and the stages are joined together by circumferential electron beam welds. The engine shaft is also a 17-4 PH casting and is beam welded to the compressor rotor. The turbine is an investment casting of Inconel 713 LC and is bolted to the shaft. The burner is annular utilizing perforated sheet 304 stainless in the liner and drawn 304 stainless in the casing. The front bearing housing is an aluminum sand casting, and the rear bearing housing is an investment casting of AMS 5366.

In addition to this engine design work, investigation has been made of techniques for fabrication of low cost axial flow rotor stages and an experimental fabrication methods program has been conducted at NASA Lewis Research Center.

The main approaches being considered are: (1) casting, (2) sheet metal stampings. The conventional investment castings approach is being considered for use, as previously discussed, but this approach is well known in the industry and will not be further discussed in this paper. Major interest has also been centered on ways in which lower cost compressor and turbine rotors could be cast. The major approaches which appear to have cost reduction promise are: (1) use of permanent patterns to directly produce the ceramic casting molds, and (2) use of castings of the rotor hub and disks with inserted, forged or rolled blades. This latter process has been experimentally investigated at Lewis Research Center using both 17-4 PH for compressors and Inconel 713 for turbines. In this work the ring castings were furthermore made by pouring the molten metal into cooled copper or steel casting molds. In this way directional solidification was obtained and very sound, high strength castings resulted. Sound mechanical attachment to the blade insert was obtained and also, in some cases, continuous grain structure, metallurgical bonds were obtained. The general conclusion from this work was that it may represent a technique which could be developed to produce very sound gas turbine rotors at a cost much less than investment casting.

From other results on the program, however, it appears that a stamping approach, using coined blade profiles, may have the best potential for low cost and reliability. This construction has, therefore, been chiefly emphasized in the in-house fabrication and test program and its main features are illustrated in Figure 11. Referring to this figure we can see an axial flow compressor which is composed of two sheet metal disks, with blades formed on tabs on the edge of the disks. A pair of such disks is placed together, to give the solidity required for good transonic axial compressor performance, and fitted into a pair of rings. The rings are slotted to receive the blades, or a filler type material is used between the blades. A complete compressor rotor, assembled using this construction, is shown in Figure 12. There we see a 10" diameter sheet metal

compressor, installed in an end plate assembly as required for spin testing. A coining or cold forging process has been used to form the blades. This produces accurate reproducible contours with small leading and trailing edge radii. There is, consequently, no known aerodynamic performance penalty imposed by use of this type construction.

Several of these sheet metal compressor rotors, designed for long term service, have been built and tested in a Lewis Research Center spin test rig. Two types of construction have been used for the hub rings. The first type uses a 17-4 PH ring which is slotted to permit insertion of the blades. A second ring is then mated from the opposite side, and the whole four-piece assembly is then joined together by electron beam ring welding and furnace brazing. The second type construction uses two stamped sheet metal rings, which are joined to the blade plates by electron beam welding. The space between the blades is then filled with a reinforced plastic material. This plastic material then provides a smooth hub contour and produces a very lightweight rotor.

Strain measurement data, taken during spin testing of the slotted hub version of this compressor, is shown in Figure 13, where we have the calculated strain at two points on the rotor, plotted against the rotational speed. Also, plotted are the measurements taken from strain gages attached to the rotor at the same two points. It may be seen that the measured values correspond very well with the calculated ones and the measured strain is linear. The rotor has been tested to 25% above its design speed, indicating a good strength margin and safety factor at the operating speeds of our fanjet and turbojet engines.

For very low cost, short term service, as for the ordnance type engine, the use of aluminum alloys is also being investigated. These would be primarily applicable only for limited-use missile and drone engines where foreign object damage and sand and dust erosion would not be a problem. The advantage that aluminum would offer is that, due to its low cold forging pressures, complete one half blade rows could be formed in a single coining-stamping operation, and the assemblies could be joined by epoxy and spot welding or by dip brazing. By these techniques, it is expected that very low cost axial compressor assemblies can be fabricated. Rotors constructed of aluminum alloy 6061 are now being placed into test.

The sheet metal construction technique is also being evaluated for application to axial flow turbine rotors. A model of this is shown in Figure 14. Here, the problem is somewhat more complicated due to the additional camber of the turbine blades, but stress calculations show the designs to be attractive on both a centrifugal stress and a thermal stress basis. As shown in the figure, the turbine rotor would consist of two sheet metal plates formed with coined blades on their rim, fitted together and placed into rings in a manner very similar to the compressor. A test rotor of the type shown is now being constructed. Inconel 718 is the alloy being considered for the hubs and disks and for the moderate temperature levels being proposed at our design point. It seems to be a good alloy for the blade plates, since it is very ductile and easily cold-forged at room temperature. In addition to this sheet metal approach, both cast and welded turbine designs are also being investigated. For the cast construction, both investment cast Inconel 713 LC and the casting technique

with forged inserts, using Inconel 718, are being considered. For the welded construction, the primary approach is electron beam, but welding of cold forged Inconel 718 blades to a 718 disk.

For the fan, we require an axial stage, as shown in Figure 15, which is larger than the core engine and which has substantially longer blades. This stage is also the one which would be the most adversely affected by damage from foreign objects. For this rotor we have, therefore, investigated the use of hollow, stamped sheet metal blades which are removable. These blades are stamped from two stainless sheet metal sides and joined together by welding or brazing. They have a stamped or cast base to provide a low cost, freely pivoting attachment to the hub. Due to their hollow construction, they have the advantage of a high resonant vibration frequency and low root stresses and can operate without requiring midspan vibration dampers. The hollow construction also favors a lightweight, low cost rotor disk. For the blades we would use a strong, hardenable material such as 17-4 PH, Custom 455, or a 400 series stainless steel. For the hub, a forged aluminum or a thin wall cast steel construction would be used. The hollow blades have been vibration tested to verify the high bending frequencies and the complete rotor shown has been spin tested to a speed 40% above the fan rotor design speed.

Work has also been done on a low cost annular combustor, constructed from perforated sheet metal as shown in Figure 16. This combustor uses a cooling airflow layer obtained from special orientation of the pattern of holes in commercial perforated sheet, along with a simple pattern of punched holes. It also uses a very simple air-atomizing type fuel nozzle. This combustor has been built and tested and results on combustion efficiency over a range of fuel-air ratio are shown in Figure 17. Good design point combustion efficiency was obtained and ignition and blowout characteristics were very satisfactory. In addition, the combustor exhibited the good temperature variation pattern factor of about .20 and the design pressure drop of 6% at a relatively high design point Mach number. For short life versions of this combustor, 304 stainless would be used. For long life applications, a higher temperature alloy, such as Hastelloy X, would be used.

ACCESSORIES AND CONTROL

Accessories are also very important to the overall cost and size of small jet engines, since they tend to be large and expensive, when we desire just the reverse. The most critical accessory is the engine speed and fuel control which must provide capability for rapid thrust response without surging the compressor, or exceeding the allowable turbine temperature. The control is, therefore, a key to the safety and reliability of the entire engine. It is, furthermore, critical to the cost and may add up to 20% to the cost of the engine. The fuel control has, therefore, been extensively investigated, using a hydromechanical control based upon use of a zero gradient pump speed sensing technique. The principles upon which our work is based are shown in Figure 18.

Here we have a parameter consisting of fuel flow divided by speed and by the ambient pressure correction factor, plotted against the compressor

pressure ratio. The values plotted are for a current typical turbojet engine and it will be noted that the steady-state operating line, the surge temperature limit, and the combustion blowout limit can all be approximated by a linear relationship between the fuel-flow speed parameter and the pressure ratio. A control which schedules fuel flow, following a linear relationship, will, therefore, approximately provide the correct steady-state fuel flow to the engine, over the complete range of rotational speed, altitude, and flight Mach number. Such a fuel flow schedule can then be modulated by a speed error signal from a speed governor to control the speed of the engine. The engine may be kept below the surge line during an acceleration and avoid blowout during a deceleration by keeping the fuel/speed parameter between the limits shown.

Next, attention should be directed to the other plot given in Figure 19, which is the acceleration fuel flow schedule of a current jet engine. Here the uncorrected quantity, fuel flow divided by pressure, is used. The limiting fuel flow is, therefore, a function of three variables: speed, temperature and pressure. From the complexity of this limit schedule, it may be appreciated that the simple linear limit of the hydro-mechanical fuel control should offer some important simplifications in construction.

The techniques which we have used to incorporate these principles into a functional fuel control device is shown in Figure 20. As may be seen, a small speed sensing positive displacement gear pump is driven by the engine. The pressure difference across this pump is kept at zero by a pressure regulating valve which bypasses flow from the main fuel pump. Since no pressure rise occurs across the small pump, its output flow rate is directly proportional to the engine speed. This flow quantity is then passed through a fixed area orifice to generate a pressure signal which is directly proportional to the square of the engine speed. The actual speed may then be compared with the pilot's speed command setting to generate a speed error signal. The area of an orifice that bypasses the speed sensing pump is then controlled by the compressor inlet and discharge pressures. With this circuit the total fuel flow delivered to the engine at any speed and pressure is then a linear function of speed and pressure ratio, as required for the fuel flow schedules previously discussed. This orifice area may also be modulated by the speed error signal to control or govern the engine speed. Thus, when the throttle is advanced, the control provides additional fuel flow to increase the engine speed. During such speed transients, however, the changes in fuel flow are limited by the acceleration and deceleration schedules previously discussed. In an actual control, the variable area orifice would be provided by spool valves.

This simple hydraulic circuit provides all of the required functions of the jet engine control. The working parts required to construct such a control are shown in Figure 21.

Here we see the small gear pump which provides the speed signal, the fuel bypass valve which controls the zero pressure gradient, and the valve which adjusts the flow according to the speed error signal. In addition, we see two valves operated by compressor inlet and discharge pressures which provide the controlled area orifice for the fuel schedule. The

control utilizes an aluminum housing and 440 stainless in the pump and valve elements. Close fits are not required in the metering pump because of the zero pressure gradient and are not required in the valve assemblies because the maximum valve pressure drop is only 25 psi. Only two spring bias adjustments are required at assembly, one which sets the deceleration limit, and the other the acceleration limit.

For comparison, now, just briefly look at the four exploded views in Figure 22 which show the parts required for the fuel and speed controller of a current turbojet engine. The zero gradient pump control has a substantially smaller number of working parts. It is also simpler for assembly and adjustment and is direct acting, not requiring servo actuators.

This control has been extensively analyzed and its operation simulated on the analog computer. It has then been built and performed successfully in actual operation on a J85 engine. A typical operating sequence during a throttle burst from 50% to 95% is shown in Figure 23.

Here, the sequence is initiated by a sudden change in throttle position. We note the initial fuel flow increase, as the governor calls for more fuel, then a further increase, following the surge limit schedule. This produces smooth acceleration of the engine with very short response time. Finally, notice the governor cutting back the fuel flow as the speed set point is approached and the speed leveling out at the set point, with no overshoot or oscillation.

Referring now to Figure 24, we see that, in addition to the work on the fuel control, a number of other accessory areas have been considered. The more important results are summarized in the following paragraphs.

The startup technique for the engine has been extensively considered. After evaluation of numerous possible startup techniques, it has been concluded that, since a generator and battery will be needed for flight, the overall best economy will be achieved by using these same components for engine cranking. Since cost of starter-generators rise very rapidly with power output, it has become evident that cranking must be achieved with the very minimum size unit possible. This type of starter-generator has, therefore, been tested to verify its capabilities in both modes of operation and to investigate possible mechanical simplifications which may permit cost reduction. The conclusion was reached that the 150 amp starter-generator, operating at 24 volts, should be adequate for cranking of the 1000 lb. thrust engine.

Frontal area of accessories has proven to be a substantial penalty for the 8 to 10" diameter engines here considered. The accessory power takeoff shafting and gearing is also expensive and limits the allowable design configurations. A hydraulic drive system utilizing positive displacement gear pumps and motors has, therefore, been designed and is currently being tested. This system would allow remote placement of accessories.

A design study has also been undertaken on the fan drive speed gearing. The result of this study was favorable on both a technical and a cost basis. This type of a fan drive system has been shown in Figure 8 and previously

discussed. The gearing system selected provided an overall speed ratio of 28 to 15 and had the advantages of a co-axial output shaft and a small space envelope. It also has low gear tooth loads and bearing loads such that very good life can be obtained with the small, low cost bearings and gears. Both a low fabrication cost and a long life, therefore, appear possible for this design.

The geared-fan type engine requires that a means be incorporated for reducing the fan torque at idle speeds to prevent excessively high turbine inlet temperatures. Such torque reduction can be accomplished by blocking the fan flow duct. This technique has the additional advantage of reducing the engine thrust to a low level at a relatively high idle speed and could, therefore, provide rapid thrust response as well as other advantages. Preliminary tests have been performed on this system, and the necessary torque and flow reduction was obtained without causing surge.

Additional low cost accessories and auxiliaries which have been designed and investigated include engine mounting struts and vibration dampers, an accessory drive gear box and lubrication and scavenge pumps. These accessories are all being designed to fit within the engine mounting pylon in order to preserve the low frontal area of the basic fanjet engine. This type of accessory installation allows a clean overall fan engine configuration with a lightweight cowl and fan nacelle ring, as shown in Figure 25.

CONCLUDING COMMENTS

The foregoing sections of this paper have summarized and described the major aspects of this low cost engine program. At this time it appears evident that the simple turbojet and fanjet type engines have adequate performance for both general aviation aircraft and for service missiles and drones. No further major results and conclusions are to be made since the program is at an intermediate point.

For the future, it is planned to continue the fabrication development program on sheet metal axial stages, and the control development and its application to the turbojet and the fanjet engines. Design work on the fanjet engine will continue and also the final design will be completed on the Navy ordnance engine. Fabrication of prototype ordnance engines will then begin. This engine will be built so as to fully simulate a production engine, and it will be tested at its full design operating conditions.

In connection with our overall interest in low cost aircraft engines, it is instructive to examine the estimates which have been made on the production prices of the components of this engine. These are shown in Figure 26 and are based upon production rates of 2000 units per year where the tooling write-off costs may be neglected.

It is not the purpose of this paper to completely discuss these prices. The total cost of just over \$3,000 for the 650 lb. thrust engine clearly indicates, however, that we can expect to provide the advantages of turbojet propulsion to missiles and drones at a price competitive with any other form of propulsion. Similar price estimates were previously made on the

1000 lb. thrust level turbojets, using both the radial and the axial type compressors, which indicated that manufacturing costs of about \$5,000 to \$6,000 should be attained for production quantities of 2,000 per year. The production cost level of \$5.00 per pound of thrust has, therefore, been indicated for both thrust levels. The final manufacturer's selling price would, of course, be also affected by a number of indirect costs such as the costs for calibration runs, write-off of qualification expenses, sales and field engineering and distributor's mark-up. It is considered possible that these items could double the price at which the engines would be finally sold to the user.

From the estimates made in the program, however, it appears that if attention is now concentrated on minimizing the costs of the manufacturing processes, gas turbine engines of the type here considered will be attractive and cost competitive, for general aviation, for missiles and drones, for additional services uses (such as reconnaissance airplanes), and possibly also for the smaller business category aircraft. If the obstacle of high cost can be eliminated, gas turbine engines will make major performance improvements available for these purposes.

CURRENT GENERAL AVIATION ENGINE PRICES

TURBOCHARGED PISTON ENGINES - PLUS PROP	
DIRECT DRIVE, 285 HP, ENGINE "A"	\$10 200
DIRECT DRIVE, 290 HP, ENGINE "B"	11 300
GEARED, 425 HP, ENGINE "C"	17 400
TURBINE ENGINES	
LOW PRESSURE RATIO TURBOJET, 1025-LB THRUST	22 200
TURBOSHAFTE ENGINE, 605 SHP	35 300
TURBOJET ENGINE, 2850-LB THRUST	65 500
FANJET ENGINE, 2000-LB THRUST	65 000

Figure 1

CS-56766

LOW COST ENGINE SPECIFIC THRUST

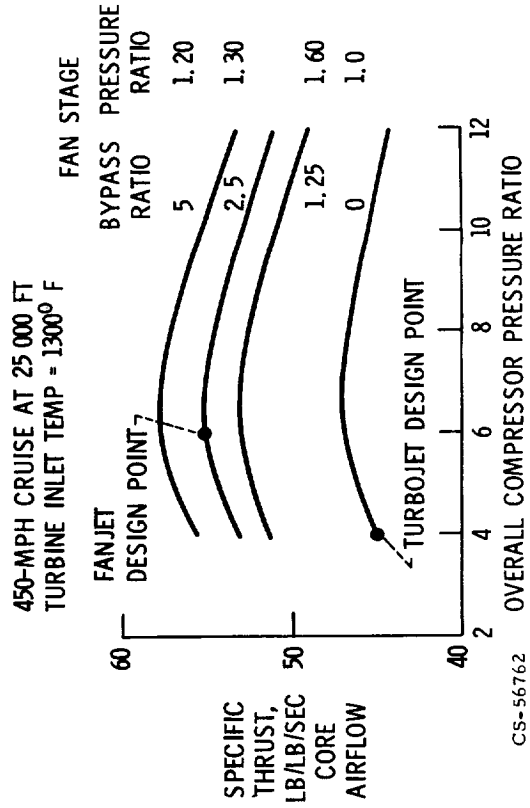

Figure 3

CS-56762

LOW COST JET ENGINE PROGRAM

- I. ENGINE & AIRPLANE PERFORMANCE ANALYSIS
- II. ENGINE CONFIGURATION & DESIGN STUDIES
- III. OFF DESIGN SIMULATION & CONTROL STUDIES
- IV. COMPRESSOR & TURBINE - FAB & SPIN TEST
- V. LOW COST COMBUSTOR - FAB & TEST
- VI. HYDROMECHANICAL FUEL CONTROL
- VII. LOW COST ACCESSORIES - EVALUATION & TEST
- VIII. COMPLETE ENGINE - CONSTRUCTION & TEST

Figure 2

CS-56767

LOW COST ENGINE SPECIFIC FUEL CONSUMPTION

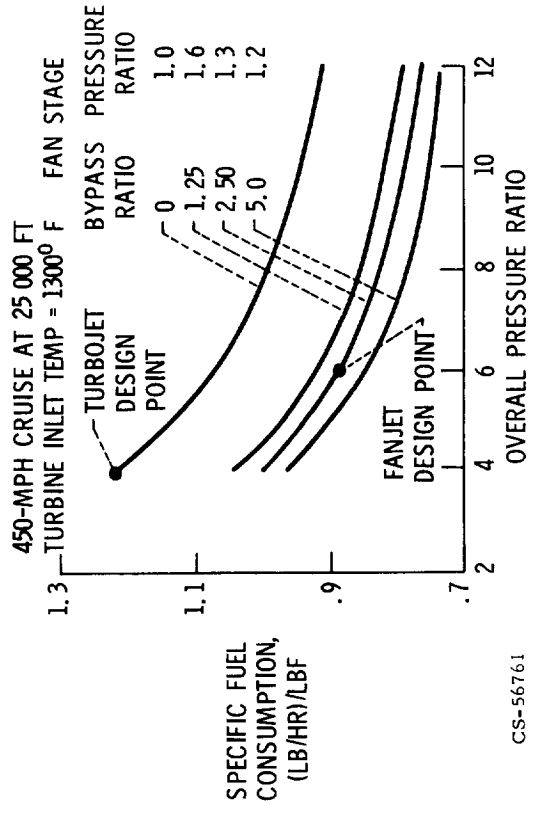

Figure 4

CS-56761

FANJET POWERED LIGHT AIRPLANE PERFORMANCE

DESIGN CRUISE: 450 MPH AT 25 000 FT

AIRPLANE CHARACTERISTICS

6000-LB GROSS WEIGHT, TWIN ENGINES
2000-LB FUEL WEIGHT, INCLUDING 3/4-HR RESERVE
TAKEOFF THRUST: 1050 LB/ENGINE
CRUISE THRUST: 350 LB/ENGINE
TAKEOFF WING LOADING: 40 LB/FT² AT $C_L = 2.5$
TAKEOFF & LANDING SPEED: APPROX 80 MPH

PERFORMANCE AT CRUISE SFC = 0.90

TAKEOFF DISTANCE, FT	USEFUL RANGE, MI	COMPARATIVE FUEL COSTS (RECIP ENG = 1.0)
1050	1070	0.81

Figure 5

CS-56764

E-6114

1000 LB SLS THRUST RADIAL COMPRESSOR TURBOJET

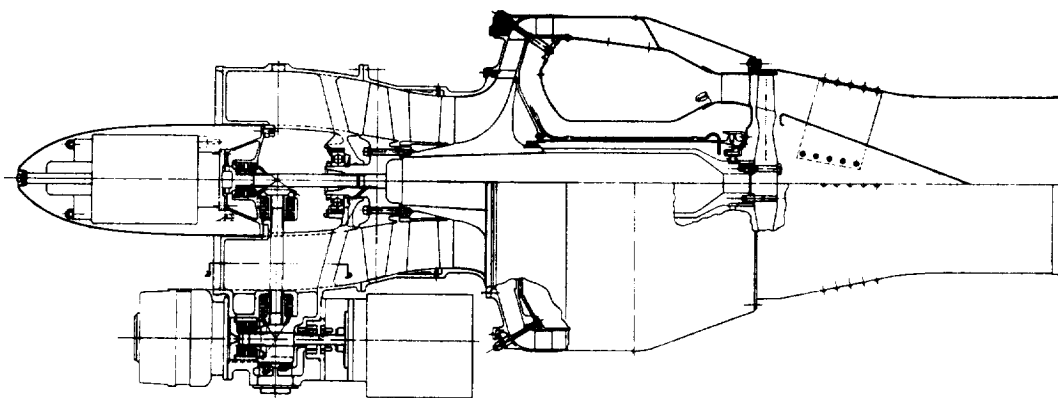

Figure 6

FANJET ENGINE GEARBOX

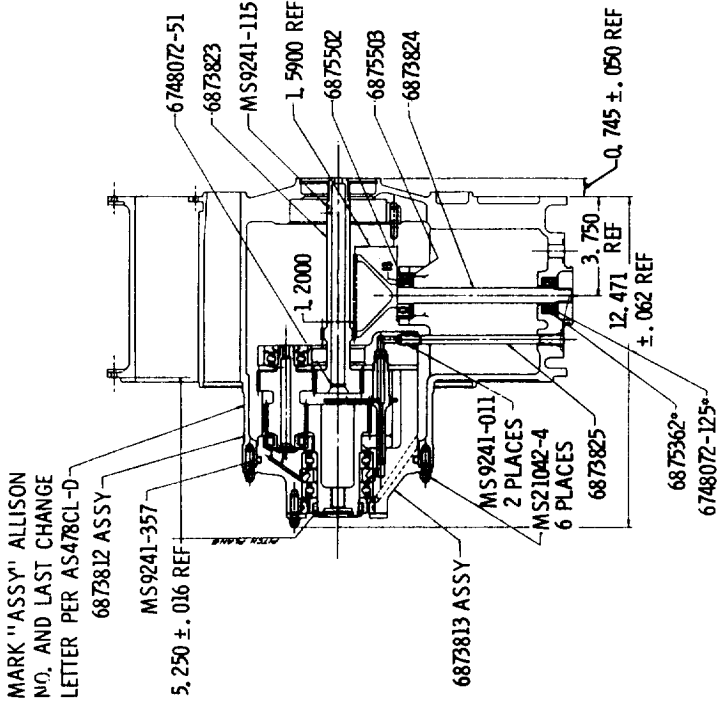

Figure 8

650 LB. SLS THRUST
NAVY ORDNANCE ENGINE

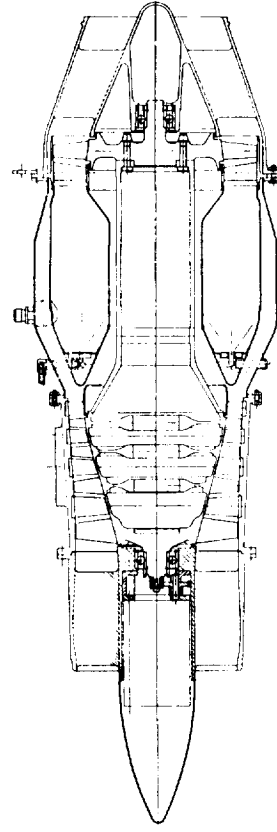

Figure 10

CS-56759

GEARED FAN JET CONFIGURATION

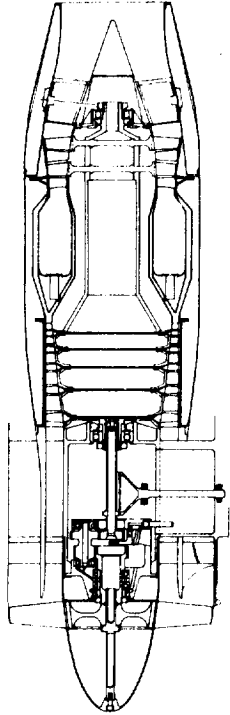

Figure 7

CS-53727

ORDNANCE ENGINE REQUIREMENTS

CRUISE CONDITION M = 0.8 AT 20 000 FT

CRUISE THRUST REQUIRED: 350 LB

SEA LEVEL STATIC THRUST: 650 LB

ENGINE WEIGHT LIMIT: 100 LB

ENGINE DIAM LIMIT: 12 IN.

SPECIFIC FUEL CONSUMPTION <1.8

WINDMILL START AT CRUISE

GAS IMPINGEMENT START AT SLS

FLIGHT DURATION: 15 MIN

Figure 9

CS-56760

SHEET METAL COMPRESSOR
ROTOR COMPONENTS

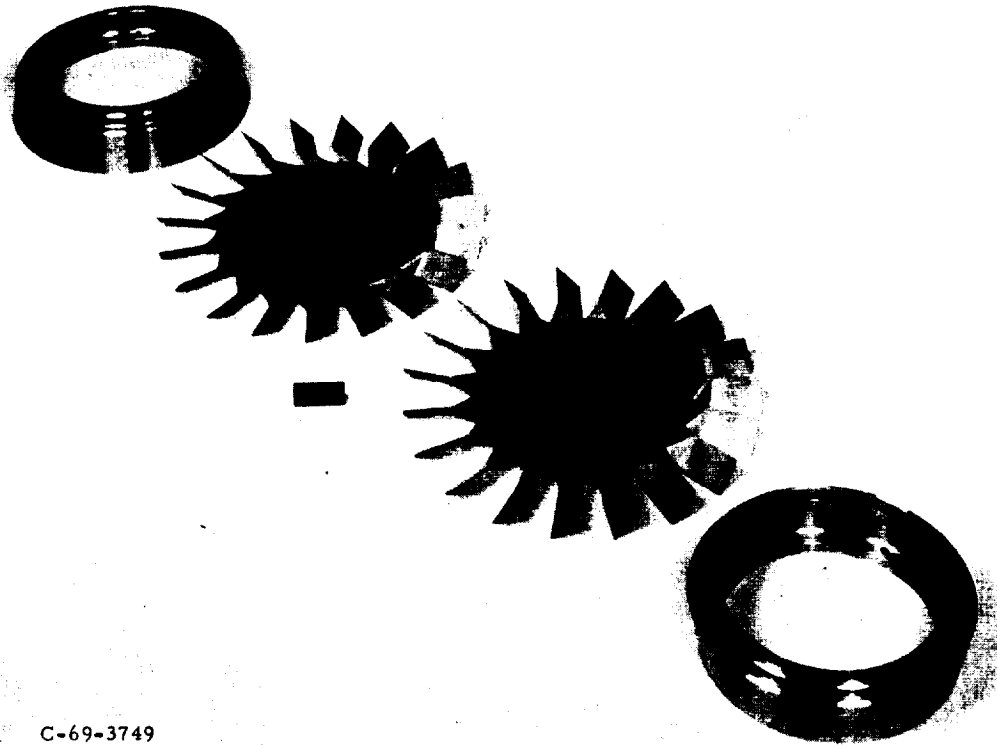

C-69-3749
CS-53729

Figure 11

E-6114

ASSEMBLED SHEET METAL COMPRESSOR ROTOR

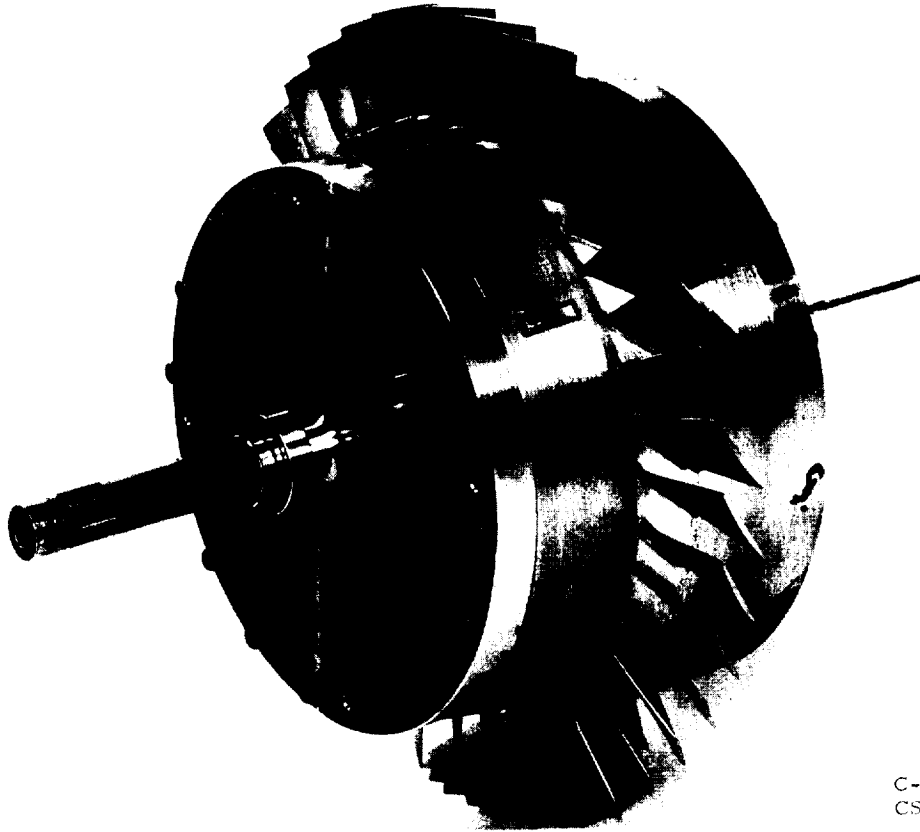

C-70-628
CS-53728

Figure 12

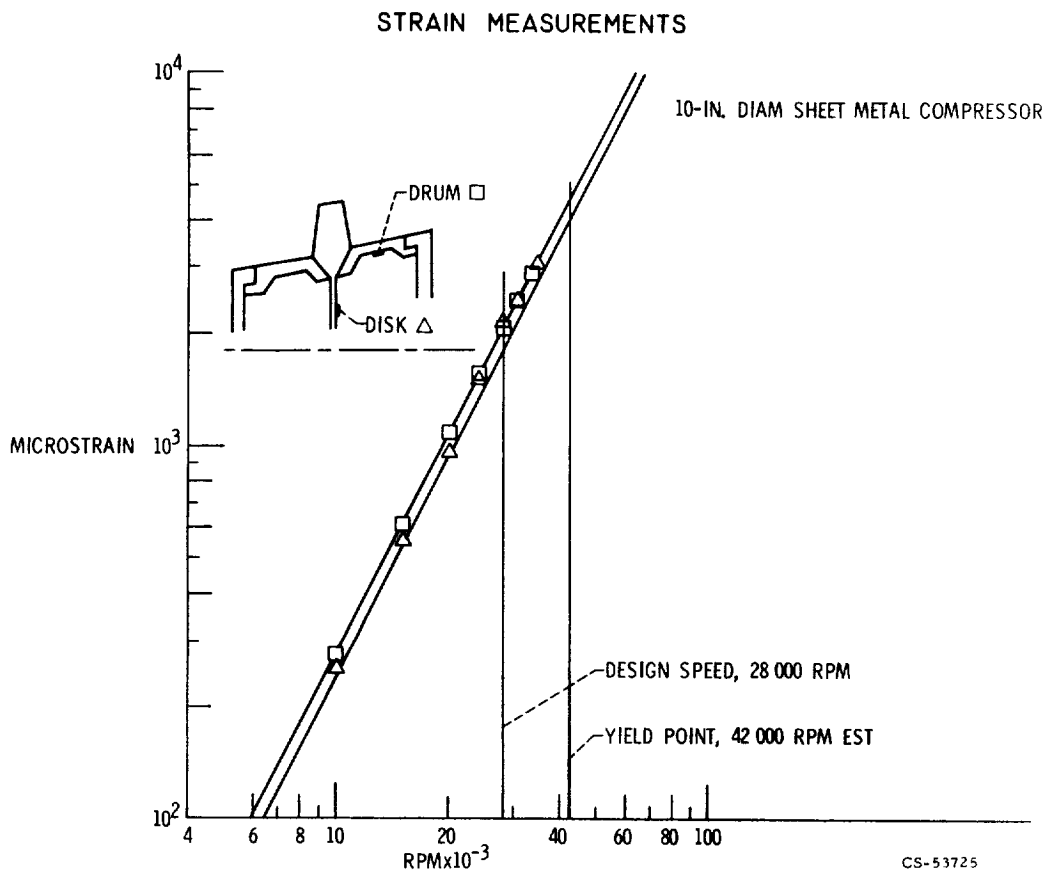

Figure 13

SHEET METAL TURBINE CONSTRUCTION



C-70-3474
CS-56821

Figure 14

SHEET METAL BLADED FAN ROTOR

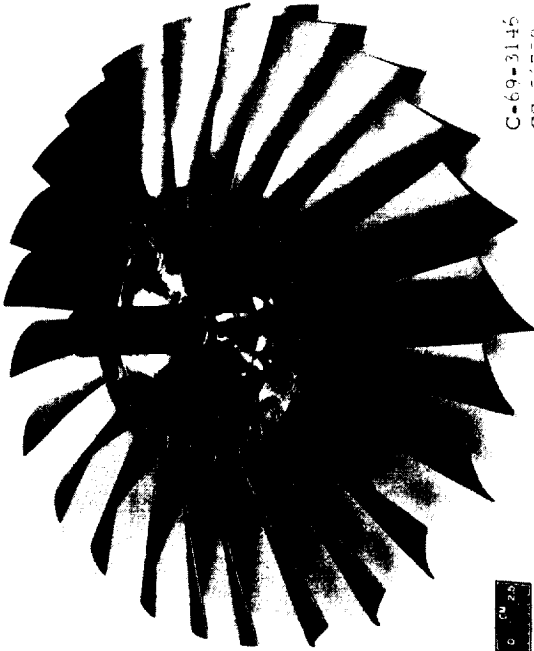

C-69-3145
CS-56758

Figure 15

LOW COST ENGINE COMBUSTOR

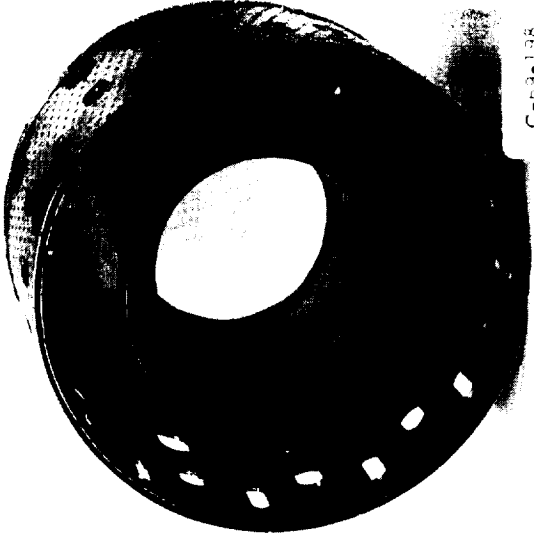

C-69-198
CS-56759

Figure 16

LOW COST ENGINE
ANNULAR COMBUSTOR TEST RESULTS

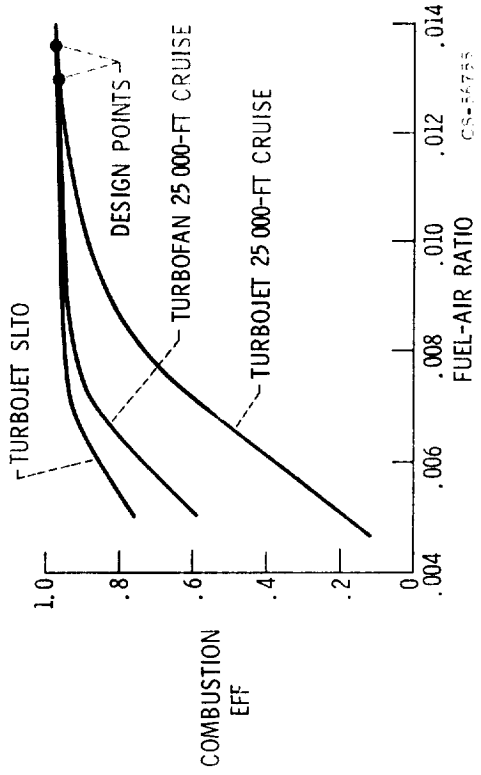

Figure 17

FUEL CONTROL ACCELERATION LIMITS
TYPICAL TURBOJET ENGINE

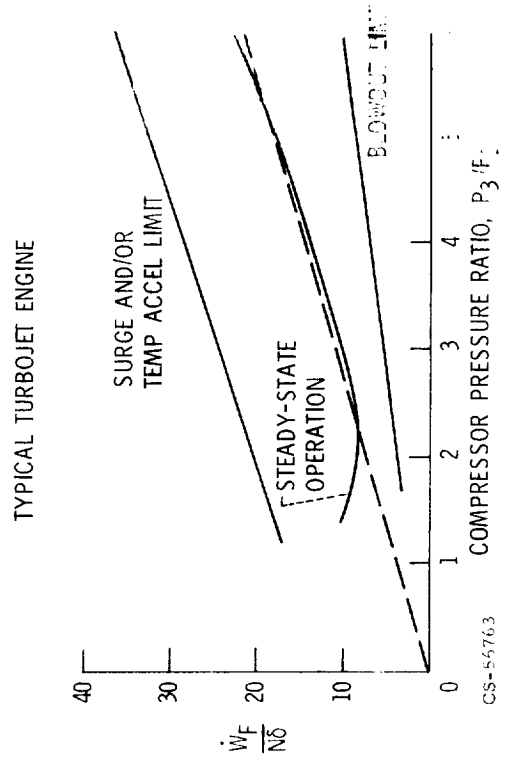

Figure 18

CURRENT JET ENGINE ACCELERATION SCHEDULE

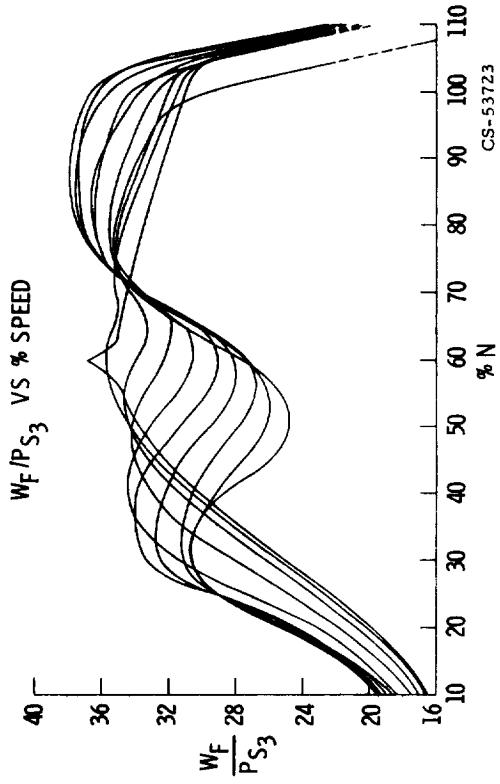

Figure 19

CS-53723

ZERO GRADIENT PUMP FUEL CONTROL

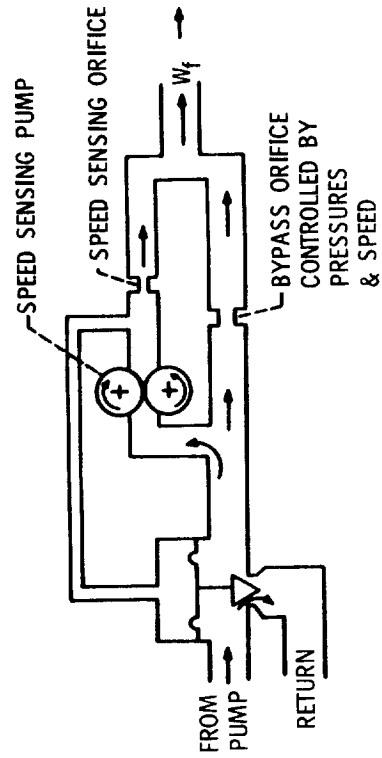

Figure 20

CS-56770

FUEL CONTROL COMPONENT PARTS

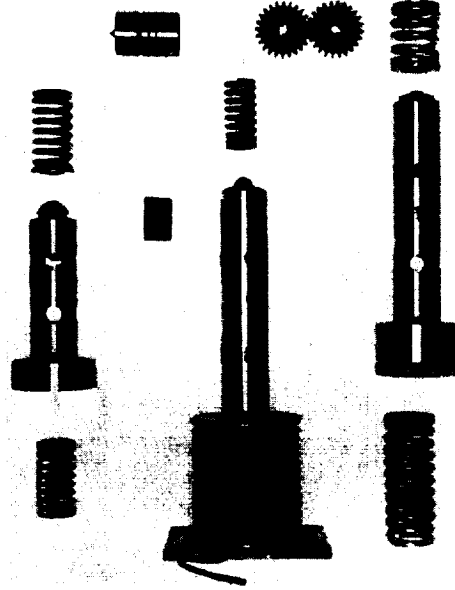
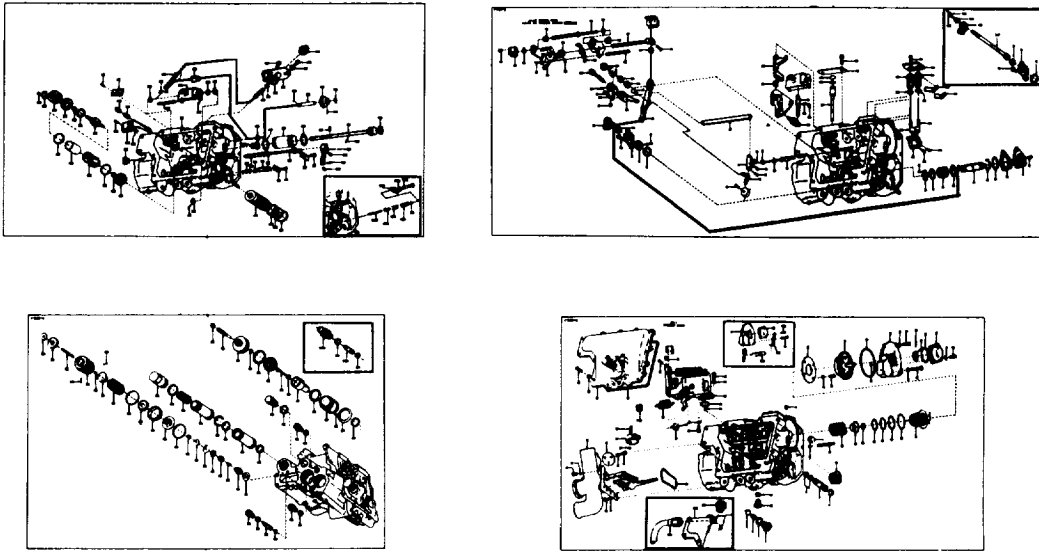

Figure 21

C-70-1346
CS-56756

EXPLODED VIEWS CURRENT TURBOJET FUEL CONTROL



E-6114

Figure 22

CS-56757

J85 ENGINE ACCELERATION 50 TO 95%

EXPERIMENTAL FUEL CONTROL

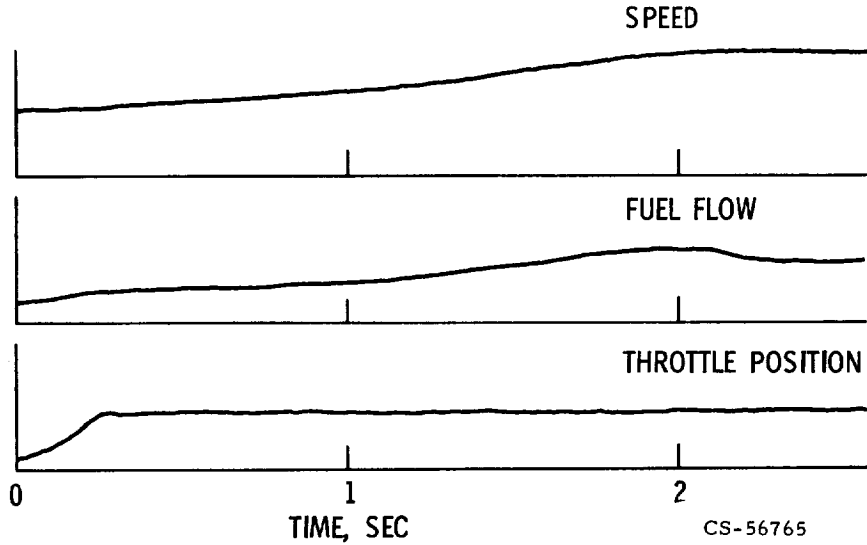

CS-56765

Figure 23

LOW COST ENGINE ACCESSORY INVESTIGATIONS

1. FUEL CONTROL
2. ELECTRIC STARTER-GENERATORS
3. HYDRAULIC MOTOR/PUMPS
4. FAN DRIVE GEARING DESIGN
5. FAN BLOCKAGE THRUST CONTROL
6. ENGINE MOUNTS & ACCESSORY INSTALLATION

Figure 24

CS-56768

E-6114

EXTERIOR VIEW FANJET ENGINE

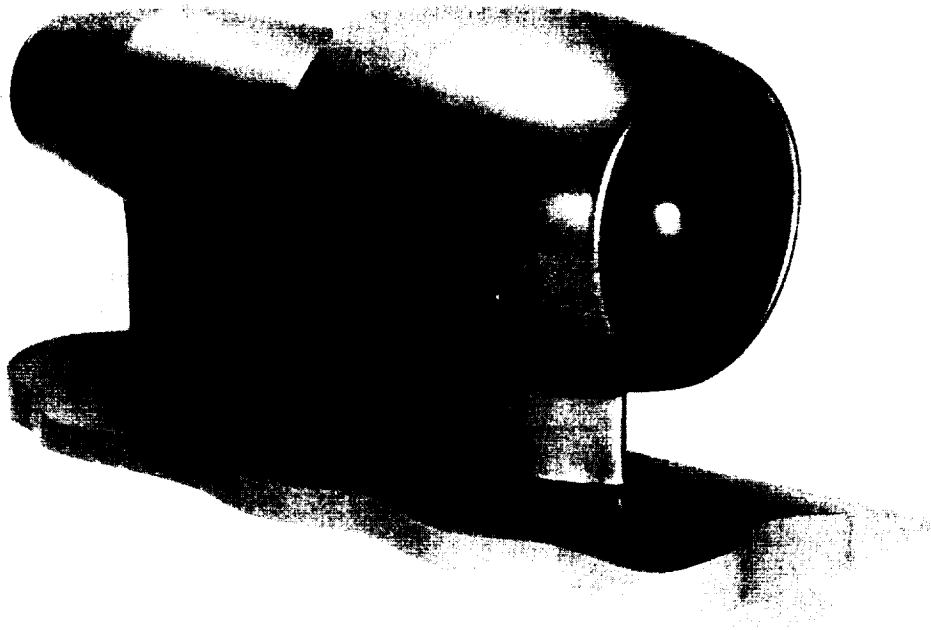

Figure 25

NAVY ORDNANCE ENGINE

PRELIMINARY COST ESTIMATES

ITEM	COST, \$
1. AXIAL COMPRESSOR & STATOR	630
2. TURBINE ROTOR & STATOR	220
3. FRONT & REAR BEARING SUPPORTS	165
4. COMPRESSOR HOUSING ASSEMBLY	55
5. COMBUSTOR & HOUSING ASSEMBLY	185
6. COMPRESSOR SHAFT	40
7. FUEL MANIFOLD & NOZZLES	55
8. BEARINGS, SPRINGS, BOLTS, ETC	50
9. FUEL CONTROL, PUMP, FILTER, ETC	385
10. IGNITION SYSTEM & IGNITERS	175
SUBTOTAL PURCHASED PARTS	<u>1960</u>
11. COST OF ASSEMBLY & INSPECTION	250
12. MATERIAL HANDLING BURDEN	200
13. MFG G & A & PROFIT	<u>755</u>
TOTAL COST, ASSEMBLED	<u>3165</u>

Figure 26

CS-56769

