

FACILITY FORM 602

N 71-16708

(ACCESSION NUMBER)

186

(PAGES)

CR-114815

(NASA CR OR TMX OR AD NUMBER)

(THRU)

G3

(CODE)

03

(CATEGORY)

Reproduced by
**NATIONAL TECHNICAL
INFORMATION SERVICE**
Springfield, Va. 22151

CR 114815

ADVANCED SPACECRAFT ELECTRICAL POWER
SYSTEMS APPLYING SOLID STATE TECHNOLOGY

by

O. H. Preston

VOUGHT AERONAUTICS
LTV AEROSPACE CORPORATION

N O T I C E

THIS DOCUMENT HAS BEEN REPRODUCED FROM THE BEST COPY FURNISHED US BY THE SPONSORING AGENCY. ALTHOUGH IT IS RECOGNIZED THAT CERTAIN PORTIONS ARE ILLEGIBLE, IT IS BEING RELEASED IN THE INTEREST OF MAKING AVAILABLE AS MUCH INFORMATION AS POSSIBLE.

ABSTRACT

A study program was conducted to investigate advanced approaches in solid state power switching, solid state circuit protection, signal sensing, control logic and multiplexing for application to advanced spacecraft electrical power distribution and control systems compatible with MIL-STD-704. Several advanced concepts are presently under development for aircraft electrical systems. These aircraft concepts and hardware were investigated to determine the modification or new development required for their use on advanced spacecraft.

Three electrical power distribution and control system concepts were established for advanced spacecraft and investigated in detail. These were (1) the conventional system concept using electromechanical switches, relays and circuit breakers; (2) the hybrid system concept using electromechanical devices for power switching and circuit protection, solid state signal sensing, and a dedicated data handling system incorporating programmable logic control and signal multiplexing; and (3) the solid state system concept using solid state devices [power controllers] for power switching and circuit protection, solid state signal sensing and a dedicated programmable logic and multiplexing control system. After an analysis and comparison of the three concepts, the solid state system was selected on the basis of weight, size, reliability, performance, flexibility, EMI compatibility, and built-in-test. After an analysis of requirements unique to spacecraft, recommendations were made for the development of multi-channel power controllers and simplified signal sources incorporating built-in-test features. Modifications to the dedicated data handling system were recommended to facilitate built-in-test of signal sources and to more efficiently handle identification and monitor signals.

TABLE OF CONTENTS

		Page No.
	Abstract	ii
	Table of Contents	iii
	List of Illustrations	v
	List of Tables	vii
1.0	INTRODUCTION	1
2.0	AIRCRAFT CONCEPTS	5
2.1	Conventional Aircraft System	6
2.2	Advanced Aircraft Concept - Solid State	10
2.2.1	System Description and Operation	10
2.2.2	Subsystem Details	13
2.2.2.1	Signal Sources	13
2.2.2.2	Power Controllers	13
2.2.2.3	Data Handling System (DHS)	37
2.2.2.4	Built-In-Test Equipment (BITE)	57
2.2.2.5	Support Equipment and Software Program	58
2.3	Advanced Aircraft Concept - Hybrid	63
3.0	ADVANCED SPACECRAFT REQUIREMENTS	65
4.0	SPACECRAFT APPLICATIONS AND DEVELOPMENT REQUIREMENTS	68
4.1	Signal Sources	68
4.2	Power Controllers	72
4.3	Data Handling System (DHS)	83
5.0	SPACECRAFT CONCEPTS	93
5.1	Solid State Concept	93
5.2	Conventional Concept	97
5.3	Hybrid System Concept	101
6.0	COMPARISONS AND TRADE STUDIES	105
6.1	Equipment Installation and Location	105
6.2	Weight and Size	116
6.3	Reliability	117
6.3.1	Introduction and Summary	117
6.3.2	Reliability Analysis	117
6.3.3	Mission Analysis Criteria	123
6.3.4	Functional Block Diagram	123
6.3.5	Reliability Block Diagrams	123
6.3.6	Mathematical Models	127
6.3.7	Reliability Prediction	131
6.3.8	Failure Mode and Effects Analysis	140
6.3.9	Reliability Design Features	140
6.3.10	Conclusions	140
6.4	Modular Construction	142
6.5	Control Logic Flexibility	144
6.6	Performance and EMI Compatibility	145

TABLE OF CONTENTS (Continued)

	Page No.	
7	Impact upon Power Sources and Utilization	152
8	Power Losses	153
9.1	Conventional System	153
9.2	Solid State System	154
9.3	Hybrid System	156
9	Development Time and Cost	157
9.1	Power Controller Development	157
9.2	Data Handling System (DHS) Development	160
9.3	Signal Source Development	160
9.4	Comparison	163
10	CONCLUSIONS	164
11	ACKNOWLEDGEMENTS	166
12	REFERENCES AND BIBLIOGRAPHY	167
APPENDIX I - PROGRAM HISTORY OF SOLID STATE ELECTRIC LOGIC SYSTEM		171
DD Form 1473		176

LIST OF ILLUSTRATIONS

		Page No.
Figure 1-1	Electrical System's Area of Primary Interest	2
Figure 2-1	A Conventional Aircraft Power Distribution and Control System	7
Figure 2-2	Advanced Aircraft Concept -- Solid State	11
Figure 2-3	Solid State Power Switching	12
Specification	Switch, Electronic Transducer; Toggle Type	14
Specification	Controller, Power, AC Bus Switching, 75 amp	18
Figure 2-4	Block Diagram -- AC Load Controllers	22
Figure 2-5	Trip Characteristics for AC Power Controllers	23
Figure 2-6	Block Diagram -- DC Load Controller	24
Figure 2-7	Trip Characteristics for DC Power Controllers	26
Figure 2-8	Overload Current Limiting Characteristics of DC Power Controllers	27
Specification	Power Controller, DC Load Switching, SPST, Normal Open, 2 thru 10.0 amperes	29
Specification	Power Controller, AC Load Switching, SPST, Normal Open, 1 thru 10 amperes	32
Figure 2-9	Power Controller Board Assembly	35
Figure 2-10	Power Controller Rack Assembly	36
Figure 2-11	Data Handling System, Block Diagram	38
Figure 2-12	Word Structure	43
Figure 2-13	Transmission Message Structure	45
Figure 2-14	Master Unit, Simplified Block Diagram	49
Figure 2-15	Master Unit, Package Design	51
Figure 2-16	Remote Input Terminal, Package Design	53
Figure 2-17	Remote Output Terminal, Package Design	55
Figure 2-18	Pilot Control Panel	56
Figure 2-19	Memory Loader/Verifier Panel Layout	58
Figure 2-20	Decoder Unit, Panel Layout	62
Figure 2-21	Advanced Aircraft Concept -- Hybrid	64
Figure 4-1	Present Signal Source Interconnection	69
Figure 4-2	Proposed Switched Impedance Signal Source Interconnection	70
Figure 4-3	Block Diagram -- 16-Channel DC Power Controller Module	73
Specification	Power Controller, DC Load Switching, 16 PST, Normal Open, 1 thru 10 amperes	77
Figure 4-4	Load Controller Built-In-Test Equipment (BITE)	80
Figure 4-5	Handling Load Controller Trip and Fault Data	82
Figure 4-6	Spacecraft Dedicated Data Handling Subsystem	85
Figure 4-7	Additional Multiplex Loops using Line Extenders	87

LIST OF ILLUSTRATIONS (Continued)

	Page No.
Figure 4-8	Parallel Multiplex Loops 88
Figure 4-9	Parallel-Extended Multiplex Loops 90
Figure 4-10	Looped/Radial Multiplex Link 91
Figure 5-1	Block Diagram -- Typical Interim Shuttle Solid State Electrical Power System 94
Figure 5-2	Approximate Dimensions of Wiring Zones on an Interim Shuttle (Solid State Concept) 95
Figure 5-3	LH Half of Forward Power Center 96
Figure 5-4	Interim Shuttle -- Two Loop Multiplex Subsystem 99
Figure 5-5	LH Half of Conventional System 100
Figure 6-1	Estimate of Conventional Circuit Breaker Panel Area 108
Figure 6-2	Estimate of Conventional Circuit Breaker Panel Volume 109
Figure 6-3	Functional Diagram -- Conventional System 124
Figure 6-4	Functional Diagram -- Hybrid System 125
Figure 6-5	Functional Diagram -- Solid State System 126
Figure 6-6	Mission Success Diagram -- Conventional System 128
Figure 6-7	Mission Success Diagram -- Hybrid System 129
Figure 6-8	Mission Success Diagram -- Solid State System 130
Figure 6-9	AC Load Controller and Thermal Breaker Trip Characteristics 148
Figure 6-10	Master Plan for Development of Power Controllers 158
Figure 6-11	Master Plan for Development of a Dedicated Data Handling System (DHS) 161
Figure 6-12	Master Plan for Development of Signal Sources 162
Figure A-1	Solid State Electric System Development History 173

LIST OF TABLES

	Page No.
Table 2-1	Alternate Subsystems for Advanced Aircraft 5
Table 2-2	Load Controller Ratings 28
Table 2-3	Data Handling System Characteristics 40
Table 2-4	PL-MUX System BITE Design -- Major Features 59
Table 5-1	Component Location -- Power Switching for Solid State Concept 98
Table 5-2	Component Location -- DHS for Solid State Concept 98
Table 5-3	Component Location -- Power Switching for Conventional Concept 102
Table 5-4	Component Location -- Power Switching for Hybrid Concept 102
Table 5-5	Component Location -- DHS for Hybrid Concept 104
Table 6-1	Equipment Location and Installation 106
Table 6-2	Concept Comparisons -- Weight and Volume 118
Table 6-3	Summary -- System Weight and Volume 119
Table 6-4	Summary -- Weight of Power and Control Wiring 120
Table 6-5	Summary -- Weight and Volume of Power Switching and Circuit Protection 121
Table 6-6	Summary -- Weight and Volume of Control Hardware 122
Table 6-7	Conventional System Failure Rate Estimate 132
Table 6-8	Hybrid System Failure Rate Estimate 133
Table 6-9	Signal Source Failure Rate Estimate 134
Table 6-10	Remote Input Terminal Failure Rate 135
Table 6-11	Master Unit Failure Rate 136
Table 6-12	Remote Output Terminal Failure Rate 137
Table 6-13	Pilot Control Panel Failure Rate Estimate 138
Table 6-14	Power Controllers Failure Rate Estimate 138
Table 6-15	Power Supply Failure Rate Estimate 139
Table 6-16	Initial Failure Mode and Effect Analysis -- Solid State System 141
Table 6-17	Comparison of Modular Packaging 142
Table 6-18	Comparison of Control Logic Flexibility 144
Table 6-19	Comparison of Performance and EMI Compatibility 145
Table 6-20	Comparison of Impact upon Power Sources and Utilization 152
Table 6-21	Summary of System Losses 153
Table 6-22	Power Controller Losses 155

1.0 INTRODUCTION

This is the final Engineering Report prepared under NASA Contract NAS 9-10408 sponsored by the Information System Division of NASA Houston Manned Spacecraft Center. The report documents investigative studies directed toward applying advanced approaches of solid state power switching, solid state circuit protection, signal sensing, control logic, and multiplexing for application to advanced spacecraft electrical power distribution and control systems.

The portion of electrical systems which is of primary interest and to which this study is addressed is shown enclosed by the dashed lines of Figure 1-1. Until recently this portion of electrical systems on both aircraft and spacecraft has been an area neglected from the standpoint of new concepts, component development, and general advancement of the state-of-the-art. For many years the conventional approach has been the use of power contactors and motor switches for bus switching; complex bus arrangements using bus monitoring instead of individual load monitoring for powering down a system; thermal circuit breakers for circuit protection; and relays and switches interconnected at the power level to form the logic for control of power to the loads. In addition, the conventional approach and associated components were adequate for the simple systems of the past. However, for the sophisticated and highly complex systems of today and those projected for the future, the conventional approach becomes unwieldy from the standpoint of wiring, performance, life, reliability, maintenance, and checkout.

During the past decade new concepts have emerged and new component developments have been initiated for advanced aircraft which offer many features for simplifying and improving the operation of the electrical power distribution and control system. A detailed account of these developments can be obtained from a review of references 9-10 through 9-32. Here, power contactors and motor switches are replaced by solid state power switching devices to perform the bus-switching functions. Solid state power switching and circuit protection are combined into a single power controller module, replacing the thermal circuit breaker and power switching relay in each load circuit. Power is routed directly from the bus to the load and is separated from control with control performed at a low power level, nominally 5 volts and 10 milliamperes. Control of the power controllers is provided by a dedicated data handling system (DHS), utilizing programmable logic for manipulating and multiplexing for transmission of digital control signals. Generation and sensing of control signals are performed by solid state signal sources, supplying the signals to remote input terminals of the dedicated DHS. Implementation of the advanced concept results in significant reductions in distribution system power and control wiring, overall

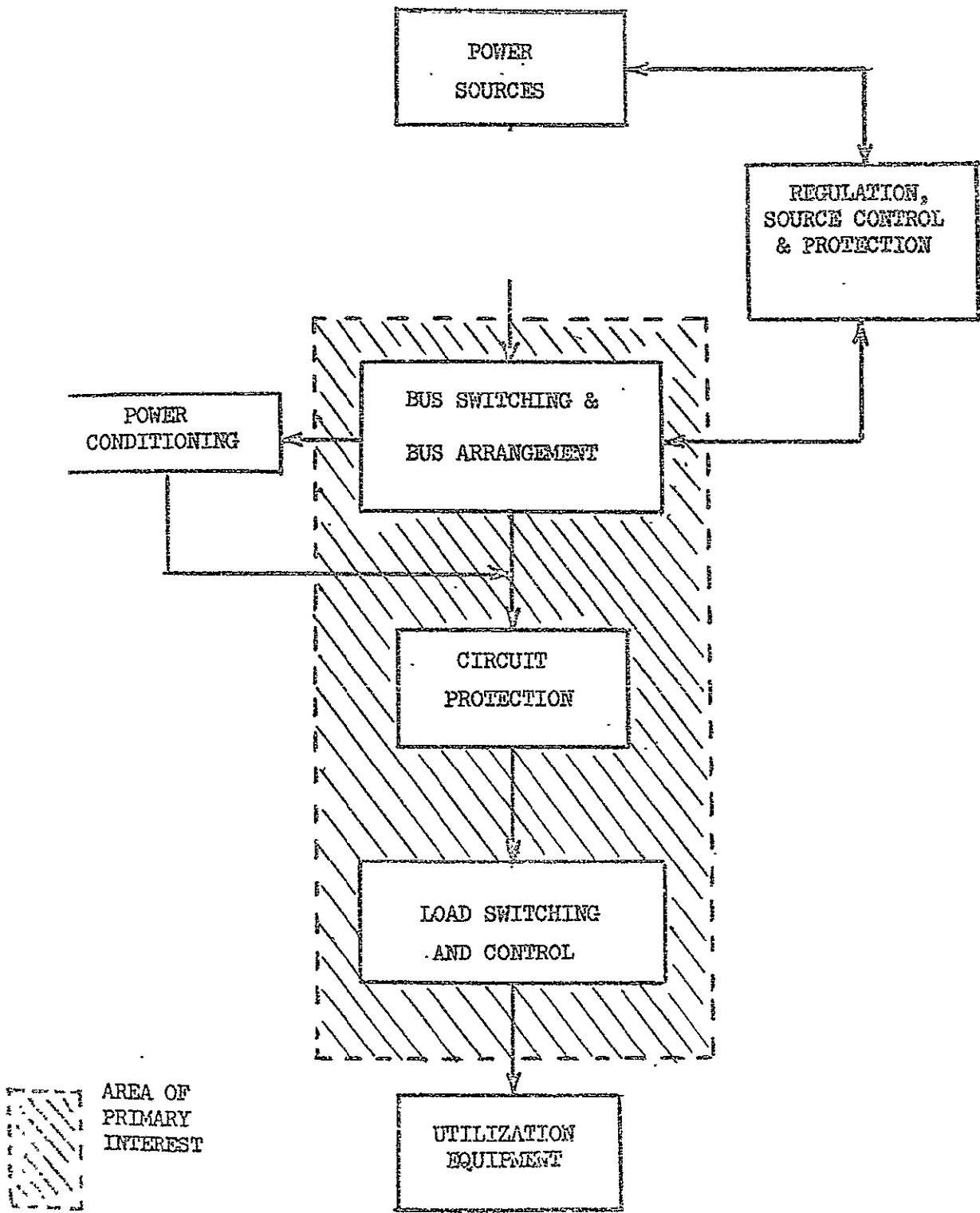

FIGURE 1-1 ELECTRICAL SYSTEM'S AREA OF PRIMARY INTEREST

system weight and size. Significant improvements are gained in performance, reliability, change flexibility, and checkout.

Recognizing the limitations and problems associated with the conventional approach and the desirable features of the advanced aircraft concepts, the purpose of the study effort was to: (1) investigate the application of advanced aircraft concepts and associated hardware to spacecraft electrical power distribution and control systems; (2) determine changes in concepts and/or hardware to satisfy any unique requirements of spacecraft; (3) determine optimum system concepts; (4) determine hardware modification cost and time to perform modifications with proper qualification testing; and (5) document the investigation.

More specific tasks completed as part of the study are outlined below:

1. Document advanced aircraft power distribution and control system concepts and associated components development.
2. Survey, study, and further define functional and interface requirements unique to spacecraft.
3. Revise aircraft concepts to accommodate those requirements unique to spacecraft.
4. Determine aircraft components compatibility with spacecraft requirements.
5. Define necessary component changes and modifications. Obtain estimated development time and costs; submit a projected development schedule.
6. Perform trade-off studies between a minimum of three system concepts to arrive at an optimum approach. The following were used as major trade-off factors:
 - a. Weight/size
 - b. Reliability
 - c. Cost
 - d. Modular construction
 - e. Prelaunch and inflight test/checkout
 - f. Flexibility in changing control logic functions
 - g. Performance
 - h. Impact upon power sources and utilization equipment
 - i. Development time
 - j. EMI compatibility.

7. Prepare a final report documenting revised system concepts, component modification requirements, modification cost and development time, trade-off studies, recommended system concept, problem areas, and recommendations for further program action.

The investigation was directed toward obtaining the following design goals:

1. Reduce overall system weight and size by 40% as compared to present spacecraft systems.
2. Improve reliability by a factor ranging from 500 to 1000%.
3. Maintain overall system losses equivalent to or less than those of the present systems.
4. Reduce power source fault current capacity requirements by 50%.
5. Utilize modular construction.
6. Provide redundancy in system critical components.
7. Incorporate prelaunch and inflight test to the replaceable module level. The system shall also incorporate an automatic, inflight, fault detection feature whereby the fault will be identified at the replaceable module level.
8. Eliminate major wiring changes to accommodate changes to control logic functions.
9. Provide remote reset capability for power switching/ protection components.
10. Optimize the entire system. There is to be no point at which failure of a single component will cause failure of the system. Failure of a control logic event to occur or premature occurrence of an event shall constitute a system failure. If failure can occur, the design shall be such as to allow the failure only in the "fail-safe" mode. Maximum emphasis should be placed throughout the mechanization to eliminate single point failures.
11. Optimize cost and function.

2.0 AIRCRAFT CONCEPTS

Over the past ten years several advanced concepts have been identified and defined for aircraft electrical power distribution and control systems. These concepts have included various combinations of electromechanical, hybrid, and solid state devices. Each of these concepts can be reduced to three major subsystems such as signal generation, control, and power switching. Table 2-1 lists the more common alternates under each major subsystem. Referring to Table 2-1, a concept could be established which would consist of hybrid

TABLE 2-1 Alternate Subsystems for Advanced Aircraft

Signal Sources	Data Handling (Control)		Power Switching
	Transmission	Logic	
(1) Mechanical	(1) Hard-wire	(1) Non-programmable Memory	(1) Electromechanical
(2) Solid State	(2) Multiplexing	(2) Solid State (Hard-wired)	(2) Solid State
(3) Hybrid		(3) Programmable Memory	(3) Hybrid

signal sources, hard-wired data transmission, hard-wired integrated logic and solid state power switching. Another combination might be solid state signal sources, multiplexed data transmission, hard-wired integrated logic and hybrid switching. It can be seen that various other combinations could be generated. Several advanced concepts were investigated, but the ones showing the greatest promise for spacecraft applications were a solid state concept and a hybrid concept. The solid state concept uses solid state signal sources, multiplexed data transmission, programmable logic and solid state power switching. The hybrid concept uses the same signal sources and dedicated data handling as above but incorporates hybrid power switching. The conventional concept was selected as a third alternate and is used as a base for discussion and comparisons.

Conventional Aircraft System

A conventional aircraft power distribution and control system is shown in Figure 2-1. A detailed discussion on system operation will not be made other than to point out a few system features.

Bus Arrangement and Switching - The bus arrangement is complex, requiring eight buses and eight power contactors. Load priorities are assigned to buses such that high priority loads are placed on emergency buses, lower priorities on main buses, and lowest priority loads on monitor buses. As sources are lost or loading exceeds a certain level, the monitor buses are dropped. Upon loss of all main power sources, the emergency generator is brought on the line and all buses are dropped except the emergency buses.

Load Circuits - On the left-hand portion of Figure 2-1, a typical load power circuit is shown. The breaks designated as A, B, C, and D represent toggle, limit, pressure, or other types of switches or relay contacts. The contacts of these devices are wired in such a way that power is applied to the load only when the switch or relay contacts are opened or closed in such a pattern as to satisfy the control logic for power application. These switch and relay contacts can be located at any places within the aircraft. Thus, to obtain proper logic operation, the power wiring from the circuit breaker must be routed to and from each of these devices before going to the load. It is immediately apparent that control is performed at the power level. Diverse location of these switching elements, multiplicity of different series and parallel arrangements of contacts, multiple contacts for the same switch function, and the large number of load circuits create an extremely complex wiring design, installation and check-out problem.

The conventional aircraft power distribution and control system suffers from many problems. These are briefly outlined below.

Bus Transfer Time - Using power contactors, a problem exists in transferring a bus from one source to another. The switching transfer time is approximately 50 milliseconds which is too long a power interruption time for certain types of sophisticated electronic systems. Systems most susceptible to memory loss and errors introduced by the loss of power are digital computers, digital logic, flight controls, radar, and navigation.

Load/Bus Assignments - Since load monitoring is performed on a priority basis, the priority of each load must be determined during design and a load assigned to the bus with the proper priority. To change a load priority after installation requires a wiring change on the vehicle. The uneven distribution of single-phase loads between buses often creates a voltage imbalance condition.

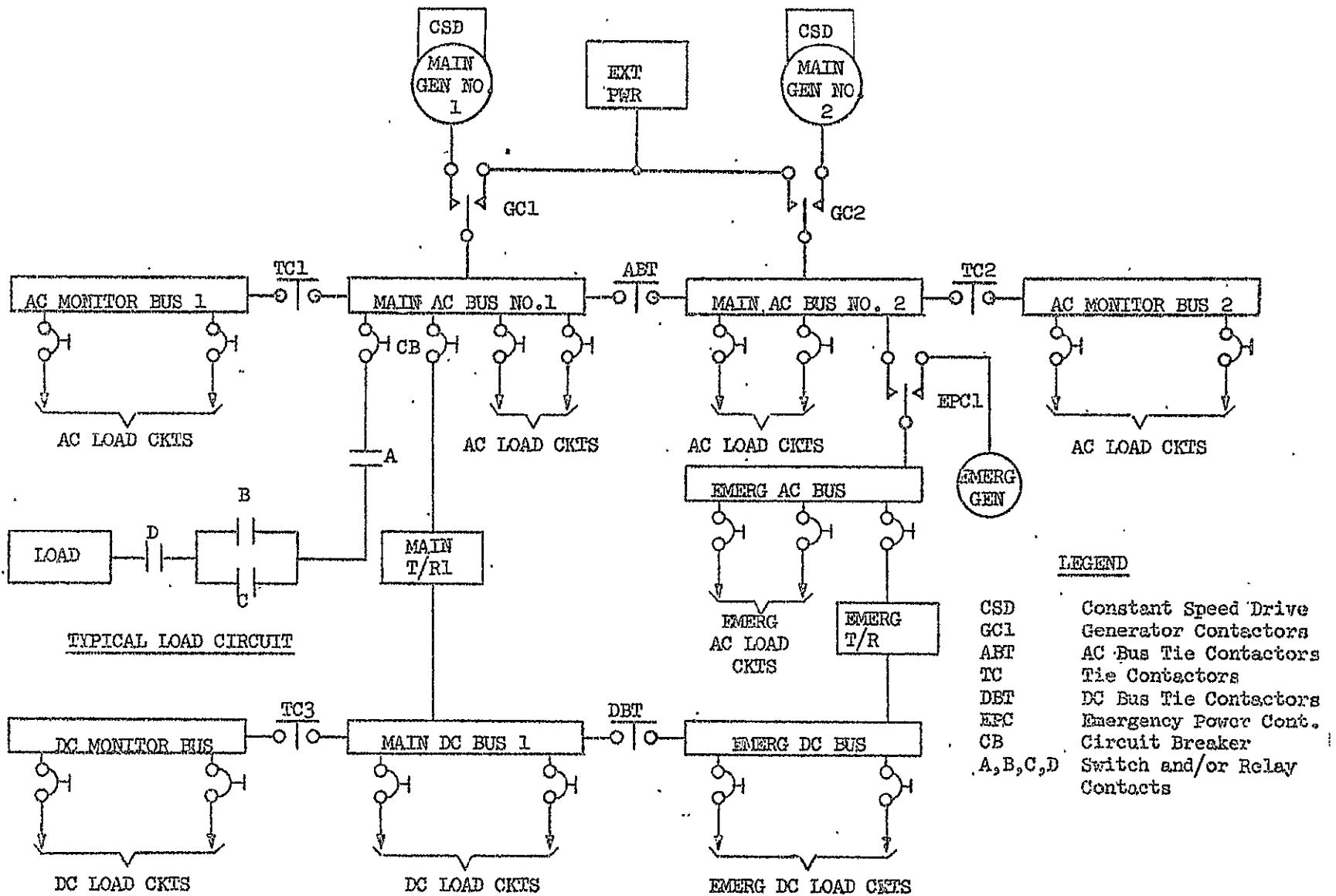

FIGURE 2-1 A CONVENTIONAL AIRCRAFT POWER DISTRIBUTION AND CONTROL SYSTEM

Load Monitoring - Load monitoring or powering down is accomplished by dropping buses and all the loads on those buses. The sudden dropping of a large block of loads creates an overvoltage surge on the system. Again, the sudden picking-up of a bus (powering up) creates an undervoltage surge on the system. Sequencing of loads would reduce the magnitude of these surges. Inflexibility exists in that under certain flight conditions, certain loads are not necessary and are off, creating an underloaded condition on say an emergency power source. Flexibility is needed to program load monitoring on a load basis rather than a bus basis and to vary load priorities according to flight conditions. It is impractical to incorporate these features on the conventional system.

Wiring - Wiring on the conventional system is a major problem. Large quantities and long lengths of power wiring are required to interconnect the switch/relay logic. Since the logic is performed at the power level and long lengths are necessary, larger sizes are often required to compensate for voltage drop. As the amount of wiring increases, the number and size of connectors increase. The reliability of connectors decreases as the number of pins per connector increases. Furthermore, the size and complexity of wiring harnesses presents greater opportunities for wiring errors and aggravates the wire routing and installation problem. As systems become more complex, proper checkout and maintenance of wiring harnesses become prohibitive.

Equipment Location - For circuit breakers to be accessible for reset in flight, they must be located in the crew station. This dictates locating buses and power contactors in the crew station. The breakers, buses and contactors require large blocks of crew station panel space and console volume, pointing out the need for a circuit protection device which can be located remotely and controlled remotely.

Circuit Breakers - Thermal circuit breaker trip characteristics have a broad and variable trip band due to manufacturing tolerances and variations with temperature. Proper coordination of large breakers in series is often difficult. Furthermore, circuit breakers of small ratings through 3 amperes have a high contact voltage drop. This drop in series with a maximum allowed drop in power wiring is prohibitive, requiring that only larger ratings of breakers such as 5 amperes be used even on circuits with milliampere loads. In turn, the higher rating of the breaker forces the use of a larger wire size to obtain proper breaker and wire coordination.

Switches - Many problems exist with the use of conventional electromechanical switches. These range from contact arcing, bounce, chatter and contact erosion to mechanical wear out. Contact resistance often increases with age and operations. Furthermore, a switch often be of a multi-pole configuration to give electrical isolation of the switch function is used in several circuits. A weight and size penalty results from the multi-pole requirement. Mechanical limit

switches used for such operations as landing gear and gear door operations have critical adjustment requirements and are often damaged by shock loading during landing and failure of mechanical supports. They are subject to damage or improper operation caused by runway gravel, debris, mud, etc. Historically, mechanical limit switches in these applications have a high failure rate. Proximity devices solve many problems on landing gear applications, but incorporation of them into a conventional system requires a sensor head and an electronic control module driving a relay.

Relays - Problems associated with relays are very similar to those of switches.

Performance and EMI - The conventional system has performance and EMI characteristics which are less than desirable. A few of these are listed below:

1. With the mass of power wiring and the inadvertent routing of long sections of wires parallel to one another, induced EMI becomes a problem.
2. Instantaneous contact opening and closing, contact bounce and chatter with arcing are a source of noise and high induction kick-back voltages, all of which contribute to the poor EMI environments. EMI can be reduced by suppression devices on relays and solenoid valves, but these degrade the performance of the device.
3. With the use of electromechanical contacts, loads are connected directly to the electrical power source; thus all transients, spikes, and other perturbations of loads and sources are passed on to each load without any buffering effect.
4. Wiring and components are designed to sustain at least a 3 per unit fault current for 5 seconds. This imposes weight and size penalties on components and subjects the system to thermal, electrical, and mechanical stresses.
5. Random switching at different points on an AC waveform is another source of transient surges. For resistive and some inductive and capacitive loads, switching at zero crossover eliminates these surges.
6. Problem areas already considered are those of slow bus transfer times and large step increases or decreases in loads.

2.2 Advanced Aircraft Concept -- Solid State

2.2.1 System Description and Operation

Figure 2-2 is a schematic block diagram of a completely solid state aircraft power distribution and control system. As noted, the system is divided into three major subsystems -- signal generation [sources], data handling, and power switching. Signal generation produces the bi-level signals associated with control of the system. These signals corresponding to manual operations, pressures, temperature, position, motion, etc. correspond to the control elements A, B, C, and D previously shown in Figure 2-1. The dedicated data handling (DHS) encodes and transmits the signals over a multiplex link to a programmable central processor called a Master Unit (MU) which performs the control logic operations. Output signals from the MU logic operations are transmitted over the same multiplex link, decoded and individually hard-wired to solid state power switching and protection devices designated as power controllers. Power controllers are of two general types -- bus switching controllers (BC) and load switching controllers (LC). As implied the BC are used for power source and bus switching operation, functioning essentially as solid state power contactors. The LC are located at the load buses and serve as load switches and circuit protectors. Individual power wires to each load are routed directly from the LC at the bus to the load.

The most apparent feature of the solid state concept is the separation of power and control. Here, control can be performed at a low power level: a nominal 5 VDC at 10 milliamperes. The low power level permits the use of small gage wire or flat conductor cable between signal sources and the remote input terminals (RIT) of the DHS and between the remote output terminals (ROT) and the power controllers.

Figure 2-3 is a schematic block diagram, showing more detail of the power switching subsystem. In referring back to Figure 2-1, it becomes apparent that the solid state system of Figure 2-3 is much simpler with fewer buses and a reduced bus switching requirement. The priority of each load is programmed into the control system, thus automatically monitoring and turning off low priority loads on a load basis as source availability or capacity is reduced. Through switching and control of the individual loads, the emergency generator can be connected as shown in Figure 2-3 and the emergency and monitor buses eliminated. Under emergency conditions, only those loads with highest priority can be enabled. Additional flexibility can be obtained by programming load priority according to flight conditions. Other features include the ability to program load sequencing such as to avoid step increases or decreases of large blocks of loads. The capability exists for complete automatic load management.

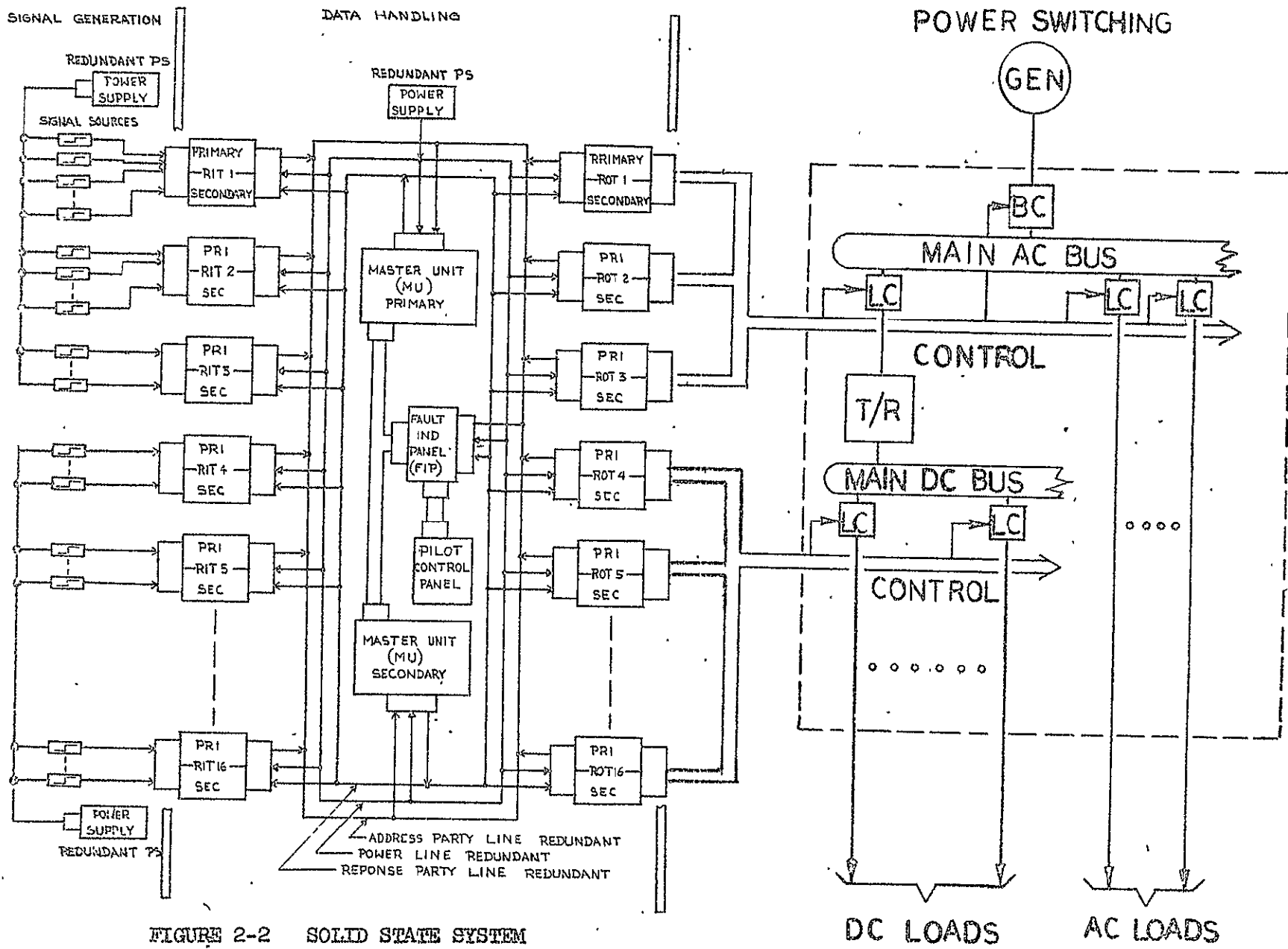
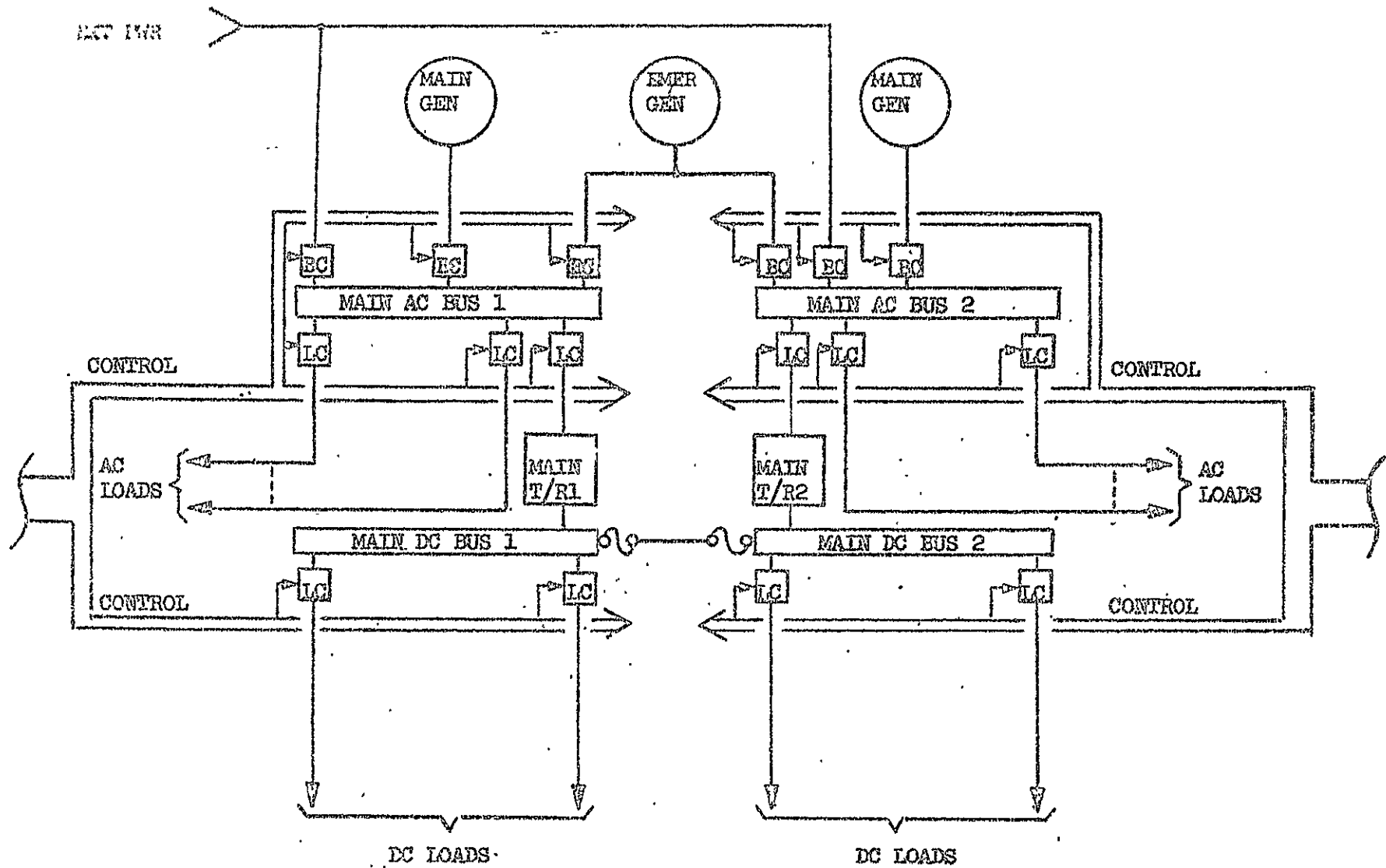

FIGURE 2-2 SOLID STATE SYSTEM



12

FIGURE 2-3 SOLID STATE POWER SWITCHING

2.2.2 Subsystem Details

2.2.2.1 Signal Sources

Signal sources for the advanced aircraft solid state system are of two general types: manual devices for crew station control, and remote sensors for functions such as position, motion, temperature, pressure, etc. The signal sources are completely solid state except for the mechanical actuators. This contributes to their high level of reliability. These devices can be designed to operate on the principle of optics, electromagnetics, nuclear, strain gage, and others. The bi-level output signal is a "0" or "1", OFF or ON respectively. The OFF condition is a nominal zero volts while the ON condition is a nominal 5 VDC feeding into a nominal impedance of 500 ohms. The signal level of 5 VDC at 10 milliamperes is chosen for noise immunity. Further, the low power level permits the use of small gage wire or flat conductor cable in connecting the signal source to its power supply and to the remote terminals of the DHS.

Three versions of the manual control signal sources have been developed to the engineering model stage. These are an ON-OFF toggle switch, an ON-OFF-ON toggle switch, and a push-button switch. The switches were developed to MIL-S-81619(A), General Specification for Solid State Transducer Switches (8 October 1969). The specification sheets which follow for the ON-OFF and ON-OFF-ON toggle switches are very similar to those of the slash sheet MIL-S-81619/1(AS), Toggle Type Electronic Transducer Switch. Additional development is necessary for other versions of toggle and push-button switches in conjunction with rotary switches.

Early models of electromagnetic [proximity] sensor heads and associated electronics were designed, built and test flown on an XC142 aircraft. They were designed into the landing gear assembly and used to sense the LOCKED or UNLOCKED condition of the down-lock and up-lock mechanisms on both main landing gears. The unique feature of these signal sources was the fact that they were small and were built into the lock mechanisms, giving a much more direct and reliable indication than the electromechanical limit switch that they replaced. The devices provided highly satisfactory performance until the crash of the test vehicle from other causes. For additional details on the early work with signal sources of this type, refer to reference 9.18. No additional development has been performed in this area.

2.2.2.2 Power Controllers

The solid state power controllers are of two general classes -- bus controllers (BC) and load switching controllers (LC). The LC can be

SPECIFICATION

SWITCH, ELECTRONIC TRANSDUCER; TOGGLE TYPE

The complete requirements for procuring the switch described herein shall consist of this document and the issue in effect of Specification MIL-S-81619(AS).

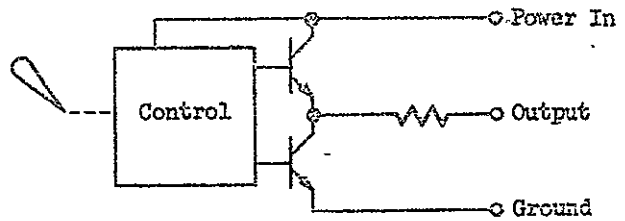
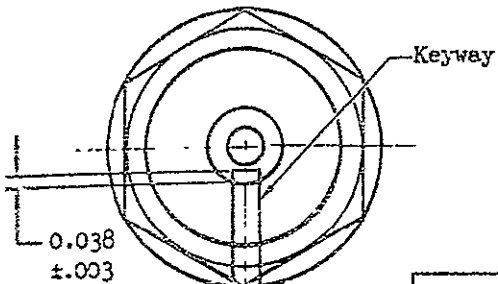

Circuit Diagram

TERMINAL IDENTIFICATION	
Wire Lead Color	
Red	Power In
White	Signal No. 1 Out
Green	Signal No. 2 Out
Black	Ground

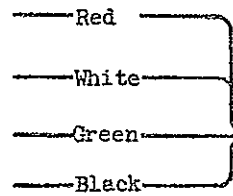
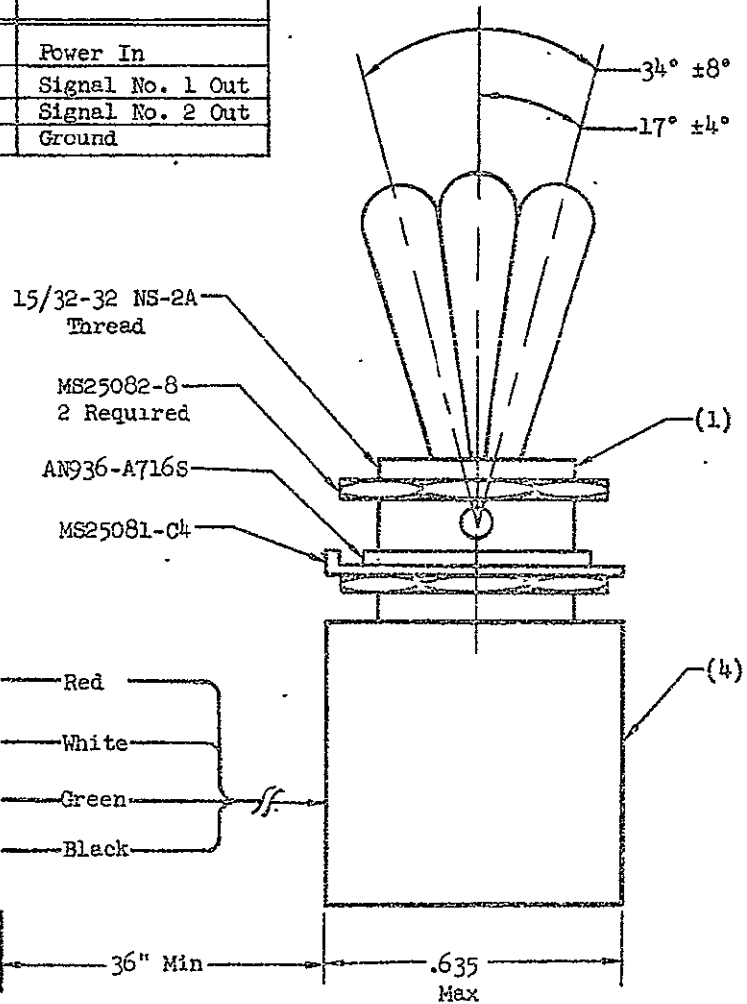
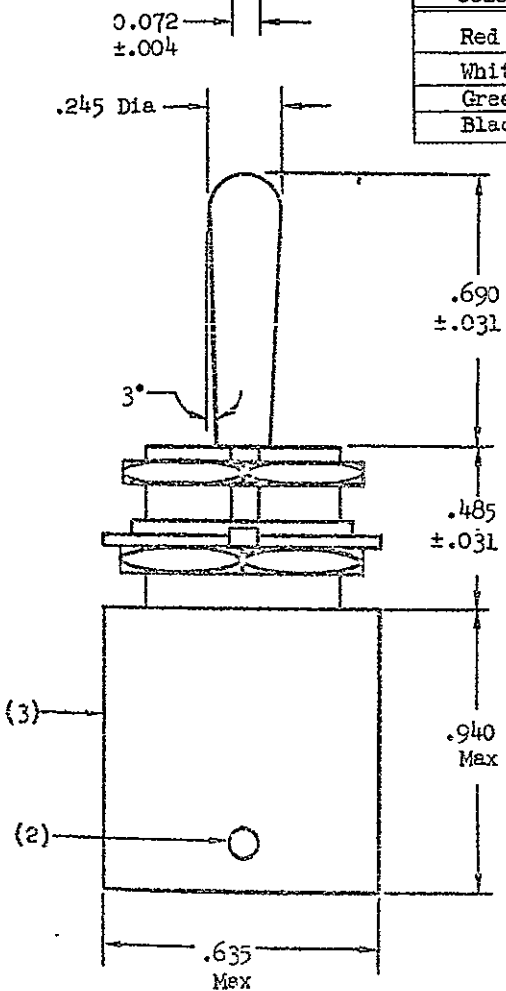

Notes:

1. Thread to within 0.062 of shoulder.
2. Wire leads shall emerge from lower half of switch body below positioning keyway.
3. Contour of switch body optional.
4. Identification to be placed on surface of switch body located 180 degrees from positioning keyway.

REQUIREMENTS:

MECHANICAL AND DIMENSIONAL CHARACTERISTICS:

Dimensions - - - - - in inches*
 Tolerances - - - - - ± 0.01 inches on decimals
 ± 0.5° on angles
 Terminals - - - - - Wire Lead (MIL-W-81381/1-26)
 Actuating Force - - - - - 0.5 lb minimum 5.0 lb maximum

Weight - - - - - 0.08 pound maximum
 Strength of Actuating Lever - - - - - 25 Pounds
 Strength of Wire Leads - - - - - 5 Pounds Tensile
 Operating Cycles - - - - - 150,000 minimum
 Enclosure - - - - - Sealed - Watertight

*Metric equivalents to the nearest 0.01 millimeter shall be based upon 1 inch = 25.40 millimeters.

ELECTRICAL CHARACTERISTICS:

Part No.	Logical State of Output Signals With Toggle Lever in These Positions					
	Opposite Keyway Side		Center		Keyway Side	
	Signal No.		Signal No.		Signal No.	
	1	2	1	2	1	2
204-99-10-2	0	1	0	0	1	0
204-99-10-1	1	None	None	None	0	None

(a) Nonfunctioning terminals shall not be supplied.

Maximum Supply Voltage - - - - - 8 volts DC
 Supply Voltage - - - - - 6 volts ±5% DC
 Output Voltage, Actuated Condition
 (Logical '1') - - - - - 4.5 volts minimum
 Output Voltage, Unactuated Condition
 (Logical '0') - - - - - 0.6 volts maximum (while
 sinking .007 amp)
 Output Current, Actuated Condition - - - - - 9 milliamperes minimum
 Output Impedance, Unactuated Condition - - - - - 50 ohms, minimum
 85 ohms maximum
 Input Power
 Actuated and Output Connected to 510 ± 1% 0.35 watt maximum

..... 0.35 watt maximum

..... 0.35 watt maximum

.....250 nanoseconds maximum
.....250 nanoseconds maximum
..... 1.5 microseconds minimum
..... 8.0 microseconds maximum
..... 1.5 microseconds minimum
..... 8.0 microseconds maximum
.....250 ohms maximum

OPERATING CONDITIONS:

Operating Temperature - - - - -54°C. to 85°C.
Storage Temperature - - - - -54°C. to 150°C.
Altitude - - - - - Sea Level to 100,000 Feet
Vibration - - - - - 10 to 2000 Hz. at 30" g's, 0.1 in DA
Shock - - - - - 50 g for 11 milliseconds 10 Hz to 78 Hz
Humidity - - - - - 50 g
Moisture - - - - - 98%
Corrosion - - - - - 5% Salt Solution for 48 Hours
Mechanical Shock - - - - - Per MIL-STD-202
Electromagnetic Compatibility - - - - - Per MIL-STD-461

further divided into AC and DC units. The BC are presently designed only for 115 V AC, 400 Hz power systems with a BC for each phase. Both BC and LC can be remotely located and remotely controlled, thus freeing valuable crew station panel area and console volume.

The BC is essentially a solid state power contactor. It does not perform any protective functions as found in the LC. It does have zero voltage crossover turn-on and zero current turn-off along with a lockout feature to prevent connecting two unsynchronized power sources together. The ON control and the LOCKOUT signals are both at a nominal 5 V DC, 10 milliampere power level. The BC has the capability of switching between two unsynchronized sources in as short a time as one cycle (2.25 milliseconds) with resistive loads connected to the buses. Regenerative loads such as motors and other inductive and capacitive loads tend to momentarily hold the bus voltage up. Switchover occurs only on a dead bus. Heat sinking is required for dissipation of losses from the BC.

Two ratings of BC are under development. One is a 10 ampere unit, the other a 75 ampere unit. These have been developed to the engineering model stage, but do reflect some deviations from the specification as concerning weight, size, and case temperature. Full compliance to the specification can be obtained through packaging using hybrid or integrated circuits. The engineering models were developed using MIL-P-81653 [reference 9.32] as a guide. The typical requirements for a 75 ampere BC would be similar to those shown on the specification below.

Load controllers (LC) replace the electromechanical thermal circuit breaker at the bus and the power switching function in the conventional system. They can be located and controlled remotely, permitting the use of a distributed power bus arrangement. ON-OFF and RESET control are provided by a nominal 5 V DC, 10 ma signal. TRIP INDICATION is supplied from the unit. The LC are snap-acting, trip-free devices. Additional operating characteristics are listed as:

1. Isolation between control and power circuits
2. Operating efficiency of 95% minimum
3. Voltage drop 0.5 V maximum DC, 1.5 V maximum AC
4. Leakage current: device rating $\times 10^{-4}$ amperes at maximum case temperature (typical)
5. Operating case temperature range of -54°C to 120°C
6. Incorporation of internal power supply.

SPECIFICATION

POWER CONTROLLER, AC BUS SWITCHING
SPST, NORMAL OPEN, 75 AMPERES

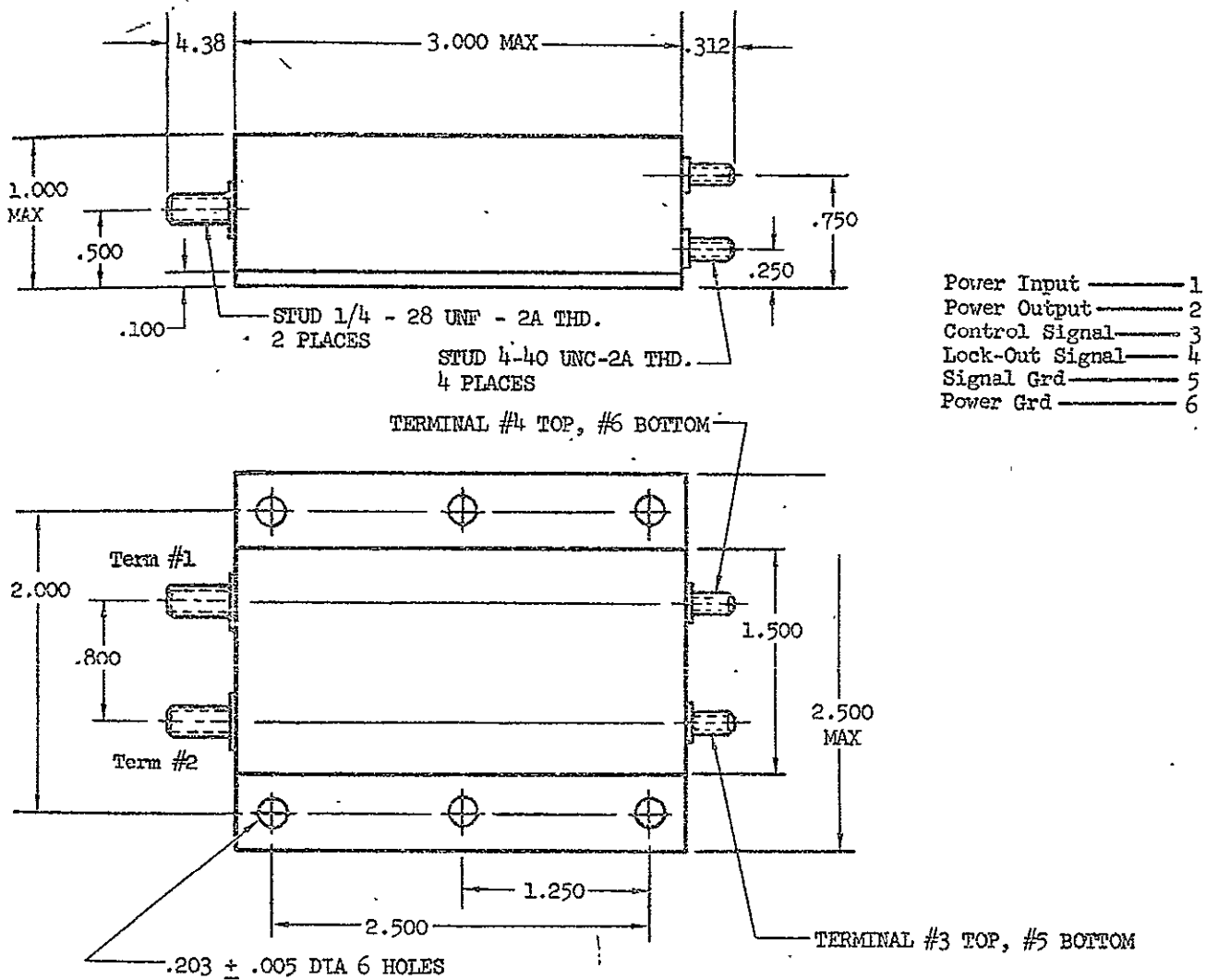

NOTES:

1. Dimensions are in inches.
2. Unless otherwise specified, tolerances are ± .02 for two place decimals and ± .005 for three place decimals.

REQUIREMENTS:

MECHANICAL AND DIMENSIONAL CHARACTERISTICS

Dimensions and Configuration	See Figure
Mounting	See Figure
Enclosure	Blade anodized metal, sealed watertight
Terminals	See Figure, terminals shall be electrically isolated from case
Weight	10.0 ounces maximum
Thermal resistance case-to-sink10° C/watt maximum with mounting torque of 15 in-lb

ELECTRICAL CHARACTERISTICS (-54°C to 120°C case temperature unless otherwise specified)

Terminal arrangement	SPST (normally open)
Rated operating voltage	105 - 120 volts rms
Rated operating frequency	400 Hz ±5%
Current rating	75.0 amperes
Control voltage	±8.0 volts dc maximum
Rated control voltage	+5.0 volts dc
Turn-on voltage	+3.5 volts dc minimum
Turn-off voltage	+2.5 volts dc maximum
Turn-on time	1.0 cycle maximum
Turn-off time	1.0 cycle maximum
Output rise time	Not applicable
Output fall time	Not applicable
Insulation resistance	100 megohms minimum
Isolation	10 megohms minimum
Control input resistance	500 ohms ±10 percent
Voltage drop	1.5 volts rms maximum @ 75.0 amperes
Leakage current	1.0 milliamperes maximum @ rated voltage
Power dissipation - ON	120 watts maximum
Power dissipation - OFF5 watts maximum
Current limiting	Not applicable
Trip-out time (non-repetitive reset)	Not applicable
Trip-out time (repetitive reset)	Not applicable
Rupture Capacity	1000 amperes maximum
Reset voltage	Not applicable
Application time to reset	Not applicable
Interruption time to reset	Not applicable
Trip indication voltage	Not applicable
Reset immunity	Not applicable
Waveform distortion	1.5 volts rms or 12.0 volts peak-to-peak maximum
Trip-free	Not applicable
Lockout control voltage	±8.0 volts maximum
Rated lockout voltage	+5.0 volts dc
Lockout "ON" voltage	+3.5 volts dc minimum
Lockout "OFF" voltage	+2.5 volts dc maximum
Lockout impedance	500 ohms ±10%
Overload	200% for 10 seconds maximum
Dim control voltage	Not applicable
Rated dim control voltage	Not applicable
Dim turn-on voltage	Not applicable
Dim turn-off voltage	Not applicable
Operating voltage transients	MIL-STD-704
Transient spike overvoltage	Not applicable
Transient standby power	MIL-STD-704
Control input transients	100 volts applied between terminals black and red, and white and red
Zero voltage turn-on and turn-off	Applicable
Fail safe current (@ 25°C case)	225 amperes
Life (operating cycles)	1,000,000 minimum
Dim mode voltage	Not applicable
Dielectric with standing voltage	1000 volts rms
Radio interference	MIL-STD-461

ENVIRONMENTAL CHARACTERISTICS

Operating temperature	-54°C to +120°C
Storage temperature	-65°C to +150°C
Shock	100G for 11 milliseconds
Vibration	30 G, 78 -2000 Hz 0.1 in. DA 10 to 78 Hz
Acceleration	100G
Altitude	Sea level to 100,000 ft.

The AC load controller as shown in Figure 2-4 contains a power switch, a power supply, a driver, circuitry for zero voltage crossover turn-on, current sensing, and circuit protection.

Power Switch - The power switching elements are silicon controlled rectifiers (SCR's) connected in inverse parallel. SCR's have sufficient voltage rating to meet MIL-STD-704 voltage characteristics and a surge current rating compatible with the fault current that can be obtained in the generating system.

Power Supply - A power supply provides regulated DC excitation for the driver, current limiting and circuit protection circuitry.

Drive Circuit - This circuit provides a continuous gate signal to the SCR's thereby ensuring SCR triggering for any load power factor during steady state operation.

Zero Crossover Sensing - The output of this circuit commands the driver circuit to turn ON only at zero voltage crossover.

Circuit Protection - Circuit protection is incorporated to protect the controllers as well as the external circuit. SCR's do not inherently limit current as do power transistors; therefore, the AC controllers contain time current sensing and trip-out to protect the SCR's and to switch incandescent lamp loads which have very high starting currents. The time duration is long enough to prevent nuisance tripping as a result of line transients (see Figure 2-5] or turning ON into rated lamp loads. This is accomplished by sensing load current, actuating a control circuit when the set level of load current is exceeded, and actuating a timing circuit which determines the time before trip-out. Notice that currents in excess of 3,000% are removed within 1/2 cycle [1.25 milliseconds]. Once tripped out, the device can be reset by applying a reset signal. The AC trip signal provides the information for three phase interlocking which prevents two-phasing of loads.

The DC load controller, as shown in Figure 2-6, contains a power switch, a regulator, a driver, and circuitry for current limiting and circuit protection.

Power Switch - The power switching element is an NPN silicon power transistor. This power transistor has sufficient voltage rating to withstand the high power dissipation during current limiting.

Regulator - The internal regulator provides a buffer effect so that the voltage to the internal circuitry is independent of the bus voltage variations.

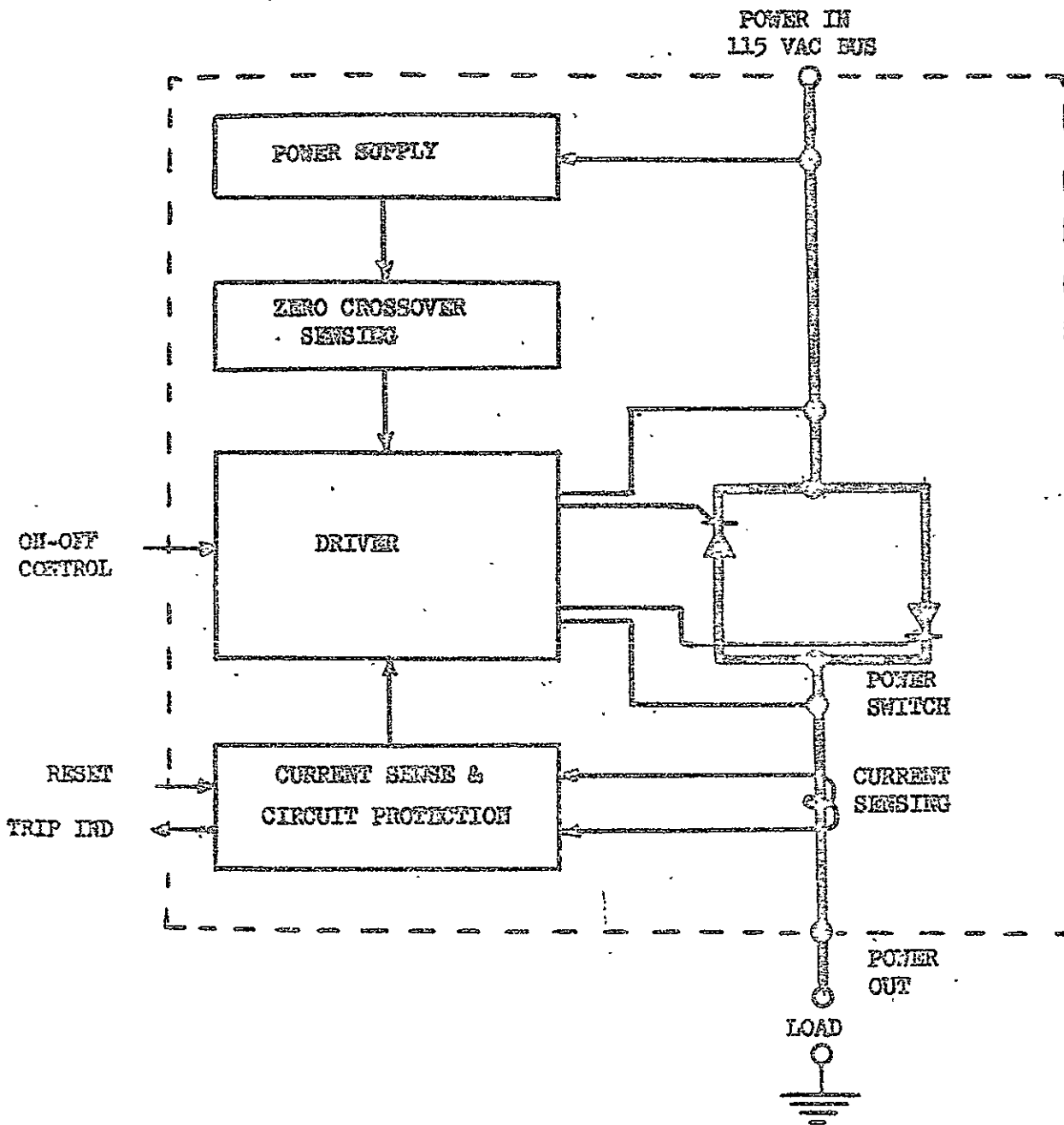
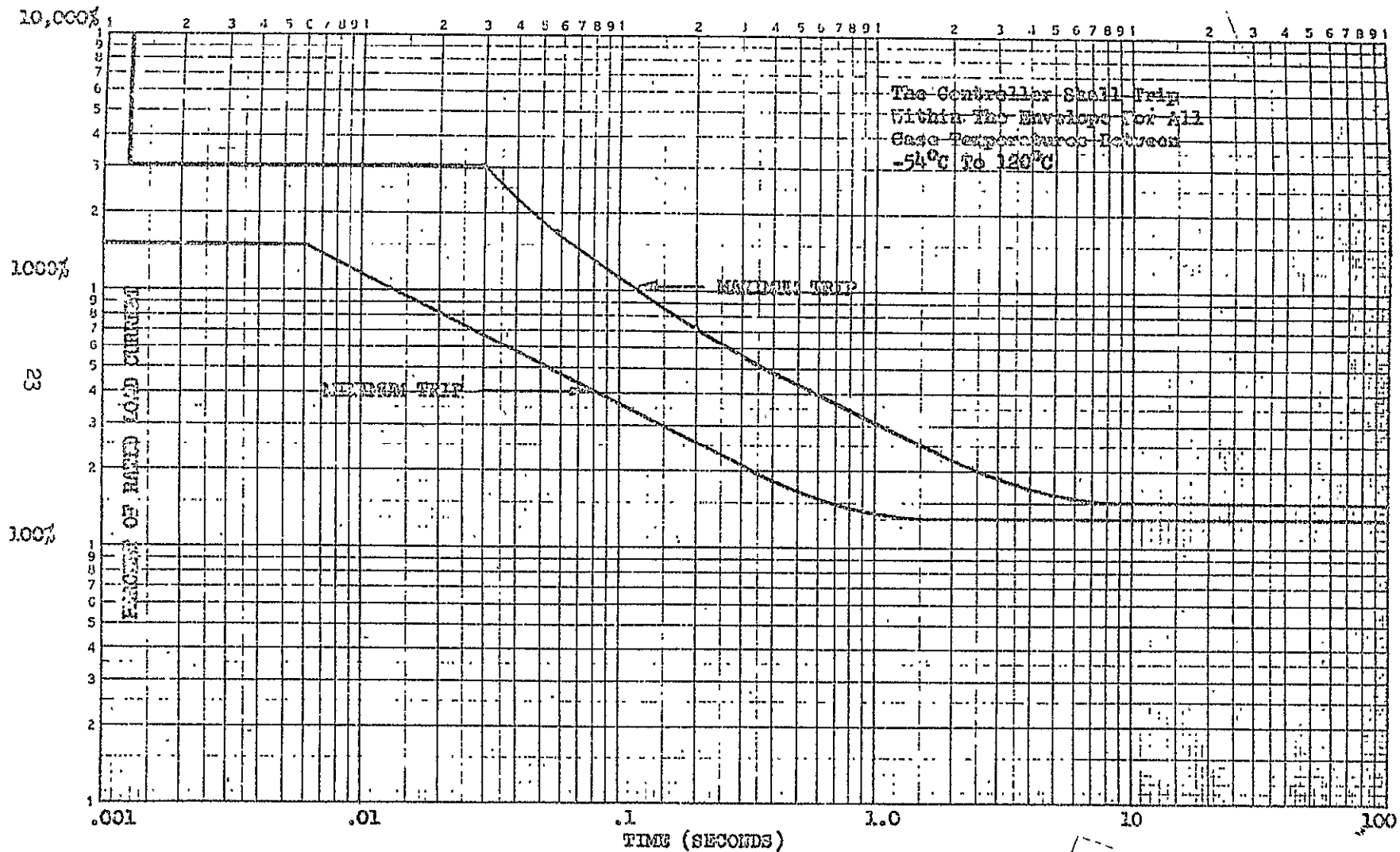

FIGURE 2-4 BLOCK DIAGRAM - AC LOAD CONTROLLERS



TRIP CHARACTERISTICS FOR AC POWER CONTROLLERS
FIGURE 2-5

NOT REPRODUCIBLE

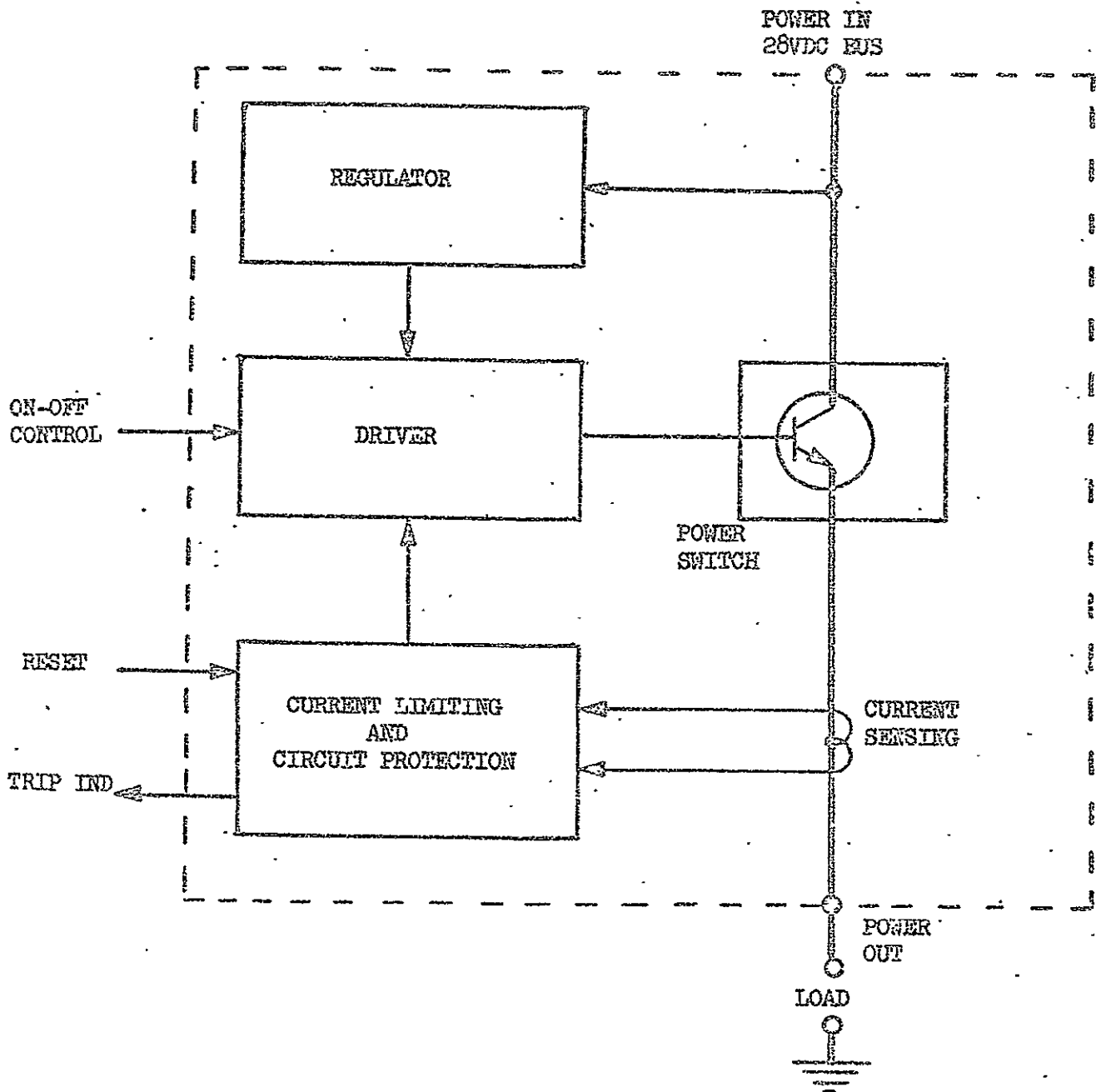

FIGURE 2-6 BLOCK DIAGRAM - DC LOAD CONTROLLER

Drive Circuit - The power transistor is driven deep into* saturation to minimize the voltage drop and power dissipation.

Current Limit and Circuit Protection - There are two reasons for incorporating these features into the unit:

- o To protect the unit itself - Limiting the power dissipation required within the power controller
- o To protect the load circuit wiring -- Limits the amount of energy delivered into a fault which greatly reduces amount of damage and fire hazard.

During overload and fault conditions, load current is limited between 100% and 150% of controller rating at rated voltage. This characteristic provides current values greater than rated for starting surges, yet allows current foldback to protect the switching transistor during circuit protection action [current limit and trip out]. In order to get this sensing and logic into the small volume of the controllers, the use of integrated circuits is required. The trip out time must be long enough to prevent nuisance tripping when using a MIL-STD-704 power source [see Figure 2-7]. When a transient condition exists for a period longer than the trip-out time, the power switch is turned off and a trip indication signal is provided. Remote reset is accomplished by application of a 5 volt 10 ma signal [reset] from an external source or by removal and reapplying of the control signal.

DC load controllers have a controlled soft turn-on and turn-off (100-500 microseconds rise and fall time). This controlled di/dt has the same advantages as zero crossover on the AC controllers; namely, less disturbance on regulator, fewer transients and less EMI, reduced capacitor peak inrush, and avoidance of SCR di/dt firing.

Figure 2-8 shows the permissible current foldback characteristic of the DC load controller under overvoltage conditions. For example, with a fault on the output and a voltage of 80 V DC (MIL-STD-704 maximum surge voltage) on the input, the current fed into the fault can vary from 30% to 150% of rated current until trip-out.

Both AC and DC load controller development has also progressed to the engineering model stage. Again, these units reflect some deviations from the specification as concerning weight, size and minor circuit designs. Full compliance to the specification can be obtained through packaging using hybrid or integrated circuits. The model development includes ratings from 1 to 35 amperes. Table 2-2 shows the full range of

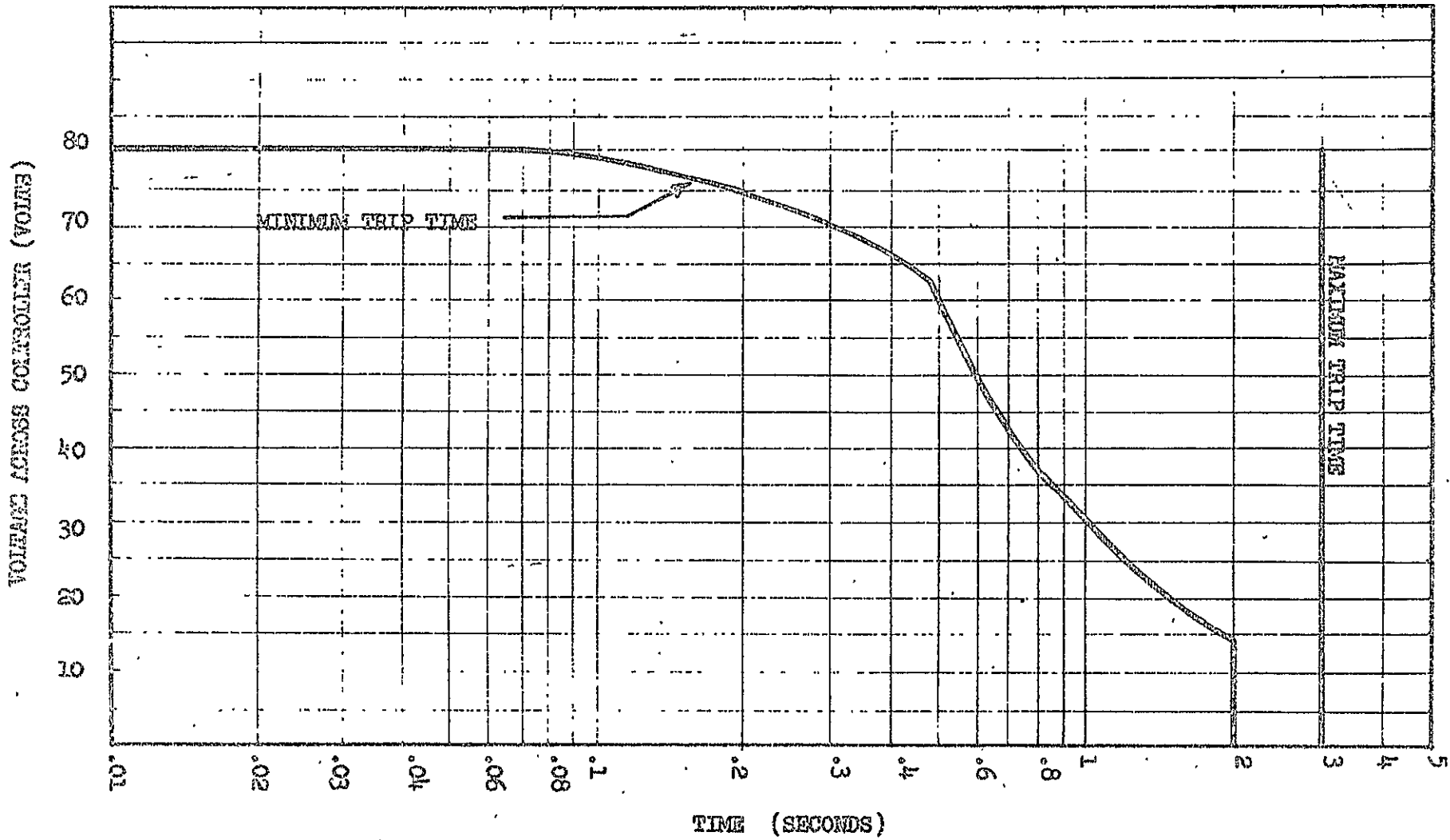

FIGURE 2-7 TRIP CHARACTERISTICS FOR DC POWER CONTROLLERS

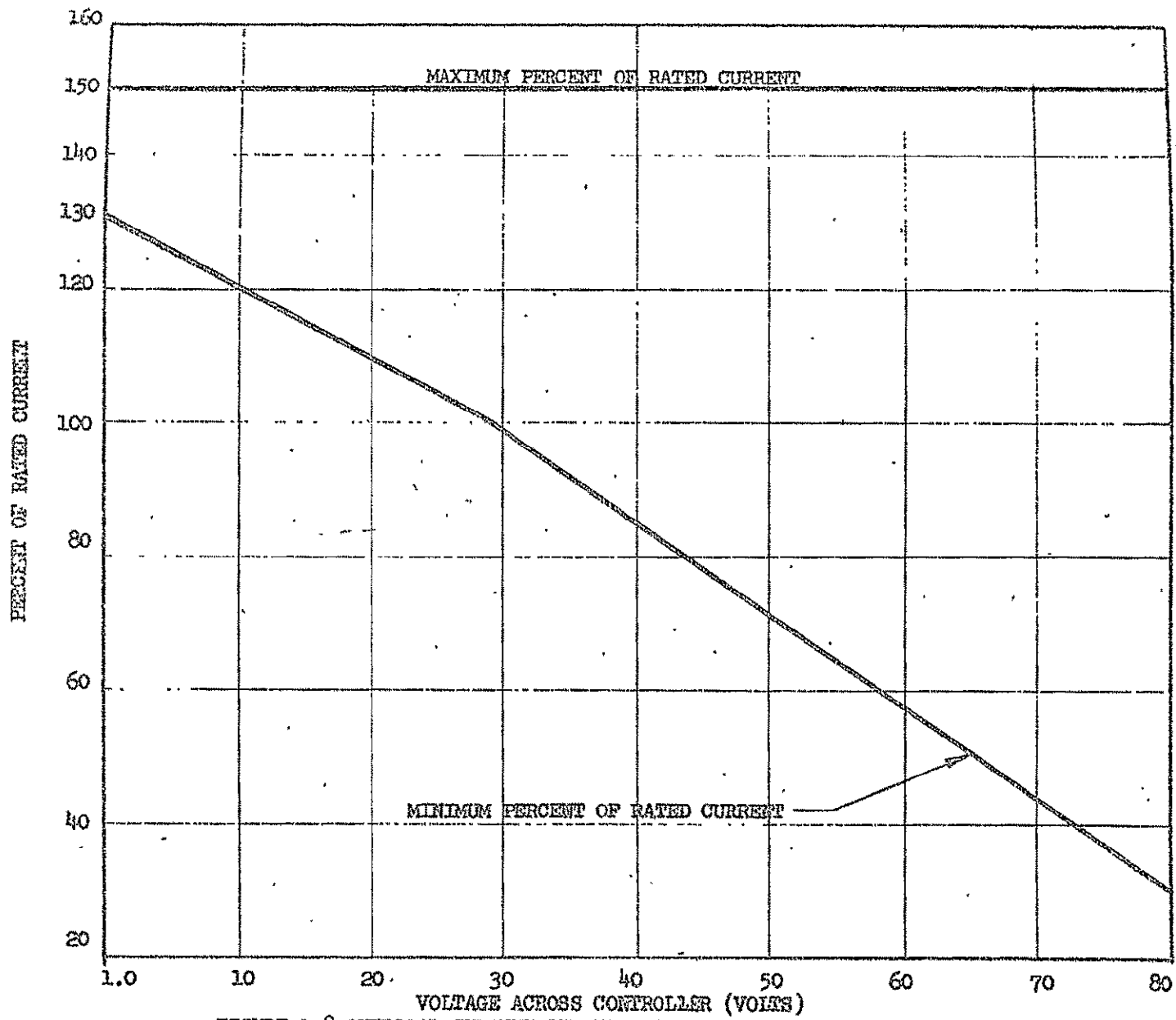

FIGURE 2-8 OVERLOAD CURRENT LIMITING CHARACTERISTICS OF DC POWER CONTROLLERS

TABLE 2-2 Load Controller Ratings

Rating (Amperes)	Type	
	AC	DC
1/2		X*
1	X**	X
2	X	X
3	X	X
5	X	X
7 1/2	X	X
10	X	X
15	X	X
25	X	X
35	X	X

* There are two configurations of an indicator driver, one with a dim mode effective voltage of 12 volts and a second with 9 volts.

** There are two configurations of 1 amp AC controller, one rated for 115 V AC, the other rated for 26 V AC.

ratings. The models were developed using MIL-P-81653 [reference 9.32] as a guide. The two specification sheets to follow represent typical requirements for DC load controllers, 2 through 10.0 amperes, and AC load controllers, 1 through 10 amperes.

To date, installation of load controllers up to 10 amperes for advanced aircraft has taken the route of mounting up to 16 load controllers on an 0.9 aluminum heatsink [see Figure 2-9]. Printed circuitboard wiring on the reverse side of the heatsink connects the terminals of the units to the connector. The board assembly is then inserted into a power controller rack assembly [see Figure 2-10] and secured. The rack assembly consists of supporting structure, bus bars, mating plugs and wiring harnesses. The load controller rack assembly is cooled by convection and/or forced air obtained from the compartment. Separate board assemblies are used for AC and DC; however, AC and DC board assemblies can be mixed within the same rack assembly. Load controller ratings and load diversification are taken into consideration in selecting the units to mount to a particular board. Worst case heat loads are about 25 watts for DC and 63 watts for AC boards.

SPECIFICATION

POWER CONTROLLER, DC LOAD SWITCHING,
SPST, NORMAL OPEN, 2 THRU 10.0 AMPERES

The complete requirements for procuring the controllers described herein shall consist of this document and the latest issue of Specification MIL-P-81653.

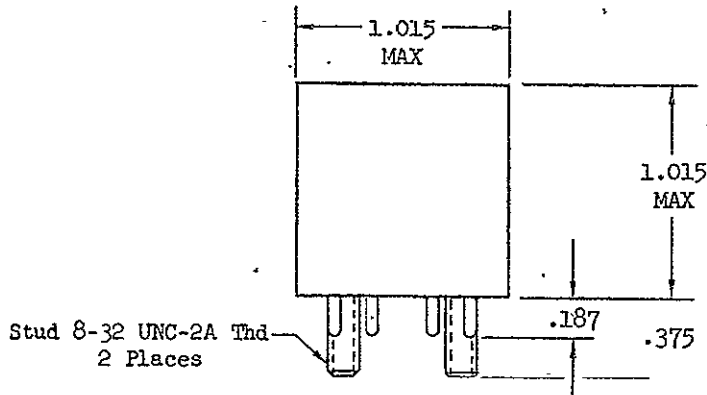

PREFERENCE PIN DIAGRAM
TERMINAL DESIGNATIONS ARE
FOR REFERENCE ONLY, DO NOT
APPEAR ON HEADER

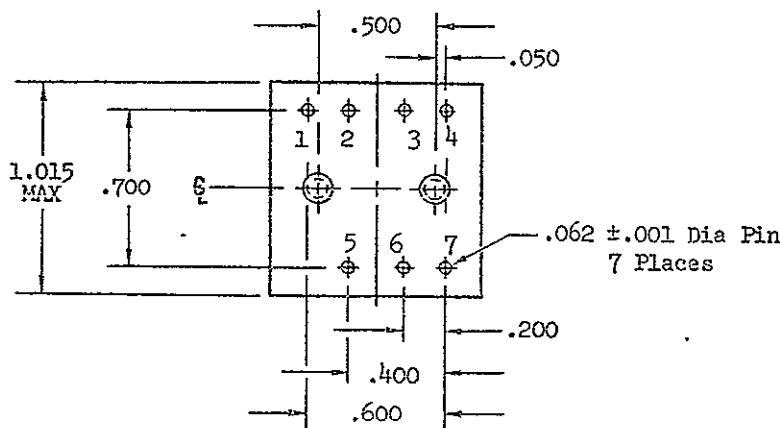

Power In	1
Power Out	2
Control	3
Trip Ind	4
Reset	5
Sig Grd	6
Pwr Ground	7

NOTES:

1. Dimensions are in inches.
2. Unless otherwise specified, tolerances are $\pm .02$ for two place decimals and $\pm .005$ for three place decimals.
3. Terminals shall be tin plated followed by a flow process or coated with composition Sn 40 to Sn 70 solder conforming to QQ-S-571 to facilitate soldering.

REQUIREMENTS:

MECHANICAL AND DIMENSIONAL CHARACTERISTICS

Dimensions and configuration	See Figure
Enclosure	Black anodized metal, sealed-watertight
Terminals	See Figure. Terminals shall be electrically isolated from case
Weight	2.0 ounces maximum
Thermal resistance-case-to-sink	.50° C/w maximum with mounting torque of 15 in-lb

ENVIRONMENTAL CHARACTERISTICS (-54°C to 120°C case temperature unless otherwise specified)

Terminal arrangement	SPST (normally open)
Rated operating voltage	21 to 29 volts dc
Rated operating frequency	Not applicable
Current rating	See Table I
Control voltage	±8.0 volts dc maximum
Rated control voltage	+5.0 volts dc
Turn-on voltage	±3.5 volts dc minimum
Turn-off voltage	+2.5 volts dc maximum
Turn-on time	1.0 milliseconds maximum
Turn-off time	6.0 milliseconds maximum
Output rise time	0.1 milliseconds minimum 0.5 milliseconds maximum
Output fall time	0.5 milliseconds minimum 5.0 milliseconds maximum
Insulation resistance	100 megohms minimum
Isolation	10 megohms minimum
Control input resistance	500 ohms ±10 percent
Voltage drop	0.5 volts dc maximum @ rated current
Leakage current	See Table I
Power dissipation - ON (Maximum)	See Table I
Power dissipation - OFF (Maximum)	See Table I
Current limiting	See Figure 1 of MIL-P-81653
Trip-out time (non-repetitive reset)	See Figure 2 of MIL-P-81653 (30 seconds minimum between resets)
Trip-out time (repetitive reset)	Applicable
Rupture capacity	4000 amperes
Reset voltage	+3.5 volts dc minimum +5.0 volts dc nominal +8.0 volts dc maximum
Application time to reset	5.0 to 20 milliseconds
Interruption time to reset	5.0 to 20 milliseconds
Trip indication voltage	+5.0 volts dc ±10% @ 10.0 milliamperes
Reset immunity	Applicable
Waveform distortion	Not Applicable
Trip-free	Applicable
Lockout control voltage	Not Applicable
Rated lockout voltage	Not Applicable
Lockout "ON" voltage	Not Applicable
Lockout "OFF" voltage	Not Applicable
Lockout impedance	Not Applicable
Dim control voltage	Not Applicable
Rated dim control voltage	Not Applicable
Dim turn-on voltage	Not Applicable
Dim turn-off voltage	Not Applicable
Operating voltage transients	MIL-STD-704
Transient spike overvoltage	±600 volts dc
Transient - standby power	Not Applicable
Control input transients	100 volts applied between 3 and 6, and 5 and 6
Zero voltage turn-on and turn-off	Not Applicable
Fail safe current (@ 25°C case)	See Table I
Life (operating cycles)	1,000,000 minimum
Dim mode voltage	Not Applicable
Dielectric with standing voltage	1000 volts rms
Radio interference	MIL-STD-461

ENVIRONMENTAL CHARACTERISTICS:

Case operating temperature	-54°C to +120°C
Case storage temperature	-65°C to +150°C
Shock	100G for 11 millisecond
Vibration	30G, 78-2000 Hz 0.1 in DA 10 to 78 Hz
Acceleration	100G
Altitude	Sea level to 100,000 feet

Part number: Consists of the basic number of this specification sheet and a dash number from Table I.

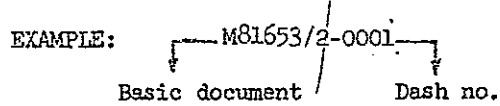

TABLE I. Dash numbers and applicable characteristics.

Part Number M81653 /2-	Current Rating * (amps)	Power Dissipation (Watts)		Leakage Current (microamperes)	Fail-safe Current (amps)
		On	Off		
0001	2	2.0	.156	500	30.0
0002	3	2.5	.158	500	30.0
0003	5	4.5	.161	500	30.0
0004	7.5	6.5	.171	1000	60.0
0005	10.0	6.5	.178	1000	60.0

* Inductive, Capacitive, Resistive or Lamp

SPECIFICATION

POWER CONTROLLER, AC LOAD SWITCHING,
SPST, NORMAL OPEN, 1 THRU 10 AMPERES

Requirements for procuring the controllers described herein shall be based on the latest issue of this document and the latest issue of Specification MIL-P-81653.

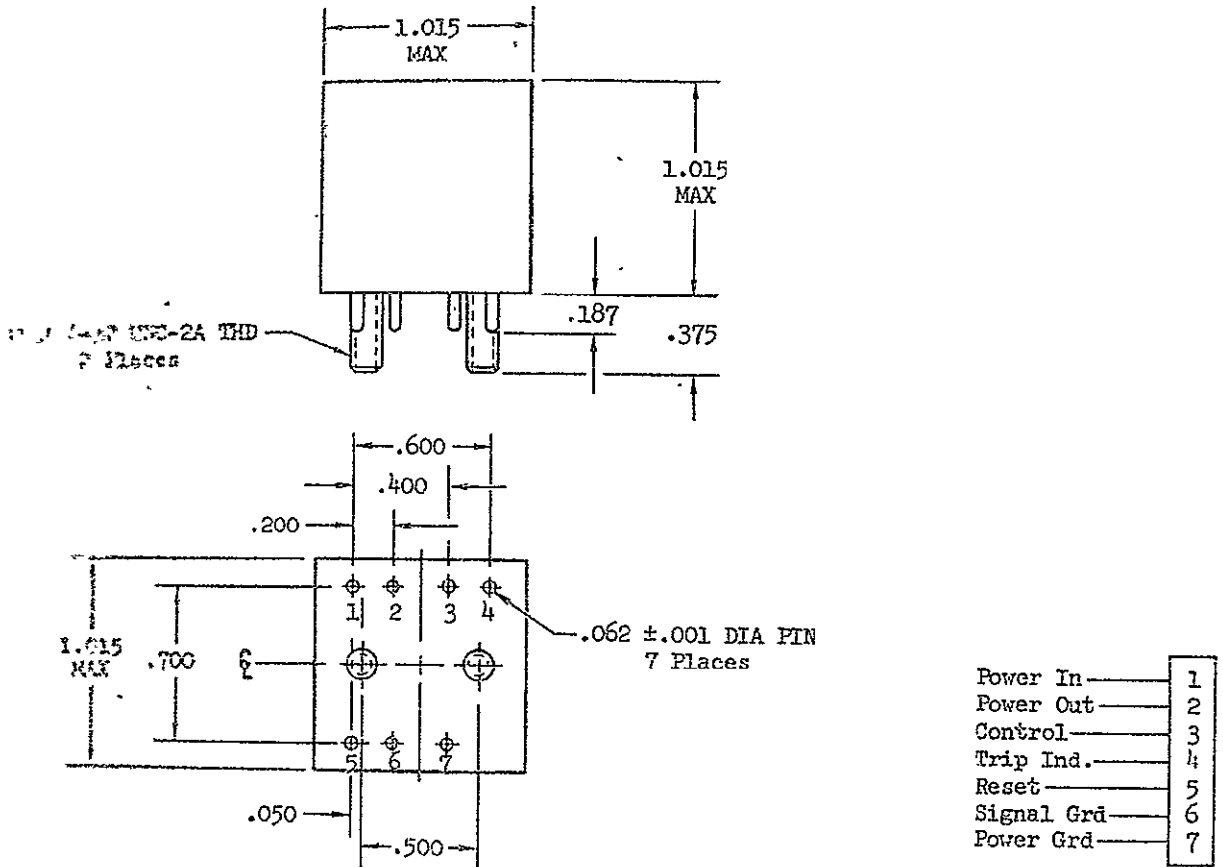

Dimensions are in inches.

Unless otherwise specified, tolerances are + .02 for two place decimals and + .005 for three place decimals.

Terminals shall be tin plated followed by a flow process or coated with a minimum Sn 40 to Sn 70 solder conforming to QQ-S-571 to facilitate soldering.

Notes:

OPERATIONAL CHARACTERISTICS

Configuration	See Figure
Case	Black anodized metal, sealed-watertight
Terminal Finish	See Figure, terminals shall be electrically isolated from case
Weight	2.0 ounces maximum
Thermal Resistance (case-to-sink)50°C/watt maximum with mounting torque of 1.5 in-lb

ELECTRICAL CHARACTERISTICS (-54°C to 120°C case temperature unless otherwise specified)

Terminal arrangement	SPST (normally open)
Rated operating voltage	105 to 120 volts rms
Rated operating frequency	400 Hz + 5%
Current rating	See Table I
Control voltage	+ 8.0 volts dc maximum
Rated control voltage	+ 5.0 volts dc
Turn-on voltage	+ 3.5 volts dc minimum
Turn-off voltage	+ 2.5 volts dc maximum
Turn-on time	1.0 cycle maximum
Turn-off time	1.0 cycle maximum
Output rise time	Not applicable
Output fall time	Not applicable
Insulation resistance	100 megohms minimum
Isolation	10 megohms minimum
Control input resistance	500 ohms + 10 percent
Voltage drop	1.5 volts rms @ rated current
Leakage current	1.0 milliamperes maximum @ rated voltage
Power dissipation - ON (maximum)	See Table I
Power dissipation - OFF (maximum)	See Table I
Current limiting	Not applicable
Trip-out time (non-repetitive reset)	See Figure 3 of MIL-P-81653 (2.0 seconds minimum between resets)
Trip-out time (repetitive reset)	Applicable
Rupture capacity	400 amperes maximum
Reset voltage	+ 8.0 volts dc maximum + 5.0 volts nominal + 3.5 volts dc minimum
Application time to reset	5.0 to 20 milliseconds
Interruption time to reset	5.0 to 20 milliseconds
Trip indication voltage	+ 5.0 volts dc + 10% @ 10.0 milliamperes
Reset immunity	Applicable
Waveform distortion	1.5 volts rms or 12.0 volts peak-to-peak maximum
Trip-free	Applicable
Lockout control voltage	Not applicable
Rated lockout voltage	Not applicable
Lockout "ON" voltage	Not applicable
Lockout "OFF" voltage	Not applicable
Lockout impedance	Not applicable
Dim control voltage	Not applicable
Rated dim control voltage	Not applicable
Dim turn-on voltage	Not applicable
Dim turn-off voltage	Not applicable
Operating voltage transients	MIL-STD-704
Transient spike overvoltage	Not applicable
Transient - standby power	MIL-STD-704
Control input transients	100 volts applied between terminals 3 and 6, 5 and 6
Zero voltage turn-on and turn-off	Applicable
Fail safe current (@ 25°C case)	See Table I
Life (operating cycles)	1,000,000 minimum
Dim mode voltage	Not applicable
Dielectric withstanding voltage	1000 volts rms
Radio interference	MIL-STD-461

ENVIRONMENTAL CHARACTERISTICS

Case operating temperature -54°C to + 120°C
 Case storage temperature -65°C to + 150°C
 Shock 100G for 11 milliseconds
 Vibration 30G, 78 -2000 Hz 0.1 in DA 10 to 78 Hz
 Acceleration 100G
 Altitude Sea level to 100,000 feet

Part number: Consists of the basic number of this specification sheet and a dash number from Table I.

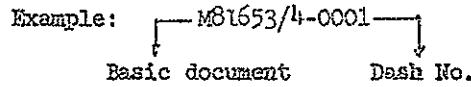

TABLE I. Dash numbers and applicable characteristics.

Part Number M81653/4	Current Rating* (amps)	Power Dissipation (Watts)		Fail Safe Current (amps)
		On	Off	
0001	1	1.75	.311	5.0
0002	2	3.25	.311	15.0
0003	3	4.75	.311	15.0
0004	5	8.0	.311	15.0
0005	7.5	11.75	.311	30.0
0006	10	16.0	.311	30.0
0007	1 (26 vac)	1.75	.186	5.0

* Inductive, Capacitive, Resistive or Lamp

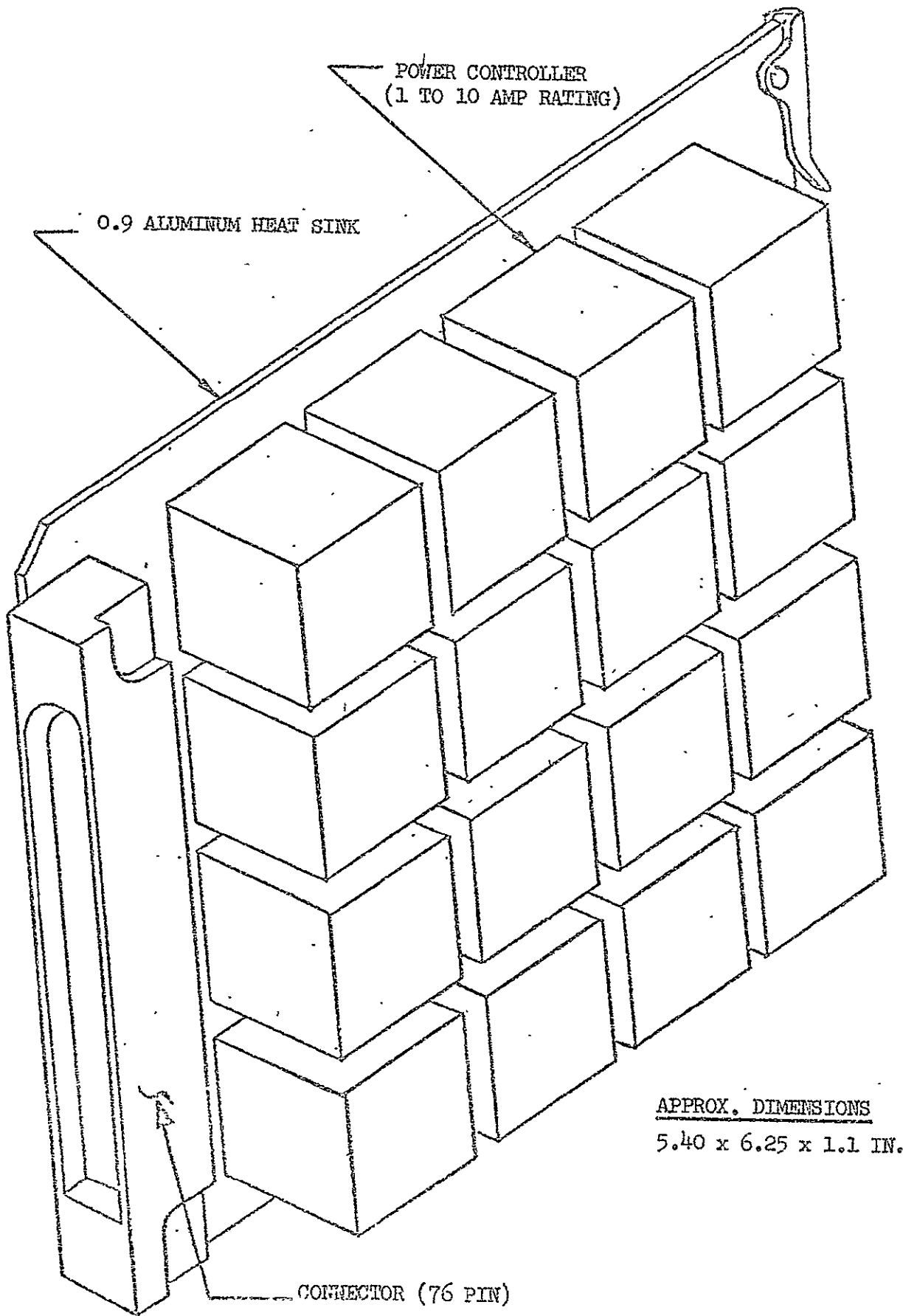

FIGURE 2-9 POWER CONTROLLER BOARD ASSEMBLY

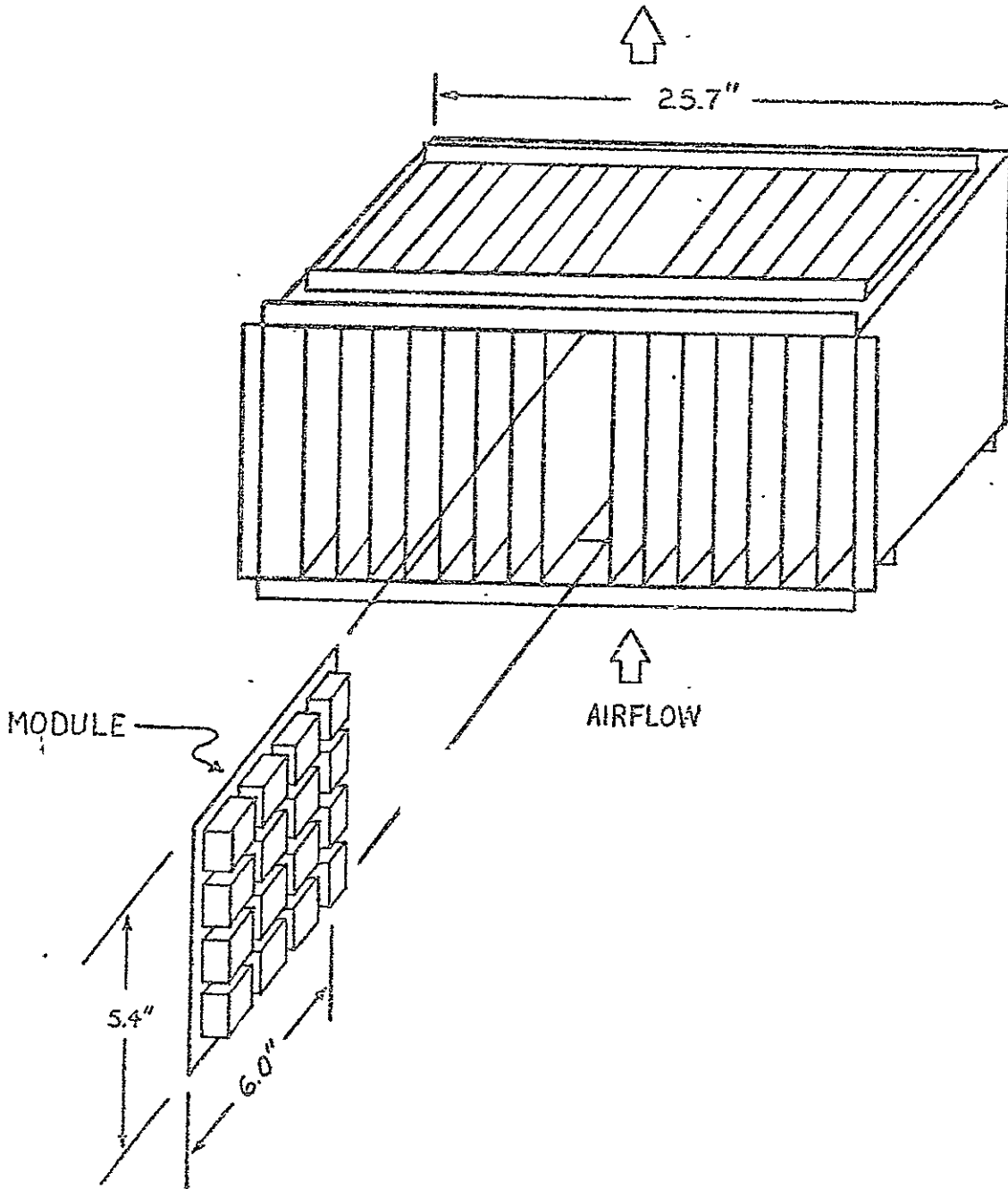

FIGURE 2-10 POWER CONTROLLER RACK ASSEMBLY

Load controllers rated above 10 amperes must be mounted to separate heatsinks, preferably vehicle structure.

2.2.2.3 Data Handling System (DHS)

The solid state Data Handling System (DHS) accepts discrete inputs from signal sources. These inputs are sampled sequentially and gathered into a central data storage. The input data samples are used as terms in the solution of power control logic equations. The results of the logic equations are supplied as inputs to remotely located solid state power controllers.

As shown in the block diagram, Figure 2-11, the system consists of Master Units (MU) and Remote Terminals (RT) interconnected on redundant power and data buses. The MU provides the central timing and control for the DHS. The MU can be reprogrammed by software to change the control logic equation. Thus control logic can be changed to meet mission requirements without any extensive rewiring. The Remote Terminals provide the interface for sampling (multiplexing) the input (source) signals and the output drivers for the power controllers. Two types of RT's are provided: (1) remote input terminal (RIT) and (2) remote output terminal (ROT). The RIT has a capacity for sampling 64 input signals, the ROT supplies control signals to 64 power controllers. The RIT are strategically located over the aircraft in close vicinity to concentrations of signal sources; the ROT are normally located in close vicinity to the power controllers.

The RT's are operated, under control of the MU, over a common transmission line called the Address party line. Up to 16 RIT's and 16 ROT's are connected to the party line depending on the system input/output requirements. Addresses are generated in the MU and sent on the common line to all RT's. The RT's are programmed to recognize a unique address. Sixteen unique addresses are assigned to the RIT's, and the same 16 are assigned to the ROT's assuming a full complement of terminals. The RIT and ROT are normally addressed in pairs.

Upon receipt of a valid address over the address party line, the addressed RIT samples the 64 input signals and responds on a separate common transmission line called the Response Party Line. The ROT selected by the same address word is activated to receive the following output data from the MU on the address line. The output data is received and presented to the ROT output for control of the power switches. A single address from the MU initiates the transfer of 64 input data bits from the RIT to the MU and 64 output data bits from the MU to the ROT. In addition, status words are transmitted to the MU from the RT's to provide information for Built-In-Test Equipment (BITE) analysis.

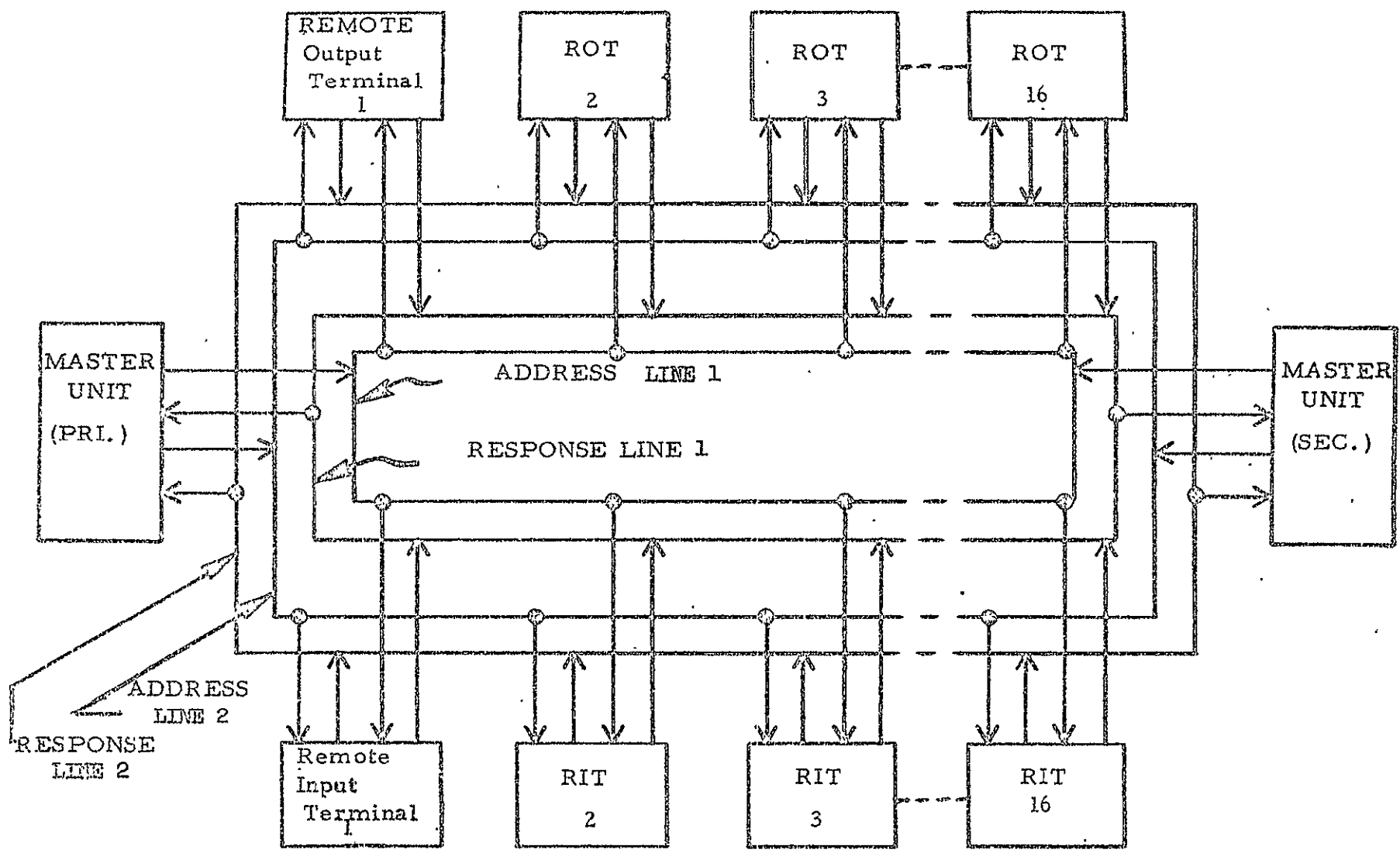

FIGURE 2-11 DATA HANDLING SYSTEM, BLOCK DIAGRAM

The reliability requirements are such that no single failure within the DHS will result in a degraded system performance. In order to achieve this degree of fault immunity, redundancy must be incorporated in the system design. Two Master Units, designated primary and secondary, are used in the flight configuration. Each RT is internally redundant with the two parts designated primary and secondary.

Redundancy is also applied to the interconnecting power and data transmission lines. Redundant primary power sources (+28 V DC) are provided with redundant buses to each unit in the system. The redundant power buses are cross-coupled at each unit so that, if one line or power source fails, the other assumes the load automatically. The address and response lines are supplied redundantly and are connected in a loop configuration as shown in Figure 2-11. The redundant lines are coupled at each MU and RT so that normal operation is maintained under multiple fault conditions. Built-In-Test Equipment (BITE) is supplied so that failures are detected during normal operation and automatic switch-over to the standby redundant circuits is effected without degradation of performance during the switch over. Fault locations (to the lowest component replaceable level) are stored in non-volatile memory in the Fault Indicator Panel (FIP). The FIP also provides pre-operational test circuitry and a manual override. The manual override control is duplicated on the Pilot Control Panel (PCP) and allows manual selection of the least severe fault should a single unit fail in both of its redundant circuits.

The Memory Loader/Verifier (ML/V) is the ground support equipment required to load the MU memory. Sequential logic instructions, for solution of the power control equations are read from paper tape (ACSII code) stored in the MU memory and verified by this unit.

The Decoder Unit (DU) is a special ground support test set primarily for troubleshooting a malfunctioning system or for initial evaluation of an installation.

A summary of the major Data Handling System characteristics is shown in Table 2-3.

The solid state Data Handling System is required to collect 1024 control input signals, perform logic equations that interrelate these signals, and distribute 1024 output signals with complete routing flexibility. The response time requirement for power controls is primarily constrained by the ability of the pilot to perceive the delay. This is accepted to be nominally 100 milliseconds (m sec); therefore, the design requirements was established that the system worst case time-to-respond should not exceed 50 m sec.

TABLE 2-3 Data Handling System Characteristics

No. Remote Input Terminals (RIT)	16 (internally redundant)
No. Remote Output Terminals (ROT)	16 (internally redundant)
No. Master Units (MU)	2 (primary and secondary)
Input Channel Capacity	1024 discrete inputs
Output Channel Capacity	1024 control outputs
Data Access Rate (frame rate)	100 frames per second
Mean Time to Respond (input to output)	25 milliseconds
Programmable (ROM) Memory Capacity	4096 words at 16 bits per word
Logic Equation Capability	1000 equations
Input/Output (RAM) Memory Size	1024 bits each
Scratch Pad (SPM) Memory Size	64 bits
Transmission Lines	dual redundant twisted pair shielded (1 set address, 1 set response)
Address Bit Rate (MU to RT)	240 K bits per second (bps)
Response Bit Rate (RT to MU)	375 K bits per second (bps)

The solid state power controllers used as the basic load switching elements will respond much faster than the presently used relays. This means that the system must be even more secure from short term transients than a relay system. This "flight-essential" system must have a data security characteristic so good that the possibility of erroneous control output is essentially eliminated.

A prime consideration in the design of a multiplex system is the weight saving that can be accomplished by the removal of large numbers of long wire runs. The installation of a multiplex terminal, of course, involves certain fixed requirements for transmission line interface, transmitters and receivers, control logic, etc. Therefore, a trade-off must be made between a few terminals with a large number of channels and a large number of terminals with a few channels for the particular system under investigation. For a typical fighter type aircraft, the optimum weight trade-off occurs at 64 channels per terminal, with the number of terminals being controlled by the complexity of the aircraft power control system. Sixteen terminals (1024 control functions) were selected as the maximum requirement for fighter aircraft of the 1970-80 time period. This arrangement, in effect, reduces the average power control wire run from approximately 20 feet in conventional systems, to approximately 2 feet in the solid state system, with the reduced wire gage providing additional weight savings.

The basic multiplexing technique utilized in the DHS is time division multiplex. Each channel is sampled in sequence, until all signals have been sampled; then the sampling is repeated. The complete cycle through all channels is called a "frame". Two fundamental approaches for identification of information are: "Addressing" where data is identified by a unique coding, and "Time Slot" where the data is identified by the position in the sequential data stream after some unique sync signal, usually at the beginning of the frame. The DHS utilizes both approaches -- the terminals are "addressed" and respond with their own number, which is verified prior to acceptance of the information; the channels within a terminal are "time slot" and appear in numerical sequence, 1 through 64, immediately after the terminal address.

The transmission of control data over a line throughout the aircraft requires a maximum noise immunity. The DHS utilizes a twisted shielded pair of wires, low impedance line, and baseband bi-phase modulation of the data. Bi-phase modulation utilizes one complete cycle for each data bit, a positive-negative cycle conveys a binary "1", and a negative-positive cycle a "0". The balanced nature of this signal, and the zero DC component, coupled with the characteristics of the twisted shielded pair provides optimum noise immunity to the electrical environment of the aircraft.

The DHS word structure is derived from two basic system considerations: data security and system reliability. The data security requirements indicate a need for more protection from erroneous data reception than normal data systems. Since the information is carried, essentially, in the phase of the signal, and the receiver clock is derived from the same signal, the most prevalent source of bit errors is receiver phasing. If a unique signal can positively identify the initiation of a data block, then the likelihood of reception error is minimized by shortening the block. The many transmitters and receivers in the system can be made simpler and therefore more reliable if the data block or word structure is identical for all transmissions.

Data security and system reliability considerations have defined the DHS word structure as shown in Figure 2-12. Each word consists of 24 bits, and is initiated by a unique sync. The "Invalid Manchester", which is a bi-phase "1" stretched in time to three bit periods, followed by a normal bi-phase "1" provides an easily recognized signal that assures receiver phase synchronization. The bit assignment in each word is as follows:

<u>Bit</u>	<u>Function</u>
1- 4	Sync
5	ID, identifies whether word is address-control "1" or data "0"
6-21	16-bit data field
22	Parity, ODD parity count for the 16 bit data field
23-24	gap. No transmission; required where multiple transmitters are used on a single line.

The wave form of the word structure in bi-phase form is shown in Figure 2-12. When the 64 channels of data from a terminal are being transmitted, it is formatted into four 16-bit word groups and transmitted in four data words. The master unit addresses the remote terminals in input/output pairs. Each terminal is individually instructed whether its primary or secondary circuits are to be used. The remainder of the data field is composed of control and BITE instructions, and expansion capability. The response from the input and output terminals includes their own identification and BITE function reports. Each of these formats is shown in the figure.

The multiplex-transmission system must accomplish two primary system functions -- the collection of a large number of control inputs and the distribution of the results of logic equation solutions to a large number of outputs. It must also convey the address, BITE, and control information between the Master Unit (MU) and each Remote Terminal (RT). Within the constraints of the system design (loop connected line, fault tolerance, etc.) this can best be accomplished using

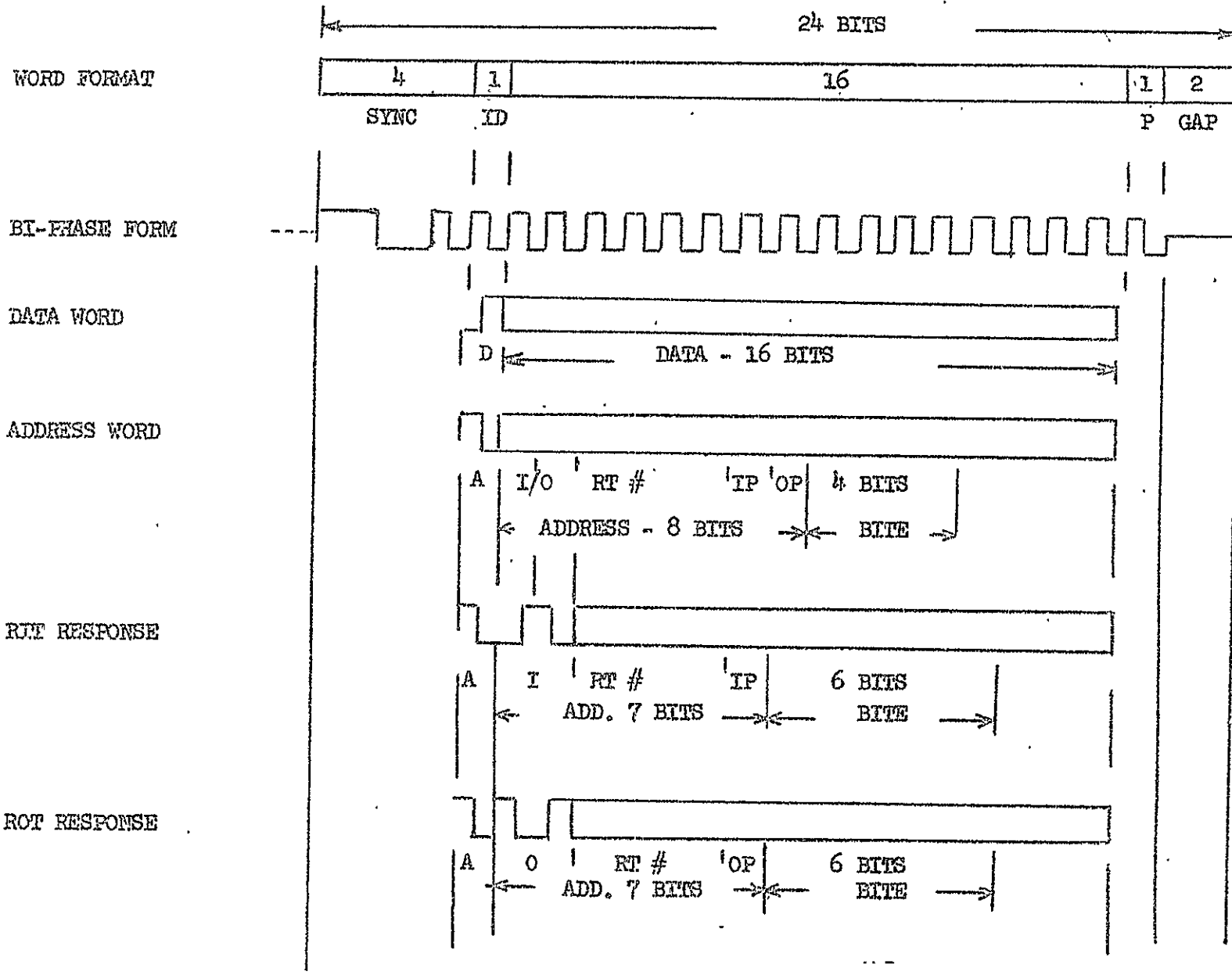

FIGURE 2-12 WORD STRUCTURE

two lines. The "address" line is used by the MU to transmit to all the terminals. The "response" line is used by all the terminals to transmit to the MU. Therefore, the address line consists of one transmitter and numerous receivers, and the response line contains many transmitters and one receiver. This allows optimization of performance and circuit design for each type of line.

The frame format, message structure, and the time relationship of the address and response lines are shown in Figure 2-13. The frame format provides a capacity for 20 messages. A message contains all the communication between the MU and an input/output pair of terminals. Only 16 of these messages may be used for control information, since the capacity of the master unit to perform the required logic operations is limited to 1024 inputs/outputs. The four spare messages may be used for direct terminal-to-terminal transfer of related monitor data. Within each of the 16 control or digital messages, the structure is identical. The message is initiated by the MU transmitting an I/O pair address on the address line. This is followed immediately by four data words, which are received by the output terminal addressed. At the conclusion of these four data words, the output terminal transmits identification and status on the response line. In addition, as soon as the input terminal recognizes its address, it replies on the response line with its status word and four words of data. The time constraint in this message structure occurs when the RIT must transmit 5 words during the time the MU is transmitting 4 output words. This 5/4 data rate ratio is modified to allow for worst line rate of 240 K bps and response line rate of 375 K bps allows the input terminal to complete its transmission somewhat sooner than the MU. During the time of the ROT status word transmission, the MU is transmitting the next I/O address.

The time division multiplex technique allows full time utilization of both lines (minimizing bit rate), provides a high degree of message security and reliability, and allows the optimization of line characteristics for the two types of transmissions.

In effect, there are two multiplex systems operating over the same data line; one to acquire control input data from the remote terminals and insert it in the MU's Input Random Access Memory (IRAM); and the second one to distribute the contents of the Output Random Access Memory (ORAM) to the remote terminals. The Output Multiplex system distributes the results of logic equation solution, and even though the inputs to the equations are derived from the input multiplex system, there is no correlation between any location or state of any output channel and

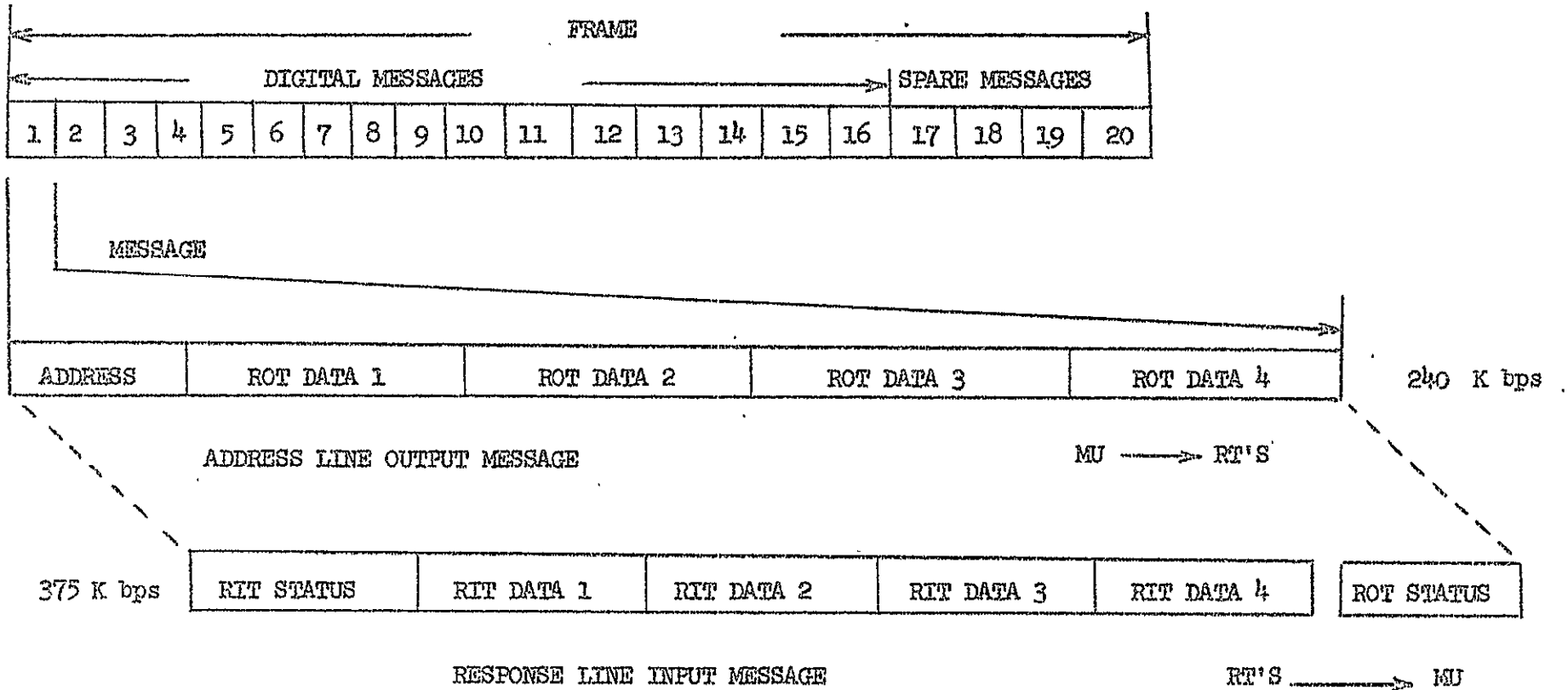

FIGURE 2-13 TRANSMISSION MESSAGE STRUCTURE

input channel that is an inherent part of the multiplex system. The complete control of the input-output relation is contained in the Read Only Memory (ROM). This memory, programmed for the logic functions of the system, controls the operation of the master unit's logic section and the routing and distribution of the signals.

The information flow through the Data Handling System may best be described by considering three simultaneous sequential operations which are not necessarily synchronized.

First, the input multiplex system sequentially samples all input signals and transfers this information to the IRAM. The control input information is updated in the IRAM in numerical sequence (terminal 1, channel 1, 2, 3, etc.; terminal 2, channel 1, 2, 3, etc.) each frame.

Second, the ROM sequentially reads all logic operations stored. Information is acquired from the IRAM, by address, at a time related to the order of instructions stored in the ROM. A phased clock is used so that input and output of information from the IRAM is on a non-interference basis. The ROM instructions may acquire a number of inputs -- perhaps widely separated -- perform various logic operations, and insert the results in the ORAM.

Third, this operation consists of sequentially sampling the contents of the ORAM, and distributing this multiplexed information to the output terminals. In this case, also, a phased clock is used so that input and output ORAM operation is non-interfering.

A fourth factor is significant in the system timing. This is the store and compare circuit in the output terminal. This circuit stores the information received from the multiplexed ORAM and provides an output only when two sequential receptions agree. In essence, this circuit requires that the three operations just described be performed twice, with the same result, prior to changing the state of an output.

The DHS timing is such that the worst time-to-respond (output change with change in input) is 40 milliseconds. The minimum time-to-respond is 10 milliseconds with a nominal time-to-respond of 25 milliseconds. System timing must be considered on time dependent or critical signals. Such signals may need to be hard-wired rather than transferred over the dedicated DHS. The equation of control signals to power controller may contain a time dependent variable. In those cases all non-dependent variables could be processed by the DHS. The output of the DHS could then be combined in the required fashion with the time dependent variable. This last step could be in the form of hard-wired

integrated logic. The output of the logic would be used to drive the power controller.

The most important design consideration for the solid state Data Handling System is the integrity and reliability of the intercommunication link. The design of the transmission lines and interfacing receivers and transmitters is one which offers the following advantages:

1. Twisted pair shielded cable driven in a balanced configuration is used for maximum noise immunity.
2. Bi-phase Phase Shift Keyed (PSK) modulation, with coherent reception, offers an optimum bit error rate versus signal to noise ratio.
3. A unique word sync provides a highly reliable synchronization.
4. Bit synchronization is not required for reception, reducing the requirements for stable clocks.
5. The operation of the transmission link can be completely asynchronous so that repetitive transmissions need not be maintained. This offers a maximum system design flexibility.
6. The transmission lines are connected in a loop for maximum immunity to open circuits. The lines are redundant and the two lines are coupled at every RT termination.
7. A "lossy" line configuration is used which provides "graceful degradation" under multiple fault conditions. The receiver operates over a wide dynamic range of 2.0 volts to 20 millivolts so that fault conditions (shorts) may be acceptable for operation.
8. Parity checks are made on each transmission to verify the data/control validity.
9. End-to-end self tests are performed to automatically verify the operational status of the line and the system hardware.

The format and coding characteristics of the transmitted address, data and status (response) information is selected to provide a high ratio of

information transfer to signal bandwidth. The basic element of data transfer in the system is the word which is defined as a grouping of binary bits. There are 24 bits per word. Three basic types of words are contained in the message. These are [1] address, [2] data, and [3] status (response) words. The status words are of two types depending on the type RT (ROT or RIT) responding. A message is defined as a grouping of words and consists of a total two-way transfer of control/data information between the MU and a selected RT. There are 20 message slots per frame, with a frame being defined as a complete cycle of data acquisition and control signal distribution. Two transmission lines are utilized for information transfer, [1] address line, and [2] response line. Frame rate is 100 frames per second, and all inputs and outputs are accessed once per frame.

The following shows the calculation for the address bit rates:

Frame Rate	=	100 F/S
Message/Frame	=	20 M/F
Words/Message	=	5 W/M
Bits/Word	=	24 B/W
Bits/Frame	=	24 x 5 x 20 = 2400 B/F
Bit Rate	=	100 F/S x 240 B/F = <u>240 K bps.</u>

The response contains six words, five of which must occur within the address/data message. Also, it is desirable to speed up the response to relieve the stability requirements on the RT clocks. The calculation for the response rate is as follows:

5/4 (Address Rate)	=	5/4 (240 k B/S) = 300 K bps minimum
Tolerance (for timing margin)	=	75 K bps
Response Bit Rate	=	<u>375 K bps.</u>

These bit rates are well within the capability of twisted pair shielded cable and offer a wide margin for communication reliability.

A simplified block diagram of the MU, shown in Figure 2-14, reveals the major functional elements of the design. The heart of the MU is the system timing and Read Only Memory (ROM) which is used to store the instructions for system control. The ROM is a Non Destructive Read Out (NDRO), non-volatile plated wire memory which is "read only" in flight but is electrically alterable on the ground by use of the Memory Loader/Verifier (ML/V) support equipment and a punched paper tape.

The system timing supplies RT addresses, which are combined with instructions, for transmission to the RT's. Address information is also supplied to the ROM to sequence the program instructions from

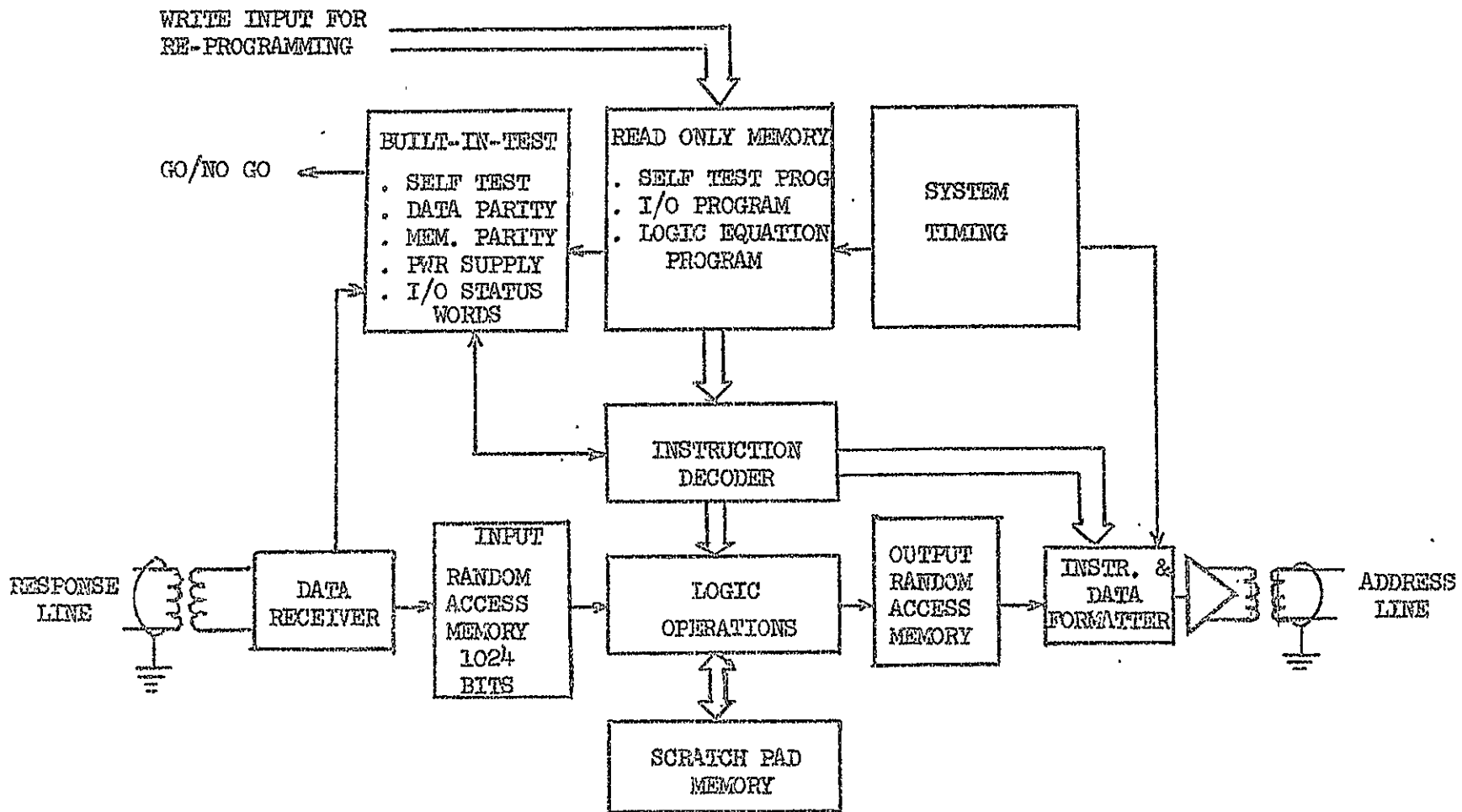

FIGURE 2-14 MASTER UNIT, SIMPLIFIED BLOCK DIAGRAM

memory. The instructions are decoded in the instruction decoder from operation (op) codes read out of the ROM. Instructions are furnished for control to the instruction/data formatter, logic operation (equation solution), and BITE circuits. The data from the RIT is received on the response party line and input to the Input Random Access Memory (IRAM). Logic operations are performed under control of the ROM utilizing data from the IRAM and the Scratch Pad Memory (SPM) for temporary storage. The results of the control equations are presented to the ORAM. Address and instructions are combined with data from the Output Random Access Memory (ORAM) for presentation to the ROT's. The Built-In-Test Equipment (BITE) in the MU provides not only an analysis of the MU faults but also receives fault data from all RT's. The MU BITE processes this information and supplies redundancy switchover control signals to all system units and failure location information to the Fault Indication Panel. Manual control from the Pilot Control Panel can override this BITE control.

The redundant MU's are identical, with the primary or secondary identification provided by the aircraft wiring. The primary unit is always in operation if no failures or manual control signals are present.

The Master Control Unit is packaged within a 6.125 x 7.750 x 5.625 inch volume as shown in Figure 2-15. The unit weighs about 15 lbs maximum. The main housing is fabricated from a combination of milled solid aluminum and honeycomb sandwich panels to provide a lightweight structure consistent with the requirements specified in MIL-E-5400K for Class 2 equipment. The single removable top panel will provide access to the "slide-out" memory and logic PC assemblies mounted in metallic printed circuit (PC) card guides and to the hard mounted memory stack and power supply. The removable electronics will plug-in to a "mother board" with resilient compression pads attached to the removable top cover panel. All electrical connections between the external Deutsch RTK connectors and the "mother board" will be made using hardwire and PC cable techniques.

The Memory Stack is a mechanically self-supporting assembly housed in its own sheet metal enclosure which provides conductive thermal paths from the aluminum memory planes to its main mounting surfaces on three sides. This assembly will plug into the "mother board" and secure directly to the main housing side-walls with screws which may be removed from outside the unit for removal of the stack. This mounting arrangement provides a mechanically rigid and thermally optimum configuration within the constraints of maintenance ease.

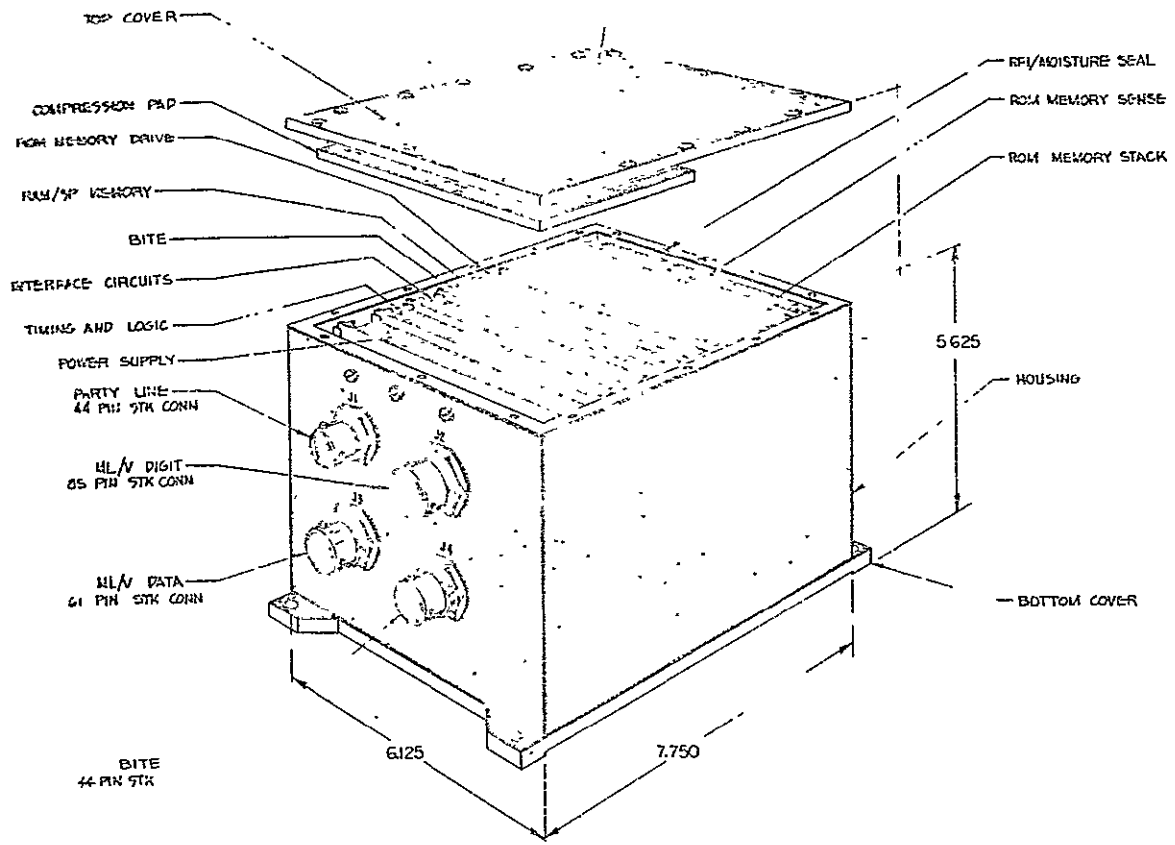

FIGURE 2-15 MASTER UNIT, PACKAGE DESIGN

The Remote Input Terminal (RIT) provides the interface between the Data Handling System and all control input signals. The 64 channels of the RIT accept a nominal zero and 5 V DC signal as the "0" and "1" bi-level control input. The RIT receives and processes all MU transmissions, and when an address-instruction word correlates with the RT code wiring in the aircraft harness, the RIT sequentially determines the state of all its input channels and transmits these to the MU.

The RIT is redundant with cross-coupling utilized to provide a measure of multiple fault tolerance. The two power supplies are coupled to redundant power sources, so that either supply will be operated from either source. Both receivers are continuously operated and will accept power from either power supply, so that the MU will maintain communication and control of the RT even under worst case conditions. Should a power supply fail, the RT will automatically switch to the alternate signal processing and transmitting circuits, and inform the MU of its action. Should any other malfunction be indicated by the internal BITE circuits, these are reported to the MU BITE for decision and control instruction.

The commonality of requirements for party line interface, address correlation, and control functions have resulted in some portions of the RIT, ROT, and MU being identical.

The RIT will be packaged within the 4.30 x 5.25 x 2.00 inch volume shown in Figure 2-16. The main housing will be machined from solid aluminum stock to provide a lightweight structure with a single removable connector end plate consistent with the requirements specified in MIL-E-5400K for Class 2 equipment. The internal electronic PC boards will cantilever mount directly to the removable connector plate. The PC assembly will be completely ruggedized after final assembly into the housing with a one-part, fill-in-place urethane foam to provide an extremely rigid mechanical structure. Conductive heat transfer paths will be provided from the high heat dissipating components such as the power supply chopper transistors using spring contact heat straps directly between the housing and the components.

The major difference in design between the remote input and output terminals is in the handling of data. The RIT, of course, delivers data on demand to the MU, while the ROT accepts 64 bits of data from the MU on the address line immediately following the address. The data is delivered in four 16-bit word groups, similar to the output of the RIT. The following are the significant features of the ROT operation:

1. Two successive identical data bits must be received before a change in output state is made to the output.

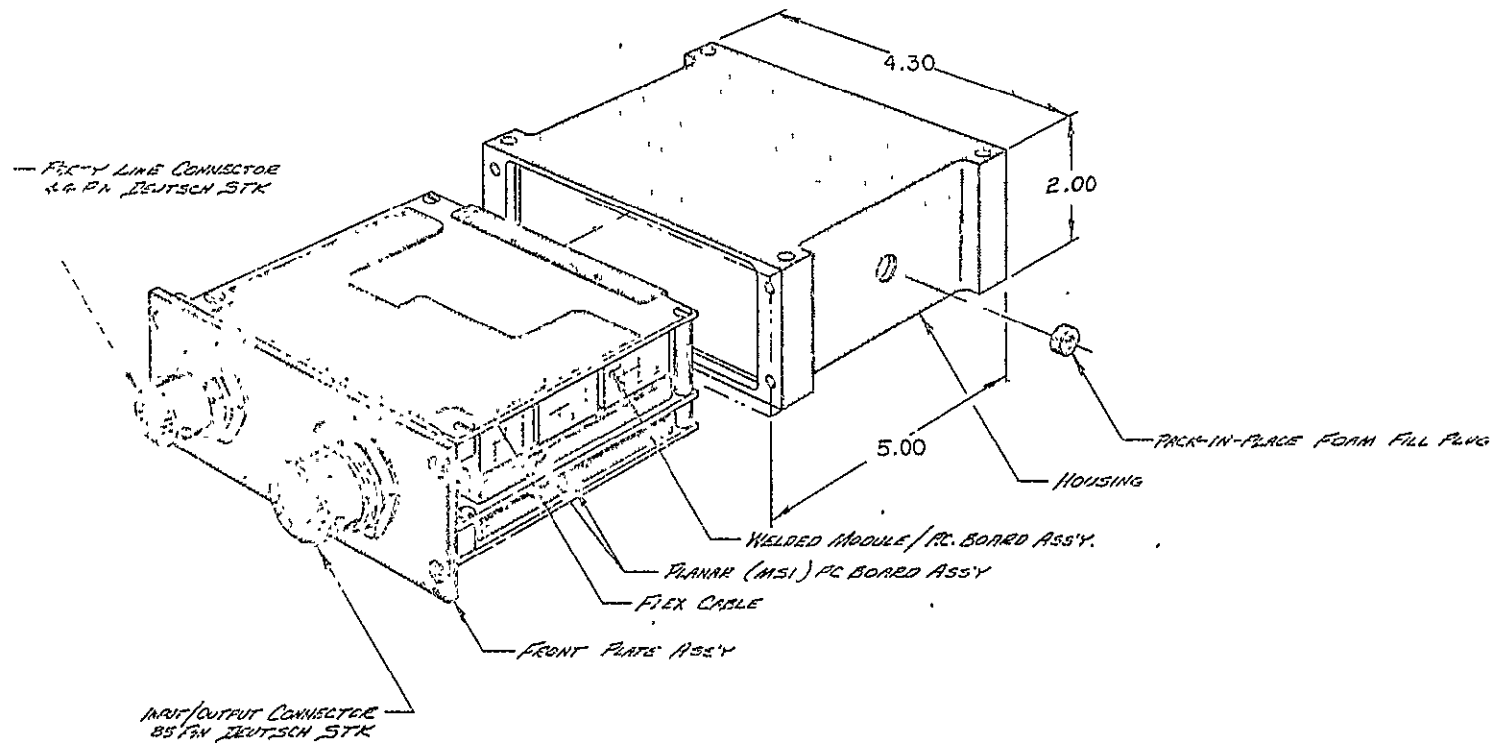

FIGURE 2-16 REMOTE INPUT TERMINAL, PACKAGE DESIGN

2. The primary/secondary switchover must be accomplished when a primary failure is detected without creating output transients.
3. The information contained at the output driver must be held in storage during a primary power interruption of at least 50 m sec to prevent excessive delays when power sources are switched.
4. The output driver must deliver 10 ma into a 500 ohm load in the high state over the full temperature range. Short circuit protection is required.

The ROT will be packaged within the 7.5 x 5.0 x 2.0 inch volume as shown in Figure 2-17 and will weigh about 2.2 lbs maximum. The general packaging technique for the ROT is identical to the RIT.

The Fault Indication Panel (FIP) performs three basic functions. First, it provides non-volatile storage of the location of any BITE detected faults to be used for system maintenance; second, a system status indication and manual override control permits the exercise of all redundant units or the pilot override of BITE under multiple failure conditions; and third, provides parity line and power source tests for pre-flight monitoring of system health.

In the final configuration, it is anticipated that the pre-flight tests will be automatically initiated from the crew station with remote go/no-go indication, and that the non-volatile storage will be accomplished with techniques similar to the COS-MOS logic used for data storage in the ROT. However, it is probable that the storage of load controller trip signals, and possibly signal source BITE information, will be incorporated into the same maintenance panel. Therefore, a breadboard FIP has been designed which will allow performance evaluation of the DHS concept. Since the FIP is a breadboard unit at present, packaging details will not be presented.

The Pilot Control Panel (see Figure 2-18) is used in conjunction with the Fault Indicator Panel (FIP) to provide manual override to the BITE. A limited display of system "status" is provided by the four indicator lights. Presently reporting failures in the system are summarized in terms of pri/sec MU or RT. Two switches provide input to the MU BITE for system control.

The development of a DHS for advanced aircraft solid state electrical system has progressed to the point of engineering models and advanced breadboards. A performance specification has been prepared

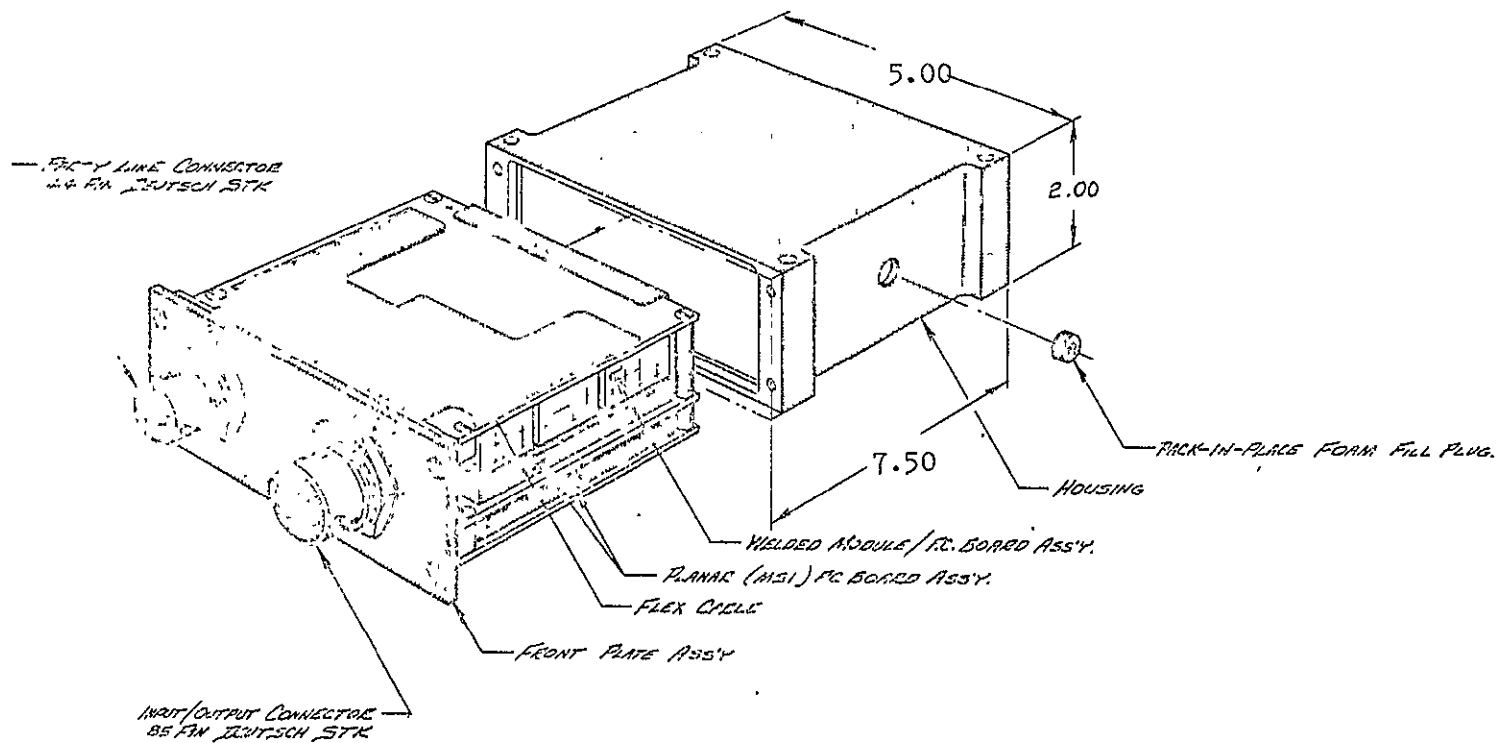

FIGURE 2-17 REMOTE OUTPUT TERMINAL, PACKAGE DESIGN

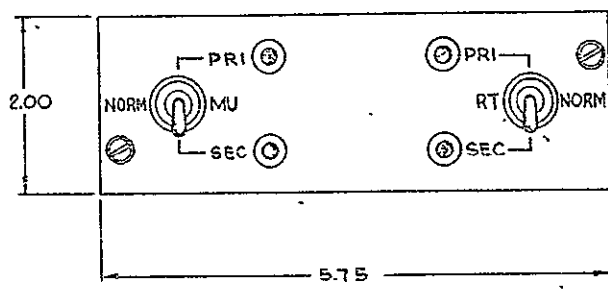
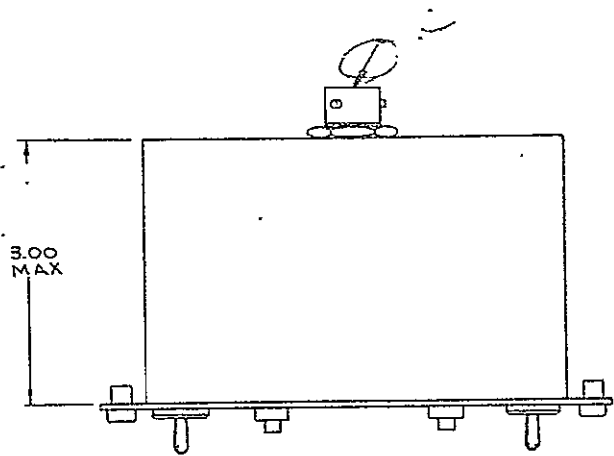

FIGURE 2-18 PILOT CONTROL PANEL

and equipment is being designed and fabricated for a solid state system simulator. The MU, remote terminals, transmission lines and support equipment have advanced to the engineering model stage. These engineering models are of the packaging configuration shown herein and do not represent the most optimum for a flight-ready system. Production equipment would be expected to use hybrid and integrated packaging techniques to reduce the size and weight of the units. The Fault Indication Panel presently designed for the simulator is an advanced breadboard unit and is considered only an interim design.

2.2.2.4 Built-In-Test Equipment (BITE)

Built-In-Test Equipment (BITE) design for the advanced aircraft solid state electrical system is limited primarily to the DHS. Some ideas have been proposed for testing signal sources; however, this requires a new type of signal source and is included under paragraph 4.1 as spacecraft development requirements. BITE for load controllers have been given considerable thought, but as of yet a completely satisfactory solution has not been found for advanced aircraft or spacecraft. Further details of BITE for load controllers are also included under paragraph 4.2.

The DHS has a complete BITE providing in many cases continuous indication of the status and health of the system. The BITE is integrated in such a manner as to provide automatic switch-over to redundant or standby components. The automatic switch-over is tempered by the ability to manually override and select the system components to provide maximum operational flexibility.

The DHS BITE must satisfy four major requirements: [1] the BITE must detect any random transient condition that would result in invalid data and instruct the system to disregard the invalid data; [2] detect most single hardware malfunctions and automatically switch over to a secondary redundant unit. Where detection and switch-over are not feasible, the possibility of a malfunction must be guarded against by the use of isolated parallel redundant techniques; [3] in the case of multiple failures where both the primary and secondary units have failed, the BITE must display the failure status to the pilot. The BITE must then provide the pilot a means of selecting the unit, which based upon his judgment will perform with a minimum of detrimental effects; and [4] provide a pre-flight and post-flight analysis of the health of the total system so that action can be taken to replace any failed units.

BITE requirement [2], immunity to errors due to hardware malfunction, is achieved through the use of isolated parallel redundant power sources, power distribution and transmission lines, and secondary standby redundant sub-units and units that are automatically switched over by detecting successive identical transient type failures as described in the previous paragraph. NOTE: A single failure is assumed to be a transient until it becomes repetitive, at which time it is then classed as a hardware malfunction.

Requirement [3], multiple failures analyzed and selective judgment implemented by manual control, is achieved by reporting (displaying) to the pilot a collective status of current hardware malfunctions and supplying switches to manually select the primary or secondary redundant unit.

Requirement [4], pre-flight and post-flight analysis, is achieved by retaining all hardware failures and reporting this status on indicators. Also manual control is provided to select individually and test each section of the isolated parallel redundant functions. Manual control provides the capability to exercise individually the primary and secondary redundant units and report their functional status.

A summary of major BITE design features is summarized in Table 2-4.

2. 2. 2. 5 Support Equipment and Software Program

To date two pieces of support equipment have been identified and defined for the advanced aircraft solid state electrical system. Both of these are in support of the DHS. One is the Memory Loader/Verifier (ML/V) and the other is the decoder unit (DU). As the design of the system progresses, undoubtedly additional support equipment requirements will be established for signal sources and power controllers as well as DHS.

The Memory Loader/Verifier (ML/V) is a portable operating/test unit that has the capability of programming and/or verifying the contents of the Read Only Memory (ROM) in the Master Unit (MU). The ML/V major assemblies are [1] photo-tape reader, [2] display and control panel, [3] logic card tray, and [4] power supply assembly. The front panel layout and overall assembly of the ML/V is shown in Figure 2-19.

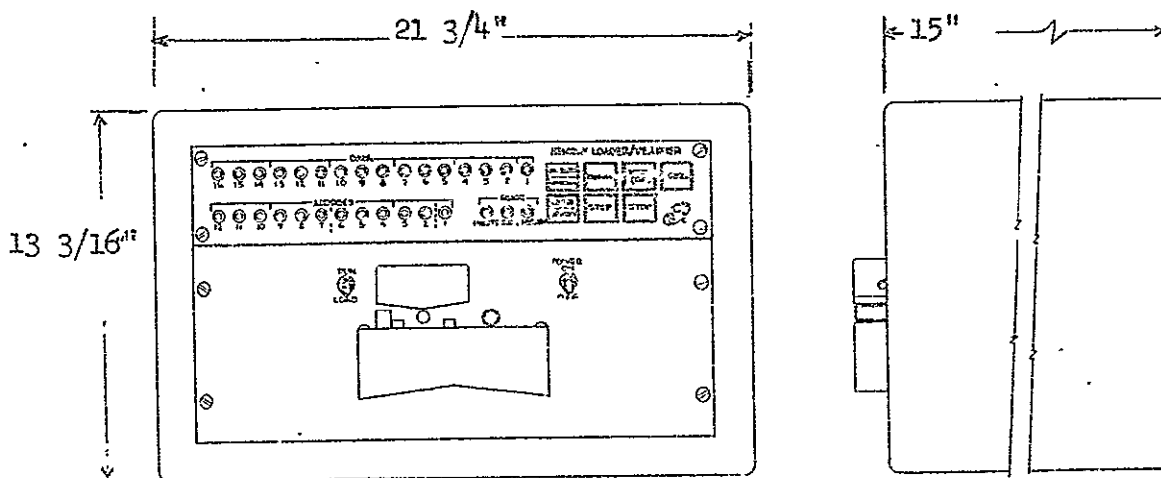

FIGURE 2-19 MEMORY LOADER/VERIFIER PANEL LAYOUT

TABLE 2-4. FL-MUX SYSTEM BITE DESIGN ----
MAJOR FEATURES

<u>FUNCTION</u>	<u>PURPOSE</u>	<u>ACTION TAKEN</u>
1) Transient Errors		
a) Program Memory Parity	Checks parity of information read from MU memory	A single parity error in a frame inhibits output to the ROT's for the remainder of the frame. A second parity error in a frame causes switch-over to the redundant MU
b) Transmission Parity	1) Checks validity of transmitted information 2) Signify transmission system hardware malfunction	1) Two successive parity errors from an RT causes the MU to switch to the secondary portion of the RT. 2) Parity errors from all RT's during two successive frames causes MU switch-over to standby MU
59 c) Output Integration (Pump-up or digital filtering)	Ignores short-time spurious disturbances (noise, spikes, etc.)	Outputs do not change until two successive identical commands are received
2) Hardware Malfunctions		
a) End to End System Test	Exercises all system components with test data to assure proper operation. This occurs on a continuous basis even during flight. Checks continuity and mating of connectors on RIT and ROT. Discontinuity shows up as failed RIT or ROT	1) Two successive failures of a RIT causes switch-over to the redundant half of RIT 2) Single error inhibits ROT output; errors in successive frames causes switch-over to the redundant half of the ROT 3) Detection of failure of all RIT or ROT BITE data inputs causes switch-over to standby MU 4) Detection of failure in MU input/output memories, RGM, scratch pad memory or equation computation causes switch-over to standby MU
		Note: Operational status of MU's, RIT's, and ROT's are indicated on BITE panel.

TABLE 2-4 PL-MUX SYSTEM BITE DESIGN (CONT'D)

<u>FUNCTION</u>	<u>PURPOSE</u>	<u>ACTION TAKEN</u>
b) Improper/no response check	Determine if the proper RT addressed did reply with a response word and that this response word did occur at the proper time with correct response information	Upon detection of malfunction the addressed RT is switched to its redundant half
c) MU timing check	Detect failure of MU timing	Switch-over to standby MU
3) Pre-flight and post-flight checkout indication	Maintain status and failure indication for monitoring system status and health	Most cases indicators are latched to hold an indication of a failure
4) Power Control		
60 a) RT	Detect failure of RT power supply	Switch to redundant power supply
b) MU	Detect failure of MU power supply	Switch to standby MU

Preparation of the tape for programming the MU and used on the ML/V can be prepared manually, but is tedious and time-consuming. Considering several hundred Boolean equations and other instructions which must be programmed into the MU, it is economical from the standpoint of time and cost to use a commercial computer with a tape punch output to prepare the octal (ASC II) coded tape. A software program has been prepared to perform this function. The program accepts unsimplified Boolean switching equations in any one of several formats, simplifies and factors the equations, converts them to computer machine language, accepts DHS address data and punches out the paper tape. The present program is designed around specific computer facilities, but has the potential for being revised and adapted to other data processing systems. The program has been run and debugged. A tape has been prepared for programming an aircraft solid state electrical system simulator.

The Decoder Unit (DU) is a test device which will be utilized to monitor the signals of the system transmission lines. The unit will be especially valuable during the initial system tests, and also for operational trouble shooting.

The DU provides a means for selecting and displaying, on indicators, any word on the address and response transmission lines. Test points are also provided so that external test equipment may be utilized for monitoring the line signals. The unit is packaged in a portable form for convenience, and may be connected to the system at the Fault Indicator Panel (FIP) or at any remote terminal connection point. This facility will allow monitoring at all points on the lines for fault isolation in the system.

The front panel layout for the DU is shown in Figure 2-20. Remote terminal and word selection is facilitated with thumb wheel switches. Indicators are included for the selected address word and the selected data/status word. The numbers 1-16 at the data indicators identify data bits. The status word bits and address word bits are marked on the panel for convenience in identification. Test points are provided at the panel for use of external test equipment.

Three cable assemblies are furnished with the DU for interconnection with the DHS and the power source. A power cable for connection to the 115 V, 400 Hz power source is provided. A cable assembly is provided to connect the DU to the FIP and a second cable allows connection to the DHS transmission lines at any selected remote terminal location.

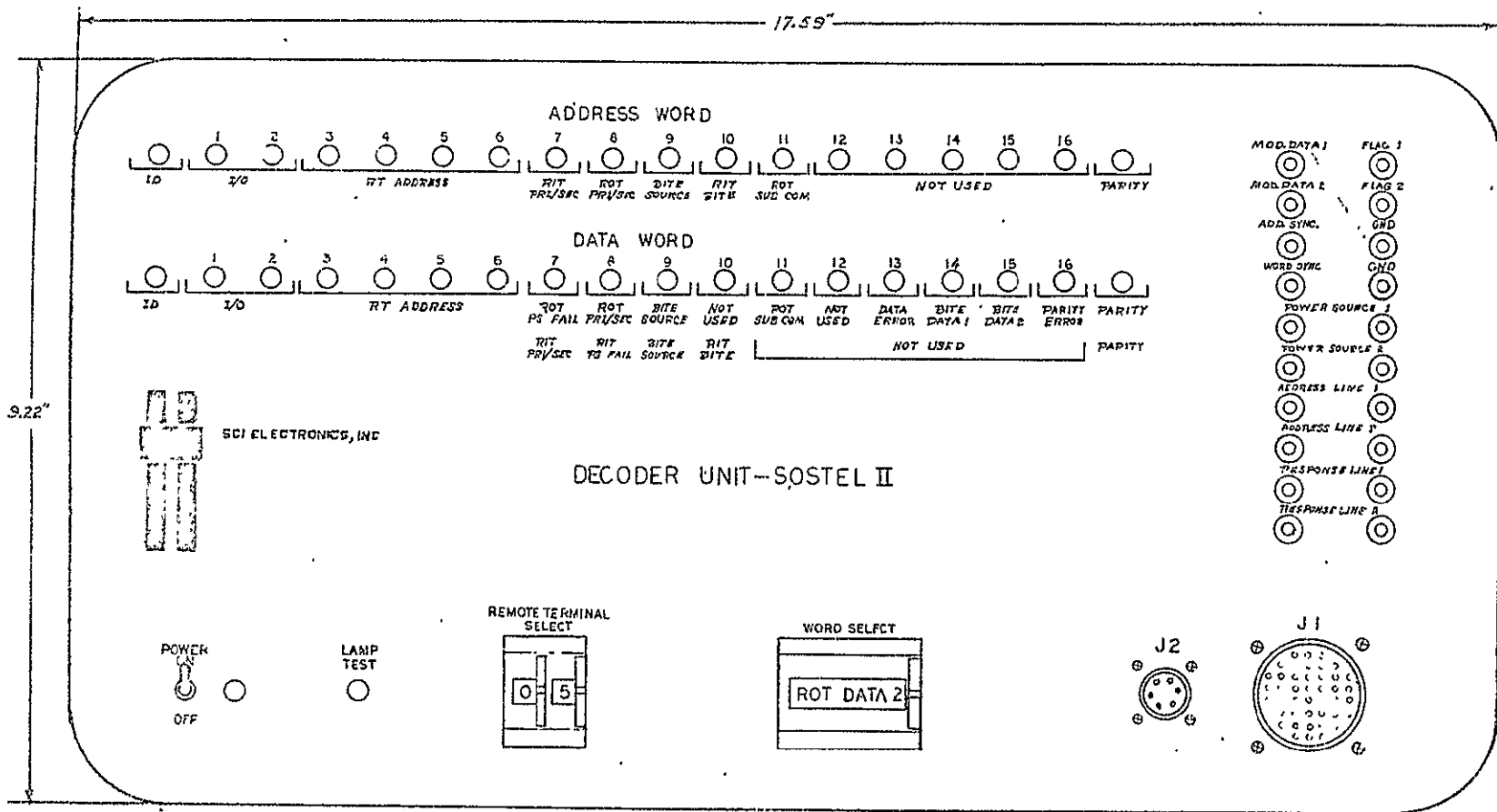

FIGURE 2-20 DECODER UNIT, PANEL LAYOUT

2.3 Advanced Aircraft Concept -- Hybrid

Figure 2-21 is a schematic block diagram of the selected hybrid aircraft power distribution and control system. The hybrid concept uses the identical signal sources and data handling subsystems as the solid state concept, the difference being in the power switching subsystem. Bus switching is performed by electromechanical power contactors. Power to each load is switched by a power relay in each load circuit. Conventional thermal circuit breakers are used in each load circuit. The load switching relays are located within or in close proximity to the breaker panel and are controlled by solid state relay drivers.

The bus switching and bus arrangement are similar to that for the solid state system as far as the reduction in bus switching devices and the number of buses when compared to the aircraft conventional system. With the use of electromechanical power contactors, the hybrid system is still subject to the 50 millisecond delay in transferring a bus from one source to another. Since each load is controlled individually, programmed load monitoring and load sequencing can be used just as proposed for the solid state system. It is also apparent that the hybrid system has a distinct separation of power and control, enabling the use of small gage, printed circuit or flat conductor cable for the low power level control. The use of the multiplexing approach and direct routing of power wires provides a substantial reduction in the amount of wiring, size and complexity of the harnesses. The hybrid system is still subjected to the problems associated with electromechanical circuit breakers and relays. For access during flight, the circuit breakers, buses and bus switching devices must be located in the crew station, requiring valuable panel and console space while limiting the bus arrangement to a centralized concept. Similar to the described solid state system, built-in-test is limited to the DHS.

The hybrid system is a compromise between the conventional and completely solid state approach. It does not satisfy all the objectives of this program, but does offer an excellent compromise.

SIGNAL GENERATION
 (IDENTICAL TO FIGURE 2-2)

DATA HANDLING
 (IDENTICAL TO FIGURE 2-2)

POWER SWITCHING

64

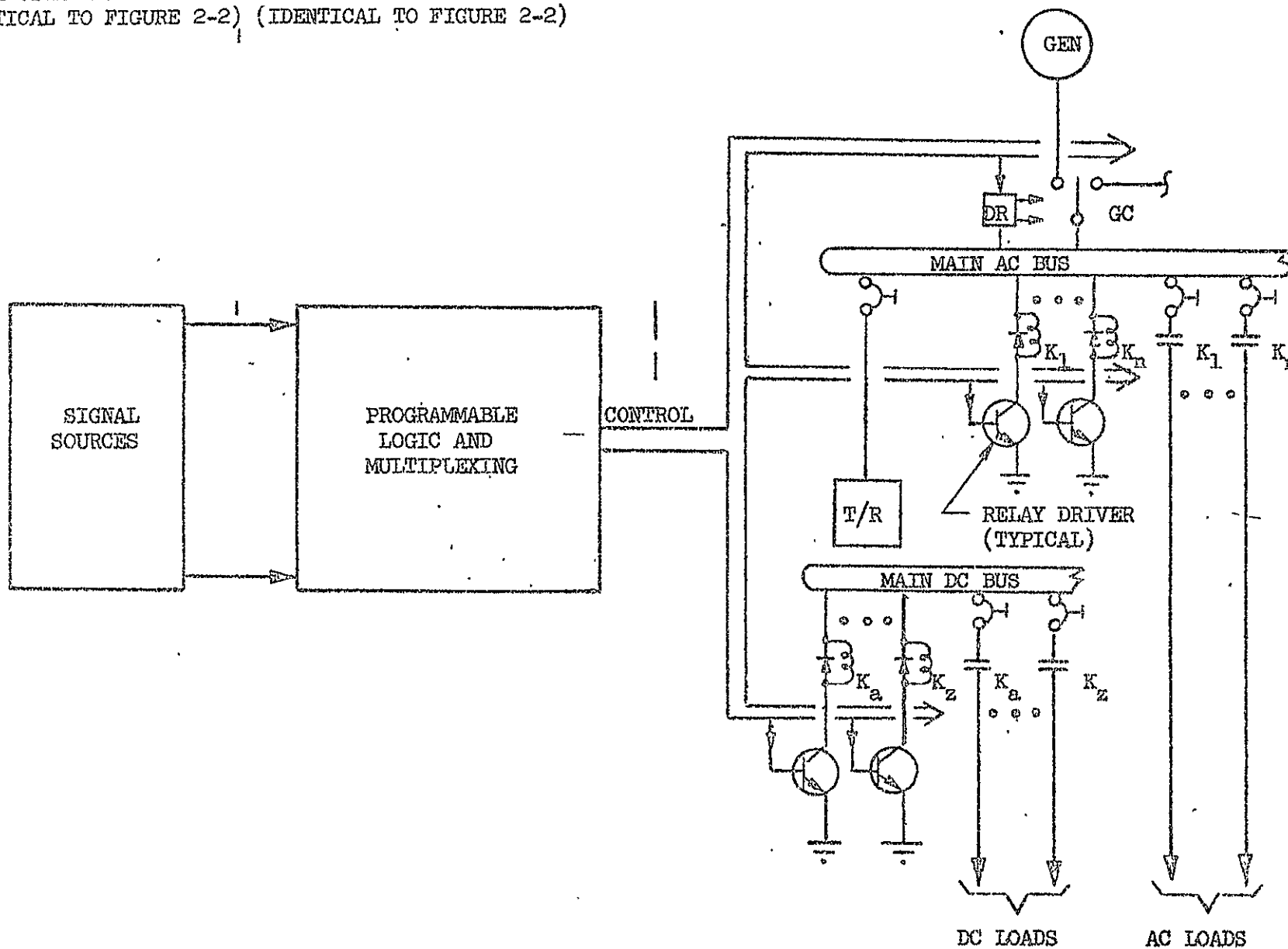

FIGURE 2-21 ADVANCED AIRCRAFT CONCEPT - HYBRID

There are several differences in requirements and operation between electrical power distribution and control systems for spacecraft and those for aircraft. There are also many common requirements. The proposed shuttle vehicle poses an interesting challenge, incorporating the requirements and operation of both a spacecraft and an aircraft into a single vehicle.

Standardization of systems hardware for aircraft systems is considered an important item. This is due to the large numbers of aircraft produced during a specific production program; the similarity between most aircraft systems even though the vintage, purpose, and mission of aircrafts may be different; the large number of aircraft in operation at any one time; the need to minimize spares and logistic problems; the need for commonality of support and maintenance facilities; the long operational life of an aircraft; reduced maintenance and operations training, etc. Standardization of systems hardware for spacecraft is not nearly so strenuous a constraint. Granted, the goals set for the shuttle vehicle are to have a number of vehicles operating over many years and performing 50 to 100 missions, but even here the number of vehicles over a specific time period is minute compared to the number of aircraft in operation. There are many differences between different types of spacecraft as related to configurations of systems, purpose, and mission. Standardization often dictates a compromise in weight, size, reliability, and performance. Often the spacecraft design constraints cannot tolerate the compromises imposed by standardization. With these points in mind, it becomes economical to consider unique designs for different types of spacecraft.

Reliability is considered important for aircraft but usually has to be traded off against standardization, weight, and cost. The aircraft mission time is measured in minutes and hours, thus offering an early opportunity for correction of malfunctions and failed equipment. Proposed missions for advanced spacecraft are measured in days, months and years; the opportunity for maintenance and repair is limited. The aircraft mission cost and thus the cost of an aborted mission is negligible compared to an aborted space mission. These items point to a requirement for greater reliability confidence level for spacecraft hardware than those for aircraft. Normally higher safety factors are designed into the spacecraft hardware.

The vacuum and thermal vacuum problem is alien to aircraft designers. For spacecraft, special considerations must be given to packaging, sealing, out-gassing and voltage breakdown. Arc-over and voltage breakdown are critical at altitudes from 80,000 to 300,000 feet. In a thermal vacuum, equipment power dissipation and losses become of prime

importance. Not only must waste heat be dissipated by sophisticated cooling systems, but the losses impose critical penalties on electrical power sources and their fuel supplies. To date most cooling of aircraft systems equipment has been accomplished by free-convection and forced air with only occasional resort to cold plate, liquid cooling. Application of the solid state electrical power distribution and control system to spacecraft will require modification to incorporate the cold plate cooling. Further, means must be investigated to reduce the power dissipation and losses.

Primary electrical power for larger aircraft has, in recent years, become fairly well standardized at 120/208 V AC, 400 Hz, three phase. The power is obtained from engine-driven alternators. Most significant electrical loads have been standardized to use the AC power directly. Secondary electrical power for aircraft has become deeply entrenched at 28 V DC. Historically, past spacecraft have used 28 V DC as the primary power voltage, being readily available from fuel cells and batteries. It is anticipated that the larger, near-future spacecraft will continue to use 28 V DC as the primary power for space operation. This being the case, DC solid state device current ratings are anticipated to be much larger than normally used on aircraft DC systems. For longer range applications such as the space base, AC power at higher voltages and/or higher frequencies (1200 Hz) may materialize. High voltage DC systems may find application. In any case, the more exotic types of power will generate the need for redesign of solid state switching systems.

Rather sophisticated general purpose data handling systems (DHS) are under investigation for advanced spacecraft. This poses the question of whether electrical power systems (EPS) should use the general-purpose DHS or the dedicated DHS similar to that described for aircraft advanced systems. Considerations involved here include criticality of the EPS, signal safeguards, volume of data, essentially continuous control logic equation computations, efficiency of operations, programming, and many more. If the general purpose DHS is selected, then the solid state switching and DHS must be designed for a compatible interface. The problem of general versus dedicated DHS must be given serious consideration since that effort was not within the scope of this program.

The volume of data, computations and transmission line lengths of the dedicated DHS for the aircraft solid state system is based upon the requirements for a two-engine fighter aircraft. The larger physical size and greater anticipated volumes of data for such spacecraft as the shuttle and space base will dictate an extension of the data handling capabilities and transmission line lengths of the aircraft DHS.

Advanced spacecraft systems are considering sophisticated integrated controls and displays. The solid state system and controls/display interface remain to be defined.

Advanced spacecraft will be subject to space and in some cases nuclear radiation. The solid state devices must take radiation effects into consideration.

The larger sized spacecraft dictates the need for use of remotely located power buses and thus the use of a distributed bus system.

The aircraft solid state system is lacking in complete system coverage with built-in test. Expansion of the built-in test capability is desirable for spacecraft application.

4.0 SPACECRAFT APPLICATIONS AND DEVELOPMENT REQUIREMENTS

4.1 Signal Sources

Signal sources presently under development for aircraft solid state systems suffer from several disadvantages. Figure 4-1 is a block diagram of the present solid state signal source and its interconnection to the remote input terminal (RIT) and power supply. As shown, the signal source is a three-wire device requiring 0.35 watts of excitation and driving power. The output signal to the RIT is zero (OFF) or 5 V DC at 10 ma (ON). The RIT input impedance is normally very high; however, dropping resistors (typically 500 ohm) are added solely for the purpose of developing 10 ma in the interconnecting signal lead for EMI immunity. As shown, the 5 V DC logic level is sampled via a multiplex link for transmission as OFF or ON data to the MU for correlation and system control. Several "less than optimum" characteristics and observations can be made and stated for the present solid state signal source. These are:

1. A power supply is required for excitation and driving power, supplying a group of signal sources.
2. Three wire leads are required -- power, signal and ground.
3. Built-In-Test Equipment (BITE) is not included. To incorporate BITE requires additional design, components and overall complexity.
4. Excessive power is required, much of which is dissipated as heat. For 600 signal sources energized simultaneously, the power requirement is 210 watts.

The above characteristics led to a search for a better approach to be used for advanced applications and resulted in the concept for a solid state switched impedance signal source. Figure 4-2 is a block diagram of the switched impedance signal source and its interconnection to the modified remote input terminal (RIT). The same basic function is performed by the switched impedance signal source as was for the previously described signal source but now the power supply is eliminated, signal source power is reduced, a wiring lead is eliminated, and full-time BITE incorporated. The RIT does require modification, replacing and adding additional circuitry.

69

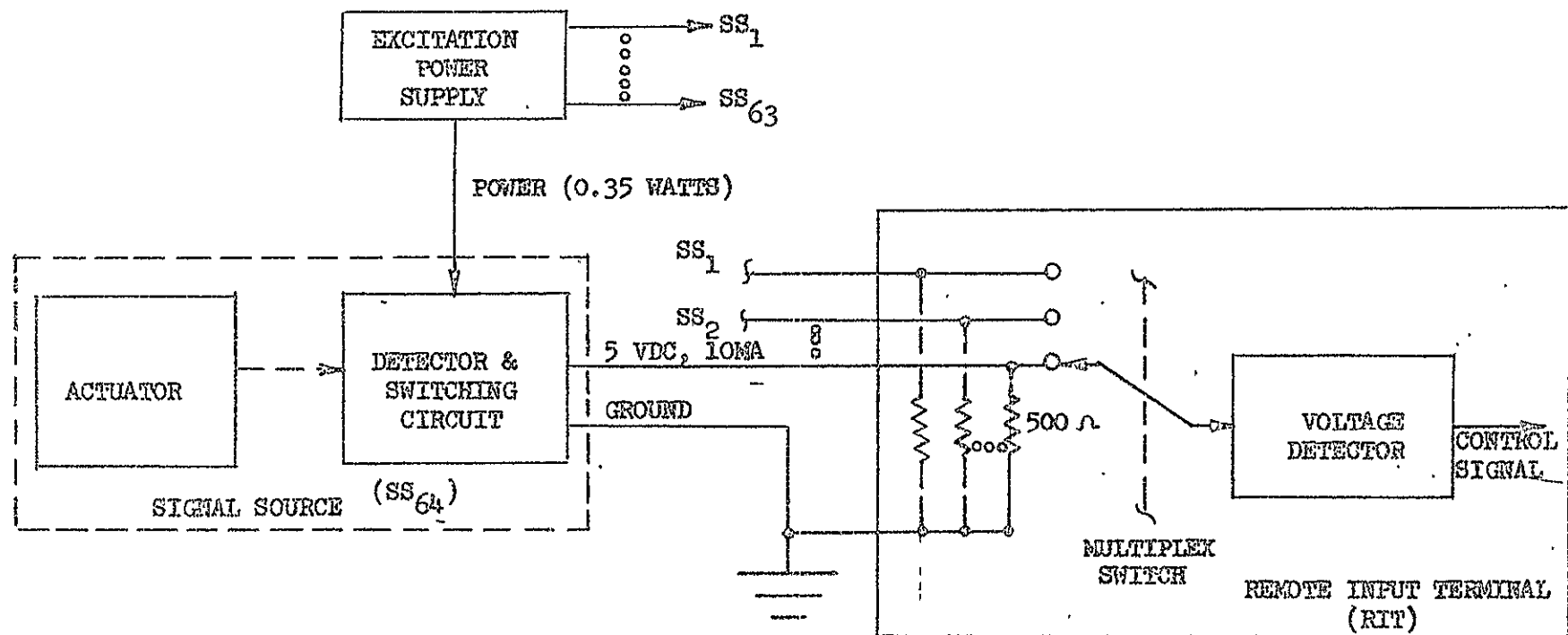

FIGURE 4-1 PRESENT SIGNAL SOURCE INTERCONNECTION

70

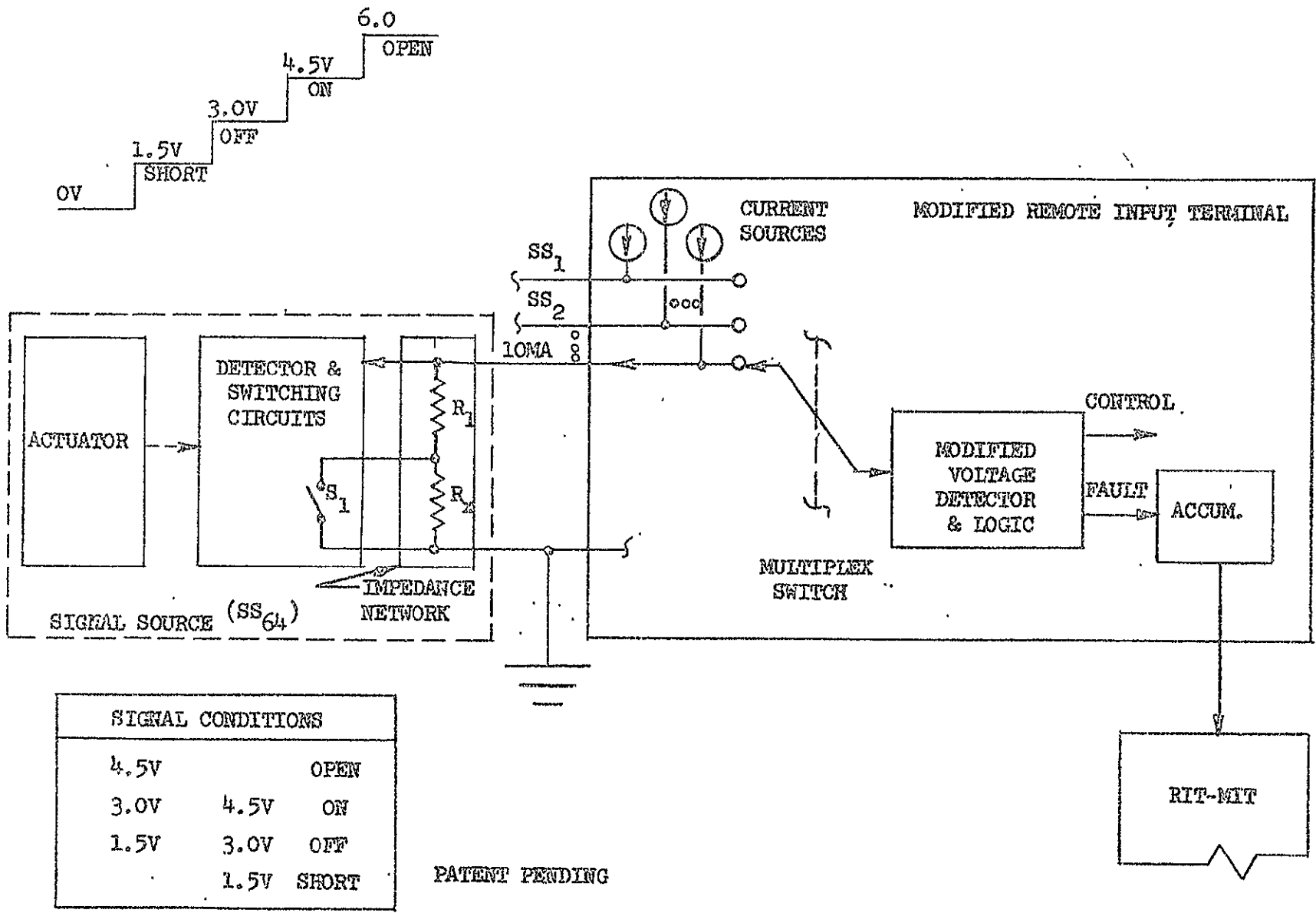

FIGURE 4-2 PROPOSED SWITCHED IMPEDENCE SIGNAL SOURCE INTERCONNECTION

The basic changes include the addition of circuitry equivalent to a switched impedance network in the signal source. The signal source circuitry would probably be redesigned to up-date and simplify. The RIT would be modified to incorporate 10 ma constant current generators, one for each of the 64 channels in the RIT. The current generators replace the dropping resistors in the present RIT. The voltage detection circuit is redesigned to include additional detection and control logic functions. The control logic is used to distinguish between a control signal and a BITE fault signal. Power to the signal source (10 ma for EMI immunity) is supplied from the constant current generators in the RIT eliminating the need for a separate power supply. The same 5 V DC logic level is used so the power per signal source is $5 \times .01 = .05$ watts. Furthermore, the 64 current generators associated with a RIT are turned on only when the RIT is being interrogated, thus total signal source power at any one time is $.05 \times 64 = 3.20$ watts. This is compared with the 210 watts for the present units.

For purposes of discussion a switch (S_1) is shown symbolically as part of the signal source switching circuit. Actually, neither a switch nor an impedance network would be used; instead, the output stage of the signal source would be a solid state circuit which changes impedance level as a function of the input. With a constant current source applied, the impedance looking into the signal source is at two levels -- R_1 and R_2 where $R_2 = R_1 + R_x$. The signal source output is therefore a developed voltage that is IR_1 or IR_2 for "OFF" and "ON" respectively. The impedance values are selected such that the output voltage is suitable for driving the detector circuit logic. An intriguing facet is a very simple full-time BITE capability which can also be included in the threshold/ logic. A failure in the constant current source, the interconnecting signal line or the signal source circuitry will result in an abnormally high or low output voltage as opposed to the normal IR_1 or IR_2 voltage. Voltage detector thresholds can thus be set to monitor on a continuous basis for such failures for BITE. Logic levels for the OFF-ON states and faults (denoted as shorts and opens) can be established as indicated in Figure 4-2. At present, several circuits have been conceived for implementing various types of manual and sensor activated signal sources,

As the modified RIT serially samples its 64 signal sources, those fault signals detected are stored in an accumulator. At the end of the RIT sample period, the fault signals are serially transferred to shift registers in the Remote Input Terminal-Monitor Input Terminal (RIT-MIT). The functions of the RIT-MIT will be discussed later under the Data Handling System (DHS).

4.2 Power Controllers

There are several modifications and improvements which could be made for application of power controllers to a spacecraft system. Some of these are deemed necessary; others are desirable from an improved weight, size, reliability, and performance standpoint. Foremost is packaging to satisfy specification requirements. Others include multi-channel load controllers, current limiting for AC units, improved fail-safe capability for AC load controllers, cooling (cold plate), built-in test, higher rated DC units, and more realistic electrical power characteristics.

Development of power controllers for spacecraft applications is primarily a problem of packaging. Practical weight, size and reliability can be gained through the use of hybrid and integrated circuit techniques. Another means of improving these parameters is through multi-channel power controllers covered below. The use of multi-channel power controllers, hybrid and/or integrated circuits and suitable cooling design can provide units of high quality for spacecraft application.

The present bus controllers are designed for AC and require a separate unit for each phase. The multi-channel bus controller would incorporate three power channels per package, forming a three-phase unit. Greater packaging efficiency can be gained as well as potential sharing of control circuitry.

The volume of solid state power switching and circuit protection is approximately 46% of the total solid state system volume. The load controller rack assemblies accounted for the bulk of this volume, resulting in the investigation of means to reduce the volume of load controller assemblies.

A completely new concept in load controller packaging and installation has evolved. This is the idea of a multi-channel load controller module.

The multi-channel load controller module incorporates the internal control and power circuits of several load controllers into a single package, resulting in substantially improved packaging efficiency and some sharing of common circuitry and components such as power supplies, terminals and surge blocks. Figure 4-3 shows a block diagram of a 16-channel load controller module. Typical package configuration and requirements for a 16-channel load controller are given in the preliminary specification sheets at the conclusion of this section. The module as shown would mount into a rack assembly, providing the cold-plate cooling. Similar specification sheets have been prepared for an 18-channel AC load controller.

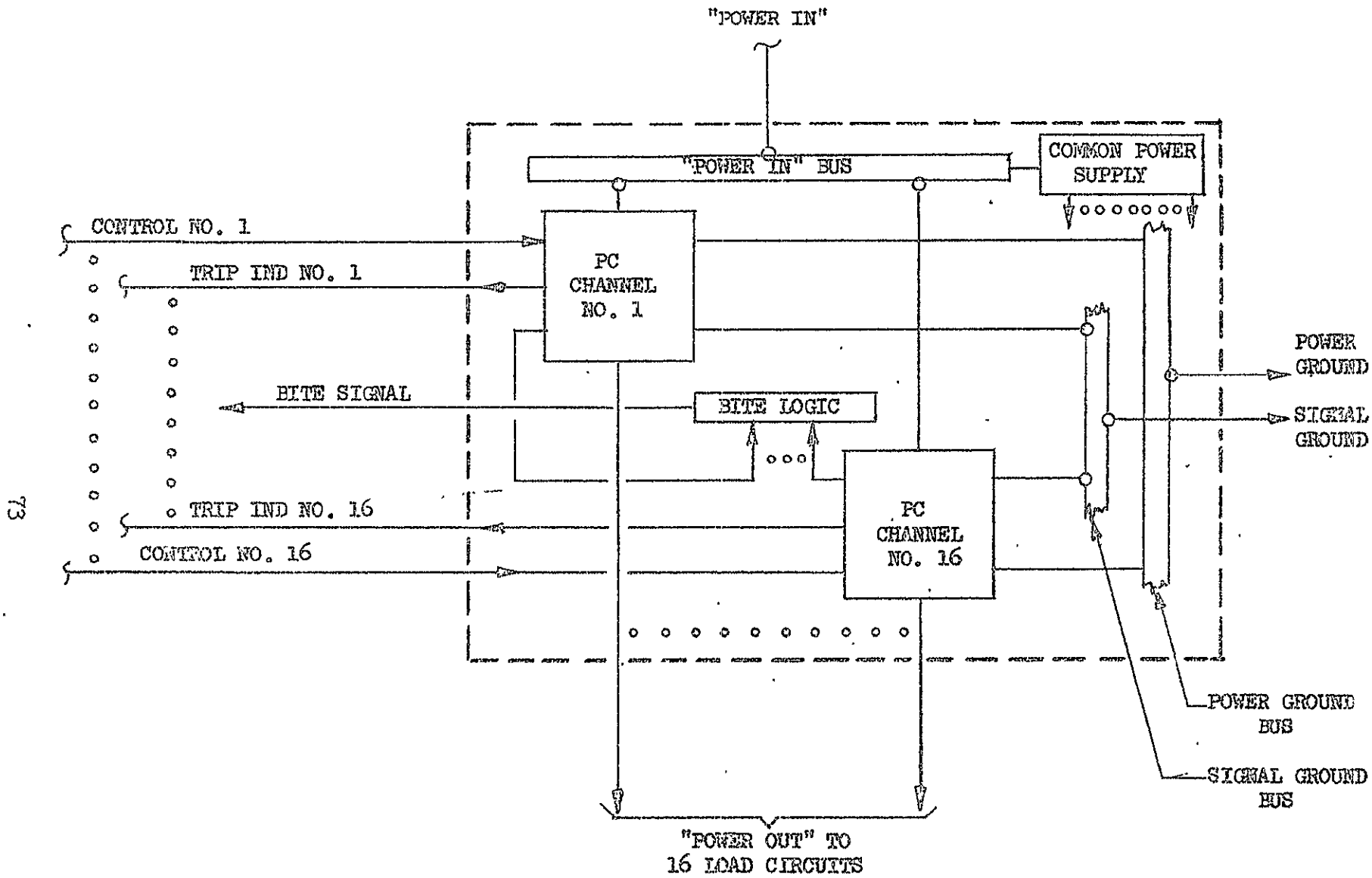

FIGURE 4-3 BLOCK DIAGRAM - 16 CHANNEL DC POWER CONTROLLER MODULE

Advantages of the 16-channel DC load controller module are listed below:

- (1) Instead of a separate, small power supply for each load controller module as used in the single-channel unit, the multi-channel unit would use a higher capacity, more rugged power supply serving control circuitry in all 16 channels. The higher capacity power supply can be designed economically to provide a much higher level of performance. Even considering a fully redundant power supply, the higher capacity unit would be several times lighter and smaller than the 16 single-channel power supplies.
- (2) The multi-channel unit allows greater packaging density and greater flexibility in packaging.
- (3) The multi-channel unit would realize a significant savings in packaging material due to higher density packaging and improved packaging flexibility. For example 16 single-channel modules have a surface area (tops, side and ends) of 80 sq. in. while the 16-channel module would have a surface area of less than 18 sq. in.
- (4) The package walls would serve as a common surge block and heat sink which in effect eliminates the equivalent weight of 16 surge blocks on 16 single-channel load controllers.
- (5) Input power, power grounds and signal grounds can be bused within the multi-channel load controller module with two terminals (two for redundancy) brought out for each of the three functions. This results in reducing the number of external terminals and connections from 48 to 6.
- (6) Conservative estimates give a 1/3 reduction in weight and volume of a 16-channel load controller module compared to 16 individual single-channel load controller modules. A further reduction to as much as one half is not unrealistic.
- (7) Overall improved circuit performance and simplification can be realized in the multi-channel load controller module. The higher capacity power supply with improved performance can provide higher control circuit driving power resulting in higher gains and improved operating efficiency.

Current limiting is a desirable feature to add to the AC load controller, permitting the surge current rating of the SCR to be reduced. High surge current ratings in an SCR require a large, expensive chip. The larger the chip and its associated surge block, the larger the overall load controller must become. The first cycle of fault current on a 20 KVA generator can peak at about 680 amperes. An SCR of reasonable price and size would be rated for a surge current of 300 amperes. In order to use this chip in an AC load controller on a system with 20 KVA generators and larger, a bus crowbar device has to be used. The bus crowbar is a device using large SCR with appropriate sensing circuitry to sense a fault current building up and to shunt this current to ground. Essentially it clamps the bus to ground through the crowbar. The crowbar then permits the load controllers to use a smaller chip with lower surge current rating. However, if the AC controller had current limiting, the lower rated SCR could be used and any crowbar devices eliminated. Certain bulk semiconductor devices have exhibited a current limiting ability. Such devices exhibit a high impedance at a high temperature; the high temperature caused by flow of overload or fault current. The bulk semiconductor would be placed in series with the power chip. Additional investigations are needed to more fully understand the operation and characteristics of the device, voltage drop, and effect upon load controller operation under normal conditions.

The load controllers presently under development have no means of performing Built-In-Test. This problem has been considered in some depth but no simple and reliable means of providing Built-In-Test has emerged. There is a TRIP INDICATION signal provided which indicates the load controller has tripped from a fault on the load line or an overload condition of the load, but no information is provided as to the condition of the load controller. The primary problem of testing the load controller is the undesirability of operating the controller and thus activating the load.

The circuitry within the load controller can be divided into two general types -- control circuits and power circuit. The control circuits using highly reliable hybrid integrated circuits can be built with large safety factors and is not subject to the high stress levels of the power circuit. Due to the expected high reliability of the control circuits, emphasis will be placed on checkout of the power circuit. The power chip used for the solid state power switch is subjected to high electrical and thermal stress levels. Further, the chip is operated close to its rating during these transient periods. The primary function of the power controller BITE is to check whether the power chip is open or shorted (primary failure mode). The fail safe device as presently visualized for the power controller is a slow-blow fusible link incorporated in the power source.

side of the power controller. The BITE must check the open or closed condition of this fuse. Based on the above, any BITE, as a minimum, must check the condition of the load controller power circuit.

BITE can be implemented in several ways. One approach is to sense bus power (LC input), LC output, and LC control signal. These signals can be supplied to a RIT of the DHS where a BITE equation is computed and the result is transmitted to a display. This approach requires a BITE equation for each load controller, quickly limiting the control equation capacity of the DHS. Further, the TRIP INDICATION signal must also be supplied to the DHS and become a part of the BITE equation in order to distinguish between a load controller malfunction and a normal trip. Second, BITE logic can be incorporated into the load controller and supplied as an output to a FAULT INDICATION pin on the load controller. In this case the TRIP INDICATION and FAULT INDICATION on each load controller would be hard-wired into a Monitor Input Terminal and transmitted as a point-to-point indication signal to a display device. Either of the approaches results in substantial wiring, two leads (TRIP and FAULT INDICATION) from each controller to a remote terminal. Nor do these approaches provide any indication of the condition of the control signal, TRIP and FAULT INDICATION wiring.

A stimuli approach to load controller BITE could be considered in which the load controller power circuit would be tested without application of bus power. By stimulating the power circuit at a low power level (low voltage, low current) and exercising the load controller, the condition of the power circuit could be determined by proper sensing and BITE logic. This approach is illustrated in Figure 4-4. Here, a BITE STIMULI signal is interlocked with INPUT POWER and CONTROL SIGNAL. In the absence of INPUT POWER, the application of a momentary BITE STIMULI signal and simultaneous cycling of the CONTROL signal would exercise the load controller. The BITE STIMULI signal provides a low level of power for checking the power circuit. The BITE STIMULI signal could be a nominal 5 V at 10 ma with R selected to give a voltage level which would assure no operation of the connected load. For the above to function controller power must be supplied from the CONTROL or BITE STIMULI signal during test. Even here the incorporation of BITE adds components and complexity such as the BITE input terminal and circuit, BITE sensing and logic. Under normal operating conditions the BITE sensing and logic is subjected to the full rated voltage and/or current level of the power circuit which means they would have to be disabled, providing no inflight test capability.

SPECIFICATION
 POWER CONTROLLER, DC LOAD SWITCHING
 16PST, NORMAL OPEN, 1 THRU 10 AMPERES

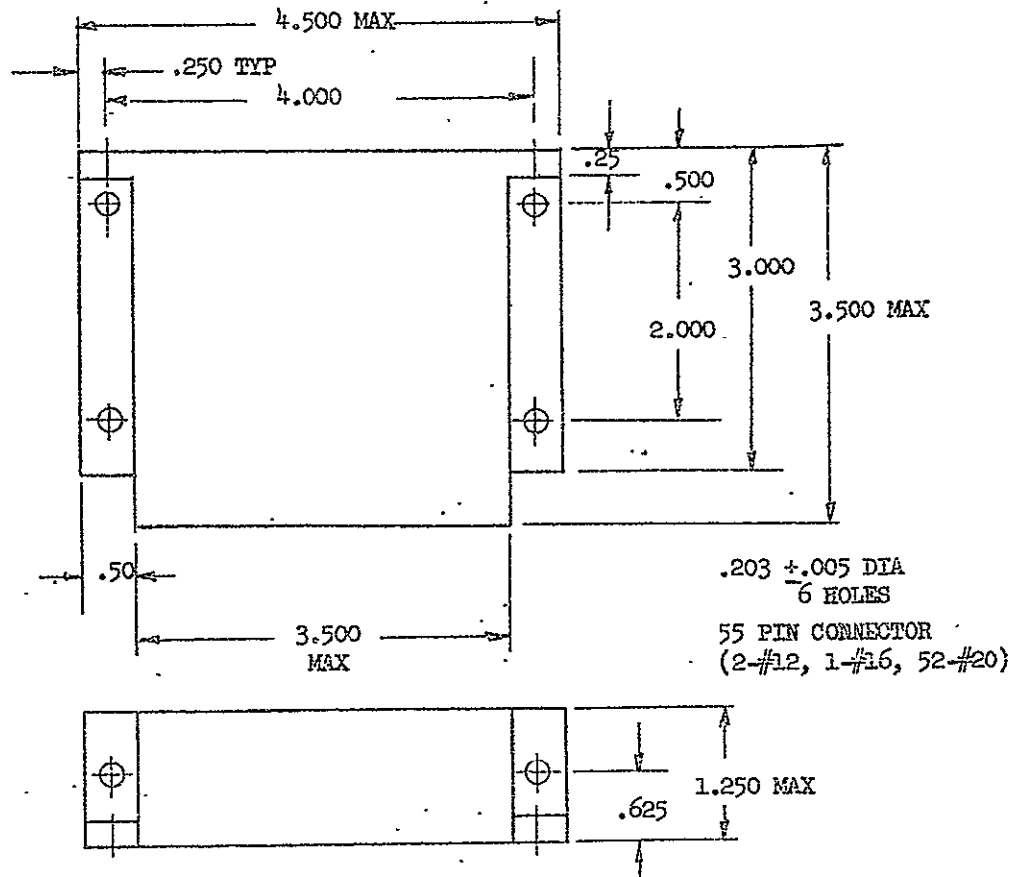

NOTES:

1. Dimensions are in inches
2. Unless otherwise specified, tolerances are \pm .02 for two place decimals and \pm .005 for three place decimals

REQUIREMENTS:

MECHANICAL AND DIMENSIONAL CHARACTERISTICS

Dimensions and configuration	See Figure
Enclosure	Black anodized metal, sealed watertight
Terminations	Rack-Panel type connector
Weight	1.25 lb maximum

FIGURE 2 - CONNECTOR IDENTIFICATION

PIN NO.	FUNCTION	PIN NO.	FUNCTION	PIN NO.	FUNCTION
1	POWER IN	21	CONTROL CH 3	41	TRIP IND CH 7
2	POWER IN	22	" CH 4	42	" CH 8
3	POWER OUT CH 1	23	" CH 5	43	" CH 9
4	" " CH 2	24	" CH 6	44	" CH 10
5	" " CH 3	25	" CH 7	45	" CH 11
6	" " CH 4	26	" CH 8	46	" CH 12
7	" " CH 5	27	" CH 9	47	" CH 13
8	" " CH 6	28	" CH 10	48	" CH 14
9	" " CH 7	29	" CH 11	49	" CH 15
10	" " CH 8	30	" CH 12	50	" CH 16
11	" " CH 9	31	" CH 13	51	BITE
12	" " CH 10	32	" CH 14	52	SIGNAL GRD
13	" " CH 11	33	" CH 15	53	SIGNAL GRD
14	" " CH 12	34	" CH 16	54	POWER GRD
15	" " CH 13	35	TRIP IND CH 1	55	POWER GRD
16	" " CH 14	36	" CH 2		
17	" " CH 15	37	" CH 3		
18	" " CH 16	38	" CH 4		
19	CONTROL CH 1	39	" CH 5		
20	" CH 2	40	" CH 6		

NOTE: Pin Nos. 1 & 2 are #12, 18 is #16, all others are #20.

ELECTRICAL CHARACTERISTICS (-54°C to 120°C case temperature unless otherwise noted)
(per channel unless otherwise noted)

Channel arrangement	SPST (normally open)
Number of channels	16
Rated operating voltage	21 to 29 volts DC
Rated operating frequency	Not applicable
Current rating	See Table I
Control voltage	+8.0 volts dc maximum
Rated control voltage	+ 5.0 volts dc
Turn-on voltage	+ 3.5 volts dc minimum
Turn-off voltage	+ 2.5 volts dc maximum
Turn-on time	1.0 milliseconds maximum
Turn-off time	6.0 milliseconds maximum
Output rise time	0.1 milliseconds minimum
	0.5 milliseconds maximum
Output fall time	0.5 milliseconds minimum
	5.0 milliseconds maximum
Insulation resistance	100 megohms minimum
Isolation	10 megohms minimum
Control input resistance	500 ohms ± 10 percent
Voltage drop	0.5 volts dc maximum
	at rated current
Leakage current	See Table I
Power dissipation - OFF	0.5 watts maximum
Power dissipation - ON (all channels operating at rated current)	30 watts maximum

ELECTRICAL CHARACTERISTICS (continued)

Current limiting	See Figure 1 of 204-99-9E
Trip-out time (non-repetitive reset)	See Figure 2 of 204-99-9E (30 seconds min. between resets)
Trip-out time (repetitive resets)	Applicable
Rupture capacity	4000 amperes maximum
Reset voltage	Not applicable
Application time to reset	Not applicable
Interruption time to reset	5.0 to 20 milliseconds
Trip indication voltage	+ 5.0 volts dc \pm 10% at 10.0 milliamperes
Reset immunity	Not applicable
Trip-free	Applicable
Lockout control	Not applicable
Rated lock out voltage	
Lockout "ON" voltage	Not applicable
Lockout "OFF" voltage	Not applicable
Lockout impedance	Not applicable
Dim control voltage	Not applicable
Rated dim control voltage	Not applicable
Dim turn-on voltage	Not applicable
Dim turn-off voltage	Not applicable
Operating voltage transients	MIL-STD-704
Transient spike overvoltage	+ 600 volts dc
Transient - standby power	Not applicable
Control input transients	100 volts applied between each control channel and signal ground; and between each trip-ind channel and signal ground.
Zero voltage turn-on and turn-off	Not applicable
Fail safe current (@ 25°C case)	See Table I
Life (operating cycles)	1,000,000 minimum
Dim mode voltage	Not applicable
Dielectric withstanding voltage	1000 volts rms
Radio interference	MIL-STD-461

ENVIRONMENTAL CHARACTERISTICS

Case operating temperature	-54°C to 120°C
Case storage temperature	-65°C to + 150°C
Shock	100G for 11 milliseconds
Vibration	30G, 78-2000 Hz 0.1 in DA 10 to 78 Hz
Acceleration	100 G
Altitude	Sea level to 1,000,000 ft

Part number: 204-99-9-100B

TABLE I

CHANNEL NO.	CURRENT RATING (amps)*	Leakage Current (microamperes)	Failsafe Current (amps)
1 thru 8	1.0	500	30
9 thru 12	2.0	500	30
13 & 14	3.0	500	30
15	5.0	500	30
16	10.0	1000	60

* Inductive, Capacitive, Resistive or Lamp

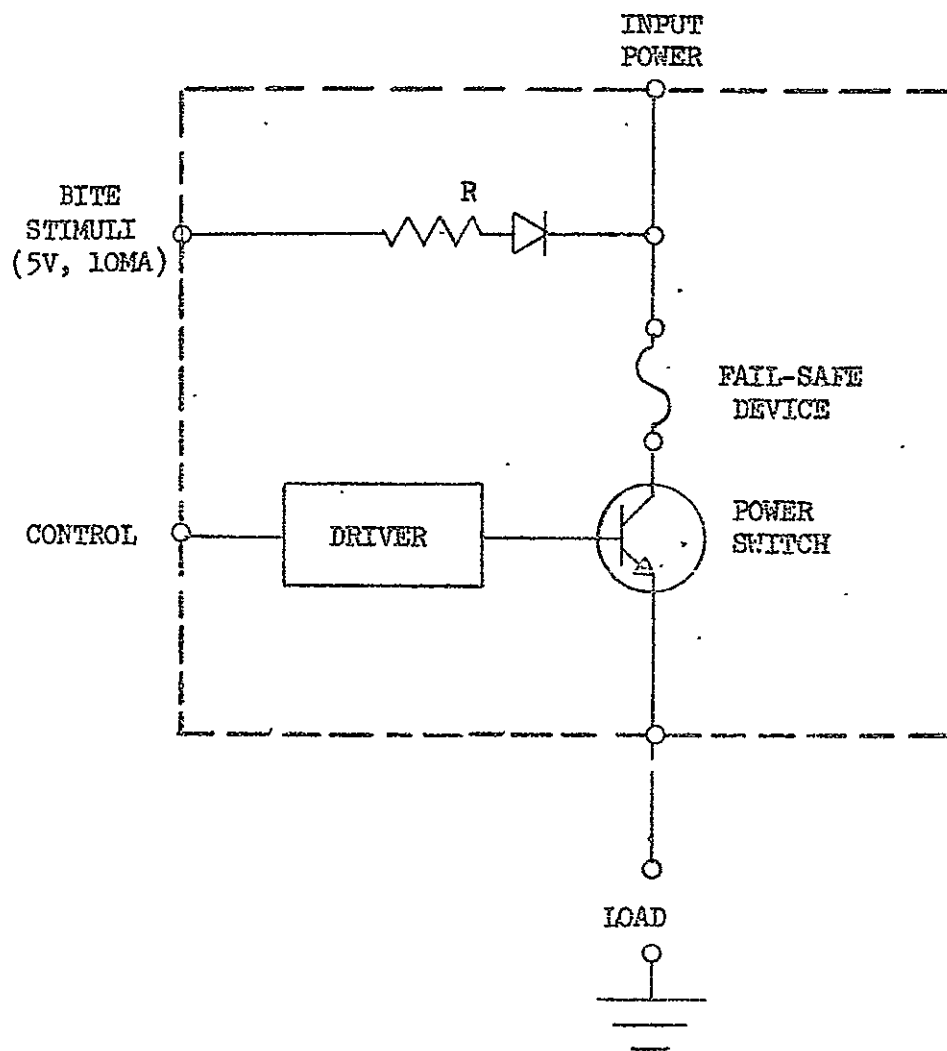

FIGURE 4-4 LOAD CONTROLLER BUILT-IN-TEST EQUIPMENT (BITE)

Assuming a practical approach for full load controller BITE, the problem still exists in handling the TRIP and FAULT INDICATION signals. One approach would be to hard-wire both INDICATION signals into a Monitor Input Terminal associated with the DHS, resulting in substantial wiring complexity -- two additional wires per load controller. A second approach would be to transmit the two INDICATION signals over a single wire at differing voltage levels to a Monitor Terminal. A third approach is to handle them over the CONTROL signal lead, similar to that used for the switched impedance signal source. The latter approach is given consideration below.

To handle FAULT and TRIP data over the CONTROL signal lead requires modification of both the load controller (LC) and the Remote Output Terminal (ROT). The LC would use a two-level switched impedance circuit as shown in Figure 4-5 and would be driven by a constant current source from the ROT instead of a constant voltage source. Operation is similar to that of the switched impedance signal source except another voltage level has been added which could dictate increasing the voltage level of the control signal to obtain sufficient bandwidth between levels. Figure 4-5 shows a control voltage of 10 volts. The various voltage levels are detected by a voltage detector and logic circuit within the ROT. The TRIP and FAULT signals are identified, separated and transferred to an accumulator. From the accumulator they are serially transferred to shift registers within the Remote Output Terminal -- Monitor Input Terminal.

Finally, load controller development for advanced spacecraft should consider several other problems. First, the load controller size, weight, reliability and performance is affected by the type of characteristics of the electrical power sources. The trend in electrical power characteristics is toward tighter limits than those specified for aircraft through MIL-STD-704. Both bus and load controllers can be built to be lighter weight, smaller and more reliable where power characteristics are less severe than MIL-STD-704. Second, bus and load controllers of higher ratings, particularly DC units, will probably be required. DC units up to 200 amps DC are visualized. Third, in the absence of current limiting for AC units, a better fail-safe device would be developed. The purpose of the fail-safe device is to prevent the failure of a load or bus controller from affecting the balance of the system. There is no problem in DC units with current limiting, but in AC units the fusible link used for fail-safe is difficult to coordinate with the overload and fault trip characteristics. The need is for a slow-blow link of a suitable size and characteristics to be compatible with the AC load controller.

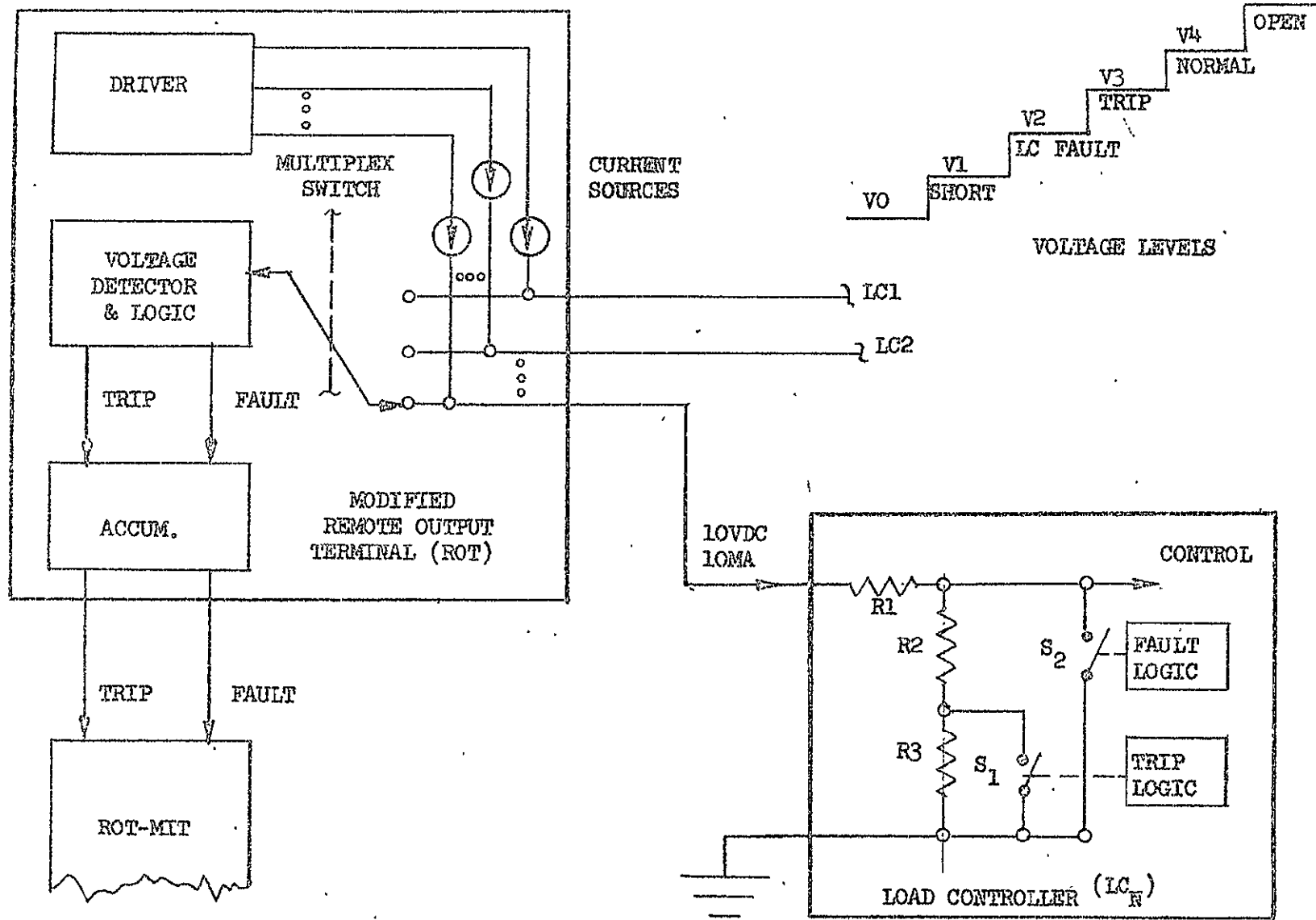

FIGURE 4-5 HANDLING LOAD CONTROLLER TRIP AND FAULT DATA

4.3 Data Handling System (DHS)

The first order of priority for development of controls for a spacecraft electrical power distribution system is to investigate, compare and decide whether to use a dedicated or a general purpose DHS for performing the logic and handling the signals associated with power control. The balance of this discussion assumes that a dedicated DHS will be used for electrical power distribution control. A dedicated DHS for advanced aircraft has already been discussed in Section 2.0. The same basic type of approach is considered for a dedicated DHS to be applied to an advanced spacecraft. Several modifications have already been mentioned under the switched impedance signal source and the switched impedance/voltage level detection of INDICATION signals for load controllers. The incorporation of a point-to-point data transfer feature (monitor subsystem) has been hinted. The need for longer multiplex transmission line and a system to handle an expanded quantity of data has been mentioned. These factors and others are considered in the following paragraphs.

Referring to Figure 4-2, reference is made to a modified Remote Input Terminal (RIT). The modified RIT is basically the same as the RIT presently under development except it is modified to accept the switched impedance signal source and to perform the voltage detection and logic necessary to separate the control signal and the BITE FAULT signal. Constant current generators are substituted for the signal source loading resistors previously within the RIT. Several levels of threshold voltage detectors are added to distinguish between SHORT, ON, OFF and OPEN conditions in the signal sources and interconnecting leads. Logic is performed, combining SHORT and OPEN conditions to form the BITE FAULT signal. Further, the CONTROL signal is inhibited upon detection of a BITE FAULT signal, the affected channel being inhibited until the FAULT condition is corrected. An accumulator is added within the RIT. The BITE FAULT signal for each channel is stored within the accumulator. Upon a signal the BITE FAULT signals within the accumulator are serially transmitted and stored in shift registers within the RIT-MIT. In fact the RIT-MIT function could be incorporated into the RIT, eliminating the requirement for a separate package and providing a gain in packaging efficiency.

Figure 4-5 refers to a modified Remote Output Terminal (ROT). The ROT is modified to handle the switched impedance TRIP and BITE FAULT signals from the power controllers. Modification includes substitution of constant current drive for voltage drive; addition of voltage detection and logic circuits; and addition of an accumulator for temporary storage of TRIP and BITE FAULT data. Constant current generators are added to drive the load controllers and to provide power for the switched impedance sensing function. Voltage threshold detectors are added to sense the SHORT, LC FAULT, TRIP, NORMAL and OPEN conditions of the load controller and its interconnecting lead. Logic circuitry is added within the ROT to OR the SHORT, OPEN, and LC FAULT signals; forming the LC BITE FAULT

signal. The TRIP and LC BITE FAULT signal for each channel are then temporarily stored within an accumulator. Upon a signal the contents of the accumulator are serially transferred to shift registers within the ROT-MIT. Again, the ROT-MIT functions could be incorporated within the ROT package, gaining packaging efficiency.

Figure 4-6 shows a suggested dedicated DHS for an advanced spacecraft. System characteristics are similar to that for advanced aircraft. A monitor subsystem is shown in Figure 4-6 and consists of the RIT-MITs, the ROT-MITs and the Monitor Output Terminal (MOT). The Monitor feature (point-to-point transfer of data) is incorporated to handle signal source BITE FAULT, power controller TRIP and BITE FAULT indication signals. Remote Input Terminal-Monitor Input Terminals (RIT-MIT) are provided to temporarily store and then serially transmit signal source BITE FAULT signals. The number of channels per terminal are anticipated to be 320, one RIT-MIT serving four RIT. Remote Output Terminal-Monitor Input Terminal (ROT-MIT) are provided to temporarily store and then serially transmit power controller TRIP and BITE FAULT indication signals. With a DHS capacity of 1024 inputs and 1024 outputs, the Monitor subsystem would be designed to handle a minimum of $3 \times 1024 = 3072$ indication signals. It is probable that the RIT-MIT and ROT-MIT would be identical and could then be designated as a MIT. Signals between the RIT and RIT-MIT and between the ROT and ROT-MIT would be handled over a pair of wires from each RIT and each ROT. The Monitor Output Terminal (MOT) is visualized as a receiver and memory with TRIP and BITE FAULT information stored until called up and displayed. An incoming TRIP or BITE FAULT signal would activate an indicator light or flag. The crewman would then activate a readout which would cycle through the memory of the MOT, calling up all TRIP and FAULT information. The readout would identify the malfunction and the specific affected component -- signal source, power controller or DHS component. The MOT would be expected to be interfaced with the Integrated Controls and Display System.

The monitor or indication functions are transmitted over the multiplex party line from the Monitor Input Terminal (MIT) directly to the Monitor Output Terminal (MOT). These signals are direct point-to-point transfer and do not involve the MU for anything other than multiplex control and BITE. The monitor terminals are nonredundant, but do incorporate built-in-test and automatic failure indication. No control logic operation is involved in this data transfer. Although the monitor subsystem will handle more information per terminal than the control system, several factors in the subsystem allow less complex hardware implementation. Since this is strictly an information or monitor function and no control signals are handled, it is not essential to provide the redundancy that the control system has. So long as the monitor subsystem will test itself and

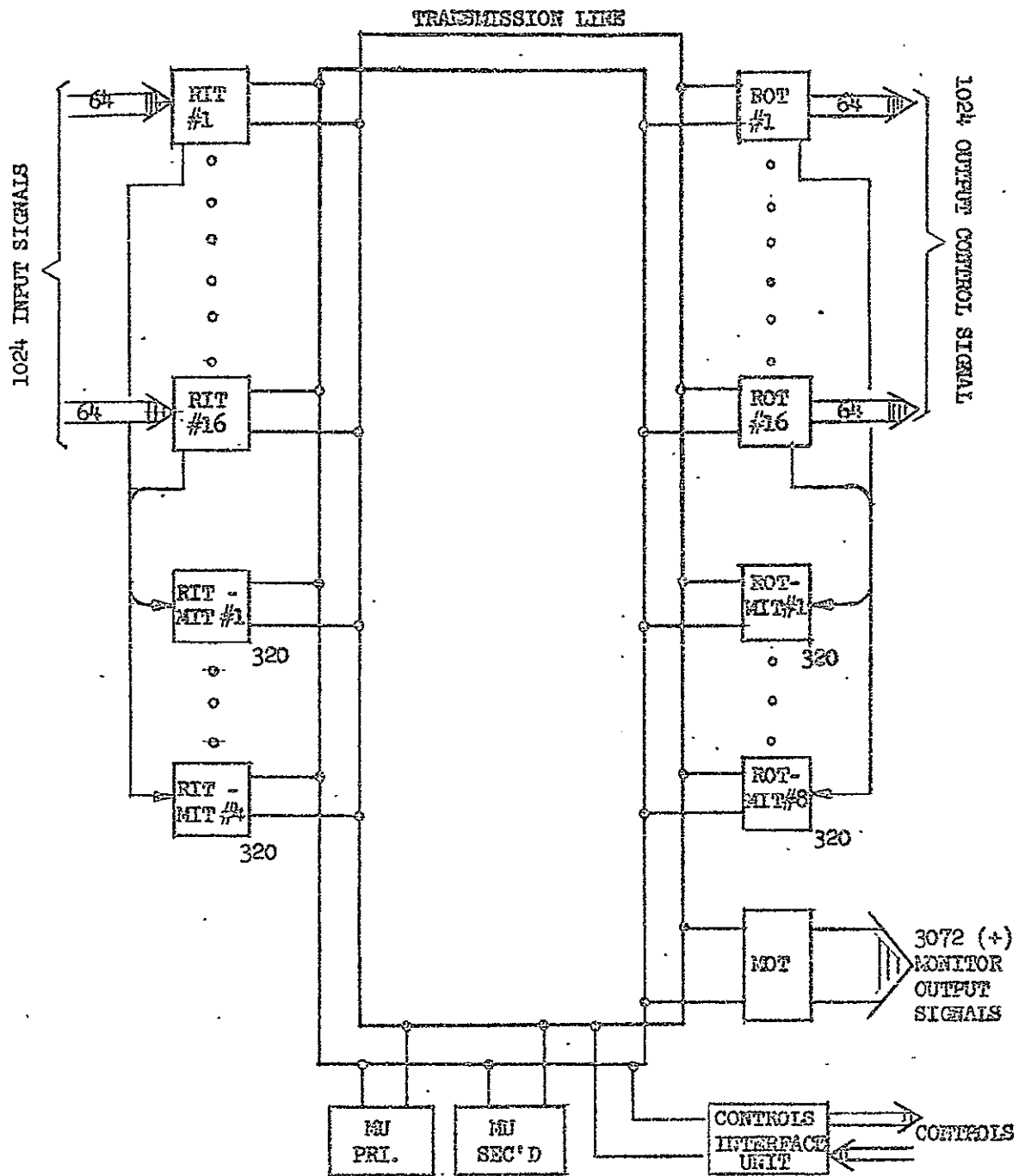

FIGURE 4-6 SPACECRAFT DEDICATED DATA HANDLING SUBSYSTEM

inform the pilot that it has malfunctioned, no spacecraft system function is disabled. The type of signals to be handled is data rather than control, which allows less complicated interfaces. Since single BIT errors may be ignored in the data utilization, the security of signal integration (pump-up) used in the control system is not needed here.

The Monitor subsystem can be incorporated into the present DHS without significant impact. The amount of data to be handled by the Monitor subsystem is a function of the lowest allowable data output rate. The subsystem uses a sub-multiplex technique such that the effective data access and output rate is approximately seven samples per second in order to handle the projected 3072 inputs and outputs. This corresponds to seven up-dates per second on the status of signal sources and power controllers which is considered adequate for an indication system.

The length of the multiplex data transmission line must be considered. In order to use a twisted shielded conductor, the multiplex line shown in Figure 4-6 is limited to 200 feet end-to-end or a looped length of 100 feet. Circuitous routing of the multiplex line must be taken into consideration. Conceptual drawings for the shuttle and space base show vehicle dimensions greater than 100 feet. Multiplex line length is also a function of data rate; i. e., doubling data rate cuts line length in half while halving data rate doubles permissible line length. There are several concepts which can be used to obtain greater line length. These are shown in Figures 4-7 through 4-10 and are discussed below.

Figure 4-7 shows additional multiplex loops connected together through line extenders (LE). Assuming the same data rates as in the present DHS, the line length of each loop is 100 feet (looped); thus three loops give a line length of 300 feet (looped). The function of the line extender is to accept redundant signals from the first looped transmission line, select the "best" one through comparison and logic, provide wave form correction, and transmit the signal over the second redundant loop. The line transit times and the LE delay times are such as to allow up to three loops and still have a comfortable margin of safety. The line extenders are redundant, cross-strapped units consisting of receivers, gates, transmitters, test and control circuits.

A second approach to obtain added transmission line length is shown in Figure 4-8. Here, two maximum length loops are paralleled, each supplied separately from the centrally located MU. Each loop is operated at the same data rate as one loop is presently operated. This gives essentially twice the line length of the present system. The parallel loop approach is also good where more inputs, outputs and logic equations must be handled than are presently designed into the system. The MU doubles up on memory, inputs, outputs, etc. to handle the greater amount of information.

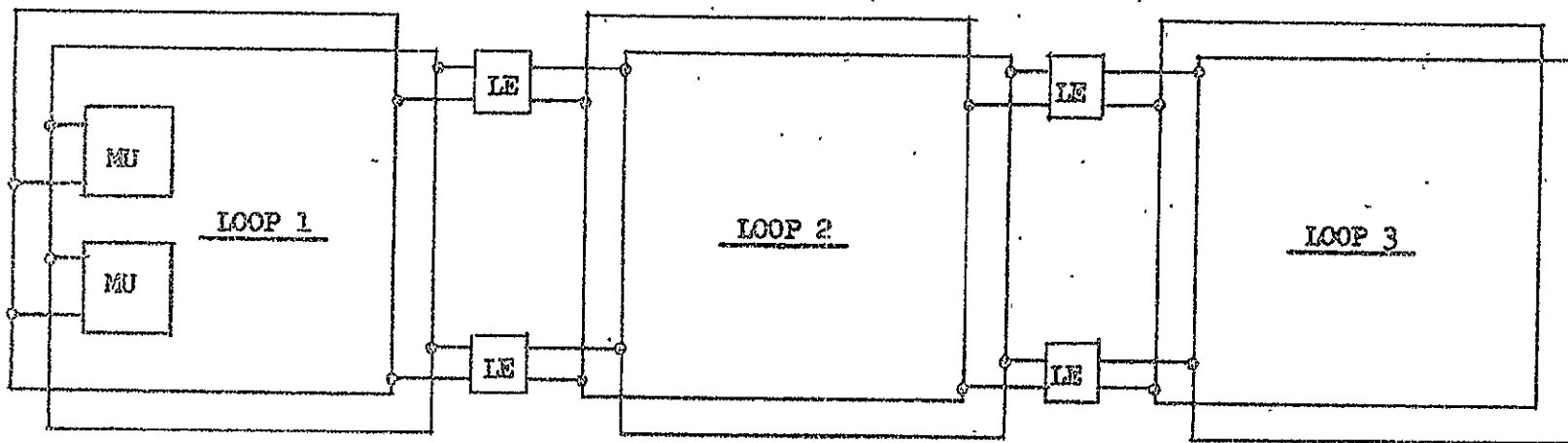

FIGURE 4-7 ADDITIONAL MULTIPLEX LOOPS USING LINE EXTENDERS (LE)

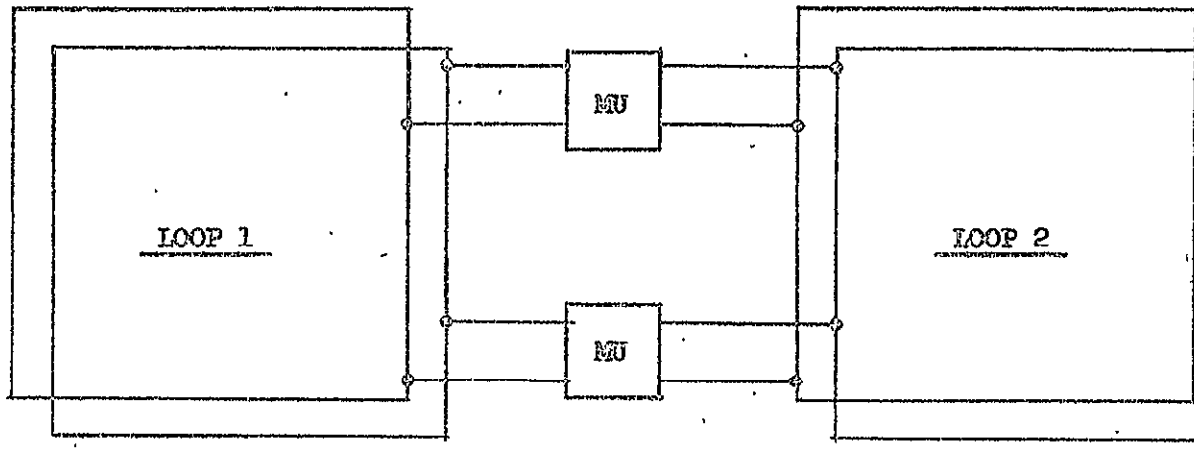

FIGURE 4-8 PARALLEL MULTIPLEX LOOPS

Figure 4-9 shows a combination of parallel and extended loops. This configuration doubles the amount of data which can be handled and quadruples the standard line length (400 feet looped). The main constraint is that the MU must be centrally located in order to take advantage of the full line length.

Figure 4-10 shows a special case. The looped line handles the major portion of the data. Radial multiplex lines are run to remotely located terminals which handle much less information. The radial lines become less justifiable as the number of remote terminals increases.

The present DHS under development for aircraft is based on remote terminals of 64 channels with all components cooled by convection. Further, packaging is not yet optimum as far as weight, size, reliability and performance. Considering that the DHS equipment for spacecraft applications will require cold-plate cooling, it appears more desirable to incorporate more channels into each terminal and reduce the number of individual channels. The weight and size per channel decreases as the number of channels per terminal increases. Furthermore, initial data on the space shuttle indicates a concentration of input signals and loads. These areas are the crew station, the forward fuselage section, the wing root sections, and the aft fuselage section. With the concentrations of inputs and outputs, the use of more channels per terminal can be further justified. The eventual flight configuration of the DHS hardware would incorporate hybrid and integrated circuits to reach the practical limits of weight, size and reliability.

The spacecraft integrated display and control system would interface with the dedicated DHS. There appears to be no direct interface with the signal sources nor the power controllers other than through the DHS. Although Figure 4-6 shows a Monitor Output Terminal for indication outputs and a control interface unit, these could easily be combined into a single interface unit. The interface unit would collect and store all TRIP and BITE FAULT information and would inject all control functions into the system. Approximately 3200 INDICATION and BITE signals are anticipated for a full capacity system (1024 inputs, 1024 outputs and 1000 logic equations). Control requirements are listed below:

- (1) Up to 32 manual switches for manual selection of redundant parts of remote terminals.
- (2) One manual switch for manual selection of MU.
- (3) One 4-position rotary switch for transmission line tests
- (4) A manual switch to activate readout of system status.

06

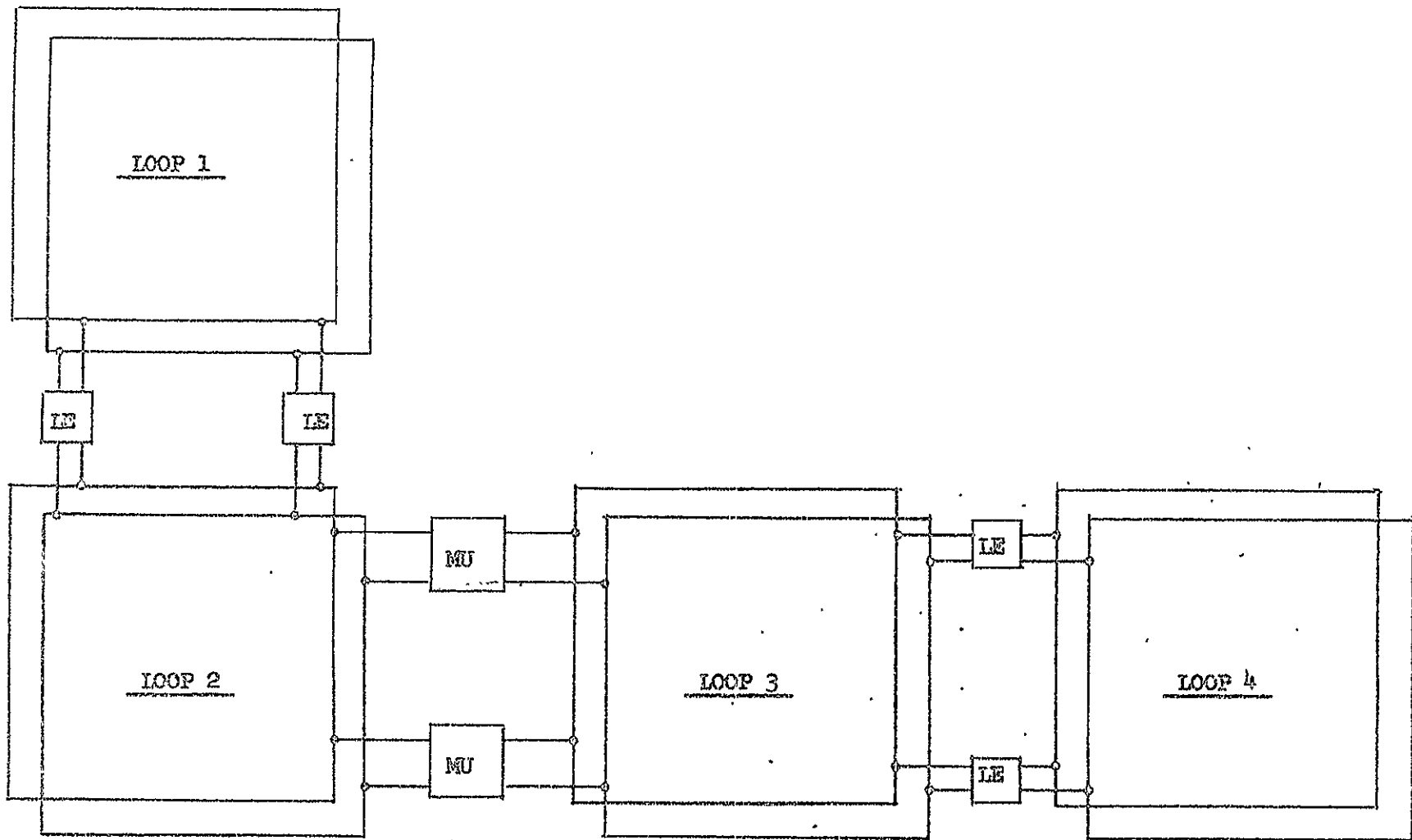

LE = LINE EXTENDER

FIGURE 4-9 PARALLEL - EXTENDED MULTIPLEX LOOPS

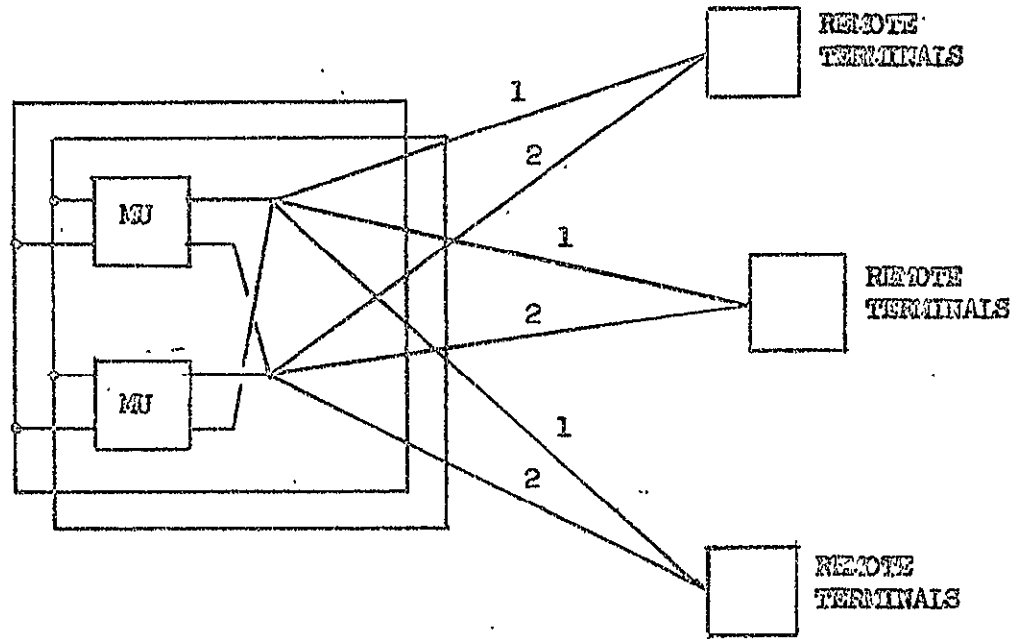

FIGURE 4-10 LOOPED/RADIAL MULTIPLEX LINK

- (5) A manual control switch associated with each power load circuit. This switch would be used to cycle individual control signals for load controller reset. The switch would normally be one required for normal system control input and is not installed specifically for reset.

5.0 SPACECRAFT CONCEPTS

For comparison and trade study, three spacecraft electrical power distribution and control system concepts were selected. These are designated as the solid state, conventional, and hybrid systems. In order to make a more objective comparison of these three concepts, each is applied to a typical interim shuttle vehicle. The interim shuttle was selected because more information is available on this vehicle than other advanced spacecraft. However, the system concepts are applicable to other spacecraft. The paragraphs to follow describe the implementation of these concepts.

5.1 Solid State Concept

The block diagram of Figure 5-1 shows the arrangement of the solid state system. Due to the size of the vehicle and distribution of electrical loads, a distributed bus system was selected. As indicated all power sources feed into a forward power center located in the nose section of the vehicle. Electrical power, 115 V AC and 28 V DC per MIL-STD-704, is then distributed over feeder transmission lines to power centers located in the crew station, wings, and aft section of the vehicle. Each power center serves the electrical loads located in close proximity to it. Because the solid state power controllers used for power control and circuit protection can be controlled remotely, the distributed bus arrangement with its remote power centers can be utilized to advantage. The major advantage of the distributed bus system is to minimize the length of power wiring from the buses to each load, resulting in simplification of overall vehicle wiring. Figure 5-2 shows the assumed dimension of the vehicle and the installation of the power system.

More details of the forward power center are shown in Figure 5-3. The power center is essentially divided into two electrical power generation, conversion and distribution channels. The channels are designated LH FWD and RH FWD. The channels normally operate isolated (non-parallel). Solid state bus controllers (BC), essentially solid state contactors, are used for switching between AC sources and external power. Solid state AC and DC power controllers (PC) are used for load switching and circuit protection as well as feeder switching and protection. Control signals associated with the power controllers are handled by the Data Handling Subsystem (DHS). The use of the remotely operated power controllers permits the buses to be located in close proximity to the power sources and conversion equipment, resulting in a compact power distribution center with short feeders between the buses and the power sources, conversion equipment and external power. Due to the compact installation and short feeder lengths, it will be shown in later discussion

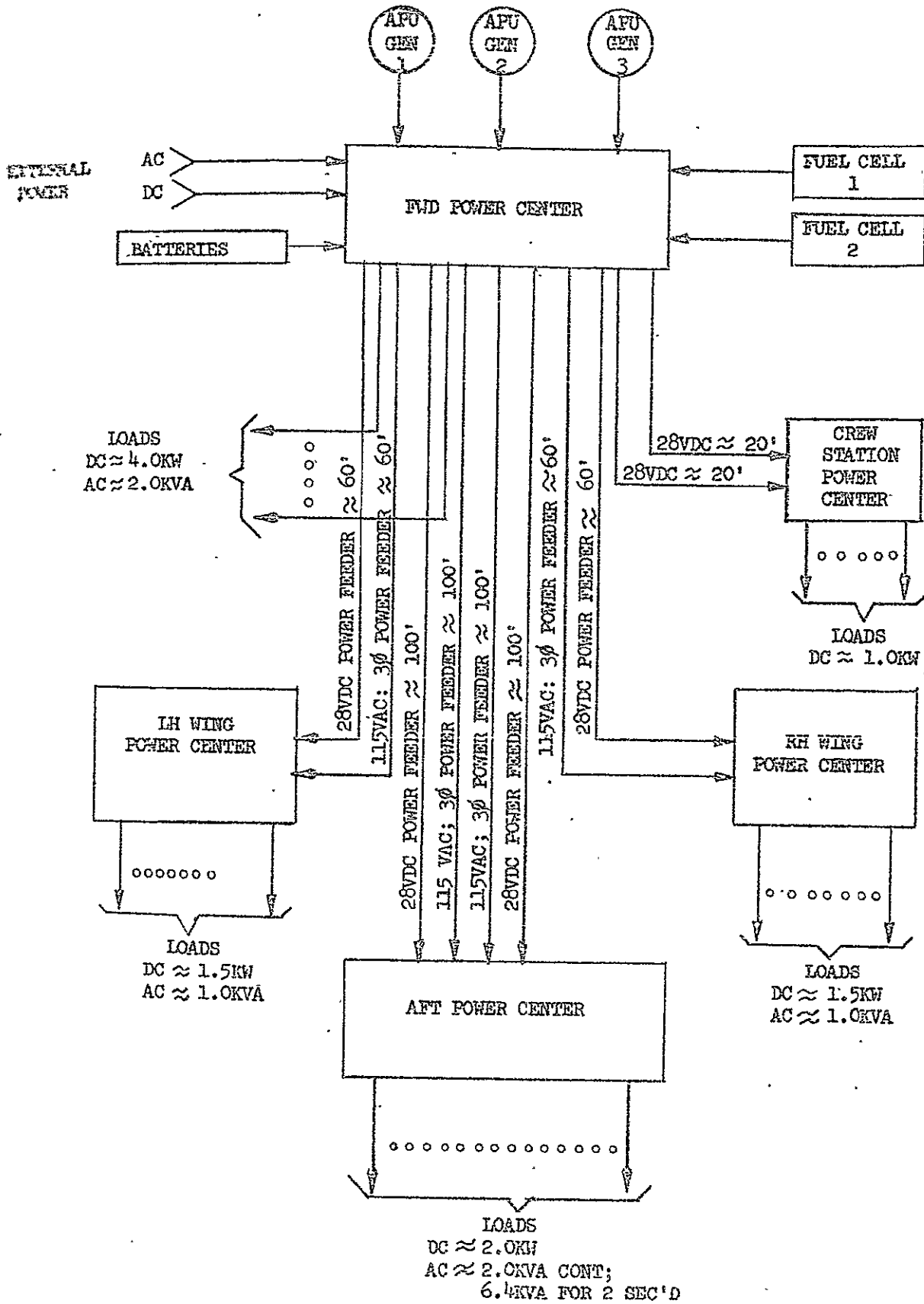

FIGURE 5-1 BLOCK DIAGRAM - TYPICAL INTERIM SHUTTLE SOLID STATE ELECTRICAL POWER SYSTEM

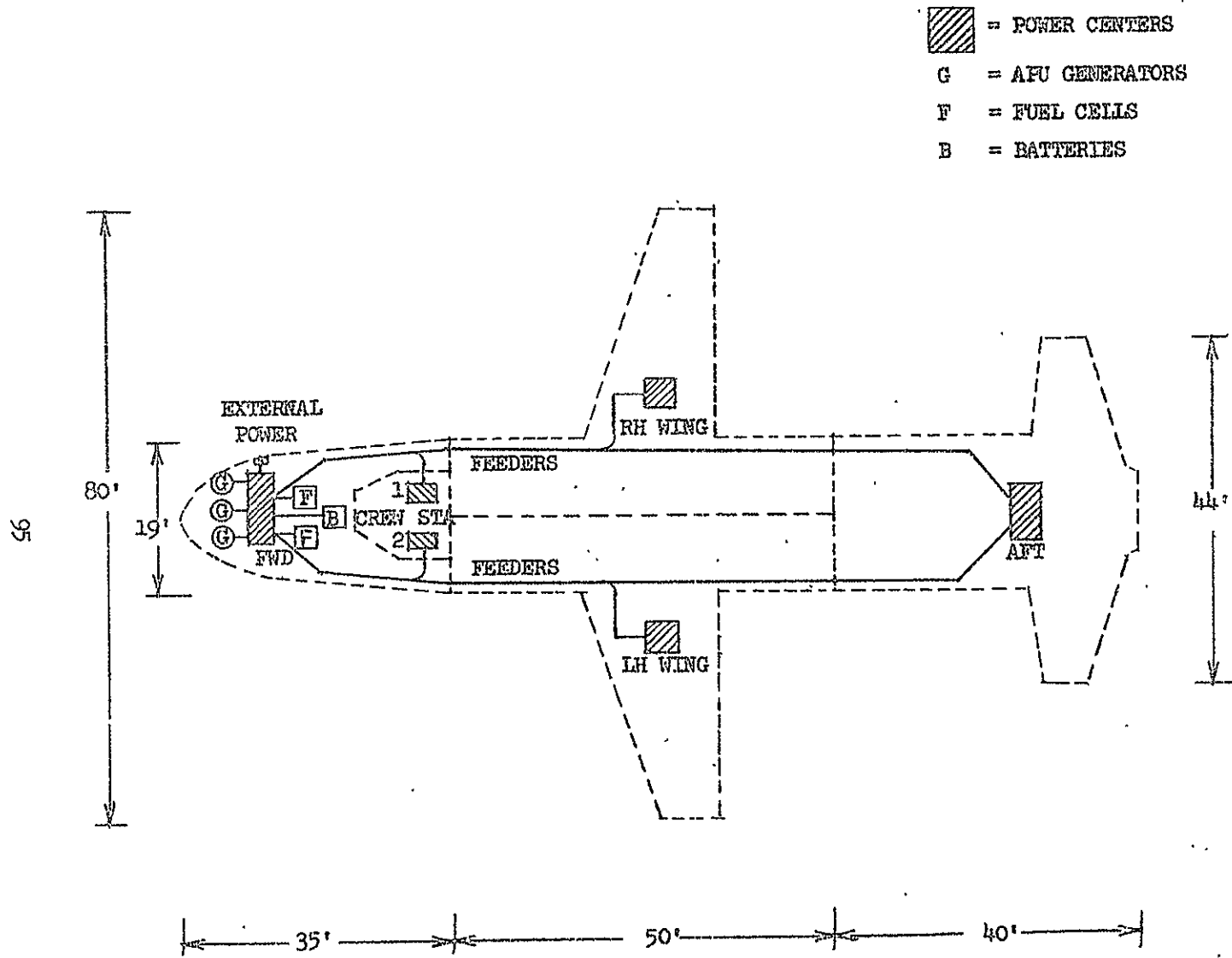

FIGURE 2 APPROXIMATE DIMENSIONS OF WIRING ZONES ON AN INTERIM SHUTTLE (SOLID STATE CONCEPT)

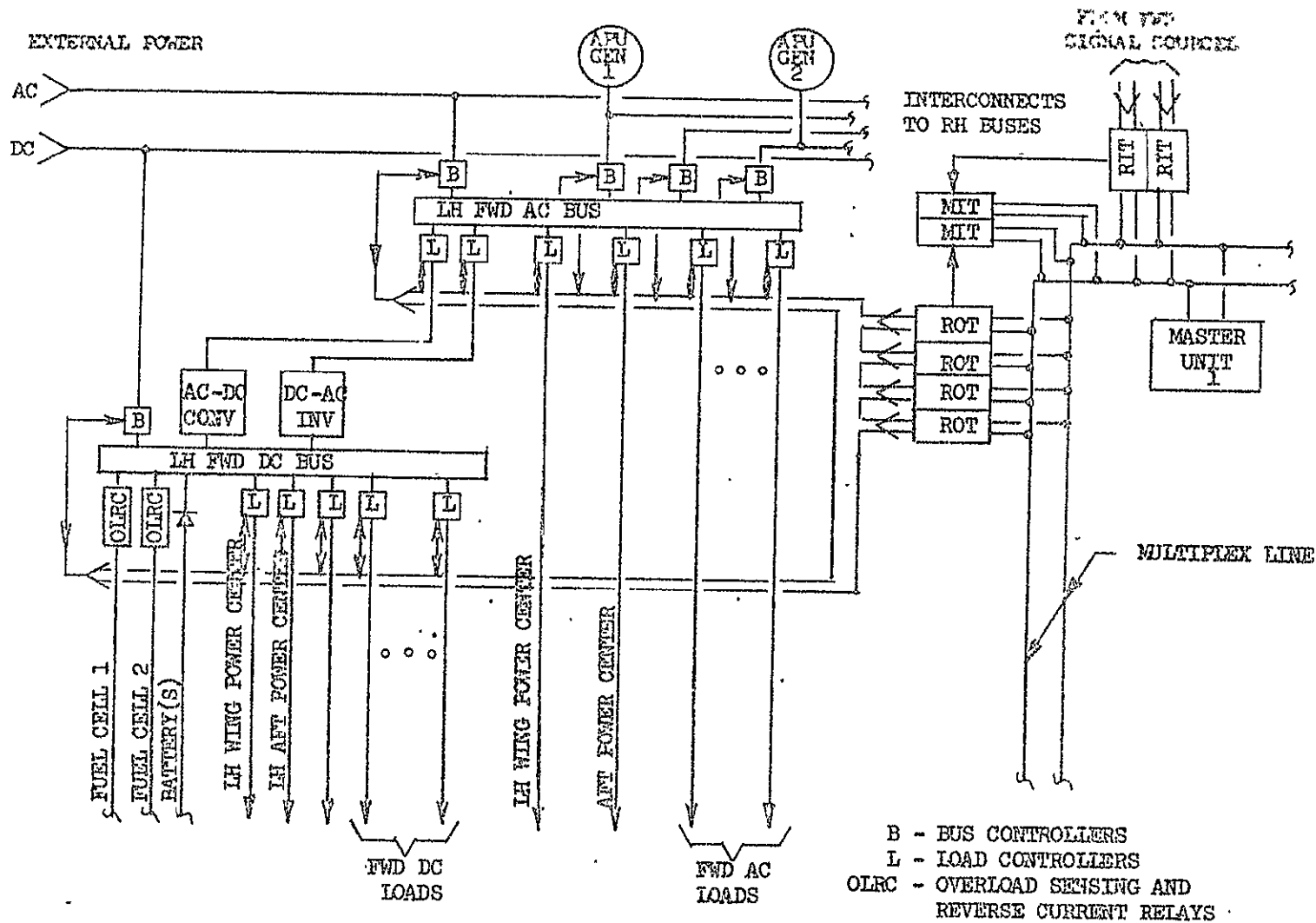

FIGURE 5-3 LH HALF OF FORWARD POWER CENTER

that the weight of power sources and distribution feeders on the solid state system offsets the power source and conversion equipment feeders of the conventional and hybrid system concepts.

Additional details of the aft, wing, and crew station power centers are not shown. These centers are relatively simple, consisting of buses, load controllers (LC), and DHS components. The interconnection of these components is similar to those shown in Figure 5-3. The quantities of these items assumed for each load center are shown in Table 5-1 and will be used later in concept comparisons and trade-offs. LC are shown as single-channel units but could be taken as the quantity of active channels in multi-channel units. The LC incorporate BITE as discussed in Section 4.0.

The dedicated DHS for the interim shuttle is similar to that for advanced aircraft but requires some modification and development. It would utilize switched impedance signal sources, modified RIT and ROT and a monitor subsystem with Monitor Input Terminals (MIT) to collect LC and signal source TRIP and BITE FAULT indication signals. An interface unit is provided to interface with an integrated controls and display system. The anticipated number of inputs, outputs, and control equations for an interim shuttle is well within the capacity of the present DHS concept. The physical dimensions of an interim shuttle are expected to be such that the multiplex line would exceed the 200 feet limitation imposed on the present system. Estimated length of the multiplex line for an interim shuttle is 390 feet, including necessary circuitous routing. To accommodate the added length, a two-loop multiplex system is proposed. The layout of the two loops in the vehicle is illustrated in Figure 5-4. The two loops are interconnected through Line Extenders (LE) located at the wing power and control centers. Table 5-2 is the assumed quantities of DHS components located within or in close vicinity to the power and control centers.

5.2 Conventional Concept

The conventional concept for advanced spacecraft electrical power distribution and control systems uses electromechanical power contactors, relays, switches, thermal circuit breakers, and switch/relay logic for control. The lefthand half of the conventional system as applied to an interim shuttle is shown in Figure 5-5. As indicated the AC system consists of two main AC buses and two AC monitor buses with a bus tie between main buses and a bus tie between each main bus and its associated monitor bus. The AC system is powered from APU-driven alternators, external power, and a DC to AC inverter supplied from the DC system. The DC system consists of two main DC buses, two monitor DC buses and one or more start/logic buses. The main DC buses are

TABLE 5-1 Component Location
Power Switching for Solid State Concept

Location	AC	Buses			Power Conditioning	
		DC	BC	LC	AC/DC	DC/AC
Forward Power Center	2	2	26*	312	2	2
Crew Sta. Power Center	-	2	-	234	-	-
OH Wing Power Center	1	1	-	50	-	-
OH Wing Power Center	1	1	-	50	-	-
Aft Power Center	2	2	-	134	-	-
TOTAL	6	8	26	780	2	2

- * (1) 24 AC bus controllers (BC) rated at 75 amperes
(2) 2 DC bus controllers (BC) rated at 200 amperes

TABLE 5-2 Component Location
DHS for Solid State Concept

Location	RIT	ROT	MU	MIT	LE	Interface Unit
Forward Power Center	3	7	2	4	-	-
Crew Sta. Power Center	7	4	-	-	-	1
OH Wing Power Center	2	1	-	1	1	-
OH Wing Power Center	2	1	-	1	1	-
Aft Power Center	2	3	-	2	-	-
TOTAL	16	16	2	8	2	1

NOTES:

- (1) No MIT are provided in the crew station. It is assumed that INDICATION and FAULT signals from this area would be wired directly into the Interface Unit.
- (2) The Interface Unit is provided for interface with the Integrated Control and Display System.
- (3) ROT-MIT and ROT-MIT functions are combined into a MIT.
- (4) LE Extenders (LE) are dual redundant units.

 = POWER/CONTROL CENTERS
LE = LINE EXTENDER

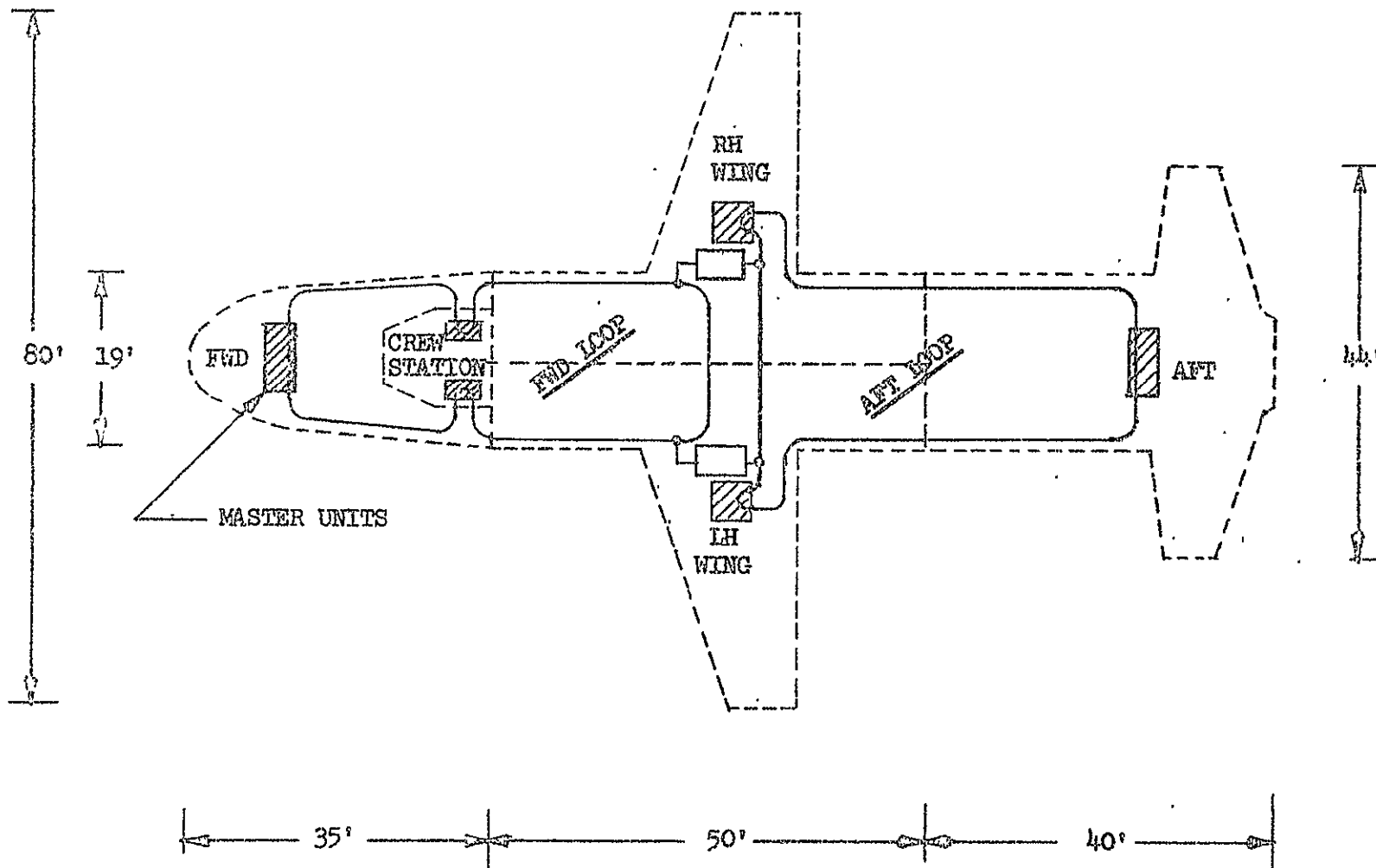

FIGURE 5-4 INTERIM SHUTTLE - TWO LOOP MULTIPLEX SUBSYSTEM

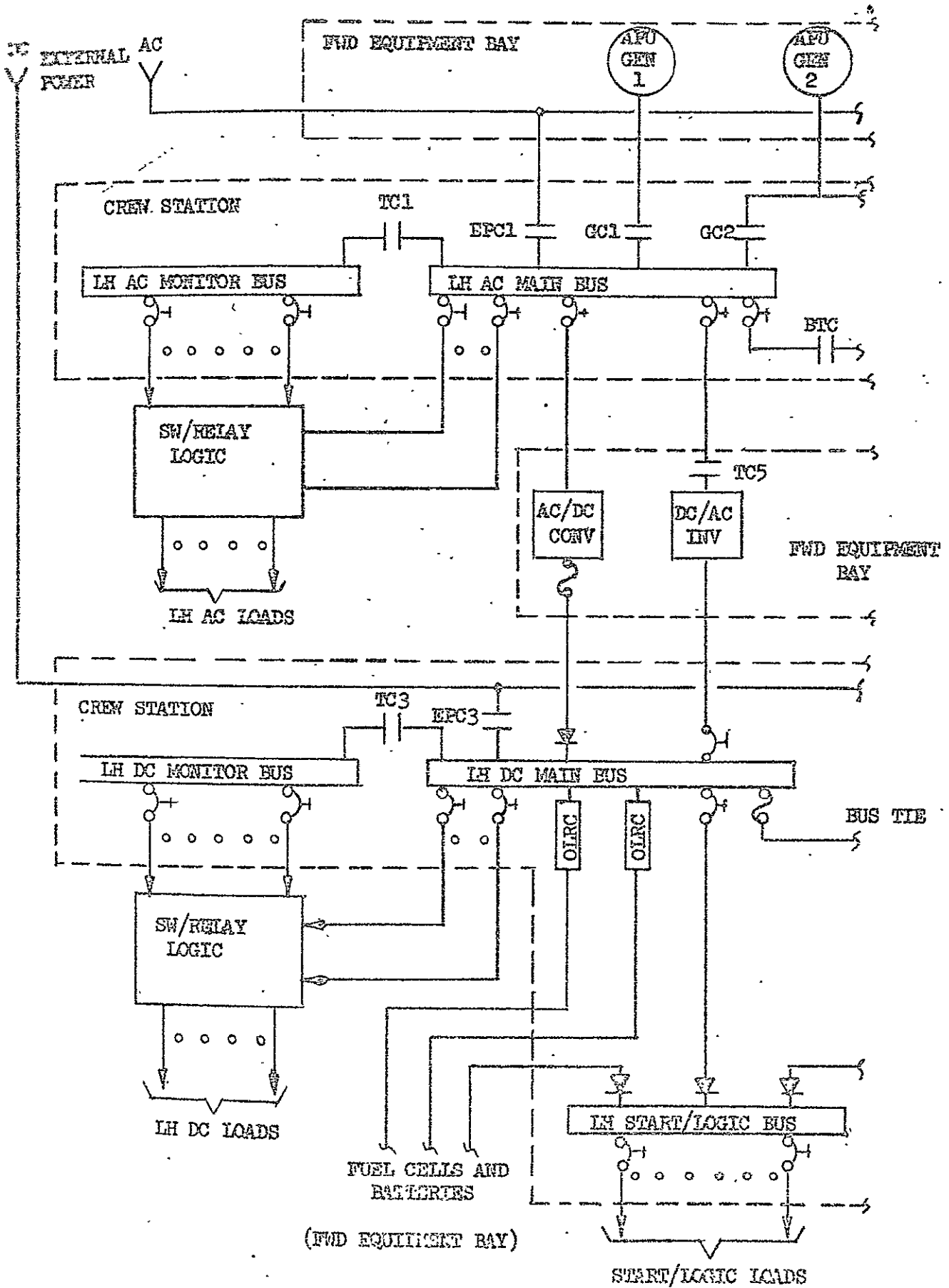

FIGURE 5-5 LH HALF OF CONVENTIONAL SYSTEM

tied together through a bus tie and each monitor DC bus is tied through a contactor to its respective main bus. Fuel cells, batteries and external power supply the DC system as well as a feed from the AC system through a transformer rectifier unit. Power sources and conversion equipment is located in the forward equipment bay with interconnecting feeder to and from the buses, bus switching and circuit breakers located in the crew station. The circuit breakers are placed in the crew station so as to be accessible for reset in flight. All power wiring to the loads originates from the breakers in the crew station, routed throughout the vehicle to interconnect the switch and relay logic and is then routed to the load. The shortest direct route from crew station to remote aft sections of an interim shuttle is approximately 95 feet. Considering the circuitous routing to interconnect the logic, most power wiring to the aft section would be much more than 95 feet. At this distance and with any significant load, the wire size has to be increased by several gages to satisfy voltage drop limitations.

Remotely controlled circuit breakers were considered for the conventional and hybrid concepts but packaging, cooling and "trip" calibration problems were encountered. Hermetically sealed units were recommended which would be prohibitively heavy and of large size. Forced or cold-plate cooling would be required for such mission phases as re-entry. Cold-plate cooling on thermal breakers affects the "trip" calibration, thus a magnetic type of breaker must be used. The magnetic breaker for space environment would require development. Faced with these problems, the remotely controlled circuit breaker was not considered further.

The quantities and location of components for the conventional system are shown in Table 5-3. The quantity of load circuit breakers is less than the number of load controllers used in the solid state system. The difference occurs in the conventional system where a single breaker may serve several branch circuits and several loads. The load controller serves only one load.

5.3 Hybrid System Concept

The hybrid system concept is a compromise between the solid state and conventional system concept. The hybrid system would use the same data handling subsystem as described under the solid state concept with some minor exceptions which will be discussed later.

The bus, bus switching, circuit switching, and protection are similar to that for the conventional system. In reference back to Figure 5-5, the hybrid system would not have the monitor buses or the

TABLE 5-3 Component Location
Power Switching for Conventional Concept

Location	Buses		Power	Bus	Load	Power Conditioning	
	AC	DC	Contactors	Breakers	Breakers	AC/DC	DC/AC
Crew Station	4	6	15	22	625	-	-
Forward Equipment Bay	-	-	-	-	-	2	2
TOTAL	4	6	15	22	625	2	2

TABLE 5-4 Component Location
Power Switching for Hybrid Concept

Location	Buses		Power	Bus	Load	Power Conditioning	
	AC	DC	Contactors	Breakers	Ckt Bkr	AC/DC	DC/AC
Crew Station	4	4	11	14	780	-	-
Forward Equipment Bay	-	-	-	-	-	2	2
TOTAL	4	4	11	14	780	2	2

start/logic buses as shown for the conventional system. All loads would be served from the main AC and main DC buses with load priority and load monitoring programmed into the Master Control Unit (MU) of the DHS. Each load would be served from the bus through a circuit breaker, a relay contact, and wire routed directly from the relay to the load. The coil of each relay in each load circuit is controlled by a relay driver which in turn is under the control of the DHS. Since circuit breakers are used, the breakers, buses, bus switching, relays, and relay drivers are installed within the crew station. The power relays and drivers are located within or in close proximity to the circuit breaker panels. As with the conventional system, power sources and conversion equipment are located in the forward equipment bay with interconnecting power feeders to the buses. A listing of power system quantities and locations is given in Table 5-4.

The data handling subsystem (DHS) is very similar to that for the solid state system. A two loop multiplex data line is used and has approximately the same routing as that for the solid state system shown in Figure 5-4. The location and quantities of DHS components differ some from that of the solid state concept. The distribution of RIT is the same while all ROT are now located in the crew station where their outputs are used to activate relay drivers in that location. The ROT is modified as for the solid state system but retains the voltage drive. The quantity of MIT is reduced because only the handling of signal source BITE FAULT indication signals is required. Table 5-5 is a listing of the components and locations for the hybrid concept DHS.

TABLE 5-5 Component Location
DHS for Hybrid Concept

Location	RIT	ROT	MU	MIT	LE	Interface Unit
Forward Control Center	3	--	2	1	-	-
Crew Sta. Control Center	7	16	-	-	-	1
LH Wing Control Center	2	-	-	1	1	-
RH Wing Control Center	2	-	-	1	1	-
Aft Control Center	2	-	-	1	-	-
TOTAL	16	16	2	4	2	1

6.0 COMPARISONS AND TRADE STUDIES

Three advanced spacecraft electrical power distribution and control system concepts were described in Section 5.0. These concepts were the solid state, conventional, and hybrid systems. Here, a comparison and trade study will be made between the concepts using the system configurations, quantities of components and baselines as laid out in Section 5.0. Factors to be considered will include:

- (1) Equipment installation and location
- (2) Weight and size
- (3) Reliability
- (4) Modular construction
- (5) Control logic flexibility
- (6) Performance and EMI compatibility
- (7) Impact on power sources and utilization
- (8) Power losses
- (9) Development time and cost.

6.1 Equipment Installation and Location

Table 6-1 gives a side-by-side comparison of equipment location and installation considerations for the three system concepts. Particular emphasis is applied to panel space and console volume required within the crew station.

Significant results obtained from the comparison are listed below:

- (1) The solid state concept requires approximately 0.54 ft² of crew station panel area.
- (2) The conventional concept requires 7.5 ft² of crew station panel area.
- (3) The hybrid concept requires 9.25 ft² of crew station panel area.
- (4) Total estimated volume of distribution system equipment located in the crew station:

Solid State System	2,000 in ³
Conventional System	6,290 in ³
Hybrid System	10,700 in ³

TABLE 6-1 EQUIPMENT LOCATION AND INSTALLATION

ITEM	(A) SOLID STATE SYSTEM	(B) CONVENTIONAL SYSTEM	(C) HYBRID SYSTEM
1) Power Sources	Power sources are located in the forward equipment bay in the nose section of the vehicle near the center of loads in that area. Other locations are impractical due to fuel storage tanks, engines, and other large equipment items.	Same as A	Same as A
a) APU-Driven Generators			
b) Fuel Cells			
c) Batteries			
d) Source Control Equipment			
2) Power Conversion Equipment	Same as 1.	Same as A, location in crew station is desirable but size makes it impractical.	Same as A.
a) AC-DC Converters			
b) DC-AC Inverters			
3) External Power Monitor	Same as 1	Same as A	Same as A
4) Power Buses	Use of remotely controlled solid state power controllers permit a distributed bus arrangement to be employed. Buses are located in vicinity of heavy concentrations of loads, i.e. 1) Forward equipment bay 2) Wing root equipment bays (2) 3) Aft equipment bay 4) Crew station	In order to provide access to each circuit breaker for reset during flight all power buses must be located in the crew station compartment. Buses located here consume valuable crew station console volume.	Same as B

(Continued)

TABLE 6-1 (Continued)

ITEM	(A) SOLID STATE SYSTEM	(B) CONVENTIONAL SYSTEM	(C) HYBRID SYSTEM
4) Power Buses (continued)	<p>The crew station buses are optional. Loads served by these could be served from the buses in the forward equipment bay, but this results in longer runs of power wiring to the crew station and results in having to provide crew station compartment penetration for the power wire to each load in the crew station.</p>		
5) Circuit Protection	<p>Remotely controlled solid state power controllers are located at each bus location. (See 4 above.) Since these are remotely located, valuable crew station panel area and console volume are free for other equipment. A volume of 1000 in³ is estimated for the power controller assemblies to be located in the crew station. Control and indication panel area required for power controllers is estimated at .15 to .27 ft².</p>	<p>Conventional thermal circuit breakers are provided at the buses in the crew station to provide access for reset during flight. Substantial and valuable panel space in the crew compartment must be allocated for these breakers. Fig. 6-1 shows typical panel square footage VS number of circuit breakers. An estimate of 625 breakers for the shuttle shows a need for 7.5 ft² of panel area. Again, the circuit breakers, require valuable crew station console volume. Fig. 6-2 shows a volume requirement of 3,750 in³ for 625 breakers (includes bus bars and harnesses).</p>	<p>As in the conventional system circuit breakers are provided at the buses in the crew station to provide access for reset during flight. More circuit breakers are required than for the conventional system. A quantity of 780 breakers are estimated. From Fig. 6-1 and 6-2 panel space area and console volume are estimated at 9.25 ft² and 4,750 in³. In addition power control relays and relay drivers must be located close to the buses. The volume of relays and drivers is estimated at 3,900 in³, giving a total console volume of 8,650 in³.</p>

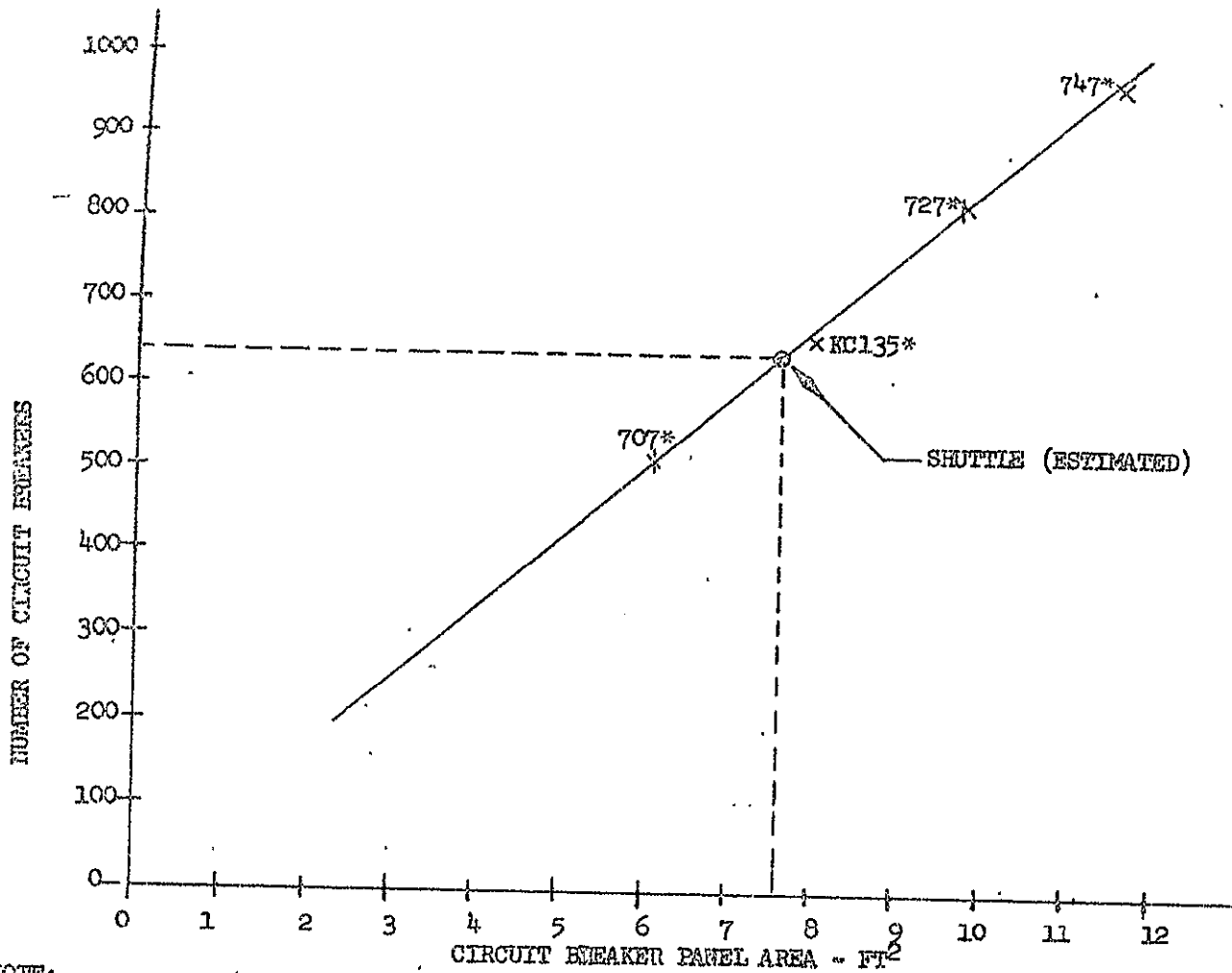

NOTE:

- 1) The 707, 727 and 747 are commercial passenger aircraft.
- 2) The KC135 is an Air Force aerial refueling tanker.
- *3) The basic information used to obtain this curve is derived from Reference 21.

FIGURE 6-1 ESTIMATE OF CONVENTIONAL CIRCUIT BREAKER PANEL AREA

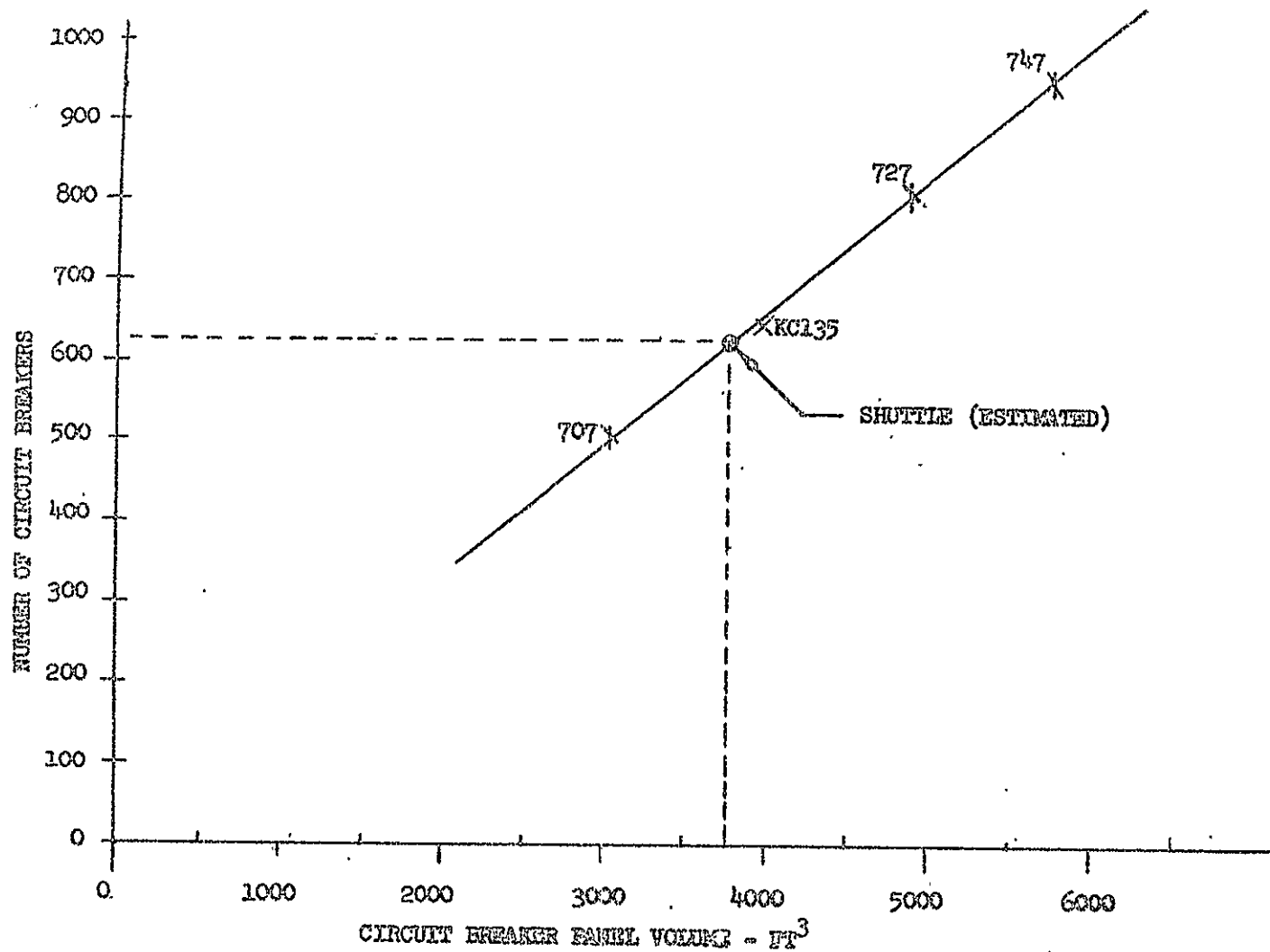

NOTE:

- 1) A panel depth of 3.5 inches was assumed for volume calculations.
- 2) The basic information used to obtain this curve is derived from Reference 21.

FIGURE 6-2 ESTIMATE OF CONVENTIONAL CIRCUIT BREAKER PANEL VOLUME

TABLE 6-1 (Continued)

	(A) SOLID STATE SYSTEM	(B) CONVENTIONAL SYSTEM	(C) HYBRID SYSTEM
6) Power Feeders			Same as B.
a) Power Sources			
1. Generators [3]	Since sources and buses are located in close vicinity to each other, the feeders should be 5 ft. or less in length.	With buses located in the crew station and sources in forward equipment bay, lengths could be as much as 25 ft. with circuitous routing. With redundant feeds and extended lengths from fuel cells, feeders become heavy. Added length and weight of generator feeders becomes significant.	
2. Fuel Cells [2]			
3. Batteries			
b) External Power Feeders (AC and DC)	Assuming the external power receptacles will be located in close vicinity to the forward equipment bay the length of these feeders should be 5 ft. or less. This is due to buses being located in close vicinity to sources and receptables.	With buses in crew station the external power feeders have a greater length, up to 30 ft. with circuitous routing.	Same as B.
c) Feeders between buses and conversion equipment	AC and DC feeder wiring between buses and conversion equipment is reduced to a minimum. Again, this is due to the buses being located in close vicinity to the conversion equipment. Lengths should be 5 ft. or less.	With buses located in the crew station and conversion equipment located in the forward equipment bay, feeders must be routed from buses to equipment and back to buses. Feeder weight becomes significant considering a distance of approximately 25 ft. from buses to equipment and 25 ft. back to buses.	Same as B.

TABLE 6-1 (Continued)

ITEM	(A) SOLID STATE SYSTEM	(B) CONVENTIONAL SYSTEM	(C) HYBRID SYSTEM
6) Power Feeders			
d) Feeders to remote buses	Ten feeders are required to link remote power centers to the forward power center. Wire sizes to #2 gage are required for these feeders.	None	None
e) Summary	Rough estimates on feeder weight including distribution weight gives 174 lbs. Surprisingly, feeder weight trades off well with the conventional system -- 174 lbs VS 175 lbs.	Rough estimates on feeder weight gives 175 lbs. for above feeders.	Same as B.
	Here, only those feeders to the crew station power controller assembly are required to penetrate the crew station, two penetrations of #6 wire VS 34 penetrations for the conventional system (wire sizes ranging from #14 to #2).	Another significant point is the number of feeders which must penetrate the crew compartment. This becomes significant where there is a firewall required between equipment bay and crew compartment. A firewall requires power feed-thrus which in themselves become heavy. Further, at least 12 control wires are required between equipment bay and buses just for differential fault protection on the generator and external power feeders.	Same as B.

TABLE 6-1 (Continued)

ITEM	(A) SOLID STATE SYSTEM	(B) CONVENTIONAL SYSTEM	(C) HYBRID SYSTEM
7) Bus Switching and Source Isolation Hardware	All bus switching and source isolation hardware are located within the forward equipment bay with exception of two isolating power diodes at the crew station DC buses. These diodes require negligible volume.	The bulk of the bus switching and source isolation hardware must be located at the buses within the crew station. In excess of 1000 in ³ of volume within the crew station are required for these components.	Same as B except four contactors are eliminated.
8) Power Control Multiplexing Hardware	Table 5-1, Sect. 5 shows the equipment location and quantity of the power control multiplexing hardware. The most significant point shows incorporation of 4 ROT, an Interface Control Unit and 7 RIT in the crew station compartment. The volume of this equipment is estimated at 1000 in ³ .	None	Table 5-5, Sect. 5 shows the configuration and equipment location of the power control multiplexing hardware. Up to 16 ROT and 7 RIT are shown within the crew station. Approximately 1000 in ³ of volume are required by the equipment, same as in A.
9) Power Wiring to loads	Figure 5-2 shows approximate dimensions of typical wiring zones for an interim shuttle. As can be seen the maximum length of power wiring to loads does not exceed 30 ft. even considering circuitous routing. Roughly 90% of loads can	Maximum length of power wiring to loads is a function of amount of switch and relay logic. Load power wires could conceivably be 200 ft. in length. In any case the wire length and wire weight will be substantially greater than A or C. Particularly at	Maximum length of power wiring should not exceed 100 feet with circuitous routing; 2/3 of load power wiring would be 30 ft. or less in length.

TABLE 6-1 (Continued)

ITEM	(A) SOLID STATE SYSTEM	(B) CONVENTIONAL SYSTEM	(C) HYBRID SYSTEM
9) Power Wiring to loads (Continued)	be served with power wires of less than 15 ft. in length.	28 VDC, long wire lengths to accommodate switch and relay logic require wire size to be increased to satisfy voltage drop limitations. This further aggravates wire weight and routing problems.	
10) Control Logic Wiring	Maximum length of control logic wiring does not exceed 30 ft. even with circuitous routing. Again, roughly 90% of control wiring will be less than 10 ft. in length; however 10 small gage wires would be required to form the redundant multiplex transmission line. The transmission line would be routed throughout the vehicle thru all power centers and the crew compartment eventually closing on itself to form a loop.	Since much of the control logic is performed at the power level, the amount of control logic wiring is reduced to a minimum; yet a substantial amount is still required for relay control, etc. The same wire lengths and problems are encountered as in the load power wiring. [See 9B.]	Same as A.
11) Signal Sources	A rough estimate was made of toggle switches. The estimate was an extrapolation from the Apollo CM and resulted in an extrapolated count of over 400 such devices. Assuming 400 toggle-type	Here, conventional type toggle switches are assumed. Many of these are 4PDT. For the comparison made in A, the average switch was assumed to be a 2PDT with 6 terminals.	Same as A.

TABLE 6-1 (Continued)

ITEM	(A) SOLID STATE SYSTEM	(B) CONVENTIONAL SYSTEM	(C) HYBRID SYSTEM
11) Signal Sources (continued)	<p>signal sources, the use of advanced signal sources results in a panel volume reduction of 540 in³. This savings is equivalent to a panel of 2 ft² and 2 in. deep. Amount of wiring to and from each switch is reduced substantially - from an average of 6 wires to 3 wires. Further, wire routing is direct from a signal source to a RIT. This substantially reduces the mass of wiring normally found on a panel and simplifies wire tracing and troubleshooting.</p>		
12) Distribution System Modular Packages (DSMP)	<p>Particularly for the interim shuttle, the approach lends itself to a modular packaging of distribution system equipment. From Fig. 5-3, Sect. 5, it can be seen that a modular package could be built up of all equipment associated with say the LH FWD channel. The modular package would consist of buses, BC, PC, converters, inverters, OLRG, DHS equipment, external power monitor, etc. The package would be pallet mounted and plumbed for coolant. Such a package could be assembled on a factory floor, checked as a major assembly at a computerized test station and then installed in the vehicle as one package. A minimum number of electrical and plumbing connections would have to be made upon installation within the vehicle. (Continued)</p>	<p>Modular packaging is not practical due to the wide dispersion of distribution equipment.</p>	<p>Same as B</p>

111

TABLE 6-1 (Concluded)

ITEM	(A) SOLID STATE SYSTEM	(B) CONVENTIONAL SYSTEM	(C) HYBRID SYSTEM
12) Distribution System Modular Packages (DSMP) (Continued)	All power centers could be packaged in a similar manner. The mentioned computerized test station with appropriate power sources and load simulation could accommodate all modular distribution system packages and essentially test the complete vehicle distribution system prior to installation.		

- (5) Weight of power source and remote distribution feeders on the solid state system trade off even or better than power source and conversion equipment feeders of the conventional and hybrid system concepts.
- (6) The solid state system results in substantially reduced complexity of wiring within the crew station.
- (7) The solid state system is compatible with a power center modular packaging concept.

Weight and Size

Weight and size (volume) are estimated for the solid state, conventional and hybrid system concepts. Summaries and comparisons of weight and volume for the three concepts are included in the following tables:

Table 6-2	Concept Comparisons - Weight and Volume
Table 6-3	Summary - System Weight and Volume
Table 6-4	Summary - Weight of Power and Control Wiring
Table 6-5	Summary - Weight and Volume of Power Switching and Circuit Protection
Table 6-6	Summary - Weight and Volume of Control Hardware.

Table 6-2 is a comparison of percent weight and volume reduction obtained in comparing the (1) solid state concept to the conventional concept, (2) hybrid concept to the conventional concept, and (3) solid state concept to the hybrid concept. The comparisons are made for two cases. The first case is based on weight and volume data for the solid state concept using board-mounted, single-channel load controllers. The second case is based on weight and volume data for the solid state concept using an integrated, 16-channel load controller module.

Program goals state as an objective a 40% reduction in system weight and volume. From Table 6-2 it can be seen that these goals have been surpassed with a fair margin of safety for both cases. It is felt that the comparisons are realistic based on the limited data available. It should be noted that the ground return wiring and power conversion equipment weight and volume are not included in these calculations. They are present in all three systems.

In comparing the weight and volume of the solid state and conventional concepts, the most significant improvements are made in wire weight. Table 6-4 shows the solid state concept to have a wire weight reduction of 65.6%. The greatest gain occurs in load power and control wiring, representing a weight reduction of 81.7% for that wiring.

Tables 6-4 through 6-6 give a breakdown of the weight and volume for the major system component areas.

6.3 Reliability

6.3.1 Introduction and Summary

Three different electrical power distribution and control systems for a space shuttle vehicle are subjected to a reliability analysis. These systems are the conventional system, the hybrid system, and the solid state system.

The salient composition of the conventional system is contactors, relays, and switches. The composition of the solid state system is basically solid state electronics. The hybrid system is an amalgamation of the solid state and the conventional.

Comparison of equivalent failure rates of the systems shows the solid state system to be more than twice as reliable as the hybrid system and over nine times as reliable as the conventional system, indicating that attainment of one order of magnitude improvement in reliability is feasible. This improved reliability is attainable through the use of design simplicity, solid state component reliability, and the judicious use of redundancy.

Reliability mathematical models, predictions, and failure mode and effects analyses are based on mission analysis criteria defined herein. The absolute values of reliability calculated for the three concepts are extremely conservative (low) due to the assumption that all components were essential to safety and mission completion. This assumption was made for simplicity and brevity. A thorough and detailed analysis would take into account only those loads and supporting devices absolutely essential for safety and mission completion. For comparison purposes, the assumptions and calculations are more than adequate to show the magnitude of difference between the systems.

6.3.2 Reliability Analysis

The methods used in reliability modeling are in accordance with MIL-STD-765 and MIL-HDBK-217A. Modeling is based on the

TABLE 6-2 Concept Comparisons
Weight and Volume

ITEM	Weight		Volume	
	Ratio	% Reduction	Ratio	% Reduction
A. Using Single-Channel LC Modules				
1) Solid State/Conventional	.534	46.6*	.567	43.3*
2) Hybrid/Conventional	.895	10.5	.954	4.6
3) Solid State/Hybrid	.595	40.5	.595	40.5
B. Using Multi-Channel LC Modules				
1) Solid State/Conventional	.495	50.5*	.494	50.6*
2) Hybrid/Conventional	.895	10.5	.954	4.6
3) Solid State/Hybrid	.554	44.6	.518	48.2

* Program goals for Percent Weight and Volume Reduction are 40%.
Goals are exceeded by using either single- or multi-channel load controllers.

TABLE 6-3 Summary - System Weight and Volume

Item	SOLID STATE SYSTEM		CONVENTIONAL SYSTEM		HYBRID SYSTEM	
	Weight (Lbs)	Volume (In ³)	Weight (Lbs)	Volume (In ³)	Weight (Lbs)	Volume (In ³)
Wiring (Power & Control)	303	2,730	884	7,950	601	5,410
Switching and Circuit Protection	171	4,525	201	8,325	303	8,931
Control System	88	2,355	--	--	73	1,935
Signal Sensing	48	180	60	990	48	180
TOTAL ① ③	610	9,790	1,145	17,265	1,025	16,456
Less ④	-43	-1,260				
TOTAL ② ③	567	8,530	1,145	17,265	1,025	16,456

① Total weight and volume using single-channel load controller modules

② Total weight and volume using multi-channel load controller modules

③ Weight and size of ground return wiring and conversion equipment are not included. They are the same for all three system concepts.

④ Difference between weight and volume on single-channel and multi-channel load controller assemblies.

TABLE 6-1 Summary - Weight of Power and Control Wiring

ITEM	SOLID STATE SYSTEM			CONVENTIONAL SYSTEM			HYBRID SYSTEM		
	Wire Wt (Lbs)	*Installation Multiplier	Installed Wire Wt (Lbs)	Wire Wt (Lbs)	*Installation Multiplier	Installed Wire Wt (Lbs)	Wire Wt (Lbs)	*Installation Multiplier	Installed Wire Wt (Lbs)
Distribution Feeders	118.0	1.15	136.0	---	-	---	---	-	---
Source, Conversion Equip & Bus Inter-connecting Feeders	32.7	1.15	37.6	152.4	1.15	175.5	152.4	1.15	175.5
Load Power Wiring	69.0	1.36	94.0	520.0	1.36	708.0	293.9	1.36	400.0
Control Wiring	26.2	1.36	35.7	---	-	---	18.9	1.36	25.7
Total Installed Wire Weight	245.9	-	303.3	672.4	-	883.5	465.2	-	601.2

Percent Weight Reduction (Installed)

- (1) Solid State Versus Conventional = $(1 - 303/883)100 = (1 - .344)100 = 65.6\%$.
- (2) Solid State Versus Hybrid = $(1 - 303/601)100 = (1 - .505)100 = 49.5\%$.

* The installation multiplier accounts for all hardware required to build up the harness assembly and install it in the vehicle. It includes connectors, terminal lugs, clamps, ties, conduit, wiring troughs, braiding, boots, terminal pins, terminal blocks, etc.

TABLE 6-5 Summary - Weight and Volume of Power Switching and Circuit Protection

ITEM	SOLID STATE SYSTEM		CONVENTIONAL SYSTEM		HYBRID SYSTEM	
	Weight	Volume	Weight	Volume	Weight	Volume
Bus & Heavy Power Switching	40.2	745	26.6	521	20.0	371
Load Switching and Circuit Protection	131.0	3,780	125.0	3,780	156.0	4,660
Power & Control Relay Switching	-	-	49.4	4,024	127.0	3,900
TOTAL	171.2	4,525	201.0	8,325	303.0	8,931

TABLE 6-6 Summary - Weight and Volume of Control Hardware

SOLID STATE SYSTEM

Item	Qty	Unit Wt (Lbs)	Unit Volume (In ³)	Wt (Lbs)	Volume (In ³)
RIT	16	1.2	30	19.2	480
ROT	16	1.2	30	19.2	480
MU	2	10.0	200	20.0	400
MIT (320 ch ⁷)	8	2.0	60	16	480
Interface Unit	1	11	435	11	435
Line Extenders	2	1.5	40	3.0	80
TOTAL				88.4	2,355

H. HYBRID SYSTEM

Item	Qty	Unit Wt (Lbs)	Unit Volume (In ³)	Wt (Lbs)	Volume In ³
RIT	16	1.2	30	19.2	480
ROT	16	1.2	30	19.2	480
MU	2	10.0	200	20.0	400
MIT	4	2.0	60	8.0	240
Interface Unit	1	11	435	11.0	435
Line Extenders	2	1.5	40	3.0	80
TOTAL				80.4	2,115

NOTE: The multiplex transmission line is included under wiring.

electrical distribution subsystem functional requirements necessary to complete the space shuttle mission from liftoff through landing/recovery. Failure rates have been estimated for the development items considering the more severe equipment operating environments of the launch and re-entry phases and the nominal operating conditions for the near-earth space environment. The initial failure mode and effects analysis considers the likelihood of failure mode occurrence and impact of subsystem functional failures on subsystem, spacecraft, and mission.

6.3.3 Mission Analysis Criteria

The electrical power distribution system will be operated in near-space on an earth orbiting mission. There will be a launch phase followed by separation at about 300,000 feet, orbit correction, docking, personnel and cargo transfer, and standby for several days. Personnel and cargo loading will then take place, followed by decoupling from the space-base, maneuver into earth entry orbit, entry, conversion from space to aero maneuvering, cruising as an aircraft for 300 miles and landing.

The equipment operating environment will include such parameters as vibration, shock, and temperatures up to 150°C. Radiation effects are not considered.

Failure rates for the launch and re-entry phases are as tabulated. Failure rates for orbit are assumed to be 0.1 of those used for the more rigorous environment of launch and re-entry.

Equipment operating time for the combined launch and re-entry phases is assumed to be one hour. Orbit operating time is assumed to be 59 hours. Equipment is considered to be on-duty continuously for the sequential mission phases from liftoff through landing.

6.3.4 Functional Block Diagram

Figures 6-3, 6-4, and 6-5 show the respective system functional block diagrams defining electrical distribution for the conventional, hybrid, and solid state concepts respectively. Redundancies are identified where applicable.

6.3.5 Reliability Block Diagrams

Subsystem reliability block diagrams are constructed considering functional requirements shown in Figures 6-3, 6-4 and 6-5. An equipment block, arranged in a success path, is identified for each of the mission-significant equipment necessary to provide the functions of the subsystem.

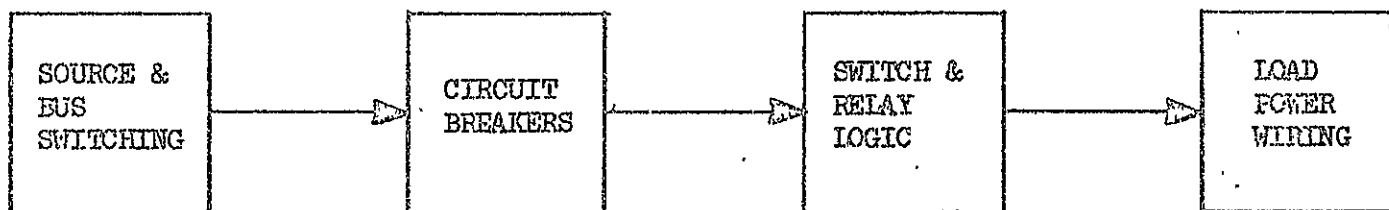
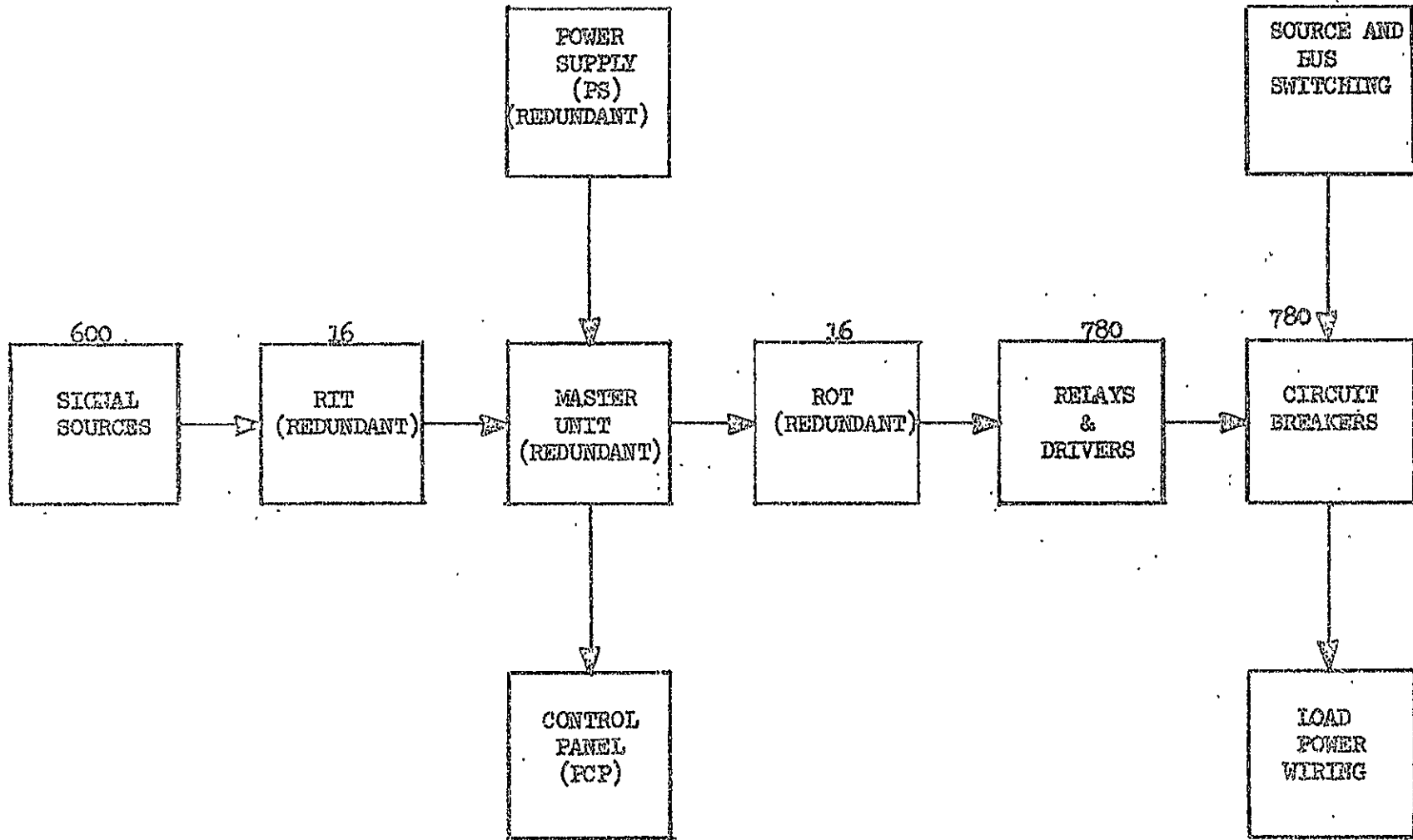
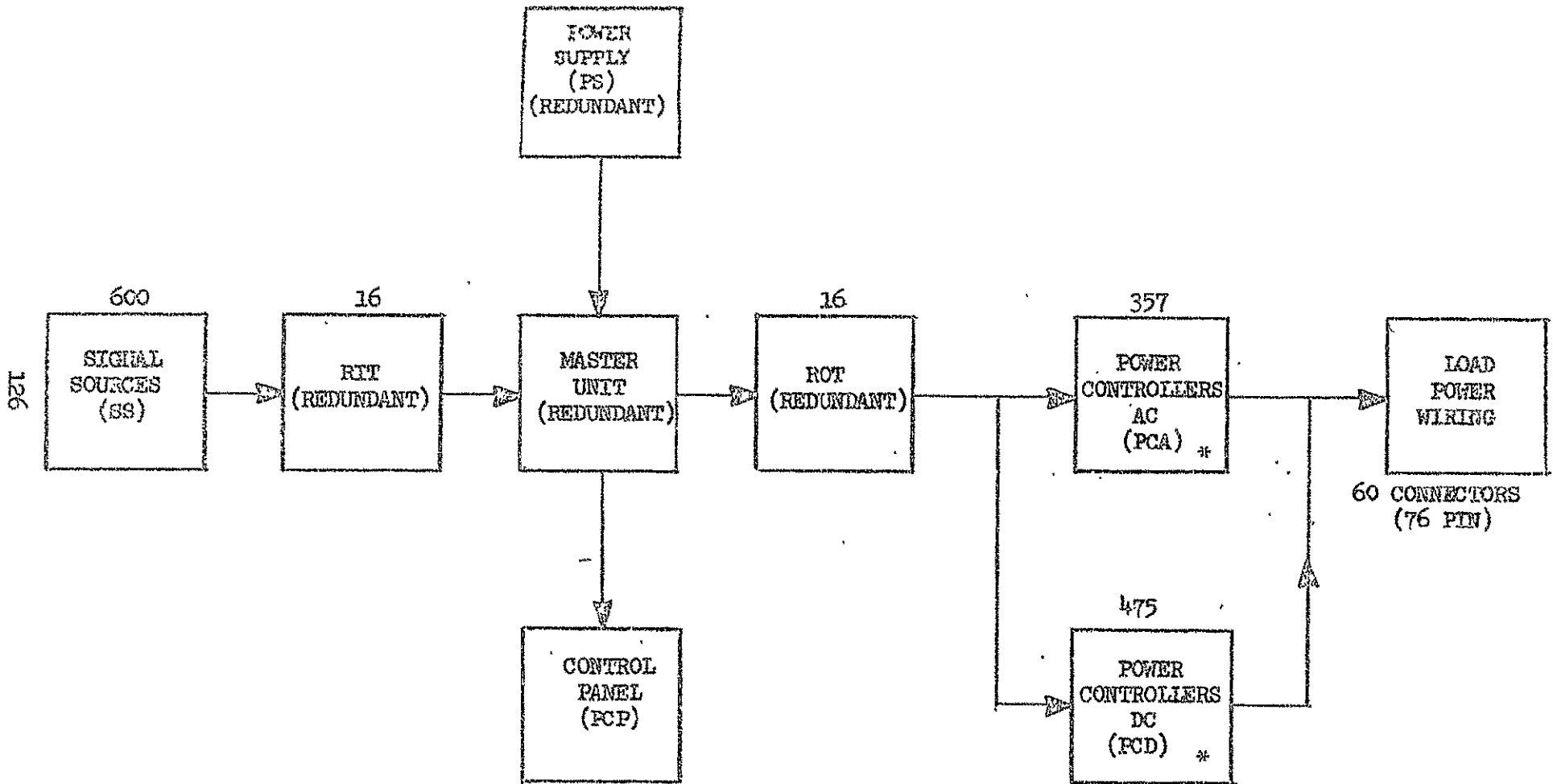

FIGURE 6-3 FUNCTIONAL DIAGRAM - CONVENTIONAL SYSTEM



115 CONNECTORS
(76 PIN)

FIGURE 6-4 FUNCTIONAL DIAGRAM - HYBRID SYSTEM -



*Includes source and bus switching

FIGURE 6-5 FUNCTIONAL DIAGRAM - SOLID STATE SYSTEM

Reliability block diagrams are presented in Figures 6-6, 6-7, and 6-8 for the conventional, hybrid, and solid state concepts, respectively.

6.3.6 Mathematical Models

The reliability block diagram provides the basis for developing the mathematical models used for predicting system mission reliability. These models use the exponential reliability function to combine equipment failure rates and operating time. The mathematical model for the electrical distribution system is:

$$R_{\text{system}} = \prod_{i=1}^3 R_i$$

where

- R_1 = Probability of the electrical power distribution system completing the launch phase without incurring a significant (abort or catastrophic) failure
- R_2 = Probability of the electrical power distribution system completing the orbit phase without incurring a significant (abort or catastrophic) failure
- R_3 = Probability of the electrical power distribution system completing the re-entry (including landing/recovery) phase without incurring a significant (abort or catastrophic) failure

This system model has been simplified to

$$R_{\text{system}} = R_1 R_2$$

for calculation purposes since failure rates for the launch and re-entry phases are assumed identical. Time is therefore additive for these phases in the following. R_1 represents the product $R_2 R_3$.

Subsystem mission reliability is determined by combining equipment failure rates and operating time in accordance with the following reliability relationship:

$$R_{\text{system element}} = e^{-t\lambda}$$

where

t = Equipment operating time

λ = Equipment failure rate.

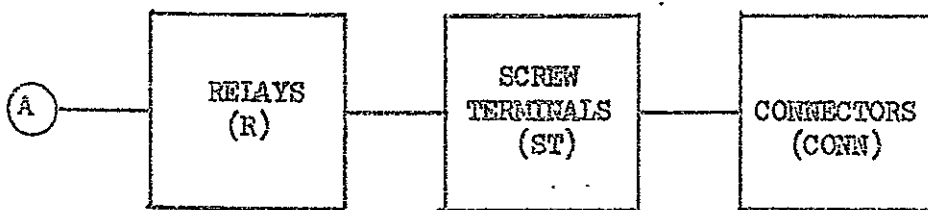
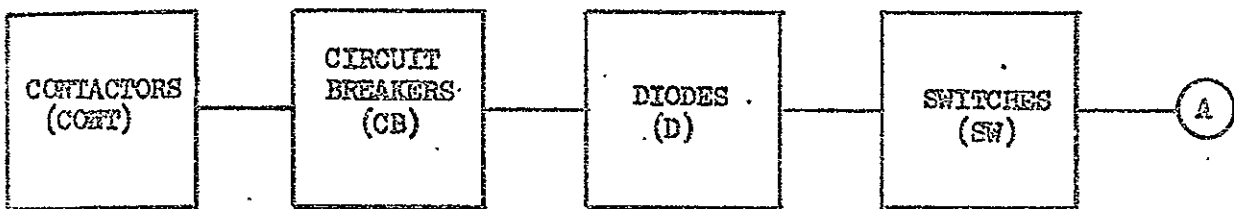

FIGURE 6-6 MISSION SUCCESS DIAGRAM - CONVENTIONAL SYSTEM

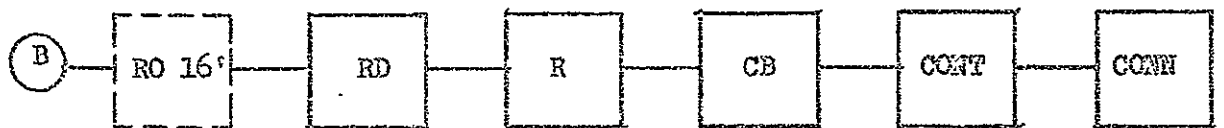
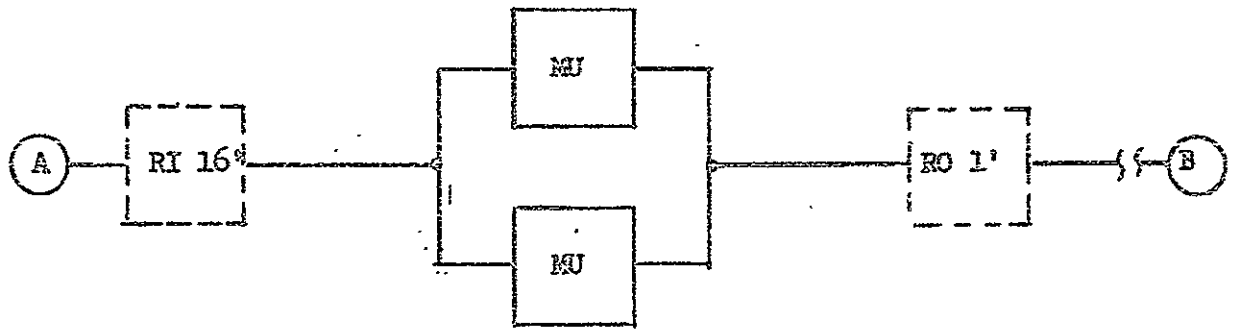
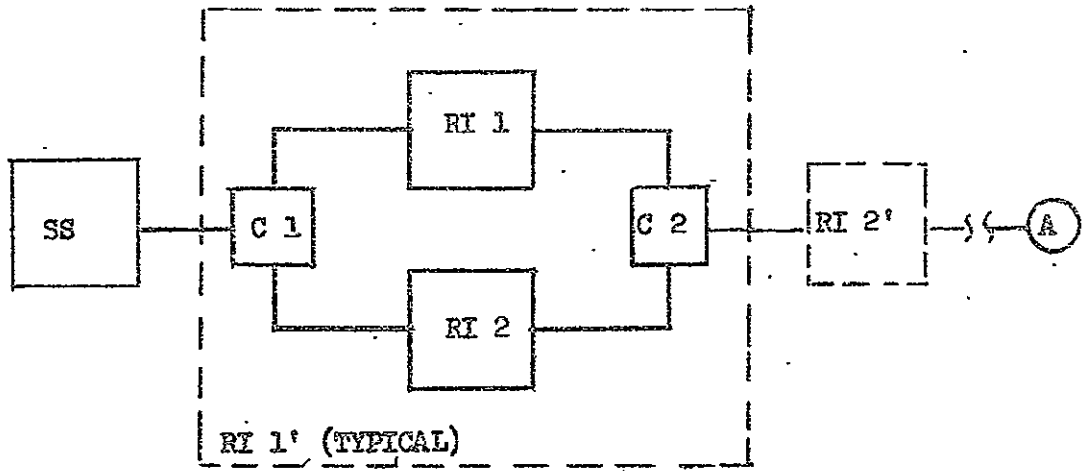

FIGURE 6-7 MISSION SUCCESS DIAGRAM - HYBRID SYSTEM

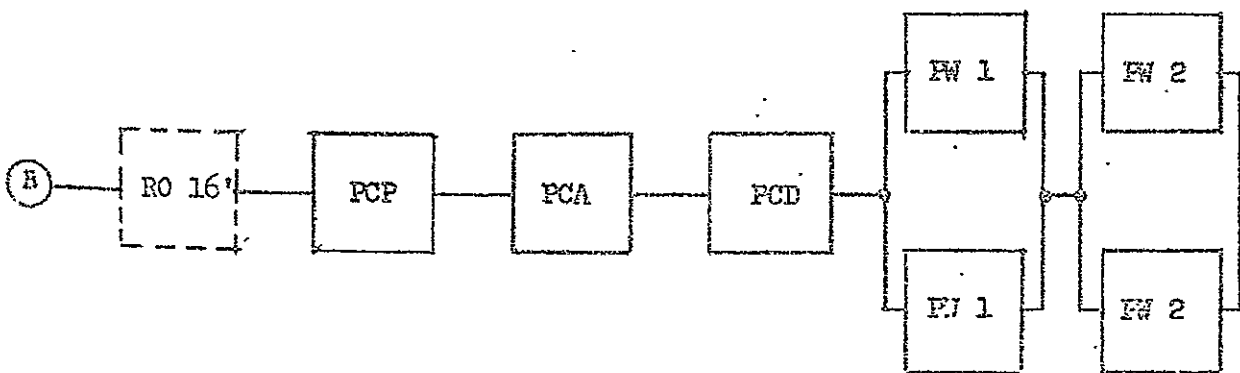
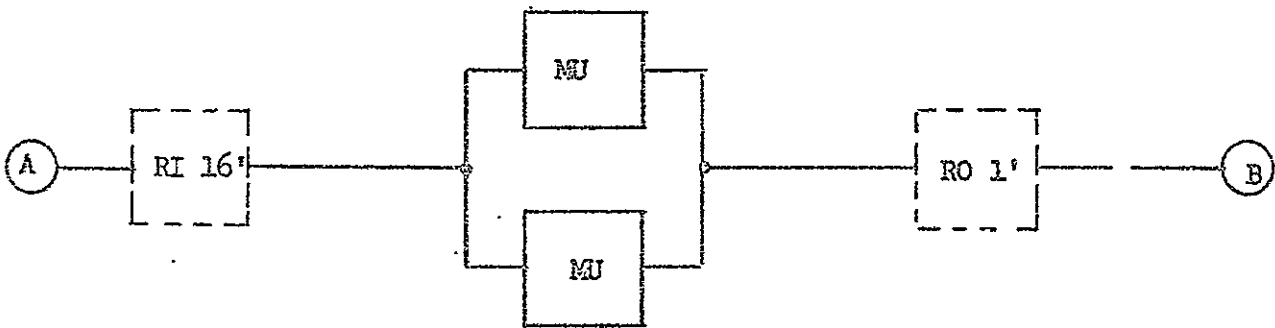
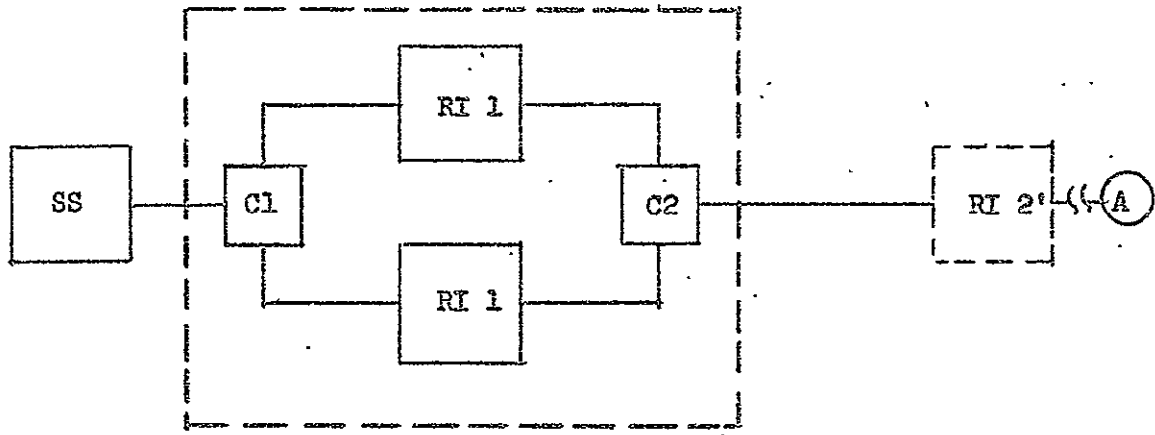

FIGURE 6-8 MISSION SUCCESS DIAGRAM - SOLID STATE SYSTEM

Specific reliability relationships for the conventional, hybrid and solid state systems are respectively:

$$P_{CONV} = P_{CONT} \cdot P_{CB} \cdot P_D \cdot P_{SW} \cdot P_R \cdot P_{ST} \cdot P_{CONN}$$

$$P_{HYBR} = P_{SS} \cdot P_{RI}^{16} \cdot (2P_{MU} - P_{MU}^2) \cdot P_{RO}^{16} \cdot P_{RD} \cdot P_{RD} \cdot P_R \cdot P_{CB} \cdot P_{CONT} \cdot P_{CONN}$$

where

$$P_{RI}^{16} = (P_{C1} \cdot [2P_{RI} - P_{RI}^2] \cdot P_{C2})^{16}$$

$$\text{and } P_{RO}^{16} = (P_{C1} \cdot [2P_{RI} - P_{RI}^2] \cdot P_{C2})^{16}$$

$$P_{Solid\ State} = P_{SS} \cdot P_{RI}^{16} \cdot (2P_{MU} - P_{MU}^2) \cdot P_{RO}^{16} \cdot P_{PCP} \cdot P_{PCA} \cdot P_{PCD} \cdot (2P_{PWI} - P_{PWI}^2) \cdot (2P_{PW2} - P_{PW2}^2)$$

These models reflect the success logic shown in Figures 6-6, 6-7 and 6-8 respectively and are applicable for the three mission phases included in the overall mathematical model. Solution of specific models requires the use of the appropriate time (one hour for R_{11} and 59 hours for R_2 in the simplified system model) and failure rates for each system element of the reliability block diagram to evaluate each model term.

6.3.7 Reliability Prediction

Solution of the reliability models of paragraph 6.3.6 results in the following overall electrical distribution system mission reliability predictions:

<u>Concept</u>	<u>Mission Reliability</u>
Conventional	.695736
Hybrid	.938630
Solid State	.959769

Failure rates used in mission reliability predictions are presented in Tables 6-7 and 6-8 for the conventional and hybrid concepts respectively. Tables 6-9 through 6-15 include the failure rates used for the solid state concept.

TABLE 6-7
 CONVENTIONAL SYSTEM
 FAILURE RATE ESTIMATE

Description	Failure Rate $\times 10^{-6}$ (λ)	Quantity (N)	Total Failure $\times 10^{-6}$ (N λ)
Contactors			
(3 ϕ , TPST, 60A)	100	3	300
(DC, SPST, 180A)	100	2	200
(3 ϕ , TPDT, 60A)	100	3	300
(3 ϕ , TPST, 25A)	100	4	400
(DC, SPST, 100A)	100	2	200
(DC, SPST, 25A)	100	1	100
(DC, 180A)	100	4	400
Diodes			
(200A)	20	2	40
Diodes			
(25A)	20	3	60
Switch			
(2PDT)	50	600	30,000
Relay			
(10A, 2PDT, 1op/Hr)	100	40	4,000
(10A, 4PDT, 1op/Hr)	100	40	4,000
(2A, 2PDT, 2op/Hr)	100	100	10,000
Circuit Breakers	1	645	645
Screw Terminals	.02	3,125	62.5
Connectors (76 Pin)	.11	170	1,870

TABLE 6-8
HYBRID SYSTEM
FAILURE RATE ESTIMATE

Description	Failure Rate $\times 10^{-6}$ (λ)	Quantity (N)	Total Failures $\times 10^{-6}$ ($N \lambda$)
Relays (2A,lop/HR)	100	390	39,000
Relays (10A,lop/HR)	100	390	39,000
Diodes	1	780	780
Resistors (Suppression)	1	780	780
Transistors	3	780	2,340
Resistor (Driver)	1	1,560	1,560
Connectors (76 PIN)	11	115	1,265
Circuit Breakers	1.0	780	780
Signal Sources	4	600	2,400
Remote Input Terminals	142.89	16	2286.24
Connector (1)	5.9	16	94.4
Connector (2)	0.3	16	4.8
Master Unit	565.19	1	565.19
Remote Output	255.3	16	3784.8
Connector (1)	5.9	16	94.4
Connector (2)	0.3	16	4.8
Contactors			
(3 ϕ , TPST, 60A)	100	3	300
(DC, SPST, 180A)	100	2	200
(3 ϕ , TPDT, 60A)	100	3	300
(3 ϕ , TPST, 25A)	100	2	200
(DC, SPST, 25A)	100	1	100
(DC, 180A)	100	4	400

TABLE 6-9
 SIGNAL SOURCE
 FAILURE RATE ESTIMATE

Description	Failure Rate $\times 10^{-6}$ (λ)	Quantity (N)	Total Failure Rate ($N\lambda$)
Actuator	0.8	1	0.8
Transducer	0.8	1	0.8
Linear IC	2.4	1	<u>2.4</u>
			$\Sigma \lambda =$ 4.0

Total Signal Source Failure Rate = $600 (4.0) = 2400.0$

TABLE 6-10 REMOTE INPUT TERMINAL FAILURE RATE

(One-Half of a Redundant Unit)

<u>Description</u>	<u>Qty. (N)</u>	<u>FR X 10⁻⁶</u>	<u>N X FR X 10⁻⁶</u>
Integrated Circuit	75	0.40	30.00
Transistor	15	0.90	13.50
Zener Diodes	3	1.60	4.80
Capacitor			
Ceramic	9	0.03	0.27
Tantalum (Solid)	16	1.40	22.40
Transformer & Inductor	12	1.36	16.32
Connections (Internal)	1400	0.034	47.60
Hybrid Circuit	8	1.00	8.00
			<hr/>
	$\lambda = N \times FR =$		142.89 x 10 ⁻⁶
	MTRF =		7,000 hours
Connector *			
Input/Code	1	5.9	5.9
Output/Address	1	0.3	0.3

The connectors are common to both halves.

TABLE 6-11 MASTER UNIT FAILURE RATE

<u>Item</u>	<u>Qty. (N)</u>	<u>FR X 10⁻⁶</u>	<u>N X FR X 10⁻⁶</u>
Integrated Circuit	344	0.40	137.60
Transistors	12	0.90	10.80
Diode			
Switching	20	0.50	10.00
Zener	1	1.60	1.60
Resistor	50	0.33	19.00
Capacitor			
Ceramic	38	0.03	1.14
Tantalum	62	1.40	86.80
Transformer & Inductor	20	1.36	27.20
Plated Wire Stack (2 mil wire)	1	23.25	23.25
Connector (External)	4	8.2	32.80
Connector (Internal)	4	6.0	24.00
Connections (Internal)	5500	0.034	187.00
Hybrid Circuit	4	1.00	4.00
			<hr/>
		$\lambda_s = N \times FR =$	565.19 x 10 ⁻⁶
		MTBF =	1,769 Hrs

Because the use of 2 mil plated-wire memory stack (mini-wire).
This allows use of integrated circuit memory drivers.

TABLE 6-12 REMOTE OUTPUT TERMINAL FAILURE RATE

(One-Half of a Redundant Unit)

<u>Description</u>	<u>Qty. (N)</u>	<u>FR X 10⁻⁶</u>	<u>N X FR X 10⁻⁶</u>
Integrated Circuit	110	0.40	44.0
Transistor	13	0.90	11.7
Diode			
Switching	25	0.50	12.5
Zener	1	1.60	1.6
Resistor	50	0.38	19.0
Capacitor			
Ceramic	14	0.03	0.4
Tantalum	22	1.40	30.8
Transformer and Inductor	18	1.36	25.3
Connections (Internal)	3000	0.034	102.0
Hybrid Circuit	8	1.00	8.0
		$\lambda = N \times FR =$	<u>255.3 x 10⁻⁶</u>
		MTBF =	<u>3,917 hours</u>
Connector *			
Output/Code	1	5.9	5.9
Input/Address	1	0.3	0.3

* The connectors are common to both halves.

TABLE 6-13⁷
PILOT CONTROL PANEL
FAILURE RATE ESTIMATE

DESCRIPTION	FAILURE RATE $\times 10^{-6}$ (λ)	QUANTITY (N)	TOTAL FAILURE RATE $\times 10^{-6}$ ($N\lambda$)
switch	10	2	20
lamp	1	4	4
connector	.07	1	.07
			24.07

TABLE 6-14
POWER CONTROLLERS
FAILURE RATE ESTIMATE

DESCRIPTION	FAILURE RATE $\times 10^{-6}$ (λ)	QUANTITY (N)	TOTAL FAILURE RATE $\times 10^{-6}$ ($N\lambda$)
AC Power Controller	4.89	357	1745.73
DC Power Controller	3.31	475	1572.25

TABLE 6-15
POWER SUPPLY
FAILURE RATE ESTIMATE

PART DESCRIPTION	FAILURE RATE $\times 10^{-6} (\lambda)$	QUANTITY (N)	TOTAL FAILURE $\times 10^{-6} (\lambda)$
Capacitors			
Molded, Mica	.25	15	3.75
Tantalum	3.6	10	36.0
Diodes, Silicon			
Reference	3.36	3	10.08
Switch	1.28	10	12.8
Integrated Circuits	.4	6	2.4
Thermister	.3	2	0.6
Transistor, Silicon			
NPN 1W	2.92	2	5.84
PNP 1W	8.56	1	8.56
NPN 1W	5.84	1	5.84
PNP 1W	17.12	1	17.12
Resistors			
RL07	1.46	20	29.2
RN60	.24	2	0.48
Solder Joints	1.0	1	1.0
Transformer	1	1	1.0
TOTAL (N λ)			= 124.62

Failure rates for development items were estimated by comparison with existing equipments considering factors such as similarity of design, complexity, state-of-the-art, criticality to mission success, operational application and operating environment. The methods of MIL-STD-1629 and MIL-HDBK-517A provided a basis for estimating reliability of systems without available operational histories. A factor of 0.1 was assumed applicable for correcting failure rates in a launch entry environment to those expected in the shuttle during orbit operation.

6.1.3 Failure Mode and Effects Analysis

The initial failure mode and effects analysis for the solid state power distribution system is presented in Table 6-16. System functional failure modes are identified for each element of the reliability block diagram. The probability of failure occurrence is estimated for each failure mode. Failure mode effects are categorized for impact on the system, spacecraft and mission objectives. Single point failures that result in loss of mission objectives are identified.

6.1.7 Reliability Design Features

The solid state system concept incorporates input and output components (i. e., signal sources and power controllers) with failure rates of approximately 4×10^{-6} failures per hour being estimated. The data handling portion of the system and the DC power source for the system are redundant. Simplicity of overall design in the attainment of maximum functional capability is a design goal.

6.1.10 Conclusions

If the system reliability equations be solved for the three systems considered, using 60 hours in the equation $P = e^{-\lambda t}$, an equivalent λ is obtained which can be used for comparison purposes.

Conventional system	$\lambda_{eq} = 6046 \times 10^{-6}$ failures/hour
Hybrid system	$\lambda_{eq} = 1055$ failures/hour
Solid state system	$\lambda_{eq} = 684 \times 10^{-6}$ failures/hour

Comparison of the equivalent failure rates reveals the conventional system to be approximately 9 times more prone to failure than the solid state system. A similar comparison between the hybrid and solid state systems reveals the hybrid system to be over twice as susceptible to failure as the solid state system.

TABLE 6-16 Initial Failure Mode and Effect Analysis -
Solid State System

Sys/Subsystem Element		System/ Subsystem	System/ Subsystem Functional Failure Mode	Probability of Failure Occurrence (1-P)	Failure Mode Effect			See NOTE
Nomenclature	Reliability Model Code				Subsystem	Space Shuttle	Mission	
Remote Output Terminal	ROT	Transmis- sion of MU Control signals to power con- trollers	Defective con- trol of power	.001803	Alternate ROT switched into system	None	None	[1]
Master Unit	MU	Generation of power control logic functions	Defective gen- eration of power control logic functions	.003892	Alternate MU switched into system	None	None	
Remote Input Terminal	RIT	Transmis- sion of remote data to MU	Defective transmission of remote data to MU	.001028	Alternate RIT switched into system	None	None	[1]
DC Power Supply	PS	Supply power to electrical power con- trol system	Dead electri- cal power con- trol system	.00860	Alternate power sup- ply switched into system	None	None	
Signal Source	SS	Generation of discrete signals	Incorrect digital signal	.016424	Garbled signals	Incorrect power dis- tribution	May be aborted	
AC Power Controller	PCA	Control of shuttle AC power	Defective con- trol of shuttle AC power	.004545	Defective control of shuttle AC power	Incorrect power distri- bution	May be aborted	
DC Power Controller	PCD	Control of shuttle DC power	Defective con- trol of shuttle DC power	.004512	Defective control of shuttle DC power	Incorrect power distri- bution	May be aborted	

[1] Probability of failure includes input and output connector.

TABLE 6-17 Comparison of Modular Power Switching

517

(A)
SOLID STATE SYSTEM

Solid state power switching devices, bus controllers and load switching power controllers are modular in nature. In other words, the addition or deletion of bus or load switching power controllers is implemented by adding or deleting functional modules. The use of multi-channel power controller modules results in some inflexibility compared to card-mounted, single-channel modules; however, this inflexibility is off-set by substantial gains in weight and size. The modular nature of bus and load switching power controllers offers some advantage over that of the conventional and hybrid system components.

First, the load switching power controller incorporates both the functions of a circuit breaker and power switch, thus resulting in a simpler, more compact package than separate breaker panels and relay racks. Furthermore, the remote operation of these modules permits them to be located outside the crew station, saving valuable space. Also space provisions can be more readily provided for future growth.

(B)
CONVENTIONAL SYSTEM

Power contactors, circuit breakers and relays could be considered modular in nature. In other words individual circuit breaker and relay modules are normally installed in such a fashion as to form circuit breaker panels and relay racks. The addition or deletion of circuit breakers and relays is accomplished by installing or removing these modules. For access during flight and for environmental reasons, it is necessary to install these panels and racks in the controlled environment of the crew station where space is at a premium. Thus the number of spares or space provisions for spares must be kept to a minimum, limiting the potential for future growth.

~~HYBRID SYSTEM~~

The use of power contactors, circuit breakers and relays in this system is similar to that for the conventional system. Here, circuit breaker modules are mounted in a circuit breaker panel. Within or adjacent to the breaker panel are the relays and relay drivers mounted on printed circuit boards. Again, it is necessary to install these assemblies within the crew station where space is at a premium.

(A)
SOLID STATE SYSTEM

The control system is built-up of modular components. For example, each remote input (RIT) and each remote output (ROT) terminal are modules. Based upon the present system under development for aircraft, a control system of from one to 16 RIT or one to 16 ROT modules can be built up to meet the specific control signal input and output requirements for a specific control system. The control system can grow to 16 RIT and 16 ROT, providing growth capability to this capacity. Further, each RIT is interchangeable and each ROT is interchangeable providing greater system flexibility. The Master Unit (MU) is of modular construction with capabilities of using memory building blocks to obtain a memory capacity to 64K Bits.

For a discussion of Distribution System Modular Packaging, refer to Table 6-1, Item 12.

TABLE 6-17 (Concluded)
(B)
CONVENTIONAL SYSTEM

Control within the conventional system is performed by switch and relay logic. Aside from modular packaging of relays, the control system components are dispersed over the vehicle which rules out further modular packaging.

(C)
HYBRID SYSTEM

Control for the hybrid system is identical to that of the solid state system.

Control Logic Flexibility

TABLE 6-18 Comparison of Control Logic Flexibility

<u>(A)</u> <u>SOLID STATE SYSTEM</u>	<u>(B)</u> <u>CONVENTIONAL SYSTEM</u>	<u>(C)</u> <u>HYBRID SYSTEM</u>
<p>Control logic functions (equations) can be changed by reprogramming the MU. Another condition would be the addition of input control variables. This requires the addition of the required number of signal sources and the short length of wiring between the signal sources and the nearest RJT with available channel capacity. Where a new load is necessary, a load controller, power wiring to the load and control wiring from the nearest ROT and MIT must be added. Even in the worst case condition, the amount of rewiring is held to a minimum.</p>	<p>Any changes of control logic functions on the conventional system require changes in vehicle wiring. Even without the addition of control variables (switch and/or relay contacts), the change can result in extensive rewiring affecting several harnesses, connectors, switches, and relays. Wire tracing, handling, troubleshooting, wire installation, checkout, etc., associated with wiring changes introduce the possibilities for wire, connector or termination degradation resulting in premature failures.</p>	<p>Changes in control logic functions for the hybrid system are very similar to those for the solid state system.</p>

447

6.6 Performance and EMI Compatibility

TABLE 6-19 Comparison of Performance and EMI Compatibility

<u>(A)</u> <u>SOLID STATE SYSTEM</u>	<u>(B)</u> <u>CONVENTIONAL SYSTEM</u>	<u>(C)</u> <u>HYBRID SYSTEM</u>
<p>Significant gains in performance and EMI compatibility are realized with the solid state system. A major improvement in performance and the EMI environment is accomplished by separation of power and control. The separation permits a significant reduction in the wiring and harnesses operating at power levels and voltages. Reduced amount of power wiring, simplified power harnesses and routing reduce the amount of induced EMI in adjacent wiring.</p>	<p>In the conventional system control is performed at the power level and often within the load power circuit. This results in a much larger quantity of wiring operating at the power level, subject to the perturbations of both source and utilization equipment. The larger quantities of power wiring, complex routings, transients and spikes present in conventional systems induce EMI into adjacent systems and wiring.</p>	<p>The hybrid system is a compromise between A and B. It has the separation between power and control, but requires larger quantities of power wiring than A. The hybrid system power wiring is subject to the perturbations of the source and utilization equipment similar to B.</p>
<p>The current limiting feature on DC load controllers reduces the surge voltages as seen by the load. The maximum voltage as seen by the load cannot exceed 42.0 volts. Current limiting prevents high lamp and capacitor charging currents, thus improving the EMI environment. Furthermore, current limiting solves the protection coordination problems such as found in coordinating large load breakers on the secondary of transformer/rectifiers with supply breakers in the primary.</p>	<p>The conventional system has no provision for current limiting.</p>	<p>Same as B.</p>
<p>Controlled or soft turn-on and turn-off are provided in the DC load controller to reduce the amplitude of voltage spikes generated when controlling</p>	<p>Inductive kick-back voltages to -700 volts have been measured in recent tests on circuits powering a solenoid valve switched through an</p>	<p>Same as B.</p>

141

SOLID STATE SYSTEM

CONVENTIONAL SYSTEM

HYBRID SYSTEM

inductive loads. Fall time is between .5 and 5 milliseconds.

electro mechanical device. The literature refers to inductive kick-back voltages as high as 1000 volts.

Same as B.

Zener diodes are provided in the input of the DC load controller to protect the controller and prevent source-generated spikes from reaching load equipment. The DC unit blocks spikes generated by load equipment from feeding back to the load bus. Blocking is provided by a commutating diode which also protects the load controller.

The conventional system has no provisions for preventing source generated spikes from reaching utilization equipment. Further, no provisions are provided for containing spikes generated by utilization equipment. Each piece of load equipment is responsible for handling both source generated spikes and spikes from other subsystems.

146

The AC load controller provides zero crossover turn-on and turn-off, further reducing voltage transients. Zero crossover switching of certain loads such as highly efficient transformers can produce current surges about 50% of the time.

Switching at points other than zero crossover produces arcing between contacts, surges and steep wave fronts. Zero crossover switching surges on certain transformers occurs on a random basis.

Same as B.

The AC load controller can trip out within 1/2 cycle (1.25 milliseconds) at fault currents between 15 and 30 per unit. Rapid trip-out means minimum disturbance to the sources and load equipment. Single phase fault tests on a 20 KVA generator have shown the unfaulted phases to drop from 116 volts to 108 volts during the fault. After fault removal the phases peaked at 133 volts RMS and fully recovered within 25 milliseconds after fault removal.

With a 30 per unit fault current, the conventional thermal circuit breaker could take up to 60 milliseconds to trip at 25°C. At 15 per unit the breaker could take up to 180 milliseconds to trip at 25°C. It can be seen from A that the solid state system has already recovered from the fault before the conventional breaker can trip.

Same as B.

TABLE 6-19 (Continued)

(A) <u>SOLID STATE SYSTEM</u>	(B) <u>CONVENTIONAL SYSTEM</u>	(C) <u>HYBRID SYSTEM</u>
<p>Figure 6-9 shows the trip envelope of the AC load controller with typical breaker envelopes superimposed. The breaker envelope for 25°C represents manufacturing tolerances. The load controller envelope is for a case temperature spread of -54°C to 120°C. A major difference occurs at the short time intervals (less than .01 seconds) where the load controller is designed to trip in 1/2 cycle on fault currents of 15 to 30 per unit. Another significant point is the tighter trip tolerance for the load controller. The closer tolerance permits more precise and repeatable protection with a simpler task of coordination between protective devices. The trip tolerance on the breaker becomes wider as variations in ambient temperature are taken into consideration. This magnifies the problems of breaker and wire selection and coordination. Breaker derating is necessary at the high temperature. Wire derating is necessary at the low temperature.</p>	<p>Thermal breakers for spacecraft systems such as the shuttle must be located in a controller environment such as the crew station. Cold plate cooling cannot be used for a thermal breaker because the conductive cooling affects the breaker calibration.</p>	<p>Same as B.</p>
<p>Control signals of AC load controllers (PC) can be simply interlocked to provide trip of all three PC in a 3 phase circuit, preventing single-phasing of loads. Thus the same LC can be used in both single and three phase circuits.</p>	<p>Reliable protection in three phase circuits using thermal breakers requires three phase breakers. This creates the need for one or more ratings and/or configurations of three phase breakers.</p>	<p>Same as B.</p>

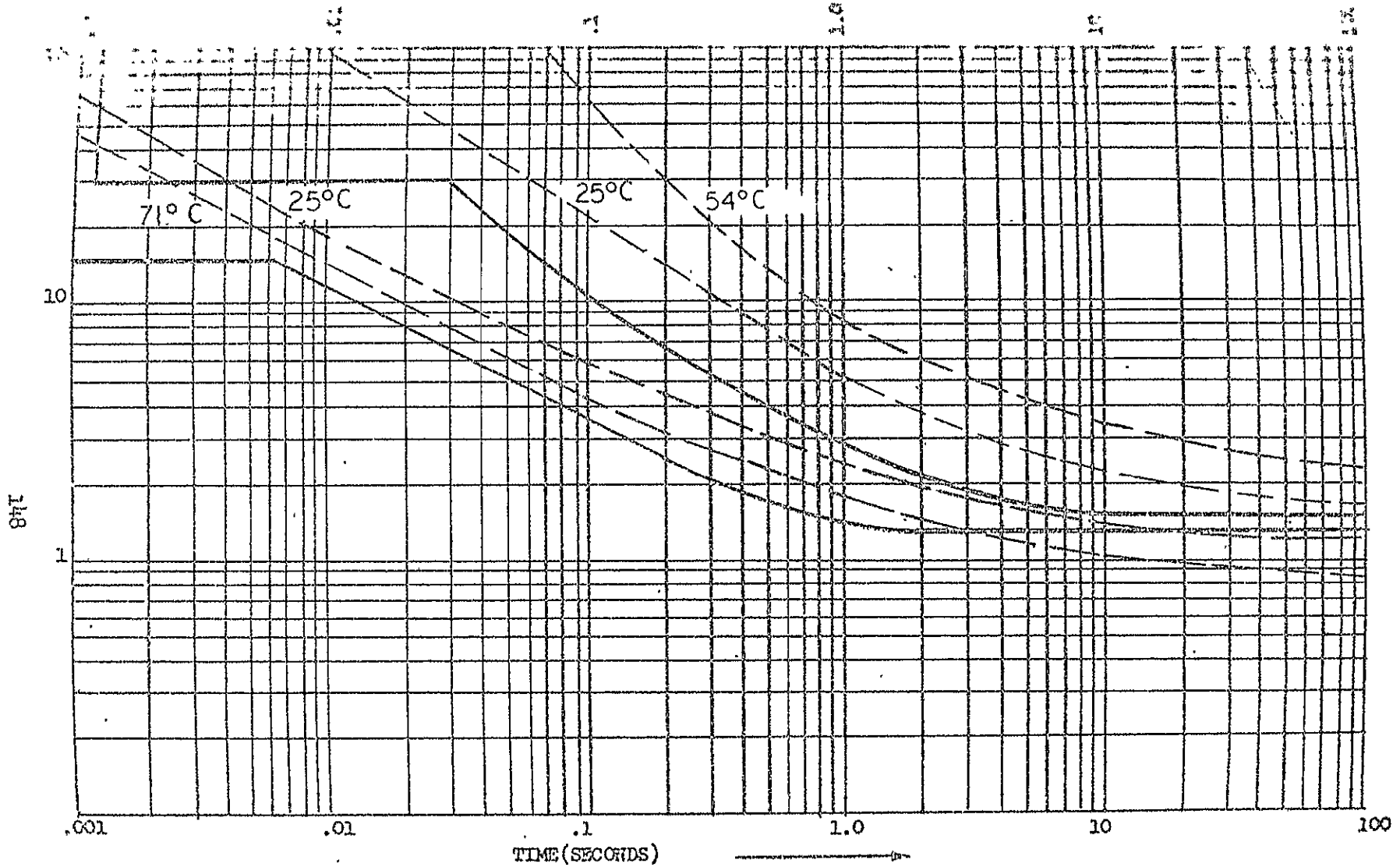

———— Power Controller Trip Envelope; Case Temperature -54°C to 120°C

----- Typical Thermal Breaker Trip Envelope

..... Manufacturing Tolerance

..... Manufacturing Tolerance and Ambient Temperature

..... at 100% IBS and 100% Case Temperature

TABLE 6-19 (Continued)

(A) <u>SOLID STATE SYSTEM</u>	(B) <u>CONVENTIONAL SYSTEM</u>	(C) <u>HYBRID SYSTEM</u>
Contact bounce and chatter found in electromechanical devices are not present in the solid state power controllers. The absence of these factors contributes to a more desirable EMI environment.	Contact bounce and chatter cause arcing in DC circuits, resulting in the generation of EMI. Recent tests on solenoids show that arcing caused by opening a switch persisted for as long as 0.28 milliseconds. Erratic voltages occurred on the line with amplitudes to 250 volts. Further, arcing and burning along with normal wear cause deteriorated performance such as increased contact resistance and drop.	Same as B.
The solid state system has incomplete isolation between the source and load. This means some leakage current, approximately 10^{-4} times the current rating of the power controller.	The conventional system has complete isolation between source and load.	Same as B.
Solid state load controllers are unidirectional devices, even AC units which have the power supply in the source end. In instances where unidirectional flow is desired, two controllers are required. In some cases, unidirectional characteristics can be used to advantage.	Electromechanical devices are for the most part bidirectional devices.	Same as B.
Bus controllers are designed to switch between unsynchronized AC power sources in as short a time as 2.5 milliseconds. This greatly reduces the amount of energy which must be stored in batteries or capacitors to	To switch between unsynchronized sources using mechanical contactors require approximately 50 milliseconds -- 25 milliseconds for the contactor of the off-going source and 25 milliseconds for the contactor of	Same as B

150

... power to critical loads such as radar, navigation and certain computer equipment during power transfers. Switching times in excess of 2.5 milliseconds is a function of the number and size of devices such as motors acting as generators feeding power back onto the bus and thus holding bus voltage up momentarily. Transfer occurs only on a "dead" bus. Filter capacitors in existing power conditioning and power supplies should have sufficient energy storage to carry through the short transfer time.

Further reductions in EMI can be obtained by twisting each load power wire with its ground wire. This is made possible by locating load controllers in the vicinity of large concentrations of loads. This reduces the length of twisted lines to a minimum.

With the flexibility of control and power switching on the solid state system, sequencing of loads is attractive. By sequencing loads large step changes in source loading are

the in-circuit source. With the sophisticated equipment expected for vehicles such as the shuttle, one or more batteries would need to "float" on the bus to supply power to all loads during bus transfers and other momentary outages. To supply power to all loads may penalize the battery system. Another alternative is to provide battery support power to selected loads; however, this is complicated by the need for high speed switching of selected equipment between normal power and battery power. The best solution is the capability to rapidly and automatically switch between unsynchronized sources as done in A.

Twisting of load power wires and ground wires is not practical in the conventional system. To do so would essentially double the power wire and wire weight.

Load sequencing is not practical with the conventional system. Buses rather than individual loads are switched in such a system. Bus switching can provide only a

Same as B.

The hybrid system has the flexibility of the control system of A. It also has a power switching device (relay) in each load power circuit. Therefore, it essentially has all the

TABLE 6-19 (Concluded)
(E)

(A)

SOLID STATE SYSTEM

eliminated. This reduces the magnitude of over and under voltage transients due to sudden load changes. Since each load can be programmed and controlled individually, load sequencing is a matter of proper programming of the Master Unit. There is an inherent built-in sequencing in loads -- approximately 20 m sec delay between energization of each load. Whether this delay is sufficient is a function of number, types and power requirements of the loads.

151

Another improvement which can readily be incorporated into the solid state system is that of automatic load monitoring. Here, each load is assigned a priority during programming of the MU. In operation low priority loads are automatically "dumped" as power source capacity is lost or reduced. An abbreviated version could be used to optimize loading on an emergency electrical system. Again the use of a switching device in each load power circuit and the programmable flexibility of the control system permits the incorporation of load monitoring with minimum penalty.

CONVENTIONAL SYSTEM

sequencing of large blocks of loads. To switch individual loads would require incorporation of a switching device such as a relay in each load power circuit. A switching device (power controller) is present in each load power circuit in A.

The conventional system is much less flexible than A in regard to load monitoring. Here, load monitoring is performed by "dumping" load priority buses through bus switching. This drops large blocks of loads and each load must have its priority established during design. To change priority in operation requires a wiring change -- moving the load from one bus to another. Automatic monitoring to the individual load level requires the addition of considerable switching and control complexity. This is not normally practical even on emergency loads, thus the loading of the emergency system is dependent upon the ON-OFF condition of its preassigned loads.

(C)

HYBRID SYSTEM

capabilities of A for incorporation of a load sequencing program.

The hybrid system essentially has all the capabilities of A in regard to automatic load monitoring.

TABLE 6-20 Comparison of Impact upon Power Sources and Utilization

(A) <u>SOLID STATE SYSTEM</u>	(B) <u>CONVENTIONAL SYSTEM</u>	(C) <u>HYBRID SYSTEM</u>
<p>The most significant impact that the solid state system has upon power sources is the opportunity to reduce fault current capacity. To properly trip and coordinate circuit breakers and fuses, turbo-alternators have been required to supply 3 per unit fault current into a 3-phase fault for 5 seconds. To meet the 3-phase requirement, single phase-to-ground faults (worst case) can reach a source capacity of 12 per unit in the first few cycles of an asymmetrical fault current. Fault current capacities of power sources can be reduced to 1.25 to 1.5 per unit by using load controllers incorporating current limiting, rapid trip and close tolerance trip bands. Advantages to be gained by reducing fault current capacity are 1) reductions in power source weight up to 30%, 2) reduction in voltage transients under normal operation and 3) reduction in thermal and mechanical transients in power source, wiring and distribution equipment.</p> <p>The reduced magnitude and duration of transients cause less disturbance to power source regulators, contributing to a more stable source control. This in turn results in further reduced transient levels.</p> <p>Reduced transients cause less power dissipation in power conditioning regulator equipment for the duration of the transient.</p> <p>Improved EMI environment has an impact on utilization equipment. Features contributing to improved EMI compatibility have been covered.</p>	<p>The conventional system would still require the 3 per unit fault current to clear circuit breakers and fuses.</p>	<p>Same as B.</p>

6.8 Power Losses

An objective of the program is to maintain power losses in the proposed electrical power distribution system less or at least equivalent to the losses in the conventional system. An analysis of the power losses for the conventional, solid state and hybrid systems was performed and documented below. Table 6-21 provides a summary of the analysis.

TABLE 6-21 Summary of System Losses

<u>System</u>	<u>Power Losses (Watts)</u>
Conventional	3779
Solid State	3903
Hybrid	3422

Those items common to all three systems are not included. Source feeder losses on the conventional and hybrid systems are about the same as the source and distribution feeder losses on the solid state system. The losses on the solid state system are only 124 watts more than those of the conventional system. The improved transient performance of the solid state system could easily account for a savings of 124 watts in power conditioning and power supplies within utilization equipment. The numerical values obtained in Table 6-21 are high based upon rated currents. Most often actual current is much less than rates, which reduces losses substantially. Since the same assumption is made for all three cases, the comparison is valid.

6.8.1 Conventional System

Power losses in the conventional system are composed of [1] circuit breaker, relay and switch contact resistance; [2] relay and contactor coil power, and [3] I^2R losses in power wiring. From a review of several specifications, switch contact losses average out to be approximately 0.9 watts per contact. In calculating the power losses for the conventional system, the following assumptions were made:

- (1) Assume 625 power circuits, many of which are branched.
- (2) Assume an average of 6 contacts per circuit.
- (3) Assume power dissipation of 0.9 watts per contact.
- (4) Assume coil current of 100 ma with one relay per four circuits or 0.7 watts per circuit for coil power.

- (5) Assume a load factor of 70% for all load circuits.
- (6) Assume 54 contactor contacts and 0.6 amperes per coil.

Calculations

A. Load Circuit Losses

(1)	Contacts (6)(0.9)(625) =	3,380 watts
(2)	Relay coils (0.7)(625) =	437
(3)	Power Wiring (rough estimate) =	<u>1,200</u>
(4)	Total Load Circuit Losses	5,017
(5)	Load Factor	<u>x 0.7</u>
(6)	Estimated Load Circuit Losses	3,611.9 watts

B. Power Contactor Losses

(1)	Contacts (54)(0.9) =	48.6
(2)	Coils (7)(0.6)(28) =	<u>118.0</u>
(3)	Estimated Contactor Losses	166.6

C. Total Losses

(1)	Load Circuit Losses	3,612 watts
(2)	Power Contactor Losses	<u>167 watts</u>
(3)	Total Losses	3,779 watts

6.8.2 Solid State System

Power losses in the solid state system are comprised of (1) power controller dissipation; (2) data handling system power; (3) signal source excitation power; and (4) I²R losses in power wiring. Load factor is assumed to be 0.7. The quantity of power controllers was subdivided, 60% were assumed to be DC and 40% were assumed to be AC.

Calculations

A.	Power Controller Dissipation per Table 6-22	3,420 watts
B.	Power Wiring Losses (0.7 of 1/3 of conventional)	280
C.	Data Handling	200
D.	Signal Sources	<u>3</u>
	Total System Power Dissipation	3,903 watts

TABLE 6-22 POWER CONTROLLER LOSSES

<u>Current Rating</u>	<u>Type</u>	<u>Dissipation OFF/Unit</u>	<u>No. of PC OFF</u>	<u>Dissipation OFF (Watts)</u>	<u>Dissipation ON/Unit</u>	<u>No. of PC ON</u>	<u>Dissipation ON (Watts)</u>
1	DC	.153	60	9.25	1.5	140	210.0
2	DC	.156	36	5.61	2.0	83	166.0
3	DC	.158	19	3.00	2.5	44	110.0
5	DC	.164	14	2.30	4.5	34	153.0
7½	DC	.171	2	.34	6.5	3	19.5
10	DC	.178	6	1.07	6.5	15	97.5
15	DC	.192	4	.76	12.5	7	87.5
25	DC	.220	2	.44	22.0	4	88.0
35	DC	.248	0	----	31.0	4	124.0
50	DC	----	----	----	35.0	2	70.0
200	DC	1.42	2	2.84	125.0	2	250.0
1	AC	.311	41	12.73	1.75	96	168.0
2	AC	.311	24	7.46	3.25	55	179.0
3	AC	.311	13	4.05	4.75	30	142.5
5	AC	.311	10	3.11	8.0	22	176.0
7½	AC	.311	0	----	11.75	3	35.3
10	AC	.311	4	1.24	16.0	8	128.0
15	AC	.311	3	.93	25.0	0	-----
25	AC	.311	3	.93	40.0	3	120.0
35	AC	.311	0	----	55.0	6	330.0
75(BC)	AC	5.0	18	<u>90.00</u>	120.0	6	<u>720.0</u>

Watts Dissipation

146.06

3,374.3

Power Controller "OFF" Dissipation = 146.0 watts

Power Controller "ON" Dissipation = 3374.0 watts

Total Dissipation = 3420.0 watts

Hybrid System

Power losses in the hybrid system are composed of (1) circuit contact resistance; (2) relay and contactor coil power; (3) relay drivers; (4) I^2R losses in power wiring; (5) data handling power; and (6) signal source excitation power. The following assumptions were made in calculating power dissipation:

- (1) Assume 780 power circuits, circuit breakers, relays and relay drivers.
- (2) Assume power dissipation of 0.9 watts per contact.
- (3) Assume 100 ma coil power for each relay.
- (4) Assume a load factor of 70%.
- (5) Assume 36 contactor contacts and 0.6 amperes per coil.
- (6) Assume power wiring losses are 70% of conventional system ($.70 \times 1200 = 840$ watts)

Calculations

Load Circuit Losses

(1) Contacts - Breakers	$(780)(0.9) =$	702 watts
(2) Contacts - Relays	$(780)(0.9) =$	702
(3) Coil Power - Relays	$(780)(0.1)(28) =$	2,184
(4) Drivers	$(780)(0.5) =$	36
(5) Power Wiring Losses		<u>840</u>
Total Load Circuit Losses in Watts		4,464
(6) With 0.7 load factor losses	$= 4464 \times .7 =$	3,120 watts

Contactor Losses

(1) Contacts	$(54)(0.9) =$	48.6
(2) Coils	$(3)(0.6)(28) =$	<u>50.4</u>
Total Contactor Losses		99.0

Total Losses

(1) Load Circuit Losses	3,120 watts
(2) Contactor Losses	99
(3) Data Handling System	200
(4) Signal Sources	<u>3</u>
Total Hybrid Losses	3,422 watts

6.9 Development Time and Cost

6.9.1 Power Controller Development

From prior program planning efforts and other inputs, a recommended master plan for power controller development was derived and is shown in Figure 6-10. Where necessary the overall development plan can be accelerated at least one year by eliminating the demonstrator and its evaluation phases. A minimum cost and time program would be to eliminate the engineering model phase and substitute production and qualification of first ship set plus spares, obtaining qualified hardware in mid 1973.

Budgetary funding was estimated and provided only through the Engineering Model Phase because of the uncertainty of pricing and economic conditions beyond 1973, the uncertainty of power controller configurations and the unknown quantities of units. Funding for the Engineering Model Phase is based upon three alternates. The first alternate considers all ratings of single channel power controllers, both AC and DC, through 75 amperes AC and 200 amperes DC. The second alternate considers only single channel power controllers, both AC and DC, through 10 amperes. The last alternate considers multi-channel units, AC and DC.

Funding has been adjusted to reflect a compounded rate of inflation of 5% through 1972. An additional 15% has been added to take care of contingencies. The quantities of engineering models considered for each alternate are listed below.

1. Alternate 1 - Full family of single channel power controllers

Part Number	Type	Rating	Quantity
204-99-12-1	DC	Driver	10
204-99-12-2	DC	Driver	10
204-99-9-1B	DC	1	10
204-99-9-2B	DC	2	10
204-99-9-3B	DC	3	10
204-99-9-5B	DC	5	5
204-99-9-7B	DC	7.5	5
204-99-9-10B	DC	10	5
204-99-9-15B	DC	15	3
204-99-9-25B	DC	15	3
204-99-9-35B	DC	35	3
204-99-9-50B	DC	50	2
204-99-9-75B	DC	72	2
204-99-9-99B	DC	100	2
204-99-9-200B	DC	200	2

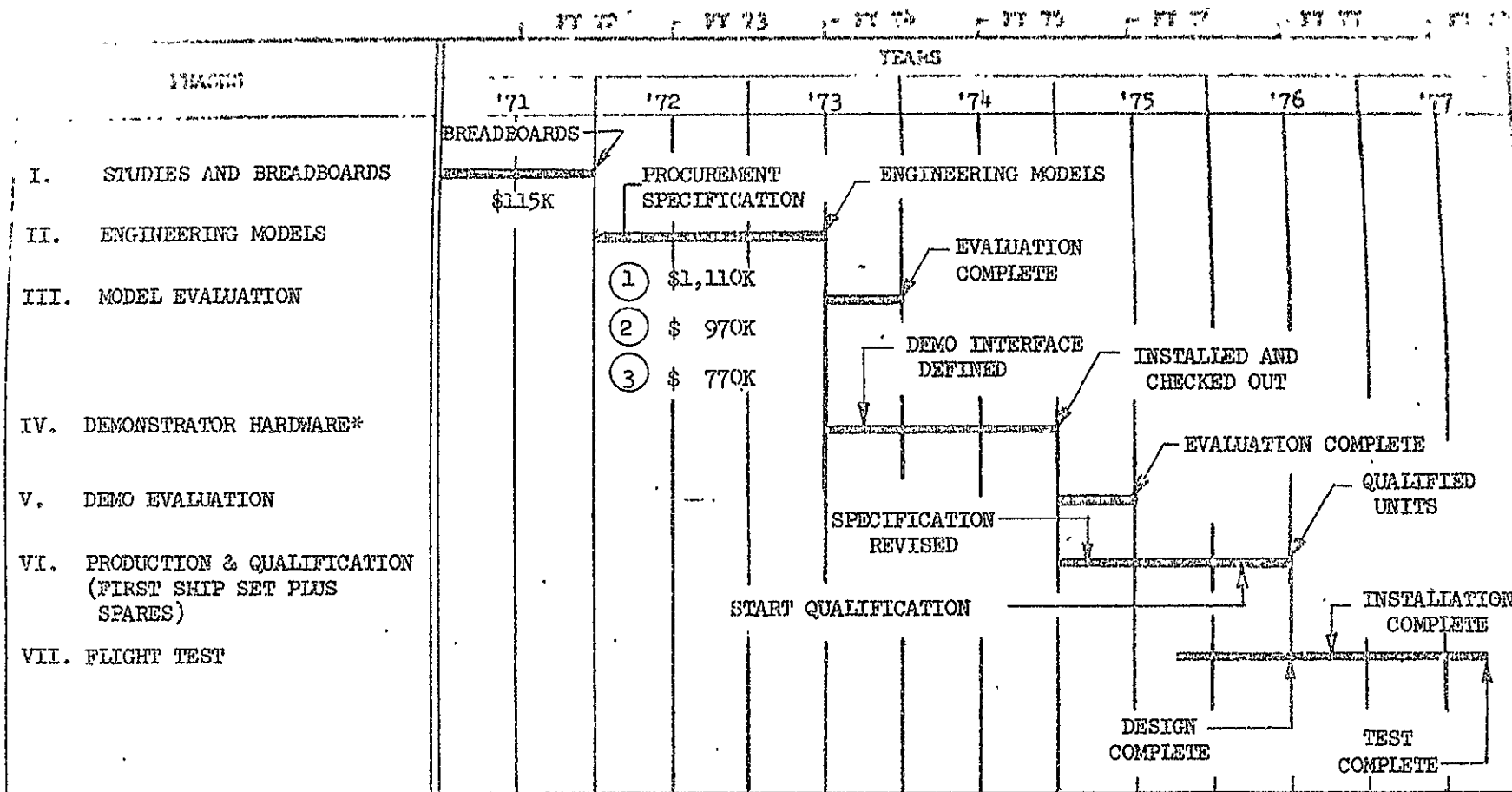

*1) Could be simulator hardware.
 2) Includes power controller hardware only which would be identical or similar to engineering models.

(1) All ratings of single channel units.
 (2) Single channel units; AC and DC through 10 ampere.
 (3) Multi-channel units per specification

FIGURE 6-10 MASTER PLAN FOR DEVELOPMENT OF POWER CONTROLLERS

Part Number	Type	Rating	Quantity
204-99-9-1A	AC	1	10
204-99-9-2A	AC	2	10
204-99-9-3A	AC	3	10
204-99-9-5A	AC	5	6
204-99-9-7A	AC	7.5	6
204-99-9-10A	AC	10	6
204-99-9-15A	AC	15	3
204-99-9-25A	AC	25	3
204-99-9-35A	AC	35	3
204-99-9-75A	AC	75 (Bus Controller)	2

2. Alternate 2 - Lower ratings of single channel power controllers

Part Number	Type	Rating	Quantity
204-99-12-1	DC	Driver	10
204-99-12-2	DC	Driver	10
204-99-9-1B	DC	1	10
204-99-9-2B	DC	2	10
204-99-9-3B	DC	3	10
204-99-9-5B	DC	5	5
204-99-9-7B	DC	7.5	5
204-99-9-10B	10	5	
204-99-9-1A	AC	1	10
204-99-9-2A	AC	2	10
204-99-9-3A	AC	3	10
204-99-9-5A	AC	5	6
204-99-9-7A	AC	7.5	6
204-99-9-10A	AC	10	6

3. Alternate 3 - Multi-channel power controllers

(16-channels DC and 18-channels AC)

Part Number	Type	Rating	Quantity
204-99-9-100B	DC	Various	3
204-99-9-100A	AC	Various	2

The engineering model(s) are essentially pre-production units. In order to be as similar as practical to a production configuration and of a size and weight to meet the specification, the unit must use hybrid circuits. To minimize future production cost, it is desirable to

design and fabricate the hybrid and/or integrated circuits to satisfy production requirements. This was considered in establishing funding requirements and is the major factor in the high cost shown for the engineering model(s).

In order for a cost analysis to be complete, system operating cost and a life cycle cost should be considered; however, at this early stage of development, insufficient data on system configurations, mission profiles, life, number of vehicles, etc., are available to make a meaningful analysis.

6.9.2 Data Handling System (DHS) Development

The recommended master plan for development of a dedicated DHS for spacecraft is illustrated in Figure 6-11. The plan parallels that of power controller development. Statements made in regard to power controller program acceleration and minimum cost and time are applicable for the DHS. Again, the same inflation rates and contingencies are assumed for the DHS funding.

The engineering models would incorporate hybrid and/or integrated circuits to obtain production configuration, weight, and size. This is a major factor in the high cost shown in Figure 6-11 for the engineering models. The quantities of engineering models assumed for the estimates are listed as follows:

Item	Description	Quantity
1.	Master Unit	1
2.	Remote Input Terminal - Modified (RIT)	2
3.	Remote Output Terminal - Modified (ROT)	2
4.	Monitor Input Terminal (MIT)	1
5.	Line Extenders	2
6.	Interface Unit	1
7.	Support Equipment - Loader/Verifier	1
8.	Support Equipment - Decoder	1

6.9.3 Signal Source Development

The recommended master plan for development of signal sources for spacecraft electrical power distribution control systems is shown in Figure 6-12. Again, the plan parallels that for development of power controllers. It should be noted that shorter times are necessary for engineering models, demonstrator hardware, and production/qualification; but no overlap is provided between these tasks and NASA operations. Also statements made in regard to program acceleration, minimum cost and time, inflation rates and contingencies apply to signal source development.

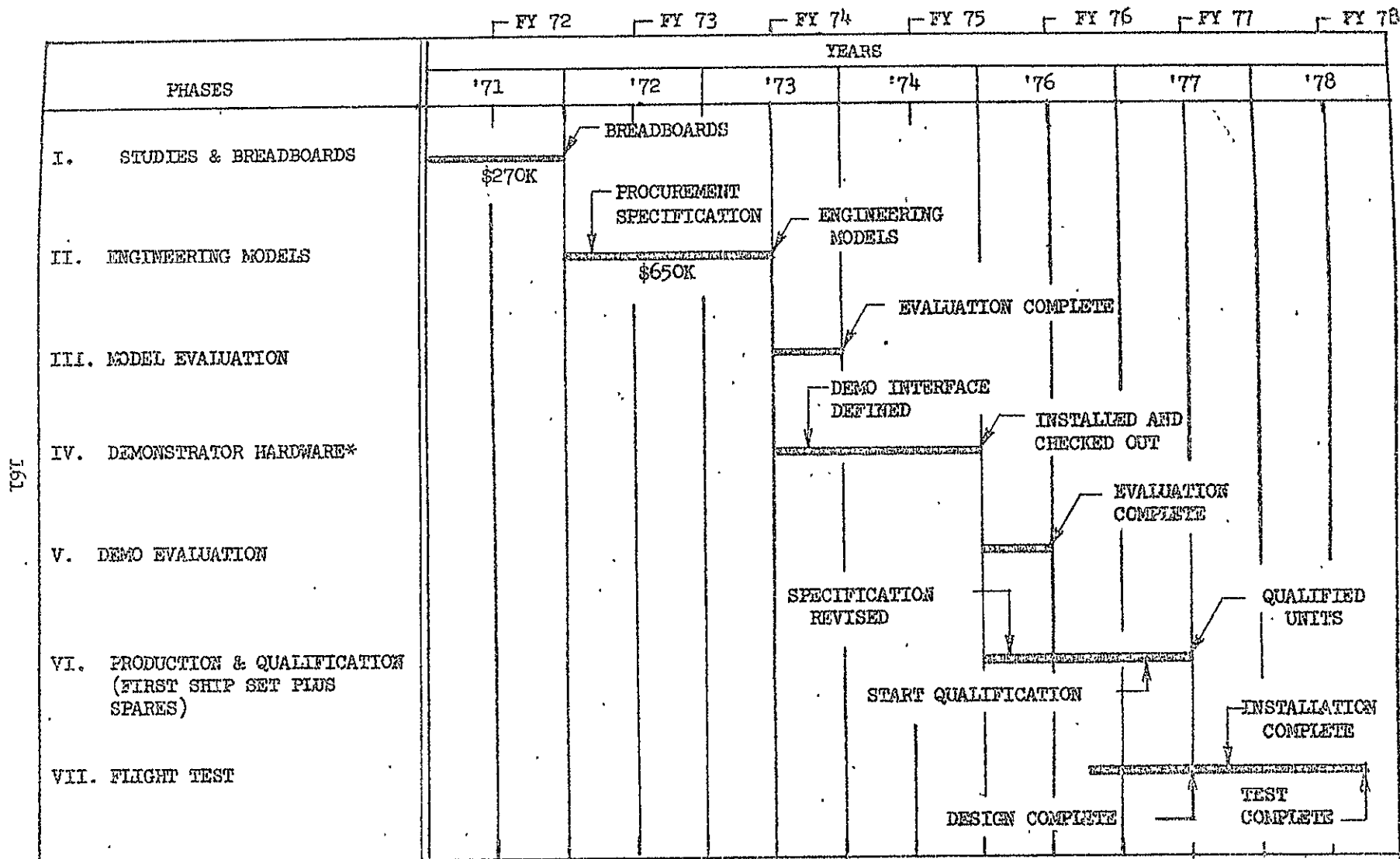

- *1) This could be simulator hardware.
- 2) Includes DHS hardware only which would be identical or similar to engineering models.

FIGURE 6-11 MASTER PLAN FOR DEVELOPMENT OF A DEDICATED DATA HANDLING SYSTEM (DHS)

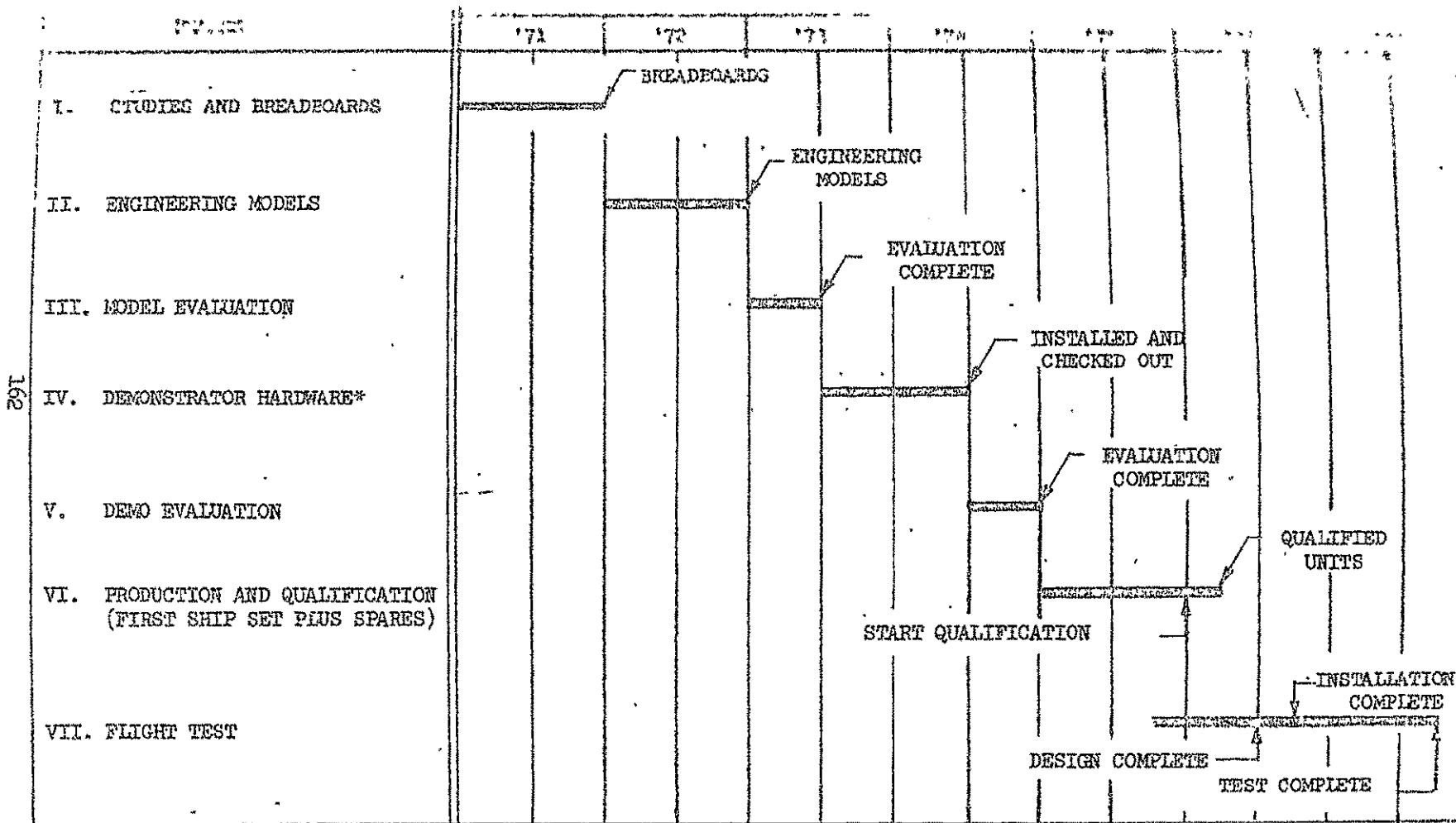

*1) Could be simulator hardware.

2) Includes signal source hardware only which would be identical or similar to engineering models.

FIGURE 6-12 MASTER PLAN FOR DEVELOPMENT OF SIGNAL SOURCES

The engineering models include development of production hybrid and/or integrated circuits to obtain production equivalent packaging, weight and size. The quantities and types of engineering models assumed for the estimates are listed as follows:

Item	Description	Quantity
1.	Toggle ON-OFF Switch	10
2.	Toggle ON-OFF-ON Switch	10
3.	Push-Button ON-OFF Switch	10
4.	Rotary Switch - Four Position	5
5.	Rotary Switch - Three Position	5
6.	Electronic Module - Proximity	3
7.	Electronic Module - Temperature	3
8.	Electronic Module - Pressure	3

6.9.4 Comparison

In comparing development time and cost for the three concepts, it is assumed that the conventional system can be implemented without development time and cost. The hybrid system would require the development times and costs for the signal sources and DHS. The solid state system requires the development times and cost for signal sources, DHS and power controllers. Based solely upon development time and cost, it is apparent that the concepts would be rated in the order of conventional, hybrid and solid state. The many other factors in favor of the solid state system make it unwise to make a judgment based solely on development and cost.

4.3 CONCLUSIONS

It has been demonstrated that the solid state electrical power distribution and control system concept, as applied to advanced spacecraft, satisfies all of the design goals enumerated in Section 1.0. As compared to a conventional system, the solid state system concept:

1. Reduces overall system weight and size by 50%. The program design goal was established at 40%.
2. Improves reliability by a factor of 9. Program goal was to improve reliability by a factor ranging from 5 to 10.
3. Maintains overall system losses approximately equivalent to those of the conventional system which is the goal of the program.
4. Reduces power source fault current capacity requirements from 3.0 per unit to 1.5 per unit, representing a 50% reduction which is the goal of the program.
5. Utilizes modular construction, a program goal.
6. Incorporated pre-flight, in-flight and post-flight test to the replaceable module level, a program goal.
7. Eliminates major wiring changes to accommodate changes to control logic functions by incorporation of programmable logic.
8. Provides remote reset capability for load controllers, another program goal.
9. Optimizes the entire system, cost and function. Redundant components, built-in test and automatic switch-over are provided where component failure could endanger the system. Components are design to fail in a "fail-safe" mode.

The solid state system concept cannot meet the billing given above without additional design, development, modification, and cost. For spacecraft applications, the major changes to the system hardware presently under development for aircraft are summarized below:

1. Design and development of switched impedance signal sources to satisfy built-in test, reduced power and wiring requirements.
2. Modification of Remote Input Terminals (RIT) to interface with the switched impedance signal sources.

3. Modification of Remote Output Terminals (ROT) to interface with the power controller which now incorporates built-in test.
4. Design and development of Line Extender (LE) for increasing the allowable length of multiplex transmission lines.
5. Design and development of Monitor Input Terminals (MIT) for point-to-point data handling of signal source BITE FAULT and load controller TRIP and BITE FAULT indication signals.
6. Design and development of a unit to interface the solid state power distribution and control system with an integrated controls and display system.
7. Modification of power controller to utilize the multi-channel packaging concept and to incorporate the built-in test feature. Investigate possibilities for incorporation of current limiting into AC units.
8. Modify and finalize packaging to incorporate hybrid and integrated circuits and to accommodate cold plate cooling.

The design, development and modifications above are all within the state-of-the-art and have been proven from an analytical and conceptual standpoint. System implementation is a matter of detail design, qualification, and funding.

ACKNOWLEDGEMENTS

Appreciation is extended to the following organizations for providing data, information, and assistance during the course of the program.

- 1.3 Leach Corporation, Relay Division; Los Angeles, California.
- 1.7 LTV ElectroSystems; Garland, Texas.
- 1.8 NASA Manned Spacecraft Center; Information Division - Power Distribution Section; Houston, Texas.
- 1.4 SCI Systems; Huntsville, Alabama.
- 1.5 Teledyne Relays, Inc.; Hawthorne, California.
- 1.6 Texas Instruments Inc.; Attleboro, Massachusetts.

- 9.0 REFERENCES AND BIBLIOGRAPHY
- 9.1 Monthly Progress Report, "Advanced Spacecraft Electrical Power Systems Applying Solid State Technology", 9 February 1970, NASA Contract NAS9-10418.
- 9.2 Monthly Progress Report, "Advanced Spacecraft Electrical Power Systems Applying Solid State Technology", 10 March 1970, NASA Contract NAS9-10418.
- 9.3 Monthly Progress Report, "Advanced Spacecraft Electrical Power Systems Applying Solid State Technology", 13 April 1970, NASA Contract NAS9-10408.
- 9.4 Monthly Progress Report, "Advanced Spacecraft Electrical Power Systems Applying Solid State Technology", 13 May 1970, NASA Contract NAS9-10408.
- 9.5 Monthly Progress Report, "Advanced Spacecraft Electrical Power Systems Applying Solid State Technology", 11 June 1970, NASA Contract NAS9-10408.
- 9.6 Monthly Progress Report, "Advanced Spacecraft Electrical Power Systems Applying Solid State Technology", 13 July 1970, NASA Contract NAS9-10408.
- 9.7 Monthly Progress Report, "Advanced Spacecraft Electrical Power Systems Applying Solid State Technology", 12 August 1970, NASA Contract NAS9-10408.
- 9.8 Monthly Progress Report, "Advanced Spacecraft Electrical Power Systems Applying Solid State Technology", 11 September 1970, NASA Contract NAS9-10408.
- 9.9 Monthly Progress Report, "Advanced Spacecraft Electrical Power Systems Applying Solid State Technology", 13 October 1970, NASA Contract NAS9-10408.
- 9.10 R. N. Stock, R. W. Powell, "Development of a Solid State Electrical Distribution System", Final Report, prepared by American Machine and Foundry Company, Alexandria, Virginia, for AF Aero-Propulsion Lab under Contract No. AF33(657)-8688, Report No. ASD-TDR-63-805, October 1963 (AD422380)

- 7.11 L. D. Dickey, A. J. Marek, "Investigation of Contactless Switching Concepts for Application to Aircraft Electrical Systems, Volume I - Aircraft Systems Requirements", LTV Vought Aeronautics Division, LTV Aerospace Corp., Dallas, Texas. (AD417130)
- 7.12 L. D. Dickey, W. M. Drum, A. J. Marek, "Investigation of Electrical Systems, Volume II - Concept Design Studies", LTV Vought Aeronautics Division, LTV Aerospace Corp., Dallas, Texas. (AD417245)
- 7.13 L. D. Dickey, W. M. Drum, A. J. Marek, "Investigation of Contactless Switching Concepts for Application to Aircraft Electrical Systems, Volume III - System Investigations and Developmental Requirements", LTV Vought Aeronautics Division, LTV Aerospace Corp., Dallas, Texas. (AD417131)
- 9.14 W. E. Hutt, A. J. Marek, "Investigation of Contactless Switching Concepts for Application to Aircraft Electrical Systems, Volume IV - Development and Evaluation of Contactless Switching Components", LTV Vought Aeronautics Division, LTV Aerospace Corp., Dallas, Texas. (AD543826)
- 9.15 W. M. Drum, J. L. Jones, "Investigation of Contactless Switching Concepts for Application to Aircraft Electrical Systems, Volume V - Investigation of Multiple Signal Generation, Transmission and Detection", LTV Aerospace Corp., Dallas, Texas. (AD618527)
- 9.16 A. J. Marek, "Investigation of Contactless Switching Concepts for Application to Aircraft Electrical Systems, Volume VI - Flight Test Evaluation of a Prototype Contactless Switching System", LTV Aerospace Corp., Dallas, Texas. (AD628581)
- 7.17 H. S. Bates, "Investigation of Contactless Switching Concepts for Application to Aircraft Electrical Systems, Volume VIII - Development and Evaluation of Checkout Concepts for a Contactless Switching System", LTV Aerospace Corp., Dallas, Texas (AD45428)
- 7.18 C. M. Jones, A. J. Marek, H. S. Bates, L. D. Dickey, "Exploratory Development Program to Prove the Feasibility of Solid-State Switching for a Complex Electrical Control Network", LTV Vought Aeronautics Division, LTV Aerospace Corp., Dallas, Texas (AD818554)

- 9.19 J. L. Jones, O. H. Preston, F. D. Forbes, "Advanced Aircraft Electric System Studies and Consultation for a Proposed Technical Approach (PTA) Documentation", Final Report 2-50100/9R-2607, July 1969, LTV Vought Aeronautics Division, LTV Aerospace Corp., Dallas, Texas, Navy Contract N00019-68-C-0424. (AD856506).
- 9.20 J. L. Jones, J. E. Russell, H. W. Heinzman, "Advanced Aircraft Electric System Studies and Technical Consultation:", Final Report 2-55900/0R-2830, September 1970, LTV Vought Aeronautics Company, Dallas, Texas, Navy Contract N62269-69-C-0379.
- 9.21 "Integrated Circuit and Aircraft Supply Compatibility - Why Not?" a paper presented by Alex M. Taylor of the Boeing Company at the IEEE Power Conditioning Specialists Conference in Greenbelt, Maryland, 20 April 1970.
- 9.22 "Application of Contactless Switching to Aircraft Electrical Systems", by L. D. Dickey, presented at the Bureau of Naval Weapons Symposium on Advanced Techniques for Aircraft Electric Systems on 15 October 1962 in Washington, D. C.
- 9.23 "Application of Contactless Switching to Aircraft Electrical Systems", by L. D. Dickey, presented at the Bureau of Naval Weapons Symposium on Advanced Techniques for Aircraft Electric Systems on 15 October 1963, in Washington, D. C.
- 9.24 "Development Program for, and the Application of Contactless Switching to Aircraft Electrical Systems", Progress Report by L. D. Dickey and A. J. Marek, presented at the Bureau of Naval Weapons Symposium on Advanced Techniques for Aircraft Electric Systems on 13 October 1964, in Washington, D. C.
- 9.25 "Application of Contactless Switching to Aircraft Electrical Systems", Progress Report by H. S. Bates and A. J. Marek, presented at the Naval Air Systems Command Symposium on Advanced Techniques for Aircraft Electrical Systems on 12-13 October 1965. in Washington, D. C.
- 9.26 "Application of Contactless Switching to Aircraft Electrical Systems", Progress Report by H. S. Bates and A. J. Marek, presented at the Naval Air Systems Command Symposium on Advanced Techniques for Aircraft Electrical Systems on 11-12 October 1965, in Washington, D. C.

"Contactless Switching - An Application of Solid State Switching Technology to Aircraft Electric Systems", presented by C. M. Jones at the IEEE, NAECON in Dayton, Ohio, 16 May 1967.

"Built-In-Test for Aircraft Solid State Electrical Systems", presented by H. S. Bates at the IEEE, NAECON in Dayton, Ohio, 19-21 May 1969.

"Guide Lines for the Application of Semiconductor Technology to Electric Power Distribution Systems", presented by C. M. Jones at the Ohmite Think-In Seminar No. III, Los Angeles, California, 18 February 1970.

"Solid State Power Controller Circuits and Their Effect upon Power Conditioning Requirements", C. M. Jones, H. W. Heinzman, presented at the Power Conditioning Specialist Conference - IEEE Goddard Space Flight Center, Greenbelt, Maryland, 20 April 1970; and the SAE - Naval Air Transportation Meeting, New York, N. Y., 23 April 1970.

MIL-S-81619A/1(AS), "Switches, Solid State Transducer, General Specification for", 8 October 1969; approved by the Naval Air Systems Command, Department of the Navy.

MIL-P-81653(AS), "Power Controller, Solid State, General Specification for", 17 November 1969; approved by the Naval Air Systems Command, Department of the Navy.

APPENDIX I

PROGRAM HISTORY OF SOLID STATE
ELECTRIC LOGIC SYSTEM

In 1960, the Vought Aeronautics Division of LTV Aerospace Corporation inaugurated an in-house R&D study program to determine the feasibility of using solid state switching devices in aircraft electric power control and distribution systems. The results of these initial studies indicated that the use of semiconductor devices in the areas of switching, control, and protection would provide an electrical system with improved performance and less weight and volume than could be obtained with a functionally equivalent electromechanical system.

In 1962, the Naval Air Systems Command awarded a study contract to VAD to further investigate the application of semiconductor devices to aircraft electrical systems. Since 1962, the Naval Air Systems Command along with the Air Force and NASA have continued to fund programs relating to the solid state concept. Figure A-1 shows the programs conducted, the contracting agency, the contract number, and the time period the programs were conducted. A brief description of the tasks performed during each program and the Defense Documentation number of the final engineering report follows.

1. The program conducted under Contract NOw-62-0944c is entitled "Investigation of Contactless Switching Concepts for Application to Aircraft Electrical Systems" and consists of three phases as described below:

Phase I - Aircraft System Requirements AD-417130

Specific factors that must be considered when developing solid state devices for performing functions presently performed with relays, switches, and circuit breakers were defined. Aircraft electrical power characteristics such as voltage transients, voltage surges, voltage regulation, frequency transients, etc., were investigated to determine the effect of these characteristics on semiconductor components. Semiconductor characteristics are discussed in light of aircraft electrical system requirements so that design criteria can be established. A basic system philosophy was adopted which allowed the separation of signal circuits from power circuits and permitted the use of a minimum number of switching devices in the power circuit. A survey was made on power semiconductors to determine availability and development trends. Preliminary electrical characteristic requirements were established for semiconductor components to be used in an aircraft electrical system.

Phase II - Concept Design Studies AD-417245

Contactless switching design techniques were developed and evaluated for application to aircraft electrical systems. Circuits have

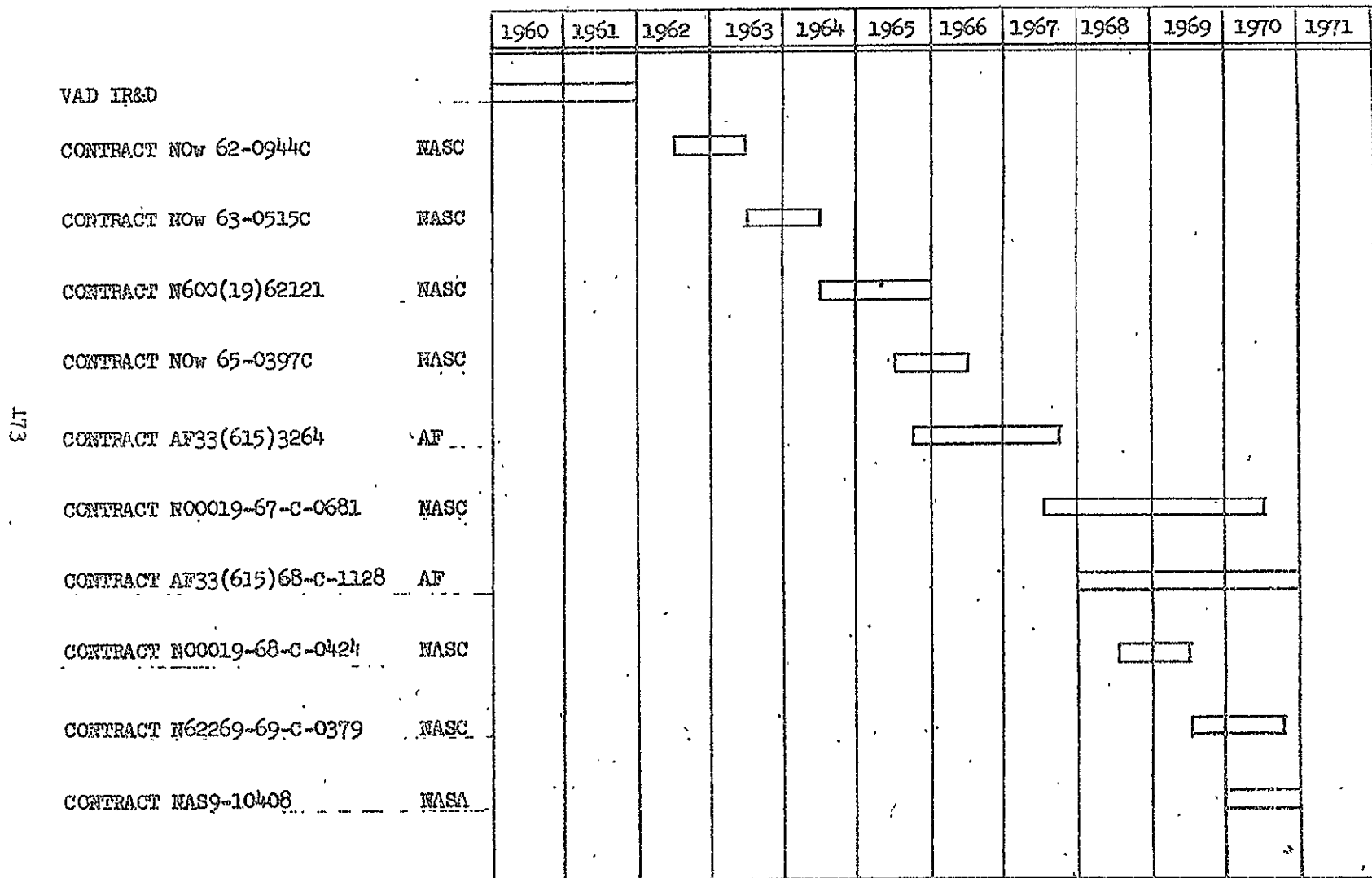

FIGURE A-1 SOLID STATE ELECTRIC SYSTEM DEVELOPMENT HISTORY

designed, breadboarded and evaluated that will perform the functions of conventional switches, relays and circuit breakers. Mechanical characteristics are discussed for signal sources, control logic and power controllers.

Phase III - System Investigation and Developmental Requirements
AD-417131

The system philosophy adopted for the SOSTEL system was defined. A breadboard system was assembled and evaluated. System design, operation, packaging and installation requirements were investigated from an aircraft system designer's viewpoint. Design criteria and performance goals were established for components comprising the SOSTEL system. A program plan is presented for the development of the required components.

2. Phase IV of the Solid State Program was conducted under Contract N0w63-0515c and is entitled "Development and Evaluation of Contactless Switching Components". The final report is assigned number AD-458826.

The tasks performed during this phase included the development and evaluation of prototype signal sources, a control logic assembly and power controllers. The prototype hardware was connected to simulate a system and operated to determine compatibility. Preliminary specifications were prepared for signal sources, a control logic assembly, and power controllers.

3. Phase V was conducted under Contract N0w 63-0515c and is entitled "Investigation of Multiple Signal Generation, Transmission and Detection". The final report is assigned number AD-618527.

The tasks performed during this phase include establishing requirements for a multiplexing system to be used in conjunction with the solid state system. Several system concepts were developed and analyzed. Conclusions on the feasibility of using multiplexing for aircraft applications were presented.

4. Phase VI was conducted under Contract N600(19)62121 and is entitled "Flight Test Evaluation of a Prototype Contactless Switching System". The final report is assigned number AD-628581.

This task included the design of a solid state system to operate a limited number of circuits in an F-8 type airplane. Prototype signal sources, a control logic package, and power controllers were developed. The prototype solid state system was evaluated in the laboratory and flight tests. Results of the flight test are presented. "Proposed" military standard specifications for signal sources, control logic modules, and power controllers were prepared and included in the final engineering

5. Phase VII was conducted under Contract NOW 65-03970, entitled "Development and Evaluation of Checkout Concepts for a Contactless Switching System".

This phase of the program was devoted to establishing methods for checking out a solid state system. Factors affecting the design of a checkout system were discussed. A breadboard of a checkout concept was designed, fabricated, and evaluated.

6. The program conducted under Contract AF33(615)3264 is entitled "Exploratory Development Program to Prove the Feasibility of Solid State Switching for a Complex Electrical Control Network".

Under this program, a solid state sensing and indicator system for the XC-142A main landing gear was developed and evaluated. Solid state components were used to provide position sensing, power control and circuit protection. Proposed military standard specifications were prepared for position sensors and for indicator drivers. These specifications are included in the final engineering report.

7. The program conducted under Contract AF33(615)-68-C-1128 is entitled "Solid State Aircraft Electrical Power Transmission System". Two A-7B electrical system simulators were designed and fabricated. One simulator was designed using conventional technology and the other was designed using solid state technology. The two simulators were tested in the laboratory to establish a functional and physical comparison of the two concepts. This program is not complete at this writing. Scheduled completion date is 1 February 1970.

8. The program conducted under Contract N00019-68-C-0242 is entitled "Advanced Aircraft Electric System Studies and Consultation for a Proposed Technical Approach (PTA)". The final report is assigned number AD-85650c. This was a study program to define the requirements of a second generation solid state system. The second generation system incorporates multiplexing and power conditioning hardware. Studies were conducted and requirements were established for the second generation system. A development program plan for SOSTEL II was established and submitted to the Naval Air Systems Command.

9. The program conducted under Contract N62269-69-C-0379 is entitled "Advanced Aircraft Electric System Studies and Technical Consultation". An AD number has not been assigned at this writing. Under this contract, a study program was conducted to more completely define the second generation solid state system. A proposed military standard specification was prepared for the data handling system and is included in the final engineering report.

DOCUMENT CONTROL DATA - R&D

Classification of title, body of abstract and indexing annotation must be entered when the overall report is classified

1. REPORTING ACTIVITY (Corporate author) Flight Aeronautics Division LTV Aerospace Corporation	2a REPORT SECURITY CLASSIFICATION
	Unclassified 2b GROUP 2-55900

3. REPORT TITLE
 Advanced Spacecraft Electrical Power Systems Applying Solid State Technology

4. DISTRIBUTIVE NOTES (Type of report and inclusive dates)
 FINAL REPORT 1 Jan 1970 31 Dec 1970

5. AUTHOR (Last name, first name, initial)
 Preston, O. H.

6. REPORT DATE December 1970	7a TOTAL NO. OF PAGES 177	7b NO. OF REFS 32
8. CONTRACT OR GRANT NO. NAS 9-10408	9a. ORIGINATOR'S REPORT NUMBER(S) 2-55900/OR-2870	
9. PROJECT NO.	9b OTHER REPORT NO(S) (Any other numbers that may be assigned this report)	

10. AVAILABILITY/LIMITATION NOTICES

11. SUPPLEMENTARY NOTES	12. SPONSORING MILITARY ACTIVITY
-------------------------	----------------------------------

ABSTRACT

A study program was conducted to investigate advanced approaches to solid state circuit protection, signal sensing, control logic and multiplexing for application to advanced spacecraft electrical power distribution and control systems compatible with MIL-STD-704. Several advanced concepts are presently under development for aircraft electrical systems. These aircraft concepts and hardware were investigated to determine the modification or new development required for their use on advanced spacecraft.

Three electrical power distribution and control system concepts were established for advanced spacecraft and investigated in detail. These were (1) the conventional concept using electromechanical switches, relays and circuit breakers; (2) the hybrid system concept using electromechanical devices for power switching and circuit protection, solid state signal sensing, and a dedicated data handling system incorporating programmable logic control and signal multiplexing; and (3) the solid state system concept using solid state devices (power controllers) for power switching and circuit protection, solid state signal sensing and a dedicated programmable logic and multiplexing control system. After an analysis and comparison of the three concepts, the solid state system was selected on the basis of weight, size, reliability, performance, flexibility, EMI compatibility, and maintainability. After an analysis of requirements unique to spacecraft, modifications were made for the development of multi-channel power controllers and dedicated signal sources incorporating built-in test features. Modifications to the dedicated data handling system were recommended to facilitate built-in test signal sources and to more efficiently handle indication and monitor signals.

14. KEY WORDS	LINK A		LINK B		LINK C	
	ROLE	WT	ROLE	WT	ROLE	WT
Solid State						
Power Switching						
Circuit Protection						
Signal Sensing						
Control Logic						
Multiplexing						
Advanced Spacecraft Electrical Power						
Electrical Power Distribution						
Electromechanical Switches						
Hybrid System						
Data Handling						
Programmable Logic						
Signal Multiplexing						

INSTRUCTIONS

1. **ORIGINATING ACTIVITY:** Enter the name and address of the contractor, subcontractor, grantee, Department of Defense activity or other organization (corporate author) issuing the report.

2a. **REPORT SECURITY CLASSIFICATION:** Enter the overall security classification of the report. Indicate whether "Restricted Data" is included. Marking is to be in accordance with appropriate security regulations.

2b. **GROUP:** Automatic downgrading is specified in DoD Directive 5200.10 and Armed Forces Industrial Manual. Enter the group number. Also, when applicable, show that optional markings have been used for Group 3 and Group 4 as authorized.

3. **REPORT TITLE:** Enter the complete report title in all capital letters. Titles in all cases should be unclassified. If a meaningful title cannot be selected without classification, show title classification in all capitals in parenthesis immediately following the title.

4. **DESCRIPTIVE NOTES:** If appropriate, enter the type of report, e.g., interim, progress, summary, annual, or final. Give the inclusive dates when a specific reporting period is covered.

5. **AUTHOR(S):** Enter the name(s) of author(s) as shown on or in the report. Enter last name, first name, middle initial. If military, show rank and branch of service. The name of the principal author is an absolute minimum requirement.

6. **REPORT DATE:** Enter the date of the report as day, month, year, or month, year. If more than one date appears on the report, use date of publication.

7a. **TOTAL NUMBER OF PAGES:** The total page count should follow normal pagination procedures, i.e., enter the number of pages containing information.

7b. **NUMBER OF REFERENCES:** Enter the total number of references cited in the report.

8a. **CONTRACT OR GRANT NUMBER:** If appropriate, enter the applicable number of the contract or grant under which the report was written.

8b, 8c, & 8d. **PROJECT NUMBER:** Enter the appropriate military department identification, such as project number, subject number, system numbers, task number, etc.

9a. **ORIGINATOR'S REPORT NUMBER(S):** Enter the official report number by which the document will be identified and controlled by the originating activity. This number must be unique to this report.

9b. **OTHER REPORT NUMBER(S):** If the report has been included in any other report number (either by the originator or by the sponsor), also enter this number(s).

10. **AVAILABILITY/LIMITATION NOTES:** Enter any line indicating a further dissemination of the report, other than that

imposed by security classification, using standard statements such as:

- (1) "Qualified requesters may obtain copies of this report from DDC."
- (2) "Foreign announcement and dissemination of this report by DDC is not authorized."
- (3) "U. S. Government agencies may obtain copies of this report directly from DDC. Other qualified DDC users shall request through _____."
- (4) "U. S. military agencies may obtain copies of this report directly from DDC. Other qualified users shall request through _____."
- (5) "All distribution of this report is controlled. Qualified DDC users shall request through _____."

If the report has been furnished to the Office of Technical Services, Department of Commerce, for sale to the public, indicate this fact and enter the price, if known.

11. **SUPPLEMENTARY NOTES:** Use for additional explanatory notes.

12. **SPONSORING MILITARY ACTIVITY:** Enter the name of the departmental project office or laboratory sponsoring (paying for) the research and development. Include address.

13. **ABSTRACT:** Enter an abstract giving a brief and factual summary of the document indicative of the report, even though it may also appear elsewhere in the body of the technical report. If additional space is required, a continuation sheet shall be attached.

It is highly desirable that the abstract of classified reports be unclassified. Each paragraph of the abstract shall contain an indication of the military security classification of the information in the paragraph, represented as (TS), (S), (C), or (U).

There is no limitation on the length of the abstract. However, the suggested length is from 150 to 225 words.

14. **KEY WORDS:** Key words are technically meaningful terms or short phrases that characterize a report and may be used as index entries for cataloging the report. Key words must be selected so that no security classification is required. Identifiers, such as equipment model designation, trade name, symbol, project code name, geographic location, may be used as key words but will be followed by an indication of technical context. The assignment of links, roles, and weights is optional.