

# STUDY OF APPLICATIONS OF BIO-SPACE TECHNOLOGY TO PATIENT MONITORING SYSTEMS

## PROGRESS REPORT NO. 3

CONTRACT NO. NASW-2073

8 & 9 DECEMBER 1970

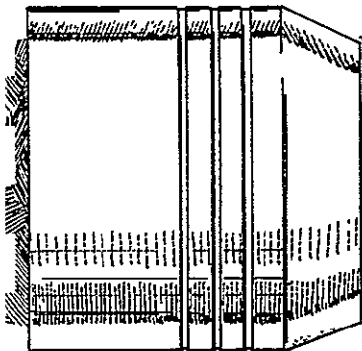
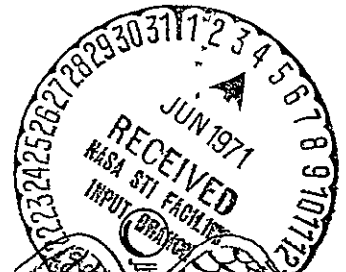

FACILITY FORM 602

NTI-25942

(ACCESSION NUMBER)

304

(PAGES)

CR-118645

(NASA CR OR TMX OR AD NUMBER)

(THRU)

63

(CODE)

05

(CATEGORY)

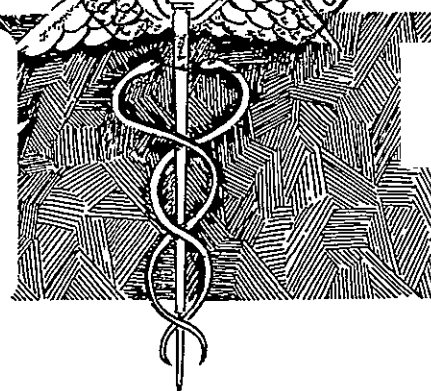

**GENERAL  ELECTRIC**

**Re-entry & Environmental  
Systems Division**

3198 Chestnut St., Philadelphia, Pa. 19101

Reproduced by  
**NATIONAL TECHNICAL  
INFORMATION SERVICE**  
Springfield, Va. 22151

167710

## TABLE OF CONTENTS

### I INTRODUCTION

Agenda  
Objective and Scope  
Purpose of Meeting and Theme of  
Progress Report #3

### II PROGRAM SUMMARY

Schedule  
Block Diagram

### III SURVEY SUMMARY

Medical Center Surveys  
Survey Team  
Survey

### IV EVALUATION SUMMARY

Approach  
Results  
Preliminary Requirements

### V SYSTEM DEFINITION

Objective  
Scope  
Approach  
Concept  
Rationale - Trade-Offs  
System Requirements

### VI SYSTEM SPECIFICATION

Scope  
Applicable Documents  
Requirements  
Quality Assurance Provisions  
Preparation & Delivery/Receipt  
Installation & Validation  
Operation and Maintenance  
Notes

TABLE OF CONTENTS (Continued)

VII PROGRAM PLAN

System Implementation  
R & D Tasks

***SECTION I***

***INTRODUCTION***

# ***AGENDA***

STUDY OF APPLICATIONS OF BIO-SPACE TECHNOLOGY  
TO PATIENT MONITORING SYSTEMS

PROGRESS REPORT NO. 3

GENERAL ELECTRIC COMPANY  
RE-ENTRY & ENVIRONMENTAL SYSTEMS DIVISION

8 & 9 DECEMBER 1970

AGENDA

LATTER DAY SAINTS HOSPITAL  
SALT LAKE CITY, UTAH

8 DEC 1970

	OPENING REMARKS	B. HALL	9:00 - 9:15
1.0	INTRODUCTION	R. WELSCH	9:15 - 9:30
2.0	PROGRAM SUMMARY	W. BUCK	9:30 - 9:45
3.0	SYSTEM DEFINITION	S. KRITZSTEIN	9:45 - 10:45
	COFFEE BREAK		10:45 - 11:00
	SYSTEM DEFINITION (CONT'D)		11:00 - 12:45
	LUNCH		12:45 - 2:00
4.0	SYSTEM SPECIFICATION	B. BURGESS	2:00 - 3:00
	COFFEE BREAK		3:00 - 3:15
	SYSTEM SPECIFICATION (CONT'D)		3:15 - 4:30

9 DEC 1970

5.0	PROGRAM PLAN	W. BUCK	8:30 - 10:00
6.0	SUMMARY	W. BUCK	10:00 - 10:30
	TOUR OF MEDLAB FACILITIES	DR. R. GARDNER	10:30 - 1:00
	LUNCH		1:00 - 2:00
	ADVISORY COMMITTEE MEETING	DR. D. FOX	2:00 - 3:00

***OBJECTIVE***

***&***

***SCOPE***

## OBJECTIVE

Establish the application of NASA developed technology to cardiovascular and pulmonary patient monitoring to improve the availability, reliability and utility of data for medical diagnosis.

## SCOPE

Six (6) month study to:

- Define the performance requirements (specified as objective criteria) for cardio-pulmonary patient monitoring.
- Define preferred system configurations.
- Identify areas requiring further research and development, including schedule and cost estimates.
- Breadboard such hardware and software as are required to provide a rapid means of validating certain approaches that may appear particularly promising as the study progresses.

**PURPOSE OF MEETING**  
**&**  
**THEME OF PROGRESS REPORT NUMBER 3**

## PURPOSE OF MEETING

REVIEW OF THE OVERALL PROGRESS OF THE STUDY AND PRESENTATION OF THE RESULTS TO DATE.

## THEME FOR PROGRESS REPORT NO. 3

- SUMMARIZE THE SYSTEM DEFINITION, BRIEFLY TREATING THE SYSTEM REQUIREMENTS, RATIONALE AND TRADE OFFS.
- REVIEW THE SYSTEM SPECIFICATIONS.
- DISCUSS THE PROGRAM PLAN, ITS IMPLEMENTATION, IDENTIFIED R&D TASKS, AND RECOMMENDATIONS FOR FURTHER WORK.

**SECTION II**

**PROGRAM SUMMARY**

## PROGRAM SUMMARY

The schedule for the study of the application of bio-space technology to patient monitoring systems reflect a three phase effort executed by the contractor. The first two phases of the effort (surveys and evaluation) have already been performed and are recorded in Program Reports #1 and #2. The third phase of the contract which involves the system definition is being reported through two documents, Study of Applications of Bio-Space Technology to Patient Monitoring Systems - (1) Progress Report No. 3 and (2) the Final Report as well as through the oral presentation. The schedule (first chart) indicates the time that the Program Report No. 3 shall be delivered along with its oral presentation. One week later the Final Report will be delivered.

The manner by which these documents were produced is represented in the second chart.

Application of Aerospace Technologies to the Patient Monitoring Study is illustrated in the third chart. NASA developed aerospace techniques were employed by the team of scientists and engineers who participated in the performance of this study (see the third chart). The four areas of System Evaluation, System Requirements, System Specification, and the Program Plan were approached and executed using standard methods developed for handling such programs as Biosatellite, OAO, Gravity Gradient Test Satellite, Advanced Technology Satellite, Advent Communication Satellite, Nimbus Weather Satellite, Discoverer Re-entry Vehicle, Mark 2 Space Lab, Viking Program, Ranger, and Apollo Lunar Orbiter.

In order to effect the evaluation of the patient monitoring system being developed and employed by four leading medical institutions, the NASA developed aerospace technique of system engineering approach was brought to bear. This enabled the team to assemble the essential field information and to put this mass of information into a meaningful and representative order. A systems trade-off analysis was used by the team to sift this information providing the fundamental data necessary to conduct the system requirement phase of work.

The identification of the system requirements was effected through the employment of the techniques developed and commonly employed by NASA's contractors in the areas of:

Systems Requirements Analysis

Human Factors (Man-Machine Interface) Technology

Data Processing

Communications

Biological and Physiological Monitoring Systems

Following the system requirements, the system specification was developed. Again, NASA developed aerospace techniques adopted by industry were employed. Broad specification categories such as specification synthesis, safety, standards, reliability, etc., which classically exist in NASA aerospace specifications were categorically considered and, as applicable, specified for the patient monitoring systems.

In order to implement the systems as specified, a program plan was created. NASA has developed certain successful methods and practices in generating program plans which were adopted in this effort. These include such elements as:

Program Task Analysis

Program Integration and Management

Build Plans

Integrated Test Plans

Quality Plans

Operations and Maintenance Plans

Within the study of patient monitoring systems, the potential applications of NASA and aerospace hardware and equipment were identified. The application of equipments common in the space programs such as mini computers, CRT's, data acquisition subsystems, etc., have been specified alike to the patient monitoring system. Within the program plan are delineated direct extensions of applications to the hospital environment of equipments from Biosatellite and related programs. Identified hardware/technologies have been discussed in Section VII for possible use within the patient monitoring system.

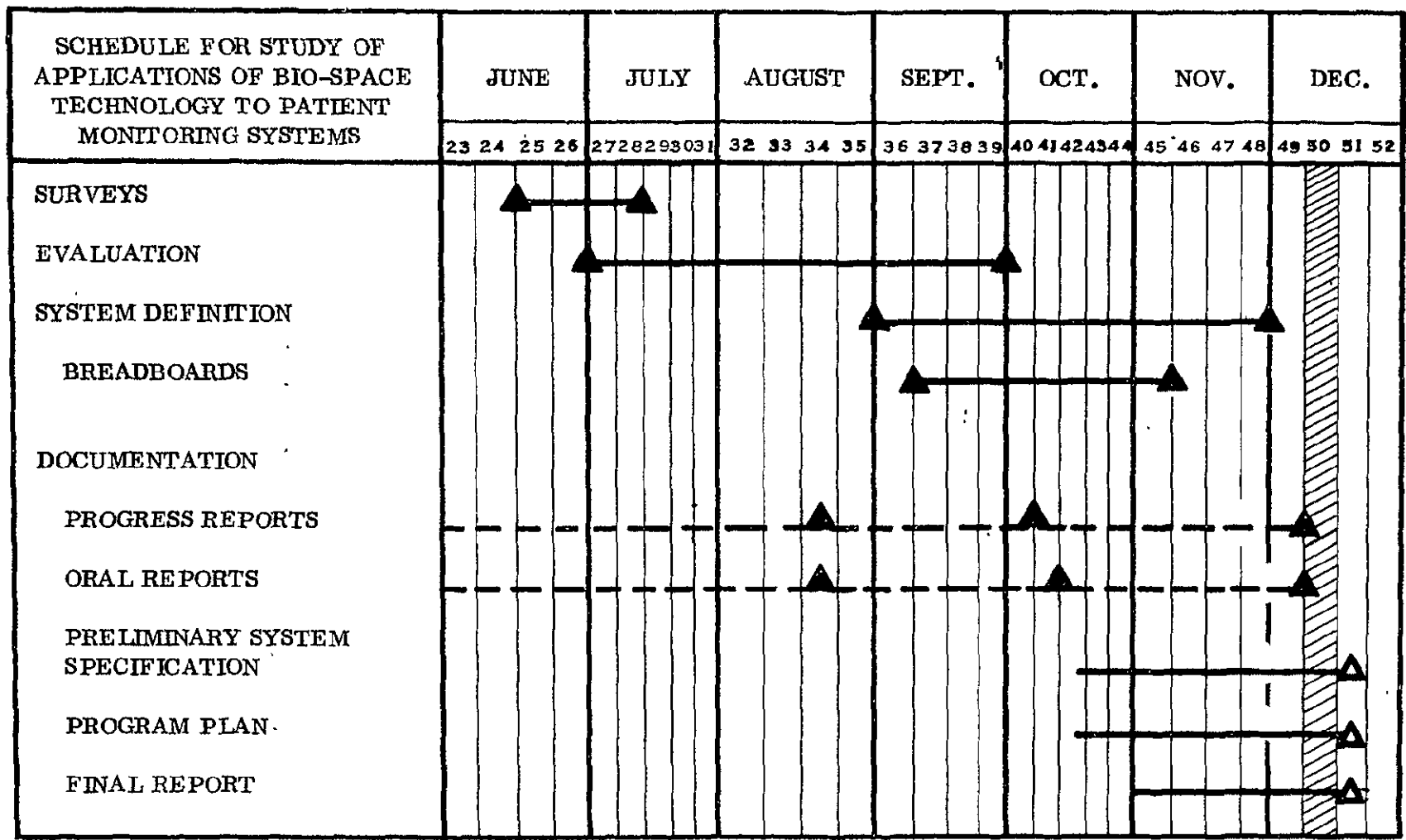

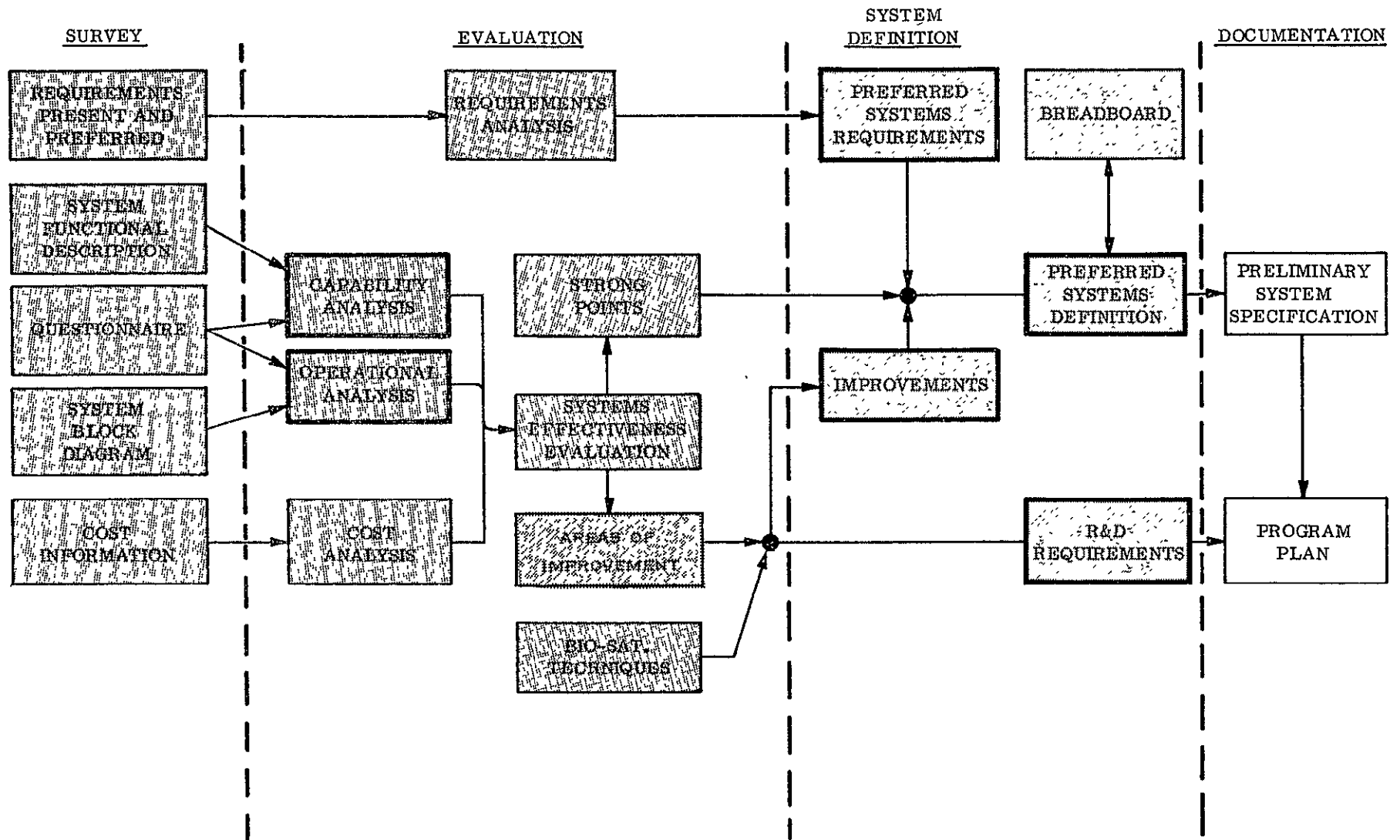

## PATIENT MONITORING STUDY

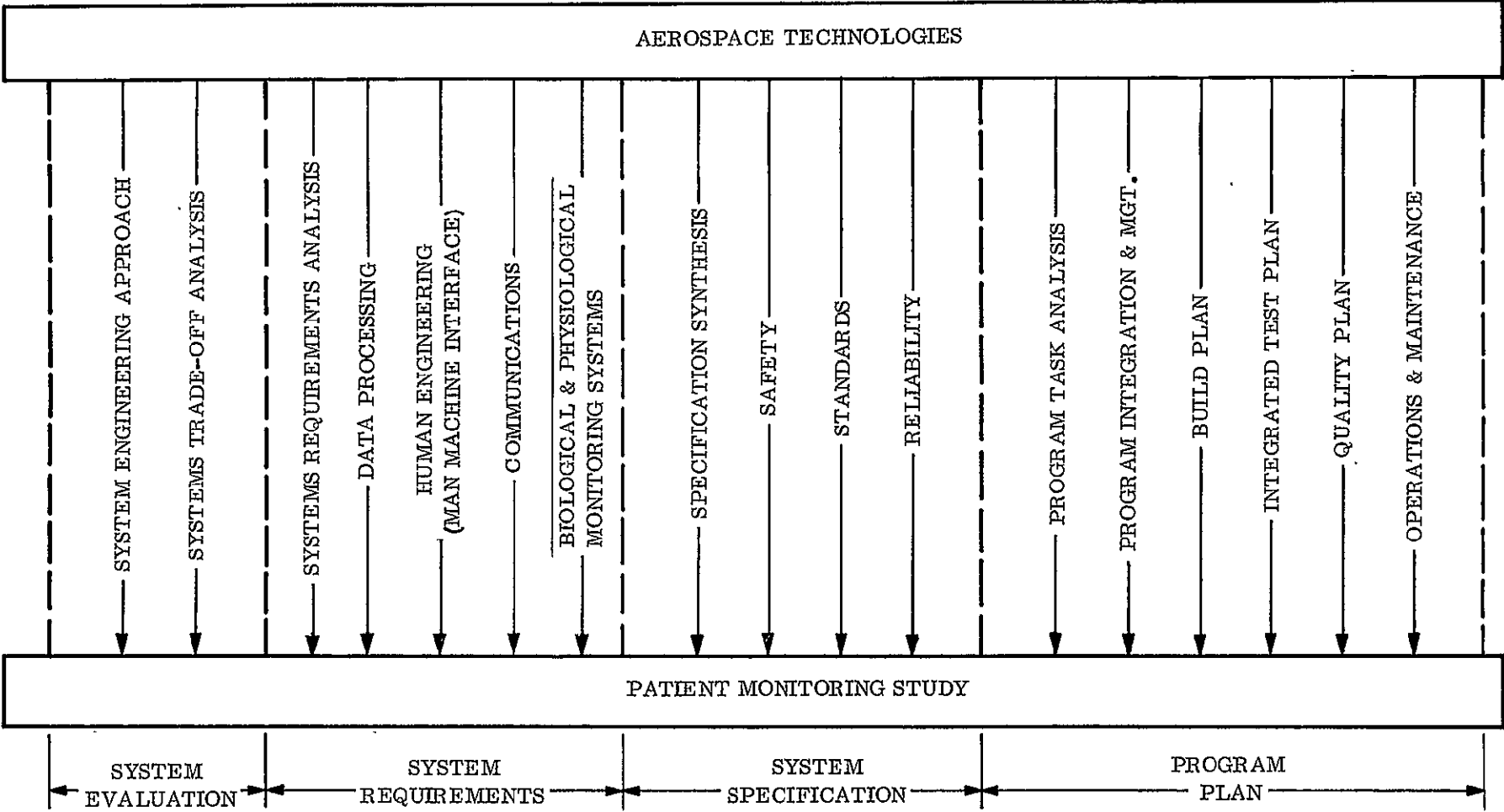

**SECTION III**  
**SURVEY SUMMARY**

## ***MEDICAL CENTER SURVEYS***

<u>Medical Center</u>	<u>Date of Survey</u>	<u>Personnel Contacted</u>	<u>Trip Report</u>	<u>Selection Criteria</u>
1. University of Alabama Medical Center, Birmingham, Alabama	25 June	L. Sheppard J. Action Dr. N. Cachntalun	Complete	<ul style="list-style-type: none"> <li>● Computer Controlled Administration of Blood and Drugs</li> </ul>
2. Methodist Hospital Texas Medical Center Houston, Texas	30 June and 1 July	Dr. C. Flynn Dr. D. Glaeser W. Fox	Complete	<ul style="list-style-type: none"> <li>● Only Hospital with a Monitoring Dept.</li> <li>● Large ICU</li> <li>● Large No. of Open Heart Operations</li> </ul>
3. Pacific Medical Center San Francisco, California	14 July	Dr. J. Osborne Dr. Radke (IBM)	Complete	<ul style="list-style-type: none"> <li>● Respiratory Patient Monitoring</li> </ul>
4. Latter-Day Saints Hospital Salt Lake City, Utah	15, 16 July	Dr. Homer Warner Dr. R. Gardner A. Pryor	Complete	<ul style="list-style-type: none"> <li>● Medlab System</li> </ul>

Medical Center Survey Status

***SURVEY TEAM***

SURVEY TEAM

NASA - OSSA

B. B. HALL

DR. J. F. SAUNDERS

DR. D. FOX

HEW - NIH

DR. R. DUBOIS

GE-RESO

R. WELSCH

DR. N. BIRKHEAD

W. BUCK

B. BURGESS

J. GANNON

S. KRITZSTEIN

J. BARNEY

# ***SURVEY*** ..

## SURVEY SUMMARY

Four medical centers were surveyed by members of NASA-OSSA, HEW-NIH, and GE-RESO. The places and dates were as follows: University of Alabama Medical Center, 25 June; Methodist Hospital, Texas Medical Center, 30 June and 1 July; Pacific Medical Center, 14 July; and Latter-Day Saints Hospital, 15-16 July.

The University of Alabama Medical Center administers intravenous fluids under computer control. The system is developmental but is used for real patient care to its full capacity. The user acceptance in the ICU is high. The mortality rate was decreased and a reduction in ICU occupancy time has resulted. The central computer oriented design gives flexibility. Time sharing is used by the computer and the overall utilization level is low.

A moderate number of derived parameters is available. Signal conditioning and preprocessing is done at bedside which facilitates relatively long wire transmission to the computer. Careful grounding has been implemented with the result that Electro-magnetic interference is not a problem. Skilled/motivated personnel are available to effect emergency workarounds in the event of system failure. Interactive bedside display and manual data request/entry is used.

The Methodist Hospital has established a Department of Monitoring which includes a staff of specially trained Monitoring Technicians and electronic engineers for equipment design, construction, maintenance, and operation. No central computer is presently used to control the system but on-line computer support is planned for the near future. The ICU uses bedside monitors for ECG and blood pressure and each of four operating rooms have dedicated monitoring of the primary physiological parameters. Continuous monitoring is enabled by portable ECG monitors from the operating room to the ICU. Operating room data is magnetically recorded for history, teaching, and research. The computer systems now in place are all for research/off-line use. Plans exist to use some of this capability as bedside processing supervised by a central computer. ECG analysis programs are being modularized for possible pre-processing. Electromagnetic interference exists but does not pose operational difficulties. A large number of patient monitoring equipments have been systematically evaluated by the Monitoring Department.

The Pacific Medical Center monitors pulmonary parameters as well as cardiovascular. The system services the ICU, heart catheterization lab, exercise lab, animal lab, pulmonary function lab, and, in the future, another local hospital. A large number of derived parameters are produced by a flexible centralized computer that employs time sharing. Each monitored patient has a 24 hour report produced by the system. A resident IBM staff enhances system maintenance and development. The bedside data acquisition, interactive display, and manual data request/entry is effective but different from any of the other hospital's surveyed. Utilization of electric typewriter to obtain hardcopy was being minimized due to the noise.

The Latter-Day Saints Hospital's system is most extensive in its applications throughout the hospital, remote hospitals, and planned further extensions. Cost effectiveness is enhanced by this extensive utilization. The University engineering department and the hospital have a

close tie. Maintenance and operating costs have been analyzed. A compatible and redundant dual centralized computer system runs patient monitoring. Bedside data conditioning minimizes operator adjustments and calibrations. An operationally compact and attractive bedside interactive display and manual data request/entry is used.

***SECTION IV.***  
***EVALUATION SUMMARY***

## ***APPROACH***

SURVEY

EVALUATION

DEFINITION

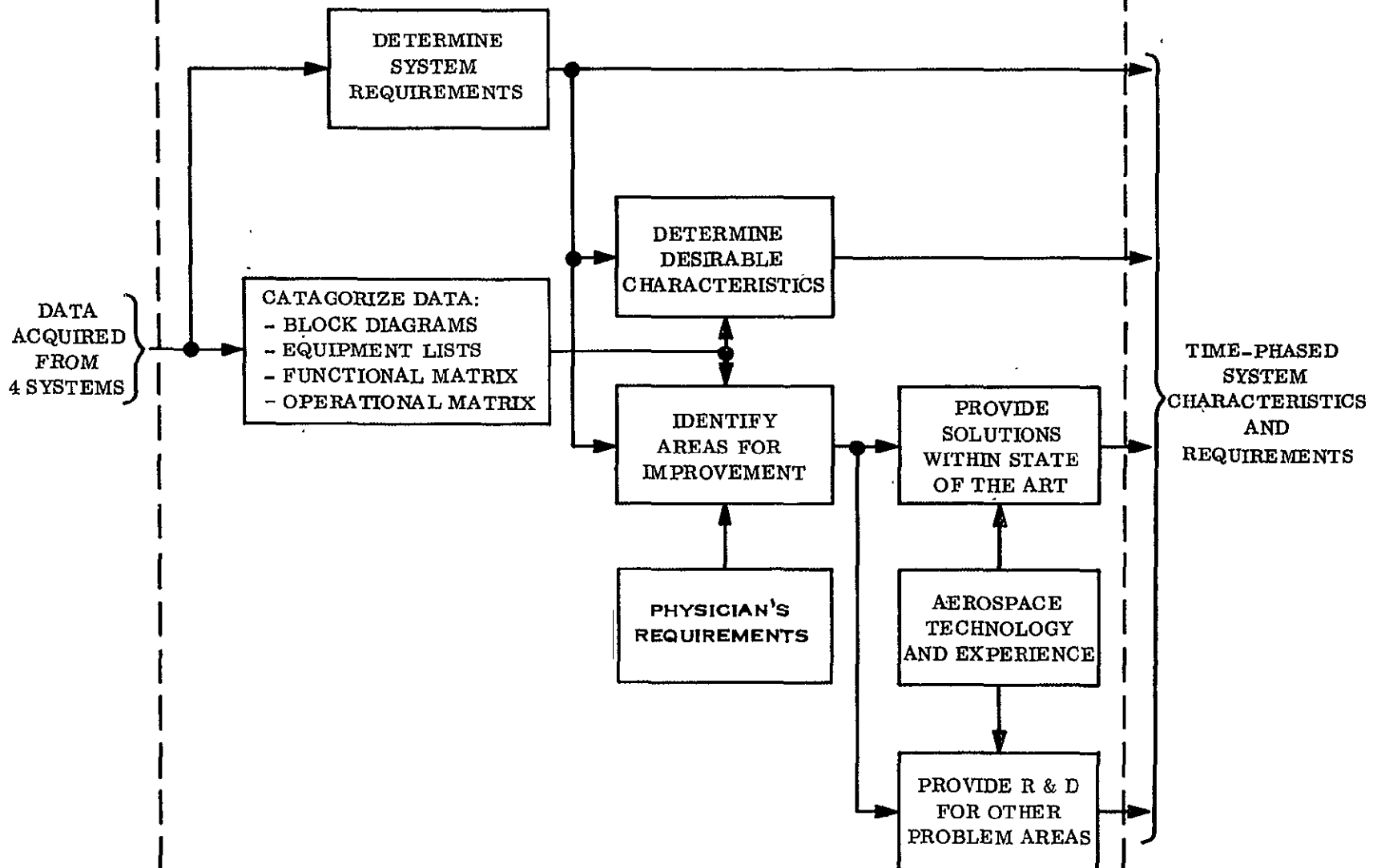

FLOW DIAGRAM: EVALUATION APPROACH

## ***RESULTS***

## EVALUATION RESULTS

The evaluation of the surveys of the four health institutes resulted in:

- An evaluation matrix which listed the outstanding features of each system surveyed
- Areas of improvement
- Research and development required
- Areas of standardization

Also, a summary of the parameters monitored in the four hospitals, in which areas they were taken, and the number of times they were taken by the hospitals.

A cost analysis identifying the problems affecting the cost structure with solution recommendations. Example cost information from Latter-Day Saints Hospital on maintenance and operations was also given.

## ***PRELIMINARY REQUIREMENTS***

## PRELIMINARY REQUIREMENTS

The system is required to perform the following major functions:

- acquire data
- pre-process portions of it
- locally transmit this data
- execute a processing function on the data
- distribute this processed data
- display and perform control functions with the processed data
- remotely service terminals

This system will be oriented toward the servicing of a hospital user. This is in contrast to a hospital whose requirements are also those of research and development.

The system should be capable of incorporating multiple additional applications along with patient monitoring. These additional applications could include combinations of business, process control, library, programmed instruction, and storage/retrieval services.

The patient monitoring application of the system should be capable at a minimum of delivering services in all or in various combinations to the following physical locations within a hospital:

- patient screening
- catheterization laboratory
- X-ray laboratory
- operating room
- intensive care room
- cardiac care unit
- exercise laboratory
- rehabilitation facility

The patient services rendered by the patient monitoring system should be applicable to cardiovascular, pulmonary, temperature, blood chemistry, and urinary systems. The measurements taken and derived are in the following Parameter Matrix.

PARAMETER MATRIX

(key: X-required measurements)  
O-optional measurements)

1. **CARDIO VASCULAR**

- heart rate
- stroke volume
- cardiac output
- duration of systole ejection
- peripheral resistance
- systolic pressure
- diastolic pressure
- mean venous pressure
- electrocardiogram signals
- vector cardiogram signals
- mitral insufficiency index
- appearance time
- buildup time
- mean circulation time
- central blood volume
- cardiac index
- average arterial pressure
- pulse deficit
- premature beat rate
- arterial pressure first derivative
- premature ventricular contraction
- arrythmia (premature & widened beat)
- left atrial pressure
- densitometer calibration
- superior vena cava % saturation
- mid right atrium % saturation
- pulmonary artery trunk % saturation
- pulmonary artery wedge % saturation
- radial artery % saturation

2. **PULMONARY**

- respiration amplitude
- respiratory rate
- forced vital capacity
- max. expiratory flow rate
- one second expiratory volume
- maximal mid expiratory flow rate
- maxdum instantaneous respiratory pressure

screening	catheterization lab	X-ray lab	operating room	intensive care unit	cardiac care unit	exercise lab	rehabilitation	remote
X	X	X	X	X	X	X	X	X
	X		O	X	O	O		X
	X		X	X	O	O	O	X
	X			O				X
	X		O	X				X
X	X	X	X	X	X	X	X	X
X	X	X	X	X	X	X	X	X
	X		X	X	O			X
X	X	X	X	X	X	X	X	X
O	O	O		O	O	O	O	O
	X							X
	X			O				X
	X			O				X
	X			O				X
	X		O	X				X
	X		X	X	O	O	O	X
	X			O				X
	X			O				X
	X			X				X
	X							X
	X			O				X
								X
				X				X
X	X	X	X	X	X	X	X	X
X								X
X								X
X								X
X								X
				O				O

PARAMETER MATRIX (Continued)

(key: X-required measurements)  
O-optional measurements)

	screening	catheterization lab	X-ray lab	operating room	intensive care unit	cardiac care unit	exercise lab	rehabilitation	remote
respiratory minute volume				X	X	O	O	O	X
tidal volume				X	X	O	O	O	X
respiratory work, inspiration					O				O
respiratory work, expiration					O				O
lung compliance				O	O				O
oxygen uptake		X			O	O	X	X	X
respiratory quotient		X			O		X	X	X
respiratory resistance		X			O		X	X	X
<b>3. TEMPERATURE</b>									
central temperature		X		X	X	X			X
extremity temperature				X					
<b>4. BLOOD CHEMISTRY</b>									
arterial blood bicarbonate				O	O				O
venous blood bicarbonate				O	O				O
blood analysis	X			X	X	X	X	O	X
blood oxygen concentration		X		X	X	O	O	O	X
<b>5. URINE</b>									
urine output volume				X	X	X			X
urine output volume per hour				X	X	X			X
<b>6. OTHER</b>									
electroencephalograph				X	O				X
measurement of empty blood unit				X					X
chest drainage fluid volume					X				X
chest drainage fluid volume per hour					X				X

***SECTION V***  
***SYSTEM DEFINITION***

## ***OBJECTIVE***

## OBJECTIVE

As a result of the survey and evaluation; define the performance requirements, the preferred system configuration, the critical areas of research and development, and as required, to breadboard hardware/software to validate promising approaches.

## ***SCOPE***

## Scope

The Patient Monitoring System defined in this document was formulated by a team of engineers and physicians, based on a survey of existing state-of-the-art systems followed by an evaluation of these systems. It represents an attempt to improve the capabilities of existing systems by appropriate applications of aerospace technology. The most significant application of this type has been a systems engineering approach of defining the system; the real needs for a comprehensive system were determined, and the best available techniques were selected to fill the needs. The system which was evolved is a modular one, tailored to fulfill a variety of hospital requirements. It monitors primarily cardiac, cardiovascular, pulmonary, and body chemistry (blood and urine) parameters, with growth capability for other functions at a later date. The following paragraphs describe the approach followed to evolve the system and the rationale involved. The system is more fully defined in the System Specification Section.

## ***APPROACH***

## Approach

Definition of the Patient Monitoring System was accomplished by considering the actual needs of a large number of hospitals for monitoring equipment and by then configuring a system which best meets the needs. During the course of the survey, it became apparent that the state-of-the-art in monitoring systems is quite impressive from a technological standpoint. The systems reviewed, however, all were designed for the particular needs of the people involved, and represent a less than optimum approach to fulfilling the needs of a great number of hospitals. For example, a very small, remote hospital would probably have staff and financial constraints which would prohibit a large-scale system, yet would welcome a system which provides sophistication over and above that available on a component basis. In addition, specialized interests of hospitals, such as cardiac surveillance or pulmonary monitoring, were not easily separable from the overall surgery-oriented large scale systems. These points led to a suggestion that the new system be defined by several separable sets of functions, rather than in terms of location within a hospital or in terms of a single set of large system equipment.

An analysis of potential applications for a Patient Monitoring System resulted in the identification of eleven different patient types and four broad categories of measurable patient parameters, which are described in detail in the section on System Specification. By separating the system into four functional categories allied to the four measurement groups, a definition emerged which was easily handled, and which seemed to cover the needs of the eleven patient types. Furthermore, it became apparent that a hospital could utilize only those functional elements which it needed at the time, if the four broad functional areas could be made to be self-sustaining. This led to the concept of a modular system, consisting of four separable and autonomous modules covering the measurement parameters. These modules consist of a Cardiac Surveillance Module (Module I) to monitor EKG and to detect arrhythmias and produce an alarm; A Cardiovascular Module (Module II) containing a large general purpose digital computer to monitor and analyze EKG and pressures, and to compute significant cardiovascular system parameters; a Pulmonary Module (Module III) to monitor primary pulmonary parameters and to display them in real-time; a Body Chemistry Module (Module IV) to supplement any of the other modules by acquiring blood and urine data for display. Each of the first three modules can be used alone, and all modules can interface with each other. The intent behind this approach is to enable a hospital to configure a Patient Monitoring System out of the four modules offered, by selecting any number of the appropriate modules and interconnecting them. By careful design, the modules can be made to complement each other in the display and computational areas, thereby, eliminating duplication of hardware. With the capability to intercommunicate data, the modules can be connected to form a system network of limited or extensive capability in terms of number of functions as well as number of patients served. For example, a hospital with a need for extensive cardiac monitoring of chest pain patients could be satisfied with the appropriate number of Cardiac Surveillance Modules (Module I) and nothing else. Another hospital, with a history of cardiac surgery might require a Cardiovascular Module (Module II) tied to a Body Chemistry Module (Module IV). Another hospital doing cardiac

surgery could add a Pulmonary Module (Module III) to the combination above if they emphasize the role of pulmonary monitoring. In other words, each hospital need could be satisfied, with some freedom of choice provided for the hospital's particular desires.

Another feature of the system is its adaptability. This refers to the ability to extend the functional performance of the system generally by adding new types of modules at a later date. In addition, a conversion capability has been built into the Cardiac Surveillance Module (Module I) which enables it to act as a patient station for the Cardiovascular Module (Module Two). This was purposely done because it was felt that the cardiac Surveillance Module will be most extensively used, and that some patients who are normally monitored by this module may require more extensive monitoring on short notice. By providing this conversion feature, an existing Cardiovascular Module could be extended beyond its autonomous patient stations as required.

Thus, a modular system was evolved to cover the significant list of monitoring parameters. In detailing the system definition, major subsystem areas were identified:

- Sensor Subsystem
- Signal Conditioning S/S
- Data Processing S/S
- Display S/S
- Control S/S
- Software S/S
- Data Transmission S/S

These areas were investigated to determine functional requirements of the modules as pertaining to the subsystems. Then, any major trade-off areas were investigated as to the proper approach for implementing the functions. Of these, the most significant was the question of a central computer capability versus distributed local processors in the modules. The factors considered included cost, accessibility, sampling frequency, and the resulting preferred configuration consisted of a central computer in the Cardiovascular Module (where it is required) operating in conjunction with minicomputers in the individual modules. The functional requirements and design implementation recommendations for the subsystems appear in the System Specification section.

The final point to be made in describing the system approach is related to system coverage, and concerns remote location tie-ins. To extend the system capability in the general case, the concept of remote hospitals must be considered (remote refers to hospitals which must depend on a larger hospital for support.) To accommodate this situation, a data transmission subsystem was included to communicate data from the remote to the main hospital and vice-versa. It is anticipated that this type of link would be mostly used to take advantage of Cardiovascular Module's computational capability in the main hospital, but it could also be used for other functions, such as visual monitoring of EKG's from the remote hospital. Regardless of the use, the most significant factor in the remote/main communication is the link utilized. The most desirable, by far, is a telephone line for economic reasons, but this imposes a bandwidth restriction which must be met. Higher bandwidth links, including

microwave relay, are generally prohibitively expensive on a rental basis, and may be economically infeasible on a buy basis. Therefore, the Patient Monitoring System is designed to accept data from and provide data to modules in remote hospital stations over telephone lines. This is accomplished by digitizing and serial buffering all signals at the interfaces, and reading them out at a rate compatible with the telephone line bandwidth.

The system has been designed to make use of state-of-the-art techniques, married to available low-cost high performance computational equipment, to provide a means for extending patient monitoring capability to a wide variety and large number of medical centers. Sufficient flexibility has been designed into the system so as to enable the later incorporation of newly-developed techniques and equipment without major impact on the equipment in place. This flexibility is concentrated in the areas of the software programs, which are easily expandable by subprogram addition, and in the hardware implementation, where spare amplifiers and connectors are provided.

## ***CONCEPT***

## SYSTEM CONCEPT

The Patient Monitoring System (PMS) is a functionally modular system which monitors significant body parameters of patients in various locations throughout a medical center. The measurements include Cardiac Surveillance, Cardiovascular, Pulmonary and Body Chemistry, with further parameter breakdowns listed elsewhere in this report. The system can be expanded to handle virtually any number of patients simultaneously. Physically, the equipment comprising the system consists of three major groups: the patient station, the nurses' station and the computational facility (refer to the system block diagram and conceptual illustrations (Figures V-1 thru V-6)). The patient station (which may be portable or fixed) typically includes sensors to attach to the patient, and a console containing signal conditioning and local processing electronics (hidden from view) and a control keyboard with auxiliary switches as well as multi-channel constant-intensity, non-fading, CRT and digital display panel. Strip or chart recorders and printers for hard copy record may also be included in the console. The functional measurement capability of the station is modularly selectable, and is determined by the physical blocks of equipment and by the software program in the local processor. To operate the patient station, the equipment is first connected to power and signal plugs which are provided at the bedside to tie the station into the overall system. Then the patient connections are made, consisting of surface electrodes, thermistors, catheter transducer attachments, etc. The station is then initialized and calibrated by the operator and data pertaining to the patient is entered via the keyboard control. The data includes physical patient parameters, computational modes desired, alarm limits and special medical instructions. The patient is then monitored by the system, which displays the patient data at the bedside station, as well as at the nurses' station. Control and display are interactive, using the "tree" technique. At any time (and from any station), data from any patient (current or historical) can be displayed by properly sequencing through the tree via the keyboard.

The nurses' station typically consists of a console with displays for each patient in the area who is connected to the system. The Patient, (not latent) displays are grouped into 4-patient sets, with the nurses' station expandable, in groups of four patients, by the addition of one or more 4-patient sets. Each set includes a four channel constant-intensity, non-fading CRT, four groups of four digital displays (one group of four for each patient), one to four chart recorders for hard copy and four alarm lights and buzzers (one for each patient). In addition to the four-patient display set(s), the nurses' station also includes a keyboard for data entry into the system, a multi-channel CRT for displaying alpha-numeric and graphical data (parameter trends, histories, and selection trees, for example), a printer for hard copy patient data, and an intercom/telephone connection and control which enables voice communications with patient stations, other nurses' stations and the computational facility. Functional performance of the nurses' station is selectable in a modular manner, by means of the patient stations chosen for use. The data acquired by each patient station is made available to the nurses' station by means of cable interconnections, which also serve to connect the controls of the nurses' station to the appropriate patient station. A single nurses' station can be used to monitor a number of different configurations of patient stations, with the different patient parameters displayed and correctly labeled by the nurses' station. Each patient station requires one quarter of a four-patient display set in the nurses' station.

Operation of the nurses' station involves activating the four-patient sets corresponding to the patient stations in use, followed by selection of parameter labels for each display. Then, alarm limits are set by means of the keyboard at the nurses' station (or at the patient station), and monitoring at the nurses' station commences. The keyboard and multi-channel display enables the operator to select any patient on the system for data display, just as at a patient station.

The computational facility consists of a large capacity central processing unit, used for the cardiovascular monitoring functions, plus a station for data display and control. The station placed with the computational equipment is similar to the nurses' station, but includes only one four-patient display set, with additional logic provided to enable switching of data from any patient connected to the computational facility onto the display. This station is intended for trouble-shooting and maintenance use, and could be integrated with the computational equipment itself. Neither the large CPU nor the station is necessary unless the cardiovascular measurements module is included in the system.

In addition to equipment groups at the bedside, the nurses' desk and the computational facility, there are other locations where groups of equipment could be located. These include (as examples) the operating room, and the cardiac catheterization laboratory. It is anticipated that these equipment groups would essentially be patient stations with slight modifications to tailor them for special use. For example, an operating room station will put great emphasis on easily read displays (large, wall-mounted CRTs, color-coded traces, if possible) and less emphasis on full control capability.

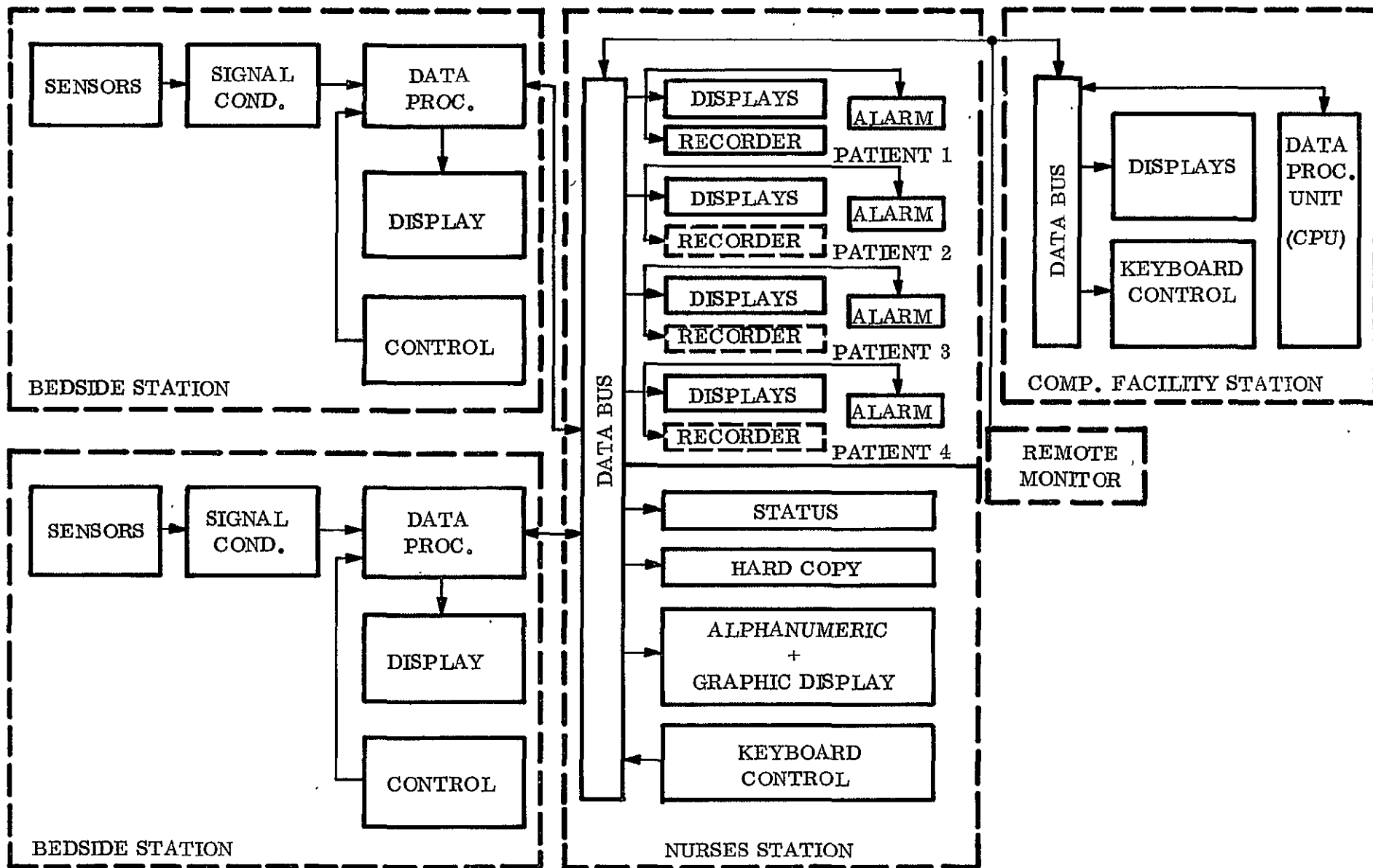

Figure V-1. Typical System Block Diagram

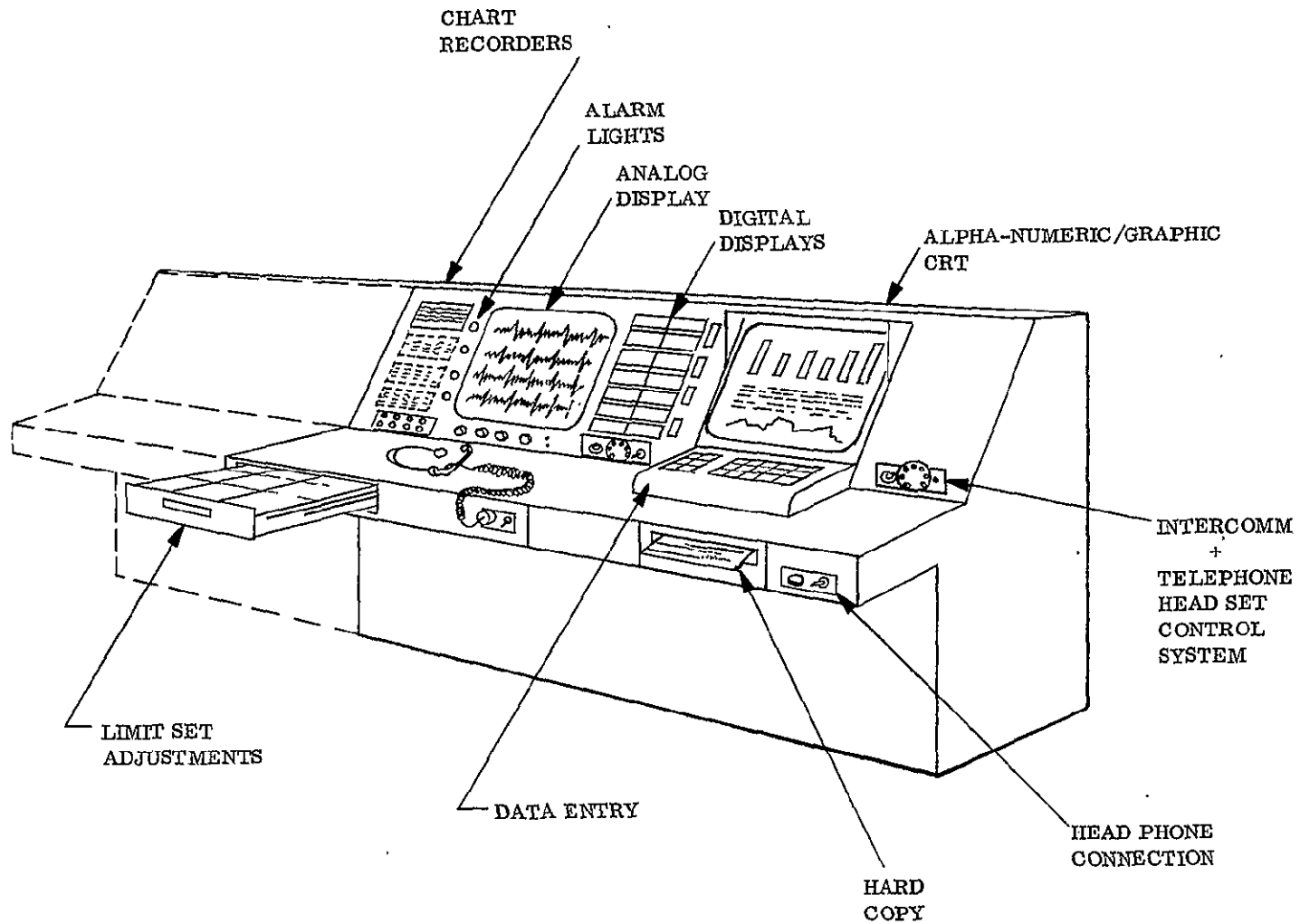
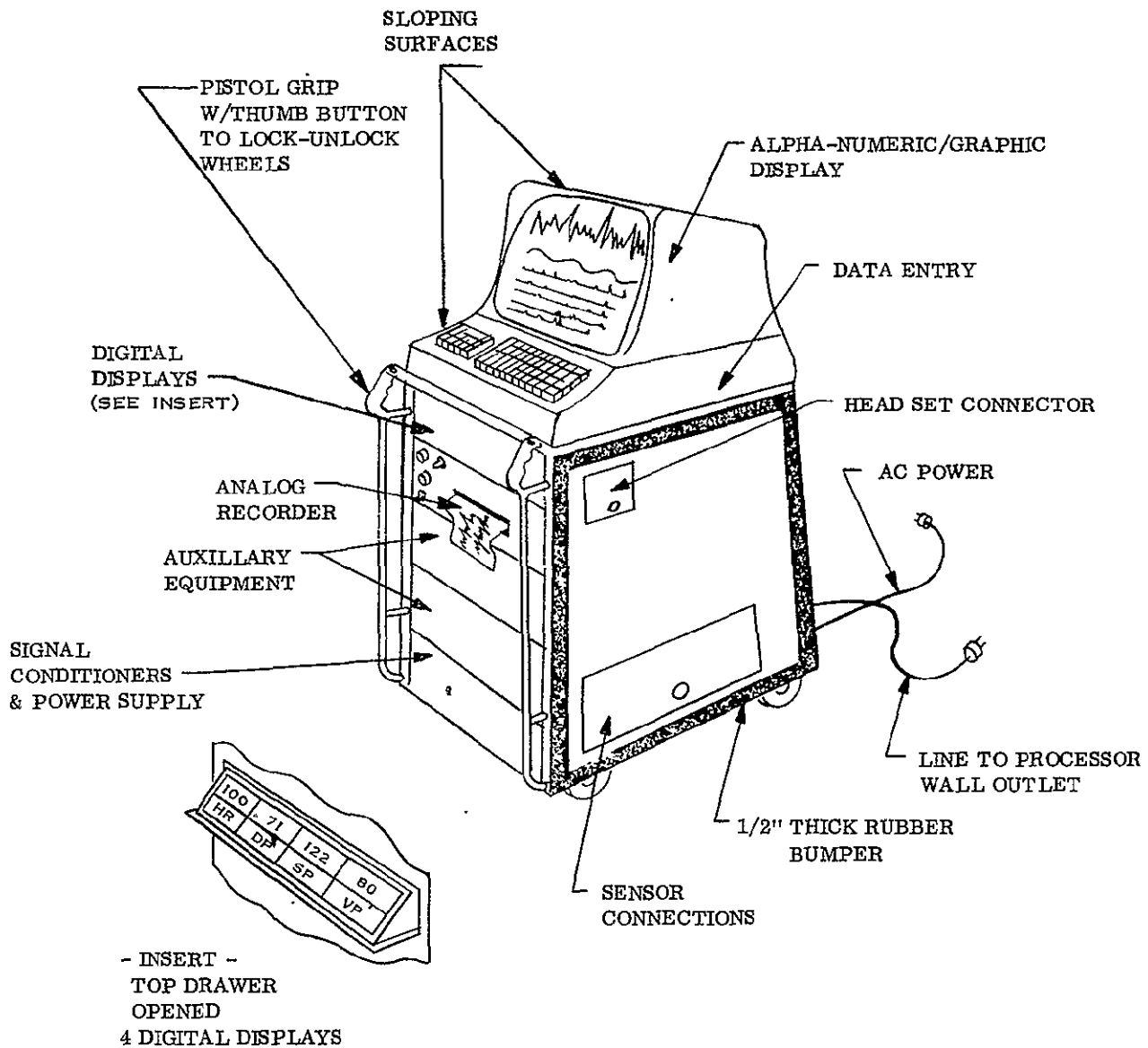

Figure V-2. Nurses Station (Conceptual)  
(Typical)



- 4 THREE DIGIT DIGITAL DISPLAY
- ALPHA-NUMERIC/GRAPHIC DISPLAY
- DATA ENTRY
- VOICE COMMUNICATIONS (HEAD SET W/MIC)
- SIGNAL CONDITIONING
- SELF-CONTAINED POWER SUPPLY
- COMMUNICATION LINK TO COMPUTER
- DUAL CHANNEL CHART RECORDER
- OPTIONAL AUXILLARY EQUIPMENT
- DEFIBRILLATOR

Figure V-3. Remote Portable Unit (Conceptual)

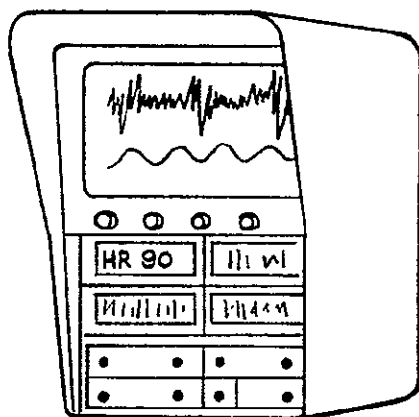

Figure V-4. Bedside (Conceptual)

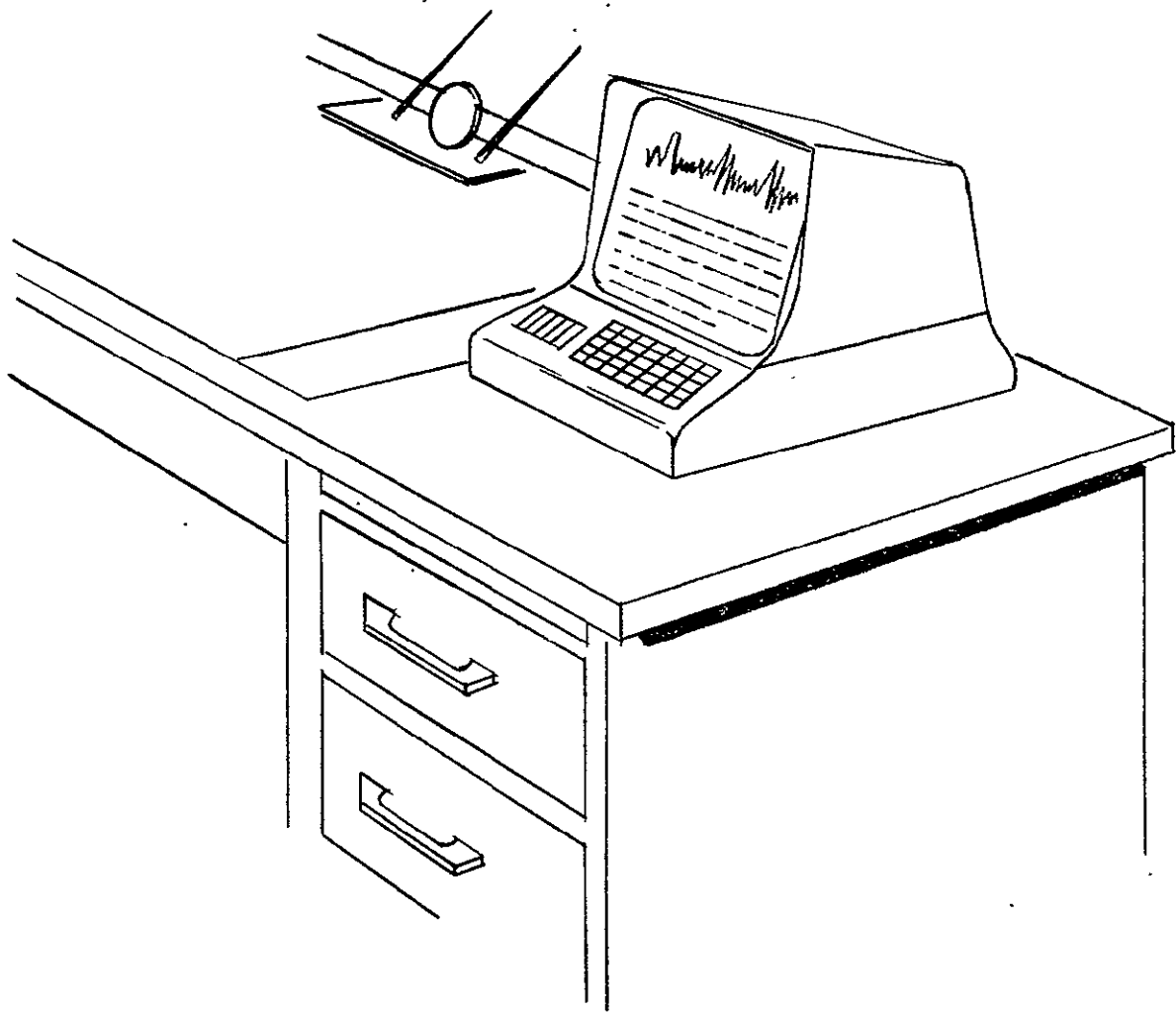
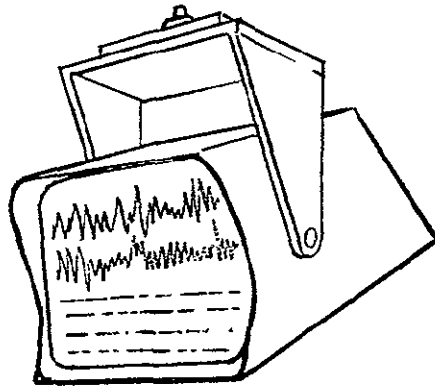
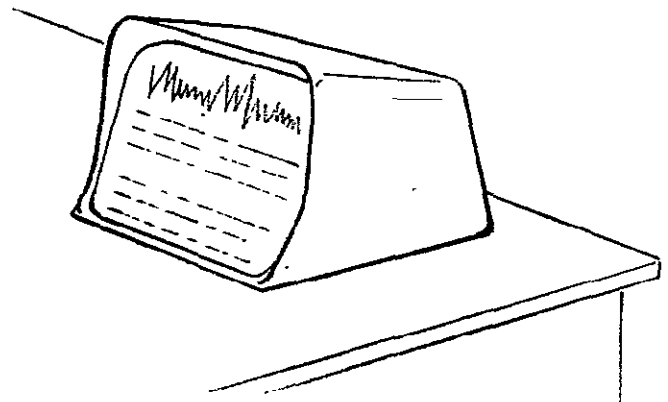

Figure V-5. Remote Desk-Top Unit (Conceptual)

Display & Data Entry



OVERHEAD



DESK

Figure V-6. Remote Monitor Conceptual

## ***RATIONALE - TRADE OFFS***

## RATIONALE-TRADEOFFS

The intent of this section is to report on the activities which centered around developing the rationale and tradeoffs for the patient monitoring system specified in this document.

This section provided a mechanism by which technical discussions, selectivity in systems concepts, and components would be effected. This was necessary in order to provide a system that would operate in accordance to the demands of a modern patient monitoring system. The tradeoff would provide such things as the proper configurations, flexibility, and modularity. Also, to take advantage of recent technological developments, (both medical and engineering), types of processing methods, speeds, capacities, and modes as well as many other technical, operational, and cost effective considerations. The rationale-tradeoffs provided a means of separating and selecting the meaningful system determinates from multiple alternatives. The mechanisms by which these tradeoffs were made involved both rating systems and technical discussion. The topics reported upon in this document are only those of primary importance and of highest complexity to a patient monitoring system namely: the processing and the communications systems.

## DATA PROCESSING TRADE-OFFS

An automated Patient Monitoring System definition is challenged initially on the basis of the optimum approach to data processing. Three (3) primary options are defined and evaluated (other options are possible):

- A. Relatively autonomous data processor within a modular subsystem structure designed for use within a patient room or cubicle. Primary data processing, control and display are accomplished in-situ; limited remote display may be provided. Data processing capability of this configuration is limited.
- B. A master controller, processor and central display system (Central Processing Unit - CPU) designed for interface with all modules of one or more units (for instance of four (4) patients per unit). This system provides for central control, monitor and display of parameters, extensive data processing, remote (other than CPU) control, monitor and/or display of patient status and the potential for growth. The system additionally provides the capability for processing, storing and displaying records, lab data, medical texts, patient billing, care schedules, etc. Extremely limited local processing exists within the modules.
- C. A combination of, or the capability for combination of (A) and (B).

Providing a system (rather than several) will reduce overall cost of automated care, simplify professional adaptation, accelerate further development from well defined baselines, etc. The accompanying charts (trade matrices) Figure V-7 are intended to provide a logical verification of the intuitive selection of a system capable of satisfying the majority of the requirements.

Systems (B) and (C) may not be economically feasible for single hospitals, hospitals not associated with research institutes, hospitals in the 200 or less bed range, and institutions not dedicated in part or entirely to specialty care such as heart-lung patients. System (A) however, may be implemented on a modular basis by nearly all institutes for a minimum of one (1) or more patient capability or in combinations of modules dependent upon the hospitals particular needs and budgets. The system could be interfaced with a regional computer and may eventually be upgraded to provide the equivalent of system (C). System (A), with its limited capabilities, is less than optimum for the institutions not included above and would not provide the degree of extended capability necessary for the size and scope of activities and the budget constraint profiles. System (B) satisfies this category of institutions but entails a system different from (A) and not necessarily compatible. System (C), however, is a growth version of system (A). It satisfies the basic modular concept, and allows for

growth while not requiring it. The basic CPU may be added at anytime with a selected range of peripherals that provide for either physiological monitor only, or patient monitoring plus additional peripherals for billing, or patient monitoring plus billing and etiologies, and so forth. System (C) also has the inherent capability for reversion in operational mode to System (A) in varying degrees dependent upon the need. Selected patients would be monitored via the central display and/or room displays with local processing rather than CPU processing. Situations which may require reversion, for example, are: significantly increased patient load (temporary peaks), CPU downtime required, etc. Thus, system (C) has both an equipment emplacement and an operational flexibility and is considered to be the optimum system of which incremental portions will satisfy the majority of health center needs in concert with their particular constraints.

The following chart, Figure V-7, represents a quantitative evaluation of the trade-offs concerned with the data processing subsystem.

#### A. CHART CONTENT NOTES

Areas that are equivalent or nearly so are excluded; some areas are or would be designed to an equivalent level (safety, reliability, etc.); however, certain system characteristics provide mitigating circumstances resulting in listing of that factor.

#### B. WEIGHTING FACTORS ASSIGNMENTS

1. Two Equivalent Salient Goals of the Patient Monitor System are:

- Provide improved medical care
- Provide a system on as expandable basis as possible (make available to the community hospitals as well as the large, research supported hospitals)

Each of these factors is assigned a weighting factor of 10 as the highest possible rating.

2. Patient safety and equipment reliability are rated next at 9 each.
3. Maintainability, flexibility and growth, autonomous operation capability, simplicity, patient/attendant loading are rated 8 each.
4. Data handling capability, dedicated monitor capability, integral cal and fault isolation and initial cost are rated 7 each.
5. Capability for specialized physiologic data processing, and capability for application to maintenance of patient records, billing, etc. are rated 6 each.
6. Each configuration's ability to satisfy the criteria is assigned a range for application of the weighting criteria. The figure of merit is the range (percent) times the weighting factor.

### C. SYSTEM TRADEOFF RESULTS

As a result of the characteristics evaluated in the charts of the following pages, system C (LPU plus CPU) was identified as optimum. Specifying this one integrated, modular system provides both standardization and a modular build-up approach such that all levels of procurement capability may be satisfied.

Weighting Factor	Problem Definition and Selection Criteria	Range of Weighting Factor Applied	Problem: Determine Preferred Patient Monitoring Data Processing System			Selection Comments	Figure of Merit		
			<u>Alternate A</u> - LPU Only	<u>Alternate B</u> - CPU Only	<u>Alternate C</u> - LPU Plus CPU		A	B	C
6	Capability for maintaining and/or accepting patient records, schedules, etc.	10% 80% 80%	Practically None	High	High	0.6	4.8	4.8	
9	Reliability Aspects (See Notes)	70% 40% 80%	System lacks extensive failure monitor and diagnostic routines but has component monitors which would indicate that replacement of a particular monitor is required.	Least reliable system wise since system is ineffective when CPU goes out (See notes); sophisticated failure monitor and diagnostic routine is available however.	Most reliable system performance is adequate via LPU's when CPU is down; room modules replaceable; sophisticated failure monitor and diagnostic routine is available (For both CPU & LPU equipment).	6.3	3.6	7.2	
9	Safety Aspects (See Notes)	70% 40% 80%							
10	Medical Efficacy	50% 60% 80%	Provides limited automation but presents basic capability; significant improvement over non-automated system but not the optimum.	Significant extension of capabilities and automation - similar to "C", however, system "B" lacks expandability by reverting specific patients to LPU only mode.	Provides a sophisticated system with capability for extensive data correlation, plotting, etc. with a back-up operating mode; adjustable for patient load.	5.0	6.0	8.0	
8	Simplicity	80% 60% 70%	Relatively simple equipment with line level adjustments and controls minimized.	Complex machine and programs; prodigious data handling and storage - this is essentially a combination of LPU and CPU functions - in one machine.	Complex but in workable entities of both hardware and software.	6.4	4.8	5.6	
7	Integral Cal & Fault Isolation	40% 80% 80%	Integral cal available; fault isolation not extensive if it exists at all.	Integral cal and/or cal via CPU available; extensive fault isolation available.	Same as "B"	2.8	5.6	5.6	
Selection Result: Subtotal						27.5	28.4	38.4	

Figure V-7. System Configuration Trade Matrix

Weighting Factor	Problem Definition and Selection Criteria	Range of Weighting Factor Applied	Problem: Determine Preferred Patient Monitoring Data Processing System			Selection Comments	Figure of Merit		
			<u>Alternate A</u> - LPU Only	<u>Alternate B</u> - CPU Only	<u>Alternate C</u> - LPU Plus CPU		A	B	C
			5	Facilities Cost (Room, Sub-Floors, Air Conditioning, etc.)	30% 20% 60%		Minimal Cost - Generally compatible with patient room; central display area and cabling is the only significant burden.	Computer facility requirements are extensive - significant cost. Machine I/O and data storage requirements requires facilities more extensive than any other configurations.	Computer facility requirements are moderately less than "B" since CPU complex is less extensive.
5	Compatibility With Existing Equipment and Software	30% 60% 20%	Extensive mini-computer programs do not exist - new software packages required for LPU.	Existing software packages developed for IBM 1800, CDC 3200/3300 probably compatible - (However, few are compatible with each other).	New software packages for both CPU and LPU.	1.5	3.0	1.0	
5	Back-up and spares inventory required.	80% 40% 20%	Lowest	Median	Highest	4.0	2.0	1.0	
Selection Result: Subtotal						9.5	6.0	5.0	
Grand Total						68.4	68.4	89.8	

Figure V-7. System Configuration Trade Matrix (Continued)

Problem: Determine Preferred Patient Monitor Data Processing System										
Weighting Factor	Problem Definition and Selection Criteria	Range of Weighting Factor Applied	Alternate A - Small Local Processor* Only (Patients Room)	Alternate B - Large Central Processor (Minimal Local Processing, if any)	Alternate C - Large CPU Couplable to small Local Processors & Related Equip.	Selection Comments	Figure of Merit			
							A	B	C	
10	Equipment "available" to "all" hospitals large and small	20% 80% 100%	Yes (assume 80% of institutions may apply this equipment only)	No (assume 20% may procure this equipment)	No for total system Yes for portions (assume 100% of users served)		2.0	8.0	10.	
8	Flexibility and growth capability	20% 40% 80%	Growth in number of parameters monitored and degree of processing is limited by LPU size and by cost of extending each LPU employed.	Growth capability reasonable by adding peripherals, modifying software, etc., may be also applied for non-patient monitor tasks.	Offers optimum as combination of A and B where growth attained primarily via CPU; additionally, a CPU may be shared by several small regional hospitals.		1.6	3.2	6.4	
8	Patient/Attendant Loading	20% 40% 40%	Requires personnel for control and monitor of trends and diagnosis outside the scope of LPU.	Provides extensive data analysis, trend indicating etc. and therefore may provide for reducing monitor & control manpower.	Same as B		1.6	3.2	3.2	
8	Autonomous Operation	50% 20% 80%	Modules operate independently; when one goes down, others not affected; defective module replaceable; difficult to accomplish meaningful data interface between modules.	If CPU goes down, system goes down; room equipment modules are still replaceable; CPU correlates all patient module data; nearly impossible to schedule downtime.	CPU breakdown and scheduled downtime has minimal impact on patient since modules (including LPU's) function independently with a decrease in system sophistication.		4.0	1.6	6.4	
7	Data Handling Capabilities	20% 20% 50%	Limited by capability of LPU; increase of data handling sophistication results in increased cost for each independent unit.	CPU must handle large quantities of patient data reducing effectiveness and limiting application of CPU for billing, research, etc. requires complex I/O.	Pre-processing reduces data flow and central processor load; allows for scaling data handling in accordance with patient requirements.		1.4	1.4	3.5	
*All three solutions assume a central remote display is provided.							Selection Result: Subtotal	10.6	17.4	20.5

Figure V-7. System Configuration Trade Matrix (Continued)

Weighting Factor	Problem Definition and Selection Criteria	Range of Weighting Factor Applied	Problem: Determine Preferred Patient Monitoring Data Processing System			Selection Comments	Figure of Merit		
			<u>Alternate A</u> - LPU Only	<u>Alternate B</u> - CPU Only	<u>Alternate C</u> - LPU Plus CPU		A	B	C
7	Dedicated Monitor and Processing	50% 20% 70%	Continuous monitor and processing of a limited quantity of critical parameters is possible. Extensive processing for such things as full range arrhythmia detection and <u>classification</u> is not probable.	A many patient oriented CPU cannot perform continuous monitor of EKG and other assigned critical items; interrupts for other operational tasks, system downtime, etc. and number of patients monitored prevent continuous monitor.	LPU may perform limited continuous monitor in conjunction with high sample rates of other parameters; e.g. LPU may perform arrhythmia detection while the CPU would prefer the arrhythmia classification including correlation of "associated physiologic parameters".	3.5	1.4	4.9	
7	Initial Cost Hardware	80% 40% 20%	Minimum (LPU 10-15K)	High (CPU in six to seven figures)	Selectable - cost vs capability. To provide system A which is expandable to system C, a small increase (over A) is probable	5.6	2.8	2.4	
	Software	80% 40% 20%	Minimum due to limited analytical capability required.	High - total detection, classification and control.		5.6	2.8	2.4	
8	Operations & Maintenance Costs	70% 60% 30%	LPU's may not significantly reduce number of personnel required on floor; in comparison to B and total C maintenance cost small; no auxiliary functions may be accomplished to improve operational cost picture; equipment operation & maintenance accomplishable by relatively unskilled personnel.	Personnel required for maintenance programming functions are additional skilled individuals; system would relieve medical personnel from routine duties; system may be applied to billing, research and other areas to improve cost effectiveness of operation.  Equipment servicing repair and calibration cost higher than "A".	LPU - Same as "A";  Combination - Operation and maintenance cost is approximately "A" plus "B" since the skilled personnel required for the CPU computer will be the same personnel servicing the LPU's and associated equipment but there are several LPU's plus the CPU.	5.6	4.8	2.4	
6	Capability for Specialized Data Correlation, Plots, etc.	10% 80% 80%	Practically None	High	High	0.6	4.8	4.8	
Selection Result: Subtotal						20.9	16.6	16.9	

Figure V-7. System Configuration Trade Matrix (Continued)

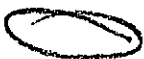

## DATA PROCESSING SUBSYSTEM ARCHITECTURE

Data Processing can be accomplished with a variety of machines, ranging from simple programmer/sequencers to sophisticated large scale general computers, depending on functions to be performed. The complete Patient Monitoring System will be implemented with a combination of these machines, including a Central Processing Unit (CPU) operating in conjunction with local module processors. The CPU will be included in the cardiovascular module, and the local processors will be minicomputers, one to each module. The minicomputers will have easily expandable memories, so that different data storage requirements in each module can be accommodated with the same basic hardware. In addition, the software programs of the minicomputers will be modular, so that the differing requirements of each functional system module can be programmed into the same hardware.

Emphasis has been placed on the use of "minicomputers", and each of the 4 PMS modules utilizes a minicomputer as a preprocessor or total processor. The term "minicomputer" is catchy but misleading; while "mini" is appropriate when referring to physical size and cost, it is not when one is considering computer power. Today's small computers outperform many of yesterday's large computers. There are available commercially small digital computers, low in cost, that can do a variety of jobs extremely well.

One can view the computer as an element in the hierarchy of information transfer devices as indicated in Figure V-8. The central processing unit (or mainframe) does all of the logical and arithmetic processing associated with the computer. Figure V-9 presents the block diagram of a basic minicomputer while Figure V-10 presents a generalized minicomputer system. The host computer represents a larger computer to which the minicomputer can be tied for configuration which require larger capability. Peripheral subsystems are connected to the I/O bus utilizing standard interface characteristics. Through this I/O bus flow commands or output data from the minicomputer to its attached display subsystem and control subsystems, while measurement information, buffered by the signal conditioning subsystem, flows in the opposite direction.

The low cost availability of minicomputers permits their assignment for specialized monitoring and control tasks that remain cost effective while possessing adequate flexibility and computational strength. The architecture of minicomputers will be described later, but two significant formulations are the "general purpose" and the "special purpose" configurations.

The general purpose configuration offers a powerful computer having a "normal" instruction capability of mathematical operations, and input/output control, etc.; this configuration can be used for any general purpose by changing its stored program. This general flexibility would permit the minicomputer to perform varied functions, such as EKG monitoring, temperature monitoring, or blood pressure monitoring, etc. by changes of its program memory.

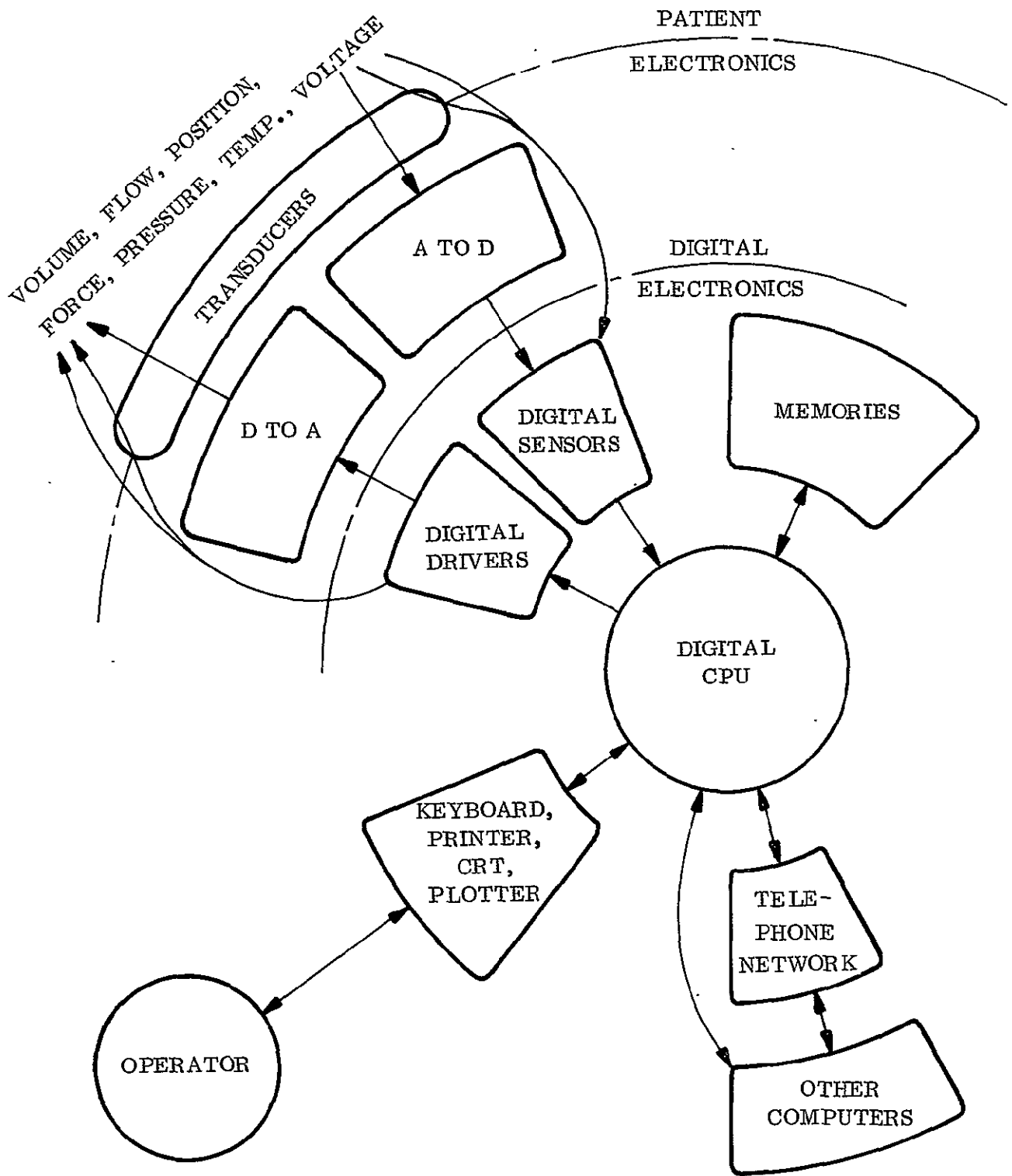

Figure V-8. Computer's Role in an Information Network

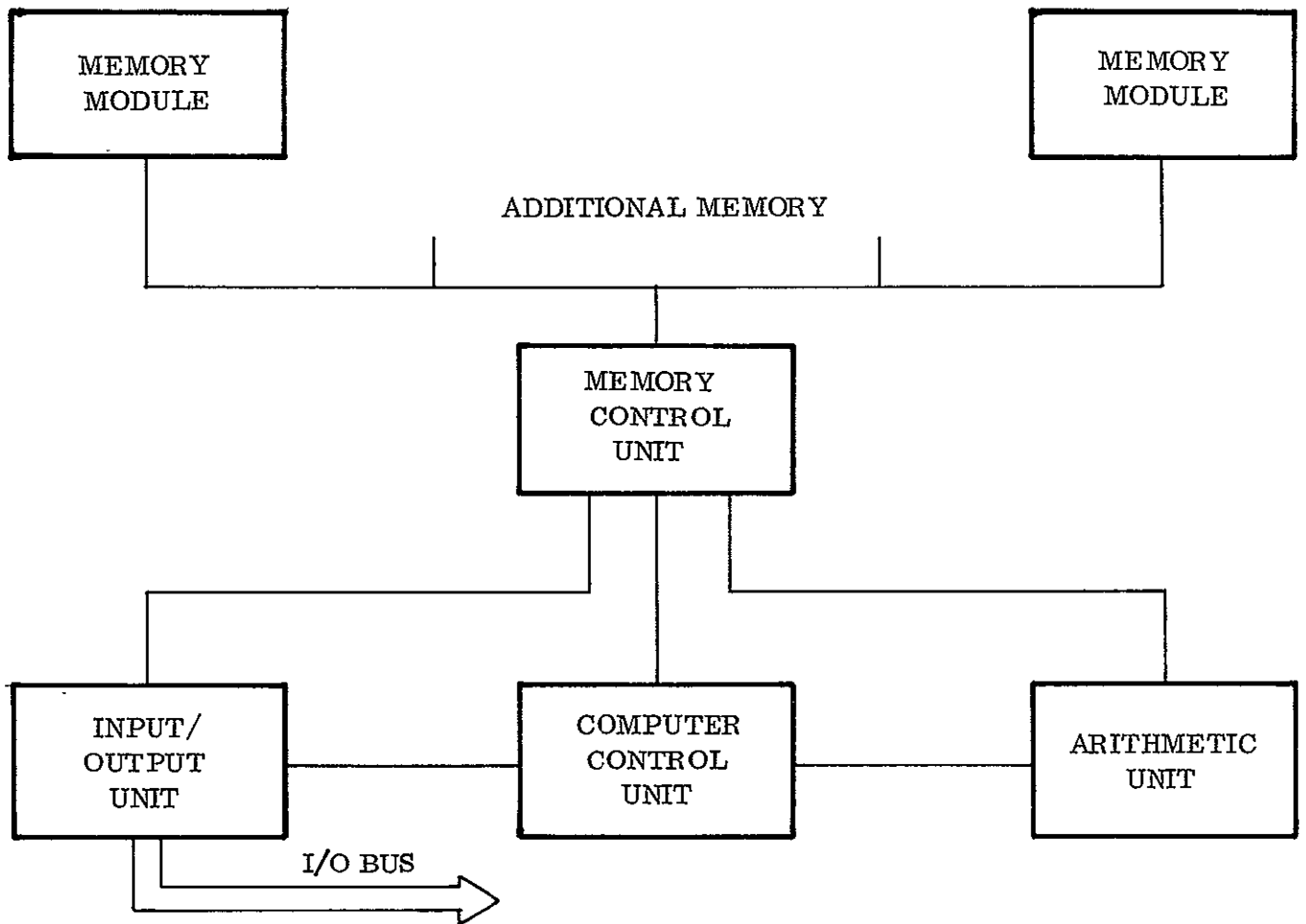

Figure V-9. Block Diagram of Basic Minicomputer

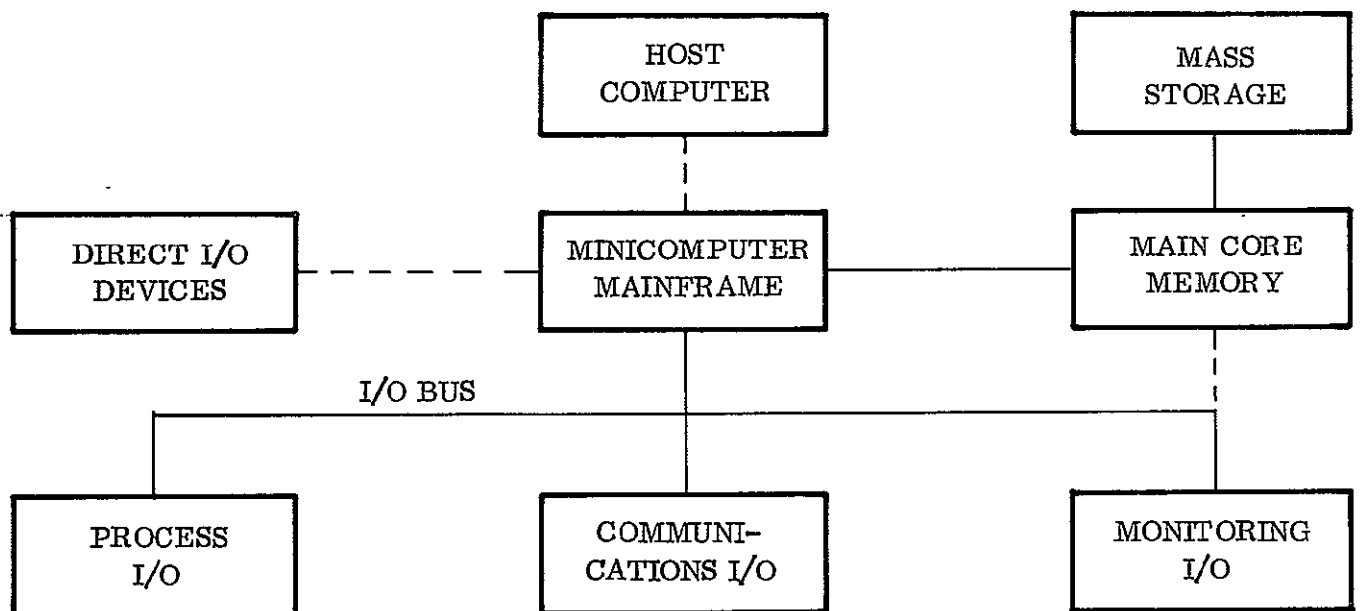

Figure V-10. Generalized Minicomputer System

The special purpose configuration permits the arithmetic operations to be changed beyond "normal" operations to specialized, more efficient algorithms. Special algorithms, such as Fast Fourier Transforms for frequency spectrum analysis, may be desired to classify arrhythmia patterns, and to detect and alert the staff in the event of a serious change of the pattern. Incorporating these special algorithms with normal instruction repertoire is inefficient in both computer size and speed; the special arithmetic capability permits these computational algorithms to be performed in less time and using less of the computers capability.

The minicomputer, using its I/O bus, can store and retrieve information from varied peripheral data repositories. Thus monitored data could be accumulated on tape units or disc storage units for either off-line processing by other computer systems or for later retrieval by the minicomputer. The standard interface of the I/O bus also allows the minicomputer to communicate with a larger "host" computer receiving information from a large data base, receiving instructions from this off-line computational facility, and sending data to the host computer, as in the case of the cardiovascular module.

The host computer (used only if cardiovascular monitoring is required) is a large data processing system which can serve multiple functions in addition to supporting the PMS computational modules. The transfer of information between the host computer and many minicomputers can be accomplished by data phone modems or by hardwire connections and sequential servicing of the host computer to each of the minicomputers. The large storage, computational, and control capacity of the host computer enable it to serve as a central data repository, a central controlled of the remote PMS modules, and to perform complex computational tasks such as EKG arrhythmia analysis, and determining cardiac output. In addition to these roles, the host computer may be available to perform background functions, such as accounting/billing, to ensure its complete utilization.

The low cost of the minicomputer is obtained through the design of a basic computer which will have broad application. The use of minicomputers in a larger system then is not an activity of designing a computer to satisfy the system requirements, but utilizing an existing computer configuration in a method which can best satisfy the system requirements. From this apparent component inflexibility arises the system strengths:

- low cost -- mass production
- interchangeability -- standardized computer
- standardized interface
- computational strength

In addition to minicomputers which are organized along the structure of normal general purpose data processing machines, some models are available which utilize micro-programming architecture. A micro-programmed machine separates the arithmetic segment of the computer into small functional pieces, which can be interconnected by memory control words to perform non-standard arithmetic activity. This additional capability enables the minicomputer to perform special algorithms in less time than possible with standard instructions; this feature is desirable whenever "real-time" computing is required as it raises the bandwidth of the computational system, resulting in better performance.

The drawback to such a feature is that when the machine has been changed at the micro level then maintenance, troubleshooting, documentation, and operations (especially at the programming level) become non-standard with the difficulties that accompany non-standard situations.

The minicomputer thus offers a distinct, cost effective method to provide local monitoring of the patient's status, display of pertinent parameters, and local data reduction/data storage. When interconnected with larger systems the minicomputer provides an effective data transfer path between the patient and the central computer, and can preprocess measurement data to achieve desirable data compression.

The following paragraphs discuss the data processing functions to be performed in each module, and show how the computational subsystem architecture selected for the system can fulfill all of the requirements.

## MODULE ONE - CARDIAC SURVEILLANCE

The data processing requirements of the cardiac surveillance module include the acquisition and conversion of EKG data and the subsequent analysis of the converted data. Existing techniques for cardiac surveillance (in the form of available hardware) are rather simple and suffer from susceptibility to artifacts (noise), yielding false alarms. Attempts to overcome this susceptibility often involve decreasing the sensitivity of the basic technique, thereby increasing the probability of missing a true ectopic beat. One example of simple available arrhythmia surveillance is the R-R interval technique, based on detecting the large amplitude R waves and measuring their space in time. Even with a large amplitude signal, noise presents a problem, and artifacts appearing as R waves must be discriminated. Amplitude and pulse width discrimination can be employed, as well as setting a requirement for detecting several abnormalities, in effect, before classifying an arrhythmia. These steps, although somewhat effective, effectively lower the probability that any single, true ectopic beat will be detected as an arrhythmia. This is undesirable, since even a single ectopic beat can be extremely important to a patient and his doctor. On the other hand, an overly sensitive instrument will quickly become a nuisance, and, as the survey showed, the medical staff will tend to turn it off.

What is needed, therefore, is a more sophisticated technique to analyze acquired data, especially candidate ectopic beats. Analysis of rise and fall times, pulse widths and amplitudes and zero crossover times, all related to previous waveshapes and other parts of the same waveform, are possible approaches, and are currently being pursued. It is anticipated that the next few years will see the development of improved cardiac surveillance techniques which overcome the problems of those available today. It is further anticipated that the implementation of these techniques will require the capabilities of a digital computer. Preliminary results of work being performed today on these advanced techniques indicate that incoming EKG analog data will generally be acquired in the standard fashion on (six) leads and will be digitized continuously by A-D converters. The waveshapes will then be analyzed by measuring times of zero crossovers, amplitudes, pulse widths, rise and fall times, etc. Conversion of these parameters to a convenient set of digital code values will enable storage and subsequent analysis of complete waveshape in a fixed number of bits. This first step of translation of analog waveshapes to a set of digital bits is expected to be implemented by means of a special-purpose algorithm. It forms the basis for providing data to the second step of cardiac surveillance, namely the arrhythmia detection routine, as well as providing translated EKG data to a CPU in Module Two for further categorization and further analysis. The arrhythmia detection routine is also expected to be an algorithm which compares the waveshape parameters with stored and updated limits as well as previous values from the same patient.

The data processing equipment, therefore, must be capable of storing and executing the two algorithms mentioned above. Preliminary estimates of memory required for this function range around 4K bits. In addition, at least 4 continuously available A-D input channels must be provided to accept EKG signals and a temperature signal. An output register with associated control discrettes must be provided to enable communication of translated EKG data to a higher order CPU (if required) or to an associated bulk memory (if required). Appropriate

I/O for accepting control inputs (approximately six discrettes and a parallel input register for inserting limits) is required, as well as output discrettes (6) for controlling displays. Additionally, channelization must be provided to handle program loading peripherals and readout devices. A relatively inexpensive (less than \$5K) and standard minicomputer with standard I/O can fulfill all of these requirements.

## MODULE TWO - CARDIOVASCULAR

The Computational Subsystem for Cardiovascular Module is the most sophisticated part of the PMS. The complex functions to be performed require a large-capacity Central Processing Unit (CPU). The acquisition and pre-processing of cardiac data is performed by means of a minicomputer and software for each patient, identical to that described in Module One. In addition, however, cardiovascular pressures and dye dilution data are acquired by the minicomputer, and the translated cardiac data, the pressure data, the dye dilution data and the results of the cardiac surveillance analysis are all presented at the output of the minicomputer for transfer to the CPU. The CPU can be used with a large number of minicomputers, and it may be located anywhere in the facility. It obtains data from its minicomputer(s) by sequential closed-loop data transfers between its I/O and the output of the minicomputer(s). In detail, the CPU obtains a batch of patient data from a minicomputer by sampling an output discrete flag in the minicomputer, and, when the flag is set indicating new data available, the CPU provides high-frequency shift pulses to serially read the data from an output register in the minicomputer to an input register in the CPU. This operation is performed sequentially for each patient minicomputer.

Since each patient has a dedicated minicomputer, his critical cardiac data is monitored continuously. Further analysis by the CPU, however, is on a time-shared basis. CPU sampling of each patient will be at least one sample per five minutes. The CPU will analyze the translated cardiac data to categorize and diagnose arrhythmias by comparing waveshape characteristics to those in a stored library. It will also update the library based on measured arrhythmias. In addition, the CPU will compute significant cardiovascular parameters based on the cardiac and pressure data, as well as the dye dilution data. It will also store patient data for at least 24 hours, and will compute trends for selected parameters. It will generate digital and analog display data at its output, and it will provide this data to the local processor for local display. It will select modes of operation, branches in software, and will accept input limit data, all from control subsystem input data, provided to the CPU by the local minicomputer in formatted form.

For sizing purposes, a capability of four patients for the cardiovascular module has been assumed. Additional patients can be accommodated by software modifications and by additional bulk memory. Also included in the estimate of sizing is the capacity to accept data from four other types of modules and to utilize this data in the cardiovascular module displays.

### MODULE THREE - PULMONARY MODULE

The computational subsystem for the Pulmonary Module is a minicomputer, programmed to acquire data from the thermistor, pneumotachograph, pressure sensors, and blood gas (or breath gas) analyzer. Data is inputted by analog-to-digital converters in the minicomputer's I/O on a continuous basis. In the case of the blood gas analyzer, its digital output will automatically be presented to an input register at the minicomputer, and can be read in by the software. If a breath gas analyzer is used, its output may be analog, and would be inputted via an A/D converter. Control signals, in the form of discrettes and thumbwheel - generated limit data, is read in by discrettes and inputting register. Displays are driven directly by a minimum of six D/A converters and a minimum of twelve digital output discrettes in the minicomputer I/O. Data is transferred to other modules on demand, by the minicomputer I/O, using the "closed-loop" method described above.

Computation includes the derivation of pulmonary resistance, tidal volume, respiration rate and amplitude. Preliminary estimates indicate that 4K words of memory are sufficient, as well as is a 1 usec add time.

## MODULE FOUR - BODY CHEMISTRY MODULE

A minicomputer forms the computational subsystem for the Body Chemistry Module. Its primary function is data acquisition and formatting, since body chemistry computations are performed in special purpose analysis equipment. It also transmits data to another module (probably a CPU in Module Two), since module four is not intended for autonomous use. It is anticipated that a urine analyzer and a blood analyzer will be used to compute various parameters for inputting to the system. Since these analyzers are rather costly, they will probably be centrally located in a hospital laboratory, and will be used for a large number of patients, with hand-drawn samples provided for analysis. If this is the case, then the analyzers will input digital data directly into the system network (probably into a CPU in Module Two) for incorporation into the patient's overall display. In cases where the need for frequent body chemistry measurements justifies dedicating analysis equipment to one or a few patients, then the minicomputer will accept the outputs of the analyzers acting as a buffer, and will format the data into words directly useable by the CPU. It will also control the sampling of blood and urine by indicating sampling times and, in the case of catheter use, automatically providing samples to the analyzers. It will also accept inputs from urine volume measuring devices, and will compute urine volume and urine rate, for transfer to the CPU. Although the functional requirements for data processing in this module are very simple and might not in themselves justify the use of a minicomputer, it is recommended for the sake of conformity and standardized data interfaces within the overall system. A 4K word machine with at least six A/D converters, serial input and output registers and at least twelve input and twelve output discretets, with a 1 usec add time, will certainly be sufficient.

## DATA TRANSMISSION SUBSYSTEM TRADE-OFFS

The utilization of the patient monitoring facilities, either in part or whole, by outlying hospitals, clinics, health aid centers, etc. who for any number of reasons do not take the option of having the central equipment within their facility may rationally use communications to provide them with the selected functions. The trend is toward this type configuration. There are many advantages to this type system in that advances made with the central system are immediately available to those subscribing to that system. The operability of the system is forced to be maintained at a lower technician level. Economically there are advantages in non-duplication of central equipment which is not fully off-set by judicious selection of the communications subsystem's equipment. The same is true for the duplication of operating personnel including technicians, programmers, and systems engineers. A difficulty is generated in that now organizations have an interface through the system. The disagreements that arise naturally whenever this occurs are easily avoided by the selective functional modularity of the system. If a user wishes to use only selected functions within the system, he may do so without disrupting the integrity of the overall system.

In selecting the correct communications media, trade-offs were categorically made across the spectrum of those communications media practical for use by patient monitoring as it will exist within the foreseeable future. These trade-offs are reflected in the following paragraphs.

### GENERAL

Commercially available communications circuits that have been considered from slow speed 150 baud telegraph circuits up to video 6 megahertz television circuits. A list of these available services is given in Table V-1.

To evaluate the cost-effectiveness of these circuits for meeting specific requirements, the following aspects will be considered:

- a. Inputs to the transmission signal -
  1. analog
  2. digital
  
- b. Multiplex systems - combining input channels within the capacity of the transmission media:
  1. Frequency Division Multiplex - to combine analog data channels into a single composite analog channel.
  2. Time Division Multiplex - to combine digital data channels into a single composite data channel.
  
- c. Conversion of signal form to meet transmission facility requirements:
  1. MODEMS (Modulators/Demodulators) to convert a digital signal for transmission over analog communication media and

TABLE V-1. COMMERCIAL CIRCUIT CLASSIFICATIONS

<u>Category</u>	<u>Series</u>	<u>Bandwidth/Signalling Speed</u>
Sub-Voice	1000	Up to 150 baud telegraphy
Voice Band	2000	3 KHz voice services
	3000	3 KHz data services
	4000	4 KHz Western Union Allocation
Wide Band	5000	Analog facility services:
		19.2 Kbs
		40.8 Kbs
		50.0 Kbs
		200.0 Kbs
		230.4 Kbs
		Digital Facility Services:
		50 Kbs
		250 Kbs
		500 Kbs
13400 Kbs - (future)		
Audio Services for Video	6000	15 K Hz
Video	7000	8 M Kz
Wideband Intrastate	8000	40.8 Kbs
		50 Kbs

2. CODECS (Coders/Decoders) to convert an analog signal for transmission over digital communication media.

The capacity of a data channel is given by the relationship

$$\text{Capacity (bits/second)} = \text{Bandwidth} \times \log_2 \left( 1 + \frac{\text{carrier power}}{\text{noise power}} \right)$$

According to Nyquist's theorem a channel of B Hz bandwidth can be used to transmit a 2 level (binary) signal at a rate of 2 B bits/second. With other coding schemes, according to Shannon, this rate can be exceeded whereby, theoretically, a C2-conditioned voice band line having a bandwidth of 2400 Hz can have a signalling capacity of 25 Kbs at 30 db signal-to-noise ratio.

A list of the commercial Modem/Codec offerings with signalling speeds is given by way of example in Table V-2. The following sections describe these services and the transmission media available.

TABLE V-2. COMMERCIAL MODEMS/CODECS

<u>Series</u>	<u>Service</u>
100	Low speed digital, less than 300 bps
200	Medium speed digital, 1200-2400 bps
300	High speed digital, 19.2-230.4 Kbs
400	Low speed multifrequency, digital, 20-75 char/sec.
500	Reserved for high speed wideband, digital
600	Specialized analog for facsimile, ECG
700	Reserved for high speed wideband, analog
800	Data Set Auxiliary Equipment
900	Test Equipment

## SERVICES

### SUBVOICE SERVICE

The subvoice circuits provide communications of up to 150 baud speed; this speed is suitable for telegraph systems such as:

Type 32 teletype	7.5 level	45-75 baud
33 teletype	11 level (ASCII)	110 baud

For budgetary purposes, these circuits normally cost less than \$1.00/mile/month.

### VOICEBAND- VOICE SERVICES

These 3 KHz voiceband circuits are used for normal voice services. In the patient-monitoring area they are used for transmitting ECG and EEG 100 Hz analog data, the 603 data set transmitting 1 channel and the 604 data set 3 channels simultaneously.

Other frequency division multiplex systems are available for ECG/EEG transmissions, one Frequency Modulated Subcarrier System using 6 channel oscillators between 645-2795 Hz, with a  $\pm 125$  Hz max deviation/channel and a 305 Hz guard between channels.

Work has been done using phase-lock loop channel units for ECG/EEG transmission; these units comprise a phase comparator, low pass filter and amplifier to vary the frequency of a voltage controlled oscillator in sympathy with the incoming signal. Up to 8 channels have been obtained by this technique which will provide a greater FM improvement factor when the subcarrier system is below 10 db signal-to-noise input.

These circuits may be used for slow speed facsimile transmissions which operate at a rate of 6 minutes per 8-1/2" X 11" page; in one model, a dataphone/adaptor combination recognizes a telephone ring signal, answers, and hangs up electronically when the call has been completed.

Transmission characteristics for these circuits are as follows:

Typical loss	16 $\pm$ 1 db
Message Circuit SNR	24 db
Impulse Noise	15 counts in 15 minutes over 60 db SNR

Associated services available include:

DDD	Direct dial - subscriber dials distant subscriber's extension
FX	Foreign exchange - subscriber dials local number assigned to distant subscriber
PL	Private line

The DDD and FX services are paid according to the number of message units used. The PL service for budgetary purposes costs approximately \$3.00/mile/month for the first 25 miles, with sliding scale reductions for longer distances.

### VOICEBAND DATA SERVICES

These circuits are private line services carrying up to 9.6 Kbs data over conditioned lines using the 203 MODEMS. Numerous time division multiplex and codec equipments are available for these circuits; particularly for teletypes, time division multiplex units can be obtained accepting up to 128 channels at speeds of 37.5, 45, 50, 74.2, 75, 110, 150 and 300 bauds, the total speed not, however, exceeding 2400 bauds. Data sets are available using frequency shift keying, and differentially coherent, or AM suppressed carrier vestigial sideband modulation techniques.

Normally, the error count of these services is kept to 1 in  $10^5$ . At the higher speeds, the Modem/Codecs also incorporate error control techniques such as:

1. Error detection and retransmission or
2. Error detection and forward correction.

The error detection and retransmission technique can be of two kinds:

- a. Stop and wait - in which the data is transmitted in blocks, at the end of which the transmitter waits for an acknowledgement (ACK) or non-acknowledgement (NACK). In the latter case the block is retransmitted.
- b. Buffered Retransmission - in which the first block is transmitted and at the same time stored in a buffer; the second block is then sent and also stored in a second buffer. If an ACK is received the first buffer can be discarded and the third block transmitted and stored therein.

The forward error control technique employs code words based on exact statistical properties of the channel and the error correction capabilities of the code, the code acting as an algorithm to add redundant bits, process the received message and perform the correction.

For budgetary purposes, the cost of these circuits are approximately \$4-7/mile/month for the first 25 miles, with sliding scale reductions for longer distances.

### WIDEBAND SERVICES

These circuits can be considered an extension of the series 3000 circuits:

<u>Speed</u>	<u>Transmission Bandwidth</u>	<u>Est. Price \$/Mile/Month</u>
19.2 Kbs	Half group	18
40.8 Kbs	Group	30
50 Kbs	Group	30
230.4 Kbs	Super Group	85

Above 230.4 Kbs

Individual Pricing

Picturephone can be considered in this wideband offering. These signals have a bandwidth of 1 mc/S, and are sampled at the Nyquist rate (2 MC/S quantized to 3 bits). The restriction to 3 bits per sample produces a graininess which is overcome by differential pulse code modulation. This system has utilized a vast amount of research and engineering, and has a reported waiting list of 5,000 customers.

#### AUDIO SERVICES FOR VIDEO

This is a 15 KHz high quality audio service for commercial television.

#### VIDEO SERVICES

This offering covers the video service for commercial television of 6 M Hz bandwidth. This includes a 15 KHz channel centered at the 5.75 MHz point for the "lip-synchronized" audio.

## COMMUNICATIONS MEDIA

The communications media available for these services include

Coaxial Cable  
Microwave, and  
Satellite

### COAXIAL CABLE

Coaxial Cable systems have several advantages over radio systems, mostly due to the fact that the medium of transmission is more stable and noise free. The principle disadvantages is that cable attenuation is much greater than that of free space and repeaters are required at regular intervals. A 1/2" diameter cable can provide up to 1 GHz bandwidth, multiplex equipment being available for providing 6, 12, 18 or 24 color TV channels on one such cable over a bandwidth 54-270 MHz.

For budgetary purposes, it is estimated that a cable route can cost between approximately \$4000/mile - \$15,000/mile for 6 and 24 channel capacity cables respectively, with an additional \$2500/mile for poles should poles be required.

### MICROWAVE COMMUNICATIONS

Private microwave communication systems in the 0.75 to 13.25 Gigahertz (GHz) band are available from commercial suppliers. These systems can provide up to 20-30 M Hz of available bandwidth permitting the transmission of high data rates, or very wideband analog. The propagation between stations must be over a line-of-sight path which can be affected by reflections from bodies of water and sand, grazing-path refraction, and fading; however, a well designed system will give acceptable performance.

In that line-of-sight is a requirement, receiver/transmitter repeaters are installed enroute; the average hop distance between terminal and repeater, or between terminals, can be taken as 30 miles for budgetary purposes.

The average microwave station can involve

1. Land acquisition
2. Building and access roads
3. Power
4. Tower and Tower lighting
5. Antennas
6. Transmission lines (antennas - equipment)
7. Transmitter(s)/Receiver(s)
8. Alarm System
9. Multiplex/Service Channel equipment and
10. Maintenance

For budgetary purposes, the cost of microwave equipment, excluding buildings, power and towers, can be roughly estimated to be:

Terminal	\$18,000
Repeater	\$36,000

### SYNCHRONOUS SATELLITES

Except for the fact that the relay or repeater station is flying at 22,300 miles over the equator in synchronous orbit, satellite links are basically the same as microwave systems with two hops and one repeater. From the specified altitude the satellite can see 42% of the earth's surface.

At the present NASA has two Applications Technology Satellites (ATS) and COMSAT has three INTELSAT III satellites in use capable of handling 1200 2-way voice circuits, 4 1-way color TV channels or combinations thereof. In addition, COMSAT is proposing additional satellites:

INTELSAT IV	2 horns for earth coverage 2 steerable dish antennas 4° 5000 2-way phone ccts or 12 color TV channels ERP 36 dbw/channel
DOMESTIC	21,600 trunk channels 9600 multipoint message channels or 12 color RV channels ERP 38 dbw

Due to present limitations in satellite effective radiated power, ground stations must use highly directive antennas and ultra-low-noise parametric amplifiers to ensure adequate signal-to-noise ratios for high quality wideband communication. Transmission requirements for the satellites and ground stations for the present INTELSAT and proposed DOMESTIC Satellites are given in Table V-3. Channel capacity is given in Table V-4.

Due to the increased satellite capabilities it is expected that adequate communications with the INTELSAT IV and proposed DOMESTIC Satellite can be obtained with small 15 foot roof-top mounted antennas and without the need for cooled parametric amplifiers. Such a situation will open up the communications facilities for remote patient monitoring and diagnosis.

TABLE V-3. SATELLITE & GROUND TRANSMITTING REQUIREMENTS

Satellite	Satellite ERP	Ground Station ERP Requirements
INTELSAT III	22 db	
Voice		61 dbw
Television		86 dbw
PROPOSED DOMESTIC	38 db	
Message		86.8 dbw
Television		75.4 dbw

TABLE V-4. CHANNEL CAPACITY

Satellite	Bandwidth MHz	Equivalent 2-Way Voice Channels	Equivalent TV Channels
INTELSAT III	500	1200	4
INTELSAT IV	500	5000	12
PROPOSED DOMESTIC	500	10,300	12

## ***SYSTEM REQUIREMENTS***

## SYSTEM REQUIREMENTS

### SYSTEM SENSOR REQUIREMENTS

The patient monitoring system sensor interfaces with the patient and the signal conditioning subsystem. These sensors will be employed to detect electrical parameters cutaneously, as well as parameters routed externally from body openings and from percutaneous locations. In addition, patient parameters must be detected that are not electrical but are pressures, changes in velocities of gases and fluids, changes in physical dimension and changes in temperature. Non-invasive techniques shall be employed whenever possible.

The physiological parameters to be detected include blood pressures, body temperature, respiratory flow and amplitude, ECG, and urine output. Also, there is an optional requirement to detect the flow rate of IV fluids and/or drugs, and chest drainage.

### SYSTEM SIGNAL CONDITIONING REQUIREMENTS

The signal conditioning shall provide interfacing and processing functions between the sensor and data processing subsystems. The outputs from the sensors shall be interfaced and converted to system standard voltage levels. Adequate amplification, shaping, electrical filtering, and input-output connectors will be required. Appropriate lead lengths, with shielding, grounding, and routing shall be required to be supplied by the signal conditioning subsystem.

### SYSTEM DATA ACQUISITION REQUIREMENTS

The data acquisition subsystem portion of the patient monitoring system is actually the input/output of the data processing subsystem. It must provide the interface and processing required between the sensor/signal conditioning subsystems and the data processing subsystem. The signals being handled are both analog and digital. The analog signals originate from physiological sources. The digital signals are from manual inputs, equipment sources, communications, and clock inputs.

The analog signals must be converted by the data acquisition subsystem to digital. This conversion must result in system compatible words in bit positions, rate, and voltage levels (considering distance to be transmitted with minimum distortion). A scheme must be provided by which multiple analog sources may be serviced concurrently. The length of dwell on any one or more data sources shall be controllable. The sampling rate for the analog data shall be appropriate for the physiological signals being sampled.

The system must have a time source. The time data must be resolved to hour, minute, seconds, and milliseconds as well as provide start and stop time intervals.

The digital interfacing must be system compatible in length, rate, and voltage level. The word length shall be required to handle system data words, command words, etc.

## SYSTEM DATA PROCESSING REQUIREMENTS

The Patient Monitoring System shall require off the shelf (if possible) general purpose, programmable, digital, automatic equipment to process its physiological, manual and equipment inputs as well as provide messages for display/printout and control functions.

The processing should be configured to handle four major categories of applications: cardiac surveillance, cardiovascular, pulmonary, and body fluids. These would be applied in the physical locations within the hospital of: screening, X-ray, catheter lab, operating room, intensive care ward, cardiac care unit, and rehabilitation facilities. Additionally, these same areas should be provided for in the design capacity of the procuring equipment from a minimum of one and up to eight remote locations.

Three (3) of the data processing modules should be of similar compatible design capacity (i. e., the cardiac surveillance, pulmonary, and body chemistry. The fourth processing module (cardiovascular) shall be compatible with the other three modules but shall be of larger capacity.

The requirements for the cardiac surveillance, pulmonary, and body chemistry modules includes the following:

The memory subsystem shall be high speed.

The cycle time of the high-speed memory should be commensurate with the processing requirements of the physiological parameters being measured and derived or no more than two (2)  $\mu$  sec. The length of the word should include the lengths required to contain the standard system word length, the instruction word length, plus the parity bit position. This is sixteen (16) bit positions plus the parity bit position or a total of seventeen (17) bit positions within high speed memory. Capacity of storage shall be adequate to contain the supervisor, the applications programs, and the data being processed, or utility programs (such as the diagnostic, higher or lower order language program etc.). This shall not be necessarily at the time. At no time is this expected to exceed 4K words.

The central processor shall contain the necessary registers, logic and timing making it compatible with the standard systems word length (16 bit position), and capable of performing standard arithmetic, logic, and transfer functions. Also, the word length shall be large enough to address all core locations (from 4096 to 32,768 locations), address modes, and operation codes/modifiers.

The central processor shall contain the necessary registers, logic and timing to provide standard mini to intermediate digital data processing power. The instruction word length shall be large enough to accommodate a repertory that includes standard arithmetic, logical, store/retrieve, I/O, and transfer instructions. In addition the instruction word length shall be long enough to accommodate special instruction modification indexing, and address modifier bit positions. The instruction word shall also be large enough to accommodate addressing directly or indirectly from 4096 to 32,768 words. The arithmetic operation speeds shall

be commensurate with the physiological parameters being measured or derived and shall be based upon a fundamental add time not to exceed one (1.0)  $\mu$  sec. Double precision shall be provided.

The input/output (I/O) shall be system word length (16 bit positions) compatible. The speed shall be memory cycle time compatible. The number of parts shall be variable to match the individual requirements as determined by each user. An external interrupt and priority scheme shall be included.

Power failure recovery, a restart sequence, and clock-both real and interval shall be provided for.

Peripheral equipment for the Modules I, III, and IV shall consist of low speed, low capacity read in/write out equipment only.

The Module II - Cardiovascular subsystem shall be compatible with Modules I, III, and IV but shall have higher memory access speed, the ability to expand its high speed memory to eight (8) times its initial capacity, its arithmetic operations shall be of at least of the next category of higher speed available. The I/O should be capable of handling both the input-output parameters of the cardiovascular monitoring function as well as other modules, a bulk storage media, and peripherals. The peripherals working in conjunction with other modules, shall include standard slow to intermediate speed card and magnetic tape handling equipment. Also, a small to intermediate bulk storage media should be provided. The capacity of this bulk media storage should accommodate in a modular fashion from 1-32 million characters storage with an average access time of approximately 17 milliseconds. Autonomously the Module II peripherals shall include only slow speed, low capacity read in/write out equipment only.

#### SYSTEM DISPLAY REQUIREMENTS

The patient monitoring systems displays will provide readouts designed for medical and systems personnel. This system shall work in close conjunction with the control subsystem.

It is required that this system services the operators in the following five (5) modes: monitoring, trauma, data retrieval, data entry and maintenance.

The monitoring mode requires the displaying of direct and derived patient parameters that have are being obtained in real time.

The trauma mode requires the appropriate displaying and alarm of critical condition patient data. Some method of a permanent written copy of the trauma data is also required. Alarm features must be built into this display mode which would alert and inform the attending personnel.

## SYSTEM CONTROL REQUIREMENTS

The control subsystem must provide the interface between the operators of the system and the system itself. Manual and automatic control signals that cause the system to perform its function will be provided the necessary hardware to perform these functions by this system.

The system must have the control functions of manually inserting, deleting, and/or changing data. This data will be in the form of system commands, patient/system information, etc., which shall update the computer's files and/or cause the system to execute functions. Some form of physical data entry equipment must be provided by the control subsystem which is designed for optimum usability by the hospital staff. This involves the human engineering techniques handling the considerations of open ended messages flexibility, standard short form message input, enter-edit-correct before execute, keyboard lockout, etc.

These control functions must be applicable to all configurations of the system.

## SYSTEM SOFTWARE REQUIREMENTS

In order to cause the computers that constitute part of the function automatically handled by a patient monitoring system to execute their assigned function, programs must be written and/or modified from existing programs. The requirements of these software packages follow.

The overall configuration of the software must support and compliment the needs of the patient, physician, and the hardware configuration. The individual functions performed by the programs should be constructed in such a manner that they could be executed autonomously or in concert with many other functions. These functions must also be controlled by an overall directing scheme that would ensure efficiency, reliability, and operability. The configuration of the software must be able to match not only the hardware configuration but equally be able to support the functional configuration of the physical plant organization of the hospital including:

Screening Facility  
Catheterization Room  
X-Ray Room  
Operating Rooms

Intensive Care Unit  
Cardiac Care Unit  
Exercise and Rehabilitation Facilities

Compatibility of the system's software to change either in adding, deleting, or modifying accompanying application packages without reprogramming the rest of the system is required.

The data retrieval mode requires of the system the capability to automatically retrieve stored patient data. The type of data to be retrieved includes, but is not limited to, historical records, drug schedules, lab analysis data and administrative material.

The data entry mode of operation requires that the operator be given the ability to interactively enter data into the patient monitoring system. This mode will enable the addition, deletion, and or modification of data.

The maintenance mode requires that assistance data be provided to operating personnel in setting up the system both in calibrations and in patient to system set-up.

There are essentially four (4) categories of different display requirements as far as physical locations within the hospital is concerned. The four (4) categories are: bedside, nurses' station, remote, and operating room.

The bedside display requires that adequate and appropriate presentation of the data be provided for operating personnel (physician, nurses', P.M. technicians, etc) in the environment of medium light intensity, reading distance of from two and one half to twenty feet and a viewing angle of approximately 130°. The data to be presented shall be analog waveform of physiological measurements as detected from the patient. A digital display is required to present quantized physiological data measured directly or derived. The bedside displays should be augmented with other instrumentation as required to enhance the the display systems capability to communicate to operating personnel.

The nurses' station display shall require that each patients data be equally available and on display at that centralized location. The type of data to be displayed will be ECG analog data, dynamic alpha-numeric digital data, charts, hard copy, and alarm data.

The requirements for display at a remote station shall be compatible to the requirements listed for the bedside and the nurses station. This shall include ECG, EEG, and blood pressures; digital, and chart recordings. Additionally, voice communications shall be required between the remote sites and the local patient monitoring areas.

The operating room environment has display requirements that encompass the possibility of having severe environment constraints such as: being doused in corrosive and conductive fluids, being situated in a location difficult to see by the user. etc.

The data to be displayed shall be EKG, EEG, and blood pressure, body temperature, blood gas analysis, and times. This data will be presented in analog and/or digital as is appropriate.

Maximum throughput time must be achieved as well as minimum response time to meet the demands of the physiological characteristics vs the minimum equipment configuration required to meet and match that demand. At the same time the system's data and programs must be inviolate by any other procuring software and/or its data.

Concurrency and simultaneity of operation of equipments and functions is required.

The operators of the software system shall not be concerned with how the system is operated or integrated as software. The operators will be concerned with dealing with the applications and as such shall be provided with lower and higher order language(s) to facilitate ease of programming. Additionally, automatic and simplified programming aids are required to ease the loading of programs and data as well as the conversion of media, editing, and peripheral interfacing.

The patient monitoring system must have a uniform method by which its data files are handled, accessed, updated, protected--all at optimum rates both by the equipment and by the users.

Maximum utilization of the equipment must be made possible by the software both in its application to patient monitoring as well as to other applications at the users option. A complete methodology for accomplishing this should be furnished as a package.

Access to the system from remote locations using a variety of rates up to but not including broadband must be made available utilizing the most efficient means available. The computer shall have the software capability of servicing multiple applications concurrently and to satisfy real time jobs to the extent allowed by the equipment's capabilities.

A software system is required that will test and confirm the operability of the equipment. Also, scheme should be furnished which would measure the operating characteristics of the system.

The patient monitoring applications program shall be constructed in whole or in part of those routines, subroutines, and algorithms researched, developed, proven, and approved by the members of the medical profession. The programs should occupy a minimum of core. The length of time evident in core shall be also at a minimum. These applications programs shall be callable both locally as well as remotely. Physiological and manual inputs from the patients, operators, and equipment shall be accepted by the software. The response times must be compatible to the signal characteristics that are meaningful to the measurements being taken or derived. The parameters measured or derived shall be those listed in Parameter Matrix in Section IV Evaluation Summary under Requirements.

Optional measurements and control functions should be offered. These should be addable as modules at the users option.

## SYSTEM DATA TRANSMISSION REQUIREMENTS

The requirements for data transmission in the patient monitoring system encompasses the communicating of serial digital data of slow and medium speeds and analog data over distances from a few hundred yards to across states. The digital data requirements are for teletype data speed and format. Also, additional digital data must be transmitted at a higher speed at frequencies up to 3000 Hz. The analog data must be transmitted via singular or multiple circuits ranging from DC to 105 Hz input.

***SECTION VI***  
***SYSTEM SPECIFICATION***

## ***SCOPE***

This preliminary specification was developed basically for use by the NASA, NIH, and the P.M. Advisory Committee. However, due to the national interest in the Intensive Care Medical Program this document may be available to other Federal, State and Municipal agencies interested in monitoring devices.

It is recognized that changes to this document will be required. This may be accomplished by amendments as frequently as requirements dictate.

## 1. Scope

This specification establishes the minimum functional performance and test requirements for Patient Monitoring Systems (PMS). A monitoring system consists of an integrated set of sensors and medical electronic units for monitoring selected physiological parameters of patients, displaying information at a remote station and/or bedside, initiating out-of-limit alarms and automatic monitor switching, and the devices required for physiological stimuli.

## ***APPLICABLE DOCUMENTS***

## 2.0 APPLICABLE DOCUMENTS

### 2.1 GOVERNMENT DOCUMENTS

The following documents cover topics related to this specification and form a part of this specification only to the extent specified herein.

#### Specifications

##### Military

MIL-J-641C  
Supplement 1  
25 July 1966

Jacks, Telephone, General Specification for

MIL-D-642B

Supplement 1  
21 September 1966

Plugs, Telephone and Accessory Screws

##### Standards

MS-3102A-14S-(6S)  
21 April 1959

Connector, Receptacle, Electric Box Mounting

MS-3102A-14S-(8S)  
21 April 1959

Connector, Receptacle, Electric Box Mounting

##### Federal

Fed-STD-123  
4 November 1957

Marking for Domestic Shipment (Civilian Agencies)

Veterans Administration  
Specification X1414  
1 January 1970  
(Amendment No. 1  
1 Sept. 1970)

Biomedical Monitoring Units  
(Electro-BioMetrics for Intensive Care Units)

## 2.2 OTHER

### 2.2.1 Other Publications

The following publications cover topics related to this specification and form a part of this specification only to the extent specified herein.

Report of Committee on Electrocardiography, American Heart Association, Recommendations for Standardization of Leads and of Specifications for Instruments in Electrocardiography and Vectorcardiography; Circulation Volume XXXV, March 1967.

### 2.2.2 General

**Special Provisions.** Prospective bidders should visit the site and examine the location where the equipment will be installed. Failure to do so prior to bidding will be at the bidder's risk.

### 2.2.3 Precedence of Documents

In the event of conflict between this document and any other document, the order of precedence shall be:

- a. Purchase Order or Contract
- b. This specification
- c. Applicable documents referenced in this specification

### 2.2.4 Referenced Documents

The following documents cover topics related to this specification and form a part of this standard only to the extent referenced:

1. USA Standard C1-1968:  
"National Electrical Code"  
(NFPA No. 70), National Fire Protection Association, Boston, Mass. 1968  
(Article 517)
2. "Code for the Use of Flammable Anesthetics"  
NFPA No. 56, National Fire Protection Association, Boston, Mass. 1968
3. "Inhalation Therapy"  
NFPA No. 56B, National Fire Protection Association, Boston, Mass. 1968
4. "Essential Electrical Systems for Hospitals"  
NFPA No. 76A, National Fire Protection Association, Boston, Mass. June, 1970

5. "General Standards of Construction and Equipment for Hospital and Medical Facilities"  
U.S. Dept. H.E.W., Public Health Service Pub. No. 930-A-7, Rev. Feb. 1969
6. Draft of Standard for Medical and Dental Equipment Subject 544; Underwriters' Laboratories, Inc., Melville, Long Island, N.Y.
7. AAMI Safety Standards for Electromedical Apparatus (Part One Safe Current Limits)  
AAMI Electrical Safety Subcommittee 10-20-70.

#### 2.2.5 Classification of Apparatus

2.2.5.1 For the purposes of this specification, the following classifications of electro-medical apparatus will be used. In determining compliance with the requirements of this specification, electro-medical apparatus shall be assigned the type designation corresponding to its most hazardous anticipated application.

2.2.5.2 Therapeutic - "Therapeutic" includes all apparatus that applies energy of any kind to the subject in order to cause a physiological change. Examples: defibrillators, fibrillators, pacers, heating lamps and apparatus used in: shock-therapy, cautery, diathermy, and cryogenic treatment.

2.2.5.3 Nontherapeutic - "Nontherapeutic" equipment includes all apparatus that does not apply therapeutic energy to the subject. Examples: electrocardiographs, electroencephalographs, coronary and intensive care monitors and impedance pneumographs.

2.2.5.4 Type "A" - Apparatus to be used on or within the reach of patients having devices whose terminal end is introduced into the thorax and is conductively connected to a point accessible outside of the body.

2.2.5.5 Type "B" - Apparatus used only on patients not having devices whose terminal end is introduced into the thorax and conductively connected to a point accessible outside of the body.

## ***REQUIREMENTS***

### 3.0 REQUIREMENTS

#### 3.1 PATIENT MONITORING SYSTEM FUNCTIONAL DESCRIPTION

A Patient Monitoring System (PMS) is an integrated set of sensors and other electronic units to perform patient physiological monitoring, with capability for monitoring and control of appropriate therapeutic (treatment) devices, in any of several areas within a Hospital. The PMS comprises, primarily, fixed or semi-fixed installations in such designated areas as:

Screening

X-Ray

Catheter Lab

Intensive Care Unit (or equivalent)

Coronary Care Unit (or equivalent)

Operating Room

Diagnostic Facility

Rehabilitation Facility

but provisions are incorporated for:

Remote Monitoring via a "Communication/Data Link"

Use with/or portable single-patient monitors of limited (but defined) monitoring capacity

Remote Display

Data Interface with Administrative (Business) Systems

Data Interface with Academic and/or Research Systems

The PMS contains functions for:

Monitoring basic physiological parameters

Computing (defined) derived parameters

Data Entry (Non-monitored parameters, desired limits, etc.)

Display of desired parameters and related data

Alarms for undesirable conditions

Switching and Control of sensor, computing, and display functions

Data Storage and Retrieval

Monitoring of system operation

Monitoring and Control of (defined) therapeutic devices

The physical set of equipment may vary with the manufacturer. All functions specified must comply singly and in combination to the requirements of this specification. Standardization of interfaces shall be incorporated to enhance system growth and expansion, without requiring either system redesign or utilization of the original manufacturer to provide the units for such growth.

Monitoring and display functions are as follows:

- (a) Heart Waveform - Continuous monitoring cathode raytube (CRT) display (or equivalent) at bedside. Selectable or continuous CRT display (or equivalent) selectable direct writing recorder and continuous interval tape recorder (or equivalent) at the remote station.
- (b) Heart and/or pulse rate continuous monitoring and meter or equivalent display at bedside, and selectable meter or equivalent display at the remote station.
- (c) Blood Pressure - (Function selectable or continuous monitoring with meter or equivalent display of the systolic, diastolic, mean or venous pressure at bedside. Patient selectable meter or equivalent display at the remote station.)
- (d) Temperature monitoring and display functions include monitoring and meter or equivalent display at bedside. Selectable meter or equivalent display at the remote station.
- (e) Respiration rate monitoring and display functions include: Continuous monitoring and meter or equivalent display at bedside. Selectable meter or equivalent displays at the remote station.

Alarm functions consist of separate alarm lights automatically illuminated for each monitored and meter or equivalent displayed parameter which violates preset low or high limits. Alarm lights are manually (or automatically) reset when the alarm condition has been corrected.

Remote station alarm functions consist of separate alarm lights automatically illuminated for each patient whose monitored and meter or equivalent displayed parameter falls above one bedside preset limit or below another bedside preset limit. A single aural alarm

sounds whenever any alarm condition occurs. Visual and aural alarms are automatically (or manual) reset when alarm conditions are corrected.

During an alarm condition all physiological displays will continue to function.

The following switching and control functions are in addition to the essential switching and control functions for operating, calibration, alarm setting and resetting, etc.:

- (a) Manual selection for display at the remote station of all monitored parameters of (a specific) patient.
- (b) Automatic initiation of the direct writing ECG recorder and selection for display at the remote station of all monitored parameters of patient in alarm status.

The PMS includes the following interconnection or connection interface functions:

- (a) Patient Operational Interface. Those interfaces between the patient and the cabling; including electrical connections such as ECG electrodes, physical contact connections such as temperature probes and blood pressure transducer connectors (electrical).
- (b) Equipment Operational Interfaces. Those electrical connectors interfacing cabling and equipment which require mating and demating for routine PMS operational activities such as sensor or transducer replacement or operational mode changes.
- (c) Maintenance Interfaces. Those electrical connectors interfacing cabling and equipment which require mating and demating only for performing maintenance on any part of the PMS.
- (d) Power Interface. Those electrical connectors interfacing individual instrument power line cord ends with the power distribution system.

### 3.1.1 System Scope

The goal in designing the Patient Monitoring System (PMS) is to make it applicable to a wide range and number of patients, fulfilling the immediate critical needs of the medical profession, with easily adopted growth capability to accommodate future needs. The immediate critical needs are primarily in the areas of cardiac, cardiovascular and pulmonary monitoring, as well as basic body chemistry and temperature analysis on an automated basis. Future growth areas include encephalography and automatic fluid infusion. Categories of patients, established for the purpose of scoping the application of a general PMS are:

1. General Screening
2. Chest Pain

3. Post-surgical (general)
4. Post-surgical with cardiovascular history
5. Post-surgical (cardiovascular)
6. Post-surgical with pulmonary history
7. Post-surgical (pulmonary)
8. Cardiac catheterization
9. Exercise cardiology
10. In surgery
11. Acute Medical Emergency

The PMS shall be capable of application to each listed patient category, generally in a medical center environment. It shall sense, acquire, process, compute, display, store, and print specific medical data from patients under local and/or remote control. It shall be flexible enough to be extended throughout a medical building as required, as well as connected to remote buildings through an appropriate communication network. Although communication links themselves will not be considered as part of the system, the capability to interface with and to utilize existing and/or planned links shall be a design requirement.

The PMS shall provide monitoring capability consistent with good medical practice. Only acceptable medical techniques shall be implemented, and patient safety shall be the foremost design requirement. Time-critical parameters shall be monitored continuously and other parameters shall be sampled at a frequency consistent with their anticipated worst-case rate of change. Analytical methods, sampling rates, logic, limits, and other parametric data in the system shall be based on medically accepted physicians' research and data consistent with the current state-of-the-art. The PMS shall be based on their requirements, and shall produce outputs easily utilized by them. Use of the PMS shall in no way interfere with the treatment or physical well-being of the patient.

In order that the system may be easily incorporated into a wide variety of medical centers, it shall be designed to utilize generally available physical facilities. The system design shall take into account typical existing patient facilities and methods currently in use, and the final system design shall be compatible with them, placing no unrealistic demands on existing installations. In addition, an important goal of the system design shall be to attempt compatibility with as much patient monitoring equipment currently in use as is feasible, without unduly constraining the flexibility or the practicality of the system. To achieve this end, a listing will be made of those current equipments which appear to be most frequently in use and with which the PMS is most likely to overlap in capability. Compatibility with these equipments will be assured, wherever feasible, by provision for

handling specific inputs and outputs and physical space allotments. Significant parameters, including impedances, signal levels and frequencies, subroutines, will be accommodated in the system's input/output electronics and software programs. Flexibility will be ensured by providing the system with options in terms of input/output connections and software sub-routines.

### 3.1.2 System Modularity

The approach to fulfillment of the goal of treating large numbers and many types of patients with one basic system is utilization of modular system design. In such a system each module is capable of autonomous operation at a low level of complexity, but can be easily operated with other modules to form a larger system with more complex capabilities. With judicious specification of design requirements for the modules, the resulting modular set will accommodate functional and coverage needs ranging from simple and few to complex and many. To implement this approach, a set of four functional modules has been selected, based on parameter functions. These are described below, with their primary characteristics listed. In order that specific measurement requirements peculiar to a particular monitoring situation might be accommodated, as well as future growth capability, additional input/output capability will be provided with each module, as well as provision for easily adding to computational programs. The characteristics listed, therefore, shall be considered a set of suggested minimum performance requirements, with provisions made for additional spare capability.

#### MODULE I - CARDIAC SURVEILLANCE

Measures:	EKG, Temperature
Computes:	Heart Rate Arrhythmia surveillance (ST segment analysis) - Option
Displays:	Heart Rate Arrhythmia alarm Delayed hard copy EKG on alarm or on option Time Temperature (ST segment depression/elevation) - Option
Patient System Interface:	EKG electrodes Temperature Sensor

BLOCK DIAGRAM OF MODULE I:

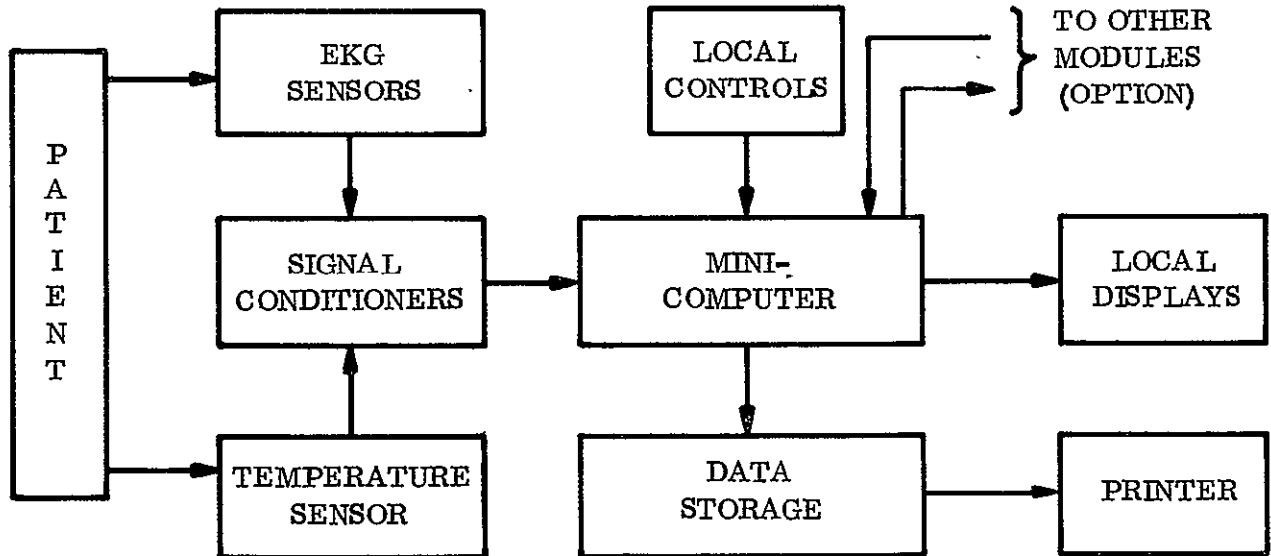

Figure 3.1.1

MODULE II - CARDIOVASCULAR

Measures:

Temperature  
EKG  
Blood pressures  
Stroke Volume

Computes:

Heart Rate  
Arrhythmia detection  
Arrhythmia classification  
Systolic pressure  
Diastolic pressure  
Mean venous pressure  
Cardiac output  
ST segment depression  
Parameter trend analysis

Displays:

- Temperature
- Heart rate (last reading or history)
- Arrhythmia alarm
- Arrhythmia classification (probabilities)
- Delayed hard copy EKG on alarm
- Systolic pressure (last reading or history)\*
- Diastolic pressure (last reading or history)\*
- Mean venous pressure (last reading or history)\*
- Cardiac output (last reading or history)
- Analyses results (last reading or history)
- EKG waveform display (real time)

Patient System Interface:

- EKG electrodes
- Implanted catheters
- Temperature sensors

\*Either available at selection of attendant

BLOCK DIAGRAM OF MODULE II:

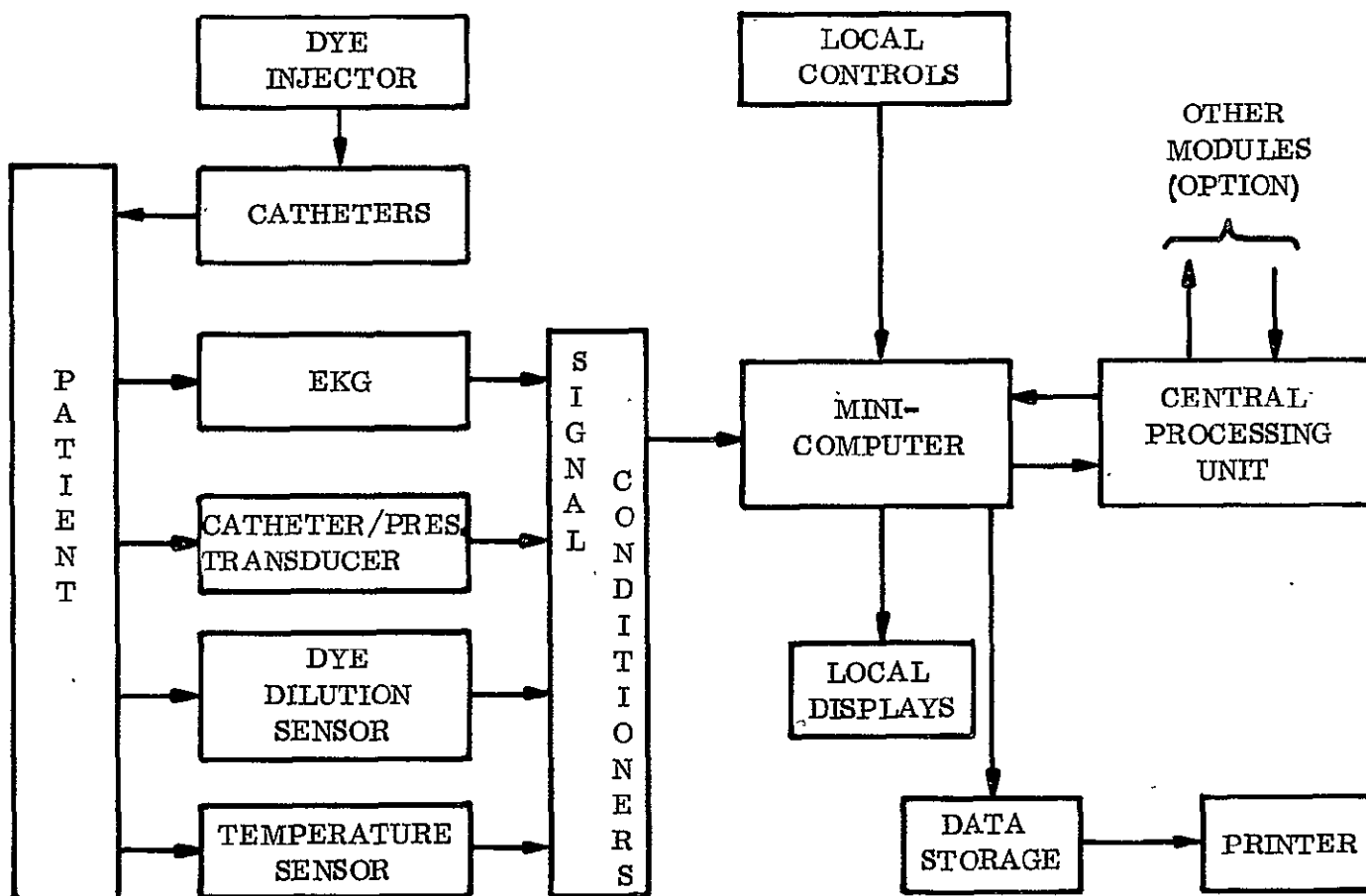
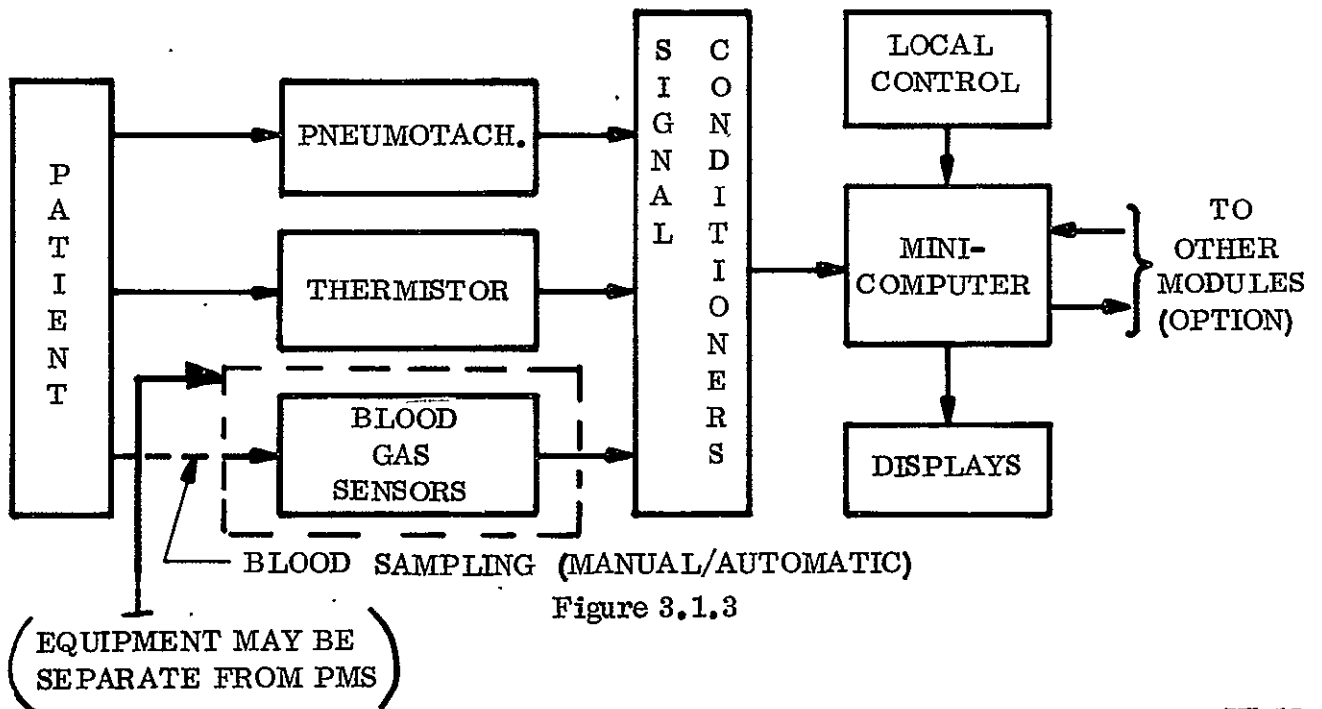

Figure 3.1.2

MODULE III - PULMONARY

- Measures:
- Temperature
  - Respiration rate
  - Respiration amplitude
  - PO<sub>2</sub> } By blood gas analysis (semi-automatic)
  - PCO<sub>2</sub> } or by direct air analysis
  - Airway pressure
- Computes:
- Respiration rate
  - Tidal volume
  - Pulmonary compliance
  - PO<sub>2</sub>
  - PCO<sub>2</sub>
  - pH
- Displays:
- Time
  - Respiration rate
  - Tidal volume
  - Pulmonary compliance
  - PO<sub>2</sub>
  - PCO<sub>2</sub>
  - Equipment status
  - pH, temp., airway pressure
- Patient/System Interface:
- Pneumotachograph
  - Blood samples (once/hour)
  - Temperature sensor

BLOCK DIAGRAM OF MODULE III:



MODULE IV - BODY CHEMISTRY

(this module is not meant to be used alone)

Measures: Urine Output

Accepts: Data from Blood and Urine Analyzers

Computes: ( L<sub>A</sub>T )  
( T<sub>E</sub>R )  
( )  
Urine volume  
Urine Rate

Displays: Hard copy of all parameters and real time display of some parameters via other modules displays

Patient/System Interface: Blood Sampling (manual or catheter)  
Urine Sampling (manual or catheter)

BLOCK DIAGRAM OF MODULE IV:

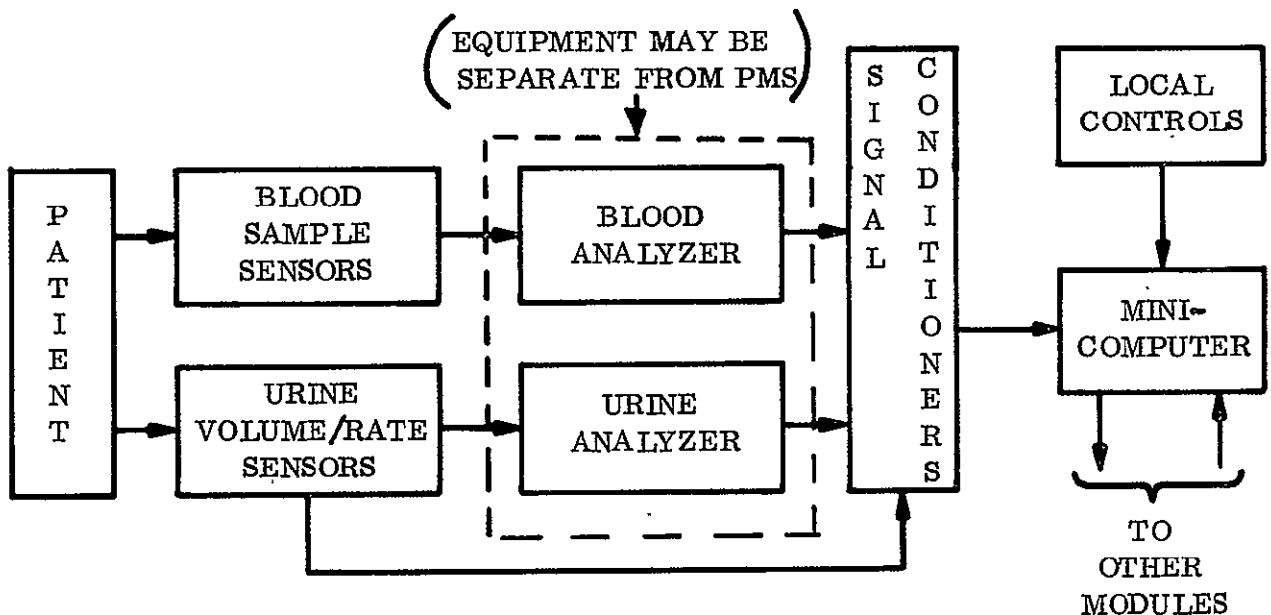

Figure 3.1.4

The application of this set of modules to fulfilling the needs of patients is straightforward. In cases where simple functions are required, basic modules will be utilized. The number of modules required will be determined by the number of patients which the module is designed to monitor simultaneously, as well as the worst-case expectation of the number of patients requiring simultaneous monitoring of the same type. For complex functions crossing over the capabilities of more than one module, a system will be assembled using different types of modules, with the numbers of modules determined as described above. The system shall be designed such that all modules are capable of cross-communicating data, so that the grouping together of many modules and many types of modules will pose no interface problems.

Module II, the Cardiovascular module, will be the core of any large system, due to its extensive computational capability. Modules I, III, and IV will each be capable of interfacing with Module II (as well as with each other) to extend their functions. For example, if Module I is being used for cardiac surveillance in a Cardiac Care Unit, and a situation arises where extensive cardiovascular monitoring is desired in the CCU, a link to and existing Module II elsewhere in the system will convert Module I to and Module II extension. Similarly, in a case where Module II is being used to monitor cardiovascular functions in an Intensive Care Unit, the addition of a Module III can cover the needs of those patients requiring monitoring of pulmonary parameters.

An application of the four selected modules to the eleven categories of patients is shown below in Table 3.1.1.

Figure 3.1.5 shows a typical installation in a medical center of various modules, interconnected to form a system of extensive coverage and capability. In this typical installation, the most sophisticated capability is associated with the ICU for patients recovering from cardiac surgery. Current medical practice requires extensive monitoring of these patients, and a cardiovascular module is certainly required. This module forms the core of the medical center's system because of its' large data processing capability. The addition of a pulmonary module and a body chemistry module fulfills the patient monitoring requirements for this ICU. Another ICU, for patients recovering from general surgery, is implemented with a number of cardiac surveillance modules to cover the worst-case expected patient load. A link is provided to the cardiac surgery ICU so that the capabilities of the cardiac surveillance modules in the general surgery ICU can be extended if necessary. By similar links elsewhere, the cardiac surveillance module can be used to provide extended cardiovascular service throughout the center. Another example of this potential to expand capability is in the CCU. Ordinarily, chest pain patients and diagnosed heart attack patients could be monitored by cardiac surveillance modules. In cases where a patient's situation may require more sophisticated monitoring capability, the service can be easily extended to the CCU by means of the link and modular equipment to convert a cardiac surveillance module to cardiovascular module. This equipment includes sensors, signal conditioning equipment, controls and displays. The cardiac surveillance module will be designed such that this additional equipment can be easily added on a "plug-in" basis. The fourth group of modules shown in the typical installation services the operating room patient, and consists of a cardiac surveillance module, a pulmonary module and a body chemistry

TABLE 3.1.1. FUNCTIONAL MODULE APPLICATION TO PATIENT CATEGORIES

Patient Type	Cardiac Surveillance Module	Cardiovascular Module	Pulmonary Module	Body Chemistry Module
1. General Screening	X		X	
2. Chest Pain	X	(X)	(X)	
3. Post-Surgical (general)	X		X	X
4. Post-surgical with cardiovascular history	(X)		X	X
5. Post cardiovascular surgery		X	X	X
6. Post surgical with pulmonary history	X		X	X
7. Post-pulmonary surgery	X		X	X
8. Cardiac Catheterization		X		
9. Exercise Cardiology		X		
10. In-surgery (OR)	X	(X)	(X)	(X)
11. Acute Medical Emergency	X	(X)		X

( X ) = optional application suggested

module. These are interconnected to share displays and controls and to synchronize timing and calibrations. The modules will be designed to interface in this manner. In addition, a link is once again provided to extend the capability of the OR, if desired, by means of Module II in the cardiac surgery ICU.



Figure 3.1.5. Typical Medical Center Modular PMS Installation

### 3.1.3 & 3.1.4 Measured and Derived Parameters

The following charts present physiological parameters monitoring of which is considered to be required of a cardio pulmonary oriented Patient Monitoring System. Measured parameters are those which are evaluated on the basis of basic physiological sampling only; derived parameters are those which are attained through manipulation of one or more measured (or previously derived) parameters. Extended parameters are generally classified as derived parameters that are detail evaluations of measured or derived data.

For example:

ECG Waveform = basic

Heart Rate = derived (from ECG)

Arrhythmia = extended-derived (detail analysis of ECG)

Preliminary equipment and facilities monitors are included (but should not be limited to those shown) to indicate the necessity for monitors that will provide for environmental references, indication of equipment operability and safety, verification of configuration and command response interfaces. Auxiliary parameters indicate the probable extension of utilization of the PMS System when an integral CPU is included for a particular application.

Measured Parameters are listed in Table 3.1.2, Derived Parameters are listed in Table 3.1.3, Equipment and Facilities Parameters are listed in Table 3.1.4, and Auxillary Parameters are listed in Table 3.1.5.

Additional details such as Derivation Sources, Derivation Techniques (Manual, Automatic, Dimensions, Derivation Formula or Relationship), Amplitude, Frequency-Duration-or-Interval, Analytical Range, etc. shall be furnished in the Final Report.

TABLE 3.1.2. BASIC PHYSIOLOGICAL PARAMETERS

<u>Direct Measurement Physiological Parameters</u>	<u>Direct Measurement Physiological Parameters</u>
<u>Cardio-Vascular</u>	<u>Temperatures</u>
Electrocardiogram (Scalar)	Body Temperatures
Vector Cardiogram (Orthogonal Vector's X, Y, Z)	<u>Fluids Analysis</u>
Phonocardiogram	Hematology
Blood Pressure	Pressure - (See Previous)
	PO <sub>2</sub>
	PCO <sub>2</sub>
	PH
	O <sub>2</sub> Saturation
<u>Pulmonary</u>	Urology
Flow (Pneumotachograph, Spirometer)	Urine Flow Vol.
	Urine Vol/Unit Time
Volume	<u>Encephalography-Neurology</u>
Pressure Total	Electroencephalograms
Partial O <sub>2</sub> Pressure	Alpha Rhythms
Partial CO <sub>2</sub> Pressure	Beta Rhythms
	Delta Rhythms
	Theta Rhythms

TABLE 3.1.3 BASIC PHYSIOLOGICAL PARAMETERS FOR EXTENDED/DERIVED  
PHYSIOLOGICAL PARAMETERS

<u>Average Heart Rate</u>	<u>Arrythmias (Disrhythms)</u>	Ventricular Standstill
<u>Instantaneous pulse rate</u>	Atrial Premature Systole	Ventricular Tachycardia
<u>Pulse rate, average</u>	Atrial Tachycardia	Interventricular Block
<u>Pulse deficit</u>	Atrial Flutter	Ventricular Fibrillation
	Atrial Filbrillation	Ventricular Parasystole
	Atrial Standstill	Sinoatrial Block
	Atrioventricular Nodal Premature Systoles	Sino-Atrial Arrest
<u>Artifacts Causes:</u>	Atrioventricular Nodal Rhythm	Sinus Bradycardia
AC Interference		Sinus Arrythmia
Patient Movement	Atrioventricular Nodal Tachycardia	Sinus Rhythm Normal But Approaching Paroxysmal Atrial Tachycardia
Muscle Tremor		Sinus Tachycardia
Perspiration (Poor Electrode Contact) (Inferior Electrode Po- sition/Location)	Atrioventricular Nodal Escape	Wenckebach Block
	Atrioventricular Blocks	Wandering Pacemaker
<u>Rhythms</u>	Supraventricular Tachycardia	Complete Heart Block
Sinus Rhythm - Normal	Idioventricular Rhythm	Nodal Tachycardia and Paroxysmal Nodal Tachycardia
Heart Rate Normal	Premature Beat Rate	

TABLE 3.1.3 BASIC PHYSIOLOGICAL PARAMETERS FOR EXTENDED, DERIVED  
PHYSIOLOGICAL PARAMETERS (Continued)

Paroxysmal Atrial Tachycardia		Antebasal Infarct
Premature Atrial Contraction		Posteroinferior Infarct (Diaphragmatic)
Premature Ventricular Contractions (Approaching Ventricular Tachycardia)		Posterior (Postero-Septal) Infarct
Premature Atrioventricular Nodal Contractions (See Atrioventricular Nodal Premature Systoles)		Posterolateral Infarct
Premature Nodal Contractions		Posterobasal Myocardial Infarct
Ventricular Escape		<u>Blood Pressures</u>
Ventricular Premature Systole	INFARCTS - (Various Myocardial Ischemia Injury and Infarction)	Pulmonary Artery Pressure (PA) (Trunk)
Orthostatic Tachycardia	Anterolateral Myocardial Infarct	Pulmonary Wedge (W) Pressure
Reflex Tachycardia	Anterior (Anteroseptal) Myocardial Infarct	Right Ventricular Pressure (RV)
Paroxysmal Atrial Tachycardia with Block (A-V Node)	Apical Infarct	Left Ventricular Pressure (LV)
		Aortic Pressure, $A_0$
		Maximum Instantaneous Arterial Pressure
		Average Venous Pressure

TABLE 3.1.3 BASIC PHYSIOLOGICAL PARAMETERS FOR EXTENDED/DERIVED  
PHYSIOLOGICAL PARAMETERS (Continued)

Blood Pressures (Cont.)

	Peripheral Resistance (Circulatory System)	Respiratory Work, Inspiration
	Central Blood Volume	Respiratory Work, Expiration
Mean Venous (Right Atrial) Pressure	Mitral Insufficiency Index	End Expiratory Pressure
Left Atrial Pressure	<u>Pulmonary Monitors</u>	Lung Compliance
Average Arterial Pressure	Respiration Rate	Oxygen Uptake

Other Cardiovascular

	Respiration Amplitude	Respiratory Quotient
Arterial Pressure First Derivative	Maximum Expiratory Flow Rate (Direct)	Partial Oxygen Concentration
Duration of Systolic Ejection	Forced Vital Capacity	Partial Carbon Dioxide Concentration
Duration of Diastole	One Second Expiratory Volume	Chest Drainage Fluid Volume
Barach's Index	Minute/Volume, Respiratory	
Stroke Volume	Maximal Mid-expiratory Flow Rate	Chest Drainage Fluid Volume/Hour
Relative Stroke Volume	Maximum Instantaneous Respiratory Pressure (and Deviations)	
Cardiac Output (Pulmonary Blood Flow; Cardiac minute volume)	Tidal Volume (Exhaled Volume - Include Sigh Cycle)	

TABLE 3.1.3 BASIC PHYSIOLOGICAL PARAMETERS FOR EXTENDED/DERIVED  
PHYSIOLOGICAL PARAMETERS (Continued)

<u>Dye Dilution/Or Tracer</u>	
Densitometer Calibration	Left Ventricle
Appearance Time	Aorta
Build-up Time	<u>Fluids Analysis</u>
Max % Indicator	Blood
Mean Concentration	Hematology
Passage Time	Chemistry
	Other
Mean Circulation Time	<u>Urine</u>
<u>Blood O<sub>2</sub> Saturation</u>	pH
Superior Vena Cava	Blood
Mid-Right Atrium (RA)	Na (+), Cl (-)
Pulmonary (PA) Artery Trunk	K (+), Glucose
	Protein
Pulmonary (W) Artery Wedge	Microscopic
Radial Artery	<u>Drainage</u>
Left Atrium	Chest
Right Ventricle	

TABLE 3.1.4 EQUIPMENT AND FACILITIES PARAMETERS

Equipment &  
Facilities  
Parameters

Fluid Decrement &  
empty fluid infu-  
sion bag/bottle  
measurement

Drip. Flow Rate  
(IV-Nasal-Etc.)

Room Temperature

Power Status

Primary

Back Up

Nodal Leakage  
Current

Gas Supply Flow  
Rate

Gas Supply Pressure  
and Temp. Consti-  
nents by volume  
percent

Infusion Control  
Monitors

Interrupt Monitor  
active sensor moni-  
tor, remote display  
monitor

TABLE 3.1.5 AUXILIARY PARAMETERS

Auxiliary  
Parameters

Programmable Pace-  
maker

Programmable De-  
fibrillator

Nurses Notes and com-  
mentary

Doctors Notes, Pre-  
scriptions and Sche-  
dules

Patient data (Name, Sex,  
Age, Height, Weight,  
prior medical history,  
current medical diagno-  
sis, care program)

Medical records/Data  
library

Computer assisted  
Teaching/research

Patient billing data

### 3.2 PMS FUNCTIONAL PERFORMANCE REQUIREMENTS

In order to reasonably satisfy both functional and economic criteria of a broad range of institutions, the Patient Monitoring System (PMS) shall be designed to satisfy the functional requirements delineated in detail paragraphs of this section. Modularity is a salient critical requirement in order to make medically sound equipment for patient care and monitor readily available to the small institutions as well as the large hospital and research center. Secondly, modularity will provide the capability for limited selection of equipment satisfying the physicians' or hospitals particular preference of technique for monitor of functions while also providing for expansion and rapid, economic updating of range, sensitivity, accuracy and reliability as advances in state-of-the-art accrue.

Functional performance shall address the following characteristics in the order indicated:

- (a) Medical efficacy
- (b) Patient Safety
- (c) Reliability (accuracy, life, etc.)
- (d) Maintainability
- (e) Adaptability/Modularity
- (f) Simplicity
- (g) Integral Calibration and Fault Location

Equipment considered for use in the PMS will be evaluated on the above characteristics as well as the detail requirements as stated in the subsequent paragraphs.

### 3.2.1 Subsystem Requirements

Each subsystem shall be designed for primary application to the module for which it is intended, however; the design shall include consideration of compatibility with all other modules. Primary design considerations shall be directed towards physiological characteristics and events in the parent module including intra-subsystem modular design, intra-module compatibility of subsystems, inter-module compatibility and interchangeability where inter-module relationship is specified in the detail requirements in subsequent paragraphs.

Inter-modular relationship of subsystems shall be synergistic wherever possible and a subsystem of one module may not detract in any way from the operation of any external subsystem or module. Except for specific circuits interconnected with power and/or timing subsystems, each subsystem shall be autonomous insofar as practical, (e.g., loss of a portion of the central circuit functions should not affect the Monitor and Display subsystem). Automatic subsystem failure indicators and fail-safe techniques shall be evidenced by both audible and visible annunciators of tone and color different from that used for pathological alarms.

### 3.2.1.1 Primary Sensor Subsystem -

- (a) The sensor subsystem is defined as being comprised of all elements that provide primary detection of physiologic events and/or changes in physical quantities associated with these events including biological potentials, pressures, temperatures, sound, and so forth. Additional sensors for detection of basic equipment and environmental parameters are included in the subsystem to the extent defined herein.
- (b) The sensor subsystem includes elements as follows:

**ELECTRODES** - includes all classes of conductive elements used for detection of electrical parameters by making contact with non-metallic portions of electrical circuits to be measured. Examples are EEG, ZPG, VCG, ECG/EKG and GSR electrodes or contactors applied cutaneously. Percutaneous contactors are included in this set only when the detected signal is not routed externally.

**PROBES** - includes all classes of detection elements applied percutaneously or in body openings and cavities when the sensed parameter is routed externally for measurement. Probes include subcutaneous EEG, ECG/EKG electrodes, intravenous catheters used for pressure measurement and so forth. Probes are subclassified as electrode probe or transducer probe. The electrode or transducer may be integral with the probe (needle type EEG), or separate (miniature transducer in a catheter).

**TRANSDUCERS** - includes elements for detection of all classes of parameters other than electrical that are not measureable directly by electrical means but are transformed (transduced) into electrical analogs to enable electrical amplification, transmission and presentation. Transducer types commonly used include variable reluctance, accelerometer, strain gage, thermistor, photovoltaic cell, thermocouple, moving potentiometer and expansion or displacement types.

(NOTE: Devices for direct display or interpretation of non-electrical parameters and conversion from one form of energy to another non-electrical form of energy are not defined as sensors nor contained in the sensor subsystem herein. Stethoscopes, visual monitors (including TV, X-ray, fluoroscope) manometers, tactile sensors, and similar methodology are defined as portions of Monitor and Display Equipment, metering, or indicating instruments (pressure gages, etc.)

- (c) Sensors for the PMS system are categorized as follows:

Primary sensors are those employed to detect basic parameters; secondary sensors which are employed to detect detail characteristics of the parameters (i.e. cross-over detectors, phase detectors, etc.) only primary sensors are included in the sensor subsystem; other monitors, detectors, and similar devices shall be (as noted above) included in monitor, display, etc. equipment and/or in the data conditioning, processing portions of the PMS system.

The primary sensor subsystem therefore consists of:

- (1) Primary physiologic sensors (electrodes, transducers, probes or a combination thereof).
  - (2) Primary equipment sensors (transducers and transducer probes; transducer probes or any transducer inserted by means of an extension arm, suspension bracket, etc., into a closed volume (non-ambient), e.g., thermistor probe inserted in air flow of equipment rack to measure output air temperature).
  - (3) Primary environment sensors (transducer for monitor of room temperature, humidity).
- (d) All sensors shall satisfy the following general requirements:

- (1) Physiologic sensors:

- physiological sensors shall be non-invasive wherever practicable, i.e., the sensors (and related equipment) provided to detect those parameters defined in the included parameter tables (para. 3.1) shall satisfy all the requirements contained in this specification, Table 3.2.1 without requiring probes (subcutaneous, intra-cardiac, intra-venous, esophageal, etc.)
- where practical, currently available sensors shall be employed. Where superior performance and/or non-invasive technique of proposed sensor can be demonstrated and accepted, this criterion may be waived.
- capability for simple calibration and/or calibration verification shall be provided; transducers preferably do not require or have adjustments; all sensor calibrations shall be accomplished via related electronics and data processing equipment.
- All sensors designed for PMS application will be terminated in accordance with requirements of Table 3.2-1.

TABLE 3.2-1 PRIMARY SENSOR SUBSYSTEM

PHYSIOLOGICAL PARAMETER SENSORS

Electrodes	Attachment Technique; Sensor/Patient Interface	Sensor Type	Dimensional Range (Each Electrode)	Electrode Used Yes/No (Surface Only)	Sensor Material	Polarization Potential (Volts)	Patient Sensor Interface Impedance	V Between Electrodes (Millivolts)	Temperature Response	Linearity and Repeatability ( $\Delta T = 0$ )	Termination (Interface To Leads)
ECG/VCG (External)	Skin Surface-Adhesive; Elastic Strap with Velcro Fastener	Patch Round Square	8 to 15 mm $\phi$ 2 cm <sup>2</sup> to 2.5 cm <sup>2</sup>	Yes	AG, AGCL; AG Particles in flexible elastomer	-0.22 to zero	500 $\Omega$ to 10 K $\Omega$	< 0.10	$\frac{\Delta V \leq 1 \mu v}{10^{\circ} C}$	$\pm 1\%$ of* actual	TBD # ↑
ZPG	← SAME AS ECG/VCG ELECTRODES →										
EEG	Skin Surface-Adhesive; Subcutaneous-taped	Patch Needle	0.02 cm <sup>2</sup> to 0.25 cm <sup>2</sup> ; 28 gage to 26 gage	Yes	Stainless Steel	0.4 to zero	< 10 K $\Omega$	< 0.10	$\frac{\Delta V \leq 1 \mu v}{10^{\circ} C}$	$\pm 1\%$ of actual	
GSR	Skin Surface-Strap or Wrap (Palms of hands)	Plate - Curvilinear	5-6.5 cm <sup>2</sup>	No	Stainless Steel	0.4 to zero	< 300K $\Omega$	< 0.10	$\frac{\Delta R \leq 0.500 \Omega}{^{\circ} C}$	$\pm 1\%$ of actual	
ECG/VCG (Internal)	Tissue Surface-sutured; Sub-Tissue - Sutured	Patch Round Square Needle	4-8 mm dia( $\phi$ ) 0.25 - 0.5 cm <sup>2</sup> 28 gage to 24 gage	No	Stainless Steel	0.4 to zero	500 $\Omega$ to 10K $\Omega$	< 0.10	$\frac{V}{1 v}$ 10 <sup>0</sup> G	$\pm 1\%$ of* actual	TBD ↓
<p>NOTE: Alternates will be considered for application when submitted for evaluation (12 items plus full particulars)</p> <p>#TBD - To be determined at later date and added to specification</p> <p>*Over 10 microvolt to 2 millivolt range of input</p>											

TABLE 3.2-1 (Continued)  
PRIMARY SENSOR SUBSYSTEM

PHYSIOLOGICAL PARAMETER SENSORS

Transducers	Patient Interface Attachment Technique	Sensor Type	Dimensional Range	Calibration	Adjustments	Linearity And Repeatability (T = 0)	Temperature Response	Output Impedance	Band-Width	Sensitivity	Capacitance	Resolution	Response Time	Termination (Interface To Leads)
Blood Pressure	Sub-cutaneous - Taped	Cylindrical Transducers in-line connection to catheter.	$\leq 2.5 \text{ cm } \phi$ ( $< 2 \text{ oz. weight}$ )	None-Verify Linearity & repeatability per cal curve**	None Desired	The greater of $\pm 1\%$ of actual or 1 mm Hg;	$\pm 0.1 \text{ mmHg } ^\circ\text{F}$				TBD	1mm Hg		TBD
	Surface-taped, strapped or adhesive bonding	Ultrasonic Pickup Microphone	$\leq 1 \text{ cm}^2$			TBD	$\pm 0.02 \text{ db}/^\circ\text{C}$	$> 2\text{M } \Omega$	TBD	TBD ( $>0.5 \text{ mv}/\text{N}/\text{M}^2$ )	TBD			
Heart Sounds	Adhesive Ring; Strap Tape	Microphone	$\leq 6.5 \text{ cm}^2$			TBD	$\pm 0.2 \text{ db}/^\circ\text{C}$	$> 2\text{M } \Omega$	TBD	TBD ( $\geq 0.5 \text{ mv}/\text{N}/\text{M}^2$ )	TBD			
Body Temperature	Taped (Leads)	Thermistor Capsule (See Probes)				The greater of $\pm 0.1\%$ or $0.1^\circ\text{F}$						TBD	$0.1^\circ\text{C}$	
	Adhesive or tape	Patch Thermistor	5-6.5cm <sup>2</sup> (general) 2.5-4cm <sup>2</sup> (large toe)											
Respiratory Flow	Taped	Nasal Thermistor		None-Verify Range Linearity and repeatability to cal curve	None Desired	The greater of $\pm 0.1\%$ or $0.1^\circ\text{F}$								
Amplitude	Adhesive, Tape	Strain Gage Bridge	5-6.5cm <sup>2</sup>							*G.F. = $\frac{\Delta R/R}{\Delta L/L} \geq 100$	TBD	$0.1^\circ\text{C}$	$\frac{0.1 \text{ sec}}{\Delta T 1^\circ\text{F}}$	TBD

TBD - To be determined

\*\* Processor will interpret parameter measurement to cal curve

\* Gage Factor

3.2.1.2 Signal Conditioning Subsystem - The outputs of most sensors will not necessarily be compatible with the rest of the system. In addition, some of these signals will be quite low in amplitude and subject to electrical interference if they are to be transmitted over any significant distance. The signal conditioning equipment shall accept inputs from the sensors and shall amplify them to a standard full-scale signal level, compatible with the rest of the system. It shall provide the signals with sufficient current drive and impedance matching characteristics so that they may be transmitted to the next subsystem with insignificant loss of fidelity. The signal conditioning equipment shall be physically small enough to be located at the patient's bedside, to minimize the distance of transmission of unconditioned signals. The signal conditioning equipment may be co-located with the sensor or the sensor transducer. All signals shall be conditioned to a standard full-scale level within five feet of the sensor, with less than 1% distortion and fidelity loss. Amplifiers shall be compatible with the amplitude, impedance and frequency characteristics of the sensors. Solid-state devices shall be used exclusively. Power shall be provided by the module's power supply. (Ref. module descriptions Section 3.1.2).

Isolation requirements of the system will be adhered to by the use of adequate grounding and double-ended signal amplification, where appropriate. Amplifiers shall be modularized within the equipment so that a faulty circuit can be totally replaced by a technician unskilled in electronics within a few minutes. Signal conditioning equipment will not, in general, be visible as a displayed portion of the system, since no controls or displays are associated with it except for amplifier calibrate and balance adjustments, which will be hidden from view. Connections to the signal conditioning equipment shall be by standard connectors providing a secure electrical path, capable of being disconnected easily.

#### Module I

The Signal Conditioning Subsystem for the Cardiac Surveillance module shall consist of a bank \* of EKG amplifiers, a bank \* of VCG amplifiers, temperature sensor amplifiers, \* and three spare amplifiers, one of each type. Provision will be made for an additional six amplifiers in terms of plug-in provisions for the circuits and input-output connectors for use in future conversion of this module to have additional capability.

#### Module II

The Signal Conditioning Subsystem for the cardiovascular module shall consist of a bank \* of EKG amplifiers, a bank \* of VKG amplifiers, a temperature amplifier, four catheter transducer amplifiers, an amplifier for the dye dilution sensor, and five spare amplifiers, one of each type. Provision shall be made for at least six additional amplifiers, in terms of plug-in space and input-output connector space, for future growth.

\*To be specified in ordering data

### Module III

The signal conditioning equipment for the Pulmonary Module shall include an amplifier for a pneumotachograph, temperature sensor amplifiers, \* and two amplifiers for spare purposes, one of each type. If blood gas analysis is performed as a patient-associated function within this module, then an amplifier set shall be provided for the blood gas sensors. Provision for this possibility shall be provided in terms of plug-in space and input-output connector capacity.

### Module IV

Signal conditioning equipment for the Body Chemistry Module is difficult to define. It is anticipated that blood and urine analyses will be performed by standard equipment with self-contained signal conditioning. Therefore, the only further conditioning required would be that which is necessary to standardize voltage levels to the rest of the system. After blood and urine functions and their implementations are defined, provision shall be made to provide standardizing amplification with adequate spares capability.

\*To be specified in ordering data

3.2.1.3 Data Acquisition Subsystem - The data acquisition subsystem is specified in accordance to the four (4) modular options three (3) of which can stand alone or up to four (4) in combination. The following data represents the data acquisition equipment necessary for each module alone. This subsystem could be commonly employed by multiple modules.

A/D Conversion - A minimum of an eight (8) channel analog multiplexer, modularly expandable to 128, which is capable of accepting signals in the range of  $\pm 10$  VDC shall be provided. The scan rate of the multiplexer should be no less than 30,000 points per second and up to 50,000 points per second. The sampling rate shall be deliverable at 25, 200, and at 500 samples/second. The analog subsystem should include the features of sample and hold, address control (random or sequential) and the analog-to-digital converter.

A  $\pm 10$  VDC analog input to the multiplexer shall produce full scale deflection of the A/D converter with maximum voltage overload of 100% full scale. The converters output shall be 12 bits expandable to 16 bits. Visual bit indication shall be available on a front panel register of the converter.

Random scan rates shall be available under program control at no less than half the hardware scan rate. The A/D shall have an accuracy of no less than  $0.02\% \pm 1/2$  LSB. The performance accuracy at DC shall include the following:

The linearity shall be no less than  $0.01 \pm 1/2$  LSB.

The long term drift shall be no greater than 0.01% typical.

The temperature coefficient shall be 10 ppm / $^{\circ}$ C max.

Crosstalk shall not exceed 80db with 1K source impedance at 400 cps.

The voltage reference stability shall be no less than 0.001%.

Typical accuracy at  $25^{\circ}$ C will be within 0.02% ( $\pm 1/2$  LSB) of full scale.

### Clocks

The system shall have two clocks to be employed as required. The first clock shall provide BCD input sense lines of hours, minutes, seconds, and milliseconds. Additionally, provision for the transmission of the "Hold" command from computer to clock shall be made. The second clock shall provide programmable time intervals via priority interrupts. Minimum resolution shall be 0.1 milliseconds. No computer time or memory access shall be consumed by this clock for counting.

The data acquisition subsystems digital word length shall be no more than 16 bits. The bit length and logical voltage level shall be at the manufacturers option but shall be compatible throughout Modules I, II, III, and IV.

Standard interfacing shall be provided between the computer and its peripherals including data words, command word/control word sequences, and interrupts. Data words shall be up to full 16 bits. The command word shall consume one (1) 16 bit word. The control words shall also consume one (1) 16 bit word. Interrupts and events shall be handled as either a logical steady state or a discrete.

3.2.1.4 Data Processing Sub-System - The data processing subsystem is delineated by the following chart which is divided into four sections. Each section is specifically for each of the standard module configurations. In combining these modules into various configurations many of the elements will be used commonly by the other modules. All module interfaces shall be compatible with all other modules.

DATA PROCESSING SUB-SYSTEM

	Module I Cardiac Surveillance	Module II Cardio- vascular	Module III Pulmonary	Module IV Body Fluids
<b>• Memory</b>				
Memory cycle time	no more than two (2) $\mu$ sec.	no more than one (1) $\mu$ sec.	no more than two (2) $\mu$ sec.	no more than two (2) $\mu$ sec.
Memory word length	no less than 16 bits	no less than 16 bits	no less than 16 bits	no less than 16 bits
Minimum memory size	4,096 words	4,096 words	4,096 words	4,096 words
Memory size increments	4,096 words	4,096 words	4,096 words	4,096 words
Maximum memory size	4,096 words	32,768 words	4,096 words	4,096 words
Parity check	shall be included	shall be included	shall be included	shall be included
Memory protect	shall be include	shall be included	shall be included	shall be included
<b>• Central Processor</b>				
Instruction word length	no less than 16 bits	no less than 16 bits	no less than 16 bits	no less than 16 bits
Number of accumulators (or general purpose registers that can be used as accumulators)	one (1)	one (1)	one (1)	one (1)
Number of hardware registers (not including index registers)	at designer's option	at designer's option	at designer's option	at designer's option
Number of index registers	no less than three (3), hardware; optional for software	no less than three (3), hardware; optional for software	no less than three (3), hardware; optional for software	no less than three (3), hardware; optional for software
Number of bits for operation code	4 - 6 bits	4 - 6 bits	4 - 6 bits	4 - 6 bits
Number of bits for address modes	1 - 3 bits	1 - 3 bits	1 - 3 bits	1 - 3 bits
Number of address modes	2 to 8	2 to 8	2 to 8	2 to 8
Number of address bits	at designer's option	at designer's option	at designer's option	at designer's option
Number of directly addressable words	4,096 words	up to 32,768 words	up to 4,096 words	up to 4,096 words
Time of direct addressability	no more than two (2) $\mu$ sec.	no more than one (1) $\mu$ sec.	no more than one (1) $\mu$ sec.	no more than two (2) $\mu$ sec.
Number of indirectly addressable words	4,096 words	up to 32,768 words	up to 4,096 words	up to 4,096 words
Time of indirect addressability	no more than four (4) $\mu$ sec.	no more than two (2) $\mu$ sec.	no more than two (2) $\mu$ sec.	no more than four (4) $\mu$ sec.
Indirect addressing	multi-level	multi-level	multi-level	multi-level
Relative addressing	shall be provided	shall be provided	shall be provided	shall be provided
<b>• Arithmetic Operations</b>				
Store time for full word ( $\mu$ s)	no more than four (4.0) $\mu$ sec.	no more than two (2.0) $\mu$ sec.	no more than two (2.0) $\mu$ sec.	no more than four (4.0) $\mu$ sec.
Add time for full word ( $\mu$ s)	no more than one (1.0) $\mu$ sec.	no more than one (1.0) $\mu$ sec.	no more than one (1.0) $\mu$ sec.	no more than one (1.0) $\mu$ sec.
Fixed point hardware mult/divide	optional	shall be included	shall be included	shall be included
Multiply time-hardware ( $\mu$ s)	no more than (24.0) $\mu$ sec.	no more than six (6.0) $\mu$ sec.	no more than six (6.0) $\mu$ sec.	no more than (24.0) $\mu$ sec.
Divide time-hardware ( $\mu$ s)	no more than 30.0 $\mu$ sec.	no more than seven (7.0) $\mu$ sec.	no more than seven (7.0) $\mu$ sec.	no more than seven (7.0) $\mu$ sec.
Multiply time-software ( $\mu$ s)	no more than 450 $\mu$ sec.	no more than 300 $\mu$ sec.	no more than 300 $\mu$ sec.	no more than 450 $\mu$ sec.
Divide time-software ( $\mu$ s)	no more than 600 $\mu$ sec.	no more than 600 $\mu$ sec.	no more than 600 $\mu$ sec.	no more than 600 $\mu$ sec.
Double precision arithmetic	shall be provided	shall be provided	shall be provided	shall be provided

DATA PROCESSING SUB-SYSTEM (Continued)

	Module I Cardiac Surveillance	Module II Cardio- vascular	Module III Pulmonary	Module IV Body Fluids
• <u>I/O Capability</u>				
Data path width (bits)	16 bits	16 bits	16 bits	16 bits
Direct memory address (DMA) channel	shall be included	shall be included	shall be included	shall be included
Maximum DMA word transfer rate	no more than 500 KHz	no more than one (1) MHz	no more than one (1) MHz	no more than 500 KHz
Number of external priority interrupt levels	no less than three (3)	no less than twelve (12)	no less than five (5)	no less than five (5)
Maximum number of external interrupts	16	96 in increments of eight (8)	32 in increments of eight (8)	32 in increments of eight (8)
• <u>Other Features</u>				
Power failure protect	shall be included	shall be included	shall be included	shall be included
Automatic restart after power failure	shall be included	shall be included	shall be included	shall be included
Real-time clock or internal timer	shall be included	shall be included	shall be included	shall be included
• <u>Peripherals</u>				
Magnetic tape and controller	optional	two (2)*	optional	optional
Magnetic tape capacity	optional	7 - track * 60K bytes per sec. transfer rate H&V parity	optional	optional
Card reader and controller	optional	one (1)*	optional	optional
Card reader capacity	optional	no more than 200* CPM binary hollerith 80 columns	optional	optional
Card punch and controller	optional	one (1)*	optional	optional
Card punch capacity	optional	more than 80* columns/sec.	optional	optional
Disc and controller	optional	1-32 million char- * acters (min. ~ max.) according to patient load random access 30-35 milliseconds maximum access time 15-18 milliseconds average access time 280,000-300,000 (6 bit bytes) max- imum data transfer rate	optional	optional
Paper tape reader	one (1) no less than 300 characters/sec.	optional*	one (1) no less than 300 characters/sec.	One (1) no less than 300 characters
Paper tape punch	one (1) no less than 50 characters/sec.	optional*	one (1) no less than 50 characters/sec.	one (1) no less than 50 characters/sec.
Typewriter	optional	one (1)* 60-65 alphanumeric characters 10-15 characters/sec. max. speed 72 characters/line minimum	optional	optional

\* NOTE: Module II's peripheral configuration shall include the listed peripherals of operating in combined configuration with Modules III and/or IV or as desired by the user. If operating autonomously the listed peripherals would be optional to be supplied by the paper tape reader/punch equipment.

### 3.2.1.5 Display Subsystem -

#### A. Operating Modes

The display subsystem in conjunction with the control subsystem will provide data display for the following modes of operation:

1. Monitoring mode will require the capability of displaying selected patient parameter data of both direct and derived origin on a real-time basis. This mode is concerned with the requirements of displaying patient data at the bedside, nurses' station and remote stations during normal monitoring, i. e., non-traumatic periods.
2. Trauma mode will require immediate display recording and hard copy of critical patient data on a top priority and also non-interference basis with regard to the general monitoring of the other patients on the same system. The alarm system based on pre-determined limits of selected data parameters will activate the chart recorder as well as activating an audio/visual trauma indicator at the nurses' station and a visual alarm at bedside.

Capability will exist for immediate data retrieval with appropriate priority interrupt to view the patients recent data, e.g., lab analysis, trend data, drug administration, etc. via an alpha numeric display device and provide a hard copy of the displayed data.

3. Data retrieval mode will provide recall and display of patients data, i. e., historical data, trend analysis, drug administration, lab analysis, etc. The retrieved data will be displayed on demand via the data entry keyboard with the optional capability of providing on-the-spot hard copy of the data displayed on alpha-numeric display device.
4. Data entry mode will allow the operator of the system to enter data into the processor for purposes of changing or updating patient data. Provisions will be made for data entry to be accomplished in the following stages:
  - a. data will be entered via keyboard per operational instructions.
  - b. as data is entered, it will be displayed on an alpha-numeric display allowing entry to be edited prior to transfer into the processor storage.
  - c. once the entry is edited, an execute command is activated on the keyboard which enables the processor to act on the entered data.

- d. automatically, following activation of the execute command, the completely revised page of data is displayed on the alpha-numeric display for a duration of one minute unless a manual override key is depressed on the keyboard which provides for additional display time.

Capability will exist to provide the required user identification/authorization to be used as a security key in entering certain data areas, i.e., it may be desirable or mandatory to have only select personnel enter instructions into the drug administration data.

5. Maintenance mode will include provisions for display of equipment status data during patient-sensor set-up, calibration and self-diagnostic procedures. The display capability necessary to support these requirements must be capable of operating on a non-interference basis with the other display modes and must not interfere with the operational routines carried out by the hospital personnel in their duties to monitor the patients.

## B. Display Capability

The patient monitoring display subsystem required capabilities are summarized in Table 3.2-2.

## C. Display Subsystem Requirements

### 1. Bedside Displays

The display equipment at the bedside will be designed to allow wall mounting. The unit will provide the following display capabilities:

#### Analog Waveform Display

Provision will be made in the basic cabinet for either a single or dual channel capability for display of ECG, EEG or arterial pressure on a CRT. This display will operate directly from the output of the local signal conditioners, e.g., ECG amplifier, and therefore will be independent of any processor operations.

#### Size

The CRT shall have a minimum diameter of 5" or equivalent area.

#### Inputs

The CRT shall have the capability of either a single channel or two independent channels for display of data.

DISPLAY CAPABILITY	OPERATIONAL MODE USAGE					LOCATION REQ'MTS				NOMINAL DISPLAY CAPACITIES			
	MONITORING	TRAUMA	DATA RETRIEVAL	DATA ENTRY	MAINTENANCE	BEDSIDE	NURSES' STN.	REMOTE	OR	BEDSIDE	NURSE/S STATION	REMOTE	OR
1. Analog (waveform) Display	x	x				x	x	x	x	2 channels	3 channels		4 channels (1) 4 channels (2)
2. Digital Display	x	x				x	(x)	(x)	x	4 three digit displays	1 per patient	Optional	1 displays (1) 4 displays (2)
3. Alpha-Numeric Display	x	x	x	x	x	(x)	x	x	x	Optional	See format discussion	Both analog and N capability	See format discussion
4. Analog Chart Recorder	(x)	x					x	(x)	(x)	Not required	1 channel for each patient (4)	Optional	Optional (3)
5. Alpha-Numeric Hard Copy		x	x	x			x	(x)	(x)	Not required	Copy of CRT display	Optional	Optional (3)
6. Alarms/Events	x	x		x		x	x	x		Local/Remote Alarms for 4 parameters	1 alarm per patient	Optional	Optional
7. Status Indicator	x			x			x			Not required	Monitoring Trauma (alarm) Maintenance Not in use	Optional Optional	Not required

KEY:

- x Required
- (x) Optional

NOTES:

- (1) For Surgeon
- (2) For Anesthesiologist
- (3) If used, equipment would probably be located external and adjacent to OR.
- (4) Up to 4 patients, then 1 channel/2 patients

DISPLAY CAPABILITY TABLE 3.2-2

### Frequency Response

The frequency response shall be flat to within  $\pm 0.5$ db from 0.1 to 50Hz and not more than 3db down from 0.14 to 100Hz.

### Gain

The nominal and minimum gains of the function shall be:

ECG - 1cm (nominal) and 0.2cm (minimum) of display deflection per millivolt on the patient leads. Adjustable gain to range from 0.2 to 2cm/mv.

Arterial blood pressure - 1cm of deflection per 100mm Hg of arterial pressure. Adjustable gain from 0 to 4cm/100mm Hg.

EEG - 1cm (nominal) and 0.2cm (minimum) of display deflection per microvolt on the patient leads. Adjustable gain from 0.2 cm to 2cm/microvolt.

DRIFT - with gain set at nominal the display baseline shall not drift more than 10%/hr. and gain shall be stable to within 0.2% per  $^{\circ}$ C after suitable warm up period.

### Horizontal Sweep Rate

Display shall have at least two sweep rates, 2.5 and 5.0  $\pm 5\%$ cm/sec.

Noise Level - the visible noise or ripple on the CRT display shall not exceed a signal to noise ratio of 100 to 1 regardless of setting. Measurement to be made with:

- (1) arterial pressure transducer removed from patient
- (2) the ECG or EEG leads each connected to ground by a shielded 25,000 ohm resistor.

Display Phosphor - the display CRT shall use a long persistence display with a minimum time to decay to 0.1% of 1500ms.

Filters - CRT shall be equipped with optical filters to optimize visibility in the ambient illumination to be specified (in the ordering data) by the customer for the particular installation.

### Digital Display

Provision will be made in the basic bedside cabinet for up to four digital displays which comply with the requirements for measured and derived parameters stated in 3.1.3 and 3.1.4.

The digital displays will have the following basic requirements:

Accuracy - minimum requirements are as follows:

Blood Pressure - true pressure shall be displayed over the range 0-250mm Hg (0.30mm Hg venous) with an accuracy of  $\pm 5\%$  of reading or  $\pm 5$ mm Hg ( $\pm 0.5$ mm Hg for venous whichever is greater).

Heart Rate - true heart rate and/or pulse rate shall be displayed over the range 20 to 200 BPM with an accuracy of  $\pm 5\%$  of reading or  $\pm 3$  BPM whichever is greater.

Temperature - the true temperature shall be displayed over a range of  $96^{\circ}\text{F}$  -  $106^{\circ}\text{F}$  with an accuracy of  $\pm 0.5^{\circ}\text{F}$ .

NOTE: Extended range capability ( $86^{\circ}\text{F}$  -  $96^{\circ}\text{F}$ ) may be specified in ordering data.

Respiration Rate - the true respiration rate shall be displayed over a range of 0-75 bpm (minimum) with an accuracy of  $\pm 5\%$  of reading or  $\pm 3$  bpm whichever is greater.

Display - three digits plus polarity.

Polarity - automatic

Decimal Point - set internally and/or by external program function, BCD.

Packaging design will provide for plug-in capability.

### Options

- a. Panel analog meter plug-in modules can be used in place of any or all of the digital display modules if the user prefers the meter display.
- b. Since both the digital displays and respective signal conditioning are plug-in modules, any combination of patient parameters may be displayed up to four parameters. This, in addition to the dual channel analog waveform display, allows up to six parameters for patient to be displayed at bedside.

## 2. Nurses' Station Displays

The display capability at the nurses' station will consist basically of the following:

- ECG, waveform for each patient
- up to four digital displays for each patient
- chart recorder which will record ECG waveform either on demand or automatically
- alpha-numeric/graphic display with data entry keyboard
- hard copy capability for data displayed on alpha-numeric display
- audible and visible alarms

The requirements for each the capabilities is listed as follows:

### ECG Waveform Display

This will nominally have a four channel capability with the option of expanding to an eight channel unit.

Size - minimum 17 inch tube (diagonal measurement)

Inputs - up to eight

Trace Speed - minimum selectable of 25 and 50 mm/second.

Vertical Gain - for each input channel adjustable in three increments, 0.5 v/cm, 1.0 v/cm and 2.0 v/cm with gain calibration control.

Frequency Response - d.c. to 100 Hz (3db)

Linear Distortion - less than 5% full scale

Input Impedance - 300K OHM minimum for each input

Trace Persistence - Minimum time to decay to 0.1% of 1500 Msec.

DIGITAL DISPLAYS - Same as specified under Bedside Displays.

CHART RECORDER

The basic recorder shall be a single channel instrument and only one patient shall be connected to the recorder at any one time. The recorder shall function under either of two modes of operation:

1. Automatic on-line alarm such that the 10 seconds of data previous to the alarm are recorded and unit continues to run until manually shut-off.
2. Manual switch on nurses' station control console will activate recorder upon demand.

SPEED - Selectable at either 25 or 50mm/sec.

ACCURACY -  $\pm 2\%$  full scale.

SKEW - shall not exceed 0.1mm of horizontal displacement per 1.0cm of vertical deflection.

RECORDER OUTPUT - the vertical width of the undeflected trace shall not exceed 1.0mm at any paper speed. Both the upstroke and downstroke of the writing device at rates of deflection less than 1.000 mm/sec shall leave a visible continuous trace with sharp edges.

HARD COPY OF ALPHA-NUMERIC DISPLAY

Capability shall exist for obtaining a legible, permanent or semi-permanent, 8 1/2" x 11" copy of the alpha-numeric display. This process shall be initiated by manually activating a switch on the nurses' console. Provision shall also be made for the copy to be initiated by the proper command from the processor. The copy shall be available within 120 seconds after the copy command, either manual or programmed, has been initiated.

Alarm Functions - Selected physiological monitoring functions shall be provided with automatic alarms which provide signals at the bedside and remote station indicating that the monitored parameter is outside of preset limits. The existence of an alarm situation shall be identified by a visible alarm signal at the bedside, and visible and audible alarm signals at the remote station. The patient whose monitored parameter initiated the alarm shall be considered to be in an alarm status until the alarm is manually reset.

Status Indication - When any patient is in an alarm status, the visible alarm at the remote station shall automatically indicate which patient is in an alarm status. The bedside visible alarms shall indicate the patient in the alarm status and the monitored parameter which initiated the alarm. Independent visible alarm indicators are required for each patient at the remote station; and independent visible alarm indicators are required on each selected monitored parameter on each patient at the bedside.

Alarm Isolation - The alarm circuitry shall incorporate isolation features as required to prevent any ambiguity in status indication.

Simultaneous Multiple Alarms - The alarms functions of the PMS shall be so designed that proper status indication and automatic switching is achieved in the presence of multiple alarms from one patient and alarms from multiple patients.

Alarm Limit Settings - The PMS shall be designed to permit setting of alarm limits only at the bedside unless otherwise specified in the ordering data.

Alarm Reset - When an alarm has been initiated, the system shall be resettable on the front panel to a normal status only at the bedside of the patient in an alarm status. If the physiological parameter which initiated the alarm is still outside of the present limits, the visual alarm shall immediately repeat after reset and shall continue to do so until the alarm initiating condition is corrected. (This could be accomplished automatically or manually).

Visual Alarm Check - The PMS shall include provisions for checking the alarm visual indicators by manual actuation of front panel controls. The alarm check control may be combined with some other control such as a power switch or alarm reset.

Alarm Delay - Any delay in the actuation of the alarm signal, after display/reading exceeds the high limit or falls below the low limit, shall not exceed 10 seconds with 3 seconds or less desirable.

Alarm Indicator Visibility - The alarm lights at the bedside and at the remote station shall be clearly visible at distances of up to 30 feet from the light in an ambient illumination level of 100 ft. candles.

Alarm Indicator Audibility - The alarm of the remote station shall have an output of 60db (re.  $.002 \text{ dyne/cm}^2$ ) corrected to 1 KHz at any point within 10 feet of the alarm transducer.

Hazard Alarm - It is desirable that the PMS shall include the initiation of an alarm signal when a class III or IV hazard condition as related to the equipment (see 3.4 occurs).

Alpha-numeric displays shall have a feature of "blinking" that data which is the cause of the alarm situation. This data will be automatically presented, in priority over other data, when the alarm situation occurs

### 3. OPERATING ROOM DISPLAY

The display capability for the operating room will consist of selected display modules previous specified for use in the bedside and nurses' station areas. The basic or display system will have capability for the following:

#### ANALOG WAVEFORM DISPLAY

Provision shall be made for independent display of four channels of data. Each channel shall be on a display with a minimum diameter of 8" or equivalent.

The analog waveform display shall be capable of displaying ECG, EEG, arterial and venous pressures. The displays will conform to the specifications also applied to the bedside analog waveform display.

#### DIGITAL DISPLAY

Provision shall be made for following:

1. four displays for hemodynamics data
2. two displays for body temperature
3. five displays for blood gas analysis data

#### TIME DISPLAYS

Provision shall be made for digital display of the following times:

1. one display for elapsed time of operation
2. two displays for elapsed time availability for various procedures

#### SPECIAL PROVISIONS

Sample time for blood gas analysis data entry should be displayed concurrent with the display of such data.

4. PORTABLE REMOTE STATION DISPLAY

The portable remote stations shall have the following display capability:

- dual channel analog waveform display for ECG, EEG or arterial pressure.
- four digital displays (3 digits each plus polarity)
- single or dual channel chart recorder
- alpha-numeric display with data entry keyboard
- voice intercommunications with headset (via hardware connection to an installed facility circuits)

The requirements for the above capabilities have been listed under Bedside Displays and Nurses' Station Displays.

5. DATA FORMATS

ALPHA-NUMERIC/GRAPHIC DISPLAY

Page Format - Display shall consist of either two half pages of data, each half capable of being separately selected or the display may be made up of a single full page format. Analog (wavetrains or plots) and alpha-numeric data may be interleaved. Trend data shall be graphically displayed (rather than tabular).

Characters - The display shall be at least 21" diameter to display 24 lines of data, 40 characters per line. Each character shall be approximately .26" high x .19" wide.

Numerical Displays (Analog and/or Digital)

- a. Scale Graduations. The minimum scale graduations on any indicator shall not be less than 2.0mm.
- b. Readability. In selecting numerical displays, primary consideration shall be given to readability to preclude possible display or dial reading errors.

3.2.1.6 Control Subsystem - Operation of each module will be performed by means of its control subsystem equipment. This subsystem will interface directly with the computational subsystem and will control the operational modes of the computer by means of control discrettes. Activation of computer input discrettes will cause appropriate software subroutines to be activated, which will activate equipment in other subsystems and enable the computer to accept data from them. The control subsystem will also enable the operator to enter data into the system by means of a keyboard and a data entry button. It will also enable the operator to communicate data with other modules (by means of a data transmission subsystem) as well as place the module under remote control of another module, by enabling appropriate modes in the computer. Finally, it will also enable the operator to interactively call up data for display via the display subsystem, by means of keyboard entries. Keyboard control terminals shall be located at bedside patient stations, nurses' stations, appropriate laboratories, and central processing facilities.

#### MODULE I

The control subsystem for the Cardiac Surveillance Module shall provide power on/off and initializing for the module; a local/remote selector for choosing between autonomous or network operation; and EKG print switch to cause hard copy EKG to be printed by the display subsystem; alarm limit settings (thumb-wheels or keyboard); alarm reset switch for re-initializing. Conversion of this module to Cardiovascular capability (Module II) will be accomplished in part by providing a Module II Control subsystem to the Module I equipment. The interface between the control and computational subsystems in Module I shall be designed such that this replacement can be effected on a plug-in basis.

#### MODULE II

The control subsystem for the Cardiovascular Module shall perform all of the functions of Module I, plus the capability to perform dye-dilution application and calibration. Implementation shall be a keyboard controlling an interactive display. The final design of the keyboard will depend upon the display technique chosen for implementation. The "tree" type of display technique, however, appears to be the most likely approach, and the Module II control subsystem keyboard shall be compatible with it. Buttons shall be provided for calling up the tree, for sequencing through the tree, and for selecting tree parameters, for re-setting the tree sequence, and for entering data parameters into the system. Interaction of the control subsystem and the display subsystem shall enable the operator to select parameters for display, to update system parameters, and to select trends or historical parameter displays. Additionally, the Module II control subsystem shall enable remote control and display to be accomplished utilizing other modules in a network.

Data acquired by other modules shall be transferred to Module II, and output display data from Module II shall be transferred to appropriate remote modules, all under modes controlled by the Module II keyboard.

### MODULE III

The control subsystem for the Pulmonary Module shall provide power on/off switching and initializing capability, local/remote operation switching, data display selection to select parameters for real-time display and for printing, and capability to input blood gas analysis data. Implementation shall be a keyboard similar to or identical to the Module II keyboard.

### MODULE IV

The control subsystem for the Body Chemistry Module shall provide power on/off switching and initializing capability, and a simple keyboard to input the results of blood and urine analyses.

### 3.2.1.7 PATIENT MONITORING SYSTEM'S SOFTWARE SUBSYSTEM

#### 3.2.1.7.1 INTRODUCTION

The Patient Monitor System's supervisor program shall be designed from the total system viewpoint. Integration of the processing of local batch, remote access, and time-sharing will be effected. The Patient Monitor System shall be hospital staff/patient oriented-- processing physiological parameters when needed in those areas requiring these measurements. The problems of local/remote locations, hybrid-systems, and hospital environment will be analyzed and met. Through integration of a central general purpose processor, local and remote special purpose digital and analog processing, and a communications network, the Patient Monitoring System will provide an effective base for development of better patient care.

Full software support of the Module I - Cardiac Surveillance, Module II - Cardiovascular, Module III - Pulmonary, and Module IV - Body Chemistry shall be provided. This will include both the individual - limited scope applications programs employed by the Module I - Cardiac Surveillance system to the fully developed system, incorporating the extended applications programs and a system supervisor, which can combine all modules.

Maximum hardware utilization shall be achieved through application of multi-programming and hybrid processing techniques. The supervisor program will integrate local batch processing, remote access processing, and time-sharing with a common file system. In addition, true real-time processing, efficiency of pre-processing, and redundancy shall be achieved through the sun-satellite configuration of analog/digital processors supervised by the system's supervisor.

The Patient Monitor System's supervisor is a new software package. It will employ the collective advantages of patient monitoring systems already developed and proven in medical R&D centers plus the techniques developed in industry. At the same time the user applications programs, researched and developed by multiple eminent health institutes, shall be integrated and made mutually compatible within the supervisor program's control.

The Patient Monitor System shall be complemented by an extensive software library, providing a wide spectrum of compiling, assembling, editing, sorting, loading, utility and applications programs. This will facilitate an effective and integrated operation. The primary language capabilities will include FORTRAN and an assembler. Secondary languages could include COBOL, BASIC, ALGOL, JOVIAL, or a macro assembler.

#### 3.2.1.7.2 SOFTWARE CONFIGURATION

The programs will support the combinations of Module I - Cardiac Surveillance, Module II - Cardiovascular, Module III - Pulmonary, and Module IV - Body Chemistry as applied throughout the local and remote health institute areas of: screening, catheterization, X-ray, operating room, intensive care, cardiac care, exercise, and rehabilitation.

The previous sections of this document have specified the hardware configurations and their application functions per each of the modules I, II, III, and IV. With this hardware function description having already been specified, the software will be specified against the needs of the physical areas within the hospital. The appropriate hardware configurations will be employed in accordance to the needs and wishes of the hospitals and as such will be different in most cases. The appropriate software functions will be applied to the hardware configurations in a modular fashion. The functional characteristics of these programs, from which the individual software configurations can be constructed, are specified in the following paragraphs.

#### 3.2.1.7.3 GROWTH CAPABILITIES

The Patient Monitor System's software shall enable the user to tailor configurations to their own particular processing needs and to expand their workload capacity by adding additional software packages. Growth throughout the entire range of software capabilities shall be accomplished without changing the supervisor or the applications programs. Changing the configuration will not require reprogramming.

#### 3.2.1.7.4 MULTIPROGRAMMING

The Patient Monitor System shall be designed to operate in the multiprogramming mode of operation to achieve maximum job throughput and minimum response time for computer access. A combination of hardware and operating system features will control the multiprogramming of as many user programs as the system configuration will permit; and ensure that user programs and files in the system are not inadvertently or intentionally violated.

#### 3.2.1.7.5 SUPERVISOR

The supervisor system shall maintain the status of all system resources (peripherals, memory, and processor) and all user programs in queue in the systems. These programs may be called through the central system or through remote terminals concurrent with the execution of programs. System resources will be allocated to programs in the queue in accordance with the priority of the program, and will supervise the concurrent/simultaneous execution of as many programs as the configuration can accommodate. The supervisor program shall also control the concurrent printing/punching of output from completed programs as well as output media conversion. High priority programs shall be expedited by swapping out programs in execution. This will be done by temporary suspension and removal from memory (swapout) of programs in execution to make room for a high-priority program.

The supervisor will occupy no less than 2.5K and no more than 5.25K words of core memory, it shall reside in core, and will be written in assembly language.

The supervisor system will provide the programmer with a complete logical approach to problem solving. There shall be no constraints or unusual programming considerations

imposed on the programmer because of the multiprogramming environment in which his program will be executed. File processing will be performed sequentially or randomly at the logical file level; the programmer will not be burdened with the physical characteristics and constraints of the peripheral device used, nor shall he be concerned with the organization of the supervisor system.

The supervisor shall encompass many automatic and simplified programming aids as follows:

- The loader will not only serve to load a program but will link program segments and subroutines, provide for overlays, call in other programs from the library, create file control blocks for I/O, provide options for selected outputs during execution, and provide a load map.
- In order to relieve the user of the necessity for programming I/O routines a program will be included to control files and records. It shall provide: the ability to consider inputs and outputs as records and files of arbitrary lengths; to move logical records without regard to physical media, block size, or record sizes; the ability to interchange media or devices without reprogramming; to improve performance through the use of record blocking without program change; system software compatibility; and means of automatic error detection and correction.
- Large media conversion for either input or output that exceeds limits set for system media conversion in the supervisor. No volume limitations shall be set and no mixed files unscrambling shall be present. Successive files will be handled and media conversion shall be performed for the card reader, magnetic tape, magnetic disc, printer, punch, plotter, and CRT.
- An editor shall be used to maintain system libraries in any of the three forms of symbolic, object, or system (fast load format).
- A utility package shall be a generalized system providing storage device processing capabilities. It will permit copying, comparing, positioning, and printing. The utility shall be used mainly for operational and debug purposes. It will reside in disc and will be called by the user through the supervisor either unconditionally or conditionally.

The Patient Monitor System shall incorporate language processors as follows:

An assembler, preferably MACRO, which will be two pass and symbolic. This will provide the programmer with the option of coding in the MACRO assembler open-ended language or directly in machine-oriented symbolic instructions. The assembler will occupy 12K words of memory, it will be stored on disc, shall be executed in core, and shall be written in machine language. The principal functions performed by the assembler will be as follows:

- translation of control and assembly-edit formatting pseudo-operations.
- recognition and translation of addresses that are absolute or relative to subprogram origin, to common storage, to labeled or block common storage, and to externally define symbols.
- production of relocatable or absolute binary subprograms that can be combined at load time.
- allowances for programmer-defined MACRO instructions at assembly time.
- provision for accepting compressed symbolic decks plus any desired alter cards as input and producing an updated compressed deck as output.
- complete listing of assembled program, plus a symbol reference table, is provided.

A FORTRAN compiler shall be included which encompasses the USASI (USA Standard Institute) FORTRAN IV. It will consume 16K words of storage, reside in disc, and be executed in core.

#### 3.2.1.7.6 COMMON FILE SYSTEM

The file system shall be centralized of hierarchical, tree-structured design, accessible by programs operating in the local batch, remote access, and/or time-sharing modes or processing. Catalogs and files are secured by passwords. File access is controlled by the supervisor. Several programs may read a file concurrently, but only one program at a time may update a file.

The supervisor's file system shall be a hierarchical, "true-structured" design with multi-level cataloging capabilities stemming from a overall catalog which lists all users known to the file system.

File sharing shall also be provided by the supervisor's file system. Users may provide for general sharing of their files or may specify specific user (or programs) who may access the files. Full read-write access or read-only access shall be also granted.

All catalogs and files shall be protected by pass-words. When a file or a catalog is protected by a pass-word the user must provide that password in order to gain access to the file.

The file system shall be completely transparent to the user; yet provide complete sub-cataloging protection, access control, and file-sharing capabilities for the more sophisticated programmer.

The type of access which a user may have to a file shall also be controlled. A file may be allocated to several user programs concurrently for read only, but will be allocated to only

one user program at a time for update. A user requesting read-only access will be prevented from writing on the file.

File processing from the programming standpoint shall be completely logical. The programmer will process his files as a logical entity, either sequentially (as in tape processing) or randomly. The physical characteristics and restrictions of the device on which his file is physically located will be handled entirely by the supervisor.

Removable media such as magnetic tape shall be filed by catalog entry in the file system. A programmer may then request a file for processing by specifying the file name. Files so entered in the file system will be protected by passwords against unauthorized access. When a programmer requests a removable media file by name and provides the proper password, the supervisor will then instruct the operator, by number, as to the proper file to be mounted.

The file system shall be a device-independent structure. The file system will catalog and allocate the storage of all devices which are a part of the file system and will provide for the movement of files between different types of devices.

The file system maintenance shall be device-oriented. The catalog entries for a file will be on the devices on which the files resides. This allows the restructuring of a file system device (i.e., repacking the device after files have been purged) to be accomplished one device at a time, while production programs continue to access other portions of the file system.

#### 3.2.1.7.7 BATCH PROCESSING

The supervisor program will effect an optimum use of all system resources in its processing of batch workload. The system will accept new programs at any time and from any source, both remote and local; it will allocate and keep in execution as many programs as the configuration will permit. Automatic scheduling of batch programs into execution as soon as resources are available for allocation to the program will be effected. No restrictions will exist as to the types of programs which may be multiprogrammed. The supervisor program will expedite high priority programs by swapping out lower priority programs when core space is needed.

Batch jobs will flow through five phases in the Patient Monitoring System's supervisor in the course of processing:

- input media conversion
- compilation or object program allocation
- compilation or object program execution
- compilation or object program termination
- output media conversion

### Input Media Conversion

Input media conversion user inputs will enter the system from multiple central and remote peripherals simultaneously. These inputs will be placed on temporary files.

As the sequence number is detected in each case it will be assigned an internal number and be placed in queue according to its relative priority. All of the time-sharing programs will be considered as singular in the total queue. Inputs may carry an initial priority established by the user; if not, the supervisor will calculate a priority for the job based upon its system requirements.

The major features of the input queue processing shall be:

- multiple inputs will come from a combination of central system and remote sources.
- the input image in the file system is preserved intact throughout processing. Inter supervisor restart is possible.
- each input entering the system shall be scanned for gross system (peripheral and memory) requirements to ensure that the concurrently operational system configuration can accommodate the input. A single input which exceeds configuration capabilities will be immediately deleted from the system with appropriate operator notification.
- inputs entering the system will be also screened for the estimated amount of processor time required, the amount of core memory required, the estimated output volume, and the amount of bulk (tape and/or disc) storage required; these shall be compared to limits established by the operating staff. Programs exceeding these limits will be flagged to operations and executed unless held by operations. This prevents the unrecognized hanging up of the queue.

### Compilation or Object Program Allocation

The compilation or object program allocation shall be activated when a new input is placed in the queue from the input media conversion and becomes a candidate for allocation, or when the necessary parts of the system are released that can be assigned to a new program.

Allocation of the system will be performed in two subphases:

- peripheral allocation
- memory allocation

The input queue will be ordered according to priority. Peripheral allocation routines will examine each job in sequence, allocating peripherals to the current program.

Peripherals will not be allocated to an activity until the program's (or sub-program/routine as defined by the user) total peripheral requirements are available. Instead, the job shall be bypassed until the next allocation cycle in favor of lower priority programs whose requirements can be met. If a program proves difficult to allocate, provision will be made to block allocation of lower priority jobs until sufficient resources become available.

#### Compilation or Object Program Execution

A program shall be candidate for memory allocation only after peripheral allocation is complete and the activity is ready for execution. Multiprogramming will concurrently execute multiple programs resident in memory. Those programs ready for execution will utilize the processor while others await completion of I/O operations.

Effective multiprogramming shall be achieved through full memory utilization (memory allocation). This will be effected through efficient handling of variable length programs. The Patient Monitor System's supervisor program shall allocate core memory in 1024-work (1K) blocks. A program may request any number of 1K blocks up to the full size of total memory less the amount occupied by the resident portion of the supervisor. The blocks allocated to an activity will be contiguous. When a program terminates, its blocks will be made available for reallocation. When required, the programs will be compacted in memory by the supervisor to make multiple noncontiguous areas contiguous. With this technique, all available memory will be effectively utilized making the Patient Monitoring System more powerful.

#### Compilation or Object Program Termination

A program in execution may terminate normally or abnormally. The processing of each type is different.

Normal termination processing will first look ahead to the next program (if there is one). If it is a compilation of the same type as that terminating, the new program will be merged with the present program (initiated immediately) using the same parts of the system used by the present activity. If the next program is not the same, the operator will be notified of any files which require dismounting. Notation will be made in the program file in the file system of any file used in the activity which will be used in subsequent programs and these files will be saved. An accounting file will be written itemizing the system resources used by the program. The allocation phase will be notified that the resources used by the program are available for reuse, and that the next activity is a candidate for allocation.

The Patient Monitoring System supervisor shall run successive compilations of the same type, thus avoiding the deallocation of resources at the end of a compilation only to re-allocate the same type and amount of resources to the following program.

Abnormal termination (abort) processing may be initiated by the program or by the supervisor when the program tries to execute an illegal operation (e. g., an attempt to access memory outside of its boundary).

The aborting program may at its option have a dump of its allocated memory. The user may also define abort subactivities (useful for dumping data files) which are executed only when an abort occurs.

As with normal termination, the resources used by the aborting program will be released for reallocation. Compilation activities following an aborted program will be executed. Whether or not subsequent object programs are executed will be a user option.

### Output Media Conversion

The output phase shall consist of an output collection mechanism and an output disbursing function.

Multiple output files (for printing and punching) from all programs in execution will be collected in the file system on disc, along with those generated by the supervisor in the course of job processing (e.g. accounting reports and abort memory dumps). This mechanism avoids the necessity of dedicating peripheral devices to small volume print or punch files, which would utilize a peripheral inefficiently.

The output disbursing routines will read the data collected in the file system, and batch the output from many programs on multiple output devices. This provides a more effective utilization of peripherals.

Output printing, punching, and display will be performed concurrently with the execution of other programs in the system and the entry of still more programs into the input stack.

### 3.2.1.7.8 REMOTE ACCESS

Concurrent remote access input/output capabilities will exist through the inclusion of communications processing in the configuration. The communications processing shall permit a variety of terminal, transmission rate, and processing options. The terminal options will include on-line analog physiological monitors, teletype, CRT's, data entry keyboards, printers, and special applications mini-computers. Transmission options will include but not be limited to Telpak A (40.8K bps), voice grade (2-2.4K bps) low speed (110 bps), and analog in combination.

The Patient Monitor System's supervisor shall include the handling of reactive terminal interface which provides reactive terminal processing concurrent with local batch. This interface will provide direct terminal access to the information system and to the common file system.

### 3.2.1.7.9 TIME-SHARING

The time-sharing supervisor subsystem, which will utilize the reactive terminal interface, will provide the Patient Monitor System with concurrent time-sharing. FORTRAN and a text-editing package will be available. Full upper/lower case ASC II character handling will be provided.

Catalog structuring, file protection, file sharing, access control, and source/object file storage capabilities will be available.

The Patient Monitor System supervisor program shall provide time-sharing that will not disrupt batch processing commitments. The portion of the system dedicated to time-sharing will be dynamically variable under operator control, offering a wide range of batch, remote access, and time-sharing processing options variable throughout the day.

This system will feature multiple subsystems. These subsystems can be divided into four categories: programming subsystems, subsystems providing time-sharing access to batch, media conversion subsystems, and a subsystem allowing file creation and maintenance.

The time-sharing executive will perform the functions of selecting, allocating, dispatching, and swapping time-sharing user programs. The time-sharing executive shall be structured as a single slave program to the supervisor. It will in turn suballocate memory and will subdispatch the processor to individual time-sharing user programs. In the process of subdispatching, the time-sharing executive will establish as new program start address setting around the user program to be executed, insuring the integrity of other user programs in memory.

The time-sharing executive will also perform various services for individual programs, including file system I/O, terminal I/O, and creation and modification of files, catalogues, and their security definitions. It will also account for the parts of the system used by the individual time-sharing users.

Time-sharing user core memory will be allocated to individual user programs for execution. Several programs may occupy portions of this area. A program may be swapped to allow another user of higher priority to be allocated memory space.

#### REAL-TIME SYSTEM

The Patient Monitor System shall provide a real-time on-line interactive software package enabling multiple applications to operate simultaneously. It will provide the user with means of handling interrupts and a centralized routine for making I/O requests. I/O devices will be run at their maximum capacity through channel queuing. Job priority scheduling will be provided. All programs will be monitored and passed-on to higher priority via a sequence control. Sub-functions will be shared between the real-time program and the time-share program under the supervisor's control.

Interrupts will be permitted to occur on a priority or scanned basis. Memory protection will be provided.

Priorities will be programmable. Events which are interrupt activated will be assigned the priority of the hardware interrupt level. Any events initiated and controlled by software will be given a lower priority. The user can schedule jobs at a software priority. These jobs will be placed on a queue and given control in the order of their priority by a job control routine.

Queuing will be under user control. At any time a program will be able to be placed in queue by calling a queuing routine.

All supervisor functions shall be coded to be re-entrant. The user shall be required to use re-entrant code if the applications routines are to be executed at different priorities under interrupt control.

Means of counting time will be provided. At regular intervals on on-demand time interval measurements will be provided. The user will call this feature by setting up an interval timer interrupt response routine which will respond by setting flags.

#### 3.2.1.7.10 ON-LINE SYSTEM TEST SYSTEM

The Patient Monitor System's supervisor will include a comprehensive on-line peripheral test system made up of test and diagnostic routines. This system will enable the diagnostic testing of peripheral devices concurrent with the production workload. Additionally, this system will accumulate recovered error statistics for continual measurement of peripheral device performance. Through subsequent analysis, problems can be detected and corrected.

#### 3.2.1.7.11 SYSTEM CAPABILITY MONITOR

The system capability monitor shall provide quantitative measurements of system balance and performance. The monitor will reflect the flow of programs through the system, the status and requirements of programs in the system queue, and the status of the resource allocation tables maintained by the executive. Gross imbalances (such as consistently unused memory while programs in the program stack are waiting for disc or magnetic tapes) can be readily determined.

Operational inefficiencies and programming "bottlenecks" can be identified. The monitor will also be useful in determining the cost/performance advantages of alternatives for augmenting an existing configuration.

#### 3.2.1.7.12 APPLICATIONS PROGRAMS

Applications software shall be an integral part of the total information system's problem-solving, answer-producing capability. These programs will be a result of medical research and development as well as computer oriented system operational development within health institutes. They will be the product of the combination of the medical profession and the computer sciences. These programs will average 2000 words each, are to be stored on disc, executed from core, will be written in assembly (extended computation in FORTRAN), and will be under the control and integration of the supervisor. Partitioning will be employed for control. The programs will be constructed as a series of overlays which will be read in as needed reducing the amount of core. Time-shared background programs will be executed concurrently on a non-interference basis under the supervisor's control. These will include compilations, statistical analysis programs, report generators, and other nonreal-time programs. The applications program packages described in the following paragraphs are representative of the applications software library.

### 3.2.1.7.13 SCREENING

This application shall be designed to assist in patient screening primarily for admission to the hospital. The program will operate either from local or from remote locations. Inputs to the program will be in the form of manual entry or from the automated patient physiological data acquisition system. The outputs will be in the form of hard copy reports, graphs, and CRT display.

A patient file shall be generated on disc using an assigned unique patient number produced and bookkept by this program. The number will be produced and displayed on demand. A patient number duplication and previously established record sort edit shall be performed.

Manual keyboard entry shall be accepted consisting of the physiological and personal parameters of: systolic/diastolic pressure, temperature, respiration rate, hemoglobin, hematocrit, white blood count, urine sugar, urine protein, age, height, weight, name and physician.

On-line physiological measurements shall be processed as the measurements are forwarded from the patient interface on an external interrupt basis. Returns from spirometric data will yield total volume expired (Forced Vital Capacity), the volume expired after one second (one second expiration volume), maximum flow rate, respiratory resistance, and maximal mid expiratory flow rate. The program will execute algorithms to correct for temperature, barometric pressure, and spirometer calibration. This data will be formatted for communication (9 bits for display and 3 control bits), outputted under the supervisor's control, inserted into the fixed format of the display generator, and displayed on the CRT. The three control bits will determine writing of alpha numeric characters, using ASC II code, plot graphical information, set up control functions, or output 9 bits parallel to remote control devices. The data will be also temporarily stored on disc to be used in a hard copy print-out.

Three vector signals from the ECT will be sampled at 200 sps. A pattern recognition algorithm will be executed and will produce ECG classification including but not limited to normal sinus rhythm, sinus arrhythmia, atrial fibrillation, premature beat rate, regular rhythm, and abnormal rhythm. Also, morphological classifications of P wave (A-V block, intra-atrial block, abnormal atrial focus, atrial enlargement), QRS wave, and ST wave will be calculated. This data shall be handled as described before for on-line display and hard copy purposes.

The output from a 12-channel blood chemistry autoanalyzer shall be inputted on-line, on an external interrupt basis. This data will be accepted, formatted for storage, and forwarded to the patient's file on disc. It will also be processed for display upon request.

Aside from the CRT output a hard copy printed report of the screening data will be available with the results of the tests and a listing of all values which are outside of normal limits.

At the time of patient discharge the disc file stored patient data plus a discharge diagnosis will be transferred under the supervisor to magnetic tape inactive file.

#### 3.2.1.7.14 CATHETERIZATION

This application will be designed to assist in monitoring and displaying measured and derived physiological patient parameters in the catheterization laboratory. The program will operate either from local or remote locations. Its inputs will be direct or pre-processed physiological on-line parameters. The outputs will be in the form of hard copy, CRT, or graphics.

Data entry/program execution will be initiated when a manual key entry is made identifying the patient as described in Screening.

On-line physiological direct and derived measurements will be calculated from catheters: heart rate, central volume, stroke volume, cardiac output, duration of systole ejection, peripheral resistance, systolic/diastolic pressure, mean venous pressure, mitral insufficiency index, appearance time, buildup time, mean circulation time, cardiac index, average arterial pressure, left atrial pressure, and respiratory rate. ECG processing will provide measurements of premature or widened beats. Also the dye-dilution procedure's densitometer calibration algorithm will be executed by the program. Superior vena cava percent saturation, mid right atrium percent saturation, pulmonary artery trunk percent saturation, pulmonary artery wedge percent saturation, and radial artery percent saturation derived parameters will be available through the program. Oxygen uptake shall be calculated. The respiratory quotient will be manually entered as measured. Blood oxygen concentration will be accepted from a oximeter.

These measurements, direct or derived, will be displayed in the catheterization lab's CRT after being formatted and transmitted. The data will also be stored on in the patients file on option. All measurements shall be available for hard copy printout.

#### 3.2.1.7.15 X-RAY

X-Ray room support will be supplied by making available physiological measurements through local monitors obviating the need for the central computer program.

#### 3.2.1.7.16 OPERATING ROOM

This application will be designed to assist in monitoring and displaying measured and derived physiological patient parameters in the operating room. The program will operate either from local or remote locations. Its inputs will be direct or pre-processed physiological on-line parameters, surgical/anesthesiology notes, and direct access manual inputs. The outputs will be in the form of hard copy, CRT, graphics, or event indicators.

The patient's file will be established or re-entered through manual insertion of the patient number as detailed in the section on Screening.

On-line physiological measurements will be processed as the signals are forwarded from the patient interface equipment on an external interrupt basis. The following parameters

will be measured and derived (at 200 S/S) from the ECG signal by subroutines for: heart rate, premature beat rate, premature ventricular contraction, and premature and widened beat. Catheter and pneumotachograph outputs will also be accepted by the program to produce cardiac output, systolic/diastolic pressures, mean venous pressures cardiac index, respiratory rate, respiratory minute volume and tidal volume.

From each heart beat the following will be calculated using the arterial catheter output:

detection of onset and end of systole

calculation of stroke volume

heart rate

cardiac output

duration of systole

mean pressure

systolic pressure

diastolic pressure

Using the central venous catheter output the following will be calculated on a beat to beat basis:

mean central venous pressure

respiratory rate

respiratory amplitude (as average excursion in pressure with the respiratory cycle)

The central venous pressure signal shall be averaged over each heart cycle to eliminate cardiac-induced fluctuations leaving respiratory cycle interthoracic pressure wave form fluctuations.

The stroke volume will use central aortic pressure requiring one calibration against an independent cardiac output method such as Fick or dye-dilution procedures.

On-line central and/or extremity temperature measurement will be also processed by the program. Blood oxygen concentration and the output from the 12-channel chemistry auto-analyzer will also be processed. Also, blood loss per sample,  $PO_2$ ,  $PCO_2$ , and  $p^H$  will be calculated. A two-point blood gas electrode calibration shall also be performed. Urine output volume and rate/hour will be calculated as well as the event measurement of empty blood unit. Densitometer calibration shall also be performed by the program for the dye-dilution procedure.

As an option, routines for administration of fluids and medicines shall be provided. The infusions could include: whole blood, urine production stimulants (such as Mannitol or Ethacrinic acid), ganglionic blocking agents (such as Arfonad), premature ventricular contraction preventatives (such as Xylocaine), myocardial stimulants (such as Isuprel), and body fluid maintenance (such as D5-W).

Manual entries of both anesthesiology and surgical notes will be accepted through key and/or through card entry. These will be formatted, stored with the patient's records, and/or be made available for CRT or hard copy recall.

The outputs of these calculations will be forwarded to the operating room's CRT for alphanumeric and graphic display as well as being available for hard copy. This data will also be transferred to disc for patient's record storage. When the patient is discharged from the hospital this data will be transferred to magnetic tape and stored. Also, a discharge diagnosis will be produced.

### 3.2.1.7.17 INTENSIVE CARE

The intensive care unit will be supported by monitoring, measuring, and displaying direct and derived on-line physiological patient parameters and nurses notes. This information will be augmented by manually entered data. This support will be available from both local and remote terminals. The output shall be formulated and supplied in compatible form for hard copy, CRT, graphics, and event indicators.

The patient's file shall be re-entered on disc using an assigned unique patient number previously generated by the program. After an edit sort to eliminate an incorrectly inserted patient number the program will be initialized for on-line physiological patient monitoring and nurses notes.

The following parameters will be measured and derived from either catheters, ECG, or pneumotachograph:

- heart rate
- stroke volume
- cardiac output
- peripheral resistance
- systolic pressure
- diastolic pressure
- mean venous pressure
- central blood volume
- cardiac index
- pulse deficit
- premature beat rate
- premature ventricular contraction
- premature and widened beat
- left atrial pressure

respiratory rate  
respiratory minute volume  
tidal volume

Central temperature measurements will also be accepted as well as blood analysis, blood oxygen concentration,  $p^H$ ,  $PCO_2$ , and  $PO_2$ .

Urine output volume, hourly rate, chest drainage volume, and hourly rate will be accepted, and processed for display. As an option, routines for administration of blood fluids, drugs, and gases shall be provided. The infusions could include whole blood, urine production stimulants (osmoticdiuretics such as Mannitol), ganglionic blocking agents (such as Arfonad), premature ventricular contraction preventatives (such as Xylocaine), myocardial stimulants (such as Isuprel), body fluid maintenance (such as D5-W) and positive pressure breathing via endotracheal tube.

Nurses notes will be accepted by the program from a manual terminal. The message will be of both fixed format (question-answer type) and free style and open ended. On request, the program will present, on CRT and/or hard copy, a fixed format array of questions which will be answered as presented by the operator or a free style option. These options will accept, format, present for display/edit, and store in the patient's record on disc.

All physiological measurements will be filtered for disc storage to include only those measurements that fall outside preset limits. The infusion data will be stored on a time event, initial rate, and change of rate basis. The outputs will be presented as processed on CRT, on-demand on hard copy, and on-demand on hard copy in summary form.

### 3.2.1.7.18 CARDIAC CARE

The cardiac care unit will be supported by this system in monitoring selected physiological signals and processing nurses notes. This application will operate from local or remote locations. The outputs will be in the form of CRT, hard copy, graphic, and event indication.

The patient file will be re-entered via the patient number already specified in SCREENING.

The following physiological parameters will be measured and derived:

heart rate  
systolic pressure  
diastolic pressure  
pulse deficit  
premature beat rate  
premature ventricular contraction  
arrythmia (premature or widened beat)  
respiration amplitude  
central temperature  
blood  $p^H$ ,  $PCO_2$ ,  $PO_2$   
urine output volume and rate

The nurses notes support will be identical to that specified under Intensive Care.

The outputs will be presented on the basis of: periodic, display on exceeding of preset limits, on demand, or continuous. These outputs will be presented on CRT and can be called for on hard copy. The data will be also stored on disc while the patient is in the cardiac care unit or transferred to magnetic tape on his release. A summary patient record report will be available on demand.

### 3.2.1.7.19 EXERCISE AND REHABILITATION

The program to support both the exercise facility and the rehabilitation facility will be very similar. The inputs will be gained both locally and/or remotely and will be physiological on-line.

The measurements produced, either direct or derived, will include:

- heart rate
- systolic pressure
- diastolic pressure
- pulse deficit
- premature beat rate
- premature ventricular contraction
- arrhythmia (premature & widened beat)
- respiratory rate
- oxygen uptake
- respiratory quotient
- respiratory resistance
- pH, PO<sub>2</sub>, PCO<sub>2</sub>

The output will be provided on CRT, hard copy print, or graphic.

3.2.1.7.20 OPTIONAL MEASUREMENTS

Aside from the infusion options listed under Operating Room and Intensive Care, the Patient Monitoring System will provide optional application measurements as follows:

Measurement	Screening	Cath. Lab.	X-Ray Lab.	Oper. Room	ICU	CCU	Exer. Lab.	Rehabilitation
stroke volume				X		X	X	
cardiac output						X	X	X
duration of systole ejection					X			
peripheral resistance				X				
mean venous pressure						X		
vector cardiogram	X	X	X			X	X	X
appearance time					X			
build up time					X			
mean circulation time					X			
central blood volume				X				
cardiac index						X	X	X
average arterial pressure					X			
pulse deficit				X				
arterial pressure first derivative		X			X	X		
left atrial pressure						X		
densitometer calibration						X	X	X
superior vena cave % saturation					X			
mid right atrium % saturation					X			

OPTIONAL MEASUREMENTS (Continued)

Measurement	Screening	Cath. Lab.	X-Ray Lab.	Oper. Room	ICU	CCU	Exer. Lab.	Rehabili- tation
radial artery % saturation					X			
max. instantaneous respiratory pressure					X			
respiratory minute volume						X	X	X
tidal volume						X	X	X
respiratory work, inspiration					X			
respiratory work, expiration					X			
lung compliance				X	X			
oxygen uptake					X	X		
respiratory quotient					X			
respiratory resistance					X			
extremity temperature					X			
arterial blood bicarbonate				X	X			
venous blood bicarbonate				X	X			
blood analysis								X
blood oxygen concentration						X	X	X
electroencephalograph					X			

### 3.2.1.8 Data Transmission - Subsystem

#### I. Narrow Band Facilities for Health Field Applications

1. Narrow band facilities will provide two services:
  1. Telegraph grade service consisting of DC pulses transmitted directly over private line facilities.
  2. Carrier service in which the DC pulses are transmitted by multiplexed carrier.
2. These facilities will be used for teletype channels between 45-150 baud except when the number of circuits required indicates that a multiplexed series 3000 service is required.
3. Teletype machines will use a 5 level (7.42 unit transmission) code at 45 baud rate for direct intercommunication. They will use the ASC II 8 level (11 unit transmission) code at between 110-330 bauds rate for computer applications. These standards will be considered by way of guidance, exceptions being normally required for special applications.
4. Carrier Service Modems covered by this specification will include:

MODEM TYPE	SERVICE	SPEED
108 109	Private Line	45-150 baud
103	Dial Up	110-300 baud ASC III Multiplexed

#### II. Voice Band Services

1. The channel bandwidth for voice transmission will be normally 3000 Hz.

The services provided will include:

Dedicated lines

Public switched lines

Multistation leased systems

2. The general standards for voice band services will be as follows:

Maximum signal power	0 dbm data 0 vu voice
Net Loss	16 ± 1 db @ 1000 Hz
Variation - Short term	± 3 db
Long term	± 4 db
Frequency 30-3000 Hz	- 3 to + 12 db minimum
500-2500 Hz	- 2 to + 8 db minimum
Frequency error	± 5 Hz
Message circuit noise	24 db SNR
Impulse count	15 counts in 15 minutes at - 6 db impulse SNR

Dialed data line loss may be nominally 20 db, however, this loss can be exceeded in specific circumstances.

3. Data sets available for the transmission of ECG and EEG physiological data over voice band will include:

<u>TYPE</u>	<u>NO. OF CHANNELS</u>	<u>INPUT</u>	<u>OUTPUT</u>
603	1	DC - 100 Hz ± 2v	1988 ± 262 Hz
604	3	DC - 105 Hz 0 - 2.5v	1075 ± 100 Hz 1935 ± 100 Hz 2065 ± 100 Hz

Additional channel capacity multiplex systems will use Inter-Range Instrumentation Group (IRIG) standard frequencies for proportional bandwidth and constant bandwidth subcarrier channels listed in Table , IRIG FM/FM Telemetry Standards.

4. Modems/Codecs for the transmission of display and command discrete and analog information will use IRIG standards when applicable.

# IRIG FM/FM TELEMETRY STANDARDS

## PROPORTIONAL-BANDWIDTH SUBCARRIER CHANNELS

Band	-7.5%	Center Freq.	+7.5%	Intelligence, Hz	
				MI = 1	MI = 5
1	370	400	430	30	6
2	518	560	602	42	8
3	675	730	785	55	11
4	888	960	1,032	72	14
5	1,202	1,300	1,398	98	20
6	1,572	1,700	1,828	128	25
7	2,127	2,300	2,473	173	35
8	2,775	3,000	3,225	225	45
9	3,607	3,900	4,193	293	59
10	4,995	5,400	5,805	405	81
11	6,799	7,350	7,901	551	110
12	9,712	10,500	11,288	788	160
13	13,412	14,500	15,588	1,088	220
14	20,350	22,000	23,650	1,650	330
15	27,750	30,000	32,250	2,250	450
16	37,000	40,000	43,000	3,000	600
17	48,562	52,500	56,438	3,938	790
18	64,750	70,000	75,250	5,250	1,050
19	86,025	93,000	99,975	6,975	1,395
20	114,700	124,000	133,300	9,300	1,860
21	152,625	165,000	177,375	12,375	2,475
Band	-15%	Center Freq.	+15%	Intelligence, Hz	
				MI = 1	MI = 5
A	18,700	22,000	25,300	3,300	660
B	25,500	30,000	34,500	4,500	900
C	34,000	40,000	46,000	6,000	1,200
D	44,625	52,500	60,375	7,875	1,575
E	59,500	70,000	80,500	10,500	2,100
F	79,050	93,000	106,950	13,950	2,790
G	105,400	124,000	142,600	18,600	3,720
H	140,250	165,000	189,750	24,750	4,950

### USE OF OPTIONAL BANDS

- Band A may be employed by omitting Band 15 and B.
- Band B may be employed by omitting Band 14, 16, A and C.
- Band C may be employed by omitting Band 15, 17, B and D.
- Band D may be employed by omitting Band 16, 18, C and F.
- Band E may be employed by omitting Band 17, 19, D and F.
- Band F may be employed by omitting Band 18, 20, E and G.
- Band G may be employed by omitting Band 19, 21, F and H.
- Band H may be employed by omitting Band 20 and G.

NOTE: Bands 20, 21, G and H are to be used on 1435-1535 and 2200-2300 megahertz systems only.

## CONSTANT-BANDWIDTH SUBCARRIER CHANNELS

±2 KHZ DEVIATION		±4 KHZ DEVIATION		±8 KHZ DEVIATION	
Modulation Index	Data Frequencies	Modulation Index	Data Frequencies	Modulation Index	Data Frequencies
M = 1	2000	M = 1	4000	M = 1	8000
M = 2	1000	M = 2	2000	M = 2	4000
M = 4	500	M = 4	1000	M = 4	2000
Channel Number	Center Frequency (kHz)	Channel Number	Center Frequency (kHz)	Channel Number	Center Frequency (kHz)
1A	16				
2A	24				
3A	32	3B	32		
4A	40				
5A	48	5B	48		
6A	56				
7A	64	7B	64	7C	64
8A	72				
9A	80	9B	80		
10A	88				
11A	96	11B	96	11C	96
12A	104				
13A	112	13B	112		
14A	120				
15A	128	15B	128	15C	128
16A	136				
17A	144	17B	144		
18A	152				
19A	160	19B	160	19C	160
20A	168				
21A	176	21B	176		

TABLE 3.2.3

### 3.2.2 Facility Requirements

The facility in which the PMS will be installed may be considered to have six basic "monitoring system oriented" classes of locations or sites. These are:

- Central Computer (Processor) Area
- Central Maintenance/Repair Service Area
- Monitoring Locations - Primary (Bedside)
- Monitoring Locations - Secondary (Remote Display, Central Display)
- Analytical Equipment Areas (Blood Analysis Lab, etc.)
- Portable/Mobile Equipment "Ready Service" Areas

The detail system design shall specify the appropriate physical and functional requirements for these areas as related to the PMS. It is anticipated that additional requirements for these areas, as related to patient care, housekeeping, etc., will be provided by the customer for use by a contractor constructing or modifying the facility. The System Contractor shall integrate and coordinate all requirements, subject to final approval by the customer and will be responsible for verification and acceptance of the completed (PMS related portions of the) facility or modifications.

(NOTE: Facility construction/modification and the contracting thereof shall be the responsibility of the customer unless otherwise stated in the ordering data).

#### 3.2.2.1 Space - Adequate space shall be provided at each location, considering:

- Installation and replacement of major units
- Operator and Maintenance personnel access to the equipment
- Area Traffic (including operations staff and distribution of hard copy data)
- Materials and Maintenance Equipment Storage
- Maintenance (work) space in Central Computer Area
- Wall space requirements (e.g. windows, doors, etc.)

3.2.2.2 Environmental Control - Environmental requirements shall be established for each area and shall consider:

- Medical requirements (e.g. of patients in a patient area or treatment procedures in a treatment area)
- Operator comfort (especially in a Central processor area)
- Equipment heat dissipation and humidity requirements

These requirements will govern lighting, temperature, humidity, ventilation, sound and vibration control.

3.2.2.3 Special Structures and Construction - Requirements will be defined for special structures or construction, such as reinforced floors, False floors (Computer installations), cable runs, vibration isolation structures, heavy equipment handling devices (hoists), etc.

3.2.2.4 Electrical Power System -

a) Primary Power

It is intended that primary power for fixed installations shall be obtained from existing power utility sources, nominally 108/122 volts, 60Hz. Power sources for portable/mobile equipment shall be as specified by the system designer, however, if maintenance of such sources in a "ready" condition requires facility power, such power will be obtained from the primary source referred to above.

b) Emergency Power

The system design will detail requirements for emergency power operation of the entire system and appropriately separable subsystems, enabling establishment of a set of priorities for power, to facilitate rapid adaptation to several degrees of primary power source or distribution failure, and to Emergency Power Source capacity. Capability of the Emergency Power source to provide "Readiness maintenance" of portable/mobile equipments will be clearly stated and the ability of such equipment to cope with this situation will be detailed.

c) Power Distribution

Facility power circuits involved with the PMS (including grounds and returns) shall be isolated from other power circuits within the facility. This isolation will serve several purposes, including:

- Facilitating analysis and design of ground return circuits with a view towards patient/operator safety;

- Providing a measure of control over electrical noise and ground return voltage drops as affecting computer operations and data transmission;
- Alleviating some of the design and operating problems associated with Emergency (Back-up) Electrical Power systems.

3.2.2.5 Communications - On Site - Voice communications circuits, separate from the normal facility circuits, will be provided, to permit rapid information exchange between all areas involved with the PMS. Communications to appropriate facility Utilities control areas will be provided by way of the Central Computer Area/Central Maintenance Area. Communications devices in Monitoring locations shall incorporate "hands-off" operating features.

3.2.2.6 Communications - Remote Locations - Voice and data communications with remote (off-site) monitoring locations shall be routed through and controlled by the central processing area.

### 3.2.3 Self Test Requirements

To maintain a high level of confidence in operating performance and to aid in preventive and corrective maintenance of the PMS, Self-test features are to be incorporated. A routine, periodic, automatically programmed operation (time shared with normal operations) will provide at short intervals a go/no-go and/or calibration status of the system as it affects each function of each monitoring location. No-go or excessive error indications will be accompanied by indications of fault location to the replaceable module level. This feature will include tests of portions of the system not in use in order to indicate readiness for use. Self-test fault indications will appear at each affected monitoring area, the central processing area and the central maintenance/repair area. Calibration status data (specifically the amount of "off-calibration" condition) will be retained for trend information, useful for preventive maintenance. Such trend data will be appropriately modified by entry of data indicating replacement or repair of the affected units.

### 3.3 PMS SAFETY

The PMS shall be designed to minimize the risk of electrical shock or physical injury to patients or hospital personnel and damage to equipment. In all cases, safety of patients and hospital personnel shall take precedence over equipment damage protection.

#### 3.3.1 Hazard Condition Classification

Hazardous conditions shall be classified in accordance with the following criteria; (personnel, as used here, includes operators, intermediaries and patients).

Class I. SAFE - Condition(s) such that personnel error, deficiency/inadequacy of design, or equipment malfunction will not produce functional damage or personnel injury.

Class II. MARGINAL - Condition(s) such that personnel error, deficiency/inadequacy of design, or equipment malfunction will degrade performance but which can be counteracted or controlled without major damage or any injury to personnel.

Class III. CRITICAL - Condition(s) such that personnel error, deficiency/inadequacy of design, or equipment malfunction will degrade performance by personnel injury or substantial damage or will result in a hazard requiring immediate corrective action for personnel or equipment survival.

Class IV. CATASTROPHIC - Condition(s) such that personnel error, deficiency/inadequacy of design, or equipment malfunction will severely degrade performance and cause subsequent death or multiple injuries to personnel or equipment loss.

#### 3.3.2 PMS Safety Sequences

Safety engineering actions shall be in the following order of preference as a guide.

3.3.2.1 Design for Minimum Hazard - Insure during design, the optimum degree of inherent safety through the selection of appropriate design features and proven components.

3.3.2.2 Safety Devices - Known hazards which cannot be eliminated by design selection shall be reduced to a minimum through use of appropriate safety devices as part of the system.

3.3.2.3 Warning Devices - Where it is impossible to preclude occurrence of a known hazardous condition, appropriate devices shall be employed for detection of the condition and generation of an adequate warning signal.

3.3.2.4 Special Emergency Procedures - Where design consideration or use of safety and warning devices fail to reduce the magnitude of a known or potential hazard to an acceptable level, the vendor shall develop special procedures. These procedures shall include identification of the hazardous period time span, actions required if such hazards occur, and where applicable, special operating procedures to reduce possibility for occurrence.

### 3.3.3 Grounding

3.3.3.1 Attachment Cord Plugs - All line operated instruments shall be supplied with plugs providing separate power and chassis ground connections. For instruments operated on 120 volt power, the plug shall be a three terminal plug (hot line, power ground and chassis ground). To be determined at time of system design (See para. 3.2.2.4c).

3.3.3.2 Cabinet and Chassis - All cabinets shall be connected to a facility common earth ground. The facility common earth ground shall be connected at only one point in the PMS. This connection shall be a large surface, positive connection of extremely high reliability. Coaxial or shielded signal cables from the patient location to a remote station shall be grounded only at the patient location.

3.3.3.3 Power Line Isolation - All power supplied shall be designed with floating grounds such that there is no direct electrical path from the AC line to the cabinets. All hot power lines shall be fused to interrupt current in the event of an incorrect connection or internal equipment malfunction which would connect the chassis or cabinet to either side of the line. All chassis grounds shall be connected to the utility ground through the green line in power plug. Chassis ground lines shall not be fused.

### 3.3.4 Patient Connections

3.3.4.1 Transducer Isolation - To the maximum extent possible, transducers and sensors shall be isolated from the chassis and cabinet grounds (by isolation transformers for example).

3.3.4.2 Multiple Connections - The existence of multiple connections between a patient and line operated units of the PMS creates a potential hazard. Maximum protection in terms of isolation transformers, fuses, or other circuit interruptors shall be provided to protect the patient under any of the following circumstances present singly or in any combination. All equipment attached to a patient must be at the same potential.

- (a) Incorrect patient connections.
- (b) Patient grounding.
- (c) Equipment malfunction resulting in a "hot" chassis.
- (d) Incorrectly wired equipment.

### 3.3.5 CRT Implosion Protection

Positive protection devices shall be provided to prevent injury to personnel or patients in the event of implosion of a cathode ray tube.

### 3.3.6 Leakage Current

A maximum tolerance of leakage current shall be adhered to for all devices which are subject to physical contact by hospital personnel and/or can be used in direct electrical contact with patients.

3.3.6.1 Risk Current Limits\* for Individual Non-Therapeutic Apparatus\*\* - The risk currents of individual non-therapeutic electromedical apparatus shall not exceed the values specified in this section during continuous operation under the worst-case combination of the environmental operating conditions specified by the manufacturer. These values shall not be exceeded after the manufacturer's recommended sterilization or disinfection procedures are performed. Measurements of risk current shall be performed as described in Section 4.6.

3.3.6.2 Low Frequency (D.C. to 1KHz) Risk Current Limits - In the pass-band of D.C. to 1KHz the absolute maximum nontransient risk current shall not exceed 10. microamperes, R.M.S., for Type A\*\* apparatus and shall not exceed 500 microamperes, R.M.S., for Type B\*\* apparatus.

Type A: 10 microamperes, R.M.S.

Type B: 500 microamperes, R.M.S.

3.3.6.3 High Frequency (1KHz to 1MHz) Risk Current Limits - The low frequency Risk Current limits of Section 3.3.6.2 shall increase with frequency according to the relationships:

Type A:  $I_{LIM} = 10\mu a$ , when  $0 \leq f \leq 1KHz$

$I_{LIM} = k_1 xf$ , when  $1KHz < f \leq 200KHz$

$I_{LIM} = 2ma$ , when  $200 KHz < f \leq 1MHz$

Type B:  $I_{LIM} = 500 \mu a$ , when  $0 \leq f \leq 1KHz$

$I_{LIM} = k_2 xf$ , when  $1KHz < f \leq 20KHz$

$I_{LIM} = 10ma$ , when  $20KHz < f \leq 1MHz$

\* Note: This specification only sets limits for the risk currents of individual electromedical apparatus. The risk of use of multiple apparatus on a patient must be evaluated by the system contractor for the specific system design involved.

\*\*NOTE: See Para. 2.2.5

Where  $I_{LIM}$  is the Risk Current limit,  $f$  is the frequency of the current,  $k_1 = 1 \times 10^{-8}$  and  $k_2 = 5 \times 10^{-7}$ . Regardless of frequency the Risk Current limits shall not exceed the following values:

Type A: 2.0 milliamperes, R.M.S.

Type B: 10.0 milliamperes, R.M.S.

The above requirements are described in the following Figure 3.3.1 and Figure 3.3.2.

**3.3.6.4 Transient Risk Current Limits** - Any pulse or transient risk current, measured as described in Section 4.6, shall not exceed a 45. microampere peak, decaying to 14.0 microamperes peak within 5. milliseconds.

### **3.3.7 Risk Current Limits for Individual Therapeutic Apparatus**

For equipment rated as "Therapeutic" (Section 2.2.5), the absolute maximum risk current limits are as follows:

**Passive State:** The limits given in Section 3.3.6 apply at all times when therapeutic energy is not being intentionally delivered to the patient. The apparatus shall be tested in accordance with Section 4.6.

**Active State:** The provisions of Section 3.3.6 are not intended to limit therapeutic energy applied to the patient during normal operation of the equipment. However, the designer and manufacturer will minimize the risk currents flowing in unintentional paths while the equipment is delivering energy.

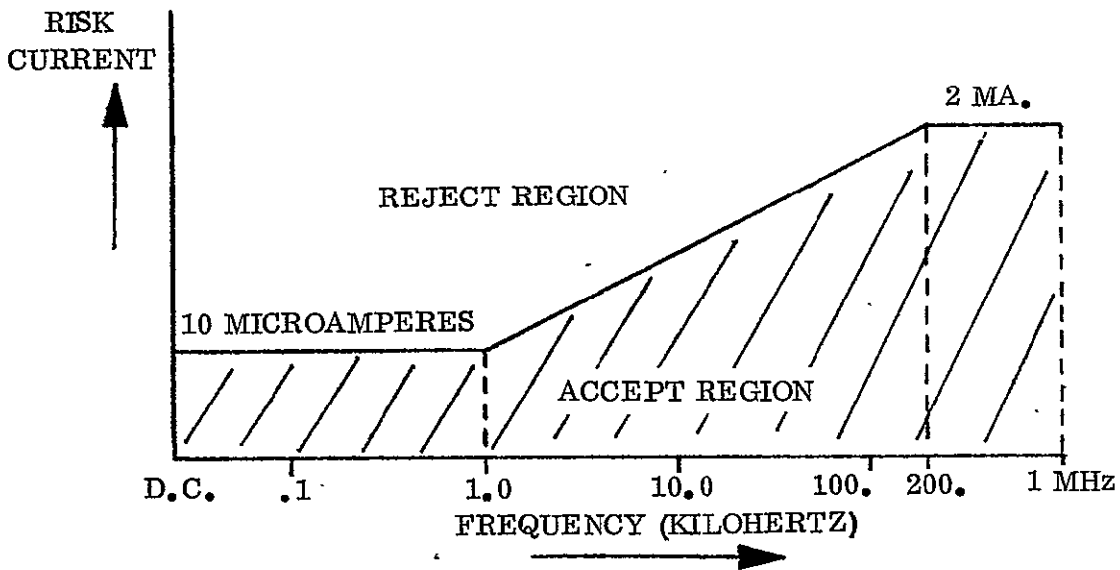

Figure 3.3.1. Type A Risk Current Limits

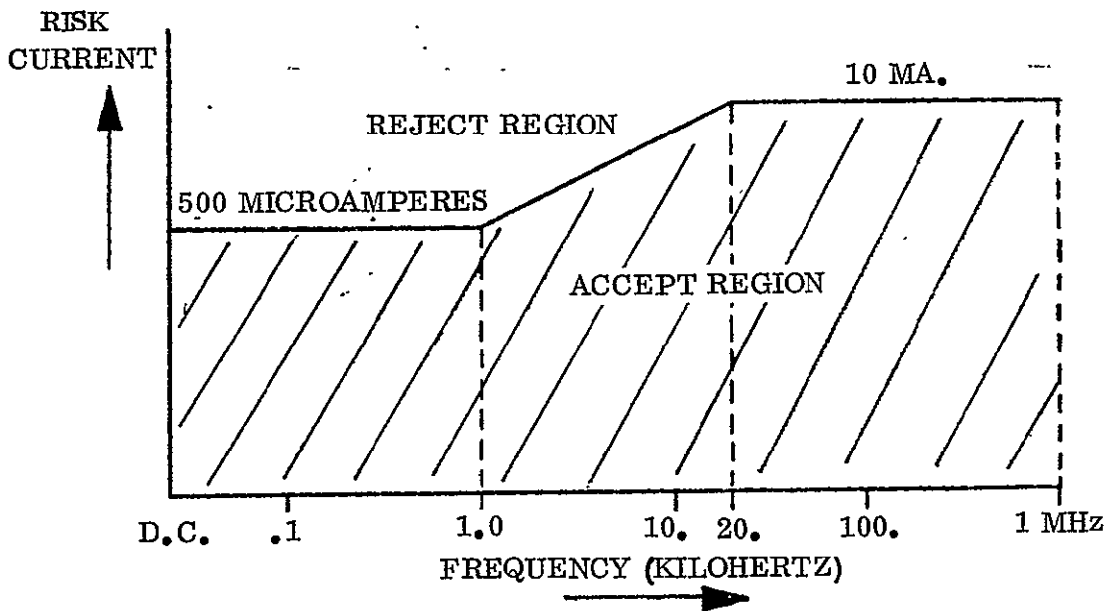

Figure 3.3.2. Type B Risk Current Limits

### 3.4 DESIGN REQUIREMENTS

The design and construction of electromedical apparatus shall be such that, when properly used for the purpose intended, there shall be minimal danger to the patient, intermediary, operator, or any person. Safety shall be retained after exposure to manufacturer's specified sterilization or disinfection and during and after mechanical, electrical, and environmental stress as is likely to be encountered in normal use.

All apparatus shall be safe for that anticipated application that presents the greatest hazard to the subject, and shall meet the following minimum safety requirements.

#### 3.4.1 Human Engineering

State of the art human engineering practices shall be employed to insure that at least the following are considered.

- |                              |   |
|------------------------------|---|
| Displays                     | <ul style="list-style-type: none"><li>- Are silent (optional selection in the Patient area - may have Audio Alarms at remote monitor)</li><li>- Present critical data in an attention getting manner</li><li>- Do not require unusual ability or training (of medical personnel) to interpret</li><li>- Do not display data to the patient unless specifically desired</li></ul>  |
| Controls                     | <ul style="list-style-type: none"><li>- Are appropriately positioned for the most frequent usage and prevention of inadvertent operation</li><li>- Are not confusing in operation</li><li>- Are interlocked, if possible to prevent harmful "out-of-sequence" operations</li><li>- Do not require unusual ability or training (of medical personnel)</li><li>- Visual appearance does not cause patient anxiety</li></ul> |
| Interconnections             | <ul style="list-style-type: none"><li>- Are easily identified as to location of mating piece or body (anatomical) position</li><li>- Are keyed or otherwise coded to minimize incorrect mating</li><li>- Are easily made/unmade</li></ul>   |
| Consoles and Equipment Racks | <ul style="list-style-type: none"><li>- Can be serviced without interferring (physically) with the operator or presenting an adverse image of reliability to the patient</li><li>- Ease of disassembly or access for service</li><li>- Adequate identification of all parts</li></ul>   |

### 3.4.2 Data Interface

The PMS equipment shall satisfy the data interface requirements imposed in order to be completely compatible between the four (4) module configurations (Module I - Cardiac Surveillance, Module II - Cardiovascular, Module III - Pulmonary, and Module IV - Body Chemistry) either alone or in combinations. The data interface requirements are as follows:

3.4.2.1 Patient to System Interface - The patient to system interface shall consist of standard physiological measurement devices and their attaching techniques (catheters, electrodes, thermistors, transducers, strain gauges, etc.). The patient monitor system shall be capable of interfacing with any or all of these devices.

The system interface shall match the particular configuration of Module I, II, III, or IV with the appropriate number of devices required to convert and/or transmit the signals from the patient to the bedside equipment or remote equipment. The system interface will provide the functions of converting the patient signals to standard system voltage levels, data rates, bit/word numbers, and codes. These standard system data interface requirements shall be compatible to that equipment selected to be the main processor for Modules I, II, III, and IV.

3.4.2.2 Data Acquisition, Transmission, and Display Interface - The patient monitoring data acquisition, transmission and display interface shall provide system compatibility between the patient to system block of equipment, the computer system, and the subject interface which shall include but not be limited to the following:

bi-polar DAC's - 12 bits, 100KC

uni-polar DAC's - 1- bits, 100KC

A/D Converter - 10K sps

Digital transmission: digital format shall be 12 bits total minimum (16 bits to be system compatible); 3 bits sync, parity, and control; 9 bits, data

200 bps, serial, voice grade line, asynchronous, non-private line, auto call

2 KBS, voice grade line, non-private line, auto call, synchronous, serial

2.4 KBS, voice grade line, private line, non-auto call, synchronous, serial

40.8 KBS, non private line, non auto call, synchronous, serial

Analog transmission:

1 line,  $\pm 2v$  input/output, DC-100 Hz bandwidth

3 or 6 lines,  $\pm 2.5v$  input/output, DC-100 Hz bandwidth

Manual input - 12-16 bits parallel

Operational amplifiers -  $\pm 10v$  (full-scale output)

3.4.2.3 Computers Interface - The patient monitoring computer interface shall provide system compatibility between the patient to system block of equipment; the data acquisition, transmission and display system; and the subject interface which shall include but not be limited to the following:

16 parallel bit word interface for logic, core, discs, communications

Magnetic tape - 7 track, 150 ips, 800 bps, parallel

Peripherals - standard 16 bit interface

core - 2  $\mu$  sec, access

disc - 37K words/sec. transfer rate

### 3.4.3 Decontamination and Sterilization

Equipments shall not be damaged nor shall they exceed the specified hazard current limits (3.3.6) due to repeated exposures to applicable chemicals, including but not necessarily limited to:

Gases: Oxygen and anesthetics, helium, carbon dioxide, nitrogen and ethylene oxide

Liquids: Saline solutions, hospital disinfectants, processing chemicals (as used in copying machines) or caustic chemicals (as used in analytical processes)

Spillage of any of the above liquids on controls, enclosure openings or electrical interface connectors shall not cause a hazard from entry of the spilled material into the equipment or connector enclosure.

Elements requiring sterilization\* and the method of sterilization shall be described by the manufacturer.

### 3.4.4 Environments

The PMS equipment shall satisfy the performance requirements of 3.2 after transportation to the medical facility and exposure to the following storage environments; and while exposed to operating environments.

a. Temperature: 70  $\pm$  30<sup>o</sup>F

b. Pressure: 10.0 to 15.4 psig

c. Humidity (storage): 5 to 80% RH, (operating); 5 to 85% RH

\* Generally items contacting patients or subject to handling by persons who have just handled patients.

- d. **Mechanical Stress:** Rotational drops pivoting on one edge of the base of units  
Edge opposite pivot is raised 2" or till the base makes an angle of 45 degrees  
with the horizontal, whichever is less, and then dropped
- e. **Chemical exposure:** All exposed surfaces of equipment, sensors and trans-  
ducers, and harnesses and cabling shall not suffer degradation of performance  
or appearance from repeated exposure to the following chemical agents:
  - (1) Gases: oxygen, helium and anesthesias, etc.,
  - (2) Liquids: saline solution and hospital disinfectants

#### 3.4.5 Electrical Power, Electromagnetic Compatibility

3.4.5.1 Electrical Power - The nominal conditions for the power source for units intended for fixed or semi-fixed installation shall be 120/240 (+ 10% volts single phase, 3 wire-centered grounded, 60 Hz alternating current. Power sources for portable (including mobile use), and emergency or standby equipment shall be as described by the manufacturer.

3.4.5.2 Electromagnetic Compatibility - The PMS shall be designed to minimize mutual interference between functions and between the system and other electronic equipment. This shall include susceptibility to, and generation of, conducted and radiated interference. In medical instrumentation systems employing stimulus functions such as heart pacers or defibrillators, gating or blanking circuits in other equipment of the system may be required to prevent erroneous readings or equipment damage due to stimulus pulses.

#### 3.4.6 Endurance

3.4.6.1 Service Life - The intended service life for the PMS is 10 years.

3.4.6.2 Duty Cycle - All equipment shall be designed for continuous operation.

3.4.6.3 Endurance - All equipment shall be designed to operate in accordance with the performance requirements and duty cycle specified herein for a period of not less than one year without maintenance beyond the manufacturer's recommended maintenance program in-place calibration adjustments and replacement of manufacturer's identified expendable items (see 9.4.2.4). The vendor shall identify in the maintenance program (3.5.3) the calibration frequency for each system function, the expendable items and their replacement frequency and any other operating adjustments required to satisfy these requirements. The system shall be so designed that routine maintenance can be performed on any unit of the system without disrupting performance of other system units except those with essential functional dependence on the unit being serviced.

3.4.6.4 Storage Life - The system shall satisfy the requirements of this specification after up to 3 months storage under the environmental conditions of 3.4.4 unless otherwise specified. Elements of the system, such as batteries, not capable of this storage life shall be identified by the vendor. The vendor and procuring agency shall establish storage life requirements for these items.

3.4.6.5 Repair - When a system malfunction occurs, the defective unit shall be identified and serviced using the prescribed fault isolation and repair instructions in the vendor supplied service manual (3.5). After repair and restoration of full system operation the original endurance capability of the system shall not be adversely effected.

#### 3.4.7 Reliability

The reliability of the PMS is a measure of the degree of satisfaction of the performance and endurance requirements of the system under the specified service conditions. It is the probability that the performance requirements will be satisfied without failure throughout any specified interval of the service life. For the purposes of reliability, a failure is defined as any deviation of the PMS or elements thereof from the requirements of this specification when the system is serviced in accordance with the vendors prescribed maintenance program (3.5.3). No single failure or combination of failures of the PMS or elements thereof shall cause a Class IV hazard condition (see 3.3.1).

3.4.7.1 Fail Safe/Fail Soft - The system shall be designed to meet Fail Safe criteria which is interpreted here to mean that system failure shall not cause a situation of grave danger for the patient by virtue of producing erroneous data, incorrect control signals for therapeutic devices, or hazardous electrical currents. The system shall be farther designed to possess a Fail Soft characteristic such that failures of major subsystems such as the Central Processing Computer or the Local Processing Computer will not degrade fundamental Physiological monitoring displays such as ECG, Heart rate, certain Respiration parameters, etc. located at the bedside or in the local units central nursing station, assuming that this is a primary monitor display area.

#### 3.4.8 Maintainability

To the maximum extent possible consistent with the functional requirements maintainability shall be a major design criterion. In maintenance of the equipment, the throw-away level shall be the lowest possible level of assembly consistent with state of the art circuit design and packaging techniques. The PMS shall be constructed of repairable assemblies and sub-assemblies. The largest assembly module shall be of such a size and weight that it can be safely handled by two men.

\*To be determined

### 3.4.8.1 Design Guidelines -

- a. Reduce the complexity of maintenance by:
  - Providing adequate accessibility, work space and work clearance.
  - Providing for interchangeability of like components, materials and parts within a given system installation.
  - Utilizing standard parts readily available to the procuring agency.
  - Limiting the required number and variety of tools, accessories and support equipment.
  
- b. Reduce the need for, and frequency of, design-dictated maintenance activities by using:
  - Fail-safe features.
  - Components which require little or no preventive maintenance.
  - Tolerances which allow for use and wear throughout life.
  - Adequate corrosion prevention/control features.
  
- c. Reduce maintenance downtime by designing for:
  - Rapid and positive detection of malfunction or degradation.
  - Rapid and positive localization of malfunctions to the repair level for which skills, spaces and test equipment are planned.
  - Ease of fault correction.
  - Rapid and positive adjustment and calibration.
  - Rapid and positive verification of correction.
  
- d. Reduce the potential for maintenance error by designing to eliminate:
  - The possibility of incorrect connection, assembly, or installation.
  - Dirty, awkward and tedious job elements.
  - Ambiguity in maintenance labeling, coding and technical data.

### 3.4.9 Transportability/Mobility

3.4.9.1 Transportability refers to ability to be relocated, in a non-operating condition, after one or more degrees of disassembly using conventional "moving" equipment. Consideration will be given to means for securing internal moveable parts which could be damaged or misaligned by the normal transportation environment, (e.g. meter movements, sliding doors, drawers, etc.). Further consideration will be given to the probable facility construction of the equipment site (e.g. doorway sizes, etc.).

3.4.9.2 Mobility refers to the ability to be relocated rapidly, either operating or in ready for operation condition, independently or in association with a patient carrying device. Consideration will be given to quick disconnect (maintenance) power cords, large wheels, ease of handling by a single attendant, rugged construction.

#### 3.4.10 Workmanship

Workmanship shall be of the highest commercial quality. All equipment shall be constructed and finished in a thoroughly workmanlike manner. Particular attention shall be given to neatness, cleanliness, and thoroughness of soldering, welding, brazing, bonding, wiring, marking of parts, painting, protective coatings, riveting, machine screw assembly, freedom of parts from burrs and sharp edges and fit of interfacing equipment.

#### 3.4.11 Materials Parts Processes Finishes and Coatings

3.4.11.1 Materials - The materials used in the PMS shall be of the highest quality and selected on the basis of physical or other essential properties and suitability to the service conditions of 3.4.3 and 3.4.4. Dissimilar metals shall not be used in intimate contact unless suitably protected against corrosion by plating, painting, or other surface treatment. All materials used in contact with, or penetrating the patient's body shall have histories of acceptable use in contact with the skin without causing irritation. In no case shall a material be employed which has a history of causing acute or extended irritation in any significant percentage of the population or has caused chronic ailments in otherwise healthy adults. Whenever possible, materials used in contact with the skin shall be materials which have been previously approved by the Food and Drug Administration for medical applications for skin contact.

3.4.11.2 Parts - Wherever possible, standard parts shall be used to ensure high quality and facilitate procurement for servicing. Where specialized parts unique to the satisfaction of the functional requirements of the PMS are required, they shall be so indicated on the equipment parts lists (3.5.4).

3.4.11.3 Finishes and Coatings - Surface finishes and protective coatings shall conform to good commercial practice and shall be compatible with the service conditions of 3.4.3 and 3.4.4.

#### 3.4.12 Identification and Marking

Each separable unit in a monitoring system shall be permanently and legibly marked with the manufacturer's or supplier's name or registered trademark as well as a catalog or model number. Electrodes and interconnecting cables are excluded from this requirement.

3.4.12.1 Ratings - Each unit in a monitoring system which receives line power from a facility source shall be permanently and legibly marked with proper voltage, frequency and current requirements.

#### 3.4.13 Storage

Storage environment covers long term warehousing with minimal environment control, movement within the medical facility and routine maintenance or preparations to put the PMS or units thereof in service. The environmental extremes in 3.4.4 are considered as being applied to unpackaged equipment.

A less severe form of storage is that of Emergency equipment or Low usage items in accessible but essentially unmonitored locations.

#### 3.4.14 Interchangeability

3.4.14.1 Patient Cables - Patient-machine interface connectors must be polarized and keyed in such a way that they cannot be mated with any other operator accessible connectors in the system, or in any other commonly available equipment, which does not perform exactly the same function in the same manner.

3.4.14.2 Plugs or sockets of equipment shall not be interchangeable with other plugs or sockets operating on different voltages or containing different circuit functions. Where correct polarities are required, the plugs and sockets shall be so constructed as to prevent connection with incorrect polarity.

3.4.14.3 Interchangeability - Each part, component, assembly or instrument in the PMS shall be directly interchangeable with regard to form, fit and function with every other unit having the same drawing or model number. The use of matched parts or selective fits shall be avoided wherever possible. Where matched parts or selective fits are required, this shall be clearly indicated in the appropriate service manual (3.5).

#### 3.4.15 Protective Measures

Where there is a possibility of "danger" due to equipment malfunction, a state-of-the-art protective device, circuit or system should be arranged to safeguard against such danger.

3.4.15.1 Double Protection - Where there is a possibility for a "grave danger" to the patient, intermediary or equipment operator due to equipment malfunction, a state-of-the-art double safety construction should be provided whereby a second safety device, circuit, or system will insure safety if the primary protective device fails.

3.4.15.2 Prevention of Contact with Live Parts - To prevent shock to the patient, intermediary, or operator when electro-medical apparatus is in normal use, all accessible metal parts shall be protected from contact with live parts.

Access covers protecting live parts shall be removable only with the aid of a tool, unless automatic disconnection from the supply shall be arranged when the cover is opened or removed. Lamp holders and fuse holders accessible without a tool shall be placed so as to avoid operator contact with live parts.

3.4.15.3 Grounding - All accessible non-live conductors and accessible metal parts shall be firmly connected, electrically and mechanically, to the grounding terminal.

Alternatively, a nonconductive housing may be used so that no conductive part is accessible to contact with the human body.



Exception: This section shall not apply to transducers or sensors such as patient electrodes.

3.4.15.4 Patient Circuit Physical Separation - Any wiring that is connected directly to the patient shall be physically separated from other circuits of the apparatus and routed through separate cables, wiring harnesses, or wiring troughs.

3.4.15.5 Patient Circuit Electrical Protection - Isolation transformers, current limiters, fuses, or other safety circuits or devices shall be inserted between patient circuitry and all other circuitry, so that the electromedical apparatus conforms to the requirements of this standard.

3.4.15.6 Power Supply Switches and Transformer - Each portable line-operated apparatus shall have an independent power cord. The length of this power cord shall be kept as short as practical. Plugs of these cords shall be replaceable and not molded in as part of the cord's flexible insulation, with separate power and chassis grounding lines (3 prong).

Power on-off switches shall switch both sides of the power line (DPST) and shall have clearly visible indication of the power status ("on" or "off"). Where the supply cord passes through the outer casing of the apparatus, a properly secured, tapered grommet or equivalent device shall be provided to relieve stress on the conductors and prevent sharp bends and abrasions of the flexible cord at the entry point. The surface of the stress relief device in contact with the flexible cord shall be insulating.

No apparatus shall be designed to operate directly from the electricity supply of the premises, without isolation. A power transformer or transformers shall be used to provide electricity supply isolation, containing at least one full primary-to-secondary shield, connected to power ground. Alternative supply isolation methods will be acceptable if they provide an equivalent degree of isolation from the electricity supply.

3.4.15.7 Over-Current Protection - All circuit wiring and components shall be protected against excessive current by means of a correctly rated fuse or an automatic type circuit breaker inserted into the positive (hot) supply conductor. Either fast or slow-blow fuses may be used, but the rating of the chosen fuse shall be the lowest available value capable of safely and continuously carrying the current required by the apparatus.

### 3.5 DOCUMENTATION

In addition to documentation supporting readiness of equipment for initial delivery the vendor shall prepare, for delivery to each customer, sufficient documentation to enable training and operation, along with appropriate levels of maintenance, and replenishment.

#### Operating and Service Manuals

Detailed operating and service manual(s) shall be prepared for each equipment item. Separate operating and service manual(s) shall be prepared for those equipment items functioning together as a system. System operating and service manual(s) will satisfy this requirement.

##### 3.5.1 Training

A training program will be developed with the customer. Operating handbooks specially modified for training purposes will be provided. "Programmed" learning techniques will be considered. A Formal Training Plan will be delivered.

##### 3.5.2 Operation

Formal operating instructions will be provided, highlighting Hazard areas, Special Precautions and contingency procedures. Routine operation, including Preparation for use, sterilization/decontamination, Post-use Procedures, calibration (operator level) and replenishment of consumables shall be included. Operating manual(s) shall contain step-by-step operating procedures for each operating mode fully illustrated by pictures, diagrams, charts, etc., and must cover all contingencies in operation.

##### 3.5.3 Maintenance and Calibration

The vendor shall prepare a detailed maintenance and calibration program for both routine and periodic maintenance. The program shall include the maintenance schedule, detailed maintenance procedures, lists of maintenance tools and materials, spare parts lists and parts replacement schedules.

Provision shall be made, by means of a Maintenance reporting system, for feedback of maintenance data to the manufacturer for system upgrading studies. Service manual(s) or service portions of operating and service manuals must include all drawings in 3.5.4 unless included elsewhere in the manual and must fully describe all equipment servicing which is not limited to factory service. A complete set of diagnostic charts must be included which will indicate the observed fault, the possible causes and the corrective action for each possible cause. For each service condition complete and fully illustrated step-by-step disassembly, part replacement, reassembly and test procedures must be included. This requirement does not include those service conditions for which equipment must be returned to the factory.

#### 3.5.4 Drawings

The vendor shall prepare and include in the operating and service manuals the following drawings:

- a. Block diagrams. Functional block diagrams down to the individual circuit level to demonstrate the functioning of the equipment from an engineering viewpoint.
- b. Schematic diagrams. Detailed circuit diagrams showing and identifying each part to the parts list nomenclature. These diagrams should also indicate normal electrical characteristics which can be expected at various key points.
- c. Wiring diagrams. Detailed diagrams showing the actual wiring of the equipment and each connection and interconnection.
- d. Parts lists. Detailed lists of all parts cross-referenced to the circuit diagram and including part number, part nomenclature and sources for procurement. Where vendor standards are employed, they must be available to the procuring agency.

#### 3.5.5 Test Procedures

Detailed test procedures shall be prepared by the vendor for tests specified in 4.0.

#### 3.5.6 Test Reports

Detailed test reports shall be prepared by the vendor for the procedures specified in 4.2.1 and 4.3.1.

#### 3.5.7 Log Books

Each system shall have a (set of) log book(s) containing the Test Reports of 3.5.5, and space for estimated 10 years (Life) worth of maintenance (performed) entries.

Each replaceable module of sufficient complexity/cost to warrant serialization shall have an associated log book or similar record.

3.5.8 The systems contractor shall prepare a Program for system validation data acquisition, analysis, and reporting, for use in conjunction with initial installation (6.5).

### 3.6 SYSTEMS INTEGRATION AND DEVELOPMENT TESTING

A single contractor shall be the systems contractor and shall be responsible for integration of all subsystems and components into the total system. The systems contractor shall by careful analysis determine the detail interface requirements for all interfaces (system, sub-system and module). Functional interfaces will be thoroughly verified in development tests and completely documented. Physical (mechanical) interface will be accomplished by specification on the vendor (sub-contractor) or by use of (mechanical) mounting and panel face adapters.

***QUALITY ASSURANCE PROVISIONS***

#### 4. QUALITY ASSURANCE PROVISIONS

##### 4.1 CLASSIFICATION OF TESTS

The inspection and testing of the PMS shall be classified as follows.

###### 4.1.1 Qualification

Unless otherwise specified in the ordering data, qualification tests shall be performed to establish the environmental capability of the equipment. (See 4.7)

###### 4.1.2 Factory Acceptance

Unless otherwise specified in the ordering data, Factory Acceptance Tests shall consist of visual inspection, operability assurance tests and functional tests. (See 4.8)

###### 4.1.3 Operational Demonstration

Upon completion of installation and checkout of the PMS by the system contractor at the procuring medical facility, a demonstration test shall be performed. (See 4.9)

###### 4.1.4 Service

The service history of the PMS shall be regarded as a service test. (See 4.10.)

## 4.2 TEST CONSTRAINTS

### 4.2.1 Test Procedures

Detailed test procedures for all tests in 4.1 shall be prepared by the vendor subject to approval by the procuring agency.

### 4.2.2 Test Quantities

Factory acceptance (when specified in the ordering data), operational demonstration, and service tests shall be performed on all components, assemblies, etc. of the PMS.

### 4.2.3 Test Conditions

Unless otherwise specified, tests shall be conducted under the following ambient conditions.

- a. Temperature:  $70 \pm 10^{\circ}\text{F}$
- b. Relative Humidity: 5 to 85
- c. Barometric Pressure: 14.3 to 15.3 psia

### 4.2.4 Measurements

All pertinent signal and environmental inputs to the unit under test and all pertinent performance parameters shall be measured and recorded as specified in the detailed test procedures (4.2.1) during tests. To the maximum extent possible, measurements shall be made in terms of standard units rather than arbitrary dial, indicator or control settings.

4.2.4.1 Tolerance Ratio - Whenever possible a ratio of not less than 10 to 1 shall be maintained between the tolerance of the measured parameter and the tolerance of the measurement. The tolerance of the measurement shall include basic instrument accuracy and instrument-use errors such as resolution, repeatability and parallax.

4.2.4.2 Calibration - All test instruments shall be under the control of a calibration plan. The plan shall specify the frequency of calibration, accuracy of the calibration standards and maintenance of calibration records. The calibration records shall be available for inspection at any time by the procuring agency. All standards shall be traceable to the U.S. Bureau of Standards.

### 4.3 TEST DOCUMENTATION

#### 4.3.1 Performance Records

Records shall be made of all data necessary to determine compliance with this specification and the test procedures (4.2.1). This data shall provide criteria for checking satisfactory performance of the unit during testing. Test data shall be recorded before, during and after each test as specified in the test procedure.

#### 4.3.2 Test Data Reports

Reports, for the tests in 4.1 providing the data required by paragraph 4.3.1 shall be submitted to the procuring agency within 30 days of test completion.

#### 4.4 FAILURES

##### 4.4.1 Definition

Any reading, indication or measurement which is not within the limits specified by this specification or the test procedure (4.2.1) when the inputs and environmental factors are within tolerances; any deterioration or corrosion which could in any way prevent the unit under test from meeting its operational requirements; any loose, bent, cracked or otherwise damaged or improperly adjusted parts; or any evidence of poor workmanship shall constitute a failure.

##### 4.4.2 Procedure

Units under test, in which failures are detected during individual tests, shall be rejected. Testing of other units may continue. A failure log shall be maintained for each PMS, from the start of equipment installation. Each failure of any unit shall be recorded in the log book identifying the nonconforming unit, the test failed, the nature of the failure and the corrective action taken. The procuring agency reserves the right to refuse to accept any unit in the PMS which has to be reworked more than once to achieve specification compliance.

#### 4.5 TEST MONITORING

The procuring agency reserves the right to witness all qualifications, factory acceptance and operational demonstration tests.

#### 4.6 RISK CURRENT MEASUREMENTS

The risk currents of individual electromedical apparatus shall be measured by the methods described in this section. The risk current shall be first investigated using an oscilloscope. Essentially sinusoidal, complex sinusoidal, or rectangular repetitive currents may be measured using any commercial R.M.S. indicating meter. Transients and repetitive spikes shall be measured using an oscilloscope.

When multiple risk currents of various frequency and phase relationships are present, the total risk current shall be considered to be the instantaneous sum of the individual currents.

##### 4.6.1 Test Conditions

The risk current of an apparatus shall be considered to be the greatest of the following:

- a) For Type A or B apparatus, the risk current flowing between any patient connection or chassis, and power ground, or between any combination of patient leads (Figure 4.6.1):
  - 1) | When electrical supply polarity is normal or reversed;
  - 2) | When electrical supply grounding contact (wall outlet) is intact or open;
  - 3) | During the operation of all accessible controls, with all controls operated in any possible pattern or combination; and
  - 4) | When any internal power supply or supplies fails in an open or shorted mode.
- b) On Type A apparatus only, the greatest current flowing in any nongrounded patient lead when a potential of 117. volts R.M.S. 60 Hz is applied through a series 120 Kilohm resistance to the patient lead with respect to power ground. If an apparatus is damaged by this test, it shall fail safe in all respects. This test shall be conducted with the apparatus both ON and OFF and properly connected to its electrical supply (Figure 4.6.2). (The 120 Kilohm resistance is intended to protect the test operator.)
- c) For Type A or Type B apparatus, the risk current flowing with the electricity supply ground contact open, and the chassis connected to the rated supply voltage (Figure 4.6.3). CAUTION: Chassis is HOT! Test to be performed with electrical supply polarity normal or reversed. Risk currents shall be measured between any ungrounded patient connection and power ground or between any combination of patient leads, with power switch ON and OFF. (The 120 Kilohm resistor is intended to protect the test operator.)

The measuring instrument used during the above tests shall have an input impedance of at least 100 Kilohms; a frequency response of D.C. to 10 MHz; and an accuracy of at least +5%.

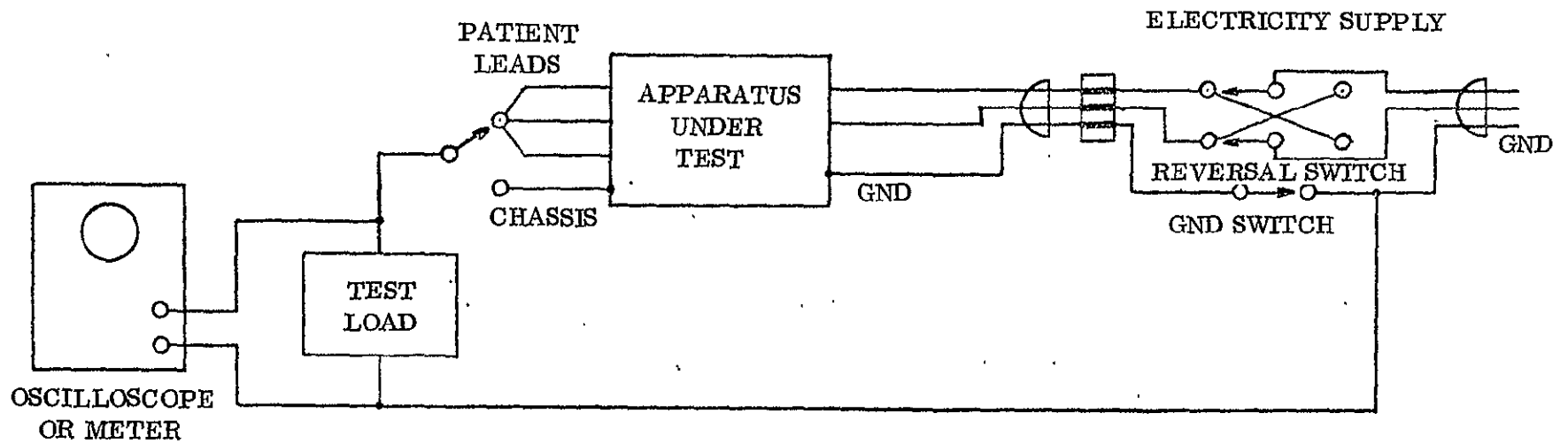

Figure 4.6.1. Test Circuit One (Paragraph 4.6.1 (a) )

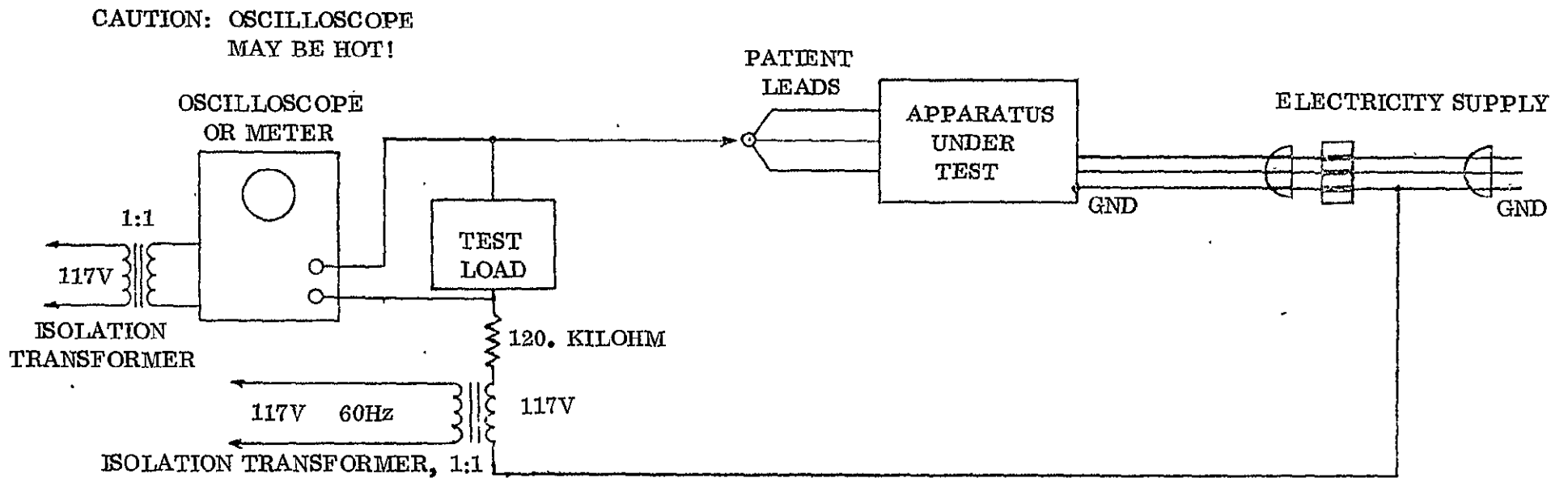

Figure 4.6.2. Test Circuit Two (Paragraph 4.6.1 (b) )

DANGER: CHASSIS HOT!

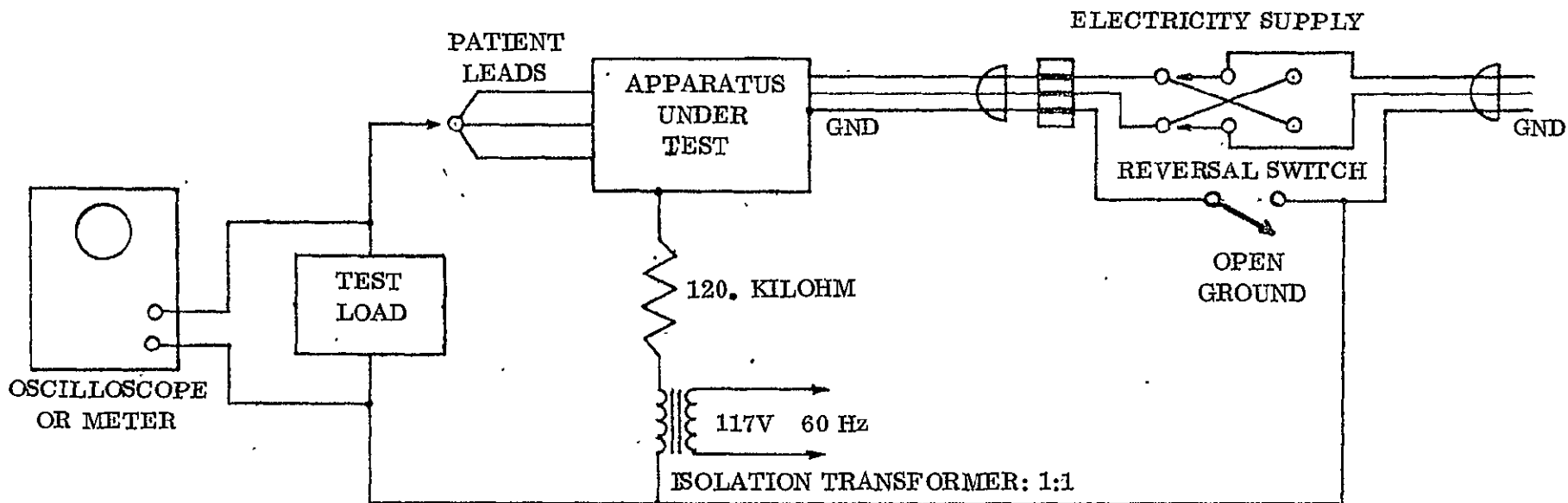

Figure 4.6.3. Test Circuit Three (Paragraph 4.6.1 (c) )

#### 4.6.2 Standard Test Loads

All tests of Sections 4.6 shall be performed using the Test Loads, Figures 4.6.4 and 4.6.5. These test loads shall be constructed using 1% tolerance or better metal film type resistors and a 5% tolerance or better mica or plastic dielectric capacitor.

The standard test loads have an impedance-frequency characteristic, shown in Figure 4.6, that is the approximate inverse of the allowed risk current versus frequency curves, Figures 3.3.1 and 3.3.2.

#### 4.6.3 Standard Test Circuits and Procedure

The tests described in 4.6.1 (a), (b), and (c) shall be performed using the Type A Load for Type A apparatus and using the Type B Load for Type B apparatus.

The individual apparatus under test shall be connected as in Test Circuits One, Two and Three and subjected to the corresponding tests of 4.6.1 (a), (b) and (c). Where the apparatus is operated by a self-contained power supply, the current drain between the circuit which is directly connected to the patient and the ground terminal is measured as shown in Test circuit 4, Figure 4.6.7. The Test Load shall be first connected to an oscilloscope to test for the presence of D.C., transient, or A.C. risk currents. Where for functional reasons it is necessary to drain a current into the circuit that directly contacts the patient (output circuit), measurement shall be made with the output current at 0. The individual apparatus risk current is given in total frequency-weighted microamperes by:

$$I = \frac{E \text{ (Millivolts, R.M.S.)}}{Z \text{ (Load)}}$$

The values of I so determined shall be less than:

Type A: 10 microamperes, R.M.S.

Type B: 500 microamperes, R.M.S.

Except that, the stated limit for risk current from the apparatus chassis (4.6.1 (a) or 4.6.1 (c) may be exceeded when the electricity supply grounding contact is open, provided that such risk current does not exceed 50. microamperes. Apparatus using this exclusion shall be marked to indicate the necessity for proper grounding, and shall meet all requirements of this standard when properly grounded.

#### 4.6.4 Decontamination and Sterilization

Equipment shall not exceed the above risk current limits due to repeated exposures to the method of sterilization or disinfection described by the manufacturer.

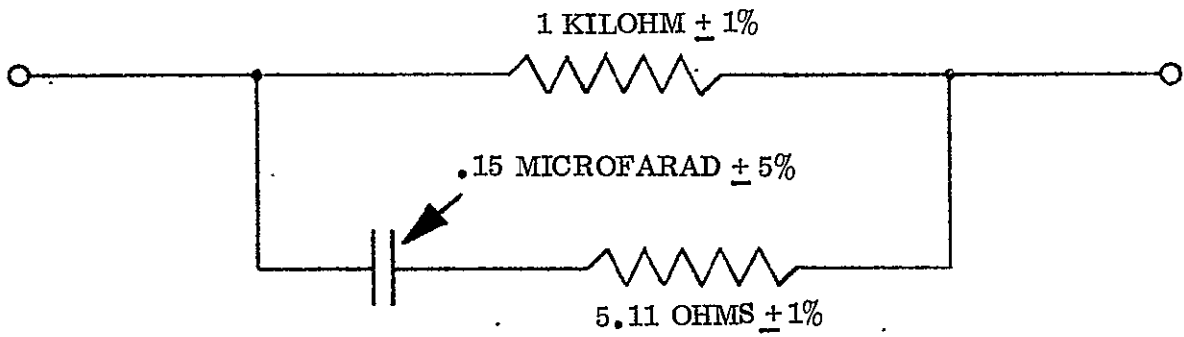

Figure 4.6.4. Test Load, Type A

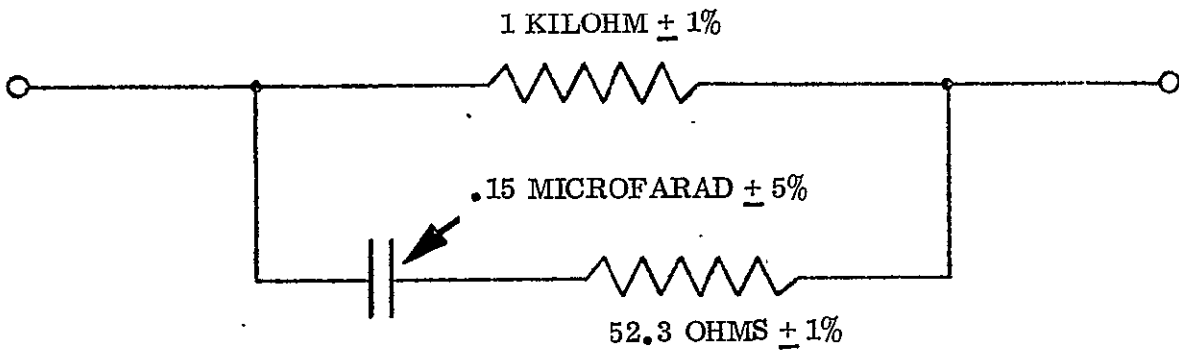

Figure 4.6.5. Test Load, Type B

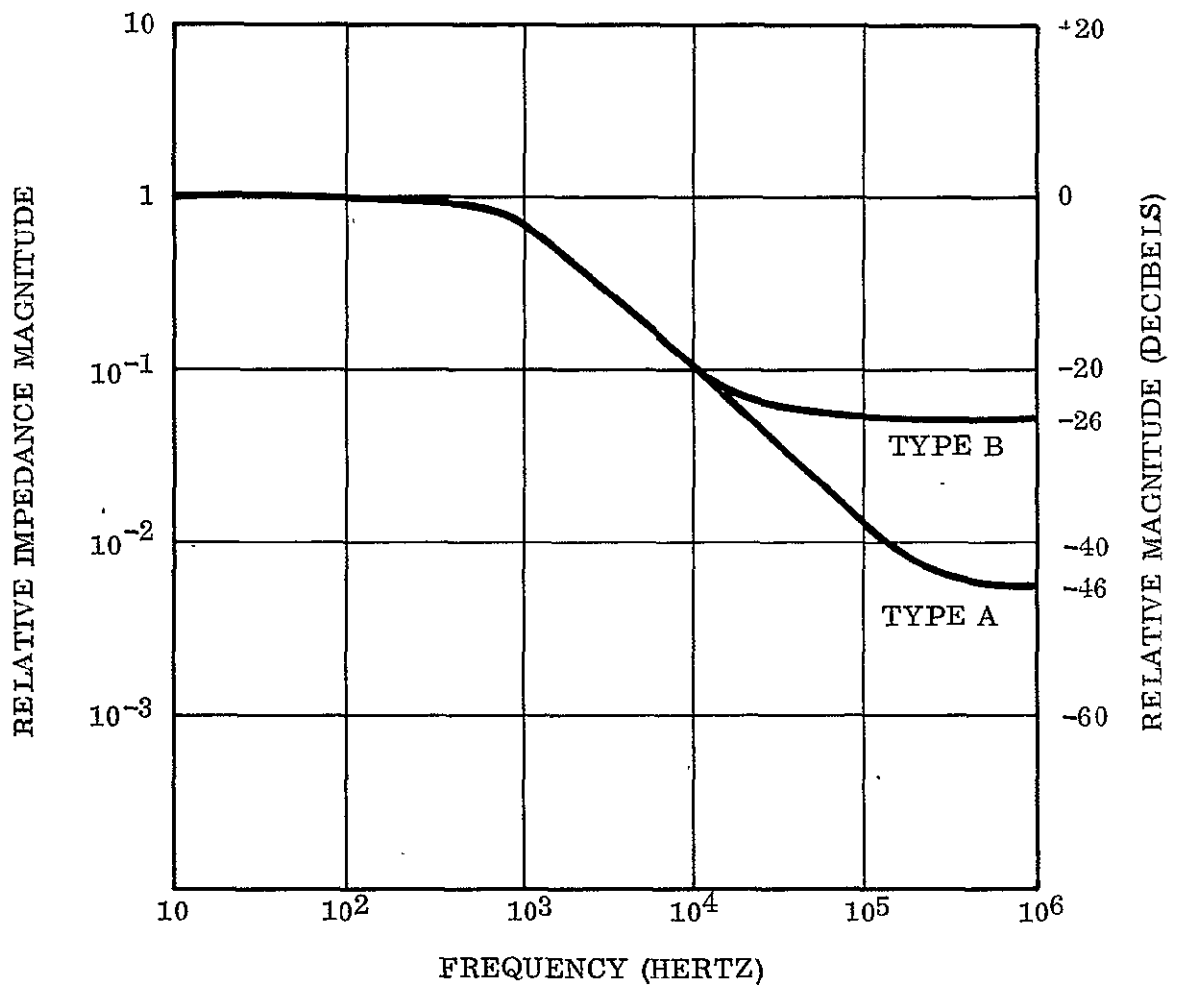

Figure 4.6.6. Impedance-Frequency Characteristics of Test Loads

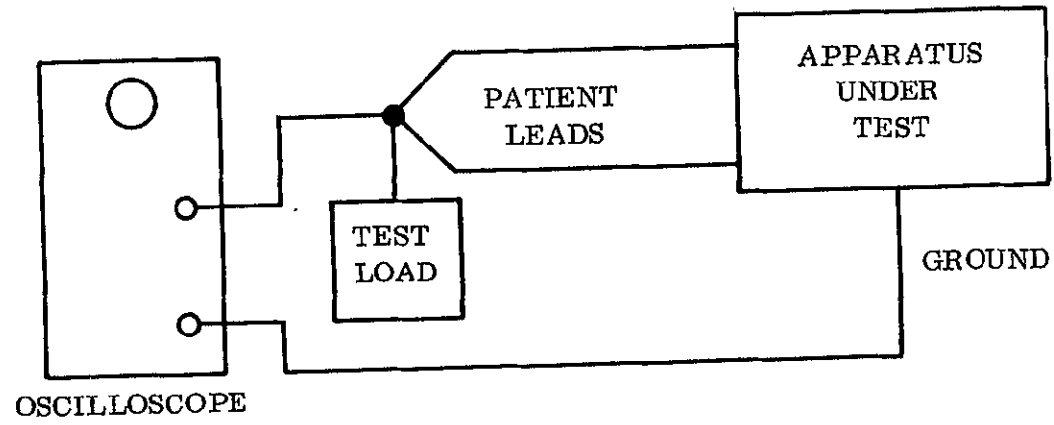

Figure 4.6.7. Test Circuit Four (Para. 4.6.1 d)

#### 4.6.5 Sensor Amplifier Input Impedance

The differential input impedance shall be measured using Test Circuit five, Figure 4.6.8 with SW1 closed, record output  $V_o$ . With SW1 open, adjust R until output  $V_o$  equals one half previously recorded value. Value of R then equals input impedance. Note it may be necessary to insert a 60 Hz filter between the sensor amplifier and the AC voltmeter.

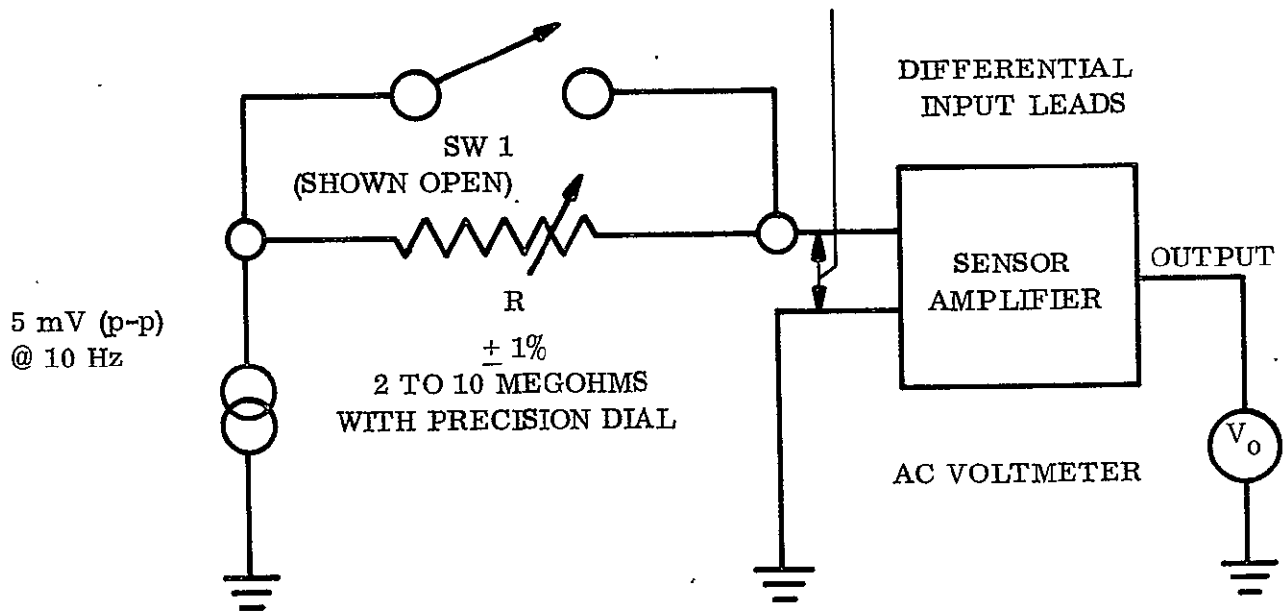

Figure 4.6.8. Test Circuit Five

## 4.7 QUALIFICATION

Unless otherwise specified in the ordering data, each type of unit employed in the PMS shall be qualified to establish the capability of the units to withstand the service conditions of 3.4.3 and 3.4.4 and satisfactory performance in accordance with 3.2.

### 4.7.1 Methods of Qualification

Qualification shall be predicated on data secured by one or a combination of the following methods:

- a. Specific qualification tests conducted on one sample of each type of unit employed in the PMS.
- b. Available test data on units identical to those being qualified.
- c. Available test data on units similar to those being qualified with all points of similarity and dissimilarity defined.

### 4.7.2 Qualification Status

Any unit shall be considered to be qualified when the qualification data is accepted by the procuring agency as having met the qualification requirements. Requalification will be required if (1) design or construction changes in units are made which are judged by the procuring agency to make these units significantly different from the qualification test samples; or (2) the transportation and service history of the units indicates that previously qualified units are not capable of withstanding the service conditions and rendering adequate performance and reliability.

### 4.7.3 Test Procedure

The detailed test procedures shall be prepared by the vendor (4.2.1) with test levels being predicated on the service conditions of 3.4.3 and 3.4.4. Procuring agency reserves the right to review and approve/disapprove procedures prior to application for subject procurement. The environmental tests shall be preceded by the factory acceptance tests of 4.7 and shall be followed by factory acceptance test with the exception of the operability assurance tests of 4.8.3. The environmental tests shall include the following:

#### 4.7.3.1 Non-Operating Service Conditions -

- a. Temperature: High, low cycling
- b. Pressure: High low
- c. Vibration
- d. Shock
- e. Humidity: High
- f. Chemical environment
- g. Decontamination and Sterilization

4.7.3.2 Operating Service Conditions -

- a. Temperature: High, low cycling
- b. Pressure: High, low
- c. Humidity: High
- d. Chemical environment

#### 4.8 FACTORY ACCEPTANCE

Unless otherwise specified in the ordering data factory acceptance tests shall be performed on a 100% basis on all items of the PMS at the functional black box or unit level (e.g. CRT display unit) or at the system level at the vendor's option. If the tests are performed at the unit level, the vendor shall supply to the procuring agency analyses which establish that vendor imposed specifications at the unit level will assure satisfaction of the system level functional requirements of this specification.

##### 4.8.1 Visual Examination

Each unit shall be inspected for workmanship and compliance with this specification and vendor's drawing.

##### 4.8.2 Performance Tests

The specific performance tests to be accomplished shall be specified in the test procedure (4.2.1). These tests shall exercise the full capabilities of the PMS as specified in Section 3.0 and demonstrate compliance with each requirement. Recalibration during testing shall not be permitted except as previously defined in the test procedure to demonstrate the capabilities of internal calibration functions of the system. In addition to functional tests, the performance tests shall include quality tests such as hi-pot and insulation resistance where applicable.

##### 4.8.3 Operability Assurance Tests

Operability assurance tests are reduced stress environmental tests intended to provide a measure of craftsmanship quality and to activate incipient failure modes so as to minimize failure due to transportation and handling and to minimize infant mortality failures during operation. When otherwise specified by the ordering data, operability assurance tests may be performed at the unit or system level as appropriate. The units shall be subjected to visual inspection and performance tests before and after operability assurance tests.

4.8.3.1 Vibration (non-operating) - The unit under test shall be mounted in a test fixture and shall be subjected to the following sinusoidal vibration levels once in each of three mutually perpendicular axis.

<u>Method I</u>	<u>Frequency (hz)</u>	<u>Amplitude</u>
	2-27	0.6g rms
	27-52	±.0009 inches
	52-500	2.5g rms

The frequency shall be swept from 2 to 500 hz and back to 2 hz at a rate of 8 octaves per minute (2 minutes per axis).

<u>Method II</u>	<u>Frequency (hz)</u>	<u>Amplitude</u>
	10-55	<u>+0.002 inches</u>

The frequency shall be swept from 10 to 55 hz and back to 10 hz in 1 minute (2 minutes per axis).

4.8.3.2 Shock (Non-Operating) - The unit under test shall be placed on a horizontal bench top and pivoted on one edge of the base until the base makes an angle of 45 degrees with bench top or until the base edge opposite the pivoted edge is 2 inches above the bench top, whichever is less. The unit shall then be released and allowed to fall back to the bench top. This test shall be repeated using each edge of the base as the pivoted edge twice.

4.8.3.3 High Temperature (Operating) - The unit under test shall be energized at room temperature. The temperature shall then be raised to 100°F at a rate of not more than 2 degrees per minute and operated at 100°F for 8 hours. One shot cyclic equipment shall be actuated once per hour while at the elevated temperature. At the end of the 8 hour period, the unit under test shall be returned to room temperature through free convection.

#### 4.9 OPERATIONAL DEMONSTRATION

The installed system at the procuring medical facility shall be demonstrated by the system contractor prior to final acceptance. These tests are intended to demonstrate that the assembled PMS does, in fact comply with the subsystem requirements as specified herein. The general philosophy to be adopted for these tests should be performance of rigorous tests to verify accuracy for nominal settings followed by an exercise of the full range subsystem capabilities using simulated patient signals and loads. However, the tests shall be of the complete integrated system including all applicable patient leads and transducers. Included in the demonstration test is a burn-in test to remove early failures. This burn-in test shall consist of both a 6-hour, 30-minute on-off cycle and a 48-hour continuous operation test.

#### 4.10 SERVICE

The service tests of the PMS shall consist of the routine operation of the system. During the warranty period (9.2) routine calibration and replacement of expendable items shall be performed in accordance with the vendor's maintenance program (3.5.3). All other maintenance shall be performed by the vendor or his designated service agency. (Following the warranty period, the procuring agency may assume full responsibility for maintenance). Meticulous service records shall be maintained on each unit of each PMS and these records shall be assessed against the requirements of 3.4.6 and 3.4.7.

*PREPARATION FOR DELIVERY / RECEIPT*

## 5. PREPARATION FOR DELIVERY

### 5.1 PACKAGING AND PACKING

Each item of equipment shall be packed in accordance with commercial practice to insure carrier acceptance and safe delivery in containers complying with rules and regulations applicable to the mode of transportation.

### 5.2 MARKING

Shipping containers shall be marked in accordance with Fed-STD-123.

## ***INSTALLATION & VALIDATION***

## 6.0 INSTALLATION AND VALIDATION

### 6.1 SITE (FACILITY) PREPARATION

The system contractor shall prepare detailed facility requirements specification in accordance with 3.2.2 and shall retain responsibility for verification that the completed facility does in fact meet those specifications.

### 6.2 ON-SITE EQUIPMENT RECEIPT

The system contractor shall supervise the on-site delivery of major (hard to move) system elements, verifying correct location and package contents.

### 6.3 ON-SITE SETUP

The systems contractor shall unpack, inspect (and report discrepancies) and perform required mechanical set up and electrical interconnection. Interconnection to the facility prime power shall be performed in conjunction with appropriate customer personnel having cognizance and responsibility for the facility power system.

### 6.4 DEMONSTRATION

The system contractor shall perform an operational demonstration as specified in 4.9.

### 6.5 VALIDATION

The systems contractor will participate in analysis of system performance for a minimum of   \* patients or   \* operating days, whichever is attained first and will prepare and submit a system performance validation report.

\* To be specified in ordering data

***OPERATION, TRAINING AND MAINTENANCE***

## 7.0 OPERATIONS - TRAINING - MAINTENANCE

### 7.1 OPERATIONS

The PMS will be operated by several different categories of personnel, each with specific medical and/or engineering skills, experience and attitudes. Use of the PMS must help them treat their patients, by providing accurate, timely data without requiring that their attention be diverted from the patient at critical moments. The newly emerging Monitoring Technician is medically trained but is also well attuned to the "machine" operation and the patient/machine/operator interfaces. The Bio-medical engineers and customer (hospital) electrical maintenance staff are oriented towards keeping the hardware operating to its original specification level. There is no clearly defined line of demarcation to separate the tasks in the operation of the PMS into these three categories.

Regardless of module configuration, there are five fundamental modes of operation

- Set up and calibrate for use
- Normal monitoring
- Contingency (system problem)
- Emergency (medical)
- Maintenance

Operating procedures can be classified as

- Patient (data acquisition or treatment) oriented and
- Machine or system oriented

These cannot be mutually exclusive

For systems using a central processor, a sixth operating mode exists for "Computer Program Development, Modification and Debugging". Which must be time-shareable with the regular operations and maintenance functions.

### 7.2 TRAINING

Operations in connection with the Training Program (3.5.1) shall equip all operators with the necessary knowledge and skills to operate the PMS for the maximum benefit to the patient, and shall cover ALL (Set-up, Normal, Contingency, Emergency, and Maintenance) Modes for ALL operators (Medical-Engineering-Maintenance) so that each appreciates the others job requirements as well as knowing his (her) own, thus enabling the nurses or doctors to describe, adequately, trouble symptoms or performance difficulties, and the maintenance personnel to maintain, at the required level, the performance of the system.

### 7.3 MAINTENANCE

The basic corrective maintenance philosophy shall be that the system provide sufficient self diagnostic capability to permit isolation of difficulty, to a rapidly replaceable module, by the normal operator. Self-diagnostic features shall be incorporated which will exercise routinely all portions of the system. Normal usage may not require use of all portions all of the time and trouble symptoms based on use obviously would not indicate troubles in the unused portions. Replacement of modules may be made by the normal operator from in-position spares. Further analysis of the trouble and appropriate repair or replacement will be performed off-line by the engineering/maintenance group charged with that responsibility. To this end an adequate stock of (on-site) spares is required.

A detailed Maintenance Program, including training of maintenance personnel, identification and provisioning of spares, assignment of repair responsibilities, scheduled Preventive Maintenance, and System Contractor support, will be prepared by the System Contractor. This program will include capacity for system upgrading via modification kits or their equivalent.

Required Special Service Tools and/or Test Equipment to maintain and repair the system will be identified and shall be provided to the organization charged with maintenance/repair responsibilities. Maintenance and repair of the Special Tools/Test Equipment will be provided by the System Contractor. Design and manufacture of such items will reflect appropriate portions of this specification as stated in the ordering data.

*NOTES*

## 9.0 NOTES

### 9.1 INTENDED USE

This specification shall be for procurement of medical instrumentation systems and subsystems for areas using patient monitoring devices.

### 9.2 WARRANTY

The vendor shall warrant in writing that the equipment furnished will satisfy the requirements of this specification for a period of not less than one year from the operational demonstration. During the warranty period, the vendor shall be responsible at no cost to the procuring agency for all required service and maintenance except for scheduled replacement of expendable items as prescribed in the vendor prepared maintenance program (3.5.3). The vendor shall warrant the availability of expendables (or substitutes) and all necessary repairs throughout the ten year service life of the PMS.

### 9.3 REQUESTS FOR BID

The request for bid shall call out this specification and provide additional definition to describe the subsystem requirements for a specific procurement. The additional information defines the patient capacity of the PMS and the requesting agency's choices where this specification permits options. The following information shall be made a part of the requests for bid.

### 9.4 EQUIPMENT COMPLEMENT, CONFIGURATION AND OPTIONS

#### 9.4.1 Request for Bid

The request for bid shall contain the functional equipment complement requirements, equipment configuration, and display and other options of the agency for the procurement.

9.4.1.1 Substitutions, Waivers or Extensions to Baseline System - Any deviation from the requirements of this specification desired by the requesting agency in the form of substitutions, waivers or extensions to the baseline system shall be specifically identified in the request for bid. Requests for deviations must be approved by the customer. Requests for deviations shall include justification of each deviation. Detailed justification of clinical need shall be provided for any extensions to the baseline system.

9.4.1.2 Equipment Enclosure Requirements - The requesting agency shall specify their requirements for independence of equipment enclosures for the shared monitoring and stimulus functions. The housing of shared equipment affects the operational flexibility of the functions. For example, if respiration rate and temperature monitoring functions are housed in a single enclosure, this may preclude simultaneous use of these functions on two different patients. In addition, any requirements for a console for the remote station shall be specified.

9.4.1.3 Special Marking Requirements - Any special marking requirements of the requesting agency shall be specified.

9.4.1.4 Transducer Types and Quantities - The requesting agency shall designate the types and quantities of transducers, patient leads and electrodes required for the specific PMS. In establishing quantities, consideration should be given to normal operations by the agency including factors such as sterilization of transducers between use on two patients and damage due to improper handling by hospital personnel.

9.4.1.5 Facility Drawings - Drawings covering details such as floor plans and bedside equipment and junction box mounting locations shall be provided to permit vendors to evaluate the cabling requirements.

9.4.1.6 Other Requirements - Requirements such as vendor training of user personnel may be included in the request for bid.

#### 9.4.2 Bid Responses and/or Contracts

The bids in response to a request for bids or contracts shall call out this specification and provide additional definition to describe the subsystem to be supplied. The following information shall be made a part of the bid or contract.

9.4.2.1 Warranty - The proposed terms of the vendor's warranty shall be specified (see 9.2).

9.4.2.2 Specific Equipment Complement - The specific vendor's equipment shall be indicated including transducers, cables, enclosures and accessories by model number and quantity to satisfy the requirements of this specification as modified by approved deviations (see 9.4.2.4). Specifications for all equipment to permit evaluation of the vendor's proposed PMS shall be included. The vendor shall assume sole responsibility for the satisfaction of the requirements, and inclusion of the specific equipment complement in the contract shall in no way waive this responsibility in whole or part.

9.4.2.3 Deviations - All deviations from this specification (additions, deletions, or substitutions) shall be specified in the bid and/or contract. These deviations shall have been agreed to by the vendor and procuring agency prior to execution of the contract. The procuring agency shall be responsible for obtaining approval for all requested deviations. Requests for deviations shall include justification of each deviation. Detailed justification of clinical need shall be provided for any extensions to the baseline system. Deviations approved for the request for bids need not be re-approved for the procurement contract.

9.4.2.4 Spares and Expendables - Identify the spares and expendables to be supplied for one year of operation of the PMS. Short shelf life items shall be identified separately along with quantities to be delivered with the PMS and price and delivery schedule for re-orders, within one year of acceptance of the PMS by the procuring agency.

9.4.2.5 Special Service Tools and Test Equipment - All special service tools and test equipment required to maintain or repair the PMS shall be identified and indication made whether each identified item is to be supplied as part of the procurement of the PMS.

9.4.2.6 Qualification Basis - The basis for qualification of each type of item to be supplied shall be identified. Where the vendor proposes qualification on a basis other than environmental testing during the contract period, the bid response shall contain supporting technical data and discussion to permit evaluation by the procuring agency of the proposed qualification basis. (The contract shall identify the basis of qualification and the supporting technical documentation.)

9.4.2.7 Special Marking Requirements - Any special marking requirements of the procuring agency shall be specified.

9.4.2.8 Other Requirements - Requirements such as vendor training of user personnel may be included in the procurement contract.

## 9.5 ACCURACY

### 9.5.1 Tolerance Band

Where accuracies are stated in terms of plus or minus some number of units (e.g.  $\pm 0.1^{\circ}$  F; or +3, -0%) this error tolerance band shall be considered to include 100% of all cases. The tolerance band shall include errors due to all sources. Typical error sources to be considered shall include, but not be limited to drift, scale factor, linearity, hysteresis, repeatability, quantizing errors and display or dial reading errors.

### 9.5.2 Reading Accuracy

Error contribution due to reading of an analog display or dial scale shall be considered to be plus or minus one-quarter the smallest scale division nearest the reading point, or plus or minus one-half the width of the display or dial indicator (e.g. needle, reticle, chart pen trace or electron beam) whichever is greater. For scales in which the ratio of the smallest scale division to the distance from indicator to scale is less than 1.5, reading error shall be regarded as being double the above unless parallax correction is provided.

### 9.5.3 Error Accumulation

Individual error contributions from several sources shall be algebraically summed.

## 9.6 INSTRUMENTATION INDEPENDENCE

Satisfaction of the detailed functional requirements of Section 3.2 does not require the use of independent instrumentation for each function. For example, if the instrumentation for pulse rate monitoring produces a pulse wave signal, this signal may be used for pulse wave form monitoring. (This option shall in no way relax the performance specification for each function.)

## 9.7 ABBREVIATIONS AND GLOSSARY

AC	Alternating current
bpm	Breaths per minute
BPM	Beats per minute
cm	Centimeters
CRT	Cathode Ray Tube
DC	Direct Current
H <sub>z</sub>	Hertz (cycles per second)
ICU	Intensive Care Unit
Khz	Kilohertz
ma	Milliamperes
ua	Microamperes
MM	Millimeters
MM Hg	Millimeters of mercury
ms	(or msec) Milliseconds
ppm	Pulses per minute
rms	Root mean square

### Accessible Metal Parts

Metal parts which could come into contact with the human body without the aid of a tool. They include metal parts which can be touched before and after removal of interchangeable parts. They do not include name plates and other small parts provided that they are electrically insulated from other live parts.

### Accuracy

A degree of conformity to some recognized standard value, or more specifically, the deviation of a result obtained by a particular method from the true value.

### Ambient Temperature

The temperature of the medium, such as air, water, or earth into which the heat of the equipment is dissipated.

### Apparatus Power Terminals

Apparatus terminals to which connection is made to bring electrical power from the electricity supply to the equipment.

### Auxiliary Equipment

Auxiliary equipment includes all optional and accessory equipment intended to be connected to electromedical apparatus, but not for direct connection to the patient. Examples: strip-chart recorders, remote meters and displays, oscilloscopes and central monitoring consoles.

### Common Mode Rejection

The ability of a differential amplifier to reject common signals. The common mode rejection ratio is defined as:

$$\text{CM rej} = \frac{\text{gain of amplifier to difference signal}}{\text{gain of amplifier to common signal}}$$

### Deflection Sensitivity

Ratio of oscilloscope beam deflection to ECG amplifier input signal. Usually stated as millimeters of deflection per millivolt input.

### Continuous Operation

Operation for a time sufficiently long for temperature equilibrium to be reached in constant ambient conditions.

### Danger

"Danger" includes: electric shock, thermal or electrical burns, mechanical or chemical injury, combustion or explosion, or generation of toxic gas, injuring or affecting the patient, intermediary, or operator.

### Electrical Power Source Terminals

Electricity supply terminals from which electrical power is derived for connection to the equipment.

### Electrical Supply

Electrical energy supplied by the wiring system of the premises, by batteries, or by other primary source of electrical energy.

### Electromedical Apparatus

Any instrument, equipment, system, or device that directly or indirectly uses electricity for any medical purpose. Also included are all parts that are connected to such equipment, and all additional apparatus which is to be connected to the equipment and which is requisite for the normal use of the equipment, including the associated leads or cables.

### Exposed (as applied to live parts)

The live part can be touched or approached nearer than a safe distance by a person. Exposure resulting from removal of interchangeable parts is included.

### External Electrical Terminals

Terminals for external electrical connection of the apparatus, e.g., input and output connections.

### Frequency Response

A measure of uniformity of amplitude of the oscilloscope or direct writer indication as a constant amplitude sinusoidal signal of varying frequency is applied to the monitoring amplifier input terminals.

### Gain

The ratio of the amplitude of the output to the input, usually expressed in millimeter/millivolt for a direct-writer, and volts/volt for an amplifier or preamplifier.

### Grave Danger

"Grave Danger" exists when there is a high probability that the failure of a protective feature will result in serious injury or death.

### Grounding Terminal

The point within the electromedical apparatus at which the grounding conductor from the Apparatus Power Terminals is electrically connected to the apparatus metallic chassis or case.

### Impedance

The total opposition to flow of an alternating current in a circuit. Analogous to the actual electrical resistance to a direct current, the impedance is the ratio of the effective voltage to the effective current. In addition to actual resistance, impedance includes reactance which results from capacitative or inductive properties of the circuit.

### Input

1) The energy (signal) put into an electronic device. 2) The terminal or terminals for the inputs signal of such a device, and 3) The part of the electronic circuit immediately adjacent to the input terminals.

### Insulation, Double

Insulation comprising both functional insulation and supplementary insulation.

### Insulation, Functional

Insulation necessary for the proper functioning of equipment and for basic protection against electric shock.

### Insulation, Protective; (supplementary insulation)

Independent insulation provided in addition to the functional insulation in order to insure protection against electric shock in the case of failure of the functional insulation.

### Insulation, Reinforced

Insulation, with electrical and mechanical qualities beyond the requirements of functional insulation, intended to reduce the probability of failure and hence the need for double insulation.

### Intermediary

Any person present in the area of the patient, including: doctors, nurses, assistants, equipment operators and technicians.

### Leakage Current

An undesired flow of electricity through or across insulators that are used to separate electrical conductors; including both real and reactive phased components.

### Linearity

Linearity provides a measure of the nonlinear distortion in an instrument. Since nonlinear distortions may enter in a number of ways and result in peculiar effects, the linearity specification may be written in several ways. Commonly it deals with the departure from a sinusoidal wave shape for a sinusoidal input. The characteristics of the writing device pose a particular problem in establishing specifications for direct-writers. Linearity as used in this report refers to zero-based linearity. That is, a graphic plot of output voltage (or deflection in the case of direct-writers) versus input voltage will yield a series of points. If a straight line is drawn which passes through the origin, the deviation of any of the actual points from this straight line is a measure of the nonlinearity of the system.

### Live Parts

Parts that are electrically connected to a source of potential difference, or electrically charged so as to have a potential difference from that of the earth. (Derived from NBS Handbook 81)

### Measurement Current

Any current that is intentionally applied for any nontherapeutic purpose. Examples: currents applied to measure body electrical impedance during impedance pneumography, impedance plethysmography or rheoencephalography; or currents applied to determine the connection or contact resistance of patient electrodes. Such currents may include high frequency, sinusoidal carrier, square waves, or direct current.

### Noise

Noise refers to unwanted "signal" introduced from other sources, including the sensor electronics circuit itself. An example is 60 cycle alternating current "interference".

### Output

1) The power, energy, signal or information delivered from an electronic device after conversion of the input into another form or modification (such as amplification). 2) The terminals or terminal of an amplifier for delivery of the output, and 3) That part of the electronic circuit immediately adjacent to the output terminals.

### Patient Circuit

An electrical circuit of the apparatus that is connected to the body of the patient.

### Patient Electrode

An object in contact with the human body and used to conduct electrical energy or signals into or out of the body.

### Rated Current

The maximum current drawn by the apparatus from the electricity supply in any normal mode of operation as specified by the manufacturer.

### Rated Supply Frequency

The supply frequency specified by the manufacturer for the apparatus (usually 60 Hz within the United States).

### Rated Supply Voltage

The supply voltage (for three-phase supply the line-to-line voltage) for which the manufacturer has designed the apparatus.

### Risk Current Individual Apparatus

Individual apparatus risk current is any non-therapeutic current that may flow through the patient, medical staff, or bystander as a result of the use of an individual electromedical apparatus. Excluded are currents used for therapeutic purposes. Examples of risk currents include: leakage currents, surge currents, fault currents, or measurement currents.

### Risk Current Composite

The composite risk current is the total current that may flow through the patient, medical staff, or bystander; that is, the sum of the individual apparatus risk currents of all the apparatus in use.

### Signal-to-noise Ratio

The ratio of an appropriate parameter characterizing the amplitude of the wanted signal to a similar parameter of the unwanted noise.

### Therapeutic Current

Therapeutic currents are those currents whose characteristics are known and under the control of medical personnel, which are intentionally applied for intended physiological benefit.

### Trace Stability

Deviation in position of the oscilloscope trace from its preset value with time (or ambient temperature). Stated for a no-signal condition at the amplifier input and should be distinguished from "Trace Wander" due to very low frequency components when an input signal is present at the amplifier.

### Ungrounded (floating)

Not electrically connected to earth or to any conducting body serving in place of earth.

***SECTION VII***  
***PROGRAM PLANS***

## CONTENTS

- 1.0 SCOPE
- 2.0 OBJECTIVES
- 3.0 APPROACH
- 4.0 SYSTEM IMPLEMENTATION
  - 4.1 SCHEDULE
  - 4.2 REQUIREMENTS
  - 4.3 DESIGN
  - 4.4 MANUFACTURING
  - 4.5 QUALITY CONTROL
  - 4.6 INTEGRATED TEST PLAN
  - 4.7 OPERATIONS PLAN
  - 4.8 MANAGEMENT PLAN
- 5.0 R&D TASKS
  - 5.1 SCHEDULE
  - 5.2 DESCRIPTIONS
- 6.0 SUMMARY

## 1.0 SCOPE

This Program Plan delineates all of the tasks, their sub-tasks, and schedules required to implement the specified patient monitoring system to its full operational status.

Similarly detailed information is also provided for the performance of the recommended R&D tasks, as well as an overall schedule which integrates the appropriate R&D tasks into the system implementation schedule.

## 2.0 OBJECTIVES

1. Describe the approach to be taken in the overall implementation of the system, and the integration of appropriate R&D tasks.
2. Identify all program tasks required to fully implement the specified patient monitoring system.
3. Delineate the recommended R&D tasks which will include stated objective, requirements, sub tasks, and intended results.
4. Provide scheduling estimates required to support both the system implementation and performance of the tasks.

### 3.0 APPROACH

The Program Plan has been categorized into two major areas - the first part is concerned with the System Implementation and its associated tasks, while the other delineates in detail the Recommended R&D tasks. Within the System Implementation section, the major tasks are identified for each function encountered in the systematic build up of the system.

## ***SYSTEM IMPLEMENTATION***

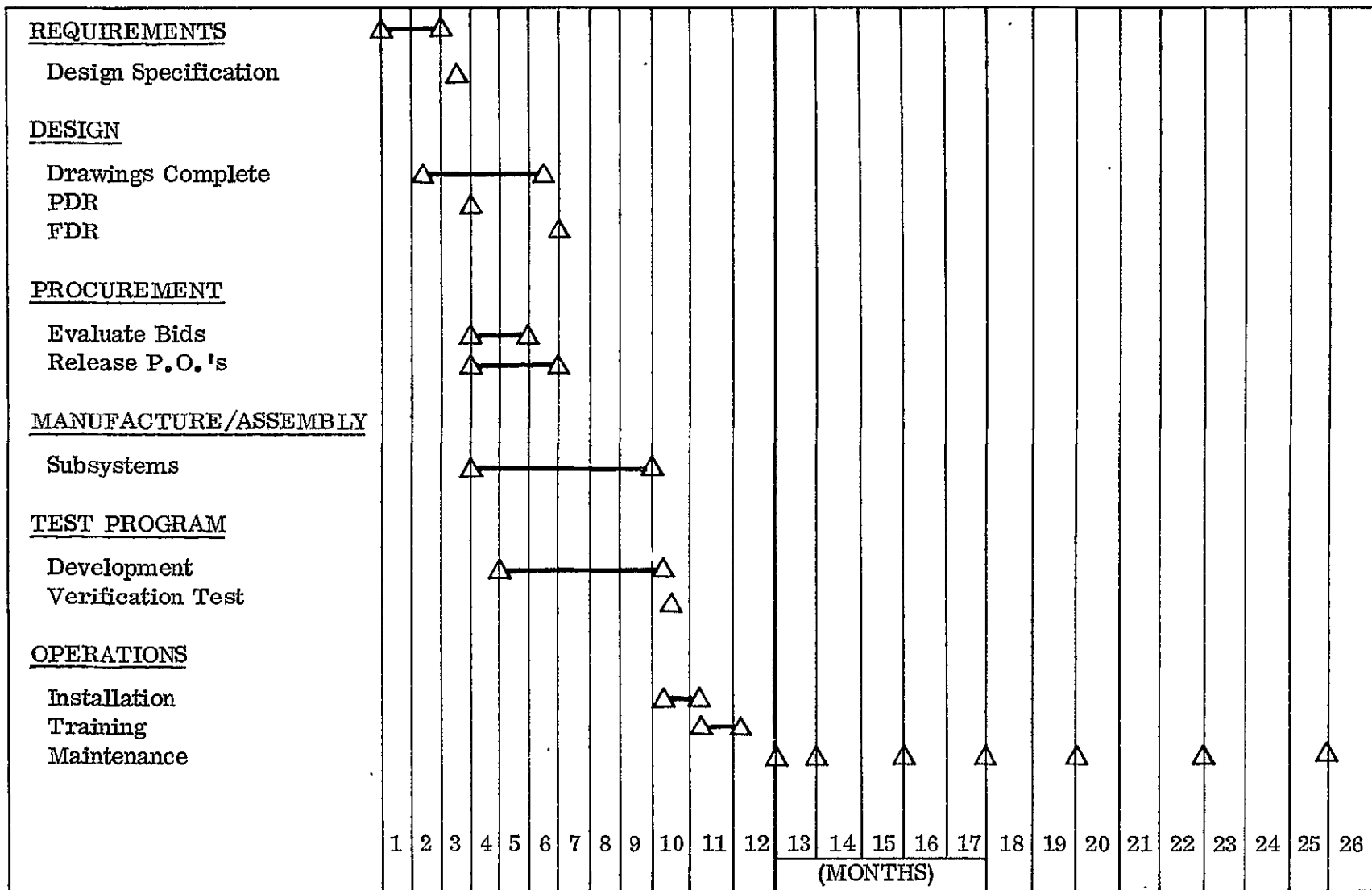

4.1 OVERALL IMPLEMENTATION SCHEDULE (PRILIMINARY)

## 4.2 REQUIREMENTS

It will be necessary to determine the detailed requirements of the specific application for which the system will be implemented. The assessment of the specific requirements will be coupled with the preliminary systems specification and will result in the generation of a design specification which will be the basis for design and procurement efforts.

The requirements phase will consist of the following tasks:

- 1) Perform detailed systems requirements analysis of specific user's requirements
  - a) immediate needs
  - b) growth requirements
  - c) use of existing equipment
  - d) facility requirements
  - e) special design requirements
  - f) personnel requirements
- 2) Perform trade-off evaluations relative to user's specific requirements.
- 3) Generate design specification.

### 4.3 DESIGN

#### Specifications

The formal source for the system engineering direction for the design effort will be the Design Specification.

#### Design Tasks

Systems Engineering shall maintain control of the technical integration of design efforts to assure the timely completion of design tasks and technical design compatibility. The basic tasks in the design area are as follows:

- 1) Perform system design
- 2) Design of subsystems
  - sensors
  - signal conditioning
  - data processing
  - display
  - control
  - software
  - data transmission
  - special support subsystems, e.g., urine collection
- 3) Generate subsystem and system interface specifications as required.
- 4) Conduct preliminary and final design reviews.
- 5) Generate drawings and procurement documentation.
- 6) Generate a Facility Specification.

#### 4.4 MANUFACTURING

The manufacturing effort will consist of fabrication of the selected "make" items and subsequent assembly of the make and buy items. The major manufacturing tasks are outlined as follows:

- 1) Establish a Make or Buy list which will include potential vendors.
- 2) Generate a Build Plan which encompasses both procured and make items and will include a fabrication and assembly flow chart. See Figure 4.4.1.
- 3) Generate the necessary material request forms (purchase orders).
- 4) Implement production and control plan.

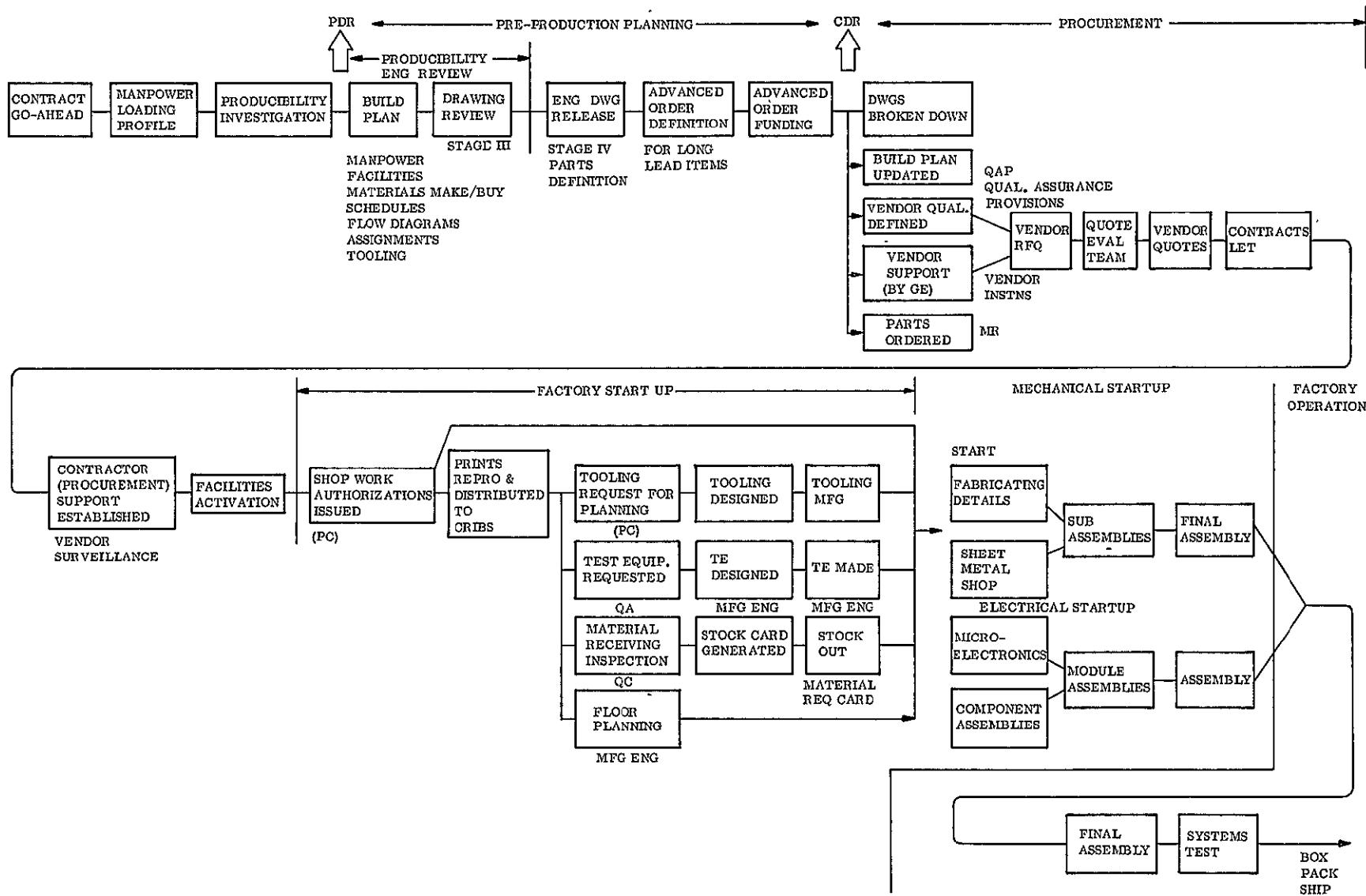

Figure 4.4-1. Manufacturing Flow

#### 4.5 QUALITY CONTROL

Quality Control will be responsible for quality assurance of both the make and buy items, and during the system assembly. Specific tasks include:

- 1) Implement Quality Assurance Provisions
  - vendors
  - incoming inspection
  - in-process inspection
  - final inspection
- 2) Establish and maintain configuration control.

#### 4.6 INTEGRATED TEST PLAN

The Integrated Test Plan will be a composite delineation of all tests to be performed during the implementation of the patient monitoring system. It will provide a systematic approach to the various levels of testing required to verify the design and fabrication/assembly of the system and subsystems. This approach is intended to provide the minimum number of tests in the most effective manner to assure validation of design integrity with respect to functional performance, safety and reliability.

This plan also requires each major vendor, e. g., computer subsystem, to submit for approval a test plan for the subsystem being supplied. The Integrated Test Plan will include the following:

- 1) test schedules
- 2) test flow plans
- 3) development tests
- 4) component/subsystem tests
- 5) vendor tests
- 6) system test
- 7) installation verification test

#### 4.7 OPERATIONS PLAN

The Operations Plan will contain detailed task descriptions and schedules concerning the following operational aspects:

- 1) installation
  - facility preparation
  - installation
  - verification
  - schedule
- 2) training of user personnel
  - implementation of training plan
  - schedule
- 3) maintenance plan
  - full contract
  - emergency contract
  - spares provisioning

#### 4.8 MANAGEMENT PLAN

This Management Plan

- 1) Organization
- 2) Program Management
- 3) Manpower Requirements
- 4) Estimated Costs
- 5) Schedule

## ***R&D TASKS***

## RECOMMENDED R&D TASKS

During the course of performing the survey of the four hospitals, analyzing the data gathered in combination with Bio-satellite technologies, and performing a preliminary design of an advanced patient monitoring system; certain areas became apparent that could be enhanced by the further application of scientific, engineering, and operational research and development.

The development of the recommendations for further work occurred in two phases. The first phase involved the categorical listing and brief over-view of each of the Bio-satellite products and technologies. Against each category was recorded a "shopping list" of possible applications of the Bio-satellite products and technologies to the medical field - more specifically that of patient monitoring. In creating these possible applications informal discussions on many of the work categories were held with members of the advisory committee during the field trips to the four medical centers. A formal presentation and discussion of the completely developed list was then conducted. The next step involved the incorporation of the advisory committee's recommendations which added to, deleted from, and modified the list. Additional refinement of the list was made in eliminating those areas which did not have unique attributes and/or were not already commercially available. On each item of the list that remained, a fuller explanation was developed along with estimates of scheduling, manpower, and costs. More recommended R&D tasks were uncovered during the work interval between the Second Program and the Third Program report. Three R&D tasks are included for review by the advisory committee along with the refined items.

There resulted essentially fifteen areas for the application of bio-science, bio-satellite, and/or aero-space technologies to patient monitoring. These are summarized as follows:

<u>Biosatellite and Other Aerospace Technology</u>	<u>Application</u>
I. Telemetry of physiological parameters.	Patient monitoring using telemetry techniques.
II. Primate feces collection and storage unit with gas management assembly.	Odor controlled waste collection system for calostomy and ileostomy patients requiring surgical appliances.
III. Phenol analysis of Biosatellite water supply.	Analysis of phenolic compounds (natural products, drugs, drug metabolites) of clinical interest.
IV. Day/night photographic surveillance of primates.	Day/night monitoring of patients requiring real-time or near-real-time unobtrusive surveillance.
V. Aerospace experience in techniques for non-destructive testing.	Non-invasive techniques for patient monitoring.

Biosatellite and Other Aerospace Technology

Application

- |  |   |
|--|---|
| VI. Aerospace experience in computer analysis of complex waveforms.                  | Computer analysis techniques for ECG wave shape analysis, arrhythmia detection and classification, etc. |
| VII. same as V - Plus GMA (Provisioning of Habitable Atmosphere).                    | Respiratory analysis that does not interface with the patient.  |
| VIII. Systems engineering. High reliability parts, parts and materials standards.    | Sensor connector standardization.   |
| IX. Production of systems requirements in Bio-satellite.                             | Sensor materials and attachment requirements study.   |
| X. same as IX  | Standard amplifiers and signal conditioners requirements specification.                                 |
| XI. Primate heparin system technology in Bio-satellite, pneumatic and fluid systems. | Positive control of IV fluid dispensing.  |
| XII. Systems engineering in aerospace data handling and measurement systems.         | Standard measurements lists; standard derivations, terminology, etc., for patient monitoring.           |
| XIII. same as VIII plus extensive development and test techniques.                   | Narrow band video systems for remote patient monitoring, consultation and diagnosis.                    |
| XIV. Bio-satellite urine-analyzer.   | Evaluation and development of automated urinalysis techniques.  |
| XV. Bio-satellite urine transport system.  | Urine collection and measurement.   |

The following paragraphs explain in more detail what the recommendations involve, how they could be useful, the schedules for implementation, and cost estimates.

## I. PATIENT MONITORING USING TELEMETRY TECHNIQUES

### 1. EXPLANATION OF THE TECHNOLOGY

There exists a growing need for techniques which will automatically and remotely monitor the physiological parameters of patients. Some specific applications are:

#### A. In Hospitals

1. In intensive care units (see NASA SP-5023, p. 5)
2. In surgery (NASA SP-5023, p. 11)
3. In ambulances
4. For ambulatory patients

#### B. For Out Patients

1. For patients during recovery from disease
2. For patients having diseases in a dormant state, but who need advanced warning of acute attacks (cardiac problems, epilepsy, diabetes)

Thus, there is a need for small, light transducers and transmitters which can measure physiological parameters and transmit the data, without physical linkages, to data reproduction centers which may be located at distances ranging from a few feet to a few miles from the patient.

One of the components developed during the Biosatellite program was a microminiature remote temperature sensor and transmitter. The unit is 0.6 inches in diameter, 0.2 inches thick, and weighs 4 grams. It is powered by a mercury cell. This device provides a basis for the development of similar devices which will measure other parameters as well. Some important parameters are discussed below:

1. Temperature - Temperature is often not a critical parameter which must be monitored continuously, although improved, automated techniques may lead to its increased relevance (NASA SP-5023, p. 7). It appears that the best sensor, from both the physiological and patient comfort standpoints, is the ear drum transducer.

One possible use of temperature measurement is for the automatic detection of the ovulation time in females. This technique could increase the effectiveness of the rhythm method of contraception.

2. EKG - The EKG is a critical parameter for cardiac patients. United Aircraft has developed an EKG telemetry unit (see NASA SP-5023, p. 7), but it is not completely satisfactory. A device based on EKG measurements which would detect and warn

of abnormalities such as arrhythmias, and pattern abnormalities would be very useful in both intensive-care units and for out patients with cardiac problems.

3. Blood Pressure - Present transducers are not satisfactory for continuous monitoring and transmission of pressure in the ambulatory patient. The newer force-balance probes are attractive but still have problems.
4. EEG Monitoring - A sensor-telemetry system for detecting the classic spike-wave complex (an indicator of petit-mal seizure) has been developed at Marquette University (see Proc. of 8th Int. Conf. on Eng. in Med. and Biol., 1969, p. 17-7). This device apparently cannot warn of impending epileptic seizure, but does record the occurrence of seizure in patients at home or in hospital wards. In this regard, there appear to be no cardiovascular symptoms, such as heart rate changes, etc., which could be used to forecast an impending seizure.
5. Diabetic Shock Monitoring - Warning of impending shock is undoubtedly a possibility, since relatively long transients in blood chemistry are involved. A good indication of trouble is the development of acidosis (that is, a lowering of blood pH), or an increase in the Na concentration in the urine. These manifestations may provide the basis for a warning system, but require the development of either an implantable pH detector for the blood stream or a Na detector for the bladder.
6. Arrhythmia Detector Based on EKG - A Japanese group has described an automated system for detecting rhythm change based on EKG measurements (see attached paper). Although the technique is rather well developed (it is also used on present GE/MDO EKG equipment), it appears that some reduction in the size of the electronic equipment is needed before a truly portable system is possible.
7. Others - See R.S. Mackay, Bio-Medical Telemetry, for an exhaustive list of uses for transducer-telemetry systems.

## 2. UNIQUENESS OF THE TECHNOLOGY

Virtually all of the parameters mentioned above are routinely monitored for hospital patients having severe problems. The uniqueness of the technology is that, by coupling the transducers with transmitters and data reproduction equipment, monitoring is extended to ambulatory patients, both in and out of hospitals. Furthermore, techniques such as warning systems for out-patients are not presently in use. However, these technological advances, largely developed on NASA programs have been employed by numbers of medical investigators who have assimilated these techniques into their own areas for the past several years. Implementation for the purposes mentioned below appears relatively straightforward.

TAKASHI MATSUNABE and SHIGEO UBUKATA  
 Research Institute for Chronic Diseases of Gunma,  
 Gunma, Japan.

SHIZUO SHIRASAWA and YOSHINORI OKAMOTO  
 Fukuda Medical Electric Co., Tokyo, Japan.

Although the accurate diagnosis of ischemic heart disease may be obtained by ECG examination, ischemic heart disease may sometimes be overlooked because neither the resting nor the exercise ECG shows an abnormal pattern in the remission period of angina pectoris. In such cases, continuous monitoring of the ECG may detect otherwise missed transient electrocardiographic changes.

To be successful, automatic detection of ECG evidence of myocardial ischemia requires the following considerations:

- 1.) A lead must be selected which shows the ischemic changes in a particular patient.
- 2.) In the ECG, ischemia may be manifested not only in ST-J or ST Segment changes but also by T wave changes.
- 3.) Ischemic changes in the ECG may be superimposed on an already abnormal ECG pattern.
- 4.) Frequent premature beats or other arrhythmias may occur in the absence of ST-T changes.

A detector was developed which permits separate determination of variations of the potential of ST-J, ST Segments and the T wave. These potentials are compared to optionally set standard potentials. Potential variations of ST-T Segments are averaged over eight consecutive cardiac cycles. The detector can detect not only single premature beats, but also series of premature beats. The heart rate is calculated by averaging 20 consecutive R-R intervals measured to detect atrial fibrillation.

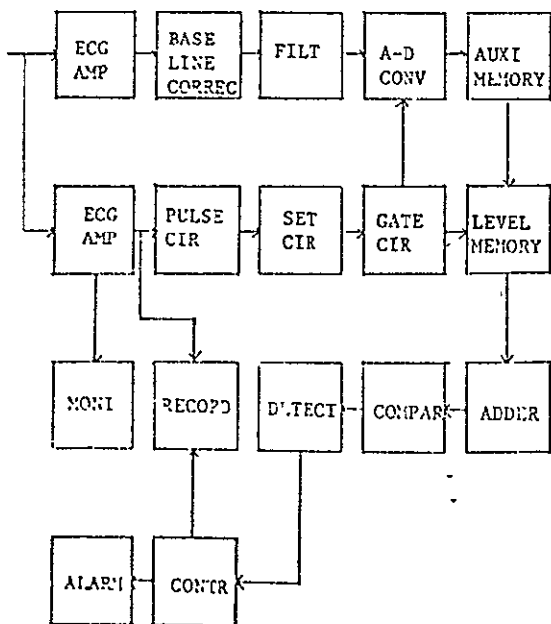

Auto-detector of ST-T change

Figure 1

Auto-detector of ST-T changes (Fig. 1)

The ECG baseline is corrected. The ECG is also pulse shaped through another amplifier. The electrical potentials of the ST-J, ST Segments and the peak of the T wave are stored in the auxiliary memory after A/D conversion.

Under control of the gate circuit (which also controls the A/D converter) the data are transferred into the level memory. The average level changes for eight consecutive beats are computed by an adder. If these changes exceed the level set on the comparator, an alarm goes off, and the recorder begins to record the ECG for 15 seconds.

Auto-detector for arrhythmias

The ECG is fed into a frequency modulator whose output is recorded on tape. The ECG is also fed into a pulse circuit and two pulse converters which calculate the instantaneous heart rate from one R-R interval and the average heart rate from 20 consecutive R-R intervals.

If the heart rate exceeds the comparator level the tape recorder is rewound after a 30 second delay, and the data recorded during the previous and subsequent 30 seconds are regenerated. In addition, if the number of short R-R intervals exceeds a level set on the comparator, an alarm goes off, and the same rewind-replay cycle described above is initiated.

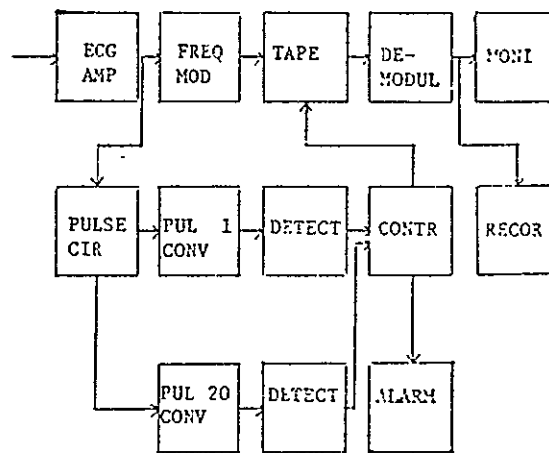

Auto-detector of rhythm change

Figure 2

### 3. END PRODUCTS

The end products involve two separate aspects:

1. Microminiature sensor-transmitter packages which can be implanted or strapped to patients. Here, the blood pressure sensor and improved EKG sensor are probably the best choice from the patient monitor point of view.
2. The use of automated data handling techniques which will sift the data gathered for important signs (abnormalities) and then send warnings, etc. This insures that the data center is not bogged down in gathering, storing and displaying masses of essentially irrelevant data. Most physiological parameters are not significant unless they exceed certain bounds.

### 4. RECOMMENDED PROGRAM

An initial program is recommended to define candidate systems which are to be developed for the monitoring of physiological parameters within and outside of the hospital environment by telemetry techniques.

Following an extensive requirements and applications survey, candidate systems for monitoring individual or a multiplicity of physiological parameters, will be breadboarded and evaluated with animals. Ultimate selection of systems for prototype development and human trials will be based upon this study.

**SCHEDULE PLANNING SHEET**

PROGRAM NAME

**PATIENT MONITORING**

RESP. ORG. PROG WORK IDENT.	CUST. TASK NO.	PREPARED BY	RM.	EXT.	DATE ISSUED	TITLE OF SEGMENT OF WORK
PURPOSE FOR ESTIMATE		APPROVALS	REFERENCES - P.P.I. NO.		REV.	OTHER

**PHASE I LITERATURE SEARCH/  
SURVEYS**

ITEM NO.	DESCRIPTION OF WORK ITEM	ELAPSED TIME SCHEDULE											
		(INDICATE YEARS/ QUARTERS/ MONTHS/ FISCAL WEEKS AS APPLICABLE)											
		MONTH											
		#1	#2	#3	#4								
1.0	Establish Criteria	▲	▲	▲									
	1.0 Applications												
	2.0 Patient/Physician Acceptance												
	3.0 Circuit Design Requirements												
2.0	Existing Product Survey	▲	▲	▲									
	2.1 Specifications/Design												
	2.2 Physician Acceptance												
	2.3 Patient Acceptance												
	2.4 Data Acquisition and Processing												
	2.5 Range												
	2.6 Patient Signatures												
	2.7 Rapid Identification												
	2.8 Monitoring Eqpt. Available												
	2.8.1 USA												
	2.8.2 Europe												
	2.8.3 Japan												
3.0	Physician Surveys			▲	▲	▲							
	3.1 Mail												
	3.2 Personal												
4.0	Hospital Surveys			▲	▲	▲							
	4.1 Mail												
	4.2 Personal												
5.0	Final Report - Recommendations for Systems to be Breadboarded and Evaluated									▲	▲	▲	

△=MILESTONES - DISCRETE, AUDITABLE EVENTS  
E.G. - REPORT, HARDWARE DELIVERY, FLIGHT TEST, ETC.

▲=COMPLETED MILESTONES

◇=PROJECTED MILESTONE SLIP

◆=SLIPPED MILESTONE

—=TIME PERIOD OF WORK

STATUS AS OF	11-22-70
PAGE	1 OF 1

## II. ODOR CONTROLLED WASTE COLLECTION SYSTEM FOR COLOSTOMY AND ILEOSTOMY PATIENTS REQUIRING SURGICAL APPLIANCES (FECES COLLECTION)

### INTRODUCTION

A Primate Feces Collection and Storage Assembly was developed for the Biosatellite Program to provide retention of primate feces (liquid and solid) for periods in excess of 30 days.

Liquids and solids accumulating during this period were retained by a filter in the container wall while permitting gasses to flow through a bacterial filter into a Gas Management Assembly system equipped with a charcoal scrubber. Recirculation of air in this system provided continuous removal of primate flatus and odors emanating from waste materials.

It would be of considerable interest to apply this technology, or modifications thereof, to the development of an advanced odor controlled waste collection system suitable for colostomy and ileostomy patients.

### STATE OF THE ART TECHNOLOGY

Radical surgery of the intestinal tract in adults and children frequently requires the terminal end of the colon or ileum to be exteriorized in the abdominal wall. Waste products are collected in a plastic or rubber container frequently referred to as "-ostomy or surgical appliances".

The appliance is attached to the "stoma" (Figure 1) with a non-irritating gasket and held in place with a belt fastened around the patient's waist. Although the gasket is primarily intended to minimize friction between the stoma and collection system, it likewise acts as a seal to prevent leakage of intestinal secretions capable of irritating the skin and staining clothing.

Filling of the waste collection system is partially dependent on intra-intestinal flow produced by successive peristaltic waves, and gravity displacement of air in the appliance (Figure 2). Offensive odors, e. g.,  $H_2S$ , emanating from the feces may leak out at the seal site or diffuse through the appliance wall.

Gas production and the volume of waste products collected daily varies with the physiological status of the individual, age, eating habits, as well as miscellaneous contributory factors. For this reason, some patient types may have severe odor problems and require frequent emptying and/or replacement of the appliances. Bed ridden geriatric patients, conversely, may only require appliance replacement every 7-10 days, but will still have annoying moderate to severe odor associated problems. Chemical masking agents have been variously used, but unfortunately only provide a temporary relief. In many instances, these may be highly perfumed and not aesthetically acceptable to the patient or his associates.

To date waste collection systems are not available that provide effective control of odor producing gases and/or constituents of feces.

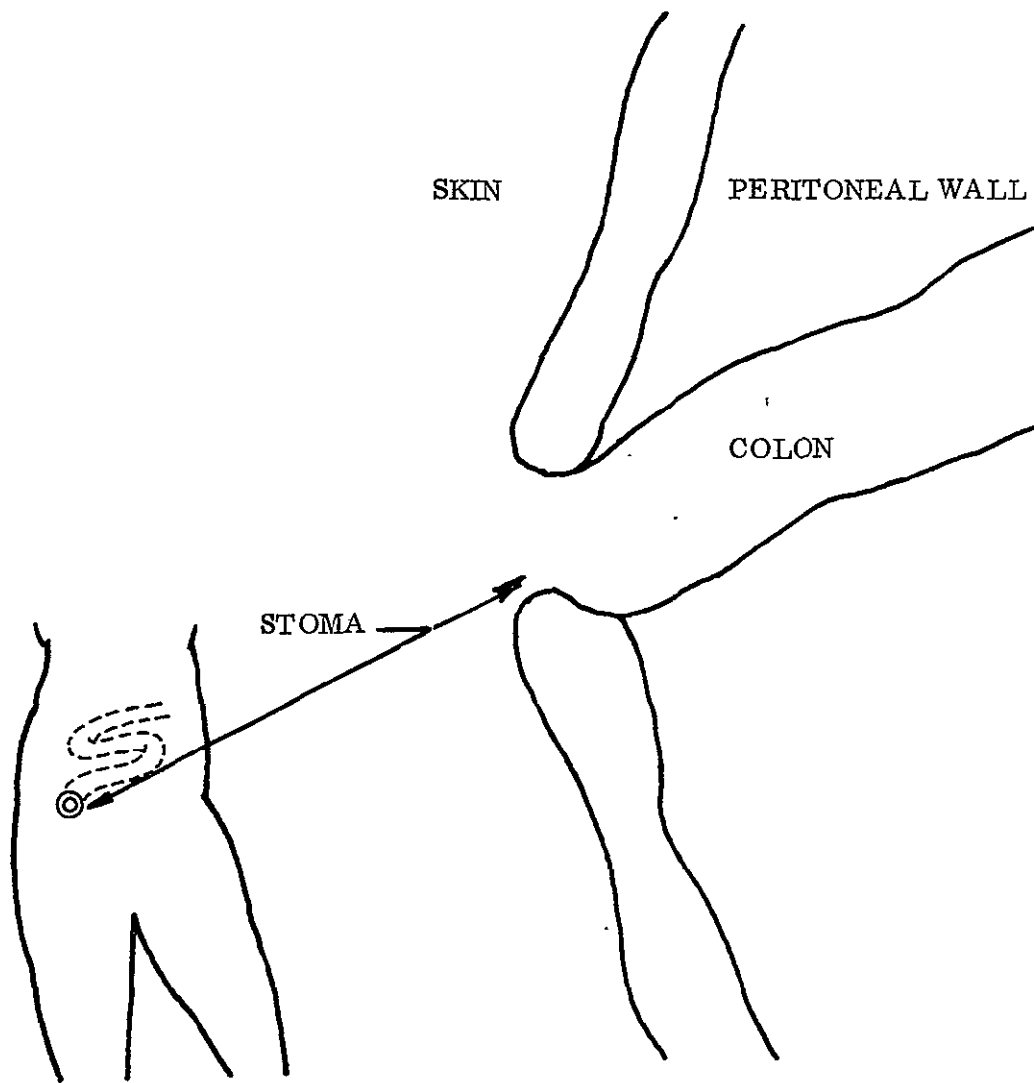

A. Locus of stoma in colostomy patient.

B. Cross section of abdominal wall, colon, and stoma.

Figure 1. Exteriorized Colon with Exposed Stoma in Colostomy Patient

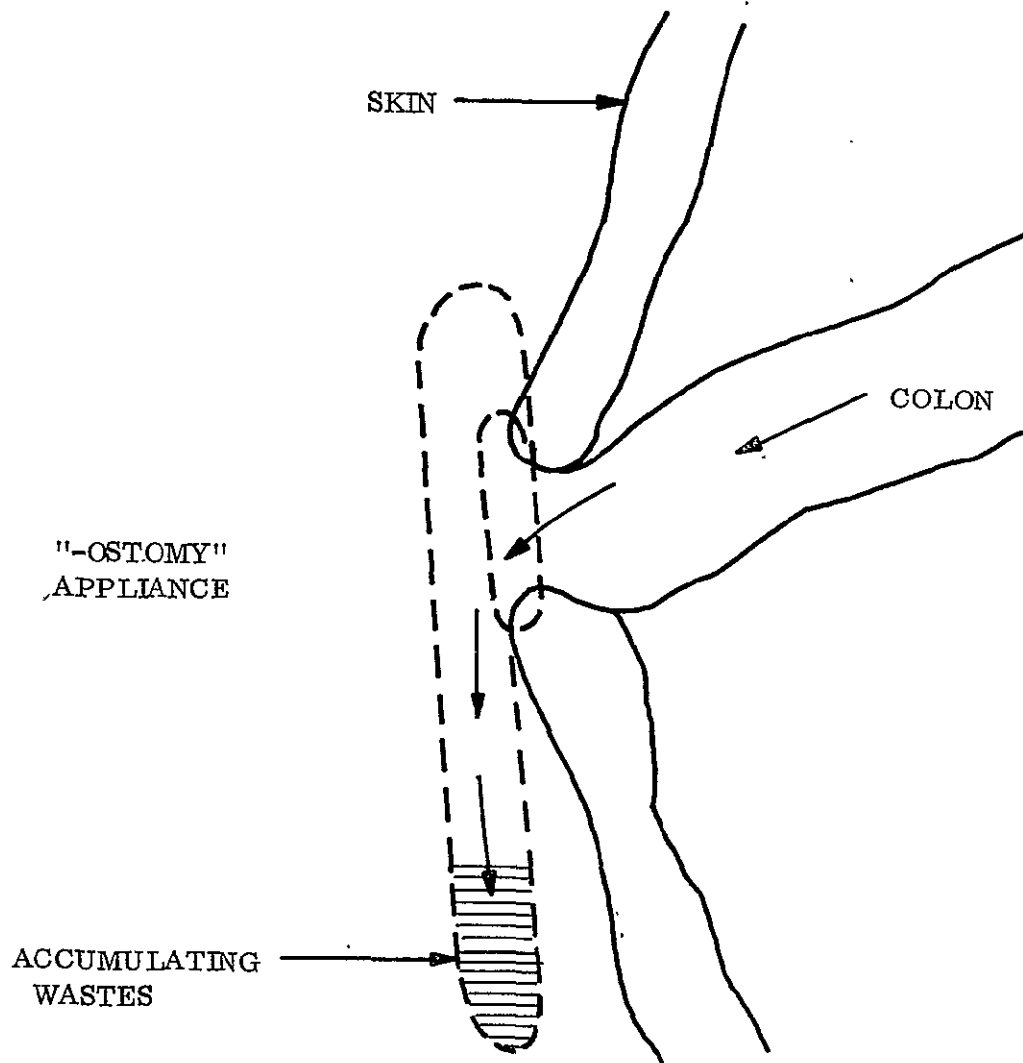
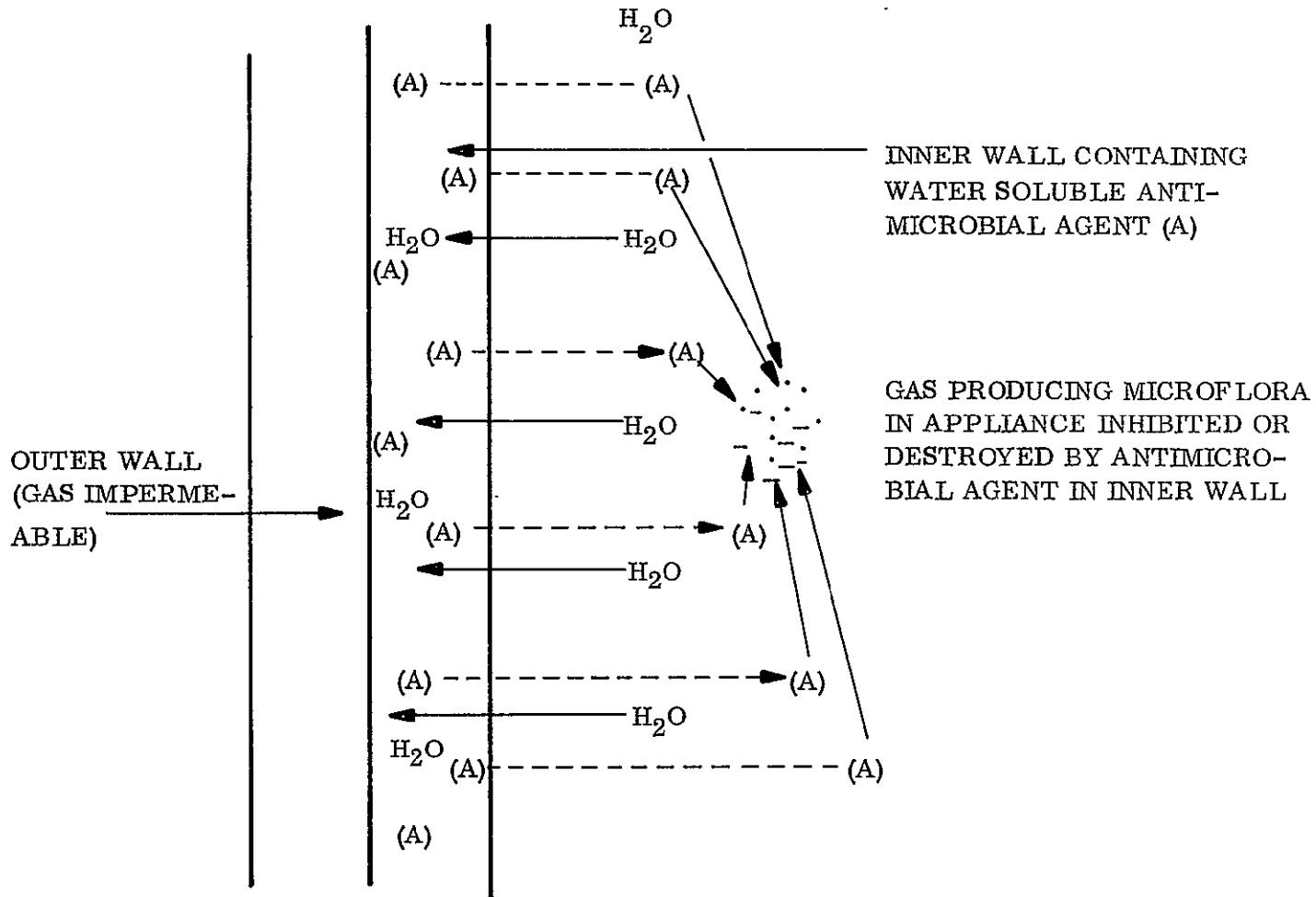

Figure 2. Conventional "-Ostomy Appliance" Attached to Stoma of Colostomy Patient. Gas and Odors Escape from Appliance at Site of Attachment (Stoma) to Body

CROSS SECTION OF  
HYPOTHETICAL LAMINATED  
APPLIANCE MATERIAL



- (1) Water ( $H_2O$ ) in feces leaches antimicrobial agent, e.g., sodium dibutyldithiocarbamate (A), from inner wall of appliance and kills and/or inhibits the growth of gas (odor) producing microflora.
- (2) This is intended to minimize or eliminate "back pressure" of gases and their subsequent escape into the surrounding environment.

Figure 3. Leaching of Water Soluble Antimicrobial Agent from Internal Wall of Appliance and Destruction of Gas Producing Microflora

## UNIQUE ADVANCED TECHNOLOGY

An advanced waste collection system for colostomy and ileostomy patients would provide the following features:

- 1) Disposable appliances
  - a) adult sizes
  - b) children sizes
- 2) Gas scrubber options
  - a) Self contained scrubber
  - b) Reuseable cartridge type
  - c) Gas management assembly (self contained scrubber): line or battery operated
- 3) Appliance materials
  - a) Laminated plastic (gas impermeable) exterior
  - b) Antimicrobial containing lining
  - c) gas permeable lining
- 4) Silastic seal
- 5) Non-toxic
- 6) Adjustable belt

The proposed system would use a new concept in odor control for this type of product: (a) scrubbing of odor producing flatus and gases by means of (1) a self-contained activated carbon scrubber (Figure 4), (2) replaceable, cartridge-type scrubber (Figure 5), (3) isolated gas management assembly (GMA) suitable for operation from a nickel-cadmium battery or from 110 VAC (Figure 8) (b) retard growth of gas producing microflora in the feces by incorporating a water soluble antimicrobial agent in the lining of the gas-permeable lining (Figures 6, 7).

In addition, the appliance would be equipped with a non-toxic, non-irritating silastic seal based upon the size of the patient's stoma (Figure 1); an adjustable belt to hold the appliance securely to the body; and a polyethylene bag and tie for disposal purposes.

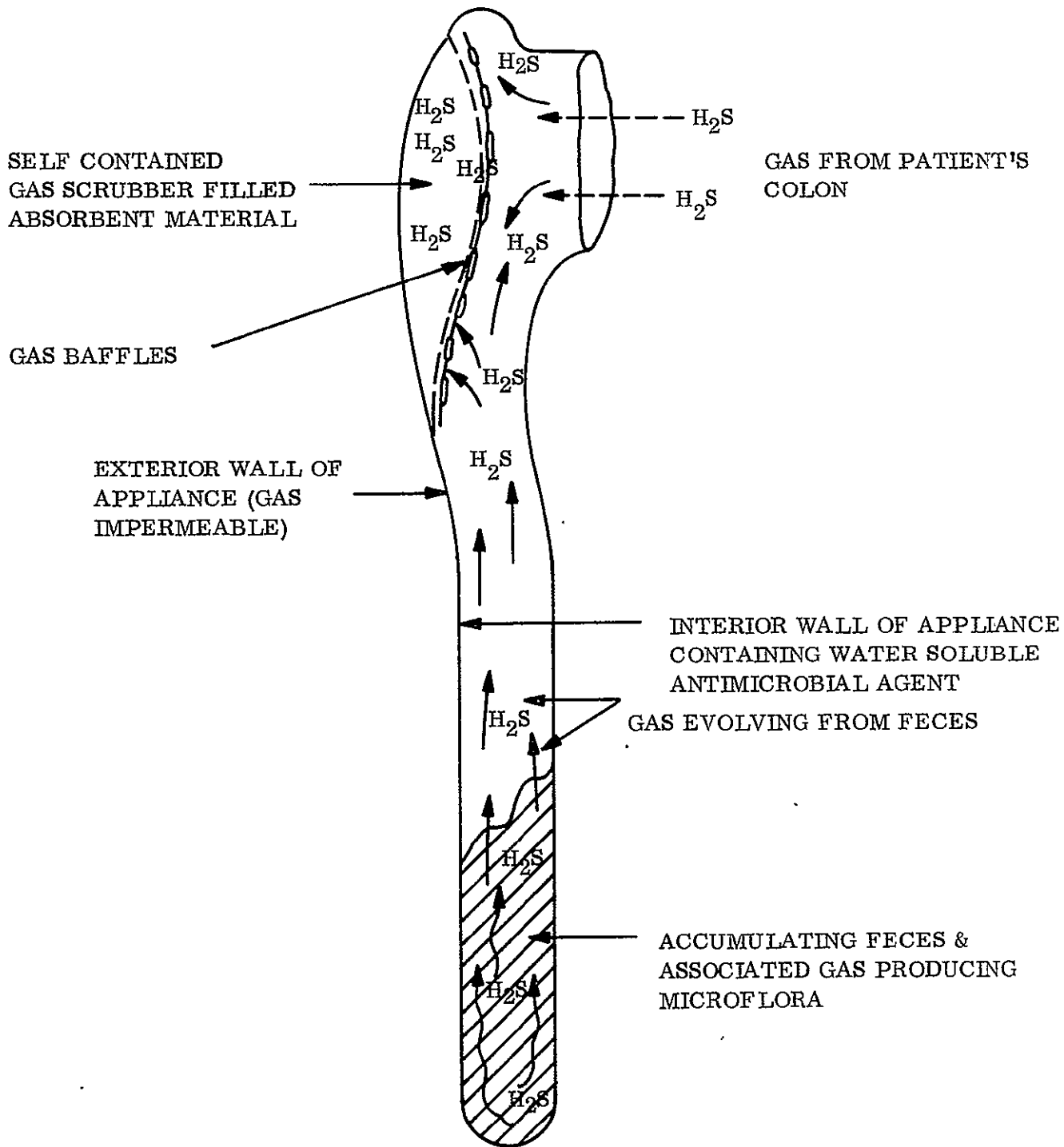

Figure 4. Conceptual Design of a Odor Control System for a Disposable "Ostomy" Appliance. Cross Section to Show Gas Scrubber in Operation





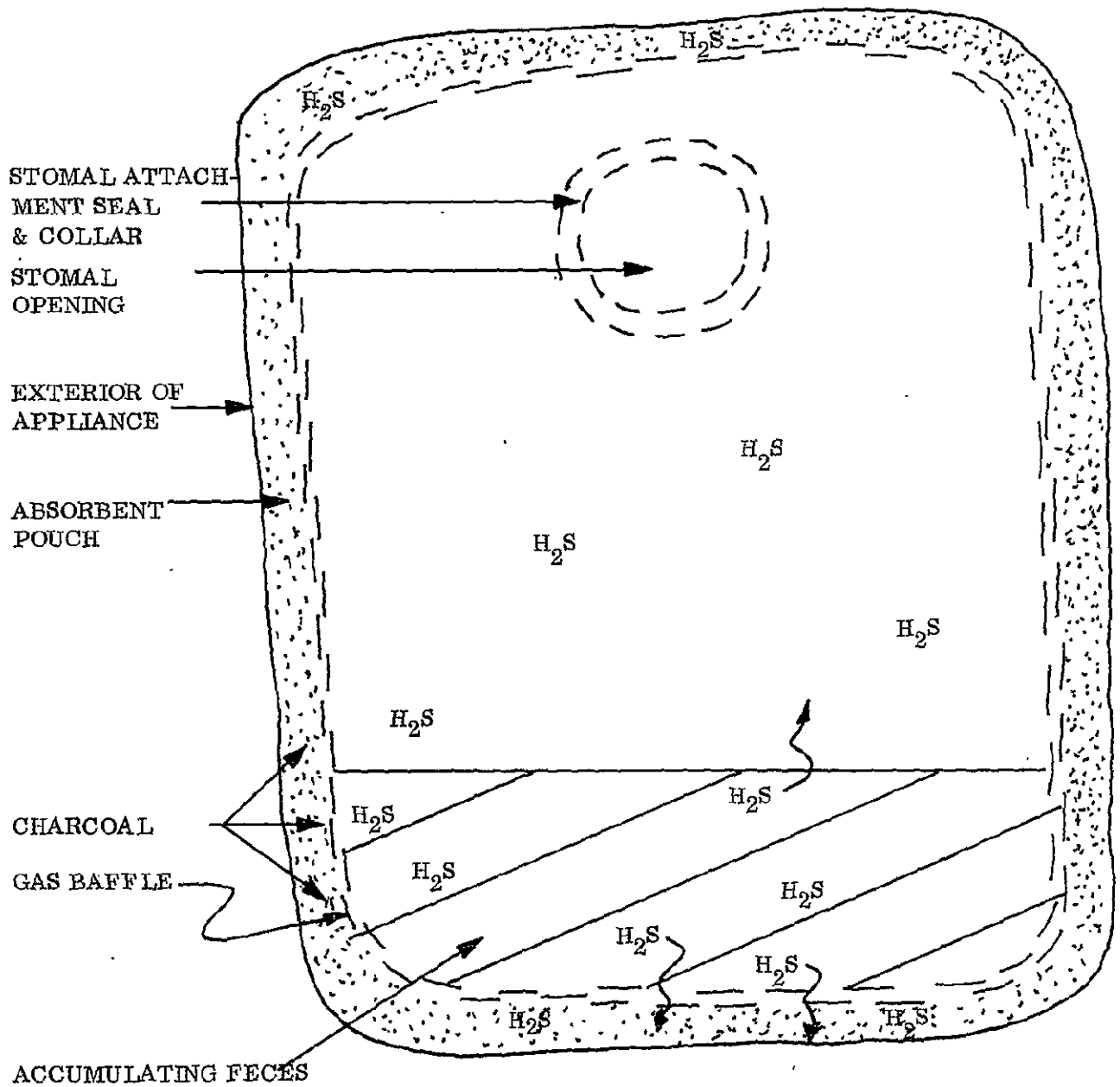
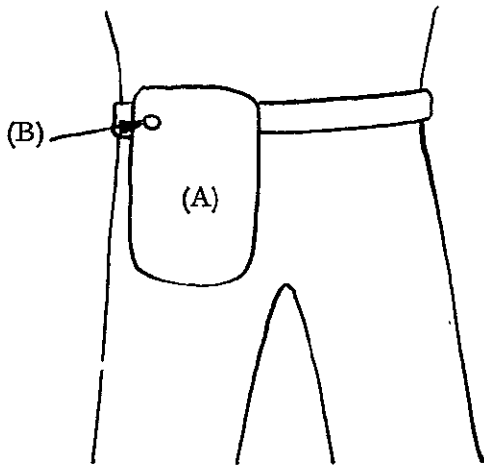
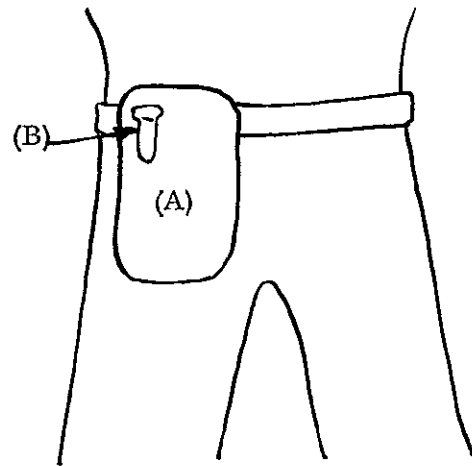

Figure 7. Conceptual Design of a Odor Control System for a Disposable "Ostomy" Appliance. In Comparison to Design Illustrated in Figure 6 Pouch for Absorbent is Continuous and Not Limited to the Top of the Unit.

ODOR CONTROLLED WASTE COLLECTION SYSTEM: CONCEPTUAL DESIGN  
OF GAS MANAGEMENT ASSEMBLY



Concept #1. Disposable waste collection system (A) with self contained odor control sub-system, See Figs. 4,6,7, equipped with a bacterial filter vent (B).



Concept #2. Re-useable waste collection system (A) with disposable (cartridge-type) charcoal scrubber (B).

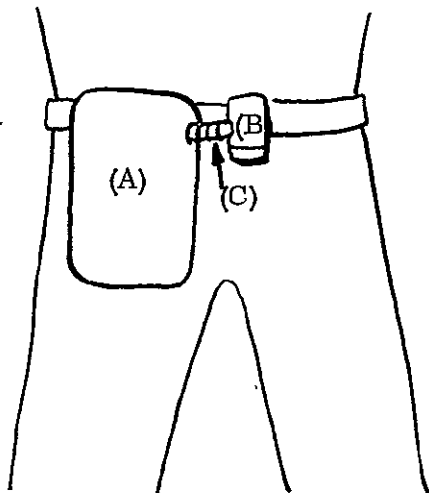

Concept #3. Disposable waste collection system in situ (A) connected with flexible tubing (C) to battery operated Gas Management Assembly (B).

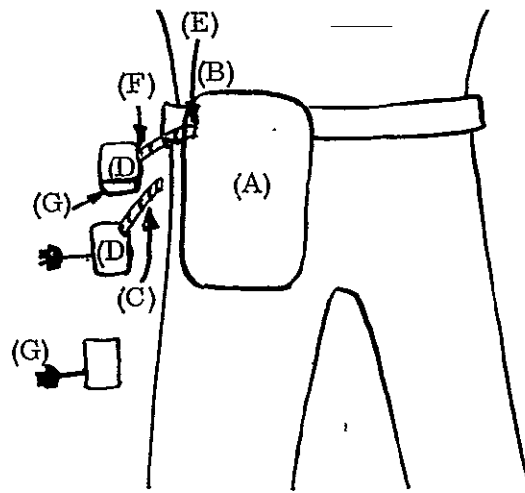

Concept #4. Disposable waste collection system (A). (B) Flexible tubing with quick disconnect tubing terminating in patient's belt. Flexible tubing segment (C) is connected to Gas Management Assembly (D) with quick-disconnect fittings (E & F). Management Assembly Unit can be operated from 110 VAC or rechargeable battery pack (G).

## SUGGESTIONS FOR PRODUCING AN END PRODUCT

- 1) Optimize design of gas scrubbing sub-systems and breadboard
- 2) Optimize materials for appliance fabrication
- 3) Optimize appliance and seal design
- 4) Breadboard system and test
- 5) Prototype fabrication
- 6) 6-9 month clinical trials



### III. ANALYSIS OF PHENOLIC COMPOUNDS OF CLINICAL INTEREST

#### INTRODUCTION

NASA specifications for fuel cell derived potable water in the Biosatellite Program called for the total phenol concentration not to exceed one (1.0) part per billion (ppb). Methods of analysis available, including the Standard Methods<sup>(1)</sup> procedure, lacked accuracy and precision, or were too time consuming to insure a completed analysis within 30 minutes of launch.

For this reason it was considered essential to develop methodology which would permit analysis with a high degree of confidence at the 1.0 ppb level within the allotted time limit.

#### UNIQUE TECHNOLOGY

The method of choice resulting from this effort is based upon continuous liquid-liquid extraction of aqueous samples with diethyl ether and the elimination of interfering substances by the selective partitioning of phenols into the ether phase<sup>(2)</sup>.

These are separated from the ether as lithium phenolates with lithium hydroxide and re-converted to phenols with hydrochloric acid in a volume of deionized water equivalent to the original volume of the sample (100 ml). Analysis is achieved by treating the aqueous mixture of phenols with a modification of the 4-aminoantipyrene/potassium ferricyanide reagents and comparing a chloroform extract of the 4-aminoantipyrene dye complex with an appropriate standard in a spectrophotometer at 458 nanometers.

Reduction of the concentration of 4-aminoantipyrene from 60  $\mu$  moles to 40  $\mu$  moles per test significantly reduced reagent blank color and enhanced sensitivity. This was further augmented by optimization of the reaction pH and final adjustment of the dye complex with tartaric acid buffer to pH 4.0 immediately prior to extraction with chloroform.

Many phenolic compounds, including phenol per se and those capable of influencing the taste and odor of the Biosatellite water supply, e.g., 2-chlorophenol; 2,4-dichlorophenol, 2,6-dichlorophenol, can be detected in concentrations of 1.0 ppb or less in approximately 20 minutes.

(1) Standard Methods for the Examination of Water & Wastewater. APHA, AWWA, & WPCF, 514-523, 12th ed (1965).

(2) STARKEY, R.J. & ORR, E.D. Rapid Total Phenols Analysis by Liquid-Liquid Extraction with Diethyl Ether. Presented at 160th ACS Meeting, September 14, 1970.

For the most part phenolic compounds analyzed have been limited exclusively to contaminants of potable water and have not included derivatives frequently found in biological materials.

The proposed study will consider application of the Biosatellite method of phenol analysis or modifications thereof, to the analysis of phenolic compounds found in body fluids as urine, feces, sputum, blood serum and gastric washings.

New or improved methods of analysis would be of interest to clinical biochemists, physiologists, pharmacologists, pathologists, toxicologists and others concerned with the fate and distribution of phenolic compounds in biological materials.

## PRELIMINARY STUDIES AND GOALS

An extensive evaluation is required to identify phenolic compounds of clinical interest for which suitable analytical methodology is not available. Based upon the results of this study recommendations will be made to develop analytical techniques for the analysis of specific naturally occurring phenols; phenolic pharmaceuticals and their metabolites.

### 1.0 SURVEY OF STATE OF THE ART TECHNIQUES USED FOR THE ANALYSIS OF PHENOLIC COMPOUNDS IN BIOLOGICAL MATERIALS

#### 1.1 Literature survey of analytical procedures for compounds outlined in Tables 1 and 2

1.1.1 Wet chemistry/UV spectroscopy

1.1.2 Fluorescence spectroscopy

1.1.3 Infrared spectroscopy

1.1.4 Thin layer chromatography

1.1.5 Gas-liquid chromatography

#### 1.2 Compile the following information:

1.2.1 Limits of sensitivity

1.2.2 Normal and pathological limits in body fluids

1.2.3 Significance and frequency of analysis in the clinical pathology laboratory

1.2.4 Problems associated with interfering substances

1.2.5 Time constraints

1.2.6 Reagents required

1.2.7 Glassware required

1.2.8 Special equipment required

1.2.9 Economics of analysis

## 2.0 CHOICE OF CANDIDATE COMPOUNDS

2.1 Choice of compounds for which advanced analytical methodology will be developed is dependent upon the data derived from item 1.1 and 2.2

2.2 Answers to the following questions will be documented.

2.2.1 Are there requirements for advanced analytical techniques for the analysis of specific phenolic compounds for which methodology is either not satisfactory or available?

2.2.1.1 Natural products

2.2.1.2 Drugs (conventional therapeutic agents)

2.2.1.3 Drug metabolites

2.2.2 What other phenolic type compounds should be considered for the development of analytical methodology, e.g., experimental pharmacological agents and their metabolites?

# SCHEDULE PLANNING SHEET

PROGRAM NAME  
Adv. Phenol Methods

RESP. ORG.	PROG. WORK IDEN.	CUST. TASK NO.	PREPARED BY	RM.	EXT.	DATE ISSUED	TITLE OF SEGMENT OF WORK
							Survey
PURPOSE FOR ESTIMATE			APPROVALS	REFERENCES - P.P.I. NO.		REV.	OTHER

ITEM NO.	DESCRIPTION OF WORK ITEM	ELAPSED TIME SCHEDULE			
		(INDICATE YEARS/ QUARTERS/ MONTHS/ FISCAL (WEEKS) AS APPLICABLE )			
		#1	#2	#3	#4
1.0	ANALYTICAL METHODS AND REQUIREMENTS EVALUATION				
1.0	Compounds in Tables 1 and 2 attached	▲	▲		
1.1	Wet Chemistry				
1.2	UV/Visible Spectroscopy				
1.3	IR Spectroscopy				
1.4	Fluorescence Spectroscopy				
1.5	TLC				
1.6	GLC				
2.0	Compare	▲	▲		
2.1	Limits of Sensitivity				
2.2	Normal and pathological limits				
2.3	Significance and frequency of analysis in clinical path lab.				
2.4	Problems with interfering substances				
2.5	Problems associated with different body fluids				
2.6	Time Constraints				
2.7	Reagents required				
2.8	Glassware required				
2.9	Special equipment required				
2.10	Economics of analysis				
3.0	Survey of Clinical Labs/ Pharmaceutical Companies			▲	▲
4.0	Report and Program Recommendations				▲

▲ = MILESTONES - DISCRETE, AUDITABLE EVENTS  
E.G. - REPORT, HARDWARE DELIVERY, FLIGHT TEST, ETC.

▲ = COMPLETED MILESTONES

◇ = PROJECTED MILESTONE SLIP

— = TIME PERIOD OF WORK

◆ = SLIPPED MILESTONE

STATUS AS OF	11/17/70
PAGE	1 OF 1

68-IIA

TABLE 1. PHENOLIC PHARMACEUTICAL PRODUCTS

	<u>NANOMETERS</u>	
Terramycin	390	520
Achromycin	390	515
Isoreserpine	390	510
Dehydroreserpine Perchlorate	390	510
Harmaline Hydrochloride	390	490
Aureomycin	355	445
Chlorpromazine	350	480
Norharmane	350	380
Tetradehydroreserpine Chloride	340	440
Menadione	335	480
Chloroquin	335	400
Chlorpromazine Sulfonide	335	400
Oxychloroquin	335	380
LSD	325	465
Pentothal	315	530
Cinchonine	320	420
Brom LSD	315	460
Cinchonidine	315	445
Surital	310	530
Rescinnamine N-oxide	310	440
Rescinnamine	310	440
Salicylic Acid	310	435

TABLE 1. PHENOLIC PHARMACEUTICAL PRODUCTS (Continued)

	<u>NANOMETERS</u>	
Rescinnamine	310	400
Plasmoquin	300, 370	530
N-ethylharmine	300, 365	450
p-Aminosalicylic Acid	300	405
Harmine	300, 365	400
Trimethoxycinnamic Acid	300	400
Reserpine	300	375
Methyl Reserpate	300	360
Syrosingopine	300	360
Reserpine	300	360
Eserine	300	360
Methyl 0-(3, 5-dimethoxy 4 hydroxybensoyl reserpate	300	360
Adrenalin	295	335
Norepinephrine	295	335
Epinephrine	295	335
Syrosingopine N-oxide	290	350
Piperoxan	290	325
Quinacrine	285, 420	500
Norhanmane	285	380
Allylmorphine	285	355
Azaguanine	285	405

TABLE 1. PHENOLIC PHARMACEUTICAL PRODUCTS (Continued)

		<u>NANOMETERS</u>
Aminopterin	280, 370	460
Thiophenobarbital	280	470
Methotrexate	280, 375	460
Deserpidine	280	360
Renoxidine (reserpine N-oxide)	280	360
Reserpine	280	360
Trimethoxybenzoic Acid	280	360
Indole	280	340
Podophyllotoxin	280	325
Mc Niel	280	320
Flexin	280	320
Neocinchophen	275, 345	455
Tolserol	280	315
Procaine	275	345
Dromoran	275	320
Paredrin	275	300
Neosynephrin	270	305
Yohimbine	270	360
Synephrin	270	310
Phenobarbital	265	440
Pentobarital	265	440
Amytal	265	410

TABLE 1. PHENOLIC PHARMACEUTICAL PRODUCTS (Continued)

	<u>NANOMETERS</u>	
Acetylcolchinol	265	380
Thymol	265	300
Quinine	250, 350	450

Note: Measurements in mu

TABLE 2. NATURALLY OCCURRING PHENOLIC COMPOUNDS  
FOUND IN BIOLOGICAL MATERIALS

	<u>NANOMETERS</u>	
5-Hydroxykynurenine	375	460
Kynurenine	370	490
Folinic Acid	370	460
Thiochrome	370	445
3-Hydroxykynurenine	365	460
Pterotic Acid	365	450
Folic Acid	365	450
p-Hydroxycinnamic Acid	350	440
DPNH	340	435
5-Hydroxyanthranilic Acid	340	430
Pyridoxine	340	400
Pyridoxamine	335	400
Pyridoxal	330	385
Vitamin A	325	470
Kynurenic Acid	325	440
Kynurenic Acid	325	405
Uric Acid	325	370
3-Hydroxyanthranilic Acid	320	415
Xanthine	315	435
Anthranilic Acid	300	405
p-Hydroxymandelic Acid	300	380

TABLE 2. NATURALLY OCCURRING PHENOLIC COMPOUNDS  
 FOUND IN BIOLOGICAL MATERIALS (Continued)

		<u>NANOMETERS</u>
5-Hydroxyindolenetic Acid	300	355
Serotonin	295	540
p-Aminobenzoic Acid	295	345
Serotonin	295	340
Tocopherol	295	330
Tryptamine	290	360
5-Hydroxyindole	290	355
Equilin	290	345, 420
p-Hydroxyphenylpyruvic Acid	290	345
Homogentisic Acid	290	340
p-Hydroxyphenylserine	290	320
ATP	285	395
Adenylic Acid	285	395
Adenosine	285	395
Tryptophan	285	365
Guanine	285	365
Estradiol	285	330
3, 4-Dihydroxyphenylalanine	285	325
Estrone	285	325
3, 4-Dihydroxyphenethylamine	285	325
Adrenalin	285	325

TABLE 2. NATURALLY OCCURRING PHENOLIC COMPOUNDS  
 FOUND IN BIOLOGICAL MATERIALS (Continued)

	<u>NANOMETERS</u>	
Noradrenalin	285	325
p-Hydroxyphenethylamine	285	325
Adenine	280	375
Indole	280	355
3,4-Dihydroxyphenylacetic Acid	280	330
3,4-Dihydroxyphenylserine	280	320
p-Hydroxyphenylacetic Acid	280	310
Tyramine	275	310
Tyrosine	275	310
Vitamin B12	275	305
Riboflavin	270, 370, 445	520
Homovanillic Acid	270	315
Equilenin	250, 290, 340	370

Note: Measurements in  $m_{\mu}$  (millimicrons or nanometers)

	<u>NANOMETERS</u>	
Th-1-amino-4 hydroxyanthraquinone	550-580	660
Be-1-4-dihydroxy anthraquinone	530-570	630
Be-1-amino-4 hydroxyanthraquinone	530-560	620
Al-PBBR	470, 580	630
Al-AAGR	470	590
Re-morin	470	555-585
Al-morin	430	500
Zr-flavonol	400	465
A-Creatinine	390	495
B-Dimethyl-guanidine	390	495
C-Guanido Acetic Acid	390	495
D-Methy guandine	390	495
E-Aginine	390	495
F-Guandine	390	495
Li-oxine	370	580
B-benzoin	370	480
7-Hydroxyquinolines	370	490
Hydroxyquinolines	365	460
7-Hydroxycoumanins	365	460
Hydroxycoumanins	320	480

		<u>NANOMETERS</u>
0-Hydroxycinnamic (cis) (coumarinic acid)	365	510
0-Hydroxycinnamic (trans) (coumaric acid)	365	500
4-Pyridioxie Acid lactone	360	440-445
8-Naphthol	350	460
p-Hydroxycinnamic	350	440
3-Hydroxyquinolines	350	450 420-430
2:6-di (Y-resorcylic)	340	455
3-(10 ug./ml.) hydroxycoumanins	340	480
a-Naphthol	330	480
2-Hydroxyquinolines	325	380
2:5-di-(gentisic)	325	455
o-Hydroxydiphenyl	320	420
Warfairn in methanol	320	385
Potasan (in methanol)	320	385
3-Salicylic Acid	315	425
2,3-Dihydroxy indole	315	400
3,4,Dibenzpyrene 8,9	310, 335, 390, 410	480, 510
p-Hydroxydiphenyl	310	410
Hydroxycoumanins	310	390-400
4-(5 ug./ml.) hydroxycoumanins	310	360-380
Indoxyl	310	395
2:3-di-(catechuic)	305	440

	<u>NANOMETERS</u>	
1,12 Benzperylene	305, 375, 395	430
3:4-di-(protocatechuic)	300	370
Oxindole	300	345
p-Hydroxymandelic	300	380
8,9 Benzfluoranthrene	295, 330, 385, 405	480, 515
2-(salicylic acid)	295	420
2:4-di-(B-resorcylic)	295	400
3-Salicylic Acid	295	350
Naphthacene	290, 310	480, 515
1,2 Benzpyrene in cyclohexane	290, 330	410
Skatole	290	370
Methylaniline	290	360
p-Hydroxyphenylpyruvic	290	340-350
2:5-Dihydroxy (homogentisic)	290	340
Indoxyl acetate	285	375
Indole acetic acid in methanol	285	345
Quinol (1:4)	285	340
p-Cresol	285	315
2:4-Xylenol	285	310
Naphthacenene	280, 390, 415, 445	480
8-Methyl Fluorene	280, 290, 365	460-480
1-2 Benzanthrene	280, 340	390, 410

	<u>NANOMETERS</u>	
2-Methyl indole	280	355
Indole	280	350
Aniline	280	340
Aniline	280	340
3:4-Dihydroxy (homoprotocatechuic)	280	330
3:4-Dimethoxy	280	325
1-Artemol Bitartrate	280	320
1-Epinephrine Bitartrate	280	320
3:4-Xylenol	280	310
m-Cresol	280	305
4-Hydroxy	275	315
o-Cresol	275	305
2:6-Xylenol	275	305
3:4-trimethoxy-benzoic acid 5-	270	375
Catechol (1:2)	270	325
3-Hydroxy-4-methoxy (homovanillic)	270	315
Phenol	270	310
2-Hydroxy	270	310
Phenol	270	310
Anisole	270	300
Resorcinol (1:3)	265	315
3:4-Dibenzpyrene 9, 10	255, 290, 300 395, 415, 445	455, 485

	<u>NANOMETERS</u>	
Dimethylaniline	255	370
Guthione	250, 312	380
Chrysene	250, 300, 310	360, 380
n-Propylisome	248, 292	326
Piperonyl butoxide in methanol	248, 292	320
Benzanthrene	245, 325, 340	385, 400
1, 2, Dibenzpyrene 3, 4	230, 285, 305 325, 340, 375	440, 470
Naphthalene acetamide in methanol	230, 286	327
Naphthalene acetic acid	230, 282	325

Note: Measurements in  $m_{\mu}$  (millimicrons or nanometers)

#### IV. DAY-NIGHT PHOTOGRAPHY

Behavioral studies of the Primate Mission required black and white still and cine mode photography of the animal subject during both day and night periods while maintaining the day to night lighting intensity ratio at greater than 30:1 in the visible spectrum to maintain circadian response.

Plus X Pan-film was employed which has a dynamic range of only 8:1 with incandescent lighting, and therefore required two different exposure settings to obtain both day and night photographs if unfiltered incandescent lighting were employed. Because variable exposure represented major modification to the camera and to the electronic control components, a means was sought to provide high resolution day and night photography without such changes.

The system developed took advantage of the difference in spectral response of the film and the primates' eye. Because about one third of the film's response is in the visible range and two-thirds in the near infrared, the night light was filtered with a Wratten 70 (deep red) filter while the day light remained unfiltered. The resulting night light had a visible energy content 1/30 to 1/125 of that of the day light while maintaining a film-responsive energy content 1/2 to 1/8 that of the day light, or within the latitude of the film. Consequently, a single camera setting could then accommodate both day and night lighting conditions.

The influence of the white/red day/night lighting system on circadian response was tested at the Ames Research Center, using both chickens and primates. Normal circadian rhythms were reported.

#### UNIQUENESS

Although state-of-the-art technology was used in this method of black and white day-night photography, its application to medicine may provide costs savings where it is desired to provide unattended photography for recording visual observations of patients. Where the normal method involves changing exposure for different lighting conditions, less expensive equipment without automated exposure setting may be employed with the photography/lighting method described.

#### END PRODUCTS

Economical lighting and photography systems for automated time-lapse monitoring of psychiatric patients or high-security prison behavior may be an application of this technique. The application is straightforward with existing off-the-shelf cameras, lamps and filters.

## RECOMMENDED PROGRAM

Investigate the potential usefulness of day-night photographic techniques for monitoring different types of patients, e.g., psychiatric, pediatric etc., who require continuous or intermittent surveillance. This would include application of state of the art time-lapse or continuous cinema-photography with closed circuit (CCTV) options.

An initial program would call for an applications evaluation to determine the requirements of the medical profession for such a system. Based upon the outcome of this study, recommendations would be made to design and fabricate a prototype system which would be evaluated clinically.

# SCHEDULE PLANNING SHEET

PROGRAM NAME  
**DAY-NIGHT PHOTOGRAPHY**

RESP. ORGAN	PROG WORK IDENT	CUST TASK NO.	PREPARED BY	RM.	EXT.	DATE ISSUED	TITLE OF SEGMENT OF WORK
PURPOSE FOR ESTIMATE			APPROVALS	REFERENCES - P.P.I.NO.		REV.	OTHER

ITEM NO.	DESCRIPTION OF WORK ITEM	ELAPSED TIME SCHEDULE		
		(INDICATE YEARS/ QUARTERS/ MONTHS/ FISCAL WEEKS AS APPLICABLE)		
		#1	#2	#3
		MONTHS		
1.0	Prepare/Update Survey Criteria	▲		
2.0	Hospital Survey (Mail & Interview)	▲		
	2.1 Pediatric			
	2.2 Psychiatric			
	2.3 Geriatric			
3.0	Physicians Survey (Mail & Pers Inter)	▲		
	3.1 Private Practice			
	3.2 Hospital Only			
	3.1 Psychiatrists			
	3.2 Pediatricians			
	3.3 Others Requiring Patient			
	Surveillance			
4.0	Hospital Audio-Visual Survey	▲		
5.0	Final Report with Recommendations for Advanced Program	▲		

▲ = MILESTONES - DISCRETE, AUDITABLE EVENTS  
 E.G. - REPORT, HARDWARE DELIVERY, FLIGHT TEST, ETC.  
 ▲ = COMPLETED MILESTONES      ◊ = PROJECTED MILESTONE SLIP.  
 — = TIME PERIOD OF WORK          ◆ = SLIPPED MILESTONE

STATUS AS OF	
11-22-70	
PAGE	1 OF 1

VII-54

## V. NON-INVASIVE TECHNIQUES FOR PATIENT MONITORING

Survey, document, and/or develop non-invasive techniques to monitor/measure/analyze blood flow, volume, and rate plus blood pressure as applicable to patient monitoring.

This task is, in part, related to item I.

Present invasive methods using catheters and needles have at least the following disadvantages:

- Continuous monitoring is a problem in invasive techniques due to:
  - Patient usually required to be supine if not immobile
  - Patient discomfort or pain
  - Blood clotting and/or infection
  - Interface leakages
  - Perfusion for patency obscures readout
- High skill levels required to insert invasive devices

Areas for survey and investigation include application of

- Ultrasonic sensors
- Photo-optic sensors
- Magnetic sensors
- Breath/urine analyzers (chromatographs, colorimeters, etc.)
- IR Sensors (thermal gradients)
- Neutron radiography and other techniques potentially applicable from the non-destructive test domain

The following work items would have to be executed in order to effect this program:

institute/medical center contact and survey

requirements definition

efficacy analysis

design/fab recommendations

prototype discussions

periodic reporting

prototype development & test (not included in these preliminary costs)

final reporting

The following Schedule Planning Sheet outlines the estimated schedule.



VI. COMPUTER ANALYSIS TECHNIQUES FOR ECG, ARRYHTHMIA DETECTION AND CLASSIFICATION, ETC.

Evaluate and define arrhythmia detection techniques as associated with patient monitoring.

In performing this program the following will be executed:

- determine and define hardware and software requirements using electrocardiograph and vectorcardiograph signals
- determine related parameters and characteristics for verification and/or classification of arrhythmias
- evaluate, comparatively, the advantages of ECG vs VCG in patient monitoring applications

Typical tasks to be accomplished includes:

- center/institute surveys
- requirements/analysis and definition
- sample data collection and correlation
- program matrices and flow diagrams for patient monitoring application
- program development and debugging
- program validation
- patient monitoring handbook using the VCG/ECG
- VCG additions to patient monitoring specifications
- task review and discussion
- periodic reports
- final reports

The following Schedule Planning Sheet outlines the estimated schedule.

**SCHEDULE PLANNING SHEET**

<b>PROGRAM NAME</b> PMS STUDY FOLLOW-ON
<b>TITLE OF SEGMENT OF WORK</b> PMS APPLICATION OF VCG

<b>RESP. ORGAN</b>	<b>PROG WORK IDEN</b>	<b>CUST TASK NO.</b>	<b>PREPARED BY</b> M. A. MAIO	<b>RM.</b> 6425H	<b>EXT.</b> 2629	<b>DATE ISSUED</b> 11/20/70
<b>PURPOSE FOR ESTIMATE</b>			<b>APPROVALS</b>	<b>REFERENCES - P.P.I. NO.</b>		<b>REV. OTHER</b>

ITEM NO.	DESCRIPTION OF WORK ITEM	ELAPSED TIME SCHEDULE																																															
		(INDICATE YEARS/ QUARTERS/ MONTHS/ FISCAL WEEKS AS APPLICABLE ) WEEKS FROM INITIATION																																															
		00+												10+												20+												30+											
		0	1	2	3	4	5	6	7	8	9	0	1	2	3	4	5	6	7	8	9	0	1	2	3	4	5	6	7	8	9	0	1	2	3	4	5	6	7	8	9								
(1)	Equipment Surveys	—————▲																																															
(2)	Center/Institute Surveys	—————▲																																															
(3)	Requirements/Analysis & Definition	▲—————▲																																															
(4)	Sample Data Collection and Correlation	▲—————▲																																															
(5)	Program Matrices & Flow Diagrams for PMS Application													▲—————▲																																			
(6)	Program Devel. & Debug													▲—————▲																																			
(7)	Program Validation																									▲——▲																							
(8)	PM Handbook, VCG																									▲——▲																							
(9)	VCG additions to PMS Spec.																									▲——▲																							
(10)	Task Review & Discussion																									▲												▲											
(11)	Periodic Reports (Letters)	▲												▲												▲												▲											
(12)	Final Report																																					▲											

MAY BE ACCOMPLISHED IN PARALLEL WITH ITEM ONE AT NEARLY NO ADDITIONAL TIME

▲ = MILESTONES - DISCRETE, AUDITABLE EVENTS  
E.G. - REPORT, HARDWARE DELIVERY, FLIGHT TEST, ETC.

▲ = COMPLETED MILESTONES

◆ = PROJECTED MILESTONE SLIP

◆ = SLIPPED MILESTONE

———— = TIME PERIOD OF WORK

STATUS AS OF
PAGE
OF

69-11A

## VII. RESPIRATORY ANALYSIS

Investigate techniques, develop and document methods for accurate respiratory analysis that does not interfere with patients normal rhythm and flow, provide breath to breath capability.

Present techniques have one or more of the following characteristics:

- Large volume collectors lacking single breath collection capability for analysis
- Back pressure effect on respiration due to collected gas pressure; collector (tube, mask, etc.) impedance and/or gas supply pressure
- Problems of corrosion

Potential areas of investigation:

- All existing developments
- Environmental enclosures (helmet, face masks, partial tents)
- Multichambered, cyclic, pressure balanced collector distributor systems

The work items that would comprise the program outlined would include:

- vendor surveys
- institution and medical center survey
- requirements analysis and definition
- available equipment evaluation (available to hospitals)
- developmental equipment evaluate (not yet available to hospitals)
- propose modifications and/or new techniques/equipment
- develop and test/demonstrate prototype
- issue specification (preliminary)
- producibility engineering and fabrication/test of acceptance unit
- provide operations and maintenance handbooks
- task review and discussions; periodic reports
- final reports

# SCHEDULE PLANNING SHEET

PROGRAM NAME <b>PMS STUDY FOLLOW-ON</b>
TITLE OF SEGMENT OF WORK <b>ACCURATE RESPIRATORY MEAS.</b>
OTHER TECHNIQUES

RESP. ORGAN <b>R O M</b>	PROG WORK IDEN	CUST TASK NO.	PREPARED BY <b>M. A. MALO</b>	RM. <b>6425H</b>	EXT. <b>2629</b>	DATE ISSUED <b>11/20/70</b>
PURPOSE FOR ESTIMATE <b>R O M</b>			APPROVALS	REFERENCES - P.P.I.NO.		REV.

ITEM NO.	DESCRIPTION OF WORK ITEM	ELAPSED TIME SCHEDULE																																											
		(INDICATE YEARS/ QUARTERS/ MONTHS/ FISCAL WEEKS AS APPLICABLE ) WEEKS FROM INITIATION																																											
		00+						10+						20+						30+																									
		0	1	2	3	4	5	6	7	8	9	0	1	2	3	4	5	6	7	8	9	0	1	2	3	4	5	6	7	8	9	0	1	2	3	4	5	6	7	8	9	0			
(1)	Vendor Surveys	—————▲																																											
(2)	Institutional & Med. Center Surveys	—————▲																																											
(3)	Requirements Analysis & Definition	▲—————▲																																											
(4)	Available Equipment Evaluation (Available to Hospitals)					▲—————▲																																							
(5)	Evaluate Developmental Equipment (Not Yet Aval to Hospitals)					▲—————▲																																							
(6)	Propose Modifications and/or New Equipment/Techniques					▲—————▲																																							
(7)	Develop and Test/Demonstrate Prototype	NOT INCLUDED IN THIS ESTIMATE																																											
(8)	Issue Specification (Prelim)					▲—————▲																																							
(9)	Producibility Eng'g and Fab/Test of Acceptance Units	NOT INCLUDED IN THIS ESTIMATE																																											
(10)	Provide Ops & Maintenance Handbooks																			▲—————▲																									
(11)	Task Reviews & Discussions, Periodic Reports							▲								▲								▲																					
(12)	Final Reports																																					▲							

▲ = MILESTONES - DISCRETE, AUDITABLE EVENTS  
 E.G. - REPORT, HARDWARE DELIVERY, FLIGHT TEST, ETC.  
 ▲ = COMPLETED MILESTONES  
 ◆ = PROJECTED MILESTONE SLIP  
 ◆ = SLIPPED MILESTONE  
 ——— = TIME PERIOD OF WORK

STATUS AS OF
PAGE
OF

I9-IIA

### VIII. SENSOR CONNECTOR STANDARDIZATION

Develop and document standards and requirements for a connector series for EEG, ECG/VCG, GSR, transducers, signal conditioners, and include types for standard lead wire, cable and coax.

The work items necessary to effect the program is as follows:

- survey current usage/requirements (medical institutes, centers, etc.)
- survey market (connector manufacturers)
- define detail requirements (preliminary standards)
- task review and discussion
- update and submit specification for industry review
- review, evaluate, and/or integrate industry comments
- test designs, provide "approved parts list, vendor list"
- periodic reports
- final reports

The following Schedule Planning Sheet outlines the estimated schedule.

# SCHEDULE PLANNING SHEET

PROGRAM NAME <b>PMS STUDY - FOLLOW ON</b>
TITLE OF SEGMENT OF WORK <b>CONNECTOR</b>
STANDARD

RESP. ORG. PROG. WORK IDEN. CUST. TASK NO.	PREPARED BY	RM.	EXT.	DATE ISSUED
PURPOSE FOR ESTIMATE	APPROVALS	REFERENCES - P.P.I. NO.	REV.	

ITEM NO.	DESCRIPTION OF WORK ITEM	ELAPSED TIME SCHEDULE																																										
		(INDICATE YEARS/ QUARTERS/ MONTHS/ FISCAL WEEKS AS APPLICABLE ) WEEKS FROM INITIATION																																										
		00+				10+				20+				30+				40+																										
		0	1	2	3	4	5	6	7	8	9	0	1	2	3	4	5	6	7	8	9	0	1	2	3	4	5	6	7	8	9	0	1	2	3	4	5	6	7	8	9	0	1	2
(1)	Establish Standards Format	—————▲																																										
(2)	Survey Current Usage/Rqmts. (Med. Inst., Centers, etc.)	—————▲																																										
(3)	Survey Market (Connector Manufacturers)	—————▲																																										
(4)	Define Detail Requirements (Preliminary Standards)					▲—————▲																																						
(5)	Task Review & Discussion													▲																														
(6)	Update and Submit Spec for Industry Review (HEW Document?)													▲—————▲																														
(7)	Review, evaluate and/or Integrate Industry Comments													▲—————▲																														
(8)	Test Designs, provide "Approved Part List, Vendor List"	NOT DEFINABLE UNTIL QUANTITY & DESCRIPTIONS AVAIL. - NOT INCLUDED -																																										
(9)	Periodic Reports					▲				▲				▲																														
(10)	Final Report																																											

▲ = MILESTONES - DISCRETE, AUDITABLE EVENTS  
E.G. - REPORT, HARDWARE DELIVERY, FLIGHT TEST, ETC.

▲ = COMPLETED MILESTONES

◇ = PROJECTED MILESTONE SLIP

————— = TIME PERIOD OF WORK

◆ = SLIPPED MILESTONE

STATUS AS OF
PAGE
OF

VII-63

## IX. SENSOR MATERIALS AND ATTACHMENT REQUIREMENTS STUDY

Investigate, develop and document requirements for sensor materials and attachment (sensor - patient, interface) techniques with intent of promulgating standardization and providing producibility effort to expedite availability of "production" items.

- Determine optimum size, shape and materials for various sensors (evaluate multitude now available and proposed items)
- Define, develop and document attachment requirements and existing techniques for long term, short term, disabled, ambulatory and exercise type applications

### EXAMPLE:

EEG sensor fastened by Velcro to a shaped inflatable belt that provides both placement and pressure; consider effect of pressure on respiration and subsequent interpretation of data.

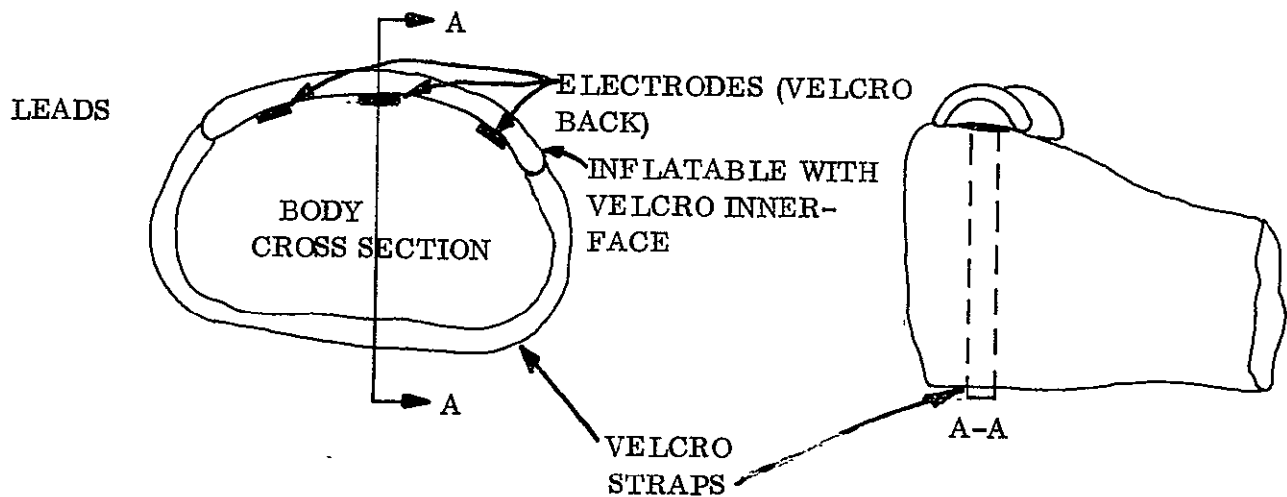

The work tasks involved in executing the above are as follows:

- utilization surveys & manufacturer surveys/requirements
- requirements definition
- task review and discussion
- issue update requirements document

- fabricate and test prototype systems or test and document result of submitted systems
- review industry comments, etc. - update specification
- periodic reports
- final report

# SCHEDULE PLANNING SHEET

PROGRAM NAME  
**PMS STUDY FOLLOW-ON**

RESP. ORG.	PROG WORK IDEN	CUST TASK NO.	PREPARED BY	RM.	EXT.	DATE ISSUED	TITLE OF SEGMENT OF WORK
PURPOSE FOR ESTIMATE			APPROVALS	REFERENCES - P.P.I.NO.		REV.	OTHER

ITEM NO.	DESCRIPTION OF WORK ITEM	ELAPSED TIME SCHEDULE																																																																							
		(INDICATE YEARS/ QUARTERS/ MONTHS/ FISCAL WEEKS AS APPLICABLE)																																																																							
		00+												10+												20+												30+												40+												50+											
		0	1	2	3	4	5	6	7	8	9	0	1	2	3	4	5	6	7	8	9	0	1	2	3	4	5	6	7	8	9	0	1	2	3	4	5	6	7	8	9	0	1	2	3	4	5	6	7	8	9	0	1	2	3	4	5	6	7	8	9	0	1	2	3	4	5	6	7	8	9		
(1)	Requirements Study	—————▲																																																																							
(2)	Utilization Surveys & Manufacturer Surveys/Reports	—————▲																																																																							
(3)	Requirements Definition													▲————▲																																																											
(4)	Task Review & Discussion													▲																																																											
(5)	Issue Updated Requirements Document													▲																																																											
(6)	Fabricate & Test Prototype Systems or Test and Document Results of Submitted Systems	(NOT INCLUDED FOR THIS WORK PACKAGE)																																																																							
(7)	Review Industry Comments, etc. - Update Specification																									▲—▲																																															
(8)	Periodic Reports													▲												▲												▲																																			
(9)	Final Report																																					▲																																			

▲ = MILESTONES - DISCRETE, AUDITABLE EVENTS  
 E.G. - REPORT, HARDWARE DELIVERY, FLIGHT TEST, ETC.

▲ = COMPLETED MILESTONES

◆ = PROJECTED MILESTONE SLIP

◆ = SLIPPED MILESTONE

———— = TIME PERIOD OF WORK

STATUS AS OF \_\_\_\_\_

PAGE \_\_\_\_\_

OF \_\_\_\_\_

99-IIA

## X. POSITIVE CONTROL OF IV FLUID DISPENSING

Investigate and demonstrate non-gravity techniques of IV fluid dispensing - to avoid holding or hanging of bottles and bags, etc. and develop a better means for controlled infusion. One system recently developed by a southern university in response to needs of medical profession uses plastic bags compressed by negator springs. An interesting alternate is a double bag with a gas cartridge. See the diagram below.

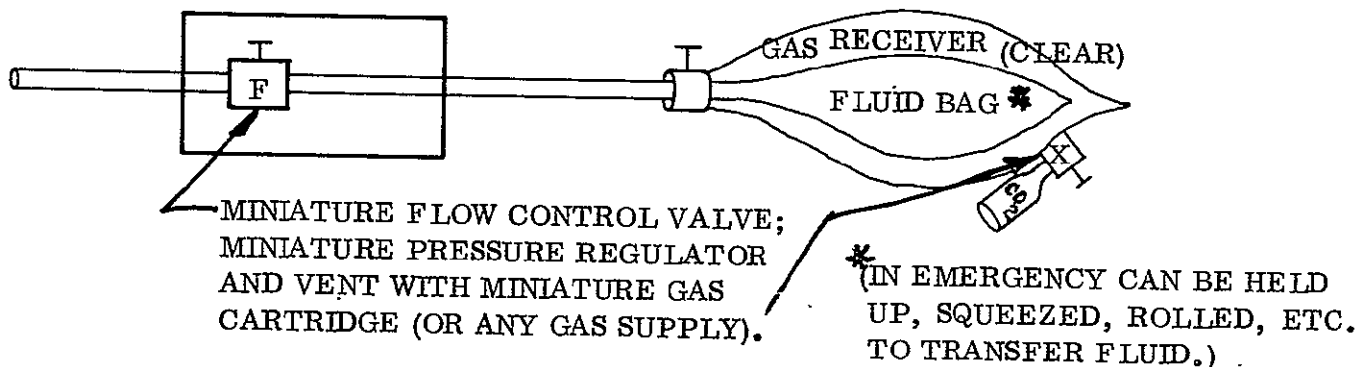

The work items that must be effected in order to accomplish the program are as follows:

- evaluate existing alternate means
- evaluate the need/vs approximate costs
- define requirements
- fabricate and test prototypes
- system review and discussion
- issue detail specification
- fabricate demonstration units
- periodic reports
- final report



XI. STANDARD AMPLIFIERS AND SIGNAL CONDITIONERS REQUIREMENTS SPECIFICATION

Investigate availability and capabilities of standard amplifiers - signal conditioners, i.e., modules with selectable input/output impedance, gain change, etc., such that they are adaptable and interchangeable as well as cost effective. Generate requirements for desirable units.

The work tasks for completing this project are as follows:

- survey equipment in use
- evaluate equipment in use
- contact manufacturers and determine equipment designed and/or available
- define requirements (preliminary specifications)
- review and discussion
- update and issue to industry
- review and/or incorporate applicable comment from industry
- provide equipment/vendor listing
- periodic reports
- final report

The following Schedule Planning Sheet outlines the estimated schedule.

# SCHEDULE PLANNING SHEET

PROGRAM NAME <b>PMS STUDY - FOLLOW-ON</b>
TITLE OF SEGMENT OF WORK <b>STANDARD AMPLIFIER FOR</b>
<b>MULTIPLE USE - PM SYSTEMS</b>

RESP. ORGAN	PROG WORK IDEN	CUST TASK NO.	PREPARED BY	RM.	EXT.	DATE ISSUED
PURPOSE FOR ESTIMATE			APPROVALS	REFERENCES - P.P.I. NO.		REV.

ITEM NO.	DESCRIPTION OF WORK ITEM	ELAPSED TIME SCHEDULE																																																		
		(INDICATE YEARS/ QUARTERS/ MONTHS/ FISCAL WEEKS AS APPLICABLE )																																																		
		00+										10+										20+										30+																				
		0	1	2	3	4	5	6	7	8	9	0	1	2	3	4	5	6	7	8	9	0	1	2	3	4	5	6	7	8	9	0	1	2	3	4	5	6	7	8	9	0										
(1)	Survey Equipment in Use	—		▲																																																
(2)	Evaluate Equip. In Use	—		▲																																																
(3)	Con tact Manufacturers Determine Equipment Designed and/or available.				▲	—				▲																																										
(4)	Define Requirements (Preliminary Specifications)							▲	—				▲																																							
(5)	Review and Discussion												▲																																							
(6)	Update and Issue to Industry												▲	—		▲																																				
(7)	Review and/or Incorporate Appli- cable Comment from Industry															▲	—			▲																																
(8)	Provide Equipment/Vendor Listing																			▲	—		▲																													
(9)	Periodic Reports											▲																																								
(10)	Final Report																					▲																														

▲ = MILESTONES - DISCRETE, AUDITABLE EVENTS  
E.G. - REPORT, HARDWARE DELIVERY, FLIGHT TEST, ETC.

▲ = COMPLETED MILESTONES

◊ = PROJECTED MILESTONE SLIP

— = TIME PERIOD OF WORK

◆ = SLIPPED MILESTONE

STATUS AS OF
PAGE
OF

XII. STANDARD MEASUREMENTS LISTS, STANDARD DERIVATIONS, TERMINOLOGY, ETC., FOR PATIENT MONITORING

Accomplish the documentation (and/or development) of Measurement Lists, Standard Derivations, Terminology, etc., including dimensions and "conditions" under which they are valid for application to patient monitoring data processing and handling.

For example there are about nine formulas for determining body volume from weight and height (body volume is used for example in determination of cardiac index) - the hardware and software designers need be told which formula is required to be used for each particular calculation.

The work tasks for executing the project are as follows:

- review data derivations (via tests, advisory committee, consulting doctors)
- expand patient monitoring system measurement list definition for derivations
- delineate measurement methodology - computational methodologies and variations
- detail evaluation of sample rates, accuracies, etc., for each patient monitoring system application
- update measurement list for specifications per (4)
- provide initial data processing and handling specification criteria
- periodic reports
- final report

The following Schedule Planning Sheet outlines the estimated schedule.



### XIII NARROW BAND VIDEO SYSTEMS FOR REMOTE PATIENT MONITORING, CONSULTATION, AND DIAGNOSIS

#### 1. INTRODUCTION

It has been generally accepted that video systems can play a basic part in the health field for both remote observation of patients and for access to diagnostic measurements, tables and files of symptomology when consultation and personal presence is not available. Examples of such instances include remote clinic operations in rural and ghetto areas, disaster area and shipboard emergencies, first aid, and anywhere where medical assistance is limited.

The systems should be adaptable so that consultants in one field can consult with specialists in allied fields, or in the same field to give support to their diagnoses.

With the widespread use of such video systems in conjunction with physiological data systems, it can be foreseen that not only will the physicians and patients benefit, but monitoring physicians can continue their association and education with their procedures transmitted and discussed. Recordings of the transmissions including both video and related data will form a bank of medical information for future review by students and practitioners. The technique may be used in some cases to accelerate the student's exposure to a large cross section of cases, and thus to broaden his education.

However, normal video signals require a wideband transmission media of the order of 4-8 MHz bandwidth, such as a coaxial cable or microwave circuit. These media are costly, and require special semi-permanent installation. It should therefore be a design objective that the video be transmitted over inexpensive telephone circuits and provide a close man-machine relationship between patients, paramedics, physicians and consultants; this objective, moreover, must be realized taking into account the requirements of resolution, must be realized taking into account the requirements of resolution, grey scale or color quality, and commercial error rates, over all available communications media including cable, microwave and satellite.

#### 2. RECOMMENDED DESIGN STUDY APPROACH

For the purpose of explanation, bandwidth can be expressed by the relation:

$$\text{Bandwidth} \propto \left( \begin{array}{c} \text{No. of picture} \\ \text{elements} \end{array} \right) \times \left( \begin{array}{c} \text{No. of grey or} \\ \text{color levels} \end{array} \right) \times \left( \begin{array}{c} \text{Frame} \\ \text{Rate} \end{array} \right)$$

The number of picture elements and the number of grey or color levels required for medical purposes shall be a subset of this study; however, it may be assumed that the minimum requirements are comparable with commercial television standards. Accordingly, for bandwidth reduction it is considered that the frame rate is the prime candidate for achieving the design goals.

Techniques are available for implementing reduced frame rate video including:

a. At the transmitting end: -

Slowspeed scan cameras  
Storage tube converters with standard cameras  
Sampling scan converters with standard cameras

b. At the receiving end: -

Storage monitor CRT's each with one standard monitor.  
Storage tube scan converters with standard monitors.  
Magnetic disc scan converters with standard monitors.

According to available information, "snap-shot" representation with a new frame displayed instantaneously on the order of once every 10 seconds may be an acceptable design approach for medical video systems.

### 3. RECOMMENDED TASK

It is recommended that a technical and clinical evaluation be held to identify a practical cost-effective, narrow band video system for the health field within the current state-of-the-art, and to establish subjective signal-to-noise and resolution standards for such a system.

The following equipment would be required for this evaluation:

	<u>Reference Table 1</u>
Slow Scan TV camera (modified)	A-1
Standard Vidicon with Princeton Electronic PEP400 Storage terminal	A-2(b)/B-1
Video Magnetic Disc Scan Converter	B-2
Standard Video Monitors	

This equipment will enable a comparison to be made between the performance of:

1. Slow scan camera versus storage tube transmission, and
2. Storage tube versus magnetic disc scan conversion.

The evaluation should not however be limited to using the equipment above described, and any other equipment identified as being applicable would be evaluated by mutual agreement.

An Implementation Plan for the proposed evaluation is shown in the attached schedule planning sheet.

## TABLE 1

### TYPICAL TRANSMISSION & RECEPTION EQUIPMENT

#### (A) Transmission Equipment (See Figure 1)

Based upon a 1 in 10 frame rate, the following transmission equipment is available for use, either in development or production state:

##### 1. Slow Scan TV Cameras

Most vidicon cameras can be used for slow scan transmission, however with modifications to the deflection system.

For special high resolution the General Electric 1" (Z7872, Z7873 and Z7894) and 1 1/2" (Z7921 and Z7940) FPS Vidicons are available with magnetic, electrostatic or hybrid deflection and focusing designed for military and space cameras. These tubes have been used for up to 1600 lines resolution in the focus projection and scanning mode.

The RCA 1" (RCA-7735) Vidicons are specified for resolutions up to 900 lines.

A review will be made to determine applicability of these tubes with the necessary modifications for their use in commercial cameras.

##### 2. Storage Tube Converters

(a) Marconi 3V21 camera capable of 800 lines resolution at the center and 650 lines at the corners of the picture, and standard sweeps of 525 and 800 lines, modified with a Westinghouse Permachron Tube WX-5123

(b) Standard Vidicon camera GE-TE33; and Princeton Electronic Products PEP400 storage terminal using a Lithicon storage tube. The tube has a resolution of 800 or 1200 lines.



3. Magnetic Disc Converters

Standard Vidicon Camera GE-TE33; and Colorado Video Magnetic Disc 220B to convert 525 line video to slow scan video with selectable bandwidth of 8, 4, 2, 1 or 0.5 KHz

4. Sampling Scan Converters

Standard Vidicon Camera GE-TE33; and Colorado Video Converter/transmitter VC201B which compresses the video bandwidth to the audio range of 8, 4, 2, 1 or 0.5 KHz as desired. Time taken to reproduce a single frame will vary from 7 seconds to 2 minutes according to the bandwidth selected.

(B) Reception Equipment (See Figure 1)

Video processing equipment to receive the slow scan video and convert it to 30 frames/sec. 525 line or 800 line video for display on standard video monitors.

1. Princeton Electronics Storage Tube Scan Converter PEP 400, using a Lithicon storage tube (See 3.2 above) for storage of the incoming video at slow rate and simultaneous playback at conventional rates. A separate converter is required for each video channel.
2. Colorado Video Magnetic Disc Scan Converter 220B, using a rotating video memory disc to store the sampled picture with a frame rate of between 4 seconds and 2 minutes. The converter is available in one, two, three and four channel versions.
3. Data Disc Video Disc Files capable of storing up to 600 images from the disc's 600 separate tracks. Is designed specifically for pulsed and time-lapsed fluoroscopy including instant history, image subtraction and animation.

TRANSMITTING END:

RECEIVING END:

1. SLOW SCAN

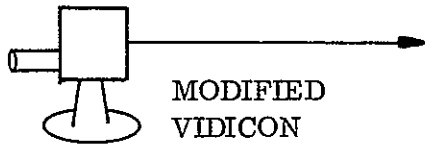

MODIFIED VIDICON

2. STORAGE TUBE CONVERTERS

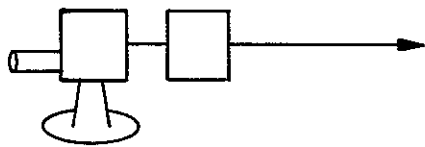

- A. STANDARD VIDICON WITH LITHOCON STORAGE TUBE OR
- B. MODIFIED CAMERA WITH PERMACHRON STORAGE TUBE

3. MAGNETIC DISC CONVERTERS

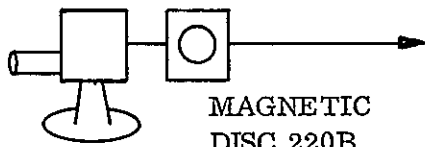

STANDARD VIDICON  
MAGNETIC DISC 220B

4. SAMPLE SCAN CONVERTERS

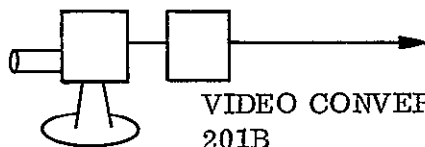

STANDARD VIDICON  
VIDEO CONVERTER 201B

1. STORAGE TUBE SCAN CONVERTERS



LITHOCON STORAGE TUBE  
VIDEO MONITOR

2. STORAGE DISC SCAN CONVERTERS

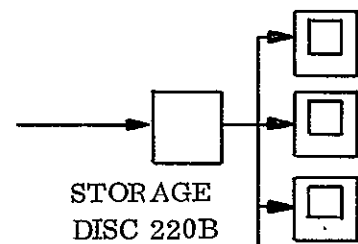

STORAGE DISC 220B  
VIDEO MONITORS

Figure 1. Transmitting and Receiving Equipment



## XIV A STUDY TASK LEADING TO EVALUATION OF THE PACE/RHO AUTOMATIC URINE ANALYSIS EQUIPMENT FOR CLINICAL APPLICATION

### 1.0 INTRODUCTION

The Pace/Rho system was designed to provide real time analysis of urinary calcium, creatine and creatinine during the 30 day Mission of the Biosatellite.

### 2.0 UNIQUE TECHNOLOGY

This system (11.75 long x 5.5" high x 6.0" deep) contained a fluid handling block; calcium analyzer; creatinine-creatinine analyzer; reagent reservoirs, reagents; calibration fluid reservoirs; optical read out unit; metering pumps; pressure regulator; timers; and associated electronic equipment (Figure XIV-1).

Two milliliter aliquots of urine were sequentially analyzed according to a pre-determined schedule or on command from a ground station. Data transmitted included the concentrations and temperature of calcium, creatine and creatinine, the number of samples and dilutions, and engineering status (power, lamps, internal temperature and pressure). In addition, provisions was made for flushes between samples and automatic calibration with pre-loaded calibration fluids.

Based on the compactness of this unit and its flight proven reliability, it would be of interest to investigate application of the automated Pace/Rho urine analysis techniques to analyses of clinical interest. This would include those normally accomplished on a "routine" basis in clinical chemistry laboratories as well as specialized analyses required for research activities. Initial emphasis would be placed on urine analysis but may later be extended to include blood serum analysis.

### 3.0 PRELIMINARY STUDIES AND GOALS

An initial program would include survey and evaluation of requirements for manual and automatic urine analysis. Emphasis would be placed on comparing specifications of available manual instrumentation and evaluation of adopting and integrating that methodology, identifying specific tests and techniques which appear amendable to the automated Pace/Rho approach. Application of membrane technology, toxicity studies, electrode separation techniques and related methods will be evaluated in conjunction with the automated colorimetric techniques employed in the Biosatellite system for application to a urinalysis system for patient monitoring. Blood serum analysis capabilities will also be evaluated.

A prototype system breadboard with capability for automatic analysis of parameters critical to cardio-vascular and pulmonary patients will be developed and tested (extensive measurement capability will be developed but may not be breadboarded within the cost structure defined).

**SCHEDULE PLANNING SHEET**

PROGRAM NAME **CLINICAL APPLICATIONS PACE/RHO**

RESP. ORG.	PROG. WORK IDEN.	CUST. TASK NO.	PREPARED BY	RM.	EXT.	DATE ISSUED	TITLE OF SEGMENT OF WORK
PURPOSE FOR ESTIMATE			APPROVALS	REFERENCES - P.P.I.NO.		REV.	OTHER

ITEM NO.	DESCRIPTION OF WORK ITEM	ELAPSED TIME SCHEDULE		
		(INDICATE YEARS/ QUARTERS/ MONTHS/ FISCAL WEEKS AS APPLICABLE)		
		#1	#2	#3
1.0	REQUIREMENTS DEFINITION	[Timeline bar from start to approx. 1.5 months]		
	1.1 URINE ANALYSIS	[Timeline bar from start to approx. 0.5 months]		
	1.11 MANUAL TECHNIQUES	[Timeline bar from start to approx. 0.5 months]		
	1.12 MANUAL VARIATIONS	[Timeline bar from start to approx. 0.5 months]		
	1.13 AUTOMATIC TECHNIQUES	[Timeline bar from start to approx. 0.5 months]		
	1.14 AUTOMATIC EQUIPMENT	[Timeline bar from start to approx. 0.5 months]		
2.0	SERUM ANALYSIS	[Timeline bar from approx. 0.5 months to 1.5 months]		
	2.1 MANUAL TECHNIQUES	[Timeline bar from approx. 0.5 months to 1.5 months]		
	2.11 MANUAL VARIATIONS	[Timeline bar from approx. 0.5 months to 1.5 months]		
	2.12 AUTOMATIC TECHNIQUES	[Timeline bar from approx. 0.5 months to 1.5 months]		
	2.13 AUTOMATIC EQUIPMENT	[Timeline bar from approx. 0.5 months to 1.5 months]		
3.0	COMPARATIVE ANALYSIS OF TECHNIQUES & EQUIPMENT	[Timeline bar from approx. 1.5 months to 2.5 months]		
4.0	FINAL REPORT	[Timeline bar from approx. 2.5 months to 3.0 months]		

▲ = MILESTONES - DISCRETE, AUDITABLE EVENTS  
 E.G. - REPORT, HARDWARE DELIVERY, FLIGHT TEST, ETC.  
 ▲ = COMPLETED MILESTONES  
 ◊ = PROJECTED MILESTONE SLIP  
 ◆ = SLIPPED MILESTONE  
 ——— = TIME PERIOD OF WORK

STATUS AS OF
PAGE
OF

08-111

## XV. DEVELOPMENT OF AN AUTOMATED URINE COLLECTION AND MEASUREMENT SYSTEM

### 1.0 TECHNOLOGY DESCRIPTION

Urine collection and measurement was accomplished on the Biosatellite Primate Mission to provide urine for analysis (See XIV) and to maintain the cabin habitable for the primate. This task was accomplished with a 100 milliliter capacity collector, a peristaltic pump and a metering valve (10 cc), see Biosatellite Technology Summary. It is proposed that a prototype system, based on this technology, be developed and clinically demonstrated.

### 2.0 RECOMMENDED PROGRAM

Early verification of the applicability of the biosatellite type system may be demonstrated utilizing available biosatellite hardware. Conversion of the equipment design to satisfy clinical application and remove aerospace constraints would be followed by fabrication, installation and checkout of a prototype operational unit in a receptive hospital (approximately four months after contractual authority to proceed). Technical liaison, data evaluation and reporting in support of the hospital staff would be accomplished over a three month period.

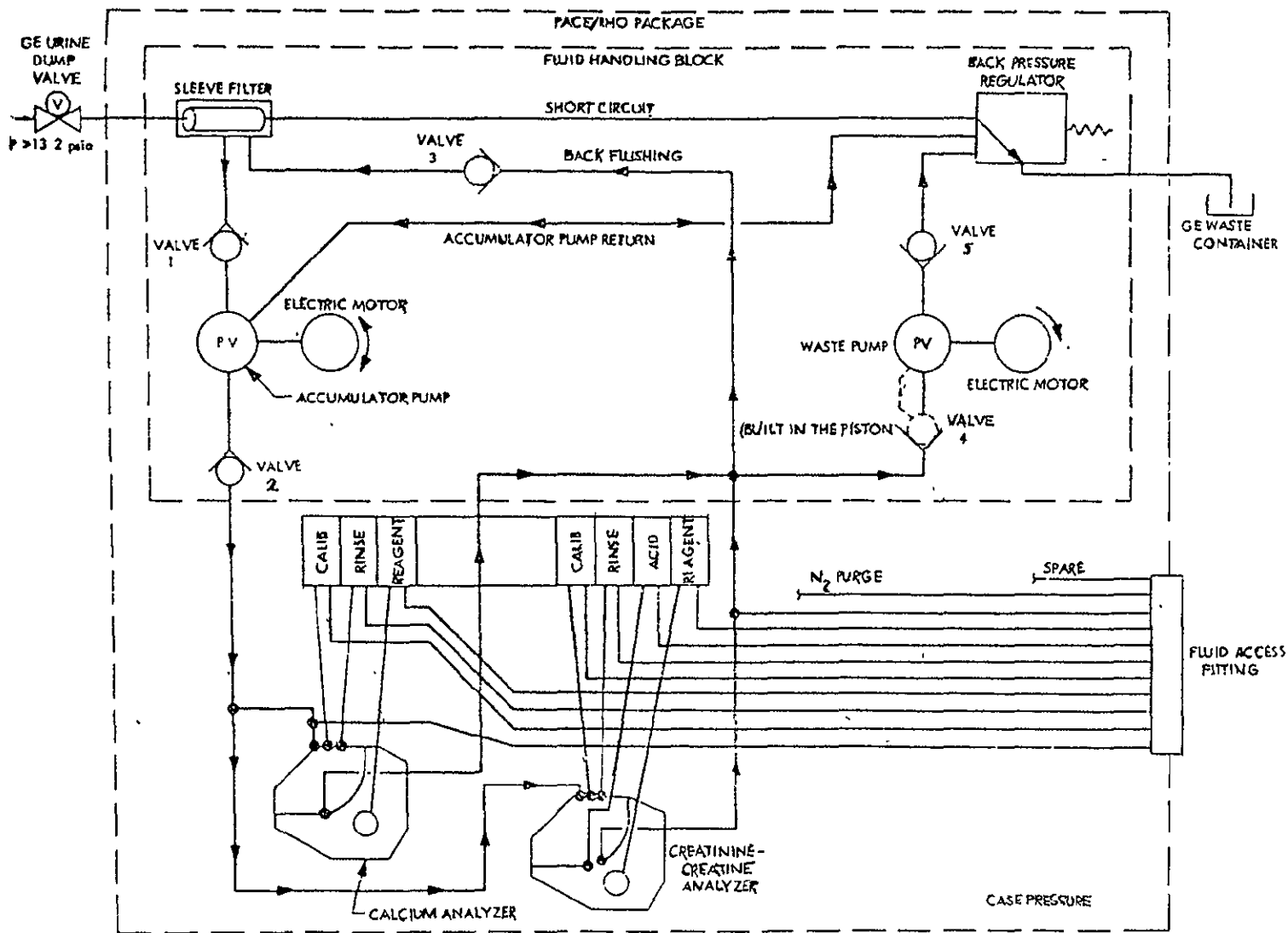



## Preliminary Design of PMS

The work performed on the study contract has resulted in the evolution of a conceptual design for a patient monitoring system. The concept utilizes a modular approach, and marries advanced state-of-the-art medical techniques to available low-cost high-performance minicomputers. The result is a system which will have wide applicability to a variety of hospitals by fulfilling a multiplicity of needs with the same basic equipment.

To realize the full benefit of the study effort, it is recommended that the conceptual design be further developed and refined to evolve a hardware and software oriented design which can then be implemented. This detailed design work is further delineated by the following tasks:

### Task Descriptions -

1. Review conceptual design and iterate requirements. Factor in results of consultations with the study contract advisory board, and the reactions of hospitals who would be potential users of the system. Finalize measurement parameters and modular breakdowns.
2. Perform trade-offs in significant areas, including computation, data transmission, display techniques, sampling rates, blood and urine analysis techniques. Select approaches for system implementation, considering overall cost efficiency, patient usage, medical acceptance.
3. Review available hardware and software to establish the state-of-the-art. Select hardware approaches and software programs and algorithms to implement the functions required. Factor in the results of current or planned R&D activities to ensure the current and future timeliness of the system, including growth potential.
4. Perform breadboard and computer simulation tests as necessary to validate the selection of hardware and software techniques. Iterate the design based on the results of these tests.
5. Generate system documentation, including equipment specifications, software specifications, interconnection diagrams, block diagrams, timing and logic diagrams where appropriate, manufacturing and test plans.
6. Generate an estimate of costs to build, install and test the system, based on quotations from vendors and estimates by the system contractor.

# SCHEDULE PLANNING SHEET

PROGRAM NAME  
**PATIENT MONITORING**

RESP. ORG.	PROG WORK IDEN	CUST TASK NO.	PREPARED BY	RM.	EXT.	DATE ISSUED	TITLE OF SEGMENT OF WORK <b>PRELIMINARY DESIGN OF PMS</b>
PURPOSE FOR ESTIMATE			APPROVALS	REFERENCES - P.P.I.NO.		REV.	OTHER

ITEM NO.	DESCRIPTION OF WORK ITEM	ELAPSED TIME SCHEDULE																													
		(INDICATE YEARS/ QUARTERS/ MONTHS/ <u>FISCAL WEEKS</u> AS APPLICABLE) From Go-Ahead																													
TASK		1	5	10	15	20	25																								
1.0	REVIEW CONCEPTUAL DESIGN AND ITERATE REQUIREMENTS	▼		▲																											
2.0	PERFORM TRADE-OFFS AND SELECT IMPLEMENTATION APPROACHES		▼			▲																									
3.0	REVIEW STATE-OF-THE-ART AND SELECT HARDWARE AND SOFTWARE			▼				▲																							
4.0	PERFORM BREADBOARD AND SIMULATION TESTS				▼				▲																						
5.0	GENERATE SYSTEM DOCUMENTATION						▼																								
6.0	GENERATE COST ESTIMATE									▼																					

△ = MILESTONES - DISCRETE, AUDITABLE EVENTS  
E.G. - REPORT, HARDWARE DELIVERY, FLIGHT TEST, ETC.

▲ = COMPLETED MILESTONES

◊ = PROJECTED MILESTONE SLIP

— = TIME PERIOD OF WORK

◆ = SLIPPED MILESTONE

STATUS AS OF	
PAGE	OF

58-114

**GENERAL  ELECTRIC**